



# Installation and Operation Manual

## Side Discharge AC Models

*For coastal applications where units are installed within one (1) mile of salt water, epoxy coated models are recommended. These models have an 8 week lead time after order.*

### Epoxy Coated Model

4TTL6018A1000A  
4TTL6024A1000A  
4TTL6030A1000A  
4TTL6036A1000A  
4TTL6042A1000A  
4TTL6048A1000A  
4TTL6060A1000A

4TTL6018A1COTA  
4TTL6024A1COTA  
4TTL6030A1COTA  
4TTL6036A1COTA  
4TTL6042A1COTA  
4TTL6048A1COTA  
4TTL6060A1COTA

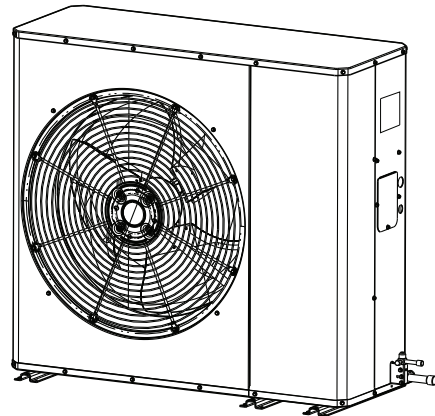

*Note: "Graphics in this document are for representation only. Actual model may differ in appearance."*

### **▲ SAFETY WARNING**

Only qualified personnel should install and service the equipment. The installation, starting up, and servicing of heating, ventilating, and air-conditioning equipment can be hazardous and requires specific knowledge and training. Improperly installed, adjusted or altered equipment by an unqualified person could result in death or serious injury. When working on the equipment, observe all precautions in the literature and on the tags, stickers, and labels that are attached to the equipment.



# SAFETY SECTION

**Important** — This document contains service information. This is customer property and is to remain with this unit. Please return to service information pack upon completion of work.

## ⚠ WARNING

### HAZARDOUS VOLTAGE!

Failure to follow this Warning could result in property damage, severe personal injury, or death.

Disconnect all electric power, including remote disconnects before servicing. Follow proper lockout/tagout procedures to ensure the power cannot be inadvertently energized.

## ⚠ WARNING

### REFRIGERANT OIL!

Failure to follow this Warning could result in property damage, severe personal injury, or death.

These units use R-410A refrigerant which operates at 50–70% higher pressures than R-22. Use only R-410A approved service equipment. Refrigerant cylinders are painted a “Rose” color to indicate the type of refrigerant and may contain a “dip” tube to allow for charging of liquid refrigerant into the system. All R-410A systems use a POE oil that readily absorbs moisture from the atmosphere. To limit this “hygroscopic” action, the system should remain sealed whenever possible. If a system has been open to the atmosphere for more than 4 hours, the compressor oil must be replaced. Never break a vacuum with air and always change the driers when opening the system for component replacement. For specific handling concerns with R-410A and POE oil, reference Retrofit Bulletin TRN-APG02-EN.

## ⚠ CAUTION

### HOT SURFACE!

May cause minor to severe burning. Failure to follow this Caution could result in property damage or personal injury.

Do not touch top of compressor.

## ⚠ CAUTION

### CONTAINS REFRIGERANT!

Failure to follow proper procedures can result in personal illness or injury or severe equipment damage.

System contains oil and refrigerant under high pressure. Recover refrigerant to relieve pressure before opening system.

## ⚠ CAUTION

### GROUNDING REQUIRED!

Failure to inspect or use proper service tools may result in equipment damage or personal injury. Reconnect all grounding devices. All parts of this product that are capable of conducting electrical current are grounded. If grounding wires, screws, straps, clips, nuts, or washers used to complete a path to ground are removed for service, they must be returned to their original position and properly fastened.

## ⚠ WARNING

### SERVICE VALVES!

Failure to follow this warning will result in abrupt release of system charge and may result in personal injury and/or property damage. Extreme caution should be exercised when opening the Suction and Liquid Line Service Valve. Turn valve stem counterclockwise only until the stem contacts the rolled edge. No torque is required.

## ⚠ WARNING

### BRAZING REQUIRED — IF USING MECHANICAL CONNECTIONS, ENSURE LEAK TEST IS NEGATIVE!

Failure to inspect lines or use proper service tools may result in equipment damage or personal injury. If using existing refrigerant lines make certain that all joints are brazed, not soldered.

## ⚠ WARNING

### Warning!

This product can expose you to chemicals including lead which are known to the State of California to cause cancer and birth defects or other reproductive harm.

For more information go to [www.P65Warnings.ca.gov](http://www.P65Warnings.ca.gov)

**Important:** If using other than copper pipe, follow manufacturer’s installation instructions. Joints must be brazed or other UL/IMC/URMC approved joint that meets pressure requirements.



# Table of Contents

Unit Location Considerations.....	4	System Start Up.....	18
Unit Location Considerations.....	6	Subcooling Charging in Cooling between 55° F and 120° OD Ambient.....	19
Unit Preparation.....	8	System Charge Adjustment.....	20
Setting Up the Unit.....	8	Refrigerant Charging Chart.....	21
Refrigerant Line Considerations.....	9	Subcool Charging Charts.....	22
Refrigerant Line Brazing.....	12	Charging the Unit.....	23
Refrigerant Line Leak Check.....	14	Checkout Procedures.....	25
Refrigerant Line and Indoor Coil Evacuation.....	14	Wiring Diagrams.....	26
Service Valves.....	15	Pressure Curves.....	30
Electrical — Low Voltage Non Communicating.....	16		
Low Voltage Hook-up Diagrams.....	16		
Electrical — High Voltage.....	17		



# Unit Location Considerations

**Table 1. Unit Dimensions (in inches) and Weight**

Models	H x D x W (in)	A	B	C	D	E	F	Weight * (lb)
4TTL6018A1	36.75 x 14 1/2 x 40	26.75	40.0	36.75	14.5	16.5	17.5	145
4TTL6024A1	36.75 x 14 1/2 x 40	26.75	40.0	36.75	14.5	16.5	17.5	145
4TTL6030A1	36.75 x 14 1/2 x 40	26.75	40.0	36.75	14.5	16.5	17.5	160
4TTL6036A1	36.75 x 17 1/2 x 47	32.75	47.0	36.75	17.5	19.5	20.5	215
4TTL6042A1	36.75 x 17 1/2 x 47	32.75	47.0	36.75	17.5	19.5	20.5	216
4TTL6048A1	36.75 x 17 1/2 x 47	32.75	47.0	36.75	17.5	19.5	20.5	216
4TTL6060A1	42.75 x 17 1/2 x 47	32.75	47.0	42.75	17.5	19.5	20.5	236

\* Weight values are estimated (uncrated).

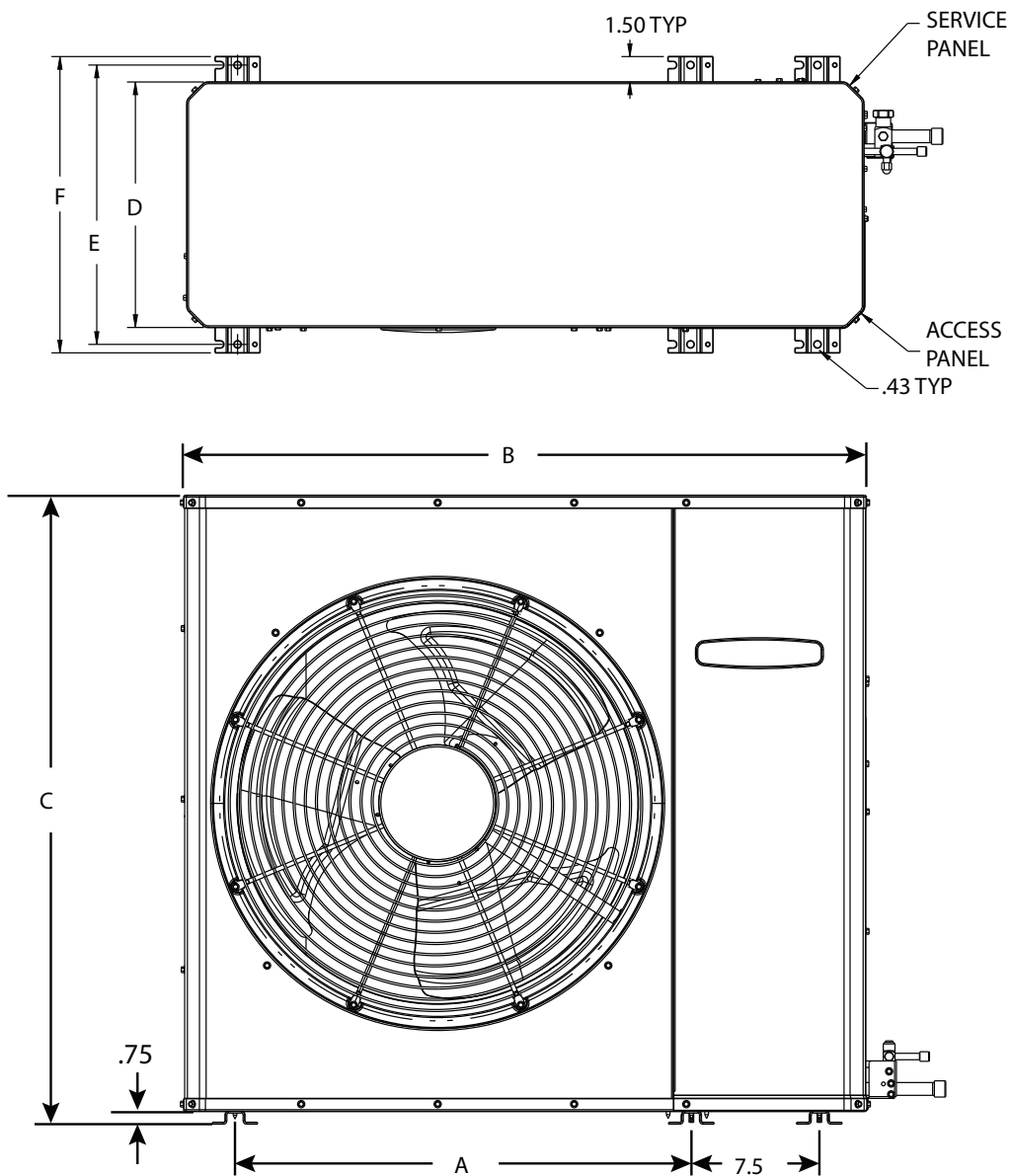

**Table 2. Refrigerant Piping Limits**

1. The maximum length of refrigerant lines from outdoor to indoor unit should NOT exceed 150 feet.
2. The maximum vertical change should not exceed 50 feet.
3. Service valve connection diameters are shown in "Refrigerant Line and Service Valve Connection Size Chart."

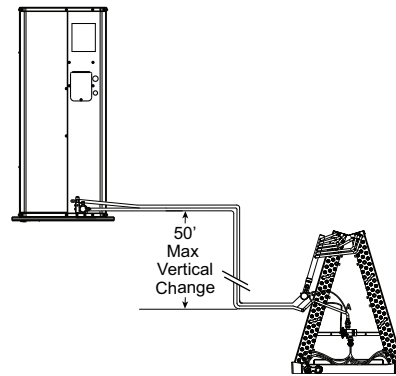
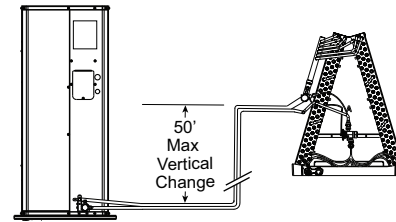
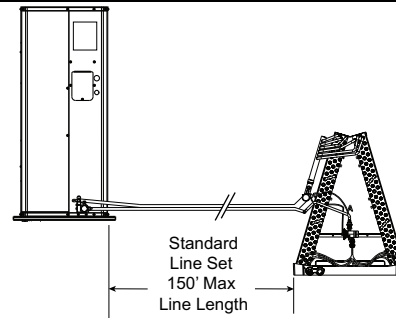



## Unit Location Considerations

### Unit Location Considerations

Table 3. Suggested Locations for Best Reliability

- Do not locate close to bedrooms as operational sounds may be objectionable.
- Avoid locations near windows and similar areas where condensation and freezing defrost vapor can annoy a customer.
- The **coil side** of the outdoor unit must be a minimum of 6" from any wall or surrounding shrubbery to ensure adequate airflow.

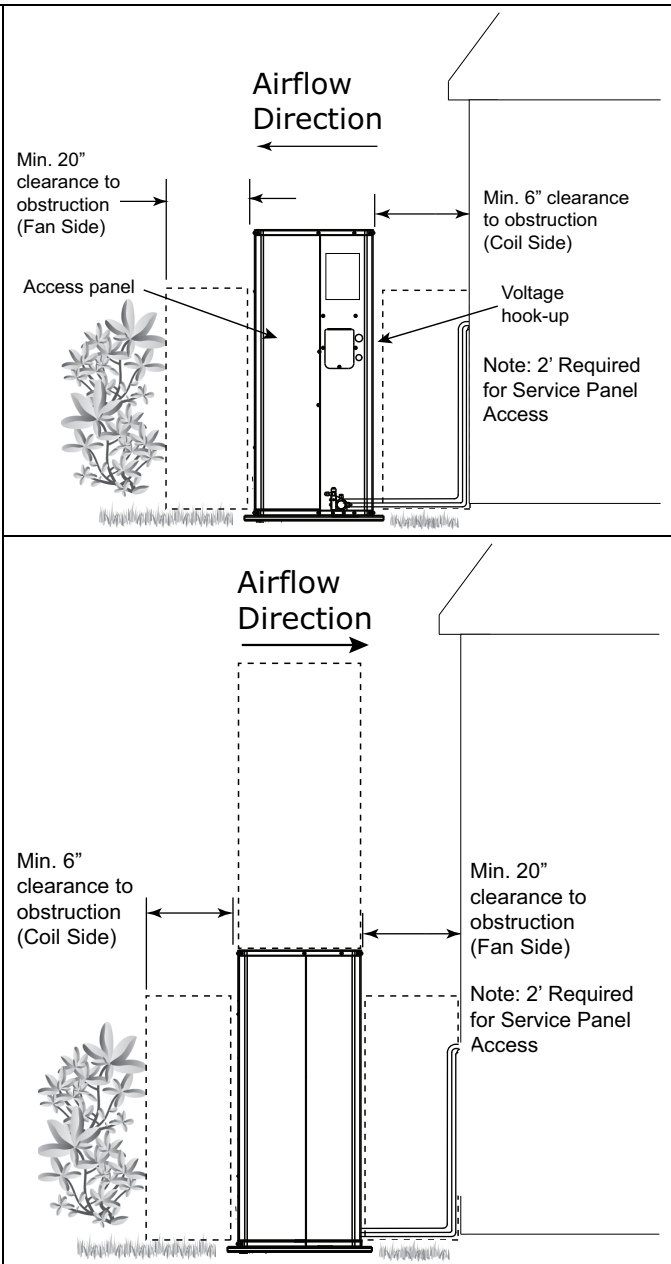

**Table 3. Suggested Locations for Best Reliability (continued)**

<ul style="list-style-type: none"> <li>• A 36" minimum clearance is required on the line voltage electrical service side access panel to any wall or obstruction.</li> <li>• For ease of service maintenance, provide 24" clearance in front of the control box (access panel) and any other side requiring service.</li> <li>• It is recommended to leave a minimum clearance of 2" above unit for future top removal.</li> </ul>	<p>A 12" clearance is suggested for obstructions above the unit.</p> <p>A 2" minimum clearance is required to allow for removal of top</p> <p>Note: 12" clearance not required with stacking kit.</p> <p>A 36" minimum clearance is required from service panel to additional units or other obstructions.</p>
--	--

**Table 4. Cold Climate Considerations**

<p><b>Note:</b> It is recommended that these precautions be taken for units being installed in areas where snow accumulation and prolonged below-freezing temperatures occur.</p> <ul style="list-style-type: none"> <li>• Units should be elevated 3–12 inches above the pad or rooftop, depending on local weather. This additional height will allow drainage of snow and ice melted during defrost cycle prior to its refreezing. Ensure that drain holes in unit base pan are not obstructed, preventing drainage of defrost water.</li> <li>• If possible, avoid locations that are likely to accumulate snow drifts. If not possible, a snow drift barrier should be installed around the unit to prevent a build-up of snow on the sides of the unit.</li> </ul>	<p>Min. 20" clearance to obstruction (Fan Side)</p> <p>Snow Barrier</p> <p>Snow Legs</p> <p>3-12" Elevation</p> <p>Pad</p>
--	--

**Table 5. Coastal Considerations**

<p>If installed within one mile of salt water, including seacoasts and inland waterways, models with epoxy coated coils are available. Model numbers with "COT" in the eleventh (11) through thirteenth (13) digits represent epoxy coated coil. These models have an 8 week lead time after order.</p>
---



## Unit Location Considerations

### Unit Preparation

1. Check for damage and report promptly to the carrier any damage found to the unit.

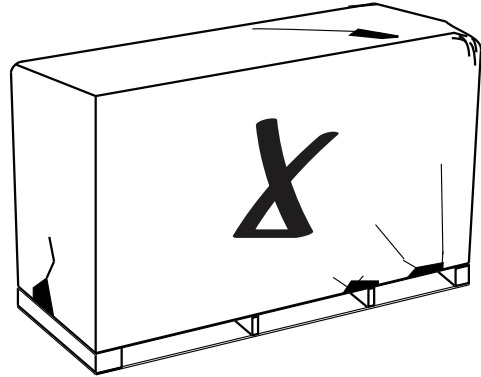

1. To remove the unit from the pallet, remove wood screws from mounting brackets.

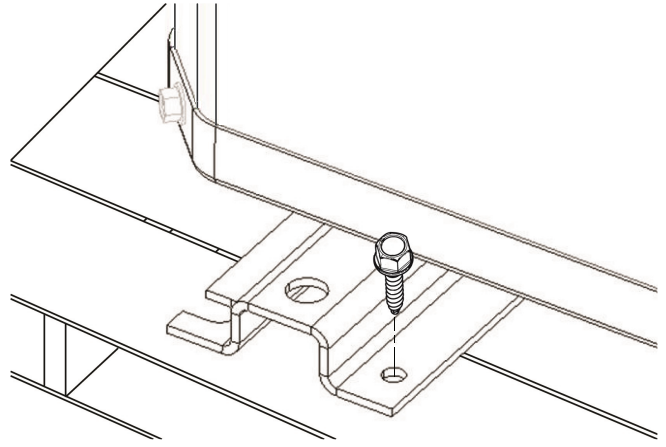

### Setting Up the Unit

**Table 6. Pad Installation**

When installing the unit on a support pad, such as a concrete slab, consider the following:

- The pad should be at least 1" larger than the unit on all sides.
- The pad must be separate from any structure.
- The pad must be level.
- The pad should be high enough above grade to allow for drainage.
- The pad location must comply with National, State, and Local codes.

**Important:**

- Unit can be secured to the pad if there is concern of the unit tipping.

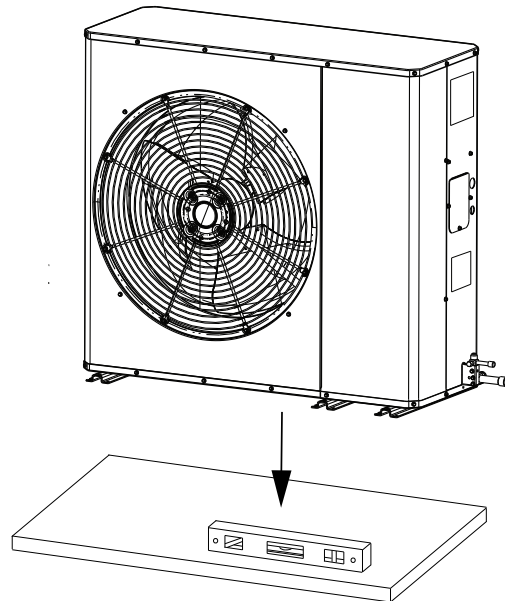

**Note:** If using a stacking kit, follow stacking kit instructions.

**Important:** Heat Pump models should never be stacked!



## Refrigerant Line Considerations

**Table 7. Refrigerant Line and Service Valve Connection Sizes**

Model	Rated Line Sizes		Service Valve Connection Sizes	
	Vapor Line	Liquid Line	Vapor Line Connection	Liquid Line Connection
4TTL6018A1	3/4	3/8	3/4	3/8
4TTL6024A1	3/4	3/8	3/4	3/8
4TTL6030A1	3/4	3/8	3/4	3/8
4TTL6036A1	3/4	3/8	3/4	3/8
4TTL6042A1	7/8	3/8	7/8	3/8
4TTL6048A1	7/8	3/8	7/8	3/8
4TTL6060A1	1-1/8	3/8	7/8	3/8

**Table 8. Factory Charge**

The outdoor condensing units are factory charged with the system charge required for the outdoor condensing unit, ten (10) feet of tested connecting line, and the smallest rated indoor evaporative coil match. Always verify proper system charge via subcooling (TXV/EEV) or superheat (fixed orifice) per the unit nameplate.

**Table 9. Required Refrigerant Line Length**

Determine required line length and lift. You will need this to determine the subcooling charging corrections later in the installation process.

Total Line Length = \_\_\_\_\_ Ft.

Total Vertical Change (lift) = \_\_\_\_\_ Ft.

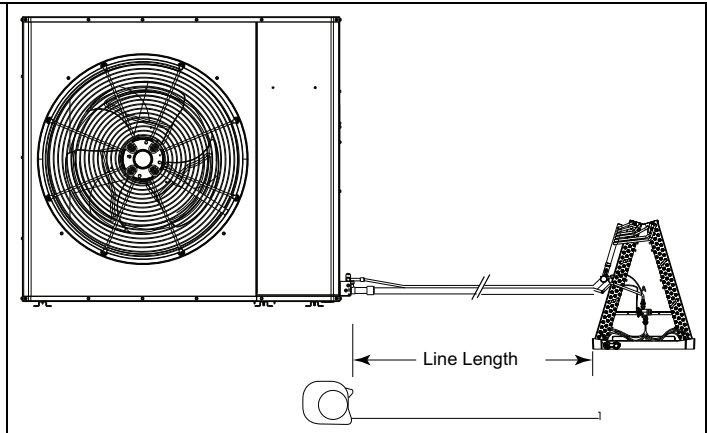

## Unit Location Considerations

**Table 10. Refrigerant Line Insulation**

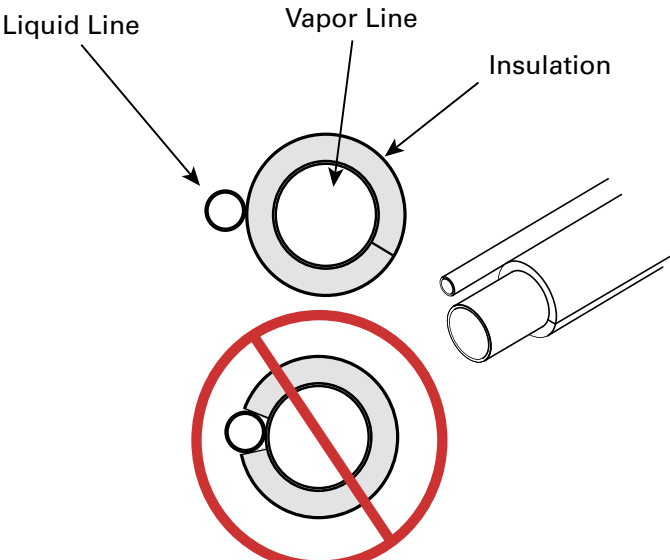
<p><b>Important:</b> The Vapor Line must always be insulated. DO NOT allow the Liquid Line and Vapor Line to come in direct (metal to metal) contact.</p> <p><b>Note:</b> The gas line must always be insulated. Insulating the liquid line through attic spaces may benefit system performance by minimizing heat gain in the liquid line.</p>	
---	--

**Table 11. Reuse Existing Refrigerant Lines**

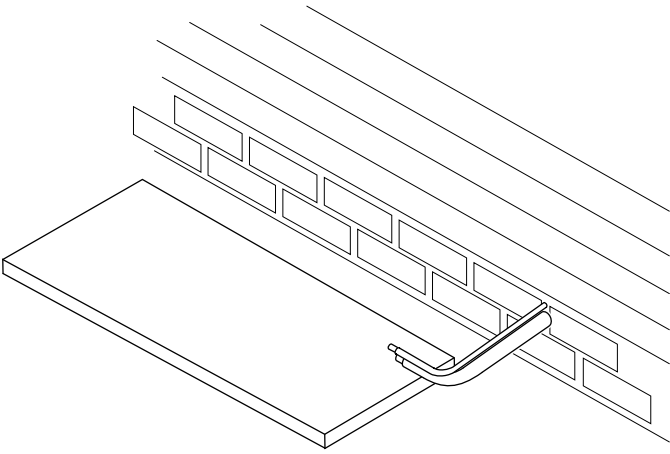
<div style="background-color: black; color: white; padding: 5px; text-align: center;"> <p><b>⚠ CAUTION</b></p> <p><b>REFRIGERANT!</b></p> </div> <p>Failure to inspect or use proper service tools may result in equipment damage or personal injury. If using existing refrigerant lines make certain that all joints are brazed, not soldered.</p> <p>For retrofit applications, where the existing indoor evaporator coil and/or refrigerant lines will be used, the following precautions should be taken.</p> <ul style="list-style-type: none"> <li>• Ensure that the indoor evaporator coil and refrigerant lines are the correct size.</li> <li>• Ensure that the refrigerant lines are free of leaks, acid, and oil.</li> </ul> <p><b>Important:</b> For more information, see publication number SS-APG006-EN</p>	
---	---

**Table 12. Refrigerant Line Routing Precautions**

<p><b>Important:</b> Comply with National, State, and Local Codes when isolating line sets from joists, rafters, walls, or other structural elements.</p> <p><b>Important:</b> Take precautions to prevent noise within the building structure due to vibration transmission from the refrigerant lines.</p> <p>For Example:</p> <ul style="list-style-type: none"> <li>• When the refrigerant lines must be fastened to floor joists or other framing in a structure, use isolation type hangers.</li> <li>• Isolation hangers should also be used when refrigerant lines are run in stud spaces or enclosed ceilings.</li> <li>• Where the refrigerant lines run through a wall or sill, they should be insulated and isolated.</li> <li>• Isolate the lines from all duct work.</li> <li>• Minimize the number of 90° turns.</li> </ul>
--

**Table 13. Isolation From Joist/Rafter**

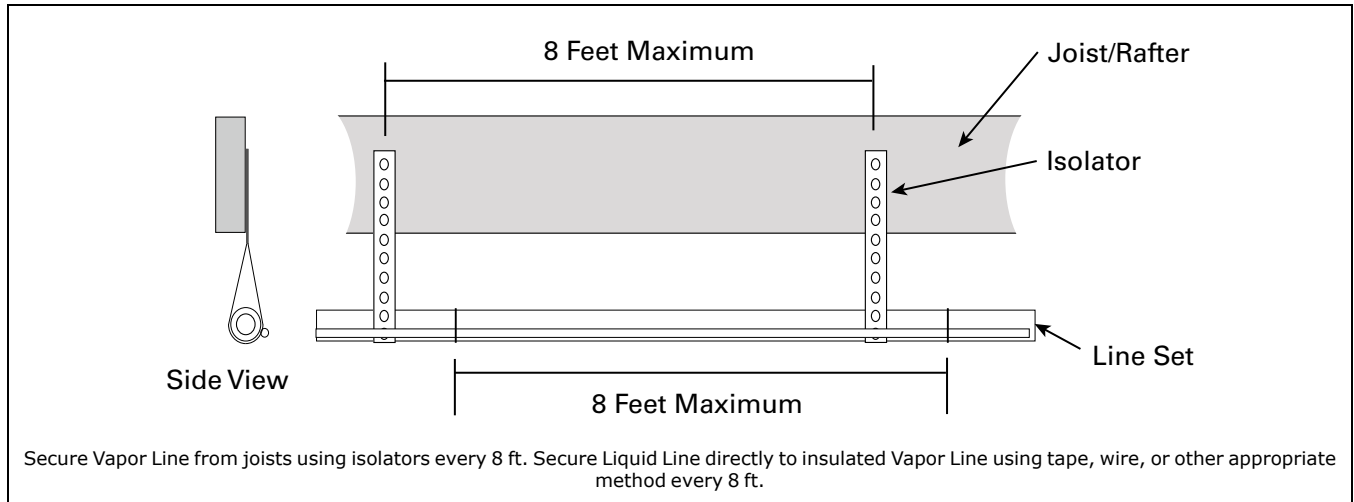

**Table 14. Isolation In Wall Spaces**

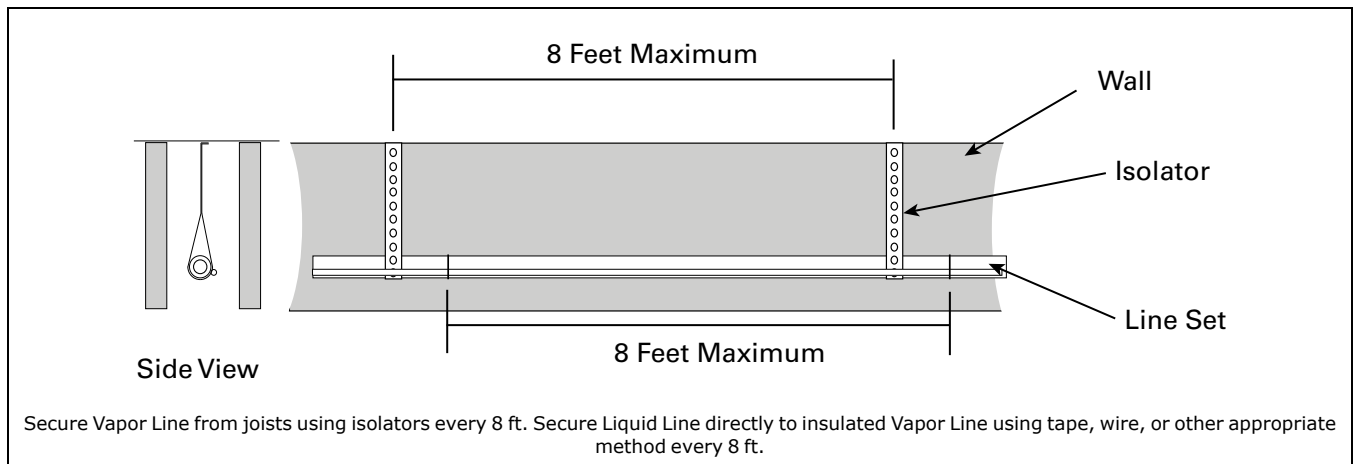

**Table 15. Isolation Through Wall**

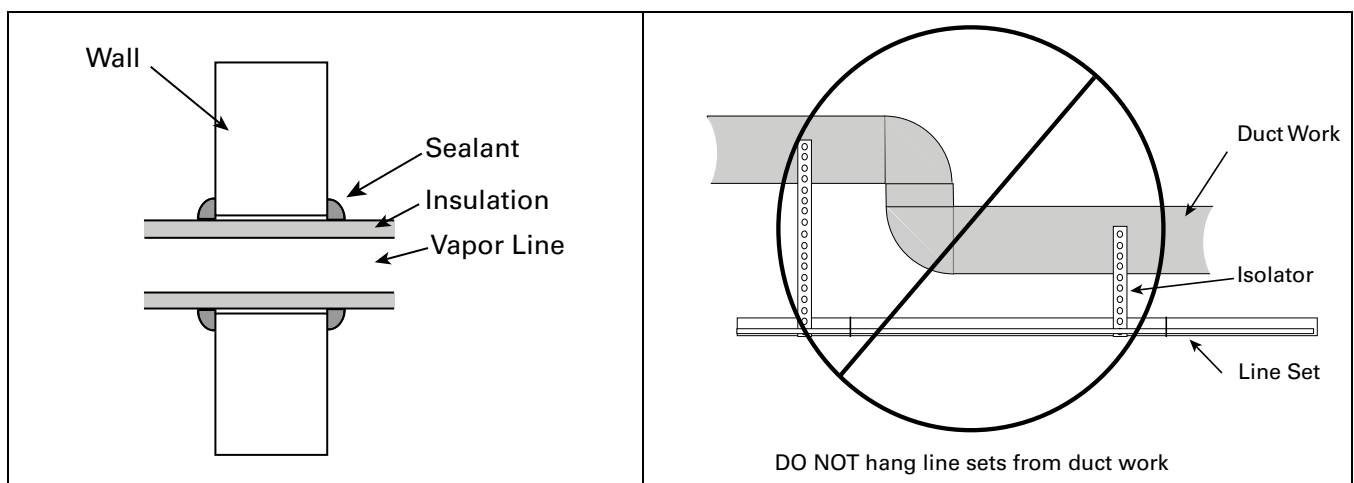

**Refrigerant Line Brazing****Table 16. Braze the Refrigerant Lines**

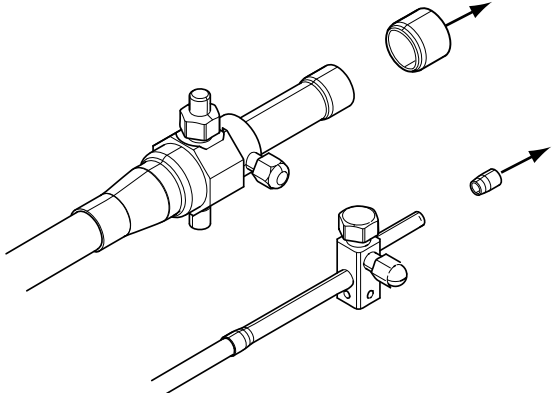
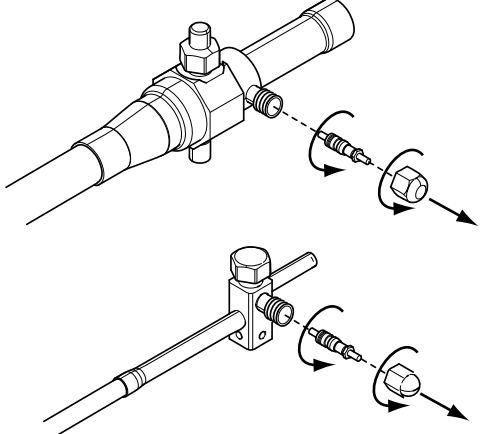
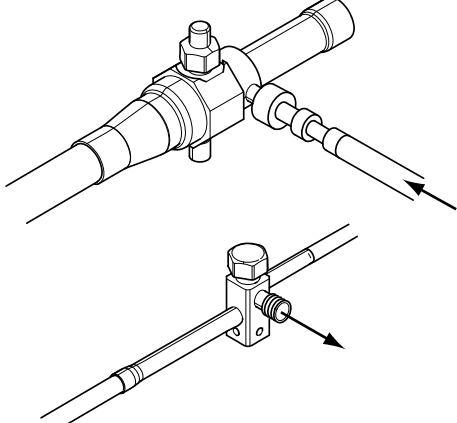
<p>1. Remove caps or plugs. Use a deburring tool to deburr the pipe ends. Clean both internal and external surfaces of the tubing using an emery cloth.</p>	 <p>The diagram illustrates the first step of the brazing process. It shows two refrigerant lines with service valves. In the top view, a cap is being removed from the top of the service valve. In the bottom view, a cap is being removed from the side of the service valve. Arrows indicate the direction of removal. The pipe ends are shown with a deburring tool being applied to them.</p>
<p>2. Remove the pressure tap cap and valve core from each service valves.</p>	 <p>The diagram illustrates the second step of the brazing process. It shows the same two refrigerant lines. In the top view, a pressure tap cap is being removed from the side of the service valve. In the bottom view, a valve core is being removed from the top of the service valve. Arrows indicate the direction of removal.</p>
<p>3. Purge the refrigerant lines and indoor coil with dry nitrogen.</p>	 <p>The diagram illustrates the third step of the brazing process. It shows the same two refrigerant lines. In the top view, a dry nitrogen gas cylinder is connected to the side of the service valve. In the bottom view, a dry nitrogen gas cylinder is connected to the top of the service valve. Arrows indicate the direction of gas flow into the lines.</p>

**Table 16. Braze the Refrigerant Lines (continued)**

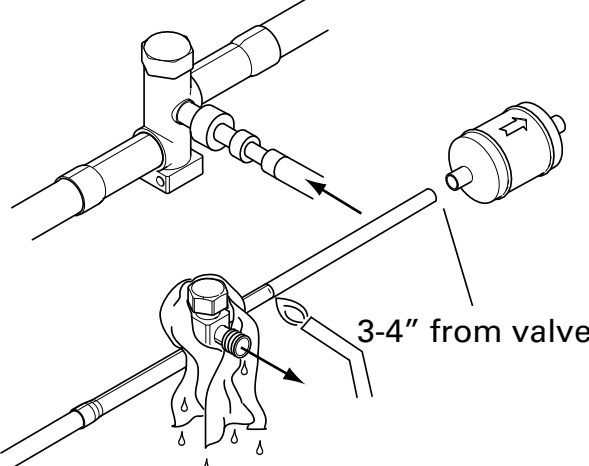
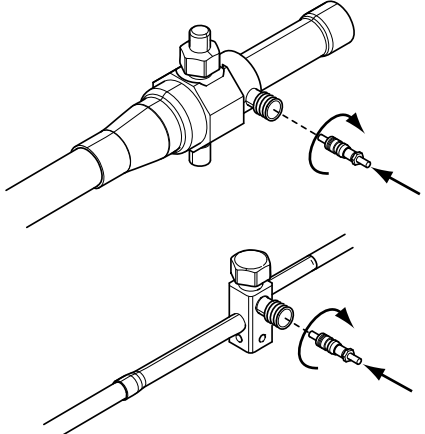
<p>4. Wrap a wet rag around the valve body to avoid heat damage and continue the dry nitrogen purge.</p> <p>5. Braze the refrigerant lines to the service valves.</p> <p>a. For Units shipped with a field-installed external drier, check liquid line filter drier's directional flow arrow to confirm correct direction of refrigeration flow (away from outdoor unit and toward evaporator coil) as illustrated. Braze the filter drier to the Liquid Line.</p> <p>6. Continue the dry nitrogen purge. Do not remove the wet rag until all brazing is completed.</p> <p><b>Important:</b> Remove the wet rag before stopping the dry nitrogen purge.</p> <p><b>Note:</b> Precautions should be taken to avoid heat damage to base pan during brazing. It is recommended to keep the flame directly off of the base pan.</p>	
<p>7. Replace the pressure tap valve cores after the service valves have cooled.</p>	



## Unit Location Considerations

### Refrigerant Line Leak Check

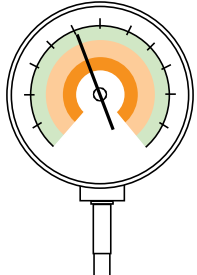
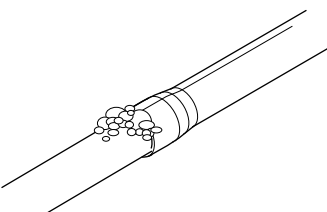
**Table 17. Check for Leaks**

<p>1. Pressurize the refrigerant lines and evaporator coil to 150 PSIG using dry nitrogen.</p>	<p style="text-align: center;"><b>150 PSIG</b></p> 
<p>2. Check for leaks by using a soapy solution at each brazed location. <b>Note:</b> Remove nitrogen pressure and repair any leaks before continuing.</p>	

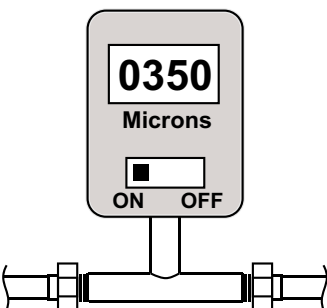
### Refrigerant Line and Indoor Coil Evacuation

<p><b>Important:</b> Do not open the service valves until the refrigerant lines and indoor coil leak check and evacuation are complete.</p> <p>1. Evacuate until the micron gauge reads no higher than 350 microns, then close off the valve to the vacuum pump.</p>	
<p>2. Observe the micron gauge. Evacuation is complete if the micron gauge does not rise above 500 microns in one (1) minute.</p> <p>3. When evacuation is complete, blank off the vacuum pump and micron gauge, and close the valves on the manifold gauge set.</p>	

# Service Valves

**Table 18. Open the Gas Service Valve**

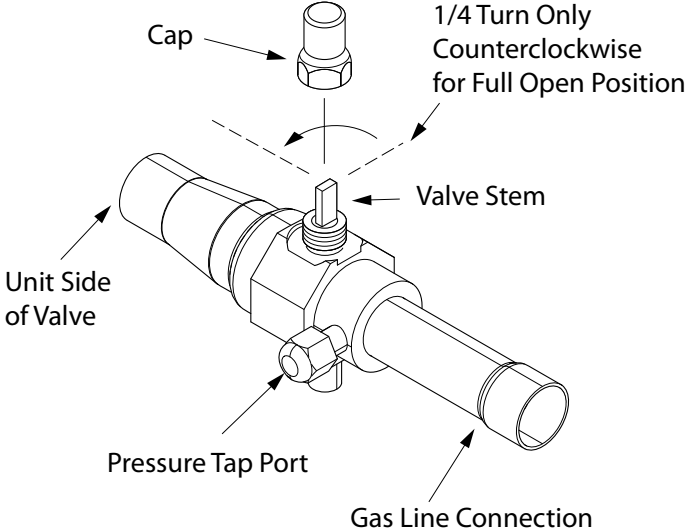
<p><b>Important:</b> Leak check and evacuation must be completed before opening the service valves.</p> <p><b>Note:</b> Do not vent refrigerant gases into the atmosphere.</p> <ol style="list-style-type: none"> <li>1. Remove valve stem cap.</li> <li>2. Using a wrench, turn valve stem 1/4 turn counterclockwise to the fully open position.</li> <li>3. Replace the valve stem cap to prevent leaks. Tighten finger tight plus an additional 1/4 turn.</li> </ol>	
---	--

**Table 19. Open the Liquid Service Valve**

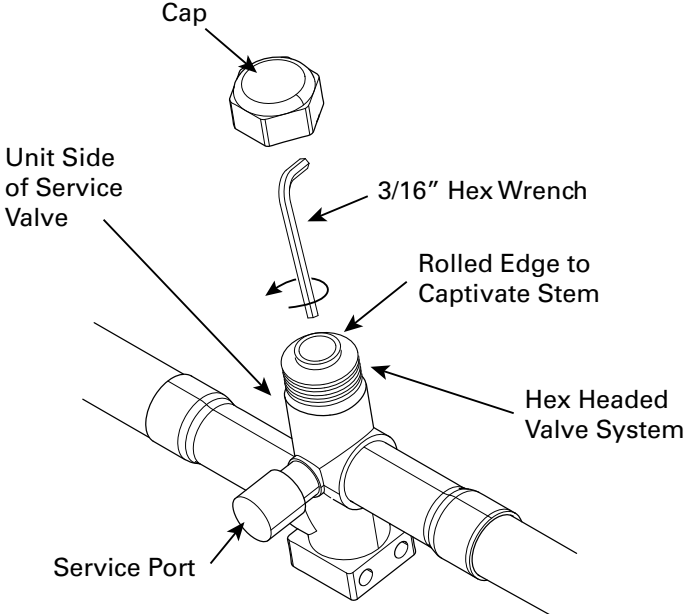
<div style="background-color: black; color: white; padding: 5px; text-align: center;"> <p><b>⚠ WARNING</b></p> <p><b>SERVICE VALVES!</b></p> <p>Failure to follow this warning will result in abrupt release of system charge and may result in personal injury and/or property damage. Extreme caution should be exercised when opening the Suction and Liquid Line Service Valve. Turn valve stem counterclockwise only until the stem contacts the rolled edge. No torque is required.</p> </div> <p><b>Important:</b> Leak check and evacuation must be completed before opening the service valves.</p> <ol style="list-style-type: none"> <li>4. Remove service valve cap.</li> <li>5. Fully insert 3/16" hex wrench into the stem and back out counterclockwise until valve stem just touches the rolled edge (approximately five (5) turns).</li> <li>6. Replace the valve cap to prevent leaks. Tighten finger tight plus an additional 1/4 turn.</li> </ol>	
---	---



# Electrical – Low Voltage Non Communicating

**Table 20. Low Voltage Maximum Wire Length**

<p>The table defines the maximum total length of low voltage wiring from the outdoor unit, to the indoor unit, and to the thermostat.</p> <p><b>Note:</b> The use of color coded low voltage wire is recommended to simplify connections between the outdoor unit, the control, and the indoor unit.</p>	24 VOLTS	
	WIRE SIZE	MAX. WIRE LENGTH
	18 AWG	150 Ft.
	16 AWG	225 Ft.
	14 AWG	300 Ft.

## Low Voltage Hook-up Diagrams

### With TEM 3, 4, 6, 8

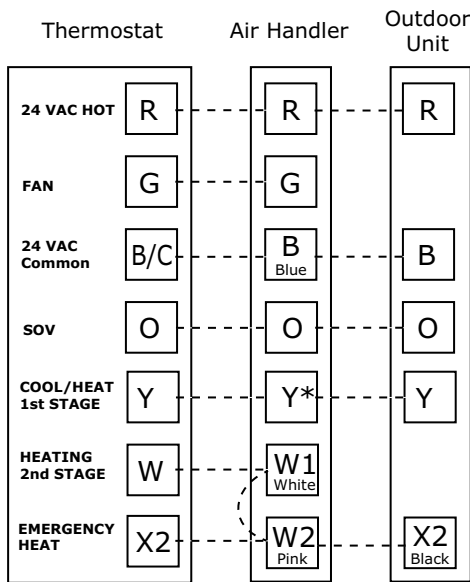

### With TAM 4, 5, 7, 9

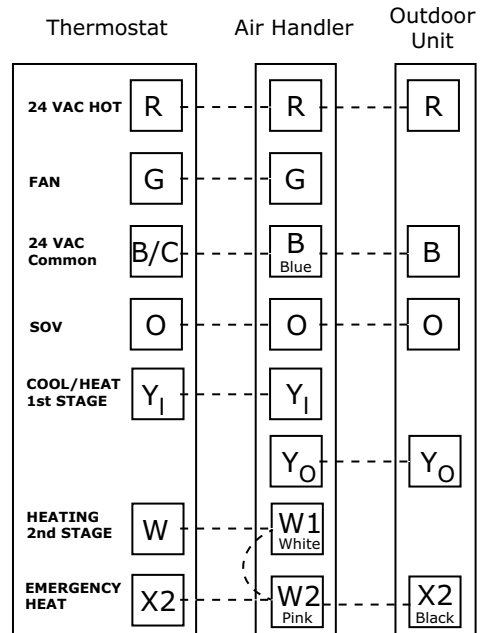

- Units with pigtails require wirenuts for connections.
- In AC systems for multiple stages of electric heat, jumper W1 and W2 together if comfort control has only one stage of heat.
- \* Y2 for TEM6



## Electrical — High Voltage

Table 21. High Voltage Power Supply

<p style="text-align: center;"><b>⚠ WARNING</b></p> <p><b>LIVE ELECTRICAL COMPONENTS!</b> Failure to follow this Warning could result in property damage, severe personal injury, or death. Follow all electrical safety precautions when exposed to live electrical components. It may be necessary to work with live electrical components during installation, testing, servicing, and troubleshooting of this product.</p> <p>The high voltage power supply must agree with the equipment nameplate.</p> <p>Power wiring must comply with national, state, and local codes.</p> <p>Follow instructions on unit wiring diagram located on the inside of the control box cover.</p>	
---	--

Table 22. High Voltage Disconnect Switch

<p style="text-align: center;"><b>⚠ WARNING</b></p> <p><b>HIGH LEAKAGE CURRENT!</b> Failure to follow this Warning could result in property damage, severe personal injury, or death. Earth connection essential before connecting electrical supply.</p> <p>Install a separate disconnect switch at the outdoor unit.</p> <p>For high voltage connections, flexible electrical conduit is recommended whenever vibration transmission may create a noise problem within the structure.</p> <p style="text-align: center;"><b>⚠ WARNING</b></p> <p><b>HAZARDOUS VOLTAGE!</b> Voltage may be present with power disconnected due to high winds causing fan rotation. See Service Facts or Technical Manual for servicing instructions.</p>	
---	--

Table 23. High Voltage Disconnect Switch

<p>Ground the outdoor unit per national, state, and local code requirements.</p>	
--	--

## System Start Up

1. Set the system thermostat to OFF.

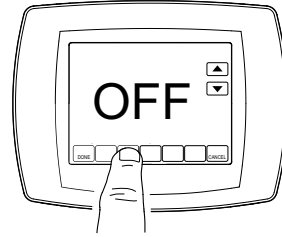

2. Turn on electrical power disconnect(s) to apply power to the indoor and outdoor units.

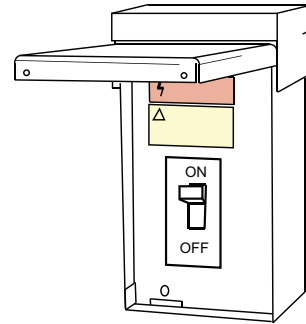

3. Wait one (1) hour before starting the unit if compressor crankcase heater accessory is used and the Outdoor Ambient is below 70°F.



4. Set the system thermostat to ON.

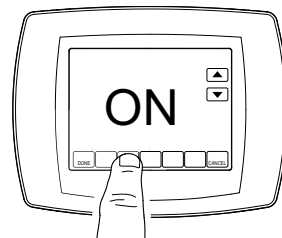



# Subcooling Charging in Cooling between 55° F and 120° OD Ambient

Trane has always recommended installing Trane approved matched indoor and outdoor systems.

The benefits of installing approved indoor and outdoor split systems are maximum efficiency, optimum performance and the best overall reliability.

The following charging methods are therefore prescribed for matched systems with indoor TXVs/EEVs.

1. Subcooling (in the cooling mode) is the only recommended method of charging above 55° ambient temperatures.
2. For best results — the indoor temperature should be kept between 70° to 80° F. Add system heat if needed.
3. At startup, or whenever charge is removed or added, the system must be operated for a minimum of (20) minutes to stabilize before accurate measurements can be made.
4. Measure Liquid Line Temperature and Refrigerant Pressure at service valves.
5. Determine total refrigerant line length, and height (lift) if indoor section is above the condenser.
6. Determine the Design Subcooling Charging Temperature from the unit nameplate.
7. Locate this value in the appropriate column of the Subcooling Charging Table. Locate your liquid line temperature in the left column of the table, and the intersecting liquid line pressure under your nameplate subcool value column. Add refrigerant to raise the pressure to match the table, or remove refrigerant to lower the pressure. Again, wait (20) minutes for the system conditions to stabilize before adjusting charge again.
8. When system is correctly charged, you can refer to System Pressure Curves to verify typical performance.



# System Charge Adjustment

**Table 24. Temperature Measurements (Systems can be rated with TXV, EEV or Piston. Ensure charging method is correct).**

<p>Check the outdoor temperatures.</p> <p>Subcooling using <b>"Charging Mode-Cooling"</b> is the only recommended method of charging between 55 ° F and 120° F ambient outdoor temperature.</p> <p><b>Note:</b> For Superheat (In Cooling Mode), refer to the Superheat Charging Table</p>	
<p>For best results the indoor temperature should be kept between 70° F to 80° F.</p>	

**Table 25. Subcooling Charging Corrections**

<p>Determine the final subcooling value using total Line Length and Lift — See Required Refrigerant Line Length and the Subcooling Charging Corrections Charts.</p> <p><b>Subcooling Charging Correction Worksheet</b></p> <p>Total Line Length (ft) _____</p> <p>Total Vertical Charge (lift) _____ (Values from — Required Refrigerant Line Length)</p> <p>Design Subcooling Value _____ (from nameplate)</p> <p><b>Final Subcooling Value</b> _____</p>	
--	--



# Refrigerant Charging Chart

R-410A REFRIGERANT CHARGING CHART							
LIQUID TEMP (°F)	DESIGN SUBCOOLING (°F)						
	8	9	10	11	12	13	14
	LIQUID GAGE PRESSURE (PSI)						
55	179	182	185	188	191	195	198
60	195	198	201	204	208	211	215
65	211	215	218	222	225	229	232
70	229	232	236	240	243	247	251
75	247	251	255	259	263	267	271
80	267	271	275	279	283	287	291
85	287	291	296	300	304	309	313
90	309	313	318	322	327	331	336
95	331	336	341	346	351	355	360
100	355	360	365	370	376	381	386
105	381	386	391	396	402	407	413
110	407	413	418	424	429	435	441
115	435	441	446	452	458	464	470
120	464	470	476	482	488	495	501
125	495	501	507	514	520	527	533



# Subcool Charging Charts

**Figure 1. 1.5 Ton Models**

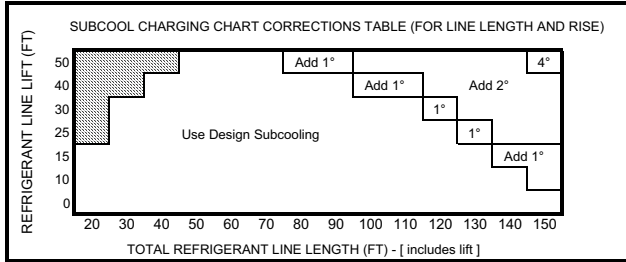

**Figure 5. 3.5 Ton Models**

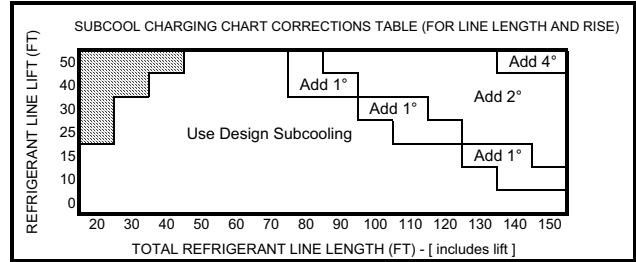

**Figure 2. 2.0 Ton Models**

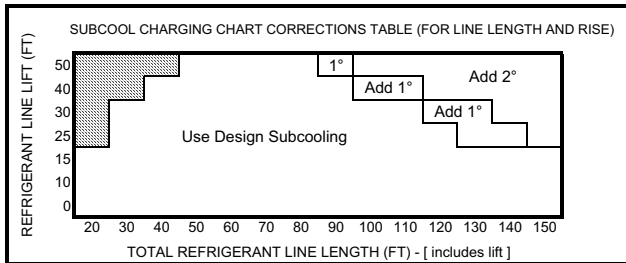

**Figure 6. 4.0 Ton Models**

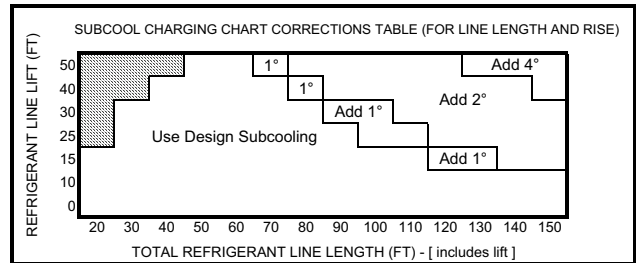

**Figure 3. 2.5 Ton Models**

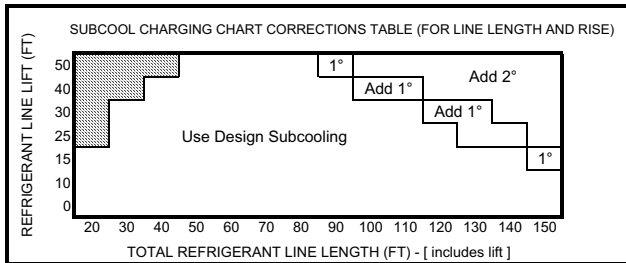

**Figure 7. 5.0 Ton Models**

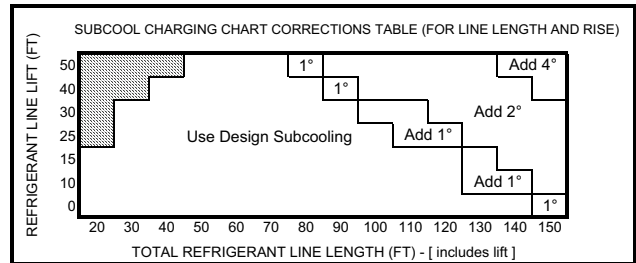

**Figure 4. 3.0 Ton Models**

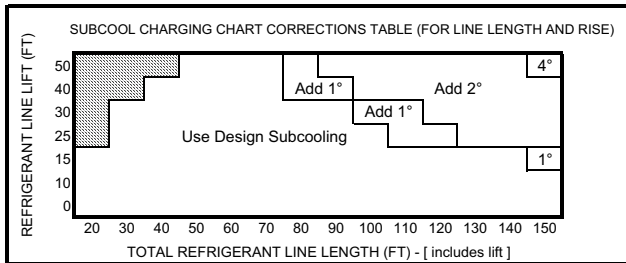

# Charging the Unit

**Table 26. Stabilize the system**

<ol style="list-style-type: none"> <li>Wait 20 minutes for the system condition to stabilize between adjustments.</li> </ol> <p><b>Note:</b> When the Liquid Line Temperature and Gage Pressure approximately match the chart, the system is properly charged.</p> <ol style="list-style-type: none"> <li>Remove gauges.</li> <li>Replace service port caps to prevent leaks. Tighten finger tight plus an additional 1/4 turn.</li> </ol>	
--	---

**Table 27. Proper Gage Pressure**

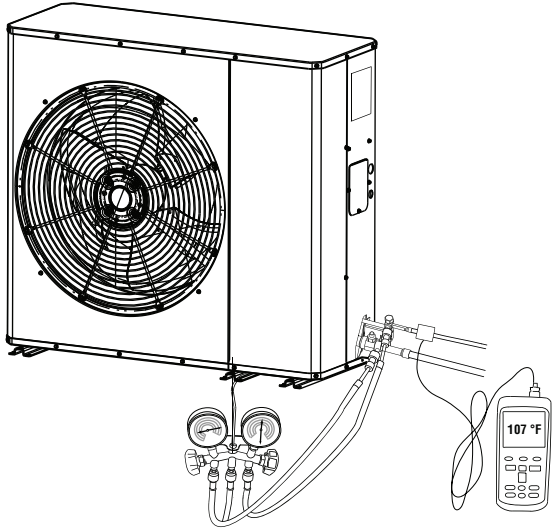
<p>Measure the liquid line temperature and pressure at the outdoor unit's service valve.</p> <p>Measure Liquid Line Temp = _____ °F</p> <p>Liquid Gage Pressure = _____ PSI</p> <p>Final Subcooling Value = _____ °F</p>	
--	---

**Table 28. Verify Performance**

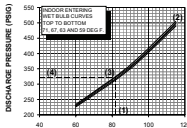
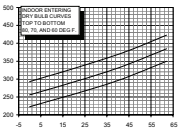
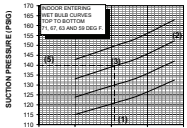
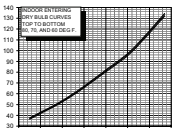
<ol style="list-style-type: none"> <li>Refer to System Pressure Curves at the end of the document to verify typical performance.</li> </ol>	<p style="text-align: center;"><b>PRESSURE CURVE SAMPLE</b></p> <div style="display: flex; justify-content: space-around;"> <div style="text-align: center;"> <p><b>Cooling @ 1450 SCFM</b></p>  </div> <div style="text-align: center;"> <p><b>Heating @ 1350 SCFM</b></p>  </div> </div> <div style="text-align: center; margin-top: 10px;"> <p><b>OUTDOOR TEMPERATURE (Degree F)</b></p> <div style="display: flex; justify-content: space-around;"> <div style="text-align: center;">  </div> <div style="text-align: center;">  </div> </div> </div>
---	---



## Charging the Unit

**Table 29. Proper Gage Pressure**

<p>Adjust refrigerant level to attain proper gage pressure.</p> <p>Add refrigerant if the Liquid Gage Pressure is lower than the chart value.</p> <ol style="list-style-type: none"> <li>5. Connect gauges to refrigerant bottle and unit as illustrated.</li> <li>6. Purge all hoses.</li> <li>7. Open bottle.</li> <li>8. Stop adding refrigerant when liquid line temperature and Liquid Gage Pressure match the charging chart.</li> </ol> <p><b>Note:</b> Recover refrigerant if the Liquid Gage Pressure is higher than the chart value.</p>	
--	--

**Table 30. System Information**

<p>9. Record system pressures and temperatures after charging is complete.</p> <p>Outdoor model number = _____</p> <p>Measured Outdoor Ambient = _____ °F</p> <p>Measured Indoor Ambient = _____ °F</p> <p>Measured Liquid Line Temp = _____ °F</p> <p>Measured Suction Line Temp = _____ °F</p>	<p>Indoor Wet Bulb = _____ °F</p> <p>Liquid Gage Pressure = _____ PSIG</p> <p>Suction Gage Pressure = _____ PSIG</p>
--	--





# Checkout Procedures

The final phase of the installation is the system Checkout Procedures. The following list represents the most common items covered in a Checkout Procedure. Confirm all requirements in this document have been met.

<ul style="list-style-type: none"><li><input type="checkbox"/> All wiring connections are tight and properly secured.</li><li><input type="checkbox"/> Voltage and running current are within limits.</li><li><input type="checkbox"/> All refrigerant lines (internal and external to equipment) are isolated, secure, and not in direct contact with each other or structure.</li><li><input type="checkbox"/> All braze connections have been checked for leaks. A vacuum of 350 microns provides confirmation that the refrigeration system is leak free and dry.</li><li><input type="checkbox"/> Final unit inspection to confirm factory tubing has not shifted during shipment. Adjust tubing if necessary so tubes do not rub against each other or any component when unit runs.</li><li><input type="checkbox"/> Ductwork is sealed and insulated.</li><li><input type="checkbox"/> All drain lines are clear with joints properly sealed. Pour water into drain pan to confirm proper drainage. Provide enough water to ensure drain trap is primed.</li></ul>	<ul style="list-style-type: none"><li><input type="checkbox"/> Supply registers and return grilles are open, unobstructed, and air filter is installed.</li><li><input type="checkbox"/> Indoor blower and outdoor fan are operating smoothly and without obstruction.</li><li><input type="checkbox"/> Indoor blower motor set on correct speed setting to deliver required CFM. "Blower and fan set screws are tight."</li><li><input type="checkbox"/> Cover panels are in place and properly tightened.</li><li><input type="checkbox"/> For gas heating systems, manifold pressure has been checked and all gas line connections are tight and leak free.</li><li><input type="checkbox"/> For gas heating systems, flue gas is properly vented.</li><li><input type="checkbox"/> System functions safely and properly in all modes.</li><li><input type="checkbox"/> Owner has been instructed on use of system and given manual.</li></ul>
--	---

# Wiring Diagrams

**Figure 8. 1.5, 2.0, 2.5, 3.0, 3.5 and 4.0 Ton Models**

TO POWER SUPPLY PER UNIT NAMEPLATE AND LOCAL CODES

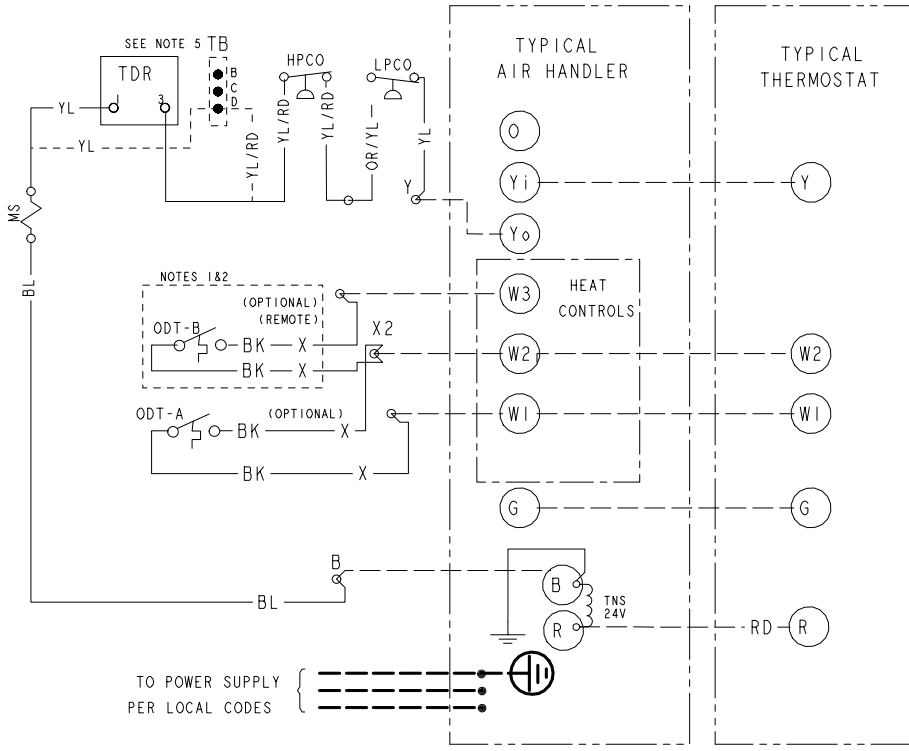
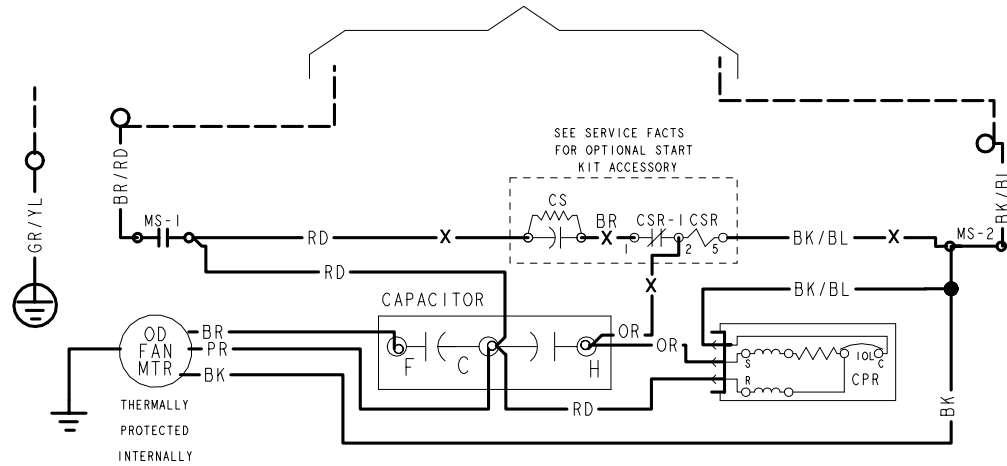

## LEGEND

- CF FAN CAPACITOR
- CN WIRE CONNECTOR
- CPR COMPRESSOR
- CR RUN CAPACITOR
- CS STARTING CAPACITOR
- CSR CAPACITOR SWITCHING RELAY
- ODT OUTDOOR THERMOSTAT
- HPCO HIGH PRESSURE CUTOUT SWITCH
- LPCO LOW PRESSURE CUTOUT SWITCH
- MS COMPRESSOR MOTOR CONTACTOR
- TNS TRANSFORMER
- IOL INTERNAL OVERLOAD PROTECTOR
- TB TERMINAL BLOCK

COLOR OF WIRE  
 BK/BL COLOR OF MARKER

- BK BLACK RD RED OR ORANGE
- BL BLUE WH WHITE GR GREEN
- BR BROWN YL YELLOW PR PURPLE
- PK PINK

FOR CANADIAN INSTALLATIONS  
POUR INSTALLATIONS CANADIENNES

CAUTION: NOT SUITABLE FOR USE ON SYSTEMS EXCEEDING 150V-TO-GROUND  
ATTENTION: NE CONVIENT PAS AUX INSTALLATIONS DE PLUS DE 150 V A LA TERRE

**NOTES:**

1. IF ODT-B IS NOT USED, ADD JUMPER BETWEEN W2 & W3 AT AIR HANDLER. IF USED, ODT-B MUST BE MOUNTED REMOTE OF CONTROL BOX IN AN APPROVED WEATHER PROOF ENCLOSURE.
2. IF ODT-A IS NOT USED, ADD JUMPER BETWEEN W1 & W2 AT AIR HANDLER.
3. LOW VOLTAGE (24 V) FIELD WIRING MUST BE 18 AWG MINIMUM.
4. USE COPPER CONDUCTORS ONLY!
5. USE EITHER TDR OR TB. DO NOT USE BOTH IN ONE MODEL. TB IS ALTERNATE FOR TDR.

PRINTED FROM D161696P01 REV B

**Figure 9. 1.5, 2.0, 2.5, 3.0, 3.5 and 4.0 Ton Models**

- ### LEGEND
- 24 V LINE } FACTORY WIRING
  - 24 V LINE } FIELD WIRING
  - 24 V LINE } FIELD INSTALLED FACTORY WIRING
  - OPTIONAL CONNECTION
  - MAGNETIC COIL
  - GROUND
  - JUNCTION
  - CAPACITOR
  - WIRE NUT OR TERMINAL
  - TRANSFORMER
  - TERMINAL BLOCK/BOARD
  - RELAY CONTACT (N.O.)
  - RELAY CONTACT (N.C.)
  - THERMISTOR
  - TEMP ACTUATED SWITCH
  - INTERNAL OVERLOAD PROTECTION
  - PRESSURE ACTUATED SWITCH
  - RESISTOR OR HEATING ELEMENT
  - MOTOR WINDING
  - POL. PLUG FEMALE HOUSING (MALE TERMINALS)
  - POL. PLUG MALE HOUSING (FEMALE TERMINALS)

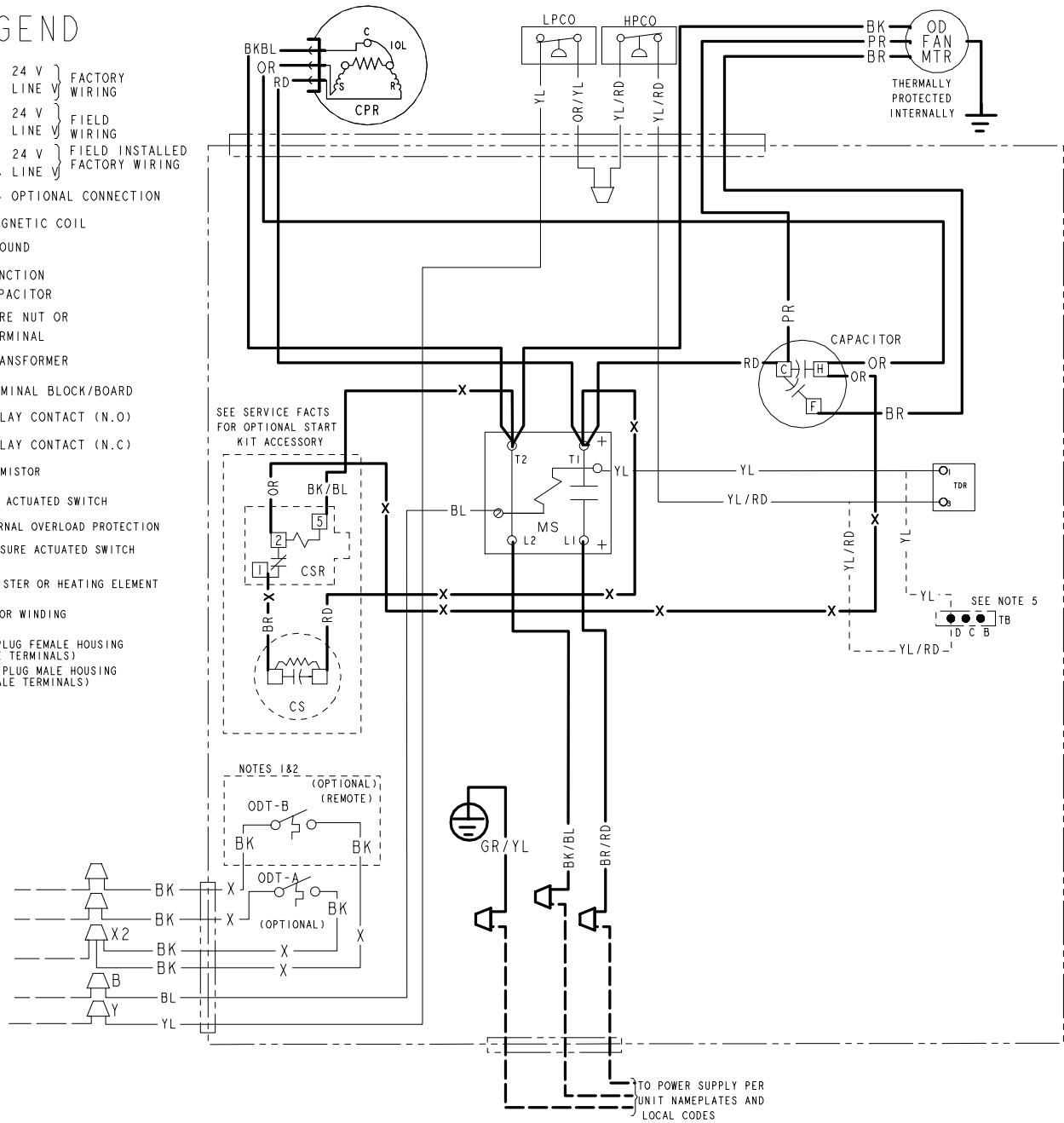

PRINTED FROM DI61696P01 REV B

### Figure 10. 5.0 Ton Models

TO POWER SUPPLY PER UNIT NAMEPLATE AND LOCAL CODES

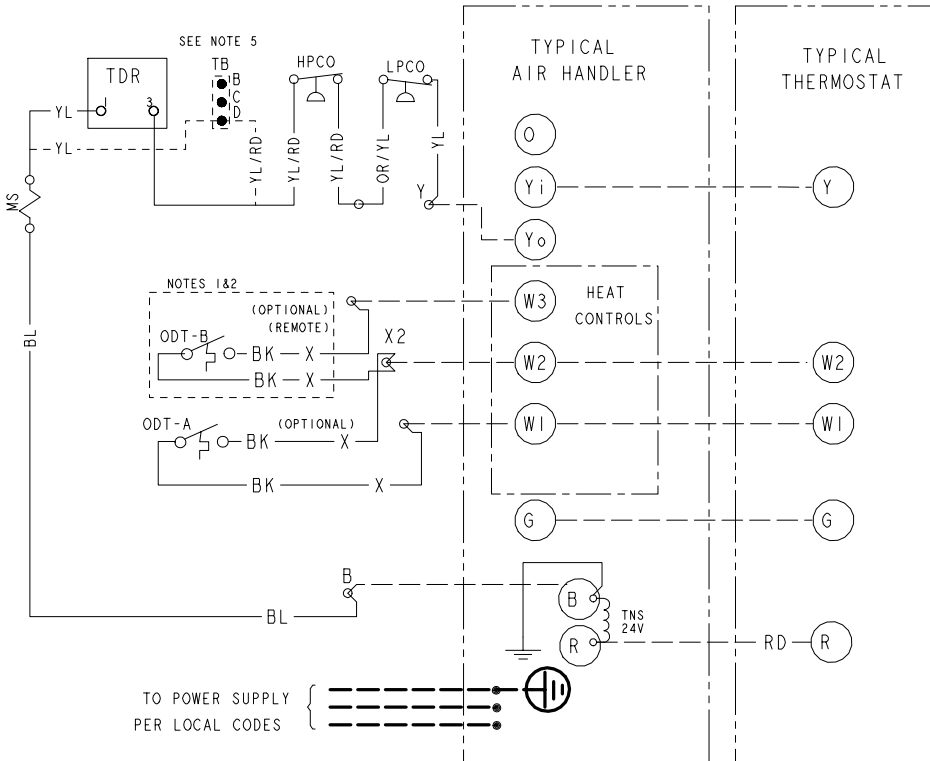
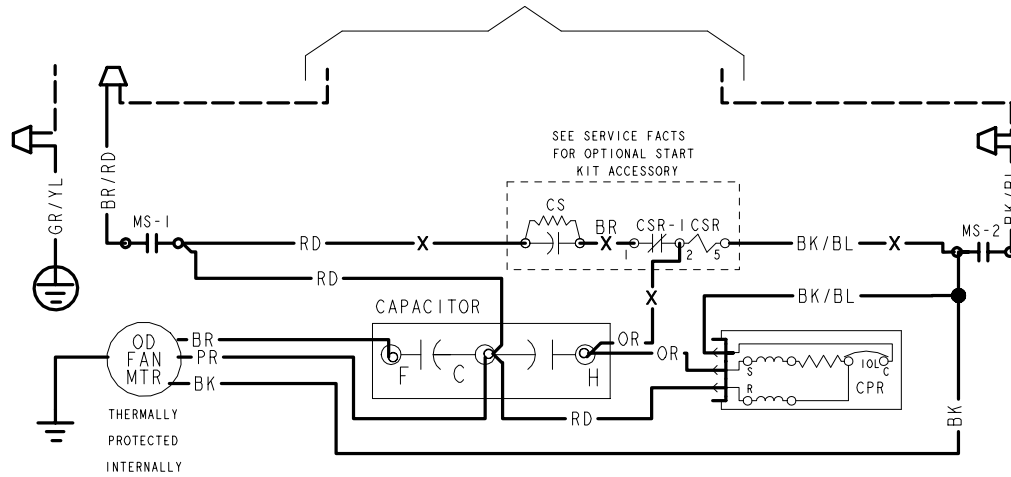

## LEGEND

- CF FAN CAPACITOR
- CN WIRE CONNECTOR
- CPR COMPRESSOR
- CR RUN CAPACITOR
- CS STARTING CAPACITOR
- CSR CAPACITOR SWITCHING RELAY
- ODT OUTDOOR THERMOSTAT
- HPCO HIGH PRESSURE CUTOUT SWITCH
- LPCO LOW PRESSURE CUTOUT SWITCH
- MS COMPRESSOR MOTOR CONTACTOR
- TNS TRANSFORMER
- IOL INTERNAL OVERLOAD PROTECTOR
- TB TERMINAL BLOCK

← COLOR OF WIRE  
BK/BL ← COLOR OF MARKER

- BK BLACK RD RED OR ORANGE
- BL BLUE WH WHITE GR GREEN
- BR BROWN YL YELLOW PR PURPLE
- PK PINK

FOR CANADIAN INSTALLATIONS  
POUR INSTALLATIONS CANADIENNES

CAUTION: NOT SUITABLE FOR USE ON SYSTEMS EXCEEDING 150V-TO-GROUND  
ATTENTION: NE CONVIENT PAS AUX INSTALLATIONS DE PLUS DE 150 V A LA TERRE

PRINTED FROM D161698P01 REV B

#### NOTES:

1. IF ODT-B IS NOT USED, ADD JUMPER BETWEEN W2 & W3 AT AIR HANDLER. IF USED, ODT-B MUST BE MOUNTED REMOTE OF CONTROL BOX IN AN APPROVED WEATHER PROOF ENCLOSURE.
2. IF ODT-A IS NOT USED, ADD JUMPER BETWEEN W1 & W2 AT AIR HANDLER.
3. LOW VOLTAGE (24 V) FIELD WIRING MUST BE 18 AWG MINIMUM.
4. USE COPPER CONDUCTORS ONLY!
5. USE EITHER TDR OR TB. DO NOT USE BOTH IN ONE MODEL. TB IS ALTERNATE FOR TDR.

**Figure 11. 5.0 Ton Models**

## LEGEND

- 24 V } FACTORY WIRING
- LINE V } FACTORY WIRING
- 24 V } FIELD WIRING
- LINE V } FIELD WIRING
- 24 V } FIELD INSTALLED
- LINE V } FACTORY WIRING
- OPTIONAL CONNECTION
- MAGNETIC COIL
- GROUND
- JUNCTION
- CAPACITOR
- WIRE NUT OR CONNECTOR
- TERMINAL
- TRANSFORMER
- TERMINAL BLOCK/BOARD
- RELAY CONTACT (N.O.)
- RELAY CONTACT (N.C.)
- THERMISTOR
- TEMP ACTUATED SWITCH
- INTERNAL OVERLOAD PROTECTION
- PRESSURE ACTUATED SWITCH
- RESISTOR OR HEATING ELEMENT
- MOTOR WINDING
- POL. PLUG FEMALE HOUSING (MALE TERMINALS)
- POL. PLUG MALE HOUSING (FEMALE TERMINALS)

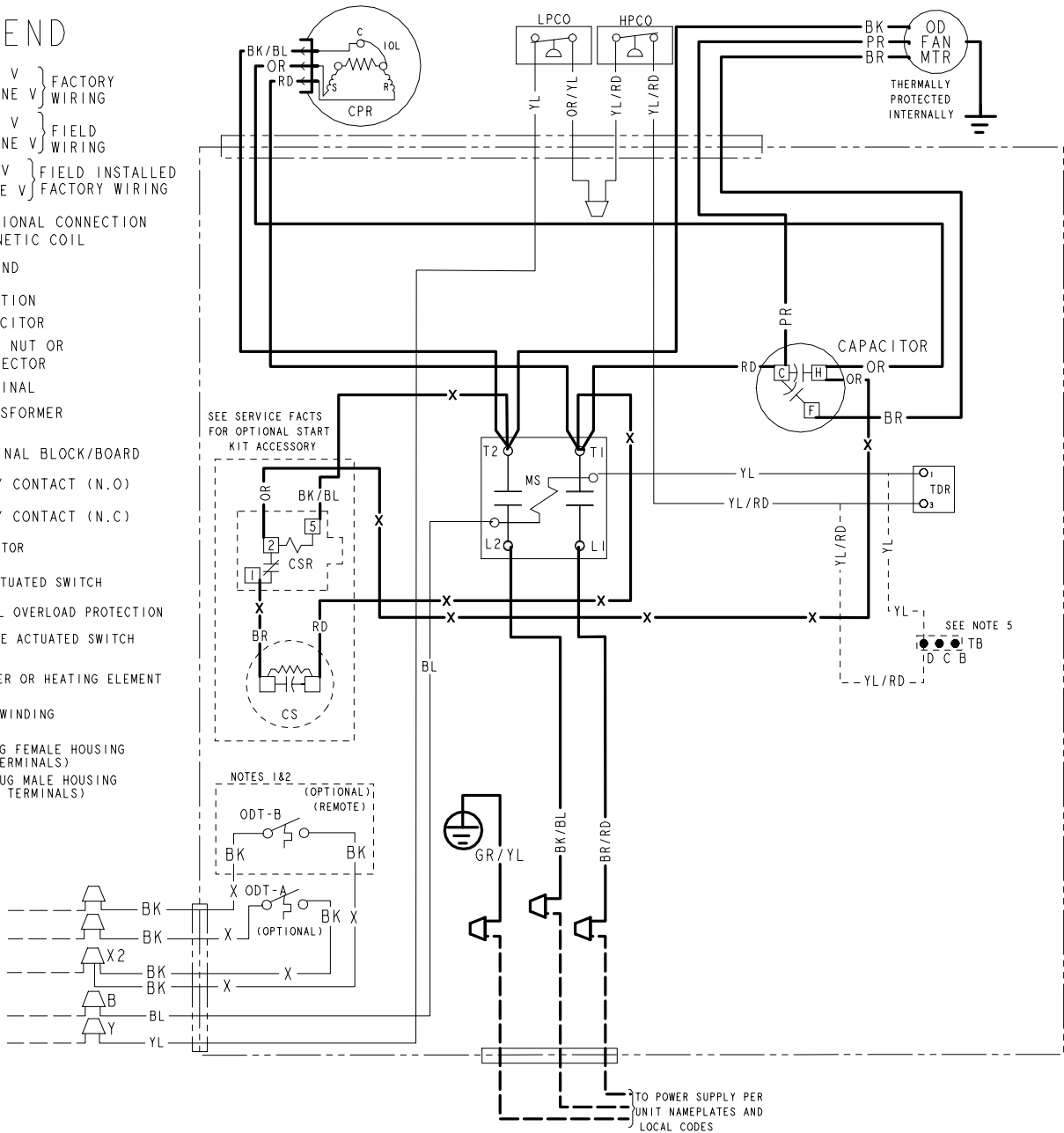

PRINTED FROM D161698P01 REV B



# Pressure Curves

## PRESSURE CURVES (Refer below table for models)

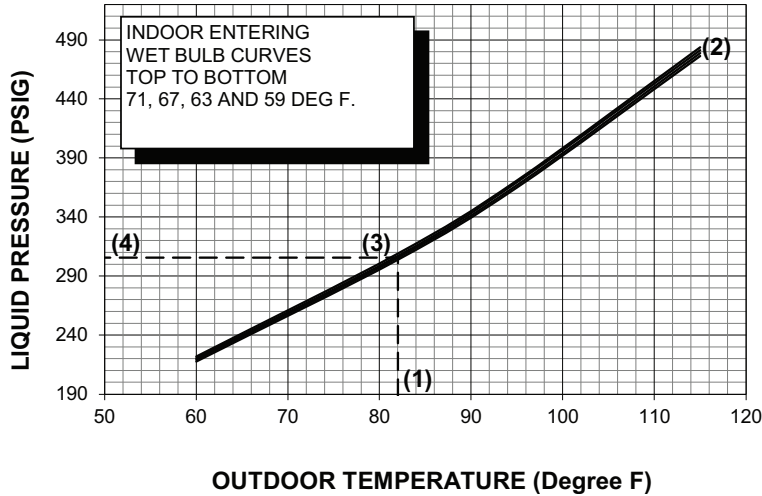

OD Model	Cooling @SCFM
4TTL6018A1	650
4TTL6024A1	800
4TTL6030A1	950

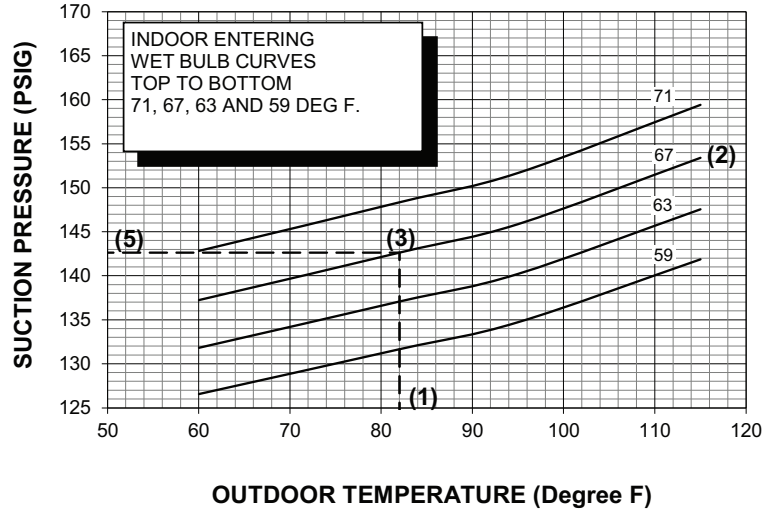

COOLING PERFORMANCE CAN BE CHECKED WHEN THE OUTDOOR TEMP IS ABOVE 65 DEG F.

TO CHECK COOLING PERFORMANCE, SELECT THE PROPER INDOOR CFM, ALLOW PRESSURES TO STABILIZE. MEASURE INDOOR WET BULB TEMPERATURE, OUTDOOR TEMPERATURE, LIQUID AND SUCTION PRESSURES. ON THE PLOTS LOCATE OUTDOOR TEMPERATURE (1); LOCATE INDOOR WET BULB (2); FIND INTERSECTION OF OD TEMP. & ID W.B. (3); READ LIQUID (4) OR SUCTION (5) PRESSURE IN LEFT COLUMN.

- EXAMPLE: (1) OUTDOOR TEMP. 82 F.  
 (2) INDOOR WET BULB 67 F.  
 (3) AT INTERSECTION  
 (4) LIQUID PRESSURE @ 600 CFM IS 306 PSIG  
 (5) SUCTION PRESSURE @ 600 CFM IS 143 PSIG

ACTUAL:  
 LIQUID PRESSURE SHOULD BE +/- 10 PSI OF CHART  
 SUCTION PRESSURE SHOULD BE +/- 3 PSIG OF CHART

**PRESSURE CURVES (Refer below table for models)**

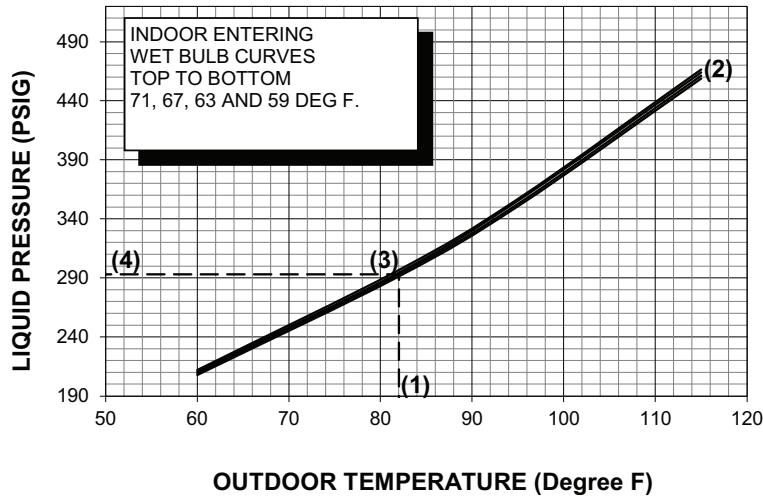

OD Model	Cooling @SCFM
4TTL6036A1	1050

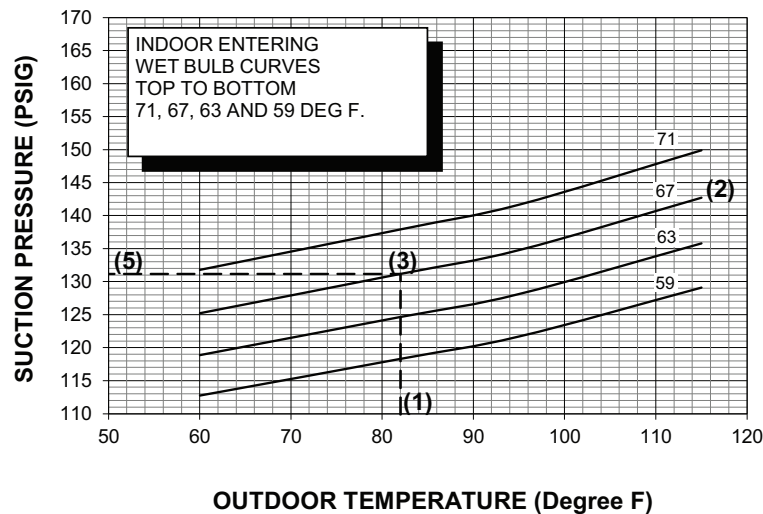

**COOLING PERFORMANCE CAN BE CHECKED WHEN THE OUTDOOR TEMP IS ABOVE 65 DEG F.**

TO CHECK COOLING PERFORMANCE, SELECT THE PROPER INDOOR CFM, ALLOW PRESSURES TO STABILIZE. MEASURE INDOOR WET BULB TEMPERATURE, OUTDOOR TEMPERATURE, LIQUID AND SUCTION PRESSURES. ON THE PLOTS LOCATE OUTDOOR TEMPERATURE (1); LOCATE INDOOR WET BULB (2); FIND INTERSECTION OF OD TEMP. & ID W.B. (3); READ LIQUID (4) OR SUCTION (5) PRESSURE IN LEFT COLUMN.

- EXAMPLE: (1) OUTDOOR TEMP. 82 F.  
 (2) INDOOR WET BULB 67 F.  
 (3) AT INTERSECTION  
 (4) LIQUID PRESSURE @ 600 CFM IS 293 PSIG  
 (5) SUCTION PRESSURE @ 600 CFM IS 131 PSIG

ACTUAL:  
 LIQUID PRESSURE SHOULD BE +/- 10 PSI OF CHART  
 SUCTION PRESSURE SHOULD BE +/- 3 PSIG OF CHART



# Pressure Curves

## PRESSURE CURVES (Refer below table for models)

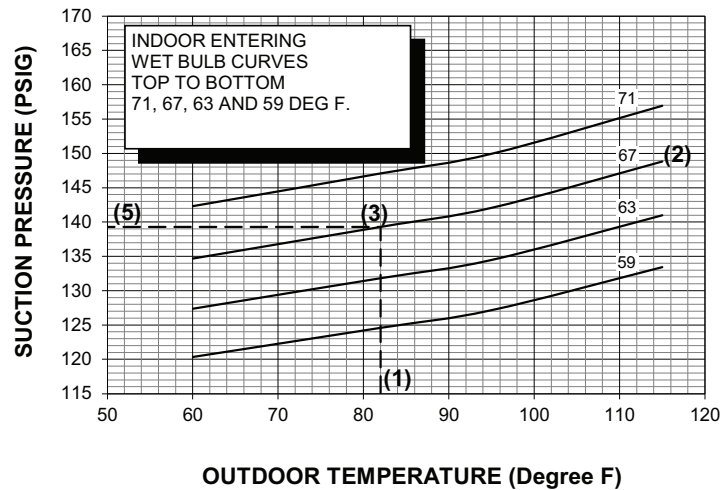
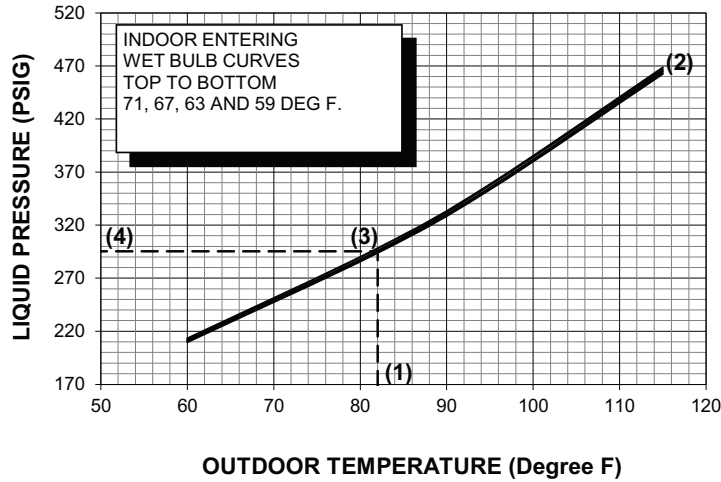

OD Model	Cooling @SCFM
4TTL6042A1	1250
4TTL6048A1	1450

**COOLING PERFORMANCE CAN BE CHECKED WHEN THE OUTDOOR TEMP IS ABOVE 65 DEG F.**  
 TO CHECK COOLING PERFORMANCE, SELECT THE PROPER INDOOR CFM, ALLOW PRESSURES TO STABILIZE. MEASURE INDOOR WET BULB TEMPERATURE, OUTDOOR TEMPERATURE, LIQUID AND SUCTION PRESSURES. ON THE PLOTS LOCATE OUTDOOR TEMPERATURE (1); LOCATE INDOOR WET BULB (2); FIND INTERSECTION OF OD TEMP. & ID W.B. (3); READ LIQUID (4) OR SUCTION (5) PRESSURE IN LEFT COLUMN.

EXAMPLE: (1) OUTDOOR TEMP. 82 F.  
 (2) INDOOR WET BULB 67 F.  
 (3) AT INTERSECTION  
 (4) LIQUID PRESSURE @ 600 CFM IS 295 PSIG  
 (5) SUCTION PRESSURE @ 600 CFM IS 139 PSIG

ACTUAL:  
 LIQUID PRESSURE SHOULD BE +/- 10 PSI OF CHART  
 SUCTION PRESSURE SHOULD BE +/- 3 PSIG OF CHART



**PRESSURE CURVES (Refer below table for models)**

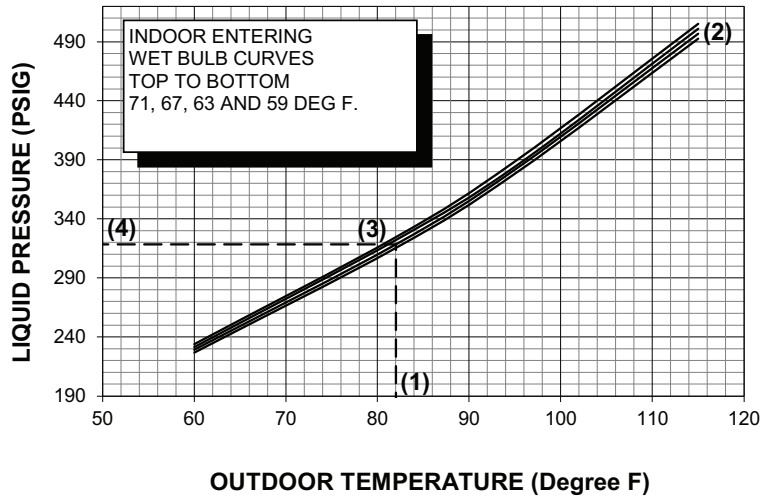

OD Model	Cooling @SCFM
4TTL6060A1	1600

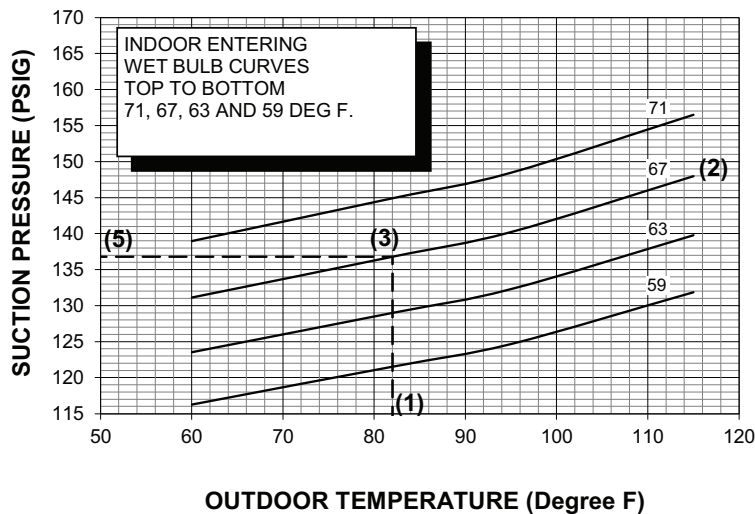

**COOLING PERFORMANCE CAN BE CHECKED WHEN THE OUTDOOR TEMP IS ABOVE 65 DEG F.**

TO CHECK COOLING PERFORMANCE, SELECT THE PROPER INDOOR CFM, ALLOW PRESSURES TO STABILIZE. MEASURE INDOOR WET BULB TEMPERATURE, OUTDOOR TEMPERATURE, LIQUID AND SUCTION PRESSURES. ON THE PLOTS LOCATE OUTDOOR TEMPERATURE (1); LOCATE INDOOR WET BULB (2); FIND INTERSECTION OF OD TEMP. & ID W.B. (3); READ LIQUID (4) OR SUCTION (5) PRESSURE IN LEFT COLUMN.

- EXAMPLE: (1) OUTDOOR TEMP. 82 F.  
 (2) INDOOR WET BULB 67 F.  
 (3) AT INTERSECTION  
 (4) LIQUID PRESSURE @ 600 CFM IS 318 PSIG  
 (5) SUCTION PRESSURE @ 600 CFM IS 137 PSIG

ACTUAL:  
 LIQUID PRESSURE SHOULD BE +/- 10 PSI OF CHART  
 SUCTION PRESSURE SHOULD BE +/- 3 PSIG OF CHART







Trane - by Trane Technologies (NYSE: TT), a global innovator - creates comfortable, energy efficient indoor environments for commercial and residential applications. For more information, please visit [trane.com](http://trane.com) or [tranetechnologies.com](http://tranetechnologies.com).

---



The AHRI Certified mark indicates Trane U.S. Inc. participation in the AHRI Certification program. For verification of individual certified products, go to [ahridirectory.org](http://ahridirectory.org).

Trane has a policy of continuous data improvement and it reserves the right to change design and specifications without notice. We are committed to using environmentally conscious print practices.