

# Installer's Guide

## Side Discharge Heat Pump

5HPL5024A1000A  
5HPL5036A1000A  
5HPL5048A1000A  
5HPL5060A1000A

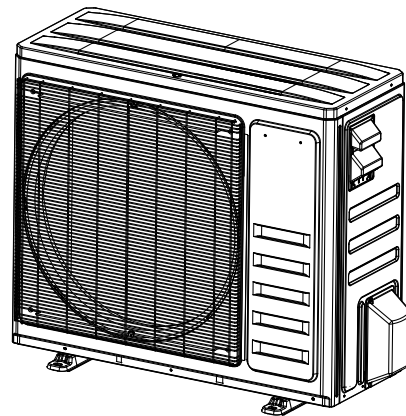

*Note: Graphics in this document are for representation only. Actual model may differ in appearance.*

*Note: The manufacturer recommends installing only approved matched indoor and outdoor systems. All of the manufacture's split systems are AHRI rated only with TXV/EEV indoor systems. Some of the benefits of installing approved matched indoor and outdoor split systems are maximum efficiency, optimum performance and the best overall system reliability.*

### **▲ SAFETY WARNING**

Only qualified personnel should install and service the equipment. The installation, starting up, and servicing of heating, ventilating, and air-conditioning equipment can be hazardous and requires specific knowledge and training. Improperly installed, adjusted or altered equipment by an unqualified person could result in death or serious injury. When working on the equipment, observe all precautions in the literature and on the tags, stickers, and labels that are attached to the equipment.

# Safety Section

**Important:** This document contains a wiring diagram and service information. This is customer property and is to remain with this unit. Please return to service information pack upon completion of work.

## **⚠ WARNING**

### **Warning!**

Only qualified personnel should install and service the equipment. The installation, starting up, and servicing of heating, ventilating, and air-conditioning equipment can be hazardous and requires specific knowledge and training. Improperly installed, adjusted or altered equipment by an unqualified person could result in death or serious injury. When working on the equipment, observe all precautions in the literature and on the tags, stickers, and labels that are attached to the equipment.

## **⚠ WARNING**

### **RISK OF FIRE!**

Flammable refrigerant used. To be repaired only by trained service personnel. Do not puncture refrigerant tubing. Dispose of properly in accordance with federal or local regulations. Flammable refrigerant used.

## **⚠ WARNING**

### **Warning!**

This information is intended for use by individuals possessing adequate backgrounds of electrical and mechanical experience. Any attempt to repair a central air conditioning product may result in personal injury and/or property damage. The manufacturer or seller cannot be responsible for the interpretation of this information, nor can it assume any liability in connection with its use.

## **⚠ WARNING**

### **UNIT CONTAINS R-454B REFRIGERANT!**

Proper service equipment is required. Failure to use proper service tools may result in equipment damage or personal injury.  
**USE ONLY R-454B REFRIGERANT AND APPROVED COMPRESSOR OIL.**

## **⚠ WARNING**

### **Warning!**

Ensure that the area is in the open or that it is adequately ventilated before breaking into the system or conducting any hot work.

## **⚠ WARNING**

### **HAZARDOUS VOLTAGE!**

Voltage may be present with power disconnected due to high winds causing fan rotation. See Service Facts or Technical Manual for servicing instructions.

## **⚠ WARNING**

### **Warning!**

The appliance shall be stored in a room without continuously operating ignition sources (for examples: open flames, an operating gas appliance or an operating electric heater). Do not pierce or burn. Be aware that refrigerants may not contain an odor.

## **⚠ WARNING**

### **LIVE ELECTRICAL COMPONENTS!**

During installation, testing, servicing, and troubleshooting of this product power should be disconnected. It may be necessary to work with live electrical components. Failure to follow all electrical safety precautions when exposed to live electrical components could result in death or serious injury.

## **⚠ WARNING**

### **Warning!**

The appliance is not to be used by persons (including children) with reduced physical, sensory or mental capabilities, or lack of experience and knowledge, unless they have been given supervision or instruction.

## **⚠ WARNING**

### **Warning!**

Children should be supervised to ensure that they do not play with the appliance.

## **⚠ WARNING**

### **VENTILATION!**

Ensure that the area is in the open or that it is adequately ventilated before breaking into the system or conducting any hot work.

**⚠ WARNING**

**HAZARDOUS VOLTAGE!**

Failure to follow this Warning could result in property damage, severe personal injury, or death.

Disconnect all electric power, including remote disconnects before servicing. Follow proper lockout/tagout procedures to ensure the power cannot be inadvertently energized.

**⚠ CAUTION**

**GROUNDING REQUIRED!**

Failure to inspect or use proper service tools may result in equipment damage or personal injury.

Reconnect all grounding devices. All parts of this product that are capable of conducting electrical current are grounded. If grounding wires, screws, straps, clips, nuts, or washers used to complete a path to ground are removed for service, they must be returned to their original position and properly fastened.

**⚠ WARNING**

**BRAZING REQUIRED!**

IF BRAZING - Make certain that all joints are brazed, not soldered. IF USING MECHANICAL CONNECTIONS - Ensure leak test is negative.

Failure to inspect lines or use proper service tools may result in equipment damage or personal injury.

**⚠ WARNING**

**HIGH LEAKAGE CURRENT!**

Failure to follow this Warning could result in property damage, severe personal injury, or death.

Earth connection essential before connecting electrical supply.

**⚠ WARNING**

**Warning!**

This product can expose you to chemicals including lead which are known to the State of California to cause cancer and birth defects or other reproductive harm.

For more information go to [www.P65Warnings.ca.gov](http://www.P65Warnings.ca.gov)

Table 1. Operating Range

Mode	Model	Operating Range
Cooling	2 - 5 Ton	5 °F - 115°F
Heating	2 - 5 Ton	-4° F - 86°F

# Table of Contents

Unit Location Considerations.....	5	Operation Mode Display.....	24
Setting Up the Unit .....	11	Start Up .....	26
Refrigerant Line Considerations .....	12	System Charge Adjustment .....	27
Refrigerant Line Connections.....	15	Checkout Procedures .....	28
Flare the Refrigerant Line.....	15	Unit Capacity Adjustment .....	29
Braze the Refrigerant Line .....	16	Troubleshooting .....	30
Refrigerant Line Leak Check .....	17	Pressure Curves .....	32
Evacuation and Servicing.....	18	Refrigerant Circuit (Only for Reference) .....	35
Service Valve.....	19	Symbols.....	36
Electrical - Low Voltage.....	20		
Electrical - High Voltage .....	23		

# Unit Location Considerations

Figure 1. Outdoor unit dimensions (024 and 036 models)

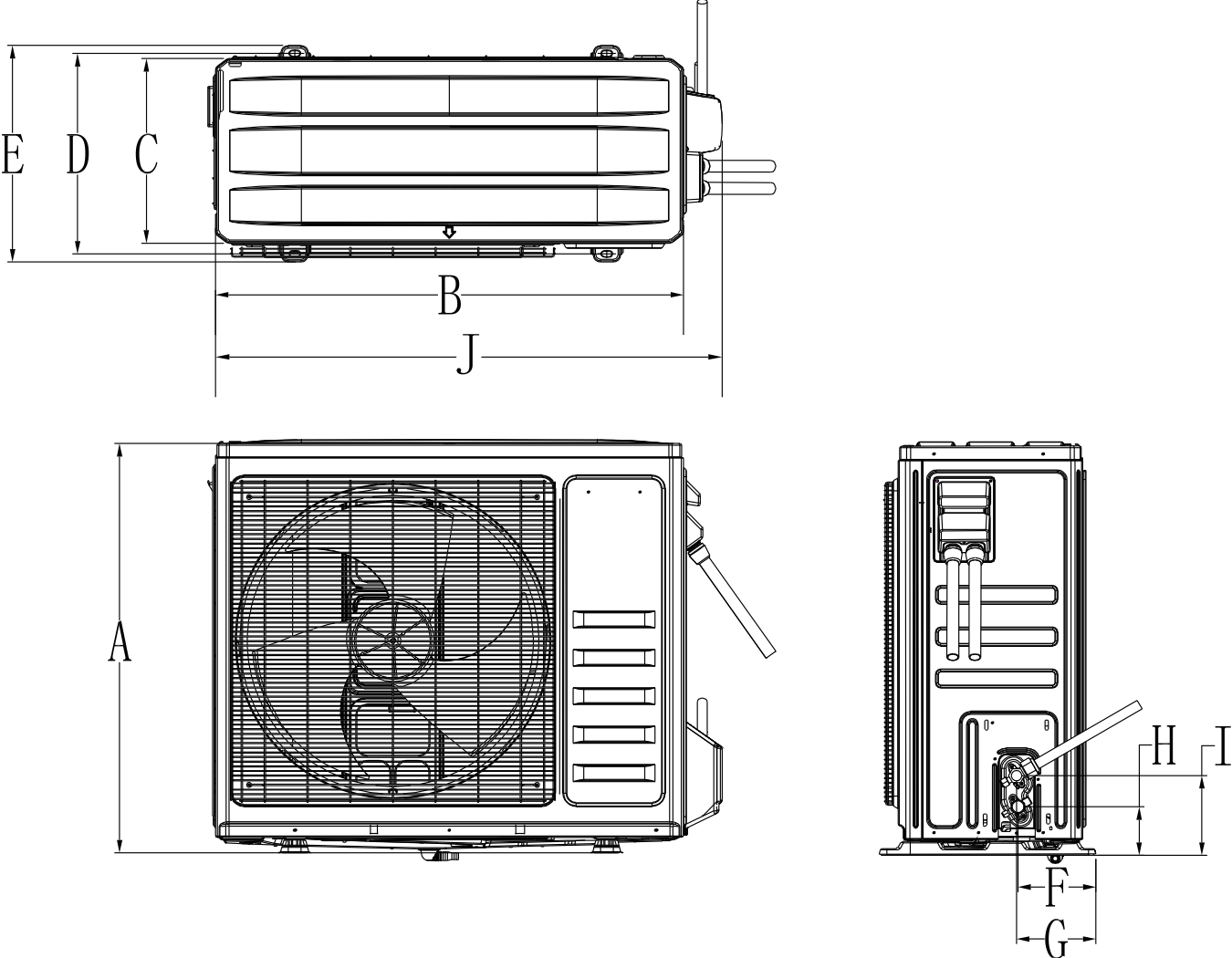

Table 2. Unit Dimensions (024 and 036 models)

Model	A/(in)	B/(in)	C/(in)	D/(in)	E/(in)	F/(in)	G/(in)	H/(in)	I/(in)	J/(in)
5HPL5024A1	31.35	35.83	14.13	15.36	16.59	5.97	6.07	3.71	6.09	38.54
5HPL5036A1	33.77	39.54	15.89	18.19	19.45	8.30	9.67	3.70	6.10	42.28

## Unit Location Considerations

Figure 2. Outdoor unit dimensions (048 and 060 models)

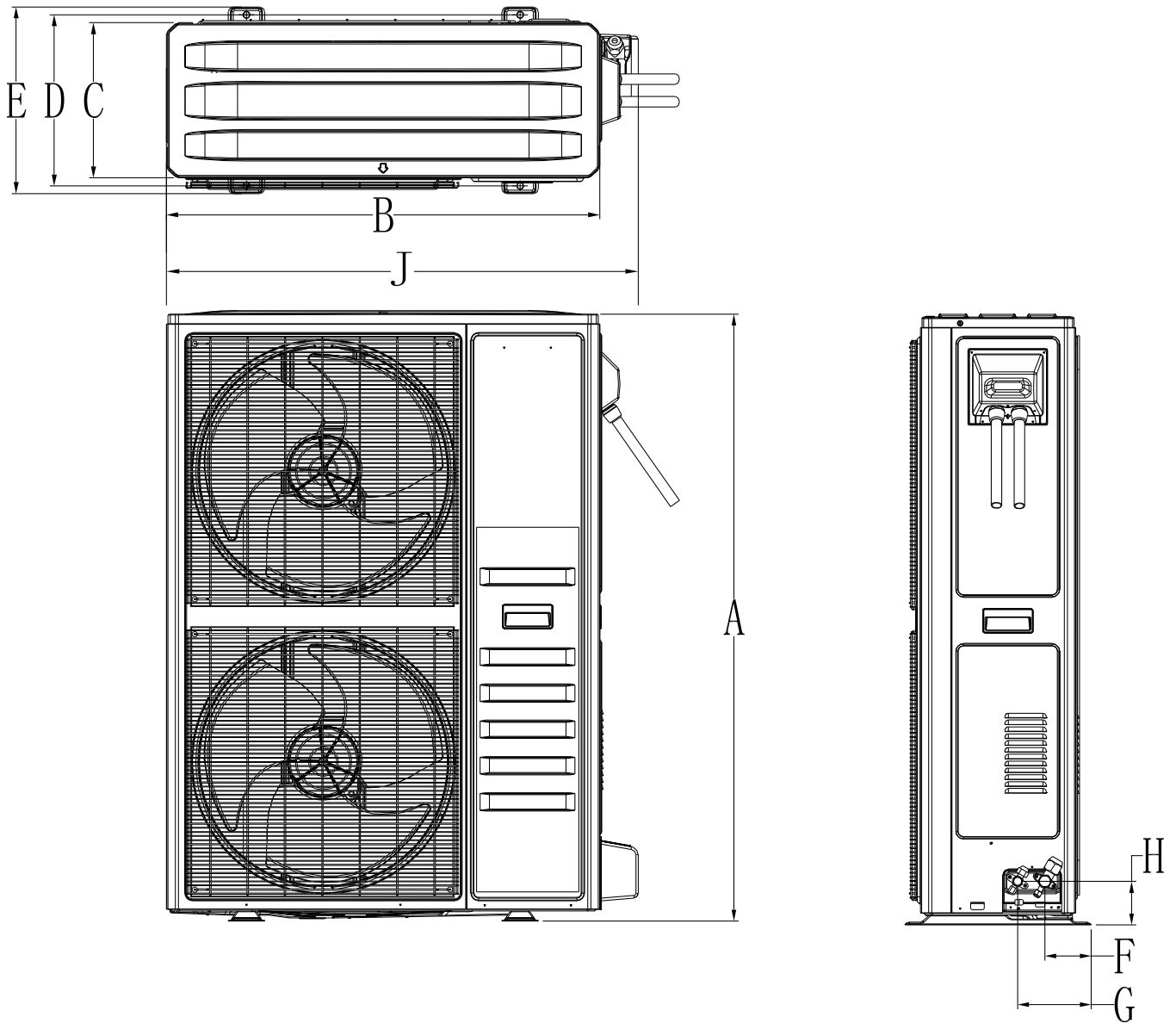

Table 3. Unit Dimensions (048 and 060 models)

Model	A/(in)	B/(in)	C/(in)	D/(in)	E/(in)	F/(in)	G/(in)	H/(in)	J/(in)
5HPL5048A1	52.40	37.40	13.39	14.76	16.10	4.00	6.37	3.75	40.71
5HPL5060A1									

**Table 4. Suggested Locations for Best Reliability, Single Unit**

- Do not locate close to bedrooms as operational sounds may be objectionable.
- Avoid locations near windows and similar areas where condensation and freezing defrost vapor can annoy a customer.

**Important:** When installing multiple units, ensure the discharge air from one unit is not drawn into another unit. When installing single or multiple units in an alcove, roof well, or partially enclosed area, ensure there is adequate ventilation to prevent recirculation of discharge air.

**Important:** If installation is in areas with known prevailing winds in excess of 25 mph, a wind baffle kit is suggested.

**Important:** Units shall not be stacked vertically.

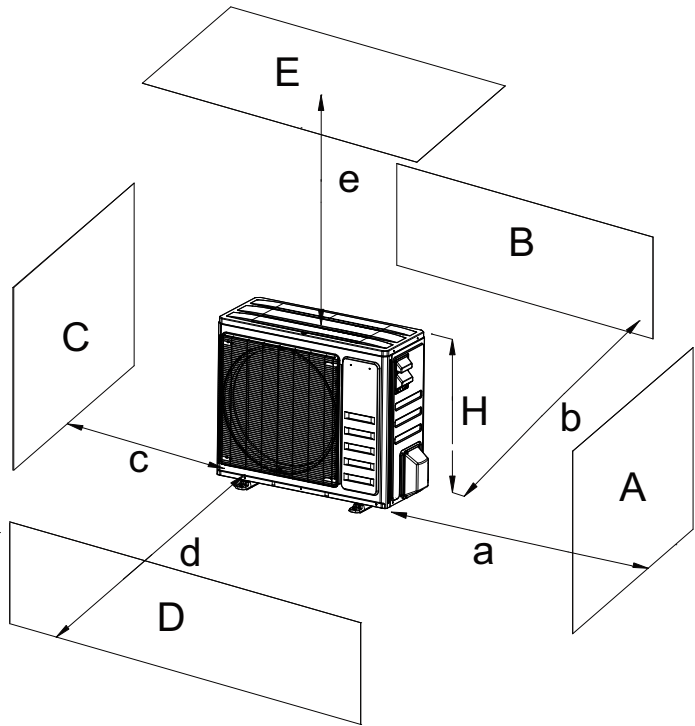

**Table 5. Single Outdoor Unit Installation Clearance Requirement**

A-E	inches (in)				
	a	b	c	d	e
B		≥3.94			
A, B, C	≥11.81	≥3.94	≥3.94		
B, E		≥3.94			≥39.37*
A, B, C, E	≥11.81	≥5.9	≥5.9		≥39.37*
D				≥39.37	
D, E				≥39.37	≥39.37*
B, D		≥3.94		≥39.37	

**Note:** \* Clearance needed for servicing.

# Unit Location Considerations

**Table 6. Suggested Locations for Best Reliability, Multiple Units**

- Do not locate close to bedrooms as operational sounds may be objectionable.
- Avoid locations near windows and similar areas where condensation and freezing defrost vapor can annoy a customer.

**Important:** When installing multiple units, ensure the discharge air from one unit is not drawn into another unit. When installing single or multiple units in an alcove, roof well, or partially enclosed area, ensure there is adequate ventilation to prevent recirculation of discharge air.

**Important:** If installation is in areas with known prevailing winds in excess of 25 mph, a wind baffle kit is suggested.

**Important:** Units shall not be stacked vertically.

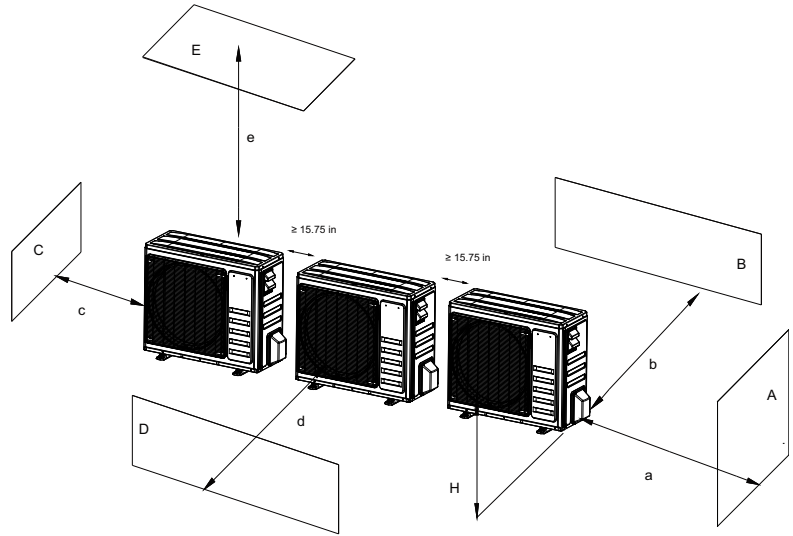

**Table 7. Multiple Outdoor unit Installation Clearance Requirement**

A-E	inches (in)				
	a	b	c	d	e
A, B, C	≥11.81	≥11.81	≥39.37		
A, B, C, E	≥11.81	≥11.81	≥39.37		≥39.37*
D				≥78.74	
D, E				≥78.74	≥39.37*
B, D		≥11.81		≥98.43	

**Note:** \*Clearance needed for servicing.



**Table 8. Refrigerant Piping Limits**

1. The maximum length of refrigerant lines from outdoor to indoor unit should NOT exceed 98 feet for 2T and 3T models and 164 feet for 4T and 5T models.
2. The maximum vertical change should not exceed 49 feet for 2T and 3T models and 98 feet for 4T and 5T models.
3. Service valve connection diameters are shown in "Refrigerant Line and Service Valve Connection Size Chart."

**Important:** Follow charge adjustment chart.

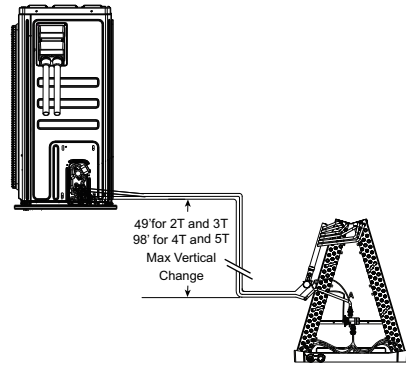
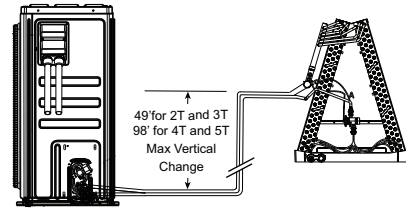
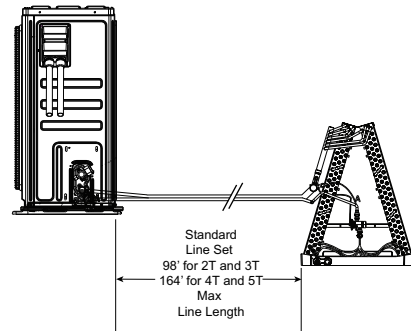

# Unit Location Considerations

**Table 9. Oil Traps**

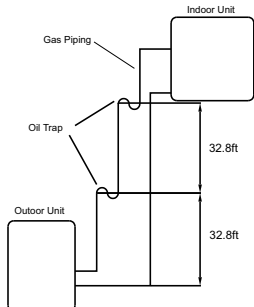
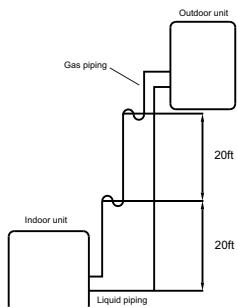
<p><b>Important:</b> If the indoor unit is installed higher than the outdoor unit.</p> <p>If oil flows back into the outdoor unit's compressor, it might cause liquid compression or deterioration. Oil traps in the rising gas piping can prevent this. Therefore, an oil trap should be installed every 32.8 ft of vertical suction line riser.</p>	
<p><b>Important:</b> If the outdoor unit is installed higher than the indoor unit.</p> <p>It is recommended that vertical suction risers not be up-sized. Proper oil returns to the compressor should be maintained. An oil trap should be installed every 20 ft of vertical suction line riser.</p>	

**Table 10. Cold Climate Considerations**

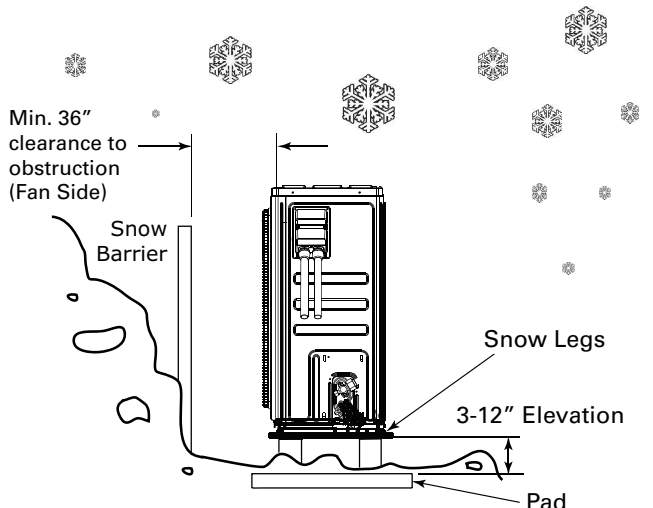
<p><b>Note:</b> It is recommended that these precautions be taken for units being installed in areas where snow accumulation and prolonged below-freezing temperatures occur.</p> <ul style="list-style-type: none"> <li>Units should be elevated 3–12 inches above the pad or rooftop, depending on local weather. This additional height will allow drainage of snow and ice melted during defrost cycle prior to its refreezing. Ensure that drain holes in unit base pan are not obstructed, preventing drainage of defrost water.</li> <li>If possible, avoid locations that are likely to accumulate snow drifts. If not possible, a snow drift barrier should be installed around the unit to prevent a build-up of snow on the sides of the unit.</li> </ul>	
--	--

## Setting Up the Unit

**Table 11. Pad Installation**

When installing the unit on a support pad, such as a concrete slab, consider the following:

- The pad should be at least 1" larger than the unit on all sides.
- The pad must be separate from any structure.
- The pad must be level.
- The pad should be high enough above grade to allow for drainage.
- The pad location must comply with National, State, and Local codes.

**Important:** Unit can be secured to the pad if there is concern of the unit tipping.

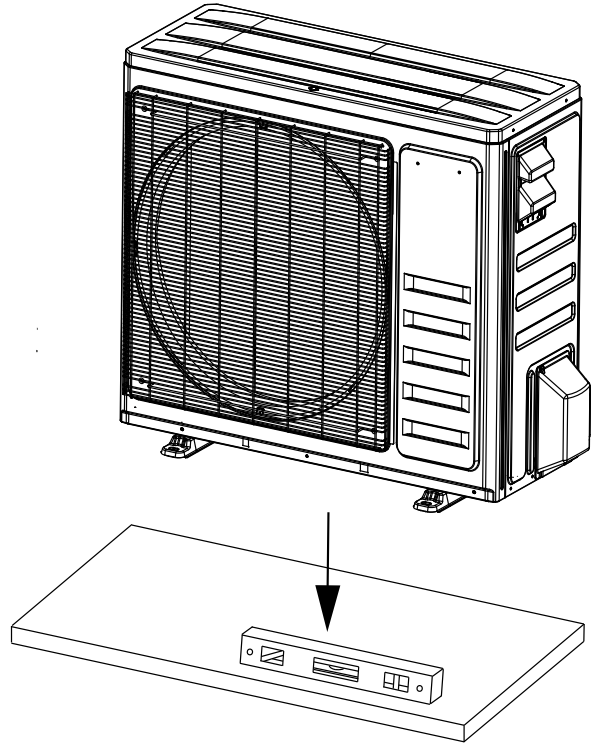

# Refrigerant Line Considerations

**Table 12. Required Refrigerant Line Length**

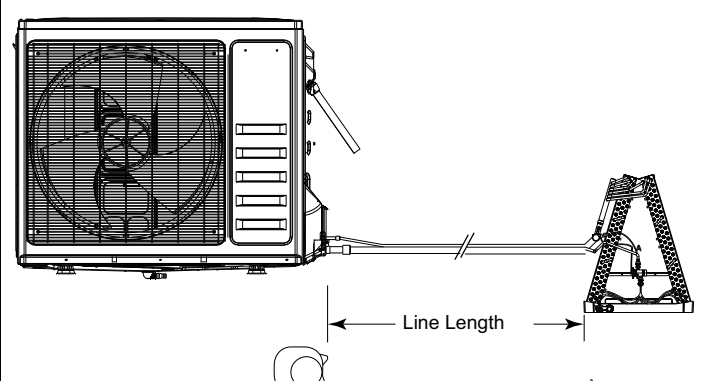
<p>Determine required line length and lift.</p> <p>Total Line Length = _____ Ft.</p> <p>Total Vertical Change (lift) = _____ Ft.</p>	
--	--

**Table 13. Refrigerant Line Insulation**

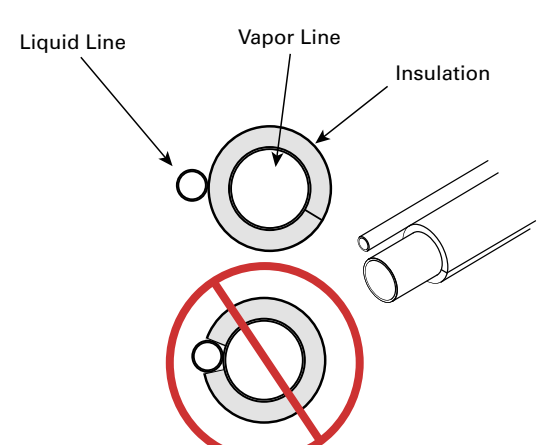
<p><b>Important:</b> The vapor line must always be insulated. DO NOT allow the Liquid Line and Vapor Line to come in direct (metal to metal) contact.</p> <p><b>Note:</b> The vapor line must always be insulated. Insulating the liquid line through attic spaces may benefit system performance by minimizing heat gain in the liquid line.</p>	
---	---

**Table 14. Refrigerant Line and Service Valve Connections**

Model	Rated Line Sizes		Alternate Line Sizes		Service Valve Connection Sizes	
	Vapor Line	Liquid Line	Vapor Line	Liquid Line	Vapor Line Connection	Liquid Line Connection
5HPL5024A1	3/4	3/8	5/8, 3/4	3/8	5/8	3/8
5HPL5036A1	3/4	3/8	5/8, 3/4	3/8	5/8	3/8
5HPL5048A1	7/8	3/8	3/4, 7/8	3/8	3/4	3/8
5HPL5060A1	7/8	3/8	3/4, 7/8	3/8	3/4	3/8

**Table 15. Reuse Existing Refrigerant Lines**

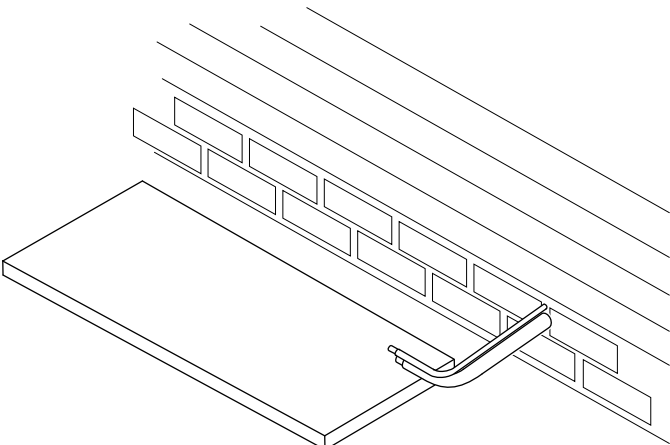
<div style="background-color: black; color: white; text-align: center; padding: 5px;"><b>⚠ CAUTION</b></div> <div style="background-color: #f0f0f0; padding: 5px;"><b>REFRIGERANT!</b></div> <p>Failure to inspect or use proper service tools may result in equipment damage or personal injury. If using existing refrigerant lines make certain that all joints are brazed, not soldered.</p> <p>For retrofit applications, where the existing indoor evaporator coil and/or refrigerant lines will be used, the following precautions should be taken.</p> <ul style="list-style-type: none"> <li>• Ensure that the indoor evaporator coil and refrigerant lines are the correct size.</li> <li>• Ensure that the refrigerant lines are free of leaks, acid, and oil.</li> </ul>	
--	--

**Table 16. Refrigerant Line Routing Precautions**

**Important:** Comply with National, State, and Local Codes when isolating line sets from joists, rafters, walls, or other structural elements.

**Important:** Take precautions to prevent noise within the building structure due to vibration transmission from the refrigerant lines.

For Example:

- When the refrigerant lines must be fastened to floor joists or other framing in a structure, use isolation type hangers.
- Isolation hangers should also be used when refrigerant lines are run in stud spaces or enclosed ceilings.
- Where the refrigerant lines run through a wall or sill, they should be insulated and isolated.
- Isolate the lines from all duct work.
- Minimize the number of 90° turns.

**Table 17. Isolation From Joist/Rafter**

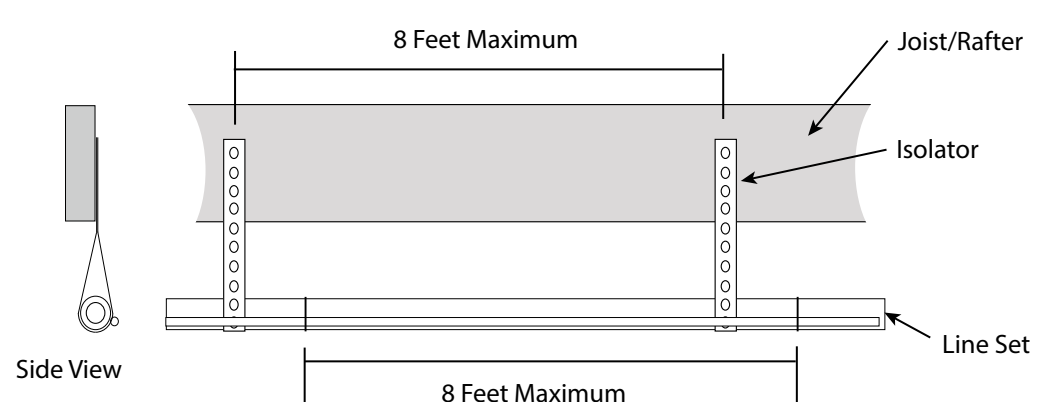

Secure Vapor Line from joists using isolators every 8 ft. Secure Liquid Line directly to insulated Vapor Line using tape, wire, or other appropriate method every 8 ft.

# Refrigerant Line Considerations

**Table 18. Isolation In Wall Spaces**

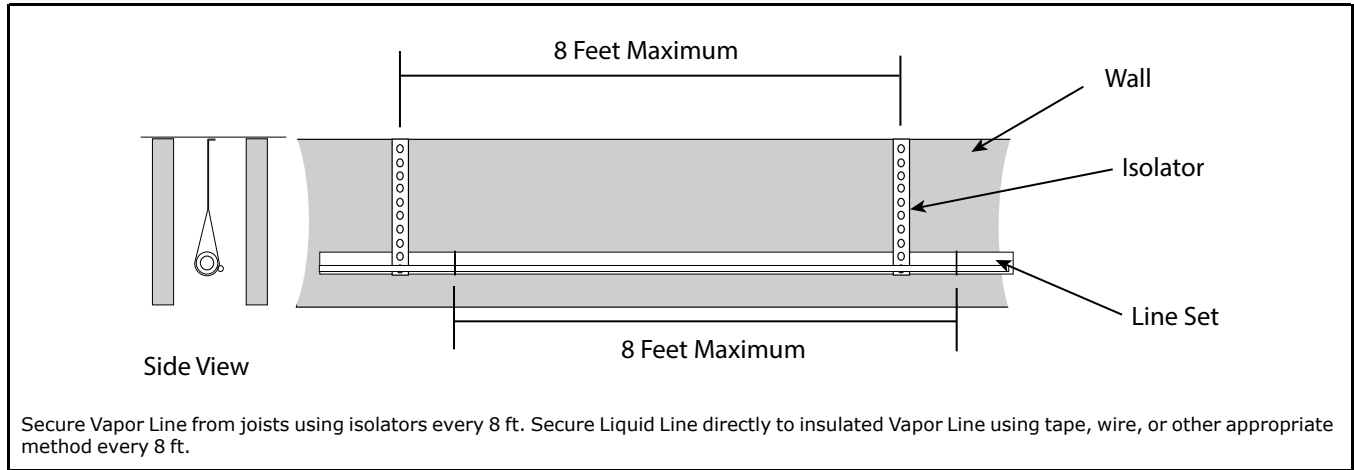

**Table 19. Isolation Through Wall**

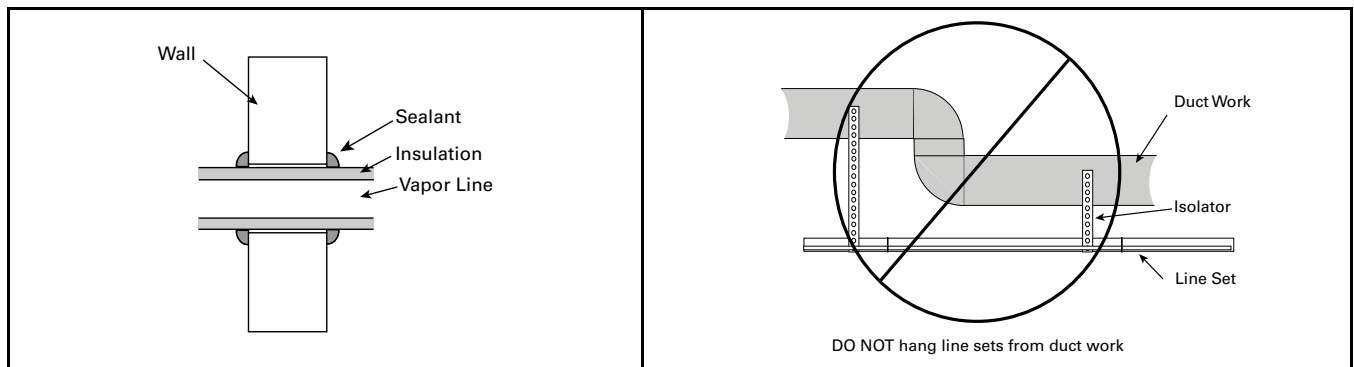

# Refrigerant Line Connections

## Flare the Refrigerant Line

**Important:** This side discharge unit comes with factory mechanical connections (flare). Unit will ship with stub tubes for brazing see following section.

**Note:** A2L equipment shall have red marked service ports and pipes through which refrigerant is serviced.

### ⚠ CAUTION

#### Caution!

Do not deform pipe while cutting. Be careful not to damage, dent, or deform the pipe while cutting.

1. **Cut tubes:** When preparing refrigerant tubing, pay attention to cutting and flaring them properly. This will ensure efficient operation and minimize the need for future maintenance.
  - a. Use the tube accessory kit or tubes purchased locally.
  - b. Measure the distance between the indoor and the outdoor units.
  - c. Cut the tubes longer than measured distance.

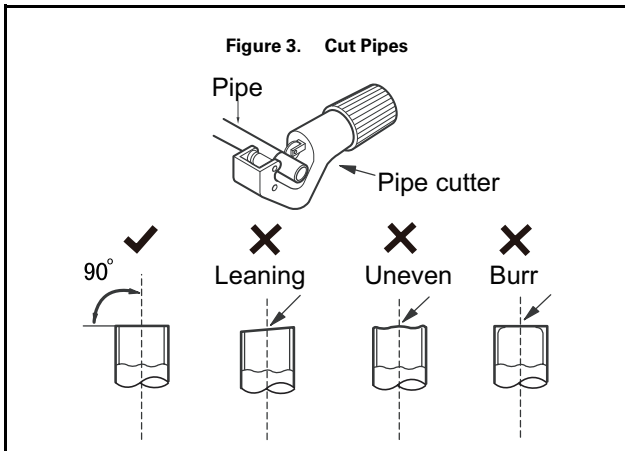

2. **Remove Burrs:** Burrs must be completely removed to ensure an air-tight seal.
  - a. Completely remove all burrs from the cut cross section of tube.
  - b. Put the end of the copper tube in a downward direction as you remove burrs in order to avoid dropping burrs into the tubing.

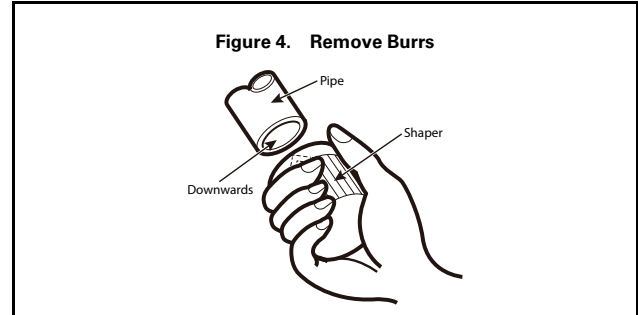

3. **Flaring:** Flare using a flaring tool as shown in the table below.

Table 20. Flaring Work Dimension

Outside Diameter	A
Inch	Inch
3/8	0.03~0.04
3/4	0.02~0.03
7/8	0.02~0.03

Firmly hold copper pipe in a die in the dimension shown in the table above.

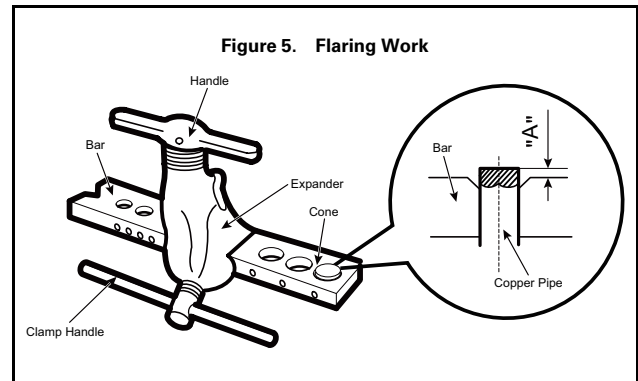

4. **Check**
  - a. Compare flare with the below figure.
  - b. If flare is noted to be defective, cut off flared section and redo.

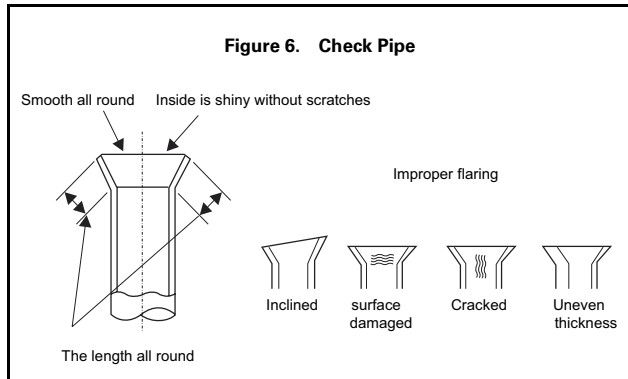

## 5. Connection

- a. Align the center of the two tube that will be connected.
- b. Tighten the flare nut as tightly as possible by hand.
- c. Using a wrench, grip the nut on the unit tubing.  
**Note:** Use two wrenches to tighten to avoid cracking.
- d. Recommended torque values are given in [Table 20, p. 15](#) for flare nut.
- e. Insert.

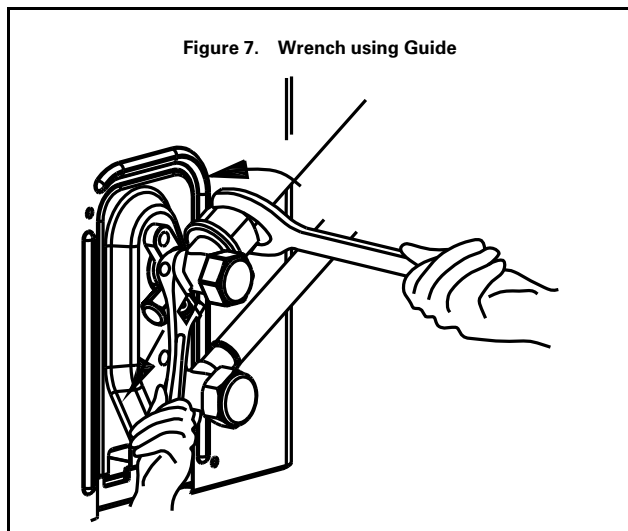

## Braze the Refrigerant Line

**Note:** A2L equipment shall have red marked service ports and pipes through which refrigerant is serviced.

1. Remove caps or plugs. Use a deburring tool to debur the pipe ends. Clean both internal and external surfaces of the tubing using an emery cloth.
2. Remove the pressure tap cap and valve cores from both service valves.
3. Purge the refrigerant lines and indoor coil with dry nitrogen.
4. Wrap a wet rag around the valve body to avoid heat damage and continue the dry nitrogen purge. Braze the refrigerant lines to the service valves.

For units shipped with a field-installed external drier, check liquid line filter drier's directional flow arrow to confirm correct direction of refrigeration flow (away from outdoor unit and toward evaporator coil) as illustrated. Braze the filter drier to the Liquid Line. Continue the dry nitrogen purge. Do not remove the wet rag until all brazing is completed.

**Important:** Remove the wet rag before stopping the dry nitrogen purge.

### Notes:

- Install drier in liquid line.
  - Precautions should be taken to avoid heat damage to basepan during brazing. It is recommended to keep the flame directly off of the basepan.
5. Replace the pressure tap valve cores after the service valves have cooled.

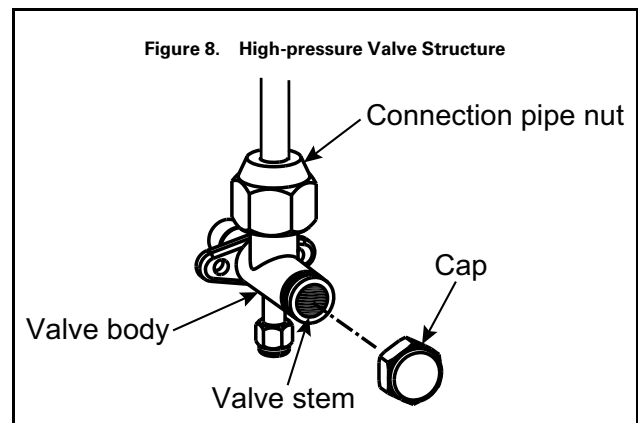



# Refrigerant Line Leak Check

**Table 21. Check For Leaks**

After completion of field piping for split systems, the field pipework shall be pressure tested with nitrogen and then vacuum tested prior to refrigerant charging.

**Important:**



- *Under no circumstances shall potential sources of ignition be used in the searching for or detection of refrigerant leaks.*
- *The following leak detection methods are deemed acceptable for all refrigerant systems:*
  - *Electronic leak detectors calibrated for R-454B (with a sensitivity of 5 grams/year).*
- *The outdoor unit should not be tested higher than 450 psig for servicing or component replacement. The indoor unit and linesets should be tested to the max pressure specified on the outdoor or indoor unit nameplate. The service valves should be closed when pressure testing the evaporator coil and linesets to separate the outdoor unit from the indoor unit.*

**STEP 1 (Final Pressure Check)** - Isolate the outdoor unit from the evaporator coil and linesets using the service valves. Pressurize the evaporator coil and linesets to the max pressure specified on the outdoor or indoor unit nameplate for a minimum of 60 minutes. Do not add additional refrigerant or test gas after reaching the evaporator coil specified pressure. The system should show no loss of pressure once pressurized. Once the pressure test is complete follow the steps for evacuation.

**\*OPTIONAL (Preliminary Pressure Check)** - Pressurize the refrigerant lines and evaporator coil to 150 PSIG using dry nitrogen. Check for leaks by using a soapy solution or bubbles at each brazed location. Remove pressure and repair any leaks before continuing.

# Evacuation and Servicing

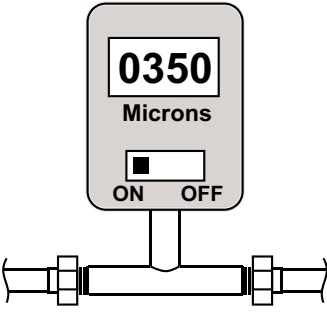
**Table 22. Evacuate the Refrigerant Lines and Indoor Coil**

<p><b>Important:</b> Do not open the service valves until the refrigerant lines and indoor coil leak check and evacuation are complete.</p> <ol style="list-style-type: none"> <li>1. Evacuate until the micron gauge reads no higher than 350 microns, then close off the valve to the vacuum pump.</li> </ol>	
<ol style="list-style-type: none"> <li>2. Observe the micron gauge. Evacuation is complete, if the micron gauge does not rise above 500 microns in one (1) minute and 1500 microns in ten (10) minutes.</li> <li>3. Once evacuation is complete, blank off the vacuum pump and micron gauge, and close the valve on the manifold gauge set.</li> </ol>	

**Table 23. Servicing**

<ul style="list-style-type: none"> <li>• If repairs must be made after system is charged, properly and safely remove or isolate refrigerant and purge the section of the system needing repair with nitrogen gas or oxygen-free nitrogen prior to opening the circuit.</li> <li>• The REFRIGERANT CHARGE shall be recovered into the correctly marked recovery cylinders.</li> <li>• Ensure that the outlet for the vacuum pump is not close to any potential ignition sources and the ventilation is available.</li> <li>• Prior to recharging the system, it shall be pressure-tested with the appropriate purging gas. The system shall be leak-tested on completion of charging but prior to commissioning. A follow up leak test shall be carried out prior to leaving the site.</li> <li>• Ensure that only appropriate refrigerant recovery cylinders are employed. Ensure that the correct number of cylinders for holding the total system charge is available. Only use cylinders designated for the recovered refrigerant and labelled for the refrigerant. Cylinders shall be complete with pressure-relief valve and associated shut-off valves in good working order.</li> <li>• A set of calibrated weighing scales shall be available and in good working order. Hoses shall be complete with leak-free disconnect couplings and in good condition. Ensure any associated electrical components are sealed.</li> <li>• The recovered refrigerant shall be returned to the refrigerant supplier in the correct recovery cylinder. Do not mix refrigerants.</li> <li>• If compressors or compressor oils are to be removed, ensure that they have been evacuated to an acceptable level to make certain that FLAMMABLE REFRIGERANT does not remain within the lubricant.</li> </ul>
---

# Service Valve

**Table 24. Open the Gas Service Valve**

**Important:** Leak check and evacuation must be completed before opening the service valves.

**Note:** Do not vent into the atmosphere.

1. Remove valve stem cap.
2. Using an adjustable wrench, turn valve stem 1/4 turn counterclockwise to the fully open position.
3. Replace the valve cap to prevent leaks. Tighten finger tight plus an additional 1/4 turn.

## **⚠ WARNING**

### **SERVICE VALVES!**

Extreme caution should be exercised when opening the Service Valve. Turn counterclockwise until the valve stem just touches the rolled edge. No torque is required. Failure to follow this warning will result in abrupt release of system charge and may result in personal injury and /or property damage.

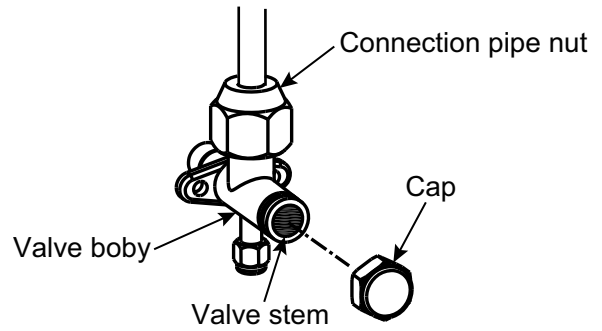

# Electrical - Low Voltage

**Notes:**

- Field installed electrical conduit is required at the low voltage wire entry point to prevent pests from entering into the control box resulting in PCB damage.
- The use of color coded low voltage wire is recommended to simplify connections between the outdoor unit, the control, and the indoor unit.

**Table 25. Low Voltage Maximum Wire Length**

CONTROL WIRING	
WIRE SIZE	MAX. WIRE LENGTH
18 AWG	150 Ft.
16 AWG	225 Ft.
14 AWG	300 Ft.

**Table 26. 2T and 3T Wiring Diagram**

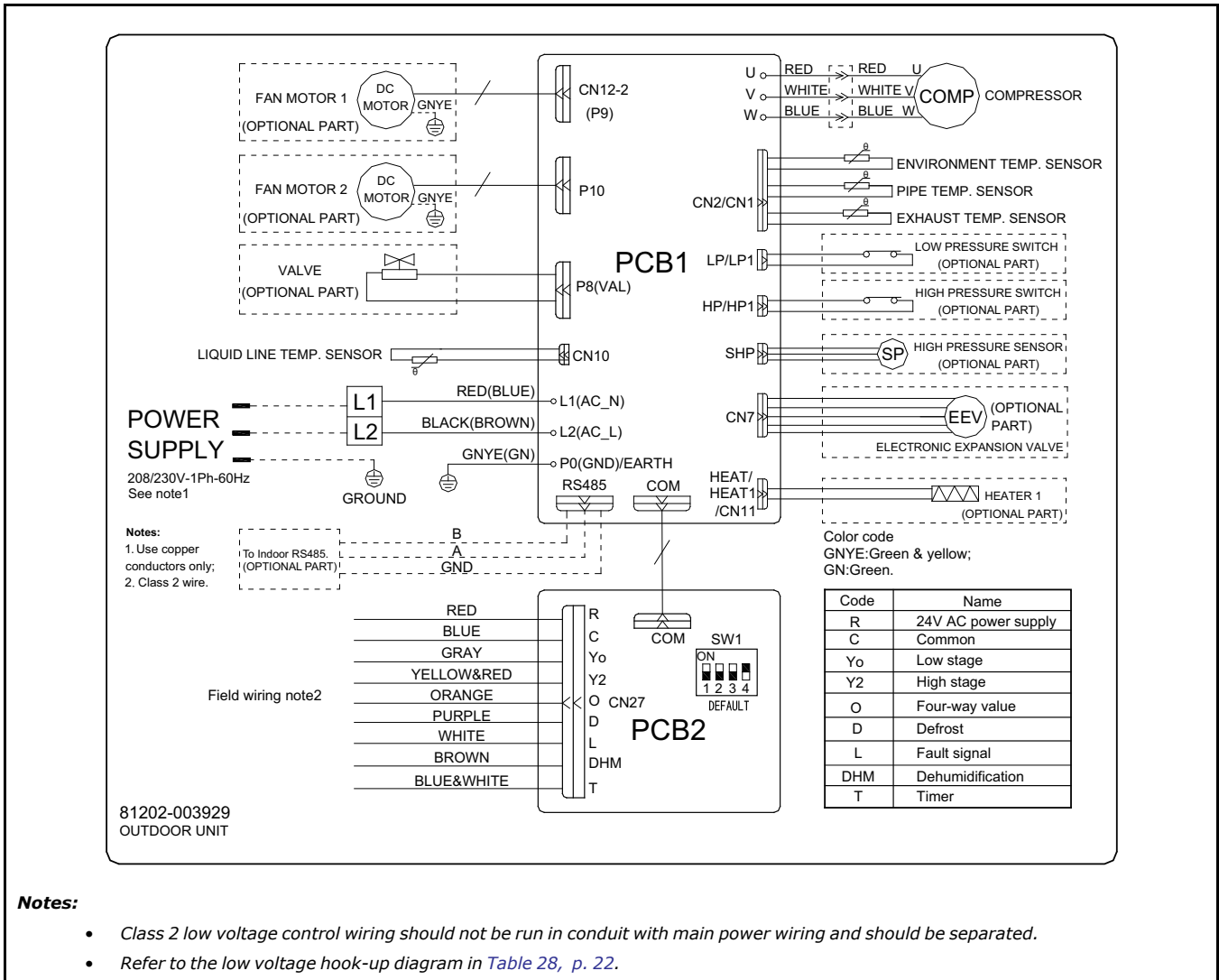

**Notes:**

- Class 2 low voltage control wiring should not be run in conduit with main power wiring and should be separated.
- Refer to the low voltage hook-up diagram in Table 28, p. 22.

Table 27. 4T and 5T Wiring Diagram

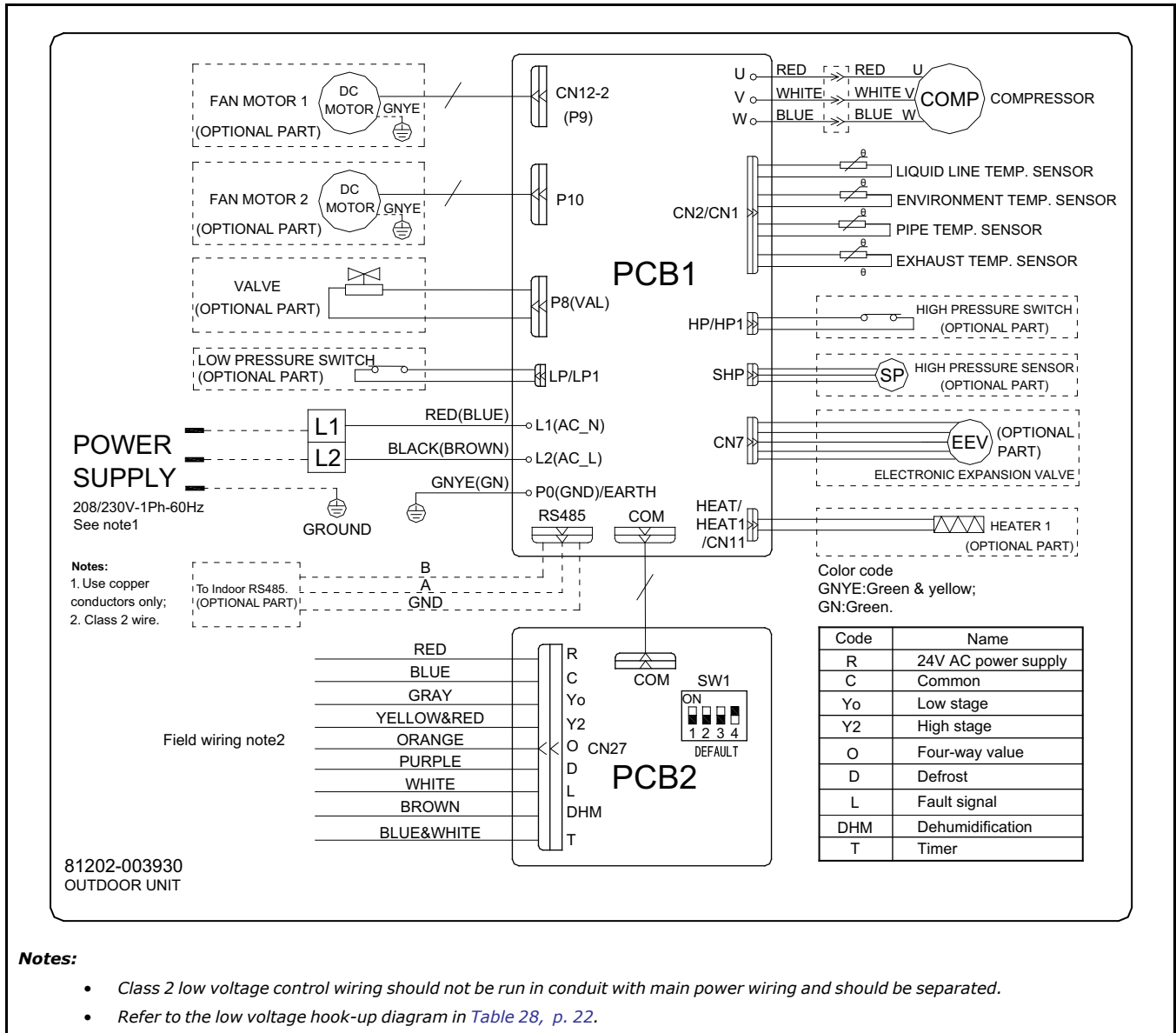

Table 28. Low Voltage Hook-up

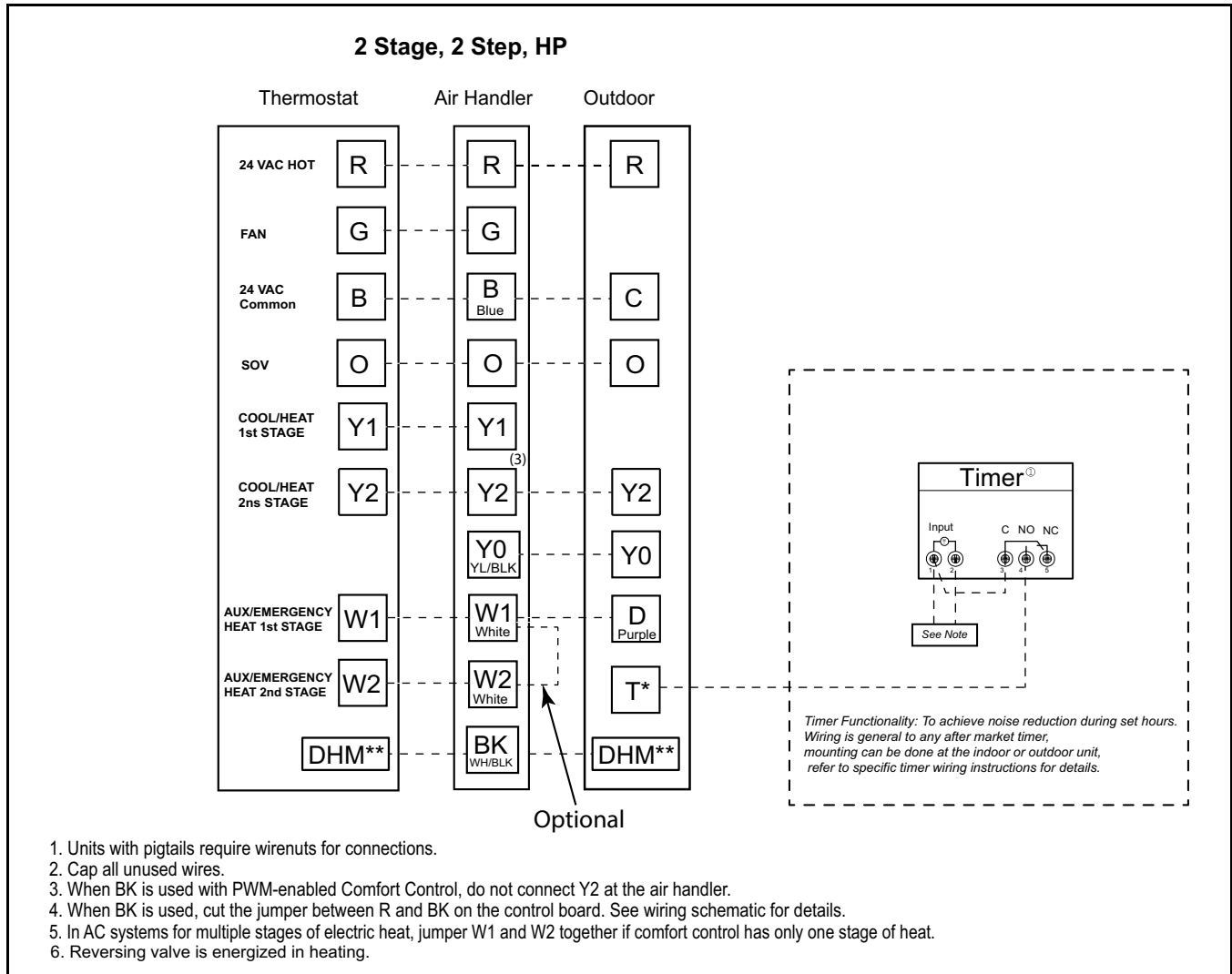

Table 29. Mitigation Board Guidelines

- The approved ID/OD combination will provide sufficient safe ventilation in case of a leak.
- Refer to Indoor Unit Installer's Guide for correct specifications on indoor unit install.
- All systems require mitigation boards so an altitude adjustment factor may be required.
- Mitigation Control Board needs to be included in an A2L System.



# Operation Mode Display

## 1. Side Discharge Operation Mode Display:

The display enables the technician to observe the unit's mode of operation. When the unit is running in normal condition, the left and center positions on

the digital display will not be illuminated. The right position of the digital display will indicate the ODU operation mode. Refer to the following chart for the indicators of the different modes.

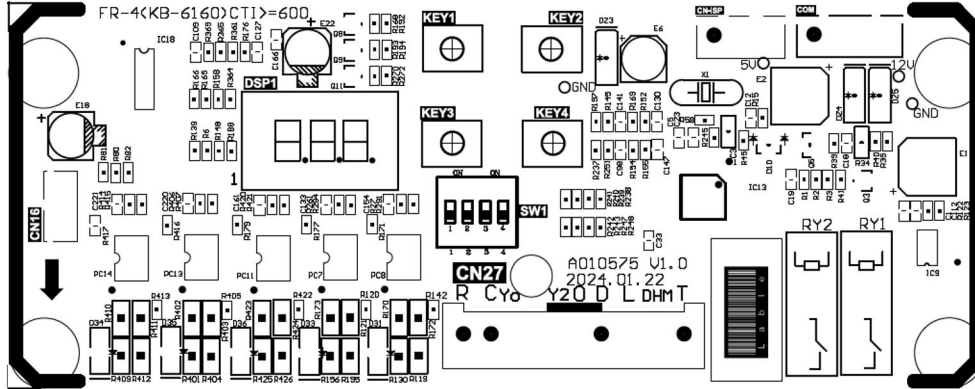

S3 is the indicator for the ODU operation mode, the display description is as below:

0	0 No startup signal is received, stop state
1	Startup signal has been received, ready to start up
2	Cooling mode
3	Heating mode
4	Oil return mode
5	Defrosting mode
6	Force defrosting mode
7	Force cooling mode
8	Force heating mode
A	Failure or protection, stop state
H	Dehumidification mode
q	Low noise mode

## 2. Error code display:

The same digital display is used for error codes using the left and center positions. In the case of

multiple failures or protections, the error codes will alternate on the display. Please refer to the list of error codes in the following chart.

**Table 33. Error Codes List**

Code	Reason	Remark
E3	ODU Coil temperature sensor failure. (OPT)	ODU coil sensor and ODU PCB.
E7	ODU Ambient Temperature sensor failure.(OAT)	ODU ambient sensor and ODU PCB.
E8	ODU Exhaust Temperature sensor failure.(ODT)	ODU Exhaust sensor and ODU PCB.
E9	IPM / Compressor driving control abnormal.	ODU PCB , compressor, etc.
EA	ODU current sampling failure	ODU PCB
EB	The Communication abnormal of Main PCB and operating board ( IDU failure )	Display board and main PCB.



**Table 33. Error Codes List (continued)**

Code	Reason	Remark
EC	The communication abnormal of ODU main PCB and operating PCB	ODU main PCB, ODU operating PCB.
EE	ODU EEPROM failure.	1. ODU PCB broken? 2. Try to re-power on AC unit.
EF	ODU DC fan motor failure.	Fan motor, ODU PCB.
P0	IPM module protection.	ODU PCB
P1	Over / under voltage protection.	1. ODU PCB broken? 2. Power supply abnormal?
P4	ODU Exhaust pipe Over temperature protection.	Please check the troubleshooting for detail.
P5	Sub-cooling protection on Cooling mode.	Please check the troubleshooting for detail.
P6	Overheating protection on Cooling mode.	Please check the troubleshooting for detail.
P7	Overheating protection on Heating mode.	Please check the troubleshooting for detail.
P8	Outdoor Over temperature/Under temperature protection.	Please check the troubleshooting for detail.
P9	Compressor driving protection (Load abnormal).	Please check the troubleshooting for detail.
F5	PFC PROTECTION	Please check the troubleshooting for detail.
F6	The Compressor lack of phase / Anti-phase PROTECTION	Please check the troubleshooting for detail.
F7	IPM Module over temperature PROTECTION.	Please check the troubleshooting for detail.
F8	4-Way Value reversing abnormal.	Please check the troubleshooting for detail.
FA	The compressor Phase-current test circuit failure.	ODU PCB
H1	High pressure switch failure	1. High pressure switch damage. 2. High pressure switch connection is loose. 3. DU main PCB damage.
H2	Low pressure switch failure	1. Low pressure switch damage. 2. Low pressure switch connection is loose. 3. ODU main PCB damage.
H3	High pressure sensor failure	1. High pressure sensor damage. 2. High pressure sensor connection is loose. 3. ODU main PCB damage.
H4	Low pressure sensor failure	1. Low pressure sensor damage. 2. Low pressure sensor connection is loose. 3. ODU main PCB damage.

# Start Up

**Table 34. System Start Up**

1. Ensure Sections Refrigerant Line Connections through Electrical High Voltage have been completed.
2. Set System Thermostat to OFF.
3. Turn on disconnect(s) to apply power to the indoor and outdoor units.
4. Wait one (1) hour before starting the unit if compressor crankcase heater is used and the Outdoor Ambient is below 70° F.
5. Set system thermostat to ON.

# System Charge Adjustment

Table 35. Additional Refrigerant per Line Set Length

Liquid pipe diameter	1/4"	3/8"
Additional charge for ft pipe (R454B)	0.16OZ	0.32OZ

# Checkout Procedures

Final phases of this installation are the unit Operational and Checkout Procedures. To obtain proper performance, all units must be operated and charge adjustments made.

**Important:** Perform a final unit inspection to be sure that factory tubing has not shifted during shipment. Adjust tubing if necessary so tubes do not rub against each other when the unit runs. Also be sure that wiring connections are tight and properly secured.

After installation has been completed, it is recommended that the entire system be checked against the following list:

<ul style="list-style-type: none"><li><input type="checkbox"/> Leak check refrigerant lines.</li><li><input type="checkbox"/> Properly insulate suction lines and fittings.</li><li><input type="checkbox"/> Properly secure and isolate all refrigerant lines.</li><li><input type="checkbox"/> Seal passages through masonry. If mortar is used, prevent mortar from coming into direct contact with copper tubing.</li><li><input type="checkbox"/> Verify that all electrical connections are tight.</li><li><input type="checkbox"/> Observe outdoor fan during on cycle for clearance and smooth operation.</li></ul>	<ul style="list-style-type: none"><li><input type="checkbox"/> Be sure that indoor coil drain line drains freely. Pour water into drain pan.</li><li><input type="checkbox"/> Be sure that supply registers and return grilles are open and unobstructed.</li><li><input type="checkbox"/> Be sure that a return air filter is installed.</li><li><input type="checkbox"/> Be sure that the correct airflow setting is used. (Indoor blower motor).</li><li><input type="checkbox"/> Operate complete system in each mode to ensure safe operation.</li><li><input type="checkbox"/> Check the MCB or RDS is operational.</li></ul>
---	---

# Unit Capacity Adjustment

This switch allows the capacity of the unit to be adjusted during installation. The default setting (SW1-2 at the digit end (down)) represents 100% capacity. The capacity can be adjusted by positioning the SW1-2 to the ON position.

**Note:** The dip switch should be adjusted only when the unit is powered off. If the dip switch is activated when the unit is powered on, there will be no change until it is power cycled.

**Table 36. Capacity Adjustment using Unit Dip Switches**

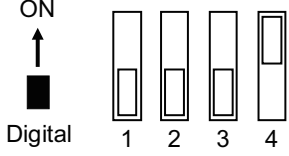
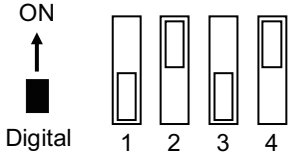
SW1-2	Unit capacity selection		100% capacity (default setting)
			2T-> 1.5T, 3T->2.5T, 4T->3.5T, 5T->4.5T

# Troubleshooting

## ⚠ CAUTION

### Caution!

If one of the following conditions occurs, switch off the power supply immediately and contact your dealer for further assistance:

- The operation light continues to flash rapidly after the unit has been restarted.
- The unit continually trips fuses or circuit breakers.
- A foreign object or water enters the unit.
- Other abnormal situations.

The following symptoms are not a malfunction and in most situations will not require repairs:

**Table 37. Common Problems**

Problem	Possible Cause
Abnormal noises of outdoor unit	The unit will make different sounds based on its current operating mode.
Both the indoor and outdoor units make noises	The outdoor may hum during operation. This is a normal phenomenon, which is caused by refrigerant gas flowing through the indoor and outdoor units.
	When the unit is turned on, and just stopped or defrosted, a hiss may be heard. This noise is normal and is caused by refrigerant gas stopping or turning.
Unit does not turn on when pressing ON/ OFF button	The unit has a 3-minute protection feature that prevents the unit from overloading. The unit cannot be restarted within three minutes of being turned off.
	Cooling and Heating Models: If the Operation light and PRE-DEF (Pre-heating/ Defrost) indicators are lit up, the outdoor temperature is too cold and the unit's anti-cold wind is activated in order to defrost the unit.
The unit changes from COOL mode to FAN mode	The unit changes its setting to prevent frost from forming on the unit. Once the temperature increases, the unit will start operating again.
	The set temperature has been reached, at which point the unit turns off the compressor. The unit will resume operating when the temperature fluctuates again.
Both the indoor and outdoor units emit white mist	When the unit restarts in HEAT mode after defrosting, white mist may be emitted due to moisture generated from the defrosting process.
Dust is emitted from either the indoor or outdoor unit	The unit may accumulate dust during extended periods of nonuse, which will be emitted when the unit is turned on. This can be mitigated by covering the unit during long periods of inactivity.
The unit emits a bad odor	The unit may absorb odors from the environment (such as furniture, cooking, cigarettes, etc.), which will be emitted during operations.
	The unit filters have become moldy and should be cleaned.
The fan of the outdoor unit does not operate	During operation, the fan speed is controlled to optimize product operation.

When problem occur, please check the following points before contacting a repair company.

**Table 38. Troubleshooting**

Problem	Possible Cause	Solution
The unit is not working	Power failure	Wait for the power to be restored
	The power switch is off	Turn on the power
	The fuse is burned out	Replace the fuse
	The unit's 3-minute protection has been activated.	Wait three minutes after restarting the unit.
Poor cooling performance	Temperature setting may be higher than the ambient room temperature	Lower the temperature setting
	The heat exchanger on the indoor or outdoor unit is dirty	Clean the affected heat exchanger
	The air filter is dirty	Remove the filter and clean it according to instructions
	The air inlet or outlet of either unit is blocked	Turn the unit off, remove the obstruction and turn it back on
	Doors and windows are open	Make sure that all doors and windows are closed while operating the unit
	Excessive heat is generated by sunlight	Close windows and curtains during periods of high heat or bright sunshine
	Low refrigerant due to leak or long-term use	Check for leaks, reseal if necessary and top off refrigerant
The unit starts and stops frequently	There's too much or too little refrigerant in the system	Check for leaks and recharge the system with refrigerant
	There is air, incompressible gas or foreign material in the refrigeration system.	Evacuate and recharge the system with refrigerant
	System circuit is blocked	Determine which circuit is blocked and replace the malfunctioning piece of equipment
	The compressor is broken	Replace the compressor
	The voltage is too high or too low	Install a monostatic to regulate the voltage
Poor heating performance	The outdoor temperature is lower than 44.5°F	Check for leaks and recharge the system with refrigerant
	Cold air is entering through doors and windows	Make sure that all doors and windows are closed during use
	Low refrigerant due to leak or long-term use	Check for leaks, reseal if necessary and top off refrigerant

# Pressure Curves

**COOLING PERFORMANCE CAN BE CHECKED WHEN THE OUTDOOR TEMP IS ABOVE 65 DEG F.**  
 TO CHECK COOLING PERFORMANCE, SELECT THE PROPER INDOOR CFM, ALLOW PRESSURES TO STABILIZE. MEASURE INDOOR WET BULB TEMPERATURE, OUTDOOR TEMPERATURE, DISCHARGE AND SUCTION PRESSURES. ON THE PLOTS LOCATE OUTDOOR TEMPERATURE (1); LOCATE INDOOR WET BULB (2); FIND INTERSECTION OF OD TEMP. & ID W.B. (3); READ DISCHARGE OR SUCTION PRESSURE IN LEFT COLUMN (4).

EXAMPLE: (1) OUTDOOR TEMP. 82 F.  
 (2) INDOOR WET BULB 67 F.  
 (3) AT INTERSECTION  
 (4) DISCHARGE PRESSURE @ 865 CFM IS 320 PSIG.  
 (5) SUCTION PRESSURE @ 865 CFM IS 134 PSIG.

ACTUAL: DISCHARGE PRESSURE SHOULD BE +/- 10 PSI OF CHART  
 SUCTION PRESSURE SHOULD BE +/- 3 PSIG OF CHART

PRESSURE CURVES for 5HPL5024A1

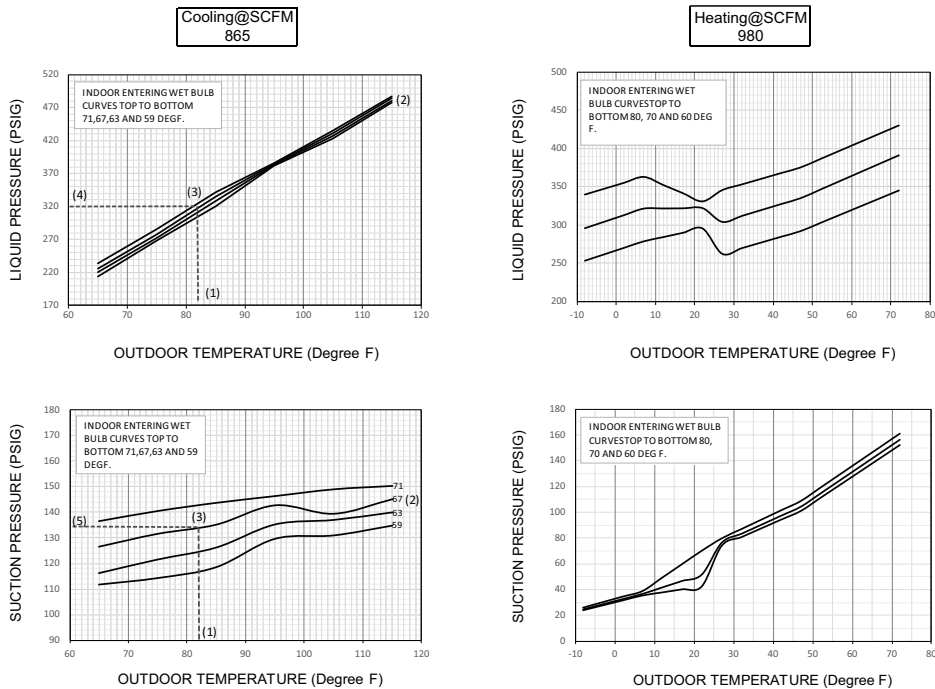



PRESSURE CURVES for 5HPL5036A1

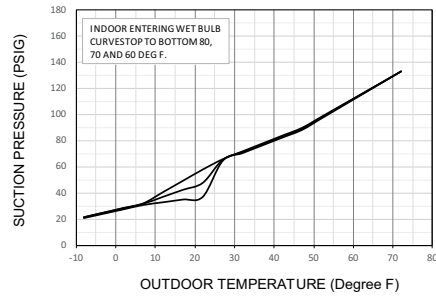
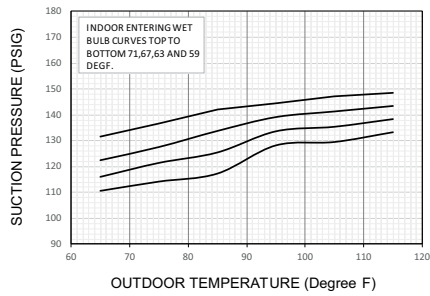
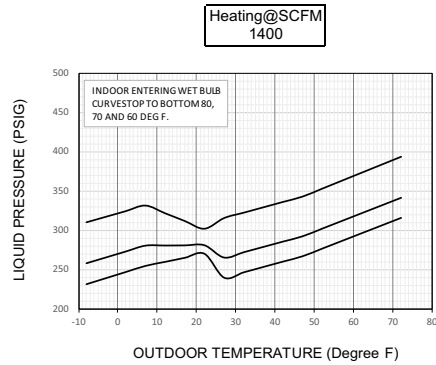
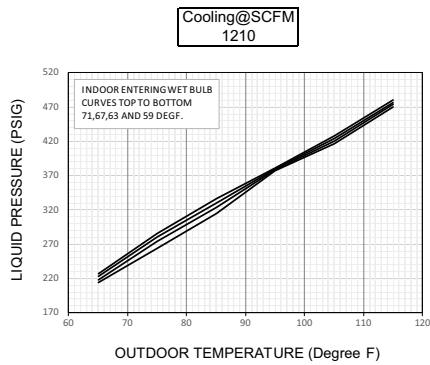

PRESSURE CURVES for 5HPL5048A1

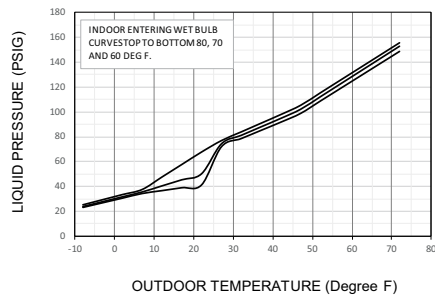
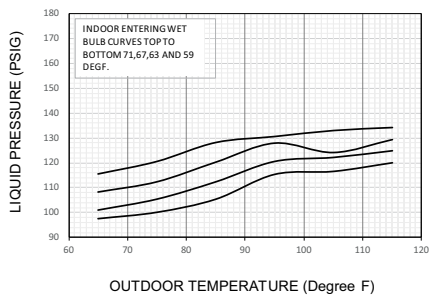
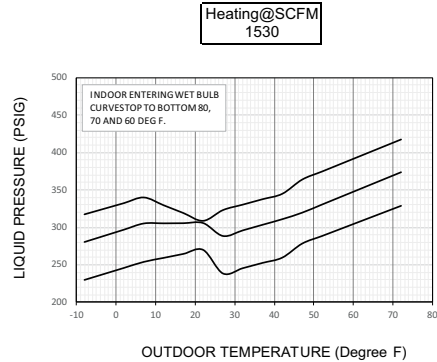
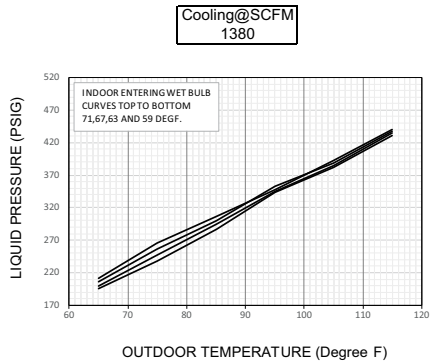

# Pressure Curves

## PRESSURE CURVES for 5HPL5060A1

Cooling@SCFM  
1830

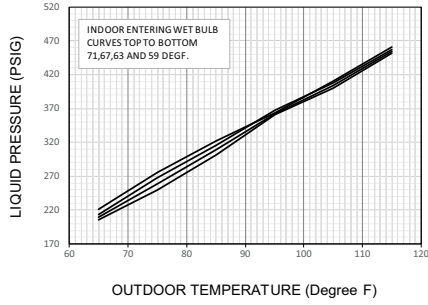



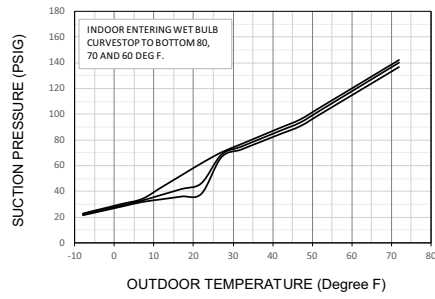
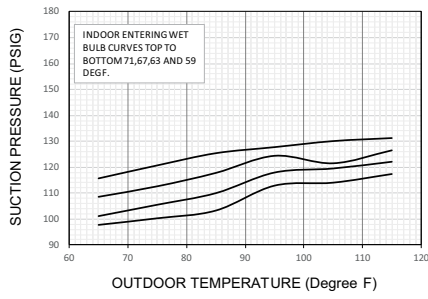
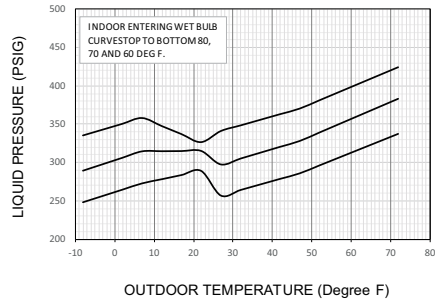

Heating@SCFM  
1850

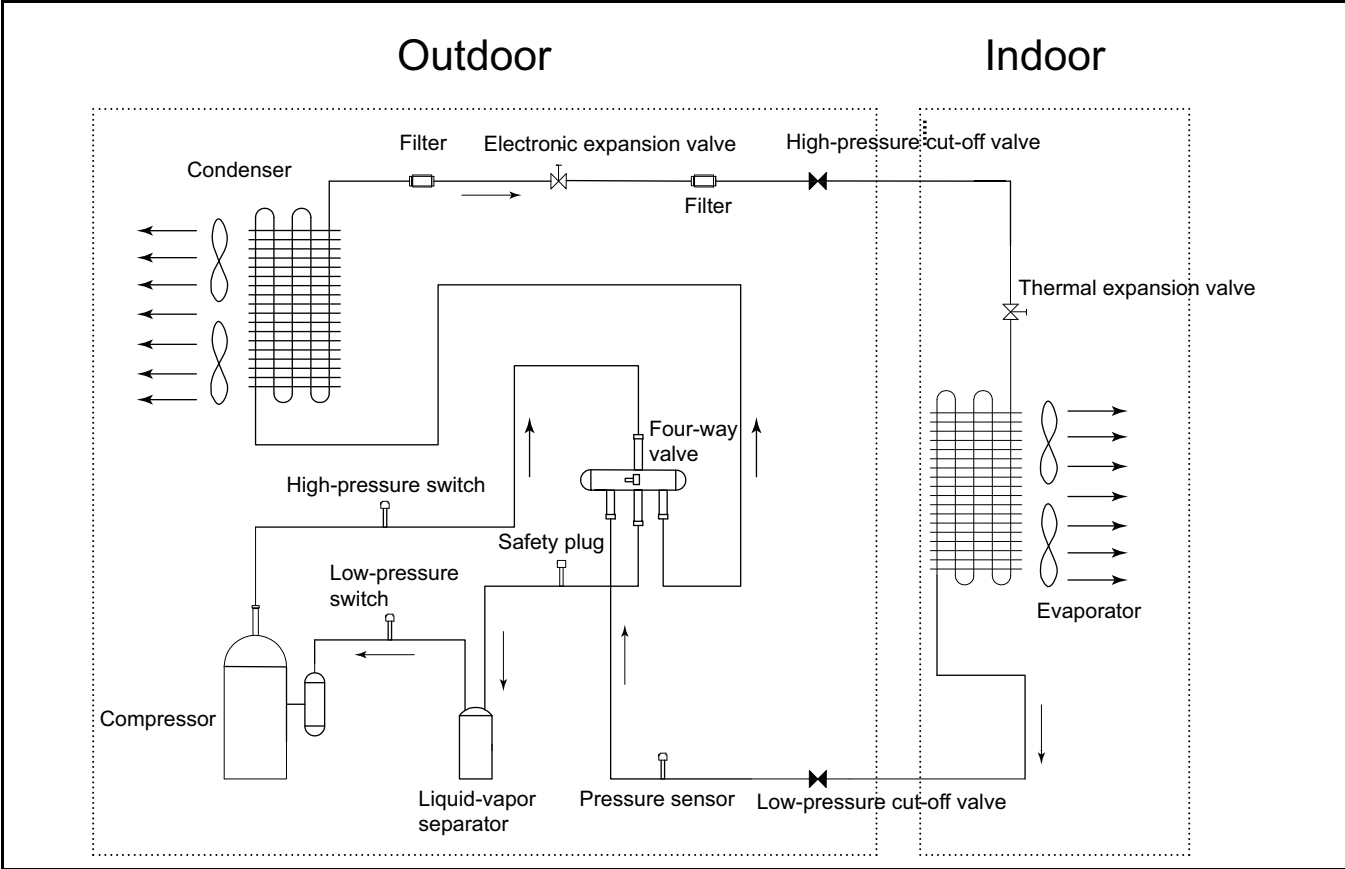

# Refrigerant Circuit (Only for Reference)

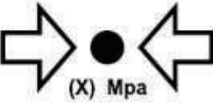

# Symbols

	[symbol UN GHS]	warning; flammable materials
	[symbol ISO 7000-1659 (2004-01)]	service indicator; read technical manual
	A2L symbol	warning; low burning velocity material
	[symbol ISO 7000-1701 (2004-01)]	pressure
	[symbol IEC 60417-6040 (2010-08)]	ultraviolet radiation, instructional safeguard
	[symbol ISO 7000-1641 (2004-01)]	operator's manual; operating instructions

	Refrigerant class per UN GHS
---	------------------------------







## About Trane and American Standard Heating and Air Conditioning

Trane and American Standard create comfortable, energy efficient indoor environments for residential applications. For more information, please visit [www.trane.com](http://www.trane.com) or [www.americanstandardair.com](http://www.americanstandardair.com).



The AHRI Certified mark indicates company participation in the AHRI Certification program. For verification of individual certified products, go to [ahridirectory.org](http://ahridirectory.org).

The manufacturer has a policy of continuous data improvement and it reserves the right to change design and specifications without notice. We are committed to using environmentally conscious print practices.