

Installation and Operations Manual

Single Packaged Heat Pump 14 SEER Convertible, 2 – 5 Ton, R-410A

4WCY4036B3
4WCY4048A3
4WCY4060A3

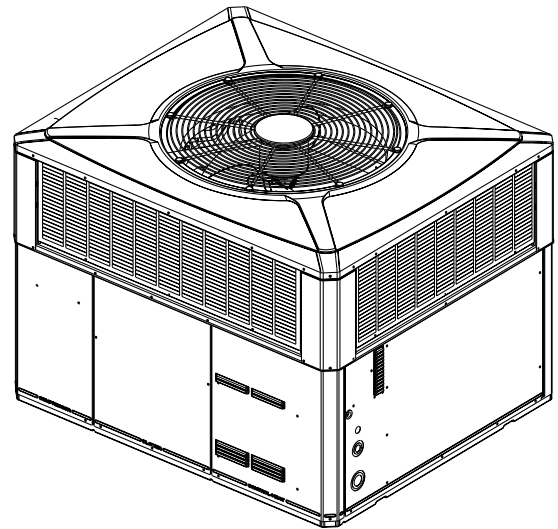

Note: "Graphics in this document are for representation only. Actual model may differ in appearance."

Note: "Unit specific Service Facts available online."

▲ SAFETY WARNING

Only qualified personnel should install and service the equipment. The installation, starting up, and servicing of heating, ventilating, and air-conditioning equipment can be hazardous and requires specific knowledge and training. Improperly installed, adjusted or altered equipment by an unqualified person could result in death or serious injury. When working on the equipment, observe all precautions in the literature and on the tags, stickers, and labels that are attached to the equipment.

SAFETY SECTION

Important: This document contains a wiring diagram, a parts list, and service information. This is customer property and is to remain with this unit. Please return to service information pack upon completion of work.

⚠ WARNING

HAZARDOUS VOLTAGE!

Failure to follow this Warning could result in property damage, severe personal injury, or death.

Disconnect all electric power, including remote disconnects before servicing. Follow proper lockout/tagout procedures to ensure the power cannot be inadvertently energized.

⚠ WARNING

SAFETY AND ELECTRICAL HAZARD!

Failure to follow this Warning could result in property damage, severe personal injury, or death.

These servicing instructions are for use by qualified personnel only. To reduce the risk of electrical shock, do not perform any servicing other than that contained in these operating instructions unless you are qualified to do so.

⚠ CAUTION

GROUNDING REQUIRED!

Failure to inspect or use proper service tools may result in equipment damage or personal injury.

Reconnect all grounding devices. All parts of this product that are capable of conducting electrical current are grounded. If grounding wires, screws, straps, clips, nuts, or washers used to complete a path to ground are removed for service, they must be returned to their original position and properly fastened.

⚠ WARNING

UNIT CONTAINS R-410A REFRIGERANT!

Failure to use proper service tools may result in equipment damage or personal injury.

R-410A operating pressure exceeds the limit of R-22. Proper service equipment is required. Service using only R-410A Refrigerant and approved POE compressor oil.

⚠ WARNING

SAFETY HAZARD!

Operating the unit without the access panels properly installed may result in severe personal injury or death.

Do not operate the unit without the evaporator fan access panel or evaporator coil access panel in place.

⚠ WARNING

WARNING!

This product can expose you to chemicals including lead, which are known to the State of California to cause cancer and birth defects or other reproductive harm. For more information go to www.P65Warnings.ca.gov.

Important: Wear appropriate gloves, arm sleeve protectors and eye protection when servicing or maintaining this equipment.

Important: Air filters and media wheels or plates shall meet the test requirements in UL 900.

Table of Contents

Introduction, Unit Inspection and Specification	4	Attaching Downflow Ductwork to Roof Frame.....	15
Introduction.....	4	Attaching Horizontal Ductwork to Unit.....	15
Inspect Shipment.....	4	Condensate Drain Piping	15
Product Specification	5	Air Filter Installation	15
Charging in Cooling above 55°F OD Ambient	6	Electrical Wiring.....	16
Determine Unit Clearances	7	Unit Startup	18
Review Location and Recommendation Information.....	9	Pre-Start Quick Checklist	18
Unit Installation	10	Starting the Unit in Cooling Mode.....	18
Ground Level Installation.....	10	Starting the Unit in Heating Mode.....	18
Rooftop Installation — Curb Mounting	10	Sequence of Operation.....	19
Lifting and Rigging.....	11	Final Installation Checklist	20
Rooftop Installation — Frame Mounting	12	Maintenance	20
Rooftop Installation — No Curb/Frame	12	Owner Maintenance.....	20
Ductwork Installation	15	Service Maintenance	21
Attaching Downflow Ductwork to Roof Curb	15	Fault Detection.....	21
		Pressure Curves	24
		Indoor Fan Performance.....	27
		Refrigerant Circuit	28
		Troubleshooting Chart	29
		Important Product Information	32

Introduction, Unit Inspection and Specification

Introduction

Read this manual carefully before attempting to install, operate, or perform maintenance on this unit. Installation and maintenance should be performed by qualified service technicians only. This unit is listed by Underwriters Laboratory.

Packaged units are designed for outdoor mounting with a vertical condenser discharge. They can be located either at ground level or on a roof in accordance with local codes. Each unit contains an operating charge of refrigerant as shipped.

Extreme mounting kits are available for slab (BAYEXMK003A), utility curb (BAYEXMK002B) and perimeter curb (BAYEXMK001A) mountings.

Inspect Shipment

1. Check for damage after the unit is unloaded. Report promptly to the carrier any damage found to the unit. Do not drop the unit.

Important: To prevent damage to the sides and top of the unit when hoisting, use "spreader bars" see, "Rooftop Installation — No Curb/Frame," p. 12.

2. Check the unit's nameplate to determine if the unit is correct for the intended application. The power supply must be adequate for both the unit and all accessories.
3. Check to be sure the refrigerant charge has been retained during shipment. Remove the Compressor access panel to access the 1/4" flare pressure taps.
4. If this unit is being installed on a curb, verify that the correct curb is provided with the unit.
 - 4WCY4024-036 use model BAYCURB050A,
 - 4WCY4042-060 use model BAYCURB051A
5. If the unit is being hoisted, accessory kit BAYLIFT002A is recommended. It includes a kit of four (4) lifting lugs and instructions.

Notes:

- If practical, install any internal accessories to the unit at the shop.
- The packaged units have been evaluated in accordance with the Code of Federal Regulations, Chapter XX, Part 3280 or the equivalent. "SUITABLE FOR MOBILE HOME USE."

Product Specification

MODEL	4WCY4036B3	4WCY4048A3	4WCY4060A3
RATED Volts/PH/Hz	208-230/3/60		
Performance Cooling BTUH (a)	36000	47000	58000
Indoor Airflow (CFM)	1200	1400	1780
Power Input (KW)	LOCATED ON UNIT NAMEPLATE		
EER/SEER (BTU/Watt-Hr.) (b)	11.75 / 14.0	11.75 / 14.0	11.5/14
Sound Power Rating [dB(A)] (c)	69	73	76
PERFORMANCE HEATING			
(High Temp.) BTUH	32400	42500	55000
Power Input (KW)	LOCATED ON UNIT NAMEPLATE		
(Low Temp.) BTUH	24800	27299	37600
Power Input (KW)	LOCATED ON UNIT NAMEPLATE		
HSPF (BTUH/Watt-Hr)	8		
POWER CONN. — V/Ph/Hz			
208-230/3/60			
Min. Brch. Cir. Ampacity (d)	LOCATED ON UNIT NAMEPLATE		
Fuse Size — Max. (amps)	LOCATED ON UNIT NAMEPLATE		
Fuse Size — Recmd. (amps)	LOCATED ON UNIT NAMEPLATE		
COMPRESSOR			
SCROLL			
VOLTS/PH/HZ	208-230/3/60		
R.L. Amps — L.R. Amps	LOCATED ON UNIT NAMEPLATE		
OUTDOOR COIL — TYPE			
SPINE FIN			
Rows/F.P.I	2 / 24		
Face Area (sq. ft.)	15.49	18.1	23.57
Tube Size (in.)	3/8		
Refrigerant Control	EXPANSION VALVE		
INDOOR COIL — TYPE			
PLATE FIN			
Rows/F.P.I	4 / 15		
Face Area (sq. ft.)	3.5	5.0	
Tube Size (in.)	3/8		
Refrigeration Control	EXPANSION VALVE		
Drain Conn. Size (in.)	3/4 FEMALE NPT		
OUTDOOR FAN — TYPE			
PROPELLER			
DIA. (IN.)	23.4	28.2	
DRIVE/NO. SPEEDS	DIRECT / 1		
CFM @ 0.0 in. w.g. (e)	3250	4440	5700
Motor — HP/R.P.M	1/5 / 830	1/4 / 825	1/3 / 830
Volts/Ph/Hz	230/1/60		
F.L. Amps/L.R Amps	LOCATED ON UNIT NAMEPLATE		
INDOOR FAN — TYPE			
CENTRIFUGAL			
Dia. x Width (in.)	10 X 10		11 X 10
Drive/No. Speeds	DIRECT / VARIABLE		
CFM @ 0.0 in. w.g. (f)	SEE FAN PERFORMANCE TABLE		
Motor — HP / R.P.M.	0.5/VARIABLE	0.75/VARIABLE	1 / VARIABLE
Volts/Ph/Hz	230/1/60		
F.L. Amps	LOCATED ON UNIT NAMEPLATE		
FILTER / FURNISHED			
NO			
Type Recommended	THROWAWAY		
Recmd. Face Area (sq. ft) (g)	4	5.3	
REFRIGERANT			
R-410			
Charge (lbs.)	LOCATED ON UNIT NAMEPLATE		
Subcooling	LOCATED ON UNIT NAMEPLATE		

Charging in Cooling above 55°F OD Ambient

If servicing the equipment requires system evacuation, then re-charge the system to the weight specified on the nameplate. Verify the system subcooling using the Subcooling Charging Table and, if necessary, adjust the charge using the procedure below.

1. For best results — the indoor temperature should be kept between 70°F to 80°F. Add system heat if needed.
2. Whenever charge is removed or added, the system must be operated for a minimum of 20 minutes to stabilize before accurate measurements can be made.
3. Measure Liquid Line Temperature and Refrigerant Pressure at service valved in the compressor compartment.
4. Locate your liquid line temperature in the left column of the table, and the intersecting liquid line pressure under the subcool value column, Add refrigerant to raise the pressure to match the table, or remove refrigerant to lower the pressure. Again, wait 20 minutes for the system conditions to stabilize before adjusting charge again.

Note: System charge shall never be more than 110% or less than 90% of nameplate charge. If specified subcooling cannot be achieved within those charge bounds, contact your Field Service Representative.

5. When system is correctly charged, you can refer to System Pressure Curves to verify typical performance.

CHARGING BELOW 55°F

Evacuate system and weigh in nameplate charge or use factory charge. Correct subcooling may be verified when the temperature is above 55°F.

R-410A Subcooling Charging Table		
Liquid Temperature	Liquid Pressure	
	11°F	12°F
(°F)	PSIG	
55	188	191
60	204	207
65	221	224
70	239	242
75	258	262
80	278	282
85	299	303
90	321	326
95	345	349
100	369	374
105	395	400
110	422	428
115	451	457
120	481	487
125	512	519

Charging Below 55°F OD Ambient in Heating Only

1. The Subcool Charging Method in cooling is NOT recommended below 55°F outdoor ambient.
2. The only recommended method of charging at outdoor ambients below 55°F, is to weigh in the charge in the heating mode.
3. Use Nameplate charge.
4. Check liquid line temperature and pressure (at the OD valves) to obtain a minimum of the subcooling shown in the subcooling table.
5. Add charge if the minimum subcooling as shown in the table is not obtained with the nameplate charge.
6. It is important to return in the spring or summer to accurately charge the system in the cooling mode at outdoor ambients above 55°F.

Determine Unit Clearances

Figure 1. Space on Sides Requirements

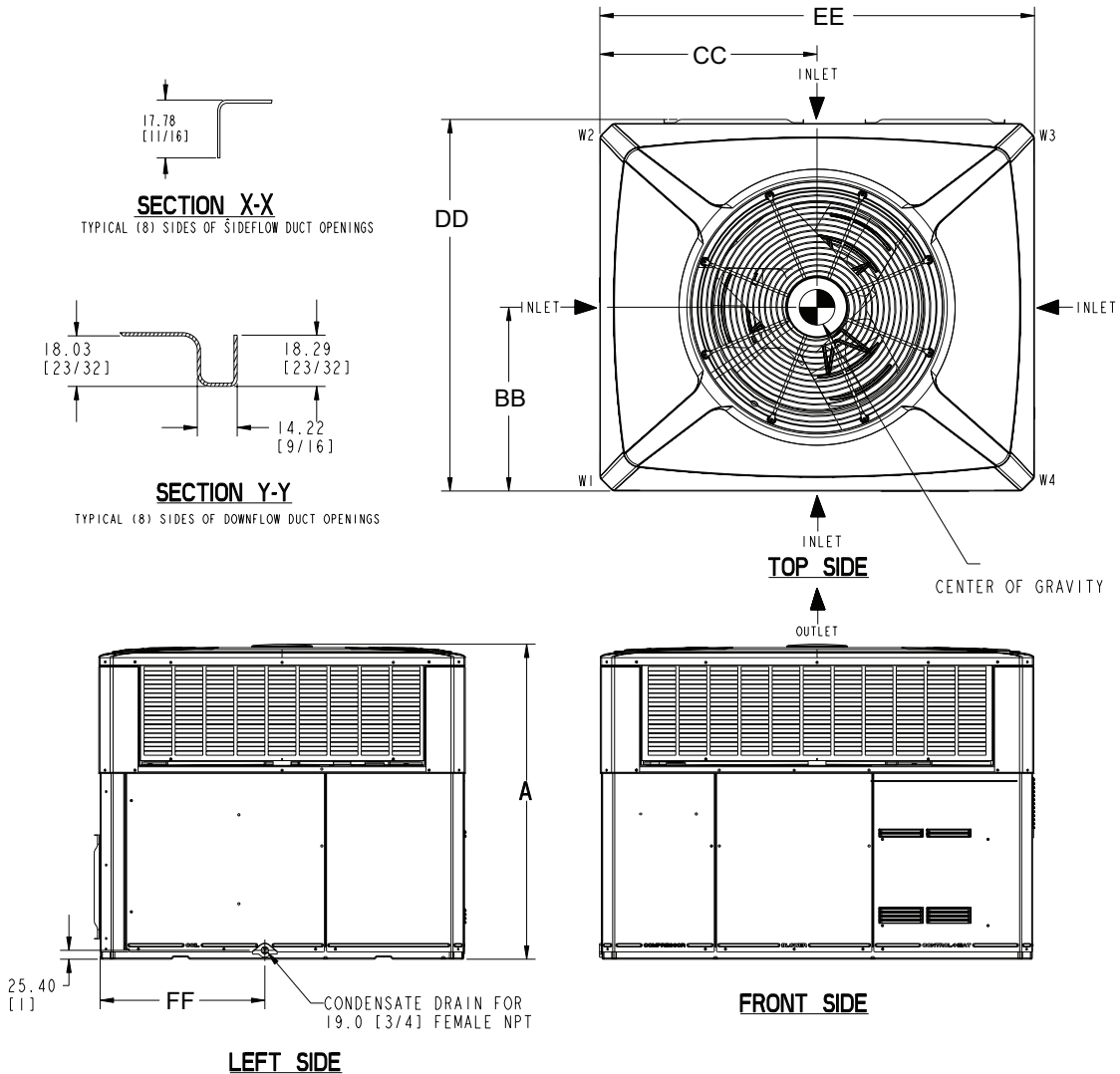

	2 - 3 TON Units		3.5 - 5 TON Units	
	RECOMMENDED SERVICE CLEARANCE mm [Inches]			
	W/ ECONOMIZER		W/ ECONOMIZER	
BACK SIDE	305 [12]	762 [30]	305 [12]	762 [30]
LEFT SIDE	762 [30]	914 [36]	914 [36]	1067 [42]
RIGHT SIDE	610 [24]	-	610 [24]	-
FRONT SIDE	1067 [42]	-	762 [30]	-
CLEARANCE TO COMBUSTIBLE MATERIAL mm [Inches]				
BOTTOM	0		0	
BACK SIDE	25 [1]		25 [1]	
LEFT SIDE	152 [6]		152 [6]	
RIGHT SIDE	152 [6]		152 [6]	
FRONT SIDE	305 [12]		305 [12]	
TOP	914 [36]		914 [36]	
DIMENSIONS mm [Inches]				
A	HEIGHT OF UNIT - TABLE NEXT PAGE			
BB	CENTER OF GRAVITY - TABLE NEXT PAGE			
CC	CENTER OF GRAVITY - TABLE NEXT PAGE			
DD -Depth	1093.72 [43-1/16]		1173.99 [46-1/4]	
EE -Width	1284.99 [50-5/8]		1535.94 [60-1/2]	
FF	497.8 [19-5/8]		576.00 [22-11/16]	

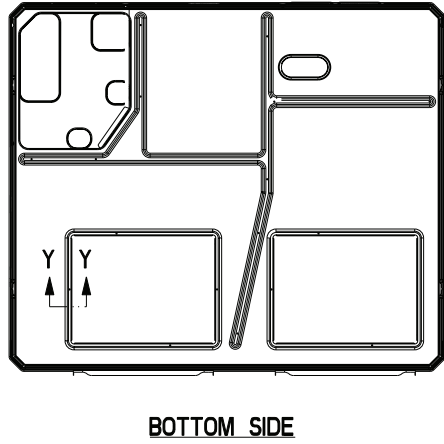

Determine Unit Clearances

Figure 2. Bottom and Back Duct Openings

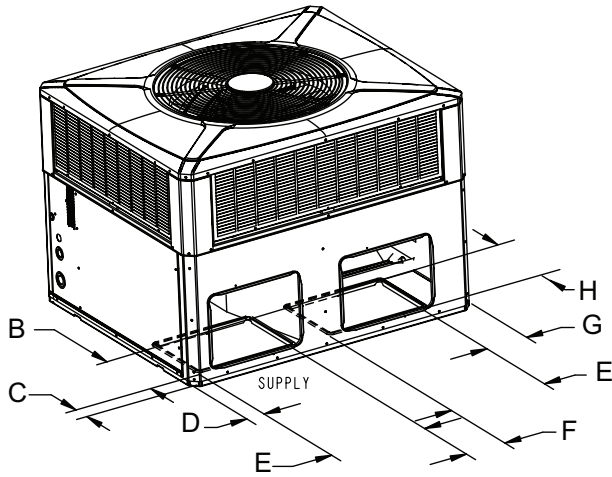

BOTTOM DUCT OPENINGS

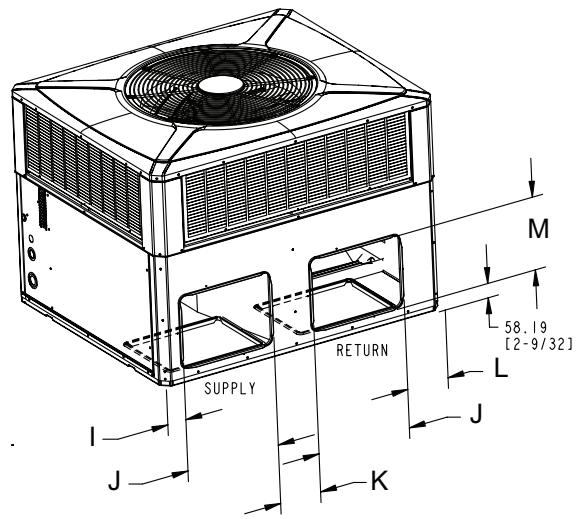

BACK DUCT OPENINGS

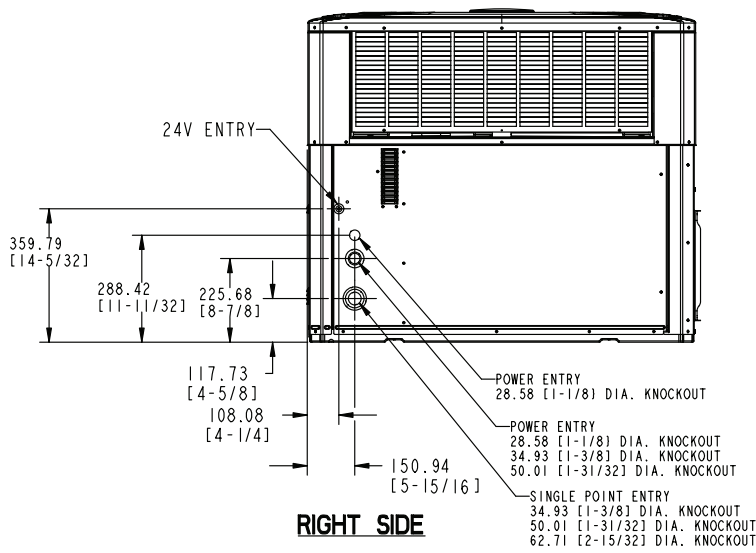

RIGHT SIDE

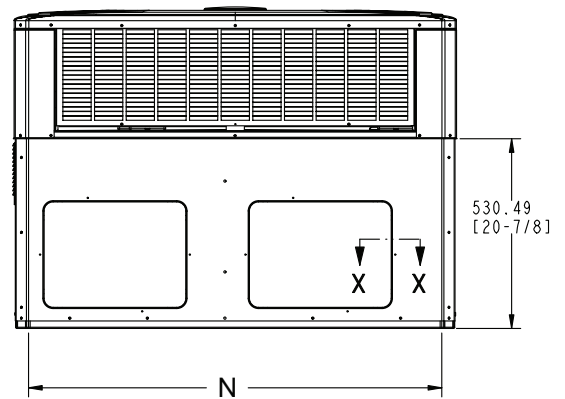

BACK SIDE

	Height mm[in]	PHYSICAL DIMENSIONS mm[in]												
	A-Height	B	C	D	E	F	G	H	I	J	K	L	M	N
4WCY4036	949.33 [37.38]	304.80 [12]	84.46 [3.32]	82.16 [3.23]	406.40 [16]	167.89 [6.61]	180.20 [7.09]	304.80 [12]	86.25 [3.39]	398.22 [15.68]	176.07 [6.93]	177.55 [6.99]	296.62 [11.68]	1105.06 [43.50]
4WCY4048		457.20 [18]	82.16 [3.23]	82.16 [3.23]	381.00 [15]	244.09 [9.61]	325.49 [12.81]	381.00 [15]	86.25 [3.39]	449.02 [17.68]	176.07 [6.93]	329.58 [12.97]	372.82 [14.68]	1351.95 [53.22]
4WCY4060	1050.93 [41.38]													

	Corner Weights KG/LBS				SHIPPING WEIGHT KG/LBS	UNIT WEIGHT KG/LBS	Center Of Gravity mm[inch]	
	W1	W2	W3	W4			BB	CC
4WCY4036	60.8 [134]	38.1 [84]	27.2[60]	42.6 [94]	212.5 [468]	168.7 [372]	401.3 [15.8]	508.0 [20]
4WCY4048	78 [172]	49.4 [109]	37.6 [83]	59.4 [131]	282.5 [623]	224.5 [495]	414 [16.3]	635 [25.01]
4WCY4060	80.3 [177]	47.6 [105]	35.8 [79]	60.8 [134]	282.8 [623]	224.5 [495]	414 [16.3]	635 [25]

Review Location and Recommendation Information

Horizontal Airflow Units

1. Location of the unit must allow service clearance around it to ensure adequate serviceability, maximum capacity, and peak operating efficiency.
2. These units are designed for outdoor installation. They may be installed directly on a slab, wood flooring, or on Class A, B, or C roof covering material. The discharge air from the condenser fans must be unrestricted for a minimum of 3 feet above the unit.
3. Exhaust vents or other sources of contaminated air should not be near the unit's air inlet if outside air is to be introduced as make-up air or a ventilation feature is to be used. Contamination from exhaust vents or chimneys may also foul the condenser causing degraded performance.
4. Check the handling facilities to ensure the safety of personnel and the unit(s).
5. The unit must be mounted level for proper drainage of water through the drain holes in the base pan.
6. The unit should not be exposed to direct roof water runoff.
7. Flexible duct connectors must be of a flame retardant material. All duct work outside of the structure must be insulated and weatherproofed in accordance with local codes.
8. Holes through exterior walls or roof must be sealed in accordance with local codes.
9. All fabricated outdoor ducts should be as short as possible.

Clearances

1. The recommended clearances for single-unit installations are illustrated in "[Determine Unit Clearances](#)," p. 7.
2. Any reduction of the unit clearances indicated in these figures may result in condenser coil starvation or the recirculation of warm condenser air. Actual clearances, which appear to be inadequate should be reviewed with a local engineer.
3. See the unit's nameplate for the absolute minimum clearance between the unit and any combustible surfaces.

Down Airflow Units

1. Location of the unit must allow service clearance around it to ensure adequate serviceability, maximum capacity, and peak operating efficiency.
2. Refer to the Installation section for instruction on converting the supply and return airflow covers to down airflow.

3. The field assembled Roof Mounting Curb (BAYCURB050A or BAYCURB051A) or a field fabricated curb should be in place before the unit is hoisted to the roof top.
The Roof Mounting Curb (frame) must be installed on a flat, level section of the roof (maximum of 1/4" per foot pitch) and provide a level mounting surface for the unit. Also, be sure to provide sufficient height above the roof to prevent water from entering the unit.
4. Be sure the mounting curb spans structural members (trusses) of the roof, thereby providing sufficient support for the weight of the unit, the curb, the duct(s), and any factory or field installed accessories.
5. The unit must be mounted level for proper drainage of water through the drain holes in the base pan.
6. Be sure the hole in the structure for the ducts is large enough to accommodate the fabricated ducts and the insulation surrounding them. Flexible duct connectors must be of a flame retardant material. All duct work outside of the structure must be insulated and weatherproofed in accordance with local codes.
7. Holes through exterior walls or roof must be sealed in accordance with local codes.
8. These units are design certified for outdoor installation. They may be installed directly on a slab, wood flooring, or on Class A, B, or C roof covering material. The discharge air from the condenser fans must be unrestricted for a minimum of 3 feet above the unit.
9. Exhaust vents or other sources of contaminated air should not be near the unit's air inlet if outside air is to be introduced as make-up air or a ventilation feature is to be used. Contamination from exhaust vents or chimneys may also foul the condenser causing degraded performance.
10. Check the handling facilities to ensure the safety of personnel and the unit(s).

Clearances

1. The recommended clearances for single-unit installations are illustrated in "[Determine Unit Clearances](#)," p. 7.
2. Any reduction of the unit clearances indicated in these figures may result in condenser coil starvation or the recirculation of warm condenser air. Actual clearances, which appear to be inadequate should be reviewed with a local engineer.
3. See the unit's nameplate for the absolute minimum clearance between the unit and any combustible surfaces.

Unit Installation

Note: The factory ships this unit for horizontal installation.

Ground Level Installation

To Install the unit at ground level:

1. Place the unit on a pad the size of the unit or larger. The unit must be mounted level for proper drainage of water through the holes in the base pan. To attach the unit securely to the slab, use extreme mounting kit, BAYEXMK003A. Usage of the extreme mounting kit accessories is a recommendation, not a requirement.

The pad must not come in contact with the structure. Be sure the outdoor portion of the supply and return air ducts are as short as possible. As indicated in [Table 1, p. 12](#), vibration support is a recommendation, not a requirement.

2. Location of the unit must allow service clearance around it. Clearance of the unit must be given careful consideration. See "[Determine Unit Clearances](#)," p. 7.

Note: Any reduction of the unit clearances indicated in these illustrations may result in condenser coil starvation or the recirculation of warm condenser air. Actual clearances, which appear to be inadequate should be reviewed with a local engineer.

Important: A minimum 0" clearance to combustible material shall be maintained on air outlet duct.

3. Attach the supply and return air ducts to the unit as explained in the ductwork Installation section.
4. Flexible duct connectors must be of a flame retardant material. Insulate any ductwork outside of the structure with at least two (2) inches of

insulation and weatherproof. There must be a weatherproof seal where the duct enters the structure.

5. Do not expose the unit to direct roof water runoff.
6. Seal all holes through exterior walls in accordance with local codes.
7. Continue with the following installation sections to complete the installation: Ductwork, Filter and Electrical Wiring.

Rooftop Installation – Curb Mounting

Convert Horizontal Airflow to Down Airflow

The factory ships the unit for horizontal airflow. Perform this procedure to convert it to down airflow:

1. Remove the three (3) sheet metal screws securing the supply air cover and the four (4) sheet metal screws securing the return air cover from the base of the unit. Remove the covers from the base.
2. Place the covers over the horizontal supply and return openings (painted side out). Align the screw holes, and secure using the same screws removed in step 1.

Install Full Perimeter Roof Mounting Curb

1. Verify that the roof mounting curb is correct for the unit. There are two curbs depending on the unit cabinet sizes:
 - 4WCY4024–036 use model BAYCURB050A,
 - 4WCY4042–060 use model BAYCURB051A
2. Assemble and install the curb following the instructions in the Installer's Guide included with the appropriate curb.

Figure 3. Typical Ground Level Application

Note: Use the extreme mounting kit, BAYEXMK002AA, to secure the unit to the slab.

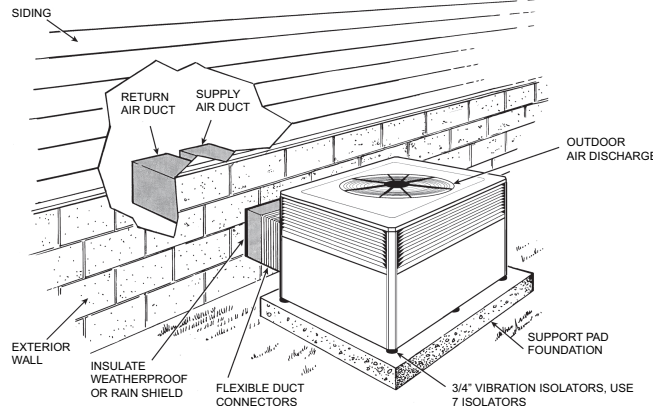
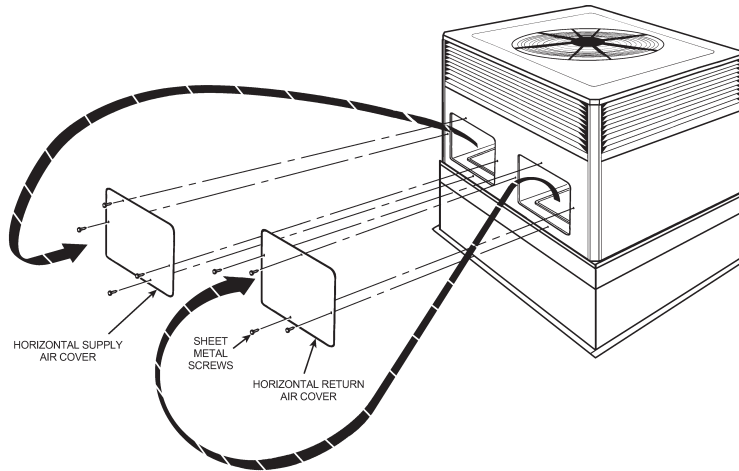

Figure 4. Converting Horizontal to Down Airflow



Lifting and Rigging

⚠ WARNING

IMPROPER UNIT LIFT!

Failure to properly lift unit could result in death or serious injury or possible equipment or property-only damage.

Test lift unit approximately 24 inches to verify proper center of gravity lift point. To avoid dropping of unit, reposition lifting point if unit is not level.

Important: Do not lift the unit without test lifting for balance and rigging. Do not lift the unit in windy conditions or above personnel. Do not lift the unit by attaching clevis, hooks, pins, or bolts to the unit casing, casing hardware, corner lugs, angles, tabs, or flanges. Failure to observe these warnings may result in equipment damage.

1. Before preparing the unit for lifting, check the unit dimension drawings for center of gravity for lifting safety ("Determine Unit Clearances," p. 7). Because of placement of internal components, the unit's weight may be unevenly distributed. Approximate unit weights are also provided in the unit drawings.

Note: Unit rigging and hoisting requires accessory kit BAYLIFT002BA. It includes a kit of four (4) lifting lugs.

2. Insert the four lifting lugs in the openings provided in the drip lip on each end of the unit. A tap or jerk to the lug will overcome the interference that arises due to the dimple on the lug.
3. When hoisting the unit, be sure that a proper method of rigging is used. Use slings and spreader bars for protection during lifting. Always test-lift the unit to determine the exact unit balance and

stability before hoisting it to the installation location.

4. When the curb and air ducts have been properly installed, the unit is ready to be hoisted to the roof and set in position.

Important:

- To prevent damage to the sides and top of the unit when hoisting use "spreader bars".
- The unit must be lowered into position. The P.V.C. rubber tape on the curb flange permits the unit to be repositioned if required without destroying the P.V.C. rubber seals affixed to the mounting curb.

Placing the Unit on the Mounting Curb

1. The unit is designed with a perimeter drip lip that is lower than the unit base pan, see Table 2, p. 13.
2. Position the unit drip lip down over and in contact with the outside corner of the curb.. Continue to lower the unit on top of the curb, with the unit drip lip astraddle, and in contact with, both the end and side rail of the curb. The unit should now rest on top of the curb. Consider using the extreme mounting kit, BAYEXMK001A, to add additional hold down strength to the mounting.

Notes:

- For rooftop applications, the use of extreme mounting kits and vibration isolators is optional and not mandatory.
- The ductwork is installed as part of the curb installation. Do not attach ductwork to the unit and lower the unit with ductwork onto the curb.

Table 1. Vibration Isolators/Snow Feet Locations

Note: The installation instructions indicate typical installation only, but actual installation may differ.

Note: These views represent the base as viewed looking up from underneath the unit.

Important: Unit vibration isolator support is recommended in the general areas shown. Locate 3/4" thick vibration isolators on the bottom of the basepan as illustrated by black dots for ground level pad applications. Modify vibration isolator location as necessary for frame and rail applications.

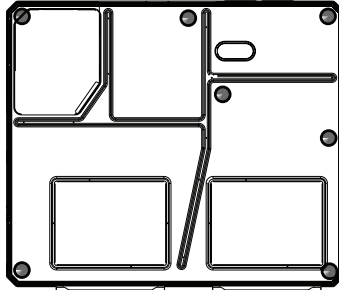

Small Cabinet
****4024 - 4036

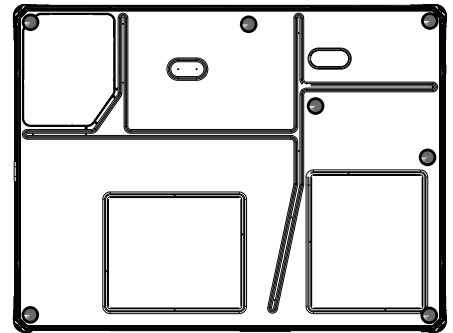

Medium Cabinet
****4042 - 4060

Rooftop Installation – Frame Mounting

For rooftop applications using field fabricated frame and ducts use the following procedure:

1. Locate and secure the frame to the roof by bolting or welding. Frame must provide adequate center support via a cross member centrally located channel rail. See [Table 5, p. 14](#). Vibration isolators should be installed as indicated in [Table 1, p. 12](#), adjust as necessary for your frame. The isolators must be placed on base pan, not drip lip. Add flashing as required. Flashing must conform to local building codes.
2. Prepare the hole in the roof in advance of installing the unit.
3. Secure the horizontal or down airflow ducts to the roof. Refer to the previous Convert from Horizontal Airflow to Down Airflow section if conversion is needed.
4. All fabricated outdoor ducts should be as short as possible.
5. Place the unit on the frame.
6. The unit must be mounted level for proper drainage of water through the holes in the base pan.
7. Secure the unit to the frame.
8. Insulate any ductwork outside of the structure with at least two (2) inches of insulation and then weatherproof. There must be a weatherproof seal where the duct enters the structure.
9. The unit should not be exposed to direct roof water runoff.
10. Flexible duct connectors must be of a flame retardant material. All duct work outside of the structure must be insulated and weatherproofed in accordance with local codes.
11. Access and service clearances for the unit must be given careful consideration when locating the duct

entrance openings. “[Determine Unit Clearances,](#)” p. 7 provide unit dimensions.

12. Continue with the following installation sections to complete the installation: Ductwork, Filter, and Electrical Wiring.

Rooftop Installation – No Curb/Frame

For roof top applications using field fabricated ducts and sleeper rails rather than a curb or frame, use the following procedure:

1. Locate and secure the sleeper rails to the roof by bolting (three (3) rails required). One on each end to support the edges of the unit and one across the center of the unit. The center rail must run inside both drip lips. Vibration isolators should be installed, adjust as necessary for your sleeper rails. The isolators must be placed on base pan, not drip lip. Add flashing as required. Flashing must conform to local building codes.
2. Prepare the hole in the roof in advance of installing the unit.
3. Secure the horizontal or down airflow ducts to the roof. Refer to the previous Convert from Horizontal Airflow to Down Airflow section if conversion is needed.
4. All fabricated outdoor ducts should be as short as possible.
5. Place the unit on the rails.
6. The unit must be mounted level for proper drainage of water through the holes in the base pan.
7. Secure the unit to the rails.
8. Insulate any ductwork outside of the structure with at least two (2) inches of insulation and then weatherproof. There must be a weatherproof seal where the duct enters the structure.
9. No exposure to direct roof water runoff.

- 10. Flexible duct connectors must be of a flame retardant material. All duct work outside of the structure must be insulated and weatherproofed in accordance with local codes.
- 11. Access and service clearances for the unit must be

- given careful consideration when locating the duct entrance openings. "Determine Unit Clearances," p. 7 provide unit dimensions.
- 12. Continue with the following installation sections: Ductwork, Filter and Electrical Wiring.

Table 2. Lifting and Rigging

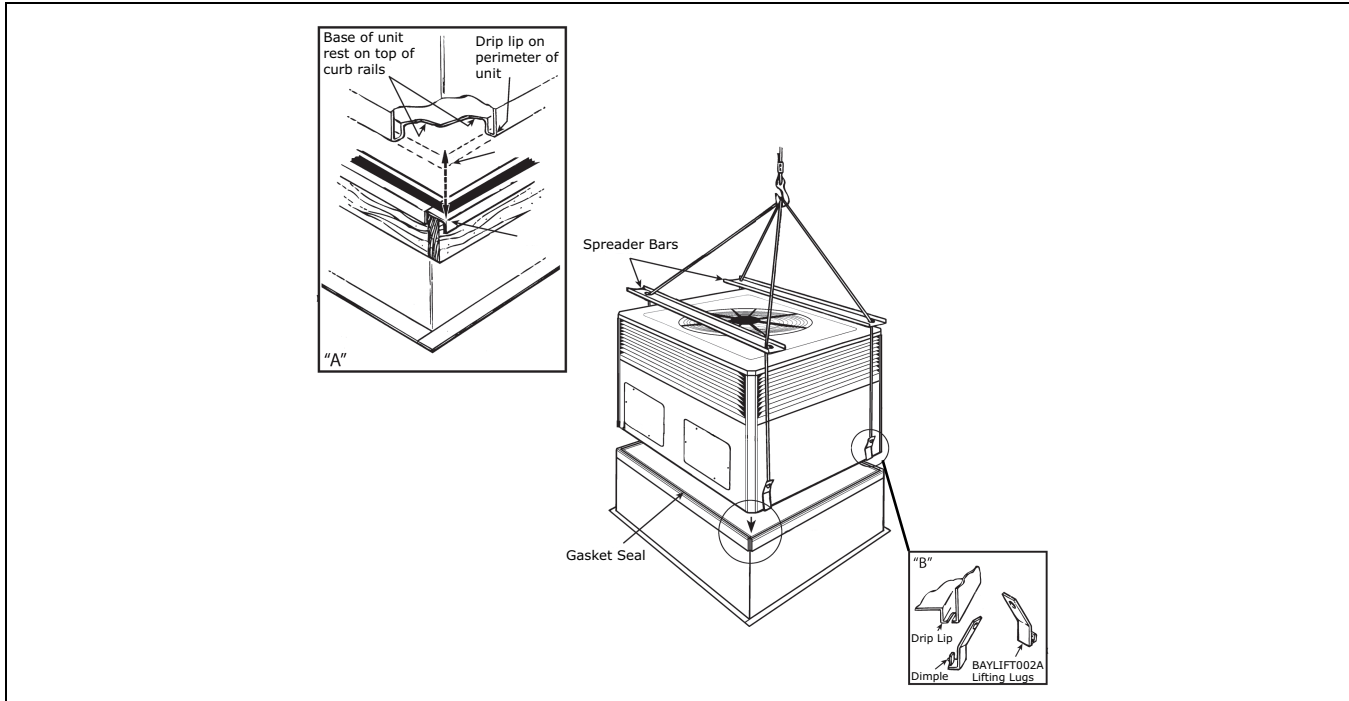
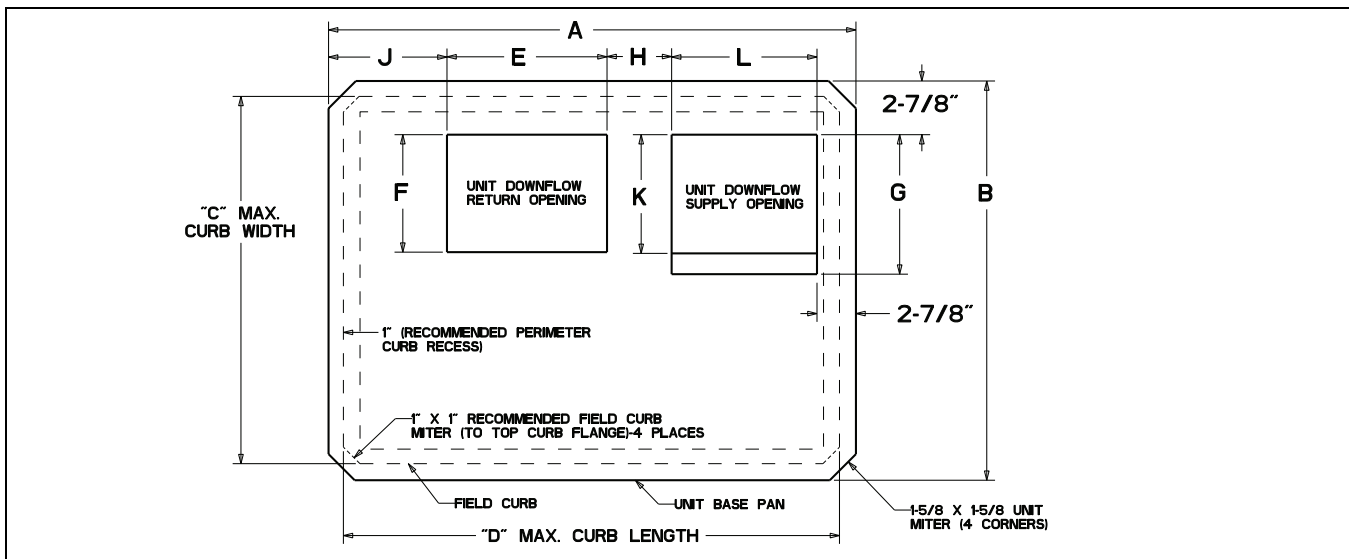

Table 3. Curb Dimensions



TOP VIEW OF UNIT BASE PAN WITH FIELD CURB BELOW
REFERENCE ILLUSTRATION FOR A CUSTOMER SUPPLIED ROOF CURB

MODEL	A	B	C	D	E	F	G	H	J	K	L
4 TC*, YC*, WC*, DC*018, 024, 030, 036	48-3/8	40-7/8	38-7/8	46-3/8	16	12	12	6-5/8	6-7/8	12	16
4 TC*, YC*, WC*, DC*042, 048, 060	58	43-7/8	41-7/8	56	18	15	18	9-5/8	12-1/2		15

This drawing was prepared by the manufacturer in order to provide detail regarding job layout only. This drawing is not intended to be used as a basis to construct, build or modify the item depicted in the drawing. The manufacturer is not responsible for the unauthorized use of this drawing and expressly disclaims any liability for damages resulting from such unauthorized use.

Table 4. Typical Rooftop Horizontal Airflow Application with Frame

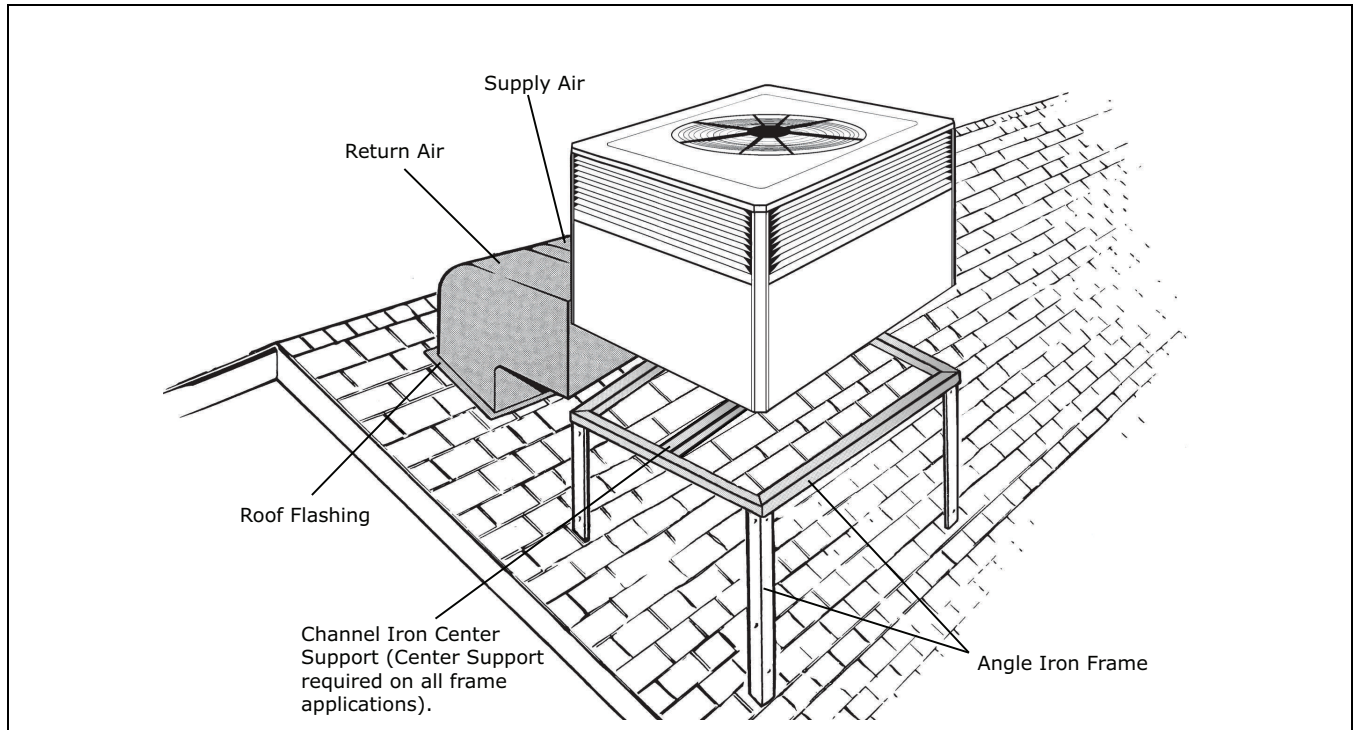
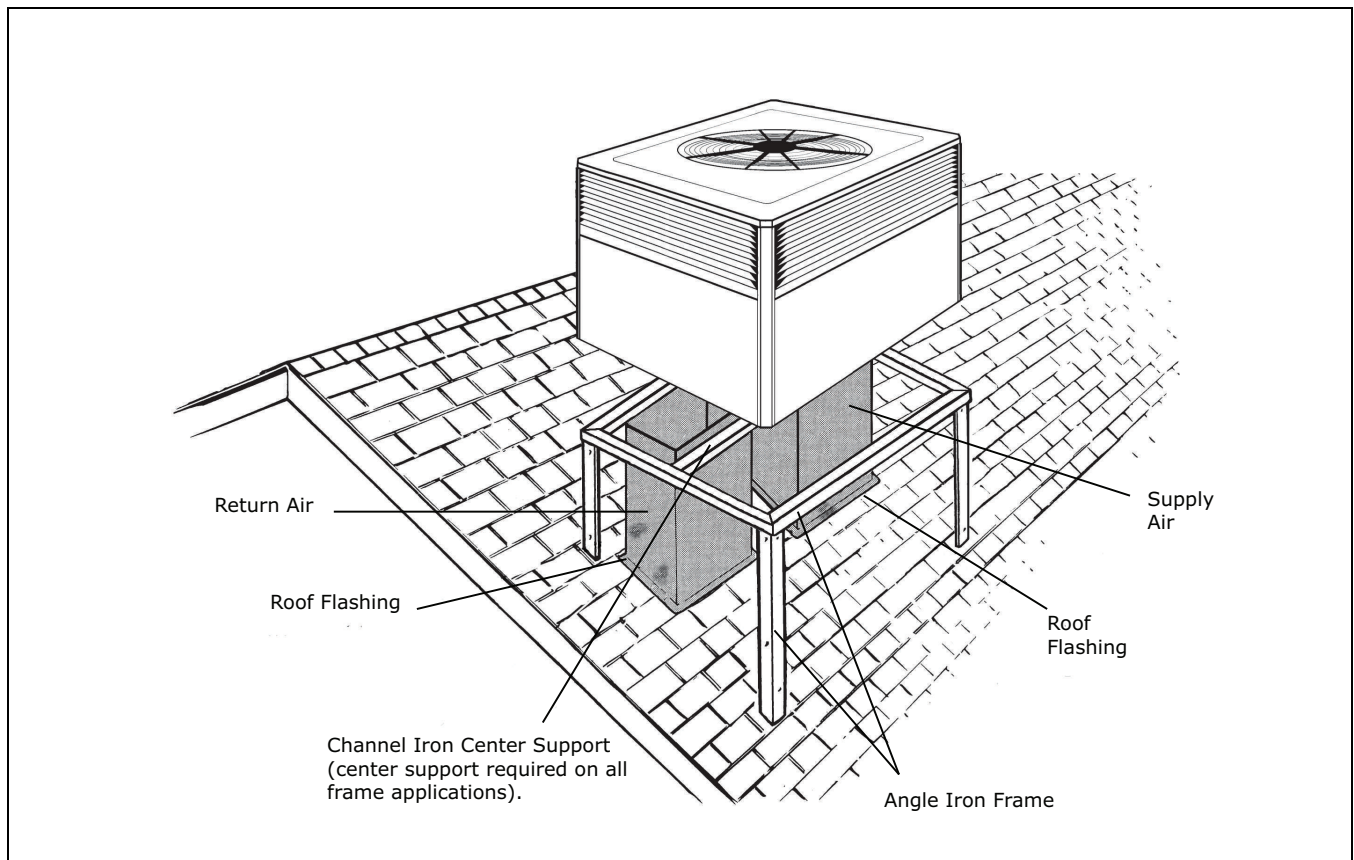

Table 5. Typical Rooftop Down Airflow Application with Frame



Ductwork Installation

Attaching Downflow Ductwork to Roof Curb

Supply and return air flanges are provided on the roof curb for easy duct installation. All ductwork must be run and attached to the curb before the unit is set into place.

Attaching Downflow Ductwork to Roof Frame

Follow these guidelines for ductwork construction:

Connections to the unit should be made with three (3) inch canvas connectors to minimize noise and vibration transmission.

Elbows with turning vanes or splitters are recommended to minimize air noise and resistance.

The first elbow in the ductwork leaving the unit should be no closer than two (2) feet from the unit, to minimize noise and resistance.

To prevent leaking, do not attach the ductwork to the bottom of the unit base. Refer to the bottom example in the figure below.

Figure 5. Attaching Down Airflow Ductwork

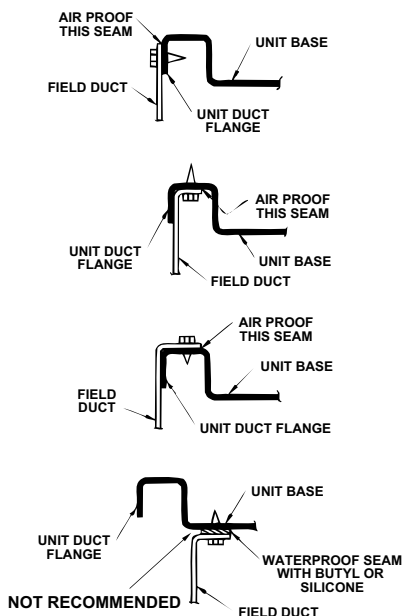

Attaching Horizontal Ductwork to Unit

All conditioned air ductwork should be insulated to minimize heating and cooling duct losses. Use a minimum of two (2) inches of insulation with a vapor barrier. The outside ductwork must be weatherproofed between the unit and the building.

When attaching ductwork to a horizontal unit, provide a flexible watertight connection to prevent noise

transmission from the unit to the ducts. The flexible connection **must** be indoors and made out of heavy canvas.

Note: Do not draw the canvas taut between the solid ducts.

Figure 6. Attaching Horizontal Airflow Ductwork

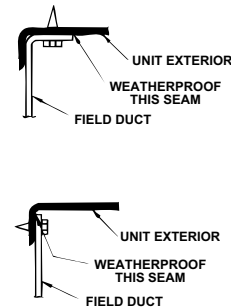

Condensate Drain Piping

A 3/4-inch female NPT condensate drain connection is provided on the evaporator access panel end of the unit. Provide a trap and fill it with water before starting the unit to avoid air from being drawn through. Follow local codes and standard piping practices when running the drain line. Pitch the line downward away from the unit. Avoid long horizontal runs. See Figure 7, p. 15.

Note: Do not use reducing fittings in the drain lines.

The condensate drain must be:

- Made of 3/4" pipe size
- Pitched 1/4" per foot to provide free drainage to convenient drain system
- Trapped
- Must be connected to a closed drain system unless the trap is properly vented

Figure 7. Typical Condensate Drain Piping

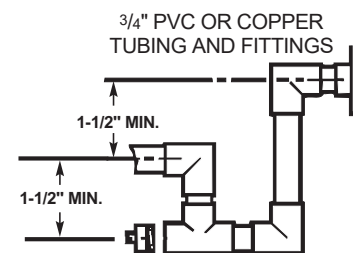

Air Filter Installation

The packaged unit requires an air filter. The unit does not come with a factory installed filter rack in it, however, two filter frame accessories are offered that will allow the installation of a filter within the unit, BAYFLTR101 & BAYFLTR201. Otherwise a field supplied filter rack must be installed by the installer in the return duct work. Refer to table for field supplied filter racks.

Unit Installation

Table 6. Filter Sizes (field supplied filter rack)

UNIT	NOMINAL CFM	FILTER ^(a) SIZE (Sq Ft)	FILTER RESISTANCE ("W.C.)
4WCY4036A	1200	4.00	0.08
4WCY4048A	1600	5.33	0.08
4WCY4060A	2000	6.67	0.08

^(a) Filters must be installed in the return air system. The above square footages are based on 300 F.P.M. face velocity. If permanent filters are used, size per mfg. Recommendation with clear resistance of 0.05"W.C.

Important: Air filters and media wheels or plates shall meet the test requirements in UL 900.

Electrical Wiring

Note: This unit is factory wired for 230V. See wiring diagram for 208V conversion.

Electrical Connections

Electrical wiring and grounding must be installed in accordance with local codes or, in the absence of local codes, with the National Electrical Code ANSI/NFPA 70, Latest Revision.

Electrical Power

It is important that proper electrical power be available for the unit. Voltage variation should remain within the limits stamped on the unit nameplate.

Disconnect Switch

Provide an approved weatherproof disconnect within close proximity and **within sight of the unit**. If disconnect must be mounted to the cabinet, the location shown in [Table 9, p. 16](#) should be the only one considered.

Over Current Protection

The branch circuit feeding the unit must be protected as shown on the unit's rating plate.

Power Wiring

The power supply lines must be run in weather-tight conduit to the disconnect and into the side of the unit control box. Provide strain relief for all conduit with suitable connectors.

Provide flexible conduit supports whenever vibration transmission may cause a noise problem within the building structure.

1. Remove the Control/Heat access panel. Pass the power wires through the Power Entry hole in the end of the unit. See [Table 7, p. 16](#).
2. Connect the high voltage wires to the appropriate contactor terminals. Single phase units use a two (2) pole contactor and three phase units use three (3) pole contactor. Connect the ground to the ground lug on the chassis. See [Table 9, p. 16](#).

Ensure all connections are tight.

Table 7. Power Wiring

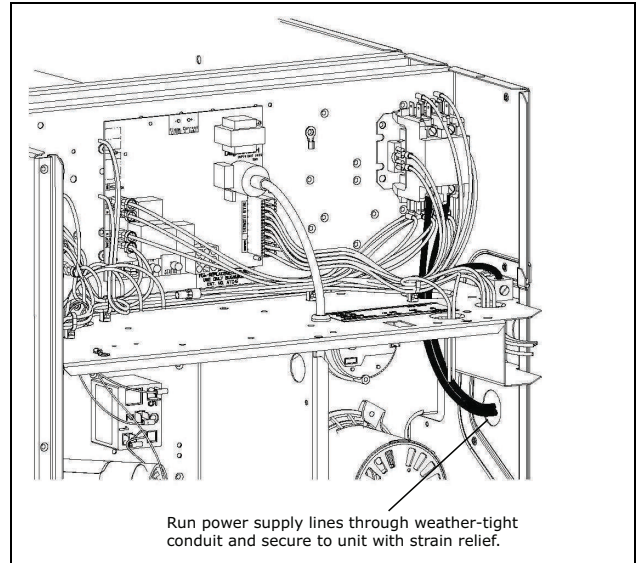

Table 8. Power Connections

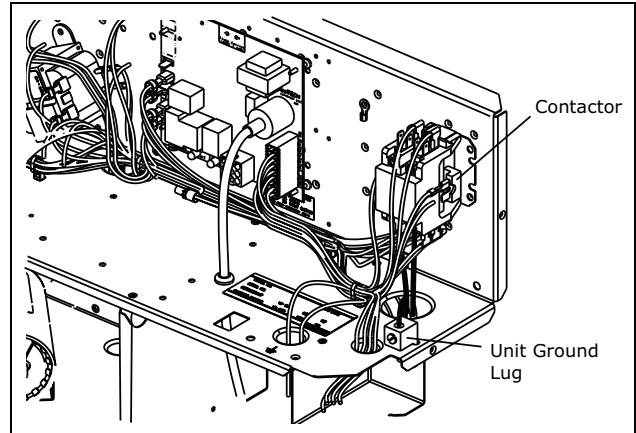
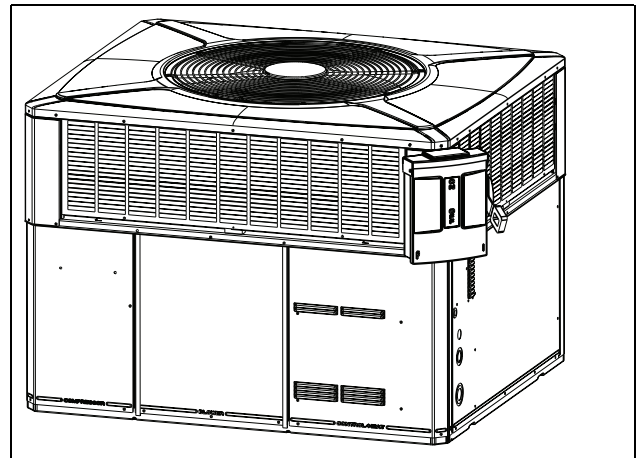
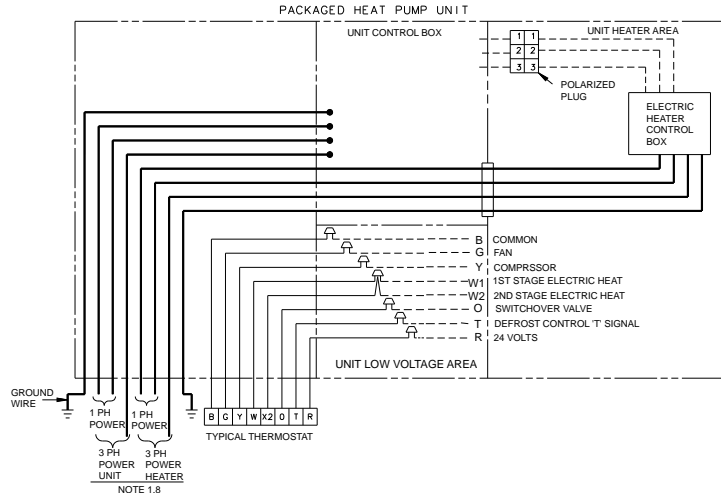
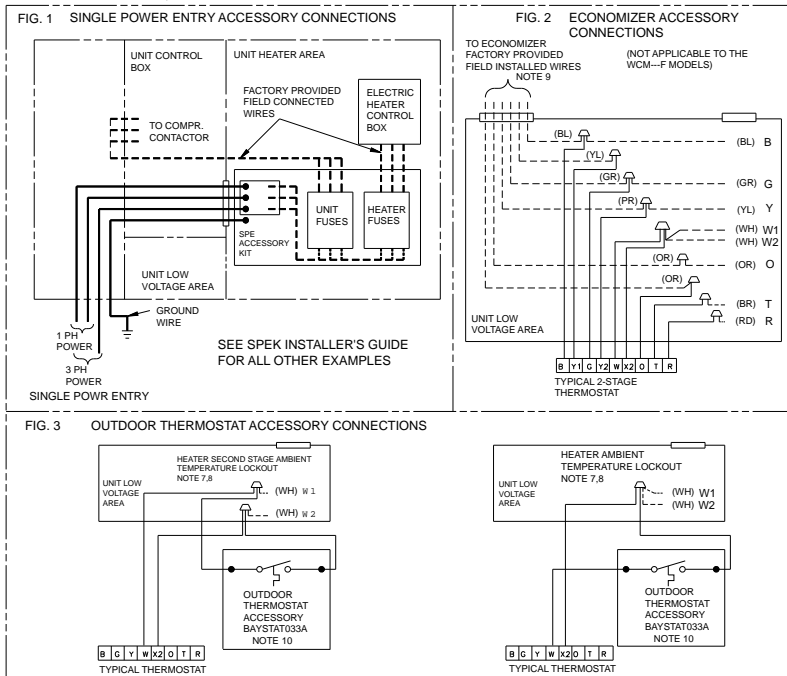

Table 9. Mounted Disconnect Location





- NOTES:
1. FUSED DISCONNECTS SEE WIRING AND GROUNDING OF EQUIPMENT MUST COMPLY WITH CODES.
 2. BE SURE POWER SUPPLY AGREES WITH EQUIPMENT AND HEATER NAMEPLATE.
 3. LOW VOLTAGE WIRING TO BE 18 AWG MINIMUM CONDUCTOR.
 4. SEE HEATER NAMEPLATE FOR CURRENT RATING OF HEATER USED.
 5. SEE UNIT AND HEATER DIAGRAM FOR ELECTRICAL CONNECTION DETAILS.
 6. IF ELECTRIC HEATER ACCESSORY IS NOT INSTALLED ON THE ELECTRIC HEATER, ASSOCIATED POWER WIRES AND THE W1 AND W2 THERMOSTAT WIRES.
 7. FIG. 3 DEMONSTRATES CONNECTION OF THE OUTDOOR THERMOSTAT ACCESSORY ONLY. FOR FURTHER UNIT CONNECTION DETAILS REFER TO THE OTHER FIGURES.
 8. THE 41C BR WIRE IS FIRST STAGE ELECTRIC HEAT. IF THE ELECTRIC HEATER ACCESSORY HAS TWO HEATING STAGES THE 41C BR WIRE IS SECOND STAGE ELECTRIC HEAT.
 9. WHEN THE BAYCON054A OR -055A ECONOMIZER IS INSTALLED THE BAYPLA003 RELAY ACCESSORY KIT IS REQUIRED TO INTERFACE THE ECONOMIZER TO THE HEAT PUMP FOR PROPER SYSTEM OPERATION. WHEN THE BAYCON054B OR -055B OR 073A ECONOMIZER IS INSTALLED, THE BAYPLA004A RELAY ACCESSORY KIT IS REQUIRED TO INTERFACE THE ECONOMIZER TO THE HEAT PUMP FOR PROPER SYSTEM OPERATION.
 10. THE BAYSTAT033A OUTDOOR THERMOSTAT ACCESSORY KIT CONTAINS A THERMOSTAT AND A RELAY. THE RELAY IS NOT REQUIRED TO BE USED IN THE APPLICATION.



Control Wiring (Class II)

Low voltage control wiring should not be run in conduit with power wiring unless Class 1 wire of proper voltage rating is used. Route the thermostat cable or equivalent single leads of No. 18 AWG colored wire from the thermostat subbase terminals through the rubber grommet on the unit. See "Determine Unit Clearances," p. 7 for the control entry (24V Entry) location. Make connections as shown on the wiring diagrams.

Do not short thermostat wires since this will damage the control transformer.

Refer to the table below for recommended wire sizes and lengths for installing the unit thermostat. The total resistance of these low voltage wires must not exceed one (1) ohm. Any resistance in excess of 1 ohm may

cause the control to malfunction because of the excessive voltage drop.

Table 10. Thermostat Wire Size and Maximum Length

Wire Size	Maximum Length (Ft)
18	75
16	125
14	200

Important: Upon completion of wiring, check all electrical connections, including factory wiring within the unit, and make sure all connections are tight. Replace and secure all electrical box covers and access panels before leaving the unit or turning on the power to the unit.

Unit Startup

Pre-Start Quick Checklist

- Is the unit properly located and level with the proper clearances? See, “[Determine Unit Clearances](#),” p. 7.
- Is the duct work correctly sized, run, taped, insulated, and weatherproofed with proper unit arrangement as shown in the ductwork installation section?
- Is the condensate line properly sized, run, trapped, and pitched and shown in the Condensate Drain Piping section?
- Is the filter of the correct size and quantity? Is it clean and in place? See Air Filter Installation section.
- Is the wiring properly sized and run according to the unit wiring diagram?
- Are all the wiring connections, including those in the unit tight?
- Has the unit been properly grounded and fused with the recommended fuse size?
- Is the thermostat well located, level, and correctly wired? See Electrical Wiring section
- Have the air conditioning systems been checked at the service ports for charge and leak tested if necessary?
- Do the condenser fan and indoor blower turn free without rubbing and are they tight on the shafts?
- Has all work been done in accordance with applicable local and national codes?
- Are all covers and access panels in place to prevent air loss and safety hazards?

Starting the Unit in Cooling Mode

Note: See the section on *Sequence of Operation* for a description of the cooling operating sequence.

To start the unit in the cooling mode, set the comfort control to **COOL** and to a setting below room temperature. The condenser fan motor, compressor and evaporator fan motor will operate automatically. Continuous fan mode during Cooling operation may not be appropriate in humid climates. If the indoor air exceeds 60% relative humidity or simply feels uncomfortably humid, it is recommended that the fan only be used in the **AUTO** mode.

Operating Pressure Checks

After the unit has operated in the cooling mode for a short period of time, install pressure gauges on the gauge ports of the discharge and suction line valves (behind the Compressor access panel). Check the suction and discharge pressures and compare them to the normal operating pressures provided in the unit’s SERVICE FACTS.

Note: Do not use the *PRESSURE CURVES* from the unit’s SERVICE FACTS to determine the unit refrigerant charge. The correct charge is shown on the unit nameplate. To charge the system accurately, weigh in the charge according to the unit nameplate and check subcooling against the Subcooling Charging Table in the SERVICE FACTS.

Voltage Check

With the compressor operating, check the line voltage at the unit (contactor is located behind the Control access panel). The voltage should be within the range shown on the unit nameplate. If low voltage is encountered, check the size and length of the supply line from the main disconnect to the unit. The line may be undersized for the length of the run.

Cooling Shut Down

Set the comfort control to **OFF** or to a setting above room temperature.

Important: De-energize the main power disconnect *ONLY* when servicing the unit. Power may be required to keep the heat pump compressor warm and to boil off refrigerant in the compressor.

Starting the Unit in Heating Mode

Note: See the section on *Sequence of Operation* for a description of the heat pump heating operating sequence.

Check that all grills and registers are open and all unit access panels are closed before start-up.

Set the comfort control above room temperature until achieving a first stage call for heat and set the fan to **AUTO** or **ON**.

Heating Shut Down

Set the comfort control to **OFF** or at a setting below room temperature.

Sequence of Operation

General

Operation of the unit heating and cooling cycles is automatic when the system is in the **HEAT** or **COOL** functions (the optional automatic changeover thermostat, when in the **AUTO** position, automatically changes to heat or cool with an appropriate room temperature change). The fan can be set to **ON**, causing continuous evaporator (indoor) fan operation or set to **AUTO** causing fan operation to coincide with heating or cooling run cycles. Continuous fan mode during Cooling operation may not be appropriate in humid climates. If the indoor air exceeds 60% relative humidity or simply feels uncomfortably humid, it is recommended that the fan only be used in the **AUTO** mode.

Cooling Mode

Note: The TSH and TSC are contacts that are internal to the indoor comfort control.

With the disconnect switch in the **ON** position, current is supplied to the control transformer. The cooling cycle is enabled through the low voltage side of the control transformer to the "R" terminal on the indoor thermostat. With the comfort control set to **AUTO** and **TSC-1** contacts closed, power is supplied to the "O" terminal on the indoor thermostat to the switchover valve coil (**SOV**). This energizes the switch-over valve (**SOV**) and places it in the cooling position (it is in the heating position when de-energized).

When the indoor temperature rises 1-1/2 degrees, **TSC-2** contacts close, supplying power to the "Y" terminal on the indoor thermostat, and to the compressor contactor (**CC**). This starts the outdoor fan motor and compressor. The **TSC-2** contacts also provide power to the "G" terminal which provides power to the indoor fan motor.

Heating Mode

With the comfort control set to **ON**, current is supplied to the transformer. Starting at the "R" terminal on the indoor comfort control, current goes through the system switch (which is in "AUTO" position) to the **TSH-1** contacts. When closed, these contacts supply power to terminal "Y" on the indoor thermostat as well as to the heating anticipator. The switch-over valve will not energize because of the high resistance of the heating anticipator in the thermostat. Power is provided from "Y" to the compressor contactor (**CC**)

which starts the compressor and outdoor fan motor. The indoor thermostat contact **TSH-1** also provides power to "G" terminal on the indoor thermostat energizing the indoor fan motor.

Supplementary Heat

The supplementary electric heat is brought on when the indoor temperature drops 1-1/2 degrees below the thermostat setting. **TSH-2** contacts close providing power to the "W" terminal on the indoor thermostat and to the supplementary heater control circuit. An outdoor thermostat may have been added to disallow the second stage (if provided) of electric heat above a selected outdoor temperature. If the outdoor temperature falls below the setting on the outdoor thermostat, this additional heater stage will come on. When the outdoor air temperature rises, and the outdoor T-stat setpoint is reached, the system will revert back to first stage electric heating.

When the indoor ambient is satisfied, **TSH-2** contacts will open and the unit will revert back to the compressor only heating mode and then off. For **emergency heat** (use of supplementary electric heat only), an emergency (**EMERG**) heat switch is provided within the comfort control. When placed in the emergency heat position, it will disable the compressor, bypass the outdoor thermostats, if provided, and engage the supplementary electric heaters and indoor fan.

Demand Defrost Operation

During the heating cycle, the outdoor coil may require a defrost cycle which is determined by the demand defrost control (**DFC**). This control continuously measures the outdoor coil temperature (**CBS**) and the outdoor ambient temperature (**ODS-B**) and calculates the difference or delta-T measurement. When the calculated delta-T is met, the demand defrost control (**DFC**) opens the circuit to the outdoor fan motor (**ODM**) and energizes the switch-over valve (**SOV**), placing the unit in the cooling mode to defrost the outdoor coil. The outdoor coil temperature sensor (**CBS**) terminates the defrost cycle, or times out after fifteen minutes in defrost, the (**DFC**) energizes the outdoor fan motor (**ODM**) and twelve seconds later de-energizes the (**SOV**), which returns the unit to the heating mode. Supplementary electric heat, if provided, is brought on to control indoor temperature during the defrost cycle.

ECM Fan Motor Adjustments

If the airflow needs to be increased or decreased, see the Airflow Table in the Service Facts. Information on changing the speed of the blower motor is in the Blower Performance Table.

Blower speed changes are made on the ICM Fan Control mounted in the control box. The ICM Fan Control controls the variable speed motor.

There is a bank of 8 dip switches located at the upper left side of the board. The dip switches work in pairs to match the cooling/heat airflow (CFM/TON), Fan off-delay options, and electric heat airflow adjustment. The switches appear as shown in Figure 8, p. 20.

Figure 8. ECM Fan Control

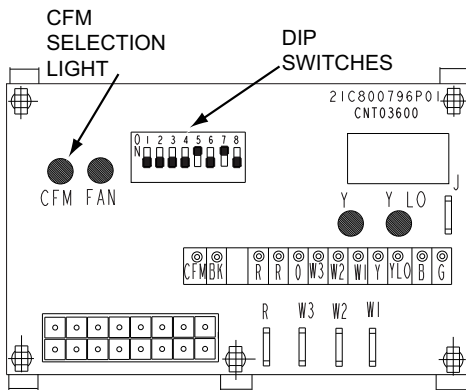
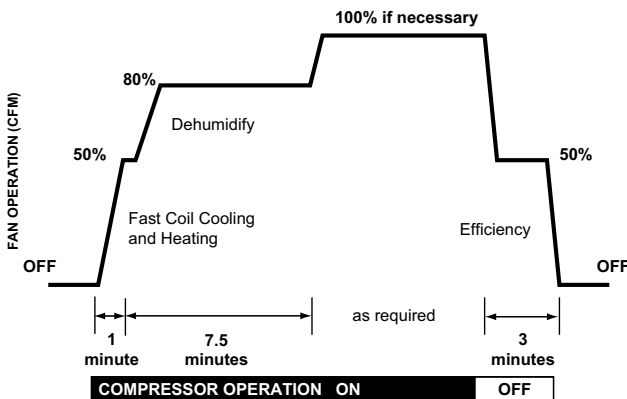

Table 11. Cooling Off - Delay Options

SWITCH SETTINGS		SELECTION	NOMINAL AIRFLOW
5 - OFF	6 - OFF	NONE	SAME
5 - ON	6 - OFF	45 SECONDS	100%*
5 - OFF	6 - ON	1.5 MINUTES	50%
5 - ON	6 - ON	**	50 -100%

* - This setting is equivalent to the BAY24X045 relay benefit.

** - This ENHANCED MODE selection provides a ramping up and ramping down of the blower speed to provide improved comfort, quietness, and potential energy savings. The graph below show the ramping process.



Final Installation Checklist

Important: Perform a final unit inspection to be sure that factory tubing has not shifted during shipment. Adjust tubing if necessary so tubes do not rub against each other when the unit runs. Also be sure that wiring connections are tight and properly secured.

- Does the unit run and operate as described in the Sequence of Operation section in response to the room thermostat?
- Are the condenser fan and indoor blower operating correctly with proper rotation and without undue noise?
- Is the compressor operating correctly and has the system been checked with a charging chart?
- Has the voltage and running current been checked to determine if it is within limits?
- Has the thermostat been checked for calibration and the air discharge grills adjusted to balance the system?
- Has the ductwork been checked for air leaks and condensation?
- Has the furnace manifold pressure been checked and adjusted if necessary?
- Has the heating air temperature rise been checked?
- Has the unit been checked for tubing and sheet metal rattles? Are there any other unusual noises to be checked?
- Are all covers and panels in place and properly fastened?
- Has the owner been instructed on the proper operation and maintenance of the unit? Be sure to leave this manual with the owner.

Maintenance

Owner Maintenance

Some of the periodic maintenance functions of the unit can be performed by the owner; this includes replacing the disposable or cleaning the permanent air filters, cleaning the unit cabinet, cleaning the condenser coil, and conducting a general unit inspection on a regular basis.

Filters

When the system is in constant operation, inspect the filters at least once each month.

If the unit has disposable-type filters, replace them with new filters of the same type and size. **Do not attempt to clean disposable filters.**

Permanent-type filters can be cleaned by washing them with a mild detergent and water. Make sure that the filters are thoroughly dry before reinstalling them in the unit (or duct system).

Note: It may be necessary to replace permanent filters annually if washing fails to clean the filter or if the filter shows signs of deterioration. Be sure to use the same type and size as was originally installed.

Condenser Coil

Be sure to keep all vegetation and debris away from the condenser coil area.

Service Maintenance

Cooling Season

To keep the unit operating safely and efficiently, the manufacturer recommends that a qualified service technician check the entire system at least once each year or sooner if needed. The service technician should examine these areas of the unit:

- filters (for cleaning or replacement)
- motors and drive system components
- economizer gaskets (for possible replacement)
- safety controls (for mechanical cleaning)
- electrical components and wiring (for possible replacement and connection tightness)
- condensate drain (for proper sealing and cleaning)
- unit duct connections (to see that they are physically sound and sealed to the unit casing)
- unit mounting support (for structural integrity)
- the unit (for obvious unit deterioration)

Heating Season

Complete the following unit inspections and service routines at the beginning of each heating season.

- Visually inspect the unit to ensure that the airflow required for combustion and condenser coil is not obstructed from the unit.
- Inspect the control panel wiring to verify that all electrical connections are tight and that the wire insulation is intact.

Indoor Fan Motor Speed Tap Setting

The units are factory set to medium speed.

Fault Detection

A fault condition is indicated by the flashing light on the defrost control board located inside the heat pump control box.

In normal operation, the defrost control light will flash once each second. If the light is flashing more than once per second or not at all, refer to the Demand Defrost Control Checkout table.

PIN Identification

1. TEST_COMMON (Shorting any of the other pins to this pin causes the function of the other pin to be

executed. Leaving this pin open results in the normal mode of operation.)

2. TST = Test (Shorting TEST_COMMON to this pin speeds up all defrost board timings.)
3. FRC_DFT = Forced Defrost (Short TEST_COMMON to this pin for two (2) seconds to initiate a forced defrost. Remove the short after defrost initiates.)

Defrost Control Checkout

Normal operation requires:

- LED on board flashing 1 time/second.
- 24V AC between R & B
- 24V AC between Y & B with unit operating
- Defrost initiation when FRC_DFT pin is shorted to TEST_COMMON pin.

If a defrost control problem is suspected, proceed to the Demand Defrost Control Checkout table.

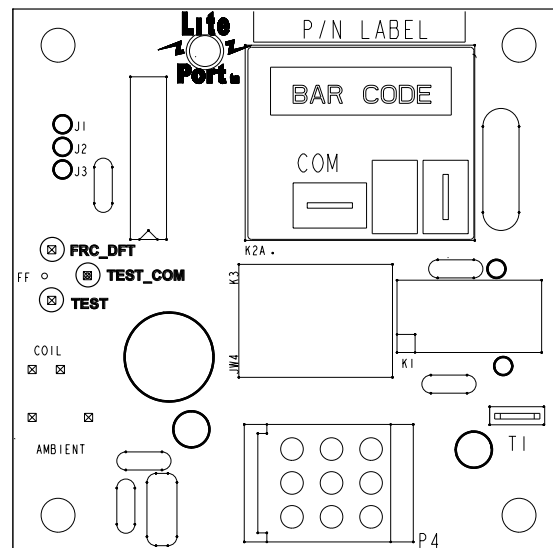

Test Sensors

Using the chart below, locate (as close as possible) the actual sensor temperature. The measured resistance should be relatively close to the resistance value shown in the chart.

Example:

Sensor temp. = 19°F.

Measured Resistance = 46K ohms

This sensor is good since the measured value is relatively close to the chart value.

Unit Startup

1 — Flash/ Second	= Normal operation.
2 — Flashes/ Second	= Fault A (Low ΔT): Inoperative compressor, loss of charge, open ambient sensor, shorted coil sensor.
3 — Flashes/ Second	= Fault B (20 defrosts terminated on time) Fault C (High ΔT): SOV stuck in heating, shorted ambient sensor, open coil sensor, closed TXV, OD motor failure, OD fan on in defrost, undercharged unit.
4 — Flashes/ Second	= Fault A & C or A & B

For additional information consult Pub. No. 34-1001 Heat Pump Defrost Controls.

TEMP (°F)	RESISTANCE
86	7.85K
81	8.85K
75	10.24K
70	11.59K

TEMP (°F)	RESISTANCE
65	13.14K
59	15.32K
55	16.93K
50	19.41K
45	22.20K
41	24.76K
36	28.45K
32	31.84K
25	37.50K
19	46.44K
14	53.94K
10	57.64K
5	67.06K
0	78.05K

Table 12. Demand Defrost Control Checkout Table

SYMPTOMS	CHECKS	YES/NO	ACTIONS
1. LED off.	1. 24V R-B & Y-B at board, with unit running?	N	Repair low voltage wiring.
		Y	Complete Check #2.
	2. Short FRC_DFT pin to TEST_COMMON pin. Is defrost cycle initiated?	N	Replace defrost control.
		Y	LED is bad but control will still function.
2. LED flashing very rapidly (greater than 4 times/ sec) or appears to be on continuously.	TEST_COMMON pin shorted to TST pin?	Y	Remove short.
		N	Replace defrost control.
3. Control does not initiate a normal defrost.	1. OD Temp. below 49°F.? OD Coil temp. below 35°F.? "Delta" T increasing	N	Check refrigerant circuits for balanced distribution of refrigerant if OD coil is frosting and delta T is not increasing.
		N	Refer to SYMPTOM #1.
	2. LED flashing?	Y	Complete Check #2.
		N	Repair low voltage wiring.
	3. Check for 24V Y-B at board with unit running.	Y	Complete Check #3.
			Remount or replace sensor if necessary.
4. Check sensors for correct mounting (connection) and resistance.	N	Replace defrost control.	
	Y	Y-B signal or control may be intermittent.	
5. Short FRC_DFT pin to TEST_COMMON pin. Is defrost cycle initiated?	N	Replace defrost control.	
	Y	Y-B signal or control may be intermittent.	
4. Control does not initiate a forced defrost.	24V R-B & Y-B at board with unit running?	N	Repair low voltage wiring.
		Y	Replace defrost control.
5. Defrost initiates manually but terminates in less than 10 seconds.			Replace defrost control.
6. Defrost initiates manually but terminates on time.	1. Coil sensor circuit open or reading at a very high resistance?	Y	Replace coil sensor.
	2. Does OD fan cycle off in defrost?	N	Replace defrost control.
	3. Windy weather preventing normal termination?		
7. Defrost initiates on approximately 15/25 minute intervals.	1. Be sure OD coil is clean.	N	Complete Check #2.
	2. Coil sensor open or reading a very high resistance?	Y	Replace coil sensor.
	3. Ambient sensor reading less than normal?	N	Complete Check #3.
		Y	Replace ambient sensor.
4. OD fan off in defrost?	N	Replace defrost control.	

Table 12. Demand Defrost Control Checkout Table (continued)

SYMPTOMS	CHECKS	YES/NO	ACTIONS
8. Defrost initiates on approximately 30/45 minute intervals.	1. TEST_COMMON pin shorted to TST pin?	Y	Remove short.
	2. Do both sensors check OK?	N	Replace defective sensor (Clear coil and re-ignity heat light).
		Y	Complete SYMPTOM #3.
	3. Verify correct system charge.		Adjust as needed.
	4. Verify a "forced defrost" terminates less than 15 minutes.	N	Replace defrost control.
	5. OD fan motor off in defrost.		See SYMPTOM #9.
	6. Verify proper SOV operation.		Replace if necessary.
9. OD fan runs during defrost.			Replace defrost control.
10. No SOV delay on defrost termination.	Has J1 been cut?	Y	The soft-switch time is defeated when J1 is cut.
		N	Replace defrost control.
11. ODS-A burned out.	B to T greater than 10 volts?	Y	Check low voltage wiring for miswire.
		N	Check for short in low voltage wiring.
12. On SCROLL bearing units, compressor does not operate.	1. 24V R-B at board & 24V Y-B at board?	N	Repair low voltage wiring.
	2. Check protective devices in YO circuit. 24V YO-B present after 30 seconds.	N	Y-B signal or control may be intermittent
13. On SCROLL bearing units, no 30 second off delay at defrost initiation.	Check voltage between control terminals 2 and 7, force a defrost cycle. Is 24V present for 30 seconds and 0V thereafter?	N	Replace defrost control.

Pressure Curves

Figure 9. 4WCY4036B

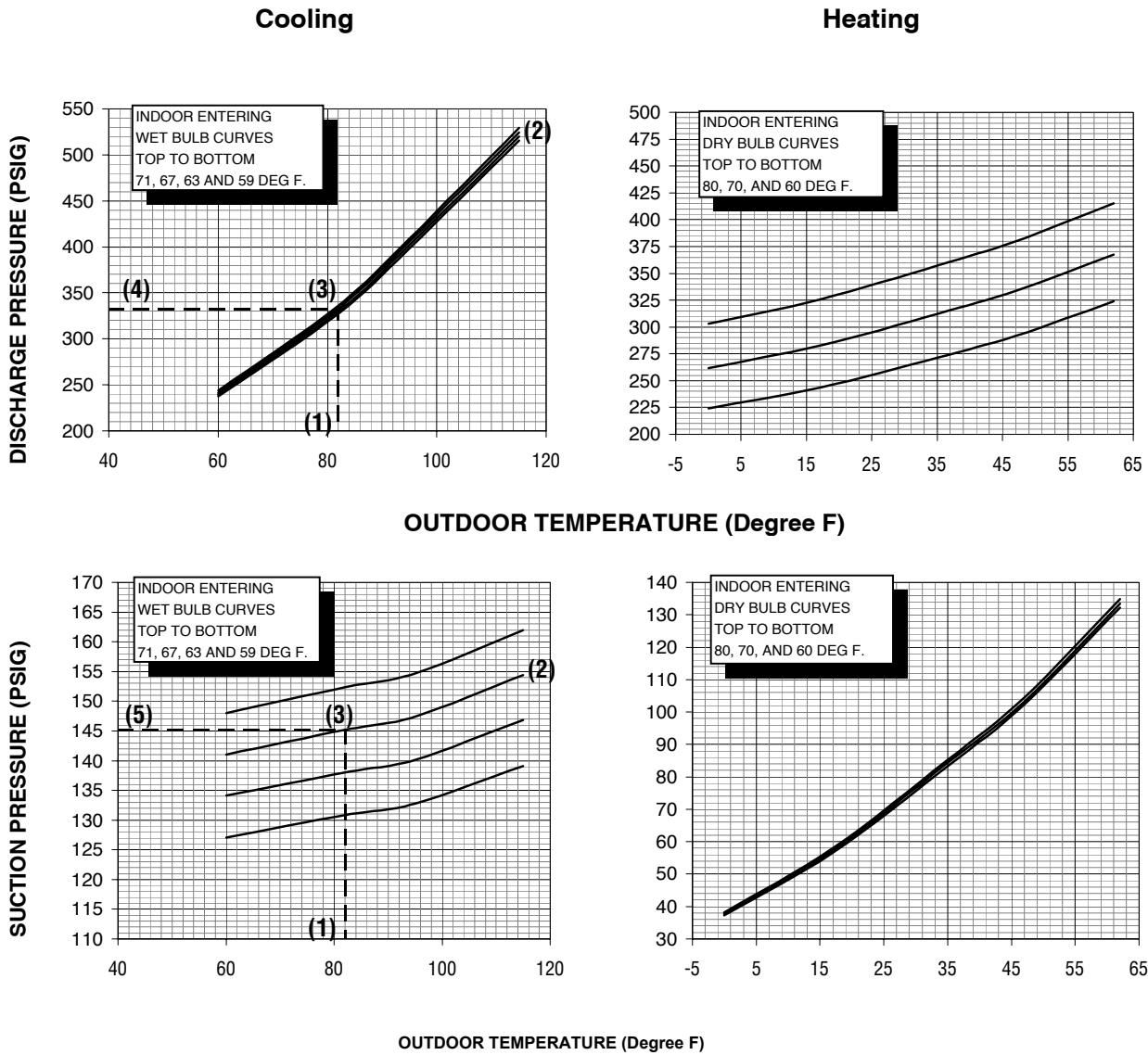

COOLING PERFORMANCE CAN BE CHECKED WHEN THE OUTDOOR TEMP IS ABOVE 65 DEG F.

TO CHECK COOLING PERFORMANCE, SELECT THE PROPER INDOOR CFM, ALLOW PRESSURES TO STABILIZE. MEASURE INDOOR WET BULB TEMPERATURE, OUTDOOR TEMPERATURE, DISCHARGE AND SUCTION PRESSURES. ON THE PLOTS LOCATE OUTDOOR TEMPERATURE (1); LOCATE INDOOR WET BULB (2); FIND INTERSECTION OF OD TEMP. & ID W.B. (3); READ DISCHARGE OR SUCTION PRESSURE IN LEFT COLUMN (4).

- EXAMPLE: (1) OUTDOOR TEMP. 82 F.
 (2) INDOOR WET BULB 67 F.
 (3) AT INTERSECTION
 (4) DISCHARGE PRESSURE @ 1730 CFM IS 326 PSIG
 (5) SUCTION PRESSURE @ 1780 CFM IS 141 PSIG

- ACTUAL:
 DISCHARGE PRESSURE SHOULD BE +/- 10 PSI OF CHART
 SUCTION PRESSURE SHOULD BE +/- 3 PSIG OF CHART

DWG.NO. 4WCY4036

Figure 10. 4WCY4048A

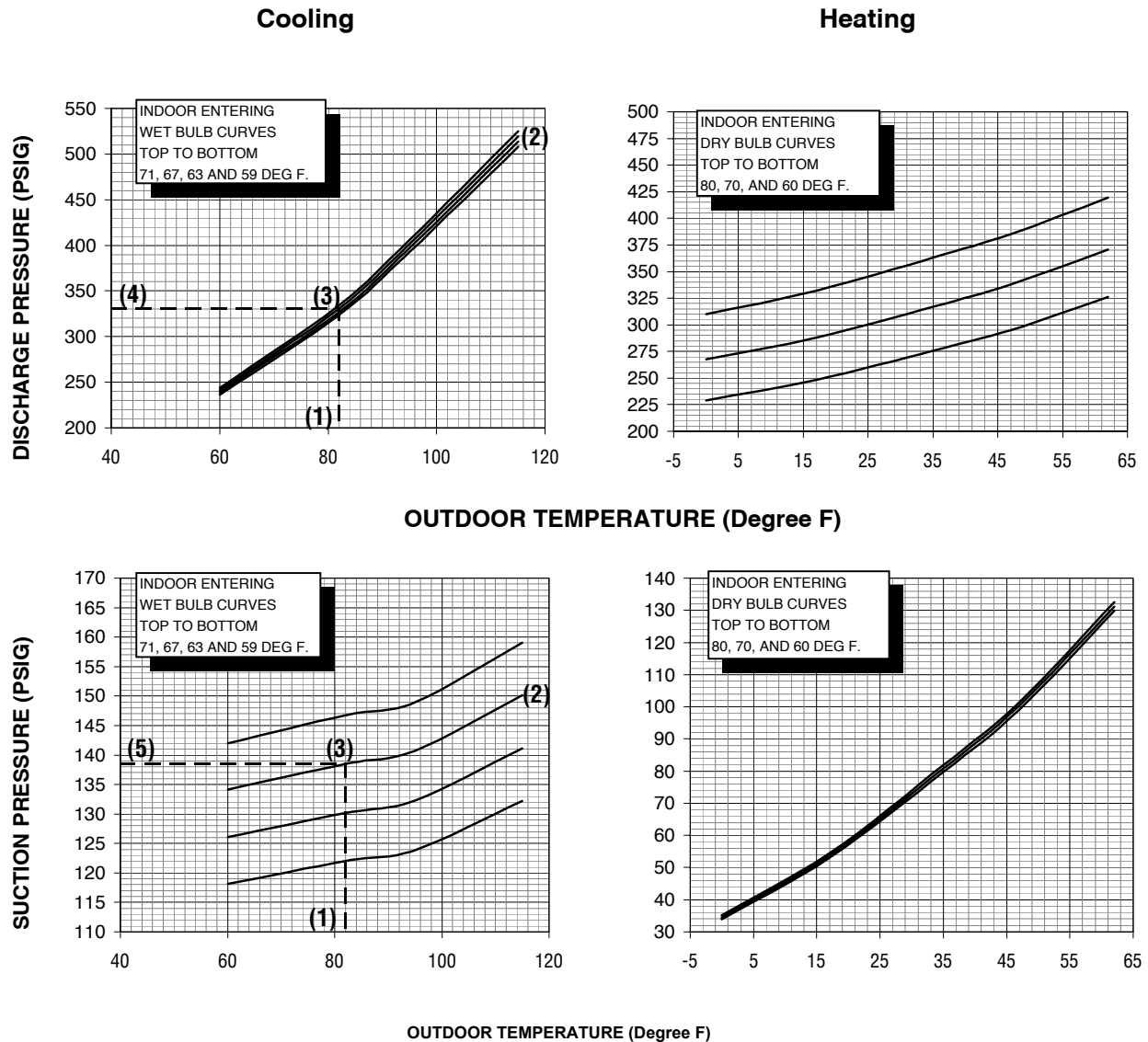

COOLING PERFORMANCE CAN BE CHECKED WHEN THE OUTDOOR TEMP IS ABOVE 65 DEG F.

TO CHECK COOLING PERFORMANCE, SELECT THE PROPER INDOOR CFM, ALLOW PRESSURES TO STABILIZE. MEASURE INDOOR WET BULB TEMPERATURE, OUTDOOR TEMPERATURE, DISCHARGE AND SUCTION PRESSURES. ON THE PLOTS LOCATE OUTDOOR TEMPERATURE (1); LOCATE INDOOR WET BULB (2); FIND INTERSECTION OF OD TEMP. & ID W.B. (3); READ DISCHARGE OR SUCTION PRESSURE IN LEFT COLUMN (4).

EXAMPLE: (1) OUTDOOR TEMP. 82 F.

(2) INDOOR WET BULB 67 F.

(3) AT INTERSECTION

(4) DISCHARGE PRESSURE @ 1730 CFM CFM IS 326 PSIG

(5) SUCTION PRESSURE @ 1780 CFM CFM IS 141 PSIG

ACTUAL:

DISCHARGE PRESSURE SHOULD BE +/- 10 PSI OF CHART

SUCTION PRESSURE SHOULD BE +/- 3 PSIG OF CHART

DWG.NO. 4WCY4048

Figure 11. 4WCY4060A

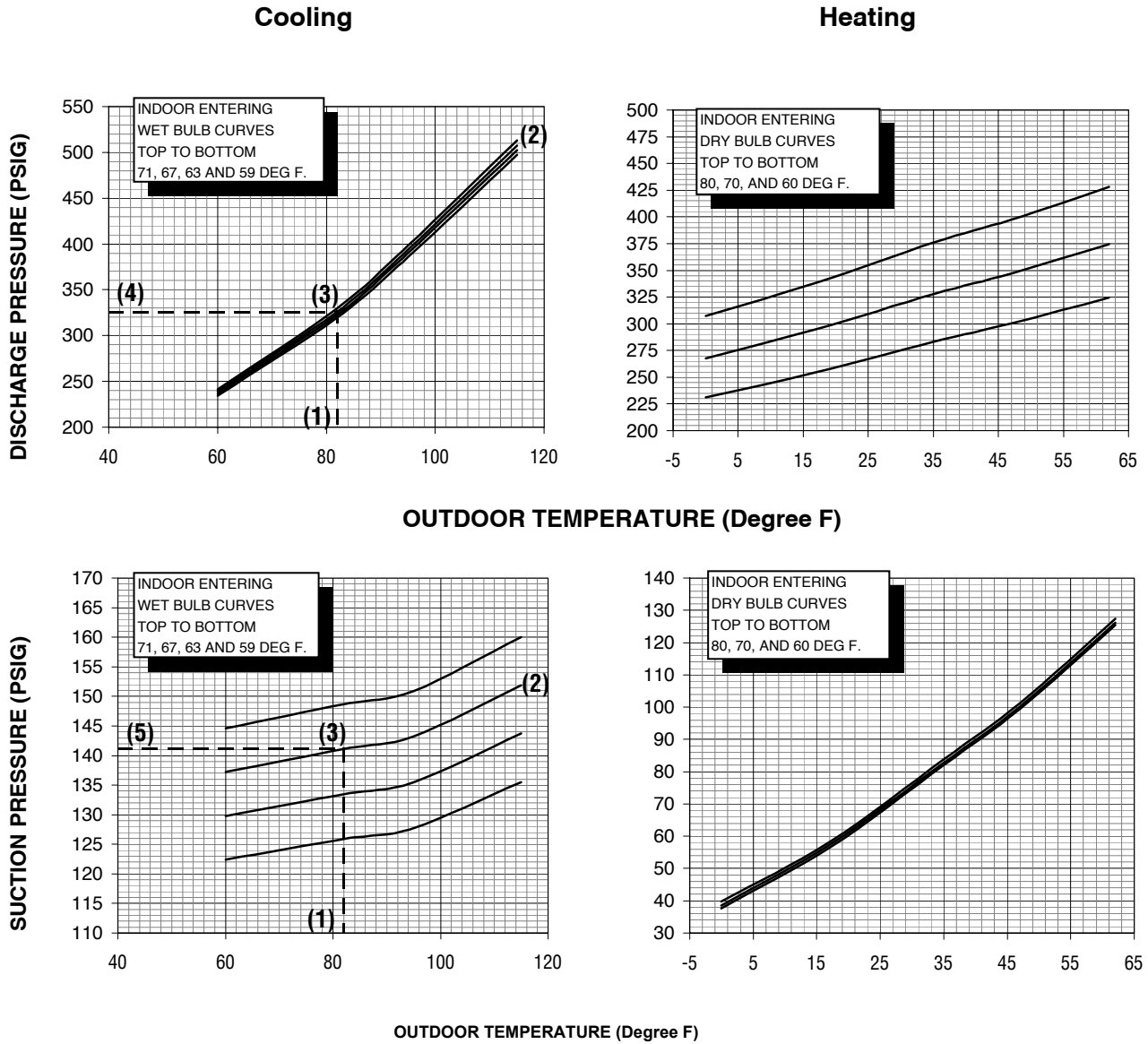

COOLING PERFORMANCE CAN BE CHECKED WHEN THE OUTDOOR TEMP IS ABOVE 65 DEG F.

TO CHECK COOLING PERFORMANCE, SELECT THE PROPER INDOOR CFM, ALLOW PRESSURES TO STABILIZE. MEASURE INDOOR WET BULB TEMPERATURE, OUTDOOR TEMPERATURE, DISCHARGE AND SUCTION PRESSURES. ON THE PLOTS LOCATE OUTDOOR TEMPERATURE (1); LOCATE INDOOR WET BULB (2); FIND INTERSECTION OF OD TEMP. & ID W.B. (3); READ DISCHARGE OR SUCTION PRESSURE IN LEFT COLUMN (4).

- EXAMPLE: (1) OUTDOOR TEMP. 82 F.
 (2) INDOOR WET BULB 67 F.
 (3) AT INTERSECTION
 (4) DISCHARGE PRESSURE @ 1730 CFM IS 326 PSIG
 (5) SUCTION PRESSURE @ 1780 CFM IS 141 PSIG

ACTUAL:
 DISCHARGE PRESSURE SHOULD BE +/- 10 PSI OF CHART
 SUCTION PRESSURE SHOULD BE +/- 3 PSIG OF CHART

Indoor Fan Performance

Horizontal and Downflow External Static Pressure (IN.WG)																
4WC-Y4036	DIP Switch Setting				Horizontal Airflow [Down Airflow in Brackets]											
Airflow Setting	1	2	3	4		0.0	0.1	0.2	0.3	0.4	0.5	0.6	0.7	0.8	0.9	1.0
350 CFM/TON	OFF	OFF	OFF	ON	Watts	162 [169]	173 [182]	197 [210]	226 [243]	256 [273]	285 [301]	313 [331]	343 [370]	360 [433]	-	-
					CFM	1058 [1025]	1062 [1062]	1063 [1068]	1063 [1063]	1062 [1060]	1060 [1061]	1057 [1064]	1053 [1055]	1010 [1015]	-	-
400 CFM/TON (Factory Default)	OFF	OFF	OFF	OFF	Watts	179 [225]	230 [253]	265 [283]	296 [315]	329 [348]	366 [381]	403 [414]	431 [449]	436 [484]	-	-
					CFM	1179 [1187]	1196 [1201]	1204 [1203]	1206 [1201]	1205 [1198]	1203 [1197]	1199 [1194]	1194 [1184]	1185 [1157]	-	-
45000 CFM/TON	OFF	OFF	ON	OFF	Watts	318 [339]	336 [357]	365 [390]	399 [424]	435 [455]	469 [483]	502 [516]	533 [571]	-	-	-
					CFM	1390 [1391]	1376 [1377]	1370 [1377]	1366 [1375]	1361 [1366]	1354 [1352]	1349 [1344]	1351 [1360]	-	-	-
4WC-Y4048	DIP Switch Setting				Horizontal Airflow [Down Airflow in Brackets]											
Airflow Setting	1	2	3	4		0.0	0.1	0.2	0.3	0.4	0.5	0.6	0.7	0.8	0.9	1
350 CFM/TON	OFF	OFF	OFF	ON	Watts	187 [208]	232 [254]	264 [284]	291 [312]	318 [343]	347 [379]	379 [414]	413 [437]	446 [460]	473 [490]	-
					CFM	1355 [1337]	1387 [1393]	1396 [1398]	1392 [1388]	1382 [1383]	1370 [1390]	1360 [1399]	1351 [1384]	1341 [1380]	1326 [1370]	-
400 CFM/TON (Factory Default)	OFF	OFF	OFF	OFF	Watts	315 [302]	324 [349]	352 [386]	389 [423]	428 [465]	464 [509]	498 [552]	529 [583]	563 [599]	606 [628]	-
					CFM	1603 [1574]	1581 [1580]	1577 [1585]	1580 [1589]	1583 [1594]	1583 [1598]	1577 [1601]	1567 [1597]	1558 [1584]	1556 [1556]	-
45000 CFM/TON	OFF	OFF	ON	OFF	Watts	301 [501]	431 [528]	507 [555]	552 [592]	584 [631]	615 [672]	651 [714]	694 [760]	739 [800]	779 [845]	-
					CFM	1752 [1847]	1794 [1823]	1812 [1817]	1816 [1818]	1812 [1820]	1806 [1819]	1800 [1817]	1797 [1820]	1793 [1815]	1985 [1810]	-
4WC-Y4060	DIP Switch Setting				Horizontal Airflow [Down Airflow in Brackets]											
Airflow Setting	1	2	3	4		0.0	0.1	0.2	0.3	0.4	0.5	0.6	0.7	0.8	0.9	1
350 CFM/TON	OFF	OFF	OFF	ON	Watts	394 [443]	427 [461]	464 [493]	504 [532]	548 [571]	591 [607]	633 [642]	668 [680]	-	-	-
					CFM	1673 [1796]	1772 [1741]	1799 [1726]	1793 [1725]	1799 [1722]	1771 [1712]	1767 [1698]	1756 [1692]	-	-	-
400 CFM/TON (Factory Default)	OFF	OFF	OFF	OFF	Watts	695 [740]	642 [697]	660 [715]	710 [763]	764 [819]	811 [866]	849 [892]	893 [894]	966 [872]	-	-
					CFM	2054 [2010]	2036 [1987]	2031 [1779]	2032 [1977]	2033 [1976]	2031 [1969]	2023 [1950]	2012 [1913]	2002 [1852]	-	-

Airflow with Auxiliary Heat (CFM)					
SWITCH SETTINGS		SELECTION	NOMINAL AIRFLOW		
			4WCY4036	4WCY4048	4WCY4060
7 - OFF	8 - OFF	LOW	1050 CFM	1400 CFM	1400 CFM
7 - ON	8 - OFF	HIGH	1200 CFM	1600 CFM	1600 CFM
7 - OFF	8 - ON	HIGH	1200CFM	1600 CFM	1600 CFM
7 - ON	8 - ON	HIGH	1200CFM	1600 CFM	1600 CFM

Refrigerant Circuit

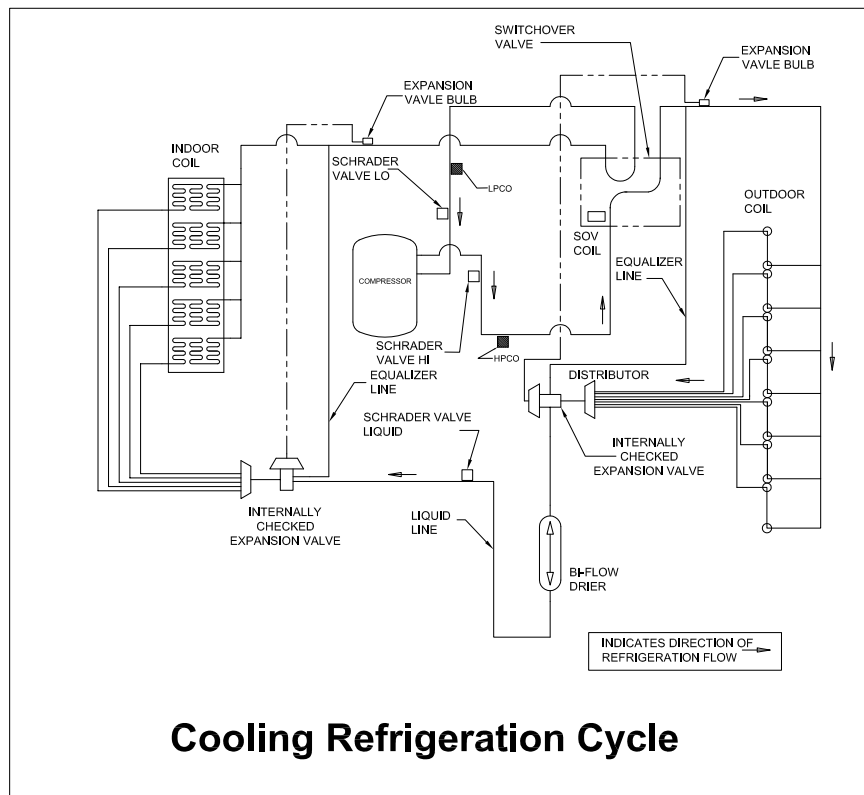
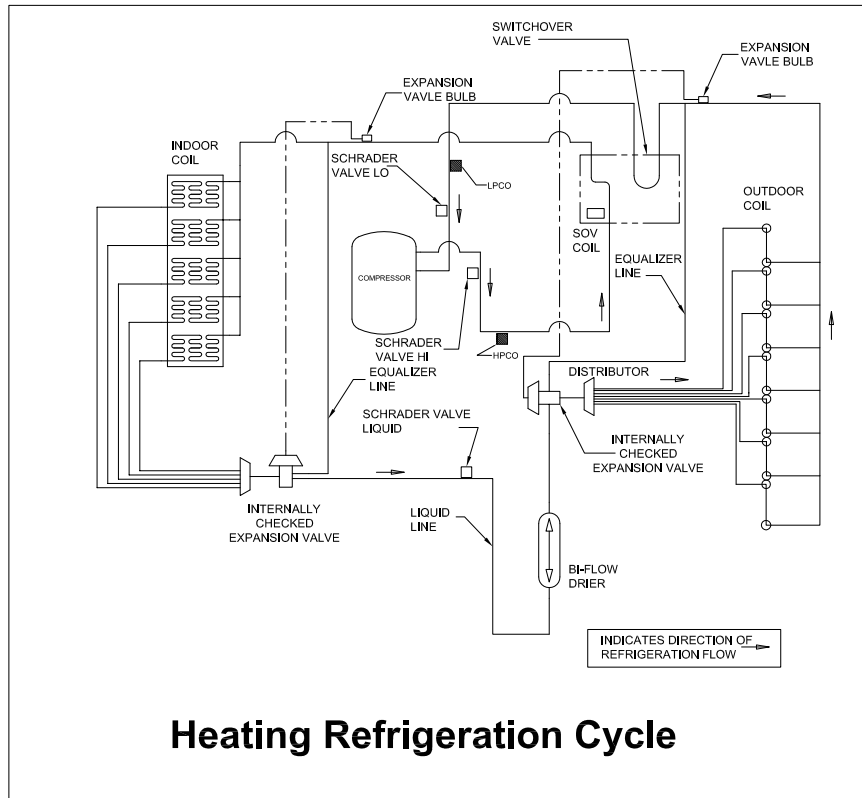

Troubleshooting Chart

P-PRIMARY CAUSES / S-SECONDARY CAUSES

SYSTEM FAULTS	Power Supply	High Voltage Wiring	Compr. IOL	Run Capacitor	Start capacitor	Start Relay	Contactors Contacts	Low Voltage Wiring	Control Transformer	Contactor Coil	Low Voltage Fuse	Stuck Compressor	Ineffecient Compressor	Refrigerant Undercharge	Refrigerant Overcharge	Excessive Evap. Load	Noncondensables	Restricted O.D. Airflow	O.D. Air Recirculation	TXV Stuck Open	Low Superheat	High Superheat	Restricted I.D. Airflow	Ref. Circuit Restrictions
REFRIGERANT CIRCUIT																								
Liquid Pressure too High															P		S	P	S					S
Liquid Pressure too Low													S	P						S		S		S
Suction Pressure too High													S		P	P				S	S			
Suction Pressure too Low														S								S	P	S
Liquid Refrigerant Floodback (TXV System)																				S	S		P	
I.D. Coil Frosting															P						S		P	S
Compressor Runs Inadequate or No Cooling													S	P		P	S	S	S			S	P	S
ELECTRICAL																								
Compressor & O.D. Fan Do Not Start	P	P					S	S	P	P	P													
Compressor will not Start but O.D. Fan Runs		P	S	P	P	P						S												
O.D. Fan will Not Start		P		P																				
Compressor Hums but will Not Start		P		P	P	P	S					S												
Compressor Cycles on IOL		P	S	P	P	P	S					P	S	P	S	S	S	S	S			S		S
I.D. Blower willnot Start	P	S					S	P		P														

Important Product Information

Packaged Unit Serial Number _____

Packaged Unit Model Number _____

Date of Installation _____

Dealer _____

Service Information

Call your installing dealer if the unit is inoperative. Before you call, always check the following to be sure service is required:

1. Be sure the main switch that supplies power to the unit is in the ON position.
2. Replace any burned-out fuses or reset circuit breakers.
3. Be sure the thermostat is properly set.

Service Phone _____

About Trane and American Standard Heating and Air Conditioning

Trane and American Standard create comfortable, energy efficient indoor environments for residential applications. For more information, please visit www.trane.com or www.americanstandardair.com.



The AHRI Certified mark indicates company participation in the AHRI Certification program. For verification of individual certified products, go to ahridirectory.org.

The manufacturer has a policy of continuous data improvement and it reserves the right to change design and specifications without notice. We are committed to using environmentally conscious print practices.

18-BB34D1-19D-EN 19 Jan 2024

Supersedes 18-BB34D1-19C-EN (February 2023)

©2024