



Replacement Coils

Includes coil models:

COL32944, 32945, 32946, 32947, 32948, 32949, 32950, 32951, 32952, 32953, 33006

ALL phases of this installation must comply with NATIONAL, STATE AND LOCAL CODES

IMPORTANT— This Document is **customer property** and is to remain with this unit. Please return to service information pack upon completion of work.

These instructions do not cover all variations in systems nor provide for every possible contingency to be met in connection with the installation. Should further information be desired or should particular problems arise which are not covered sufficiently for the purchaser's purposes, the matter should be referred to your installing dealer or local distributor.

CONTENTS:

Safety	1
Preparation	2
Existing Coil Removal	3
TXV Replacement Coil Procedure	4
EEV Replacement Coil Procedure	5
Installing and Reconnecting Replacement Coil	8

A. Safety:

WARNING

This information is intended for use by individuals possessing adequate backgrounds of electrical and mechanical experience. Any attempt to repair a central air conditioning product may result in personal injury and/or property damage. The manufacture or seller cannot be responsible for the interpretation of this information, nor can it assume any liability in connection with its use.

WARNING

RISK OF FIRE!

In systems using flammable refrigerants, observe all safety instructions and markings with the air handler. Ensure all safety devices are in place and functional. To be repaired only by trained professional. Do not puncture refrigerant tubing. Dispose of properly in accordance with federal or local regulations..

WARNING

PRESSURIZED REFRIGERANT!

Failure to follow this warning could result in personal injury. System contains oil and refrigerant under high pressure. Recover refrigerant to relieve pressure before opening the system. Do not use non-approved refrigerants, refrigerant substitutes, or refrigerant additives.

WARNING

WARNING!

This product can expose you to chemicals including lead, which are known to the State of California to cause cancer and birth defects or other reproductive harm.
For more information go to www.P65Warning.ca.gov.

WARNING

LIVE ELECTRICAL COMPONENTS!

Failure to follow this warning could result in property damage, severe personal injury, or death. Follow all electrical safety precautions when exposed to live electrical components. It may be necessary to work with live electrical components during installations, testing, servicing, and troubleshooting of this product.

WARNING

COIL IS PRESSURIZED!

- Coil is pressurized with approximately 8-12 psi dry air and factory checked for leaks.
- Carefully release the pressure by removing the rubber plug on the liquid line.
- If no pressure is released, check for leaks.

Installer's Guide

⚠ CAUTION

Extreme caution should be exercised when opening the Liquid Line Service Valve. Turn counterclockwise until the valve stem just touches the rolled edge. No torque is required.

⚠ CAUTION

SHARP EDGE HAZARD!

Failure to follow this caution could result in property damage or severe personal injury. Be careful of sharp edges on equipment or any cuts made on sheet metal while installing or servicing.

B. PREPARATION:

These instructions are designed for installing a replacement coil into a previously installed air handler.

The air handler may be installed in one of the following orientations: upflow, downflow, horizontal left, or horizontal right.

Actual air handler units and coil configurations may differ from models depicted.

Note: All legacy Apex coils will be replaced with square-cut coils. See Figures 1 and 2.

⚠ WARNING

RISK OF FIRE!

In systems using flammable refrigerants, observe all safety instructions and markings with the air handler. Ensure all safety devices are in place and functional. To be repaired only by trained professional. Do not puncture refrigerant tubing. Dispose of properly in accordance with federal or local regulations.

1. Pump down or recover the refrigerant in the system.
2. Turn off high voltage power to the unit.
3. Remove the condensate drain lines from the indoor coil. Be prepared to catch any water that might be in the drain line and drain pan.
4. Disconnect the refrigerant lines to the indoor coil. Be sure to protect the refrigerant lines so debris does not enter the piping system.
5. Remove the air handler's front panels. Retain all screws to reinstall panels in a later step.

Note: For air handlers with a CDA in the front panel, disconnect the plug to the display assembly before removing the front panel.

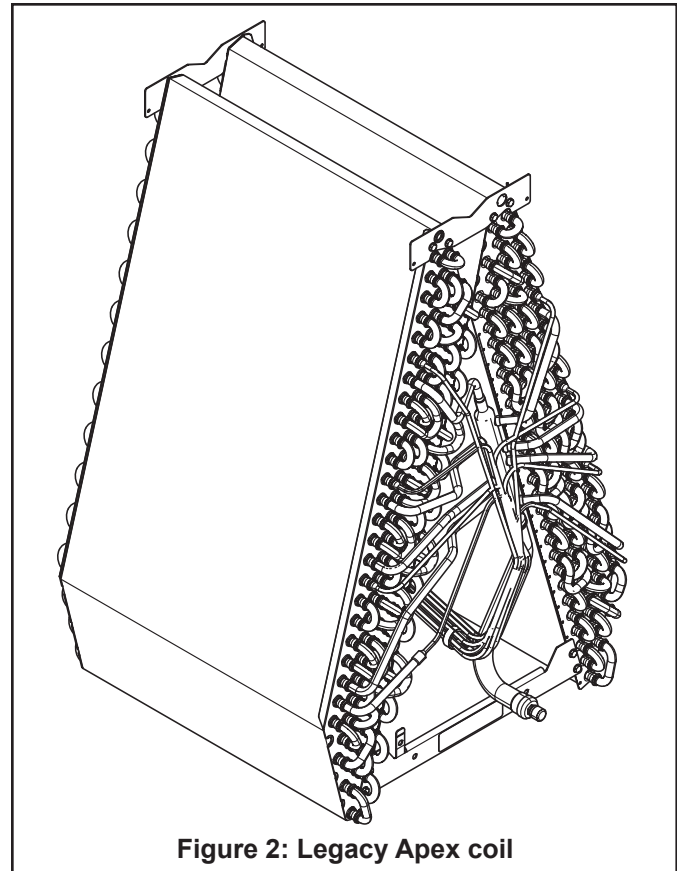
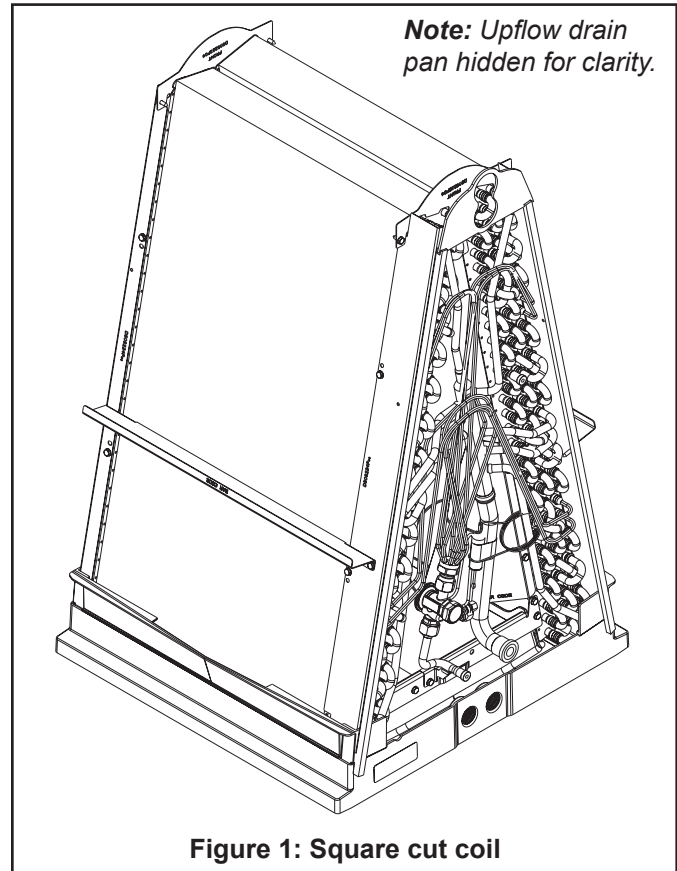

C. EXISTING COIL REMOVAL:

1. If equipped, disconnect wires to EEV motor and temperature sensors inside the coil assembly.
2. If equipped, remove and discard the airflow diverter from the bottom of the upflow drain pan. Grip the plastic diverter by using your thumbs to spread the top of the diverter slightly outwards, then pull down. See Figure 3.
3. If equipped and installed on the coil, disconnect the refrigerant leak detection sensor by unclipping it from the assembly and set aside. Take care not to snag the refrigerant sensor wiring harness before removing the coil.
4. Slide coil assembly out of unit using built-in coil support channels and set aside. See Figure 4.

Note: Blower may be removed to make it easier to remove the air diverter as shown in Figure 3. Follow steps in *Installer's Guide* to remove the blower.

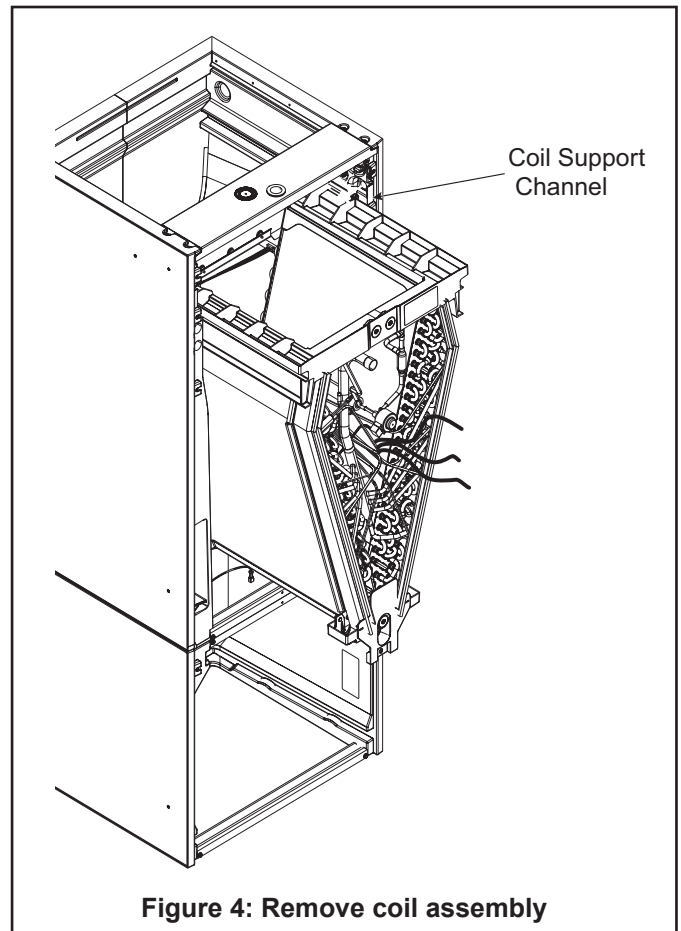
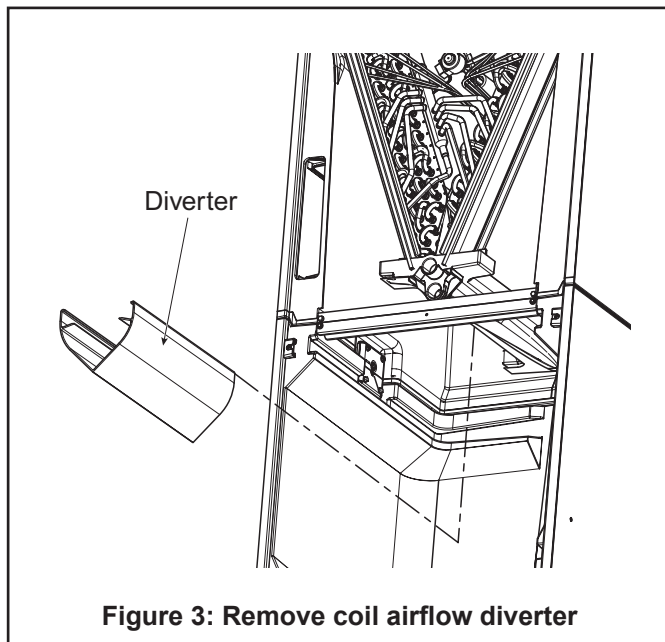

Installer's Guide

D. TXV REPLACEMENT COIL PROCEDURE:

Note: If your system has an EEV, skip to Section E.

TXV Removal from Existing Coil (See Figure 5)

1. Remove TXV sensing bulb from vapor line. Discard used bulb insulation. Retain TXV bulb clip to install later.
2. Disconnect TXV equalizer fitting.
3. Remove and discard inlet tube from TXV. New inlet tube is provided with replacement coil.
4. Using a back-up wrench, disconnect TXV outlet fitting from distributor assembly. Remove TXV from coil.
5. Retain TXV to install on replacement coil. Protect the TXV assembly set so that debris does not enter.

TXV Installation on Replacement Coil

1. Remove new inlet tube from distributor by loosening mechanical fitting on distributor with back-up wrench. See Figure 6.
2. Remove existing O-rings from the outlet of the TXV and from the new inlet tube and replace with new O-rings supplied with the replacement coil.
3. Install TXV assembly and hand tighten the mechanical fitting. TXV should be in the orientation shown in Figure 5. Use back-up wrench and tighten assembly firmly. Do not over tighten.
4. Install new inlet tube on the TXV and hand tighten the mechanical fitting. Inlet tube should be in the orientation shown in Figure 5 such that it clips to the inlet tube hook. Use back-up wrench and tighten assembly firmly. Do not over tighten.
5. Install external equalizer and hand tighten the fitting. Use back-up wrench and tighten assembly firmly. Do not over tighten.
6. Install TXV sensing bulb on the copper portion of the suction manifold using the existing bulb clip. Wrap the sensing bulb with new insulation provided with the replacement coil. Use tie wrap to secure insulation.

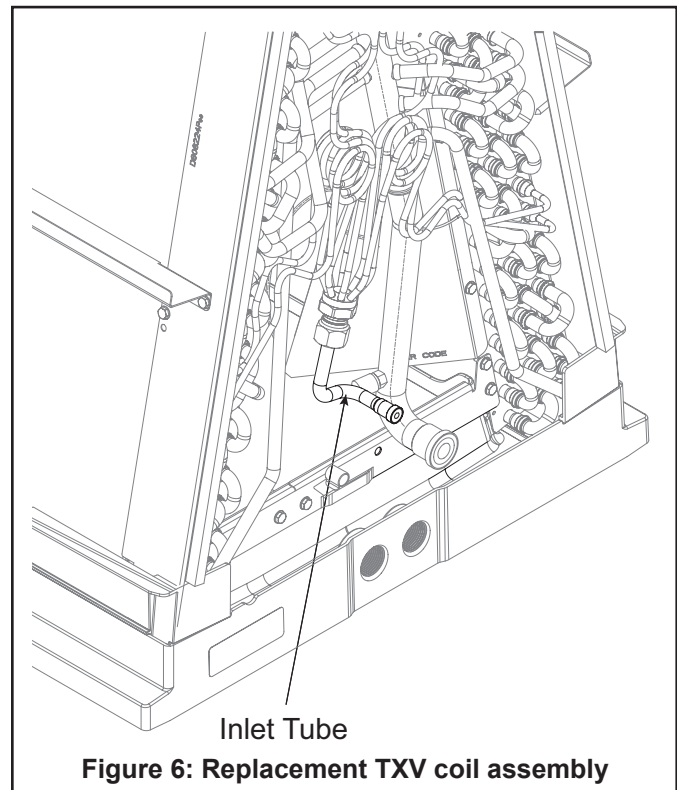
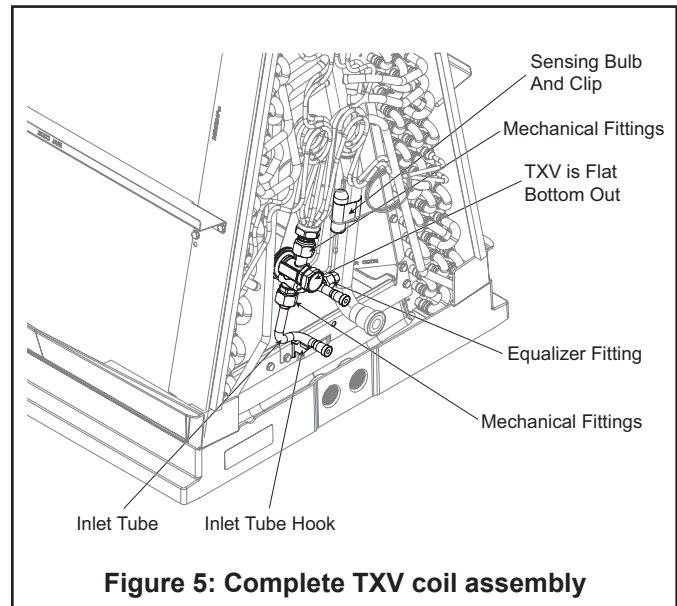

E. EEV REPLACEMENT COIL PROCEDURE:

Note: If your replacement coil shipped with an EEV and stepper motor attached, skip to Section F.

EEV Flow Control Removal from Existing Coil

1. Before removing flow control assembly, carefully cut any retaining wire ties or unscrew any retaining brackets that hold the assembly or any wiring to the coil.
2. Remove evaporator temp (ET), gas temp (GT), and saturation temp (ST, if equipped) temperature sensors by carefully unclipping from coil assembly. If temperature sensors are not the self-insulating type, discard temperature sensor insulation. New insulation is provided with replacement coil.
3. If equipped, slide the distributor tubing insulation as far back on the distributor lines as possible so that the mechanical fitting is visible. See Figure 7.
4. Remove EEV flow control assembly by loosening the mechanical fitting using a back-up wrench. See Figure 9. Remove and keep distributor insulation if equipped.
5. Retain EEV flow control assembly and EEV stepper motor to install on replacement coil. Protect the assembly set so that debris does not enter

EEV Flow Control Installation on Replacement Coil

1. Remove tubing adaptor assemblies from replacement coil as follows:
 - a. If existing flow control assembly is oriented such that EEV stepper motor is in front of distributor fitting, remove the stub tube assembly using a back-up wrench. See Figure 8.
 - b. If existing flow control assembly is oriented such that EEV stepper motor is behind distributor fitting, remove both the stub tube and U-shaped adaptor assemblies using a back-up wrench. See Figure 8.
2. If distributor insulation is retained, install by sliding over U-shaped adaptor assembly.
3. Using a back-up wrench, install the EEV assembly to the replacement coil. Take care not to over tighten these fittings, as they may become deformed and cause leaks. Inlet tube should be in the orientation such that it clips to the inlet tube hook. See Figure 9.

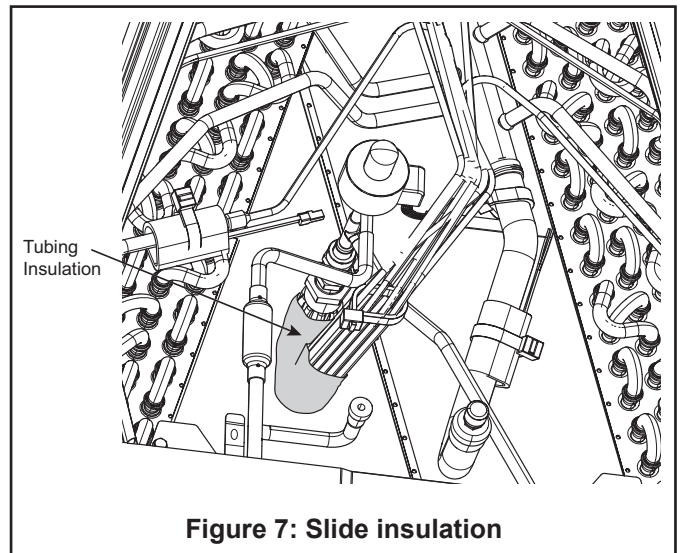

Figure 7: Slide insulation

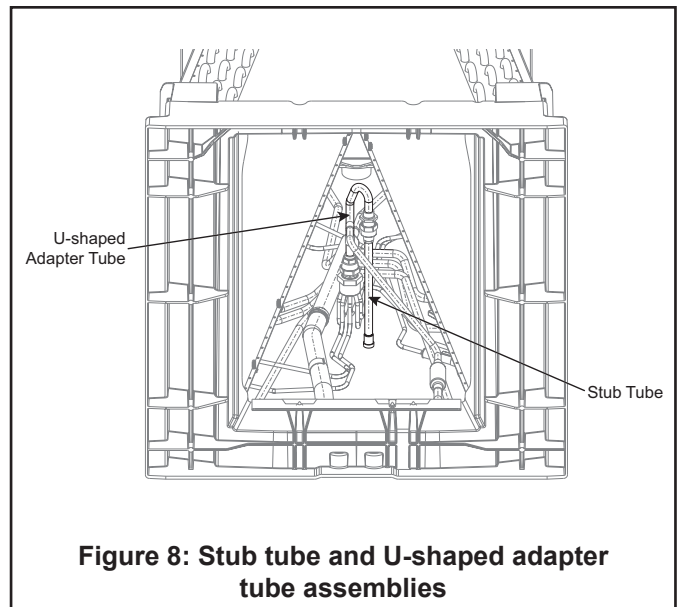

Figure 8: Stub tube and U-shaped adapter tube assemblies

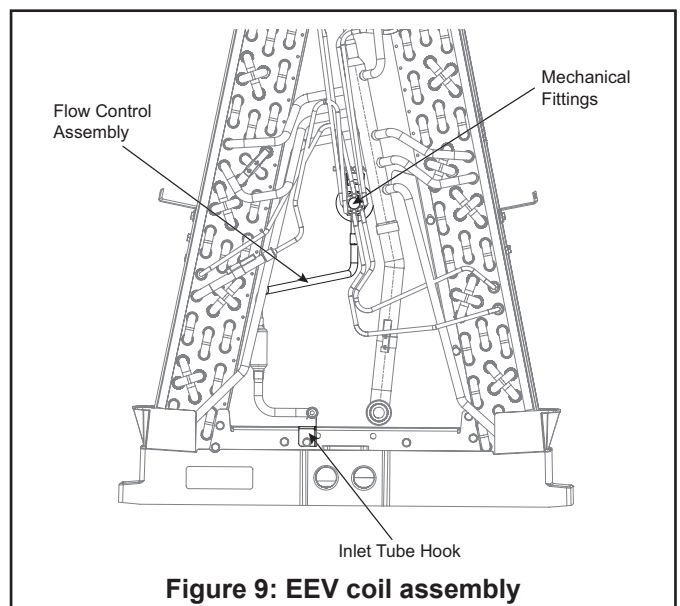

Figure 9: EEV coil assembly

Installer's Guide

Note: Correct tightening of the couplings is very important. Under or over-tightening may result in a coupling leak.

Note: If equipped, the check valve of the liquid assembly should be in the location shown relative to the gas line as shown in Figure 10.

Note: For some flow control assemblies, small adjustments to the distributor and tubes are needed. Use care when bending tubes to not cause any kinks or ruptures.

4. If equipped, slide the distributor insulation tubing over distributor fittings.
5. Clip the temperature sensors to the replacement coil assembly at the locations shown in Figure 11, 12, 13, 14, or 15. The wire entry side of the temperature sensor should be oriented upward such that water running down the wire will not collect at the wire entry.

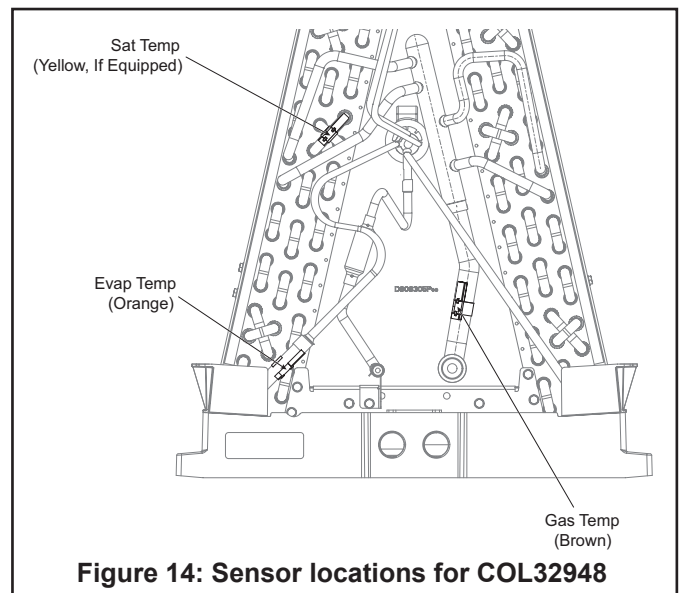
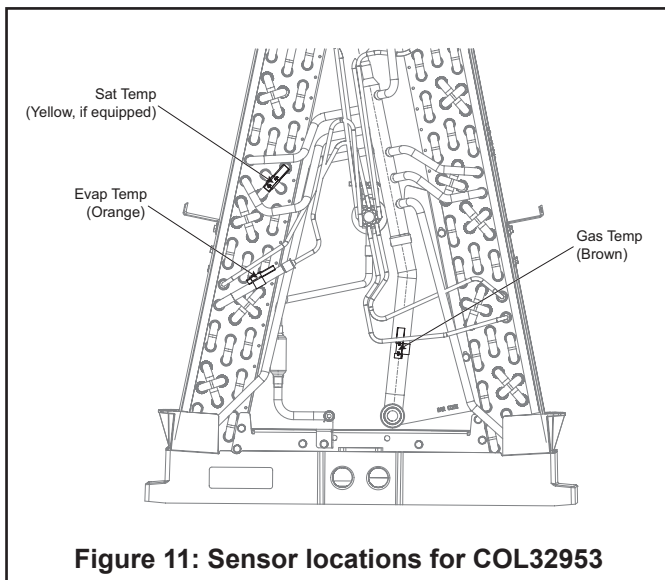
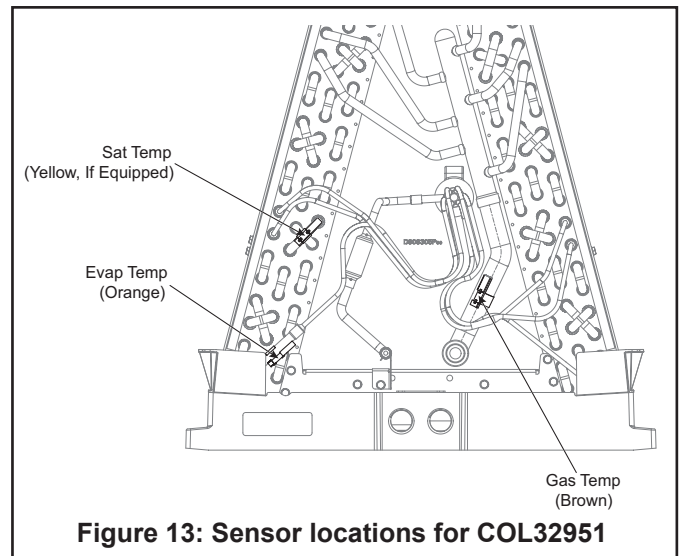
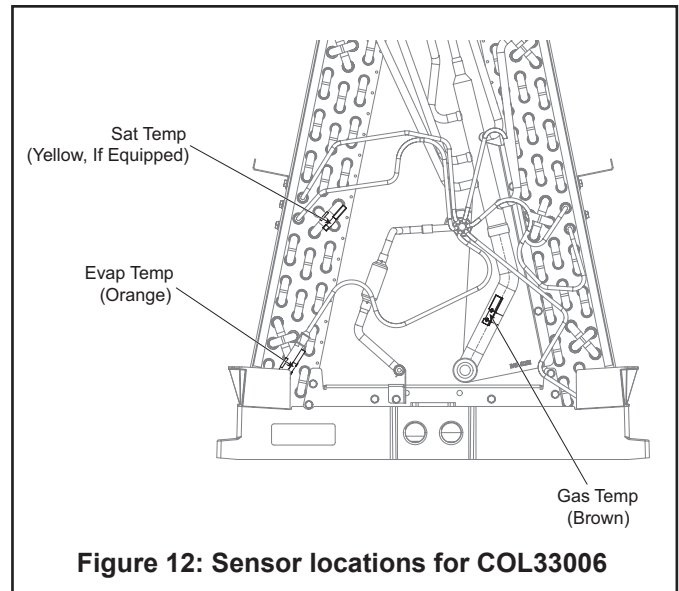
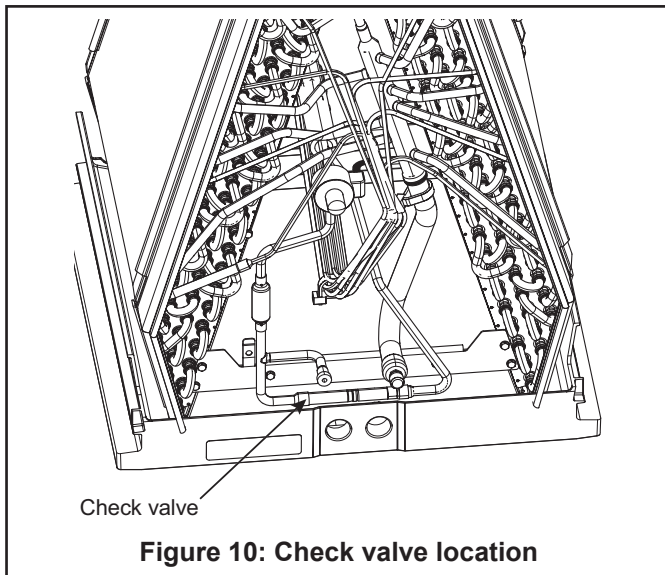

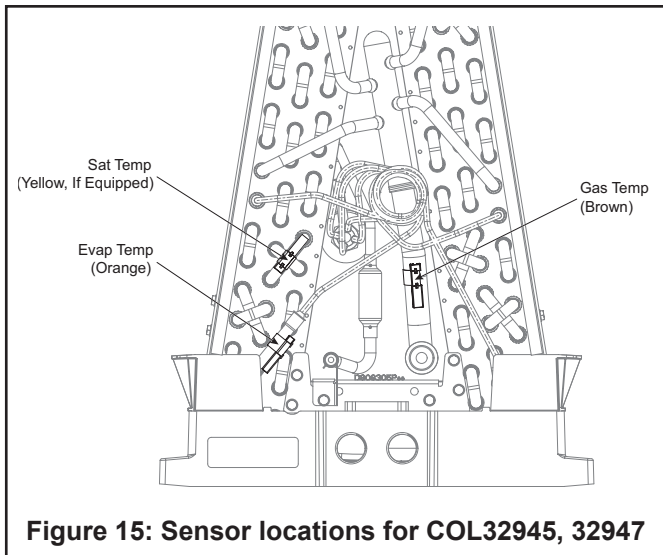

Figure 15: Sensor locations for COL32945, 32947

6. If temperature sensors are not the self-insulating type, place supplied insulation over the sensor and secure with tie wrap as shown in Figure 16.

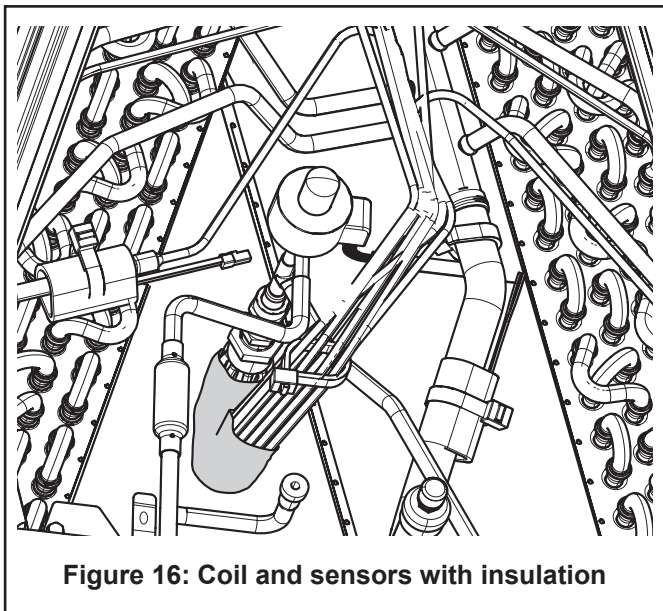

Figure 16: Coil and sensors with insulation

7. Neatly route temperature sensor and EEV stepper motor wiring on coil assembly using field-supplied wire ties to attach wiring to tubing.
- Important:** In a downflow installation, the wires must be pulled tight to avoid contact with the electric heater.
8. Route wires through slot in front of upflow drain pan by gently peeling back the upflow drain pan gasket and placing wires in slot. Press gasket back down firmly. See Figure 17.

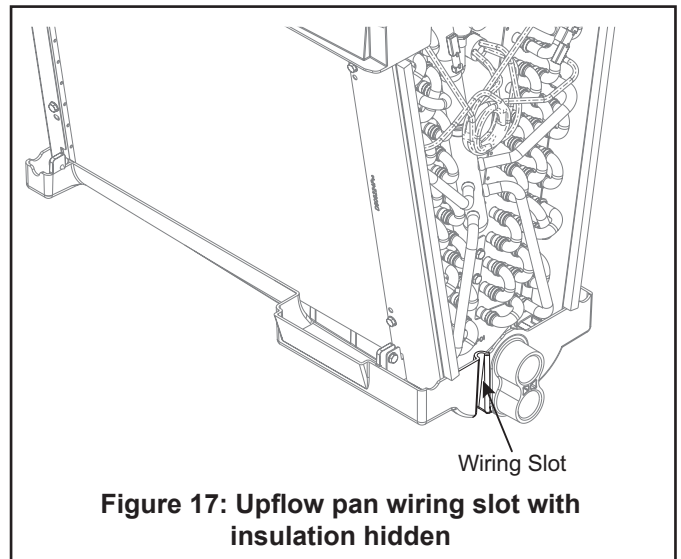

Figure 17: Upflow pan wiring slot with insulation hidden

F. INSTALLING AND RECONNECTING REPLACEMENT COIL:

Replacing the Coil in the Air Handler

1. Put the new coil assembly in the air handler using care not to damage any of the coil components.
2. If equipped and installed on the coil assembly, reinstall refrigerant leak detection sensor in same location as it was on the existing coil.
3. If equipped, reconnect the sensor wires and EEV stepper motor wiring. Use field-supplied wire ties to hold any slack in the cabinet wiring harness.

Note: Wet rags must be applied to all braze joints before and during heating to prevent overheating of internal coil components.

4. Remove rubber plugs from the suction and liquid lines.
5. Reconnect the field refrigerant piping.
6. Slide new seal plate onto upflow drain pan condensate port connections. Use the seal plate which allows the retaining bracket screw clearance hole to align with the engagement hole in the unit. See Figure 18.
7. Reconnect condensate drain piping.
8. Reinstall front panels of the unit.
9. Install front panel retaining bracket.

Installer's Guide

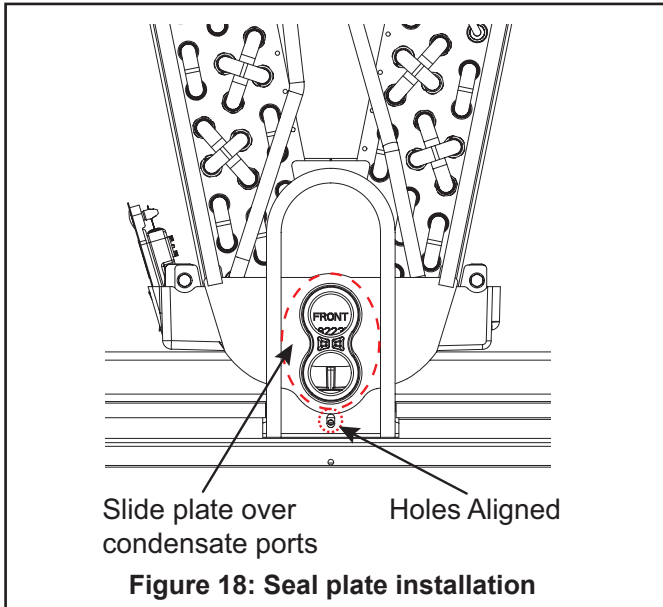

Refilling Refrigerant System (R-22 or R-410A systems)

1. Pressure test the refrigerant system using dry nitrogen. Test all connections for leaks to ensure integrity of the refrigerant piping system.
2. Pull a vacuum on the refrigerant system to 500 microns or less.
3. Refill the system with new refrigerant or release the charge from the outdoor unit to the refrigerant piping system.
4. Start outdoor unit and set refrigerant charge per the outdoor unit installation instructions.

Refilling Refrigerant System (R-454B systems)

After completion of field piping for split systems, the field pipework shall be pressure tested with nitrogen and then vacuum tested prior to refrigerant charging, according to the following requirements:

Pressure test:

1. Using dry nitrogen, pressurize the field piping and indoor coil to the lower of the maximum operating pressures listed on the name plates of the indoor and outdoor units (likely 600 psi).
2. The test pressure after removal of the pressure source shall be maintained for at least one (1) hour with no decrease of pressure indicated by the test gauge, with the test gauge resolution not exceeding 30 psi.
3. Check for leaks by using a soapy solution at each field-made joint.

Note: Remove nitrogen pressure and repair any leaks before continuing.

Vacuum test:

Important: Do not open the service valves until the refrigerant lines and indoor coil leak check and evacuation are complete.

1. Evacuate until the micron gauge reads no higher than 350 microns, then close off the valve to the vacuum pump.
2. Observe the micron gauge. Evacuation is complete if the micron gauge does not rise above 500 microns in one (1) minute and 150 microns in ten (10) minutes.
3. Once evacuation is complete, blank off the vacuum pump and micron gauge, and close the valve on the manifold gauge set.
4. All procedures for charging the system with refrigerant shall be according to the instructions provided by the manufacturer of the outdoor unit.

Important: Under no circumstances shall potential sources of ignition be used in the searching for or detection of refrigerant leaks.

After charging the system, all indoor field-made joints of the field piping shall be checked for refrigerant leaks using an electronic leak detector calibrated for R-454B having a sensitivity of 5 grams per year or better.

About Trane and American Standard Heating and Air Conditioning

Trane and American Standard create comfortable, energy efficient indoor environments for residential applications. For more information, please visit www.trane.com or www.americanstandardair.com

The manufacturer has a policy of continuous data improvement and it reserves the right to change design and specifications without notice. We are committed to using environmentally conscious print practices.