

Installer's Guide



Horizontal Conversion Kit

Kits used to convert 4PXC*U or 5PXC*U dedicated Upflow coil to Horizontal Left or Horizontal Right or convert 4PXC*D or 5PXC*D dedicated Downflow coil to Horizontal Right.

BAYCONV18B **BAYCONV30B**
BAYCONV23B **BAYCONV30C**
BAYCONV27B

ALL phases of this installation must comply with NATIONAL, STATE AND LOCAL CODES

IMPORTANT — This Document is **customer property** and is to remain with this unit. Please return to service information pack upon completion of work.

IMPORTANT:

These instructions do not cover all variations in systems nor provide for every possible contingency to be met in connection with the installation. Should further information be desired or should particular problems arise which are not covered sufficiently for the purchaser's purposes, the matter should be referred to your installing dealer or local distributor.

A. GENERAL

These kits are designed for use in combination with a 4PXC or 5PXC coil to convert the coil for horizontal use. Dedicated upflow coils may be converted to either horizontal left or horizontal right. Dedicated downflow coils may only be converted to horizontal right.

The 4PXC or 5PXC equipment has been evaluated in accordance with the Code of Federal Regulations, Chapter XX, Part 3280 or the equivalent. "Suitable for Mobile Home use" The height of the Furnace, Coil and discharge duct work must be 7 ft. or less.

Inspect the kit components for shipping damage. Notify the transportation company immediately if the coil is damaged.

B. KIT COMPONENTS

Item	Qty	Description
1	1	Horizontal Drain Pan
2	2	Side-Pull Plugs
3	1	Splash Guard
4	1	Channel for Splash Guard
5	1	Coil Support Bracket
6	1	Heat Shield*

NOTE: All items are used for horizontal left conversion. Part 3 not required for horizontal right conversion.

* Part 6 only included with kits having Horizontal Drain Pans with part numbers D346112P01 through P04. Refer to part number embossed on rear of pan.

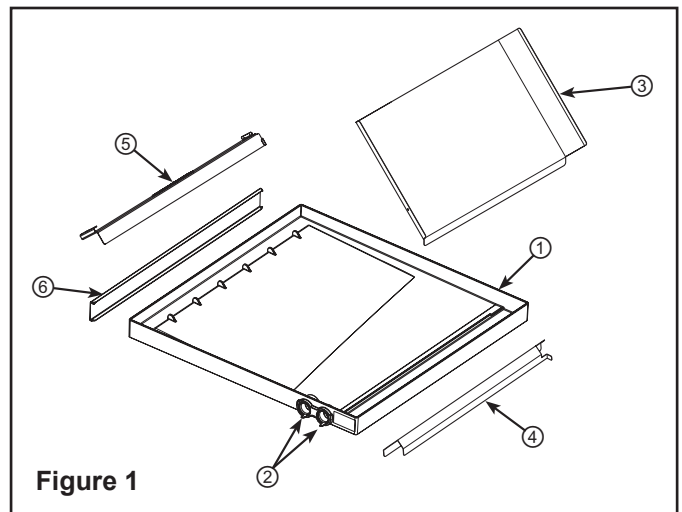

Figure 1

Installer's Guide

C. APPLICATION INFORMATION

See the table below to verify the coil and kit match. The application specific sections will show what changes are needed for the coils.

Model Number 4PXC	Model Number 5PXC	Allowable Installations	Horizontal Kit No.
4PXCAU24BS3HA* 4PXCAU32BS3HA* 4PXCBU24BS3HA* 4PXCBU30BS3HA* 4PXCCU30BS3HA*	5PXCA001AS3HA* 5PXCA002AS3HA* 5PXCBD003AS3HA*	Horizontal Left or Horizontal Right	BAYCONV18B
4PXCBD30BS3HD*	5PXCBD03AS3HD*	Horizontal Right Only	
4PXCBU36BS3HA* 4PXCCU36BS3HA*	5PXCBD004AS3HA* 5PXCC005AS3HA*	Horizontal Left or Horizontal Right	BAYCONV23B
4PXCBD36BS3HD* 4PXCCD36BS3HD*	5PXCBD04AS3HD* 5PXCCD05AS3HD*	Horizontal Right Only	
4PXCBU42BS3HA* 4PXCCU42BS3HA* 4PXCBU48BS3HA* 4PXCCU48BS3HA* 4PXCDCU48BS3HA*	5PXCBD006AS3HA* 5PXCC007AS3HA* 5PXCDC008AS3HA*	Horizontal Left or Horizontal Right	BAYCONV27B
4PXCBD42BS3HD* 4PXCCD42BS3HD*	5PXCBD06AS3HD* 5PXCCD07AS3HD*	Horizontal Right Only	
4PXCCU60BS3HAA 4PXCDCU60BS3HAA	N/A	Horizontal Left or Horizontal Right	BAYCONV30B
4PXCCD60BS3HDA 4PXCDD60BS3HDA	N/A	Horizontal Right Only	
4PXCCU60BS3HAB 4PXCDCU60BS3HAB	5PXCC009AS3HA* 5PXCDC010AS3HA*	Horizontal Left or Horizontal Right	BAYCONV30C
4PXCCD60BS3HDB 4PXCDD60BS3HDB	5PXCCD09AS3HD* 5PXCDD10AS3HD*	Horizontal Right Only	

D. RECOMMENDATION

Use the Installer's Guide packaged with the coil for the physical installation of the coil.

If a coil is part of the total system installation, use the Installer's Guide packaged with the furnace, outdoor section, and thermostat for physically installing those components.

NOTE: Water blow-off could occur in certain installation position if the airflow setting exceeds the maximum values listed. Please refer to "maximum airflow setting" label or literature shipped with unit.

E. COIL CONVERSION PROCEDURE

CAUTION

Dedicated downflow coils may NOT be installed in the horizontal left position.

IMPORTANT:

The cased coil must be placed downstream of the furnace. See Figure 9 for proper orientation.

1. Remove coil front panels and slide out coil assembly.
2. Modify coil and cabinet as shown in Figure 2, Figure 3, and Figure 4.

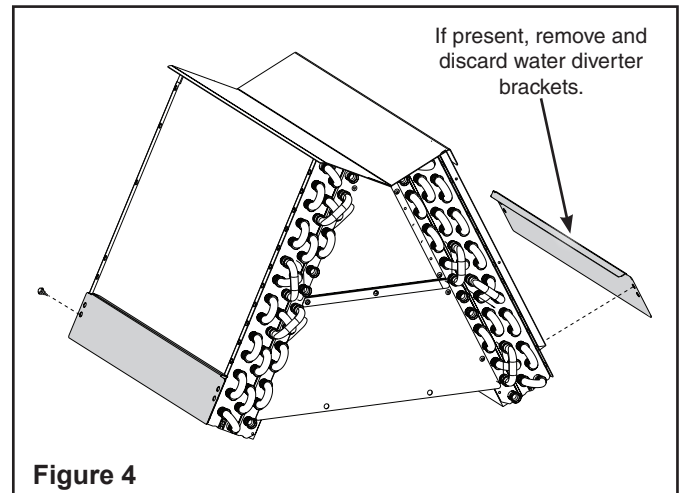
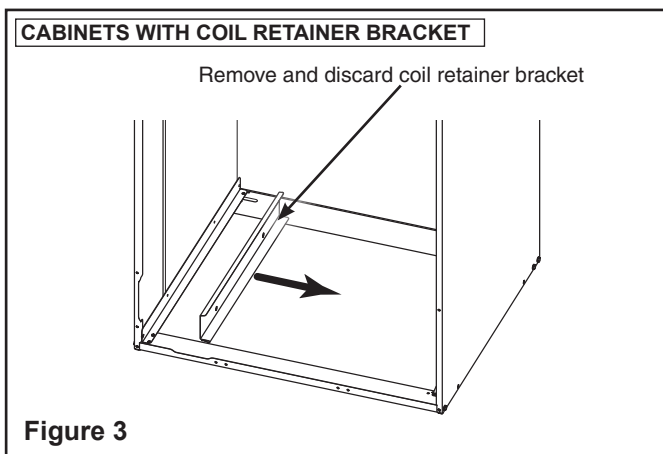
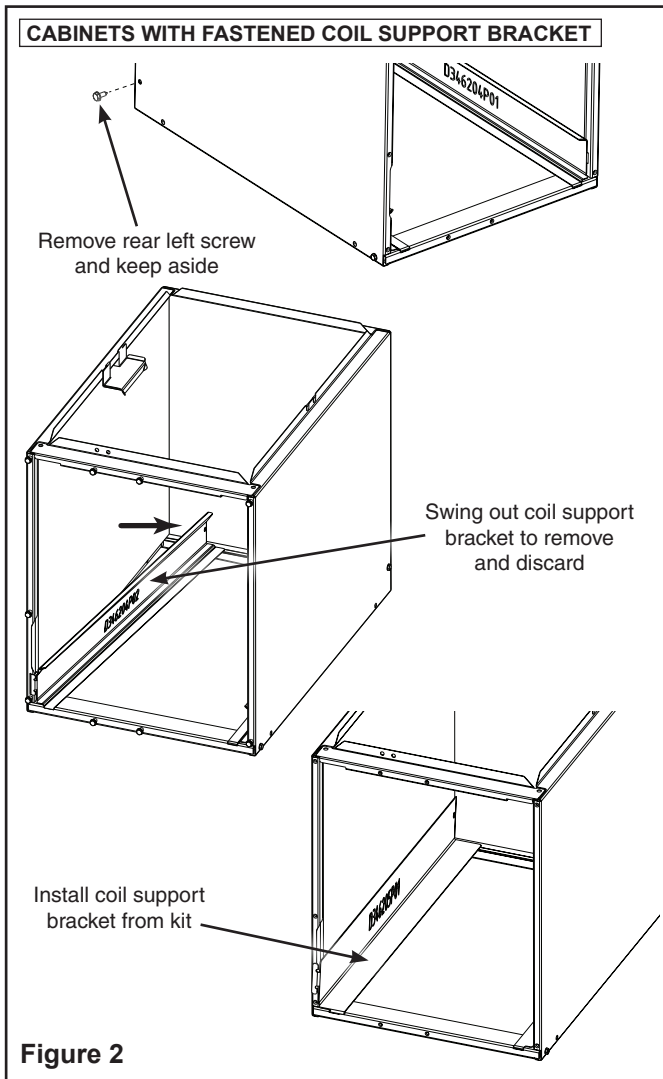

3. **REQUIRED FOR HORIZONTAL LEFT COIL CONVERSION ONLY.** Splash Guard installation is required to prevent water blowoff.
- Place Channel for Splash Guard into Horizontal Drain Pan as shown in Figure 5.

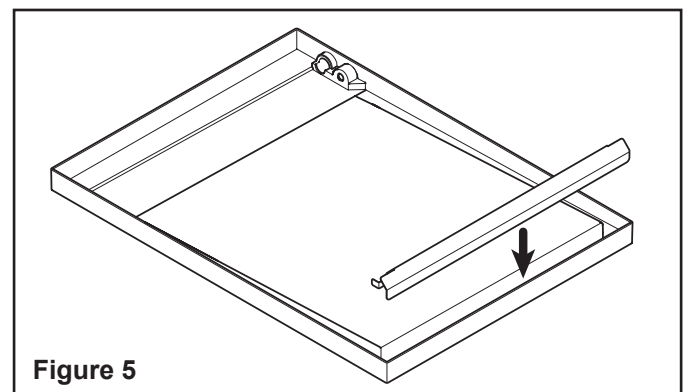

- Slide Horizontal Drain Pan and coil assembly into cabinet. Refer to Step 4 and Figure 7 below.
- Wedge flange of Splash Guard between Channel for Splash Guard and Horizontal Drain Pan as shown in Figure 6.
- Drive one field-supplied sheet metal screw into Splash Guard through factory-provided clearance hole in the front duct flange on the coil case. Refer to Figures 6 and 8.

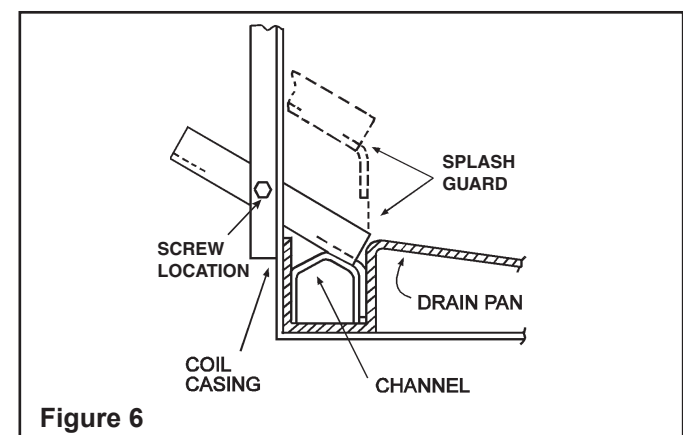

Installer's Guide

⚠ CAUTION

To prevent damage to pan, ensure metal heat shield is assembled to the secondary drain pan. See Figure 7.

- If supplied with kit, ensure Heat Shield is installed on Horizontal Drain Pan. Slide the new Horizontal Drain Pan onto the coil and slide back into the coil cabinet. See Figure 7.

NOTE: Heat Shield only required for Horizontal Drain Pans having part numbers D346112P01 through P04. Refer to part number embossed on rear of pan. See Figure 7.

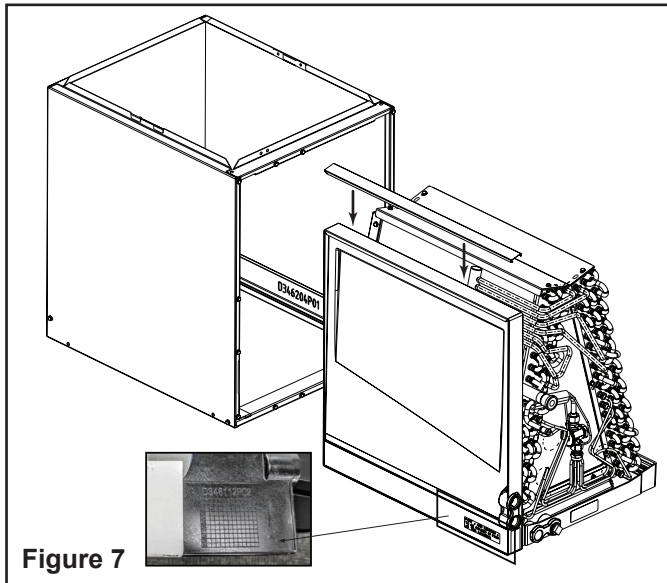

Figure 7

- Remove the insulation and cap blocking the Horizontal Drain Pan condensate ports on the front panel of the coil case.
- Remove the Side-Pull Plugs from the Horizontal Drain Pan and install into downflow drain pan as shown in Figure 8. Put front panels back on.

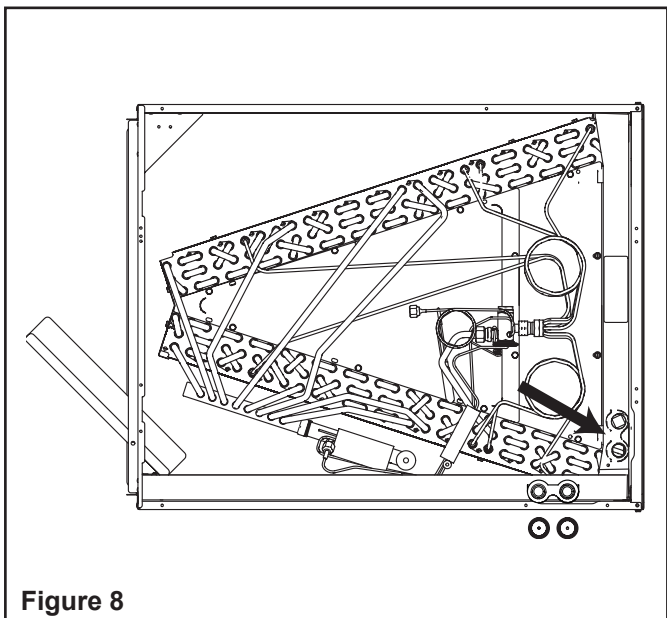

Figure 8

- Attach the coil to the furnace as shown in Figure 9 and Figure 10.

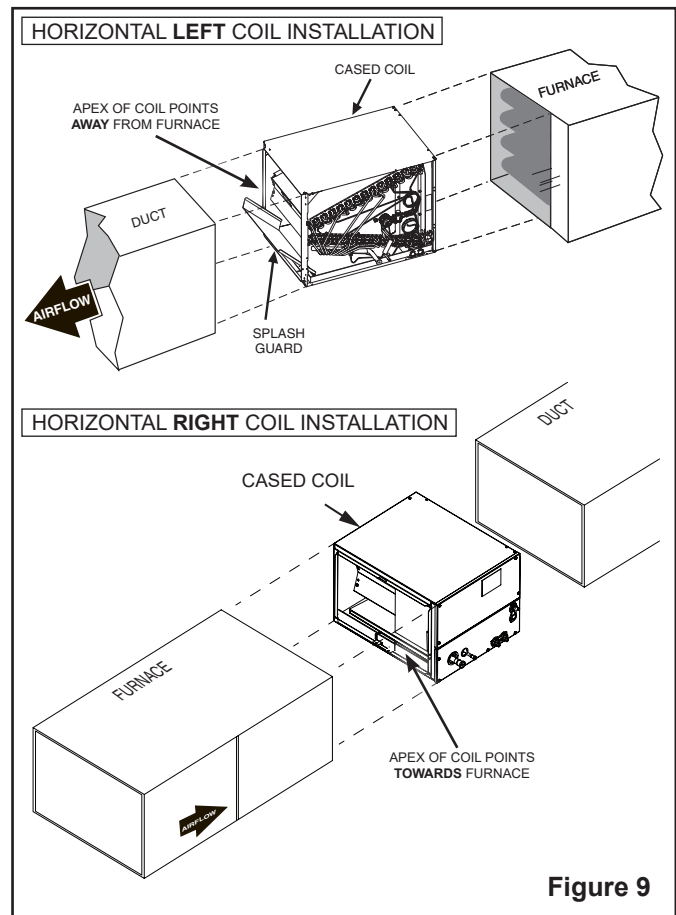
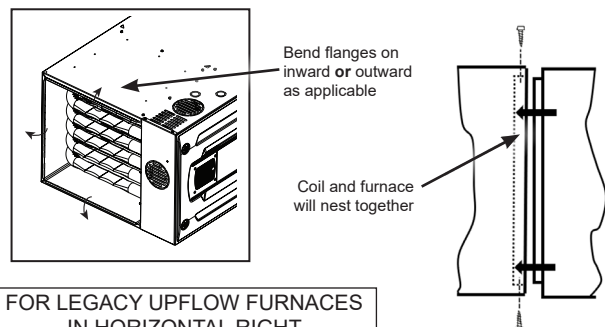

Figure 9

Attached furnace and coil using field-supplied self-drilling screws not longer than 1.5".

FOR S-SERIES FURNACES



FOR LEGACY UPFLOW FURNACES IN HORIZONTAL RIGHT

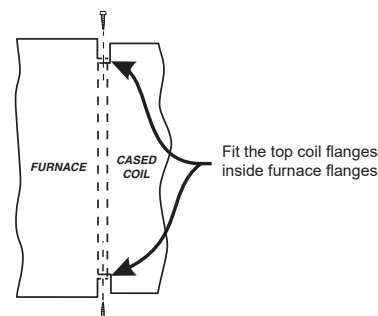

Figure 10

F. LEAK SENSOR RELOCATION

All 5PXC models are equipped with a Refrigerant Detection System (RDS), which includes a mitigation control board (MCB) and leak detection sensor.

WARNING

LEAK DETECTION SENSOR!

Leak Detection Sensor must be relocated to the horizontal drain pan for proper leak detection in horizontal installations.

1. Pull refrigerant sensor and clip up and off of the primary drain pan.
2. Relocate sensor to secondary drain pan by pressing sensor clip down on drainpan edge. The sensor orientation should be pointing in toward the coil to function properly. See Figure 11. Ensure all sensor harness wires are well clear of copper braze connections to avoid damage.
3. In some models, the plastic clip attaching the sensor harness near the TXV may need to be pulled loose to allow the harness to fully extend for correct sensor placement.
4. Refer to installer's guide packaged with coil for all other installation instructions associated with the RDS.

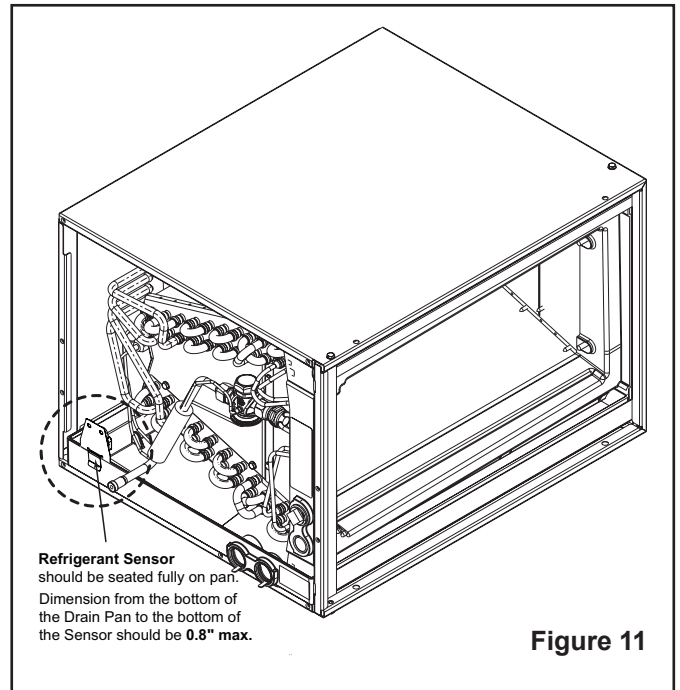

About Trane and American Standard Heating and Air Conditioning

Trane and American Standard create comfortable, energy efficient indoor environments for residential applications. For more information, please visit www.trane.com or www.americanstandardair.com

The manufacturer has a policy of continuous data improvement and it reserves the right to change design and specifications without notice. We are committed to using environmentally conscious print practices.