

INSTALLER'S GUIDE

18-AH72D1-1BO-EN

**ONLINE Only version with
Heat Shield Dimensions
for Field Fabrication**

ALL phases of this installation must comply with NATIONAL, STATE AND LOCAL CODES

Accessory Heat Shield

MAYAFERCOLKIT, MAYBFERCOLKIT
MAYCFERCOLKIT, MAYDFERCOLKIT

For use with coil models:

4GXC & 4MXC

IMPORTANT – This Document is customer property and is to remain with this unit. Please return to service information pack upon completion of work.

Section 1. General Information

This accessory shield is designed protect the drain pan from radiant heat from the heat exchanger.

1. Check the shield to confirm that it is the correct size for the coil being installed.
2. Check the components received for damage. Report any defects or shortages to the transportation company immediately.
3. 4MXC coils installed in upflow or downflow orientations should have the horizontal drain pan removed before installation for airflow efficiency.

Section 2. Safety Information

⚠ WARNING

SAFETY HAZARD! This information is intended for use by individuals possessing adequate backgrounds of electrical and mechanical experience. Any attempt to repair a central air conditioning product may result in personal injury and/or property damage. The manufacturer or seller cannot be responsible for the interpretation of this information, nor can it assume any liability in connection with its use.

⚠ WARNING

SAFETY HAZARD! Sharp Edge Hazard. Be careful of sharp edges on equipment or any cuts made on sheet metal while installing or servicing. Personal injury may result.

⚠ CAUTION

COIL REQUIREMENT!

Failure to follow this Caution could result in property damage or personal injury. 4GXC* or 4MXC* coils installed on this furnace without a factory installed metal drain pan shield must use a MAY*FERCOLKITAA kit. Coils installed on this furnace must have drain pans that are suitable for 400° F (205° C) or have a metal drain pan shield. See Installers Guide for kit information.

Section 3. Installation

NOTE: Illustrations may vary from the actual unit.

STEP 1 - Lay the coil on its back and remove the screws from the lower front panel. Remove panel and retain screws.



STEP 2 - Remove the four 1/4" screws from the front channel. Retain the screws and discard the channel.



STEP 3 - Place heat shield as shown with flanges down, and align the thru holes of the shield with the engagement holes of the coil support. Install the four screws previously removed from Step 2.

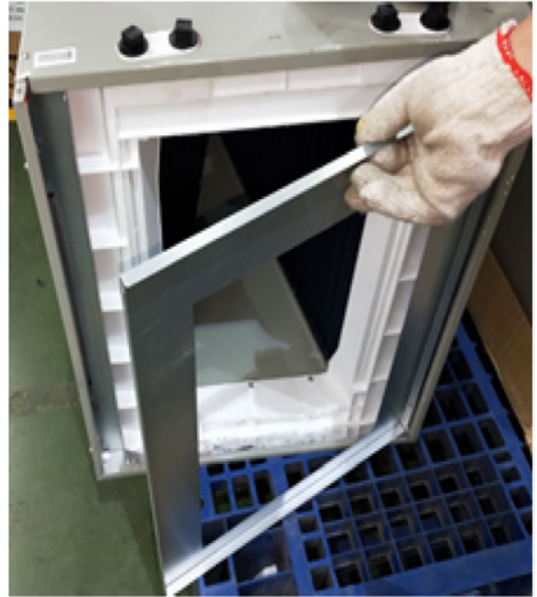

STEP 4 - Align the back of the shield to the same height as the side channels and drill a 1/8" pilot hole through the side channel opening of the heat shield. Install one screw per side.



STEP 5 - Reinstall the lower front panel using the screws removed in Step 1.

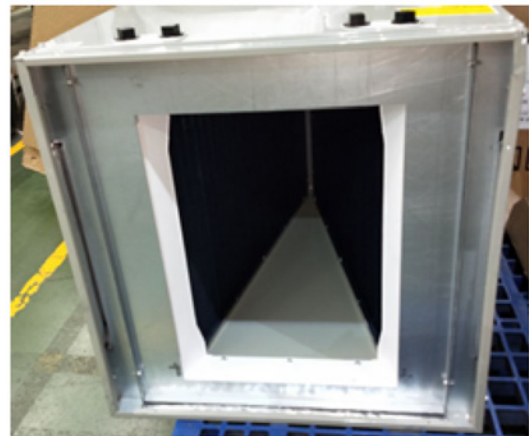

Field Fabrication of Metal Heat Shield

NOTE:

1. MATERIAL: G60 GALVANIZED STEEL 24 GAUGE
2. ALL BENDS 90 DEGREES UNLESS OTHERWISE NOTED
3. ALL DIMENSIONS ARE OUTSIDE TO OUTSIDE UNLESS OTHERWISE NOTED

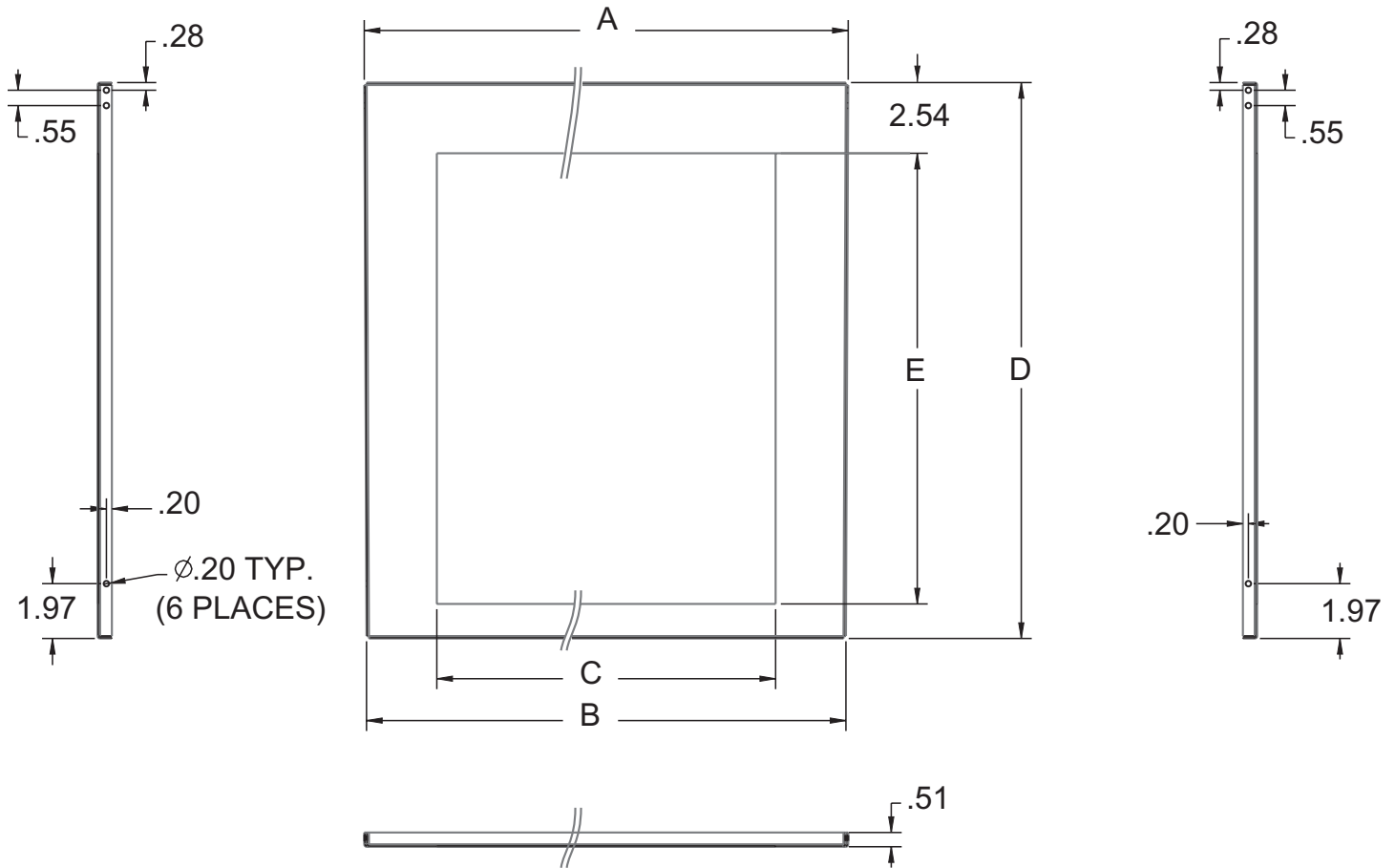

Model	Dimension A (Inches)	Dimension B (Inches)	Dimension C (Inches)	Dimension D (Inches)	Dimension E (Inches)
MAYAFERCOLKIT (14.5" Cabinet)	10.94	10.77	8.88	20.00	16.30
MAYBFERCOLKIT (17.5" Cabinet)	13.88	13.65	10.28	20.00	16.22
MAYCFERCOLKIT (21.0" Cabinet)	17.38	17.21	12.17	19.96	16.18
MAYDFERCOLKIT (24.5" Cabinet)	20.91	20.79	15.67	19.96	16.18

About Trane and American Standard Heating and Air Conditioning

Trane and American Standard create comfortable, energy efficient indoor environments for residential applications. For more information, please visit www.trane.com or www.americanstandardair.com

The manufacturer has a policy of continuous data improvement and it reserves the right to change design and specifications without notice. We are committed to using environmentally conscious print practices.

18-AH72D1-1BO-EN 03 Jul 2020

Supersedes 18-AH72D1-1AO-EN (July 2019)

© 2020