



## High Efficiency Horizontal, Flat “Cased” Coils

All Aluminum: 5PXFH005AZ3HHA

5PXFH009AZ3HHA

**ALL phases of this installation must comply with NATIONAL, STATE AND LOCAL CODES**

**IMPORTANT**— This Document is **customer property** and is to remain with this unit. Please return to service information pack upon completion of work.

**IMPORTANT** — These instructions do not cover all variations in systems nor provide for every possible contingency to be met in connection with the installation. Should further information be desired or should particular problems arise which are not covered sufficiently for the purchaser's purposes, the matter should be referred to your installing dealer or local distributor.

### **⚠ SAFETY WARNING**

Only qualified personnel should install and service the equipment. The installation, starting up, and servicing of heating, ventilating, and air-conditioning equipment can be hazardous and requires specific knowledge and training. Improperly installed, adjusted or altered equipment by an unqualified person could result in death or serious injury. When working on the equipment, observe all precautions in the literatures and on the tags, stickers, and labels, and that are attached to the equipment.

### **⚠ WARNING**

**SAFETY HAZARD!**  
This coil shall only be connected to an outdoor unit suitable for use with refrigerant R-454B.

### **⚠ WARNING**

**SAFETY HAZARD!**  
This appliance is not to be used by persons (including children) with reduced physical, sensory, or mental capabilities, or lack of experience and knowledge, unless they have been given supervision or instructions concerning the use of appliance by a person responsible for their safety.

### **⚠ WARNING**

**RISK OF FIRE!**  
Flammable refrigerant used. To be repaired only by trained service professional. Do not puncture refrigerant tubing. Dispose of properly in accordance with federal or local regulations.

### **⚠ WARNING**

**PRESSURIZED REFRIGERANT!**  
Failure to follow this Warning could result in personal injury.  
System contains oil and refrigerant under high pressure. Recover refrigerant to relieve pressure before opening the system. Do not use non-approved refrigerants or refrigerant substitutes or refrigerant additives.

### **⚠ WARNING**

**HAZARDOUS VAPORS!**  
Failure to follow this caution could result in property damage or personal injury. Equipment corrosion damage. To prevent shortening its service life, the unit should not be used during the finishing phases of construction or remodeling. The low return air temperatures can lead to the formation of condensate. Condensate in the presence of chlorides and fluorides from paint, varnish, stains, adhesives, cleaning compounds, and cement creates a corrosive condition which may cause rapid deterioration of the cabinet and internal components.

### **⚠ WARNING**

**RISK OF FIRE!**  
Failure to following this warning could result in serious injury, death, or property damage.  
The following requirements apply to the room where the cased coil is installed:

- All combustion appliances located in the same room that have continuous pilot lights are equipped with an effective flame arrest.
- Auxiliary devices which may be a potential ignition source, such as hot surfaces or electric switching devices, shall not be installed in the connecting ductwork unless they have been approved by the manufacturer or declared suitable with the refrigerant used.
- All indoor field-made joints of the field piping have been checked for refrigerant leaks after charging using an electronic leak detector calibrated for R-454B having a sensitivity of 5 grams per year or better.
- The room is constructed to ensure that should any refrigerant leak it will not stagnate and create a fire hazard.

### **⚠ WARNING**

**WARNING!**  
This product can expose you to chemicals including lead, which are known to the State of California to cause cancer and birth defects or other reproductive harm. For more information go to [www. P65Warnings.ca.gov](http://www.P65Warnings.ca.gov)

# Installer's Guide

## ⚠ CAUTION

Do NOT install coils with any OIL or DRUM type furnaces.

## ⚠ CAUTION

**SHARP EDGE HAZARD!**  
Failure to follow this caution could result in property damage or personal injury.  
Be careful of sharp edges on equipment or any cuts made on sheet metal while installing or servicing.

**Important:** Installation of this unit shall be made in accordance with the National Electric Code, NFPA No. 90A and 90B, and any other local codes or utilities requirements.

**Important:** Cased coils do not require repositioning of the refrigerant leak detection sensor for upflow or downflow installations. Horizontal applications require sensor repositioning. See conversion instructions section for details.

**Note:** This unit is a PARTIAL UNIT AIR CONDITIONER, complying with PARTIAL UNIT requirements of Standard UL 60335-2-40/CSA 22.2 NO. 60335-2-40, and must only be connected to other units that have been confirmed as complying to corresponding PARTIAL UNIT requirements of this Standard.

**Note:** There is no declared maximum altitude for operating the appliance.

**Note:** Charging of the refrigerating system shall be according to the instructions provided by the manufacturer of the outdoor unit.

**Note:** Both the drain pans and the refrigerant detection sensor installed on this unit are designed to be heat resistant to temperatures produced by all residential Trane and American Standard gas fired furnaces\*.

## TABLE OF CONTENTS

General .....	2
Application Information .....	2
Recommendation .....	2
Information on Servicing .....	2
Installing 5PXFH Coil/ Enclosure .....	4
Installing / Brazing Refrigerant Lines .....	5
Duct Connections .....	6
TXV Bulb Horizontal Mounting .....	6
TXV Bulb Vertical Mounting .....	6
Pressure Test .....	7
Vacuum Test .....	7
Condensate Drain Piping .....	7
Cleaning The Coil .....	7
Maximum and Minimum Airflow Settings .....	8
Pressure Drop Table.....	8
Refrigerant Leak Detection System .....	9
Wiring .....	9
Field Wiring Diagrams.....	11
Verification And Trouble Shooting Refrigerant Detection System.....	13
Control Box Relocation (Optional).....	15
Outline Drawing .....	16
Troubleshooting Indoor TXV / Cooling Mode .....	17
Checkout Procedures .....	19

## A. GENERAL:

These coils are designed for use as cooling only or in combination with a Heat Pump outdoor section.

## B. APPLICATION INFORMATION:

1. FURNACE AND COIL  
The coil MUST BE installed downstream (in the outlet air) of the furnace.
2. INDOOR UNIT AIRFLOW  
Indoor unit must provide the required airflow for Cooling only or Heat Pump System Combination.

## INSPECTION

Check carefully for any shipping damage. This must be reported to and claims made against the transportation company immediately. Check to be sure all major components are in the unit. Any missing parts should be reported to your supplier at once, and replaced with authorized parts only.

## C. RECOMMENDATIONS:

### ⚠ CAUTION

**This coil is pressurized with 8-12 psig of dry air. Do not stand directly in front of the coil connections when removing sealing plugs. If no pressure is released, check for leaks.**

1. If this coil is a part of the total system installation, then use the Installer's Guide packaged with the furnaces, Heat Pump outdoor sections, and Control Center for physically installing those components.
2. It is recommended that the outline drawing (page 15) be studied and dimensions properly noted and checked against selected installation site. By noting in advance proper clearance allowances for installation and possible future service of the coil.

## D. INFORMATION ON SERVICING:

All replacement parts shall be in accordance with the manufacturer's specifications.

### Prior to Beginning Work

Prior to beginning work on systems containing flammable refrigerants, safety checks are necessary to ensure that the risk of ignition is minimized. For repair to the refrigerating system, the following shall be completed prior to conducting work on the system:

- Work shall be undertaken under a controlled procedure to minimize the risk of a flammable gas or vapor being present while the work is being performed.
- All maintenance staff and others working in the local area shall be instructed on the nature of work
- The area shall be checked with an appropriate refrigerant detector prior to and during work, to ensure the technician is aware of potentially toxic or flammable atmospheres. Ensure that the leak detection equipment being used is suitable for use with all applicable refrigerants, i.e., non-sparking, adequately sealed or intrinsically safe.

- If any hot work is to be conducted on the refrigerating equipment or any associated parts, appropriate fire extinguishing equipment shall be available to hand. Have a dry powder or CO2 fire extinguisher adjacent to the charging area.
- No person carrying out work in relation to a refrigerating system which involves exposing any pipe work shall use any sources of ignition in such a manner that it may lead to the risk of fire or explosion. All possible ignition sources, including cigarette smoking, should be kept sufficiently far away from the site of installation, repairing, removing and disposal, during which refrigerant can possibly be released to the surrounding space. Prior to work taking place, the area around the equipment is to be surveyed to make sure that there are no flammable hazards or ignition risks. "No Smoking" signs shall be displayed.
- Ensure that the area is in the open or that it is adequately ventilated before breaking into the system or conducting any hot work. A degree of ventilation shall continue during the period that the work is carried out. The ventilation should safely disperse any released refrigerant and preferably expel it externally into the atmosphere.
- The following checks shall be applied to installations using flammable refrigerants:
  - marking to the equipment continues to be visible and legible. Markings and signs that are illegible shall be corrected;
  - refrigerating pipe or components are installed in a position where they are unlikely to be exposed to any substance which may corrode refrigerant containing components, unless the components are constructed of materials which are inherently resistant to being corroded or are suitably protected against being so corroded.

## Repairs to Electrical Components

Where electrical components are being changed, they shall be fit for the purpose and to the correct specification. At all times the manufacturer's maintenance and service guidelines shall be followed. If in doubt, consult the manufacturer's technical department for assistance.

Repair and maintenance to electrical components shall include initial safety checks and component inspection procedures. If a fault exists that could compromise safety, then no electrical supply shall be connected to the circuit until it is satisfactorily dealt with. If the fault cannot be corrected immediately but it is necessary to continue operation, an adequate temporary solution shall be used. This shall be reported to the owner of

Initial safety checks shall include:

- that capacitors are discharged; this shall be done in a safe manner to avoid possibility of sparking;
- that no live electrical components and wiring are exposed while charging, recovering or purging the system;
- that there is continuity of earth bonding.

Check that cabling will not be subject to wear, corrosion, excessive pressure, vibration, sharp edges or any other adverse environmental effects. The check shall also take into account the effects of aging or continual vibration from sources such as compressors or fans.

## Detection of Flammable Refrigerants

Under no circumstances shall potential sources of ignition be used in the searching for or detection of refrigerant leaks. A halide torch (or any other detector using a naked flame) shall not be used.

The following leak detection methods are deemed acceptable for all refrigerant systems:

- Electronic leak detectors may be used to detect refrigerant leaks but, in the case of flammable refrigerants, the sensitivity may not be adequate, or may need re-calibration. (Detection equipment shall be calibrated in a refrigerant-free area.) Ensure that the detector is not a potential source of ignition and is suitable for the refrigerant used. Leak detection equipment shall be set at a percentage of the LFL of the refrigerant and shall be calibrated to the refrigerant employed, and the appropriate percentage of gas (25 % maximum) is confirmed.

Examples of leak detection fluids are:

- bubble method

If a leak is suspected, all naked flames shall be removed/ extinguished.

If a leakage of refrigerant is found which requires brazing, all of the refrigerant shall be recovered from the system, or isolated (by means of shut off valves) in a part of the system remote from the leak.

## Removal and Evacuation

When breaking into the refrigerant circuit to make repairs - or for any other purpose - conventional procedures shall be used. However, for flammable refrigerants it is important that best practice be followed, since flammability is a consideration. The following procedure shall be adhered to:

- safely remove refrigerant following local and national regulations;
- evacuate;
- purge the circuit with inert gas (optional for A2L);
- evacuate (optional for A2L);
- continuously flush or purge with inert gas when using flame to open circuit;
- and open the circuit.

The refrigerant charge shall be recovered into the correct recovery cylinders if venting is not allowed by local and national codes. For appliances containing flammable refrigerants,

This process might need to be repeated several times. Compressed air or oxygen shall not be used for purging refrigerant systems.

For appliances containing flammable refrigerants, refrigerant purging shall be achieved by breaking the vacuum in the system with oxygen-free nitrogen and continuing to fill until the working pressure is achieved, then venting to atmosphere, and finally pulling down to a vacuum (optional for A2L). This process shall be repeated until no refrigerant is within the system (optional for A2L). When the final oxygen-free nitrogen charge is used, the system shall be vented down to atmospheric pressure to enable work to take place.

# Installer's Guide

The outlet for the vacuum pump shall not be close to any potential ignition sources, and ventilation shall be available.

## Charging Procedures

In addition to conventional charging procedures, the following requirements shall be followed.

- Ensure that contamination of different refrigerants does not occur when using charging equipment. Hoses or lines shall be as short as possible to minimise the amount of refrigerant contained in them.
- Cylinders shall be kept in an appropriate position according to the instructions.
- Ensure that the refrigerating system is earthed prior to charging the system with refrigerant.
- Label the system when charging is complete (if not already).
- Extreme care shall be taken not to overfill the refrigerating system.

Prior to recharging the system, it shall be pressure tested with the appropriate purging gas. The system shall be leak-tested on completion of charging but prior to commissioning. A follow up leak test shall be carried out prior to leaving the site.

See installation instructions below for further details.

## Recovery

When removing refrigerant from a system, either for servicing or decommissioning, it is recommended good practice that all refrigerants are removed safely.

When transferring refrigerant into cylinders, ensure that only appropriate refrigerant recovery cylinders are employed. Ensure that the correct number of cylinders for holding the total system charge is available.

All cylinders to be used are designated for the recovered refrigerant and labelled for that refrigerant (i.e., special cylinders for the recovery of refrigerant). Cylinders shall be complete with pressure-relief valve and associated shut-off valves in good working order. Empty recovery cylinders are evacuated and, if possible, cooled before recovery occurs.

The recovery equipment shall be in good working order with a set of instructions concerning the equipment that is at hand and shall be suitable for the recovery of the flammable refrigerant. If in doubt, the manufacturer should be consulted. In addition, a set of calibrated weighing scales shall be available and in good working order. Hoses shall be complete with leak free disconnect couplings and in good condition.

The recovered refrigerant shall be processed according to local legislation in the correct recovery cylinder, and the relevant waste transfer note arranged. Do not mix refrigerants in recovery units and especially not in cylinders.

If compressors or compressor oils are to be removed, ensure that they have been evacuated to an acceptable level to make certain that flammable refrigerant does not remain within the lubricant. The compressor body shall not be heated by an open flame or other ignition sources to accelerate this process. When oil is drained from a system, it shall be carried out safely.

## Decommissioning

Before carrying out this procedure, it is essential that the technician is completely familiar with the equipment and all its detail. It is recommended good practice that all refrigerants are recovered safely. Prior to the task being carried out, an oil and refrigerant sample shall be taken in case analysis is required prior to re-use of recovered refrigerant. It is essential that electrical power is available before the task is commenced.

1. Become familiar with the equipment and its operation.
2. Isolate system electrically.
3. Before attempting the procedure, ensure that:
  - a. Mechanical handling equipment is available, if required, for handling refrigerant cylinders;
  - b. All personal protective equipment is available and being used correctly;
  - c. The recovery process is supervised at all times by a competent person;
  - d. Recovery equipment and cylinders conform to the appropriate standards.
4. Pump down refrigerant system, if possible.
5. If a vacuum is not possible, make a manifold so that refrigerant can be removed from various parts of the system.
6. Make sure that cylinder is situated on the scales before recovery takes place.
7. Start the recovery machine and operate in accordance with instructions.
8. Do not overfill cylinders (no more than 80 % volume liquid charge).
9. Do not exceed the maximum working pressure of the cylinder, even temporarily.
10. When the cylinders have been filled correctly and the process completed, make sure that the cylinders and the equipment are removed from site promptly and all isolation valves on the equipment are closed off.
11. Recovered refrigerant shall not be charged into another refrigerating system unless it has been cleaned and checked.

Equipment shall be labelled stating that it has been decommissioned and emptied of refrigerant. The label shall be dated and signed. For appliances containing flammable refrigerant, ensure that there are labels on the equipment stating the equipment contains flammable refrigerant.

## E. INSTALLING 5PXFH COIL/ ENCLOSURE:

Coil/enclosure assembly can be used for all horizontal furnaces (gas and electric) applications (Figure 1), and for applications of vertical upflow furnaces (Figure 2), where the top clearance is insufficient for installing an "A" coil and enclosure, and there is access to a run of horizontal duct.



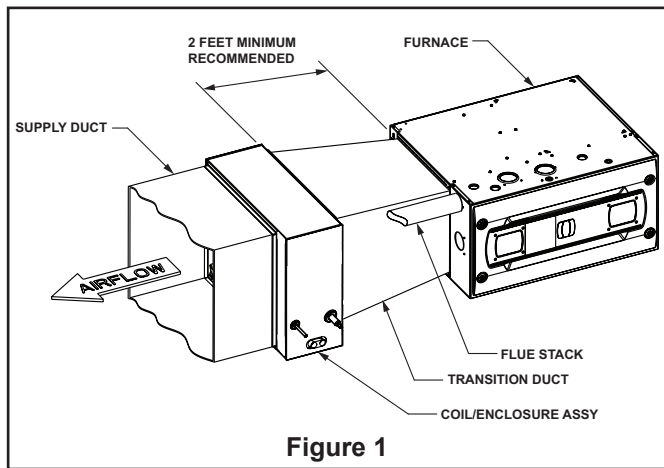

Figure 1

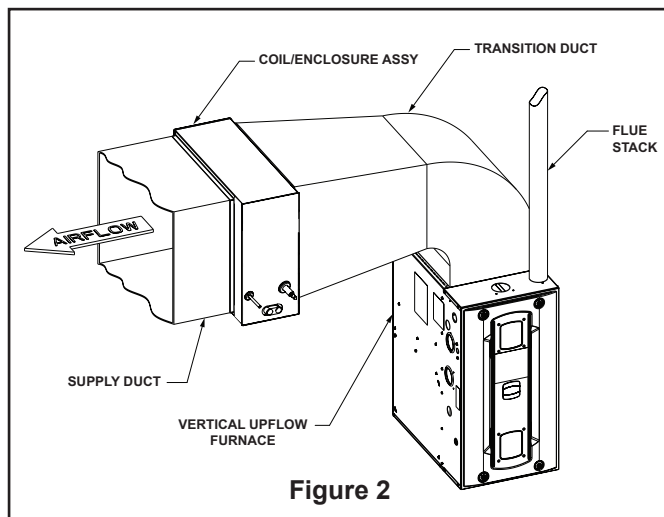

Figure 2

Since coil/ enclosure assembly must be installed within the horizontal run of duct, a transition duct must be fabricated to mate with the furnace supply outlet duct flange on one end and the duct flange connection on the coil/ enclosure assembly on the other end.

For maximum performance, it is recommended that the transition duct be at least 2 feet in length.

1. Secure the transition duct to the furnace with the furnace in position.
2. The refrigerant lines and condensate connections of cased coils may be on either side of the supply air duct. The air may be directed through the coil from either side of the coil.
3. Attach the coil/ enclosure assembly to the transition from the furnace, providing proper support for coil/ enclosure assembly's weight. Keep the coil level. Extra pitch is not required for coil to drain properly.
4. Secure the downstream side of coil/ enclosure assembly to the supply air duct.

**NOTE:** Secure properly so there will be no air leakage.

5. When hanging the coil for ceiling mounted applications, do not assemble screws in the cabinet in areas that may puncture the coil or drainpan. Areas to be avoided include the back, bottom, front, top center, and lower 3" of the left and right sides of the coil cabinet.
6. The indoor coil must be evacuated through the refrigerant lines at the outdoor unit before opening the service valves. See evacuation procedure in Field Fabricated Refrigerant Lines section of the Installer's Guide for the outdoor unit.
7. Complete the installation of the unit per installation instructions.

## F. INSTALLING / BRAZING REFRIGERANT LINES:

### ⚠ WARNING

#### RISK OF FIRE!

Failure to following this warning could result in serious injury, death, or property damage. The following requirements apply to the room where the cased coil is installed:

- All combustion appliances located in the same room that have continuous pilot lights are equipped with an effective flame arrest.
- Auxiliary devices which may be a potential ignition source, such as hot surfaces or electric switching devices, shall not be installed in the connecting ductwork unless they have been approved by the manufacturer or declared suitable with the refrigerant used.
- All indoor field-made joints of the field piping have been checked for refrigerant leaks after charging using an electronic leak detector calibrated for R-454B having a sensitivity of 5 grams per year or better.
- The room is constructed to ensure that should any refrigerant leak it will not stagnate and create a fire hazard.

### ⚠ CAUTION

**Do NOT open refrigerant valve at the outdoor unit until the refrigerant lines and coil have been brazed, evacuated, and leak checked. This would cause contamination of the refrigerant or possible discharge of refrigerant to the atmosphere.**

The following steps are to be considered when installing the refrigerant lines:

- a. Determine the most practical way to run the lines.
- b. Consider types of bends to be made and space limitations.
- c. Route the tubing making all required bends and properly secure the tubing before making final connections.

# Installer's Guide

**NOTE:** Refrigerant lines must be isolated from the structure and the holes must be sealed weather tight after installation.

**IMPORTANT:** Do not unseal refrigerant tubing until ready to fit refrigerant lines.

There is only a holding charge of dry air in the indoor coil, therefore no loss of operating refrigerant charge occurs when the sealing plugs are removed.

**NOTE:** TXV bulb **MUST** be protected (wrapped with wet rag) or removed, while brazing the tubing. Overheating of the sensing bulb will affect the functional characteristics and performance of the comfort coil.

**NOTE:** Install/braze refrigerant lines **PRIOR** to connection/installation of refrigerant detection system.

1. Slide the uncased coil into the field provided coil casing. Slide the red discs (one for the liquid and suction line each) over the field piping and away from the brazing area.
2. Clear all A2L sensor wires well away from the braze connections both inside and outside the coil plenum/box.
3. Remove both rubber plugs from the indoor coil.
4. Field supplied tubing should be cut square, round and free of burrs at the connecting end. Clean the tubing to prevent contaminants from entering the system.
5. Run the refrigerant tubing into the stub tube sockets of the indoor unit coil.
6. Flow a small amount of nitrogen through the tubing while brazing.
7. Use good brazing technique to make leakproof joints.
8. Minimize the use of sharp 90 degree bends.
9. Insulate the suction line and its fittings.
10. Do NOT allow un-insulated lines to come into contact with each other.

**NOTE:** When replacing the TXV bulb, reinstall the bulb in the proper orientation. Some models will use a spring steel clip to attach the TXV bulb, and some models will use a hose clamp. When supplied with a hose clamp, the clamp should be "snug" but not "tight" - (clamp screw torque 20 +/- 5 in-lbs).

11. Rewrap the TXV bulb, spring clip or hose clamp, and suction line with insulation after the bulb is reinstalled. Insulation is provided in the documentation pack for spring clip models.

**NOTE:** The TXV setting on this unit may run high superheat by design (15-25F) when measured at the outdoor unit.

12. For optimal performance, the TXV bulb may be relocated outside the coil cabinet after the field line brazing is complete.
  - a. Remove the bulb insulation and bulb clip/hose clamp.
  - b. Assemble the TXV bulb to the field provided suction line outside the unit.

## G. DUCT CONNECTIONS

The supply and return air duct should be connected to the unit with a flame retardant duct connectors. Duct flange connections are provided at both supply and discharge openings of the coil.

## H. TXV BULB HORIZONTAL MOUNTING

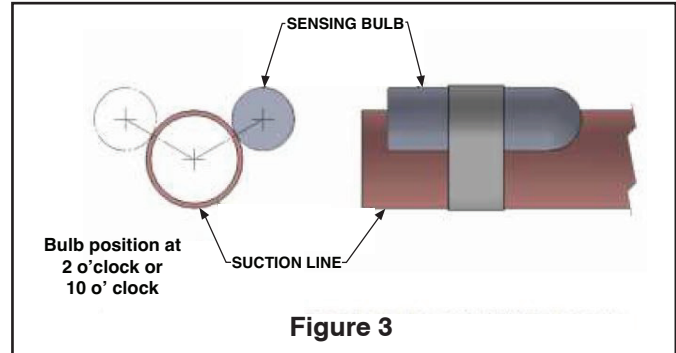

### ⚠ CAUTION

**TXV sensing bulb is sensitive to heat. Do not assemble to suction/vapor line until after field brazing is complete and line is cool to touch.**

The orientation and location of the TXV bulb has a major influence on the system performance.

It is recommended that the TXV bulb be installed parallel to the ground (on a horizontal plane). The bulb position must be at 2 o'clock or 10 o'clock. Figure 3 shows the recommended position for the TXV bulb installation in the horizontal plane.

The TXV sensing bulb **SHOULD** be mounted on the suction line approximately 6" away from outlet tubes of the circuit using the metal clamp provided. Should **NOT** be placed near any bends. In order to obtain a good temperature reading and correct superheat control, the TXV sensing bulb must conform to **ALL** the following criteria:

1. The sensing bulb must be in direct and continuous contact with the suction line.
2. The sensing bulb should be mounted horizontally on the suction line.
3. The sensing bulb should be mounted at the 2 o'clock or 10 o'clock position on the circumference of the suction line.
4. The sensing bulb must be insulated from outside air.

A properly mounted sensing bulb will prevent false readings caused by liquid refrigerant that may have formed inside the suction/vapor line. Insulation will protect the sensing bulb from false readings due to contact with warm air.

## I. TXV BULB VERTICAL MOUNTING

As recommended in Section F, the TXV sensing bulb should be mounted in a horizontal plane in relation to the suction/vapor line. However, some installation configurations may require that the sensing bulb be mounted vertically. In this instance, place the bulb opposite the piping wall being hit by refrigerant and oil leaving the distributor tubes, and with capillary tubes directed upwards as shown in Figure 4.

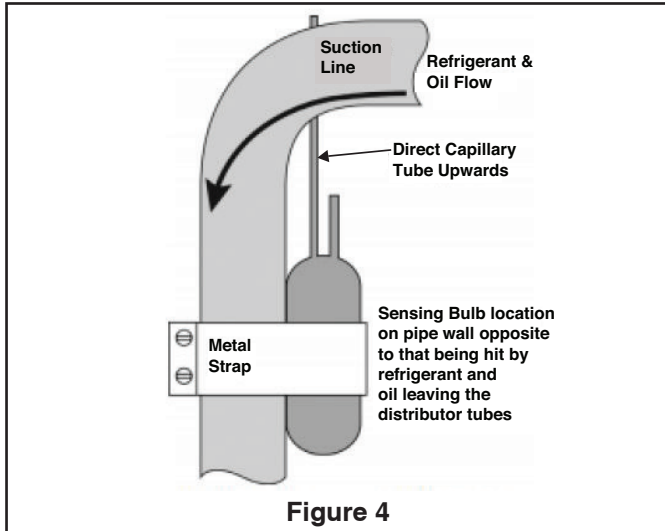

## J. PRESSURE TEST:

- Using dry nitrogen, pressurize the field piping and indoor coil to the lower of the maximum operating pressures listed on the name plates of the indoor and outdoor units (likely 600 psi).

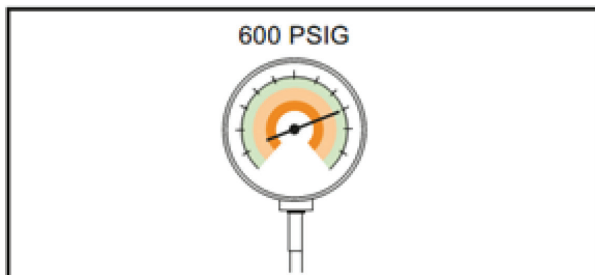

- The test pressure after removal of the pressure source shall be maintained for at least one (1) hour with no decrease of pressure indicated by the test gauge, with the test gauge resolution not exceeding 30 psi.
- Check for leaks by using a soapy solution at each field-made joint.

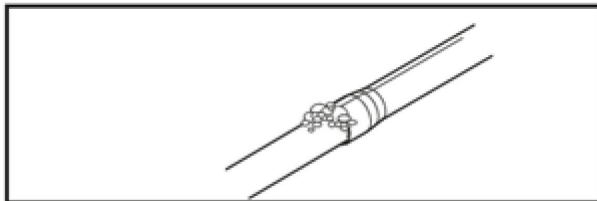

**NOTE:** Remove nitrogen pressure and repair any leaks before continuing.

## K. VACUUM TEST:

**IMPORTANT:** Do not open the service valves until the refrigerant lines and indoor coil leak check and evacuation are complete.

- Evacuate until the micron gauge reads no higher than 350 microns, then close off the valve to the vacuum pump.

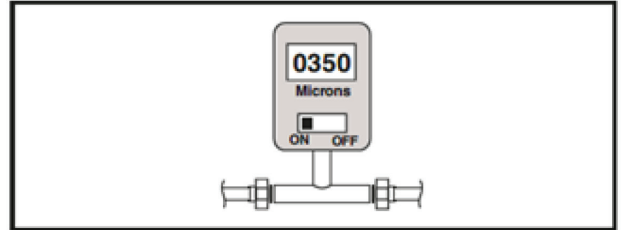

- Observe the micron gauge. Evacuation is complete if the micron gauge does not rise above 500 microns in one (1) minute and 1500 microns in ten (10) minutes.
- Once evacuation is complete, blank off the vacuum pump and micron gauge, and close the valve on the manifold gauge set.

All procedures for charging the system with refrigerant shall be according to the instructions provided by the manufacturer of the outdoor unit.

**IMPORTANT:** Under no circumstances shall potential sources of ignition be used in the searching for or detection of refrigerant leaks.

After charging the system, all indoor field-made joints of the field piping shall be checked for refrigerant leaks using an electronic leak detector calibrated for R-454B having a sensitivity of 5 grams per year or better.

## L. CONDENSATE DRAIN PIPING:

Condensate drain connections are located in the drain pan at the bottom of the coil/enclosure assembly. The female threaded fitting protrudes outside of the enclosure for external connection. A field fabricated trap is not required for proper drainage due to the positive pressure of the furnace; however, it is recommended to prevent efficiency loss of conditioned air.

- The drain hole in the drain pan must be cleared of all insulation.
- Insulate the primary drain line to prevent sweating where dew point temperatures may be met. (Optional depending on climate and application needs)
- Connect the secondary drain line to a separate drain line (no trap is needed in this line).

## M. CLEANING THE COIL:

The manufacturer's recommendation for coil cleaning is to initially use only water to wash away debris that may have collected on and in the coil fin surface. Removing an evaporator coil is the best way to effectively clean a coil that is heavily contaminated. This is accomplished by removing the coil from the cabinet, sealing the liquid and vapor line and using a strong water stream such as from a garden hose, being careful to prevent fin damage. Use chemical cleaners, only when necessary.

**NOTE:** Refer to Service Guideline, UN-SVG001C-EN, Evaporator Coil Cleaning and Condensate Drain Maintenance Guidelines for important information on cleaning coils with chemical treatments.

# Installer's Guide

## N. MINIMUM AIRFLOW SETTINGS:

When a refrigerant leak of the indoor coil is detected, the refrigerant leak detection system turns on the blower of the furnace to dilute leaked refrigerant.

The installer must verify that the indoor airflow setting is sufficient to dilute leaked refrigerant. The nominal airflow settings for first-stage cooling, first-stage heat pump, and first-stage furnace heat should not be less than shown in the minimum airflow table below.

**NOTE:** The airflow setting should be verified by comparison to the airflow at the lowest listed external static pressure for the setting. Refer to the airflow table provided by the manufacturer of the furnace.

Minimum Airflow Setting	
Total System Charge (lb)	Minimum Airflow Setting (CFM)
less than 4	no minimum
4	108
5	135
6	162
7	189
8	216
9	244
10	271
11	298
12	325
13	352
14	379
15	406
16	433
17	460
18	487
19	514
20	541

+ The system refrigerant charge is the total system charge which is marked on the system according to the instructions provided by the manufacturer of the outdoor unit.

**NOTE:** Ensure continuous fan operation meets minimum airflow required to dissipate refrigerant leak during mitigation call. Refer to minimum airflow table in Section I (Maximum and Minimum Airflow). If minimum airflow is not met, consider adjusting or disabling continuous fan setting on thermostat.

## O. PRESSURE DROP TABLE:

PRESSURE DROP CHARACTERISTICS FOR 5PXFH COOLING AND HEAT PUMP COILS									
WET COIL STATIC PRESSURE DROP (INCHES OF WATER COLUMN) @ VARIOUS CFM									
MODEL	400	600	800	1000	1200	1400	1600	1800	2000
5PXFH005AZ3HHA	0.03	0.05	0.07	0.1	0.13	0.16	0.2	0.23	0.28
5PXFH009AZ3HHA	0.02	0.04	0.06	0.08	0.1	0.13	0.16	0.19	0.23



## P. REFRIGERANT LEAK DETECTION SYSTEM:

For all tables contained in this section of the manual, the refrigerant charge is the total system charge which is marked on the system according to the instructions provided by the manufacturer of the outdoor unit.

### ⚠ WARNING

#### RISK OF FIRE!

Flammable refrigerant used. To be repaired only by trained service professional. Do not puncture refrigerant tubing. Dispose of properly in accordance with federal or local regulations. Flammable refrigerant used.

### ⚠ WARNING

**LEAK DETECTION SYSTEM INSTALLED!**  
Unit must be powered except for service.

To ensure safety of the building occupants, the unit is equipped with a refrigerant leak detection system. The system is comprised of a refrigerant sensor and a mitigation control board. The system automatically detects leaks in the indoor coil and initiates actions to mitigate the risk of ignition of the leaked refrigerant, including:

- Turning on the blower of the indoor unit to dilute leaked refrigerant;
- Fully opening any zoning dampers, when applicable;
- Turning off the compressor of the outdoor unit;
- De-energizing potential sources of ignition connected to the system;
- Energizing an audible alarm, if so equipped.

### ⚠ WARNING

#### RISK OF FIRE!

Failure to following this warning could result in serious injury, death, or property damage. The following requirements apply to the room where the cased coil is installed:

- All combustion appliances located in the same room that have continuous pilot lights are equipped with an effective flame arrest.
- Auxiliary devices which may be a potential ignition source, such as hot surfaces or electric switching devices, shall not be installed in the connecting ductwork unless they have been approved by the manufacturer or declared suitable with the refrigerant used.
- All indoor field-made joints of the field piping have been checked for refrigerant leaks after charging using an electronic leak detector calibrated for R-454B having a sensitivity of 5 grams per year or better.
- The room is constructed to ensure that should any refrigerant leak it will not stagnate and create a fire hazard.

Refrigerant sensors for refrigerant leak detection systems shall only be replaced as specified by the manufacturer.

#### Minimum Conditioned Space

The installer must verify that the total space conditioned by the system is large enough to safely dilute any leaked refrigerant in the event of a refrigerant leak of the indoor coil.

The minimum space conditioned by the appliance shall be according to Table below. The conditioned space includes any parts of the space connected via an air duct system. The altitude of installation is the altitude above sea level of the site where the equipment is installed.

Charge (lb)	Altitude (ft)								
	sea level- 2,000	2,001- 4,000	4,001- 6,000	6,001- 8,000	8,001- 10,000	10,001- 12,000	12,001- 14,000	14,001- 15,000	above 15,000
	<b>Minimum Conditioned Space (ft<sup>2</sup>)</b>								
4	63	66	70	74	79	85	91	94	98
5	79	83	88	93	99	106	113	118	122
6	95	100	105	112	119	127	136	141	147
7	110	116	123	130	138	148	159	165	171
8	126	133	140	149	158	169	181	188	196
9	142	149	158	167	178	190	204	212	220
10	158	166	175	186	198	211	227	235	245
11	173	183	193	205	218	232	249	259	269
12	189	199	211	223	237	254	272	282	294
13	205	216	228	242	257	275	295	306	318
14	221	232	246	260	277	296	318	330	343
15	236	249	263	279	297	317	340	353	367
16	252	266	281	298	317	338	363	377	392
17	268	282	298	316	336	359	386	400	416
18	284	299	316	335	356	380	408	424	440
19	299	315	333	353	376	402	431	447	465
20	315	332	351	372	396	423	454	471	489

**NOTE:** The mitigation requirements for evaporator coils using A2L refrigerants are calculated at sea level. For altitudes above 2625 ft, the minimum conditioned area must be adjusted by the corresponding altitude adjustment factor (AF) shown in the reference table below

# Installer's Guide

## Q. WIRING:

The MCB must be wired to the furnace, thermostat, and outdoor unit in order for the Refrigerant Detection System to function as intended.

For 24VAC systems, use the wiring harness supplied with this guide.

For communicating/Link systems, no harness is provided. Use the extra CAN connectors provided in the HUB kit or communicating furnace and field supplied wiring.

**Note:** For communicating systems, only the CAN bus connection is required for connection to the furnace, thermostat, and OD.

- **24VAC only:** Connect the white (furnace) connector and the black (Thermostat and OD) connector to the MCB as shown in Figure 5.
- **Communicating/Link only:** Connect the white field supplied CAN harness to the white CAN connector on the MCB as shown in Figure 6.
- Press the harness through the saddle grommet on the side of the MCB control box.
- Insert the arrow head wire tie provided in the documentation pack through the hole on the side of the MCB control box near the saddle grommet.
- Wrap the tie around both the 24V harness/CAN harness and the A2L sensor harness, and pull the wire tie tight. This ensures MCB connections are not strained or damaged due to harness weight. See Figure 7.

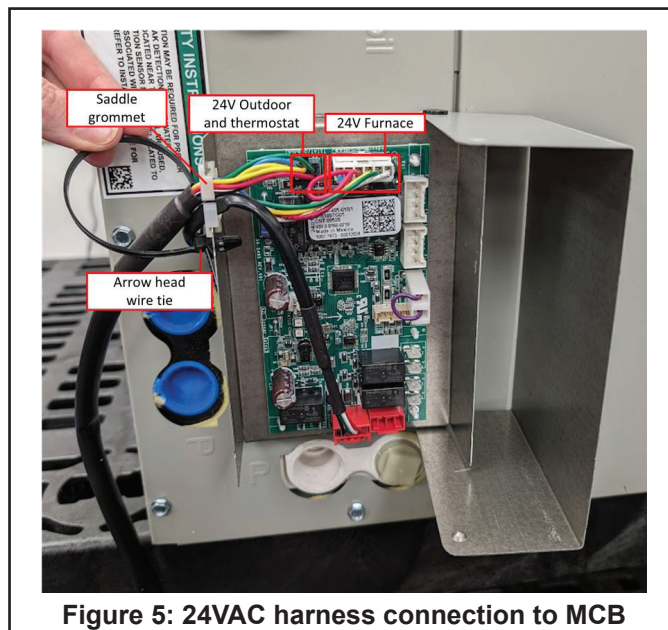

Check that the 24VAC harness is connected properly to the furnace, thermostat, and OD units. See field wiring diagrams in this guide for further information.

1. Wires bundled with "To Furnace" flag label should be wired to the furnace low voltage terminal strip.
2. Wires bundled with "To Thermostat" flag label should be spliced to field provided thermostat wire within the furnace cabinet.
3. Wires bundled with "To Outdoor" flag label should be spliced to field provided outdoor wire within the furnace cabinet.

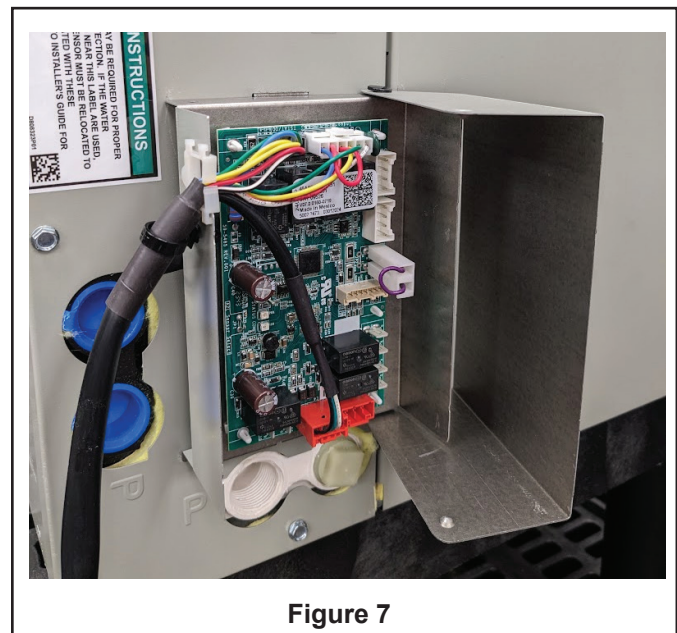
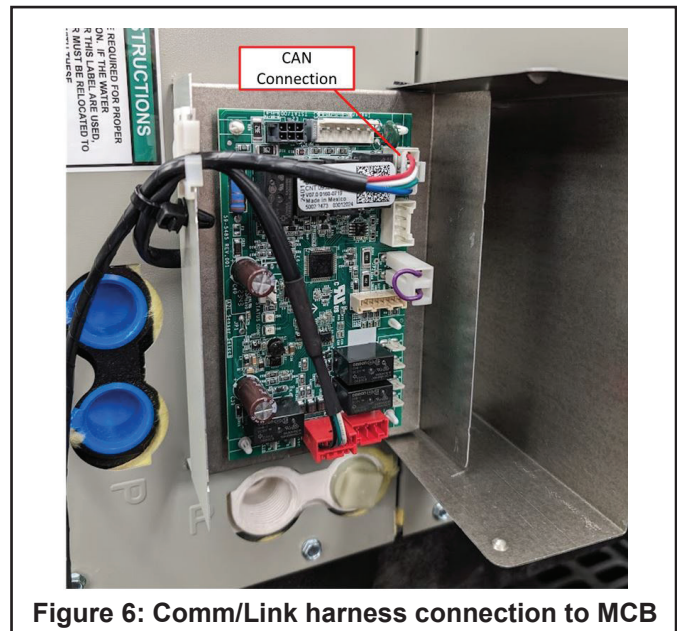

## R: FIELD WIRING DIAGRAMS:

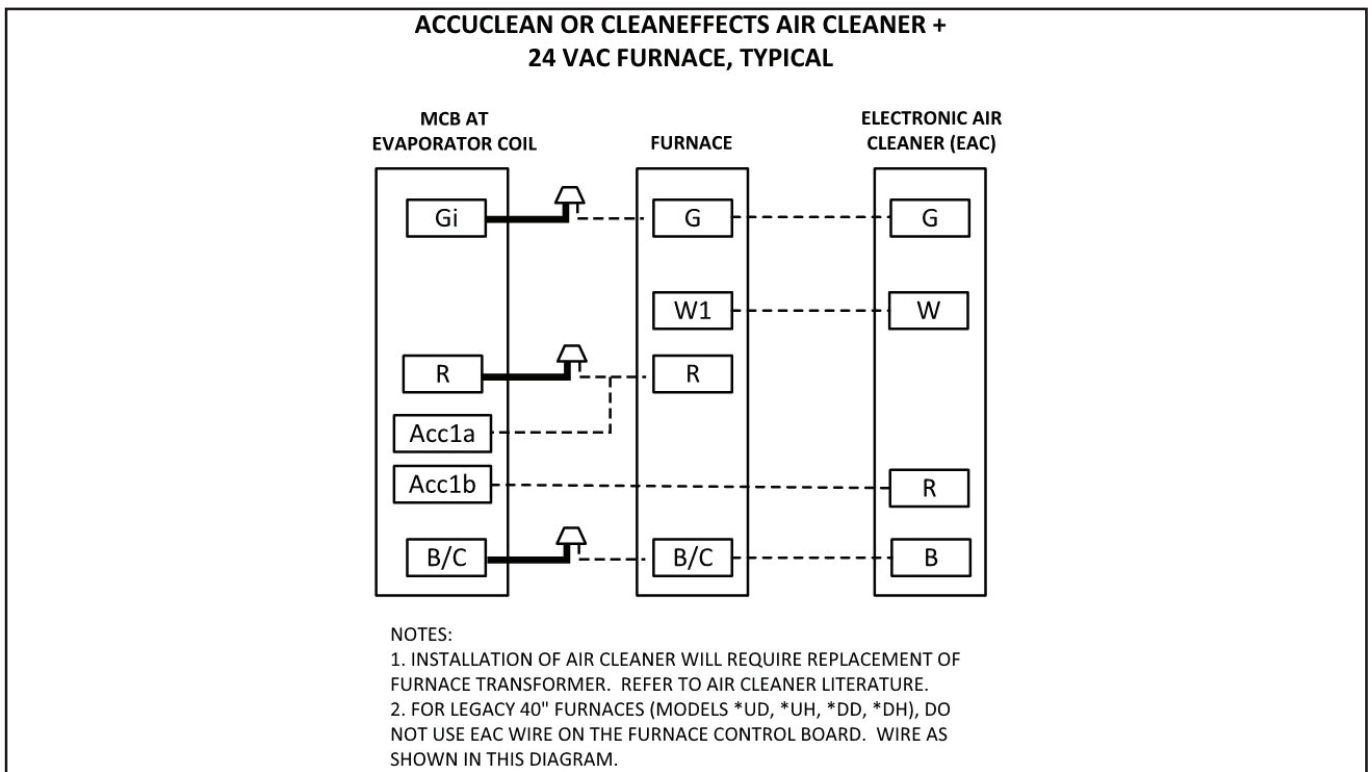
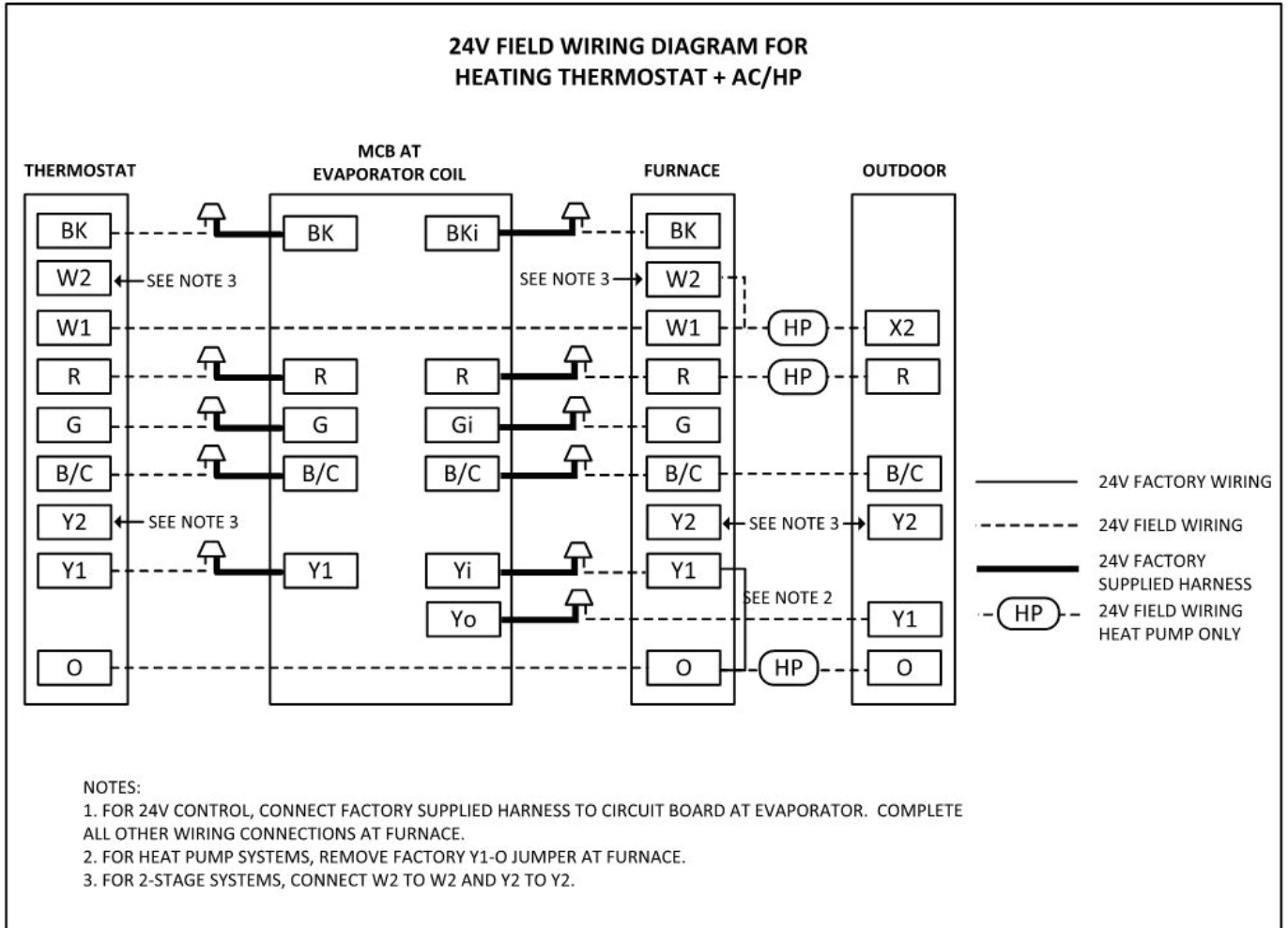

# Installer's Guide

## ACCUCLEAN OR CLEANEFFECTS AIR CLEANER + FURNACE WITH DRY CONTACT EAC TERMINALS, TYPICAL

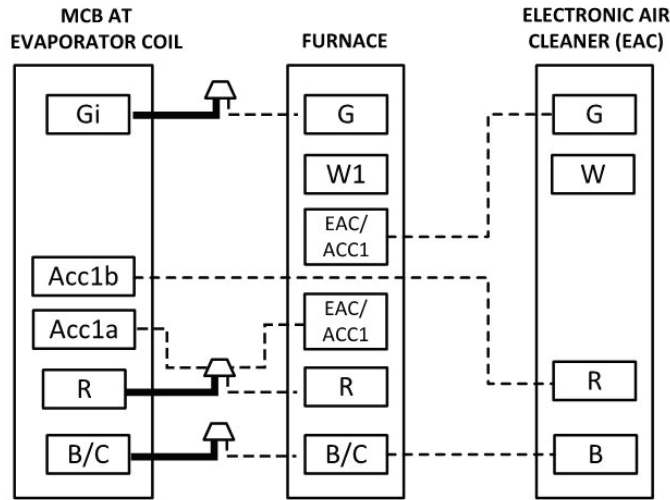

**NOTES:**

1. INSTALLATION OF AIR CLEANER WILL REQUIRE REPLACEMENT OF FURNACE TRANSFORMER. REFER TO AIR CLEANER LITERATURE.
2. S\*X, S\*V, A9, L8, OR P0 FURNACE MODELS INCLUDE EAC OR ACC DRY CONTACTS AS SHOWN. (\*UD, \*UH, \*DD, \*DH, OR S\*B FURNACE MODELS DO NOT UTILIZE DRY CONTACT ACCESSORY CONNECTIONS.)

## SECONDARY TRANSFORMER OF SECOND ACCUCLEAN OR CLEANEFFECTS AIR CLEANER + 24 VAC FURNACE (IF EQUIPPED)

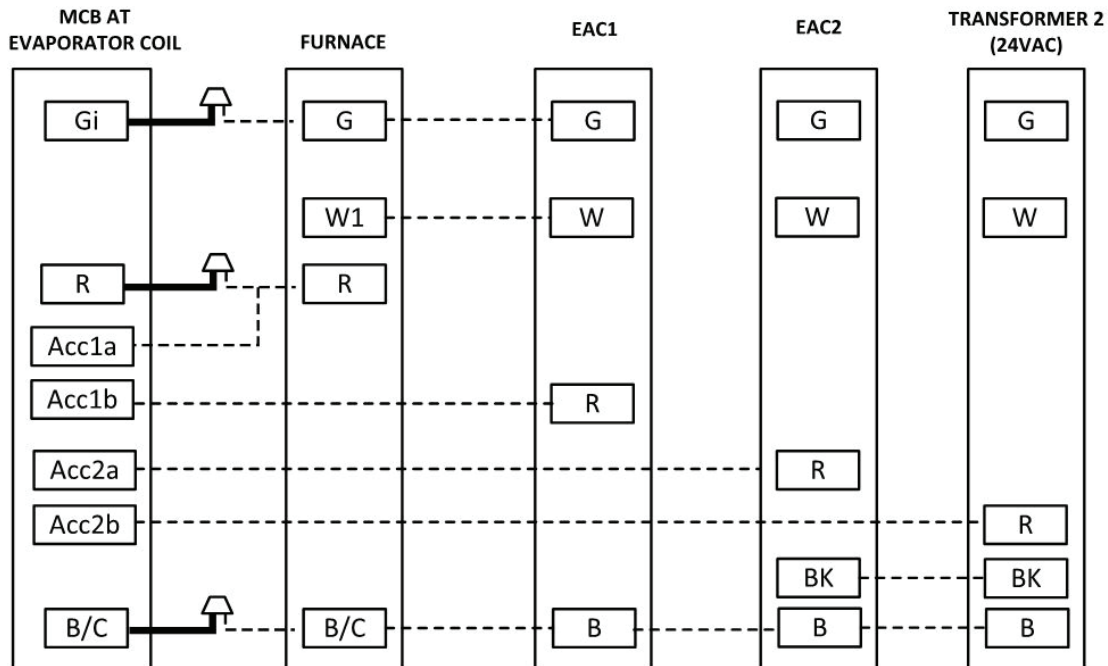

**NOTES:**

1. REFER TO AIR CLEANER LITERATURE TO DETERMINE IF SECOND AIR CLEANER AND/OR SECONDARY TRANSFORMER IS REQUIRED.
2. SEE THE OTHER AIR CLEANER WIRING DIAGRAMS FOR CONTROL WIRING CONNECTIONS.



## Audible Alarm

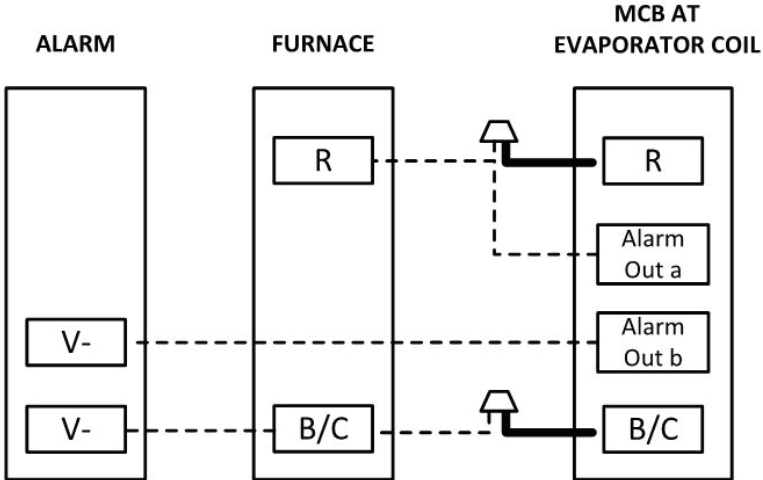



# Installer's Guide

## S. VERIFICATION AND TROUBLE SHOOTING REFRIGERANT DETECTION SYSTEM:

Figure 8. Mitigation Control Board (MCB) Connections

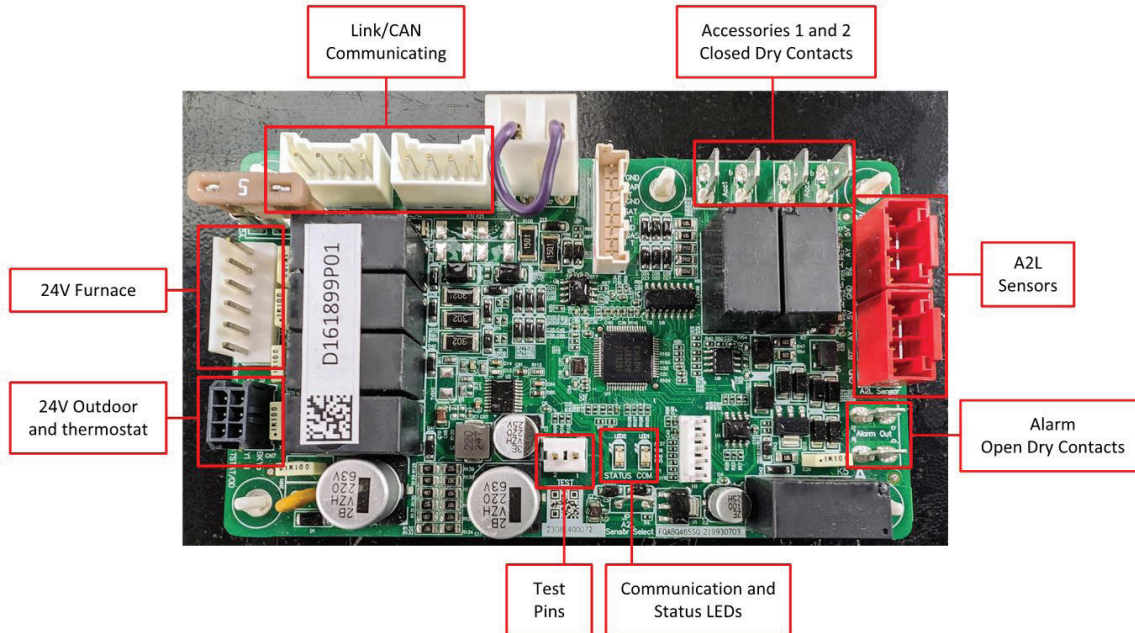

After installation, the installer must verify that the refrigerant leak detection system actuates all mitigating actions listed above.

### TEST PINS: Force Test: (See Figure 8)

- The test can be initiated by shorting the two test pins on the header of the mitigation control board inside of the unit.
- The mitigating actions will continue for two minutes with the jumper in place.
- The control will resume normal operation after two minutes or when the jumper is removed.

If any of the mitigating actions are not actuated by the system during the test, please check the following:

- All field wiring connections should be checked against the diagrams in the “Field Wiring Diagrams,” page 11 section of this manual.
- The diagnostic indicators on the mitigation control board should be checked against the diagnostic codes given in Table 1 on page 15.
- Scan the QR code for more information on field troubleshooting of the refrigerant leak detection system.



If the MCB is showing an active alarm at startup (see Table 1 on page 15):

- Check the RED A2L sensor is fully connected at MCB.
- Check the BLACK A2L sensor to sensor harness connection inside the unit and ensure fully connected. (See Figure 9 on how to connect/disconnect the sensor harness.)
  - a. To disconnect the black connector, first pull out the grey tab, and then actively push down on the grey tab while simultaneously pulling the connection apart to get it loose.
  - b. To connect the black connector, press together and push in grey tab to lock.
- Ensure no refrigerant is present.

The MCB will take approximately 20 seconds to reboot when power is cycled in 24VAC mode. The 5 minute mitigation timer can be reset by cycling power to the unit.

**Figure 9. Connect/Disconnect sensor harness**

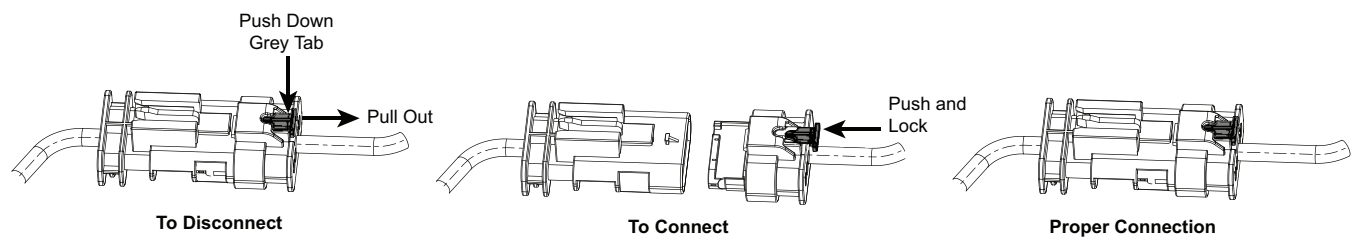

**Table 1: MCB Diagnostic Codes**

Amber LED	COMM Condition
Off	No Power/Off
On	24V Mode Active, Normal Operation
Node Count	Communication Mode is Active, Normal Operation
Fast Blink	CAN Communication lost

Green LED	Status Condition
Off	No Power/Off
On	Start Up
Slow Blink	Normal Operation
3 Flash	Active Mitigation Alarm - Refrigerant Leak Detected, Loss of Sensor Communication or Sensor Failure
4 Flash	Past Refrigerant Leak Detected, Normal Operation
5 Flash	Past Sensor Communication Error, Normal Operation
6 Flash	Past Sensor Failure or Error, Normal Operation

**NOTE:** All past alarm flash codes will remain present for 30 days post occurrence.

**Clearing Alarms:**

- With power OFF to the mitigation control board, place a jumper across the test pins.
- Turn power ON, wait until the control fully boots up and remove the jumper.

**T. CONTROL BOX RELOCATION (OPTIONAL):**

The control box may be relocated from the coil cabinet to allow for clearance to braze connections, condensate connections, or other space constraints, with use of extension kit optional accessory BAYMCBHARNESS. To avoid puncturing refrigerant tubes, it is not recommended to screw control box to coil cabinet.

**Note:** For communicating systems, only the CAN bus connection is required for connection to the furnace, thermostat, and OD.

**Functional Replacement Parts:**

- Mitigation Control Board (MCB)
- A2L Refrigerant Sensor
- 24V Wire Harness
- Refrigerant Sensor Wire Harness

**Note:** Refer to the evaporator coil model and serial number when ordering MCB replacement parts.



## V. TROUBLESHOOTING:

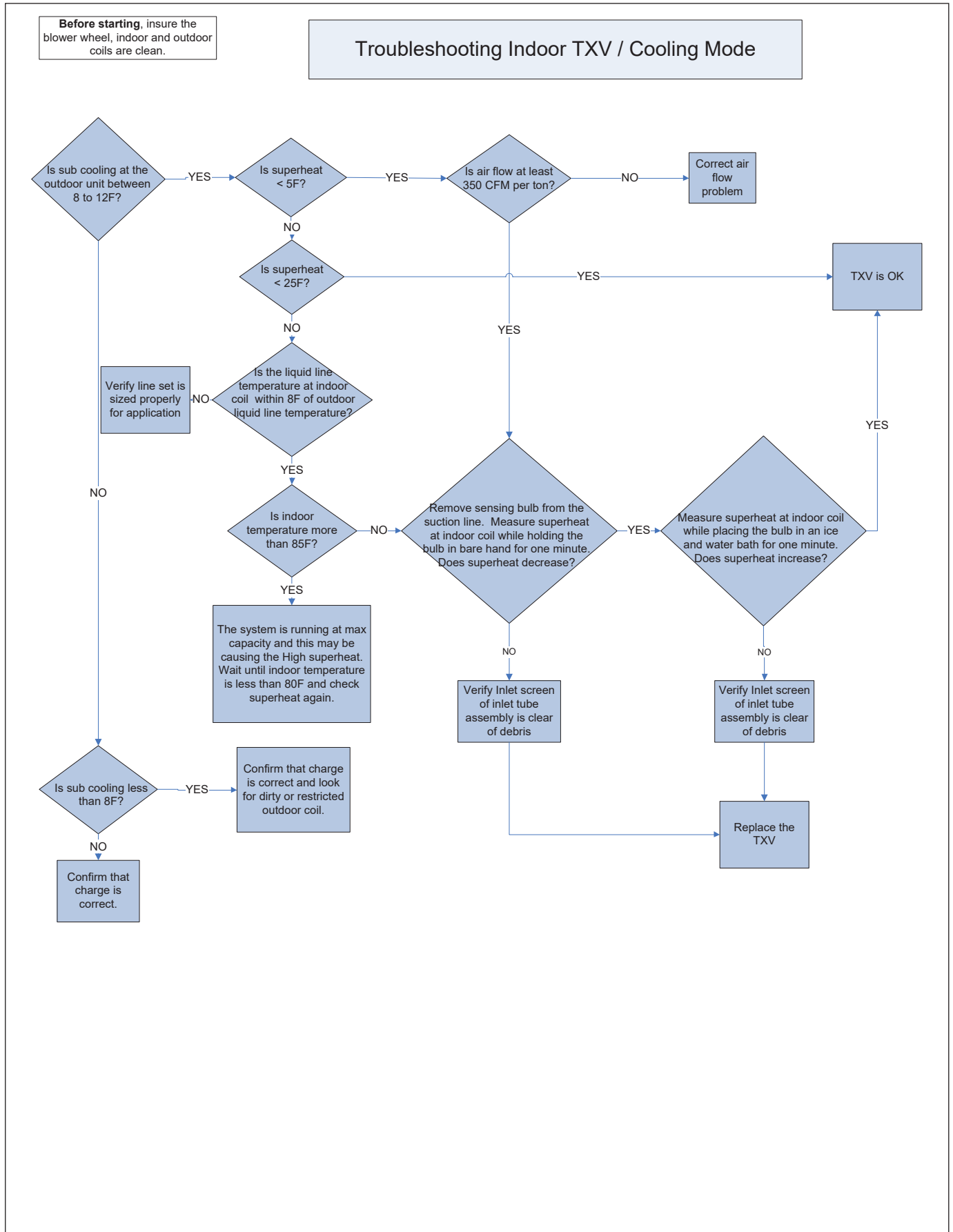

# Installer's Guide

---

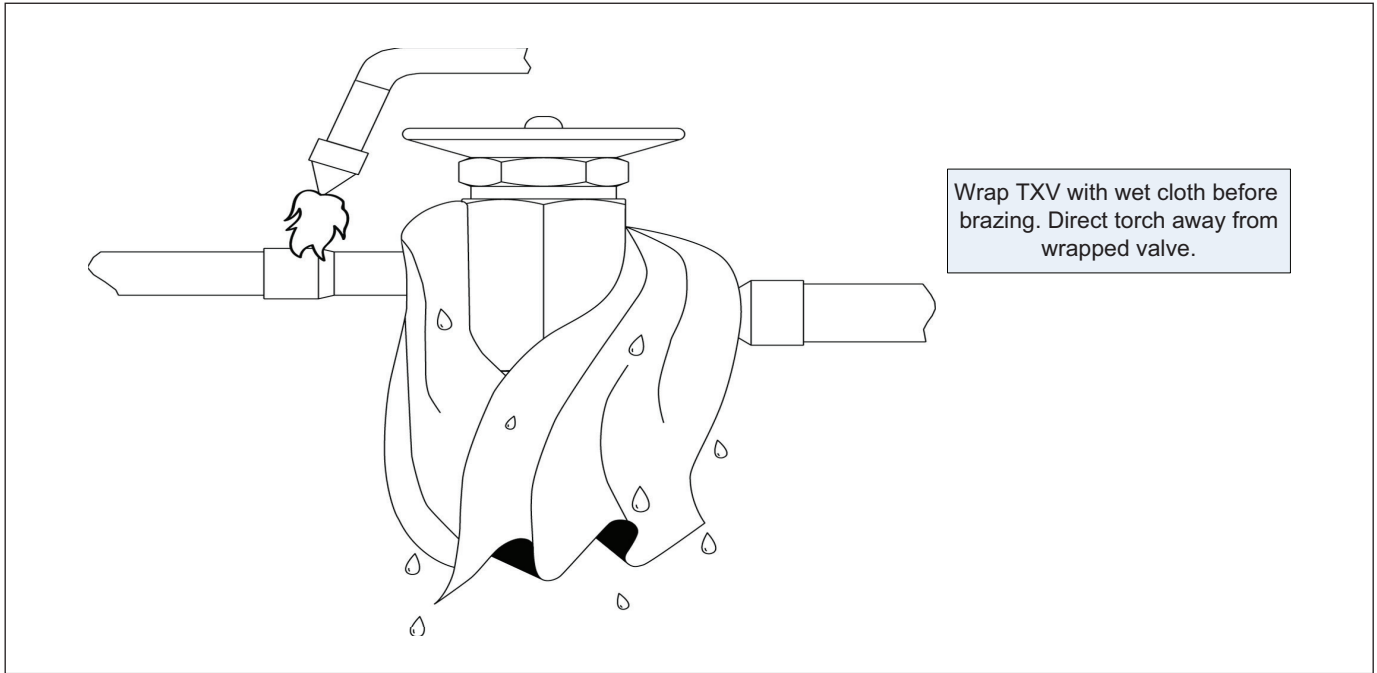



## W: CHECKOUT PROCEDURES:

The final phase of the installation is the system Checkout Procedures. The following list represents the most common items covered in a Checkout Procedure. Confirm all requirements in this document have been met.

<ul style="list-style-type: none"><li>❑ All wiring connections are tight and properly secured.</li><li>❑ Voltage and running current are within limits.</li><li>❑ All refrigerant lines (internal and external to equipment) are isolated, secure, and not in direct contact with each other or structure.</li><li>❑ All braze connections have been checked for leaks. A vacuum of 350 microns provides confirmation that the refrigeration system is leak free and dry. Additional refrigerant weight is recorded on a label by the unit nameplate.</li><li>❑ If unit is installed in any orientation other than upflow, refrigerant sensor is properly relocated.</li><li>❑ Final unit inspection to confirm factory tubing has not shifted during shipment. Adjust tubing if necessary so tubes do not rub against each other or any component when unit runs.</li><li>❑ Ductwork is sealed and insulated.</li></ul>	<ul style="list-style-type: none"><li>❑ All drain lines are clear with joints properly sealed. Pour water into drain pan to confirm proper drainage. Provide enough water to ensure drain trap is primed.</li><li>❑ Supply registers and return grilles are open, unobstructed, and air filter is installed.</li><li>❑ Indoor blower and outdoor fan are operating smoothly and without obstruction.</li><li>❑ Indoor blower motor set on correct speed setting to deliver required CFM. "Blower and fan set screws are tight."</li><li>❑ Cover panels are in place and properly tightened.</li><li>❑ System functions safely and properly in all modes.</li><li>❑ Refrigerant leak detection system mitigation actions are verified.</li><li>❑ All refrigerant safety procedures have been verified.</li><li>❑ Owner has been instructed on use of system and given manual.</li></ul>
--	--

## About Trane and American Standard Heating and Air Conditioning

Trane and American Standard create comfortable, energy efficient indoor environments for residential applications. For more information, please visit [www.trane.com](http://www.trane.com) or [www.americanstandardair.com](http://www.americanstandardair.com)

---



**Intertek**

The manufacturer has a policy of continuous data improvement and it reserves the right to change design and specifications without notice. We are committed to using environmentally conscious print practices.