

Installer's Guide

18-AD45D1-1B-EN



Cased Aluminum "Convertible" Coil

Model:

5TXCB004AS3HCA

5TXCD010AS3HCA

ALL phases of this installation must comply with NATIONAL, STATE AND LOCAL CODES

IMPORTANT— This Document is **customer property** and is to remain with this unit. Please return to service information pack upon completion of work.

⚠ SAFETY WARNING

Only qualified personnel should install and service the equipment. The installation, starting up, and servicing of heating, ventilating, and air-conditioning equipment can be hazardous and requires specific knowledge and training. Improperly installed, adjusted or altered equipment by an unqualified person could result in death or serious injury. When working on the equipment, observe all precautions in the literatures and on the tags, stickers, and labels, and that are attached to the equipment.

IMPORTANT: *These instructions do not cover all variations in systems nor provide for every possible contingency to be met in connection with the installation. Should further information be desired or should particular problems arise which are not covered sufficiently for the purchaser's purposes, the matter should be referred to your installing dealer or local distributor.*

⚠ WARNING

SAFETY HAZARD!

This air handler shall only be connected to an outdoor unit suitable for use with refrigerant R-454B.

⚠ WARNING

SAFETY HAZARD!

This appliance is not to be used by persons (including children) with reduced physical, sensory, or mental capabilities, or lack of experience and knowledge, unless they have been given supervision or instructions concerning the use of appliance by a person responsible for their safety.

⚠ WARNING

RISK OF FIRE!

Flammable refrigerant used. To be repaired only by trained service professional. Do not puncture refrigerant tubing. Dispose of properly in accordance with federal or local regulations.

⚠ WARNING

WARNING!

This product can expose you to chemicals including lead, which are known to the State of California to cause cancer and birth defects or other reproductive harm. For more information go to [www. P65Warnings.ca.gov](http://www.P65Warnings.ca.gov)

⚠ WARNING

HAZARDOUS VAPORS!

Failure to follow this caution could result in property damage or personal injury. Equipment corrosion damage. To prevent shortening its service life, the unit should not be used during the finishing phases of construction or remodeling. The low return air temperatures can lead to the formation of condensate. Condensate in the presence of chlorides and fluorides from paint, varnish, stains, adhesives, cleaning compounds, and cement creates a corrosive condition which may cause rapid deterioration of the cabinet and internal components.

⚠ WARNING

RISK OF FIRE!

Failure to following this warning could result in serious injury, death, or property damage.

The following requirements apply to the room where the cased coil is installed:

- All combustion appliances located in the same room that have continuous pilot lights are equipped with an effective flame arrest.
- Auxiliary devices which may be a potential ignition source, such as hot surfaces or electric switching devices, shall not be installed in the connecting ductwork unless they have been approved by the manufacturer or declared suitable with the refrigerant used.
- All indoor field-made joints of the field piping have been checked for refrigerant leaks after charging using an electronic leak detector calibrated for R-454B having a sensitivity of 5 grams per year or better.
- The room is constructed to ensure that should any refrigerant leak it will not stagnate and create a fire hazard.

⚠ WARNING

PRESSURIZED REFRIGERANT!

Failure to follow this Warning could result in personal injury.

System contains oil and refrigerant under high pressure. Recover refrigerant to relieve pressure before opening the system. Do not use non-approved refrigerants or refrigerant substitutes or refrigerant additives.

Installer's Guide

⚠ CAUTION

SHARP EDGE HAZARD!
Failure to follow this caution could result in property damage or personal injury.
Be careful of sharp edges on equipment or any cuts made on sheet metal while installing or servicing.

⚠ CAUTION

COIL IS PRESSURIZED!
Coil is pressurized with approximately 8-12 psi dry air and factory checked for leaks. Carefully release the pressure by removing the rubber plug on the liquid line. If no pressure is released, check for leaks.

Important: Installation of this unit shall be made in accordance with the National Electric Code, NFPA No. 90A and 90B, and any other local codes or utilities requirements.

Important: Cased coils do not require repositioning of the refrigerant leak detection sensor for upflow or downflow installations. Horizontal applications require sensor repositioning. See conversion instructions section for details.

Note: This unit is a PARTIAL UNIT AIR CONDITIONER, complying with PARTIAL UNIT requirements of Standard UL 60335-2-40/CSA 22.2 NO. 60335-2-40, and must only be connected to other units that have been confirmed as complying to corresponding PARTIAL UNIT requirements of this Standard.

Note: There is no declared maximum altitude for operating the appliance.

Note: Charging of the refrigerating system shall be according to the instructions provided by the manufacturer of the outdoor unit.

Note: Unit not to be used with oil drum type furnaces.

Note: Both the drain pans and the refrigerant detection sensor installed on this unit are designed to be heat resistant to temperatures produced by all Trane residential and American Standard furnaces.

TABLE OF CONTENTS

General	2
Application Information	2
Information on Servicing	2
Refrigerant Leak Detection System	4
Recommendation	6
Furnace in Upflow Position	6
Furnace in Downflow Position	6
Furnace in Horizontal Right Position	7
Furnace in Horizontal Left Position	8
Maximum And Minimum Airflow Settings	9
Installing / Brazing Refrigerant Lines	10
Pressure Test	11
Vacuum Test	11
Condensate Drain Piping	12
Cleaning the Coil	12
Wiring - Communicating Systems	12
AHC Board Connections	13
Troubleshooting the Refrigerant Detection System	13
Control Box Relocation (Optional)	13
Flash Codes	13
Wiring	14
Field Wiring Diagrams	15
Outline Drawing	20
Troubleshooting Indoor TXV / Cooling Mode	21
Checkout Procedures	22

A. GENERAL:

This coil is designed for use in combination with a heat pump or cooling outdoor section using **R-454B REFRIGERANT**.

The 5TXC equipment has been evaluated in accordance with the Code of Federal Regulations, Chapter XX, Part 3280 or the equivalent. "Suitable for Mobile Home use" The height of the Furnace, Coil and discharge duct work must be 7 ft. or less.

Inspect the coil for shipping damage. Notify the transportation company immediately if the coil is damaged.

B. APPLICATION INFORMATION:

- FURNACE AND COIL**
The coil MUST BE installed downstream (in the outlet air) of the furnace.
- INDOOR UNIT AIRFLOW**
Indoor unit must provide the required airflow for the heat pump or cooling combinations approved for this coil.

Note: The manufacturer recommends installing ONLY A.H.R.I approved, matched indoor and outdoor systems. Some of the benefits of installing approved matched indoor and outdoor split systems are maximum efficiency, optimum performance, and the best overall system reliability.

IMPORTANT:

Review your installation requirements. Check the table on the outline drawing and note all dimensions for your coil before beginning the installation.

Figure 1

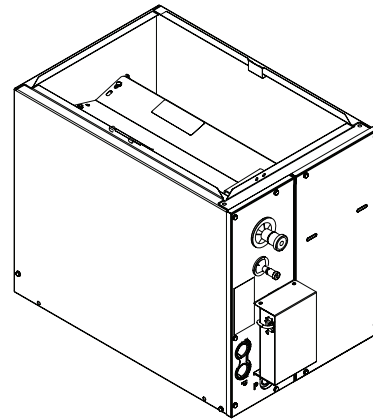

C. INFORMATION ON SERVICING:

All replacement parts shall be in accordance with the manufacturer's specifications.

Prior to Beginning Work

Prior to beginning work on systems containing flammable refrigerants, safety checks are necessary to ensure that the risk of ignition is minimized. For repair to the refrigerating system, the following shall be completed prior to conducting work on the system:

- Work shall be undertaken under a controlled procedure to minimize the risk of a flammable gas or vapor being present while the work is being performed.

- All maintenance staff and others working in the local area shall be instructed on the nature of work being carried out. Work in confined spaces shall be avoided.
- The area shall be checked with an appropriate refrigerant detector prior to and during work, to ensure the technician is aware of potentially toxic or flammable atmospheres. Ensure that the leak detection equipment being used is suitable for use with all applicable refrigerants, i.e., non-sparking, adequately sealed or intrinsically safe.
- If any hot work is to be conducted on the refrigerating equipment or any associated parts, appropriate fire extinguishing equipment shall be available to hand. Have a dry powder or CO2 fire extinguisher adjacent to the charging area.
- No person carrying out work in relation to a refrigerating system which involves exposing any pipe work shall use any sources of ignition in such a manner that it may lead to the risk of fire or explosion. All possible ignition sources, including cigarette smoking, should be kept sufficiently far away from the site of installation, repairing, removing and disposal, during which refrigerant can possibly be released to the surrounding space. Prior to work taking place, the area around the equipment is to be surveyed to make sure that there are no flammable hazards or ignition risks. "No Smoking" signs shall be displayed.
- Ensure that the area is in the open or that it is adequately ventilated before breaking into the system or conducting any hot work. A degree of ventilation shall continue during the period that the work is carried out. The ventilation should safely disperse any released refrigerant and preferably expel it externally into the atmosphere.
- The following checks shall be applied to installations using flammable refrigerants:
 - marking to the equipment continues to be visible and legible. Markings and signs that are illegible shall be corrected;
 - refrigerating pipe or components are installed in a position where they are unlikely to be exposed to any substance which may corrode refrigerant containing components, unless the components are constructed of materials which are inherently resistant to being corroded or are suitably protected against being so corroded.

Repairs to Electrical Components

Where electrical components are being changed, they shall be fit for the purpose and to the correct specification. At all times the manufacturer's maintenance and service guidelines shall be followed. If in doubt, consult the manufacturer's technical department for assistance.

Repair and maintenance to electrical components shall include initial safety checks and component inspection procedures. If a fault exists that could compromise safety, then no electrical supply shall be connected to the circuit until it is satisfactorily dealt with. If the fault cannot be corrected immediately but it is necessary to continue operation, an adequate temporary solution shall be used. This shall be reported to the owner of the equipment, so all parties are advised.

Initial safety checks shall include:

- that capacitors are discharged; this shall be done in a safe manner to avoid possibility of sparking;
- that no live electrical components and wiring are exposed while charging, recovering or purging the system;
- that there is continuity of earth bonding.

Check that cabling will not be subject to wear, corrosion, excessive pressure, vibration, sharp edges or any other adverse environmental effects. The check shall also take into account the effects of aging or continual vibration from sources such as compressors or fans.

Detection of Flammable Refrigerants

Under no circumstances shall potential sources of ignition be used in the searching for or detection of refrigerant leaks. A halide torch (or any other detector using a naked flame) shall not be used.

The following leak detection methods are deemed acceptable for all refrigerant systems:

- Electronic leak detectors may be used to detect refrigerant leaks but, in the case of flammable refrigerants, the sensitivity may not be adequate, or may need re-calibration. (Detection equipment shall be calibrated in a refrigerant-free area.) Ensure that the detector is not a potential source of ignition and is suitable for the refrigerant used. Leak detection equipment shall be set at a percentage of the LFL of the refrigerant and shall be calibrated to the refrigerant employed, and the appropriate percentage of gas (25 % maximum) is confirmed.
- Leak detection fluids are also suitable for use with most refrigerants but the use of detergents containing chlorine shall be avoided as the chlorine may react with the refrigerant and corrode the copper pipe-work.

Examples of leak detection fluids are:

- bubble method,
- fluorescent method agents

If a leak is suspected, all naked flames shall be removed/ extinguished.

If a leakage of refrigerant is found which requires brazing, all of the refrigerant shall be recovered from the system, or isolated (by means of shut off valves) in a part of the system remote from the leak.

Removal and Evacuation

When breaking into the refrigerant circuit to make repairs - or for any other purpose - conventional procedures shall be used. However, for flammable refrigerants it is important that best practice be followed, since flammability is a consideration. The following procedure shall be adhered to:

- safely remove refrigerant following local and national regulations;
- evacuate;
- purge the circuit with inert gas (optional for A2L);
- evacuate (optional for A2L);
- continuously flush or purge with inert gas when using flame to open circuit;
- and open the circuit.

Installer's Guide

The refrigerant charge shall be recovered into the correct recovery cylinders if venting is not allowed by local and national codes. For appliances containing flammable refrigerants, the system shall be purged with oxygen-free nitrogen to render the appliance safe for flammable refrigerants.

This process might need to be repeated several times. Compressed air or oxygen shall not be used for purging refrigerant systems.

For appliances containing flammable refrigerants, refrigerants purging shall be achieved by breaking the vacuum in the system with oxygen-free nitrogen and continuing to fill until the working pressure is achieved, then venting to atmosphere, and finally pulling down to a vacuum (optional for A2L). This process shall be repeated until no refrigerant is within the system (optional for A2L). When the final oxygen-free nitrogen charge is used, the system shall be vented down to atmospheric pressure to enable work to take place.

The outlet for the vacuum pump shall not be close to any potential ignition sources, and ventilation shall be available.

Charging Procedures

In addition to conventional charging procedures, the following requirements shall be followed.

- Ensure that contamination of different refrigerants does not occur when using charging equipment. Hoses or lines shall be as short as possible to minimise the amount of refrigerant contained in them.
- Cylinders shall be kept in an appropriate position according to the instructions.
- Ensure that the refrigerating system is earthed prior to charging the system with refrigerant.
- Label the system when charging is complete (if not already).
- Extreme care shall be taken not to overfill the refrigerating system.

Prior to recharging the system, it shall be pressure tested with the appropriate purging gas. The system shall be leak-tested on completion of charging but prior to commissioning. A follow up leak test shall be carried out prior to leaving the site.

See installation instructions below for further details.

Recovery

When removing refrigerant from a system, either for servicing or decommissioning, it is recommended good practice that all refrigerants are removed safely.

When transferring refrigerant into cylinders, ensure that only appropriate refrigerant recovery cylinders are employed. Ensure that the correct number of cylinders for holding the total system charge is available. All cylinders to be used are designated for the recovered refrigerant and labelled for that refrigerant (i.e., special cylinders for the recovery of refrigerant). Cylinders shall be complete with pressure-relief valve and associated shut-off valves in good working order. Empty recovery cylinders are evacuated and, if possible, cooled before recovery occurs.

The recovery equipment shall be in good working order with a set of instructions concerning the equipment that is at hand and shall be suitable for the recovery of the flammable

refrigerant. If in doubt, the manufacturer should be consulted. In addition, a set of calibrated weighing scales shall be available and in good working order. Hoses shall be complete with leak free disconnect couplings and in good condition.

The recovered refrigerant shall be processed according to local legislation in the correct recovery cylinder, and the relevant waste transfer note arranged. Do not mix refrigerants in recovery units and especially not in cylinders.

If compressors or compressor oils are to be removed, ensure that they have been evacuated to an acceptable level to make certain that flammable refrigerant does not remain within the lubricant. The compressor body shall not be heated by an open flame or other ignition sources to accelerate this process. When oil is drained from a system, it shall be carried out safely.

Decommissioning

Before carrying out this procedure, it is essential that the technician is completely familiar with the equipment and all its detail. It is recommended good practice that all refrigerants are recovered safely. Prior to the task being carried out, an oil and refrigerant sample shall be taken in case analysis is required prior to re-use of recovered refrigerant. It is essential that electrical power is available before the task is commenced.

1. Become familiar with the equipment and its operation.
2. Isolate system electrically.
3. Before attempting the procedure, ensure that:
 - a. Mechanical handling equipment is available, if required, for handling refrigerant cylinders;
 - b. All personal protective equipment is available and being used correctly;
 - c. The recovery process is supervised at all times by a competent person;
 - d. Recovery equipment and cylinders conform to the appropriate standards.
4. Pump down refrigerant system, if possible.
5. If a vacuum is not possible, make a manifold so that refrigerant can be removed from various parts of the system.
6. Make sure that cylinder is situated on the scales before recovery takes place.
7. Start the recovery machine and operate in accordance with instructions.
8. Do not overfill cylinders (no more than 80 % volume liquid charge).
9. Do not exceed the maximum working pressure of the cylinder, even temporarily.
10. When the cylinders have been filled correctly and the process completed, make sure that the cylinders and the equipment are removed from site promptly and all isolation valves on the equipment are closed off.
11. Recovered refrigerant shall not be charged into another refrigerating system unless it has been cleaned and checked.

Equipment shall be labelled stating that it has been decommissioned and emptied of refrigerant. The label shall

be dated and signed. For appliances containing flammable refrigerant, ensure that there are labels on the equipment stating the equipment contains flammable refrigerant.

D. REFRIGERANT LEAK DETECTION SYSTEM:

For all tables contained in this section of the manual, the refrigerant charge is the total system charge which is marked on the system according to the instructions provided by the manufacturer of the outdoor unit.

⚠ WARNING

Risk of Fire!
Flammable refrigerant used. To be repaired only by trained service professional. Do not puncture refrigerant tubing.
Dispose of properly in accordance with federal or local regulations. Flammable refrigerant used.

⚠ WARNING

LEAK DETECTION SYSTEM!
Leak Detection System installed. Unit must be powered except for service.

To ensure safety of the building occupants, the unit is equipped with a refrigerant leak detection system. The system is comprised of a refrigerant sensor and a mitigation control board. The system automatically detects leaks in the indoor coil and initiates actions to mitigate the risk of ignition of the leaked refrigerant, including:

- Turning on the blower of the indoor unit to dilute leaked refrigerant;
- Fully opening any zoning dampers, when applicable;
- Turning off the compressor of the outdoor unit;
- De-energizing potential sources of ignition connected to the system;
- Energizing an audible alarm, if so equipped.

⚠ WARNING

RISK OF FIRE!

Failure to following this warning could result in serious injury, death, or property damage.

The following requirements apply to the room where the cased coil is installed:

- All combustion appliances located in the same room that have continuous pilot lights are equipped with an effective flame arrest.
- Auxiliary devices which may be a potential ignition source, such as hot surfaces or electric switching devices, shall not be installed in the connecting ductwork unless they have been approved by the manufacturer or declared suitable with the refrigerant used.
- All indoor field-made joints of the field piping have been checked for refrigerant leaks after charging using an electronic leak detector calibrated for R-454B having a sensitivity of 5 grams per year or better.
- The room is constructed to ensure that should any refrigerant leak it will not stagnate and create a fire hazard.

Refrigerant sensors for refrigerant leak detection systems shall only be replaced as specified by the manufacturer.

Minimum Conditioned Space

The installer must verify that the total space conditioned by the system is large enough to safely dilute any leaked refrigerant in the event of a refrigerant leak of the indoor coil.

The minimum space conditioned by the appliance shall be according to Table below. The conditioned space includes any parts of the space connected via an air duct system. The altitude of installation is the altitude above sea level of the site where the equipment is installed.

Charge (lb)	Altitude (ft)								
	sea level- 2,000	2,001- 4,000	4,001- 6,000	6,001- 8,000	8,001- 10,000	10,001- 12,000	12,001- 14,000	14,001- 15,000	above 15,000
	Minimum Conditioned Space (ft²)								
4	63	66	70	74	79	85	91	94	98
5	79	83	88	93	99	106	113	118	122
6	95	100	105	112	119	127	136	141	147
7	110	116	123	130	138	148	159	165	171
8	126	133	140	149	158	169	181	188	196
9	142	149	158	167	178	190	204	212	220
10	158	166	175	186	198	211	227	235	245
11	173	183	193	205	218	232	249	259	269
12	189	199	211	223	237	254	272	282	294
13	205	216	228	242	257	275	295	306	318
14	221	232	246	260	277	296	318	330	343
15	236	249	263	279	297	317	340	353	367
16	252	266	281	298	317	338	363	377	392
17	268	282	298	316	336	359	386	400	416
18	284	299	316	335	356	380	408	424	440
19	299	315	333	353	376	402	431	447	465
20	315	332	351	372	396	423	454	471	489

Installer's Guide

E. RECOMMENDATION:

If a coil is part of the total system installation, use the Installer's Guide packaged with the furnaces, outdoor sections, and thermostat for physically installing those components.

F. FURNACE IN UPFLOW POSITION:

1. UPFLOW COIL CONVERSION

While not required, optional removal of some coil components will maximize airflow efficiency.

- Remove the coil by sliding the coil out of the coil enclosure.
- Optional for maximum efficiency: Remove the horizontal drain pan from the coil and discard.

2. UPFLOW GAS FURNACE

- Apply gasket material (duct seal field supplied) to ALL mating surfaces between the furnace and the coil case.
- Set the coil case on top of the furnace. Connect the ductwork to the coil case using supplied screws.
- Secure the coil case to the furnace and seal for air leaks as required.
- Ensure the sensor is secured to the primary drain pan as shown in Figure 2.

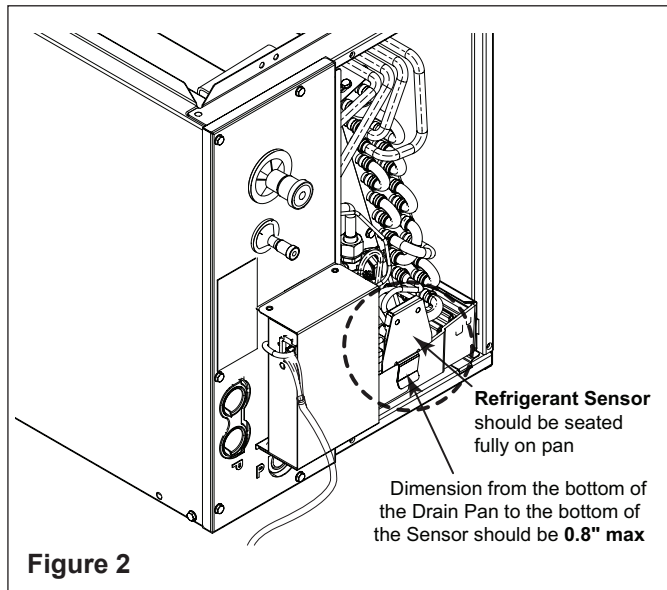

G. FURNACE IN DOWNFLOW POSITION:

⚠ CAUTION

To prevent damage to pan, ensure Heat Shield is assembled to Horizontal Drain Pan. See Figure 10.

NOTE: When installing onto an S-Series furnaces in horizontal right or downflow configuration the flanges will be bent inward for a flush fit. See Figure 6.

1. DOWNFLOW COIL CONVERSION

- Remove the coil by sliding the coil out of the coil enclosure.
- Optional for maximum efficiency: Remove the horizontal drain pan from the coil and discard.
- On model 5TXCD010AS, installing the water diverter baffles is required for water management in downflow installations. Install the two outer water baffles closest to the drain pan using the provided 5/16" hex screws. See Figure 3.
- Ensure the refrigerant sensor is attached to the primary pan per Figure 2. Sensor should face inward toward coil and may be positioned anywhere on the front lip of the pan. Ensure mounting bracket is seated as far down on the pan as possible.

2. DOWNFLOW GASKET INSTALLATION (OPTIONAL)

For unusually humid applications that expect prolonged operation above 70% RH, it is recommended to use the BAYGSKT001A0 gasket kit to prevent water from forming on the bottom of the drain pan and dripping into the supply ductwork.

- Lay the coil on its back side.
- Locate the 4" wide gasket material found in BAYGSKT001A0.
- Attach the 4" gasket material to three sides of the bottom of the drain pan as shown in Figure 5. Make sure to start by matching up the edge of the gasket material to the inner edge of the drain pan by the coil fins and working outwards.
- The gasket material can be cut or ripped easily so that it can be tailored to fit. The gasket material must cover the three sides along the entire length of the coil as shown in Figure 5.

3. DOWNFLOW GAS FURNACE

When a coil is used with a downflow furnace, a subbase is not required between the coil case and combustible flooring.

- Place the coil case on the furnace supply air plenum.
- Secure the coil case to the plenum.
- Set the furnace on top of the coil case, making sure that the back side of the discharge opening is snug against the duct flange at the top rear of the coil case.
- Secure the coil case to the furnace and seal for air leaks as required.

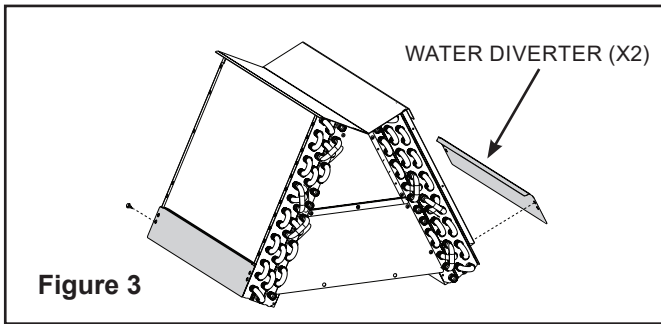

Figure 3

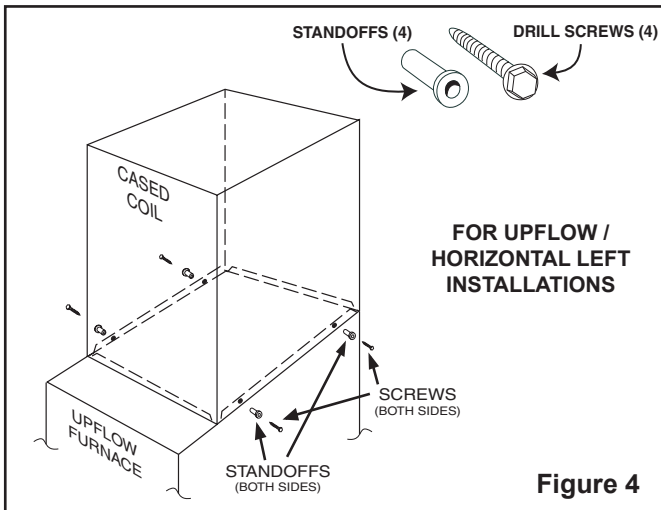

Figure 4

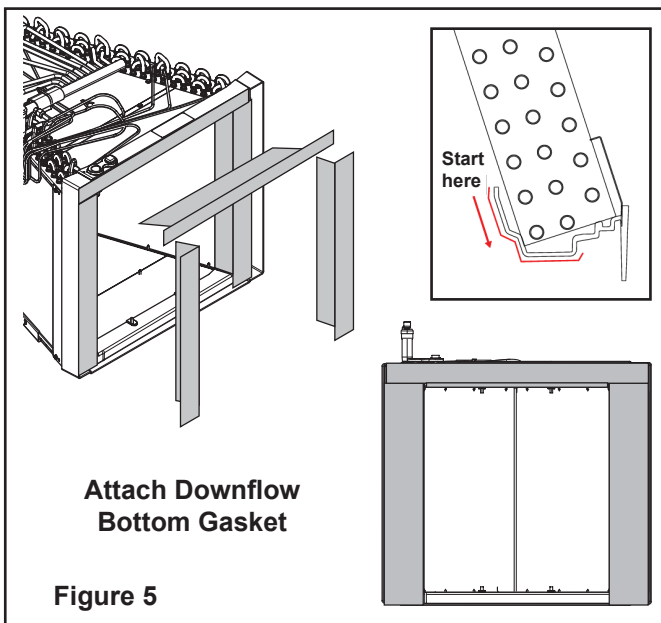

Figure 5

H. FURNACE IN HORIZONTAL RIGHT POSITION:

⚠ CAUTION

Both the coil and furnace must be fully supported. Do not attempt to suspend the coil using the brackets.

NOTE:

When installing onto an S-Series furnaces in horizontal right or downflow configuration the flanges will be bent inward for a flush fit. See Figure 6.

⚠ CAUTION

To prevent damage to pan, ensure Heat Shield is assembled to Horizontal Drain Pan. See Figure 9.

IMPORTANT:

The cased coil must be placed downstream of the furnace. See Figure 7 for proper orientation.

HORIZONTAL RIGHT COIL CONVERSION:

1. Attach the coil and furnace in the orientation shown in Figure 8. For S-Series furnaces, bend flanges to accommodate installation as shown in Figure 6. For legacy upflow or horizontal furnaces, attach as shown in Figure 9.
2. There are self drilling screws included which can be used for this connection. Seal all gaps between the furnace and coil.
3. Pull refrigerant sensor and clip up and away from the primary drain pan and remove it from the pan. Secure sensor to secondary pan using provided clip. Sensor should be positioned close to secondary drain lines. See Figure 7 for detail.

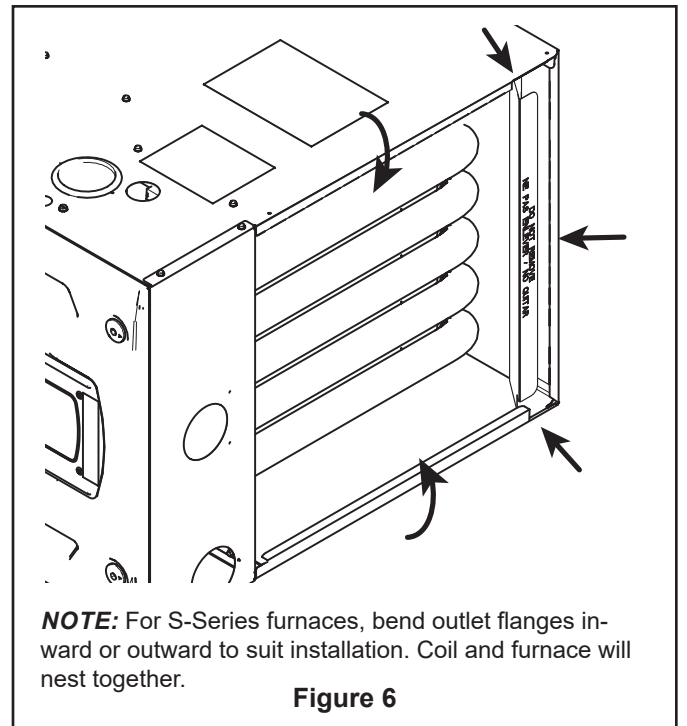
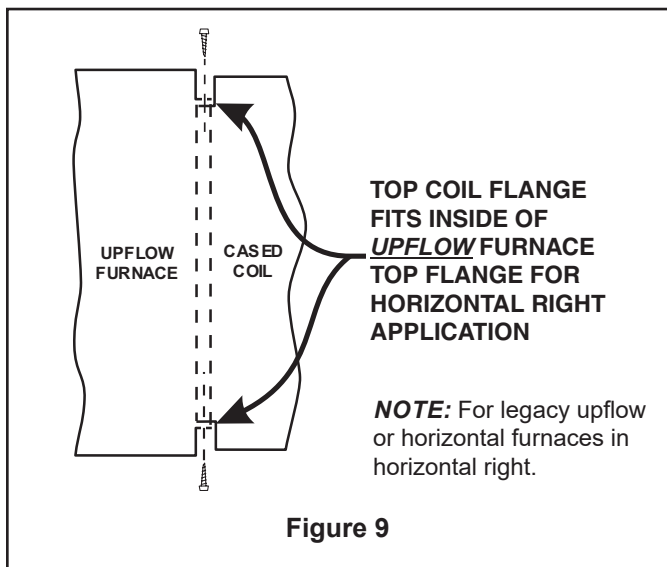
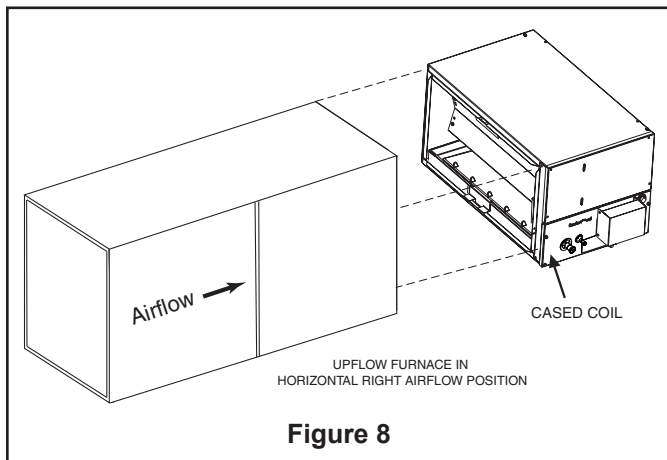
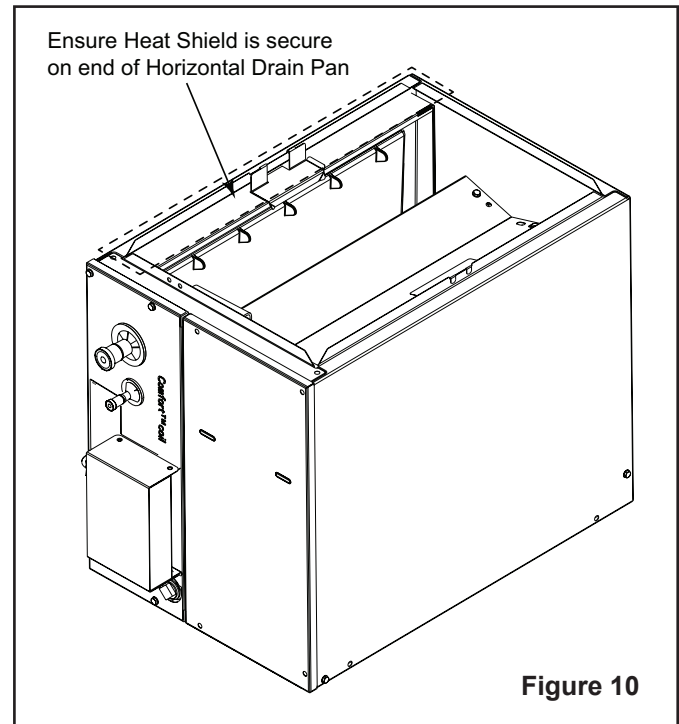
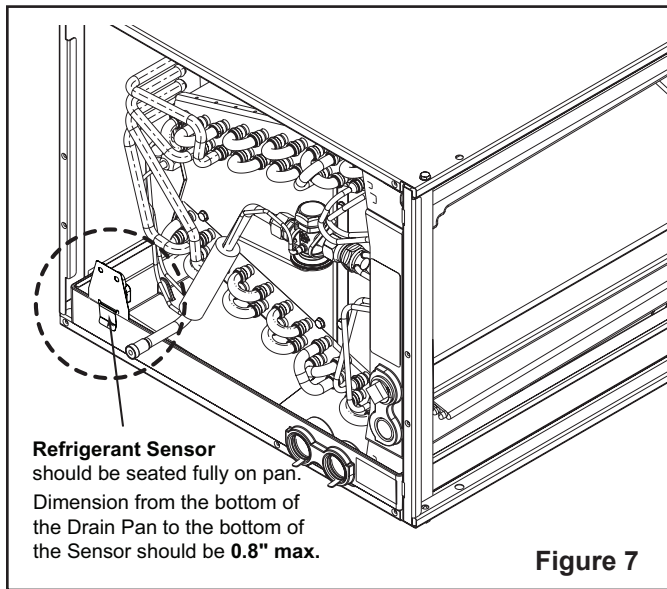

Figure 6

Installer's Guide



I. FURNACE IN HORIZONTAL LEFT POSITION:

⚠ CAUTION

Both the coil and furnace must be fully supported. Screws and standoffs are provided for alignment only.

HORIZONTAL LEFT COIL CONVERSION:

1. Splash Guard installation is required to prevent water blowoff.
 - a. Place Channel for Splash Guard into Horizontal Drain Pan as shown in Figure 11.
 - b. Slide the new Horizontal Drain Pan onto the coil and slide back into the coil cabinet.
 - c. Bend rear tab on top baffle inward towards the coil to avoid interference with splash guard. See Figure 14.
 - d. Wedge flange of Splash Guard between Channel for Splash Guard and Horizontal Drain Pan as shown in Figure 13.
 - e. Drive one field-supplied sheet metal screw into Splash Guard through factory-provided clearance hole in the front duct flange on the coil case. Refer to Figure 13.
2. Attach the coil and furnace in the orientation shown in Figure 12. For S-Series furnaces, bend flanges to accommodate installation as shown in Figure 6.
3. Insert standoffs into clearance holes in coil cabinet and use self-drilling screws to align coil and furnace. See Figure 4. Seal all gaps between the furnace and coil.
4. Pull refrigerant sensor and clip up and away from the primary drain pan and remove it from the pan. Secure sensor to secondary pan using provided clip. Sensor should be positioned close to secondary drain lines. See Figure 7 for detail.

Ensure sensor wiring harness is clear of refrigerant lines to avoid damage during field connection brazing. In some models, the wire tie attaching the sensor harness to the TXV body may need to be snipped to allow for wire harness to be extended for correct sensor placement.

NOTE:

Screws and standoffs are for alignment only. Equipment must be fully supported when installed in horizontal.

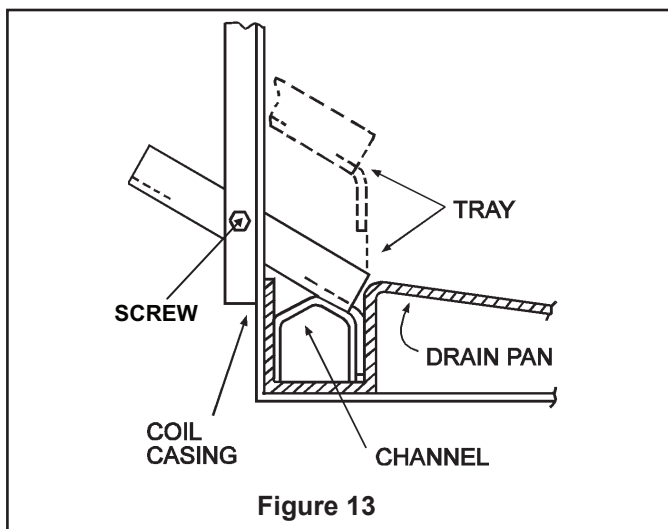
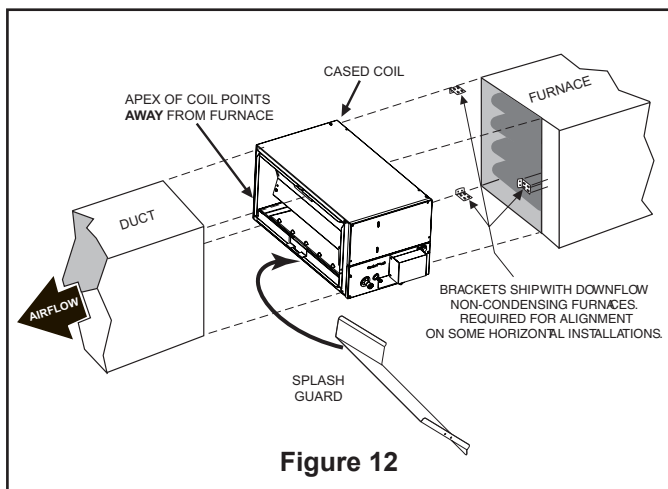
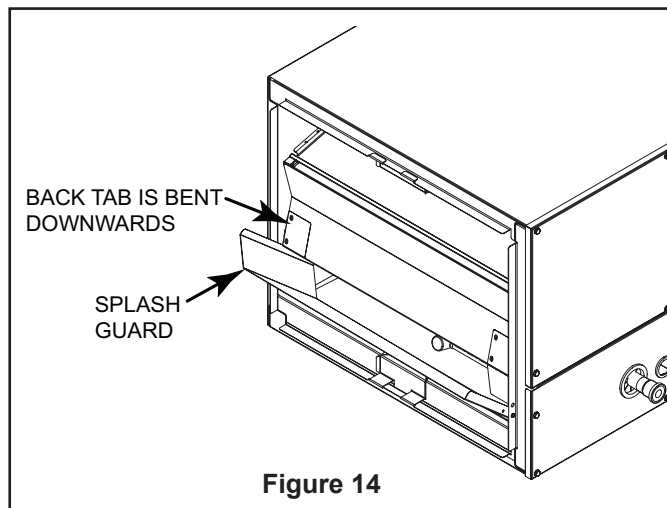
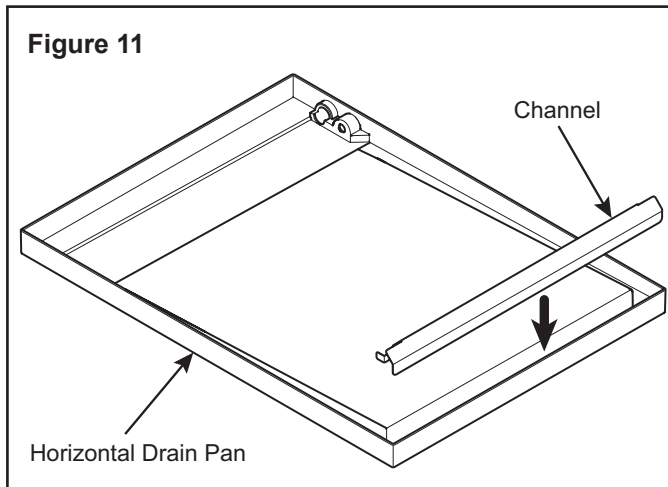

J. MAXIMUM AND MINIMUM AIRFLOW SETTINGS:

NOTE:

Water blow-off could occur in certain installation positions if the airflow setting exceeds the maximum values listed.

Maximum airflow settings (CFM)				
Coil	Upflow	Downflow	Horizontal Left	Horizontal Right
5TXCB004AS	1350	1100	1200	1350
5TXCD010AS	2250	1850	2000	2250

When a refrigerant leak of the indoor coil is detected, the refrigerant leak detection system turns on the blower of the furnace to dilute leaked refrigerant.

The installer must verify that the indoor airflow setting is sufficient to dilute leaked refrigerant. The nominal airflow settings for first-stage cooling, first-stage heat pump, and first-stage furnace heat should not be less than shown in the minimum airflow table below.

NOTE:

The airflow setting should be verified by comparison to the airflow at the lowest listed external static pressure for the setting. Refer to the airflow table provided by the manufacturer of the furnace.

Installer's Guide

Minimum Airflow Setting	
System refrigerant charge (lb) +	Minimum Airflow Setting (CFM)
less than 4	no minimum
4	108
5	135
6	162
7	189
8	216
9	244
10	271
11	298
12	325
13	352
14	379
15	406
16	433
17	460
18	487
19	514
20	541

+ The system refrigerant charge is the total system charge which is marked on the system according to the instructions provided by the manufacturer of the outdoor unit.

K. INSTALLING/BRAZING REFRIGERANT LINES:

⚠ WARNING

RISK OF FIRE!

Failure to following this warning could result in serious injury, death, or property damage. The following requirements apply to the room where the cased coil is installed:

- All combustion appliances located in the same room that have continuous pilot lights are equipped with an effective flame arrest.
- Auxiliary devices which may be a potential ignition source, such as hot surfaces or electric switching devices, shall not be installed in the connecting ductwork unless they have been approved by the manufacturer or declared suitable with the refrigerant used.
- All indoor field-made joints of the field piping have been checked for refrigerant leaks after charging using an electronic leak detector calibrated for R-454B having a sensitivity of 5 grams per year or better.
- The room is constructed to ensure that should any refrigerant leak it will not stagnate and create a fire hazard.

⚠ CAUTION

Do **NOT** open refrigerant valve at the outdoor unit until the refrigerant lines and coil have been brazed, evacuated, and leak checked. This would cause contamination of the refrigerant or possible discharge of refrigerant to the atmosphere.

1. The following steps are to be considered when installing the refrigerant lines:
 - a. Determine the most practical way to run the lines.
 - b. Consider types of bends to be made and space limitations.
 - c. Route the tubing making all required bends and properly secure the tubing before making final connections.

NOTE:

Refrigerant lines must be isolated from the structure and the holes must be sealed weather tight after installation.

IMPORTANT:

Do not unseal refrigerant tubing until ready to fit refrigerant lines.

There is only a holding charge of dry air in the indoor coil, therefore no loss of operating refrigerant charge occurs when the sealing plugs are removed.

NOTE:

TXV bulb MUST be protected (wrapped with wet rag) or removed, while brazing the tubing. Overheating of the sensing bulb will affect the functional characteristics and performance of the comfort coil.

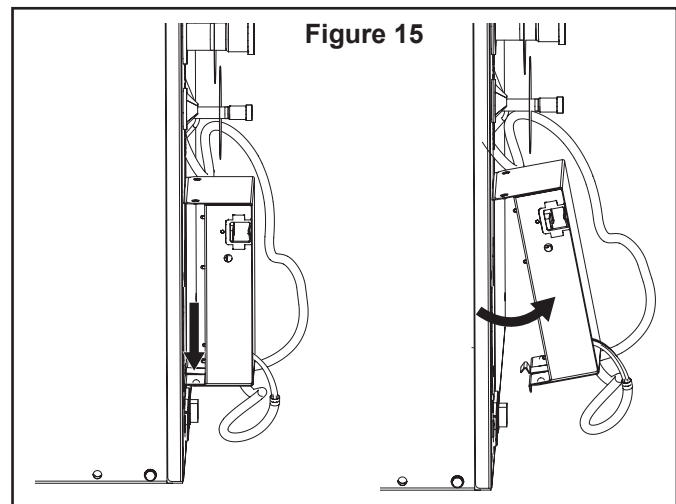

1. Clear all A2L sensor wires well away from the braze connections both inside and outside the coil cabinet. If needed, the control box may be removed from the lineset panel by pressing outward on snap and rotation out for clearance. See Figure 15.
2. Remove both rubber plugs from the indoor coil.
3. Field supplied tubing should be cut square, round and free of burrs at the connecting end. Clean the tubing to prevent contaminants from entering the system.
4. Run the refrigerant tubing into the stub tube sockets of the indoor unit coil.

PAINTED AREAS OF THE UNIT MUST BE SHIELDED DURING BRAZING.

5. Flow a small amount of nitrogen through the tubing while brazing.
6. Use good brazing technique to make leakproof joints.
7. Minimize the use of sharp 90 degree bends.
8. Insulate the suction line and its fittings.
9. Do NOT allow un-insulated lines to come into contact with each other.

Note:

When replacing the TXV bulb, reinstall the bulb in the proper orientation using the spring clip provided.

9. Rewrap the TXV bulb, spring clip, and suction line with insulation after spring clip is reinstalled.

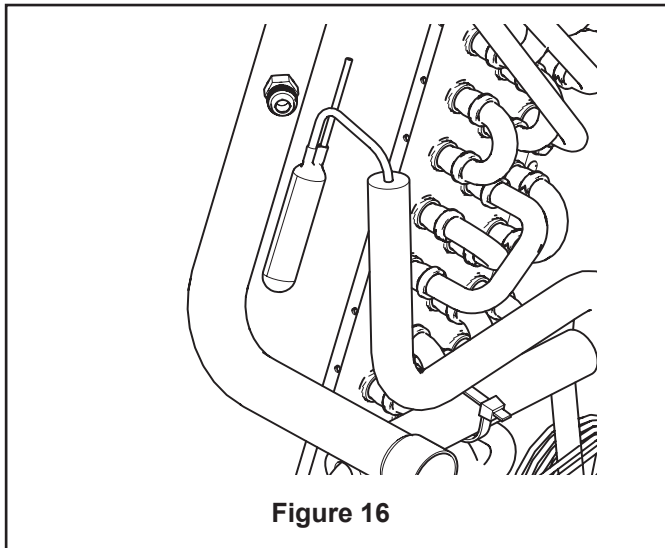

Figure 16

NOTE:

The TXV setting on this unit may run high superheat (15-25 °F) when measured at the outdoor unit when installed in upflow or horizontal left positions.

10. For optimal performance, the TXV bulb may be relocated outside the coil cabinet after the field line brazing is complete.
 - a. Remove the bulb insulation and bulb clip/hose clamp.
 - b. Lace the TXV bulb through the large coil panel grommet.
 - c. Assemble the TXV bulb to the field provided suction line outside the unit using the hose clamp provided in the documentation pack. Ensure the bulb is mounted on a straight, smooth section of the copper line. The bulb should be clear of any field braze joints and located away from any bends in the pipe.
 - d. The recommend installation position for the TXV bulb is parallel to the ground (on a horizontal plane). The bulb position should be at 2 o'clock or 10 o'clock. See Figure 17.
 - e. Wrap the bulb and suction with field provided insulation after the hose clamp is installed.

L. PRESSURE TEST:

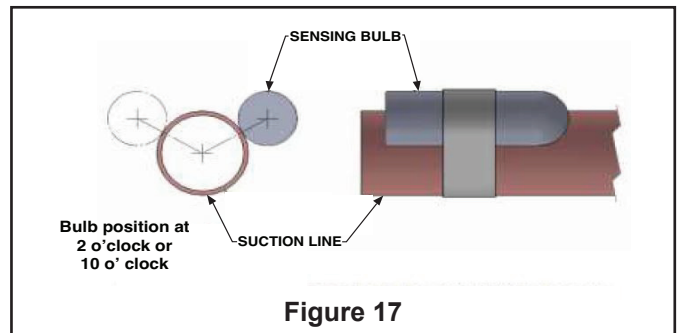
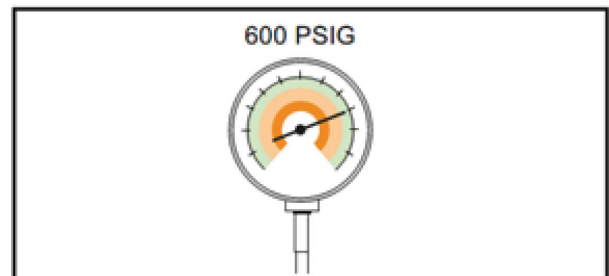
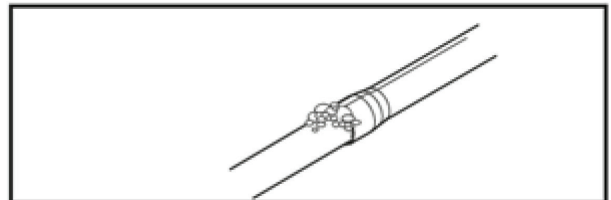

Figure 17

- Using dry nitrogen, pressurize the field piping and indoor coil to the lower of the maximum operating pressures listed on the name plates of the indoor and outdoor units (likely 600 psi).



- The test pressure after removal of the pressure source shall be maintained for at least one (1) hour with no decrease of pressure indicated by the test gauge, with the test gauge resolution not exceeding 30 psi.
- Check for leaks by using a soapy solution at each field-made joint.



Note: Remove nitrogen pressure and repair any leaks before continuing.

M. VACUUM TEST:

Important: Do not open the service valves until the refrigerant lines and indoor coil leak check and evacuation are complete.

- Evacuate until the micron gauge reads no higher than 350 microns, then close off the valve to the vacuum pump.

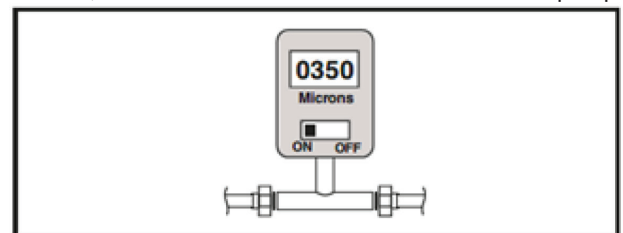

- Observe the micron gauge. Evacuation is complete if the micron gauge does not rise above 500 microns in one (1)

Installer's Guide

minute and 1500 microns in ten (10) minutes.

- Once evacuation is complete, blank off the vacuum pump and micron gauge, and close the valve on the manifold gauge set.

All procedures for charging the system with refrigerant shall be according to the instructions provided by the manufacturer of the outdoor unit.

Important: *Under no circumstances shall potential sources of ignition be used in the searching for or detection of refrigerant leaks.*

After charging the system, all indoor field-made joints of the field piping shall be checked for refrigerant leaks using an electronic leak detector calibrated for R-454B having a sensitivity of 5 grams per year or better.

N. CONDENSATE DRAIN PIPING:

Condensate drain connections are located in the drain pan at the bottom of the coil/enclosure assembly. The female threaded fitting protrudes outside of the enclosure for external connection. A field fabricated trap is not required for proper drainage due to the positive pressure of the furnace; however, it is recommended to prevent efficiency loss of conditioned air.

1. The drain hole in the drain pan must be cleared of all insulation.
2. Insulate the primary drain line to prevent sweating where dew point temperatures may be met. (Optional depending on climate and application needs)
3. Connect the secondary drain line to a separate drain line (no trap is needed in this line).

O. CLEANING THE COIL:

The two piece door allows removal of the outer casing doors without interference from refrigerant or condensate lines. Once the outer doors are removed the inner coil panels can be removed. The inside and outside of the coil can be cleaned with a brush and vacuum with the panels removed. See Figure 18.

The foil covered insulation should be wiped down and residual dirt and dust should be vacuumed up to maintain good air quality. See Figure 19.

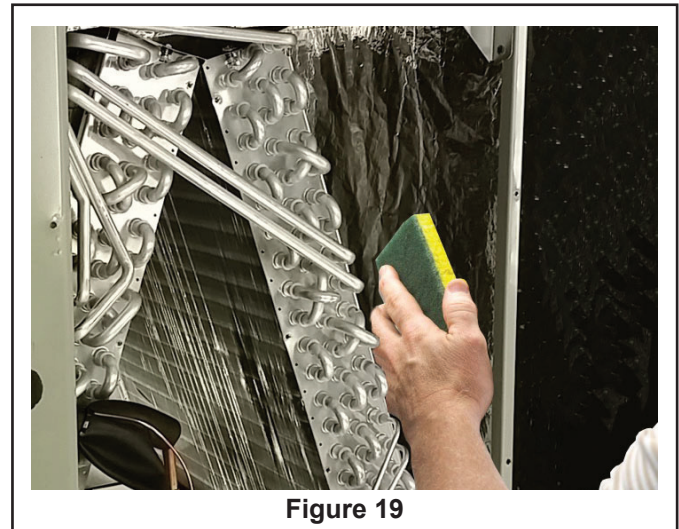

P. WIRING - COMMUNICATING SYSTEMS:

Use extra CAN connectors provided with communicating furnaces and/or SMART HUB accessories and field provided wiring.

After installation, the installer must verify that the refrigerant leak detection system actuates all mitigating actions listed above.

The test can be initiated by shorting the two test pins on the header of the mitigation control board inside of the unit. The mitigating actions will continue for approximately 5 minutes. See Figure 20 above.

If any of the mitigating actions are not actuated by the system during the test, please check the following:

- All field wiring connections should be checked against the diagrams in the "Field Wiring Diagrams" page 15 section of this manual.
- The diagnostic indicators on the mitigation control board should be checked against the diagnostic codes given in below.
- Scan the QR code below for more information on field troubleshooting of the refrigerant leak detection system.

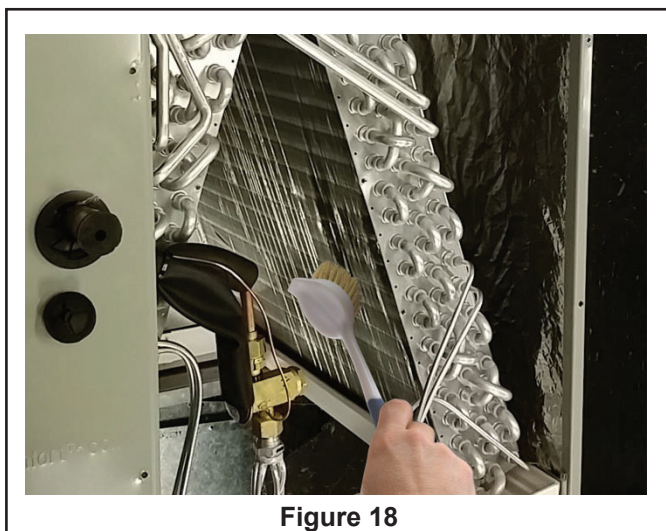

Q. AHC BOARD CONNECTIONS:

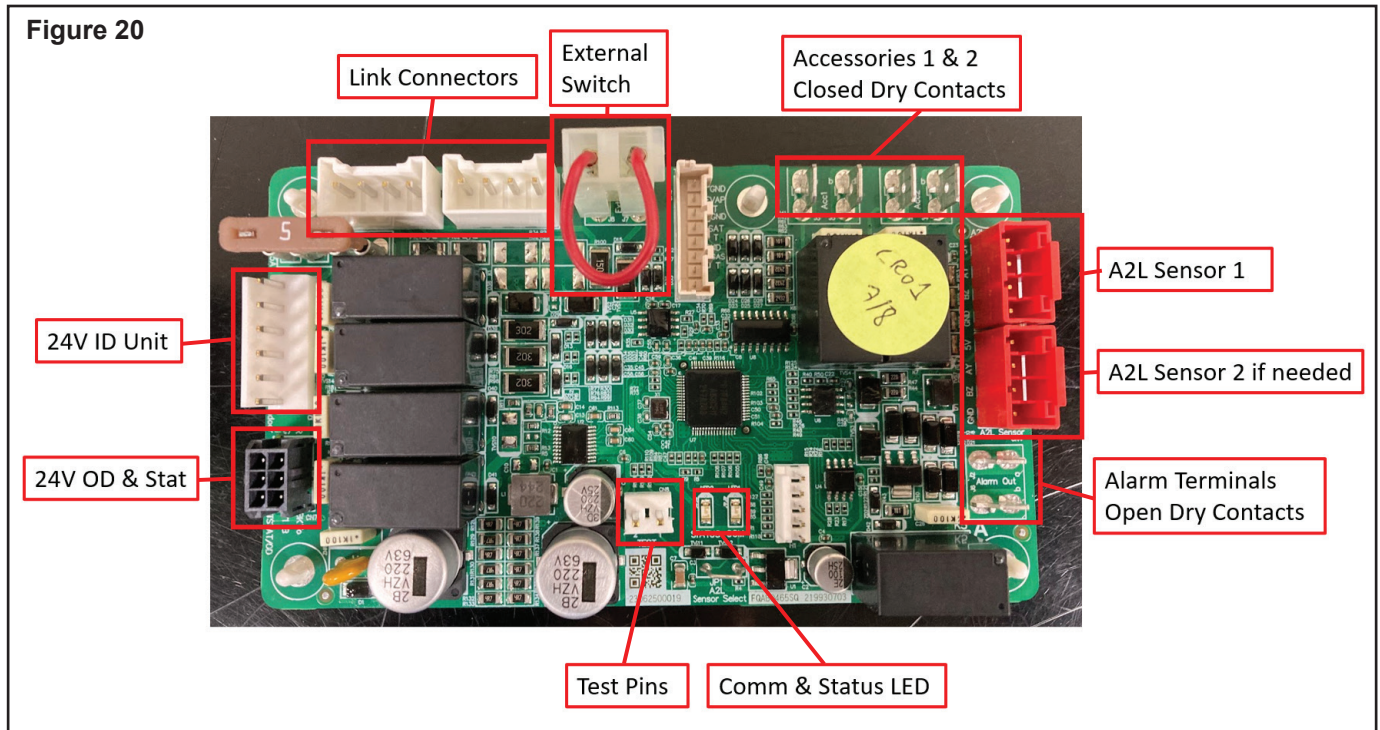

R. TROUBLESHOOTING THE REFRIGERANT DETECTION SYSTEM:

If MCB is showing active alarm at startup:

Check harness connections at MCB and sensor. Wait 20 seconds to see if mitigation clears.

If refrigerant is detected, the 5 minute timer can be reset by cycling power to the unit.

S. CONTROL BOX RELOCATION (OPTIONAL):

The control box may be relocated from the coil cabinet to allow for clearance to braze connections, condensate connections, or other space constraints, with use of extension kit optional accessory BAYMCBHARNESH. To avoid puncturing refrigerant tubes, it is not recommended to screw control box to coil cabinet.

T. FLASH CODES:

FLASH CODES	MCB COMM (AMBER LED)	FLASH CODES	MCB STATUS (GREEN LED)
OFF	No Power/Off or in 24V mode	OFF	No Power/Off
ON	24V mode active	ON	Start Up
NODE COUNT	Communication Mode Active/Normal Operation	SLOW BLINK	Normal Operation
FAST BLINK	CAN Communication lost	3	Active Alarm - Refrigerant Leak, Sensor Comm Error or Sensor Error
		4	Past Refrigerant Detected Alarm
		5	Past Sensor Comm Error
		6	Past Sensor Error

NOTE: All Past Alarm flash codes are present for 30 days post occurrence.

Installer's Guide

U. WIRING:

The refrigerant detection system must be wired to the furnace thermostat, and outdoor unit in order to function as intended. A 24V wire harness is provided for connections to non-communicating systems. Route 24V harness wires and any extra accessory wires through saddle grommet and provided strain relief wire tie located on MCB control box. An arrowhead wire tie is provided in the documentation pack to strain relieve the two wires passing through the saddle grommet. When wire tie is applied, it should be wrapped around the 24V harness and the sensor harness for strain relief. See Figure 21. No harness is provided for communicating systems that use CAN connections. For communicating systems, use extra CAN connectors provided in HUB hit and/or communicating furnace to connect MCB to furnace. See Figure 22.

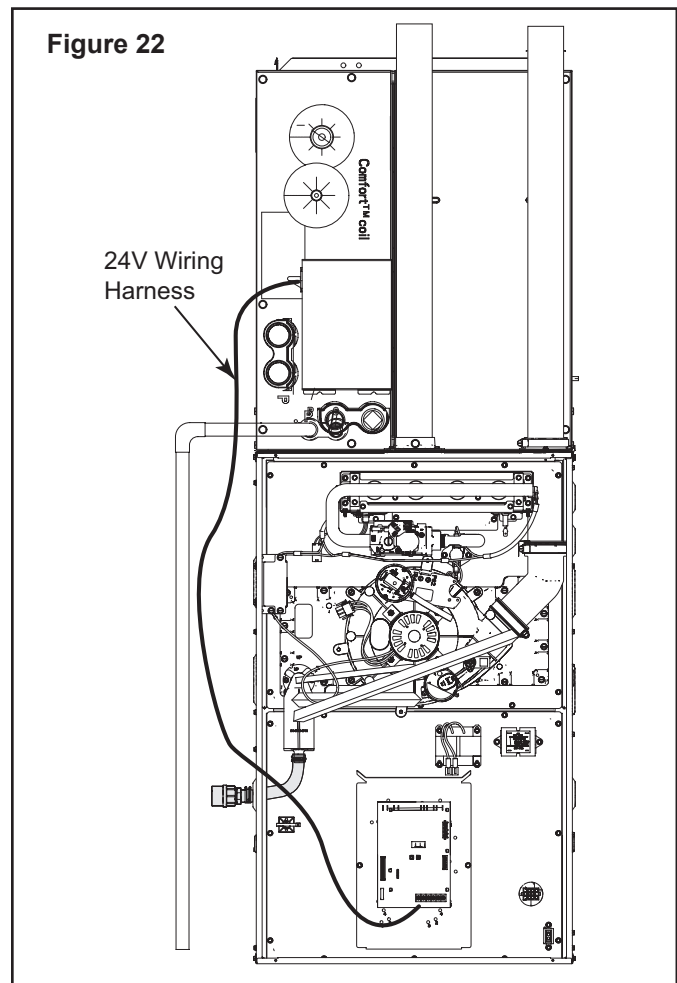
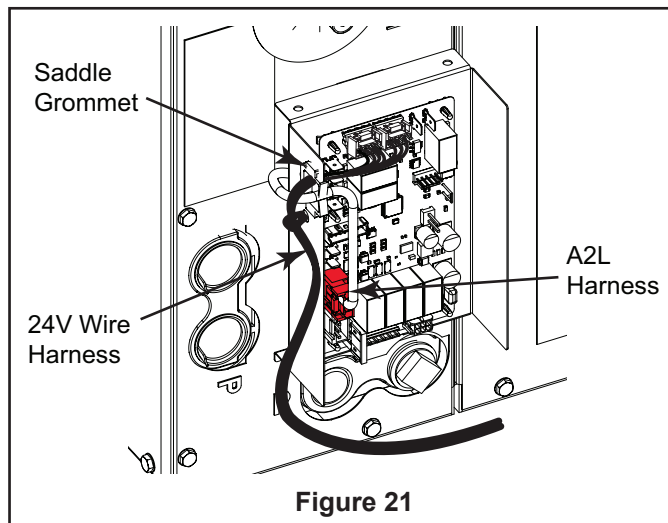

For 24V systems, use field provided wire harness.

1. Wires bundled with "To Furnace" flag label should be wired to the furnace low voltage terminal strip.
2. Wires bundled with "To Thermostat" flag label should be spliced to field provided thermostat wire within the furnace cabinet.
3. Wires bundled with "To Outdoor" flag label should be spliced to field provided outdoor wire within the furnace cabinet.

See Figure 23.

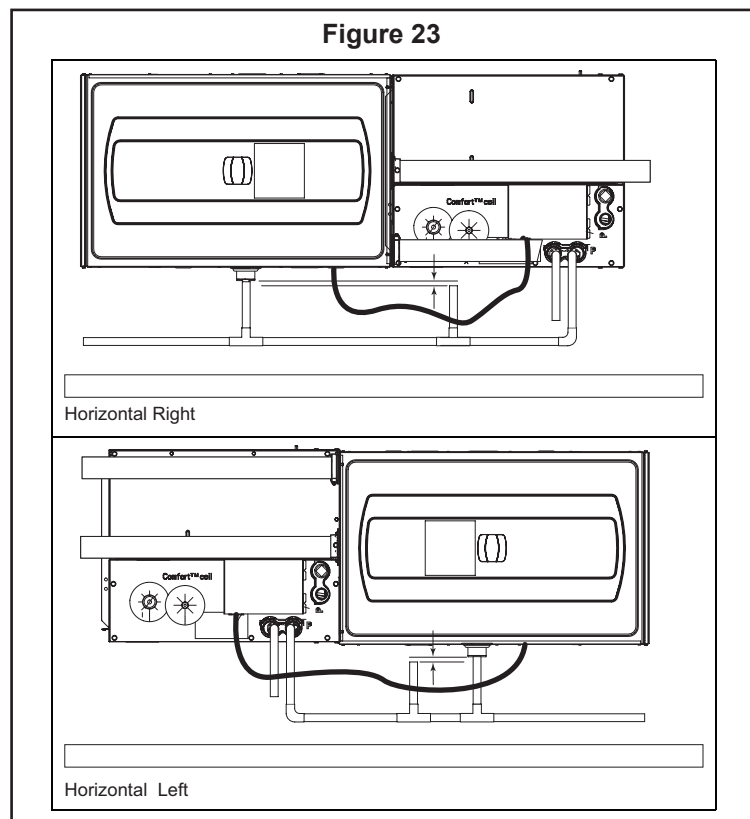

V: FIELD WIRING DIAGRAMS:

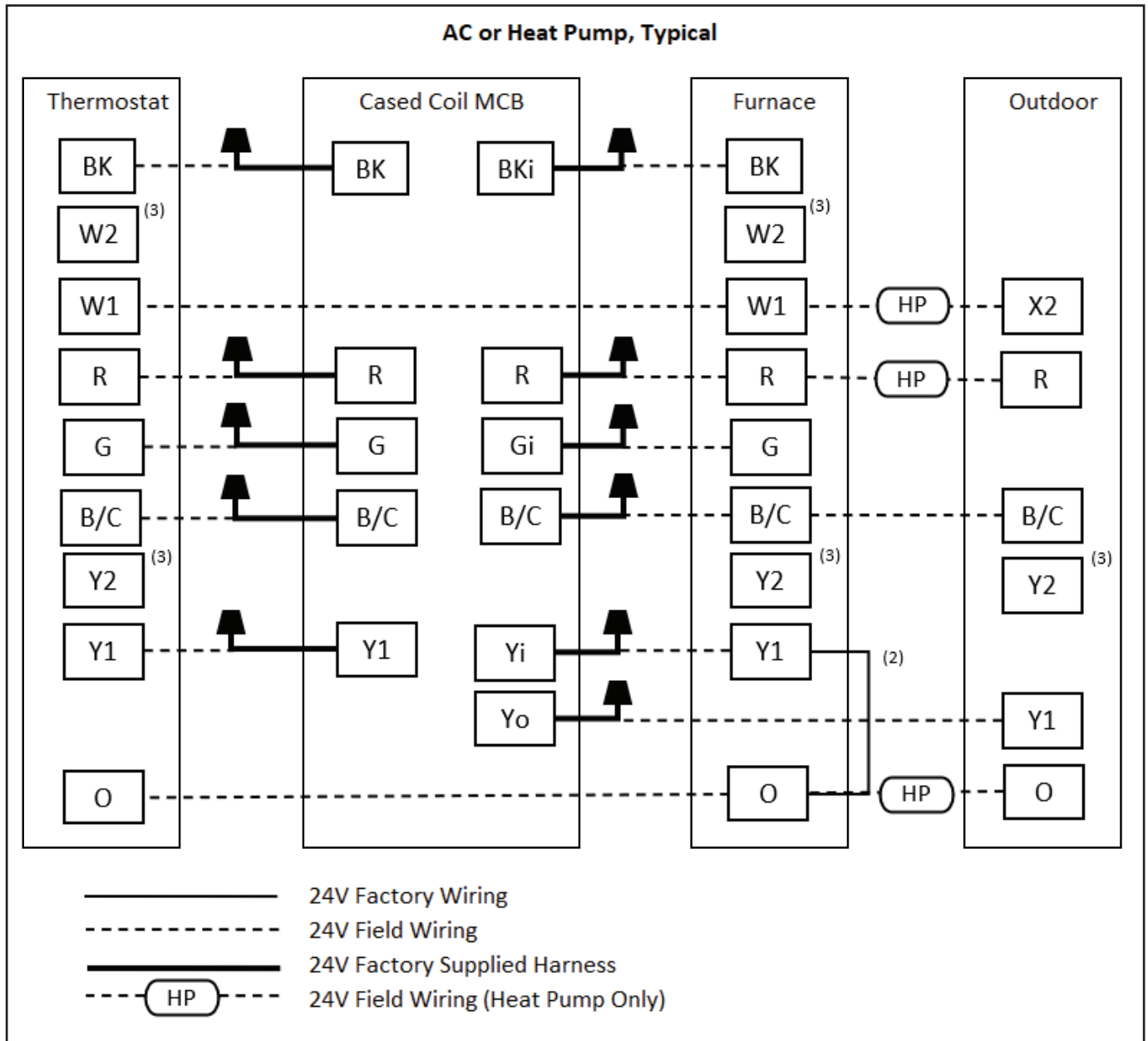

Notes:

1. For 24V control, connect factory supplied harness to circuit board at evaporator. Complete all other wiring connections at furnace.
2. For heat pump systems, remove factory Y1 - O jumper at furnace (if equipped).
3. For 2-stage systems, connect W2 to W2 and Y2 to Y2.
4. For Link enabled systems, omit all 24V wiring and use "CAN" connection only.

Installer's Guide

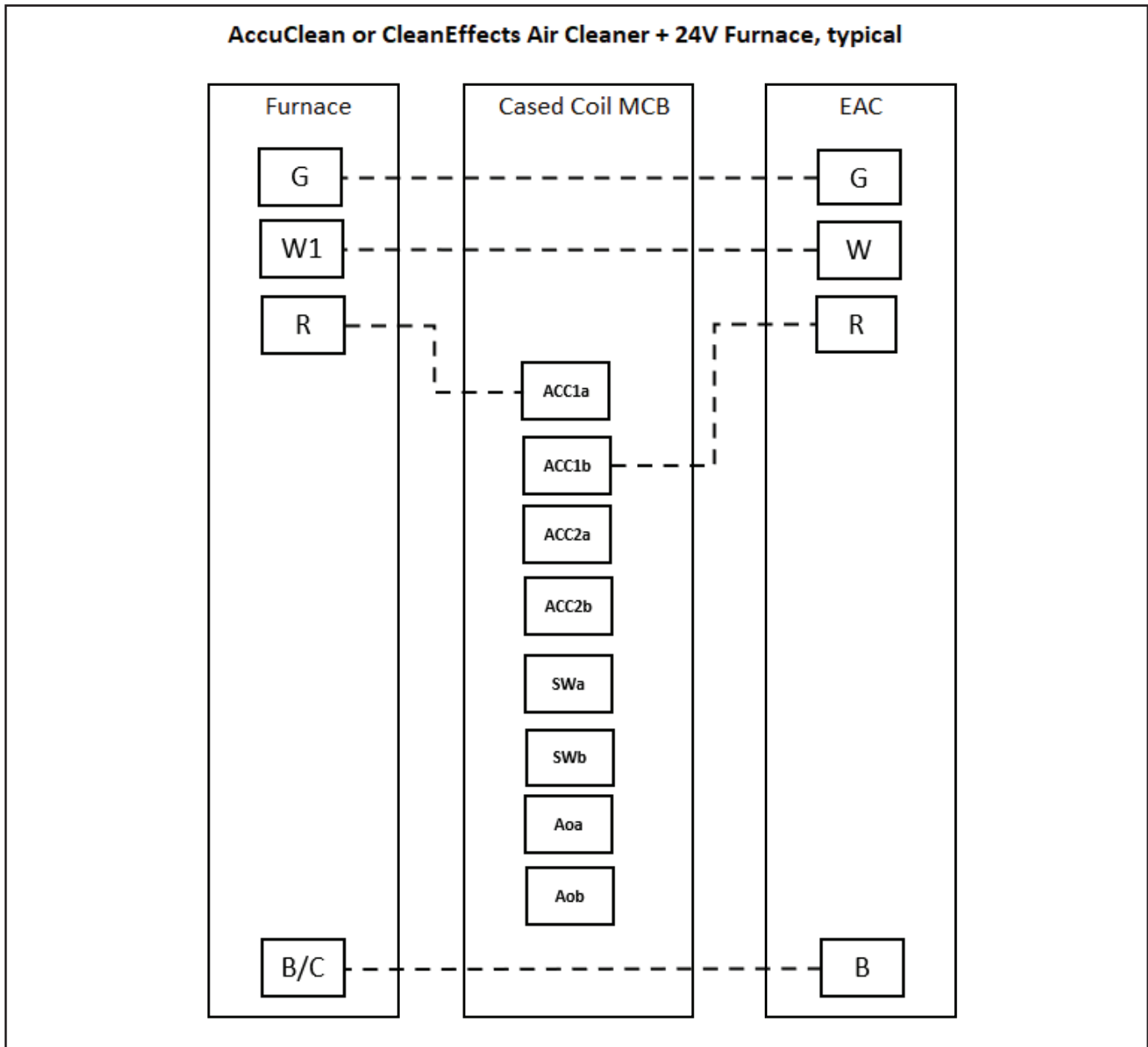

Notes:

1. Installation of air cleaner will require replacement of furnace transformer. Refer to air cleaner literature.
2. For legacy 40" furnaces (models *UD, *UH, *DD, *DH), do not use EAC wire on the furnace control board. Wire as shown in this diagram.

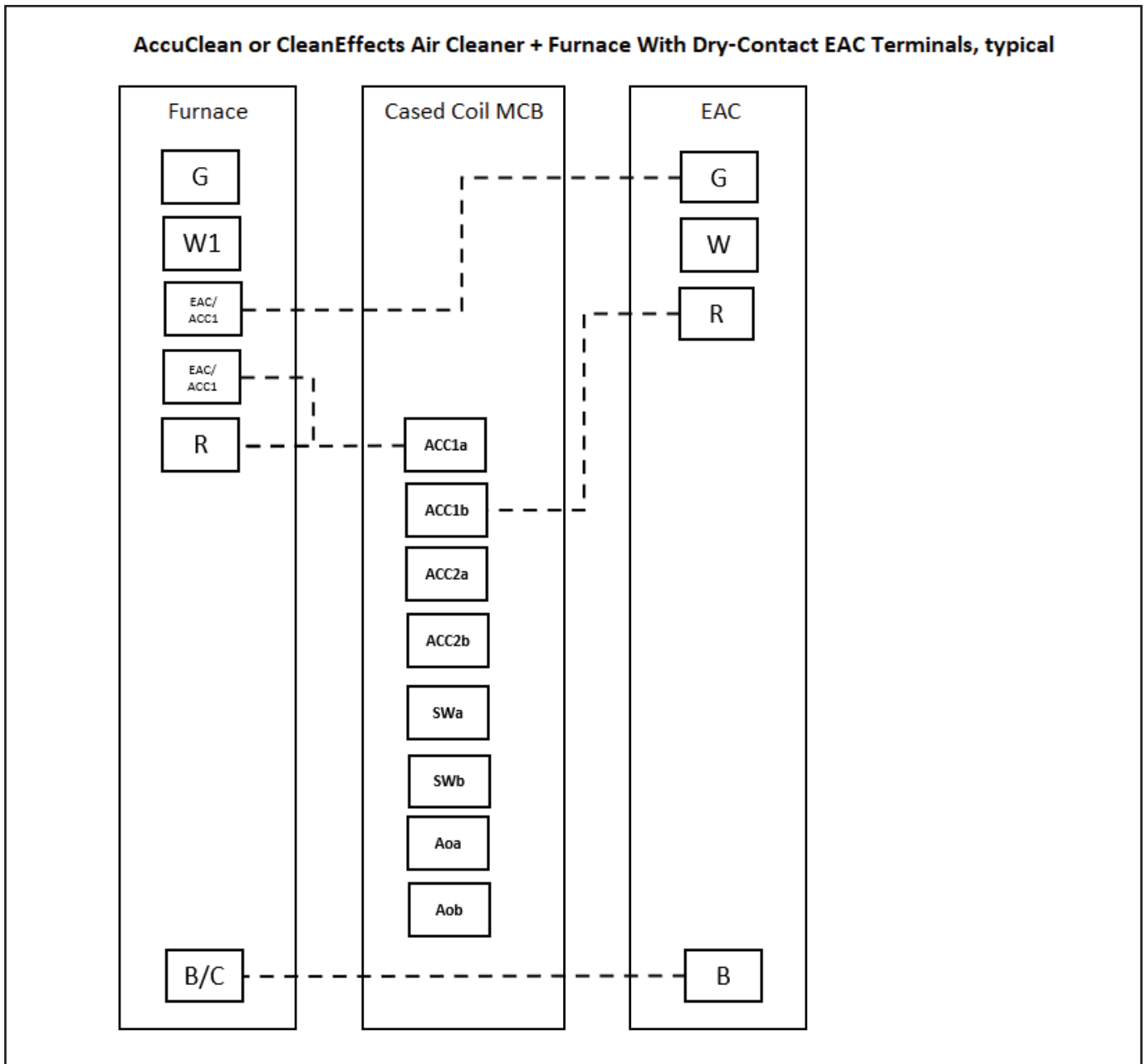

Notes:

1. Installation of air cleaner will require replacement of furnace transformer. Refer to air cleaner literature.
2. S*X, S*V, A8, A9, L8, or P0 models include EAC or ACC dry contacts as shown. (*UD, *UH, *DD, *DH, or S*B models do not utilize dry contact accessory connections.)

Installer's Guide

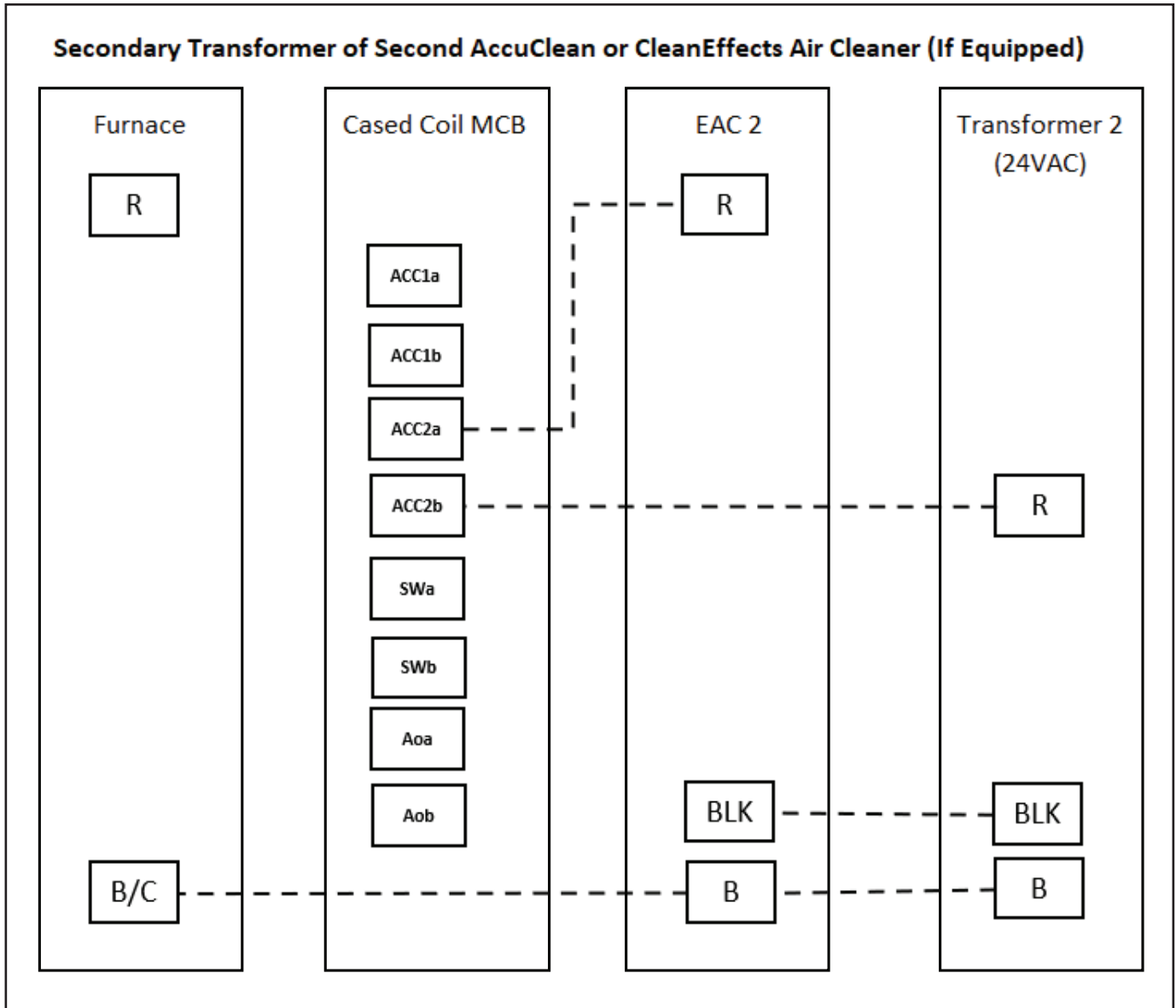

Notes:

1. Refer to air cleaner literature to determine if second air cleaner and/or secondary transformer is required.
2. See the other air cleaner wiring diagrams for control wiring connections.

24VAC Audible Alarm, typical

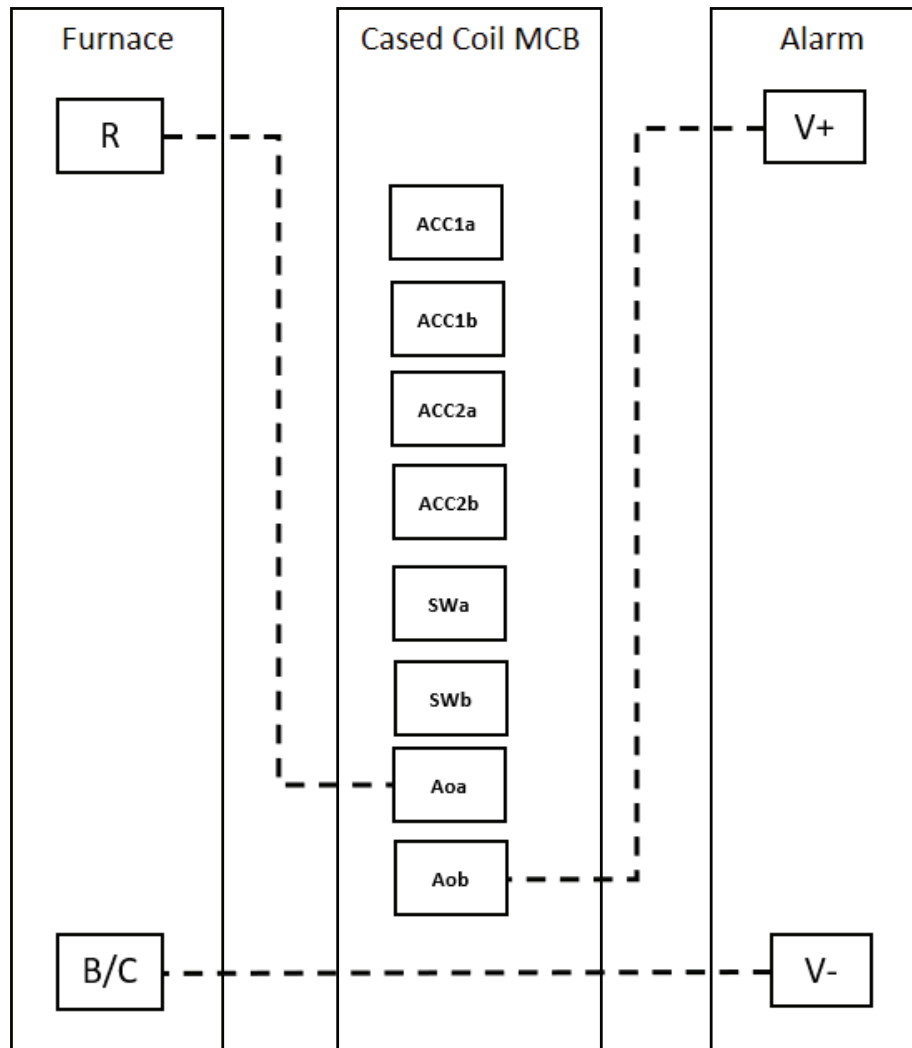

Installer's Guide

W: OUTLINE DRAWING for model: 5TXCB004DS3HCC, 5TXCD010DS3HCC

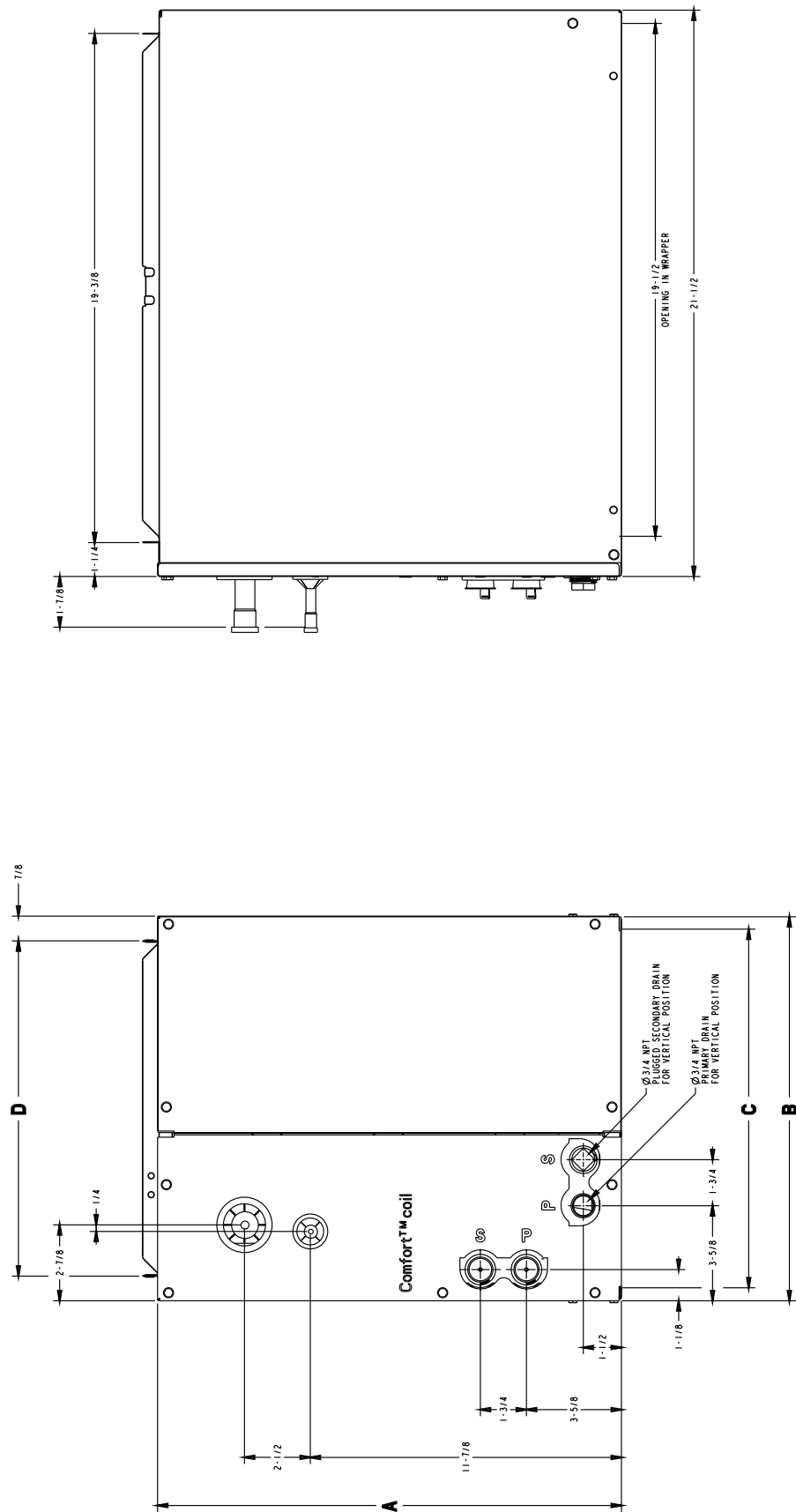

MODEL	4TXCB004DS3	4TXCD010DS3
SEE FIGURE	FIGURE A	FIGURE A
SHIPPING WEIGHT (LBS.)	58	81
REFRIGERANT CONTROL	TXV (NON-BLEED)	
HEIGHT "A" (IN.)	22-1/2	30-3/4
OVERALL WIDTH "B" (IN.)	17-1/2	24-1/2
OPENING WIDTH "C" (IN.)	16-5/8	23-5/8
TOP OPENING "D"	15-3/4	22-3/4
GAS CONNECTION	7/8	
LIQUID CONNECTION	3/8	
MATCHED FURNACE WIDTH (NO ADAPTER REQUIRED)	17-1/2	24-1/2
DRAIN PAN	PLASTIC	

From Dwg. D346710 Rev. A

X: TROUBLESHOOTING:

Before starting, insure the blower wheel, indoor and outdoor coils are clean.

Troubleshooting Indoor TXV / Cooling Mode

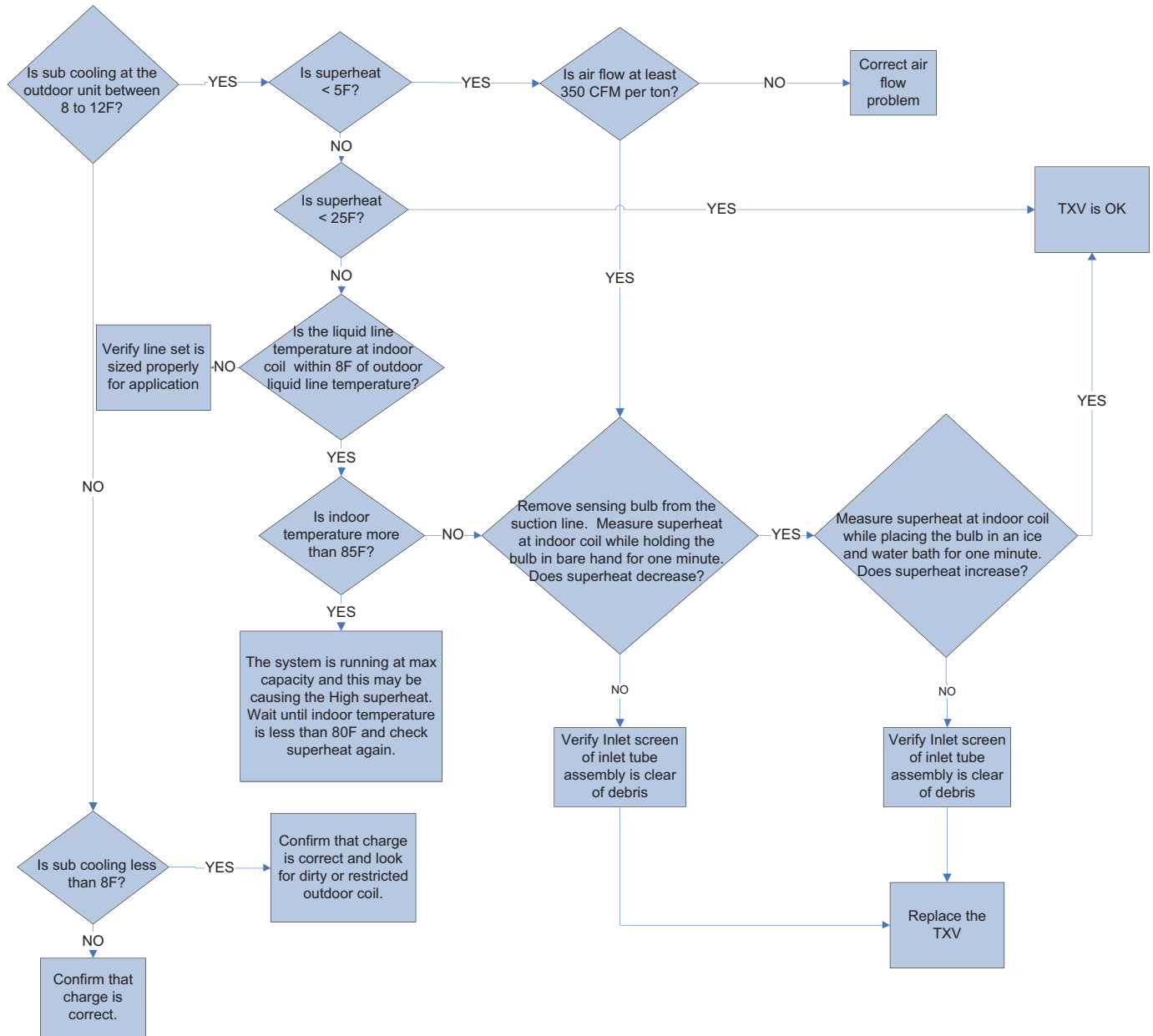

Installer's Guide

Y: CHECKOUT PROCEDURES:

The final phase of the installation is the system Checkout Procedures. The following list represents the most common items covered in a Checkout Procedure. Confirm all requirements in this document have been met.

<ul style="list-style-type: none"><input type="checkbox"/> All wiring connections are tight and properly secured.<input type="checkbox"/> Voltage and running current are within limits.<input type="checkbox"/> All refrigerant lines (internal and external to equipment) are isolated, secure, and not in direct contact with each other or structure.<input type="checkbox"/> All braze connections have been checked for leaks. A vacuum of 350 microns provides confirmation that the refrigeration system is leak free and dry. Additional refrigerant weight is recorded on a label by the unit nameplate.<input type="checkbox"/> If unit is installed in any orientation other than upflow, refrigerant sensor is properly relocated.<input type="checkbox"/> Final unit inspection to confirm factory tubing has not shifted during shipment. Adjust tubing if necessary so tubes do not rub against each other or any component when unit runs.<input type="checkbox"/> Ductwork is sealed and insulated.	<ul style="list-style-type: none"><input type="checkbox"/> All drain lines are clear with joints properly sealed. Pour water into drain pan to confirm proper drainage. Provide enough water to ensure drain trap is primed.<input type="checkbox"/> Supply registers and return grilles are open, unobstructed, and air filter is installed.<input type="checkbox"/> Indoor blower and outdoor fan are operating smoothly and without obstruction.<input type="checkbox"/> Indoor blower motor set on correct speed setting to deliver required CFM. "Blower and fan set screws are tight."<input type="checkbox"/> Cover panels are in place and properly tightened.<input type="checkbox"/> System functions safely and properly in all modes.<input type="checkbox"/> Refrigerant leak detection system mitigation actions are verified.<input type="checkbox"/> All refrigerant safety procedures have been verified.<input type="checkbox"/> Owner has been instructed on use of system and given manual.
---	---

NOTES:

About Trane and American Standard Heating and Air Conditioning
Trane and American Standard create comfortable, energy efficient indoor environments for residential applications.
For more information, please visit www.trane.com or www.americanstandardair.com



The manufacturer has a policy of continuous data improvement and it reserves the right to change design and specifications without notice. We are committed to using environmentally conscious print practices.

18-AD45D1-1B-EN 29 Jan 2024
Supersedes 18-AD45D1-1A-EN (January 2024)

© 2024