



Cased Aluminum Coils

"Dedicated Upflow / Downflow"

Convertible to horizontal with separately purchased kit

Upflow models:

- 4PXCAU24BS3HAA
- 4PXCAU32BS3HAA
- 4PXCBU24BS3HAA
- 4PXCBU30BS3HAA
- 4PXCCU30BS3HAA
- 4PXCBU36BS3HAA
- 4PXCCU36BS3HAA
- 4PXCBU42BS3HAA
- 4PXCCU42BS3HAA
- 4PXCBU48BS3HAA
- 4PXCCU48BS3HAA
- 4PXCDU48BS3HAA
- 4PXCCU60BS3HAA
- 4PXC60BS3HAA

Downflow models:

- 4PXCAD24BS3HDA
- 4PXCBD24BS3HDA
- 4PXCBD30BS3HDA
- 4PXCCD30BS3HDA
- 4PXCBD36BS3HDA
- 4PXCCD36BS3HDA
- 4PXCBD42BS3HDA
- 4PXCCD42BS3HDA
- 4PXCBD48BS3HDA
- 4PXCCD48BS3HDA
- 4PXCDD48BS3HDA
- 4PXCCD60BS3HDA
- 4PXCDD60BS3HDA

ALL phases of this installation must comply with NATIONAL, STATE AND LOCAL CODES

IMPORTANT—This Document is **customer property** and is to remain with this unit. Please return to service information pack upon completion of work.

⚠ WARNING

WARNING (Medium/high pressure)
Contains Refrigerant!

System contains oil and refrigerant under high pressure. Recover refrigerant to relieve pressure before opening the system. See unit nameplate for refrigerant type. Do not use non-approved refrigerants, refrigerant substitutes, or refrigerant additives.

Failure to follow proper procedures or the use of non-approved refrigerants, substitutes, or refrigerant additives could result in death, serious injury, or equipment damage.

⚠ WARNING

This product can expose you to chemicals including lead, which are known to the State of California to cause cancer and birth defects or other reproductive harm. For more information go to www.P65Warnings.ca.gov

A. GENERAL

These coils are designed for use in combination with a heat pump or cooling outdoor section using **R-410A REFRIGERANT**.

The 4PXC equipment has been evaluated in accordance with the Code of Federal Regulations, Chapter XX, Part 3280 or the equivalent. "Suitable for Mobile Home use" The height of the Furnace, Coil and discharge duct work must be 7 ft. or less.

Inspect the coil for shipping damage. Notify the transportation company immediately if the coil is damaged.

B. APPLICATION INFORMATION

NOTE: 4PXC upflow coils may be installed in Upflow, Downflow, Horizontal Right with kit, and Horizontal Left with kit.

4PXC downflow coils may be installed in Downflow and Horizontal Right with kit.

1. FURNACE AND COIL

The coil **MUST BE** installed downstream (in the outlet air) of the furnace.

Table of Contents

General	1
Application Information	1
Recommendation	2
Furnace in Upflow Position	2
Furnace in Downflow Position	3
Maximum Airflow Setting, CFM	3
Installing / Brazing Refrigerant Lines	3
Leak Check.....	4
Condensate Drain Piping.....	4
Cleaning the Coil	4
Outline Drawings	5
Troubleshooting Indoor TXV / Cooling Mode.....	8

NOTE:

OPTIONAL DOWNFLOW GASKET INSTALLATION: For unusually humid applications that expect prolonged operation above 70% RH, it is recommended to use the **BAYGSKT001A0** gasket kit to prevent water from forming on the bottom of the drain pan and dripping into the supply ductwork.

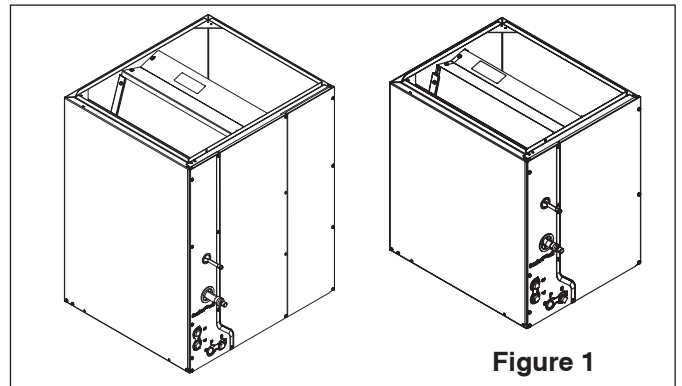

2. INDOOR UNIT AIRFLOW

Indoor unit must provide the required airflow for the heat pump or cooling combinations approved for these coils.

IMPORTANT: Review your installation requirements. Check the table on the outline drawings and note all dimensions for your coil before beginning the installation.

Installer's Guide

C. RECOMMENDATION

If a coil is part of the total system installation, use the Installer's Guide packaged with the furnaces, outdoor sections, and thermostat for physically installing those components.

IMPORTANT:

If installing the coil in the horizontal position, you MUST use the horizontal kit listed below for this coil model number and follow the instructions in the installation guide provided with the conversion kit.

NOTE:

4PXC upflow coils may be installed in Upflow, Downflow, Horizontal Right with kit, and Horizontal Left with kit. 4PXC downflow coils may be installed in Downflow and Horizontal Right with kit.

Model Number	Horizontal Kit No.
4PXCAU24BS3HAA 4PXCAU32BS3HAA 4PXCBU24BS3HAA 4PXCBU30BS3HAA 4PXCCU30BS3HAA 4PXCAD24BS3HDA 4PXCBD24BS3HDA 4PXCBD30BS3HDA 4PXCCD30BS3HDA	BAYCONV18A
4PXCBU36BS3HAA 4PXCCU36BS3HAA 4PXCBD36BS3HDA 4PXCCD36BS3HDA	BAYCONV23A
4PXCBU42BS3HAA 4PXCCU42BS3HAA 4PXCBU48BS3HAA 4PXCCU48BS3HAA 4PXC48BS3HAA 4PXCBD42BS3HDA 4PXCCD42BS3HDA 4PXCBD48BS3HDA 4PXCCD48BS3HDA 4PXCDD48BS3HDA	BAYCONV27A
4PXCCU60BS3HAA 4PXC48BS3HAA 4PXCCD60BS3HDA 4PXCDD60BS3HDA	BAYCONV30A

D. FURNACE IN UPFLOW POSITION

APPLICATION USES UPFLOW COIL MODELS ONLY

⚠ CAUTION

Caution: This coil is pressurized with 8-12 psig of dry air. Do not stand directly in front of the coil connections when removing sealing plugs. If no pressure is released, check for leaks.

1. UPFLOW COIL CONVERSION (Models:

4PXCBU36BS3HAA, 4PXCCU36BS3HAA, 4PXCBU42BS3HAA, 4PXCCU42BS3HAA, 4PXCBU48BS3HAA, 4PXCCU48BS3HAA, 4PXC48BS3HAA, 4PXC48BS3HAA, 4PXCCU60BS3HAA, 4PXC48BS3HAA only)

- For maximum efficiency, remove the factory installed two-piece baffle assembly from the apex of the coil by removing the 5/16" hex head screws. See Figure 2.
- Replace only the top baffle using the same screws previously removed.

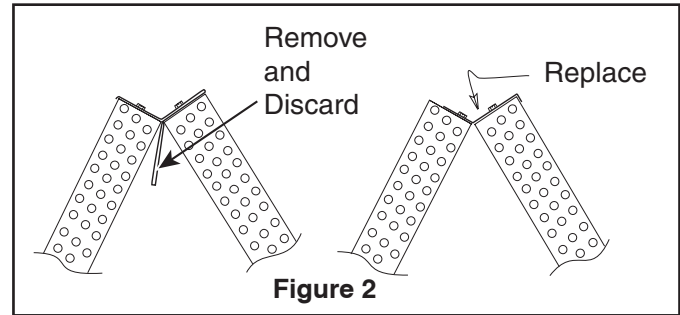

Figure 2

2. UPFLOW GAS FURNACE

- Apply gasket material (duct seal field supplied) to ALL mating surfaces between the furnace and the coil case.
- Set the coil case on top of the furnace. Connect the ductwork to the coil case using field supplied screws.
- Secure the coil case to the furnace and seal for air leaks as required.

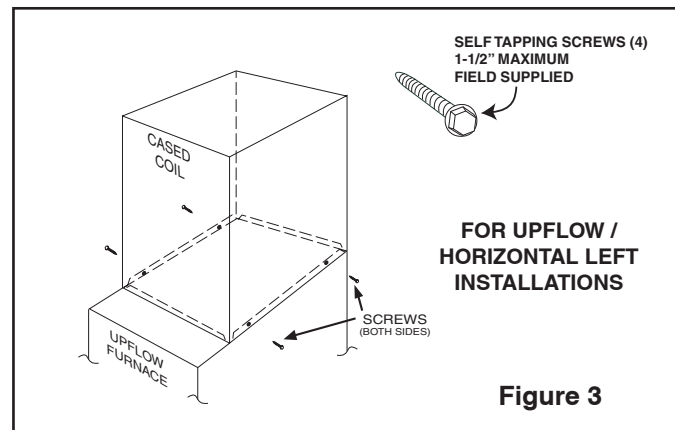

Figure 3

E. FURNACE IN DOWNFLOW POSITION

⚠ CAUTION

Caution: This coil is pressurized with 8-12 psig of dry air. Do not stand directly in front of the coil connections when removing sealing plugs. If no pressure is released, check for leaks.

1. DOWNFLOW GAS FURNACE

When a coil is used with a downflow furnace, a subbase is not required between the coil case and combustible flooring.

- Place the coil case on the furnace supply air plenum.
- Secure the coil case to the plenum.
- Set the furnace on top of the coil case, making sure that the back side of the discharge opening is snug up against the duct flange at the top rear of the coil case.
- Secure the coil case to the furnace and seal for air leaks as required.

2. DOWNFLOW GASKET INSTALLATION (OPTIONAL):

- For unusually humid applications that expect prolonged operation above 70% RH, it is recommended to use the BAYGSKT001A0 gasket kit to prevent water from forming on the bottom of the drain pan and dripping into the supply ductwork.
- Lay the coil on its back side.
 - Locate the 4" wide gasket material found in

BAYGSKT001A0.

c. Attach the 4" gasket material to three sides of the bottom of the drain pan as shown. Make sure to start by matching up the edge of the gasket material to the inner edge of the drain pan by the coil fins and working outwards.

d. The gasket material can be cut or ripped easily so that it can be tailored to fit. The gasket material must cover the three sides along the entire length of the coil as shown in Figure 4.

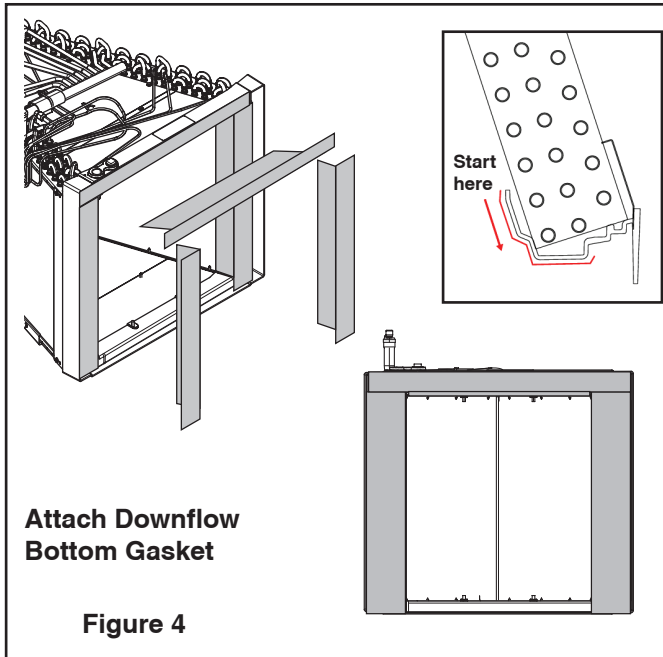

Note: when installing coil onto an S-Series furnaces in horizontal right or downflow configuration, bend the flanges downward for a flush fit.

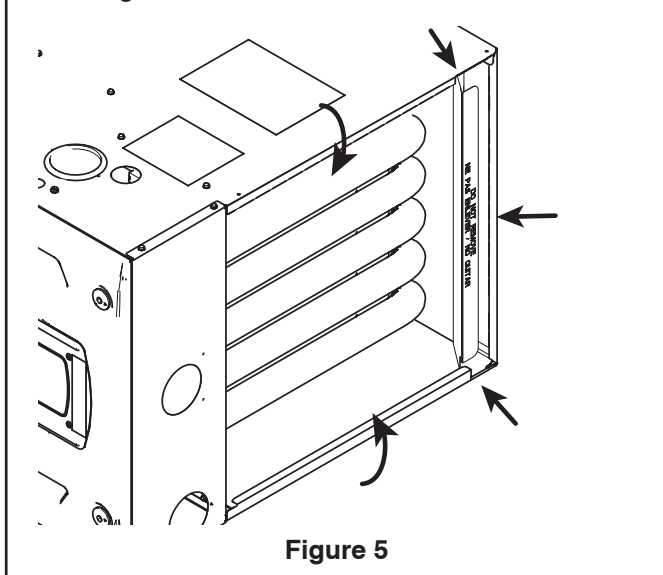

F. MAXIMUM AIRFLOW SETTING, CFM

NOTE:

Water blow-off could occur in certain installation positions if the airflow setting exceeds the maximum values listed.

Maximum airflow setting, CFM				
Coil	Upflow	Downflow	Horizontal Left	Horizontal Right
4PXC*U24BS3HAA	900	750	800	900
4PXC*D24BS3HDA	n/a		n/a	
4PXC*U30BS3HAA	1125	925	1000	1125
4PXC*D30BS3HDA	n/a		n/a	
4PXC*U32BS3HAA	1350	1200	1350	1350
4PXC*U36BS3HAA		1100	1200	
4PXC*D36BS3HDA	n/a		n/a	
4PXC*U42BS3HAA	1575	1300	1400	1575
4PXC*D42BS3HDA	n/a		n/a	
4PXC*U48BS3HAA	1800	1475	1600	1800
4PXC*D48BS3HDA	n/a		n/a	
4PXC*U60BS3HAA	2250	1850	2000	2250
4PXC*D60BS3HDA	n/a		n/a	

* May be "A", "B", "C", or "D"

NOTE:

The TXV setting on this unit may run high superheat (15-25°F) by design when measured at the outdoor unit.

G. INSTALLING / BRAZING REFRIGERANT LINES

⚠ CAUTION

Do NOT open refrigerant valve at the outdoor unit until the refrigerant lines and coil have been brazed, evacuated, and leak checked. This would cause contamination of the refrigerant or possible discharge of refrigerant to the atmosphere.

1. The following steps are to be considered when installing the refrigerant lines:

- Determine the most practical way to run the lines.
- Consider types of bends to be made and space limitations.
- Route the tubing making all required bends and properly secure the tubing before making final connections.

NOTE: Refrigerant lines must be isolated from the structure and the holes must be sealed weather tight after installation.

IMPORTANT:

Do not unseal refrigerant tubing until ready to fit refrigerant lines.

There is only a holding charge of dry air in the indoor coil, therefore no loss of operating refrigerant charge occurs when the sealing plugs are removed.

Installer's Guide

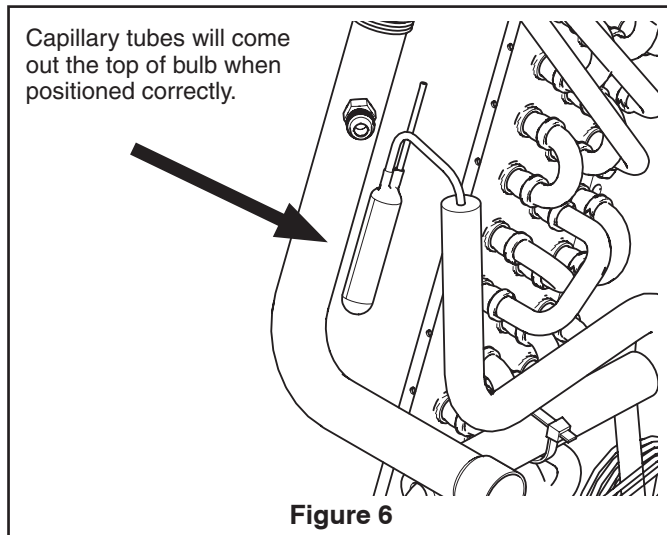

NOTE:
TXV bulb MUST be protected (wrapped with wet rag) or removed, while brazing the tubing. Overheating of the sensing bulb will affect the functional characteristics and performance of the comfort coil.

1. Remove both rubber plugs from the indoor coil.
2. Field supplied tubing should be cut square, round and free of burrs at the connecting end. Clean the tubing to prevent contaminants from entering the system.
3. Run the refrigerant tubing into the stub tube sockets of the indoor unit coil.

PAINTED AREAS OF THE UNIT MUST BE SHIELDED DURING BRAZING.

4. Flow a small amount of nitrogen through the tubing while brazing.
5. Use good brazing technique to make leakproof joints.
6. Minimize the use of sharp 90 degree bends.
7. Insulate the suction line and its fittings.
8. Do NOT allow un-insulated lines to come into contact with each other.

When replacing the bulb and hose clamp, the clamp should be "snug" but not "tight" - spec is to torque the hose clamp to 20+/-5in-lb.

9. Wrap the TXV with insulation after the hose clamp has been installed.

H. LEAK CHECK

1. Using a manifold gauge, connect an external supply of dry nitrogen to the gauge port on the liquid line.
2. Pressurize the connecting lines and indoor coil to 150 PSIG maximum.
3. Leak check brazed line connections using soap bubbles. Repair leaks (if any) after relieving pressure.
4. Evacuate and charge the system per the instructions packaged with the outdoor unit.

I. CONDENSATE DRAIN PIPING

Condensate drain connections are located in the drain pan at the bottom of the coil/enclosure assembly. The female threaded fitting protrudes outside of the enclosure for external connection. A field fabricated trap is not required for proper drainage due to the

positive pressure of the furnace; however, it is recommended to prevent efficiency loss of conditioned air.

1. The drain hole in the drain pan must be cleared of all insulation.
2. Insulate the primary drain line to prevent sweating where dew point temperatures may be met. (Optional depending on climate and application needs)
3. Connect the secondary drain line to a separate drain line (no trap is needed in this line).

J. CLEANING THE COIL

The two piece door (3-piece on 24.5" wide models) allows removal of the outer casing doors without interference from refrigerant or condensate lines. Once the outer doors are removed the split inner coil panels can be easily removed. The inside and outside of the coil can be easily cleaned with a brush and vacuum with the panels removed. See Figure 7.

The foil covered insulation on 4PXC coils should be wiped down and residual dirt and dust should be vacuumed up to maintain good air quality. See Figure 8.

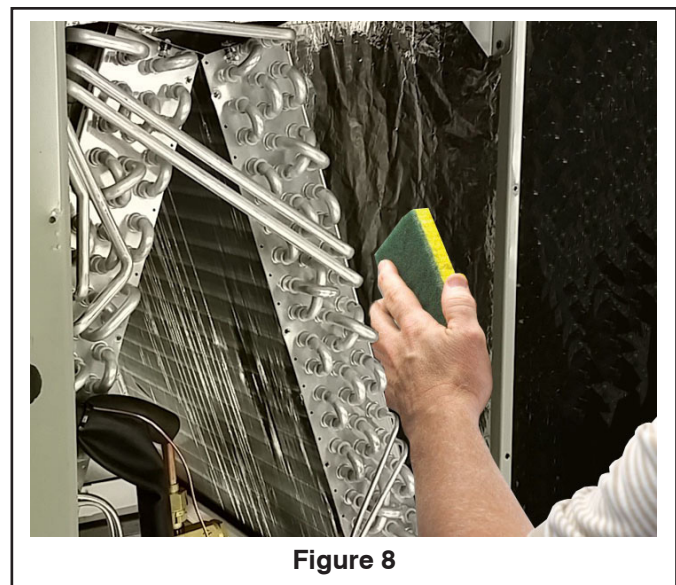
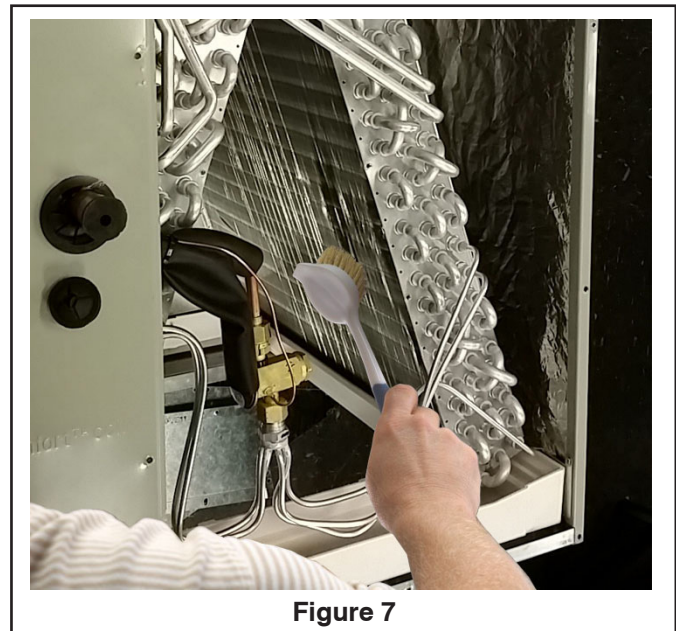

Outline Drawing for Upflow models: 4PXC-AU24BS3HAA, 4PXC-AU32BS3HAA, 4PXC-BU24BS3HAA, 4PXC-CU36BS3HAA, 4PXC-CU42BS3HAA, 4PXC-CU48BS3HAA, 4PXC-CU60BS3HAA, 4PXC-CU60BS3HDA, 4PXC-CAD18BS3HDA, 4PXC-CAD24BS3HDA, 4PXC-CAD24BS3HDA, 4PXC-CAD24BS3HDA, 4PXC-CBD24BS3HDA, 4PXC-CBD36BS3HDA, 4PXC-CBD42BS3HDA, 4PXC-CBD48BS3HDA, 4PXC-CBD48BS3HDA, 4PXC-CBD48BS3HDA, 4PXC-CBD60BS3HDA, 4PXC-CDD36BS3HDA, 4PXC-CDD42BS3HDA, 4PXC-CDD48BS3HDA, 4PXC-CDD48BS3HDA, 4PXC-CDD60BS3HDA

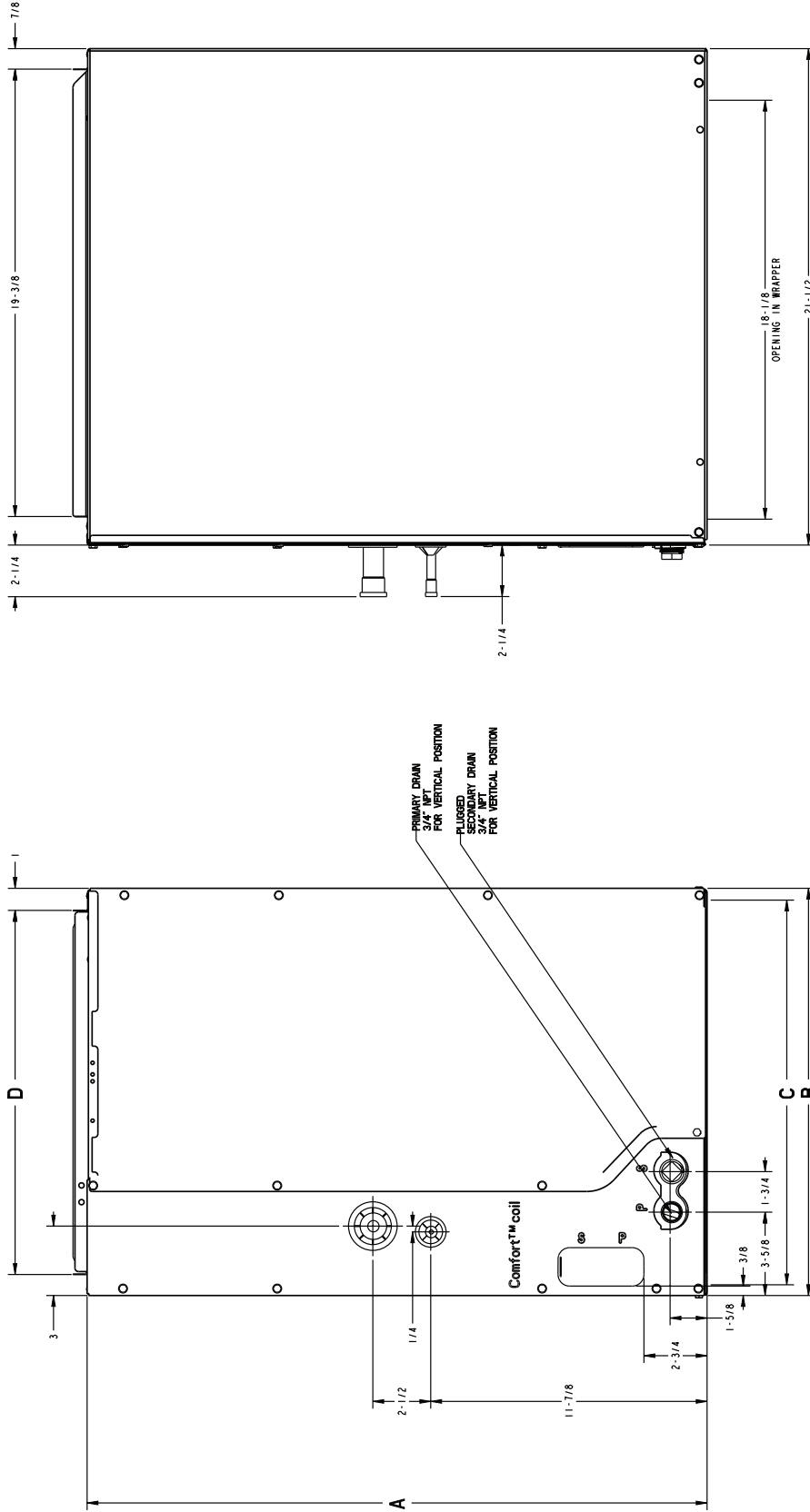

MODEL	4PXC-AU24BS3 4PXCAD24BS3	4PXC-AU32BS3	4PXC-BU24BS3 4PXCBD24BS3	4PXC-CU36BS3 4PXC-CU36BS3	4PXC-CU42BS3 4PXC-CU42BS3 4PXC-CU48BS3 4PXC-CU48BS3	4PXC-CU48BS3 4PXC-CU48BS3 4PXC-CU48BS3	4PXC-CU60BS3 4PXC-CU60BS3
WEIGHT (LBS.)	39	43	42	54	56	61	64
REFRIGERANT CONTROL	TXV (NON-BLEED)						
HEIGHT "A" (IN.)	17-1/2	22-1/2	17-1/2	22-1/2	22-1/2	26-7/8	26-7/8
OVERALL WIDTH "B" (IN.)	14-1/2	14-1/2	17-1/2	17-1/2	21	21	21
OPENING WIDTH "C" (IN.)	13-5/8	13-5/8	16-5/8	16-5/8	20-1/8	20-1/8	20-1/8
TOP OPENING "D"	12-3/4	12-3/4	15-3/4	15-3/4	19-1/4	19-1/4	19-1/4
GAS CONNECTION	3/4	3/4	3/4	7/8	7/8	7/8	7/8
LIQUID CONNECTION	3/8	3/8	3/8	3/8	3/8	3/8	3/8
MATCHED FURNACE WIDTH (NO ADAPTER REQUIRED)	14-1/2	14-1/2	17-1/2	17-1/2	21	17-1/2	21
DRAIN PAN	PLASTIC						

From Dwg.
D345397 RevE

Installer's Guide

Outline Drawing for Upflow models: 4PXCUBU30BS3HAA, 4PXCCU30BS3HAA, and
Downflow models: 4PXCBD30BS3HDA, 4PXCCD30BS3HDA

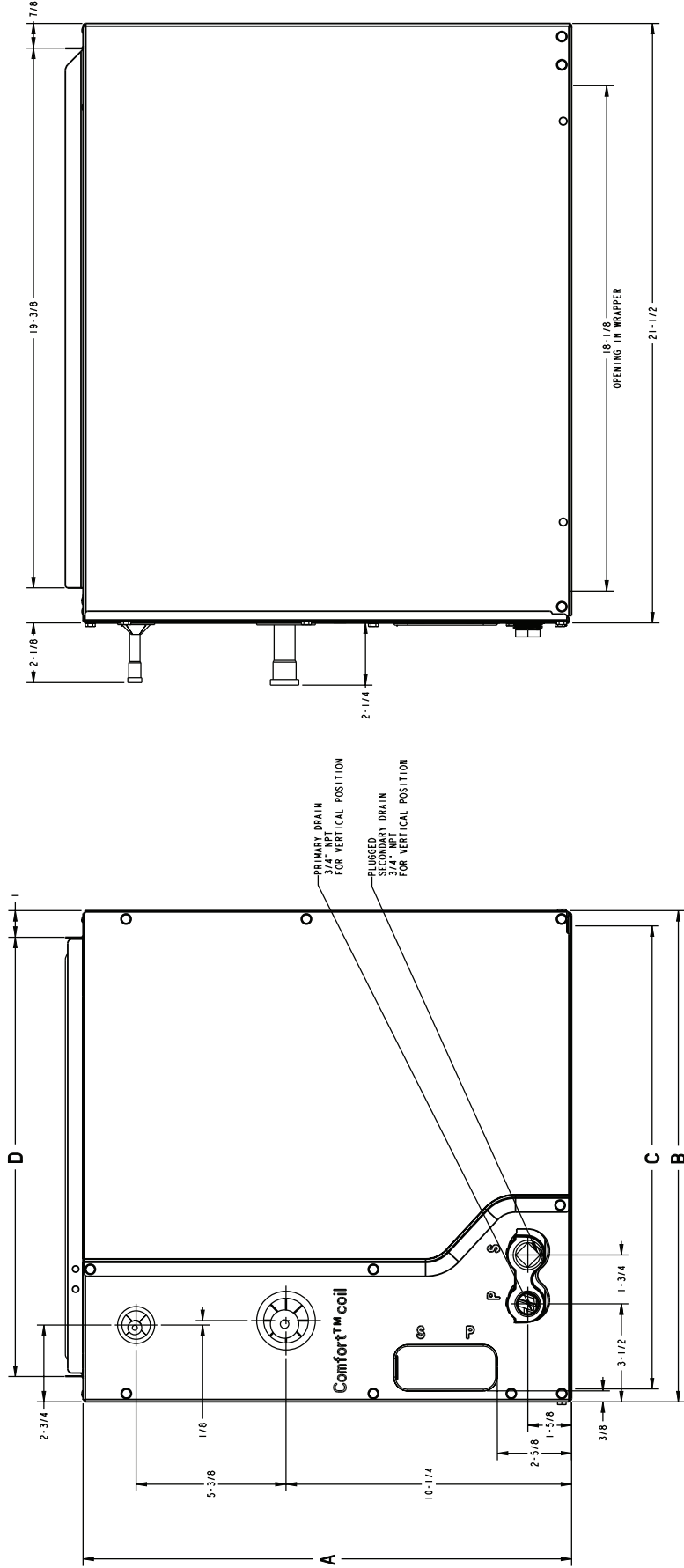

MODEL	4PXCUBU30BS3 4PXCBD30BS3	4PXCCU30BS3 4PXCCD30BS3
WEIGHT (LBS.)	47	49
REFRIGERANT CONTROL	TXV (NON-BLEED)	
HEIGHT (IN.)	17-1/2	17-1/2
OVERALL WIDTH (IN.)	17-1/2	21
OPENING WIDTH (IN.)	16-5/8	20-1/8
TOP OPENING	15-3/4	19-1/4
GAS CONNECTION	3/4	3/4
LIQUID CONNECTION	3/8	3/8
MATCHED FURNACE WIDTH (NO ADAPTER REQUIRED)	17-1/2	21
DRAIN PAN	PLASTIC	

From Dwg. D345398 RevC

Outline Drawing for Upflow models: 4PXCDU48BS3HAA, 4PXCDU60BS3HAA, and
Downflow models: 4PXCDD48BS3HDA, 4PXCDD60BS3HDA

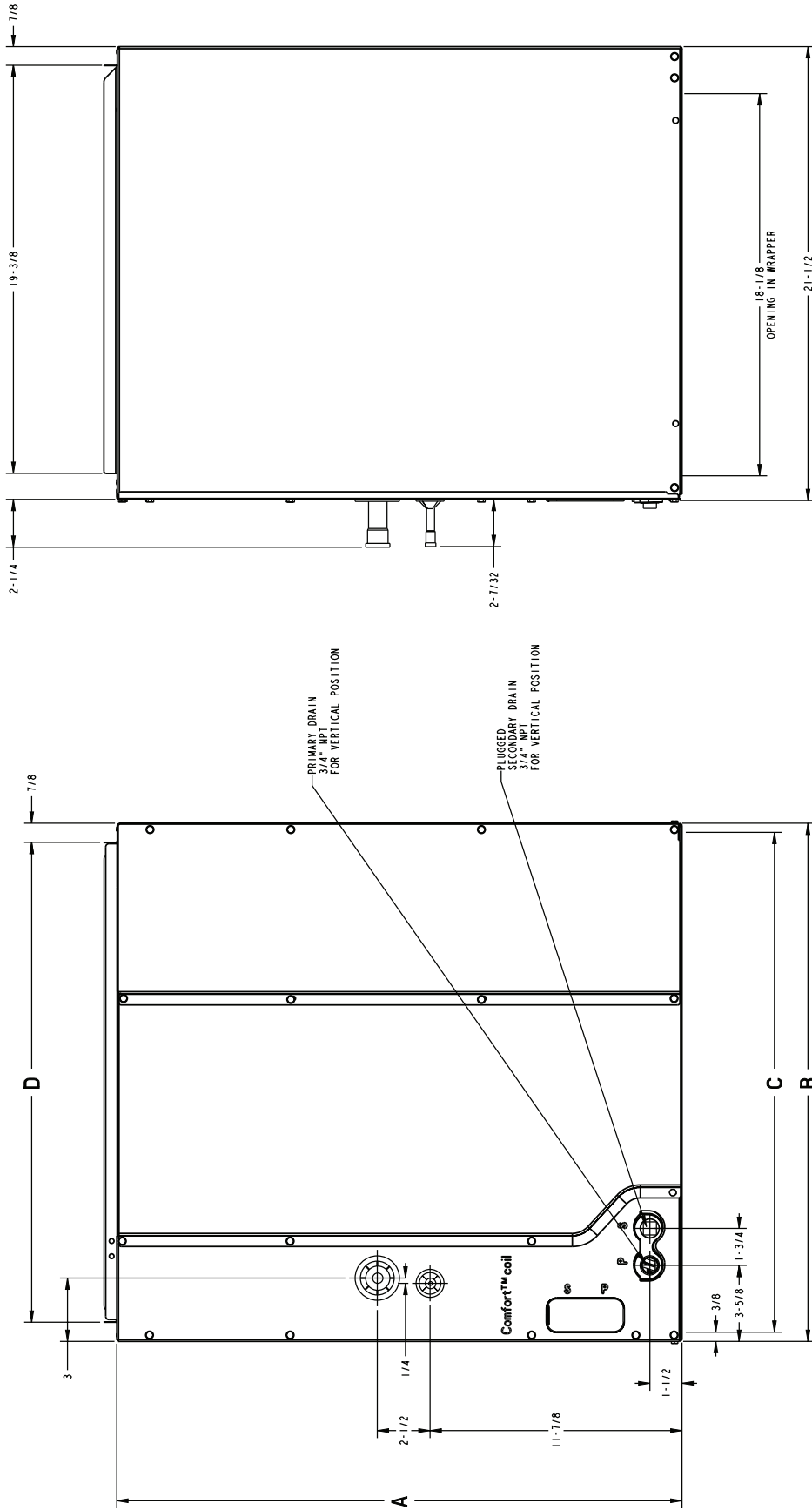

MODEL	4PXCDU48BS3 4PXCDD48BS3	4PXCDU60BS3 4PXCDD60BS3
WEIGHT (LBS.)	68	77
REFRIGERANT CONTROL	TXV (NON-BLEED)	
HEIGHT (IN.)	26-7/8	30-3/4
OVERALL WIDTH (IN.)	24-1/2	24-1/2
OPENING WIDTH (IN.)	23-5/8	23-5/8
TOP OPENING	22-3/4	22-3/4
GAS CONNECTION	7/8	7/8
LIQUID CONNECTION	3/8	3/8
MATCHED FURNACE WIDTH (NO ADAPTER REQUIRED)	24-1/2	24-1/2
DRAIN PAN	PLASTIC	

From Dwg. D345408 RevD

Before starting, insure the blower wheel, indoor and outdoor coils are clean.

Troubleshooting Indoor TXV / Cooling Mode

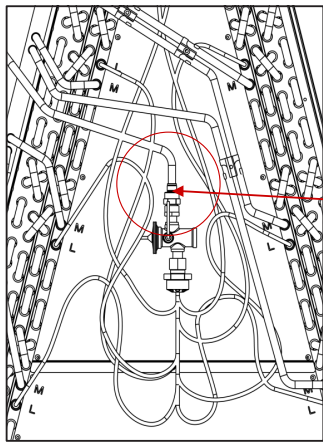
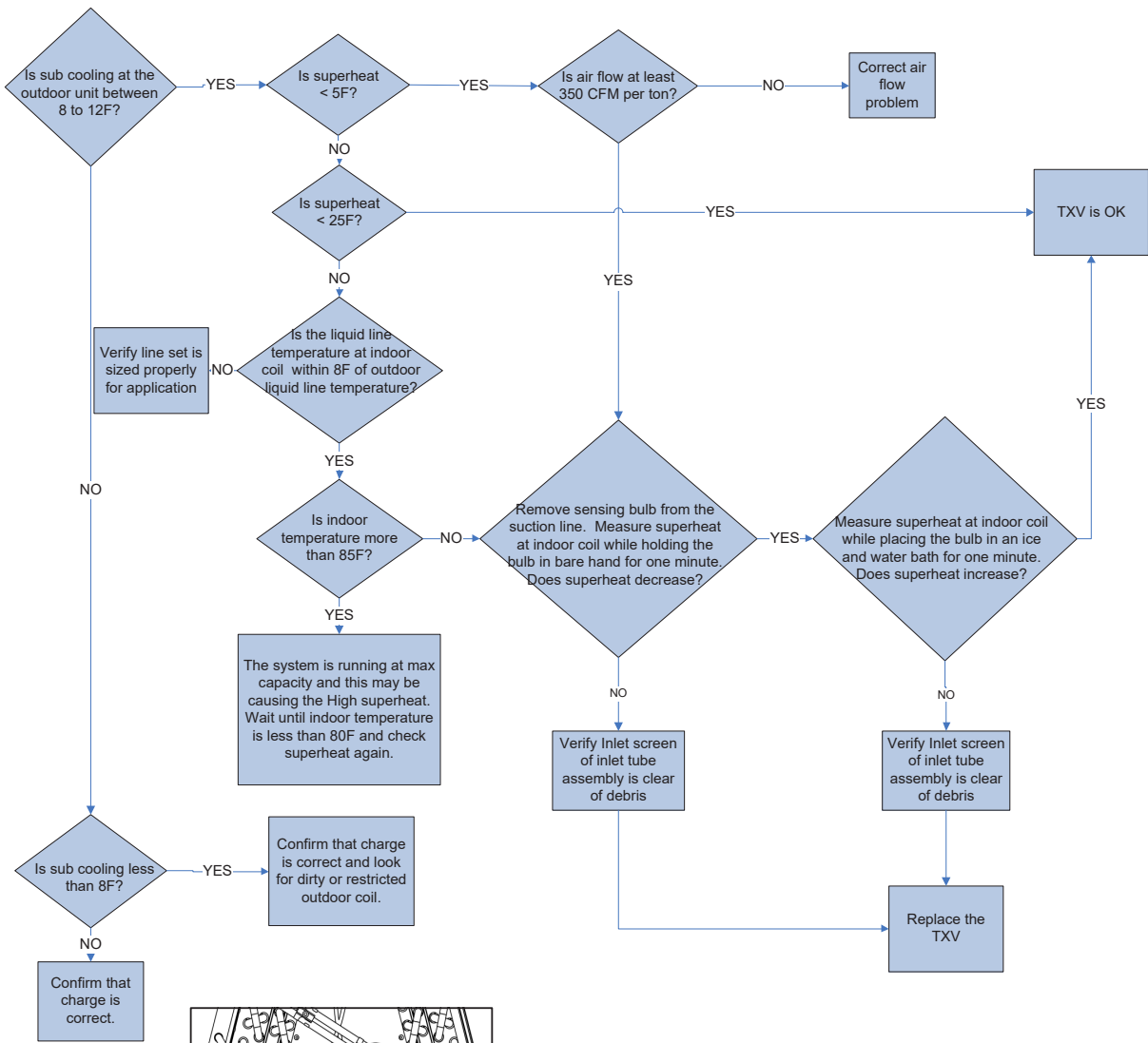

About Trane and American Standard Heating and Air Conditioning
 Trane and American Standard create comfortable, energy efficient indoor environments for residential applications.
 For more information, please visit www.trane.com or www.americanstandardair.com

The manufacturer has a policy of continuous data improvement and it reserves the right to change design and specifications without notice. We are committed to using environmentally conscious print practices.