



Installer's Guide

Horizontal, Flat "Cased" Coils

All Aluminum Coils: 4TXFH024CZ3HH*, 4TXFH033CC3HH*,
4TXFH036CZ3HH*, 4TXFH041CC3HH*, 4TXFH054CC3HH*,
4TXFH063CZ3HH*, 4TXFH064AZ3HHA ** May be "A" or "B"

ALL phases of this installation must comply with NATIONAL, STATE AND LOCAL CODES

IMPORTANT— This Document is **customer property** and is to remain with this unit. Please return to service information pack upon completion of work.

⚠ WARNING

WARNING (Medium/high pressure) Contains Refrigerant!

System contains oil and refrigerant under high pressure. Recover refrigerant to relieve pressure before opening the system. See unit nameplate for refrigerant type. Do not use non-approved refrigerants, refrigerant substitutes, or refrigerant additives.

Failure to follow proper procedures or the use of non-approved refrigerants, substitutes, or refrigerant additives could result in death, serious injury, or equipment damage.

⚠ WARNING

This product can expose you to chemicals including lead, which are known to the State of California to cause cancer and birth defects or other reproductive harm. For more information go to www.P65Warnings.ca.gov

A. GENERAL

These coils are designed for use as cooling only or in combination with a Heat Pump outdoor section.

B. APPLICATION INFORMATION

- FURNACE AND COIL**
Coil **MUST BE** installed downstream (discharge air) of the furnace.
- INDOOR UNIT AIRFLOW**
Indoor unit must provide the required airflow for Cooling only or Heat Pump System Combination.

INSPECTION

Check carefully for any shipping damage. This must be reported to and claims made against the transportation company immediately. Check to be sure all major components are in the unit. Any missing parts should be reported to your supplier at once, and replaced with authorized parts only.

C. RECOMMENDATIONS

⚠ CAUTION

This coil is pressurized with 8-12 psig of dry air. Do not stand directly in front of the coil connections when removing sealing plugs. If no pressure is released, check for leaks.

- If this coil is a part of the total system installation, then use the Installer's Guide packaged with the furnaces, Heat Pump outdoor sections, and Control Center for physically installing those components.
- It is recommended that the outline drawing (page 2) be studied and dimensions properly noted and checked against selected installation site. By noting in advance proper clearance allowances for installation and possible future service of the coil.

D. INSTALLING 4TXFH COIL / ENCLOSURE

Coil/enclosure assembly can be used for all horizontal furnaces (gas and electric) applications (Figure 1), and for applications of vertical upflow furnaces (Figure 2), where the top clearance is insufficient for installing an "A" coil and enclosure, and there is access to a run of horizontal duct.

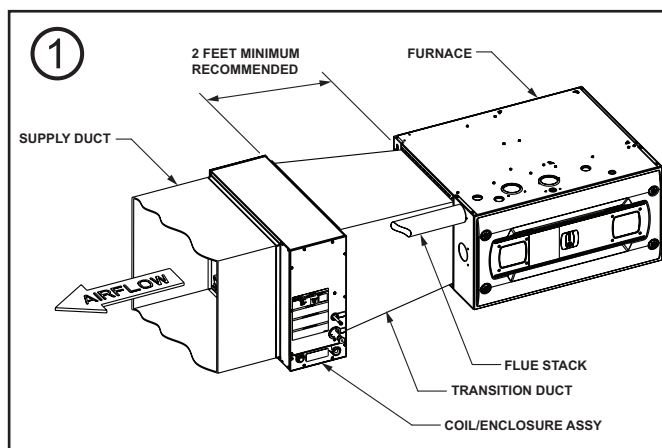

Installer's Guide

Outline Drawing - 4TXFH024CZ3HHB, 4TXFH033CC3HHB, 4TXFH036CZ3HHB, 4TXFH041CC3HHB, 4TXFH054CC3HHB, 4TXFH064AZ3HHA

All dimensions are in inches.

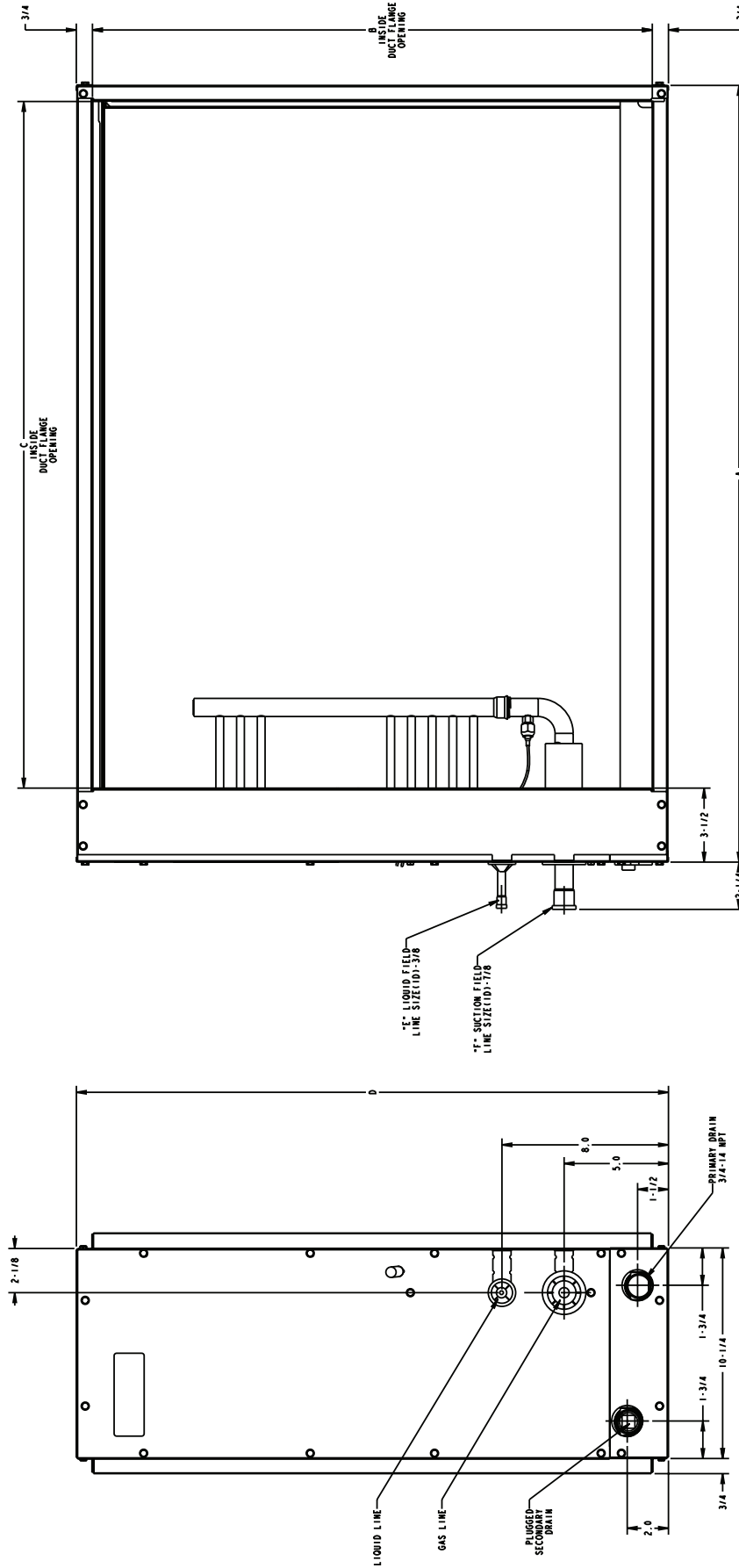

MODEL	"A"	"B"	"C"	"D"	"E"	"F"
4TXFH024CZ3HHB	31-1/2	21	33-1/4	22-3/4	3/8	3/4
4TXFH033CC3HHB	28-1/4	21	24	22-3/4	3/8	3/4
4TXFH036CZ3HHB	31-1/2	21	33-1/4	22-3/4	3/8	3/4
4TXFH041CC3HHB	31-1/2	21	33-1/4	22-3/4	3/8	3/4
4TXFH054CC3HHB	31-1/2	21	33-1/4	22-3/4	3/8	3/4
4TXFH064AZ3HHA	31-1/2	27	33-1/4	28-3/4	3/8	7/8

**May be 2" or 2 1/2"

From Dwg. D345541 Rev. B

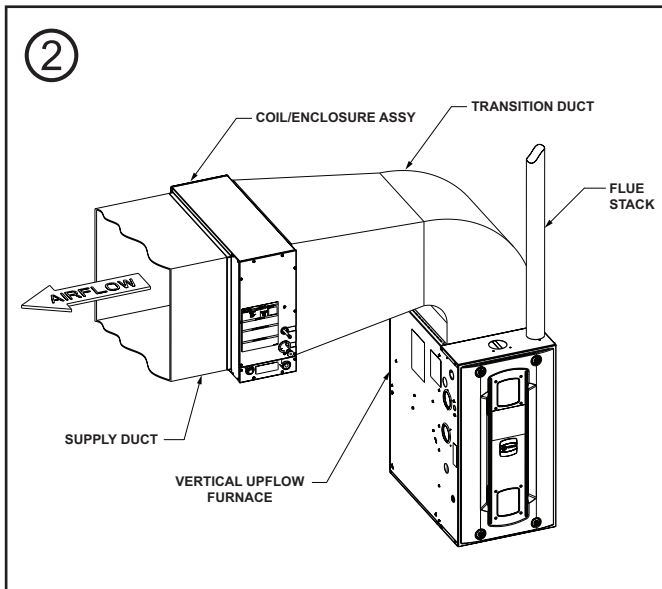

Since coil/ enclosure assembly must be installed within the horizontal run of duct, a transition duct must be fabricated to mate with the furnace supply outlet duct flange on one end and the duct flange connection on the coil/ enclosure assembly on the other end.

For maximum performance, it is recommended that the transition duct be at least 2 feet in length.

1. Secure the transition duct to the furnace with the furnace in position.
2. The refrigerant lines and condensate connections of cased coils may be on either side of the supply air duct. The air may be directed through the coil from either side of the coil.
3. Attach the coil/ enclosure assembly to the transition from the furnace, providing proper support for coil/ enclosure assembly's weight. Keep the coil level. Extra pitch is not required for coil to drain properly.
4. Secure the downstream side of coil/ enclosure assembly to the supply air duct.

NOTE:

Secure properly so there will be no air leakage.

5. The indoor coil must be evacuated through the refrigerant lines at the outdoor unit before opening the service valves. See evacuation procedure in Field Fabricated Refrigerant Lines section of the Installer's Guide for the outdoor unit.
6. Complete the installation of the unit per installation instructions.

E. INSTALLING/BRAZING REFRIGERANT LINES

⚠ CAUTION

Do NOT open refrigerant valve at the outdoor unit until the refrigerant lines and coil have been brazed, evacuated, and leak checked. This would cause contamination of the refrigerant or possible discharge of refrigerant to the atmosphere.

3

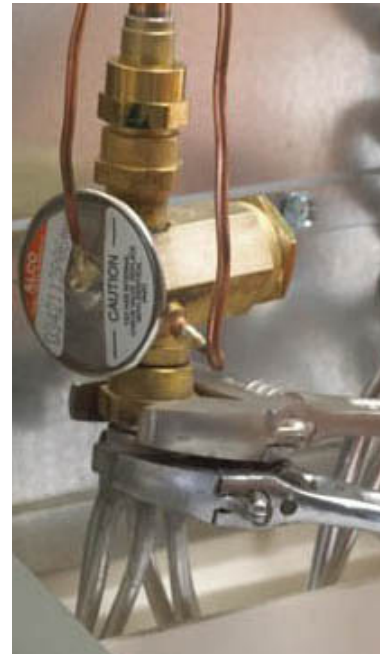

1. The following steps are to be considered when installing the refrigerant lines:
 - a. Determine the most practical way to run the lines.
 - b. Consider types of bends to be made and space limitations.
 - c. Route the tubing making all required bends and properly secure the tubing before making final connections.

NOTE:

Refrigerant lines must be isolated from the structure and the holes must be sealed weather tight after installation.

IMPORTANT:

Do not unseal refrigerant tubing until ready to fit refrigerant lines.

There is only a holding charge of dry air in the indoor coil, therefore no loss of operating refrigerant charge occurs when the sealing plugs are removed.

NOTE:

TXV bulb MUST be protected (wrapped with wet rag) or removed, while brazing the tubing. Overheating of the sensing bulb will affect the functional characteristics and performance of the comfort coil.

Installer's Guide

1. Remove both sealing rubber plugs from the indoor coil.
2. Field supplied tubing should be cut square, round and free of burrs at the connecting end. Clean the tubing to prevent contaminants from entering the system.
3. Run the refrigerant tubing into the stub tube sockets of the indoor unit coil.

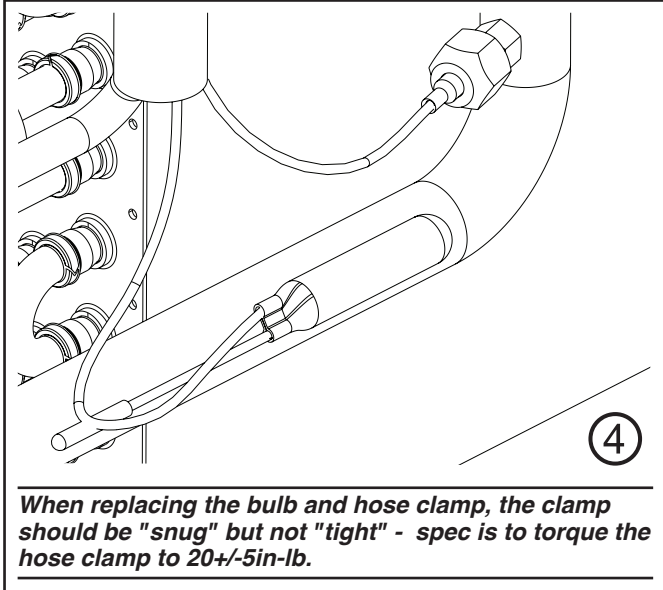

PAINTED AREAS OF THE UNIT MUST BE SHIELDED DURING BRAZING.

4. Flow a small amount of nitrogen through the tubing while brazing.
5. Use good brazing technique to make leakproof joints.
6. Minimize the use of sharp 90 degree bends.
7. Insulate the suction line and its fittings.
8. Do NOT allow un-insulated lines to come into contact with each other.

NOTE:

Torque specification for TXV equals 1/6 turn past finger tight. Make sure to backwrench when tightening as shown in Figure 3.

F. LEAK CHECK

1. Using a manifold gauge, connect an external supply of dry nitrogen to the gauge port on the liquid line.
2. Pressurize the connecting lines and indoor coil to 150 PSIG maximum.
3. Leak check brazed line connections using soap bubbles. Repair leaks (if any) after relieving pressure.
4. Evacuate and charge the system per the instructions packaged with the outdoor unit.

G. CONDENSATE DRAIN PIPING (SEE FIGURE 5)

NOTE:

When coils are installed above ceilings or in other locations where damage from condensate overflow may occur. A field fabricated auxiliary drain pan shall be installed under the coil enclosure. Drain lines from this pan must be installed, but should NOT be connected to the primary drain.

Condensate drain connections are located in the drain pan at the bottom of the coil/enclosure assembly. The female threaded fitting protrudes outside of the enclosure for external connection. A field fabricated trap is not required for proper drainage due to the positive pressure of the furnace; however, it is recommended to prevent efficiency loss of conditioned air.

1. The drain hole in the drain pan must be cleared of all insulation.
2. Insulate the primary drain line to prevent sweating where dew point temperatures may be met. (Optional depending on climate and application needs).

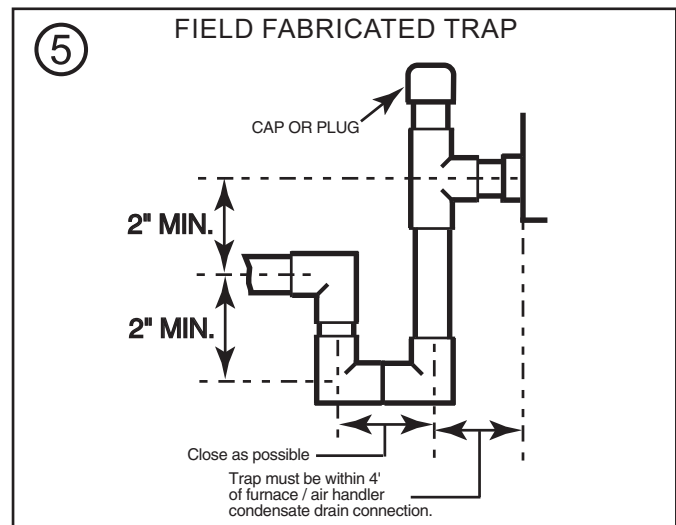

H. SECONDARY CONDENSATE DRAIN

A secondary condensate drain connection, now called for by many building codes, has been provided, on 4TXFH coils. Reducing fittings and copper tubing can be used in most cases.

IMPORTANT:

Plug all drain line connection(s) not used. Do NOT use heat or torch near drain fittings.

I. DUCT CONNECTIONS

The supply and return air duct should be connected to the unit with a flame retardant duct connectors. Duct flange connections are provided at both supply and discharge openings of the coil.

Before starting, insure the blower wheel, indoor and outdoor coils are clean.

Troubleshooting Indoor TXV / Cooling Mode

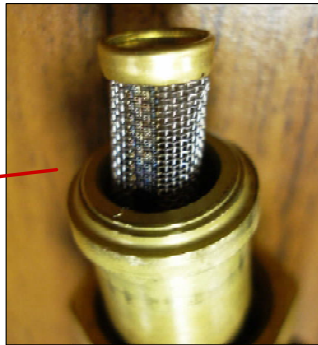
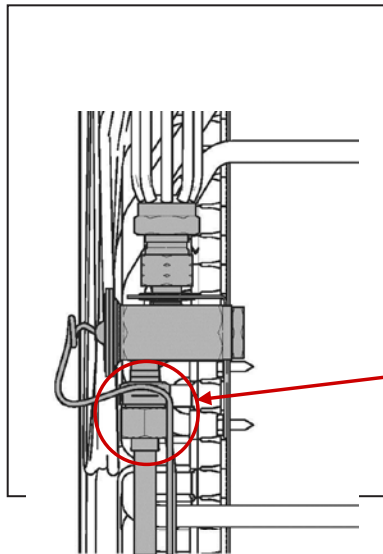
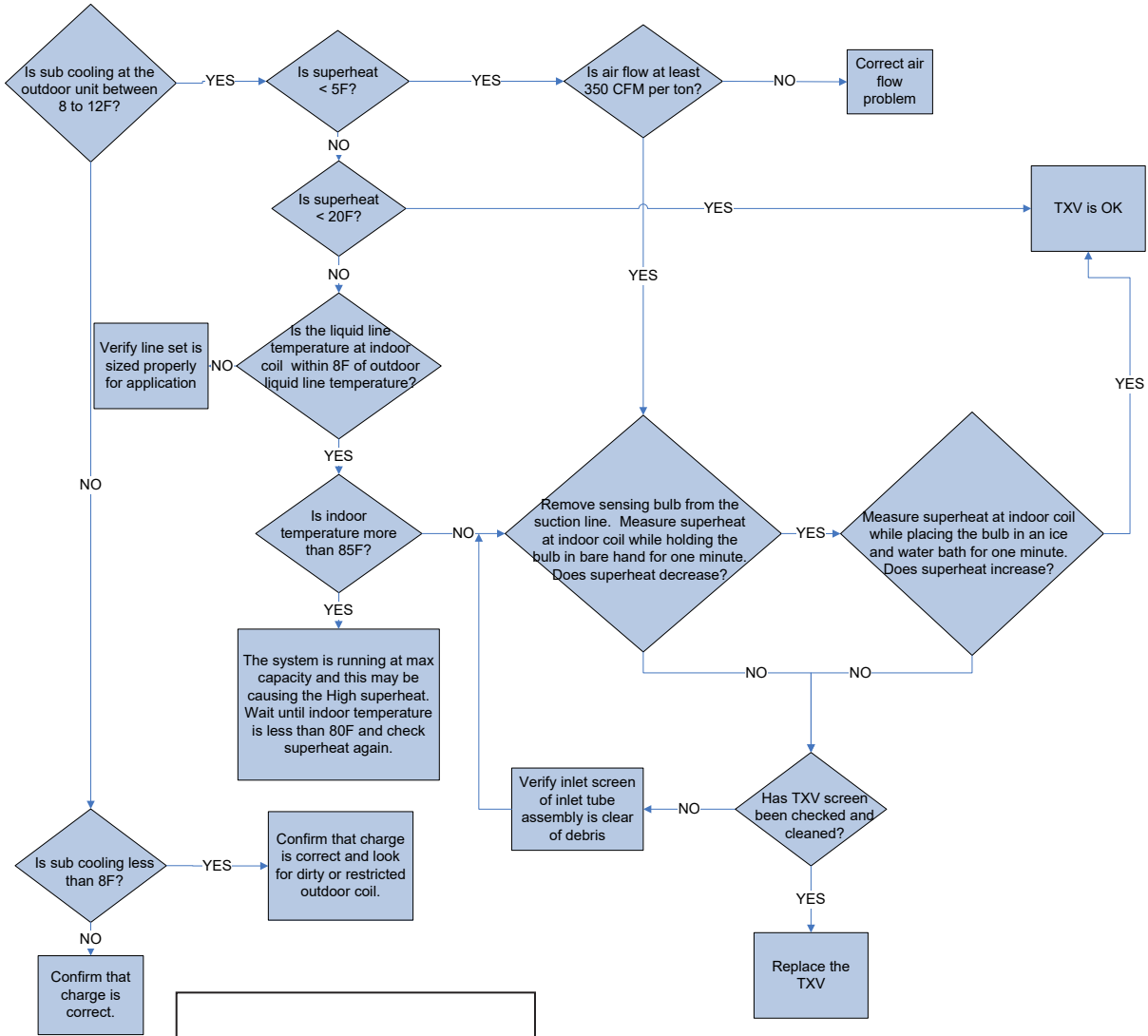

Inlet screen located in liquid line. Check, clean, & replace if necessary.

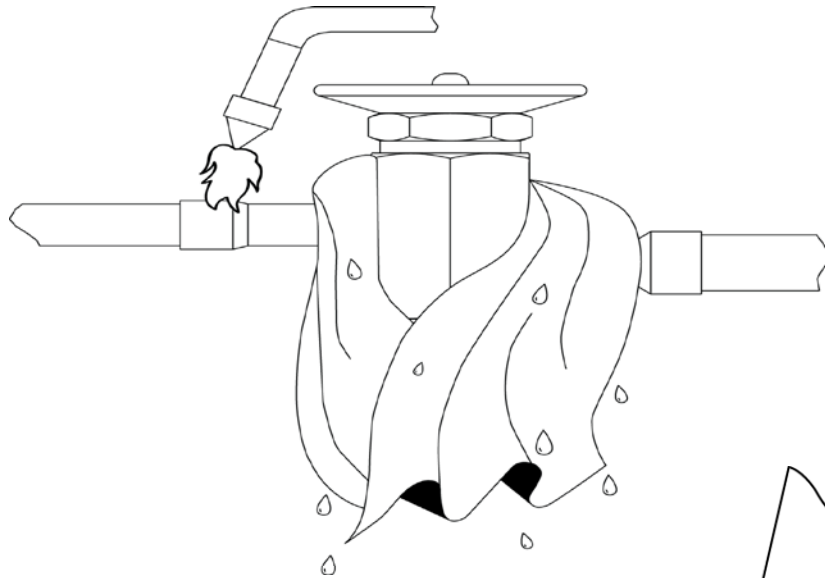

Wrap TXV with web cloth before brazing. Direct torch away from wrapped valve.

The sensing bulb should be located between the 8 o'clock & 4 o'clock positions; it should not be located in the shaded area as shown in the illustration. The gas line should be clean and the sensing bulb clamped and insulated for proper operation.

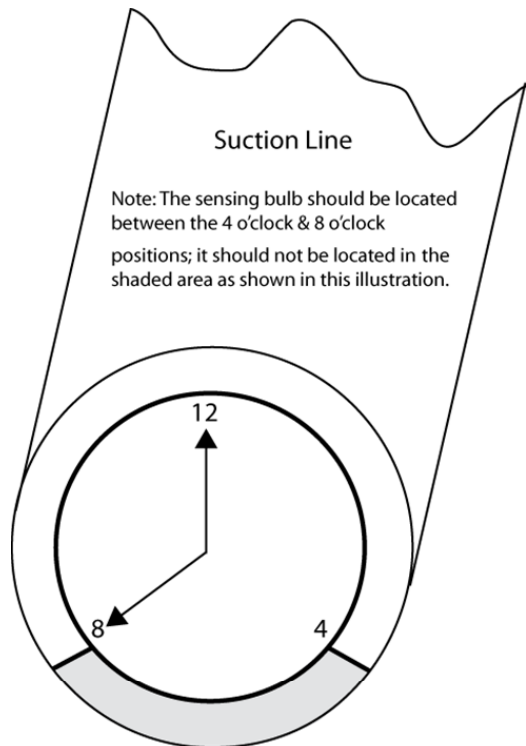

About Trane and American Standard Heating and Air Conditioning

Trane and American Standard create comfortable, energy efficient indoor environments for residential applications. For more information, please visit www.trane.com or www.americanstandardair.com

The manufacturer has a policy of continuous data improvement and it reserves the right to change design and specifications without notice. We are committed to using environmentally conscious print practices.