



# Installation and Operation Manual

## Condensing Units

4TTR6024 – 060

ALL phases of this installation must comply with NATIONAL, STATE AND LOCAL CODES

**IMPORTANT** – This Document is customer property and is to remain with this unit. Please return to service information pack upon completion of work.

These instructions do not cover all variations in systems or provide for every possible contingency to be met in connection with the installation. Should further information be desired or should particular problems arise which are not covered sufficiently for the purchaser's purposes, the matter should be referred to your installing dealer or local distributor.

**Note:** The manufacturer recommends installing only approved matched indoor and outdoor systems. Some of the benefits of installing approved matched indoor and outdoor split systems are maximum efficiency, optimum performance and the best overall system reliability.

### Table of Contents

- Section 1. Safety ..... 2
- Section 2. Unit Location Considerations..... 3
- Section 3. Unit Preparation..... 4
- Section 4. Setting the Unit ..... 4
- Section 5. Refrigerant Line Considerations ..... 4
- Section 6. Refrigerant Line Routing ..... 5
- Section 7. Refrigerant Line Brazing ..... 7
- Section 8. Refrigerant Line Leak Check ..... 7
- Section 9. Evacuation..... 8
- Section 10. Service Valves ..... 8
- Section 11. Electrical – Low Voltage ..... 9
- Section 12. Electrical – High Voltage ..... 10
- Section 13. Start Up..... 11
- Section 14. System Charge Adjustment..... 11
- Section 15. Checkout Procedures..... 14
- Section 16. Refrigeration Circuits..... 15
- Section 17. Wiring Diagrams..... 17
- Section 18. Pressure Curves..... 21

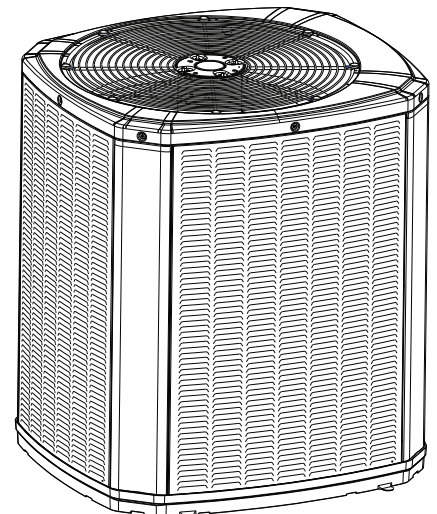

## Section 1. Safety

### WARNING

This information is intended for use by individuals possessing adequate backgrounds of electrical and mechanical experience. Any attempt to repair a central air conditioning product may result in personal injury and/or property damage. The manufacturer or seller cannot be responsible for the interpretation of this information, nor can it assume any liability in connection with its use.

### WARNING

These units use R-410A refrigerant which operates at 50 to 70% higher pressures than R-22. Use only R-410A approved service equipment. Refrigerant cylinders are painted a "Rose" color to indicate the type of refrigerant and may contain a "dip" tube to allow for charging of liquid refrigerant into the system. All R-410A systems use a POE oil that readily absorbs moisture from the atmosphere. To limit this "hygroscopic" action, the system should remain sealed whenever possible. If a system has been open to the atmosphere for more than 4 hours, the compressor oil must be replaced. Never break a vacuum with air and always change the driers when opening the system for component replacement. For specific handling concerns with R-410A and POE oil reference Retrofit Bulletins SS-APG006-EN and APP-APG011-EN.

### WARNING

**UNIT CONTAINS R-410A REFRIGERANT!**  
R-410A operating pressures exceed the limit of R-22. Proper service equipment is required. Failure to use proper service tools may result in equipment damage or personal injury.

#### **SERVICE**

**USE ONLY R-410A REFRIGERANT AND APPROVED POE COMPRESSOR OIL.**

### WARNING

Extreme caution should be exercised when opening the Liquid Line Service Valve. Turn counterclockwise until the valve stem just touches the rolled edge. No torque is required. Failure to follow this warning will result in abrupt release of system charge and may result in personal injury and /or property damage.

### WARNING

#### **LIVE ELECTRICAL COMPONENTS!**

During installation, testing, servicing, and troubleshooting of this product, it may be necessary to work with live electrical components. Failure to follow all electrical safety precautions when exposed to live electrical components could result in death or serious injury.

### WARNING

The appliance is not to be used by persons (including children) with reduced physical, sensory or mental capabilities, or lack of experience and knowledge, unless they have been given supervision or instruction.

### WARNING

Children should be supervised to ensure that they do not play with the appliance.

### CAUTION

If using existing refrigerant lines make certain that all joints are brazed, not soldered.

### CAUTION

Scroll compressor dome temperatures may be hot. Do not touch the top of compressor; it may cause minor to severe burning.

### WARNING

#### **WARNING!**

**This product can expose you to chemicals including lead, which are known to the State of California to cause cancer and birth defects or other reproductive harm. For more information go to [www.P65Warnings.ca.gov](http://www.P65Warnings.ca.gov)**

## Section 2. Unit Location Considerations

### 2.1 Unit Dimensions and Weight

Table 2.1

Unit Dimensions and Weight		
Models	H x D x W (in)	Weight* (lb)
4TTR6024N	41 x 34 x 37	244
4TTR6036N	45 x 34 x 37	250
4TTR6048N	45 x 34 x 37	254
4TTR6060N	45 x 34 x 37	275

\* Weight values are estimated.

When mounting the outdoor unit on a roof, be sure the roof will support the unit's weight.

Properly selected isolation is recommended to alleviate sound or vibration transmission to the building structure.

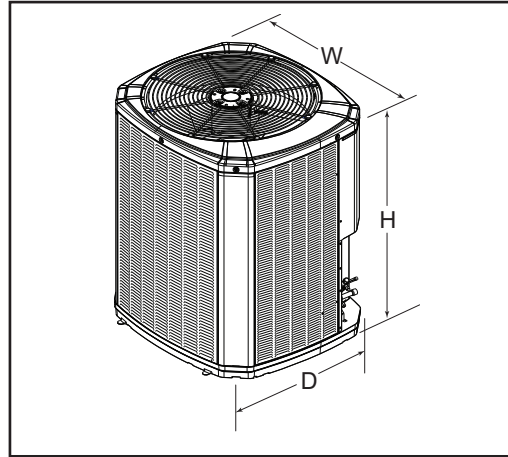

### 2.2 Refrigerant Piping Limits

1. The maximum TOTAL length of refrigerant lines from outdoor to indoor unit should NOT exceed 150 feet (including lift).
2. The maximum vertical change should not exceed 50 feet.
3. Service valve connection diameters are shown in Table 5.1.

**Note:** For other line lengths, Refer to Refrigerant Piping Application Guide, SS-APG006F-EN, or Refrigerant Piping Software Program.

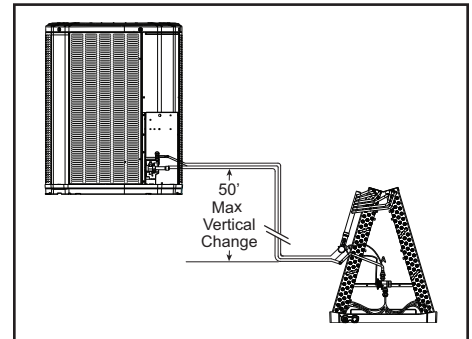
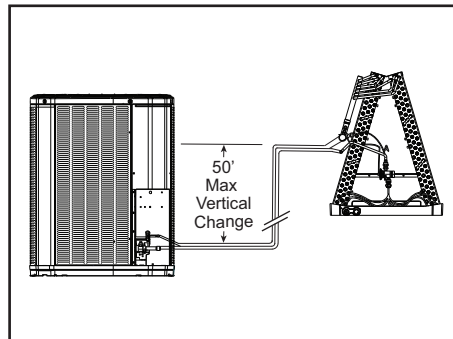
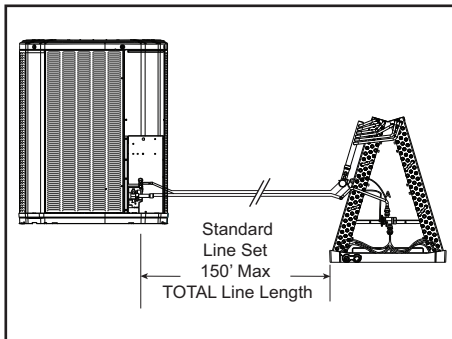

### 2.3 Suggested Locations for Best Reliability

Ensure the top discharge area is unrestricted for at least five (5) feet above the unit.

Three (3) feet clearance must be provided in front of the control box (access panels) and any other side requiring service.

Do not locate close to bedrooms as operational sounds may be objectionable.

Position the outdoor unit a minimum of 12" from any wall or surrounding shrubbery to ensure adequate airflow.

Outdoor unit location must be far enough away from any structure to prevent excess roof runoff water from pouring directly on the unit.

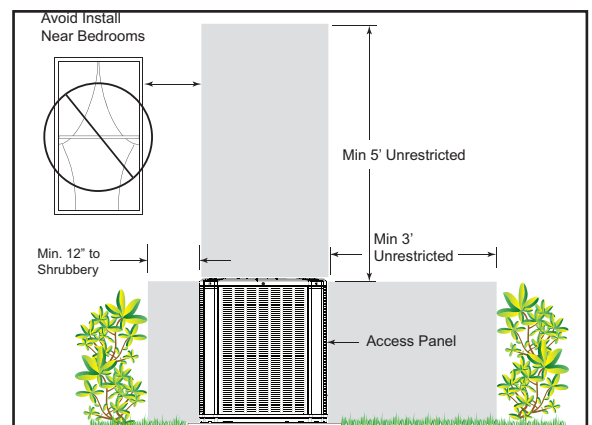

## 2.4 Coastal Considerations

If installed within one mile of salt water, including seacoasts and inland waterways, models without factory supplied Seacoast Salt Shields require the addition of BAYSEAC001 (Seacoast Kit) at installation time.

## Section 3. Unit Preparation

### 3.1 Prepare The Unit For Installation

- STEP 1** - Check for damage and report promptly to the carrier any damage found to the unit.  
**STEP 2** - To remove the unit from the pallet, remove tabs by cutting with a sharp tool.

## Section 4. Setting the Unit

### 4.1 Pad Installation

When installing the unit on a support pad, such as a concrete slab, consider the following:

- The pad should be at least 1" larger than the unit on all sides.
- The pad must be separate from any structure.
- The pad must be level.
- The pad should be high enough above grade to allow for drainage.
- The pad location must comply with National, State, and Local codes.

## Section 5. Refrigerant Line Considerations

### 5.1 Refrigerant Line and Service Valve Connection Sizes

**Table 5.1**

Model	Line Sizes		Service Valve Connection Sizes		Max Line & Lift Lengths	
	Vapor Line	Liquid Line	Vapor Line Connection	Liquid Line Connection	TOTAL Max Line Length (ft.)	Max Lift (ft.)
4TTR6024N	3/4	3/8	3/4	3/8	150	50
4TTR6036N	3/4	3/8	3/4	3/8	150	50
4TTR6048N	7/8	3/8	7/8	3/8	150	50
4TTR6060N	1-1/8	3/8	7/8	3/8	150	50

### 5.2 Factory Charge

The outdoor condensing units are factory charged with the system charge required for the outdoor condensing unit, ten (10) feet of tested connecting line, and the smallest rated indoor evaporative coil match. Always verify proper system charge via subcooling (TXV/EEV) or superheat (fixed orifice) per the unit nameplate.

### 5.3 Required Refrigerant Line Length

Determine required line length and lift. You will need this later in STEP 2 of Section 14.

Total Line Length = \_\_\_\_\_ Ft.

Total Vertical Change (lift) = \_\_\_\_\_ Ft.

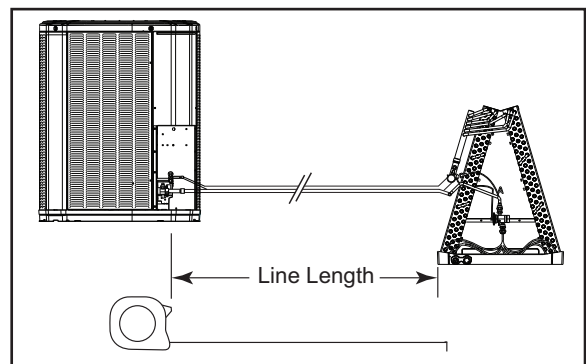

## 5.4 Refrigerant Line Insulation

**Important:** The Vapor Line must always be insulated. DO NOT allow the Liquid Line and Vapor Line to come in direct (metal to metal) contact.

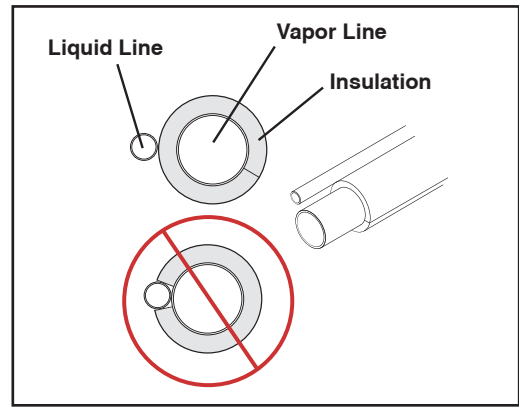

## 5.5 Reuse Existing Refrigerant Lines

### ⚠ CAUTION

If using existing refrigerant lines make certain that all joints are brazed, not soldered.

For retrofit applications, where the existing indoor evaporator coil and/or refrigerant lines will be used, the following precautions should be taken:

- Ensure that the indoor evaporator coil and refrigerant lines are the correct size.
- Ensure that the refrigerant lines are free of leaks, acid, and oil.

## Section 6. Refrigerant Line Routing

### 6.1 Precautions

**Important:** Take precautions to prevent noise within the building structure due to vibration transmission from the refrigerant lines.

For Example:

- When the refrigerant lines have to be fastened to floor joists or other framing in a structure, use isolation type hangers.
- Isolation hangers should also be used when refrigerant lines are run in stud spaces or enclosed ceilings.
- Where the refrigerant lines run through a wall or sill, they should be insulated and isolated.
- Isolate the lines from all ductwork.
- Minimize the number of 90° turns.

Comply with National, State, and Local Codes when isolating line sets from joists, rafters, walls, or other structural elements.

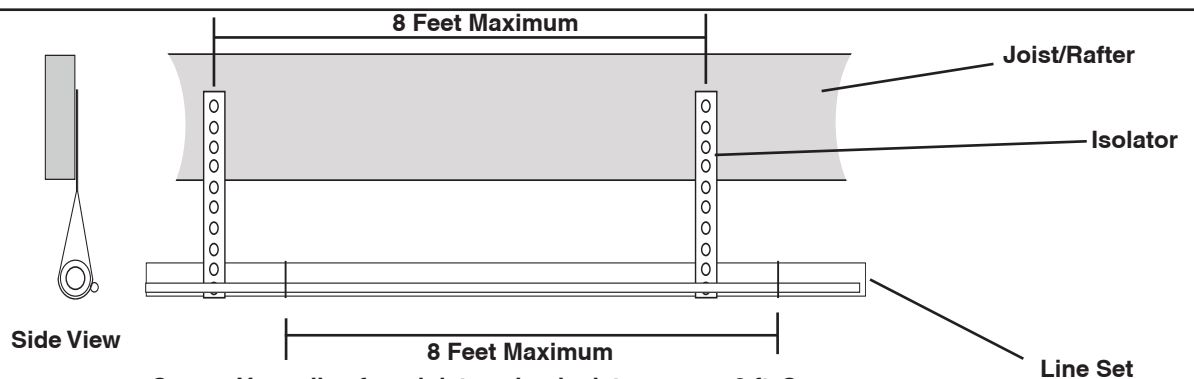

Secure Vapor line from joists using isolators every 8 ft. Secure Liquid Line directly to Vapor line using tape, wire, or other appropriate method every 8 ft.

Isolation From Joist/Rafter

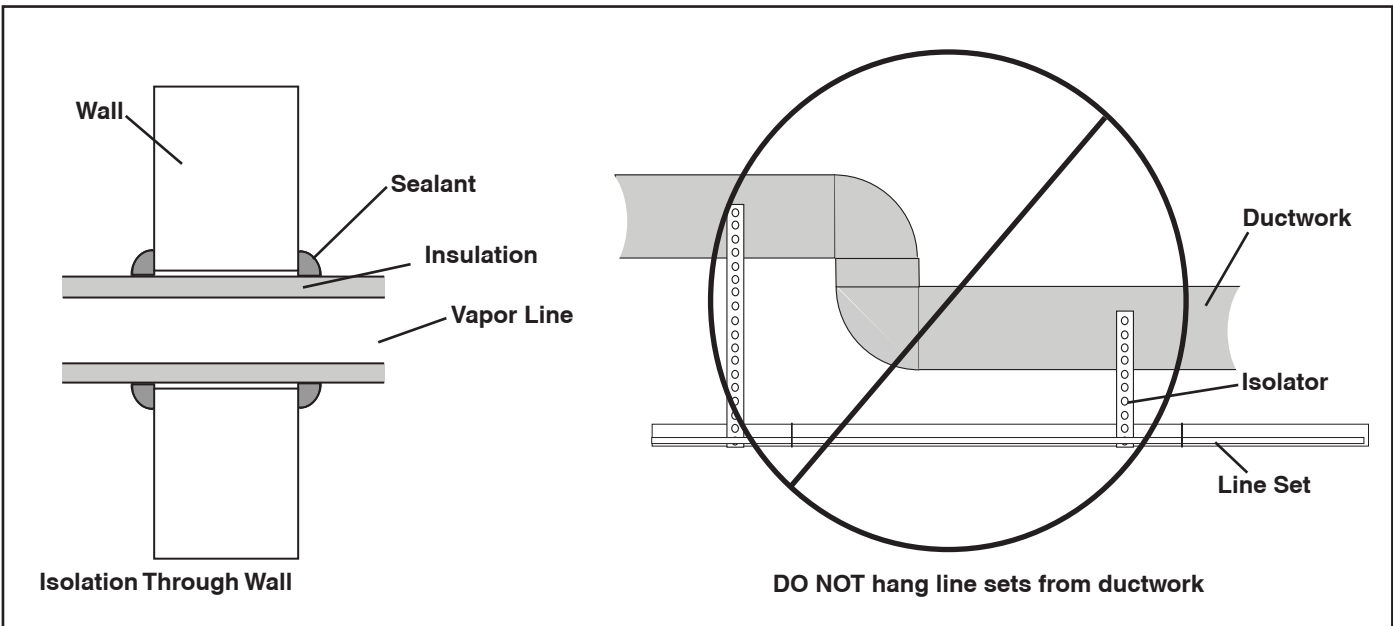
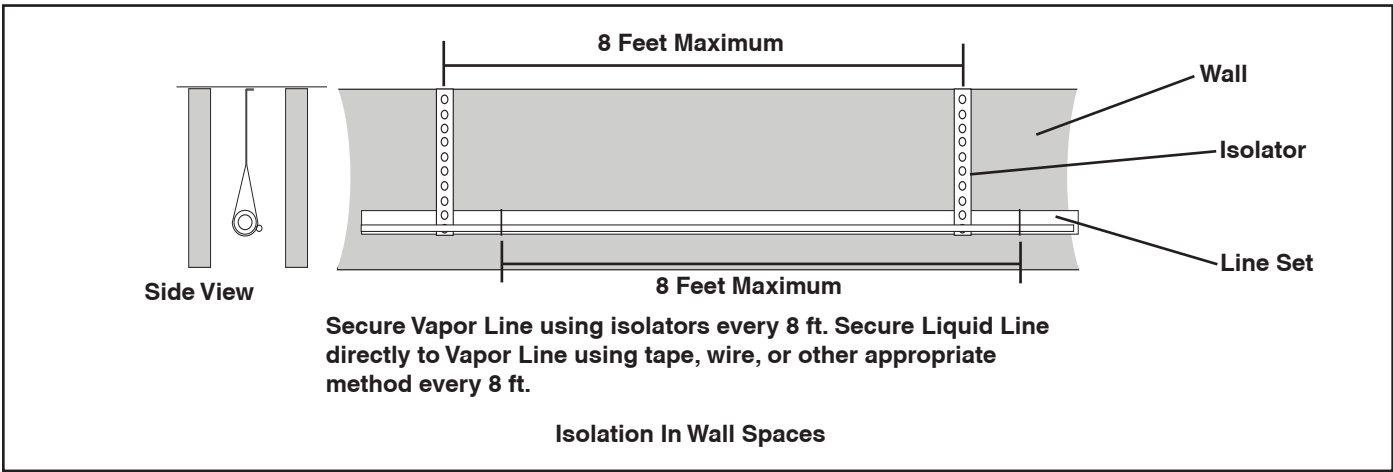

## Section 7. Refrigerant Line Brazing

### 7.1 Braze The Refrigerant Lines

**STEP 1** - Remove caps or plugs. Use a deburring tool to deburr the pipe ends. Clean both internal and external surfaces of the tubing using an emery cloth.

**STEP 2** - Remove the pressure tap cap and valve cores from both service valves.

**STEP 3** - Purge the refrigerant lines and indoor coil with dry nitrogen.

**STEP 4** - Wrap a wet rag around the valve body to avoid heat damage and continue the dry nitrogen purge.

Braze the refrigerant lines to the service valves.

For units shipped with a field-installed external drier, check liquid line filter drier's directional flow arrow to confirm correct direction of refrigeration flow (away from outdoor unit and toward evaporator coil) as illustrated. Braze the filter drier to the Liquid Line.

Continue the dry nitrogen purge. Do not remove the wet rag until all brazing is completed.

Important: Remove the wet rag before stopping the dry nitrogen purge.

**Note:** Install drier in Liquid Line.

**NOTE:** Precautions should be taken to avoid heat damage to basepan during brazing. It is recommended to keep the flame directly off of the basepan.

**STEP 5** - Replace the pressure tap valve cores after the service valves have cooled.

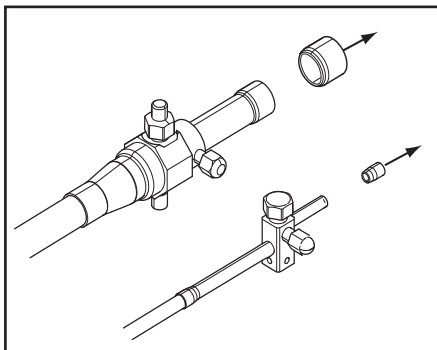

**STEP 1**

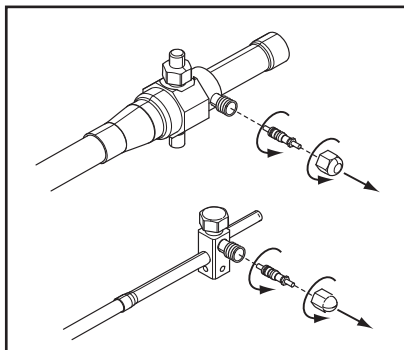

**STEP 2**

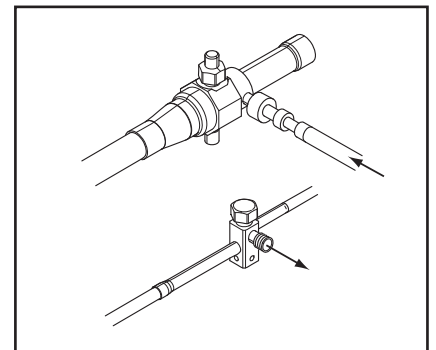

**STEP 3**

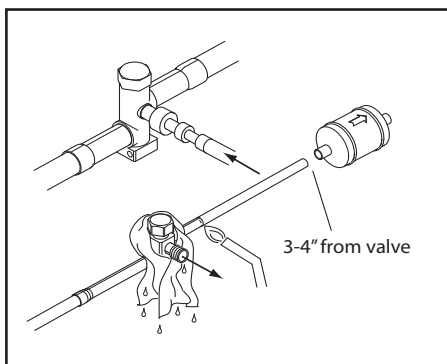

**STEP 4**

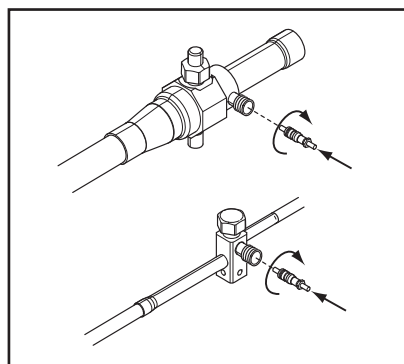

**STEP 5**

## Section 8. Refrigerant Line Leak Check

### 8.1 Check For Leaks

**STEP 1** - Pressurize the refrigerant lines and evaporator coil to 150 PSIG using dry nitrogen.

**STEP 2** - Check for leaks by using a soapy solution or bubbles at each brazed location.

Remove nitrogen pressure and repair any leaks before continuing.



## Section 9. Evacuation

### 9.1 Evacuate the Refrigerant Lines and Indoor Coil

**Important:** Do not open the service valves until the refrigerant lines and indoor coil leak check and evacuation are complete.

**STEP 1** - Evacuate until the micron gauge reads no higher than 350 microns, then close off the valve to the vacuum pump.

**STEP 2** - Observe the micron gauge. Evacuation is complete if the micron gauge does not rise above 500 microns in one (1) minute.

Once evacuation is complete blank off the vacuum pump and micron gauge, and close the valves on the manifold gauge set.

## Section 10. Service Valves

### 10.1 Open the Gas Service Valve

**Important:** Leak check and evacuation must be completed before opening the service valves.

**NOTE:** Do not vent refrigerant gases into the atmosphere

**STEP 1** - Remove valve stem cap.

**STEP 2** - Using an adjustable wrench, turn valve stem 1/4 turn counterclockwise to the fully open position.

**STEP 3** - Replace the valve stem cap to prevent leaks. Tighten finger tight plus an additional 1/6 turn.

### 10.2 Open the Liquid Service Valve

#### **⚠ WARNING**

Extreme caution should be exercised when opening the Liquid Line Service Valve. Turn counterclockwise until the valve stem just touches the rolled edge. No torque is required. Failure to follow this warning will result in abrupt release of system charge and may result in personal injury and /or property damage.

**Important:** Leak check and evacuation must be completed before opening the service valves.

**STEP 1** - Remove service valve cap.

**STEP 2** - Fully insert 3/16" hex wrench into the stem and back out counterclockwise until valve stem just touches the rolled edge (approximately five (5) turns.)

**STEP 3** - Replace the valve cap to prevent leaks. Tighten finger tight plus an additional 1/6 turn.

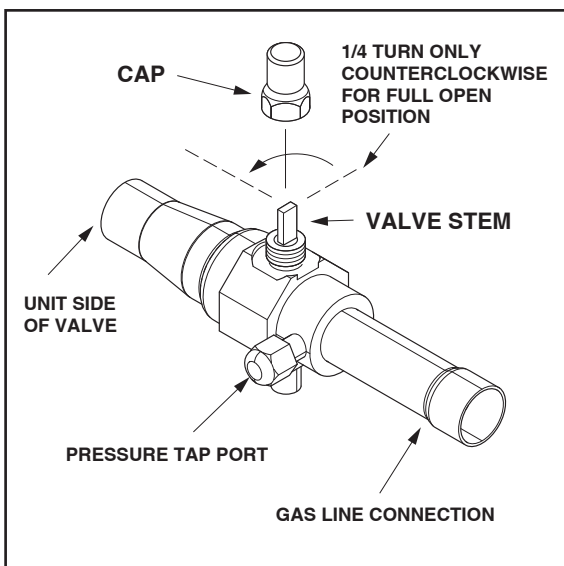

**Gas Service Valve**

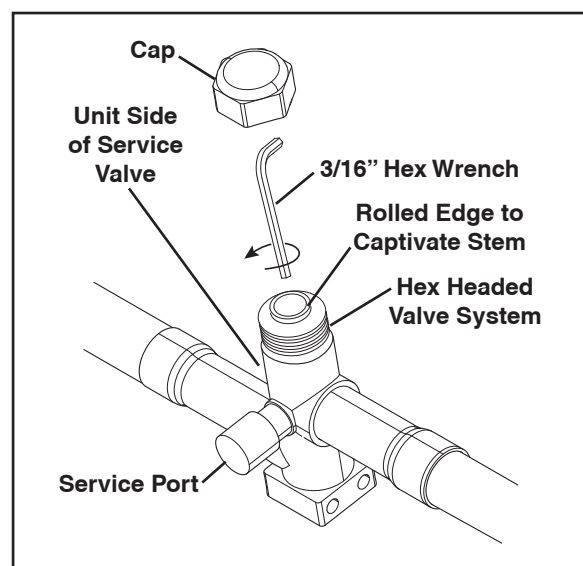

**Liquid Service Valve**



# Section 11. Electrical – Low Voltage

## 11.1 Low Voltage Maximum Wire Length

Table 11.1 defines the maximum total length of low voltage wiring from the outdoor unit, to the indoor unit, and to the thermostat.

**Table 11.1**

24 VOLTS	
WIRE SIZE	MAX. WIRE LENGTH
18 AWG	150 Ft.
16 AWG	225 Ft.
14 AWG	300 Ft.

## 11.2 Low Voltage Hook-up Diagrams

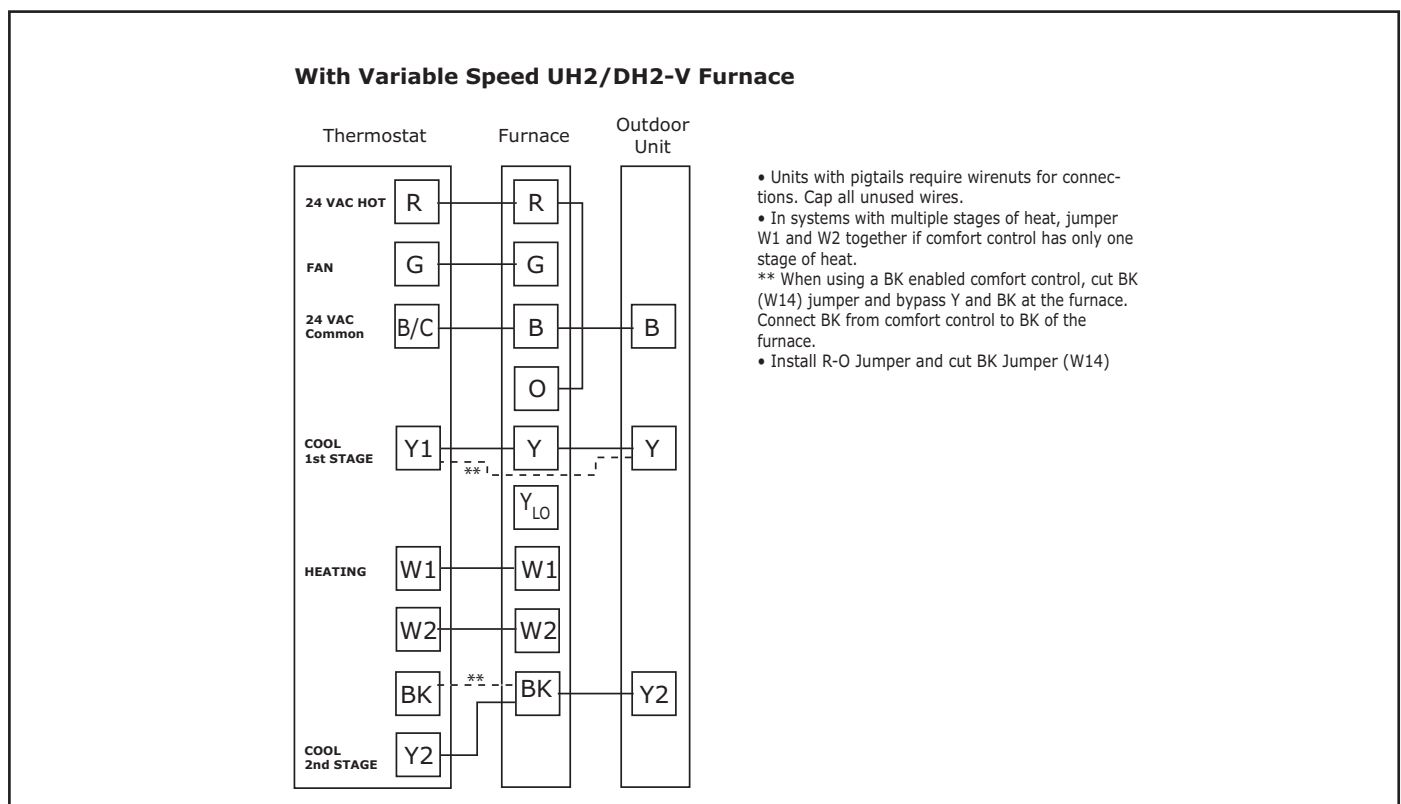
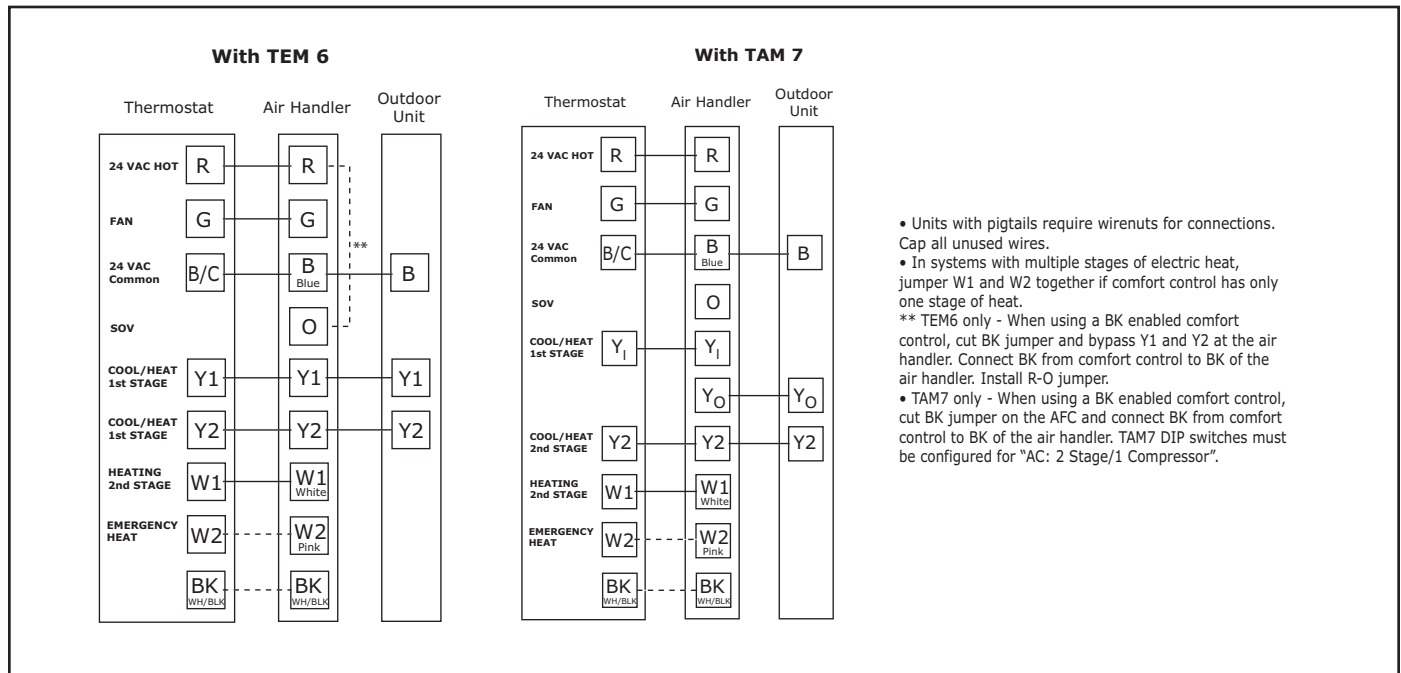

## With Variable Speed S-Series Furnace

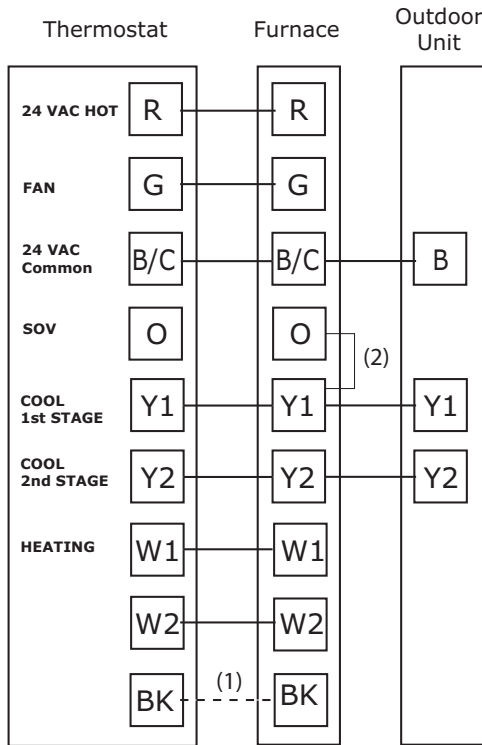

### NOTES:

- 1) For PWM (BK) enabled thermostats, cut the BK jumper on the IFC and connect wiring.
- 2) The factory Y1-O jumper must remain in place for proper LED read out in cooling mode.
- 3) Y1 and Y2 wiring from the thermostat must connect to the IFC for proper airflow and LED readout.
- 4) Single compressor and two compressor airflow is automatically set with the IFC Menu options in ODU section.

2-1=2 stage / 1 compressor (1st stage airflow = 75%)  
 2-2=2 stage / 2 compressors (1st stage airflow = 50%)

## Section 12. Electrical – High Voltage

### 12.1 High Voltage Power Supply

#### ⚠ WARNING

#### LIVE ELECTRICAL COMPONENTS!

During installation, testing, servicing, and troubleshooting of this product, it may be necessary to work with live electrical components. Failure to follow all electrical safety precautions when exposed to live electrical components could result in death or serious injury.

The high voltage power supply must agree with the equipment nameplate.

Power wiring must comply with national, state, and local codes.

Follow instructions on unit wiring diagram located on the inside of the control box cover and in the Service Facts document included with the unit.

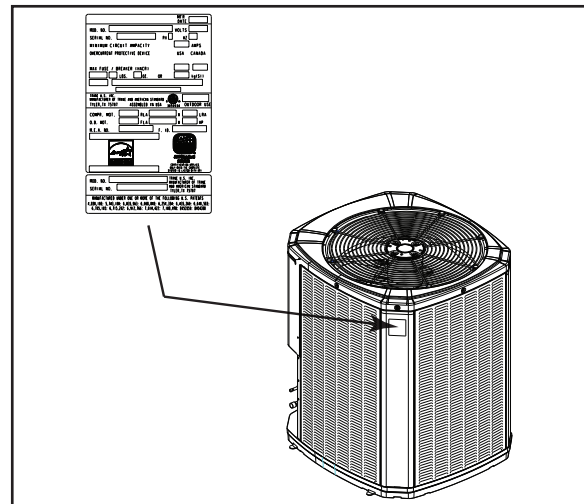

### 12.2 High Voltage Disconnect Switch

Install a separate disconnect switch at the outdoor unit.

For high voltage connections, flexible electrical conduit is recommended whenever vibration transmission may create a noise problem within the structure.

### 12.3 High Voltage Ground

Ground the outdoor unit per national, state, and local code requirements.

# Section 13. Start Up

## 13.1 System Start Up

- STEP 1** - Ensure Sections 7 through 12 have been completed.
- STEP 2** - Set System Thermostat to OFF.
- STEP 3** - Turn on disconnect(s) to apply power to the indoor and outdoor units.
- STEP 4** - Wait one (1) hour before starting the unit if compressor crankcase heater accessory is used and the Outdoor Ambient is below 70°F.
- STEP 5** - Set system thermostat to ON.

# Section 14. System Charge Adjustment

## 14.1 Temperature Measurements (Systems can be rated with TXV, EEV or Piston. Ensure charging method is correct).

- STEP 1** - Check the outdoor temperatures.
- Subcooling** (in cooling mode) is the only recommended\* method of charging above 55° F ambient outdoor temperature.
- Note:** For Superheat (In Cooling Mode), refer to the Superheat Charging Table on pg 19.
- \*Weigh-In Method** can be used for initial installation, or system replacement when power is not available or when the desired temperatures for the standard charging method are outside normal bounds. See Section 14.3. For best results the indoor temperature should be kept between 70° F to 80° F.
- Note:** It is important to return in the spring or summer to accurately charge the system in the cooling mode when outdoor ambient temperature is above 55° F.

## 14.2 Subcooling Charging in Cooling (Above 55° F Outdoor Temp.)

**STEP 1** - Use the refrigerant line total length and lift measurements from Section 5.3.

Total Line Length = \_\_\_\_\_ Ft.

Vertical Change (Lift) = \_\_\_\_\_ Ft.

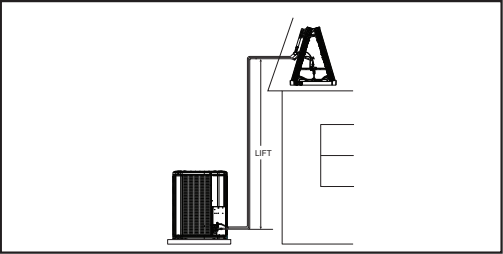

**STEP 2** - Determine the final subcooling value using total Line Length and Lift measured in STEP 1 and the charts below.

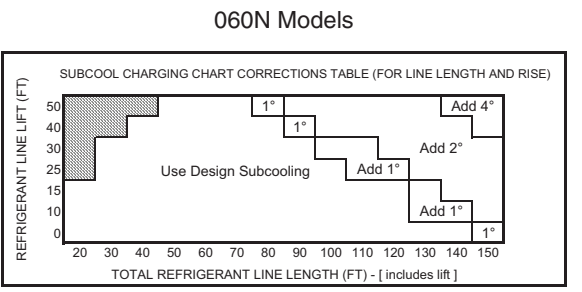
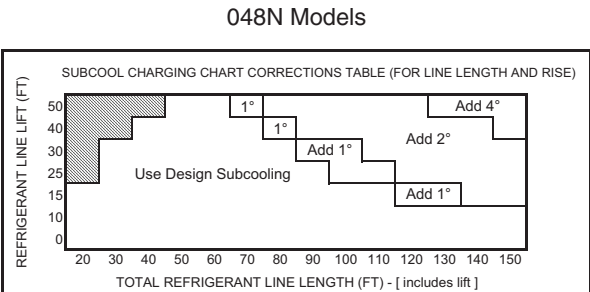
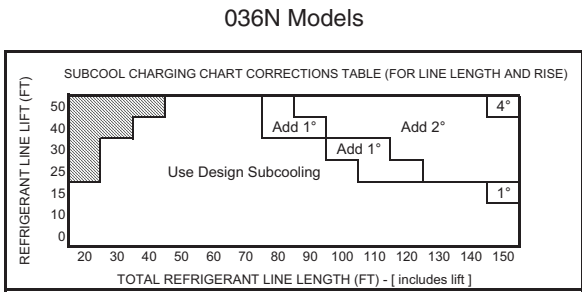
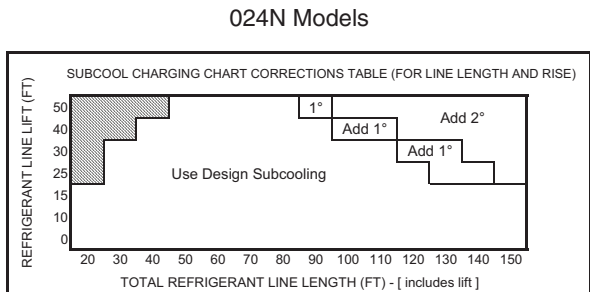

Design Subcooling Value = \_\_\_\_\_ ° F

Final Subcooling Value = \_\_\_\_\_ ° F

(from nameplate or Service Facts)

Subcooling Correction = \_\_\_\_\_ ° F

**STEP 3** - Stabilize the system by operating for a minimum of 20 minutes.

At startup, or whenever charge is removed or added, the system must be operated for a minimum of 20 minutes to stabilize before accurate measurements can be made.

**STEP 4** - Measure the liquid line temperature and pressure at the outdoor unit's service valve.

Measured Liquid Line Temp = \_\_\_\_\_ ° F

Liquid Gage Pressure = \_\_\_\_\_ PSI

Final Subcooling Value = \_\_\_\_\_ ° F

**STEP 5** - Use the final subcooling value, refrigerant temperature and pressure from STEP 4, to determine the proper liquid gage pressure using Table 14.2.

Example: Assume a 12° F Final Subcooling value and liquid temp of 90° F.

1. Locate 12° F Final Subcooling in Table 14.2.
2. Locate the Liquid Temperature (90° F) in the left column.
3. The Liquid Gage Pressure should be approximately 327 PSI. (This is shown as the intersection of the Final Subcooling column and the Liquid Temperature row.)

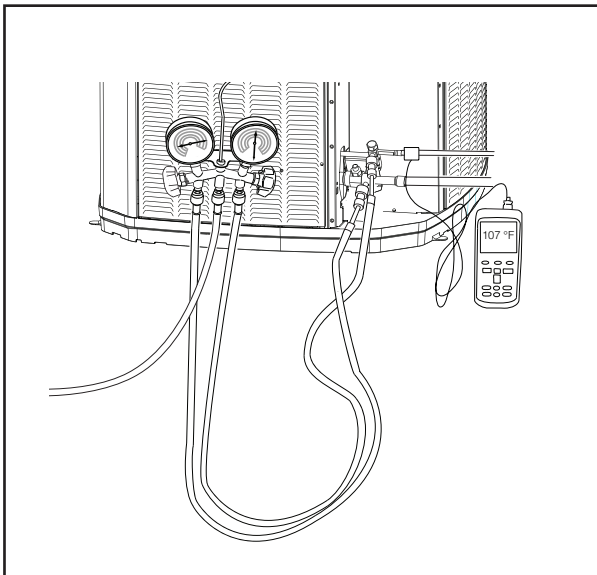

**Table 14.2**

R-410A REFRIGERANT CHARGING CHART							
LIQUID TEMP (°F)	FINAL SUBCOOLING (°F)						
	8	9	10	11	12	13	14
LIQUID GAGE PRESSURE (PSI)							
55	179	182	185	188	191	195	198
60	195	198	201	204	208	211	215
65	211	215	218	222	225	229	232
70	229	232	236	240	243	247	251
75	247	251	255	259	263	267	271
80	267	271	275	279	283	287	291
85	287	291	296	300	304	309	313
90	309	313	318	322	327	331	336
95	331	336	341	346	351	355	360
100	355	360	365	370	376	381	386
105	381	386	391	396	402	407	413
110	407	413	418	424	429	435	441
115	435	441	446	452	458	464	470
120	464	470	476	482	488	495	501
125	495	501	507	514	520	527	533

From Dwg. D154557P01 Rev. 3

**STEP 6** - Adjust refrigerant level to attain proper gage pressure.

**Add refrigerant** if the Liquid Gage Pressure is lower than the chart value.

1. Connect gages to refrigerant bottle and unit as illustrated.
2. Purge all hoses.
3. Open bottle.
4. Stop adding refrigerant when liquid line temperature and Liquid Gage Pressure matches the charging chart Final Subcooling value.

**Recover refrigerant** if the Liquid Gage Pressure is higher than the chart value.

**STEP 7** - Stabilize the system.

1. Wait 20 minutes for the system condition to stabilize between adjustments.

**Note:** When the Liquid Line Temperature and Gage Pressure approximately match the chart, the system is properly charged.

2. Remove gages.
3. Replace service port caps to prevent leaks. Tighten finger tight plus an additional 1/6 turn.

**STEP 8** - Verify typical performance.

Refer to System Pressure Curves at the end of the document to verify typical performance.

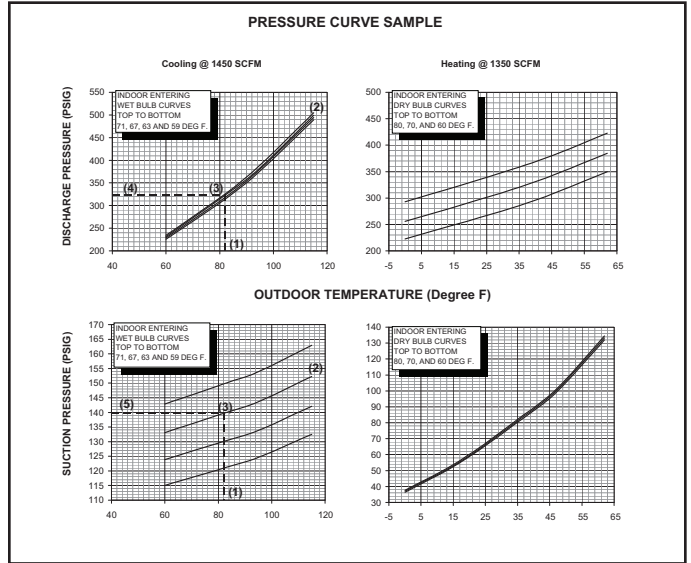
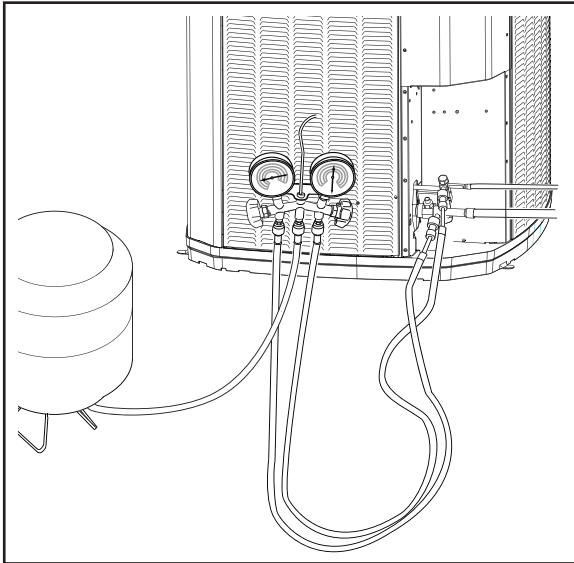

**STEP 9 - Record System Information for reference.**

Record system pressures and temperatures after charging is complete.

Outdoor model number = \_\_\_\_\_

Measured Outdoor Ambient = \_\_\_\_\_ °F

Measured Indoor Ambient = \_\_\_\_\_ °F

Measured Liquid Line Temp = \_\_\_\_\_ °F

Measured Suction Line Temp = \_\_\_\_\_ °F

Liquid Gage Pressure = \_\_\_\_\_ PSI

Suction Gage Pressure = \_\_\_\_\_ PSI

**Fixed Orifice Superheat Charging Table**

		Indoor Wet Bulb Temp (F)																														
		50	51	52	53	54	55	56	57	58	59	60	61	62	63	64	65	66	67	68	69	70	71	72	73	74	75	76	77	78		
Outdoor Dry Bulb Temp. (F)	55	7	9	10	11	12	14	15	17	18	20	21	23	24	26	27	29	30														
	60	5	7	8	9	10	12	13	15	16	18	19	21	22	24	25	27	28	30	31												
	65			4	6	8	10	11	13	14	16	17	18	19	21	22	24	25	27	28	27	31										
	70					5	7	8	10	11	13	14	16	17	18	19	21	22	24	25	27	28	30	31								
	75							5	6	7	9	10	12	14	16	18	19	21	22	24	26	28	29	31	32							
	80									4	6	7	9	10	11	12	14	16	18	19	21	23	25	26	28	29	31	33				
	85										4	6	7	9	10	13	14	16	18	20	21	23	24	26	28	29	30	31	32			
	90											4	6	8	10	11	13	14	16	18	20	22	24	25	27	28	30	31				
	95													4	6	8	10	13	14	16	18	20	22	23	25	26	28	29				
	100																6	8	10	12	13	16	18	20	21	23	25	27	29			
	105																	4	6	7	9	11	13	15	18	20	22	24	26	28		
	110																			4	7	9	11	13	16	18	21	23	26	28		
115																						6	9	12	14	16	19	21	24	26		

Using a digital psychrometer, measure the return air wet-bulb temperature at the unit just before the coil. Also measure the outdoor dry-bulb temperature. Use these temperatures to locate the target superheat on the charging table. Do not attempt to charge the system if these conditions fall outside of this charging table.

ADD refrigerant to DECREASE total superheat. REMOVE refrigerant to INCREASE total superheat. Always allow 10 to 15 minutes of operation after any refrigerant or air flow change prior to determining the final superheat.

### 14.3 Weigh-In Method for Charging

Weigh-In Method can be used for the initial installation, or anytime a system charge is being replaced. Weigh-In Method can also be used when power is not available to the equipment site or operating conditions (indoor/outdoor temperatures) are not in range to verify with the subcooling charging method.

#### Calculating Charge Using the Weigh-In Method

**STEP 1** – Measure in feet the distance between the outdoor unit and the indoor unit and record on Line 1. Include the entire length of the line from the service valve to the IDU.

**STEP 2** – Enter the charge multiplier (0.6 oz/ft). Each linear foot of interconnecting tubing requires the addition of 0.6 oz of refrigerant.

**STEP 3** – Multiply the total length of refrigerant tubing (Line 1) times the value on Step 2. Record the result on Line 3 of the Worksheet.

**STEP 4** – This is the amount of refrigerant to weigh-in prior to opening the service valves.

- |                      |   |                 |
|----------------------|---|-----------------|
| 1. Line length (ft)  |   | _____           |
| 2. Charge multiplier | x | _____ 0.6 _____ |
| 3. Step 1 x Step 2   | = | _____           |
| 4. Refrigerant       | = | _____           |

## Section 15. Checkout Procedures

### 15.1 Operational And Checkout Procedures

Final phases of this installation are the unit Operational and Checkout Procedures. To obtain proper performance, all units must be operated and charge adjustments made.

**Important:** Perform a final unit inspection to be sure that factory tubing has not shifted during shipment. Adjust tubing if necessary so tubes do not rub against each other when the unit runs. Also be sure that wiring connections are tight and properly secured.

#### CHECKOUT PROCEDURE

After installation has been completed, it is recommended that the entire system be checked against the following list:

- |  |  |
|--|--|
| 1. Leak check refrigerant lines. .... [ ]  | 7. Be sure that indoor coil drain line drains freely. Pour water into drain pan..... [ ] |
| 2. Properly insulate suction lines and fittings..... [ ]   | 8. Be sure that supply registers and return grilles are open and unobstructed..... [ ]   |
| 3. Properly secure and isolate all refrigerant lines..... [ ]  | 9. Be sure that a return air filter is installed..... [ ]                                |
| 4. Seal passages through masonry.<br>If mortar is used, prevent mortar from coming into direct contact with copper tubing..... [ ] | 10. Be sure that the correct airflow setting is used.<br>(Indoor blower motor) ..... [ ] |
| 5. Verify that all electrical connections are tight..... [ ]   | 11. Operate complete system in each mode to ensure safe operation..... [ ]               |
| 6. Observe outdoor fan during on cycle for clearance and smooth operation..... [ ]   |  |

# Section 16. Refrigeration Circuits

## 024N Models

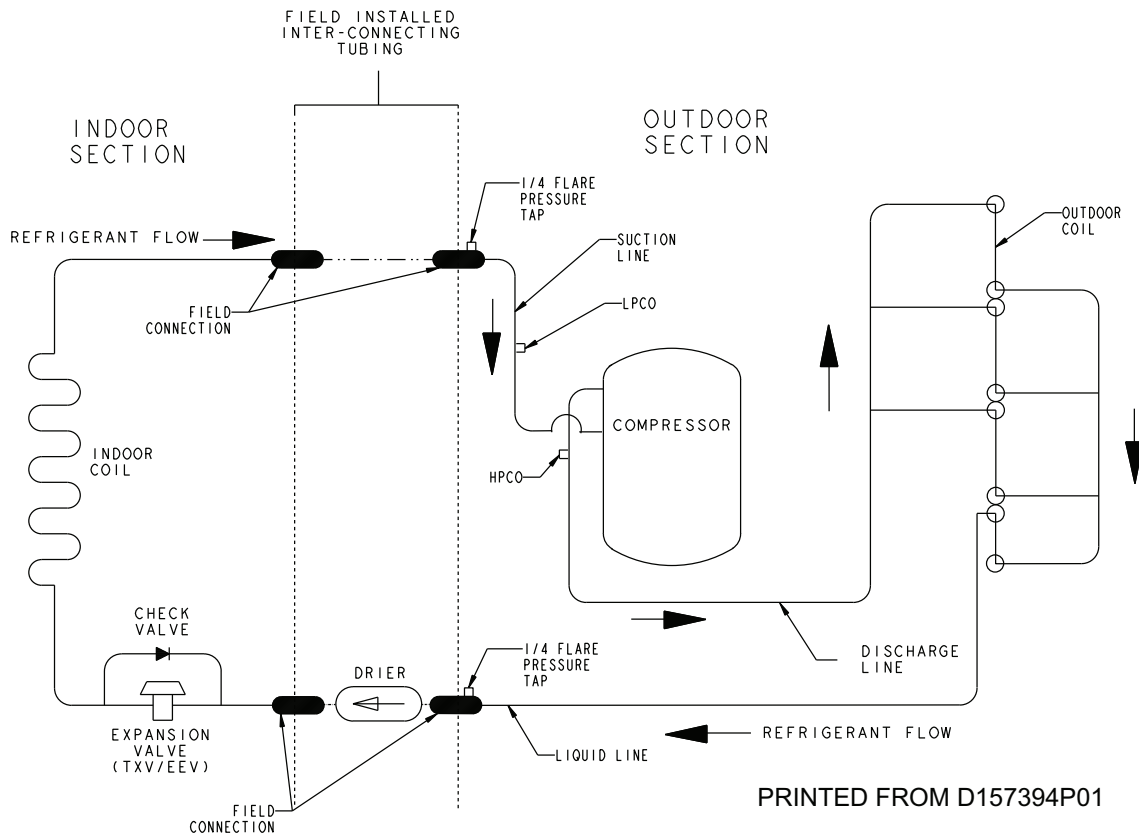

## 036N Models

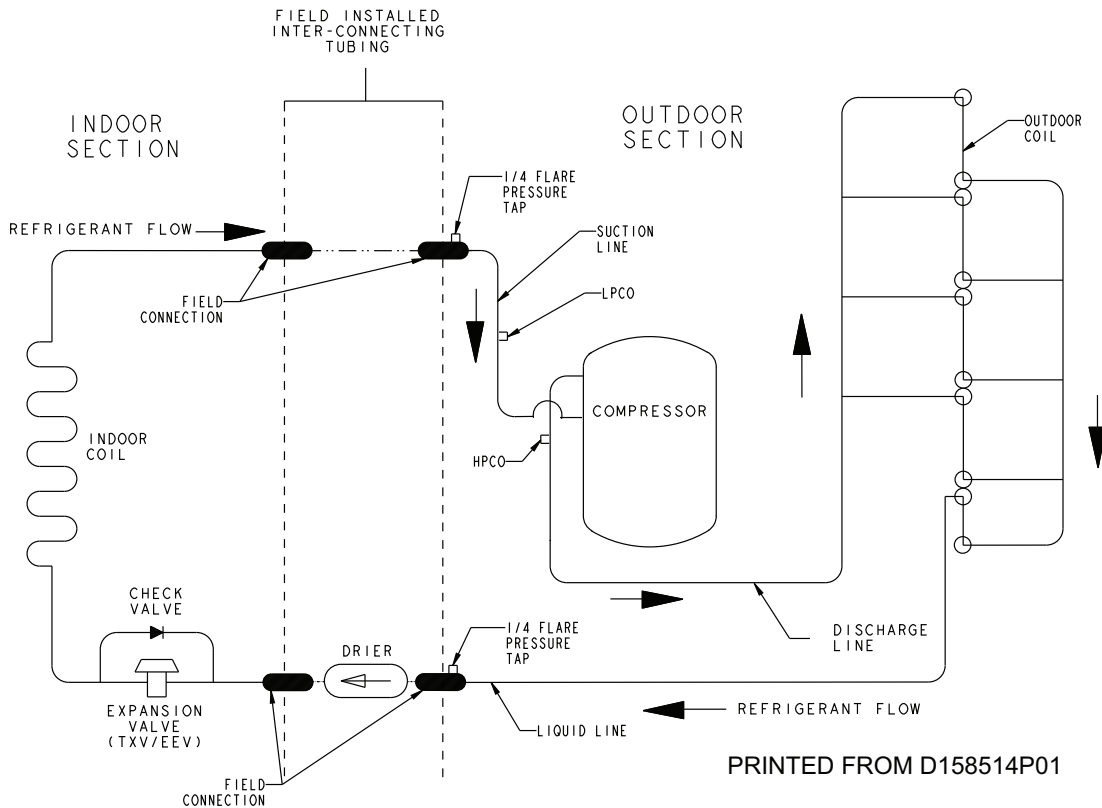



## 048N Models

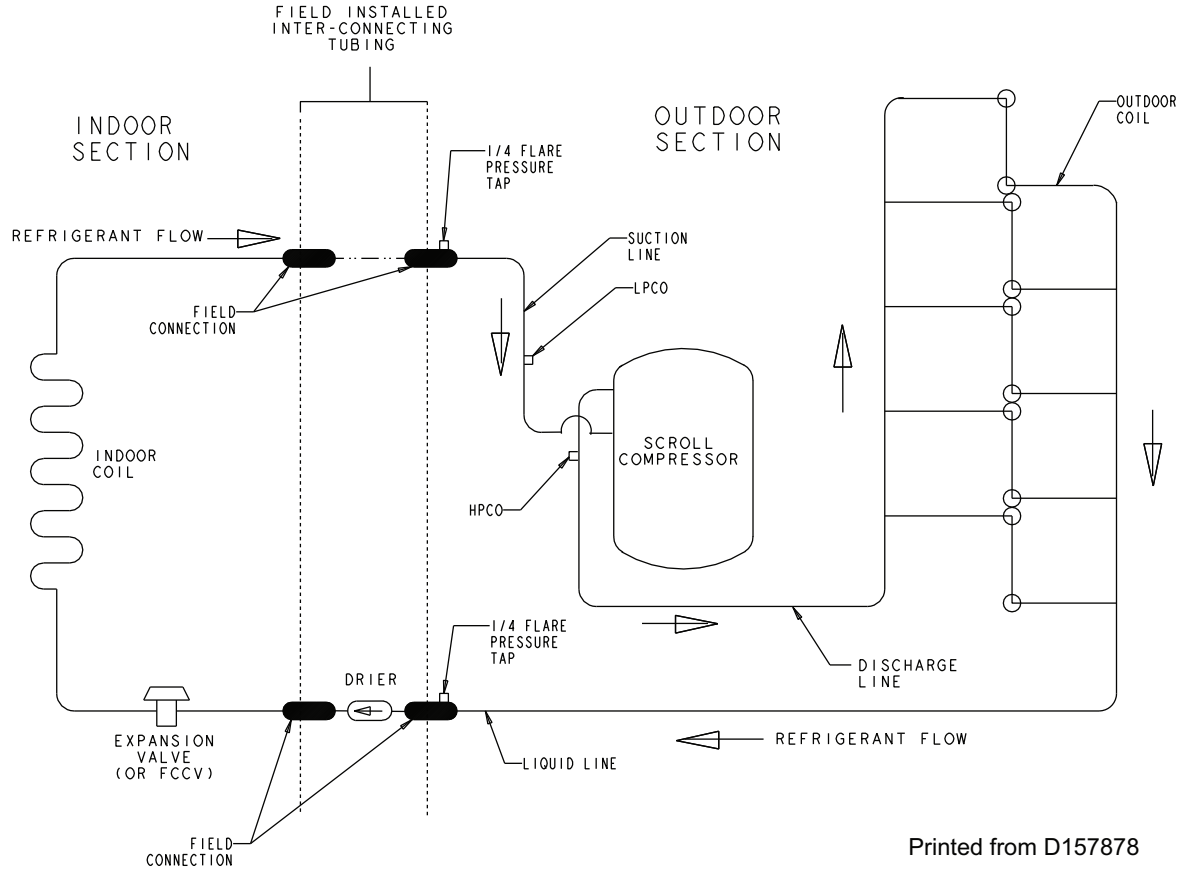

## 060N Models

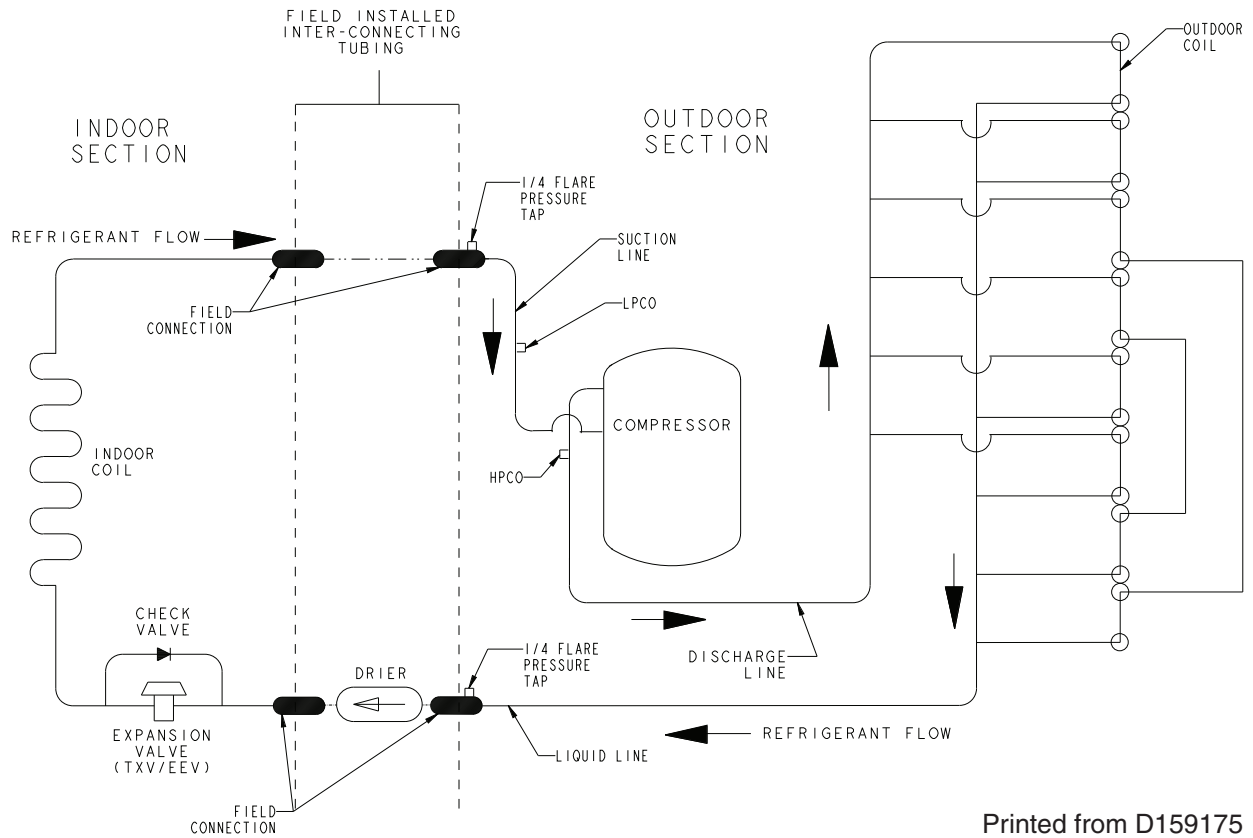

# Section 17. Wiring Diagrams

## 024N & 036N Models

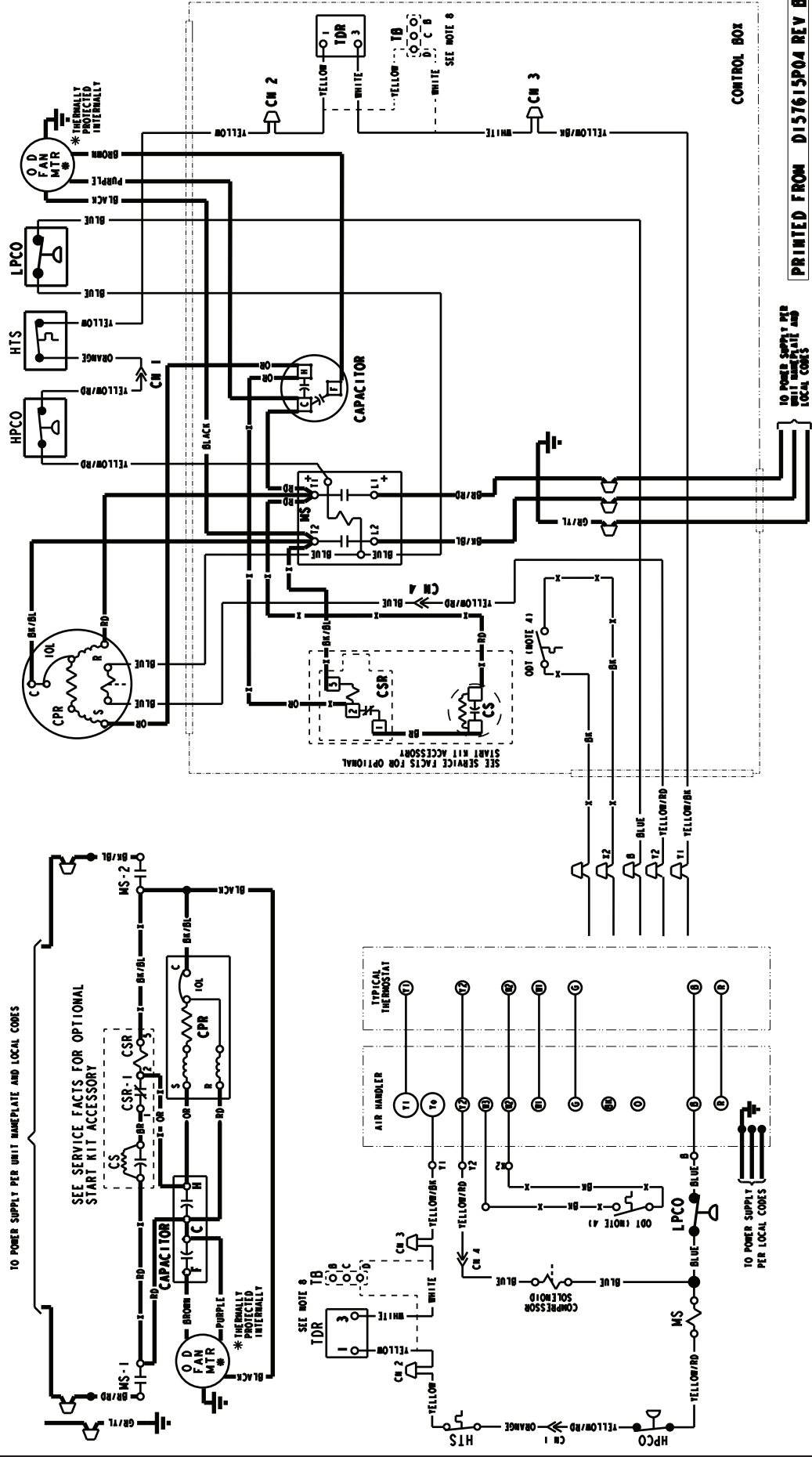

# 048N Models

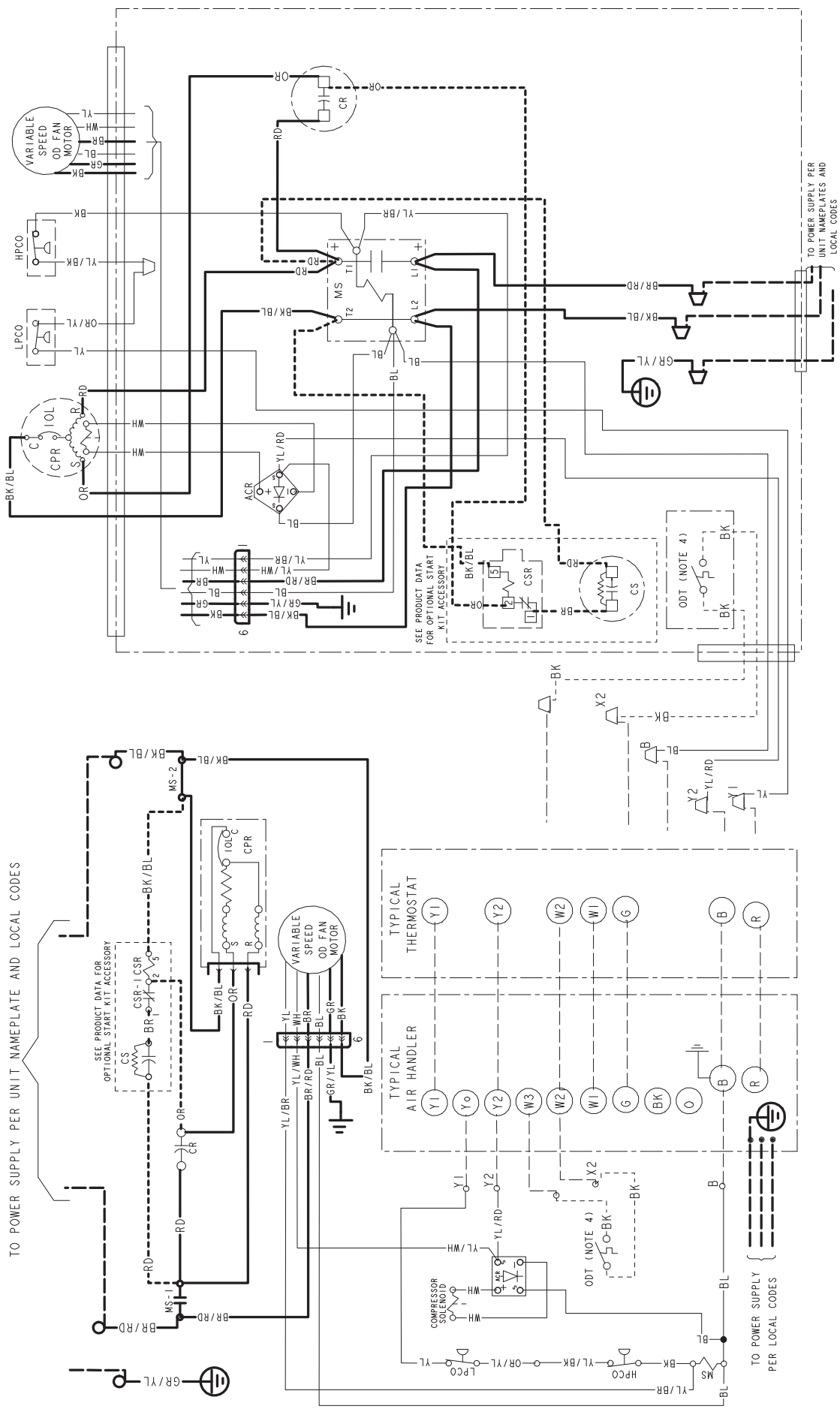

PRINTED FROM D160141P01 REV B

060N Models

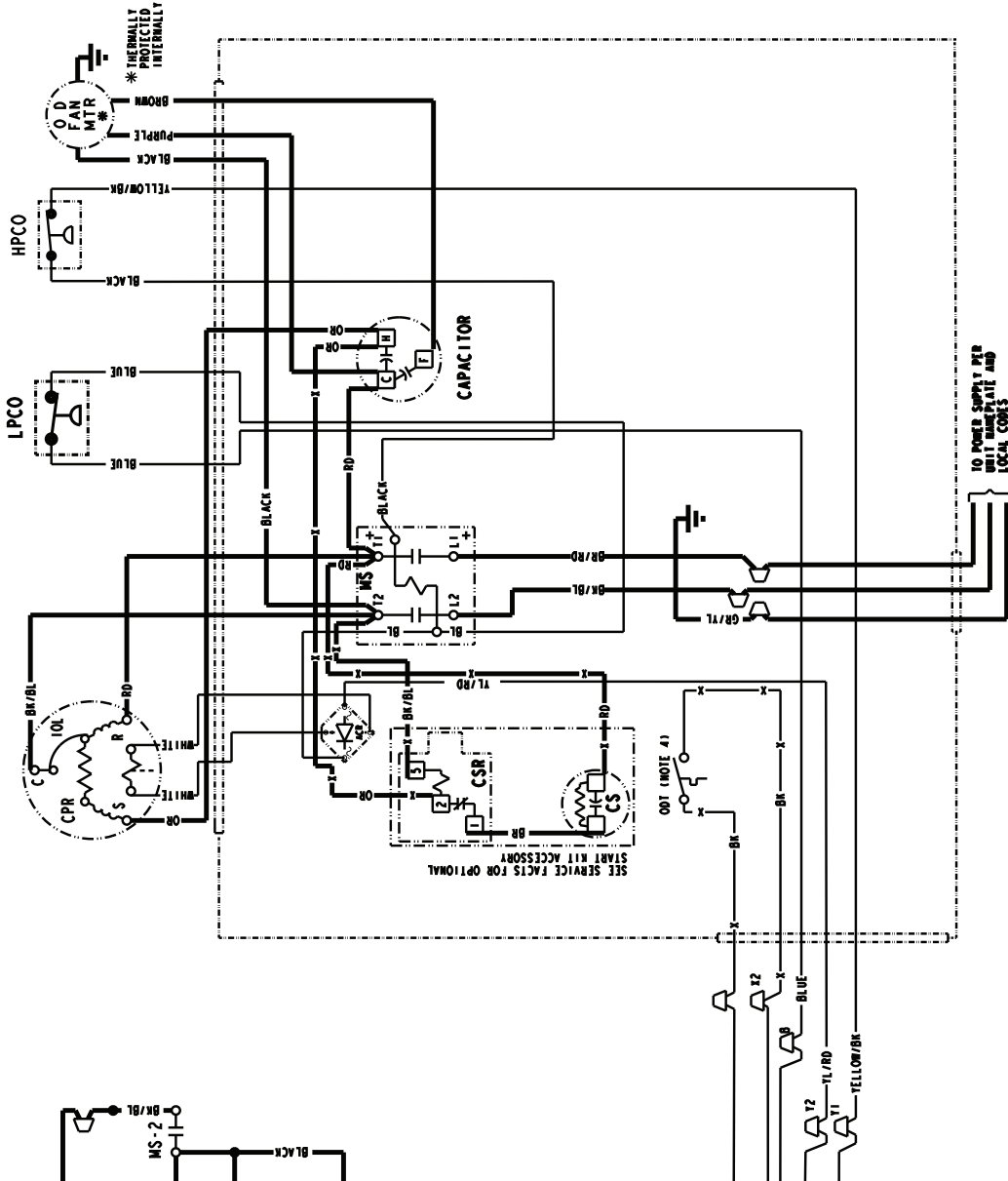
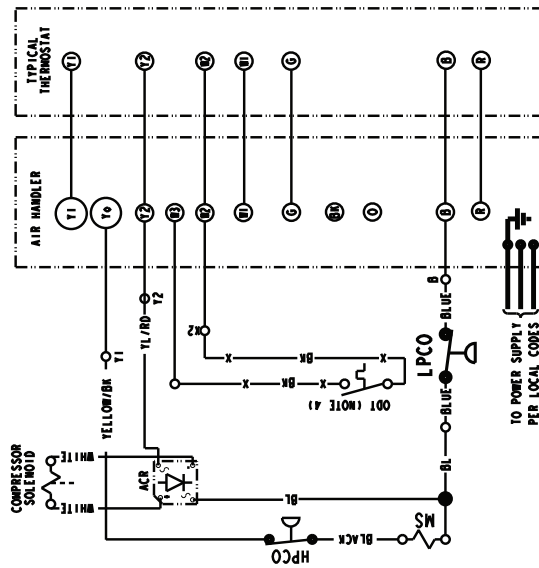
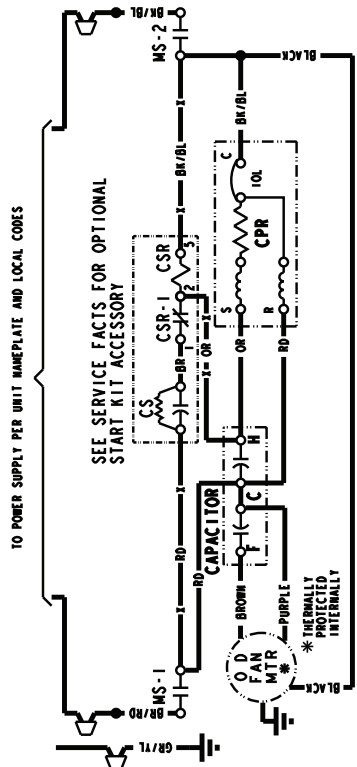

PRINTED FROM DI5761SP03 REV A

NOTES:

1. BE SURE POWER SUPPLY AGREES WITH EQUIPMENT NAMEPLATE.
2. POWER WIRING AND GROUNDING OF EQUIPMENT MUST COMPLY WITH LOCAL CODES.
3. LOW VOLTAGE WIRING TO BE NO. 18 AWG MINIMUM CONDUCTOR.
4. IF OUTDOOR THERMOSTAT (ODT) IS NOT USED, CONNECT W2 TO W3.
5. WITH Y1 ENERGIZED, INDOOR FAN IS 1ST STAGE AIRFLOW.
6. WITH Y1 & Y2 ENERGIZED, INDOOR FAN IS 2ND STAGE AIRFLOW.
7. SEE AIR HANDLER INSTALLER GUIDE FOR DIP SWITCH CONFIGURATIONS.
8. USE EITHER TDR OR TB. DO NOT USE BOTH IN ONE MODEL. TB IS ALTERNATE FOR TDR.

FOR CANADIAN INSTALLATIONS  
POUR INSTALLATIONS CANADIENNES

CAUTION: NOT SUITABLE FOR USE ON SYSTEMS EXCEEDING 150V-TO-GROUND.  
ATTENTION: NE CONVIENT PAS AUX INSTALLATIONS DE PLUS DE 150 V A LA TERRE.

▲ NOTE:

MATERIAL: WHITE POLYPROPYLENE SUITABLE FOR USE IN OUTDOOR ENVIRONMENT.  
ADHESIVE: PRESSURE SENSITIVE ADHESIVE WITH RELEASE PAPER SUITABLE FOR OUTDOOR APPLICATION ON PAINTED OR GALVANIZED SHEET METAL SURFACES.  
SIZE: 8 1/2" X 11"

## LEGEND

<p>  COLOR OF WIRE                  BK/BL BLACK WIRE WITH BLUE MARKER   COLOR OF MARKER                  BK BLACK OR ORANGE YL YELLOW                  BL BLUE RD RED GR GREEN                  BR BROWN WH WHITE PR PURPLE                  CA COOLING ANTICIPATOR                  CBS COIL BOTTOM SENSOR                  CF FAN CAPACITOR                  CN WIRE CONNECTOR                  CPR COMPRESSOR                  CR RUN CAPACITOR                  CS STARTING CAPACITOR                  CSR CAPACITOR SWITCHING RELAY                  DFC DEFROST CONTROL                  F INDOOR FAN RELAY                  HA HEATING ANTICIPATOR                  HPCO HIGH PRESSURE CUTOUT SW.                  IOL INTERNAL OVERLOAD PROTECTOR                  ACR A/C RECTIFIER                  LPCO LOW PRESSURE CUTOUT SW.                  MS COMPRESSOR MOTOR CONTACTOR                  ODA OUTDOOR ANTICIPATOR                  OFT OUTDOOR FAN THERMOSTAT                  ODS OUTDOOR TEMPERATURE SENSOR                  ODT OUTDOOR THERMOSTAT                  RHS RESISTANCE HEAT SWITCH                  SC SWITCHOVER VALVE SOLENOID                  SM SYSTEM "ON-OFF" SWITCH                  TDL DISCHARGE LINE THERMOSTAT                  TDR TIME DELAY RELAY (5 SEC DELAY ON)                  TNS TRANSFORMER                  TS HEATING-COOLING THERMOSTAT                  TSH HEATING THERMOSTAT     TEMP. ACTUATED SWITCH   MOTOR WINDING   TERMINAL             </p>	<table border="0" style="width: 100%;"> <tr> <td style="width: 15%;"></td> <td style="width: 15%;">24 V.</td> <td rowspan="2" style="font-size: 2em; vertical-align: middle;">}</td> <td rowspan="2">FACTORY WIRING</td> </tr> <tr> <td></td> <td>LINE V.</td> </tr> <tr> <td></td> <td>24 V.</td> <td rowspan="2" style="font-size: 2em; vertical-align: middle;">}</td> <td rowspan="2">FIELD WIRING</td> </tr> <tr> <td></td> <td>LINE V.</td> </tr> <tr> <td></td> <td>GROUND</td> <td></td> <td></td> </tr> <tr> <td></td> <td>JUNCTION</td> <td></td> <td></td> </tr> <tr> <td></td> <td>WIRE NUT OR CONNECTOR</td> <td></td> <td></td> </tr> <tr> <td></td> <td>COIL</td> <td></td> <td></td> </tr> <tr> <td></td> <td>CAPACITOR</td> <td></td> <td></td> </tr> <tr> <td></td> <td>RELAY CONTACT (N.O.)</td> <td></td> <td></td> </tr> <tr> <td></td> <td>RELAY CONTACT (N.C.)</td> <td></td> <td></td> </tr> <tr> <td></td> <td>THERMISTOR</td> <td></td> <td></td> </tr> <tr> <td></td> <td>INTERNAL OVERLOAD PROTECTOR</td> <td></td> <td></td> </tr> <tr> <td></td> <td>PRESSURE ACTUATED SWITCH</td> <td></td> <td></td> </tr> <tr> <td></td> <td>POL. PLUG FEMALE HOUSING (MALE TERM.)</td> <td></td> <td></td> </tr> <tr> <td></td> <td>POL. PLUG MALE HOUSING (FEMALE TERM.)</td> <td></td> <td></td> </tr> <tr> <td></td> <td>RESISTOR OR HEATING ELEMENT</td> <td></td> <td></td> </tr> </table>		24 V.	}	FACTORY WIRING		LINE V.		24 V.	}	FIELD WIRING		LINE V.		GROUND				JUNCTION				WIRE NUT OR CONNECTOR				COIL				CAPACITOR				RELAY CONTACT (N.O.)				RELAY CONTACT (N.C.)				THERMISTOR				INTERNAL OVERLOAD PROTECTOR				PRESSURE ACTUATED SWITCH				POL. PLUG FEMALE HOUSING (MALE TERM.)				POL. PLUG MALE HOUSING (FEMALE TERM.)				RESISTOR OR HEATING ELEMENT		
	24 V.	}	FACTORY WIRING																																																														
	LINE V.																																																																
	24 V.	}	FIELD WIRING																																																														
	LINE V.																																																																
	GROUND																																																																
	JUNCTION																																																																
	WIRE NUT OR CONNECTOR																																																																
	COIL																																																																
	CAPACITOR																																																																
	RELAY CONTACT (N.O.)																																																																
	RELAY CONTACT (N.C.)																																																																
	THERMISTOR																																																																
	INTERNAL OVERLOAD PROTECTOR																																																																
	PRESSURE ACTUATED SWITCH																																																																
	POL. PLUG FEMALE HOUSING (MALE TERM.)																																																																
	POL. PLUG MALE HOUSING (FEMALE TERM.)																																																																
	RESISTOR OR HEATING ELEMENT																																																																

▲ WARNING

HAZARDOUS VOLTAGE!

DISCONNECT ALL ELECTRIC POWER INCLUDING REMOTE DISCONNECTS BEFORE SERVICING.

FAILURE TO DISCONNECT POWER BEFORE SERVICING CAN CAUSE SEVERE PERSONAL INJURY OR DEATH!

▲ CAUTION

USE COPPER CONDUCTORS ONLY!

UNIT TERMINALS ARE NOT DESIGNED TO ACCEPT OTHER TYPES OF CONDUCTORS.

FAILURE TO DO SO MAY CAUSE DAMAGE TO THE EQUIPMENT!

## Section 18. Pressure Curves

COOLING PERFORMANCE CAN BE CHECKED WHEN THE OUTDOOR TEMP IS ABOVE 65 DEG F.

TO CHECK COOLING PERFORMANCE, SELECT THE PROPER INDOOR CFM, ALLOW PRESSURES TO STABILIZE. MEASURE INDOOR WET BULB TEMPERATURE, OUTDOOR TEMPERATURE, LIQUID AND SUCTION PRESSURES. ON THE PLOTS LOCATE OUTDOOR TEMPERATURE (1); LOCATE INDOOR WET BULB (2); FIND INTERSECTION OF OD TEMP. & ID W.B. (3); READ LIQUID (4) OR SUCTION (5) PRESSURE IN LEFT COLUMN.

EXAMPLE: (1) OUTDOOR TEMP. 82 F.

(2) INDOOR WET BULB 67 F.

(3) AT INTERSECTION

(4) LIQUID PRESSURE @ 600 CFM IS 305 PSIG

(5) SUCTION PRESSURE @ 600 CFM IS 141 PSIG

ACTUAL:

LIQUID PRESSURE SHOULD BE +/- 10 PSI OF CHART

SUCTION PRESSURE SHOULD BE +/- 3 PSIG OF CHART

**PRESSURE CURVES (Refer below table for models)**

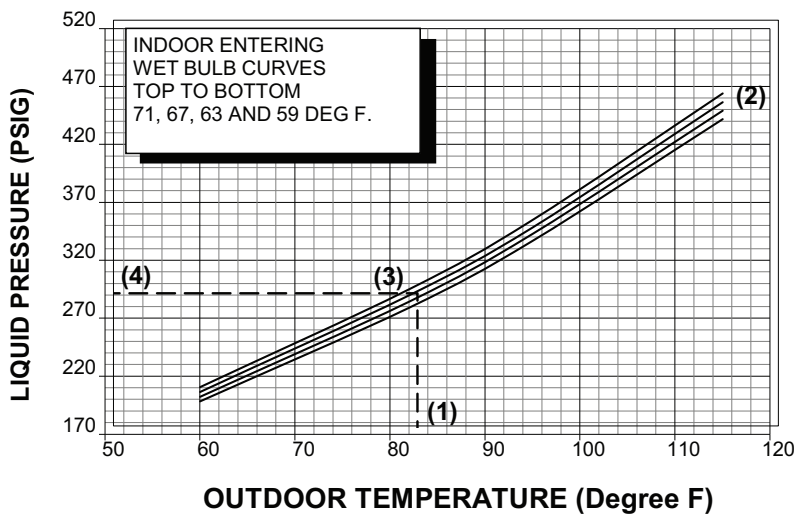

OD Model	Cooling @SCFM
4TTR6024N1	700
4TTR6036N1	1000
4TTR6048N1	1300

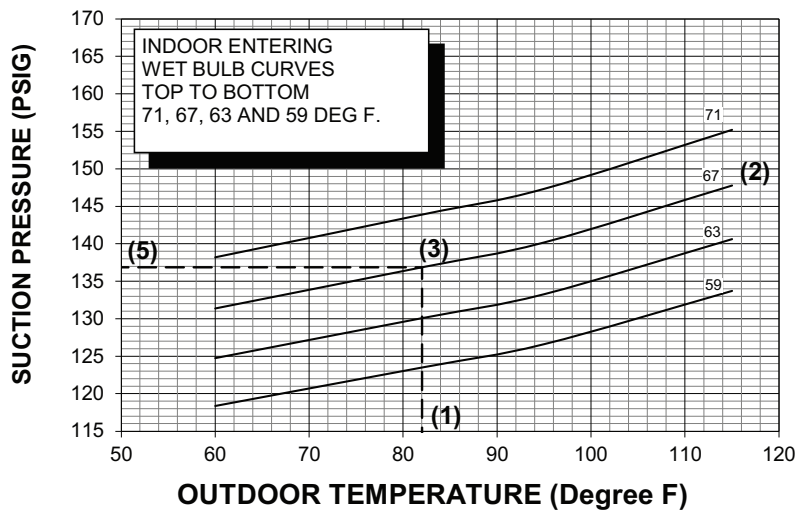

**PRESSURE CURVES (Refer below table for models)**

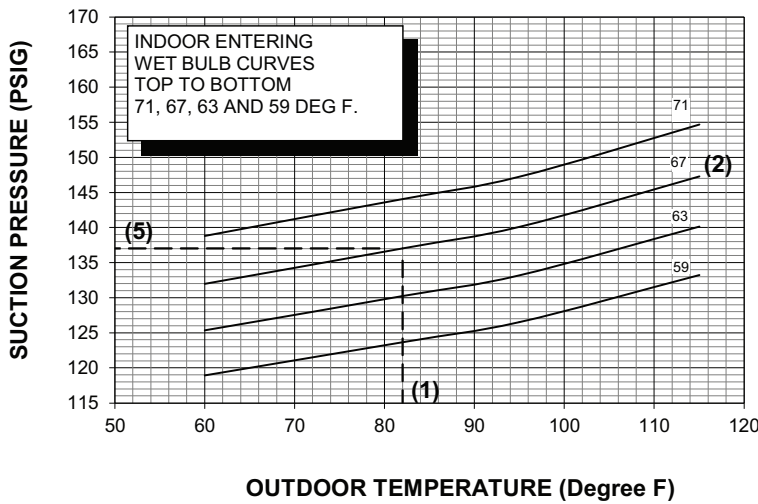
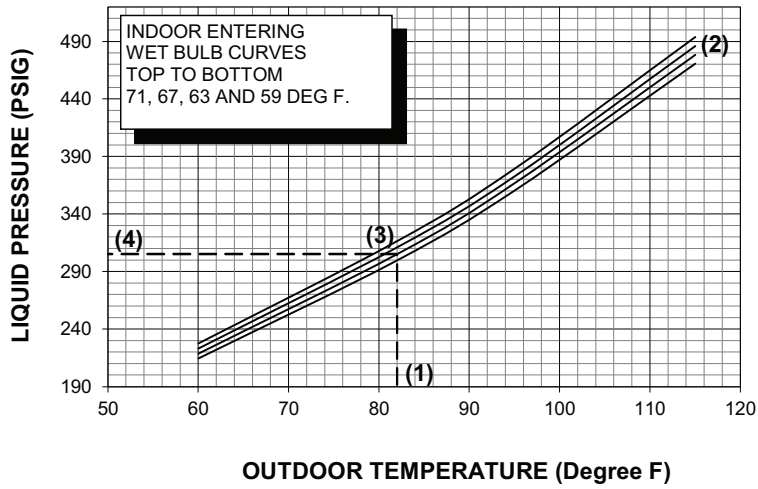

OD Model	Cooling @SCFM
4TTR6060N1	1600



Trane - by Trane Technologies (NYSE: TT), a global climate innovator - creates comfortable, energy efficient indoor environments for commercial and residential applications. For more information, please visit [trane.com](http://trane.com) or [tranetechnologies.com](http://tranetechnologies.com).



The AHRI Certified mark indicates Trane U.S. Inc. participation in the AHRI Certification program. For verification of individual certified products, go to [ahridirectory.org](http://ahridirectory.org).

Trane has a policy of continuous data improvement and it reserves the right to change design and specifications without notice. We are committed to using environmentally conscious print practices.