

# Installation, Operation, and Maintenance

## Modular Air Handlers – No Heat

P0V0A000M30SDA  
P0V0B000M40SDA  
P0V0C000M50SDA  
P0V0D000M50SDA

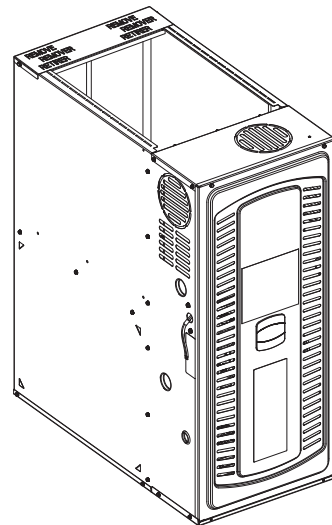

*Note: The P0V0 series modular air handler is designed for installation in a closet, utility room, alcove, basement, crawlspace or attic. These versatile units are applicable to air conditioning and heat pump applications. Several models are available to meet the specific requirements of the outdoor equipment.*

### **⚠ WARNING**

#### **FIRE HAZARD!**

Failure to follow this Warning could result in property damage, severe personal injury, or death.

This Warning applies to installations with a flammable refrigeration system. The furnace must be powered except for service. The furnace shall be installed and connected according to installation instructions and wiring diagrams that are provided with the evaporator coil.



P0V0-SVX001-1B-EN

### **⚠ SAFETY WARNING**

Only qualified personnel should install and service the equipment. The installation, starting up, and servicing of heating, ventilating, and air-conditioning equipment can be hazardous and requires specific knowledge and training. Improperly installed, adjusted or altered equipment by an unqualified person could result in death or serious injury. When working on the equipment, observe all precautions in the literature and on the tags, stickers, and labels that are attached to the equipment.

# SAFETY SECTION

## MODULAR AIR HANDLERS

**Important:** This document contains a wiring diagram, a parts list, and service information. This is customer property and is to remain with this unit. Please return to service information pack upon completion of work.

**Important:** These instructions do not cover all variations in systems nor provide for every possible contingency to be met in connection with the installation. Should further information be desired or should particular problems arise which are not covered sufficiently for the purchaser's purposes, the matter should be referred to your installing dealer or local distributor.

### ⚠ WARNING

#### HAZARDOUS VOLTAGE!

Failure to follow this Warning could result in property damage, severe personal injury, or death.

Disconnect all electric power, including remote disconnects before servicing. Follow proper lockout/tagout procedures to ensure the power cannot be inadvertently energized.

### ⚠ CAUTION

#### GROUNDING REQUIRED!

Failure to inspect or use proper service tools may result in equipment damage or personal injury.

Reconnect all grounding devices. All parts of this product that are capable of conducting electrical current are grounded. If grounding wires, screws, straps, clips, nuts, or washers used to complete a path to ground are removed for service, they must be returned to their original position and properly fastened.

### ⚠ WARNING

#### LIVE ELECTRICAL COMPONENTS!

Failure to follow this Warning could result in property damage, severe personal injury, or death.

Follow all electrical safety precautions when exposed to live electrical components. It may be necessary to work with live electrical components during installation, testing, servicing, and troubleshooting of this product.

### ⚠ CAUTION

#### IMPROPER VOLTAGE CONNECTION!

Failure to follow this Caution could result in property damage.

Do NOT connect the modular air handler line voltage to a GFCI protected circuit.

### ⚠ CAUTION

#### SHARP EDGE HAZARD!

Failure to follow this Caution could result in property damage or personal injury.

Be careful of sharp edges on equipment or any cuts made on sheet metal while installing or servicing.

### ⚠ WARNING

#### WARNING!

This product can expose you to chemicals including lead, which are known to the State of California to cause cancer and birth defects or other reproductive harm. For more information go to [www.P65Warnings.ca.gov](http://www.P65Warnings.ca.gov).

### ⚠ WARNING

#### SAFETY HAZARD!

This appliance is not to be used by persons (including children) with reduced physical, sensory, or mental capabilities, or lack of experience and knowledge, unless they have been given supervision or instruction.

### ⚠ WARNING

#### SAFETY HAZARD!

Children should be supervised to ensure that they do not play with the appliance.

**Important:** Installation of this unit shall be made in accordance with the National Electric Code, NFPA No. 90A and 90B, and any other local codes or utilities requirements.

**Notes:**

- *The modular air handlers have been evaluated in accordance with the Code of Federal Regulations Title 24 Subtitle B Chapter XX Part 3280 or the equivalent. "SUITABLE FOR MOBILE HOME USE."*
- *The manufacturer recommends installing ONLY A.H.R.I approved, matched indoor*

*and outdoor systems. Some of the benefits of installing approved matched indoor and outdoor split systems are maximum efficiency, optimum performance, and the best overall system reliability.*

- *There is no declared maximum altitude for operating the appliance.*
- *Appliance accessible to the general public.*

# Table of Contents

Features and Accessories.....	5	Return Air Filters .....	22
Parts List.....	5	Electrical Connections .....	23
Product Specifications.....	6	Field Wiring .....	23
Location and Clearances.....	7	Integrated Modular Air Handler Control Menu.....	24
Installation Instructions.....	8	Integrated Modular Air Handler Control (IMAHC) Display Codes.....	26
Outline Drawing .....	10	Fault Code Recovery .....	27
Wiring Diagram .....	11	Troubleshooting.....	28
Airflow Tables .....	12	Sequence of Operation .....	37
General Installation.....	16	Periodic Servicing Requirements .....	38
Panel Removal .....	16	Checkout Procedures .....	39
Horizontal Installation in an Attic or Crawlspace .....	16		
Duct Connections.....	17		



# Features and Accessories

**Table 1. Standard Features**

- MULTI-POSITION UPFLOW, DOWNFLOW, HORIZONTAL LEFT AND HORIZONTAL RIGHT
- PAINTED FINISH ON GALVANIZED STEEL EXTERIOR WITH FULLY INSULATED CABINET THAT MEETS 4.0 R VALUE. BLOWER COMPARTMENT INSULATION IS ONLY INSTALLED IN B, C AND D SIZE PRODUCTS AND HAS A 2.1 R VALUE
- 120 VAC OPERATION
- VARIABLE SPEED DIRECT DRIVE BLOWER
- SIDE AND BOTTOM RETURN
- MEETS THE MINIMUM LEAKAGE REQUIREMENTS FOR THE FLORIDA AND CALIFORNIA BUILDING CODES
- THESE MODULAR AIR HANDLER ARE APPROVED FOR INSTALLATION IN MANUFACTURER/MOBILE HOUSING.
- THIS MODULAR AIR HANDLER MUST BE INSTALLED IN ACCORDANCE WITH THE MANUFACTURER'S INSTRUCTIONS AND THE MANUFACTURED HOME CONSTRUCTION AND SAFETY STANDARD, TITLE 24 CFR, PART 3280 OR WHEN SUCH STANDARD IS NOT APPLICABLE, THE STANDARD FOR MODEL MANUFACTURED HOME INSTALLATION, NFPA 225, OR THE CANADIAN STANDARD FOR MANUFACTURED HOMES, CSA Z240 MH.

**Table 2. Accessories**

Model Number	Description	Use with
BAYHANG	Horizontal Hanging Kit	All modular air handlers
BAYLIFTB	Dual Return Kit (B size extension)	B Cabinet modular air handlers
BAYLIFTC	Dual Return Kit (C size extension)	C Cabinet modular air handlers
BAYLIFTD	Dual Return Kit (D size extension)	D Cabinet modular air handlers
BAYFLTR206	Filter Access Door Kit (Downflow only)	All modular air handlers blowers in Downflow orientation
BAYSF1165AA <sup>(a)</sup>	1" SlimFit Box with MERV 4 Filter	All modular air handlers blowers
BAYSF1255BA	1" SlimFit Filter and Insulated Frame	All modular air handlers when used in side return application B Cabinet modular air handlers only when in bottom return application
FLRSF1255	1" Filter replacement (Qty 12)	BAYSF1255BA
BAYFLTR203	Horizontal Filter Kit	B Cabinet modular air handlers in Downflow/Horizontal
BAYFLTR204	Horizontal Filter Kit	C Cabinet modular air handlers in Downflow/Horizontal
BAYFLTR205	Horizontal Filter Kit	D Cabinet modular air handlers in Downflow/Horizontal

<sup>(a)</sup> Airflow greater than 1600 CFM requires dual returns

## Parts List

- Blower Motor
- Blower Wheel
- IMAHC (Integrated Modular Air Handler Control)

# Product Specifications

MODEL	P0V0A000M30SDA	P0V0B000M40SDA	P0V0C000M50SDA	P0V0D000M50SDA
<b>TYPE</b>	Upflow / Horizontal / Downflow	Upflow / Horizontal / Downflow	Upflow / Horizontal / Downflow	Upflow / Horizontal / Downflow
<b>BLOWER DRIVE</b>	DIRECT	DIRECT	DIRECT	DIRECT
Diameter - Width (in.)	11 X 8	11 X 8	11 X 10	11 X 10
No. Used	1	1	1	1
Speeds (No.)	Variable	Variable	Variable	Variable
CFM vs. in. w.g.	See Fan Performance Table	See Fan Performance Table	See Fan Performance Table	See Fan Performance Table
Motor HP	1/2	3/4	1	1
R.P.M.	Variable	Variable	Variable	Variable
Volts / Ph / Hz	120 / 1 / 60	120 / 1 / 60	120 / 1 / 60	120 / 1 / 60
FLA	6.4	9.6	10.0	10.0
<b>FILTER – Furnished?</b>	No	No	No	No
Type recommended	High Velocity	High Velocity	High Velocity	High Velocity
Hi Vel. (No.-Size-Thk.)	1 - 14 X 25 - 1 in.	1 - 16 X 25 - 1 in.	1 - 20 X 25 - 1 in.	1 - 24 X 25 - 1 in.
<b>POWER CONN. – V/Ph/Hz</b> <sup>(a)</sup>	120 / 1 / 60	120 / 1 / 60	120 / 1 / 60	120 / 1 / 60
Ampacity (In Amps)	8.2	12.2	12.7	12.7
Max. Overcurrent Protection (Amps)	15	15	15	15
<b>WEIGHT</b>				
Shipping (Lbs.)	83	92	101	107

<sup>(a)</sup> The wiring specifications are in accordance with National Electrical Code; however, installations must comply with local codes.

# Location and Clearances

## Minimum clearance to combustible materials

### INSTALLATION CLEARANCE TO COMBUSTIBLE CONSTRUCTION

THIS MODULAR AIR HANDLER IS APPROVED FOR UPFLOW, DOWNFLOW AND HORIZONTAL APPLICATIONS.

LINE CONTACT ONLY PERMISSIBLE BETWEEN LINES FORMED BY INTERSECTIONS OF THE TOP AND TWO SIDES OF THE MODULAR AIR HANDLER JACKET, AND BUILDING JOISTS, STUDS OR FRAMING.

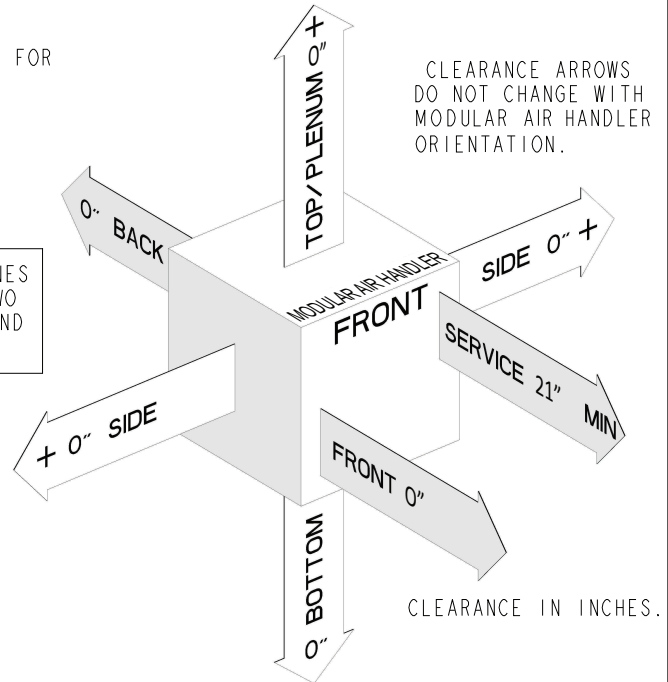

# Installation Instructions

## 1. Unpacking

Carefully unpack the unit and inspect the contents for damage. If any damage is found at the time of delivery, proper notification and claims should be made with the carrier.

Check the rating plate to assure model number and voltage match with what you ordered. The manufacturer should be notified within 5 days of any discrepancy or parts shortage.

## 2. Location

The modular air handler should be centrally located and may be installed in a closet, alcove, utility room, basement, crawl space or attic. Minimum clearances must be met.

When the unit is installed in a closet or utility room, the room should be large enough, and have an opening to allow replacement of the unit. All servicing is done from the front and a clearance of 21" is needed for service unless the closet door aligns with the front of the modular air handler.

If you are installing the unit in an unconditioned space such as an attic or crawl space, you must ensure that the area provides sufficient air circulation to prevent moisture collection on the cabinet during high dew point conditions.

## 3. Duct Work

The duct work should be installed in accordance with the NFPA No. 90A "Installation of Air Conditioning and Ventilating systems" and No. 90B "Residential Type Warm Air Heating and Air Conditioning Installation."

The duct work should be insulated in accordance with the applicable requirements for the particular installation as required by HUD, FHA, VA the applicable building code, local utility or other governing body.

## 4. Blower

This unit is supplied with a variable speed motor with a direct drive blower wheel which can obtain various air flows. The unit is shipped with factory set cooling and heating air flows. Airflow performance tables are available for additional air flows. Be sure to check the air flow and the temperature drop across the evaporator coil to ensure sufficient air flow.

## 5. Wiring

Consult all schematic and pictorial wiring diagrams of this unit and the outdoor equipment to determine compatibility of wiring connections and to determine specific requirements.

All field wiring to the modular air handler should be installed in accordance with the latest edition of the National Electric Code NFPA No. 70 and any local codes. Check rating plates on unit for rated volts, minimum circuit ampacity and maximum over current protection. Supply circuit power wiring must be 75 degree C (167 degree F) minimum copper conductors only. Copper supply wires shall be sized to the National Electric Code or local code requirements, whichever is more stringent.

The unit is shipped wired for 120 Volt AC 60 HZ 1 Phase Operation (Ensure unit is properly grounded). Do Not use GFCI plug.

Class 2 low voltage control wiring should not be run in conduit with power wiring and must be separated from power wiring unless class 1 wire with proper voltage rating is used.

Low voltage control wiring should be 18 AWG, color coded (105 degree C minimum). For lengths longer than 100ft., 16 AWG wire should be used. Make certain that separation of control wiring and power wiring has been maintained.

## 6. Air Filter

To protect the coil, blower and other internal parts from excessive dirt and dust an air filter must be installed before air enters the evaporator coil. A remote filter must be installed. Consult the filter manufacturer for proper sizing and maximum velocity requirements.

## 7. Thermostat

Select a thermostat that is commonly used with HP or AC two stage or Variable speed Heating/Cooling outdoor unit. The thermostat will energize the fan on a demand for heat or cool.

Install the thermostat on an inside wall, away from drafts, lights or other heat sources in a location that has sufficient air circulation from other rooms being controlled by the thermostat.

### 8. Operational and Checkout Procedures

To obtain proper performance, all units must be operated and charge adjustments made in accordance with procedures found in the Service Facts document of the outdoor unit. After installation has been completed, it is recommended that the entire system be checked against the checkout list located at the back of this document. See ["Checkout Procedures," p. 39](#).

### 9. Maintenance

The system air filter(s) should be inspected, cleaned or replaced at least monthly. Make certain that the access panels are replaced and secured properly before placing the unit back in operation. This product is designed for dependable service; however, periodic maintenance should be scheduled and conducted by trained professional service personnel. This service should be conducted at least annually, and should include testing and inspection of electrical components. The blower motor is permanently lubricated for normal operating conditions.

# Outline Drawing

Table 3. 14.5", 17.5", 21" and 24.5" Width Cabinets

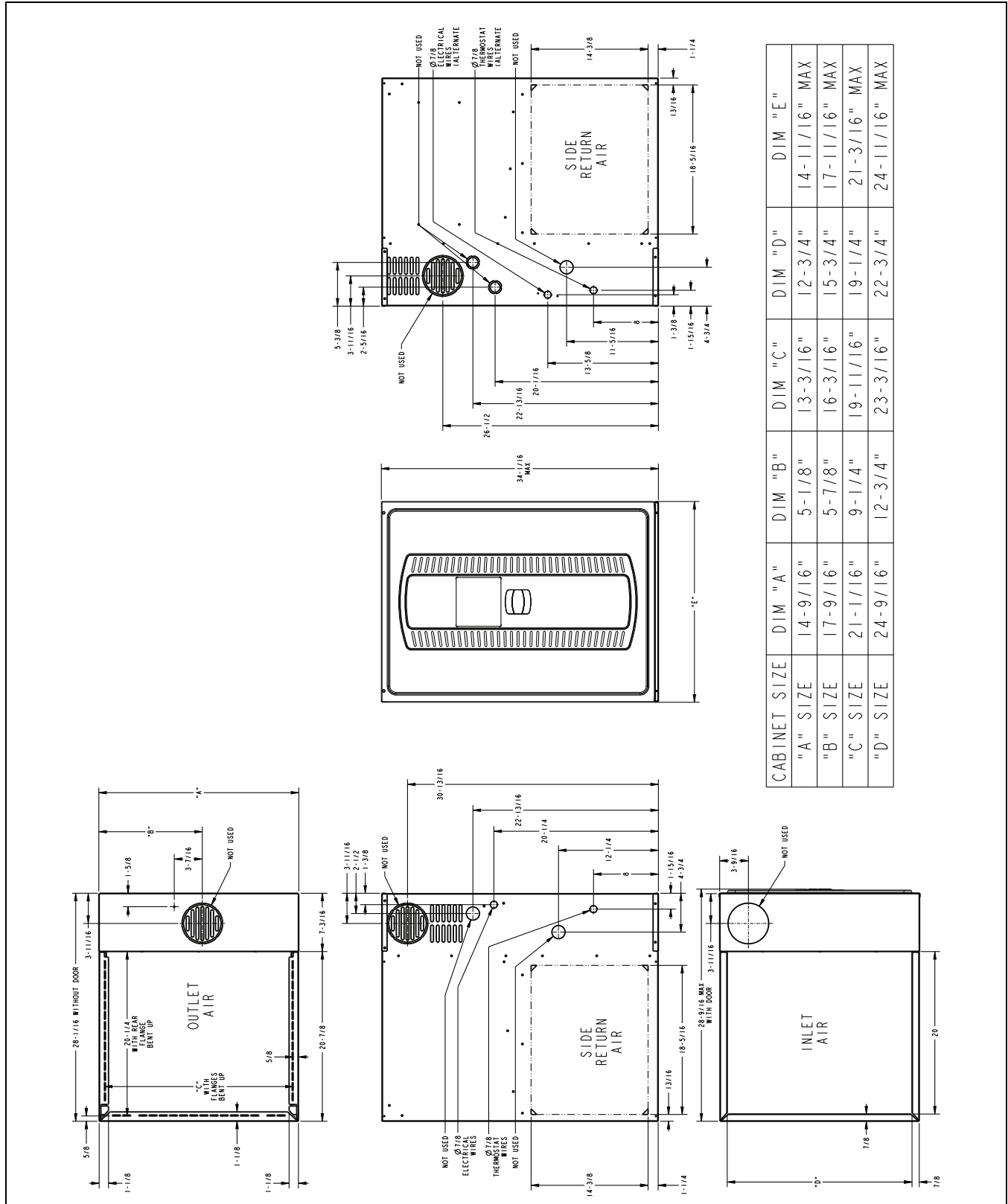

# Wiring Diagram

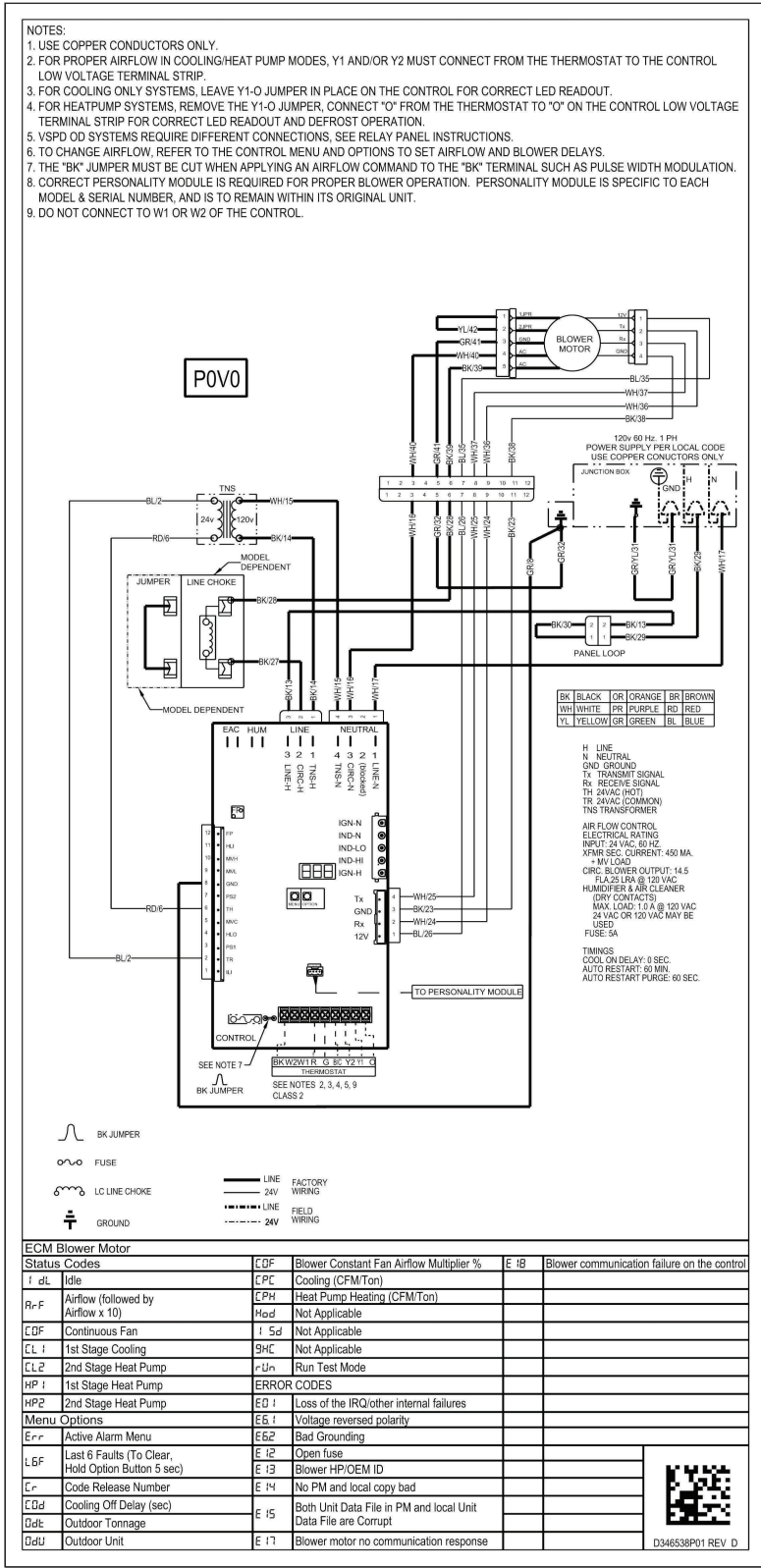

# Airflow Tables

POV0A000M30SDA Modular Air Handler Cooling Airflow (CFM) and Power (Watts) vs. External Static Pressure without Filter								
Cooling	Unit Outdoor	Airflow Setting (CFM/Ton)		EXTERNAL STATIC PRESSURE (IN. W. C.)				
				0.1	0.3	0.5	0.7	0.9
Cooling	1.5 Ton	Cooling 450 CFM/Ton	CFM / Watts	671 / 46	676 / 91	681 / 135	685 / 178	690 / 219
		Cooling 420 CFM/Ton	CFM / Watts	627 / 40	631 / 83	636 / 125	642 / 166	648 / 206
		Cooling 400 CFM/Ton	CFM / Watts	597 / 37	601 / 78	606 / 119	613 / 159	620 / 197
		Cooling 370 CFM/Ton	CFM / Watts	553 / 32	556 / 72	562 / 111	569 / 149	578 / 185
		Cooling 350 CFM/Ton	CFM / Watts	523 / 29	525 / 67	532 / 105	540 / 142	549 / 178
		Cooling 330 CFM/Ton	CFM / Watts	493 / 27	495 / 63	502 / 100	511 / 136	521 / 171
		Cooling 310 CFM/Ton	CFM / Watts	464 / 24	465 / 60	472 / 95	481 / 130	492 / 164
		Cooling 290 CFM/Ton	CFM / Watts	434 / 22	434 / 56	442 / 91	452 / 125	463 / 158
Cooling	2.0 Ton	Cooling 450 CFM/Ton	CFM / Watts	896 / 84	901 / 141	901 / 196	900 / 249	898 / 300
		Cooling 420 CFM/Ton	CFM / Watts	836 / 72	841 / 126	843 / 178	843 / 228	843 / 276
		Cooling 400 CFM/Ton	CFM / Watts	796 / 65	801 / 116	803 / 167	805 / 215	806 / 261
		Cooling 370 CFM/Ton	CFM / Watts	736 / 55	741 / 104	745 / 151	748 / 196	750 / 240
		Cooling 350 CFM/Ton	CFM / Watts	696 / 49	701 / 96	705 / 141	709 / 185	713 / 227
		Cooling 330 CFM/Ton	CFM / Watts	656 / 44	661 / 88	666 / 132	671 / 174	676 / 215
		Cooling 310 CFM/Ton	CFM / Watts	617 / 39	621 / 82	626 / 123	632 / 164	639 / 203
		Cooling 290 CFM/Ton	CFM / Watts	577 / 35	581 / 75	587 / 115	593 / 154	601 / 192
Cooling	2.5 Ton	Cooling 450 CFM/Ton	CFM / Watts	1126 / 143	1126 / 212	1122 / 279	1114 / 343	1104 / 405
		Cooling 420 CFM/Ton	CFM / Watts	1048 / 121	1051 / 186	1048 / 249	1043 / 309	1035 / 367
		Cooling 400 CFM/Ton	CFM / Watts	997 / 107	1001 / 170	999 / 230	995 / 288	990 / 344
		Cooling 370 CFM/Ton	CFM / Watts	921 / 89	926 / 148	926 / 204	924 / 258	921 / 310
		Cooling 350 CFM/Ton	CFM / Watts	871 / 79	876 / 134	877 / 188	877 / 240	875 / 290
		Cooling 330 CFM/Ton	CFM / Watts	821 / 69	826 / 122	828 / 173	829 / 223	829 / 271
		Cooling 310 CFM/Ton	CFM / Watts	771 / 61	776 / 111	779 / 160	781 / 207	783 / 252
		Cooling 290 CFM/Ton	CFM / Watts	721 / 53	726 / 101	730 / 147	733 / 192	737 / 235
Cooling	3.0 Ton	Cooling 450 CFM/Ton	CFM / Watts	1361 / 228	1355 / 310	1343 / 389	1327 / 466	1309 / 539
		Cooling 420 CFM/Ton	CFM / Watts	1266 / 191	1263 / 268	1255 / 342	1242 / 413	1227 / 482
		Cooling 400 CFM/Ton	CFM / Watts	1203 / 168	1202 / 242	1195 / 312	1185 / 381	1172 / 446
		Cooling 370 CFM/Ton	CFM / Watts	1110 / 138	1111 / 207	1107 / 273	1100 / 336	1090 / 397
		Cooling 350 CFM/Ton	CFM / Watts	1048 / 121	1051 / 186	1048 / 249	1043 / 309	1035 / 367
		Cooling 330 CFM/Ton	CFM / Watts	987 / 105	991 / 167	990 / 226	986 / 284	980 / 339
		Cooling 310 CFM/Ton	CFM / Watts	926 / 90	931 / 149	931 / 206	929 / 260	926 / 313
		Cooling 290 CFM/Ton	CFM / Watts	866 / 78	871 / 133	872 / 187	872 / 238	870 / 288



POV0B000M40SDA Modular Air Handler Cooling Airflow (CFM) and Power (Watts) Vs. External Static Pressure without Filter								
Cooling	Unit Outdoor	Airflow Setting (CFM/Ton)		EXTERNAL STATIC PRESSURE (IN. W. C.)				
				0.1	0.3	0.5	0.7	0.9
Cooling	1.5 Ton	Cooling 450 CFM/Ton	CFM / Watts	661 / 41	663 / 74	666 / 111	668 / 150	671 / 191
		Cooling 420 CFM/Ton	CFM / Watts	614 / 35	616 / 68	618 / 104	621 / 142	623 / 183
		Cooling 400 CFM/Ton	CFM / Watts	582 / 32	584 / 64	587 / 100	589 / 138	592 / 178
		Cooling 370 CFM/Ton	CFM / Watts	534 / 28	537 / 59	539 / 94	542 / 131	544 / 171
		Cooling 350 CFM/Ton	CFM / Watts	502 / 25	505 / 56	507 / 90	510 / 128	512 / 168
		Cooling 330 CFM/Ton	CFM / Watts	470 / 23	473 / 53	475 / 87	477 / 124	480 / 164
		Cooling 310 CFM/Ton	CFM / Watts	438 / 20	440 / 50	443 / 84	445 / 121	448 / 162
Cooling	2.0 Ton	Cooling 290 CFM/Ton	CFM / Watts	406 / 19	408 / 48	411 / 81	413 / 119	415 / 160
		Cooling 450 CFM/Ton	CFM / Watts	893 / 81	895 / 116	898 / 157	900 / 200	903 / 244
		Cooling 420 CFM/Ton	CFM / Watts	832 / 68	834 / 103	837 / 143	839 / 185	841 / 228
		Cooling 400 CFM/Ton	CFM / Watts	791 / 61	793 / 95	795 / 134	798 / 175	800 / 218
		Cooling 370 CFM/Ton	CFM / Watts	729 / 50	731 / 84	733 / 122	736 / 163	738 / 204
		Cooling 350 CFM/Ton	CFM / Watts	687 / 44	689 / 78	692 / 115	694 / 155	697 / 196
		Cooling 330 CFM/Ton	CFM / Watts	645 / 39	648 / 72	650 / 109	652 / 148	655 / 188
Cooling	2.5 Ton	Cooling 310 CFM/Ton	CFM / Watts	603 / 34	606 / 67	608 / 103	610 / 141	613 / 181
		Cooling 290 CFM/Ton	CFM / Watts	561 / 30	563 / 62	566 / 97	568 / 135	571 / 175
		Cooling 450 CFM/Ton	CFM / Watts	1118 / 147	1120 / 183	1123 / 225	1125 / 271	1127 / 320
		Cooling 420 CFM/Ton	CFM / Watts	1044 / 122	1046 / 158	1048 / 199	1051 / 245	1053 / 292
		Cooling 400 CFM/Ton	CFM / Watts	994 / 107	996 / 142	999 / 184	1001 / 229	1003 / 275
		Cooling 370 CFM/Ton	CFM / Watts	918 / 87	921 / 122	923 / 163	925 / 207	928 / 252
		Cooling 350 CFM/Ton	CFM / Watts	867 / 76	870 / 110	872 / 151	875 / 193	877 / 237
Cooling	3.0 Ton	Cooling 330 CFM/Ton	CFM / Watts	816 / 65	819 / 100	821 / 139	824 / 181	826 / 224
		Cooling 310 CFM/Ton	CFM / Watts	765 / 56	767 / 90	770 / 129	772 / 170	775 / 212
		Cooling 290 CFM/Ton	CFM / Watts	713 / 48	715 / 82	718 / 120	720 / 160	723 / 201
		Cooling 450 CFM/Ton	CFM / Watts	1336 / 242	1338 / 280	1340 / 324	1343 / 372	1345 / 423
		Cooling 420 CFM/Ton	CFM / Watts	1249 / 200	1252 / 237	1254 / 280	1257 / 328	1259 / 378
		Cooling 400 CFM/Ton	CFM / Watts	1191 / 175	1194 / 212	1196 / 254	1198 / 301	1201 / 351
		Cooling 370 CFM/Ton	CFM / Watts	1103 / 141	1105 / 178	1108 / 220	1110 / 266	1113 / 314
Cooling	3.5 Ton	Cooling 350 CFM/Ton	CFM / Watts	1044 / 122	1046 / 158	1048 / 199	1051 / 245	1053 / 292
		Cooling 330 CFM/Ton	CFM / Watts	984 / 104	986 / 140	989 / 181	991 / 226	993 / 272
		Cooling 310 CFM/Ton	CFM / Watts	923 / 89	926 / 124	928 / 164	931 / 208	933 / 253
		Cooling 290 CFM/Ton	CFM / Watts	862 / 75	865 / 109	867 / 150	870 / 192	872 / 236
		Cooling 450 CFM/Ton	CFM / Watts	1546 / 373	1549 / 414	1551 / 459	1554 / 508	1556 / 560
		Cooling 420 CFM/Ton	CFM / Watts	1449 / 307	1451 / 347	1454 / 391	1456 / 440	1458 / 491
		Cooling 400 CFM/Ton	CFM / Watts	1383 / 268	1385 / 307	1388 / 351	1390 / 399	1393 / 450
Cooling	4.0 Ton	Cooling 370 CFM/Ton	CFM / Watts	1283 / 216	1285 / 253	1288 / 297	1290 / 344	1293 / 394
		Cooling 350 CFM/Ton	CFM / Watts	1215 / 185	1218 / 222	1220 / 265	1223 / 312	1225 / 362
		Cooling 330 CFM/Ton	CFM / Watts	1147 / 157	1150 / 194	1152 / 237	1154 / 283	1157 / 332
		Cooling 310 CFM/Ton	CFM / Watts	1078 / 133	1081 / 169	1083 / 211	1086 / 257	1088 / 304
		Cooling 290 CFM/Ton	CFM / Watts	1009 / 111	1011 / 147	1014 / 188	1016 / 233	1018 / 280
		Cooling 450 CFM/Ton	CFM / Watts	1750 / 546	1752 / 589	1755 / 636	1757 / 687	1760 / 740
		Cooling 420 CFM/Ton	CFM / Watts	1642 / 448	1645 / 490	1647 / 536	1649 / 586	1652 / 639
Cooling	4.0 Ton	Cooling 400 CFM/Ton	CFM / Watts	1569 / 390	1572 / 431	1574 / 477	1576 / 526	1579 / 578
		Cooling 370 CFM/Ton	CFM / Watts	1458 / 313	1461 / 353	1463 / 397	1465 / 446	1468 / 497
		Cooling 350 CFM/Ton	CFM / Watts	1383 / 268	1385 / 307	1388 / 351	1390 / 399	1393 / 450
		Cooling 330 CFM/Ton	CFM / Watts	1307 / 227	1309 / 265	1312 / 309	1314 / 356	1317 / 407
		Cooling 310 CFM/Ton	CFM / Watts	1230 / 191	1232 / 228	1235 / 271	1237 / 319	1240 / 368
		Cooling 290 CFM/Ton	CFM / Watts	1152 / 159	1154 / 196	1157 / 238	1159 / 285	1162 / 334

# Airflow Tables

POV0C000M50SDA Modular Air Handler Cooling Airflow (CFM) and Power (Watts) vs. External Static Pressure without Filter								
Cooling	Unit Outdoor	Airflow Setting (CFM/Ton)		EXTERNAL STATIC PRESSURE (IN. W. C.)				
				0.1	0.3	0.5	0.7	0.9
Cooling	2.5 Ton	Cooling 450 CFM/Ton	CFM / Watts	1145 / 87	1143 / 141	1141 / 195	1138 / 247	1136 / 295
		Cooling 420 CFM/Ton	CFM / Watts	1071 / 74	1069 / 125	1067 / 178	1065 / 227	1062 / 273
		Cooling 400 CFM/Ton	CFM / Watts	1022 / 66	1020 / 116	1018 / 167	1015 / 215	1013 / 259
		Cooling 370 CFM/Ton	CFM / Watts	948 / 56	946 / 103	944 / 152	942 / 198	939 / 240
		Cooling 350 CFM/Ton	CFM / Watts	899 / 50	897 / 96	895 / 143	892 / 187	890 / 229
		Cooling 330 CFM/Ton	CFM / Watts	850 / 44	848 / 89	846 / 134	843 / 178	841 / 219
		Cooling 310 CFM/Ton	CFM / Watts	801 / 39	799 / 82	796 / 127	794 / 169	792 / 209
		Cooling 290 CFM/Ton	CFM / Watts	752 / 34	750 / 77	747 / 120	745 / 161	743 / 201
Cooling	3.0 Ton	Cooling 450 CFM/Ton	CFM / Watts	1366 / 137	1364 / 198	1362 / 260	1360 / 320	1357 / 376
		Cooling 420 CFM/Ton	CFM / Watts	1278 / 115	1276 / 173	1273 / 232	1271 / 288	1269 / 341
		Cooling 400 CFM/Ton	CFM / Watts	1219 / 102	1217 / 158	1214 / 215	1212 / 269	1210 / 320
		Cooling 370 CFM/Ton	CFM / Watts	1130 / 84	1128 / 138	1126 / 192	1124 / 243	1121 / 291
		Cooling 350 CFM/Ton	CFM / Watts	1071 / 74	1069 / 125	1067 / 178	1065 / 227	1062 / 273
		Cooling 330 CFM/Ton	CFM / Watts	1012 / 65	1010 / 114	1008 / 165	1006 / 212	1003 / 257
		Cooling 310 CFM/Ton	CFM / Watts	953 / 56	951 / 104	949 / 153	947 / 199	944 / 242
		Cooling 290 CFM/Ton	CFM / Watts	894 / 49	892 / 95	890 / 142	888 / 186	885 / 228
Cooling	3.5 Ton	Cooling 450 CFM/Ton	CFM / Watts	1588 / 205	1585 / 274	1583 / 344	1581 / 412	1579 / 476
		Cooling 420 CFM/Ton	CFM / Watts	1484 / 170	1482 / 236	1480 / 302	1478 / 366	1475 / 427
		Cooling 400 CFM/Ton	CFM / Watts	1416 / 150	1413 / 213	1411 / 277	1409 / 338	1407 / 396
		Cooling 370 CFM/Ton	CFM / Watts	1312 / 123	1310 / 182	1308 / 242	1306 / 300	1303 / 354
		Cooling 350 CFM/Ton	CFM / Watts	1244 / 107	1241 / 164	1239 / 222	1237 / 277	1234 / 329
		Cooling 330 CFM/Ton	CFM / Watts	1175 / 93	1172 / 147	1170 / 203	1168 / 256	1166 / 305
		Cooling 310 CFM/Ton	CFM / Watts	1106 / 80	1104 / 132	1101 / 186	1099 / 236	1097 / 283
		Cooling 290 CFM/Ton	CFM / Watts	1037 / 68	1035 / 119	1032 / 170	1030 / 218	1028 / 263
Cooling	4.0 Ton	Cooling 450 CFM/Ton	CFM / Watts	1809 / 295	1807 / 372	1805 / 450	1802 / 527	1800 / 600
		Cooling 420 CFM/Ton	CFM / Watts	1691 / 244	1689 / 317	1686 / 390	1684 / 462	1682 / 531
		Cooling 400 CFM/Ton	CFM / Watts	1612 / 214	1610 / 283	1608 / 354	1606 / 423	1603 / 489
		Cooling 370 CFM/Ton	CFM / Watts	1494 / 174	1492 / 239	1490 / 306	1488 / 370	1485 / 431
		Cooling 350 CFM/Ton	CFM / Watts	1416 / 150	1413 / 213	1411 / 277	1409 / 338	1407 / 396
		Cooling 330 CFM/Ton	CFM / Watts	1337 / 129	1335 / 189	1332 / 250	1330 / 309	1328 / 364
		Cooling 310 CFM/Ton	CFM / Watts	1258 / 110	1256 / 168	1254 / 226	1251 / 282	1249 / 334
		Cooling 290 CFM/Ton	CFM / Watts	1180 / 94	1177 / 148	1175 / 204	1173 / 257	1171 / 307
Cooling	4.5 Ton	Cooling 450 CFM/Ton	CFM / Watts	2030 / 411	2028 / 496	2026 / 583	2024 / 668	2021 / 751
		Cooling 420 CFM/Ton	CFM / Watts	1898 / 338	1895 / 418	1893 / 500	1891 / 580	1888 / 657
		Cooling 400 CFM/Ton	CFM / Watts	1809 / 295	1807 / 372	1805 / 450	1802 / 527	1800 / 600
		Cooling 370 CFM/Ton	CFM / Watts	1676 / 238	1674 / 310	1672 / 383	1669 / 455	1667 / 523
		Cooling 350 CFM/Ton	CFM / Watts	1588 / 205	1585 / 274	1583 / 344	1581 / 412	1579 / 476
		Cooling 330 CFM/Ton	CFM / Watts	1499 / 175	1497 / 241	1495 / 308	1492 / 372	1490 / 433
		Cooling 310 CFM/Ton	CFM / Watts	1411 / 149	1408 / 211	1406 / 275	1404 / 336	1402 / 394
		Cooling 290 CFM/Ton	CFM / Watts	1322 / 125	1320 / 185	1318 / 245	1315 / 304	1313 / 358
Cooling	5.0 Ton	Cooling 450 CFM/Ton	CFM / Watts	2252 / 555	2249 / 650	2247 / 745	2245 / 839	2243 / 931
		Cooling 420 CFM/Ton	CFM / Watts	2104 / 455	2102 / 544	2100 / 633	2097 / 722	2095 / 807
		Cooling 400 CFM/Ton	CFM / Watts	2006 / 396	2003 / 481	2001 / 566	1999 / 651	1997 / 733
		Cooling 370 CFM/Ton	CFM / Watts	1858 / 318	1856 / 397	1854 / 477	1851 / 556	1849 / 631
		Cooling 350 CFM/Ton	CFM / Watts	1760 / 273	1758 / 348	1755 / 424	1753 / 499	1751 / 571
		Cooling 330 CFM/Ton	CFM / Watts	1662 / 232	1659 / 304	1657 / 376	1655 / 447	1652 / 515
		Cooling 310 CFM/Ton	CFM / Watts	1563 / 196	1561 / 264	1559 / 333	1556 / 401	1554 / 464
		Cooling 290 CFM/Ton	CFM / Watts	1465 / 164	1463 / 229	1460 / 295	1458 / 358	1456 / 418

POV0D000M50SDA Modular Air Handler Cooling Airflow (CFM) and Power (Watts) vs. External Static Pressure without Filter								
Cooling	Unit Outdoor	Airflow Setting (CFM/Ton)		EXTERNAL STATIC PRESSURE (IN. W. C.)				
				0.1	0.3	0.5	0.7	0.9
Cooling	3.0 Ton	Cooling 450 CFM/Ton	CFM / Watts	1347 / 126	1353 / 182	1354 / 240	1352 / 300	1352 / 361
		Cooling 420 CFM/Ton	CFM / Watts	1259 / 107	1265 / 159	1265 / 215	1262 / 272	1260 / 330
		Cooling 400 CFM/Ton	CFM / Watts	1200 / 95	1206 / 146	1205 / 199	1201 / 254	1197 / 311
		Cooling 370 CFM/Ton	CFM / Watts	1111 / 79	1117 / 127	1114 / 178	1108 / 230	1102 / 284
		Cooling 350 CFM/Ton	CFM / Watts	1052 / 70	1058 / 116	1053 / 164	1045 / 215	1037 / 267
		Cooling 330 CFM/Ton	CFM / Watts	994 / 61	998 / 105	992 / 152	981 / 200	971 / 251
		Cooling 310 CFM/Ton	CFM / Watts	935 / 53	938 / 95	930 / 140	917 / 187	904 / 236
		Cooling 290 CFM/Ton	CFM / Watts	876 / 46	878 / 86	867 / 129	851 / 175	837 / 222
Cooling	3.5 Ton	Cooling 450 CFM/Ton	CFM / Watts	1570 / 185	1573 / 248	1573 / 314	1574 / 381	1577 / 450
		Cooling 420 CFM/Ton	CFM / Watts	1466 / 155	1470 / 215	1471 / 277	1471 / 342	1473 / 407
		Cooling 400 CFM/Ton	CFM / Watts	1397 / 138	1402 / 195	1403 / 255	1402 / 317	1403 / 380
		Cooling 370 CFM/Ton	CFM / Watts	1293 / 114	1299 / 168	1299 / 224	1297 / 283	1296 / 342
		Cooling 350 CFM/Ton	CFM / Watts	1224 / 100	1231 / 151	1230 / 206	1226 / 262	1223 / 319
		Cooling 330 CFM/Ton	CFM / Watts	1155 / 87	1162 / 136	1160 / 188	1154 / 242	1150 / 297
		Cooling 310 CFM/Ton	CFM / Watts	1087 / 75	1092 / 122	1089 / 172	1082 / 223	1075 / 276
		Cooling 290 CFM/Ton	CFM / Watts	1018 / 65	1023 / 109	1017 / 157	1008 / 206	999 / 257
Cooling	4.0 Ton	Cooling 450 CFM/Ton	CFM / Watts	1795 / 260	1792 / 330	1790 / 403	1790 / 479	1795 / 555
		Cooling 420 CFM/Ton	CFM / Watts	1675 / 218	1675 / 284	1675 / 353	1675 / 425	1679 / 497
		Cooling 400 CFM/Ton	CFM / Watts	1595 / 192	1597 / 256	1597 / 323	1598 / 391	1602 / 461
		Cooling 370 CFM/Ton	CFM / Watts	1476 / 158	1480 / 218	1481 / 281	1481 / 345	1483 / 411
		Cooling 350 CFM/Ton	CFM / Watts	1397 / 138	1402 / 195	1403 / 255	1402 / 317	1403 / 380
		Cooling 330 CFM/Ton	CFM / Watts	1318 / 119	1324 / 174	1324 / 231	1322 / 291	1322 / 351
		Cooling 310 CFM/Ton	CFM / Watts	1239 / 103	1245 / 155	1245 / 210	1241 / 266	1239 / 324
		Cooling 290 CFM/Ton	CFM / Watts	1160 / 88	1167 / 137	1165 / 189	1159 / 243	1155 / 298
Cooling	4.5 Ton	Cooling 450 CFM/Ton	CFM / Watts	2020 / 353	2011 / 430	2005 / 511	2003 / 594	2007 / 678
		Cooling 420 CFM/Ton	CFM / Watts	1885 / 295	1879 / 368	1876 / 444	1876 / 522	1880 / 602
		Cooling 400 CFM/Ton	CFM / Watts	1795 / 260	1792 / 330	1790 / 403	1790 / 479	1795 / 555
		Cooling 370 CFM/Ton	CFM / Watts	1660 / 213	1660 / 278	1660 / 347	1661 / 418	1665 / 490
		Cooling 350 CFM/Ton	CFM / Watts	1570 / 185	1573 / 248	1573 / 314	1574 / 381	1577 / 450
		Cooling 330 CFM/Ton	CFM / Watts	1481 / 159	1485 / 219	1486 / 282	1486 / 347	1488 / 413
		Cooling 310 CFM/Ton	CFM / Watts	1392 / 137	1397 / 194	1398 / 254	1397 / 315	1398 / 378
		Cooling 290 CFM/Ton	CFM / Watts	1303 / 116	1309 / 170	1309 / 227	1307 / 286	1306 / 346
Cooling	5.0 Ton	Cooling 450 CFM/Ton	CFM / Watts	2247 / 466	2230 / 551	2219 / 639	2214 / 729	2215 / 821
		Cooling 420 CFM/Ton	CFM / Watts	2096 / 388	2084 / 468	2076 / 551	2074 / 637	2076 / 723
		Cooling 400 CFM/Ton	CFM / Watts	1995 / 341	1987 / 418	1981 / 498	1980 / 580	1983 / 663
		Cooling 370 CFM/Ton	CFM / Watts	1845 / 279	1840 / 350	1838 / 426	1838 / 503	1842 / 581
		Cooling 350 CFM/Ton	CFM / Watts	1745 / 241	1743 / 310	1742 / 382	1743 / 455	1747 / 530
		Cooling 330 CFM/Ton	CFM / Watts	1645 / 208	1646 / 273	1646 / 342	1647 / 412	1650 / 483
		Cooling 310 CFM/Ton	CFM / Watts	1546 / 177	1548 / 239	1549 / 305	1550 / 372	1553 / 439
		Cooling 290 CFM/Ton	CFM / Watts	1446 / 150	1451 / 209	1452 / 271	1452 / 334	1453 / 399

# General Installation

The following sections give general instructions for the installation of the modular air handlers.

## Panel Removal

**Note:** For the POV0, a 1/4" nut driver is required to remove the two screws at the top of the front panel. The front panel can then be removed by lifting upwards.

**Note:** Tinnerman clips are provided in the doc pack if the door panel flange hole(s) becomes stripped.

**Note:** Remove shipping bracket before installation.

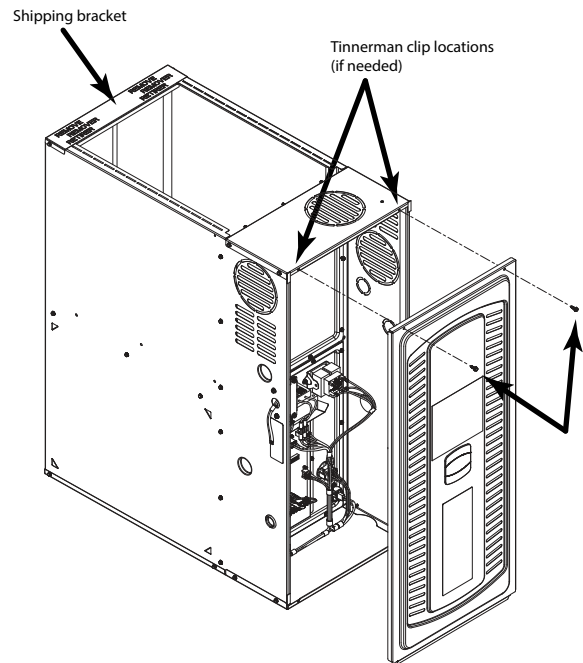

## Horizontal Installation in an Attic or Crawlspace

The modular air handler may be installed in an attic or crawl space in the horizontal position by placing it on its left or right side (as viewed from the front in the vertical position). The horizontal installation in an attic should be on a service platform large enough to allow for proper clearances on all sides and service access to the front of the modular air handler. See "Location and Clearances," p. 7. Line contact is only permissible between lines formed by intersections of the top and two sides of the modular air handler casing and building joists, studs, or framing.

The modular air handler may be placed horizontally in a crawl space on a pad or other noncombustible material. Place blocks underneath to support the modular air handler and raise the unit for sufficient protection from moisture.

The modular air handler may be installed hanging in a hanging position using straps. The modular air handler should be supported at both ends and have an additional support in the center of the modular air handler in back.

WHEN SUSPENDING THE HORIZONTAL MODULAR AIR HANDLER, IT SHOULD BE SUSPENDED BY ATTACHING TO THE CABINET IN THE PLACES SHOWN.

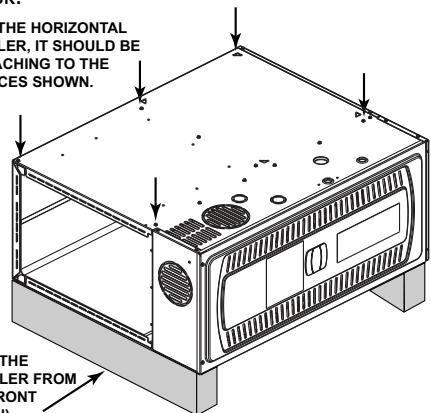

WHEN SUPPORTING THE MODULAR AIR HANDLER FROM BELOW, SUPPORT FRONT TO BACK (AS SHOWN) OR SIDE TO SIDE.

## Duct Connections

Table 4. Supply Duct Connections

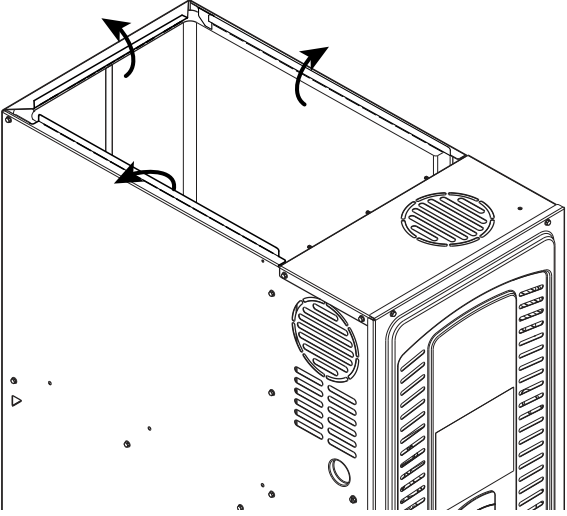
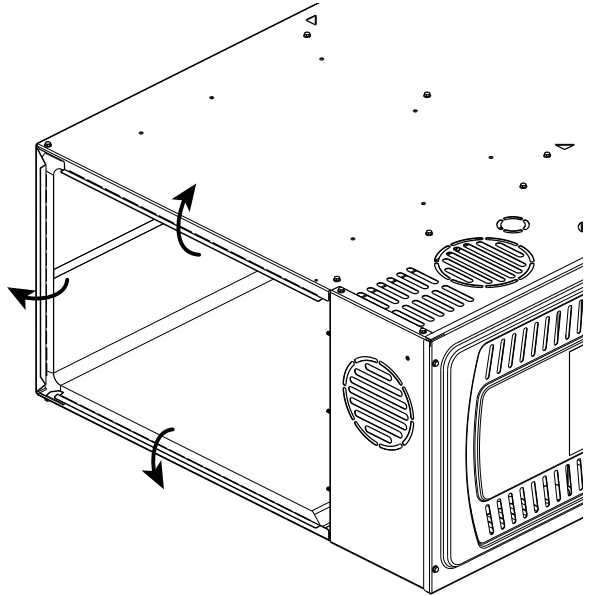
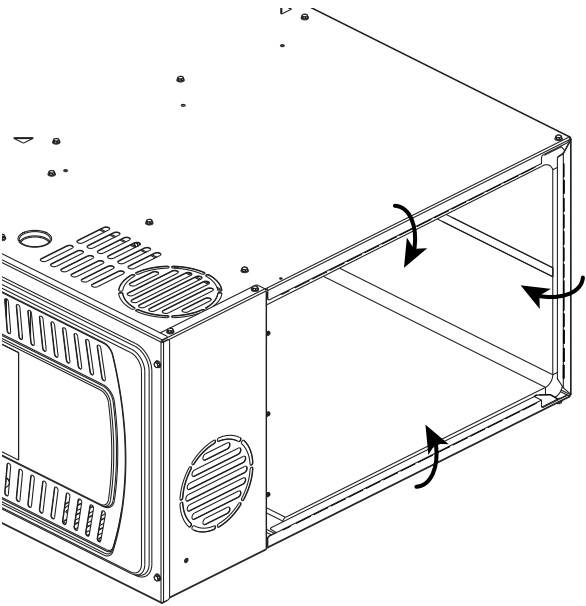
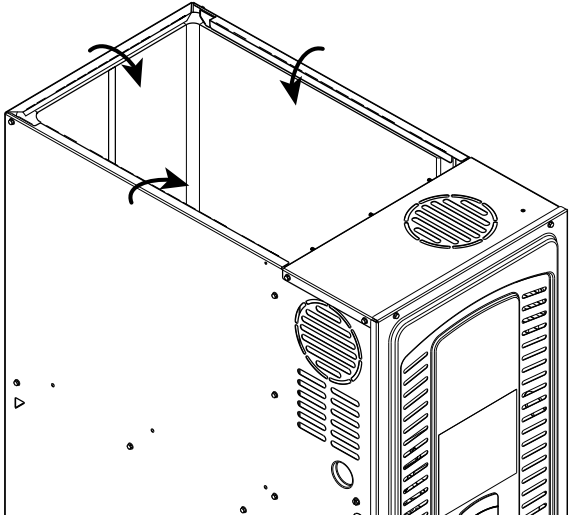
<p><b>Upflow Modular Air Handler with Coil</b></p> <p><i>Note:</i> There are no longer guide holes located on the modular air handler flange.</p>  <p>Refer to <a href="#">Step 1</a>. <a href="#">Step 2</a>. <a href="#">Step 3</a>. <a href="#">Step 4</a>.</p>	<p><b>Modular Air Handler in Horizontal Left with Coil</b></p> <p><i>Note:</i> There are no longer guide holes located on the modular air handler flange.</p>  <p>Refer to <a href="#">Step 1</a>. <a href="#">Step 5</a>. <a href="#">Step 3</a>. <a href="#">Step 4</a>.</p>
<p><b>Modular Air Handler in Horizontal Right with "A" Coil</b></p> <p><i>Note:</i> Flat or dedicated horizontal coils may require flanges to be bent upward.</p>  <p>Refer to <a href="#">Step 6</a>. <a href="#">Step 5</a>. <a href="#">Step 7</a>. <a href="#">Step 4</a>.</p>	<p><b>Downflow Modular Air Handler with Coil</b></p>  <p>Refer to <a href="#">Step 6</a>. <a href="#">Step 8</a>. <a href="#">Step 4</a>.</p>

**Table 4. Supply Duct Connections (continued)**

**Horizontal Right and Downflow Modular Air Handler – no Coil**

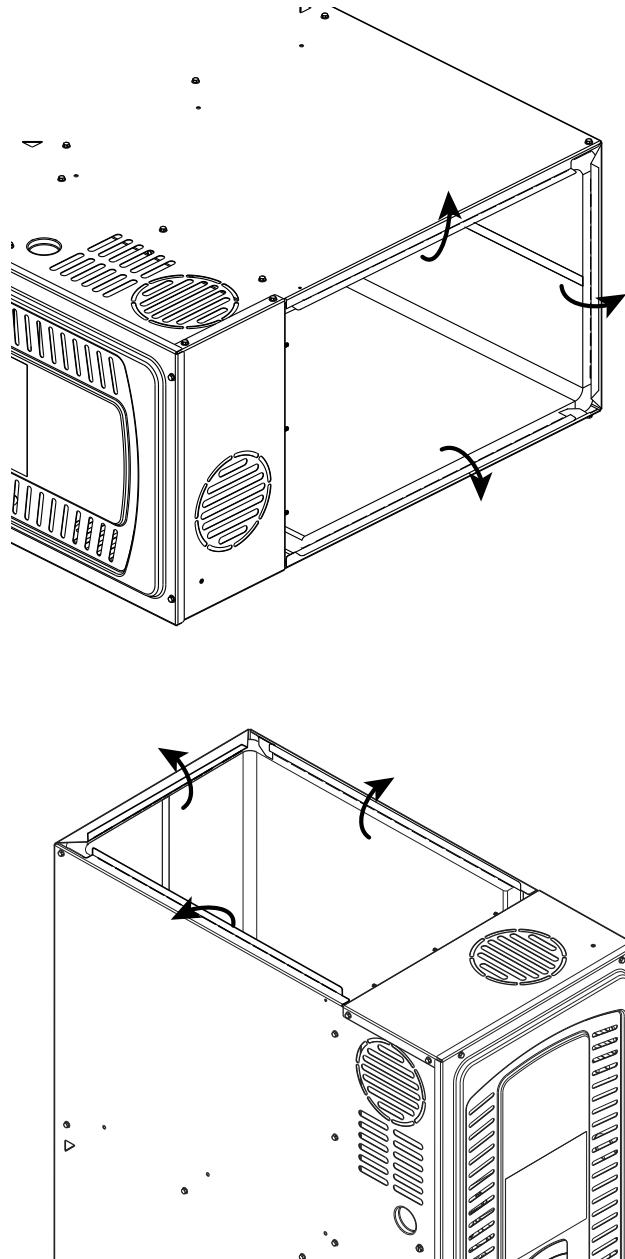

Refer to [Step 1](#). [Step 9](#). [Step 4](#).

**Installation Instructions**

1. Bend modular air handler flanges up.
2. Set the coil on top of the modular air handler.
3. Screw through the coil cabinet into the modular air handler flange. Guide holes are located on the coil.
4. Seal per local codes and requirements.
5. Support the modular air handler and coil independently.
6. Bend modular air handler flanges down.
7. Match the coil up flush to the back of the modular air handler.
8. Set the modular air handler on top of the coil so that it is flush with the back of the modular air handler.
9. Attach ducting.

**Table 5. Return Duct Connections**

**Return Ducting General Guidelines**

- Back returns are not allowed on any S-Series Modular Air Handlers.
- Side returns are not allowed on downflow or horizontal S-Series Modular Air Handlers
- Mounting flanges must be located on ducting
- Shoot screws through the mount flanges into the modular air handler cabinet
- Always seal per local codes and requirements
- Modular air handler, coil, and ducting must be supported separately
- An external overflow drain pan must be installed in all applications over a finished ceiling to prevent property damage

**Upflow Modular Air Handler with Bottom Return in Closet with Remote Filter**

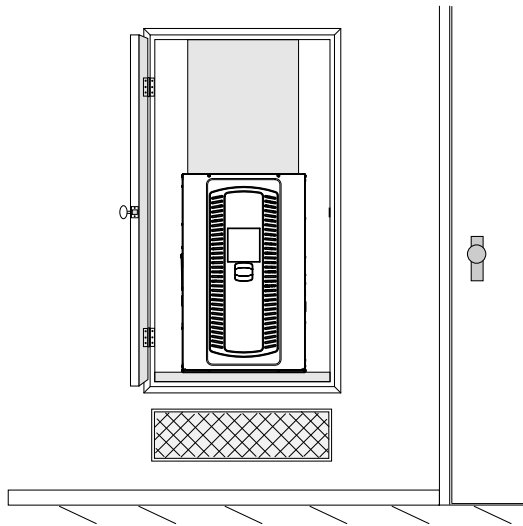

Refer to Step 1. Step 2. Step 3. Step 4.

**Upflow Modular Air Handler with Bottom Return in Closet with Filter Box**

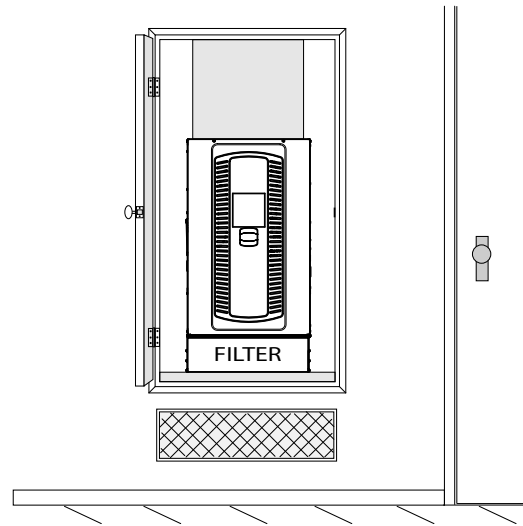

Refer to Step 1. Step 5. Step 6. Step 4.

**Upflow Modular Air Handler with Bottom Return Mounted on a Ducted Pedestal**

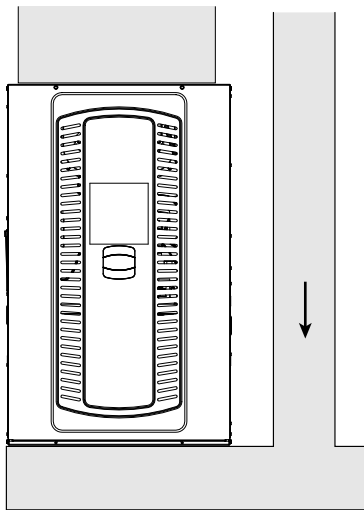

Refer to Step 1. Step 7. Step 8. Step 4.

**Upflow Modular Air Handler with Bottom Return Mounted on a Ducted Pedestal with Filter Box**

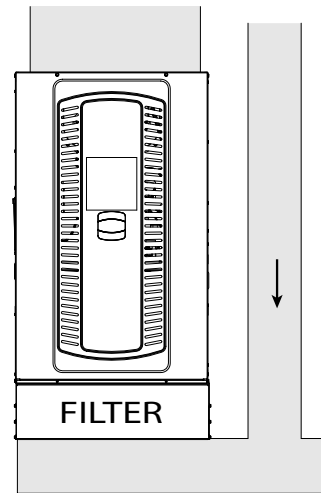

Refer to Step 1. Step 9. Step 4.

**Table 5. Return Duct Connections (continued)**

**Upflow Modular Air Handler with Bottom and Side Returns Mounted on a Ducted Pedestal with Side Return and Filter Box**

**Important:** Make sure the thermostat wiring hole is sealed on the cabinet side with the side return.

**Important:** Make sure not to cut the cabinet in the "No Cut" area.

**Important:** Remove Blower Assembly and Panel Loop before cutting cabinet to avoid cutting wires.

**Note:** Use Optional BAYLIFT kit to lift modular air handler. Follow kit instructions.

**Note:** The modular air handler bottom pedestal must be a minimum of 6" in height.

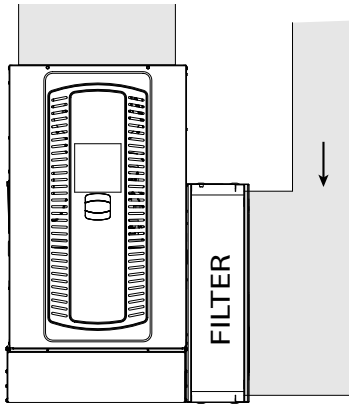

Refer to [Step 1](#). [Step 10](#). [Step 11](#). [Step 12](#). [Step 13](#). [Step 14](#). [Step 15](#). [Step 4](#).

Cabinet cutout when used with BAYLIFT

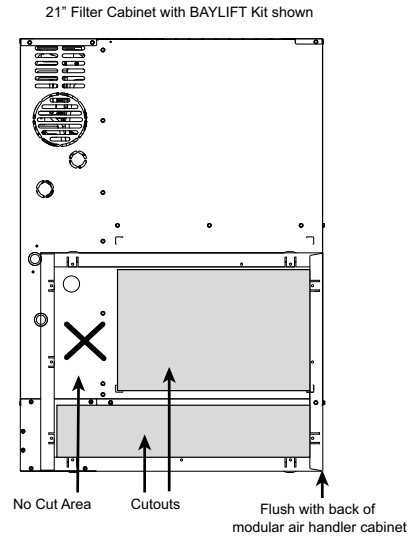

**Upflow Modular Air Handler with Side Return**

**Important:** Make sure the thermostat wiring hole is sealed on the cabinet side with the side return.

**Important:** Make sure not to cut the cabinet in the "No Cut" area.

**Important:** Remove Blower Assembly and Panel Loop before cutting cabinet to avoid cutting wires.

**Note:** If using a filter box, use a transition, if possible, to attach the filter box to the modular air handler cabinet.

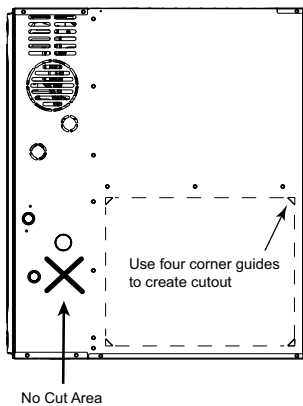

Refer to [Step 16](#). [Step 17](#). [Step 18](#). [Step 19](#).

**Upflow Modular Air Handler with Two Side Returns**

**Important:** One of the sides must have a transition to allow the thermostat wiring to exit the cabinet.

**Important:** If a transition is not a viable option, a hole will need to be drilled in the side of the cabinet for the thermostat wiring to exit.

**Important:** Make sure not to cut the cabinet in the "No Cut" area.

**Important:** Remove Blower Assembly and Panel Loop before cutting cabinet to avoid cutting wires.

**Note:** If using one transition, the thermostat wiring will exit on the transition side.

**Note:** If using a filter boxes, use transitions, if possible, to attach the filter boxes to the modular air handler cabinet.

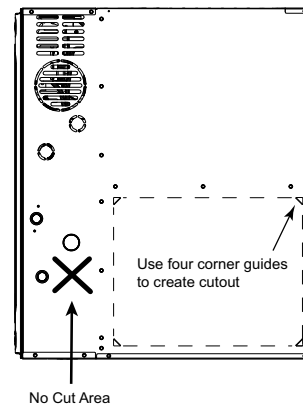

Refer to [Step 16](#). [Step 17](#). [Step 18](#). [Step 19](#).

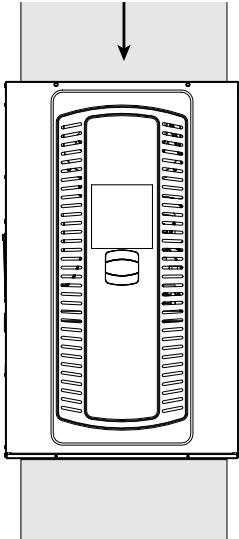
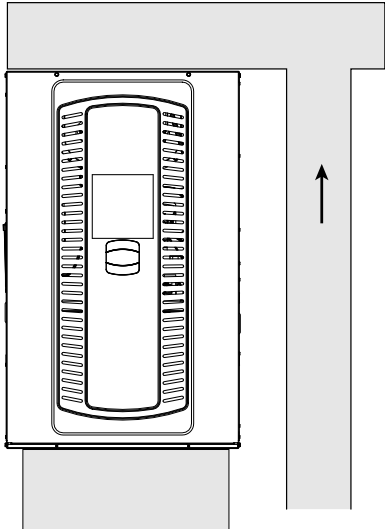
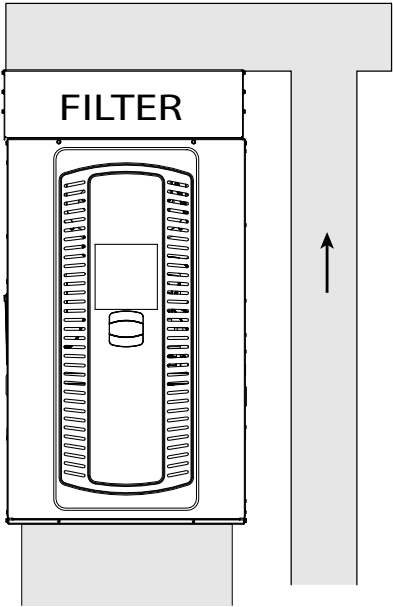

Table 5. Return Duct Connections (continued)

<p><b>Downflow Modular Air Handler with Top Return</b></p>  <p>Refer to Step 20. Step 21. Step 3. Step 4.</p>	<p><b>Downflow Modular Air Handler with Top Return and Plenum</b></p>  <p>Refer to Step 20. Step 22. Step 3. Step 4.</p>
<p><b>Downflow Modular Air Handler with Top Return and Plenum with Filter Box</b></p>  <p>Refer to Step 20. Step 23. Step 24. Step 4.</p>	<p><b>Installation Instructions</b></p> <ol style="list-style-type: none"> <li>1. Remove the bottom plate.</li> <li>2. Set the modular air handler on the base inside closet.</li> <li>3. Install remote filter.</li> <li>4. Seal per local codes and requirements.</li> <li>5. Set the modular air handler on the filter box inside closet.</li> <li>6. Must have grille present for air.</li> <li>7. Set the modular air handler on the ducted pedestal. The ducted pedestal will use ducted air from a remote location.</li> <li>8. Install filter at a remote location.</li> <li>9. Set the modular air handler on the filter box. The ducted pedestal will use ducted air from a remote location.</li> <li>10. Create ducting and set the modular air handler in place.</li> <li>11. Match the filter cabinet flush to the back and bottom sides of the modular air handler cabinet and secure in place with screws.</li> <li>12. Mark the two areas to be cut out for the return air.</li> <li>13. Cut out the two sections of the cabinet and BAYLIFT kit to be removed.</li> <li>14. Attach ducting to the filter box.</li> <li>15. The ducted pedestal will use ducted air from a remote location.</li> <li>16. Using guides, remove the cutout for the side return.</li> <li>17. Create ducting and set the modular air handler in place. Use screws to attach ducting to the modular air handler cabinet.</li> <li>18. Seal bottom panel per local codes and requirements.</li> <li>19. Seal all other panels per local codes and requirements.</li> <li>20. Remove the top plate.</li> <li>21. Attach the ducting to the top of the modular air handler.</li> <li>22. Attach the plenum ducting to the top of the modular air handler.</li> <li>23. Attach the filter box to the top of the modular air handler.</li> <li>24. Attach ducting.</li> </ol>

## Return Air Filters

### TYPICAL AIR FILTER INSTALLATIONS

Filters are not factory supplied for modular air handlers. Filter size needed will be dependent on type of filter and CFM requirement. Filters must be installed externally to the unit.

**Important:** It is recommended to transition return ducting to the same size as the opening. It is acceptable for return duct or filter frame to extend forward of the opening but plastic plugs **MUST** be installed in any opening that the duct or filter frame may cover.

Modular Air Handler Width	Filter Qty and Size
14-1/2"	1 – 14" x 25" x 1"
17-1/2"	1 – 16" x 25" x 1"
21"	1 – 20" x 25" x 1"
24-1/2"	1 – 24" x 25" x 1"

**Note:** For upflow airflow modular air handlers where the airflow requirement exceeds 1600 CFM - modular air handlers will require return air openings and filters on: (1) both sides, or (2) one side and the bottom, or (3) just on the bottom.

### Preparation for Upflow Bottom and Side Return Air Filter Installations

All return air duct systems should provide for installation of return air filters.

**Important:** Remove Blower Assembly and Panel Loop before cutting cabinet to avoid cutting wires.

- Determine the appropriate position to set the modular air handler in order to connect to existing supply and return ductwork.
- For upflow side return installations, remove the insulation around the opening in the air handler compartment.
- The side panels of the upflow modular air handler include locating notches that are used as guides for cutting an opening for return air, refer to the figure and the upflow modular air handler outline drawing for duct connection dimensions for various modular air handlers.
- If a 3/4" flange is to be used for attaching the air inlet duct, add to cut where indicated by dotted lines. Cut corners diagonally and bend outward to form flange.
- If flanges are not required, and a filter frame is installed, cut between locating notches as in illustration.
- The bottom panel of the upflow modular air handler must be removed for bottom return air.

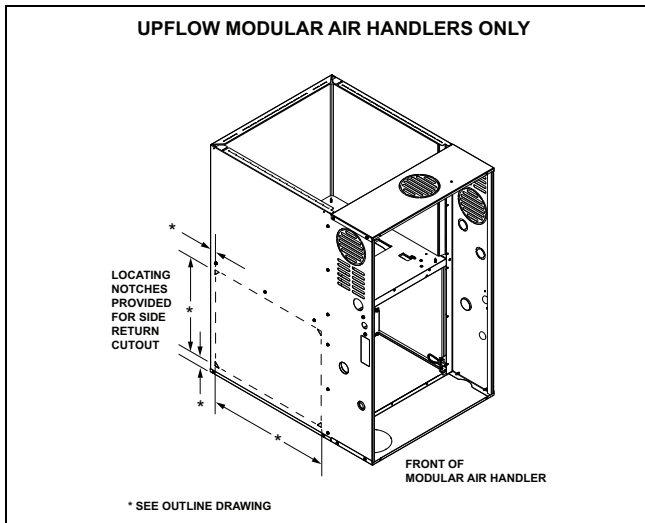

### RETURN AIR FILTERS FOR MODULAR AIR HANDLER IN HORIZONTAL CONFIGURATION

When the modular air handler is installed in the horizontal configuration, the return air filters must be installed exterior to the modular air handler cabinet. Remote filter grilles may be used for homeowner convenience, refer to Figure 1, p. 22 or the filters may be installed in the duct work upstream of the modular air handler, refer to Figure 2, p. 22.

Filter kits are available for horizontal applications.

**Direct coupled side returns are not allowed to the air handler cabinet.**

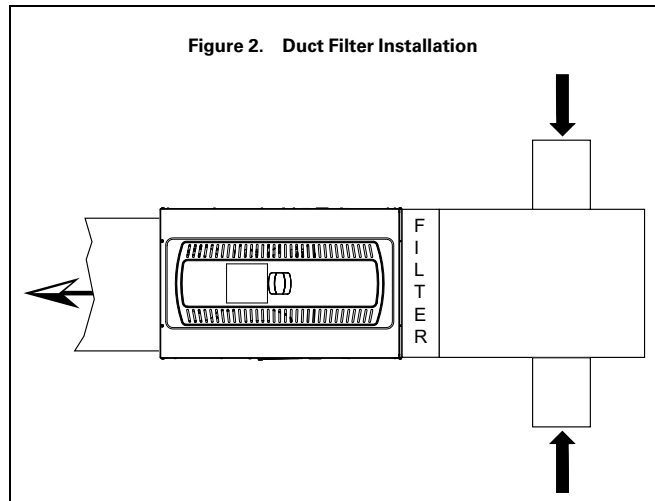
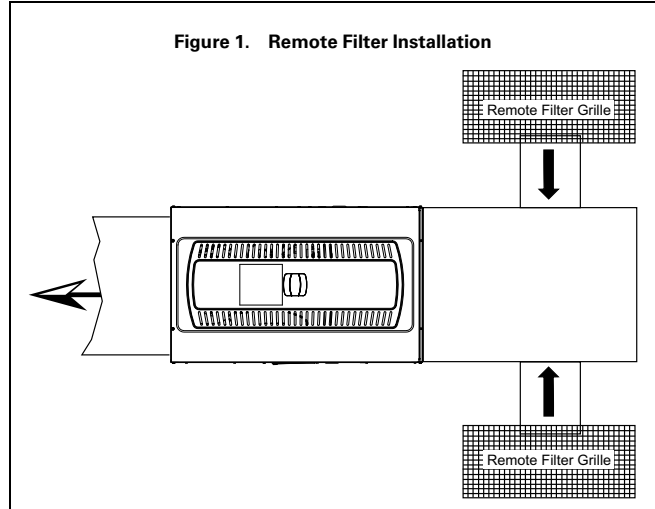

## Electrical Connections

Make wiring connections to the unit as indicated on enclosed wiring diagram. This modular air handler shall be connected into a permanently live electric circuit. It is recommended that modular air handler be provided with a separate "circuit protection device" electric circuit. The modular air handler must be electrically grounded in accordance with local codes or in the absence of local codes with the National Electrical Code, ANSI/NFPA 70, if an external electrical source is utilized. **The integrated modular air handler control is polarity sensitive.** The hot leg of the 120V power supply must be connected to the black power lead as indicated on the wiring diagram. Refer to the Wiring Diagram section in this document and unit wiring diagram attached to modular air handler.

### ⚠ WARNING

#### FIRE HAZARD!

Failure to follow this Warning could result in property damage, severe personal injury, or death. This Warning applies to installations with a flammable refrigeration system. The furnace must be powered except for service. The furnace shall be installed and connected according to installation instructions and wiring diagrams that are provided with the evaporator coil.

## Field Wiring

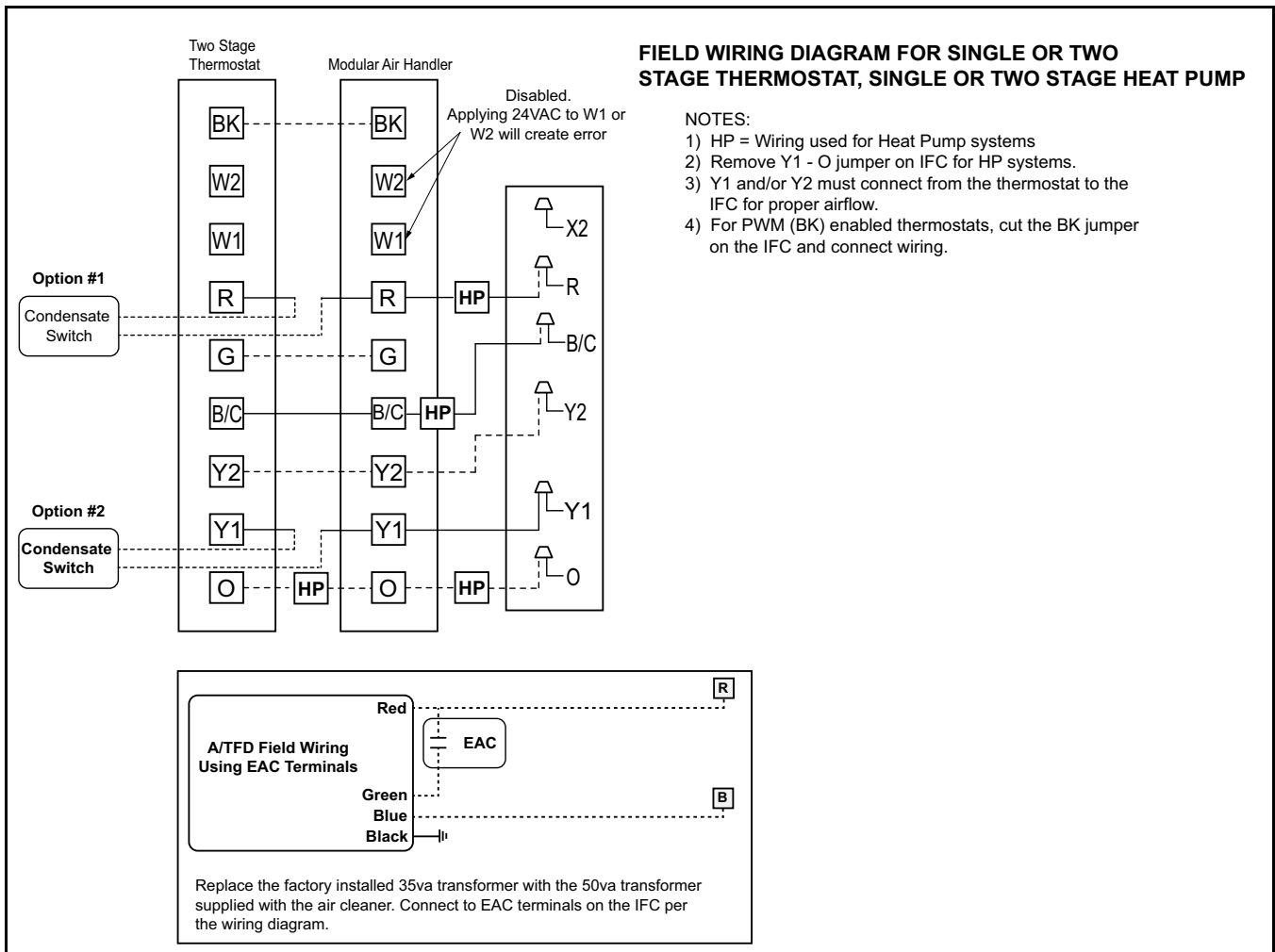

# Integrated Modular Air Handler Control Menu

## POVO Control System Menu

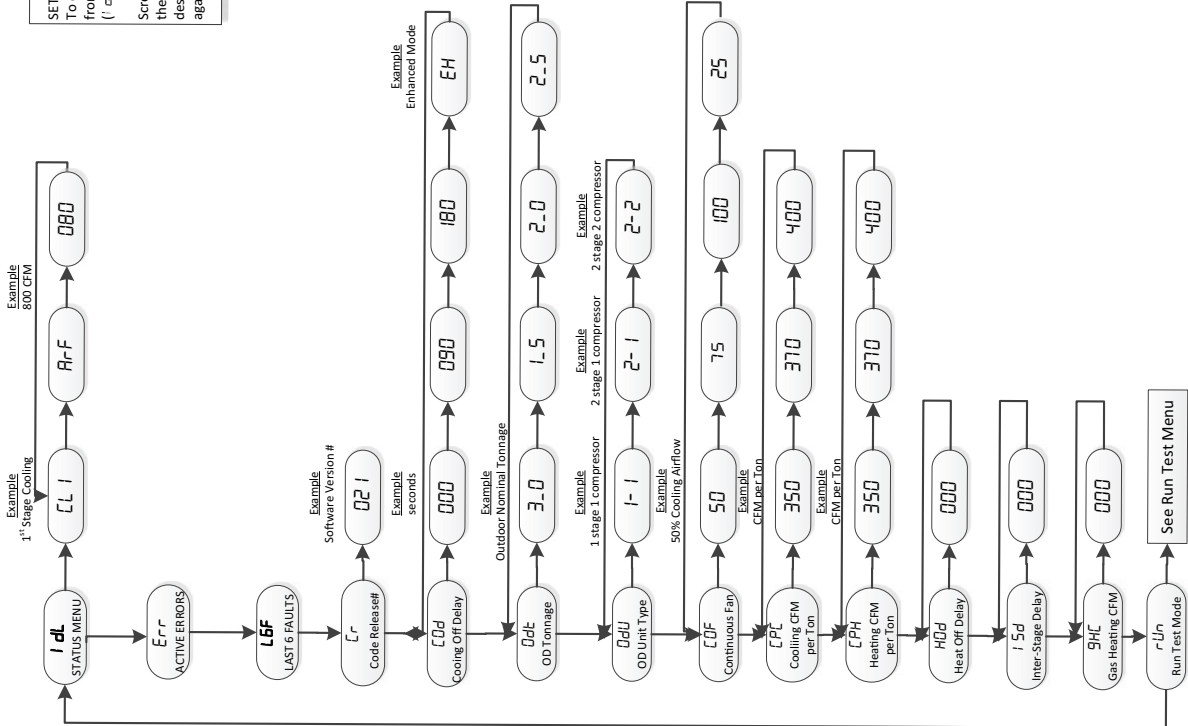

**SETTING UP YOUR SYSTEM:**  
To change any factory default value, first remove any "call" from the furnace and allow any fan off delays to finish. (i dL should be seen on the display)  
Scroll to the selected Menu item by momentarily depressing the "MENU" key and then depress the "OPTION" key to the desired setting. Then momentarily depress the "MENU" key again to save the change.

**CLEARING THE LAST 6 FAULTS:**  
To clear the stored faults, scroll to the last 6 faults menu, enter the menu by scrolling to the right and hold the "Option" key for at least 5 seconds. This confirms the faults have been cleared

**Model ODT Options [ ] = Default**

Upflow	3T[3T], 1.5T, 2T, 2.5T
POVOA	4T[4T], 1.5T, 2T, 2.5T, 3T, 3.5T
POVOB	5T[5T], 2.5T, 3T, 3.5T, 4T, 4.5T
POVOC	5T[5T], 3T, 3.5T, 4T, 4.5T
POVOD	

**Do not adjust COF above 50%**

**Important:**  
When applied with zoning or a VSPD outdoor unit, the CFM/Ton must be set to 400

**Designated Maximum 1st Stage Heat Pump Airflow Setting**  
ODU = 2-1 (1st stage airflow is 75% of the total airflow)  
ODU = 2-2 (1st stage airflow is 50% of the total airflow)  
**Total airflow = CPH x Tonnage (400 x 3 = 1200)**

Model Number	Heating CFM
POVOA000M30SDA	1000 (Total = 1240)
POVOB000M46SDA	1200 (Total = 1440)
POVOC000M50SDA	1400 (Total = 1680)
POVOD000M50SDA	1400 (Total = 1680)

POVO  
Examples of System Status

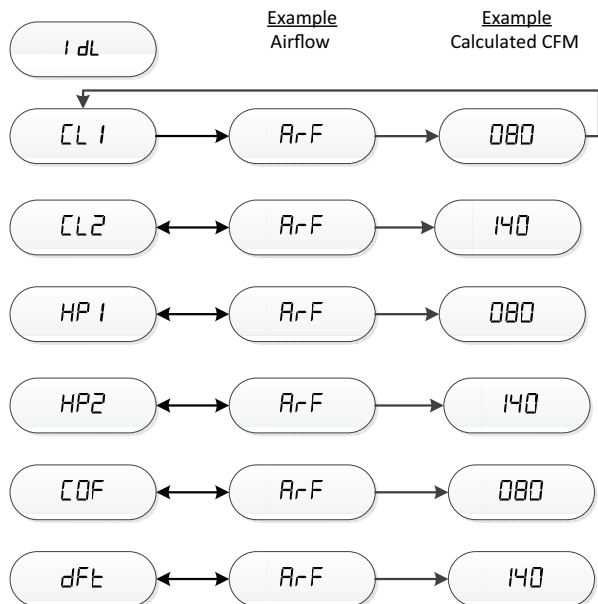

*IDL* = Idle, no demand for cooling, heating, or fan  
*CL1* = Demand for 1<sup>st</sup> stage cooling  
*CL2* = Demand for 2<sup>nd</sup> stage cooling  
*HP1* = Demand for 1<sup>st</sup> stage heat pump  
*HP2* = Demand for 2<sup>nd</sup> stage heat pump  
*CDF* = Demand for continuous fan  
*dFt* = Demand for outdoor unit defrost  
*ArF / 080* = Calculated airflow is 800 CFM.

Airflow display is rounded down to the nearest 10 cfm

NOTES:

- (1) The menu status displayed is solely dependent on the input of 24VAC that is applied to the low voltage terminal strip.
- (2) The status will alternate between the system mode and the airflow request every 2 seconds.
- (3) If an error occurs, an E\*.\* will alternately flash with the system mode and airflow request.
- (4) Some units will show demand airflow while others will show calculated airflow. Calculated airflow will gradually ramp up and may take ~1-2 minutes to stabilize.

Note: During run test mode, depressing the option key will allow the user to hold (HLD) that test sequence if measurements want to be taken. The exception is RU3 (ignitor).



Run Test Mode:  
 To enter Run Test Mode, scroll to *rUn* using the Menu key, then push the option key. The LED will flash *rUn* three times, then begin the test.  
 To exit the test mode, momentarily push the Menu key, cycle power to the modular air handler, or make a valid thermostat call for capacity or fan.

Sequence of Run Test Mode  
*rU4* – Turns the circulating blower on 1st stage compressor speed for 30 seconds  
*rU5* – Turns the circulating blower on 2nd stage compressor speed for 30 seconds  
 The above sequence will repeat two more times unless the Run Test Mode is exited, see above

**Important:** The Run Test Mode does not bring the outdoor unit on. It is designed to allow the technician to observe each mode to ensure the IMAHC, circulating blower are performing as intended. The run test for the blower will take approximately 70 seconds to begin.

# Integrated Modular Air Handler Control (IMAHC) Display Codes

Modular Air Handler	
<i>IdL</i>	Idle
<i>ArF</i>	Calculated Airflow times (followed by Airflow x 10)
<i>COF</i>	Continuous Fan
<i>CL1</i>	First Stage Cooling
<i>CL2</i>	Second Stage Cooling
<i>HPI</i>	First Stage Heat Pump
<i>HP2</i>	Second Stage Heat Pump
Menu Options	
<i>Err</i>	Active Alarm Menu
<i>L6F</i>	Last 6 Faults (To clear — Hold Option button down for 5 seconds)
<i>Cr</i>	Code Release Number
<i>COd</i>	Cooling Off Delay (Seconds)
<i>OdL</i>	Outdoor Tonnage
<i>OdU</i>	Outdoor Unit
<i>COF</i>	Blower Constant Fan Airflow Multiplier (Percentage)
<i>CPCL</i>	Cooling (CFM/Ton)
<i>CPHL</i>	Heat Pump Heating (CFM/Ton)
<i>Mod</i>	Not Applicable
<i>ISd</i>	Not Applicable
<i>SHC</i>	Not Applicable
<i>rUn</i>	Run Test Mode

Error Codes	
Alarm Error Code	Alarm Explanation
<i>E01</i>	Loss of the IRQ or other internal failures (Internal IMAHC error)
<i>E6_1</i>	Voltage reversed polarity
<i>E6_2</i>	Bad grounding
<i>E1_2</i>	Open fuse
<i>E1_3</i>	Blower HP/OEM ID
<i>E1_4</i>	No PM and local copy bad
<i>E1_5</i>	Both of unit Data File in PM and local Unit Data File are corrupt
<i>E1_7</i>	Blower motor no communication response
<i>E1_8</i>	Blower communication failure on the control

## Fault Code Recovery

### Fault Code Recovery

1. To view the last 6 faults, press the "Menu" key until the "Last 6 Faults" (L6F) menu appears.
2. Enter the menu by pressing the "Option" key.
3. The last 6 faults can be viewed.

### Clearing the Last 6 Faults

1. To clear the last 6 faults, press the "Menu" key until the "Last 6 Faults" (L6F) menu appears.
2. Enter the menu by pressing the "Option" key.
3. Hold the "Option" key for at least 5 seconds.
4. Release and a set of 3 dashes with be seen 3 times. This confirms the faults have been cleared.

### Resetting Factory Defaults

1. Display must be in Idle Mode.
2. Push the "Menu" and "Option" buttons at the same time for 15 seconds then release.
3. The 7 segment will flash "Fd" 3 times. This confirms the unit has been reset to the factory defaults.

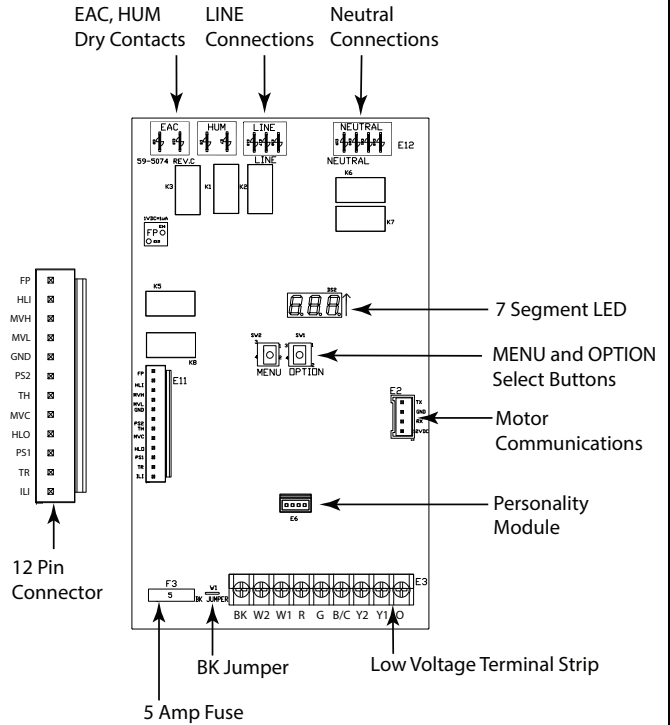

# Troubleshooting

The following pages include troubleshooting flowcharts in reference for the POV0 family of Modular Air Handler only. The information contained is for reference only and does not cover all scenarios or problems that may be encountered. ONLY qualified technicians should attempt to install, troubleshoot, or repair this appliance. Failure to follow all cautions and /or warnings could result in personal or property damage, including death.

Error Codes	
Alarm Error Code	Alarm Explanation
E01	Loss of the IRQ or other internal failures (Internal IMAHC error)
E06	Voltage reversed polarity or Bad Grounding
E12	Open fuse
E13	Blower HP/OEM ID
E14	No PM and local copy bad
E15	Both of unit Data File in PM and local Unit Data File are corrupt
E17	Blower motor no communication response
E18	Blower communication failure on the control

## IMAHC Component Layout

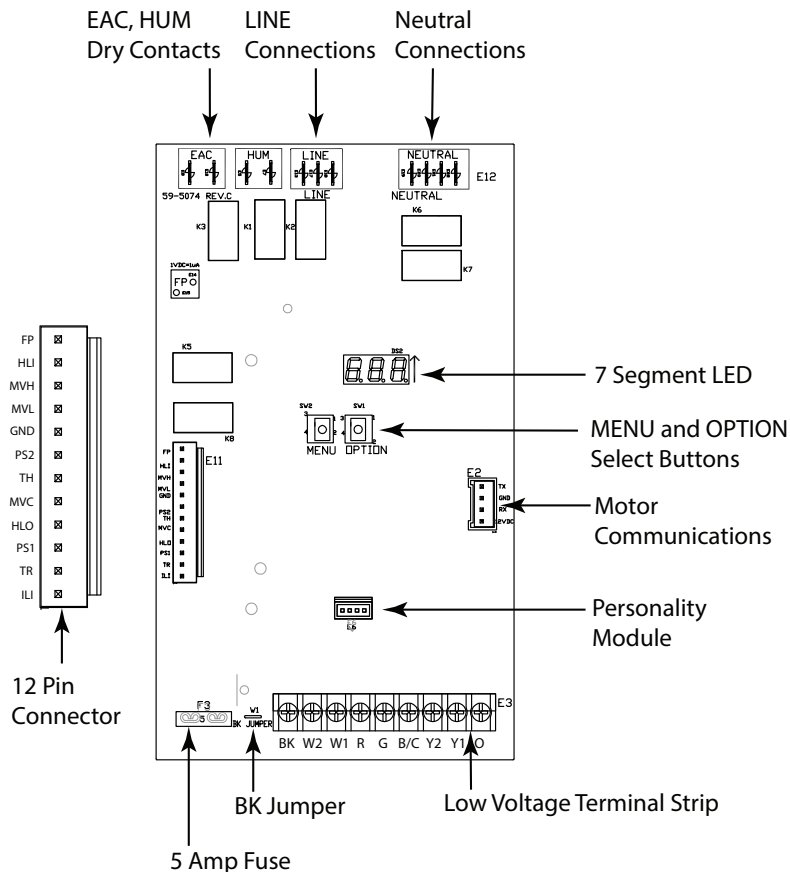



GETTING STARTED

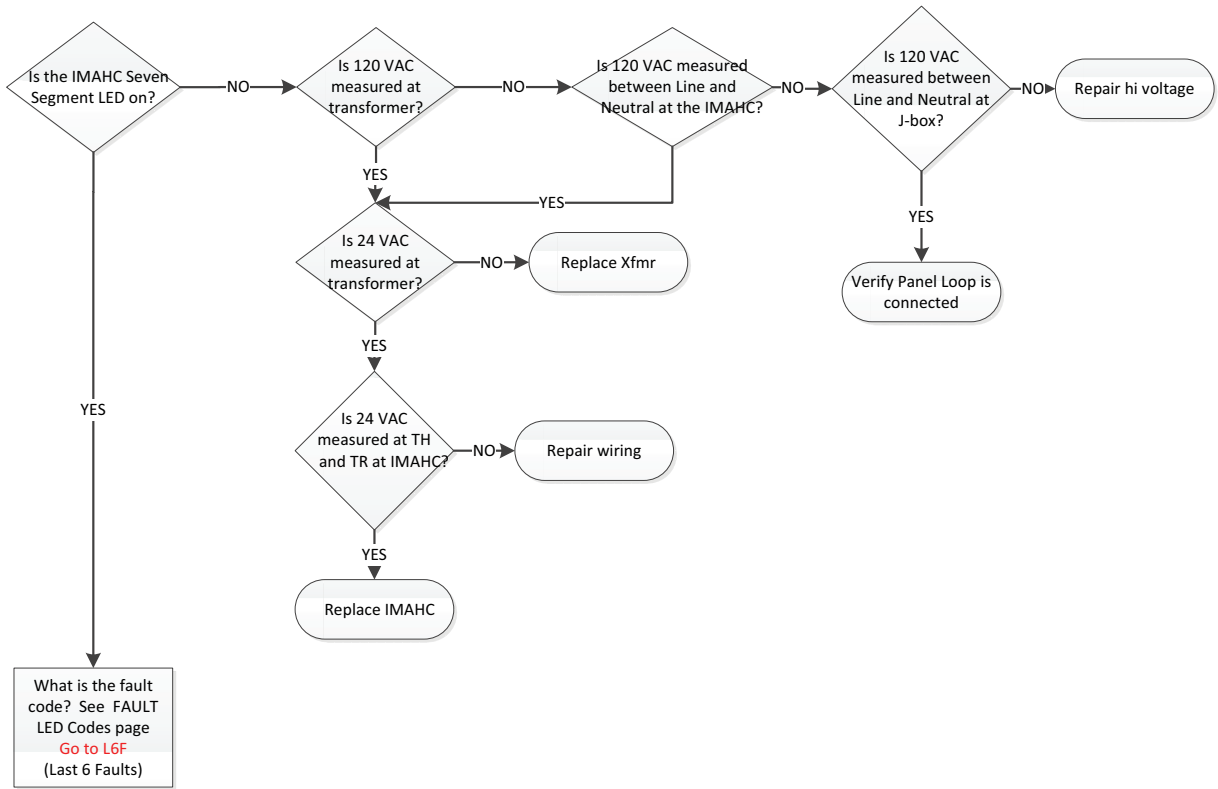

DEFINITION:  
Internal failure of the control board

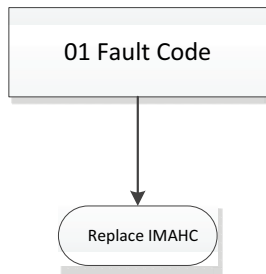

# Troubleshooting

**DEFINITION:**  
Polarity Fault – Incoming high voltage wiring is reversed

**06 Fault Code  
Reversed Polarity**

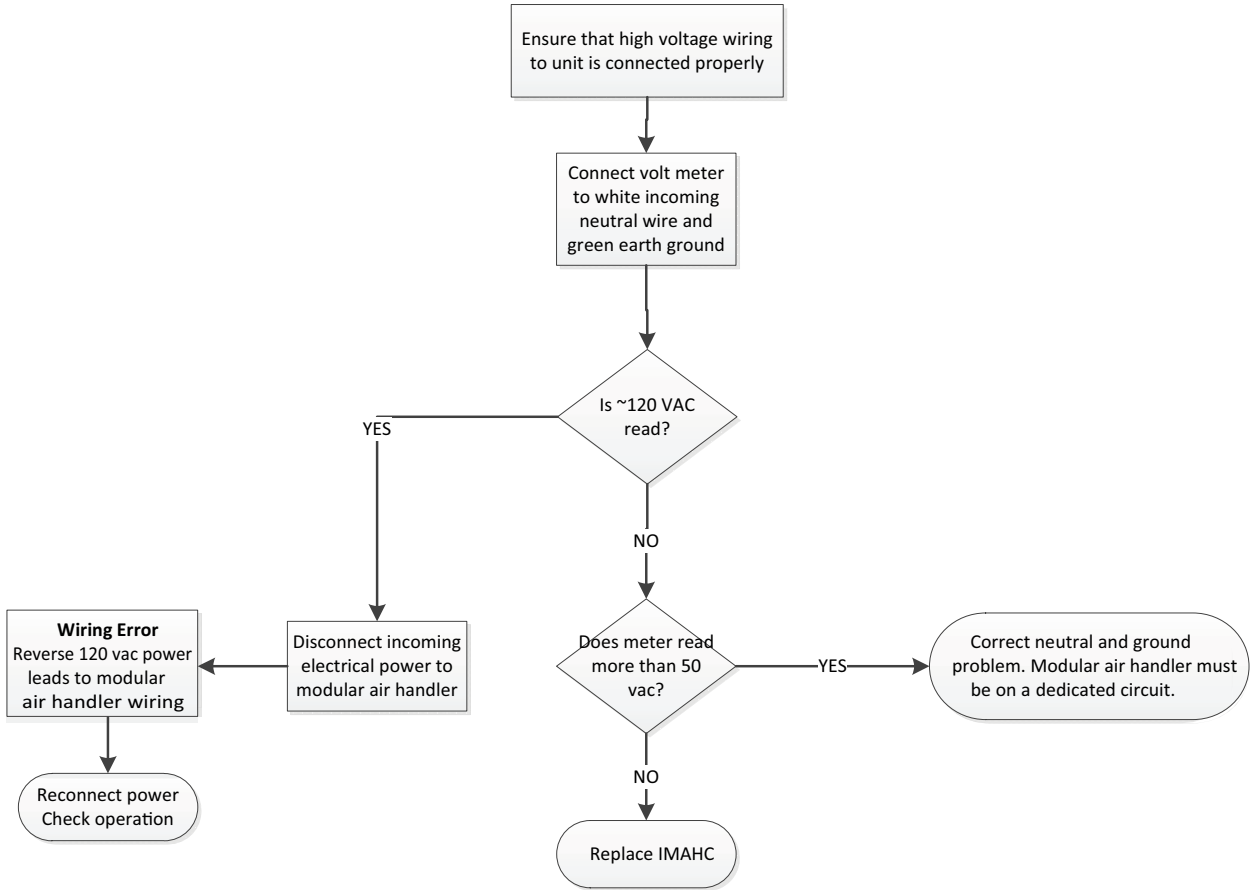

**DEFINITION:**  
Ground Fault - Incoming or chassis  
ground connection is not sensed

**06 Fault Code**  
**Faulty Ground**

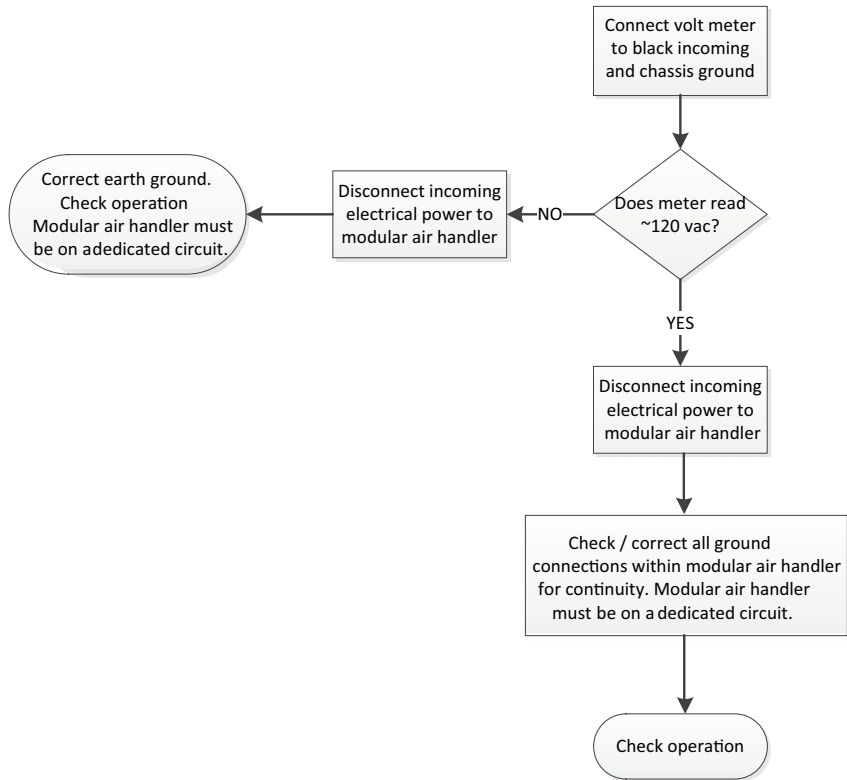

# Troubleshooting

Definition:  
The onboard 5 amp fuse is open or missing.

## 12 Fault Code

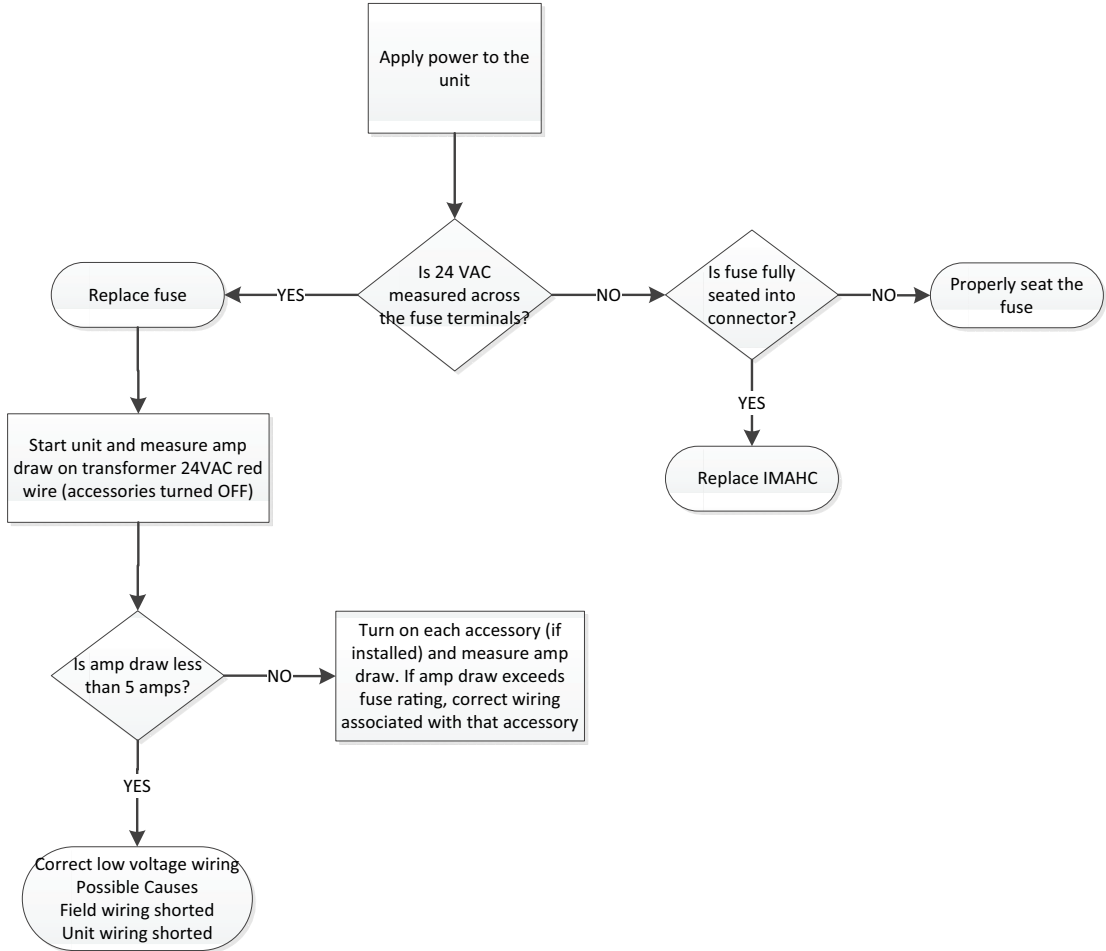

**DEFINITION:**  
This fault is generated when the HP or OEM ID of the blower motor does not match the value that is programmed on the Personality Module

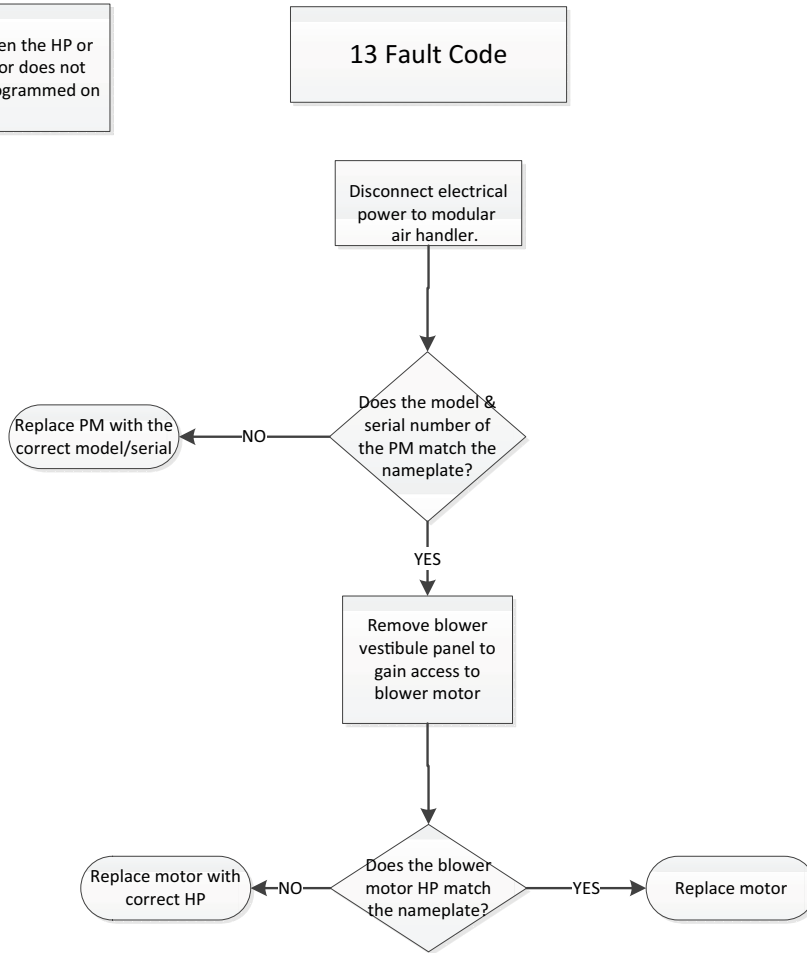

**DEFINITION:**  
This fault is generated when the PM is missing and the onboard information cannot be read

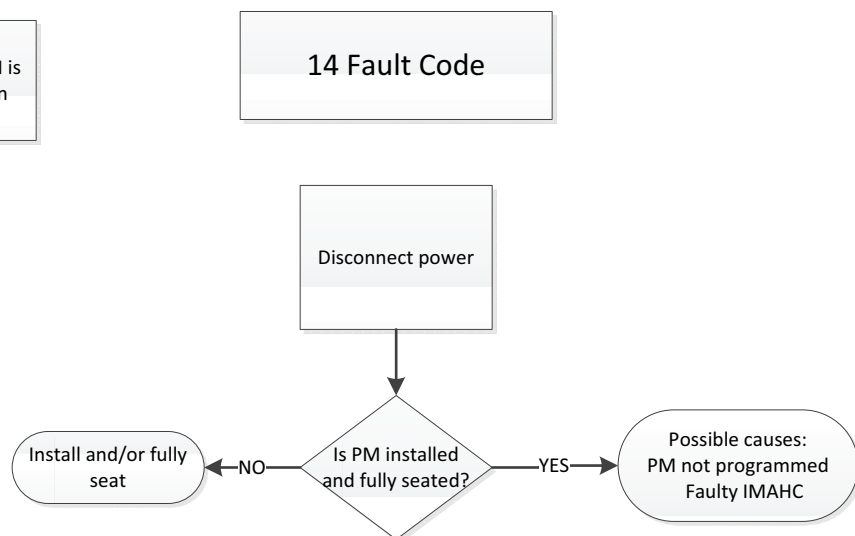

**DEFINITION:**  
This fault is generated when the PM and the IMAHC information is corrupted

## 15 Fault Code

Disconnect power

Possible causes  
PM corrupted  
Faulty IMAHC

**DEFINITION:**  
This fault is generated when IMAHC does not see a return signal from the blower motor

## 17 Fault Code

Disconnect power

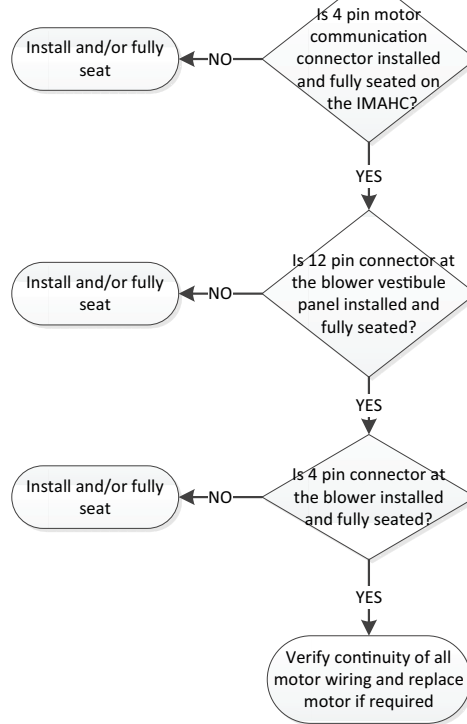

DEFINITION:  
This fault is generated when the IMAHC does not see a send message itself.

### 18 Fault Code

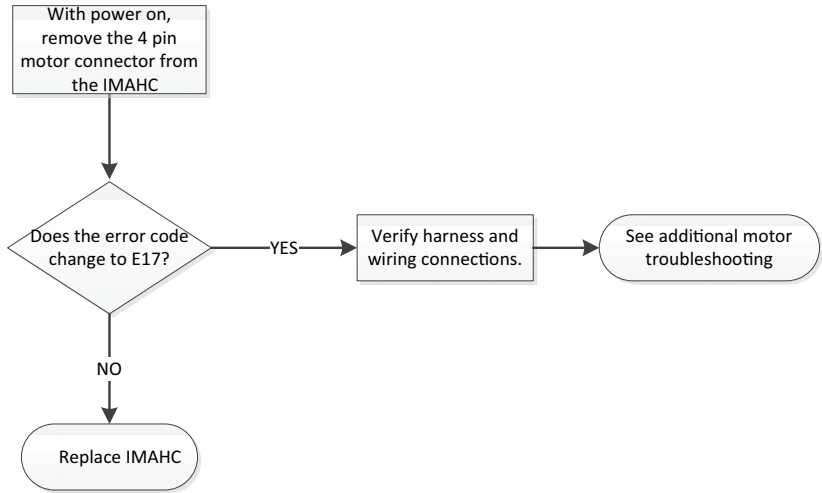

Serial Motor  
Troubleshooting

Serial Motor Troubleshooting

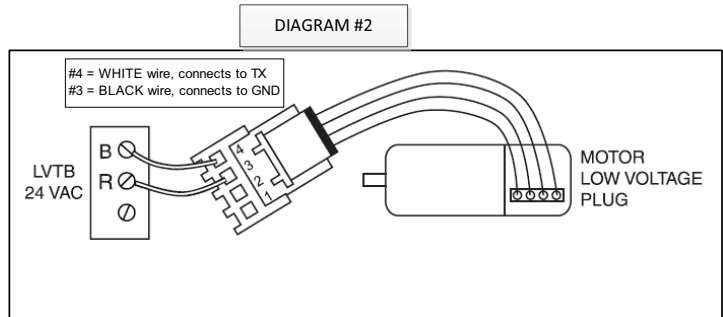
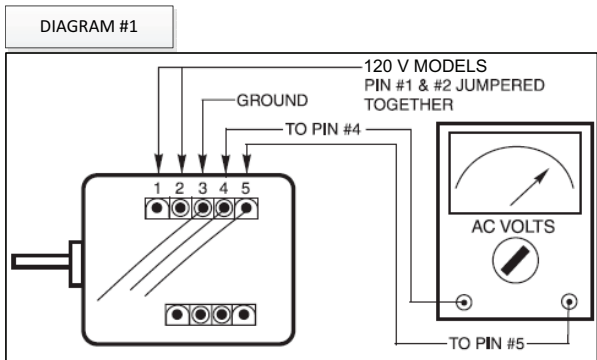
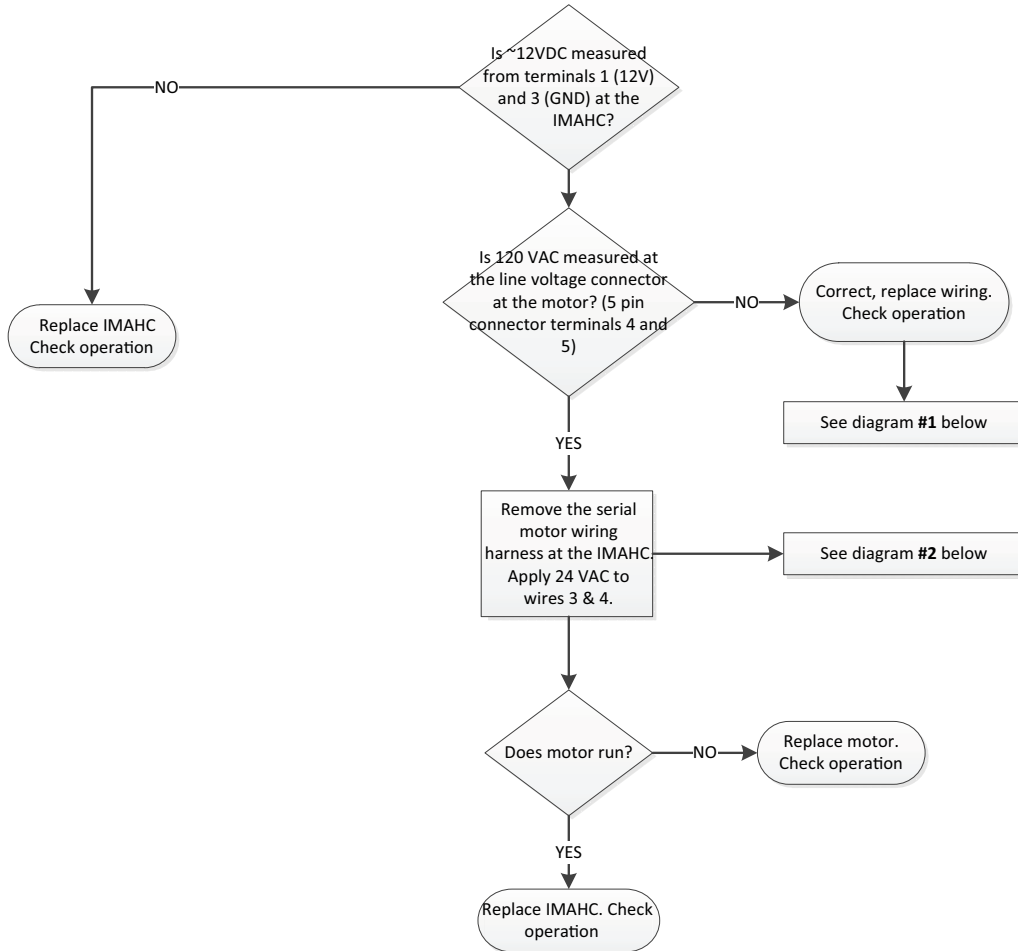



# Sequence of Operation

**Note:** The seven segment LED readout is based on thermostat input.

**Note:** Some units will show demand airflow while others will show calculated airflow. Calculated airflow will gradually ramp up and may take ~1-2 minutes to stabilize.

## EAC and HUM Timing

- EAC relay closes approximately 2 seconds after the blower starts.
- EAC relay opens when the blower motor stops.
- HUM relay closes on any heating call (HP) approximately 1 second after the blower motor starts.
- HUM relay opens when any heating call (HP) is removed.

## Single Stage Cooling

1. R-Y1-G contacts on the thermostat close sending 24VAC to the Y1 and G low voltage terminals on the IMAHC. Technician should read 24VAC between Y1-B/C and between G-B/C.

**Note:** Factory supplied Y1-O jumper must remain in place for proper seven segment LED readout. If removed, seven segment LED will read "HP 1".

2. 24VAC is sent to the OD unit via thermostat wiring energizing 1<sup>st</sup> stage compressor operation.
3. The indoor blower ramps to the 1<sup>st</sup> stage cooling airflow. The seven segment LED for example will alternately read:  
 $\overline{L}L1$  = Cooling, Stage 1  
 $RrF$  = Airflow  
 $\overline{000}$  = 800 calculated cfm (value shown x 10)
4. When the temperature is lowered enough to satisfy the thermostat setting, contacts R-Y1-G will open. The OD unit shuts off and the indoor blower shuts off, unless a blower off delay has been enabled in the IMAHC setup menu options. The seven segment LED will read "i dL" = Idle, no thermostat demand.

## Two Stage Cooling

1. See sequence of operation for Single stage cooling operation above (see steps 1-4).
2. R-Y2 contact on the thermostat closes sending 24VAC to Y2 low voltage terminal on the IMAHC. Technician should read 24VAC between Y2 and B/C.
3. 24VAC is sent to the OD unit via thermostat wiring.
4. The indoor airflow ramps to 2<sup>nd</sup> stage cooling airflow. The seven segment LED for example will read:

$\overline{L}L2$  = Cooling, Stage 2  
 $RrF$  = Airflow

$\overline{160}$  = 1600 calculated cfm (value shown x 10)

5. When the temperature is lowered enough to satisfy the thermostat setting, contacts R-Y1-Y2-G will open.
6. The OD unit shuts off and the indoor blower shuts off, unless a blower off delay has been enabled in the IMAHC setup menu options. The seven segment LED will read "i dL" = Idle, no thermostat demand.

## Single Stage Heat Pump

1. R-Y1-G contacts on the thermostat close sending 24VAC to the Y1 and G low voltage terminals on the IMAHC. Technician should read 24VAC between Y1-B/C and between G-B/C.

**Note:** Factory supplied Y1-O jumper must be removed for proper seven segment LED readout. If left in place, seven segment LED will read "CL 1".

2. 24VAC is sent to the OD unit via thermostat wiring energizing 1<sup>st</sup> stage compressor operation.
3. The indoor blower ramps to the 1<sup>st</sup> stage heat pump airflow. The seven segment LED for example will alternately read:

$HP1$  = Heat Pump heating, Stage 1

$RrF$  = Airflow

$\overline{000}$  = 800 calculated cfm (value shown x 10)

4. When the temperature is raised enough to satisfy the thermostat setting, contacts R-Y1-G will open. The OD unit shuts off and the indoor blower shuts off, unless a blower off delay has been enabled in the IMAHC setup menu options. The seven segment LED will read "i dL" = Idle, no thermostat demand.

## Two Stage Heat Pump

1. See sequence of operation for Single stage heat pump operation above (see steps 1-4).
2. R-Y2 contact on the thermostat closes sending 24VAC to Y2 low voltage terminal on the IMAHC. Technician should read 24VAC between Y2 and B/C.
3. 24VAC is sent to the OD unit via thermostat wiring energizing 2<sup>nd</sup> stage compressor operation.
4. The indoor blower ramps to the 2<sup>nd</sup> stage heat pump airflow. The seven segment LED for example will alternately read:

$HP2$  = Heat Pump heating, Stage 2

$RrF$  = Airflow

$\overline{160}$  = 1600 calculated cfm (value shown x 10)

5. When the temperature is raised enough to satisfy the thermostat setting, contacts R-Y1-Y2-G will open.
6. The OD unit shuts off and the indoor blower shuts off. The seven segment LED will read "i dL" = Idle, no thermostat demand.

# Periodic Servicing Requirements

1. GENERAL INSPECTION – *Examine the modular air handler installation annually for the following items:*
2. FILTERS – Filters should be cleaned or replaced (with high velocity filters only), monthly and more frequently during high use times of the year such as midsummer or midwinter.
3. BLOWERS – The Blower size and speed determine the air volume delivered by the Modular Air Handler. The Blower motor bearings are factory lubricated and under normal operating conditions

- do not require servicing. Annual cleaning of the Blower wheel and housing is recommended for maximum air output, and this must be performed only by a qualified servicer or service agency.
4. COOLING COIL CONDENSATE DRAIN - If a cooling coil is installed with the Modular Air Handler, condensate drains should be checked and cleaned periodically to assure that condensate can drain freely from coil to drain. If condensate cannot drain freely water damage could occur.

# Checkout Procedures

The final phase of the installation is the system Checkout Procedures. The following list represents the most common items covered in a Checkout Procedure. Confirm all requirements in this document have been met.

<ul style="list-style-type: none"><li><input type="checkbox"/> All wiring connections are tight and properly secured.</li><li><input type="checkbox"/> Voltage and running current are within limits.</li><li><input type="checkbox"/> Ductwork is sealed and insulated.</li></ul>	<ul style="list-style-type: none"><li><input type="checkbox"/> Supply registers and return grilles are open, unobstructed, and air filter is installed.</li><li><input type="checkbox"/> Indoor blower and outdoor fan are operating smoothly and without obstruction.</li><li><input type="checkbox"/> Indoor blower motor set on correct speed setting to deliver required CFM. "Blower and fan set screws are tight."</li><li><input type="checkbox"/> Cover panels are in place and properly tightened.</li><li><input type="checkbox"/> System functions safely and properly in all modes.</li><li><input type="checkbox"/> Owner has been instructed on use of system and given manual.</li></ul>
--	---

**About Trane and American Standard Heating and Air Conditioning**

Trane and American Standard create comfortable, energy efficient indoor environments for residential applications. For more information, please visit [www.trane.com](http://www.trane.com) or [www.americanstandardair.com](http://www.americanstandardair.com).

---



The manufacturer has a policy of continuous data improvement and it reserves the right to change design and specifications without notice. We are committed to using environmentally conscious print practices.