



# Installation, Operation, and Maintenance

## Upflow/Horizontal and Dedicated Downflow Gas-Fired, Direct/Non-Direct Vent, Single Stage Condensing Furnaces with High Efficiency Motor

### Upflow, Convertible to Horizontal Right or Horizontal Left

A951X040BU3SAC  
A951X060BU4SAC  
A951X080BU4SAC  
A951X080CU5SAC  
A951X100CU5SAC  
A951X120DU5SAC

### Downflow Only

A951X040BD3SAC  
A951X060BD3SAC  
A951X080BD4SAC  
A951X100CD5SAC  
A951X120DD5SAC

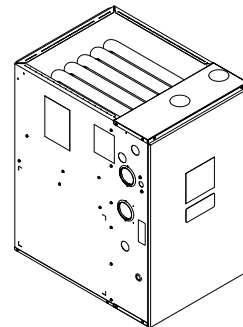

*Note: Graphics in this document are for representation only.  
Actual model may differ in appearance.*



FNR-SVX004A-EN

### **⚠ SAFETY WARNING**

Only qualified personnel should install and service the equipment. The installation, starting up, and servicing of heating, ventilating, and air-conditioning equipment can be hazardous and requires specific knowledge and training. Improperly installed, adjusted or altered equipment by an unqualified person could result in death or serious injury. When working on the equipment, observe all precautions in the literature and on the tags, stickers, and labels that are attached to the equipment.

# Introduction

Read this manual thoroughly before operating or servicing this unit.

This document is customer property and is to remain with this unit. Return to the service information pack upon completion of work.

## Warnings, Cautions, and Notices

Safety advisories appear throughout this manual as required. Your personal safety and the proper operation of this machine depend upon the strict observance of these precautions.

The three types of advisories are defined as follows:



Indicates a potentially hazardous situation which, if not avoided, could result in death or serious injury.



Indicates a potentially hazardous situation which, if not avoided, could result in minor or moderate injury. It could also be used to alert against unsafe practices.



Indicates a situation that could result in equipment or property-damage only accidents.

### **⚠ WARNING**

#### **Proper Field Wiring and Grounding Required!**

**Failure to follow code could result in death or serious injury.**

**All field wiring MUST be performed by qualified personnel. Improperly installed and grounded field wiring poses FIRE and ELECTROCUTION hazards. To avoid these hazards, you MUST follow requirements for field wiring installation and grounding as described in NEC and your local/state/national electrical codes.**

### **⚠ WARNING**

#### **Personal Protective Equipment (PPE) Required!**

**Failure to wear proper PPE for the job being undertaken could result in death or serious injury.**

**Technicians, in order to protect themselves from potential electrical, mechanical, and chemical hazards, MUST follow precautions in this manual and on the tags, stickers, and labels, as well as the instructions below:**

- **Before installing/servicing this unit, technicians MUST put on all PPE required for the work being undertaken (Examples; cut resistant gloves/sleeves, butyl gloves, safety glasses, hard hat/bump cap, fall protection, electrical PPE and arc flash clothing). ALWAYS refer to appropriate Safety Data Sheets (SDS) and OSHA guidelines for proper PPE.**
- **When working with or around hazardous chemicals, ALWAYS refer to the appropriate SDS and OSHA/GHS (Global Harmonized System of Classification and Labelling of Chemicals) guidelines for information on allowable personal exposure levels, proper respiratory protection and handling instructions.**
- **If there is a risk of energized electrical contact, arc, or flash, technicians MUST put on all PPE in accordance with OSHA, NFPA 70E, or other country-specific requirements for arc flash protection, PRIOR to servicing the unit. NEVER PERFORM ANY SWITCHING, DISCONNECTING, OR VOLTAGE TESTING WITHOUT PROPER ELECTRICAL PPE AND ARC FLASH CLOTHING. ENSURE ELECTRICAL METERS AND EQUIPMENT ARE PROPERLY RATED FOR INTENDED VOLTAGE.**

**⚠ WARNING****Follow EHS Policies!**

Failure to follow instructions below could result in death or serious injury.

- All Trane personnel must follow the Environmental, Health and Safety (EHS) policies when performing work such as hot work, electrical, fall protection, and lockout/tagout. Where local regulations are more stringent than these policies, those regulations supersede these policies.
- Non-Trane personnel should always follow local regulations.

**⚠ WARNING****Cancer and Reproductive Harm!**

This product can expose you to chemicals, including lead, which are known to the State of California to cause cancer and birth defects or other reproductive harm. For more information go to [www.P65Warnings.ca.gov](http://www.P65Warnings.ca.gov).

**⚠ WARNING****Safety Hazard!**

Failure to follow instructions below could result in death or serious injury or property damage.

This unit is not to be used by persons (including children) with reduced physical, sensory, or mental capabilities, or lack of experience and knowledge, unless they have been given supervision or instruction concerning the use of the appliance by a person responsible for their safety.

Do not allow children to play or climb on the unit or to clean or maintain the unit without supervision.

**⚠ WARNING****Fire Hazard!**

Failure to follow instructions below could result in death or serious injury or property damage.

For installations with flammable refrigeration system, the furnace must be powered at all times except during servicing. The furnace must be installed and connected according to installation instructions and wiring diagrams provided with the evaporator coil.

**⚠ WARNING****Explosion Hazard!**

Failure to follow instruction below could result in death or serious injury or property damage.

Install a gas detector for leak warnings. The manufacturer does not test or endorse any specific brand or type of detector.

**⚠ WARNING****Fire or Explosion Hazard!**

Failure to follow safety warnings exactly could result in serious injury, death, or or property damage.

Never test for gas leaks with an open flame. Use a commercially available soap solution made specifically for the detection of leaks to check all connections. A fire or explosion can result causing property damage, personal injury, or loss of life.

**⚠ WARNING****Electrical Shock, Fire, or Explosion Hazard!**

Failure to follow the safety warnings exactly could result in dangerous operation, serious injury, death, or property damage.

Improper servicing could result in dangerous operation, serious injury, death, or property damage.

- Before servicing, disconnect all electrical power to the furnace.
- When servicing controls, label all wires prior to disconnecting. Reconnect wires correctly.
- Verify proper operation after servicing.

**⚠ WARNING****Carbon Monoxide Poisoning!**

Failure to follow instructions below could result in death or serious injury, or property damage.

• To confirm the furnace is vented properly, do not replace factory-supplied venting components with field fabricated parts. Fabricating parts can result in damaged vents and components, allowing carbon monoxide to escape the venting system.

• Follow the service and/or periodic maintenance and installation and operation instructions for the furnace and the venting system. Do not attempt to change the venting system.

• Verify the blower door is in place and not ajar. Dangerous fumes could escape an improperly secured door.

• Inspect the chimney liner thoroughly to verify no cracks or other potential areas for flue gas leaks are present in the liner. Liner leaks will result in early damage to the chimney. Furnace venting into an unlined masonry chimney or concrete chimney is prohibited.

**⚠ WARNING****Carbon Monoxide Poisoning!**

Failure to follow instructions below could cause result in death or serious injury, or property damage.

Follow the installation and operation instructions for the venting system. Do not attempt to change the venting system.

**⚠ WARNING**

**Fire Hazard!**

Failure to follow instructions below could result in death or serious injury or property damage. Do not install the furnace directly on carpet or other combustible material other than wood flooring. Use subbase (BAYBASE205) between the furnace and combustible flooring for vertical downflow applications. When the downflow furnace is installed vertically with a cased coil, a subbase is not required.

**⚠ WARNING**

**Explosion Hazard!**

Failure to follow instruction below could result in death or serious injury or property damage. Propane gas is heavier than air and can accumulate in low areas or confined spaces. Odorant fade may make it undetectable without a warning device. If a gas furnace is installed in a basement, excavated areas, or a confined space, it is strongly recommended to contact a gas supplier to install a gas detector for leak warnings. The manufacturer does not test or endorse any specific brand or type of detector.

**⚠ WARNING**

**Electrical Shock Hazard!**

Failure to follow instructions below could result in death or serious injury or property damage. Do not bypass the door switch or the panel loop permanently.

**⚠ WARNING**

**Electrical Shock Hazard!**

Failure to follow instructions below could result in death or serious injury or property damage.. Do not touch any components other than the Menu and Option buttons on IFC when setting up the system or during fault code recovery.

**⚠ WARNING**

**Risk of Fire or Explosion!**

Failure to follow instruction below could result in death or serious injury or property damage. Do NOT attempt to manually light the furnace.

**⚠ WARNING**

**Electrical Shock Hazard!**

Failure to follow instructions below could result in death or serious injury or property damage. Disconnect power to the unit before removing the blower door and wait at least 10 seconds for the IFC power supply to discharge to 0 volts.

**⚠ WARNING**

**Safety Hazard!**

Failure to follow instructions below could result in death or serious injury or property damage. These furnaces are not approved or intended for installation in trailers or recreational vehicles. Installation in manufactured (mobile) housing is only approved with BAYMFGH Kit.

**⚠ WARNING**

**Explosion Hazard!**

Failure to follow instruction below could result in death or serious injury or property damage. If electrical, fuel, or mechanical failures occur, shut off the gas supply at the manual valve on the supply piping before turning off the furnace's electrical power. Contact your dealer's designated service agency.

**⚠ WARNING**

**Safety Hazard!**

Failure to follow instructions below could result in death or serious injury or property damage. Do not use semi-rigid metallic gas connectors (flexible gas lines) within the furnace cabinet.

**⚠ WARNING**

**High Voltage Moving Parts!**

Failure to follow instructions below could result in death or serious injury or property damage due to high voltage electrical components, fast-moving fans, and combustible gas. During installation and servicing, turn off the main gas valve and disconnect the electrical supply. If operating checks must be performed with the unit operating, the technician must recognize these hazards and proceed safely.

**⚠ WARNING**

**Safety Hazard!**

Failure to follow instructions below could result in death or serious injury or property damage. Do not install the filter in the return duct directly above the furnace in horizontal applications. Install the filter remotely.

**⚠ WARNING****Carbon Monoxide Poisoning Hazard!**

Failure to follow the steps outlined below for each appliance connected to the venting system being placed into operation could result in carbon monoxide poisoning or death.

The following steps shall be followed for each appliance connected to the venting system being placed into operation, while all other appliances connected to the venting system are not in operation:

- Seal any unused openings in the venting system.
- Inspect the venting system for proper size and horizontal pitch as required in the National Fuel Gas Code, ANSI Z223.1/NFPA 54 or the Natural Gas and Propane Installation Code, CSA B149.1 and these instructions. Determine there is no blockage or restriction, leakage, corrosion, or other deficiencies which could cause an unsafe condition.
- As far as practical, close all building doors and windows and all doors between the space in which the appliance(s) connected to the venting system are located and other spaces of the building.
- Close fireplace dampers.
- Turn on clothes dryers and any appliance not connected to the venting system. Turn on any exhaust fans, such as range hoods and bathroom exhausts, so they are operating at maximum speed. Do not operate a summer exhaust fan.
- Follow the lighting instructions. Place the appliance being inspected into operation. Adjust the thermostat so appliance is operating continuously.
- Test for spillage from draft hood equipped appliances at the draft hood relief opening after 5 minutes of main burner operation. Use the flame of a match or candle.
- If improper venting is observed during any of the above tests, correct the venting system in accordance with the National Fuel Gas Code, ANSI Z223.1/NFPA and/or Natural Gas and Propane Installation Code, CSA B149.1 .
- After it has been determined that each appliance connected to the venting system properly vents when tested as outlined above, return doors, windows, exhaust fans, fireplace dampers, and any other gas-fired burning appliance to their previous conditions of use.

**⚠ WARNING****Safety Hazard!**

Failure to follow instructions below could result in death or serious injury or property damage. Turn off the power to the furnace before servicing filters to avoid contact with moving parts.

**⚠ WARNING****Shock Hazard!**

Failure to follow instructions below could result in death or serious injury or property damage. If a disconnect switch is present, always lock in the open position before servicing the unit.

**⚠ WARNING****Electrical Shock Hazard!**

Failure to follow this warning could result in an electric shock, fire, injury, or death. Ensure cabinet has an uninterrupted or unbroken ground in accordance with National Electrical Code, ANSI/NFPA 70 – latest edition and Canadian Electrical Code, CSA C22.1 or local codes in case of an electrical fault.

**⚠ WARNING****Overheating and Explosion Hazard!**

Failure to follow this warning could result in property damage, personal injury, or death. Should the gas supply fail to shut off or if overheating occurs, shut off the gas valve to the furnace before shutting off the electrical supply.

**⚠ WARNING****Safety Hazard!**

Failure to follow instructions below could result in death or serious injury or property damage. The vent for this appliance must not terminate over public walkways, near soffit or crawl space vents, or where condensate could cause damage or be detrimental to the operation of regulators, relief valves, or other equipment.

**⚠ WARNING****Hot Surface!**

Failure to follow instructions below could result in minor to moderate injuries. Do not touch igniter. It is extremely hot.

**⚠ CAUTION****Improper Voltage Connection!**

Failure to follow instructions below could result in personal injury or equipment damage. Do NOT connect the furnace line voltage to a GFCI-protected circuit.

**⚠ CAUTION**

**Corrosion Hazard!**

Failure to follow instructions below could result in minor to moderate injury or property damage. Do not install the furnace in a corrosive or contaminated atmosphere.

**⚠ CAUTION**

**Sharp Edges!**

Failure to follow instructions below could result in minor to moderate injury. The service procedure described in this document involves working around sharp edges. To avoid being cut, technicians **MUST** put on all necessary Personal Protective Equipment (PPE), including gloves and arm guards.

**⚠ CAUTION**

**Valve Damage!**

Failure to follow instructions below could result in minor to moderate injury or equipment damage. Use a backup wrench on the gas valve when installing gas piping to prevent damage to the valve and manifold assembly.

**⚠ CAUTION**

**Freeze Damage!**

Failure to follow instructions below could result in minor to moderate injury or property damage. Insulate vent pipes with 1/2 inch (12.7 mm) Armaflex-type insulation or equivalent when passing through unheated spaces exposed to freezing temperatures. Insulation is not needed if the space is heated enough to prevent freezing. If domestic water pipes are not protected from freezing, the space is considered heated. Schedule qualified personnel to inspect the temperature if the house is vacant during freezing weather. A furnace failure could lead to frozen water pipes.

**⚠ CAUTION**

**Freeze Damage!**

Failure to follow instructions below could result in minor to moderate injury or property damage. Take measures to prevent drains from freezing or causing slippery conditions. Excessive draining of condensate may cause saturated ground conditions that may result in damage to plants.

**⚠ CAUTION**

**Ignition Function!**

Failure to follow instructions below could result in minor to severe injury and result in poor ignition characteristics. Maintain manifold pressure in high altitude installations.

**⚠ CAUTION**

**Water Damage!**

Failure to follow instructions below could result in minor to moderate injury or property damage. Install an external overflow drain pan in all applications over a finished ceiling to prevent leaking condensate.

**⚠ CAUTION**

**Furnace Service Caution!**

Failure to follow instructions below could result in property damage or personal injury. Label all wires prior to disconnection when servicing controls. Verify proper operation after servicing. Wiring errors can cause improper and dangerous operation.

**⚠ CAUTION**

**Do NOT Use as Construction Heater!**

Failure to follow instructions below could result in property damage or personal injury. To prevent shortening its service life, do not use the furnace as a construction heater during the finishing phases of construction until the furnace installation guidelines are met. Condensate in the presence of chlorides and fluorides from paint, varnish, stains, adhesives, cleaning compounds, and cement, create a corrosive condition which may cause rapid deterioration of the heat exchanger.

**⚠ CAUTION**

**Wiring Hazard!**

Failure to follow instructions below could result in minor to moderate injury or property damage. The integrated furnace control is polarity sensitive. Connect the hot leg of the 120 VAC power to the black field lead.

**⚠ CAUTION****Venting Required!**

Failure to follow instructions below could result in minor to moderate injury or property damage.

- Condensing furnaces may be vented through unused chimneys. Do not vent through chimneys used for wood-burning, oil furnaces, incinerators or any other gas appliance. If remaining free area between single wall flue pipe and masonry chimney is used for another gas appliance, venting area must be sufficient and that appliance must be connected to the chimney with separate entry openings.
- The single wall flue pipe joints must be sealed. The 90° elbow connection to the vertical pipe must be sealed to prevent condensate leakage to base of the masonry chimney.

**⚠ CAUTION****Coil Requirement!**

Failure to follow instructions below could result in minor to moderate injury or property damage.

For 4GXC\* and 4MXC\* coils on upflow furnaces in vertical, horizontal left, or horizontal right orientations without a factory-installed metal drain pan shield, must use a MAY\*FERCOLKITAA kit. Coils installed on upflow furnaces must have drain pans suitable for 400° F (205° C) or metal drain pan shield. Downflow furnaces do not require a metal drain pan shield or MAY\*FERCOLKITAA kit.

**NOTICE****Equipment Damage!**

Failure to follow instructions below could result in equipment damage.

UV light exposure can deteriorate plastic blower material, potentially damaging the blower housing. For units with plastic blower housings, do not install third-party UV air cleaners where the blower housing is exposed to UV light.

For more information, visit [www.trane.com](http://www.trane.com) and [www.americanstandardair.com](http://www.americanstandardair.com) or contact your installing dealer.

6200 Troup Highway

Tyler, TX 75707

**Copyright**

This document and the information in it are the property of Trane, and may not be used or reproduced in whole or in part without written permission. Trane reserves the right to revise this publication at any time, and to make changes to its content without obligation to notify any person of such revision or change.

**Trademark**

All trademarks referenced in this document are the trademarks of their respective owners.

**Revision History**

- A951X-SVX001-1D-EN replaced by a new literature number FNR-SVX004A-EN.
- Updated accessories tables, product specifications, installation instructions, menu options, error codes, airflow tables, and the Troubleshooting chapter.
- Updated model numbers for belly band location.

# Table of Contents

Accessories .....	9	Return Air Filters for Furnace in Horizontal Configuration .....	48
Document Pack Contents .....	10	Typical Downflow Furnace Return Air Filter Installations .....	48
Parts List .....	10	Electrical Connections .....	48
Product Specifications .....	11	Field Wiring .....	49
Furnace Installation Guidelines .....	15	Twinning .....	49
Safety Practices and Precautions .....	15	Condensate Drain Instructions .....	51
General Guidelines .....	15	Vertical Applications .....	51
Locations and Clearances .....	16	Upflow Furnace .....	51
Dimensional Data .....	17	Downflow Furnace .....	53
Wiring Diagrams .....	19	Horizontal Applications .....	55
Airflow Tables .....	20	General Start-Up and Adjustment .....	56
Upflow .....	20	Preliminary Inspections .....	56
Downflow .....	21	Lighting Instructions .....	56
CFM Versus Temperature Rise .....	23	Control and Safety Switch Adjustment .....	56
Furnace General Installation .....	24	Furnace Combustion Air Exhaust Options .....	57
Horizontal Installation in an Attic or Crawlspace .....	24	Factory Set Up - Upflow and Downflow Orientation .....	58
Horizontal Installation Hanging Using Straps .....	24	Upflow Position - Top Vented .....	58
Gas Piping .....	24	Upflow Position - Left Side Vented .....	59
Combustion and Input Check .....	26	Horizontal Left Position - Top Vented .....	61
Gas Valve Adjustment .....	27	Horizontal Left Position - Side Vented .....	63
High Altitude Derate .....	28	Horizontal Right Position - Top Vented .....	65
General Venting .....	29	Horizontal Right Position - Left Vented .....	68
3-Inch Venting Requirements .....	29	Downflow Furnace - Top Vented .....	70
Typical Venting .....	30	Downflow Furnace - Left Side Vented .....	71
Special Case Venting .....	31	Integrated Furnace Control Menu .....	74
Vent Terminations .....	32	Setting Airflow .....	76
Attaching Vent Piping .....	32	Integrated Furnace Control Display Codes .....	77
Maximum Vent Length .....	34	Fault Code Recovery .....	77
Horizontal Venting .....	35	Troubleshooting .....	78
Horizontal Venting Through Wall with Concentric Vent Kit .....	37	Belly Band Location .....	89
Air for Combustion and Ventilation .....	40	Sequence of Operation .....	90
Duct Connections .....	42	Gas Heating .....	90
Supply Duct Connections .....	42	Cooling / Heat Pump .....	90
Return Duct Connections .....	44	Periodic Servicing Requirements .....	91
Return Air Filters .....	47		
Typical Upflow Return Air Filter Installations .....	47		
Preparation for Upflow Bottom and Side Return Air Filter Installations .....	48		

# Accessories

**Table 1. Accessories**

Model Number	Description	Use with
MAYBFERCOLKITA	Heat Shield Kit for B-width 4GXCB or 4MCXB Coils	B width 4GXCB or 4MCXB Coils when installed with Upflow Furnace in all orientations
MAYCFERCOLKITA	Heat Shield Kit for C-width 4GXCC or 4MCXC Coils	C-width 4GXCC or 4MCXC Coils when installed with Upflow Furnace in all orientations
MAYDFERCOLKITA	Heat Shield Kit for D-width 4GXCD or 4MCXD Coils	D width 4GXCD or 4MCXD Coils when installed with Upflow Furnace in all orientations
BAYHANG	Horizontal Hanging Kit	All Upflow Furnaces
BAYVENT200B	Sidewall Vent Termination Kit	All Furnaces
BAYVENTCN200B	Sidewall Vent Termination Kit (Canada —CPVC)	All Furnaces
BAYAIR30AVENTA	Concentric Vent Kit	All Furnaces
BAYAIR30CNVENT	Concentric Vent Kit (Canada — CPVC)	All Furnaces
BAYREDUCE	Reducing Coupling (CPVC)	All Furnaces
BAYLIFTB <sup>(a)</sup>	Dual Return Kit (B size extension)	B Cabinet Upflow Furnaces
BAYLIFTC <sup>(a)</sup>	Dual Return Kit (C size extension)	C Cabinet Upflow Furnaces
BAYLIFTD <sup>(a)</sup>	Dual Return Kit (D size extension)	D Cabinet Upflow Furnaces
BAYBASE205	Downflow Subbase	All Downflow Furnaces
BAYFLTR203	Horizontal Filter Kit	B Cabinet Modular Blowers in Downflow/Horizontal
BAYFLTR204	Horizontal Filter Kit	C Cabinet Modular Blowers in Downflow/Horizontal
BAYFLTR205	Horizontal Filter Kit	D Cabinet Modular Blowers in Downflow/Horizontal
BAYFLTR206	Filter Access Door Kit (Downflow only)	All Downflow Furnaces
BAYSF1165 <sup>(a) (b)</sup>	1-in. SlimFit Box with MERV 4 Filter	All Upflow Furnaces
BAYSF1255 <sup>(b)</sup>	1-in. SlimFit Filter and Insulated Frame	All furnaces when used in side return application B Cabinet furnaces only when in bottom return application
BAYLPSS400 <sup>(b)</sup>	Propane Conversion Kit with Stainless Steel Burners	All Furnaces
BAYBURNERSS	All Stainless Steel Natural Gas Burners - Set of Six	All Upflow Furnaces - Special Case
BAYMFGH200B	Manufactured/Mobile Housing Kit	All Furnaces
BAYCNDTRAP2A	Inline Condensate Trap Kit used with Special Venting on 2-in. Vent Pipe	All Furnaces
BAYCNDTRAP3A	Inline Condensate Trap Kit used with Special Venting on 3-in. Vent Pipe	All Furnaces
FLRSF1255	1-in. Filter replacement (Qty 12)	BAYSF1255 <sup>(b)</sup>

<sup>(a)</sup> Airflow greater than 1600 CFM, Furnace will require return air openings and filters on: (1) both sides, (2) one side and the bottom, or (3) just on the bottom.

<sup>(b)</sup> Latest revision.

## Document Pack Contents

Table 2. Document pack contents

Item	Qty.	Description
1	1	Condensate Drain Tube Assembly
2	1	Inlet Vent (2-inch - ADP01586 and 3-inch - ADP01587) <sup>(a)</sup>
3	1	Inlet Vent Gasket
4	1	Outlet Vent Assembly
5	1	Outlet Vent Gasket
6	6	Screws
7	1	Condensate Trap Grommet
8	1	Plug — Condensate/Gas
9	1	Plug — Electrical
10	2	Grommet — Condensate/Gas
11	1	Installation, Operation, and Maintenance
12	1	Owner Guide
13	1	Limited Warranty
14	1	2-inch to 3-inch Coupling — CPL01544 <sup>(b)</sup>
15	2	Tinnerman Clips (not pictured) <b>Note:</b> <i>Tinnerman Clips should be kept with unit and are used if the door panel flange hole(s) becomes stripped.</i>
16	2	Brand labels <sup>(c)</sup>

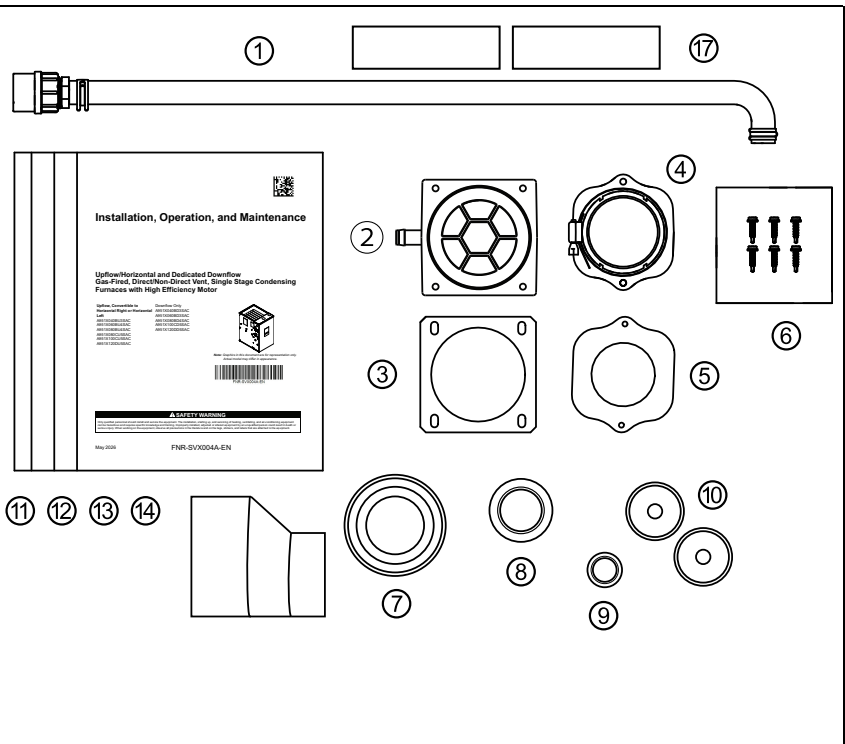

<sup>(a)</sup> 3-inch inlet vent supplied with A951X120DU and A951X120DD only. 2-inch inlet vent supplied with all other models.

<sup>(b)</sup> Supplied with A951X120DU and A951X120DD only

<sup>(c)</sup> Place appropriate brand label below the warning label on the front panel using stencil marks as guides.

## Parts List

- Igniter
- Flame Sensor
- In-shot Burner(s)
- Gas Valve
- Inducer Assembly
- Blower Motor
- Blower Wheel
- IFC (Integrated Furnace Control)
- Pressure Switch(es)
- Main Thermal Limit
- Roll-Out Switch(es)
- Reverse Air Switch(es)

# Product Specifications

**Table 3. Models A951X040BU3SAC, A951X060BU4SAC, A951X080BU4SAC, and A951X080CU5SAC**

Model	A951X040BU3SAC <sup>(a)</sup>	A951X060BU4SAC <sup>(a)</sup>	A951X080BU4SAC <sup>(a)</sup>	A951X080CU5SAC <sup>(a)</sup>
Type	Upflow / Horizontal	Upflow / Horizontal	Upflow / Horizontal	Upflow / Horizontal
Ratings <sup>(b)</sup>	—			
Input BTUH	40,000	60,000	80,000	80,000
Capacity BTUH (ICS) <sup>(c)</sup>	39,000	58,300	77,200	77,800
Temp. Rise (Min.-Max.)	30 - 60	30 - 60	45 - 75	40 - 70
AFUE (%) <sup>(c)</sup>	96.0	96.0	96.0	96.0
Return Air Temp. (Min. - Max.)	45°F - 80°F	45°F - 80°F	45°F - 80°F	45°F - 80°F
CEE Tier	Tier 2	Tier 2	Tier 2	Tier 2
Energy Star Rating Before July 31, 2026	US - All/Canada	US - All/Canada	US - All/Canada	US - All/Canada
Energy Star Rating On or After July 31, 2026	US - South	US - South	US - South	US - South
Energy Star Orientation	Upflow / Horizontal	Upflow / Horizontal	Upflow / Horizontal	Upflow / Horizontal
Integrated Furnace Control	—			
Input-Communication Protocol	24 Volts	24 Volts	24 Volts	24 Volts
Blower Drive	Direct	Direct	Direct	Direct
Diameter — Width (In.)	11 X 8	11 X 8	11 X 8	11 X 10
No. Used	1	1	1	1
Speeds (No.) <sup>(d)</sup>	9	9	9	9
CFM vs. in. w.g.	See Fan Performance Table	See Fan Performance Table	See Fan Performance Table	See Fan Performance Table
Motor HP	1/2	3/4	3/4	1
RPM	1075	1075	1075	1075
Volts/Ph/Hz	120 / 1 / 60	120 / 1 / 60	120 / 1 / 60	120 / 1 / 60
FLA	6.4	8.4	8.4	10.6
Combustion Fan — Type	Centrifugal	Centrifugal	Centrifugal	Centrifugal
Drive — No. Speeds	Direct - 1	Direct - 1	Direct - 1	Direct - 1
Motor HP — RPM	3300	3300	3300	3300
Volts/Ph/Hz	120 / 1 / 60	120 / 1 / 60	120 / 1 / 60	120 / 1 / 60
FLA	2.14	2.14	2.14	0.66
Filter — Furnished?	No	No	No	No
Type recommended	High Velocity	High Velocity	High Velocity	High Velocity
Hi Vel. (No.-Size-Thk.)	1 - 16 X 25 - 1 in.	1 - 16 X 25 - 1 in.	1 - 16 X 25 - 1 in.	1 - 20 X 25 - 1 in.
Vent Pipe Diameter— Min (in.) <sup>(e) (f)</sup>	2 Round	2 Round	2 Round	2 Round
Inlet Air Diameter— Min (in.) <sup>(f)</sup>	2 Round	2 Round	2 Round	2 Round
Heat Exchanger	—			
Type — Fired	409 Stainless Steel	409 Stainless Steel	409 Stainless Steel	409 Stainless Steel
— Unfired	29-4C Stainless Steel	29-4C Stainless Steel	29-4C Stainless Steel	29-4C Stainless Steel
Gauge (Fired)	20	20	20	20
Orifices — Main	—			
Nat. Gas Qty. — Drill Size	2 - 45	3 - 45	4 - 45	4 - 45
LP Gas Qty. — Drill Size	2 - 56	3 - 56	4 - 56	4 - 56
Gas Valve	Redundant - One Stage	Redundant - One Stage	Redundant - One Stage	Redundant - One Stage

# Product Specifications

**Table 3. Models A951X040BU3SAC, A951X060BU4SAC, A951X080BU4SAC, and A951X080CU5SAC (continued)**

Model	A951X040BU3SAC (a)	A951X060BU4SAC(a)	A951X080BU4SAC(a)	A951X080CU5SAC(a)
<b>Pilot Safety Device</b>	—			
Type	120 V SiNi Igniter	120 V SiNi Igniter	120 V SiNi Igniter	120 V SiNi Igniter
<b>Burners — Type</b>	Multiport Inshot			
Number	2	3	4	4
<b>Power Conn. — V/Ph/Hz (g)</b>	120 / 1 / 60			
Ampacity (In Amps)	10.3	12.8	12.8	14.1
Max. Overcurrent Protection (Amps)	15	15	15	15
<b>Pipe Conn. Size (in.)</b>	1/2			

- (a) Central Furnace heating designs are certified to ANSI Z21.47 / CSA 2.3 - Latest Edition.
- (b) For U.S. applications, above input ratings (BTUH) are up to 2,000 feet, derate 4% per 1,000 feet for elevations above 2,000 feet above sea level. For Canadian Applications, above input ratings (BTUH) are up to 4,500 feet, derate 4% per 1,000 feet for elevations above 4,500 feet above sea level.
- (c) Based on U.S. Government standard tests.
- (d) 9 Speed constant Torque ECM Blower Motor.
- (e) See the [Maximum Vent Length](#), p. 34 in this document.
- (f) All furnace models have a vent outlet diameter that equals 2-in.
- (g) The above wiring specifications are in accordance with National Electrical Code; however, installations must comply with local codes.

**Table 4. Models A951X100CU5SAC, A951X120DU5SAC, A951X040BD3SAC, and A951X060BD3SAC**

Model	A951X100CU5SAC (a)	A951X120DU5SAC(a)	A951X040BD3SAC(a)	A951X060BD3SAC(a)
<b>Type</b>	Upflow / Horizontal	Upflow / Horizontal	Downflow	Downflow
<b>Ratings (b)</b>	—			
Input BTUH	100,000	120,000	40,000	60,000
Capacity BTUH (ICS) (c)	97,400	113,400	38,900	57,600
Temp. Rise (Min.-Max.)	40 - 70	40 - 70	30 - 60	35 - 65
AFUE (%) <sup>(c)</sup>	95.0	95.0	96.0	96.0
Return Air Temp. (Min. - Max.)	45°F - 80°F	45°F - 80°F	45°F - 80°F	45°F - 80°F
CEE Tier	Tier 2	Tier 2	Tier 2	Tier 2
Energy Star Rating Before July 31, 2026	US - All/Canada	US - All/Canada	US - All/Canada	US - All/Canada
Energy Star Rating On or After July 31, 2026	US - South	US - South	US - South	US - South
Energy Star Orientation	Upflow / Horizontal	Upflow / Horizontal	Downflow	Downflow
<b>Integrated Furnace Control</b>	—			
Input-Communication Protocol	24 Volts	24 Volts	24 Volts	24 Volts
<b>Blower Drive</b>	Direct			
Diameter — Width (In.)	11 X 10	11 X 10	11 X 8	11 X 8
No. Used	1	1	1	1
Speeds (No.) (d)	9	9	9	9
CFM vs. in. w.g.	See Fan Performance Table	See Fan Performance Table	See Fan Performance Table	See Fan Performance Table
Motor HP	1	1	1/2	1/2
RPM	1075	1075	1075	1075
Volts/Ph/Hz	120 / 1 / 60			
FLA	10.6	10.6	6.4	6.4
<b>Combustion Fan — Type</b>	Centrifugal			
Drive — No. Speeds	Direct - 1			
Motor HP — RPM	3300			
Volts/Ph/Hz	120 / 1 / 60			

**Table 4. Models A951X100CU5SAC, A951X120DU5SAC, A951X040BD3SAC, and A951X060BD3SAC (continued)**

Model	A951X100CU5SAC (a)	A951X120DU5SAC(a)	A951X040BD3SAC(a)	A951X060BD3SAC(a)
FLA	0.66	0.66	2.14	2.14
Filter — Furnished?	No	No	No	No
Type recommended	High Velocity	High Velocity	High Velocity	High Velocity
Hi Vel. (No.-Size-Thk.)	1 - 20 X 25 - 1 in.	1 - 24 X 25 - 1 in.	1 - 16 X 25 - 1 in.	1 - 16 X 25 - 1 in.
Vent Pipe Diameter— Min (in.) (e) (f)	2 Round	3 Round	2 Round	2 Round
Inlet Air Diameter— Min (in.) (f)	2 Round	3 Round	2 Round	2 Round
Heat Exchanger	—			
Type — Fired	409 Stainless Steel	409 Stainless Steel	409 Stainless Steel	409 Stainless Steel
— Unfired	29–4C Stainless Steel	29–4C Stainless Steel	29–4C Stainless Steel	29–4C Stainless Steel
Gauge (Fired)	20	20	20	20
Orifices — Main	—			
Nat. Gas Qty. — Drill Size	5 - 45	6 - 45	2 - 45	3 - 45
LP Gas Qty. — Drill Size	5 - 56	6 - 56	2 - 56	3 - 56
Gas Valve	Redundant - One Stage	Redundant - One Stage	Redundant - One Stage	Redundant - One Stage
Pilot Safety Device	—			
Type	120 V SiNi Igniter	120 V SiNi Igniter	120 V SiNi Igniter	120 V SiNi Igniter
Burners — Type	Multiport Inshot	Multiport Inshot	Multiport Inshot	Multiport Inshot
Number	5	6	2	3
Power Conn. — V/Ph/Hz (g)	120 / 1 / 60	120 / 1 / 60	120 / 1 / 60	120 / 1 / 60
Ampacity (In Amps)	14.1	14.1	10.3	10.3
Max. Overcurrent Protection (Amps)	15	15	15	15
Pipe Conn. Size (in.)	1/2	1/2	1/2	1/2

- (a) Central Furnace heating designs are certified to ANSI Z21.47 / CSA 2.3 - Latest Edition.
- (b) For U.S. applications, above input ratings (BTUH) are up to 2,000 feet, derate 4% per 1,000 feet for elevations above 2,000 feet above sea level. For Canadian Applications, above input ratings (BTUH) are up to 4,500 feet, derate 4% per 1,000 feet for elevations above 4,500 feet above sea level.
- (c) Based on U.S. Government standard tests.
- (d) 9 Speed constant Torque ECM Blower Motor.
- (e) See the [Maximum Vent Length](#), p. 34 in this document.
- (f) All furnace models have a vent outlet diameter that equals 2-in.
- (g) The above wiring specifications are in accordance with National Electrical Code; however, installations must comply with local codes.

**Table 5. Models A951X080BD4SAC, A951X100CD5SAC, and A951X120DD5SAC**

Model	A951X080BD4SAC (a)	A951X100CD5SAC(a)	A951X120DD5SAC(a)
Type	Downflow	Downflow	Downflow
Ratings (b)	—		
Input BTUH	80,000	100,000	120,000
Capacity BTUH (ICS) (c)	76,900	96,800	115,500
Temp. Rise (Min.-Max.)	45-75	40-70	45-75
AFUE (%) (c)	95.0	96.0	95.0
Return Air Temp. (Min. - Max.)	45°F - 80°F	45°F - 80°F	45°F - 80°F
CEE Tier	Tier 2	Tier 2	Tier 2
Energy Star Rating Before July 31, 2026	US - All/Canada	US - All/Canada	US - All/Canada
Energy Star Rating On or After July 31, 2026	US - South	US - South	US - South
Energy Star Orientation	Downflow	Downflow	Downflow
Integrated Furnace Control	—		

## Product Specifications

**Table 5. Models A951X080BD4SAC, A951X100CD5SAC, and A951X120DD5SAC (continued)**

Model	A951X080BD4SAC <sup>(a)</sup>	A951X100CD5SAC <sup>(a)</sup>	A951X120DD5SAC <sup>(a)</sup>
Input-Communication Protocol	24 Volts	24 Volts	24 Volts
<b>Blower Drive</b>	Direct	Direct	Direct
Diameter — Width (In.)	11 X 8	11 X 10	11 X 10
No. Used	1	1	1
Speeds (No.) <sup>(d)</sup>	9	9	9
CFM vs. in. w.g.	See Fan Performance Table	See Fan Performance Table	See Fan Performance Table
Motor HP	3/4	1	1
RPM	1075	1075	1075
Volts/Ph/Hz	120 / 1 / 60	120 / 1 / 60	120 / 1 / 60
FLA	9.3	10.6	10.6
<b>Combustion Fan — Type</b>	Centrifugal	Centrifugal	Centrifugal
Drive — No. Speeds	Direct - 1	Direct - 1	Direct - 1
Motor HP — RPM	3300	3300	3300
Volts/Ph/Hz	120 / 1 / 60	120 / 1 / 60	120 / 1 / 60
FLA	2.14	0.66	0.66
<b>Filter — Furnished?</b>	No	No	No
Type recommended	High Velocity	High Velocity	High Velocity
Hi Vel. (No.-Size-Thk.)	1 - 16 X 25 - 1 in.	1 - 20 X 25 - 1 in.	1 - 24 X 25 - 1 in.
<b>Vent Pipe Diameter— Min (in.)</b> <sup>(e) (f)</sup>	2 Round	2 Round	3 Round
<b>Inlet Air Diameter— Min (in.)</b> <sup>(f)</sup>	2 Round	2 Round	3 Round
<b>Heat Exchanger</b>	—		
Type — Fired	409 Stainless Steel	409 Stainless Steel	409 Stainless Steel
— Unfired	29-4C Stainless Steel	29-4C Stainless Steel	29-4C Stainless Steel
Gauge (Fired)	20	20	20
<b>Orifices — Main</b>	—		
Nat. Gas Qty. — Drill Size	4 - 45	5 - 45	6 - 45
LP Gas Qty. — Drill Size	4 - 56	5 - 56	6 - 56
<b>Gas Valve</b>	Redundant - One Stage	Redundant - One Stage	Redundant - One Stage
<b>Pilot Safety Device</b>	—		
Type	120 V SiNi Igniter	120 V SiNi Igniter	120 V SiNi Igniter
<b>Burners — Type</b>	Multiport Inshot	Multiport Inshot	Multiport Inshot
Number	4	5	6
<b>Power Conn. — V/Ph/Hz</b> <sup>(g)</sup>	120 / 1 / 60	120 / 1 / 60	120 / 1 / 60
Ampacity (In Amps)	13.9	14.1	14.1
Max. Overcurrent Protection (Amps)	15	15	15
<b>Pipe Conn. Size (in.)</b>	1/2	1/2	1/2

<sup>(a)</sup> Central Furnace heating designs are certified to ANSI Z21.47 / CSA 2.3 - Latest Edition.

<sup>(b)</sup> For U.S. applications, above input ratings (BTUH) are up to 2,000 feet, derate 4% per 1,000 feet for elevations above 2,000 feet above sea level. For Canadian Applications, above input ratings (BTUH) are up to 4,500 feet, derate 4% per 1,000 feet for elevations above 4,500 feet above sea level.

<sup>(c)</sup> Based on U.S. Government standard tests.

<sup>(d)</sup> 9 Speed constant Torque ECM Blower Motor.

<sup>(e)</sup> See the [Maximum Vent Length](#), p. 34 in this document.

<sup>(f)</sup> All furnace models have a vent outlet diameter that equals 2-in.

<sup>(g)</sup> The above wiring specifications are in accordance with National Electrical Code; however, installations must comply with local codes.

# Furnace Installation Guidelines

The following sections give general guidelines for the installation of the gas furnaces.

## Safety Practices and Precautions

The following safety practices and precautions must be followed during the installation, servicing, and operation of this Furnace.

1. Use only with the type gas approved for this Furnace. Refer to the Furnace rating plate.
2. Install the Furnace only in a location and position as specified in “[Locations and Clearances](#),” p. 16 of these instructions.
3. Provide adequate combustion and ventilation air to the Furnace space as specified in “[Air for Combustion and Ventilation](#),” p. 40 of these instructions.
4. Combustion products must be discharged outdoors. Connect this Furnace to an approved vent system only, as specified in the “[General Venting](#),” p. 29 section of these instructions.
5. Never test for gas leaks with an open flame. Use a commercially available soap solution made specifically for the detection of leaks to check all connections, as specified in the “[Gas Piping](#),” p. 24 section of these instructions.
6. Always install the Furnace to operate within the Furnace’s intended temperature-rise range with a duct system which has an external static pressure within the allowable range, as specified on the unit rating plate. Airflow within temperature rise for cfm versus static is shown in the CFM Versus Temperature Rise section in this document accompanying this Furnace.
7. When a Furnace is installed so that the supply ducts carry air circulated by the Furnace to areas outside the space containing the Furnace, the return air shall also be handled by a duct(s) sealed to the Furnace casing and terminating outside the space containing the Furnace.
8. A gas-fired Furnace for installation in a residential garage must be installed as specified in “[Locations and Clearances](#),” p. 16 section of these instructions.
9. The furnace may be used for temporary heating of buildings or structures under construction only when the following conditions have been met:
  - a. The Furnace venting system must be complete and installed per manufacturer’s instructions.
  - b. The Furnace is controlled only by a room Comfort Control (no field jumpers).
  - c. The Furnace return air duct must be complete and sealed to the Furnace.
  - d. The Furnace input rate and temperature rise must be verified to be within the nameplate marking.
- e. A minimum 4–inch MERV 11 air filter must be in place.
- f. 100% of the Furnace combustion air requirement must come from outside the structure.
- g. The Furnace return air temperature range is between 45 and 80 Fahrenheit.  
80% models = 55°F  
90%+ models = 45°F
- h. Clean the Furnace, duct work, and components upon substantial completion of the construction process, and verify Furnace operating conditions including ignition, input rate, temperature rise, and venting, according to the manufacturer’s instructions.
10. The installer must verify that at least one carbon monoxide alarm has been installed within the residential living space or home following the alarm manufacturer’s instructions and applicable local codes before putting the appliance into operation.
11. **In the Commonwealth of Massachusetts, this product must be gas piped by a Licensed Plumber or Gas Fitter.**

This Furnace is certified to leak 1.4% or less of nominal air conditioning CFM delivered when pressurized to .5–inch water column with all inlets, outlets, and drains sealed.

## General Guidelines

The manufacturer assumes no responsibility for equipment installed in violation of any code or regulation.

It is recommended that Manual J of the Air Conditioning Contractors Association (ACCA) or A.R.I. 230 be followed in estimating heating requirements. When estimating heating requirements for installation at Altitudes above 2000 ft., remember the gas input must be reduced. See “[”](#).”

Material in this shipment has been inspected at the factory and released to the transportation agency without known damage. Inspect exterior of carton for evidence of rough handling in shipment. Unpack carefully after moving equipment to approximate location. If damage to contents is found, report the damage immediately to the delivering agency.

Codes and local utility requirements governing the installation of gas fired equipment, wiring, plumbing, and flue connections must be adhered to. In the absence of local codes, the installation must conform with latest edition of the National Fuel Gas Code ANSI Z223.1 / NFPA 54 • National Installation Code, CAN/CGA B149.1. The latest code may be obtained from the American Gas Association, 400 N. Capitol St. NW, Suite 450 Washington, D.C. 20001, 1-855-999-9870 or [www.aga.org](http://www.aga.org).

These furnaces have been classified as CATEGORY IV furnaces in accordance with latest edition of ANSI Z21.47

## Furnace Installation Guidelines

standards • CSA 2.3. Category IV furnaces operate with positive vent static pressure and with a flue loss less than 17 percent. These conditions require special venting systems, which must be gas tight and water tight. These Category IV Direct Vent furnaces are approved for installation in Manufactured/ Mobile housing when used with BAYMFGH200B.

A manufactured (mobile) home installation must conform with the *Manufactured Home Construction and Safety Standard, Title 24 CFR, Part 3280*, or when this standard is not applicable, the *Standard for Model Manufactured Home Installation, NFPA 225*, or the *Canadian Standard for Manufactured Homes, CSA Z240 MH*.

### Locations and Clearances

The location of the furnace is normally selected by the architect, the builder, or the installer. However, before the furnace is moved into place, be sure to consider the following requirements:

1. Is the location selected as near the chimney or vent and as centralized for heat distribution as practical?
2. Do all clearances between the furnace and enclosure equal or exceed the minimums stated in the table below?

**Table 6. Location and clearances**

Minimum clearance to combustible materials (in.)	
<b>Closet</b>	
Sides	0
Back	1
Top	1
Front	0
Bottom	0
Flue	0
24-in. minimum front clearance recommended for service	
<b>Horizontal Closet and Alcove</b>	
Right Side	0
Left Side	0
Back	1
Top	1
Bottom	0
Flue	0
<b>Horizontal Flue (discharge on left)</b>	
<b>Closet</b>	
Right Side	0
Left Side	0
Rear	1
Top	1
Bottom	0
Flue	0

3. Is there sufficient space for servicing the furnace and other equipment? A minimum of 24 inches front accessibility to the furnace must be provided. Any access door or panel must permit removal of the largest component.
4. Are there at least 3 inches of clearance between the furnace combustion air openings in the front panel and any closed panel or door provided?
5. Are the ventilation and combustion air openings large enough and will they remain unobstructed? If outside air is used, are the openings set 12-inch above the highest snow accumulation level?
6. Allow sufficient height in supply plenum above the furnace to provide for cooling coil installation, if the cooling coil is not installed at the time of this furnace installation.
7. The furnace shall be installed so electrical components are protected from water.
8. A vertical downflow furnace without a coil, must use BAYBASE205 when installed on combustible flooring.
9. If the furnace is installed in a garage, it must be installed so that the burners, and the ignition source are located not less than 18 inches above the floor and the furnace must be located or protected to avoid physical damage from vehicles.
10. The gas furnace must not be located where excessive exposure to contaminated combustion air will result in safety and performance related problems. Avoid the following contaminants:
  - Permanent wave solutions
  - Chlorinated waxes and cleaners
  - Chlorine based swimming pool chemicals
  - Water softening chemicals
  - De-icing salts or chemicals
  - Carbon tetrachloride
  - Halogen type refrigerants
  - Cleaning solvents (such as perchloroethylene)
  - Printing inks, paint removers, varnishes, etc.
  - Hydrochloric acid, Cements and glues
  - Antistatic fabric softeners for clothes dryers
  - Masonry acid washing materials

**Important:** *The furnace must be installed level. The only allowable variation would be slightly to the left and/or forward in upflow or downflow installations or slightly toward the front in horizontal installations. This is necessary for proper condensate drainage.*



# Dimensional Data

Figure 2. Downflow cabinets — 17.5-inch, 21-inch, and 24.5-inch

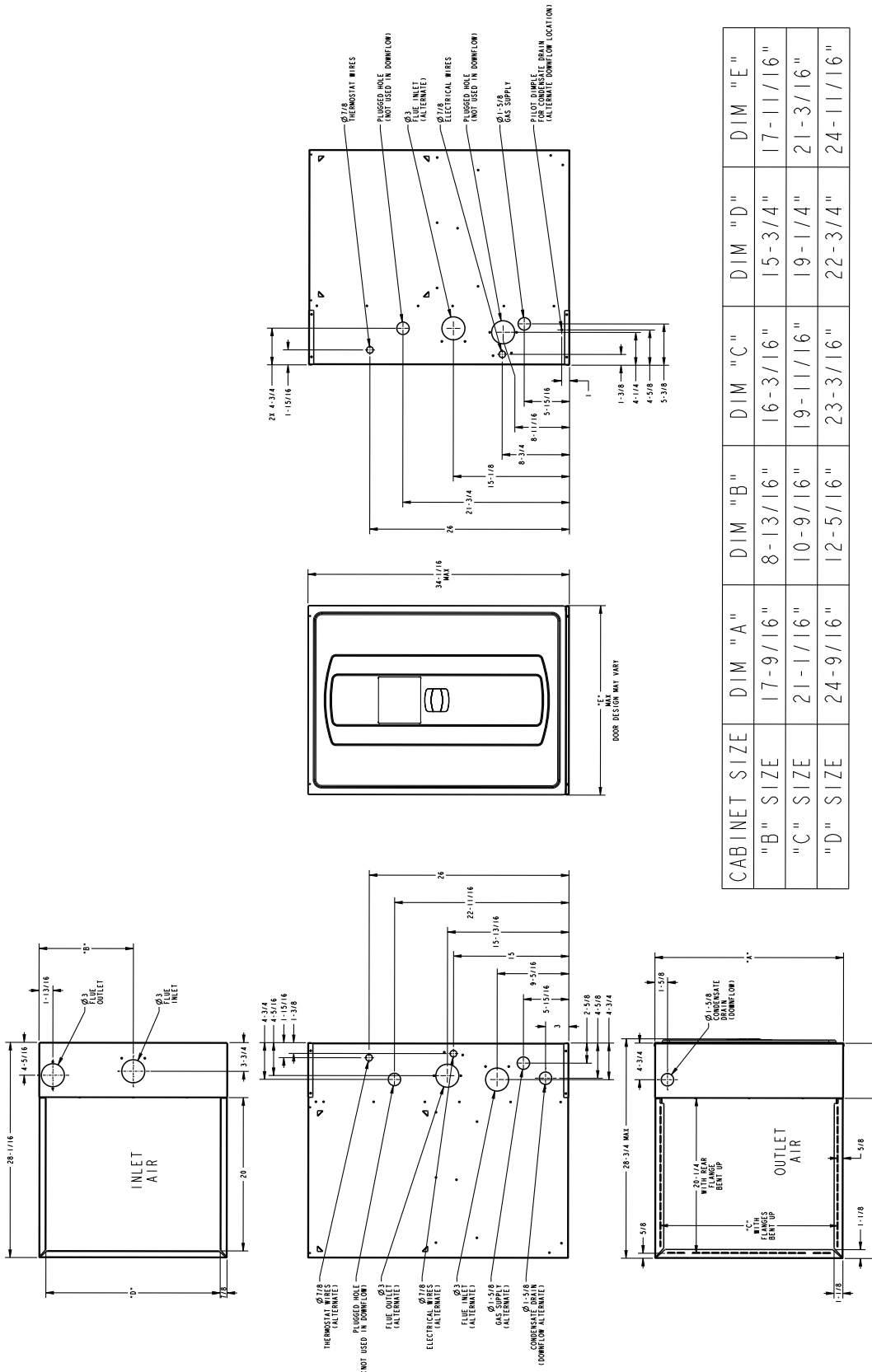

# Wiring Diagrams

Figure 3. Wiring diagram - A951X

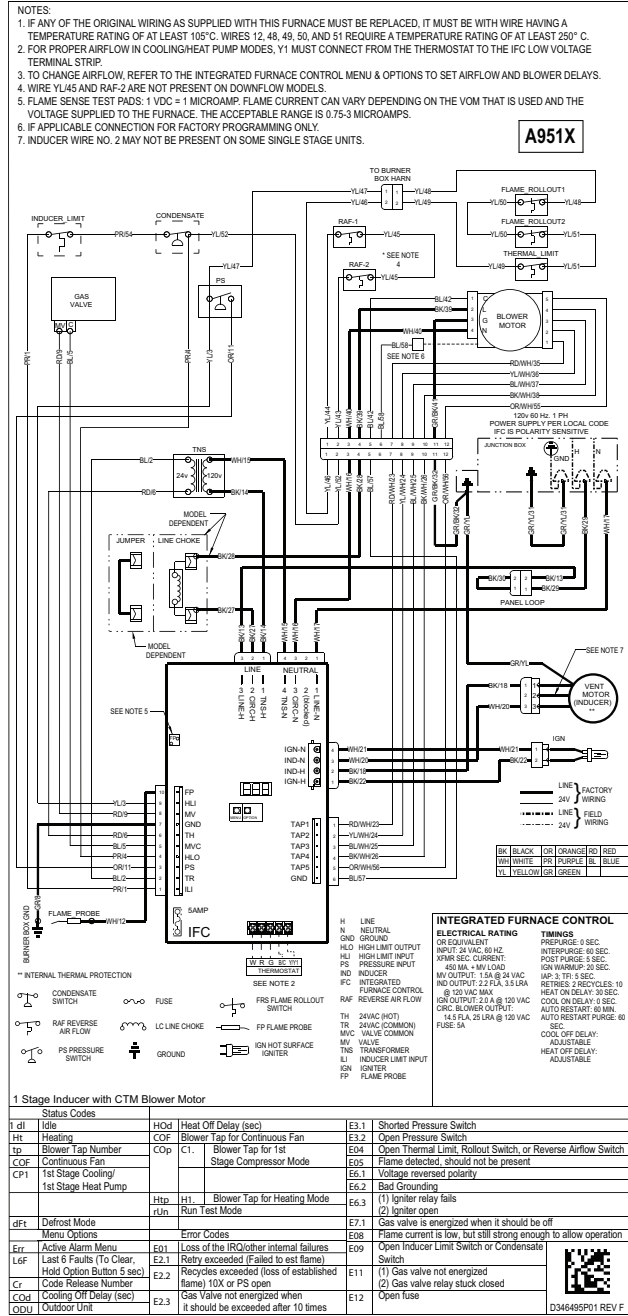
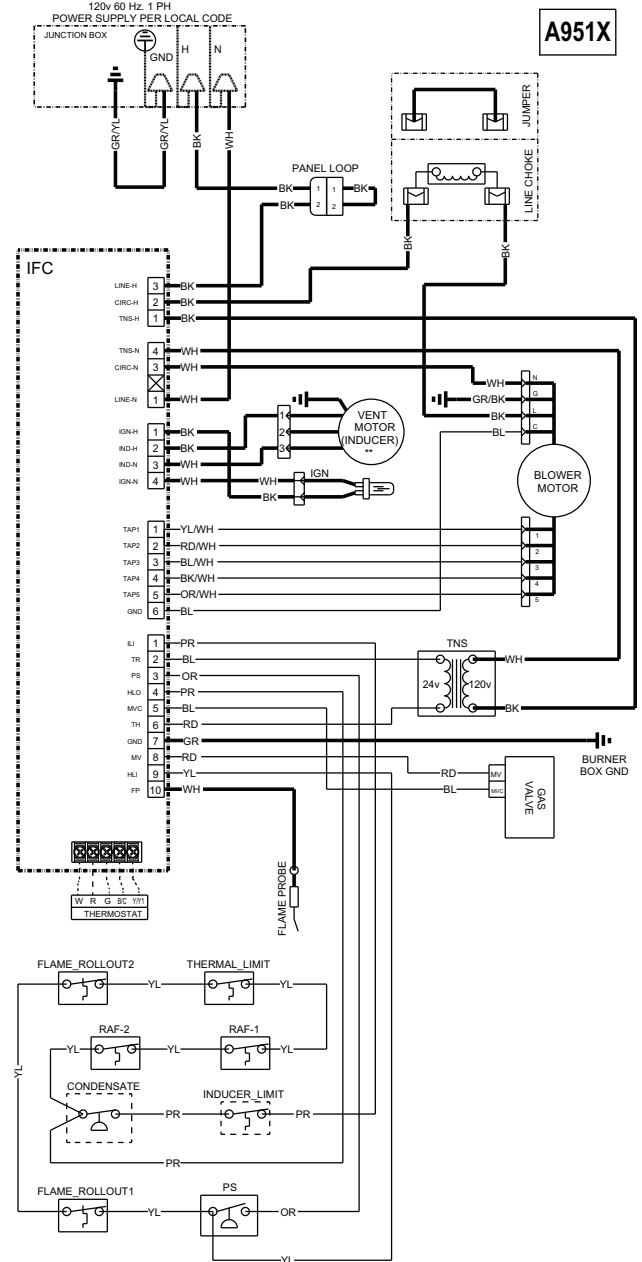

Figure 4. Ladder diagram - A951X



# Airflow Tables

## Upflow

**Table 7. A951X040BU3SAC furnace airflow**

Furnace Airflow (CFM) Vs. External Static Pressure (in. W.C.)							
Model	Tap		0.1	0.3	0.5	0.7	0.9
A951X040BU3SAC	1	SCFM / Watts	510 / 34	314 / 43	118 / 52	-	-
	2	SCFM / Watts	532 / 36	341 / 45	150 / 54	-	-
	3	SCFM / Watts	877 / 91	748 / 104	620 / 118	491 / 131	362 / 144
	4	SCFM / Watts	933 / 106	813 / 120	693 / 133	573 / 147	452 / 161
	5	SCFM / Watts	1056 / 140	950 / 156	843 / 172	737 / 188	631 / 204
	6	SCFM / Watts	1111 / 157	1009 / 174	908 / 190	806 / 207	705 / 223
	7	SCFM / Watts	1174 / 182	1078 / 199	983 / 216	887 / 233	791 / 251
	8	SCFM / Watts	1376 / 285	1297 / 305	1218 / 325	1140 / 344	1061 / 364
	9	SCFM / Watts	1512 / 382	1445 / 403	1378 / 424	1312 / 445	1245 / 466

**Table 8. A951X060BU4SAC furnace airflow**

Furnace Airflow (CFM) Vs. External Static Pressure (in. W.C.)							
Model	Tap		0.1	0.3	0.5	0.7	0.9
A951X060BU4SAC	1	SCFM / Watts	840 / 91	702 / 101	565 / 111	427 / 121	290 / 130
	2	SCFM / Watts	1001 / 137	893 / 149	786 / 162	678 / 174	571 / 186
	3	SCFM / Watts	1140 / 193	1051 / 207	963 / 221	875 / 235	786 / 249
	4	SCFM / Watts	1208 / 223	1128 / 238	1048 / 253	969 / 268	889 / 283
	5	SCFM / Watts	1299 / 270	1224 / 284	1148 / 298	1073 / 312	998 / 327
	6	SCFM / Watts	1413 / 343	1348 / 359	1283 / 375	1217 / 391	1152 / 406
	7	SCFM / Watts	1444 / 354	1380 / 370	1315 / 386	1251 / 403	1186 / 419
	8	SCFM / Watts	1727 / 612	1674 / 631	1622 / 650	1570 / 668	1518 / 687
	9	SCFM / Watts	1790 / 694	1741 / 712	1691 / 729	1642 / 747	1593 / 765

**Table 9. A951X080BU4SAC furnace airflow**

Furnace Airflow (CFM) Vs. External Static Pressure (in. W.C.)							
Model	Tap		0.1	0.3	0.5	0.7	0.9
A951X080BU4SAC	1	SCFM / Watts	911 / 94	766 / 104	622 / 115	477 / 125	332 / 136
	2	SCFM / Watts	1075 / 139	963 / 153	851 / 168	740 / 182	628 / 197
	3	SCFM / Watts	1215 / 185	1121 / 202	1028 / 219	934 / 236	840 / 253
	4	SCFM / Watts	1250 / 203	1164 / 221	1077 / 239	990 / 257	903 / 274
	5	SCFM / Watts	1349 / 251	1272 / 271	1194 / 291	1116 / 310	1039 / 330
	6	SCFM / Watts	1453 / 313	1387 / 335	1321 / 356	1254 / 378	1188 / 400
	7	SCFM / Watts	1505 / 340	1438 / 362	1372 / 384	1305 / 406	1239 / 427
	8	SCFM / Watts	1657 / 453	1597 / 477	1538 / 500	1479 / 524	1419 / 547
	9	SCFM / Watts	1878 / 669	1815 / 686	1752 / 702	1690 / 718	1627 / 735

Table 10. A951X080CU5SAC furnace airflow

Furnace Airflow (CFM) Vs. External Static Pressure (in. W.C.)							
Model	Tap		0.1	0.3	0.5	0.7	0.9
A951X080CU5SAC	1	SCFM / Watts	643 / 45	384 / 53	125 / 62	-	-
	2	SCFM / Watts	1125 / 126	982 / 142	838 / 158	694 / 174	551 / 190
	3	SCFM / Watts	1192 / 140	1038 / 157	884 / 174	730 / 191	576 / 208
	4	SCFM / Watts	1509 / 245	1377 / 268	1246 / 291	1115 / 314	983 / 337
	5	SCFM / Watts	1548 / 257	1428 / 281	1308 / 304	1187 / 328	1067 / 352
	6	SCFM / Watts	1602 / 320	1467 / 345	1331 / 371	1196 / 396	1061 / 421
	7	SCFM / Watts	1640 / 352	1512 / 379	1383 / 406	1255 / 433	1127 / 459
	8	SCFM / Watts	1831 / 521	1778 / 550	1726 / 579	1673 / 608	1621 / 637
	9	SCFM / Watts	2351 / 886	2278 / 918	2204 / 950	2131 / 982	2058 / 1014

Table 11. A951X100CU5SAC furnace airflow

Furnace Airflow (CFM) Vs. External Static Pressure (in. W.C.)							
Model	Tap		0.1	0.3	0.5	0.7	0.9
A951X100CU5SAC	1	SCFM / Watts	1013 / 104	847 / 116	680 / 129	514 / 142	348 / 155
	2	SCFM / Watts	1261 / 168	1126 / 185	990 / 202	854 / 219	718 / 236
	3	SCFM / Watts	1519 / 267	1407 / 290	1296 / 313	1184 / 336	1072 / 358
	4	SCFM / Watts	1554 / 283	1446 / 307	1337 / 330	1229 / 353	1120 / 377
	5	SCFM / Watts	1749 / 385	1651 / 411	1554 / 436	1457 / 462	1359 / 488
	6	SCFM / Watts	1868 / 464	1778 / 491	1688 / 519	1599 / 546	1509 / 574
	7	SCFM / Watts	2018 / 573	1936 / 602	1853 / 631	1770 / 660	1688 / 689
	8	SCFM / Watts	2191 / 718	2112 / 750	2033 / 782	1954 / 815	1875 / 847
	9	SCFM / Watts	2395 / 966	2303 / 981	2212 / 996	2120 / 1012	2028 / 1027

Table 12. A951X120DU5SAC furnace airflow

Furnace Airflow (CFM) Vs. External Static Pressure (in. W.C.)							
Model	Tap		0.1	0.3	0.5	0.7	0.9
A951X120DU5SAC	1	SCFM / Watts	707 / 46	443 / 55	179 / 64	-	-
	2	SCFM / Watts	1344 / 163	1218 / 183	1092 / 202	966 / 222	840 / 241
	3	SCFM / Watts	1532 / 225	1419 / 247	1307 / 268	1195 / 290	1083 / 312
	4	SCFM / Watts	1584 / 247	1477 / 270	1370 / 292	1263 / 315	1156 / 338
	5	SCFM / Watts	1915 / 401	1818 / 428	1722 / 454	1625 / 480	1529 / 506
	6	SCFM / Watts	2104 / 525	2016 / 553	1927 / 582	1839 / 610	1750 / 639
	7	SCFM / Watts	2132 / 546	2045 / 575	1958 / 604	1870 / 633	1783 / 662
	8	SCFM / Watts	2410 / 833	2328 / 868	2247 / 903	2165 / 937	2084 / 972
	9	SCFM / Watts	2472 / 909	2401 / 944	2329 / 979	2257 / 1013	2186 / 1048

## Downflow

Table 13. A951X040BD3SAC furnace airflow

Furnace Airflow (CFM) Vs. External Static Pressure (in. W.C.)							
Model	Tap		0.1	0.3	0.5	0.7	0.9
A951X040BD3SAC	1	SCFM / Watts	378 / 28	153 / 32	-	-	-
	2	SCFM / Watts	514 / 35	330 / 45	145 / 55	- / 64	- / 74
	3	SCFM / Watts	765 / 69	618 / 81	471 / 93	324 / 105	178 / 116
	4	SCFM / Watts	827 / 81	691 / 94	554 / 106	418 / 119	281 / 132
	5	SCFM / Watts	988 / 124	879 / 140	770 / 156	661 / 171	553 / 187
	6	SCFM / Watts	1085 / 156	986 / 173	887 / 190	787 / 207	688 / 224
	7	SCFM / Watts	1125 / 170	1030 / 188	934 / 205	839 / 222	743 / 239
	8	SCFM / Watts	1129 / 170	1035 / 187	941 / 204	847 / 221	753 / 239
	9	SCFM / Watts	1492 / 369	1419 / 390	1346 / 411	1273 / 431	1200 / 452

## Airflow Tables

**Table 14. A951X060BD3SAC furnace airflow**

Furnace Airflow (CFM) Vs. External Static Pressure (in. W.C.)							
Model	Tap		0.1	0.3	0.5	0.7	0.9
A951X060BD3SAC	1	SCFM / Watts	624 / 47	451 / 57	277 / 68	104 / 79	-
	2	SCFM / Watts	866 / 89	734 / 102	602 / 116	470 / 129	338 / 142
	3	SCFM / Watts	949 / 113	833 / 128	718 / 142	602 / 156	486 / 171
	4	SCFM / Watts	1122 / 165	1025 / 182	928 / 200	831 / 217	733 / 235
	5	SCFM / Watts	1178 / 191	1087 / 209	996 / 227	905 / 246	814 / 264
	6	SCFM / Watts	1260 / 233	1180 / 252	1100 / 271	1021 / 290	941 / 309
	7	SCFM / Watts	1370 / 296	1299 / 316	1228 / 336	1158 / 355	1087 / 375
	8	SCFM / Watts	1480 / 365	1416 / 387	1352 / 408	1287 / 429	1223 / 450
	9	SCFM / Watts	1504 / 384	1440 / 406	1376 / 427	1312 / 449	1249 / 470

**Table 15. A951X080BD4SAC furnace airflow**

Furnace Airflow (CFM) Vs. External Static Pressure (in. W.C.)							
Model	Tap		0.1	0.3	0.5	0.7	0.9
A951X080BD4SAC	1	SCFM / Watts	499 / 36	306 / 43	113 / 49	-	-
	2	SCFM / Watts	1017 / 143	922 / 158	828 / 173	734 / 188	640 / 203
	3	SCFM / Watts	1119 / 176	1029 / 192	940 / 207	850 / 223	761 / 239
	4	SCFM / Watts	1205 / 215	1125 / 233	1044 / 250	964 / 268	883 / 285
	5	SCFM / Watts	1237 / 231	1160 / 250	1083 / 268	1006 / 286	928 / 305
	6	SCFM / Watts	1378 / 315	1309 / 334	1240 / 354	1172 / 373	1103 / 393
	7	SCFM / Watts	1453 / 360	1389 / 380	1324 / 399	1260 / 419	1195 / 439
	8	SCFM / Watts	1618 / 496	1562 / 518	1505 / 540	1449 / 561	1392 / 583
	9	SCFM / Watts	1794 / 682	1742 / 704	1691 / 726	1639 / 748	1587 / 770

**Table 16. A951X100CD5SAC furnace airflow**

Furnace Airflow (CFM) Vs. External Static Pressure (in. W.C.)							
Model	Tap		0.1	0.3	0.5	0.7	0.9
A951X100CD5SAC	1	SCFM / Watts	1002 / 103	823 / 117	644 / 130	465 / 144	285 / 157
	2	SCFM / Watts	1385 / 223	1276 / 243	1167 / 264	1057 / 284	948 / 304
	3	SCFM / Watts	1527 / 286	1430 / 310	1333 / 333	1236 / 357	1139 / 380
	4	SCFM / Watts	1610 / 328	1516 / 352	1421 / 377	1326 / 401	1231 / 425
	5	SCFM / Watts	1761 / 433	1677 / 459	1593 / 486	1509 / 512	1425 / 538
	6	SCFM / Watts	1861 / 492	1783 / 520	1706 / 549	1628 / 577	1551 / 605
	7	SCFM / Watts	1984 / 548	1902 / 577	1820 / 606	1738 / 635	1656 / 663
	8	SCFM / Watts	2173 / 728	2097 / 760	2020 / 792	1944 / 824	1867 / 856
	9	SCFM / Watts	2342 / 945	2269 / 973	2196 / 1002	2123 / 1031	2050 / 1060

**Table 17. A951X120DD5SAC furnace airflow**

Furnace Airflow (CFM) Vs. External Static Pressure (in. W.C.)							
Model	Tap		0.1	0.3	0.5	0.7	0.9
A951X120DD5SAC	1	SCFM / Watts	680 / 47	419 / 56	159 / 66	-	-
	2	SCFM / Watts	1025 / 237	1063 / 259	1101 / 282	1139 / 304	1177 / 327
	3	SCFM / Watts	1566 / 268	1461 / 292	1357 / 316	1253 / 340	1149 / 363
	4	SCFM / Watts	1803 / 393	1711 / 420	1619 / 446	1527 / 472	1435 / 498
	5	SCFM / Watts	1891 / 445	1801 / 472	1711 / 500	1621 / 527	1532 / 555
	6	SCFM / Watts	2132 / 568	2025 / 601	1919 / 633	1812 / 666	1705 / 698
	7	SCFM / Watts	2154 / 644	2068 / 675	1982 / 705	1896 / 736	1810 / 766
	8	SCFM / Watts	2344 / 837	2267 / 870	2190 / 902	2113 / 934	2035 / 967
	9	SCFM / Watts	2414 / 896	2333 / 928	2251 / 961	2170 / 993	2088 / 1026

# CFM Versus Temperature Rise

**Table 18. Heating table — upflow**

CFM VS. Temperature Rise																		
Model	CFM (Cubic Feet Per Minute)																	
	600	700	800	900	1000	1100	1200	1300	1400	1500	1600	1700	1800	1900	2000	2100	2200	2300
A951X040BU3SAC	60	51	45	40	36	33	30	—	—	—	—	—	—	—	—	—	—	—
A951X060BU4SAC	—	—	—	60	54	49	45	42	39	36	34	32	30	—	—	—	—	—
A951X080BU4SAC	—	—	—	—	72	65	60	55	51	48	45	—	—	—	—	—	—	—
A951X080CU5SAC	—	—	—	—	—	65	60	55	51	48	45	42	40	—	—	—	—	—
A951X100CU5SAC	—	—	—	—	—	—	—	68	63	59	55	52	49	47	44	42	40	—
A951X120CU5SAC	—	—	—	—	—	—	—	—	—	—	66	63	59	56	53	51	48	46

**Table 19. Heating table — downflow**

CFM VS. Temperature Rise																		
Model	CFM (Cubic Feet Per Minute)																	
	600	700	800	900	1000	1100	1200	1300	1400	1500	1600	1700	1800	1900	2000	2100	2200	2300
A951X040BD3SAC	60	51	45	40	36	33	30	—	—	—	—	—	—	—	—	—	—	—
A951X060BD3SAC	—	—	—	60	54	49	45	42	39	36	—	—	—	—	—	—	—	—
A951X080BD4SAC	—	—	—	—	71	64	59	55	51	47	—	—	—	—	—	—	—	—
A951X100CD5SAC	—	—	—	—	—	—	—	69	64	60	56	53	50	47	45	43	41	—
A951X120DD5SAC	—	—	—	—	—	—	—	—	—	71	66	63	59	56	53	51	48	46

# Furnace General Installation

The following sections give general instructions for the installation of the gas furnaces.

**Note:** For the A951X furnace, a 1/4-inch nut driver is required to remove the two screws at the top of the front panel. The front panel can then be removed by lifting upwards.

## Horizontal Installation in an Attic or Crawlspace

The upflow condensing furnace may be installed in an attic or crawl space in the horizontal let or right position for needed airflow direction. The horizontal furnace installation in an attic should be on a service platform large enough to allow for proper clearances on all sides and service access to the front of the furnace. See “the Locations and Clearance section,” p. 16. Line contact is only permissible between lines formed by intersections of the top and two sides of the furnace casing and building joists, studs, or framing.

The furnace may be placed horizontally in a crawl space on a pad or other noncombustible material which will raise the unit for sufficient protection from moisture.

The furnace must be supported at both ends when installed horizontally. The Furnace must also be elevated approximately 6 inches to allow clearance for the condensate drain to exit the cabinet in the horizontal position.

**Figure 5. Horizontal installation**

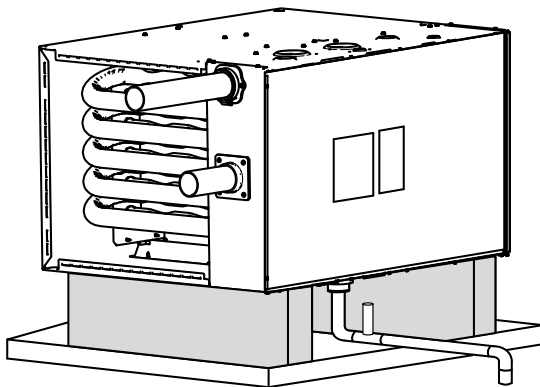

FURNACE MUST BE SUPPORTED AT ALL FOUR CORNERS. BAYHANG - OPTIONAL HORIZONTAL HANGING BRACKET KIT TO APPROVED OPEN / VENTED DRAIN

**Note:** The overflow stand pipe termination must be even with or slightly below the bottom of the condensate trap.  
**Note:** Water from the overflow pipe must drain into the emergency drain pan.

## Horizontal Installation Hanging Using Straps

The furnace may be installed hanging in a hanging position using straps. The furnace should be supported at both ends and have an additional support in the center of the furnace in front.

**Figure 6. Horizontal installation — hanging straps**

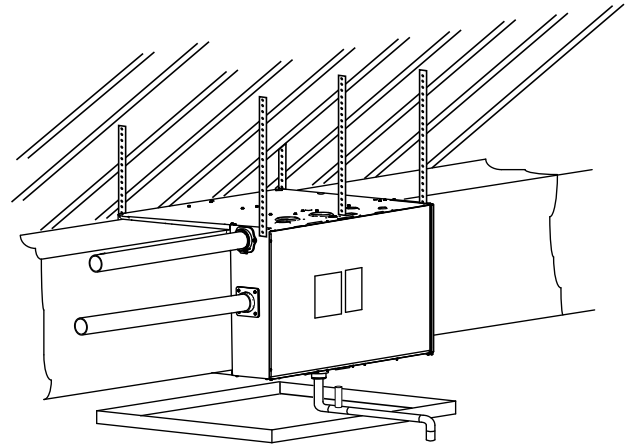

## Gas Piping

**Important:** When converting the gas piping from the factory default, the plug must be removed from the new gas piping location and swapped with the grommet from the default location. The upflow furnace default is left side gas piping. The downflow furnace default is right side gas piping.

**Figure 7. Upflow furnace with gas piping on left side**

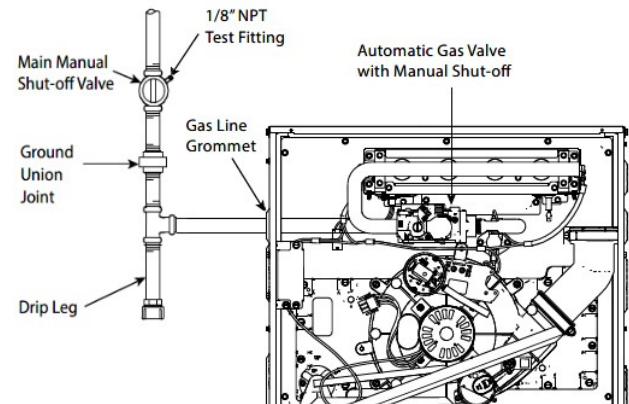

Figure 8. Upflow furnace with gas piping on right side

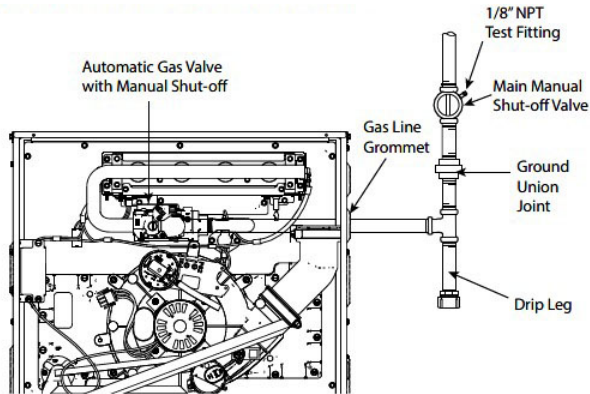

Figure 9. Downflow furnace with gas piping on left side

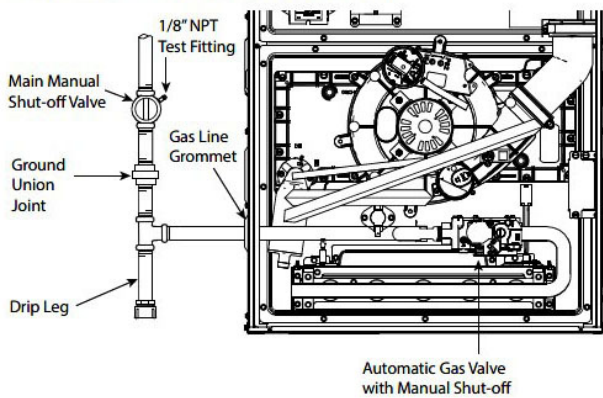

Figure 10. Downflow furnace with gas piping on right side

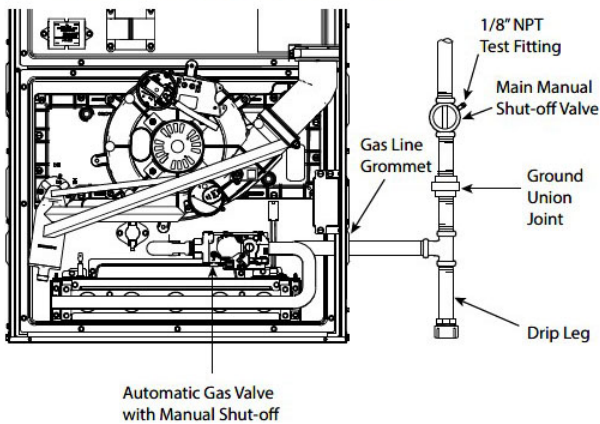

Figure 11. Horizontal left furnace with gas piping out left side

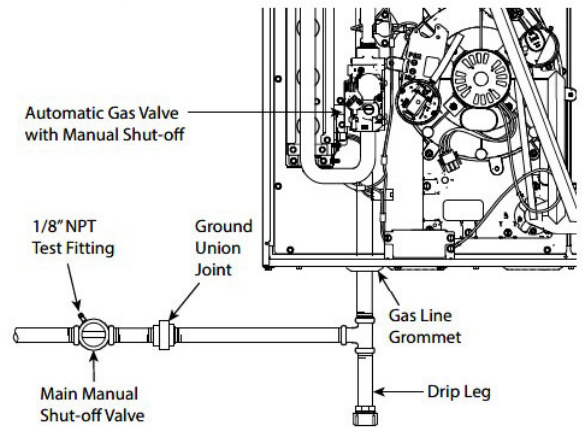

Figure 12. Horizontal left furnace with gas piping out right side

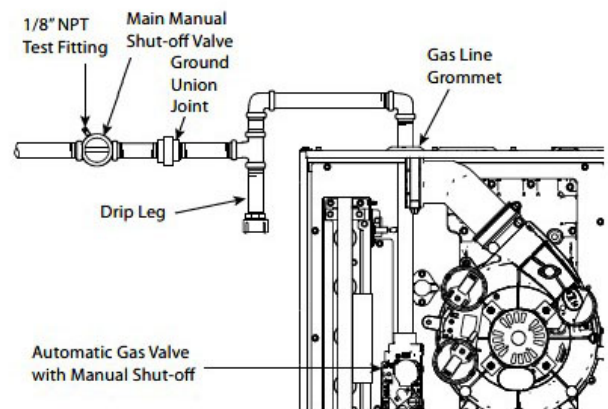
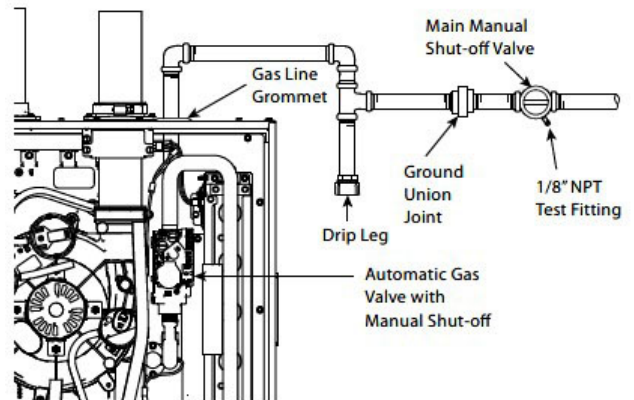
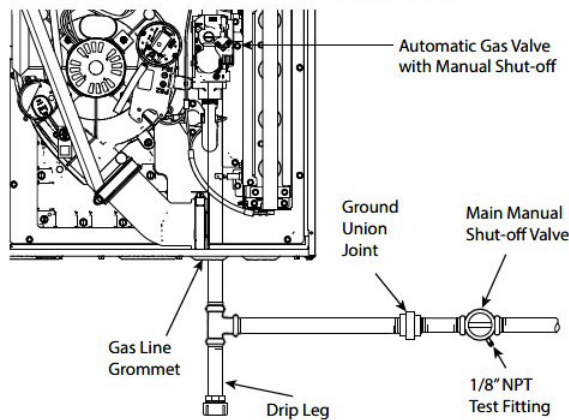

Figure 13. Horizontal right furnace with gas piping out left side



## Furnace General Installation

**Figure 14. Horizontal right furnace with gas piping out right side**



The upflow/horizontal furnace is shipped standard for left side installation of gas piping. An opening with plug is provided on the right side for an alternate gas piping arrangement.

The installation of piping shall be in accordance with piping codes and the regulations of the local gas company. Pipe joint compound must be resistant to the chemical reaction with liquefied petroleum gases.

**Important:** If local codes allow the use of flexible gas appliance connector, always use a new listed connector. Do not use a connector which has previously serviced another gas appliance.

Refer to the piping table for delivery sizes. Connect gas supply to the unit, using a ground joint union and a manual shut-off valve. National codes require a condensation drip leg to be installed ahead of the gas valve.

The furnace and its individual shut-off valve must be disconnected from the gas supply piping system during any pressure testing of that system at test pressures in excess of 1/2 psig (3.5 kPa).

The furnace must be isolated from the gas supply piping by closing its individual manual shut-off valve during any pressure testing of the gas supply piping system at test pressures equal to or less than 1/2 psig (3.5 kPa).

**Note:** Maximum pressure to the gas valve for natural gas is 13.8" W.C. Minimum pressure is 5.0" W.C. Maximum pressure to the gas valve for propane is 13.8" W.C. Minimum pressure is 11.0" W.C.

**Table 20. Cubic feet per hour of gas for various pipe sizes and lengths (natural gas only)**

Pipe size	Length of pipe						
	10	20	30	40	50	60	70
1/2	131	90	72	62	55	50	46
3/4	273	188	151	129	114	104	95
1	514	353	284	243	215	195	179
1-1/4	1060	726	583	499	442	400	368

**Note:** This table is based on Pressure Drop of 0.3 inch W.C. and 0.6 SP. GR. Gas

All gas fittings must be checked for leaks using a soapy solution before lighting the furnace. **DO NOT CHECK WITH AN OPEN FLAME!**

For propane conversions on all S-Series Furnaces, use BAYLPSS400\* conversion kit with stainless steel burners.

When installing our furnaces in a manufactured house, use Manufactured Housing Accessory Kit, BAYMFGH200B.

**Table 21. Orifice sizes**

Input Rating (BTUH)	Number of burners	Main Burner Orifice Drill Size	
		Nat. Gas	Propane Gas
40,000	2	45	56
60,000	3	45	56
80,000	4	45	56
100,000	5	45	56
120,000	6	45	56

## Combustion and Input Check

1. Make sure all gas appliances are off except the furnace.
2. Clock the gas meter with the furnace operating (determine the dial rating of the meter) for one revolution.
3. Match the "Sec" column in the gas flow table with the time clocked.
4. Read the "Flow" column opposite the number of seconds clocked.
5. Use the following factors if necessary:
  - a. For 1 Cu. Ft. Dial Gas Flow CFH = Chart Flow Reading ÷ 2
  - b. For 1/2 Cu Ft. Dial Gas Flow CFH = Chart Flow Reading ÷ 4
  - c. For 5 Cu. Ft. Dial Gas Flow CFH = 10X Chart Flow Reading ÷ 4
6. Multiply the final figure by the heating value of the gas obtained from the utility company and compare to the nameplate rating. This must not exceed the nameplate rating.

**Table 22. Gas flow in cubic feet per hour**

2 Cubic Foot Dial							
Sec.	Flow	Sec.	Flow	Sec.	Flow	Sec.	Flow
30	244	46	159	64	114	100	73
31	236	47	156	66	111	104	70
32	229	48	153	68	108	108	68
33	222	49	149	70	105	112	65
34	215	50	146	72	102	116	63
35	209	51	144	74	99	120	61
36	203	52	141	76	96	130	56
37	198	53	138	78	94	140	52
38	193	54	136	80	92	150	49
39	188	55	133	82	89	160	46
40	183	56	131	84	87	170	43
41	179	57	128	86	85	180	41
42	174	58	126	88	83	190	39
43	170	59	124	90	81	200	37
44	166	60	122	94	78	—	—
45	163	62	118	98	75	—	—

Note: Excerpted from NFPA 54/ANSI Z223.1 Table A.11.1.1

### Gas Valve Adjustment

Changes can be made by adjusting the manifold pressure, or changing orifices (orifice change may not always be required). To adjust the manifold pressure:

1. Turn off all electrical power to the system.
2. Loosen (Do Not remove) the pressure tap test set screw one turn with 3/32-inch hex wrench.
  - a. The pressure tap adjustment kit (KIT07611) contains a 3/32-inch hex wrench, a 5/16-inch hose and a connector and can be ordered through Global Parts.
3. Attach a manifold pressure gauge with flexible tubing to the outlet pressure boss marked "OUT P" on White-Rodgers gas valve model 36J.
4. Turn on system power with NO call for heat.
5. Adjust 1st stage gas heat by removing the low (LO) adjustment regulator cover screw.
  - a. To increase outlet pressure, turn the regulator adjust screw clockwise.
  - b. To decrease outlet pressure, turn the regulator adjust screw counterclockwise.
  - c. Adjust regulator until pressure shown on manometer matches the pressure specified in the table.

The input of no more than nameplate rating and no less than 93% of the nameplate rating, unless the unit is derated for high altitude.

- d. Replace and tighten the regulator cover screw securely.
6. Cycle the valve several times to verify regulator setting.
  - a. Repeat steps Step 5.through Step 7. if needed.
7. Turn off all electrical power to the system.
8. Remove the manometer and flexible tubing and tighten the pressure tap screw.
9. Using a leak detection solution or soap suds, check for leaks at the pressure outlet boss and pressure tap test screw.
10. Turn on system power and check operation of the unit.

**Figure 15. Gas valve adjustment**

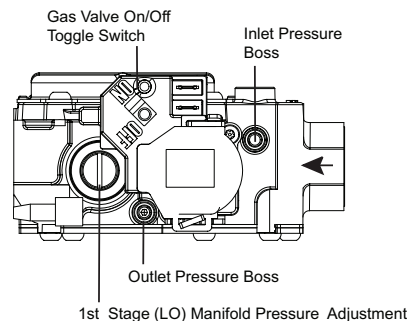

## Furnace General Installation

**Table 23. Fuel manifold pressure settings (inches w. c.)**

	Natural Gas	Propane Gas
Maximum	13.8	13.8
Minimum	5	11
Manifold pressure setting (inches w.c.)		
All models	3.5	10

### High Altitude Derate

Input ratings (BTUH) of these Furnaces are based on sea level operation and should not be changed at elevations up to 2,000 ft. (610 m).

If the installation is 2,000 ft. (610 m) or above, the Furnace input rate (BTUH) shall be reduced 4% for each 1,000 ft. above sea level.

Installations of this furnace at altitudes above 2,000 ft. (610 m) shall be made utilizing the Vent Length table and/or Part Numbers for Replacement Orifices table in these installation instructions.

The Furnace input rate shall be checked by clocking the gas flow rate (CFH) and multiplying by the heating value obtained from the local utility supplier for the gas being delivered at the installed altitude. Input rate changes can be made by adjusting the Manifold Pressure (min 3.0 - max 3.7 in. W.C. - Natural Gas) or changing orifices (orifice change may not always be required).

If the desired input rate can not be achieved with a change in Manifold Pressure, then the orifices must be changed. Propane installations will require an orifice change.

**Important:** *Reinstall the replacement orifices to the same depth as the orifices supplied with the equipment.*

See the table for help in selecting orifices if orifice change is required. Furnace input rate and temperature rise should be checked again after changing orifices to confirm the proper rate for the altitude.

**Table 25. Main burner orifices**

Orifice Twist Drill Size If Installed at Sea Level	Altitude Above Sea Level and Orifice Required at Other Elevations								
	2000	3000	4000	5000	6000	7000	8000	9000	10000
42	42	43	43	43	44	44	45	46	47
43	44	44	44	45	45	46	47	47	48
44	45	45	45	46	47	47	48	48	50
45	46	47	47	47	48	48	49	49	50
46	47	47	47	48	48	49	49	50	51
47	48	48	49	49	49	50	50	51	52
54	54	55	55	55	55	55	56	56	56
55	55	55	55	56	56	56	56	56	57

The vent length table shows the required vent lengths for installations at various altitudes. Optional high altitude kits are available for installations over 5000 feet. Installations above 12,000 feet are not allowed.

Turn the main Gas Valve toggle switch within the unit to the "OFF" position. Turn the external gas valve to "ON". Purge the air from the gas lines. After purging, check all gas connections for leaks with a soapy solution – **DO NOT CHECK WITH AN OPEN FLAME.** Allow 5 minutes for any gas that might have escaped to dissipate.

Propane Gas being heavier than air may require forced ventilation. Turn the toggle switch on the Gas Valve in the unit to the "ON" position.

**Table 24. Part numbers for replacement orifices**

Drill Size	Part Number	Drill Size	Part Number
44	ORF00501	54	ORF00555
45	ORF00644	55	ORF00693
—	—	56	ORF00907
47	ORF00910	—	—
—	—	58	ORF01338
49	ORF00503	59	ORF01339

**Note:** If 46, 48, 50, or 57 orifice is required, use the next smaller drill size and reduce the manifold pressure to achieve rate.

The table lists the main burner orifices used with the furnace. If a change of orifices is required to correct the furnace input rating refer to the part number for replacement orifices table.

Installation of this furnace at altitudes above 2000 ft (610m) shall be in accordance with local codes, or in the absence of local codes, the *National Fuel Gas Code, ANSI Z223.1/ NFPA 54* or *National Standard of Canada, Natural Gas and Propane Installation Code, CSA B149.1*. Installation of this furnace at altitudes above 2,000 ft (610 m) shall be made in accordance with the listed high altitude conversion kit available with the furnace.

**Table 25. Main burner orifices (continued)**

Orifice Twist Drill Size If Installed at Sea Level	Altitude Above Sea Level and Orifice Required at Other Elevations								
	2000	3000	4000	5000	6000	7000	8000	9000	10000
56	56	56	57	57	57	58	59	59	60
57	58	59	59	60	60	61	62	63	63
58	59	60	60	61	62	62	63	63	64

*Note: From National Fuel Gas Code — Table E.1.1(d)*

## General Venting

Furnace exhaust must be vented to the outdoors. These furnaces are induced draft vented and must not be connected to any vent serving another appliance. Please note that these furnaces use positive-pressure vent systems.

Proper venting is essential to obtain maximum efficiency from a condensing furnace. Proper installation of the vent system is necessary to assure drainage of the condensate and prevent deterioration of the vent system.

ETL has certified the design of condensing furnaces for a minimum of 0-inch clearance from combustible materials to single wall plastic vent pipe.

The recommended system is assembled from 2-inch or 3-inch plastic pipe and fittings found in the [“Attaching Vent Piping,”](#) p. 32. Where the system is routed to the outdoors through an existing masonry chimney containing flue products from another gas appliance, or where required by local codes, then 3-inch venting of Type 29- 4C stainless steel must be used in place of PVC material.

These Furnaces have been classified as Category IV Furnaces in accordance with ANSI Z21.47 “latest edition” standards. Category IV - a central furnace that operates with a positive vent static pressure and with a flue loss less than 17 percent. These conditions require special venting systems, which must be gas tight and water tight.

**Note:** *When an existing Furnace is removed from a venting system serving other gas appliances, the venting system is likely to be too large to properly vent the remaining attached appliances.*

### Important:

- *These Furnaces may be installed as Direct Vent (sealed combustion) or as Nondirect Vent (single pipe). The Furnaces are shipped Direct Vent with sealed combustion.*
- *Products installed in Canada must use vent systems that are certified to the Standard for Type BH Gas Venting Systems (ULC S636) for Class II-A venting systems (up to 65°C). Components of the vent system must not be interchanged with other vent systems or unlisted pipe or fittings. Plastic components, specified primers, and glues must be from a single system manufacturer and not intermixed with other system manufacturer’s vent system parts. In addition, the first three feet of the vent pipe must be visible for inspection.*

When the vent pipe is exposed to temperatures below freezing, that is, when it passes through unheated spaces, the pipe must be insulated with 1/2-inch (12.7 mm) thick Armaflex-type insulation or equal.

If the space is heated sufficiently to prevent freezing, then the insulation will not be required. If domestic water pipes are not protected from freezing then the space meets the condition of a heated space.

## 3-Inch Venting Requirements

### Important:

- *To determine if your application requires 3-inch venting, see the [“Maximum Vent Length,”](#) p. 34.*
- *Horizontal venting application must use the 2-inch x 3-inch offset reducing coupling. Vertical venting applications do not require the reducing coupling to be offset.*

# Furnace General Installation

## Notes:

- If your furnace comes with a factory supplied 2-inch x 3-inch offset reducing coupling it is used for 3-inch vent pipe installation. Make sure the marking "TOP" is located on the top side of the pipe in horizontal venting applications. The straight side of the coupling must be on bottom for proper drainage of condensate.
- For Canadian applications, BAYREDUCE 2-inch x 3-inch offset reducing coupling meets ULC-S636 requirements. Make sure the marking "TOP" is located on the top side of the pipe. The straight side of the coupling must be on bottom for proper drainage of condensate in horizontal venting.

**Figure 16. Horizontal coupling**

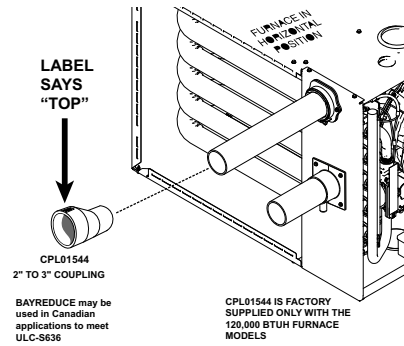

**Figure 17. Vertical coupling**

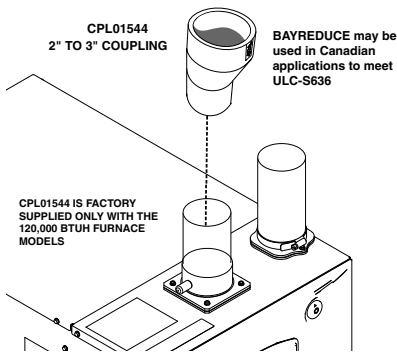

## Typical Venting

This combustion air intake has a built-in condensate collection system. Condensate that may collect is drained by field supplied 1/2-inch ID tubing. The tubing must be routed to form a trap and water seal (see Figure 19, p. 30, Figure 20, p. 30, and Figure 21, p. 31).

A field supplied hose clamp is recommended but not required. The tubing is not under pressure.

Combustion air piping must be square cut and de-burred for proper drainage. For side entry combustion inlet applications, ensure the drain is pointed downwards.

**Figure 18. Condensing furnace vent**



**Figure 19. Upflow top entry**

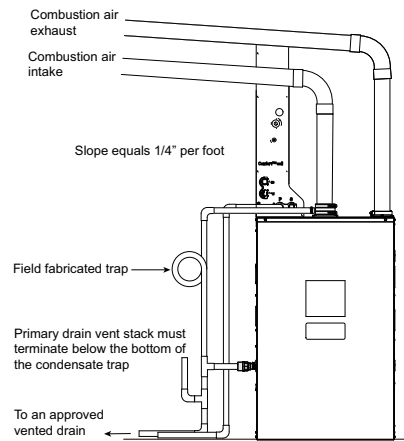

**Figure 20. Horizontal top entry**

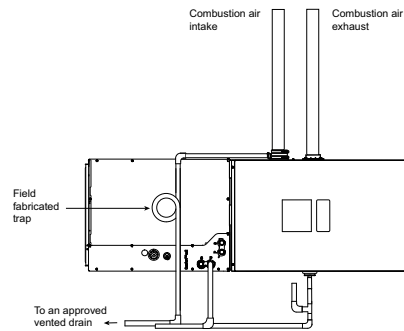

Figure 21. Upflow side entry

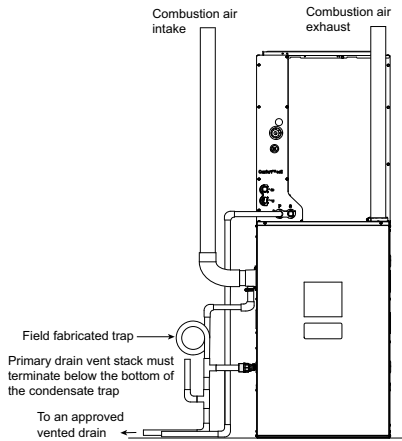
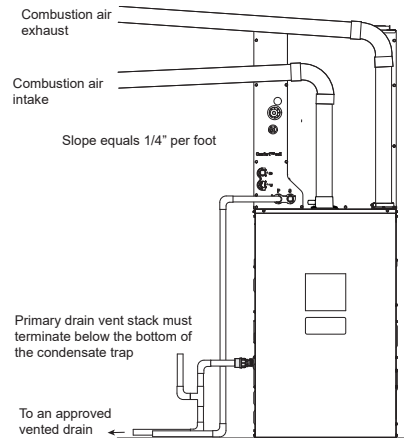

Figure 22. Option 1



## Special Case Venting

### Special instructions for direct vent furnace air intake.

In certain applications, particularly when the furnace is located in a basement, there are certain conditions that can be met where warm humid air from the outside is drawn into combustion air piping. If the area where the piping is located is conditioned below 70° F, condensation could occur inside the piping and ultimately drain into the furnace compartment, which could lead to premature component failure.

**Note:** Inlet air piping is not considered to be part of the venting system. The inlet air piping may be made from PVC.

We recommend following one of the options to prevent this condition from occurring and possibly damaging components within the furnace:

#### Option 1

If possible, slope the inlet combustion air piping away from the furnace. Condensation that may occur will now drain outside of the home. The combustion air outlet piping must remain sloped back to the furnace.

**Note:** Combustion air drain fitting must remain capped if not using the drain function. See “Condensate Drain Instructions,” p. 51 section.

#### Option 2

If sloping the combustion air intake pipe is not possible, install a DWV Tee as close to the furnace as possible with drain and trap to prevent condensation from occurring in the furnace cabinet. Do not tee AC condensate and combustion air condensate trap together.

**Note:** Combustion air drain fitting must remain capped if not using the drain function. See “Condensate Drain Instructions,” p. 51 section.

Figure 23. Option 2

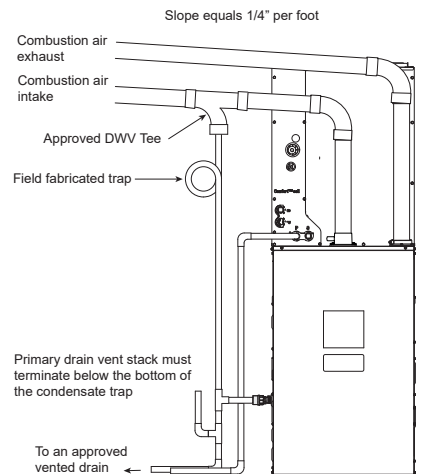

#### Option 3

If sloping the combustion air intake pipe is not possible, install an approved DWV Tee as close to the furnace as possible with drain and trap.

**Note:** Combustion air drain fitting must remain capped if not using the drain function. See “Condensate Drain Instructions,” p. 51 section.

**Figure 24. Option 3**

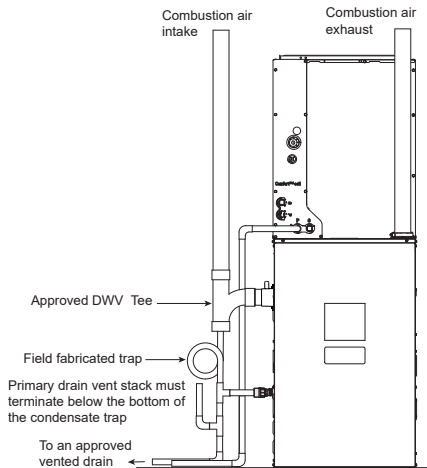

## Vent Terminations

**Direct Vent Application:** The Furnaces must be vented to the exterior of the house and combustion air must come through the inlet air pipe from outside air.

**Note:** BAYVENT\* accessories can be used for inlet and outlet terminals when the pipes do not exit the structure together. For Canadian applications, venting systems must meet ULC-S636 requirements.

**Non-direct Vent Application:** The Furnace shall be vented to the exterior of the house, but combustion air may enter from the surrounding area as long as combustion air requirements are met. (See “Air for Combustion and Ventilation,” p. 40)

Vent terminations.

- BAYVENT200B
- BAYAIR30AVENTA

Vent terminations — Canadian applications. Meets ULC-S636 requirements.

- BAYVENTCN200B
- BAYAIR30CNVENT

### Furnace Vent / Inlet Pipe Installation in Two Pressure Zone Configurations are not allowed

**Note:** For single pressure zone applications, see the Horizontal Venting section.

The following are examples only.

**Note:** If only the flue gas pipe is to the outside of the structure, a straight section of pipe (long enough to exit the furnace cabinet) must be attached to the inlet air side with an elbow (which is 5 to 10 equiv. ft.) installed on the end to prevent dust and debris from falling directly into the furnace.

**Example 1:** shows the vent pipe exhausting through the roof and the inlet air coming from the interior of the house. The inlet air coming from the interior of the house must meet combustion requirements for area as shown in “Air for Combustion and Ventilation,” p. 40.

**Figure 25. Example 1**

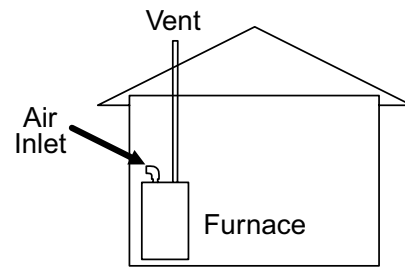

**Example 2:** shows the inlet air may come from the attic if the requirements for combustion air are met as shown in “Air for Combustion and Ventilation,” p. 40. The inlet air does not have to come from outside the structure.

**Figure 26. Example 2**

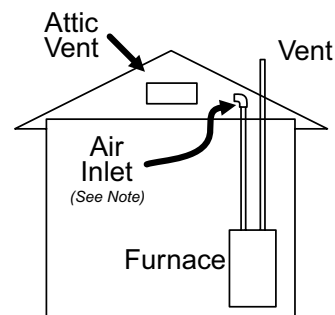

## Attaching Vent Piping

### Vent Fitting Material — Plastic

Gas and liquid tight single wall vent fittings, designed for resistance to corrosive flue condensate, MUST be used throughout.

Listed in the Approved Vent Pipe Materials table are designations for different types of 2-inch and 3-inch size pipe and fittings that meet these requirements. The materials listed are various grades of PVC, CPVC, ABS, PolyPro® by DuraVent, Z-Dens by Novaflex Group, Innoflue® by Centrotherm, ECCO™ polypropylene venting system, and PolyFlue™ polypropylene venting systems.

### Attaching Vent Piping

**Important:** Products installed in Canada must use vent systems that are certified to the Standard for Type BH Gas Venting Systems (ULC S636) for Class II-A venting systems (up to 65°C). Components of the vent system must not be interchanged with other vent systems or unlisted pipe or fittings. Plastic components, specified primers, and glues must be from a single system manufacturer and not intermixed with other system manufacturer's vent system parts. In addition, the first three feet of the vent pipe must be visible for inspection.

### Pipe Joints

All joints must be fastened and sealed per manufacturer instructions and local and national codes to prevent escape of combustion products into the building.

### Manufactured Modular Venting Systems

**⚠ WARNING**

**Carbon Monoxide Poisoning!**  
 Failure to follow instructions below could result in death or serious injury, or property damage. Refer to the Approved Vent Pipe Materials table for manufactured modular venting systems approved for use with this product. Follow the manufacturer's installation instructions when installing the venting system.

**⚠ WARNING**

**Carbon Monoxide Poisoning!**  
 Failure to follow instructions below could result in death or serious injury, or property damage. Do not use cement on polypropylene venting systems. Follow the manufacturer's installation instructions when installing the venting system.

**Note:** For manufactured modular venting systems that are approved with this product see PVC vent fitting material table. Do not drill into polypropylene venting pipes.

### Bonding of PVC

**Note:** It is recommended to connect and seal the first joints from the furnace with high temperature RTV enabling the pipes to be removed later without cutting.

Verify joints are supported well. Commercially available solvent cement for PVC must be used to join PVC pipe fittings. Follow instructions on container carefully.

Pipe and Fitting – ASTM D1785, D2466, D2661, and D2665

PVC Primer and Solvent Cement – ASTM D2564

**Table 26. Approved pipe materials**

PVC Vent Fitting Material			
ANSI/UL 1738 APPROVED VENT PIPE MATERIAL			
ASTM STANDARD	PIPE TYPE	ALLOWABLE TEMPERATURE °F	MARKING
N/A	N/A	158	UL 1738
PVC			
ASTM STANDARD	PIPE TYPE	ALLOWABLE TEMPERATURE °F	MARKING
D2665	DWV PIPE	158	ASTM D2665
D1785	SCH 40, 80, 120	158	ASTM 1785
D2241	SDR SERIES	158	ASTM D2241
CPVC			

### Procedure for Cementing Joints – Ref ASTM D2855

1. Cut pipe square and remove ragged edges and burrs. Chamfer the pipe end, then clean fitting socket and pipe joint area of all debris.
2. Check the fit, then wipe socket and pipe with cleaner-primer and apply a liberal coat to the socket interior and pipe exterior. Do not let the primer dry before cementing.
3. Apply a thin coat of cement evenly in the socket and a heavy coat on the pipe end, then insert pipe into fitting with a slight twisting until it bottoms out.
4. Hold the pipe in the fitting for 30 seconds to prevent tapered socket from pushing the pipe out of the fitting.
5. Wipe all excess cement from the joint with a rag and allow 15 minutes before handling; curing depends on fit, temperature and humidity.

Connection of the pipe and collar of the combustion air inlet should just be a friction fit. Seal the inlet air joint with RTV sealant so joint can be separated for future service. Support the inlet and vent pipes throughout the entire length.

**Note:** Follow venting instructions carefully when using PVC cement.

**Important:** All joints must be water tight. Flue condensate is somewhat acidic, and leaks can cause equipment damage.

**Figure 27. Sealing inlet air pipe**

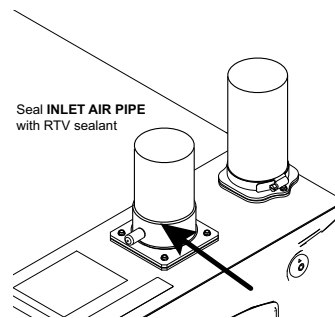

## Furnace General Installation

**Table 26. Approved pipe materials (continued)**

PVC Vent Fitting Material			
ASTM STANDARD	PIPE TYPE	ALLOWABLE TEMPERATURE °F	MARKING
D2846	CPVC 41	212	ASTM D2846
F441	SCH 40, 80	212	ASTM F441
F442	SDR SERIES	212	ASTM F442
ABS			
ASTM STANDARD	PIPE TYPE	ALLOWABLE TEMPERATURE °F	MARKING
D2661	SCH 40 DWV	180	ASTM D2661
PolyPro® by DuraVent, Z-Dens by Novaflex Group, InnoFlue® by Centrotherm, System 1738 by IPEX, ECCO™ polypropylene venting system, and PolyFlue™ polypropylene venting systems.			
ASTM STANDARD	PIPE TYPE	ALLOWABLE TEMPERATURE °F	MARKING
N/A	N/A	230	ULC-S636

## Maximum Vent Length

**Table 27. Maximum vent length**

Model	1.5-inch Pipe	2-inch Pipe	2.5-inch Pipe	3-inch Pipe	4-inch Pipe
Altitude 0–2,000 Feet					
A951X040B, A951X060B	50	200	200	200	250
A951X080B, A951X080C	30	100	200	200	250
A951X100C	(a)	50	100	200	250
A951X120D	(a)	(a)	(a)	200	250
Altitude 2,001–5,400 Feet					
A951X040B, A951X060B	50	200	200	200	250
A951X080B, A951X080C	20	80	120	120	200
A951X100C	(a)	50	100	150	200
A951X120D	(a)	(a)	(a)	200	250
Altitude 5,401–7,800 Feet					
A951X040B, A951X060B	25	100	150	150	200
A951X080B, A951X080C	(a)	50	70	70	140
A951X100C	(a)	(a)	(a)	100	200
A951X120D	(a)	(a)	(a)	100	200
Altitude 7,801–10,100 Feet					
A951X040B, A951X060B	(a)	50	90	90	180
A951X080B, A951X080C	(a)	(a)	(a)	50	100
A951X100C	(a)	(a)	(a)	50	100
A951X120D	(a)	(a)	(a)	50	100

**Notes:**

1. Installation Instructions must be followed for installation of the venting system.
2. Maximum Total Equivalent Length In Feet for Vent or Inlet Air, not combined total.
3. For PolyPro® by DuraVent, Z-DENS by Novaflex Group, InnoFlue® by Centrotherm, ECCO™ polypropylene venting system, and PolyFlue™ manufactured modular venting systems that are in the approved vent pipe material table, fitting equivalent vent lengths may be different from what is shown in Note 5. See the venting system manufacturer's installation instruction for appropriate venting diameters and equivalent lengths.
4. Minimum vent length for all models: 15' equivalent.
5. Do not mix pipe diameters in the same length of pipe outside the furnace cabinet (Except adapters at the top of the furnace). If different inlet and vent pipe sizes are used, the vent pipe must adhere to the maximum length limit shown in the table above (See note 6 below for exception). The inlet pipe can be of a larger diameter, but never smaller than the vent pipe.
6. Maximum pipe lengths must not be exceeded! The length shown is not a combined total, it is maximum length of each (Vent or Inlet air pipes).
7. One short radius 90° elbow is equivalent to 10' of 4-inch pipe, 10' of 3-inch pipe, or 8' of 2-inch pipe. One long radius elbow is equivalent to 6' of 4-inch pipe, 7' of 3-inch pipe, or 5' of 2-inch pipe. Two 45° elbows equal one 90° long elbow. One mitered elbow is equivalent to 12' of 3-inch pipe or 12' of 2-inch pipe.
8. The termination tee or bend must be included in the total number of elbows. If the BAYAIR30AVENTA or BAYAIR30CNVENT termination kit is used, the equivalent length of pipe is 5 feet. For BAYVENT200B and BAYVENTCN200B the equivalent length is 0 feet.
9. For Canadian applications, venting systems must meet ULC-S636 requirements.
10. The inlet air of one pipe systems require the installation of a minimum of one 90° elbow (to prevent dust and debris from falling straight into the furnace).

(a) Not allowed.

## Horizontal Venting

**Note:** Confirm the vent piping is sloped 1/4-inch per foot and that piping is supported properly to prevent sags and condensate pooling.

### 3-inch Venting requirements

**Important:**

- To determine if your application requires 3-inch venting, see the “ ”
- Horizontal venting application must use the 2-inch x 3-inch offset reducing coupling. Vertical venting applications do not require the reducing coupling to be offset.

When the vent pipe is exposed to temperatures below freezing, (for example when it passes through unheated spaces), the pipe must be insulated with 1/2-inch (12.7 mm) thick Armaflex-type insulation or equal.

If the space is heated sufficiently to prevent freezing, then the insulation will not be required. If domestic water pipes are not protected from freezing then the space meets the condition of a heated space.

**Note:** If your furnace comes with a factory supplied 2-inch x 3-inch offset reducing coupling it is used for 3-inch vent pipe installation. Make sure the marking "TOP" is located on the top side of the pipe in horizontal venting applications. The straight side of the coupling must be on bottom for proper drainage of condensate.

Figure 28. Horizontal venting

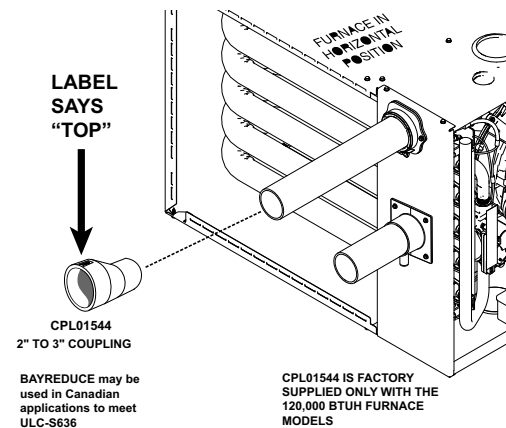
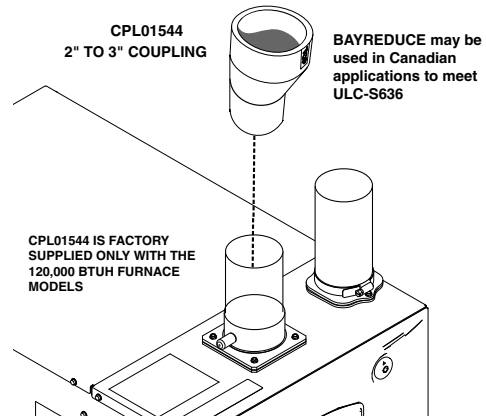

Figure 29. Vertical venting



### Combustible Material Wall

A minimum clearance of 1-inch to combustible materials must be maintained when using single wall stainless steel venting.

Shield material to be a minimum of 24 gauge stainless or aluminized sheet metal. Minimum dimensions are 12-inch x 12-inch. Shield must be fastened to both inside and outside of wall. Use screws or anchor type fasteners suited to the outside or inside wall surfaces.

Figure 30. Combustible material wall

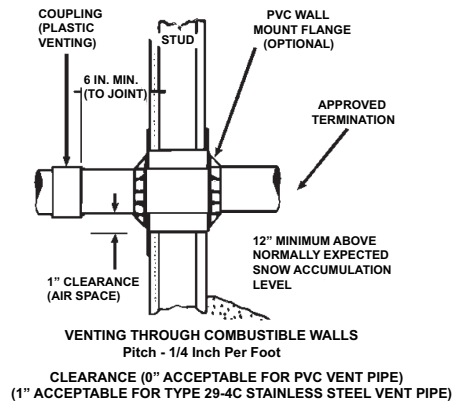

### Non-combustible Material Wall

The hole through the wall must be large enough to maintain pitch of vent and properly seal.

Use cement mortar seal on inside and outside of wall.

**Note:** For Canadian applications, BAYREDUCE 2-inch x 3-inch offset reducing coupling meets ULC-S636 requirements. Make sure the marking "TOP" is located on the top side of the pipe. The straight side of the coupling must be on bottom for proper drainage of condensate in horizontal venting.

**Figure 31. Non-combustible material wall**

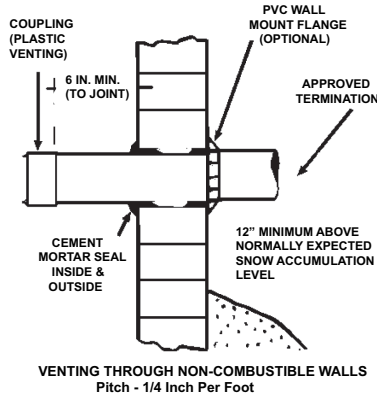

## Horizontal Venting Through Wall

The vent for this appliance shall not terminate:

- Over public walkways.
- Near soffit vents or crawl space vents or other areas where condensate or vapor could create a nuisance or hazard or cause property damage.
- Where condensate vapor could cause damage or could be detrimental to the operation of regulators, relief valves, or other equipment.

Possible configurations for two pipe venting systems are located in the same pressure zone.

**Important:** Maintain 12-inch minimum clearance above highest anticipated snow level or grade, whichever is greater.

**Note:** All distances are center line to center line.

**Figure 32. Configurations one pipe venting systems — type 1**

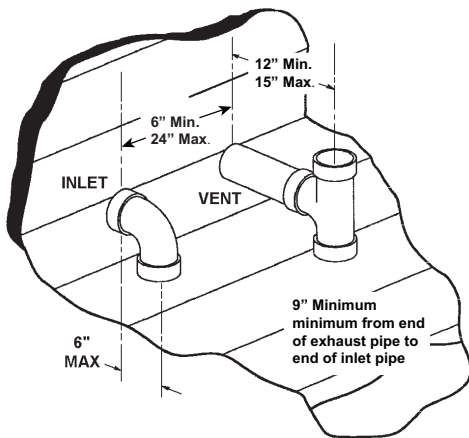

**Figure 33. Configurations one pipe venting systems — type 2**

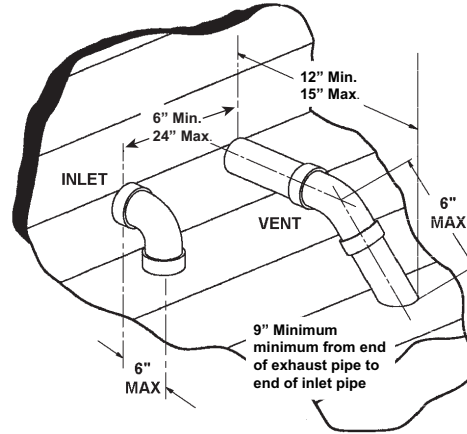

**Figure 34. Configurations one pipe venting systems — type 3**

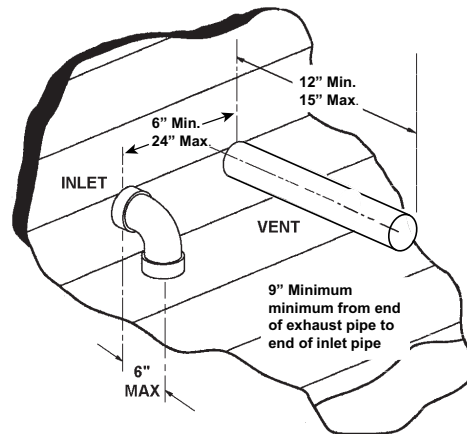

**Figure 35. Configurations one pipe venting systems — type 4**

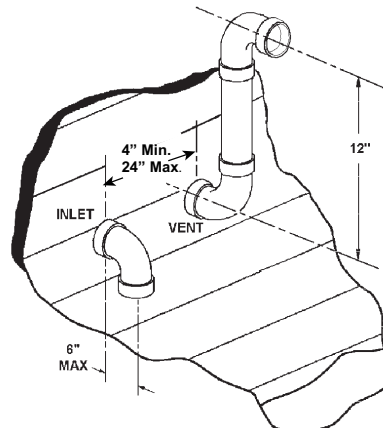

**Figure 36. Configurations one pipe venting systems — type 5**

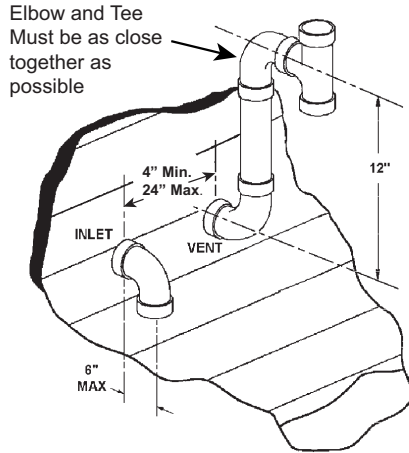

**Figure 37. Configurations one pipe venting systems — type 6**

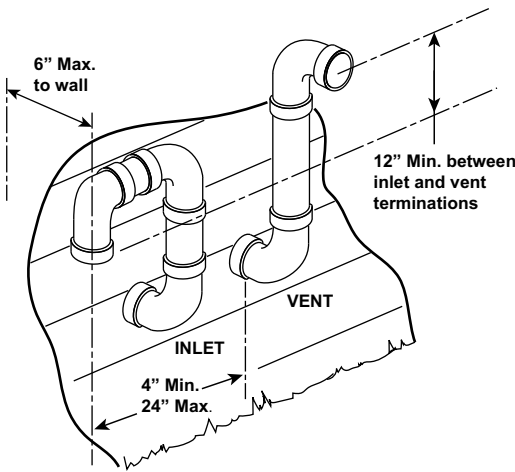

**Horizontal Venting Through Wall with Concentric Vent Kit**

These Furnaces may be installed as direct vent (as shipped) or as nondirect vent. Installation must conform to national, state, and local codes.

The BAYVENT200B, BAYVENTCN200B, BAYAIR30AVENTA, and BAYAIR30CNVENT vent & inlet terminals kits must be located at least 12-inch minimum above normally expected snow accumulation level.

Avoid areas where staining or condensate drippage may be a problem.

Location of the vent/wind terminal should be chosen to meet the requirements for either direct or non-direct vent applications.

**Pitch** — Venting through the wall must maintain 1/4-inch per foot pitched upward to insure that condensate drains back to the Furnace.

**Flue Gas Degradation** — The moisture content of the flue gas may have a detrimental effect on some building materials.

This can be avoided by using the roof or chimney venting option. When wall venting is used on any surface that can be affected by moisture, it is recommended that a corrosion resistant shield (24 inches square) be used behind the vent terminal.

This shield can be wood, plastic, sheet metal, etc. Also, silicone caulk all cracks, seams and joints within 3 feet of the vent terminal.

The vent for this appliance shall not terminate

1. Over public walkways; or
2. Near soffit vents or crawl space vents or other areas where condensate or vapor could create a nuisance or hazard or cause property damage; or
3. Where condensate vapor could cause damage or could be detrimental to the operation of regulators, relief valves, or other equipment.

For Canadian installations, if you used a ULC-S636 approved manufactured modular venting system, a copy of the manufacturer's instructions should remain with the system.

The installation instruction can be obtained from the vent termination manufacturer. BAYVENTCN200B and BAYAIR30CNVENT meet ULC-S636 requirements.

**Note:** For Canadian applications, horizontal vent termination kits must meet ULC-S636..

**Figure 38. BAYVENT200B / BAYVENTCN200B**

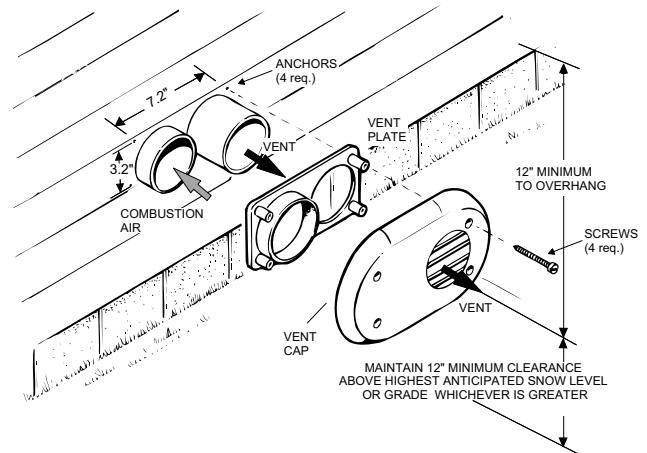

**Figure 39. BAYAIR30AVENTA / BAYAIR30CNVENT (Sidewall)**

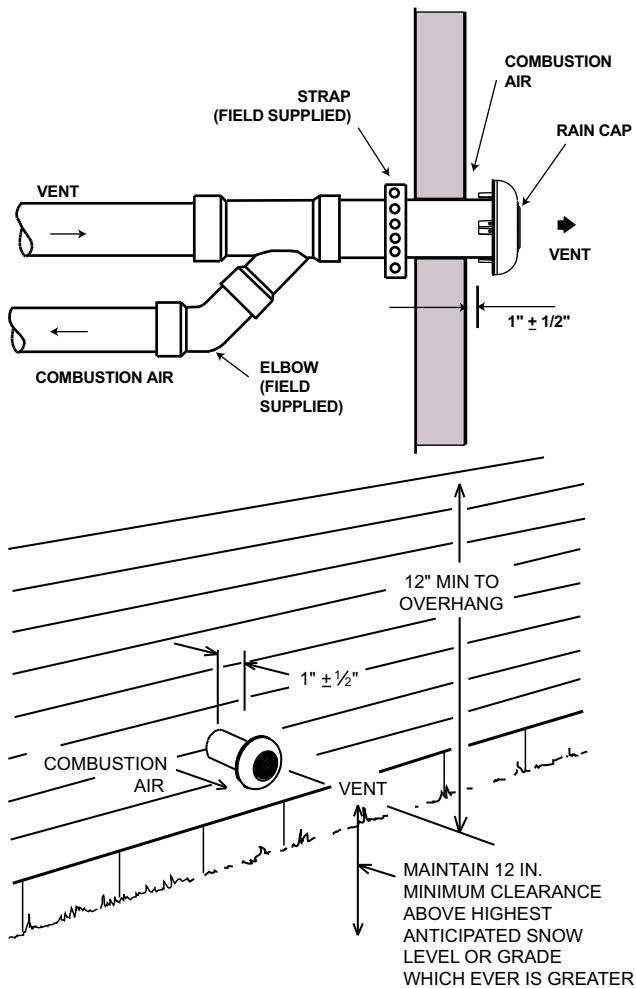

**Important:** The Commonwealth of Massachusetts requires compliance with regulation 248 CMR 4.00 and 5.00 for installation of through – the – wall vented gas appliances as follows:

For all side wall horizontally vented gas fueled equipment installed in every dwelling, building or structure used in whole or in part for residential purposes, including those owned or operated by the Commonwealth and where the side wall exhaust vent termination is less than seven (7) feet above finished grade in the area of the venting, including but not limited to decks and porches, the following requirements shall be satisfied:

1. **Installation of carbon monoxide detectors** — At the time of installation of the side wall horizontal vented gas fueled equipment, the installing plumber or gasfitter shall observe that a hard wired carbon monoxide detector with an alarm and battery back-up is installed on the floor level where the gas equipment is to be

installed. In addition, the installing plumber or gasfitter shall observe that a battery operated or hard wired carbon monoxide detector with an alarm is installed on each additional level of the dwelling, building or structure served by the side wall horizontal vented gas fueled equipment. It shall be the responsibility of the property owner to secure the services of qualified licensed professionals for the installation of hard wired carbon monoxide detectors.

- a. In the event that the side wall horizontally vented gas fueled equipment is installed in a crawl space or an attic, the hard wired carbon monoxide detector with alarm and battery back-up may be installed on the next adjacent floor level.
  - b. In the event that the requirements of this subdivision can not be met at the time of completion of installation, the owner shall have a period of thirty (30) days to comply with the above requirements; provided, however, that during said thirty (30) day period, a battery operated carbon monoxide detector with an alarm shall be installed.
2. **Approved carbon monoxide detectors** — Each carbon monoxide detector as required in accordance with the above provisions shall comply with NFPA 72 and be ANSI/UL 2034 listed, IAS 6-96 certified or CSA 6.19.
  3. **Signage.** A metal or plastic identification plate shall be permanently mounted to the exterior of the building at a minimum height of eight (8) feet above grade directly in line with the exhaust vent terminal for the horizontally vented gas fueled heating appliance or equipment. The sign shall read, in print size no less than one-half (1/2) inch in size, " Gas Vent Directly Below. Keep Clear of all Obstructions".
  4. **Inspection.** The state or local gas inspector of the side wall horizontally vented gas fueled equipment shall not approve the installation unless, upon inspection, the inspector observes carbon monoxide detector(s) and signage installed in accordance with the provisions of 248 CMR 9.1.23 and 12.9.7 respectively.

This appliance requires a special venting system. If BAYAIR30AVENTA or BAYVENT200B are used, a copy of the installation instructions for the kit shall remain with the appliance or equipment at the completion of installation. The venting system installation instructions can be obtained from the manufacturer by writing to the following address:

Trane and American Standard  
6200 Troup Highway  
Tyler, TX 75707

Attention: Manager of Field Operations Excellence

Horizontal Vent Clearances

Figure 40. Horizontal vent clearances

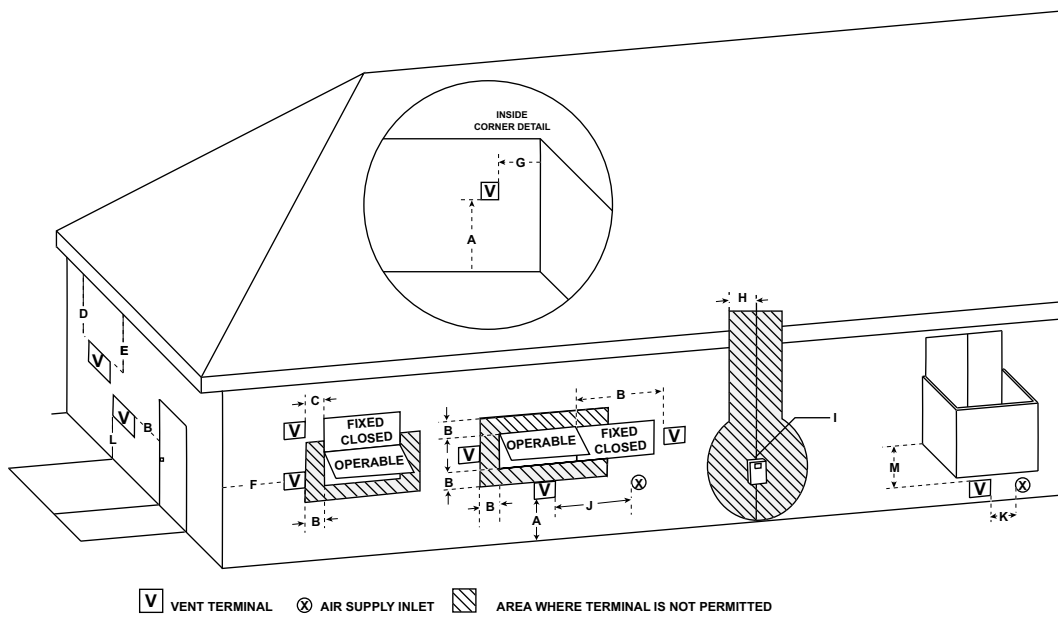

Table 28. Vent termination clearances - direct/non-direct

Vent Termination Clearances- Direct/Non-Direct				
		Canadian Installations	US Installations Non-Direct	US Installations Direct
A=	Clearance above grade, veranda, porch, deck, or balcony	12 inches (30 cm)		
B=	Clearance to window or door that may be opened	12 inches (30 cm) for appliances > 10,000 BTUH (3 kw) and ≤ 100,000 BTUH (30 kw), 36 inches (91 cm) for appliances > 100,000 BTUH (30 kw)	4 feet (1.2m) below or to the side of opening; 1 foot (0.3m) above opening	9 inches (23 cm) for appliances > 10,000 BTUH (3 kw) and ≤ 50,000 BTUH (15 kw), 12 inches (30 cm) for appliances > 50,000 BTUH (15 kw)
C=	Clearance to permanently closed window	(a)	(a)	(a)
D=	Vertical clearance to ventilated soffit located above the terminal within a horizontal distance of 2 feet (61 cm) from the center line of the terminal	(a)	(a)	(a)
E=	Clearance to unventilated soffit	(a)	(a)	(a)
F=	Clearance to outside corner	(a)	(a)	(a)
G=	Clearance to inside corner	(a)	(a)	(a)
H=	Clearance to each side of center line extended above meter/regulator assembly	3 feet (91 cm) with a height 15 feet (4.5 m) above the meter/regulator assembly	(a)	(a)
I=	Clearance to service regulator vent outlet	3 feet (91 cm)	(a)	(a)
J=	Clearance to nonmechanical air supply inlet to building or the combustion air inlet to any other appliance	12 inches (30 cm) for appliances > 10,000 BTUH (3 kw) and ≤ 100,000 BTUH (30 kw), 36 inches (91 cm) for appliances > 100,000 BTUH (30 kw)	4 feet (1.2 m) below or to side of opening; 1 foot (300 m) above opening	9 inches (23 cm) for appliances > 10,000 BTUH (3 kw) and ≤ 50,000 BTUH (15 kw); 12 inches (30 cm) for appliances > 50,000 BTUH (15 kw)
K=	Clearance to a mechanical air supply inlet	6 feet (1.83m)	3 feet (91 cm) above if within 10 feet (3m) horizontally	3 feet (91 cm) above if within 10 feet (3m) horizontally

# Furnace General Installation

**Table 28. Vent termination clearances - direct/non-direct (continued)**

Vent Termination Clearances- Direct/Non-Direct				
		Canadian Installations	US Installations Non-Direct	US Installations Direct
L=	Clearance above a paved sidewalk or paved driveway located on public property	7 feet (2.13 m) and not located above public walkways or other areas where condensate or vapor can cause a nuisance or hazard		
M=	Clearance under veranda, porch, deck, or balcony	12 inches (30 cm) if veranda, porch, deck, or balcony is fully open on a minimum of two sides beneath the floor	12 inches (30 cm) where the area beneath the veranda, porch, deck, or balcony is open on not less than two sides. The vent terminal is prohibited in this location where only one side is open	

**Notes:**

1. The Canadian venting installations must be in accordance with local codes or in the absence of local codes with the current CSA B149.1 Natural Gas and Propane Installation Code.
2. The US venting installations must be in accordance with local codes or in the absence of local codes with the current ANSI Z223.1/NFPA 54 National Fuel Gas Code.

(a) Clearance in accordance with local installation codes and the requirements of the gas supplier.

## Air for Combustion and Ventilation

Adequate flow of combustion and ventilating air must not be obstructed from reaching the Furnace. Air openings provided in the Furnace casing must be kept free of obstructions which restrict the flow of air. Airflow restrictions affect the efficiency and safe operation of the Furnace. Keep this in mind should you choose to remodel or change the area which contains your Furnace. Furnaces must have a free flow of air for proper performance.

Provisions for combustion and ventilation air shall be made in accordance with "latest edition" of Section 9.3, Air for Combustion and Ventilation, of the National Fuel Gas Code, ANSI Z223.1 / NFPA 54, or Sections 8.2, 8.3 or 8.4 of CSA B149.1 Installation Codes, and applicable provisions of the local building codes. Special conditions created by mechanical exhausting of air and fireplaces must be considered to avoid unsatisfactory Furnace operation.

Furnace location may be in an unconfined space or a confined space.

Unconfined space are installations with 50 cu. ft. or more per 1000 BTU/hr input from all equipment installed. Unconfined spaces are defined in the table and illustration for various furnace sizes. These spaces may have adequate air by infiltration to provide air for combustion, ventilation, and dilution of flue gases. Buildings with tight construction (for example, weather stripping, heavily insulated, caulked, vapor barrier, etc.), may need additional air provided as described for confined space.

**Table 29. Minimum area in square feet for unconfined space installations**

Furnace Maximum BTUH Input Rating	With 8 Ft. Ceiling; Minimum Area in Square Feet of Unconfined Space
40,000	250
60,000	375

**Table 29. Minimum area in square feet for unconfined space installations (continued)**

Furnace Maximum BTUH Input Rating	With 8 Ft. Ceiling; Minimum Area in Square Feet of Unconfined Space
80,000	500
100,000	625
120,000	750

**Figure 41. Unconfined space**



Confined spaces are installations with less than 50 cu. ft. of space per 1000 BTU/ hr input from all equipment installed. Confined spaces are defined in the table and illustration for various furnace sizes. Air for combustion and ventilation requirements can be supplied from inside the building.

The following types of installations will require use of OUTDOOR AIR for combustion, due to chemical exposures:

- Commercial buildings
- Buildings with indoor pools
- Furnaces installed in commercial laundry rooms
- Furnaces installed near chemical storage areas

Exposure to the following substances in the combustion air supply will also require OUTDOOR AIR for combustion:

- Permanent wave solutions
- Chlorinated waxes and cleaners
- Chlorine based swimming pool chemicals

- Water softening chemicals
- Deicing salts or chemicals
- Carbon Tetrachloride
- Halogen type refrigerants
- Cleaning solvents (such as perchloroethylene)
- Printing inks, paint removers, varnish, etc.
- Hydrochloric acid
- Cements and glues
- Antistatic fabric softeners for clothes dryers
- Masonry acid washing material

**Note:** Extended warranties are not available in some instances. Extended warranty does not cover repairs to equipment installed in establishments with corrosive atmospheres, including but not limited to, dry cleaners, beauty shops, and printing facilities.

**Table 30. Minimum free area in square inches each opening (furnace only) in a confined space**

Furnace Max BTUH.Input Rtg.	Air From Inside	Air From Outside	
		Vertical Duct (a)	Horizontal Duct(b)
40,000	100	10	20
60,000	100	15	30
80,000	100	20	40
100,000	100	25	50
120,000	120	30	50

(a) 1 Square inch per 4000 BTU/hr Vertical Duct.  
 (b) 1 Square inch per 2000 BTU/hr Horizontal Duct.

**Figure 42. Confined space**

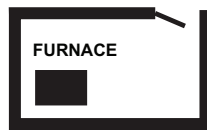

**LESS THAN 50 CU. FT. PER 1000 BTU/HR INPUT ALL EQUIP. INSTALLED**

**All air from inside the building** — The confined space shall be provided with two permanent openings communicating directly with an additional room(s) of sufficient volume so that the combined volume of all spaces meets the criteria for an unconfined space. The total input of all gas utilization equipment installed in the combined space shall be considered in making this determination. Refer to the Minimum Free Area in square inches for confined spaces table, for minimum open areas required.

**Figure 43. Air from inside building**

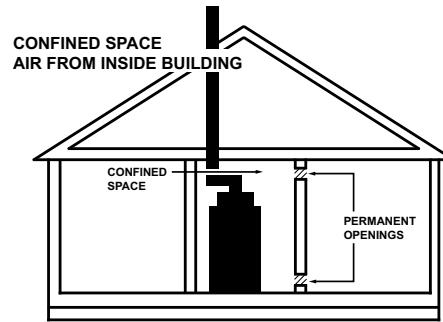

**All air from outdoors** — The confined space shall be provided with two permanent openings, one commencing within 12 inches of the top and one commencing within 12 inches of the bottom of the enclosure.

The openings shall communicate directly, or by ducts, with the outdoors or spaces (crawl or attic) that freely communicate with the outdoors. Refer to the Minimum Free Area in square inches for confined spaces table, for minimum open areas required.

**Figure 44. Air from outdoors**

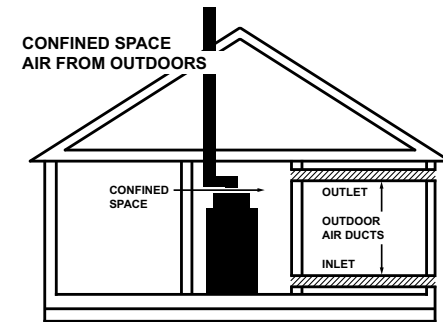

**Figure 45. Air from ventilated attic/crawl space**

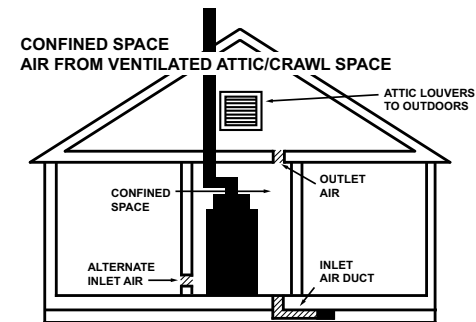

**Figure 46. Air from ventilated attic**

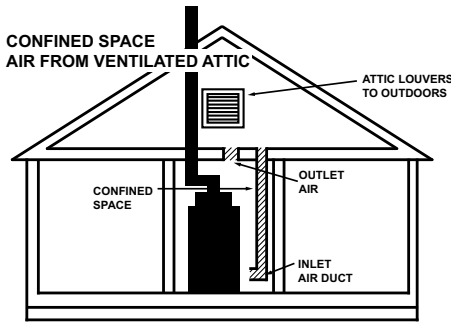

## Duct Connections

Air duct systems should be installed in accordance with standards for air conditioning systems, National Fire Protection Association Pamphlet No. 90. They should be sized in accordance with ACCA Manual D or whichever is applicable. Check on controls to make certain they are correct for the electrical supply.

Central furnaces, when used in connection with cooling units, shall be installed in parallel or on the upstream side of the cooling units to avoid condensation in the heating element, unless the furnace has been specifically approved for downstream installation. With a parallel flow arrangement, the dampers or other means used to control flow of air shall be adequate to prevent chilled air from entering the furnace, and if manually operated, must be equipped with means to prevent operation of either unit unless the damper is in full heat or cool position.

Flexible connections of nonflammable material may be used for return air and discharge connections to reduce the transmission of vibration. Though these units have been specifically designed for quiet, vibration free operation, air ducts can act as sounding boards and could, if poorly installed, amplify the slightest vibration to the annoyance level.

When the furnace is located in a utility room adjacent to the living area, the system should be carefully designed with returns which minimize noise transmission through the return air grille. Although these winter air conditioners are designed with large blowers operating at moderate speeds, any blower moving a high volume of air will produce audible noise which could be objectionable when the unit is located very close to a living area. It is often advisable to route the return air ducts under the floor or through the attic. Such design permits the installation of air return remote from the living area (i.e. central hall).

When the furnace is installed so that the supply ducts carry air circulated by the furnace to areas outside the space containing the furnace, the return air shall also be handled by a duct(s) sealed to the furnace and terminating outside the space containing the furnace.

For furnaces not equipped with a cooling coil, it is recommended that the outlet duct be provided with a removable access panel. The opening shall be accessible when the furnace is installed and shall be of such a size

that the heat exchanger can be viewed for possible openings using light assistance or a probe can be inserted for sampling the air stream. The removable cover must be sealed to prevent air leaks.

Where there is no complete return duct system, the return connection must be run full size from the Furnace to a location outside the utility room, basement, attic, or crawl space.

**Important:** Do not install return air through the back of the Furnace cabinet. Do not install return air through the side of the furnace cabinet on horizontal applications without following the guidelines in Return Air Filter section of this document.

Carbon monoxide, fire or smoke can cause serious bodily injury, death, and/or property damage.

A variety of potential sources of carbon monoxide can be found in a building or dwelling such as gas-fired clothes dryers, gas cooking stoves, water heaters, furnaces and fireplaces. The U.S. Consumer Product Safety Commission recommends that users of gas-burning appliances install carbon monoxide detectors as well as fire and smoke detectors per the manufactures installation instructions to help alert dwelling occupants of the presence of fire, smoke or unsafe levels of carbon monoxide. These devices should be listed by Underwriters Laboratories, Inc. *Standards for Single and Multiple Station Carbon Monoxide Alarms, UL 2034* or CSA International Standard, *Residential Carbon Monoxide Alarming Devices, CSA 6.19*.

**Notes:**

- *The manufacturer of your Furnace DOES NOT test any detectors and makes no representations regarding any brand or type of detector.*
- *Seal per local codes.*

## Supply Duct Connections

**Table 31. Supply duct connections**

Furnace Orientation	Steps to be followed	Images for Reference
Upflow and Horizontal Furnace without Coil	Step 1., Step 12., Step 4., Step 5.	Figure 47, p. 43, Figure 48, p. 43
Upflow Furnace with Coil	Step 1., Step 2., Step 3., Step 4.	Figure 47, p. 43, Figure 49, p. 43, Figure 51, p. 43
Furnace in Horizontal Left with Coil	Step 1., Step 5., Step 3., Step 4.	Figure 47, p. 43, Figure 49, p. 43, Figure 53, p. 43
Furnace in Horizontal Right with "A" Coil	Step 7., Step 8., Step 9., Step 6., Step 10., Step 4.	Figure 47, p. 43, Figure 48, p. 43, Figure 52, p. 43

**Table 31. Supply duct connections (continued)**

Furnace Orientation	Steps to be followed	Images for Reference
Downflow Furnace with Coil	Step 7., Step 8., Step 9., Step 6., Step 10., Step 4.	Figure 47, p. 43, Figure 48, p. 43, Figure 54, p. 43
Downflow Furnace without Coil	Step 1., Step 12., Step 4., Step 5.	Figure 47, p. 43, Figure 49, p. 43

**Figure 47. Initial position**

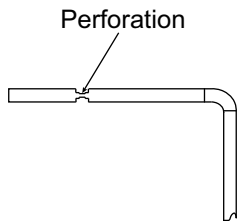

**Figure 48. Flange orientation for upflow and horizontal left**

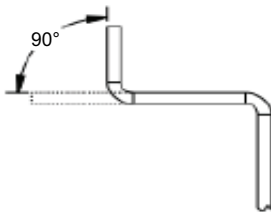

**Figure 49. Flange orientation for downflow and horizontal right**

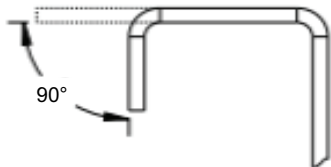

**Figure 50. Perforated discharge duct flange**

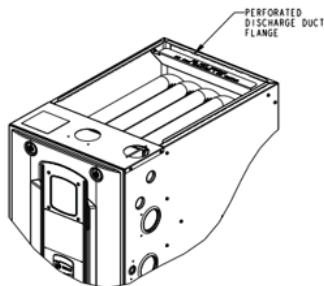

**Figure 51. Upflow furnace with coil**

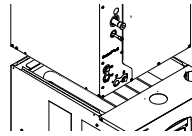

**Figure 52. Horizontal left with or without coil**

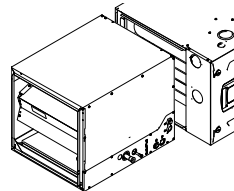

**Figure 53. Horizontal right furnace with or without coil**

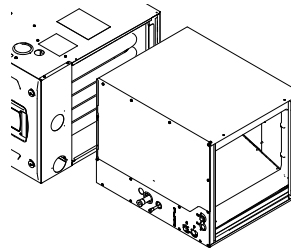

**Figure 54. Downflow furnace with coil**

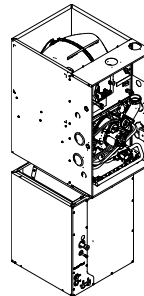

**Installation Steps**

1. Bend furnace flanges up.
2. Set the coil on top of the furnace.
3. Screw through the coil cabinet into the furnace flange. Guide holes are located on the coil.
4. Seal per local codes and requirements.
5. Insulate the first 6–12 inches of the supply duct.
6. Support the furnace and coil independently.
7. Cut the back flange along perforation.
8. Starting at the back of the furnace, cut the side flanges along perforations until past the end of the heat shield to avoid interference when bending.
9. Bend furnace side flanges down.
10. Match the coil up flush to the back of the furnace.

11. Set the furnace on top of the coil so that it is flush with the back of the furnace.
12. Attach ducting.

### Return Duct Connections

#### Return Ducting General Guideline

- Back returns are not allowed on any S-Series Furnaces
- Side returns are not allowed on downflow or horizontal S-Series Furnaces
- Mounting flanges must be located on ducting
- Shoot screws through the mount flanges into the furnace cabinet
- Always seal per local codes and requirements
- Furnace, coil, and ducting must be supported separately
- An external overflow drain pan must be installed in all applications over a finished ceiling to prevent property damage

**Figure 55. Upflow furnace with bottom return in closet with remote filter**

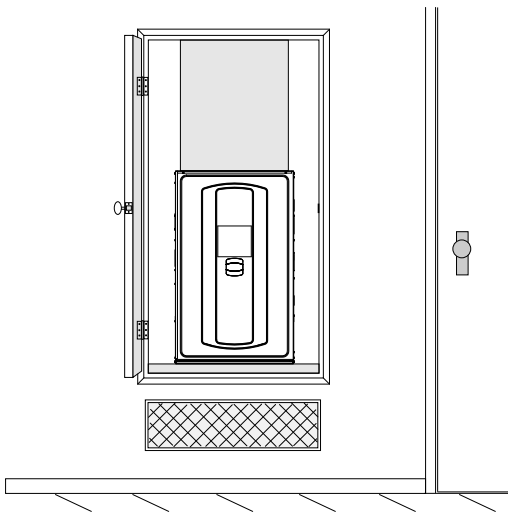

See [Step 1.](#), [Step 2.](#), [Step 3.](#), [Step 4.](#)

**Figure 56. Upflow furnace with bottom return in closet with filter box**

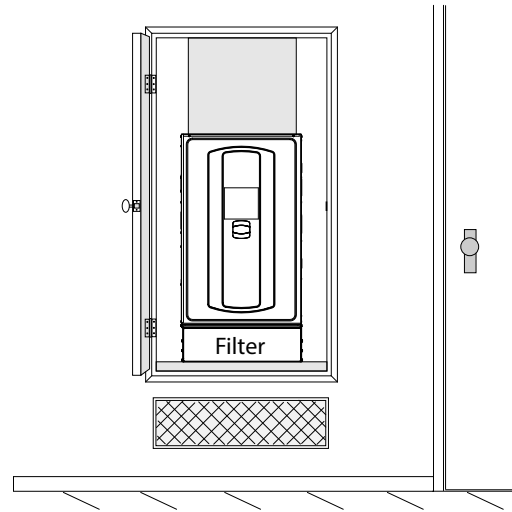

See [Step 1.](#), [Step 5.](#), [Step 6.](#), [Step 4.](#)

**Figure 57. Upflow furnace with bottom return mounted on a ducted pedestal**

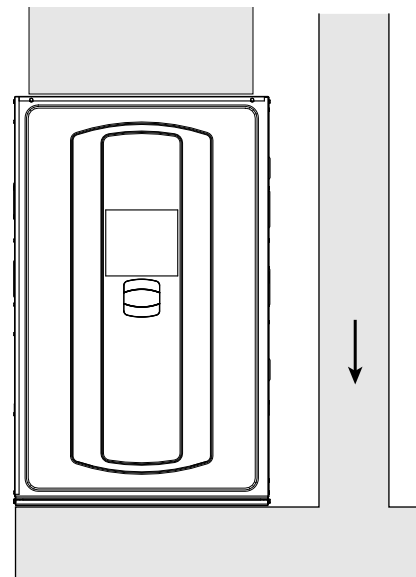

See [Step 1.](#), [Step 7.](#), [Step 8.](#), [Step 4.](#)

**Figure 58. Upflow furnace with bottom return mounted on a ducted pedestal with filter box**

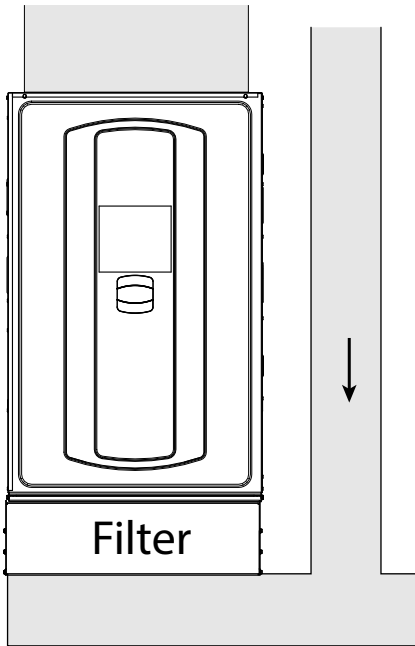

See Step 1., Step 9., Step 4.

**Figure 59. Upflow furnace with bottom and side returns mounted on a ducted pedestal with side return and filter box**

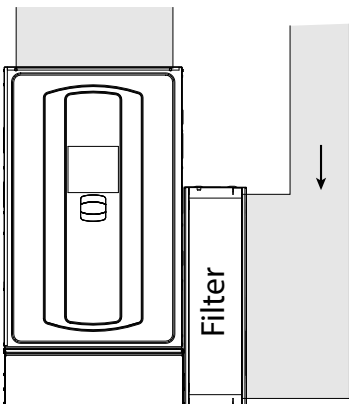

**Important:**

- Make sure the condensate and thermostat wiring holes are sealed on the cabinet side with the side return. The plugs and grommets may need to be changed with those on the opposite side of the cabinet..
- Make sure not to cut the cabinet in the “No Cut” area.

**Notes:**

- Use Optional BAYLIFT kit to lift furnace. Follow kit instructions.
- furnace bottom pedestal must be a minimum of 6-inch in height.

See Step 1., Step 10., Step 11., Step 12., Step 13., Step 14., Step 15., Step 4.

**Figure 60. 17.5-inch filter cabinet with BAYLIFT kit**

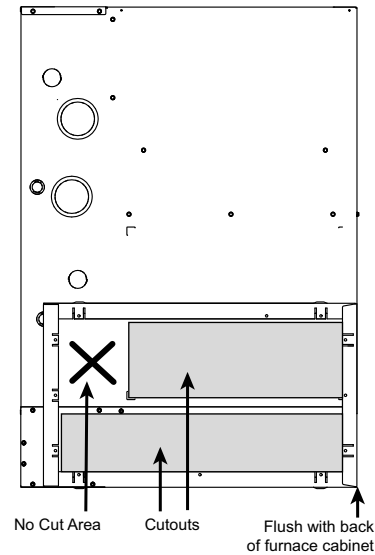

**Figure 61. 21-inch filter cabinet with BAYLIFT kit**

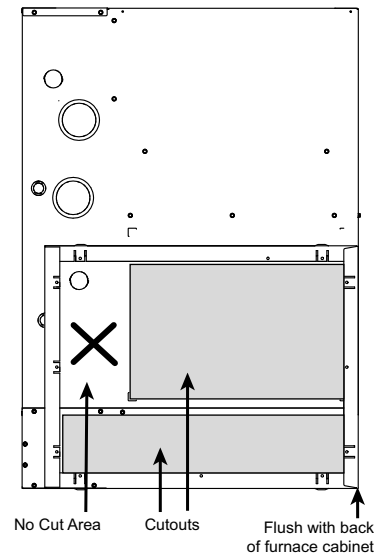

**Figure 62. Upflow furnace with side return**

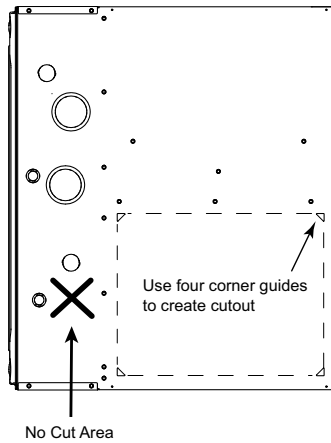

**Important:**

- Make sure the condensate and thermostat wiring holes are sealed on the cabinet side with the side return. The plugs and grommets may need to be changed with those on the opposite side of the cabinet.
- Make sure not to cut the cabinet in the “No Cut” area.

**Notes:**

- Return air on right side with the condensate on the left or return air on left with the condensate on the right do not require a transition.
- If using a filter box, use a transition, if possible, to attach the filter box to the furnace cabinet.

See [Step 16.](#), [Step 17.](#), [Step 18.](#), [Step 19.](#)

**Figure 63. Upflow furnace with two side returns**

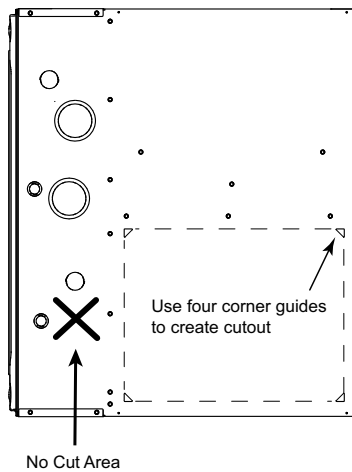

**Important:**

- One of the sides must have a transition to allow the condensate and thermostat wiring to exit the cabinet.
- If a transition is not a viable option, a hole may be drilled in the bottom of the cabinet to allow the condensate to exit. Also, a hole will need to be drilled in the side of the cabinet for the thermostat wiring to exit.
- Make sure not to cut the cabinet in the “No Cut” area.

**Notes:**

- If using one transition, the condensate and thermostat wiring will exit on the transition side.
- If using a filter boxes, use transitions, if possible, to attach the filter boxes to the furnace cabinet. If transitions are not used, condensate may exit through the bottom of the furnace.

See [Step 16.](#), [Step 17.](#), [Step 18.](#), [Step 19.](#)

**Figure 64. Downflow furnace with top return**

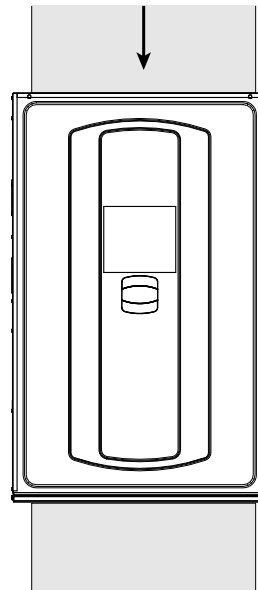

See [Step 20.](#), [Step 21.](#), [Step 3.](#), [Step 4.](#)

**Figure 65. Downflow furnace with top return and plenum**

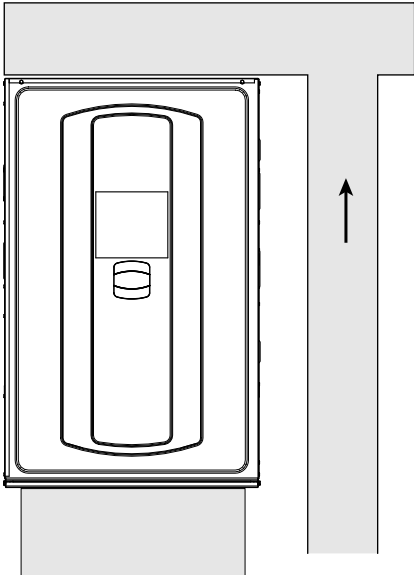

See Step 20., Step 22., Step 3., Step 4.

**Figure 66. Downflow furnace with top return and plenum with filter box**

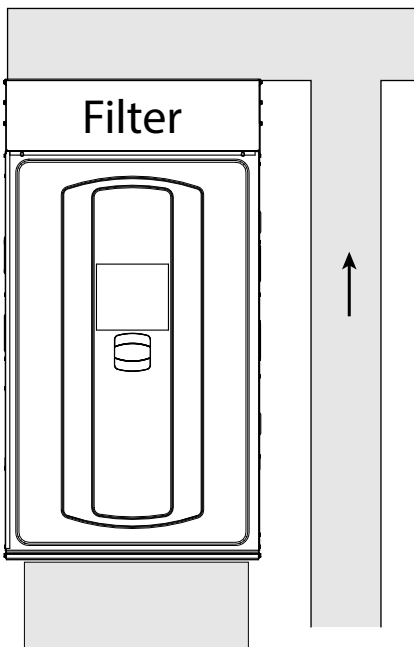

See Step 20., Step 23., Step 24., Step 4.

**Installation Steps**

1. Remove the bottom plate.
2. Set the furnace on the base inside closet.
3. Install remote filter.
4. Seal per local codes and requirements.
5. Set the furnace on the filter box inside closet.

6. Must have grill present for air.
7. Set the furnace on the ducted pedestal. The ducted pedestal will use ducted air from a remote location.
8. Install filter at a remote location.
9. Set the furnace on the filter box. The ducted pedestal will use ducted air from a remote location.
10. Create ducting and set the furnace in place.
11. Match the filter cabinet flush to the back and bottom sides of the furnace cabinet and secure in place with screws.
12. Mark the two areas to be cut out for the return air.
13. Cut out the two sections of the cabinet and BAYLIFT kit to be removed.
14. Attach ducting to the filter box.
15. The ducted pedestal will use ducted air from a remote location.
16. Using guides, remove the cutout for the side return.
17. Create ducting and set the furnace in place. Use screws to attach ducting to the furnace cabinet.
18. Seal bottom panel per local codes and requirements.
19. Seal all other panels per local codes and requirements.
20. Remove the top plate.
21. Attach the ducting to the top of the furnace.
22. Attach the plenum ducting to the top of the furnace.
23. Attach the filter box to the top of the furnace.
24. Attach ducting.

**Return Air Filters**

**Typical Upflow Return Air Filter Installations**

Filters are not factory supplied for upflow furnaces. Filter size needed will be dependent on type of filter and CFM requirement. Filters must be installed externally to the unit.

**Important:** *It is recommended to transition return ducting to the same size as the opening. It is acceptable for return duct or filter frame to extend forward of the opening but plastic plugs MUST be installed in any opening that the duct or filter frame may cover.*

**Table 32. Upflow return air filters**

Furnace Width (inches)	Filter Quantity and Size (inches)
17-1/2	1 — 16 x 25 x 1
21	1 — 20 x 25 x 1
24-1/2	1 — 24 x 25 x 1

**Note:** For upflow furnace models in any configuration, where the airflow requirement exceeds 1600 CFM - Furnaces will require return air openings and filters on: (1) both sides, or (2) one side and the bottom, or (3) just on the bottom.

## Preparation for Upflow Bottom and Side Return Air Filter Installations

All return air duct systems should provide for installation of return air filters.

1. Determine the appropriate position to set the furnace in order to connect to existing supply and return ductwork.
2. For upflow side return installations, remove the insulation around the opening in the blower compartment
3. The side panels of the upflow furnace include locating notches that are used as guides for cutting an opening for return air, refer to the figure and the upflow furnace outline drawing for duct connection dimensions for various furnaces.
4. If a 3/4" flange is to be used for attaching the air inlet duct, add to cut where indicated by dotted lines. Cut corners diagonally and bend outward to form flange.
5. If flanges are not required, and a filter frame is installed, cut between locating notches as in illustration.
6. The bottom panel of the upflow furnace must be removed for bottom return air.

Figure 67. Upflow furnaces

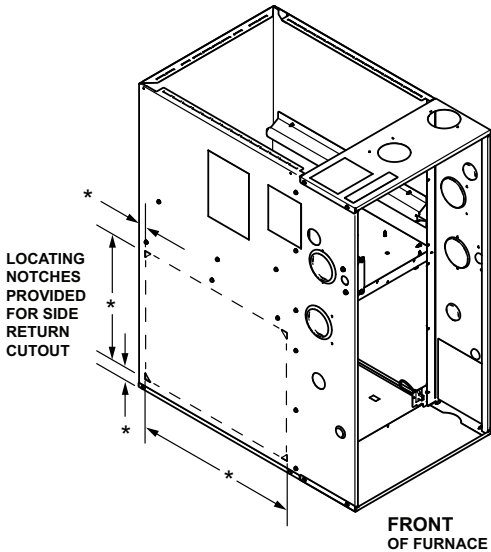

## Return Air Filters for Furnace in Horizontal Configuration

When the modular blower is installed in the horizontal configuration, the return air filters must be installed exterior to the modular blower cabinet. Remote filter grilles may be used for homeowner convenience, refer to or the filters may be installed in the duct work upstream of the modular blower, refer to

Filter kits are available for horizontal applications.

**Note:** Direct coupled side returns are not allowed to the blower cabinet.

Figure 68. Remote filter installation

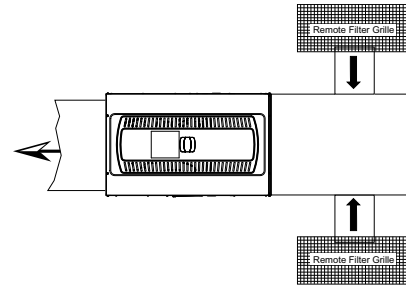
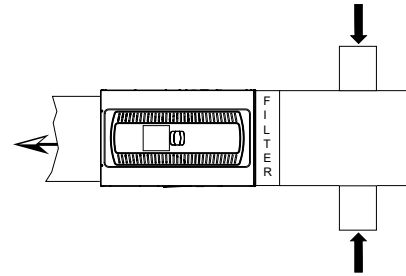

Figure 69. Duct filter installation



## Typical Downflow Furnace Return Air Filter Installations

Filters are not factory supplied for downflow furnaces. Filter size needed will be dependent on type of filter and CFM requirement. Filters must be installed externally to the unit.

Table 33. Downflow return air filters

Furnace Width (inches)	Filter Quantity and Size (inches)
17-1/2	1 - 16 X 25 X 1
21	1 - 20 x 25 x 1
24-1/2	1 - 24 X 25 X 1

## Electrical Connections

Make wiring connections to the unit as indicated on enclosed wiring diagram. As with all gas appliances using electrical power, this furnace shall be connected into a permanently live electric circuit. It is recommended that furnace be provided with a separate "circuit protection device" electric circuit. The furnace must be electrically grounded in accordance with local codes or in the absence of local codes with the National Electrical Code, ANSI/ NFPA 70, if an external electrical source is utilized. *The integrated furnace control is polarity sensitive.* The hot leg of the 120V power supply must be connected to the black power lead as indicated on the wiring diagram.

See the "Wiring Diagrams," p. 19 section in this document and unit wiring diagram attached to furnace.

### Field Wiring

Figure 70. Field wiring diagram for A951X with one / two stage AC or heat pump

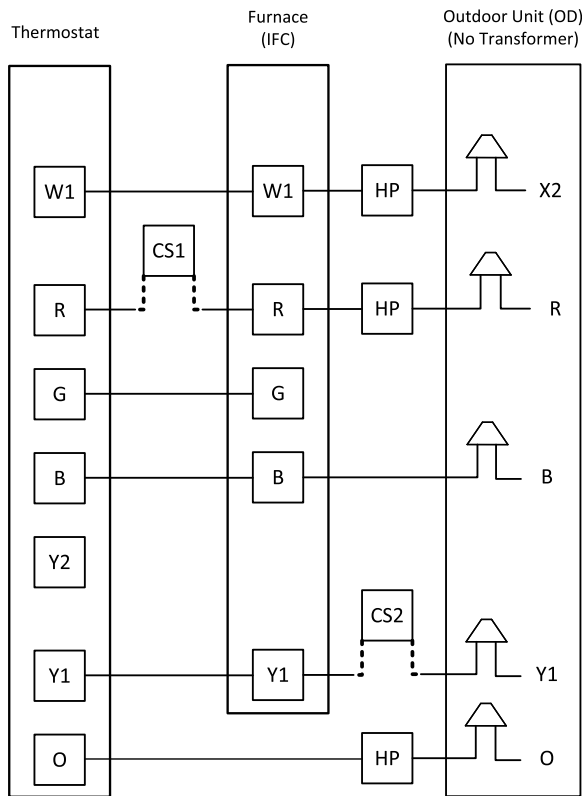

NOTES:

- 1) HP = Wiring used for Heat Pump System.
- 2) CS = wiring used for Condensate Switch (2 Options).
- 3) Y1 must be connected from the thermostat to the IFC for proper airflow.
- 4) A/TCONT824 thermostats do not require the use of X2.

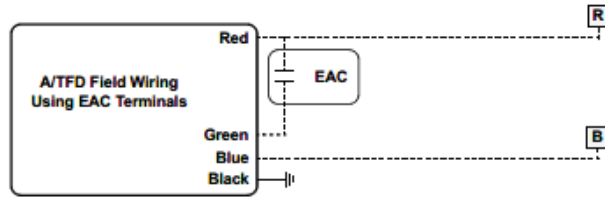

Replace the factory installed 35va transformer with the 50va transformer supplied with the air cleaner. Connect to EAC terminals on the IFC per the wiring diagram.

### Twinning

Figure 71. Twinning connection diagram for twinning S-series furnaces 1 stage heat or 2 stage cooling thermostat for non-A2L systems

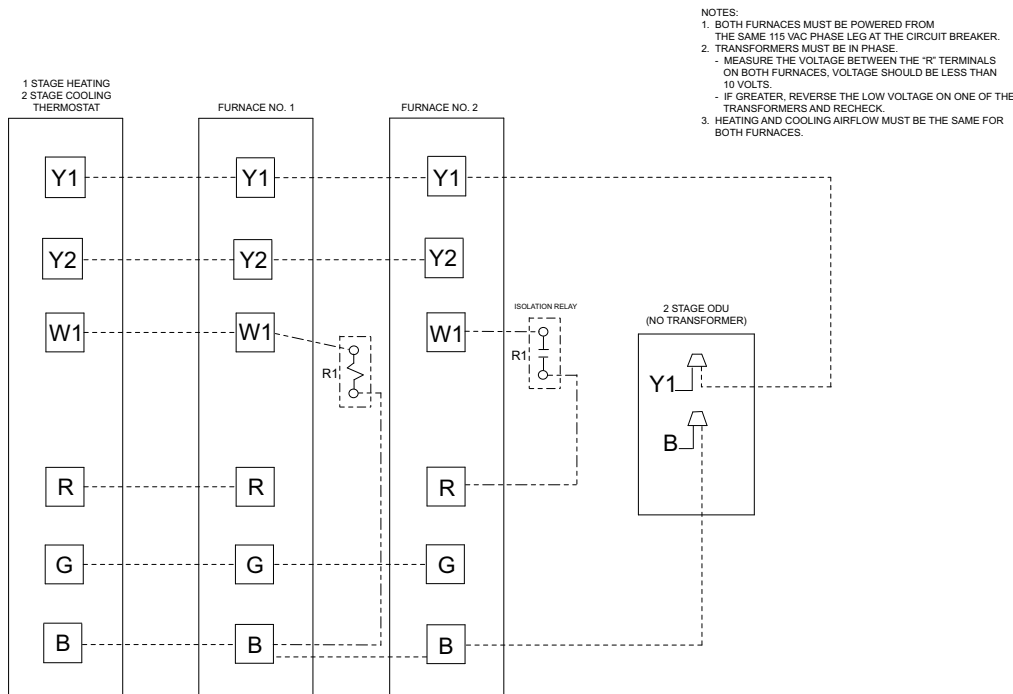

- NOTES:
- 1. BOTH FURNACES MUST BE POWERED FROM THE SAME 115 VAC PHASE LEG AT THE CIRCUIT BREAKER.
  - 2. TRANSFORMERS MUST BE IN PHASE.
    - MEASURE THE VOLTAGE BETWEEN THE "R" TERMINALS ON BOTH FURNACES, VOLTAGE SHOULD BE LESS THAN 10 VOLTS.
    - IF GREATER, REVERSE THE LOW VOLTAGE ON ONE OF THE TRANSFORMERS AND RECHECK.
  - 3. HEATING AND COOLING AIRFLOW MUST BE THE SAME FOR BOTH FURNACES.

# Furnace General Installation

**Figure 72. Twinning connection diagram for twinning S-series furnaces 1 stage heat or 2 stage cooling (with transformer) thermostat for non-A2L systems**

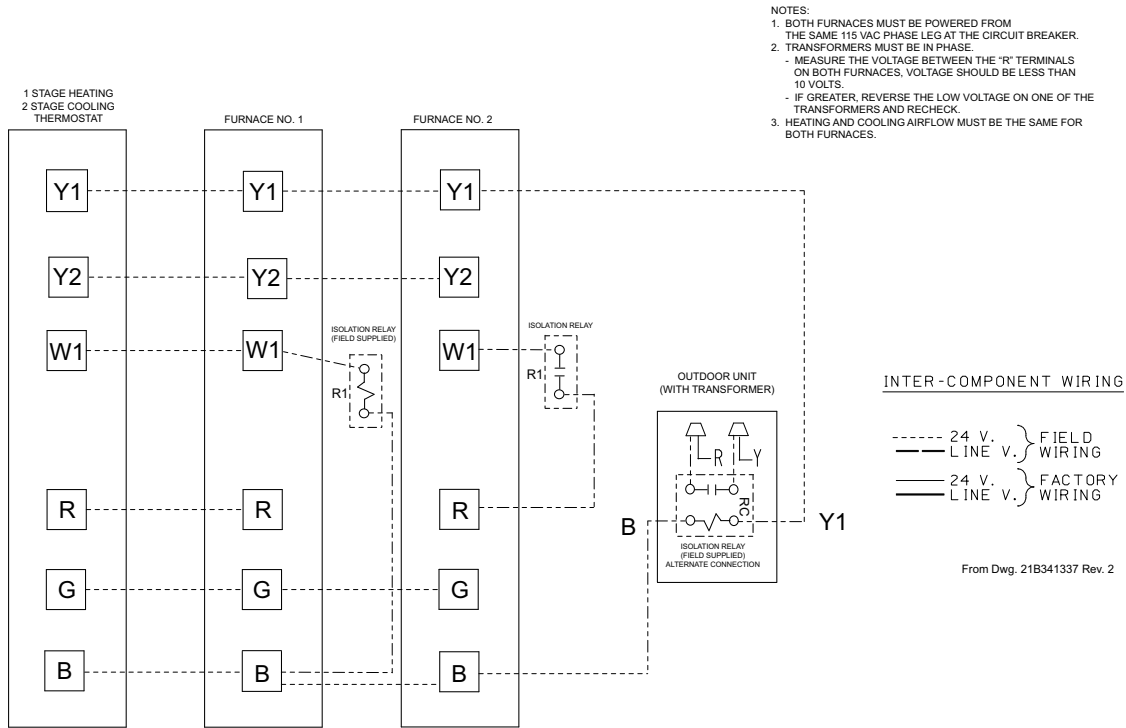

# Condensate Drain Instructions

The following sections give general instructions for installing condensate drains. Repositioning of the condensate trap is covered in “Furnace Combustion Air Exhaust Options,” p. 57.

Cutouts with plugs and grommets are provided on the left and right hand side of the furnace cabinets for drain connections in vertical applications. The standard arrangement is for the drain connection on the left side. The tubing may have to be trimmed in this application to avoid kinking.

The upflow (vertical application) also has provisions for right side drain connections. Exchange the grommet and plugs from the left and right side. Trim all excess tubing to avoid kinking.

It is always recommended that an auxiliary drain pan be installed under a horizontally installed evaporator or 90% gas furnace. Connect the auxiliary drain line to a separate drain line (no trap is needed in this line).

Horizontal applications require repositioning the condensate canister trap. Additionally the drain tubing connected to the inducer housing may need to be repositioned for removing the plug and reconnecting the tubing to the lower connection on the inducer housing.

Connections must be made to an open/vented drain.

## Notes:

- All condensate drain piping supplies included with the furnace are for internal piping only and should not be applied external to the furnace. All external piping must use 1/2-inch minimum size PVC pipe and fittings throughout for drain connections (fittings, pipe and PVC solvent cement not provided with furnace, must be field supplied). A 3/4-inch coupling is supplied to connect to systems that are using 3/4-inch piping with an air conditioner coil.
- A corrosion resistant condensate pump must be used if a pump is required for a specific drain system.

## ⚠ CAUTION

### Water Damage!

Failure to follow instructions below could result in minor to moderate injury or equipment damage  
Install a drain pan under the furnace to prevent leaking condensate.

Figure 73. Condensate management



**Important:** The condensate drain should be installed with provisions to prevent winter freeze-up of the condensate drain line. Frozen condensate will block drains, resulting in furnace shutdown. If the drain line cannot be installed in a conditioned space and/ or its surrounding ambient temperature is expected to fall below freezing, then heat tape should be applied as required to prevent freezing (per manufacturer’s instructions). The heat tape should be rated at 5 or 6 watts per foot at 120 volts. Self-regulating (preferred) or thermostatically controlled heat tape is required.

Typical sources of UL listed heat tapes are W.W. Granger, Inc. (Wintergard Plus™ Series), McMaster Carr Supply Co. (3554 Series), or your equipment supplier.

The condensate drain may be cleaned or inspected by removal of the drain tube at the header.

Evaporator and Furnace condensate drain piping may be manifolded together. A primary drain vent stack must be installed and terminated below the outlet of the secondary heat exchanger drain connection to prevent water from damaging Furnace controls if the primary drain outlet plugs up.

Where the Furnace is installed above a finished ceiling, the primary drain vent stack must be installed such that overflow from the vent stack opening will flow into an auxiliary drain pan in order to prevent water damage to the finished ceiling below.

## Vertical Applications

### Upflow Furnace

Remove the plug from the side panel where the condensate will exit.

Install the condensate grommet into the side panel.

Install the connection tubing from the trap to the side of the unit and trim all excess tubing to avoid kinks.

**Note:** For easiest installation, remove the spring clip from the end of the condensate line and feed through the grommet.

**Important:** Condensate grommet must be installed for proper operation.

# Condensate Drain Instructions

**Figure 74. Upflow furnace with left side drain**

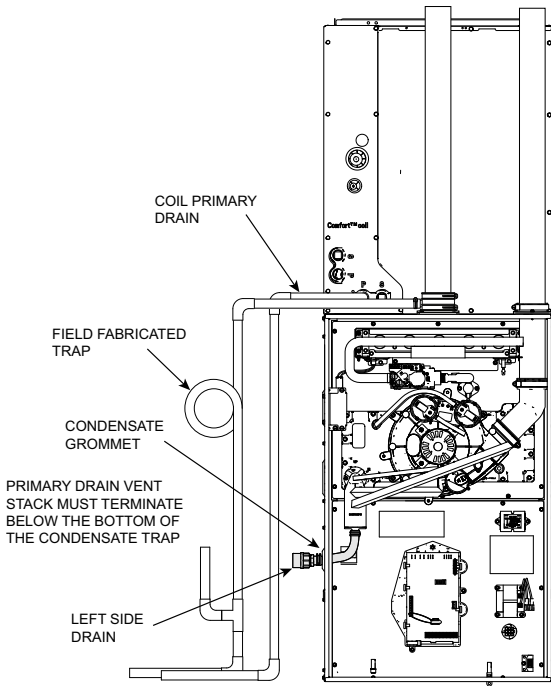

**Figure 76. Upflow furnace with left side drain**

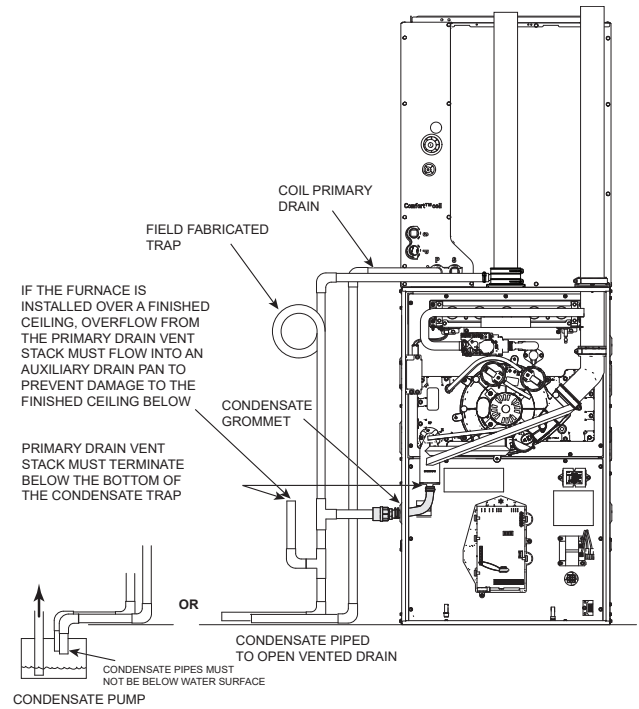

**Figure 75. Upflow furnace with right side drain**

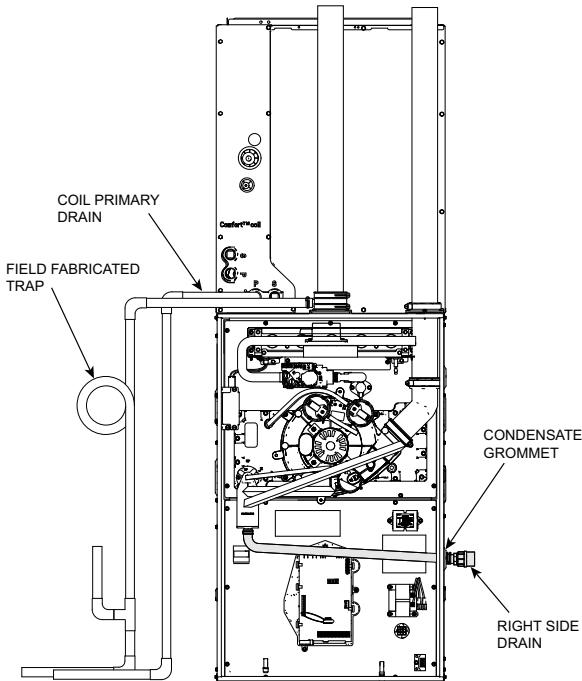

**Figure 77. Upflow furnace with right side drain**

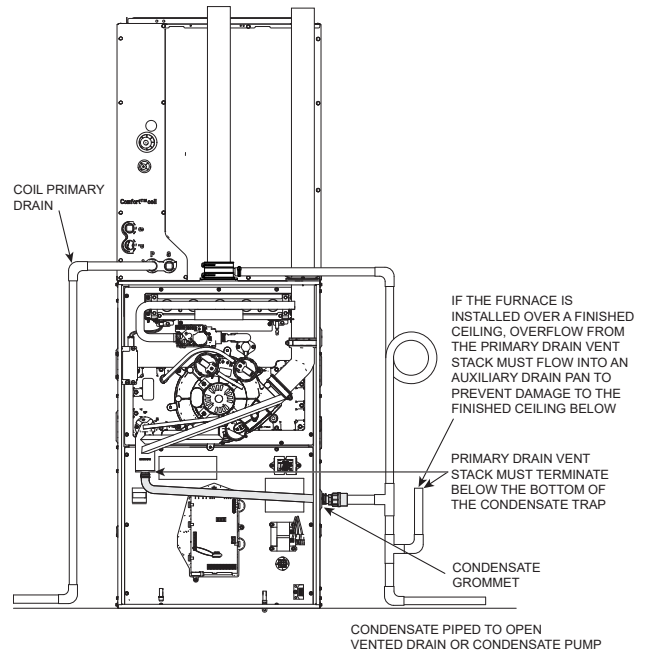

Figure 78. Upflow furnace with left side drain

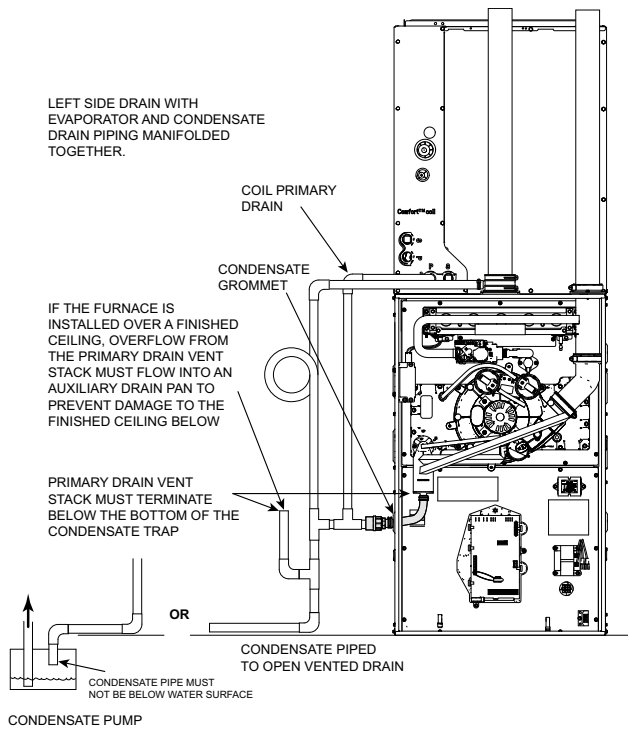
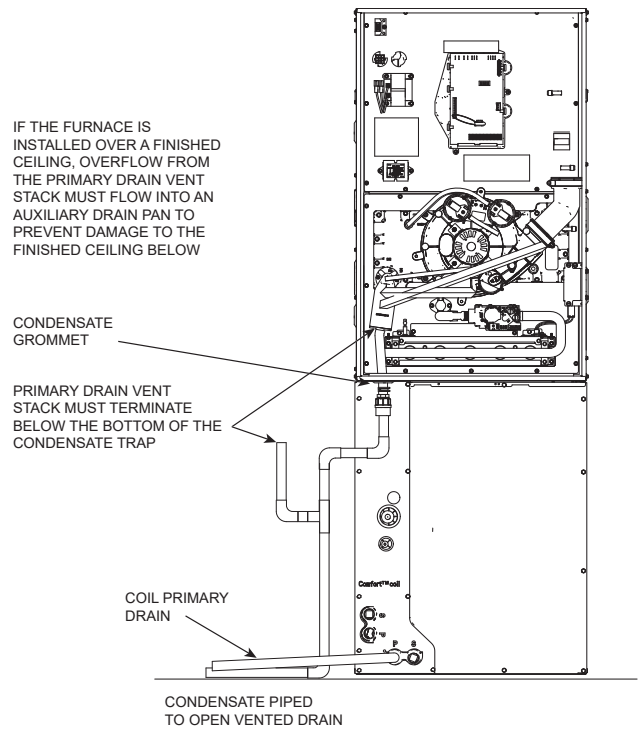

Figure 79. Downflow furnace with bottom drain



## Downflow Furnace

Cut the 90 degree section of the condensate tubing off and connect the tubing to the condensate trap. Install the condensate grommet into the bottom panel. Cut to length as needed.

### Downflow furnace with Left Side Condensate:

1. Remove left hand condensate plug.
2. Install into bottom cross member.

Figure 80. Downflow furnace with left side condensate

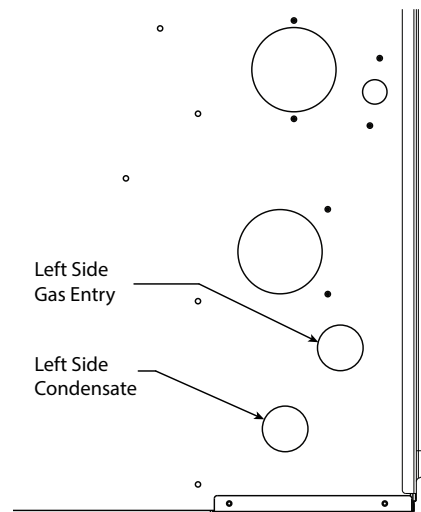

3. Plug the bottom hole with plug provided in document pack.

## Condensate Drain Instructions

**Figure 81. Downflow furnace with right side condensate — plug installation**

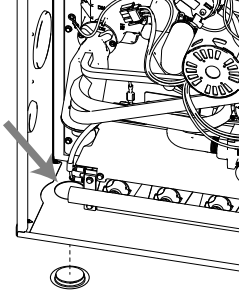

### Attaching the condensate drain line:

1. Locate the condensate grommet and the condensate drain line assembly in the doc pack.
2. Insert the condensate grommet in the 1-5/8-inch hole in the side of the cabinet.
3. Remove the fitting at the end of the drain line assembly and insert it through the cabinet from the inside out. Attach the 90 degree section of the hose to the condensate drain trap.
4. Cut off the excess tube and reinstall the end fitting to the drain hose.

**Figure 82. Downflow furnace with left side drain**

### DOWNFLOW FURNACES LEFT SIDE DRAIN

1-5/8" DIAMETER HOLE MUST BE CUT IN LEFT SIDE OF CASE. BOTTOM HOLE MUST BE PLUGGED.

IF THE FURNACE IS INSTALLED OVER A FINISHED CEILING, OVERFLOW FROM THE PRIMARY DRAIN VENT STACK MUST FLOW INTO AN AUXILIARY DRAIN PAN TO PREVENT DAMAGE TO THE FINISHED CEILING BELOW

CONDENSATE GROMMET

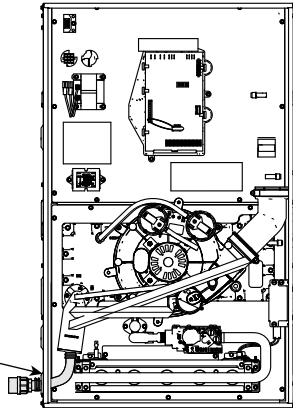

### Downflow furnace with Right Side Condensate:

Drill an 11/16-inch diameter hole in the right side of the case at the dimensions shown.

**Figure 83. Downflow furnace with right side condensate**

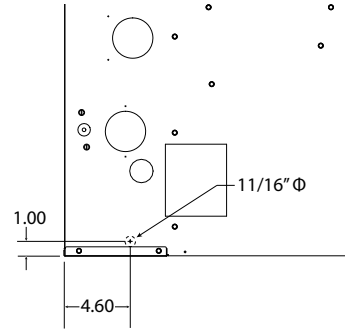

Plug the bottom hole with plug provided in document pack.

**Figure 84. Plug hole**

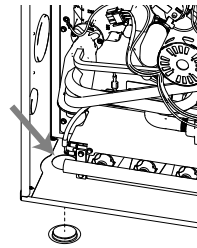

### Attaching the condensate drain line:

1. Locate the condensate drain line assembly in the doc pack.

**Important:** It is best to cut the condensate drain hose assembly longer than 4 inches and then fit in place. It can then be trimmed to needed length. The 4-inch measurement is an approximation.

2. Cut the condensate drain line assembly as shown.
3. Use a field supplied hose clamp to secure the condensate drain line to the condensate trap.
4. Insert a field supplied piece of 1/2-inch CPVC pipe through the 11/16-inch hole drilled through the cabinet and insert into drain line hose. Secure with the spring clip.

**Note:** Seal around the condensate drain tubing where it exits the cabinet.

**Figure 85. Condensate drain line**

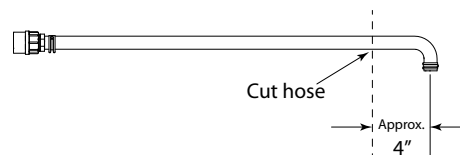
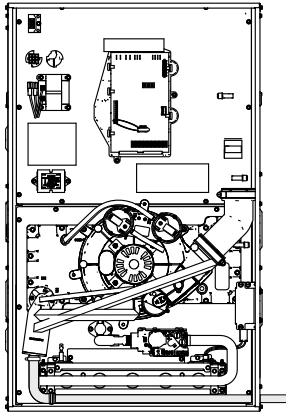

Figure 86. Downflow furnace with right side drain



DOWNFLOW FURNACES  
RIGHT SIDE DRAIN

11/16" DIAMETER HOLE MUST BE CUT IN RIGHT SIDE OF CASE. BOTTOM HOLE MUST BE PLUGGED. CUT FACTORY SUPPLIED CONDENSATE ASSEMBLY HOSE AND ATTACH TO FIELD SUPPLIED CPVC TUBE. SECURE WITH SPRING CLIP AND FIELD SUPPLIED HOSE CLAMP.

IF THE FURNACE IS INSTALLED OVER A FINISHED CEILING, OVERFLOW FROM THE PRIMARY DRAIN VENT STACK MUST FLOW INTO AN AUXILIARY DRAIN PAN TO PREVENT DAMAGE TO THE FINISHED CEILING BELOW

To prevent AC condensate from backing up into the furnaces, follow these instructions for condensate drainage.

**Notes:**

- The overflow stand pipe termination must be even with or slightly below than the bottom of the condensate trap.
- Water from the overflow pipe must drain into the emergency drain pan.
- It is recommended to use the secondary drain. The secondary drain pipe must terminate over the emergency drain pan.

## Horizontal Applications

**Upflow models in horizontal** - It is always recommended that the auxiliary drain pan be installed under a horizontally installed evaporator and/or 90% gas furnace. Connect the drain pan to a separate drain line (no trap is needed in this line).

Connect to an open/vented drain. Outdoor draining of the furnace and coil condensate is permissible if allowed by local codes. Prevent drains from freezing or causing slippery conditions that could lead to personal injury, and avoid excessive draining that could saturate ground conditions damaging plants.

**Notes:**

- Use 1/2-inch or larger PVC or CPVC pipe and fittings as required for drain connections (fittings, pipe and solvent cement not provided).
- A corrosion resistant condensate pump must be used if a pump is required for a specific drain system.

**Important:** Install the condensate drain with provisions to prevent winter freeze-up, which can block the line and shut down the furnace. If the drain line cannot be installed in a conditioned space, apply UL-listed 5 or 6 watts per foot, 120V heat tape (per manufacturer's instructions), preferably self-regulating or thermostatically controlled.

Figure 87. Horizontal applications

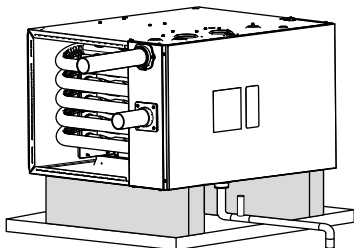

FURNACE MUST BE SUPPORTED AT ALL FOUR CORNERS. BAYHANG - OPTIONAL HORIZONTAL HANGING BRACKET KIT TO APPROVED OPEN / VENTED DRAIN

Note: The overflow stand pipe termination must be even with or slightly below the bottom of the condensate trap.  
Note: Water from the overflow pipe must drain into the emergency drain pan.

## NOTICE

### Equipment Damage!

Failure to follow instructions below could result in intermittent or improper operation, or equipment damage.

A blocked main drain with an overflow standpipe that is higher than the bottom of the condensate trap can result in an E09 Condensate Pressure Switch Trip error. Additionally, a condensate pressure switch hose that is not trimmed to fit can also cause this error. In extreme cases, these issues can lead to an E04 Rollout Thermal Limit Trip error.

An overflow standpipe with an opening even with or slightly below the bottom of the condensate trap must be installed. The condensate pressure switch hose must be trimmed to fit.

Figure 88. Horizontal right

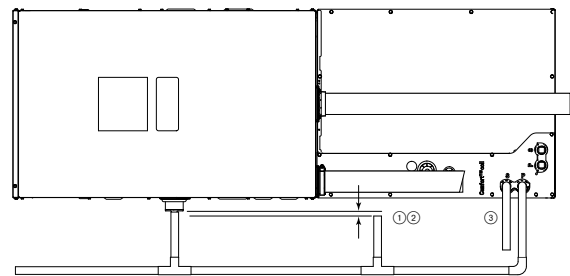
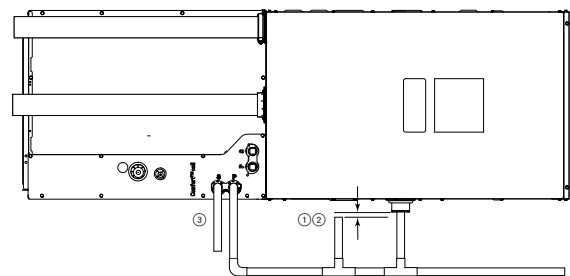

Figure 89. Horizontal left



# General Start-Up and Adjustment

The following sections provide instructions for the general start-up and adjustment of the gas furnaces.

## Preliminary Inspections

**With gas and electrical power "OFF", confirm:**

1. Duct connections are properly sealed.
2. Filters are in place.
3. Venting is properly assembled.
4. Blower vestibule panel and all screws are in place.

Turn knob on main gas valve within the unit to "OFF". Turn the external gas valve to "ON". Purge the air from the gas lines. After purging, check all gas connections for leaks with a soapy solution.

Do not check with an open flame allow 5 minutes for any gas that might have escaped to dissipate. Turn the gas valve in the unit to the "ON" position.

Propane Gas being heavier than air may require forced ventilation. Turn the toggle switch on the Gas Valve in the unit to the "ON" position.

## Lighting Instructions

Lighting instructions appear on each unit. Each installation must be checked out at the time of initial start up to ensure proper operation of all components. Check out should include putting the unit through one complete cycle as outlined below.

Turn on the main electrical supply and set the comfort control above the indicated temperature. The igniter will automatically heat and the gas valve is energized to permit the flow of gas to the burners. After ignition and flame is established, the flame control module monitors the flame and supplies power to the gas valve until the comfort control is satisfied.

### **⚠ WARNING**

#### **Risk of Fire or Explosion!**

**Failure to follow instruction below could result in death or serious injury or property damage.**

**Do NOT attempt to manually light the furnace.**

To shut off

For complete shutdown, turn the toggle or control switch located on the main gas valve inside the unit to OFF and the external main gas shutoff valve to OFF. Disconnect the electrical supply to the unit.

Inspect temperature in a vacant house especially during freezing weather. If for any reason your furnace should fail to operate damage could result, such as frozen water pipes.

### **⚠ CAUTION**

#### **Freeze Damage!**

**Failure to follow instructions below could result in minor to moderate injury or property damage.**

**Insulate vent pipes with 1/2 inch (12.7 mm) Armaflex-type insulation or equivalent when passing through unheated spaces exposed to freezing temperatures. Insulation is not needed if the space is heated enough to prevent freezing. If domestic water pipes are not protected from freezing, the space is considered heated. Schedule qualified personnel to inspect the temperature if the house is vacant during freezing weather. A furnace failure could lead to frozen water pipes.**

## Control and Safety Switch Adjustment

### Limit Switch Check Out

The limit switch is a safety device designed to close the gas valve should the furnace become overheated. Since proper operation of this switch is important to the safety of the unit, it must be checked out on initial start up by the installer.

To check for proper operation of the limit switches, set the thermostat to a temperature higher than the indicated temperature to bring on the gas valve. Restrict the airflow by blocking the return air to the blower. When the furnace reaches the maximum outlet temperature as shown on the rating plate, the burners must shut off. If they do not shut off after a reasonable time and overheating is evident, a faulty limit switch is probable and the limit switch must be replaced. After checking the operation of the limit control, be sure to remove the paper or cardboard from the return air inlet, or reconnect the blower.

# Furnace Combustion Air Exhaust Options

**Important:**

- All plugs must be in place for sealed combustion.
- If the locations are changed from the defaults, the default holes not being used must be plugged.
- The combustion air exhaust must be vented to the outdoors.

**Notes:**

- Default is left side for electric and natural gas connections. Default for the combustion air inlet and exhaust is top of the furnace.
- If the electrical and natural gas connections are moved to the right side, remove the plugs and move them to the left side. The grommets will move from the left side to the right side.
- The grommets are different for the natural gas and condensate connections.
- The combustion air inlet does not have to be on the same side as the combustion air exhaust.

See the illustrations below to find the approved venting options for upflow and horizontal left furnace applications.

**Note:** Choose any combination such that it must have one inlet and one outlet.

**Figure 90. Upflow application**

Combustion air exhaust vented out at the top.

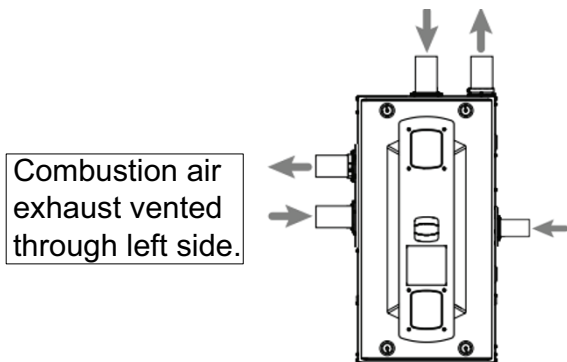

**Figure 91. Horizontal left application**

Combustion air exhaust vented out at the top.

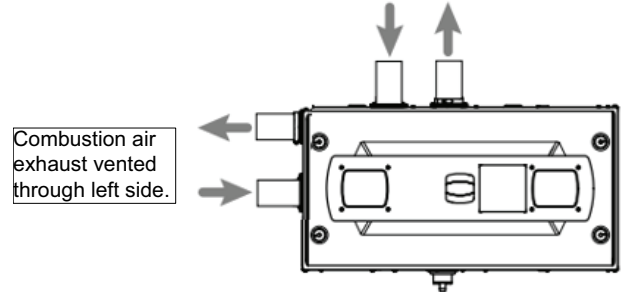

**Figure 92. Horizontal right application**

Combustion air exhaust vented out at the top.

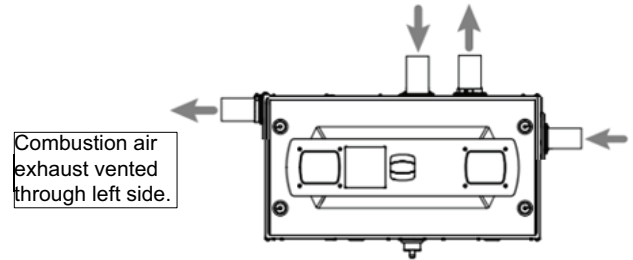

**Figure 93. Downflow application**

Combustion air exhaust vented out at the top.

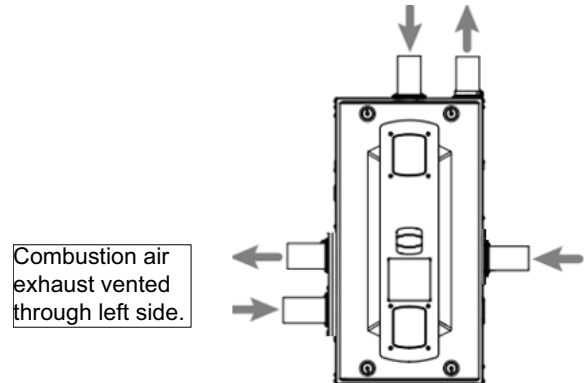

## Factory Set Up - Upflow and Downflow Orientation

Figure 94. Furnace for upflow, horizontal left and horizontal right orientations

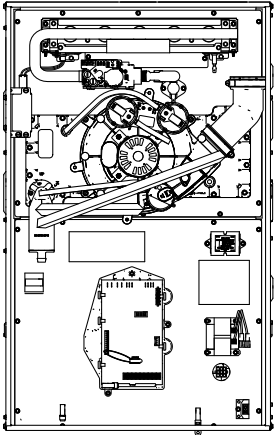

Figure 95. Furnace for downflow orientation

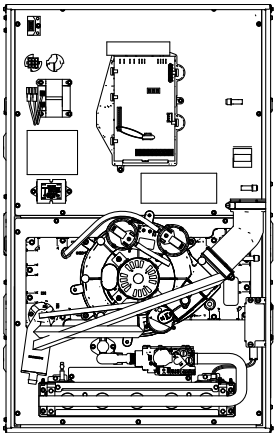

Figure 96. Grommet trap for horizontal left and right

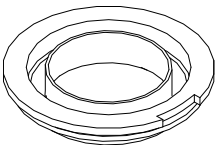

Figure 97. Conversion instructions



Conversion Instructions

## Upflow Position - Top Vented

### Important:

- Trim the condensate pressure switch tubing to length to prevent creating a sag or trap.
- Refer to the image at the initial part of this section to see the furnace as seen from the factory.

1. Attach the vent outlet gasket to the vent outlet.
2. Install vent outlet to top of cabinet using two screws supplied in the doc pack.
3. Install vent inlet gasket and vent inlet using four screws supplied in the doc pack.

Figure 98. Vent inlet/outlet

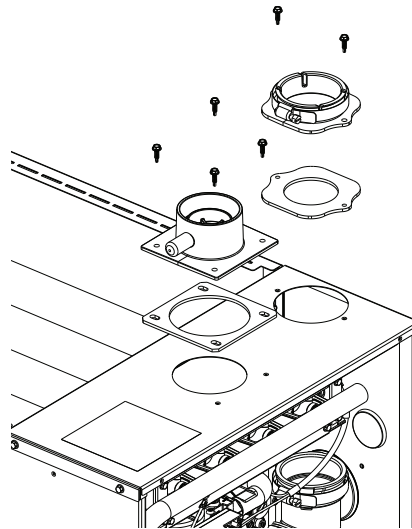

4. Slide PVC pipe through vent outlet adaptor and insert into inducer outlet.
5. Twist to ensure PVC is fully inserted.
6. Tighten the clamp on the end of the 45° elbow.
7. Tighten the clamp on the outlet vent adapter.

**Note:** The vent outlet adapter is used for strain relief against the weight of the venting. The clamp should be tightened after the internal connection is made.

8. Install the combustion air inlet PVC pipe.

**Note:** If required, transition to larger venting within 2' of the cabinet. CPL00938 – 2-inch x 3-inch offset coupling may be used and is factory supplied with 120 KBTUH furnaces. Canadian applications may use BAYREDUCE to meet ULC-S636 requirements..

Figure 99. Upflow furnace in upflow position

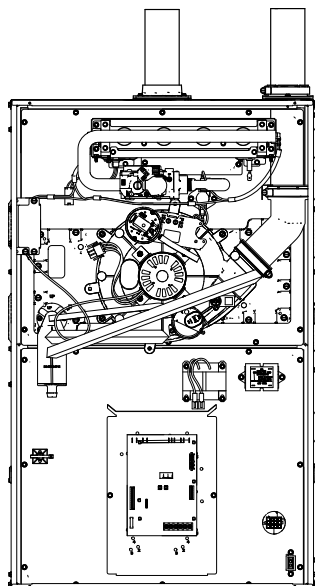

## Upflow Position - Left Side Vented

Follow the steps below to modify the furnace for upflow with side venting of combustion air.

**Important:** Right side vent outlet is not allowed because condensate will not drain.

Before proceeding, lay unit on its back to make conversion easier.

1. Disconnect all drain tubes from condensate trap.

**Note:** Hold the condensate trap when removing the hoses to prevent breakage. Alternatively, remove the trap first.

2. Remove drain tubing from bottom of inducer housing.
3. Remove rain gutter tubing from inducer outlet.
4. Remove tubing from condensate pressure switch.
5. Loosen hose clamp and remove 45° adapter. If the rubber boot pulls out of the inducer opening, remove from the adapter and reinstall onto the inducer. Remove and discard the elbow.

Figure 100. Removing tubing

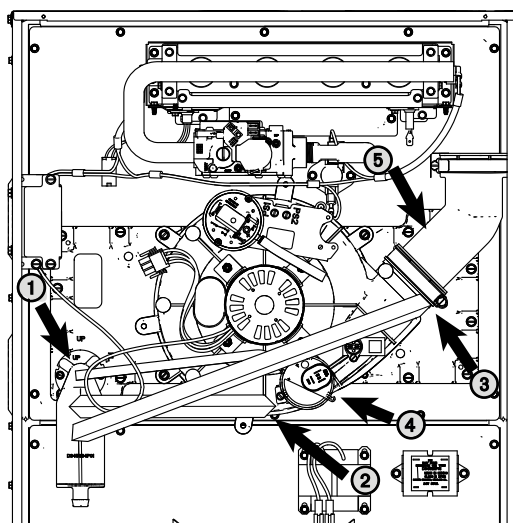

6. Remove two 3-inch plugs on left side of cabinet – to be used for combustion air and vent exhaust.
7. Install the two 3-inch plugs into the two 3-inch default openings on the top of the cabinet.

Figure 101. Plug installation

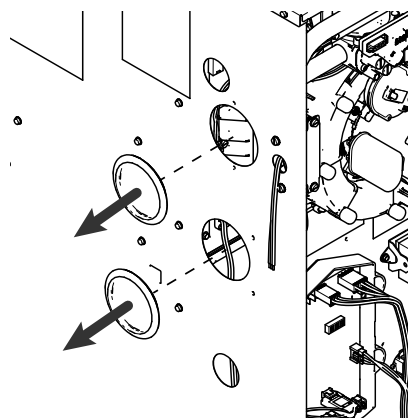

8. Remove the three inducer mounting screws.
9. Rotate inducer counter-clockwise so that the inducer outlet aligns with the exhaust vent outlet.
10. Insert and re-tighten screws to 30 in.-lbs. Do not overtighten.

Figure 102. Tightening screws

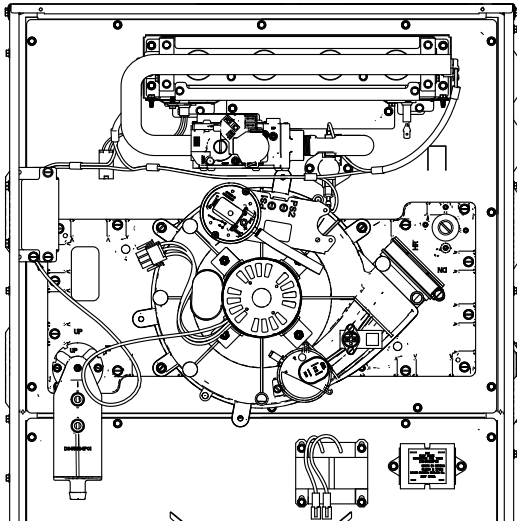
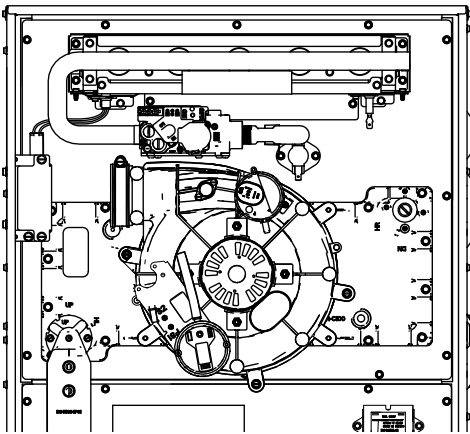
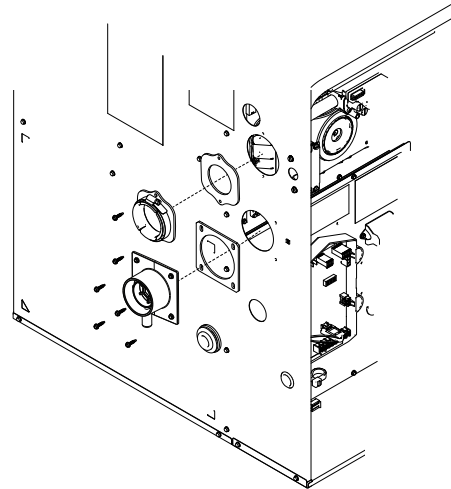

Figure 103. Tightening screws



11. Attach the vent outlet gasket to the vent outlet.
12. Install vent outlet to top of cabinet using two screws supplied in the dock pack.
13. Install vent inlet gasket and vent inlet using four screws supplied in the dock pack.
14. Install the grommet for the condensate drain tube. The drain may be located on either side of the cabinet.

Figure 104. FIGURE TITLE NEEDED



15. Slide PVC through vent outlet adaptor and insert into inducer outlet.
16. Twist to insure PVC is fully inserted.
17. Tighten the two clamps.
18. Install the combustion air inlet pipe.

**Note:** The vent outlet adapter is used for strain relief against the weight of the venting. The clamp should be tightened after the internal connection is made.

**Note:** If required, transition to larger venting within 2' of the cabinet. A 2-inch x 3-inch offset coupling is required if the transition is made in a horizontal plane. Use coupling CPL01544 (Canadian applications may use BAYREDUCE to meet ULC-S636 requirements.) See Horizontal Venting section for proper orientation of 2-inch x 3-inch offset coupling.

Figure 105. Condensate tubing

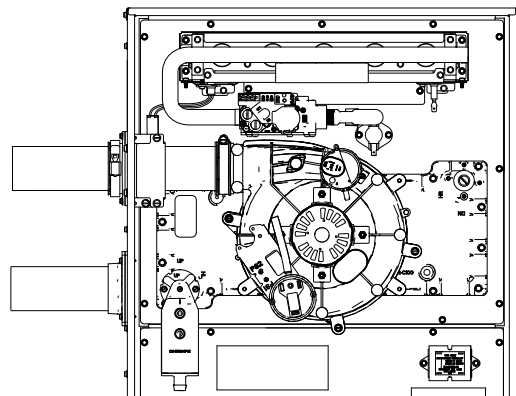

19. Remove port cap at bottom of inducer and connect inducer condensate tubing. Connect other end of inducer condensate tubing to top port on the condensate trap. Cut tubing to length, if necessary.

20. Install previously removed port cap onto bottom port of the inducer (as viewed in upflow)
21. Connect condensate pressure switch tubing to pressure port on the condensate trap.

**Important:** Trim the condensate pressure switch tubing to length to prevent creating a sag or trap.

22. Remove port plug from rain gutter and install in new position on opposite side of the rain gutter.
23. Connect rain gutter condensate hose to the rain gutter and the lower port of the condensate trap. Cut to length, if necessary.

**Figure 106. Condensate tubing**

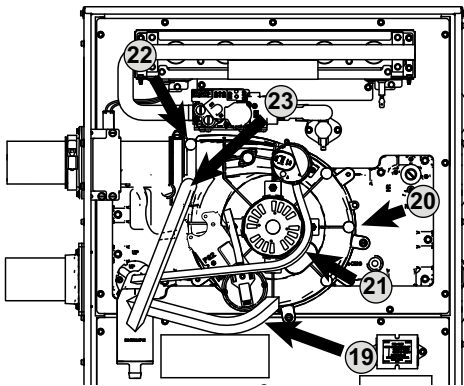

### Horizontal Left Position - Top Vented

Changes need to be made to the inducer orientation when installing the upflow furnace in the horizontal left position with the combustion air vented through the side. Additional changes are needed for hose routing, condensate trap orientation, and inducer hoses.

The figure below shows the furnace as it is sent from the factory.

Follow the steps below to modify the furnace for horizontal left with side venting of combustion air.

Before proceeding, lay unit on its back to make the conversion easier.

1. Remove all drain hoses from condensate trap.

**Note:** Hold the condensate trap when removing the hoses to prevent breakage. Alternatively, remove the trap first.

2. Remove drain tubing from bottom of inducer housing.
3. Remove rain gutter tubing from inducer outlet.
4. Remove tubing from condensate pressure switch.
5. Remove the screws that hold the condensate trap bracket. The condensate trap should not be removed from the condensate trap bracket. Remove assembly and retain for later installation.

**Note:** There is a plastic adapter with O-rings located inside the cold header that is held in place by the condensate trap bracket. Do not lose this adapter. This adapter needs to be in place when the condensate trap bracket is reattached.

6. Loosen hose clamp and remove 45° adapter. If the rubber boot pulls out of the inducer opening, remove from the adapter and reinstall onto the inducer. Remove the elbow and discard.

**Figure 107. Removing tubing**

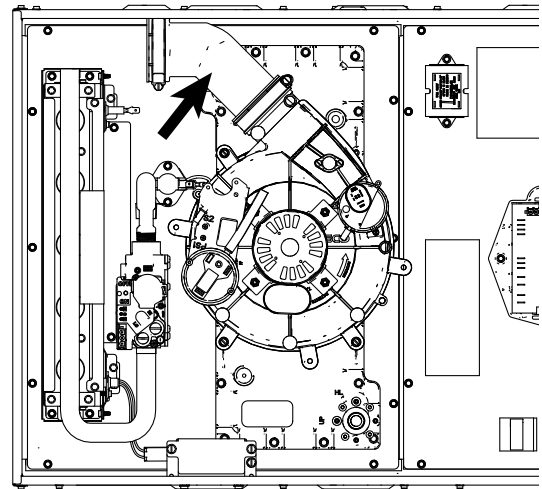

7. Remove three inducer screws.
8. Rotate the inducer so that the outlet is pointing vertically.
9. Use the three screws to reattach the inducer to the cold header to 30 in.-lbs. Do not overtighten.

**Figure 108. Inducer screw removal**

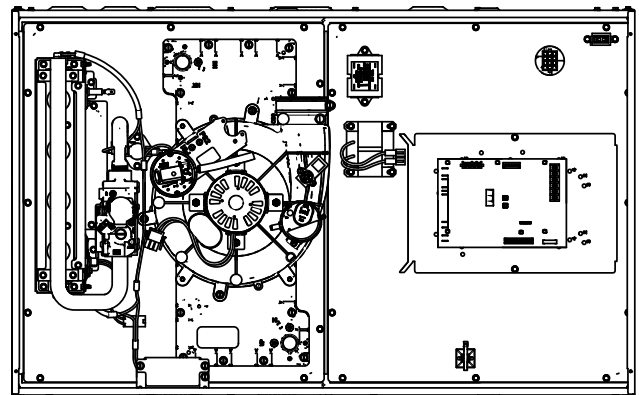

10. Remove 3-inch plug on left side of unit. To be used for condensate trap.
11. Install condensate trap grommet.
12. Remove two 3-inch plugs on right side of cabinet. To be used for combustion air exhaust and inlet.

## Furnace Combustion Air Exhaust Options

- Reuse the two 3-inch plugs to seal the two 3-inch default openings on the top of the furnace.

**Figure 109. Sealing default openings**

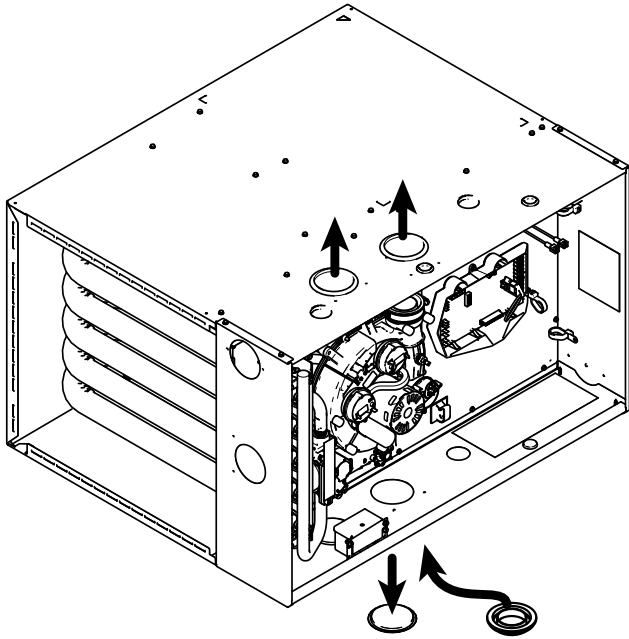

- Attach the vent outlet gasket to the vent outlet.
- Install vent outlet to top of cabinet using two screws supplied in the dock pack.
- Install vent inlet gasket and vent inlet using four screws supplied in the dock pack.

**Figure 110. Installing screws**

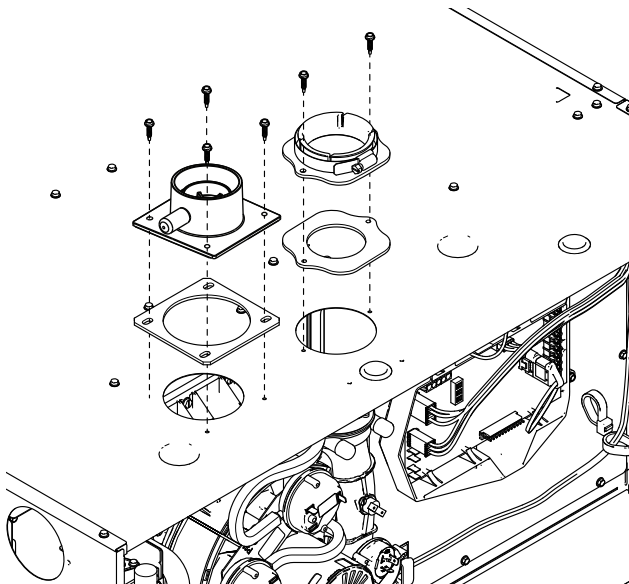

- Slide PVC through vent outlet adaptor and insert into inducer outlet.
- Twist to insure PVC is fully inserted.

- Tighten the two clamps.
- Install the combustion air inlet PVC pipe.

**Notes:**

- The vent outlet adaptor is used for strain relief against the weight of the venting. The clamp should be tightened after the internal connection is made.
- If required, transition to larger venting within 2' of the cabinet. CPL01544 – 2-inch x 3-inch offset coupling may be used and is factory supplied with 120 MBTUH furnaces. Canadian applications may use BAYREDUCE to meet ULC-S636 requirements.

**Figure 111. PVC installation**

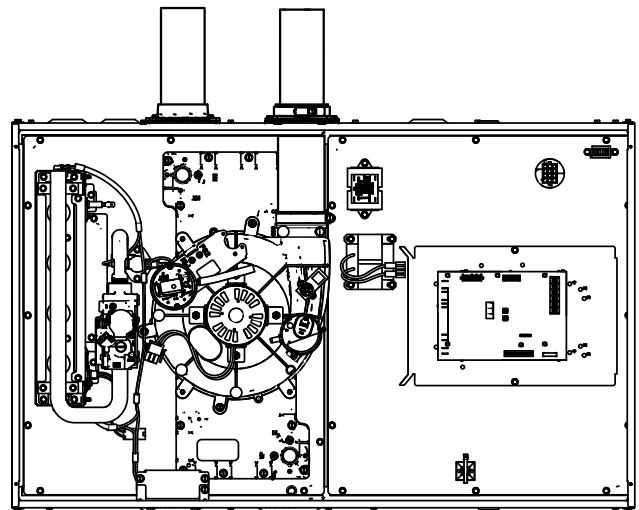

**Condensate Trap Installation**

- Reinstall the condensate adapter if it was earlier removed or ensure adapter is still in place.

**Important:** The condensate adapter must be present for proper condensate drain operation.

- Install condensate trap into new location by fitting into grommet and aligning the hole on the condensate trap with the hole labeled "HL".

**Important:** When installing a 21.0-inch wide S-Series furnace, rotate the grommet so the notch faces the cabinet's outer edge as shown in the illustrations. This allows the rain gutter tubing to fully seat onto the lower condensate port trap.

- Hand tighten screw with a 1/4" nut driver. Do not over torque or use a drill gun.

Figure 112. Tightening screws

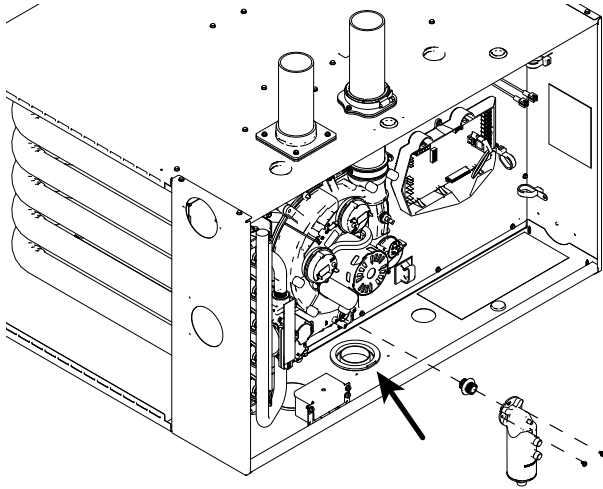
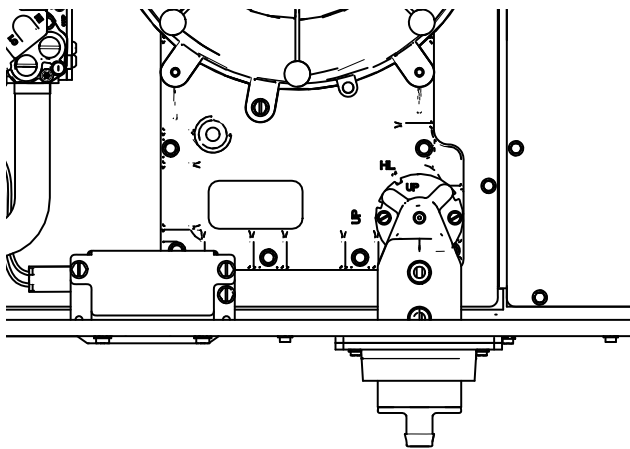

Figure 113. Condensate tubing



24. Remove port cap on left of inducer and connect inducer condensate tubing. Connect other end of inducer condensate tubing to top port on the condensate trap. Cut tubing to length, if necessary.

25. Install previously removed port cap onto bottom port of the inducer.

26. Connect condensate pressure switch tubing to pressure port on the condensate trap.

**Important:** Trim the condensate pressure switch tubing to length to prevent creating a sag or trap.

27. Connect rain gutter condensate hose to the rain gutter and the lower port of the condensate trap.

Figure 114. Condensate tubing

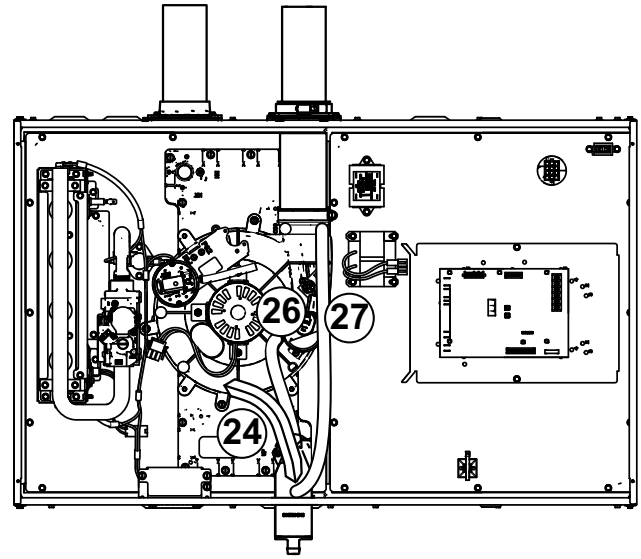

## Horizontal Left Position - Side Vented

Changes do not need to be made to the inducer orientation when installing the upflow furnace in the horizontal left position with the combustion air vented through the top. Changes are needed for hose routing, condensate trap orientation, and inducer port caps.

The figure below shows the furnace as it is sent from the factory.

Use the following steps to modify the furnace for horizontal left with top venting of combustion air.

Before proceeding, lay unit on its back to make the conversion easier.

1. Remove all drain hoses from condensate trap.

**Note:** Hold the condensate trap when removing the hoses to prevent breakage. Alternatively, remove the trap first.

2. Remove drain tubing from bottom of inducer housing.
3. Remove rain gutter tubing from inducer outlet.
4. Remove tubing from condensate pressure switch.
5. Remove the screws that hold the condensate trap bracket. The condensate trap should not be removed from the condensate trap bracket. Remove assembly and retain for later installation.

**Note:** There is a plastic adapter with O-rings located inside the cold header that is held in place by the condensate trap bracket. Do not lose this adapter. This adapter needs to be in place when the condensate trap bracket is reattached.

## Furnace Combustion Air Exhaust Options

**Figure 115. Removing tubing**

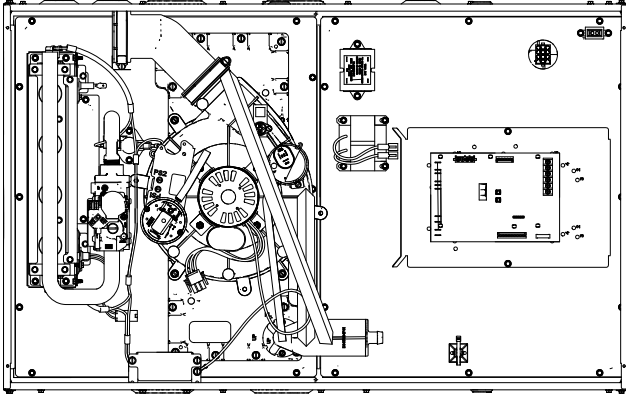

6. Remove plug from 3-inch hole.
7. Install condensate trap grommet.

**Figure 116. Condensate trap grommet**

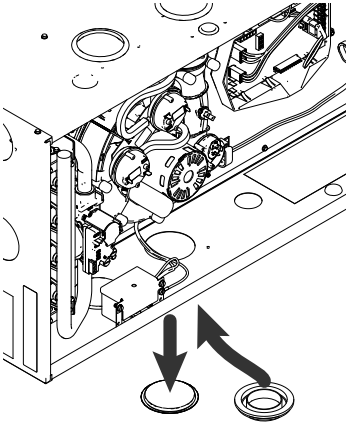

8. Attach the vent outlet gasket to the vent outlet.
9. Install vent outlet to top of cabinet using two screws supplied in the doc pack.
10. Install vent inlet gasket and vent inlet using four screws supplied in the doc pack.

**Figure 117. Vent inlet/outlet**

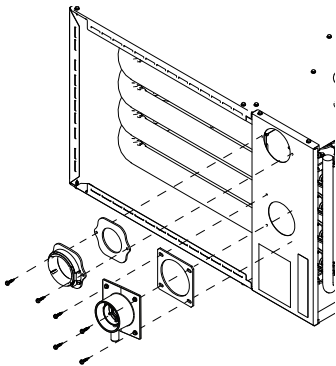

11. Slide PVC through vent outlet adaptor and insert into inducer outlet.
12. Twist to insure PVC is fully inserted.
13. Tighten the two clamps.
14. Install the combustion air inlet PVC pipe.

**Note:** The vent outlet adaptor is used for strain relief against the weight of the venting. The clamp should be tightened after the internal connection is made.

**Note:** If required, transition to larger venting within 2' of the cabinet. An 2-inch x 3-inch offset coupling is required if the transition is made in a horizontal plane. Use coupling CPL01544 (Canadian applications may use BAYREDUCE to meet ULC-S636 requirements.) See Horizontal Venting section for proper orientation of 2-inch x 3-inch offset coupling.

**Figure 118. Condensate tubing**

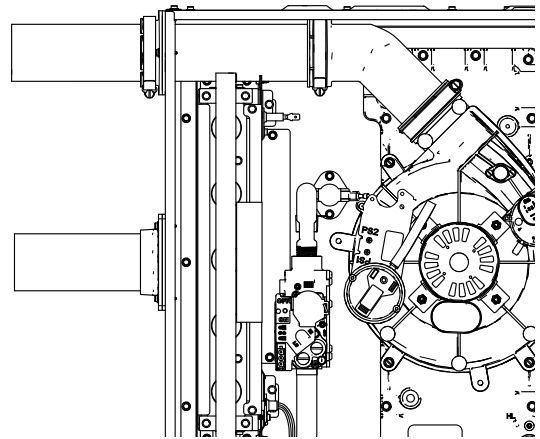

### Condensate Trap Installation

15. Reinstall the condensate adapter if it was earlier removed or ensure adapter is still in place.

**Important:** The condensate adapter must be present for proper condensate drain operation.

16. Install condensate trap into new location by fitting into grommet and aligning the hole on the condensate trap with the hole labeled HL.

**Important:** When installing a 21.0-inch wide S-Series furnace, rotate the grommet so the notch faces the cabinet's outer edge as shown in the illustrations. This allows the rain gutter tubing to fully seat onto the lower condensate port trap.

17. Hand tighten screw with a 1/4-inch nut driver. Do not over torque or use a drill gun.

Figure 119. Tightening screws

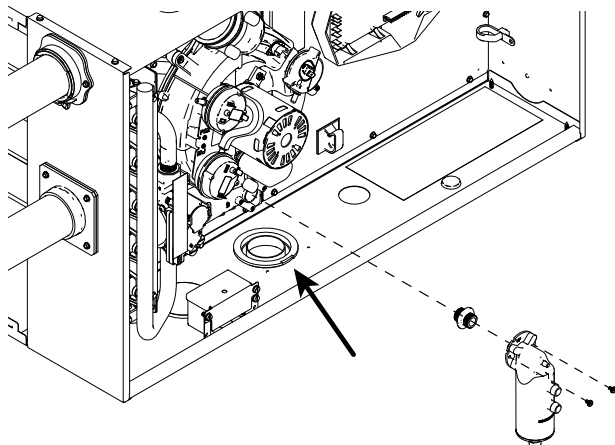
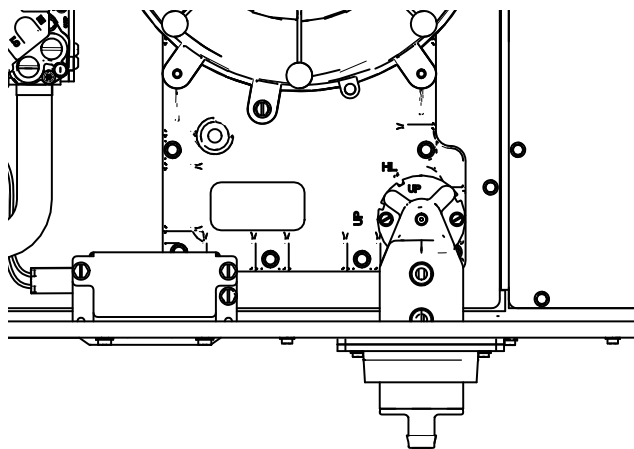
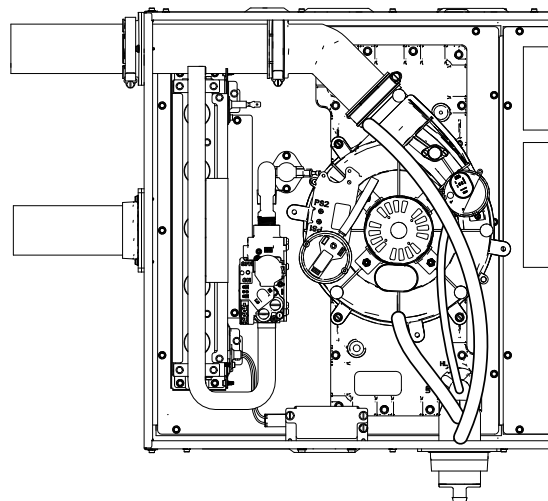

Figure 120. Condensate tubing



18. Remove port cap on left side of inducer and connect inducer condensate tubing. Connect other end of inducer condensate tubing to top port on the condensate trap. Cut tubing to length, if necessary.
  19. Install previously removed port cap onto bottom port of the inducer (as viewed in upflow).
  20. Connect condensate pressure switch tubing to pressure port on the condensate trap.
- Important:** Trim the pressure switch tubing to length to prevent creating a sag or trap.
21. Remove port plug from rain gutter and install in new position on opposite side of the rain gutter.
  22. Connect rain gutter condensate hose to the rain gutter and the lower port of the condensate trap. Route rain gutter condensate hose to the right of the inducer motor.

Figure 121. Condensate tubing



## Horizontal Right Position - Top Vented

Changes need to be made to the inducer orientation when installing the upflow furnace in the horizontal right position with the combustion air vented through the left side. Additional changes are needed for hose routing, condensate trap location, and inducer port caps, and the condensate plug.

The figure below shows the furnace as it is sent from the factory.

Follow the steps below to modify the furnace for horizontal right with left side venting of combustion air.

Before proceeding, lay unit on its back to make the conversion easier.

1. Remove all drain hoses from condensate trap.

**Note:** Hold the condensate trap when removing the hoses to prevent breakage. Alternatively, remove the trap first.

2. Remove drain tubing from bottom of inducer housing.
3. Remove rain gutter tubing from inducer outlet.
4. Remove tubing from condensate pressure switch.
5. Remove the screws that hold the condensate trap bracket. The condensate trap should not be removed from the condensate trap bracket. Remove assembly and retain for later installation.
6. Remove the adapter located inside the condensate trap connection on the cold header and retain for later installation.

**Note:** The plastic adapter with O-rings located inside the cold header that is held in place by the condensate trap bracket. Do not lose this adapter. This adapter needs to be in place when the condensate trap bracket is reattached.

# Furnace Combustion Air Exhaust Options

**Figure 122. Removing tubing**

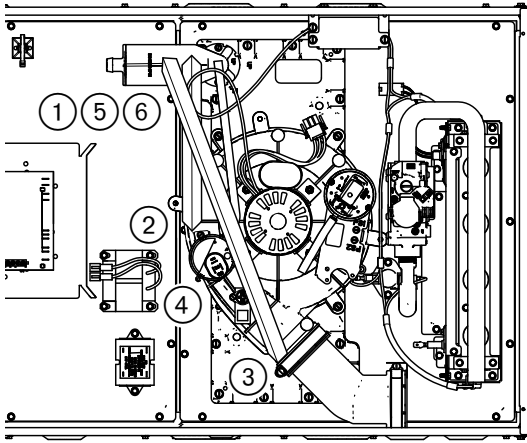

7. Remove 3-inch plug on right side of unit. To be used for condensate trap.
8. Install condensate trap grommet.
9. Remove two 3-inch plugs on left side of cabinet.
10. Reuse the two 3-inch plugs to seal the two 3-inch default openings on the top of the cabinet.

**Figure 123. Sealing default openings**

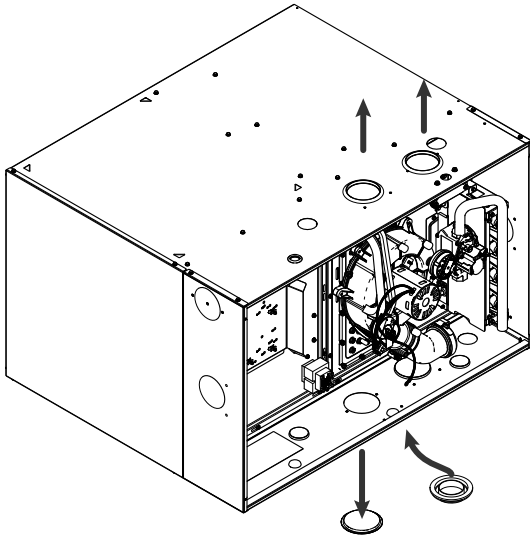

11. Attach the vent outlet gasket to the vent outlet.
12. Install vent outlet to top of cabinet using two screws supplied in the doc pack.
13. Install vent inlet gasket and vent inlet using four screws supplied in the doc pack.

**Figure 124. Vent inlet/outlet**

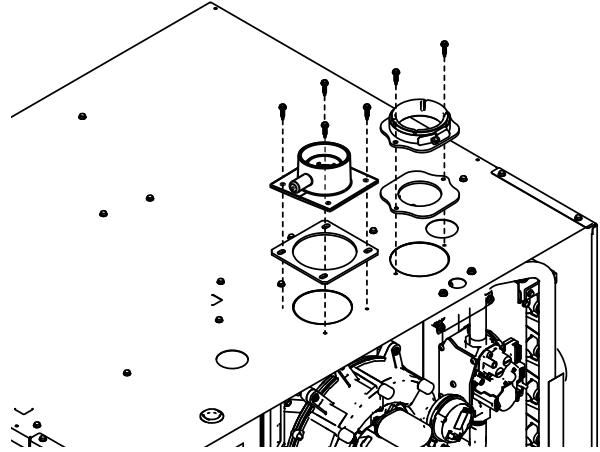

14. Remove three inducer screws.
15. Loosen hose clamp and remove 45° adapter. If the rubber boot pulls out of the inducer opening, remove from the adapter and reinstall onto the inducer.
16. Rotate the inducer so that the outlet is pointing vertically.
17. Use the three inducer screws to reattach the inducer to the cold header. Torque to 30 in.-lbs. Do not overtighten.
18. Remove condensate drain plug from top right location on cold header.
19. Place condensate drain plug onto the cold header outlet located on the bottom left of the cold header.

**Figure 125. Tightening screws**

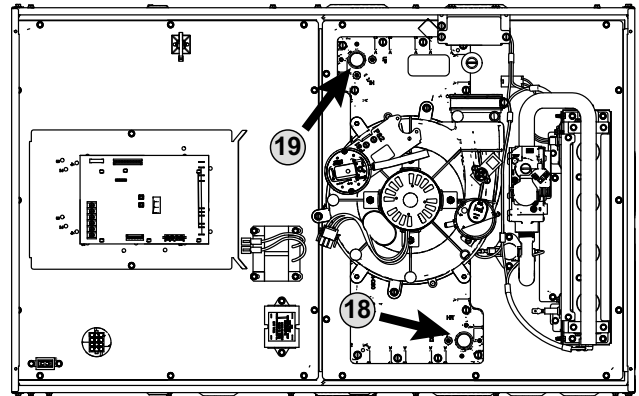

20. Slide PVC through vent outlet adaptor and insert into inducer outlet.
21. Twist to insure PVC is fully inserted.
22. Tighten the two clamps.
23. Install the combustion air inlet PVC pipe.

**Notes:**

- The vent outlet adapter is used for strain relief against the weight of the venting. The clamp should be tightened after the internal connection is made.
- If required, transition to larger venting within 2' of the cabinet. CPL01544 – 2-inch x 3-inch offset coupling may be used and is factory supplied with 120 MBTUH furnaces. Canadian applications may use BAYREDUCE to meet ULC-S636 requirements.

**Figure 126. PVC installation**

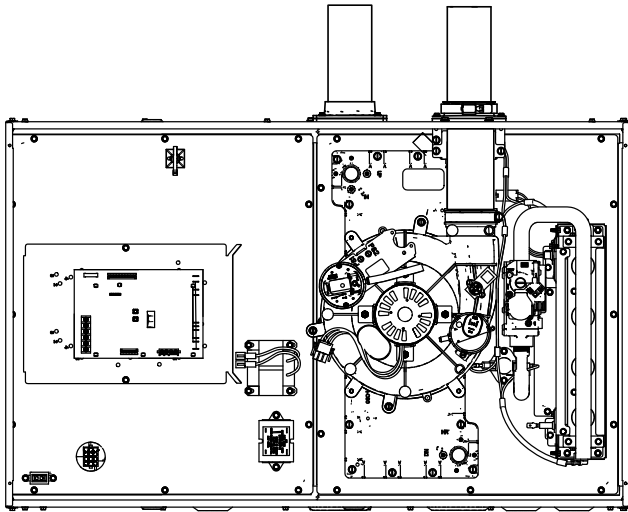

**Condensate Trap Installation**

24. Reinstall the condensate adapter if it was earlier removed or ensure adapter is still in place.

**Important:** The condensate adapter must be present for proper condensate drain operation.

25. Install condensate trap into new location by fitting into grommet and aligning the hole on the condensate trap with the hole labeled HR.

**Important:** When installing a 21.0-inch wide S-Series furnace, rotate the grommet so the notch faces the cabinet's outer edge as shown in the illustrations. This allows the rain gutter tubing to fully seat onto the lower condensate port trap.

26. Hand tighten screw with a 1/4-inch nut driver. Do not over torque or use a drill gun.

**Figure 127. Tightening screws**

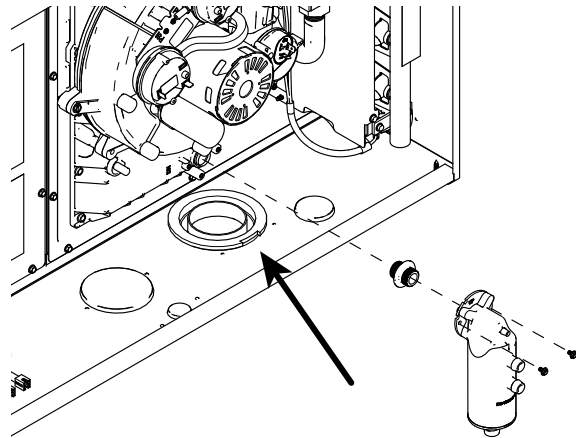

**Figure 128. Condensate tubing**

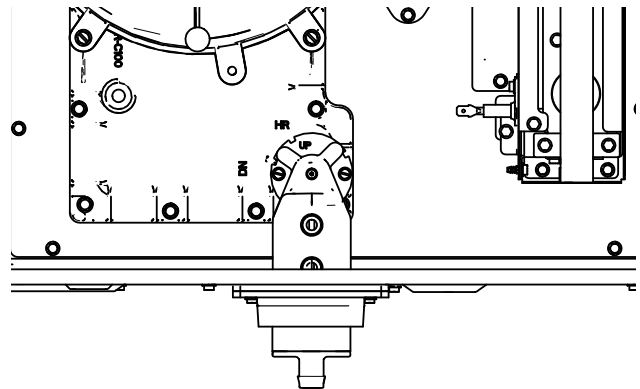

27. Remove port cap on the right side of the inducer and connect inducer condensate tubing. Connect other end of inducer condensate tubing to top port on the condensate trap. Cut tubing to length, if necessary.

28. Install previously removed port cap onto bottom port of the inducer.

29. Connect condensate pressure switch tubing to pressure port on the condensate trap.

**Important:** Cut to length to prevent creating a sag or trap.

30. Connect rain gutter condensate hose to the rain gutter and the lower port of the condensate trap.

**Figure 129. Condensate tubing**

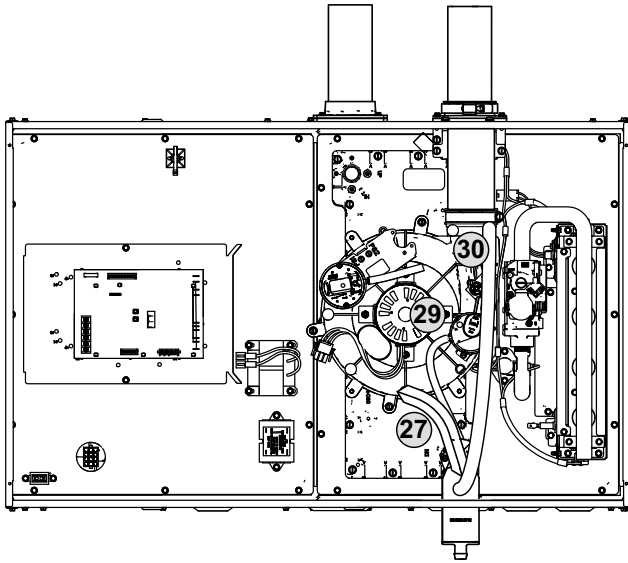

### Horizontal Right Position - Left Vented

Changes need to be made to the inducer orientation when installing the upflow furnace in the horizontal right position with the combustion air vented through the bottom. Additional changes are needed for hose routing, condensate trap location, and inducer port caps, and the condensate plug.

The figure below shows the furnace as it is sent from the factory.

Follow the steps below to modify the furnace for horizontal right with bottom venting of combustion air.

Before proceeding, lay unit on its back to make the conversion easier.

1. Remove all drain hoses from condensate trap.

**Note:** Hold the condensate trap when removing the hoses to prevent breakage. Alternatively, remove the trap first.

2. Remove drain tubing from bottom of inducer housing.
3. Remove rain gutter tubing from inducer outlet.
4. Remove tubing from condensate pressure switch.
5. Remove the screws that hold the condensate trap bracket. The condensate trap should not be removed from the condensate trap bracket. Remove assembly and retain for later installation.
6. Remove the condensate adapter located inside the condensate trap connection on the cold header and retain for later installation.

**Note:** The plastic condensate adapter with O-rings located inside the cold header that is held in place by the condensate trap bracket. Do not lose this adapter. The condensate adapter needs to be in place when the condensate trap bracket is reattached.

**Figure 130. Removing tubing**

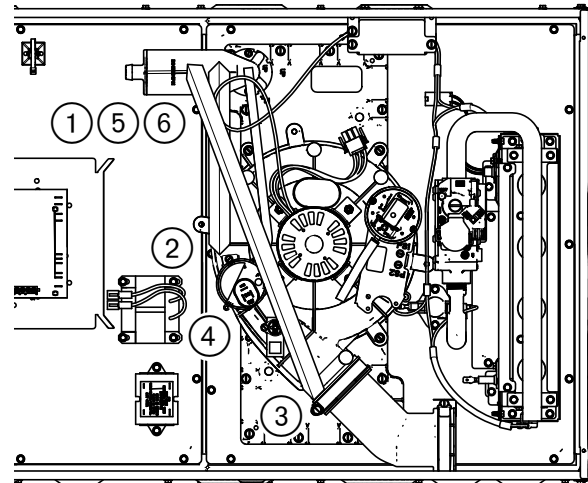

7. Remove 3-inch plug on right side of unit. To be used for condensate trap.
8. Install condensate trap grommet.
9. Remove 3-inch plugs on the left side of the cabinet. To be used for combustion air inlet.
10. Reuse the two 3-inch plugs to seal the two 3-inch default openings on the top of the furnace.

**Figure 131. Sealing default openings**

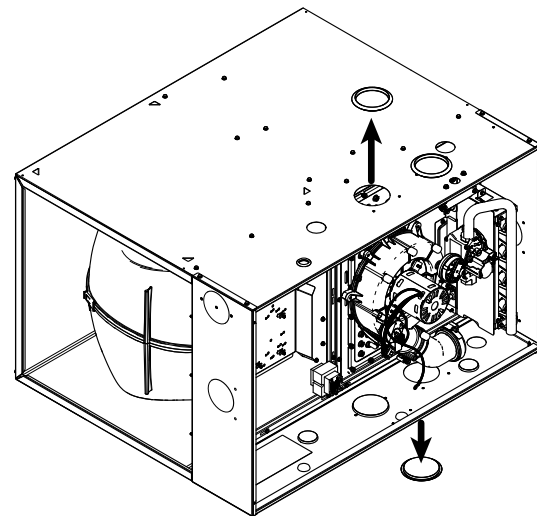

11. Remove three inducer screws.
12. While the inducer is loose, remove condensate drain plug from top right location on cold header.

13. Place condensate drain plug onto the cold header outlet located on the bottom left of the cold header.
14. Rotate the inducer 180° so that the elbow is pointing towards the left.
15. Use the three inducer screws to reattach the inducer to the cold header. Torque to 30 in.-lbs. Do not overtighten.

**Figure 132. Removing tubing**

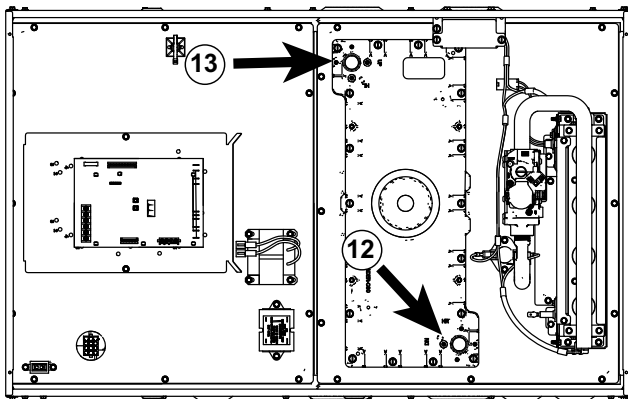

16. Cut 3-inch hole in bottom panel using large dimple as guide.

**Figure 133. Cutting hole**

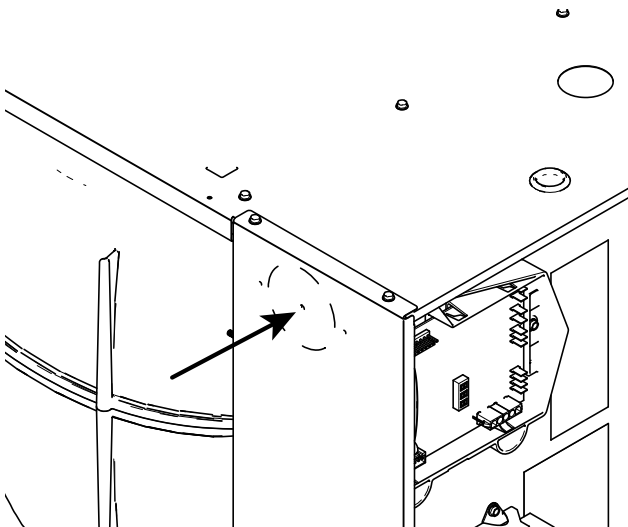

17. Attach the vent outlet gasket to the vent outlet.
18. Install vent outlet to top of cabinet using two screws supplied in the doc pack.
19. Install vent inlet gasket and vent inlet using four screws supplied in the doc pack.

**Notes:**

- The vent outlet adapter is used for strain relief against the weight of the venting. The clamp should be tightened after the internal connection is made.
- If required, transition to larger venting within 2' of the cabinet. An 2-inch"x 3-inch offset coupling is required if the transition is made in a horizontal plane. Use coupling CPL01544 (Canadian applications may use BAYREDUCE to meet ULC-S636 requirements.) See Horizontal Venting section for proper orientation of 2-inch x 3-inch offset coupling.

**Figure 134. Vent inlet/outlet**

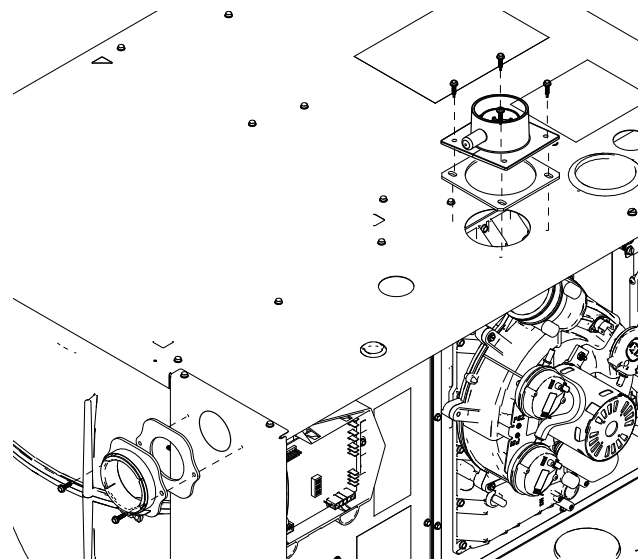

20. Slide PVC through vent outlet adaptor and insert into inducer outlet.
21. Twist to insure PVC is fully inserted.
22. Tighten the two clamps.
23. Install the combustion air inlet PVC pipe.

**Figure 135. Condensate tubing**

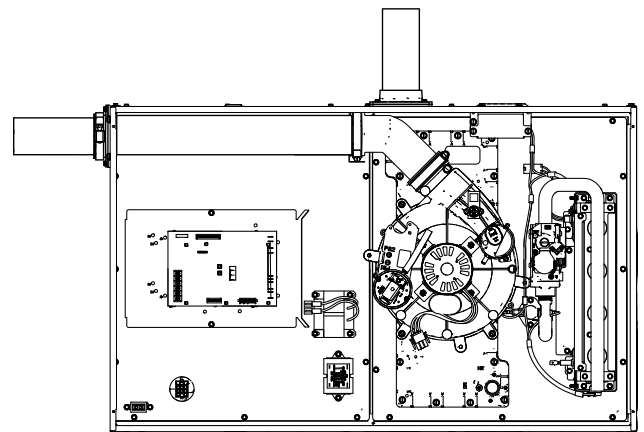

## Furnace Combustion Air Exhaust Options

### Condensate Trap Installation

24. Reinstall the condensate adapter if it was earlier removed or ensure adapter is still in place.

**Important:** The condensate adapter must be present for proper condensate drain operation.

25. Install condensate trap into new location by fitting into grommet and aligning the hole on the condensate trap with the hole labeled HR.

**Important:** When installing a 21.0-inch wide S-Series furnace, rotate the grommet so the notch faces the cabinet's outer edge as shown in the illustrations. This allows the rain gutter tubing to fully seat onto the lower condensate port trap.

26. Hand tighten screw with a 1/4-inch nut driver. Do not over torque or use a drill gun.

**Figure 136. Tightening screws**

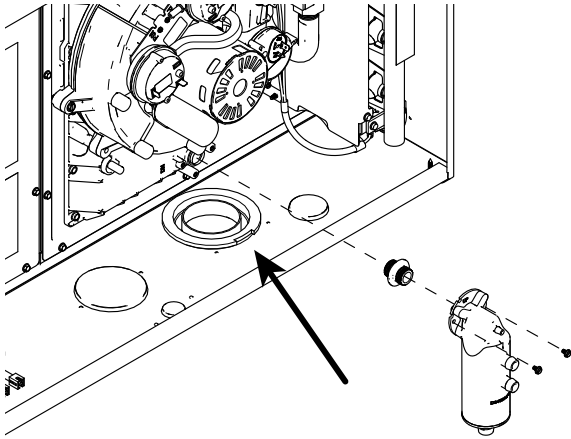

**Figure 137. Condensate tubing**

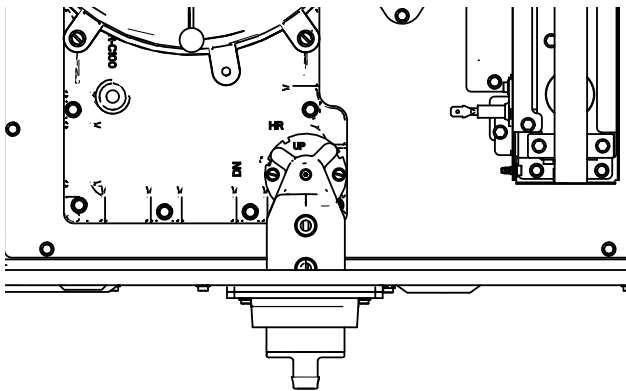

27. Remove port cap on the right side of inducer and connect inducer condensate tubing. Connect other end

of inducer condensate tubing to top port on the condensate trap. Cut tubing to length, if necessary.

28. Install previously removed port cap onto bottom port of the inducer (as viewed in upflow).

29. Connect condensate pressure switch tubing to pressure port on the condensate trap.

**Important:** Cut to length to prevent creating a sag or trap.

30. Remove port plug from rain gutter and install in new position on opposite side of the rain gutter.

31. Connect rain gutter condensate hose to the rain gutter and the lower port of the condensate trap. Route the hose to the right of the inducer motor.

**Figure 138. Condensate tubing**

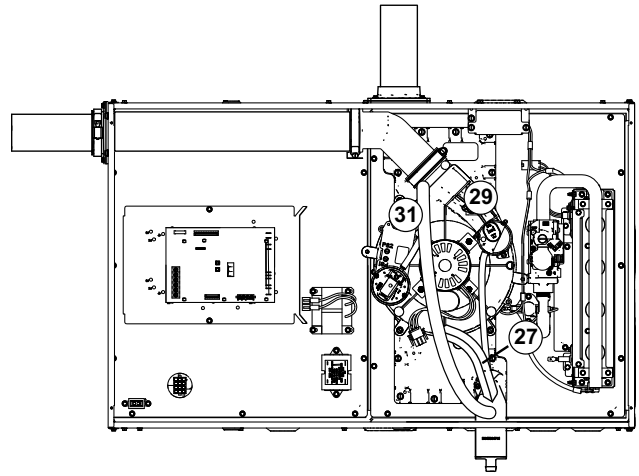

## Downflow Furnace - Top Vented

No changes need to be made to the inducer when installing the downflow furnace with the combustion air vented through the top.

1. Attach the vent outlet gasket to the vent outlet.
2. Install vent outlet to top of cabinet using two screws supplied in the doc pack.
3. Install vent inlet gasket and vent inlet using four screws supplied in the doc pack.

Figure 139. Vent inlet/outlet

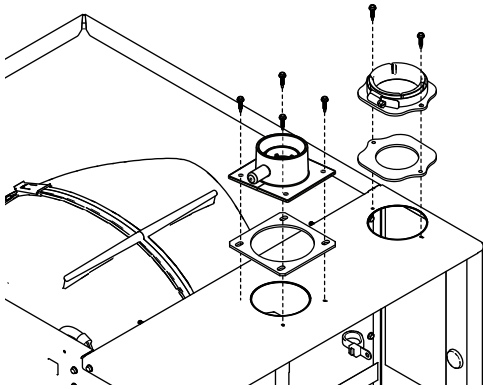

4. Slide PVC pipe through vent outlet adaptor and insert into inducer outlet.
5. Twist to insure PVC is fully inserted.
6. Tighten the two clamps.
7. Install the combustion air inlet PVC pipe.

**Notes:**

- The vent outlet adaptor is used for strain relief against the weight of the venting. The clamp should be tightened after the internal connection is made.
- If required, transition to larger venting within 2' of the cabinet. CPL01544 – 2-inch x 3-inch offset coupling may be used and is factory supplied with 120 MBTUH furnaces. Canadian applications may use BAYREDUCE to meet ULC-S636 requirements.

**Important:** Trim the pressure switch tubing to length to prevent creating a sag or trap.

Figure 140. PVC pipe installation

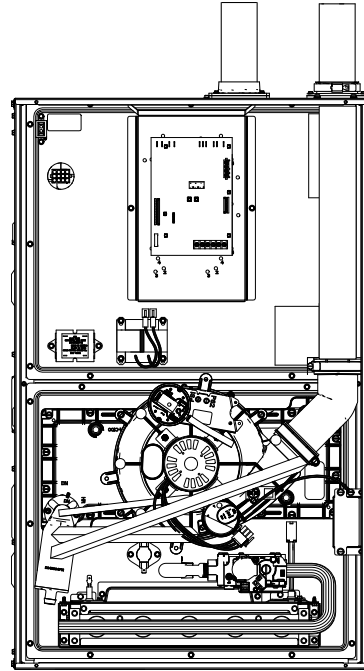

## Downflow Furnace - Left Side Vented

Changes need to be made to the inducer orientation when installing the downflow furnace with the combustion air vented through the side.

The figure below shows the furnace as it is sent from the factory.

Use the following steps to modify the furnace for downflow with side venting of combustion air.

**Important:** Right side vent outlet is not allowed because condensate will not drain.

Before proceeding, lay unit on its back to make conversion easier.

1. Disconnect all drain tubes from condensate trap.

**Note:** Hold the condensate trap when removing the hoses to prevent breakage. Alternatively, remove the trap first.

2. Remove drain tubing from bottom of inducer housing.
3. Remove rain gutter tubing from inducer outlet.
4. Remove tubing from condensate pressure switch.
5. Remove two 3-inch plugs on left side of cabinet. To be used for combustion air exhaust and inlet.
6. Reuse the two 3-inch plugs to seal the two 3-inch default openings on the top of the cabinet.

**Figure 141. Left vent plug removal**

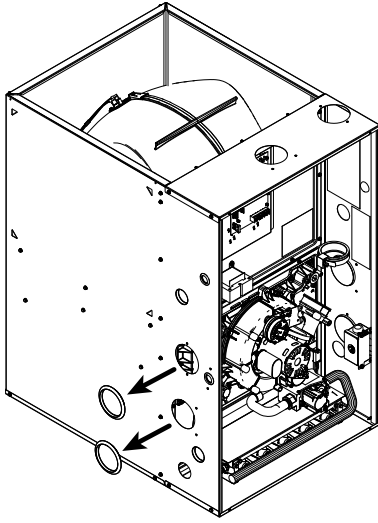

7. Loosen hose clamp and remove 45° adapter. If the rubber boot pulls out of the inducer opening, remove from the adapter and reinstall onto the inducer. Remove the elbow and discard.
8. Remove the three inducer mounting screws.
9. Rotate inducer counterclockwise so that the inducer outlet aligns with the exhaust vent outlet.
10. Reinsert and tighten screws to 30 in.-lbs. Do not overtighten.
11. Attach the vent outlet gasket to the vent outlet.
12. Install vent outlet to cabinet using 2 screws supplied in the doc pack.
13. Install vent inlet gasket and vent inlet using 4 screws supplied in the doc pack.
14. Install the grommet for the condensate drain tube. The drain may be located on either side of the cabinet.

**Figure 142. Grommet installation**

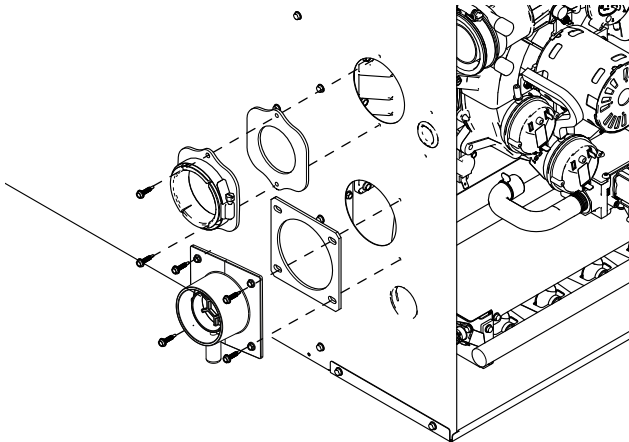

15. Slide PVC through vent outlet adaptor and insert into inducer outlet.
16. Twist to insure PVC is fully inserted.
17. Tighten the two clamps.
18. Install the combustion air inlet PVC pipe.

**Notes:**

- *The vent outlet adapter is used for strain relief against the weight of the venting. The clamp should be tightened after the internal connection is made.*
- *If required, transition to larger venting within 2' of the cabinet. An 2-inch x 3-inch offset coupling is required if the transition is made in a horizontal plane. Use coupling CPL01544 (Canadian applications may use BAYREDUCE to meet ULC-S636 requirements.) See Horizontal Venting section for proper orientation of 2-inch x 3-inch offset coupling.*

**Figure 143. PVC pipe installation**

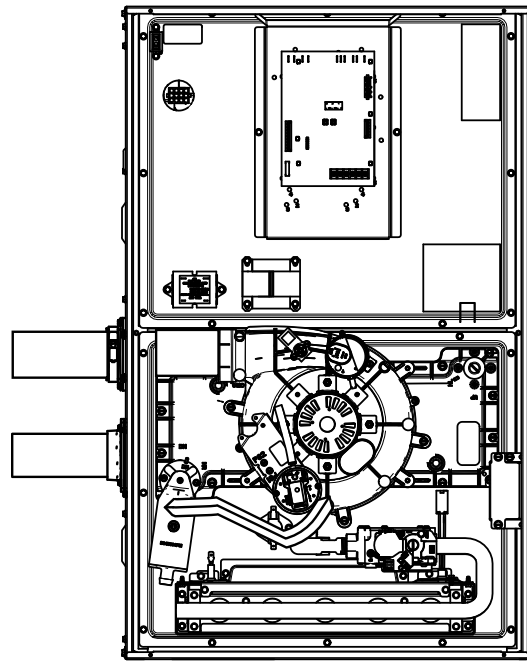

19. Remove port cap at bottom of inducer and connect inducer condensate tubing. Connect other end of inducer condensate tubing to top port on the condensate trap. Cut tubing to length, if necessary.
  20. Install previously removed port cap onto bottom port of the inducer.
  21. Connect condensate pressure switch tubing to pressure port on the condensate trap.
- Important:** *Trim the condensate pressure switch tubing to length to prevent creating a sag or trap.*
22. Remove port plug from rain gutter and install in new position on opposite side of the rain gutter.

23. Connect rain gutter condensate hose to the rain gutter and the lower port of the condensate trap. Cut to length, as required.

Figure 144. Tightening screws

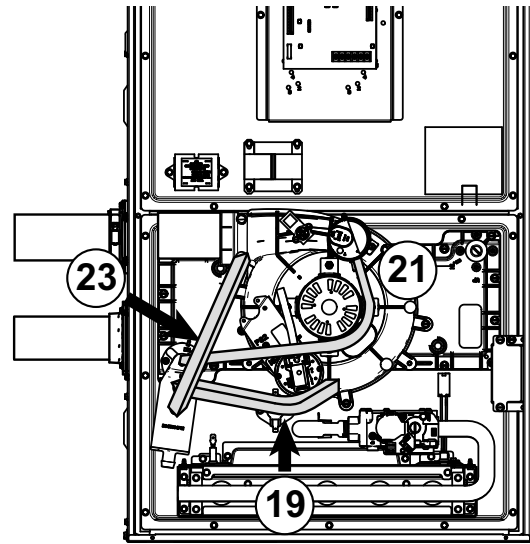

# Integrated Furnace Control Menu

Figure 145. A951X control menu

## A951X Control System Menu Single Stage OD

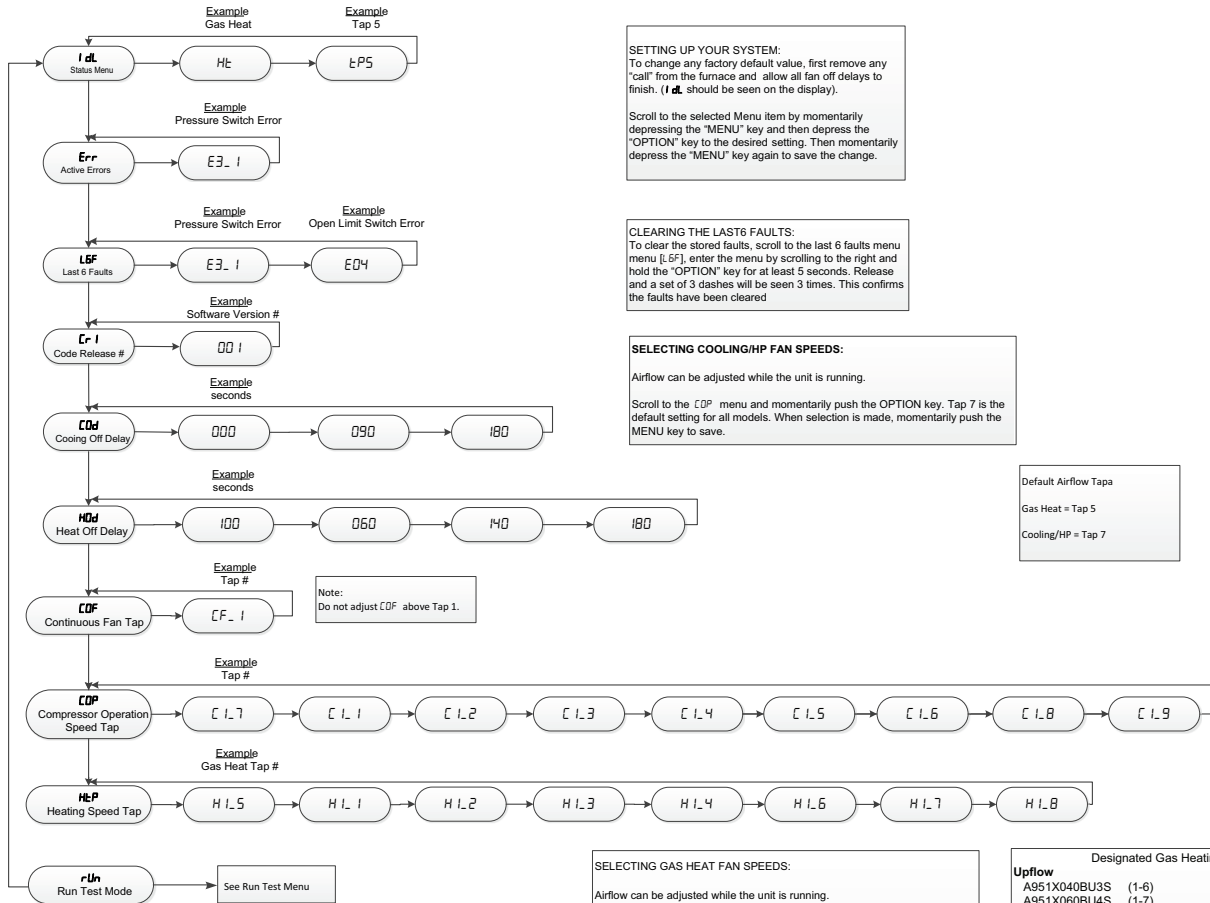

**SETTING UP YOUR SYSTEM:**  
To change any factory default value, first remove any "call" from the furnace and allow all fan off delays to finish. (**I dL** should be seen on the display).  
Scroll to the selected Menu item by momentarily depressing the "MENU" key and then depress the "OPTION" key to the desired setting. Then momentarily depress the "MENU" key again to save the change.

**CLEARING THE LAST 6 FAULTS:**  
To clear the stored faults, scroll to the last 6 faults menu [LSF], enter the menu by scrolling to the right and hold the "OPTION" key for at least 5 seconds. Release and a set of 3 dashes will be seen 3 times. This confirms the faults have been cleared

**SELECTING COOLING/HP FAN SPEEDS:**  
Airflow can be adjusted while the unit is running.  
Scroll to the **COF** menu and momentarily push the OPTION key. Tap 7 is the default setting for all models. When selection is made, momentarily push the MENU key to save.

Default Airflow Taps  
Gas Heat = Tap 5  
Cooling/HP = Tap 7

**SELECTING GAS HEAT FAN SPEEDS:**  
Airflow can be adjusted while the unit is running.  
Scroll to the **HEP** menu and momentarily push the OPTION key. Tap #5 is the default setting for all models. When selection is made, momentarily push the MENU key to save.  
If the temperature rise is too high, increase airflow. If the temperature rise too low, decrease airflow.  
**NOTE:** Tap 9 is not available for gas heating.

Designated Gas Heating Airflow Taps

Upflow	
A951X040BU3S	(1-6)
A951X060BU4S	(1-7)
A951X080BU4S	(1-7)
A951X080CU5S	(1-7)
A951X100CU5S	(1-7)
A951X120DU5S	(1-7)
Downflow	
A951X040BD3S	(1-6)
A951X060BD3S	(1-7)
A951X080BD4S	(1-6)
A951X100CD5S	(1-7)
A951X120DD5S	(1-7)

Figure 146. A951X system status menu

A951X  
System Status Menu

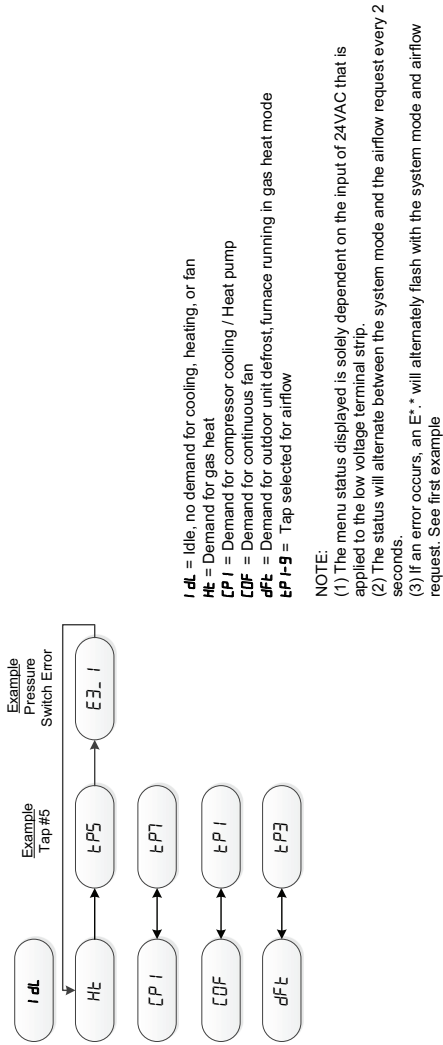

# Setting Airflow

With all ductwork connected and a clean filter in place, measure the External Static Pressure (ESP) of the unit in locations below. Use the appropriate airflow table in the Airflow Tables section for the furnace and outdoor unit installed.

Measurements must be made prior to the evaporator coil, if equipped, and after the filter.

**Note:** Check out [fieldtechhelp.com](http://fieldtechhelp.com) to watch a short video.

**Figure 147. Airflow setting**



**Setting Air Flow on the 9-Tap Motor**  
 Date: Sessions: Availability:  
 Location: Cost: USD 0.00

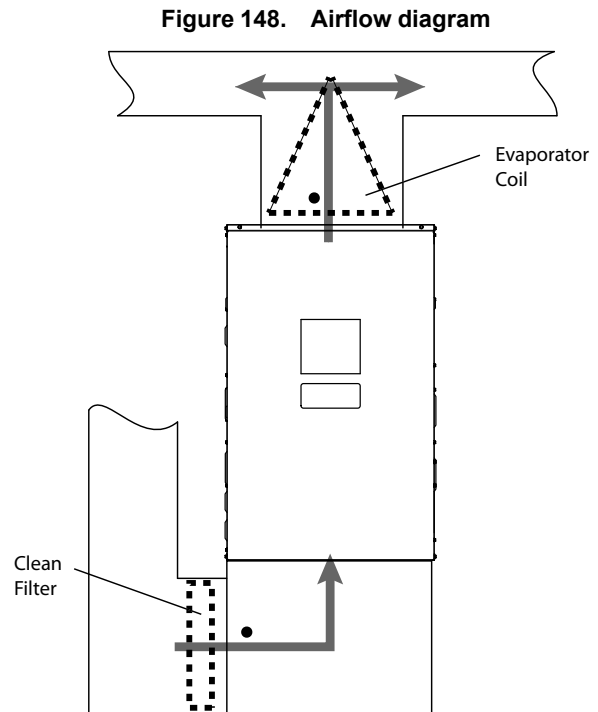

**Table 34. Airflow setting**

A951X080BU4 Furnace Airflow (CFM) at External Static Pressure (in. W.C.) versus Tap						
Tap	Units	Static				
		0.1	0.3	0.5	0.7	0.9
1	SCFM / Watts	911 / 94	766 / 104	622 / 115	477 / 125	332 / 136
2	SCFM / Watts	1075 / 139	963 / 153	851 / 168	740 / 182	628 / 197
3	SCFM / Watts	1215 / 185	1121 / 202	1028 / 219	934 / 236	840 / 253
4	SCFM / Watts	1250 / 203	1164 / 221	1077 <sup>(a)</sup> / 239	990 / 257	903 / 274
5	SCFM / Watts	1349 / 251	1272 / 271	1194 / 291	1116 <sup>(a)</sup> / 310	1039 / 330
6	SCFM / Watts	1453 / 313	1387 / 335	1321 / 356	1254 / 378	1188 / 400
7	SCFM / Watts	1505 / 340	1438 / 362	1372 / 384	1305 / 406	1239 / 427
8	SCFM / Watts	1657 / 453	1597 / 477	1538 / 500	1479 / 524	1419 / 547
9	SCFM / Watts	1878 / 669	1815 / 686	1752 / 702	1690 / 718	1627 / 735

<sup>(a)</sup> Example 1

Example 1: A951X080BU4SAB (Default Tap 7)

Cooling / HP

- 3 Ton Single Stage Outdoor
- Total ESP = 0.7" W.C.

- Required Airflow = 1050 cfm (3T x 350 cfm/ton)
- New Tap Number = Tap 5 (Re-check static pressure and adjust airflow as necessary)

# Integrated Furnace Control Display Codes

**Table 35. Menu options**

<i>i dL</i>	Idle
<i>Err</i>	Active Alarm Errors
<i>L6F</i>	Last 6 Faults (To clear — Hold Option button down for 5 seconds after entering the <i>L6F</i> menu)
<i>Cr</i>	Code Release Number
<i>COd</i>	Cooling Off Delay (Seconds)
<i>OUU</i>	Outdoor Unit Type
<i>COF</i>	Blower Constant Fan Airflow
<i>HOd</i>	Heat Off Delay (Seconds)
<i>GHc</i>	Gas Heating CFM
<i>rUn</i>	Run Test Mode

**Table 36. Error codes**

Alarm Error Code	Alarm Explanation
<i>E01</i>	Loss of the IRQ or other internal failures (Internal IFC error)
<i>E2_1</i>	Retry Exceeded (Flame never sensed, one hour lockout after 6 times)
<i>E2_2</i>	Recycles Exceeded (Flame sensed then lost, one hour lockout after 10 times)
<i>E2_3</i>	Gas Valve Not Energized When It Should Be exceeded after 10 times
<i>E3_1</i>	Shorted Pressure Switch
<i>E3_2</i>	Open Pressure Switch
<i>E04</i>	Open Limit (Main Thermal, Rollout Switch, or Reverse Airflow Switch)
<i>E05</i>	Flame detected, should not be present
<i>E6_1</i>	Voltage reversed polarity
<i>E6_2</i>	Bad grounding
<i>E6_3</i>	(1) Igniter relay fails (2) Igniter open
<i>E7_1</i>	Gas valve (MVL) is energized when it should be off
<i>E08</i>	Flame current is low, but still strong enough to allow operation
<i>E09</i>	Open Inducer Limit Switch or Condensate Pressure Switch
<i>E11</i>	Gas valve not energized when it should be Gas valve relay stuck closed

**Table 36. Error codes (continued)**

Alarm Error Code	Alarm Explanation
<i>E12</i>	Open fuse

## Fault Code Recovery

1. To view the last 6 faults, press the **Menu** key until the **Last 6 Faults (L6F)** menu appears.
2. Enter the menu by pressing the **Option** key.
3. The last 6 faults can be viewed.

### Clearing the Last 6 Faults

1. To clear the last 6 faults, press the **Menu** key until the **Last 6 Faults (L6F)** menu appears.
2. Enter the menu by pressing the **Option** key.
3. Hold the **Option** key for at least 5 seconds.
4. Release and a set of 3 dashes will be seen 3 times. This confirms the faults have been cleared.

### Resetting Factory Defaults

1. Display must be in Idle Mode.
2. Push the **Menu** and **Option** buttons at the same time for 15 seconds then release.
3. The 7 segment will flash *Fd* 3 times. This confirms the unit has been reset to the factory defaults.

**Figure 149. A951X IFC component layout**

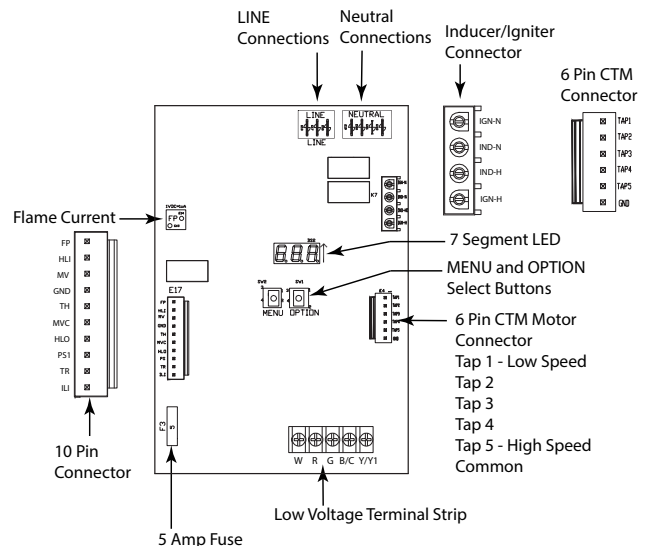

# Troubleshooting

The following pages include troubleshooting flowcharts in reference to the A951X single stage furnaces only

The information contained is for reference only and does not cover all scenarios or problems that may be encountered.

ONLY qualified technicians should attempt to install, troubleshoot, or repair this appliance.

Failure to follow all cautions and/or warnings could result in personal or property damage, including death.

See "Integrated Furnace Control Display Codes," p. 77 for possible error codes.

## GETTING STARTED

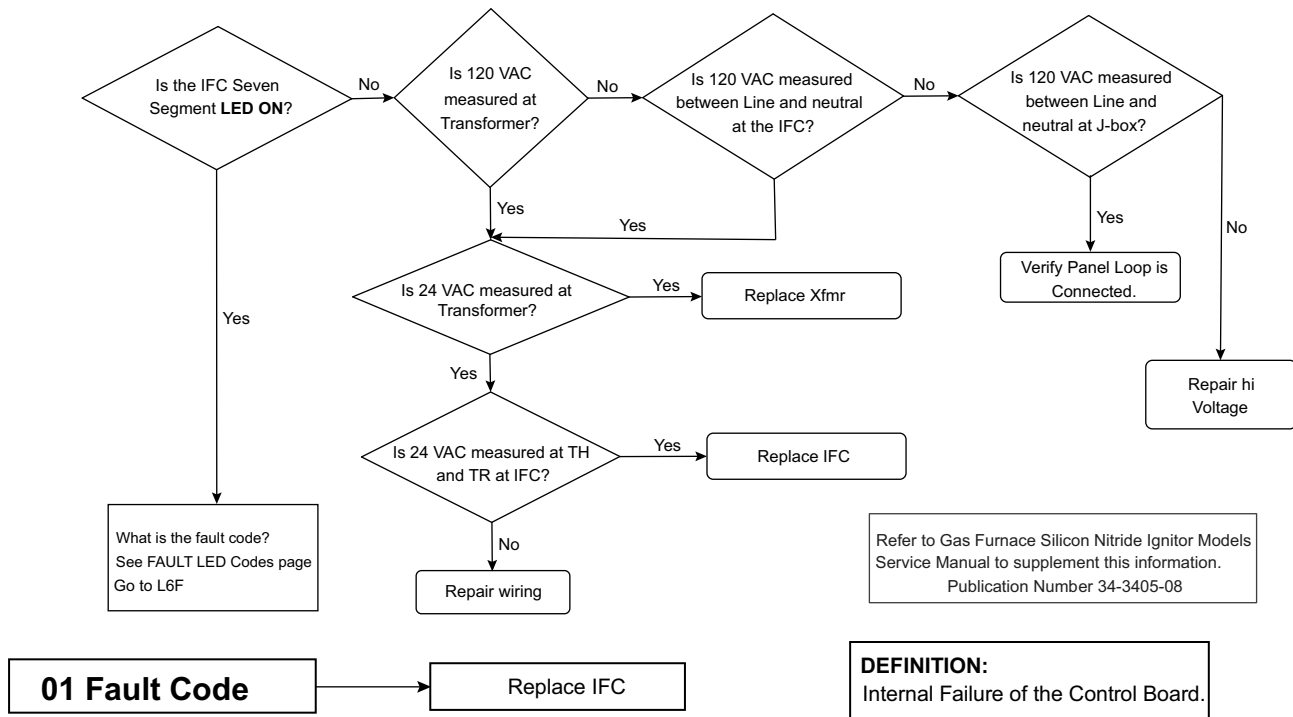

**2.1 Fault Code**



**DEFINITION:**  
RETRY Lock Out = 3 unsuccessful tries for ignition within a single call for heat. Lockout period is for one hour.

**Flame has never been sensed  
Turn All gas appliances ON**

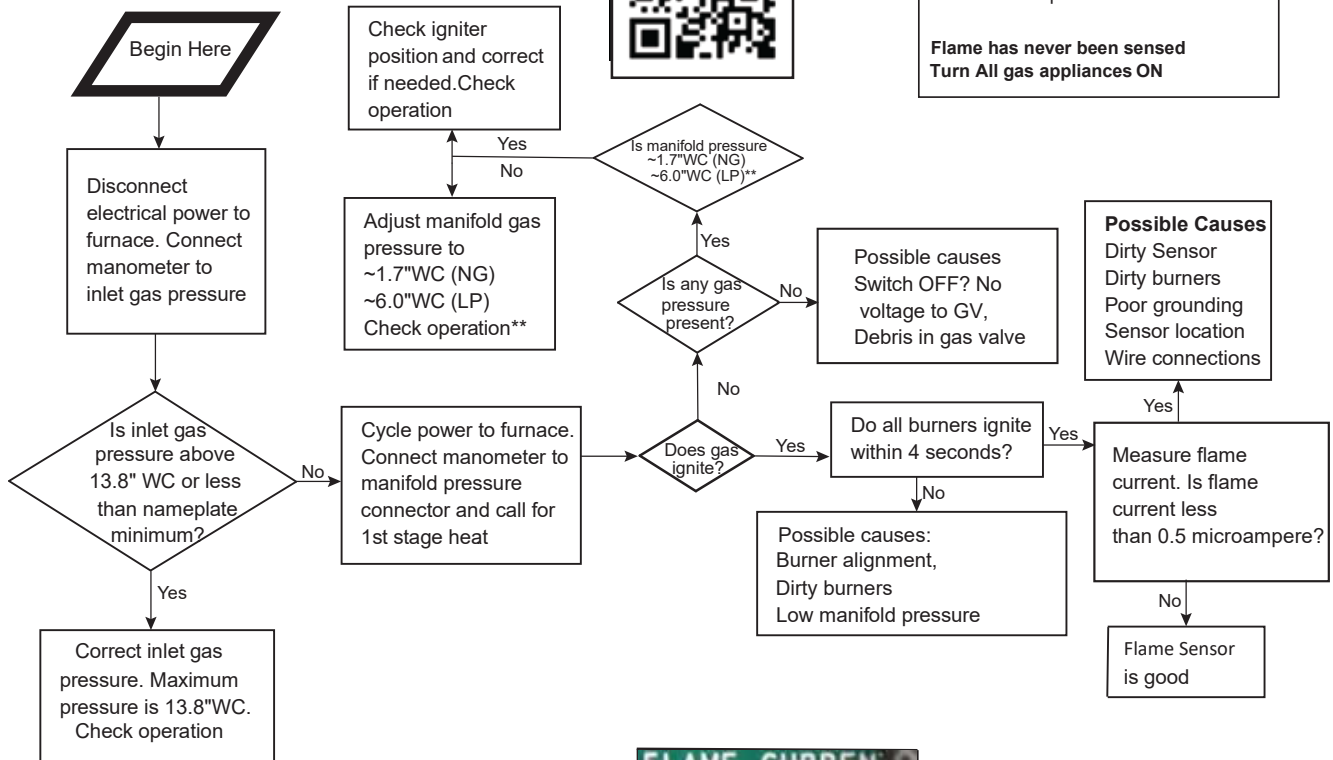

There are two flame sense pads located on the IFC, marked "FP". To measure flame current, use a VOM set to DC volts. Flame current will vary depending on the type of meter used. Typical flame current ranges from 0.75 – 3.0 micro-amps (0.75 – 3.0 VDC)



\*\*  
Manifold pressure  
~3.5"WC (NG)  
~10.0"WC (LP)

## 2.2 Fault Code



**DEFINITION**  
 RECYCLE Lock Out = 10 recycles within a single call for heat. Lockout period is for one hour.  
**Flame has never been sensed**  
 Turn All gas appliances ON

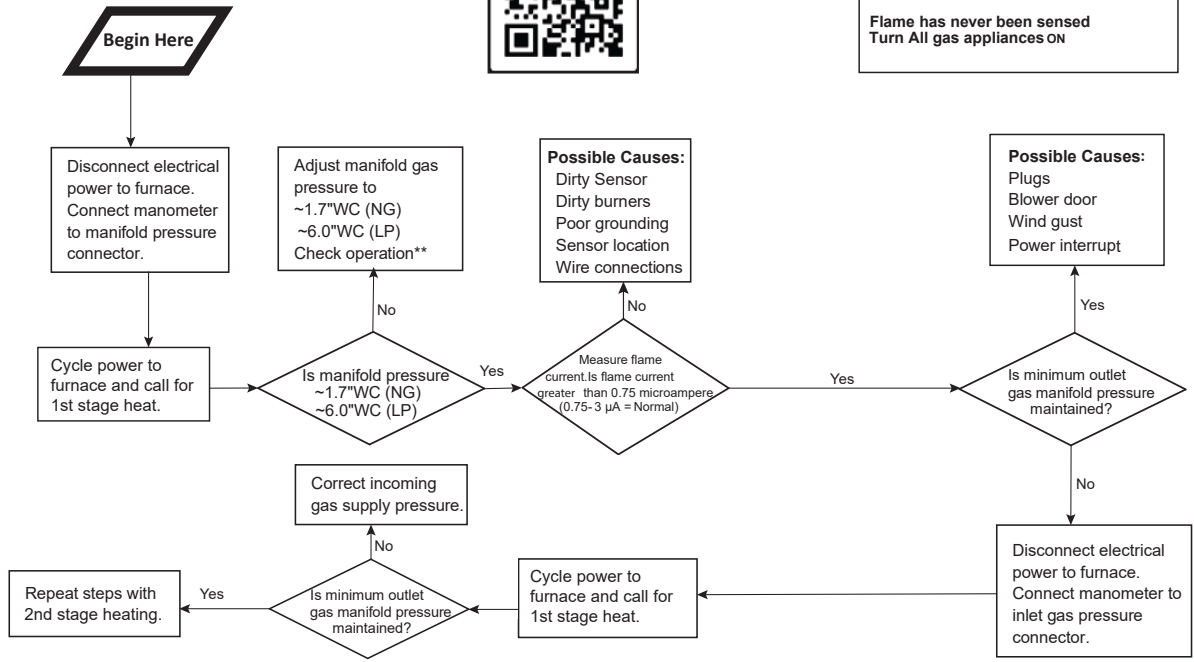

There are two flame sense pads located on the IFC, marked "FP". To measure flame current, use a VOM set to DC volts. Flame current will vary depending on the type of meter used. Typical flame current ranges from 0.75 – 3.0 micro-amps (0.75 – 3.0 VDC).

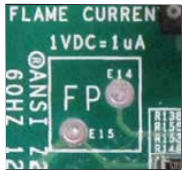

\*\*  
 Manifold pressure  
 ~3.5"WC (NG)  
 ~10.0"WC (LP)

## 2.3 Fault Code

Replace IFC

**DEFINITION:**  
 1st Stage Gas Valve not energized when it should be 10 times within the same call for heat.  
**24VAC not sensed on MVL 10 TIMES**

## 3.1 Fault Code



**DEFINITION:**  
 An error has occurred with the PS1, indicating that the pressure switch is closed when it should be open.  
**In most cases, the pressure switch is not the problem.**  
**NOTE:** Verify pressure switch wiring and tube routing are correct.

**Note #1**  
 OL = Open Switch  
 0 ohms = Closed Switch

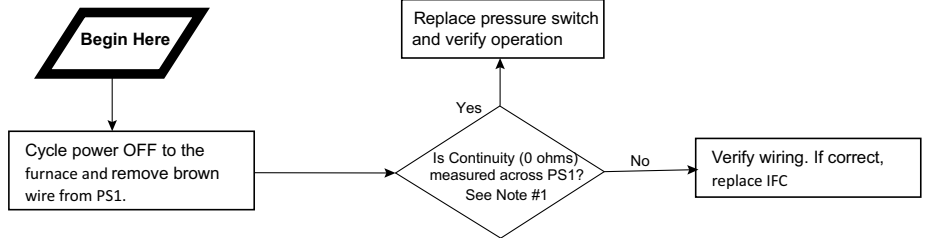

**3.2 Fault Code**

**Note #1**

24 volts = Open Switch  
0 volts = Closed Switch

**Note #2**

Measured pressure is negative, greater than refers to magnitude only.



**DEFINITION:**

An error has occurred with the PS1 indicating that the pressure switch is open when it should be closed.

**In most cases, the pressure switch is not the problem.**

NOTE: Verify pressure switch wiring and tube routing are correct.

PS1 Open errors can occasionally happen when wind gusts occur.

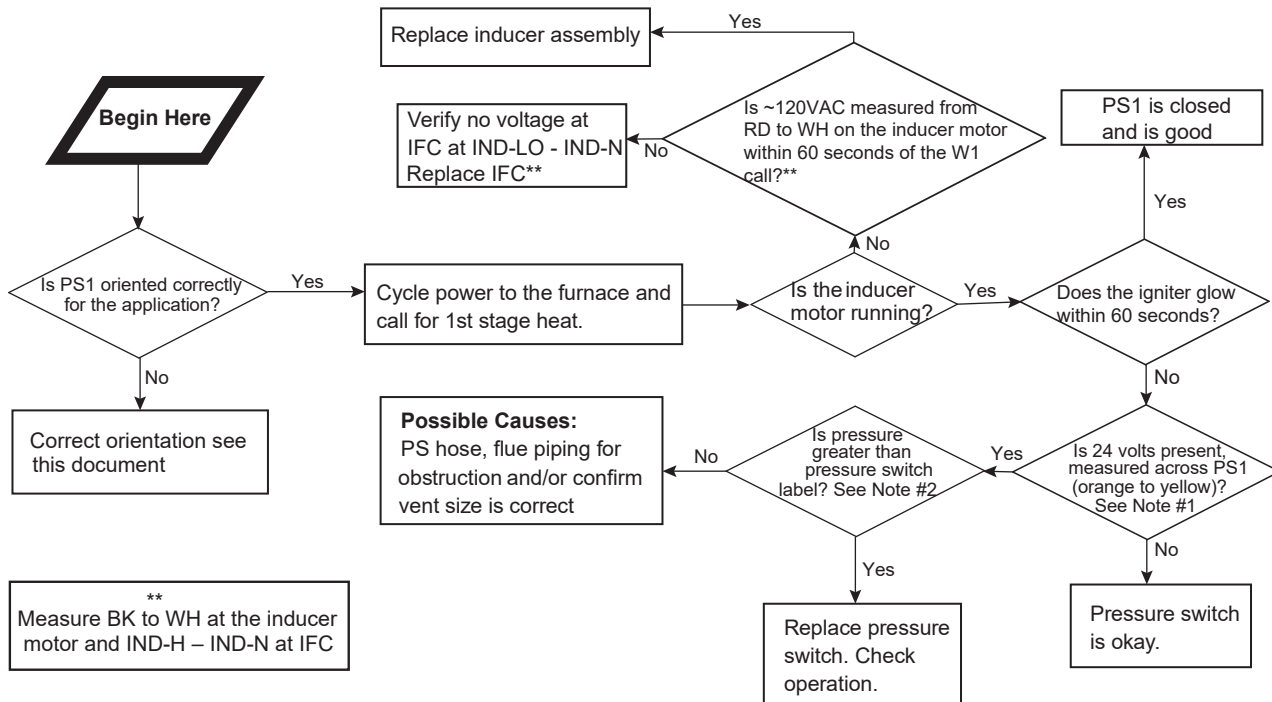



**DEFINITION:**  
 Limit switches are safety devices that will open when an abnormal high temperature has been sensed. REMOVE ALL JUMPER WIRING TO SWITCHES!  
 Under no circumstances, shall these switches be left jumpered when not troubleshooting.  
 Verify filters and blower wheels are clean.

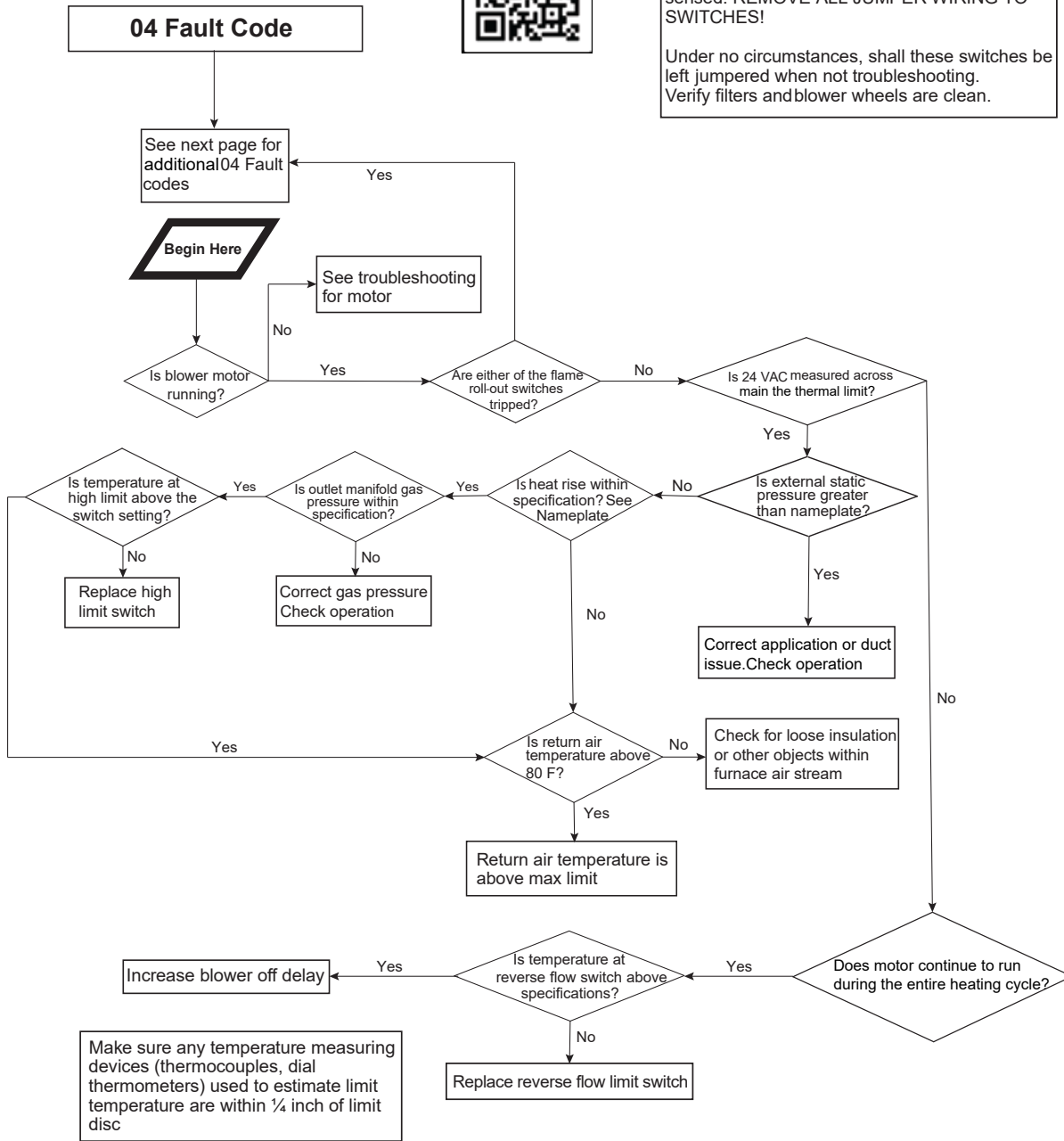

### 04 Fault Code Flame Rollout

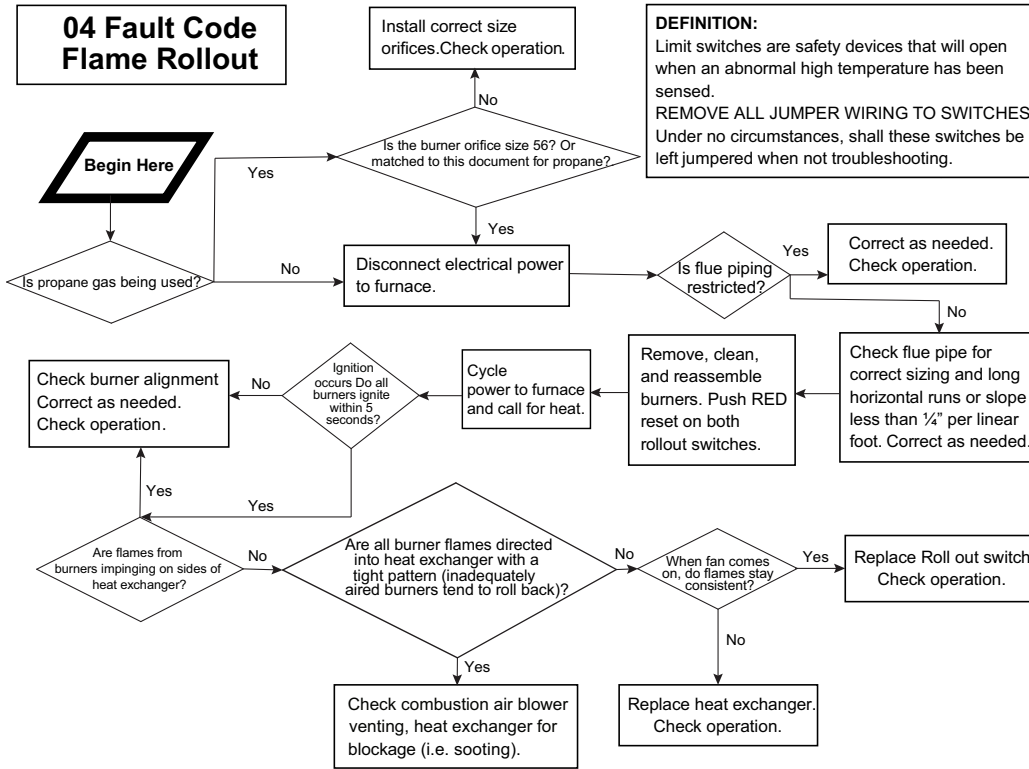

**DEFINITION:**  
Limit switches are safety devices that will open when an abnormal high temperature has been sensed.  
**REMOVE ALL JUMPER WIRING TO SWITCHES!**  
Under no circumstances, shall these switches be left jumpered when not troubleshooting.

### 05 Fault Code

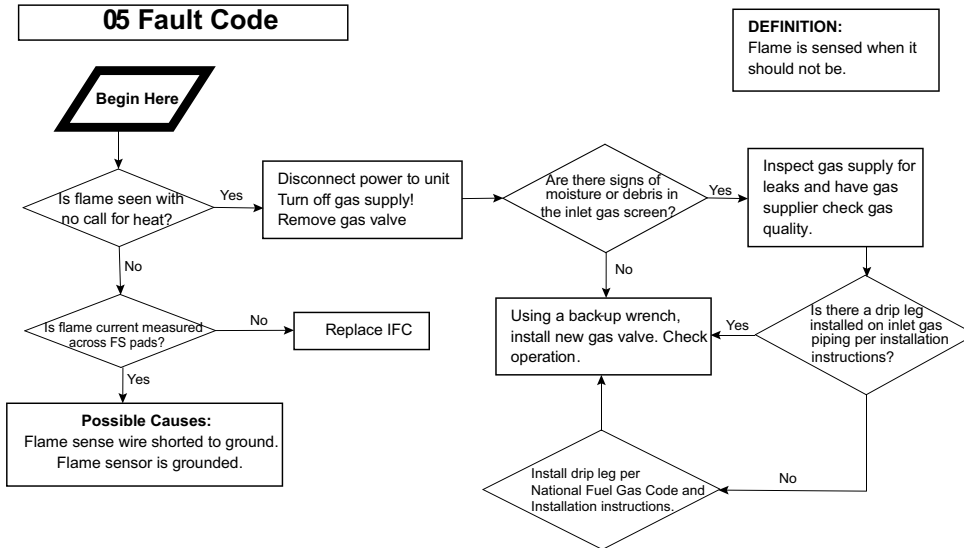

**DEFINITION:**  
Flame is sensed when it should not be.

There are two flame sense pads located on the IFC, marked "FP". To measure flame current, use a VOM set to DC volts. Flame current will vary depending on the type of meter used. Typical flame current ranges from 0.75 – 3.0 micro-amps (0.75 – 3.0 VDC).



**6.1 Fault Code**



**DEFINITION:**  
Polarity Fault-Incoming high voltage wiring is reversed.

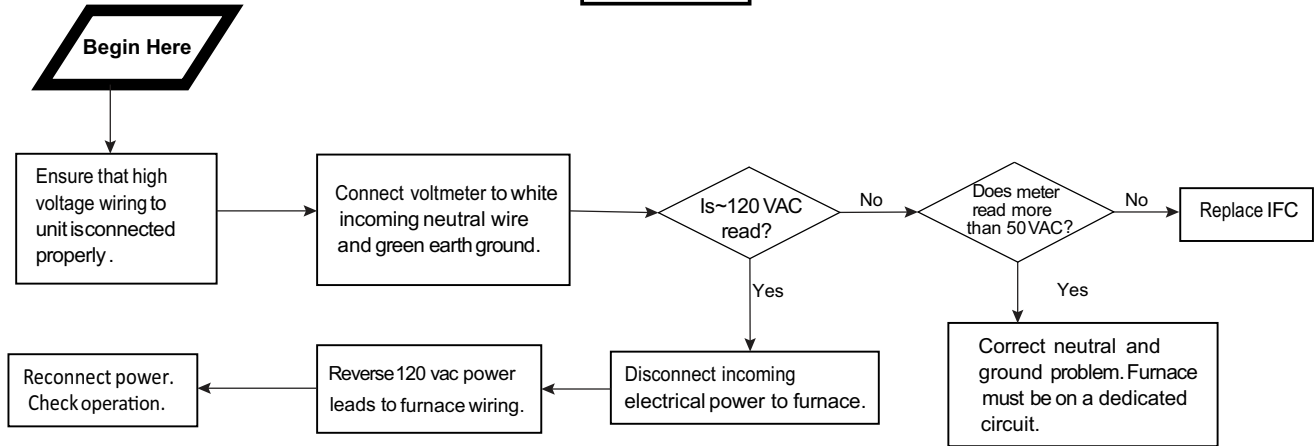

**6.2 Fault Code**

**DEFINITION:**  
Ground Fault-Incoming or chassis ground connection is not sensed

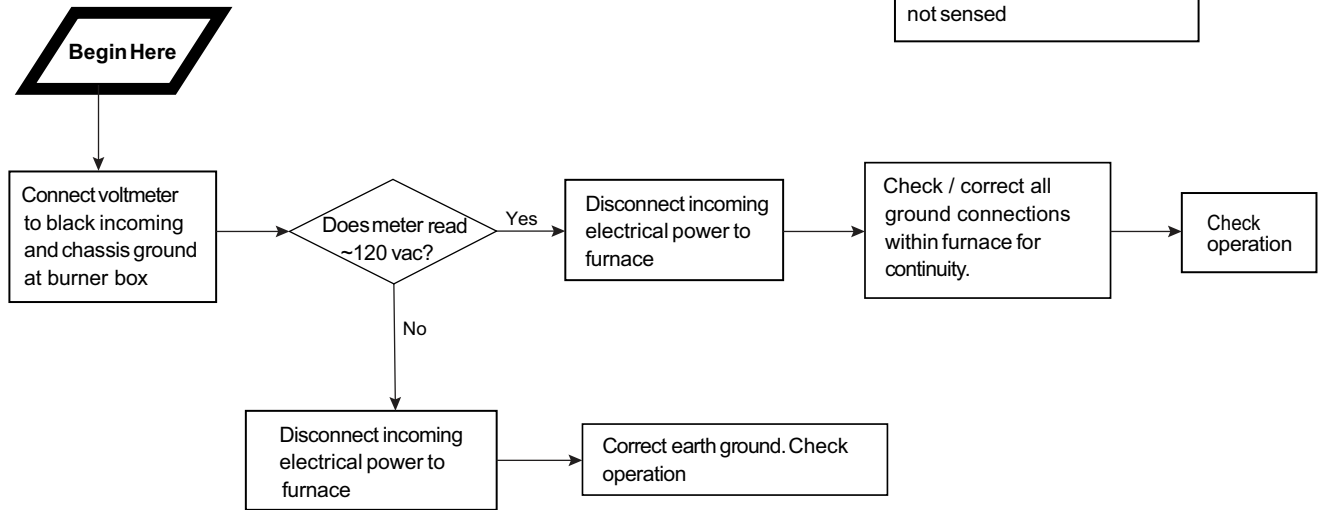

### 6.3 Fault Code

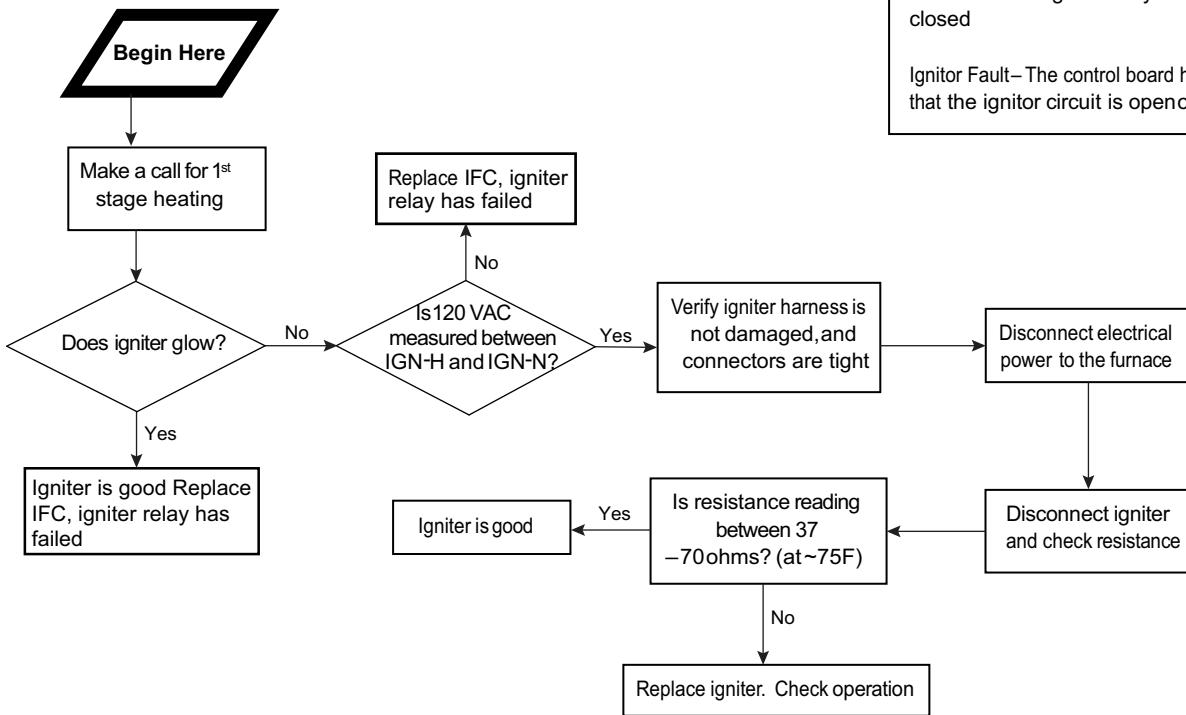

**DEFINITION:**

Igniter Relay Fault–The control board has sensed that the igniter relay has stuck closed

Ignitor Fault– The control board has sensed that the ignitor circuit is open or shorted.

### 7.1 Fault Code

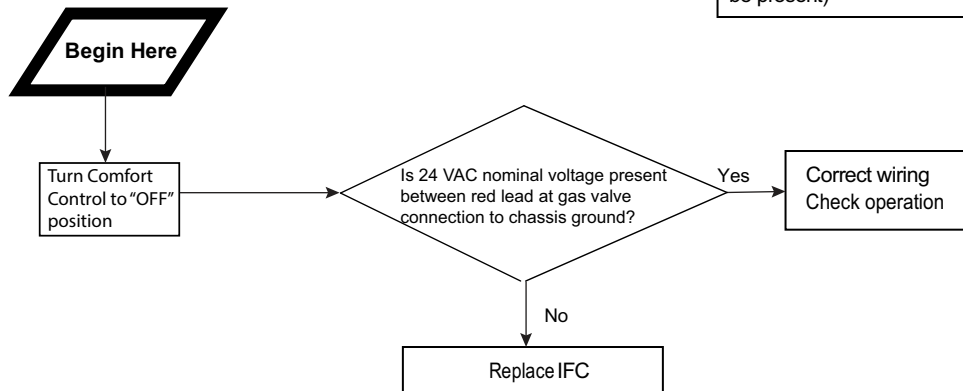

**DEFINITION:**

External Gas Valve Circuit Error (24 volts is present when it should not be present)

**8 Fault Code**

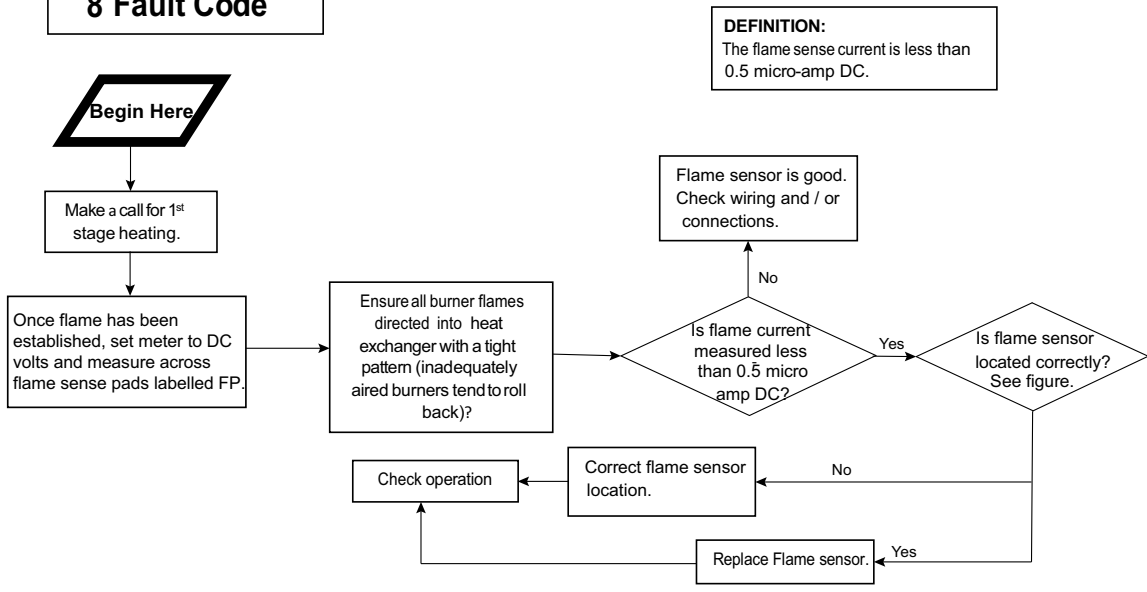

**DEFINITION:**  
The flame sense current is less than 0.5 micro-amp DC.

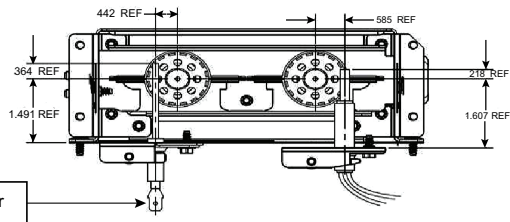

There are two flame sense pads located on the IFC, marked "FP". To measure flame current, use a VOM set to DC volts. Flame current will vary depending on the type of meter used. Typical flame current ranges from 0.75 – 3.0 micro-amps (0.75 – 3.0 VDC).

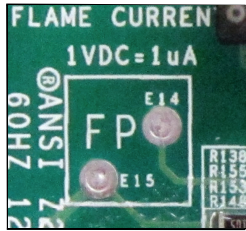

**9 Fault Code**



**DEFINITION:**  
 Condensate Pressure Switch Open: The condensate system is not free flowing and opened the safety switch OR.  
  
 Inducer Limit: This error is normally caused by improper installation or application of the furnace venting system.

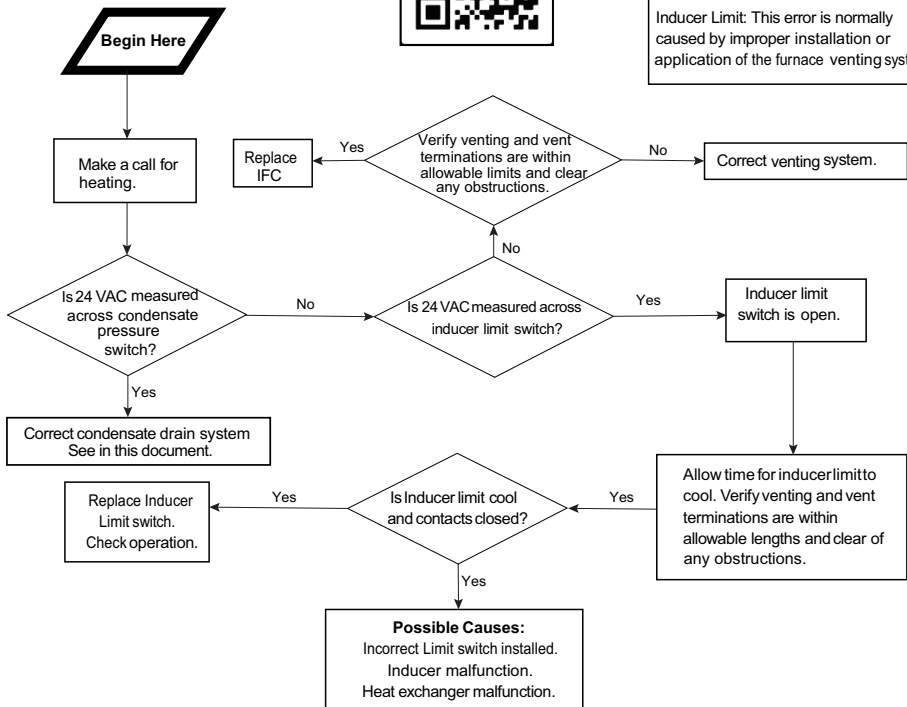

**DEFINITION:**  
 The IFC has detected that internal gas valve relays have failed

**11 Fault Code**

Verify all wiring  
 Replace IFC

**12 Fault Code**

**DEFINITION:**  
 The onboard 5 amp fuse is open or missing.

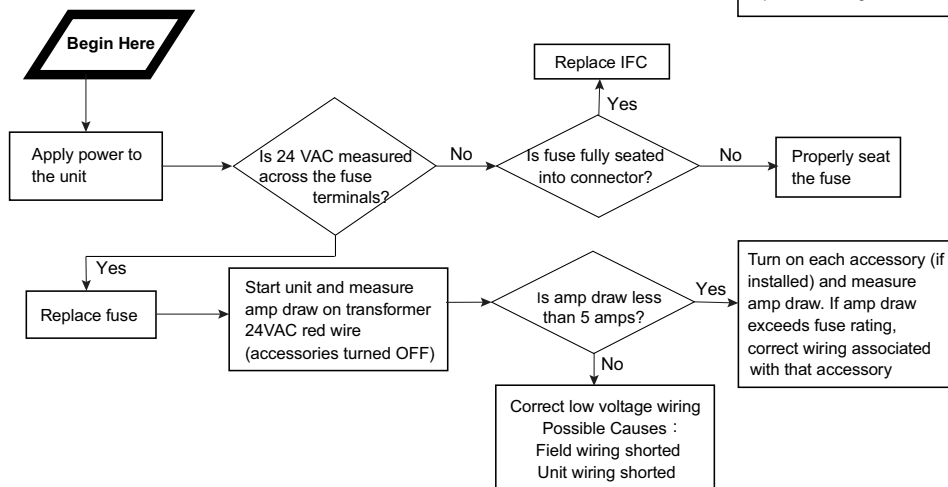

# Troubleshooting

## Constant Torque Motor Troubleshooting

Continuous FAN on this unit is limited to TAP 1 only. No field adjustment can be made. If troubleshooting other speed taps, use the method as outlined below using the voltages listed for the tap number being used.

**Begin Here**

Ensure power is applied to the unit and Seven Segment LED's are ON with no active error codes

Turn fan to ON at thermostat and verify that COF and TP1 alternately appear on the seven segment display

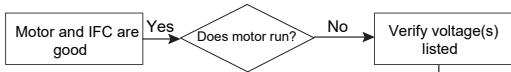

If voltage is not present, remove 6 pin connector from IFC and re-check. If voltage is present, verify voltage at panel connectors and at motor. If voltage is present at the motor, replace motor

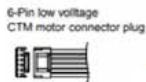
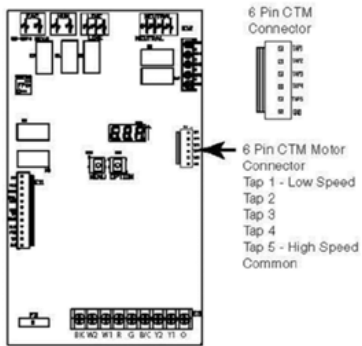

1. Remove the 6-pin low voltage connector from the IFC
2. Apply 24 VAC to Common tap (Blue) and any speed tap on the CTM motor 6-pin plug. The motor should run.

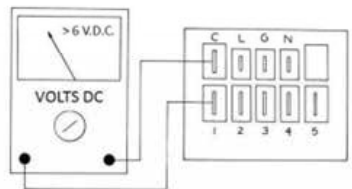
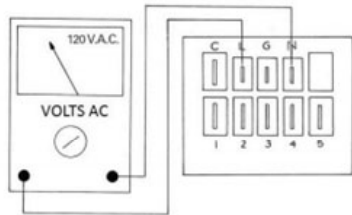

### Output Voltage

RD/W	Tap 1
YL/W	Tap 2
BL/W	Tap 3
BK/W	Tap 4
OR/W	Tap 5
BLUE	24v C

Tap 1	~ 8vdc	
Tap 2	~ 8vdc	
Tap 3	~ 18vdc	
Tap 4	~ 8vdc	
Tap 5	~ 18vdc	
Tap 6 (1+2)	~ 8vdc	~ 8vdc
Tap 7 (1+3)	~ 8vdc	~ 18vdc
Tap 8 (1+4)	~ 8vdc	~ 8vdc
Tap 9 (1+5)	~ 8vdc	~ 18vdc

All Voltages Reference Ground

# Belly Band Location

The illustration below shows the distance from belly band to the lead end of motor for minimum vibration.

**Figure 150. Belly band location**

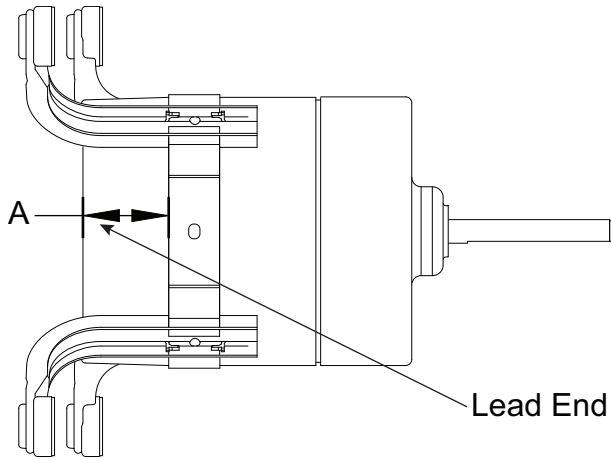

Blower housings and wheel removed from view for clarity.

**Table 37. Belly band dimensions**

Furnace Model Number	Dimension A (inches)
A951X060BU4SAC A951X080BU4SAC	2.65
A951X080CU5SAC A951X120DU5SAC A951X080BD4SAC A951X100CD5SAC A951X120DD5SAC	3.54
A951X100CU5SAC	3.81
A951X040BU3SAC A951X040D3SAC A951X060BD3SAC	3.91

# Sequence of Operation

## Gas Heating

1. R – W contacts close on the thermostat sending 24VAC to the W1 low voltage terminal of the IFC. Technician should read 24VAC from W1 to B/C. The seven-segment LED will read:

H<sub>L</sub> = Gas Heating

2. The IFC performs a self-check routine and then confirms that the:
  - a. Condensate pressure switch and Inducer limit switch are closed by sending 24VAC out the HLO terminal and monitoring the ILI input.
  - b. Flame roll-out switches (FRS) 1 & 2, main thermal limit (TCO), and any reverse air flow (RAF) switches are closed by sending 24VAC out the HLO terminal and monitoring the HLI input.
  - c. Pressure switch 1 (PS1) is opened by sending 24VAC out the HLO terminal, through the limit switches, and monitoring the PS1 input.

**Note:** *If a thermal limit is open, 24VAC will not be present at the pressure switch.*

3. After steps a, b, and c are confirmed, the inducer relay is closed energizing the inducer motor.
4. As the inducer ramps up, PS will close.
5. When PS closes, the ignitor relay on the IFC will close. The ignitor is energized. The ignitor warm up is approximately 17 seconds.
6. After the ignitor warm up, the gas valve relay is closed, which energizes the gas valve solenoid to allow ignition.
7. The first burner will ignite, and flame will crossover to the remaining burners, establishing current to the flame sensor. Proof of flame must be established within 4 seconds.

**Note:** *There are two flame sense pads located on the IFC marked as "FP". To measure the flame current, use a VOM set to DC volts. 1VDC = 1 micro-amp. Flame current will vary depending on the type of meter used. Typical flame current ranges from 0.75 – 3.0 micro-amperes (0.75 – 3 VDC).*

8. Once flame sense has been established, a timer on the IFC starts, and the indoor blower will energize after the blower "Heat On Delay" has completed. The seven-segment LED for example will alternately read:

H<sub>L</sub> = Gas heating

L<sub>P5</sub> = Speed Tap 5

9. When the temperature raises enough to satisfy the thermostat setting, contacts R-W will open.
10. The gas valve relay will open, closing the gas valve. The inducer will continue to run for approximately 5 seconds to remove any combustion by-products from inside the furnace.
11. The indoor blower continues to run to remove heat from the heat exchangers. The blower off time is field adjustable through the IFC menu setup option. The seven segment LED will read *IDL* = Idle, no thermostat demand.

## Cooling / Heat Pump

1. R-Y1-G contacts on the thermostat close sending 24VAC to the Y1 and G low voltage terminals on the IFC. Technician should read 24VAC between Y1-B/C and between G-B/C.
2. 24VAC is sent to the OD unit via thermostat wiring.
3. The indoor blower ramps to the cooling / heat pump airflow. The seven-segment LED, for example, will alternately read:

L<sub>P1</sub> = Cooling / Heat Pump

L<sub>P7</sub> = Speed Tap 7

4. When the temperature is lowered / raised (PH mode) enough to satisfy the thermostat setting, contacts R-Y-G will open.
5. The OD unit shuts off and the indoor blower shuts off, unless a blower "Cool Off Delay" has been enabled in the IFC setup menu options. The seven-segment LED will read *IDL* = Idle, no thermostat demand.

# Periodic Servicing Requirements

1. General Inspection – *Examine the furnace installation annually for the following items:*
  - a. All flue product carrying areas external to the Furnace (i.e. chimney, vent connector) are clear and free of obstruction. A vent screen in the end of the Vent (flue) Pipe must be inspected for blockage annually, if applicable.
  - b. The vent connector is in place, slopes upward and is physically sound without holes or excessive corrosion.
  - c. The return air duct connection(s) is physically sound, is sealed to the Furnace and terminates outside the space containing the Furnace.
  - d. The physical support of the Furnace should be sound without sagging, cracks, gaps, etc., around the base so as to provide a seal between the support and the base.
2. Filters – Filters should be cleaned or replaced (with high velocity filters only), monthly and more frequently during high use times of the year such as midsummer or midwinter.
3. Blowers – The Blower size and speed determine the air volume delivered by the Furnace. The Blower motor bearings are factory lubricated and under normal operating conditions do not require servicing. Annual cleaning of the Blower wheel and housing is recommended for maximum air output, and this must be performed only by a qualified servicer or service agency.
4. Igniter – This unit has a special hot surface direct ignition device that automatically lights the burners. Please note that it is very fragile and should be handled with care.

## **⚠ CAUTION**

### **Hot Surface!**

**Failure to follow instructions below could result in minor to moderate injuries.  
Do not touch igniter. It is extremely hot.**

5. Burner – Gas burners do not normally require scheduled servicing, however, accumulation of foreign material may cause a yellowing flame or delayed ignition. Either condition indicates that a service call is required. For best operation, burners must be cleaned annually using brushes and vacuum cleaner. Turn off gas and electric power supply. To clean burners, remove burner bottom plate (2 screws) and bottom burner bracket (2 screws). Twist burner towards slot, lift, and push forward away from orifice. Remove burners.

Alternate method — Remove manifold assembly, bottom burner plate, and bottom burner bracket. Remove burners.

**Note:** *Be careful NOT to break igniter when removing burners.*

Clean burners with brush and/ or vacuum cleaner. Reassemble parts by reversal of the above procedure.

### **Notes:**

- *Natural gas units should not have any yellow tipped flames. This condition indicates that a service call is required. For best operation, burners must be cleaned annually using brushes and vacuum cleaner.*
- *On Propane units, due to variations in BTU content and altitude, servicing may be required at shorter intervals.*

6. Heat Exchanger/Flue Pipe – These items must be inspected for signs of corrosion, and/ or deterioration at the beginning of each heating season by a qualified service technician and cleaned annually for best operation. To clean flue gas passages, follow recommendations below:
  - a. Turn off gas and electric power supply.
  - b. Inspect flue pipe exterior for cracks, leaks, holes or leaky joints. Some discoloration of PVC pipe is normal.
  - c. Remove door from Furnace.
  - d. Inspect around insulation covering flue collector box. Inspect induced draft Blower connections from recuperative cell and to the flue pipe connection.
  - e. Remove burners. (See [Step 5.](#))
  - f. Use a mirror and flashlight to inspect interior of Heat Exchanger, be careful not to damage the Igniter, Flame Sensor or other components.
  - g. If any corrosion is present, the Heat Exchanger should be cleaned by a qualified service technician.
  - h. After inspection is complete replace burners and Furnace door.
  - i. Restore gas supply. Check for leaks using a soap solution. Restore electrical supply. Check unit for normal operation.
7. Cooling Coil Condensate Drain - If a cooling coil is installed with the Furnace, condensate drains should be checked and cleaned periodically to assure that condensate can drain freely from coil to drain. If condensate cannot drain freely water damage could occur.

### About Trane and American Standard Heating and Air Conditioning

Trane and American Standard create comfortable, energy efficient indoor environments for residential applications. For more information, please visit [www.trane.com](http://www.trane.com) or [www.americanstandardair.com](http://www.americanstandardair.com).



The manufacturer has a policy of continuous data improvement and it reserves the right to change design and specifications without notice. We are committed to using environmentally conscious print practices.