

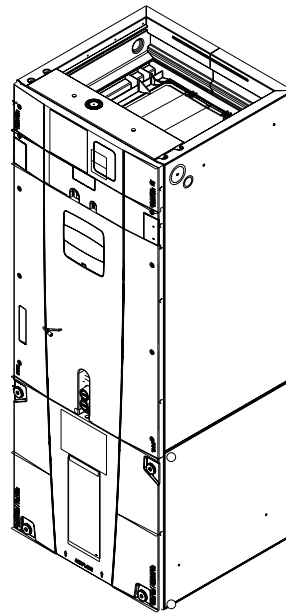

Installation, Operation, and Maintenance

Convertible Air Handlers 1-1/2 – 5 Ton

5TAM5B01AC21SA
5TAM5B02AC21SA
5TAM5C03AC21SA
5TAM5C04AC31SA
5TAM5D05AC31SA
5TAM5D06AC41SA
5TAM5D07AC51SA



Note: Graphics in this document are for representation only.
Actual model may differ in appearance.

SAFETY WARNING

Only qualified personnel should install and service the equipment. The installation, starting up, and servicing of heating, ventilating, and air-conditioning equipment can be hazardous and requires specific knowledge and training. Improperly installed, adjusted or altered equipment by an unqualified person could result in death or serious injury. When working on the equipment, observe all precautions in the literature and on the tags, stickers, and labels that are attached to the equipment.

Safety Information

Important: Repositioning of the refrigerant sensor is required for horizontal or downflow applications. See Unit Conversion section for instructions.

Important: Installation of this unit shall be made in accordance with the National Electric Code, NFPA No. 90A and 90B, and any other local codes or utilities requirements.

Important: Panel damage can occur with prolonged exposure to POE lubricants. Air handler front panels that come in contact with POE oil must be washed immediately with soapy water.

Important: Can not leave door panels in the sun during installation as the extreme temperature has a tendency to warp the plastic outer panel.

Important: This document contains a wiring diagram, a parts list, and service information. This is customer property and is to remain with this unit. Please return to service information pack upon completion of work.

Important: These instructions do not cover all variations in systems nor provide for every possible contingency to be met in connection with the installation. Should further information be desired or should particular problems arise which are not covered sufficiently for the purchaser's purposes, the matter should be referred to your installing dealer or local distributor.

Note: Air handlers have been evaluated in accordance with the Code of Federal Regulations, Chapter XX, Part 3280 or the equivalent. "SUITABLE FOR MOBILE HOME USE."

Note: Condensation may occur on the surface of the air handler when installed in an unconditioned space. When units are installed in unconditioned spaces, verify that all electrical and refrigerant line penetrations on the air handler are sealed completely.

Note: The manufacturer recommends installing ONLY A.H.R.I approved, matched indoor and outdoor systems. Some of the benefits of installing approved matched indoor and outdoor split systems are maximum efficiency, optimum performance, and the best overall system reliability.

Note: Charging of the refrigerating system shall be according to the instructions provided by the manufacturer of the outdoor unit.

Note: There is no declared maximum altitude for operating the appliance.

WARNING

HAZARDOUS VOLTAGE!

Failure to follow this Warning could result in property damage, severe personal injury, or death.

Disconnect all electric power, including remote disconnects before servicing. Follow proper lockout/tagout procedures to ensure the power cannot be inadvertently energized.

WARNING

SAFETY HAZARD!

This air handler shall only be connected to an outdoor unit suitable for use with refrigerant R454B.

WARNING

SAFETY HAZARD!

Children should be supervised to ensure that they do not play with the appliance.

WARNING

RISK OF FIRE!

Flammable refrigerant used. To be repaired only by trained service professional. Do not puncture refrigerant tubing.

Dispose of properly in accordance with federal or local regulations. Flammable refrigerant used.

WARNING

LIVE ELECTRICAL COMPONENTS!

Failure to follow this Warning could result in property damage, severe personal injury, or death.

Follow all electrical safety precautions when exposed to live electrical components. It may be necessary to work with live electrical components during installation, testing, servicing, and troubleshooting of this product.

WARNING

PRESSURIZED REFRIGERANT!

Failure to follow this Warning could result in personal injury

System contains oil and refrigerant under high pressure. Recover refrigerant to relieve pressure before opening the system. Do not use nonapproved refrigerants or refrigerant substitutes or refrigerant additives.

WARNING

SAFETY HAZARD!

This appliance is not to be used by persons (including children) with reduced physical, sensory, or mental capabilities, or lack of experience and knowledge, unless they have been given supervision or instruction concerning the use of the appliance by a person responsible for their safety.

WARNING

WARNING!

This product can expose you to chemicals including lead, which are known to the State of California to cause cancer and birth defects or other reproductive harm. For more information go to www.P65Warnings.ca.gov.

CAUTION

SHARP EDGE HAZARD!

Failure to follow this Caution could result in property damage or personal injury.

Be careful of sharp edges on equipment or any cuts made on sheet metal while installing or servicing.

⚠ CAUTION

GROUNDING REQUIRED!

Failure to inspect or use proper service tools may result in equipment damage or personal injury. Reconnect all grounding devices. All parts of th is product that are capable of conducting electrical current are grounded. If grounding wires, screws, straps, clips, nuts, or washers used to complete a path to ground are removed for service, they must be returned to their original position and properly fastened.

⚠ CAUTION

CORROSION HAZARD!

To prevent shortening its service life, the air handler should not be used during the finishing phases of construction. The low return air temperatures can lead to the formation of condensate. Condensate in the presence of chlorides and fluorides from paint, varnish, stains, adhesives, cleaning compounds, and cement creates a corrosive condition which may cause rapid deterioration of the cabinet and internal components.

⚠ CAUTION

HAZARDOUS VAPORS!

Failure to follow this caution could result in property damage or personal injury. Equipment corrosion damage. To prevent shortening its service life, the air handler should not be used during the finishing phases of construction or remodeling. The low return air temperatures can lead to the formation of condensate. Condensate in the presence of chlorides and fluorides from paint, varnish, stains, adhesives, cleaning compounds, and cement creates a corrosive condition which may cause rapid deterioration of the cabinet and internal components.

⚠ CAUTION

COIL IS PRESSURIZED!

- Coil is pressurized with approximately 8–12 psi dry air and factory checked for leaks.
- Carefully release the pressure by removing the rubber plug on the liquid line.
- If no pressure is released, check for leaks.

Table of Contents

Section 2. Information on Servicing4

Section 3. Unit Outline Drawing7

Section 4. Wiring Diagram8

Section 5. Refrigerant Leak Detection System9

Section 6. Unit Design 11

Section 7. Unit Preparation 13

Section 8. Optional Cabinet Disassembly 14

Section 9. Place Unit at Location 18

Section 10. Unit Location Considerations 19

Section 11. Setting the Unit - Vertical Installation 27

Section 12. Setting the Unit - Horizontal Installation 29

Section 13. Connecting the Duct work 30

Section 14. Refrigerant Line 31

Section 15. Refrigerant Line Brazing35

Section 16. Condensate Drain Piping35

Section 17. Electrical - High Voltage 37

Section 18. Electrical - Low Voltage 40

Section 19. Airflow Adjustment45

Section 20. Product Specifications46

Section 21. Airflow Performance48

Section 22. Minimum Airflow Setting 51

Section 23. Wiring Data 52

Section 24. Distance from Belly Band to Shaft Face of Motor for Minimum Vibration 55

Section 25. Filters 56

Section 26. Sequence of Operation 57

Section 27. Checkout Procedures 58

Section 28. Troubleshooting 59

Section 2. Information on Servicing

All replacement parts shall be in accordance with the manufacturer's specifications.

Prior to Beginning Work

Prior to beginning work on systems containing flammable refrigerants, safety checks are necessary to ensure that the risk of ignition is minimized. For repair to the refrigerating system, the following shall be completed prior to conducting work on the system:

- Work shall be undertaken under a controlled procedure to minimize the risk of a flammable gas or vapor being present while the work is being performed.
- All maintenance staff and others working in the local area shall be instructed on the nature of work being carried out. Work in confined spaces shall be avoided.
- The area shall be checked with an appropriate refrigerant detector prior to and during work, to ensure the technician is aware of potentially toxic or flammable atmospheres. Ensure that the leak detection equipment being used is suitable for use with all applicable refrigerants, i.e., non-sparking, adequately sealed or intrinsically safe.
- If any hot work is to be conducted on the refrigerating equipment or any associated parts, appropriate fire extinguishing equipment shall be available to hand. Have a dry powder or CO₂ fire extinguisher adjacent to the charging area.
- No person carrying out work in relation to a refrigerating system which involves exposing any pipe work shall use any sources of ignition in such a manner that it may lead to the risk of fire or explosion. All possible ignition sources, including cigarette smoking, should be kept sufficiently far away from the site of installation, repairing, removing and disposal, during which refrigerant can possibly be released to the surrounding space. Prior to work taking place, the area around the equipment is to be surveyed to make sure that there are no flammable hazards or ignition risks. "No Smoking" signs shall be displayed.
- Ensure that the area is in the open or that it is adequately ventilated before breaking into the system or conducting any hot work. A degree of ventilation shall continue during the period that the work is carried out. The ventilation should safely disperse any released refrigerant and preferably expel it externally into the atmosphere.
- The following checks shall be applied to installations using flammable refrigerants:
 - marking to the equipment continues to be visible and legible. Markings and signs that are illegible shall be corrected;
 - refrigerating pipe or components are installed in a position where they are unlikely to be exposed to any substance which may corrode refrigerant

containing components, unless the components are constructed of materials which are inherently resistant to being corroded or are suitably protected against being so corroded.

Repairs to Electrical Components

Where electrical components are being changed, they shall be fit for the purpose and to the correct specification. At all times the manufacturer's maintenance and service guidelines shall be followed. If in doubt, consult the manufacturer's technical department for assistance.

Repair and maintenance to electrical components shall include initial safety checks and component inspection procedures. If a fault exists that could compromise safety, then no electrical supply shall be connected to the circuit until it is satisfactorily dealt with. If the fault cannot be corrected immediately but it is necessary to continue operation, an adequate temporary solution shall be used. This shall be reported to the owner of the equipment, so all parties are advised.

Initial safety checks shall include:

- that capacitors are discharged; this shall be done in a safe manner to avoid possibility of sparking;
- that no live electrical components and wiring are exposed while charging, recovering or purging the system;
- that there is continuity of earth bonding.

Check that cabling will not be subject to wear, corrosion, excessive pressure, vibration, sharp edges or any other adverse environmental effects. The check shall also take into account the effects of aging or continual vibration from sources such as compressors or fans.

Detection of Flammable Refrigerants

Under no circumstances shall potential sources of ignition be used in the searching for or detection of refrigerant leaks. A halide torch (or any other detector using a naked flame) shall not be used.

The following leak detection method is deemed acceptable for all refrigerant systems:

- Electronic leak detectors may be used to detect refrigerant leaks but, in the case of flammable refrigerants, the sensitivity may not be adequate, or may need re-calibration. (Detection equipment shall be calibrated in a refrigerant-free area.) Ensure that the detector is not a potential source of ignition and is suitable for the refrigerant used. Leak detection equipment shall be set at a percentage of the LFL of the refrigerant and shall be calibrated to the refrigerant employed, and the appropriate percentage of gas (25 % maximum) is confirmed.

Example of leak detection fluids is **bubble method**.

If a leak is suspected, all naked flames shall be removed/ extinguished.

If a leakage of refrigerant is found which requires brazing, all of the refrigerant shall be recovered from the system, or isolated (by means of shut off valves) in a part of the system remote from the leak.

Removal and Evacuation

When breaking into the refrigerant circuit to make repairs - or for any other purpose - conventional procedures shall be used. However, for flammable refrigerants it is important that best practice be followed, since flammability is a consideration. The following procedure shall be adhered to:

- safely remove refrigerant following local and national regulations;
- evacuate;
- purge the circuit with inert gas (optional for A2L);
- evacuate (optional for A2L);
- continuously flush or purge with inert gas when using flame to open circuit;
- and open the circuit.

The refrigerant charge shall be recovered into the correct recovery cylinders if venting is not allowed by local and national codes. For appliances containing flammable refrigerants, the system shall be purged with oxygen-free nitrogen to render the appliance safe for flammable refrigerants.

This process might need to be repeated several times. Compressed air or oxygen shall not be used for purging refrigerant systems.

For appliances containing flammable refrigerants, refrigerants purging shall be achieved by breaking the vacuum in the system with oxygen-free nitrogen and continuing to fill until the working pressure is achieved, then venting to atmosphere, and finally pulling down to a vacuum (optional for A2L). This process shall be repeated until no refrigerant is within the system (optional for A2L). When the final oxygen-free nitrogen charge is used, the system shall be vented down to atmospheric pressure to enable work to take place.

The outlet for the vacuum pump shall not be close to any potential ignition sources, and ventilation shall be available.

Charging Procedures

In addition to conventional charging procedures, the following requirements shall be followed.

- Ensure that contamination of different refrigerants does not occur when using charging equipment. Hoses or lines shall be as short as possible to minimise the amount of refrigerant contained in them.
- Cylinders shall be kept in an appropriate position according to the instructions.

- Ensure that the refrigerating system is earthed prior to charging the system with refrigerant.
- Label the system when charging is complete (if not already).
- Extreme care shall be taken not to overfill the refrigerating system.

Prior to recharging the system, it shall be pressure tested with the appropriate purging gas. The system shall be leak-tested on completion of charging but prior to commissioning. A follow up leak test shall be carried out prior to leaving the site.

See installation instructions below for further details.

Recovery

When removing refrigerant from a system, either for servicing or decommissioning, it is recommended good practice that all refrigerants are removed safely.

When transferring refrigerant into cylinders, ensure that only appropriate refrigerant recovery cylinders are employed. Ensure that the correct number of cylinders for holding the total system charge is available. All cylinders to be used are designated for the recovered refrigerant and labelled for that refrigerant (i.e., special cylinders for the recovery of refrigerant). Cylinders shall be complete with pressure-relief valve and associated shut-off valves in good working order. Empty recovery cylinders are evacuated and, if possible, cooled before recovery occurs.

The recovery equipment shall be in good working order with a set of instructions concerning the equipment that is at hand and shall be suitable for the recovery of the flammable refrigerant. If in doubt, the manufacturer should be consulted. In addition, a set of calibrated weighing scales shall be available and in good working order. Hoses shall be complete with leakfree disconnect couplings and in good condition.

The recovered refrigerant shall be processed according to local legislation in the correct recovery cylinder, and the relevant waste transfer note arranged. Do not mix refrigerants in recovery units and especially not in cylinders.

If compressors or compressor oils are to be removed, ensure that they have been evacuated to an acceptable level to make certain that flammable refrigerant does not remain within the lubricant. The compressor body shall not be heated by an open flame or other ignition sources to accelerate this process. When oil is drained from a system, it shall be carried out safely.

Decommissioning

Before carrying out this procedure, it is essential that the technician is completely familiar with the equipment and all its detail. It is recommended good practice that all refrigerants are recovered safely. Prior to the task being carried out, an oil and refrigerant sample shall be taken

in case analysis is required prior to re-use of recovered refrigerant. It is essential that electrical power is available before the task is commenced.

1. Become familiar with the equipment and its operation.
2. Isolate system electrically.
3. Before attempting the procedure, ensure that:
 - a. mechanical handling equipment is available, if required, for handling refrigerant cylinders;
 - b. all personal protective equipment is available and being used correctly;
 - c. the recovery process is supervised at all times by a competent person;
 - d. recovery equipment and cylinders conform to the appropriate standards.
4. Pump down refrigerant system, if possible.
5. If a vacuum is not possible, make a manifold so that refrigerant can be removed from various parts of the system.
6. Make sure that cylinder is situated on the scales before recovery takes place.

7. Start the recovery machine and operate in accordance with instructions.
8. Do not overfill cylinders (no more than 80 % volume liquid charge).
9. Do not exceed the maximum working pressure of the cylinder, even temporarily.
10. When the cylinders have been filled correctly and the process completed, make sure that the cylinders and the equipment are removed from site promptly and all isolation valves on the equipment are closed off.
11. Recovered refrigerant shall not be charged into another refrigerating system unless it has been cleaned and checked.

Equipment shall be labelled stating that it has been decommissioned and emptied of refrigerant. The label shall be dated and signed. For appliances containing flammable refrigerant, ensure that there are labels on the equipment stating the equipment contains flammable refrigerant.

Section 3: Unit Outline Drawing

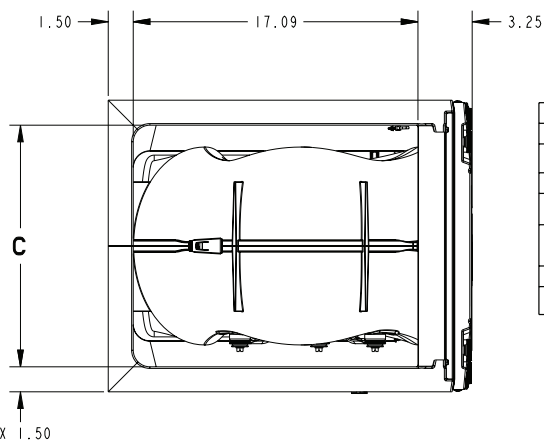
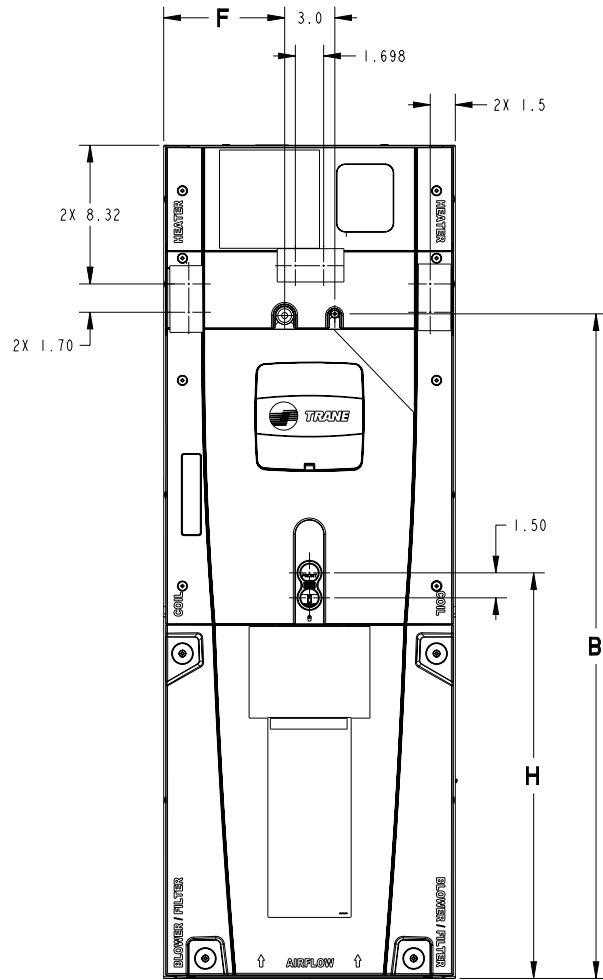
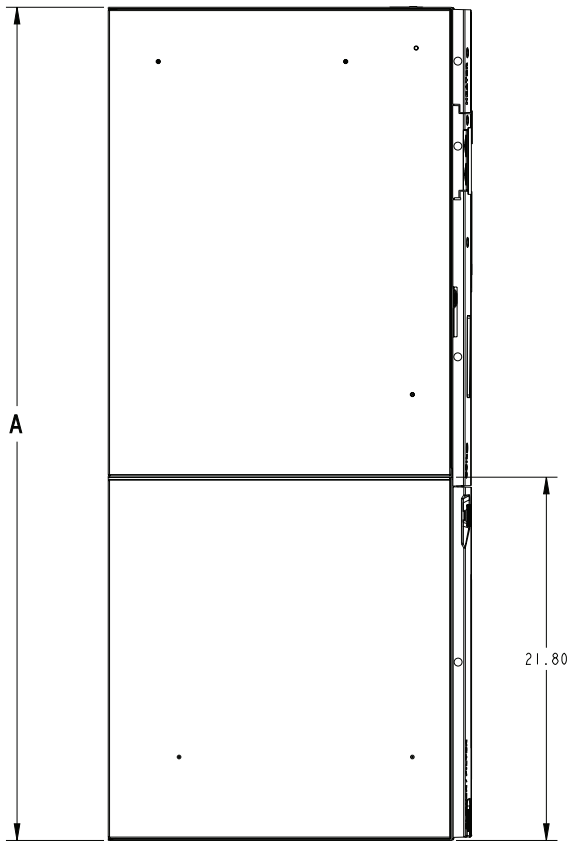
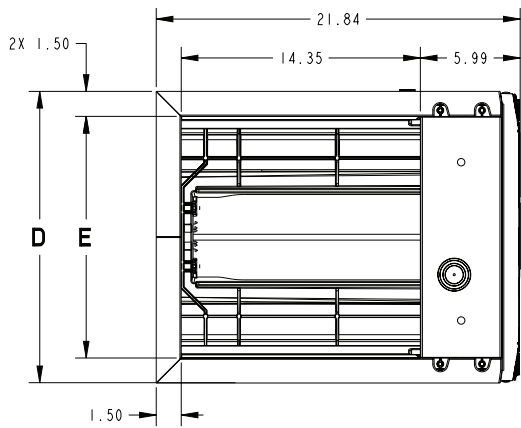

NOTE:
THIS UNIT IS APPROVED FOR INSTALLATION CLEARANCES
TO COMBUSTIBLE MATERIAL AS STATED ON THE UNIT NAME
PLATE.

MODEL NO.	A	B	C	D	E	F	H	FLOW CONTROL	GAS LINE BRAZE
5TAM5B01								TXV	3/4"
5TAM5B02	49.9	39.6	14.5	17.5	14.5	7.3	24.3	TXV	3/4"
5TAM5C03								TXV	3/4"
5TAM5C04	55.7	45.5	18.4	21.3	18.4	9.2	26.3	TXV	7/8"
5TAM5D05	56.9	46.7	20.5	23.5	20.5	10.3	25.7	TXV	7/8"
5TAM5D06								TXV	7/8"
5TAM5D07	61.7	51.5	20.5	23.5	20.5	10.3	24.4	TXV	7/8"

Section 4. Wiring Diagram

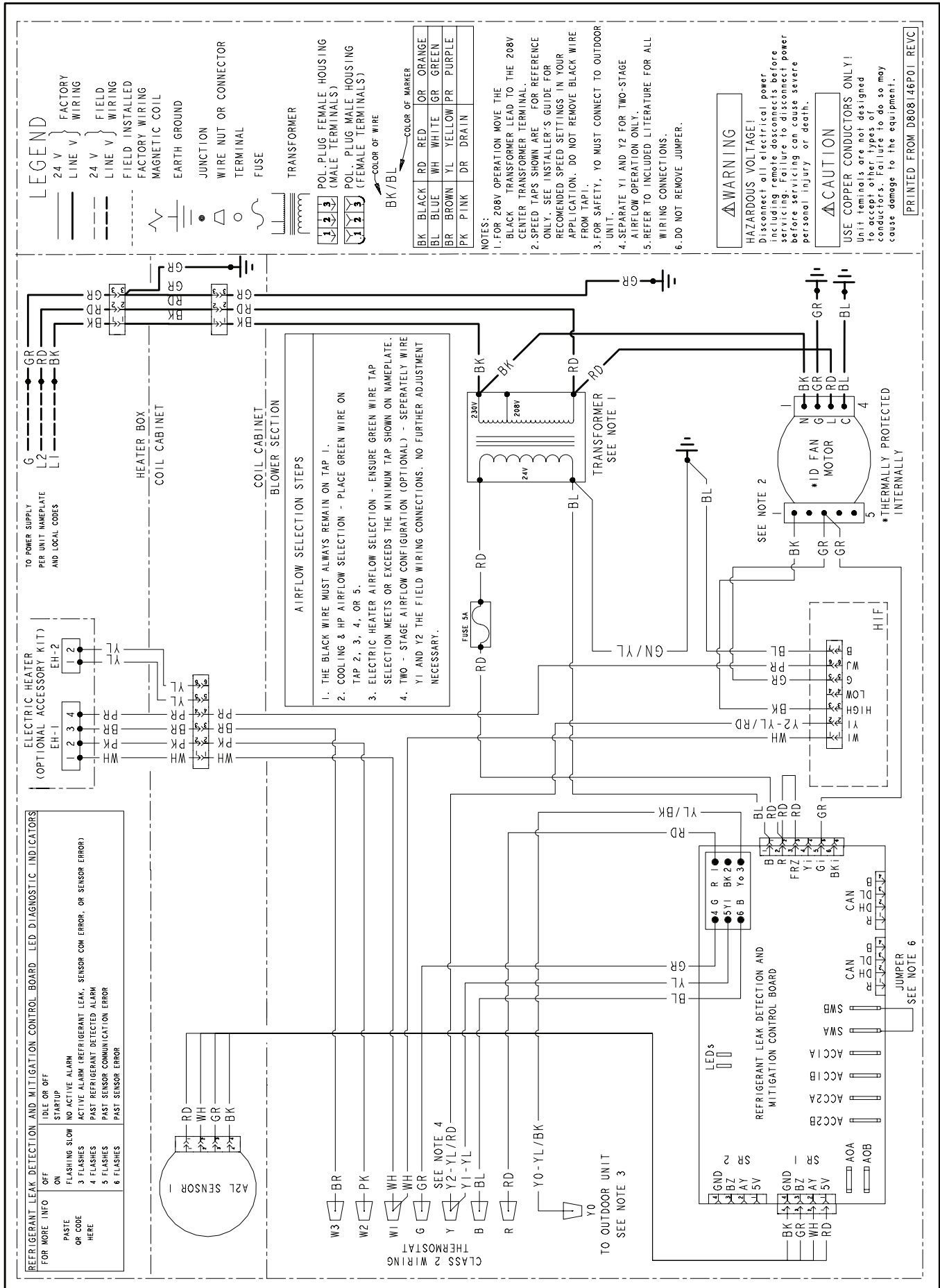

Section 5. Refrigerant Leak Detection System

For all tables contained in this section of the manual, the refrigerant charge is the total system charge which is marked on the system according to the instructions provided by the manufacturer of the outdoor unit.

WARNING

RISK OF FIRE!

Flammable refrigerant used. To be repaired only by trained service professional. Do not puncture refrigerant tubing.

Dispose of properly in accordance with federal or local regulations. Flammable refrigerant used.

WARNING

LEAK DETECTION SYSTEM!

LEAK DETECTION SYSTEM installed. Unit must be powered except for service.

To ensure safety of the building occupants, the air handler is equipped with a refrigerant leak detection system. The system is comprised of a refrigerant sensor and a mitigation control board. The system automatically detects leaks in the indoor coil and initiates actions to mitigate the risk of ignition of the leaked refrigerant, including:

- Turning on the blower of the indoor unit to dilute leaked refrigerant;
- Fully opening any zoning dampers, when applicable;
- Turning off the compressor of the outdoor unit;

- De-energizing potential sources of ignition connected to the system;
- Energizing an audible alarm, if so equipped.

Examples of potential ignition sources that are deenergized include electrostatic air cleaners.

WARNING

RISK OF FIRE!

If installing the unit in any other orientation other than upflow, the refrigerant sensor must be relocated. See Unit Conversion Instructions section.

Refrigerant sensors for refrigerant leak detection systems shall only be replaced as specified by the manufacturer.

Minimum Conditioned Space

The installer must verify that the total space conditioned by the system is large enough to safely dilute any leaked refrigerant in the event of a refrigerant leak of the indoor coil.

The minimum space conditioned by the appliance shall be according to Table given below. The conditioned space includes any parts of the space connected via an air duct system. The altitude of installation is the altitude above sea level of the site where the equipment is installed.

	Altitude (ft)								
	sea level– 2,000	2,001– 4,000	4,001– 6,000	6,001– 8,000	8,001– 10,000	10,001– 12,000	12,001– 14,000	14,001– 15,000	above 15,000
Charge (lb)	Minimum Conditioned Space (ft ²)								
4	63	66	70	74	79	85	91	94	98
5	79	83	88	93	99	106	113	118	122
6	95	100	105	112	119	127	136	141	147
7	110	116	123	130	138	148	159	165	171
8	126	133	140	149	158	169	181	188	196
9	142	149	158	167	178	190	204	212	220
10	158	166	175	186	198	211	227	235	245
11	173	183	193	205	218	232	249	259	269
12	189	199	211	223	237	254	272	282	294
13	205	216	228	242	257	275	295	306	318
14	221	232	246	260	277	296	318	330	343
15	236	249	263	279	297	317	340	353	367
16	252	266	281	298	317	338	363	377	392
17	268	282	298	316	336	359	386	400	416
18	284	299	316	335	356	380	408	424	440
19	299	315	333	353	376	402	431	447	465
20	315	332	351	372	396	423	454	471	489

Airflow Adjustment

Note: All 5TAM5 model air handlers have been factory configured to provide sufficient airflow to dilute leaked refrigerant.

Verification of Mitigation Actions

After installation, the installer must verify that the refrigerant leak detection system actuates all mitigating actions listed above.

The test can be initiated by shorting the two test pins on the header of the mitigation control board inside of the unit. The mitigating actions will continue for approximately 5 minutes. See Figure MCB Board below.

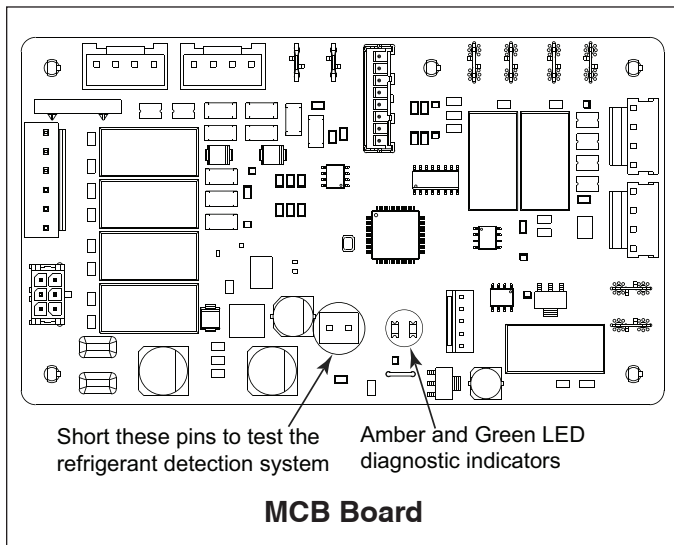

If any of the mitigating actions are not actuated by the system during the test, please check the following:

- All field wiring connections should be checked against the diagrams in the “Electrical - Low Voltage” section of this manual.
- The diagnostic indicators on the mitigation control board should be checked against the diagnostic codes given in below.
- Scan the QR code below for more information on field troubleshooting of the refrigerant leak detection system.

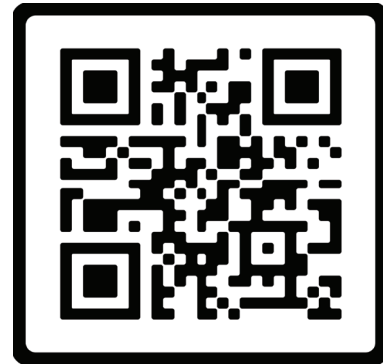

Table 2. MCB Diagnostic Code Table

Condition	Green LED
Idle or Off	Off
Startup	On
No Active Alarm	Slow Flash
Active Alarm (Refrigerant Leak, Sensor Communication Error, or Sensor Error)	3 Flash
Past Refrigerant Detected Alarm	4 Flash
Past Sensor Communication Error	5 Flash
Past Sensor Error	6 Flash

Note: Amber LED diagnostic indicator should always be “ON”.

Section 6. Unit Design

6.1 Cabinet Penetration

Important: Due to the unique design of this unit, which allows the electrical wiring to be routed within the insulation, do not screw, cut, or otherwise puncture the unit cabinet in any location other than the ones illustrated.

Important: Under no conditions should metal strapping be attached to the unit to be used as support mechanisms for carrying or suspension purposes.

Note: Remove the cardboard from the bottom of the blower. Cut the tie wrap and remove the foam block located at the motor.

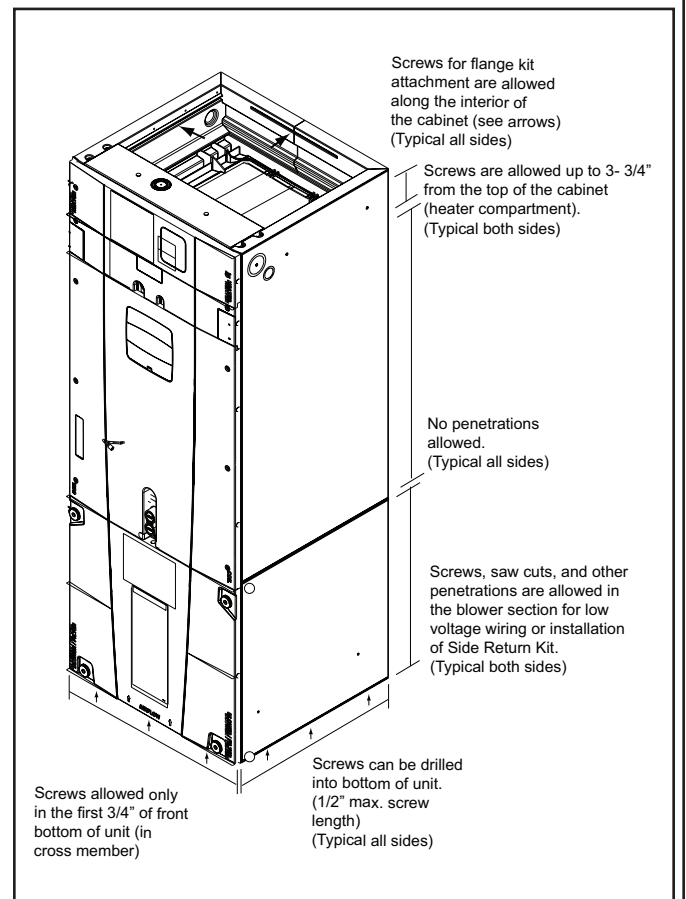

6.2 Panel Removal

The unit contains four (4) access panels: Blower/Filter, Coil, Line Set, and Heater.

The Blower/Filter panel is removed using thumb screws.

1. Turn thumb screws on Blower/Filter panel.
2. Pull top of panel out, away from cabinet.
3. Lift panel up out of channel.
4. Set aside.

The Block off plate is removed with a 5/16" nut driver.

1. Remove the two 5/16" screws at the top of the block off plate
2. Pull top of panel out, away from cabinet.
3. Lift panel up and off mounting bosses at the bottom
4. Set aside.

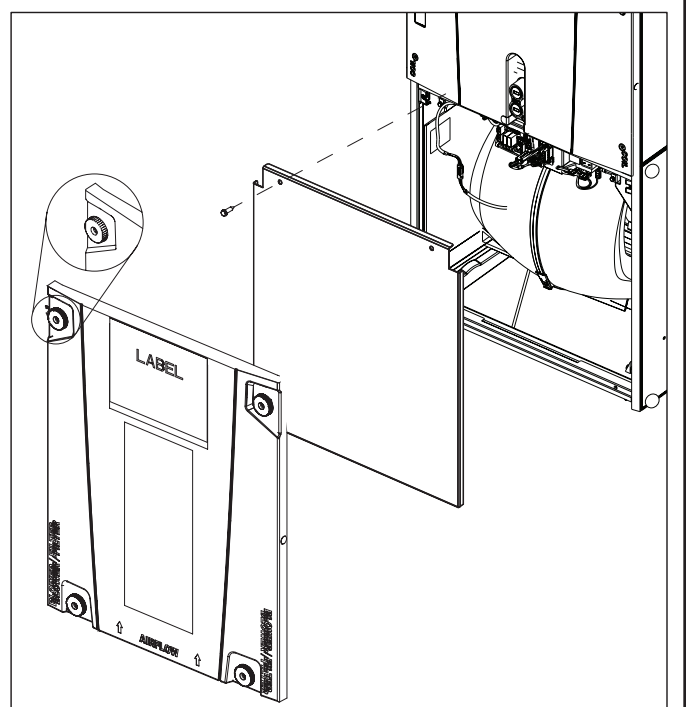

The Coil, Line Set, and Heater panels are removed using Phillips head screws.

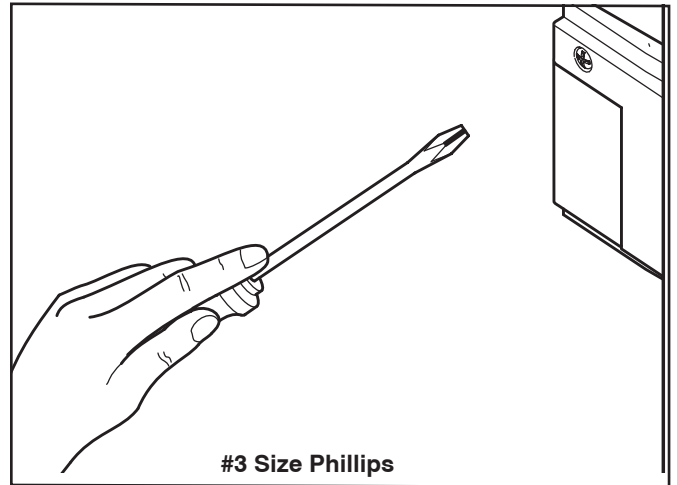

Coil and Heater panels must be removed prior to removing the Line Set panel.

To remove Coil Panel:

1. Turn screws on Coil panel.
2. Pull top of panel out, away from cabinet.
3. Pull panel up and out of channel.
4. Set aside.

To remove Heater Panel:

1. Turn screws on Heater panel.
2. Pull panel straight out, away from cabinet.
3. Set aside.

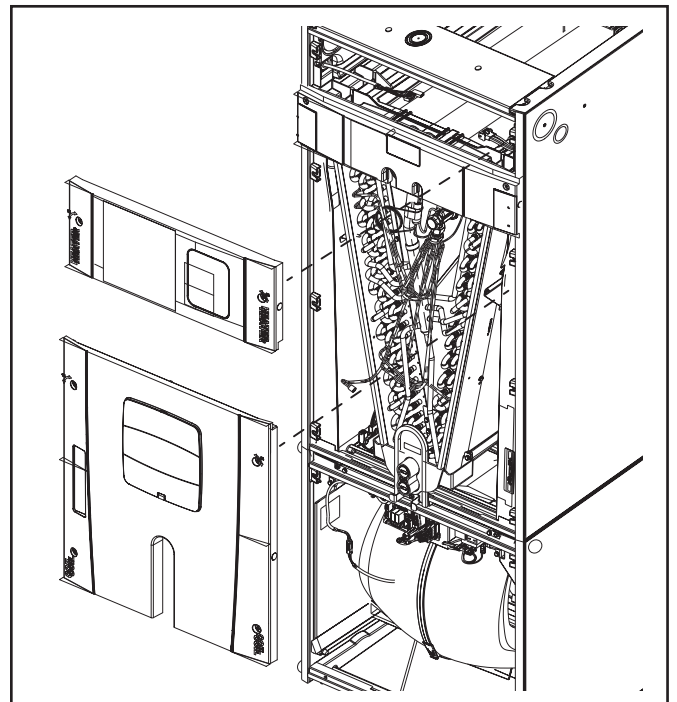

Removal of the Line Set panel is required for all refrigerant line brazing and some condensate line assembly depending on your orientation.

To remove Line Set panel:

1. Remove both Heater and Coil panels.
2. Turn screws on Line Set Panel.
2. Pull panel straight out, away from cabinet.
3. Set aside.

Note: After replacing all panels, loosen the Line Set Panel screws approximately 1/4 - 1/2 turn. This will improve the seal between the Heater Panel and Line Set Panel.

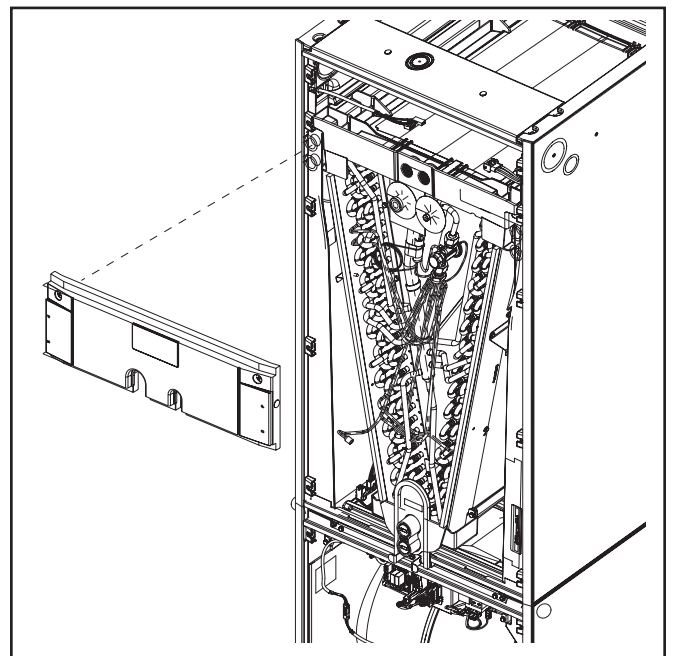

Section 7. Unit Preparation

7.1 Prepare The Unit For Installation

Check for damage and report promptly to the carrier any damage found to the unit.

Note: If the unit must be transported in a horizontal position, it must be laid on its back (marked "REAR" on carton).

Note: After the unit is removed from the carton, release pressure from the coil to verify coil is pressurized and leak free.

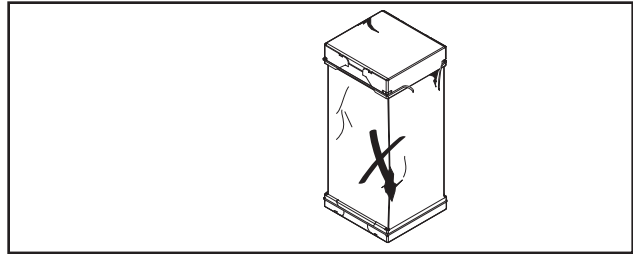

7.2 Unit Accessories

Table 3.1

Accessory Number	Description	Fits Cabinet Width
BAYEA(AC/13)04BK1 (a)	Electric Heater, 4kW, Breaker, 24V Control, 1 Ph	17.5", 21.0", 23.5"
BAYEA(AC/13)04LG1 (a)	Electric Heater, 4kW, Lugs, 24V Control, 1 Ph	17.5", 21.0", 23.5"
BAYEA(AC/13)05BK1 (a)	Electric Heater, 5kW, Breaker, 24V Control, 1 Ph	17.5", 21.0", 23.5"
BAYEA(AC/13)05LG1 (a)	Electric Heater, 5kW, Lugs, 24V Control, 1 Ph	17.5", 21.0", 23.5"
BAYEA(AC/13)08BK1 (a)	Electric Heater, 8kW, Breaker, 24V Control, 1 Ph	17.5", 21.0", 23.5"
BAYEA(AC/13)08LG1 (a)	Electric Heater, 8kW, Lugs, 24V Control, 1 Ph	17.5", 21.0", 23.5"
BAYEA(AC/13)10BK1 (a)	Electric Heater, 10kW, Breaker, 24V Control, 1 Ph	17.5", 21.0", 23.5"
BAYEA(AC/13)10LG1 (a)	Electric Heater, 10kW, Lugs, 24V Control, 1 Ph	17.5", 21.0", 23.5"
BAYEA(AC/13)10LG3 (a)	Electric Heater, 10kW, Lugs, 24V Control, 3 Ph	17.5", 21.0", 23.5"
BAYEA(BC/23)15BK1 (a)	Electric Heater, 15kW, Breaker, 24V Control, 1 Ph	21.0", 23.5"
BAYEA(BC/23)15LG3 (a)	Electric Heater, 15kW, Lugs, 24V Control, 3 Ph	21.0", 23.5"
BAYEA(BC/23)20BK1 (a)	Electric Heater, 20kW, Breaker, 24V Control, 1 Ph	21.0", 23.5"
BAYEA(CC/33)25BK1 (a)	Electric Heater, 25kW, Breaker, 24V Control, 1 Ph	23.5"
BAYSUPFLGAA	Supply Duct Flange 17.5"	17.5"
BAYSUPFLGBA	Supply Duct Flange 21.0"	21.0"
BAYSUPFLGCA	Supply Duct Flange 23.5"	23.5"
BAYRETFLGAA	Return Duct Flange 17.5"	17.5"
BAYRETFLGBA	Return Duct Flange 21.0"	21.0"
BAYRETFLGCA	Return Duct Flange 23.5"	23.5"
BAYSRKIT100A	Side Return Kit	17.5", 21.0", 23.5"
BAYFLR1620A	High Velocity Filter Kit, 16" X 20' X 1" (10 filters)	17.5"
BAYFLR2020A	High Velocity Filter Kit, 20" X 20' X 1" (10 filters)	21.0"
BAYFLR2220A	High Velocity Filter Kit, 22" X 20' X 1" (10 filters)	23.5"
TASB175SB	Plenum Stand with Integrated Sound Baffle 17.5"	17.5"
TASB215SB	Plenum Stand with Integrated Sound Baffle 21.0"	21.0"
TASB235SB	Plenum Stand with Integrated Sound Baffle 23.5"	23.5"
MITISRKIT1620	Side Return Kit with 16" x 20" Filter	17.5", 21.0", 23.5"
BAYFRKIT175	Front Return Kit for 17.5" Cabinet	17.5"
BAYFRKIT210	Front Return Kit for 21.0" Cabinet	21.0"
BAYFRKIT235	Front Return Kit for 23.5" Cabinet	23.5"
BAYBAFKT175	Sound Baffle Kit for 17.5" Cabinet	17.5"
BAYBAFKT210	Sound Baffle Kit for 21.0" Cabinet	21.0"
BAYBAFKT235	Sound Baffle Kit for 23.5" Cabinet	23.5"
TASSBK175	Sound Baffle Kit for 17.5" Cabinet	17.5"
TASSBK215	Sound Baffle Kit for 21.0" Cabinet	21.0"
TASSBK235	Sound Baffle Kit for 23.5" Cabinet	23.5"
BAYICKSKIT01A	Internal Condensate Switch Kit	17.5", 21.0", 23.5"
BAYHHKIT001A	Horizontal Hanger Kit	17.5", 21.0", 23.5"
BAYUVCLK001A	UVC Lights	17.5", 21.0", 23.5"
BAYLVKIT100A	Low Voltage Conduit Entry Kit	17.5", 21.0", 23.5"
BAYSPEKT200A	Single Point Power Entry Kit	21.0", 23.5"
BAYWA(AA/17)05SC1AA (a)	Hydronic heater, 17.5" cabinet, no control, slide-in	17.5"
BAYWA(BB/21)07SC1AA (a)	Hydronic heater, 21.0" cabinet, no control, slide-in	21.0"
BAYWA(CC/23)08SC1AA (a)	Hydronic heater, 23.5" cabinet, no control, slide-in	23.5"
BAYWA(CC/23)11SC1AA (a)	Hydronic heater, 23.5" cabinet, no control, external	23.5"
BAYINSKT175A	Solcoustic® Liner Kit - 17.5" Cabinet	17.5"
BAYINSKT215A	Solcoustic® Liner Kit - 21.5" Cabinet	21.0"
BAYINSKT235A	Solcoustic® Liner Kit - 23.5" Cabinet	23.5"
BAYCNDPIP01A	3/4" PVC Threaded Pipe Kit Foam Seal (10 per box)	17.5", 21.0", 23.5"

(a) Model number may have either of the pairs of characters in parenthesis.

Section 8. Optional Cabinet Disassembly

8.1 Disassemble cabinet for installation in tight areas or as needed.

Note: If the unit must be transported in a horizontal position, it must be laid on its back (marked "REAR" on carton).

Note: To reassemble cabinet, follow the steps in reverse order. Ensure electrical connections are secure and the plug clips are engaged.

STEP 1 - Remove all four front panels. See Section 2.2.

STEP 2 - Remove the two screws on the seal bar and pull the seal bar straight out.

STEP 3 - Disconnect all wiring connections routed to the blower assembly.

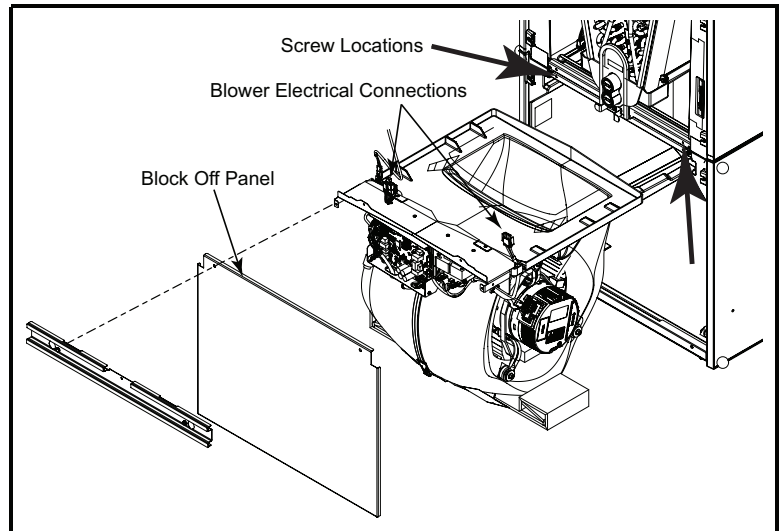

STEP 4 - Slide Blower assembly out of unit using built-in blower support channels and set aside.

Note: Remove the cardboard from the bottom of the blower. Cut the tie wrap and remove the foam block located at the motor.

Note: If system is installed prior in the horizontal position, remove the refrigerant sensor and clip before sliding blower out. See section 10.3 for details on horizontal sensor installation.

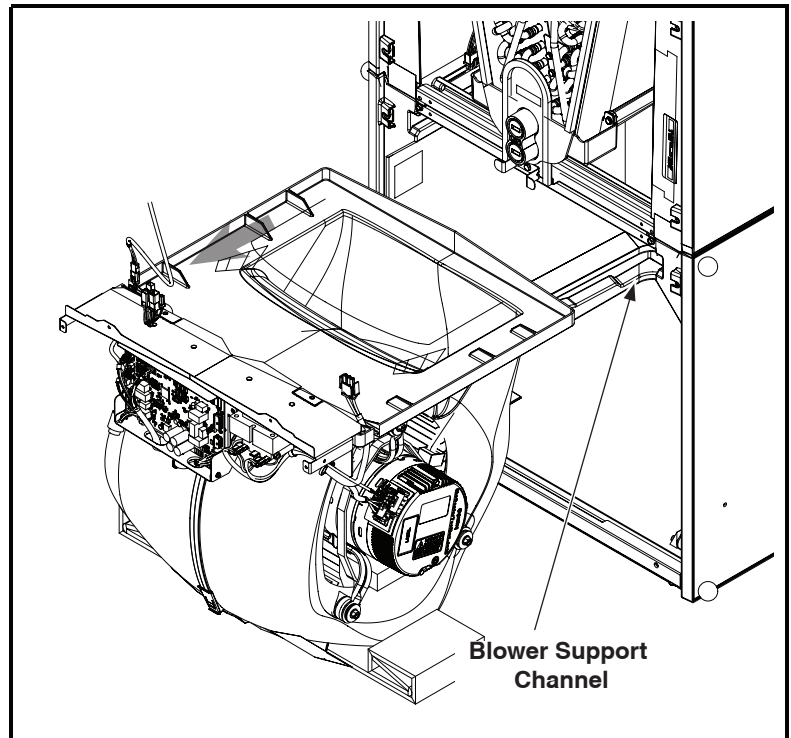

STEP 5 - Slide Coil assembly out of unit using built-in coil support channels and set aside.

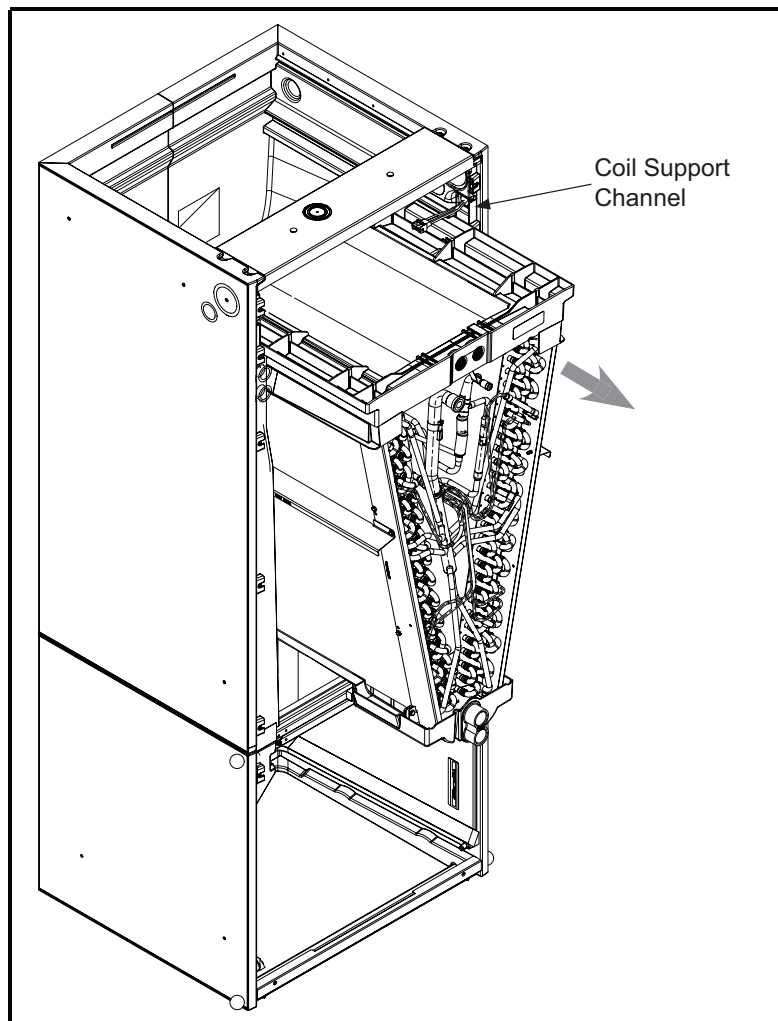

STEP 6 - Use a 5/16 Allen wrench on the locking mechanism on each side of the bottom half of the cabinet to loosen the locking mechanism. The locks loosen by turning counter-clockwise approximately 3/4 of a turn.

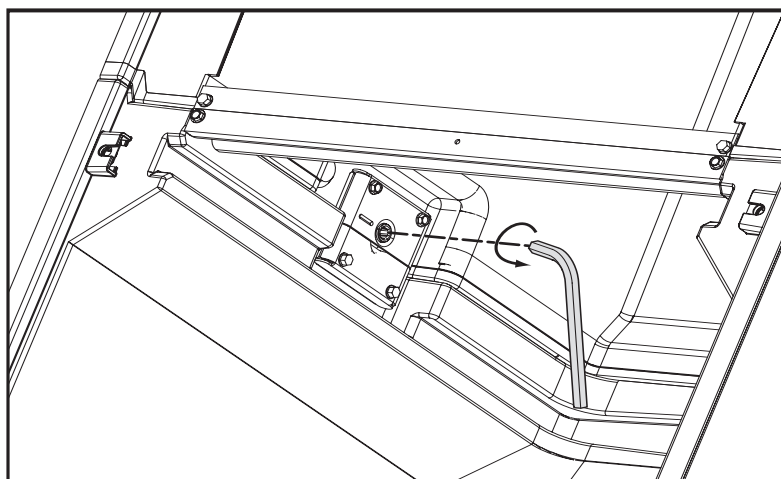

STEP 7 - Lift the Coil section up and away from the Blower section. Set aside.

Note: When separating the two cabinet pieces, make sure the gasket remains intact.

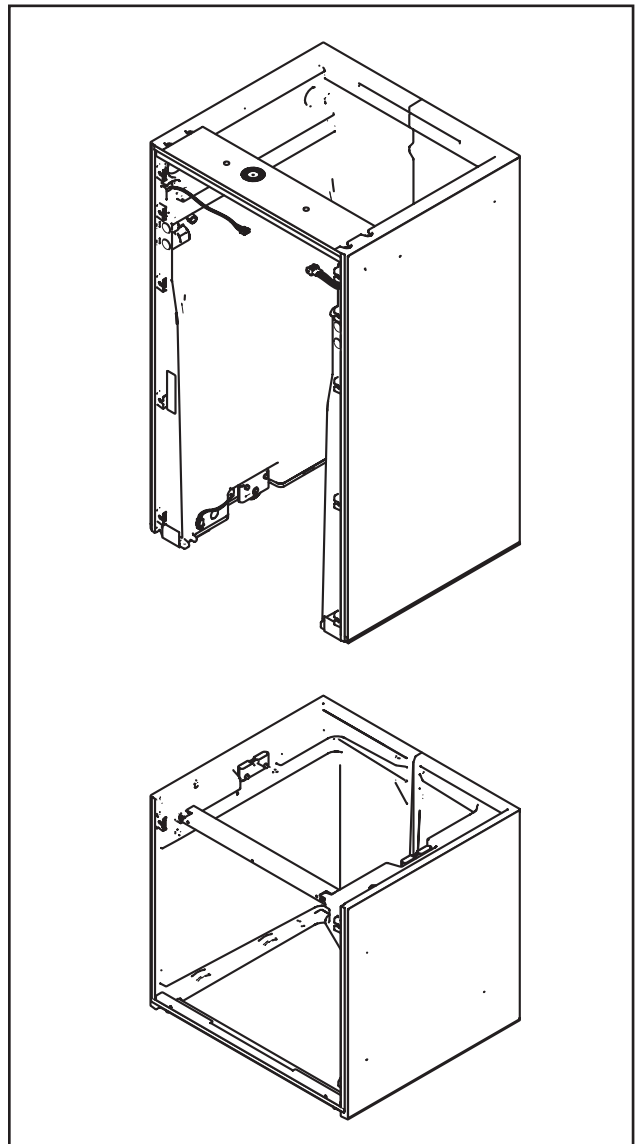

STEP 8 - For extremely tight spaces where the cabinet needs to be rotated through a small opening, remove the top panel. Use a manual driver to avoid stripping screw holes.

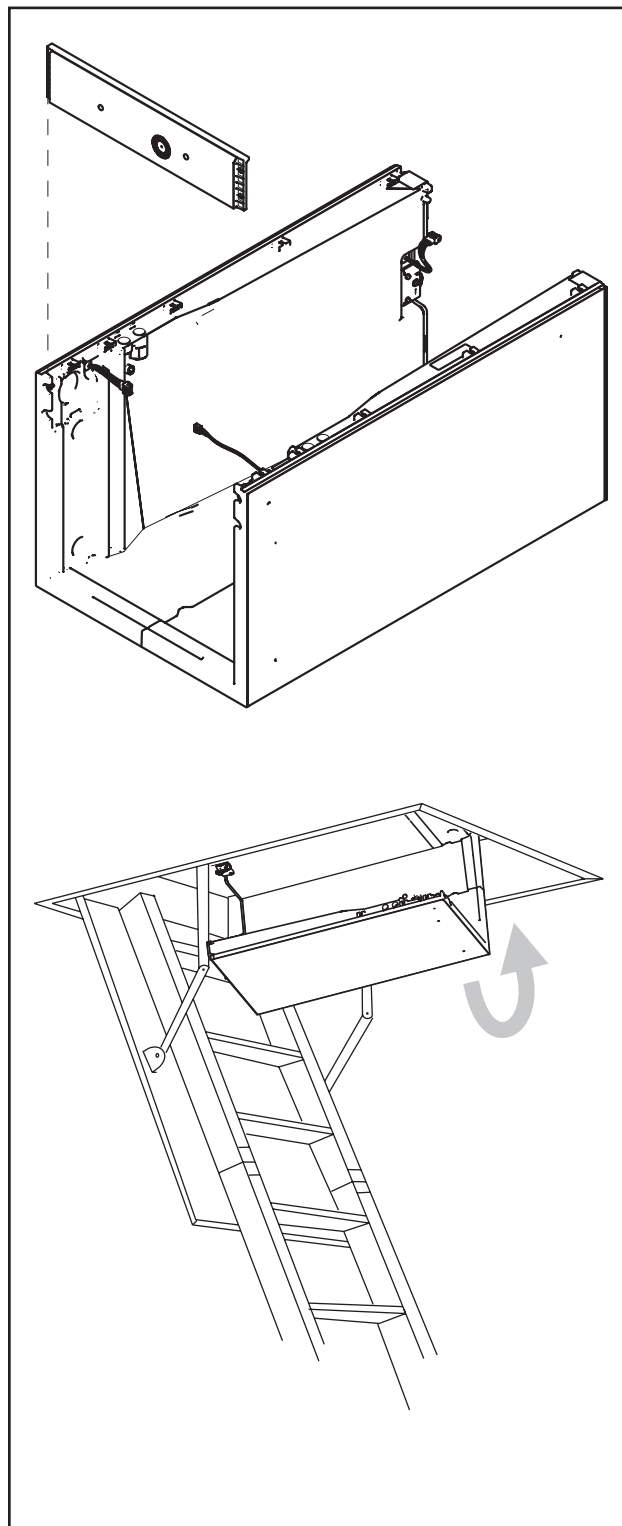

STEP 9 - Continue preparation by following the proper carrying procedures shown in Section 5.

Section 9. Place Unit at Location

9.1 Carry Unit

STEP 1 - Carry the unit to the installation location.

STEP 2 - Reassemble by reversing the steps listed in Section 4 if disassembly was required.

Important: Under no conditions should metal strapping be attached to the unit to be used as support mechanisms for carrying or suspension purposes.

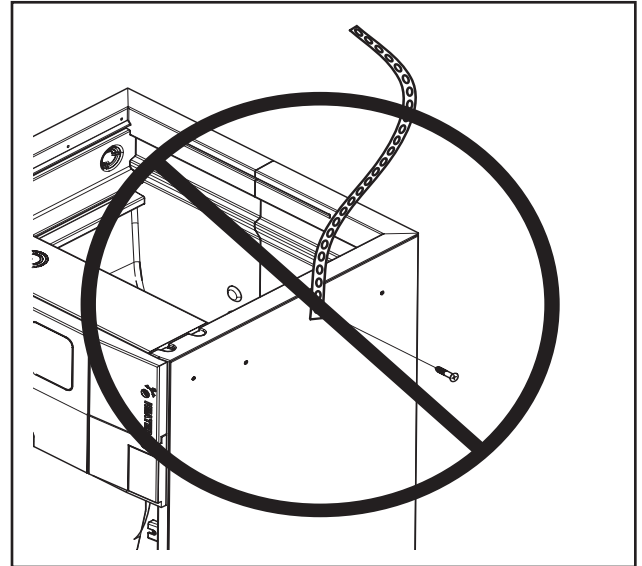

9.2 Approved carrying:

1. Hold by the unit top plate or crossmembers and use as handle for lifting and carrying the coil and blower sections.

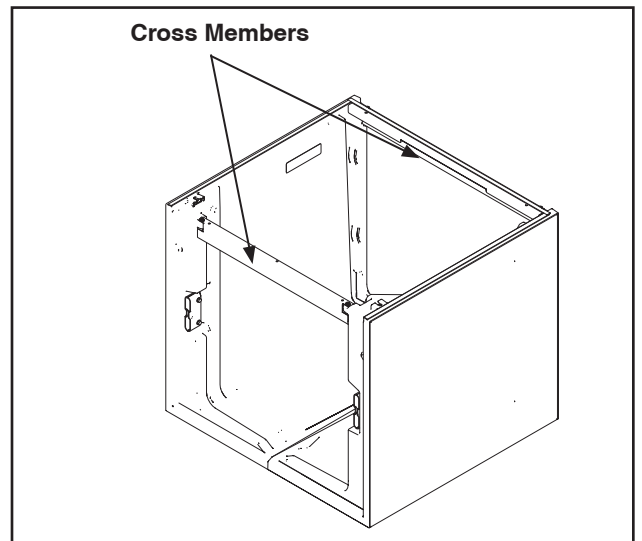
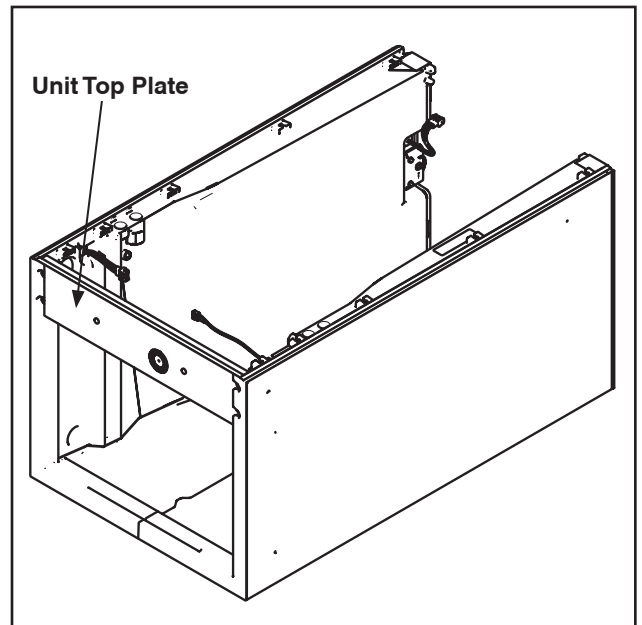

Section 10. Unit Location Considerations

⚠ WARNING

RISK OF FIRE!

The following requirements apply to the room where the air handler is installed:

- All combustion appliances located in the same room that have continuous pilot lights are equipped with an effective flame arrest.
- All indoor field-made joints of the field piping have been checked for refrigerant leaks after charging using an electronic leak detector calibrated for R-454B having a sensitivity of 5 grams per year or better.
- The room is constructed to ensure that should any refrigerant leak it will not stagnate and create a fire hazard.

Note: Equipment shall be installed in such a way which reduces the likelihood of ignition of leaked refrigerant.

10.1 Unit Dimensions and Weight

Table 4

Model Number	H x D x W in.	*Blower Compartment in.	Unit Net Weight lbs.
5TAM5B01AC21SAA	49-7/8 x 17-1/2 x 21-3/4	22	120
5TAM5B02AC21SAA	49-7/8 x 17-1/2 x 21-3/4	22	120
5TAM5C03AC21SAA	55-3/4 x 21-1/4 x 21-3/4	22	142
5TAM5C04AC31SAA	55-3/4 x 21-1/4 x 21-3/4	22	142
5TAM5D05AC31SAA	56-7/8 x 23-1/2 x 21-3/4	22	153
5TAM5D06AC41SAA	61-3/4 x 23-1/2 x 21-3/4	22	166
5TAM5D07AC51SAA	61-3/4 x 23-1/2 x 21-3/4	22	170

*Subtract from total height to get Coil and Heater compartment height.

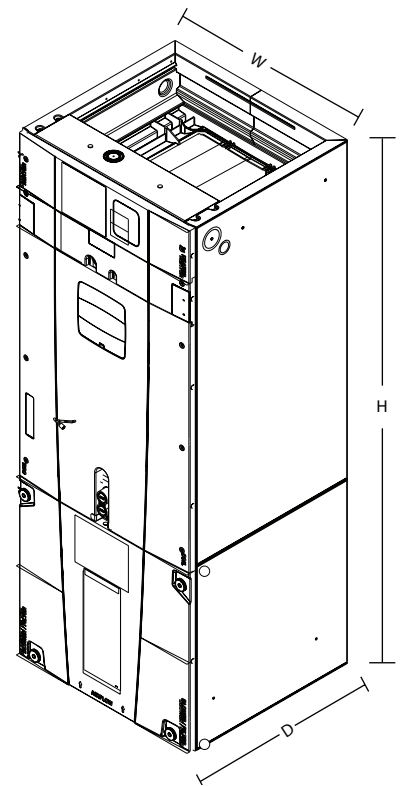

10.2 Four-Way Conversion

To place the unit in the configuration your application requires (upflow, downflow, horizontal right, or horizontal left), simply turn the unit to that orientation.

Note: The air handlers are shipped from the factory suitable for four-way application.

Note: Entry for low voltage connections is allowed on either side of cabinet.

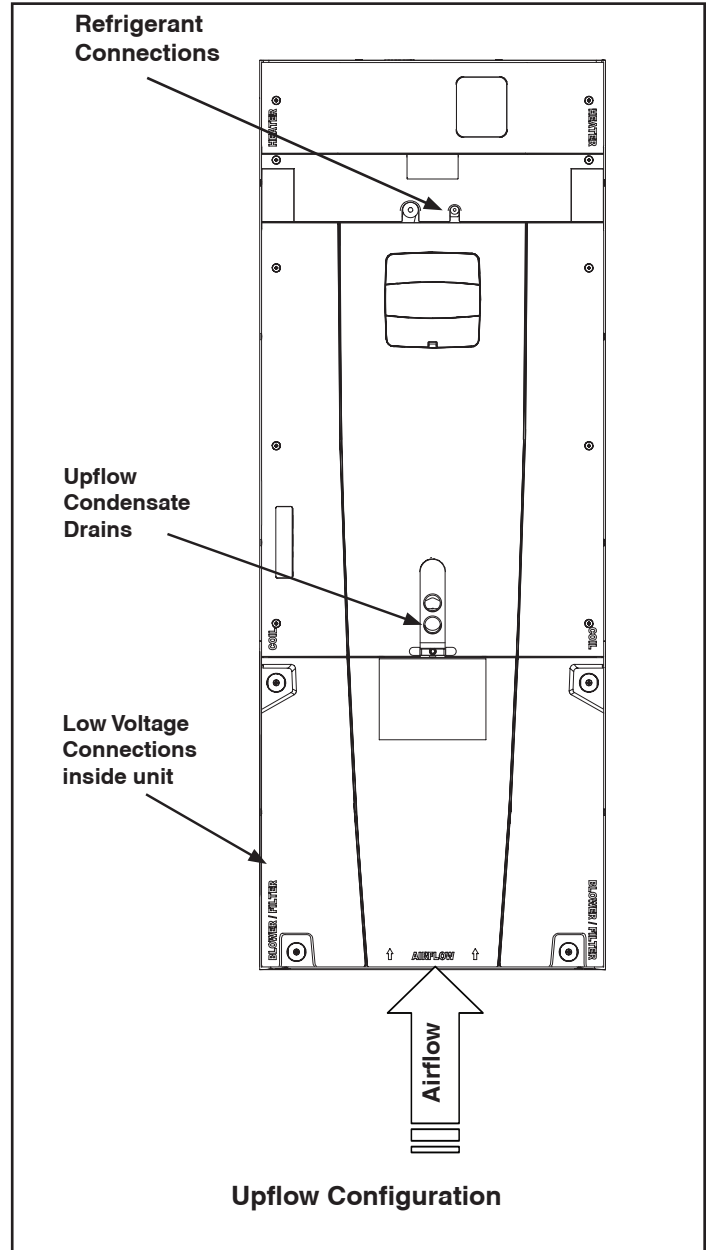
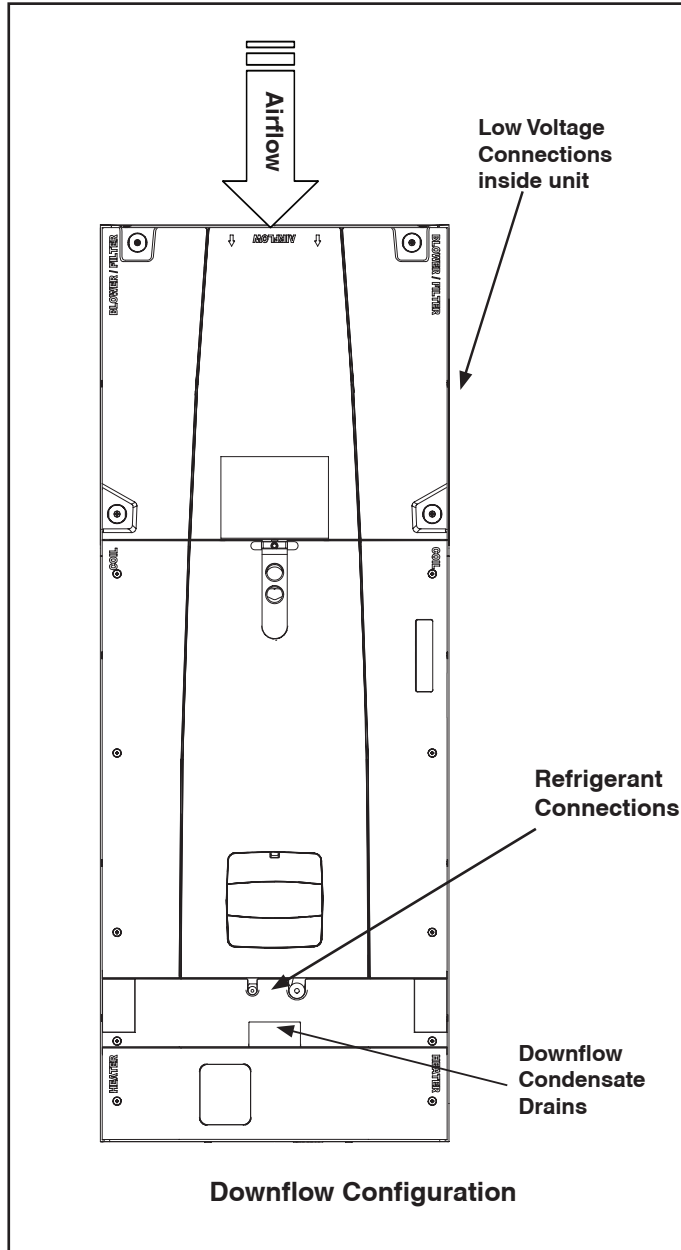

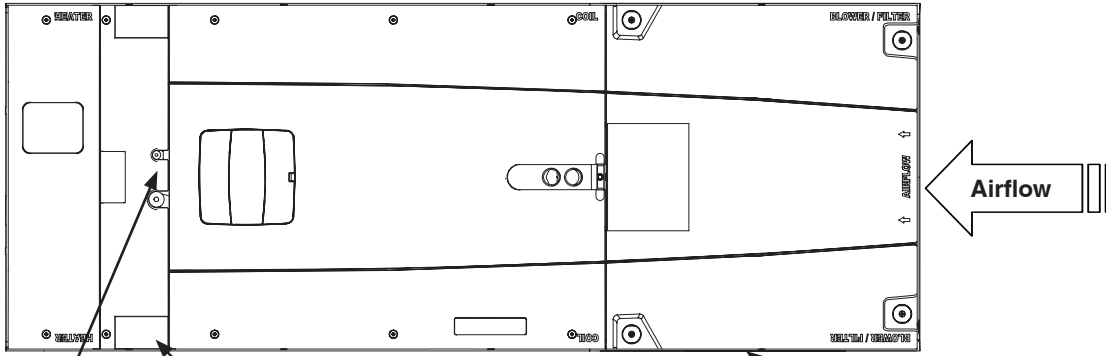

Refrigerant Connections

Horizontal Left Condensate Drains

Low Voltage Connections inside unit

Horizontal Left Configuration

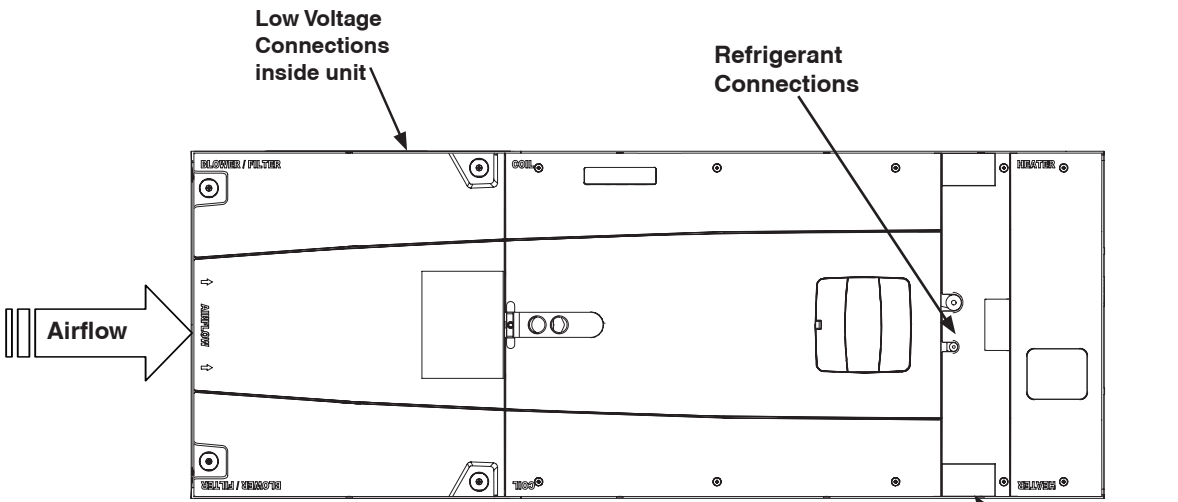

Low Voltage Connections inside unit

Refrigerant Connections

Horizontal Right Condensate Drains

Horizontal Right Configuration

10.3 Horizontal Sensor Relocation:

Note: The A2L sensor does not need to be relocated for upflow applications. It comes installed from the factory in the upflow position.

1. Remove the coil panel and locate the A2L sensor on the upflow drain pan.

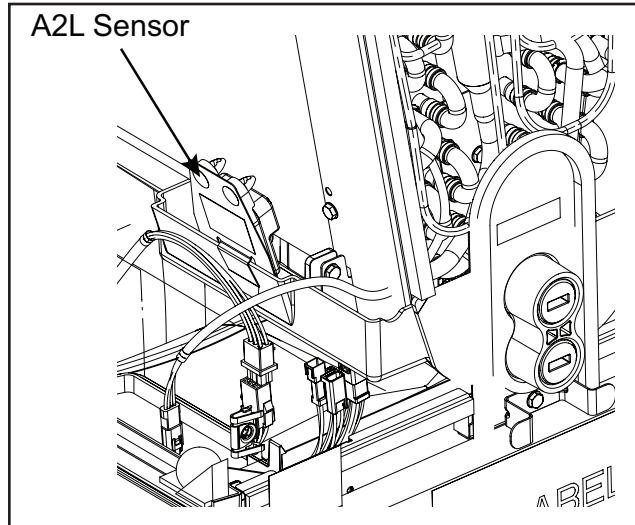

2. Remove the A2L sensor from the drain pan by pulling directly up.

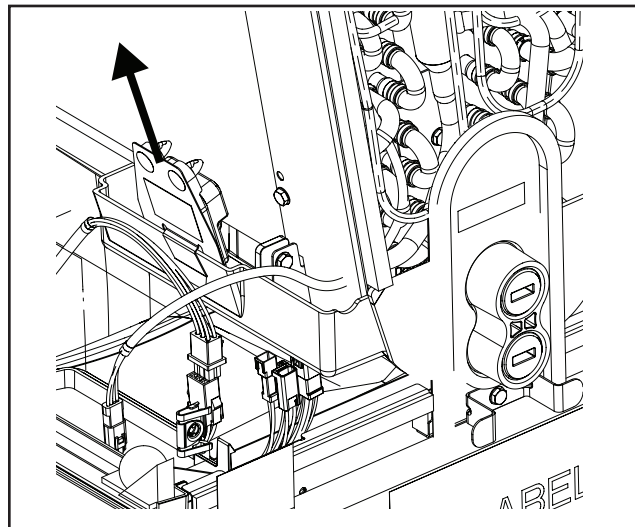

3. Clip the sensor onto the blower deck just in front of the roto latch.
 - For horizontal right applications, clip the sensor on the right side of the unit.
 - For horizontal left applications, clip the sensor on the left side of the unit.

Note: If the blower needs to be removed after this point, the A2L sensor will need to be removed and set aside before the blower is removed.

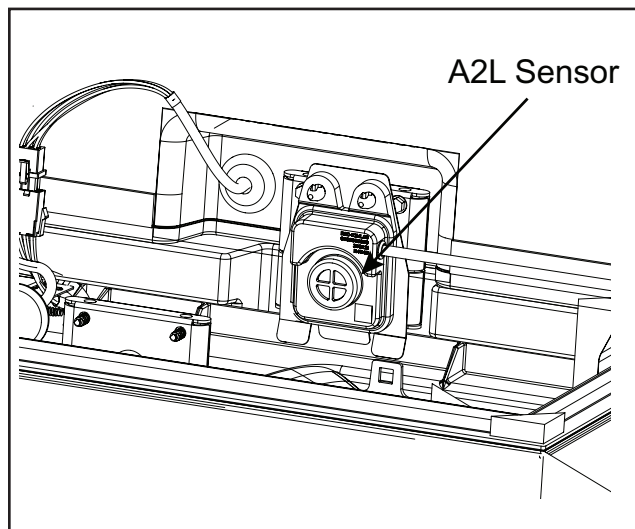

10.4 Downflow Sensor Relocation:

Note: To avoid damaging the refrigerant sensor, sensor should be relocated only after field braze joints have been completed.

1. Remove the coil panel and locate the A2L sensor on the upflow drain pan.

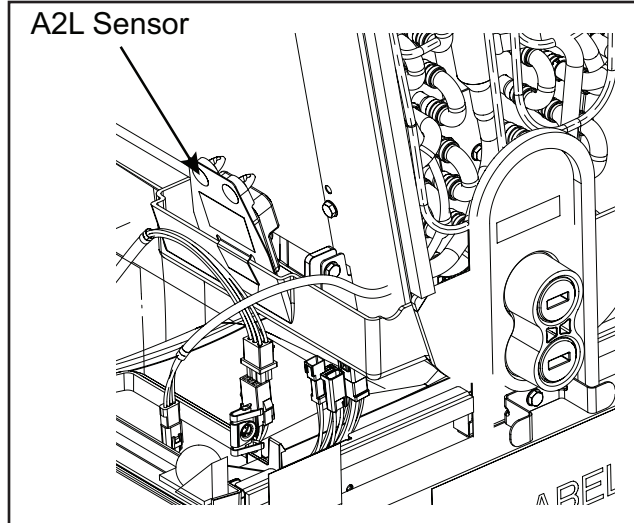

2. Remove the A2L sensor from the drain pan by pulling directly up.

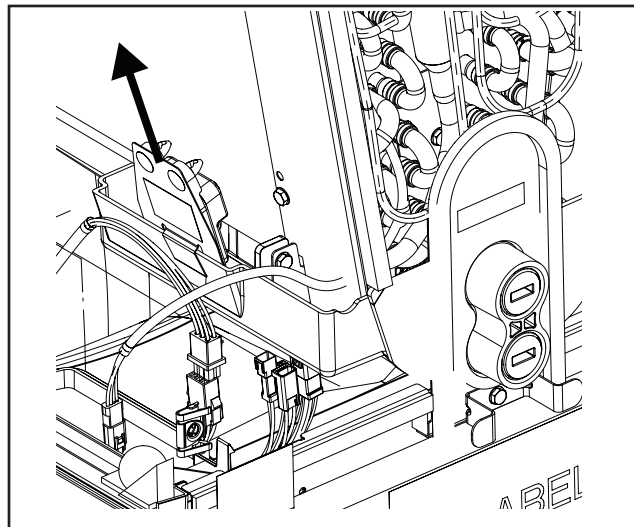

3. Remove the A2L sensor from the metal bracket by removing the plastic push pins. Keep the push pins as they will be used later.

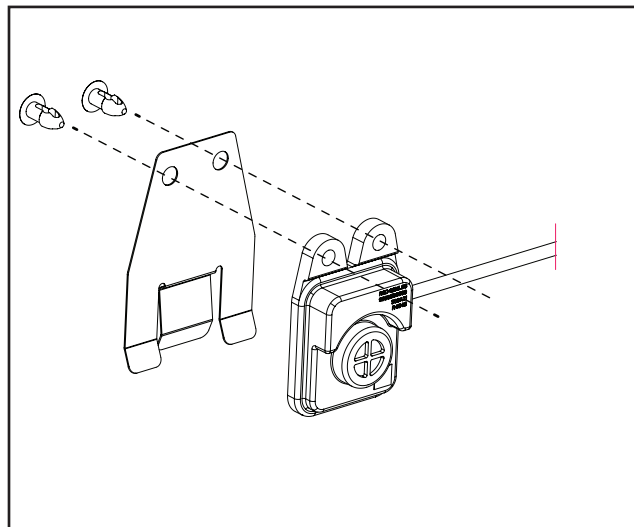

4. Locate the downflow sensor bracket in the Documentation package.

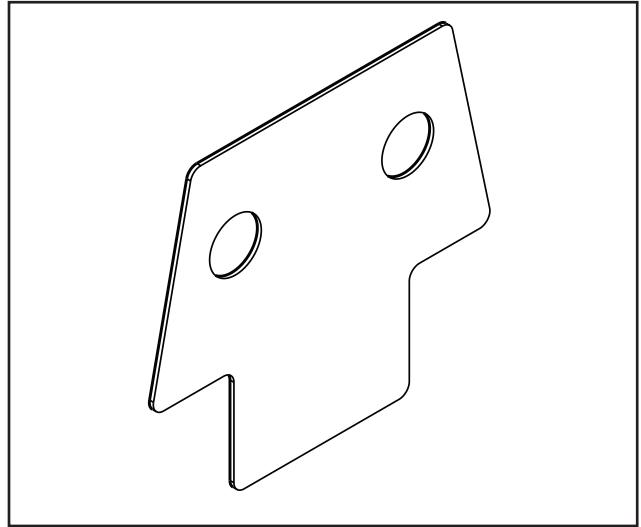

5. Secure the A2L sensor to the downflow bracket using the push pins.

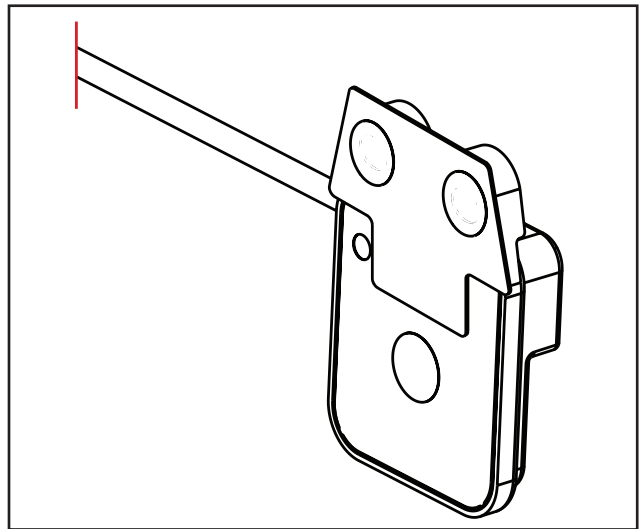

6. Place the tab of the downflow bracket into the slot on the coil support.

- Unbundle refrigerant sensor harness.
- Neatly route across front of coil by using field-supplied wire ties.
- Connect harness to refrigerant sensor.

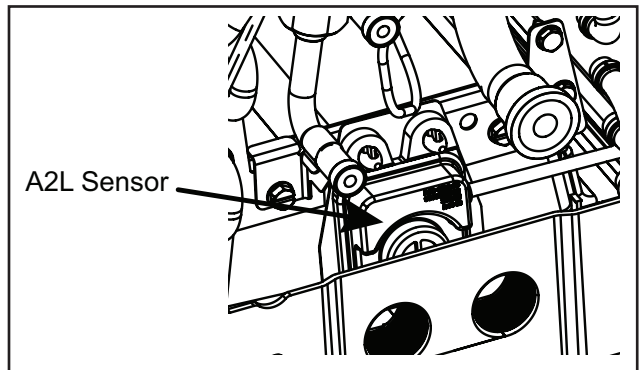
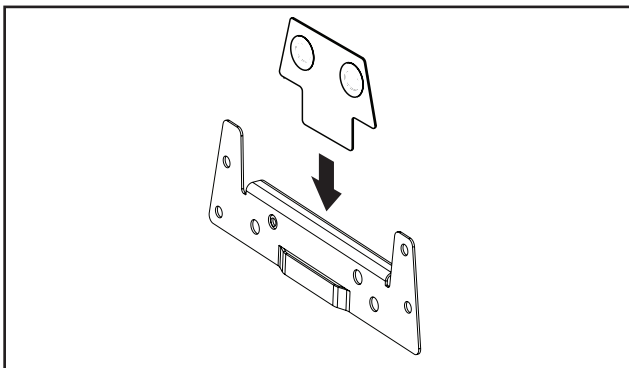

10.5 Non Ducted Applications

⚠ CAUTION

HAZARDOUS VAPORS! Do not install an air handler with a non-ducted return in the same closet, alcove, or utility room as a fossil fuel device. Hazardous vapors can be distributed throughout the conditioned space and equipment damage can result.

Non-Ducted Return Installations:

- Installation in a closet, an alcove, or a utility room without a return duct requires the use of a plenum accessory kit as it uses the area space as a return air plenum. Minimum clearances to combustibles materials and service access must be observed (see outline drawing).
- This area may also be used for other purposes, including an electric hot water heater, but in no case shall a fossil fuel device be installed and/or operated in the same closet, alcove, or utility room.
- Review local codes to determine limitations if the unit is installed without a return air duct.

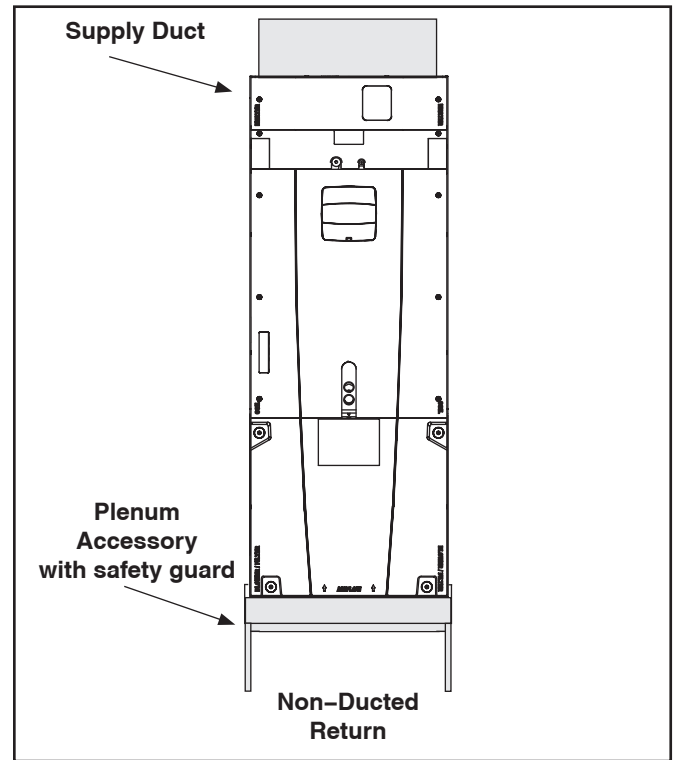

10.6 Ducted Applications

Ducted Return Installations:

- Installation in an attic, garage, or crawl space with ducted supply and return air is appropriate. Minimum clearances to combustibles materials and service access must be observed (see outline drawing).

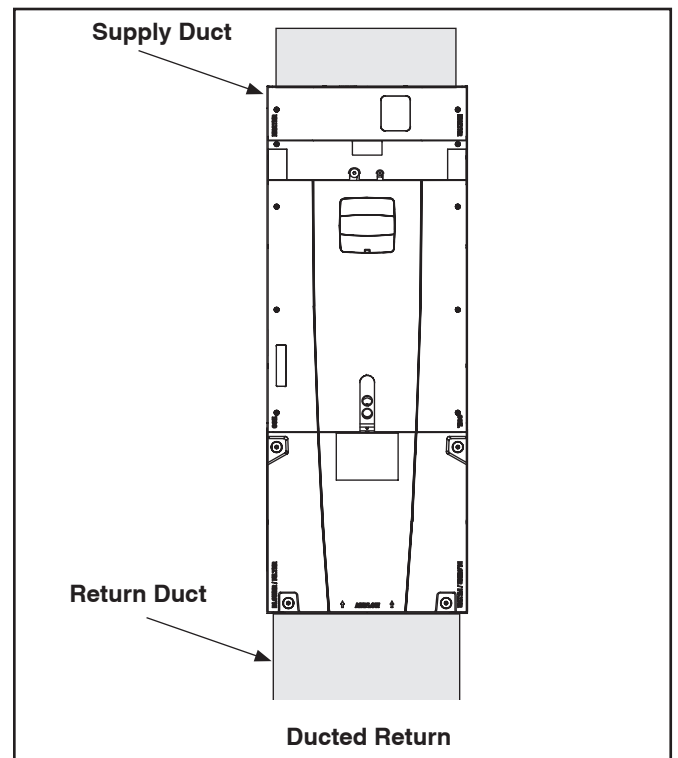

10.7 Additional Unit Preparation Considerations

For proper installation the following items must be considered prior to moving the unit to its installation site:

- Important: When the air handler is located adjacent to the living area, the system should be carefully designed with returns which minimize noise transmission through the return air grill. Although the air handler is designed with large blowers operating at moderate speeds, any blower moving a high volume of air will produce audible noise which could be objectionable when the unit is located very close to a living area. It is often advisable to route the return ducts under the floor through the attic. Such design permits the installation of air return remote from the living area (i.e. central hall).
- Pursuant to Florida Building Code 13-610.2.A.2.1, this unit meets the criteria for a factory sealed air handler.
- If a side return is needed for your application, the side return MUST be installed prior to moving the air handler to its installation location. Unless two side returns are used, the Side Return Kit may not be on the same side as the LV wiring entry point. See the Side Return Kit # BAYSRKIT100A Installer Guide for detailed instructions, if used.
- Study the unit's outline drawing and dimensions prior to selecting the installation site. Note in advance which electrical conduit entry points and condensate drain holes are to be used, so that proper clearance allowances can be made for installation and future maintenance.
- Installation of the air handler must be made prior to, or at the same time as, the installation of the outdoor unit in order to allow access for refrigerant lines.
- Consider the overall space needed when external accessories are used, additional height and width requirements may exist.

- These units are not approved for outdoor installation.
- These units must be installed in the proper air flow direction.
- Any third-party heater accessories, including hydronic coils and duct heaters must be downstream of the unit.
- Note: No atomizing style humidifier is allowed in the return plenum with the use of this unit.
- Excessive bypass air may cause water blow-off, which will adversely affect system operation and air cleaner performance. To verify bypass airflow, follow the Bypass Humidifier Pre-Installation Checkout and Set-Up Procedures available through your local distributor. Ask for publication number 18-CH37D1-* Steam and Flow-through Fan Power Duct-mounted Humidifiers. Follow the humidifier installation instructions. These should only be installed on the supply air side of the system.

Note: *The air handlers have been evaluated in accordance with the Code of Federal Regulations, Chapter XX, Part 3280 or the equivalent. "SUITABLE FOR MOBILE HOME USE."*

Section 11. Setting the Unit – Vertical Installation

11.1 Considerations

Provide a minimum height of 14 inches for proper unrestricted airflow below the unit. Allow a minimum of 21 inches clearance in front of the air handler to permit maintenance and removal of filter.

- Position unit on suitable foundation. If a manufacturer approved accessory is not used, a frame strong enough to support the total weight of the unit, accessories, and duct work must be provided.
- Isolate unit from the foundation using a suitable isolating material.

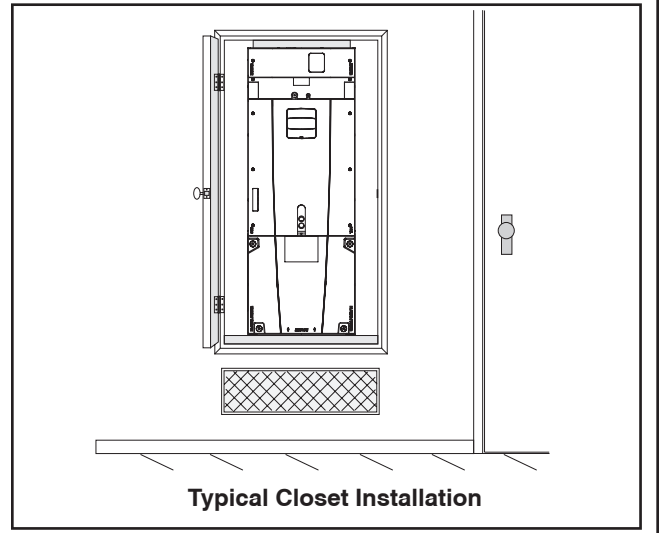

11.2 Upflow Installation

TASB Installation

1. Assemble the TASB using the TASB's Installer Guide.

TASB175SB for use with 17.5" cabinets
TASB215SB for use with 21.5" cabinets
TASB235SB for use with 23.5: cabinets

Contact your distributor for more information.

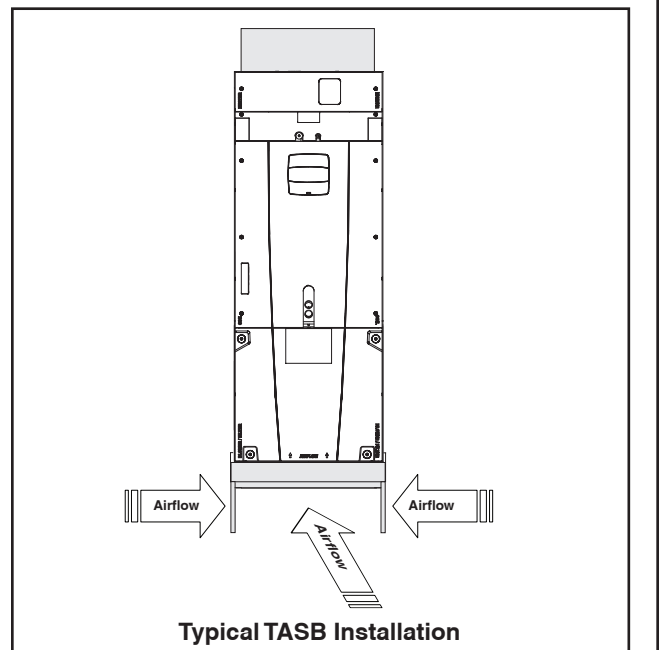

Plenum Installation

1. Assemble the plenum using the plenum's Installer Guide.

On units with sheet metal returns: Return plenum must be flanged. Sheet metal drill point screws must be 1/2" in length or shorter.

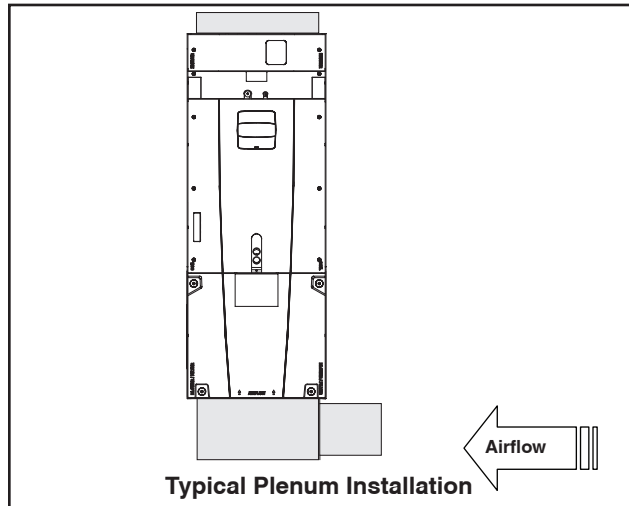

11.3 Downflow Installation

- Downflow installation must comply with national, state, and local codes.
- The air handlers are rated for zero clearance from combustible materials.

STEP 1 - Prepare the location site as appropriate for your application and per national, state, and local code requirements.

STEP 2 - Set the unit in position.

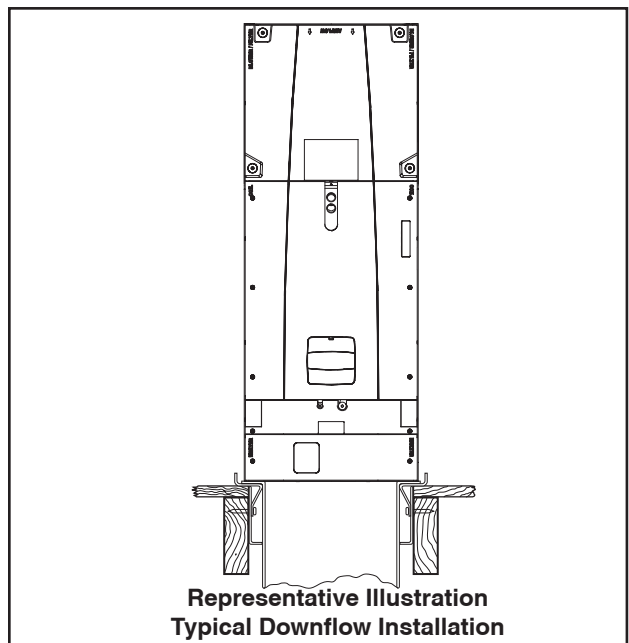

Section 12. Setting the Unit – Horizontal Installation

12.1 Considerations

Important: Due to the unique design of this unit, which allows the electrical wiring to be routed within the insulation, do not screw, cut, or otherwise puncture the unit cabinet in any location other than the ones illustrated in this Installer Guide or in an approved accessory's Installer Guide.

Important: Make certain that the unit has been installed in a level position to ensure proper draining.

Important: Under no conditions should metal strapping be attached to the unit to be used as support mechanisms for carrying or suspension purposes.

STEP 1 - Support the unit from the bottom (near both ends). The service access must remain unobstructed.

Important: The unit can only be supported from the bottom unless using kit BAYHHKIT001A. Do not drill or screw supports into any area of the cabinet.

Note: Do not allow the unit to be used as strain relief.

- Approved bottom support methods are rails, u-channels (Unistrut®), or other load bearing materials.
- The unit must be isolated carefully to prevent sound transmission. Field supplied vibration isolators are recommended.

STEP 2 – Install an auxiliary drain pan under the horizontal air handler to prevent possible damage to ceilings.

- Isolate the auxiliary drain pan from the unit and from the structure.
- Connect the auxiliary drain pan to a separate drain line and terminate according to local codes.

Important: To avoid water blow off in horizontal or downflow applications, observe all airflow limitations given in the Airflow Performance section of this manual.

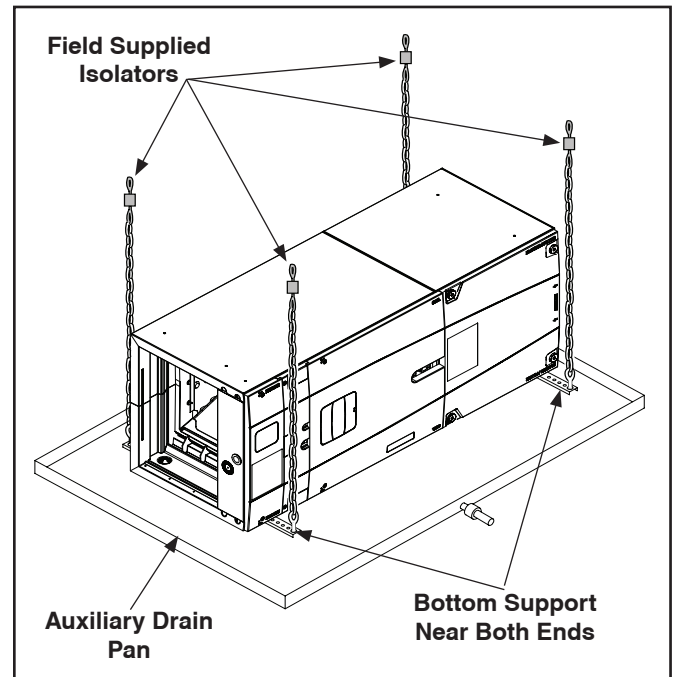

Note: BAYHHKIT001A Hanging Bracket Kit may be ordered separately.

Important: The BAYHHKIT001A may not be used if the cabinet has been altered per Installer Guide 18-GJ58D1-1.

Section 13. Connecting the Duct work

13.1 Duct Connection Considerations

⚠ WARNING

RISK OF FIRE!

Failure to follow this warning could result in serious injury, death, or property damage. Auxiliary devices which may be a potential ignition source, such as hot surfaces or electric switching devices, shall not be installed in the connecting ductwork unless they have been approved by the manufacturer or declared suitable with the refrigerant used.

Important: Due to the unique design of this unit, which allows the electrical wiring to be routed within the insulation, do not screw, cut, or otherwise puncture the unit cabinet in any location other than the ones illustrated in this Installer Guide or in an approved accessory's Installer Guide.

Important: Under no conditions should metal strapping be attached to the unit to be used as support mechanisms for carrying or suspension purposes.

Important: On units with sheet metal returns: Return air plenum must be flanged. Sheet metal drill point screws must be 1/2" in length or shorter.

- The supply and return air ducts must be connected to the unit with non flammable duct connectors.
- See the Outline drawing for sizes of the duct connections.
- After the ducts are secured, seal around the supply and return ducts to prevent air leakage.
- Insulate all duct work that will be outside of conditioned spaces.
- Convertible Duct Flange Kits are available to connect the supply plenum or for mounting on the discharge opening to provide a "flush fit" for 1-1/2" duct board applications.
- If front or rear return is required, the air handler must be elevated - placed on a pedestal or plenum and duct must be connected to this pedestal or plenum.
- If side return is required, the Side Return Kit # BAYSRKIT100A accessory must be used. A remote filter will be required.
- To ensure maximum efficiency and system performance, the existing supply and return duct system static pressures must not exceed the total available static pressure of the air handler. Reference ACCA Manual D, Manual S and Manual RS along with the air handler Product Data and Service Facts for additional information.

Note: Side return is not approved without Side Return Kit # BAYSRKIT100. More than one Side Return Kit may be necessary depending on the application. Refer to the Installation Guide in BAYSRKIT100 for approved duct connections, sizing, number, transitions, and accessory application.

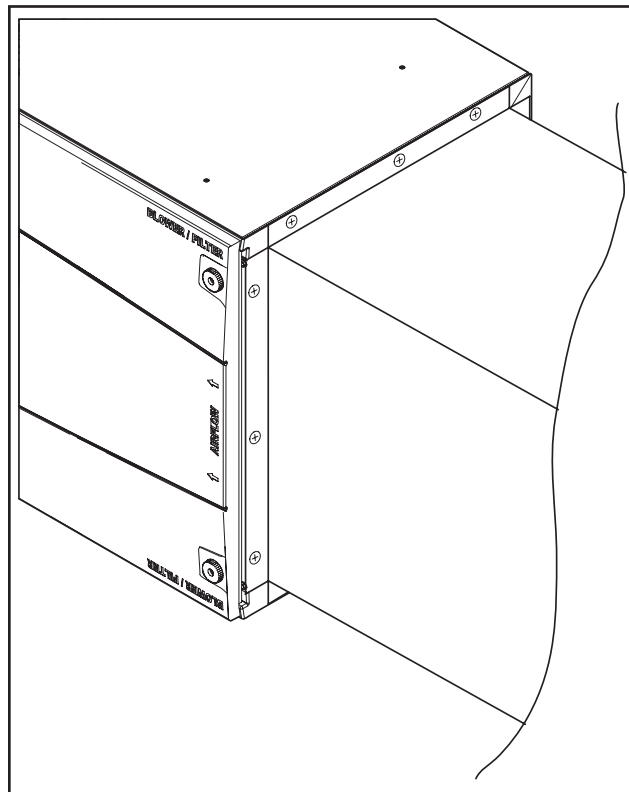
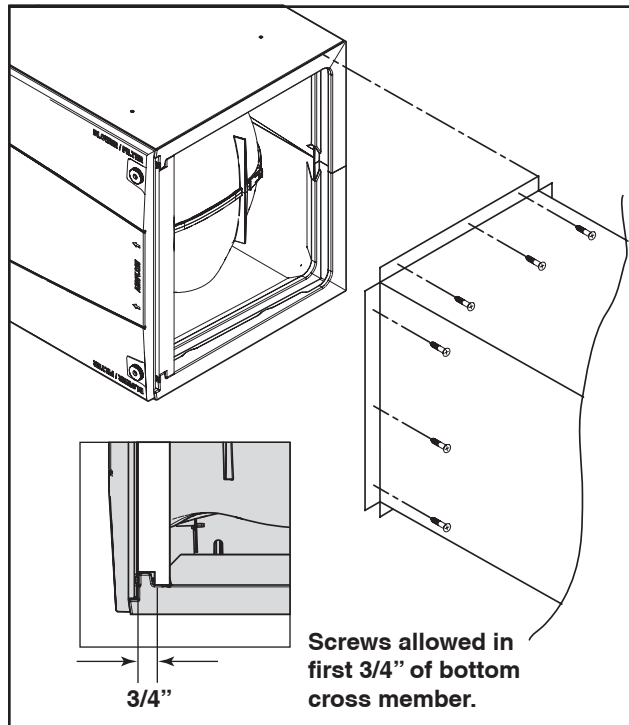

Note: Duct work must be supported as appropriate. See National and local codes for guidelines. Do not depend on the unit to support duct work.

Section 14. Refrigerant Line

14.1 Refrigerant Line Connection Sizes

Table 5

Refrigerant Line Set and Connection Sizes		
Model	Vapor Line Connection	Liquid Line Connection
5TAM5B01AC21SA	3/4	3/8
5TAM5B02AC21SA	3/4	3/8
5TAM5C03AC21SA	3/4	3/8
5TAM5C04AC31SA	3/4	3/8
5TAM5D05AC31SA	7/8	3/8
5TAM5D06AC41SA	7/8	3/8
5TAM5D07AC51SA	7/8	3/8

Note: For appropriate refrigerant line set diameter, refer to the instructions included with the outdoor unit.

14.2 Refrigerant System Layout

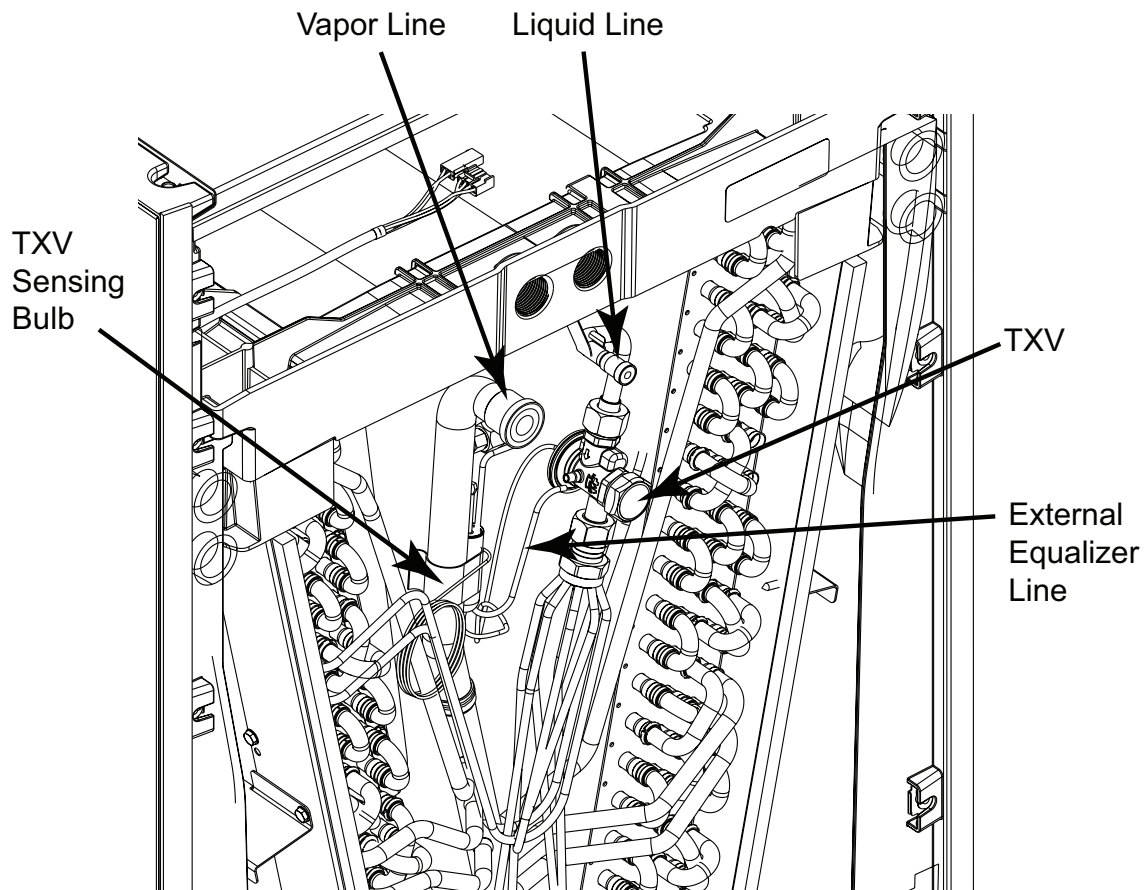

Section 15. Refrigerant Line Brazing

15.1 Braze The Refrigerant Lines

STEP 1 - Remove Heater, Coil, and Line Set panels.
(See Section 2.2 Panel Removal)

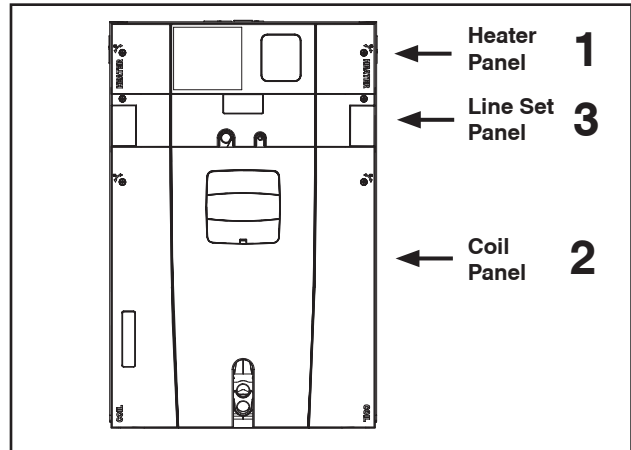

Important: Do NOT unseal coil refrigerant connection stubs until ready to make connections.

Important: Heat Sensitive Bulb.

The TXV sensing bulb must be removed or a wet rag must be wrapped around the suction line between the Bulb and the braze joint to protect the Bulb from failure due to overheating.

Caution: This coil is pressurized with 8-12 psig of dry air. Do not stand directly in front of the coil connections when removing sealing plugs.

STEP 2 - Remove the sealing plug from the indoor coil suction (vapor) line.

STEP 3 - Remove the sealing plug from the indoor coil liquid connection.

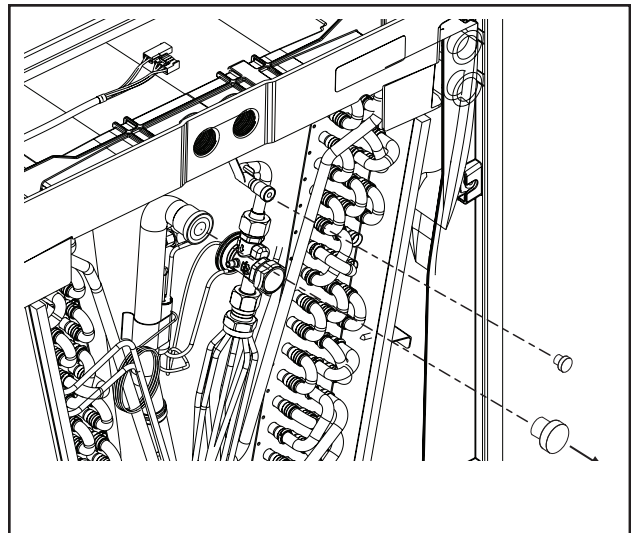

STEP 4 - Connect, but do not braze, field line set to indoor coil.

Allow a minimum of 1.5 inches of refrigerant line set before using an elbow coupling.

Important: Service access to the auxiliary heater must remain unobstructed.

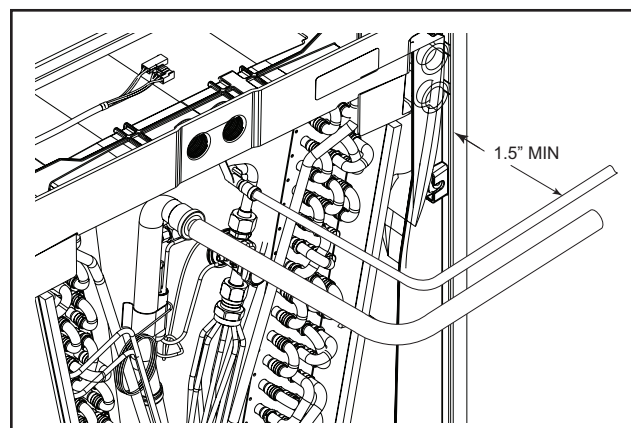

Important: Heat Sensitive Bulb.

The TXV sensing bulb must be removed or a wet rag must be wrapped around the suction line between the Bulb and the braze joint to protect the Bulb from failure due to overheating.

Note: The two flammable refrigerant red warning tags on the line set connections should be removed prior to brazing and replaced once brazing is complete.

STEP 5 - Braze refrigerant line connections.

Note: The suction line must be insulated prior to brazing the line set to the air handler stubs.

1. Wrap the TXV sensing bulb and line section between the bulb and braze with a wet rag.
2. Braze the refrigerant line connections.
3. After brazing coil, wrap TXV sensing bulb with insulation supplied in dock pack.

Important: Care must be taken during brazing to avoid damage to unit components and wiring.

Note: If system is installed in downflow, refrigerant sensor must be relocated after brazing. See section 10.4 of this manual for details.

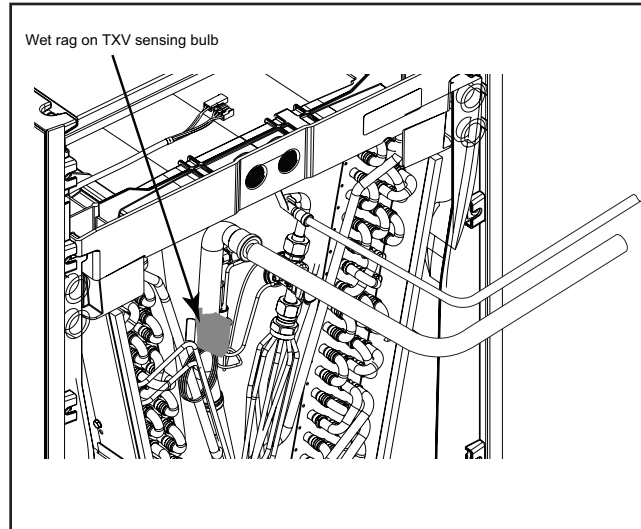

STEP 6 - Using dry nitrogen, pressurize the field piping and indoor coil to the lower of the maximum operating pressures listed on the name plates of the indoor and outdoor units (likely 600 psi).

The test pressure after removal of the pressure source shall be maintained for at least one (1) hour with no decrease of pressure indicated by the test gauge, with the test gauge resolution not exceeding 30 psi.

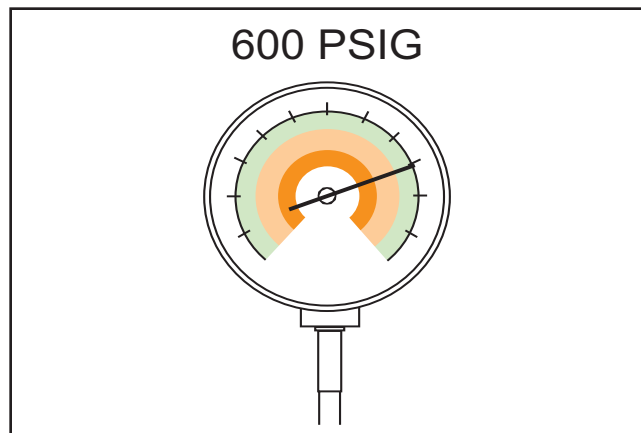

STEP 7 - Check for leaks by using a soapy solution or bubbles at each brazed location.

Note: Remove nitrogen pressure and repair any leaks before continuing.

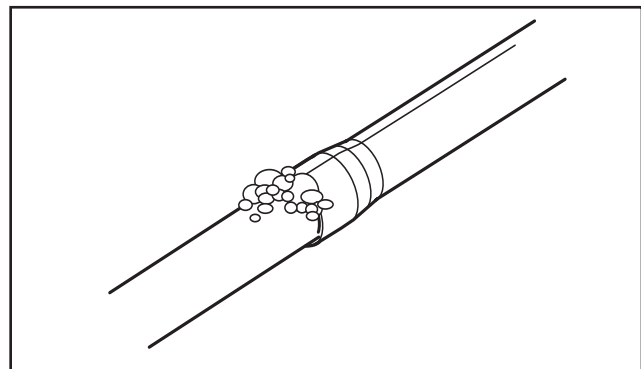

Important: Do not open the service valves until the refrigerant lines and indoor coil leak check and evacuation are complete.

STEP 8 - Evacuate until the micron gauge reads no higher than 350 microns, then close off the valve to the vacuum pump.

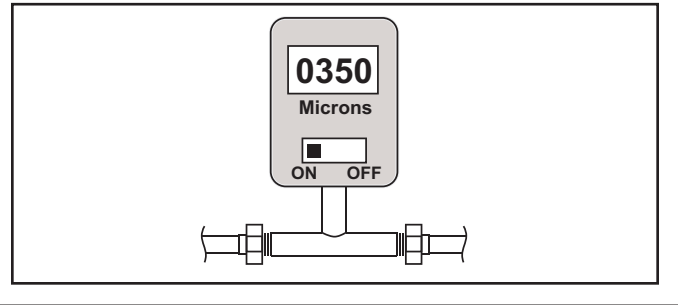

STEP 9 - Observe the micron gauge. Evacuation is complete if the micron gauge does not rise above 500 microns in one (1) minute and 1500 microns in ten (10) minutes.

Once evacuation is complete blank off the vacuum pump and micron gauge, and close the valves on the manifold gauge set.

Note: All procedures for charging the system with refrigerant shall be according to the instructions provided by the manufacturer of the outdoor unit.



STEP 10 - After charging the system, all indoor field-made joints of the field piping shall be checked for refrigerant leaks using an electronic leak detector calibrated for R-454B having a sensitivity of 5 grams per year or better.

STEP 11 - Replace the Line Set panel.

1. Allow time for tubing to cool.
2. Install grommets to line set piping.

Note: A slight amount of dish soap can be used to aid in the installation of the grommets. Remove any excess from the tubing and grommet after the grommet is installed.

3. Slide the bottom of the Line Set panel down over the refrigerant lines and grommets. The grommets will seal the line openings.

Note: If installing in a horizontal application, complete the condensate connection preparations per Section 12, Step 3 before installing the Line Set panel.

4. Tighten screws on the Line Set panel.

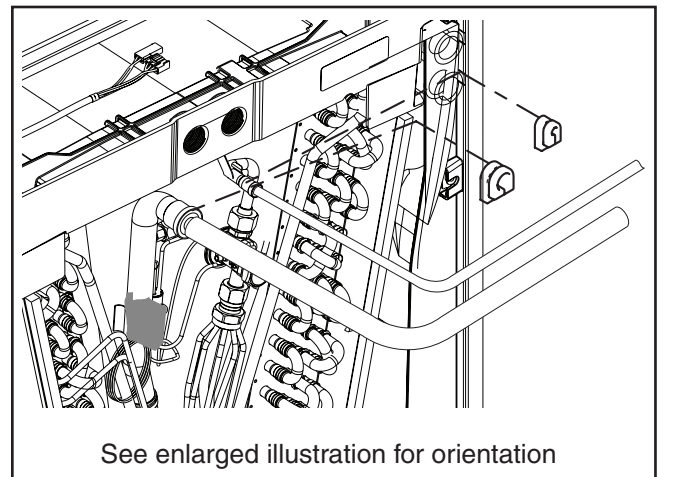

See enlarged illustration for orientation

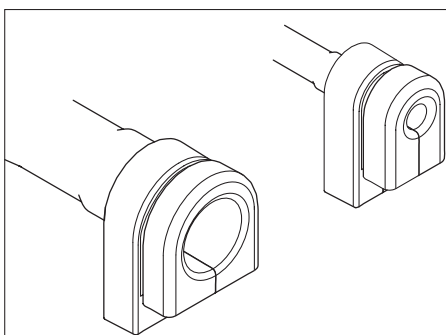
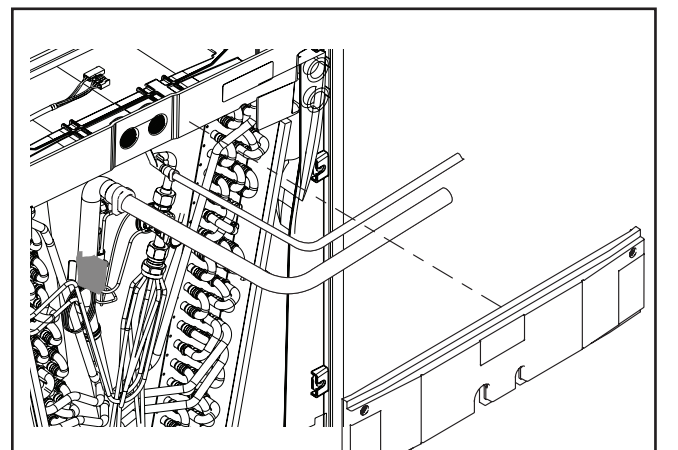

Section 16. Condensate Drain Piping

16.1 Condensate Drain Piping Considerations

- Condensate drain plumbing must comply with national, state, and local codes.
- Route condensate drain lines away from air handler so they do not interfere with access panels.
- Slope the drain lines downward a minimum of 1/4" per foot, support per local codes.
- A 1.5" minimum distance from the coil panel to the inside of the condensate tubing is recommended for coil panel removal.
- Do not use reducing fittings in the condensate drain lines.
- Do not connect the drain line to a closed drain system.
- Do not use a torch or flame near the plastic drain pan coupling.
- A P-trap is not required for proper drainage due to the positive pressure of the air handler; however, it is recommended to prevent efficiency loss of conditioned air.

16.2 Connect Condensate Drain Piping

Note: Downflow and horizontal orientations require the Line Set panel to be removed in order to make the drain connections. **Note:** Make certain that the unit has been installed in a level position to allow for proper draining.

STEP 1 - Select the drain connections that are oriented for your application.

STEP 2 - Prepare the condensate drain connections.

- From the factory, the unit comes with plugs in both upflow condensate drains and an additional plug in the documentation packet.
- For upflow applications, remove upflow condensate plug(s) and connect condensate piping.
- For all other applications, do not remove upflow condensate plugs. Remove the cover from the needed condensate drain connections and connect condensate piping.
- If the secondary condensate opening is not used, plug the condensate opening with the fitting supplied in the documentation pack. Use scissors to cut the air seal in half and re-install over the unused opening.

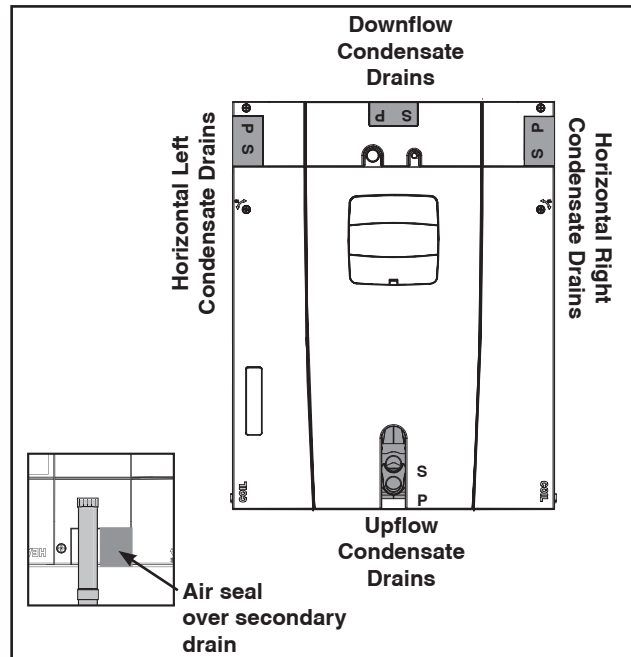

Note: A small amount of sealant must be applied around the drain line(s) passing through the panel to prevent air leakage and possible water drips.

- **Dry fit and test clearance for coil panel removal before applying PVC/CPVC cement**
- **Use Teflon tape on the air handler drain line connections. Do not use pipe joint compound or PVC/CPVC cement on drain nipple.**
- **Hand tighten the drain pipe.**

STEP 3 - For Upflow installations, connect 3/4" PVC pipe to the threaded drain nipple with PVC/CPVC cement. 1.5" minimum clearance to the condensate piping is needed for coil panel removal. Thread the assembly into the primary drain connection (repeat for the secondary drain connection if used).

Important: For Horizontal and Downflow installations, the following order must be observed:

- 1) Remove panel and insert the 3/4" nipples.
- 2) Reinstall the panel.
- 3) Connect the condensate lines to the nipples.

Note: A small amount of sealant must be applied around the drain line(s) passing through the panel to prevent air leakage and possible water drips.

Optional pipe kit BAYCNDPIP01A is available (10 pcs per kit).

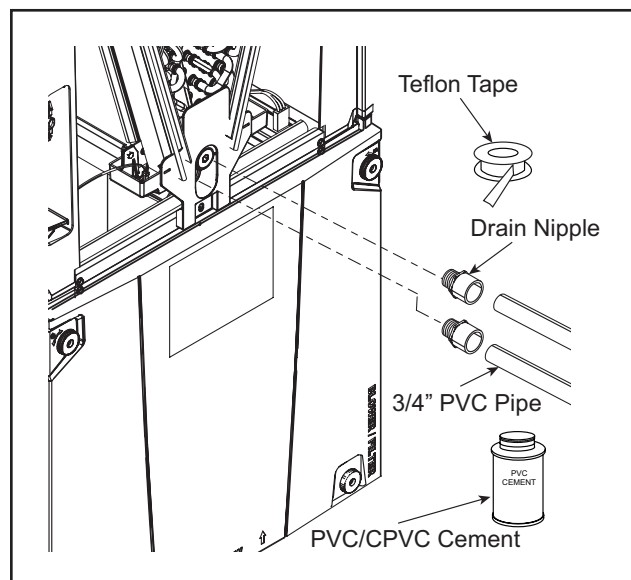

STEP 4 - Install a clean-out tee in the primary drain line for future maintenance. It is recommended that you install a cap on the top of the tee.

1.5" minimum clearance is recommended from cabinet to inside edge of tubing

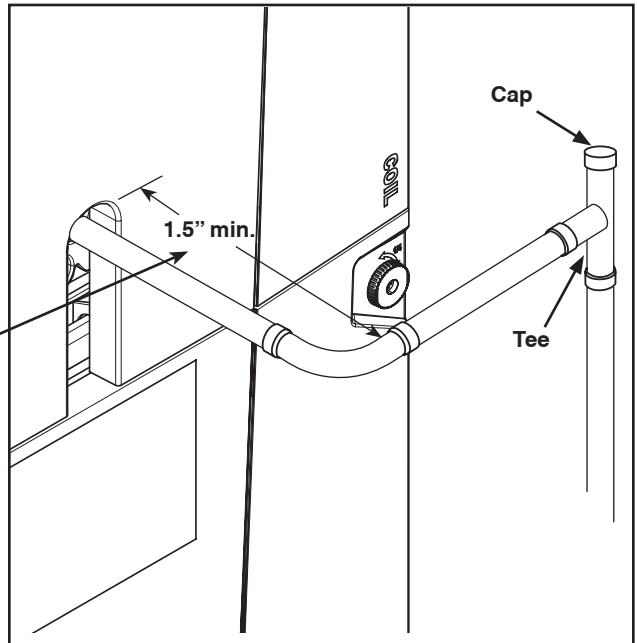

STEP 5 - Insulate the primary drain line to prevent sweating where dew point temperatures may be met. (Optional depending on climate and application needs.)

Provide a means of drainage to prevent winter freeze-up of condensate line. (Optional depending on climate and application needs.)

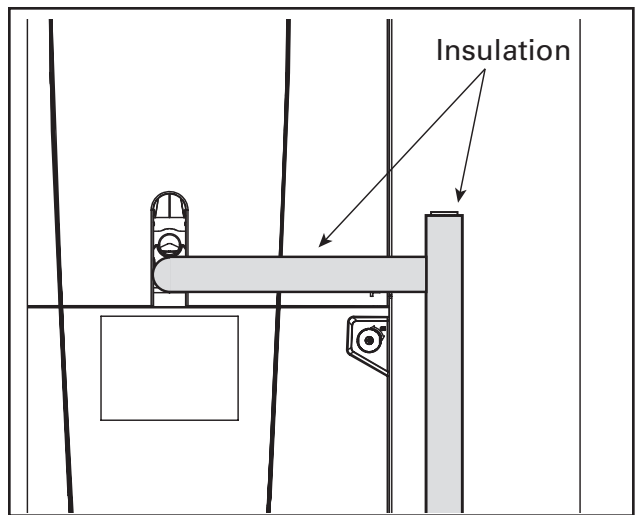

STEP 6 - Support the condensate piping outside the unit per local codes for proper drainage and to prevent sagging.

Allow 1/4" of downward slope for each foot of pipe.

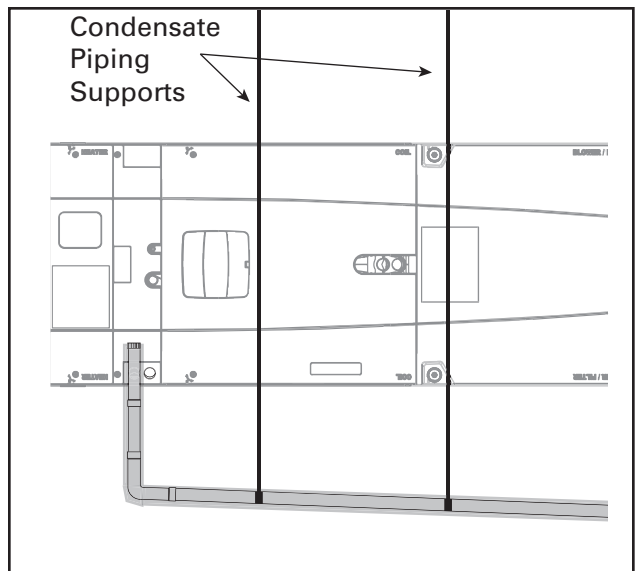

Section 17. Electrical – High Voltage

17.1 High Voltage Power Supply

The high voltage power supply must match the equipment nameplate.

Power wiring, including ground wiring, must comply with national, state, and local codes.

Field wiring diagrams for supplementary electric heaters are shipped with the heater.

To allow disconnection of the air handler from the power supply, a disconnection from the supply mains having a contact separation in all poles must be incorporated into the fixed wiring in accordance with national, state, and local codes.

⚠ WARNING

LIVE ELECTRICAL COMPONENTS!

During installation, testing, servicing, and troubleshooting of this product, it may be necessary to work with live electrical components. Failure to follow all electrical safety precautions when exposed to live electrical components could result in death or serious injury.

17.2 Make Electrical Connections

STEP 1 - Route High Voltage wiring to unit.

STEP 2 - Select a conduit entry point. Drill a hole for the desired conduit size (up to 1-1/2"). Locating targets are identified on the units.

1. Select the entry point you will use to bring in your high voltage wiring.

Note: When drilling access through cabinet do not drill into any internal components. Remove internal components before drilling through cabinet if possible. Damage to the air handler or heater could result.

Conduit Entry Points

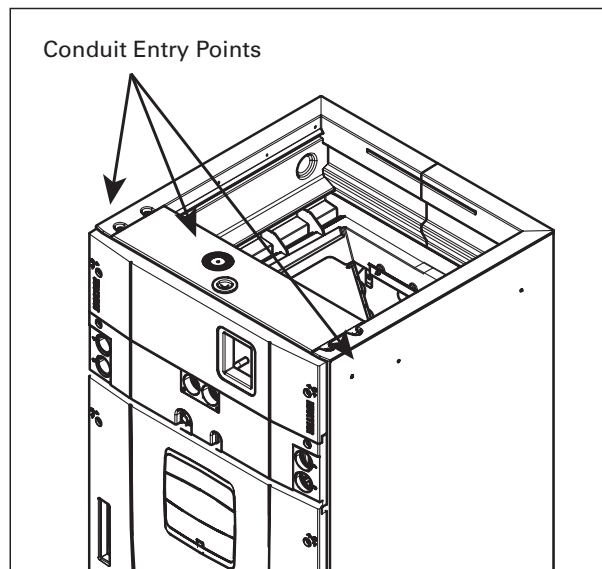

STEP 3 - Route conduit (if used) to the entry point and connect.

1. Use one hand to secure the conduit nut from inside of the heater compartment.
2. Connect field supplied conduit (up to 1-1/2") to conduit nut.

Note: Reducing bushings may be required for your application.

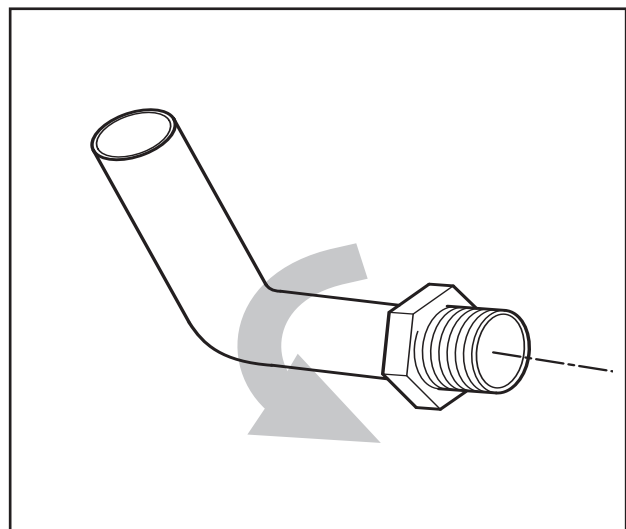

STEP 4 - If an electric heater IS NOT being installed, remove the pigtail harness from the documentation pack and connect it to the plug on the inside of the Heater Compartment in the cabinet.

If an electric heater IS being installed, see the Installer's Guide shipped with the electric heater.

Connect L1, L2, and ground wiring to pigtail harness in Heater Compartment using wire nuts. The incoming ground wiring will mate up with the green wire shown in the illustration.

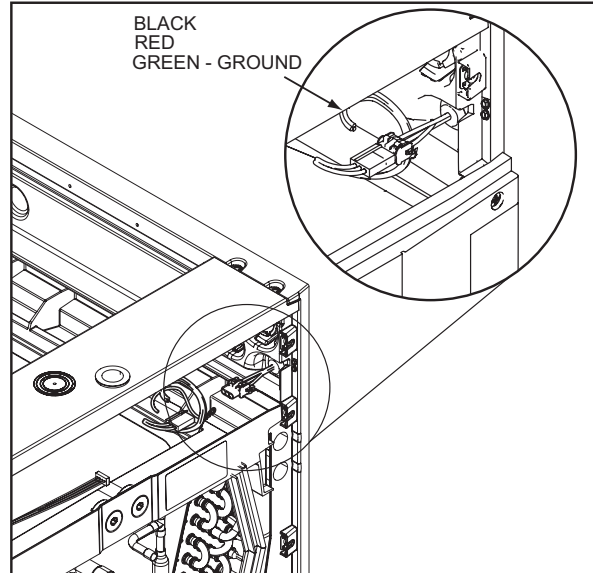

STEP 5 - If the L1, L2, and ground wires enter the case from the left side, use a field supplied 1/2"-5/8" maximum length screw and wire tie to hold the wires to the top center of the Heater Compartment.

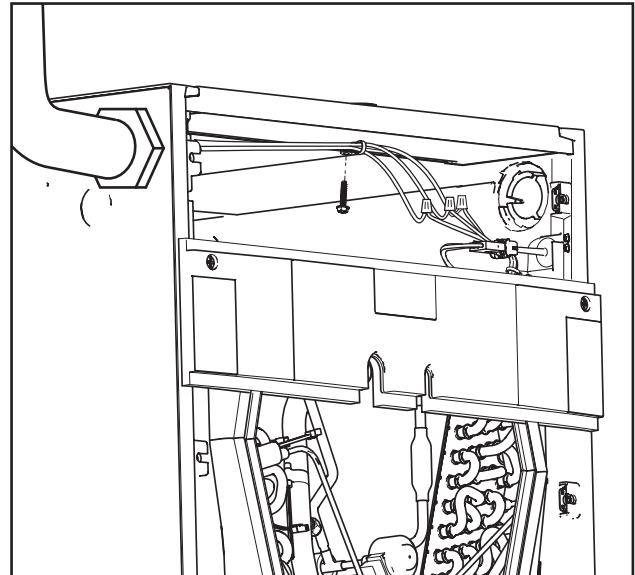

STEP 6 - Reinstall all panels before starting the air handler.

NOTE: After replacing all panels, loosen the Line Set Panel screws approximately 1/4 - 1/2 turn. This will improve the seal between the Heater Panel and Line Set Panel.

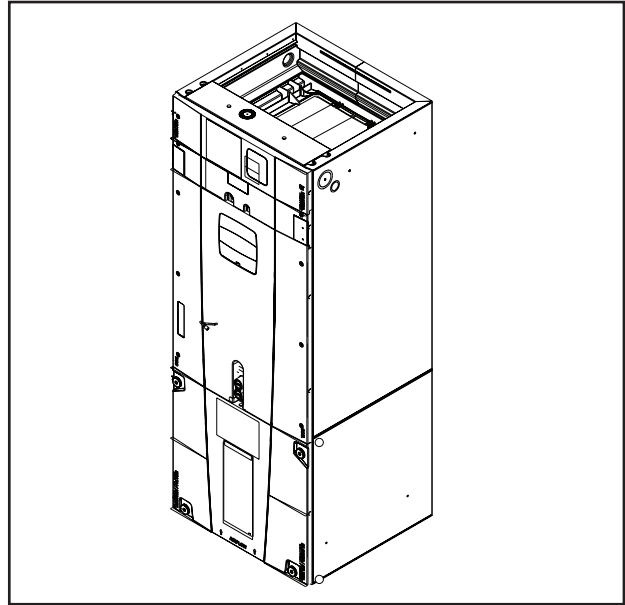

17.3 Secure Coil (All Applications)

STEP 1 - Remove screw and coil panel bracket from documentation packet.

STEP 2 - Place the coil panel bracket into position and use screw to secure the coil panel bracket and seal plate to the support bar.

Important: The Coil Seal Plate and screw secure the coil in the center of the air handler. Failure to follow these steps can prevent the Coil Panel from being easily replaced on the unit.

Important: The Blower Panel may be removed if needed to help align the new screw with the seal plate and crossmember.

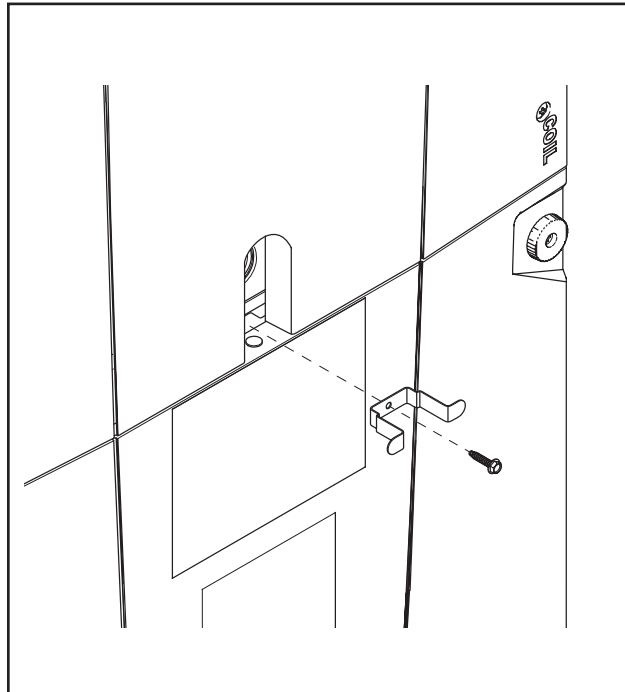

Section 18. Electrical – Low Voltage

18.1 Low Voltage Maximum Wire Length

Table 18.1 defines the maximum total length of low voltage wiring from the outdoor unit, to the indoor unit, and to the thermostat.

24 VOLTS	
WIRE SIZE	MAX. WIRE LENGTH
18 AWG	150 Ft.
16 AWG	225 Ft.
14 AWG	300 Ft.

18.2 Low Voltage Hook-up Instructions

STEP 1 - Remove the Blower panels by removing the four fasteners and then pulling away from the cabinet to remove.

STEP 2 - Remove the block off plate by removing the two 5/16" screws at the top and pulling the top out and up off the support bosses at the bottom.

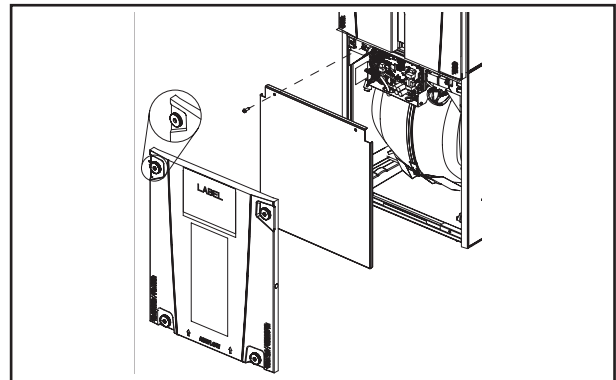

STEP 3 - For Low voltage entry, drill a .5" diameter hole size in side of blower cabinet at location shown on illustration. A 3/8" bushing is supplied in the doc pack.

STEP 4 - Route control wiring to unit and Insert Low voltage wiring.

Note: After the LV wires have been inserted through the new hole, the hole must be sealed.

Note: If a side return kit is used, the LV entry must be on the opposite side of the air handler.

Note: When drilling access through cabinet do not drill into any internal components. Remove internal components before drilling through cabinet if possible. Damage to the air handler or heater could result.

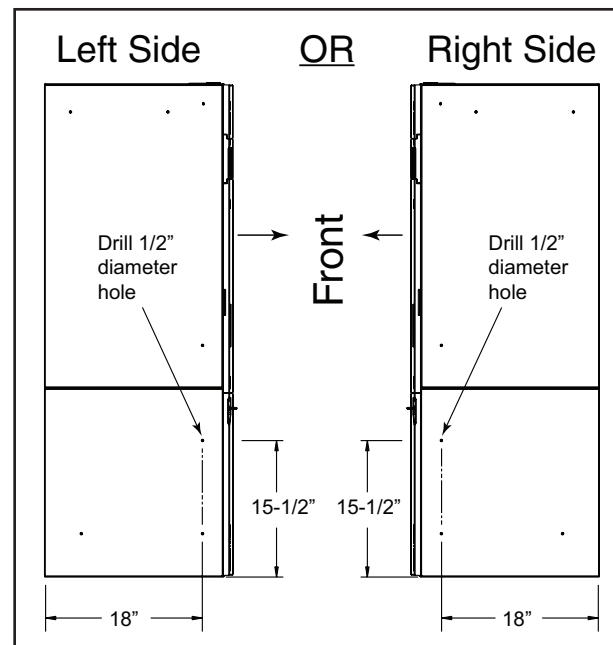

Note: Strain relief must be provided on the inside of the air handler cabinet for the low voltage wiring. Field supplied thermostat wires may be wire tied as a bundle to the existing strain relieved low voltage pigtail leads in the air handler unit.

STEP 5 - Remove the external sheathing of the wiring approximately 5".

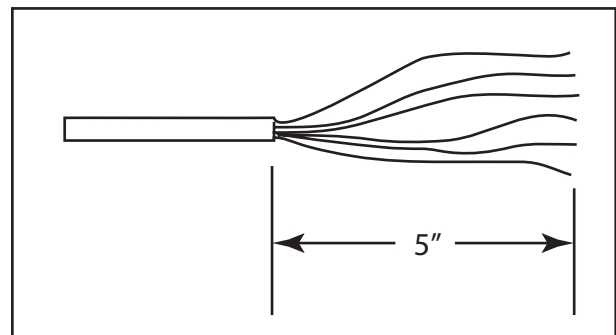

STEP 6 - Using field supplied wire nuts, make connections per hookup diagrams.

Air Handler Hook-up Diagram Single Stage, Cooling Only

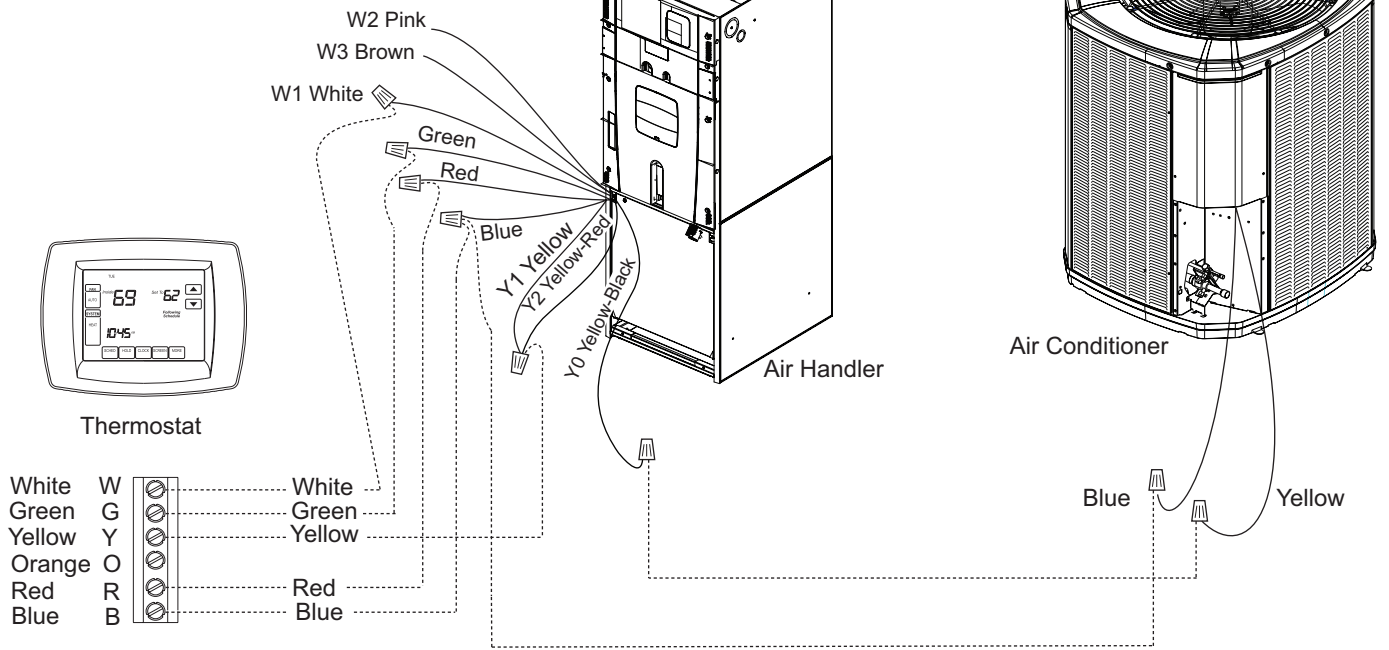

..... Field wiring

• * For multiple stages of electric heat, jumper W1, W2, and W3 together if comfort control has only one stage of heat.

Air Handler Hook-up Diagram Single Stage, HP

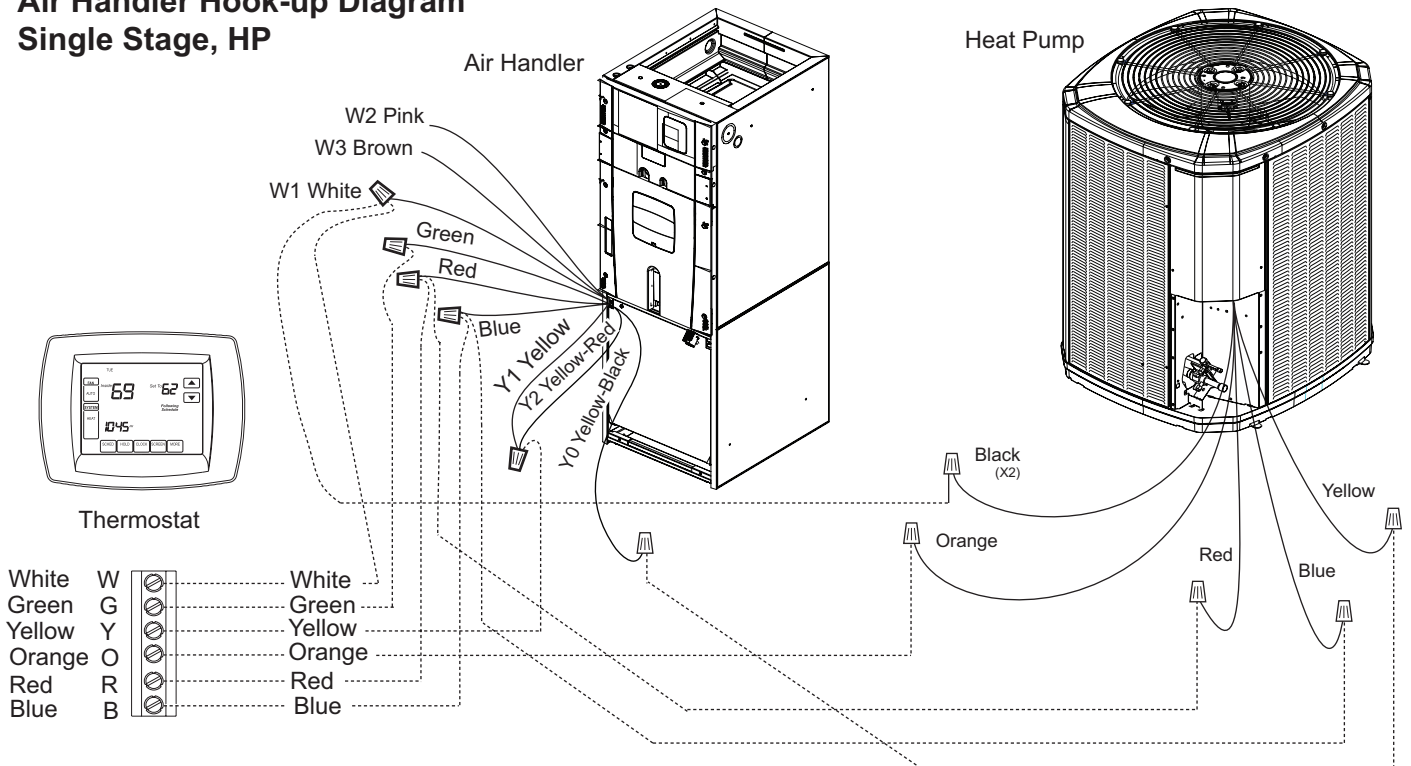

..... Field wiring

• * For multiple stages of electric heat, jumper W1, W2, and W3 together if comfort control has only one stage of heat

Air Handler Hook-up Diagram 2 Stage Indoor Airflow, Cooling Only

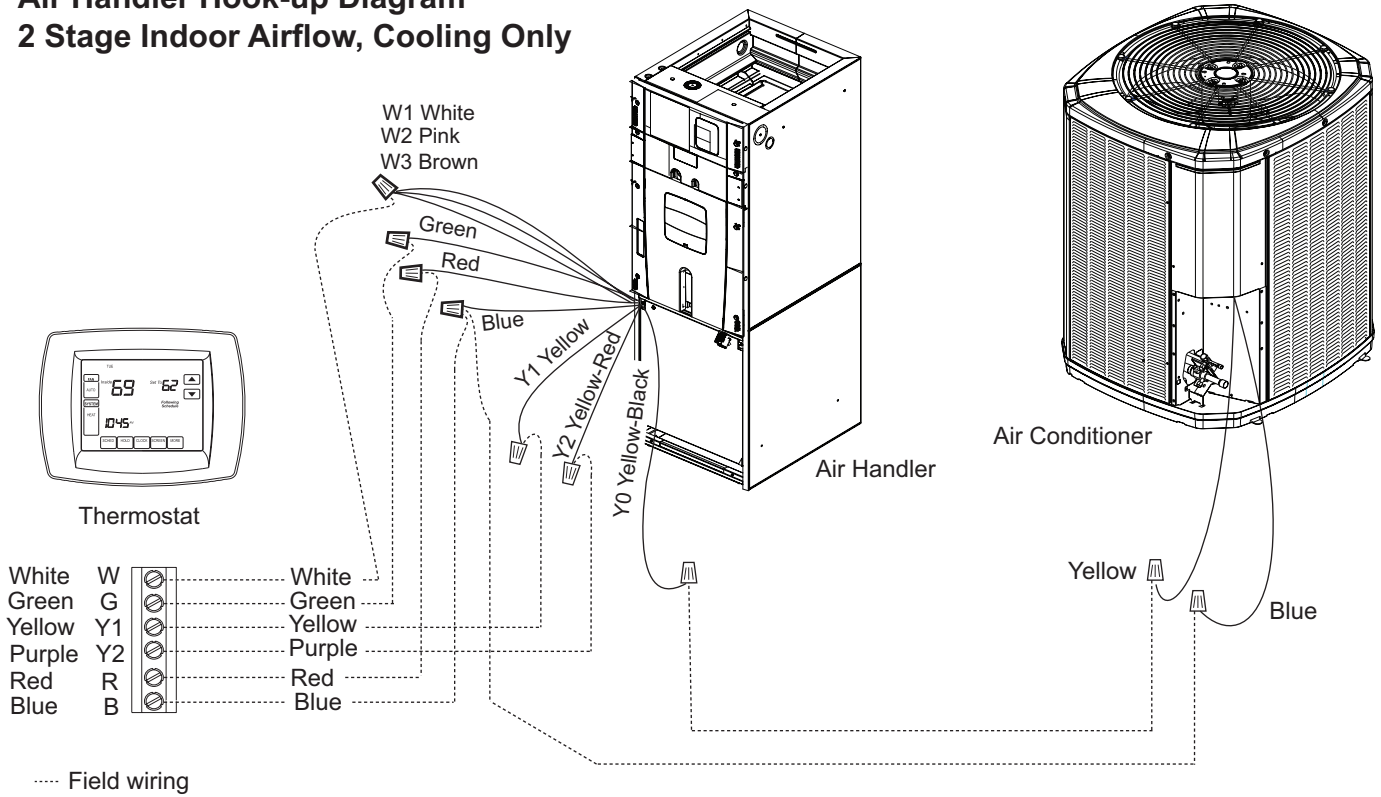

* For multiple stages of electric heat, jumper W1, W2, and W3 together if comfort control has only one stage of heat.

Air Handler Hook-up Diagram 2 Stage Indoor Airflow, HP

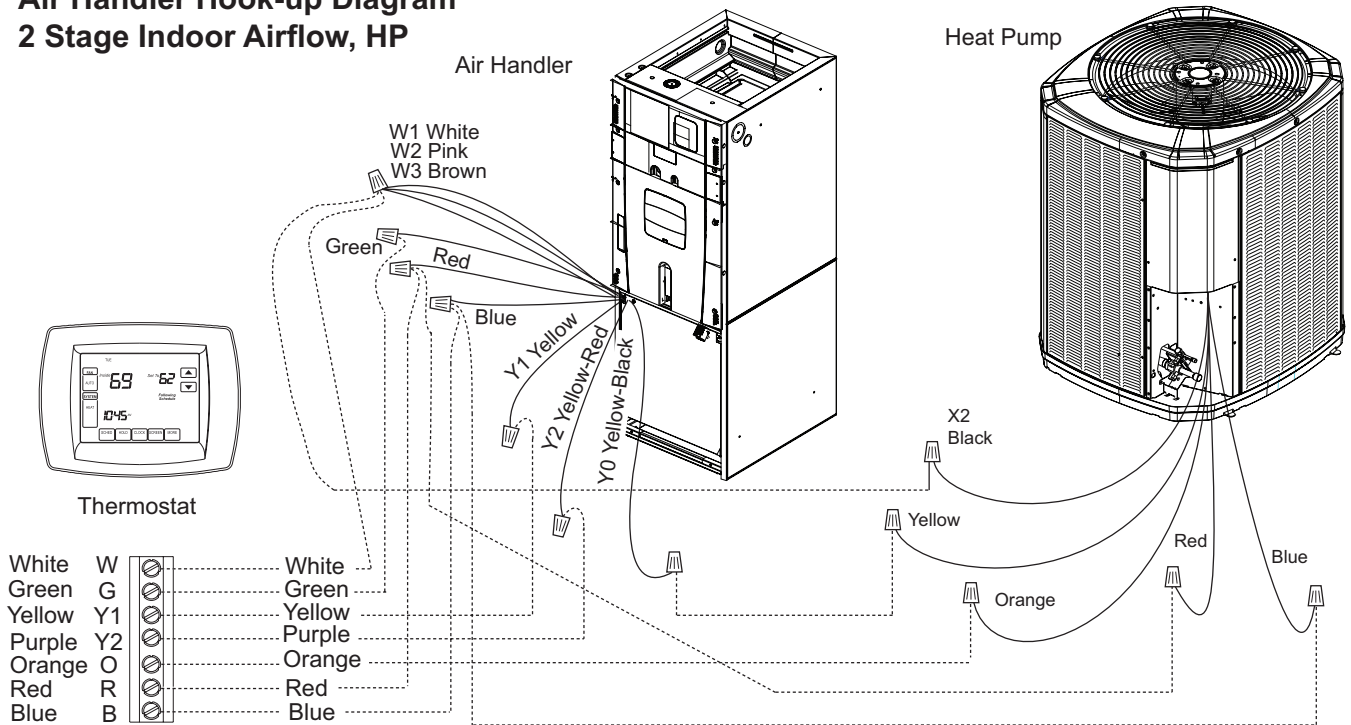

* For multiple stages of electric heat, jumper W1, W2, and W3 together if comfort control has only one stage of heat.

Air Handler Hook-up Diagram 3 Stage, 24V Inverter, Cooling Only

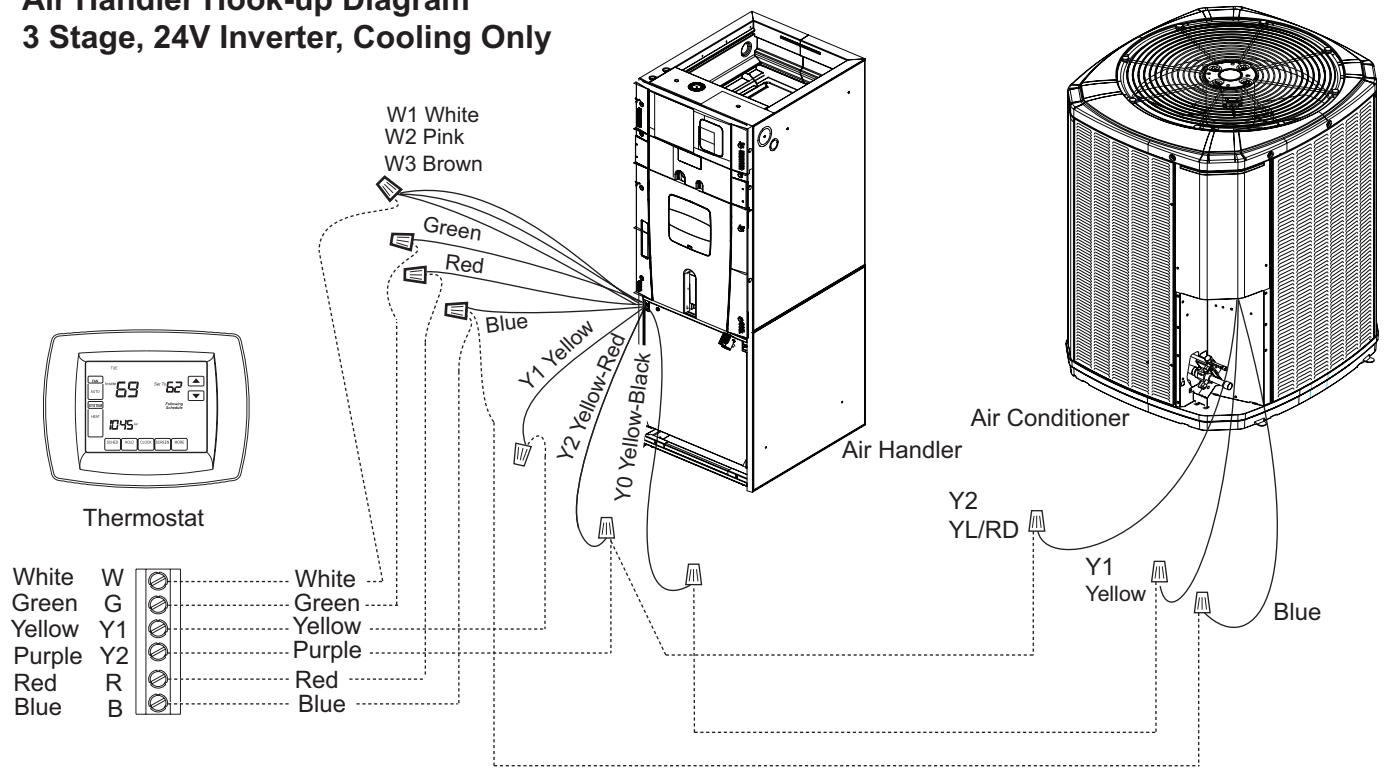

..... Field wiring

- * For multiple stages of electric heat, jumper W1, W2, and W3 together if comfort control has only one stage of heat.

Air Handler Hook-up Diagram 3 Stage, 24V Inverter, HP

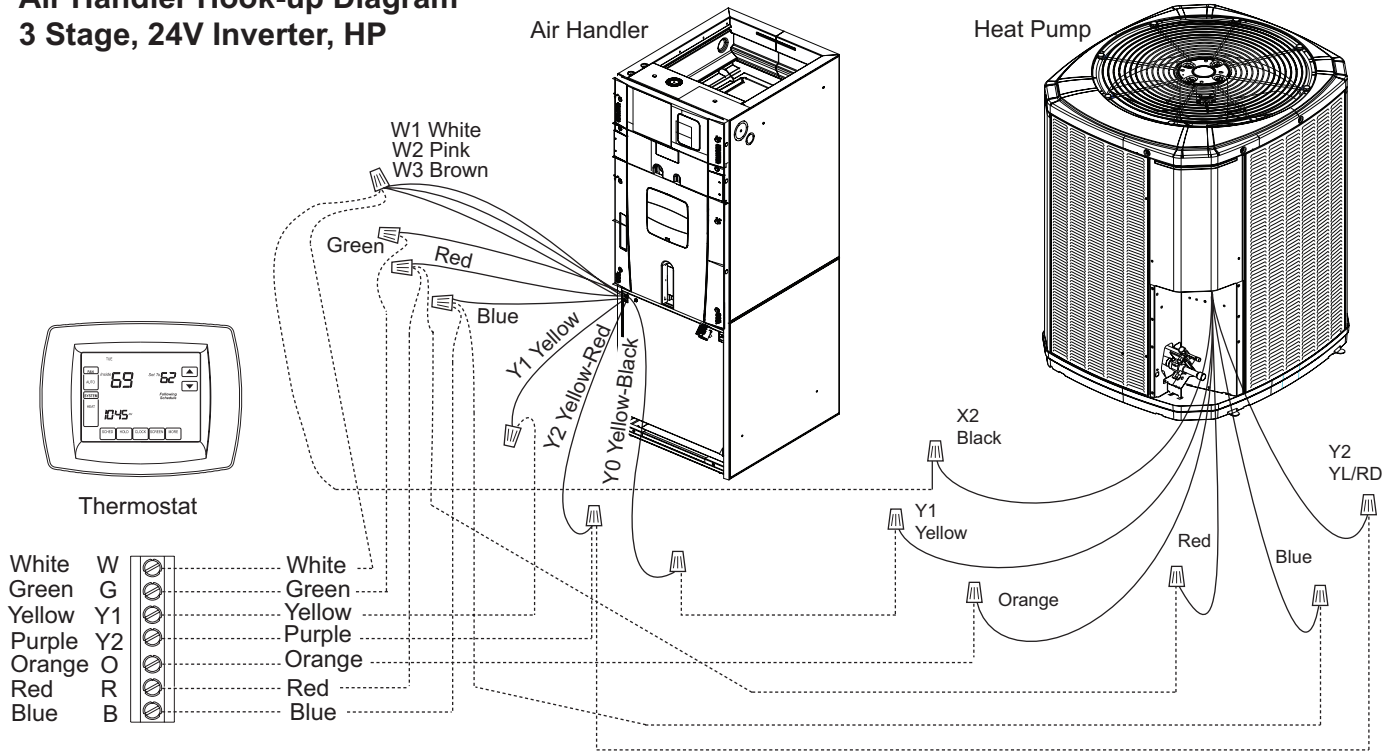

..... Field wiring

- * For multiple stages of electric heat, jumper W1, W2, and W3 together if comfort control has only one stage of heat.

18.3 External Switches and Accessories

The following optional connections are available on the mitigation control board (See Accessories Diagram Figure):

- ACC1 and ACC2 accessory connections. Use when connecting an accessory to the air handler that could be considered a source of ignition (ex. electronic air cleaner).

- Aoa/Aob audible alarm connections. Use when configuring an audible alarm on the refrigerant detection system of the air handler.

ACC1, ACC2, and Aoa/Aob are dry contacts and need source voltage provided from either the accessory or the unit's control wiring.

Connect using field-supplied 3/16" (Aoa/Aob) or 1/4" (ACC1, ACC2) female spade connections.



SCAN ME

Scan QR code to view instructional videos on field wiring for CleanEffects or AccuClean electronic air cleaners.

Accessories Diagram

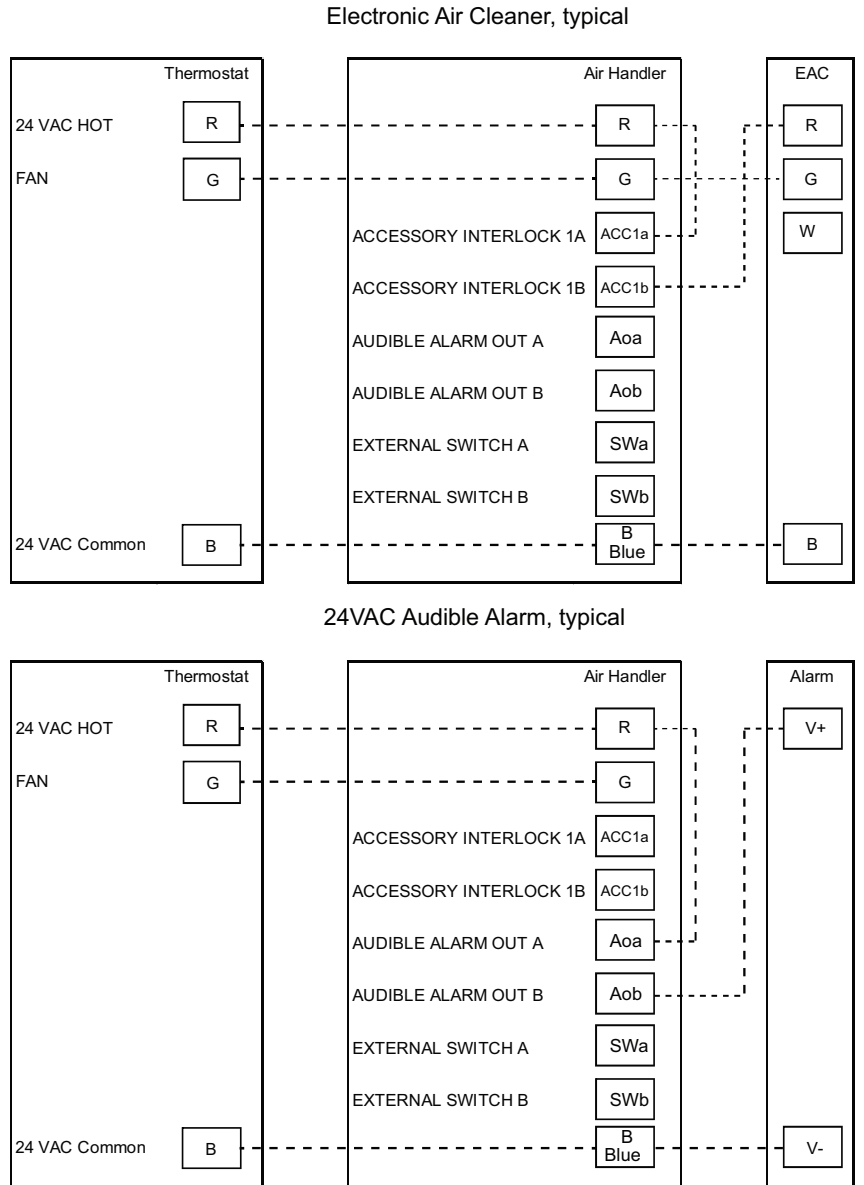

Section 19. Airflow Adjustment

Indoor airflow changes are made by connecting the green wire to the appropriate speed taps on the motor as follows:

- a. The black wire must always remain on Tap 1.
- b. Cooling and Heat Pump Airflow Selection - Place green wire on tap 2, 3, 4, or 5.
- c. Electric Heater Minimum Airflow Selection - Ensure green wire tap selection meets or exceeds the minimum tap selection shown on name plate.
- d. Two-Stage Airflow Configuration (optional) - Separately wire Y1 and Y2 at the field wiring connections. No further adjustment necessary.

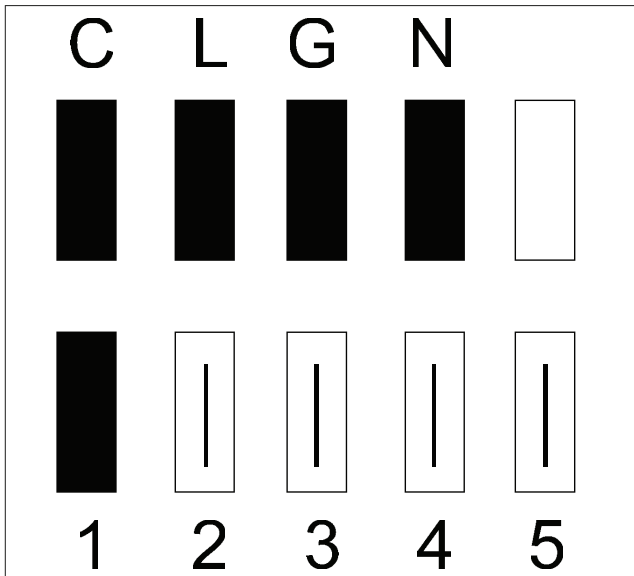

For cooling and heat pump airflow settings, refer to the airflow tables in the Performance and Electrical Data section of this manual.

To configure two-stage indoor airflow operation, separately wire the Y1 (yellow) and Y2 (yellow/red) wires in the low-voltage pigtail field connections to a compatible two-stage thermostat. Refer to the Field Wiring Diagrams section of this manual.

Note: The blower motor is programmed to run the low-stage of the two-stage configuration when Y2 is not energized (no additional tap selection required).

If equipping an optional electric heater, the airflow must be configured at or above the airflow selection shown on the name plate or in the Minimum Airflow CFM section of this manual.

Note: The system is configured to always provide high-stage airflow when the electric heater is operating even when the unit is configured for two stages of airflow.

Section 20. Product Specifications

Table 7

MODEL	5TAM5B01AC21SA	5TAM5B02AC21SA	5TAM5C03AC21SA	5TAM5C04AC31SA
Family	5TAM5	5TAM5	5TAM5	5TAM5
Brand	Trane, American Standard	Trane, American Standard	Trane, American Standard	Trane, American Standard
Family Description	R-454B Convertible Air Handler	R-454B Convertible Air Handler	R-454B Convertible Air Handler	R-454B Convertible Air Handler
Description	R-454B Convertible Air Handler, All-Aluminum Plate Fin Coil, 4-Way Poise, 24V System Control, 208-230/1/60, 18K - 24K BTUH Capacity	R-454B Convertible Air Handler, All-Aluminum Plate Fin Coil, 4-Way Poise, 24V System Control, 208-230/1/60, 18K - 24K BTUH Capacity	R-454B Convertible Air Handler, All-Aluminum Plate Fin Coil, 4-Way Poise, 24V System Control, 208-230/1/60, 24K - 36K BTUH Capacity	R-454B Convertible Air Handler, All-Aluminum Plate Fin Coil, 4-Way Poise, 24V System Control, 208-230/1/60, 24K - 36K BTUH Capacity
Application Configuration	4-Way	4-Way	4-Way	4-Way
RATED CAPACITY RANGE (BTUH)	18K - 24K	18K - 24K	24K - 36K	24K - 36K
SYSTEM CONTROL TYPE	24V	24V	24V	24V
POWER CONN. – V/PH/HZ	208-230/1/60	208-230/1/60	208-230/1/60	208-230/1/60
Max Breaker Size, Without Electric Heater (Amps)	15	15	15	15
Max Breaker Size, With Electric Heater (Amps) ①	60	60	60	60
Name Plate	Check Unit	Check Unit	Check Unit	Check Unit
COIL TYPE	All-Aluminum Plate Fin	All-Aluminum Plate Fin	All-Aluminum Plate Fin	All-Aluminum Plate Fin
Refrigerant Type	R-454B	R-454B	R-454B	R-454B
Refrigerant Control	TXV	TXV	TXV	TXV
Refrigerant Line Connection - Gas (in.)	3/4	3/4	3/4	3/4
Refrigerant Line Connection - Liquid (in.)	3/8	3/8	3/8	3/8
BLOWER TYPE	Direct Drive Centrifugal	Direct Drive Centrifugal	Direct Drive Centrifugal	Direct Drive Centrifugal
Configuration	Blow Through	Blow Through	Blow Through	Blow Through
Dimensions (Diameter x Width (in.))	11 x 8	11 x 8	11 x 10	11 x 10
Motor Type	Constant Torque	Constant Torque	Constant Torque	Constant Torque
Nominal CFM ②	600	800	1000	1200
Speed (RPM)	1050	1050	1050	1050
Volts/Ph/Hz	208-230/1/60	208-230/1/60	208-230/1/60	208-230/1/60
Full Load Amps	2.6	2.6	3.8	3.8
FILTER RACK (YES, NO)	Yes	Yes	Yes	Yes
Dimensions (Length x Width (in.))	16 x 20 x 1	16 x 20 x 1	20 x 20 x 1	20 x 20 x 1
DUCT CONNECTIONS	L x W	L x W	L x W	L x W
Supply (in.)	14.5 x 14.35	14.5 x 14.35	18.4 x 14.35	18.4 x 14.35
Return (in.)	14.5 x 17.15	14.5 x 17.15	18.4 x 17.15	18.4 x 17.15
DRAIN CONN. SIZE (IN.)	3/4 NPT	3/4 NPT	3/4 NPT	3/4 NPT
DIMENSIONS	H x W x D	H x W x D	H x W x D	H x W x D
Uncrated (in.)	49-7/8 x 17-1/2 x 21-3/4	49-7/8 x 17-1/2 x 21-3/4	55-3/4 x 21-1/4 x 21-3/4	55-3/4 x 21-1/4 x 21-3/4
Crated (in.)	51-3/8 x 20-1/2 x 25-3/4	51-3/8 x 20-1/2 x 25-3/4	57-1/4 x 24-1/4 x 25-3/4	57-1/4 x 24-1/4 x 25-3/4
WEIGHT – SHIPPING/NET (LBS.)	126/120	126/120	150/142	150/142

① Maximum overcurrent protection is dependent on which electric heater is installed. See Installation, Operation, and Maintenance manual or unit name plate.

② For CFM versus external static pressure (in. w.c.), refer to Installation, Operation, and Maintenance manual.

MODEL	5TAM5D05AC31SA	5TAM5D06AC41SA	5TAM5D07AC51SA
Family	5TAM5	5TAM5	5TAM5
Brand	Trane, American Standard	Trane, American Standard	Trane, American Standard
Family Description	R-454B Convertible Air Handler	R-454B Convertible Air Handler	R-454B Convertible Air Handler
Description	R-454B Convertible Air Handler, All-Aluminum Plate Fin Coil, 4-Way Poise, 24V System Control, 208-230/1/60, 36K - 48K BTUH Capacity	R-454B Convertible Air Handler, All-Aluminum Plate Fin Coil, 4-Way Poise, 24V System Control, 208-230/1/60, 42K - 60K BTUH Capacity	R-454B Convertible Air Handler, All-Aluminum Plate Fin Coil, 4-Way Poise, 24V System Control, 208-230/1/60, 48K - 60K BTUH Capacity
Application Configuration	4-Way	4-Way	4-Way
RATED CAPACITY RANGE (BTUH)	36K - 48K	42K - 60K	48K - 60K
SYSTEM CONTROL TYPE	24V	24V	24V
POWER CONN. - V/PH/HZ	208-230/1/60	208-230/1/60	208-230/1/60
Max Breaker Size, Without Electric Heater (Amps)	15	15	15
Max Breaker Size, With Electric Heater (Amps) ①	60	60	60
Name Plate	Check Unit	Check Unit	Check Unit
COIL TYPE	All-Aluminum Plate Fin	All-Aluminum Plate Fin	All-Aluminum Plate Fin
Refrigerant Type	R-454B	R-454B	R-454B
Refrigerant Control	TXV	TXV	TXV
Refrigerant Line Connection - Gas (in.)	7/8	7/8	7/8
Refrigerant Line Connection - Liquid (in.)	3/8	3/8	3/8
BLOWER TYPE	Direct Drive Centrifugal	Direct Drive Centrifugal	Direct Drive Centrifugal
Configuration	Blow Through	Blow Through	Blow Through
Dimensions (Diameter x Width (in.))	11 x 10	11 x 10	11 x 10
Motor Type	Constant Torque	Constant Torque	Constant Torque
Nominal CFM ②	1400	1600	2000
Speed (RPM)	1050	1050	1050
Volts/Ph/Hz	208-230/1/60	208-230/1/60	208-230/1/60
Full Load Amps	3.8	5.4	7.0
FILTER RACK (YES, NO)	Yes	Yes	Yes
Dimensions (Length x Width (in.))	22 x 20 x 1	22 x 20 x 1	22 x 20 x 1
DUCT CONNECTIONS	L x W	L x W	L x W
Supply (in.)	20.5 x 14.35	20.5 x 14.35	20.5 x 14.35
Return (in.)	20.5 x 17.15	20.5 x 17.15	20.5 x 17.15
DRAIN CONN. SIZE (IN.)	3/4 NPT	3/4 NPT	3/4 NPT
DIMENSIONS	H x W x D	H x W x D	H x W x D
Uncrated (in.)	56-7/8 x 23-1/2 x 21-3/4	61-3/4 x 23-1/2 x 21-3/4	61-3/4 x 23-1/2 x 21-3/4
Crated (in.)	58-1/2 x 27-1/2 x 25-3/4	63-1/4 x 27-1/2 x 25-3/4	63-1/4 x 27-1/2 x 25-3/4
WEIGHT - SHIPPING/NET (LBS.)	163/153	176/166	180/170

① Maximum overcurrent protection is dependent on which electric heater is installed. See Installation, Operation, and Maintenance manual or unit name plate.

② For CFM versus external static pressure (in. w.c.), refer to Installation, Operation, and Maintenance manual.

Section 21. Airflow Performance

Table 8

5TAM5B01AC21SAA				
EXTERNAL STATIC (in w.g.)	AIRFLOW (CFM)			
	Speed Taps: 208 – 230 VOLTS			
	TAP 5	TAP 4	TAP 3†	TAP 2
0.1	949	832	796	748
0.2	917	802	769	718
0.3	895	771	736	685
0.4	863	745	707	647
0.5	838	709	668	607
0.6	805	674	629	564
0.7	771	637	590	527
0.8	740	600	554	493
0.9	707	567	522	451

· In horizontal and downflow applications, airflow should be limited to 800 CFM due to condensate blowoff.

5TAM5B02AC21SAA				
EXTERNAL STATIC (in w.g.)	AIRFLOW (CFM)			
	Speed Taps: 208 – 230 VOLTS			
	TAP 5	TAP 4	TAP 3†	TAP 2
0.1	1039	955	855	793
0.2	1010	930	822	760
0.3	984	900	789	729
0.4	956	873	764	700
0.5	931	848	735	667
0.6	906	824	702	628
0.7	884	794	667	589
0.8	855	762	631	554
0.9	823	731	597	524

· In horizontal and downflow applications, airflow should be limited to 800 CFM due to condensate blowoff.

5TAM5C03AC21SAA				
EXTERNAL STATIC (in w.g.)	AIRFLOW (CFM)			
	Speed Taps: 208 – 230 VOLTS			
	TAP 5	TAP 4	TAP 3†	TAP 2
0.1	1236	1170	1043	946
0.2	1201	1132	1000	894
0.3	1161	1098	950	837
0.4	1121	1049	881	761
0.5	1071	994	825	707
0.6	1011	938	764	631
0.7	963	891	702	568
0.8	917	841	640	520
0.9	869	774	584	480

· In horizontal and downflow applications, airflow should be limited to 1200 CFM due to condensate blowoff.

5TAM5C04AC31SAA				
EXTERNAL STATIC (in w.g.)	AIRFLOW (CFM)			
	Speed Taps: 208 – 230 VOLTS			
	TAP 5	TAP 4	TAP 3†	TAP 2
0.1	1341	1295	1184	1109
0.2	1309	1256	1142	1066
0.3	1274	1216	1103	1021
0.4	1238	1180	1063	970
0.5	1195	1141	1005	913
0.6	1145	1082	953	860
0.7	1098	1033	907	800
0.8	1056	991	846	730
0.9	1014	940	780	678

· In horizontal and downflow applications, airflow should be limited to 1200 CFM due to condensate blowoff.

5TAM5D05AC31SAA				
EXTERNAL STATIC (in w.g.)	AIRFLOW (CFM)			
	Speed Taps: 208 – 230 VOLTS			
	TAP 5	TAP 4	TAP 3†	TAP 2
0.1	1590	1497	1324	1202
0.2	1553	1460	1283	1156
0.3	1515	1423	1243	1110
0.4	1480	1386	1201	1063
0.5	1442	1356	1159	1014
0.6	1405	1308	1113	956
0.7	1365	1267	1068	900
0.8	1322	1224	1012	839
0.9	641	1170	958	761

· In horizontal and downflow applications, airflow should be limited to 1400 CFM due to condensate blowoff.

5TAM5D06AC41SAA				
EXTERNAL STATIC (in w.g.)	AIRFLOW (CFM)			
	Speed Taps: 208 – 230 VOLTS			
	TAP 5	TAP 4	TAP 3†	TAP 2
0.1	1849	1700	1637	1583
0.2	1816	1664	1607	1548
0.3	1787	1623	1570	1512
0.4	1753	1592	1538	1474
0.5	1721	1555	1500	1436
0.6	1688	1517	1464	1400
0.7	1654	1482	1428	1365
0.8	1628	1445	1391	1325
0.9	1595	1446	1350	1283

· In horizontal and downflow applications, airflow should be limited to 1800 CFM due to condensate blowoff.

5TAM5D07AC51SAA				
EXTERNAL STATIC (in w.g.)	AIRFLOW (CFM)			
	Speed Taps: 208 – 230 VOLTS			
	TAP 5	TAP 4	TAP 3†	TAP 2
0.1	2116	2051	1803	1762
0.2	2083	2025	1769	1731
0.3	2055	1995	1736	1696
0.4	2033	1963	1706	1661
0.5	2000	1937	1670	1628
0.6	1975	1904	1637	1591
0.7	1942	1875	1599	1552
0.8	1910	1843	1565	1517
0.9	1880	1809	1524	1480

· In horizontal and downflow applications, airflow should be limited to 1800 CFM due to condensate blowoff.

Notes:

- TAP 1 is not an airflow selection. Black wire must always be on TAP 1.
- Values are with wet coil and no filter. Contact filter manufacturer for pressure drop data.
- Electric heater pressure drop is negligible and is included within the airflow data.
- Add 3% for dry coil CFM correction.
- † is Factory Setting.

Section 22. Minimum Airflow Setting

Table 9

5TAM5B01AC21SA		
Heater	Minimum Heat Speed Tap	
	Without Heat Pump	With Heat Pump
BAYEA(AC/13)04+++1, BAYEA(AC/13)05+++1, BAYEA(AC/13)08+++1	TAP 3	TAP 4
BAYEA(AC/13)10+++1	TAP 3 ①	TAP 5 ①
BAYEA(AC/13)10LG3	TAP 5	TAP 5 ②

5TAM5B02AC21SA		
Heater	Minimum Heat Speed Tap	
	Without Heat Pump	With Heat Pump
BAYEA(AC/13)04+++1, BAYEA(AC/13)05+++1, BAYEA(AC/13)08+++1	TAP 3	TAP 4
BAYEA(AC/13)10+++1	TAP 3 ①	TAP 5 ①
BAYEA(AC/13)10LG3	TAP 3	TAP 5 ②

5TAM5C03AC21SA, 5TAM5C04AC31SA		
Heater	Minimum Heat Speed Tap	
	Without Heat Pump	With Heat Pump
BAYEA(AC/13)04+++1, BAYEA(AC/13)05+++1	TAP 2	TAP 3
BAYEA(AC/13)08+++1	TAP 3	TAP 4
BAYEA(AC/13)10+++1, BAYEA(AC/13)10LG3, BAYEA(BC/13)15LG3, BAYEA(BC/23)15BK1	TAP 4	TAP 5

5TAM5D05AC31SA		
Heater	Minimum Heat Speed Tap	
	Without Heat Pump	With Heat Pump
BAYEA(AC/13)04+++1, BAYEA(AC/13)05+++1, BAYEA(AC/13)08+++1, BAYEA(AC/13)10+++1, BAYEA(AC/13)10LG3	TAP 2	TAP 3
BAYEA(BC/13)15LG3, BAYEA(BC/23)15BK1	TAP 3	TAP 4

5TAM5D06AC41SA, 5TAM5D07AC51SA		
Heater	Minimum Heat Speed Tap	
	Without Heat Pump	With Heat Pump
BAYEA(AC/13)04+++1, BAYEA(AC/13)05+++1, BAYEA(AC/13)08+++1, BAYEA(AC/13)10+++1, BAYEA(AC/13)10LG3	TAP 2	TAP 3
BAYEA(BC/13)15LG3, BAYEA(BC/23)15BK1, BAYEA(BC/23)20BK1	TAP 3	TAP 4
BAYEA(CC/33)25BK1	TAP 4	TAP 5

Note: Heater model number digits “++” are LG or BK.

Note: Heater model numbers may have either of the pairs of characters in parenthesis.

① Heater not qualified for downflow installations.

② Approved for 240V only.

Section 23. Wiring Data

Table 10

5TAM5B01AC21SAA											
Heater Model No	No. of Circuits	240 VOLT					208 VOLT				
		Capacity		Heater Amps per Circuit	Minimum Circuit Ampacity	Maximum Overload Protection	Capacity		Heater Amps per Circuit	Minimum Circuit Ampacity	Maximum Overload Protection
		kW	BTUH				kW	BTUH			
No Heater	-	-	-	2.6*	3	15	-	-	2.6*	3	15
BAYEA(13/AC)04BK1 BAYEA(13/AC)04LG1	1	3.84	13100	16.0	23	25	2.88	9800	13.8	21	25
BAYEA(13/AC)05BK1 BAYEA(13/AC)05LG1	1	4.80	16400	20.0	28	30	3.60	12300	17.3	25	25
BAYEA(13/AC)08BK1 BAYEA(13/AC)08LG1	1	7.68	26200	32.0	43	45	5.76	19700	27.7	38	40
BAYEA(13/AC)10BK1 ① BAYEA(13/AC)10LG1 ①	1	9.60	32800	40.0	53	60	7.20	24600	34.6	47	50
BAYEA(13/AC)10LG3 ②	1-3 PH	9.60	32800	23.1	32	35	7.20	24600	20.0	28	30

Note: * Motor Amps
 ① Heater not qualified for downflow installations
 ② Approved for 240 V only with Heat Pump

5TAM5B02AC21SAA											
Heater Model No	No. of Circuits	240 VOLT					208 VOLT				
		Capacity		Heater Amps per Circuit	Minimum Circuit Ampacity	Maximum Overload Protection	Capacity		Heater Amps per Circuit	Minimum Circuit Ampacity	Maximum Overload Protection
		kW	BTUH				kW	BTUH			
No Heater	-	-	-	2.6*	3	15	-	-	2.6*	3	15
BAYEA(13/AC)04BK1 BAYEA(13/AC)04LG1	1	3.84	13100	16.0	23	25	2.88	9800	13.8	21	25
BAYEA(13/AC)05BK1 BAYEA(13/AC)05LG1	1	4.80	16400	20.0	28	30	3.60	12300	17.3	25	25
BAYEA(13/AC)08BK1 BAYEA(13/AC)08LG1	1	7.68	26200	32.0	43	45	5.76	19700	27.7	38	40
BAYEA(13/AC)10BK1 ① BAYEA(13/AC)10LG1 ①	1	9.60	32800	40.0	53	60	7.20	24600	34.6	47	50
BAYEA(13/AC)10LG3 ②	1-3 PH	9.60	32800	23.1	32	35	7.20	24600	20.0	28	30

Note: * Motor Amps
 ① Heater not qualified for downflow installations
 ② Approved for 240 V only with Heat Pump

5TAM5C03AC21SAA											
Heater Model No	No. of Circuits	240 VOLT					208 VOLT				
		Capacity		Heater Amps per Circuit	Minimum Circuit Ampacity	Maximum Overload Protection	Capacity		Heater Amps per Circuit	Minimum Circuit Ampacity	Maximum Overload Protection
		kW	BTUH				kW	BTUH			
No Heater	-	-	-	3.8*	5	15	-	-	3.8*	5	15
BAYEA(13/AC)04BK1 BAYEA(13/AC)04LG1	1	3.84	13100	16.0	25	25	2.88	9800	13.8	22	25
BAYEA(13/AC)05BK1 BAYEA(13/AC)05LG1	1	4.80	16400	20.0	30	30	3.60	12300	17.3	26	30
BAYEA(13/AC)08BK1 BAYEA(13/AC)08LG1	1	7.68	26200	32.0	45	45	5.76	19700	27.7	39	40
BAYEA(13/AC)10BK1 BAYEA(13/AC)10LG1	1	9.60	32800	40.0	55	60	7.20	24600	34.6	48	50
BAYEA(13/AC)10LG3	1-3 PH	9.60	32800	23.1	33	35	7.20	24600	20.0	29	30
BAYEA(23/BC)15LG3 ①	1-3 PH	14.40	49200	34.6	47	50	10.80	36900	30.0	42	45
BAYEA(23/BC)15BK1 - Circuit 1 ②	2	9.60	32800	40.0	55	60	7.20	24600	34.6	48	50
BAYEA(23/BC)15BK1 - Circuit 2		4.80	16400	20.0	25	25	3.60	12300	17.3	22	25

Note: * Motor Amps
 ① 208 V not approved for upflow installations
 ② MCA and MOP for circuit 1 contains the motor amps

5TAM5C04AC31SAA											
Heater Model No.	No. of Circuits	240 VOLT					208 VOLT				
		Capacity		Heater Amps per Circuit	Minimum Circuit Ampacity	Maximum Overload Protection	Capacity		Heater Amps per Circuit	Minimum Circuit Ampacity	Maximum Overload Protection
		kW	BTUH				kW	BTUH			
No Heater	-	-	-	3.8*	5	15	-	-	3.8*	5	15
BAYEA(13/AC)04BK1 BAYEA(13/AC)04LG1	1	3.84	13100	16.0	25	25	2.88	9800	13.8	22	25
BAYEA(13/AC)05BK1 BAYEA(13/AC)05LG1	1	4.80	16400	20.0	30	30	3.60	12300	17.3	26	30
BAYEA(13/AC)08BK1 BAYEA(13/AC)08LG1	1	7.68	26200	32.0	45	45	5.76	19700	27.7	39	40
BAYEA(13/AC)10BK1 BAYEA(13/AC)10LG1	1	9.60	32800	40.0	55	60	7.20	24600	34.6	48	50
BAYEA(13/AC)10LG3	1-3 PH	9.60	32800	23.1	33	35	7.20	24600	20.0	29	30
BAYEA(23/BC)15LG3	1-3 PH	14.40	49200	34.6	47	50	10.80	36900	30.0	42	45
BAYEA(23/BC)15BK1 - Circuit 1 ①	2	9.60	32800	40.0	55	60	7.20	24600	34.6	48	50
BAYEA(23/BC)15BK1 - Circuit 2		4.80	16400	20.0	25	25	3.60	12300	17.3	22	25

Note: * Motor Amps
① MCA and MOP for circuit 1 contains the motor amps

5TAM5D05AC31SAA											
Heater Model No.	No. of Circuits	240 VOLT					208 VOLT				
		Capacity		Heater Amps per Circuit	Minimum Circuit Ampacity	Maximum Overload Protection	Capacity		Heater Amps per Circuit	Minimum Circuit Ampacity	Maximum Overload Protection
		kW	BTUH				kW	BTUH			
No Heater	-	-	-	3.8*	5	15	-	-	3.8*	5	15
BAYEA(13/AC)04BK1 BAYEA(13/AC)04LG1	1	3.84	13100	16.0	25	25	2.88	9800	13.8	22	25
BAYEA(13/AC)05BK1 BAYEA(13/AC)05LG1	1	4.80	16400	20.0	30	30	3.60	12300	17.3	26	30
BAYEA(13/AC)08BK1 BAYEA(13/AC)08LG1	1	7.68	26200	32.0	45	45	5.76	19700	27.7	39	40
BAYEA(13/AC)10BK1 BAYEA(13/AC)10LG1	1	9.60	32800	40.0	55	60	7.20	24600	34.6	48	50
BAYEA(13/AC)10LG3	1-3 PH	9.60	32800	23.1	33	35	7.20	24600	20.0	29	30
BAYEA(23/BC)15LG3	1-3 PH	14.40	49200	34.6	47	50	10.80	36900	30.0	42	45
BAYEA(23/BC)15BK1 - Circuit 1 ①	2	9.60	32800	40.0	55	60	7.20	24600	34.6	48	50
BAYEA(23/BC)15BK1 - Circuit 2		4.80	16400	20.0	25	25	3.60	12300	17.3	22	25

Note: * Motor Amps
① MCA and MOP for circuit 1 contains the motor amps

5TAM5D06AC41SAA											
Heater Model No.	No. of Circuits	240 VOLT					208 VOLT				
		Capacity		Heater Amps per Circuit	Minimum Circuit Ampacity	Maximum Overload Protection	Capacity		Heater Amps per Circuit	Minimum Circuit Ampacity	Maximum Overload Protection
		kW	BTUH				kW	BTUH			
No Heater	-	-	-	5.4*	7	15	-	-	5.4*	7	15
BAYEA(13/AC)04BK1 BAYEA(13/AC)04LG1	1	3.84	13100	16.0	27	30	2.88	9800	13.8	24	25
BAYEA(13/AC)05BK1 BAYEA(13/AC)05LG1	1	4.80	16400	20.0	32	35	3.60	12300	17.3	28	30
BAYEA(13/AC)08BK1 BAYEA(13/AC)08LG1	1	7.68	26200	32.0	47	50	5.76	19700	27.7	41	45
BAYEA(13/AC)10BK1 BAYEA(13/AC)10LG1	1	9.60	32800	40.0	57	60	7.20	24600	34.6	50	50
BAYEA(13/AC)10LG3	1-3 PH	9.60	32800	23.1	35	35	7.20	24600	20.0	31	35
BAYEA(23/BC)15LG3	1-3 PH	14.40	49200	34.6	49	50	10.80	36900	30.0	43	45
BAYEA(23/BC)15BK1 - Circuit 1 ①	2	9.60	32800	40.0	57	60	7.20	24600	34.6	50	50
BAYEA(23/BC)15BK1 - Circuit 2		4.80	16400	20.0	25	25	3.60	12300	17.3	22	25
BAYEA(23/BC)20BK1 - Circuit 1 ①	2	9.60	32800	40.0	57	60	7.20	24600	34.6	50	50
BAYEA(23/BC)20BK1 - Circuit 2		9.60	32800	40.0	50	50	7.20	24600	34.6	43	45
BAYEA(33/CC)25BK1 - Circuit 1 ①	3	9.60	32800	40.0	57	60	7.20	24600	34.6	50	50
BAYEA(33/CC)25BK1 - Circuit 2		9.60	32800	40.0	50	50	7.20	24600	34.6	43	45
BAYEA(33/CC)25BK1 - Circuit 3		4.80	16400	20.0	25	25	3.60	12300	17.3	22	25

Note: * Motor Amps
① MCA and MOP for circuit 1 contains the motor amps

5TAM5D07AC51SAA											
Heater Model No	No. of Circuits	240 VOLT					208 VOLT				
		Capacity		Heater Amps per Circuit	Minimum Circuit Ampacity	Maximum Overload Protection	Capacity		Heater Amps per Circuit	Minimum Circuit Ampacity	Maximum Overload Protection
		kW	BTUH				kW	BTUH			
No Heater	-	-	-	7.0*	9	15	-	-	7.0*	9	15
BAYEA(13/AC)04BK1 BAYEA(13/AC)04LG1	1	3.84	13100	16.0	29	30	2.88	9800	13.8	26	30
BAYEA(13/AC)05BK1 BAYEA(13/AC)05LG1	1	4.80	16400	20.0	34	35	3.60	12300	17.3	30	30
BAYEA(13/AC)08BK1 BAYEA(13/AC)08LG1	1	7.68	26200	32.0	49	50	5.76	19700	27.7	43	45
BAYEA(13/AC)10BK1 BAYEA(13/AC)10LG1	1	9.60	32800	40.0	59	60	7.20	24600	34.6	52	60
BAYEA(13/AC)10LG3	1-3 PH	9.60	32800	23.1	37	40	7.20	24600	20.0	33	35
BAYEA(23/BC)15LG3	1-3 PH	14.40	49200	34.6	51	60	10.80	36900	30.0	45	45
BAYEA(23/BC)15BK1 - Circuit 1 ①	2	9.60	32800	40.0	59	60	7.20	24600	34.6	52	60
BAYEA(23/BC)15BK1 - Circuit 2		4.80	16400	20.0	25	25	3.60	12300	17.3	22	25
BAYEA(23/BC)20BK1 - Circuit 1 ①	2	9.60	32800	40.0	59	60	7.20	24600	34.6	52	60
BAYEA(23/BC)20BK1 - Circuit 2		9.60	32800	40.0	50	50	7.20	24600	34.6	43	45
BAYEA(33/CC)25BK1 - Circuit 1 ①	3	9.60	32800	40.0	59	60	7.20	24600	34.6	52	60
BAYEA(33/CC)25BK1 - Circuit 2		9.60	32800	40.0	50	50	7.20	24600	34.6	43	45
BAYEA(33/CC)25BK1 - Circuit 3		4.80	16400	20.0	25	25	3.60	12300	17.3	22	25

Note: * Motor Amps
① MCA and MOP for circuit 1 contains the motor amps

Section 24. Distance from Belly Band to Shaft Face of Motor for Minimum Vibration

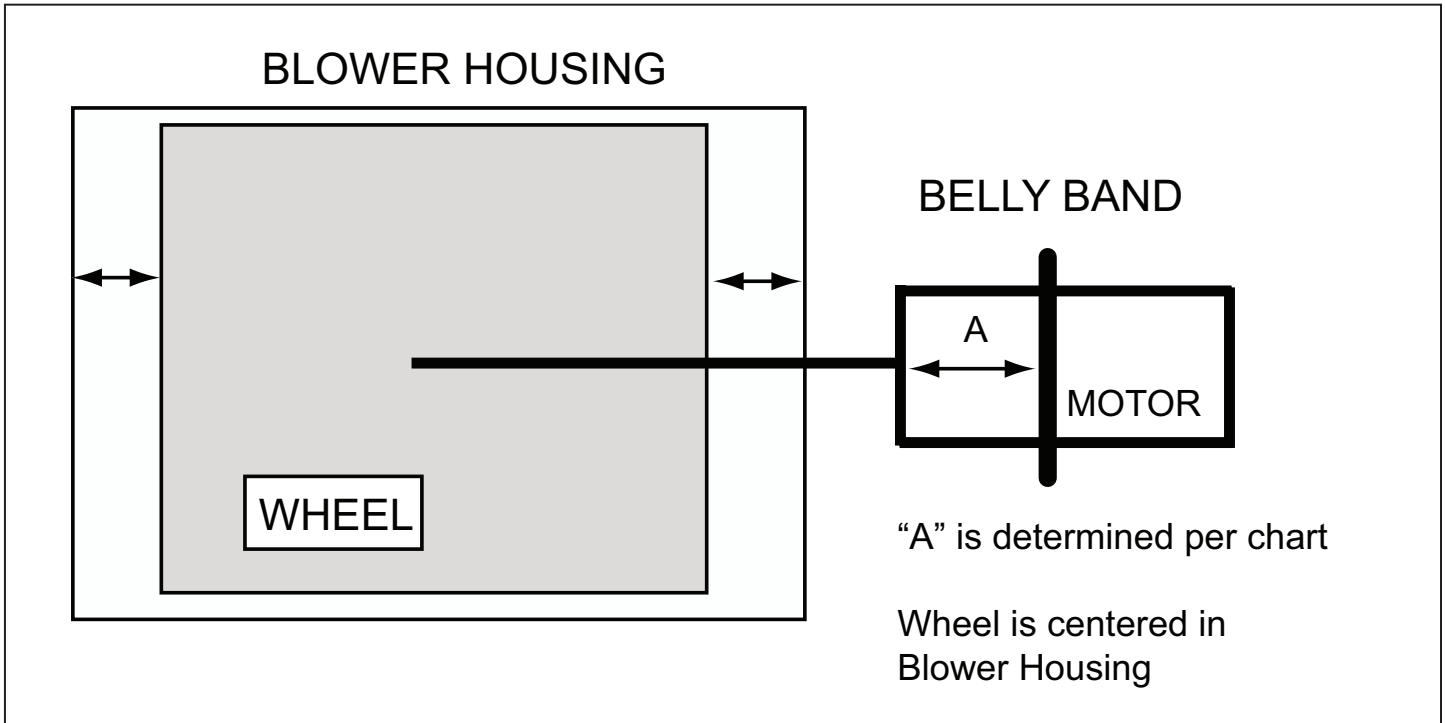

Table 11

MODEL	DIM "A"
5TAM5B01AC21SA	1-1/8
5TAM5B02AC21SA	1-1/8
5TAM5C03AC21SA	1-1/2
5TAM5C04AC31SA	1-1/2
5TAM5D05AC31SA	1-1/2
5TAM5D06AC41SA	2-1/4
5TAM5D07AC51SA	2-1/4

Section 25. Filters

25.1 Filter Considerations

- A filter must be installed within the system.
- A filter channel is provided in the unit, at the bottom of the Blower/Filter compartment.
- For customer ease of filter maintenance, it is recommended that a properly sized remote filter grill(s) be installed for units that are difficult to access. Airflow should not exceed the maximum rated velocity of the filter being used.

Table 12. Filter Sizes

Cabinet Width	17.5"	21.0"	23.5"
Filter Size	16 x 20	20 x 20	22 x 20

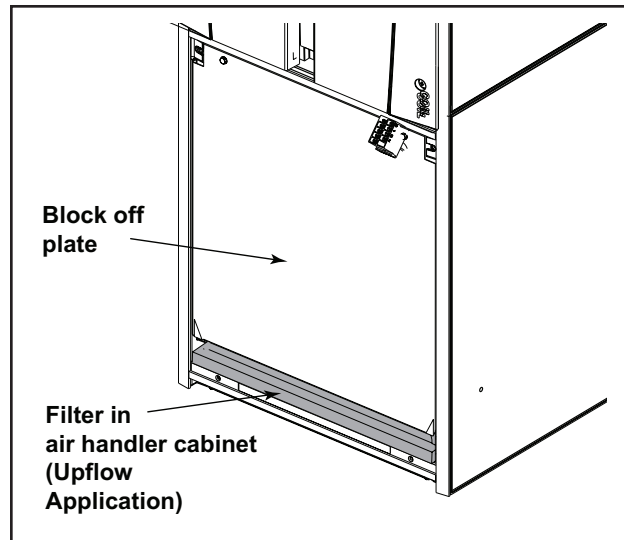

25.2 System Start Up

STEP 1 - Make sure all panels are securely in place and that all wiring has been properly dressed and secured.

STEP 2 - Set the system thermostat to OFF.

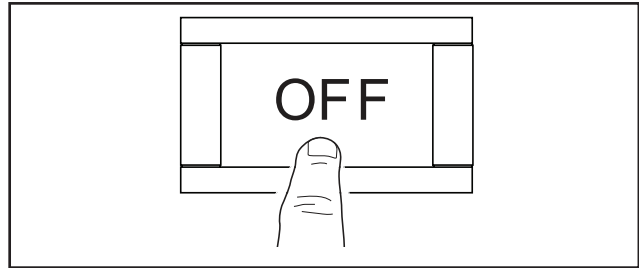

STEP 3 - Turn on electrical power disconnect(s) to apply power to the indoor and outdoor units.

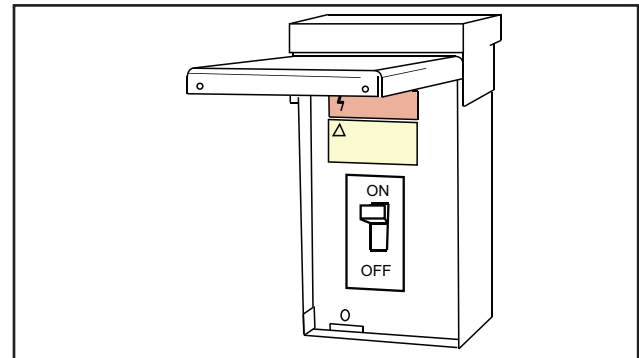

STEP 4 - Set the system thermostat to ON.

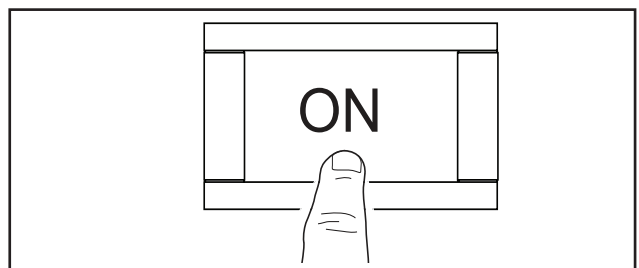

Section 26. Sequence of Operation

26.1 Sequence of Operation

5TAM5 Sequence of Operation:

See unit, electric heat, and field wiring diagrams for additional information.

Continuous Fan

IMPORTANT: *If the indoor air exceeds 60% relative humidity or simply feels uncomfortably humid, it is recommended that the indoor fan only be used in the AUTO mode.*

1. R-G contacts close on comfort control sending 24VAC to G wire tap on the motor.
2. Indoor blower speed is selected by placing the G wire on either TAP 2, 3, 4, or 5. Blower motor will now run on first stage airflow.

Single Stage Heat Pump OD (cooling)

1. R-Y1 (or Y) contacts close on the comfort control sending 24VAC to the Y1 input on the refrigerant leak detection and mitigation control board. The board then outputs 24VAC via the Yo wire to Y in the outdoor unit.
2. R-G contacts also close on the comfort control sending 24VAC to the G wire on the motor. Indoor blower speed is selected by placing the G wire on either TAP 2, 3, 4, or 5. (G without Y2 will run the fan on the low stage setting.)
3. R-O contacts on the comfort control close sending 24VAC to the O terminal on the switch over valve in the outdoor unit.
4. R-Y2 (or Y if jumped to Y1 at indoor unit) contacts close on the comfort control sending 24VAC to the Y/Y2 input on the fan relay which closes between G and TAP 1, energizing TAP 1 on the motor. (G with TAP 1 will run the fan on the high stage setting).

Two Stage Heat Pump OD (cooling)

1. R-Y1 contacts close on the comfort control sending 24VAC to the Y1 input on the refrigerant leak detection and mitigation control board. The board then outputs 24VAC via the Yo wire to Y1 in the outdoor unit.
2. R-G contacts also close on the comfort control sending 24VAC to the G wire on the motor. Indoor blower speed is selected by placing the G wire on either TAP 2, 3, 4, or 5. (G without Y2 will run the fan on the low stage setting.)
3. R-O contacts on the comfort control close sending 24VAC to the O terminal on the switch over valve in the outdoor unit.

4. R-Y2 contacts close on the comfort control sending 24VAC to the Y/Y2 input on the fan relay which closes between G and TAP 1, energizing TAP 1 on the motor. (G with TAP 1 will run the fan on the high stage setting). 24VAC is also sent to Y2 on the outdoor unit.

Single Stage Heat Pump OD (heating)

1. R-Y1 (or Y) contacts close on the comfort control sending 24VAC to the Y1 input on the refrigerant leak detection and mitigation control board. The board then outputs 24VAC via the Yo wire to Y in the outdoor unit.
2. R-G contacts also close on the comfort control sending 24VAC to the G wire on the motor. Indoor blower speed is selected by placing the G wire on either TAP 2, 3, 4, or 5. (G without Y2 will run the fan on the low stage setting.)
3. R-Y2 (or Y if jumped to Y1 at indoor unit) contacts close on the comfort control sending 24VAC to the Y/Y2 input on the fan relay which closes between G and TAP 1, energizing TAP 1 on the motor. (G with TAP 1 will run the fan on the high stage setting).

Two Stage Heat Pump OD (heating)

1. R-Y1 contacts close on the comfort control sending 24VAC to the Y1 input on the refrigerant leak detection and mitigation control board. The board then outputs 24VAC via the Yo wire to Y1 in the outdoor unit.
2. R-G contacts also close on the comfort control sending 24VAC to the G wire on the motor. Indoor blower speed is selected by placing the G wire on either TAP 2, 3, 4, or 5. (G without Y2 will run the fan on the low stage setting.)
3. R-Y2 contacts close on the comfort control sending 24VAC to the Y/Y2 input on the fan relay which closes between G and TAP 1, energizing TAP 1 on the motor. (G with TAP 1 will run the fan on the high stage setting). 24VAC is also sent to Y2 on the outdoor unit.

Single Stage Cooling OD

1. R-Y1 (or Y) contacts close on the comfort control sending 24VAC to the Y1 input on the refrigerant leak detection and mitigation control board. The board then outputs 24VAC via the Yo wire to Y in the outdoor unit.
2. R-G contacts also close on the comfort control sending 24VAC to the G wire on the motor.

Indoor blower speed is selected by placing the G wire on either TAP 2, 3, 4, or 5. (G without Y2 will run the fan on the low stage setting.)

3. R-Y2 (or Y if jumped to Y1 at indoor unit) contacts close on the comfort control sending 24VAC to the Y/Y2 input on the fan relay which closes between G and TAP 1, energizing TAP 1 on the motor. (G with TAP 1 will run the fan on the high stage setting).

Two Stage Cooling OD

1. R-Y1 contacts close on the comfort control sending 24VAC to the Y1 input on the refrigerant leak detection and mitigation control board. The board then outputs 24VAC via the Yo wire to Y1 in the outdoor unit.
2. R-G contacts also close on the comfort control sending 24VAC to the G wire on the motor. Indoor blower speed is selected by placing the G wire on either TAP 2, 3, 4, or 5. (G without Y2 will run the fan on the low stage setting.)
3. R-Y2 contacts close on the comfort control sending 24VAC to the Y/Y2 input on the fan relay which closes between G and TAP 1, energizing TAP 1 on the motor. (G with TAP 1 will run the fan on the high stage setting). 24VAC is also sent to Y2 on the outdoor unit.

Electric Heating

1. R-W contacts close on the comfort control sending 24VAC to the W terminal on the fan relay. 24VAC is also sent to EHC to energize the heat relay.
2. R-G contacts close on the comfort control sending 24VAC to the G terminal on the fan relay. (The combination of 24VAC on terminals W and G on the fan relay will close the high speed contacts of the fan relay)
3. WJ contacts on the fan relay close providing an interlock circuit to allow the electric heat relays to operate

The comfort control must be setup to control R-G contacts with a call for electric heat. This closes the interlock circuit and allows the heat relay circuit to be energized.

Section 27. Checkout Procedures

27.1 Operational And Checkout Procedures

Final phases of this installation are the unit Operational and Checkout Procedures. To obtain proper performance, all units must be operated and charge adjustments made in accordance with procedures found in the Service Facts of the Outdoor Unit.

CHECKOUT PROCEDURE

After installation has been completed, it is recommended that the entire system be checked against the following list:

- | | |
|--|---|
| <ol style="list-style-type: none"> 1. Be sure unit suspension (if used) is secure and that there are no tools or loose debris in or around or on top of the unit. [] 2. Properly insulate suction lines and fittings. [] 3. Properly secure and isolate all refrigerant lines. [] 4. Verify that all electrical connections are tight. [] 5. Check all duct outlets; they must be open and unrestricted. [] 6. Check drain lines and be sure all joints are tight. [] 7. Be sure the return air filter is installed. [] | <ol style="list-style-type: none"> 8. Be sure that the correct airflow setting is used. (Indoor Blower Motor). [] 9. Operate complete system in each mode to verify proper performance. Verify operation of supplementary electric heater. [] 10. All braze connections have been checked for leaks. A vacuum of 350 microns provides confirmation that the refrigeration system is leak free and dry. [] 11. Refrigerant leak detection system mitigating actions are verified. [] 12. All refrigerant safety procedures have been verified. .. [] |
|--|---|

Section 28. Troubleshooting

Before starting, insure the blower wheel, indoor and outdoor coils are clean.

Troubleshooting Indoor TXV / Cooling Mode

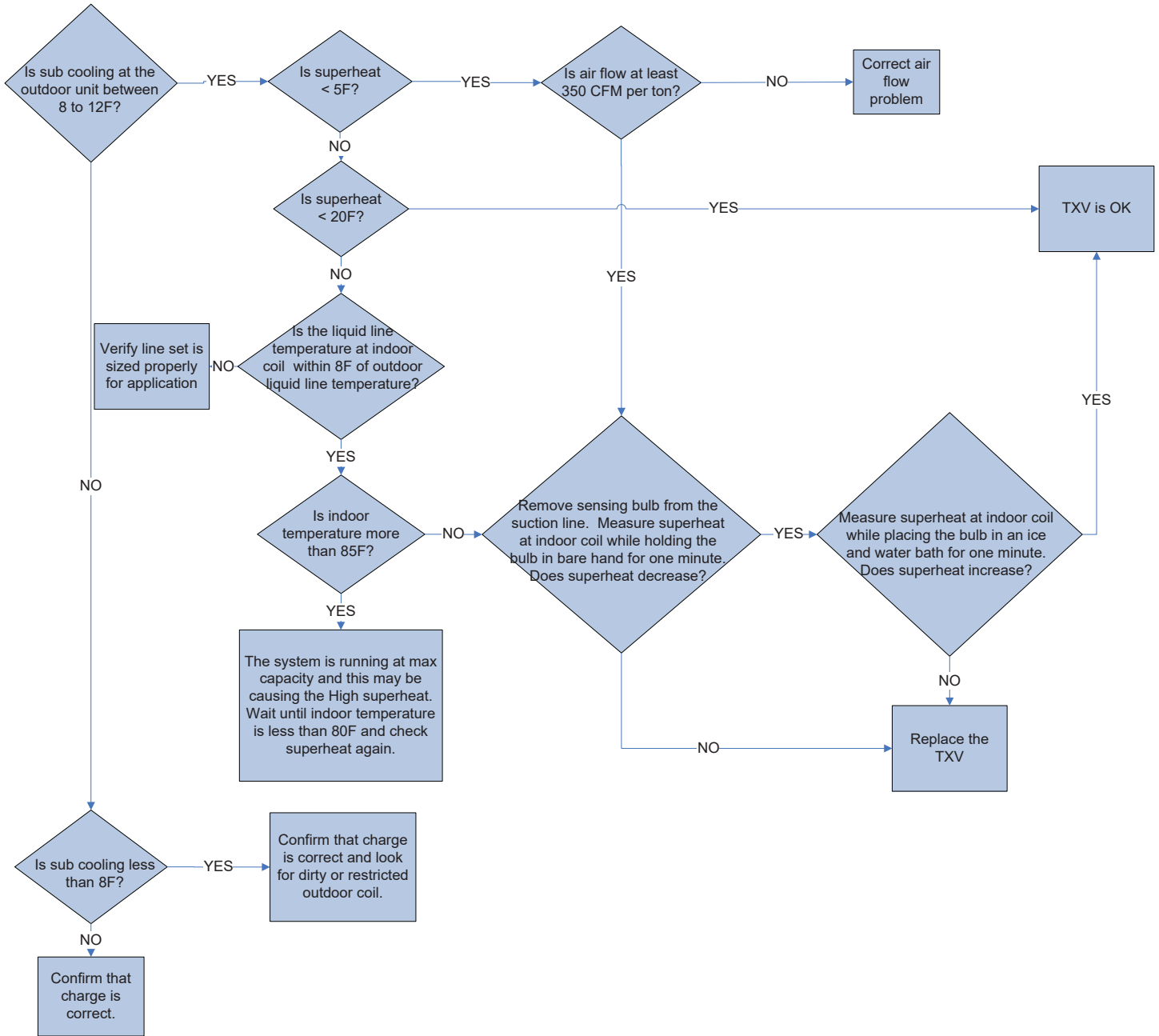

CONSTANT TORQUE MOTOR TROUBLESHOOTING FOR 5TAM5

Constant Torque Motor Troubleshooting

This terminal block is located on the motor. Look for labels below on the motor side of the connection.

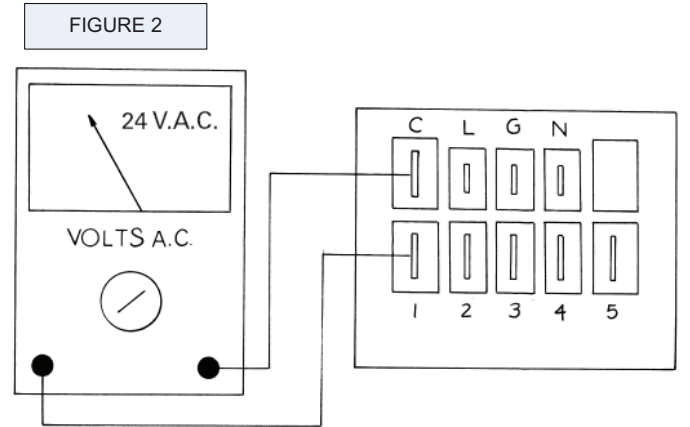
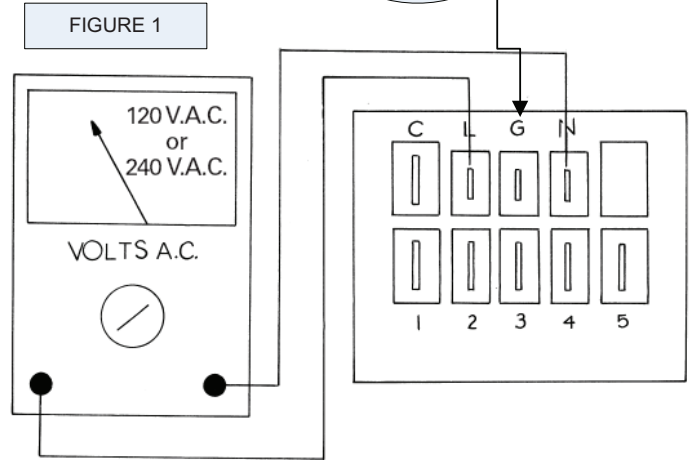
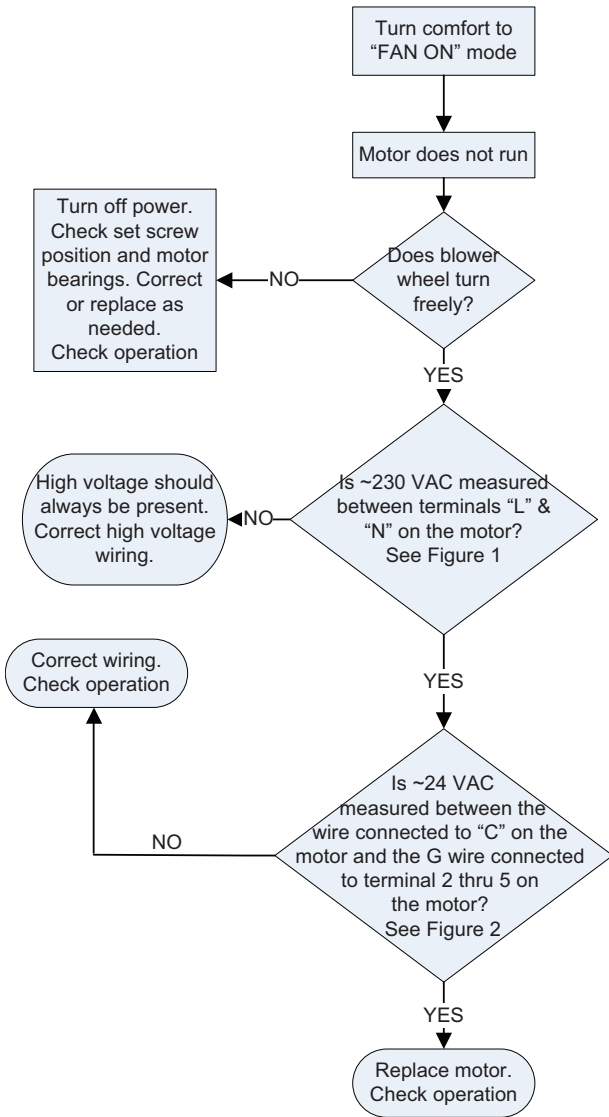

About Trane and American Standard Heating and Air Conditioning
 Trane and American Standard create comfortable, energy efficient indoor environments for residential applications.
 For more information, please visit www.trane.com or www.americanstandardair.com



The manufacturer has a policy of continuous data improvement and it reserves the right to change design and specifications without notice. We are committed to using environmentally conscious print practices.