

SEE UNIT NAMEPLATE FOR LINE VOLTAGE AND MAX FUSE SIZE

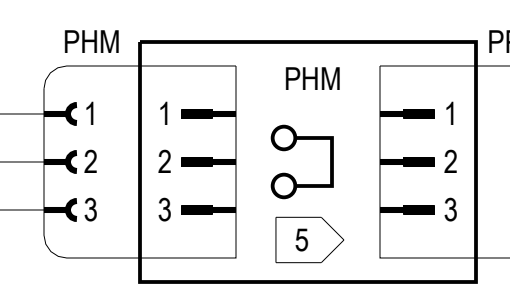

SEE CONTROL SCHEMATIC FOR REMAINDER OF PHM CIRCUIT 9

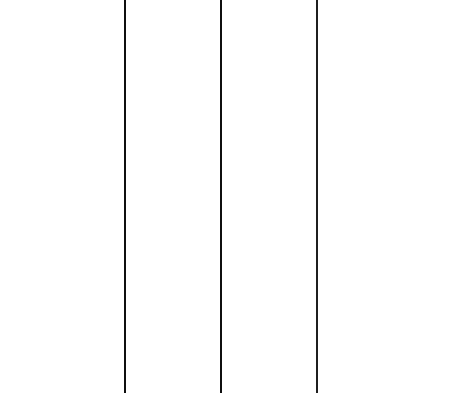
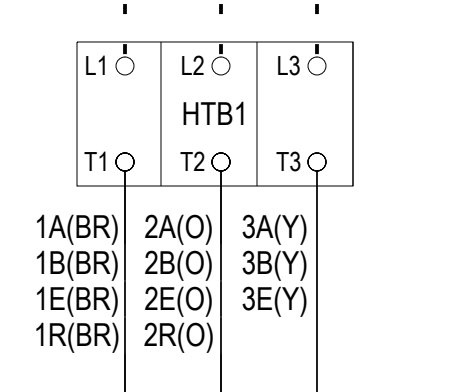
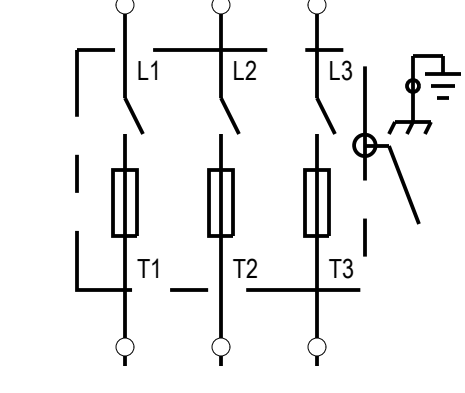
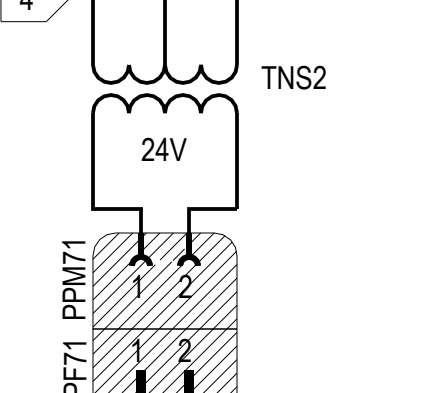
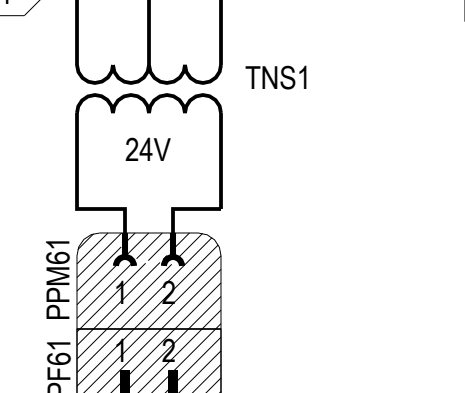
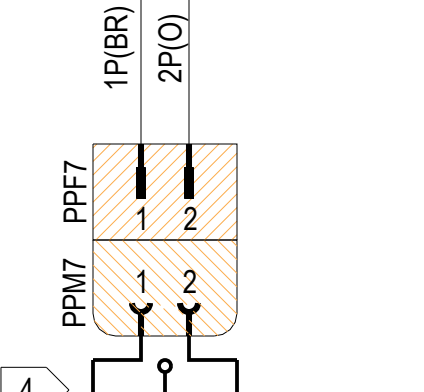
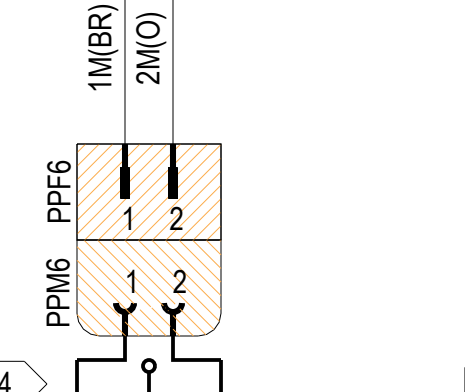
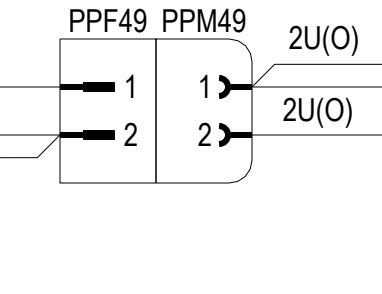
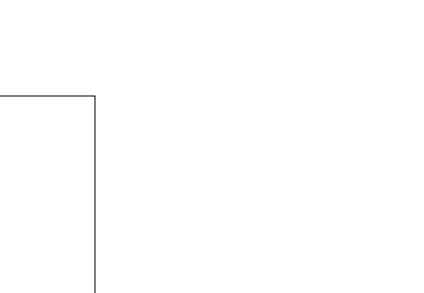
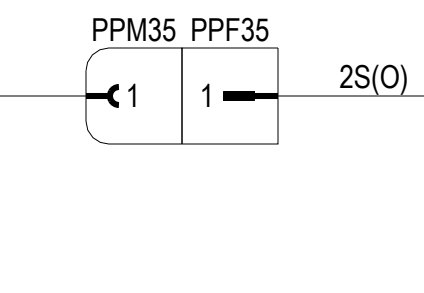
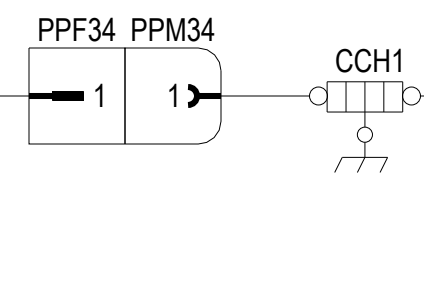
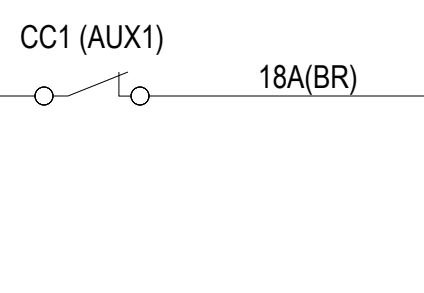
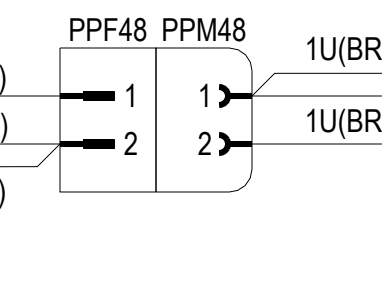
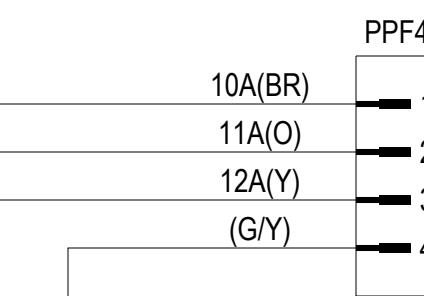
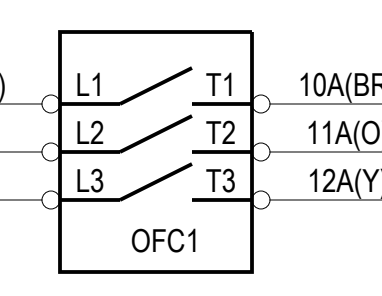
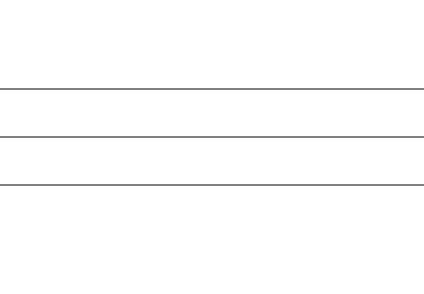
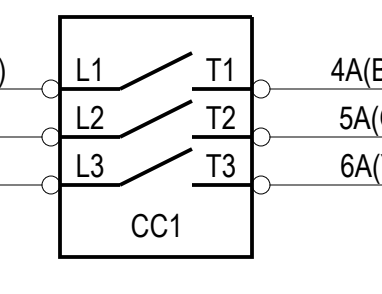

SEE CONTROL SCHEMATIC FOR REMAINDER OF TNS1 CIRCUIT

SEE CONTROL SCHEMATIC FOR REMAINDER OF TNS2 CIRCUIT

REF DES	DESCRIPTION	LINE NO
CC1	COMPRESSOR CONTACTOR 1	21
CC1 (AUX1)	CC1 AUX1 NC	41
CCH1	CRANCASE HEATER 1	41
CPR1	COMPRESSOR 1	21
HTB1	HIGH VOLTAGE TERMINAL BLOCK	7
ODM1	OUTDOOR MOTOR 1	31
OFC1	OUTDOOR FAN CONTACTOR 1	31
PHM	PHASE MONITOR	16
TNS1	TRANSFORMER 1	54
TNS2	TRANSFORMER 2	54

NOTES:

- UNLESS OTHERWISE NOTED, ALL SWITCHES ARE SHOWN AT 25 C (77 F), AT ATMOSPHERIC PRESSURE, AT 50% RELATIVE HUMIDITY, WITH ALL UTILITIES TURNED OFF, AND AFTER A NORMAL SHUTDOWN HAS OCCURRED
- DASHED LINES INDICATE RECOMMENDED FIELD WIRING BY OTHERS, DASHED LINE ENCLOSURES AND/OR DASHED DEVICE OUTLINES INDICATE COMPONENTS PROVIDED BY THE FIELD. PHANTOM LINE ENCLOSURES INDICATE ALTERNATE CIRCUITRY OR AVAILABLE SALES OPTIONS. SOLID LINE INDICATES WIRING BY TRANE CO.
- NUMBERS ALONG THE RIGHT SIDE OF THE SCHEMATIC DESIGNATE THE LOCATION OF CONTACTS BY LINE NUMBER. AN UNDERLINED NUMBER INDICATES A NORMALLY CLOSED CONTACT. AN OPEN ARROWHEAD BELOW THE LINE NUMBER POINTING UPWARD INDICATES A TIMED CONTACT WHICH BEGINS TIMING WHEN ENERGIZED
- CONNECTIONS SHOWN ARE FOR 230V/60HZ/3PH UNITS. FOR 208V/60HZ/3PH OPERATION, MOVE WIRE FROM 230V TERMINAL TO 208V TERMINAL ON UNIT TRANSFORMER(S) TNS1 AND TNS2 (IF PRESENT). FOR ALL OTHER VOLTAGES TRANSFORMERS ARE SINGLE TAP PRIMARY AND WILL BE SHIPPED FROM FACTORY WITH THE APPROPRIATE WIRING.
- CLIP PHM JUMPER WIRE FOR 50HZ OPERATION.
- CAUTION: DO NOT OPERATE OR APPLY POWER TO COMPRESSORS WHILE UNDER A VACUUM. FAILURE TO FOLLOW THESE INSTRUCTIONS WILL RESULT IN COMPRESSOR FAILURE.

CAUTION USE COPPER CONDUCTORS ONLY IN THIS DEGREE CELSIUS UNIT TERMINALS ARE NOT DESIGNED TO ACCEPT OTHER TYPES OF CONDUCTORS FAILURE TO DO SO MAY CAUSE DAMAGE TO THE EQUIPMENT.	ATTENTION UTILISER SEUL DES CONDUCTEURS EN CUivre! LES BORNES DE L'UNITÉ NE SONT PAS CONÇUES POUR RECEVOIR D'AUTRES TYPES DE CONDUCTEURS. L'UTILISATION DE TOUT AUTRE CONDUCTEUR PEUT ENDOMMAGER L'EQUIPEMENT.	PRECAUCIÓN ¡UTILICE ÚNICAMENTE CONDUCTORES DE COBRE! LAS TERMINALES DE LA UNIDAD NO ESTÁN DISEÑADAS PARA ACEPTAR OTROS TIPOS DE CONDUCTORES. SI NO LO HACE, PUEDE OCASIONAR DAÑO AL EQUIPO.
---	--	---

WARNING HAZARDOUS VOLTAGE! DISCONNECT ALL ELECTRIC POWER INCLUDING REMOTE DISCONNECTS AND FOLLOW LOCK OUT AND TAG PROCEDURES BEFORE SERVICING. INSURE THAT ALL MOTOR CAPACITORS HAVE DISCHARGED STORED VOLTAGE. UNITS WITH VARIABLE SPEED DRIVE, REFER TO DRIVE INSTRUCTIONS FOR CAPACITOR DISCHARGE. FAILURE TO DO THE ABOVE BEFORE SERVICING COULD RESULT IN DEATH OR SERIOUS INJURY.	AVERTISSEMENT TENSION DANGEREUSE! COUPER TOUTES LES TENSIONS ET OUVRIR LES SECTIONNEURS A DISTANCE. PUIS SUIVRE LES PROCEDURES DE VERROUILLAGE ET DES ETIQUETTES AVANT TOUTE INTERVENTION. VERIFIER QUE TOUTS LES CONDENSATEURS DES MOTEURS SONT DECHARGES. DANS LE CAS D'UNITES A VITESSE VARIABLE SE REPORTER AUX INSTRUCTIONS DE L'ENTRAÎNEMENT POUR DECHARGER LES CONDENSATEURS. NE PAS RESPECTER CES MESURES DE PRECAUTION PEUT ENTRAÎNER DES BLESSURES GRAVES POUVANT ETRE MORTELLES.	ADVERTENCIA ¡VOLTAJE PELIGROSO! DESCONECTE TODA LA ENERGIA ELECTRICA INCLUSO LAS DESCONEXIONES REMOTAS Y SIGA LOS PROCEDIMIENTOS DE ETIQUETADO ANTES DE PROCEDER AL SERVICIO. ASEGURESE DE QUE TODOS LOS CAPACITORES DEL MOTOR HAYAN DESCARGADO EL VOLTAJE ALMACENADO. PARA LAS UNIDADES CON EJE DE DIRECCION DE VELOCIDAD VARIABLE CONSULTE LAS INSTRUCCIONES PARA LA DESCARGA DEL CONDENSADOR. EL NO REALIZARLO ANTERIORMENTE INDICADO, PODRIA OCASIONAR LA MUERTE O SERIAS LESIONES PERSONALES.
---	---	--

WIRE COLOR ABBREVIATION CODES			
CODE	COLOR	CODE	COLOR
BK	BLACK	PK	PINK
BL	BLUE	R	RED
BR	BROWN	TQ	TURQUOISE
G	GREEN	V(PRI)	PURPLE
GY	GREEN/YELLOW	W	WHITE
O	ORANGE	Y	YELLOW

DESIGNER: RAM R
ENGINEER: SANJUNATH S
TRANE © DATE: 19-JUL-2023
REPLACES:
SIMILAR TO:
REVISION DATE:
REVISED BY:
APPROVED BY: SANJUNATH S
CAD SYSTEM USED: CREO SCHEMATICS

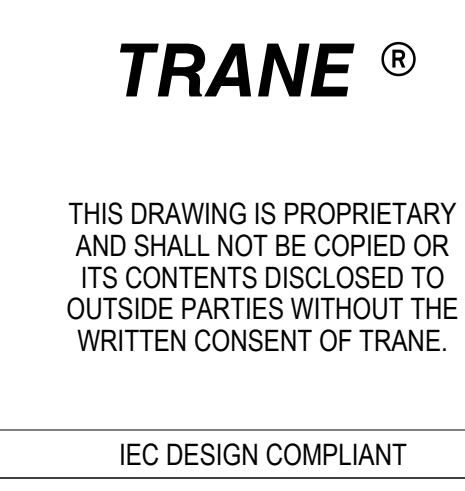

ODYSSEY SCHEMATIC			
POWER, COOLING CONDENSER/HEAT PUMP SINGLE COMPRESSOR SINGLE FAN			
MASTER NUMBER:	DRAWING NUMBER:	SHEET:	REV
	12134780	1 OF 2	A