



High-efficiency Terminal Products

Single-zone VAV Solutions



Trane Family of Terminal Products

It's time to take another look at the terminal. As your partner, Trane® understands it takes more than a concept to design an effective HVAC system. Between cost and code compliance—not to mention comfort, acoustics and efficiency—the complicated priorities can be challenging to satisfy.

The Trane family of terminal products has been redesigned from the inside out, with innovative high-efficiency upgrades guaranteed to fulfill virtually any building's requirements without compromising your needs. Now, these terminal units come standard with an exclusive Trane electronically commutated motor (ECM)—an industry first. Integrated with the industry's first factory programmed variable speed controller, the single-zone variable air volume (VAV) solution improves efficiency by up to 66 percent compared to other motor options.

Single-source solution

From chillers to compressors, the complete line of variable speed Trane HVAC solutions are designed to work together to deliver exceptional performance and value. These high-efficiency systems with flexible configurations can be the perfect fit for your building.

Fan Coil

A Trane® UniTrane® fan coil is an in-room unit composed of a fan and chilled or hot water coils. Trane also offers vertical units specifically intended for high-rise applications. Fan coil units are ideal for hotels, condominiums, dormitories and apartments. Trane® Force-Flo® cabinet heaters are high-capacity forced-air fan coil units for entryways and corridors in large office buildings, schools, hospitals and dormitories.



Unit Ventilators

Trane unit ventilator operates on the same principles as the fan coil but is tailored specifically for schools with a sturdy institutional design and an integrated airside economizer. Our unit ventilator units are an especially effective solution for K-12 classroom renovation projects.



Blower Coils

A Trane blower coil is an entry level air handler for chilled water or refrigeration systems with ducted air distribution. Applications include schools, hospitals, offices, retail stores and stadiums.





Single-zone VAV System

Single-zone variable air volume (VAV) is a high-efficiency system in which the motor speed and air volume automatically adjust in response to a space's needs. Those spaces—in which occupancy varies—include classrooms, office buildings, gymnasiums, dormitories and barracks.

Single-zone VAV offers substantial operating savings over a constant volume system because a high-efficiency motor-driven variable fan speed can be the most energy-efficient way to address partial load conditions. Single-zone VAV lowers operating costs because of the efficiency gains that come from the ability to operate at low speeds for partial loads.

A single-zone VAV system can improve comfort for building occupants through:

Temperature stability variable speed technology gradually changes fan speed, which reduces temperature swings.

Quiet operation variable speed units run at the lowest fan speed necessary and move up and down slowly between speeds. This soft ramp capability means fewer audible changes and a substantial 5-to-8-decibel reduction in system noise.

Dehumidification operating at lower speeds for more time improves dehumidification, a key factor in IAQ and comfort.

Trane® ECM terminal units integrated with the Symbio 400-B unit controller offers the only factory-commissioned single-zone VAV solution in the industry.

Building Life

Trane knows that careful attention to the unique needs of a building can improve life of the equipment, controls and the HVAC systems.

This solutions-oriented commitment to delivering exceptional performance fosters an environment that has a positive impact on the lives of the people within it.

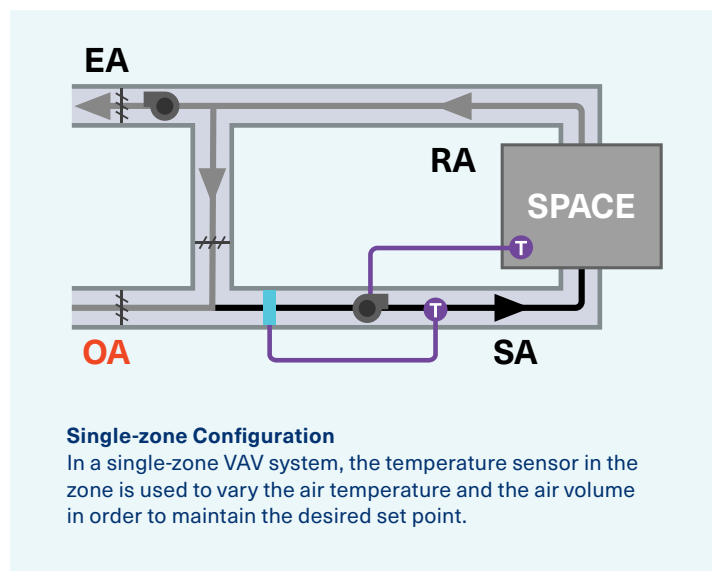



Terminal Transformed

Terminal units shouldn't be an industry afterthought. Trane® understands these are critical system components, with special consideration given to every design and technical specification to transform our family of terminal solutions into a high-performing driver for your building's efficiency. Whether you're concerned with occupant comfort or system design, Trane can work with you to find the right solution.

Innovations in ECM

Terminal products were updated from conventional permanent split capacitor (PSC) motors to our exclusive new electronically commutated motor (ECM), making Trane the only manufacturer currently offering environmental conditioning systems (ECSs) as standard technology on all terminal products.

Trane ECMs ...	Giving you ...
Have sealed bearings and completely enclosed construction	Extended motor life and lower maintenance costs over the life of the system
Optimize performance at every speed	Dramatically enhanced efficiency, with energy savings up to 66 percent
Have fewer moving parts and are much more reliable	Lower maintenance systems with lower total cost of ownership
Are 30 percent smaller	Less restricted air flow

Real-time Feedback

VelociTach™ is our ECM control board that features a Trane exclusive LED screen to provide real-time feedback to installers and maintenance staff. This eliminates the inconvenience of using a separate service tool.

Single-zone VAV

Trane terminal ECM units integrated with the Symbio 400-B unit controller are the industry's first factory-commissioned single-zone VAV solution, with automated and optimized motor speed adjustments to meet a space's heating or cooling needs.

Control Board Benefits

Enhances serviceability and improves response time for maintenance staff.

Allows maintenance to monitor performance and maximize efficiency.

Eliminates cost of additional computer hardware and software.

Reduces the time needed to balance the unit during installation.

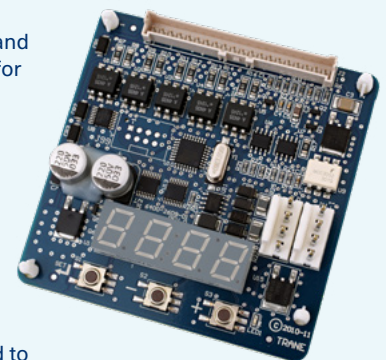



Terminal Transformed

Trane® developed innovative control algorithms that maximize the performance and efficiency for each of the units under all operating conditions.

Only Trane terminal products are available with factory mounted, wired and programmed Symbio® unit controllers, providing unmatched system integration and performance optimization.

Flexible Connectivity

High-efficiency terminal products—unlike competitive offerings—allow for building connectivity through multiple control options. Preprogrammed controls with factory addressed Air-Fi wireless can offer plug-and-play connectivity, as well as individual guest control.

Symbio 400-B Unit Controller

The Symbio 400-B single-zone VAV controller maximizes fan speed while reducing energy consumption by delivering only the airflow necessary to address the space load.

This programmable controller's functions include:

- Random start
- Warm-up, pre-cool
- Freeze avoidance
- Built-in dehumidification
- Auto fan speed adjustment
- Discharge air temperature control

Controlled Costs

The lowest total cost of ownership in the industry makes the new Trane high-efficiency terminal units a value-added asset to any building's HVAC system.

Separation Innovation

We separated the Trane ECM from the VelociTach™ motor control board, and added an LED display and manual interface.

This delivers the convenience of a visual status report and the ease of push button adjustments, facilitating optimal performance and simplifying serviceability.

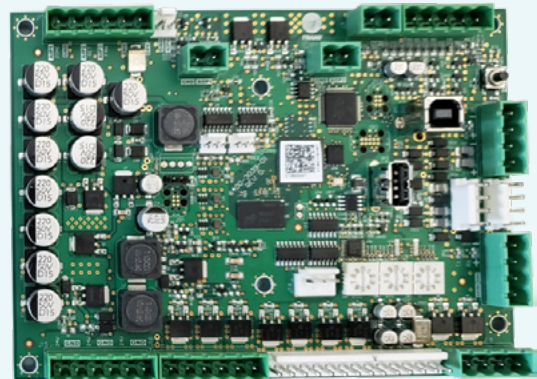

Symbio 400-B Unit Controller



Understanding the Upgrades

The terminal products upgrade is more revolution than redesign. Rather than incremental improvements, we took a technological leap forward and elevated the industry standard for this product class.

We leveraged the synergy of the new technology suite to produce dramatic improvements in ease of installation, cost of ownership, acoustics and temperature control.

Streamlined Installation

Units, unit controls and piping packages are installed, configured and tested during assembly. A factory commissioned system makes the job-site installation a streamlined plug-and-play process and ensures long-term trouble-free operation.

Quiet Operation

Soft ramp technology slowly ramps motor speeds up and down to address the space load and eliminates the distracting noise associated with units turning on and off. And because the moderated air flow achieves the same comfort levels as running at full capacity, variable units are 5 to 8 decibels quieter than traditional three-speed models.

Continuous Comfort

Innovative tempering algorithms in Symbio 400-B unit controllers eliminate the typical temperature variations that cause occupants discomfort. This discharge air temperature control means your space reached the desired set point more quickly and the temperature maintenance is more stable.

Superior Performance

ECM is a high-efficiency programmable motor technology. Motors require less maintenance, are more reliable and have longer service life. They can be performance optimized at any speed, dramatically increasing energy efficiency over conventional three-speed PSC motors.

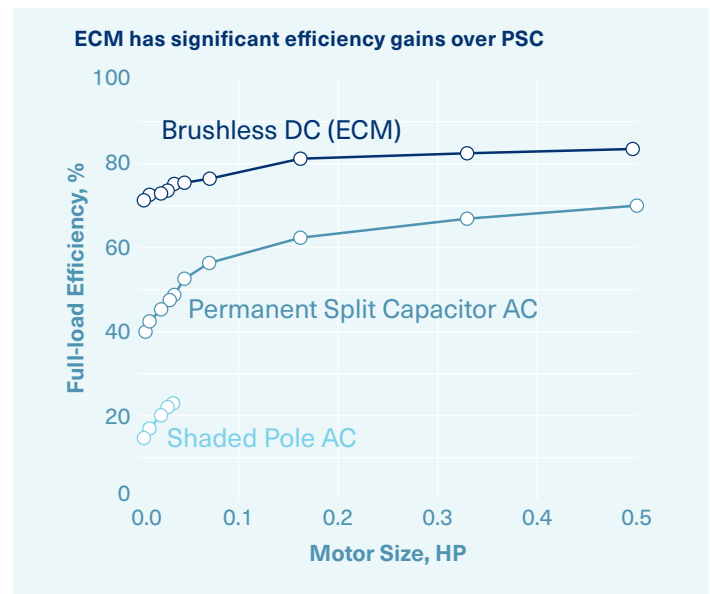

No Compromise Solution

The features you want. The technology you need.

Trane® asked customers what they need in a terminal unit. Then we built their feedback into the new designs. The result is a flexible line of high-efficiency solutions that meet all of your new construction and renovation needs. No compromise necessary.

	Total Cost of Ownership	Efficiency	Serviceability	Flexibility	Acoustics	Comfort	Trane Exclusive
ECM Standard	●	●	●	●	●	●	●
Advanced Controls		●	●	●	●	●	●
Plug & Play	●						●
Soft Ramp	●	●		●	●		
Discharge Air Temperature Control	●	●				●	●
Real-time Feedback				●			●
Reduced FLA				●			●

Universal Compatibility

Trane terminal units offer flexible solutions for variable speed operation through compatibility with existing thermostats and controllers.

The open communication protocol of the Symbio 400-B unit controller supports seamless integration at the building system or equipment level through BACnet communication.

With a smart controls retrofit solution, there are no limits to what Trane can do for you.

Trane Select Assist

High-efficiency terminal products are now available through Trane Select Assist. This web-based program improves efficiency and accuracy in your selection process, and enhanced outputs and reports are intuitive and easy to read. With just a few clicks, the program's guided selections eliminate time spent setting common fields across multiple units.

Trusted Partners

Your new Trane system is built on a foundation of expertise earned with a century of hard work. We bring commitment to industry leadership, product innovation and superior performance, and we are focused on providing comprehensive solutions you can count on.

Learn more at trane.com/terminalunits



TRANE

Trane – by Trane Technologies (NYSE: TT), a global climate innovator – creates comfortable, energy efficient indoor environments through a broad portfolio of heating, ventilating and air conditioning systems and controls, services, parts and supply. For more information, please visit trane.com or tranetechnologies.com.

All trademarks referenced in this document are the trademarks of their respective owners.

© Trane. All Rights Reserved.

UNT-SLB030-EN
01/11/2024