



Trane[®] Intelligent VAV Systems

Self Contained Applications: Improved efficiency and more advanced control.

**Human-centric.
Planet-friendly.
Technology-driven.**

Trane Intelligent VAV systems combine modern Tracer® controls, our latest water-cooled self-contained SWUD units with higher efficiency ratings, and variable air volume boxes. New technologies deliver both personalized comfort and building decarbonization.

Today's VAV is a planet-friendly way to deliver targeted zoned comfort to every part of the building. Intelligent systems control the temperature and indoor air quality for multiple zones from one or more large, self-contained units per floor. Inside, VAV boxes that serve multiple zones can provide cooling and heating as needed.

Complicated? Not at all. Everything from equipment to controls is part of our pre-packaged solution. Trane's system design support and in-factory programming ensure that everything works together on arrival to deliver spot-on comfort while making sure every kilowatt of consumed energy counts.

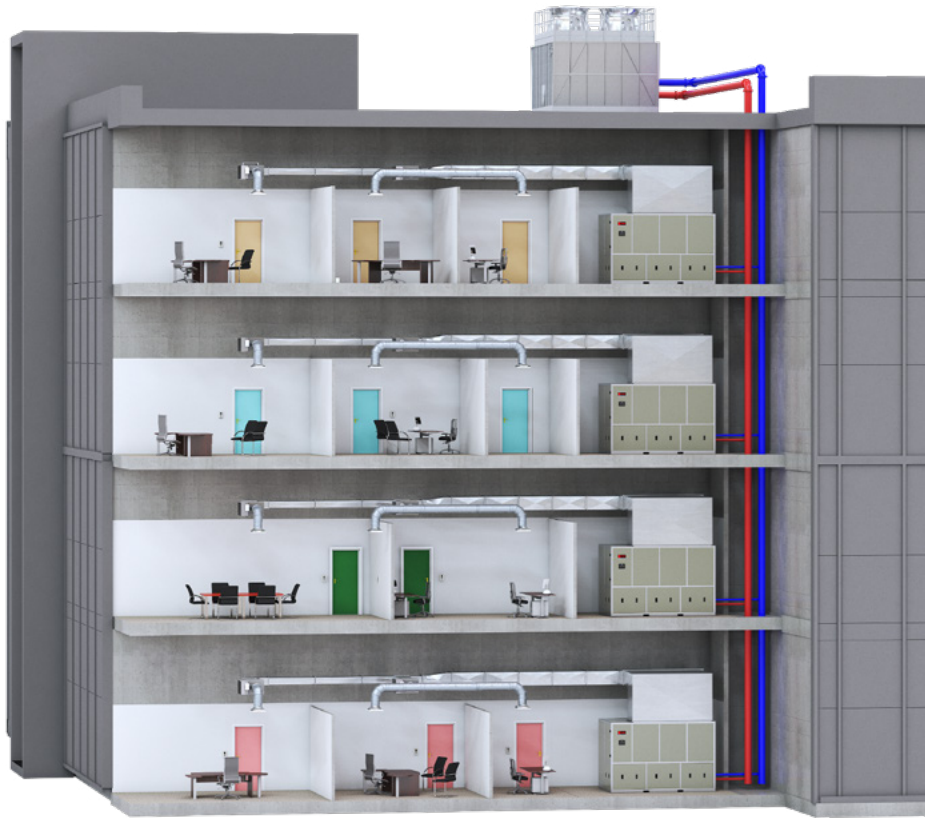

State-of-the-art indoor air quality and comfort.

Surpass higher expectations for commercial buildings. Intelligent VAV systems capably control the temperature and humidity in multiple zones, even when they have dissimilar cooling and heating requirements.



Control comfort dynamically and responsibly.

"Intelligent" VAV means systems use dynamic building strategies to deliver the right temperature to the right spaces, while operating in energy-saving mode when people are not present.



More power to occupants, less work for facility staff.

Trane controls provide owners and operators the option to empower tenants and occupants to report issues, adjust comfort settings, and request after-hours access directly—without involving the busy facility management team. The application can send invoices for building use outside of normal billing hours. The flexibility of the application puts the facility team in control of how they manage their buildings.



Keep the sound level low.

Unlike systems which place noisy equipment in or near the occupied space, water-cooled self-contained SWUD units can be located away from sound-sensitive areas in mechanical rooms that are attenuated. They feature 1" foam-injected double-wall panels and standard ECM fans that modulate speed to deliver the right amount of air to the system while reducing sound levels & operating cost. VAV terminal units are available with integral sound attenuators and variable speed fans for improved acoustical performance near occupied spaces.



Indoor air feels fresh and clean.

With a wide variety of filter options, from MERV 8 to 13 filters, 2 to 6-inch alternatives, SWUD units deliver high indoor air quality while operating unobtrusively in the background.



Adapt to changing spaces

Air-Fi® wireless controls are the Trane standard choice for Intelligent VAV systems communication media because it is reliable and flexible. Redundant communication paths are created via a wireless mesh network and signal range is twice that of other systems creating four times the potential paths for message transmission. Since you're not tied down by wires, Trane Air-Fi wireless lets you easily expand or change your space whenever or wherever you need—while also minimizing occupant disruption.



Bring the right amount of outdoor air in.

A SWUD system integrated with VAV boxes can be coupled with a DOAS unit or energy recovery unit to provide outside air to comply with ASHRAE 62.1.

Decarbonize through electrification and energy efficiency.

Achieve regulatory compliance and elevate sustainability standards. By standardizing control routines, Trane simplifies code compliance. Factory programming accommodates specialized needs, too.

Electrify heating and benefit from a clean-energy grid.

Systems can be designed as all-electric to eliminate emissions from fossil fuel heating methods.

Highly efficient systems.

Next-gen self-contained SWUD units provide high efficiency (up to 22.8 IEER) and cost effectiveness with pre-packaged, factory-installed controls. Trane's redesigned SWUD delivers improved full-load efficiency on average 30% higher than our legacy units. Because it's a single-piece unit with straightforward installation, you'll save on first costs. Over its lifetime, features such as double-wall foam-insulated panel construction, waterside economizer, fan wall with ECM motors and factory-installed Symbio® 500 controller enable you to save on energy costs well into the future.

Use data as a decision tool.

Current-generation Tracer® controls enable more data points, improving remote monitoring and providing greater input for energy trend analysis.

Use the lowest amount of energy possible.

Controls are factory-programmed allowing the use of ASHRAE Guideline 36 sequences. Trim and respond control methods ensure Intelligent VAV systems use the energy minimum to maintain a super-comfortable environment.

Get more from the latest advancements.

Energy recovery, staged and variable speed compressors help lower energy use, energy cost, and emissions. Centralized fans deliver ventilation and conditioned air. Variable speed fans on fan-powered VAV units further reduce the system's energy use while keeping sound levels low.

Intelligent system design delivers efficiency improvements of 20 to 30% compared to other systems.

Packaged Performance.

Intelligent VAV Systems are all-inclusive. Equipment components feature factory-installed, Trane-programmed controls.



Water-Cooled Self-Contained SWUD Unit

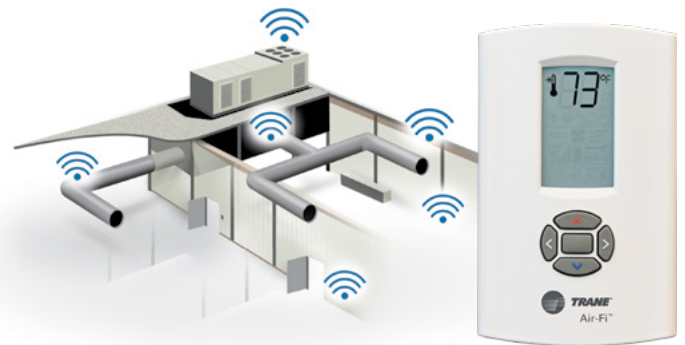

Zone Temperature Sensors

Air-Fi® Wireless Communication (*Wired communication also available*)

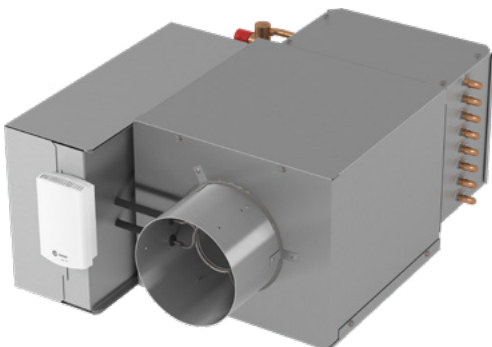

VariTrane™ VAV Terminal Units

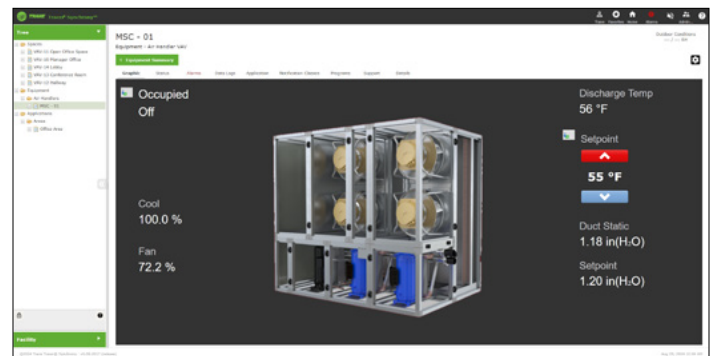

Tracer® System Controller includes standard, pre-programmed applications with optimized control sequences. User-friendly interface, energy dashboards, mobile access and more.

Updating an existing system?

Use existing ductwork and upgrade easily with retrofit dampers, new controls and Air-Fi Wireless Communication.

Need a replacement unit?

Our Modular Self-Contained line is designed for fast assembly and quick over-the-weekend changeouts.

Key components of the system are engineered cassettes for easy shipping and transport, think building blocks. Once everything arrives, the system is assembled and commissioned in the mechanical room – fast. So the system can be back up and running within a 48-hour period.

Each cassette fits through standard doorways and freight elevators, and are easily moved throughout the building using hand trucks. The modular unit footprint is as small or smaller than the being replaced. Options to break down the evaporator cassette and coil are also available.

Visit trane.com/intelligent-vav to learn more.



Trane – by Trane Technologies (NYSE: TT), a global climate innovator – creates comfortable, energy efficient indoor environments through a broad portfolio of heating, ventilating and air conditioning systems and controls, services, parts and supply. For more information, please visit trane.com or tranetechnologies.com.

All trademarks referenced in this document are the trademarks of their respective owners.

© 2024 Trane. All Rights Reserved.

SYS-SLB040-EN
08/29/2024