



Product Data

Combination Zone Sensors

Data Sheet



SAFETY WARNING

Only qualified personnel should install and service the equipment. The installation, starting up, and servicing of heating, ventilating, and air-conditioning equipment can be hazardous and requires specific knowledge and training. Improperly installed, adjusted or altered equipment by an unqualified person could result in death or serious injury. When working on the equipment, observe all precautions in the literature and on the tags, stickers, and labels that are attached to the equipment.



Trademarks

All trademarks referenced in this document are the trademarks of their respective owners.

Overview

Trane® relative humidity and temperature sensors utilize a polymer capacitive-sensing element for reliable sensing accuracy and superb recovery from saturation. Temperature output is provided by a 10 kΩ Type II thermistor. Both sensors are housed in a common enclosure for reduced installation costs and improved appearance.

Features, Benefits, and Part Number

Features	Benefits
Two sensors in one enclosure	Reduces installation costs and improved building aesthetics
High accuracy	Reduces energy costs and improves environmental control and comfort
Maintenance-free design	Reduces field calibration and maintenance costs
Polymer capacitive element	Superb recovery from saturation reduces maintenance and downtime
Trane wall enclosure	Consistent enclosure design improves building aesthetics

Model Description		Part Number	BAYSENS	Global Parts
Sensors	3% Relative Humidity and Temperature	X1379044401	BAYSENS036A	SEN01561

Specifications

Description	
Sensor operating temperature	From -20°F to 140°F (-29°C to 60°C)
Storage temperature	From -85°F to 158°F (-65°C to 70°C)
Operating humidity range	From -40°F to 185°F (-40°C to 85°C)
Storage/operating humidity range	99% relative humidity (RH), noncondensing
Accuracy	±3% RH over 20% to 95% RH at 77°F (25°C) and includes hysteresis, linearity, and repeatability
Hysteresis	Less than 1% RH
Repeatability	0.5% RH
Sensitivity	0.1% RH
Thermistor resistance	10 kΩ at 77°F
Temperature accuracy	±0.36°F (±0.2°C)
Supply voltage	18 to 36 Vdc
Output characteristics	4-20 mA for 0% to 100% RH
Drift rate	Less than 1% per year
Sensing element	Polymer capacitive
Mounting	Fits a standard 2 in. by 4 in. junction box (vertical mount only). Mounting holes are spaced 3.2 in. (83 mm) apart on vertical center line. Includes mounting screws for junction box or wall anchors for sheetrock walls. Overall dimensions: 2.9 in. (74 mm) by 4.7 in. (119 mm)

Schematic (Typical)

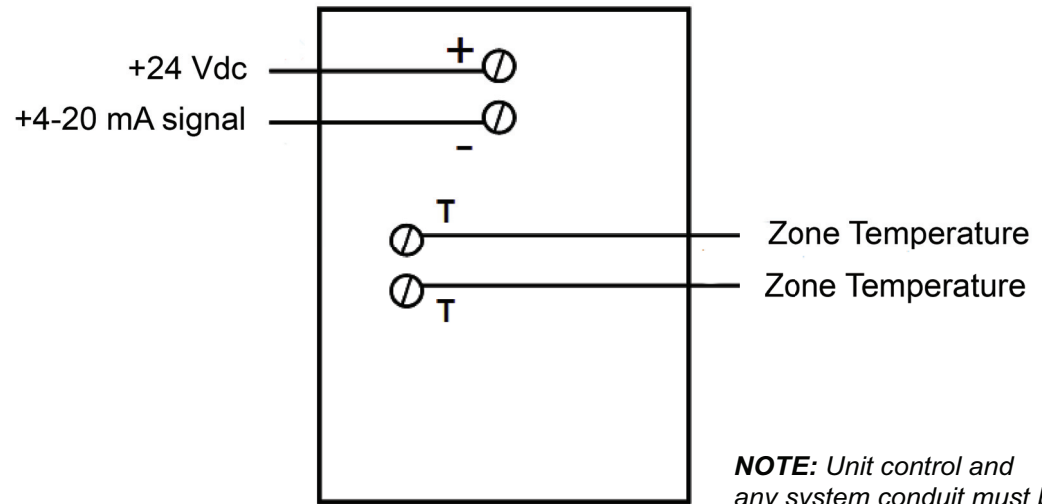

NOTE: Unit control and any system conduit must be properly grounded.

Trane - by Trane Technologies (NYSE: TT), a global climate innovator - creates comfortable, energy efficient indoor environments for commercial and residential applications. For more information, please visit trane.com or tranetechnologies.com.

Trane has a policy of continuous product and product data improvement and reserves the right to change design and specifications without notice. We are committed to using environmentally conscious print practices.