



Quick Reference Guide

Water Source Heat Pump Axiom™
High Efficiency 0.75 to 6 Tons – EXHG/EXVG
Two Stage High Efficiency 2 to 6 Tons – DXHG/DXVG



June 2023

WSHP-PRC030D-EN
©2023 Trane



1 Copyright

This document and the information in it are the property of Trane, and may not be used or reproduced in whole or in part without written permission. Trane reserves the right to revise this publication at any time, and to make changes to its content without obligation to notify any person of such revision or change.

Trademarks

All trademarks referenced in this document are the trademarks of their respective owners.

Revision History

Added Symbio™ 400-B to the table 1 List of options.

Table 1. List of options

Factory Installed Options	Field Installed Options
1-inch or 2-inch Ducted Filter Rack	2-inch or 4-inch Ducted Filter Rack
Air-F [®] Wireless Communications	Ducted Panel
Deluxe 24V, Symbio™ 400-B/UC400-B Controls	Hose Kits (or ship separate hoses and valves)
Factory-mounted Isolation Valve	Low, Medium and High Electric Heat
Hot Gas Reheat	Pump Module
Matte or Foil Face Insulation	Pump Module Hose Kit
MERV 8 or 13 Filters	Thermostats or Zone Sensors
Polymer or Stainless Steel IAQ Drain Pan	Waterside Economizer
Recessed Unit Mounted Disconnect Switch	
Standard or Deluxe Sound Package	

2

Table 2. General data - models EXHG009-024

Model EXHG	009	012	015	018	024
Unit size width x depth x height (in.)	25.5 x 46 x 17.75	25.5 x 46 x 17.75	25.5 x 49 x 18.75	25.5 x 55 x 19.75	25.5 x 55 x 19.75
Compressor type	Rotary	Rotary	Rotary	Rotary	Scroll
Net weight (lbs.)	173	173	173	269	269
Ship weight (lbs.)	297	297	297	393	393
Filter size nominal (in.)	16 x 19	17 x 19	17 x 20	18 x 23	19 x 23
Water in/out size (FPT)	1/2	1/2	1/2	3/4	3/4
Condensate size (NPTI)	3/4	3/4	3/4	3/4	3/4
Blower wheel Size (in.)	9 x 8	9 x 8	10 x 8	10 x 9	10 x 9

Table 3. General data - models EXHG030-070

Model EXHG	030	036	042	048	060	070
Unit size width x depth x height (in.)	28 x 68 x 21.75	28 x 68 x 21.75	29.38 x 77.75 x 22.13	29.38 x 77.75 x 22.13	29.38 x 86.75 x 22.13	29.38 x 86.75 x 22.13
Compressor type	Scroll	Scroll	Scroll	Scroll	Scroll	Scroll
Net weight (lbs.)	313	313	381	381	434	434
Ship weight (lbs.)	458	458	560	560	613	613
Filter size nominal (in.)	20 x 30	20 x 30	20 x 20 (qty-2)	20 x 20 (qty-2)	30 x 20 20 x 20	30 x 20 20 x 20
Water in/out size (FPT)	3/4	3/4	1.00	1.00	1.00	1.00
Condensate size (NPTI)	3/4	3/4	3/4	3/4	3/4	3/4
Blower wheel Size (in.)	11 x 11	11 x 11	11 x 11	11 x 11	11 x 11	11 x 11

Table 4. General data - models EXVG009-030

Model EXVG	009	012	015	018	024	030
Unit size width x depth x height (in.)	21.5 x 21.5 x 34	21.5 x 21.5 x 34	21.5 x 23 x 36	21.5 x 26 x 38	21.5 x 26 x 38	24 x 32.5 x 42
Compressor type	Rotary	Rotary	Rotary	Rotary	Scroll	Scroll
Net weight (lbs.)	152	152	188	222	236	280
Ship weight (lbs.)	207	207	246	282	296	343
Filter size nominal (in.)	16 X 19	16 X 19	17 X 20	18 X 23	18 X 23	20 X 30
Water in/out size (FPT)	0.50	0.50	0.75	0.75	0.75	1.00

3

Table 4. General data - models EXVG009-030 (continued)

Model EXVG	009	012	015	018	024	030
Condensate size (NPTI)	0.75	0.75	0.75	0.75	0.75	0.75
Blower wheel Size (in.)	9 x 8	9 x 8	10 x 8	10 x 9	10 x 9	11 x 11

Table 5. General data - models EXVG036-070

Model EXVG	036	042	048	060	070
Unit size width x depth x height (in.)	24 x 32.5 x 42	25.4 x 32.5 x 49	25.4 x 32.5 x 49	25.4 x 32.5 x 55	25.4 x 32.5 x 55
Compressor type	Scroll	Scroll	Scroll	Scroll	Scroll
Net weight (lbs.)	281	329	345	367	432
Ship weight (lbs.)	344	394	410	436	501
Filter size nominal (in.)	20 X 30	27 X 30	27 X 30	30 X 33	30 X 33
Water in/out size (FPT)	1.00	1.00	1.00	1.00	1.00
Condensate size (NPTI)	0.75	0.75	0.75	0.75	0.75
Blower wheel Size (in.)	11 x 11	11 x 11	11 x 11	11 x 11	11 x 11

Table 6. General data - models DXHG024-070

Model DXHG	024	036	048	060	070
Unit size width x depth x height (in.)	25.5 x 55 x 19.75	28 x 68 x 21.75	29.38 x 77.75 x 22.13	29.38 x 86.75 x 22.13	29.38 x 86.75 x 22.13
Compressor type	Two-Stage Scroll	Two-Stage Scroll	Two-Stage Scroll	Two-Stage Scroll	Two-Stage Scroll
Net weight (lbs.)	269	313	381	434	434
Ship weight (lbs.)	393	458	560	613	613
Filter size nominal (in.)	18 x 23	20 x 30	20 x 20 (qty-2)	30 x 20 20 x 20	30 x 20 20 x 20
Water in/out size (FPT)	3/4	3/4	1.00	1.00	1.00
Condensate size (NPTI)	3/4	3/4	3/4	3/4	3/4
Blower wheel Size (in.)	10 x 9	11 x 11	11 x 11	11 x 11	11 x 11

4

Table 7. General data - models DXVG024-070

Model DXVG	024	036	048	060	070
Unit size width x depth x height (in.)	21.5 x 26 x 38	24 x 32.5 x 42	25.4 x 32.5 x 49	25.4 x 32.5 x 55	25.4 x 32.5 x 55
Compressor type	Two-Stage Scroll	Two-Stage Scroll	Two-Stage Scroll	Two-Stage Scroll	Two-Stage Scroll
Net weight (lbs.)	236	279	354	371	437
Ship weight (lbs.)	296	342	419	440	506
Filter size nominal (in.)	18 x 23	23 x 30	27 x 30	30 x 33	30 x 33
Water in/out size (FPT)	0.75	1.00	1.00	1.00	1.00
Condensate size (NPTI)	0.75	0.75	0.75	0.75	0.75
Blower wheel Size (in.)	10 x 9	11 x 11	11 x 11	11 x 11	11 x 11

Table 8. ANSI/AHRI/ASHRAE/ISO13256-1 WLHP, GWHP and GLHP performance - 0.75 to 6 tons

Model	Rated GPM	Rated CFM	Water Loop Heat Pump				Ground Water Heat Pump				Ground Loop Heat Pump			
			Cooling 86°F		Heating 68°F		Cooling 59°F		Heating 50°F		Full Cool 77°F		Full Heat 32°F	
			Capacity Btuh	EER	Capacity Btuh	COP	Capacity Btuh	EER	Capacity Btuh	COP	Capacity Btuh	EER	Capacity Btuh	COP
EXV/H009	2.25	285	7900	16.10	9900	5.6	8800	25.0	8200	4.8	8300	18.8	6100	3.7
EXV/H012	3.00	380	11600	16.40	15200	5.8	13700	27.9	12300	5.0	12300	19.5	9300	4.0
EXV/H015	3.75	475	15100	16.10	18700	5.3	17000	25.8	15300	4.6	15800	19.0	12100	3.8
EXV/H018	4.50	570	18800	17.60	23600	5.7	21100	28.7	18800	4.9	19600	20.6	14600	4.1
EXV/H024	6.00	760	24600	17.40	32100	5.7	27400	27.2	25900	5.0	25600	20.3	19500	3.9
EXV/H030	7.50	950	31400	17.80	38400	5.8	35000	27.2	31000	5.0	32800	20.7	23600	4.1
EXV/H036	9.00	1140	35500	17.60	43100	5.8	39400	26.5	35000	5.0	37100	20.4	27200	4.1
EXV/H042	10.50	1330	38400	18.00	48000	6.4	43300	27.5	38500	5.5	40500	21.1	29400	4.3
EXV/H048	12.00	1520	45400	17.70	55600	6.1	50400	26.4	44800	5.3	47100	20.3	34600	4.3
EXV/H060	15.00	1900	55700	17.50	69000	5.9	60800	25.7	55900	5.1	57700	20.1	42900	4.1
EXV/H070	17.50	2215	63800	17.30	82100	5.40	68900	24.9	66900	4.8	66100	19.80	52000	4.1

Note: Rated in accordance ANSI/AHRI/ASHRAE/ISO13256-1. Certified conditions are 80.6°F DB/66.2°F WB EAT in cooling and 68°F DB/59°F WB EAT in heating. Entering liquid temperature in cooling is 86°F for Water Loop, 77°F for Ground Loop (full load), 68°F for Ground Loop (part load), and 59°F for Ground Water. Entering liquid temperature in heating is 68°F for Water Loop, 32°F for Ground Loop (full load), 41°F for Ground Loop (part load), and 50°F for Ground Water.

Table 9. ANSI/AHRI/ASHRAE/ISO13256-1 WLHP, GWHP and GLHP performance - 2 to 6 tons

Model	Load	Rated GPM	Rated CFM	Water Loop Heat Pump				Ground Water Heat Pump				Ground Loop Heat Pump			
				Cooling 86°F		Heating 68°F		Cooling 59°F		Heating 50°F		Full Cool 77°F		Full Heat 32°F	
				Capacity Btuh	EER	Capacity Btuh	COP	Capacity Btuh	EER	Capacity Btuh	COP	Capacity Btuh	EER	Capacity Btuh	COP
DXV/H024	Full	6.0	760	24700	16.8	32100	5.5	27500	24.4	25700	4.9	25900	19.2	19400	3.9
DXV/H024	Part	6.0	608	18500	17.7	24100	5.9	20500	28.3	18900	4.9	20000	24.5	16300	4.3
DXV/H036	Full	9.0	1140	33000	17.3	40900	5.9	37100	25.1	32900	5.1	34500	19.7	25500	4.1
DXV/H036	Part	9.0	912	24500	18.3	30500	6.3	27600	29.3	24300	5.2	26600	25.2	21100	4.5
DXV/H048	Full	12.0	1520	45200	17.9	55200	6.1	50400	26.4	44400	5.3	46600	20.6	34500	4.3
DXV/H048	Part	12.0	1216	32800	18.7	40000	6.6	36900	31.2	31900	5.3	35700	26.7	28000	4.7
DXV/H060	Full	15.0	1900	52100	17.6	63900	6.0	56600	24.8	51700	5.2	53900	19.9	39800	4.2
DXV/H060	Part	15.0	1520	38300	18.7	47300	6.6	42000	29.9	37800	5.4	41000	25.8	32400	4.6
DXV/H070	Full	17.5	2215	64400	17.3	82700	5.4	69100	23.8	67400	4.8	66800	19.6	52900	4.0
DXV/H070	Part	17.5	1772	47100	18.9	59700	6.0	51100	29.7	48000	5.0	50000	25.6	42000	4.4

Note: Performance data EXVG 0.5 Ton or 0.75 Ton Rated in accordance with ANSI/AHRI/ASHRAE/ISO13256-1. Certified conditions are 80.6°F DB/66.2°F WB EAT in cooling and 68°F DB/59°F WB EAT in heating. Entering liquid temperature in cooling is 86°F for Water Loop, 77°F for Ground Loop (full load), 68°F for Ground Loop (part load), and 59°F for Ground Water. Entering liquid temperature in heating is 68°F for Water Loop, 32°F for Ground Loop (full load), 41°F for Ground Loop (part load), and 50°F for Ground Water.

Table 10. Electrical data - 0.75 to 6 tons, EX*009-070

Model No.	Unit Volts	Blower Motor HP	Minimum Circuit Ampacity	Maximum Overcurrent Protective Device
EXH/EXV009	208-230/60/1	1/3	6/6	15/15
EXH/EXV009	265/60/1	1/3	5	15
EXH/EXV012	208-230/60/1	1/3	8/8	15/15
EXH/EXV012	265/60/1	1/3	7	15
EXH/EXV015	208-230/60/1	1/3	10/10	15/15
EXH/EXV015	265/60/1	1/3	7	15

Table 10. Electrical data - 0.75 to 6 tons, EX*009-070 (continued)

Model No.	Unit Volts	Blower Motor HP	Minimum Circuit Ampacity	Maximum Overcurrent Protective Device
EXH/EXV070	460/60/3	1	13	20

Table 11. Electrical data - 2 to 6 tons, DX*024-070

Model No.	Unit Volts	Blower Motor HP	Minimum Circuit Ampacity	Maximum Overcurrent Protective Device
DXH/DXV024	208-230/60/1	1/2	17/17	25/25
DXH/DXV024	265/60/1	1/2	13	20
DXH/DXV024	208-230/60/3	1/2	10/10	15/15
DXH/DXV024	460/60/3	1/2	6	15
DXH/DXV036	208-230/60/1	3/4	19/19	30/30
DXH/DXV036	265/60/1	3/4	15	20
DXH/DXV036	208-230/60/3	3/4	13/13	20/20
DXH/DXV036	460/60/3	1	7	15
DXH/DXV048	208-230/60/1	1	25/25	40/40
DXH/DXV048	208-230/60/3	1	21/21	30/30
DXH/DXV048	460/60/3	1	10	15
DXH/DXV060	208-230/60/1	1	31/31	50/50
DXH/DXV060	208-230/60/3	1	22/22	35/35
DXH/DXV060	460/60/3	1	10	15
DXH/DXV070	208-230/60/1	1	39/39	60/60
DXH/DXV070	208-230/60/3	1	26/26	40/40
DXH/DXV070	460/60/3	1	12	15

Table 10. Electrical data - 0.75 to 6 tons, EX*009-070 (continued)

Model No.	Unit Volts	Blower Motor HP	Minimum Circuit Ampacity	Maximum Overcurrent Protective Device
EXH/EXV018	208-230/60/1	1/2	12/12	20/20
EXH/EXV018	265/60/1	1/2	10	15
EXH/EXV024	208-230/60/1	1/2	19/19	30/30
EXH/EXV024	265/60/1	1/2	13	20
EXH/EXV024	208-230/60/3	1/2	11/11	15/15
EXH/EXV024	460/60/3	1/2	6	15
EXH/EXV030	208-230/60/1	3/4	20/20	30/30
EXH/EXV030	265/60/1	3/4	16	25
EXH/EXV030	208-230/60/3	3/4	13/13	20/20
EXH/EXV030	460/60/3	3/4	7	15
EXH/EXV036	208-230/60/1	3/4	23/23	35/35
EXH/EXV036	265/60/1	3/4	17	25
EXH/EXV036	208-230/60/3	3/4	15/15	20/20
EXH/EXV036	460/60/3	1	7	15
EXH/EXV042	208-230/60/1	3/4	25/25	40/40
EXH/EXV042	208-230/60/3	3/4	17/17	25/25
EXH/EXV042	460/60/3	1	9	15
EXH/EXV048	208-230/60/1	1	25/25	40/40
EXH/EXV048	208-230/60/3	1	20/20	30/30
EXH/EXV048	460/60/3	1	9	15
EXH/EXV060	208-230/60/1	1	31/31	50/50
EXH/EXV060	208-230/60/3	1	22/22	35/35
EXH/EXV060	460/60/3	1	10	15
EXH/EXV070	208-230/60/1	1	39/39	60/60
EXH/EXV070	208-230/60/3	1	26/26	40/40

Figure 1. Clearances – EXHG/DXHG 0.75 to 6 tons

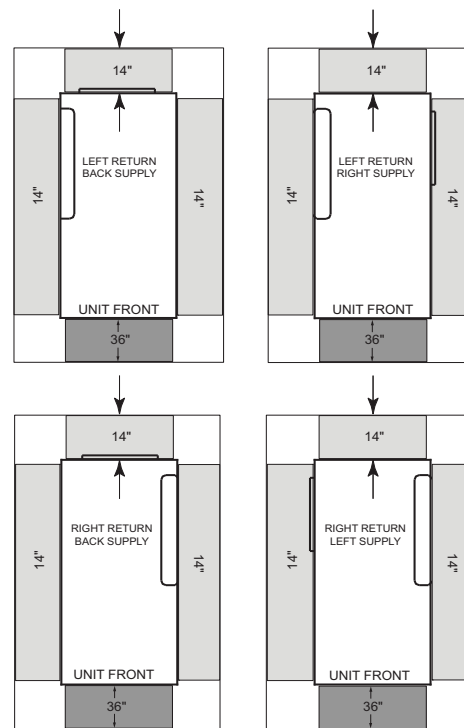

A minimum 14-inch clearance for servicing the unit is required for all EXH 0.75 to 6 tons configurations from other mechanical and electrical equipment (where shown) to enable panel removal from the unit for service/maintenance ability. The optimum clearance required is 20 inches.

Figure 2. Clearances – EXVG/DXVG 0.75 to 6 tons

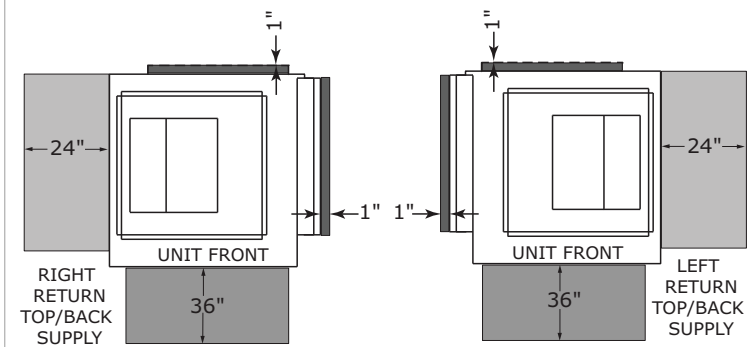

A 24-inch clearance from other mechanical and electrical equipment (where shown) is recommended for most unit configurations. This will enable panel removal from the unit for service/maintenance. The 24-inch side clearance on EXVG/DXVG 0.75-6T models is for optimal access only. Side clearance is not a requirement as most components can be accessed from the front of the unit. A 1-inch minimum clearance between the filter rack and any obstacle is required for units in a free return application to provide proper air flow to the air-to-refrigerant coil. A 12-inch minimum clearance between the filter rack and any obstacle should be provided to properly attached ductwork. The 1-inch dimension shown in the back of the unit represents the supply duct collar for the back supply option. This clearance is needed to clear these flanges.

Trane - by Trane Technologies (NYSE: TT), a global climate innovator - creates comfortable, energy efficient indoor environments for commercial and residential applications. For more information, please visit trane.com or tranetechnologies.com.

Trane has a policy of continuous product and product data improvement and reserves the right to change design and specifications without notice. We are committed to using environmentally conscious print practices.