



Product Catalog

# Water Source Heat Pump

## Axiom™ Water-to-Water — EXW

5 to 20 Tons – 60 Hz





## Introduction

Similar to a small reverse cycle chiller, a water-to-water heat pump contains a source-side water-to-refrigerant heat exchanger, and a load-side water-to-refrigerant heat exchanger. The source for the water-to-water heat pump is typically connected to a boiler/cooling tower, or a ground-source loop system. During the refrigeration cycle, heat is transferred from the source-side heat exchanger to the load-side heat exchanger, or vice versa. The load-side heat exchanger provides conditioned fluid (hot or cold) to a mechanical device such as radiant systems, hydronic fan coils or fresh air ventilation systems.

The units may be applied in a boiler/cooling tower setting, in a geothermal closed or open loop application, or in a hybrid application.

All units accommodate service access to the controls, and other major components to contribute to greater serviceability and maintainability of the unit.

Each unit is verified for total unit performance before shipping to insure quality standards are inherent in every unit.

Features for the EXW unit:

- High efficiency scroll compressor with vibration mounting isolation
- Co-axial heat exchanger (copper or cupro-nickel option is available on the source-side of the unit only)
- Slender design allows unit to fit through a 36-inch doorway
- Rackable, modular design
- Low pressure drops
- Microprocessor based 24V electro-mechanical controls (with 100 VA transformer)

## Copyright

This document and the information in it are the property of Trane, and may not be used or reproduced in whole or in part without written permission. Trane reserves the right to revise this publication at any time, and to make changes to its content without obligation to notify any person of such revision or change.

## Trademarks

All trademarks referenced in this document are the trademarks of their respective owners.



# Table of Contents

Introduction .....	2
Features and Benefits .....	4
Accessible Unit Control Box .....	4
Application Considerations .....	7
Selection Procedure .....	12
Model Number Descriptions .....	13
General Data .....	14
Performance Data .....	15
Unit Fan Performance .....	41
Antifreeze Correction Factors .....	41
Example 1 (Ethylene Glycol): .....	41
Example 2 (Propylene Glycol): .....	41
Electrical Data .....	43
Dimensional Data .....	44
Mechanical Specifications .....	48



# Features and Benefits

## Accessible Unit Control Box

The unit control box is accessible through the unit's front access panel. The unit is equipped with the deluxe 24-volt control package. Components are easily accessible for service, maintenance and start-up. Twenty-four volt thermostat connection is made at the unit terminal strip located in the left corner of the control box.

### Anti-Short Cycle Timer

The anti-short cycle timer provides a three minute time delay between compressor stop and compressor restart.

### Brown-out Protection

The brown-out protection function measures the input voltage to the controller and halts the compressor operation. Once a brown-out situation has occurred, the anti-short cycle timer will become energized. The general fault contact will not be affected by this condition. The voltage will continue to be monitored until the voltage increases. The compressors will be enabled at this time if all start-up time delays have expired, and all safeties have been satisfied.

### Compressor

All units are equipped with a high efficiency scroll compressor to aid in the reduction of sound, increases reliability and to provide efficient operation.

### Compressor Disable

The compressor disable relay provides a temporary disable in compressor operation. The signal would be provided from a water loop controller in the system. It would disable the compressor because of low water flow, peak limiting or if the unit goes into an unoccupied state. Once the compressor has been disabled, the anti-short cycle time period will begin. Once the compressor disable signal is no longer present, and all safeties are satisfied, the control will allow the compressor to restart.

### Deluxe Controls

The deluxe 24-volt electronic controls provide component protection devices with upgraded features to maximize system performance. The deluxe control offering is unique to Trane's water-source equipment and is designed to control the unit as well as provide outputs for unit status and fault detection. The microprocessor board is factory wired to a terminal strip to provide all necessary terminals for field connections.

Deluxe 24-volt features include:

- 100 VA transformer
- Compressor contactor
- Compressor lockout relay
- Anti-short cycle
- Compressor protection
- Random start delay
- Brown-out protection
- Low pressure time delay
- Low pressure switch
- High pressure switch
- Compressor delay on start
- Reversing valve coil
- 18-pole terminal strip (for low voltage field wiring)

### Expansion Valve

The refrigerant flow metering is made through a thermal expansion valve (TXV). The TXV allows the unit to operate with an entering fluid temperature from 25° F to 120° F on the source-side. The valve precisely meters refrigerant flow through the circuitry to achieve desired heating or cooling.

Unlike cap-tube assemblies, the TXV allows the exact amount of refrigerant required to meet the heat exchanger load demands. This precise metering increases the overall efficiency of the unit.



### Filter Drier

Every unit is equipped with a bi-directional filter drier to dehydrate and clean the refrigeration system, adding to the life of the equipment.

### Generic Relay

The generic relay is provided for field use. An external Class II 24 Vac signal will energize the relay coil on terminals R1 and R2. Terminals C (common), NO (normally open), and NC (normally closed) will be provided for the relay contacts.

### Random Start

The random start relay provides a time delay start-up of the compressor when cycling in the occupied mode. A new start delay time between 3 and 10 seconds is applied each time power is enable to the unit.

### Refrigeration Circuit

All heat pump designs include: a reversing valve, thermal expansion valve, two water-to-refrigerant heat exchanger (source and load), and a compressor selected for the optimal efficiency of each circuit.

The 10 and 20 ton units incorporate a dual circuit refrigeration design, duplicating the major components listed above.

The unit's copper tubing is created from a 99% pure copper formation that conforms to the American Society of Testing (ASTM) B743 for seamless, light-annealed processing.

The unit's copper refrigeration system is designed to be free from contaminants and conditions such as drilling fragments, dirt, or oil. This excludes the possibility of these contaminants from damaging the compressor motor.

### Reversing Valve

A system reversing valve (4-way valve) is included with all heat pumps. This valve is piped to be energized in the cooling mode to allow the system to provided heat if valve failure were to occur. Once the valve is energized for cooling, it will remain energized until the control system is turned to the OFF position, or a heating cycle is initiated.



### Safety Control

The deluxe microprocessor receives separate input signals from the refrigerant high pressure switch or low suction pressure switch.

In a high pressure situation, the compressor contactor is de-energized, which suspends compressor operation. The control will go into soft lockout mode initializing a three minute time delay and a random start of 3 to 10 second time delays. Once these delays have expired, the unit will be allowed to run. If a

## Features and Benefits

---

high pressure situation occurs within one hour of the first situation, the control will be placed into a manual lockout mode, halting compressor operation, and initiating the general alarm.

In a **low temperature situation**, the low pressure switch will transition open after the compressor starts. If the switch is open for 45 seconds during compressor start, the unit will go into soft lockout mode initializing a three minute time delay and a random start of 3 to 10 second time delays. Once these delays have expired, the unit will be allowed to run. If the low pressure situation occurs again within 30 minutes, and the device is open for more than 45 seconds, the control will be placed into a manual lockout mode, halting compressor operation, and initiating the general alarm.

The **general alarm** is initiated when the control goes into a manual lockout mode for either high pressure or low pressure.

### Schrader Connections

The connections for the low and high side of the refrigeration system are located conveniently on the unit's right side behind the front, refrigeration access panel.

### Sound

All units are internally walled with 1/2-inch thick dual density, acoustical fiberglass insulation to attenuate compressor noise.

Compressors are internally isolated to reduce vibration. A compressor base plate and full-length channel stiffeners are installed to further reduce vibration.

### Unit Description

The cabinet, which allows easy access for installation and service is constructed of heavy gauge steel. The EXW unit includes a galvanized metal finish for maximum durability and corrosive resistive exterior.

Each cabinet design accommodates modular racking of the equipment to incorporate multiple unit installations within a tight or constraining space.

Before shipment, each unit is leak tested, dehydrated, charged with refrigerant and run tested for proper operation. The cabinet insulation meets UL 181 requirements.

### Water Connections

The water-in/water-out connections to the water-to-refrigerant heat exchangers are located on the unit's opposite ends. The source-side, water-to-refrigerant connection and the load side, water-to-refrigerant connections are located at the unit's back.

The connections are located internal to the unit to help alleviate damage to the water copper piping during shipment or job storage of the units prior to installation. Fittings for the load-side and source-side connections are FPT (internal pipe threaded).

### Water-to-Refrigerant Coil

The water-to-refrigerant coils for the unit includes a co-axial design.

The co-axial design is a seamless tube-within-a-tube construction. The inner-water tube contains a deep fluted curve to enhance heat transfer and minimize fouling and scaling. It is available in either a copper or cupro-nickel (selectable option) on the source-side heat exchanger, and a copper only on the load-side heat exchanger. The outer refrigerant tube is made from steel material. The coil is leak tested to assure there is no cross leakage between the water tube and the refrigerant gas (steel tube) coil.





# Application Considerations

## Flexibility

The high efficiency water-to-water heat pump system is versatile for installation in boiler/cooling tower applications, as well as ground-source (geothermal) applications. The system design may employ either a central pumping design, or a distributed pumping design.

A central pumping design involves a single pump design, usually located within a basement or mechanical room to fulfill pumping requirements for the entire building system. An auxiliary pump is typically applied to lessen the likelihood of system downtime if the main pump malfunctions.

A distributed pumping system contains a single pump module connected directly to the units supply and return. This module is field installed and piped to the unit. This design requires individual pump modules specifically sized for each water-source heat pump.

## Advantages of Geothermal

The advantages of a geothermal heat pump system can literally cut a business' heating and cooling costs by 30 to 40-percent. The units are durable, and typically last longer than conventional systems because they are protected from harsh outdoor weather conditions, because the unit is installed indoors and the loop underground. (According to ASHRAE, the estimated service life for a commercial water-to-air heat pump is 19-years.)

Geothermal heat pumps have fewer mechanical components, making them more reliable and less prone to failure. Manufacturers of the loop materials guarantee their products for up to 25-years, with no maintenance required.

Geothermal heat pumps work toward the preservation of the environment by reducing the environmental impacts of electric power generation.

A ground source (geothermal) system consist of:

- a ground water heat pump
- a closed loop ground heat exchanger made of high density polyethylene pipe (guaranteed 25- years or more by many manufacturers); and
- a low wattage circulating pump(s)

The fluctuating temperatures of fluid from the earth are more stable than air, allowing the equipment to operate at a lower discharge pressure and use fewer kilowatts. The constant earth temperature will heat or cool the fluid running through buried polyethylene pipe to provide heating and cooling to a building.

A geothermal loop can be installed either horizontally or vertically. Vertical loops require less overall land area to reject (i.e., sink) the excess heat from the building. Horizontal loops require trenches in the ground spanning a larger overall land area.

Although external piping is the responsibility of the installer and/or piping manufacturer, many electric utilities and rural electric cooperatives are offering monetary incentives to install geothermal systems. Utility companies offer the incentives because of reduced peak loads that flatten out their demand curve over time, and save them money. These savings are ultimately transferred to the consumer.

**Figure 2. Hybrid loop**

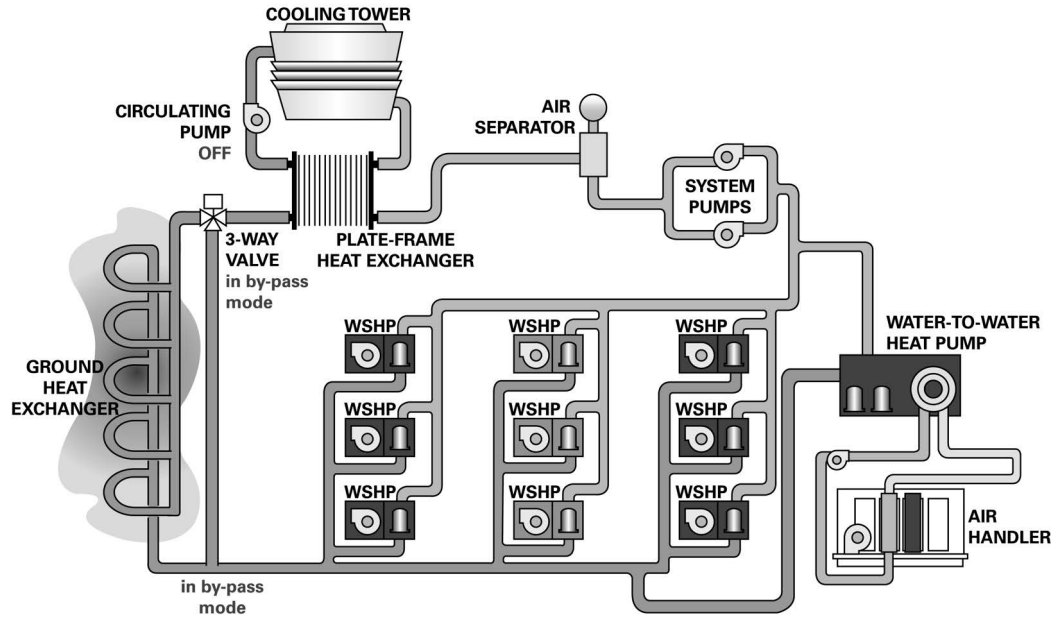

### Source vs. Load

The water-to-water heat pump contains two water-to-refrigerant heat exchangers. The two heat exchangers enable the system to be divided into a source and load separation.

The source-side heat exchanger performs as a standard water-to-air heat pump system. The source is typically supplied through a cooling tower, boiler, closed loop, or open well system. During the refrigeration cycle, heat is transferred from the source-side heat exchanger to the load-side heat exchanger.

The load-side heat exchanger takes the place of a DX (direct expansion) air coil. It provides treated fluid (hot or cold) to a mechanical device. These mechanical devices include designs such as radiant slab heating, hydronic coils, or fresh air ventilation units.

See below for a basic schematic of source-side versus load-side of a water-to-water system.

**Figure 3. Source vs. load**

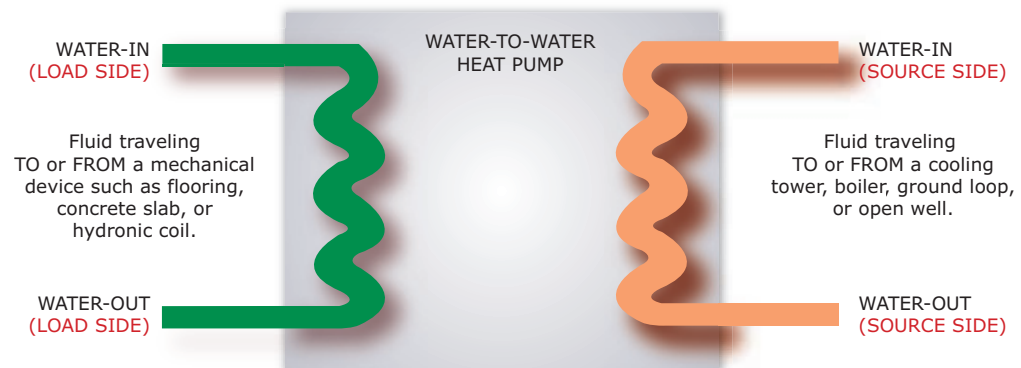



### Unit Installation

Installation of the water-to-water is made easier through its unique compact design. The units are typically racked in a mechanical room or penthouse allowing easy access to the units and other mechanical equipment.

Service access to these units is through the unit front panel for most major components.

### Geothermal Integrated System

The water-to-water heat pump is highly efficient in service station applications.

This integrated system design takes advantage of the earth's relatively constant temperature (45° F to 70° F) to space condition the building. In addition, appliances such as freezers, ice makers and display coolers may be added to the loop for further gains in the reduction of consumed energy.

Cold climates may take an even greater advantage of the heat rejected by the stores refrigeration equipment and space conditioning heat pumps. This rejected heat may be used by Trane's water-to-water heat pump(s) to heat water for a car wash and melt ice off of a driveway (allowing the car wash to remain open all winter).

This integrated system also eliminates thermal short circuits between the intakes and the exhausts of an air cooled refrigeration system.

Typical Benefits include:

- Annual energy savings means lower operational costs.
- Takes advantage of the earth's constant temperature rather than high fluctuation of ambient temperature.
- Heat energy rejected from the space conditioner can be utilized for ice or snow melting of the parking lot in colder climates.
- Two or three year estimated payback on installation costs.

**Figure 4. Geothermal design in a service station application**

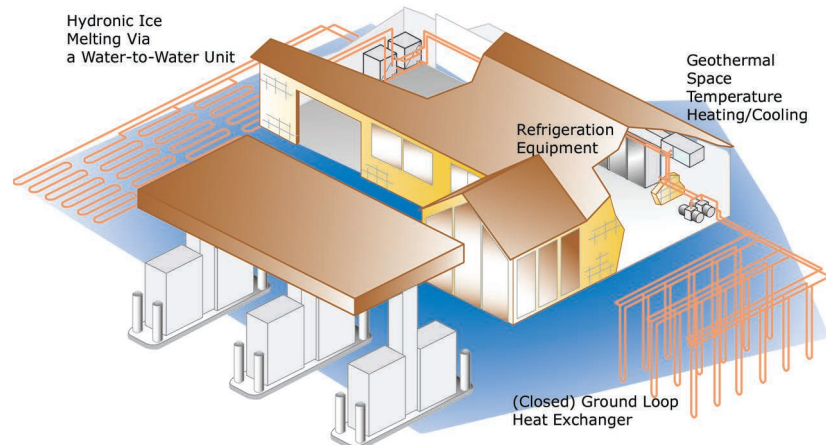

### Water-to-Water and Fresh Air Ventilation

Geothermal energy systems take advantage of the fact that subsurface earth temperatures are constant year round, which makes the earth an ideal heat source and heat sink for heat pumps.

The following water-to-water and fresh air ventilation image goes further than just space heating and cooling. Fresh air ventilation is achieved by using Trane's water-to-water units teamed with a M-Series Climate Changer air handler, and exhaust air unit to meet total building requirements.

In the cooling season, the load-side water from the heat pumps is circulated through a hydronic coil in the M-Series unit to provide cooling and dehumidification. The source-side water is used to provide reheat energy to temper the ventilated air in accordance with the building needs. After leaving the reheated hydronic coil, the condenser water is then returned to the building loop for further heat rejection.

In heating, the water-to-water units switch to hot water generation. The water for ventilation air tempering circulates through the hydronic coil to the exhaust unit to pick up heat from the building exhaust airstream. The water then circulates through the water-to-water heat pumps for further heat introduction before being used by the makeup air unit hydronic coil to heat the makeup air to maintain building requirements. This ventilation system incorporates its own circulating pumps to pull system water off the loop and return it. There is no need for additional heat injection using boilers for this system. For a mechanical schematic, reference the fresh air ventilation drawing.

Typical Benefits include:

- Annual energy savings means lower energy costs.
- Building comfort and climate control
- Energy recovery

**Figure 5. Water-to-water and fresh air ventilation**

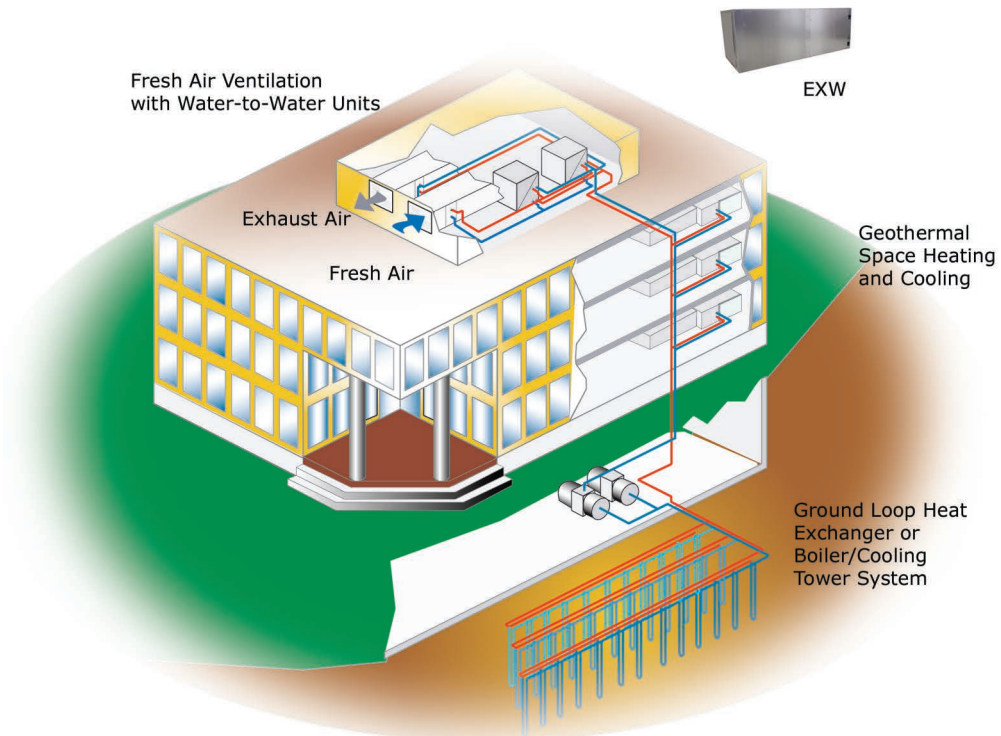
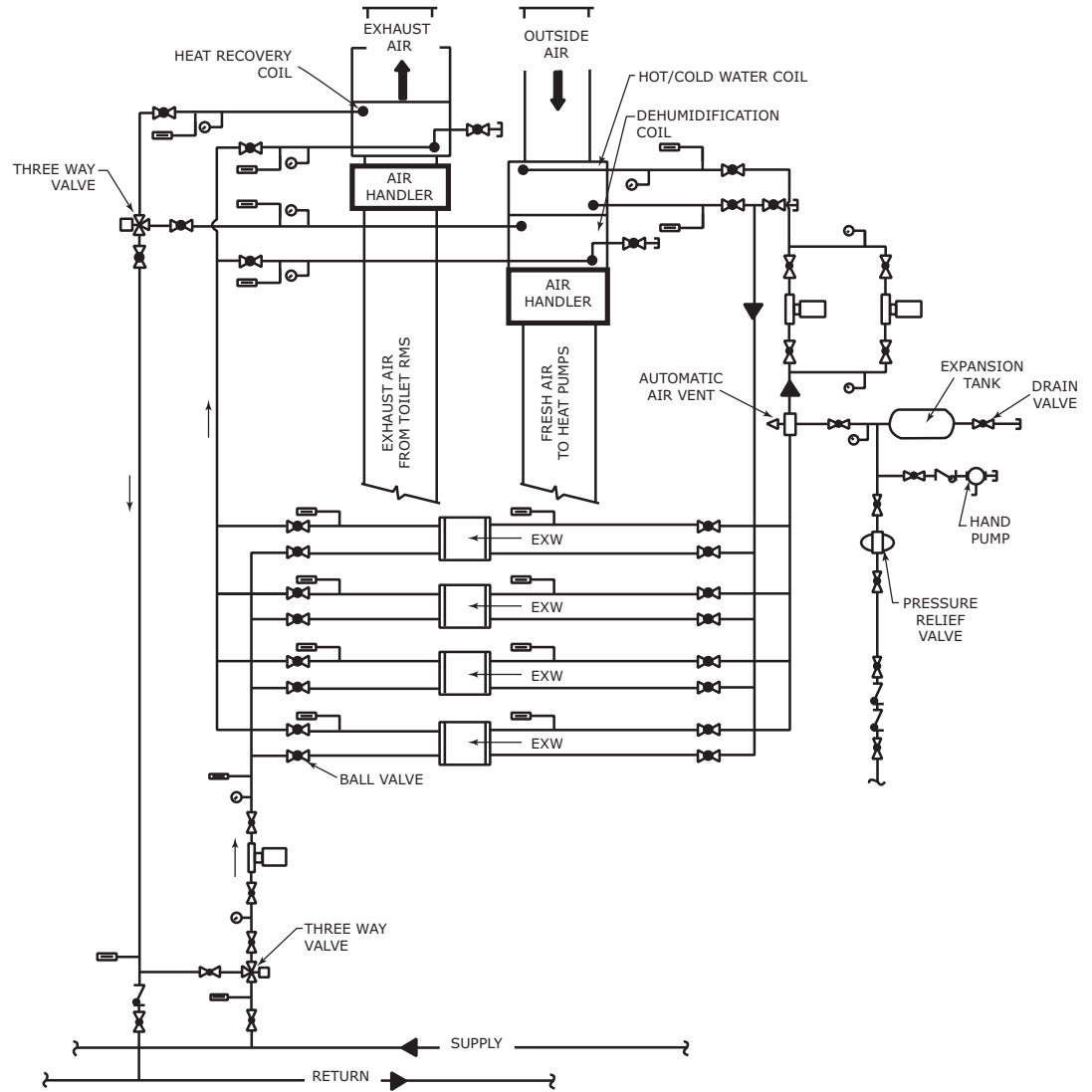

Figure 6. Fresh air ventilation mechanical schematic





## Selection Procedure

Unit performance for the EXW equipment is tabulated under ANSI/AHRI/ASHRAE/ISO 13256-2. To select unit(s):

1. Determine the system design conditions for both the source and load-side(s) of the equipment.

**Note:** *Entering liquid temperatures for the source-side can be 25° F to 120° F, and for the load-side, 50° F to 120° F.*

2. Define the selection parameters. (i.e. entering water temperature (EWT), fluid flow rate, and fluid pressure drop).
3. Determine unit requirements. (i.e. total cooling capacity/total heating capacity).
4. Refer to the performance data tables and select possible units.

When making unit selections, there are a few considerations that need to be made. If unit capacity is greater than largest unit available in the performance section, multiple units may be required to fulfill capacity requirements. When adding two or more together, the system pumping pressure drop may be lowered, perhaps lowering the pump horsepower.

- Staging of capacity to satisfy cooling requirements.
- Pressure drop reduction through the load-side of multiple units, even when a single unit might meet capacity.
- If source-side leaving water temperature falls below 35° F, antifreeze will be required in the fluid loop. See Antifreeze Correction Factors in the Unit Fan Performance section for antifreeze correction factors.



# Model Number Descriptions

## Digits 1, 2, 3 — Unit Configuration

EXW = Water to Water Heat Pump

## Digit 4 — Development Sequence

E = R-410A

## Digits 5, 6, 7 — Nominal Size (Tons)

060 = 5 Tons

120 = 10 Tons

240 = 20 Tons

## Digit 8 — Voltage (Volts/Hz/Phase)

1 = 208/60/1

2 = 230/60/1

3 = 208/60/3

4 = 460/60/3

5 = 575/60/3

8 = 230/60/3

## Digit 9 — Heat Exchanger (Source Side)

1 = Copper-Water Coil

2 = Cupro-Nickel Water Coil

**Note:** Heat exchanger for the load side is copper-water coil only.

7 = Insulated Copper Water Coil/Suction Line

8 = Insulated Cupro-Ni Water Coil/Suction Line

**Note:** Insulated heat exchanger is recommended when EWT < 60°F.

## Digit 10 — Current Design Sequence

## Digit 11 — Refrigeration Circuit

0 = Heat Pump

## Digit 12 — Open Digit

## Digit 13 — Freeze Protection (Source Side)

A = 20°F (For Glycol Loop)

B = 35°F (For Water Loop)

**Note:** The load side will have a 35°F freeze protection.

## Digit 14 — Open Digit

## Digit 15 — Open Digit

## Digit 16 — Open Digit

## Digit 17 — Control Type

D = Deluxe 24V Control

## Digit 18 — Tstat Location

0 = Field Supplied

**Note:** 20°F Freezestat is typically used in a geothermal application. 35°F Freezestat is typically used in a boiler/tower application.



# General Data

**Table 1. General data 5 to 20 tons**

<b>Model Unit Size</b>	<b>EXW060</b>	<b>EXW120</b>	<b>EXW240</b>
Width (in)	40	58	81½
Height (in)	22	24	30
Depth (in)	20	33	31 3/8
Compressor Type	Scroll	Scroll	Scroll
Approximate Weight with Pallet (lb)	326	653	1222
Approximate Weight without Pallet (lb)	296	613	1156
Water in/out size (NPTI) inches	1	1.5	2



# Performance Data

**Table 2. ANSI/AHRI/ASHRAE/ISO13256-2 WLHP, GWHP and GLHP performance - 5, 10, 20 tons**

Model	Nom Tons	Water Loop Heat Pump				Ground Water Heat Pump				Ground Water Heat Pump			
		Cooling		Heating		Cooling		Heating		Cooling		Heating	
		Indoor 53.6° F		Indoor 104° F		Indoor 53.6° F		Indoor 104° F		Indoor 53.6° F		Indoor 104° F	
		Outdoor 86° F		Outdoor 68° F		Outdoor 59° F		Outdoor 50° F		Outdoor 77° F		Outdoor 50° F	
		Capacity Btuh	EER Btuh/W	Capacity Btuh	COP	Capacity Btuh	EER Btuh/W	Capacity Btuh	COP	Capacity Btuh	EER Btuh/W	Capacity Btuh	COP
EXW060	5	52,100	12.73	71,000	4.30	56,900	19.57	60,900	3.60	54,000	14.73	48,100	2.80
EXW120	10	105,100	12.09	139,400	3.90	118,700	19.05	118,400	3.30	110,100	14.20	95,300	2.60
EXW240	20	192,300	13.50	262,700	4.10	221,300	20.60	224,200	3.60	204,000	15.70	172,600	2.80

**Note:** Rated in accordance with ANSI/AHRI/ASHRAE/ISO 13256-2.



Performance Data

Table 3. Cooling capacities 5 tons - EXW060

Source		Load																	
		Flow 7.5 GPM			Flow 12.5 GPM			Flow 17.5 GPM											
EWT °F	WPD FT	Power kW	HR Mbtuh	LWT °F	EER	WPD FT	TC Mbtuh	Power kW	HR Mbtuh	LWT °F	EER	WPD FT	TC Mbtuh	Power kW	HR Mbtuh	LWT °F	EER	WPD FT	
50	7.5	2.9	50	2.44	57.3	36.9	20.1	3.6	54.0	2.46	62.4	41.4	21.9	8.7	56.6	65.0	43.5	22.8	15.7
50	12.5	7.0	50	2.26	58.3	36.5	22.4	3.6	55.7	2.29	63.5	41.1	24.4	8.7	58.4	66.3	43.3	25.4	15.7
50	17.5	13.0	50	2.19	58.7	36.3	23.3	3.6	56.5	2.22	64.0	41.0	25.5	8.7	59.2	66.8	43.2	26.5	15.7
50	7.5	2.9	60	2.47	66.0	44.6	23.3	3.5	63.5	2.50	72.0	49.8	25.4	8.4	66.5	75.1	52.4	26.5	15.2
50	12.5	7.0	60	2.29	67.3	44.1	25.9	3.5	65.6	2.32	73.5	49.5	28.3	8.4	68.7	76.7	52.1	29.5	15.2
50	17.5	13.0	60	2.23	67.9	43.9	27.1	3.5	66.4	2.25	74.1	49.4	29.5	8.4	69.6	77.3	52.0	30.8	15.2
50	7.5	2.9	70	2.52	75.8	52.1	26.7	3.3	74.1	2.55	82.7	58.2	29.1	8.2	77.6	86.3	61.1	30.3	14.8
50	12.5	7.0	70	2.34	77.3	51.5	29.7	3.3	76.5	2.36	84.5	57.8	32.4	8.2	80.1	88.2	60.8	33.7	14.8
50	17.5	13.0	70	2.27	78.0	51.3	31.0	3.3	77.5	2.29	85.3	57.6	33.8	8.2	81.2	89.0	60.7	35.2	14.8
50	7.5	2.9	80	2.60	86.7	59.2	29.9	3.3	85.8	2.63	94.8	66.3	32.6	8.0	89.9	98.9	69.7	34.0	14.4
50	12.5	7.0	80	2.41	88.6	58.6	33.3	3.3	88.6	2.44	96.9	65.8	36.3	8.0	92.8	101.2	69.4	37.8	14.4
50	17.5	13.0	80	2.34	89.4	58.3	34.7	3.3	89.8	2.37	97.8	65.6	37.9	8.0	94.0	102.2	69.3	39.5	14.4
50	7.5	2.9	85	2.66	92.7	62.7	31.4	3.2	92.2	2.69	101.3	70.3	34.3	7.9	96.6	105.8	74.0	35.7	14.2
50	12.5	7.0	85	2.47	94.8	62.0	35.0	3.2	95.2	2.50	103.7	69.8	38.1	7.9	99.7	108.3	73.6	39.7	14.2
50	17.5	13.0	85	2.40	95.6	61.7	36.5	3.2	96.4	2.42	104.7	69.6	39.8	7.9	101.0	109.3	73.5	41.4	14.2
60	7.5	2.6	50	2.83	56.4	37.5	16.5	3.6	51.5	2.86	61.3	41.8	18.0	8.7	54.0	63.8	43.8	18.7	15.7
60	12.5	6.5	50	2.63	57.2	37.1	18.4	3.6	53.2	2.66	62.3	41.5	20.0	8.7	55.7	64.8	43.6	20.8	15.7
60	17.5	12.1	50	2.55	57.6	37.0	19.2	3.6	53.9	2.58	62.7	41.4	20.9	8.7	56.4	65.3	43.5	21.8	15.7
60	7.5	2.6	60	2.87	65.1	45.3	19.3	3.5	60.9	2.90	70.8	50.2	21.0	8.4	63.8	73.8	52.7	21.9	15.2
60	12.5	6.5	60	2.66	66.2	44.8	21.4	3.5	62.9	2.69	72.1	49.9	23.4	8.4	65.9	75.2	52.5	24.3	15.2
60	17.5	12.1	60	2.58	66.6	44.6	22.4	3.5	63.7	2.61	72.7	49.8	24.4	8.4	66.8	75.8	52.4	25.4	15.2
60	7.5	2.6	70	2.92	74.6	52.8	22.1	3.3	71.3	2.95	81.3	58.6	24.1	8.2	74.7	84.8	61.5	25.1	14.8
60	12.5	6.5	70	2.71	76.0	52.2	24.6	3.3	73.6	2.74	82.9	58.2	26.9	8.2	77.1	86.5	61.2	28.0	14.8
60	17.5	12.1	70	2.63	76.6	52.0	25.7	3.3	74.5	2.66	83.6	58.1	28.0	8.2	78.1	87.2	61.1	29.2	14.8
60	7.5	2.6	80	3.00	85.2	60.0	25.0	3.3	82.7	3.04	93.0	66.8	27.2	8.0	86.6	97.0	70.1	28.3	14.4
60	12.5	6.5	80	2.79	86.9	59.4	27.8	3.3	85.4	2.82	95.0	66.3	30.3	8.0	89.4	99.1	69.8	31.5	14.4
60	17.5	12.1	80	2.71	87.7	59.1	29.0	3.3	86.5	2.73	95.8	66.2	31.6	8.0	90.6	100.0	69.6	32.9	14.4
60	7.5	2.6	85	3.06	91.0	63.5	26.3	3.2	88.8	3.10	99.4	70.8	28.7	7.9	93.0	103.7	74.4	29.9	14.2
60	12.5	6.5	85	2.84	92.9	62.8	29.2	3.2	91.7	2.87	101.5	70.3	31.9	7.9	96.1	106.0	74.0	33.2	14.2
60	17.5	12.1	85	2.76	93.7	62.5	30.5	3.2	92.9	2.79	102.4	70.1	33.3	7.9	97.3	106.9	73.9	34.7	14.2
70	7.5	2.5	50	3.26	57.0	37.8	14.1	3.6	50.6	3.29	61.8	41.9	15.4	8.7	53.0	64.3	43.9	16.0	15.7
70	12.5	6.2	50	3.02	57.7	37.4	15.7	3.6	52.2	3.05	62.6	41.6	17.1	8.7	54.7	65.2	43.7	17.8	15.7
70	17.5	11.4	50	2.93	58.0	37.2	16.4	3.6	52.9	2.96	63.0	41.5	17.8	8.7	55.4	65.6	43.7	18.6	15.7



**Table 3. Cooling capacities 5 tons - EXW060 (continued)**

Source			Load																	
			Flow 7.5 GPM				Flow 12.5 GPM				Flow 17.5 GPM									
EWT °F	Flow GPM	WPD FT	TC Mbtuh	Power kW	HR Mbtuh	LWT °F	EER	WPD FT	TC Mbtuh	Power kW	HR Mbtuh	LWT °F	EER	WPD FT	TC Mbtuh	Power kW	HR Mbtuh	LWT °F	EER	WPD FT
70	7.5	2.5	54.1	3.29	65.4	45.6	16.4	3.5	59.7	3.33	71.1	50.5	17.9	8.4	62.5	3.35	74.0	52.9	18.7	15.2
70	12.5	6.2	55.9	3.06	66.3	45.1	18.3	3.5	61.6	3.09	72.2	50.1	19.9	8.4	64.6	3.11	75.2	52.6	20.8	15.2
70	17.5	11.4	56.6	2.97	66.8	44.9	19.1	3.5	62.4	3.00	72.7	50.0	20.8	8.4	65.4	3.02	75.7	52.5	21.7	15.2
70	7.5	2.5	63.1	3.35	74.6	53.2	18.9	3.3	69.6	3.38	81.2	58.9	20.6	8.2	72.9	3.40	84.6	61.7	21.4	14.8
70	12.5	6.2	65.2	3.11	75.8	52.6	21.0	3.3	71.9	3.14	82.6	58.5	22.9	8.2	75.3	3.16	86.1	61.4	23.8	14.8
70	17.5	11.4	66.1	3.02	76.3	52.4	21.9	3.3	72.8	3.05	83.2	58.3	23.9	8.2	76.3	3.07	86.8	61.3	24.9	14.8
70	7.5	2.5	73.0	3.43	84.8	60.5	21.3	3.3	80.5	3.47	92.4	67.1	23.2	8.0	84.4	3.49	96.3	70.4	24.2	14.4
70	12.5	6.2	75.4	3.18	86.3	59.9	23.7	3.3	83.2	3.22	94.2	66.7	25.8	8.0	87.1	3.24	98.2	70.0	26.9	14.4
70	17.5	11.4	76.4	3.09	87.0	59.6	24.7	3.3	84.2	3.12	94.9	66.5	27.0	8.0	88.3	3.14	99.0	69.9	28.1	14.4
70	7.5	2.5	85	3.49	90.3	64.1	22.5	3.2	86.4	3.53	98.5	71.2	24.5	7.9	90.5	3.55	102.7	74.7	25.5	14.2
70	12.5	6.2	80.9	3.24	92.0	63.4	25.0	3.2	89.2	3.27	100.4	70.7	27.3	7.9	93.5	3.30	104.7	74.3	28.4	14.2
70	17.5	11.4	82.0	3.14	92.7	63.1	26.1	3.2	90.4	3.18	101.2	70.5	28.4	7.9	94.7	3.20	105.6	74.2	29.6	14.2
80	7.5	2.4	44.4	3.72	57.1	38.2	11.9	3.6	48.9	3.76	61.8	42.2	13.0	8.7	51.3	3.78	64.2	44.1	13.6	15.7
80	12.5	5.9	45.8	3.45	57.6	37.8	13.3	3.6	50.5	3.49	62.4	41.9	14.5	8.7	52.9	3.51	64.9	44.0	15.1	15.7
80	17.5	10.9	46.4	3.35	57.9	37.6	13.9	3.6	51.2	3.39	62.7	41.8	15.1	8.7	53.6	3.41	65.3	43.9	15.7	15.7
80	7.5	2.4	52.3	3.76	65.2	46.0	13.9	3.5	57.7	3.80	70.7	50.8	15.2	8.4	60.5	3.82	73.5	53.1	15.8	15.2
80	12.5	5.9	54.0	3.49	66.0	45.6	15.5	3.5	59.6	3.53	71.6	50.5	16.9	8.4	62.4	3.55	74.5	52.9	17.6	15.2
80	17.5	10.9	54.7	3.39	66.3	45.4	16.2	3.5	60.4	3.42	72.0	50.3	17.6	8.4	63.2	3.44	75.0	52.8	18.4	15.2
80	7.5	2.4	61.0	3.81	74.0	53.7	16.0	3.3	67.2	3.85	80.4	59.2	17.5	8.2	70.4	3.87	83.6	62.0	18.2	14.8
80	12.5	5.9	63.0	3.54	75.0	53.2	17.8	3.3	69.4	3.57	81.6	58.9	19.4	8.2	72.7	3.60	85.0	61.7	20.2	14.8
80	17.5	10.9	63.8	3.43	75.5	53.0	18.6	3.3	70.3	3.47	82.2	58.8	20.3	8.2	73.7	3.49	85.6	61.6	21.1	14.8
80	7.5	2.4	70.4	3.89	83.7	61.2	18.1	3.3	77.6	3.93	91.1	67.6	19.7	8.0	81.3	3.96	94.9	70.7	20.6	14.4
80	12.5	5.9	72.7	3.61	85.0	60.6	20.1	3.3	80.2	3.65	92.6	67.2	22.0	8.0	84.0	3.67	96.5	70.4	22.9	14.4
80	17.5	10.9	73.7	3.50	85.6	60.4	21.0	3.3	81.2	3.54	93.3	67.0	22.9	8.0	85.1	3.57	97.3	70.3	23.9	14.4
80	7.5	2.4	75.5	3.95	89.0	64.9	19.1	3.2	83.3	3.99	96.9	71.7	20.9	7.9	87.2	4.02	100.9	75.0	21.7	14.2
80	12.5	5.9	78.0	3.67	90.5	64.2	21.3	3.2	86.0	3.70	98.6	71.2	23.2	7.9	90.1	3.73	102.8	74.7	24.2	14.2
80	17.5	10.9	79.0	3.56	91.1	63.9	22.2	3.2	87.1	3.59	99.4	71.1	24.2	7.9	91.2	3.62	103.6	74.6	25.2	14.2
90	7.5	2.4	42.2	4.23	56.6	38.7	10.0	3.6	46.5	4.27	61.1	42.6	10.9	8.7	48.7	4.30	63.4	44.4	11.3	15.7
90	12.5	5.7	43.6	3.92	57.0	38.4	11.1	3.6	48.0	3.97	61.6	42.3	12.1	8.7	50.3	3.99	64.0	44.2	12.6	15.7
90	17.5	10.4	44.1	3.81	57.1	38.2	11.6	3.6	48.7	3.85	61.8	42.2	12.6	8.7	51.0	3.87	64.2	44.2	13.2	15.7
90	7.5	2.4	49.8	4.27	64.4	46.7	11.7	3.5	54.9	4.31	69.7	51.2	12.7	8.4	57.6	4.34	72.4	53.4	13.3	15.2
90	12.5	5.7	51.5	3.96	65.0	46.3	13.0	3.5	56.7	4.00	70.4	50.9	14.2	8.4	59.4	4.03	73.2	53.2	14.8	15.2
90	17.5	10.4	52.1	3.84	65.2	46.1	13.6	3.5	57.5	3.88	70.7	50.8	14.8	8.4	60.2	3.91	73.6	53.1	15.4	15.2

# Performance Data

**Table 3. Cooling capacities 5 tons - EXW060 (continued)**

Source			Load																	
EWT °F	Flow GPM	WPD FT	Flow 7.5 GPM				Flow 12.5 GPM				Flow 17.5 GPM									
			TC Mbtuh	Power kW	HR Mbtuh	LWT °F	EER	WPD FT	TC Mbtuh	Power kW	HR Mbtuh	LWT °F	EER	WPD FT	TC Mbtuh	Power kW	HR Mbtuh	LWT °F	EER	WPD FT
90	7.5	2.4	58.1	4.31	72.8	54.5	13.5	3.3	64.1	4.36	78.9	59.8	14.7	8.2	67.1	4.39	82.1	62.3	15.3	14.8
90	12.5	5.7	60.0	4.01	73.7	54.0	15.0	3.3	66.1	4.05	80.0	59.4	16.3	8.2	69.3	4.07	83.2	62.1	17.0	14.8
90	17.5	10.4	60.8	3.89	74.0	53.8	15.6	3.3	67.0	3.93	80.4	59.3	17.1	8.2	70.2	3.95	83.7	62.0	17.8	14.8
90	7.5	2.4	67.1	4.39	82.1	62.1	15.3	3.3	74.0	4.44	89.2	68.2	16.7	8.0	77.6	4.47	92.8	71.1	17.4	14.4
90	12.5	5.7	69.3	4.08	83.2	61.5	17.0	3.3	76.4	4.12	90.5	67.8	18.5	8.0	80.1	4.15	94.2	70.8	19.3	14.4
90	17.5	10.4	70.2	3.96	83.7	61.3	17.7	3.3	77.4	4.00	91.1	67.6	19.4	8.0	81.1	4.02	94.9	70.7	20.2	14.4
90	7.5	2.4	72.0	4.45	87.2	65.8	16.2	3.2	79.4	4.49	94.7	72.3	17.7	7.9	83.2	4.52	98.6	75.5	18.4	14.2
90	12.5	5.7	74.4	4.13	88.4	65.2	18.0	3.2	82.0	4.17	96.2	71.9	19.6	7.9	85.9	4.20	100.2	75.2	20.5	14.2
90	17.5	10.4	75.3	4.01	89.0	64.9	18.8	3.2	83.0	4.05	96.9	71.7	20.5	7.9	87.0	4.08	100.9	75.1	21.3	14.2
100	7.5	2.3	39.5	4.79	55.9	39.5	8.2	3.6	43.6	4.84	60.1	43.0	9.0	8.7	45.7	4.87	62.3	44.8	9.4	15.7
100	12.5	5.6	40.8	4.45	56.0	39.1	9.2	3.6	45.0	4.50	60.3	42.8	10.0	8.7	47.1	4.53	62.6	44.6	10.4	15.7
100	17.5	10.0	41.3	4.32	56.1	39.0	9.6	3.6	45.6	4.36	60.5	42.7	10.4	8.7	47.8	4.39	62.8	44.5	10.9	15.7
100	7.5	2.3	46.9	4.83	63.3	47.5	9.7	3.5	51.7	4.88	68.3	51.7	10.6	8.4	54.1	4.91	70.9	53.8	11.0	15.2
100	12.5	5.6	48.4	4.48	63.7	47.1	10.8	3.5	53.4	4.53	68.8	51.5	11.8	8.4	55.9	4.56	71.5	53.6	12.3	15.2
100	17.5	10.0	49.0	4.35	63.9	46.9	11.3	3.5	54.0	4.40	69.1	51.4	12.3	8.4	56.6	4.42	71.7	53.5	12.8	15.2
100	7.5	2.3	54.8	4.87	71.4	55.4	11.2	3.3	60.4	4.92	77.2	60.3	12.3	8.2	63.3	4.96	80.2	62.8	12.8	14.8
100	12.5	5.6	56.6	4.52	72.0	54.9	12.5	3.3	62.4	4.57	78.0	60.0	13.6	8.2	65.4	4.60	81.1	62.5	14.2	14.8
100	17.5	10.0	57.3	4.39	72.3	54.7	13.1	3.3	63.2	4.44	78.3	59.9	14.2	8.2	66.2	4.46	81.4	62.4	14.8	14.8
100	7.5	2.3	63.5	4.94	80.3	63.1	12.8	3.3	70.0	5.00	87.0	68.8	14.0	8.0	73.3	5.03	90.5	71.6	14.6	14.4
100	12.5	5.6	65.5	4.59	81.2	62.5	14.3	3.3	72.3	4.64	88.1	68.4	15.6	8.0	75.7	4.67	91.6	71.3	16.2	14.4
100	17.5	10.0	66.4	4.45	81.6	62.3	14.9	3.3	73.2	4.50	88.6	68.3	16.3	8.0	76.7	4.53	92.1	71.2	16.9	14.4
100	7.5	2.3	68.1	5.00	85.2	66.8	13.6	3.2	75.1	5.05	92.3	73.0	14.9	7.9	78.7	5.08	96.0	76.0	15.5	14.2
100	12.5	5.6	70.3	4.64	86.2	66.2	15.2	3.2	77.6	4.69	93.6	72.6	16.5	7.9	81.3	4.72	97.4	75.7	17.2	14.2
100	17.5	10.0	71.3	4.50	86.6	66.0	15.8	3.2	78.6	4.55	94.1	72.4	17.3	7.9	82.3	4.58	97.9	75.6	18.0	14.2
110	7.5	2.2	36.6	5.42	55.1	40.2	6.8	3.6	40.4	5.48	59.1	43.5	7.4	8.7	42.3	5.52	61.1	45.2	7.7	15.7
110	12.5	5.4	37.8	5.03	55.0	39.9	7.5	3.6	41.7	5.09	59.0	43.3	8.2	8.7	43.7	5.12	61.1	45.0	8.5	15.7
110	17.5	9.7	38.3	4.88	55.0	39.8	7.8	3.6	42.2	4.94	59.1	43.2	8.5	8.7	44.2	4.97	61.2	44.9	8.9	15.7
110	7.5	2.2	43.7	5.45	62.3	48.4	8.0	3.5	48.1	5.51	67.0	52.3	8.7	8.4	50.4	5.55	69.4	54.2	9.1	15.2
110	12.5	5.4	45.1	5.06	62.4	48.0	8.9	3.5	49.7	5.12	67.2	52.0	9.7	8.4	52.1	5.15	69.7	54.0	10.1	15.2
110	17.5	9.7	45.7	4.91	62.4	47.8	9.3	3.5	50.4	4.97	67.3	51.9	10.1	8.4	52.8	5.00	69.8	54.0	10.6	15.2
110	7.5	2.2	51.3	5.49	70.0	56.3	9.3	3.3	56.5	5.55	75.5	61.0	10.2	8.2	59.2	5.58	78.3	63.2	10.6	14.8
110	12.5	5.4	53.0	5.10	70.4	55.9	10.4	3.3	58.4	5.15	76.0	60.7	11.3	8.2	61.2	5.19	78.9	63.0	11.8	14.8
110	17.5	9.7	53.7	4.95	70.5	55.7	10.8	3.3	59.2	5.00	76.2	60.5	11.8	8.2	62.0	5.03	79.1	62.9	12.3	14.8

Table 3. Cooling capacities 5 tons - EXW060 (continued)

Source			Load																		
			Flow 7.5 GPM				Flow 12.5 GPM				Flow 17.5 GPM										
EWT °F	Flow GPM	WPD FT	EWT° F	TC Mbtuh	Power kW	HR Mbtuh	LWT °F	EER	WPD FT	TC Mbtuh	Power kW	HR Mbtuh	LWT °F	EER	WPD FT	TC Mbtuh	Power kW	HR Mbtuh	LWT °F	EER	WPD FT
110	7.5	2.2	80	59.6	5.55	78.6	64.1	10.7	3.3	65.7	5.61	84.9	69.5	11.7	8.0	68.9	5.65	88.2	72.1	12.2	14.4
110	12.5	5.4	80	61.6	5.16	79.2	63.6	11.9	3.3	67.9	5.21	85.7	69.1	13.0	8.0	71.1	5.25	89.0	71.9	13.6	14.4
110	17.5	9.7	80	62.4	5.00	79.5	63.4	12.5	3.3	68.8	5.06	86.0	69.0	13.6	8.0	72.0	5.09	89.4	71.8	14.2	14.4
110	7.5	2.2	85	64.1	5.60	83.2	67.9	11.4	3.2	70.7	5.66	90.0	73.7	12.5	7.9	74.1	5.70	93.5	76.5	13.0	14.2
110	12.5	5.4	85	66.2	5.20	84.0	67.3	12.7	3.2	73.0	5.26	90.9	73.3	13.9	7.9	76.5	5.29	94.5	76.3	14.5	14.2
110	17.5	9.7	85	67.1	5.05	84.3	67.1	13.3	3.2	73.9	5.10	91.3	73.2	14.5	7.9	77.5	5.13	95.0	76.1	15.1	14.2
120	7.5	2.0	50	33.6	6.12	54.5	41.0	5.5	3.6	37.0	6.19	58.1	44.1	6.0	8.7	38.8	6.23	60.0	45.6	6.2	15.7
120	12.5	5.2	50	34.7	5.69	54.1	40.8	6.1	3.6	38.2	5.75	57.8	43.9	6.6	8.7	40.0	5.78	59.8	45.4	6.9	15.7
120	17.5	9.3	50	35.1	5.52	54.0	40.6	6.4	3.6	38.7	5.58	57.8	43.8	6.9	8.7	40.6	5.61	59.7	45.4	7.2	15.7
120	7.5	2.0	60	40.4	6.15	61.4	49.2	6.6	3.5	44.5	6.21	65.7	52.9	7.2	8.4	46.7	6.25	68.0	54.7	7.5	15.2
120	12.5	5.2	60	41.7	5.71	61.2	48.9	7.3	3.5	46.0	5.77	65.7	52.6	8.0	8.4	48.2	5.81	68.0	54.5	8.3	15.2
120	17.5	9.3	60	42.2	5.54	61.2	48.7	7.6	3.5	46.6	5.60	65.7	52.5	8.3	8.4	48.8	5.63	68.0	54.4	8.7	15.2
120	7.5	2.0	70	47.7	6.18	68.8	57.3	7.7	3.3	52.6	6.24	73.9	61.6	8.4	8.2	55.1	6.28	76.6	63.7	8.8	14.8
120	12.5	5.2	70	49.3	5.74	68.9	56.9	8.6	3.3	54.4	5.80	74.1	61.3	9.4	8.2	56.9	5.83	76.9	63.5	9.8	14.8
120	17.5	9.3	70	49.9	5.57	68.9	56.7	9.0	3.3	55.1	5.63	74.3	61.2	9.8	8.2	57.7	5.66	77.0	63.4	10.2	14.8
120	7.5	2.0	80	55.8	6.23	77.1	65.1	8.9	3.3	61.5	6.30	83.0	70.2	9.8	8.0	64.4	6.34	86.1	72.6	10.2	14.4
120	12.5	5.2	80	57.6	5.79	77.3	64.6	10.0	3.3	63.5	5.85	83.5	69.8	10.9	8.0	66.5	5.89	86.6	72.4	11.3	14.4
120	17.5	9.3	80	58.3	5.62	77.5	64.4	10.4	3.3	64.3	5.68	83.7	69.7	11.3	8.0	67.4	5.71	86.9	72.3	11.8	14.4
120	7.5	2.0	85	60.1	6.28	81.5	69.0	9.6	3.2	66.3	6.34	87.9	74.4	10.4	7.9	69.4	6.38	91.2	77.1	10.9	14.2
120	12.5	5.2	85	62.1	5.83	81.9	68.4	10.7	3.2	68.4	5.89	88.5	74.1	11.6	7.9	71.7	5.93	91.9	76.8	12.1	14.2
120	17.5	9.3	85	62.9	5.65	82.2	68.2	11.1	3.2	69.3	5.71	88.8	73.9	12.1	7.9	72.6	5.75	92.3	76.7	12.6	14.2

Notes:

1. For ANSI/AHRI/ASHRAE/ISO13256-2 certified ratings, refer to the ANSI/AHRI/ASHRAE/ISO13256-2 WLHP, GWHP and GLHP performance table.
2. EWT= Entering Water Temperature; LWT = Leaving Water Temperature WPD = Waterside Pressure Drop; TC = Total Cooling Capacity HA = Heat of Absorption; COP = Coefficient of Performance; GPM = Gallons per Minute; Source is sometimes called the outdoor side; Load is sometimes called the indoor side.



Performance Data

Table 4. Heating capacities 5 tons - EXW060

Source			Load																	
			Flow 7.5 GPM				Flow 12.5 GPM				Flow 17.5 GPM									
EWT °F	WPD FT		HC Mbtuh	Power kW	HA Mbtuh	LWT °F	EER	WPD FT	HC Mbtuh	Power kW	HA Mbtuh	LWT °F	EER	WPD FT	HC Mbtuh	Power kW	HA Mbtuh	LWT °F	EER	WPD FT
25	7.5	4.3	43.2	2.83	33.5	71.5	4.5	3.5	43.5	2.70	34.3	67.0	4.7	8.4	43.6	2.67	34.5	65.0	4.8	15.2
25	12.5	9.3	46.2	2.83	36.6	72.3	4.8	3.5	46.6	2.71	37.3	67.5	5.0	8.4	46.7	2.67	37.6	65.3	5.1	15.2
25	17.5	16.5	47.7	2.83	38.0	72.7	4.9	3.5	48.1	2.71	38.8	67.7	5.2	8.4	48.2	2.67	39.1	65.5	5.3	15.2
25	7.5	4.3	42.5	3.25	31.4	81.3	3.8	3.3	42.9	3.11	32.2	76.9	4.0	8.2	43.0	3.07	32.5	74.9	4.1	14.8
25	12.5	9.3	45.5	3.25	34.4	82.1	4.1	3.3	45.8	3.11	35.2	77.3	4.3	8.2	46.0	3.07	35.5	75.3	4.4	14.8
25	17.5	16.5	46.9	3.26	35.8	82.5	4.2	3.3	47.3	3.11	36.7	77.6	4.5	8.2	47.4	3.07	36.9	75.4	4.5	14.8
25	7.5	4.3	41.8	3.72	29.1	91.1	3.3	3.3	42.1	3.56	30.0	86.7	3.5	8.0	42.2	3.51	30.3	84.8	3.5	14.4
25	12.5	9.3	44.7	3.73	32.0	91.9	3.5	3.3	45.1	3.56	32.9	87.2	3.7	8.0	45.2	3.51	33.2	85.2	3.8	14.4
25	17.5	16.5	46.1	3.73	33.4	92.3	3.6	3.3	46.5	3.57	34.3	87.4	3.8	8.0	46.6	3.52	34.6	85.3	3.9	14.4
25	7.5	4.3	41.1	4.26	26.6	101.0	2.8	3.2	41.4	4.07	27.5	96.6	3.0	7.8	41.5	4.02	27.8	94.7	3.0	14.1
25	12.5	9.3	44.0	4.26	29.4	101.7	3.0	3.2	44.3	4.08	30.4	97.1	3.2	7.8	44.4	4.02	30.7	95.1	3.2	14.1
25	17.5	16.5	45.4	4.27	30.8	102.1	3.1	3.2	45.7	4.08	31.8	97.3	3.3	7.8	45.8	4.02	32.1	95.2	3.3	14.1
25	7.5	4.3	40.4	4.87	23.8	110.8	2.4	3.1	40.7	4.66	24.8	106.5	2.6	7.6	40.8	4.60	25.1	104.7	2.6	13.7
25	12.5	9.3	43.2	4.88	26.6	111.5	2.6	3.1	43.6	4.66	27.7	107.0	2.7	7.6	43.7	4.60	28.0	105.0	2.8	13.7
25	17.5	16.5	44.6	4.88	28.0	111.9	2.7	3.1	45.0	4.67	29.0	107.2	2.8	7.6	45.1	4.60	29.4	105.2	2.9	13.7
25	7.5	4.3	39.8	5.58	20.7	120.6	2.1	3.0	40.1	5.34	21.9	116.4	2.2	7.4	40.2	5.27	22.2	114.6	2.2	13.4
25	12.5	9.3	42.6	5.59	23.5	121.3	2.2	3.0	42.9	5.34	24.7	116.9	2.4	7.4	43.0	5.27	25.0	114.9	2.4	13.4
25	17.5	16.5	43.9	5.59	24.8	121.7	2.3	3.0	44.3	5.35	26.0	117.1	2.4	7.4	44.4	5.27	26.4	115.1	2.5	13.4
35	7.5	3.6	50.7	2.81	41.1	73.5	5.3	3.5	51.1	2.69	41.9	68.2	5.6	8.4	51.2	2.66	42.1	65.8	5.6	15.2
35	12.5	8.2	54.2	2.82	44.6	74.5	5.6	3.5	54.6	2.69	45.4	68.7	5.9	8.4	54.8	2.66	45.7	66.3	6.0	15.2
35	17.5	14.9	55.9	2.82	46.3	74.9	5.8	3.5	56.4	2.70	47.2	69.0	6.1	8.4	56.5	2.66	47.4	66.5	6.2	15.2
35	7.5	3.6	49.8	3.24	38.7	83.3	4.5	3.3	50.2	3.10	39.6	78.0	4.7	8.2	50.3	3.06	39.9	75.7	4.8	14.8
35	12.5	8.2	53.3	3.24	42.2	84.2	4.8	3.3	53.7	3.10	43.1	78.6	5.1	8.2	53.8	3.06	43.4	76.2	5.2	14.8
35	17.5	14.9	55.0	3.25	43.9	84.7	5.0	3.3	55.4	3.11	44.8	78.9	5.2	8.2	55.5	3.06	45.1	76.3	5.3	14.8
35	7.5	3.6	48.9	3.72	36.2	93.0	3.9	3.3	49.3	3.55	37.2	87.9	4.1	8.0	49.4	3.50	37.5	85.6	4.1	14.4
35	12.5	8.2	52.3	3.72	39.6	94.0	4.1	3.3	52.7	3.56	40.6	88.4	4.3	8.0	52.9	3.51	40.9	86.0	4.4	14.4
35	17.5	14.9	54.0	3.72	41.3	94.4	4.3	3.3	54.4	3.56	42.3	88.7	4.5	8.0	54.5	3.51	42.6	86.2	4.6	14.4
35	7.5	3.6	48.0	4.25	33.5	102.8	3.3	3.2	48.4	4.06	34.5	97.7	3.5	7.8	48.5	4.01	34.8	95.5	3.5	14.1
35	12.5	8.2	51.4	4.25	36.9	103.7	3.5	3.2	51.8	4.07	37.9	98.3	3.7	7.8	51.9	4.01	38.2	95.9	3.8	14.1
35	17.5	14.9	53.0	4.25	38.5	104.1	3.7	3.2	53.4	4.07	39.5	98.5	3.8	7.8	53.5	4.01	39.8	96.1	3.9	14.1
35	7.5	3.6	47.1	4.85	30.6	112.6	2.8	3.1	47.5	4.64	31.7	107.6	3.0	7.6	47.6	4.58	32.0	105.4	3.0	13.7
35	12.5	8.2	50.4	4.86	33.8	113.4	3.0	3.1	50.8	4.65	35.0	108.1	3.2	7.6	50.9	4.58	35.3	105.8	3.3	13.7
35	17.5	14.9	52.0	4.86	35.4	113.9	3.1	3.1	52.4	4.65	36.6	108.4	3.3	7.6	52.6	4.59	36.9	106.0	3.4	13.7

**Table 4. Heating capacities 5 tons - EXW060 (continued)**

Source			Load																		
			Flow 7.5 GPM				Flow 12.5 GPM				Flow 17.5 GPM										
EWT °F	Flow GPM	WPD FT	HC Mbtuh	Power kW	HA Mbtuh	LWT °F	EER	WPD FT	HC Mbtuh	Power kW	HA Mbtuh	LWT °F	EER	WPD FT	HC Mbtuh	Power kW	HA Mbtuh	LWT °F	EER	WPD FT	
35	7.5	3.6	46.3	5.55	27.3	122.3	2.4	3.0	46.6	5.31	28.5	117.5	2.6	7.4	46.8	5.24	28.9	115.3	2.6	13.4	13.4
35	12.5	8.2	49.5	5.55	30.6	123.2	2.6	3.0	49.9	5.31	31.8	118.0	2.8	7.4	50.0	5.24	32.2	115.7	2.8	13.4	13.4
35	17.5	14.9	51.1	5.56	32.1	123.6	2.7	3.0	51.5	5.31	33.4	118.2	2.8	7.4	51.6	5.24	33.7	115.9	2.9	13.4	13.4
35	7.5	3.6	45.5	6.35	23.8	132.1	2.1	2.9	45.9	6.07	25.1	127.3	2.2	7.2	46.0	5.99	25.5	125.3	2.2	13.1	13.1
35	12.5	8.2	48.7	6.35	27.0	133.0	2.2	2.9	49.1	6.08	28.3	127.8	2.4	7.2	49.2	5.99	28.7	125.6	2.4	13.1	13.1
35	17.5	14.9	50.2	6.36	28.5	133.4	2.3	2.9	50.6	6.08	29.9	128.1	2.4	7.2	50.7	6.00	30.3	125.8	2.5	13.1	13.1
45	7.5	3.1	58.0	2.83	48.4	75.5	6.0	3.5	58.5	2.71	49.3	69.4	6.3	8.4	58.6	2.67	49.5	66.7	6.4	15.2	15.2
45	12.5	7.3	62.1	2.83	52.4	76.6	6.4	3.5	62.6	2.71	53.3	70.0	6.8	8.4	62.7	2.67	53.6	67.2	6.9	15.2	15.2
45	17.5	13.6	64.1	2.84	54.4	77.1	6.6	3.5	64.6	2.71	55.3	70.3	7.0	8.4	64.7	2.67	55.6	67.4	7.1	15.2	15.2
45	7.5	3.1	57.0	3.26	45.8	85.2	5.1	3.3	57.4	3.12	46.8	79.2	5.4	8.2	57.6	3.08	47.0	76.6	5.5	14.8	14.8
45	12.5	7.3	60.9	3.27	49.8	86.3	5.5	3.3	61.4	3.12	50.8	79.8	5.8	8.2	61.6	3.08	51.1	77.0	5.9	14.8	14.8
45	17.5	13.6	62.9	3.27	51.7	86.8	5.6	3.3	63.4	3.13	52.7	80.1	5.9	8.2	63.5	3.08	53.0	77.3	6.0	14.8	14.8
45	7.5	3.1	55.9	3.74	43.1	94.9	4.4	3.3	56.3	3.57	44.1	89.0	4.6	8.0	56.4	3.52	44.4	86.4	4.7	14.4	14.4
45	12.5	7.3	59.8	3.74	47.0	95.9	4.7	3.3	60.2	3.58	48.0	89.6	4.9	8.0	60.4	3.53	48.3	86.9	5.0	14.4	14.4
45	17.5	13.6	61.6	3.74	48.9	96.4	4.8	3.3	62.1	3.58	49.9	89.9	5.1	8.0	62.3	3.53	50.2	87.1	5.2	14.4	14.4
45	7.5	3.1	54.7	4.26	40.2	104.6	3.8	3.2	55.2	4.08	41.2	98.8	4.0	7.8	55.3	4.02	41.6	96.3	4.0	14.1	14.1
45	12.5	7.3	58.6	4.27	44.0	105.6	4.0	3.2	59.0	4.08	45.1	99.4	4.2	7.8	59.2	4.03	45.4	96.8	4.3	14.1	14.1
45	17.5	13.6	60.4	4.27	45.8	106.1	4.1	3.2	60.9	4.08	46.9	99.7	4.4	7.8	61.0	4.03	47.3	97.0	4.4	14.1	14.1
45	7.5	3.1	53.6	4.86	37.0	114.3	3.2	3.1	54.0	4.65	38.2	108.6	3.4	7.6	54.2	4.59	38.5	106.2	3.5	13.7	13.7
45	12.5	7.3	57.4	4.87	40.8	115.3	3.5	3.1	57.8	4.65	41.9	109.3	3.6	7.6	58.0	4.59	42.3	106.6	3.7	13.7	13.7
45	17.5	13.6	59.2	4.87	42.6	115.8	3.6	3.1	59.6	4.66	43.8	109.5	3.8	7.6	59.8	4.59	44.1	106.8	3.8	13.7	13.7
45	7.5	3.1	52.5	5.55	33.6	124.0	2.8	3.0	52.9	5.30	34.8	118.5	2.9	7.4	53.1	5.23	35.2	116.1	3.0	13.4	13.4
45	12.5	7.3	56.2	5.55	37.3	125.0	3.0	3.0	56.7	5.31	38.5	119.1	3.1	7.4	56.8	5.23	38.9	116.5	3.2	13.4	13.4
45	17.5	13.6	58.0	5.55	39.0	125.5	3.1	3.0	58.4	5.31	40.3	119.4	3.2	7.4	58.6	5.24	40.7	116.7	3.3	13.4	13.4
45	7.5	3.1	51.5	6.33	29.9	133.7	2.4	2.9	51.9	6.05	31.2	128.3	2.5	7.2	52.0	5.97	31.7	125.9	2.6	13.1	13.1
45	12.5	7.3	55.1	6.33	33.5	134.7	2.5	2.9	55.5	6.06	34.9	128.9	2.7	7.2	55.7	5.97	35.3	126.4	2.7	13.1	13.1
45	17.5	13.6	56.8	6.34	35.2	135.2	2.6	2.9	57.3	6.06	36.6	129.2	2.8	7.2	57.4	5.98	37.0	126.6	2.8	13.1	13.1
55	7.5	2.7	65.7	2.87	55.9	77.5	6.7	3.5	66.3	2.75	56.9	70.6	7.1	8.4	66.4	2.71	57.2	67.6	7.2	15.2	15.2
55	12.5	6.7	70.3	2.87	60.5	78.8	7.2	3.5	70.9	2.75	61.5	71.3	7.6	8.4	71.1	2.71	61.8	68.1	7.7	15.2	15.2
55	17.5	12.5	72.6	2.87	62.8	79.4	7.4	3.5	73.1	2.75	63.8	71.7	7.8	8.4	73.3	2.71	64.1	68.4	7.9	15.2	15.2
55	7.5	2.7	64.4	3.31	53.1	87.2	5.7	3.3	64.9	3.16	54.1	80.4	6.0	8.2	65.1	3.12	54.4	77.4	6.1	14.8	14.8
55	12.5	6.7	68.9	3.31	57.6	88.4	6.1	3.3	69.5	3.16	58.7	81.1	6.4	8.2	69.6	3.12	59.0	78.0	6.5	14.8	14.8
55	17.5	12.5	71.1	3.31	59.8	89.0	6.3	3.3	71.7	3.17	60.9	81.5	6.6	8.2	71.8	3.12	61.2	78.2	6.7	14.8	14.8



Performance Data

Table 4. Heating capacities 5 tons - EXW060 (continued)

Source			Load																	
EWT °F	Flow GPM	WPD FT	Flow 7.5 GPM				Flow 12.5 GPM				Flow 17.5 GPM									
			HC Mbtuh	Power kW	HA Mbtuh	LWT °F	EER	WPD FT	HC Mbtuh	Power kW	HA Mbtuh	LWT °F	EER	WPD FT	HC Mbtuh	Power kW	HA Mbtuh	LWT °F	EER	WPD FT
55	7.5	2.7	63.0	3.78	50.2	96.8	4.9	3.3	63.6	3.61	51.2	90.2	5.2	8.0	63.7	3.57	51.5	87.3	5.2	14.4
55	12.5	6.7	67.5	3.78	54.6	98.0	5.2	3.3	68.0	3.62	55.7	90.9	5.5	8.0	68.2	3.57	56.0	87.8	5.6	14.4
55	17.5	12.5	69.6	3.78	56.7	98.6	5.4	3.3	70.1	3.62	57.8	91.2	5.7	8.0	70.3	3.57	58.1	88.0	5.8	14.4
55	7.5	2.7	61.7	4.30	47.0	106.4	4.2	3.2	62.2	4.12	48.1	99.9	4.4	7.8	62.3	4.06	48.5	97.1	4.5	14.1
55	12.5	6.7	66.0	4.31	51.3	107.6	4.5	3.2	66.5	4.12	52.4	100.6	4.7	7.8	66.7	4.06	52.8	97.6	4.8	14.1
55	17.5	12.5	68.1	4.31	53.4	108.2	4.6	3.2	68.6	4.12	54.5	101.0	4.9	7.8	68.8	4.06	54.9	97.9	5.0	14.1
55	7.5	2.7	60.3	4.89	43.6	116.1	3.6	3.1	60.8	4.68	44.8	109.7	3.8	7.6	60.9	4.62	45.2	107.0	3.9	13.7
55	12.5	6.7	64.5	4.89	47.8	117.2	3.9	3.1	65.0	4.68	49.0	110.4	4.1	7.6	65.2	4.62	49.4	107.4	4.1	13.7
55	17.5	12.5	66.5	4.90	49.8	117.7	4.0	3.1	67.1	4.69	51.1	110.7	4.2	7.6	67.2	4.62	51.5	107.7	4.3	13.7
55	7.5	2.7	58.9	5.56	39.9	125.7	3.1	3.0	59.4	5.32	41.2	119.5	3.3	7.4	59.5	5.25	41.6	116.8	3.3	13.4
55	12.5	6.7	63.0	5.57	44.1	126.8	3.3	3.0	63.6	5.32	45.4	120.2	3.5	7.4	63.7	5.25	45.8	117.3	3.6	13.4
55	17.5	12.5	65.0	5.57	46.0	127.3	3.4	3.0	65.6	5.33	47.4	120.5	3.6	7.4	65.7	5.25	47.8	117.5	3.7	13.4
55	7.5	2.7	57.6	6.33	36.0	135.4	2.7	2.9	58.1	6.05	37.4	129.3	2.8	7.2	58.2	5.97	37.8	126.7	2.9	13.1
55	12.5	6.7	61.6	6.33	40.0	136.4	2.9	2.9	62.1	6.06	41.5	129.9	3.0	7.2	62.3	5.97	41.9	127.1	3.1	13.1
55	17.5	12.5	63.6	6.34	42.0	137.0	2.9	2.9	64.1	6.06	43.4	130.3	3.1	7.2	64.3	5.98	43.9	127.3	3.2	13.1
65	10.0	4.2	77.3	2.92	67.3	80.6	7.7	3.5	77.9	2.80	68.4	72.5	8.2	8.4	78.1	2.76	68.7	68.9	8.3	15.2
65	15.0	8.8	80.8	2.93	70.8	81.5	8.1	3.5	81.4	2.80	71.9	73.0	8.5	8.4	81.6	2.76	72.2	69.3	8.7	15.2
65	7.5	2.5	74.2	2.92	64.2	79.8	7.4	3.5	74.8	2.80	65.2	72.0	7.8	8.4	74.9	2.76	65.5	68.6	8.0	15.2
65	7.5	2.5	72.6	3.36	61.1	89.3	6.3	3.3	73.1	3.22	62.2	81.7	6.7	8.2	73.3	3.17	62.5	78.4	6.8	14.8
65	12.5	6.3	77.6	3.36	66.2	90.7	6.8	3.3	78.3	3.22	67.3	82.5	7.1	8.2	78.4	3.17	67.6	79.0	7.2	14.8
65	17.5	11.7	80.1	3.37	68.6	91.4	7.0	3.3	80.7	3.22	69.7	82.9	7.3	8.2	80.9	3.18	70.1	79.2	7.5	14.8
65	7.5	2.5	70.9	3.83	57.8	98.9	5.4	3.3	71.5	3.67	59.0	91.4	5.7	8.0	71.6	3.62	59.3	88.2	5.8	14.4
65	12.5	6.3	75.9	3.84	62.8	100.2	5.8	3.3	76.5	3.67	63.9	92.2	6.1	8.0	76.6	3.62	64.3	88.8	6.2	14.4
65	17.5	11.7	78.3	3.84	65.2	100.9	6.0	3.3	78.9	3.67	66.4	92.6	6.3	8.0	79.1	3.62	66.7	89.0	6.4	14.4
65	7.5	2.5	69.2	4.35	54.4	108.5	4.7	3.2	69.8	4.16	55.6	101.2	4.9	7.8	69.9	4.11	55.9	98.0	5.0	14.1
65	12.5	6.3	74.1	4.36	59.2	109.8	5.0	3.2	74.7	4.17	60.4	101.9	5.3	7.8	74.8	4.11	60.8	98.6	5.3	14.1
65	17.5	11.7	76.4	4.36	61.5	110.4	5.1	3.2	77.0	4.17	62.8	102.3	5.4	7.8	77.2	4.11	63.2	98.8	5.5	14.1
65	7.5	2.5	67.5	4.93	50.7	118.0	4.0	3.1	68.1	4.72	52.0	110.9	4.2	7.6	68.2	4.65	52.4	107.8	4.3	13.7
65	12.5	6.3	72.3	4.94	55.4	119.3	4.3	3.1	72.8	4.72	56.7	111.7	4.5	7.6	73.0	4.66	57.1	108.3	4.6	13.7
65	17.5	11.7	74.6	4.94	57.7	119.9	4.4	3.1	75.1	4.72	59.0	112.0	4.7	7.6	75.3	4.66	59.4	108.6	4.7	13.7
65	7.5	2.5	65.9	5.59	46.8	127.6	3.5	3.0	66.4	5.35	48.2	120.6	3.6	7.4	66.6	5.27	48.6	117.6	3.7	13.4
65	12.5	6.3	70.5	5.59	51.4	128.8	3.7	3.0	71.0	5.35	52.8	121.4	3.9	7.4	71.2	5.28	53.2	118.1	4.0	13.4
65	17.5	11.7	72.7	5.60	53.6	129.4	3.8	3.0	73.3	5.35	55.0	121.7	4.0	7.4	73.5	5.28	55.5	118.4	4.1	13.4

Table 4. Heating capacities 5 tons - EXW060 (continued)

Source			Load																		
			Flow 7.5 GPM				Flow 12.5 GPM				Flow 17.5 GPM										
EWT °F	Flow GPM	WPD FT	HC Mbtuh	Power kW	HA Mbtuh	LWT °F	EER	WPD FT	HC Mbtuh	Power kW	HA Mbtuh	LWT °F	EER	WPD FT	HC Mbtuh	Power kW	HA Mbtuh	LWT °F	EER	WPD FT	
65	7.5	2.5	64.3	6.34	42.6	137.1	3.0	2.9	64.8	6.06	44.1	130.4	3.1	7.2	64.9	5.98	44.5	127.4	3.2	13.1	
65	12.5	6.3	68.8	6.34	47.1	138.3	3.2	2.9	69.3	6.07	48.6	131.1	3.3	7.2	69.5	5.98	49.0	127.9	3.4	13.1	
65	17.5	11.7	70.9	6.35	49.3	138.9	3.3	2.9	71.5	6.07	50.8	131.4	3.5	7.2	71.7	5.99	51.2	128.2	3.5	13.1	
75	7.5	2.5	83.7	2.98	73.6	82.3	8.2	3.5	84.4	2.85	74.7	73.5	8.7	8.4	84.6	2.81	75.0	69.7	8.8	15.2	
75	12.5	6.0	89.6	2.98	79.4	83.9	8.8	3.5	90.3	2.85	80.6	74.4	9.3	8.4	90.5	2.81	80.9	70.3	9.4	15.2	
75	17.5	11.1	92.4	2.98	82.2	84.6	9.1	3.5	93.2	2.85	83.4	74.9	9.6	8.4	93.4	2.81	83.8	70.7	9.7	15.2	
75	7.5	2.5	81.8	3.42	70.1	91.8	7.0	3.3	82.4	3.27	71.3	83.2	7.4	8.2	82.6	3.23	71.6	79.4	7.5	14.8	
75	12.5	6.0	87.5	3.42	75.8	93.3	7.5	3.3	88.2	3.28	77.0	84.1	7.9	8.2	88.4	3.23	77.4	80.1	8.0	14.8	
75	17.5	11.1	90.3	3.43	78.6	94.1	7.7	3.3	91.0	3.28	79.8	84.6	8.1	8.2	91.2	3.23	80.2	80.4	8.3	14.8	
75	7.5	2.5	79.8	3.89	66.5	101.3	6.0	3.3	80.5	3.72	67.7	92.9	6.3	8.0	80.6	3.67	68.1	89.2	6.4	14.4	
75	12.5	6.0	85.4	3.89	72.1	102.8	6.4	3.3	86.1	3.73	73.4	93.8	6.8	8.0	86.3	3.67	73.7	89.9	6.9	14.4	
75	17.5	11.1	88.1	3.90	74.8	103.5	6.6	3.3	88.8	3.73	76.1	94.2	7.0	8.0	89.0	3.68	76.5	90.2	7.1	14.4	
75	7.5	2.5	77.8	4.41	62.8	110.7	5.2	3.2	78.4	4.21	64.0	102.5	5.5	7.8	78.6	4.16	64.4	99.0	5.5	14.1	
75	12.5	6.0	83.2	4.41	68.2	112.2	5.5	3.2	83.9	4.22	69.5	103.4	5.8	7.8	84.1	4.16	69.9	99.6	5.9	14.1	
75	17.5	11.1	85.9	4.41	70.8	112.9	5.7	3.2	86.6	4.22	72.2	103.9	6.0	7.8	86.8	4.16	72.6	99.9	6.1	14.1	
75	7.5	2.5	75.8	4.98	58.8	120.2	4.5	3.1	76.4	4.76	60.1	112.2	4.7	7.6	76.6	4.70	60.6	108.8	4.8	13.7	
75	12.5	6.0	81.1	4.98	64.1	121.6	4.8	3.1	81.7	4.76	65.5	113.1	5.0	7.6	81.9	4.70	65.9	109.4	5.1	13.7	
75	17.5	11.1	83.7	4.98	66.6	122.3	4.9	3.1	84.3	4.77	68.1	113.5	5.2	7.6	84.5	4.70	68.5	109.7	5.3	13.7	
75	7.5	2.5	73.8	5.62	54.6	129.7	3.8	3.0	74.4	5.38	56.0	121.9	4.1	7.4	74.6	5.30	56.5	118.5	4.1	13.4	
75	12.5	6.0	78.9	5.62	59.8	131.1	4.1	3.0	79.6	5.38	61.2	122.7	4.3	7.4	79.8	5.30	61.7	119.1	4.4	13.4	
75	17.5	11.1	81.4	5.63	62.2	131.7	4.2	3.0	82.1	5.38	63.7	123.1	4.5	7.4	82.3	5.31	64.2	119.4	4.5	13.4	
75	7.5	2.5	71.8	6.35	50.1	139.2	3.3	2.9	72.4	6.07	51.7	131.6	3.5	7.2	72.6	5.99	52.1	128.3	3.5	13.1	
75	12.5	6.0	76.8	6.35	55.2	140.5	3.5	2.9	77.4	6.08	56.7	132.4	3.7	7.2	77.6	5.99	57.2	128.9	3.8	13.1	
75	17.5	11.1	79.3	6.36	57.6	141.1	3.7	2.9	79.9	6.08	59.1	132.8	3.8	7.2	80.1	6.00	59.6	129.2	3.9	13.1	
85	7.5	2.4	94.8	3.03	84.5	85.3	9.2	3.5	95.6	2.90	85.7	75.3	9.7	8.4	95.8	2.86	86.0	70.9	9.8	15.2	
85	12.5	5.8	101.4	3.03	91.1	87.1	9.8	3.5	102.3	2.90	92.4	76.4	10.3	8.4	102.5	2.86	92.7	71.7	10.5	15.2	
85	17.5	10.6	104.7	3.04	94.3	87.9	10.1	3.5	105.5	2.90	95.6	76.9	10.6	8.4	105.7	2.86	96.0	72.1	10.8	15.2	
85	7.5	2.4	70	3.48	80.7	94.7	7.8	3.3	93.3	3.33	81.9	84.9	8.2	8.2	93.5	3.28	82.3	80.7	8.4	14.8	
85	12.5	5.8	70	3.48	87.1	96.4	8.3	3.3	99.8	3.33	88.4	86.0	8.8	8.2	100.0	3.28	88.8	81.4	8.9	14.8	
85	17.5	10.6	70	3.48	90.3	97.2	8.6	3.3	102.9	3.33	91.6	86.5	9.1	8.2	103.2	3.28	92.0	81.8	9.2	14.8	
85	7.5	2.4	80	3.95	76.7	104.1	6.7	3.3	90.9	3.77	78.0	94.5	7.1	8.0	91.1	3.72	78.4	90.4	7.2	14.4	
85	12.5	5.8	80	3.95	83.0	105.7	7.2	3.3	97.3	3.78	84.4	95.6	7.5	8.0	97.5	3.72	84.8	91.1	7.7	14.4	
85	17.5	10.6	80	3.95	86.1	106.5	7.4	3.3	100.3	3.78	87.4	96.1	7.8	8.0	100.6	3.73	87.9	91.5	7.9	14.4	



Performance Data

Table 4. Heating capacities 5 tons - EXW060 (continued)

Source		Load																			
		Flow 7.5 GPM						Flow 12.5 GPM						Flow 17.5 GPM							
		Flow GPM	WPD FT	EWT °F	HC Mbtuh	Power kW	HA Mbtuh	LWT °F	EER	WPD FT	HC Mbtuh	Power kW	HA Mbtuh	LWT °F	EER	WPD FT	HC Mbtuh	Power kW	HA Mbtuh	LWT °F	EER
85	7.5	2.4	90	87.8	4.45	72.6	113.4	5.8	3.2	88.5	4.26	74.0	104.2	6.1	7.8	88.7	4.20	74.4	100.1	6.2	14.1
85	12.5	5.8	90	94.0	4.46	78.7	115.1	6.2	3.2	94.7	4.26	80.2	105.2	6.5	7.8	94.9	4.20	80.6	100.8	6.6	14.1
85	17.5	10.6	90	96.9	4.46	81.7	115.8	6.4	3.2	97.7	4.27	83.1	105.6	6.7	7.8	97.9	4.21	83.6	101.2	6.8	14.1
85	7.5	2.4	100	85.4	5.01	68.3	122.8	5.0	3.1	86.1	4.80	69.7	113.8	5.3	7.6	86.3	4.73	70.2	109.9	5.3	13.7
85	12.5	5.8	100	91.4	5.02	74.3	124.4	5.3	3.1	92.1	4.80	75.7	114.7	5.6	7.6	92.3	4.73	76.2	110.6	5.7	13.7
85	17.5	10.6	100	94.3	5.02	77.2	125.1	5.5	3.1	95.0	4.80	78.7	115.2	5.8	7.6	95.3	4.74	79.1	110.9	5.9	13.7
85	7.5	2.4	110	83.0	5.64	63.8	132.1	4.3	3.0	83.7	5.40	65.3	123.4	4.5	7.4	83.9	5.32	65.7	119.6	4.6	13.4
85	12.5	5.8	110	88.9	5.65	69.6	133.7	4.6	3.0	89.6	5.40	71.1	124.3	4.9	7.4	89.8	5.33	71.6	120.3	4.9	13.4
85	17.5	10.6	110	91.7	5.65	72.4	134.4	4.8	3.0	92.4	5.41	73.9	124.8	5.0	7.4	92.6	5.33	74.4	120.6	5.1	13.4
85	7.5	2.4	120	80.7	6.36	59.0	141.5	3.7	2.9	81.3	6.08	60.6	133.0	3.9	7.2	81.5	6.00	61.1	129.3	4.0	13.1
85	12.5	5.8	120	86.3	6.36	64.6	143.0	4.0	2.9	87.0	6.08	66.3	133.9	4.2	7.2	87.2	6.00	66.8	130.0	4.3	13.1
85	17.5	10.6	120	89.1	6.36	67.4	143.8	4.1	2.9	89.8	6.09	69.0	134.4	4.3	7.2	90.0	6.00	69.5	130.3	4.4	13.1

Notes:

- For ANSI/AHRI/ASHRAE/ISO13256-2 certified ratings, refer to the ANSI/AHRI/ASHRAE/ISO13256-2 WLHP, GWHP and GLHP performance table.
- EWT= Entering Water Temperature; LWT = Leaving Water Temperature WPD = Waterside Pressure Drop; TC = Total Cooling Capacity HA = Heat of Absorption; COP = Coefficient of Performance; GPM = Gallons per Minute; Source is sometimes called the outdoor side; Load is sometimes called the indoor side.

Table 5. Cooling capacities 10 tons - EXW120

Source		Load																			
		Flow 15 GPM						Flow 25 GPM						Flow 35 GPM							
		Flow GPM	WPD FT	EWT °F	TC Mbtuh	Power kW	HR Mbtuh	LWT °F	EER	WPD FT	TC Mbtuh	Power kW	HR Mbtuh	LWT °F	EER	WPD FT	TC Mbtuh	Power kW	HR Mbtuh	LWT °F	EER
50	15.0	4.3	50	102.3	4.95	119.2	36.4	20.7	3.6	112.8	5.01	129.9	41.0	22.5	8.7	118.2	5.04	135.4	43.2	23.5	15.6
50	25.0	11.2	50	105.7	4.60	121.4	35.9	23.0	3.6	116.5	4.65	132.4	40.7	25.1	8.7	122.0	4.68	138.0	43.0	26.1	15.6
50	35.0	20.4	50	107.0	4.46	122.3	35.7	24.0	3.6	118.0	4.51	133.4	40.6	26.2	8.7	123.6	4.54	139.1	42.9	27.2	15.6
50	15.0	4.3	60	120.0	5.01	137.1	44.0	23.9	3.5	132.3	5.07	149.6	49.4	26.1	8.5	138.6	5.10	156.0	52.1	27.2	15.2
50	25.0	11.2	60	123.9	4.65	139.8	43.5	26.6	3.5	136.6	4.70	152.6	49.1	29.0	8.5	143.1	4.73	159.3	51.8	30.2	15.2
50	35.0	20.4	60	125.5	4.52	140.9	43.3	27.8	3.5	138.4	4.57	153.9	48.9	30.3	8.5	145.0	4.59	160.6	51.7	31.6	15.2
50	15.0	4.3	70	139.5	5.10	156.9	51.4	27.3	3.4	153.7	5.15	171.3	57.7	29.8	8.2	161.1	5.19	178.8	60.8	31.1	14.8
50	25.0	11.2	70	144.0	4.73	160.2	50.8	30.4	3.4	158.8	4.78	175.1	57.3	33.2	8.2	166.3	4.82	182.8	60.5	34.5	14.8
50	35.0	20.4	70	145.9	4.59	161.6	50.6	31.8	3.4	160.8	4.64	176.7	57.1	34.6	8.2	168.5	4.67	184.4	60.4	36.1	14.8
50	15.0	4.3	80	160.7	5.22	178.6	58.6	30.8	3.2	177.2	5.28	195.2	65.8	33.6	8.0	185.7	5.31	203.8	69.4	35.0	14.3
50	25.0	11.2	80	166.0	4.85	182.5	57.9	34.3	3.2	183.0	4.90	199.7	65.4	37.4	8.0	191.7	4.93	208.6	69.0	38.9	14.3
50	35.0	20.4	80	168.1	4.70	184.2	57.6	35.8	3.2	185.4	4.75	201.6	65.2	39.0	8.0	194.2	4.78	210.6	68.9	40.6	14.3



**Table 5. Cooling capacities 10 tons - EXW120 (continued)**

Source			Load																		
EWT °F	Flow GPM	WPD FT	Flow 15 GPM				Flow 25 GPM				Flow 35 GPM										
			TC Mbtuh	Power kW	HR Mbtuh	LWT °F	EER	WPD FT	TC Mbtuh	Power kW	HR Mbtuh	LWT °F	EER	WPD FT	TC Mbtuh	Power kW	HR Mbtuh	LWT °F	EER	WPD FT	
50	15.0	4.3	85	172.1	5.30	190.1	62.1	32.5	3.2	189.7	5.35	208.0	69.8	35.4	7.8	198.7	5.39	217.1	73.6	36.9	14.1
50	25.0	11.2	85	177.7	4.92	194.4	61.3	36.1	3.2	195.9	4.97	212.8	69.3	39.4	7.8	205.2	5.00	222.3	73.3	41.0	14.1
50	35.0	20.4	85	180.0	4.77	196.3	61.0	37.7	3.2	198.4	4.82	214.9	69.1	41.1	7.8	207.9	4.85	224.5	73.1	42.8	14.1
60	15.0	3.7	50	97.0	5.72	116.6	37.1	17.0	3.6	107.0	5.79	126.7	41.4	18.5	8.7	112.1	5.82	132.0	43.6	19.3	15.6
60	25.0	10.1	50	100.2	5.31	118.3	36.6	18.9	3.6	110.5	5.37	128.8	41.2	20.6	8.7	115.8	5.41	134.2	43.4	21.4	15.6
60	35.0	18.4	50	101.5	5.16	119.1	36.5	19.7	3.6	111.9	5.21	129.7	41.0	21.5	8.7	117.3	5.25	135.2	43.3	22.4	15.6
60	15.0	3.7	60	114.7	5.80	134.5	44.7	19.8	3.5	126.4	5.86	146.4	49.9	21.6	8.5	132.4	5.90	152.6	52.4	22.4	15.2
60	25.0	10.1	60	118.4	5.39	136.8	44.2	22.0	3.5	130.5	5.44	149.1	49.6	24.0	8.5	136.8	5.48	155.5	52.2	25.0	15.2
60	35.0	18.4	60	119.9	5.23	137.8	44.0	22.9	3.5	132.2	5.28	150.3	49.4	25.0	8.5	138.5	5.32	156.7	52.1	26.1	15.2
60	15.0	3.7	70	134.0	5.91	154.1	52.1	22.7	3.4	147.7	5.97	168.1	58.2	24.7	8.2	154.7	6.01	175.3	61.2	25.7	14.8
60	25.0	10.1	70	138.3	5.49	157.1	51.6	25.2	3.4	152.5	5.54	171.4	57.8	27.5	8.2	159.8	5.58	178.8	60.9	28.6	14.8
60	35.0	18.4	70	140.1	5.32	158.3	51.3	26.3	3.4	154.5	5.38	172.9	57.6	28.7	8.2	161.9	5.41	180.3	60.8	29.9	14.8
60	15.0	3.7	80	154.9	6.06	175.6	59.3	25.6	3.2	170.8	6.12	191.7	66.3	27.9	8.0	179.0	6.16	200.0	69.8	29.1	14.3
60	25.0	10.1	80	160.0	5.62	179.2	58.7	28.5	3.2	176.4	5.68	195.8	65.9	31.0	8.0	184.8	5.72	204.3	69.4	32.3	14.3
60	35.0	18.4	80	162.1	5.46	180.7	58.4	29.7	3.2	178.7	5.51	197.5	65.7	32.4	8.0	187.2	5.55	206.2	69.3	33.7	14.3
60	15.0	3.7	85	166.1	6.15	187.0	62.9	27.0	3.2	183.1	6.21	204.3	70.4	29.5	7.8	191.8	6.25	213.2	74.0	30.7	14.1
60	25.0	10.1	85	171.5	5.71	190.9	62.1	30.0	3.2	189.0	5.77	208.7	69.9	32.8	7.8	198.1	5.80	217.9	73.7	34.1	14.1
60	35.0	18.4	85	173.7	5.54	192.6	61.8	31.4	3.2	191.5	5.60	210.6	69.7	34.2	7.8	200.6	5.63	219.9	73.5	35.6	14.1
70	15.0	3.4	50	94.0	6.57	116.4	37.5	14.3	3.6	103.6	6.64	126.3	41.7	15.6	8.7	108.6	6.68	131.4	43.8	16.3	15.6
70	25.0	9.4	50	97.1	6.10	117.9	37.1	15.9	3.6	107.0	6.16	128.1	41.4	17.4	8.7	112.1	6.20	133.3	43.6	18.1	15.6
70	35.0	17.2	50	98.3	5.92	118.5	36.9	16.6	3.6	108.4	5.98	128.8	41.3	18.1	8.7	113.6	6.02	134.1	43.5	18.9	15.6
70	15.0	3.4	60	111.0	6.65	133.7	45.2	16.7	3.5	122.3	6.72	145.3	50.2	18.2	8.5	128.2	6.77	151.3	52.7	18.9	15.2
70	25.0	9.4	60	114.6	6.18	135.7	44.7	18.6	3.5	126.3	6.24	147.6	49.9	20.2	8.5	132.4	6.28	153.8	52.4	21.1	15.2
70	35.0	17.2	60	116.1	5.99	136.5	44.5	19.4	3.5	128.0	6.06	148.7	49.8	21.1	8.5	134.1	6.10	154.9	52.3	22.0	15.2
70	15.0	3.4	70	129.5	6.77	152.7	52.7	19.1	3.4	142.8	6.85	166.2	58.6	20.9	8.2	149.6	6.89	173.1	61.4	21.7	14.8
70	25.0	9.4	70	133.8	6.29	155.2	52.2	21.3	3.4	147.5	6.36	169.2	58.2	23.2	8.2	154.5	6.40	176.3	61.2	24.2	14.8
70	35.0	17.2	70	135.5	6.10	156.3	51.9	22.2	3.4	149.4	6.17	170.4	58.0	24.2	8.2	156.5	6.21	177.7	61.1	25.2	14.8
70	15.0	3.4	80	149.7	6.94	173.4	60.0	21.6	3.2	165.0	7.01	189.0	68.8	23.5	8.0	172.9	7.05	197.0	70.1	24.5	14.3
70	25.0	9.4	80	154.6	6.44	176.5	59.4	24.0	3.2	170.4	6.51	192.6	68.4	26.2	8.0	178.5	6.55	200.9	69.8	27.3	14.3
70	35.0	17.2	80	156.6	6.25	177.9	59.1	25.1	3.2	172.6	6.32	194.2	68.2	27.3	8.0	180.9	6.36	202.6	69.7	28.5	14.3
70	15.0	3.4	85	160.3	7.04	184.4	63.6	22.8	3.2	176.8	7.11	201.1	70.9	24.9	7.8	185.2	7.16	209.6	74.4	25.9	14.1
70	25.0	9.4	85	165.6	6.53	187.9	62.9	25.3	3.2	182.5	6.60	205.1	70.4	27.6	7.8	191.3	6.65	213.9	74.1	28.8	14.1
70	35.0	17.2	85	167.7	6.34	189.4	62.6	26.5	3.2	184.9	6.41	206.8	70.2	28.9	7.8	193.7	6.45	215.8	73.9	30.0	14.1



Performance Data

Table 5. Cooling capacities 10 tons - EXW120 (continued)

Source			Load																	
			Flow 15 GPM				Flow 25 GPM				Flow 35 GPM									
EWT °F	Flow GPM	WPD FT	TC Mbtuh	Power kW	HR Mbtuh	LWT °F	EER	WPD FT	TC Mbtuh	Power kW	HR Mbtuh	LWT °F	EER	WPD FT	TC Mbtuh	Power kW	HR Mbtuh	LWT °F	EER	WPD FT
80	15.0	3.1	90.1	7.50	115.6	38.0	12.0	3.6	99.3	7.58	125.2	42.1	13.1	8.7	104.0	7.62	130.1	44.1	13.6	15.6
80	25.0	9.0	93.0	6.96	116.8	37.6	13.4	3.6	102.5	7.03	126.5	41.8	14.6	8.7	107.4	7.08	131.6	43.9	15.2	15.6
80	35.0	16.4	94.2	6.75	117.3	37.4	14.0	3.6	103.9	6.83	127.2	41.7	15.2	8.7	108.8	6.87	132.3	43.8	15.8	15.6
80	15.0	3.1	106.2	7.58	132.1	45.8	14.0	3.5	117.1	7.66	143.2	50.6	15.3	8.5	122.7	7.71	149.0	53.0	15.9	15.2
80	25.0	9.0	109.7	7.04	133.7	45.4	15.6	3.5	120.9	7.11	145.2	50.3	17.0	8.5	126.7	7.16	151.1	52.8	17.7	15.2
80	35.0	16.4	111.1	6.83	134.4	45.2	16.3	3.5	122.5	6.90	146.0	50.2	17.7	8.5	128.3	6.95	152.0	52.7	18.5	15.2
80	15.0	3.1	123.9	7.70	150.2	53.5	16.1	3.4	136.6	7.79	163.1	59.1	17.5	8.2	143.1	7.84	169.8	61.8	18.3	14.8
80	25.0	9.0	127.9	7.15	152.3	52.9	17.9	3.4	141.0	7.23	165.7	58.7	19.5	8.2	147.8	7.27	172.6	61.6	20.3	14.8
80	35.0	16.4	129.6	6.94	153.3	52.7	18.7	3.4	142.9	7.01	166.8	58.6	20.4	8.2	149.7	7.06	173.8	61.4	21.2	14.8
80	15.0	3.1	143.1	7.87	169.9	60.9	18.2	3.2	157.7	7.96	184.9	67.4	19.8	8.0	165.3	8.01	192.6	70.6	20.6	14.3
80	25.0	9.0	147.7	7.31	172.7	60.3	20.2	3.2	162.9	7.39	188.1	67.0	22.0	8.0	170.6	7.44	196.0	70.2	22.9	14.3
80	35.0	16.4	149.7	7.09	173.9	60.0	21.1	3.2	165.0	7.17	189.5	66.8	23.0	8.0	172.9	7.22	197.5	70.1	24.0	14.3
80	15.0	3.1	153.2	7.98	180.4	64.6	19.2	3.2	168.9	8.07	196.4	71.5	20.9	7.8	177.0	8.12	204.7	74.9	21.8	14.1
80	25.0	9.0	158.2	7.41	183.5	63.9	21.4	3.2	174.4	7.49	200.0	71.0	23.3	7.8	182.7	7.54	208.5	74.6	24.2	14.1
80	35.0	16.4	160.3	7.19	184.8	63.6	22.3	3.2	176.7	7.27	201.5	70.9	24.3	7.8	185.1	7.31	210.1	74.4	25.3	14.1
90	15.0	2.9	85.1	8.52	114.2	38.7	10.0	3.6	93.8	8.62	123.2	42.5	10.9	8.7	98.3	8.67	127.9	44.4	11.3	15.6
90	25.0	8.8	87.9	7.91	114.9	38.3	11.1	3.6	96.9	8.00	124.2	42.3	12.1	8.7	101.5	8.05	129.0	44.2	12.6	15.6
90	35.0	15.9	89.0	7.68	115.2	38.1	11.6	3.6	98.1	7.76	124.6	42.1	12.6	8.7	102.8	7.81	129.5	44.1	13.2	15.6
90	15.0	2.9	100.4	8.60	129.7	46.6	11.7	3.5	110.7	8.69	140.3	51.1	12.7	8.5	116.0	8.74	145.8	53.4	13.3	15.2
90	25.0	8.8	103.7	7.98	130.9	46.2	13.0	3.5	114.3	8.07	141.8	50.9	14.2	8.5	119.7	8.12	147.5	53.2	14.7	15.2
90	35.0	15.9	105.0	7.75	131.4	46.0	13.6	3.5	115.8	7.83	142.5	50.7	14.8	8.5	121.3	7.88	148.2	53.1	15.4	15.2
90	15.0	2.9	117.2	8.71	146.9	54.4	13.4	3.4	129.2	8.81	159.2	59.7	14.7	8.2	135.3	8.86	165.6	62.3	15.3	14.8
90	25.0	8.8	121.0	8.09	148.6	53.9	15.0	3.4	133.4	8.18	161.3	59.3	16.3	8.2	139.8	8.23	167.8	62.0	17.0	14.8
90	35.0	15.9	122.6	7.85	149.4	53.7	15.6	3.4	135.1	7.94	162.2	59.2	17.0	8.2	141.6	7.99	168.8	61.9	17.7	14.8
90	15.0	2.9	135.4	8.88	165.7	61.9	15.2	3.2	149.3	8.98	179.9	68.1	16.6	8.0	156.4	9.04	187.2	71.1	17.3	14.3
90	25.0	8.8	139.8	8.25	168.0	61.4	17.0	3.2	154.2	8.34	182.6	67.7	18.5	8.0	161.5	8.39	190.1	70.8	19.3	14.3
90	35.0	15.9	141.6	8.00	169.0	61.1	17.7	3.2	156.2	8.09	183.8	67.5	19.3	8.0	163.6	8.14	191.4	70.7	20.1	14.3
90	15.0	2.9	145.1	8.99	175.7	65.7	16.1	3.2	159.9	9.09	190.9	72.2	17.6	7.8	167.6	9.14	198.8	75.4	18.3	14.1
90	25.0	8.8	149.8	8.35	178.3	65.0	17.9	3.2	165.1	8.44	193.9	71.8	19.6	7.8	173.0	8.49	202.0	75.1	20.4	14.1
90	35.0	15.9	151.7	8.10	179.4	64.8	18.7	3.2	167.3	8.19	195.2	71.6	20.4	7.8	175.3	8.24	203.4	75.0	21.3	14.1
100	15.0	2.8	79.5	9.66	112.4	39.4	8.2	3.6	87.6	9.77	120.9	43.0	9.0	8.7	91.8	9.83	125.3	44.8	9.3	15.6
100	25.0	8.6	82.1	8.97	112.7	39.1	9.1	3.6	90.5	9.07	121.4	42.8	10.0	8.7	94.8	9.13	125.9	44.6	10.4	15.6
100	35.0	15.6	83.1	8.71	112.8	38.9	9.5	3.6	91.6	8.80	121.7	42.7	10.4	8.7	96.0	8.86	126.2	44.5	10.8	15.6

**Table 5. Cooling capacities 10 tons - EXW120 (continued)**

Source		Load																			
		Flow 15 GPM			Flow 25 GPM			Flow 35 GPM													
EWT °F	Flow GPM	WPD FT	TC Mbtuh	Power kW	HR Mbtuh	LWT °F	EER	WPD FT	TC Mbtuh	Power kW	HR Mbtuh	LWT °F	EER	WPD FT							
100	15.0	2.8	60	94.0	9.72	127.1	47.5	9.7	3.5	103.6	9.82	137.1	51.7	10.5	8.5	108.5	9.88	142.3	53.8	11.0	15.2
100	25.0	8.6	60	97.0	9.02	127.8	47.1	10.8	3.5	107.0	9.12	138.1	51.4	11.7	8.5	112.1	9.18	143.4	53.6	12.2	15.2
100	35.0	15.6	60	98.3	8.75	128.2	46.9	11.2	3.5	108.4	8.85	138.6	51.3	12.2	8.5	113.5	8.91	143.9	53.5	12.8	15.2
100	15.0	2.8	70	109.9	9.82	143.4	55.3	11.2	3.4	121.2	9.92	155.1	60.3	12.2	8.2	127.0	9.99	161.0	62.7	12.7	14.8
100	25.0	8.6	70	113.5	9.12	144.6	54.9	12.5	3.4	125.1	9.21	156.6	60.0	13.6	8.2	131.1	9.27	162.8	62.5	14.1	14.8
100	35.0	15.6	70	115.0	8.85	145.2	54.7	13.0	3.4	126.8	8.94	157.3	59.9	14.2	8.2	132.8	9.00	163.5	62.4	14.8	14.8
100	15.0	2.8	80	127.3	9.98	161.3	63.0	12.8	3.2	140.3	10.08	174.7	68.8	13.9	8.0	147.0	10.15	181.6	71.6	14.5	14.3
100	25.0	8.6	80	131.4	9.26	163.0	62.5	14.2	3.2	144.9	9.36	176.8	68.4	15.5	8.0	151.8	9.42	184.0	71.3	16.1	14.3
100	35.0	15.6	80	133.1	8.99	163.8	62.2	14.8	3.2	146.8	9.08	177.8	68.3	16.2	8.0	153.8	9.14	185.0	71.2	16.8	14.3
100	15.0	2.8	85	136.5	10.08	170.9	66.8	13.5	3.2	150.4	10.19	185.2	73.0	14.8	7.8	157.6	10.25	192.6	76.0	15.4	14.1
100	25.0	8.6	85	140.9	9.36	172.8	66.2	15.1	3.2	155.4	9.46	187.6	72.6	16.4	7.8	162.8	9.52	195.3	75.7	17.1	14.1
100	35.0	15.6	85	142.7	9.08	173.7	66.0	15.7	3.2	157.4	9.18	188.7	72.4	17.1	7.8	164.9	9.24	196.4	75.6	17.9	14.1
110	15.0	2.6	50	73.5	10.93	110.8	40.2	6.7	3.6	81.1	11.05	118.8	43.5	7.3	8.7	85.0	11.12	122.9	45.1	7.6	15.6
110	25.0	8.5	50	75.9	10.15	110.6	39.9	7.5	3.6	83.7	10.26	118.7	43.3	8.2	8.7	87.7	10.32	123.0	45.0	8.5	15.6
110	35.0	15.4	50	76.9	9.85	110.5	39.7	7.8	3.6	84.8	9.95	118.8	43.2	8.5	8.7	88.9	10.02	123.0	44.9	8.9	15.6
110	15.0	2.6	60	87.3	10.95	124.7	48.4	8.0	3.5	96.3	11.07	134.1	52.3	8.7	8.5	100.9	11.14	138.9	54.2	9.1	15.2
110	25.0	8.5	60	90.2	10.17	124.9	48.0	8.9	3.5	99.4	10.28	134.5	52.0	9.7	8.5	104.2	10.34	139.5	54.0	10.1	15.2
110	35.0	15.4	60	91.3	9.87	125.0	47.8	9.3	3.5	100.7	9.97	134.7	51.9	10.1	8.5	105.5	10.04	139.8	54.0	10.5	15.2
110	15.0	2.6	70	102.5	11.03	140.1	56.3	9.3	3.4	113.0	11.15	151.0	61.0	10.1	8.2	118.4	11.22	156.7	63.2	10.6	14.8
110	25.0	8.5	70	105.8	10.24	140.8	55.9	10.3	3.4	116.7	10.35	152.0	60.7	11.3	8.2	122.3	10.42	157.8	63.0	11.7	14.8
110	35.0	15.4	70	107.2	9.94	141.1	55.7	10.8	3.4	118.2	10.04	152.5	60.5	11.8	8.2	123.8	10.11	158.3	62.9	12.3	14.8
110	15.0	2.6	80	119.0	11.17	157.1	64.1	10.7	3.2	131.2	11.29	169.8	69.5	11.6	8.0	137.5	11.36	176.3	72.1	12.1	14.3
110	25.0	8.5	80	122.9	10.37	158.3	63.6	11.9	3.2	135.5	10.48	171.3	69.2	12.9	8.0	142.0	10.55	178.0	71.9	13.5	14.3
110	35.0	15.4	80	124.5	10.06	158.9	63.4	12.4	3.2	137.3	10.17	172.0	69.0	13.5	8.0	143.8	10.23	178.8	71.8	14.1	14.3
110	15.0	2.6	85	127.8	11.26	166.2	68.0	11.3	3.2	140.9	11.38	179.8	73.7	12.4	7.8	147.6	11.45	186.7	76.6	12.9	14.1
110	25.0	8.5	85	132.0	10.45	167.7	67.4	12.6	3.2	145.5	10.57	181.6	73.4	13.8	7.8	152.5	10.63	188.7	76.3	14.3	14.1
110	35.0	15.4	85	133.7	10.15	168.3	67.2	13.2	3.2	147.4	10.25	182.4	73.2	14.4	7.8	154.4	10.32	189.7	76.2	15.0	14.1
120	15.0	2.4	50	67.6	12.33	109.7	41.0	5.5	3.6	74.5	12.47	117.1	44.0	6.0	8.7	78.1	12.54	120.9	45.5	6.2	15.6
120	25.0	8.4	50	69.8	11.45	108.9	40.7	6.1	3.6	76.9	11.57	116.4	43.8	6.6	8.7	80.6	11.65	120.4	45.4	6.9	15.6
120	35.0	15.3	50	70.7	11.11	108.6	40.6	6.4	3.6	77.9	11.23	116.3	43.8	6.9	8.7	81.7	11.30	120.2	45.3	7.2	15.6
120	15.0	2.4	60	80.7	12.32	122.7	49.2	6.5	3.5	88.9	12.45	131.4	52.9	7.1	8.5	93.2	12.53	136.0	54.7	7.4	15.2
120	25.0	8.4	60	83.3	11.44	122.3	48.9	7.3	3.5	91.9	11.56	131.3	52.7	7.9	8.5	96.2	11.63	135.9	54.5	8.3	15.2
120	35.0	15.3	60	84.4	11.10	122.3	48.7	7.6	3.5	93.0	11.22	131.3	52.6	8.3	8.5	97.5	11.29	136.0	54.4	8.6	15.2

**Table 5. Cooling capacities 10 tons - EXW120 (continued)**

Source		Load																			
		Flow 15 GPM				Flow 25 GPM				Flow 35 GPM											
EWT °F	WPD FT	Flow GPM	TC Mbtuh	Power kW	HR Mbtuh	LWT °F	EER	WPD FT	TC Mbtuh	Power kW	HR Mbtuh	LWT °F	EER	WPD FT	TC Mbtuh	Power kW	HR Mbtuh	LWT °F	EER	WPD FT	
120	15.0	2.4	70	95.2	12.36	137.3	57.3	7.7	3.4	104.9	12.49	147.6	61.6	8.4	8.2	109.9	12.57	152.8	63.7	8.7	14.8
120	25.0	8.4	70	98.3	11.48	137.4	56.9	8.6	3.4	108.3	11.60	147.9	61.3	9.3	8.2	113.5	11.67	153.3	63.5	9.7	14.8
120	35.0	15.3	70	99.5	11.14	137.5	56.7	8.9	3.4	109.7	11.26	148.2	61.2	9.7	8.2	115.0	11.33	153.6	63.4	10.1	14.8
120	15.0	2.4	80	111.0	12.47	153.5	65.2	8.9	3.2	122.3	12.60	165.4	70.2	9.7	8.0	128.2	12.68	171.5	72.7	10.1	14.3
120	25.0	8.4	80	114.6	11.58	154.1	64.7	9.9	3.2	126.3	11.70	166.3	69.9	10.8	8.0	132.4	11.77	172.6	72.4	11.2	14.3
120	35.0	15.3	80	116.1	11.23	154.4	64.5	10.3	3.2	128.0	11.35	166.7	69.8	11.3	8.0	134.1	11.43	173.1	72.3	11.7	14.3
120	15.0	2.4	85	119.4	12.55	162.2	69.1	9.5	3.2	131.6	12.68	174.9	74.5	10.4	7.8	137.9	12.76	181.5	77.1	10.8	14.1
120	25.0	8.4	85	123.3	11.65	163.0	68.6	10.6	3.2	135.9	11.78	176.1	74.1	11.5	7.8	142.4	11.85	182.8	76.9	12.0	14.1
120	35.0	15.3	85	124.9	11.31	163.5	68.4	11.0	3.2	137.7	11.43	176.7	74.0	12.0	7.8	144.2	11.50	183.5	76.8	12.5	14.1

**Notes:**

1. For ANSI/AHR/ASHRAE/ISO13256-2 certified ratings, refer to the ANSI/AHR/ASHRAE/ISO13256-2 WLHP, GWHP and GLHP performance table.
2. EWT = Entering Water Temperature; LWT = Leaving Water Temperature; WPD = Waterside Pressure Drop; TC = Total Cooling Capacity; HA = Heat of Absorption; COP = Coefficient of Performance; GPM = Gallons per Minute; Source is sometimes called the outdoor side; Load is sometimes called the indoor side.

**Table 6. Heating capacities 10 tons - EXW120**

Source		Load																			
		Flow 15 GPM				Flow 25 GPM				Flow 35 GPM											
EWT °F	WPD FT	Flow GPM	HC Mbtuh	Power kW	HA Mbtuh	LWT °F	EER	WPD FT	HC Mbtuh	Power kW	HA Mbtuh	LWT °F	EER	WPD FT	HC Mbtuh	Power kW	HA Mbtuh	LWT °F	EER	WPD FT	
25	15.0	9.3	60	90.5	6.19	69.4	72.1	4.3	3.5	91.2	5.92	71.0	67.3	4.5	8.5	91.4	5.84	71.5	65.2	4.6	15.2
25	25.0	19.9	60	96.8	6.19	75.7	72.9	4.6	3.5	97.6	5.92	77.4	67.8	4.8	8.5	97.8	5.84	77.9	65.6	4.9	15.2
25	35.0	33.8	60	99.9	6.19	78.7	73.3	4.7	3.5	100.7	5.92	80.4	68.1	5.0	8.5	100.9	5.84	80.9	65.8	5.1	15.2
25	15.0	9.3	70	87.8	7.00	63.9	81.7	3.7	3.4	88.5	6.70	65.6	77.1	3.9	8.2	88.7	6.61	66.1	75.1	3.9	14.8
25	25.0	19.9	70	93.9	7.01	70.0	82.5	3.9	3.4	94.6	6.70	71.8	77.6	4.1	8.2	94.9	6.61	72.3	75.4	4.2	14.8
25	35.0	33.8	70	96.9	7.01	72.9	82.9	4.0	3.4	97.6	6.71	74.8	77.8	4.3	8.2	97.9	6.61	75.3	75.6	4.3	14.8
25	15.0	9.3	80	85.2	7.93	58.1	91.4	3.1	3.2	85.9	7.59	60.0	86.9	3.3	8.0	86.1	7.48	60.6	84.9	3.4	14.3
25	25.0	19.9	80	91.2	7.94	64.1	92.2	3.4	3.2	91.9	7.59	66.0	87.4	3.5	8.0	92.1	7.49	66.6	85.3	3.6	14.3
25	35.0	33.8	80	94.1	7.94	66.9	92.5	3.5	3.2	94.8	7.60	68.9	87.6	3.7	8.0	95.0	7.49	69.5	85.4	3.7	14.3
25	15.0	9.3	90	82.9	8.99	52.2	101.0	2.7	3.2	83.5	8.60	54.2	96.7	2.8	7.7	83.7	8.48	54.8	94.8	2.9	14.0
25	25.0	19.9	90	88.6	9.00	57.9	101.8	2.9	3.2	89.4	8.61	60.0	97.1	3.0	7.7	89.6	8.49	60.6	95.1	3.1	14.0
25	35.0	33.8	90	91.5	9.00	60.7	102.2	3.0	3.2	92.2	8.61	62.8	97.4	3.1	7.7	92.4	8.49	63.4	95.3	3.2	14.0
25	15.0	9.3	100	80.7	10.20	45.9	110.8	2.3	3.1	81.4	9.75	48.1	106.5	2.4	7.6	81.6	9.62	48.8	104.7	2.5	13.6
25	25.0	19.9	100	86.4	10.20	51.6	111.5	2.5	3.1	87.1	9.76	53.8	107.0	2.6	7.6	87.3	9.62	54.4	105.0	2.7	13.6
25	35.0	33.8	100	89.1	10.21	54.3	111.9	2.6	3.1	89.8	9.77	56.5	107.2	2.7	7.6	90.1	9.63	57.2	105.1	2.7	13.6
25	15.0	9.3	110	78.9	11.56	39.5	120.5	2.0	3.0	79.6	11.06	41.8	116.4	2.1	7.4	79.8	10.90	42.5	114.6	2.1	13.4

Table 6. Heating capacities 10 tons - EXW120 (continued)

Source			Load																	
			Flow 15 GPM				Flow 25 GPM				Flow 35 GPM									
EWT °F	Flow GPM	WPD FT	HC Mbtuh	Power kW	HA Mbtuh	LWT °F	EER	WPD FT	HC Mbtuh	Power kW	HA Mbtuh	LWT °F	EER	WPD FT	HC Mbtuh	Power kW	HA Mbtuh	LWT °F	EER	WPD FT
25	25.0	19.9	84.5	11.57	45.0	121.3	2.1	3.0	85.1	11.06	47.4	116.8	2.3	7.4	85.3	10.91	48.1	114.9	2.3	13.4
25	35.0	33.8	87.1	11.57	47.6	121.6	2.2	3.0	87.8	11.07	50.0	117.0	2.3	7.4	88.0	10.92	50.8	115.0	2.4	13.4
35	15.0	6.2	102.5	6.06	81.8	73.7	5.0	3.5	103.3	5.79	83.5	68.3	5.2	8.5	103.5	5.72	84.0	65.9	5.3	15.2
35	25.0	14.7	109.6	6.06	88.9	74.6	5.3	3.5	110.5	5.80	90.7	68.8	5.6	8.5	110.8	5.72	91.3	66.3	5.7	15.2
35	35.0	26.0	113.1	6.07	92.4	75.1	5.5	3.5	114.0	5.80	94.2	69.1	5.8	8.5	114.3	5.72	94.7	66.5	5.9	15.2
35	15.0	6.2	100.0	6.91	76.4	83.3	4.2	3.4	100.8	6.61	78.3	78.1	4.5	8.2	101.1	6.52	78.8	75.8	4.5	14.8
35	25.0	14.7	107.0	6.92	83.4	84.3	4.5	3.4	107.9	6.62	85.3	78.6	4.8	8.2	108.1	6.52	85.9	76.2	4.9	14.8
35	35.0	26.0	110.4	6.92	86.8	84.7	4.7	3.4	111.3	6.62	88.7	78.9	4.9	8.2	111.6	6.53	89.3	76.4	5.0	14.8
35	15.0	6.2	97.6	7.87	70.8	93.0	3.6	3.2	98.4	7.53	72.7	87.9	3.8	8.0	98.7	7.42	73.3	85.6	3.9	14.3
35	25.0	14.7	104.5	7.87	77.6	93.9	3.9	3.2	105.3	7.53	79.6	88.4	4.1	8.0	105.6	7.43	80.2	86.0	4.2	14.3
35	35.0	26.0	107.8	7.88	80.9	94.4	4.0	3.2	108.6	7.54	82.9	88.7	4.2	8.0	108.9	7.43	83.5	86.2	4.3	14.3
35	15.0	6.2	95.3	8.94	64.8	102.7	3.1	3.2	96.1	8.55	66.9	97.7	3.3	7.7	96.3	8.43	67.5	95.5	3.3	14.0
35	25.0	14.7	102.0	8.95	71.5	103.6	3.3	3.2	102.8	8.56	73.6	98.2	3.5	7.7	103.1	8.44	74.3	95.9	3.6	14.0
35	35.0	26.0	105.2	8.95	74.7	104.0	3.4	3.2	106.1	8.56	76.9	98.5	3.6	7.7	106.3	8.44	77.5	96.1	3.7	14.0
35	15.0	6.2	93.2	10.14	58.6	112.4	2.7	3.1	93.9	9.70	60.8	107.5	2.8	7.6	94.1	9.57	61.5	105.4	2.9	13.6
35	25.0	14.7	99.7	10.15	65.0	113.3	2.9	3.1	100.5	9.71	67.3	108.0	3.0	7.6	100.7	9.57	68.0	105.8	3.1	13.6
35	35.0	26.0	102.8	10.16	68.2	113.7	3.0	3.1	103.7	9.71	70.5	108.3	3.1	7.6	103.9	9.58	71.2	105.9	3.2	13.6
35	15.0	6.2	91.2	11.49	52.0	122.2	2.3	3.0	91.9	10.99	54.4	117.4	2.4	7.4	92.1	10.84	55.1	115.3	2.5	13.4
35	25.0	14.7	97.6	11.50	58.3	123.0	2.5	3.0	98.3	11.00	60.8	117.9	2.6	7.4	98.6	10.85	61.6	115.6	2.7	13.4
35	35.0	26.0	100.7	11.51	61.4	123.4	2.6	3.0	101.5	11.01	63.9	118.1	2.7	7.4	101.7	10.86	64.7	115.8	2.7	13.4
35	15.0	6.2	89.5	13.00	45.1	131.9	2.0	2.9	90.2	12.44	47.7	127.2	2.1	7.2	90.4	12.27	48.5	125.2	2.2	13.1
35	25.0	14.7	95.7	13.01	51.3	132.8	2.2	2.9	96.5	12.44	54.0	127.7	2.3	7.2	96.7	12.27	54.8	125.5	2.3	13.1
35	35.0	26.0	98.7	13.02	54.3	133.2	2.2	2.9	99.5	12.45	57.0	128.0	2.3	7.2	99.8	12.28	57.8	125.7	2.4	13.1
45	15.0	4.8	60	5.99	93.7	75.2	5.6	3.5	115.0	5.73	95.5	69.2	5.9	8.5	115.3	5.65	96.0	66.6	6.0	15.2
45	25.0	12.1	60	5.99	101.6	76.3	6.0	3.5	123.1	5.73	103.5	69.8	6.3	8.5	123.4	5.65	104.1	67.0	6.4	15.2
45	35.0	21.8	60	5.99	105.5	76.8	6.2	3.5	127.0	5.73	107.4	70.2	6.5	8.5	127.3	5.65	108.0	67.3	6.6	15.2
45	15.0	4.8	70	6.87	88.3	84.9	4.8	3.4	112.7	6.57	90.2	79.0	5.0	8.2	112.9	6.48	90.8	76.5	5.1	14.8
45	25.0	12.1	70	6.87	96.1	85.9	5.1	3.4	120.5	6.57	98.1	79.6	5.4	8.2	120.8	6.48	98.7	76.9	5.5	14.8
45	35.0	21.8	70	6.88	99.9	86.4	5.3	3.4	124.4	6.58	101.9	79.9	5.5	8.2	124.7	6.49	102.5	77.1	5.6	14.8
45	15.0	4.8	80	7.84	82.6	94.6	4.1	3.2	110.2	7.50	84.6	88.8	4.3	8.0	110.5	7.40	85.2	86.3	4.4	14.3
45	25.0	12.1	80	7.85	90.2	95.6	4.4	3.2	117.9	7.51	92.3	89.4	4.6	8.0	118.2	7.40	92.9	86.8	4.7	14.3
45	35.0	21.8	80	7.85	93.9	96.1	4.5	3.2	121.7	7.51	96.0	89.7	4.7	8.0	122.0	7.41	96.7	87.0	4.8	14.3
45	15.0	4.8	90	8.92	76.5	104.3	3.5	3.2	107.8	8.53	78.6	98.6	3.7	7.7	108.0	8.42	79.3	96.2	3.8	14.0

# Performance Data

**Table 6. Heating capacities 10 tons - EXW120 (continued)**

Source			Load																		
			Flow 15 GPM				Flow 25 GPM				Flow 35 GPM										
EWT °F	Flow GPM	WPD FT	HC Mbtuh	Power kW	HA Mbtuh	LWT °F	EER	WPD FT	HC Mbtuh	Power kW	HA Mbtuh	LWT °F	EER	WPD FT	HC Mbtuh	Power kW	HA Mbtuh	LWT °F	EER	WPD FT	
45	25.0	12.1	90	114.4	8.93	83.9	105.3	3.8	3.2	115.3	8.54	86.2	99.2	4.0	7.7	115.6	8.42	86.8	96.6	4.0	14.0
45	35.0	21.8	90	118.0	8.93	87.5	105.7	3.9	3.2	118.9	8.54	89.8	99.5	4.1	7.7	119.2	8.43	90.5	96.8	4.1	14.0
45	15.0	4.8	100	104.5	10.12	70.0	113.9	3.0	3.1	105.3	9.68	72.3	108.4	3.2	7.6	105.6	9.54	73.0	106.0	3.2	13.6
45	25.0	12.1	100	111.8	10.12	77.2	114.9	3.2	3.1	112.7	9.68	79.6	109.0	3.4	7.6	113.0	9.55	80.4	106.5	3.5	13.6
45	35.0	21.8	100	115.3	10.13	80.8	115.4	3.3	3.1	116.3	9.69	83.2	109.3	3.5	7.6	116.5	9.56	83.9	106.7	3.6	13.6
45	15.0	4.8	110	102.1	11.44	63.1	123.6	2.6	3.0	103.0	10.95	65.6	118.2	2.8	7.4	103.2	10.80	66.4	115.9	2.8	13.4
45	25.0	12.1	110	109.3	11.45	70.2	124.6	2.8	3.0	110.2	10.95	72.8	118.8	2.9	7.4	110.4	10.80	73.6	116.3	3.0	13.4
45	35.0	21.8	110	112.7	11.46	73.6	125.0	2.9	3.0	113.6	10.96	76.2	119.1	3.0	7.4	113.9	10.81	77.0	116.5	3.1	13.4
45	15.0	4.8	120	99.9	12.92	55.8	133.3	2.3	2.9	100.7	12.36	58.5	128.1	2.4	7.2	101.0	12.19	59.4	125.8	2.4	13.1
45	25.0	12.1	120	106.9	12.93	62.8	134.3	2.4	2.9	107.8	12.37	65.6	128.6	2.6	7.2	108.0	12.20	66.4	126.2	2.6	13.1
45	35.0	21.8	120	110.3	12.94	66.1	134.7	2.5	2.9	111.2	12.38	68.9	128.9	2.6	7.2	111.5	12.21	69.8	126.4	2.7	13.1
55	15.0	4.0	60	126.4	5.97	106.1	76.9	6.2	3.5	127.4	5.71	108.0	70.2	6.5	8.5	127.7	5.63	108.5	67.3	6.6	15.2
55	25.0	10.6	60	135.3	5.97	114.9	78.0	6.6	3.5	136.3	5.71	116.9	70.9	7.0	8.5	136.7	5.63	117.5	67.8	7.1	15.2
55	35.0	19.3	60	139.6	5.97	119.2	78.6	6.8	3.5	140.7	5.71	121.2	71.3	7.2	8.5	141.0	5.64	121.8	68.1	7.3	15.2
55	15.0	4.0	70	124.0	6.87	100.5	86.5	5.3	3.4	125.0	6.57	102.5	80.0	5.6	8.2	125.3	6.48	103.1	77.2	5.7	14.8
55	25.0	10.6	70	132.7	6.88	109.2	87.7	5.7	3.4	133.7	6.58	111.3	80.7	6.0	8.2	134.0	6.49	111.9	77.7	6.1	14.8
55	35.0	19.3	70	136.9	6.88	113.4	88.2	5.8	3.4	137.9	6.58	115.5	81.0	6.1	8.2	138.3	6.49	116.1	77.9	6.2	14.8
55	15.0	4.0	80	121.4	7.86	94.5	96.2	4.5	3.2	122.3	7.51	96.7	89.8	4.8	8.0	122.6	7.41	97.3	87.0	4.8	14.3
55	25.0	10.6	80	129.8	7.86	103.0	97.3	4.8	3.2	130.9	7.52	105.2	90.5	5.1	8.0	131.2	7.42	105.9	87.5	5.2	14.3
55	35.0	19.3	80	134.0	7.87	107.1	97.9	5.0	3.2	135.0	7.52	109.3	90.8	5.3	8.0	135.3	7.42	110.0	87.7	5.3	14.3
55	15.0	4.0	90	118.6	8.93	88.1	105.8	3.9	3.2	119.5	8.54	90.4	99.6	4.1	7.7	119.8	8.43	91.1	96.8	4.2	14.0
55	25.0	10.6	90	126.9	8.94	96.4	106.9	4.2	3.2	127.9	8.55	98.7	100.2	4.4	7.7	128.2	8.43	99.4	97.3	4.5	14.0
55	35.0	19.3	90	130.9	8.94	100.4	107.5	4.3	3.2	131.9	8.55	102.7	100.6	4.5	7.7	132.3	8.44	103.5	97.6	4.6	14.0
55	15.0	4.0	100	115.7	10.11	81.2	115.4	3.4	3.1	116.6	9.67	83.6	109.3	3.5	7.6	116.9	9.54	84.4	106.7	3.6	13.6
55	25.0	10.6	100	123.8	10.12	89.3	116.5	3.6	3.1	124.8	9.68	91.8	110.0	3.8	7.6	125.1	9.54	92.5	107.1	3.8	13.6
55	35.0	19.3	100	127.7	10.12	93.2	117.0	3.7	3.1	128.8	9.68	95.7	110.3	3.9	7.6	129.1	9.55	96.5	107.4	4.0	13.6
55	15.0	4.0	110	112.8	11.41	73.9	125.0	2.9	3.0	113.7	10.92	76.5	119.1	3.1	7.4	114.0	10.77	77.3	116.5	3.1	13.4
55	25.0	10.6	110	120.7	11.42	81.8	126.1	3.1	3.0	121.7	10.92	84.4	119.7	3.3	7.4	122.0	10.77	85.2	117.0	3.3	13.4
55	35.0	19.3	110	124.5	11.43	85.5	126.6	3.2	3.0	125.5	10.93	88.2	120.0	3.4	7.4	125.8	10.78	89.0	117.2	3.4	13.4
55	15.0	4.0	120	110.0	12.85	66.1	134.7	2.5	2.9	110.8	12.29	68.9	128.9	2.6	7.2	111.1	12.12	69.7	126.3	2.7	13.1
55	25.0	10.6	120	117.6	12.86	73.8	135.7	2.7	2.9	118.6	12.30	76.6	129.5	2.8	7.2	118.9	12.13	77.5	126.8	2.9	13.1
55	35.0	19.3	120	121.4	12.86	77.5	136.2	2.8	2.9	122.3	12.31	80.3	129.8	2.9	7.2	122.6	12.14	81.2	127.0	3.0	13.1
65	20.0	6.6	60	146.3	6.00	125.9	79.5	7.1	3.5	147.5	5.74	127.9	71.8	7.5	8.5	147.9	5.66	128.6	68.4	7.7	15.2

**Table 6. Heating capacities 10 tons - EXW120 (continued)**

Source			Load																	
			Flow 15 GPM				Flow 25 GPM				Flow 35 GPM									
EWT °F	Flow GPM	WPD FT	HC Mbtuh	Power kW	HA Mbtuh	LWT °F	EER	WPD FT	HC Mbtuh	Power kW	HA Mbtuh	LWT °F	EER	WPD FT	HC Mbtuh	Power kW	HA Mbtuh	LWT °F	EER	WPD FT
65	30.0	13.3	153.0	6.00	132.5	80.4	7.5	3.5	154.2	5.74	134.6	72.3	7.9	8.5	154.5	5.66	135.2	68.8	8.0	15.2
65	15.0	3.5	140.5	6.00	120.0	78.7	6.9	3.5	141.6	5.74	122.0	71.3	7.2	8.5	141.9	5.66	122.6	68.1	7.3	15.2
65	15.0	3.5	137.7	6.92	114.1	88.4	5.8	3.4	138.8	6.62	116.2	81.1	6.1	8.2	139.2	6.53	116.9	78.0	6.2	14.8
65	25.0	9.7	147.4	6.92	123.7	89.6	6.2	3.4	148.5	6.62	125.9	81.9	6.6	8.2	148.9	6.53	126.6	78.5	6.7	14.8
65	35.0	17.8	152.0	6.93	128.4	90.3	6.4	3.4	153.2	6.63	130.6	82.3	6.8	8.2	153.6	6.54	131.3	78.8	6.9	14.8
65	15.0	3.5	134.7	7.91	107.7	98.0	5.0	3.2	135.8	7.56	110.0	90.9	5.3	8.0	136.1	7.46	110.6	87.8	5.3	14.3
65	25.0	9.7	144.1	7.91	117.1	99.2	5.3	3.2	145.3	7.57	119.4	91.6	5.6	8.0	145.6	7.46	120.1	88.3	5.7	14.3
65	35.0	17.8	148.7	7.92	121.7	99.8	5.5	3.2	149.9	7.57	124.0	92.0	5.8	8.0	150.2	7.47	124.7	88.6	5.9	14.3
65	15.0	3.5	131.4	8.97	100.8	107.5	4.3	3.2	132.5	8.58	103.2	100.6	4.5	7.7	132.8	8.46	103.9	97.6	4.6	14.0
65	25.0	9.7	140.6	8.97	110.0	108.7	4.6	3.2	141.7	8.58	112.4	101.3	4.8	7.7	142.1	8.47	113.2	98.1	4.9	14.0
65	35.0	17.8	145.0	8.98	114.4	109.3	4.7	3.2	146.2	8.59	116.9	101.7	5.0	7.7	146.6	8.47	117.6	98.4	5.1	14.0
65	15.0	3.5	127.9	10.13	93.4	117.1	3.7	3.1	128.9	9.69	95.9	110.3	3.9	7.6	129.2	9.55	96.6	107.4	4.0	13.6
65	25.0	9.7	136.9	10.13	102.3	118.2	4.0	3.1	138.0	9.69	104.9	111.0	4.2	7.6	138.3	9.56	105.7	107.9	4.2	13.6
65	35.0	17.8	141.2	10.14	106.6	118.8	4.1	3.1	142.3	9.70	109.2	111.4	4.3	7.6	142.7	9.57	110.0	108.2	4.4	13.6
65	15.0	3.5	124.3	11.39	85.4	126.6	3.2	3.0	125.3	10.90	88.1	120.0	3.4	7.4	125.6	10.75	88.9	117.2	3.4	13.4
65	25.0	9.7	133.0	11.40	94.1	127.7	3.4	3.0	134.0	10.90	96.8	120.7	3.6	7.4	134.4	10.75	97.7	117.7	3.7	13.4
65	35.0	17.8	137.2	11.41	98.3	128.3	3.5	3.0	138.3	10.91	101.0	121.1	3.7	7.4	138.6	10.76	101.9	117.9	3.8	13.4
65	15.0	3.5	120.6	12.78	76.9	136.1	2.8	2.9	121.5	12.22	79.8	129.7	2.9	7.2	121.8	12.06	80.7	127.0	3.0	13.1
65	25.0	9.7	129.0	12.79	85.3	137.2	3.0	2.9	130.0	12.23	88.3	130.4	3.1	7.2	130.3	12.06	89.2	127.4	3.2	13.1
65	35.0	17.8	133.1	12.80	89.4	137.7	3.0	2.9	134.1	12.24	92.4	130.7	3.2	7.2	134.5	12.07	93.2	127.7	3.3	13.1
75	15.0	3.3	157.2	6.08	136.5	81.0	7.6	3.5	158.5	5.81	138.7	72.7	8.0	8.5	158.9	5.73	139.3	69.1	8.1	15.2
75	25.0	9.2	168.2	6.08	147.5	82.4	8.1	3.5	169.6	5.82	149.7	73.6	8.5	8.5	170.0	5.74	150.4	69.7	8.7	15.2
75	35.0	16.8	173.6	6.08	152.8	83.1	8.4	3.5	174.9	5.82	155.1	74.0	8.8	8.5	175.4	5.74	155.8	70.0	9.0	15.2
75	15.0	3.3	154.0	7.01	130.1	90.5	6.4	3.4	155.3	6.70	132.4	82.4	6.8	8.2	155.6	6.61	133.1	78.9	6.9	14.8
75	25.0	9.2	164.8	7.01	140.9	92.0	6.9	3.4	166.1	6.70	143.2	83.3	7.3	8.2	166.5	6.61	143.9	79.5	7.4	14.8
75	35.0	16.8	170.0	7.01	146.1	92.7	7.1	3.4	171.4	6.71	148.5	83.7	7.5	8.2	171.8	6.62	149.2	79.8	7.6	14.8
75	15.0	3.3	150.4	7.99	123.1	100.1	5.5	3.2	151.6	7.64	125.5	92.1	5.8	8.0	152.0	7.53	126.2	88.7	5.9	14.3
75	25.0	9.2	160.9	7.99	133.6	101.5	5.9	3.2	162.2	7.64	136.1	93.0	6.2	8.0	162.6	7.54	136.9	89.3	6.3	14.3
75	35.0	16.8	166.0	8.00	138.7	102.1	6.1	3.2	167.3	7.65	141.2	93.4	6.4	8.0	167.7	7.54	142.0	89.6	6.5	14.3
75	15.0	3.3	146.4	9.03	115.6	109.5	4.7	3.2	147.6	8.64	118.1	101.8	5.0	7.7	147.9	8.52	118.8	98.5	5.1	14.0
75	25.0	9.2	156.6	9.04	125.8	110.9	5.1	3.2	157.9	8.65	128.4	102.6	5.4	7.7	158.3	8.53	129.2	99.0	5.4	14.0
75	35.0	16.8	161.6	9.04	130.7	111.5	5.2	3.2	162.9	8.65	133.4	103.0	5.5	7.7	163.3	8.53	134.2	99.3	5.6	14.0
75	15.0	3.3	142.1	10.16	107.4	118.9	4.1	3.1	143.2	9.72	110.1	111.5	4.3	7.6	143.6	9.58	110.9	108.2	4.4	13.6



Performance Data

Table 6. Heating capacities 10 tons - EXW120 (continued)

Source			Load																	
			Flow 15 GPM				Flow 25 GPM				Flow 35 GPM									
EWT °F	Flow GPM	WPD FT	HC Mbtuh	Power kW	HA Mbtuh	LWT °F	EER	WPD FT	HC Mbtuh	Power kW	HA Mbtuh	LWT °F	EER	WPD FT	HC Mbtuh	Power kW	HA Mbtuh	LWT °F	EER	WPD FT
75	25.0	9.2	152.0	10.17	117.3	120.3	4.4	3.1	153.3	9.72	120.1	112.3	4.6	7.6	153.6	9.59	120.9	108.8	4.7	13.6
75	35.0	16.8	156.9	10.17	122.1	120.9	4.5	3.1	158.1	9.73	124.9	112.6	4.8	7.6	158.5	9.60	125.7	109.1	4.8	13.6
75	15.0	3.3	137.5	11.38	98.7	128.3	3.5	3.0	138.6	10.89	101.5	121.1	3.7	7.4	139.0	10.74	102.3	117.9	3.8	13.4
75	25.0	9.2	147.2	11.39	108.3	129.6	3.8	3.0	148.3	10.89	111.2	121.9	4.0	7.4	148.7	10.74	112.0	118.5	4.1	13.4
75	35.0	16.8	151.8	11.40	112.9	130.2	3.9	3.0	153.0	10.90	115.8	122.2	4.1	7.4	153.4	10.75	116.7	118.8	4.2	13.4
75	15.0	3.3	132.8	12.71	89.4	137.7	3.1	2.9	133.8	12.16	92.3	130.7	3.2	7.2	134.2	11.99	93.2	127.7	3.3	13.1
75	25.0	9.2	142.1	12.72	98.6	138.9	3.3	2.9	143.2	12.17	101.7	131.5	3.4	7.2	143.5	12.00	102.6	128.2	3.5	13.1
75	35.0	16.8	146.6	12.73	103.1	139.5	3.4	2.9	147.7	12.18	106.2	131.8	3.6	7.2	148.1	12.01	107.1	128.5	3.6	13.1
85	15.0	3.0	177.8	6.20	156.6	83.7	8.4	3.5	179.2	5.93	159.0	74.3	8.9	8.5	179.6	5.85	159.7	70.3	9.0	15.2
85	25.0	8.9	190.2	6.20	169.1	85.4	9.0	3.5	191.7	5.93	171.5	75.3	9.5	8.5	192.2	5.85	172.2	71.0	9.6	15.2
85	35.0	16.1	196.3	6.21	175.1	86.2	9.3	3.5	197.8	5.94	177.6	75.8	9.8	8.5	198.3	5.86	178.3	71.3	9.9	15.2
85	15.0	3.0	173.9	7.13	149.6	93.2	7.1	3.4	175.3	6.82	152.0	84.0	7.5	8.2	175.7	6.73	152.8	80.0	7.7	14.8
85	25.0	8.9	186.1	7.13	161.7	94.8	7.6	3.4	187.6	6.82	164.3	85.0	8.1	8.2	188.0	6.73	165.0	80.7	8.2	14.8
85	35.0	16.1	192.0	7.14	167.6	95.6	7.9	3.4	193.5	6.83	170.2	85.5	8.3	8.2	194.0	6.73	171.0	81.1	8.4	14.8
85	15.0	3.0	169.5	8.10	141.9	102.6	6.1	3.2	170.9	7.74	144.4	93.7	6.5	8.0	171.3	7.64	145.2	89.8	6.6	14.3
85	25.0	8.9	181.4	8.10	153.7	104.2	6.6	3.2	182.8	7.75	156.4	94.6	6.9	8.0	183.2	7.64	157.2	90.5	7.0	14.3
85	35.0	16.1	187.1	8.11	159.4	104.9	6.8	3.2	188.6	7.75	162.1	95.1	7.1	8.0	189.0	7.65	162.9	90.8	7.2	14.3
85	15.0	3.0	164.6	9.12	133.5	112.0	5.3	3.2	165.9	8.72	136.2	103.3	5.6	7.7	166.3	8.60	137.0	99.5	5.7	14.0
85	25.0	8.9	176.1	9.12	145.0	113.5	5.7	3.2	177.5	8.73	147.8	104.2	6.0	7.7	178.0	8.61	148.6	100.2	6.1	14.0
85	35.0	16.1	181.7	9.13	150.5	114.2	5.8	3.2	183.2	8.73	153.4	104.7	6.1	7.7	183.6	8.61	154.2	100.5	6.2	14.0
85	15.0	3.0	159.3	10.21	124.5	121.2	4.6	3.1	160.6	9.76	127.3	112.8	4.8	7.6	161.0	9.63	128.1	109.2	4.9	13.6
85	25.0	8.9	170.5	10.21	135.6	122.7	4.9	3.1	171.8	9.77	138.5	113.7	5.2	7.6	172.2	9.64	139.3	109.8	5.2	13.6
85	35.0	16.1	175.9	10.22	141.0	123.4	5.0	3.1	177.3	9.78	143.9	114.2	5.3	7.6	177.7	9.64	144.8	110.2	5.4	13.6
85	15.0	3.0	153.6	11.38	114.8	130.5	4.0	3.0	154.9	10.88	117.7	122.4	4.2	7.4	155.2	10.73	118.6	118.9	4.2	13.4
85	25.0	8.9	164.4	11.39	125.5	131.9	4.2	3.0	165.7	10.89	128.5	123.3	4.5	7.4	166.1	10.74	129.4	119.5	4.5	13.4
85	35.0	16.1	169.6	11.39	130.7	132.6	4.4	3.0	170.9	10.90	133.7	123.7	4.6	7.4	171.3	10.75	134.7	119.8	4.7	13.4
85	15.0	3.0	147.6	12.65	104.5	139.7	3.4	2.9	148.8	12.10	107.5	131.9	3.6	7.2	149.2	11.93	108.4	128.5	3.7	13.1
85	25.0	8.9	158.0	12.65	114.8	141.1	3.7	2.9	159.2	12.10	117.9	132.7	3.9	7.2	159.6	11.94	118.9	129.1	3.9	13.1
85	35.0	16.1	163.0	12.66	119.7	141.7	3.8	2.9	164.3	12.11	122.9	133.1	4.0	7.2	164.6	11.95	123.9	129.4	4.0	13.1

Notes:

- For ANSI/AHRI/ASHRAE/ISO13256-2 certified ratings, refer to the ANSI/AHRI/ASHRAE/ISO13256-2 WLHP, GWHP and GLHP performance table.
- EWT = Entering Water Temperature; LWT = Leaving Water Temperature; WPD = Waterside Pressure Drop; TC = Total Cooling Capacity; HA = Heat of Absorption; COP = Coefficient of Performance; GPM = Gallons per Minute; Source is sometimes called the outdoor side; Load is sometimes called the indoor side.



Table 7. Cooling capacities 20 tons - EXW240

Source		Load																			
		Flow 30 GPM				Flow 50 GPM				Flow 70 GPM											
		WPD FT	EWT °F	TC Mbtuh	Power kW	HR Mbtuh	LWT °F	EER	WPD FT	TC Mbtuh	Power kW	HR Mbtuh	LWT °F	EER	WPD FT	TC Mbtuh	Power kW	HR Mbtuh	LWT °F	EER	WPD FT
50	30.0	3.4	50	189.1	9.57	221.8	37.4	19.8	3.6	208.5	9.68	241.6	41.7	21.5	8.7	218.5	9.74	251.7	43.8	22.4	15.7
50	50.0	8.1	50	195.3	8.89	225.7	37.0	22.0	3.6	215.3	8.99	246.0	41.4	24.0	8.7	225.6	9.04	256.5	43.6	25.0	15.7
50	70.0	14.1	50	197.9	8.63	227.3	36.8	22.9	3.6	218.1	8.72	247.9	41.3	25.0	8.7	228.5	8.77	258.5	43.5	26.0	15.7
50	30.0	3.4	60	220.9	9.88	254.6	45.3	22.4	3.5	243.6	9.98	277.6	50.3	24.4	8.4	255.2	10.05	289.5	52.7	25.4	15.2
50	50.0	8.1	60	228.1	9.17	259.4	44.8	24.9	3.5	251.5	9.27	283.1	49.9	27.1	8.4	263.5	9.33	295.4	52.5	28.3	15.2
50	70.0	14.1	60	231.1	8.90	261.5	44.6	26.0	3.5	254.8	8.99	285.5	49.8	28.3	8.4	266.9	9.05	297.8	52.4	29.5	15.2
50	30.0	3.4	70	256.3	10.26	291.3	52.9	25.0	3.3	282.5	10.37	317.9	58.7	27.2	8.2	296.0	10.43	331.6	61.5	28.4	14.8
50	50.0	8.1	70	264.6	9.52	297.1	52.4	27.8	3.3	291.7	9.63	324.6	58.3	30.3	8.2	305.7	9.69	338.7	61.3	31.6	14.8
50	70.0	14.1	70	268.1	9.24	299.6	52.1	29.0	3.3	295.5	9.34	327.4	58.2	31.6	8.2	309.6	9.40	341.7	61.2	32.9	14.8
50	30.0	3.4	80	296.6	10.73	333.2	60.2	27.7	3.2	327.0	10.84	364.0	66.9	30.2	8.0	342.6	10.91	379.9	70.2	31.4	14.5
50	50.0	8.1	80	306.3	9.96	340.3	59.6	30.8	3.2	337.7	10.07	372.1	66.5	33.5	8.0	353.8	10.13	388.4	69.9	34.9	14.5
50	70.0	14.1	80	310.3	9.66	343.3	59.3	32.1	3.2	342.1	9.77	375.4	66.3	35.0	8.0	358.4	9.83	392.0	69.8	36.5	14.5
50	30.0	3.4	85	319.1	11.00	356.7	63.7	29.0	3.2	351.9	11.11	389.8	70.9	31.7	7.9	368.7	11.18	406.8	74.5	33.0	14.3
50	50.0	8.1	85	329.6	10.21	364.4	63.0	32.3	3.2	363.3	10.32	398.6	70.5	35.2	7.9	380.7	10.38	416.1	74.1	36.7	14.3
50	70.0	14.1	85	333.8	9.91	367.7	62.7	33.7	3.2	368.1	10.01	402.2	70.3	36.8	7.9	385.6	10.08	420.0	74.0	38.3	14.3
60	30.0	3.0	50	181.9	10.88	219.0	37.9	16.7	3.6	200.6	11.00	238.1	42.0	18.2	8.7	210.1	11.07	247.9	44.0	19.0	15.7
60	50.0	7.4	50	187.8	10.10	222.3	37.5	18.6	3.6	207.1	10.21	241.9	41.7	20.3	8.7	217.0	10.27	252.0	43.8	21.1	15.7
60	70.0	13.0	50	190.3	9.80	223.7	37.3	19.4	3.6	209.8	9.91	243.6	41.6	21.2	8.7	219.8	9.97	253.8	43.7	22.0	15.7
60	30.0	3.0	60	213.1	11.19	251.3	45.8	19.0	3.5	234.9	11.31	273.6	50.6	20.8	8.4	246.2	11.38	285.0	53.0	21.6	15.2
60	50.0	7.4	60	220.1	10.39	255.5	45.3	21.2	3.5	242.6	10.50	278.5	50.3	23.1	8.4	254.2	10.57	290.3	52.7	24.0	15.2
60	70.0	13.0	60	222.9	10.08	257.3	45.1	22.1	3.5	245.8	10.19	280.5	50.2	24.1	8.4	257.5	10.26	292.5	52.6	25.1	15.2
60	30.0	3.0	70	247.6	11.59	287.1	53.5	21.4	3.3	272.9	11.72	312.9	59.1	23.3	8.2	286.0	11.79	326.2	61.8	24.3	14.8
60	50.0	7.4	70	255.6	10.76	292.4	53.0	23.8	3.3	281.9	10.88	319.0	58.7	25.9	8.2	295.3	10.95	332.7	61.6	27.0	14.8
60	70.0	13.0	70	259.0	10.44	294.6	52.7	24.8	3.3	285.5	10.56	321.5	58.6	27.0	8.2	299.1	10.62	335.4	61.5	28.2	14.8
60	30.0	3.0	80	286.8	12.09	328.0	60.9	23.7	3.2	316.2	12.22	357.9	67.4	25.9	8.0	331.3	12.29	373.2	70.5	26.9	14.5
60	50.0	7.4	80	296.1	11.22	334.4	60.3	26.4	3.2	326.5	11.34	365.2	66.9	28.8	8.0	342.1	11.41	381.0	70.2	30.0	14.5
60	70.0	13.0	80	300.0	10.89	337.2	60.0	27.6	3.2	330.8	11.00	368.3	66.8	30.1	8.0	346.5	11.07	384.3	70.1	31.3	14.5
60	30.0	3.0	85	308.6	12.37	350.9	64.4	25.0	3.2	340.3	12.50	382.9	71.4	27.2	7.9	356.5	12.58	399.5	74.8	28.3	14.3
60	50.0	7.4	85	318.7	11.48	357.9	63.8	27.8	3.2	351.4	11.61	391.0	70.9	30.3	7.9	368.1	11.68	408.0	74.5	31.5	14.3
60	70.0	13.0	85	322.9	11.14	360.9	63.5	29.0	3.2	356.0	11.26	394.4	70.8	31.6	7.9	372.9	11.33	411.6	74.3	32.9	14.3
70	30.0	2.8	50	174.7	12.28	216.6	38.4	14.2	3.6	192.6	12.41	234.9	42.3	15.5	8.7	201.8	12.49	244.4	44.2	16.2	15.7
70	50.0	6.9	50	180.4	11.40	219.3	38.0	15.8	3.6	198.9	11.52	238.2	42.0	17.3	8.7	208.3	11.59	247.9	44.0	18.0	15.7
70	70.0	12.3	50	182.7	11.06	220.5	37.8	16.5	3.6	201.4	11.18	239.6	41.9	18.0	8.7	211.1	11.25	249.5	44.0	18.8	15.7
70	30.0	2.8	60	205.1	12.59	248.1	46.3	16.3	3.5	226.2	12.72	269.6	51.0	17.8	8.4	237.0	12.80	280.7	53.2	18.5	15.2
70	50.0	6.9	60	211.8	11.69	251.7	45.9	18.1	3.5	233.5	11.81	273.9	50.7	19.8	8.4	244.7	11.89	285.3	53.0	20.6	15.2
70	70.0	12.3	60	214.6	11.34	253.3	45.7	18.9	3.5	236.6	11.46	275.7	50.5	20.6	8.4	247.9	11.53	287.2	52.9	21.5	15.2



Performance Data

Table 7. Cooling capacities 20 tons - EXW240 (continued)

Source			Load																	
EWT °F	Flow GPM	WPD FT	Flow 30 GPM				Flow 50 GPM				Flow 70 GPM									
			TC Mbtuh	Power kW	HR Mbtuh	LWT °F	EER	WPD FT	TC Mbtuh	Power kW	HR Mbtuh	LWT °F	EER	WPD FT	TC Mbtuh	Power kW	HR Mbtuh	LWT °F	EER	WPD FT
70	30.0	2.8	238.6	12.99	283.0	54.1	18.4	3.3	263.1	13.13	307.9	59.5	20.0	8.2	275.6	13.21	320.7	62.1	20.9	14.8
70	50.0	6.9	246.4	12.06	287.6	53.6	20.4	3.3	271.7	12.19	313.3	59.1	22.3	8.2	284.6	12.27	326.5	61.9	23.2	14.8
70	70.0	12.3	249.6	11.70	289.5	53.4	21.3	3.3	275.2	11.83	315.6	59.0	23.3	8.2	288.3	11.90	329.0	61.8	24.2	14.8
70	30.0	2.8	276.6	13.49	322.6	61.6	20.5	3.2	304.9	13.64	351.5	67.8	22.4	8.0	319.5	13.72	366.3	70.9	23.3	14.5
70	50.0	6.9	285.6	12.53	328.3	61.0	22.8	3.2	314.9	12.66	358.1	67.4	24.9	8.0	329.9	12.74	373.4	70.6	25.9	14.5
70	70.0	12.3	289.3	12.16	330.8	60.7	23.8	3.2	319.0	12.29	360.9	67.2	26.0	8.0	334.2	12.36	376.4	70.5	27.0	14.5
70	30.0	2.8	297.7	13.78	344.7	65.2	21.6	3.2	328.2	13.93	375.7	71.9	23.6	7.9	343.9	14.02	391.7	75.2	24.5	14.3
70	50.0	6.9	307.4	12.80	351.1	64.5	24.0	3.2	338.9	12.93	383.0	71.4	26.2	7.9	355.1	13.02	399.5	74.9	27.3	14.3
70	70.0	12.3	311.4	12.42	353.8	64.2	25.1	3.2	343.3	12.55	386.1	71.3	27.4	7.9	359.7	12.63	402.8	74.7	28.5	14.3
80	30.0	2.7	167.2	13.81	214.3	38.9	12.1	3.6	184.3	13.95	231.9	42.6	13.2	8.7	193.1	14.04	241.0	44.5	13.8	15.7
80	50.0	6.6	172.6	12.82	216.4	38.5	13.5	3.6	190.3	12.95	234.5	42.4	14.7	8.7	199.4	13.04	243.9	44.3	15.3	15.7
80	70.0	11.8	174.9	12.44	217.3	38.3	14.1	3.6	192.8	12.57	235.7	42.3	15.3	8.7	202.0	12.65	245.2	44.2	16.0	15.7
80	30.0	2.7	196.8	14.10	244.9	46.9	14.0	3.5	217.0	14.25	265.6	51.3	15.2	8.4	227.3	14.34	276.3	53.5	15.9	15.2
80	50.0	6.6	203.2	13.09	247.9	46.5	15.5	3.5	224.1	13.23	269.2	51.0	16.9	8.4	234.7	13.31	280.2	53.3	17.6	15.2
80	70.0	11.8	205.9	12.70	249.2	46.3	16.2	3.5	227.0	12.84	270.8	50.9	17.7	8.4	237.8	12.92	281.9	53.2	18.4	15.2
80	30.0	2.7	229.1	14.49	278.6	54.7	15.8	3.3	252.6	14.65	302.6	59.9	17.2	8.2	264.7	14.74	315.0	62.4	18.0	14.8
80	50.0	6.6	236.6	13.45	282.5	54.2	17.6	3.3	260.9	13.60	307.3	59.6	19.2	8.2	273.3	13.69	320.0	62.2	20.0	14.8
80	70.0	11.8	239.7	13.06	284.3	54.0	18.4	3.3	264.3	13.20	309.3	59.4	20.0	8.2	276.9	13.28	322.2	62.1	20.8	14.8
80	30.0	2.7	265.7	14.99	316.8	62.3	17.7	3.2	292.9	15.15	344.6	68.3	19.3	8.0	306.9	15.25	358.9	71.2	20.1	14.5
80	50.0	6.6	274.4	13.92	321.9	61.7	19.7	3.2	302.5	14.07	350.5	67.9	21.5	8.0	316.9	14.16	365.2	70.9	22.4	14.5
80	70.0	11.8	277.9	13.50	324.0	61.5	20.6	3.2	306.4	13.65	353.0	67.7	22.4	8.0	321.0	13.74	367.9	70.8	23.4	14.5
80	30.0	2.7	286.0	15.28	338.1	65.9	18.7	3.2	315.3	15.44	368.0	72.4	20.4	7.9	330.4	15.54	383.4	75.6	21.3	14.3
80	50.0	6.6	295.3	14.19	343.7	65.3	20.8	3.2	325.6	14.34	374.5	72.0	22.7	7.9	341.1	14.43	390.4	75.3	23.6	14.3
80	70.0	11.8	299.2	13.77	346.2	65.1	21.7	3.2	329.8	13.91	377.3	71.8	23.7	7.9	345.6	14.00	393.4	75.1	24.7	14.3
90	30.0	2.6	159.2	15.50	212.1	39.4	10.3	3.6	175.5	15.67	229.0	43.0	11.2	8.7	183.9	15.77	237.7	44.7	11.7	15.7
90	50.0	6.4	164.4	14.40	213.5	39.0	11.4	3.6	181.2	14.55	230.9	42.8	12.5	8.7	189.9	14.64	239.9	44.6	13.0	15.7
90	70.0	11.4	166.5	13.97	214.2	38.9	11.9	3.6	183.6	14.12	231.8	42.7	13.0	8.7	192.4	14.21	240.9	44.5	13.5	15.7
90	30.0	2.6	187.8	15.77	241.6	47.5	11.9	3.5	207.1	15.94	261.5	51.7	13.0	8.4	217.0	16.04	271.7	53.8	13.5	15.2
90	50.0	6.4	194.0	14.64	243.9	47.1	13.2	3.5	213.8	14.80	264.3	51.4	14.5	8.4	224.0	14.89	274.9	53.6	15.0	15.2
90	70.0	11.4	196.5	14.20	245.0	46.9	13.8	3.5	216.6	14.36	265.6	51.3	15.1	8.4	227.0	14.45	276.3	53.5	15.7	15.2
90	30.0	2.6	218.9	16.13	274.0	55.4	13.6	3.3	241.4	16.31	297.0	60.3	14.8	8.2	252.9	16.41	308.9	62.8	15.4	14.8
90	50.0	6.4	226.0	14.98	277.2	54.9	15.1	3.3	249.2	15.14	300.9	60.0	16.5	8.2	261.1	15.24	313.1	62.5	17.1	14.8
90	70.0	11.4	229.0	14.54	278.6	54.7	15.8	3.3	252.5	14.69	302.6	59.9	17.2	8.2	264.5	14.79	315.0	62.4	17.9	14.8
90	30.0	2.6	253.9	16.61	310.6	63.1	15.3	3.2	279.9	16.79	337.3	68.8	16.7	8.0	293.3	16.90	351.0	71.6	17.4	14.5
90	50.0	6.4	262.2	15.42	314.8	62.5	17.0	3.2	289.1	15.59	342.3	68.4	18.5	8.0	302.9	15.69	356.4	71.3	19.3	14.5
90	70.0	11.4	265.6	14.97	316.7	62.3	17.7	3.2	292.8	15.13	344.5	68.3	19.4	8.0	306.8	15.22	358.8	71.2	20.2	14.5

Table 7. Cooling capacities 20 tons - EXW240 (continued)

Source		Load																		
		Flow 30 GPM				Flow 50 GPM				Flow 70 GPM										
EWT °F	WPD FT	Flow GPM	TC Mbtuh	Power kW	HR Mbtuh	LWT °F	EER	WPD FT	TC Mbtuh	Power kW	HR Mbtuh	LWT °F	EER	WPD FT	TC Mbtuh	Power kW	HR Mbtuh	LWT °F	EER	WPD FT
90	30.0	2.6	273.4	16.90	331.0	66.8	16.2	3.2	301.4	17.08	359.7	72.9	17.6	7.9	315.8	17.19	374.4	76.0	18.4	14.3
90	50.0	6.4	282.3	15.69	335.8	66.2	18.0	3.2	311.2	15.85	365.3	72.6	19.6	7.9	326.1	15.96	380.5	75.7	20.4	14.3
90	70.0	11.4	285.9	15.22	337.9	65.9	18.8	3.2	315.3	15.39	367.8	72.4	20.5	7.9	330.3	15.48	383.1	75.6	21.3	14.3
100	30.0	2.5	150.4	17.41	209.9	40.0	8.6	3.6	165.9	17.60	225.9	43.4	9.4	8.7	173.8	17.71	234.2	45.0	9.8	15.7
100	50.0	6.2	155.4	16.17	210.5	39.6	9.6	3.6	171.3	16.34	227.1	43.1	10.5	8.7	179.5	16.45	235.6	44.9	10.9	15.7
100	70.0	11.2	157.4	15.69	210.9	39.5	10.0	3.6	173.5	15.86	227.6	43.1	10.9	8.7	181.8	15.96	236.3	44.8	11.4	15.7
100	30.0	2.5	178.0	17.63	238.1	48.1	10.1	3.5	196.2	17.82	257.0	52.2	11.0	8.4	205.6	17.93	266.8	54.1	11.5	15.2
100	50.0	6.2	183.8	16.37	239.6	47.7	11.2	3.5	202.6	16.54	259.1	51.9	12.2	8.4	212.3	16.65	269.1	53.9	12.8	15.2
100	70.0	11.2	186.2	15.88	240.4	47.6	11.7	3.5	205.2	16.05	260.0	51.8	12.8	8.4	215.0	16.16	270.2	53.9	13.3	15.2
100	30.0	2.5	207.7	17.96	268.9	56.2	11.6	3.3	228.9	18.15	290.9	60.8	12.6	8.2	239.9	18.27	302.2	63.1	13.1	14.8
100	50.0	6.2	214.4	16.67	271.3	55.7	12.9	3.3	236.4	16.85	293.9	60.5	14.0	8.2	247.7	16.96	305.6	62.9	14.6	14.8
100	70.0	11.2	217.2	16.18	272.4	55.5	13.4	3.3	239.5	16.35	295.3	60.4	14.6	8.2	250.9	16.46	307.1	62.8	15.2	14.8
100	30.0	2.5	241.0	18.40	303.8	63.9	13.1	3.2	265.7	18.60	329.2	69.4	14.3	8.0	278.4	18.72	342.3	72.0	14.9	14.5
100	50.0	6.2	248.9	17.08	307.2	63.4	14.6	3.2	274.4	17.27	333.3	69.0	15.9	8.0	287.5	17.38	346.8	71.8	16.5	14.5
100	70.0	11.2	252.1	16.58	308.7	63.2	15.2	3.2	277.9	16.76	335.1	68.9	16.6	8.0	291.2	16.86	348.8	71.7	17.3	14.5
100	30.0	2.5	259.5	18.67	323.2	67.7	13.9	3.2	286.1	18.87	350.5	73.6	15.2	7.9	299.8	18.99	364.6	76.4	15.8	14.3
100	50.0	6.2	268.0	17.33	327.1	67.1	15.5	3.2	295.4	17.52	355.2	73.2	16.9	7.9	309.5	17.63	369.7	76.2	17.6	14.3
100	70.0	11.2	271.5	16.82	328.9	66.9	16.1	3.2	299.3	17.00	357.3	73.0	17.6	7.9	313.6	17.11	372.0	76.0	18.3	14.3
110	30.0	2.5	140.7	19.57	207.5	40.6	7.2	3.6	155.1	19.78	222.6	43.8	7.8	8.7	162.5	19.91	230.5	45.4	8.2	15.7
110	50.0	6.1	145.3	18.17	207.3	40.3	8.0	3.6	160.2	18.37	222.9	43.6	8.7	8.7	167.8	18.48	230.9	45.2	9.1	15.7
110	70.0	10.9	147.2	17.63	207.4	40.2	8.3	3.6	162.3	17.82	223.1	43.5	9.1	8.7	170.0	17.94	231.2	45.1	9.5	15.7
110	30.0	2.5	167.0	19.73	234.3	48.9	8.5	3.5	184.1	19.94	252.1	52.6	9.2	8.4	192.9	20.07	261.4	54.5	9.6	15.2
110	50.0	6.1	172.4	18.31	234.9	48.5	9.4	3.5	190.1	18.51	253.3	52.4	10.3	8.4	199.2	18.63	262.7	54.3	10.7	15.2
110	70.0	10.9	174.7	17.77	235.3	48.4	9.8	3.5	192.6	17.96	253.9	52.3	10.7	8.4	201.8	18.08	263.5	54.2	11.2	15.2
110	30.0	2.5	195.1	20.00	263.4	57.0	9.8	3.3	215.1	20.21	284.1	61.4	10.6	8.2	225.4	20.34	294.8	63.6	11.1	14.8
110	50.0	6.1	201.5	18.57	264.9	56.6	10.9	3.3	222.2	18.77	286.2	61.1	11.8	8.2	232.8	18.89	297.2	63.3	12.3	14.8
110	70.0	10.9	204.1	18.02	265.6	56.4	11.3	3.3	225.1	18.21	287.2	61.0	12.4	8.2	235.8	18.33	298.3	63.3	12.9	14.8
110	30.0	2.5	226.7	20.40	296.3	64.9	11.1	3.2	249.9	20.62	320.3	70.0	12.1	8.0	261.9	20.75	332.7	72.5	12.6	14.5
110	50.0	6.1	234.1	18.94	298.7	64.4	12.4	3.2	258.1	19.14	323.4	69.7	13.5	8.0	270.4	19.26	336.1	72.3	14.0	14.5
110	70.0	10.9	237.1	18.38	299.8	64.2	12.9	3.2	261.4	18.57	324.8	69.5	14.1	8.0	273.9	18.69	337.7	72.2	14.7	14.5
110	30.0	2.5	244.2	20.64	314.6	68.7	11.8	3.2	269.2	20.86	340.4	74.2	12.9	7.9	282.1	21.00	353.7	76.9	13.4	14.3
110	50.0	6.1	252.2	19.17	317.6	68.2	13.2	3.2	278.0	19.37	344.1	73.9	14.4	7.9	291.3	19.49	357.8	76.7	14.9	14.3
110	70.0	10.9	255.4	18.60	318.9	68.0	13.7	3.2	281.6	18.80	345.8	73.7	15.0	7.9	295.1	18.92	359.6	76.6	15.6	14.3
120	30.0	2.5	129.7	22.02	204.8	41.4	5.9	3.6	143.0	22.25	218.9	44.3	6.4	8.7	149.8	22.39	226.2	45.7	6.7	15.7
120	50.0	6.0	133.9	20.44	203.7	41.1	6.6	3.6	147.7	20.66	218.2	44.1	7.1	8.7	154.7	20.79	225.7	45.6	7.4	15.7
120	70.0	10.8	135.7	19.83	203.4	41.0	6.8	3.6	149.6	20.05	218.0	44.0	7.5	8.7	156.7	20.17	225.6	45.5	7.8	15.7

Table 7. Cooling capacities 20 tons - EXW240 (continued)

Source		Load																			
		Flow 30 GPM				Flow 50 GPM				Flow 70 GPM											
EWT °F	WPD FT	Flow GPM	TC Mbtuh	Power kW	HR Mbtuh	LWT °F	EER	WPD FT	TC Mbtuh	Power kW	HR Mbtuh	LWT °F	EER	WPD FT	TC Mbtuh	Power kW	HR Mbtuh	LWT °F	EER	WPD FT	
120	30.0	2.5	60	154.6	22.09	230.0	49.7	7.0	3.5	170.4	22.33	246.7	53.2	7.6	8.4	178.6	22.47	255.3	54.9	7.9	15.2
120	50.0	6.0	60	159.6	20.51	229.6	49.4	7.8	3.5	176.0	20.73	246.8	53.0	8.5	8.4	184.4	20.87	255.6	54.7	8.8	15.2
120	70.0	10.8	60	161.7	19.91	229.7	49.2	8.1	3.5	178.3	20.12	247.0	52.9	8.9	8.4	186.8	20.25	255.9	54.7	9.2	15.2
120	30.0	2.5	70	181.1	22.30	257.2	57.9	8.1	3.3	199.7	22.54	276.6	62.0	8.9	8.2	209.2	22.68	286.6	64.0	9.2	14.8
120	50.0	6.0	70	187.0	20.70	257.7	57.5	9.0	3.3	206.2	20.93	277.6	61.8	9.9	8.2	216.0	21.06	287.9	63.8	10.3	14.8
120	70.0	10.8	70	189.5	20.09	258.0	57.4	9.4	3.3	208.9	20.31	278.2	61.6	10.3	8.2	218.8	20.44	288.6	63.7	10.7	14.8
120	30.0	2.5	80	210.7	22.63	288.0	66.0	9.3	3.2	232.3	22.88	310.4	70.7	10.2	8.0	243.4	23.02	322.0	73.0	10.6	14.5
120	50.0	6.0	80	217.6	21.01	289.3	65.5	10.4	3.2	239.9	21.24	312.4	70.4	11.3	8.0	251.4	21.37	324.3	72.8	11.8	14.5
120	70.0	10.8	80	220.4	20.39	290.0	65.3	10.8	3.2	243.0	20.61	313.4	70.3	11.8	8.0	254.6	20.74	325.4	72.7	12.3	14.5
120	30.0	2.5	85	227.2	22.85	305.2	69.9	9.9	3.2	250.4	23.10	329.3	75.0	10.8	7.9	262.4	23.24	341.7	77.5	11.3	14.3
120	50.0	6.0	85	234.6	21.22	307.0	69.4	11.1	3.2	258.6	21.44	331.8	74.7	12.1	7.9	271.0	21.58	344.6	77.3	12.6	14.3
120	70.0	10.8	85	237.6	20.59	307.9	69.2	11.5	3.2	262.0	20.81	333.0	74.5	12.6	7.9	274.5	20.94	346.0	77.2	13.1	14.3

Notes:  
 1. For ANSI/AHRI/ASHRAE/ISO13256-2 certified ratings, refer to the ANSI/AHRI/ASHRAE/ISO13256-2 WLHP, GWHP and GLHP performance table.  
 2. EWT= Entering Water Temperature; LWT = Leaving Water Temperature WPD = Waterside Pressure Drop; TC = Total Cooling Capacity HA = Heat of Absorption; COP = Coefficient of Performance; GPM = Gallons per Minute; Source is sometimes called the outdoor side; Load is sometimes called the indoor side.

Table 8. Heating capacities 20 tons

Source		Load																			
		Flow 30 GPM				Flow 50 GPM				Flow 70 GPM											
EWT °F	WPD FT	Flow GPM	HC Mbtuh	Power kW	HA Mbtuh	LWT °F	COP	WPD FT	HC Mbtuh	Power kW	HA Mbtuh	LWT °F	COP	WPD FT	HC Mbtuh	Power kW	HA Mbtuh	LWT °F	COP	WPD FT	
25	30.0	4.5	60	153.5	10.64	117.2	70.2	4.2	3.5	154.8	10.17	120.0	66.2	4.5	8.4	155.1	10.04	120.9	64.4	4.5	15.2
25	50.0	11.4	60	164.3	10.64	128.0	71.0	4.5	3.5	165.6	10.18	130.8	66.6	4.8	8.4	166.0	10.04	131.7	64.7	4.8	15.2
25	70.0	19.6	60	169.5	10.65	133.1	71.3	4.7	3.5	170.8	10.19	136.1	66.8	4.9	8.4	171.2	10.05	136.9	64.9	5.0	15.2
25	30.0	4.5	70	151.5	12.03	110.5	80.1	3.7	3.3	152.7	11.50	113.4	76.1	3.9	8.2	153.1	11.35	114.4	74.4	4.0	14.8
25	50.0	11.4	70	162.1	12.03	121.0	80.8	3.9	3.3	163.4	11.51	124.1	76.5	4.2	8.2	163.8	11.35	125.0	74.7	4.2	14.8
25	70.0	19.6	70	167.2	12.04	126.1	81.1	4.1	3.3	168.6	11.52	129.2	76.7	4.3	8.2	169.0	11.36	130.2	74.8	4.4	14.8
25	30.0	4.5	80	149.7	13.60	103.3	90.0	3.2	3.2	150.9	13.01	106.5	86.0	3.4	8.0	151.3	12.83	107.5	84.3	3.5	14.5
25	50.0	11.4	80	160.2	13.61	113.8	90.7	3.4	3.2	161.5	13.02	117.1	86.5	3.6	8.0	161.9	12.84	118.1	84.6	3.7	14.5
25	70.0	19.6	80	165.3	13.62	118.8	91.0	3.6	3.2	166.6	13.02	122.1	86.7	3.7	8.0	167.0	12.85	123.2	84.8	3.8	14.5
25	30.0	4.5	90	148.2	15.39	95.6	99.9	2.8	3.2	149.4	14.72	99.1	96.0	3.0	7.8	149.7	14.52	100.2	94.3	3.0	14.1
25	50.0	11.4	90	158.5	15.40	106.0	100.6	3.0	3.2	159.8	14.73	109.5	96.4	3.2	7.8	160.2	14.53	110.6	94.6	3.2	14.1
25	70.0	19.6	90	163.6	15.41	111.0	100.9	3.1	3.2	164.9	14.74	114.5	96.6	3.3	7.8	165.3	14.54	115.6	94.7	3.3	14.1
25	30.0	4.5	100	146.7	17.44	87.2	109.8	2.5	3.1	147.9	16.68	91.0	105.9	2.6	7.6	148.2	16.45	92.1	104.2	2.6	13.7
25	50.0	11.4	100	157.0	17.45	97.4	110.5	2.6	3.1	158.2	16.69	101.3	106.3	2.8	7.6	158.6	16.46	102.4	104.5	2.8	13.7
25	70.0	19.6	100	161.9	17.46	102.4	110.8	2.7	3.1	163.2	16.70	106.2	106.5	2.9	7.6	163.6	16.47	107.4	104.7	2.9	13.7

Table 8. Heating capacities 20 tons (continued)

Source			Load																		
EWT °F	Flow GPM	WPD FT	Flow 30 GPM				Flow 50 GPM				Flow 70 GPM										
			HC Mbruh	Power kW	HA Mbruh	LWT °F	COP	WPD FT	HC Mbruh	Power kW	HA Mbruh	LWT °F	COP	WPD FT	HC Mbruh	Power kW	HA Mbruh	LWT °F	COP	WPD FT	
25	30.0	4.5	110	145.3	19.77	77.8	119.7	2.2	3.0	146.5	18.91	81.9	115.9	2.3	7.4	146.8	18.65	83.1	114.2	2.3	13.4
25	50.0	11.4	110	155.5	19.79	87.9	120.4	2.3	3.0	156.7	18.92	92.1	116.3	2.4	7.4	157.1	18.66	93.4	114.5	2.5	13.4
25	70.0	19.6	110	160.4	19.80	92.8	120.7	2.4	3.0	161.6	18.94	97.0	116.5	2.5	7.4	162.0	18.68	98.3	114.6	2.5	13.4
35	30.0	4.3	60	179.5	10.68	143.0	72.0	4.9	3.5	180.9	10.21	146.0	67.2	5.2	8.4	181.3	10.07	147.0	65.2	5.3	15.2
35	50.0	9.9	60	192.0	10.68	155.6	72.8	5.3	3.5	193.6	10.22	158.7	67.7	5.5	8.4	194.0	10.08	159.6	65.5	5.6	15.2
35	70.0	16.9	60	198.1	10.69	161.6	73.2	5.4	3.5	199.7	10.23	164.8	68.0	5.7	8.4	200.2	10.09	165.7	65.7	5.8	15.2
35	30.0	4.3	70	176.8	12.07	135.6	81.8	4.3	3.3	178.2	11.55	138.8	77.1	4.5	8.2	178.7	11.39	139.8	75.1	4.6	14.8
35	50.0	9.9	70	189.2	12.08	148.0	82.6	4.6	3.3	190.7	11.55	151.3	77.6	4.8	8.2	191.2	11.39	152.3	75.5	4.9	14.8
35	70.0	16.9	70	195.2	12.09	153.9	83.0	4.7	3.3	196.7	11.56	157.3	77.9	5.0	8.2	197.2	11.40	158.3	75.6	5.1	14.8
35	30.0	4.3	80	174.4	13.64	127.9	91.6	3.7	3.2	175.8	13.04	131.3	87.0	3.9	8.0	176.2	12.87	132.3	85.0	4.0	14.5
35	50.0	9.9	80	186.6	13.65	140.1	92.4	4.0	3.2	188.1	13.05	143.6	87.5	4.2	8.0	188.6	12.87	144.6	85.4	4.3	14.5
35	70.0	16.9	80	192.5	13.66	145.9	92.8	4.1	3.2	194.1	13.06	149.5	87.8	4.4	8.0	194.5	12.88	150.6	85.6	4.4	14.5
35	30.0	4.3	90	172.2	15.41	119.6	101.5	3.3	3.2	173.5	14.74	123.2	96.9	3.4	7.8	174.0	14.54	124.3	95.0	3.5	14.1
35	50.0	9.9	90	184.2	15.42	131.6	102.3	3.5	3.2	185.7	14.75	135.3	97.4	3.7	7.8	186.1	14.55	136.5	95.3	3.7	14.1
35	70.0	16.9	90	190.0	15.43	137.4	102.7	3.6	3.2	191.5	14.76	141.2	97.7	3.8	7.8	192.0	14.56	142.3	95.5	3.9	14.1
35	30.0	4.3	100	170.0	17.44	110.5	111.3	2.9	3.1	171.3	16.68	114.4	106.9	3.0	7.6	171.7	16.45	115.6	104.9	3.1	13.7
35	50.0	9.9	100	181.9	17.45	122.3	112.1	3.1	3.1	183.3	16.69	126.3	107.3	3.2	7.6	183.8	16.46	127.6	105.3	3.3	13.7
35	70.0	16.9	100	187.6	17.46	128.0	112.5	3.1	3.1	189.1	16.70	132.1	107.6	3.3	7.6	189.6	16.47	133.3	105.4	3.4	13.7
35	30.0	4.3	110	167.8	19.74	100.4	121.2	2.5	3.0	169.1	18.88	104.7	116.8	2.6	7.4	169.5	18.62	105.9	114.8	2.7	13.4
35	50.0	9.9	110	179.5	19.75	112.1	122.0	2.7	3.0	180.9	18.90	116.4	117.2	2.8	7.4	181.4	18.64	117.8	115.2	2.9	13.4
35	70.0	16.9	110	185.2	19.77	117.7	122.3	2.7	3.0	186.7	18.91	122.1	117.5	2.9	7.4	187.1	18.65	123.5	115.3	2.9	13.4
35	30.0	4.3	120	165.5	22.37	89.1	131.0	2.2	2.9	166.8	21.39	93.8	126.7	2.3	7.2	167.2	21.10	95.2	124.8	2.3	13.1
35	50.0	9.9	120	177.0	22.38	100.7	131.8	2.3	2.9	178.4	21.41	105.4	127.1	2.4	7.2	178.9	21.11	106.8	125.1	2.5	13.1
35	70.0	16.9	120	182.6	22.40	106.2	132.2	2.4	2.9	184.1	21.42	111.0	127.4	2.5	7.2	184.5	21.13	112.4	125.3	2.6	13.1
45	30.0	3.6	60	206.6	10.89	169.5	73.8	5.6	3.5	208.3	10.42	172.7	68.3	5.9	8.4	208.8	10.27	173.7	66.0	6.0	15.2
45	50.0	8.5	60	221.1	10.90	183.9	74.7	5.9	3.5	222.8	10.42	187.3	68.9	6.3	8.4	223.4	10.28	188.3	66.4	6.4	15.2
45	70.0	14.8	60	228.1	10.90	190.9	75.2	6.1	3.5	229.9	10.43	194.3	69.2	6.5	8.4	230.4	10.29	195.3	66.6	6.6	15.2
45	30.0	3.6	70	203.2	12.28	161.2	83.5	4.8	3.3	204.8	11.75	164.7	78.2	5.1	8.2	205.3	11.59	165.7	75.9	5.2	14.8
45	50.0	8.5	70	217.4	12.29	175.4	84.5	5.2	3.3	219.1	11.75	179.0	78.8	5.5	8.2	219.6	11.59	180.0	76.3	5.6	14.8
45	70.0	14.8	70	224.2	12.30	182.3	84.9	5.3	3.3	226.0	11.76	185.9	79.0	5.6	8.2	226.6	11.60	187.0	76.5	5.7	14.8
45	30.0	3.6	80	199.9	13.84	152.6	93.3	4.2	3.2	201.5	13.24	156.3	88.1	4.5	8.0	201.9	13.06	157.4	85.8	4.5	14.5
45	50.0	8.5	80	213.8	13.85	166.6	94.3	4.5	3.2	215.5	13.25	170.3	88.6	4.8	8.0	216.1	13.06	171.5	86.2	4.8	14.5
45	70.0	14.8	80	220.6	13.86	173.3	94.7	4.7	3.2	222.4	13.26	177.1	88.9	4.9	8.0	222.9	13.07	178.3	86.4	5.0	14.5
45	30.0	3.6	90	196.7	15.60	143.4	103.1	3.7	3.2	198.3	14.92	147.3	97.9	3.9	7.8	198.7	14.72	148.5	95.7	4.0	14.1
45	50.0	8.5	90	210.4	15.61	157.2	104.0	4.0	3.2	212.1	14.93	161.2	98.5	4.2	7.8	212.6	14.73	162.4	96.1	4.2	14.1
45	70.0	14.8	90	217.1	15.62	163.8	104.5	4.1	3.2	218.8	14.94	167.8	98.8	4.3	7.8	219.4	14.74	169.1	96.3	4.4	14.1

# Performance Data

**Table 8. Heating capacities 20 tons (continued)**

Source			Load																	
EWT °F	Flow GPM	WPD FT	Flow 30 GPM				Flow 50 GPM				Flow 70 GPM									
			HC Mbtuh	Power kW	HA Mbtuh	LWT °F	COP	WPD FT	HC Mbtuh	Power kW	HA Mbtuh	LWT °F	COP	WPD FT	HC Mbtuh	Power kW	HA Mbtuh	LWT °F	COP	WPD FT
45	30.0	3.6	193.5	17.60	133.5	112.9	3.2	3.1	195.1	16.83	137.6	107.8	3.4	7.6	195.5	16.60	138.9	105.6	3.5	13.7
45	50.0	8.5	207.1	17.61	147.0	113.8	3.4	3.1	208.7	16.84	151.2	108.3	3.6	7.6	209.2	16.61	152.5	106.0	3.7	13.7
45	70.0	14.8	213.6	17.62	153.5	114.2	3.6	3.1	215.3	16.85	157.8	108.6	3.7	7.6	215.8	16.62	159.1	106.2	3.8	13.7
45	30.0	3.6	190.3	19.87	122.5	122.7	2.8	3.0	191.8	19.00	127.0	117.7	3.0	7.4	192.3	18.74	128.3	115.5	3.0	13.4
45	50.0	8.5	203.6	19.88	135.8	123.6	3.0	3.0	205.2	19.01	140.3	118.2	3.2	7.4	205.7	18.75	141.7	115.9	3.2	13.4
45	70.0	14.8	210.1	19.89	142.2	124.0	3.1	3.0	211.7	19.03	146.8	118.5	3.3	7.4	212.2	18.77	148.2	116.1	3.3	13.4
45	30.0	3.6	187.0	22.45	110.3	132.5	2.4	2.9	188.4	21.47	115.2	127.5	2.6	7.2	188.9	21.18	116.6	125.4	2.6	13.1
45	50.0	8.5	200.0	22.46	123.4	133.3	2.6	2.9	201.6	21.48	128.3	128.1	2.7	7.2	202.1	21.19	129.8	125.8	2.8	13.1
45	70.0	14.8	206.4	22.48	129.6	133.8	2.7	2.9	208.0	21.50	134.6	128.3	2.8	7.2	208.5	21.20	136.1	126.0	2.9	13.1
55	30.0	3.2	235.9	11.23	197.6	75.7	6.2	3.5	237.8	10.74	201.1	69.5	6.5	8.4	238.4	10.59	202.2	66.8	6.6	15.2
55	50.0	7.7	252.4	11.24	214.1	76.8	6.6	3.5	254.4	10.75	217.7	70.2	6.9	8.4	255.0	10.60	218.8	67.3	7.0	15.2
55	70.0	13.5	260.4	11.25	222.0	77.4	6.8	3.5	262.5	10.76	225.8	70.5	7.1	8.4	263.1	10.61	226.9	67.5	7.3	15.2
55	30.0	3.2	231.4	12.62	188.3	85.4	5.4	3.3	233.2	12.07	192.0	79.3	5.7	8.2	233.8	11.91	193.1	76.7	5.8	14.8
55	50.0	7.7	247.6	12.63	204.5	86.5	5.7	3.3	249.5	12.08	208.3	80.0	6.1	8.2	250.1	11.91	209.5	77.1	6.2	14.8
55	70.0	13.5	255.4	12.64	212.3	87.0	5.9	3.3	257.4	12.09	216.2	80.3	6.2	8.2	258.0	11.92	217.4	77.4	6.3	14.8
55	30.0	3.2	227.0	14.17	178.6	95.1	4.7	3.2	228.8	13.55	182.5	89.2	4.9	8.0	229.3	13.37	183.7	86.6	5.0	14.5
55	50.0	7.7	242.9	14.18	194.5	96.2	5.0	3.2	244.8	13.56	198.5	89.8	5.3	8.0	245.4	13.37	199.7	87.0	5.4	14.5
55	70.0	13.5	250.6	14.19	202.1	96.7	5.2	3.2	252.5	13.57	206.2	90.1	5.5	8.0	253.2	13.38	207.5	87.2	5.5	14.5
55	30.0	3.2	222.7	15.91	168.4	104.8	4.1	3.2	224.4	15.21	172.5	99.0	4.3	7.8	225.0	15.01	173.8	96.4	4.4	14.1
55	50.0	7.7	238.2	15.92	183.9	105.9	4.4	3.2	240.1	15.22	188.2	99.6	4.6	7.8	240.7	15.02	189.5	96.9	4.7	14.1
55	70.0	13.5	245.8	15.93	191.4	106.4	4.5	3.2	247.7	15.23	195.7	99.9	4.8	7.8	248.3	15.03	197.0	97.1	4.8	14.1
55	30.0	3.2	218.3	17.87	157.3	114.6	3.6	3.1	220.1	17.10	161.7	108.8	3.8	7.6	220.6	16.86	163.0	106.3	3.8	13.7
55	50.0	7.7	233.6	17.88	172.5	115.6	3.8	3.1	235.4	17.11	177.1	109.4	4.0	7.6	236.0	16.87	178.4	106.7	4.1	13.7
55	70.0	13.5	241.0	17.90	179.9	116.1	3.9	3.1	242.9	17.12	184.5	109.7	4.2	7.6	243.5	16.88	185.8	107.0	4.2	13.7
55	30.0	3.2	213.9	20.11	145.2	124.3	3.1	3.0	215.6	19.23	149.9	118.6	3.3	7.4	216.1	18.97	151.3	116.2	3.3	13.4
55	50.0	7.7	228.8	20.12	160.2	125.3	3.3	3.0	230.6	19.24	165.0	119.2	3.5	7.4	231.2	18.98	166.4	116.6	3.6	13.4
55	70.0	13.5	236.1	20.13	167.3	125.7	3.4	3.0	237.9	19.26	172.2	119.5	3.6	7.4	238.5	18.99	173.7	116.8	3.7	13.4
55	30.0	3.2	209.2	22.64	132.0	133.9	2.7	2.9	210.9	21.65	137.0	128.4	2.9	7.2	211.4	21.36	138.5	126.0	2.9	13.1
55	50.0	7.7	223.8	22.65	146.5	134.9	2.9	2.9	225.6	21.67	151.7	129.0	3.1	7.2	226.2	21.37	153.2	126.5	3.1	13.1
55	70.0	13.5	230.9	22.67	153.6	135.4	3.0	2.9	232.8	21.68	158.8	129.3	3.1	7.2	233.3	21.38	160.3	126.7	3.2	13.1
65	40.0	4.9	279.5	11.66	239.7	78.6	7.0	3.5	281.7	11.16	243.7	71.3	7.4	8.4	282.4	11.00	244.9	68.1	7.5	15.2
65	60.0	9.6	292.1	11.68	252.3	79.5	7.3	3.5	294.5	11.17	256.4	71.8	7.7	8.4	295.2	11.01	257.6	68.4	7.9	15.2
65	30.0	2.9	268.3	11.66	228.5	77.9	6.7	3.5	270.4	11.16	232.3	70.8	7.1	8.4	271.1	11.00	233.5	67.7	7.2	15.2
65	30.0	2.9	262.5	13.05	217.9	87.5	5.9	3.3	264.6	12.48	222.0	80.6	6.2	8.2	265.2	12.31	223.2	77.6	6.3	14.8
65	50.0	7.1	280.8	13.06	236.3	88.7	6.3	3.3	283.1	12.49	240.4	81.3	6.6	8.2	283.7	12.32	241.7	78.1	6.8	14.8
65	70.0	12.6	289.7	13.06	245.1	89.3	6.5	3.3	292.0	12.50	249.4	81.7	6.8	8.2	292.7	12.32	250.6	78.4	7.0	14.8

Table 8. Heating capacities 20 tons (continued)

Source			Load																		
			Flow 30 GPM				Flow 50 GPM				Flow 70 GPM										
EWT °F	Flow GPM	WPD FT	HC Mbruh	Power kW	HA Mbruh	LWT °F	COP	WPD FT	HC Mbruh	Power kW	HA Mbruh	LWT °F	COP	WPD FT	HC Mbruh	Power kW	HA Mbruh	LWT °F	COP	WPD FT	
65	30.0	2.9	80	256.7	14.58	207.0	97.1	5.2	3.2	256.8	13.94	211.2	90.4	5.4	8.0	259.4	13.75	212.5	87.4	5.5	14.5
65	50.0	7.1	80	274.7	14.59	224.9	98.3	5.5	3.2	276.9	13.95	229.3	91.1	5.8	8.0	277.5	13.76	230.6	87.9	5.9	14.5
65	70.0	12.6	80	283.4	14.60	233.6	98.9	5.7	3.2	285.6	13.96	238.0	91.4	6.0	8.0	286.3	13.77	239.3	88.2	6.1	14.5
65	30.0	2.9	90	251.0	16.29	195.4	106.7	4.5	3.2	253.0	15.59	199.8	100.1	4.8	7.8	253.6	15.37	201.2	97.2	4.8	14.1
65	50.0	7.1	90	268.6	16.30	212.9	107.9	4.8	3.2	270.7	15.59	217.5	100.8	5.1	7.8	271.4	15.38	218.9	97.8	5.2	14.1
65	70.0	12.6	90	277.1	16.32	221.4	108.5	5.0	3.2	279.3	15.61	226.0	101.2	5.2	7.8	280.0	15.39	227.4	98.0	5.3	14.1
65	30.0	2.9	100	245.3	18.23	183.1	116.4	3.9	3.1	247.2	17.44	187.7	109.9	4.2	7.6	247.8	17.20	189.1	107.1	4.2	13.7
65	50.0	7.1	100	262.4	18.24	200.2	117.5	4.2	3.1	264.5	17.45	205.0	110.6	4.4	7.6	265.1	17.21	206.4	107.6	4.5	13.7
65	70.0	12.6	100	270.7	18.25	208.4	118.0	4.3	3.1	272.9	17.46	213.3	110.9	4.6	7.6	273.5	17.22	214.8	107.8	4.7	13.7
65	30.0	2.9	110	239.3	20.42	169.7	126.0	3.4	3.0	241.3	19.53	174.6	119.7	3.6	7.4	241.8	19.26	176.1	116.9	3.7	13.4
65	50.0	7.1	110	256.1	20.43	186.4	127.1	3.7	3.0	258.1	19.54	191.4	120.3	3.9	7.4	258.7	19.27	193.0	117.4	3.9	13.4
65	70.0	12.6	110	264.2	20.45	194.4	127.6	3.8	3.0	266.3	19.56	199.5	120.7	4.0	7.4	266.9	19.29	201.1	117.6	4.1	13.4
65	30.0	2.9	120	233.2	22.90	155.0	135.5	3.0	2.9	235.0	21.90	160.3	129.4	3.1	7.2	235.6	21.60	161.9	126.7	3.2	13.1
65	50.0	7.1	120	249.5	22.91	171.3	136.6	3.2	2.9	251.5	21.92	176.7	130.1	3.4	7.2	252.1	21.62	178.3	127.2	3.4	13.1
65	70.0	12.6	120	257.4	22.93	179.1	137.2	3.3	2.9	259.4	21.93	184.6	130.4	3.5	7.2	260.1	21.63	186.2	127.4	3.5	13.1
75	30.0	2.7	60	304.7	12.14	263.2	80.3	7.4	3.5	307.1	11.62	267.4	72.3	7.7	8.4	307.8	11.46	268.7	68.8	7.9	15.2
75	50.0	6.7	60	326.0	12.15	284.5	81.7	7.9	3.5	328.6	11.62	288.9	73.1	8.3	8.4	329.4	11.46	290.2	69.4	8.4	15.2
75	70.0	12.0	60	336.3	12.16	294.8	82.4	8.1	3.5	339.0	11.63	299.3	73.6	8.5	8.4	339.8	11.47	300.6	69.7	8.7	15.2
75	30.0	2.7	70	297.3	13.52	251.2	89.8	6.4	3.3	299.7	12.93	255.6	82.0	6.8	8.2	300.4	12.75	256.9	78.6	6.9	14.8
75	50.0	6.7	70	318.1	13.53	272.0	91.2	6.9	3.3	320.7	12.94	276.5	82.8	7.3	8.2	321.4	12.76	277.9	79.2	7.4	14.8
75	70.0	12.0	70	328.2	13.54	282.0	91.9	7.1	3.3	330.8	12.95	286.6	83.2	7.5	8.2	331.6	12.77	288.0	79.5	7.6	14.8
75	30.0	2.7	80	290.1	15.03	238.7	99.3	5.7	3.2	292.4	14.38	243.3	91.7	6.0	8.0	293.1	14.18	244.7	88.4	6.1	14.5
75	50.0	6.7	80	310.3	15.04	259.0	100.7	6.0	3.2	312.8	14.39	263.7	92.5	6.4	8.0	313.6	14.19	265.1	89.0	6.5	14.5
75	70.0	12.0	80	320.2	15.05	268.8	101.3	6.2	3.2	322.7	14.40	273.6	92.9	6.6	8.0	323.5	14.20	275.0	89.2	6.7	14.5
75	30.0	2.7	90	282.7	16.72	225.7	108.8	5.0	3.2	285.0	15.99	230.4	101.4	5.2	7.8	285.7	15.77	231.8	98.2	5.3	14.1
75	50.0	6.7	90	302.5	16.73	245.4	110.2	5.3	3.2	304.9	16.00	250.3	102.2	5.6	7.8	305.7	15.78	251.8	98.7	5.7	14.1
75	70.0	12.0	90	312.1	16.74	254.9	110.8	5.5	3.2	314.6	16.01	259.9	102.6	5.8	7.8	315.3	15.79	261.4	99.0	5.8	14.1
75	30.0	2.7	100	275.3	18.62	211.8	118.4	4.3	3.1	277.5	17.81	216.7	111.1	4.6	7.6	278.2	17.57	218.2	107.9	4.6	13.7
75	50.0	6.7	100	294.6	18.63	231.0	119.6	4.6	3.1	296.9	17.82	236.1	111.9	4.9	7.6	297.6	17.58	237.6	108.5	5.0	13.7
75	70.0	12.0	100	303.9	18.64	240.3	120.3	4.8	3.1	306.3	17.83	245.4	112.3	5.0	7.6	307.0	17.59	247.0	108.8	5.1	13.7
75	30.0	2.7	110	267.7	20.76	196.8	127.8	3.8	3.0	269.8	19.86	202.0	120.8	4.0	7.4	270.5	19.59	203.6	117.7	4.0	13.4
75	50.0	6.7	110	286.4	20.78	215.5	129.1	4.0	3.0	288.7	19.87	220.9	121.5	4.3	7.4	289.4	19.60	222.5	118.3	4.3	13.4
75	70.0	12.0	110	295.5	20.79	224.5	129.7	4.2	3.0	297.8	19.89	230.0	121.9	4.4	7.4	298.6	19.61	231.6	118.5	4.5	13.4
75	30.0	2.7	120	259.8	23.19	180.7	137.3	3.3	2.9	261.9	22.18	186.2	130.5	3.5	7.2	262.5	21.88	187.8	127.5	3.5	13.1
75	50.0	6.7	120	278.0	23.21	198.8	138.5	3.5	2.9	280.2	22.20	204.4	131.2	3.7	7.2	280.9	21.89	206.1	128.0	3.8	13.1
75	70.0	12.0	120	286.8	23.22	207.5	139.1	3.6	2.9	289.1	22.21	213.2	131.6	3.8	7.2	289.8	21.91	215.0	128.3	3.9	13.1



# Performance Data

**Table 8. Heating capacities 20 tons (continued)**

Source			Load																	
			Flow 30 GPM				Flow 50 GPM				Flow 70 GPM									
EWT °F	Flow GPM	WPD FT	HC Mbtuh	Power kW	HA Mbtuh	LWT °F	COP	WPD FT	HC Mbtuh	Power kW	HA Mbtuh	LWT °F	COP	WPD FT	HC Mbtuh	Power kW	HA Mbtuh	LWT °F	COP	WPD FT
85	30.0	2.6	346.0	12.64	302.9	83.1	8.0	3.5	348.8	12.09	307.5	74.0	8.5	8.4	349.6	11.92	308.9	70.0	8.6	15.2
85	50.0	6.5	370.2	12.64	327.0	84.7	8.6	3.5	373.1	12.09	331.9	74.9	9.0	8.4	374.0	11.93	333.3	70.7	9.2	15.2
85	70.0	11.6	381.9	12.65	338.7	85.5	8.8	3.5	385.0	12.10	343.6	75.4	9.3	8.4	385.9	11.94	345.1	71.0	9.5	15.2
85	30.0	2.6	336.9	14.00	289.1	92.5	7.1	3.3	339.6	13.39	293.9	83.6	7.4	8.2	340.4	13.21	295.4	79.7	7.6	14.8
85	50.0	6.5	360.5	14.01	312.7	94.0	7.5	3.3	363.4	13.40	317.6	84.5	7.9	8.2	364.2	13.21	319.1	80.4	8.1	14.8
85	70.0	11.6	371.9	14.02	324.1	94.8	7.8	3.3	374.9	13.41	329.1	85.0	8.2	8.2	375.8	13.22	330.6	80.7	8.3	14.8
85	30.0	2.6	327.9	15.49	275.0	101.9	6.2	3.2	330.5	14.82	279.9	93.2	6.5	8.0	331.3	14.61	281.4	89.5	6.6	14.5
85	50.0	6.5	350.8	15.50	297.9	103.4	6.6	3.2	353.6	14.82	303.0	94.1	7.0	8.0	354.4	14.62	304.5	90.1	7.1	14.5
85	70.0	11.6	361.9	15.51	308.9	104.1	6.8	3.2	364.8	14.84	314.1	94.6	7.2	8.0	365.6	14.63	315.7	90.4	7.3	14.5
85	30.0	2.6	318.7	17.15	260.2	111.2	5.4	3.2	321.2	16.40	265.3	102.8	5.7	7.8	322.0	16.18	266.8	99.2	5.8	14.1
85	50.0	6.5	341.0	17.16	282.4	112.7	5.8	3.2	343.7	16.41	287.7	103.7	6.1	7.8	344.5	16.19	289.3	99.8	6.2	14.1
85	70.0	11.6	351.8	17.17	293.2	113.5	6.0	3.2	354.6	16.42	298.5	104.2	6.3	7.8	355.4	16.20	300.2	100.2	6.4	14.1
85	30.0	2.6	309.4	19.01	244.5	120.6	4.8	3.1	311.9	18.18	249.8	112.5	5.0	7.6	312.6	17.93	251.4	108.9	5.1	13.7
85	50.0	6.5	331.0	19.02	266.1	122.1	5.1	3.1	333.7	18.19	271.6	113.3	5.4	7.6	334.5	17.94	273.3	109.6	5.5	13.7
85	70.0	11.6	341.5	19.03	276.6	122.8	5.3	3.1	344.2	18.20	282.1	113.8	5.5	7.6	345.1	17.95	283.8	109.9	5.6	13.7
85	30.0	2.6	299.9	21.10	227.8	130.0	4.2	3.0	302.3	20.19	233.4	122.1	4.4	7.4	303.0	19.91	235.0	118.7	4.5	13.4
85	50.0	6.5	320.8	21.12	248.8	131.4	4.5	3.0	323.4	20.20	254.5	122.9	4.7	7.4	324.2	19.92	256.2	119.3	4.8	13.4
85	70.0	11.6	331.0	21.13	258.9	132.1	4.6	3.0	333.6	20.21	264.6	123.3	4.8	7.4	334.4	19.93	266.4	119.6	4.9	13.4
85	30.0	2.6	290.0	23.48	209.9	139.3	3.6	2.9	292.3	22.45	215.7	131.7	3.8	7.2	293.0	22.15	217.4	128.4	3.9	13.1
85	50.0	6.5	310.3	23.49	230.1	140.7	3.9	2.9	312.8	22.47	236.1	132.5	4.1	7.2	313.5	22.16	237.9	129.0	4.1	13.1
85	70.0	11.6	320.1	23.51	239.9	141.3	4.0	2.9	322.7	22.48	245.9	132.9	4.2	7.2	323.4	22.17	247.8	129.2	4.3	13.1

**Notes:**

- For ANSI/AHRI/ASHRAE/ISO13256-2 certified ratings, refer to the ANSI/AHRI/ASHRAE/ISO13256-2 WLHP, GWHP and GLHP performance table.
- EWT= Entering Water Temperature; LWT = Leaving Water Temperature; WPD = Waterside Pressure Drop; TC = Total Cooling Capacity; HA = Heat of Absorption; COP = Coefficient of Performance; GPM = Gallons per Minute; Source is sometimes called the outdoor side; Load is sometimes called the indoor side.





# Unit Fan Performance

## Antifreeze Correction Factors

### Example 1 (Ethylene Glycol):

Determine the corrected cooling capacity and source side water pressure drop for an EXW060 when the EWT for the source side is 80° F and the GPM is 12.5 and the EWT for the load side is 70° F and the GPM is 12.5. The antifreeze solution is 20% by volume of Ethylene Glycol on the source side.

From the catalog data, the cooling capacity at these conditions with 100% water on the source side is 69.0 MBTUH and the water side pressure drop is 5.9 ft. of head. At 20% Ethylene Glycol, the correction factor for the cooling capacity is 0.9912 and the correction factor for the water side pressure drop is 1.068.

The corrected cooling capacity (MBTUH) = 69.0 \* 0.9912 = 68.4 MBTUH.

The corrected water side pressure drop (Ft. Head) = 5.9 \* 1.068 = 6.3.

### Example 2 (Propylene Glycol):

Determine the corrected heating capacity and source side water pressure drop for an EXW240 when the EWT for the source side is 45° F and the GPM is 50 and the EWT for the load side is 100° F and the GPM is 50. The antifreeze solution is 30% by volume of Propylene Glycol on the source side.

From the catalog data, the heating capacity at these conditions with 100% water on the source side is 208.8 MBTUH and the water side pressure drop is 8.9 ft. of head. At 30% Propylene Glycol, the correction factor for the heating capacity is 0.9603 and the correction factor for the water side pressure drop is 1.174.

The corrected heating capacity (MBTUH) = 208.8 \* 0.9603 = 200.5 MBTUH.

The corrected water side pressure drop (Ft. Head) = 8.9 \* 1.174 = 10.4.

**Table 9. Correction factors for antifreeze solutions**

Item	Concentration by Volume				
	10%	20%	30%	40%	50%
<b>Methanol</b>					
Cool Capacity	.9980	.9965	.9949	.9932	.9915
Heat Capacity	.9950	.9898	.9846	.9794	.9742
Pressure Drop	1.023	1.057	1.091	1.122	1.160
<b>Ethylene Glycol</b>					
Cool Capacity	.9955	.9912	.9870	.9830	.9790
Heat Capacity	.9925	.9848	.9770	.9690	.9610
Pressure Drop	1.024	1.068	1.124	1.188	1.263
<b>Propylene Glycol</b>					
Cool Capacity	.9934	.9869	.9804	.9739	.9681
Heat Capacity	.9863	.9732	.9603	.9477	.9350
Pressure Drop	1.040	1.098	1.174	1.273	1.405

# Unit Fan Performance

Figure 7. Correction factors

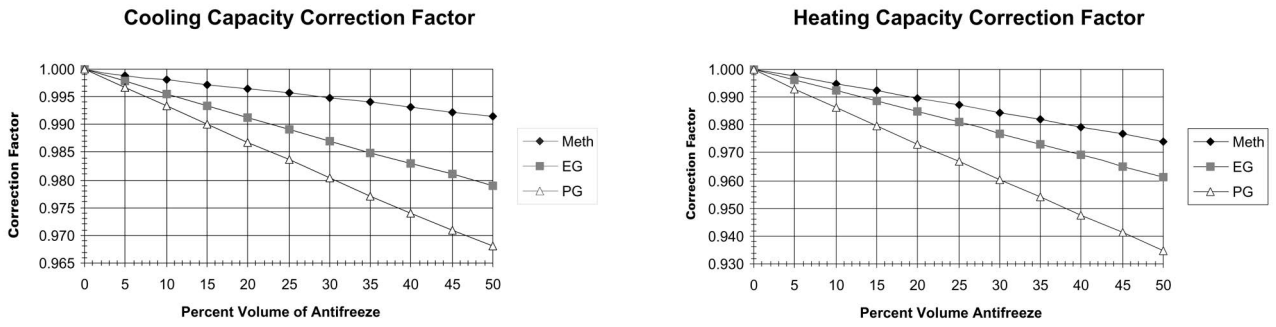
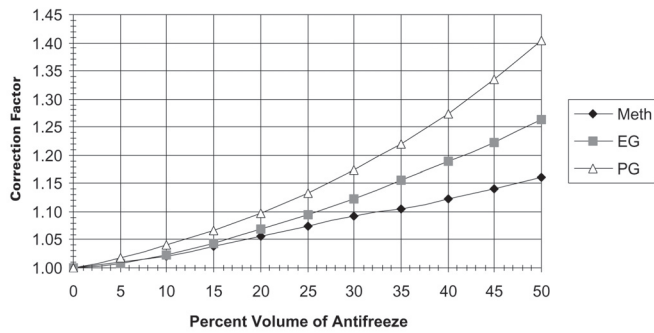

Figure 8. Water pressure drop correction factor





# Electrical Data

**Table 10. Electrical performance EXW units**

Model No.	VOLTS-AC/ HZ/PH	Minimum Utilization Voltage	Maximum Utilization Voltage	Total Unit FLA	Comp RLA (ea)	Comp LRA (ea)	No. of Compressors	Minimum Circuit Ampacity	Maximum Overcurrent Protective Device
EXW060	208/60/1	197	229	26.3	26.3	134.0	1	32.88	50
	230/60/1	207	254	26.3	26.3	134.0	1	32.88	50
	208/60/3	187	229	15.6	15.6	110.0	1	19.50	35
	230/60/3	207	254	15.6	15.6	110.0	1	19.50	35
	460/60/3	414	506	7.8	7.8	52.0	1	9.75	15
	575/60/3	518	633	5.8	5.8	38.9	1	7.25	15
EXW120	208/60/1	197	229	52.6	26.3	134.0	2	59.18	80
	230/60/1	207	254	52.6	26.3	134.0	2	59.18	80
	208/60/3	187	229	31.2	15.6	110.0	2	35.10	50
	230/60/3	207	254	31.2	15.6	110.0	2	35.10	50
	460/60/3	414	506	15.6	7.8	52.0	2	17.55	25
	575/60/3	518	633	11.6	5.8	38.9	2	13.05	15
EXW240	208/60/3	187	229	60.2	30.1	225.0	2	67.70	90
	230/60/3	207	254	60.2	30.1	225.0	2	67.70	90
	460/60/3	414	506	33.4	16.7	114.0	2	37.60	50
	575/60/3	518	633	27.2	13.6	80.0	2	30.60	40

# Dimensional Data

Figure 12. EXW060 dimensional data

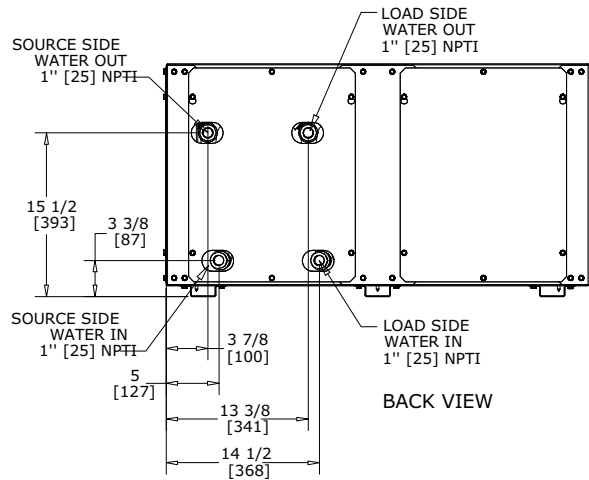
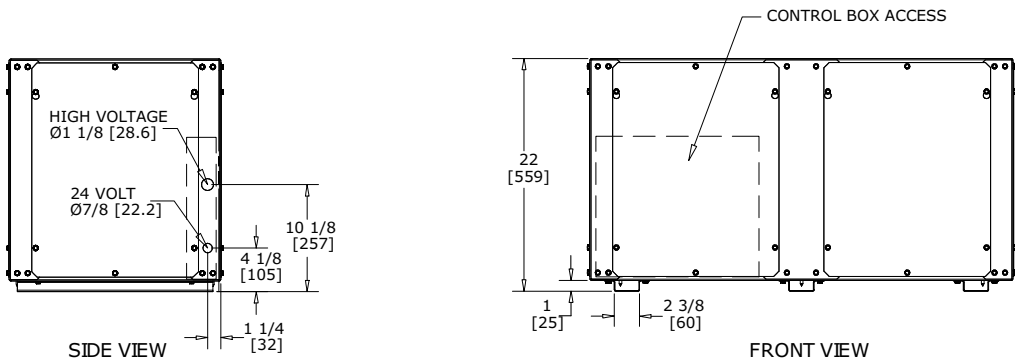
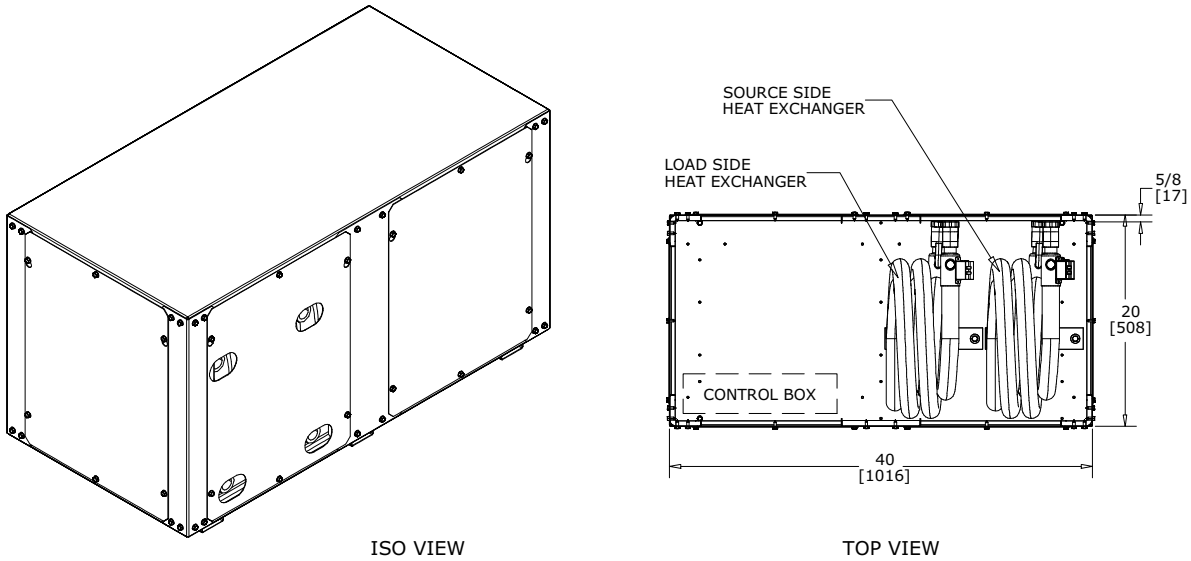
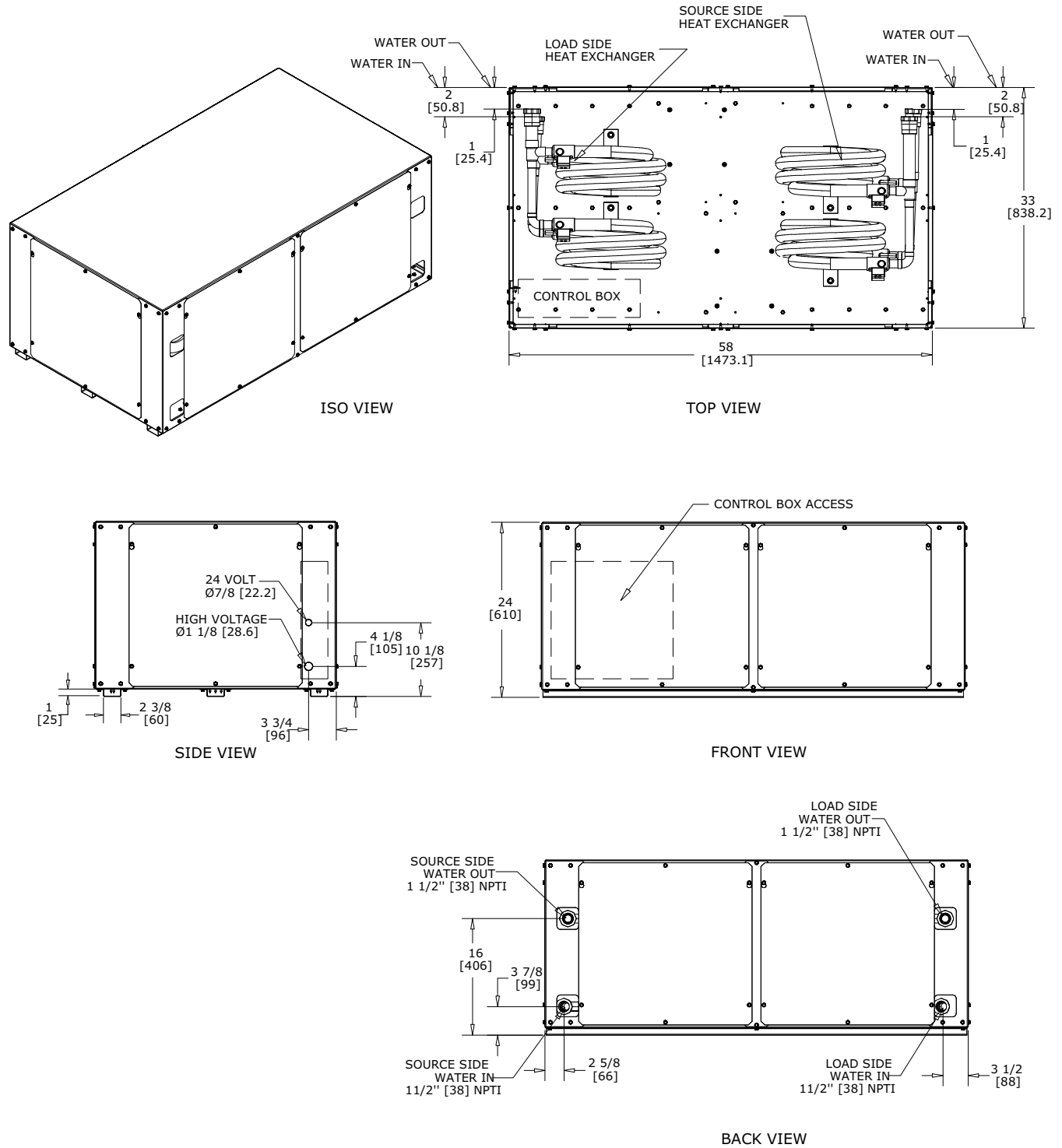

Figure 13. EXW120 dimensional data



# Dimensional Data

Figure 14. EXW240 dimensional data

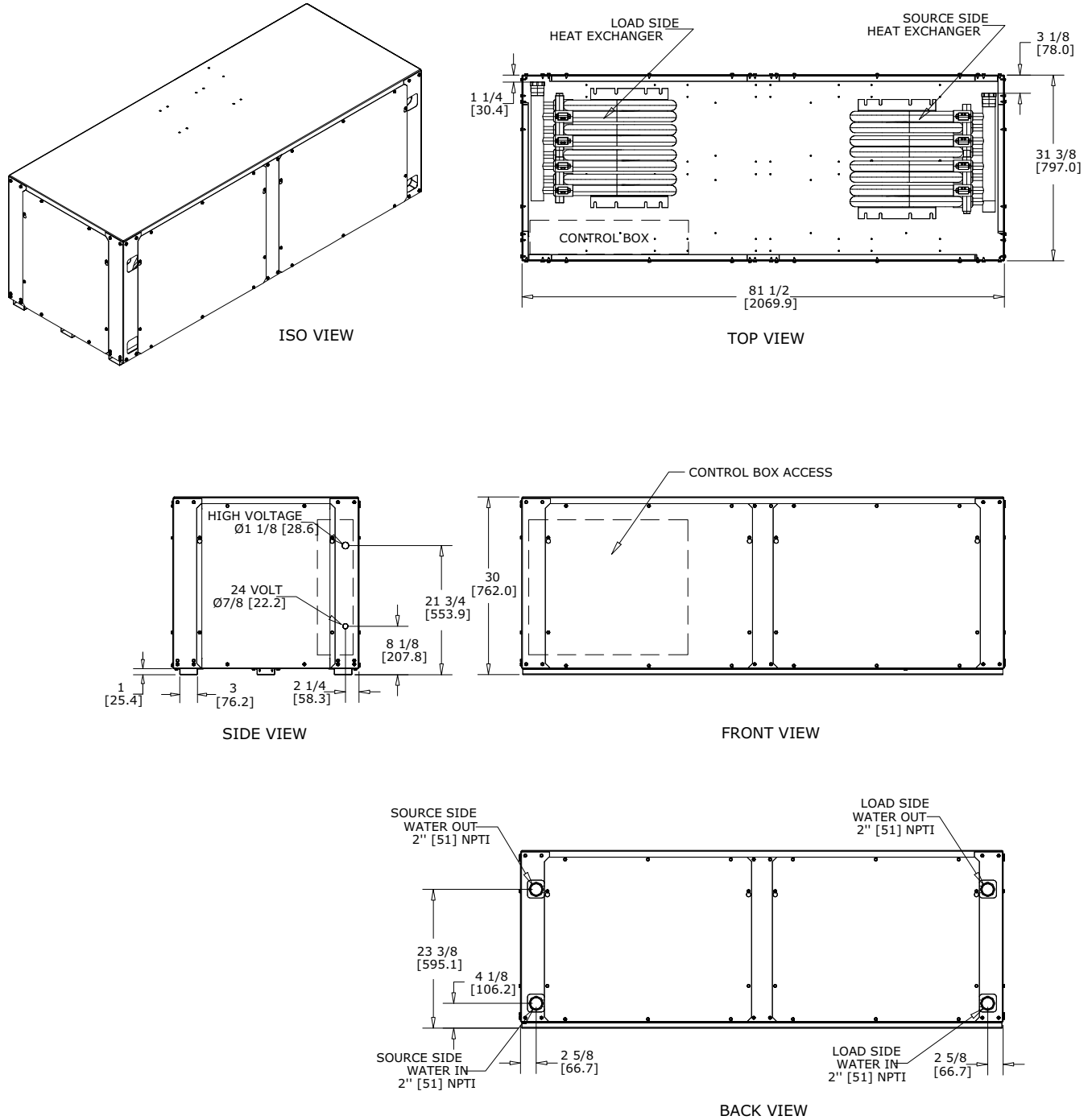
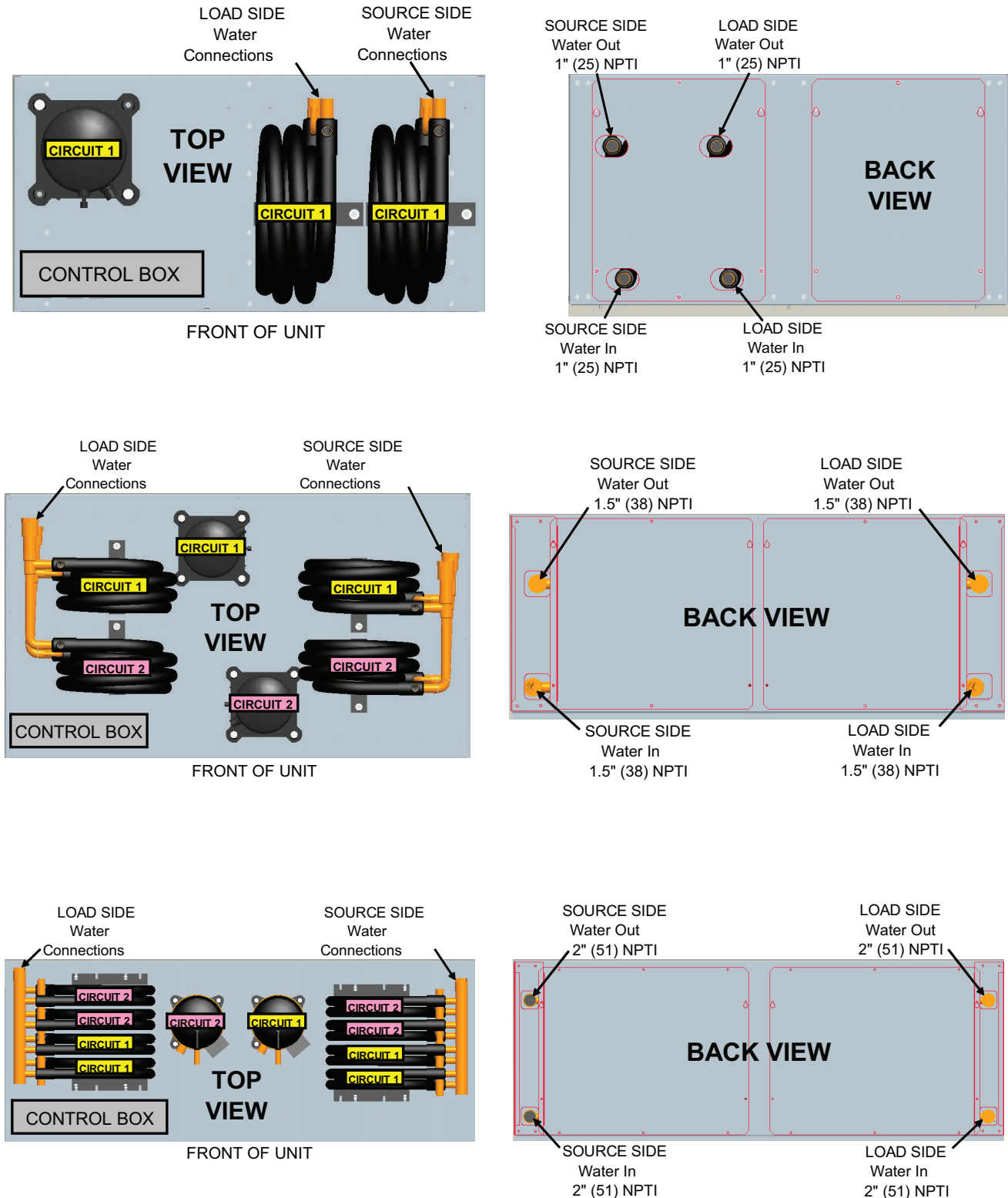

Figure 15. Water connections





## Mechanical Specifications

Equipment shall be completely assembled, piped, internally wired, fully charged with R-410A, and test operated at the factory. A controls field interface terminal strip, and all safety controls shall be furnished, installed and tested by the unit manufacturer. The unit shall be certified and rated in accordance with ANSI/AHRI/ASHRAE/ISO 13256-2.

The system's water inlet and outlet for the source and load-side connections will be internal NPT composed of copper. Service and caution labels shall be placed on the unit in their appropriate locations.

### Cabinet

Unit casing shall be constructed of zinc coated, heavy gauge, galvanized steel. Access to the refrigerant and controls shall be provided through the front and side, access panels.

All panels shall be insulated with ½-inch thick dual density bonded glass fiber. The insulation shall meet the erosion requirements of UL 181. It shall have a flame spread of less than 25 and a smoke developed classification of less than 50 per ASTM E-84 and UL 723.

The unit shall be installed for proper access. Procedures for proper access inspection and cleaning of the unit shall be included in the maintenance manual.

### Compressors

Vibration isolation shall be provided through rubber mounting devices located underneath the compressor. Internal thermal overload protection shall be provided. Protection against excessive discharge pressure shall be provided by means of a high-pressure switch. A loss of charge shall be detected by a low-pressure safety.

### Deluxe Controls

The Deluxe control package shall provide a 100 VA transformer with a circuit breaker. The controller shall include a lockout relay, anti-short cycle compressor protection, random start delay, brown-out protection, low pressure time delay, compressor delay on start and an open relay for ancillary controls request. Three LEDs, Light Emitting Diodes, shall also be included for diagnostics of each refrigeration circuit.

### Electrical

The unit control box shall contain the necessary devices to allow heating and cooling operation to occur from a remote wall thermostat. These devices shall be as follows:

- A 24 Vac energy limiting class II 100 VA transformer
- A 24 Vac compressor contactor for compressor control
- Field control connections shall be provided for ease of hook-up to a terminal strip located in the unit's control box
- A lockout relay, which controls cycling of the compressor, shall be provided to protect the compressor during adverse operating conditions. This device shall be capable of reset by interrupting power to the 24 Vac control circuit. Reset may be done either at a remote thermostat or through a momentary main power interruption.
- A high-pressure switch shall be provided to protect the compressor against operation at refrigerant system pressure exceeding 650 psig.
- A low pressure switch shall be provided to protect the compressor against operation at refrigerant system pressure below 40 psig (loss of charge).
- Freeze protection shall be provided to prevent the unit from operating at low water temperatures.
- Discharge line thermostat shall be provided to protect the compressor against a high discharge temperatures in case of loss of charge or other conditions which could drive the discharge temperature higher.

Nameplate information shall be provided for the application of either time-delay fuses or HACR circuit breakers for branch circuit protection from the primary source of power.



### **Pump Module**

The pump module shall consist of either a single or dual 1/6 hp cast iron pump and a brass 3-way shut-off valve. The pump module kits shall contain the necessary components for the installation, operation and maintenance of the water circuit of a closed-loop distributed pumping application.

### **Refrigerant Circuits**

The refrigerant circuit shall contain a thermal expansion device. Service pressure ports shall be factory supplied on the high and low pressure sides for easy refrigerant pressure or temperature testing.

### **Refrigerant Tubing**

The refrigerant tubing shall be of 99% pure copper. This system shall be free from contaminants and conditions such as drilling fragments, dirt and oil.

### **Reversing Valve**

The reversing valve shall be a pilot operating, sliding piston type with a replaceable, encapsulated magnetic coil. The reversing valve shall be energized in the cooling cycle.

### **Water-to-Refrigerant Heat Exchangers**

The water-to-refrigerant heat exchangers shall be of a high quality, co-axial coil for maximum heat transfer. The source-side heat exchanger shall be constructed of copper with an option of cupro-nickel. The load-side heat exchanger shall be constructed of copper. Both heat exchangers shall be deeply fluted to enhance heat transfer and minimize fouling and scaling. The coil shall have a working pressure of 650 psig on the refrigerant side, and 400 psig on the waterside.



## Notes

---





The AHRI Certified mark indicates Trane U.S. Inc. participation in the AHRI Certification program. For verification of individual certified products, go to [ahridirectory.org](http://ahridirectory.org).

Trane - by Trane Technologies (NYSE: TT), a global climate innovator - creates comfortable, energy efficient indoor environments for commercial and residential applications. For more information, please visit [trane.com](http://trane.com) or [tranetechnologies.com](http://tranetechnologies.com).

Trane has a policy of continuous product and product data improvement and reserves the right to change design and specifications without notice. We are committed to using environmentally conscious print practices.