



Product Catalog

Water Source Heat Pump Axiom™ High Efficiency Console — GEC

0.5 to 1.5 Tons — 50/60 Hz





Introduction

The Trane® Axiom™ (model GEC) water-source comfort system features a sloped top design providing both fundamental performance requirements, exceptional quality, sound attenuation and ease of maintenance.

Other features include:

- Dual sloped polymer drain pan
- Hot gas reheat (option)
- Electric heat (option)
- Motorized 25% outside-air (option)
- Field adjustable supply-air grille
- Integrated controls
- Quiet unit design
- Panel free filter maintenance
- High and low pressure switches as standard
- Compact size

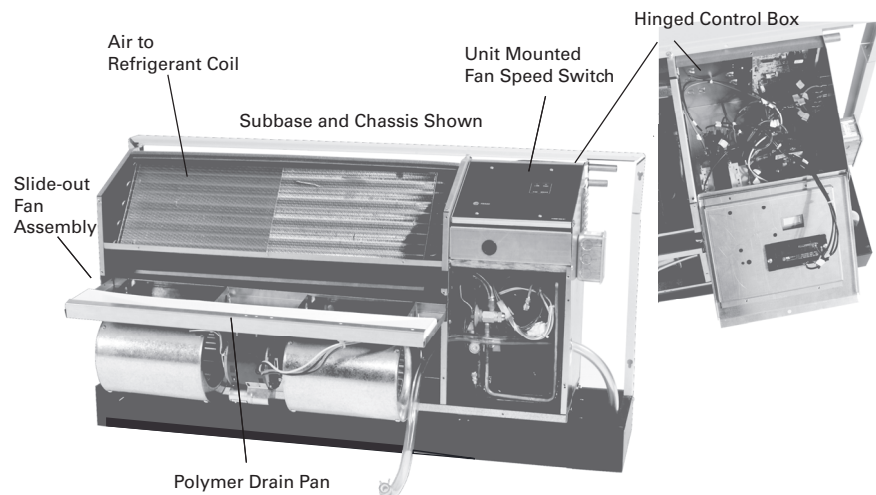

Copyright

This document and the information in it are the property of Trane, and may not be used or reproduced in whole or in part without written permission. Trane reserves the right to revise this publication at any time, and to make changes to its content without obligation to notify any person of such revision or change.

Trademarks

All trademarks referenced in this document are the trademarks of their respective owners.

Revision History

- Updated the term Symbio™ 400-B throughout the document.
- Removed Tracer® ZN524 topic in Controls chapter.
- Updated Model Number Description chapter.
- Updated Electrical Data and Thermostats and Zone Sensors chapter.



Table of Contents

Introduction	2
Features and Benefits	4
Design	4
Cabinet	4
Field Flexibility	5
Right Hand Piping	5
Left Hand Piping	5
Sound Data	11
Application Considerations	14
Geothermal System	14
Central Pumping for the GEC Product	15
Installation Considerations	16
Selection Procedure	18
Cooling Dominated Applications	18
Heating Dominated Applications	18
Model Number Description	19
General Data	20
Performance Data	21
Examples	38
Electrical Data	40
Unit Dimensions	42
Service Clearances	42
Controls	54
Deluxe 24V Controls	54
Stand-alone System	54
Deluxe 24V electronic controls include:	54
Deluxe 24V features	55
Tracer® Symbio™ 400-B/UC400-B	56
Tracer Symbio 400-B/UC400-B functions include:	56
Trane® Air-Fi® Wireless Systems	59
Thermostats and Zone Sensors	61
Mechanical Specifications	64
Electrical	64



Features and Benefits

Design

The console configuration features a tri-building block design and includes the cabinet, chassis and subbase.

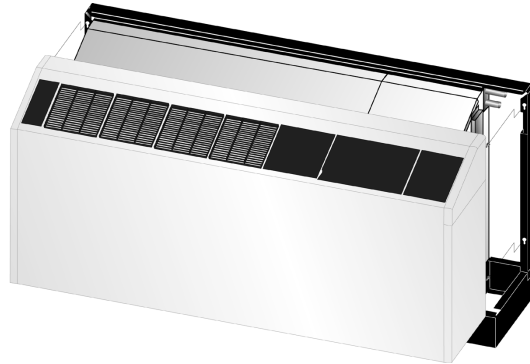

These building blocks may be ordered in several configurations. They include:

- Standard configuration (cabinet, chassis, and subbase)
- Low height configuration (chassis, cabinet, and short subbase)
- Extended length (cabinet, chassis, and subbase)
- Chassis ONLY

The console configuration model GEC product offers a range of capacities 0.5 to 1.5 tons supporting multiple application requirements in the commercial conditioning industry. This includes:

- Hotel rooms
- Offices
- Condominiums
- Assisted living facilities
- Dormitories

Cabinet

The cabinet is constructed of heavy gauge metal for maximum durability. The cabinet finish is pre-painted and available in deluxe beige, cameo white, and soft dove.

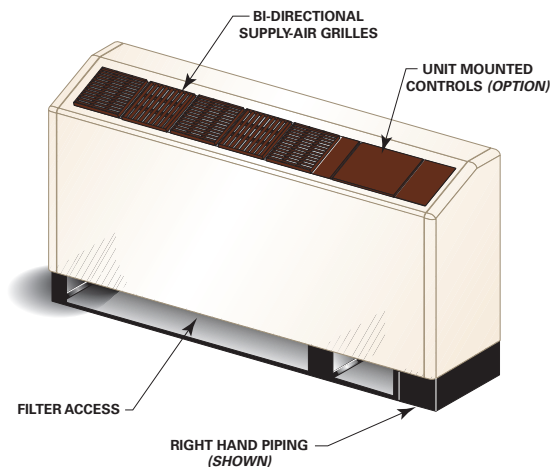

The cabinet design includes a hook-secure fit that allows complete access to piping and electrical hook-up for ease of maintenance and serviceability. The single cabinet assembly is securely fastened into the wall sleeve with four 5/16-inch bolts.

Field Flexibility

Piping and electrical connections to the console are made in either the left or right hand end pocket. The unit refrigeration platform and the unit control box is maintained in the same location whether left or right hand piping, standard unit cabinet, extended unit cabinet, or low height unit cabinet has been specified. This cloned platform poses a common look and feel to the installer, as well as aids in troubleshooting during service or maintenance check-ups.

Right Hand Piping

Console units ordered with a right hand piping connection have the end pocket located on the right hand side of the unit. This end pocket provides room for connecting field supply, return, and condensate piping to the unit. It also provides space for the high and low voltage connections.

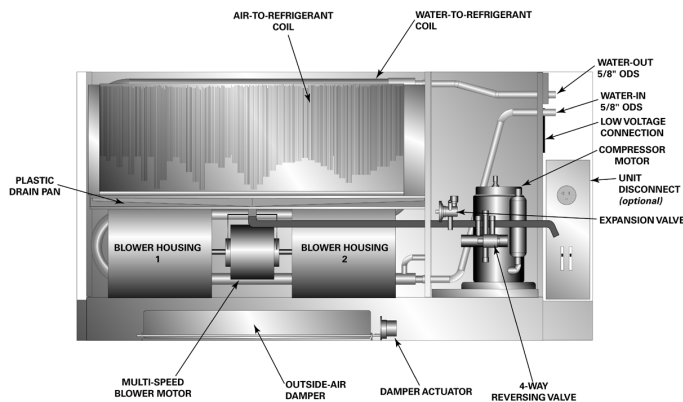

Left Hand Piping

Console units ordered with a left hand piping connection have the end pocket located on the left hand side of the unit. This end pocket provides room for the field supply, return, and condensate piping connection to the unit. Installation for the high voltage connection is also made in the left hand end pocket. Installing the low voltage controls (thermostat/sensor hook-up) is ALWAYS made on the right hand side of the unit. The low voltage termination for thermostat or sensor wires may be run along the back side of the chassis to the right hand side of the unit for connection.

Note: Units containing the unit mounted control option will ship from the factory pre-wired. No low voltage hook-up is required.

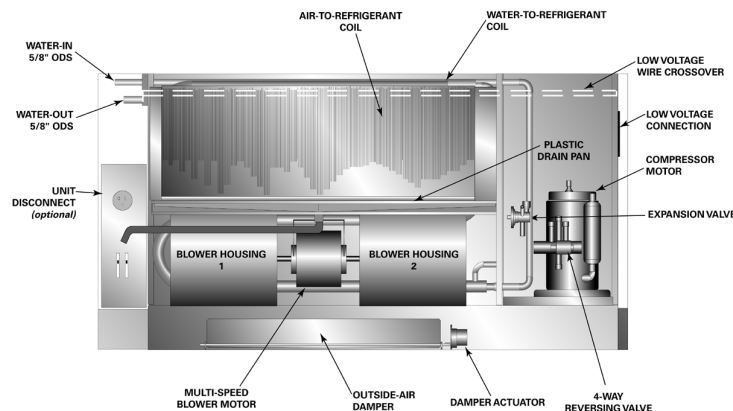

Features and Benefits

Figure 1. Air-side filter

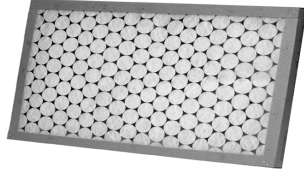

The air-side filtration option includes a 1-inch pleated filter. The filter includes an average synthetic dust weight arrestance of approximately 75%. This dust holding capability includes a colorless, odorless adhesive to retain dirt particles within the filter media after fiber contact.

Air-to-Refrigerant Coil

The air-to-refrigerant heat exchanger is constructed of staggered copper tubes with die-formed corrugated lanced aluminum fins. The fins are then mechanically bonded to the tubes through expansion.

The maximum working pressure of the coil is 650 psig. It is designed for maximum capacity with an additional benefit of physical unit size reduction.

Coil specifications for the GEC unit are in the following table.

Table 1. GEC coil specifications

Unit Size	# of Rows	Fins/inch
006, 009, 015, 018	3	14
012	2	14

Figure 2. Blower housing



The blower housing is constructed of non-corrosive galvanized steel. Serviceability to the housing is made through the chassis air-side front panel. The fan housing is mounted onto a fan board assembly which also includes the fan wheel, and fan motor. This fan board assembly may be easily removed from the chassis by sliding the fan board forward in maintenance or service situations.

Figure 3. Blower motor



The supply-air (blower) motor is a multi-speed motor with internal thermal overload protection. The motor bearings are permanently lubricated and sealed. Standard motors are rated from 220 CFM at low speed (unit size 006) to 530 CFM at high speed (unit size 018).

All motors are factory wired for low and high speed options. Switching for speed control is located in the unit control panel. See fan performance section for factory ratings of low and high speed settings.

Boilerless Control, Electric Heat System (option)

The boilerless electric heat option is composed of a nichrome open wire heating element with an internal temperature limit placed above the fan housing and an electronic (boilerless) controller located in the main control box.

The boilerless control option is comprised of a single stage of electric heat and is designed to invoice electric heat in the event that entering-water temperatures falls below 55°F. On a call for heating, the electric heater is energized, locking out the compressor. Once the entering water temperature rises, above

60°F, the boilerless controller returns the unit to normal compressor heating operation and locks out the electric heater.

For geothermal applications, the boilerless controller has an adjustable setting of 25°, 35°, 45°, 55° and 60°.

This option is available with deluxe, Symbio™ 400-B/Tracer® UC400-B, control package.

Figure 4. Boilerless control electric heat schematic

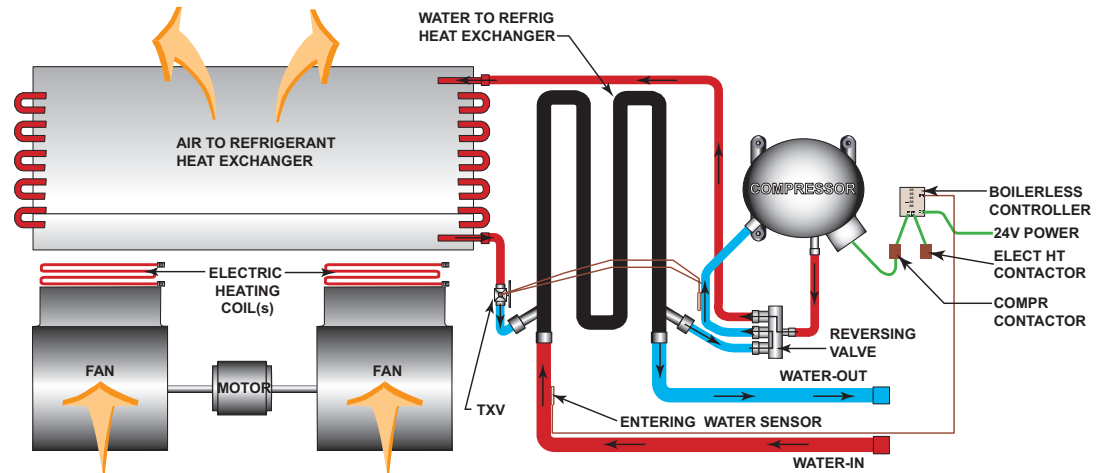

Table 2. Heating elements

Unit Size	Voltage	# of Elements	kW	Heater Total Amps	Digit 22
006	208	1	2.25	10.82	2 (minimum)
006	208	1	3.00	14.42	3 (maximum)
006	230	1	3.00	12.50	2 (minimum)*
006	265	1	3.00	10.83	2 (minimum)*
009-018	208	2	2.25	10.82	2 (minimum)
009-018	208	2	3.00	14.42	3 (maximum)
009-018	230	2	3.00	12.50	2 (minimum)
009-018	230	2	4.00	16.67	3 (maximum)
009-018	265	2	3.00	10.83	2 (minimum)
009-018	265	2	4.00	14.44	3 (maximum)

Note: * For size 006, only 3 kw is offered for 230V and 265V.

Cabinet Insulation

The cabinet insulation design meets UL 181 requirements. The air stream surface of the insulation is fabricated of a non-biodegradable source.

The insulation in the wet section of the cabinet complies with ASHRAE standard 62 to accommodate (IAQ) indoor air quality standards.

Features and Benefits

Figure 5. Co-axial coil



The unit's internal heat exchanging water coil is engineered for maximum heat transfer.

The copper or cupro-nickel seamless tubing is a tube within a tube design. The inner-tube contains a deep fluted curve to enhance heat transfer and minimize fouling and scaling. Co-axial heat exchangers are more tolerant to freeze rupture.

Figure 6. Compressor



The unit's design includes a rotary compressor motor in dedicated voltages and tonnage sizes to aid in voltage variations along with noise reduction of the unit.

As an added benefit, Trane double isolates the compressor and the mounting plate assembly in the unit to reduce sound vibration during compressor operation.

Compressor and Co-axial Coil Isolation

Vibration isolation for the compressor and co-axial water coil is accomplished by increasing the rigidity and stiffness at the base for the compressor, and at the back of the chassis for the co-axial water coil. This platform includes double isolation to the compressor and single isolation to the co-axial water coil.

Figure 7. Crankcase heater



The crankcase heater is a sealed heater installed with close contact to the outer circumference at the bottom of the compressor.

The purpose of installing this device is to protect the compressor from the negative effects of liquid refrigerant confinement.

Figure 8. Drain pan



The unit drain pan is composed of a polymer, corrosive resistive material. The pan is positively sloped to comply with ASHRAE 62 for (IAQ) indoor air quality conformity.

Access to the drain pan is provided through the front chassis access panel. The drain pan is removable for cleaning.

Figure 9. Expansion valve



The refrigerant flow metering is made through the thermal expansion valve (TXV). It allows the unit to operate with an entering fluid temperature from 25°F to 120°F and entering air temperatures from 50°F to 95°F. The valve is designed to meter refrigerant flow through the circuitry to achieve desired heating or cooling.

Unlike cap-tube assemblies, the expansion valve device allows the exact amount of refrigerant required to meet the coil load demands. This precise metering by the TXV increases the efficiency of the unit.

Figure 10. Filter drier



The filter drier is a solid core, bi-directional, liquid line filter drier for heat pump applications. Internal check valves allow flow and filtration in either direction.

With high moisture and acid removal capacity, the filter drier prevents the system from the damage of water and impurity within the refrigerant.

Figure 11. Hinged control box

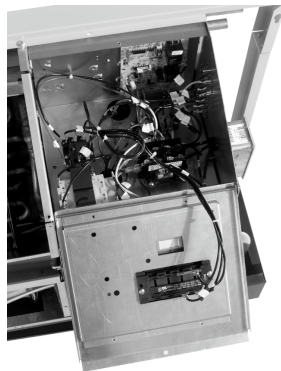

Controls for the console unit are housed on the right-hand side of the chassis. The box dwells above the refrigeration section of the chassis.

Access to the controls are made by way of a hinged control box. This hinged box allows easy access for service and installation of the controls portion of the chassis.

Hot Gas Reheat (option)

For true atmospheric conditioning and climate control, Trane provides accurate, cost effective dehumidification control through a hot gas reheat option.

With this reheat option, the return air from the space is cooled by the air-to-refrigerant coil, then reheated by the reheat coil to control not only space temperature, but to also reduce the relative humidity of the space. The amount of moisture removal of a specific heat pump is determined by the unit's latent capacity rating.

When operating in the reheat mode, the humidistat signals the reheat relay coil to energize, allowing the high pressure refrigerant gas to flow from the compressor, through the reversing valve, into the reheat valve, for passage through the reheat coil.

Note: The hot gas reheat option is available with Deluxe, Symbio 400-B/UC400-B control package.

Common Reheat Applications

- Conditioned-air delivered directly to the space.
- Auditoriums, theaters, classrooms or where a large latent load exists.
- Computer room space conditioning.
- Anywhere humidity control is a problem.

Figure 12. Hot gas reheat

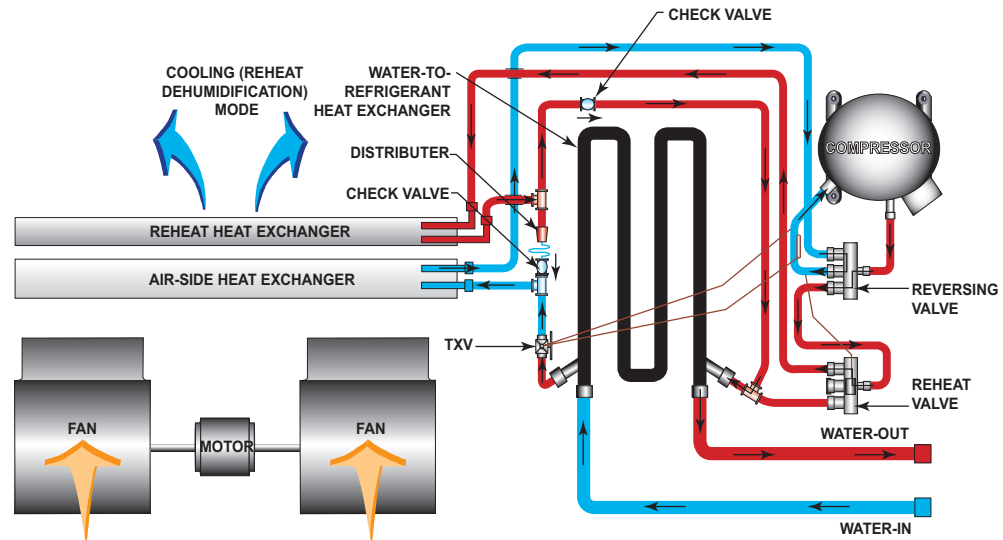
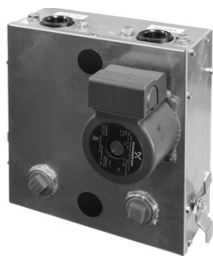

Figure 13. Pump module



The pump module and hose kit make a complete self-contained pumping package for distributed pumping systems. These kits contain all the necessary components for the installation, operation and maintenance of the water circuit of a closed loop geothermal application. Standard pump module features include insulated Grundfos pumps, insulated cabinet, cast iron pump, and 3-way brass valves. Literature number WSHP-SVN001*-EN will provide electrical and dimensional requirements for the PMCA products.

Figure 14. Pump module hose kit



The pump module hose kit consists of two brass, 3/4 in. or 1 in., external pipe thread (MPT)-by-barb fittings; two brass 90° 1-inch, MPT-by-barb elbows with pressure/temperature ports; and 10 ft of rubber hose with 4 hose clamps. The pump module hose kit is available separately from the pump module.

Refrigerant Piping

The unit's copper tubing is created from a 99% pure copper formation that conforms to the American Society of Testing (ASTM) B743 for seamless, light-annealed processing.

The unit's copper refrigeration system is designed to be free from contaminants and conditions such as drilling fragments, dirt, or oil. This excludes the possibility of these contaminants from damaging the compressor motor.

Figure 15. Reversing valve



A system reversing valve (4-way valve) is included with all heating/ cooling units. This valve is piped to be energized in the cooling mode to allow the system to provide heat if valve failure were to occur. Once the valve is energized for cooling, it will remain energized until the control system is turned to the OFF position, or a heating cycle is initiated.

Schrader Connections

The refrigerant access ports shall be factory supplied on the high and low pressure sides for easy refrigerant pressure or temperature testing.

Supply-Air Registers

Supply-air registers for the GEC product are constructed of a polymer, corrosive resistive material. The registers include a snap-in deflection design to simplify installation, as well as facilitate the ability to apply a bi-directional arrangement across the register

Figure 16. Wall sleeve

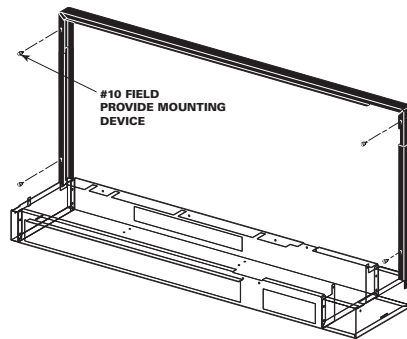

The cabinets wall sleeve is attached to the wall by (4) four, #10 field provided screws. This rigid design allows for ease of separation from the cabinet assembly during service or installation situations.

The wall sleeve is painted the same color as the cabinet for aesthetic purposes.

Sound Data

Sound Attenuation Package

The console equipment is designed to achieve the lowest noise levels possible. Extensive testing has identified the major sound generating sources within the console unit package. Every effort has been made to minimize the sound generation and transmission from the compressor, heat exchangers, and fan sources. Vibration transmission from the compressor and heat exchangers have been minimized by the use of isolation. The use of heavy metal gauges in critical areas enhance the unit acoustic performance. A patented two-stage compressor isolation system has been specifically designed for the console unit. Acoustic lining has been used to quiet compressor noise.

The unit air side acoustic performance has been engineered to obtain the quietest acoustic performance through the fan, and fan housing selection. The fin tube (air-to-refrigerant) coil and fan discharge arrangement includes an additional acoustic lining in the fan compartment to further reduce the air side sound levels.

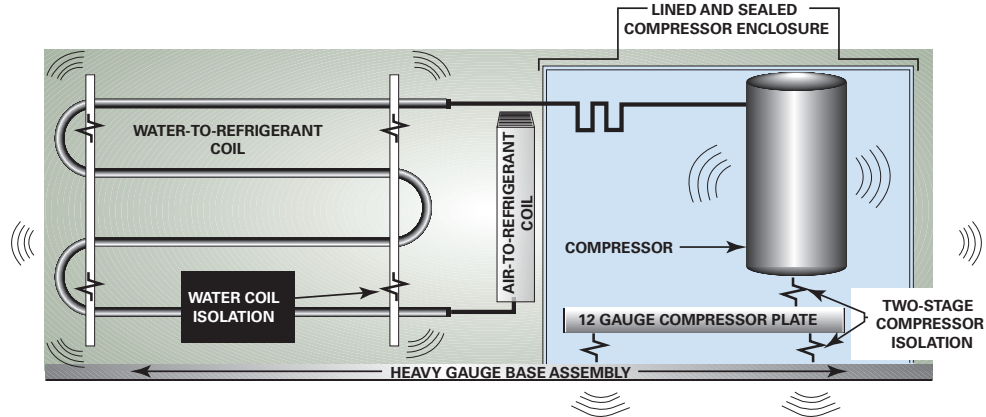
Figure 17. Console noise control

The standard unit sound package for the console unit includes:

- Two stage compressor vibration isolation
- Water-to-refrigerant heat exchanger vibration isolation
- 12-gauge intermediate mounting plate for the compressor
- Lined compressor enclosure with ½-inch cabinet insulation
- Heavy gauge base assembly
- Maximum sized return-air opening and filter sizing

To ensure consistent performance, an extensive series of tests were conducted on each cabinet size.

- Sound power testing per AHRI's standard 350 for non-ducted air handling equipment (*a noise evaluation to quantify the strength of various sound components for application in building system design*). These include:

GEC: Inlet+Casing
 Discharge

For unit specific octave band sound power data, please refer to the TOPPS selection program.

What is Sound Pressure?

Sound pressure is a pressure disturbance in the atmosphere whose intensity is influenced not only by the strength of the source, but also by the surroundings and the distance from the source to the receiver. Sound pressure is what our ears hear, and what sound meters measure. The level of sound pressure, or the *loudness* of a given noise source, depends on three factors:

1. The strength of the source
2. The environment in which the source is located
3. The listener's distance from the source

As an example, of the effect of environment, consider the sound produced by a drum. The drum is perceived to be louder in a bathroom with hard tile walls than it is in the middle of a football field. Also, the farther one moves away from the drum, the quieter it sounds. In each case, the vibration of the drum (the strength of the source) is the same; the perceived differences in noise level are due to the environment.

Because of the extremely wide range of sound pressure perceivable by a person—typically five or six order of magnitude—it is convenient to express sound pressure on a logarithmic scale. As a result, adding

two equal sound sources together will result in an overall increase of 3 dB. However, 3 dB is barely a perceptible increase in sound. It takes an increase of 10 dB to be perceived as twice as loud.

What is Sound Power?

Sound power is a measure of the acoustical energy emitted from a sound source, and is an absolute value. As discussed above, our hearing does not perceive sound power directly, as there is always some environmental medium between the source and the listener. However, from the standpoint of a building designer, sound power is often the preferred means of quantifying the noise of a given unit because it is a certifiable quantity. Using predictions are used to tailor the design to the sound pressure level requirements of the building. The environmental effects that must be taken into account when converting sound power to sound pressure for a specific location can be lumped together and called the transfer function.

Sound power should always be used when making unit-to-unit sound comparisons because it is a certifiable absolute measure of the sound energy produced by the unit. In contrast, sound pressure is not certifiable because it is difficult to ensure that each manufacturer tests in precisely the same environment. As in the case of sound pressure, it is useful to express sound power on a logarithmic scale.

What are NC and dBA?

Both NC and dBA are single number descriptors used to represent perceived loudness. Both scales take into account the fact that people are more sensitive to high frequencies than they are to low frequencies.

Noise Criterion (NC) is widely used to quantify indoor sound. The NC level is determined by the strength of sound pressure across the 63 Hz to 8000 Hz frequency range.

“A” weighted sound (dBA) is a single number descriptor often used to define sound in outdoor environments. For example, local sound ordinances typically regulate dBA levels at property lines. hearing-related safety standards written by such bodies as the Occupational Safety and Health Organization (OSHA) also commonly refer to A-weighted sound readings.

As a rule, “A” weighting is applied to octave-band sound pressure data. Applying “A” weighting sound power is only appropriate in accordance with AHRI 270. While NC and dBA are the most popular, other single number descriptors for sound are available including Room Criterion (RC), NCB and other weightings.

Figure 18. Octave band center of frequency

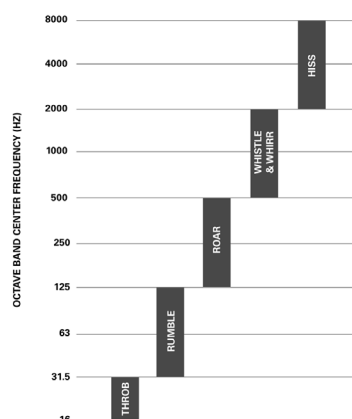

Application Considerations

Geothermal System

Closed-loop systems (both ground source and surface water) provide heat rejection and heat addition to maintain proper water-source temperatures. The choice of vertical, horizontal, or lake loop earth coupling, should be based on the characteristics of each application.

Horizontal and vertical systems can be designed to provide the same fluid temperatures under a given set of conditions. The surface (lake) loop system may see a greater variance of fluid temperatures, but the reduced installation cost may compensate for any minor reduction in performance. The three earth coupling methods should be considered at each application, with the most cost effective method chosen after all have been evaluated.

Operating and maintenance cost are low because an auxiliary electric/fossil fuel boiler and cooling tower are not required to maintain the loop temperature in a properly designed system.

The technology has advanced to the point where many electric utilities and rural electric cooperatives are offering incentives for the installation of geothermal systems. These incentives are offered because of savings to the utilities due to reduced peak loads and flatten out the system demand curve over time.

When building cooling requirements cause loop water temperatures to rise, heat is absorbed into the cooler earth through buried high density polyethylene pipe heat exchangers in a ground source geothermal system. If reversed, heating demands cause the loop temperature to fall, enabling the earth to add heat to meet load requirements.

Where local building codes require water retention ponds for short term storage of surface run-off, a ground source surface water system can be very cost effective. This system has all the advantages of the geothermal system in cooling dominated structures.

Another benefit of the ground source system is that it is environmentally friendly. The loop is made of chemically inert, non-polluting, polyethylene pipe. The heat pumps use R-410A refrigerant, which has a negligible ozone depletion potential. Because the closed-loop system does not require a heat adder, there are no local CO₂ emissions. Less electric power is consumed by the system, thereby reducing secondary emissions from the power plant. Therefore, the system offers advantages not seen by other HVAC system types.

Figure 19. Geothermal systems

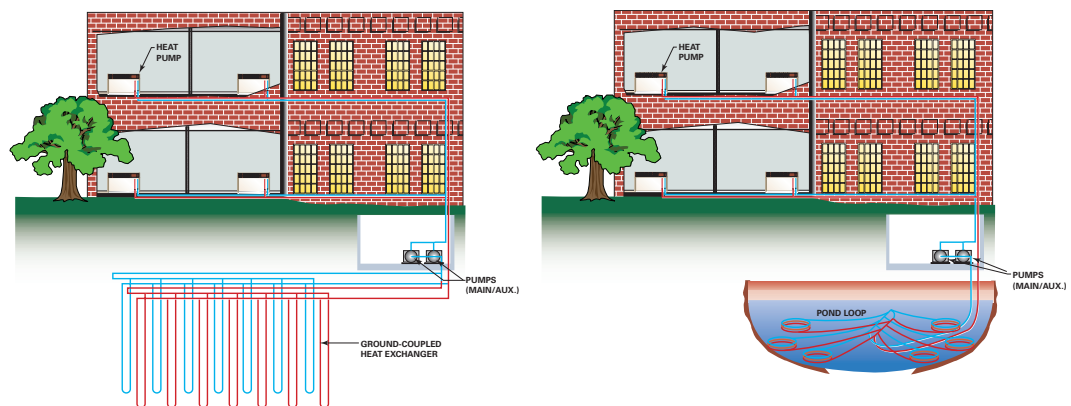

Open-Loop System

Where an existing or proposed well can provide an ample supply of suitable quality water, ground water systems may be very efficient.

Operation and benefits are similar to those for closed-loop systems. There are, however, several considerations that should be addressed prior to installation.

An acceptable way to discharge the significant volume of used water from the heat pump should be defined. It may be necessary to install a recharge well to return the water to the aquifer.

Water quality must be acceptable, with minimal suspended solids and proper pH. To help ensure clean water, a straining device may be required.

Cooling Tower/Boiler System

A cooling tower/boiler system (utilizes a closed-water loop along with multiple water-source heat pumps in a more conventional manner.

Typically, a boiler is employed to maintain closed loop temperatures above 60°F and a cooling tower to maintain closed loop temperature below 90°F. All the units function independently, either by adding heat, or removing heat from a common closed water loop. Because the heat from a building is being rejected through a cooling tower, the system is more efficient than air cooled system.

The cooling tower/boiler system provides a low installation cost to the owner when compared to other systems and is the most common application. It also allows the owner to add units to the condenser water loop as needed.

Figure 20. Geothermal systems

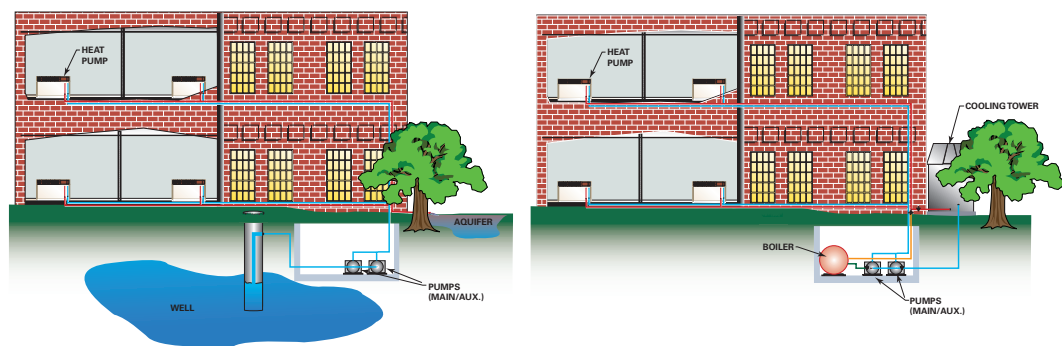

Central Pumping for the GEC Product

Central pumping systems employ a single or dual pump design to fulfill pumping requirements for the entire building system. Pumps are usually installed downstream of the cooling tower and boiler and upstream of the units to ensure positive water pressure throughout the system. The most common configuration is to use two pumps manifolded together with each pump sized to meet the flow requirements of the entire system. Only one of the pumps operates at any given time, with the second available as “standby” pump in case the operating pump was to fail.

- Hose kits are used to connect the water supply and return line to the water inlets and outlets. Trane offers various hose kit combinations to better facilitate system flow balancing. These flexible hoses also aid in the reduction of vibration between the unit and the rigid central piping system.
- A two position isolation valve is often applied to systems which incorporate variable frequency pumping. This valve is capable of stopping/starting water flow to the unit, which in turn reduces the pumping requirements for the entire system.
- The central system supply and return lines should be sized to handle the required flow with a minimum pressure drop.

Note: *Pipe will sweat if low temperature water is below the dew point of the surrounding space. Trane recommends that these lines be insulated to prevent damage from condensation when condenser loop is designed to be below 60°F. Equipment installed in attic/crawl space temperatures below 40°F may require antifreeze in the water loop.*

Installation Considerations

1. The field supplied line voltage disconnect with circuit breaker should be installed for branch circuit protection.
2. The units high voltage connection is located in the right or left hand end pocket. The field connection may be made to the factory ordered disconnect, or hard wired via the factory mounted 2 x 4 handy box.
3. The low voltage connections are made on the right hand side of the unit for units ordered with the wall mounted thermostat or sensor options. The low voltage connection is factory made if unit mounted controls are specified.
4. Because of the units blow-through design, no condensate trapping is necessary. However, it is necessary for the condensate to run in a downward motion to allow gravity to produce a constant outflow.
5. Hose kits are used to connect the water supply and return lines to the water inlet and outlets. Trane can provide various hose kit combinations to better facilitate system flow balancing. These flexible hoses, reduce vibration between the unit and the rigid piping system. For more information on the types of hose kits Trane recommends, reference WSHP-PRC025*-EN manual.
6. The console design includes a factory provided wall sleeve to facilitate installation of the unit in it's establishment.
7. The grilles are made of a durable polymer symmetrical design. The design constitutes the ability of a multi-directional supply-air from the units top.

Filter Replacement (standard height configuration)

Filter replacement is done at the front return-air opening of the console unit. No tools are required for the replacement. The maintenance process is done via a 3-STEP process:

1. Through the return-air opening, slide filter to the back of the console unit.
2. Allow the front edge of the filter to drop to floor level.
3. Pull the filter out of the front opening.

Note: *REVERSE the cycle to install a new filter.*

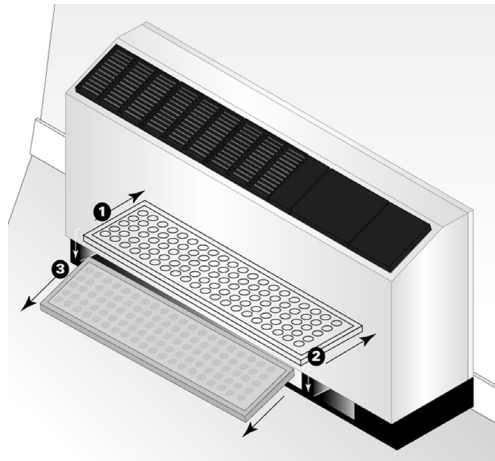

Filter Replacement (low height configuration)

Filter replacement is done at the front return-air opening of the console unit. A slotted screw driver is needed for the replacement. The maintenance process is done via a 2-STEP process.

1. Insert screw-driver and depress grill tab (2-per grille). Rotate grille down, and lift grille upward to remove grille. The removal of one grille is required.
2. Slide the filter through the grille hole in the cabinet front panel.

Note: *REVERSE the cycle to install a new filter.*

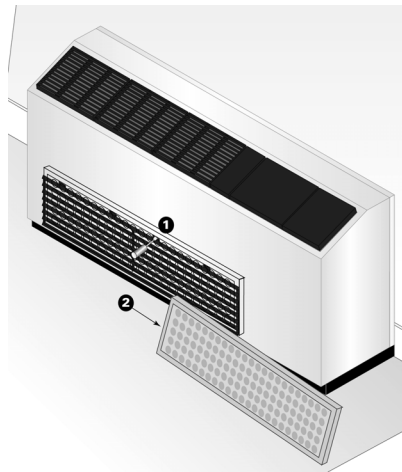



Selection Procedure

The performance standard AHRI/ISO 13256-1 became effective Jan. 1, 2000. It replaces AHRI standards 320, 325 and 330. This new standard has three major categories: Water Loop (AHRI 320), Ground Water (AHRI 325), Ground Loop (AHRI 330). Although these standards are similar there are some differences.

The cooling efficiency is measured in EER but includes a Watt-per-Watt unit of measure similar to the traditional COP measurement.

The entering water temperature has changed to reflect the centigrade temperature scale. For instance the water loop heating test is performed with 68°F water instead of 70°F. The cooling tests are performed with 80.6°F dry bulb and 66.2°F wet bulb entering air instead of the traditional 80°F dry bulb, and 67°F wet bulb entering air temperatures. This data (80.6/66.2) may be converted to 80/67 by using the entering air correction table.

A pump power correction has been added onto the existing power consumption. Within each model, only one water flow rate is specified for each performance category, and pumping watts are calculated utilizing the pump power correction formula: $(\text{gpm} \times 0.0631) \times \text{press drop} \times 2990 / 300$.

Note: *gpm relates to water flow, and press drop relates to the drop through the unit heat exchanger at rated water flow in feet of head.*

The fan power is corrected to zero external static pressure. The nominal airflow is rated at a specific external static pressure. This effectively reduces the power consumption of the unit, and increases cooling capacity but decreases heating capacity. These watts are significant enough in most cases to increase EER and COP over AHRI 320, 325, and 330 ratings.

Cooling Dominated Applications

If humidity levels are moderate to high in a cooling dominated application, the heat pump should be selected to meet or exceed the calculated sensible load. Also, the unit's sensible capacity should be no more than 115% of the total cooling load (sensible + latent), unless the calculated latent load is less than the latent capacity of the unit.

The sensible-to-total cooling ratio can be adjusted with airflow. If the airflow is lowered, the unit latent capacity will increase. When less air is pulled across the DX coil, more moisture will condense from the air.

Heating Dominated Applications

Unit sizing in heating dominated applications is based upon humidity levels for the climate, and goals for operating cost and installation costs.

If humidity levels are moderate, the heat pump should be selected with the heating capacity equal to 125% of the cooling load.

If humidity levels are low in the application and low operating cost is important, the heat pump and ground loop should be sized for 90% to 100% of the heating load.

If humidity levels are low and lower initial cost is important, then the heat pump and ground loop should be sized for 70% to 85% of the heating load, with the remaining load to be treated with electric resistance heat.

Installation cost will be reduced in this approach because of the smaller heat pump selection and less loop materials.

In general, the system will not use enough electric heat to offset the higher installation costs associated with a fully sized or oversized system.

Finally, a unit sized for the entire heating load in a heating dominated application will be oversized in cooling. Comfort is reduced from increased room humidity caused by short-run times. Short cycling will also shorten the life expectancy of the equipment and increase power consumption and operating cost.

Many rebate incentives require the heat pump and ground loop to be sized for the entire heating load. Check with your local utility for their requirements.



Model Number Description

Digits 1-3 — Unit Configuration

GEC = High Efficiency Console

Digit 4 — Unit Configuration

E

Digits 5-7 — Nominal Capacity

006 = 0.5 Tons

009 = 0.75 Tons

012 = 1 Tons

015 = 1.25 Tons

018 = 1.5 Tons

Digit 8 — Voltage Volts/Hz/Phase)

0 = 115/60/1

1 = 208/60/1

2 = 230/60/1

6 = 220-240/50/1

7 = 265/60/1

Digit 9 — Heat Exchanger

1 = Copper-Water Coil

2 = Cupro-Nickel Water Coil

Digit 10 — Design Sequence

B

Digit 11 — Refrigeration Circuit

0 = Heating and Cooling Circuit

2 = Heating and Cooling Circuit with Hot Gas Reheat

Digit 12 — Blower Configuration

1 = Standard Blower Motor

Digit 13 — Freeze Protection

A = 20° Freezestat (For Glycol Loop)
(Extended Range Geothermal)

B = 35° Freezestat (For Water Loop)

Digit 14 — Open Digit

0 = Open Digit

S = Design Special

Digit 15 — Supply-Air Arrangement

0 = Standard Supply-Air Arrangement

Digit 16 — Return-Air Arrangement

0 = Standard Return-Air Arrangement

Digit 17 — Control Types

D = Deluxe 24V Controls

E = Deluxe 24V Control with
Programmable Thermostat

H = Symbio™ 400-B/UC400-B

J = Symbio 400-B/UC400-B with Air-Fi®
Wireless Communications

Digit 18 — Tstat/Sensor Location

0 = Wall Mounted Location

1 = Unit Mounted Location with Standard
Entry

2 = Unit Mounted Location with Keylock
Entry

Digit 19 — Fault Sensors

1 = Condensate Overflow Sensor

3 = Condensate Overflow and Filter
Maintenance Timer

6 = Condensate Overflow and Fan Status

J = Condensate Overflow Sensor, Fan
Status and Filter Maintenance Timer

Digit 20 — Temperature Sensor

0 = No Additional Temperature Sensor

1 = Entering Water Sensor

Digit 21 — Open Digit

0 = Open Digit

Digit 22 — Electric Heat

0 = No Electric Heat

2 = Boilerless Control Electric Heat
(minimum)

3 = Boilerless Control Electric Heat
(maximum)

Digit 23 — Unit Mounted Disconnect

0 = No Unit Mounted Disconnect

A = Power Cord/Receptacle Box

B = Power Cord/Receptacle Box with
Circuit Breaker

C = On/Off Toggle Switch

Digit 24 — Filter Type

0 = No Filter; Chassis Only

1 = 1-inch Throwaway Filter

A = 1-inch MERV 8 Filter

Digit 25 — Acoustic Arrangement

0 = Enhanced Sound Attenuation

Digit 26 — Factory Configuration

0 = Standard Factory Configuration
(*Chassis, Cabinet and Subbase*)

1 = Chassis ONLY

2 = Low Height Factory Configuration
(*Chassis, Cabinet and Subbase*)

3 = Extended Length Factory
Configuration (*Chassis, Cabinet and
Subbase*)

Digit 27 — Paint Color

0 = No Paint Selection Available

1 = Deluxe Beige

2 = Cameo White

3 = Soft Dove

Digit 28 — Outside Air

0 = No Outside Air Option

1 = Outside Air Opening

2 = Motorized Outside Air (*2-position*)

Digit 29 — Piping Arrangement

L = Left Hand Piping Arrangement

R = Right Hand Piping Arrangement

Digit 30-36 — Does Not Apply to GEC

0000000 = Digits 30-36 are not applicable
to the GEC product



General Data

Table 3. General data

Model Number		006	009	012	015	018
Compressor Type		Rotary	Rotary	Rotary	Rotary	Rotary
Cabinet Size	Length (in.) - standard/extended	48/63	48/63	48/63	48/63	48/63
	Height (in.) - standard/low	25/22.5	25/22.5	25/22.5	25/22.5	25/22.5
	Depth (in.)	12	12	12	12	12
Refrigerant (lbs)	Heating and Cooling	1.47	1.50	1.57	1.69	1.68
	Hot Gas Reheat	1.56	1.59	1.66	1.81	2.06
Approximate weight unit	with Pallet (lb.)	218	219	234	240	242
Approximate weight unit	without Pallet (lb.)	188	189	204	210	212
Approximate weight chassis	with Pallet (lb.)	170	171	186	192	194
Approximate weight chassis	without Pallet (lb.)	140	141	156	162	164
Nominal Filter Size (standard height - 25")		1 x 10 x 32 3/8	1 x 10 x 32 3/8	1 x 10 x 32 3/8	1 x 10 x 32 3/8	1 x 10 x 32 3/8
Nominal Filter Size (low height - 22.5")		1 x 7 3/4 x 30 5/8	1 x 7 3/4 x 30 5/8	1 x 7 3/4 x 30 5/8	1 x 7 3/4 x 30 5/8	1 x 7 3/4 x 30 5/8
Blower Wheel Size		(1) 5 1/4 x 8 1/8	(2) 5 1/4 x 8 1/8	(2) 5 1/4 x 8 1/8	(2) 5 1/4 x 8 1/8	(2) 5 1/4 x 8 1/8



Performance Data

Table 4. ANSI/AHRI/ASHRAE/ISO13256-1 WLHP, GWHP and GLHP performance - 0.5 to 1.5 tons^(a)

Model	Rated GPM	Rated CFM	Water Loop Heat Pump				Ground Water Heat Pump				Ground Loop Heat Pump			
			Cooling 86°F		Heating 68°F		Cooling 59°F		Heating 50°F		Cooling 77°F		Heating 32°F	
			Capacity Btuh	EER	Capacity Btuh	COP	Capacity Btuh	EER	Capacity Btuh	COP	Capacity Btuh	EER	Capacity Btuh	COP
GECE006	1.8	290	7,500	12.50	9,100	4.70	8,500	18.54	7,600	4.03	7,800	14.42	5,900	3.20
GECE009	2.1	305	8,800	13.10	10,500	4.90	9,900	18.10	9,200	4.13	9,100	14.60	6,800	3.26
GECE012	2.8	430	11,500	13.10	14,100	4.70	12,800	19.11	11,500	3.94	11,900	14.65	9,200	3.26
GECE015	3.5	480	14,700	13.29	17,300	4.61	16,100	19.40	14,300	3.94	15,300	15.23	11,600	3.26
GECE018	4.2	530	16,500	13.00	20,100	4.61	17,700	18.33	16,400	3.94	16,900	14.26	12,900	3.20

(a) Rated in accordance with ANSI/AHRI/ASHRAE/ISO13256-1. Certified conditions are 80.6°F DB/66.2°F WB EAT in cooling and 68°F DB/59°F WB EAT in heating.

Table 5. Cooling capacities 0.5 tons (net) - GEC006

EWT	GPM	Total Mbtuh	Sen Mbtuh	SHR	Power kW	EER	Reject Mbtuh	LWT	Feet Head
45	1.1	8.4	6.7	0.79	0.42	20.2	9.8	62.8	1.7
45	1.4	8.4	6.7	0.79	0.40	20.9	9.8	59.0	2.6
45	1.6	8.5	6.7	0.79	0.40	21.2	9.9	57.3	3.3
45	1.7	8.5	6.7	0.79	0.39	21.5	9.8	56.6	3.6
45	1.8	8.5	6.7	0.79	0.39	21.8	9.8	55.9	4.0
45	1.9	8.5	6.7	0.79	0.39	22.0	9.8	55.4	4.3
45	2.0	8.5	6.7	0.79	0.38	22.3	9.8	54.8	4.6
55	1.1	8.1	6.6	0.81	0.45	17.8	9.7	72.6	1.6
55	1.4	8.2	6.6	0.81	0.44	18.4	9.7	68.8	2.6
55	1.6	8.2	6.6	0.81	0.44	18.8	9.7	67.1	3.2
55	1.7	8.2	6.6	0.81	0.43	18.9	9.7	66.4	3.6
55	1.8	8.2	6.6	0.81	0.43	19.1	9.7	65.7	3.9
55	1.9	8.2	6.6	0.80	0.43	19.3	9.7	65.2	4.2
55	2.0	8.2	6.6	0.80	0.42	19.6	9.7	64.7	4.5
68	1.1	7.7	6.4	0.84	0.50	15.3	9.4	85.0	1.6
68	1.4	7.8	6.5	0.83	0.49	15.8	9.5	81.5	2.5
68	1.6	7.8	6.5	0.83	0.49	16.1	9.5	79.8	3.1
68	1.7	7.8	6.5	0.83	0.48	16.2	9.5	79.1	3.5
68	1.8	7.8	6.5	0.83	0.47	16.6	9.4	78.5	3.8
68	1.9	7.9	6.5	0.83	0.48	16.5	9.5	78.0	4.1
68	2.0	7.9	6.5	0.83	0.47	16.7	9.5	77.5	4.4
77	1.1	7.6	6.4	0.84	0.55	13.8	9.4	94.1	1.5
77	1.4	7.6	6.4	0.84	0.53	14.3	9.4	90.4	2.4
77	1.6	7.6	6.4	0.84	0.52	14.5	9.4	88.7	3.0
77	1.7	7.6	6.4	0.84	0.52	14.6	9.4	88.0	3.3
77	1.8	7.6	6.4	0.84	0.52	14.7	9.4	87.4	3.7
77	1.9	7.6	6.4	0.84	0.51	14.8	9.4	86.9	4.0
77	2.0	7.6	6.4	0.84	0.51	14.9	9.4	86.4	4.4
86	1.1	7.5	6.4	0.85	0.61	12.2	9.6	103.4	1.5
86	1.4	7.5	6.4	0.85	0.59	12.7	9.5	99.6	2.3
86	1.6	7.5	6.4	0.85	0.58	12.9	9.5	97.9	2.9



Performance Data

Table 5. Cooling capacities 0.5 tons (net) - GEC006 (continued)

EWT	GPM	Total Mbtuh	Sen Mbtuh	SHR	Power kW	EER	Reject Mbtuh	LWT	Feet Head
86	1.7	7.5	6.4	0.85	0.58	13.0	9.5	97.1	3.2
86	1.8	7.5	6.4	0.85	0.57	13.1	9.5	96.5	3.6
86	1.9	7.5	6.4	0.85	0.57	13.2	9.5	96.0	3.9
86	2.0	7.5	6.4	0.85	0.57	13.3	9.5	95.5	4.3
95	1.1	7.4	6.3	0.86	0.70	10.5	9.7	112.7	1.5
95	1.4	7.4	6.3	0.86	0.67	11.0	9.7	108.8	2.2
95	1.6	7.4	6.3	0.86	0.66	11.2	9.6	107.0	2.8
95	1.7	7.4	6.3	0.86	0.66	11.3	9.6	106.3	3.1
95	1.8	7.4	6.3	0.86	0.65	11.3	9.6	105.7	3.5
95	1.9	7.4	6.3	0.86	0.65	11.4	9.6	105.1	3.8
95	2.0	7.4	6.3	0.86	0.65	11.5	9.6	104.6	4.2
105	1.1	7.1	6.2	0.88	0.94	7.5	10.3	123.7	1.4
105	1.4	7.1	6.2	0.87	0.87	8.2	10.1	119.4	2.2
105	1.6	7.1	6.2	0.87	0.95	7.5	10.3	117.9	2.7
105	1.7	7.1	6.2	0.87	0.93	7.6	10.3	117.1	3.1
105	1.8	7.1	6.2	0.87	0.98	7.3	10.4	116.6	3.4
105	1.9	7.1	6.2	0.87	0.93	7.7	10.3	115.8	3.7
105	2.0	7.1	6.2	0.87	0.93	7.7	10.3	115.3	4.0
115	1.1	6.8	6.1	0.89	1.21	5.6	11.0	134.9	1.2
115	1.4	6.8	6.1	0.89	1.21	5.7	10.9	130.6	2.1
115	1.6	6.8	6.1	0.89	1.20	5.7	10.9	128.7	2.7
115	1.7	6.8	6.1	0.89	1.20	5.7	10.9	127.9	3.0
115	1.8	6.8	6.1	0.89	1.20	5.7	10.9	127.1	3.3
115	1.9	6.8	6.1	0.89	1.20	5.7	10.9	126.5	3.6
115	2.0	6.9	6.1	0.89	1.19	5.7	10.9	125.9	3.9
120	1.1	6.7	6.0	0.90	1.35	5.0	11.3	140.5	1.2
120	1.4	6.7	6.0	0.90	1.34	5.0	11.3	136.1	2.0
120	1.6	6.7	6.0	0.90	1.34	5.0	11.3	134.1	2.6
120	1.7	6.7	6.0	0.90	1.33	5.0	11.3	133.2	2.9
120	1.8	6.7	6.0	0.90	1.33	5.0	11.3	132.5	3.2
120	1.9	6.7	6.0	0.90	1.33	5.0	11.3	131.8	3.5
120	2.0	6.7	6.0	0.90	1.33	5.1	11.3	131.3	3.8

Note: Cooling performance data is tabulated at 80.6°F DB/66.2°F WB entering air at ARI/ISO 13256-1 rated cfm. For ARI/ISO 13256-1 certified ratings, see Table 4, p. 21. See Performance correction tables to correct performance at conditions other than those tabulated. Data shown is for unit performance only interpolation is permissible. Extrapolation is not. Rated GPM: 1.8 Minimum cfm 220; Rated cfm 290; Maximum cfm 290.

Table 6. Heating capacities 0.5 tons (net) - GEC006

EWT	GPM	Htg. Cap Mbtuh	Absorb Mbtuh	Power kW	COP	LWT	Feet Head
25	1.1	5.3	3.5	0.51	3.0	18.6	2.5
25	1.4	5.4	3.7	0.51	3.1	19.8	3.9
25	1.6	5.5	3.7	0.51	3.2	20.3	4.9
25	1.7	5.5	3.8	0.51	3.2	20.6	5.4
25	1.8	5.5	3.8	0.51	3.2	20.8	6.0
25	1.9	5.6	3.8	0.51	3.2	21.0	6.6
25	2.0	5.6	3.8	0.51	3.2	21.2	7.2

Table 6. Heating capacities 0.5 tons (net) - GEC006 (continued)

EWT	GPM	Htg. Cap Mbtuh	Absorb Mbtuh	Power kW	COP	LWT	Feet Head
32	1.1	5.8	4.1	0.51	3.4	24.6	2.5
32	1.4	6.0	4.3	0.51	3.4	25.9	3.8
32	1.6	6.1	4.3	0.51	3.5	26.6	4.7
32	1.7	6.1	4.4	0.51	3.5	26.9	5.3
32	1.8	6.2	4.4	0.51	3.5	27.1	5.8
32	1.9	6.2	4.4	0.51	3.5	27.3	6.4
32	2.0	6.2	4.4	0.51	3.5	27.6	7.0
45	1.1	7.1	5.3	0.52	4.0	35.3	2.0
45	1.4	7.3	5.5	0.52	4.1	37.1	3.0
45	1.6	7.4	5.6	0.52	4.1	38.0	3.8
45	1.7	7.4	5.6	0.52	4.2	38.4	4.2
45	1.8	7.5	5.7	0.52	4.2	38.7	4.7
45	1.9	7.5	5.7	0.52	4.2	39.0	5.1
45	2.0	7.5	5.7	0.52	4.2	39.3	5.6
55	1.1	8.0	6.2	0.53	4.5	43.7	1.9
55	1.4	8.2	6.4	0.53	4.6	45.8	2.9
55	1.6	8.4	6.6	0.53	4.6	46.8	3.7
55	1.7	8.4	6.6	0.53	4.7	47.3	4.1
55	1.8	8.5	6.6	0.53	4.7	47.6	4.5
55	1.9	8.5	6.7	0.53	4.7	48.0	4.9
55	2.0	8.5	6.7	0.53	4.7	48.3	5.4
68	1.1	9.2	7.4	0.54	5.0	54.5	1.8
68	1.4	9.5	7.7	0.54	5.2	57.0	2.8
68	1.6	9.7	7.8	0.54	5.3	58.2	3.5
68	1.7	9.7	7.9	0.54	5.3	58.7	3.9
68	1.8	9.8	7.9	0.54	5.3	59.2	4.3
68	1.9	9.8	8.0	0.54	5.3	59.6	4.7
68	2.0	9.9	8.0	0.54	5.4	60.0	5.2
75	1.1	9.9	8.0	0.54	5.4	60.4	1.8
75	1.4	10.2	8.4	0.54	5.5	63.1	2.7
75	1.6	10.3	8.5	0.54	5.6	64.4	3.4
75	1.7	10.4	8.6	0.54	5.6	64.9	3.8
75	1.8	10.5	8.6	0.54	5.7	65.4	4.2
75	1.9	10.5	8.7	0.54	5.7	65.9	4.6
75	2.0	10.6	8.7	0.54	5.7	66.3	5.0
86	1.1	10.9	9.1	0.54	5.9	69.5	1.7
86	1.4	11.3	9.4	0.55	6.0	72.6	2.6
86	1.6	11.4	9.6	0.55	6.1	74.0	3.3
86	1.7	11.5	9.6	0.55	6.2	74.7	3.7
86	1.8	11.6	9.7	0.55	6.2	75.2	4.1
86	1.9	11.6	9.7	0.55	6.2	75.7	4.4
86	2.0	11.7	9.8	0.55	6.3	76.2	4.9

Note: Heating performance data is tabulated at 68°F DB entering air at ARI/ISO 13256-1 rated cfm. For ARI/ISO 13256-1 certified ratings, see [Table 4, p. 21](#). See Performance correction tables to correct performance at conditions other than those tabulated. Data shown is for unit performance only. Interpolation is permissible. Extrapolation is not. Rated GPM: 1.8 Minimum cfm 220; Rated cfm 290; Maximum cfm 290.



Performance Data

Table 7. Fan correction factors 0.5 tons - GEC006

Entering cfm	Cooling Capacity	Sensible Capacity	Cooling Input Watts	Heating Capacity	Heating Input Watts
220	0.962	0.860	1.012	0.984	1.087
290	1.000	1.000	1.000	1.000	1.000

Table 8. Cooling capacities 0.75 tons (net) - GEC009

EWT	GPM	Total Mbtuh	Sen Mbtuh	SHR	Power kW	EER	Reject Mbtuh	LWT	Feet Head
45	1.4	10.6	8.6	0.82	0.46	22.9	12.2	62.4	2.1
45	1.7	10.7	8.5	0.80	0.46	23.2	12.2	59.4	3.3
45	1.9	10.7	8.4	0.78	0.46	23.3	12.3	57.9	4.1
45	2.1	10.7	8.2	0.77	0.46	23.5	12.3	56.7	5.0
45	2.2	10.8	8.3	0.77	0.46	23.7	12.3	56.2	5.4
45	2.3	10.8	8.3	0.76	0.45	23.8	12.4	55.7	5.8
45	2.5	10.9	8.3	0.76	0.45	24.0	12.4	54.9	6.7
55	1.4	9.2	7.4	0.80	0.51	18.2	11.0	70.7	2.3
55	1.7	9.8	7.8	0.80	0.50	19.7	11.5	68.6	3.4
55	1.9	9.9	7.9	0.79	0.49	20.1	11.6	67.2	4.1
55	2.1	10.0	7.9	0.79	0.49	20.5	11.7	66.1	4.9
55	2.2	10.1	7.9	0.79	0.49	20.6	11.7	65.7	5.2
55	2.3	10.1	8.0	0.79	0.49	20.8	11.8	65.2	5.6
55	2.5	10.2	8.0	0.78	0.48	21.2	11.9	64.5	6.4
68	1.4	9.0	7.5	0.83	0.55	16.2	10.8	83.5	2.2
68	1.7	9.1	7.5	0.82	0.54	16.8	10.9	80.9	3.1
68	1.9	9.2	7.5	0.81	0.54	17.1	11.0	79.6	3.8
68	2.1	9.2	7.5	0.82	0.53	17.3	11.0	78.5	4.6
68	2.2	9.3	7.5	0.80	0.53	17.6	11.1	78.1	4.9
68	2.3	9.3	7.5	0.81	0.53	17.5	11.1	77.6	5.4
68	2.5	9.1	7.5	0.83	0.53	17.1	10.9	76.7	6.2
77	1.4	8.7	7.4	0.85	0.60	14.5	10.8	92.4	2.2
77	1.7	8.8	7.4	0.85	0.59	14.9	10.8	89.7	3.0
77	1.9	8.8	7.4	0.84	0.58	15.1	10.8	88.4	3.7
77	2.1	8.8	7.4	0.84	0.58	15.3	10.8	87.3	4.4
77	2.2	8.8	7.4	0.84	0.57	15.4	10.8	86.8	4.8
77	2.3	8.8	7.4	0.85	0.57	15.4	10.7	86.3	5.2
77	2.5	8.9	7.5	0.83	0.57	15.7	10.9	85.7	6.0
86	1.4	8.6	7.4	0.86	0.67	12.7	10.9	101.5	2.1
86	1.7	8.6	7.4	0.86	0.65	13.1	10.8	98.7	3.0
86	1.9	8.6	7.4	0.85	0.65	13.3	10.8	97.4	3.6
86	2.1	8.6	7.4	0.85	0.64	13.5	10.8	96.3	4.3
86	2.2	8.6	7.4	0.85	0.64	13.6	10.8	95.8	4.7
86	2.3	8.6	7.4	0.85	0.64	13.6	10.8	95.4	5.1
86	2.5	8.7	7.4	0.85	0.63	13.7	10.8	94.7	5.9
95	1.4	8.4	7.3	0.87	0.78	10.9	11.1	110.9	2.0
95	1.7	8.5	7.3	0.86	0.76	11.1	11.1	108.0	2.9
95	1.9	8.5	7.3	0.86	0.75	11.3	11.0	106.6	3.5

Table 8. Cooling capacities 0.75 tons (net) - GEC009 (continued)

EWT	GPM	Total Mbtuh	Sen Mbtuh	SHR	Power kW	EER	Reject Mbtuh	LWT	Feet Head
95	2.1	8.4	7.3	0.86	0.73	11.5	10.9	105.4	4.2
95	2.2	8.5	7.3	0.86	0.74	11.4	11.0	105.0	4.5
95	2.3	8.4	7.3	0.87	0.72	11.7	10.9	104.5	4.9
95	2.5	8.4	7.3	0.87	0.72	11.8	10.9	103.7	5.7
105	1.4	8.5	7.3	0.86	1.06	8.0	12.1	122.3	2.0
105	1.7	8.4	7.3	0.87	0.94	8.9	11.6	118.6	2.9
105	1.9	8.4	7.3	0.87	0.93	9.0	11.5	117.1	3.5
105	2.1	8.4	7.3	0.87	0.91	9.2	11.5	115.9	4.2
105	2.2	8.4	7.3	0.87	0.90	9.2	11.4	115.4	4.5
105	2.3	8.4	7.3	0.87	0.90	9.3	11.4	114.9	4.9
105	2.5	8.4	7.3	0.87	0.88	9.5	11.4	114.1	5.5
115	1.4	8.2	7.2	0.88	1.12	7.3	12.1	132.2	1.8
115	1.7	8.2	7.2	0.88	1.10	7.5	12.0	129.1	2.8
115	1.9	8.2	7.2	0.88	1.08	7.6	11.9	127.6	3.5
115	2.1	8.2	7.2	0.88	1.07	7.7	11.9	126.3	4.1
115	2.2	8.2	7.2	0.88	1.06	7.8	11.8	125.8	4.5
115	2.3	8.2	7.2	0.88	1.05	7.8	11.8	125.3	4.8
115	2.5	8.2	7.2	0.88	1.03	8.0	11.8	124.4	5.5
120	1.4	8.2	7.2	0.88	1.20	6.8	12.3	137.5	1.8
120	1.7	8.2	7.2	0.88	1.17	7.0	12.2	134.3	2.8
120	1.9	8.2	7.2	0.88	1.16	7.1	12.1	132.8	3.4
120	2.1	8.2	7.2	0.88	1.14	7.2	12.1	131.5	4.1
120	2.2	8.2	7.2	0.88	1.13	7.2	12.0	130.9	4.4
120	2.3	8.2	7.2	0.88	1.13	7.3	12.0	130.4	4.8
120	2.5	8.2	7.2	0.88	1.11	7.4	12.0	129.6	5.4

Note: Cooling performance data is tabulated at 80.6°F DB/66.2°F WB entering air at ARI/ISO 13256-1 rated cfm. For ARI/ISO 13256-1 certified ratings, see Table 4, p. 21. See Performance correction tables to correct performance at conditions other than those tabulated. Data shown is for unit performance only interpolation is permissible. Extrapolation is not. Rated GPM: 2.1 Minimum cfm 240; Rated cfm 305; Maximum cfm 305.

Table 9. Heating capacities 0.75 tons (net) - GEC009

EWT	GPM	Htg. Cap Mbtuh	Absorb Mbtuh	Power kW	COP	LWT	Feet Head
25	1.4	6.1	4.2	0.56	3.2	19.0	3.5
25	1.7	6.3	4.4	0.56	3.3	19.9	4.9
25	1.9	6.3	4.4	0.56	3.3	20.3	5.9
25	2.1	6.4	4.5	0.56	3.3	20.7	7.1
25	2.2	6.4	4.5	0.56	3.4	20.9	7.6
25	2.3	6.4	4.5	0.56	3.4	21.1	8.3
25	2.5	6.5	4.6	0.56	3.4	21.4	9.6
32	1.4	6.8	4.9	0.57	3.5	25.0	3.4
32	1.7	7.0	5.0	0.57	3.6	26.1	4.7
32	1.9	7.0	5.1	0.57	3.6	26.6	5.7
32	2.1	7.1	5.1	0.57	3.7	27.1	6.8
32	2.2	7.1	5.2	0.57	3.7	27.3	7.4
32	2.3	7.1	5.2	0.57	3.7	27.5	8.0
32	2.5	7.2	5.2	0.57	3.7	27.8	9.3



Performance Data

Table 9. Heating capacities 0.75 tons (net) - GEC009 (continued)

EWT	GPM	Htg. Cap Mbtuh	Absorb Mbtuh	Power kW	COP	LWT	Feet Head
45	1.4	8.3	6.3	0.58	4.2	36.0	2.7
45	1.7	8.4	6.4	0.58	4.2	37.4	3.8
45	1.9	8.5	6.5	0.58	4.3	38.1	4.6
45	2.1	8.6	6.6	0.58	4.3	38.7	5.5
45	2.2	8.6	6.6	0.59	4.3	39.0	6.0
45	2.3	8.7	6.7	0.58	4.3	39.2	6.4
45	2.5	8.7	6.7	0.59	4.4	39.6	7.5
55	1.4	9.3	7.3	0.59	4.6	44.6	2.6
55	1.7	9.5	7.5	0.59	4.7	46.2	3.7
55	1.9	9.6	7.6	0.59	4.8	47.0	4.4
55	2.1	9.7	7.7	0.59	4.8	47.7	5.3
55	2.2	9.8	7.7	0.59	4.8	48.0	5.7
55	2.3	9.8	7.8	0.59	4.8	48.2	6.2
55	2.5	9.9	7.8	0.59	4.9	48.7	7.2
68	1.4	10.7	8.7	0.60	5.3	55.6	2.5
68	1.7	11.0	8.9	0.60	5.4	57.5	3.5
68	1.9	11.1	9.0	0.60	5.4	58.5	4.2
68	2.1	11.2	9.1	0.60	5.5	59.3	5.0
68	2.2	11.2	9.2	0.60	5.5	59.6	5.5
68	2.3	11.3	9.2	0.60	5.5	60.0	5.9
68	2.5	11.4	9.3	0.60	5.5	60.6	6.8
75	1.4	11.5	9.4	0.60	5.6	61.5	2.4
75	1.7	11.7	9.7	0.60	5.7	63.6	3.4
75	1.9	11.9	9.8	0.60	5.8	64.7	4.1
75	2.1	12.0	9.9	0.61	5.8	65.6	4.9
75	2.2	12.0	10.0	0.61	5.8	65.9	5.3
75	2.3	12.1	10.0	0.61	5.8	66.3	5.8
75	2.5	12.2	10.1	0.61	5.9	66.9	6.7
86	1.4	12.6	10.6	0.61	6.1	70.9	2.4
86	1.7	12.9	10.8	0.61	6.2	73.2	3.3
86	1.9	13.1	11.0	0.61	6.3	74.4	4.0
86	2.1	13.2	11.1	0.61	6.3	75.4	4.8
86	2.2	13.2	11.2	0.61	6.3	75.9	5.2
86	2.3	13.3	11.2	0.61	6.4	76.3	5.6
86	2.5	13.4	11.3	0.61	6.4	77.0	6.4

Note: Heating performance data is tabulated at 68°F DB entering air at ARI/ISO 13256-1 rated cfm. For ARI/ISO 13256-1 certified ratings, see [Table 4, p. 21](#). See Performance correction tables to correct performance at conditions other than those tabulated. Data shown is for unit performance only. Interpolation is permissible. Extrapolation is not. Rated GPM: 2.1 Minimum cfm 240; Rated cfm 305; Maximum cfm 305.

Table 10. Fan correction factory 0.75 tons - GEC009

Entering cfm	Cooling Capacity	Sensible Capacity	Cooling Input Watts	Heating Capacity	Heating Input Watts
240	0.959	0.850	0.978	0.984	1.080
305	1.000	1.000	1.000	1.000	1.000

Table 11. Cooling capacities 1 tons (net) - GEC012

EWT	GPM	Total Mbtuh	Sen Mbtuh	SHR	Power kW	EER	Reject Mbtuh	LWT	Feet Head
45	1.8	12.6	9.9	0.78	0.54	23.5	14.4	61.0	4.9
45	2.2	12.7	9.9	0.78	0.52	24.2	14.5	58.1	7.3
45	2.5	12.7	9.9	0.78	0.52	24.7	14.5	56.6	9.1
45	2.8	12.8	9.9	0.78	0.51	25.2	14.5	55.4	10.7
45	2.9	12.8	9.9	0.78	0.50	25.3	14.5	55.0	11.4
45	3.1	12.8	9.9	0.77	0.50	25.5	14.5	54.4	12.9
45	3.4	12.8	9.9	0.77	0.50	25.8	14.5	53.5	15.1
55	1.8	12.2	9.8	0.80	0.60	20.5	14.3	70.8	4.5
55	2.2	12.3	9.8	0.80	0.59	20.9	14.3	68.0	6.9
55	2.5	12.3	9.8	0.79	0.57	21.5	14.3	66.4	8.5
55	2.8	12.4	9.8	0.79	0.57	21.9	14.3	65.2	10.3
55	2.9	12.4	9.8	0.79	0.56	21.9	14.3	64.9	11.0
55	3.1	12.4	9.8	0.79	0.56	22.1	14.3	64.2	12.4
55	3.4	12.5	9.8	0.79	0.56	22.4	14.4	63.4	14.2
68	1.8	11.7	9.6	0.82	0.68	17.1	14.0	83.6	4.5
68	2.2	11.8	9.7	0.82	0.67	17.6	14.1	80.8	6.4
68	2.5	11.8	9.7	0.82	0.66	17.9	14.1	79.3	8.1
68	2.8	11.9	9.7	0.81	0.65	18.2	14.1	78.1	9.9
68	2.9	11.9	9.7	0.81	0.65	18.3	14.1	77.7	10.7
68	3.1	11.9	9.7	0.81	0.65	18.4	14.1	77.1	11.8
68	3.4	11.9	9.7	0.81	0.64	18.6	14.1	76.3	13.9
77	1.8	11.6	9.6	0.83	0.76	15.2	14.2	92.8	4.4
77	2.2	11.6	9.6	0.83	0.74	15.7	14.2	89.9	6.2
77	2.5	11.6	9.6	0.83	0.73	15.9	14.1	88.3	7.8
77	2.8	11.6	9.6	0.83	0.72	16.1	14.1	87.1	9.6
77	2.9	11.7	9.6	0.83	0.72	16.2	14.1	86.7	10.2
77	3.1	11.7	9.6	0.83	0.72	16.3	14.1	86.1	11.5
77	3.4	11.7	9.6	0.83	0.71	16.4	14.1	85.3	13.5
86	1.8	11.5	9.6	0.84	0.86	13.3	14.4	102.0	4.3
86	2.2	11.5	9.6	0.83	0.84	13.7	14.3	99.0	6.1
86	2.5	11.5	9.6	0.83	0.82	14.0	14.3	97.5	7.6
86	2.8	11.5	9.6	0.83	0.81	14.1	14.3	96.2	9.3
86	2.9	11.5	9.6	0.83	0.81	14.2	14.3	95.9	9.9
86	3.1	11.5	9.6	0.83	0.81	14.3	14.3	95.2	11.1
86	3.4	11.5	9.6	0.83	0.80	14.4	14.2	94.4	13.1
95	1.8	11.3	9.6	0.85	0.99	11.4	14.7	111.3	4.1
95	2.2	11.3	9.6	0.84	0.96	11.8	14.6	108.3	5.9
95	2.5	11.3	9.6	0.84	0.95	12.0	14.5	106.6	7.4
95	2.8	11.3	9.6	0.84	0.93	12.1	14.5	105.4	9.1
95	2.9	11.3	9.6	0.84	0.93	12.1	14.5	105.0	9.6
95	3.1	11.3	9.6	0.84	0.93	12.2	14.5	104.3	10.8
95	3.4	11.3	9.6	0.84	0.92	12.3	14.5	103.5	12.7
105	1.8	11.0	9.5	0.86	1.23	8.9	15.2	121.9	4.0
105	2.2	11.0	9.5	0.86	1.20	9.2	15.1	118.7	5.7



Performance Data

Table 11. Cooling capacities 1 tons (net) - GEC012 (continued)

EWT	GPM	Total Mbtuh	Sen Mbtuh	SHR	Power kW	EER	Reject Mbtuh	LWT	Feet Head
105	2.5	11.0	9.5	0.86	1.18	9.3	15.0	117.0	7.2
105	2.8	11.0	9.5	0.87	1.16	9.4	14.9	115.7	8.8
105	2.9	11.0	9.5	0.87	1.16	9.5	14.9	115.3	9.4
105	3.1	11.0	9.5	0.86	1.15	9.5	14.9	114.6	10.5
105	3.4	11.0	9.5	0.86	1.14	9.6	14.9	113.7	12.4
115	1.8	10.6	9.4	0.89	1.45	7.3	15.6	132.3	3.5
115	2.2	10.6	9.4	0.89	1.43	7.4	15.5	129.1	5.6
115	2.5	10.6	9.4	0.89	1.41	7.5	15.5	127.4	7.2
115	2.8	10.6	9.4	0.89	1.40	7.6	15.4	126.0	8.7
115	2.9	10.6	9.4	0.89	1.39	7.6	15.4	125.6	9.3
115	3.1	10.6	9.4	0.89	1.38	7.7	15.4	124.9	10.3
115	3.4	10.6	9.4	0.89	1.37	7.8	15.3	124.0	11.9
120	1.8	10.5	9.4	0.90	1.57	6.7	15.8	137.6	3.3
120	2.2	10.5	9.4	0.90	1.55	6.8	15.7	134.3	5.4
120	2.5	10.5	9.4	0.90	1.53	6.8	15.7	132.6	7.0
120	2.8	10.5	9.4	0.90	1.52	6.9	15.6	131.2	8.6
120	2.9	10.5	9.4	0.90	1.51	6.9	15.6	130.8	9.1
120	3.1	10.5	9.4	0.90	1.50	7.0	15.6	130.1	10.2
120	3.4	10.5	9.4	0.90	1.49	7.0	15.5	129.1	11.8

Note: Cooling performance data is tabulated at 80.6°F DB/66.2°F WB entering air at ARI/ISO 13256-1 rated cfm. For ARI/ISO 13256-1 certified ratings, see Table 4, p. 21. See Performance correction tables to correct performance at conditions other than those tabulated. Data shown is for unit performance only interpolation is permissible. Extrapolation is not. Rated GPM: 2.8 Minimum cfm 360; Rated cfm 430; Maximum cfm 430.

Table 12. Heating capacities 1 tons (net) - GEC012

EWT	GPM	Htg. Cap Mbtuh	Absorb Mbtuh	Power kW	COP	LWT	Feet Head
25	1.8	8.4	5.8	0.77	3.2	18.6	6.9
25	2.2	8.5	5.9	0.77	3.2	19.6	9.8
25	2.5	8.6	6.0	0.77	3.3	20.2	12.3
25	2.8	8.6	6.0	0.77	3.3	20.7	14.9
25	2.9	8.7	6.0	0.77	3.3	20.8	15.9
25	3.1	8.7	6.1	0.77	3.3	21.1	17.8
25	3.4	8.7	6.1	0.77	3.3	21.4	20.9
32	1.8	9.2	6.5	0.77	3.5	24.8	6.7
32	2.2	9.3	6.7	0.78	3.5	25.9	9.5
32	2.5	9.4	6.8	0.78	3.5	26.6	11.9
32	2.8	9.5	6.8	0.78	3.6	27.1	14.5
32	2.9	9.5	6.8	0.78	3.6	27.3	15.4
32	3.1	9.5	6.9	0.78	3.6	27.6	17.3
32	3.4	9.6	6.9	0.78	3.6	27.9	20.3
45	1.8	10.9	8.2	0.79	4.0	35.9	5.4
45	2.2	11.1	8.3	0.79	4.1	37.4	7.7
45	2.5	11.1	8.4	0.79	4.1	38.3	9.6
45	2.8	11.2	8.5	0.80	4.1	38.9	11.7
45	2.9	11.3	8.5	0.80	4.1	39.1	12.4
45	3.1	11.3	8.6	0.80	4.2	39.5	13.9

Table 12. Heating capacities 1 tons (net) - GEC012 (continued)

EWT	GPM	Htg. Cap Mbtuh	Absorb Mbtuh	Power kW	COP	LWT	Feet Head
45	3.4	11.4	8.6	0.80	4.2	39.9	16.3
55	1.8	12.2	9.4	0.81	4.4	44.6	5.2
55	2.2	12.4	9.6	0.81	4.5	46.3	7.4
55	2.5	12.5	9.7	0.81	4.5	47.2	9.2
55	2.8	12.6	9.8	0.81	4.6	48.0	11.2
55	2.9	12.6	9.9	0.81	4.6	48.2	11.9
55	3.1	12.7	9.9	0.81	4.6	48.6	13.4
55	3.4	12.7	10.0	0.81	4.6	49.1	15.7
68	1.8	13.9	11.1	0.82	4.9	55.7	5.0
68	2.2	14.1	11.3	0.82	5.0	57.7	7.0
68	2.5	14.3	11.5	0.83	5.1	58.8	8.8
68	2.8	14.4	11.6	0.83	5.1	59.7	10.7
68	2.9	14.4	11.6	0.83	5.1	60.0	11.4
68	3.1	14.5	11.7	0.83	5.1	60.5	12.8
68	3.4	14.6	11.7	0.83	5.2	61.1	15.0
75	1.8	14.8	11.9	0.83	5.2	61.7	4.9
75	2.2	15.1	12.2	0.83	5.3	63.9	6.9
75	2.5	15.2	12.4	0.84	5.3	65.1	8.6
75	2.8	15.4	12.5	0.84	5.4	66.1	10.4
75	2.9	15.4	12.5	0.84	5.4	66.4	11.1
75	3.1	15.5	12.6	0.84	5.4	66.9	12.5
75	3.4	15.6	12.7	0.84	5.4	67.5	14.6
86	1.8	16.2	13.3	0.85	5.6	71.2	4.7
86	2.2	16.6	13.6	0.86	5.7	73.6	6.6
86	2.5	16.7	13.8	0.86	5.7	75.0	8.3
86	2.8	16.9	13.9	0.86	5.7	76.0	10.1
86	2.9	16.9	14.0	0.86	5.8	76.4	10.7
86	3.1	17.0	14.1	0.86	5.8	76.9	12.0
86	3.4	17.1	14.1	0.87	5.8	77.7	14.1
86	1.8	8.4	5.8	0.77	3.2	18.6	6.9

Note: Heating performance data is tabulated at 68°F DB entering air at AHRI/ISO 13256-1 rated CFM. For AHRI/ISO 13256-1 certified ratings, see [Table 4, p. 21](#). See Performance correction tables to correct performance at conditions other than those tabulated. Data shown is for unit performance only. Interpolation is permissible. Extrapolation is not. Rated GPM: 2.8 Minimum cfm 360; Rated cfm 430; Maximum cfm 430.

Table 13. Fan correction factory 1 tons - GEC012

Entering cfm	Cooling Capacity	Sensible Capacity	Cooling Input Watts	Heating Capacity	Heating Input Watts
360	0.969	0.882	1.006	0.994	1.063
430	1.000	1.000	1.000	1.000	1.000

Table 14. Cooling capacities 1.25 tons (net) - GEC015

EWT	GPM	Total Mbtuh	Sen Mbtuh	SHR	Power kW	EER	Reject Mbtuh	LWT	Feet Head
45	2.2	16.0	12.6	0.78	0.61	26.3	18.1	61.4	6.6
45	2.8	16.1	12.6	0.78	0.57	28.1	18.1	57.9	10.2
45	3.1	16.2	12.6	0.78	0.56	28.8	18.1	56.7	12.2



Performance Data

Table 14. Cooling capacities 1.25 tons (net) - GEC015 (continued)

EWT	GPM	Total Mbtuh	Sen Mbtuh	SHR	Power kW	EER	Reject Mbtuh	LWT	Feet Head
45	3.5	16.3	12.7	0.78	0.55	29.6	18.1	55.4	15.1
45	3.6	16.3	12.7	0.78	0.55	29.8	18.1	55.1	15.9
45	3.8	16.3	12.7	0.78	0.54	30.1	18.1	54.5	17.5
45	4.2	16.3	12.7	0.78	0.53	30.7	18.1	53.6	20.9
55	2.2	15.5	12.4	0.80	0.72	21.7	18.0	71.3	6.4
55	2.8	15.7	12.5	0.79	0.68	22.9	18.0	67.9	9.8
55	3.1	15.7	12.4	0.79	0.67	23.4	18.0	66.6	11.7
55	3.5	15.8	12.5	0.79	0.66	23.9	18.0	65.3	14.5
55	3.6	15.8	12.5	0.79	0.66	24.0	18.1	65.0	15.3
55	3.8	15.8	12.5	0.79	0.65	24.3	18.0	64.5	16.8
55	4.2	15.9	12.5	0.79	0.64	24.6	18.1	63.6	20.1
68	2.2	14.9	12.1	0.81	0.85	17.4	17.8	84.2	6.1
68	2.8	15.0	12.1	0.81	0.82	18.2	17.8	80.7	9.3
68	3.1	15.0	12.0	0.80	0.81	18.5	17.8	79.5	11.2
68	3.5	15.1	12.2	0.81	0.80	18.9	17.8	78.2	13.9
68	3.6	15.1	12.2	0.80	0.80	19.0	17.9	77.9	14.6
68	3.8	15.2	12.2	0.81	0.79	19.1	17.9	77.4	16.0
68	4.2	15.2	12.1	0.80	0.79	19.4	17.9	76.5	19.1
77	2.2	14.7	12.0	0.81	0.97	15.2	18.0	93.4	5.9
77	2.8	14.7	12.0	0.81	0.93	15.8	17.9	89.8	9.1
77	3.1	14.7	12.0	0.81	0.92	16.0	17.9	88.5	10.9
77	3.5	14.8	12.0	0.81	0.90	16.3	17.9	87.2	13.5
77	3.6	14.8	12.1	0.82	0.90	16.4	17.9	86.9	14.1
77	3.8	14.8	12.0	0.81	0.89	16.5	17.8	86.4	15.6
77	4.2	14.8	12.0	0.81	0.88	16.7	17.8	85.5	18.6
86	2.2	14.5	11.9	0.82	1.09	13.3	18.3	102.6	5.7
86	2.8	14.6	11.9	0.82	1.05	13.8	18.2	99.0	8.8
86	3.1	14.6	11.9	0.82	1.04	14.0	18.1	97.7	10.6
86	3.5	14.6	11.9	0.82	1.03	14.2	18.1	96.3	13.1
86	3.6	14.6	11.9	0.82	1.02	14.3	18.1	96.0	13.7
86	3.8	14.6	11.9	0.82	1.02	14.4	18.1	95.5	15.1
86	4.2	14.6	11.9	0.81	1.01	14.5	18.0	94.6	18.0
95	2.2	14.3	11.8	0.82	1.24	11.5	18.6	111.9	5.6
95	2.8	14.3	11.8	0.82	1.20	12.0	18.4	108.2	8.6
95	3.1	14.3	11.8	0.82	1.19	12.1	18.4	106.9	10.3
95	3.5	14.3	11.7	0.82	1.17	12.2	18.3	105.5	12.7
95	3.6	14.3	11.8	0.82	1.17	12.3	18.3	105.2	13.4
95	3.8	14.3	11.8	0.82	1.16	12.3	18.3	104.6	14.7
95	4.2	14.4	11.8	0.82	1.15	12.5	18.3	103.7	17.6
105	2.2	14.1	11.6	0.83	1.52	9.2	19.3	122.5	5.4
105	2.8	14.0	11.6	0.83	1.47	9.5	19.1	118.6	8.3
105	3.1	14.0	11.6	0.83	1.45	9.7	19.0	117.2	10.0
105	3.5	14.0	11.6	0.83	1.43	9.8	18.9	115.8	12.4
105	3.6	14.0	11.6	0.83	1.44	9.7	18.9	115.5	13.0
105	3.8	14.0	11.6	0.83	1.42	9.9	18.9	114.9	14.3

Table 14. Cooling capacities 1.25 tons (net) - GEC015 (continued)

EWT	GPM	Total Mbtuh	Sen Mbtuh	SHR	Power kW	EER	Reject Mbtuh	LWT	Feet Head
105	4.2	14.0	11.6	0.83	1.41	10.0	18.8	114.0	17.1
115	2.2	13.7	11.5	0.84	1.76	7.8	19.7	133.0	4.5
115	2.8	13.7	11.5	0.84	1.73	7.9	19.6	129.0	8.1
115	3.1	13.7	11.5	0.84	1.72	8.0	19.6	127.6	9.9
115	3.5	13.7	11.5	0.84	1.70	8.1	19.5	126.2	12.3
115	3.6	13.7	11.5	0.84	1.70	8.1	19.5	125.8	12.9
115	3.8	13.7	11.5	0.84	1.69	8.1	19.5	125.2	14.1
115	4.2	13.7	11.5	0.84	1.67	8.2	19.4	124.2	16.5
120	2.2	13.6	11.4	0.84	1.90	7.2	20.0	138.2	4.4
120	2.8	13.6	11.4	0.84	1.87	7.3	19.9	134.2	8.0
120	3.1	13.6	11.4	0.84	1.85	7.3	19.9	132.8	9.8
120	3.5	13.5	11.4	0.84	1.83	7.4	19.8	131.3	12.2
120	3.6	13.5	11.4	0.84	1.83	7.4	19.8	131.0	12.8
120	3.8	13.5	11.4	0.84	1.82	7.4	19.8	130.4	14.0
120	4.2	13.5	11.4	0.84	1.80	7.5	19.7	129.4	16.4

Note: Cooling performance data is tabulated at 80.6°F DB/66.2°F WB entering air at ARI/ISO 13256-1 rated cfm. For ARI/ISO 13256-1 certified ratings, see [Table 4, p. 21](#). See Performance correction tables to correct performance at conditions other than those tabulated. Data shown is for unit performance only interpolation is permissible. Extrapolation is not. Rated GPM: 3.5 Minimum cfm 400; Rated cfm 480; Maximum cfm 480.

Table 15. Heating capacities 1.25 tons (net) - GEC015

EWT	GPM	Htg. Cap Mbtuh	Absorb Mbtuh	Power kW	COP	LWT	Feet Head
25	2.2	10.5	7.3	0.93	3.3	18.3	9.3
25	2.8	10.7	7.5	0.94	3.4	19.6	14.2
25	3.1	10.8	7.6	0.93	3.4	20.1	16.9
25	3.5	10.9	7.7	0.94	3.4	20.6	20.9
25	3.6	10.9	7.7	0.94	3.4	20.7	21.9
25	3.8	10.9	7.7	0.94	3.4	20.9	24.1
25	4.2	11.0	7.8	0.94	3.4	21.3	28.7
32	2.2	11.4	8.2	0.95	3.5	24.5	9.0
32	2.8	11.7	8.4	0.95	3.6	26.0	13.7
32	3.1	11.8	8.5	0.95	3.6	26.5	16.4
32	3.5	11.9	8.6	0.95	3.6	27.1	20.3
32	3.6	11.9	8.6	0.95	3.6	27.2	21.3
32	3.8	11.9	8.7	0.95	3.7	27.4	23.4
32	4.2	12.0	8.7	0.95	3.7	27.8	27.8
45	2.2	13.5	10.1	0.98	4.0	35.8	7.3
45	2.8	13.8	10.4	0.98	4.1	37.6	11.1
45	3.1	13.8	10.5	0.98	4.1	38.2	13.2
45	3.5	13.9	10.6	0.98	4.2	38.9	16.3
45	3.6	14.0	10.6	0.98	4.2	39.1	17.1
45	3.8	14.0	10.7	0.98	4.2	39.4	18.8
45	4.2	14.1	10.7	0.98	4.2	39.9	22.4
55	2.2	15.0	11.6	0.99	4.4	44.5	7.0
55	2.8	15.3	11.9	1.00	4.5	46.5	10.6
55	3.1	15.5	12.0	1.00	4.5	47.2	12.7



Performance Data

Table 15. Heating capacities 1.25 tons (net) - GEC015 (continued)

EWT	GPM	Htg. Cap Mbtuh	Absorb Mbtuh	Power kW	COP	LWT	Feet Head
55	3.5	15.5	12.1	1.00	4.6	48.1	15.7
55	3.6	15.6	12.2	1.00	4.6	48.2	16.5
55	3.8	15.6	12.2	1.00	4.6	48.6	18.1
55	4.2	15.7	12.3	1.00	4.6	49.1	21.5
68	2.2	17.0	13.6	1.00	5.0	55.7	6.7
68	2.8	17.4	13.9	1.00	5.1	58.0	10.1
68	3.1	17.5	14.1	1.00	5.1	58.9	12.1
68	3.5	17.7	14.3	1.01	5.2	59.8	14.9
68	3.6	17.7	14.3	1.00	5.2	60.1	15.7
68	3.8	17.7	14.3	1.00	5.2	60.5	17.2
68	4.2	17.9	14.4	1.00	5.2	61.1	20.5
75	2.2	18.1	14.6	1.00	5.3	61.7	6.5
75	2.8	18.5	15.1	1.01	5.4	64.2	9.9
75	3.1	18.6	15.2	1.00	5.4	65.2	11.8
75	3.5	18.8	15.4	1.00	5.5	66.2	14.6
75	3.6	18.8	15.4	1.00	5.5	66.4	15.3
75	3.8	18.9	15.5	1.00	5.5	66.9	16.8
75	4.2	19.0	15.6	1.00	5.6	67.6	20.0
86	2.2	19.7	16.3	1.00	5.8	71.2	6.3
86	2.8	20.2	16.8	0.99	6.0	74.0	9.6
86	3.1	20.3	17.0	0.99	6.0	75.1	11.4
86	3.5	20.5	17.2	0.99	6.1	76.2	14.1
86	3.6	20.5	17.1	0.99	6.1	76.5	14.8
86	3.8	20.6	17.2	0.98	6.1	76.9	16.2
86	4.2	20.8	17.4	0.98	6.2	77.7	19.3

Note: Heating performance data is tabulated at 68°F DB entering air at AHRI/ISO 13256-1 rated CFM. For AHRI/ISO 13256-1 certified ratings, see [Table 4, p. 21](#). See Performance correction tables to correct performance at conditions other than those tabulated. Data shown is for unit performance only. Interpolation is permissible. Extrapolation is not. Rated GPM: 3.5 Minimum cfm 400; Rated cfm 480; Maximum cfm 480.

Table 16. Fan correction factory 1.25 tons - GEC015

Entering cfm	Cooling Capacity	Sensible Capacity	Cooling Input Watts	Heating Capacity	Heating Input Watts
400	0.966	0.911	1.007	0.987	400
480	1.000	1.000	1.000	1.000	480

Table 17. Cooling capacities 1.5 tons (net) - GEC018

EWT	GPM	Total Mbtuh	Sen Mbtuh	SHR	Power kW	EER	Reject Mbtuh	LWT	Feet Head
45	2.7	18.4	13.9	0.76	0.78	23.6	21.0	60.6	4.8
45	3.3	18.4	13.9	0.75	0.76	24.4	21.0	57.7	6.9
45	3.7	18.5	13.9	0.75	0.75	24.7	21.0	56.4	8.4
45	4.2	18.5	13.9	0.75	0.74	25.1	21.0	55.0	10.6
45	4.4	18.5	14.0	0.75	0.73	25.3	21.0	54.5	11.5
45	4.6	18.5	14.0	0.75	0.73	25.4	21.0	54.1	12.4
45	5.0	18.5	14.0	0.75	0.72	25.6	21.0	53.4	14.4
55	2.7	18.0	13.7	0.76	0.87	20.6	21.0	70.5	4.6

Table 17. Cooling capacities 1.5 tons (net) - GEC018 (continued)

EWT	GPM	Total Mbtuh	Sen Mbtuh	SHR	Power kW	EER	Reject Mbtuh	LWT	Feet Head
55	3.3	18.0	13.8	0.76	0.85	21.2	20.9	67.7	6.6
55	3.7	18.1	13.8	0.76	0.84	21.6	20.9	66.3	8.1
55	4.2	18.1	13.8	0.76	0.83	21.9	20.9	65.0	10.2
55	4.4	18.1	13.8	0.76	0.82	22.0	20.9	64.5	11.0
55	4.6	18.1	13.8	0.76	0.82	22.1	20.9	64.1	11.9
55	5.0	18.1	13.8	0.76	0.81	22.3	20.9	63.4	13.8
68	2.7	17.4	13.5	0.78	1.01	17.2	20.8	83.4	4.4
68	3.3	17.4	13.5	0.78	0.98	17.7	20.8	80.6	6.3
68	3.7	17.5	13.5	0.77	0.97	18.0	20.8	79.2	7.7
68	4.2	17.5	13.5	0.77	0.96	18.2	20.8	77.9	9.7
68	4.4	17.5	13.5	0.77	0.96	18.3	20.7	77.4	10.5
68	4.6	17.5	13.5	0.77	0.95	18.4	20.7	77.0	11.4
68	5.0	17.5	13.5	0.77	0.95	18.5	20.7	76.3	13.2
77	2.7	16.9	13.3	0.79	1.12	15.1	20.7	92.4	4.3
77	3.3	17.0	13.3	0.79	1.09	15.5	20.7	89.5	6.1
77	3.7	17.0	13.3	0.79	1.08	15.7	20.7	88.2	7.5
77	4.2	17.0	13.4	0.79	1.06	16.0	20.6	86.8	9.4
77	4.4	17.0	13.4	0.79	1.06	16.1	20.6	86.4	10.2
77	4.6	17.0	13.4	0.79	1.06	16.1	20.6	86.0	11.0
77	5.0	17.0	13.4	0.79	1.05	16.2	20.6	85.2	12.8
86	2.7	16.4	13.2	0.80	1.24	13.2	20.7	101.3	4.2
86	3.3	16.4	13.2	0.80	1.21	13.6	20.6	98.5	6.0
86	3.7	16.5	13.2	0.80	1.20	13.8	20.5	97.1	7.3
86	4.2	16.5	13.2	0.80	1.18	13.9	20.5	95.8	9.1
86	4.4	16.5	13.2	0.80	1.18	14.0	20.5	95.3	9.9
86	4.6	16.5	13.2	0.80	1.17	14.1	20.5	94.9	10.7
86	5.0	16.5	13.2	0.80	1.17	14.1	20.5	94.2	12.4
95	2.7	15.9	13.0	0.82	1.38	11.5	20.6	110.2	4.1
95	3.3	15.9	13.0	0.82	1.35	11.8	20.5	107.4	5.8
95	3.7	15.9	13.0	0.82	1.33	12.0	20.5	106.1	7.1
95	4.2	15.9	13.0	0.82	1.32	12.1	20.4	104.7	8.9
95	4.4	15.9	13.0	0.82	1.31	12.2	20.4	104.3	9.7
95	4.6	15.9	13.0	0.82	1.31	12.2	20.4	103.9	10.4
95	5.0	15.9	13.0	0.82	1.30	12.3	20.4	103.1	12.1
105	2.7	15.3	12.8	0.84	1.55	9.9	20.6	120.2	4.0
105	3.3	15.3	12.8	0.84	1.51	10.1	20.5	117.4	5.7
105	3.7	15.3	12.8	0.84	1.50	10.2	20.4	116.0	6.9
105	4.2	15.3	12.8	0.84	1.48	10.3	20.4	114.7	8.7
105	4.4	15.3	12.8	0.84	1.48	10.4	20.3	114.2	9.4
105	4.6	15.3	12.8	0.84	1.47	10.4	20.3	113.8	10.2
105	5.0	15.3	12.8	0.84	1.46	10.5	20.3	113.1	11.8
115	2.7	14.6	12.6	0.86	1.75	8.4	20.6	130.3	3.9
115	3.3	14.6	12.6	0.86	1.71	8.5	20.5	127.4	5.5
115	3.7	14.6	12.6	0.86	1.70	8.6	20.4	126.0	6.7
115	4.2	14.6	12.6	0.86	1.67	8.7	20.3	124.7	8.4



Performance Data

Table 17. Cooling capacities 1.5 tons (net) - GEC018 (continued)

EWT	GPM	Total Mbtuh	Sen Mbtuh	SHR	Power kW	EER	Reject Mbtuh	LWT	Feet Head
115	4.4	14.6	12.6	0.86	1.67	8.8	20.3	124.2	9.1
115	4.6	14.6	12.6	0.86	1.66	8.8	20.3	123.8	9.9
115	5.0	14.6	12.6	0.86	1.66	8.8	20.3	123.1	11.5
120	2.7	14.3	12.5	0.87	1.87	7.7	20.7	135.3	3.8
120	3.3	14.3	12.5	0.87	1.83	7.8	20.5	132.5	5.4
120	3.7	14.3	12.5	0.87	1.81	7.9	20.5	131.1	6.7
120	4.2	14.3	12.5	0.87	1.79	8.0	20.4	129.7	8.3
120	4.4	14.3	12.5	0.87	1.79	8.0	20.4	129.3	9.0
120	4.6	14.3	12.5	0.87	1.78	8.0	20.4	128.9	9.8
120	5.0	14.3	12.5	0.87	1.77	8.1	20.3	128.1	11.3

Note: Cooling performance data is tabulated at 80.6°F DB/66.2°F WB entering air at ARI/ISO 13256-1 rated cfm. For ARI/ISO 13256-1 certified ratings, see [Table 4, p. 21](#). See Performance correction tables to correct performance at conditions other than those tabulated. Data shown is for unit performance only interpolation is permissible. Extrapolation is not. Rated GPM: 4.2 Minimum cfm 460; Rated cfm 530; Maximum cfm 530.

Table 18. Heating capacities 1.5 tons (net) - GEC018

EWT	GPM	Htg. Cap Mbtuh	Absorb Mbtuh	Power kW	COP	LWT	Feet Head
25	2.7	11.8	8.0	1.10	3.1	19.0	6.6
25	3.3	12.0	8.2	1.10	3.2	20.0	9.4
25	3.7	12.1	8.3	1.10	3.2	20.5	11.4
25	4.2	12.1	8.4	1.10	3.2	21.0	14.3
25	4.4	12.2	8.4	1.10	3.2	21.2	15.5
25	4.6	12.2	8.5	1.11	3.2	21.3	16.7
25	5.0	12.2	8.5	1.10	3.2	21.6	19.3
32	2.7	12.9	9.1	1.11	3.4	25.3	6.4
32	3.3	13.1	9.3	1.12	3.4	26.4	9.1
32	3.7	13.2	9.4	1.12	3.5	26.9	11.1
32	4.2	13.3	9.5	1.12	3.5	27.5	13.8
32	4.4	13.3	9.5	1.12	3.5	27.7	15.0
32	4.6	13.3	9.5	1.12	3.5	27.9	16.2
32	5.0	13.4	9.6	1.12	3.5	28.2	18.7
45	2.7	15.3	11.4	1.14	3.9	36.5	5.2
45	3.3	15.6	11.7	1.15	4.0	37.9	7.3
45	3.7	15.7	11.8	1.15	4.0	38.6	8.9
45	4.2	15.8	11.9	1.15	4.0	39.3	11.1
45	4.4	15.8	11.9	1.15	4.0	39.6	12.1
45	4.6	15.8	11.9	1.15	4.0	39.8	13.0
45	5.0	15.9	12.0	1.15	4.1	40.2	15.1
55	2.7	17.2	13.2	1.17	4.3	45.2	5.0
55	3.3	17.4	13.4	1.17	4.4	46.9	7.0
55	3.7	17.6	13.6	1.17	4.4	47.7	8.6
55	4.2	17.8	13.8	1.18	4.4	48.4	10.7
55	4.4	17.8	13.8	1.18	4.4	48.7	11.6
55	4.6	17.8	13.8	1.17	4.5	49.0	12.5
55	5.0	17.9	13.9	1.17	4.5	49.4	14.5
68	2.7	19.7	15.6	1.20	4.8	56.4	4.7

Table 18. Heating capacities 1.5 tons (net) - GEC018 (continued)

EWT	GPM	Htg. Cap Mbtuh	Absorb Mbtuh	Power kW	COP	LWT	Feet Head
68	3.3	20.1	16.0	1.20	4.9	58.3	6.7
68	3.7	20.2	16.1	1.20	4.9	59.3	8.2
68	4.2	20.4	16.3	1.21	5.0	60.3	10.2
68	4.4	20.4	16.3	1.21	5.0	60.6	11.1
68	4.6	20.5	16.4	1.21	5.0	60.9	11.9
68	5.0	20.6	16.5	1.21	5.0	61.4	13.8
75	2.7	21.1	16.9	1.22	5.1	62.5	4.6
75	3.3	21.5	17.3	1.22	5.1	64.5	6.6
75	3.7	21.7	17.5	1.23	5.2	65.5	8.0
75	4.2	21.9	17.7	1.23	5.2	66.6	10.0
75	4.4	21.9	17.7	1.23	5.2	66.9	10.8
75	4.6	22.0	17.8	1.23	5.2	67.3	11.7
75	5.0	22.1	17.9	1.23	5.3	67.8	13.5
86	2.7	23.3	19.0	1.25	5.4	71.9	4.5
86	3.3	23.8	19.5	1.26	5.5	74.2	6.3
86	3.7	24.0	19.6	1.26	5.5	75.4	7.7
86	4.2	24.2	19.9	1.27	5.6	76.5	9.6
86	4.4	24.2	19.9	1.27	5.6	77.0	10.4
86	4.6	24.3	20.0	1.27	5.6	77.3	11.3
86	5.0	24.4	20.1	1.27	5.6	78.0	13.0

Note: Heating performance data is tabulated at 68°F DB entering air at AHRI/ISO 13256-1 rated CFM. For AHRI/ISO 13256-1 certified ratings, see Table 4, p. 21. See Performance correction tables to correct performance at conditions other than those tabulated. Data shown is for unit performance only. Interpolation is permissible. Extrapolation is not. Rated GPM: 4.2 Minimum cfm 460; Rated cfm 530; Maximum cfm 530.

Table 19. Fan correction factory 1.5 tons - GEC018

Entering cfm	Cooling Capacity	Sensible Capacity	Cooling Input Watts	Heating Capacity	Heating Input Watts
460	0.974	0.916	1.002	0.993	1.050
530	1.000	1.000	1.000	1.000	1.000

Table 20. Correction factors for variation in entering air temperature 0.5 tons, GEC006

Cooling Entering Air WB°F	Cooling Capacity	Cooling Input Watts	Sensible vs. Entering Dry Bulb Multipliers					Heating Entering Air DB°F	Heating Capacity	Heating Input Watts
			65.6	70.6	75.6	80.6	85.6			
49.4	0.962	1.012	0.958	1.019	1.079	*	*	53.0	1.023	0.863
56.3	0.963	1.015	0.817	1.020	1.078	*	*	58.0	1.018	0.906
60.3	0.961	1.012	0.603	0.845	1.059	*	*	63.0	1.008	0.951
63.2	0.970	1.011	0.438	0.687	0.927	1.134	*	68.0	1.000	1.000
66.2	1.000	1.000	—	0.518	0.762	1.000	1.197	73.0	0.991	1.051
72.1	1.062	0.975	—	—	0.424	0.670	0.911	78.0	0.982	1.107
77.1	1.134	0.965	—	—	—	0.380	0.589	83.0	0.975	1.164

Note: * = Sensible equals total capacity.



Performance Data

Table 21. Correction factors for variation in entering air temperature 0.75 tons, GEC009

Cooling Entering Air WB°F	Cooling Capacity	Cooling Input Watts	Sensible vs. Entering Dry Bulb Multipliers					Heating Entering Air DB°F	Heating Capacity	Heating Input Watts
			65.6	70.6	75.6	80.6	85.6			
49.4	0.956	1.032	0.940	1.003	1.067	*	*	53.0	1.038	0.872
56.3	0.956	1.033	0.802	1.016	1.066	*	*	58.0	1.024	0.911
60.3	0.956	1.033	0.573	0.838	1.072	*	*	63.0	1.012	0.953
63.2	0.968	1.026	0.417	0.675	0.925	1.135	*	68.0	1.000	1.000
66.2	1.000	1.000	—	0.542	0.774	1.000	1.195	73.0	0.989	1.050
72.1	1.087	0.974	—	—	0.607	0.764	0.977	78.0	0.980	1.104
77.1	1.173	0.949	—	—	—	0.476	0.712	83.0	0.970	1.163

Note: * = Sensible equals total capacity.

Table 22. Correction factors for variation in entering air temperature 1 tons, GEC012

Cooling Entering Air WB°F	Cooling Capacity	Cooling Input Watts	Sensible vs. Entering Dry Bulb Multipliers					Heating Entering Air DB°F	Heating Capacity	Heating Input Watts
			65.6	70.6	75.6	80.6	85.6			
49.4	0.973	1.007	0.993	1.051	1.109	*	*	53.0	1.014	0.847
56.3	0.973	1.007	0.818	1.055	1.109	*	*	58.0	1.010	0.896
60.3	0.972	1.007	0.576	0.837	1.099	*	*	63.0	1.004	0.946
63.2	0.977	1.003	0.396	0.659	0.923	1.169	*	68.0	1.000	1.000
66.2	1.000	1.000	—	0.473	0.731	1.000	1.227	73.0	0.994	1.057
72.1	1.043	0.971	—	—	0.365	0.617	0.867	78.0	0.990	1.119
77.1	1.105	0.969	—	—	—	0.299	0.558	83.0	0.983	1.185

Note: * = Sensible equals total capacity.

Table 23. Correction factors for variation in entering air temperature 1.25 tons, GEC015

Cooling Entering Air WB°F	Cooling Capacity	Cooling Input Watts	Sensible vs. Entering Dry Bulb Multipliers					Heating Entering Air DB°F	Heating Capacity	Heating Input Watts
			65.6	70.6	75.6	80.6	85.6			
49.4	0.952	1.038	0.999	1.058	1.118	*	*	53.0	1.023	0.832
56.3	0.951	1.040	0.834	1.016	1.117	*	*	58.0	1.016	0.887
60.3	0.951	1.040	0.637	0.871	1.055	*	*	63.0	1.010	0.944
63.2	0.970	1.021	0.481	0.715	0.937	1.112	*	68.0	1.000	1.000
66.2	1.000	1.000	—	0.556	0.786	1.000	1.166	73.0	0.992	1.058
72.1	1.062	0.953	—	—	0.485	0.696	0.924	78.0	0.981	1.120
77.1	1.143	0.926	—	—	—	0.452	0.665	83.0	0.970	1.179

Note: * = Sensible equals total capacity.

Table 24. Correction factors for variation in entering air temperature 1.5 tons, GEC018

Cooling Entering Air WB°F	Cooling Capacity	Cooling Input Watts	Sensible vs. Entering Dry Bulb Multipliers					Heating Entering Air DB°F	Heating Capacity	Heating Input Watts
			65.6	70.6	75.6	80.6	85.6			
49.4	0.947	1.009	0.995	1.056	1.119	*	*	53.0	1.025	0.855
56.3	0.946	1.009	0.823	1.036	1.118	*	*	58.0	1.018	0.901
60.3	0.945	1.009	0.632	0.852	1.070	*	*	63.0	1.009	0.949
63.2	0.960	1.006	0.485	0.710	0.928	1.142	*	68.0	1.000	1.000

Table 24. Correction factors for variation in entering air temperature 1.5 tons, GEC018 (continued)

Cooling Entering Air WB°F	Cooling Capacity	Cooling Input Watts	Sensible vs. Entering Dry Bulb Multipliers					Heating Entering Air DB°F	Heating Capacity	Heating Input Watts
			65.6	70.6	75.6	80.6	85.6			
66.2	1.000	1.000	—	0.561	0.781	1.000	1.211	73.0	0.992	1.054
72.1	1.086	0.980	—	—	0.481	0.706	0.920	78.0	0.983	1.111
77.1	1.154	0.972	—	—	—	0.443	0.667	83.0	0.976	1.173

Note: * = Sensible equals total capacity.

Table 25. Fan performance

Unit	Min CFM	Max CFM
GEC006 Low	220	220
GEC006 High	290	290
GEC009 Low	240	240
GEC009 High	305	305
GEC012 Low	360	360
GEC012 High	430	430
GEC015 Low	400	400
GEC015 High	480	480
GEC018 Low	460	460
GEC018 High	530	530

Table 26. Antifreeze correction factors

Methanol (concentration by volume)						
Item	0%	10%	20%	30%	40%	50%
Cooling Capacity	1.000	0.998	0.997	0.995	0.993	0.992
Heating Capacity	1.000	0.995	0.990	0.985	0.979	0.974
Pressure Drop	1.000	1.023	1.057	1.091	1.122	1.160
Ethylene Glycol (concentration by volume)						
Item	0%	10%	20%	30%	40%	50%
Cooling Capacity	1.000	0.996	0.991	0.987	0.983	0.979
Heating Capacity	1.000	0.993	0.985	0.977	0.969	0.961
Pressure Drop	1.000	1.024	1.068	1.124	1.188	1.263
Propylene Glycol (concentration by volume)						
Item	0%	10%	20%	30%	40%	50%
Cooling Capacity	1.000	0.993	0.987	0.980	0.974	0.968
Heating Capacity	1.000	0.986	0.973	0.960	0.948	0.935
Pressure Drop	1.000	1.040	1.098	1.174	1.273	1.405
Brine (NaCL) (concentration by volume)						
Item	0%	10%	20%	30%	40%	50%
Cooling Capacity	1.000	0.994	0.987	0.979	0.971	0.963
Heating Capacity	1.000	0.993	0.987	0.982	0.978	0.976
Pressure Drop	1.000	1.154	1.325	1.497	1.669	1.841

Examples

Figure 21. Cooling capacity correction factor

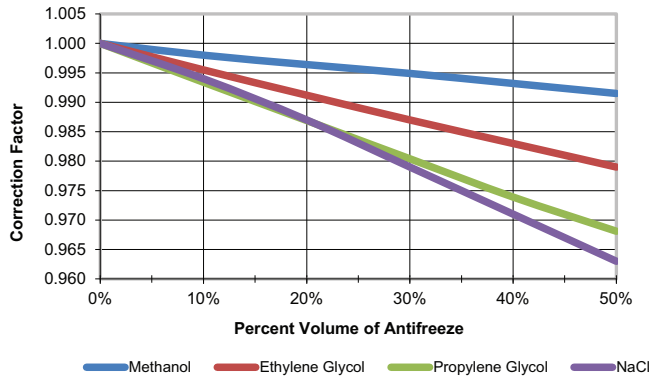

Figure 22. Heating capacity correction factor

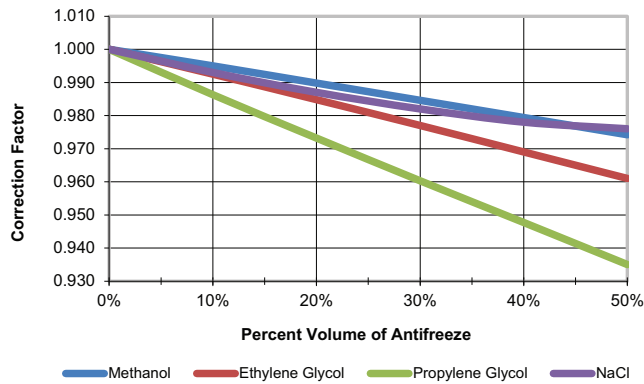
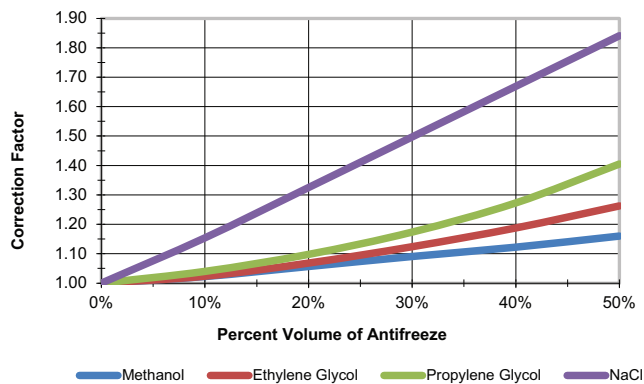

Figure 23. Water pressure drop correction factor



Example 1 (Ethylene Glycol) - The antifreeze solution is 20% by volume of Ethylene Glycol. Determine the corrected cooling capacity and waterside pressure drop for a GEC 018 when the EWT is 86°F and the GPM is 4.2.

From the catalog data, the cooling capacity at these conditions with 100% water is 17.0 MBtuh, and the waterside pressure drop is 8.9 feet of head. At 20% Ethylene Glycol, the correction factor for cool capacity is 0.9912 and the pressure drop is 1.068.

The corrected cooling capacity (MBtuh) = $17.0 * 0.9912 = 16.9$. The corrected water side pressure drop (Ft. head) = $8.9 * 1.068 = 9.5$.

Example 2 (Propylene Glycol) - The antifreeze solution is 30% by volume of Propylene Glycol. Determine the corrected heating capacity and waterside pressure drop for a GEC 012 when the EWT is 45°F and the GPM is 2.8.

From the catalog data, the heating capacity at these conditions with 100% water is 11.6 MBtuh, and the waterside pressure drop is 8.7 feet of head. At 30% Propylene Glycol, the correction factor for heat capacity is 0.9603 and the pressure drop is 1.174.

The corrected cooling capacity (MBtuh) = $11.6 * 0.9603 = 11.1$. The corrected water side pressure drop (ft. head) = $8.7 * 1.174 = 10.2$.



Electrical Data

Table 27. Electrical data (0.5 to 1.5 tons)

Model	Volts	Total Unit FLA	Comp RLA (ea)	Compl RA (ea)	No. of Comp	Cmp MCC	Blower Motor FLA	Blower Motor hp	Fan Motors	Minimum Circuit Ampacity	Maximum Overcurrent Protective Device	Electric Heat kW	Electric Heat Amps
GEC006	115/60/1	6.5	5.6	30.0	1	7.5	0.90	1/30	1	7.9	15	0.0	0.0
GEC006	208/60/1	4.1	3.3	14.0	1	4.2	0.80	1/30	1	4.9	15	0.0	0.0
GEC006	208/60/1	11.6	3.3	14.0	1	4.2	0.80	1/30	1	14.5	15	2.25	10.82
GEC006	208/60/1	15.2	3.3	14.0	1	4.2	0.80	1/30	1	19.0	20	3.0	14.42
GEC006	230/60/1	3.9	3.2	15.0	1	4.2	0.70	1/30	1	4.7	15	0.0	0.0
GEC006	230/60/1	12.7	3.2	15.0	1	4.2	0.70	1/30	1	15.8	20	2.75	11.96
GEC006	220-240/50/1	3.6	2.9	17.0	1	4.0	0.70	1/30	1	4.3	15	0.0	0.0
GEC006	220-240/50/1	13.2	2.9	17.0	1	4.0	0.70	1/30	1	16.5	20	3.0	12.5
GEC006	265/60/1	3.2	2.5	11.0	1	3.5	0.70	1/20	1	3.8	15	0.0	0.0
GEC006	265/60/1	11.1	2.5	11.0	1	3.5	0.70	1/20	1	13.9	15	2.75	10.38
GEC009	115/60/1	7.3	6.4	36.0	1	8.6	0.90	1/30	1	8.9	15	0.0	0.0
GEC009	208/60/1	4.5	3.7	16.0	1	4.8	0.80	1/30	1	5.4	15	0.0	0.0
GEC009	208/60/1	11.6	3.7	16.0	1	4.8	0.80	1/30	1	14.5	15	2.25	10.82
GEC009	208/60/1	15.2	3.7	16.0	1	4.8	0.80	1/30	1	19.0	20	3.0	14.42
GEC009	230/60/1	4.2	3.5	17.0	1	4.8	0.70	1/30	1	5.1	15	0.0	0.0
GEC009	230/60/1	12.7	3.5	17.0	1	4.8	0.70	1/30	1	15.8	20	2.75	11.96
GEC009	230/60/1	16.8	3.5	17.0	1	4.8	0.70	1/30	1	21.0	25	3.7	16.09
GEC009	220-240/50/1	6	5.3	23.0	1	7.4	0.70	1/12	1	7.3	15	0.0	0.0
GEC009	220-240/50/1	13.2	5.3	23.0	1	7.4	0.70	1/12	1	16.5	20	3.0	12.5
GEC009	220-240/50/1	17.4	5.3	23.0	1	7.4	0.70	1/12	1	21.7	25	4.0	16.67
GEC009	265/60/1	3.5	2.8	13.0	1	3.7	0.70	1/30	1	4.2	15	0.0	0.0
GEC009	265/60/1	11	2.8	13.0	1	3.7	0.70	1/30	1	13.8	15	2.74	10.34
GEC009	265/60/1	14.7	2.8	13.0	1	3.7	0.70	1/30	1	18.3	20	3.7	13.96
GEC012	115/60/1	13.3	12.1	58.0	1	16.9	1.20	1/12	1	16.3	25	0.0	0.0
GEC012	208/60/1	7.2	6.3	30.0	1	8.8	0.90	1/12	1	8.8	15	0.0	0.0
GEC012	208/60/1	11.7	6.3	30.0	1	8.8	0.90	1/12	1	14.7	15	2.25	10.82
GEC012	208/60/1	15.3	6.3	30.0	1	8.8	0.90	1/12	1	19.2	20	3.0	14.42
GEC012	230/60/1	7	6.3	30.0	1	8.8	0.70	1/12	1	8.6	15	0.0	0.0
GEC012	230/60/1	12.7	6.3	30.0	1	8.8	0.70	1/12	1	15.8	20	2.75	11.96
GEC012	230/60/1	16.8	6.3	30.0	1	8.8	0.70	1/12	1	21.0	25	3.7	16.09
GEC012	220-240/50/1	7.4	6.7	30.0	1	9.4	0.70	1/12	1	9.1	15	0.0	0.0
GEC012	220-240/50/1	13.2	6.7	30.0	1	9.4	0.70	1/12	1	16.5	20	3.0	12.5
GEC012	220-240/50/1	17.4	6.7	30.0	1	9.4	0.70	1/12	1	21.7	25	4.0	16.67
GEC012	265/60/1	5.7	5.0	23.0	1	7.0	0.70	1/12	1	7.0	15	0.0	0.0
GEC012	265/60/1	11.0	5.0	23.0	1	7.0	0.70	1/12	1	13.8	15	2.74	10.34
GEC012	265/60/1	14.7	5.0	23.0	1	7.0	0.70	1/12	1	18.3	20	3.7	13.96
GEC015	115/60/1	16.1	14.9	60.0	1	20.9	1.20	1/12	1	19.8	30	0.0	0.0
GEC015	208/60/1	8.9	7.9	36.0	1	11.1	1.00	1/12	1	10.9	15	0.0	0.0
GEC015	208/60/1	11.8	7.9	36.0	1	11.1	1.00	1/12	1	14.8	15	2.25	10.82
GEC015	208/60/1	15.4	7.9	36.0	1	11.1	1.00	1/12	1	19.3	20	3.0	14.42
GEC015	230/60/1	8.8	7.9	36.0	1	11.1	0.90	1/12	1	10.8	15	0.0	0.0

Table 27. Electrical data (0.5 to 1.5 tons) (continued)

Model	Volts	Total Unit FLA	Comp RLA (ea)	CompL RA (ea)	No. of Comp	Cmp MCC	Blower Motor FLA	Blower Motor hp	Fan Motors	Minimum Circuit Ampacity	Maximum Overcurrent Protective Device	Electric Heat kW	Electric Heat Amps
GEC015	230/60/1	12.9	7.9	36.0	1	11.1	0.90	1/12	1	16.1	20	2.76	12.0
GEC015	230/60/1	17	7.9	36.0	1	11.1	0.90	1/12	1	21.2	25	3.7	16.09
GEC015	220-240/50/1	8.6	7.9	28.0	1	11.1	0.70	1/12	1	10.6	15	0.0	0.0
GEC015	220-240/50/1	13.2	7.9	28.0	1	11.1	0.70	1/6	1	16.5	20	3.0	12.5
GEC015	220-240/50/1	17.4	7.9	28.0	1	11.1	0.70	1/6	1	21.7	25	4.0	16.67
GEC015	265/60/1	7.1	6.4	30.0	1	9.0	0.70	1/6	1	8.7	15	0.0	0.0
GEC015	265/60/1	11	6.4	30.0	1	9.0	0.70	1/12	1	13.8	15	2.74	10.34
GEC015	265/60/1	14.7	6.4	30.0	1	9.0	0.70	1/12	1	18.3	20	3.7	13.96
GEC018	208/60/1	10.0	9.0	30.0	1	12.6	1.00	1/6	1	12.3	20	0.0	0.0
GEC018	208/60/1	11.8	9.0	30.0	1	12.6	1.00	1/6	1	14.8	20	2.25	10.82
GEC018	208/60/1	15.4	9.0	30.0	1	12.6	1.00	1/6	1	19.3	20	3.0	14.42
GEC018	230/60/1	9.9	9.0	30.0	1	12.6	0.90	1/6	1	12.2	20	0.0	0.0
GEC018	230/60/1	12.9	9.0	30.0	1	12.6	0.90	1/6	1	16.1	20	2.76	12.0
GEC018	230/60/1	17	9.0	30.0	1	12.6	0.90	1/6	1	21.2	25	3.7	16.09
GEC018	265/60/1	8.5	7.8	30.0	1	10.9	0.70	1/6	1	10.5	15	0.0	0.0
GEC018	265/60/1	11	7.8	30.0	1	10.9	0.70	1/6	1	13.8	15	2.74	10.34
GEC018	265/60/1	14.7	7.8	30.0	1	10.9	0.70	1/6	1	18.3	20	3.7	13.96

Table 28. Console VA

Designator	Controls	Deluxe with Reheat (75 VA)	Deluxe with Electric Heat (75 VA)	Symbio™ 400-B/UC400-B (75 VA)	x = ON ^(a)
	Controller	6.0	6.0	12.5	
1K1	Compressor Contactor	5.5	5.5	5.5	X
1K2	Fan Relay	9.5	9.5	9.5	
2L1	Reversing Valve	5.0	5.0	5.0	X
2L2	Reheat Valve	5.0	—	—	
5B3	Damper Actuator	—	—	—	
1K10	Electric Heat Contactor	—	5.5	Optional ^(b)	X
IU3	Boilerless Control Board	—	3.0	N/A	X
	Field Supplied Solenoid	7.0	7.0	7.0	X
1K6, 1K7	Reheat Relays(2)	12.5	—	Optional ^(c)	X
1K8	Reheat Low Speed Relay	—	—	N/A	X
1U1	Thermostat-Unit Mounted	6.0	6.0	N/A	X
	Timer Delay Relay	N/A	N/A	N/A	X
	Total VA	56.5	47.5	39.5	61.40
	Extra VA	18.5	27.5	32.5	13.60

Note: Listed VA values are for reference only. Actual values may vary with operating conditions.

- (a) Consider unit options and concurrent loads.
- (b) Electric heat is optional with Symbio™ 400-B/UC400-B controller. If electric heat is selected, add 5.5 VA.
- (c) HGR is optional with the Symbio™ 400-B/UC400-B controller. If HGR is selected, add 12.5 VA.



Unit Dimensions

Service Clearances

Access to the unit for servicing purposes should be provided at installation. All configurations require clearance from other mechanical and electrical equipment on three service sides (shown below). This enables panel removal from the unit for service/maintenance ability.

Figure 24. Clearances - GEC 0.5 to 1.5 tons

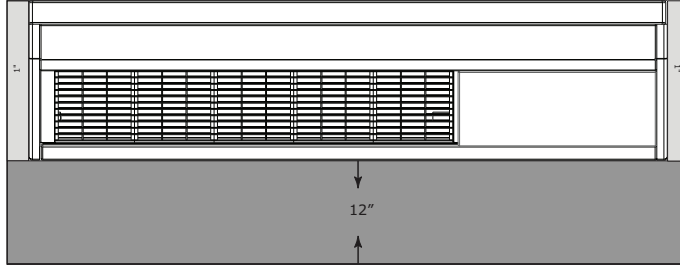

Figure 25. GEC 0.5 to 1.5 tons (60 Hz), 0.5 to 1.25 tons (50 Hz) - cabinet (RH) piping connection

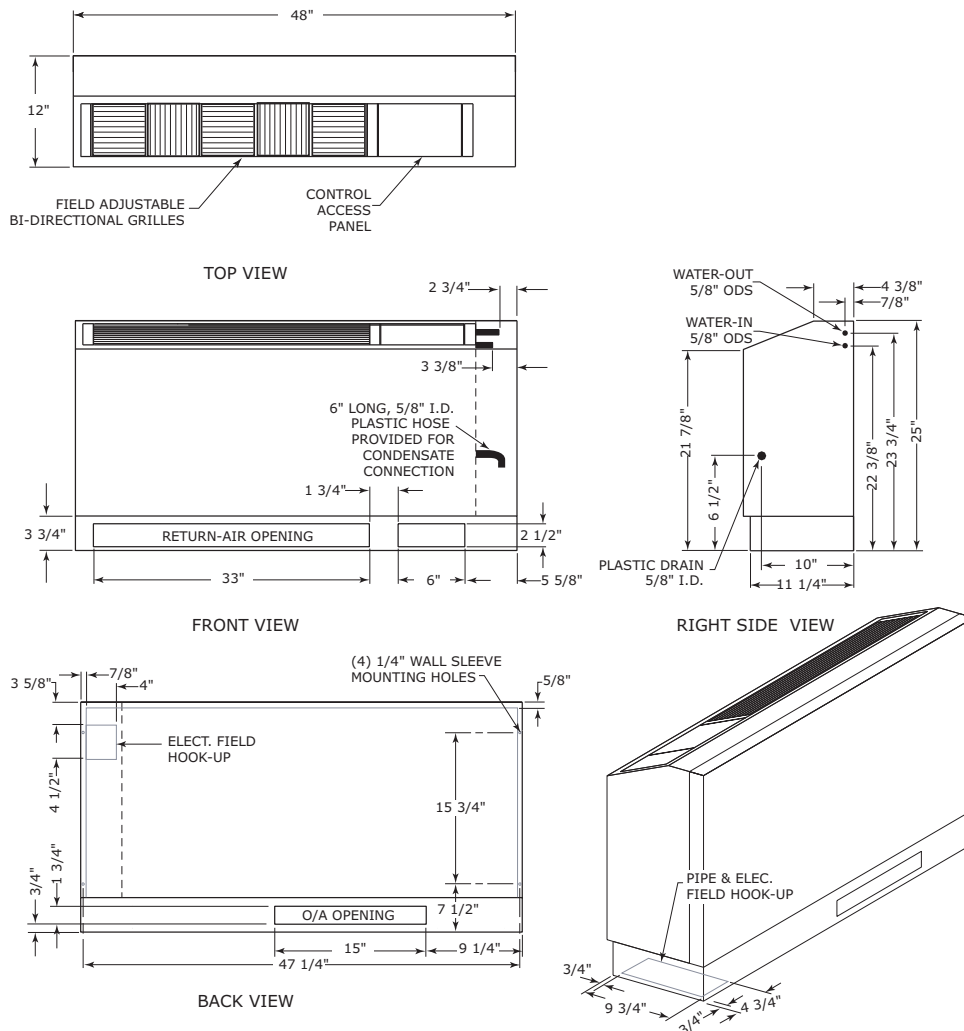
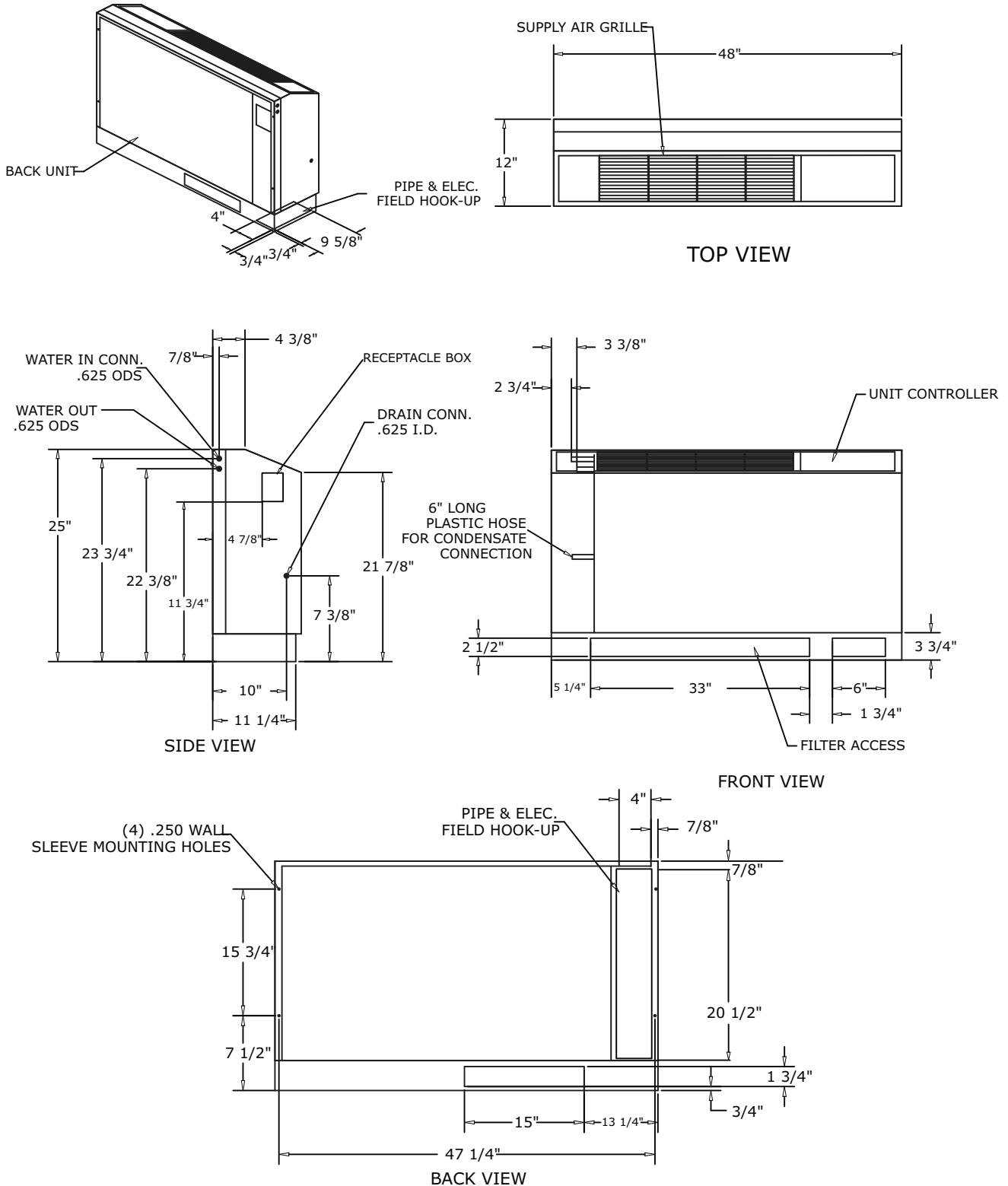
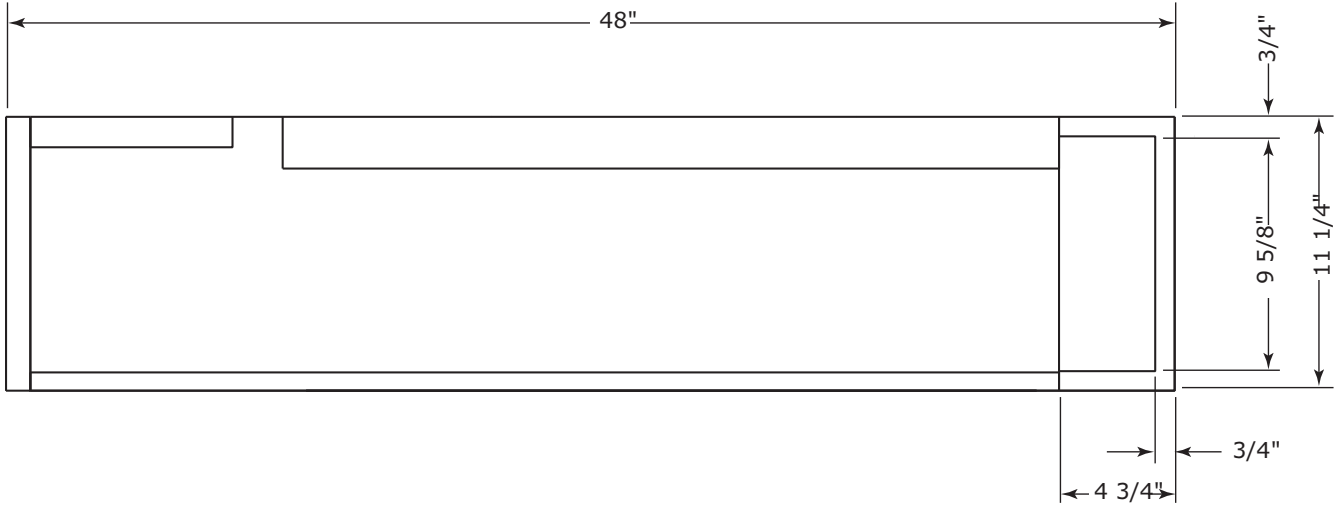

Figure 26. GEC 0.5 to 1.5 tons (60 Hz), 0.5 to 1.25 tons (50 Hz) - cabinet (LH) piping connection



Unit Dimensions

Figure 27. GEC 0.5 to 1.5 tons (60 Hz), 0.5 to 1.25 tons (50 Hz) - subbase (RH)



TOP VIEW

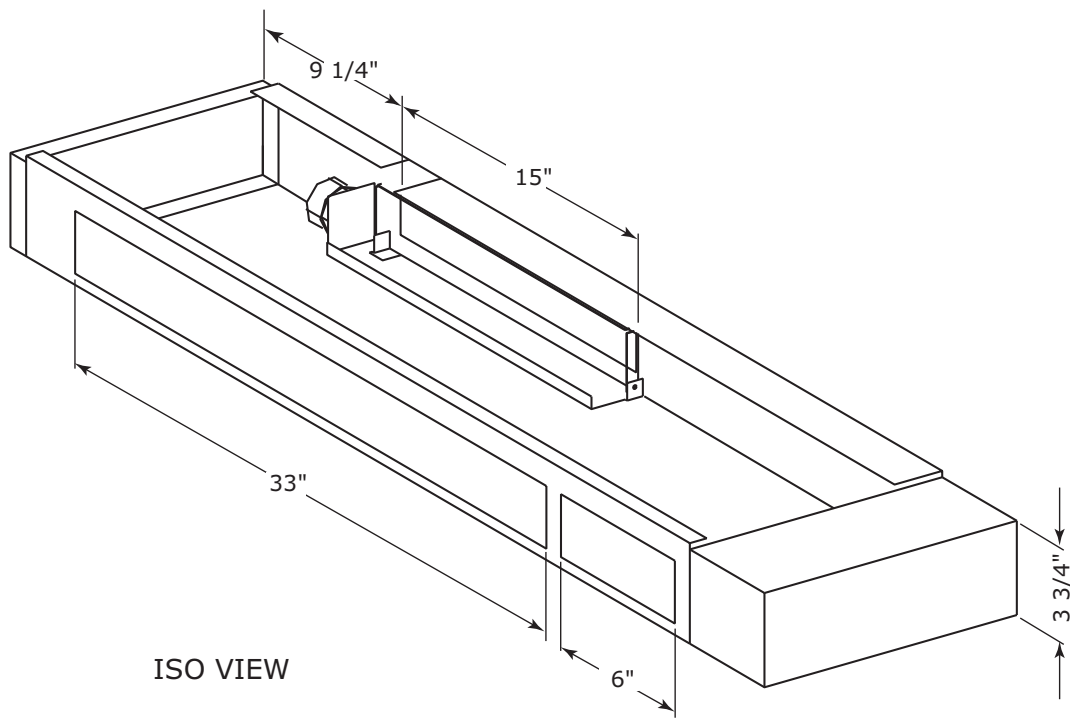

ISO VIEW

Figure 28. GEC 0.5 to 1.5 tons (60 Hz), 0.5 to 1.25 tons (50 Hz) - subbase (LH)

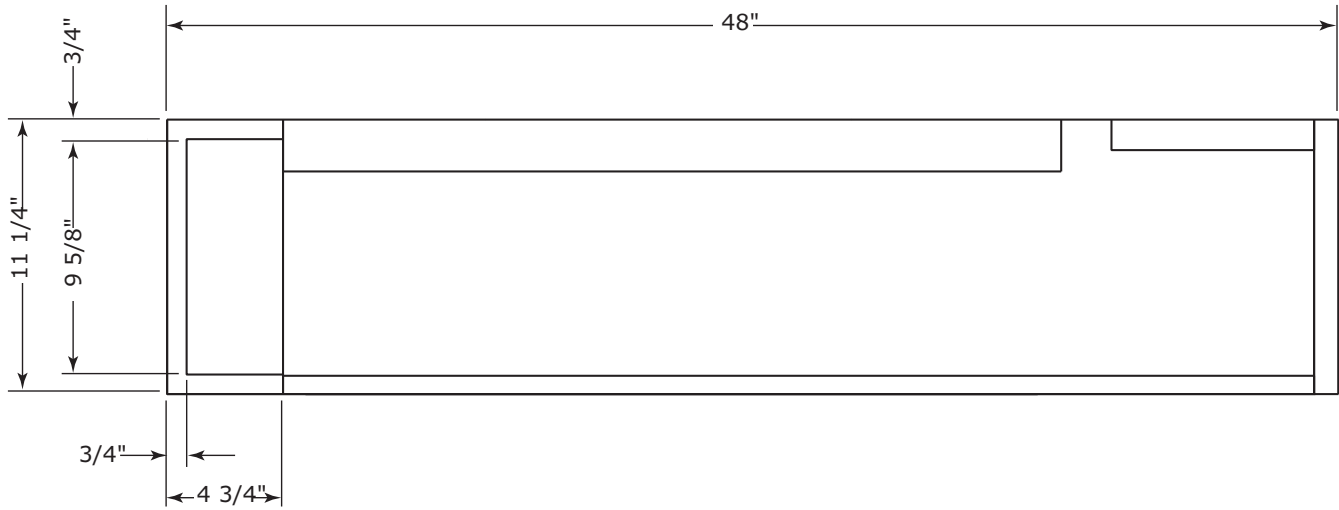

TOP VIEW

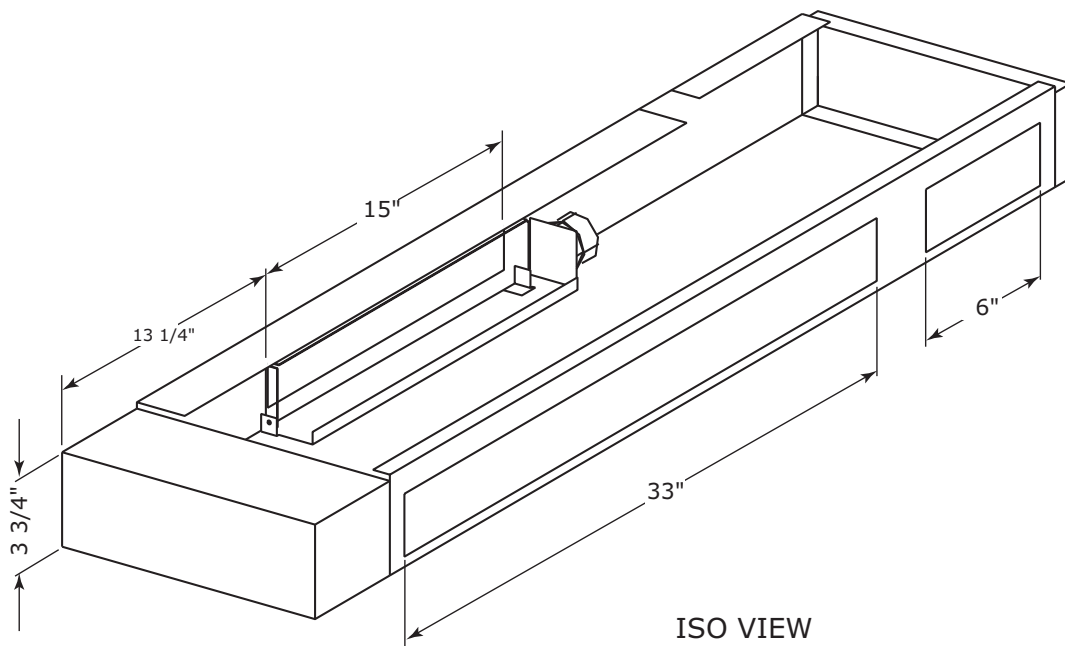

ISO VIEW

Unit Dimensions

Figure 29. GEC 0.5 to 1.5 tons (60 Hz), 0.5 to 1.25 tons (50 Hz) - cabinet (RH) piping extended length

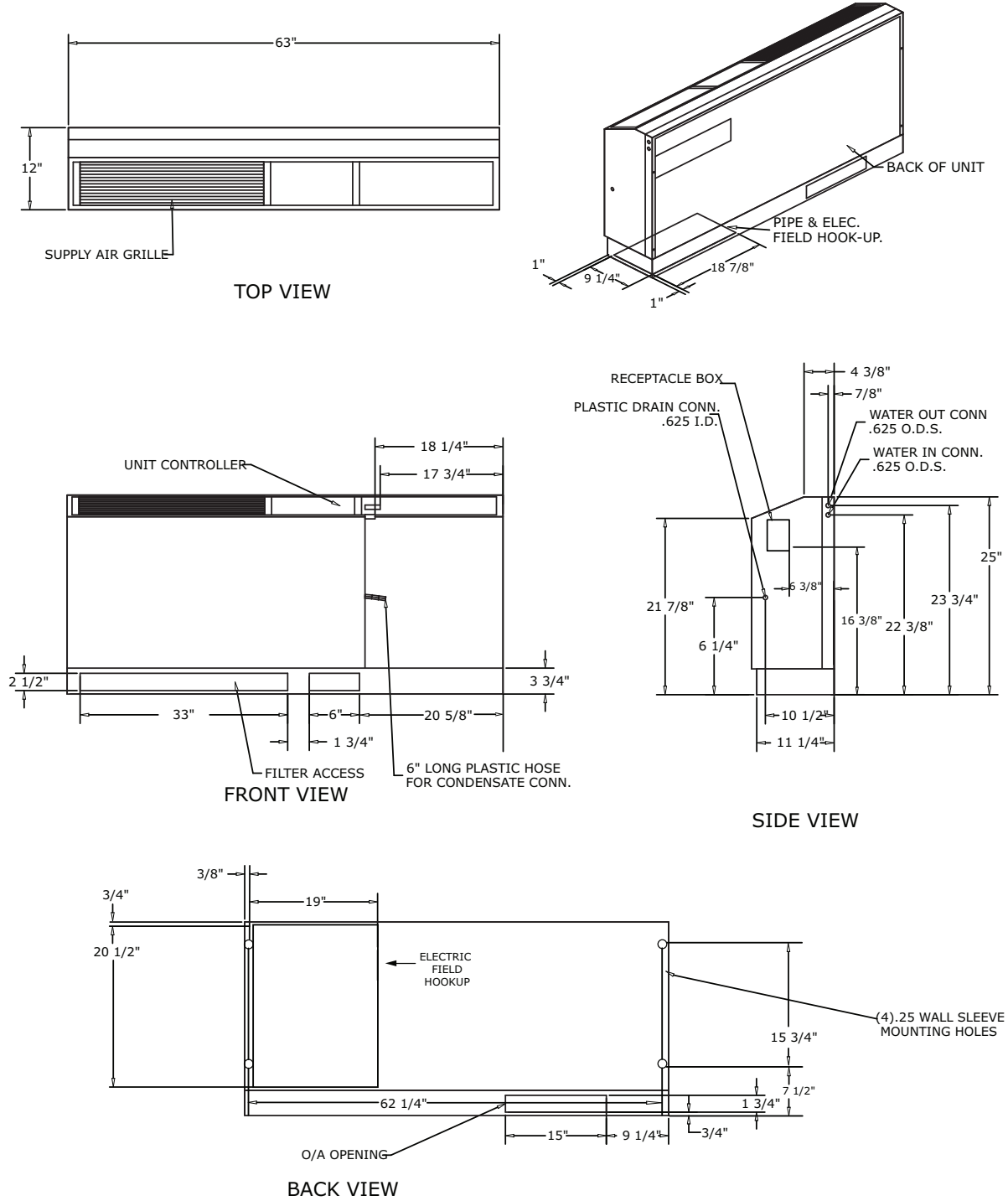
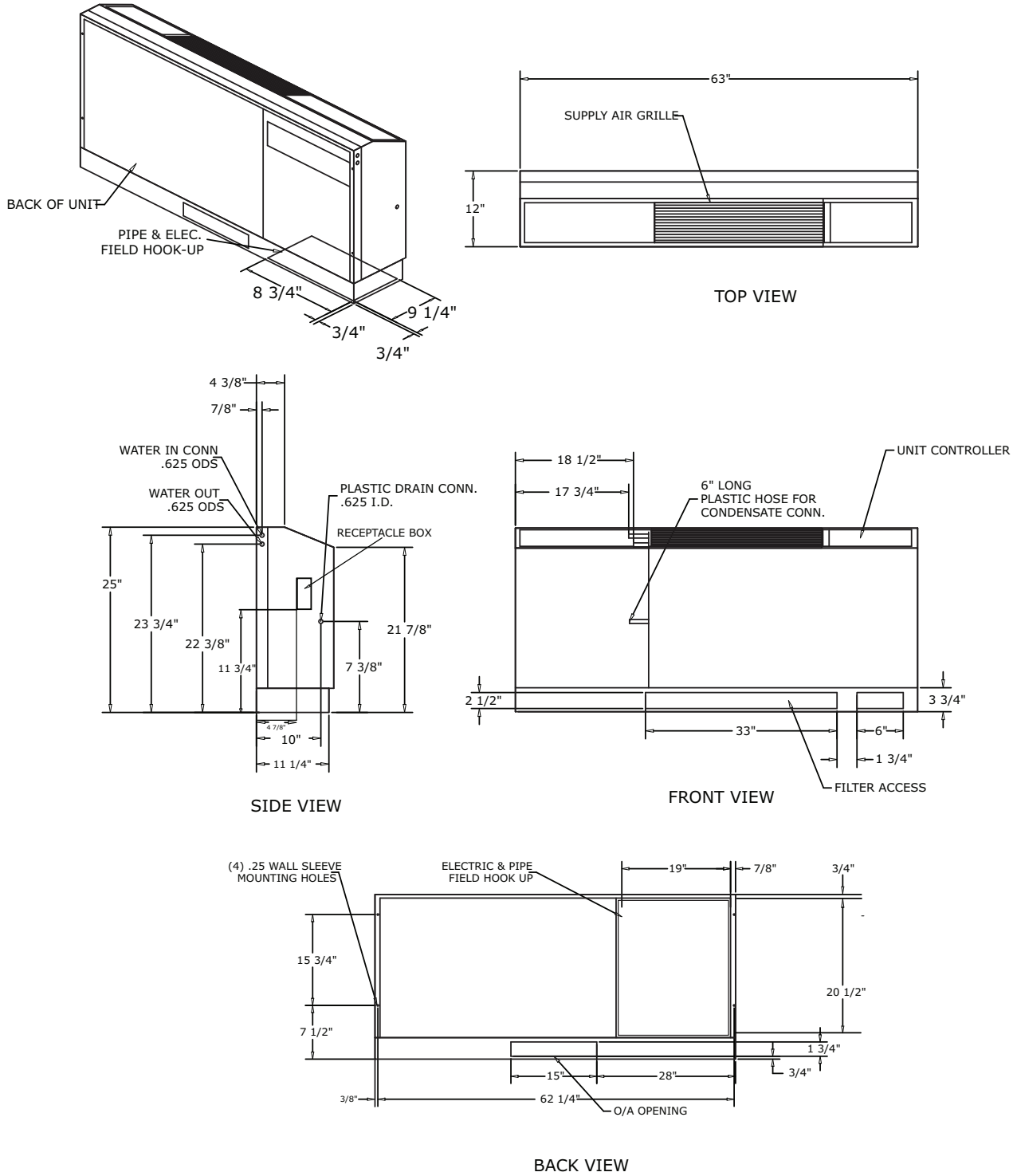
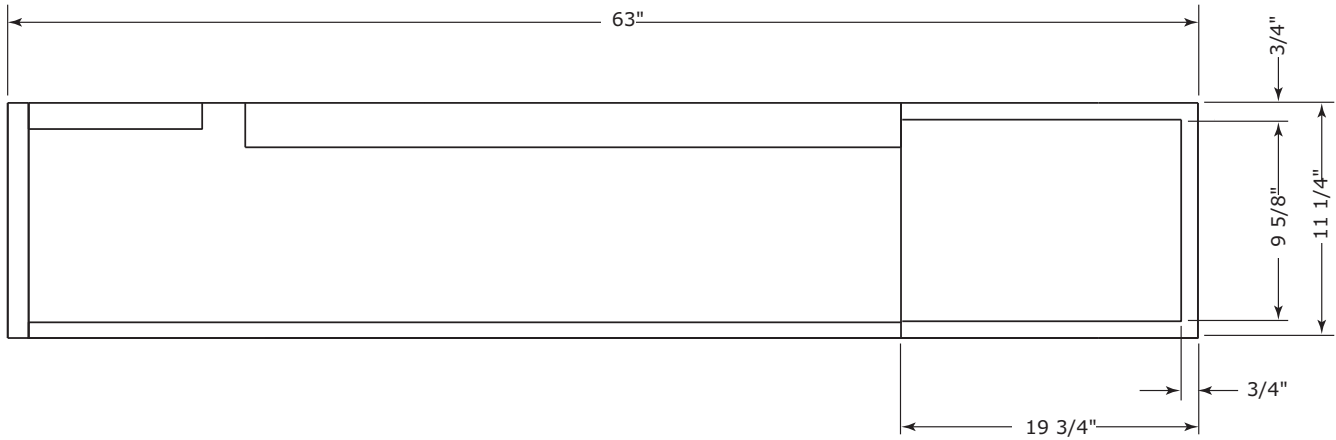

Figure 30. GEC 0.5 to 1.5 tons (60 Hz), 0.5 to 1.25 tons (50 Hz) - cabinet (LH) piping extended length



Unit Dimensions

Figure 31. GEC 0.5 to 1.5 tons (60 Hz), 0.5 to 1.25 tons (50 Hz) - subbase (RH) extended length



TOP VIEW

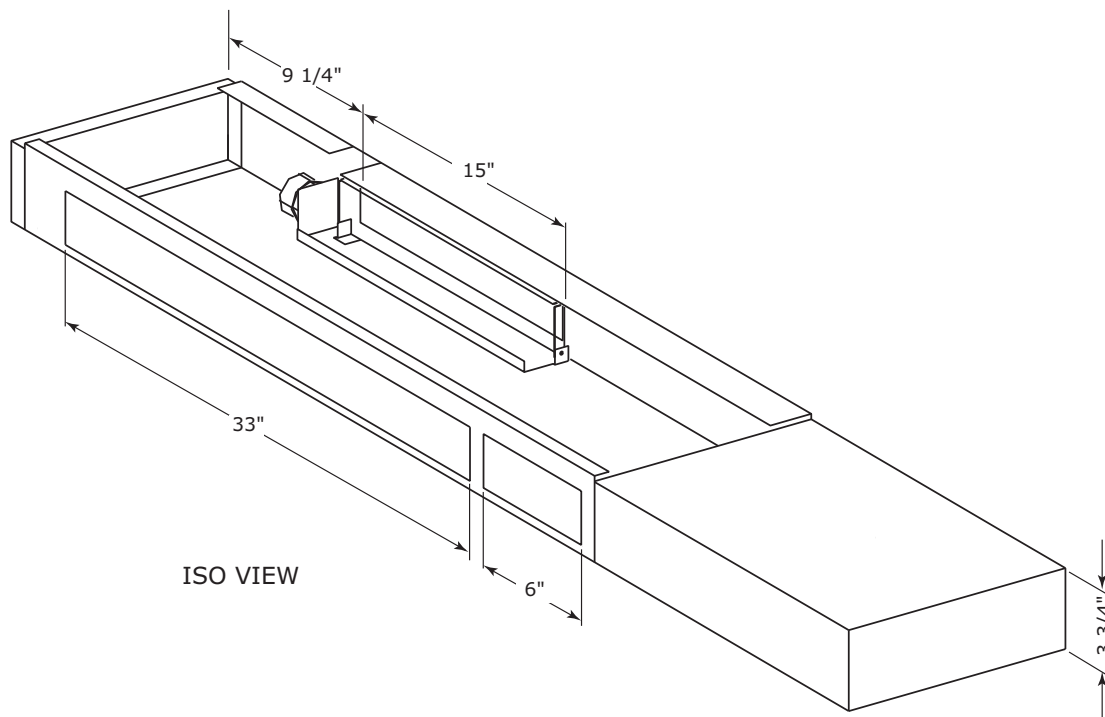

ISO VIEW

Figure 32. GEC 0.5 to 1.5 tons (60 Hz), 0.5 to 1.25 tons (50 Hz) - subbase (LH) extended length

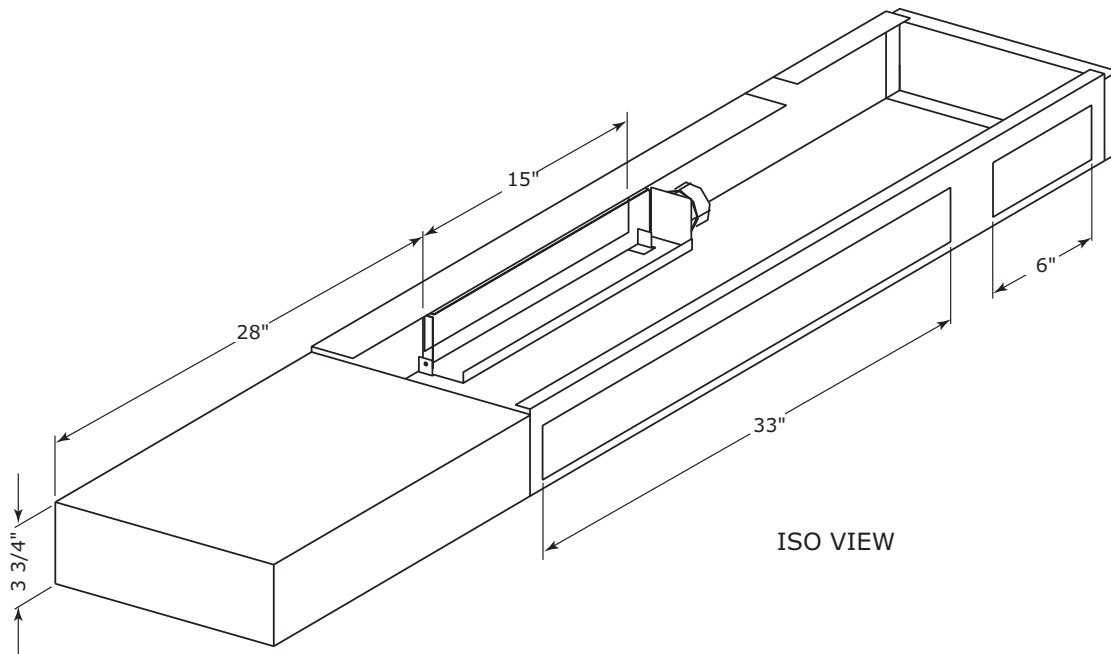
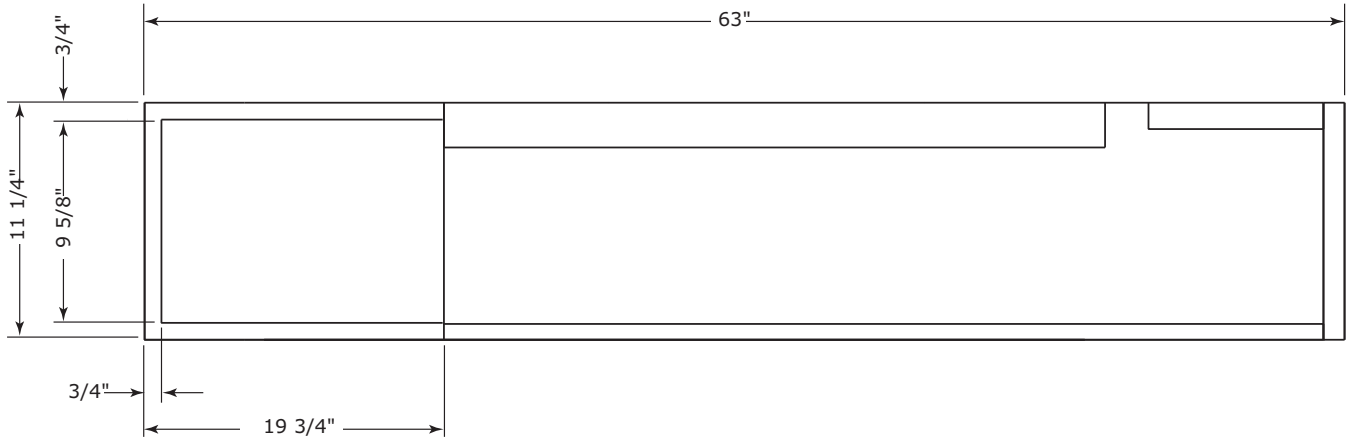

Unit Dimensions

Figure 33. GEC 0.5 to 1.5 tons (60 Hz), 0.5 to 1.25 tons (50 Hz) - cabinet (RH) low height unit

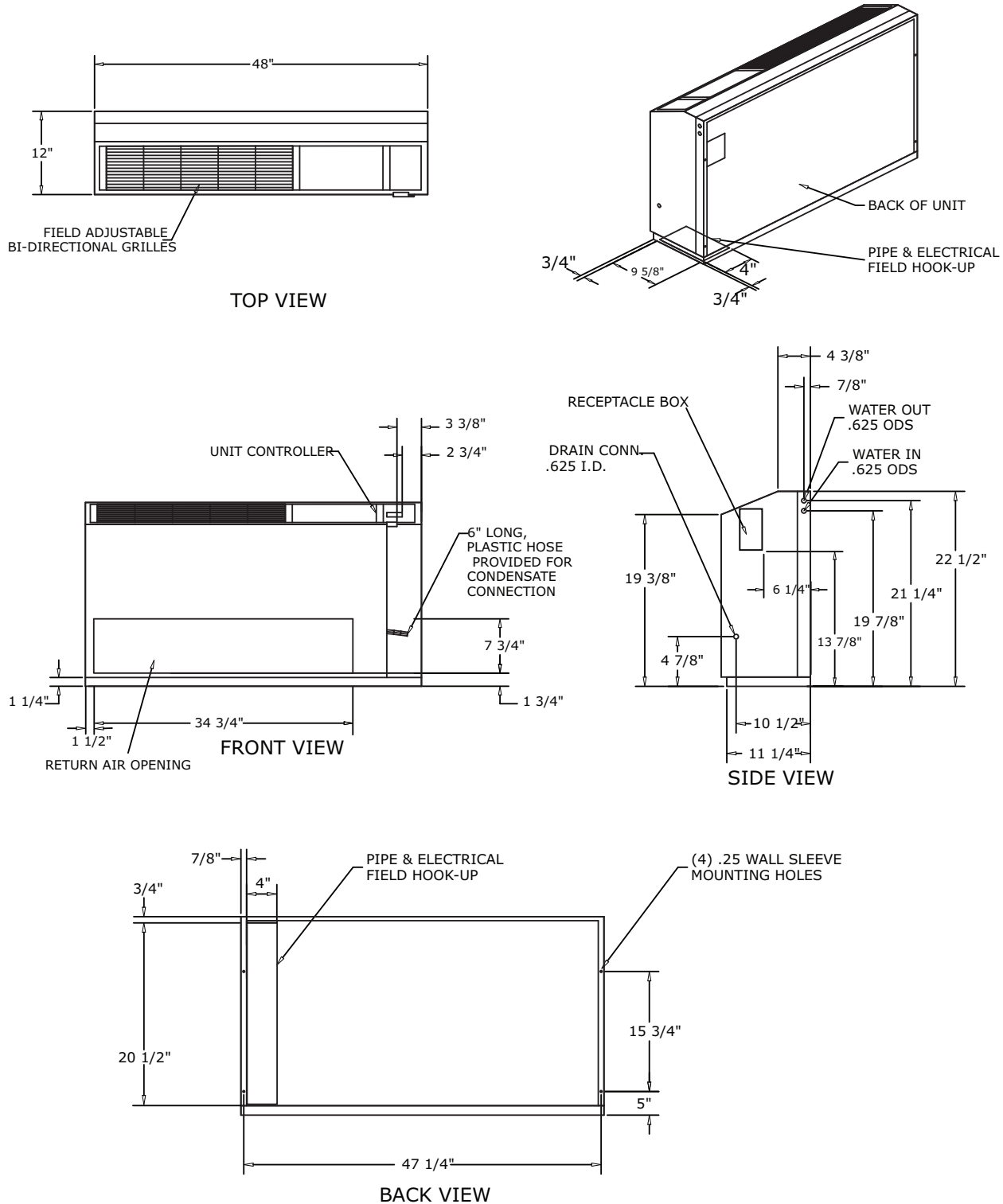
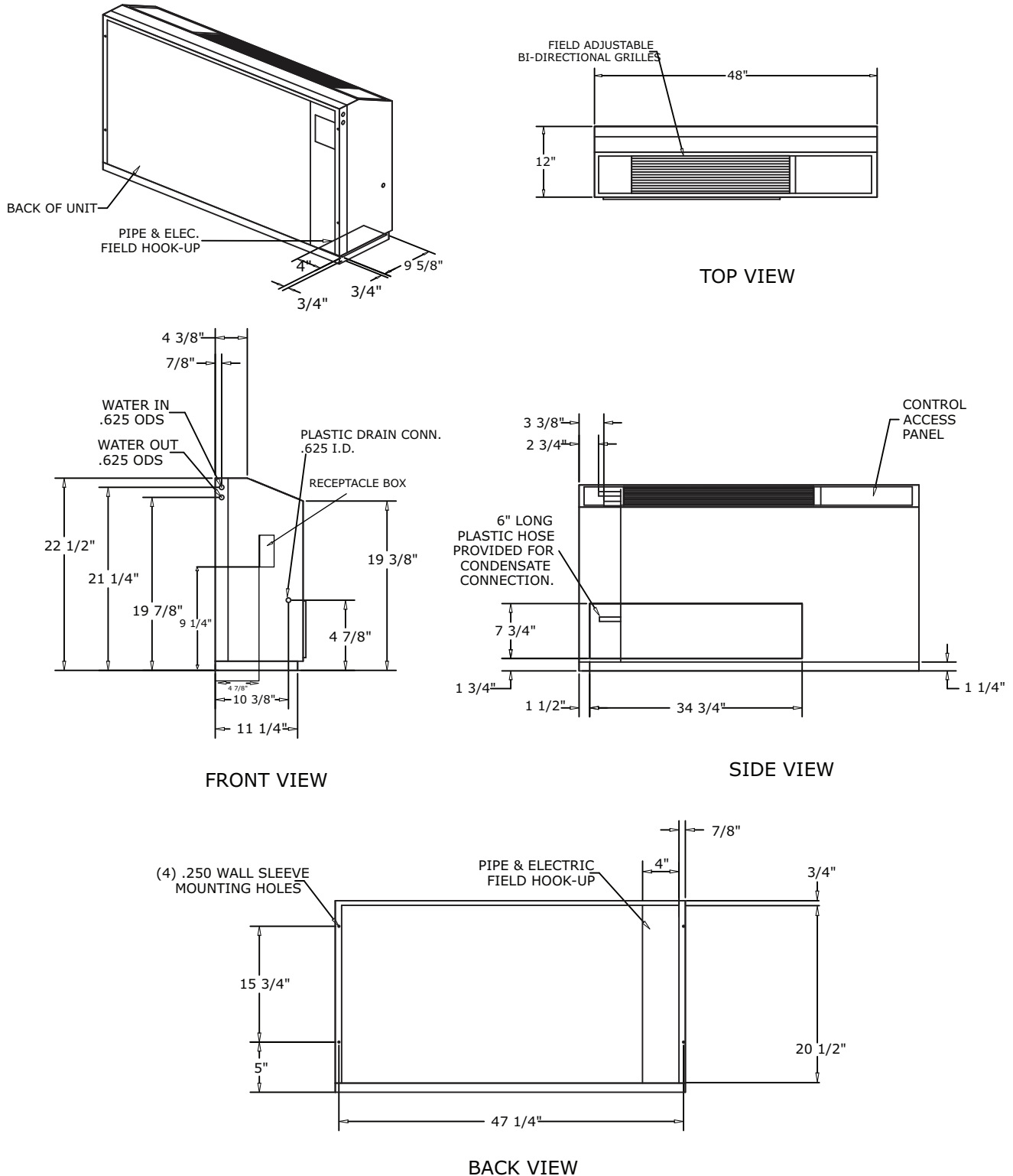

Figure 34. GEC 0.5 to 1.5 tons (60 Hz), 0.5 to 1.25 tons (50 Hz) - cabinet (LH) low height unit



Unit Dimensions

Figure 35. GEC 0.5 to 1.5 tons (60 Hz), 0.5 to 1.25 tons (50 Hz) - chassis (RH)

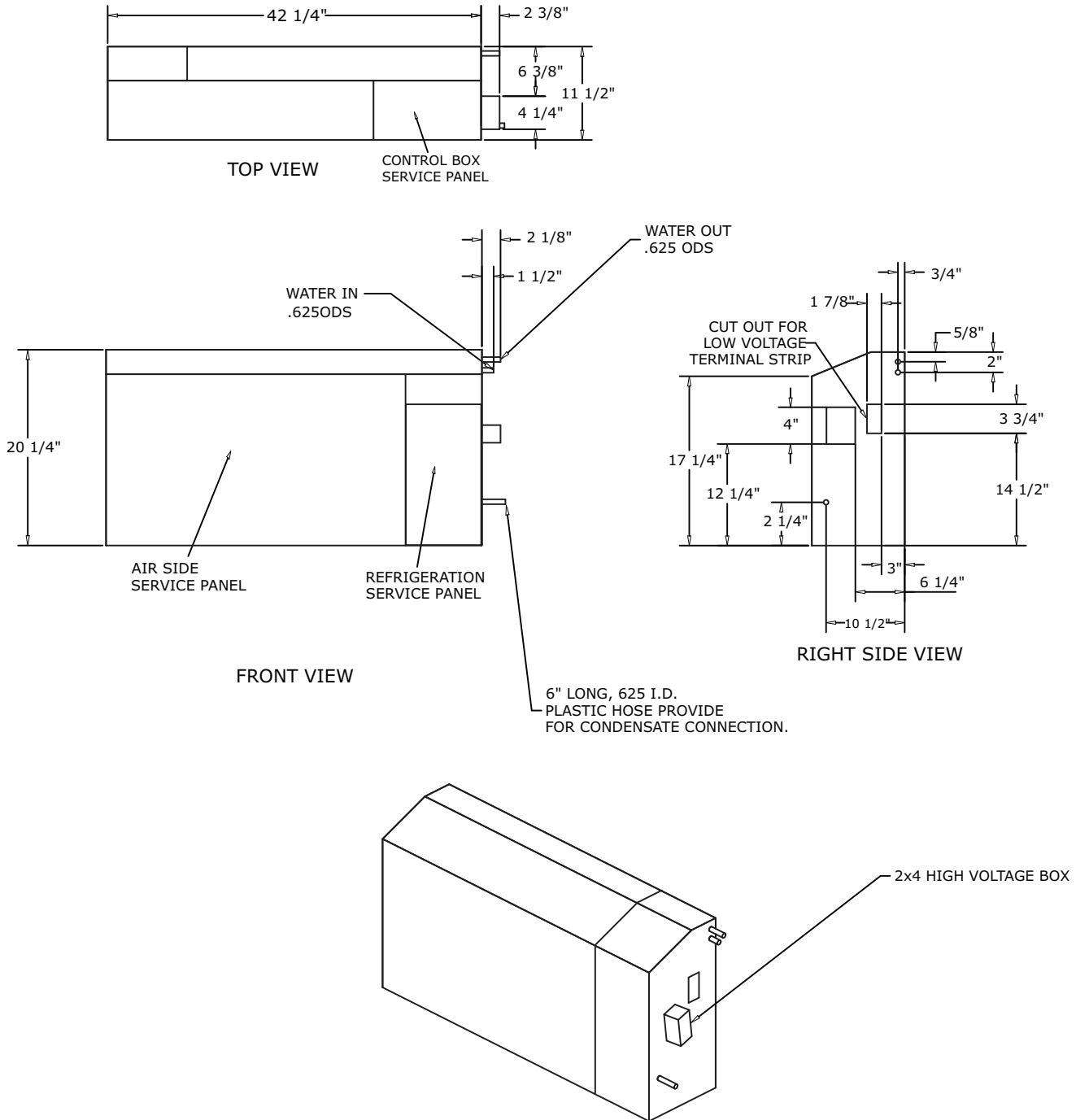
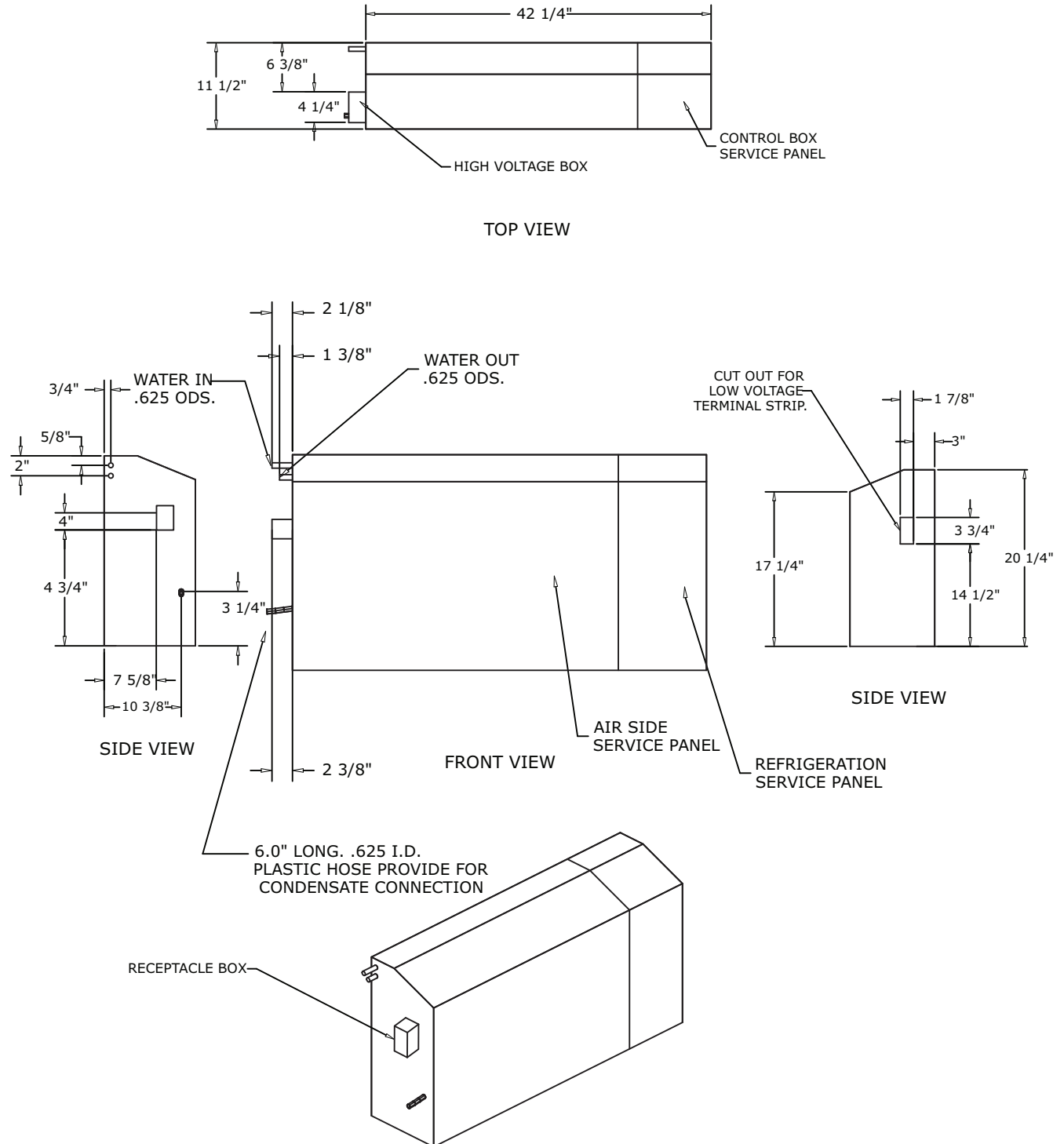

Figure 36. GEC 0.5 to 1.5 tons (60 Hz), 0.5 to 1.25 tons (50 Hz) - chassis (LH)





Controls

Deluxe 24V Controls

Stand-alone System

The deluxe 24V design may be applied as a stand-alone control system. The stand-alone design provides accurate temperature control directly through a wall-mounted electronic thermostat.

This system set-up may be utilized in a replacement design where a single unit retrofit is needed.

It may be easily interfaced with a field provided control system by way of the factory installed 18-pole terminal strip. This stand-alone control is frequently utilized on small jobs where a building controller may not be necessary, or where field installed direct digital controls are specified. This type of control design does require a constant flow of water to the water source heat pump.

With a positive way to sense flow to the unit, the units safety devices will trigger the unit off. The stand-alone system design provides a low cost option of installation while still allowing room control for each unit.

Figure 37. Deluxe 24V control board

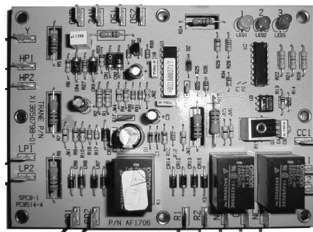

The deluxe 24 V design is a microprocessor-based control board conveniently located in the control box. The board is unique to Trane water-source products and is designed to control the unit as well as provide outputs for unit status and fault detection.

The board is factory wired to a terminal strip to provide all necessary terminals for field connections.

Deluxe 24V electronic controls include:

- 18 pole strip for low voltage field wiring
- 75 VA transformer
- Anti-short cycle compressor protection
- Brown out protection
- Compressor contactor
- Compressor delay on start
- Compressor disable input
- Compressor lock-out relay
- Compressor run capacitor (for 1-phase units only)
- Condensate overflow
- Electric heat and compressor enable
- Freeze protection
- General alarm (dry contact closure when fault detected)
- High pressure switch
- Hot gas reheat
- LED diagnostics
- Low pressure switch
- Low pressure time delay
- Motorized 2-position damper

- Multi-speed fan motor
- Random start delay
- Reversing valve coil
- Soft lockout mode
- Two-speed fan motor

Deluxe 24V features

Anti-short Cycle Timer

The anti-short cycle timer provides a three minute time delay between compressor stop and compressor restart.

Brown-out Protection

The brown-out protection function measures the input voltage to the controller and halts the compressor operation. Once a brown-out situation has occurred, the anti-short cycle timer will become energized. The general fault contact will not be affected by this condition. The voltage will continue to be monitored until the voltage increases. The compressors will be enabled at this time if all start-up time delays have expired, and all safeties have been satisfied.

Compressor Disable

The compressor disable relay provides a temporary disable in compressor operation. The signal would be provided from a water loop controller in the system. It would disable the compressor because of low water flow, peak limiting or if the unit goes into an unoccupied state. Once the compressor has been disabled, the anti-short cycle time period will begin. Once the compressor disable signal is no longer present, and all safeties are satisfied, the control will allow the compressor to restart.

Diagnostics

Three LEDs (light emitting diodes) are provided for indicating the operating mode of the controller. See the unit IOM for diagnostics or troubleshooting through the use of the LEDs.

Generic Relay

The generic relay is provided for field use. Night setback or pump restart are two options that may be wired to the available relay.

A 24 Vac signal will energize the relay coil on terminals R1 and R2. Terminals C (common), NO (normally open), and NC (normally closed) will be provided for the relay contacts.

Random Start

The random start relay provides a time delay start-up of the compressor when cycling in the occupied mode. A new start delay time between 3 and 10 seconds is applied each time power is enabled to the unit.

Safety Control

The deluxe controller receives separate input signals from the refrigerant high pressure switch, low suction pressure switch, and condensate overflow.

In a high pressure situation, the compressor contactor is de-energized, which suspends compressor operation. The control will go into soft lockout mode initializing a three minute time delay and a random start of 3 to 10 second time delays. Once these delays have expired, the unit will be allowed to run. If a high pressure situation occurs within one hour of the first situation, the control will be placed into a manual lockout mode, halting compressor operation, and initiating the general alarm.

In a low temperature situation, the low pressure switch will transition open after the compressor starts. If the switch is open for 45 seconds during compressor start, the unit will go into soft lockout mode initializing a three minute time delay and a random start of 3 to 10 second time delays. Once these delays have expired, the unit will be allowed to run. If the low pressure situation occurs again within 30 minutes, and

the device is open for more than 45 seconds, the control will be placed into a manual lockout mode, halting compressor operation, and initiating the general alarm.

In a condensate overflow situation, the control will go into manual lockout mode, halting compressor operation, and initiating the general alarm.

The general alarm is initiated when the control goes into a manual lockout mode for either high pressure, low pressure or condensate overflow conditions.

Building Control Advantages

The Symbio™ 400-B/Tracer® UC400-B controllers have the ability to share information with one or several units on the same communication link.

An advantage of installing a Symbio 400-B/UC400-B is its capability to work with other BACnet® controllers. This provides greater flexibility to the building owner, as well as greater flexibility in design.

Integrating the Symbio 400-B/UC400-B on water-source equipment, and tying it to a Tracer SC or other BAS system provides a complete building management system. With a Building Automation system like a Tracer SC, the system can initiate an alarm on a loss of performance on equipment malfunctions; allowing problems to be handled in a timely manner before compromising comfort.

This type of application would most commonly be used for a large space(s) that may require more than one unit. In addition to this application design, Symbio 400-B/UC400-B controller provides a way for units located within the same space to share the same zone sensor to prevent units from simultaneously heating and cooling in the same space.

***Note:** The sharing of information is made possible with a twisted pair of wire and a building automation system or through Tracer TU service tool.*

Symbio™ 400-B/Tracer® UC400-B

The Symbio 400-B/UC400-B is a multi-purpose, programmable (or application-specific) that provides direct-digital zone temperature control. This controller can operate as a stand-alone device or as part of a building automation system (BAS). Communication between the controller and a BAS occurs on an open standard with inter-operable protocols used in Building Automation and Control Networks (BACnet). Programming is done by means of the Tracer TU service tool.

***Note:** For more information, please reference BAS-SVX065*-EN or BAS-SVX092*-EN.*

Symbio 400-B/Tracer® UC400-B functions include:

Boilerless Control Electric Heat and Supplemental Electric Heat

The controller supports a single stage of boilerless electric heat operation.

Electric heat is used when boilerless heat is enabled/configured and the EWT is too low for compressor operation. When this condition is met, the isolation valve will be closed shutting down the water flow to the unit.

When the unit is configured for boilerless control, the EWT will be used to determine whether DX heating should be disabled and the electric heater enabled. When these conditions are met, the isolation valve(s) are driven open for three minutes and the entering water temperature reading is taken. The determination as to whether or not to utilize electric heat will be made and the controller will take appropriate action. If boilerless electric heat is enabled, then the isolation valve will be closed, shutting down the water flow to the unit.

Compressor Operation

The compressor is cycled on and off to meet heating or cooling zone demands. Units use the unit capacity and pulse width modulation (PWM) logic along with minimum on/off timers to determine the compressor's operation. The compressor is controlled ON for longer periods as capacity increases and shorter periods as capacity decreases.

Condensate Overflow

When condensate reaches the trip point, a condensate overflow signal generates a diagnostic which disables the fan, unit water valves (if present), and compressor. The unit will remain in a halted state until the condensation returns to a normal level. At this time, the switch in the drain pan will automatically reset. However, the controller's condensate overflow diagnostic must be manually reset to clear the diagnostic and restart the unit.

Data Sharing

The Symbio 400-B/UC400-B controller are capable of sending or receiving data (setpoints, fan request, or space temperature) to and from other controllers on the communication link. This allows multiple units to share a common space temperature sensor in both stand-alone and building automation applications.

Dehumidification

Dehumidification for the water-source heat pump is applicable with the Symbio 400-B/UC400-B. The controller is capable of directing one stage of DX cooling in conjunction with one stage of reheat (hot gas reheat).

Dehumidification can only occur when the controller is in the cooling mode. A humidity sensor is used to measure the zone's relative humidity (RH), then compares the zone relative humidity to the relative humidity enable/disable setpoint parameters. The dehumidification enable and disable points are configurable.

Note: Standard electrical connections are in a 2 in. x 4 in. electrical box mounted on the chassis. An optional toggle switch is available on the standard 2 in. x 4 in. electrical box. Other electrical connection options are as follow:

Receptacle Box

A factory shipped disconnect option receptacle option is available with the console configuration. With this option, the high voltage power is field wired directly through the disconnect receptacle. This safety feature provides ease of powering OFF the individual circuitry of a unit without interrupting electrical service to other equipment in a service or maintenance situation.

Trane offers two disconnection electrical connection options. Option A is non-fused. It consists of a power cord and its receptacle box. The receptacle box contains a 115 to 240V or 265V receptacle. It is factory shipped in the unit, and field installed at the jobsite. Option A is available in an extended cabinet length option.

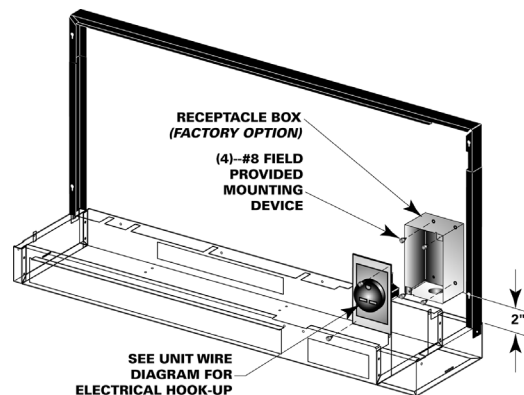

Receptacle Box with Circuit Breaker

Option B disconnect includes a power cord/receptacle box with a circuit breaker. With this option, the circuit breaker may be reset directly at the unit during a power interruption situation.

The power cord/receptacle box with circuit breaker is available in 115 to 240V or 265V options. It is factory shipped in the unit, and field installed at the jobsite.

Option B disconnect is possible with both the standard length cabinet configuration and the extended length cabinet option.

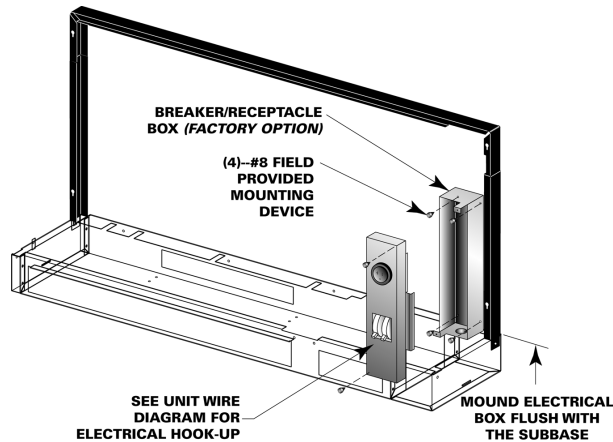

Fan Operation

The supply air fan operates at the factory wired speed in the occupied or occupied standby mode. When switch is set to AUTO, the fan is configured for cycling ON with heating or cooling. In heat mode, the fan will run for 30 seconds beyond compressor shutdown in both occupied and unoccupied mode.

Filter Maintenance Timer

The controller filter status is based on the unit fan's cumulative run hours. The controller compares the fan run time against an adjustable fan run hours limit and recommends unit maintenance as required.

High and Low Pressure Switches

The Symbio 400-B/UC400-B detects the state of the high pressure or low pressure switches. When a fault is sensed by one of these switches, the corresponding message is sent to the controller to be logged into the fault log. When the circuit returns to normal, the high pressure control and low pressure control automatically reset. If a second fault is detected within a thirty-minute time span, the unit must be manually reset.

Occupancy Modes

The four operations of the Symbio 400-B/UC400-B controller include occupied, occupied standby, occupied bypass and unoccupied.

In an occupied situation, the controller uses occupied heating and cooling setpoints to provide heating and cooling to the building. This occupied operation is normally used during the daytime hours when the building is at the highest occupancy level.

In an occupied standby situation, the controllers heating and cooling setpoints are usually wider than the occupied setpoints. This occupied standby operation is used during daytime hours when people are not present in the space (such as lunchtime or recess). To determine the space occupancy, an occupancy sensor is applied.

In an unoccupied situation, the controller assumes the building is vacant, which normally falls in evening hours when a space may be empty. In the unoccupied mode, the controller uses the default unoccupied heating and cooling setpoints stored in the controller. When the building is in unoccupied mode, individual units may be manually placed into timed override of the unoccupied mode at the units wall sensor. During timed override, the controller interprets the request and initiates the occupied setpoint operation, then reports the effective occupancy mode as occupied bypass.

In the occupied bypass mode, the controller applies the occupied heating and cooling setpoint for a 120 minute time limit.

Random Start

To prevent all of the units in a building from energizing major loads at the same time, the controller observes a random start from 0 to 25 seconds. This timer halts the controller until the random start time expires.

Reversing Valve Operation

For cooling, the reversing valve output is energized simultaneously with the compressor. It will remain energized until the controller turns on the compressor for heating. At this time, the reversing valve moves to a de-energized state. In the event of a power failure or controller OFF situation, the reversing valve output will default to the heating (de-energized) state.

Additional Functions of the Symbio 400-B/UC400-B Controller

When the building owners choice is Trane Tracer controls, the Symbio 400-B/UC400-B controller is required when any of the following applications are selected.

- Hot Gas Reheat (for Dehumidification)
- Boilerless Control for Electric Heat
- Water Isolation Valve Control (for Variable Speed Pumping)

Entering Water Temperature Sampling

The controller will sample the entering water temperature to determine proper control action for units equipped with boilerless electric heat or waterside economizer.

Water Isolation Valve

Variable speed pumping systems are supported by the controller when water isolation valves are present. up to two isolation valves are supported by the Symbio 400-B/UC400-B controller (one for each compressor circuit). The valves are normally closed unless DX heating, DX cooling, waterside economizer or dehumidification is requested. When the isolation valves are driven open for operation, the outputs will be driven for 20 seconds to ensure adequate water flow before the compressor outputs are energized. Once an isolation valve has been opened, it will remain open for a 10 minute minimum to reduce excessive cycling of the valve.

Trane® Air-Fi® Wireless Systems



Trane Air-Fi wireless systems provides significant advantages to better meet customer by providing a lower initial cost; ease of installation for reduced risk; increased reliability and flexibility for easier problem solving; and fewer maintenance issues for worry-free operation and cost savings over the life of the system. Trane Air-Fi wireless systems helps save time and money, with industry-leading technology and performance.

Air-Fi Wireless Communications Interface (WCI)

The Air-Fi Wireless Communications Interface (WCI) enables wireless communications between system controls, unit controls, and wireless sensors for Trane control products that use the BACnet protocol. The WCI replaces the need for communications wire in all system applications.

The WCI is available in three configurations:

- The universal model is the most common. It installs the same as a wired zone sensor in indoor applications.
- The outdoor model is housed in an enclosure suitable for outdoor environments. It is usually used on equipment above the roof deck.

- The flush mount model is used on fan coils, blower coils, and unit ventilators.

Air-Fi Wireless Communications Sensor (WCS)

The Air-Fi Wireless Communications Sensor (WCS) is compatible with any Trane controller that uses a WCI. The WCS provides the same functions as many currently available Trane wired sensors. No further software or hardware is necessary for site evaluation, installation, or maintenance. Space temperature is standard on all models. (A service tool cannot be connected to a Trane wireless sensor.)

Three WCS models are available:

- Digital display (WCS-SD) model.
- Base (WCS-SB) model has no exposed display or user interface.
- 2% relative humidity sensor module (WCS-SH), which can be field installed inside either the WCS-SD or WCS-SB.

In most applications, one WCS-SD or WCS-SB sensor will be used per WCI acting as a router. However, up to 6 WCS-SD or WCS-SB sensors can be associated to a single equipment controller or BCI.

Compatibility with Previous Generation Wireless Zone Products

Our previous line of wireless zone sensors (WZS, WTS, and WDS) are not compatible with the Air-Fi Wireless Communications Interface (WCI).





The new Air-Fi Wireless Communications Sensor (WCS) are compatible with old WCIs that have updated firmware.

Wired Zone Sensors

Wired zone sensors can be used with Air-Fi wireless systems.







Thermostats and Zone Sensors

Table 29. Thermostat selection for use with the deluxe 24V controller

Thermostat	Part Number	Description
	X13511535010	1 Heat/1 Cool, non-programmable commercial thermostat for conventional air conditioners and heat pumps that are configured without auxiliary heat <ul style="list-style-type: none"> • 1 H/1 C
	X13511536010	3 Heat/2 Cool, non-programmable commercial thermostat for conventional air conditioners and heat pumps that are configured with or without auxiliary heat. <ul style="list-style-type: none"> • 3 H/2 C
	X13511537010	3 Heat/2 Cool, programmable commercial thermostat for conventional (rooftop) air conditioners and heat pumps that are configured with or without auxiliary heat. <ul style="list-style-type: none"> • 3 H/2 C
	X13511538010	3Heat/2 Cool, programmable touch screen thermostat for conventional air conditioners and heat pump systems. The thermostat will provide the human interface, zone temperature sensing both local and optional remote temperature sensing, and set point scheduling on a daily/weekly basis. This thermostat can also display humidity with a control signal for dehumidification with a local humidity sensor or optional remote humidity sensor. <ul style="list-style-type: none"> • 3 H/2 C

Thermostats and Zone Sensors

Table 30. Zone sensor selection for use with Symbio™ 400-B/Tracer® UC400-B controller

Sensor	Part Number	Description
	X13790886010	Wired temperature sensor with an LCD display <ul style="list-style-type: none"> Allows an occupant to control the temperature setpoint, request timed override of system operation, and provides a COMM module to service technicians. Symbio 400-B/UC400-B Compatible.
	X13651467020	Communication Module <ul style="list-style-type: none"> Sold in packs of 12. Provides local RJ22 connection to Trane® service tools for easy, low cost maintenance.
	X13511529010	Zone Sensor <ul style="list-style-type: none"> Symbio 400-B/UC400-B compatible. External setpoint adjustment wheel.
	X13511527010	Zone Sensor <ul style="list-style-type: none"> Symbio 400-B/UC400-B compatible. External setpoint adjustment wheel. ON and CANCEL buttons.
	X1379084501	Zone Sensor <ul style="list-style-type: none"> Symbio 400-B/UC400-B compatible. External setpoint adjustment wheel. ON and CANCEL buttons. Fan switch AUTO-OFF.
	X1379044401	<ul style="list-style-type: none"> Temperature and relative humidity sensor Symbio 400-B/UC400-B compatible.

Thermostats and Zone Sensors

Table 30. Zone sensor selection for use with Symbio™ 400-B/Tracer® UC400-B controller (continued)





Sensor	Part Number	Description
	X13790993001	Commercial Touch Screen Programmable Zone Sensor <ul style="list-style-type: none"> • Supports Standby, Occupied, and Unoccupied. • 7 day, 5+2 day, and 5+1+1 day. • Cannot be used with BAS as sensor ties up BACnet link. For use with factory programmed Symbio 400-B/UC400-B. Notes: <ul style="list-style-type: none"> • <i>Adjusting the rotary switch on Symbio 400-B/UC400-B may be required to correspond address configuration in the sensor. See the installation manual for more information.</i> • <i>Additional configuration is needed in the field to use the Programmable zone sensors (to put BAS points in service on Symbio 400-B/UC400-B).</i>
	X13790992001	Residential Touch Screen Programmable Zone Sensor <ul style="list-style-type: none"> • Supports Awake, Away, Home, and Sleep. • 7 day, 5+2 day, and 5+1+1 day. • Cannot be used with BAS as sensor ties up BACnet link. For use with factory programmed Symbio 400-B/UC400-B. Notes: <ul style="list-style-type: none"> • <i>Adjusting the rotary switch on Symbio 400-B/UC400-B may be required to correspond address configuration in the sensor. See the installation manual for more information.</i> • <i>Additional configuration is needed in the field to use the Programmable zone sensors (to put BAS points in service on Symbio 400-B/UC400-B).</i>

Table 31. Wireless zone sensor selection for use with Symbio 400-B/UC400-B controller

Sensor	Part Number	Description
	X13790955050	Trane Air-Fi WCS-SD (display) <ul style="list-style-type: none"> • Symbio 400-B/UC400-B Compatible. • Easy-to-use interface for clear and simple monitoring and control.
	X13790956010	Trane Air-Fi WCS-SB (base) <ul style="list-style-type: none"> • Symbio 400-B/UC400-B Compatible. • Simplicity. • Eliminates local temperature control when higher control level is required.



Mechanical Specifications

General

Equipment shall be completely assembled, piped, internally wired and test operated at the factory. It shall be both ETL and ISO-AHRI 13256-1 listed and labeled prior to leaving the factory. Service and caution area labels shall also be placed on the unit in their appropriate locations.

Air-to-Refrigerant Coil

Internally finned, 3/8-inch copper tubes mechanically bonded to a configured aluminum plate fin as standard. Coils are leak tested at the factory to ensure the pressure integrity. The coil shall be leak tested to 450 psig and pressure tested to 650 psig. The tubes are to be completely evacuated of air and correctly charged with proper volume of refrigerant prior to shipment.

The refrigerant coil distributor assembly shall be of orifice style with round copper distributor tubes. The tubes are sized consistently with the capacity of the coil. Suction header is fabricated from rounded copper pipe.

A thermostatic expansion valve is factory selected and installed for a wide range of control.

Ball Valves

Ball valves are field installed between the unit and the supply and return lines of the loop to stop water flow to the unit in a maintenance or service situation.

Cabinet

The cabinet shall be constructed of sturdy galvanized steel, with exposed edges rounded. The steel shall include electrostatic powder paint in three attractive colors for an appliance grade finish. Service to the refrigerant and controls shall be provided through a single access panel at the front of the unit chassis. Insulation for the internal parts and surfaces exposed to the conditioned air stream shall be made of moisture resistant insulation.

The insulation shall be ½-inch thick dual density bonded glass fiber. The exposed side shall be a high density erosion proof material suitable for use in airstreams up to 4500 feet per minute (FPM). Insulation shall meet the Underwriters' Laboratories Fire Hazard Classification:

- Flame spread = 25
- Smoke developed = 50

Access for inspection and cleaning of the unit drain pan, coils and fan section shall be provided. The unit shall be installed for proper access. Procedures for proper access inspection and cleaning of the unit shall be included in the maintenance manual.

Drain Pan

The drain pan shall be constructed of corrosion resistant material and insulated to prevent sweating. The bottom of the drain pan shall be sloped on two planes which pitches the condensate to the drain connection.

Electric Heat (option)

The boilerless electric heat option shall be factory wired and tested. It shall be composed of a nichrome open wire coil designed for 2-kW per unit ton. It shall consist of a single stage of electric heat used as a primary heating source when compressor lockout has occurred due to the entering water temperature falling below 55°F in a boilerless situation.

Electrical

The factory tested and installed control box shall contain all necessary devices to allow heating and cooling operation of the equipment to occur from a remote wall thermostat or zone sensor. These devices shall be as follows:

- 24 Vac Energy Limiting Class II, 50VA breaker with external fuse or 75VA with a circuit breaker.
- 24 Vac contactor for compressor control.

- 18 pole terminal strip located inside the control box behind the service access panel. This terminal strip shall be used for low voltage (thermostat/zone sensor) connections.
- An electrically operated safety lockout relay shall help prevent cycling of the compressor during adverse conditions of operation. This device shall be reset either at the remote thermostat/zone sensor, or by cycling power to the unit.
- A high pressure switch shall help protect the compressor against operation at refrigerant system pressure in excess of 650 psig.
- A low pressure switch shall help prevent compressor operation under low charge or catastrophic loss of charge situations.
- Factory installed wire harness shall be available for the Deluxe, Symbio™ 400-B/Tracer® UC400-B and Terminal Unit Control packages.

Fans

The fans shall be placed in a blow-through configuration. They shall be constructed of corrosion resistant galvanized material.

Filters

One inch throwaway filters shall be standard and factory installed. The filters shall have an average resistance of 76-percent and dust holding capacity of 26-grams per square foot.

Hoses (option)

Hoses shall consist of a stainless steel outer braid with an inner core of tube made of a nontoxic synthetic polymer material. The hoses shall be suitable for water temperatures ranging between 33°F and 211°F without the use of glycol.

Automatic Flow Devices (option)

The automatic self-balancing device shall automatically limit the rate of flow to within 10-percent of the specified amount, over a 40 to 1 differential pressure operating range of 2 to 80 PSID. The operational temperature shall be rated from fluid freezing, to 225°F.

The valve body shall be suited for working pressures of 400 PSIG. The valve internal core shall consist of one or more high temperature elastomeric diaphragms and precision orifice with sculptured orifice seat.

Dual pressure/temperature test ports shall be standard for verifying the pressure differential and system temperature.

Motors

The motors shall be a multi-speed permanent split capacitor with thermal overload protection. A high and low switching device shall be provided for all units and accessible behind the hinged control door. The motor shall contain a quick-disconnect plug and permanently lubricated bearing.

Pump Module (field installed accessory)

The pump module shall consist of either a single or dual 1/6 HP cast iron pump and a brass 3-way shut-off valve. The pump module kits shall contain the necessary components for the installation, operation and maintenance of the water circuit of a closed-loop distributed pumping application.

Reheat Coil (option)

Dehumidification shall be provided through a hot gas reheat option. The coil shall consist of copper tubes mechanically expanded into evenly spaced aluminum fins. All coils are to be proof and leak tested. The proof must be performed at 1.5 times the maximum operating pressure and the leak test at the maximum operating pressure. In addition, the tubes are to be completely evacuated of air to check for leaks in a vacuum.

Mechanical Specifications

Refrigerant Metering

The equipment shall be provided with a (TXV) thermal expansion valve to allow operation of the unit with entering fluid temperature from 25°F to 120°F.

Refrigeration System Compressor

The unit shall include a general efficiency rotary compressor. External vibration isolation shall be provided by rubber mounting devices located underneath the mounting base of the compressor. A second isolation of the refrigeration assembly shall be supported under the compressor mounting base.

Thermal overload protection shall be provided. Protection shall be provided against excessive discharge pressure operation by means of a high pressure switch. Loss of charge protection shall be provided by a low pressure switch.

Refrigerant Tubing

The refrigerant tubing shall be of 99% pure copper. This system shall be free from contaminants and conditions such as drilling fragments, dirt and oil. All refrigerant and water lines shall be insulated with an elastomeric insulation that has a 3/8-inch thick wall where ever air is introduced to the assembly.

Sound Attenuation

Sound attenuation shall be applied as a standard feature in the product design.

The sound reduction package shall include a vibration isolation to the compressor and water-to-refrigerant coil, a second stage of vibration isolation to the compressor base pan, heavy gauge base assembly, insulated metal compressor enclosure, and maximum sized return-air opening and filter sizing.

The unit shall be tested and rated in accordance with AHRI 350.

Water-to-Refrigerant Heat Exchanger

The water-to-refrigerant heat exchanger shall be of a high quality co-axial coil for maximum heat transfer. The copper or optional cupro-nickel coil shall be deeply fluted to enhance heat transfer and minimize fouling and scaling. The coil has a working pressure of 400 psig on the water side and 650 psig on the refrigerant side. The factory shall provide rubber isolation to the heat exchanging device to enhance sound attenuation.



The AHRI Certified mark indicates Trane U.S. Inc. participation in the AHRI Certification program. For verification of individual certified products, go to ahridirectory.org.

Trane - by Trane Technologies (NYSE: TT), a global climate innovator - creates comfortable, energy efficient indoor environments for commercial and residential applications. For more information, please visit trane.com or tranetechnologies.com.

Trane has a policy of continuous product and product data improvement and reserves the right to change design and specifications without notice. We are committed to using environmentally conscious print practices.