



Product Catalog

Vertical Classroom Unit Ventilator

Model VUV

750 CFM to 1500 CFM





Introduction

Academic performance of U.S. students depends, in part, on the ability to create a comfortable, learning-friendly surrounding. Being too hot or too cold could hinder a students ability to achieve academic excellence.

Seasonal changes, mechanical/building disrepair, and even class attendance provide real challenges to HVAC mechanical systems. The only thing consistent about todays classroom is its ability to constantly change. With this in mind, Tranes classroom unit ventilator is designed to support todays changing environment. Its blow-thru design provides freeze protection, sound attenuation, and safety. It has sealed coil, which can be quickly accessed for cleaning and visual inspection.

Figure 1. Vertical classroom unit ventilator

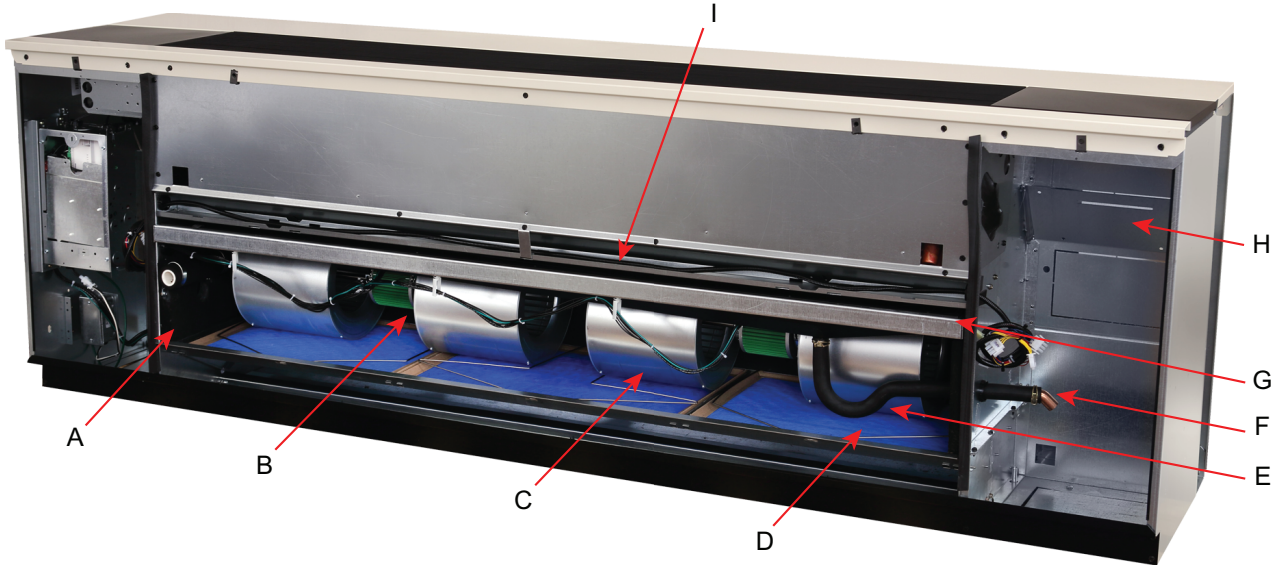

Element	Description
A	Linkage-free outside air damper
B	Maintenance free EC motor with direct-drive fans
C	Larger fans for lower sound levels
D	Off-the-shelf filters
E	P-trap
F	Hassle-free piping
G	Drain pan/fan/motor board assembly slides out for easy access
H	Roomy end pockets for easy installation and system customization
I	Drain pan

Figure 2. Back view of unit ventilator



Classroom unit ventilators are a cost effective way to heat and cool schools. Many schools choose classroom unit ventilators because of their ability to heat, cool and ventilate, as well as their durable cabinet design and small footprint. Because the unit ventilator is a single-space system, one unit installed in the classroom handles only that rooms airflow, thus minimizing the potential for cross contamination between classrooms.

Tranes commitment to providing premium quality products has led to the exclusive use of Electronically Commutated Motors (ECM) in all unit ventilator models. These brushless DC motors incorporate the latest technology for optimized energy efficiency, acoustical abatement, maintenance free and extended motor life. Each motor has a built-in microprocessor that allows for programmability, soft ramp-up, and better airflow control.

Additionally, this is the industries first solution that is factory-mounted, wired, and programmed for infinite modulation of fan speed based on space loads, using the Symbio™ 400-B.

Trane unit ventilators are UL listed, and AHRI-840 certified insuring peak performance to meet todays classroom habitat.

Copyright

This document and the information in it are the property of Trane, and may not be used or reproduced in whole or in part without written permission. Trane reserves the right to revise this publication at any time, and to make changes to its content without obligation to notify any person of such revision or change.

Trademarks

All trademarks referenced in this document are the trademarks of their respective owners.

Revision History

- Added R-32 Requirements to the Application Considerations chapter.
- Added information about R-32 refrigerant.
- Updated model number description Digit 8 and Digit 30.
- Clarified Hydronic Coil Freeze Protection information for units with R-454B refrigerant.
- Updated electrical data.



Table of Contents

Features and Benefits	6
Form, Function, and Flexibility	6
Engineered for Good IAQ	7
Energy Efficiency	9
Acoustics	9
Controls	9
Proven Performance	10
Application Considerations	11
System Design	11
Indoor Air Quality	13
Energy Optimization	14
Acoustics	14
Humidity Control	15
Dynamic Air Barrier	18
ASHRAE Control Cycles	18
A2L Application Considerations	19
Leak Detection System(Refrigerant charge greater than 3.91 lb of R-454B or 4.04 lb of R-32 per circuit)	19
R-32 Requirements	20
Selection Procedure	21
Capacity Required	21
Unit Size	21
Coil Selection	22
Model Number Descriptions	23
General Data	25
Performance Data	28

Controls	85
Why Trane Controls	85
VelociTach™ Motor Control Board	86
Control Options	87
Tracer® Controllers	88
Tracer® Controller Features	88
Sequence of Operation	91
Wireless Systems	92
Zone Sensor Options	93
End Device Options	93
Factory-Installed Piping Packages	95
Electrical Data	100
Dimensional Data	102
Standard Depth Units	102
Falseback Units	103
Dynamic Air Barrier Units	104
End Cover Dimensions	105
Crossover Piping Dimension	106
Mechanical Specifications	107
General	107
Equipment Construction	107
Coils	108
Leak Detection Sensors	108
Piping Packages	108
Dampers	111
Controls	111
Filters	112



Features and Benefits

A unit ventilator goes beyond its ability to heat and cool. Its design provides an opportunity to create a comfortable atmosphere for living, learning and playing, while supporting energy efficiency savings. Some of the featured benefits of a unit ventilator are:

- Individual room control
- Fresh air ventilation and filtration
- Individual dehumidification sequences per zone
- Energy savings solutions through economizing functions and electronically commutated motors (ECM)
- Choice in heating/cooling applied systems
- And, because the equipment is mounted directly in the living space, expense associated to installed mechanical ductwork may be avoided

Figure 3. Durable, industrial-grade metal stands up to the toughest classrooms



Form, Function, and Flexibility

Equipment Size

The unit ventilator delivers from 750 cfm to 1500 cfm. It is physically sized to fit any replacement or new construction application.

Cabinet Finish

The unit cabinet is made of a durable industrial grade metal to withstand even the most rigorous classrooms. A smooth/glossy, appliance grade paint treatment increases the aesthetics of the equipment while making it durable and easy to maintain.

Accessibility

Three-Panel Access

A three-panel front access is ergonomically safe for lifting/removal, and allows speedy set up during field commissioning. This design allows for the end pocket of the unit ventilator to be open while the fan (airside) section stays closed. The panel design provides easy access for filter change-out.

Top access to the unit-mounted fan speed/sensor option was developed with the teacher or administrative staff in mind. Access to the sensor may be made through a lock/key, or through an easy open door.

Spacious End Pockets

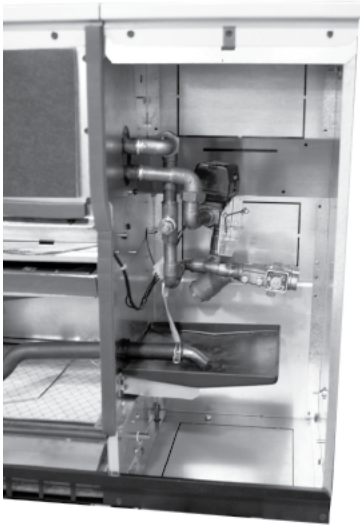

Easy access to piping and controls is made through the roomy equipment end pocket design. The coil headers and drain connections are made within the unit chassis, freeing-up valuable space in the end pockets for piping or field add-ins. This also grants a tighter seal to prevent air leakage. The roomy end pocket design allows for application requirements such as an optional auxiliary drain pan. The auxiliary pan may be placed under the factory or field piping package.

Piping Package

Hydronic piping for the unit ventilator may be factory installed or field provided. It fits freely inside the unit end pockets, for quick hook-up during the installing phase. The motorized valves include a trouble-free, pop-top allowing the maintenance or service technician access to the motor without removing the valve body from the piping package.

Sliding Fan Deck

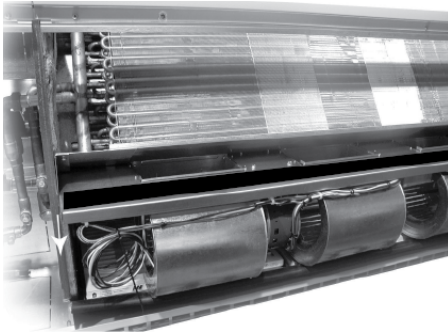

Convenient access to the fan motor and fan wheels for maintenance and serviceability is made in part of the easy-slide design of the unit ventilator fan board. The fan board assembly offers hassle free access to the contractor or maintenance technician. As an added benefit, Tranes unit ventilator includes electronically commutated motors (ECM) as standard.

Hinged Control Box

The hinged control box design maintains easy access to the electrical for connection while supporting less potential for damage on the job site from the different construction trades.

Engineered for Good IAQ

Indoor air quality (IAQ) is a top priority in classroom design. Giving students a healthy place to learn and develop is crucial in every school district. It is also crucial to maintaining the buildings overall construction and furnishings. Several features of Tranes unit ventilator attribute to improved IAQ.



Features and Benefits

Removable Drain Pan

The unit ventilator drain pan is dual sloped for effective condensate removal. This non-corrosive pan eliminates the problems associated with leaking or standing water and is removable for cleaning.

Ease of Maintenance

Internal components such as the fan and coils are accessible for visual inspection and cleaning. Maintaining a clean system increases the efficiency of the unit and is important to good, sustainable indoor air quality.

This design also places the coils farther away from the outside air opening, virtually eliminating the potential for coil freezing and the added hassles of nuisance freeze-trips.

Damper Design

OA/RA Damper Design

Figure 4. OA insulated damper



The outside/return air damper is a one-piece design which is linkage free resulting in a superior air seal. This results in lower infiltration of outside air during off cycles thus lowering the risk of freezing equipment in the winter or the intrusion of humid air into the building during the summer.

OA/RA Actuator

Figure 5. OA/RA actuator

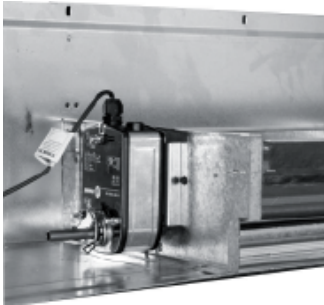

The OA/RA actuator provides true spring return operation for positive close-off of the OA/RA damper. The spring return system of the actuator closes the outside damper if power is lost to the building. When ordered with factory controls, the actuator is a 3-point floating design. A 2 to 10-Vdc actuator is also available when other than Trane controls are specified.

Filtration

Vertical classroom unit ventilators utilize an off-the-shelf filter design to reduce or eliminate stocking filters in the school. See General Data section for standard filter sizes. They come equipped with a standard-size throwaway filter to support job site installation and start-up. Trane unit ventilators are designed to accommodate a MERV 8 or MERV 13 high capacity filter to provide greater filtration of airborne contaminants

Dehumidification

Trane unit ventilators provide a broad range of dehumidification solutions. Active humidity control involves monitoring and managing both the dry bulb temperature and the humidity in the classroom. With this strategy, a reheat coil is placed downstream of the cooling coil to temper (reheat) the cold, dehumidified air leaving the cooling coil to avoid over-cooling the space. Reheat configurations are available in a variety of coil combinations.

Alternately, the Symbio™ 400-B controller can be configured to automatically reduce the fan speed at part-load conditions. This helps improve the coincidental dehumidification performance of the unit at part-load, and also lowers sound levels. To help ensure proper ventilation in the classroom at lower fan speeds, the controller adjusts the outside air being supplied to the classroom.

Energy Efficiency

Trane's commitment to providing premium quality products has led to the exclusive use of Electronically Commutated Motors (ECM) in all unit ventilator models. These brushless DC motors incorporate the latest technology for optimized energy efficiency, acoustical abatement, maintenance free and extended motor life. Each motor comes with a VelociTach™ motor control board that allows for programmability, soft ramp-up, better airflow control, and serial communication. Trane units equipped with ECMs are significantly more efficient than permanent split capacitor (PSC) motors or belt-drive motors and enable single-zone VAV control.

Single-zone VAV control varies the fan speed as the zone cooling or heating load changes, and can result in lower operating costs and improved occupant comfort compared to constant-speed units. The reduced FLA option allows units to ship with a nameplate FLA rating much lower than a typical ECM unit.

Economizer

A big advantage of this system is the ability to provide energy savings through an economizer cycle. During mild seasons outside air is used to provide free cooling, thereby, minimize or eliminate the need to run mechanical cooling equipment. To truly have an effective economizer a Unit Ventilator must be able to bring in up to 100 percent of the design airflow through the outside air damper opening. Trane Unit Ventilators are tested and certified to exceed the industry standard, as defined by AHRI 840, for economizer effectiveness. This ensures the school will realize the energy savings available through the economizer strategy.

Face-and-Bypass Actuator

The face and bypass damper actuator incorporates a direct couple design. It provides electronic protection against overload. A limit switch is not included, nor required as part of the design. When reaching the damper end position, the actuator automatically stops. The gears can be manually disengaged with a button on the housing.

Acoustics

Quiet systems are extremely important in today's classrooms. Trane offers many different system solutions to balance the requirements of sound, cost, IAQ and efficiency. The Trane vertical unit ventilator takes a comprehensive approach to delivering one of the quietest units available.

Fan and Blower Motor Assembly

Several innovative ideas have gone into the quiet design of the Trane vertical unit ventilator. The fans diameters have been maximized to reduce the motor rpm and thus lower the noise, while still maintaining the cfm requirements to support ventilation and capacity requirements. The unique direct-drive fan and blower design diminishes vibration from occurring further ensuring quiet operation.

Quiet Blow-Thru Design

The Trane blow-thru unit design enables additional sound attenuation by eliminating the fan noise from entering the space directly. The position of the internal components is optimized to enhance the performance and casing construction of Trane vertical unit ventilators further adds to this acoustically superior design.

Controls

Trane offers a broad range in control packages to fit both retrofit and new applications. From the field convertible CSTI to a complete building automation system, Trane controls integrate the highest quality components within the unit ventilator to allow greater optimization of the entire system.

Fan Speed Control

Trane provides the capability to vary airflow for suitable applications either with three speeds or with a 0 to 10 Vdc input. This lowers the sound in the space and improves the dehumidification in the cooling season at part-load. With field installed controls, this is accomplished with a unit-mounted manual fan speed switch or variable speed control with a 0 to 10 Vdc input. ECM controls provide a soft ramp between speed changes—a significant contributor to overall quiet operation.

With the inclusion of the Symbio™ 400-B unit controller, the speed of the fan is infinitely varied automatically in response to the load condition in the space. The controller also will adjust the outside air being provided to properly ventilate the classroom at the lower airflow conditions.



Features and Benefits

Controllers

- This is the industry's first solution that is factory-mounted, wired, and programmed for infinite modulation of fan speed based on space loads, using the Symbio™ 400-B.
- All controls are factory-mounted and tested to minimize field setup and improve reliability.
Note: *Factory addressing is available for Symbio 400-B Air-Fi® WCI controller types. This option allows configuration of units before delivery, reducing the field setup time.*
- Controls are wired with a 24-Vac transformer to keep only a single source power connection requirement to the unit.
- All wall-mounted zone sensors require only low voltage control wiring from the device to the unit control box. (No line voltage.)
- The controller automatically determines the unit's correct operating mode (heat/cool) by utilizing a proportional/integral (PI) control algorithm to maintain the space temperature at the active setpoint, allowing total comfort control.
- Entering water temperature sampling eliminates the need for inefficient bleedlines to sense automatic changeover on two-pipe changeover units.
- A factory configured, installed, and tested low voltage thermostat is also available.
- The random start-up feature helps reduce electrical demand peaks by randomly staggering multiple units at start-up.
- Occupied/unoccupied operation allows the controller to utilize unoccupied temperature setpoints for energy savings.
- Warm-up and cool-down energy features are standard with Trane controls.
- To customize unit control, Tracer TU software will allow field modification of default settings.
- Maximize system efficiency with free cooling economizers and modulating valves on units with Symbio 400-B.

Leak Detection System

The Leak Detection System (LDS) consists of one or more refrigerant detection sensors and is required in ducted HVAC systems that have more than 3.91 lb of R-454B or 4.04 lb of R-32 refrigerant charge, per safety standard UL 60335-2-40. For any units with more than 3.91 lb of R-454B or 4.04 lb of R-32 refrigerant charge in a circuit, an LDS will be factory-installed.

Note: *If factory installed controls are not selected, leak detection system sequence of operation must be programmed by controls contractor. See UL 60335-2-40 for more information.*

Proven Performance

Comfort, energy and IAQ are all major issues that need to be woven into today's school designs. Therefore, it is important that designers of these systems have accurate information to make system decisions. That is why the industry has developed performance standards and certification programs which ensure that the equipment information provided to the design community is correct and comparable across different manufacturers. The following list of certifications and standards identifies the commitment by Trane to providing the highest quality equipment and information to our customers:

- AHRI-840
- UL
- Tested in accordance to AHRI 350 (acoustics)
- BACnet®
- BTL (Symbio™ 400-B)

Application Considerations

Supplying proper ventilation to a classroom is challenging. The various rooms that make up a school are forever changing their ventilation needs, and building occupants and their activities generate pollutants that heighten the ventilation requirements. Students are constantly moving from room to room, and because of this intermittent occupancy, the ventilation frequency of a classroom is constantly on the move.

Ventilation systems dilute and remove indoor contaminants, while mechanical heating and cooling systems control the indoor temperature and humidity. Supplying an adequate amount of fresh air to an occupied classroom is necessary for good indoor air quality. IAQ should be considered a top priority in the school environment because children are still developing physically and are more likely to suffer the consequences of indoor pollutants. For this reason, air quality in schools is of particular concern. Proper conditioning of the indoor air is more than a quality issue; it encompasses the safety and stewardship of our investment in the students, staff and facility. The beauty of a classroom unit ventilator is its ability to provide heating, cooling, ventilation and dehumidification as a single-zone system.

System Design

Figure 6. System design for the classroom unit ventilator

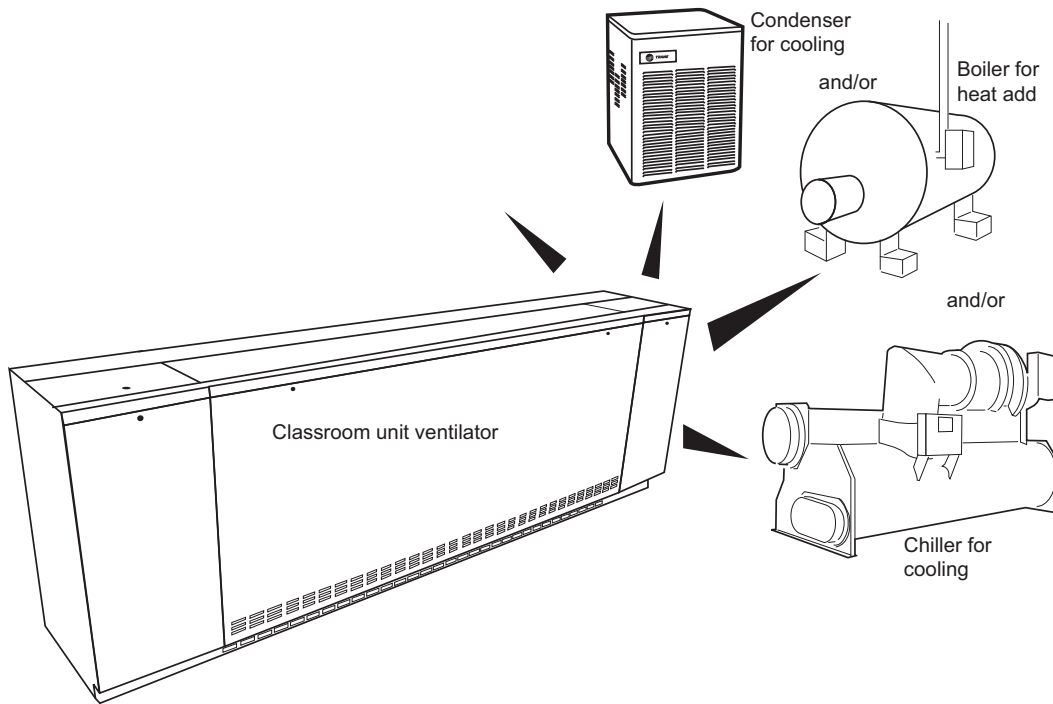

Variety of Heating/Cooling Coils

Trane offers a wide variety of coil configurations for unit ventilator applications.

In environments where cooling needs are of main interest a two-pipe coil coupled with a chiller, or a direct expansion coil joined with a traditional condensing unit or variable refrigerant outdoor unit may be used. For heat specific applications, Trane offers a two-pipe hot water only unit to be combined with a boiler. Electric heat and steam options are also available for heating selections. A direct expansion coil with heat pump or heat recovery variable refrigerant system may be used.

When there is seasonal heating and cooling, a two-pipe chilled water/hot water changeover system may be applicable to the mechanical design. This system requires a chiller and a boiler to support the changeover necessity. However, where space constraints may present a concern, the unit ventilator may be equipped with a DX coil for cooling, with an auxiliary electric heat coil, hot water coil, or steam coil for heating. Four-pipe chilled water/hot water systems are also available. This system is typically applied when both heating and cooling may be simultaneously called for in the school.



Application Considerations

Hydronic Branch Conductor

The Hydronic Branch Conductor is a self-contained valve assembly with integrated controls. This innovative system features advanced controller logic that detects both hot and cold water temperatures, seamlessly directing flow from the appropriate heat pump loops to either heat or cool specific thermal areas.

Trane Hydronic Branch Conductor revolutionizes building climate control by enabling the use of dual-purpose coils within a four-pipe distribution system, while efficiently delivering heating or cooling through just two pipes. Unlike traditional two-pipe changeover systems that switch between hot and cold water seasonally for the entire building, this advanced system can adapt to varying heating and cooling demands in different areas multiple times throughout the day.

With a central four-pipe distribution system providing the benefits of year-round heating and cooling, and area branches utilizing a two-pipe setup, the Hydronic Branch Conductor offers reduced piping complexity and enhanced efficiency. Experience the best of both worlds with a heat pump system that combines the advantages of four-pipe and two-pipe configurations for optimal climate control.

Application Considerations for the Hydronic Branch Conductor:

- Hydronic Branch Conductors are for use in hydronic heat pump systems where the cooling fluid and heating fluid are the same fluid from the same central plant. It is not for use in systems with a chiller plant for cooling and a traditional boiler system for heat.
- The Hydronic Branch Conductor conducts—commands valves to provide the appropriate fluid to meet the received thermal area HEAT/COOL mode. It also monitors and reports the status of the hydronic flows for the thermal area.
- The Hydronic Branch Conductor is placed between the main building pipe chase and a thermal area's branch piping.
- The Hydronic Branch Conductor does not take the place or function of zone control valves.
- The Hydronic Branch Conductor does not take the place of any necessary shut off or balancing valves.
- Systems with Hydronic Branch Conductors have airside equipment with dual purpose coils. These coils work well using hot water supply temperature of 100F(+/-10F) and traditional chilled water temperatures.
- See *Hydronic Brand Conductor Application Guide* (APP-APG024*-EN) for more information on system design.

Variable Refrigerant Flow (VRF) Systems

Variable Refrigerant Flow (VRF) systems provided by Mitsubishi Electric Trane HVAC connected to Trane Unit Ventilator equipment provide flexible energy efficient designs while maintaining comfort utilizing the variable speed capabilities of VRF systems. Field installed linear expansion valve (LEV) kits allow for coils to be connected to both heat recovery systems via a branch controller or heat pump outdoor units. Trane factory installed, programmed, and commissioned controls easily connect Trane unit controllers and VRF system controls for full system integration with a Tracer® building automated system (BAS).

Application considerations:

- Maximum refrigerant pressure.
- Minimum refrigerant volume to ensure oil return.
- For A2L applications, the LEV kit must installed in a location with proper air circulation, according to ASHRAE Standard 15.
- Coil volume to LEV kit requirements.
- Allowable LEV kit to coil distributor connected capacity and configuration.
- Coil tube diameter and minimum tube wall thickness for heat pump or heat recovery applications.
- Fan motor temperature limits for VRF zone temperature control.

Building Automation

As part of the building automation system, the mechanical HVAC system equipment may be optimized to lower energy consumption. By running only the mechanical devices that are required to support the building load at a given time of day or night, true energy consumption savings may be achieved.

Maintenance and service information through the unit sensing devices are easily defined and cured with an automated system. With factory shipped direct-digital controls, installation and start-up of the system are more simple.

Condensate

Proper condensate trapping is required for the classroom unit ventilators with hydronic and directexpansion (DX) coils (steam coils do not require a trapped condensate setup). In a properly trapped system, when condensate forms during normal

operation, the water level in the trap rises until there is a constant flow of water through the pipe. It is imperative to maintain water in the trap, and not allow the trap to dry out during heating season.

Equipment should be installed level to avoid condensate build-up around the coil.

Performance

Application of this product should be within the catalogs airflow and unit performance. Trane Select Assist™ will aid in the selection process for a set of given conditions. If this program has not been made available, ask a local Trane account manager to supply the desired selections or provide a copy of the program.

Freeze Protection

The most important advantage the Trane blow-through design provides is additional protection against coil freeze-up. In contrast, draw-through configurations allow little mixing of the return and outside air stream while locating the coil very close to the outside air inlet. This process creates cold spots on the coil which could lead to coil freeze-up.

With a blow-through design, face and bypass with isolation valve control is not necessary to provide proper freeze protection to the unit vent. The placement of the coil above the fan allows enough space for the coil to avoid cold spots that could cause freezing.

Indoor Air Quality

School institutes contain a diverse day of activities that have a potential for air impurity sources including cafeterias, art and science classrooms, vocational education areas, pools and locker rooms. Proper ventilation, filtration, and maintenance of these spaces can pose some challenges.

Occupant density in classrooms is much higher than that found in office or retail spaces. The amount of outdoor air required to ventilate a classroom is based predominantly on the number of students expected to occupy the space. Students also move in large groups, frequently throughout the building, resulting in widely varied thermal loads within the zones. To compound the situation, a classroom mechanical system is typically run for nine months of the year, and vacated for three months (either by turning up or off the HVAC system). To increase the IAQ challenge even more, building construction techniques that help reduce energy costs, also tightly seal the school. This can lead to uncirculated/unfiltered air.

Ventilation

Ventilation is an important factor in maintaining healthy air. In a poorly ventilated school building, fumes and vapors are not properly exhausted allowing particles to develop. A healthier building is a building where the air is exchanged more frequently and properly filtered. Through ventilation, stale indoor air is exhausted and fresh treated outdoor air is drawn into the building. The amount of ventilation air required is established by building codes and industry standards. Most building codes reference ASHRAE Standard 62–Ventilation for Acceptable Indoor Air Quality—as the minimum requirement for ventilation system design. Architects, engineers and contractors utilize this standard when determining and calculating the type of load the building environment will place on the mechanical system.

Filtration

Trane unit ventilators are tested and designed to exceed ASHRAE Standard 62. This includes the use of a higher efficiency filtration to help introduce proper levels of fresh diluted air for contaminant removal.

Maintenance

Beyond the ventilation and filtration performance of the classroom unit ventilator, maintenance of the HVAC system is a must. Enhancements to support superior IAQ performance include:

- Coil presentation allows for ease of maintenance and cleaning.
- A dual sloped non-corrosive drain pan (removable) helps keep moisture in the system to a minimum.
- Ultra low leak damper that results in a fixed air seal of the damper assembly.
- Air exchange performance that goes beyond code while maintaining the AHRI-840 certification for economizing requirements.
- An upgrade-able MERV rated filters help reduce contaminants and increase filtration.
- Side-wall power exhaust support system to help remove the stale air from the classroom and better support the air exchange.

- Options for improved dehumidification at part-load, including automatic fan-speed control, face and bypass dampers, and active humidity control through reheat.

Energy Optimization

Figure 7. Unit ventilator economizer

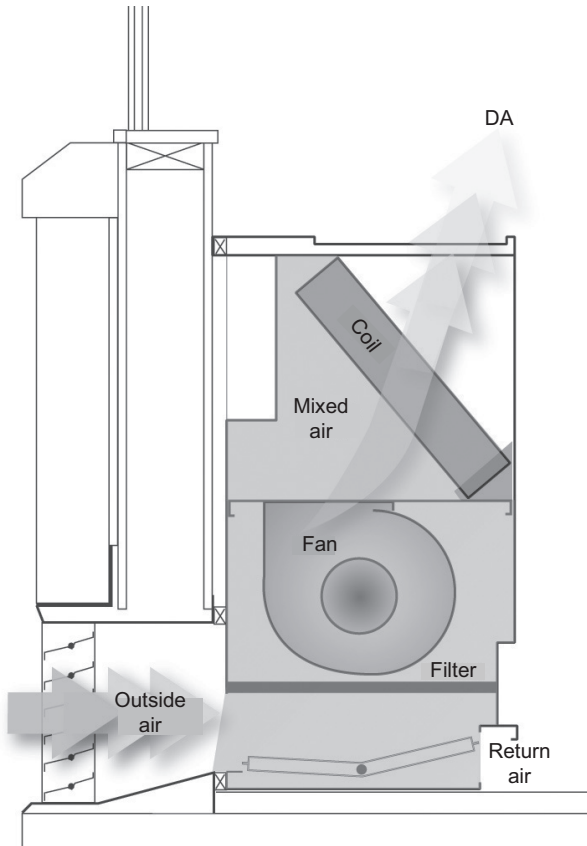

The energy consumption of a unit ventilator system can be significantly reduced through the use of an economizer cycle. To better understand the basic function of how an outside air economizer works, it is important to fully understand how it operates.

The economizer functions by opening an outside air damper, and bringing cooler outside air into the space. The economizer cycle is controlled with a modulating damper motor, which opens at specified increments dependent upon readings from outside air sensors.

Economizers also utilize a return-air damper that closes as the outside air damper opens. Depending on the room requirements, the modulating damper motor may mix the return air with the outside air to provide the maximum energy cost efficiencies without sacrificing comfort.

When the room thermostat calls for cooling, the economizer control provides the right mix of outside and return air to cool the classroom. The equipment's airflow is generated from both fan energy and the economizing dampers. This design supports optimum ventilation and provides the greatest energy savings. As the outside air temperature rises (typically above 55°F), the outside damper closes to the minimum position, activating the second cooling stage on the room thermostat—the cooling-generating device (compressor, water pump, chiller, cooling tower). The return-air and outside air dampers modulate to support the discharged air temperature.

Dampers working together with the cooling coil is called integrated economizing, which allows a unit ventilator to mix outside air with return air, delivering an energy-efficient, cost-savings solution to a school.

Industry Standards

The Air-Conditioning, Heating, and Refrigeration Institute (AHRI) created the AHRI-840 standard for classroom unit ventilators to provide a consistent method of rating the unit ventilators design performance. To achieve AHRI-840 certification, the unit ventilator must be capable of providing a minimum of 80 percent of its ventilation (airflow) through the outside air economizer function. This measurement ensures that the expected energy savings by the economizer is realized in actual operation.

Only AHRI-840 certified equipment has been independently tested for compliance to the minimum requirement. Trane was the first, and continues to be one of the few manufacturers that meet this certification. By meeting this certification, the designer can be assured that the Trane unit ventilator will perform with energy conservation in mind.

Acoustics

Growing population, and an increase in economic pressure to maximize building footprints have resulted in higher building occupancies and less space to place the HVAC equipment. Often times the close proximity of the equipment—such as a floor mounted unit ventilator—may cause noise related complaints. Reducing the likelihood of these complaints requires careful planning:

- Equipment sizing (under sizing and over sizing could increase noise level)
- Equipment placement (absorption and number of sound sources in the room greatly affect noise)

Figure 8. Equipment placement

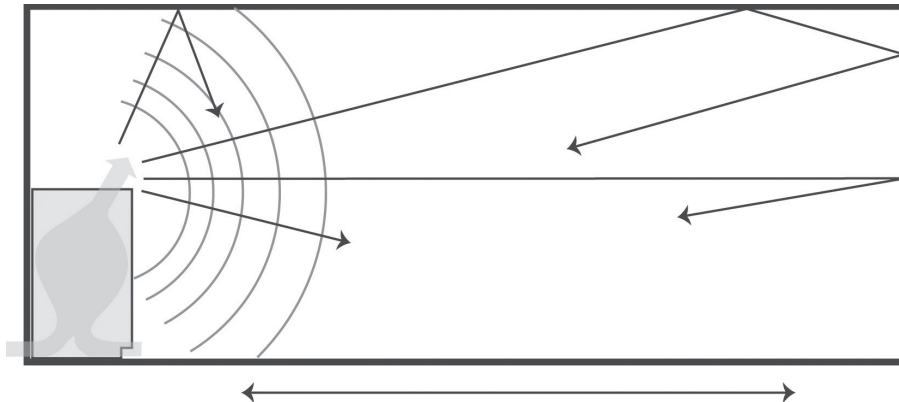

Room NC is the sum of all sounds entering the room. Its value is based on assumptions about the room's characteristics. Given the complexity of various building systems, it is extremely important to assure that the design goals (commissioning) for classroom acoustics, IAQ, and moisture control are met through all aspects of the space.

For example, it is not uncommon for a school to install unit ventilators that are manufacturer-rated for a specified airflow (cfm), but which are not AHRI-840 certified. These units may ship with a fan-speed setting that delivers a lower than specified airflow, perhaps to reduce sound levels. Without an overall building design goal, these units will be installed without delivering the specified airflow needed to support the fresh air circulation, and possibly compromise IAQ.

Note: *Unless the equipment is tested at the specified airflow, it is extremely difficult to determine whether the unit meets the specified sound level.*

Trane's unit ventilator will not compromise air quality to support a minor reduction in airflow noise. We encourage our engineers to specify their airflow needs at full building load requirements. Fine-tuning of the speed setting may be interchanged through the unit's 3-speed fan sensor quickly and easily. This mechanical feature ensures that the equipment supplies proper cfm to support IAQ in the classroom, while giving complete control of equipment noise to the administrative staff.

Acoustic Enhancements

Trane direct digital controls (Symbio™ 400-B) is another way to control airflow noise. With the Symbio 400-B controller, an infinitely variable speed fan control for the unit ventilator delivers the airflow output customized to support the cfm space needs. When less cfm is necessary to meet the load of the classroom, the equipment operates at an optimum speed, keeping sound levels to a minimum.

Another solution for acoustically sensitive applications is the option for Low Acoustics, which uses the ECM technology to manage the fan speeds. However, if the room temperature rises above the setpoint, the controller will switch to high speed for sustaining the space needs. As part of this strategy, ventilation must also be considered. The Symbio 400-B controller will reposition the outside air damper to confirm the minimum outside air cfm is met at both operating conditions. This setup allows the unit ventilator to meet the space comfort condition, while providing a lower sound level and proper ventilation.

Humidity Control

A typical unit ventilator is a constant-volume, variable-temperature device. It uses a constant fan speed and modulates water flow through a chilled water coil to maintain the dry bulb temperature in the space based off of a setpoint. Outdoor air is introduced at the back of the unit ventilator, and distributed with the supply air. At design cooling load conditions, a system controlled in this manner typically has a leaving air temperature that is cold enough (and, therefore dry enough) to sufficiently dehumidify the space, but its ability to dehumidify can decrease significantly at part-load conditions.

When the sensible load in the space decreases (part-load), the constant-volume system responds by raising the dry-bulb temperature of the supply air. In a chilled water unit ventilator, this is accomplished by modulating a valve to reduce the rate at which water flows through the coil. [Figure 9, p. 16](#) shows how this affects the supply air leaving the coil—the warmer coil surface that results from less water flow provides less sensible cooling (raising the supply air temperature) and removes less moisture from the passing air stream.

Figure 9. Part-load dehumidification with modulated chilled water

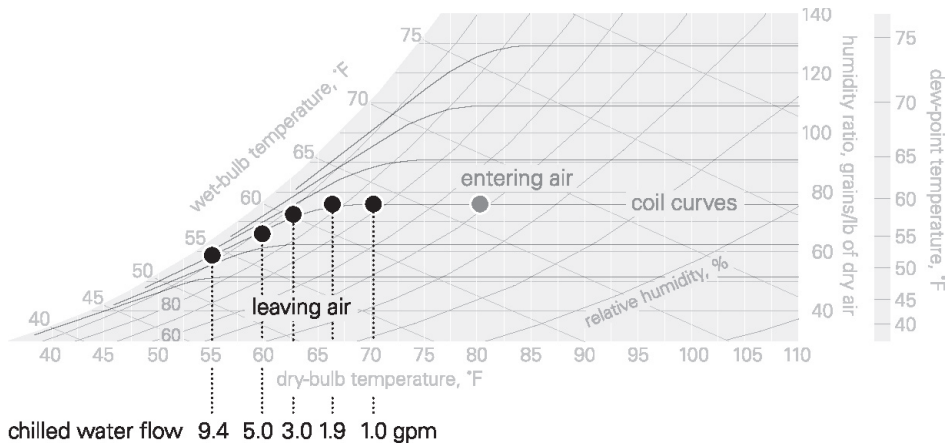

The sensible cooling capacity of a constant volume system decreases to match the smaller sensible cooling load. Any latent cooling (dehumidification) capacity is purely coincidental, whether the cooling-coil medium is chilled water or refrigerant. As the load diminishes, the system delivers even warmer supply air. Some dehumidification can occur in this situation, but only if the sensible load is high enough.

Some designers attack this problem by oversizing the unit ventilators. This does not solve the problem; in fact, it can make the situation worse. Increasing the capacity of the unit ventilator may also require increasing the supply airflow. A higher-than-necessary supply airflow results in warmer supply air and, in non arid climates, less dehumidification. It is important to understand, this is not just a unit, coil, or fansizing challenge. Rather, it is an issue of properly controlling the system in a manner provides sufficient dehumidification at all operating conditions. Proper dehumidification with terminal units is a matter of proper control.

Active Humidity Control

A common method used to address this part-load humidity control challenge in a constant-volume system is active humidity control through supply air tempering (reheat). Active humidity control involves monitoring and controlling both the dry bulb temperature and humidity in the occupied space. Whenever the space humidity is below the preset upper limit (typically 60 percent relative humidity), the system operates just like a normal constant-volume system. However, if the space humidity reaches or exceeds the upper limit, the cooling coil control valve is driven open regardless of the need for sensible cooling in the space. The coil over-cools the air, increasing the dehumidification capacity of the system.

With this control sequence, a reheat coil is placed downstream of the cooling coil to temper (reheat) the cold, dry air leaving the cooling coil in order to avoid over-cooling the space. The key to cost-effectively applying an active humidity control system is to use reheat only when it is needed. This requires the sensing of both the humidity and temperature in the occupied space.

When the space humidity falls below the upper limit, the system returns to the standard cooling mode and again operates as a traditional constant-volume system.

Basic components of a Trane reheat system include:

- Classroom unit ventilator with a main coil and an auxiliary coil downstream.
- Two sensors, one for the temperature and one for relative humidity; sensors may be located in the zone or in the return air stream.

If after hours operation is required, the addition of a building automation system (BAS) is recommended to coordinate the chillers, pumps, boiler and unit ventilators. It also assures proper operation of the exhaust fans.

Reheat may come from new energy (electric resistance heat or boilers fueled by gas or oil) or recovered energy.

Recovered energy reheat refers to the process of salvaging or transferring energy from another process within the facility. In this case, the recovered energy is the by-product of a cooling process which would normally be rejected or wasted. A common example may include a plate and frame heat exchanger in the condenser water loop of a water-cooled chiller system.

Automatic Fan-Speed Adjustment

Reducing the fan speed (supply airflow) at part-load conditions is a way to improve the coincidental dehumidification performance of a unit ventilator. The digital controller can be configured to automatically reduce fan speed when the sensible load is decreased, [Figure 11, p. 17](#). At full load, the fan operates at high speed and the control valves flow is wide open. As the

cooling load decreases, the controller modulates the valve to throttle the rate of chilled water flow through the coil. At some point, based on valve position, the unit controller switches the fan to low speed. Less airflow means that colder supply air is needed to maintain the target space temperature. The control valve opens allowing the coil to remove more moisture from the passing air stream.

The controller will also adjust the outside air damper to help properly ventilate the classroom at the lower fan speed condition.

Figure 10. Auto fan speed adjustment

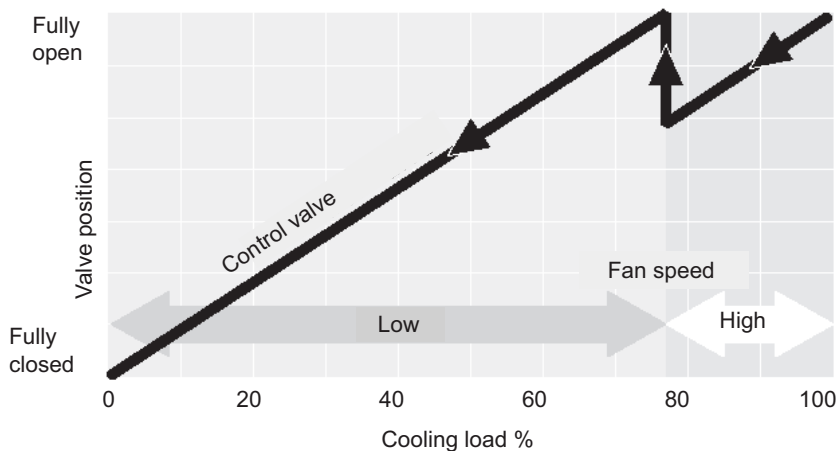

Face-and-Bypass Dampers

Figure 11. Face and bypass damper

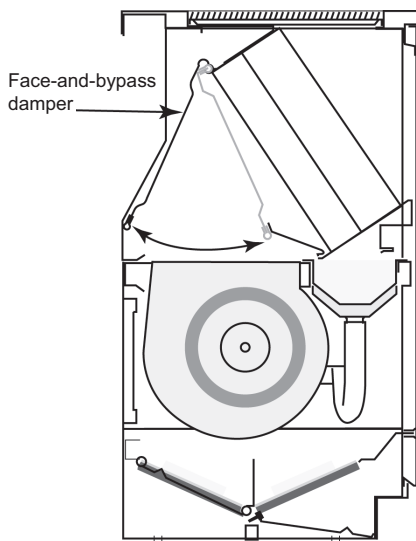

Face-and-bypass damper control is a common and accepted method of capacity control.

The face-and-bypass damper, consists of a single blade installed immediately upstream of the cooling coil. The bypass is sized to have the same pressure drop as the cooling coil so that a constant air quantity can be maintained at all times during system operation.

Bypass control maintains the dry bulb temperature in the space by modulating the amount of air flowing through the cooling coil, thus varying the supply air temperature to the space. As the face and bypass damper begins to close some of the outside/return air mix is diverted around the coil and mixed with air coming off the coil to obtain a supply air temperature that is proportional to the reduction in space load. Because the chilled water valve remains wide open, the portion of the air passing through the coil is dehumidified further, improving part-load dehumidification.

However, face and pass control does not actively control space humidity. It still allows the space humidity level to rise at part-load, often higher than desired.

For more information on various methods for improving dehumidification performance of unit ventilator systems, refer to *Dehumidification in HVAC Systems Applications Engineering Manual* (SYS-APM004*-EN).

Dynamic Air Barrier

Figure 12. Dynamic air barrier

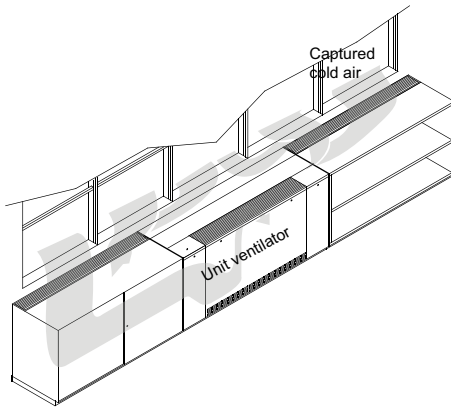

In areas that contend with colder climates for a significant period of time, a school may wish to employ a dynamic air barrier package. With this dynamic (draft) barrier system, the cold air is captured off of the window, and drawn into the classroom unit ventilators normal airflow cycle. The unit ventilator treats/warms the air as if it were part of a return-air makeup system. This captured air is then discharged into the space providing comfort to the classrooms occupants.

This draft barrier shield should be utilized when:

- Almost 50 percent of the wall includes windows.
- Outside air temperatures fall below 35°F for a significant period of time.
- Or, in retrofit applications where the windows are of a single pane thickness.

ASHRAE Control Cycles

There are a variety of control systems available for unit ventilators. The exact method of controlling the amount of outside air and heating capacity can vary. However, all systems provide a sequence of operation designed to provide rapid classroom warm-up and increasing amount of ventilation air to offset classroom load.

To help supply proper ventilation to these fluctuating heat gains, the Trane unit ventilator is designed to provide rapid classroom warm-up and increasing amounts of ventilation air to offset classroom overheating.

Figure 13. ASHRAE cycle graph

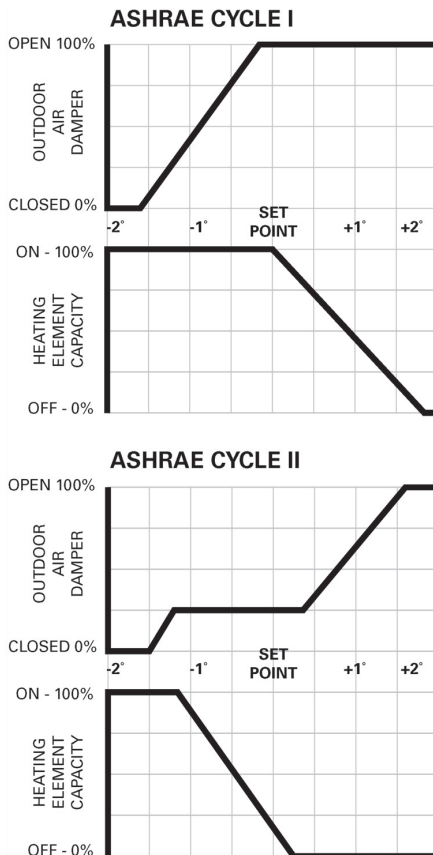

ASHRAE Cycle I

All standard unit ventilator cycles automatically close the outside air damper whenever maximum heating capacity is required. As room temperature approaches the comfort setpoint, the outside air damper opens fully, and the unit handles 100 percent outside air. Unit capacity is then controlled by modulating the heating element capacity.

ASHRAE Cycle I is typically used in areas where a large quantity of outdoor air is required to offset the air being exhausted to relieve the room of unpleasant odors and particles.

ASHRAE Cycle II

ASHRAE Cycle II is the most widely used ventilation control. Similar to Cycle I, the outside air damper is closed during warm-up. But with Cycle II, the unit handles recirculated air through the return air system. As temperature approaches the comfort setting, the outside air damper opens to admit a predetermined minimum amount of outside air. This minimum has been established by local code requirements and good engineering practices. Unit capacity is controlled by varying the heating output. If room temperature rises above the comfort setting, the heating is turned off and an increasing amount of outside air is admitted until only outside air is being delivered.

ASHRAE Cycle II is a very economical control sequence often referred to as integrated economizing. This design supports optimum ventilation and provides the greatest energy savings. This is further proof of why AHRI-840 certification is important in minimizing energy consumption through economizer performance.

A2L Application Considerations

This product is listed to UL standard 60335-2-40, Household and Similar Electrical Appliances – Safety – Part 2-40: Particular Requirements for Electrical Heat Pumps, Air-Conditioners and Dehumidifiers, which defines safe design and use strategies for equipment using A2L refrigerants. This standard limits the refrigerant concentration in a space in the event of a refrigerant leak. To meet the requirements, the UL standard defines minimum room area, refrigerant charge limit, minimum circulation airflow and/or ventilation airflow requirements, and limits the use of ignition sources in spaces. The standard requires a unit refrigerant leak detection system.

For equipment with less than or equal to 3.91 lb of R-454B or 4.04 lb of R-32 refrigerant charge per circuit, this UL standard does not prescribe a room area limit and does not require a refrigerant leak detection system or any circulation airflow or ventilation airflow mitigation strategies. However, ignition sources in ductwork must be evaluated.

Depending on the application, a specific requirement of ANSI/ASHRAE Standard 15, Safety Standard for Refrigeration Systems, could be more stringent than UL 60335-2-40 requirements. See *Refrigeration Systems and Machinery Rooms Application Considerations for Compliance with ASHRAE® Standard 15-2022 Application Engineering Manual (APP-APM001*-EN)* for more information.

Leak Detection System (Refrigerant charge greater than 3.91 lb of R-454B or 4.04 lb of R-32 per circuit)

The leak detection system consists of one or more refrigerant detection sensors. When the system detects a leak, the following mitigation actions will be initiated until refrigerant has not been detected for at least 5 minutes:

- Energize the supply fan(s) to deliver a required minimum amount of circulation airflow.
- Disable compressor operation.
- Provide an output signal to fully open all zoning dampers, such as VAV boxes.
- Provide an output to energize additional mechanical ventilation (if needed).
- Units without airflow proving will disable electric heat sources.

Building fire and smoke systems may override this function.

If the refrigerant sensor has a fault, is at the end of its life, or is disconnected, the unit will initiate the mitigation actions. Mitigation actions may be verified by disconnecting the sensor.

The refrigerant sensors do not need service. Use only manufacturer-approved sensors when replacement is required.

Notes:

- *Factory-installed Symbio™ 400-B controllers are programmed with leak detection sequence of operations at the factory.*
- *Field-installed unit controllers require field programming of the leak detection sequence of operations by the controls contractor. See UL 60335-2-40 for more information.*



Application Considerations

R-32 Requirements

For any R-32 order, a pipe cabinet must also be ordered. It houses the LEV kit and the additional refrigerant leak detection sensor required for UL 60335-2-40 compliance.

Refer to the *Classroom Ventilator Accessories from A to Z Product Catalog* (UV-PRC005*-EN) to assist with ordering a pipe cabinet.

Figure 14. Pipe cabinet





Selection Procedure

Trane vertical classroom unit ventilators provide air delivery and capacities necessary to meet the requirements of modern school classrooms. They are available with the industries widest selection of coils to precisely satisfy heating, ventilating and air conditioning loads with the best individual type of system. Unit ventilator selection involves three basic steps.

- Determine the classroom/space unit cooling and/or heating loads
- Determine the unit size
- Select the coil

Capacity Required

The first step in unit ventilator selection is to determine room heating and air conditioning loads. The calculation of this load is essential if the equipment is to be economical in first cost and operating cost.

Adequate ventilation is mandatory in classroom air conditioning design. The amount is often specified by local or state codes and, in air conditioned schools, may be either the same or less than that specified for heating systems. The usual requirement is between 15 and 25 cfm of outside air per occupant, based on the intended use of the room. For instance, a chemistry laboratory normally requires more ventilation for odor control than a low occupancy speech clinic.

Ventilation is an important concern and should be accurately determined to assure good indoor air quality. Purposely oversizing units should be avoided, since it can cause comfort and control issues.

Unit Size

Unit ventilator size is determined by three factors:

- Total air circulation
- Ventilation cooling economizer capacity required
- Total cooling or heating capacity required

Total air circulation, if not specified by code, should be sufficient to ensure comfort conditions throughout the room. This is usually from six to nine air changes per hour, but can vary with room design and exposure. Often rooms with large sun exposure require additional circulation to avoid hot spots.

Ventilation cooling capacity is determined by the amount of outside air delivered with the outside air damper fully open, and the temperature difference between the outside air and the classroom. In air conditioning applications, ventilation cooling capacities should maintain the comfort setting in the classroom whenever the outside air temperature is below the unit or system changeover temperature.

Example:

Ventilation cooling capacity = 1.085 x cfm_t x (T₁ - T₂)

cfm_t = Total air capacity of unit with outside air damper open 100 percent.

T₁ = Room temperature.

T₂ = Outside air temperature.

In classrooms with exceptionally heavy air conditioning loads, unit size may be determined by the total cooling requirement. Good practice dictates 375 to 425 cfm per ton of hydronic cooling capacity. Normally, however, Trane classroom air conditioner coils have sufficient capacities.

Example:

Given: Air circulation specified = 8 air changes per hour.

Classroom size = 35 ft long x 25 ft wide x 10 ft high

Inside design air temperature = 75 degrees F

Ventilation cooling required at 58 degrees F = 29,000 BTU

Checking ventilation cooling capacity:

$$\text{CFM required} = \frac{8 \text{ changes/hr} \times (35 \times 25 \times 10) \text{ft}^3}{60 \text{ Minutes/hr}} = 1170 \text{ cfm}$$

$$29,800 \text{ BTU} = 1.085 \times \text{CFM} \times (80-58)$$

$$\text{CFM} = 1250$$

This indicates that a 1250 cfm unit would have satisfactory ventilation cooling capacity at the design changeover point of 58°F. Coil capacity will become confirmed when the coil is selected.



Selection Procedure

Coil Selection

Selecting the correct coil is done through Trane Select Assist™. For your convenience, Trane Select Assist has a mixed air calculator built into the program.



Model Number Descriptions

Digit 1, 2, 3 — Unit Model

VUV = Vertical Unit Ventilator

Digit 4 — Development Sequence

E = 5th development sequence

Digit 5, 6, 7— Nominal Airflow

075 = 750 cfm
 100 = 1000 cfm
 125 = 1250 cfm
 150 = 1500 cfm

Digit 8 — Voltage/Hz/Phase

0 = 115/60/1
 1 = 208/60/1
 2 = 230/60/1
 3 = 208/60/3
 4 = 460/60/3
 7 = 277/60/1
 8 = 230/60/3

Digit 9 — Open Digit

0 = Standard design
 S = Special

Digit 10, 11 — Current Design Sequence

*** = Factory assigned

Digit 12 — Face-and-Bypass Damper

Y = Yes, includes damper
 N = No damper

Digit 13 — Inlet Arrangement

1 = Return air front/fresh air back
 2 = 100% return air front
 3 = 100% fresh air back
 4 = Dynamic air barrier
 5 = Energy recovery system (ERS)-compatible with RH connection
 6 = Energy recovery system (ERS)-compatible with LH connection

Digit 14 — Preheat/Reheat/Changeover Coil

A = 4-pipe preheat coil (RH cooling/LH heating)
 B = 4-pipe preheat coil (LH cooling/RH heating)
 C = 4-pipe reheat coil (RH cooling/LH heating)
 D = 4-pipe reheat coil (LH cooling/RH heating)
 E = 2-pipe coil (RH connections)
 F = 2-pipe coil (LH connections)

Digit 15 — Cooling/Changeover Coil

0 = No cooling/changeover coil
 B = 2-row low capacity cooling/ changeover /dual purpose coil
 C = 2-row high capacity cooling/ changeover /dual purpose coil
 D = 3-row low capacity cooling/ changeover /dual purpose coil
 E = 3-row high capacity cooling/ changeover /dual purpose coil
 F = 4-row low capacity cooling/ changeover /dual purpose coil
 G = 4-row high capacity cooling/ changeover /dual purpose coil
 H = EarthWise™ cooling/ changeover /dual purpose coil
 J = DX cooling coil
 T = DX cooling coil with VRF application

Digit 16 — Heating Coil

0 = None
 A = 1-row heating
 B = 2-row low capacity
 C = 2-row high capacity
 D = 3-row low capacity
 E = 3-row high capacity
 F = 4-row low capacity
 G = 4-row high capacity
 H = EarthWise™ heating coil
 K = Steam heating - low capacity
 L = Steam heating - high capacity
 M = Electric heat - low capacity

Digit 17 — Motor

0 = Electronically Commutated Motor (ECM)
 1 = ECM and low acoustic option
 2 = ECM and low FLA option
 3 = ECM and low acoustic and low FLA option

Digit 18 — Other Motor Items

B = Toggle
 C = Circuit breaker

Digit 19 — Cooling/Changeover Valve Type

0 = None
 A = 2-way, 2 position N.C.
 B = 2-way, 2 position N.O.
 C = 3-way, 2 position N.C.
 D = 3-way, 2 position N.O.
 E = 2-way, modulating
 F = 3-way, modulating
 G = 2-way, analog (2 to 10 Vdc)
 H = 3-way, analog (2 to 10 Vdc)
 J = Field supplied, 2 position N.C.
 K = Field supplied, 2 position N.O.
 L = Field supplied, modulating
 M = Field supplied, analog (2 to 10 Vdc)

Digit 20 — Cv Cooling/Changeover Valve

0 = None
 A = 2-way 2.3 Cv
 B = 2-way 3.3 Cv
 C = 2-way 4.6 Cv
 D = 2-way 6.6 Cv
 E = 3-way 2.7 Cv
 F = 3-way 4.6 Cv
 G = 3-way 7.4 Cv

Digit 21 — Heating Valve Type

0 = None
 A = 2-way, 2 position N.C.
 B = 2-way, 2 position N.O.
 C = 3-way, 2 position N.C.
 D = 3-way, 2 position N.O.
 E = 2-way, modulating
 F = 3-way, modulating
 G = 2-way, analog (2 to 10 Vdc)
 H = 3-way, analog (2 to 10 Vdc)
 J = Field supplied, 2 position N.C.
 K = Field supplied, 2 position N.O.
 L = Field supplied, modulating
 M = Field supplied, analog (2 to 10 Vdc)

Digit 22 — Cv Heating Valve

0 = None
 A = 2-way 1.4 Cv
 B = 2-way 2.4 Cv
 C = 2-way 3.4 Cv
 D = 2-way 4.8 Cv
 E = 2-way 5.9 Cv
 F = 3-way 2.7 Cv
 G = 3-way 4.6 Cv
 N = 3-way 7.4 Cv
 J = Steam 1.8 Cv
 K = Steam 4.6 Cv
 P = Steam 7.3 Cv



Model Number Descriptions

Digit 23 — Discharge Arrangement

- 0 = Opening only, no grille
- A = Grille discharge
- B = Double deflection discharge grille
- C = Grille discharge with wire mesh

Digit 24 — Outside Air Damper Control

- 0 = None
- A = 3-wire actuator
- B = 2–10 volt actuator

Digit 25 — Face-and-Bypass Damper Control

- 0 = None
- A = 3-wire actuator
- B = 2–10 volt actuator

Digit 26 — Controls

- 2 = Customer supplied terminal interface (CSTI)
- 3 = CSTI with low temperature detection
- E = Symbio™ 400-B controller
- F = Symbio™ 400-B with time clock
- G = Symbio™ 400-B with Air-Fi® WCI
- N = CSTI fan status

Digit 27 — Unit- or Wall-Mounted Controls

- 0 = None
- 1 = Unit-mounted
- 2 = Wall-mounted
- 3 = Combined unit-mounted and wallmounted sensor
- 4 = Wireless zone sensor

Digit 28 — Internal or External Set Point

- 0 = None
- 2 = External
- 3 = Digital display

Digit 29 — Timed Override

- 0 = No timed override
- 1 = Yes, Timed override

Digit 30 — Refrigerant Types

- 0 = No refrigerant
- 1 = R-410A replacements only
- 2 = R-454B
- 3 = R-32

Digit 31 — Programming Options

- 0 = None
- 1 = Humidity sensor programming
- 2 = CO₂ sensor programming
- 3 = Air-Fi® Humidity Sensor and CO₂
- 4 = Air-Fi® Humidity Sensor
- 5 = Air-Fi® CO₂

Digit 32 — Depth

- A = 16.63 in. standard depth
- B = 21.25 in. depth with baffle
- C = 21.25 in. depth with full sheet metal back with baffle
- D = 21.25 in. depth with 25 in. high falseback
- E = 221.25 in. depth with 26 in. high falseback
- F = 21.25 in. depth with 27 in. high falseback
- G = 21.25 in. depth with 28 in. high falseback
- H = 21.25 in. depth with 29 in. high falseback
- J = 21.25 in. depth without baffle

Digit 33 — End Covers

- 0 = No decorative end covers
- 1 = 16.63 in. depth without cutout
- 2 = 16.63 in. depth with standard cutout
- 3 = 16.63 in. depth with extended cutout
- 4 = 21.25 in. depth without cutout
- 5 = 21.25 in. depth with standard cutout
- 6 = 21.25 in. depth with extended cutout

Digit 34 — Front Panel or Access Panel

- 1 = Standard front panel
- 2 = Insulated front panel

Digit 35 — Sub-base

- 0 = No sub-base
- 1 = 2 in. sub-base
- 4 = 4 in. sub-base
- 6 = 6 in. sub-base

Digit 36 — Piping Package

- 0 = None
- 4 = Basic -ball valve supply and return
- 5 = Basic - ball valve supply and manual circuit setter return
- 6 = Deluxe - ball valve supply and manual circuit setter return
- 7 = Deluxe - ball valve supply and return with auto flow

Digit 37 — Cooling/Changeover Auto Flow GPM

- 0 = None
- A = 4.0
- B = 4.5
- C = 5.0
- D = 6.0
- E = 6.5
- F = 7.0
- G = 8.0

Digit 38 — Heating Auto Flow GPM

- 0 = None
- A = 1.0
- B = 1.5
- C = 2.0
- D = 2.5
- E = 3.0
- F = 3.5
- G = 4.0
- H = 4.5
- J = 5.0
- K = 6.0

Digit 39 — Auxiliary Drain Pan

- Y = Yes, auxiliary drain pan
- N = No auxiliary drain pan

Digit 40 — Crossover Piping

- 0 = No crossover piping
- 1 = Internal crossover
- 2 = External 1 3/8 in. crossover piping
- 3 = External 2 1/8 in. crossover piping

Digit 41 — Filter

- 1 = Standard throwaway filter
- 2 = Merv 8 filter
- 3 = Merv 13 filter

Digit 42 — Cabinet Color

- 1 = Standard deluxe beige
- 2 = Cameo white
- 3 = Soft dove
- 4 = Stone gray
- 5 = Driftwood gray



General Data

Table 1. General data (size in inches)

Description	Unit size			
	0750	1000	1250	1500
Unit length without end covers	69.00	81.00	93.00	105.00
Unit depth—standard	16-5/8	16-5/8	16-5/8	16-5/8
Unit depth—with false back	21-1/4	21-1/4	21-1/4	21-1/4
Unit height—standard	30.00	30.00	30.00	30.00
Shipping weight (lb)	320	405	450	470
Nominal filter size and quantity	14 x 20 x 1 (2)	14 x 24 x 1 (1) 14 x 30 x 1 (1)	14 x 20 x 1 (2) 14 x 24 x 1 (1)	14 x 24 x 1 (2) 14 x 30 x 1 (1)
Dynamic air filter nominal size and quantity	7 x 42 x 1 (1)	7 x 54 x 1 (1)	7 x 66 x 1 (1)	7 x 78 x 1 (1)
Drain connection size	7/8 ID Hose	7/8 ID Hose	7/8 ID Hose	7/8 ID Hose
Fan type/quantity	FC / 2	FC / 2	FC / 4	FC / 4
Motor quantity	1	1	2	2
Motor horsepower (ea.)	1/4	1/4	1/4	1/4
Coil volume (gal) by coil type				
A	0.178	0.228	0.277	0.327
B	0.311	0.410	0.510	0.610
C	0.311	0.410	0.510	0.610
D	0.444	0.571	0.704	0.931
E	0.444	0.571	0.704	0.931
F	0.610	0.809	1.014	1.213
G	0.610	0.809	1.014	1.213
H	0.395	0.593	0.742	0.837

Table 2. Coil volume for DX coils (cubic inches)

Description	Unit size			
	0750	1000	1250	1500
J	120	164	206	250

Table 3. Control methodology

Control	Fan Speed
CSTI	3 or infinite ^(a)
Symbio™ 400-B	Infinite

^(a) With a field-supplied 2–10 Vdc controller

Table 4. Control sequences

Control Sequence	Fan Speeds
DX operation ^(a)	1
Electric heat operation ^(a)	1

^(a) Fan speed during sequence operation.

Figure 15. Discharge and inlet arrangements

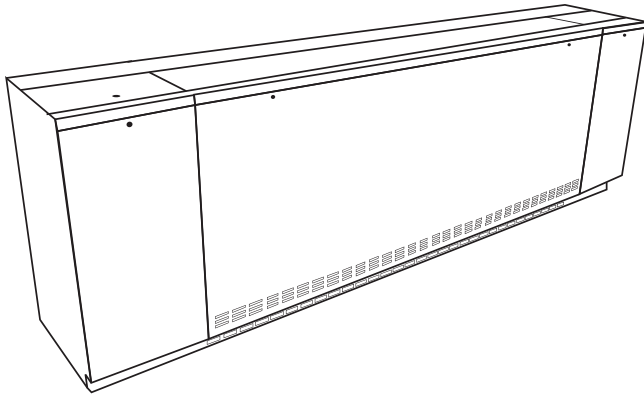

Discharge Arrangement

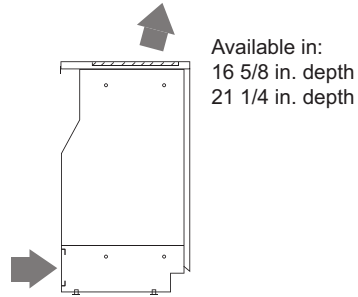

Available in:
16 5/8 in. depth
21 1/4 in. depth

Digit 23 = 0, A, B, C

- 0 = Opening only
- A = Discharge grille
- B = Double deflection discharge grille
- C = Discharge grille with wire mesh

Inlet Arrangement

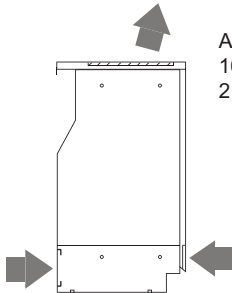

Available in:
16 5/8 in. depth
21 1/4 in. depth

Digit 13 = 1
RA front with FA back

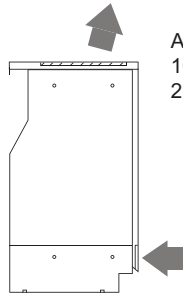

Available in:
16 5/8 in. depth
21 1/4 in. depth

Digit 13 = 2
100% Return air front

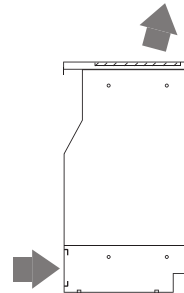

Available in:
16 5/8 in. depth
21 1/4 in. depth

Digit 13 = 3
100% Fresh air back

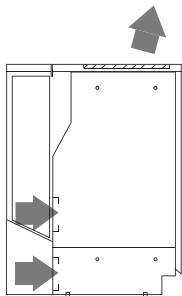

Available in:
21 1/4 in. depth
ONLY

Digit 13 = 4
Dynamic air barrier

Figure 16. Falseback unit

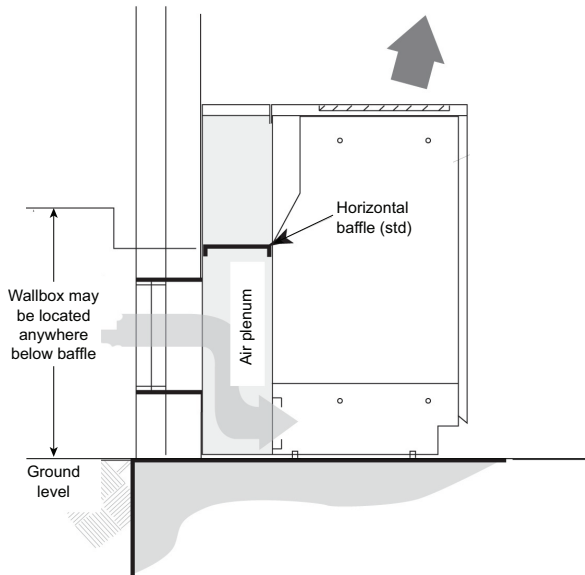

Falseback units may be utilized as an air plenum to locate the wallbox anywhere along the height of the baffle.

Figure 17. Step-down falseback unit

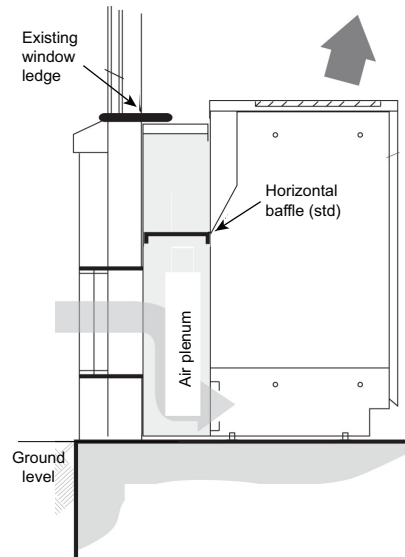

Step-down falseback unit allows the unit ventilator to be lowered from a 30-inch height to 29, 28, 27, 26, or 25-inch height. The lowered height permits the upgraded equipment to be retrofitted below an existing window ledge.

Figure 18. Insulated falseback with raised OA opening

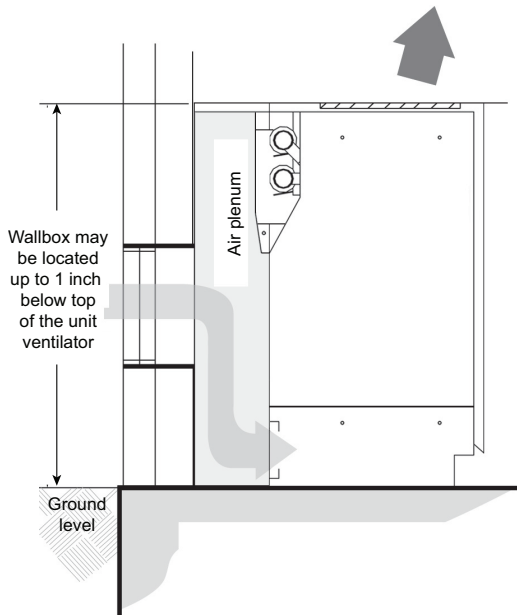

Insulated falseback for raised OA opening (21 1/4-inch depth without baffle option) allows the wallbox to be located up to one inch below the unit ventilator. This helps eliminate snow or debris from entering the wallbox and protects the crossover piping.

Figure 19. Subbase

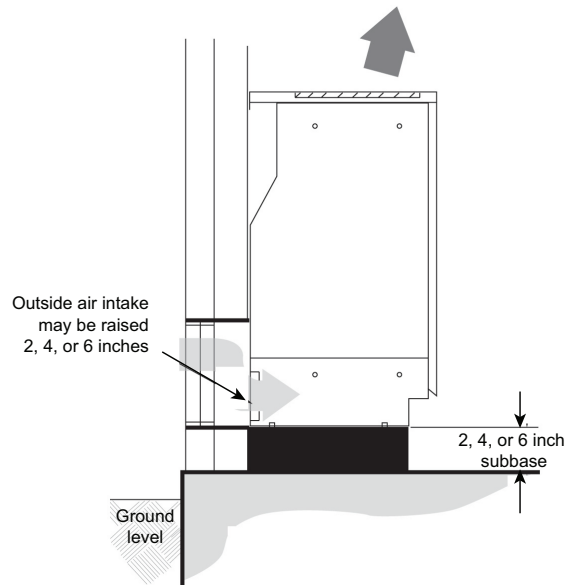

Subbases are available in both 16 5/8-inch and 21 1/4-inch depth units. The subbase increases the overall height of the unit ventilator from 30 inches to 32, 34, or 36 inches. The additional height raises the outdoor air opening to help eliminate snow or debris from entering the wallbox.



Performance Data

Table 5. Coil combination selection chart (cooling, 2-pipe changeover or heating-only coils)

Coil type	Coil description		Preheat or reheat coils					
			A	B	C	K	L	M
A	1-row, 12 fpi	B and C cooling data available in TOPSS™	Heating only					
B	2-row, 12 fpi		x	x	x	x	x	x
C	2-row, 16 fpi		x	x	x	x	x	x
D	3-row, 12 fpi		x	x	x			x
E	3-row, 16 fpi		x	x	x			x
F	4-row, 12 fpi		x					
G	4-row, 16 fpi		x					
H	3-row, 16 fpi (EarthWise)		x	x	x			
J	3-row, DX (R-410A, R-454B, R-32)		x	x	x	x	x	x
K	Steam, low capacity		Heating only					
L	Steam, high capacity							
M	Electric heat – 3-element							
T	DX – VRF applications							

Note: All coil types on the left side of the grid are available in single-coil, heating only, or 2-pipe changeover with exception of coil type A. For 2-coil or 4-pipe systems, select the cooling coil on the left side of the grid. An X corresponds to a valid heating coil combination. Shaded areas signify valid selections with face and bypass dampers.

Example 1:

4-pipe, chilled water / hot water

Type E, 3-row (16 fpi) cooling coil, may be selected with

Type B, 2-Row (12 fpi) preheat or reheat coil

Example 2:

4-pipe, DX cooling / steam heating

Type J, 3-row DX cooling coil, may be selected with

Type L, high-capacity steam heating coil

Notes:

- Supply and return coil connections are on the same side.
- In 4-pipe systems, the cooling coil connections are on the opposite end from the heating coil connections.
- DX coils are always left-hand connections.
- Electric heat coils are always right-hand connections.
- Heating coils (hot water or steam) are right-hand when in the reheat position with DX cooling coils.

Table 6. Airflow through coil combination

Coil combination	Unit size			
	0750	1000	1250	1500
A	833	1072	1406	1669
B	788	1032	1293	1578
C	759	1011	1315	1515
D	748	989	1253	1495
E	717	934	1243	1437
F	684	1005	1233	1437
G	627	983	1215	1524
H	717	934	1243	1437

Table 6. Airflow through coil combination (continued)

Coil combination	Unit size			
	0750	1000	1250	1500
J	748	989	1253	1495
K	825	1052	1377	1623
L	816	1042	1350	1600
R	748	989	1253	1495
B and A	738	1057	1178	1638
B and B	684	1016	1301	1564
B and C	650	994	1320	1504
B and D	639	971	1263	1484
B and E	808	911	1253	1421
B and H	808	911	1253	1421
B and J	669	971	1263	1484
C and A	706	1037	1196	1583
C and C	818	971	1339	1442
C and D	808	947	1282	1421
C and E	779	885	1272	1356
C and H	779	885	1272	1356
C and J	808	947	1282	1421
D and A	695	1016	1143	1564
E and A	662	959	1134	1504
F and A	627	947	1126	1504
G and A	779	923	1320	1421
H and A	662	959	1134	1504
J and A	707	1016	1357	1564
R and A	707	1016	1357	1564
B and K	728	1037	1157	1602
C and K	695	1016	1174	1544
D and K	684	994	1122	1524
E and K	650	935	1114	1463
H and K	650	935	1114	1463
J and K	699	994	1335	1524
B and L	717	1027	1136	1583
C and L	684	1005	1153	1524
D and L	673	983	1102	1504
E and L	639	923	1094	1442
H and L	639	923	1094	1442
J and L	692	983	1102	1504
B and M	767	1093	1182	1362
C and M	744	1075	1195	1324
D and M	736	1057	1156	1311
E and M	714	1005	1149	1266
H and M	714	1005	1149	1266
J and M	736	1057	1156	1475



Performance Data

Table 7. Hydronic coil performance summary

Size	Coil	Rows	CFM	Cooling Performance 80/67°F EAT, 45–55°F				Heating Performance 60°F EAT, 160°F EWT		
				GPM	QT	QS	DP	GPM	QT	DP
750	A	1	833	Not available				4.00	36.90	5.40
	B	2	788	3.20	15.40	12.70	1.60	3.00	51.60	1.40
	C	2	759	3.60	17.30	13.70	1.90	3.30	55.60	1.60
	D	3	748	4.80	23.40	16.20	3.40	3.50	57.40	1.90
	E	3	717	5.20	25.20	16.70	3.90	3.40	57.20	1.80
	F	4	684	4.70	22.80	15.10	2.20	3.50	53.50	1.40
	G	4	627	4.80	23.20	15.00	2.30	3.80	53.50	1.60
	H	3	717	5.70	27.90	17.30	10.30	3.40	61.50	4.10
1000	A	1	1071	Not available				4.00	45.60	6.40
	B	2	1035	5.10	24.70	20.10	3.70	4.20	70.80	2.50
	C	2	1013	5.80	28.00	21.70	4.80	4.50	76.00	2.90
	D	3	990	5.90	28.70	20.70	2.90	4.70	74.60	1.90
	E	3	933	6.30	30.70	20.70	3.30	4.60	73.90	1.80
	F	4	1007	7.80	38.20	25.80	6.70	4.70	76.20	2.50
	G	4	984	8.30	40.70	26.70	7.50	5.10	79.40	2.90
	H	3	933	7.40	36.00	24.20	8.80	4.70	79.70	4.00
1250	A	1	1406	Not available				6.00	63.20	15.50
	B	2	1293	6.50	31.50	24.60	6.00	5.50	81.00	4.40
	C	2	1315	7.30	35.40	26.50	7.40	5.80	90.30	4.90
	D	3	1253	8.00	38.90	27.30	6.20	6.00	95.10	3.80
	E	3	1243	8.40	41.10	27.50	6.70	5.80	94.80	3.60
	F	4	1233	7.70	37.40	27.00	4.00	5.80	92.00	2.30
	G	4	1215	8.30	40.30	28.10	4.60	6.40	95.60	2.80
	H	3	1243	9.00	43.80	29.20	15.00	5.80	101.80	7.00
1500	A	1	1669	Not available				6.00	77.70	17.40
	B	2	1578	8.30	40.50	27.60	11.20	6.40	103.90	6.90
	C	2	1515	9.10	44.20	29.00	13.30	7.10	110.30	8.40
	D	3	1495	10.40	50.80	34.40	9.10	7.10	117.40	4.60
	E	3	1437	10.90	53.40	35.00	10.00	7.00	117.20	4.50
	F	4	1437	11.90	58.30	36.60	8.80	7.20	118.50	3.60
	G	4	1524	12.60	61.60	38.10	9.80	7.70	126.90	4.10
	H	3	1437	12.20	59.70	35.80	14.50	7.20	125.10	5.70

Notes:

1. EAT = entering air temperature (°F).
2. EWT = entering water temperature (°F).
3. CFM = state of airflow (ft³/min).
4. GPM = water flow (gal/min).
5. QT = total capacity (MBh).
6. QS = sensible cooling capacity (MBh).
7. DP = waterside pressure drop (ft H₂O).

Table 8. VUV 075, cooling coil cell D, 3-row/12 fpi

Entering Wet Bulb Temp (°F)	Entering Dry Bulb Temp (°F)	Entering Water Temp (°F)	Flow Rate (gpm)											
			2			4			6			10		
			Total Capacity (MBh)	Sensible Capacity (MBh)	T (°F)	Total Capacity (MBh)	Sensible Capacity (MBh)	T (°F)	Total Capacity (MBh)	Sensible Capacity (MBh)	T (°F)	Total Capacity (MBh)	Sensible Capacity (MBh)	T (°F)
61	70	40	11.60	9.50	12.30	17.30	12.00	9.00	21.30	13.50	7.30	25.70	15.20	5.30
		42	11.00	9.20	11.70	16.40	11.70	8.50	20.10	13.00	6.90	24.00	14.50	4.90
		45	10.10	8.70	10.80	14.90	11.10	7.80	18.20	12.30	6.30	21.50	13.60	4.40
		48	9.20	8.20	9.80	13.40	10.40	7.00	16.20	11.60	5.60	18.90	12.70	3.90
	75	40	12.70	12.30	13.40	18.90	15.60	9.80	23.30	17.50	8.00	28.00	19.70	5.70
		42	12.00	11.90	12.70	17.80	15.10	9.30	21.90	16.90	7.50	26.20	18.80	5.40
		45	11.00	11.00	11.70	16.20	14.30	8.50	19.80	15.90	6.80	23.40	17.60	4.80
		48	10.00	10.00	10.70	14.60	13.50	7.70	17.70	15.00	6.10	20.60	16.40	4.30
	80	40	14.10	14.10	14.80	21.00	18.90	10.80	25.80	21.20	8.80	31.10	23.80	6.40
		42	13.30	13.30	14.00	19.80	18.30	10.20	24.30	20.40	8.30	29.10	22.80	5.90
		45	12.20	12.20	12.90	18.00	17.30	9.30	22.00	19.30	7.50	26.00	21.30	5.30
		48	11.10	11.10	11.80	16.20	16.20	8.50	19.60	18.20	6.80	22.80	19.80	4.70
	85	40	15.70	15.70	16.40	23.40	22.00	12.00	28.80	24.70	9.80	34.70	27.70	7.10
		42	14.90	14.90	15.60	22.10	21.30	11.40	27.10	23.80	9.30	32.40	26.50	6.60
		45	13.60	13.60	14.30	20.10	20.10	10.40	24.50	22.50	8.40	29.00	24.80	5.90
		48	12.40	12.40	13.10	18.10	18.10	9.40	21.90	21.10	7.50	25.50	23.10	5.20
	90	40	17.50	17.50	18.20	26.10	24.90	13.40	32.10	28.00	10.90	38.70	31.40	7.90
		42	16.60	16.60	17.30	24.60	24.10	12.70	30.20	26.90	10.30	36.10	30.10	7.40
		45	15.20	15.20	15.90	22.40	22.40	11.50	27.30	25.40	9.30	32.30	28.10	6.60
		48	13.80	13.80	14.50	20.20	20.20	10.40	24.40	23.90	8.40	28.40	26.20	5.80
67	75	40	15.90	10.20	16.60	23.70	13.00	12.20	29.10	14.50	9.90	35.10	16.30	7.10
		42	15.00	9.90	15.70	22.30	12.50	11.50	27.40	14.00	9.40	32.80	15.60	6.70
		45	13.80	9.40	14.50	20.30	11.90	10.50	24.80	13.20	8.50	29.30	14.60	6.00
		48	12.50	8.80	13.20	18.30	11.20	9.50	22.10	12.50	7.60	25.80	13.60	5.30
	80	40	16.70	13.20	17.40	24.80	16.80	12.80	30.60	18.80	10.40	36.80	21.20	7.50
		42	15.80	12.80	16.50	23.40	16.20	12.10	28.70	18.20	9.80	34.40	20.30	7.00
		45	14.40	12.10	15.10	21.30	15.40	11.00	26.00	17.10	8.90	30.70	18.90	6.30
		48	13.10	11.40	13.80	19.20	14.50	10	23.20	16.10	8.00	27.00	17.60	6
	85	40	17.70	16.10	18.40	26.40	20.50	13.60	32.50	23.00	11.10	39.20	25.80	8.00
		42	16.80	15.60	17.50	24.90	19.80	12.80	30.60	22.20	10.40	36.60	24.70	7.50
		45	15.40	14.80	16.10	22.70	18.80	11.70	27.70	20.90	9.40	32.70	23.10	6.70
		48	14.00	13.90	14.70	20.40	17.80	10.60	24.70	19.70	8.50	28.80	21.50	5.90
	90	40	19.00	18.90	19.70	28.30	24.10	14.50	34.90	27.00	11.90	42.00	30.40	8.50
		42	18.00	18.00	18.70	26.80	23.30	13.70	32.80	26.00	11.20	39.30	29.10	8.00
		45	16.50	16.50	17.20	24.30	22.10	12.50	29.70	24.60	10.10	35.10	27.10	7.20
		48	15.00	15.00	15.70	21.90	20.90	11.30	26.50	23.10	9.10	30.90	25.30	6.30



Performance Data

Table 8. VUV 075, cooling coil cell D, 3-row/12 fpi (continued)

Entering Wet Bulb Temp (°F)	Entering Dry Bulb Temp (°F)	Entering Water Temp (°F)	Flow Rate (gpm)											
			2			4			6			10		
			Total Capacity (MBh)	Sensible Capacity (MBh)	T (°F)	Total Capacity (MBh)	Sensible Capacity (MBh)	T (°F)	Total Capacity (MBh)	Sensible Capacity (MBh)	T (°F)	Total Capacity (MBh)	Sensible Capacity (MBh)	T (°F)
70	75	40	18.10	8.90	18.80	26.90	11.30	13.80	33.10	12.70	11.30	39.90	14.30	8.10
		42	17.10	8.60	17.80	25.40	11.00	13.00	31.20	12.30	10.60	37.30	13.70	7.60
		45	15.70	8.20	16.40	23.10	10.40	11.90	28.20	11.60	9.60	33.30	12.80	6.80
		48	14.20	7.70	14.90	20.80	9.80	10.80	25.20	10.90	8.60	29.30	11.90	6.00
	80	40	18.60	12.00	19.30	27.70	15.20	14.20	34.00	17.10	11.60	41.00	19.20	8.30
		42	17.60	11.60	18.30	26.10	14.70	13.40	32.00	16.50	10.90	38.30	18.40	7.80
		45	16.10	11.00	16.80	23.80	14.00	12.20	29.00	15.60	9.90	34.20	17.20	7.00
		48	14.60	10.40	15.30	21.40	13.20	11.00	25.90	14.60	8.80	30.10	16.00	6.20
	85	40	19.40	15.00	20.10	28.90	19.10	14.80	35.50	21.40	12.10	42.80	24.10	8.70
		42	18.40	14.50	19.00	27.20	18.50	14.00	33.40	20.70	11.40	40.00	23.00	8.10
		45	16.80	13.80	17.50	24.80	17.50	12.70	30.20	19.50	10.30	35.70	21.50	7.30
		48	15.30	13.00	15.90	22.30	16.50	11.50	27.00	18.30	9.20	31.40	20.00	6.40
	90	40	20.40	18.00	21.10	30.40	22.90	15.60	37.50	25.70	12.70	45.10	28.80	9.20
		42	19.30	17.40	20.00	28.70	22.10	14.70	35.20	24.70	12.00	42.20	27.60	8.60
		45	17.70	16.50	18.40	26.10	21.00	13.40	31.90	23.40	10.80	37.70	25.80	7.70
		48	16.10	15.50	16.80	23.50	19.80	12.10	28.40	22.00	9.70	33.10	24.00	6.80

Table 9. VUV 075, cooling coil E, 3-row/16 fpi

Entering Wet Bulb Temp (°F)	Entering Dry Bulb Temp (°F)	Entering Water Temp (°F)	Flow Rate (gpm)											
			2			4			6			10		
			Total Capacity (MBh)	Sensible Capacity (MBh)	T (°F)	Total Capacity (MBh)	Sensible Capacity (MBh)	T (°F)	Total Capacity (MBh)	Sensible Capacity (MBh)	T (°F)	Total Capacity (MBh)	Sensible Capacity (MBh)	T (°F)
61	70	40	12.00	9.50	12.60	17.90	12.10	9.30	22.00	13.60	7.60	26.40	15.30	5.40
		42	11.30	9.20	12.00	16.90	11.70	8.80	20.80	13.10	7.10	24.80	14.70	5.10
		45	10.40	8.80	11.10	15.40	11.10	8.00	18.80	12.40	6.50	22.20	13.70	4.60
		48	9.40	8.30	10.10	13.90	10.50	7.30	16.80	11.60	5.80	19.50	12.70	4.00
	75	40	13.00	12.40	13.70	19.50	15.70	10.10	24.00	17.70	8.20	28.80	19.90	5.90
		42	12.30	12.00	13.00	18.40	15.20	9.60	22.60	17.00	7.80	27.00	19.00	5.50
		45	11.30	11.30	12.00	16.80	14.40	8.70	20.50	16.00	7.10	24.20	17.70	5.00
		48	10.30	10.30	11.00	15.10	13.60	7.90	18.30	15.10	6.30	21.30	16.50	4.40
	80	40	14.50	14.50	15.10	21.60	19.00	11.20	26.70	21.40	9.10	32.00	24.10	6.50
		42	13.70	13.70	14.40	20.40	18.40	10.60	25.10	20.60	8.60	29.90	23.00	6.10
		45	12.50	12.50	13.20	18.60	17.50	9.70	22.70	19.40	7.80	26.80	21.50	5.50
		48	11.40	11.40	12.10	16.80	16.50	8.70	20.30	18.30	7.00	23.60	19.90	4.90
	85	40	16.10	16.10	16.80	24.20	22.10	12.40	29.80	24.90	10.10	35.70	28.00	7.30
		42	15.30	15.30	16.00	22.80	21.40	11.80	28.00	24.00	9.60	33.40	26.80	6.80
		45	14.00	14.00	14.70	20.80	20.30	10.70	25.40	22.60	8.70	29.90	25.00	6.10
		48	12.70	12.70	13.40	18.70	18.70	9.70	22.70	21.20	7.80	26.30	23.20	5.40
90	40	18.00	18.00	18.70	26.90	25.10	13.80	33.20	28.20	11.30	39.80	31.70	8.10	
	42	17.00	17.00	17.70	25.40	24.30	13.10	31.20	27.10	10.60	37.20	30.30	7.60	
	45	15.60	15.60	16.30	23.20	23.00	11.90	28.30	25.60	9.70	33.30	28.30	6.80	
	48	14.20	14.20	14.90	20.90	20.90	10.80	25.30	24.10	8.70	29.40	26.30	6.00	
67	75	40	16.30	10.30	17.00	24.40	13.10	12.50	30.10	14.70	10.30	36.10	16.50	7.40
		42	15.40	9.90	16.10	23.10	12.60	11.90	28.30	14.10	9.70	33.80	15.80	6.90
		45	14.20	9.40	14.80	21.00	12.00	10.80	25.60	13.30	8.80	30.20	14.70	6.20
		48	12.90	8.90	13.50	18.90	11.30	9.80	22.90	12.50	7.90	26.60	13.70	5.50
	80	40	17.10	13.30	17.80	25.60	16.90	13.20	31.60	19.00	10.70	37.90	21.40	7.70
		42	16.20	12.90	16.90	24.20	16.30	12.40	29.70	18.30	10.10	35.40	20.40	7.20
		45	14.80	12.20	15.50	22.00	15.50	11.40	26.90	17.20	9.20	31.70	19.10	6.50
		48	13.50	11.50	14.20	19.90	14.60	10.30	24.10	16.20	8.20	27.90	17.70	5.70
	85	40	18.20	16.20	18.90	27.30	20.60	14.00	33.60	23.20	11.40	40.30	26.10	8.20
		42	17.30	15.70	17.90	25.80	19.90	13.20	31.60	22.30	10.80	37.70	24.90	7.70
		45	15.80	14.90	16.50	23.50	18.90	12.10	28.60	21.10	9.80	33.80	23.30	6.90
		48	14.40	14.10	15.00	21.20	17.90	10.90	25.60	19.80	8.80	29.70	21.60	6.10
	90	40	19.50	19.10	20.20	29.30	24.20	15.00	36.00	27.20	12.20	43.20	30.60	8.80
		42	18.50	18.50	19.20	27.60	23.40	14.20	33.90	26.20	11.50	40.50	29.30	8.20
		45	17.00	17.00	17.60	25.20	22.20	12.90	30.70	24.70	10.50	36.20	27.30	7.40
		48	15.40	15.40	16.10	22.70	21.00	11.70	27.50	23.30	9.40	31.90	25.40	6.50



Performance Data

Table 9. VUV 075, cooling coil E, 3-row/16 fpi (continued)

Entering Wet Bulb Temp (°F)	Entering Dry Bulb Temp (°F)	Entering Water Temp (°F)	Flow Rate (gpm)											
			2			4			6			10		
			Total Capacity (MBh)	Sensible Capacity (MBh)	T (°F)	Total Capacity (MBh)	Sensible Capacity (MBh)	T (°F)	Total Capacity (MBh)	Sensible Capacity (MBh)	T (°F)	Total Capacity (MBh)	Sensible Capacity (MBh)	T (°F)
70	75	40	18.60	9.00	19.20	27.80	11.40	14.20	34.20	12.80	11.60	41.10	14.40	8.40
		42	17.60	8.70	18.30	26.30	11.00	13.50	32.20	12.40	11.00	38.40	13.80	7.80
		45	16.10	8.30	16.80	23.90	10.50	12.30	29.20	11.70	10.00	34.40	12.90	7.00
		48	14.60	7.80	15.30	21.60	9.90	11.10	26.10	11.00	8.90	30.30	12.00	6.20
	80	40	19.10	12.10	19.80	28.50	15.30	14.60	35.20	17.20	11.90	42.20	19.40	8.60
		42	18.10	11.70	18.70	27.00	14.80	13.80	33.10	16.60	11.30	39.50	18.60	8.00
		45	16.50	11.10	17.20	24.60	14.10	12.60	30.00	15.70	10.20	35.30	17.30	7.20
		48	15.00	10.50	15.70	22.20	13.30	11.40	26.80	14.70	9.20	31.10	16.10	6.40
	85	40	19.90	15.10	20.60	29.80	19.20	15.20	36.70	21.60	12.50	44.00	24.30	8.90
		42	18.80	14.70	19.50	28.10	18.60	14.40	34.50	20.80	11.70	41.20	23.20	8.40
		45	17.30	13.90	17.90	25.60	17.60	13.20	31.30	19.60	10.70	36.90	21.70	7.50
		48	15.70	13.10	16.40	23.10	16.70	11.90	28.00	18.40	9.60	32.50	20.10	6.60
	90	40	21.00	18.10	21.70	31.40	23.00	16.00	38.70	25.90	13.10	46.40	29.10	9.40
		42	19.90	17.50	20.60	29.70	22.30	15.20	36.40	24.90	12.40	43.40	27.80	8.80
		45	18.20	16.70	18.90	27.00	21.10	13.90	33.00	23.50	11.20	38.90	26.00	7.90
		48	16.50	15.70	17.20	24.40	20.00	12.50	29.50	22.10	10.10	34.20	24.10	7.00

Table 10. VUV 075, cooling coil F, 4-row/12 fpi

Entering Wet Bulb Temp (°F)	Entering Dry Bulb Temp (°F)	Entering Water Temp (°F)	Flow Rate (gpm)											
			2			4			6			10		
			Total Capacity (MBh)	Sensible Capacity (MBh)	T (°F)	Total Capacity (MBh)	Sensible Capacity (MBh)	T (°F)	Total Capacity (MBh)	Sensible Capacity (MBh)	T (°F)	Total Capacity (MBh)	Sensible Capacity (MBh)	T (°F)
61	70	40	11.90	9.10	12.60	17.10	11.40	8.90	20.90	12.70	7.20	25.10	14.30	5.20
		42	11.20	8.80	11.90	16.10	11.00	8.40	19.60	12.30	6.80	23.50	13.70	4.80
		45	10.20	8.40	10.90	14.70	10.40	7.70	17.80	11.50	6.20	21.10	12.80	4.40
		48	9.20	7.90	9.90	13.20	9.80	6.90	15.90	10.80	5.50	18.60	11.80	3.90
	75	40	13.00	11.80	13.60	18.70	14.70	9.70	22.80	16.50	7.80	27.40	18.60	5.60
		42	12.30	11.40	12.90	17.60	14.20	9.10	21.40	15.90	7.40	25.70	17.80	5.30
		45	11.20	10.80	11.90	16.00	13.50	8.30	19.40	14.90	6.70	23.00	16.50	4.70
		48	10.10	10.10	10.80	14.40	12.70	7.50	17.30	14.00	6.00	20.30	15.30	4.20
	80	40	14.40	14.30	15.10	20.70	17.80	10.70	25.20	20.00	8.60	30.40	22.50	6.20
		42	13.60	13.60	14.30	19.50	17.20	10.10	23.80	19.20	8.10	28.50	21.50	5.80
		45	12.40	12.40	13.10	17.70	16.30	9.20	21.50	18.10	7.40	25.50	20.00	5.20
		48	11.20	11.20	11.90	15.90	15.30	8.30	19.20	17.00	6.60	22.50	18.60	4.60
	85	40	16.00	16.00	16.70	23.10	20.70	11.90	28.20	23.20	9.60	33.90	26.20	6.90
		42	15.20	15.20	15.80	21.80	20.00	11.20	26.50	22.40	9.10	31.80	25.00	6.50
		45	13.80	13.80	14.50	19.80	18.90	10.20	24.00	21.00	8.20	28.50	23.30	5.80
		48	12.50	12.50	13.10	17.80	17.80	9.20	21.40	19.70	7.40	25.10	21.60	5.20
	90	40	17.90	17.90	18.60	25.70	23.50	13.20	31.40	26.30	10.70	37.80	29.70	7.70
		42	16.90	16.90	17.60	24.30	22.70	12.50	29.60	25.30	10.10	35.40	28.30	7.20
		45	15.40	15.40	16.10	22.10	21.50	11.40	26.70	23.80	9.10	31.80	26.40	6.50
		48	13.90	13.90	14.60	19.80	19.80	10.20	23.90	22.30	8.20	28.00	24.50	5.70
67	75	40	16.20	9.80	16.90	23.30	12.20	12.00	28.50	13.70	9.70	34.30	15.40	7.00
		42	15.30	9.50	16.00	22.00	11.80	11.40	26.80	13.20	9.20	32.10	14.80	6.60
		45	14.00	9.00	14.70	20.00	11.20	10.30	24.20	12.40	8.30	28.80	13.70	5.90
		48	12.60	8.50	13.30	18.00	10.50	9.30	21.60	11.60	7.40	25.40	12.70	5.20
	80	40	17.00	12.70	17.70	24.50	15.80	12.60	29.90	17.70	10.20	35.90	20.00	7.30
		42	16.10	12.30	16.80	23.10	15.30	11.90	28.10	17.10	9.60	33.70	19.10	6.90
		45	14.70	11.70	15.30	21.00	14.50	10.80	25.40	16.10	8.70	30.20	17.80	6.20
		48	13.20	11.00	13.90	18.80	13.60	9.80	22.70	15.10	7.80	26.70	16.50	5.50
	85	40	18.10	15.50	18.80	26.10	19.30	13.40	31.80	21.70	10.80	38.30	24.40	7.80
		42	17.10	15.00	17.80	24.60	18.70	12.60	29.90	20.80	10.20	35.90	23.30	7.30
		45	15.60	14.20	16.30	22.40	17.70	11.50	27.10	19.60	9.30	32.20	21.70	6.60
		48	14.10	13.40	14.80	20.10	16.60	10.40	24.20	18.40	8.30	28.40	20.10	5.80
	90	40	19.40	18.20	20.10	28.00	22.70	14.30	34.10	25.40	11.60	41.00	28.70	8.30
		42	18.40	17.60	19.10	26.40	21.90	13.50	32.10	24.50	10.90	38.50	27.40	7.80
		45	16.70	16.70	17.40	24.00	20.70	12.30	29.10	23.00	9.90	34.50	25.50	7.00
		48	15.10	15.10	15.80	21.50	19.50	11.10	25.90	21.60	8.90	30.40	23.70	6.20



Performance Data

Table 10. VUV 075, cooling coil F, 4-row/12 fpi (continued)

Entering Wet Bulb Temp (°F)	Entering Dry Bulb Temp (°F)	Entering Water Temp (°F)	Flow Rate (gpm)											
			2			4			6			10		
			Total Capacity (MBh)	Sensible Capacity (MBh)	T (°F)	Total Capacity (MBh)	Sensible Capacity (MBh)	T (°F)	Total Capacity (MBh)	Sensible Capacity (MBh)	T (°F)	Total Capacity (MBh)	Sensible Capacity (MBh)	T (°F)
70	75	40	18.50	8.60	19.10	26.60	10.70	13.60	32.40	12.00	11.00	39.00	13.50	7.90
		42	17.40	8.30	18.10	25.10	10.30	12.90	30.50	11.50	10.40	36.50	12.90	7.40
		45	15.90	7.90	16.60	22.80	9.80	11.70	27.60	10.90	9.40	32.80	12.00	6.70
		48	14.30	7.40	15.00	20.40	9.20	10.60	24.60	10.20	8.40	28.90	11.20	5.90
	80	40	19.00	11.50	19.60	27.30	14.40	14.00	33.30	16.10	11.30	40.00	18.20	8.10
		42	17.90	11.20	18.60	25.70	13.90	13.20	31.30	15.50	10.70	37.50	17.30	7.60
		45	16.30	10.60	17.00	23.40	13.10	12.00	28.30	14.60	9.70	33.70	16.20	6.90
		48	14.70	10.00	15.40	21.00	12.40	10.80	25.30	13.70	8.70	29.70	15.00	6.10
	85	40	19.80	14.40	20.50	28.50	18.00	14.60	34.70	20.20	11.80	41.80	22.70	8.50
		42	18.70	14.00	19.40	26.90	17.40	13.80	32.70	19.40	11.10	39.20	21.70	8.00
		45	17.00	13.30	17.70	24.40	16.50	12.60	29.60	18.30	10.10	35.10	20.20	7.20
		48	15.40	12.50	16.10	21.90	15.50	11.30	26.40	17.10	9.00	31.00	18.80	6.30
	90	40	20.90	17.30	21.50	30.00	21.60	15.40	36.60	24.20	12.40	44.10	27.20	8.90
		42	19.70	16.70	20.40	28.30	20.80	14.50	34.50	23.30	11.70	41.30	26.00	8.40
		45	18.00	15.90	18.70	25.70	19.70	13.20	31.20	21.90	10.60	37.00	24.20	7.50
		48	16.20	14.90	16.90	23.10	18.60	11.90	27.80	20.50	9.50	32.70	22.50	6.70

Table 11. VUV 075, coil G, 4-row/16 fpi

Entering Wet Bulb Temp (°F)	Entering Dry Bulb Temp (°F)	Entering Water Temp (°F)	Flow Rate (gpm)											
			2			4			6			10		
			Total Capacity (MBh)	Sensible Capacity (MBh)	T (°F)	Total Capacity (MBh)	Sensible Capacity (MBh)	T (°F)	Total Capacity (MBh)	Sensible Capacity (MBh)	T (°F)	Total Capacity (MBh)	Sensible Capacity (MBh)	T (°F)
61	70	40	12.00	9.00	12.70	17.30	11.20	9.00	21.00	12.60	7.20	25.10	14.10	5.20
		42	11.40	8.70	12.00	16.30	10.80	8.50	19.80	12.10	6.80	23.50	13.50	4.80
		45	10.40	8.20	11.00	14.80	10.20	7.80	17.90	11.30	6.20	21.10	12.60	4.40
		48	9.30	7.70	10.00	13.30	9.60	7.00	16.00	10.60	5.60	18.60	11.60	3.90
	75	40	13.10	11.60	13.80	18.90	14.50	9.80	22.90	16.30	7.90	27.30	18.30	5.60
		42	12.40	11.20	13.10	17.80	14.00	9.20	21.60	15.70	7.40	25.60	17.50	5.30
		45	11.30	10.70	12.00	16.20	13.20	8.40	19.60	14.70	6.70	23.00	16.30	4.70
		48	10.20	10.00	10.90	14.50	12.40	7.60	17.50	13.80	6.00	20.30	15.00	4.20
	80	40	14.60	14.10	15.20	20.90	17.60	10.80	25.40	19.70	8.70	30.30	22.20	6.20
		42	13.70	13.60	14.40	19.80	17.00	10.20	24.00	19.00	8.20	28.40	21.20	5.80
		45	12.50	12.50	13.20	18.00	16.00	9.30	21.70	17.80	7.50	25.50	19.70	5.20
		48	11.30	11.30	12.00	16.10	15.10	8.40	19.40	16.70	6.70	22.50	18.20	4.60
	85	40	16.20	16.20	16.90	23.40	20.50	12.00	28.40	22.90	9.70	33.80	25.80	6.90
		42	15.30	15.30	16.00	22.00	19.70	11.40	26.70	22.00	9.10	31.70	24.60	6.50
		45	14.00	14.00	14.70	20.00	18.60	10.40	24.20	20.70	8.30	28.50	22.90	5.80
		48	12.60	12.60	13.30	18.00	17.50	9.30	21.60	19.40	7.40	25.20	21.20	5.20
	90	40	18.10	18.10	18.80	26.00	23.20	13.40	31.60	26.00	10.80	37.70	29.20	7.70
		42	17.10	17.10	17.80	24.60	22.40	12.60	29.80	25.00	10.20	35.40	27.90	7.20
		45	15.60	15.60	16.30	22.30	21.10	11.50	27.00	23.50	9.20	31.80	26.00	6.50
		48	14.00	14.00	14.70	20.10	19.90	10.40	24.10	21.90	8.30	28.00	24.00	5.70
67	75	40	16.40	9.60	17.10	23.60	12.10	12.10	28.70	13.50	9.80	34.20	15.20	7.00
		42	15.50	9.30	16.20	22.30	11.60	11.50	27.00	13.00	9.20	32.10	14.50	6.60
		45	14.10	8.90	14.80	20.30	11.00	10.50	24.50	12.20	8.40	28.80	13.50	5.90
		48	12.70	8.30	13.40	18.20	10.30	9.40	21.80	11.40	7.50	25.40	12.50	5.20
	80	40	17.20	12.50	17.90	24.80	15.60	12.70	30.10	17.50	10.30	35.90	19.70	7.30
		42	16.30	12.10	17.00	23.40	15.10	12.00	28.40	16.80	9.70	33.70	18.80	6.90
		45	14.80	11.50	15.50	21.30	14.20	11.00	25.70	15.80	8.80	30.20	17.50	6.20
		48	13.30	10.80	14.00	19.10	13.40	9.90	22.90	14.80	7.90	26.70	16.20	5.50
	85	40	18.30	15.20	19.00	26.40	19.10	13.50	32.10	21.40	10.90	38.20	24.10	7.80
		42	17.30	14.80	18.00	24.90	18.40	12.80	30.20	20.50	10.30	35.80	23.00	7.30
		45	15.80	14.00	16.50	22.60	17.40	11.70	27.30	19.30	9.30	32.20	21.30	6.60
		48	14.20	13.20	14.90	20.30	16.30	10.50	24.40	18.00	8.40	28.40	19.70	5.80
	90	40	19.70	17.90	20.40	28.30	22.40	14.50	34.40	25.10	11.70	41.00	28.30	8.30
		42	18.60	17.30	19.30	26.70	21.60	13.70	32.40	24.10	11.00	38.40	27.00	7.80
		45	16.90	16.40	17.60	24.30	20.40	12.50	29.30	22.70	10.00	34.50	25.10	7.00
		48	15.20	15.20	15.90	21.80	19.20	11.20	26.20	21.20	9.00	30.50	23.20	6.20



Performance Data

Table 11. VUV 075, coil G, 4-row/16 fpi (continued)

Entering Wet Bulb Temp (°F)	Entering Dry Bulb Temp (°F)	Entering Water Temp (°F)	Flow Rate (gpm)											
			2			4			6			10		
			Total Capacity (MBh)	Sensible Capacity (MBh)	T (°F)	Total Capacity (MBh)	Sensible Capacity (MBh)	T (°F)	Total Capacity (MBh)	Sensible Capacity (MBh)	T (°F)	Total Capacity (MBh)	Sensible Capacity (MBh)	T (°F)
70	75	40	18.70	8.40	19.40	26.90	10.60	13.80	32.70	11.80	11.10	38.90	13.30	7.90
		42	17.60	8.20	18.30	25.40	10.20	13.00	30.80	11.40	10.50	36.50	12.70	7.40
		45	16.10	7.70	16.80	23.10	9.60	11.90	27.90	10.70	9.50	32.80	11.80	6.70
		48	14.50	7.30	15.20	20.70	9.00	10.70	24.90	10.00	8.50	28.90	10.90	5.90
	80	40	19.20	11.30	19.90	27.60	14.20	14.10	33.50	15.90	11.40	40.00	17.90	8.10
		42	18.10	11.00	18.80	26.00	13.70	13.40	31.60	15.30	10.80	37.50	17.10	7.60
		45	16.50	10.40	17.20	23.70	12.90	12.20	28.60	14.40	9.80	33.70	15.90	6.90
		48	14.90	9.80	15.60	21.30	12.10	11.00	25.50	13.40	8.70	29.70	14.70	6.10
	85	40	20.00	14.20	20.70	28.80	17.80	14.70	35.00	19.90	11.90	41.70	22.40	8.50
		42	18.90	13.70	19.60	27.20	17.10	13.90	33.00	19.10	11.20	39.10	21.40	8.00
		45	17.20	13.00	17.90	24.70	16.20	12.70	29.90	18.00	10.20	35.10	19.90	7.20
		48	15.50	12.30	16.20	22.20	15.20	11.40	26.70	16.80	9.10	31.00	18.40	6.30
	90	40	21.10	17.00	21.80	30.40	21.30	15.50	36.90	23.90	12.50	44.00	26.80	8.90
		42	19.90	16.50	20.60	28.70	20.50	14.70	34.80	22.90	11.80	41.30	25.60	8.40
		45	18.20	15.60	18.90	26.10	19.40	13.40	31.50	21.50	10.70	37.00	23.80	7.50
		48	16.40	14.70	17.00	23.40	18.20	12.00	28.10	20.10	9.60	32.70	22.00	6.70

Table 12. VUV 075, cooling coil H, 3-row/16 fpi

Entering Wet Bulb Temp (°F)	Entering Dry Bulb Temp (°F)	Entering Water Temp (°F)	Flow Rate (gpm)											
			2			4			6			10		
			Total Capacity (MBh)	Sensible Capacity (MBh)	T (°F)	Total Capacity (MBh)	Sensible Capacity (MBh)	T (°F)	Total Capacity (MBh)	Sensible Capacity (MBh)	T (°F)	Total Capacity (MBh)	Sensible Capacity (MBh)	T (°F)
61	70	40	13.80	10.50	14.50	20.10	12.70	10.40	23.20	13.80	8.00	26.10	14.90	5.40
		42	13.20	10.30	13.80	19.00	12.30	9.80	21.80	13.30	7.50	24.60	14.20	5.00
		45	12.10	9.90	12.80	17.20	11.70	8.90	19.80	12.50	6.80	22.20	13.30	4.60
		48	11.00	9.50	11.70	15.40	11.10	8.00	17.60	11.80	6.10	19.70	12.40	4.10
	75	40	15.00	13.60	15.70	21.90	16.50	11.30	25.30	17.90	8.70	28.50	19.20	5.80
		42	14.30	13.30	15.00	20.70	15.90	10.70	23.80	17.20	8.20	26.80	18.40	5.50
		45	13.20	12.80	13.90	18.80	15.10	9.70	21.50	16.20	7.40	24.20	17.20	5.00
		48	12.00	12.00	12.70	16.80	14.30	8.70	19.20	15.20	6.60	21.50	16.10	4.40
	80	40	16.70	16.40	17.40	24.30	19.90	12.50	28.10	21.70	9.60	31.60	23.30	6.50
		42	15.90	15.90	16.60	22.90	19.30	11.80	26.40	20.80	9.00	29.70	22.30	6.10
		45	14.70	14.70	15.40	20.80	18.30	10.80	23.90	19.60	8.20	26.80	20.90	5.50
		48	13.30	13.30	14.00	18.60	17.40	9.60	21.30	18.50	7.30	23.80	19.50	4.90
	85	40	18.60	18.60	19.30	27.10	23.20	13.90	31.30	25.20	10.70	35.30	27.10	7.20
		42	17.80	17.80	18.40	25.60	22.40	13.10	29.50	24.20	10.10	33.10	25.90	6.80
		45	16.40	16.40	17.10	23.20	21.30	12.00	26.70	22.80	9.10	29.90	24.30	6.10
		48	14.90	14.90	15.60	20.80	20.20	10.70	23.70	21.50	8.10	26.60	22.70	5.50
	90	40	20.80	20.80	21.40	30.30	26.30	15.50	34.90	28.60	11.90	39.30	30.70	8.00
		42	19.80	19.80	20.50	28.50	25.40	14.60	32.90	27.50	11.20	37.00	29.40	7.50
		45	18.30	18.30	18.90	25.90	24.10	13.30	29.70	25.80	10.10	33.30	27.50	6.80
		48	16.60	16.60	17.30	23.20	22.90	11.90	26.50	24.30	9.10	29.60	25.70	6.10
67	75	40	18.80	11.30	19.50	27.40	13.70	14.10	31.70	14.90	10.80	35.60	16.00	7.30
		42	17.90	11.00	18.60	25.90	13.20	13.30	29.80	14.30	10.20	33.50	15.30	6.80
		45	16.50	10.70	17.20	23.50	12.60	12.10	27.00	13.50	9.20	30.20	14.30	6.20
		48	15.00	10.20	15.70	21.00	11.90	10.80	24.00	12.70	8.20	26.90	13.40	5.50
	80	40	19.80	14.60	20.40	28.80	17.70	14.70	33.20	19.20	11.30	37.40	20.70	7.60
		42	18.80	14.30	19.50	27.20	17.10	13.90	31.30	18.50	10.70	35.20	19.80	7.20
		45	17.40	13.80	18.00	24.60	16.20	12.70	28.30	17.40	9.70	31.70	18.50	6.50
		48	15.80	13.30	16.50	22.00	15.40	11.40	25.20	16.40	8.60	28.20	17.30	5.80
	85	40	21.00	17.80	21.70	30.60	21.60	15.70	35.40	23.50	12.00	39.80	25.30	8.10
		42	20.00	17.40	20.70	28.90	20.90	14.80	33.30	22.60	11.30	37.40	24.20	7.60
		45	18.50	16.80	19.20	26.20	19.80	13.50	30.10	21.30	10.30	33.80	22.60	6.90
		48	16.80	16.20	17.50	23.50	18.80	12.10	26.80	20.00	9.20	30.00	21.10	6.10
	90	40	22.60	20.90	23.20	32.90	25.40	16.80	38.00	27.60	12.90	42.70	29.70	8.70
		42	21.50	20.50	22.20	31.00	24.60	15.90	35.70	26.50	12.10	40.20	28.40	8.20
		45	19.80	19.80	20.50	28.20	23.30	14.40	32.30	25.00	11.00	36.20	26.60	7.40
		48	18.00	18.00	18.70	25.20	22.10	12.90	28.80	23.50	9.80	32.20	24.80	6.60



Performance Data

Table 12. VUV 075, cooling coil H, 3-row/16 fpi (continued)

Entering Wet Bulb Temp (°F)	Entering Dry Bulb Temp (°F)	Entering Water Temp (°F)	Flow Rate (gpm)											
			2			4			6			10		
			Total Capacity (MBh)	Sensible Capacity (MBh)	T (°F)	Total Capacity (MBh)	Sensible Capacity (MBh)	T (°F)	Total Capacity (MBh)	Sensible Capacity (MBh)	T (°F)	Total Capacity (MBh)	Sensible Capacity (MBh)	T (°F)
70	75	40	21.40	9.90	22.10	31.20	12.00	16.00	36.00	13.00	12.20	40.60	14.00	8.30
		42	20.40	9.70	21.10	29.50	11.60	15.10	33.90	12.50	11.50	38.10	13.40	7.80
		45	18.80	9.30	19.50	26.70	11.00	13.70	30.70	11.80	10.50	34.40	12.50	7.00
		48	17.10	9.00	17.80	23.90	10.40	12.30	27.30	11.10	9.30	30.60	11.70	6.30
	80	40	22.00	13.30	22.70	32.10	16.10	16.40	37.00	17.50	12.60	41.70	18.80	8.50
		42	21.00	13.00	21.70	30.30	15.60	15.50	34.80	16.80	11.80	39.20	18.00	8.00
		45	19.30	12.50	20.00	27.50	14.80	14.10	31.50	15.80	10.70	35.30	16.80	7.20
		48	17.60	12.00	18.30	24.60	14.00	12.60	28.10	14.90	9.60	31.40	15.70	6.40
	85	40	23.00	16.60	23.70	33.50	20.10	17.10	38.60	21.90	13.10	43.50	23.50	8.80
		42	21.90	16.30	22.60	31.60	19.50	16.10	36.40	21.00	12.40	40.90	22.50	8.30
		45	20.20	15.70	20.90	28.70	18.50	14.70	32.90	19.80	11.20	36.90	21.10	7.50
		48	18.40	15.10	19.00	25.60	17.50	13.20	29.30	18.60	10.00	32.80	19.70	6.70
	90	40	24.20	19.90	24.90	35.30	24.10	18.00	40.70	26.20	13.80	45.80	28.20	9.30
		42	23.10	19.50	23.80	33.30	23.30	17.00	38.30	25.20	13.00	43.10	27.00	8.80
		45	21.30	18.80	22.00	30.20	22.10	15.40	34.70	23.70	11.80	38.90	25.20	7.90
		48	19.40	18.10	20.00	27.00	21.00	13.80	30.90	22.30	10.50	34.50	23.60	7.00

Table 13. VUV 075, cooling coil J (DX)

Size	EWB	Suct Temp	EDB = 70°F				EDB = 75°F				EDB = 80°F				EDB = 85°F			
			TC	SC	LDB	LWB	TC	SC	LDB	LWB	TC	SC	LDB	LWB	TC	SC	LDB	LWB
750	61	40	22.80	15.00	51.40	50.00	25.00	19.90	50.40	48.80	27.70	24.30	49.90	47.20	30.90	28.50	49.70	45.40
		45	19.10	13.70	53.00	52.00	20.90	18.10	52.60	51.00	23.20	22.10	52.60	49.70	25.90	25.90	52.90	48.20
		50	15.40	12.30	54.80	53.80	16.90	16.20	54.90	53.10	18.70	18.70	56.90	52.10	20.90	20.90	59.10	50.90
	64	40	27.10	13.00	53.90	51.60	28.60	18.30	52.30	50.80	30.40	23.20	51.30	49.80	32.70	27.90	50.50	48.50
		45	22.70	11.80	55.40	53.90	23.90	16.60	54.50	53.20	25.50	21.10	53.90	52.30	27.40	25.30	53.70	51.30
		50	18.30	10.60	56.90	56.00	19.30	14.90	56.60	55.50	20.60	19.00	56.50	54.80	22.10	22.10	57.60	54.00
	67	40	32.10	10.40	57.10	53.10	33.10	16.00	55.20	52.50	34.30	21.30	53.60	51.80	35.90	26.30	52.40	50.90
		45	26.90	9.40	58.40	55.70	27.80	14.50	57.10	55.10	28.80	19.30	56.10	54.60	30.10	23.90	55.40	53.90
		50	21.70	8.50	59.50	58.10	22.40	13.10	58.80	57.70	23.20	17.40	58.50	57.20	24.30	21.50	58.40	56.70
	70	40					38.40	13.20	58.70	54.10	39.20	18.70	56.90	53.60	40.30	24.00	55.30	53.00
		45					32.20	12.00	60.10	57.00	32.90	17.00	59.00	56.60	33.70	21.90	57.90	56.20
		50					26.00	10.80	61.60	59.80	26.50	15.30	61.10	59.50	27.20	19.70	60.60	59.20
73	40									44.80	15.60	60.70	55.30	45.60	21.10	58.90	54.80	
	45									37.60	14.20	62.40	58.60	38.20	19.20	61.20	58.30	
	50									30.30	12.80	64.20	61.80	30.80	17.30	63.60	61.50	

Notes:

1. EDB = Entering Air Temperature, Dry Bulb (°F).
2. EWB = Entering Air Temperature, Wet Bulb (°F).
3. TC = Total Capacity (MBh).
4. SC = Sensible Capacity (MBh).
5. LDB = Leaving Air Temperature, Dry Bulb (°F).
6. LWB = Leaving Air Temperature, Wet Bulb (°F).

Table 14. Airflow correction (% of design airflow)

%	Total Capacity (MBh)	Sensible Capacity (MBh)
120	1.03	1.11
110	1.01	1.05
100	1.00	1.00
90	0.99	0.95
80	0.97	0.89

Table 15. Airflow through coil J

Unit Model	0750
Rated cfm	748



Performance Data

Table 16. VUV 075, hydronic heating coils A (1-row/12 fpi), B (2-row/12 fpi), C (2-row/16 fpi)

Coil	Entering Air Temp, Dry Bulb (°F)	Entering Water Temp (°F)	Flow Rate (gpm)					
			2		4		6	
			Total Capacity (MBh)	Waterside Temp Drop (°F)	Total Capacity (MBh)	Waterside Temp Drop (°F)	Total Capacity (MBh)	Waterside Temp Drop (°F)
A	50	120	19.70	19.00	22.90	11.10	24.30	7.90
		140	27.50	26.80	32.10	15.70	34.10	11.10
		160	35.50	34.80	41.40	20.40	43.90	14.40
		180	43.50	42.80	50.80	25.10	53.70	17.70
	55	120	18.60	17.90	21.70	10.50	23.00	7.40
		140	26.00	25.30	30.40	14.90	32.20	10.50
		160	33.50	32.80	39.20	19.30	41.50	13.60
		180	41.20	40.50	48.00	23.70	50.80	16.70
	60	120	17.50	16.80	20.40	9.90	21.70	7.00
		140	24.60	23.90	28.70	14.00	30.40	9.90
		160	31.60	30.90	36.90	18.10	39.20	12.80
		180	38.80	38.10	45.30	22.30	47.90	15.70
	65	120	16.50	15.80	19.20	9.30	20.40	6.60
		140	23.10	22.40	26.90	13.10	28.60	9.30
		160	29.70	29.00	34.70	17.00	36.80	12.00
		180	36.50	35.80	42.60	21.00	45.10	14.80
	70	120	15.40	14.70	18.00	8.70	19.10	6.10
		140	21.60	20.90	25.20	12.30	26.70	8.70
		160	27.80	27.10	32.50	15.90	34.40	11.20
		180	34.20	33.50	39.80	19.60	42.20	13.80
B	50	120	27.30	26.60	34.40	16.90	37.60	12.30
		140	38.40	37.70	48.50	23.90	52.90	17.40
		160	49.70	49.00	62.70	31.00	68.20	22.50
		180	61.20	60.50	77.00	38.20	83.70	27.70
	55	120	25.90	25.20	32.50	15.90	35.50	11.60
		140	36.30	35.60	45.90	22.60	50.00	16.40
		160	47.00	46.30	59.30	29.30	64.60	21.30
		180	57.90	57.20	72.80	36.10	79.20	26.20
	60	120	24.40	23.70	30.70	15.00	33.50	10.90
		140	34.30	33.60	43.30	21.30	47.20	15.50
		160	44.40	43.70	55.90	27.60	60.90	20.10
		180	54.60	53.90	68.70	34.00	74.70	24.70
	65	120	22.90	22.20	28.90	14.10	31.50	10.30
		140	32.20	31.50	40.70	20.00	44.40	14.60
		160	41.70	41.00	52.60	26.00	57.30	18.90
		180	51.40	50.70	64.60	32.00	70.20	23.20
	70	120	21.50	20.80	27.00	13.20	29.50	9.60
		140	30.10	29.40	38.10	18.70	41.50	13.60
		160	39.00	38.30	49.20	24.30	53.60	17.60
		180	48.10	47.40	60.40	29.90	65.70	21.70

Table 16. VUV 075, hydronic heating coils A (1-row/12 fpi), B (2-row/12 fpi), C (2-row/16 fpi) (continued)

Coil	Entering Air Temp, Dry Bulb (°F)	Entering Water Temp (°F)	Flow Rate (gpm)					
			2		4		6	
			Total Capacity (MBh)	Waterside Temp Drop (°F)	Total Capacity (MBh)	Waterside Temp Drop (°F)	Total Capacity (MBh)	Waterside Temp Drop (°F)
C	50	120	28.30	27.60	36.10	17.70	39.50	12.90
		140	39.90	39.20	50.90	25.10	55.50	18.30
		160	51.70	51.00	65.70	32.50	71.60	23.60
		180	63.60	62.90	80.70	40.00	87.80	29.00
	55	120	26.80	26.10	34.20	16.80	37.30	12.20
		140	37.70	37.00	48.10	23.70	52.50	17.30
		160	48.90	48.20	62.20	30.80	67.80	22.40
		180	60.20	59.50	76.30	37.80	83.10	27.50
	60	120	25.30	24.60	32.20	15.80	35.20	11.50
		140	35.60	34.90	45.40	22.40	49.50	16.30
		160	46.10	45.40	58.70	29.00	63.90	21.10
		180	56.80	56.10	72.00	35.70	78.40	25.90
	65	120	23.80	23.10	30.30	14.80	33.10	10.80
		140	33.50	32.80	42.70	21.00	46.60	15.30
		160	43.30	42.60	55.10	27.20	60.10	19.80
		180	53.40	52.70	67.70	33.50	73.70	24.30
	70	120	22.20	21.50	28.30	13.80	31.00	10.10
		140	31.30	30.60	39.90	19.60	43.60	14.30
		160	40.60	39.90	51.60	25.50	56.20	18.50
		180	50.00	49.30	63.40	31.40	68.90	22.70



Performance Data

Table 17. VUV 075, steam heating coil K (low-capacity), L (high-capacity)

Size	Coil	Entering Air Temp, Dry Bulb (°F)	Steam Pressure (psig)					
			5		10		15	
			Total Capacity (MBh)	Airside Temp Rise (°F)	Total Capacity (MBh)	Airside Temp Rise (°F)	Total Capacity (MBh)	Airside Temp Rise (°F)
750	K	0	68.70	84.80	72.30	89.20	75.30	93.00
		10	65.70	81.10	69.30	85.50	72.30	89.20
		20	62.70	77.40	66.20	81.80	69.30	85.50
		30	59.70	73.60	63.20	78.00	66.30	81.80
		40	56.60	69.90	60.20	74.30	63.20	78.10
		50	53.60	66.20	57.10	70.60	60.20	74.30
		60	50.60	62.40	54.10	66.80	57.20	70.60
		70	47.50	58.70	51.10	63.10	54.20	66.90
	L	0	81.20	100.20	85.40	105.40	89.00	109.90
		10	77.60	95.80	81.80	101.00	85.40	105.40
		20	74.00	91.40	78.20	96.60	81.80	101.00
		30	70.40	87.00	74.70	92.20	78.30	96.60
		40	66.90	82.60	71.10	87.80	74.70	92.20
		50	63.30	78.20	67.50	83.40	71.10	87.80
		60	59.70	73.70	63.90	78.90	67.50	83.40
		70	56.20	69.40	60.40	74.60	64.00	79.00

Note: psig = Steam Pressure (lb/in.² gage).

Table 18. VUV 100, cooling coil E, 3-row/16 fpi

Entering Wet Bulb Temp (°F)	Entering Dry Bulb Temp (°F)	Entering Water Temp (°F)	Flow Rate (gpm)											
			2			4			6			10		
			Total Capacity (MBh)	Sensible Capacity (MBh)	T (°F)	Total Capacity (MBh)	Sensible Capacity (MBh)	T (°F)	Total Capacity (MBh)	Sensible Capacity (MBh)	T (°F)	Total Capacity (MBh)	Sensible Capacity (MBh)	T (°F)
61	70	40	12.60	11.30	13.50	18.60	14.30	9.70	23.20	16.10	8.00	29.20	18.10	6.00
		42	12.00	11.00	12.90	17.70	13.90	9.30	22.00	15.60	7.60	27.60	17.50	5.70
		45	11.00	10.40	11.90	16.20	13.40	8.60	20.20	14.90	7.00	25.10	16.60	5.20
		48	9.90	9.70	10.90	14.70	12.70	7.80	18.30	14.20	6.40	22.50	15.60	4.70
	75	40	13.70	13.70	14.70	20.30	18.50	10.60	25.30	20.80	8.70	31.90	23.50	6.60
		42	13.10	13.10	14.00	19.30	18.10	10.10	24.00	20.20	8.30	30.10	22.70	6.20
		45	12.00	12.00	12.90	17.70	17.30	9.30	22.00	19.30	7.60	27.40	21.50	5.70
		48	10.90	10.90	11.80	16.10	16.10	8.50	19.90	18.40	6.90	24.60	20.30	5.10
	80	40	15.20	15.20	16.20	22.50	22.40	11.70	28.10	25.20	9.70	35.40	28.50	7.30
		42	14.50	14.50	15.40	21.40	21.40	11.10	26.70	24.50	9.20	33.40	27.50	6.90
		45	13.40	13.40	14.30	19.70	19.70	10.30	24.40	23.40	8.40	30.40	26.00	6.30
		48	12.00	12.00	12.90	17.80	17.80	9.40	22.10	22.10	7.70	27.30	24.50	5.60
	85	40	17.00	17.00	17.90	25.10	25.10	13.00	31.40	29.30	10.80	39.50	33.10	8.10
		42	16.20	16.20	17.10	23.90	23.90	12.40	29.80	28.50	10.20	37.30	31.90	7.60
		45	14.90	14.90	15.80	21.90	21.90	11.40	27.30	27.20	9.40	33.90	30.20	7.00
		48	13.40	13.40	14.30	19.90	19.90	10.40	24.70	24.70	8.50	30.40	28.50	6.30
	90	40	19.00	19.00	19.90	28.00	28.00	14.40	35.00	33.20	12.00	44.00	37.50	9.00
		42	18.10	18.10	19.00	26.60	26.60	13.80	33.20	32.30	11.40	41.50	36.20	8.50
		45	16.60	16.60	17.50	24.40	24.40	12.70	30.40	30.40	10.40	37.80	34.30	7.70
		48	15.00	15.00	15.90	22.20	22.20	11.50	27.50	27.50	9.50	33.90	32.30	7.00
67	75	40	17.20	12.20	18.10	25.40	15.40	13.10	31.70	17.30	10.90	39.90	19.50	8.20
		42	16.40	11.80	17.30	24.10	15.00	12.50	30.10	16.80	10.30	37.70	18.80	7.70
		45	15.10	11.20	16.00	22.20	14.40	11.50	27.60	16.10	9.50	34.20	17.80	7.00
		48	13.60	10.50	14.50	20.10	13.70	10.50	24.90	15.30	8.60	30.80	16.80	6.30
	80	40	18.00	15.80	18.90	26.60	19.90	13.80	33.30	22.40	11.40	41.90	25.30	8.60
		42	17.20	15.30	18.10	25.30	19.40	13.10	31.50	21.80	10.80	39.50	24.40	8.10
		45	15.80	14.50	16.70	23.30	18.60	12.10	28.90	20.80	9.90	35.90	23.10	7.40
		48	14.20	13.60	15.10	21.10	17.70	11.00	26.20	19.80	9.00	32.30	21.80	6.60
	85	40	19.20	19.20	20.10	28.30	24.30	14.60	35.40	27.30	12.10	44.60	30.80	9.10
		42	18.30	18.30	19.20	26.90	23.70	13.90	33.60	26.60	11.50	42.10	29.80	8.60
		45	16.80	16.80	17.70	24.80	22.70	12.80	30.80	25.40	10.60	38.20	28.20	7.80
		48	15.20	15.20	16.10	22.40	21.60	11.70	27.90	24.10	9.60	34.40	26.60	7.10
	90	40	20.60	20.60	21.50	30.40	28.60	15.70	38.00	32.10	13.00	47.80	36.30	9.70
		42	19.60	19.60	20.50	28.90	27.90	14.90	36.00	31.20	12.30	45.10	35.00	9.20
		45	18.10	18.10	19.00	26.60	26.60	13.70	33.00	29.80	11.30	41.00	33.10	8.40
		48	16.30	16.30	17.20	24.10	24.10	12.50	29.90	28.40	10.30	36.90	31.20	7.60



Performance Data

Table 18. VUV 100, cooling coil E, 3-row/16 fpi (continued)

Entering Wet Bulb Temp (°F)	Entering Dry Bulb Temp (°F)	Entering Water Temp (°F)	Flow Rate (gpm)											
			2			4			6			10		
			Total Capacity (MBh)	Sensible Capacity (MBh)	T (°F)	Total Capacity (MBh)	Sensible Capacity (MBh)	T (°F)	Total Capacity (MBh)	Sensible Capacity (MBh)	T (°F)	Total Capacity (MBh)	Sensible Capacity (MBh)	T (°F)
70	75	40	19.60	10.70	20.50	28.90	13.50	14.90	36.10	15.10	12.30	45.40	17.10	9.30
		42	18.70	10.40	19.60	27.50	13.10	14.20	34.20	14.70	11.70	42.90	16.50	8.80
		45	17.10	9.80	18.00	25.20	12.60	13.10	31.40	14.10	10.80	39.00	15.60	8.00
		48	15.40	9.20	16.40	22.90	12.00	11.90	28.40	13.40	9.80	35.00	14.70	7.20
	80	40	20.10	14.30	21.00	29.70	18.10	15.30	37.10	20.30	12.70	46.60	23.00	9.50
		42	19.20	13.90	20.10	28.20	17.60	14.60	35.20	19.80	12.00	44.00	22.10	9.00
		45	17.60	13.20	18.50	25.90	16.90	13.40	32.20	18.90	11.00	40.00	21.00	8.20
		48	15.90	12.30	16.80	23.50	16.10	12.20	29.20	18.00	10.00	36.00	19.80	7.40
	85	40	21.00	17.90	21.90	31.00	22.70	15.90	38.70	25.50	13.20	48.70	28.70	9.90
		42	20.00	17.40	20.90	29.40	22.10	15.20	36.70	24.80	12.50	45.90	27.70	9.40
		45	18.40	16.50	19.30	27.00	21.20	14.00	33.60	23.70	11.50	41.80	26.30	8.50
		48	16.60	15.40	17.50	24.50	20.10	12.70	30.40	22.50	10.40	37.50	24.80	7.70
	90	40	22.10	21.50	23.00	32.60	27.10	16.80	40.80	30.50	13.90	51.30	34.40	10.40
		42	21.10	20.90	22.00	31.00	26.50	16.00	38.70	29.60	13.20	48.40	33.20	9.90
		45	19.40	19.40	20.30	28.50	25.40	14.70	35.40	28.30	12.10	44.00	31.40	9.00
		48	17.50	17.50	18.40	25.80	24.10	13.40	32.10	26.90	11.00	39.60	29.70	8.10

Table 19. VUV 100, cooling coil F, 4-row/12 fpi

Entering Wet Bulb Temp (°F)	Entering Dry Bulb Temp (°F)	Entering Water Temp (°F)	Flow Rate (gpm)											
			2			4			6			10		
			Total Capacity (MBh)	Sensible Capacity (MBh)	T (°F)	Total Capacity (MBh)	Sensible Capacity (MBh)	T (°F)	Total Capacity (MBh)	Sensible Capacity (MBh)	T (°F)	Total Capacity (MBh)	Sensible Capacity (MBh)	T (°F)
61	70	40	12.40	11.30	13.30	19.30	14.10	10.10	24.10	15.80	8.30	29.70	17.90	6.10
		42	11.80	11.00	12.70	18.40	13.80	9.60	22.80	15.40	7.90	28.00	17.30	5.80
		45	10.80	10.40	11.70	16.90	13.20	8.90	20.90	14.70	7.30	25.50	16.30	5.30
		48	9.70	9.70	10.60	15.30	12.60	8.10	19.00	14.00	6.60	23.00	15.30	4.80
	75	40	13.60	13.60	14.50	21.10	18.30	11.00	26.20	20.50	9.00	32.30	23.20	6.70
		42	12.90	12.90	13.80	20.00	17.80	10.50	24.90	19.90	8.60	30.60	22.40	6.30
		45	11.70	11.70	12.70	18.40	17.10	9.70	22.80	19.00	7.90	27.90	21.10	5.80
		48	10.60	10.60	11.50	16.70	16.30	8.80	20.70	18.10	7.20	25.10	19.90	5.20
	80	40	15.00	15.00	15.90	23.40	22.20	12.10	29.10	24.80	10.00	35.90	28.10	7.40
		42	14.30	14.30	15.20	22.20	21.60	11.60	27.60	24.10	9.50	33.90	27.10	7.00
		45	13.00	13.00	13.90	20.40	20.40	10.70	25.30	23.00	8.70	30.90	25.50	6.40
		48	11.70	11.70	12.60	18.50	18.50	9.70	23.00	21.90	8.00	27.80	24.00	5.70
	85	40	16.80	16.80	17.70	26.10	25.80	13.50	32.50	28.90	11.10	40.00	32.70	8.20
		42	15.90	15.90	16.80	24.80	24.80	12.80	30.80	28.00	10.60	37.80	31.50	7.70
		45	14.50	14.50	15.40	22.80	22.80	11.80	28.30	26.80	9.70	34.50	29.70	7.10
		48	13.10	13.10	14.00	20.70	20.70	10.80	25.70	25.50	8.90	31.00	28.00	6.40
	90	40	18.70	18.70	19.60	29.10	29.10	15.00	36.20	32.80	12.40	44.60	37.10	9.10
		42	17.70	17.70	18.60	27.60	27.60	14.30	34.40	31.80	11.80	42.20	35.70	8.60
		45	16.20	16.20	17.10	25.40	25.40	13.10	31.50	30.30	10.80	38.40	33.70	7.90
		48	14.60	14.60	15.50	23.00	23.00	12.00	28.60	28.60	9.80	34.60	31.70	7.10
67	75	40	17.00	12.20	17.90	26.40	15.20	13.60	32.80	17.00	11.20	40.50	19.30	8.30
		42	16.10	11.80	17.00	25.10	14.80	13.00	31.10	16.50	10.70	38.20	18.60	7.80
		45	14.70	11.20	15.60	23.00	14.20	12.00	28.60	15.80	9.80	34.80	17.50	7.10
		48	13.20	10.60	14.10	20.90	13.50	10.90	25.90	15.00	8.90	31.40	16.50	6.50
	80	40	17.80	15.70	18.70	27.70	19.70	14.30	34.40	22.10	11.80	42.50	25.00	8.70
		42	16.90	15.30	17.80	26.30	19.20	13.60	32.70	21.40	11.20	40.10	24.10	8.20
		45	15.40	14.60	16.30	24.10	18.40	12.50	30.00	20.40	10.30	36.60	22.70	7.50
		48	13.90	13.70	14.80	21.90	17.50	11.40	27.20	19.40	9.40	32.90	21.30	6.80
	85	40	18.90	18.90	19.80	29.50	24.00	15.20	36.70	26.90	12.50	45.20	30.50	9.20
		42	18.00	18.00	18.90	28.00	23.40	14.40	34.80	26.10	11.90	42.70	29.40	8.70
		45	16.40	16.40	17.30	25.70	22.40	13.30	31.90	24.90	10.90	38.90	27.70	8.00
		48	14.80	14.80	15.70	23.30	21.40	12.10	29.00	23.70	10.00	35.00	26.10	7.20
	90	40	20.30	20.30	21.20	31.60	28.20	16.30	39.30	31.70	13.40	48.50	35.80	9.90
		42	19.30	19.30	20.20	30.00	27.50	15.50	37.30	30.70	12.70	45.80	34.50	9.30
		45	17.60	17.60	18.50	27.60	26.30	14.20	34.30	29.30	11.70	41.80	32.50	8.50
		48	15.90	15.90	16.80	25.00	25.00	13.00	31.10	27.90	10.70	37.60	30.60	7.70



Performance Data

Table 19. VUV 100, cooling coil F, 4-row/12 fpi (continued)

Entering Wet Bulb Temp (°F)	Entering Dry Bulb Temp (°F)	Entering Water Temp (°F)	Flow Rate (gpm)											
			2			4			6			10		
			Total Capacity (MBh)	Sensible Capacity (MBh)	T (°F)	Total Capacity (MBh)	Sensible Capacity (MBh)	T (°F)	Total Capacity (MBh)	Sensible Capacity (MBh)	T (°F)	Total Capacity (MBh)	Sensible Capacity (MBh)	T (°F)
70	75	40	19.30	10.60	20.20	30.00	13.30	15.50	37.40	14.90	12.80	46.10	16.90	9.40
		42	18.30	10.30	19.20	28.50	13.00	14.70	35.50	14.50	12.10	43.50	16.30	8.90
		45	16.70	9.80	17.60	26.20	12.40	13.60	32.50	13.80	11.10	39.70	15.30	8.10
		48	15.10	9.30	16.00	23.80	11.80	12.30	29.50	13.10	10.10	35.70	14.40	7.30
	80	40	19.80	14.30	20.70	30.80	17.90	15.90	38.40	20.00	13.10	47.30	22.70	9.60
		42	18.80	13.90	19.70	29.30	17.40	15.10	36.40	19.40	12.40	44.70	21.80	9.10
		45	17.20	13.20	18.10	26.90	16.70	13.90	33.40	18.60	11.40	40.70	20.60	8.30
		48	15.50	12.50	16.40	24.40	15.90	12.70	30.30	17.70	10.40	36.70	19.40	7.50
	85	40	20.70	17.90	21.60	32.20	22.40	16.50	40.00	25.10	13.70	49.40	28.40	10.10
		42	19.60	17.40	20.50	30.60	21.80	15.70	38.00	24.40	13.00	46.70	27.40	9.50
		45	17.90	16.60	18.80	28.10	20.90	14.50	34.90	23.20	11.90	42.50	25.80	8.70
		48	16.10	15.60	17.00	25.50	19.90	13.20	31.60	22.10	10.80	38.30	24.30	7.80
	90	40	21.80	21.40	22.70	33.90	26.80	17.40	42.20	30.10	14.40	52.00	34.00	10.60
		42	20.70	20.70	21.60	32.20	26.10	16.60	40.10	29.20	13.70	49.20	32.80	10.00
		45	18.90	18.90	19.80	29.60	25.00	15.30	36.80	27.80	12.60	44.80	30.90	9.10
		48	17.00	17.00	17.90	26.90	23.90	13.90	33.40	26.50	11.40	40.30	29.10	8.20

Table 20. VUV 100, cooling coil G, 4-row/16 fpi

Entering Wet Bulb Temp (°F)	Entering Dry Bulb Temp (°F)	Entering Water Temp (°F)	Flow Rate (gpm)											
			2			4			6			10		
			Total Capacity (MBh)	Sensible Capacity (MBh)	T (°F)	Total Capacity (MBh)	Sensible Capacity (MBh)	T (°F)	Total Capacity (MBh)	Sensible Capacity (MBh)	T (°F)	Total Capacity (MBh)	Sensible Capacity (MBh)	T (°F)
61	70	40	15.00	13.10	15.90	22.90	17.10	11.90	28.80	19.40	9.90	35.90	22.30	7.40
		42	14.20	12.70	15.10	21.70	16.50	11.30	27.20	18.70	9.40	33.70	21.30	6.90
		45	13.00	12.00	13.90	19.70	15.70	10.30	24.60	17.70	8.50	30.30	19.90	6.20
		48	11.70	11.30	12.60	17.80	14.80	9.30	22.10	16.60	7.70	26.80	18.50	5.50
	75	40	16.30	16.30	17.20	25.00	22.10	13.00	31.40	25.20	10.80	39.10	28.90	8.00
		42	15.50	15.50	16.40	23.60	21.40	12.30	29.60	24.30	10.20	36.70	27.60	7.50
		45	14.10	14.10	15.00	21.50	20.30	11.20	26.90	22.90	9.30	33.00	25.80	6.80
		48	12.80	12.80	13.70	19.40	19.20	10.10	24.10	21.60	8.30	29.20	24.00	6.00
	80	40	18.10	18.10	19.00	27.70	26.80	14.30	34.90	30.50	11.90	43.40	34.90	8.90
		42	17.20	17.20	18.10	26.20	25.90	13.60	32.90	29.40	11.30	40.70	33.40	8.30
		45	15.70	15.70	16.60	23.90	23.90	12.40	29.80	27.80	10.20	36.60	31.20	7.50
		48	14.20	14.20	15.10	21.50	21.50	11.20	26.70	26.10	9.20	32.40	29.00	6.70
	85	40	20.20	20.20	21.10	31.00	31.00	15.90	38.90	35.50	13.30	48.40	40.70	9.90
		42	19.10	19.10	20.00	29.20	29.20	15.10	36.70	34.20	12.50	45.40	38.90	9.30
		45	17.50	17.50	18.40	26.60	26.60	13.80	33.30	32.30	11.40	40.90	36.30	8.40
		48	15.80	15.80	16.70	24.00	24.00	12.40	29.80	29.80	10.20	36.20	33.80	7.40
	90	40	22.60	22.60	23.50	34.50	34.50	17.70	43.40	40.20	14.80	54.00	46.10	11.00
		42	21.30	21.30	22.20	32.60	32.60	16.80	40.90	38.80	13.90	50.70	44.10	10.30
		45	19.50	19.50	20.40	29.70	29.70	15.30	37.10	36.60	12.70	45.60	41.10	9.30
		48	17.60	17.60	18.50	26.70	26.70	13.80	33.20	33.20	11.40	40.30	38.20	8.20
67	75	40	20.40	14.10	21.40	31.30	18.40	16.10	39.30	20.90	13.40	48.90	24.00	10.00
		42	19.30	13.70	20.30	29.60	17.80	15.20	37.10	20.20	12.70	45.90	22.90	9.40
		45	17.70	12.90	18.60	26.90	16.90	13.90	33.60	19.00	11.50	41.30	21.40	8.40
		48	16.00	12.20	16.90	24.20	16.00	12.60	30.10	17.90	10.30	36.60	19.90	7.50
	80	40	21.50	18.30	22.40	32.80	23.80	16.90	41.30	27.10	14.10	51.40	31.00	10.50
		42	20.30	17.70	21.20	31.00	23.00	16.00	38.90	26.10	13.30	48.20	29.70	9.80
		45	18.50	16.80	19.40	28.30	21.90	14.60	35.30	24.70	12.10	43.30	27.70	8.80
		48	16.80	15.80	17.70	25.40	20.70	13.20	31.60	23.20	10.80	38.40	25.80	7.90
	85	40	22.80	22.30	23.70	35.00	29.10	17.90	43.90	33.10	14.90	54.70	37.90	11.10
		42	21.60	21.60	22.50	33.00	28.10	17.00	41.40	31.90	14.10	51.30	36.20	10.40
		45	19.70	19.70	20.60	30.10	26.70	15.50	37.60	30.10	12.80	46.10	33.80	9.40
		48	17.80	17.80	18.80	27.10	25.20	14.00	33.60	28.30	11.50	40.90	31.50	8.40
	90	40	24.50	24.50	25.40	37.50	34.10	19.20	47.10	38.90	16.00	58.70	44.50	11.90
		42	23.20	23.20	24.10	35.40	33.00	18.20	44.40	37.50	15.10	55.00	42.60	11.20
		45	21.20	21.20	22.10	32.30	31.40	16.60	40.30	35.40	13.70	49.50	39.80	10.10
		48	19.10	19.10	20.10	29.10	29.10	15.00	36.10	33.30	12.30	43.80	37.00	8.90



Performance Data

Table 20. VUV 100, cooling coil G, 4-row/16 fpi (continued)

Entering Wet Bulb Temp (°F)	Entering Dry Bulb Temp (°F)	Entering Water Temp (°F)	Flow Rate (gpm)											
			2			4			6			10		
			Total Capacity (MBh)	Sensible Capacity (MBh)	T (°F)	Total Capacity (MBh)	Sensible Capacity (MBh)	T (°F)	Total Capacity (MBh)	Sensible Capacity (MBh)	T (°F)	Total Capacity (MBh)	Sensible Capacity (MBh)	T (°F)
70	75	40	23.30	12.30	24.20	35.60	16.10	18.30	44.80	18.30	15.20	55.70	21.00	11.30
		42	22.00	12.00	22.90	33.60	15.60	17.30	42.20	17.70	14.40	52.30	20.10	10.60
		45	20.10	11.30	21.00	30.70	14.80	15.80	38.30	16.70	13.10	47.00	18.70	9.60
		48	18.20	10.70	19.10	27.60	14.00	14.30	34.30	15.70	11.70	41.60	17.40	8.50
	80	40	23.90	16.60	24.80	36.60	21.60	18.70	46.00	24.60	15.60	57.20	28.20	11.60
		42	22.60	16.10	23.50	34.60	20.90	17.70	43.30	23.70	14.70	53.70	27.00	10.90
		45	20.70	15.20	21.60	31.50	19.90	16.20	39.30	22.40	13.40	48.30	25.20	9.80
		48	18.70	14.30	19.60	28.30	18.80	14.60	35.20	21.10	12.00	42.80	23.40	8.70
	85	40	24.90	20.80	25.90	38.20	27.10	19.50	48.00	30.80	16.30	59.70	35.30	12.10
		42	23.60	20.10	24.50	36.10	26.20	18.50	45.20	29.70	15.40	56.00	33.80	11.40
		45	21.60	19.10	22.50	32.90	24.90	16.90	41.00	28.00	14.00	50.40	31.50	10.30
		48	19.50	17.90	20.40	29.60	23.50	15.20	36.70	26.40	12.50	44.60	29.30	9.10
	90	40	26.30	24.90	27.20	40.20	32.40	20.60	50.60	36.90	17.20	63.00	42.30	12.80
		42	24.90	24.10	25.80	38.00	31.40	19.50	47.70	35.60	16.20	59.10	40.50	12.00
		45	22.70	22.70	23.60	34.60	29.80	17.80	43.20	33.60	14.70	53.10	37.80	10.80
		48	20.50	20.50	21.50	31.20	28.10	16.00	38.70	31.60	13.20	47.00	35.10	9.60

Table 21. VUV 100, cooling coil H, 3-row/16 fpi

Entering Wet Bulb Temp (°F)	Entering Dry Bulb Temp (°F)	Entering Water Temp (°F)	Flow Rate (gpm)											
			2			4			6			10		
			Total Capacity (MBh)	Sensible Capacity (MBh)	T (°F)	Total Capacity (MBh)	Sensible Capacity (MBh)	T (°F)	Total Capacity (MBh)	Sensible Capacity (MBh)	T (°F)	Total Capacity (MBh)	Sensible Capacity (MBh)	T (°F)
61	70	40	14.00	12.30	14.90	21.60	16.10	11.30	27.00	18.20	9.30	32.80	20.60	6.70
		42	13.20	11.90	14.10	20.40	15.50	10.70	25.40	17.50	8.80	30.70	19.70	6.30
		45	12.10	11.30	13.10	18.60	14.70	9.80	23.00	16.50	8.00	27.50	18.40	5.70
		48	11.00	10.70	11.90	16.80	13.90	8.90	20.60	15.60	7.20	24.20	17.10	5.00
	75	40	15.20	15.20	16.10	23.60	20.80	12.30	29.50	23.60	10.10	35.80	26.70	7.30
		42	14.40	14.40	15.30	22.30	20.10	11.60	27.70	22.70	9.60	33.50	25.50	6.90
		45	13.20	13.20	14.20	20.30	19.10	10.60	25.10	21.40	8.70	30.00	23.80	6.20
		48	12.00	12.00	12.90	18.30	18.10	9.60	22.50	20.20	7.80	26.40	22.10	5.50
	80	40	16.90	16.90	17.80	26.20	25.20	13.50	32.70	28.50	11.20	39.70	32.30	8.10
		42	16.00	16.00	16.90	24.70	24.40	12.80	30.80	27.50	10.60	37.10	30.90	7.60
		45	14.70	14.70	15.60	22.60	22.60	11.70	27.90	25.90	9.60	33.30	28.80	6.80
		48	13.40	13.40	14.30	20.30	20.30	10.60	24.90	24.40	8.60	29.30	26.80	6.00
	85	40	18.90	18.90	19.80	29.20	29.20	15.10	36.50	33.20	12.50	44.30	37.60	9.00
		42	17.90	17.90	18.80	27.60	27.60	14.30	34.30	32.00	11.70	41.40	36.00	8.50
		45	16.40	16.40	17.30	25.20	25.20	13.00	31.10	30.20	10.70	37.10	33.60	7.60
		48	14.90	14.90	15.80	22.70	22.70	11.80	27.80	27.80	9.60	32.70	31.20	6.70
	90	40	21.00	21.00	21.90	32.60	32.60	16.70	40.60	37.60	13.90	49.40	42.60	10.10
		42	19.90	19.90	20.80	30.80	30.80	15.80	38.30	36.20	13.10	46.20	40.80	9.40
		45	18.30	18.30	19.20	28.10	28.10	14.50	34.70	34.20	11.90	41.40	38.00	8.50
		48	16.60	16.60	17.50	25.30	25.30	13.10	31.00	31.00	10.60	36.40	35.30	7.50
67	75	40	19.10	13.30	20.00	29.50	17.30	15.20	36.90	19.60	12.60	44.80	22.20	9.10
		42	18.10	12.80	19.00	27.90	16.70	14.40	34.70	18.90	11.90	41.90	21.20	8.60
		45	16.60	12.20	17.50	25.40	15.90	13.20	31.40	17.80	10.80	37.50	19.80	7.70
		48	15.10	11.50	16.00	22.90	15.00	11.90	28.10	16.70	9.70	33.00	18.40	6.80
	80	40	20.00	17.20	20.90	31.00	22.40	15.90	38.70	25.30	13.20	47.00	28.70	9.60
		42	19.00	16.60	19.90	29.30	21.60	15.10	36.40	24.40	12.40	43.90	27.50	9.00
		45	17.40	15.80	18.30	26.70	20.50	13.80	33.00	23.00	11.30	39.40	25.60	8.10
		48	15.80	14.80	16.70	24.10	19.40	12.50	29.50	21.70	10.10	34.70	23.80	7.10
	85	40	21.30	20.90	22.20	33.00	27.30	16.90	41.20	30.90	14.00	50.00	35.00	10.20
		42	20.20	20.20	21.10	31.20	26.40	16.00	38.80	29.80	13.20	46.80	33.50	9.50
		45	18.50	18.50	19.40	28.40	25.10	14.70	35.10	28.10	12.00	41.90	31.30	8.60
		48	16.80	16.80	17.70	25.60	23.70	13.30	31.40	26.40	10.80	36.90	29.10	7.60
	90	40	22.80	22.80	23.70	35.40	32.10	18.10	44.20	36.30	15.00	53.60	41.20	10.90
		42	21.70	21.70	22.60	33.40	31.00	17.20	41.60	35.00	14.20	50.20	39.40	10.20
		45	19.90	19.90	20.80	30.50	29.50	15.70	37.70	33.10	12.90	45.00	36.70	9.20
		48	18.10	18.10	19.00	27.50	27.50	14.20	33.70	31.10	11.50	39.60	34.20	8.10



Performance Data

Table 21. VUV 100, cooling coil H, 3-row/16 fpi (continued)

Entering Wet Bulb Temp (°F)	Entering Dry Bulb Temp (°F)	Entering Water Temp (°F)	Flow Rate (gpm)											
			2			4			6			10		
			Total Capacity (MBh)	Sensible Capacity (MBh)	T (°F)	Total Capacity (MBh)	Sensible Capacity (MBh)	T (°F)	Total Capacity (MBh)	Sensible Capacity (MBh)	T (°F)	Total Capacity (MBh)	Sensible Capacity (MBh)	T (°F)
70	75	40	21.70	11.60	22.60	33.60	15.10	17.30	42.00	17.10	14.30	50.90	19.40	10.40
		42	20.60	11.20	21.50	31.80	14.60	16.30	39.50	16.50	13.50	47.70	18.60	9.70
		45	18.90	10.70	19.80	29.00	13.90	14.90	35.80	15.60	12.20	42.70	17.30	8.70
		48	17.10	10.00	18.10	26.10	13.10	13.50	32.00	14.70	11.00	37.60	16.10	7.70
	80	40	22.30	15.60	23.20	34.50	20.30	17.70	43.10	23.00	14.70	52.30	26.10	10.60
		42	21.10	15.10	22.00	32.60	19.70	16.80	40.60	22.20	13.80	49.00	24.90	10.00
		45	19.40	14.30	20.30	29.70	18.70	15.30	36.80	20.90	12.60	43.90	23.30	9.00
		48	17.60	13.50	18.50	26.80	17.60	13.90	32.90	19.70	11.30	38.60	21.60	7.90
	85	40	23.30	19.50	24.20	36.00	25.50	18.50	45.00	28.80	15.30	54.60	32.70	11.10
		42	22.00	18.90	23.00	34.00	24.60	17.50	42.40	27.80	14.40	51.10	31.20	10.40
		45	20.20	17.90	21.10	31.00	23.40	16.00	38.40	26.20	13.10	45.80	29.10	9.30
		48	18.40	16.90	19.30	28.00	22.10	14.40	34.30	24.60	11.70	40.30	27.10	8.20
	90	40	24.50	23.40	25.40	38.00	30.50	19.40	47.40	34.50	16.10	57.60	39.10	11.70
		42	23.20	22.60	24.10	35.90	29.50	18.40	44.60	33.30	15.20	53.90	37.40	11.00
		45	21.30	21.30	22.20	32.70	28.00	16.80	40.40	31.40	13.80	48.20	34.90	9.80
		48	19.40	19.40	20.30	29.50	26.40	15.20	36.20	29.50	12.40	42.50	32.40	8.70

Table 22. VUV 100, cooling coil J (DX)

Size	EWB	Suct Temp	EDB = 70°F				EDB = 75°F				EDB = 80°F				EDB = 85°F			
			TC	SC	LDB	LWB	TC	SC	LDB	LWB	TC	SC	LDB	LWB	TC	SC	LDB	LWB
1000	61	40	29.10	19.10	52.10	50.50	31.80	25.30	51.30	49.30	35.20	31.00	51.00	47.90	39.40	36.30	51.00	46.00
		45	24.40	17.40	53.70	52.30	26.70	23.00	53.50	51.40	29.50	28.10	53.70	50.20	33.00	33.00	54.10	48.70
		50	19.70	15.60	55.40	54.10	21.50	20.70	55.60	53.40	23.80	23.80	57.70	52.50	26.60	26.60	60.10	51.30
	64	40	34.60	16.50	54.60	52.10	36.40	23.20	53.30	51.40	38.70	29.50	52.40	50.40	41.60	35.50	51.80	49.10
		45	29.00	15.00	56.00	54.20	30.50	21.10	55.20	53.60	32.50	26.80	54.90	52.80	34.90	32.20	54.90	51.80
		50	23.40	13.50	57.40	56.30	24.60	19.00	57.20	55.80	26.20	24.10	57.40	55.20	28.20	28.20	58.60	54.40
	67	40	40.90	13.20	57.60	53.70	42.20	20.30	56.00	53.10	43.70	27.10	54.60	52.50	45.70	33.50	53.60	51.60
		45	34.30	12.00	58.80	56.10	35.40	18.50	57.70	55.60	36.70	24.60	57.00	55.10	38.30	30.50	56.40	54.40
		50	27.70	10.80	59.90	58.40	28.50	16.60	59.50	58.10	29.60	22.20	59.20	57.60	30.90	27.40	59.30	57.10
	70	40					48.90	16.80	59.30	54.80	50.00	23.80	57.70	54.30	51.30	30.60	56.40	53.70
		45					41.00	15.20	60.80	57.60	41.90	21.60	59.80	57.20	43.00	27.80	59.00	56.70
		50					33.10	13.70	62.20	60.20	33.80	19.50	61.70	60.00	34.70	25.00	61.60	59.60
73	40									57.20	19.90	61.40	56.00	58.10	26.90	59.80	55.60	
	45									47.90	18.10	63.10	59.20	48.70	24.40	62.20	58.90	
	50									38.70	16.20	64.80	62.20	39.30	22.00	64.40	61.90	

Notes:

1. EDB = Entering Air Temperature, Dry Bulb (°F).
2. EWB = Entering Air Temperature, Wet Bulb (°F).
3. TC = Total Capacity (MBh).
4. SC = Sensible Capacity (MBh).
5. LDB = Leaving Air Temperature, Dry Bulb (°F).
6. LWB = Leaving Air Temperature, Wet Bulb (°F).

Table 23. Airflow correction (% of design airflow)

%	Total Capacity (MBh)	Sensible Capacity (MBh)
120	1.03	1.11
110	1.01	1.05
100	1.00	1.00
90	0.99	0.95
80	0.97	0.89

Table 24. Airflow through coil J

Unit Model	1000
Rated cfm	989



Performance Data

Table 25. VUV 100, hydronic heating coils A (1-row /12 fpi), B (2-row /12 fpi), C (2-row /16 fpi)

Coil	Entering Air Temp, Dry Bulb (°F)	Entering Water Temp (°F)	Flow Rate (gpm)					
			2		4		6	
			Total Capacity (MBh)	Waterside Temp Drop (°F)	Total Capacity (MBh)	Waterside Temp Drop (°F)	Total Capacity (MBh)	Waterside Temp Drop (°F)
A	50	120	23.80	22.90	28.40	13.70	30.40	9.80
		140	33.30	32.40	39.70	19.40	42.50	13.90
		160	42.90	42.00	51.20	25.10	54.70	17.90
		180	52.60	51.70	62.60	30.80	66.90	22.00
	55	120	22.50	21.60	26.80	12.90	28.70	9.30
		140	31.50	30.60	37.60	18.30	40.20	13.10
		160	40.60	39.70	48.40	23.70	51.70	16.90
		180	49.70	48.80	59.20	29.10	63.30	20.80
	60	120	21.20	20.30	25.30	12.20	27.10	8.70
		140	29.70	28.80	35.50	17.30	37.90	12.30
		160	38.30	37.40	45.60	22.30	48.80	16.00
		180	46.90	46.00	55.90	27.50	59.70	19.60
	65	120	20.00	19.10	23.80	11.40	25.50	8.20
		140	27.90	27.00	33.30	16.20	35.60	11.60
		160	36.00	35.10	42.90	21.00	45.90	15.00
		180	44.10	43.20	52.50	25.80	56.10	18.40
	70	120	18.70	17.80	22.30	10.70	23.80	7.60
		140	26.10	25.20	31.20	15.10	33.40	10.80
		160	33.70	32.80	40.20	19.60	42.90	14.00
		180	41.30	40.40	49.20	24.10	52.50	17.20
B	50	120	32.60	31.70	43.10	21.10	47.60	15.60
		140	46.20	45.30	60.70	29.90	66.90	22.00
		160	59.80	58.90	78.30	38.70	86.40	28.50
		180	73.30	72.40	96.00	47.50	105.90	35.00
	55	120	30.80	29.90	40.80	19.90	45.10	14.70
		140	43.70	42.80	57.40	28.20	63.30	20.80
		160	56.60	55.70	74.10	36.60	81.70	26.90
		180	69.30	68.40	90.80	44.90	100.10	33.10
	60	120	29.10	28.20	38.50	18.80	42.50	13.90
		140	41.30	40.40	54.20	26.60	59.70	19.60
		160	53.40	52.50	69.90	34.50	77.10	25.40
		180	65.40	64.50	85.60	42.30	94.50	31.20
	65	120	27.30	26.40	36.20	17.60	40.00	13.00
		140	38.80	37.90	50.90	25.00	56.20	18.40
		160	50.20	49.30	65.70	32.40	72.50	23.90
		180	61.50	60.60	80.50	39.80	88.80	29.30
	70	120	25.60	24.70	33.90	16.50	37.40	12.20
		140	36.30	35.40	47.60	23.30	52.60	17.20
		160	47.00	46.10	61.50	30.30	67.80	22.30
		180	57.50	56.60	75.30	37.20	83.10	27.40

Table 25. VUV 100, hydronic heating coils A (1-row /12 fpi), B (2-row /12 fpi), C (2-row /16 fpi) (continued)

Coil	Entering Air Temp, Dry Bulb (°F)	Entering Water Temp (°F)	Flow Rate (gpm)					
			2		4		6	
			Total Capacity (MBh)	Waterside Temp Drop (°F)	Total Capacity (MBh)	Waterside Temp Drop (°F)	Total Capacity (MBh)	Waterside Temp Drop (°F)
C	50	120	33.70	32.80	45.40	22.20	50.20	16.40
		140	47.90	47.00	63.80	31.40	70.60	23.20
		160	62.00	61.10	82.40	40.70	91.00	30.00
		180	75.90	75.00	100.90	50.00	111.60	36.90
	55	120	31.90	31.00	42.90	21.00	47.50	15.50
		140	45.30	44.40	60.40	29.70	66.80	22.00
		160	58.60	57.70	77.90	38.50	86.10	28.40
		180	71.80	70.90	95.40	47.20	105.50	34.90
	60	120	30.10	29.20	40.50	19.80	44.80	14.60
		140	42.70	41.80	57.00	28.00	63.00	20.70
		160	55.30	54.40	73.50	36.30	81.20	26.80
		180	67.80	66.90	90.00	44.50	99.50	32.90
	65	120	28.30	27.40	38.10	18.60	42.10	13.70
		140	40.10	39.20	53.50	26.30	59.20	19.40
		160	52.00	51.10	69.10	34.10	76.40	25.20
		180	63.70	62.80	84.60	41.80	93.60	30.90
	70	120	26.50	25.60	35.60	17.30	39.40	12.80
		140	37.60	36.70	50.10	24.60	55.40	18.20
		160	48.60	47.70	64.70	31.90	71.50	23.50
		180	59.60	58.70	79.20	39.10	87.60	28.90



Performance Data

Table 26. VUV 100, steam heating coils K (low-capacity), L (high-capacity)

Size	Coil	Entering Air Temp, Dry Bulb (°F)	Steam Pressure (psig)					
			5		10		15	
			Total Capacity (MBh)	Airside Temp Rise (°F)	Total Capacity (MBh)	Airside Temp Rise (°F)	Total Capacity (MBh)	Airside Temp Rise (°F)
1000	K	0	92.90	86.00	97.70	90.50	101.80	94.30
		10	88.80	82.20	93.60	86.70	97.70	90.50
		20	84.70	78.40	89.50	82.90	93.60	86.70
		30	80.60	74.60	85.40	79.10	89.50	82.90
		40	76.50	70.80	81.30	75.30	85.40	79.10
		50	72.40	67.00	77.20	71.50	81.30	75.30
		60	68.30	63.30	73.10	67.70	77.30	71.50
	70	64.30	59.50	69.10	64.00	73.20	67.80	
	L	0	131.00	121.30	137.80	127.60	143.60	132.90
		10	125.30	116.00	132.00	122.30	137.80	127.60
		20	119.50	110.60	126.30	116.90	132.00	122.30
		30	113.70	105.30	120.50	111.60	126.30	116.90
		40	107.90	99.90	114.70	106.20	120.50	111.60
		50	102.20	94.60	108.90	100.90	114.70	106.20
60		96.40	89.30	103.20	95.60	109.00	100.90	
70	90.70	84.00	97.40	90.20	103.20	95.60		

Note: psig = steam pressure (lb/in.² gage).

Table 27. VUV 125, cooling coil D, 3-row/12 fpi

Entering Wet Bulb Temp (°F)	Entering Dry Bulb Temp (°F)	Entering Water Temp (°F)	Flow Rate (gpm)											
			6			8			10			14		
			Total Capacity (MBh)	Sensible Capacity (MBh)	T (°F)	Total Capacity (MBh)	Sensible Capacity (MBh)	T (°F)	Total Capacity (MBh)	Sensible Capacity (MBh)	T (°F)	Total Capacity (MBh)	Sensible Capacity (MBh)	T (°F)
61	70	40	27.50	19.80	9.50	31.60	21.20	8.20	34.40	22.30	7.10	38.00	23.80	5.60
		42	26.00	19.20	9.10	29.80	20.60	7.70	32.40	21.50	6.70	35.80	22.90	5.30
		45	23.80	18.40	8.30	27.10	19.60	7.10	29.40	20.40	6.10	32.40	21.50	4.80
		48	21.50	17.60	7.50	24.40	18.70	6.40	26.40	19.30	5.50	28.90	20.10	4.30
	75	40	30.00	25.60	10.40	34.50	27.50	8.90	37.50	28.90	7.70	41.40	30.90	6.10
		42	28.40	24.90	9.80	32.50	26.70	8.40	35.40	27.90	7.30	39.00	29.60	5.70
		45	26.00	23.90	9.00	29.60	25.40	7.70	32.10	26.50	6.60	35.30	27.80	5.20
		48	23.50	22.80	8.20	26.60	24.20	6.90	28.80	25.10	6.00	31.50	26.00	4.70
	80	40	33.30	31.00	11.50	38.20	33.30	9.80	41.60	34.90	8.50	45.90	37.40	6.70
		42	31.50	30.20	10.90	36.10	32.30	9.30	39.30	33.80	8.10	43.30	35.90	6.30
		45	28.80	28.80	10.00	32.80	30.80	8.50	35.60	32.00	7.30	39.20	33.70	5.80
		48	26.00	26.00	9.00	29.50	29.30	7.70	31.90	30.30	6.60	35.00	31.50	5.20
	85	40	37.10	36.10	12.70	42.70	38.70	10.90	46.50	40.70	9.50	51.30	43.50	7.50
		42	35.20	35.10	12.10	40.30	37.50	10.30	43.80	39.30	9.00	48.30	41.70	7.10
		45	32.10	32.10	11.10	36.60	35.80	9.40	39.80	37.30	8.20	43.70	39.20	6.40
		48	29.00	29.00	10.10	32.90	32.90	8.50	35.60	35.30	7.30	39.00	36.70	5.70
	90	40	41.40	40.90	14.20	47.60	43.90	12.20	51.80	46.10	10.60	57.20	49.30	8.30
		42	39.20	39.20	13.40	44.90	42.50	11.50	48.80	44.50	10.00	53.80	47.30	7.80
		45	35.80	35.80	12.30	40.90	40.60	10.50	44.30	42.20	9.10	48.70	44.40	7.10
		48	32.40	32.40	11.20	36.70	36.70	9.50	39.70	39.70	8.20	43.50	41.60	6.40
67	75	40	37.50	21.30	12.90	43.10	22.80	11.10	47.00	24.00	9.60	51.80	25.60	7.60
		42	35.50	20.70	12.20	40.70	22.10	10.50	44.30	23.20	9.10	48.80	24.60	7.10
		45	32.50	19.80	11.20	37.00	21.10	9.50	40.20	22.00	8.30	44.20	23.10	6.50
		48	29.40	18.90	10.20	33.30	20.10	8.60	36.00	20.80	7.40	39.50	21.60	5.80
	80	40	39.40	27.50	13.50	45.20	29.60	11.60	49.30	31.00	10.10	54.40	33.20	7.90
		42	37.30	26.80	12.80	42.70	28.70	11.00	46.50	30.00	9.50	51.20	31.80	7.50
		45	34.10	25.70	11.70	38.90	27.30	10.00	42.20	28.50	8.70	46.30	29.90	6.80
		48	30.80	24.50	10.60	34.90	26.00	9.00	37.80	27.00	7.80	41.40	28.00	6.10
	85	40	41.90	33.60	14.30	48.20	36.10	12.30	52.50	37.90	10.70	57.90	40.50	8.40
		42	39.70	32.70	13.60	45.50	35.00	11.60	49.50	36.60	10.10	54.50	38.90	7.90
		45	36.30	31.30	12.50	41.40	33.40	10.60	44.90	34.70	9.20	49.30	36.50	7.20
		48	32.80	29.90	11.30	37.20	31.80	9.60	40.20	32.90	8.30	44.10	34.20	6.50
	90	40	45.00	39.50	15.40	51.70	42.40	13.20	56.30	44.50	11.50	62.10	47.60	9.00
		42	42.60	38.40	14.60	48.80	41.10	12.50	53.10	43.00	10.80	58.50	45.70	8.50
		45	38.90	36.80	13.30	44.40	39.20	11.40	48.20	40.80	9.90	52.90	42.90	7.70
		48	35.20	35.20	12.10	39.90	37.30	10.20	43.10	38.70	8.80	47.30	40.20	6.90



Performance Data

Table 27. VUV 125, cooling coil D, 3-row/12 fpi (continued)

Entering Wet Bulb Temp (°F)	Entering Dry Bulb Temp (°F)	Entering Water Temp (°F)	Flow Rate (gpm)											
			6			8			10			14		
			Total Capacity (MBh)	Sensible Capacity (MBh)	T (°F)	Total Capacity (MBh)	Sensible Capacity (MBh)	T (°F)	Total Capacity (MBh)	Sensible Capacity (MBh)	T (°F)	Total Capacity (MBh)	Sensible Capacity (MBh)	T (°F)
70	75	40	42.70	18.60	14.60	49.10	20.00	12.50	53.50	21.00	10.90	59.00	22.40	8.60
		42	40.50	18.10	13.90	46.30	19.40	11.90	50.40	20.30	10.30	55.50	21.50	8.10
		45	37.00	17.40	12.70	42.20	18.50	10.80	45.70	19.20	9.40	50.30	20.20	7.30
		48	33.40	16.60	11.50	37.90	17.60	9.70	41.00	18.20	8.40	44.90	18.90	6.60
	80	40	43.90	25.00	15.00	50.40	26.80	12.90	54.90	28.20	11.20	60.60	30.10	8.80
		42	41.60	24.30	14.20	47.60	26.00	12.20	51.80	27.20	10.60	57.00	28.90	8.30
		45	38.00	23.30	13.00	43.30	24.80	11.10	47.00	25.80	9.60	51.60	27.10	7.50
		48	34.30	22.30	11.80	38.90	23.60	10.00	42.10	24.50	8.60	46.10	25.40	6.70
	85	40	45.80	31.30	15.60	52.60	33.60	13.40	57.30	35.30	11.70	63.20	37.80	9.20
		42	43.40	30.50	14.80	49.70	32.60	12.70	54.00	34.10	11.00	59.50	36.20	8.70
		45	39.60	29.20	13.60	45.20	31.10	11.60	49.00	32.40	10.00	53.90	34.00	7.90
		48	35.80	27.90	12.30	40.60	29.60	10.40	43.90	30.70	9.00	48.10	31.80	7.00
	90	40	48.30	37.50	16.50	55.50	40.30	14.10	60.40	42.30	12.30	66.70	45.20	9.70
		42	45.70	36.50	15.60	52.40	39.00	13.40	56.90	40.90	11.60	62.80	43.40	9.10
		45	41.80	35.00	14.30	47.60	37.20	12.20	51.70	38.80	10.60	56.80	40.70	8.30
		48	37.80	33.40	13.00	42.80	35.50	11.00	46.30	36.70	9.50	50.70	38.10	7.40

Table 28. VUV 125, cooling coil E, 3-row/16 fpi

Entering Wet Bulb Temp (°F)	Entering Dry Bulb Temp (°F)	Entering Water Temp (°F)	Flow Rate (gpm)											
			6			8			10			14		
			Total Capacity (MBh)	Sensible Capacity (MBh)	T (°F)	Total Capacity (MBh)	Sensible Capacity (MBh)	T (°F)	Total Capacity (MBh)	Sensible Capacity (MBh)	T (°F)	Total Capacity (MBh)	Sensible Capacity (MBh)	T (°F)
61	70	40	28.50	19.60	9.90	32.70	21.30	8.40	35.50	22.40	7.30	39.00	23.90	5.70
		42	27.00	19.10	9.40	30.90	20.60	8.00	33.50	21.60	6.90	36.80	23.00	5.40
		45	24.80	18.30	8.60	28.20	19.50	7.30	30.50	20.40	6.30	33.40	21.50	4.90
		48	22.40	17.40	7.80	25.40	18.40	6.60	27.40	19.20	5.70	29.90	20.10	4.40
	75	40	31.10	25.50	10.70	35.60	27.60	9.20	38.70	29.10	8.00	42.60	31.00	6.20
		42	29.50	24.70	10.20	33.70	26.70	8.70	36.50	28.00	7.50	40.10	29.80	5.90
		45	27.00	23.60	9.40	30.70	25.30	8.00	33.20	26.40	6.90	36.40	27.90	5.40
		48	24.50	22.50	8.50	27.70	23.90	7.20	29.80	24.80	6.20	32.60	26.10	4.80
	80	40	34.50	30.80	11.90	39.50	33.40	10.20	42.90	35.20	8.80	47.20	37.50	6.90
		42	32.70	29.90	11.30	37.40	32.30	9.60	40.50	33.90	8.30	44.50	36.00	6.50
		45	30.00	28.60	10.40	34.10	30.60	8.80	36.90	32.00	7.60	40.40	33.80	5.90
		48	27.10	27.10	9.40	30.70	28.90	7.90	33.10	30.10	6.80	36.10	31.60	5.30
	85	40	38.50	35.90	13.20	44.10	38.80	11.30	47.90	40.90	9.80	52.70	43.70	7.70
		42	36.50	34.80	12.50	41.70	37.50	10.70	45.20	39.40	9.30	49.70	41.90	7.30
		45	33.40	33.30	11.50	38.00	35.60	9.80	41.10	37.20	8.40	45.00	39.30	6.60
		48	30.30	30.30	10.50	34.20	33.60	8.80	36.90	35.00	7.60	40.30	36.70	5.90
	90	40	42.90	40.60	14.70	49.20	44.00	12.60	53.40	46.40	10.90	58.70	49.50	8.50
		42	40.70	39.50	13.90	46.50	42.50	11.90	50.40	44.70	10.30	55.30	47.50	8.10
		45	37.30	37.30	12.80	42.40	40.30	10.90	45.80	42.20	9.40	50.20	44.50	7.30
		48	33.70	33.70	11.60	38.20	38.10	9.80	41.20	39.60	8.50	45.00	41.60	6.60
67	75	40	38.90	21.10	13.30	44.60	22.90	11.40	48.40	24.10	9.90	53.20	25.80	7.80
		42	36.90	20.50	12.70	42.10	22.10	10.80	45.70	23.30	9.40	50.20	24.70	7.30
		45	33.80	19.60	11.60	38.40	21.00	9.90	41.60	22.00	8.50	45.50	23.20	6.70
		48	30.60	18.70	10.60	34.60	19.80	8.90	37.30	20.60	7.70	40.80	21.70	6.00
	80	40	40.80	27.40	14.00	46.80	29.70	12.00	50.80	31.30	10.40	55.90	33.30	8.10
		42	38.70	26.60	13.30	44.20	28.70	11.30	48.00	30.10	9.80	52.70	32.00	7.70
		45	35.50	25.40	12.20	40.30	27.20	10.40	43.60	28.40	8.90	47.80	30.00	7.00
		48	32.10	24.20	11.10	36.30	25.70	9.40	39.20	26.70	8.10	42.80	28.00	6.30
	85	40	43.50	33.40	14.90	49.80	36.20	12.70	54.10	38.20	11.00	59.50	40.70	8.70
		42	41.20	32.50	14.10	47.10	35.00	12.00	51.10	36.80	10.40	56.10	39.10	8.20
		45	37.80	31.00	13.00	42.90	33.20	11.00	46.40	34.70	9.50	50.90	36.60	7.40
		48	34.20	29.50	11.80	38.70	31.30	9.90	41.70	32.60	8.60	45.50	34.20	6.70
	90	40	46.70	39.30	15.90	53.40	42.50	13.60	58.00	44.80	11.80	63.80	47.80	9.30
		42	44.20	38.20	15.10	50.50	41.10	12.90	54.80	43.20	11.20	60.10	45.90	8.80
		45	40.50	36.50	13.90	46.10	39.00	11.80	49.80	40.80	10.20	54.60	43.10	8.00
		48	36.70	34.70	12.60	41.50	36.80	10.60	44.70	38.30	9.20	48.80	40.20	7.10



Performance Data

Table 28. VUV 125, cooling coil E, 3-row/16 fpi (continued)

Entering Wet Bulb Temp (°F)	Entering Dry Bulb Temp (°F)	Entering Water Temp (°F)	Flow Rate (gpm)											
			6			8			10			14		
			Total Capacity (MBh)	Sensible Capacity (MBh)	T (°F)	Total Capacity (MBh)	Sensible Capacity (MBh)	T (°F)	Total Capacity (MBh)	Sensible Capacity (MBh)	T (°F)	Total Capacity (MBh)	Sensible Capacity (MBh)	T (°F)
70	75	40	44.30	18.50	15.10	50.70	20.10	13.00	55.10	21.10	11.20	60.60	22.50	8.80
		42	42.00	18.00	14.40	48.00	19.40	12.30	52.00	20.40	10.60	57.10	21.60	8.30
		45	38.50	17.20	13.20	43.70	18.40	11.20	47.30	19.20	9.70	51.80	20.30	7.60
		48	34.80	16.40	12.00	39.40	17.40	10.10	42.50	18.10	8.70	46.40	19.00	6.80
	80	40	45.50	24.90	15.50	52.10	26.90	13.30	56.60	28.40	11.50	62.30	30.30	9.10
		42	43.10	24.20	14.80	49.30	26.00	12.60	53.40	27.30	10.90	58.70	29.10	8.50
		45	39.50	23.10	13.50	44.90	24.70	11.50	48.60	25.80	9.90	53.20	27.30	7.80
		48	35.80	22.00	12.30	40.50	23.30	10.40	43.60	24.20	8.90	47.70	25.50	7.00
	85	40	47.50	31.10	16.20	54.40	33.70	13.90	59.10	35.60	12.00	65.00	37.90	9.40
		42	45.00	30.30	15.40	51.40	32.60	13.10	55.80	34.30	11.40	61.20	36.40	8.90
		45	41.20	28.90	14.10	46.90	30.90	12.00	50.70	32.30	10.40	55.50	34.10	8.10
		48	37.30	27.50	12.80	42.20	29.20	10.80	45.50	30.40	9.30	49.70	31.90	7.30
	90	40	50.10	37.30	17.10	57.30	40.40	14.60	62.30	42.60	12.70	68.50	45.40	9.90
		42	47.50	36.20	16.20	54.20	39.00	13.80	58.80	41.00	12.00	64.50	43.60	9.40
		45	43.50	34.60	14.90	49.40	37.00	12.60	53.50	38.70	10.90	58.50	40.90	8.50
		48	39.40	33.00	13.50	44.50	35.00	11.40	48.00	36.40	9.80	52.40	38.20	7.60

Table 29. VUV 125, cooling coil F, 4-row/12 fpi

Entering Wet Bulb Temp (°F)	Entering Dry Bulb Temp (°F)	Entering Water Temp (°F)	Flow Rate (gpm)											
			6			8			10			14		
			Total Capacity (MBh)	Sensible Capacity (MBh)	T (°F)	Total Capacity (MBh)	Sensible Capacity (MBh)	T (°F)	Total Capacity (MBh)	Sensible Capacity (MBh)	T (°F)	Total Capacity (MBh)	Sensible Capacity (MBh)	T (°F)
61	70	40	26.40	19.50	9.20	31.30	21.40	8.10	34.90	22.90	7.20	39.70	25.10	5.80
		42	24.90	18.90	8.70	29.40	20.70	7.60	32.80	22.10	6.80	37.40	24.10	5.50
		45	22.60	18.00	7.90	26.60	19.60	6.90	29.70	20.80	6.20	33.80	22.50	5.00
		48	20.30	17.00	7.10	23.80	18.50	6.20	26.40	19.60	5.50	30.10	20.90	4.50
	75	40	28.70	25.20	10.00	34.10	27.70	8.80	38.10	29.70	7.80	43.30	32.60	6.40
		42	27.10	24.40	9.40	32.10	26.80	8.30	35.80	28.60	7.40	40.80	31.20	6.00
		45	24.60	23.30	8.60	29.00	25.40	7.50	32.40	27.00	6.70	36.80	29.10	5.40
		48	22.10	22.10	7.70	25.90	24.00	6.80	28.80	25.30	6.00	32.80	27.10	4.80
	80	40	31.90	30.50	11.00	37.80	33.60	9.70	42.20	35.90	8.70	48.10	39.40	7.00
		42	30.10	29.60	10.40	35.60	32.40	9.20	39.70	34.60	8.20	45.20	37.80	6.60
		45	27.30	27.30	9.50	32.20	30.80	8.30	35.90	32.70	7.40	40.80	35.30	6.00
		48	24.50	24.50	8.50	28.70	28.70	7.50	32.00	30.70	6.60	36.40	32.80	5.40
	85	40	35.60	35.50	12.20	42.20	39.00	10.80	47.10	41.80	9.60	53.60	45.90	7.80
		42	33.60	33.60	11.60	39.70	37.70	10.20	44.30	40.30	9.10	50.40	43.90	7.40
		45	30.50	30.50	10.50	35.90	35.80	9.30	40.00	38.00	8.20	45.60	41.00	6.70
		48	27.30	27.30	9.50	32.10	32.10	8.30	35.70	35.70	7.40	40.60	38.20	6.00
	90	40	39.70	39.70	13.60	47.00	44.20	12.00	52.50	47.40	10.70	59.80	52.00	8.70
		42	37.40	37.40	12.80	44.30	42.70	11.30	49.40	45.60	10.10	56.20	49.80	8.20
		45	34.00	34.00	11.70	40.10	40.10	10.30	44.60	43.00	9.10	50.80	46.50	7.40
		48	30.50	30.50	10.50	35.70	35.70	9.20	39.80	39.80	8.20	45.30	43.20	6.60
67	75	40	36.00	20.90	12.40	42.70	23.00	10.90	47.60	24.70	9.70	54.20	27.10	7.90
		42	33.90	20.30	11.70	40.20	22.30	10.30	44.80	23.80	9.20	51.00	25.90	7.40
		45	30.80	19.30	10.60	36.30	21.10	9.40	40.50	22.40	8.30	46.10	24.20	6.70
		48	27.60	18.30	9.60	32.40	19.90	8.40	36.10	21.10	7.40	41.00	22.50	6.00
	80	40	37.70	27.10	12.90	44.80	29.80	11.50	50.00	31.90	10.20	56.90	35.00	8.30
		42	35.60	26.30	12.20	42.10	28.80	10.80	47.00	30.70	9.60	53.50	33.50	7.80
		45	32.30	25.00	11.20	38.10	27.30	9.80	42.50	29.00	8.70	48.30	31.30	7.10
		48	29.00	23.70	10.00	34.00	25.80	8.80	37.80	27.30	7.80	43.00	29.10	6.30
	85	40	40.20	33.10	13.80	47.70	36.40	12.20	53.20	39.00	10.90	60.60	42.80	8.80
		42	37.90	32.10	13.00	44.90	35.20	11.50	50.00	37.50	10.20	57.00	40.90	8.30
		45	34.40	30.50	11.80	40.60	33.30	10.40	45.20	35.40	9.30	51.50	38.20	7.50
		48	30.90	29.00	10.70	36.20	31.50	9.30	40.30	33.30	8.30	45.80	35.60	6.70
	90	40	43.10	38.90	14.70	51.10	42.70	13.10	57.10	45.80	11.60	65.00	50.30	9.40
		42	40.70	37.70	13.90	48.10	41.30	12.30	53.70	44.10	11.00	61.10	48.10	8.90
		45	36.90	35.90	12.70	43.50	39.20	11.20	48.50	41.60	9.90	55.20	44.90	8.00
		48	33.10	33.10	11.40	38.80	37.00	10.00	43.20	39.10	8.90	49.20	41.80	7.20



Performance Data

Table 29. VUV 125, cooling coil F, 4-row/12 fpi (continued)

Entering Wet Bulb Temp (°F)	Entering Dry Bulb Temp (°F)	Entering Water Temp (°F)	Flow Rate (gpm)											
			6			8			10			14		
			Total Capacity (MBh)	Sensible Capacity (MBh)	T (°F)	Total Capacity (MBh)	Sensible Capacity (MBh)	T (°F)	Total Capacity (MBh)	Sensible Capacity (MBh)	T (°F)	Total Capacity (MBh)	Sensible Capacity (MBh)	T (°F)
70	75	40	40.90	18.30	14.00	48.60	20.10	12.40	54.20	21.60	11.10	61.70	23.70	9.00
		42	38.60	17.80	13.20	45.70	19.50	11.70	51.00	20.80	10.40	58.00	22.70	8.40
		45	35.10	16.90	12.10	41.40	18.50	10.60	46.10	19.60	9.40	52.40	21.20	7.60
		48	31.50	16.00	10.90	36.90	17.40	9.50	41.00	18.40	8.40	46.70	19.70	6.80
	80	40	42.00	24.60	14.40	49.90	27.10	12.70	55.70	29.00	11.40	63.40	31.80	9.20
		42	39.70	23.90	13.60	46.90	26.20	12.00	52.40	27.90	10.70	59.60	30.50	8.70
		45	36.00	22.70	12.40	42.50	24.80	10.90	47.30	26.30	9.70	53.90	28.40	7.90
		48	32.30	21.50	11.10	37.90	23.40	9.80	42.20	24.80	8.70	48.00	26.50	7.00
	85	40	43.90	30.80	15.00	52.00	33.90	13.30	58.10	36.30	11.80	66.20	39.90	9.60
		42	41.40	29.90	14.20	49.00	32.80	12.50	54.60	35.00	11.20	62.20	38.10	9.00
		45	37.60	28.50	12.90	44.30	31.10	11.40	49.40	33.00	10.10	56.20	35.60	8.20
		48	33.70	27.00	11.60	39.50	29.30	10.20	44.00	31.00	9.00	50.10	33.10	7.30
	90	40	46.30	36.90	15.80	54.90	40.60	14.00	61.20	43.50	12.50	69.70	47.70	10.10
		42	43.60	35.80	14.90	51.60	39.20	13.20	57.60	41.90	11.70	65.60	45.70	9.50
		45	39.60	34.10	13.60	46.70	37.20	12.00	52.10	39.50	10.60	59.20	42.70	8.60
		48	35.50	32.30	12.20	41.70	35.10	10.70	46.40	37.10	9.50	52.80	39.70	7.70

Table 30. VUV 125, cooling coil G, 4-row/16 fpi

Entering Wet Bulb Temp (°F)	Entering Dry Bulb Temp (°F)	Entering Water Temp (°F)	Flow Rate (gpm)											
			6			8			10			14		
			Total Capacity (MBh)	Sensible Capacity (MBh)	T (°F)	Total Capacity (MBh)	Sensible Capacity (MBh)	T (°F)	Total Capacity (MBh)	Sensible Capacity (MBh)	T (°F)	Total Capacity (MBh)	Sensible Capacity (MBh)	T (°F)
61	70	40	27.20	19.80	9.40	32.30	21.80	8.40	36.10	23.40	7.40	41.10	25.70	6.00
		42	25.70	19.20	8.90	30.50	21.10	7.90	34.00	22.50	7.00	38.70	24.60	5.70
		45	23.40	18.30	8.20	27.60	20.00	7.20	30.70	21.20	6.40	35.00	22.90	5.20
		48	21.00	17.30	7.40	24.60	18.80	6.40	27.40	19.90	5.70	31.20	21.30	4.60
	75	40	29.70	25.60	10.30	35.30	28.20	9.10	39.40	30.30	8.10	44.80	33.30	6.60
		42	28.00	24.90	9.70	33.20	27.30	8.60	37.10	29.20	7.60	42.20	31.90	6.20
		45	25.50	23.70	8.90	30.10	25.90	7.80	33.50	27.50	6.90	38.20	29.70	5.60
		48	22.90	22.40	8.00	26.90	24.40	7.00	29.90	25.80	6.20	34.00	27.60	5.00
	80	40	32.90	31.00	11.40	39.10	34.20	10.10	43.70	36.70	9.00	49.70	40.30	7.30
		42	31.10	30.10	10.70	36.80	33.00	9.50	41.10	35.30	8.40	46.80	38.60	6.80
		45	28.30	28.30	9.80	33.40	31.30	8.60	37.20	33.30	7.70	42.30	36.00	6.20
		48	25.40	25.40	8.80	29.80	29.60	7.70	33.20	31.20	6.90	37.70	33.40	5.50
	85	40	36.80	36.10	12.60	43.70	39.80	11.20	48.70	42.70	10.00	55.50	46.90	8.10
		42	34.70	34.70	11.90	41.10	38.40	10.60	45.90	41.10	9.40	52.20	44.90	7.60
		45	31.60	31.60	10.90	37.20	36.40	9.60	41.50	38.70	8.50	47.20	41.80	6.90
		48	28.30	28.30	9.80	33.30	33.30	8.60	37.00	36.30	7.60	42.10	38.90	6.20
	90	40	41.00	40.90	14.00	48.70	45.10	12.40	54.30	48.30	11.10	61.90	53.20	9.00
		42	38.70	38.70	13.30	45.80	43.50	11.70	51.10	46.50	10.40	58.20	50.80	8.50
		45	35.20	35.20	12.10	41.50	41.30	10.70	46.30	43.90	9.50	52.60	47.40	7.70
		48	31.60	31.60	10.90	37.10	37.10	9.50	41.20	41.20	8.50	46.90	44.00	6.90
67	75	40	37.20	21.30	12.80	44.10	23.50	11.30	49.30	25.20	10.10	56.10	27.70	8.20
		42	35.10	20.70	12.10	41.60	22.70	10.70	46.40	24.20	9.50	52.80	26.50	7.70
		45	31.90	19.70	11.00	37.60	21.50	9.70	41.90	22.80	8.60	47.70	24.70	7.00
		48	28.60	18.60	9.90	33.60	20.30	8.70	37.40	21.40	7.70	42.50	22.90	6.20
	80	40	39.00	27.60	13.40	46.30	30.40	11.90	51.70	32.60	10.60	58.90	35.80	8.60
		42	36.80	26.70	12.60	43.60	29.30	11.20	48.60	31.40	10.00	55.40	34.20	8.10
		45	33.50	25.50	11.50	39.50	27.80	10.20	44.00	29.50	9.00	50.10	31.90	7.30
		48	30.00	24.10	10.40	35.30	26.20	9.10	39.20	27.70	8.10	44.60	29.70	6.50
	85	40	41.50	33.70	14.20	49.30	37.10	12.60	55.00	39.80	11.20	62.70	43.70	9.10
		42	39.20	32.60	13.40	46.40	35.80	11.90	51.80	38.30	10.60	59.00	41.80	8.60
		45	35.60	31.10	12.20	42.00	33.90	10.80	46.80	36.10	9.60	53.30	39.00	7.80
		48	32.00	29.50	11.00	37.50	32.00	9.70	41.80	33.90	8.60	47.50	36.20	6.90
	90	40	44.50	39.50	15.20	52.90	43.60	13.50	59.00	46.70	12.00	67.20	51.40	9.80
		42	42.00	38.40	14.40	49.80	42.10	12.70	55.60	45.00	11.30	63.30	49.10	9.20
		45	38.20	36.50	13.10	45.10	39.90	11.60	50.30	42.40	10.30	57.20	45.80	8.30
		48	34.30	34.30	11.80	40.30	37.60	10.30	44.80	39.80	9.20	51.00	42.60	7.40



Performance Data

Table 30. VUV 125, cooling coil G, 4-row/16 fpi (continued)

Entering Wet Bulb Temp (°F)	Entering Dry Bulb Temp (°F)	Entering Water Temp (°F)	Flow Rate (gpm)											
			6			8			10			14		
			Total Capacity (MBh)	Sensible Capacity (MBh)	T (°F)	Total Capacity (MBh)	Sensible Capacity (MBh)	T (°F)	Total Capacity (MBh)	Sensible Capacity (MBh)	T (°F)	Total Capacity (MBh)	Sensible Capacity (MBh)	T (°F)
70	75	40	42.30	18.60	14.50	50.20	20.50	12.80	56.10	22.00	11.40	63.80	24.20	9.30
		42	39.90	18.10	13.70	47.30	19.80	12.10	52.80	21.20	10.80	60.10	23.20	8.70
		45	36.30	17.20	12.50	42.80	18.80	11.00	47.70	20.00	9.80	54.30	21.60	7.90
		48	32.60	16.30	11.20	38.30	17.70	9.80	42.60	18.80	8.70	48.40	20.10	7.10
	80	40	43.40	25.00	14.90	51.60	27.60	13.20	57.60	29.60	11.70	65.60	32.50	9.50
		42	41.00	24.30	14.00	48.60	26.70	12.40	54.20	28.50	11.10	61.70	31.10	9.00
		45	37.30	23.10	12.80	44.00	25.30	11.30	49.00	26.80	10.00	55.80	29.00	8.10
		48	33.50	21.90	11.50	39.30	23.80	10.10	43.70	25.20	9.00	49.70	26.90	7.30
	85	40	45.30	31.40	15.50	53.80	34.50	13.70	60.10	37.00	12.20	68.40	40.70	9.90
		42	42.80	30.40	14.60	50.70	33.40	13.00	56.60	35.70	11.50	64.40	39.00	9.40
		45	38.90	29.00	13.30	45.90	31.60	11.80	51.20	33.60	10.50	58.20	36.30	8.50
		48	34.90	27.40	12.00	41.00	29.90	10.50	45.60	31.60	9.30	51.90	33.70	7.60
	90	40	47.80	37.60	16.30	56.70	41.40	14.50	63.30	44.40	12.90	72.10	48.80	10.50
		42	45.10	36.40	15.40	53.50	40.00	13.60	59.60	42.70	12.10	67.90	46.70	9.90
		45	41.00	34.70	14.00	48.40	37.90	12.40	53.90	40.30	11.00	61.40	43.50	8.90
		48	36.80	32.90	12.60	43.20	35.80	11.10	48.10	37.80	9.80	54.70	40.40	8.00

Table 31. VUV 125, cooling coil H, 3-row/16 fpi

Entering Wet Bulb Temp (°F)	Entering Dry Bulb Temp (°F)	Entering Water Temp (°F)	Flow Rate (gpm)											
			6			8			10			14		
			Total Capacity (MBh)	Sensible Capacity (MBh)	T (°F)	Total Capacity (MBh)	Sensible Capacity (MBh)	T (°F)	Total Capacity (MBh)	Sensible Capacity (MBh)	T (°F)	Total Capacity (MBh)	Sensible Capacity (MBh)	T (°F)
61	70	40	30.50	21.00	10.50	34.70	22.80	9.00	37.60	24.00	7.70	41.20	25.60	6.00
		42	28.70	20.20	9.90	32.60	21.80	8.40	35.20	23.00	7.30	38.60	24.40	5.70
		45	26.00	19.10	9.00	29.30	20.50	7.60	31.60	21.40	6.50	34.60	22.70	5.10
		48	23.20	17.90	8.10	26.00	19.10	6.80	27.90	19.90	5.80	30.50	20.90	4.50
	75	40	33.30	27.20	11.50	37.90	29.50	9.70	41.00	31.10	8.40	45.00	33.20	6.60
		42	31.30	26.20	10.80	35.50	28.30	9.20	38.40	29.80	7.90	42.10	31.60	6.20
		45	28.30	24.70	9.80	32.00	26.50	8.30	34.50	27.80	7.10	37.70	29.40	5.50
		48	25.20	23.20	8.80	28.30	24.70	7.40	30.50	25.80	6.30	33.20	27.10	4.90
	80	40	36.90	32.90	12.70	42.00	35.70	10.80	45.50	37.70	9.30	49.90	40.20	7.30
		42	34.70	31.70	12.00	39.40	34.30	10.10	42.60	36.00	8.70	46.70	38.30	6.80
		45	31.40	29.90	10.80	35.50	32.10	9.10	38.20	33.60	7.90	41.80	35.50	6.10
		48	28.00	28.00	9.70	31.40	29.90	8.10	33.80	31.20	7.00	36.90	32.80	5.40
	85	40	41.20	38.30	14.10	46.90	41.60	12.00	50.70	43.80	10.40	55.60	46.70	8.10
		42	38.80	36.90	13.30	44.00	39.90	11.30	47.50	41.90	9.70	52.10	44.50	7.60
		45	35.10	34.80	12.10	39.60	37.30	10.20	42.70	39.10	8.80	46.60	41.30	6.80
		48	31.30	31.30	10.80	35.10	34.80	9.00	37.70	36.30	7.80	41.10	38.20	6.00
	90	40	45.90	43.40	15.70	52.20	47.10	13.30	56.60	49.70	11.50	62.00	52.90	9.00
		42	43.20	41.80	14.80	49.00	45.20	12.50	53.00	47.50	10.80	58.00	50.50	8.50
		45	39.10	39.10	13.40	44.10	42.30	11.30	47.60	44.30	9.70	52.00	46.80	7.60
		48	34.80	34.80	12.00	39.10	39.10	10.00	42.00	41.10	8.60	45.80	43.30	6.70
67	75	40	41.70	22.60	14.30	47.40	24.50	12.10	51.30	25.80	10.50	56.20	27.60	8.20
		42	39.20	21.80	13.40	44.40	23.50	11.40	48.10	24.70	9.80	52.60	26.30	7.70
		45	35.40	20.50	12.20	40.00	22.00	10.30	43.10	23.10	8.80	47.10	24.40	6.90
		48	31.60	19.30	10.90	35.40	20.50	9.10	38.10	21.40	7.80	41.60	22.50	6.10
	80	40	43.70	29.20	14.90	49.70	31.70	12.70	53.80	33.50	11.00	59.00	35.70	8.60
		42	41.10	28.20	14.10	46.60	30.40	11.90	50.40	32.00	10.30	55.20	34.00	8.00
		45	37.20	26.60	12.80	42.00	28.50	10.80	45.30	29.80	9.30	49.50	31.60	7.20
		48	33.10	25.00	11.40	37.20	26.60	9.60	40.00	27.70	8.20	43.60	29.20	6.40
	85	40	46.50	35.70	15.90	52.90	38.70	13.50	57.30	40.80	11.70	62.80	43.50	9.10
		42	43.80	34.40	15.00	49.60	37.10	12.70	53.70	39.10	11.00	58.80	41.50	8.60
		45	39.60	32.40	13.60	44.70	34.80	11.40	48.20	36.40	9.90	52.70	38.50	7.70
		48	35.30	30.50	12.10	39.60	32.50	10.20	42.60	33.80	8.70	46.40	35.60	6.80
	90	40	49.90	41.90	17.00	56.80	45.50	14.50	61.50	48.00	12.50	67.40	51.20	9.80
		42	47.00	40.40	16.00	53.30	43.60	13.60	57.60	45.90	11.70	63.10	48.80	9.20
		45	42.50	38.10	14.50	47.90	40.90	12.30	51.70	42.80	10.60	56.50	45.30	8.20
		48	37.90	35.80	13.00	42.50	38.10	10.90	45.70	39.80	9.40	49.80	41.80	7.30



Performance Data

Table 31. VUV 125, cooling coil H, 3-row/16 fpi (continued)

Entering Wet Bulb Temp (°F)	Entering Dry Bulb Temp (°F)	Entering Water Temp (°F)	Flow Rate (gpm)											
			6			8			10			14		
			Total Capacity (MBh)	Sensible Capacity (MBh)	T (°F)	Total Capacity (MBh)	Sensible Capacity (MBh)	T (°F)	Total Capacity (MBh)	Sensible Capacity (MBh)	T (°F)	Total Capacity (MBh)	Sensible Capacity (MBh)	T (°F)
70	75	40	47.40	19.80	16.20	53.90	21.50	13.80	58.40	22.60	11.90	64.00	24.10	9.30
		42	44.60	19.00	15.20	50.60	20.60	12.90	54.70	21.60	11.20	59.90	23.00	8.70
		45	40.30	18.00	13.80	45.50	19.30	11.70	49.10	20.20	10.00	53.70	21.30	7.80
		48	36.00	16.90	12.40	40.30	18.00	10.40	43.40	18.70	8.90	47.30	19.70	6.90
	80	40	48.70	26.50	16.60	55.40	28.80	14.10	60.00	30.40	12.20	65.80	32.40	9.60
		42	45.80	25.60	15.60	52.00	27.60	13.30	56.20	29.10	11.50	61.50	30.90	8.90
		45	41.40	24.10	14.20	46.80	25.90	12.00	50.40	27.10	10.30	55.10	28.70	8.00
		48	36.90	22.70	12.70	41.40	24.20	10.60	44.60	25.20	9.10	48.60	26.50	7.10
	85	40	50.80	33.20	17.30	57.80	36.10	14.70	62.60	38.10	12.70	68.60	40.60	10.00
		42	47.80	32.00	16.30	54.20	34.60	13.80	58.60	36.40	11.90	64.20	38.70	9.30
		45	43.20	30.20	14.80	48.80	32.40	12.50	52.60	33.90	10.70	57.50	35.90	8.40
		48	38.50	28.40	13.20	43.20	30.20	11.10	46.50	31.50	9.50	50.70	33.20	7.40
	90	40	53.60	39.80	18.20	60.90	43.20	15.50	66.00	45.60	13.40	72.30	48.60	10.50
		42	50.40	38.40	17.20	57.20	41.50	14.60	61.80	43.60	12.60	67.70	46.30	9.80
		45	45.60	36.20	15.60	51.40	38.80	13.10	55.50	40.70	11.30	60.60	43.00	8.80
		48	40.60	34.00	13.90	45.60	36.20	11.70	49.00	37.80	10.00	53.50	39.70	7.80

Table 32. VUV 125, cooling coil J (DX)

Size	EWB	Suct Temp	EDB = 70°F				EDB = 75°F				EDB = 80°F				EDB = 85°F			
			TC	SC	LDB	LWB	TC	SC	LDB	LWB	TC	SC	LDB	LWB	TC	SC	LDB	LWB
1250	61	40	35.10	23.40	52.70	51.00	38.40	30.90	52.20	49.90	42.50	37.80	52.10	48.50	47.50	44.30	52.30	46.80
		45	29.40	21.20	54.30	52.80	32.20	28.10	54.20	51.90	35.60	34.40	54.60	50.80	39.80	39.80	55.60	49.40
		50	23.70	19.10	55.90	54.50	25.90	25.30	56.30	53.80	28.70	28.70	58.80	52.90	32.10	32.10	61.30	51.80
	64	40	41.70	20.20	55.10	52.80	43.90	28.40	54.00	52.00	46.70	36.10	53.30	51.10	50.20	43.40	52.90	49.90
		45	34.90	18.30	56.50	54.80	36.80	25.80	55.90	54.20	39.10	32.80	55.80	53.40	42.10	39.40	55.90	52.50
		50	28.20	16.50	57.80	56.70	29.70	23.20	57.90	56.20	31.60	29.50	58.20	55.60	34.00	34.00	59.90	54.90
	67	40	49.30	16.20	58.00	54.40	50.90	24.90	56.60	53.90	52.80	33.10	55.50	53.30	55.10	41.00	54.70	52.50
		45	41.30	14.70	59.10	56.70	42.70	22.60	58.30	56.20	44.20	30.10	57.80	55.80	46.20	37.20	57.50	55.10
		50	33.30	13.20	60.20	58.90	34.40	20.30	60.00	58.50	35.70	27.10	60.00	58.10	37.30	33.50	60.20	57.60
	70	40					59.00	20.50	59.90	55.60	60.30	29.10	58.50	55.20	61.90	37.40	57.40	54.60
		45					49.40	18.60	61.30	58.30	50.50	26.40	60.50	57.90	51.90	34.00	59.90	57.50
		50					39.90	16.80	62.60	60.80	40.80	23.80	62.40	60.50	41.90	30.60	62.40	60.10
73	40									68.90	24.30	62.00	57.00	70.10	32.80	60.80	56.60	
	45									57.80	22.10	63.70	60.00	58.70	29.80	63.00	59.70	
	50									46.60	19.90	65.30	62.80	47.40	26.90	65.10	62.50	

Notes:

1. EDB = Entering Air Temperature, Dry Bulb (°F).
2. EWB = Entering Air Temperature, Wet Bulb (°F).
3. TC = Total Capacity (MBh).
4. SC = Sensible Capacity (MBh).
5. LDB = Leaving Air Temperature, Dry Bulb (°F).
6. LWB = Leaving Air Temperature, Wet Bulb (°F).

Table 33. Airflow correction (% of design airflow)

%	Total Capacity (MBh)	Sensible Capacity (MBh)
120	1.03	1.11
110	1.01	1.05
100	1.00	1.00
90	0.99	0.95
80	0.97	0.89

Table 34. Airflow through coil J

Unit Model	1250
Rated cfm	1253



Performance Data

Table 35. VUV 125, hydronic heating coils A (1-row/12 fpi), B (2-row /12 fpi), C (2-row/16 fpi)

Coil	Entering Air Temp, Dry Bulb (°F)	Entering Water Temp (°F)	Flow Rate (gpm)					
			2		4		6	
			Total Capacity (MBh)	Waterside Temp Drop (°F)	Total Capacity (MBh)	Waterside Temp Drop (°F)	Total Capacity (MBh)	Waterside Temp Drop (°F)
A	50	120	29.40	28.30	36.30	17.60	39.40	12.80
		140	41.10	40.00	50.80	24.80	55.10	18.00
		160	52.80	51.70	65.30	32.10	70.90	23.30
		180	64.70	63.60	80.00	39.40	86.70	28.50
	55	120	27.80	26.70	34.30	16.60	37.20	12.00
		140	38.80	37.70	48.00	23.40	52.10	17.00
		160	50.00	48.90	61.80	30.30	67.00	22.00
		180	61.20	60.10	75.70	37.30	82.00	27.00
	60	120	26.20	25.10	32.40	15.60	35.10	11.30
		140	36.60	35.50	45.30	22.10	49.10	16.00
		160	47.20	46.10	58.30	28.60	63.20	20.70
		180	57.70	56.60	71.40	35.10	77.40	25.40
	65	120	24.60	23.50	30.40	14.60	33.00	10.60
		140	34.40	33.30	42.60	20.70	46.20	15.00
		160	44.30	43.20	54.80	26.80	59.40	19.40
		180	54.30	53.20	67.10	33.00	72.70	23.90
	70	120	23.10	22.00	28.50	13.70	30.90	9.90
		140	32.20	31.10	39.90	19.40	43.20	14.00
		160	41.50	40.40	51.30	25.10	55.60	18.20
		180	50.80	49.70	62.80	30.80	68.10	22.30
B	50	120	34.80	33.70	46.10	22.50	51.10	16.70
		140	49.20	48.10	64.80	31.80	71.80	23.60
		160	63.40	62.30	83.50	41.20	92.50	30.50
		180	77.60	76.50	102.20	50.50	113.30	37.40
	55	120	33.00	31.90	43.60	21.20	48.40	15.80
		140	46.50	45.40	61.30	30.10	67.90	22.30
		160	60.00	58.90	79.00	38.90	87.50	28.80
		180	73.40	72.30	96.70	47.80	107.20	35.40
	60	120	31.10	30.00	41.10	20.00	45.60	14.80
		140	43.90	42.80	57.80	28.30	64.00	21.00
		160	56.60	55.50	74.50	36.70	82.50	27.10
		180	69.20	68.10	91.20	45.00	101.10	33.30
	65	120	29.20	28.10	38.70	18.80	42.90	13.90
		140	41.30	40.20	54.30	26.60	60.20	19.70
		160	53.20	52.10	70.00	34.40	77.60	25.50
		180	65.10	64.00	85.80	42.30	95.00	31.30
	70	120	27.40	26.30	36.20	17.50	40.10	13.00
		140	38.60	37.50	50.80	24.80	56.30	18.40
		160	49.80	48.70	65.60	32.20	72.60	23.80
		180	60.90	59.80	80.30	39.60	88.90	29.30

Table 35. VUV 125, hydronic heating coils A (1-row/12 fpi), B (2-row /12 fpi), C (2-row/16 fpi) (continued)

Coil	Entering Air Temp, Dry Bulb (°F)	Entering Water Temp (°F)	Flow Rate (gpm)					
			2		4		6	
			Total Capacity (MBh)	Waterside Temp Drop (°F)	Total Capacity (MBh)	Waterside Temp Drop (°F)	Total Capacity (MBh)	Waterside Temp Drop (°F)
C	50	120	36.90	35.80	50.30	24.60	56.30	18.40
		140	52.10	51.00	70.70	34.80	79.10	26.00
		160	67.20	66.10	91.10	45.00	102.00	33.60
		180	82.20	81.10	111.60	55.20	124.90	41.30
	55	120	34.90	33.80	47.60	23.20	53.30	17.40
		140	49.20	48.10	66.90	32.90	74.80	24.60
		160	63.60	62.50	86.20	42.50	96.50	31.80
		180	77.70	76.60	105.60	52.20	118.20	39.00
	60	120	32.90	31.80	44.90	21.90	50.20	16.40
		140	46.50	45.40	63.10	31.00	70.60	23.20
		160	60.00	58.90	81.30	40.10	91.00	30.00
		180	73.30	72.20	99.60	49.20	111.50	36.80
	65	120	30.90	29.80	42.20	20.50	47.20	15.40
		140	43.70	42.60	59.30	29.10	66.30	21.70
		160	56.40	55.30	76.50	37.70	85.60	28.20
		180	69.00	67.90	93.60	46.20	104.80	34.60
	70	120	28.90	27.80	39.50	19.20	44.20	14.40
		140	40.90	39.80	55.50	27.20	62.10	20.30
		160	52.70	51.60	71.50	35.20	80.10	26.30
		180	64.50	63.40	87.60	43.20	98.10	32.30



Performance Data

Table 36. VUV 125, steam heating coils K (low-capacity), L (high-capacity)

Size	Coil	Entering Air Temp, Dry Bulb (°F)	Steam Pressure (psig)					
			5		10		15	
			Total Capacity (MBh)	Airside Temp Rise (°F)	Total Capacity (MBh)	Airside Temp Rise (°F)	Total Capacity (MBh)	Airside Temp Rise (°F)
1250	K	0	116.90	86.60	123.00	91.10	128.10	94.90
		10	111.80	82.70	117.80	87.20	122.90	91.10
		20	106.60	79.00	112.70	83.50	117.80	87.30
		30	101.60	75.20	107.60	79.70	112.80	83.60
		40	96.50	71.50	102.50	76.00	107.70	79.80
		50	91.30	67.60	97.40	72.10	102.50	76.00
		60	86.10	63.70	92.10	68.20	97.30	72.10
	L	70	81.00	60.00	87.00	64.50	92.20	68.30
		0	138.10	102.30	145.30	107.60	151.40	112.10
		10	132.10	97.80	139.20	103.10	145.30	107.60
		20	126.00	93.30	133.10	98.60	139.20	103.10
		30	119.90	88.80	127.00	94.10	133.20	98.60
		40	113.80	84.30	121.00	89.60	127.10	94.10
		50	107.70	79.80	114.90	85.10	121.00	89.70
60	101.70	75.30	108.80	80.60	115.00	85.20		
70	95.60	70.80	102.80	76.10	108.90	80.70		

Note: psig = steam pressure (lb/in.² gage).

Table 37. VUV 150, cooling coil D, 3-row/12 fpi

Entering Wet Bulb Temp (°F)	Entering Dry Bulb Temp (°F)	Entering Water Temp (°F)	Flow Rate (gpm)											
			6			8			10			14		
			Total Capacity (MBh)	Sensible Capacity (MBh)	T (°F)	Total Capacity (MBh)	Sensible Capacity (MBh)	T (°F)	Total Capacity (MBh)	Sensible Capacity (MBh)	T (°F)	Total Capacity (MBh)	Sensible Capacity (MBh)	T (°F)
61	70	40	30.90	23.00	10.70	36.50	25.30	9.40	41.00	27.00	8.40	46.90	29.30	6.90
		42	29.20	22.20	10.10	34.50	24.40	8.90	38.50	26.00	7.90	43.90	28.10	6.40
		45	26.60	21.10	9.30	31.30	23.10	8.10	34.90	24.50	7.20	39.40	26.30	5.80
		48	24.10	19.90	8.40	28.10	21.70	7.30	31.20	23.00	6.50	34.90	24.50	5.20
	75	40	33.70	29.80	11.60	39.90	32.70	10.30	44.70	34.90	9.20	51.10	38.00	7.50
		42	31.80	28.80	11.00	37.60	31.60	9.70	42.00	33.60	8.60	47.90	36.40	7.00
		45	29.00	27.30	10.10	34.10	29.90	8.80	38.00	31.70	7.80	43.00	34.00	6.30
		48	26.20	25.80	9.10	30.70	28.20	8.00	34.00	29.80	7.00	38.00	31.80	5.60
	80	40	37.30	36.00	12.80	44.20	39.60	11.30	49.50	42.30	10.10	56.70	46.00	8.30
		42	35.30	34.90	12.20	41.70	38.20	10.70	46.60	40.70	9.60	53.10	44.00	7.80
		45	32.20	32.20	11.10	37.90	36.20	9.80	42.20	38.40	8.70	47.70	41.20	7.00
		48	29.10	29.10	10.10	34.00	34.00	8.80	37.70	36.00	7.80	42.20	38.50	6.20
	85	40	41.70	41.70	14.30	49.30	46.10	12.60	55.30	49.20	11.30	63.30	53.50	9.20
		42	39.40	39.40	13.50	46.50	44.50	11.90	52.00	47.40	10.60	59.30	51.20	8.60
		45	35.90	35.90	12.40	42.30	42.10	10.90	47.10	44.60	9.70	53.20	48.00	7.80
		48	32.50	32.50	11.20	38.00	38.00	9.80	42.10	41.90	8.70	47.10	44.80	6.90
	90	40	46.50	46.50	15.90	55.00	52.20	14.00	61.60	55.70	12.60	70.50	60.60	10.20
		42	43.90	43.90	15.00	51.80	50.40	13.30	58.00	53.70	11.80	66.10	58.00	9.60
		45	40.10	40.10	13.80	47.10	47.10	12.10	52.50	50.60	10.70	59.30	54.30	8.60
		48	36.20	36.20	12.50	42.30	42.30	10.90	46.90	46.90	9.60	52.50	50.70	7.70
67	75	40	42.10	24.70	14.40	49.90	27.20	12.80	55.90	29.00	11.40	63.90	31.50	9.30
		42	39.80	23.90	13.70	47.00	26.20	12.00	52.60	27.90	10.80	59.90	30.20	8.70
		45	36.30	22.70	12.50	42.70	24.80	11.00	47.60	26.30	9.80	53.80	28.30	7.90
		48	32.80	21.50	11.30	38.40	23.40	9.90	42.50	24.70	8.70	47.60	26.40	7.00
	80	40	44.20	32.00	15.10	52.30	35.20	13.40	58.60	37.50	12.00	67.10	40.80	9.80
		42	41.80	31.00	14.30	49.30	34.00	12.60	55.20	36.10	11.30	62.90	39.10	9.20
		45	38.10	29.40	13.10	44.80	32.10	11.50	49.90	34.10	10.20	56.50	36.60	8.20
		48	34.50	27.80	11.90	40.30	30.30	10.40	44.60	32.00	9.20	49.90	34.20	7.30
	85	40	47.10	39.10	16.10	55.70	42.90	14.20	62.40	45.80	12.70	71.40	49.80	10.40
		42	44.50	37.80	15.20	52.50	41.50	13.40	58.70	44.10	12.00	66.90	47.70	9.70
		45	40.60	35.80	13.90	47.70	39.20	12.20	53.10	41.60	10.90	60.10	44.70	8.80
		48	36.70	33.90	12.60	42.90	37.00	11.00	47.50	39.10	9.70	53.20	41.70	7.80
	90	40	50.50	45.90	17.20	59.70	50.50	15.20	67.00	53.90	13.60	76.60	58.50	11.10
		42	47.70	44.40	16.30	56.30	48.70	14.40	63.00	51.90	12.80	71.80	56.10	10.40
		45	43.50	42.10	14.90	51.20	46.10	13.10	57.00	48.90	11.60	64.50	52.50	9.40
		48	39.40	39.40	13.50	46.00	43.40	11.80	51.00	45.90	10.40	57.00	49.00	8.30



Performance Data

Table 37. VUV 150, cooling coil D, 3-row/12 fpi (continued)

Entering Wet Bulb Temp (°F)	Entering Dry Bulb Temp (°F)	Entering Water Temp (°F)	Flow Rate (gpm)											
			6			8			10			14		
			Total Capacity (MBh)	Sensible Capacity (MBh)	T (°F)	Total Capacity (MBh)	Sensible Capacity (MBh)	T (°F)	Total Capacity (MBh)	Sensible Capacity (MBh)	T (°F)	Total Capacity (MBh)	Sensible Capacity (MBh)	T (°F)
70	75	40	48.00	21.60	16.40	56.70	23.80	14.50	63.60	25.40	13.00	72.80	27.60	10.60
		42	45.30	20.90	15.50	53.50	23.00	13.70	59.80	24.40	12.20	68.20	26.40	9.90
		45	41.30	19.90	14.20	48.60	21.70	12.50	54.10	23.00	11.10	61.20	24.80	8.90
		48	37.40	18.80	12.90	43.70	20.50	11.20	48.40	21.60	9.90	54.20	23.10	7.90
	80	40	49.30	29.10	16.80	58.30	32.00	14.90	65.30	34.10	13.30	74.80	37.10	10.90
		42	46.50	28.10	15.90	55.00	30.80	14.00	61.50	32.80	12.50	70.10	35.50	10.20
		45	42.50	26.70	14.60	49.90	29.20	12.80	55.60	30.90	11.40	62.90	33.20	9.20
		48	38.40	25.20	13.20	44.90	27.50	11.50	49.70	29.10	10.20	55.70	31.00	8.10
	85	40	51.40	36.40	17.50	60.80	40.00	15.50	68.20	42.70	13.90	78.00	46.40	11.30
		42	48.60	35.20	16.60	57.40	38.60	14.60	64.20	41.10	13.10	73.10	44.50	10.60
		45	44.30	33.40	15.20	52.10	36.50	13.30	58.00	38.70	11.80	65.70	41.60	9.50
		48	40.10	31.60	13.80	46.80	34.40	12.00	51.90	36.40	10.60	58.10	38.90	8.50
	90	40	54.20	43.60	18.50	64.10	47.90	16.30	71.90	51.20	14.60	82.20	55.60	11.90
		42	51.20	42.20	17.50	60.50	46.30	15.40	67.60	49.30	13.80	77.10	53.30	11.20
		45	46.70	40.00	16.00	54.90	43.80	14.00	61.20	46.40	12.50	69.20	49.90	10.10
		48	42.20	37.80	14.50	49.40	41.30	12.60	54.70	43.60	11.20	61.20	46.50	8.90

Table 38. VUV 150, cooling coil E, 3-row/16 fpi

Entering Wet Bulb Temp (°F)	Entering Dry Bulb Temp (°F)	Entering Water Temp (°F)	Flow Rate (gpm)											
			6			8			10			14		
			Total Capacity (MBh)	Sensible Capacity (MBh)	T (°F)	Total Capacity (MBh)	Sensible Capacity (MBh)	T (°F)	Total Capacity (MBh)	Sensible Capacity (MBh)	T (°F)	Total Capacity (MBh)	Sensible Capacity (MBh)	T (°F)
61	70	40	31.80	23.10	11.00	37.70	25.40	9.70	42.20	27.20	8.70	48.20	29.50	7.10
		42	30.10	22.40	10.40	35.50	24.60	9.20	39.70	26.10	8.20	45.20	28.30	6.60
		45	27.40	21.20	9.50	32.30	23.20	8.40	36.00	24.60	7.40	40.60	26.40	6.00
		48	24.80	20.10	8.70	29.00	21.90	7.60	32.20	23.10	6.70	36.00	24.60	5.30
	75	40	34.70	30.00	12.00	41.10	33.00	10.60	46.00	35.20	9.40	52.60	38.30	7.70
		42	32.80	29.00	11.30	38.70	31.80	10.00	43.30	33.90	8.90	49.30	36.70	7.20
		45	29.90	27.50	10.40	35.20	30.10	9.10	39.20	31.90	8.10	44.30	34.30	6.50
		48	27.00	26.00	9.40	31.60	28.30	8.20	35.10	29.90	7.30	39.20	31.90	5.80
	80	40	38.50	36.30	13.20	45.50	39.90	11.70	51.00	42.60	10.40	58.30	46.40	8.50
		42	36.40	35.10	12.50	43.00	38.50	11.00	48.10	41.00	9.80	54.70	44.40	8.00
		45	33.20	33.20	11.50	39.10	36.40	10.10	43.50	38.60	8.90	49.20	41.50	7.20
		48	30.00	30.00	10.40	35.10	34.30	9.10	38.90	36.20	8.00	43.50	38.60	6.40
	85	40	42.90	42.20	14.70	50.80	46.40	13.00	57.00	49.60	11.60	65.10	53.90	9.50
		42	40.60	40.60	13.90	48.00	44.80	12.30	53.60	47.70	11.00	61.00	51.60	8.90
		45	37.00	37.00	12.70	43.60	42.40	11.20	48.60	44.90	9.90	54.90	48.30	8.00
		48	33.50	33.50	11.60	39.20	39.20	10.10	43.40	42.10	8.90	48.60	44.90	7.10
	90	40	47.90	47.80	16.30	56.70	52.60	14.50	63.50	56.10	12.90	72.60	61.10	10.50
		42	45.20	45.20	15.50	53.50	50.80	13.70	59.80	54.00	12.20	68.00	58.50	9.90
		45	41.30	41.30	14.20	48.60	48.00	12.40	54.10	50.90	11.10	61.20	54.70	8.90
		48	37.30	37.30	12.80	43.70	43.70	11.20	48.40	47.70	9.90	54.10	50.90	7.90
67	75	40	43.40	24.90	14.90	51.40	27.40	13.10	57.60	29.20	11.80	65.80	31.80	9.60
		42	41.00	24.10	14.10	48.50	26.40	12.40	54.20	28.10	11.10	61.70	30.50	9.00
		45	37.40	22.90	12.90	44.10	25.00	11.30	49.10	26.50	10.10	55.50	28.50	8.10
		48	33.80	21.60	11.70	39.60	23.50	10.20	43.90	24.80	9.00	49.10	26.50	7.20
	80	40	45.50	32.20	15.60	53.90	35.40	13.80	60.40	37.80	12.30	69.00	41.20	10.00
		42	43.00	31.20	14.70	50.80	34.20	13.00	56.90	36.40	11.60	64.70	39.40	9.40
		45	39.30	29.60	13.50	46.20	32.30	11.90	51.50	34.30	10.50	58.20	36.80	8.50
		48	35.50	28.00	12.20	41.50	30.40	10.70	46.00	32.20	9.40	51.50	34.30	7.50
	85	40	48.50	39.30	16.60	57.40	43.30	14.60	64.30	46.20	13.10	73.50	50.20	10.70
		42	45.80	38.10	15.70	54.10	41.70	13.80	60.50	44.40	12.30	68.90	48.10	10.00
		45	41.80	36.10	14.30	49.20	39.50	12.60	54.80	41.80	11.20	61.90	45.00	9.00
		48	37.80	34.10	13.00	44.20	37.20	11.40	49.00	39.30	10.00	54.80	41.90	8.00
	90	40	52.00	46.20	17.70	61.60	50.80	15.70	69.00	54.30	14.00	78.80	59.00	11.40
		42	49.20	44.70	16.80	58.10	49.10	14.80	65.00	52.20	13.20	73.90	56.60	10.70
		45	44.90	42.40	15.40	52.80	46.40	13.50	58.80	49.20	12.00	66.50	52.80	9.70
		48	40.50	40.10	13.90	47.50	43.70	12.20	52.60	46.10	10.80	58.80	49.20	8.60



Performance Data

Table 38. VUV 150, cooling coil E, 3-row/16 fpi (continued)

Entering Wet Bulb Temp (°F)	Entering Dry Bulb Temp (°F)	Entering Water Temp (°F)	Flow Rate (gpm)											
			6			8			10			14		
			Total Capacity (MBh)	Sensible Capacity (MBh)	T (°F)	Total Capacity (MBh)	Sensible Capacity (MBh)	T (°F)	Total Capacity (MBh)	Sensible Capacity (MBh)	T (°F)	Total Capacity (MBh)	Sensible Capacity (MBh)	T (°F)
70	75	40	49.40	21.80	16.90	58.50	24.00	14.90	65.50	25.60	13.30	74.90	27.80	10.90
		42	46.70	21.10	16.00	55.20	23.10	14.10	61.70	24.60	12.60	70.20	26.70	10.20
		45	42.60	20.00	14.60	50.10	21.90	12.80	55.90	23.20	11.40	63.10	24.90	9.20
		48	38.50	18.90	13.20	45.10	20.60	11.60	49.90	21.70	10.20	55.90	23.20	8.20
	80	40	50.70	29.30	17.30	60.10	32.20	15.30	67.30	34.40	13.70	76.90	37.40	11.20
		42	48.00	28.30	16.40	56.70	31.10	14.50	63.40	33.10	12.90	72.10	35.80	10.50
		45	43.80	26.90	15.00	51.50	29.40	13.20	57.40	31.10	11.70	64.80	33.50	9.40
		48	39.50	25.40	13.60	46.30	27.60	11.90	51.30	29.20	10.50	57.40	31.20	8.40
	85	40	52.90	36.60	18.00	62.70	40.30	16.00	70.20	43.00	14.30	80.30	46.80	11.60
		42	50.00	35.50	17.10	59.10	38.90	15.10	66.10	41.40	13.50	75.30	44.80	10.90
		45	45.70	33.60	15.60	53.80	36.80	13.70	59.90	39.00	12.20	67.70	41.90	9.80
		48	41.30	31.80	14.20	48.30	34.60	12.40	53.50	36.60	10.90	59.90	39.00	8.70
	90	40	55.80	43.90	19.00	66.10	48.30	16.80	74.00	51.50	15.00	84.60	56.10	12.30
		42	52.80	42.50	18.00	62.30	46.60	15.90	69.70	49.60	14.20	79.40	53.70	11.50
		45	48.10	40.30	16.40	56.70	44.00	14.50	63.10	46.70	12.90	71.30	50.20	10.40
		48	43.50	38.10	14.90	50.90	41.50	13.00	56.40	43.80	11.50	63.10	46.70	9.20

Table 39. VUV 150, cooling coil F, 4-row/12 fpi

Entering Wet Bulb Temp (°F)	Entering Dry Bulb Temp (°F)	Entering Water Temp (°F)	Flow Rate (gpm)											
			6			8			10			14		
			Total Capacity (MBh)	Sensible Capacity (MBh)	T (°F)	Total Capacity (MBh)	Sensible Capacity (MBh)	T (°F)	Total Capacity (MBh)	Sensible Capacity (MBh)	T (°F)	Total Capacity (MBh)	Sensible Capacity (MBh)	T (°F)
61	70	40	32.80	23.50	11.30	39.00	25.90	10.00	44.00	27.70	9.00	51.20	30.40	7.50
		42	31.00	22.70	10.70	36.80	25.00	9.50	41.50	26.70	8.50	48.10	29.20	7.00
		45	28.30	21.60	9.80	33.50	23.60	8.70	37.60	25.20	7.80	43.40	27.30	6.40
		48	25.60	20.40	8.90	30.10	22.30	7.80	33.70	23.60	7.00	38.50	25.40	5.70
	75	40	35.80	30.40	12.30	42.50	33.50	10.90	48.00	35.90	9.80	55.90	39.40	8.20
		42	33.80	29.40	11.70	40.10	32.40	10.30	45.30	34.60	9.30	52.50	37.80	7.70
		45	30.90	28.00	10.70	36.50	30.60	9.40	41.00	32.60	8.40	47.30	35.40	6.90
		48	27.90	26.50	9.70	32.80	28.90	8.50	36.70	30.60	7.60	42.00	33.00	6.20
	80	40	39.70	36.80	13.60	47.20	40.60	12.10	53.20	43.40	10.90	62.00	47.70	9.00
		42	37.50	35.60	12.90	44.50	39.20	11.40	50.20	41.90	10.30	58.20	45.70	8.50
		45	34.30	33.90	11.80	40.50	37.10	10.40	45.50	39.50	9.30	52.50	42.80	7.70
		48	30.90	30.90	10.70	36.40	35.00	9.40	40.70	37.10	8.40	46.60	39.90	6.80
	85	40	44.30	42.80	15.20	52.60	47.20	13.50	59.40	50.50	12.10	69.20	55.50	10.10
		42	41.90	41.50	14.40	49.70	45.60	12.70	56.00	48.70	11.40	65.00	53.20	9.50
		45	38.20	38.20	13.10	45.20	43.10	11.60	50.80	45.90	10.40	58.60	49.80	8.50
		48	34.50	34.50	11.90	40.60	40.60	10.50	45.50	43.10	9.30	52.00	46.40	7.60
	90	40	49.40	48.50	16.90	58.70	53.40	15.00	66.20	57.30	13.50	77.10	62.90	11.20
		42	46.70	46.70	16.00	55.40	51.60	14.10	62.40	55.20	12.70	72.40	60.30	10.50
		45	42.60	42.60	14.60	50.40	48.90	12.90	56.60	52.00	11.60	65.30	56.40	9.50
		48	38.50	38.50	13.20	45.30	45.30	11.60	50.70	48.90	10.40	58.00	52.60	8.50
67	75	40	44.80	25.20	15.30	53.20	27.80	13.60	60.10	29.80	12.20	69.90	32.70	10.20
		42	42.30	24.40	14.50	50.20	26.90	12.90	56.60	28.70	11.60	65.70	31.40	9.60
		45	38.60	23.20	13.30	45.70	25.40	11.70	51.30	27.10	10.50	59.20	29.40	8.60
		48	34.90	22.00	12.00	41.10	24.00	10.60	46.00	25.40	9.40	52.60	27.40	7.70
	80	40	47.00	32.70	16.10	55.80	36.00	14.30	63.00	38.60	12.80	73.40	42.40	10.60
		42	44.40	31.60	15.20	52.70	34.80	13.50	59.40	37.20	12.10	68.90	40.60	10.00
		45	40.50	30.10	13.90	47.90	32.90	12.30	53.90	35.00	11.00	62.10	38.00	9.00
		48	36.60	28.50	12.60	43.10	31.10	11.10	48.20	32.90	9.90	55.20	35.40	8.10
	85	40	50.00	39.90	17.10	59.40	44.00	15.20	67.10	47.10	13.70	78.10	51.70	11.30
		42	47.30	38.60	16.20	56.10	42.50	14.30	63.20	45.40	12.90	73.40	49.60	10.70
		45	43.20	36.70	14.80	51.00	40.20	13.10	57.30	42.80	11.70	66.10	46.40	9.60
		48	38.90	34.80	13.40	45.90	37.90	11.80	51.30	40.20	10.50	58.70	43.30	8.60
	90	40	53.70	46.90	18.30	63.70	51.70	16.20	72.00	55.30	14.60	83.80	60.80	12.10
		42	50.70	45.40	17.30	60.20	49.90	15.30	67.80	53.30	13.80	78.70	58.30	11.40
		45	46.30	43.20	15.80	54.80	47.20	14.00	61.50	50.30	12.50	71.00	54.50	10.30
		48	41.80	40.90	14.30	49.20	44.60	12.60	55.10	47.20	11.30	63.00	50.80	9.20



Performance Data

Table 39. VUV 150, cooling coil F, 4-row/12 fpi (continued)

Entering Wet Bulb Temp (°F)	Entering Dry Bulb Temp (°F)	Entering Water Temp (°F)	Flow Rate (gpm)											
			6			8			10			14		
			Total Capacity (MBh)	Sensible Capacity (MBh)	T (°F)	Total Capacity (MBh)	Sensible Capacity (MBh)	T (°F)	Total Capacity (MBh)	Sensible Capacity (MBh)	T (°F)	Total Capacity (MBh)	Sensible Capacity (MBh)	T (°F)
70	75	40	51.00	22.10	17.40	60.50	24.40	15.40	68.40	26.10	13.90	79.60	28.60	11.50
		42	48.20	21.40	16.50	57.20	23.50	14.60	64.40	25.10	13.10	74.80	27.50	10.90
		45	44.00	20.30	15.10	52.00	22.30	13.30	58.40	23.70	11.90	67.40	25.70	9.80
		48	39.70	19.30	13.60	46.70	21.00	12.00	52.30	22.30	10.70	59.90	24.00	8.70
	80	40	52.30	29.70	17.80	62.20	32.70	15.80	70.20	35.00	14.30	81.70	38.50	11.80
		42	49.50	28.70	16.90	58.70	31.60	15.00	66.20	33.80	13.50	76.80	36.90	11.10
		45	45.20	27.30	15.50	53.40	29.90	13.70	60.00	31.80	12.20	69.20	34.50	10.10
		48	40.80	25.90	14.00	48.00	28.20	12.30	53.70	29.90	11.00	61.50	32.20	9.00
	85	40	54.60	37.20	18.60	64.90	41.00	16.50	73.30	43.90	14.90	85.30	48.20	12.40
		42	51.70	36.00	17.60	61.30	39.60	15.60	69.10	42.30	14.10	80.10	46.20	11.60
		45	47.10	34.20	16.10	55.70	37.50	14.20	62.60	39.90	12.80	72.30	43.20	10.50
		48	42.50	32.40	14.60	50.10	35.30	12.80	56.10	37.50	11.50	64.20	40.30	9.30
	90	40	57.60	44.50	19.60	68.40	49.10	17.40	77.20	52.60	15.70	89.90	57.70	13.00
		42	54.50	43.10	18.50	64.60	47.40	16.40	72.80	50.60	14.80	84.50	55.30	12.20
		45	49.70	41.00	17.00	58.80	44.90	15.00	66.00	47.80	13.40	76.20	51.80	11.10
		48	44.80	38.80	15.30	52.80	42.30	13.50	59.10	44.90	12.10	67.60	48.30	9.80

Table 40. VUV 150, cooling coil G, 4-row/16 fpi

Entering Wet Bulb Temp (°F)	Entering Dry Bulb Temp (°F)	Entering Water Temp (°F)	Flow Rate (gpm)											
			6			8			10			14		
			Total Capacity (MBh)	Sensible Capacity (MBh)	T (°F)	Total Capacity (MBh)	Sensible Capacity (MBh)	T (°F)	Total Capacity (MBh)	Sensible Capacity (MBh)	T (°F)	Total Capacity (MBh)	Sensible Capacity (MBh)	T (°F)
61	70	40	33.60	24.00	11.60	40.10	26.50	10.30	45.50	28.50	9.30	53.10	31.40	7.80
		42	31.80	23.20	11.00	37.80	25.60	9.80	42.70	27.40	8.80	49.70	29.90	7.30
		45	29.20	22.20	10.10	34.50	24.30	8.90	38.80	25.80	8.00	44.80	28.00	6.60
		48	26.40	21.00	9.20	31.10	22.90	8.10	34.80	24.30	7.20	39.90	26.20	5.90
	75	40	36.70	31.10	12.60	43.80	34.40	11.20	49.60	36.90	10.20	58.00	40.60	8.40
		42	34.70	30.10	12.00	41.30	33.10	10.60	46.60	35.40	9.60	54.20	38.80	7.90
		45	31.90	28.70	11.00	37.70	31.50	9.70	42.30	33.50	8.70	48.80	36.30	7.10
		48	28.80	27.20	10.00	33.90	29.70	8.80	38.00	31.50	7.80	43.50	33.90	6.40
	80	40	40.70	37.60	14.00	48.60	41.60	12.40	55.00	44.70	11.20	64.30	49.20	9.40
		42	38.50	36.50	13.20	45.80	40.10	11.70	51.70	42.90	10.60	60.10	47.00	8.80
		45	35.30	34.80	12.20	41.80	38.10	10.70	47.00	40.50	9.60	54.20	44.00	7.90
		48	31.90	31.90	11.00	37.60	36.00	9.70	42.10	38.10	8.70	48.30	41.00	7.10
	85	40	45.40	43.80	15.50	54.20	48.40	13.80	61.40	52.00	12.50	71.70	57.20	10.40
		42	43.00	42.40	14.70	51.10	46.70	13.10	57.70	49.90	11.80	67.00	54.60	9.70
		45	39.40	39.40	13.50	46.60	44.30	12.00	52.40	47.20	10.70	60.50	51.10	8.80
		48	35.60	35.60	12.30	42.00	41.80	10.80	47.00	44.30	9.60	53.90	47.80	7.90
	90	40	50.60	49.60	17.30	60.40	54.80	15.40	68.40	58.90	13.90	80.00	64.80	11.60
		42	47.90	47.90	16.40	56.90	52.90	14.50	64.30	56.60	13.10	74.70	61.90	10.80
		45	44.00	44.00	15.10	52.00	50.20	13.30	58.40	53.40	11.90	67.40	57.90	9.80
		48	39.70	39.70	13.60	46.80	46.80	12.00	52.40	50.20	10.70	60.10	54.10	8.70
67	75	40	45.90	25.80	15.70	54.80	28.50	14.00	62.00	30.60	12.60	72.50	33.70	10.50
		42	43.40	25.00	14.90	51.60	27.50	13.20	58.30	29.40	11.90	67.80	32.20	9.80
		45	39.90	23.90	13.70	47.10	26.10	12.10	53.00	27.80	10.80	61.10	30.20	8.90
		48	36.00	22.60	12.40	42.40	24.70	10.90	47.50	26.20	9.70	54.40	28.20	7.90
	80	40	48.20	33.40	16.50	57.50	36.90	14.70	65.10	39.70	13.30	76.10	43.70	11.00
		42	45.60	32.40	15.60	54.20	35.60	13.80	61.10	38.10	12.50	71.10	41.70	10.30
		45	41.80	30.90	14.30	49.40	33.80	12.70	55.60	36.00	11.40	64.10	39.00	9.30
		48	37.70	29.30	13.00	44.50	31.90	11.40	49.90	33.90	10.20	57.10	36.50	8.30
	85	40	51.30	40.80	17.50	61.20	45.10	15.60	69.30	48.40	14.10	81.00	53.30	11.70
		42	48.50	39.50	16.60	57.70	43.50	14.70	65.10	46.50	13.30	75.70	50.90	11.00
		45	44.50	37.70	15.20	52.60	41.30	13.50	59.20	43.90	12.10	68.20	47.70	9.90
		48	40.20	35.70	13.80	47.40	39.00	12.10	53.10	41.30	10.90	60.80	44.50	8.90
	90	40	55.00	47.90	18.70	65.60	53.00	16.70	74.30	56.90	15.10	86.90	62.70	12.60
		42	52.00	46.50	17.70	61.90	51.10	15.80	69.80	54.70	14.20	81.20	59.80	11.80
		45	47.80	44.30	16.30	56.50	48.50	14.40	63.50	51.60	12.90	73.20	56.00	10.60
		48	43.10	42.00	14.80	50.80	45.80	13.00	56.90	48.60	11.60	65.30	52.30	9.50



Performance Data

Table 40. VUV 150, cooling coil G, 4-row/16 fpi (continued)

Entering Wet Bulb Temp (°F)	Entering Dry Bulb Temp (°F)	Entering Water Temp (°F)	Flow Rate (gpm)											
			6			8			10			14		
			Total Capacity (MBh)	Sensible Capacity (MBh)	T (°F)	Total Capacity (MBh)	Sensible Capacity (MBh)	T (°F)	Total Capacity (MBh)	Sensible Capacity (MBh)	T (°F)	Total Capacity (MBh)	Sensible Capacity (MBh)	T (°F)
70	75	40	52.20	22.60	17.80	62.30	25.00	15.90	70.60	26.80	14.40	82.50	29.50	12.00
		42	49.40	21.90	16.90	58.80	24.10	15.00	66.30	25.80	13.50	77.10	28.20	11.20
		45	45.40	20.90	15.50	53.60	22.90	13.70	60.30	24.30	12.30	69.50	26.40	10.10
		48	40.90	19.80	14.00	48.30	21.60	12.40	54.10	22.90	11.10	62.00	24.60	9.00
	80	40	53.70	30.40	18.30	64.00	33.60	16.30	72.50	36.00	14.70	84.80	39.70	12.30
		42	50.80	29.40	17.30	60.30	32.40	15.40	68.10	34.60	13.90	79.20	37.90	11.50
		45	46.60	28.10	15.90	55.10	30.70	14.10	61.90	32.70	12.60	71.40	35.50	10.40
		48	42.10	26.60	14.40	49.60	29.00	12.70	55.60	30.70	11.30	63.70	33.10	9.30
	85	40	56.00	38.00	19.10	66.80	42.00	17.00	75.70	45.10	15.40	88.50	49.70	12.80
		42	53.00	36.80	18.10	63.00	40.50	16.00	71.10	43.40	14.50	82.70	47.40	12.00
		45	48.60	35.10	16.60	57.50	38.50	14.70	64.60	40.90	13.20	74.50	44.40	10.80
		48	43.90	33.30	15.00	51.80	36.30	13.20	58.00	38.50	11.80	66.40	41.50	9.70
	90	40	59.00	45.50	20.10	70.50	50.30	17.90	79.80	54.00	16.20	93.20	59.50	13.50
		42	55.80	44.10	19.00	66.40	48.60	16.90	74.90	51.90	15.20	87.10	56.80	12.60
		45	51.30	42.10	17.50	60.60	46.10	15.50	68.10	49.00	13.90	78.60	53.20	11.40
		48	46.30	39.90	15.80	54.60	43.50	13.90	61.10	46.10	12.50	70.00	49.70	10.20

Table 41. VUV 150, cooling coil H, 3-row/16 fpi, EarthWise

Entering Wet Bulb Temp (°F)	Entering Dry Bulb Temp (°F)	Entering Water Temp (°F)	Flow Rate (gpm)											
			6			8			10			14		
			Total Capacity (MBh)	Sensible Capacity (MBh)	T (°F)	Total Capacity (MBh)	Sensible Capacity (MBh)	T (°F)	Total Capacity (MBh)	Sensible Capacity (MBh)	T (°F)	Total Capacity (MBh)	Sensible Capacity (MBh)	T (°F)
61	70	40	35.40	23.70	12.20	41.30	25.70	10.60	45.50	27.20	9.30	50.50	29.20	7.40
		42	33.60	23.00	11.60	39.10	24.90	10.10	43.00	26.20	8.80	47.50	28.00	7.00
		45	30.90	21.90	10.70	35.80	23.60	9.20	39.20	24.80	8.10	43.00	26.20	6.30
		48	28.10	20.70	9.70	32.40	22.30	8.40	35.40	23.30	7.30	38.40	24.50	5.70
	75	40	38.70	30.80	13.30	45.00	33.40	11.50	49.60	35.20	10.20	55.10	37.80	8.00
		42	36.70	29.80	12.60	42.60	32.30	11.00	46.90	34.00	9.60	51.90	36.20	7.60
		45	33.70	28.40	11.60	39.00	30.60	10.10	42.80	32.10	8.80	46.90	34.00	6.90
		48	30.60	26.90	10.60	35.30	28.90	9.10	38.60	30.20	8.00	41.90	31.80	6.20
	80	40	42.90	37.30	14.70	49.90	40.40	12.80	55.00	42.70	11.20	61.10	45.70	8.90
		42	40.70	36.10	14.00	47.30	39.10	12.10	52.00	41.10	10.60	57.50	43.90	8.40
		45	37.40	34.40	12.90	43.30	37.00	11.10	47.40	38.90	9.70	52.00	41.20	7.60
		48	33.90	32.50	11.70	39.20	35.00	10.10	42.80	36.60	8.80	46.50	38.50	6.80
	85	40	47.80	43.30	16.30	55.70	47.00	14.20	61.40	49.60	12.50	68.20	53.20	9.90
		42	45.40	42.00	15.50	52.80	45.40	13.50	58.10	47.90	11.80	64.20	51.10	9.30
		45	41.70	40.00	14.30	48.30	43.10	12.40	52.90	45.20	10.80	58.10	47.90	8.50
		48	37.90	37.80	13.00	43.70	40.70	11.20	47.70	42.60	9.80	51.90	44.80	7.60
	90	40	53.30	49.10	18.20	62.10	53.20	15.80	68.50	56.20	13.90	76.00	60.30	11.00
		42	50.60	47.60	17.30	58.80	51.50	15.00	64.70	54.20	13.20	71.60	57.80	10.40
		45	46.50	45.30	15.90	53.80	48.80	13.80	59.00	51.20	12.00	64.70	54.20	9.40
		48	42.20	42.20	14.50	48.70	46.10	12.50	53.20	48.20	10.90	57.80	50.70	8.40
67	75	40	48.30	25.60	16.50	56.30	27.70	14.40	62.10	29.30	12.70	69.00	31.40	10.00
		42	45.90	24.80	15.70	53.30	26.80	13.60	58.70	28.20	12.00	64.90	30.10	9.40
		45	42.10	23.60	14.40	48.80	25.40	12.50	53.50	26.70	10.90	58.70	28.20	8.60
		48	38.30	22.30	13.20	44.20	24.00	11.30	48.20	25.10	9.90	52.40	26.40	7.70
	80	40	50.70	33.10	17.30	59.10	35.90	15.10	65.10	37.90	13.30	72.30	40.60	10.50
		42	48.20	32.10	16.40	55.90	34.70	14.30	61.60	36.50	12.60	68.10	39.00	9.90
		45	44.20	30.50	15.10	51.20	32.90	13.10	56.10	34.50	11.50	61.60	36.50	9.00
		48	40.20	28.90	13.80	46.40	31.10	11.90	50.60	32.50	10.40	55.00	34.20	8.00
	85	40	54.00	40.40	18.40	62.90	43.80	16.00	69.30	46.20	14.10	77.00	49.60	11.20
		42	51.30	39.20	17.50	59.60	42.30	15.20	65.50	44.60	13.30	72.50	47.60	10.50
		45	47.10	37.30	16.10	54.50	40.10	13.90	59.80	42.10	12.20	65.60	44.60	9.50
		48	42.80	35.30	14.70	49.40	37.90	12.60	53.90	39.70	11.00	58.60	41.70	8.50
	90	40	57.90	47.50	19.70	67.50	51.40	17.20	74.40	54.30	15.10	82.60	58.30	12.00
		42	55.00	46.00	18.70	63.90	49.80	16.30	70.30	52.40	14.30	77.80	55.90	11.30
		45	50.50	43.80	17.20	58.50	47.20	14.90	64.10	49.50	13.10	70.30	52.40	10.20
		48	45.90	41.40	15.70	53.00	44.60	13.50	57.80	46.60	11.80	62.80	49.00	9.10



Performance Data

Table 41. VUV 150, cooling coil H, 3-row/16 fpi, EarthWise (continued)

Entering Wet Bulb Temp (°F)	Entering Dry Bulb Temp (°F)	Entering Water Temp (°F)	Flow Rate (gpm)											
			6			8			10			14		
			Total Capacity (MBh)	Sensible Capacity (MBh)	T (°F)	Total Capacity (MBh)	Sensible Capacity (MBh)	T (°F)	Total Capacity (MBh)	Sensible Capacity (MBh)	T (°F)	Total Capacity (MBh)	Sensible Capacity (MBh)	T (°F)
70	75	40	55.00	22.40	18.70	64.10	24.30	16.30	70.70	25.60	14.40	78.50	27.50	11.40
		42	52.20	21.70	17.80	60.70	23.50	15.50	66.80	24.70	13.60	73.80	26.40	10.70
		45	48.00	20.60	16.40	55.50	22.20	14.20	60.90	23.30	12.40	66.80	24.70	9.70
		48	43.60	19.50	14.90	50.30	21.00	12.90	54.90	22.00	11.20	59.70	23.10	8.70
	80	40	56.50	30.00	19.20	65.80	32.60	16.70	72.60	34.40	14.80	80.60	36.90	11.70
		42	53.70	29.10	18.30	62.30	31.50	15.90	68.60	33.20	14.00	75.90	35.40	11.00
		45	49.30	27.70	16.80	57.10	29.90	14.60	62.60	31.30	12.70	68.60	33.20	10.00
		48	44.80	26.20	15.30	51.70	28.20	13.20	56.40	29.50	11.50	61.30	31.00	8.90
	85	40	59.00	37.60	20.10	68.70	40.80	17.50	75.70	43.10	15.40	84.10	46.20	12.20
		42	56.00	36.50	19.10	65.10	39.50	16.60	71.60	41.60	14.60	79.20	44.30	11.50
		45	51.40	34.70	17.50	59.50	37.40	15.20	65.30	39.30	13.30	71.60	41.60	10.40
		48	46.70	32.90	16.00	53.90	35.30	13.80	58.90	37.00	12.00	64.00	38.90	9.30
	90	40	62.20	45.10	21.10	72.40	48.90	18.40	79.80	51.60	16.20	88.70	55.30	12.80
		42	59.00	43.70	20.10	68.60	47.30	17.40	75.50	49.80	15.30	83.40	53.10	12.10
		45	54.20	41.60	18.50	62.80	44.80	16.00	68.80	47.00	14.00	75.50	49.80	11.00
		48	49.20	39.40	16.80	56.80	42.30	14.50	62.10	44.30	12.60	67.40	46.60	9.80

Table 42. VUV 150, cooling coil J (DX)

Size	EWB	Suct Temp	EDB = 70°F				EDB = 75°F				EDB = 80°F				EDB = 85°F			
			TC	SC	LDB	LWB	TC	SC	LDB	LWB	TC	SC	LDB	LWB	TC	SC	LDB	LWB
1500	61	40	41.70	27.50	53.00	51.10	45.60	36.30	52.50	50.00	50.50	44.50	52.40	48.60	56.50	52.20	52.70	46.90
		45	34.90	25.00	54.50	52.80	38.20	33.00	54.60	51.90	42.40	40.50	54.90	50.80	47.30	47.30	55.70	49.40
		50	28.20	22.50	56.10	54.50	30.90	29.70	56.60	53.80	34.20	34.20	58.80	52.90	38.20	38.20	61.30	51.90
	64	40	49.50	23.70	55.30	52.80	52.20	33.40	54.30	52.10	55.50	42.40	53.70	51.20	59.70	51.00	53.40	50.00
		45	41.50	21.60	56.60	54.80	43.70	30.40	56.20	54.20	46.50	38.60	56.10	53.50	50.10	46.40	56.30	52.50
		50	33.50	19.40	58.00	56.70	35.30	27.30	58.10	56.20	37.60	34.70	58.50	55.60	40.40	40.40	60.00	54.90
	67	40	58.60	19.00	58.20	54.50	60.50	29.20	56.90	53.90	62.70	38.90	55.90	53.30	65.60	48.20	55.10	52.50
		45	49.10	17.30	59.30	56.80	50.70	26.60	58.50	56.30	52.60	35.40	58.10	55.80	55.00	43.80	57.90	55.20
		50	39.70	15.50	60.40	58.90	40.90	23.90	60.20	58.60	42.40	31.80	60.30	58.20	44.40	39.40	60.60	57.70
	70	40					70.10	24.10	60.10	55.70	71.70	34.20	58.80	55.20	73.60	44.00	57.70	54.70
		45					58.80	21.90	61.40	58.30	60.10	31.10	60.70	58.00	61.70	40.00	60.20	57.50
		50					47.40	19.70	62.80	60.80	48.50	28.00	62.70	60.50	49.80	36.00	62.70	60.20
73	40									82.00	28.60	62.30	57.10	83.30	38.60	61.10	56.70	
	45									68.70	26.00	63.90	60.00	69.80	35.10	63.30	59.70	
	50									55.40	23.40	65.50	62.80	56.40	31.60	65.40	62.60	

Notes:

1. EDB = Entering Air Temperature, Dry Bulb (°F).
2. EWB = Entering Air Temperature, Wet Bulb (°F).
3. TC = Total Capacity (MBh).
4. SC = Sensible Capacity (MBh).
5. LDB = Leaving Air Temperature, Dry Bulb (°F).
6. LWB = Leaving Air Temperature, Wet Bulb (°F).

Table 43. Airflow correction (% of design airflow)

%	Total Capacity (MBh)	Sensible Capacity (MBh)
120	1.03	1.11
110	1.01	1.05
100	1.00	1.00
90	0.99	0.95
80	0.97	0.89

Table 44. Airflow through coil J

Unit Model	1500
Rated cfm	1495+



Performance Data

Table 45. VUV 150, hydronic heating coils A (1-row/12 fpi), B (2-row/12 fpi), C (2-row/16 fpi)

Coil	Entering Air Temp, Dry Bulb (°F)	Entering Water Temp (°F)	Flow Rate (gpm)					
			2		4		6	
			Total Capacity (MBh)	Waterside Temp Drop (°F)	Total Capacity (MBh)	Waterside Temp Drop (°F)	Total Capacity (MBh)	Waterside Temp Drop (°F)
A	50	120	35.10	33.90	44.10	21.50	48.30	15.70
		140	48.90	47.70	61.80	30.30	67.70	22.20
		160	62.70	61.50	79.60	39.20	87.10	28.60
		180	76.50	75.30	97.50	48.20	106.60	35.10
	55	120	33.20	32.00	41.70	20.30	45.70	14.80
		140	46.30	45.10	58.50	28.70	64.00	20.90
		160	59.30	58.10	75.30	37.10	82.40	27.10
		180	72.40	71.20	92.20	45.50	100.80	33.20
	60	120	31.30	30.10	39.30	19.10	43.10	14.00
		140	43.60	42.40	55.20	27.00	60.40	19.70
		160	55.90	54.70	71.00	34.90	77.70	25.50
		180	68.30	67.10	87.00	42.90	95.10	31.30
	65	120	29.50	28.30	37.00	17.90	40.50	13.10
		140	41.00	39.80	51.90	25.40	56.80	18.50
		160	52.60	51.40	66.80	32.80	73.10	24.00
		180	64.20	63.00	81.80	40.30	89.40	29.40
	70	120	27.60	26.40	34.60	16.70	37.90	12.20
		140	38.40	37.20	48.50	23.70	53.10	17.30
		160	49.20	48.00	62.50	30.70	68.40	22.40
		180	60.00	58.80	76.50	37.70	83.70	27.50
B	50	120	39.00	37.80	54.50	26.70	63.00	20.60
		140	53.90	52.70	76.90	37.90	88.70	29.20
		160	68.90	67.70	99.40	49.10	114.40	37.70
		180	84.00	82.80	122.00	60.40	140.20	46.30
	55	120	36.90	35.70	51.50	25.20	59.60	19.50
		140	51.00	49.80	72.70	35.80	83.90	27.60
		160	65.20	64.00	94.00	46.40	108.20	35.70
		180	79.50	78.30	115.40	57.10	132.60	43.80
	60	120	34.80	33.60	48.60	23.70	56.20	18.30
		140	48.10	46.90	68.60	33.70	79.10	26.00
		160	61.50	60.30	88.70	43.80	102.10	33.60
		180	75.00	73.80	108.80	53.80	125.10	41.30
	65	120	32.70	31.50	45.70	22.30	52.80	17.20
		140	45.20	44.00	64.50	31.70	74.40	24.40
		160	57.80	56.60	83.40	41.10	96.00	31.60
		180	70.50	69.30	102.30	50.60	117.60	38.80
	70	120	30.60	29.40	42.70	20.80	49.40	16.10
		140	42.30	41.10	60.30	29.60	69.60	22.80
		160	54.10	52.90	78.00	38.40	89.80	29.50
		180	65.90	64.70	95.70	47.30	110.00	36.30

Table 45. VUV 150, hydronic heating coils A (1-row/12 fpi), B (2-row/12 fpi), C (2-row/16 fpi) (continued)

Coil	Entering Air Temp, Dry Bulb (°F)	Entering Water Temp (°F)	Flow Rate (gpm)					
			2		4		6	
			Total Capacity (MBh)	Waterside Temp Drop (°F)	Total Capacity (MBh)	Waterside Temp Drop (°F)	Total Capacity (MBh)	Waterside Temp Drop (°F)
C	50	120	39.50	38.30	56.00	27.40	65.00	21.30
		140	54.50	53.30	79.10	39.00	91.50	30.10
		160	69.70	68.50	102.20	50.50	118.10	39.00
		180	84.90	83.70	125.30	62.10	144.60	47.80
	55	120	37.30	36.10	53.00	25.90	61.50	20.10
		140	51.60	50.40	74.80	36.80	86.60	28.50
		160	65.90	64.70	96.70	47.80	111.70	36.80
		180	80.30	79.10	118.60	58.70	136.80	45.20
	60	120	35.20	34.00	50.00	24.40	58.00	18.90
		140	48.60	47.40	70.60	34.70	81.70	26.80
		160	62.20	61.00	91.20	45.00	105.30	34.70
		180	75.80	74.60	111.80	55.30	129.10	42.60
	65	120	33.10	31.90	47.00	22.90	54.60	17.80
		140	45.70	44.50	66.30	32.60	76.80	25.20
		160	58.40	57.20	85.70	42.30	99.00	32.60
		180	71.20	70.00	105.10	52.00	121.30	40.00
	70	120	31.00	29.80	44.00	21.40	51.10	16.60
		140	42.80	41.60	62.10	30.50	71.80	23.50
		160	54.70	53.50	80.20	39.50	92.70	30.50
		180	66.70	65.50	98.40	48.60	113.50	37.40



Performance Data

Table 46. VUV 150, steam heating coils K (low-capacity), L (high-capacity)

Size	Coil	Entering Air Temp, Dry Bulb (°F)	Steam Pressure (psig)					
			5		10		15	
			Total Capacity (MBh)	Airside Temp Rise (°F)	Total Capacity (MBh)	Airside Temp Rise (°F)	Total Capacity (MBh)	Airside Temp Rise (°F)
1500	K	0	141.10	87.10	148.40	91.60	154.70	95.50
		10	134.80	83.20	142.10	87.70	148.40	91.60
		20	128.60	79.40	135.90	83.90	142.20	87.80
		30	122.40	75.60	129.70	80.10	136.00	83.90
		40	116.20	71.70	123.50	76.20	129.80	80.10
		50	110.00	67.90	117.30	72.40	123.60	76.30
		60	103.80	64.10	111.10	68.60	117.40	72.50
	70	97.60	60.20	104.90	64.80	111.20	68.60	
	L	0	208.20	128.50	219.00	135.20	228.20	140.90
		10	199.00	122.90	209.90	129.50	219.10	135.20
		20	189.90	117.20	200.70	123.90	209.90	129.60
		30	180.80	111.60	191.60	118.20	200.80	123.90
		40	171.60	105.90	182.40	112.60	191.60	118.30
		50	162.50	100.30	173.20	106.90	182.50	112.60
60		153.30	94.60	164.10	101.30	173.30	107.00	
70	144.10	89.00	154.90	95.60	164.10	101.30		

Note: psig = steam pressure (lb/in.² gage).



Controls

Why Trane Controls

Whether involved in a retrofit or in new construction applications, Trane has the control design to fit the systems requirements. Trane offers a broad range of control packages from a field convertible end-device package, to a complete building automation system solution with BACnet® controls.

Note: Some Trane controllers have the ability to be pre-addressed in the factory. If addressing is not provided, the controllers will remain at default setting.

Trane controls are factory-mounted, factory-wired, factory-tested and configured or programmed with Trane application expertise to provide comfort, efficiency, and reliability, as well as single-source warranty and service. With Trane integrated controls, the installed costs are lower because the equipment has turn-key factory controls and every component of the system is optimized to fit with the controller. Trane installs not only the controller, but also the hardware that works intimately with the controller to allow the system to function properly (i.e., piping package, valves, dampers, actuators, etc.). When a product with Trane controls arrives on the jobsite, it is completely ready for quick installation.

Table 47. Tracer® controller input/output summary

Input/output	ZN520	Symbio™ 400-B
Binary outputs		
Single zone VAV		X
3-speed fan	X	
2-position hydronic valve	X	X
2-position mixing box damper		X
1-stage electric heat	X	X
2-stage electric heat	X	X
Reheat (hydronic or electric)	X	X
Modulating economizer damper	X	X
Modulating hydronic valve	X	X
Generic	X	
Binary inputs		
Condensate overflow detection	X	X
Low temperature detection	X	X
Occupancy	X	X
Generic input	X	X
Analog inputs		
Zone temperature	X	X
Setpoint	X	X
Fan mode: auto, high, medium, low	X	X
Entering water	X	X
Discharge air	X	X
Outside air	X	X
Generic	X	
Analog Outputs		

Table 47. Tracer® controller input/output summary (continued)

Variable speed fan		X
Analog hydronic valves		X

Table 48. Tracer controller function summary

Control functions	Symbio 400-B
Air-Fi® Factory Addressing	X
Entering water temp. sampling (purge)	X
Timed override	
Auto changeover	X
Fan cycling	X
Warm-up	
Pre-cool	
Data sharing	
Random start	X
Dehumidification	X
Staged capacity (2-stage electric supplementary)	X
DX cooling	X
DX frost protection	X
Single zone VAV	X
Other functions	
Manual test	in TU
Filter maintenance timer	X
Setpoint limits	X

VelociTach™ Motor Control Board

The VelociTach motor control board controls and reports the performance of up to two Trane brushless DC (BLDC) motors.

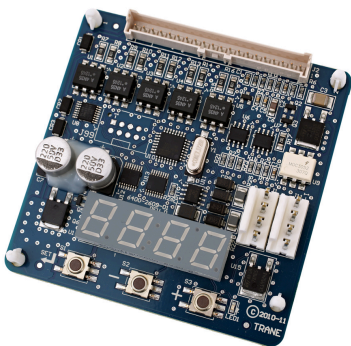
Figure 20. VelociTach motor control board

The motor control board also:

- Coordinates the operation of the fan in response to electric heat behavior and electric behavior in response to hydronic heat behavior.
- Incorporates a user interface that allows adjustment of certain unit parameters and provides constant feedback on motor operation.
- Integrates service and troubleshooting tools.
- Integrates a versatile configurable auxiliary temperature sensor.
- Incorporates various safety and lockout features, such as maintaining proper fan speeds if electric heat is called for.

Status Display

Figure 21. Status display

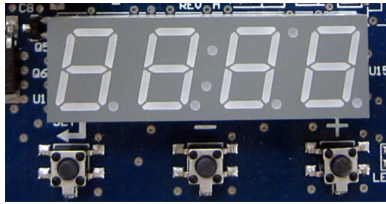

The motor control board contains a four-digit, seven-segment display that is used to present information in a format close to real-world language, while having a small-form factor. Most characters are immediately recognizable.

Control Options

Available control options:

- Customer-supplied terminal interface (CSTI)
- Symbio™ 400-B controller with Air-Fi® Wireless Communications Interface (WCI)

Control option descriptions follow below. A complete list of controller inputs and outputs are in [Table 47, p. 85](#). See [Table 49, p. 94](#) for information on end device options.

Customer Supplied Terminal Interface (CSTI)

The CSTI is intended to be used with a field-supplied, low-voltage thermostat or controller. The control box contains a relay board which includes a line voltage to 24-volt transformer and disconnect switch (for non-electric heat units). All end devices are wired to a low-voltage terminal block and are run-tested, so the only a power connection and thermostat connection is needed to commission the unit. Entering water temperature sensors and controls are provided whenever a changeover coil is selected. When N.O. valves are selected, inverting relays are provided for use with standard thermostats.

Figure 22. CSTI adapter board and field connections

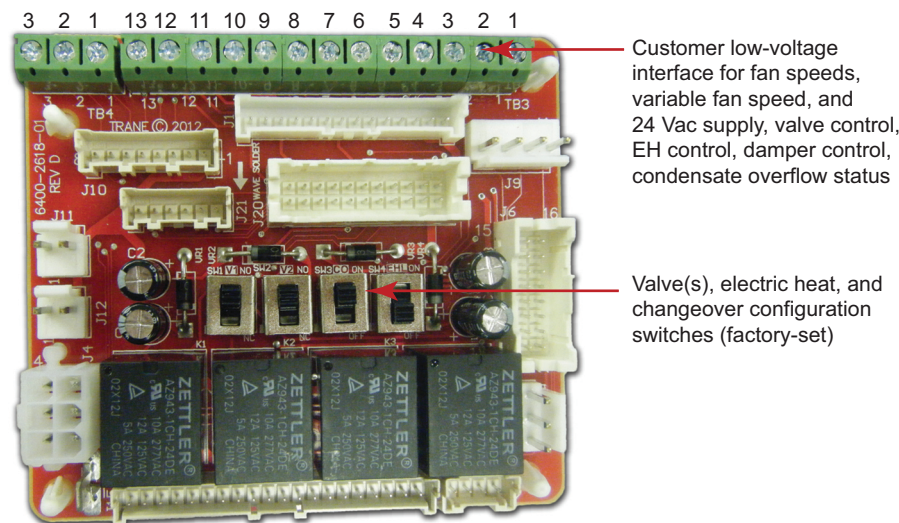

The CSTI adapter board provides all the hookups as the standard adapter board, but in addition, provides hookups for valve control (main and auxiliary coils), electric heat control, and damper control. Screw terminal blocks provide convenient access to fan controls and to end device control. In addition, a courtesy 10-Vdc supply is provided for use with an external potentiometer or rheostat. The 10-Vdc supply supports up to 10 mA draw.

Tracer® Controllers

Symbio™ 400-B Controller

Figure 23. Tracer® Symbio 400-B controller

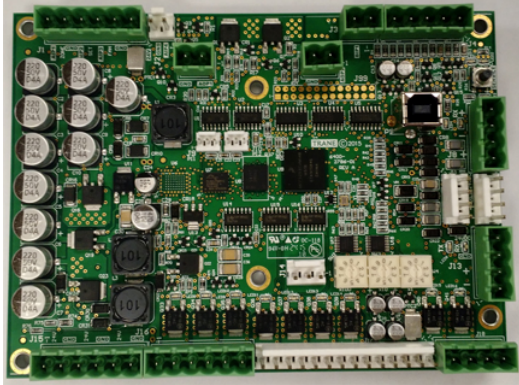

The Tracer Symbio™ 400-B single-zone VAV controller can be used in a stand-alone application or as part of a Tracer control system.

In the stand-alone configuration, Tracer Symbio 400-B receives operation commands from the zone sensor and/or the entering water temperature sensor (on auto changeover units). The entering water temperature sensor determines if the unit is capable of cooling or heating. The zone sensor module is capable of transmitting the following information to the controller:

- Timed override on/cancel request
- Zone setpoint
- Current zone temperature
- Fan mode selection (off-auto-high-med-low)

For optimal system performance, units can operate as part of a Tracer SC building automation system. The controller is linked directly to the Tracer SC via a twisted pair communication wire, requiring no additional interface device (i.e., a command unit). The Tracer control system can monitor or override Tracer Symbio 400-B control points. This includes such points as temperature and output positions.

The Symbio 400-B is a multi-purpose, programmable (or application-specific) controller that provides direct-digital zone temperature control. The controller can operate as a stand-alone device or as part of a building automation system (BAS). Communication between the controller and a BAS occurs on an open standard with inter-operable protocols used in Building Automation and Control Networks (BACnet®). Programming is done by means of the Tracer TU service tool.

Tracer® Controller Features

The Tracer family of controllers offer the combined advantages of simple and dependable operation with the latest Trane-designed controller. Standard control features include options normally available on more elaborate control systems. All control options are available factory-configured or can be field-configured using Tracer TU service software. For more detailed information, see the associated installation, operation, and maintenance manual:

Symbio™ 400-B/500 Programmable Controllers For Blower Coil, Fan Coil, and Unit Ventilator (BAS-SVX093-EN)*

Features Available on All Controllers

The following control functions are standard features on units with Symbio™ 400-B.

Entering Water Temperature Sampling Function

A system that uses a two-way control valve option might not sense the correct entering water temperature during long periods when the control valve is closed. If the demand for heating or cooling does not exist for a long period, the entering water will eventually approach ambient temperature.

Using the entering water temperature sampling function, the controller provides accurate two-pipe system changeover-without sacrificing the benefits of two-way control valves. Also, it eliminates inefficient bleed or bypass lines that can allow unnecessary waterflow through the system.

This function periodically samples the entering water temperature by opening the hydronic valve. The valve opens for 20 seconds to allow the water temperature to stabilize. Then the controller reads the entering water temperature for up to three minutes to see if the correct water temperature is available for the selected operating mode.

The entering water temperature must be five degrees or more above the space temperature to allow hydronic heating and five degrees or more below the space temperature to allow hydronic cooling. If the correct water temperature for the operating mode is available, the unit begins normal heating or cooling operation. If the correct water temperature is not available, the controller closes the control valve and waits 60 minutes before attempting to sample the entering water temperature again.

A factory-mounted thermistor senses the entering water temperature on changeover cooling/ heating coil units. If the fan coil has a factory-mounted piping package, the sensor is strapped to the entering water pipe. If the fan coil does not have a piping

package, the sensor is coiled in the end pocket for mounting on customer-supplied piping. This sensor must detect accurate water temperature for proper changeover.

Automatic Heat/Cool Mode Determination

The controller automatically determines whether heating or cooling is needed-based on space and system conditions. Using a proportional/integral (PI) control algorithm to maintain the space temperature at the active heating or cooling setpoint. The controller measures the space temperature and active setpoint temperature to determine the units heating or cooling capacity (zero to 100 percent).

Occupied/Unoccupied Operation

The occupancy input uses a binary switch (i.e., motion sensor, time clock, etc.) that allows the zone sensor to use its unoccupied internal setpoints.

Random Start

This feature randomly staggers multiple unit start-up to reduce electrical demand spikes.

Warm-up

The two-position fresh air damper option closes during the occupied mode when the space temperature is three degrees or more below the heating setpoint temperature. The damper remains closed during warm-up until the space temperature is within two degrees of the heating setpoint temperature.

Cool-down

The two-position fresh air damper option closes during the occupied mode when the space temperature is three degrees or more above the cooling setpoint temperature. The damper remains closed during cool-down until the space temperature is within two degrees of the cooling setpoint temperature.

Manual Output Test

This function may be initiated from the blue test push button on the controller or through the Tracer® TU service tool. This feature is used to manually exercise the outputs in a defined sequence. The purpose of this test sequence is to verify output and end device operation. The manual output test function may also be used in the following situations:

- Reset latching diagnostics.
- Verify output wiring and operation.
- Force the water valve(s) open to balance the hydronic system during installation set-up or service.

Peer-to-Peer Communication

Peer-to-peer communication allows multiple units in one space to share the same zone sensor and provide simultaneous heating and cooling. On the Symbio™ 400-B, zone sensor data sharing can be accomplished by use of the BAS system controller.

A thermistor to sense fresh air is factory-mounted at the units fresh air opening for use in economizer applications or as a read-only point for Tracer SC. If the fresh air temperature is a read-only value, it will not impact the control algorithm. In an economizer application, a fresh air temperature signal must be provided either by this thermistor, Tracer SC.

Additional Features

Single-zone VAV control

Figure 24. Single-zone VAV control

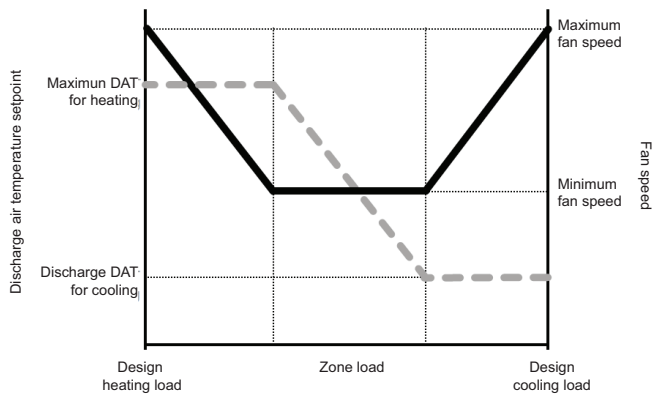

Single-zone VAV control varies the speed of the EC fan motor as the zone cooling or heating load changes. When the zone is at design cooling load, the unit operates the fan at maximum speed and cooling capacity is modulated or cycled to deliver the air at the design discharge air temperature (DAT) setpoint for cooling. As the zone cooling load decreases, fan speed is reduced to maintain zone temperature at cooling setpoint, while cooling capacity (and/or economizer) is modulated or cycled to maintain DAT at the same design setpoint.

When the fan has reached minimum speed, and the zone cooling load continues to decrease, the fan continues to operate at minimum speed while the DAT setpoint begins to reset upward to maintain zone temperature at cooling setpoint. Cooling capacity (and/or economizer) is modulated or cycled to maintain this DAT setpoint.

When the zone temperature drops to heating setpoint, the fan continues to operate at minimum speed and the DAT setpoint is reset further upward. Heating capacity is modulated or staged to maintain this DAT setpoint. If the zone heating load increases to the point where DAT reaches the maximum limit, fan speed is again increased, while heating capacity is modulated or staged to maintain DAT at this maximum limit.

Note: Single zone VAV is not supported on DX coil units.

Automatic Fan and Ventilation Reset

A multi-speed fan control for the unit delivers the airflow output customized to support the cfm space needs. When less cfm is necessary to meet the load of the classroom (typically 75 to 80 percent of the time), the equipment operates on low speed. However, if the room temperature rises, the controller will switch to high speed, and the outside air damper will adjust to satisfy the space needs. This helps maintain the proper amount of ventilation air to the occupants independent of the fan speed. As part of the ventilation strategy, the controller will reposition the outside air damper to confirm the minimum outside air cfm is met at both operating conditions.

Filter Maintenance

Filter status for the controller is based on the cumulative run hours of the unit fan. The controller compares the amount of fan run time against an adjustable fan run hour (stored in the controller) to determine when maintenance is recommended for the unit. The run-hours value may be user edited as required (through Rover or Tracer® TU). The valid range for the fan run hours limit is 0 to 5000 hours with a default of 600 hours. Once the run hours limit has been exceeded, the controller generates a maintenance required diagnostic (unit will not shut-down). The user will be notified of this diagnostic through the building automation system or when a Trane service tool is communicating with the controller.

Active Dehumidification

On units with reheat coils, the controller can provide active dehumidification. This means that the relative humidity in the space can be kept below an adjustable setpoint independent of outdoor weather conditions. Indoor humidity levels are recommended by ASHRAE to be kept below 60 percent in order to minimize microbial growth and the life span of airborne illness causing germs.

Data Sharing

The controller can send or receive data (setpoint, heat/cool mode, fan request, space temperature, etc.) to and from other controllers on the communication link with or without a building automation system. This applies to applications where multiple units might share one zone sensor for both stand-alone (with communication wiring between units) and a building automation system.

Figure 25. Data sharing system layout

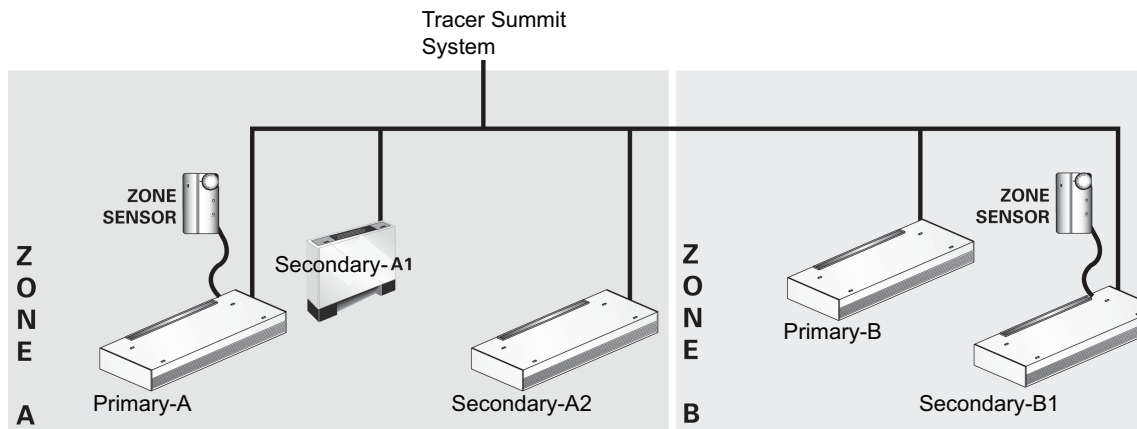

Water Valve Override

The controller can be commanded via the Rover service tool or Tracer® TU to open all hydronic valves 100 percent. This allows for the faster water balancing of each unit and the entire system when the command is sent globally to all controllers. A properly balanced system is essential for proper and efficient operation.

Hydronic Coil Freeze Protection (Freeze Avoidance)

Systems used in cold climates need to take precaution to avoid hydronic coil freeze-up. The controller does this from three different aspects. Any of these methods of protections will result in the unit fan being disabled, the outside air damper being shut, and the hydronic valves being opened 100 percent.

The three methods of freeze avoidance include:

1. A binary freeze protection thermostat is mounted on the coil and will cause a latching diagnostic if the coil temperature falls below 35°F.
Note: Units with R-454B or R-32 refrigerant will not have a binary freeze protection mounted to the coil. These units will rely on the binary freeze protection on the DX coil and protection methods 2 and 3.
2. An analog discharge air sensor monitors the temperature of the air coming off of the coil and if the temperature falls below 40°F the outside air damper is closed, the fan is turned off and the valves are fully opened.
3. When in the unoccupied mode, the controller has an adjustable freeze avoidance setpoint. If the outside air temperature is below the setpoint, the unit will open the valves to allow water to flow through the coils.

Interoperability

Inter-operability allows the owner freedom to select multiple vendors, and multiple products. With this advantage, the owner can choose the best products, the best application, and the best service from a variety of suppliers to meet their evolving building control needs in a cost effective manner.

Generic Binary Input/Output

The three generic binary inputs/outputs are not part of the normal control, but are actually controlled through the Tracer® SC or Tracer Summit™ system (when present) to issue commands to the controller to turn the generic inputs/outputs of add-on equipment (such as baseboard heating, exhaust fans, occupancy sensors, lighting, etc.) on and off. This binary port is not affected when other binary diagnostics interrupt unit operation.

Sequence of Operation

Symbio™ 400-B

Off: Fan is off; control valve options and mixing box damper options close. The low air temperature detection option is still active.

Auto: Fan speed control in the auto setting allows the modulating control valve option and single- or three-speed fan to work cooperatively to meet precise capacity requirements, while minimizing fan speed (motor/energy/acoustics) and valve position (pump energy/chilled water reset). As the capacity requirement increases at low fan speed, the water valve opens. When the



Controls

low fan speed capacity switch point is reached, the fan switches to the next higher speed and the water valve repositions to maintain an equivalent capacity. The reverse sequence takes place with a decrease in required capacity.

Units with three-speed fans on low, medium, or high: The fan runs continuously at the selected speed and the valve option cycles to meet setpoint.

Wireless Systems

Air-Fi® Wireless Communications Interface (WCI)



A factory-installed Air-Fi Wireless Communications Interface (WCI) provides wireless communication between the Tracer® SC and Tracer unit controllers. The Air-Fi WCI is the perfect alternative to a Trane BACnet® wired communication link. Eliminating the communication wire between terminal products, space sensors, and system controllers has substantial benefits:

- Reduced installation time and associated risks.
- Completion of projects with fewer disruptions.
- Easier and more cost-effective re-configurations, expansions, and upgrades.

Air-Fi® Wireless Communications Sensor (WCS)



Communicates wirelessly to a Tracer® unit controller. WCS is an alternative to a wired sensor when access and routing of communication cable are issues. A WCS allows flexible mounting and relocation.

For more detailed information on Air-Fi® Wireless systems and devices, see:

- *Air-Fi® Wireless System Installation, Operation, and Maintenance* (BAS-SVX40*-EN)
- *Air-Fi® Wireless System Data Sheet Product Data* (BAS-PRD021*-EN)
- *Air-Fi® Network Design Installation, Operation, and Maintenance* (BAS-SVX55*-EN)

Wireless Zone Sensor (WZS) Set









A wireless zone sensor (WZS) set (sensor and receiver) communicates wirelessly to a Tracer® unit controller. A wireless zone sensor set is an alternative to a wired sensor when access and routing of communication cable are issues. The sensor allows flexible mounting and relocation.

Note: A wireless zone sensor set is not compatible with an Air-Fi® wireless system.

Zone Sensor Options

A variety of unit-mounted, wall-mounted, and split-mounted zone sensors are available for design flexibility. Unit-mounted zone sensors include a thermistor in the units return air path. Wall-mounted zone sensors have an internal thermistor and operate on 24 Vac. Options with setpoint knobs are available in Fahrenheit or Celsius.

<p>Figure 26. Unit-mounted zone sensor (SP, OCC/UNOCC, OALMH)</p> 	<p>Figure 27. Wall-mounted zone sensor (SP, OCC/UNOCC, OALMH)</p> 	<p>Figure 28. Wall-mounted display sensor (SP, OCC/UNOCC, OALMH)</p> 
<p>Figure 29. Unit-mounted fan speed control, wall-mounted zone sensor (SP, OCC/UNOCC, COMM)</p> 	<p>Figure 30. Wall-mounted wireless zone sensor (WZS), unit-mounted receiver (SP, OCC/UNOCC)</p> 	<p>Figure 31. Wall-mounted wireless display sensor, unit-mounted receiver (SP, OALMH)</p> 
<p>Figure 32. Air-Fi® WCS, Air-Fi® WCI (SP, OALMH0 (Symbio™ 400-B only))</p> 		

End Device Options

All end device options are factory-installed and -tested.

Table 49. End device option availability

Device	Symbio™ 400-B	CSTI
Low limit	X	X
Filter run-time diagnostic	X	
Fan status	X	X
2-position control valves	X	X
Analog control valves	X	X
Modulating control valves	X	X
1-stage electric heat	X	X
2-stage electric heat	X	X
Frostat™ protection (DX coils)	X	X

Notes:

1. Symbio 400-B controllers are factory-provided controls that control the end devices listed in the table.
2. CSTI provides an adapter board with screw down terminals for wiring to end devices for a field-supplied controller.

Low Temperature Detection

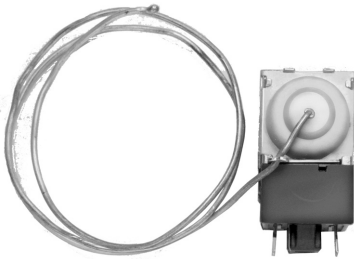
Figure 33. Low temperature detection device

When the low temperature detection device senses an entering air temperature of 36°F to the hydronic coil, the normally-closed switch opens a corresponding set of binary input terminals. The fan disables, control valves open, and the fresh air damper closes.

The low temperature detection device is an averaging type capillary tube and will reset when it detects an entering air temperature of at least 44°F.

Outside Air Sensor

The outside air sensor is field-mounted before the fan to sense the outside air temperature, primarily for use in economizer applications or as a status value when available for other applications.

Two-Position Damper Actuator

This damper actuator uses a 24V signal. It allows zero to 50 percent fresh air. The damper will drive open to an adjustable mechanical stop-position whenever the fan is running during occupied mode and will spring-return closed when the fan turns off. The two-position damper ships separate for field installation.

Note: Trane highly recommends using the low temperature detection option with mixing box dampers to detect possible freeze conditions.

Discharge Air Sensor

The discharge air sensor is factory-mounted on the fan housing downstream of the coils for use as a status point or with other control algorithms. On units with optional electric heat, the sensor is field-mounted in the ductwork, downstream of the unit discharge.

Economizer Damper Actuator

This option is a modulating, spring-return damper actuator and is factory-wired and mounted to the mixing box damper assembly. When the controller enables the economizer damper and the unit is in occupied mode, the damper modulates

between its minimum position (configurable) and the full open position to maintain setpoint temperature. If economizer operation stops or if the unit is in the heating mode, the damper adjusts to its minimum position.

Note: *Trane highly recommends using the low temperature detection option with a mixing box damper to detect possible freeze conditions.*

CO₂ Sensor for Demand-Controlled Ventilation

The unit is provided with a CO₂ sensor to enable demand-controlled ventilation (DCV). This sensor provides a 4-20mA signal and ships separate for field installation (wired to UI1). DCV can be used for modulating ECM, single-speed, two-speed, three-speed. It functions during occupied modes (Occupied, Occupied Standby, Occupied Bypass), in either heating or cooling mode, as long as the fan is operating (high, medium, low, On, or Auto). Refer to *Symbio™ 400-B/500 Programmable Controllers For Blower Coil, Fan Coil, and Unit Ventilator Installation, Operation, and Maintenance* (BAS-SVX093*-EN) for a description of DCV control and guidance in determining the appropriate CO₂ and economizer damper setpoints for a given application.

Humidity Sensor

The humidity sensor is communicated value or with a local humidity sensor.

Factory-Installed Piping Packages

Piping package options are available with Symbio™ 400-B controllers or CSTI. Field connections are brought to a point near the exterior of the unit for quick hook-up. All piping and components are positioned so that condensate drips into the auxiliary drain pan. Insulation of the factory piping package is required if an auxiliary drain pan is not selected and all field connections should be insulated to prevent condensation from missing the drain pan.

Piping Package Components

Control valves are mounted in all piping packages. All piping packages are factory installed and come in a variety of options:

- **Basic:** Union and shut-off ball valve on the supply line. Union, control valve and shut-off ball valve on the return line.
- **Basic with manual circuit setter:** Union, shut-off ball valve on the supply line. Union, control valve and manual circuit setter on the return line.
- **Deluxe with Manual Circuit Setter:** Union, strainer, P/T port, and shut-off ball valve on the supply line. Union, control valve and manual circuit setter on the return line.
- **Deluxe with Auto Flow:** Union, strainer, P/T port, and shut-off ball valve on the supply line. Union, control valve, auto flow valve, P/T port and shut-off ball valve on the return line.

Factory piping packages are available for either two or four-pipe systems with right or left hand connections.

Figure 34. Basic piping package

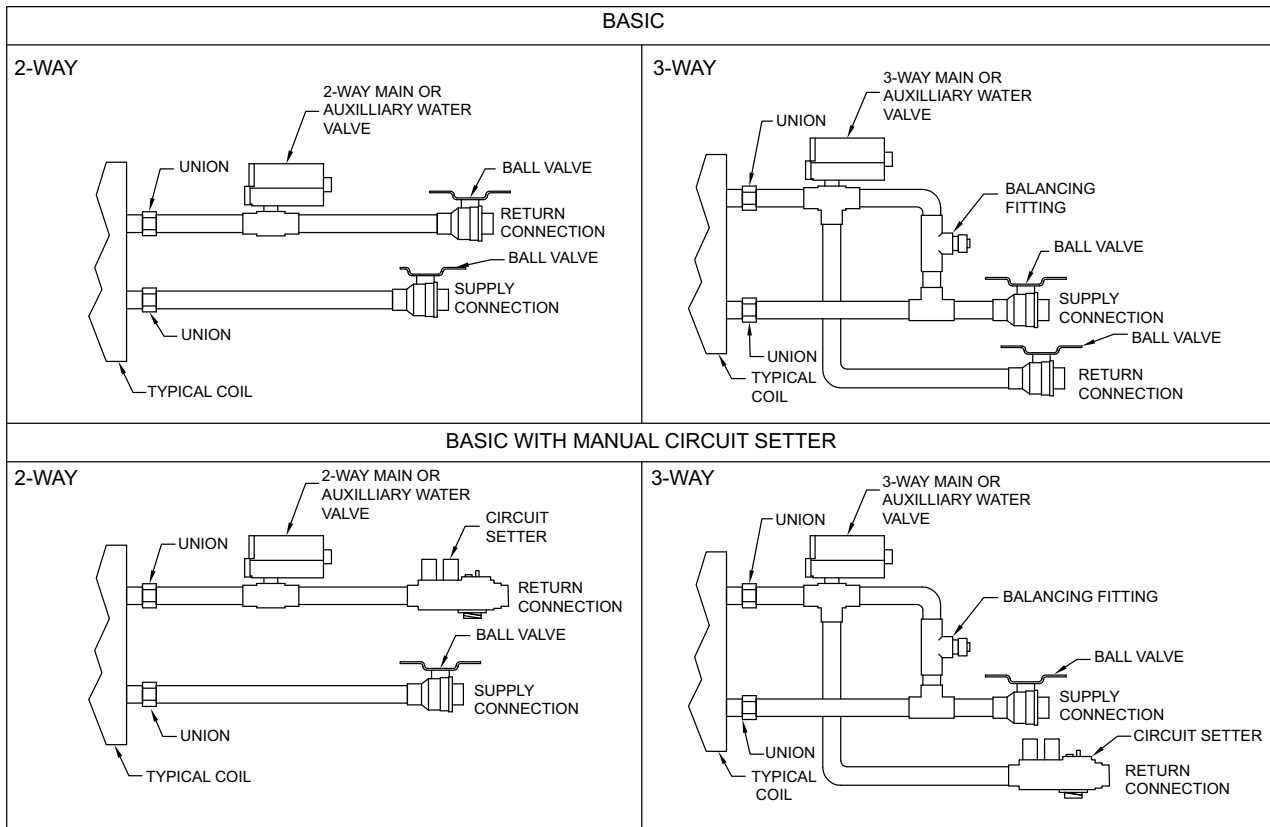
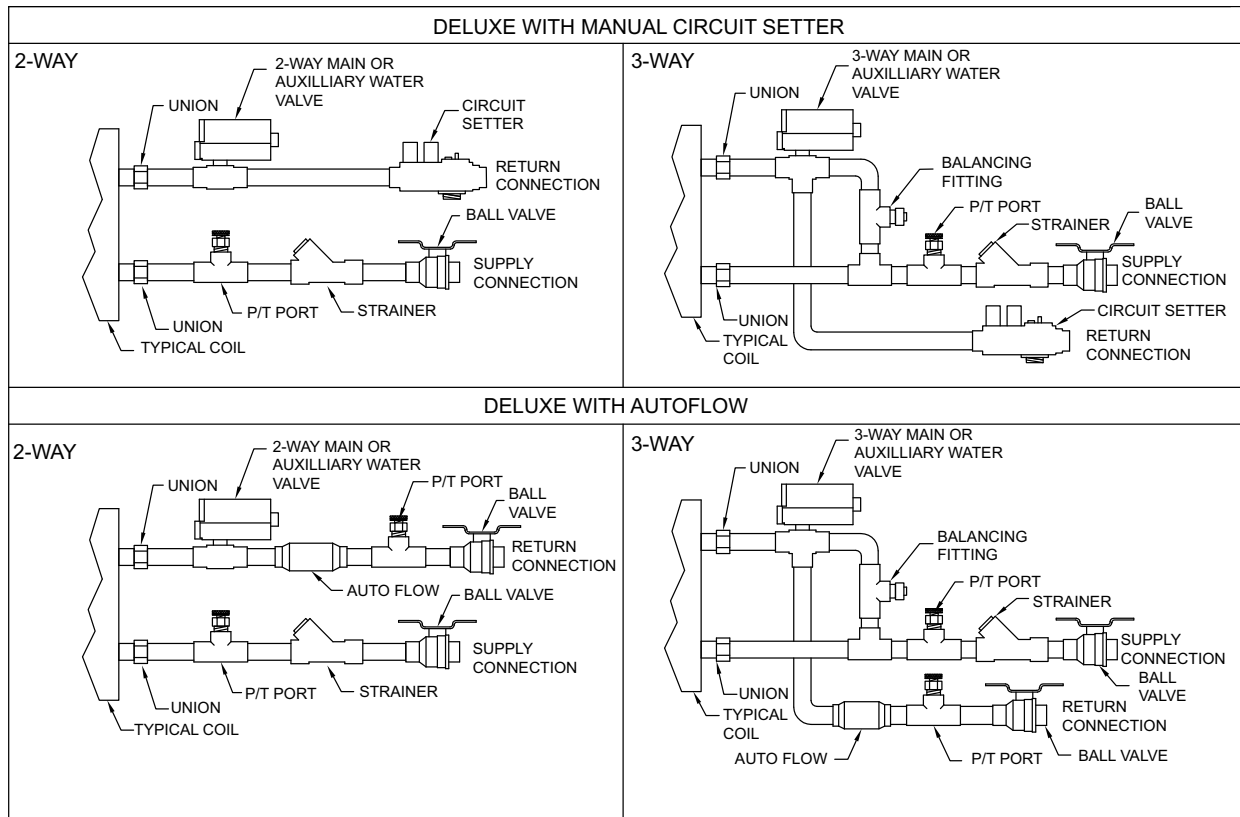
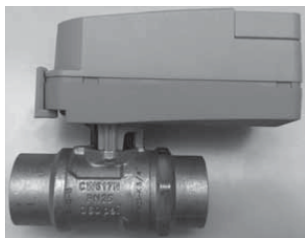

Figure 35. Deluxe piping package



Control Valves



Units with CSTI or any of the Tracer® controllers (Symbio™ 400-B) are available with chilled and hot water control valves. Control valve options include:

- Analog
- Modulating
- Two-Position, normally-open or normally-closed
- Two- or three-way configurations

See the valve availability table for a complete list of valve options by size.

Three-way valve options allow either full water flow through the coil or diverted water flow through the bypass.

Two-Position Control Valves

Two-position valve options are spring-return or capacitor discharge-return types. Valves respond to a 24V signal and will either fully open or close. These valves cannot be driven or actuated to a partially open or closed position. If the valve loses power, the valve returns to its de-energized position.

Modulating and 2 to 10 Vdc Analog Control Valves

Modulating and 2 to 10 Vdc Analog control valves offer an alternative for more precise capacity control. Modulating valves respond to a 24 V signal from the controller, which determines the valve position by control algorithm. Analog valves travel to the commanded position of the 2 to 10 Vdc control signal. If the valve loses power, it remains in its current position.

Field-Supplied Valves

This option allows the controller to be factory-configured for the normal position of the field supplied valve. A valve wire harness is provided from the control box to the piping side of the unit.

Table 50. Main valve availability

Digit 20	Cv	2-Way 2-Position N.C.	2-Way 2-Position N.O.	3-Way 2-Position N.C.	3-Way 2-Position N.O.	2-Way Modulating	3-Way Modulating	2-Way Analog (2 to 10 Vdc)	3-Way Analog (2 to 10 Vdc)
A	2.3	X	X	-	-	X	-	X	-
B	3.3	-	-	-	-	X	-	X	-
C	4.6	X	X	-	-	X	-	X	-
D	6.6	-	-	-	-	X	-	X	-
E	2.7	-	-	X	X	-	X	-	X
F	4.6	-	-	-	-	-	X	-	X
G	7.4	-	-	X	X	-	X	-	X

Table 51. Auxiliary valve availability

Digit 20	Cv	2-Way 2-Position N.C.	2-Way 2-Position N.O.	3-Way 2-Position N.C.	3-Way 2-Position N.O.	2-Way Modulating	3-Way Modulating	2-Way Analog (2 to 10 Vdc)	3-Way Analog (2 to 10 Vdc)
A	1.4	-	-	-	-	X	-	X	-
B	2.4	X	X	-	-	-	-	-	-
C	3.4	-	-	-	-	X	-	X	-
D	4.8	X	X	-	-	X	-	X	-
E	5.9	-	-	-	-	X	-	X	-
F	2.7	-	-	X	X	-	X	-	X
G	4.6	-	-	-	-	-	X	-	X
H	7.4	-	-	X	X	-	X	-	X

Face-and-Bypass Damper Actuator

An optional face-and-bypass actuator is 24 volt, 3-point modulating, non-spring return. In-coming power is 24 Vac with a consumption of 2 watts. Maximum torque of 35 in·lb.

Note: Face-and-bypass is available with all units ventilator coils, with exception of DX and electric heat.

Table 52. Face-and-bypass actuator specification



Power supply	24 Vac \pm 20% - 50/60 Hz 24 Vac \pm 10%
Power consumption	2 W
Transformer sizing	3 VA (class 2-power source)
Angle of rotation	Maximum 95°, adjustable with mechanical stop
Torque	35 in·lb
Direction of rotation	Reversible with switch L/R
Position indication	Clip-on indicator
Run time (nominal)	90-second constant
Manual override	External push button
Noise level	Less than 35 dB
Control signal	3-point floating

Outside/Return-Air Damper Actuator

Optional outside-air/return-air actuator is spring return and takes a 3-point floating signal. 2 to 10 Vdc option is also available, it provides 25 in·lb of torque. The power consumption is 7 VA with temperature limits of -25°F to 125°F.

Table 53. Outside air actuator specifications



Power supply	24 Vac \pm 20% - 50/60 Hz 24 Vac \pm 10%
Power consumption	Running: 2.5 W Holding: 1 W
Transformer sizing	5 VA (class 2-power source)
Overload protection	Electronic throughout 0 to 95° rotation
Control signal	2 to 10 Vdc 3-point floating with Trane® controls
Angle of rotation	Maximum 95°, adjustable with mechanical stop
Torque	35 in·lb
Direction of rotation	Spring return reversible with CW/CCW mounting
Position indication	Visual indicator, 0 to 95°
Run time (nominal)	90-second constant (independent of load)
Noise level	Running: 30 dB



Electrical Data

Table 54. VUV 075 to 150, electrical performance

Model Number	Unit Voltage	Blower Motor		Number of Fan Motors	Number of Heating Elements	Electric Heat		Total FLA	Minimum Circuit Ampacity	Over-current Protection Device	Low FLA Option	
		FLA (ea.)	HP			kW	Amp				Total FLA	Minimum Circuit Ampacity
VUVE075	115/60/1	3.35	0.24	1	0	0	0	3.35	4.19	15	2.20	2.75
	208/60/1	2.00	0.24	1	0	0	0	2.00	2.50	15	1.05	1.31
	208/60/1	2.00	0.24	1	3	4.39	21.10	23.10	28.88	30	22.15	27.69
	208/60/3	2.00	0.24	1	0	0	0	2.00	2.50	15	1.05	1.31
	208/60/3	2.00	0.24	1	3	4.39	12.20	14.20	17.75	20	13.25	16.56
	230/60/1	1.85	0.24	1	0	0	0	1.85	2.31	15	0.95	1.19
	230/60/1	1.85	0.24	1	3	5.85	24.40	26.25	32.81	40	25.35	31.69
	230/60/3	1.85	0.24	1	0	0	0	1.85	2.31	15	0.95	1.19
	230/60/3	1.85	0.24	1	3	5.85	14.10	15.95	19.94	20	15.05	18.81
	277/60/1	1.60	0.24	1	0	0	0	1.60	2.00	15	0.85	1.06
	277/60/1	1.60	0.24	1	3	5.82	21.00	22.60	28.25	30	21.85	27.31
	460/60/3	1.60	0.24	1	0	0	0	1.60	2.00	15	0.85	1.06
460/60/3	1.60	0.24	1	3	5.85	7.00	8.60	10.75	15	7.85	9.81	
VUVE100	115/60/1	3.35	0.24	1	0	0	0	3.35	4.19	15	2.2	2.75
	208/60/1	2.00	0.24	1	0	0	0	2.00	2.50	15	1.05	1.31
	208/60/1	2.00	0.24	1	3	5.86	28.20	30.20	37.75	40	29.25	36.56
	208/60/3	2.00	0.24	1	0	0	0	2.00	2.50	15	1.05	1.31
	208/60/3	2.00	0.24	1	3	5.86	16.30	18.30	22.88	25	17.35	21.69
	230/60/1	1.85	0.24	1	0	0	0	1.85	2.31	15	0.95	1.19
	230/60/1	1.85	0.24	1	3	7.80	32.50	34.35	42.94	50	33.45	41.81
	230/60/3	1.85	0.24	1	0	0	0	1.85	2.31	15	0.95	1.19
	230/60/3	1.85	0.24	1	3	7.80	18.80	20.65	25.81	30	19.75	24.69
	277/60/1	1.60	0.24	1	0	0	0	1.60	2.00	15	0.85	1.06
	277/60/1	1.60	0.24	1	3	7.80	28.20	29.80	37.25	40	29.05	36.31
	460/60/3	1.60	0.24	1	0	0	0	1.60	2.00	15	0.85	1.06
460/60/3	1.60	0.24	1	3	7.80	9.40	11.00	13.75	15	10.25	12.81	

Table 54. VUV 075 to 150, electrical performance (continued)

Model Number	Unit Voltage	Blower Motor		Number of Fan Motors	Number of Heating Elements	Electric Heat		Total FLA	Minimum Circuit Ampacity	Over-current Protection Device	Low FLA Option	
		FLA (ea.)	HP			kW	Amp				Total FLA	Minimum Circuit Ampacity
VUVE125	115/60/1	6.7	0.24	2	0	0	0	6.70	8.38	15	3.40	4.25
	208/60/1	4.0	0.24	2	0	0	0	4.00	5.00	15	2.10	2.63
	208/60/1	4.0	0.24	2	3	7.32	35.20	39.20	49.00	50	37.30	46.63
	208/60/3	4.0	0.24	2	0	0	0	4.00	5.00	15	2.10	2.63
	208/60/3	4.0	0.24	2	3	7.32	20.30	24.30	30.38	35	22.40	28.00
	230/60/1	3.7	0.24	2	0	0	0	3.70	4.63	15	1.90	2.38
	230/60/1	3.7	0.24	2	3	9.75	40.60	44.30	55.38	60	42.50	53.13
	230/60/3	3.7	0.24	2	0	0	0	3.70	4.63	15	1.90	2.38
	230/60/3	3.7	0.24	2	3	9.75	23.50	27.20	34.00	40	25.40	31.75
	277/60/1	3.2	0.24	2	0	0	0	3.20	4.00	15	1.70	2.13
	277/60/1	3.2	0.24	2	3	9.75	35.20	38.40	48.00	50	36.90	46.13
	460/60/3	3.2	0.24	2	0	0	0	3.20	4.00	15	1.70	2.13
	460/60/3	3.2	0.24	2	3	9.75	11.70	14.90	18.63	20	13.40	16.75
	VUVE150	115/60/1	6.7	0.24	2	0	0	0	6.70	8.38	15	3.40
208/60/1		4.0	0.24	2	0	0	0	4.00	5.00	15	2.10	2.63
208/60/1		4.0	0.24	2	3	8.56	41.20	45.20	56.50	60	43.30	54.13
208/60/3		4.0	0.24	2	0	0	0	4.00	5.00	15	2.10	2.63
208/60/3		4.0	0.24	2	3	8.56	23.80	27.80	34.75	40	25.90	32.38
230/60/1		3.7	0.24	2	0	0	0	3.70	4.63	15	1.90	2.38
230/60/1		3.7	0.24	2	3	11.40	47.50	51.20	64.00	70	49.40	61.75
230/60/3		3.7	0.24	2	0	0	0	3.70	4.63	15	1.90	2.38
230/60/3		3.7	0.24	2	3	11.40	27.40	31.10	38.88	40	29.30	36.63
277/60/1		3.2	0.24	2	0	0	0	3.20	4.00	15	1.70	2.13
277/60/1		3.2	0.24	2	3	11.40	41.20	44.40	55.50	60	42.90	53.63
460/60/3		3.2	0.24	2	0	0	0	3.20	4.00	15	1.70	2.13
460/60/3		3.2	0.24	2	3	11.40	13.70	16.90	21.13	25	15.40	19.25

Dimensional Data

Standard Depth Units

Figure 36. Standard depth unit dimensions (inches)

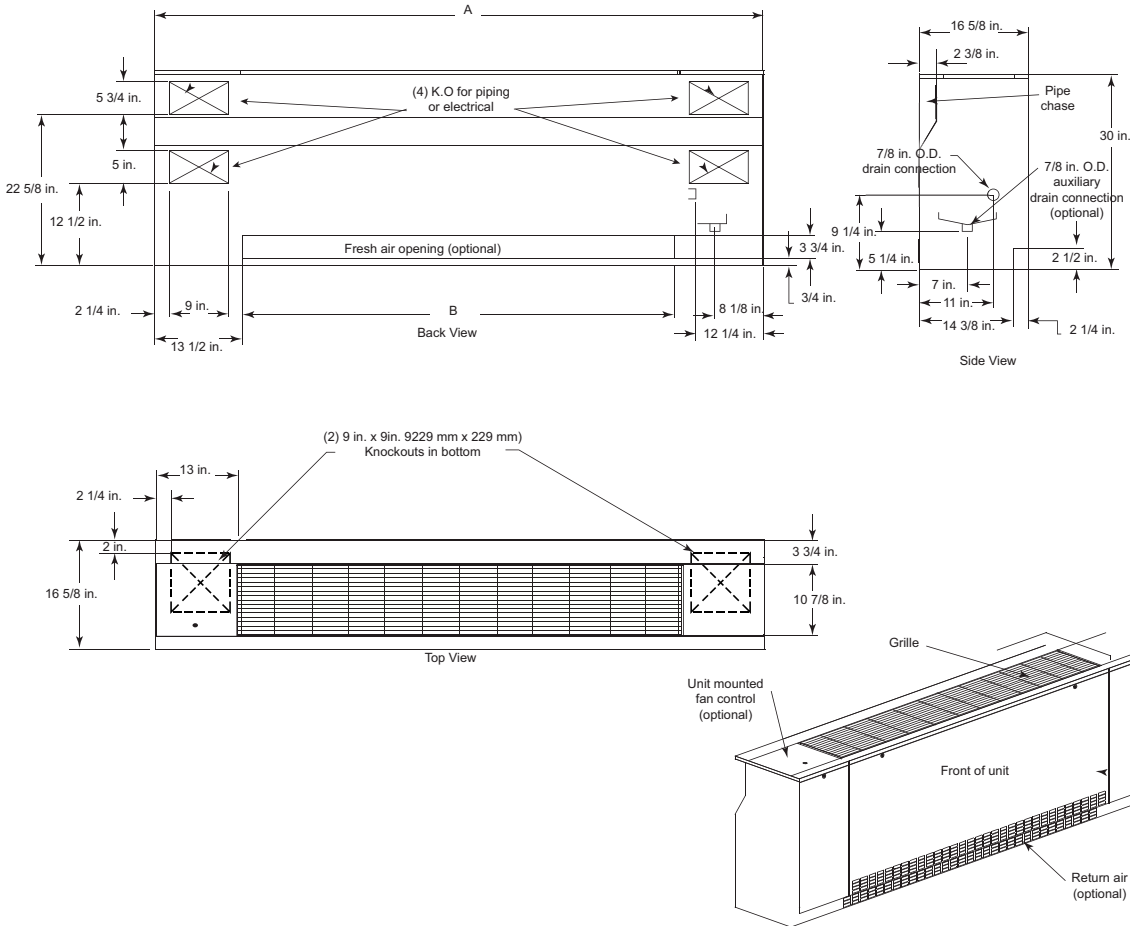
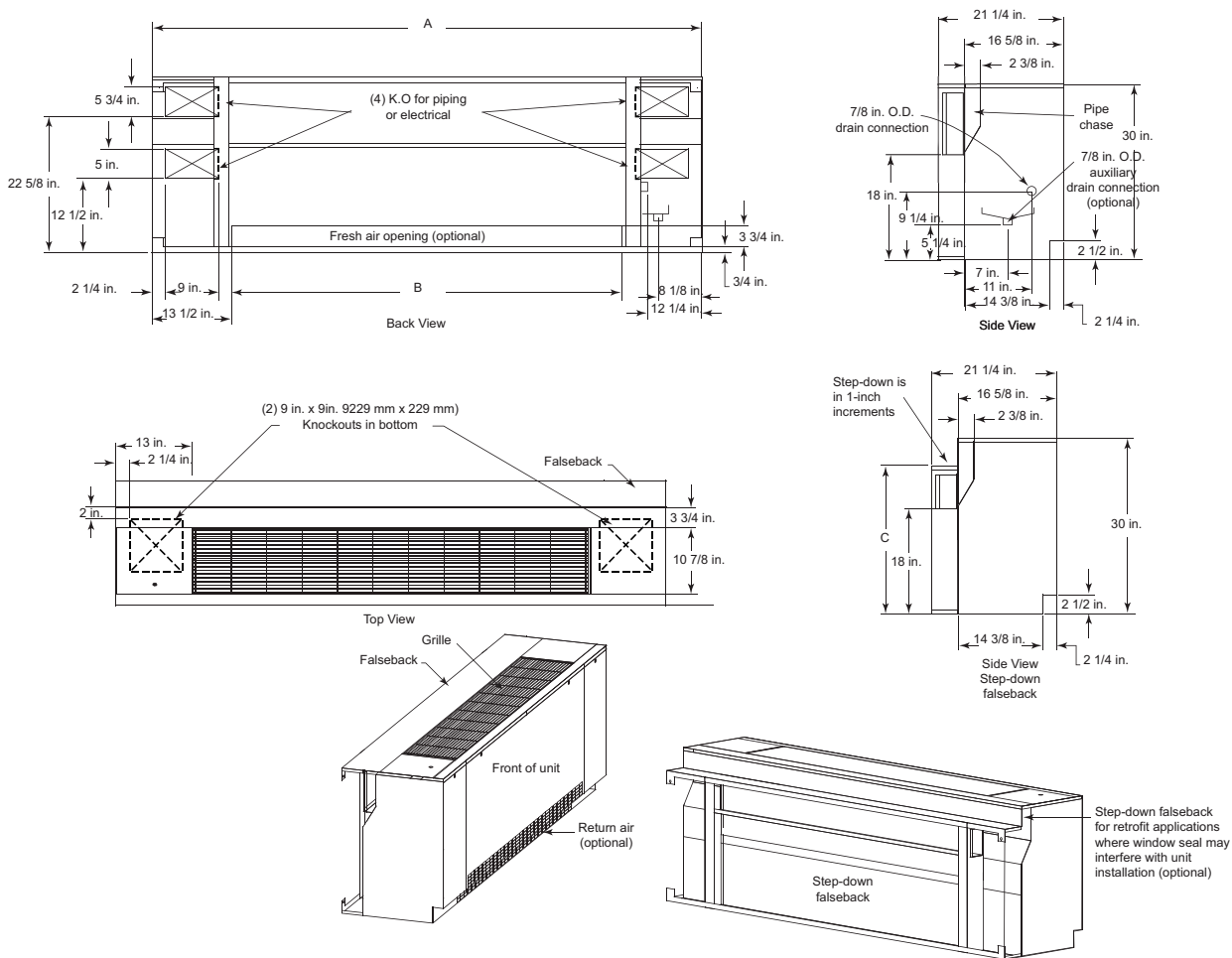

Table 55. Dimensions (inches) for standard depth vertical unit ventilator

Unit size	No. of fans	A	B
075	2	69	42
100	2	81	54
125	4	93	66
150	4	105	78

Note: Unit length does not include 5/8-inch end panels. Power connection is made in the left hand end pocket for all options except electric heat. Power connection for electric heat option is made in the right hand end pocket.

Falseback Units

Figure 37. Step-down falseback unit dimensions (inches)

Table 56. Dimensions (inches) for step-down falseback vertical unit ventilator

Unit size	No. of fans	A	B	C
075	2	69	42	25 - 29
100	2	81	54	25 - 29
125	4	93	66	25 - 29
150	4	105	78	25 - 29

Note: Unit length does not include 5/8-inch end panels. Power connection is made in the left hand end pocket for all options except electric heat. Power connection for electric heat option is made in the right hand end pocket. Unit shown includes insulated horizontal baffle option.

Dynamic Air Barrier Units

Figure 38. Dynamic Air Barrier Units

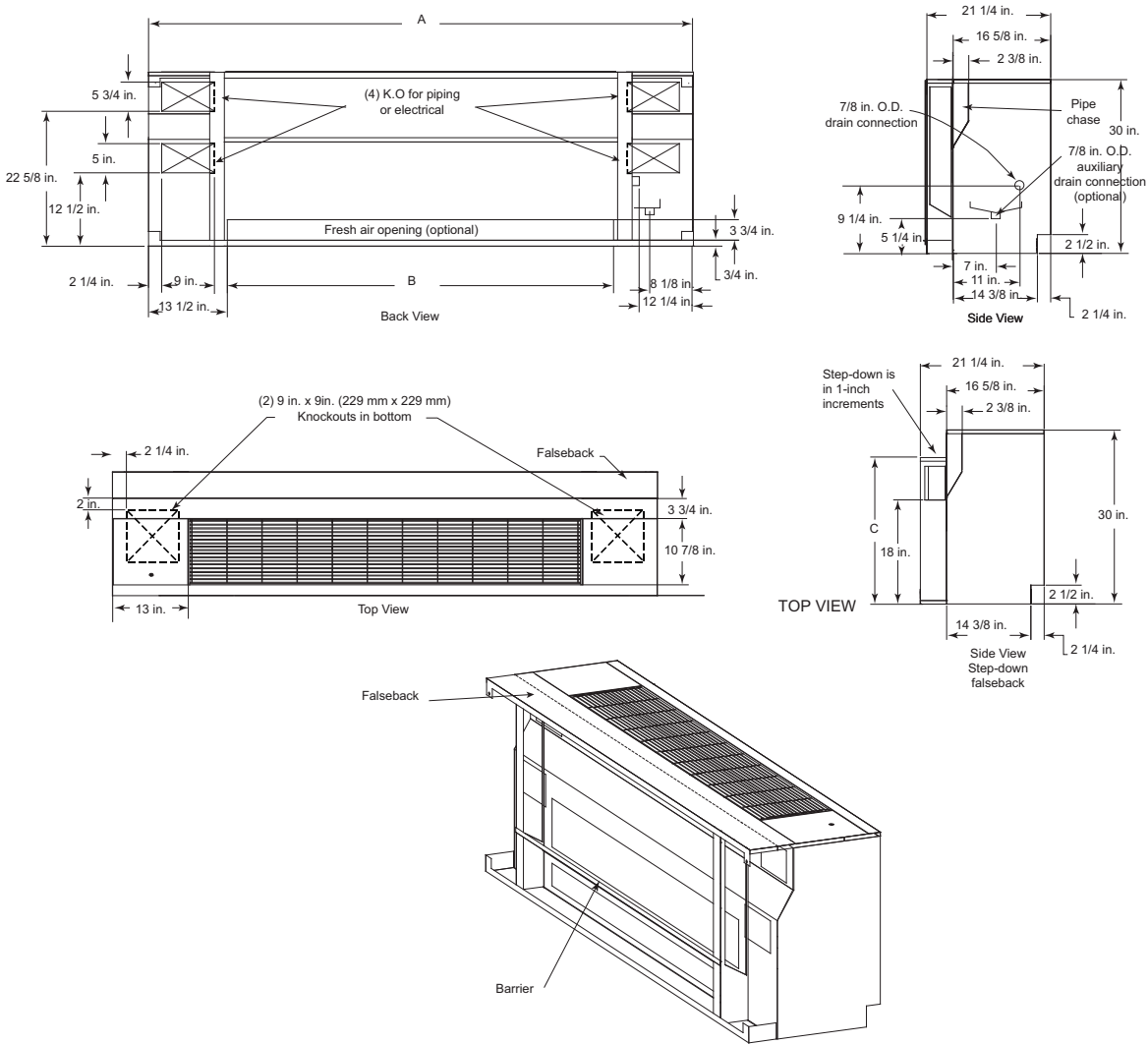
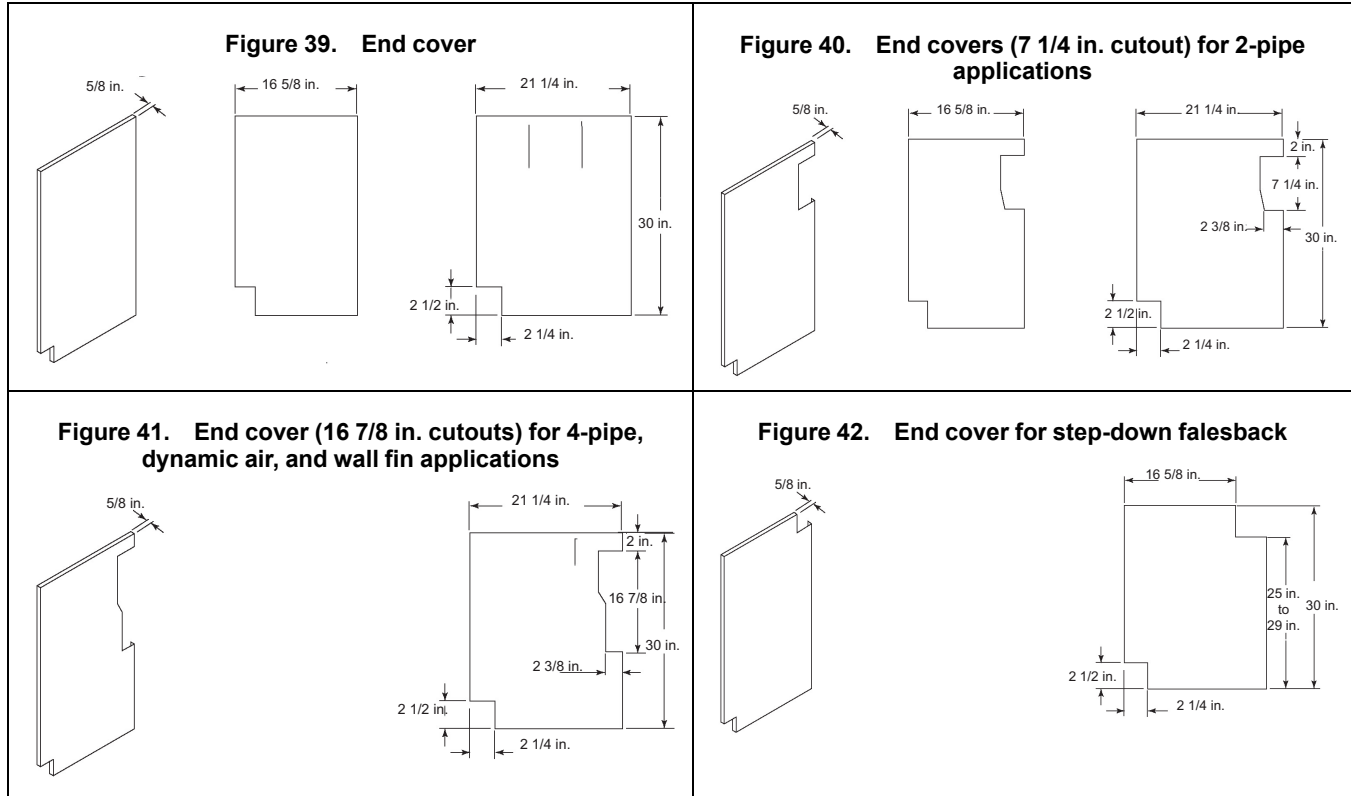

Table 57. Dimensions (inches) for dynamic air barrier unit

Unit size	No. of fans	A	B
075	2	69	42
100	2	81	54
125	4	93	66
150	4	105	78

Note: Unit length does not include 5/8-inch end panels. Power connection is made in the left hand end pocket for all options except electric heat. Power connection for electric heat option is made in the right hand end pocket.

End Cover Dimensions



Crossover Piping Dimension

Figure 43. Crossover piping dimensions (inches)

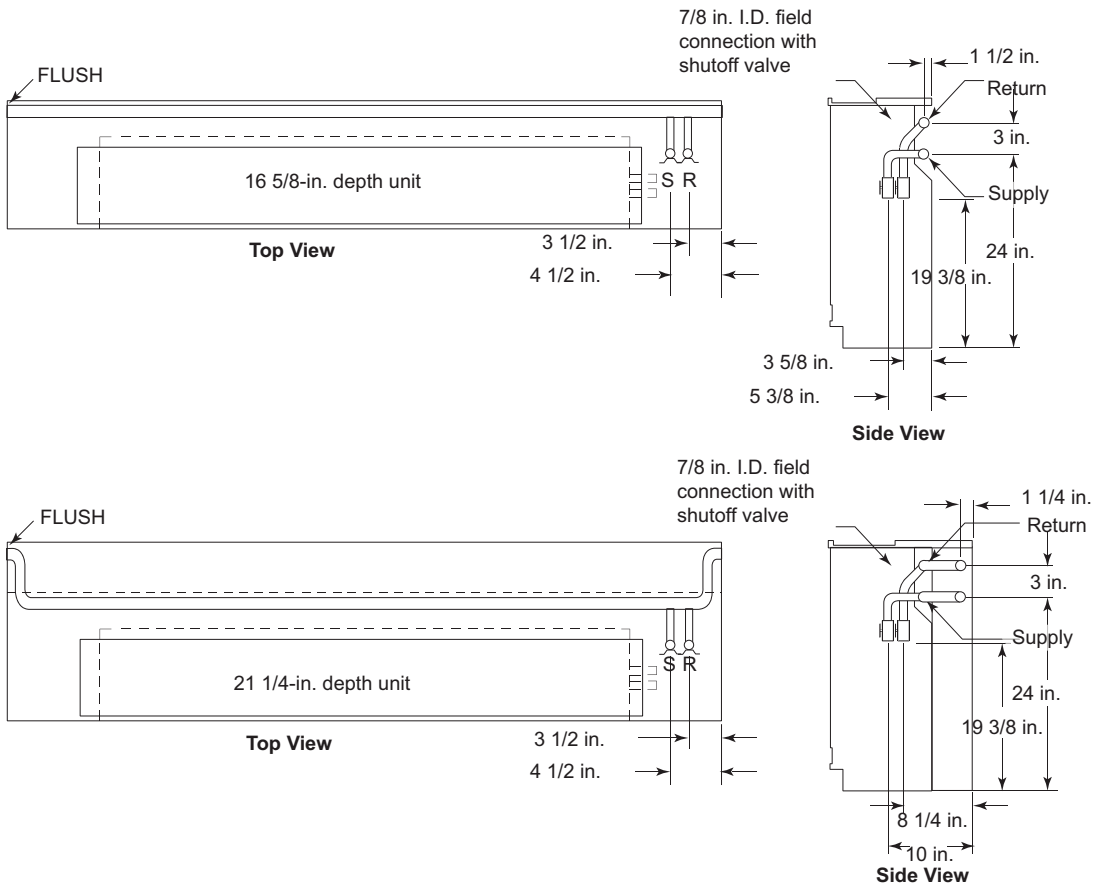

1-3/8 in. OD and 2-1/8 in. OD crossover piping:

- Crossover piping is available on 4 pipe units. Trane provides crossover for hot water piping only. The crossover piping is factory insulated with 3/8 in.- thick insulation.
- Expansion compensation between the factory piping package and the crossover piping is achieved using a flex hose rated at 250 psi working pressure. Flex hose is only available with factory-mounted piping packages.
- Expansion compensation for the crossover piping must be handled external to the unit ventilator.
- Crossover connections terminate in the same end pocket as the cooling coil for all applications.



Mechanical Specifications

General

Deliver and install a complete unit ventilator certified for ventilation at AHRI-840, or tested by an independent testing and balancing lab witnessed by owners representative.

Safety

All standard units are UL-listed in the United States and Canada and comply with NFPA 90A requirements. The unit ventilator is certified or rated in accordance to the following listings for performance proof and safety: ETL, AHRI-840, AHRI-350, BACnet®.

Equipment Construction

Exterior cabinetry is constructed of heavy-gauge metal for strength and durability. All exposed edges shall be rounded to safeguard against injury. All interior sheet metal shall be of galvanized steel to restrain against deterioration.

The front plane of the unit consists of a three panel design. The control compartment is accessible without removing the entire front panel. The discharge air grille contains rounded edged steel bars, and are placed at a 15° slope to provide proper airflow deflection.

Access for inspection and cleaning of the unit drain pan, coils, and fan section is provided. The unit shall be installed for proper access. Procedures for proper maintenance of the unit shall be included in the installing, operation manual.

Cabinet insulation is 1/2-inch thick, dual density bonded glass fiber. The exposed side is a high density, erosion proof material suitable for use in air streams up to 4500 feet per minute (FPM). Insulation shall meet the Underwriters Laboratories Fire Hazard Classification.

Piping and control end pockets are a minimum of 12 inches wide to facilitate piping, auxiliary drain pan, and service access.

Final finish of the cabinet is cleaned, phosphatized and painted with an electrostatic powder spray system, with a minimum thickness of 1.5 mil to avoid visible runs and resist abrasion.

Unit Fans

The unit fan board assembly shall ship from the factory wired to the commission schedule for engineered cfm expectancy.

The fan board is a single, rigid construction, made from corrosion resistive material. It is a trouble-free slide design to provide cleaning and serviceability ease to maintenance personnel.

The fans contain a double width/double inlet, forward curved centrifugal design to sustain appropriate air throw into the space. The wheels are galvanized metal to resist corrosion. The dynamically balanced fan and motor are of direct drive style.

The fan and coil arrangement are of a blow-thru configuration to supply unvarying coil face velocity avoiding cold spots on the coil.

Motors

All motors are brushless DC (BLDC)/electronically commutated motors (ECM) factory-programmed and run-tested in assembled units. The motor controller is mounted in a touch-safe control box with a built-in integrated user interface and LED tachometer. If adjustments are needed, motor parameters can be adjusted through momentary contact switches accessible without factory service personnel on the motor control board. Motors will soft-ramp between speeds to lessen the acoustics due to sudden speed changes. Motors can be operated at single speed, three speeds, or with single-zone VAV control. The motor will choose the highest speed if there are simultaneous/conflicting speed requests. All motors have integral thermal overload protection and are permanently lubricated with a maximum ambient operating temperature of 104°F. Motors are capable of starting at 50 percent of rated voltage and operating at 90 percent of rated voltage on all speed settings. Motors can operate up to 10 percent over voltage.

Drain Pan(s)

The unit drain pan consists of a corrosion resistant, environmentally friendly, dual sloped design to facilitate condensate removal quickly. The pan is removable for cleaning. Hook-up to the drain pan for condensate removal is made on the cooling coil union side. The drain side connection shall be easily field-inverted by removing and rotating the pan 180°.

An auxiliary drain pan (optional accessory) is factory-provided, and field-installed under the main, cooling piping package. It is constructed of the same corrosion resistance material found in the main unit drain pan. The auxiliary pan will effortlessly fit into the end pocket for condensate disposal of the piping package.



Mechanical Specifications

Coils

Hydronic Coils

All hydronic coils are a plate-fin type, mechanically bonded to tubes. The coils are hydrostatically tested to 350 psig and burst tested to 450 psig. The coils are rated in accordance with AHRI-840. A threaded drain plug is provided at the headers lowest point, and a manual air vent provided at its highest point.

The standard 4-pipe heating coil is placed in the preheat location. Optional 4-pipe heating coils are available in the reheat position for dehumidification control.

Refrigerant Coils

Direct expansion coils contain copper tubes mechanically expanded into evenly spaced aluminum fins. All coils are proof and leak tested before leaving the manufacturer. The proof test is performed at 1.5 times the maximum operating pressure, and leak tested at the maximum operating pressure. In addition, the tubes are completely evacuated of air to check for leaks in the vacuum.

The refrigerant coil distributor assemblies is Venturi or orifice style with round copper distributor tubes.

Distributors are sized consistently with capacity of coil. Suction headers are fabricated from round copper pipe.

A expansion valve is factory selected and installed for a wide-range of control to maintain optimum control of superheat. All coils are shipped with a dry nitrogen holding charge.

Electric Coil

Units equipped for electric heat contain a special resistance, heating element design inserted in an extended surface fin-tube bundle for maximum element life and safety. Units specifying electric heat include (as standard) both automatic reset and backup single-use, high temperature cut-outs with a continuous sensing element. These devices interrupt electrical power whenever excessive temperatures are sensed anywhere along the leaving side of the coil. A contactor (also provided) ensure positive disconnect of electrical power whenever the fan motor power is interrupted. All electric heat units have a power wiring console in the right hand end-pocket to better facilitate field wiring of the unit.

Steam Coil

Units including a steam coil are of a 5/8-inch, sigma-flow, tube-in-tube, distributing coil design. Steam coil tubing is mechanically expanded into evenly spaced aluminum fins. The supply and return connections are on the same side, and include a 1-inch FPT termination. The coil is pitched by the manufacturer to provide condensate drainage for freeze protection.

Leak Detection Sensors

Unit shall be furnished with a leak detection system from the factory when a circuit refrigerant charge exceeds 3.91 lb of R-454B or 4.04 lb of R-32 refrigerant. The leak detection system shall consist of one or more refrigerant detection sensors. When the system detects a leak, the unit controller shall initiate mitigation actions.

Piping Packages

All piping packages are proof-tested at 300 psig (air) and leak tested at 100 psig (air under water).

The maximum working pressure of the interconnecting piping is 300 psig. For hydronic applications, maximum working temperature is 200° F except for applications with up to 50% glycol where the limit is 180° F. Control valves are mounted in all piping packages. All piping packages are factory installed and come in a variety of options:

- **Basic:** Union and shut-off ball valve on the supply line. Union, control valve and shut-off ball valve on the return line.
- **Basic with manual circuit setter:** Union, shut-off ball valve on the supply line. Union, control valve and manual circuit setter on the return line.
- **Deluxe with manual circuit setter:** Union, strainer, P/T port, and shut-off ball valve on the supply line. Union, control valve and manual circuit setter on the return line.
- **Deluxe with auto flow:** Union, strainer, P/T port, and shut-off ball valve on the supply line. Union, control valve, auto flow valve, P/T port and shut-off ball valve on the return line.

Control Valves

Control valves are ball valve design with zero leakage. The ball valve incorporates self-cleaning technology to provide superior clog resistance. The actuator is easily removable for service without removing the valve body.

Figure 44. 2-way and 3-way water control valves - 1.4 to 6.6 Cv



Material	Media Temperature	Working Pressure	Differential Pressure	Close off Pressure
Body - Forged Brass	36°F min	360 psig	40 psig	75 psig
Ball - Chrome Plated Brass	212°F max			
Stem - Brass				
Seats - PTFE				
O-Rings - EPDM (lubricated)				

Figure 45. 3-way water control valve - 7.4 Cv



Material	Media Temperature	Working Pressure	Differential Pressure	Close off Pressure
Body - Forged Brass Nickel Plated	0°F Min	600 psig	50 psig	200 psig
Ball - Stainless Steel	250°F Max			
Stem - Stainless Steel				
Seats - PTFE				
O-Rings - EPDM (lubricated)				
Characterizing Disk - Tefzel®				

Figure 46. Steam Control Valve – 1.8, 4.6, 7.3 Cv

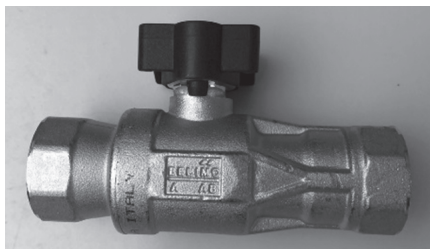

Material	Media Temperature	Working Pressure	Differential Pressure	Close off Pressure
Body - Brass	250°F Max	15 psig Max	15 psig	200 psig
Ball - Stainless Steel				
Stem - Stainless Steel				
Seats - ETFE				
Characterizing Disk - ETFE				

Table 58. Control Valve Actuators

Actuator Type	Media Temperature	Ambient Temperature	Power Supply	Transformer Sizing	Power Consumption	Stroke Time
2 Position – 1.4 to 6.6 Cv	36°F Min 200°F Max	35°F Min 104°F Max	24 Vac 50/ 60Hz	5 VA	2.5 Watts	Variable
Modulating/Analog – 1.4 to 6.6 Cv				0.6 VA	0.3 Watts	
2 Position – 7.4 Cv	0°F Min 200°F Max	-22°F Min 122°F Max		5 VA	2.5 Watts	75 seconds
Modulating/Analog – 7.4 Cv				1 VA	1.0 Watts	90 seconds
Steam – 1.8, 4.6, 7.3 Cv				2 VA		

Mechanical Specifications

End Valves

Each piping package includes a ball valve on the entering water pipe and one of the following end valves on the leaving water pipe:

- Ball valve
- Manual circuit setter

Ball Valve

The ball valve is manual shutoff with a maximum working pressure of 600 psig. The valve handle rotates 90° to a fully open position.

Manual Circuit Setter

A manual circuit setter acts as both a flow setting device and a stop valve. This valve allows water flow through the unit to be set quickly and accurately. The manual circuit setter includes ¼ in. Schrader ports in the valve body. These ports are used to measure the pressure drop across the valve. This pressure drop can be compared to factory supplied curves that relate the pressure drop to a specific flow rate. This valve also has a memory stop that helps find the correct setting quickly.

Figure 47. Manual circuit setter



Material	Temperature	Working Pressure
Body - Bronze	250°F max	300 psig max
Seats - Teflon®		
Internal Components - Brass, Teflon, EPDM		
Schrader Valve Connections - Brass 1/4 in.		
Indicator Plate - Stainless Steel		
Pointer - Die Cast Zinc		

Automatic Flow Control (Auto Flow Valve)

Automatic Flow Control is located on the return line. This device is a non-adjustable in-line flow control valve that maintains the GPM for the unit with a cartridge sized to a specific flow rate.

Figure 48. Auto flow valve

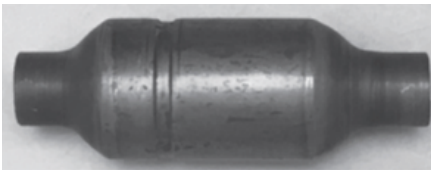

Material	Media Temperature	Working Pressure	Pressure Drop
Valve Body - Copper	32°F min	522 psig	2-80 psig 0.50-5.00 GPM
O-rings - EPDM	225°F max		3-80 psig 5.50-9.00 GPM
Retainer - Stainless Steel			
Diaphragm - EPDM			
Orifice - Polyphenyl sulfone			

Strainer

The strainer is provided with a plug to access the basket. The strainer contains a 20 mesh screen with a working pressure of 300 psig and a maximum water temperature of 210° F.

P/T Port

P/T Port has the ability to measure temperature or pressure of the line.

Figure 49. P/T Port

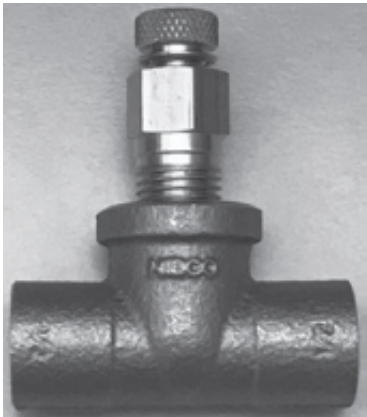

Material	Media Temperature	Working Pressure
Tee Body - Cast Bronze		
P/T Plug Body - Brass	200°F max	500 psig

Bypass Balance Valve

All three-way control valve packages include a balance fitting in the bypass line to allow flow balancing in the bypass position. The balance valve incorporates both a gland screw and stem for manual flow adjustment. The working pressure of this valve is 400 psig.

Union

Figure 50. Union



Material
Nut—Brass
Elbow—Brass
Tail—Copper

Dampers

Outside Air/Return Air Damper

Each unit ventilator is equipped with a linkage free, air-tight damper design. This linkage free design results in a fixed air seal of the damper assembly.

Face-and-Bypass Damper

The face and bypass damper control is utilized for economizing and dehumidification of the equipment during seasonal or morning warm-up. The damper is constructed of aluminum grade metal. The damper is tightly sealed and designed to minimize heat pickup in the bypass position.

Controls

Controls options are: customer supplied terminal interface (CSTI) and Symbio™ 400-B. A variety of inputs and outputs are available for the CSTI and Tracer controller options. A disconnect switch (for non-electric heat units), fused transformer, contactor(s), and terminal strip are provided with the CSTI, Thermostat and Tracer controller options.



Mechanical Specifications

Customer Supplied Terminal Interface (CSTI)

The control interface is intended to be used with a field-supplied, low-voltage thermostat or controller. The control box contains a relay board which includes a line voltage to 24-volt transformer, and an optional disconnect switch. All end devices are wired to a low-voltage terminal block and are run-tested, so the only a power connection and thermostat/controller connection is needed to commission the unit. Entering water temperature sensors are provided whenever a changeover coil is selected. CSTI board does not support changeover function with modulating valves. When N.O. valves are selected, inverting relays are provided for use with standard thermostats. Fan status is a selectable option.

Symbio™ 400-B Controller

The Tracer® Symbio™ 400-B controller delivers single zone VAV control in a stand-alone application or as part of a Trane Integrated Comfort system with BACnet® communication. The Tracer Symbio 400-B offers the combined advantages of a factory-mounted, wired, and programmed controller for dependable out-of-the box operation. Standard control features include options normally available on more elaborate control systems. All control options are available factory-programmed with additional configuration and programming in the field using a service tool.

The Symbio 400-B is a multi-purpose, programmable (or application-specific) controller that provides direct-digital zone temperature control. The controller can operate as a stand-alone device or as part of a building automation system (BAS). Communication between the controller and a BAS occurs on an open standard with inter-operable protocols used in Building Automation and Control Networks (BACnet®). Programming is done by means of the Trace TU service tool.

Zone Sensors

Trane offers a full line of wired and wireless temperature sensors. Wired temperature sensors are the suitable alternative for locations that cannot accommodate wireless sensors or that require a service tool connection. Wireless temperature sensors, which provide easy and flexible installation, are a costeffective alternative to wired sensors.

Some additional options available with the sensors include:

- Easy-to-use display interface for clear and simple monitoring and control.
- Temperature setpoint control to allow the tenant to choose a temperature setpoint that satisfies their personal preference.
- Fan speed switch to allow the tenant to locally control the fan speed to better satisfy their preference.
- Occupancy override to allow the tenant to request temporary timed override system operation that keeps the building conditions in occupied comfort conditions.
- COMM module that is compatible with all Trane® wired temperature sensors. This accessory provides a local RJ22 connection to Trane service tools for easy, low-cost maintenance.

Filters

Units equipped with a standard throwaway filter have an average resistance of 76 percent and dust holding capacity of 26 grams per square foot.

Units equipped with 1-in. MERV 8 filters have a rating based on ASHRAE Standard 52.2. The average dust spot efficiency is no less than 35 to 40 percent when tested in accordance with ASHRAE Standard 52.1 atmospheric dust spot method.

Units equipped with 1-in. MERV 13 filters have a rating based on ASHRAE Standard 52.2. The average dust spot efficiency is no less than 90 percent efficiency on 1 to 3 micron particles and greater than 90 percent efficiency on 3 to 10 micron particles when tested in accordance with ASHRAE Test Standard 52.2.



Notes



The AHRI Certified mark indicates Trane U.S. Inc. participation in the AHRI Certification program. For verification of individual certified products, go to ahridirectory.org.

Trane - by Trane Technologies (NYSE: TT), a global innovator - creates comfortable, energy efficient indoor environments for commercial and residential applications. For more information, please visit trane.com or tranetechnologies.com.

Trane has a policy of continuous product and product data improvements and reserves the right to change design and specifications without notice. We are committed to using environmentally conscious print practices.