



Product Catalog

Force-Flo™ Cabinet Heater Air Terminal Devices

Horizontal and Vertical Sizes 02 to 12





Introduction

Trane has redesigned the traditional cabinet heater to lead the industry in:

- Indoor Air Quality (IAQ) features
- Easy installation and maintenance
- High quality and durability
- Advanced controls

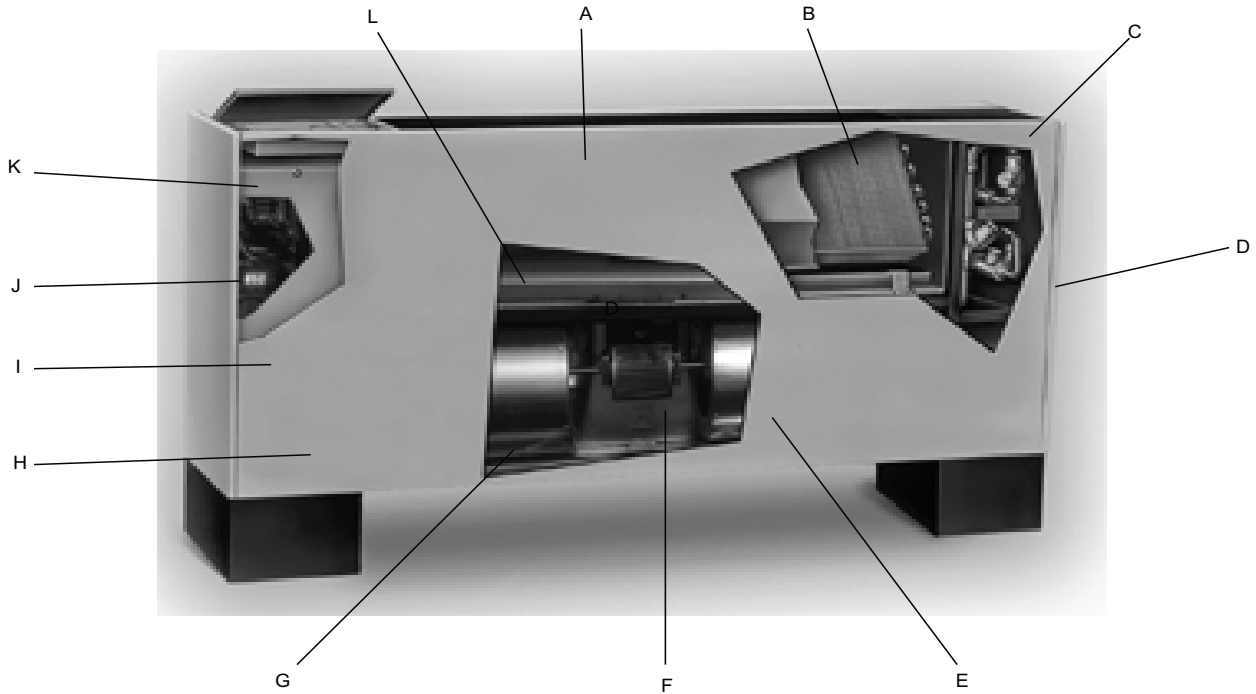

Element	Description
A	Smaller unit footprint Quiet operation
B	Two, three, or four-row coils
C	Factory-assembled, installed, and tested piping package with IAQ drain pan to collect condensate
D	Cleanable closedcell insulation (non-fiberglass)
E	Damper allows up to 100 percent fresh air
F	Energy efficient electronically commutated motor (ECM)
G	Easy filter access with front panel removal
H	18 gauge steel construction
I	Easy-to-remove fan assembly
J	Built-in field service tool with real language LED
K	Factory-installed and tested controls
L	Removable, noncorrosive, positively-sloped drain pan

Copyright

This document and the information in it are the property of Trane, and may not be used or reproduced in whole or in part without written permission. Trane reserves the right to revise this publication at any time, and to make changes to its content without obligation to notify any person of such revision or change.

Trademarks

All trademarks referenced in this document are the trademarks of their respective owners.

Revision History

Updated Performance Data information in the Mechanical Specifications.



Table of Contents

Features and Benefits	6
Energy Efficiency	6
IAQ Design	6
Controls	6
Flexibility	7
Quality	7
Serviceability	7
Components and Options	8
Motor and Control Board	8
Electric Heat	9
Factory-Installed Piping Packages	10
Model Number Descriptions	12
General Data	14
Model A, Vertical Cabinet	14
Model B, Vertical Cabinet	14
Model F, Vertical Wall Hung Cabinet	17
Model H, Vertical Recessed	18
Model J, Vertical Cabinet Slope Top	18
Model M, Inverted Vertical Cabinet	19
Model N, Inverted Vertical Recessed	19
Performance Data	21
Controls	22
Why Trane Controls?	22
Control Options	23
Fan Speed Control with Standard Adapter Board	23
Customer Supplied Terminal Interface (CSTI)	24
Thermostat	24
Tracer® ZN520 Controller	25
UC400-B/Symbio™ 400-B Controller	25
Sequence of Operation	26
Zone Sensor Options	28
Control Features	29
Tracer® ZN520 and UC400-B/Symbio™ 400-B Additional Features	29
End Device Options	30
Actuators	30
Control Valves	30
Selecting the Correct Modulating Valve Size	31
Electrical Data	32
MCA and MOP Calculations	32
Electric Heat	32
Motors	37

RPM	38
Dimensions and Weights	39
Vertical Concealed, Model A	39
Vertical Cabinet, Model B	40
Horizontal Concealed, Model C	41
Horizontal Cabinet, Model D	42
Horizontal Recessed, Model E	43
Vertical Wall Hung Cabinet, Model F	44
Vertical Recessed, Model H	45
Vertical Slope Top, Model J	46
Inverted Vertical Cabinet, Model M	47
Inverted Vertical Recessed, Model N	48
Coil Connections	49
Fresh Air Opening Locations-Horizontal Units Models C, D, and E	50
Fresh Air Opening Locations-Vertical Units Models A, B, F, and J	51
Wall Box	52
Projection Panel	53
Mechanical Specifications	54
Performance Data	54
Construction	54
Controls	55
Coils	55
Filters	56
Fresh Air Damper	56
Colors	57
Components	57
Piping Package	58



Features and Benefits

The Force-Flo™ cabinet heater meets the standards of today's market, as well as the anticipated needs of tomorrow's market. The Force-Flo cabinet heater is the leader in these key areas:

- Energy efficiency
- Indoor air quality (IAQ)
- Controls
- Flexibility
- Quality
- Serviceability

Today's HVAC market is concerned with issues such as indoor air quality (IAQ) and CFCs that demand a change in HVAC products. In addition, renovation has overtaken new construction in the cabinet heater market - demanding a design that caters to renovation issues. Trane is concerned with these issues, too. That's why we designed the Force-Flo cabinet heater as an integral part of the company's system solutions with standard IAQ-related features that comply with ASHRAE 62.

Energy Efficiency

Trane's commitment to providing premium quality products has led to the exclusive use of Electronically Commutated Motors (ECM) in all fan coil models. These brushless DC motors incorporate the latest technology for optimized energy efficiency, acoustical abatement, maintenance free and extended motor life. Each motor has a built-in microprocessor that allows for programmability, soft ramp-up, better airflow control, and serial communication.

- Trane units equipped with ECMs are significantly more efficient than the standard permanent split capacitor (PSC) motor.
- Lower operating costs on average of 50 percent (versus a PSC motor).
- The reduced FLA feature allows units to ship with a nameplate FLA rating much lower than a typical unit.

IAQ Design

- Closed-cell insulation is standard on all units to help prevent fiberglass in the airstream.
- Easy filter access encourages frequent changing.
- Blow-thru design.

Controls

- This is the industry's first solution that is factory-mounted, wired, and programmed for infinite modulation of fan speed based on space loads, using the UC400-B/Symbio™ 400-B.
- Auto Fan Speed control with the Tracer® ZN520 ramps the fan speed up and down to meet space loads.
- All controls are factory-mounted and tested to minimize field setup and improve reliability. Factory provided low voltage wall mounted or unit mounted thermostats are also available.

Note: *Factory addressing is available for Symbio 400-B and UC400-B Air-Fi® WCI controller types. This option allows configuration of units before delivery, reducing the field setup time.*

- Controls are wired with a 24 Vac transformer to keep only a single source power connection requirement to the unit.
- All wall-mounted zone sensors/thermostats require only low voltage control wiring from the device to the unit control box (no line voltage). The thermostat is factory configured based on selected options.
- The random start-up feature helps reduce electrical demand peaks by randomly staggering multiple units at start-up.

- Occupied/unoccupied operation allows the controller to utilize unoccupied temperature setpoints for energy savings.
- Warm-up and cool-down energy features are standard with Trane controls.
- Continuous fan or fan cycling is available with UC400-B/Symbio 400-B or with a Thermostat.
- Monitor unit operation using Tracer[®] TU building management system with Tracer ZN520 and UC400-B/Symbio 400-B.
- To customize unit control, Tracer[®] TU or Rover[™] software will allow field modification of Tracer ZN520 and UC400-B/Symbio 400-B default settings.
- Maximize cabinet heater system efficiency with modulating valves on units with Tracer ZN520 and UC400-B/Symbio 400-B.

Flexibility

- Two, three, and four row hot water coils allow greater design flexibility. Steam distributing or electric heat coils are also available.
- Fan motors are available for either high static (0.4-inch external static pressure) or free discharge applications.
- Piping is factory-assembled, mounted, and tested. Units are also available without piping.
- Control options range from a simple fan speed switch to a DDC controller that can tie into a Tracer[®] SC building automation system.
- The extended end pocket option adds 8 inches (20 cm) to the piping end of cabinet style units.
- Slope-top vertical cabinet units are an excellent application for school and dormitories to prevent items from being placed on top of the units.
- Vertical wall hung units are used in vestibules, bathrooms, stairwells, or other applications when the unit cannot be installed on the floor.
- Inverted unit models allow heating to circulate from the bottom of the unit.

Quality

- Coils and piping packages are leak-tested before mounting on the unit.
- Coil piping connections are also leak-tested after mounting on the unit.
- All control end devices and moving components (fans and motors) are computer-tested after units are complete.

Serviceability

- Touch-safe control box.
- Integrated user interface with LED display.
- Built-in tachometer.
- Filters are easily removable and changed without removing the front panel on vertical cabinet units.
- Motors are easy to disconnect from the fan board, allowing easy service.
- The manual output test function is an invaluable troubleshooting tool. By simply pressing the test button on the Tracer[®] ZN520; service personnel can manually exercise outputs in a pre-defined sequence.

Components and Options

Motor and Control Board

- Trane Electronically Commutated Motor (ECM)
- VelociTach™ motor control board

The motor and control board are combined as a system, and cannot work without each other. This new series delivers outstanding comfort, safety, and performance with greatly reduced energy consumption compared to traditional units.

Electronically Commutated Motor (ECM)



- The ECM has integrated electronics, overload protection and short circuit protection. The motor contains no user-serviceable components inside.
- The motor mates to the unit electrically via a single plug that contains both the operating voltage and the control signals that are needed for correct operation.

VelociTach Motor Control Board

The VelociTach motor control board controls and reports the performance of up to two Trane brushless DC (BLDC) motors.

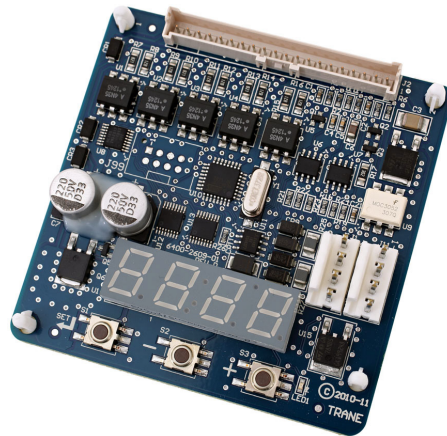

The motor control board also:

- Coordinates the operation of the fan in response to electric heat behavior and electric behavior in response to hydronic heat behavior.
- Incorporates a user interface that allows adjustment of certain unit parameters and provides constant feedback on motor operation.
- Integrates service and troubleshooting tools.
- Integrates a versatile configurable auxiliary temperature sensor.
- Incorporates various safety and lockout features, such as maintaining proper fan speeds if electric heat is called for.

Status Display



The motor control board contains a four-digit, seven-segment display that is used to present information in a format close to real-world language, while having a small-form factor. Most characters are immediately recognizable.

Electric Heat

All Force-Flo™ cabinet heaters, except inverted models M and N, are available with electric heating coils as a standard option.

Coil Construction

Electric heat coils are open wire type with a nickel chromium element design.

Power Supply

Units have single-point power since the electric heating elements operate on line voltage. Electric heat is available as 208/60/1, 230/60/1, 277/60/1, 208/60/3, or 480/60/3. Electric heat coils operate on the same voltage as the unit, except for units with 480/60/3 electric heat. In this case, the unit operates at 277/60/1, thus requiring a 4-wire supply. All fans and motors are single phase. In addition, all control options are 24-volt, utilizing a factory-installed transformer.

Power Supply Location

All electric heat cabinet heaters have a terminal block for main power on the unit's right-hand side.

Control Type

Single-stage electric heat units are controlled by either UC400-B/Symbio™ 400-B, ZN520 or Thermostat control options. Two-stage electric heat is controlled by the UC400-B/Symbio™ 400-B, ZN520 only. Both control options use PWM (pulse-width modulation) outputs to calculate the electric heat output based on the capacity request and the electric heat cycles per hour. For example, if the electric heat cycles per hour is configured for six cycles (as Trane recommends) the controller bases the output on or off time on six 10-minute periods. If the capacity request is 40 percent, the controller controls the electric heat output on for approximately four minutes each period.

Safety Features

- Fan/Valve operation to ensure safe operation and to ensure that two modes of heat are not operating simultaneously.
- All Force-Flo™ units with electric heat are UL listed.
- Units require only a single-point electrical connection.
- All electric heating coils are interlocked with the fan motor switch. Therefore, electric heat operation is only possible when the fan is running.
- Each unit has a transformer, eliminating the need for field installation of a step-down transformer.
- Unit-mounted quiet magnetic relays are supplied on all unit voltages.
- A line-break high temperature cutout, with both automatic reset and backup single-use, is provided as an integral part of the elements to de-energize the electric heat in the event of an overheat condition.

Factory-Installed Piping Packages

Piping packages are available with Tracer® ZN520 or UC400-B/Symbio™ 400-B controllers and CSTI. Field connections are located near the exterior of the unit for easy of access.

Piping Package Components

Control valves are mounted in all factory piping packages. All piping packages are factory installed and come in a variety of options:

- **Basic:** Shut-off ball valve on the supply line. Control valve and shut-off ball valve on the return line.
- **Basic with Manual circuit setter:** Shut-off ball valve on the supply line. Control valve and manual circuit setter on the return line.
- **Deluxe with Manual circuit setter:** Union, strainer, P/T port, and shut-off ball valve on the supply line. Union, control valve and manual circuit setter on the return line.
- **Deluxe with Auto flow:** Union, strainer, P/T port, and shut-off ball valve on the supply line. Union, control valve, auto flow valve, P/T port and shut-off ball valve on the return line.

Piping System/Placement

Factory piping systems are available for either right or left hand connections. A simple coil connection (a unit without a piping package) is also available in either a right or left hand configuration for applications requiring field piping.

Figure 1. Basic piping packages

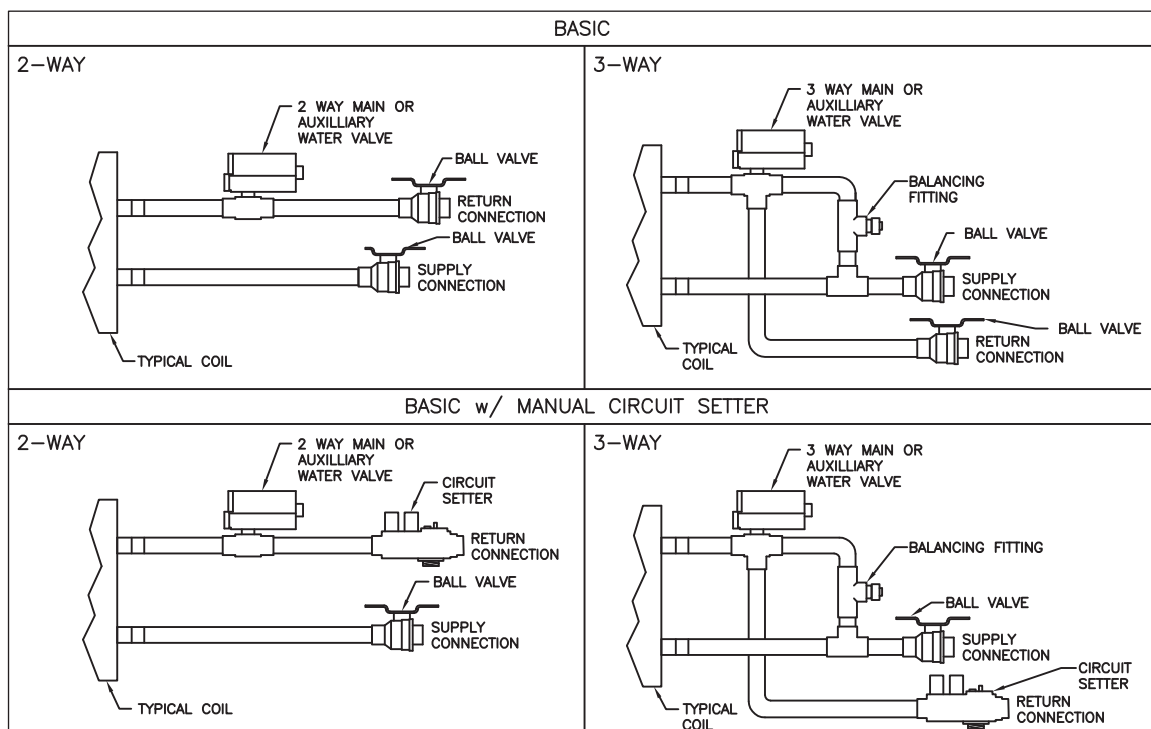
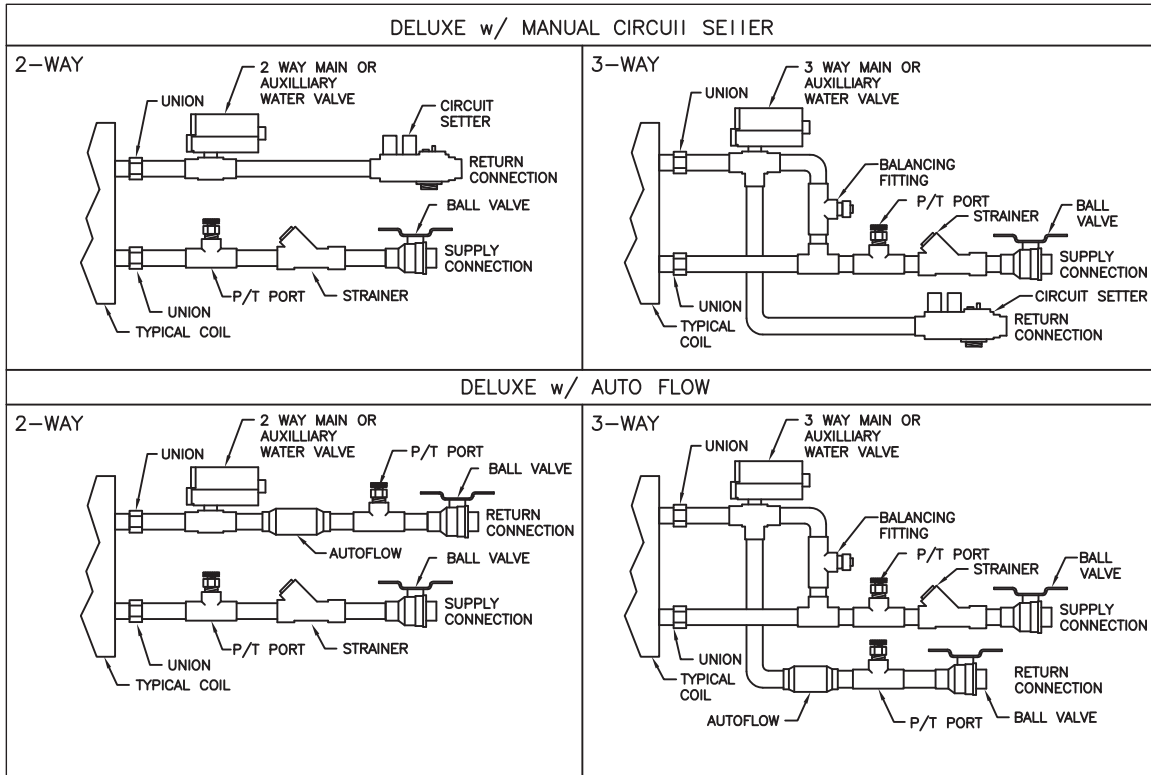

Figure 2. Deluxe piping package





Model Number Descriptions

Force-Flo Cabinet Heater Model Number Description

Following is a complete description of the cabinet heater model number. Each digit in the model number has a corresponding code that identifies specific unit options.

Note: Some options may not be available with all cabinet styles. Contact your local Trane representative for more information.

Digits 1, 2 — Unit Type

FF = Force-Flo

Digit 3 — Model

- A = Vertical concealed
- B = Vertical cabinet
- C = Horizontal concealed
- D = Horizontal cabinet
- E = Horizontal recessed
- F = Vertical wall-hung
- H = Vertical recessed
- J = Vertical slope-top
- M = Inverted vertical cabinet
- N = Inverted vertical recessed

Digit 4 — Development Sequence

B = Development B

Digits 5, 6, 7 — Unit Cabinet Size

- 020 = 200 cfm
- 030 = 300 cfm
- 040 = 400 cfm
- 060 = 600 cfm
- 080 = 800 cfm
- 100 = 1000 cfm
- 120 = 1200 cfm

Digit 8 — Unit Voltage/Hertz/Phase

- 1 = 115 V/60 Hz/1 Ph
- 2 = 208 V/60 Hz/1 Ph
- 3 = 277 V/60 Hz/1 Ph
- 4 = 230 V/60 Hz/1 Ph
- 5 = 208 V/60 Hz/3 Ph
- 6 = 230 V/60 Hz/3 Ph
- 7 = 480 V/60 Hz/3 Ph
- 8 = 115 V/50 Hz/1 Ph (SOS only)
- 9 = 220-240 V/50 Hz/1 Ph
- A = 220-240 V/50 Hz/3 Ph
- B = 380-415 V/50 Hz/3 Ph

Digit 9 — Piping System/Placement

- A = Without pipe, RH
- B = Without pipe, LH
- E = Without pipe, RH, extended end
- F = Without pipe, LH, extended end
- J = With pipe, RH
- K = With pipe, LH
- L = With pipe, RH, extended end

- M = With pipe, LH, extended end
- Q = With pipe, RH, extended end pipe and control side
- R = With pipe, extended end pipe and control side

Digits 10, 11 — Design Sequence

*** = Factory assigned

Digit 12 — Inlet style

- A = Front toe space
- B = Front bar grille
- C = Front stamped louver
- D = Bottom stamped louver
- E = Bottom toe space
- F = Back duct collar
- G = Back exposed fan
- H = Back stamped louver
- J = Top duct collar

Digit 13 — Outside Air Damper

- 0 = None
- A = Manual, bottom opening
- B = Manual, back opening
- C = Manual, top opening
- D = Auto, 2-position, bottom opening
- E = Auto, 2-position, back opening
- F = Auto, 2-position, top opening
- K = No damper, bottom opening
- L = No damper, back opening
- M = No damper, top opening

Digit 14 — Outlet Style

- A = Front duct collar
- B = Front bar grille
- C = Front stamped louver
- D = Front quad grille
- E = Bottom duct collar
- F = Bottom stamped louver
- G = Top quad grille
- H = Top bar grille
- J = Top duct collar
- K = Bottom bar grille

Digit 15 — Cabinet Paint Color

- 0 = None (not painted unit)
- 1 = Deluxe beige
- 2 = Soft dove
- 3 = Cameo white
- 4 = Driftwood grey
- 5 = Stone grey
- 6 = Rose mauve

Digit 16 — Tamperproof Locks/Leveling Feet

- 0 = None
- A = Locking panel
- B = Keylock access door
- C = Locking panel, key access door, secure grille
- D = Leveling feet
- E = Locking panel with leveling feet
- F = Keylock door with leveling feet
- G = Locking panel, key access door, secure grille, and leveling feet

Digit 17 — Motor

- A = Free discharge
- B = High static

Digit 18 — Main Coil

- G = 2-row hot water
- H = 3-row hot water
- J = 4-row hot water
- N = Electric heat only, 1-stage
- U = Electric heat only, 2-stage
- V = Electric heat, low kW, 1-stage
- W = Steam coil

Digit 19 — Drain Pan

0 = None

Digit 20 — Air Vent

- 0 = None
- A = Automatic
- M = Manual

Digits 21, 22, 23 — Electric Heat kW

- 000 = None
- 010 = 1.0 kW (0.75 kW 208V)
- 020 = 2.0 kW (1.5 kW 208 V)
- 030 = 3.0 kW (2.2 kW 208 V)
- 045 = 4.5 kW (3.3 kW 208 V)
- 060 = 6.0 kW (4.4 kW 208 V)
- 075 = 7.5 kW (5.7 kW 208 V)
- 090 = 9.0 kW (6.6 kW 208 V)
- 100 = 10 kW (N/A 208 V)
- 105 = 10.5 kW (7.9 kW 208 V)
- 110 = 11 kW (9.0 kW 208 V)
- 120 = 12.0 kW (N/A 208 V)
- 135 = 13.5 kW (10.2 kW 208 V)
- 150 = 15.0 kW (N/A 208 V)
- 180 = 18.0 kW (13.5 kW 208 V)
- 200 = 20.0 kW (15.0 kW 208 V)
- 220 = 22.0 kW (16.4 kW 208 V)

Digit 24 — Reheat Coil

0 = Without reheat

Digit 25 — Unit Mounted Disconnect Switch

- 0 = None
- D = With disconnect switch

Digit 26 — Filter Type

- 0 = None
- 1 = 1" Throwaway
- 2 = 1" Throwaway MERV 8
- 3 = 1" Throwaway + 1 extra
- 4 = 1" Throwaway MERV 8 + 1 extra
- 5 = 1" Throwaway + 2 extra
- 6 = 1" Throwaway MERV 8 + 2 extra
- 7 = 1" Throwaway + 3 extra
- 8 = 1" Throwaway MERV 8 + 3 extra
- A = 1" Throwaway MERV 13
- B = 1" Throwaway MERV 13 + 1 extra
- C = 1" Throwaway MERV 13 + 2 extra
- D = 1" Throwaway MERV 13 + 3 extra

Digit 27 — Future Option

0 = None

Digit 28 — Future Option

0 = None

Model Number Descriptions

Digit 29 — Piping Packages

- 0 = None
- A = Basic - Ball valve supply and return
- B = Basic - Ball valve supply and manual circuit setter return
- E = Deluxe - Ball valve supply and manual circuit setter return
- F = Deluxe - Ball valve supply and return with auto flow

Digit 30 — Control Type

- A = Fan speed control
- G = Tracer® ZN520
- H = Customer Supplied Terminal- STAT Interface (CSTI)
- L = Tracer® UC400-B
- M = Tracer® UC400-B with Wireless Communications Interface (WCI)
- N = CSTI with fan status
- P = Thermostat
- R = Symbio™ 400-B
- T = Symbio™ 400-B with Wireless Communications Interface (WCI)

Digit 31 — Control Options

- 0 = None
- V = Unit — mounted zone sensor module (OALMH & Setpoint dial)
- W = Wall — mounted zone sensor module (OALMH & Setpoint dial)
- X = Unit — mounted fan mode switch, Wall -mounted zone sensor (Setpoint dial)
- Y = Unit — mounted fan mode switch, wall -mounted zone sensor (Setpoint dial, on/cancel, communication jack)
- Z = Unit — mounted zone sensor module (OALMH, Setpoint dial, On/Cancel buttons)
- 1 = Wall — mounted zone sensor module (On/Cancel buttons, Communication jack)
- 2 = Wall — mounted zone sensor module (O/A/H/M/L, Setpoint dial, On/Cancel, Communication jack)
- 4 = Wall — mounted digital zone sensor (O/A/H/M/L, Setpoint, On/Cancel, Communication jack)
- 6 = Wireless zone sensor (Setpoint dial, Occupied / Unoccupied buttons)
- 7 = Wireless display sensor, Unit rec (OALMH)
- 8 = Unit — mounted variable speed control
- 9 = Wall — mounted variable speed control
- A = Wall — mounted
- B = Unit — mounted

Digit 32 — IAQ Options

- 0 = None
- 2 = VOC/CO₂
- 3 = Dehumidification and VOC/CO₂
- 7 = Air-Fi® CO₂

Digit 33 — FLA Motor Options

- 0 = Standard ECM
- A = Reduced FLA

Digit 34 - Control Option

- 0 = None
- A = Low Limit Sensor

Digit 35 — Main Valve Type

- 0 = None
- A = 2-way, 2-position N.C.
- B = 2-way, 2-position N.O.
- C = 3-way, 2-position N.C.
- D = 3-way, 2-position N.O.
- E = 2-way, Modulating
- F = 3-way, Modulating
- G = 2-way, Analog (2-10 Vdc)
- H = 3-way, Analog (2-10 Vdc)
- J = Field Supplied, 2-position N.C.
- K = Field Supplied, 2-position N.O.
- L = Field Supplied, Modulating
- M = Field Supplied, Analog (2-10 Vdc)

Digit 36 — Cv Main Valve

- 0 = None
- A = 2-way 1.4 Cv
- B = 2-way 2.4 Cv
- C = 2-way 3.4 Cv
- D = 3-way 1.0 Cv
- E = 3-way 2.7 Cv
- F = 3-way 4.6 Cv

Digits 37 — Auxiliary Valve Type

- 0 = None

Digits 38 — Cv Auxiliary Valve

- 0 = None

Digit 39 — Recessed Options

- 0 = None
- A = 5/8-in. standard recessed panel
- B = 2-in. projection panel
- C = 2.5-in. projection panel
- D = 3-in. projection panel
- E = 3.5-in. projection panel
- F = 4-in. projection panel
- G = 4.5-in. projection panel
- H = 5-in. projection panel
- J = 5.5-in. projection panel
- K = 6-in. projection panel
- L = 2-in. Falseback
- M = 3-in. Falseback
- N = 4-in. Falseback
- P = 5-in. Falseback
- Q = 6-in. Falseback
- R = 7-in. Falseback
- T = 8-in. Falseback

Digit 40 — Main Autoflow GPM

- 0 = None
- B = 0.75
- C = 1.0
- D = 1.5
- E = 2.0
- F = 2.5
- G = 3.0
- H = 3.5
- J = 4.0
- K = 4.5
- L = 5.0
- M = 6.0
- N = 7.0
- P = 8.0

Digit 41 —Auxiliary Heating Auto Flow GPM

- 0 = None

Digit 42 — Subbase Height

- 0 = None
- A = 2-in. height
- B = 3-in. height
- C = 4-in. height
- D = 5-in. height
- E = 6-in. height
- F = 7-in. height

Digit 43 — Recessed Flange

- 0 = None
- A = With recessed flange

Digit 44 — Wall Box

- 0 = None
- A = Clear anodized



General Data

Model A, Vertical Cabinet

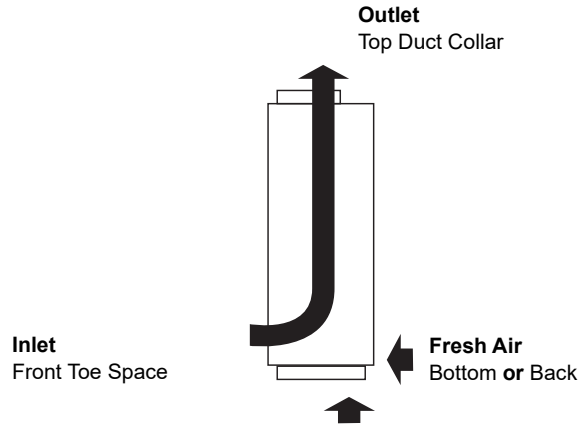
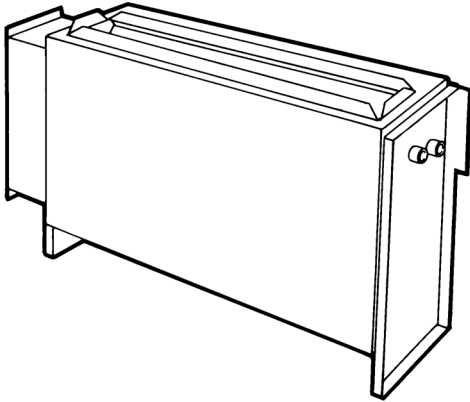

Model B, Vertical Cabinet

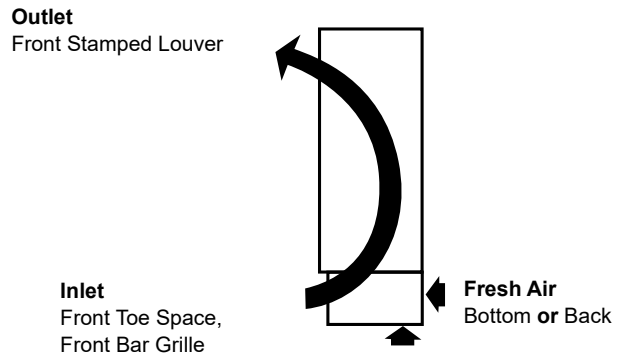
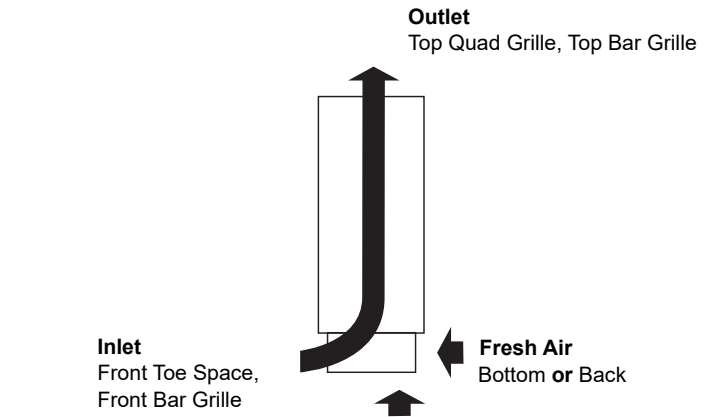
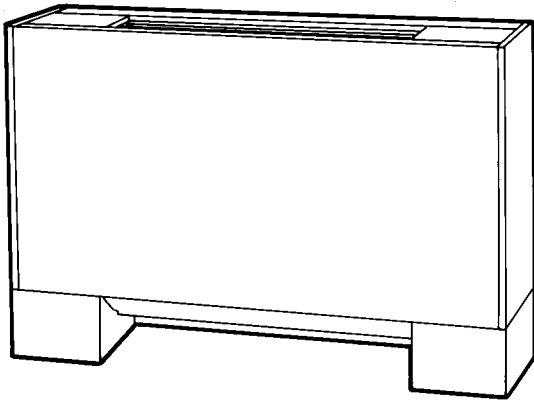

Model C, Horizontal Concealed

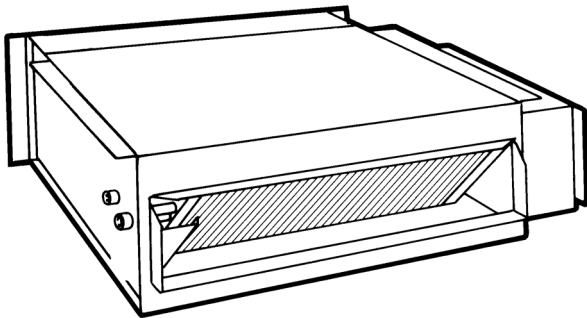

Outlet
Front Duct Collar

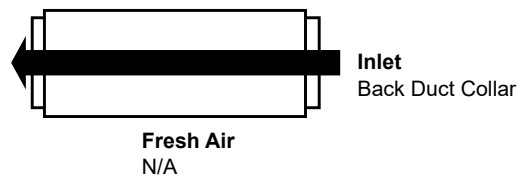

Outlet
Front Duct Collar

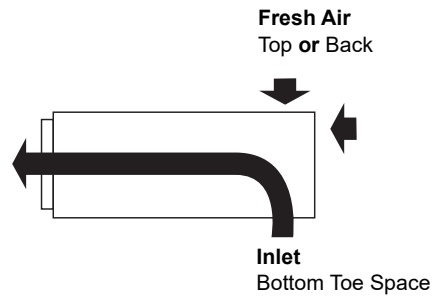

Outlet
Front Duct Collar

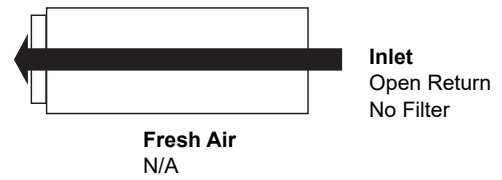

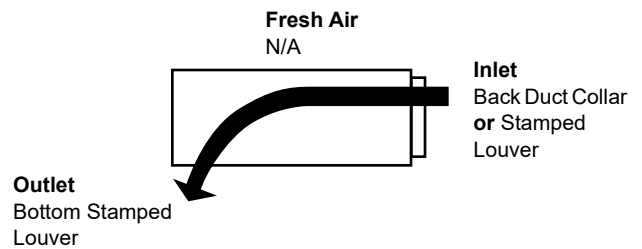
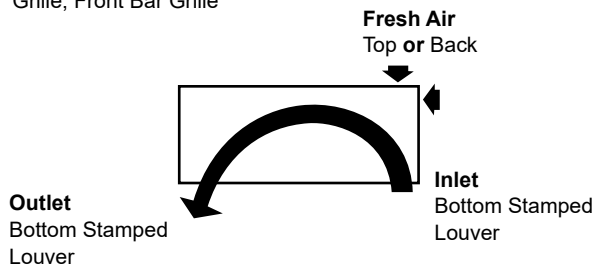
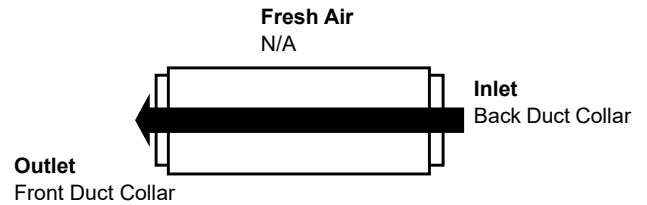
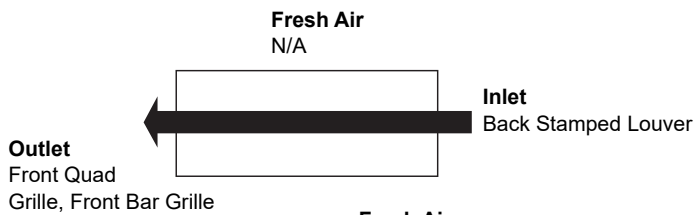
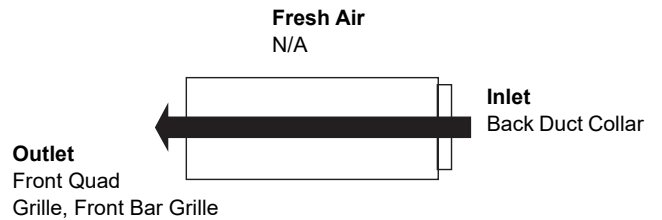
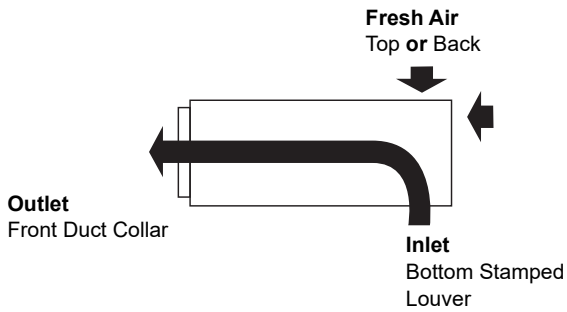
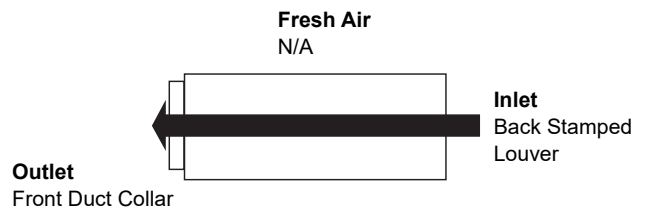
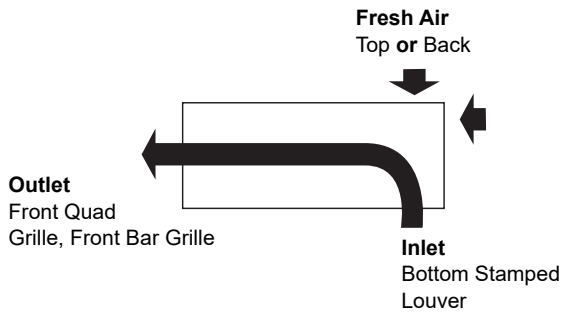
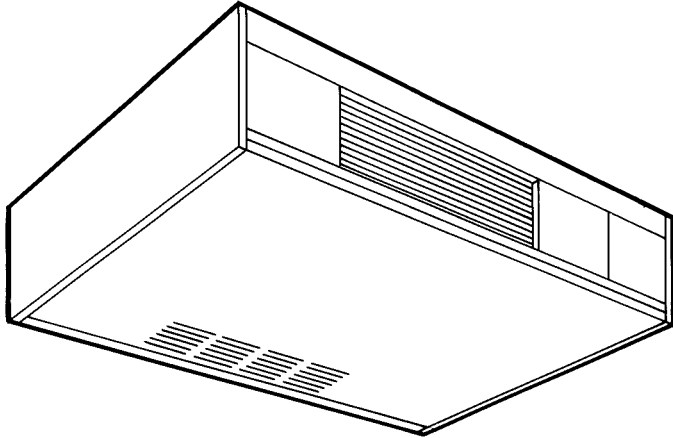
Model D, Horizontal Cabinet

Model E, Horizontal Recessed

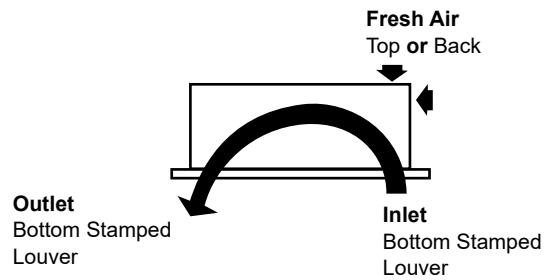
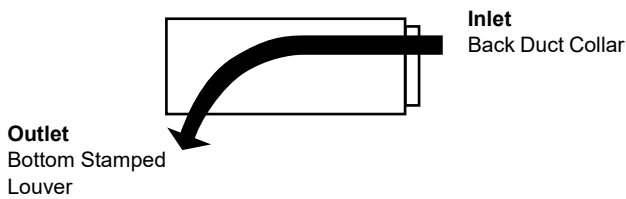
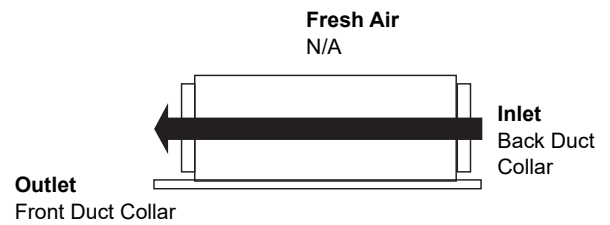
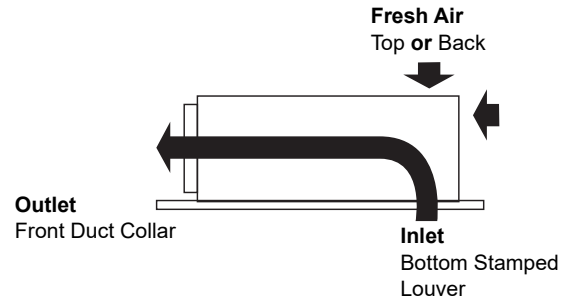
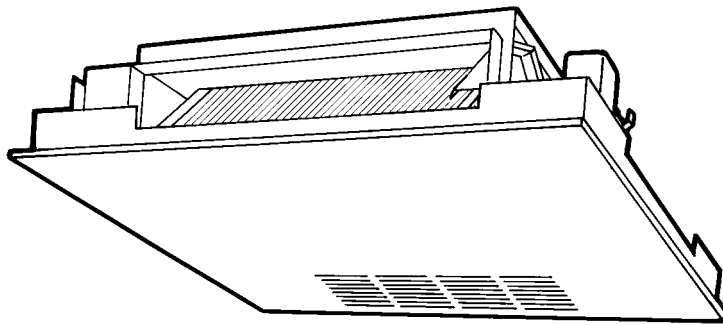

Model F, Vertical Wall Hung Cabinet

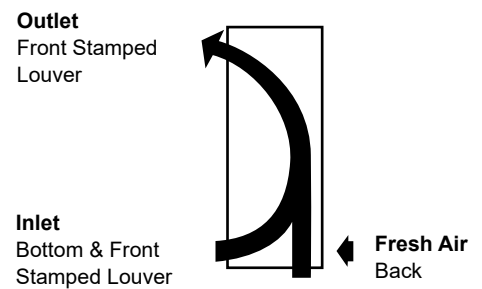
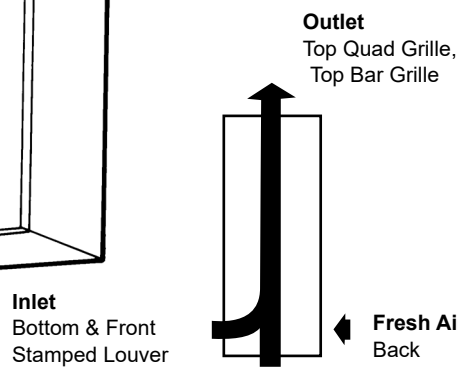
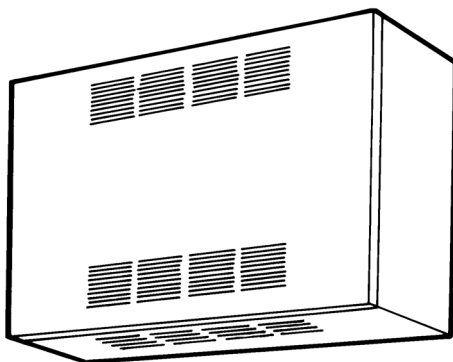

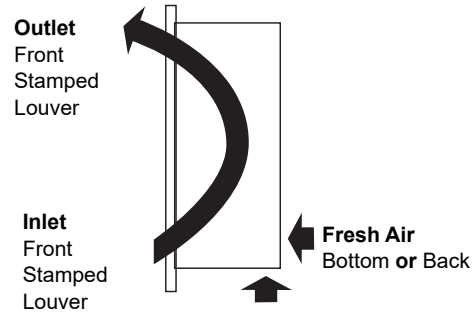
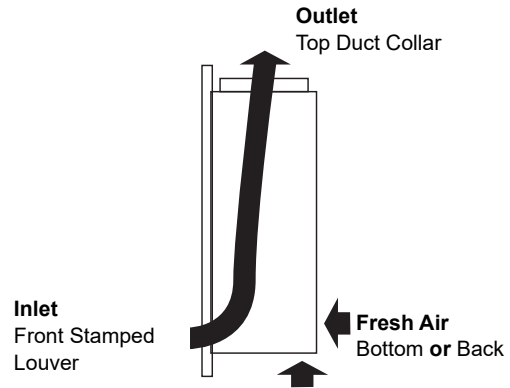
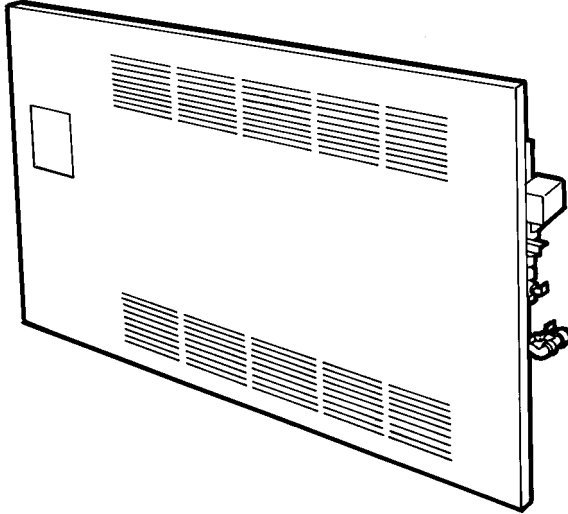
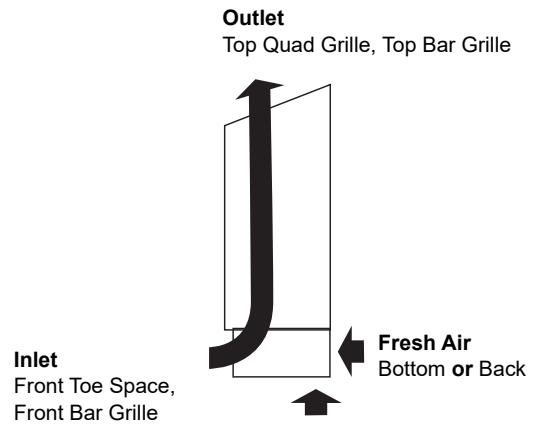
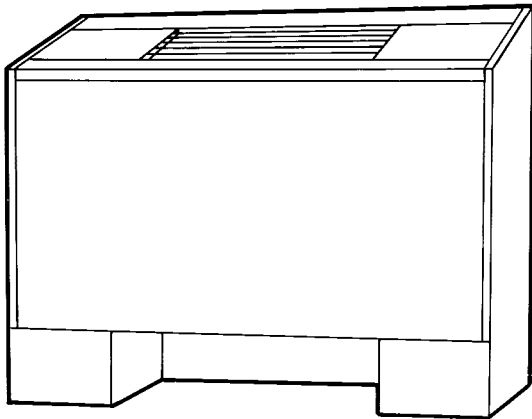
Model H, Vertical Recessed

Model J, Vertical Cabinet Slope Top

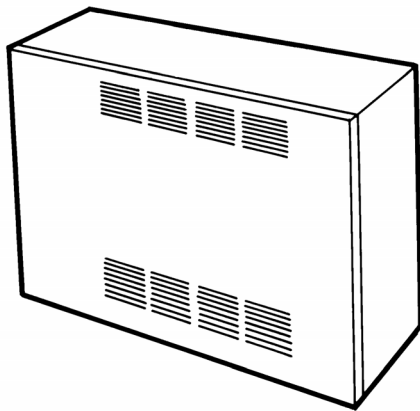
Model M, Inverted Vertical Cabinet

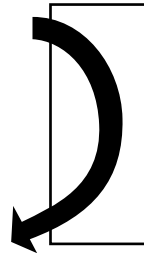

Inlet
Front Stamped
Louver



Outlet
Front Stamped
Louver

Inlet
Top Duct
Collar

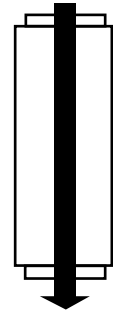

Outlet
Top Duct
Collar

Model N, Inverted Vertical Recessed

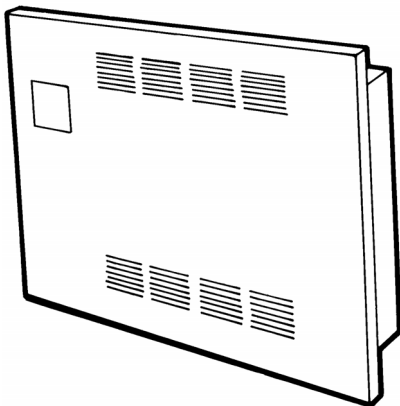

Inlet
Front Stamped
Louver

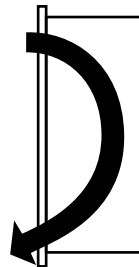

Outlet
Front Stamped
Louver

Table 1. Force-Flo cabinet heater general data

Unit Size	02	03	04	06	08	10	12
Coil Data							
Face Area-ft ²	0.8	0.8	1.1	1.6	2.1	3.2	3.2
L x D x H-in.							
2-Row	15x1.7x8	15x1.7x8	20x1.7x8	29.5x1.7x8	38x1.7x8	57x1.7x8	57x1.7x8
3-Row	15x2.6x8	15x2.6x8	20x2.6x8	29.5x2.6x8	38x2.6x8	57x2.6x8	57x2.6x8
4-Row	15x3.5x8	15x3.5x8	20x3.5x8	29.5x3.5x8	38x3.5x8	57x3.5x8	57x3.5x8
Volume-gal.							
1-Row	0.06	0.06	0.08	0.11	0.14	0.21	0.21
2-Row	0.12	0.12	0.15	0.22	0.28	0.42	0.42
3-Row	0.18	0.18	0.23	0.33	0.42	0.62	0.62
4-Row	0.24	0.24	0.30	0.44	0.56	0.83	0.83



General Data

Table 1. Force-Flo cabinet heater general data (continued)

Unit Size	02	03	04	06	08	10	12
Fins/ft							
2-Row	144	144	144	144	144	144	144
3-Row	144	144	144	144	144	144	144
4-Row	144	144	144	144	144	144	144
Fan/Motor Data							
Fan Quantity	1	1	1	2	2	3	3
Size-Dia. x Width (inches)	6.31x4	6.31x6.5	6.31x7.5	6.31x6.5	6.31x7.5	(1) 6.31x7.5 (2) 6.31x6.5	6.31x7.5
Motor Quantity	1	1	1	1	1	2	2
Filter Data							
1-in. throwaway and pleated media							
Quantity	1	1	1	1	1	1	1
Size-in.	8-7/8x19-1/8	8-7/8x19-1/8	8-7/8x24-1/8	8-7/8x33-5/8	8-7/8x42-1/8	8-7/8x61-1/8	8-7/8x61-1/8
1-in. fresh air filter (only on Cabinet Styles D, E, and H with bottom return and fresh air opening)							
Quantity	1	1	1	1	1	1	1
Size-in.	5-1/2x19-1/8	5-1/2x19-1/8	5-1/2x24-1/8	5-1/2x33-5/8	5-1/2x42-1/8	5-1/2x61-1/8	5-1/2x61-1/8

Table 2. Cabinet heater air flow

Unit Size	Coil	ESP				
		FD Motor		High Static Motor		
		0.05	0.1	0.2	0.3	0.4
02	2R144	246	344	314	283	251
	3R144	242	352	319	284	249
	4R144	222	326	295	263	230
03	2R144	313	410	380	350	319
	3R144	309	391	358	324	290
	4R144	276	360	330	299	267
04	2R144	381	446	410	373	336
	3R144	365	544	506	467	427
	4R144	340	506	470	434	397
06	2R144	609	757	700	642	582
	3R144	604	880	824	766	707
	4R144	557	812	760	706	652
08	2R144	790	1014	950	885	819
	3R144	724	992	927	861	794
	4R144	676	930	870	808	745
10	2R144	1015	1284	1199	1113	1024
	3R144	1052	1456	1360	1262	1162
	4R144	988	1366	1276	1183	1089
12	2R144	1105	1424	1330	1234	1134
	3R144	1074	1514	1419	1320	1219
	4R144	993	1421	1330	1238	1144

Note: This data is based on horizontal concealed model only, with duct inlet, duct outlet and no filter, dry coil, all voltages except 208V.



Performance Data

For performance data specific to the operating conditions, please use Trane Select Assist which can be accessed at traneselectassist.com.



Controls

Why Trane Controls?

Trane offers a broad range of control packages from a field convertible end-device package, to a complete building automation system solution with BACnet® or LonTalk® controls.

Trane controls are factory-mounted, wired, tested and configured or programmed with Trane application expertise to provide comfort, efficiency, and reliability, as well as single-source warranty and service.

Note: *Some Trane controllers have the ability to be pre-addressed in the factory. If addressing isn't provided, the controllers will remain at the default setting.*

With Trane integrated controls, the installed costs are lower because the equipment has turn-key factory controls and every component of the system is optimized to fit with the controller. Trane installs not only the controller, but also the hardware that works intimately with the controller to allow the system to function properly (i.e., piping package, valves, dampers, actuators, etc.). When a product with Trane controls arrives on the jobsite, it is completely ready for quick installation.

Table 3. Tracer® controller input/output summary

	ZN520	UC400-B/Symbio™ 400-B
Binary outputs		
Single zone VAV		X
3-speed fan	X	
2-position hydronic valve	X	X
2-position mixing box damper		X
Electric heat	X	X
Modulating mixed air damper	X	X
Modulating hydronic valve	X	X
Reheat (hydronic)	X	X
Generic	X	X
Binary inputs		
Condensate overflow detection	X	X
Low temperature detection	X	X
Occupancy	X	X
Generic input	X	X
Analog inputs		
Zone temperature	X	X
Setpoint	X	X
Hydronic valve		X
Fan mode: auto, high, medium, low	X	X
Entering water	X	X
Discharge air	X	X
Outside air	X	X
Generic		X

Note: *All functions are not available on all units. The generic input and output for ZN controls are for use with a Tracer® Summit systems only.*

Table 4. Controller function summary

Control functions	Thermostat	ZN520	UC400-B/Symbio™ 400-B
Entering water temp. sampling (purge)	X	X	X
Timed override		X	X
Auto changeover	X	X	X
Fan cycling	X		X
Warm-up		X	X
Pre-cool		X	X
Data sharing (manager/subordinate)		X	
Random start		X	X
Dehumidification		X	
DX cooling	X		X
DX frost protection	X		X
Air-Fi® factory addressing			X

Table 4. Controller function summary (continued)

Control functions	Thermostat	ZN520	UC400-B/Symbio™ 400-B
Other Functions			
Manual test		X	X
Filter maintenance timer		X	X
Setpoint limits		X	X

Control Options

Available control options:

- Fan speed control (provided when no control package is selected)
- Customer-supplied terminal interface (CSTI)
- Low voltage Thermostat controller
- Tracer® ZN520 controller
- UC400-B/Symbio™ 400-B controller with Air-Fi® Wireless Communications Interface

Fan Speed Control with Standard Adapter Board

Figure 3. Fan speed control

The fan speed control is available for units that do not have Trane factory-mounted control packages. This variable fan speed option is low-voltage and has three 24-volt relays using a factory-wired transformer and relays to control the fan motor.

The adapter allows direct customer interfacing through the use of terminal strips. Standard interfacing includes variable speed (0–10V) inputs.

The standard adapter board eliminates many separate wiring harnesses in the panel and allows simple, mistake-proofed single-plug interfacing of:

VelociTach™ motor control board

Transformers

Motors

Valves

Dampers

Electric heat control

Fan speed control

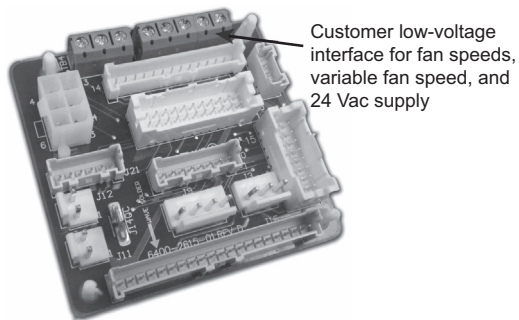
Figure 4. Standard adapter board

Customer Supplied Terminal Interface (CSTI)

The CSTI is intended to be used with a field-supplied, low-voltage thermostat or controller. The control box contains a relay board which includes a line voltage to 24-volt transformer and disconnect switch (for non-electric heat units). All end devices are wired to a low-voltage terminal block and are run-tested, so the only a power connection and thermostat connection is needed to commission the unit. Changeover sensors and controls are provided when a change-over coil is selected. When N.O. valves are selected, inverting relays are provided for use with standard thermostats.

Figure 5. CSTI adapter board and field connections

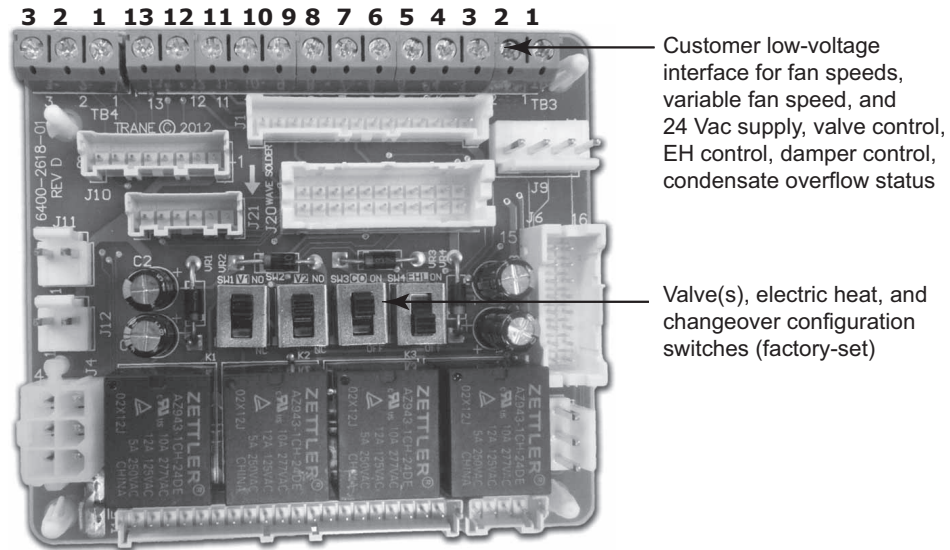

The CSTI adapter board provides all the hookups as the standard adapter board, but in addition, provides hookups for valve control (main and auxiliary coils), electric heat control, and damper control. Screw terminal blocks provide convenient access to fan controls and to end device control. In addition, a courtesy 10- Vdc supply is provided for use with an external potentiometer or rheostat. The 10- Vdc supply supports up to 10 mA draw.

Thermostat

The low voltage, wall mounted thermostat is available factory or field installed. Thermostat control is available with 2 position valves, 2 position damper actuators, low limit protection, and condensate overflow protection. The thermostat is capable of controlling cooling (hydronic or DX), heating (hydronic, electric heat or steam), and automatic changeover all with continuous fan or thermostat controlled fan speeds..

Figure 6. Unit mounted thermostat and wall mounted thermostat



Unit Mounted Thermo-

Wall Mounted Thermo-

Tracer® ZN520 Controller

The Tracer® ZN520 controller is a factory-installed, -tested and -commissioned LonTalk® control designed to provide control of Trane products. Features include:

- Automatic fan-speed reset
- Automatic ventilation reset
- Active dehumidification
- Manual output test
- Filter maintenance
- Manager/subordinate
- Water valve override
- Freeze avoidance
- Interoperability
- Three generic I/O ports

The Tracer® ZN520 controller is designed to be used in the following applications:

- As part of a Tracer® SC or Tracer Summit® building automation system (BAS), the Tracer® ZN520 becomes an important part of the Tracer® control system.
- The Tracer® ZN520 can function as a completely stand-alone controller in situations where a BAS is not present.
- For situations when a non-Trane BAS is present, the Tracer® ZN520 can be used as an inter-operable unit controller.

Through building management of the HVAC system, optimizing energy consumption becomes possible at the room level. Each unit is capable of functioning independently of one another during occupied and unoccupied hours of the day. This allows the temperature setpoint and ventilation setting to be changed automatically based on usage.

Two Systems in One

In a Tracer® system environment, the Tracer® ZN520 is pre-designed to install quickly and easily into the system. Since the controller and the unit are factory tested and commissioned, the start-up time for the entire system is minimized. Trane becomes the single source of responsibility for the equipment, unit controls, and building automation system.

As a standalone controller, the Tracer® ZN520 is ideally suited for fix-on-fail replacement of units with old pneumatic controllers, or in situations where a BAS will be added at a later date. Once power is applied to the controller, it will automatically start-up and run based upon the setpoint on the local zone sensor. An individual time clock can be added to the unit for local scheduling.

The Tracer® ZN520 is certified to the interoperable LonMark® Space Comfort Controller profile. This allows the controller to be used with another vendor BAS and thereby still provide the high quality of factory installation and testing. In addition, the Tracer® ZN520 provides one of the most extensive interoperable data lists of any controller of its type in the industry.

UC400-B/Symbio™ 400-B Controller

The UC400-B/Symbio™ 400-B single-zone VAV controller can be used in a stand-alone application or as part of a Tracer® control system.

The UC400-B/Symbio™ 400-B is a multi-purpose, programmable (or application-specific) controller that provides direct-digital zone temperature control. The controller can operate as a stand-alone device or as part of a building automation system (BAS). Communication between the controller and a BAS

occurs on an open standard with inter-operable protocols used in Building Automation and Control Networks (BACnet®). Programming is done by means of the Tracer® TU service tool. The Symbio™ 400-B is designed as a one-to-one replacement for UC400-B.

In the stand-alone configuration, UC400-B/Symbio™ 400-B receives operation commands from the zone sensor and/or the auto changeover sensor (on auto changeover units). The entering water temperature is read from the auto changeover sensor and determines if the unit is capable of cooling or heating. The zone sensor module is capable of transmitting the following information to the controller:

- Timed override on/cancel request
- Zone setpoint
- Current zone temperature
- Fan mode selection (off-auto-high-med-low)

For optimal system performance, units can operate as part of a Tracer® SC building automation system. The controller is linked directly to the Tracer® SC via a twisted pair communication wire, requiring no additional interface device (i.e., a command unit). The Tracer® control system can monitor or override UC400-B/Symbio™ 400-B control points. This includes such points as temperature and output positions.

Sequence of Operation

Fan Speed Control

A fan speed control is supplied on units with fan control or CSTI options. It provides variable speed of the motor RPM between the low and high speed factory settings.

Thermostat

Auto: Based on the setpoint and room temperature, the fan speed will automatically adjust (low, medium, high).

Tracer® ZN520 and UC400-B/Symbio™ 400-B

Off: Fan is off; control valve options and fresh air damper options close.

Auto: Fan speed control in the auto setting allows the modulating (three-wire floating point) control valve option and three-speed fan to work cooperatively to meet precise capacity requirements, while minimizing fan speed (motor/energy/acoustics) and valve position (pump energy). As the capacity requirement increases at low fan speed, the water valve opens. When the low fan speed capacity switch point is reached, the fan switches to medium speed and the water valve repositions to maintain an equivalent capacity. The reverse sequence takes place with a decrease in required capacity.

Low, Medium, High: The fan will run continuously at the selected speed and the valve option will cycle to meet setpoint.

Occupied Mode

In Occupied Mode, the UC400-B/Symbio™ 400-B controller maintains the space temperature based on the occupied space temperature setpoint \pm occupied offset. The controller uses the occupied mode as a default mode when other forms of occupancy request are not present and the fan runs continuously. The outdoor air damper, if present, will close when the fan is OFF. The temperature setpoints can be local (hard wired), communicated, or stored default values (configurable using the Tracer® TU service tool).

Unoccupied Mode

In unoccupied mode, the UC400-B/Symbio™ 400-B controller attempts to maintain the space temperature based on the unoccupied heating or cooling setpoint. The fan will cycle between high speed and **OFF**. In addition, the outdoor air damper remains closed, unless economizing. The controller always uses the stored default setpoint values (configurable using the Tracer® TU service tool), regardless of the presence of a hard wired or communicated setpoint value.

Timed Override Control

If the UC400-B/Symbio™ 400-B controller has a timed override option (**ON/CANCEL** buttons), pushing the **ON** button initiates a timed override on request. A timed override on request changes the occupancy mode from unoccupied mode to occupied bypass mode. In occupied bypass mode, the controller controls the space temperature based on the occupied heating or cooling setpoints. The occupied bypass time, which resides in the UC400-B/Symbio™ 400-B controller and defines the duration of the override, is configurable from 0 to 240 minutes (default value of 120 minutes). When the occupied bypass time expires, the unit transitions from occupied bypass mode to unoccupied mode. Pushing the **CANCEL** button cancels the timed override request. In addition, it will end the timed override before the occupied bypass time has expired and transition the unit from occupied bypass mode to unoccupied mode.

If the controller is in any mode other than unoccupied mode when the **ON** button is pressed, the controller still starts the occupied bypass timer without changing to occupied bypass mode. If the controller is placed in unoccupied mode before the occupied bypass timer expires, the controller is placed into occupied bypass mode and remains in this mode until either the **CANCEL** button is pressed on the Trane zone sensor or the occupied bypass time expires.

Zone Temperature Control

The UC400-B/Symbio™ 400-B controller has three methods of zone temperature control:

- **Cascade zone control**—used in the occupied, occupied bypass, and occupied standby modes. It maintains zone temperature by controlling the discharge air temperature to control the zone temperature. The controller uses the difference between the measured zone temperature and the active zone temperature setpoint to produce a discharge air temperature setpoint. The controller compares the discharge air temperature setpoint with the discharge air temperature and calculates a unit heating/cooling capacity accordingly (refer to the illustration below). The end devices (outdoor air damper, valves, and so on) operate in sequence based on the unit heating/cooling capacity (0–100 percent).

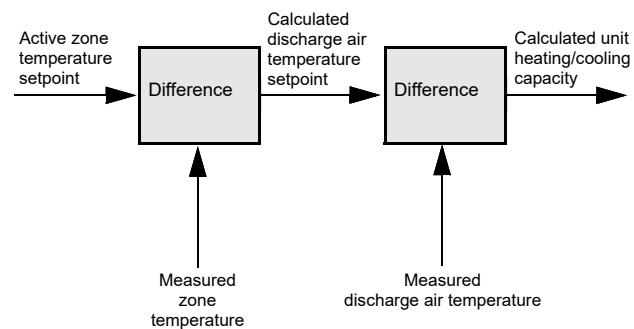

If the discharge air temperature falls below the discharge air temperature low limit setpoint, (configurable using the Tracer® TU service tool), and the cooling capacity is at a minimum, the available heating capacity is used to raise the discharge air temperature to the low limit.

- **Simplified zone control**— if discharge air temperature failure occurs, then simplified zone controls runs. In the unoccupied mode, the controller maintains the zone temperature by calculating the required heating or cooling capacity (0–100%) according to the measured zone temperature and the active zone temperature setpoint. The active zone temperature setpoint is determined by the current operating modes, which include occupancy and heat/cool modes.
- **Discharge air temperature control**— is the backup mode that runs *only* if there is not valid zone temperature. In this mode, the active space temperature setpoint is used as the discharge air temperature setpoint.

Note: *This is not a normal operating mode. The source of the invalid zone temperature needs to be corrected to restore normal operation.*

Zone Sensor Options

Zone sensor options are available as either unit-mounted (factory-installed), wall-mounted, or split-mounted options for design flexibility. The unit-mounted sensor option includes a thermistor in the return air path of the unit. Wall-mounted zone sensor options have an internal thermistor. Zone sensors operate on 24 Vac. Options with setpoint knobs are available in Fahrenheit or Celsius.

ZN520, UC400-B/Symbio™ 400-B Controller Options

<p>Figure 7. Unit-mounted temperature sensor (SP, OALMH, OCC/UNOCC)</p>	<p>Figure 8. Wall-mounted display temperature sensor (SP, OCC/UNOCC, OALMH, COMM)</p>	<p>Figure 9. Wall-mounted temperature (OCC/UNOCC, COMM)</p>
		
<p>Figure 10. Wall-mounted temperature sensor (SP, OCC/UNOCC, OALMH, COMM)</p>	<p>Figure 11. Split-mounted zone sensor, unit-mounted fan speed control, wall-mounted temperature sensor (SP, OCC/UNOCC, COMM)</p>	<p>Figure 12. Wall-mounted wireless zone sensor (WZS) with setpoint adjustment, (OCC/UNOCC) no fan speed adjustment, and unit-mounted receiver</p>
		
<p>Figure 13. Wall-mounted wireless display sensor (WDS) and unit-mounted receiver</p>	<p>Figure 14. Air-Fi® Wireless Communications Sensor (WCS)</p>	
		

Control Features

The following control functions are standard features on units with Tracer® ZN520, or UC400-B/Symbio™ 400-B:

Occupied/Unoccupied Operation

The occupancy input utilizes a binary switch (i.e. motion sensor, timeclock, etc.) that allows the zone sensor to utilize its unoccupied internal setpoints.

Random Start

This feature randomly staggers multiple unit start-up to reduce electrical demand spikes.

Warmup

The two-position fresh air damper option closes during the occupied mode when the space temperature is three degrees or more below the heating setpoint temperature. The damper remains closed during warmup until the space temperature is within two degrees of the heating setpoint temperature.

Manual Output Test Function

This feature is an invaluable tool for troubleshooting a unit. By simply pressing the controller's test button, service personnel can manually exercise outputs in a pre-defined sequence.

Peer to Peer Communication (Tracer® ZN520, and UC400-B/Symbio™ 400-B)

Peer to peer communication allows multiple units in one space to share the same zone sensor and provide simultaneous heating. The Tracer® ZN520 controller can share information between units on the same communication link using a twisted pair wire in the field. Unit configuration must be modified with Rover service tool. On the UC400-B/Symbio™ 400-B, zone sensor data sharing can be accomplished by use of the BAS system controller.

Tracer® ZN520 and UC400-B/Symbio™ 400-B Additional Features

Filter Maintenance Status

Tracer® controller has an adjustable timer that indicates through the building automation system or the service software tool when filter maintenance is necessary. Filter maintenance status is based on cumulative fan run hours.

Water Valve Override

Using the building automation system or the service software tool, the water valve override function drives all water valves in every unit fully open simultaneously. This helps reduce the time required for waterside balancing.

Cascade Control

Tracer® controller maintains discharge air temperature using a cascade control algorithm. The discharge air temperature is based on the difference between the space temperature and setpoint. Unit capacity modulates to achieve the discharge air temperature.

Interoperability

Tracer® ZN520 can be used with a Tracer Summit® system or on other control systems that support LonTalk® and the SCC profile. For more information on specific inputs and outputs, see UNT-IOM-6 (*Installation, Operation, and Maintenance: UniTrane® Fan-Coil Room Conditioners - Force Flo™ Cabinet Heaters*), or the most recent version.

The UC400-B/Symbio™ 400-B can be used with the Tracer® SC or another BACnet MS/TP building automation system. For more information see the Installation Operation and Programming Guide BAS-SVX48*-EN for more information.

End Device Options

All end device options are factory-installed and -tested.

Actuators

Two-Position Fresh Air Damper Actuator (not available with ZN520)

Figure 15. Two-position fresh air damper actuator

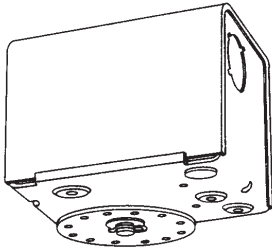

This damper actuator uses a 24V signal and is factory-wired and mounted to the damper assembly. It allows zero to 50 percent fresh air. The damper will drive open to an adjustable mechanical stop-position whenever the fan is running during occupied mode and will spring-return closed when the fan turns off.

Note: Trane recommends using the low temperature detection option with fresh air dampers to detect possible freeze conditions.

Control Valves

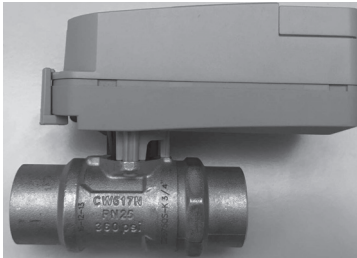

Units with either the control interface or any of the Tracer[®] controllers (Tracer[®] ZN520 or UC400-B/Symbio[™] 400-B) are available with hot water control valves for each coil configuration. Control valve options are available as:

- Analog (2-10 Vdc)
- Modulating
- Two-position, normally-open (N.O.) or normally-closed (N.C.)
- Two- or three-way configurations
- With sweat connections

Three-way valve options allow either full waterflow through the coil or diverted waterflow through the bypass.

Two-Position Control Valves

Two-position valves are capacitor discharge return. Capacitor discharge valves respond to a 24V signal and will either fully open or close. Also, these valves cannot be driven or actuated to a partially open or closed position. If the capacitor discharge return type control valve loses power, the valve returns to its de-energized position.

Modulating and 2–10V Analog Control Valves

Modulating and 2–10V Analog control valves offer an alternative for more precise capacity control by modulating or varying the water flow through the coil. Modulating valves respond to a 24V signal from the controller, which determines the valve position by a control algorithm. Analog valves travel to the commanded position of the 2–10V control signal. If the valve loses power, it remains in the position it was in when the power loss occurred.

Field-Supplied Valves

This option allows the controller to be factory-configured for a field-supplied valve, as well as a wire harnesses running from the control box to the piping side of the unit. When the field-supplied valve option is chosen, the control box is provided with low voltage components and wired back to a terminal strip (CSTI) or controller.

Note: Trane does not recommend wild coil applications.

Selecting the Correct Modulating Valve Size

The coefficient of flow is defined as the volume of water flow through a control valve in the fully open position with a 1 psig differential across the valve. It is calculated using the following formula:

$C_v = Q / \text{Square root } \Delta P$ where:

C_v = flow coefficient

Q = flow rate (Gpm)

ΔP = pressure drop across the valve or coil (psig).

For good control, the valve C_v should be approximately equal to the C_v of the water coil.

Modulating Valve Selection Example

Assume a size 06 fan-coil is selected to operate at the following conditions:

Vertical Cabinet Fan Coil

Entering water temperature = 45°F

Leaving water temperature = 55°F

EAT conditions = 80/67

The coil is selected as a four-row coil.

Select the best modulating valve size for this unit.

1. Find the ΔP across the water coil. Refer to the AHRI performance table to determine the ΔP across the water coil (or use TOPSS™ selection program). The water pressure drop is found to be 7.0' of water at a flow rate of 3.74 gpm. This converts to a pressure drop of 3.03 psig (1.0 feet of water = 0.4328 psig.)
2. Calculate the C_v of the water coil.
 $C_v = \text{Gpm} / \text{Square root } \Delta P$
 $C_v = 3.74 / \text{Square root } 3.03$
 $C_v = 2.15$

Therefore, the valve with the C_v of 2.4 should be selected since it has the C_v which is closest to the C_v of the water coil. The following tables illustrate possible valve selections at AHRI conditions for horizontal concealed units with a high static motor and vertical cabinet units with a free discharge motor.

Table 5. Valve availability

Digit 36 and Digit 38	C_v	2-way, 2-position, N.C.	2-way, 2-position, N.O.	3-way, 2-position, N.C.	3-way, 2-position, N.O.	2-way, modulating	3-way modulating	2-way, analog (2-10 Vdc)	3-way, analog (2-10 Vdc)
A	1.4	X	X			X		X	
B	2.4	X	X			X		X	
C	3.4					X		X	
D	1.0			X	X		X		X
E	2.7			X	X		X		X
F	4.6			X	X		X		X



Electrical Data

MCA and MOP Calculations

Minimum Circuit Ampacity (MCA) and Maximum Over current Protection (MOP) Calculations for fan coils with electric heat (single-phase)

Heater Amps = (Heater kW x 1000)/Heater Voltage

Note: Use 120V heater voltage for 115V units. Use 240V heater voltage for 230V units.

MCA = 1.25 x (heater amps + all motor FLAs)

MOP = (2.25 x Largest Motor FLA) + Second Motor FLA + Heater Amps (If Applicable)

MOP is required in the branch circuit wiring for all fan coils with electric heat.

Select a standard fuse size or circuit breaker equal to the MOP. Use the next smaller standard size if the MOP does not equal a standard size. Ensure the selected fuse is larger than the MCA. Standard Fuse Sizes are: 15, 20, 25, 30, 35, 40, 45, 50, 60 amps

Fan coil electric heat MBh = (Heater kW) (3.413)

Minimum Circuit Ampacity (MCA) and Maximum Overcurrent Protection (MOP) Calculations for fan coils (motors only, no electric heat)

MCA = (1.25) x [Largest Motor Amperes (FLA)] + Second Motor Amperes (FLA) (Size 10 and 12 only)

MOP = 15 Amps for all Fan Coils without Electric Heat (see previous Electrical Data for units with Electric Heat.)

Electric Heat

Table 6. Force-Flo cabinet heater two-stage electric heat

Unit Size	Voltage	# Wires	1st Stage KW	Total KW	Total Amps/Ph
02	208/60/1	2	0.8	2.3	10.9
	240/60/1	2	1.0	3.0	12.5
	277/60/1	2	1.0	3.0	10.9
	208/60/3	3	0.8	2.3	6.3
	240/60/3	3	1.0	3.0	7.3
	480/60/3	4	1.0	3.0	3.7
	220-240/50/1	2	1.0	3.0	12.5
	220-240/50/3	3	1.0	3.0	7.3
	380-415/50/3	4	1.0	3.0	4.2
03	208/60/1	2	1.5	4.5	21.7
	240/60/1	2	2.0	6.0	25.0
	277/60/1	2	2.0	6.0	21.7
	208/60/3	3	1.5	4.5	12.6
	240/60/3	3	2.0	6.0	14.5
	480/60/3	4	2.0	6.0	7.3
	220-240/50/1	2	2.0	6.0	25.0
	220-240/50/3	3	2.0	6.0	14.5
	380-415/50/3	4	2.0	6.0	8.4

Table 6. Force-Flo cabinet heater two-stage electric heat (continued)

Unit Size	Voltage	# Wires	1st Stage KW	Total KW	Total Amps/Ph
04	208/60/1	2	1.9	5.7	27.5
	240/60/1	2	2.5	7.5	31.3
	277/60/1	2	2.5	7.5	27.1
	208/60/3	3	1.9	5.7	15.9
	240/60/3	3	2.5	7.5	18.1
	480/60/3	4	2.5	7.5	9.1
	220-240/50/1	2	2.5	7.5	31.3
	220-240/50/3	3	2.5	7.5	18.1
	380-415/50/3	4	2.5	7.5	10.5
06	208/60/1	2	2.2	7.9	38.0
	240/60/1	2	3.0	10.5	43.8
	277/60/1	2	3.0	10.5	38.0
	208/60/3	3	3.4	7.9	21.9
	240/60/3	3	4.5	10.5	25.3
	480/60/3	4	4.5	10.5	12.7
	220-240/50/1	2	3.0	10.5	43.8
	220-240/50/3	3	4.5	10.5	25.3
	380-415/50/3	4	4.5	10.5	14.7
08	208/60/3	3	4.5	10.1	28.2
	240/60/3	3	6.0	13.5	32.5
	480/60/3	4	6.0	13.5	16.3
	220-240/50/3	3	6.0	13.5	32.5
	380-415/50/3	4	6.0	13.5	18.8
10	480/60/3	4	8.0	18.0	21.7
	380-415/50/3	4	8.0	18.0	25.1
12	480/60/3	4	9.0	20.0	24.1
	380-415/50/3	4	9.0	20.0	27.9

Notes: When both stages are on, the electric heat will operate only when fan is in high speed. All data based on individual units.



Electrical Data

Table 7. Force-Flo cabinet heater single-stage, max kW electric heat

Unit Size	Voltage	# Wires	Heater KW	Heater Amps/Ph
02	208/60/1	2	2.25	10.90
	240/60/1	2	3.00	12.50
	277/60/1	2	3.00	10.90
	208/60/3	3	2.25	6.30
	240/60/3	3	3.00	7.30
	480/60/3	4	3.00	3.70
	220-240/50/1	2	3.00	12.50
	220-240/50/3	3	3.00	7.30
	380-415/50/3	4	3.00	4.20
03	208/60/1	2	4.50	21.70
	240/60/1	2	6.00	25.00
	277/60/1	2	6.00	21.70
	208/60/3	3	4.50	12.60
	240/60/3	3	6.00	14.50
	480/60/3	4	6.00	7.30
	220-240/50/1	2	6.00	25.00
	220-240/50/3	3	6.00	14.50
	380-415/50/3	4	6.00	8.40
04	208/60/1	2	5.70	27.50
	240/60/1	2	7.50	31.30
	277/60/1	2	7.50	27.10
	208/60/3	3	5.70	15.90
	240/60/3	3	7.50	18.10
	480/60/3	4	7.50	9.10
	220-240/50/1	2	7.50	31.30
	220-240/50/3	3	7.50	18.10
	380-415/50/3	4	7.50	10.50
06	208/60/1	2	7.90	38.00
	240/60/1	2	10.50	43.80
	277/60/1	2	10.50	38.00
	208/60/3	3	7.90	21.90
	240/60/3	3	10.50	25.30
	480/60/3	4	10.50	12.70
	220-240/50/1	2	10.50	43.80
	220-240/50/3	3	10.50	25.30
	380-415/50/3	4	10.50	14.70

Note: All data based on individual units. Electric heat will operate only with fan at high speed.

Table 8. Force-Flo cabinet heater single-stage, low kW electric heat

Unit Size	Voltage	# Wires	kW	Amps/ph	kW	Amps/ph	kW	Amps/ph
2	208/60/1	2	0.8	3.7	1.5	7.3		
	240/60/1	2	1.0	4.2	2.0	8.4		
	277/60/1	2	1.0	3.7	2.0	7.3		
	220-240/50/1	2	1.0	4.2	2.0	8.4		
3	208/60/1	2	2.3	10.9				
	240/60/1	2	3.0	12.5				
	277/60/1	2	3.0	10.9				
	208/60/3	3	2.3	6.3				
	240/60/3	3	3.0	7.3				
	480/60/3	4	3.0	3.7				
	220-240/50/1	2	3.0	12.5				
	220-240/50/3	3	3.0	7.3				
4	380-415/50/3	4	3.0	4.2				
	208/60/1	2	2.3	10.9				
	240/60/1	2	3.0	12.5				
	277/60/1	2	3.0	10.9				
	208/60/3	3	2.3	6.3				
	240/60/3	3	3.0	7.3				
	480/60/3	4	3.0	3.7				
	220-240/50/1	2	3.0	12.5				
6	220-240/50/3	3	3.0	7.3				
	380-415/50/3	4	3.0	4.2				
	208/60/1	2	2.3	10.9	3.3	15.9		
	240/60/1	2	3.0	12.5	4.5	18.8		
	277/60/1	2	3.0	10.9	4.5	16.3		
	208/60/3	3	2.3	6.3	3.3	9.2		
	240/60/3	3	3.0	7.3	4.5	10.9		
	480/60/3	4	3.0	3.7	4.5	5.5		
	220-240/50/1	2	3.0	12.5	4.5	18.8		
220-240/50/3	3	3.0	7.3	4.5	10.9			
380-415/50/3	4	3.0	4.2	4.5	6.3			



Electrical Data

Table 8. Force-Flo cabinet heater single-stage, low kW electric heat (continued)

Unit Size	Voltage	# Wires	kW	Amps/ph	kW	Amps/ph	kW	Amps/ph
8	208/60/1	2	2.3	10.9	3.3	15.9	5	21.7
	240/60/1	2	3.0	12.5	4.5	18.8	6	25.0
	277/60/1	2	3.0	10.9	4.5	16.3	6	21.7
	208/60/3	3	2.3	6.3	3.3	9.2	5	12.5
	240/60/3	3	3.0	7.3	4.5	10.9	6	14.5
	480/60/3	4	3.0	3.7	4.5	5.5	6	7.3
	220-240/50/1	2	3.0	12.5	4.5	18.8	6	25.0
	220-240/50/3	3	3.0	7.3	4.5	10.9	6	14.5
	380-415/50/3	4	3.0	4.2	4.5	6.3	6	8.4
10	208/60/1	2	2.3	10.9	3.3	15.9	6	27.5
	240/60/1	2	3.0	12.5	4.5	18.8	8	31.3
	277/60/1	2	3.0	10.9	4.5	16.3	8	27.1
	208/60/3	3	2.3	6.3	3.3	9.2	6	15.9
	240/60/3	3	3.0	7.3	4.5	10.9	8	18.1
	480/60/3	4	3.0	3.7	4.5	5.5	8	9.1
	220-240/50/1	2	3.0	12.5	4.5	18.8	8	31.3
	220-240/50/3	3	3.0	7.3	4.5	10.9	8	18.1
	380-415/50/3	4	3.0	4.2	4.5	6.3	8	10.5
12	208/60/1	2	2.3	10.9	4.5	21.9	7	31.8
	240/60/1	2	3.0	12.5	6.0	25.2	9	37.5
	277/60/1	2	3.0	10.9	6.0	21.9	9	32.5
	208/60/3	3	2.3	6.3	4.5	12.5	7	18.4
	240/60/3	3	3.0	7.3	6.0	14.5	9	21.7
	480/60/3	4	3.0	3.7	6.0	7.3	9	10.9
	220-240/50/1	2	3.0	12.5	6.0	25.2	9	37.5
	220-240/50/3	3	3.0	7.3	6.0	14.5	9	21.7
	380-415/50/3	4	3.0	4.2	6.0	8.4	9	12.6

Note: All data based on individual units. Electric heat will operate only with fan at high speed.

Motors

Table 9. Free discharge and high static electrically commutated motors (ECMs) programmed to standard ECM mode

Unit Size	115 Volt				208–230 Volt				277 Volt			
	FLA		HP		FLA		HP		FLA		HP	
	1	2	1	2	1	2	1	2	1	2	1	2
02	2.20		0.13		1.40		0.13		1.60		0.24	
03	2.20		0.13		1.40		0.13		1.60		0.24	
04	2.20		0.13		1.40		0.13		1.60		0.24	
06	3.10		0.22		1.80		0.22		1.60		0.24	
08	3.10		0.22		1.80		0.22		1.60		0.24	
10	3.10	2.20	0.22	0.13	1.80	1.40	0.22	0.13	1.60	1.60	0.24	0.24
12	3.10	2.20	0.22	0.13	1.80	1.40	0.22	0.13	1.60	1.60	0.24	0.24

Table 10. Free discharge electrically commutated motors (ECMs) programmed to reduced FLA mode

Unit Size	115 Volt				208–230 Volt				277 Volt			
	FLA		HP		FLA		HP		FLA		HP	
	1	2	1	2	1	2	1	2	1	2	1	2
02	0.60		0.13		0.4		0.13		0.30		0.24	
03	0.60		0.13		0.4		0.13		0.30		0.24	
04	0.80		0.13		0.6		0.13		0.40		0.24	
06	1.10		0.22		0.8		0.22		0.60		0.24	
08	1.60		0.22		1.1		0.22		0.80		0.24	
10	0.70	1.20	0.22	0.13	0.5	0.80	0.22	0.13	0.40	0.60	0.24	0.24
12	0.70	1.30	0.22	0.13	0.5	0.90	0.22	0.13	0.40	0.70	0.24	0.24

Table 11. High static electrically commutated motors (ECMs) programmed to reduced FLA mode

Unit Size	115 Volt				208–230 Volt				277 Volt			
	FLA		HP		FLA		HP		FLA		HP	
	1	2	1	2	1	2	1	2	1	2	1	2
02	1.3		0.13		0.9		0.13		0.7		0.24	
03	1.3		0.13		0.9		0.13		0.7		0.24	
04	1.7		0.13		1.2		0.13		0.9		0.24	
06	2.3		0.22		1.6		0.22		1.2		0.24	
08	3.1		0.22		1.8		0.22		1.5		0.24	
10	1.4	2.0	0.22	0.13	1.0	1.4	0.22	0.13	0.7	1.1	0.24	0.24
12	1.5	2.8	0.22	0.13	1.1	1.8	0.22	0.13	0.8	1.4	0.24	0.24



RPM

Table 12. Unit RPM

Unit Size	Free Discharge—Units with 2-Row Coils			Free Discharge—Units with 3- and 4-Row Coils		
	H	M	L	H	M	L
02	980	840	655	980	840	655
03	980	780	580	1080	800	600
04	1050	780	580	1080	800	600
06	1030	780	580	1080	800	600
08	1080	800	600	1080	800	600
10	1050	780	580	1080	800	600
	1030	780	580	1080	800	600
12	1050	780	580	1080	800	600
	1080	800	600	1080	800	600

Unit Size	High Static—Units with 2-Row Coils			High Static—Units with 3- and 4-Row Coils		
	H	M	L	H	M	L
02	1480	1110	865	1480	1110	865
03	1400	1175	860	1500	1355	1110
04	1475	1315	1070	1580	1375	1240
06	1400	1070	855	1475	1285	975
08	1475	1285	975	1475	1285	975
10	1475	1315	1070	1580	1375	1240
	1400	1070	855	1475	1285	975
12	1475	1315	1070	1580	1375	1240
	1475	1285	975	1475	1285	975

Note: Actual rpm will vary with application and configuration.

Dimensions and Weights

Vertical Concealed, Model A

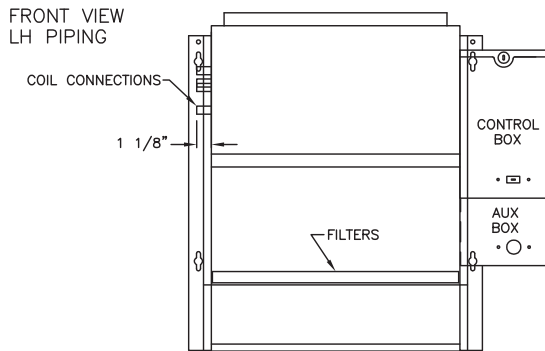
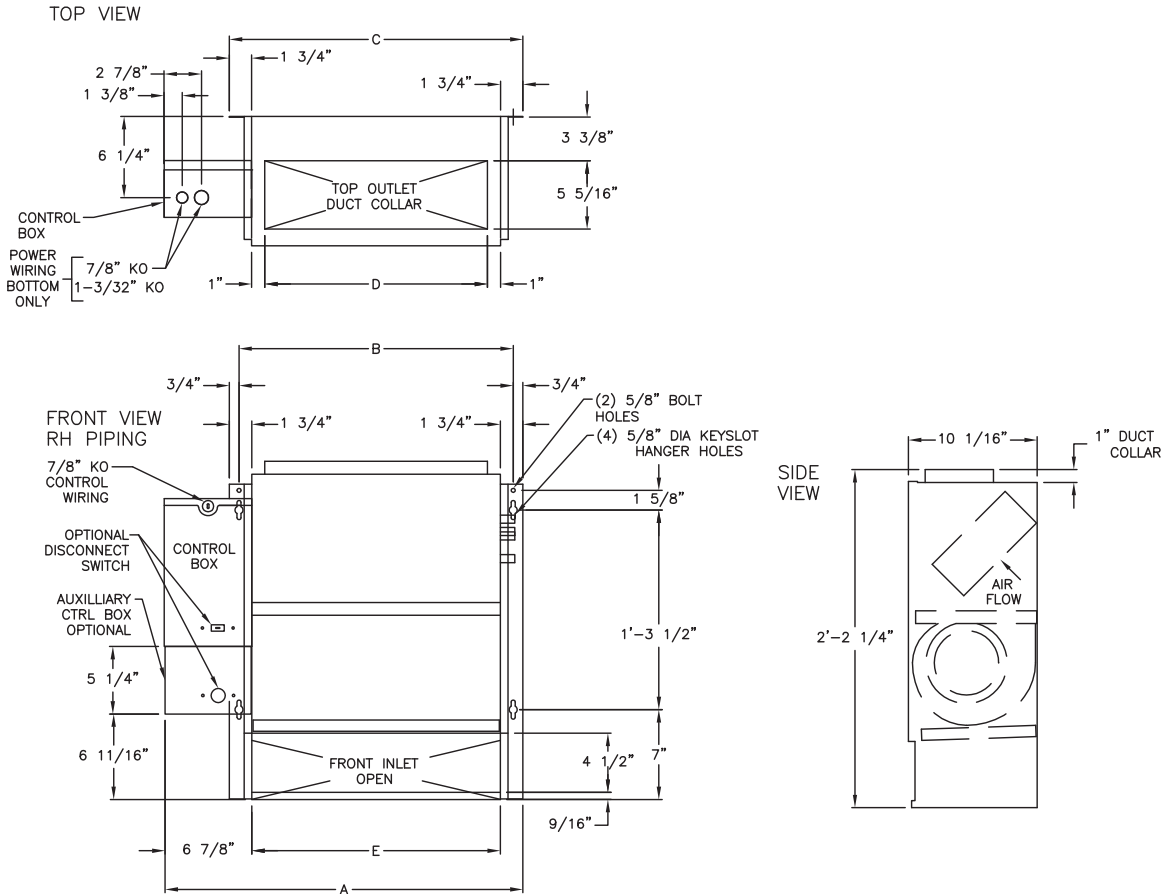

Vertical Concealed Unit

Unit Size	200-300	400	600	800	1000-1200
No. of Fans	1	1	2	2	3
No. of Motors	1	1	1	1	2
A	2'-3 7/8"	2'-8 7/8"	3'-6 3/8"	4'-2 7/8"	5'-9 7/8"
B	1'-9 5/16"	2'-2 5/16"	2'-11 13/16"	3'-8 5/16"	5'-3 5/16"
C	1'-10 13/16"	2'-3 13/16"	3'-1 5/16"	3'-9 13/16"	5'-4 13/16"
D	1'-5 5/16"	1'-10 5/16"	2'-7 13/16"	3'-4 5/16"	4'-11 5/16"
E	1'-7 5/16"	2'-0 5/16"	2'-9 13/16"	3'-4 5/16"	5'-1 5/16"

Notes:

1. Coil connections are always opposite the control box.
2. Coil connections are 5/8-inch O.D. sweat. See p. 49 for locations.
3. All duct collar dimensions are to the outside of the collar.
4. See p. 51 for dimensions for air openings.

Dimensions and Weights

Vertical Cabinet, Model B

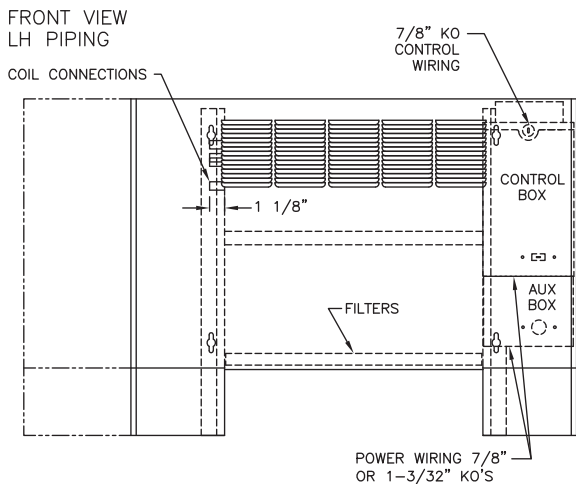
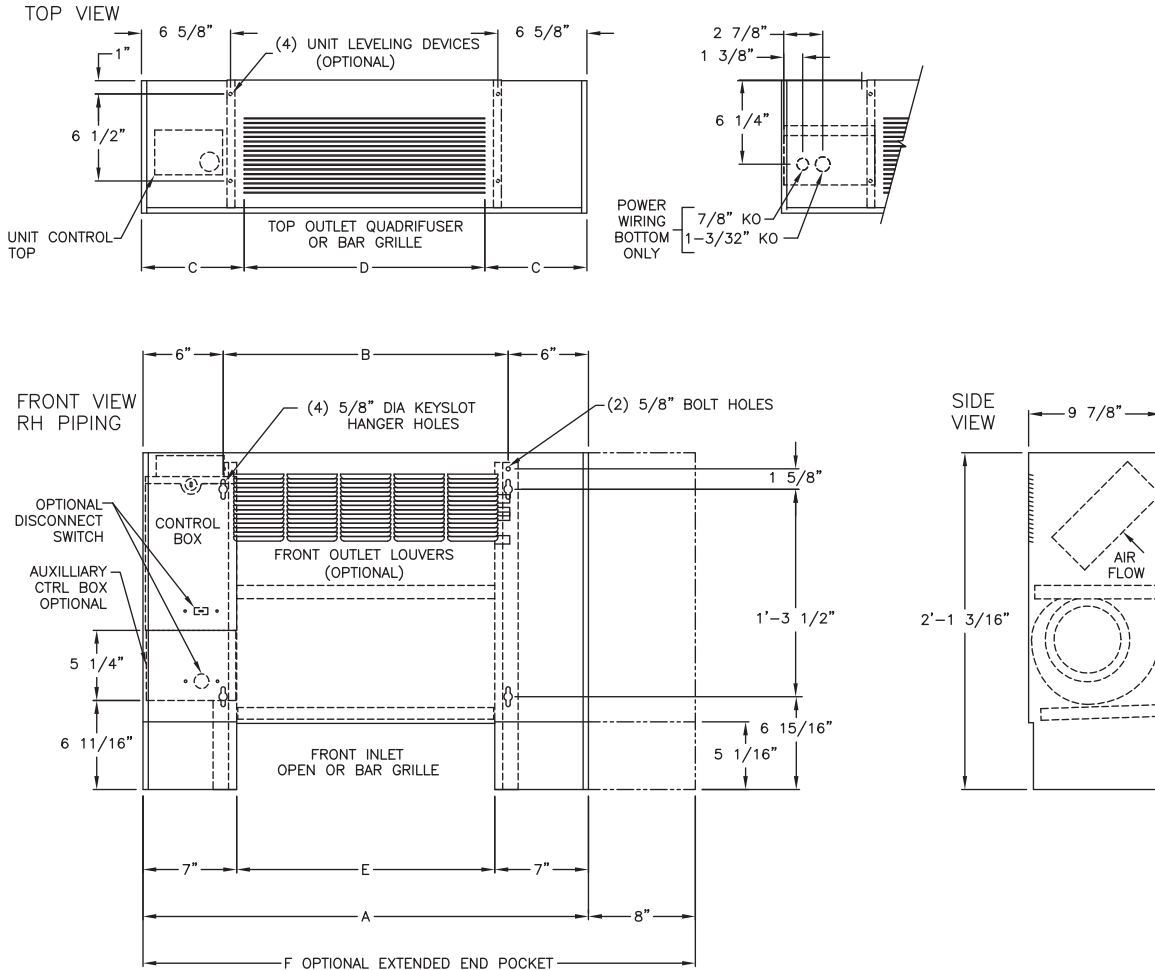

Vertical Cabinet Unit

Unit Size	200-300	400	600	800	1000-1200
No. of Fans	1	1	2	2	3
No. of Motors	1	1	1	1	2
A	2'-9 7/8"	3'-2 5/16"	3'-11 13/16"	4'-8 5/16"	6'-3 5/16"
B	1'-9 5/16"	2'-2 5/16"	2'-11 13/16"	3'-8 5/16"	5'-3 5/16"
C	7 5/8"	7 1/8"	8 7/8"	7 1/8"	7 5/8"
D	1'-6"	2'-0"	2'-6"	3'-6"	5'-0"
E	1'-7 5/16"	2'-0 5/16"	2'-9 13/16"	3'-6 5/16"	5'-1 5/16"
F	3'-5 5/16"	3'-10 5/16"	4'-7 13/16"	5'-4 5/16"	6'-11 5/16"

Notes:

1. Coil connections are always opposite the control box.
2. Coil connections are 5/8-inch O.D. sweat. See p. 49 for locations.
3. See p. 51 for dimensions for air openings.

Horizontal Concealed, Model C

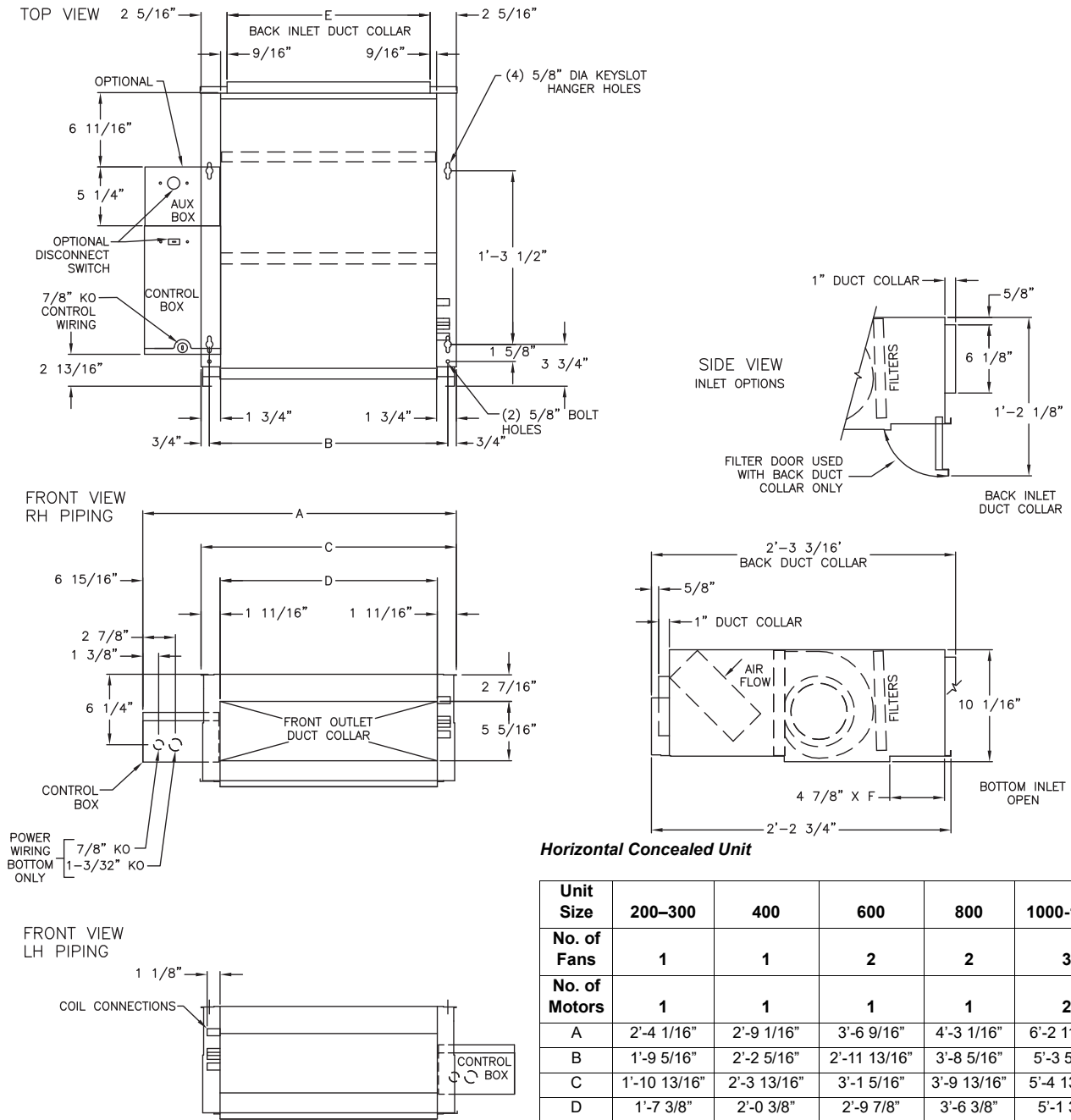

Horizontal Concealed Unit

Unit Size	200-300	400	600	800	1000-1200
No. of Fans	1	1	2	2	3
No. of Motors	1	1	1	1	2
A	2'-4 1/16"	2'-9 1/16"	3'-6 9/16"	4'-3 1/16"	6'-2 11/16"
B	1'-9 5/16"	2'-2 5/16"	2'-11 13/16"	3'-8 5/16"	5'-3 5/16"
C	1'-10 13/16"	2'-3 13/16"	3'-1 5/16"	3'-9 13/16"	5'-4 13/16"
D	1'-7 3/8"	2'-0 3/8"	2'-9 7/8"	3'-6 3/8"	5'-1 3/8"
E	1'-6 1/8"	1'-11 1/8"	2'-8 5/8"	3'-5 1/8"	5'-0 1/8"
F	1'-7 5/16"	2'-0 5/16"	2'-9 13/16"	3'-6 5/16"	5'-1 5/16"

Notes:

1. Coil connections are always opposite the control box.
2. Coil connections are 5/8-inch O.D. sweat. See p. 49 for locations.
3. All duct collar dimensions are to the outside of the collar.
4. See p. 51 for dimensions for air openings.

Dimensions and Weights

Horizontal Cabinet, Model D

TOP VIEW

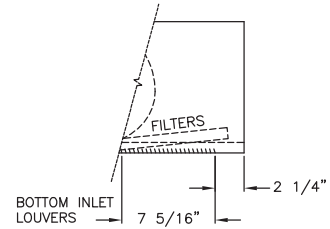
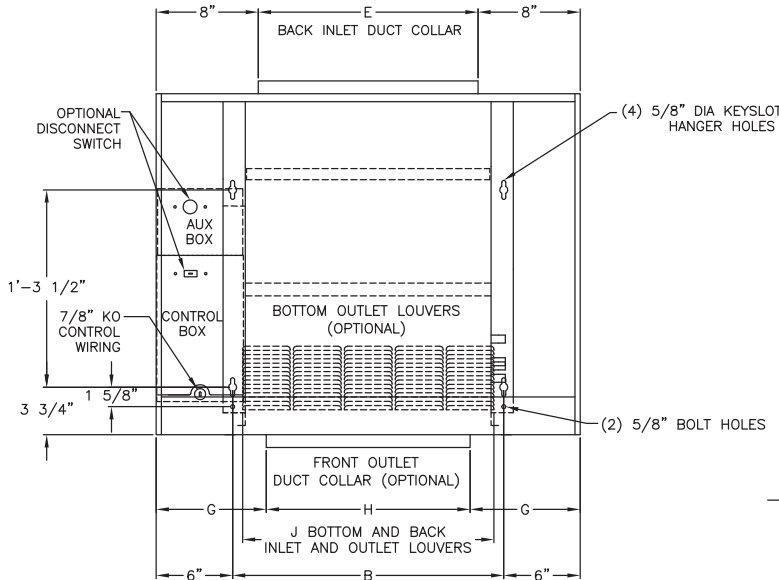

SIDE VIEW
INLET AND OUTLET
OPTIONS

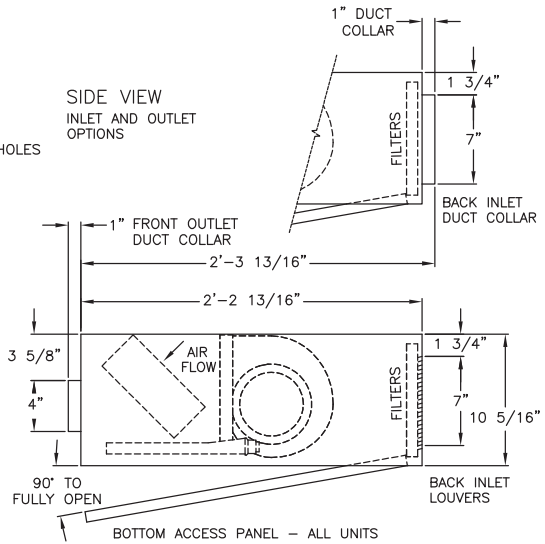

FRONT VIEW
RH PIPING

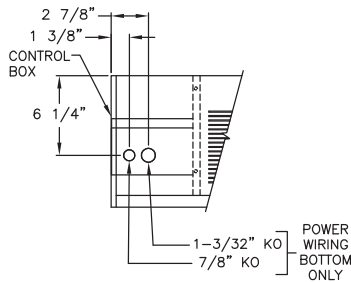
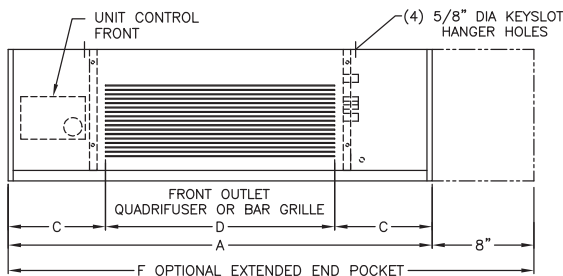

FRONT VIEW
LH PIPING

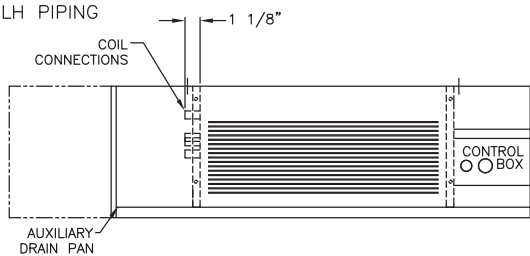

Horizontal Cabinet Unit

Unit Size	200-300	400	600	800	1000-1200
No. of Fans	1	1	2	2	3
No. of Motors	1	1	1	1	2
A	2'-9 5/16"	3'-1 5/16"	3'-11 3/16"	4'-8 5/16"	6'-3 5/16"
B	1'-9 5/16"	2'-2 5/16"	2'-11 13/16"	3'-8 5/16"	5'-3 5/16"
C	7 5/8"	7 1/8"	8 7/8"	7 1/8"	7 5/8"
D	1'-6"	2'-0"	2'-6"	3'-6"	5'-0"
E	1'-5 1/4"	1'-10 1/4"	2'-7 3/4"	3'-4 1/4"	4'-11 1/4"
F	3'-5 5/16"	3'-10 5/16"	4'-7 3/16"	5'-4 5/16"	6'-11 5/16"
G	8-5/8"	8-1/8"	9-1/8"	8-1/8"	8-5/8"
H	1'-4"	1'-10"	2'-4"	3'-4"	4'-10"
J	1'-7 3/4"	1'-11 3/4"	2'-7 3/4"	3'-3 3/4"	4'-11 3/4"

Notes:

1. Coil connections are always on the drain pan side and opposite the control box.
2. Coil connections are 5/8-inch O.D. sweat. See p. 49 for locations.
3. All duct collar dimensions are to the outside of the collar.
4. See p. 50 for dimensions for outside air openings.

Horizontal Recessed, Model E

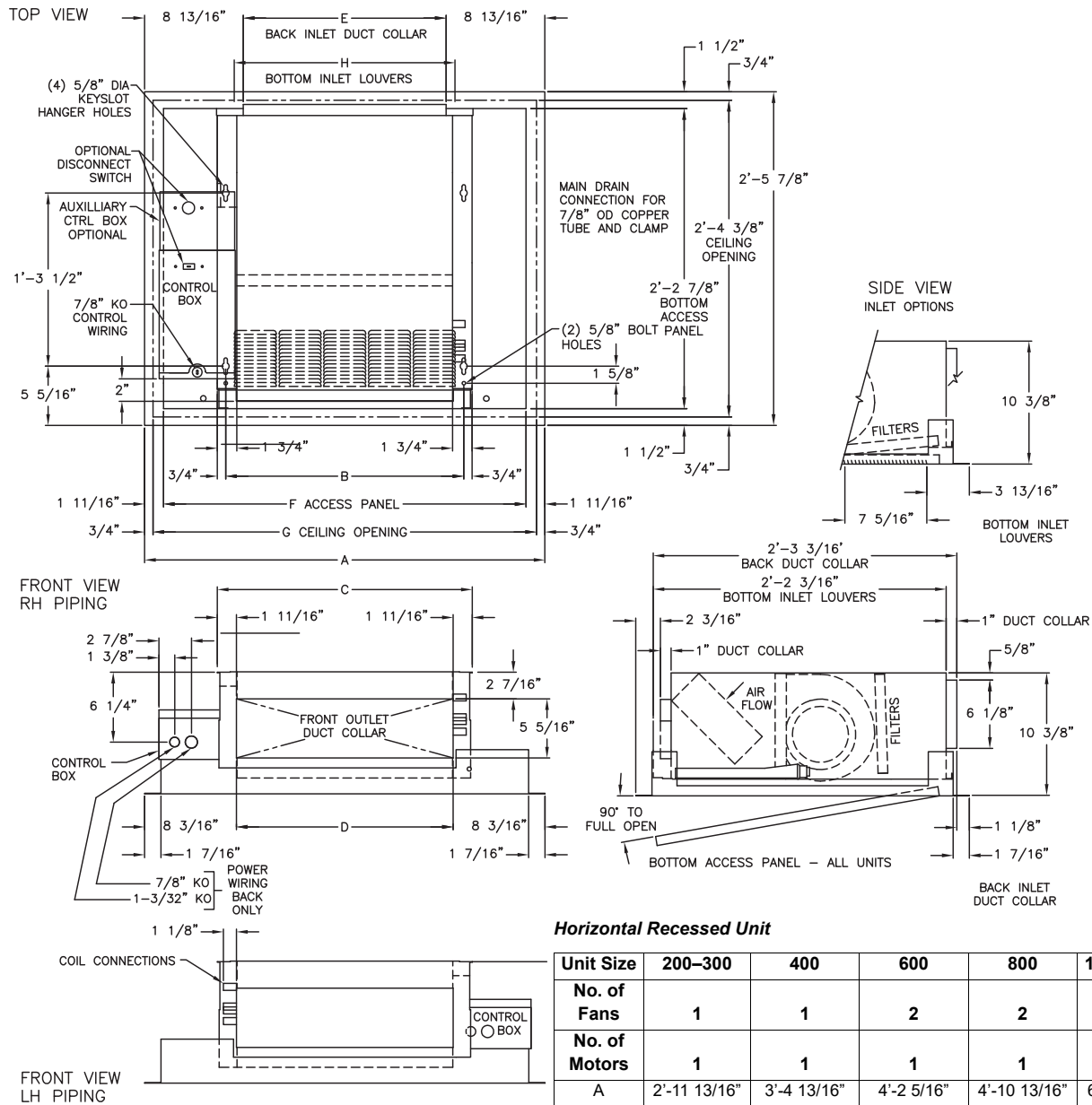

Horizontal Recessed Unit

Unit Size	200-300	400	600	800	1000-1200
No. of Fans	1	1	2	2	3
No. of Motors	1	1	1	1	2
A	2'-11 13/16"	3'-4 13/16"	4'-2 5/16"	4'-10 13/16"	6'-5 13/16"
B	1'-9 5/16"	2'-2 5/16"	2'-11 13/16"	3'-8 5/16"	5'-3 5/16"
C	1'-10 13/16"	2'-3 13/16"	3'-1 5/16"	3'-9 13/16"	5'-4 13/16"
D	1'-7 3/8"	2'-0 3/8"	2'-9 7/8"	3'-6 3/8"	5'-1 3/8"
E	1'-6 1/8"	1'-11 1/8"	2'-8 5/8"	3'-5 1/8"	5'-0 1/8"
F	2'-8 7/16"	3'-1 7/16"	3'-10 15/16"	4'-7 7/16"	6'-2 7/16"
G	2'-10 5/16"	3'-3 5/16"	4'-0 13/16"	4'-9 5/16"	6'-4 5/16"
H	1'-7 3/4"	1'-11 3/4"	2'-7 3/4"	3'-3 3/4"	4'-11 3/4"

Notes:

1. Coil connections are always opposite the drain pan side.
2. Coil connections are 5/8-inch O.D. sweat. See p. 49 for locations.
3. All duct collar dimensions are to the outside of the collar.
4. See p. 50 for dimensions for outside air openings.

Dimensions and Weights

Vertical Wall Hung Cabinet, Model F

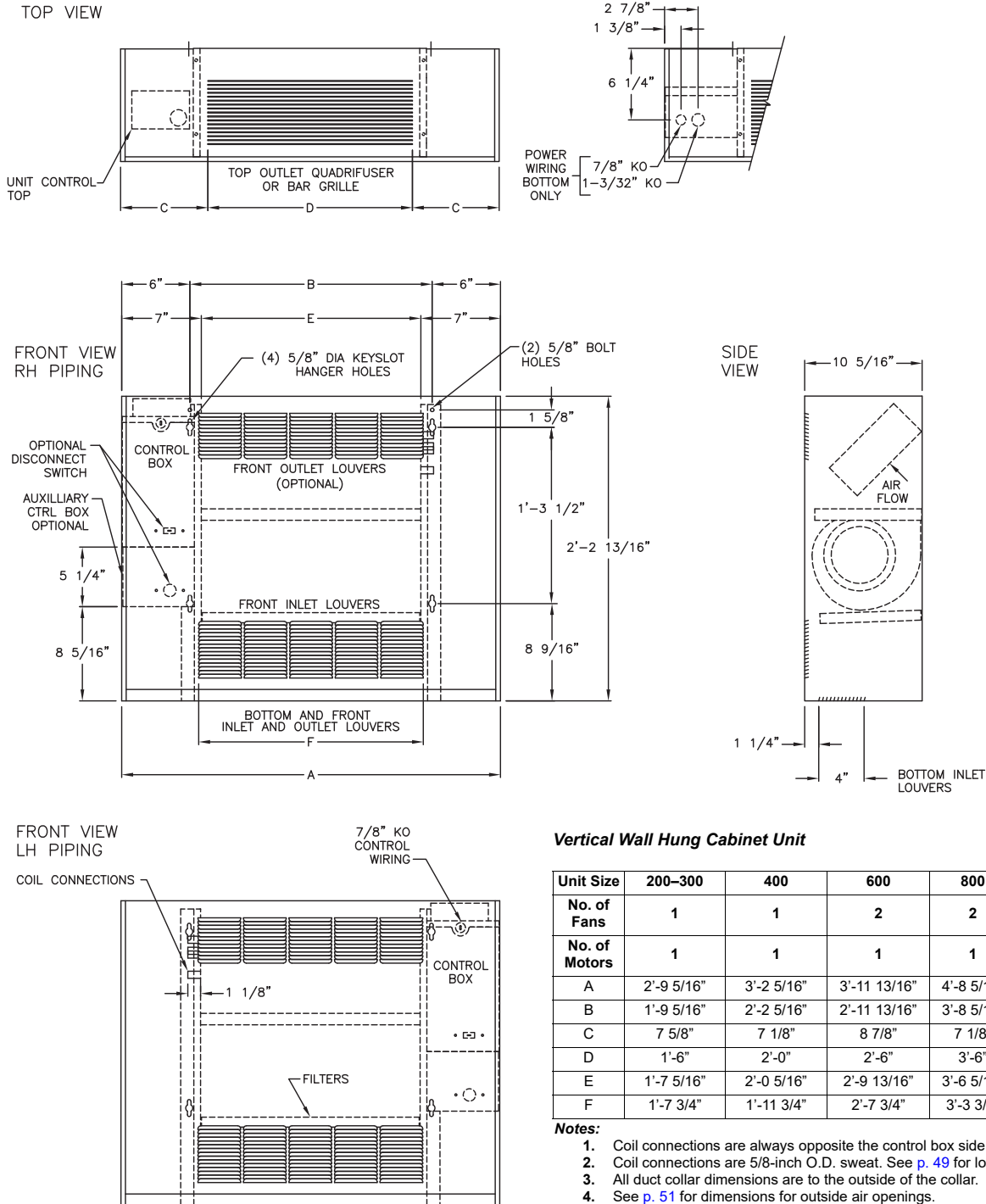

Vertical Wall Hung Cabinet Unit

Unit Size	200-300	400	600	800	1000-1200
No. of Fans	1	1	2	2	3
No. of Motors	1	1	1	1	2
A	2'-9 5/16"	3'-2 5/16"	3'-11 13/16"	4'-8 5/16"	6'-3 5/16"
B	1'-9 5/16"	2'-2 5/16"	2'-11 13/16"	3'-8 5/16"	5'-3 5/16"
C	7 5/8"	7 1/8"	8 7/8"	7 1/8"	7 5/8"
D	1'-6"	2'-0"	2'-6"	3'-6"	5'-0"
E	1'-7 5/16"	2'-0 5/16"	2'-9 13/16"	3'-6 5/16"	5'-1 5/16"
F	1'-7 3/4"	1'-11 3/4"	2'-7 3/4"	3'-3 3/4"	4'-11 3/4"

- Notes:**
1. Coil connections are always opposite the control box side.
 2. Coil connections are 5/8-inch O.D. sweat. See p. 49 for locations.
 3. All duct collar dimensions are to the outside of the collar.
 4. See p. 51 for dimensions for outside air openings.

Vertical Recessed, Model H

Vertical Recessed Unit

Unit Size	200-300	400	600	800	1000-1200
No. of Fans	1	1	2	2	3
No. of Motors	1	1	1	1	2
A	2'-3 7/8"	2'-8 7/8"	3'-6 3/8"	4'-2 7/8"	5'-9 7/8"
B	1'-9 5/16"	2'-2 5/16"	2'-11 13/16"	3'-8 5/16"	5'-3 5/16"
C	1'-10 13/16"	2'-3 13/16"	3'-1 5/16"	3'-9 13/16"	5'-4 13/16"
D	1'-5 5/16"	1'-10 5/16"	2'-7 13/16"	3'-4 5/16"	3'-11 5/16"
E	3'-11"	4'-3"	5'-3"	5'-5 1/2"	7'-5 1/2"
F	2'-6"	2'-6"	2'-6"	2'-9 1/2"	2'-9 1/2"
G	2-3/8"	2-3/8"	2-3/8"	4-1/8"	4-1/8"
H	3'-6"	4'-0"	4'-9"	5'-3"	7'-3"
J	2'-2 1/2"	2'-2 1/2"	2'-2 1/2"	2'-3 1/2"	2'-3 1/2"

Notes:

1. Coil connections are always on the drain pan side and opposite the control box.
2. Coil connections are 5/8-inch O.D. sweat. See p. 49 for locations.
3. All duct collar dimensions are to the outside of the collar.
4. See p. 50 for dimensions for outside air openings.

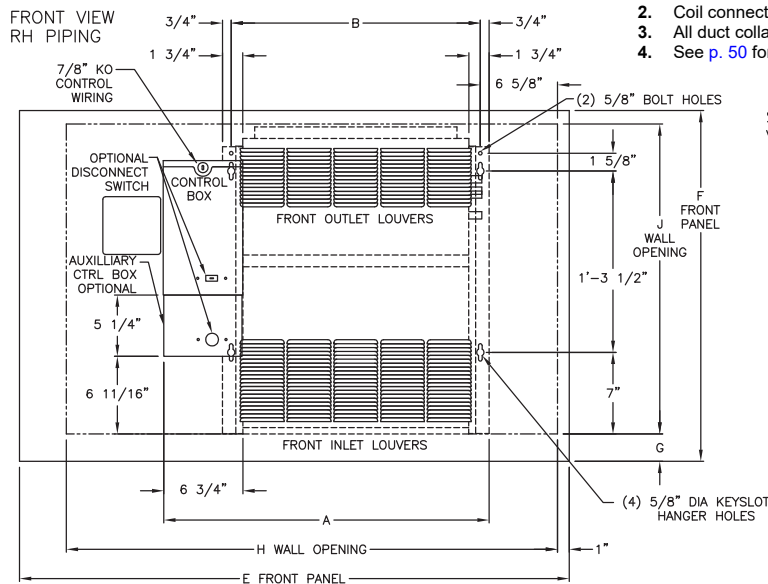
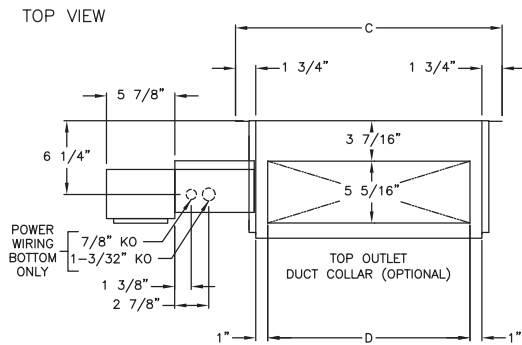

SIDE VIEW

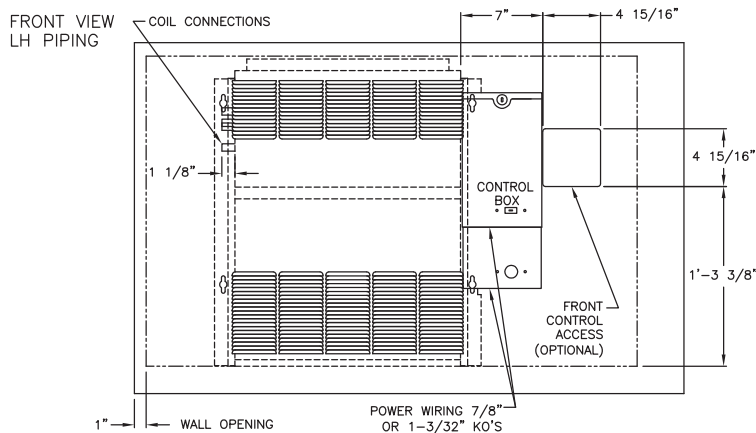
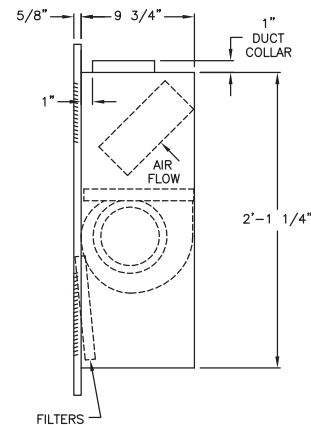

Dimensions and Weights

Vertical Slope Top, Model J

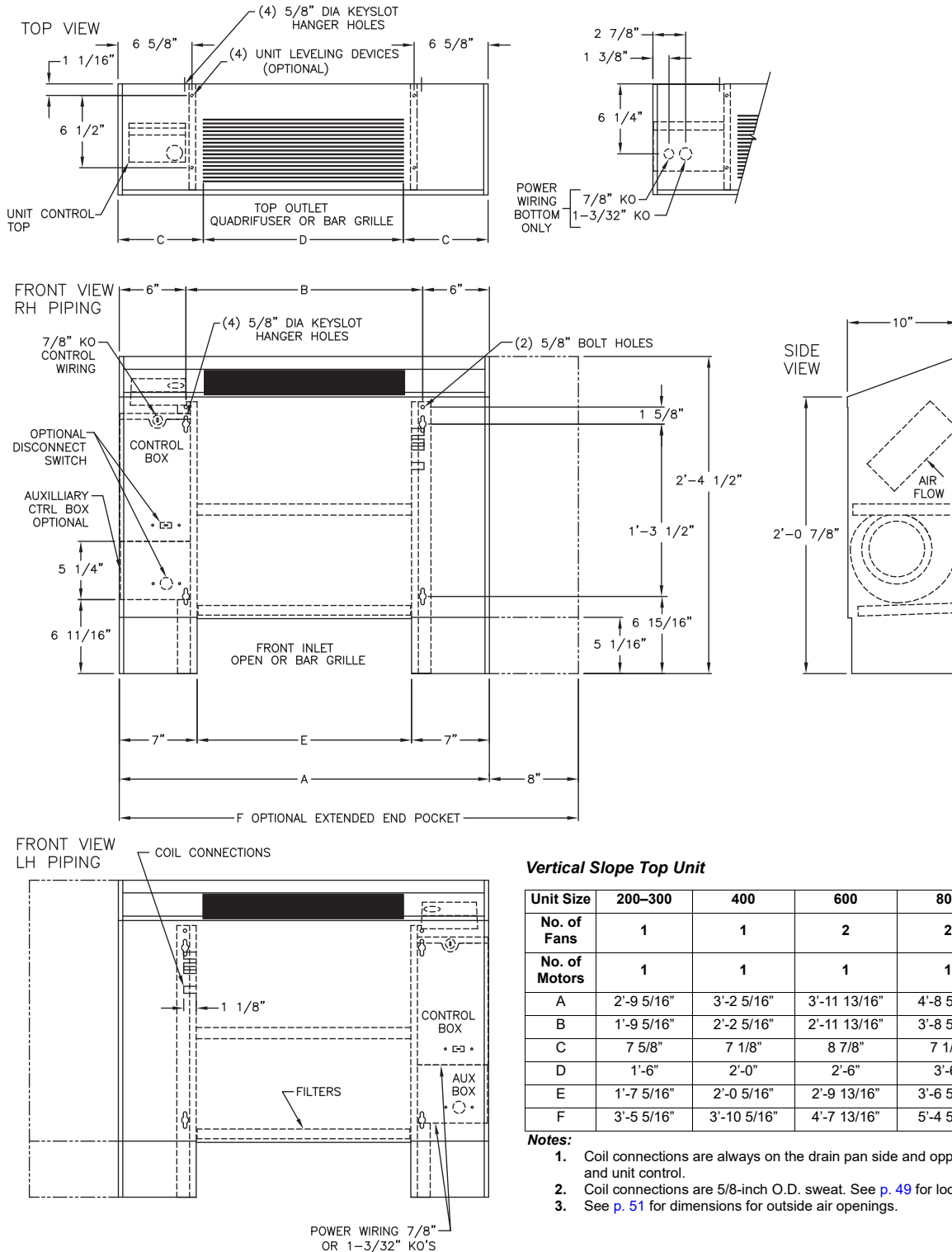

Vertical Slope Top Unit

Unit Size	200-300	400	600	800	1000-1200
No. of Fans	1	1	2	2	3
No. of Motors	1	1	1	1	2
A	2'-9 5/16"	3'-2 5/16"	3'-11 13/16"	4'-8 5/16"	6'-3 5/16"
B	1'-9 5/16"	2'-2 5/16"	2'-11 13/16"	3'-8 5/16"	5'-3 5/16"
C	7 5/8"	7 1/8"	8 7/8"	7 1/8"	7 5/8"
D	1'-6"	2'-0"	2'-6"	3'-6"	5'-0"
E	1'-7 5/16"	2'-0 5/16"	2'-9 13/16"	3'-6 5/16"	5'-1 5/16"
F	3'-5 5/16"	3'-10 5/16"	4'-7 13/16"	5'-4 5/16"	6'-11 5/16"

Notes:

- Coil connections are always on the drain pan side and opposite the control box and unit control.
- Coil connections are 5/8-inch O.D. sweat. See p. 49 for locations.
- See p. 51 for dimensions for outside air openings.

Inverted Vertical Cabinet, Model M

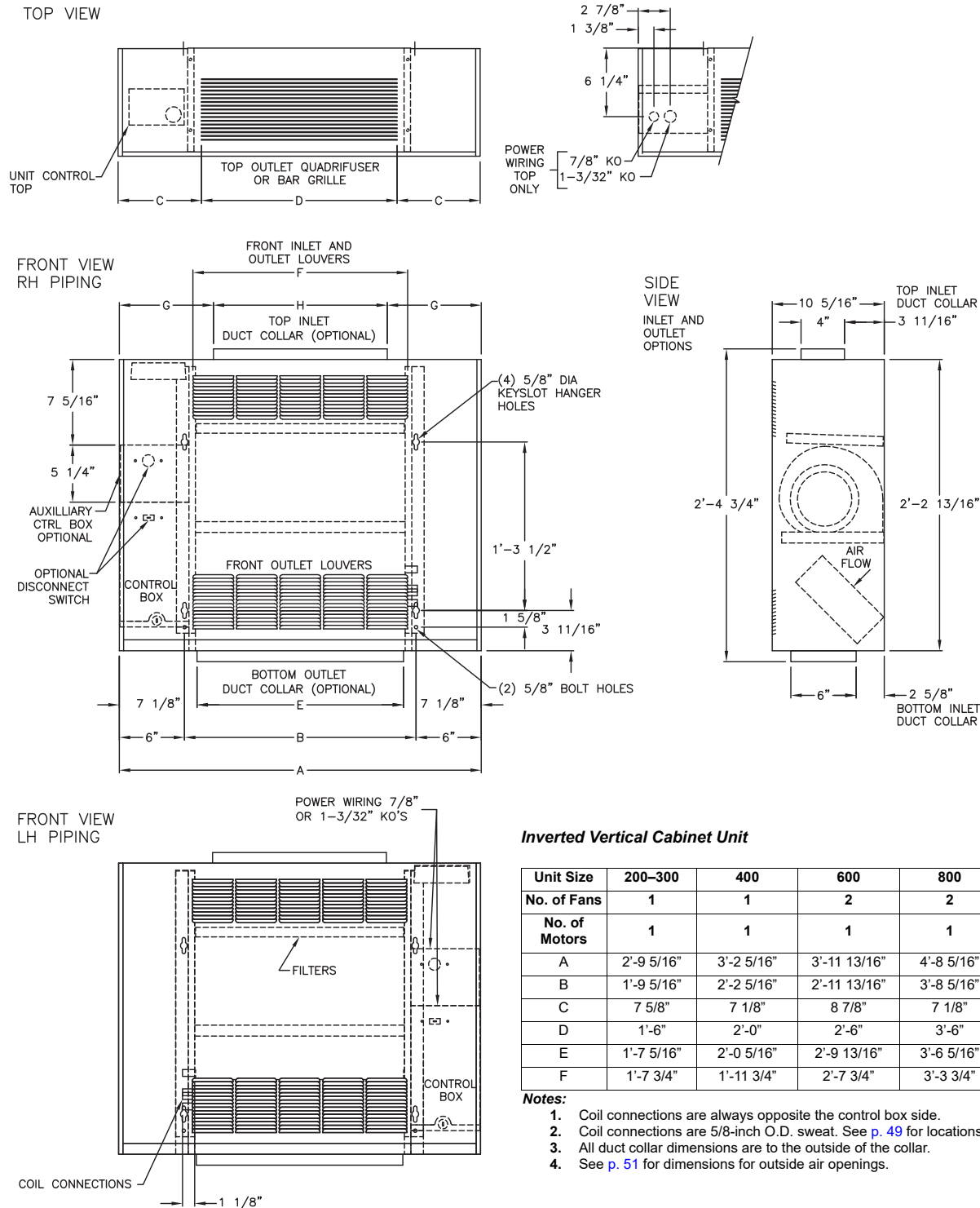

Inverted Vertical Cabinet Unit

Unit Size	200-300	400	600	800	1000-1200
No. of Fans	1	1	2	2	3
No. of Motors	1	1	1	1	2
A	2'-9 5/16"	3'-2 5/16"	3'-11 13/16"	4'-8 5/16"	6'-3 5/16"
B	1'-9 5/16"	2'-2 5/16"	2'-11 13/16"	3'-8 5/16"	5'-3 5/16"
C	7 5/8"	7 1/8"	8 7/8"	7 1/8"	7 5/8"
D	1'-6"	2'-0"	2'-6"	3'-6"	5'-0"
E	1'-7 5/16"	2'-0 5/16"	2'-9 13/16"	3'-6 5/16"	5'-1 5/16"
F	1'-7 3/4"	1'-11 3/4"	2'-7 3/4"	3'-3 3/4"	4'-11 3/4"

- Notes:**
1. Coil connections are always opposite the control box side.
 2. Coil connections are 5/8-inch O.D. sweat. See p. 49 for locations.
 3. All duct collar dimensions are to the outside of the collar.
 4. See p. 51 for dimensions for outside air openings.

Dimensions and Weights

Inverted Vertical Recessed, Model N

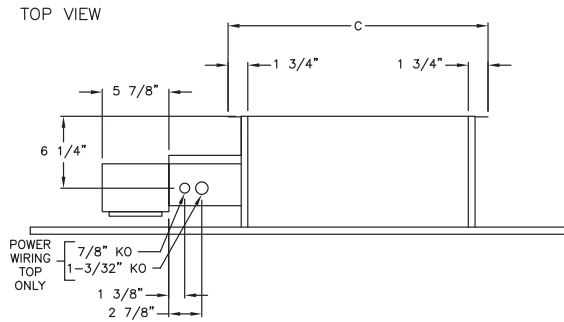

Unit Size	200-300	400	600	800	1000-1200
No. of Fans	1	1	2	2	3
No. of Motors	1	1	1	1	2
A	2'-3 7/8"	2'-8 7/8"	3'-6 3/8"	4'-2 7/8"	5'-9 7/8"
B	1'-9 5/16"	2'-2 5/16"	2'-11 13/16"	3'-8 5/16"	5'-3 5/16"
C	1'-10 13/16"	2'-3 13/16"	3'-1 5/16"	3'-9 13/16"	5'-4 13/16"
D	2' 3/8"	2' 3/8"	2' 3/8"	4' 1/8"	4' 1/8"
E	3'-11"	4'-3"	5'-3"	5'-5 1/2"	7'-5 1/2"
F	2'-6"	2'-6"	2'-6"	2'-9 1/2"	2'-9 1/2"
E	2'-2 1/2"	2'-2 1/2"	2'-2 1/2"	2'-3 1/2"	2'-3 1/2"
F	3'-6"	4'-0"	4'-9"	5'-3"	7'-3"

Notes:

1. Coil connections are always opposite the control box side.
2. Coil connections are 5/8-inch O.D. sweat. See p. 49 for locations.
3. See p. 51 for dimensions for outside air openings.

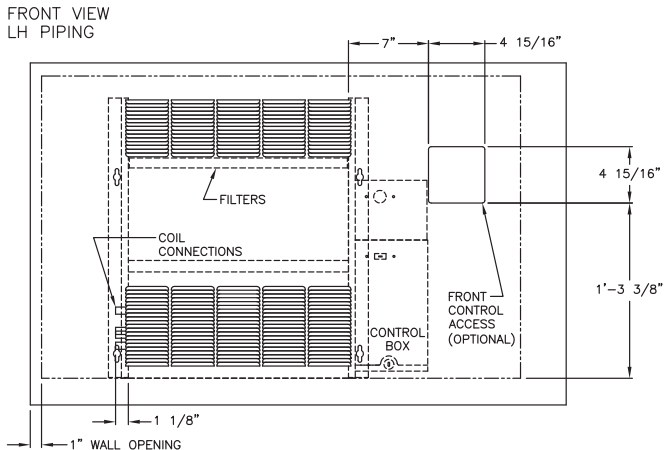
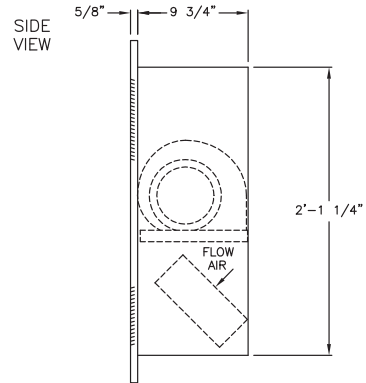
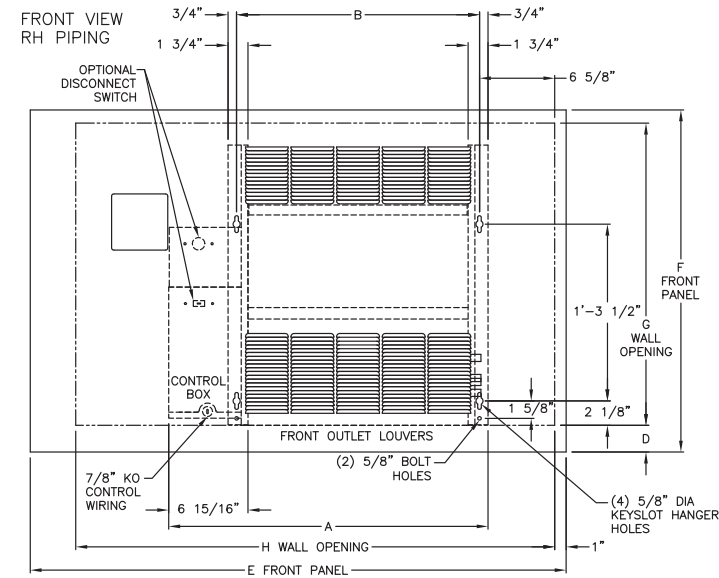

Coil Connections

Vertical Units

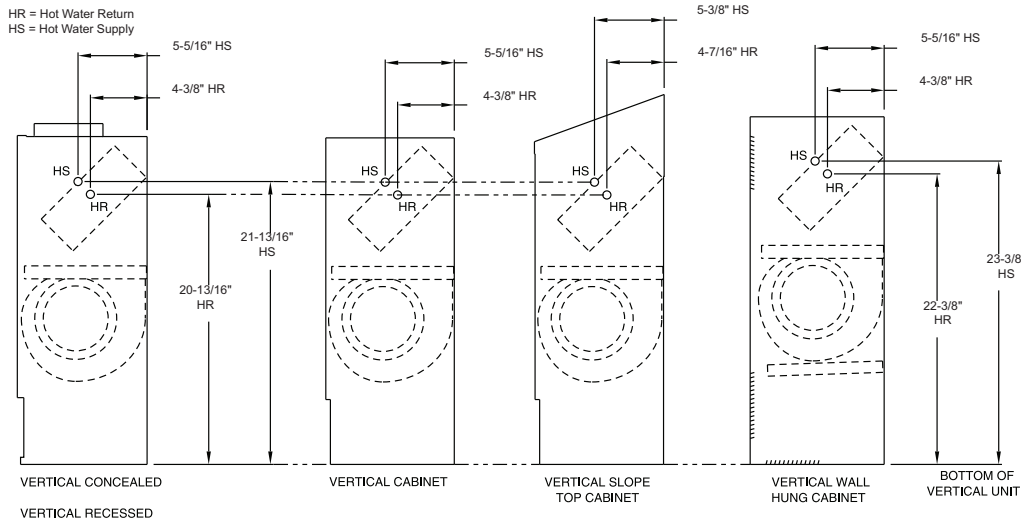

Horizontal Units

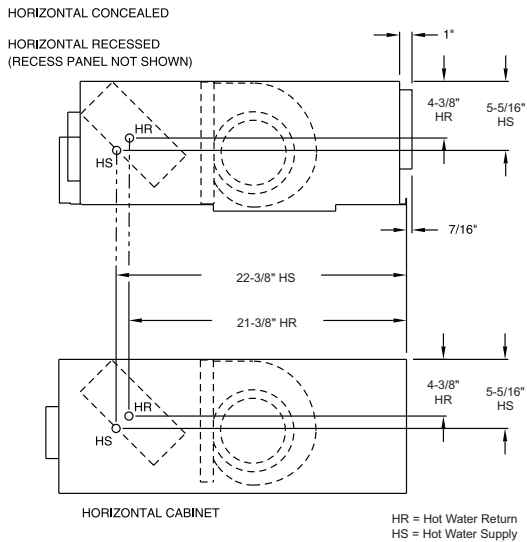

Inverted Units

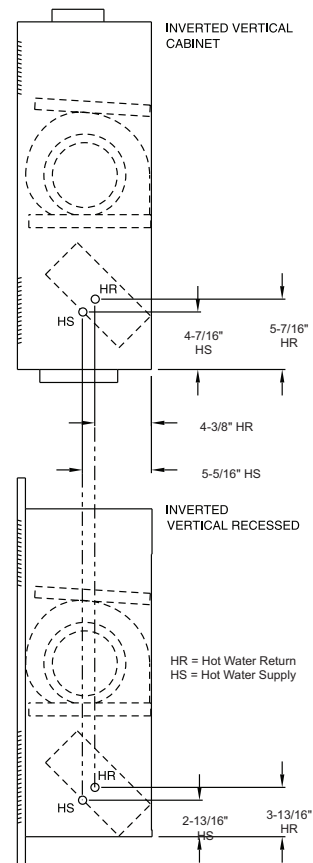

Dimensions and Weights

Fresh Air Opening Locations-Horizontal Units Models C, D, and E

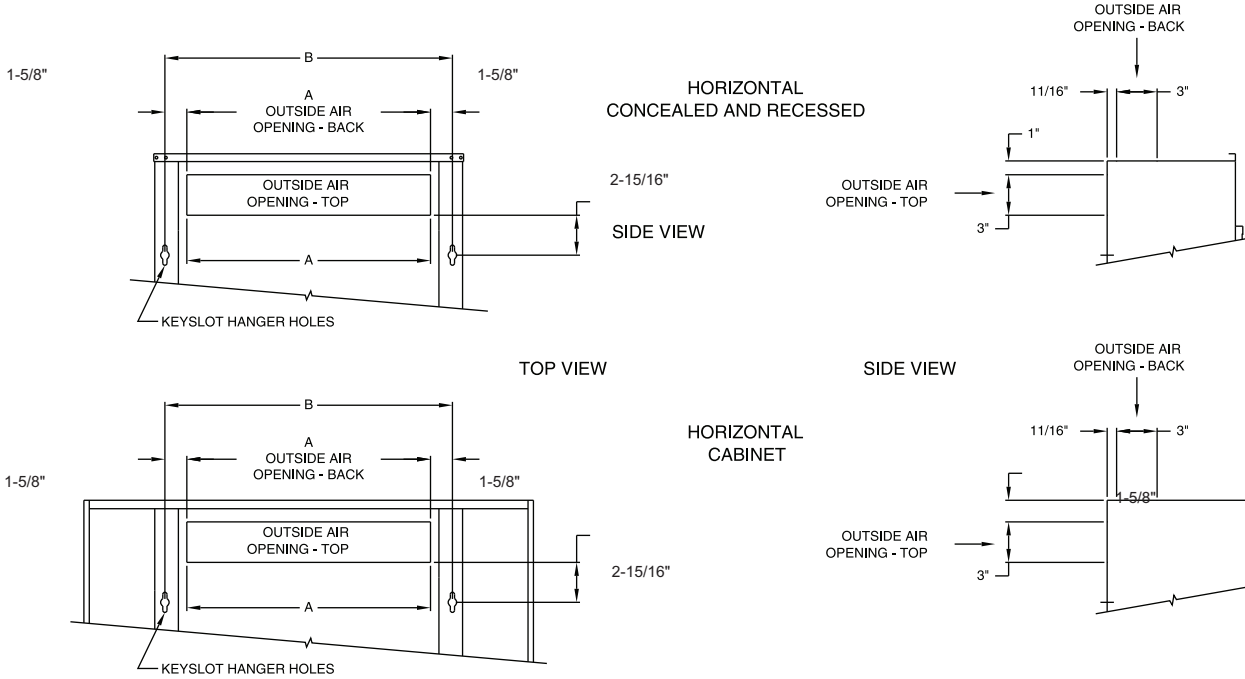

Fresh Air Opening Dimensions, Horizontal Units

Unit Size	02-03	04	06	08	10-12
A	18"	23"	32-1/2"	41"	60"
B	21-5/16"	26-5/16"	35-13/16"	44-5/16"	63-5/16"

Fresh Air Opening Locations-Vertical Units Models A, B, F, and J

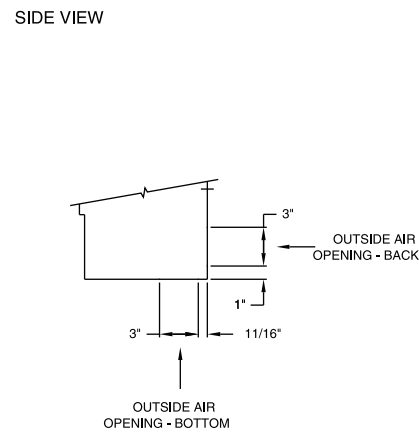
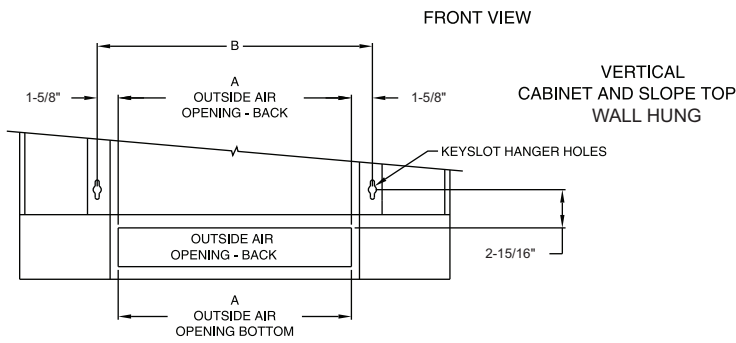
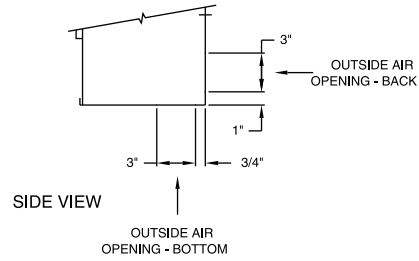
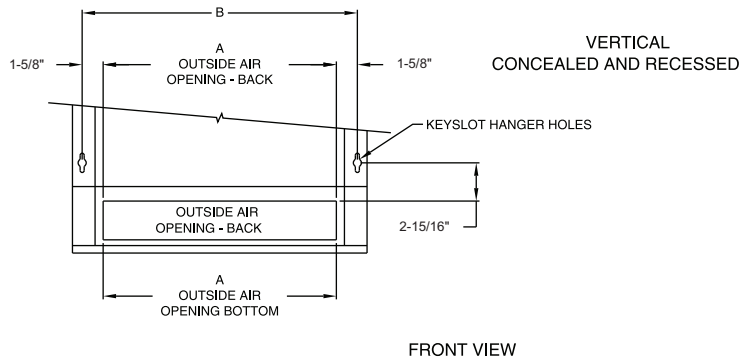

Fresh Air Opening Dimensions, Vertical Units

Unit Size	02-03	04	06	08	10-12
A	18"	23"	32-1/2"	41"	60"
B	21-5/16"	26-5/16"	35-13/16"	44-5/16"	63-5/16"

Dimensions and Weights

Wall Box

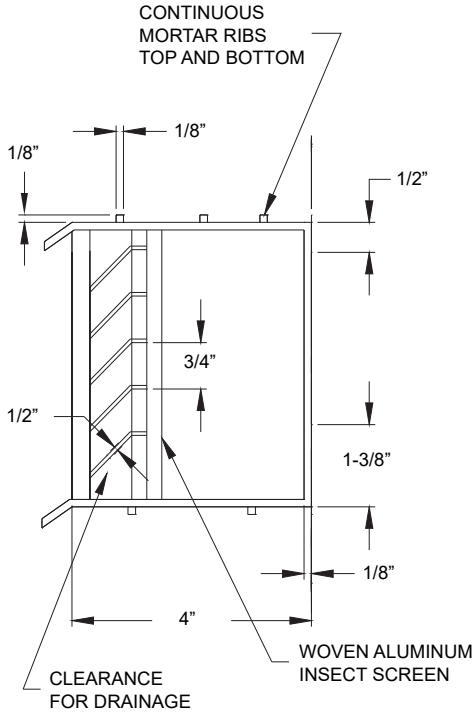

Wall Box Dimension

Unit Size Ref. Only	Dimensions A x B	Internal Supports
02-03	24-3/8" x 4-3/4"	1
04	24-3/8" x 7-1/2"	1
06	33-1/8" x 7-1/2"	2
08	37-1/2" x 7-1/2"	3
10-12	58-1/4" x 7-1/2"	4

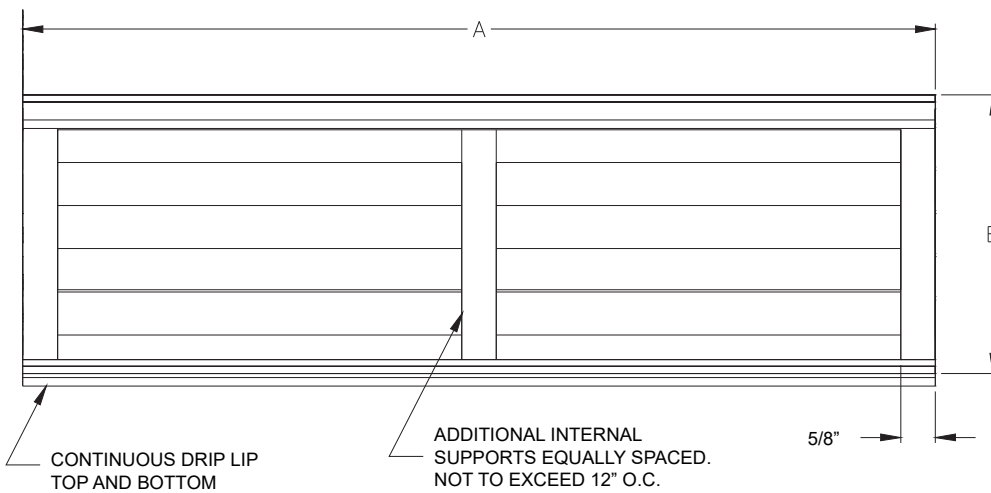

Projection Panel

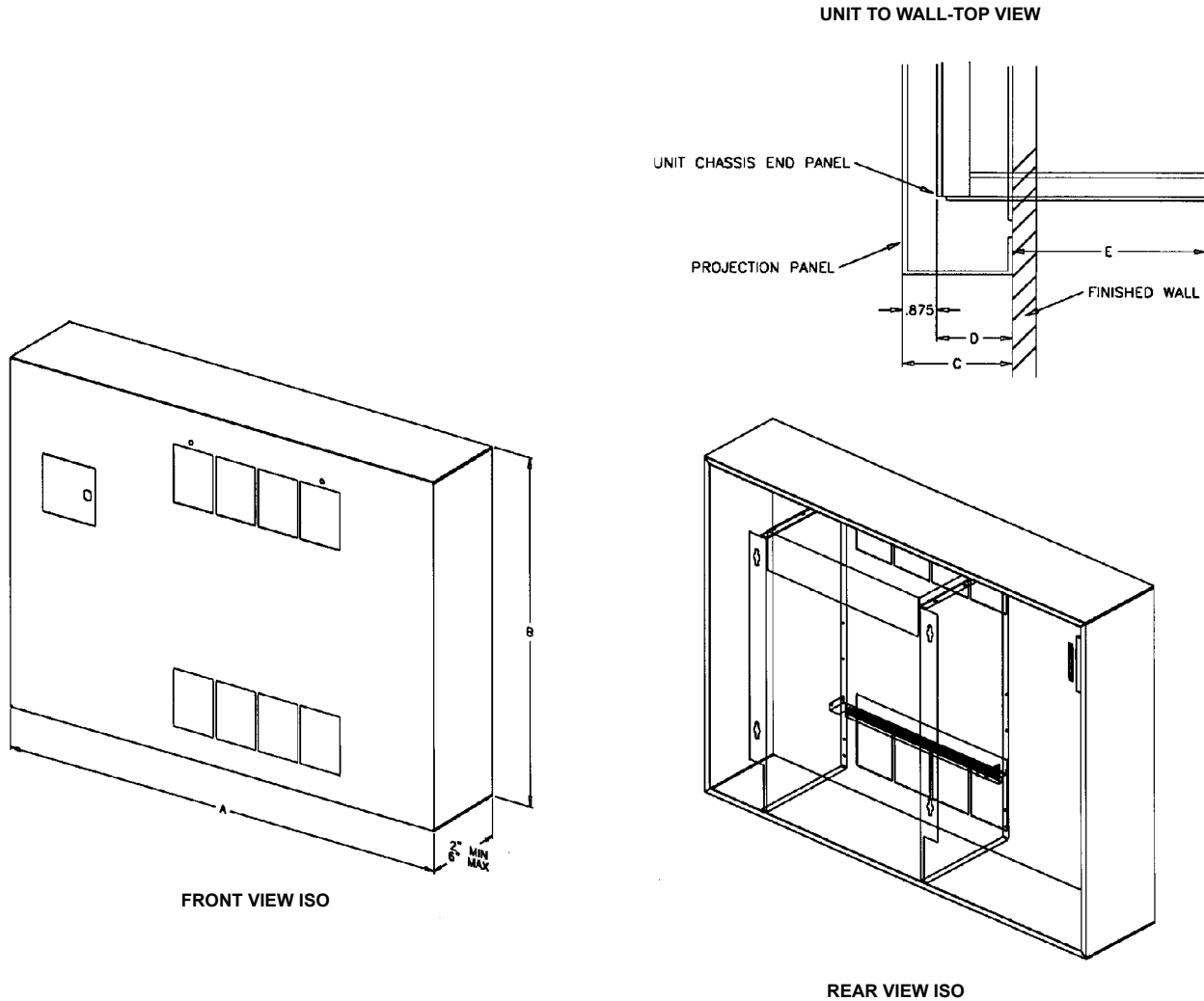

Projection Panel Dimensions

Unit Size	02-03	04	06	08	10-12
A	47"	51"	63"	65-1/2"	89-1/2"
B	30"	30"	30"	33-1/2"	33-1/2"

Projection Panel Dimensions

C	2"	2-1/2"	3"	3-1/2"	4"	4-1/2"	5"	5-1/2"	6"
D	1-1/8"	1-5/8"	2-1/8"	2-5/8"	3-1/8"	3-5/8"	4-1/8"	4-5/8"	5-1/8"
E	8-5/8"	8-1/8"	7-5/8"	7-1/8"	6-5/8"	6-1/8"	5-5/8"	5-1/8"	4-5/8"



Mechanical Specifications

Performance Data

"Capacity: Unit capacities rated in accordance with AHRI Standard 440-19. Safety: All standard units are UL listed in the United States and Canada. units comply with NFPA90A requirements".

Construction

All Units

The unit includes a chassis, coil, fan wheel(s), fan casing(s), fan board, and motor(s). The fan board assembly is easily removable. The fan board assembly includes a quick-disconnect motor plug. The chassis construction is 18-gauge galvanized steel, and continuous throughout the unit. The unit is acoustically and thermally insulated with closed-cell insulation. All panels are made rigid by channel forming.

Vertical Cabinet and Slope Top Units

Front panel fabrication is 16-gauge galvanized steel. All other panels are 18-gauge galvanized steel. Hinged access door construction is 20-gauge steel and is flush with top panel.

Vertical Wall Hung Unit

Front panel fabrication is 16-gauge galvanized steel. All other panels are 18-gauge galvanized steel. Side panels are removable for piping access.

Horizontal Cabinet Units

All panels are 18-gauge galvanized steel, including the bottom panel. The hinged access door is flush with front panel. Bottom panels ship with tamperproof screw fasteners and safety chain.

Concealed/Recessed Units

Exposed panels on recessed units are 18-gauge steel construction and ship separate from the unit. Bottom panels on horizontal recessed models ship with tamperproof screw fasteners and safety chain. Horizontal recessed units feature a telescoping panel to allow the panel to be adjusted to line up flush with the ceiling. The telescoping panel extends 1.25-inch to 2-inch depending on the configuration of airflow.

Unit Finish

All cabinet parts and exposed recessed panels are cleaned, bonderized, phosphatized, and painted with a baked powder finish available in six decorator colors. Standard finish meets ASTM B117 specifications (salt spray test).

Fans

The galvanized metal fan wheels are centrifugal forward-curved and double-width. Fan wheels and housings are corrosion resistant. Fan housing construction is formed sheet metal.

Motors

All motors are brushless DC (BLDC)/electronically commutated motors (ECM) factory-programmed and run-tested in assembled units. The motor controller is -mounted in a touch-safe control box with a built-in integrated user interface and LED tachometer. If adjustments are needed, motor parameters can be adjusted through momentary contact switches accessible without factory service personnel on the motor control board.

Motors will soft-ramp between speeds to lessen the acoustics due to sudden speed changes. Motors can be operated at three speeds or with a field-supplied variable speed controller. The motor will choose the highest speed if there are simultaneous/conflicting speed requests.

All motors have integral thermal overload protection with a maximum ambient operating temperature of 104°F and are permanently lubricated. Motors are capable of starting at 50 percent of rated voltage and

operating at 90 percent of rated voltage on all speed settings. Motors can operate up to 10 percent over voltage.

Extended End Pockets

On vertical or horizontal cabinet units, an 8-inch extended end pocket is available on the piping end.

Tamperproof Locks

Key-operated locking access doors and/or panels will help prevent nuisance tampering with unit and/or controls. Tamperproof locks are available on vertical cabinet, horizontal cabinet, vertical wall-hung cabinet, vertical recessed, and vertical slope-top units.

Leveling Feet

Refrigerator type screw-in bolts to level the unit are available on vertical units.

Controls

Controls options are: fan speed control, customer supplied terminal interface, and Tracer[®] ZN520, UC400-B/Symbio™ 400-B and Thermostat. A variety of inputs and outputs are available for the control interface and Tracer[®] controller options. A disconnect switch (for non-electric heat units), fused transformer, contactor(s), and terminal strip are provided with the control interface and Tracer[®] controller options.

Customer Supplied Terminal Interface

The control interface is intended to be used with a field-supplied, low-voltage thermostat or controller. The control box contains a relay board which includes a line voltage to 24-volt transformer, quiet contactors (for electric heat units), and an optional disconnect switch. All end devices are wired to a low-voltage terminal block and are run-tested, so the only a power connection and thermostat connection is needed to commission the unit. Changeover sensors and controls are provided whenever a change-over coil is selected. When N.O. valves are selected, inverting relays are provided for use with standard thermostats.

Fan Speed Control

The fan speed control is available with or without the control interface option and is available as wall-mount or unit-mount. The speed control incorporates a 0-10 Vdc signal providing limitless control of the motor RPM between the factory set low and high speeds. The control box contains a line voltage to 24-volt transformer, ECM motor controller, and an optional disconnect switch.

Disconnect Switch

A unit mounted disconnect switch is available as a standard option on all units.

Coils

All water coils are proof-tested at 300 psig (air) and leak-tested at 100 psig (air under water). Maximum main coil working pressure is 300 psig. Maximum entering water temperature is 200°F. Tubes and u-bends are 3/8-inch OD copper. Fins are aluminum and are mechanically bonded to the copper tubes. Coil stub-outs are 5/8-inch OD copper tubing.

Note: For coil replacement instructions, contact Technical Service.

Mechanical Specifications

Hot Water Coils

Hot water coils are proof tested at 350 psig (air under water) and leak tested at 125 psig (air under water). Additionally a pressure decay test is conducted at 120 psig.

Maximum main coil working pressure is 300 psig. Maximum entering water temperature is 200°F. Tubes and u-bends are 3/8-inch OD copper. Fins are aluminum and are mechanically bonded to the copper tubes. Coil stubouts are 5/8-inch OD copper tubing.

Steam Coils

The steam heating coil is a one-row, tube-in-tube distributing type coil. Coil construction is aluminum fins mechanically bonded with 1-inch OD copper tubing. Steam coils are (air) burst tested at 250 psig. Maximum steam coil working pressure is 100 psig. Maximum entering steam temperature is 325°F. Tubes and u-bends are 5/8-inch OD copper. Fins are aluminum, 9 fpi, and are mechanically bonded to the copper tubes. Coil stubouts are 1-inch OD copper tubing. Piping is field-supplied.

Electric Heat Coil

The auxiliary electric heating coil is provided as either the total source of heat or auxiliary intermediate season heating. The electric heat coils are located in the preheat position, and are the open-wire type. The coils are a nickel chromium element design. The electric heat operates at the same voltage as the unit, and only a single power connection is necessary.

All units with factory-mounted electric heat are UL-listed and interlocked with the fan motor switch. A call for electric heat operation will turn the fan on. Motors controls are synchronized with fan/valve operation to ensure safe operation and to ensure that two modes of heat are not operating simultaneously. A transformer is supplied on any voltage unit, eliminating the need for field installation of a step-down transformer. Unit-mounted quiet magnetic relays are supplied on all voltages. A high temperature cutout, with both automatic reset and backup single-use, is provided as an integral part of the elements to de-energize the electric heat in the event of malfunction.

Filters

Filters are concealed from sight and easily removable. Filters are located behind an integral access door on horizontal type units. Filters are either 1-inch throwaway, MERV 8, or MERV 13.

Units equipped with 1-inch MERV 8 filters have a rating based on ASHRAE Standard 52.2. The average dust spot efficiency is no less than 35 to 40 percent when tested in accordance with ASHRAE 52.1 atmospheric dust spot method.

Units equipped with 1-inch MERV 13 filters have a rating based on ASHRAE Standard 52.2. The average dust spot efficiency is no less than 90 percent efficiency on 1–3 micron particles and greater than 90 percent efficiency on 3–10 micron particles when tested in accordance with ASHRAE Test Standard 52.2.

Fresh Air Damper

A fresh air opening with damper is a factory-installed option. Dampers are constructed of 18-gauge steel. Fresh air is sealed off with gasket material when the damper is set in the closed position. Return and fresh air mixes when the damper is open.

Manual Damper

The manual damper is field-adjustable to allow zero to 100 percent fresh air. The automatic two-position damper is accompanied by a factory-installed and wired two-position (spring-return) actuator.

Auto Two-Position Damper

The auto two-position damper is factory set at 25 percent when open. The damper can be set in the field to allow from zero to 50 percent fresh air.

Disconnect Switch

A unit – mounted disconnect switch is available as a standard option on all units (except electric heat units).

Colors

Six decorator colors are available in a baked powder finish. For a color chart, contact your local Trane office for a copy of UNT-SLB017-EN (*Color Selector: Cabinet Heaters, Fan-Coils, Unit Ventilators, & Water-Source Heat Pump Consoles*).

Components

Quad Grille Outlet

Quad grilles are square multi-directional grilles that allow four different discharge directions by rotating the grilles 90°. The quad grille is constructed of a black plastic material (NORYL-SE 1-731) with a 15° angle on the discharge louvers. Quad grilles are available on all cabinet style units.

Bar Grille Inlet/Outlet

Bar grilles are formed steel grille options available on the discharge of all units and the return of vertical cabinet and vertical slope tops. The grilles have a black paint finish with 18-gauge steel construction. The louvers are formed at a 15° angle. The bar grilles are fixed in one discharge direction.

Sub-bases

Sub-bases elevate vertical cabinet or slope top cabinet units to a specified height; for example, to reach the bottom of a window sill. The sub-base also provides a cavity through which to run piping underneath the unit. Sub-bases are 16-gauge steel construction and have the same black paint finish as the unit's base. The sub-base is available in heights between 2-inch–7-inch (5 cm–18 cm) in 1/2-inch (1 cm) increments. The sub-base depth and width is identical to the unit's dimensions.

Quad grille outlet



Bar grille inlet and outlet

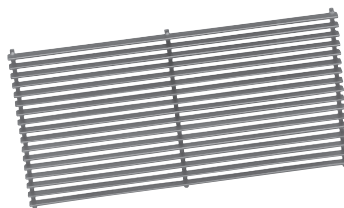

Sub-base (shown turned on its side)

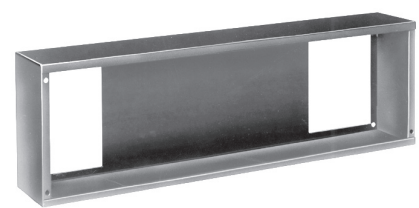

False Backs

False backs increase the depth of a vertical cabinet unit and provide a cavity through which to run piping behind the unit. False backs are also an excellent application when installing a unit beneath a window sill that extends out past the front of the unit.

False backs are 18-gauge steel construction and have the same paint finish as the unit. The false back is available in depths between 2-inch to 8-inch in 1-inch increments, with height and width identical to the unit's dimensions.

Recessing Flanges

Recessing flanges have 18-gauge steel construction and are painted the same finish as the unit. Recessing flanges provide an aesthetic architectural border or frame around vertical and horizontal cabinet units.

Mechanical Specifications

Aluminum Wall Boxes

Wall boxes have a clear anodized finish and include a single core wire mesh insect screen. The frame is 10-gauge extruded aluminum alloy 6063-T5 construction. Horizontal louvers have 16-gauge extruded aluminum alloy 6063-T5 construction.

Wall boxes ship separate for field installation. A field supplied duct or sleeve from the wall box to the unit fresh air opening is required to provide fresh air. Wall boxes are sized to handle up to 100 percent of nominal airflow.

Projection Panels

Projection panels allow semi-recessing of vertical recessed units.

Panels are 16-gauge steel construction, painted with a baked powder finish. They are available in projection depths ranging from 2-inch to 6-inch in 1/2-inch increments. There is a distance of 7/8-inch between the projection panel and the front of the unit.

False back



Recessing flange



Wall box



Project panel

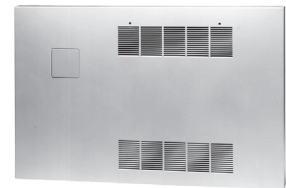

Piping Package

All piping packages are proof-tested at 300 psig (air) and leak tested at 100 (air under water.) The maximum working pressure of the interconnecting piping is 300 psig. For hydronic applications, maximum working temperature is 200°F except for applications with up to 50% glycol where the limit is 180°F.

Control valves are mounted in all factory piping packages. All piping packages are factory-installed and come in a variety of options:

- **Basic:** Shut-off ball valve on the supply line. Control valve and shut-off ball valve on the return line.
- **Basic with manual circuit setter:** Shut-off ball valve on the supply line. Control valve and manual circuit setter on the return line.
- **Deluxe with manual circuit setter:** Union, strainer, P/T port, and shut-off ball valve on the supply line. Union, control valve and manual circuit setter on the return line.
- **Deluxe with auto flow:** Union, strainer, P/T port, and shut-off ball valve on the supply line. Union, control valve, auto flow valve, P/T port and shut-off ball valve on the return line.

Two Position Control Valves

Two position control valves are ball valve designed with zero leakage. The ball valve incorporates self-cleaning technology to provide superior clog resistance. The actuator is easily removable for service without removing the valve body. Actuators are capacitor discharge return.

Modulating and Analog (2–10 Vdc) Control Valves

Modulating and analog control valves are ball valve designed with zero leakage. The ball valve incorporates self-cleaning technology to provide superior clog resistance. If the actuators fail, they can be easily removed for servicing without removing the valve body.

Figure 16. Control valve

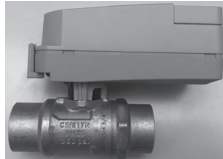

Material	Media Temperature	Working Pressure	Differential Pressure	Close off Pressure
Body - Forged Brass Ball - Chrome Plated Brass Stem - Brass Seats - PTFE O-Rings - EPDM (lubricated)	36°F Min 200°F Max	360 psig	40 psig	75 psig

End Valves

Each piping package includes a ball valve on the entering water pipe and one of the following end valve on the leaving water pipe:

- Ball valve
- Manual circuit setter
- Auto circuit setter

End valve serves as the field connection points on all the Fan Coil piping packages.

Ball Valve

Ball valves, also known as stop valves, allow the unit to be cut off for service purposes. The valve handle rotates 90 degrees to a fully open position with a maximum working pressure of 600 psig.

Manual Circuit Setter

A manual circuit setter acts as both a flow setting device and a stop valve. This valve allows water flow through the unit to be set quickly and accurately. The manual circuit setter includes ¼ in. Schrader ports in the valve body. These ports are used to measure the pressure drop across the valve. This pressure drop can be compared to factory supplied curves that relate the pressure drop to a specific flow rate. This valve also has a memory stop that helps find the correct setting quickly.

Figure 17. Manual circuit setter



Material	Media Temperature	Working Pressure
Body - Bronze Seats - Teflon® Internal Components - Brass, Teflon®, EPDM Schrader Valve Connections - Brass 1/4 in. Indicator Plate - Stainless Steel Pointer - Die Cast Zinc	250°F max	300 psig

Automatic Flow Control (Auto Flow Valve)

Automatic Flow Control is located on the return line. This device is a non-adjustable in-line flow control valve that maintains the GPM for the unit with a cartridge sized to a specific flow rate.

Figure 18. Auto flow valve

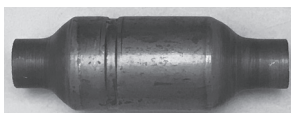

Material	Media Temperature	Working Pressure	Pressure Drop
Valve Body - Copper O-rings - EPDM Retainer - Stainless Steel Diaphragm - EPDM Orifice - Polyphenyl sulfone	32°F min 225°F max	522 psig	2-80 psig 0.50-5.00 GPM 3-80 psig 5.50-9.00 GPM

Mechanical Specifications

Strainer

The strainer is provided with a plug to access the basket. The strainer contains a 20 mesh screen with a working pressure of 300 psig and a maximum water temperature of 210 degrees.

P/T Port

P/T Port has the ability to measure temperature or pressure of the line.

Figure 19. P/T Port

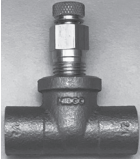

Material	Media Temperature	Working Pressure
Tee Body - Cast Bronze P/T Plug Body - Brass	200°F max	500 psig

Bypass Balance Valve

The balance valve incorporates both a gland screw and stem for manual flow adjustment. The working pressure of this valve is 400 psig.

Union

Figure 20. Union



Material
Nut—Forged Brass Body—Copper Tail—Copper



Notes



Trane - by Trane Technologies (NYSE: TT), a global climate innovator - creates comfortable, energy efficient indoor environments for commercial and residential applications. For more information, please visit trane.com or tranetechnologies.com.

Trane has a policy of continuous product and product data improvement and reserves the right to change design and specifications without notice. We are committed to using environmentally conscious print practices.