



Product Catalog

UniTrane™ Fan Coil

Air Terminal Device

Horizontal, Vertical, and Low Vertical Units

Size 02 to 12





Introduction

UniTrane™ fan coils are intended for single zone applications. These units have load capabilities of 200 to 1200 cfm. Fan coils provide cooling and heating, and are available as two-pipe, with or without electric heat (one hydronic circuit) or four-pipe (two hydronic circuits). These units feature a variety of factory mounted piping packages.

Units with the variable speed fan switch only, are available with the switch mounted on the unit, or shipped separately, to be mounted in the occupied space. The variable speed switch option, which ships separately, comes with a low voltage (24 volt AC) transformer.

The UC400-B/Symbio™ 400-B controllers are available as factory mounted, configured and tested controls.

The Customer Supplied Terminal Interface (CSTI) option, includes a 24 volt AC transformer, and an interface terminal board. Controls provided by an external source can be tied into the interface terminal board utilizing the integrated terminal block with 3mm screw connections.

Figure 1. UniTrane™ fan coil components (vertical cabinet model shown)

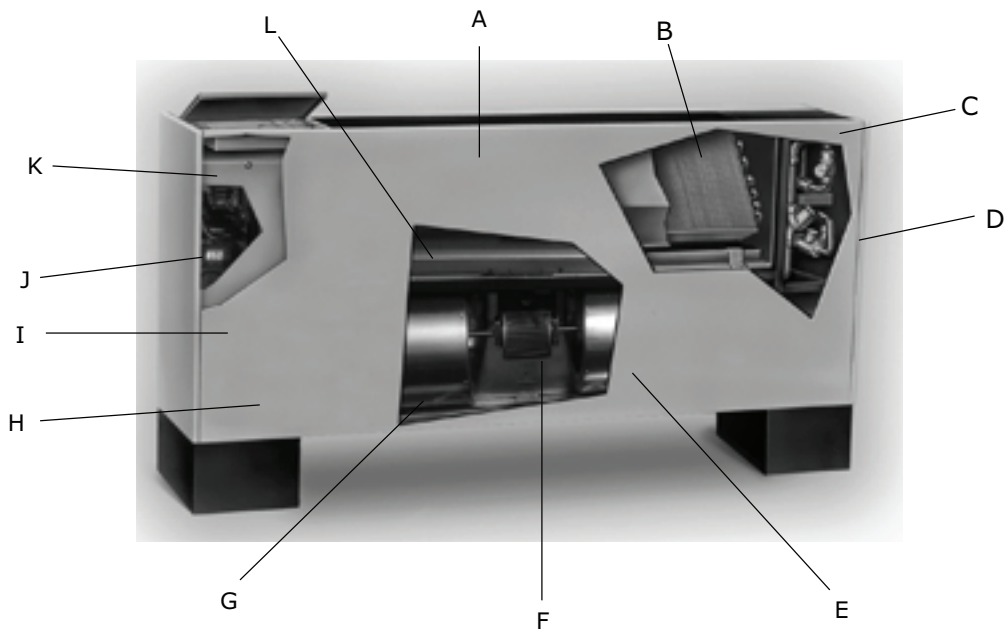

Element	Description
A	Smaller unit footprint Quiet operation
B	Two, three, or four-row coils
C	Factory-assembled, installed, and tested piping package with IAQ drain pan to collect condensate
D	Cleanable closedcell insulation (non-fiberglass)
E	Damper allows up to 100 percent fresh air
F	Energy efficient electronically commutated motor (ECM)
G	Easy filter access with front panel removal
H	18 gauge steel construction
I	Easy-to-remove fan assembly
J	Built-in field service tool with real language LED
K	Factory-installed and tested controls
L	Removable, noncorrosive, positively-sloped drain pan

Copyright

This document and the information in it are the property of Trane, and may not be used or reproduced in whole or in part without written permission. Trane reserves the right to revise this publication at any time, and to make changes to its content without obligation to notify any person of such revision or change.

Trademarks

All trademarks referenced in this document are the trademarks of their respective owners.

Revision History

- Removed Model P Compact Concealed with Recessed Panel Option in the General Data chapter.
- Removed ZN520, Tracer Summer, Factory TSTAT and Rover Option throughout the document.



Table of Contents

Features and Benefits	5
Components and Options	7
Factory-Installed Piping Packages	8
UniTrane™ Fan Coil	10
Model Number Descriptions	10
UniTrane™ Fan Coil Low Vertical Model	13
General Data	15
Unit Configuration	15
Fan Coil Data	20
Performance Data	22
Controls	23
Why Trane Controls?	23
Control Options	24
Tracer® Controller Features	26
Tracer® Controls Sequence of Operation	30
Air-Fi® Wireless Systems	30
Zone Sensor Options	32
End Device Options	33
Electrical Data	38
MCA and MOP Calculations	38
Electric Heat	38
Motors	39
Dimensions and Weights	41
Service Clearances	41
Unit Weights	61
Coil Connections	62
Fresh Air Opening Locations	66
Mechanical Specifications	70
Performance Data	70



Features and Benefits

The UniTrane™ fan coil meets the standards of today's market, as well as the anticipated needs of tomorrow's market. The UniTrane fan coil is the leader in these key areas:

- Energy Efficiency
- Indoor Air Quality (IAQ)
- Controls
- Flexibility
- Quality
- Serviceability

Today the HVAC market is concerned with issues such as indoor air quality (IAQ) and CFCs that demand a change in HVAC products. In addition, renovation has overtaken new construction in the fan coil market—demanding a design that caters to renovation issues. Trane is concerned with these issues, too. That is why we designed the UniTrane fan coil as an integral part of the company's system solutions with standard IAQ-related features that fully comply with ASHRAE 62.

Energy Efficiency

Trane's commitment to providing premium quality products has led to the exclusive use of Electronically Commutated Motors (ECM) in all fan coil models. These brushless DC motors incorporate the latest technology for optimized energy efficiency, acoustical abatement, maintenance free and extended motor life. Each motor has a built-in microprocessor that allows for programmability, soft ramp-up, better airflow control, and serial communication.

- Trane units equipped with ECMs are significantly more efficient than the standard permanent split capacitor (PSC) motor.
- Lower operating costs on average of 50 percent (versus a PSC motor).
- The reduced FLA feature allows units to ship with a nameplate FLA rating much lower than a typical unit.

IAQ Design

- Closed-cell insulation is standard on all units to help prevent fiberglass in the airstream.
- The main and auxiliary drain pans are constructed of a noncorrosive engineered plastic (ABS and CyColac T).
- The main and auxiliary drain pans are positively sloped in every plane to assure proper drainage and help maximize protection from microbial growth.
- The drain pans are removable for cleaning.
- Easy filter access encourages frequent changing.
- The auto-economizer damper option allows free cooling and ventilation to help comply with ASHRAE 62—and save energy and operating costs.
- UniTrane fan coils have a blow-thru design. Low vertical units are draw-thru.

Controls

- This is the industry's first solution that is factory-mounted, -wired, and -programmed for infinite modulation of fan speed based on space loads, using the UC400-B/Symbio™ 400-B.
- All controls are factory-mounted, configured and tested to minimize field setup and improve reliability.
Note: *Factory addressing is available for Symbio™ 400-B and UC400-B Air-Fi® WCI controller types. This option allows configuration of units before delivery, reducing the field setup time.*
- Controls are wired with a 24 Vac transformer to keep only a single source power connection requirement to the unit.



Features and Benefits

- All wall-mounted zone sensors/thermostats require only low voltage control wiring from the device to the unit control box (no line voltage).
- The controller automatically determines the unit's correct operating mode (heat/cool) by utilizing a proportional/integral (PI) control algorithm to maintain the space temperature at the active setpoint, allowing total comfort control.
- Entering water temperature sampling eliminates the need for inefficient bleedlines to sense automatic changeover on two-pipe changeover units.
- The random start-up feature helps reduce electrical demand peaks by randomly staggering multiple units at start-up.
- Occupied/unoccupied operation allows the controller to utilize unoccupied temperature setpoints for energy savings.
- Warm-up and cool-down energy features are standard with Trane controls.
- Monitor unit operation using Tracer® TU building management system with UC400-B/Symbio™ 400-B.
- To customize unit control, Tracer® TU will allow field modification default settings. UC400-B/Symbio™ 400-B uses Tracer® TU.
- Maximize fan coil system efficiency with free cooling economizers and modulating valves on units with UC400-B/Symbio™ 400-B.

Flexibility

- Two, three, and four-row coils allow greater design flexibility in two and four-pipe systems.
- Fan motors are available for either high static (0.4-inch external static pressure) or free discharge applications.
- Piping is factory assembled, mounted and tested. Units are also available without piping. Reheat coil piping is available on 2-pipe units with hot water reheat coils and either a fan speed switch or UC400-B/Symbio™ 400-B.
- Control options range from a simple fan speed switch to a DDC controller that can tie into a building automation system.
- An 8-inch extended end pocket is available on the piping end of cabinet style units. An additional 8-inch extended end pocket is also available on the controls end of the cabinet style units.
- Slope-top vertical cabinet units are also available for school and dormitory applications to prevent items from being placed on top of the units.

Quality

- Coils and piping packages are air and leak-tested before mounting on the fan coil.
- Coil piping connections are also air and leak-tested after mounting on the unit.
- All control end devices and moving components (fans and motors) are computer-tested after units are complete.

Serviceability

- Touch-safe control box.
- Integrated user interface with real language LED display.
- Built-in tachometer.
- Filters are easily removable and changed without removing the front panel on vertical cabinet units.
- Motors are easy to disconnect from the fan board, allowing easy service.
- The main and auxiliary drain pans are easily removable and wipe clean with a wet cloth.

Components and Options

Motor and Control Board

- Trane Electronically Commutated Motor (ECM)
- VelociTach™ motor control board

The motor and control board are combined as a system, and cannot work without each other. This new series delivers outstanding comfort, safety, and performance with greatly reduced energy consumption compared to traditional units.

Electronically Commutated Motor (ECM)



- The ECM has integrated electronics, overload protection and short circuit protection. The motor contains no user-serviceable components inside.
- The motor mates to the unit electrically via a single plug that contains both the operating voltage and the control signals that are needed for correct operation.

VelociTach™ Motor Control Board

The VelociTach motor control board controls and reports the performance of up to two Trane brushless DC (BLDC) motors.

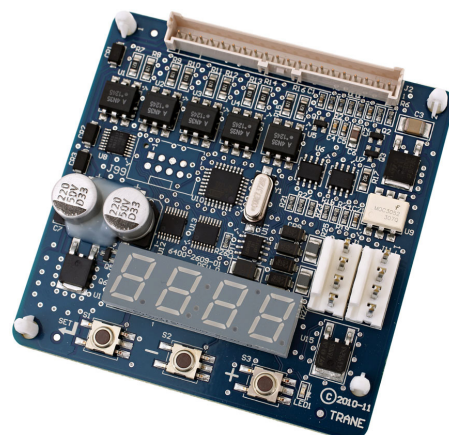

The motor control board also:

- Coordinates the operation of the fan in response to electric heat behavior and electric behavior in response to hydronic heat behavior.
- Incorporates a user interface that allows adjustment of certain unit parameters and provides constant feedback on motor operation.
- Integrates service and troubleshooting tools.
- Integrates a versatile configurable auxiliary temperature sensor.
- Incorporates various safety and lockout features, such as maintaining proper fan speeds if electric heat is called for.

Features and Benefits

Status Display

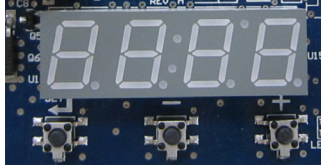

The motor control board contains a four-digit, seven-segment display that is used to present information in a format close to real-world language, while having a small-form factor. Most characters are immediately recognizable.

Factory-Installed Piping Packages

Piping packages are available with UC400-B/Symbio™ 400-B controllers and CSTI. Field connections are located near the exterior of the unit for easy of access. All piping and components are positioned so that condensate drips into the auxiliary drain pan. Insulation of the factory piping package is not required. All field connections should be insulated to prevent condensation from missing the auxiliary drain pan.

Piping Package Components

Control valves are mounted in all factory piping packages. All piping packages are factory installed and come in a variety of options:

- **Basic:** Shut-off ball valve on the supply line. Control valve and shut-off ball valve on the return line.
- **Basic with Manual circuit setter:** Shut-off ball valve on the supply line. Control valve and manual circuit setter on the return line.
- **Deluxe with Manual circuit setter:** Union, strainer, P/T port, and shut-off ball valve on the supply line. Union, control valve and manual circuit setter on the return line.
- **Deluxe with auto flow:** Union, strainer, P/T port, and shut-off ball valve on the supply line. Union, control valve, auto flow valve, P/T port and shut-off ball valve on the return line.

Piping System/Placement

Factory piping systems are available for either two or four-pipe systems with right or left hand connections. Four-pipe systems have both the heating and cooling connections on the same side of the unit. A simple coil connection (a unit without a piping package) is also available in either a right or left hand configuration for applications requiring field piping.

Figure 2. Piping package arrangements

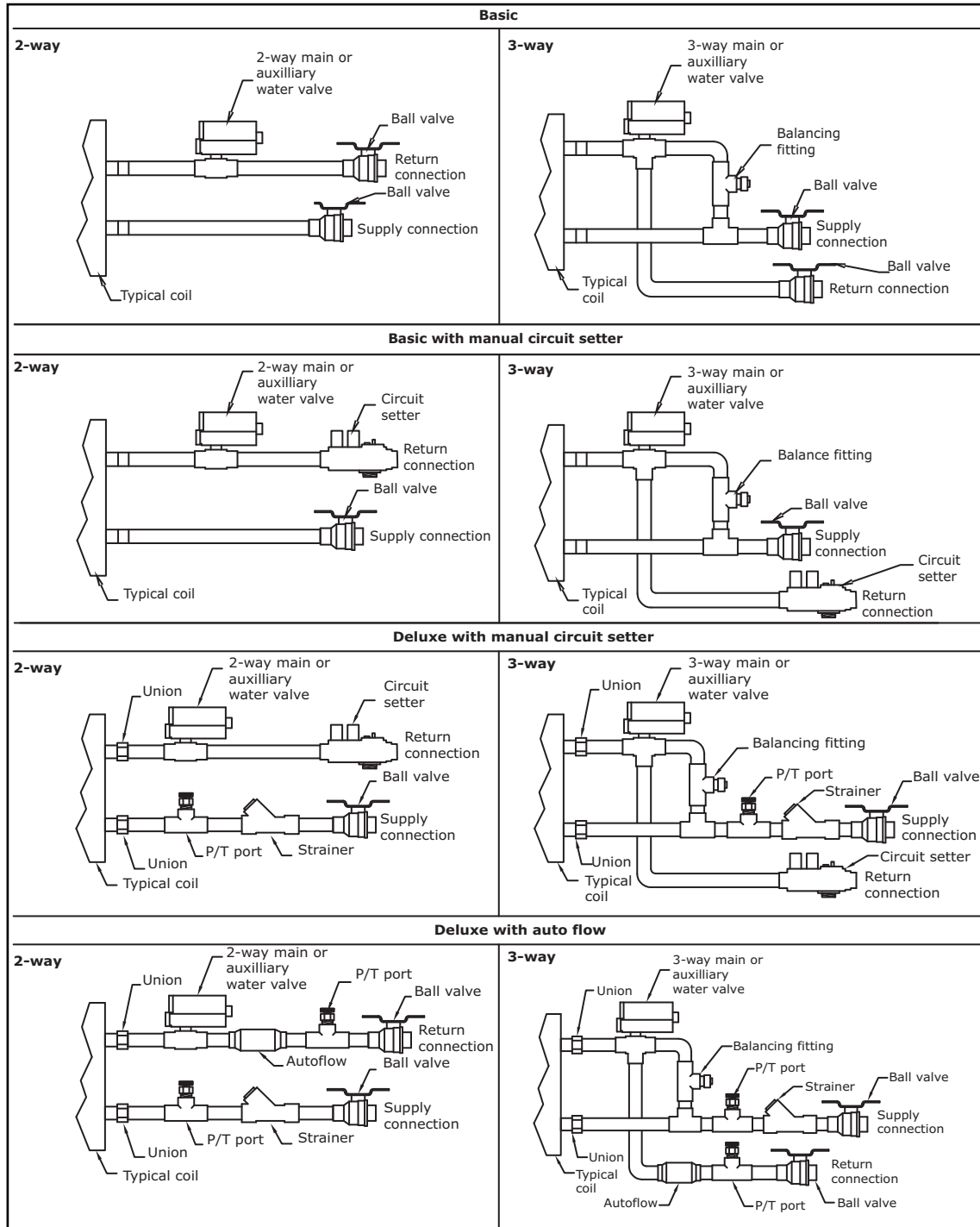



Model Number Descriptions

UniTrane™ Fan Coil

Following is a complete description of the UniTrane fan coil model number. Each digit in the model number has a corresponding code that identifies specific unit options.

Note: *Not all options are available on all cabinet styles. Contact your local Trane sales representative for more information.*

Digits 1, 2 — Unit Type

FC = Fan Coil

Digit 3 — Model

- A = Vertical concealed
- B = Vertical cabinet
- C = Horizontal concealed
- D = Horizontal cabinet
- E = Horizontal recessed
- H = Vertical recessed
- J = Vertical slope top
- P = Compact concealed

Digit 4 — Development Sequence

B = Development B

Digits 5, 6, 7 — Unit Cabinet Size

- 020 = 200 cfm
- 030 = 300 cfm
- 040 = 400 cfm
- 060 = 600 cfm
- 080 = 800 cfm
- 100 = 1000 cfm
- 120 = 1200 cfm

Digit 8 — Unit Voltage

- 1 = 115V/60Hz/1 phase
- 2 = 208V/60Hz/1 phase
- 3 = 277V/60Hz/1 phase
- 4 = 230V/60Hz/1 phase
- 9 = 220-240V/50Hz/1 phase

Digit 9 — Piping System/Placement

- A = Without pipe, RH, without auxiliary
- B = Without pipe, LH, without auxiliary
- C = Without pipe, RH, with auxiliary
- D = Without pipe, LH, with auxiliary
- E = Without pipe, RH, without auxiliary, extended end
- F = Without pipe, LH, without auxiliary, extended end
- G = Without pipe, RH, with auxiliary, extended end
- H = Without pipe, LH, with auxiliary, extended end
- J = With pipe, RH
- K = With pipe, LH
- L = With pipe, RH, extended end
- M = With pipe, LH, extended end
- N = Without pipe, RH, with auxiliary, extended end pipe and control side

- P = Without pipe, LH, with auxiliary, extended end pipe and control side
- Q = With pipe, RH, with auxiliary, extended end pipe and control side
- R = With pipe, LH, with auxiliary, extended end pipe and control side

Digits 10, 11 — Design Sequence

*** Factory assigned

Digit 12 — Inlet style

- A = Front toe space
- B = Front bar grille
- C = Front stamped louver
- D = Bottom stamped louver
- E = Bottom toe space
- F = Back duct collar
- G = Back exposed fan
- H = Back stamped louver
- J = Top duct collar
- K = Exposed fan
- L = Bottom filter

Digit 13 — Outside Air Damper

- 0 = None
- A = Manual, bottom opening
- B = Manual, back opening
- C = Manual, top opening
- D = Auto, 2-position, bottom opening
- E = Auto, 2-position, back opening
- F = Auto, 2-position, top opening
- G = Economizer, bottom opening
- H = Economizer, back opening
- J = Auto, economizer, top opening
- K = No damp, bottom opening
- L = No damp, back opening
- M = No damp, top opening

Digit 14 — Outlet style

- A = Front duct collar
- B = Front bar grille
- C = Front stamped louver
- D = Front quad grille
- G = Top quad grille
- H = Top bar grille
- J = Top duct collar

Digit 15 — Paint Cabinet Color

- 0 = None (Units not painted)
- 1 = Deluxe beige
- 2 = Soft dove
- 3 = Cameo white
- 4 = Driftwood grey
- 5 = Stone grey
- 6 = Rose mauve

Digit 16 — Tamperproof Locks/Leveling Feet

- 0 = None
- A = Locking panel
- B = Keylock access door
- C = Locking panel, key access door, secure grille
- D = Leveling feet
- F = Keylock door with leveling feet
- G = Locking panel, key access door, secure grille and leveling feet

Digit 17 — Motor Types

- A = Free discharge
- B = High static

Digit 18 — Main Coil

- A = 2-row cooling/heating
- B = 3-row cooling/heating
- C = 4-row cooling/heating
- D = 2-row cooling, 1-row heating
- E = 2-row cooling, 2-row heating
- F = 3-row cooling, 1-row heating
- G = 2-row cooling only or heating only
- H = 3-row cooling only or heating only
- J = 4-row cooling only or heating only
- K = 2-row cooling/heating, electric heat
- L = 3-row cooling/heating, electric heat
- M = 4-row cooling/heating, electric heat
- N = Electric heat only, 1 stage
- P = 2-row cooling/heating, 1-row heating
- Q = 2-row cooling/heating, 2-row heating
- R = 3-row cooling/heating, 1-row heating
- V = Electric heat, low kW, 1 stage
- X = 2-row cooling only, electric heat
- Y = 3-row cooling only, electric heat
- Z = 4-row cooling only, electric heat
- 1 = 3-row cooling, 1-row heating with high capacity
- 2 = 3-row cooling/heating, 1-row heating with high capacity
- 3 = Heat pump
- 4 = Heat pump, auxiliary electric heat
- 5 = DX cooling
- 6 = DX cooling, electric preheat

Digit 19 — Drain Pan

- 3 = Polymer drain pan
- 4 = Stainless steel drain pan

Digit 20 — Air Vent

- 0 = None
- A = Automatic air vent
- M = Manual air vent

Model Number Descriptions

Digits 21, 22, 23 — Electric Heat kW

000 =	None
010 =	1.0 kW (0.75 kW 208 V)
015 =	1.5 kW (1.1 kW 208 V)
020 =	2.0 kW (1.5 kW 208 V)
025 =	2.5 kW (1.9 kW 208 V)
030 =	3.0 kW (2.2 kW 208 V)
040 =	4.0 kW (3.0 kW 208 V)
050 =	5.0 kW (3.7 kW 208 V)
060 =	6.0 kW (4.4 kW 208 V)
070 =	7.0 kW (5.3 kW 208 V)
080 =	8.0 kW (6.0 kW 208 V)
100 =	10.0 kW (N/A 208 V)

Digit 24 — Reheat Coil

0 =	Without reheat
A =	Steam reheat (4 fpi)
B =	Hot water reheat (4 fpi)
D =	High capacity hot water reheat (12 fpi)

Digit 25 — Unit Mounted Disconnect Switch

0 =	None
D =	With disconnect switch

Digit 26 — Filter Type

0 =	None
1 =	1 in. throwaway
2 =	1 in. throwaway MERV 8
3 =	1 in. throwaway, one extra
4 =	1 in. throwaway MERV 8, one extra
5 =	1 in. throwaway, two extras
6 =	1 in. throwaway MERV 8, two extras
7 =	1 in. throwaway, three extras
8 =	1 in. throwaway MERV 8, three extras
A =	1 in. throwaway MERV 13
B =	1 in. throwaway MERV 13, one extra
C =	1 in. throwaway MERV 13, two extras
D =	1 in. throwaway MERV 13, three extras

Digit 27 — Future Option

0 =	None
-----	------

Digit 28 — Future Option

0 =	None
-----	------

Digit 29 — Piping Packages

0 =	None
A =	Basic - Ball valve supply and return
B =	Basic - Ball valve supply and manual circuit setter return
E =	Deluxe - Ball valve supply and manual circuit setter return
F =	Deluxe - Ball valve supply and return with auto flow

Digit 30 — Control Type

A =	Fan speed control
H =	Customer Supplied Terminal - STAT Interface
L =	Tracer® UC400-B
M =	Tracer® UC400-B with Wireless Communications Interface (WCI)
N =	CSTI with fan status
R =	Symbio™ 400-B
T =	Symbio™ 400-B with Wireless Communications Interface (WCI)

Digit 31 — Control Options

0 =	None
V =	Unit-mounted zone sensor module (OALMH and setpoint dial)
W =	Wall-mounted zone sensor module (OALMH and setpoint dial)
X =	Unit-mounted fan mode switch, Wall-mounted zone sensor (setpoint dial)
Y =	Unit-mounted fan mode switch Wall-mounted zone sensor (setpoint dial, ON/CANCEL, comm. jack)
Z =	Unit-mounted zone sensor module (OALMH, setpoint dial, ON/CANCEL buttons)
1 =	Wall-mounted zone sensor module (ON/CANCEL buttons, comm. jack)
2 =	Wall-mounted zone sensor module (OALMH, setpoint dial, ON/CANCEL, comm. jack)
4 =	Wall-mounted digital zone sensor (OALMH, setpoint, ON/CANCEL, comm. jack)
6 =	Wireless zone sensor (setpoint dial, occupied/unoccupied buttons)
7 =	Wireless display sensor, unit receiver (OALMH)
8 =	Unit-mounted variable speed control
9 =	Wall-mounted variable speed control
A =	Wall-mounted
B =	Unit-mounted

Digit 32 — IAQ Options

0 =	None
1 =	Dehumidification
2 =	VOC/CO ₂
3 =	Dehumidification and VOC/CO ₂
4 =	Dehumidification with sensor
5 =	Air-Fi® dehumidification and VOC/CO ₂
6 =	Air-Fi® dehumidification with sensor
7 =	Air-Fi® CO ₂

Digit 33 — FLA Motor Options

0 =	Standard ECM
A =	Reduced FLA

Digit 34 — Control Option

0 =	None
A =	Low limit sensor
B =	Condensate overflow
C =	Low limit and condensate overflow

Digit 35 — Main Valve Type

0 =	None
A =	2-way, 2 position N.C.
B =	2-way, 2 position N.O.
C =	3-way, 2 position N.C.
D =	3-way, 2 position N.O.
E =	2-way, Modulating
F =	3-way, Modulating
G =	2-way, Analog (2–10 Vdc)
H =	3-way, Analog (2–10 Vdc)
J =	Field supplied, 2 position N.C.
K =	Field supplied, 2 position N.O.
L =	Field supplied, Modulating
M =	Field supplied, Analog (2–10 Vdc)

Digit 36 — Cv Main Valve

0 =	None
A =	2-way 1.4 Cv
B =	2-way 2.4 Cv
C =	2-way 3.4 Cv
D =	3-way 1.0 Cv
E =	3-way 2.7 Cv
F =	3-way 4.6 Cv

Digits 37 — Auxiliary Valve Type

0 =	None
A =	2-way, 2 position N.C.
B =	2-way, 2 position N.O.
C =	3-way, 2 position N.C.
D =	3-way, 2 position N.O.
E =	2-way, Modulating
F =	3-way, Modulating
G =	2-way, Analog (2–10 Vdc)
H =	3-way, Analog (2–10 Vdc)
J =	Field supplied, 2 position N.C.
K =	Field supplied, 2 position N.O.
L =	Field supplied, Modulating
M =	Field supplied, Analog (2–10 Vdc)

Digits 38 — Cv Auxiliary Valve

0 =	None
A =	2-way 1.4 Cv
B =	2-way 2.4 Cv
C =	2-way 3.4 Cv
D =	3-way 1.0 Cv
E =	3-way 2.7 Cv
F =	3-way 4.6 Cv



Model Number Descriptions

Digit 39 — Recessed Options

0	=	None
A	=	5/8 in. standard recessed panel
B	=	2 in. projection panel
C	=	2.5 in. projection panel
D	=	3 in. projection panel
E	=	3.5 in. projection panel
F	=	4 in. projection panel
G	=	4.5 in. projection panel
H	=	5 in. projection panel
J	=	5.5 in. projection panel
K	=	6 in. projection panel
L	=	2 in. False back
M	=	3 in. False back
N	=	4 in. False back
P	=	5 in. False back
Q	=	6 in. False back
R	=	7 in. False back
T	=	8 in. False back

Digit 40 — Main Auto Flow GPM

0	=	None	H	=	3.5
B	=	0.75	J	=	4.0
C	=	1.0	K	=	4.5
D	=	1.5	L	=	5.0
E	=	2.0	M	=	6.0
F	=	2.5	N	=	7.0
G	=	3.0	P	=	8.0

Digit 41 — Auxiliary Auto Flow GPM

0	=	None	H	=	3.5
B	=	0.75	J	=	4.0
C	=	1.0	K	=	4.5
D	=	1.5	L	=	5.0
E	=	2.0	M	=	6.0
F	=	2.5	N	=	7.0
G	=	3.0	P	=	8.0

Digit 42 — Subbases

0	=	None
A	=	2 in. height
B	=	3 in. height
C	=	4 in. height
D	=	5 in. height
E	=	6 in. height
F	=	7 in. height

Digit 43 — Recessed Flange

0	=	None
A	=	With recessed flange

Digit 44 — Wall Box

0	=	None
A	=	Clear anodized

UniTrane™ Fan Coil Low Vertical Model

Following is a complete description of the UniTrane fan coil low height vertical model.

Digits 1, 2 — Unit Type

FC = Fan Coil

Digit 3 — Unit Model Type

K = Low vertical concealed
L = Low vertical cabinet

Digit 4 — Development Sequence

B = Development sequence B

Digit 5,6,7 — Unit CFM

030 = 300 cfm
040 = 400 cfm
060 = 600 cfm

Digit 8 — Unit Voltage

1 = 115 V/60 Hz/1 phase

Digit 9 — Piping system placement

C = Without piping, right hand, with auxiliary drain pan
D = Without piping, left hand, with auxiliary drain pan
J = With piping, right hand, with auxiliary drain pan
K = With piping, left hand, with auxiliary drain pan

Digit 10,11 — Design Sequence

*** = Factory assigned

Digit 12 — Inlet

A = Front toe space
B = Front bar grille

Digit 13 — Outside Air Damper

0 = None
B = Manual, back opening
E = Auto, 2 position, back opening

Digit 14 — Outlet

G = Top quad grille
H = Top bar grille
J = Top duct collar

Digit 15 — Unit Color

0 = None
1 = Deluxe beige
2 = Soft dove
3 = Cameo white
4 = Driftwood grey
5 = Stone grey
6 = Rose mauve
7 = To be selected later

Digit 16 — Tamperproof Locks/ Leveling Feet

0 = None
B = Keylock access door
D = Leveling feet
F = Keylock access door with leveling feet

Digit 17 — Coil Type

A = 2-row cooling/heating
B = 3-row cooling/heating
C = 4-row cooling/heating
D = 2-row cooling, 1-row heating
E = 2-row cooling, 2-row heating
F = 3-row cooling, 1-row heating
K = 2-row cooling/heating, electric heat
P = 2-row cooling/heating, 1-row heating
Q = 2-row cooling/heating, 2-row heating
R = 3-row cooling/heating, 1-row heating
X = 2-row cooling only, electric heat

Digit 18 — Air Vent (Coil)

0 = None
A = Auto air vent
M = Manual air vent

Digit 19, 20, 21 — Electric Heat kW

000 = None
010 = 1.0 kW (0.75 kW 208 V)
015 = 1.5 kW (1.1 kW 208 V)
020 = 2.0 kW (1.5 kW 208 V)
025 = 2.5 kW (1.9 kW 208 V)
030 = 3.0 kW (2.2 kW 208 V)
040 = 4.0 kW (3.0 kW 208 V)

Digit 22 — Reheat

0 = None
C = Electric Heat (N/A)

Digit 23 — Disconnect Switch

0 = None
D = With disconnect switch

Digit 24 — Filter Type

0 = None
1 = 1 in. throwaway filter

Digit 25 — Future Option

0 = None

Digit 26 — Future Option

0 = None

Digit 27 — Piping Packages

0 = None
A = Basic - Ball valve supply and return
B = Basic - Ball valve supply and manual circuit setter return
E = Deluxe - Ball valve supply and manual circuit setter return
F = Deluxe - Ball valve supply and return with auto flow

Digit 28 — Control Type

0 = None
A = Fan speed switch
H = Customer Supplied Terminal - STAT Interface
L = Tracer® UC400-B
M = Tracer® UC400-B with Wireless Communications Interface (WCI)
N = CSTI with fan status
R = Symbio™ 400-B
T = Symbio™ 400-B with Wireless Communications Interface (WCI)

Digit 29 — Control Options

0 = None
V = Unit-mounted zone sensor module (OALMH and setpoint dial)
W = Wall-mounted zone sensor module (OALMH and setpoint dial)
X = Unit-mounted fan mode switch, Wall-mounted (setpoint dial)
Y = Unit-mounted fan mode switch, Wall-mounted zone sensor (setpoint dial, ON/CANCEL, comm. jack)
Z = Unit-mounted zone sensor module (OALMH, setpoint dial, ON/CANCEL buttons)
1 = Wall-mounted zone sensor module (ON/CANCEL buttons, comm. jack)
2 = Wall-mounted zone sensor module (OALMH, setpoint dial, ON/CANCEL, comm. jack)
4 = Wall-mounted digital zone sensor (OALMH, setpoint, ON/CANCEL, comm. jack)
6 = Wireless zone sensor (setpoint dial, occupied/unoccupied buttons)
7 = Wireless display sensor, unit receiver (OALMH)
8 = Unit-mounted variable speed control
9 = Wall-mounted variable speed control
A = Wall-mounted
B = Unit-mounted

Digit 30 — IAQ (N/A)

0 = None
1 = Dehumidification
3 = Polymer drain pan
4 = Stainless steel drain pan

Digit 31 — FLA Motor Option

0 = Standard FLA ECM
A = Reduced FLA ECM

Digit 32 - Control Option

0 = None
A = Low limit sensor
B = Condensate overflow
C = Low limit and condensate overflow



Model Number Descriptions

Digit 33 — Main Valve Type

0 = None
A = 2-way, 2 position N.C.
B = 2-way, 2 position N.O.
C = 3-way, 2 position N.C.
D = 3-way, 2 position N.O.
E = 2-way, Modulating
F = 3-way, Modulating
G = 2-way, Analog (2–10 Vdc)
H = 3-way, Analog (2–10 Vdc)
J = Field supplied, 2 position N.C.
K = Field supplied, 2 position N.O.
L = Field supplied, Modulating
M = Field supplied, Analog (2–10 Vdc)

Digit 34 — Cv Main Valve

0 = None
A = 2-way 1.4 Cv
B = 2-way 2.4 Cv
C = 2-way 3.4 Cv
D = 3-way 1.0 Cv
E = 3-way 2.7 Cv

Digits 35 — Auxiliary Valve Type

0 = None
A = 2-way, 2 position N.C.
B = 2-way, 2 position N.O.
C = 3-way, 2 position N.C.
D = 3-way, 2 position N.O.
E = 2-way, Modulating
F = 3-way, Modulating
G = 2-way, Analog (2–10 Vdc)
H = 3-way, Analog (2–10 Vdc)
J = Field supplied, 2 position N.C.
K = Field supplied, 2 position N.O.
L = Field supplied, Modulating
M = Field supplied, Analog (2–10 Vdc)

Digits 36 — Cv Auxiliary Valve

0 = None
A = 2-way 1.4 Cv
B = 2-way 2.4 Cv
C = 2-way 3.4 Cv
D = 3-way 1.0 Cv
E = 3-way 2.7 Cv

Digit 37 — Main Auto Flow GPM

0 = None
A = 0.75
B = 1.0
C = 1.5
D = 2.0
E = 2.5
F = 3.0
G = 3.5
H = 4.0
J = 4.5

Digit 38 — Auxiliary Auto Flow GPM

0 = None
A = 0.75
B = 1.0
C = 1.5
D = 2.0
E = 2.5
F = 3.0
G = 3.5
H = 4.0
J = 4.5

General Data

Unit Configuration

Model A Vertical Concealed

Figure 3. Model A airflow options

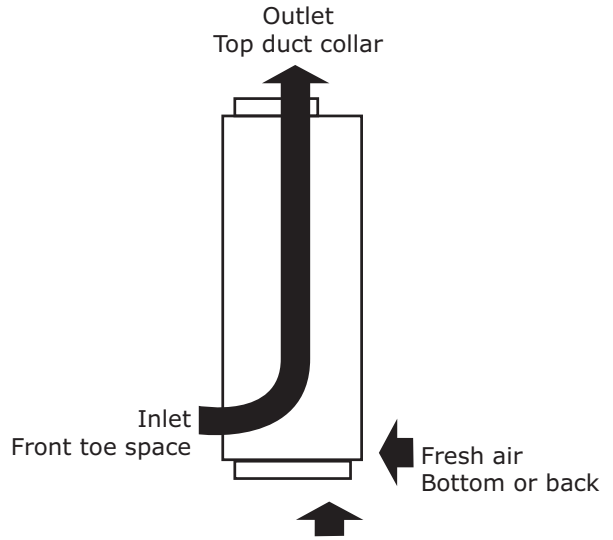
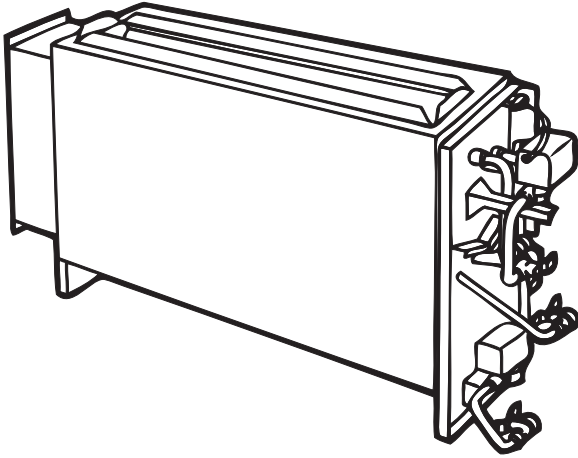

Model B Vertical Cabinet

Figure 4. Model B airflow options

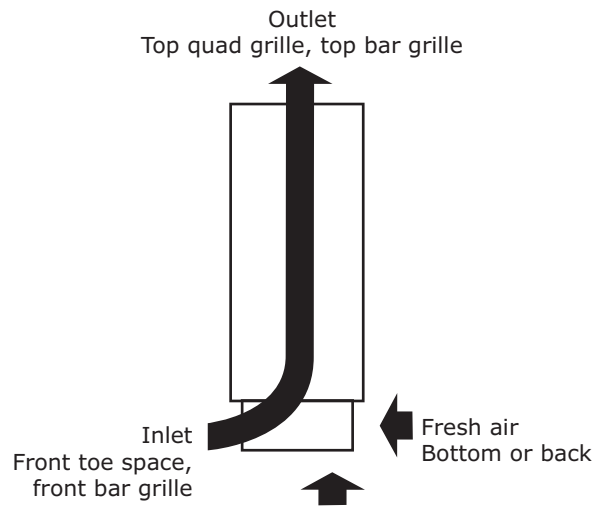
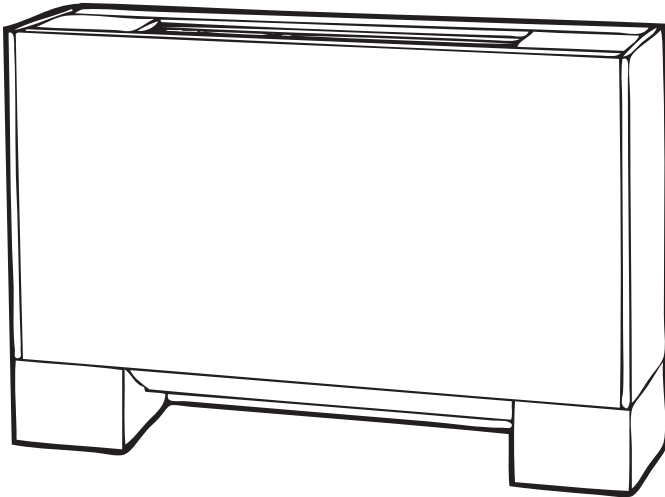

Model C Horizontal Concealed

Figure 5. Model C airflow options

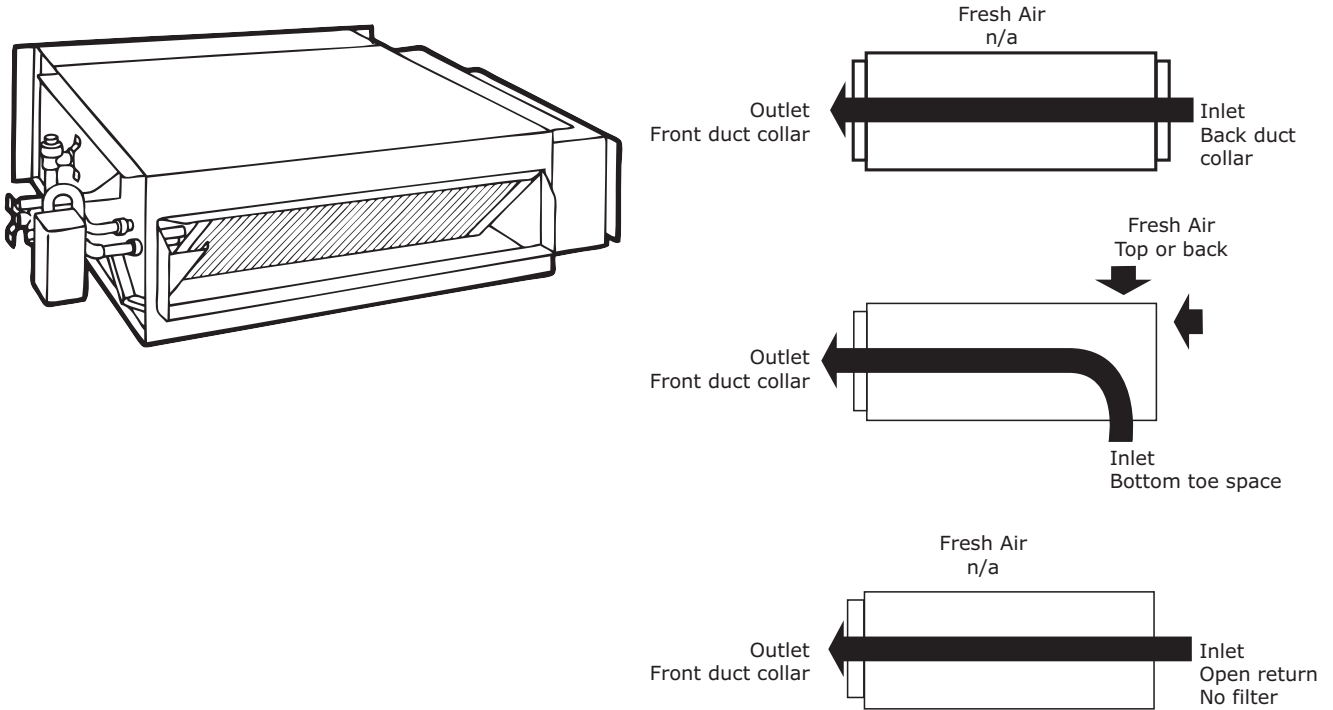

Model D Horizontal Cabinet

Figure 6. Model D airflow options

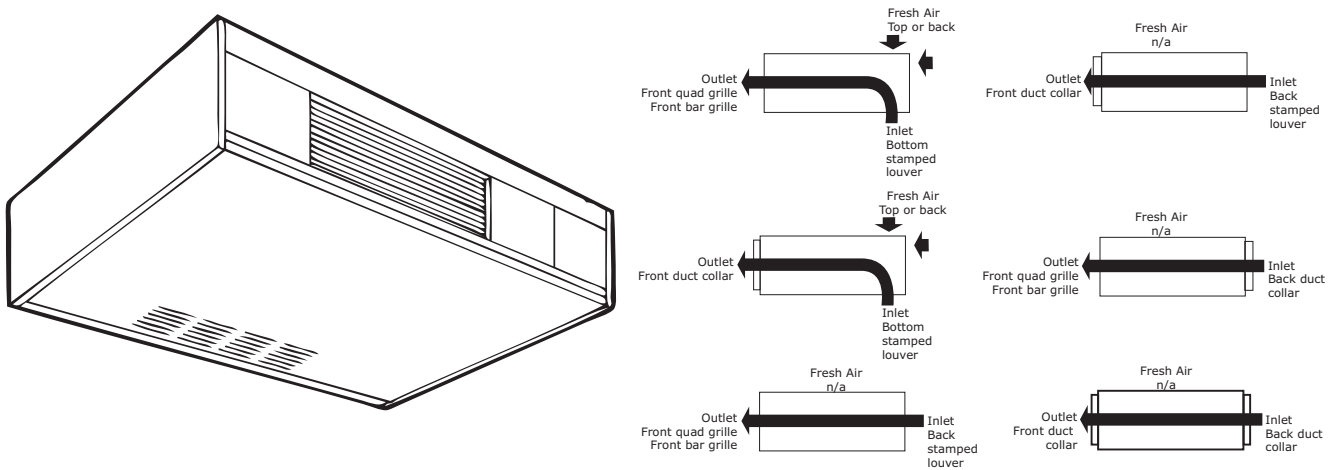

Model E Horizontal Recessed

Figure 7. Model E airflow options

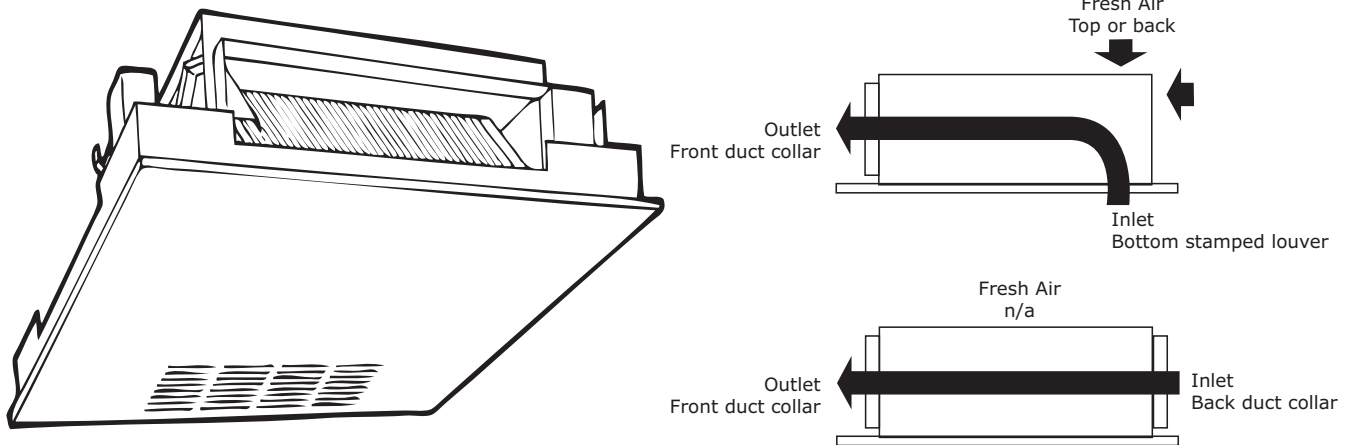

Model H Vertical Recessed

Figure 8. Model H airflow options

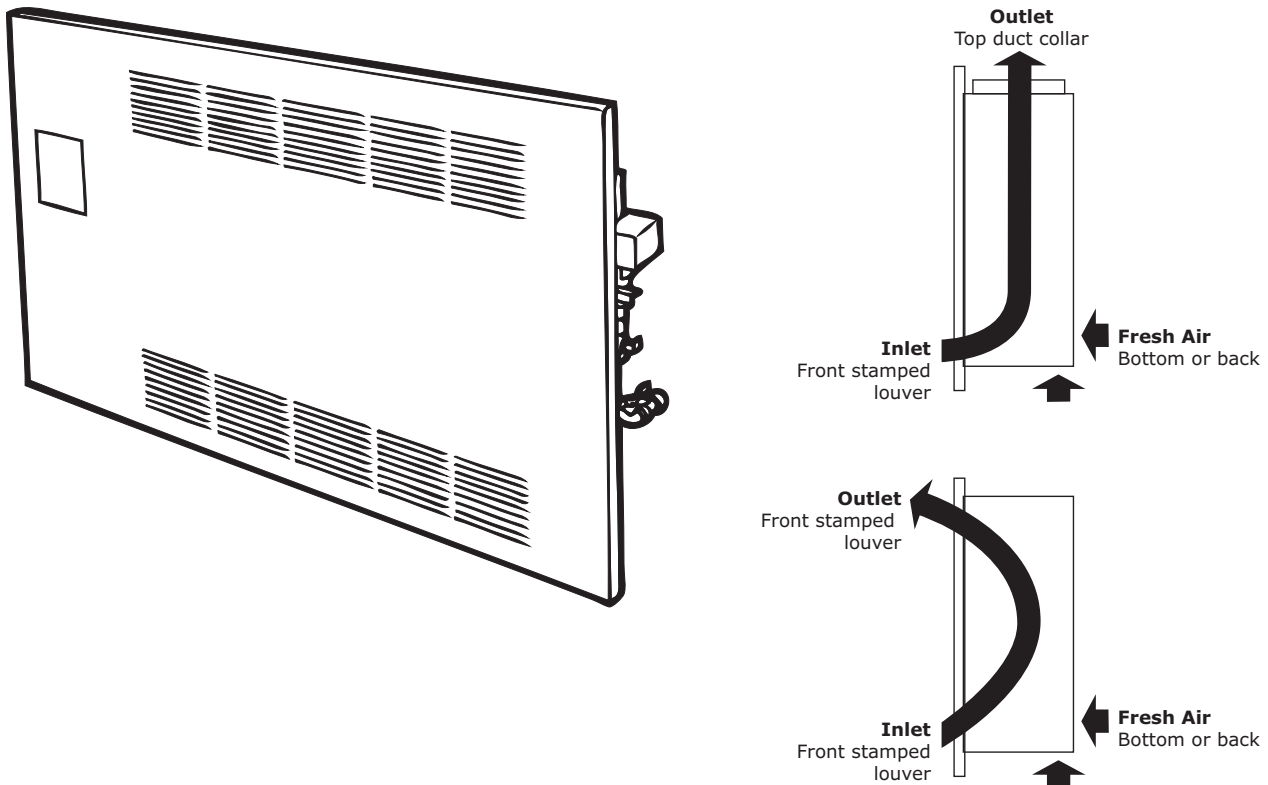

Model J Vertical Slope Top Cabinet

Figure 9. Model J airflow options

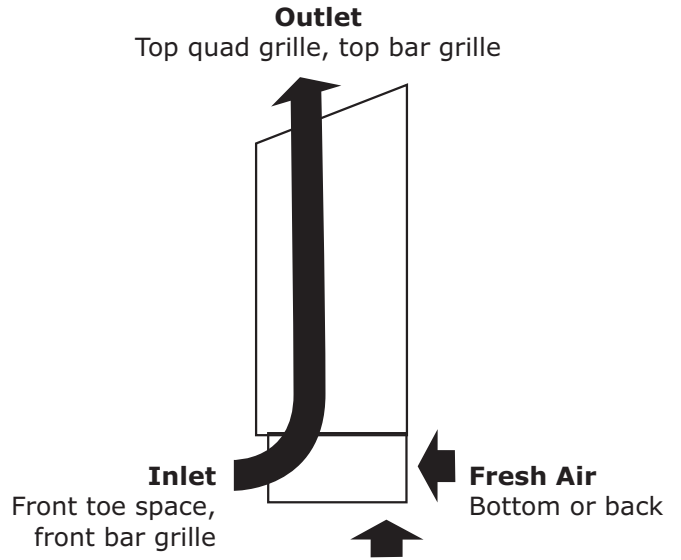
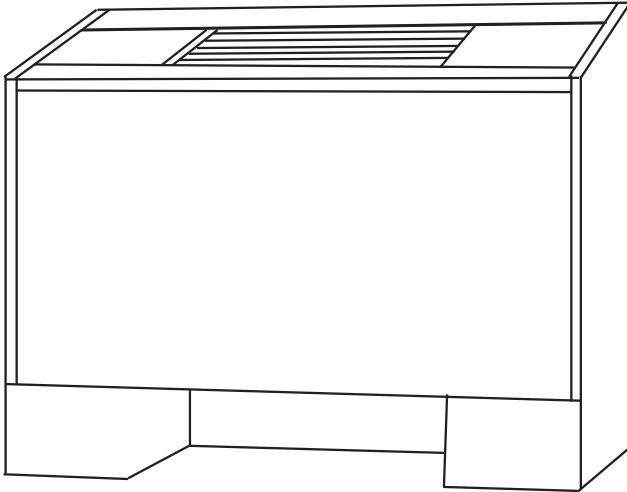

Model K Low Vertical Concealed

Figure 10. Model K airflow options

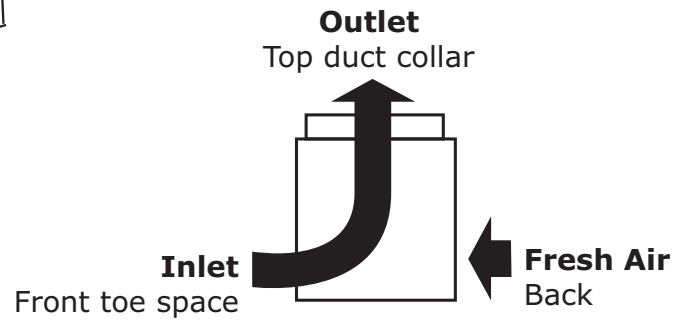
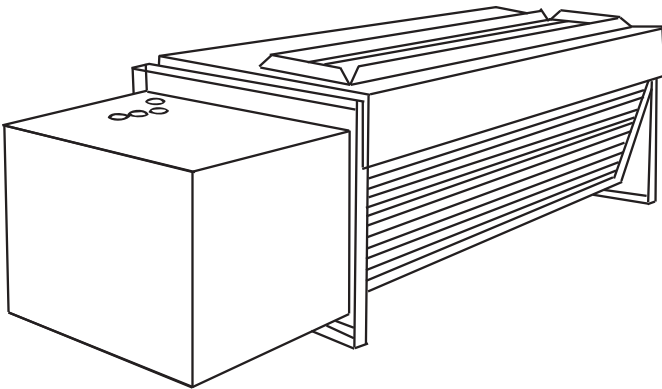

Model L Low Vertical Cabinet

Figure 11. Model L airflow options

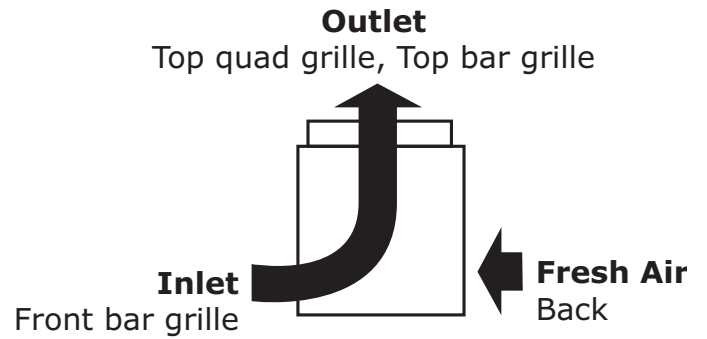
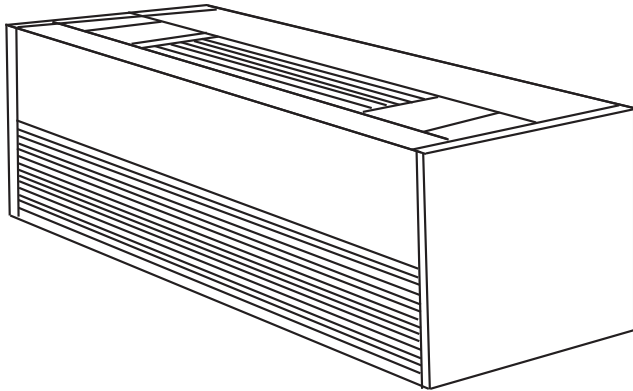

Model P Compact Concealed

Figure 12. Model P airflow options

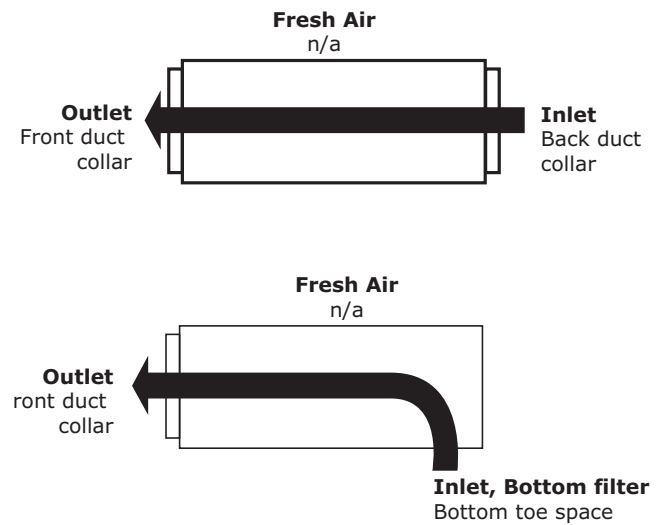
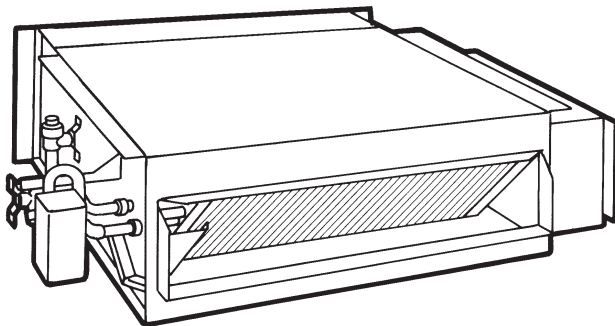



General Data

Fan Coil Data

Table 1. Fan coil component data

Unit Size	02	03	04	06	08	10	12
Coil Data							
Face Area (ft ²)	0.80	0.80	1.10	1.60	2.10	3.20	3.20
L x D x H (in.)							
2-Row	15 x 1.7 x 8	15 x 1.7 x 8	20 x 1.7 x 8	29.5 x 1.7 x 8	38 x 1.7 x 8	57 x 1.7 x 8	57 x 1.7 x 8
3-Row	15 x 2.6 x 8	15 x 2.6 x 8	20 x 2.6 x 8	29.5 x 2.6 x 8	38 x 2.6 x 8	57 x 2.6 x 8	57 x 2.6 x 8
4-Row	15 x 3.5 x 8	15 x 3.5 x 8	20 x 3.5 x 8	29.5 x 3.5 x 8	38 x 3.5 x 8	57 x 3.5 x 8	57 x 3.5 x 8
Volume (gal.)							
1-Row (Heat)	0.06	0.06	0.08	0.11	0.14	0.21	0.21
2-Row	0.12	0.12	0.15	0.22	0.28	0.42	0.42
3-Row	0.18	0.18	0.23	0.33	0.42	0.62	0.62
4-Row	0.24	0.24	0.30	0.44	0.56	0.83	0.83
Refrigerant volume (cubic in.)							
3-Row	----	----	----	76.23	97.02	143.22	----
4-Row	----	----	----	----	----	----	191.73
Fins per inch							
2-Row	12	12	12	12	12	12	12
3-Row	12	12	12	12	12	12	12
3/1-Row high capacity	16	16	16	16	16	16	16
4-Row	12	12	12	12	12	12	12
Reheat Coil Data (1-Row), Standard or High-Capacity¹							
Hot Water or Steam							
Face Area (ft ²)	0.60	0.60	0.80	1.20	1.60	2.40	2.40
L x D x H (in.)	15 x 1.5 x 6	15 x 1.5 x 6	20 x 1.5 x 6	29.5 x 1.5 x 6	38 x 1.5 x 6	57 x 1.5 x 6	57 x 1.5 x 6
Volume (gal.)	0.12	0.12	0.15	0.22	0.28	0.42	0.42
Std Capacity ¹ Fins/in.	4	4	4	4	4	4	4
High-Capacity ¹ Fins/in.	12	12	12	12	12	12	12
Fan/Motor Data							
Fan Quantity	1	1	1	2	2	3	3
Size-Dia x Width (in.)	6.31 x 4	6.31 x 6.5	6.31 x 7.5	6.31 x 6.5	6.31 x 7.5	(1) 6.31 x 7.5	6.31 x 7.5
Size-Dia x Width (in.)						(2) 6.31 x 6.5	
Motor Quantity	1	1	1	1	1	2	2
Filter Data							
1-in. Throwaway and Pleated Media							
Quantity	1	1	1	1	1	1	1
Size (in.)	8-7/8 x 19-1/8	8-7/8 x 19-1/8	8-7/8 x 24-1/8	8-7/8 x 33-5/8	8-7/8 x 42-1/8	8-7/8 x 61-1/8	8-7/8 x 61-1/8
1-in. Fresh Air Filter (only on cabinet styles D, E, and H with bottom return and fresh air opening)							
Quantity	1	1	1	1	1	1	1
Size (in.)	5-1/2 x 19-1/8	5-1/2 x 19-1/8	5-1/2 x 24-1/8	5-1/2 x 33-5/8	5-1/2 x 42-1/8	5-1/2 x 61-1/8	5-1/2 x 61-1/8

Note: ¹Standard and high-capacity reheat coils share the same component data except that standard capacity reheat coils have 4 fins/in. while high-capacity reheat coils have 12 fpi.

Table 2. Low vertical fan coil component data

Unit Size	03	04	06
Coil Data			
Face Area (ft ²)	1.10	1.60	2.10
L x D x H (in.)			
2-Row	20 x 1.7 x 8	29.5 x 1.7 x 8	38 x 1.7 x 8
3-Row	20 x 2.6 x 8	29.5 x 2.6 x 8	38 x 2.6 x 8
Volume (gal.)			
1-Row (Heat)	0.08	0.11	0.14

Table 2. Low vertical fan coil component data (continued)

Unit Size	03	04	06
2-Row	0.15	0.22	0.28
3-Row	0.23	0.33	0.42
Fins per inch			
2-Row	12	12	12
3-Row	12	12	12
Fan/Motor Data			
Fan Quantity	1	1	1
Size — Dia x Width (in.)	5.00 x 23.00	5.00 x 32.00	5.00x 41.00
Motor Quantity	1	1	1
Filter Data			
1-in. Throwaway			
Quantity	1	1	1
Size — in.	8-7/8 x 24-1/8	8-7/8 x 33-5/8	8-7/8 x 42-1/8

Note: Low vertical model not available for Force Flo cabinet heaters.

Table 3. Fan coil air flow (cfm), hydronic only

FC	Coil	External Static Pressure (ESP)				
		FD	High Static			
			0.05	0.10	0.20	0.30
02	2-row	246	344	314	283	251
	3-row	242	352	319	284	249
	4-row	222	326	295	263	230
03	2-row	313	410	380	350	319
	3-row	309	391	358	324	290
	4-row	276	360	330	299	267
04	2-row	381	446	410	373	336
	3-row	365	544	506	467	427
	4-row	340	506	470	434	397
06	2-row	609	757	700	642	582
	3-row	604	880	824	766	707
	4-row	557	812	760	706	652
08	2-row	790	1014	950	885	819
	3-row	724	992	927	861	794
	4-row	676	930	870	808	745
10	2-row	1015	1284	1199	1113	1024
	3-row	1052	1456	1360	1262	1162
	4-row	988	1366	1276	1183	1089
12	2-row	1105	1424	1330	1234	1134
	3-row	1074	1514	1419	1320	1219
	4-row	993	1421	1330	1238	1144



Performance Data

UniTrane™ fan coil performance data is submitted to AHRI 440. For performance data specific to your operating conditions, please use Trane Select Assist which can be accessed at traneselectassist.com.



Controls

Why Trane Controls?

Trane offers a broad range of control packages from a field convertible end-device package, to a complete building automation system solution with BACnet® or LonTalk® controls.

Trane controls are factory-mounted, -wired, -tested and configured or programmed with Trane application expertise to provide comfort, efficiency, and reliability, as well as single-source warranty and service.

Note: *Some Trane controllers have the ability to be pre-addressed in the factory. If addressing isn't provided, the controllers will remain at the default setting.*

With Trane integrated controls, the installed costs are lower because the equipment has turn-key factory controls and every component of the system is optimized to fit with the controller. Trane installs not only the controller, but also the hardware that works intimately with the controller to allow the system to function properly (i.e., piping package, valves, dampers, actuators, etc.). When a product with Trane controls arrives on the jobsite, it is completely ready for quick installation.

Table 4. Tracer® controller input/output summary

	UC400-B/Symbio™ 400-B
Binary outputs	
Single zone VAV	X
3-speed fan	
2-position hydronic valve	X
2-position mixing box damper	X
Electric heat	X
Modulating mixed air damper	X
Modulating hydronic valve	X
Reheat (hydronic)	X
Generic	X
Binary inputs	
Condensate overflow detection	X
Low temperature detection	X
Occupancy	X
Generic input	X
Analog inputs	
Zone temperature	X
Setpoint	X
Hydronic valve	X
Fan mode: auto, high, medium, low	X
Entering water	X
Discharge air	X
Outside air	X
Generic	X

Table 5. Controller function summary

Control functions	UC400-B/Symbio™ 400-B
Entering water temp. sampling (purge)	X
Timed override	X
Auto changeover	X
Fan cycling	X
Warm-up	X
Pre-cool	X
Data sharing (client/server)	
Random start	X
Dehumidification	
DX cooling	X
DX frost protection	X
Air-Fi® Factory Addressing	X

Table 5. Controller function summary (continued)

Control functions	UC400-B/Symbio™ 400-B
Other Functions	
Manual test	X
Filter maintenance timer	X
Setpoint limits	X

Control Options

Available control options:

- Fan speed control (provided when no control package is selected)
- Customer-supplied terminal interface (CSTI)
- UC400-B/Symbio™ 400-B controller with Air-Fi® Wireless Communications Interface

Fan Speed Control with Standard Adapter Board

Figure 13. Fan speed control

The fan speed control is available for units that do not have Trane factory-mounted control packages. This variable fan speed option is low-voltage and has three 24-volt relays using a factory-wired transformer and relays to control the fan motor.

The adapter allows direct customer interfacing through the use of terminal strips. Standard interfacing includes variable speed (0 to 10V) inputs.

The standard adapter board eliminates many separate wiring harnesses in the panel and allows simple, mistake-proofed single-plug interfacing of:

- VelociTach™ motor control board
- Transformers
- Motors
- Valves
- Dampers
- Electric heat control
- Fan speed control

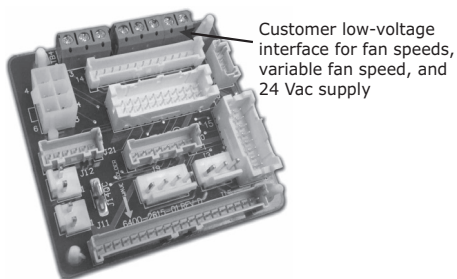
Figure 14. Standard adapter board

Customer Supplied Terminal Interface (CSTI)

The CSTI is intended to be used with a field-supplied, low-voltage thermostat or controller. The control box contains a relay board which includes a line voltage to 24-volt transformer and disconnect switch (for non-electric heat units). All end devices are wired to a low-voltage terminal block and are run-tested, so the only a power connection and thermostat connection is needed to commission the unit. Changeover sensors and controls are provided when a change-over coil is selected. When N.O. valves are selected, inverting relays are provided for use with standard thermostats.

Figure 15. CSTI adapter board and field connections

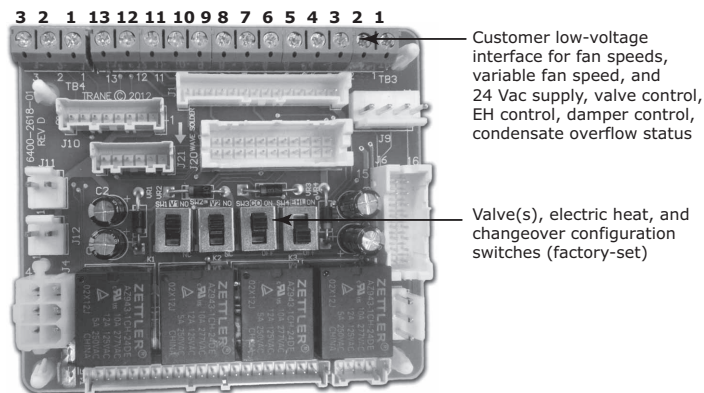

The CSTI adapter board provides all the hookups as the standard adapter board, but in addition, provides hookups for valve control (main and auxiliary coils), electric heat control, and damper control. Screw terminal blocks provide convenient access to fan controls and to end device control. In addition, a courtesy 10 Vdc supply is provided for use with an external potentiometer or rheostat. The 10 Vdc supply supports up to 10 mA draw.

Thermostat

The low voltage, wall mounted thermostat is available field installed. Thermostat control is available with 2 position valves, 2 position damper actuators, low limit protection, and condensate overflow protection. The thermostat is capable of controlling cooling (hydronic or DX), heating (hydronic, electric heat or steam), and automatic changeover all with continuous fan or thermostat controlled fan speeds.

Figure 16. Wall mounted thermostat and unit mounted thermostat



UC400-B/Symbio™ 400-B Controller

The UC400-B/Symbio™ 400-B single-zone VAV controller can be used in a stand-alone application or as part of a Tracer® control system.

The Symbio™ 400/Symbio™ 400-B is a multi-purpose, programmable (or application-specific) controller that provides direct-digital zone temperature control. The controller can operate as a stand-alone device or as part of a building automation system (BAS). Communication between the controller and a BAS

occurs on an open standard with inter-operable protocols used in Building Automation and Control Networks (BACnet®). Programming is done by means of the Tracer® TU service tool.

The Symbio™ 400-B is designed as a one-to-one replacement for UC400-B.

In the stand-alone configuration, UC400-B/Symbio™ 400-B receives operation commands from the zone sensor and/or the auto changeover sensor (on auto changeover units). The entering water temperature is read from the auto changeover sensor and determines if the unit is capable of cooling or heating. The zone sensor module is capable of transmitting the following information to the controller:

- Timed override on/cancel request
- Zone setpoint
- Current zone temperature
- Fan mode selection (off-auto-high-med-low)

For optimal system performance, units can operate as part of a Tracer® SC building automation system. The controller is linked directly to the Tracer® SC via a twisted pair communication wire, requiring no additional interface device (i.e., a command unit). The Tracer® control system can monitor or override UC400-B/ control points. This includes such points as temperature and output positions.

Tracer® Controller Features

The Tracer® family of controllers and UC400-B/Symbio™ 400-B offer the combined advantages of simple and dependable operation with the latest Trane-designed controller. Standard control features include options normally available on more elaborate control systems. All control options are available factory-configured or can be field-configured using Tracer® TU service software. For more detailed information, refer to Trane installation manuals BAS-SVX48*-EN (for UC400-B), or BAS-SZX093*-EN (for Symbio™ 400-B).

Features Available on All Controllers

The following control functions are standard features on units with or UC400-B/Symbio™ 400-B.

Entering Water Temperature Sampling Function

A system that uses a two-way control valve option might not sense the correct entering water temperature during long periods when the control valve is closed. If the demand for heating or cooling does not exist for a long period, the entering water will eventually approach ambient temperature.

Using the entering water temperature sampling function, the controller provides accurate two-pipe system changeover-without sacrificing the benefits of two-way control valves. Also, it eliminates inefficient bleed or bypass lines that can allow unnecessary waterflow through the system.

This function periodically samples the entering water temperature by opening the hydronic valve. The valve opens for 20 seconds to allow the water temperature to stabilize. Then the controller reads the entering water temperature for up to three minutes to see if the correct water temperature is available for the selected operating mode.

The entering water temperature must be five degrees or more above the space temperature to allow hydronic heating and five degrees or more below the space temperature to allow hydronic cooling. If the correct water temperature for the operating mode is available, the unit begins normal heating or cooling operation. If the correct water temperature is not available, the controller closes the control valve and waits 60 minutes before attempting to sample the entering water temperature again.

A factory-mounted thermistor senses the entering water temperature on changeover cooling/ heating coil units. If the fan coil has a factory-mounted piping package, the sensor is strapped to the entering water pipe. If the fan coil does not have a piping package, the sensor is coiled in the end pocket for mounting on customer-supplied piping. This sensor must detect accurate water temperature for proper changeover.

Automatic Heat/Cool Mode Determination

The controller automatically determines whether heating or cooling is needed-based on space and system conditions. Using a proportional/integral (PI) control algorithm to maintain the space temperature at the active heating or cooling setpoint. The controller measures the space temperature and active setpoint temperature to determine the unit's heating or cooling capacity (0 to 100%).

Occupied/Unoccupied Operation

The occupancy input uses a binary switch (i.e., motion sensor, time clock, etc.) that allows the zone sensor to use its unoccupied internal setpoints.

Random Start

This feature randomly staggers multiple unit start-up to reduce electrical demand spikes.

Warm-up

The two-position fresh air damper option closes during the occupied mode when the space temperature is three degrees or more below the heating setpoint temperature. The damper remains closed during warm-up until the space temperature is within two degrees of the heating setpoint temperature.

Cool-down

The two-position fresh air damper option closes during the occupied mode when the space temperature is three degrees or more above the cooling setpoint temperature. The damper remains closed during cool-down until the space temperature is within two degrees of the cooling setpoint temperature.

Manual Output Test

This function may be initiated from the blue test push button on the controller or through the Tracer® TU service tool. This feature is used to manually exercise the outputs in a defined sequence.

The purpose of this test sequence is to verify output and end device operation. The manual output test function may also be used in the following situations:

- Reset latching diagnostics
- Verify output wiring and operation
- Force the water valve(s) open to balance the hydronic system during installation set-up or service.

Peer-to-Peer Communication (UC400-B/Symbio™ 400-B)

Peer-to-peer communication allows multiple units in one space to share the same zone sensor and provide simultaneous heating and cooling. On the UC400-B/Symbio™ 400-B, zone sensor data sharing can be accomplished by use of the BAS system controller.

A thermistor to sense fresh air is factory-mounted at the unit's fresh air opening for use in economizer applications or as a read-only point for Tracer® SC. If the fresh air temperature is a read-only value, it will not impact the control algorithm. In an economizer application, a fresh air temperature signal must be provided either by this thermistor, Tracer® SC.

Additional Features

Single Zone VAV with Fully Modulating Fan Speed (UC400-B/Symbio™ 400-B)

The UC400-B/Symbio™ 400-B will minimize fan speed, and in turn energy usage, by only delivering the air flow needed.

Figure 17. Cool mode nominal hydronic cooling control

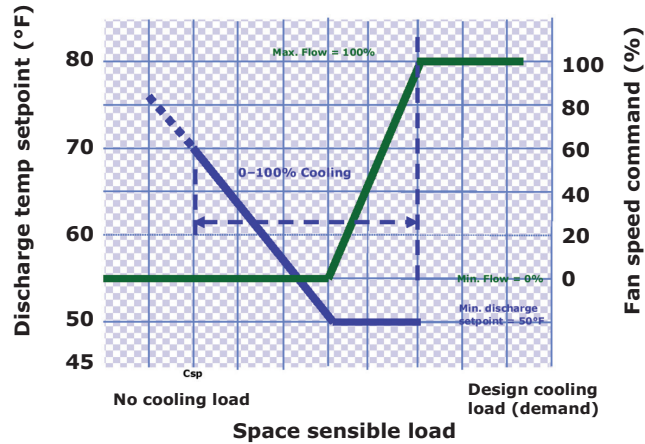

Automatic Fan and Ventilation Reset

A two-speed fan control for the unit delivers the airflow output customized to support the cfm space needs. When less cfm is necessary to meet the load of the classroom (typically 75 to 80 percent of the time), the equipment operates on low speed. However, if the room temperature rises, the controller will switch to high speed, and the outside air damper will adjust to satisfy the space needs. This helps maintain the proper amount of ventilation air to the occupants independent of the fan speed. As part of the ventilation strategy, the controller will reposition the outside air damper to confirm the minimum outside air cfm is met at both operating conditions.

Filter Maintenance

Filter status for the controller is based on the cumulative run hours of the unit fan. The controller compares the amount of fan run time against an adjustable fan run hour (stored in the controller) to determine when maintenance is recommended for the unit. The run-hours value may be user edited as required (through Tracer® TU). The valid range for the fan run hours limit is 0 to 5000 hours with a default of 600 hours. Once the run hours limit has been exceeded, the controller generates a *maintenance required diagnostic* (unit will not shutdown). The user will be notified of this diagnostic through the building automation system or when a Trane service tool is communicating with the controller.

Active Dehumidification

On units with reheat coils, the controller can provide active dehumidification. This means that the relative humidity in the space can be kept below an adjustable setpoint independent of outdoor weather conditions. Indoor humidity levels are recommended by ASHRAE to be kept below 60 percent in order to minimize microbial growth and the life span of airborne illness causing germs.

Client Server (Data Sharing)

The controller can send or receive data (setpoint, heat/cool mode, fan request, space temperature, etc.) to and from other controllers on the communication link with or without the existence of a building automation system. This applies to applications where multiple units might share one zone sensor for both stand-alone (with communication wiring between units) and a building automation system.

Water Valve Override

The controller can be commanded via the Tracer® TU to open all hydronic valves 100 percent. This allows for the faster water balancing of each unit and the entire system when the command is sent globally to all controllers. A properly balanced system is essential for proper and efficient operation.

Hydronic Coil Freeze Protection (Freeze Avoidance)

Systems in cold climates need to take precautions to avoid hydronic coil freeze-up. The controller does this from three different aspects. Any of these methods of protections will result in the unit fan being disabled, the outside air damper being shut, and the hydronic valves being opened 100 percent.

The three methods of freeze avoidance include:

1. A binary freeze protection thermostat is mounted on the coil and will cause a latching diagnostic if the coil temperature falls below 35°F.
2. An analog discharge air sensor monitors the temperature of the air coming off of the coil and if the temperature falls below 40°F the outside air damper is closed, the fan is turned off and the valves are fully opened.
3. When in the unoccupied mode, the controller has an adjustable freeze avoidance setpoint. If the outside air temperature is below the setpoint, the unit will open the valves to allow water to flow through the coils.

Interoperability

Interoperability allows the owner freedom to select multiple vendors, and multiple products. With this advantage, the owner can choose the best products, the best application, and the best service from a variety of suppliers to meet their evolving building control needs in a cost effective manner.

Generic Binary Input/Output

The three generic binary inputs/outputs are not part of the normal control, but are actually controlled through the Tracer® SC system (when present) to issue commands to the controller to turn the generic inputs/outputs of add-on equipment (such as baseboard heating, exhaust fans, occupancy sensors, lighting, etc.) on and off. This binary port is not affected when other binary diagnostics interrupt unit operation.

Tracer® Controls Sequence of Operation

Fan Speed Control

A fan speed control is supplied on units with fan control or CSTI options. It provides variable speed of the motor RPM between the low and high speed factory settings.

UC400-B/Symbio™ 400-B

Off: Fan is off; control valve options and mixing box damper options close. The low air temperature detection option is still active.

Auto: Fan speed control in the auto setting allows the modulating control valve option and single- or three-speed fan to work cooperatively to meet precise capacity requirements, while minimizing fan speed (motor/energy/acoustics) and valve position (pump energy/chilled water reset). As the capacity requirement increases at low fan speed, the water valve opens. When the low fan speed capacity switch point is reached, the fan switches to the next higher speed and the water valve repositions to maintain an equivalent capacity. The reverse sequence takes place with a decrease in required capacity.

Units with three-speed fans on low, medium, or high: The fan runs continuously at the selected speed and the valve option cycles to meet setpoint.

Air-Fi® Wireless Systems

For more detailed information on Air-Fi® Wireless systems and devices, see:

- BAS-SVX40*: *Air-Fi® Wireless Installation, Operation, and Maintenance*
- BAS-PRD021*-EN: *Air-Fi® Wireless Product Data Sheet*
- BAS-SVX55*: *Air-Fi® Wireless Network Design*

Air-Fi® Wireless Communications Interface (WCI)



A factory-installed Air-Fi® Wireless Communications Interface (WCI) provides wireless communication between the Tracer® SC and Tracer® unit controllers. The Air-Fi® WCI is the perfect alternative to a Trane BACnet® wired communication link. Eliminating the communication wire between terminal products, space sensors, and system controllers has substantial benefits:

- Reduced installation time and associated risks.
- Completion of projects with fewer disruptions.
- Easier and more cost-effective re-configurations, expansions, and upgrades

Air-Fi® Wireless Communications Sensor (WCS)



Communicates wirelessly to a Tracer® unit controller. A WCS is an alternative to a wired sensor when access and routing of communication cable are issues. A WCS allows flexible mounting and relocation.

Wireless Zone Sensor (WZS) Set









A wireless zone sensor (WZS) set (sensor and receiver) communicates wirelessly to a Tracer® unit controller. A wireless zone sensor set is an alternative to a wired sensor when access and routing of communication cable are issues. The sensor allows flexible mounting and relocation.

Note: A wireless zone sensor set is not compatible with an Air-Fi® wireless system.

Zone Sensor Options

Zone sensor options are available as either unit-mounted (factory-installed), wall-mounted, or split-mounted options for design flexibility. The unit-mounted sensor option includes a thermistor in the return air path of the unit. Wall-mounted zone sensor options have an internal thermistor. Zone sensors operate on 24 Vac. Options with setpoint knobs are available in Fahrenheit or Celsius.

UC400-B/Symbio™ 400-B Controller Options

<p>Figure 18. Unit-mounted temperature sensor (SP, OALMH, OCC/UNOCC)</p> 	<p>Figure 19. Wall-mounted display temperature sensor (SP, OCC/UNOCC, OALMH, COMM)</p> 	<p>Figure 20. Wall-mounted temperature (OCC/UNOCC, COMM)</p> 
<p>Figure 21. Wall-mounted temperature sensor (SP, OCC/UNOCC, OALMH, COMM)</p> 	<p>Figure 22. Split-mounted zone sensor, unit-mounted fan speed control, wall-mounted temperature sensor (SP, OCC/UNOCC, COMM)</p> 	<p>Figure 23. Wall-mounted wireless zone sensor (WZS) with setpoint adjustment, (OCC/UNOCC) no fan speed adjustment, and unit-mounted receiver</p> 

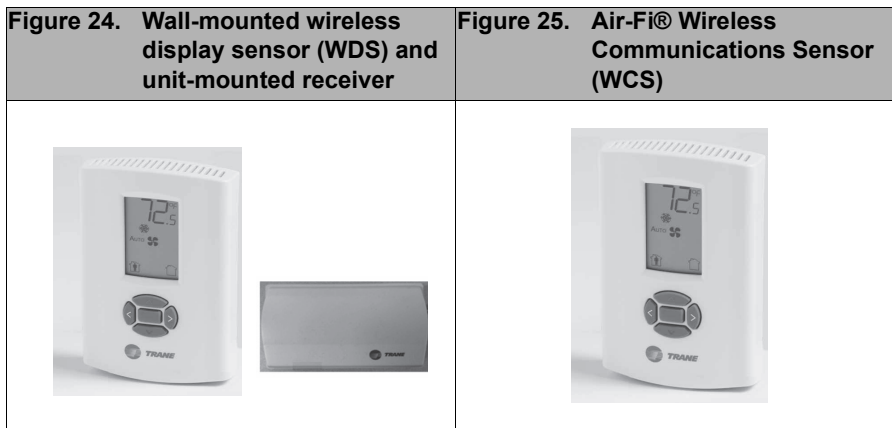

End Device Options

All end device options are factory-installed and -tested.

Table 6. End device option availability

Device	UC400-B/Symbio™ 400-B	CSTI
Condensate float switch	X	X
Low limit	X	X
Filter run-time diagnostic	X	
Fan status	X	X
2-position control valves	X	X
Modulating control valves	X	X
Analog control valve	X	X
2-position fresh air actuator	X	X
Modulating fresh air actuator	X	
Electric heat	X	X
Frostat™ protection (DX coils)	X	X

Notes:

1. The UC400-B/Symbio™ 400-B are factory-provided controls that control the end devices listed in the table.
2. CSTI provides an adapter board with screw down terminals for wiring to end devices for a field-supplied controller.

Actuators

Two-Position Fresh Air Damper Actuator

Figure 26. Two-position fresh air damper actuator

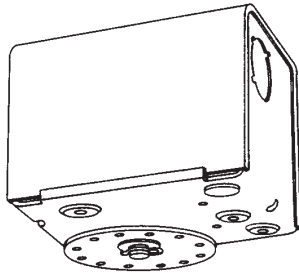

This damper actuator uses a 24 V signal and is factory-wired and mounted to the damper assembly. It allows zero to 50 percent fresh air. The damper will drive open to an adjustable mechanical stop-position whenever the fan is running during occupied mode and will spring-return closed when the fan turns off.

Note: *Trane recommends using the low temperature detection option with fresh air dampers to detect possible freeze conditions.*

Economizer Fresh Air Damper Actuator (UC400-B/Symbio™ 400-B)

Figure 27. Economizer fresh air damper actuator

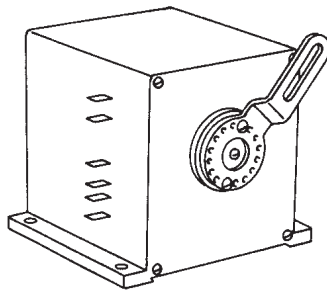

This option is a three-wire floating point, spring-return damper actuator and is factory-wired and mounted to the damper assembly. When the controller enables the economizer and the unit is in occupied mode, the fresh air damper modulates between its minimum position (editable) and the full open position to maintain setpoint temperature. If economizer operation stops or if the unit is in the heating mode, the fresh air damper adjusts to its minimum position.

Note: *Trane highly recommends using the low temperature detection option with a fresh air damper to detect possible freeze conditions.*

Detection Devices

Low Temperature Detection

Figure 28. Low temperature detection device

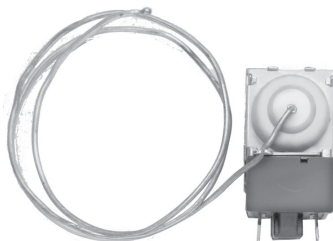

When the low temperature detection device senses an entering air temperature of 36°F to the hydronic coil, the normally-closed switch opens a corresponding set of binary input terminals. The fan disables, control valves open, and the fresh air damper closes.

The low temperature detection device is an averaging type capillary tube and will reset when it detects an entering air temperature of at least 44°F.

Condensate Overflow Detection

Figure 29. Condensate overflow detection device

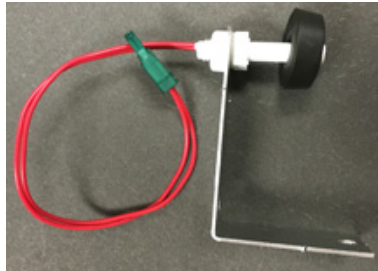

A float switch is factory-supplied for field installation in the auxiliary drain pan to detect a high condensate water level. When the float switch rises, the normally closed input opens a corresponding set of binary input terminals. With Trane controls installed, this also causes the fan to disable, and the control valve and fresh air damper options to close. Although the float switch will close when the high condensate level recedes, the controller must be manually reset before normal unit operation can occur. If using a UC400-B/Symbio™ 400-B controller, you can reset. Use Tracer® TU for units with a UC400-B/Symbio™ 400-B. When wired to the CSTI, the switch does not de-energize the unit when open position occurs. This is a dry contact only and sequence of operation of unit when this condition is reached is the responsibility of the field provided controller or thermostat.

Frostat™ Temperature Switch

Figure 30. Frostat™ temperature switch

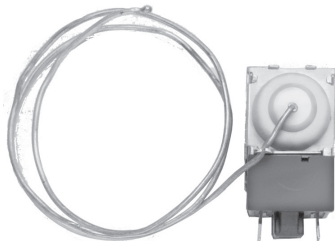

When the Frostat switch senses a coil temperature of 39° F, the Frostat switch will open and the DX signal to the condenser will be interrupted. This turns off the compressor. The fan coil will continue to operate, allowing the coil to reach a temperature of 55°F. When the coil reaches 55°F, the Frostat will close allowing normal DX operation.

Outside Air Sensor

The outside air sensor is field-mounted to sense the outside air temperature, primarily for use in economizer applications or as a status value when available for other applications.

Control Valves

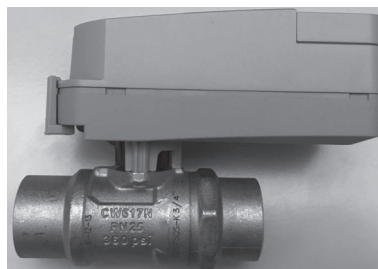

Units with CSTI or UC400-B/Symbio™ 400-B are available with chilled and/or hot water control valves. Control valve options include:

- Analog (2–10 Vdc) (UC400-B/Symbio™ 400-B only)
- Modulating (UC400-B/Symbio™ 400-B only)
- Two-position, normally-open (N.O.) or normally-closed (N.C.)
- Two- or three-way configurations

Three-way valve options allow either full waterflow through the coil or diverted waterflow through the bypass.

Two-Position Control Valves

Two-position valves are capacitor discharge return. Capacitor discharge valves respond to a 24 V signal and will either fully open or close. These valves cannot be driven or actuated to a partially open or closed position. If the valve loses power, it returns to its de-energized position.

Modulating and 2–10 V Analog Control Valves

Modulating and 2–10 V Analog control valves offer an alternative for more precise capacity control by modulating or varying the water flow through the coil. Modulating valves respond to a 24 V signal from the controller, which determines the valve position by a control algorithm. Analog valves travel to the commanded position of the 2–10 V control signal. If the valve loses power, it remains in its current position.

Field-Supplied Valves

This option allows the controller to be factory-configured for a field-supplied valve. A valve wire harness is provided from the control box to the piping side of the unit.

Note: *Trane does not recommend wild coil applications.*

Selecting the Correct Modulating Valve Size

The coefficient of flow is defined as the volume of water flow through a control valve in the fully open position with a 1 psig differential across the valve. It is calculated using the following formula:

$C_v = Q/\text{Square root } \Delta P$ where:

C_v = flow coefficient

Q = flow rate (gpm)

ΔP = pressure drop across the valve or coil (psig).

For good control, the valve C_v should be approximately equal to the C_v of the water coil.

Modulating Valve Selection Example

Assume a size 06 fan-coil is selected to operate at the following conditions:

Vertical Cabinet Fan Coil

Entering water temperature = 45°F

Leaving water temperature = 55°F

EAT conditions = 80/67

The coil is selected as a four-row coil.

Select the best modulating valve size for this unit.

1. Find the ΔP across the water coil. Refer to the AHRI performance table to determine the ΔP across the water coil (or use Trane Select Assist™ selection program). The water pressure drop is found to be 7.0' of water at a flow rate of 3.74 gpm. This converts to a pressure drop of 3.03 psig (1.0 feet of water = 0.4328 psig.)
2. Calculate the C_v of the water coil.
 $C_v = \text{GPM}/\text{Square root } \Delta P$
 $C_v = 3.74/\text{Square root } 3.03$
 $C_v = 2.15$
Therefore, the valve with the C_v of 2.4 should be selected since it has the C_v which is closest to the C_v of the water coil. The following tables illustrate possible valve selections at AHRI conditions for horizontal concealed units with a high static motor and vertical cabinet units with a free discharge motor.

Table 7. Valve availability

Digit 36 and Digit 38	Cv	2-way, 2-position, N.C.	2-way, 2-position, N.O.	3-way, 2-position, N.C.	3-way, 2-position, N.O.	2-way, Modulating	3-way Modulating	2-way, Analog (2–10 Vdc)	3-way, Analog (2–10 Vdc)
A	1.4	X	X			X		X	
B	2.4	X	X			X		X	
C	3.4					X		X	
D	1.0			X	X		X		X
E	2.7			X	X		X		X
F	4.6			X	X		X		X



Electrical Data

MCA and MOP Calculations

Minimum Circuit Ampacity (MCA) and Maximum Overcurrent Protection (MOP) Calculations for fan coils with electric heat (single-phase)

Heater Amps = (Heater kW x 1000)/Heater Voltage

Note: Use 120 V heater voltage for 115 V units. Use 240 V heater voltage for 230 V units.

MCA = 1.25 x (heater amps + all motor FLAs)

MOP = (2.25 x Largest Motor FLA) + Second Motor FLA + Heater Amps (If Applicable)

MOP is required in the branch circuit wiring for all fan coils with electric heat.

Select a standard fuse size or circuit breaker equal to the MOP. Use the next smaller standard size if the MOP does not equal a standard size. Ensure the selected fuse is larger than the MCA. Standard Fuse Sizes are: 15, 20, 25, 30, 35, 40, 45, 50, 60 amps

Fan coil electric heat MBh = (Heater kW) (3.413)

Minimum Circuit Ampacity (MCA) and Maximum Overcurrent Protection (MOP) Calculations for fan coils (motors only, no electric heat)

MCA = (1.25) x [Largest Motor Amperes (FLA)] + Second Motor Amperes (FLA) (Size 10 and 12 only)

MOP = 15 Amps for all Fan Coils without Electric Heat (see previous Electrical Data for units with Electric Heat.)

Electric Heat

Table 8. Electric heat (kW)

Unit Size	Unit Volt	kW	kW	kW	kW	kW	kW	kW	kW	kW	kW
02	115	1.0	1.5	2.0							
	230	1.0	1.5	2.0							
	277	1.0	1.5	2.0							
	208	0.8	1.1	1.5	1.9						
03	115	1.0	1.5	2.0	2.5						
	230	1.0	1.5	2.0	2.5						
	277	1.0	1.5	2.0	2.5						
	208	0.8	1.1	1.5	1.9	2.3					
04	115			2.0	2.5	3.0					
	230			2.0	2.5	3.0					
	277			2.0	2.5	3.0					
	208			1.5	1.9	2.3	3.0				
06	115			2.0		3.0					
	230			2.0		3.0	4.0	5.0	6.0		
	277			2.0		3.0	4.0	5.0	6.0		
	208			1.5		2.3	3.0	3.8	4.5	5.3	
08	115			2.0		3.0					
	230			2.0		3.0	4.0	5.0	6.0	7.0	
	277			2.0		3.0	4.0	5.0	6.0	7.0	
	208			1.5		2.3	3.0	3.8	4.5	5.3	6.0
10	115					3.0					
	230					3.0	4.0	5.0	6.0	7.0	8.0
	277					3.0	4.0	5.0	6.0	7.0	8.0
	208					2.3	3.0	3.8	4.5	5.3	6.0
12	115					3.0					
	230					3.0	4.0	5.0	6.0	7.0	8.0
	277					3.0	4.0	5.0	6.0	7.0	8.0
	208					2.3	3.0	3.8	4.5	5.3	6.0

Table 9. Electric heat (kW), low vertical units

Unit Size	Unit Voltage	kW	kW	kW
03	115	1.0	1.5	2.0
04	115	1.0	1.5	2.0
06	115	1.0	1.5	2.0

Note: Low vertical units are only available with electric heat in combination with the two-row cooling coil.

Motors

Table 10. Free discharge and high static electrically commutated motors (ECMs) programmed to standard ECM mode

Unit Size	115 Volt				208–230 Volt				277 Volt			
	FLA		HP		FLA		HP		FLA		HP	
	1	2	1	2	1	2	1	2	1	2	1	2
02	2.20		0.13		1.40		0.13		1.60		0.24	
03	2.20		0.13		1.40		0.13		1.60		0.24	
04	2.20		0.13		1.40		0.13		1.60		0.24	
06	3.10		0.22		1.80		0.22		1.60		0.24	
08	3.10		0.22		1.80		0.22		1.60		0.24	
10	3.10	2.20	0.22	0.13	1.80	1.40	0.22	0.13	1.60	1.60	0.24	0.24
12	3.10	2.20	0.22	0.13	1.80	1.40	0.22	0.13	1.60	1.60	0.24	0.24

Table 11. Free discharge electrically commutated motors (ECMs) programmed to reduced FLA mode

Unit Size	115 Volt				208–230 Volt				277 Volt			
	FLA		HP		FLA		HP		FLA		HP	
	1	2	1	2	1	2	1	2	1	2	1	2
02	0.60		0.13		0.4		0.13		0.30		0.24	
03	0.60		0.13		0.4		0.13		0.30		0.24	
04	0.80		0.13		0.6		0.13		0.40		0.24	
06	1.10		0.22		0.8		0.22		0.60		0.24	
08	1.60		0.22		1.1		0.22		0.80		0.24	
10	0.70	1.20	0.22	0.13	0.5	0.80	0.22	0.13	0.40	0.60	0.24	0.24
12	0.70	1.30	0.22	0.13	0.5	0.90	0.22	0.13	0.40	0.70	0.24	0.24

Table 12. High static electrically commutated motors (ECMs) programmed to reduced FLA mode

Unit Size	115 Volt				208–230 Volt				277 Volt			
	FLA		HP		FLA		HP		FLA		HP	
	1	2	1	2	1	2	1	2	1	2	1	2
02	1.3		0.13		0.9		0.13		0.7		0.24	
03	1.3		0.13		0.9		0.13		0.7		0.24	
04	1.7		0.13		1.2		0.13		0.9		0.24	
06	2.3		0.22		1.6		0.22		1.2		0.24	
08	3.1		0.22		1.8		0.22		1.5		0.24	
10	1.4	2.0	0.22	0.13	1.0	1.4	0.22	0.13	0.7	1.1	0.24	0.24
12	1.5	2.8	0.22	0.13	1.1	1.8	0.22	0.13	0.8	1.4	0.24	0.24



Electrical Data

Table 13. Low vertical free discharge electrically commutated motors (ECMs)

Unit Size	115 Volt		RPM		
	FLA	HP	H	M	L
03	3.1	0.22	1090	770	560
04	3.1	0.22	1090	750	560
06	3.1	0.22	1115	760	560

Note: Actual rpm will vary with application and configuration.

Table 14. Lowboy vertical free discharge electrically commutated motors (ECMs) programmed with reduced FLA mode

Unit Size	115 Volt		RPM		
	FLA	HP	H	M	L
03	0.5	0.22	1090	770	560
04	0.8	0.22	1090	750	560
06	1.0	0.22	1115	760	560

Note: Actual rpm will vary with application and configuration.

Dimensions and Weights

Service Clearances

Service access is available from the front on vertical units and from the bottom on horizontal units. Cabinet and recessed units have removable front or bottom panels to allow access into the unit.

Figure 31. Recommended service clearances for vertical units

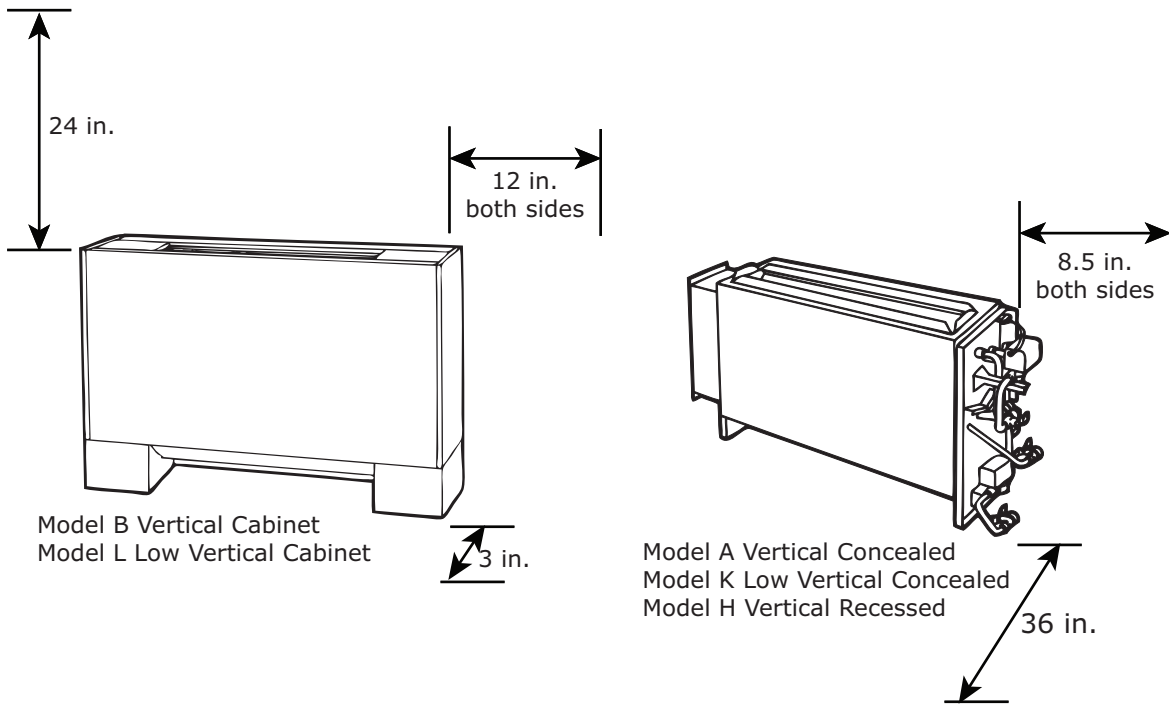
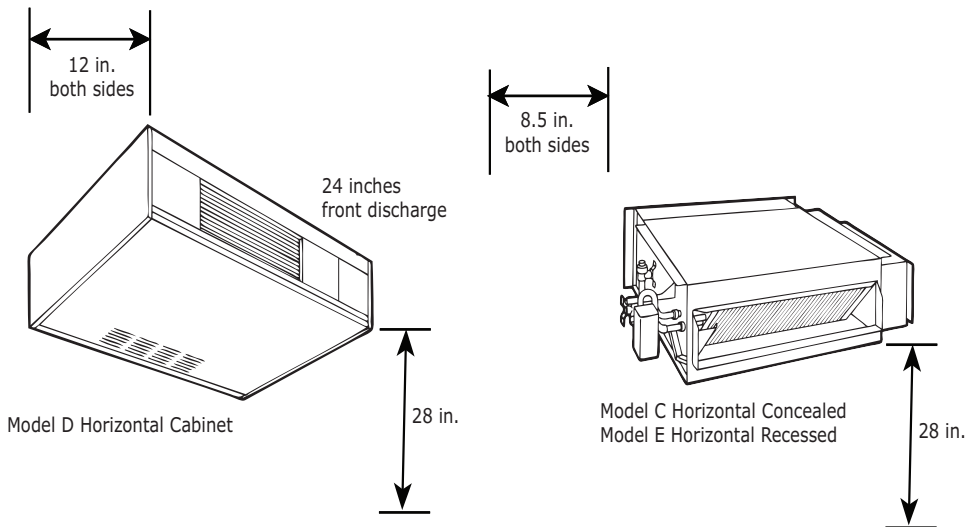

Figure 32. Recommended service clearances for horizontal units



Dimensions and Weights

Model A Vertical Concealed

Figure 33. Model A vertical concealed

Top View

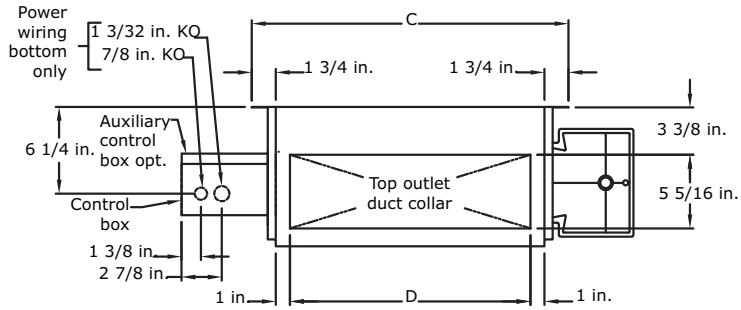

Front View
RH Piping

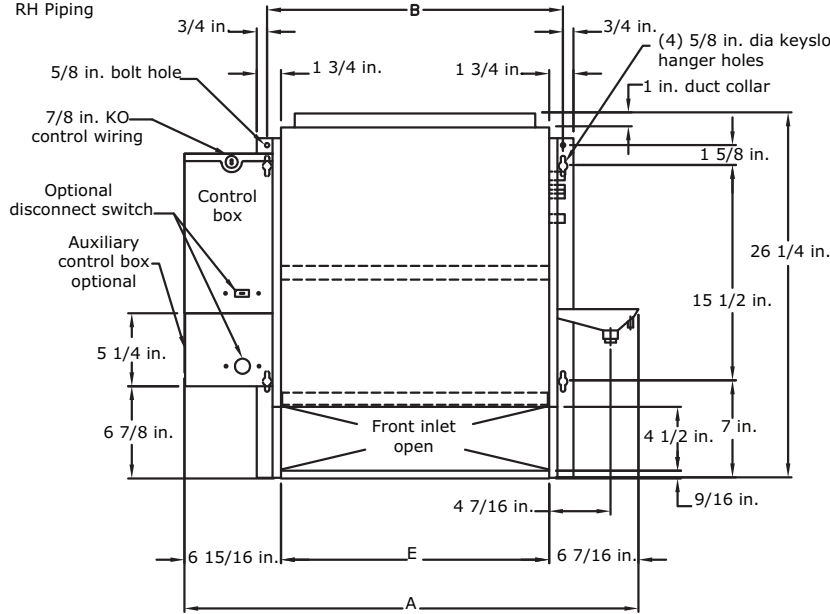

Side View

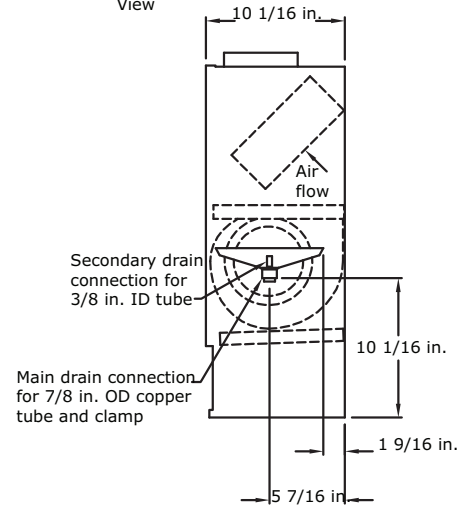

Front View
LH Piping

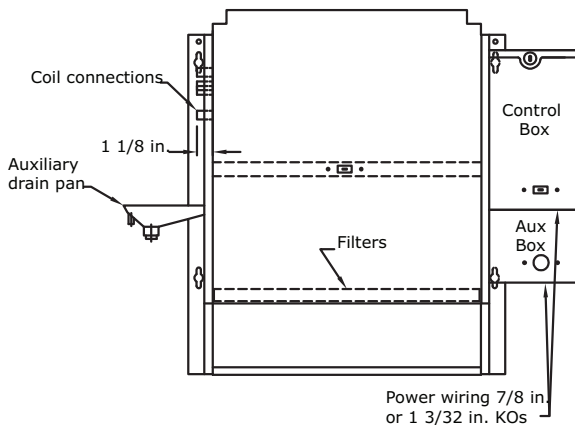

Table 15. Model A vertical concealed unit dimensions (inches)

Unit Size	200-300	400	600	800	1000-1200
No. Fans	1	1	2	2	3
No. Motors	1	1	1	1	2
A	32 11/16	37 11/16	47 3/16	55 11/16	74 11/16
B	21 5/16	26 5/16	35 13/16	44 5/16	63 5/16
C	22 13/16	27 13/16	37 5/16	45 13/16	64 13/16
D	17 5/16	22 5/16	2'-7 13/16	40 5/16	59 5/16
E	19 5/16	24 5/16	33 13/16	42 5/16	61 5/16

Note: Coil connections are always on the drain pan side and opposite the control box. Coil connections are 5/8-in. O.D. sweat. Refer to the "Coil Connections," p. 62 in the Dimension and Weights chapter for location. All duct collar dimensions are to the outside of the collar. Refer to the Fresh air opening section in the "Dimensions and Weights," p. 41 for more information.

Dimensions and Weights

Model B Vertical Cabinet

Figure 34. Model B vertical cabinet

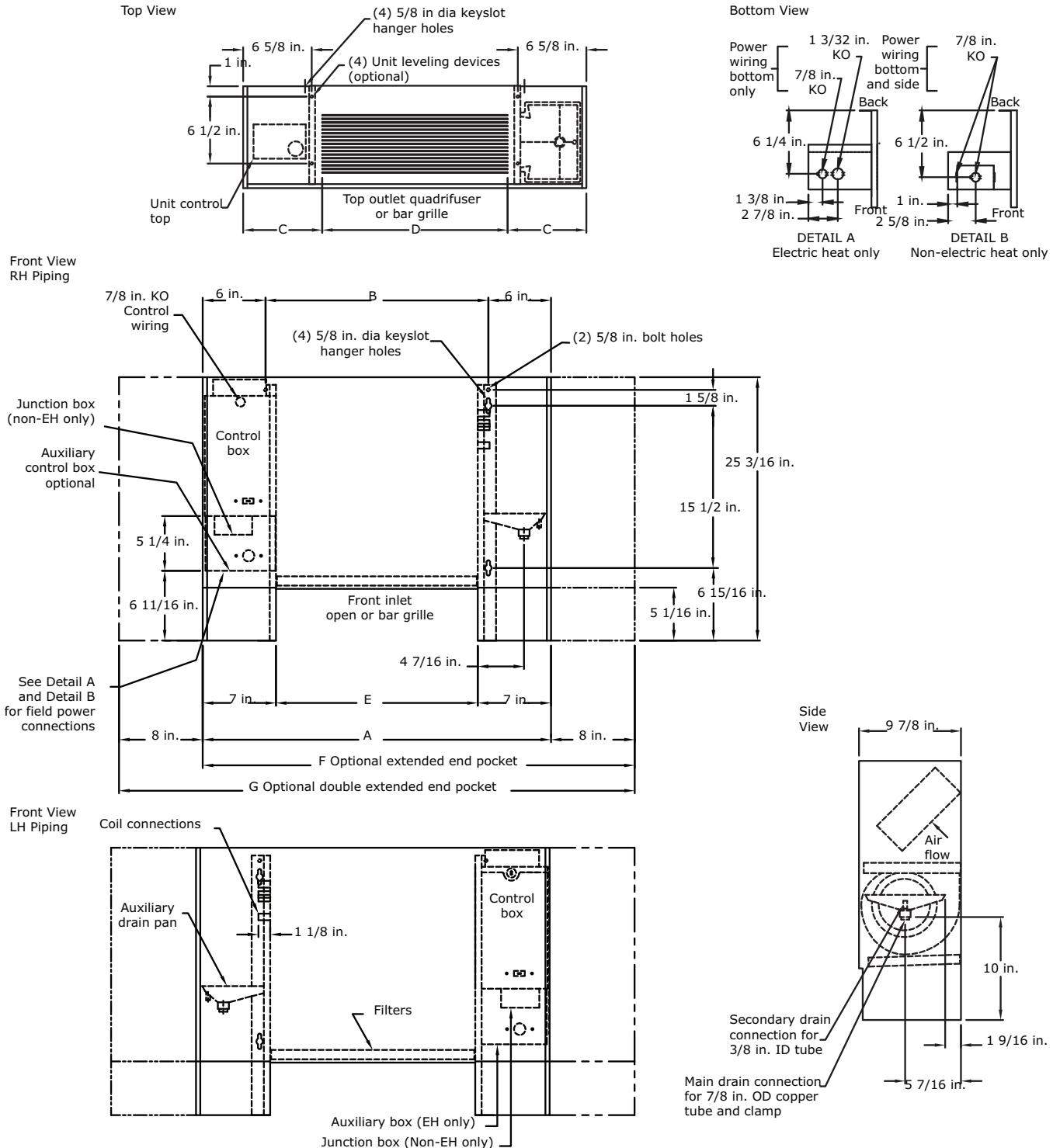

Table 16. Model B vertical cabinet unit dimensions (inches)

Unit Size	200-300	400	600	800	1000-1200
No. Fans	1	1	2	2	3
No. Motors	1	1	1	1	2
A	33 5/16	38 5/16	47 13/16	56 5/16	75 5/16
B	21 5/16	26 5/16	35 13/16	44 5/16	63 5/16
C	7 5/8	7 1/8	8 7/8	7 1/8	7 5/8
D	18	24	30	42	60
E	19 5/16	24 5/16	33 13/16	42 5/16	61 5/16
F	41 5/16	46 5/16	55 13/16	64 5/16	83 5/16
G	49 5/16	54 5/16	63 13/16	72 5/16	n/a

Note: Coil connections are always on the drain pan side and opposite the control box. Coil connections are 5/8-in. O.D. sweat. Refer to the "Coil Connections," p. 62 section in the Dimension and Weights chapter for location. All duct collar dimensions are to the outside of the collar. Refer to the Fresh air opening section in the "Dimensions and Weights," p. 41 for more information.

Dimensions and Weights

Model C Horizontal Concealed

Figure 35. Model C Horizontal concealed unit

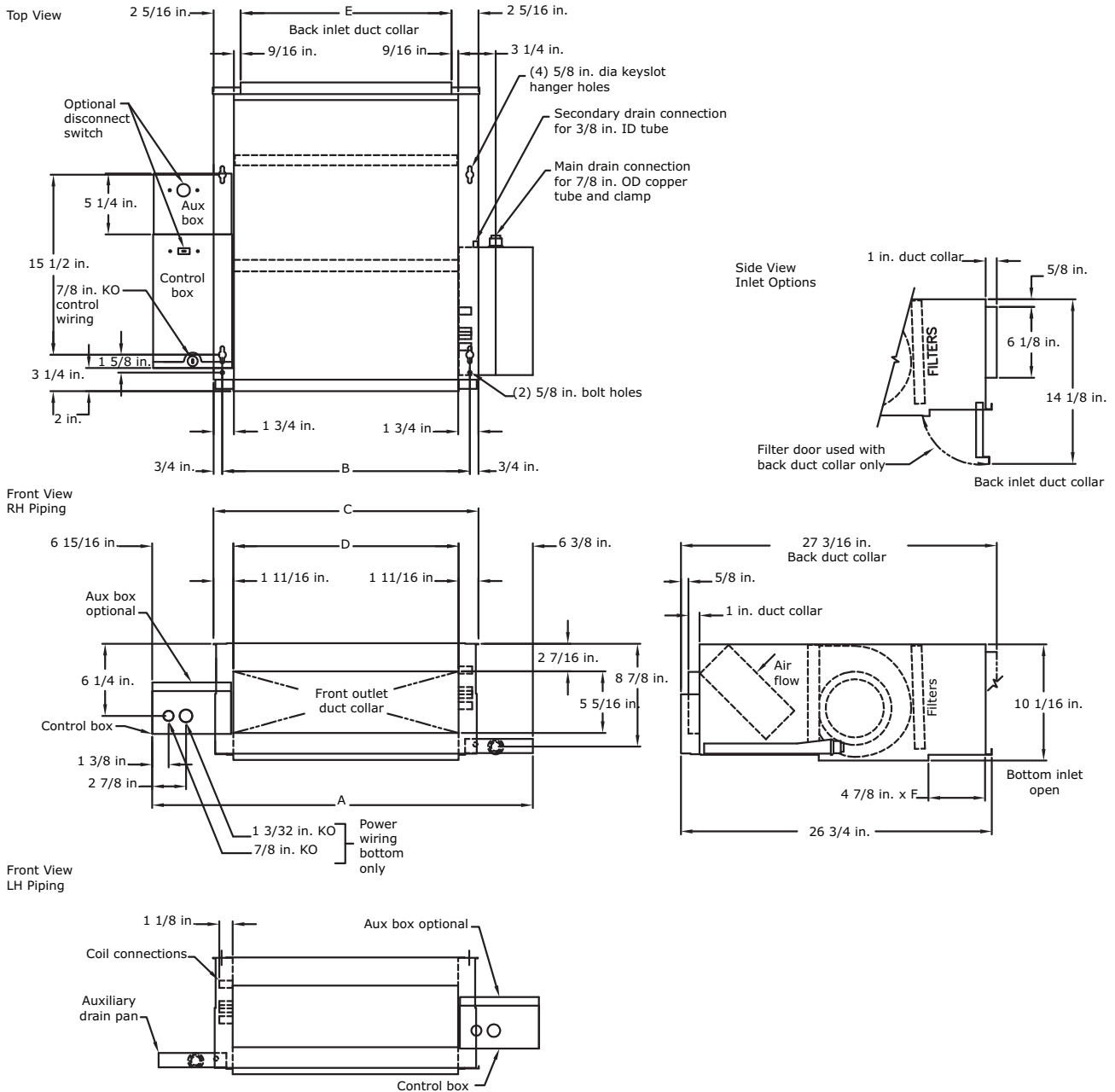

Table 17. Model C horizontal concealed unit dimensions (inches)

Unit Size	200-300	400	600	800	1000-1200
No. Fans	1	1	2	2	3
No. Motors	1	1	1	1	2
A	32 11/16	37 11/16	47 3/16	55 11/16	74 11/16
B	21 1/4	26 5/16	35 13/16	44 1/4	63 5/16
C	22 13/16	27 13/16	37 5/16	45 13/16	64 13/16
D	19 3/8	24 3/8	33 7/8	42 3/8	61 3/8
E	18 1/8	23 1/8	32 5/8	41 1/8	60 1/8
F	19 5/16	24 5/16	33 13/16	42 5/16	61 5/16

Note: Coil connections are always on the drain pan side and opposite the control box. Coil connections are 5/8-in. O.D. sweat. Refer to the "Coil Connections," p. 62 section in the Dimension and Weights chapter for location. All duct collar dimensions are to the outside of the collar. Refer to the Fresh air opening section in the "Dimensions and Weights," p. 41 for more information.

Dimensions and Weights

Model D Horizontal Cabinet

Figure 36. Model D horizontal cabinet

Top View

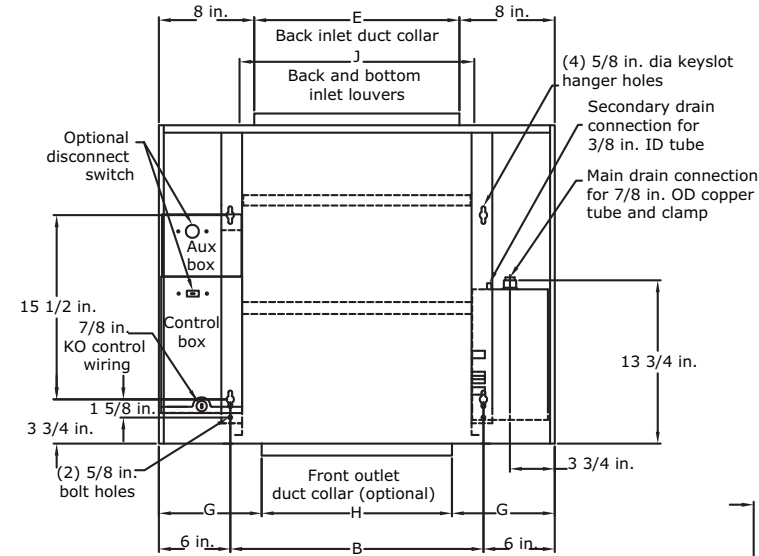

Front View
RH Piping

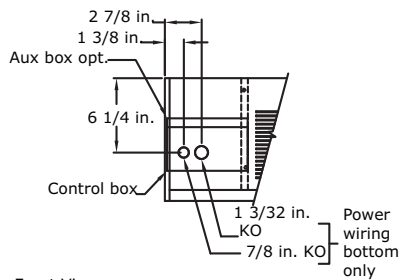
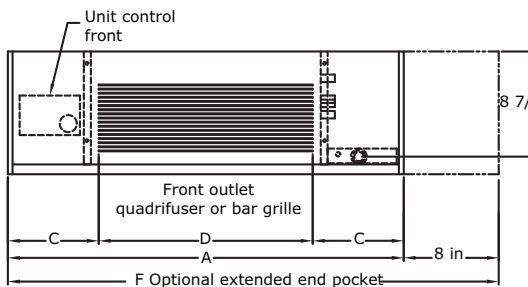

Front View
LH Piping

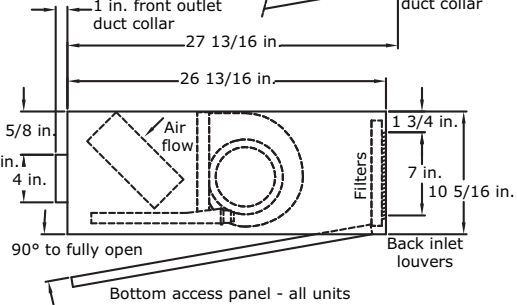
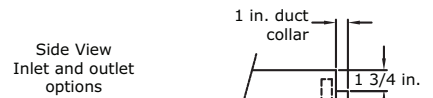
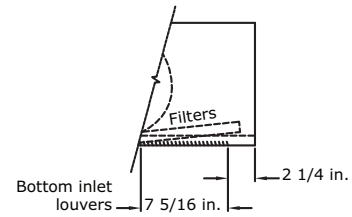
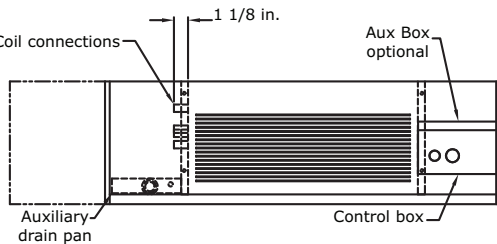

Table 18. Model D horizontal cabinet dimensions (inches)

Unit Size	200-300	400	600	800	1000-1200
No. of Fans	1	1	2	2	3
No. of Motors	1	1	1	1	2
A	33 5/16	38 5/16	47 3/16	56 5/16	75 5/16
B	21 5/16	26 5/16	35 13/16	44 5/16	63 5/16
C	7 5/8	7 1/8	8 7/8	7 1/8	7 5/8
D	18	24	30	42	60
E	17 1/4	22 1/4	19 3/4	40 1/4	59 1/4
F	41 1/4	46 5/16	55 3/16	64 5/16	83 5/16
G	8 5/8	8 1/8	9 7/8	8 1/8	8 5/8
H	16	22	28	40	58
J	19 3/4	23 3/4	31 3/4	39 3/4	59 3/4

Note: Coil connections are always on the drain pan side and opposite the control box. Coil connections are 5/8-in. O.D. sweat. Refer to the "Coil Connections," p. 62 section in the Dimension and Weights chapter for location. All duct collar dimensions are to the outside of the collar. Refer to the Fresh air opening section in the "Dimensions and Weights," p. 41 for more information.

Dimensions and Weights

Model E Horizontal Recessed

Figure 37. Model E horizontal recessed

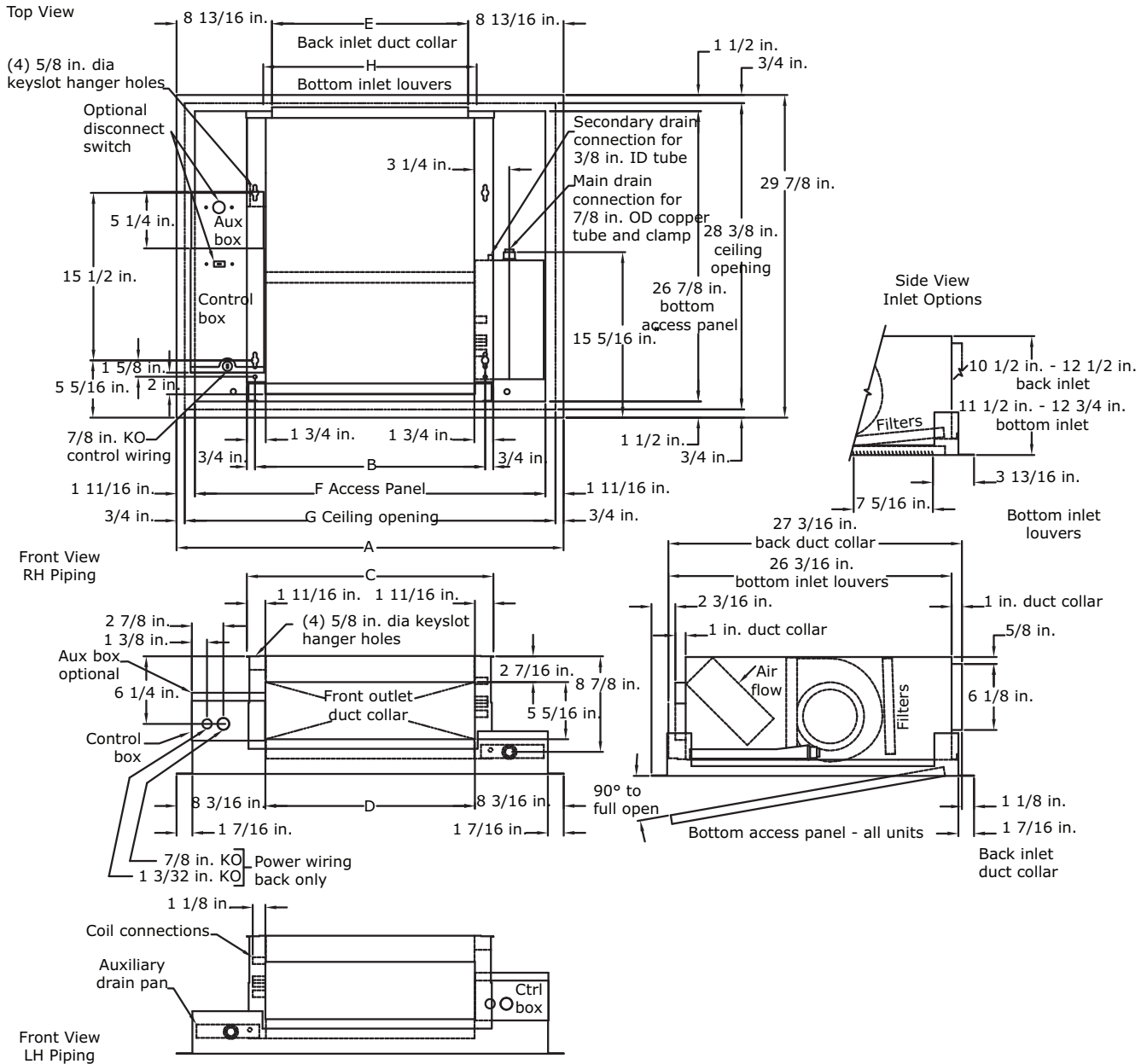

Table 19. Model E horizontal cabinet dimensions (inches)

Unit Size	200-300	400	600	800	1000-1200
No. Fans	1	1	2	2	3
No. Motors	1	1	1	1	2
A	35 13/16	40 13/16	50 5/16	58 13/16	77 13/16
B	21 5/16	26 5/16	35 13/16	44 5/16	63 5/16
C	22 13/16	27 13/16	37 5/16	45 13/16	64 13/16
D	19 3/8	24 3/8	33 7/8	42 3/8	61 3/8
E	18 1/8	23 1/8	32 5/8	41 1/8	60 1/8
F	32 7/16	37 7/16	46 15/16	55 7/16	74 7/16
G	34 5/16	39 5/16	48 13/16	57 5/16	76 5/16
H	19 3/4	23 3/4	31 3/4	39 3/4	59 3/4

Note: Coil connections are always on the drain pan side and opposite the control box. Coil connections are 5/8-in. O.D. sweat. Refer to the "Coil Connections," p. 62 section in the Dimension and Weights chapter for location. All duct collar dimensions are to the outside of the collar. Refer to the Fresh air opening section in the "Dimensions and Weights," p. 41 for more information.

Model H Vertical Recessed

Figure 38. Model H vertical recessed

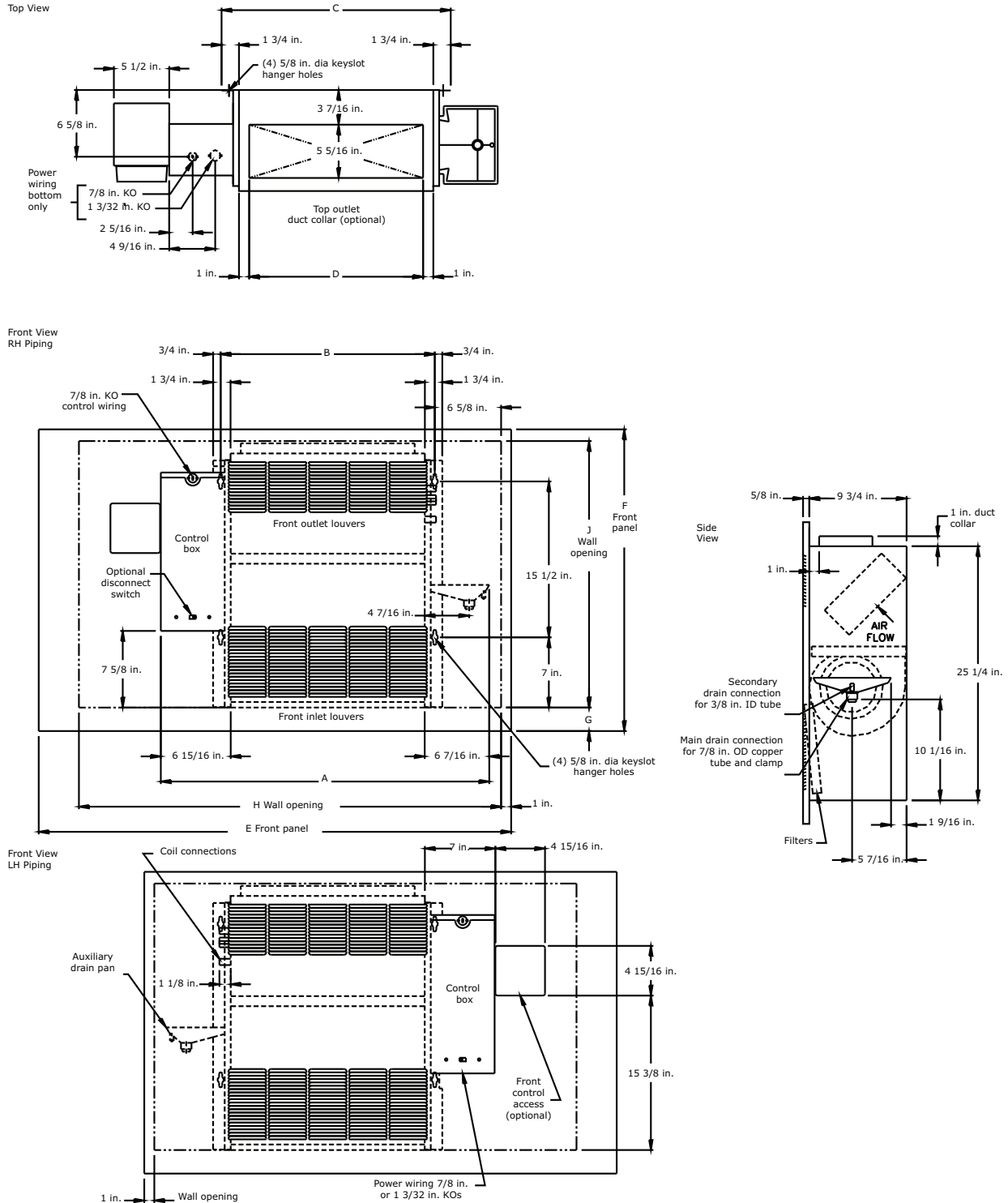

Table 20. Model H horizontal cabinet dimensions (inches)

Unit Size	200-300	400	600	800	1000-1200
No. Fans	1	1	2	2	3
No. Motors	1	1	1	1	2
A	32 11/16	37 11/16	47 3/16	55 11/16	74 11/16
B	21 5/16	26 5/16	35 13/16	44 5/16	63 5/16
C	22 13/16	27 13/16	37 5/16	45 13/16	64 13/16
D	17 5/16	22 5/16	31 13/16	40 5/16	59 5/16
E	47	51	63	65 1/2	89 1/2
F	30	30	30	33 1/2	33 1/2
G	2 3/8	2 3/8	2 3/8	4 1/8	4 1/8
H	42	48	57	63	87
J	26 1/2	26 1/2	26 1/2	27 1/2	27 1/2

Note: Coil connections are always on the drain pan side and opposite the control box. Coil connections are 5/8-in. O.D. sweat. Refer to the "Coil Connections," p. 62 section in the Dimension and Weights chapter for location. All duct collar dimensions are to the outside of the collar. Refer to the Fresh air opening section in the "Dimensions and Weights," p. 41 for more information.

Dimensions and Weights

Model J Vertical Slope Top Cabinet

Figure 39. Model J vertical slope top

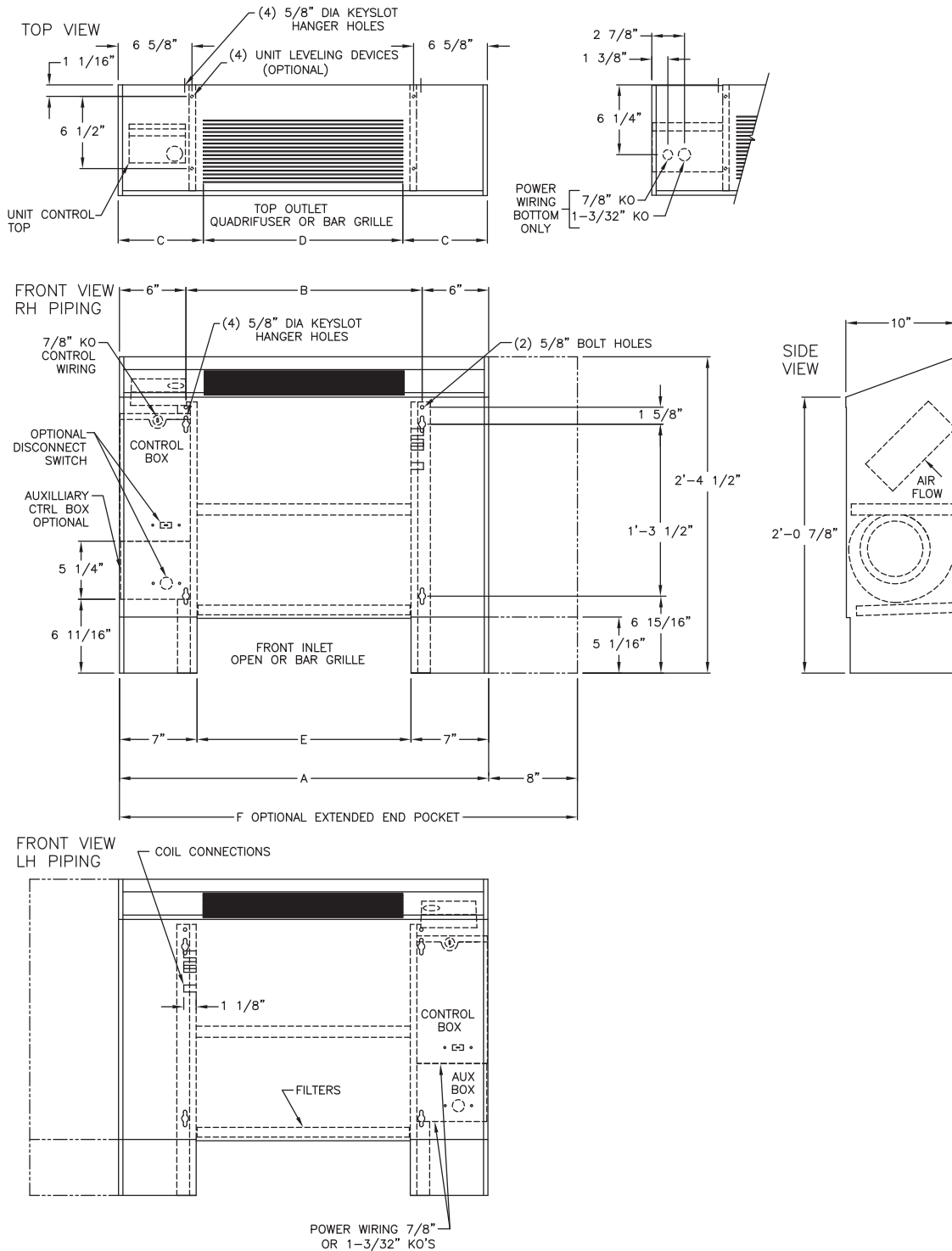

Table 21. Model J horizontal cabinet dimensions (inches)

Unit Size	200-300	400	600	800	1000-1200
No. Fans	1	1	2	2	3
No. Motors	1	1	1	1	2
A	33 5/16	38 5/16	47 13/16	56 5/16	75 5/16
B	21 5/16	26 5/16	35 13/16	44 5/16	63 5/16
C	7 5/8	7 1/8	8 7/8	7 1/8	7 5/8
D	18	24	30	42	60
E	19 5/16	24 5/16	33 13/16	42 5/16	61 5/16
F	41 5/16	46 5/16	55 13/16	64 5/16	83 5/16
G	49 5/16	54 5/16	63 13/16	72 5/16	n/a

Note: Coil connections are always on the drain pan side and opposite the control box. Coil connections are 5/8-in. O.D. sweat. Refer to the "Coil Connections," p. 62 section in the Dimension and Weights chapter for location. All duct collar dimensions are to the outside of the collar. Refer to the Fresh air opening section in the "Dimensions and Weights," p. 41 for more information.

Dimensions and Weights

Model K Low Vertical Concealed

Figure 40. Model K low vertical concealed

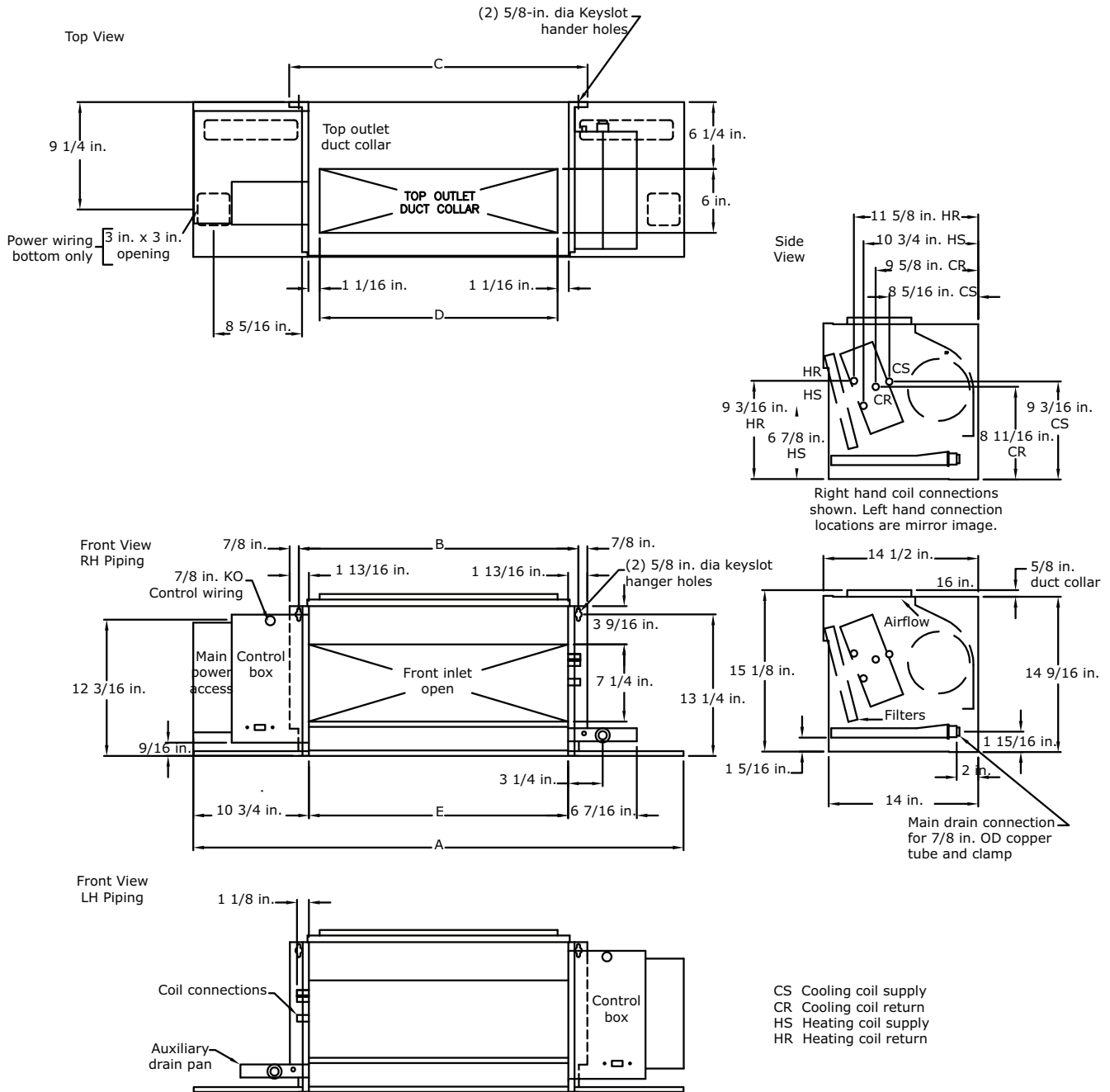

Table 22. Model K low vertical concealed unit dimensions (in.) and weights (lb)

Unit Size	03	04	06
A	41-7/16	50-15/16	59-7/16
B	26-1/4	35-3/4	44-1/4
C	27-15/16	36-13/16"	45-15/16
D	22-5/16	31-13/16	40-5/16
E	24-1/4	33-3/4	42-1/4
Operating Weight	109	139	147
Shipping Weight	96	123	131

Note: Coil connections are always on the drain pan side and opposite the control box. Coil connections are 5/8-in. O.D. sweat. Refer to the "Coil Connections," p. 62 section in the Dimension and Weights chapter for location. All duct collar dimensions are to the outside of the collar. Refer to the Fresh air opening section in the "Dimensions and Weights," p. 41 for more information.
Serviceability for some components within this unit may require panel or drain pan removal.

Dimensions and Weights

Model L Low Vertical Cabinet

Figure 41. Model L low vertical cabinet

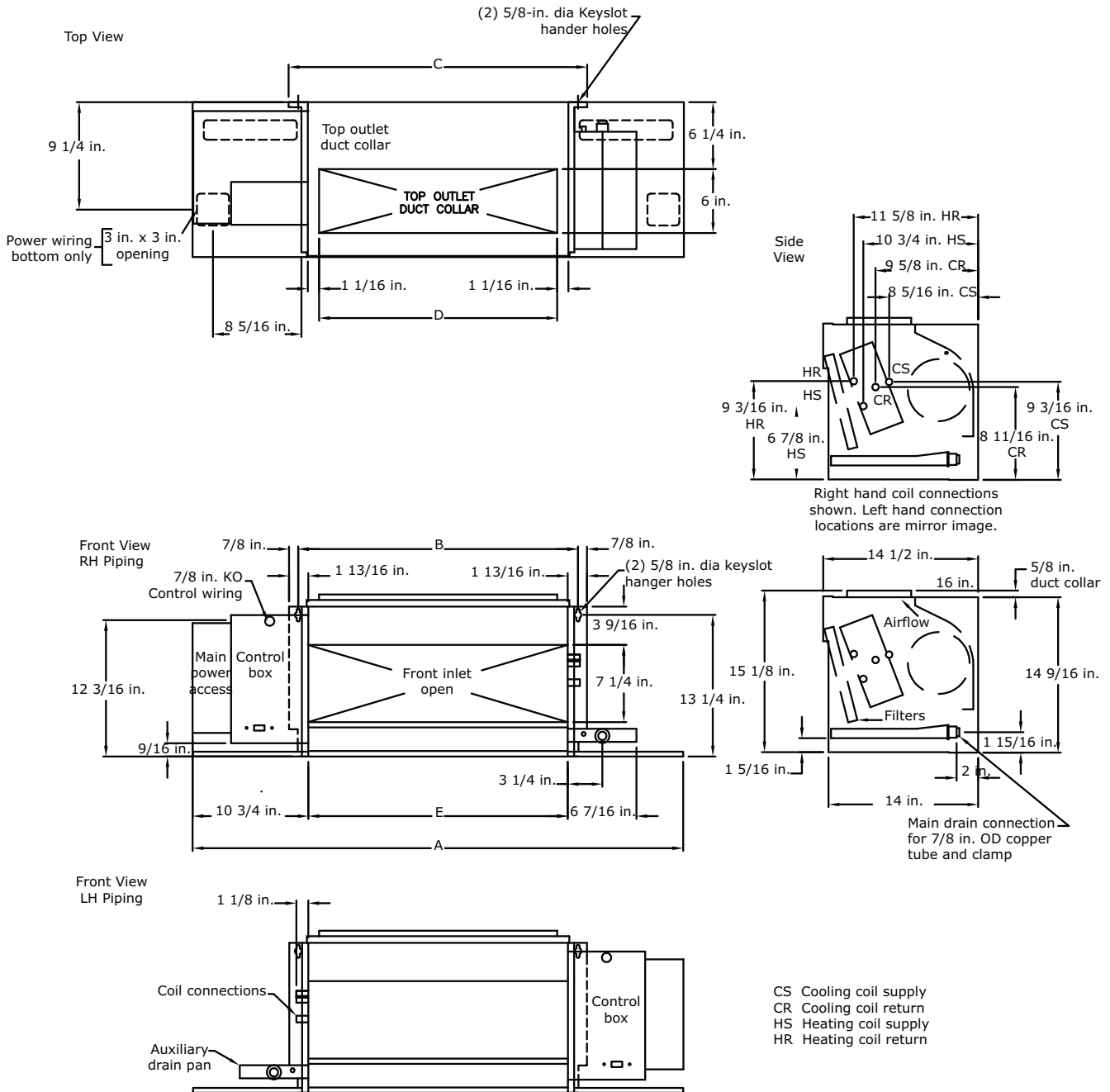

Table 23. Model K low vertical concealed unit dimensions (in.) and weights (lb)

Unit Size	03	04	06
A	45 3/4	55 1/4	63 3/4
B	26	35 3/4	44 1/4
C	27 3/4	37 1/4	45 15/16
D	22 5/16	31 13/16	40 5/16
E	24 1/4	33 3/4	42 1/4

Note: Coil connections are always on the drain pan side and opposite the control box. Coil connections are 5/8-in. O.D. sweat. Refer to the "Coil Connections," p. 62 section in the Dimension and Weights chapter for location. All duct collar dimensions are to the outside of the collar. Refer to the Fresh air opening section in the "Dimensions and Weights," p. 41 for more information.
Serviceability for some components within this unit may require panel or drain pan removal.

Dimensions and Weights

Model P Compact Concealed

Figure 42. Model P compact concealed

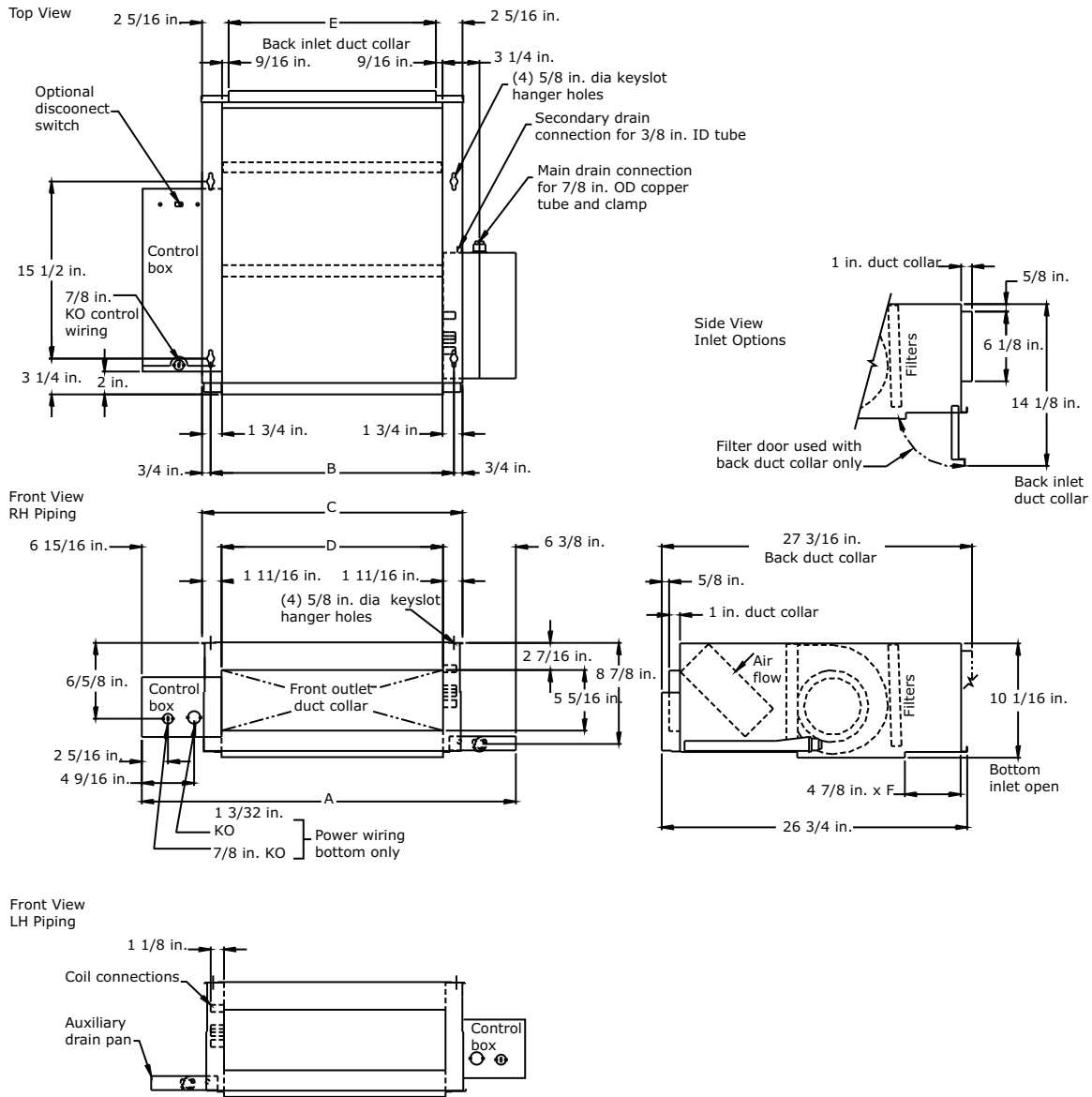

Table 24. Compact concealed unit dimensions (in.)

Unit Size	200-300	400	600	800	1000-1200
A	32 11/16	37 11/16	47 3/16	55 11/16	74 11/16
B	21 5/16	26 5/16	35 13/16	44 5/16	63 5/16
C	22 13/16	27 13/16	37 5/16	45 13/16	64 13/16
D	19 3/8	24 3/8	33 7/8	42 3/8	61 3/8
E	18 1/8	23 1/8	32 5/8	41 1/8	60 1/8
F	19 5/16	24 5/16	33 13/16	42 5/16	61 5/16

Note: Coil connections are always on the drain pan side and opposite the control box. Coil connections are 5/8-in. O.D. sweat. Refer to the "Coil Connections," p. 62 section in the Dimension and Weights chapter for location. All duct collar dimensions are to the outside of the collar. Refer to the Fresh air opening section in the "Dimensions and Weights," p. 41 for more information.

Unit Weights

Table 25. Operating weights (pounds)

Unit size	Cabinet models	Concealed models	Recessed models	Low vertical cabinet models	Low vertical concealed models
02	97	81	78	n/a	n/a
03	97	81	78	125	109
04	125	109	88	155	139
06	155	139	128	164	147
08	164	147	139	n/a	n/a
10	218	200	253	n/a	n/a
12	218	200	253	n/a	n/a

Table 26. Shipping weights (pounds)

Unit size	Cabinet models	Concealed models	Recessed models	Low vertical cabinet models	Low vertical concealed models
02	84	68	68	n/a	n/a
03	84	68	68	112	96
04	112	96	78	139	123
06	139	123	118	148	131
08	148	131	129	n/a	n/a
10	200	182	243	n/a	n/a
12	200	182	243	n/a	n/a

Coil Connections

Fan Coil Vertical Units

Figure 43. Coil connections for fan coil vertical units

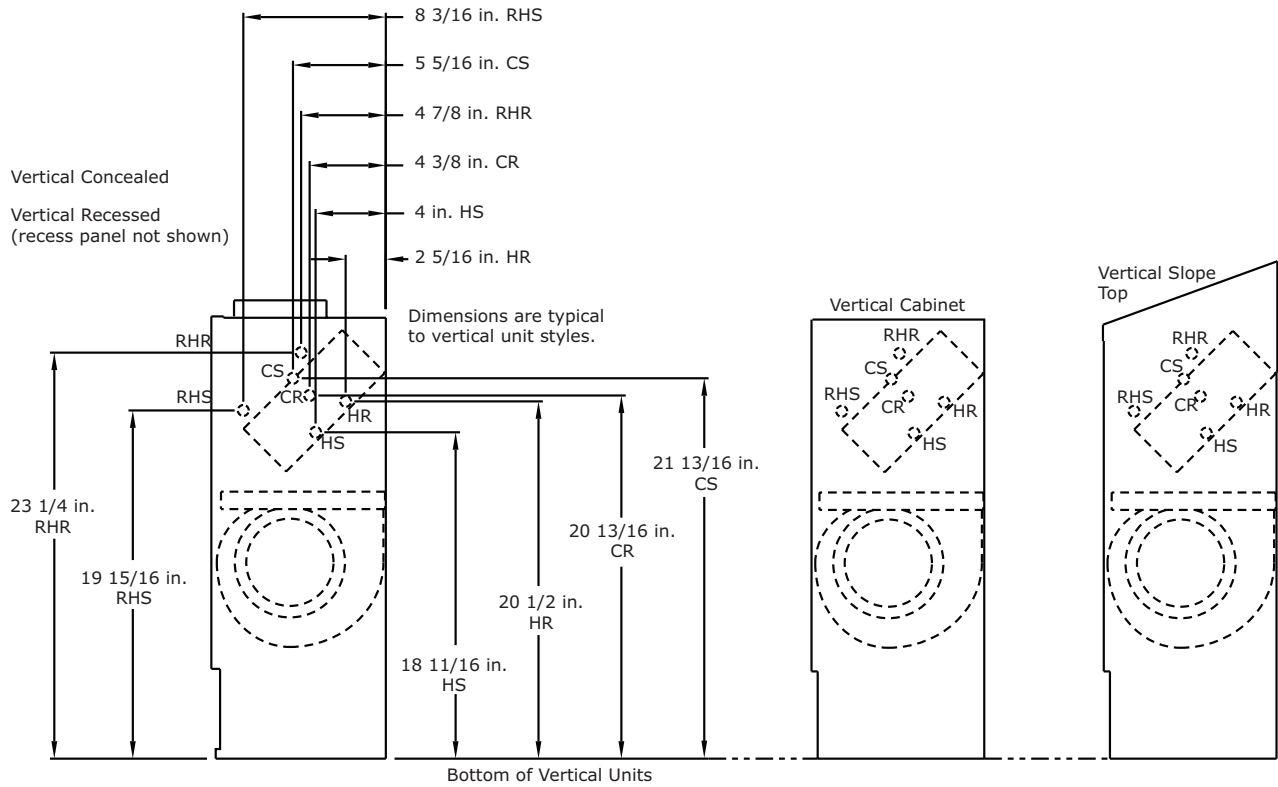

Fan Coil Horizontal Units

Figure 44. Coil connections for fan coil horizontal units

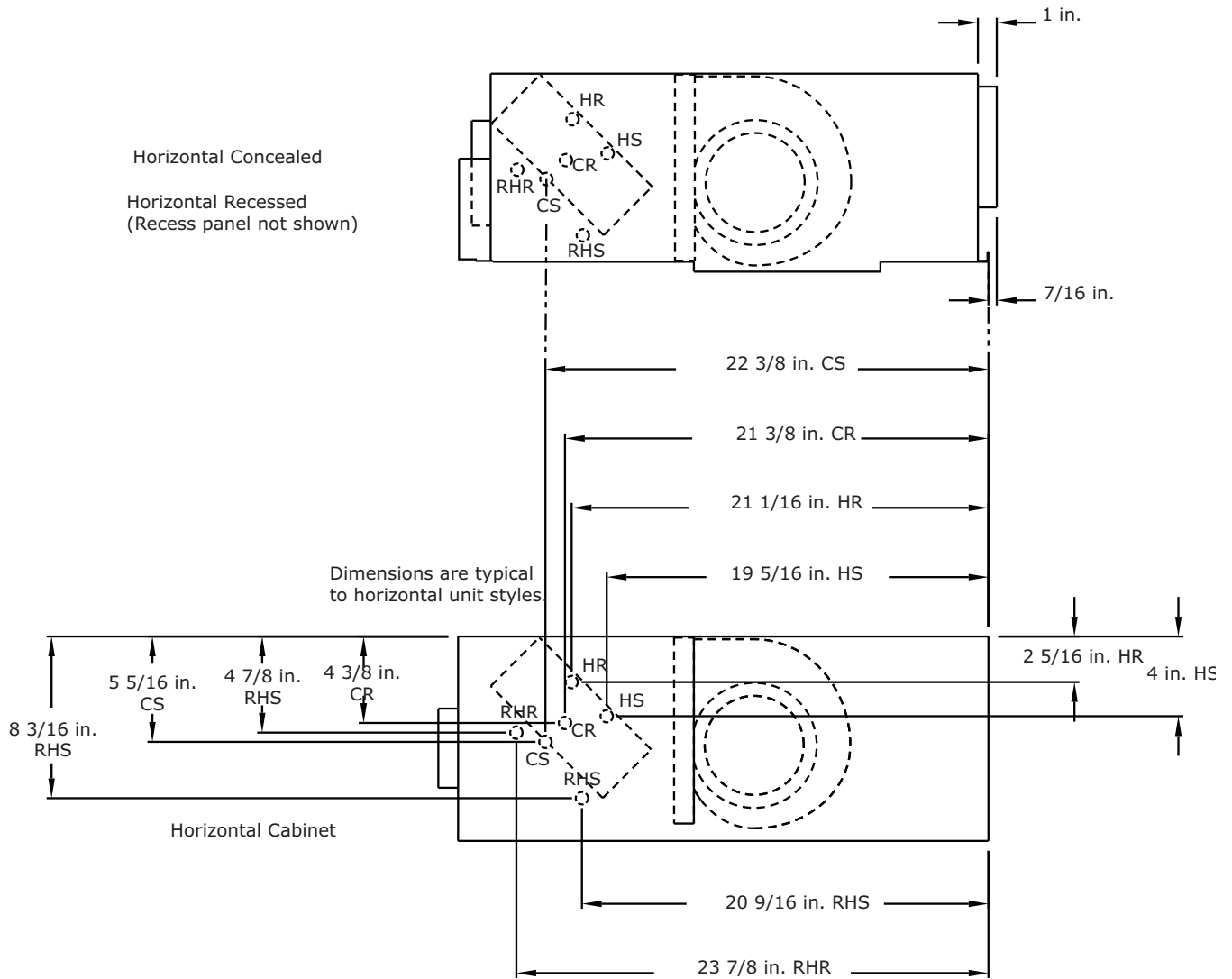

Dimensions and Weights

Figure 45. Coil connections for DX coil and heat pump

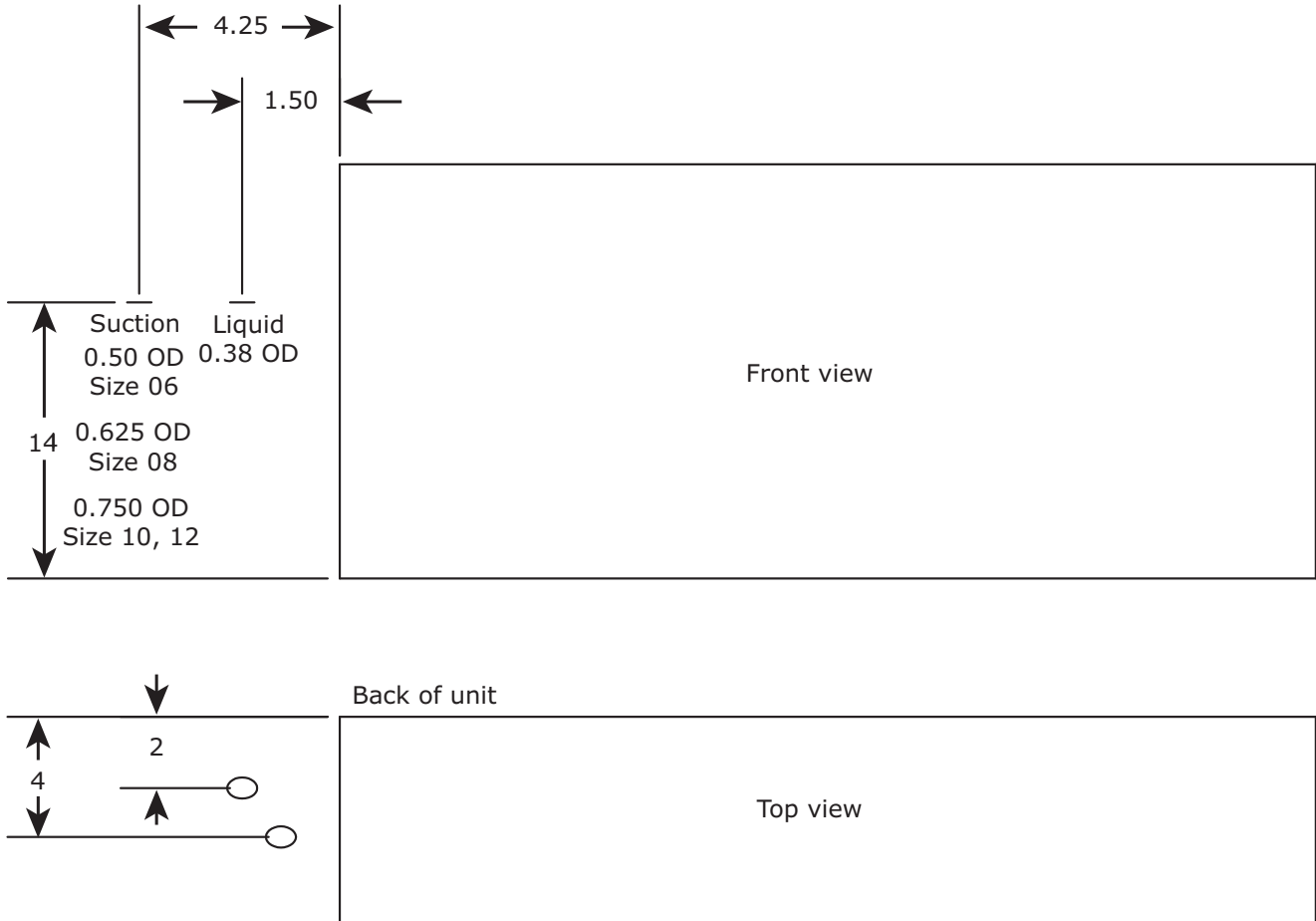

Refrigerant Connection Detail

Figure 46. DX and heat pump connections

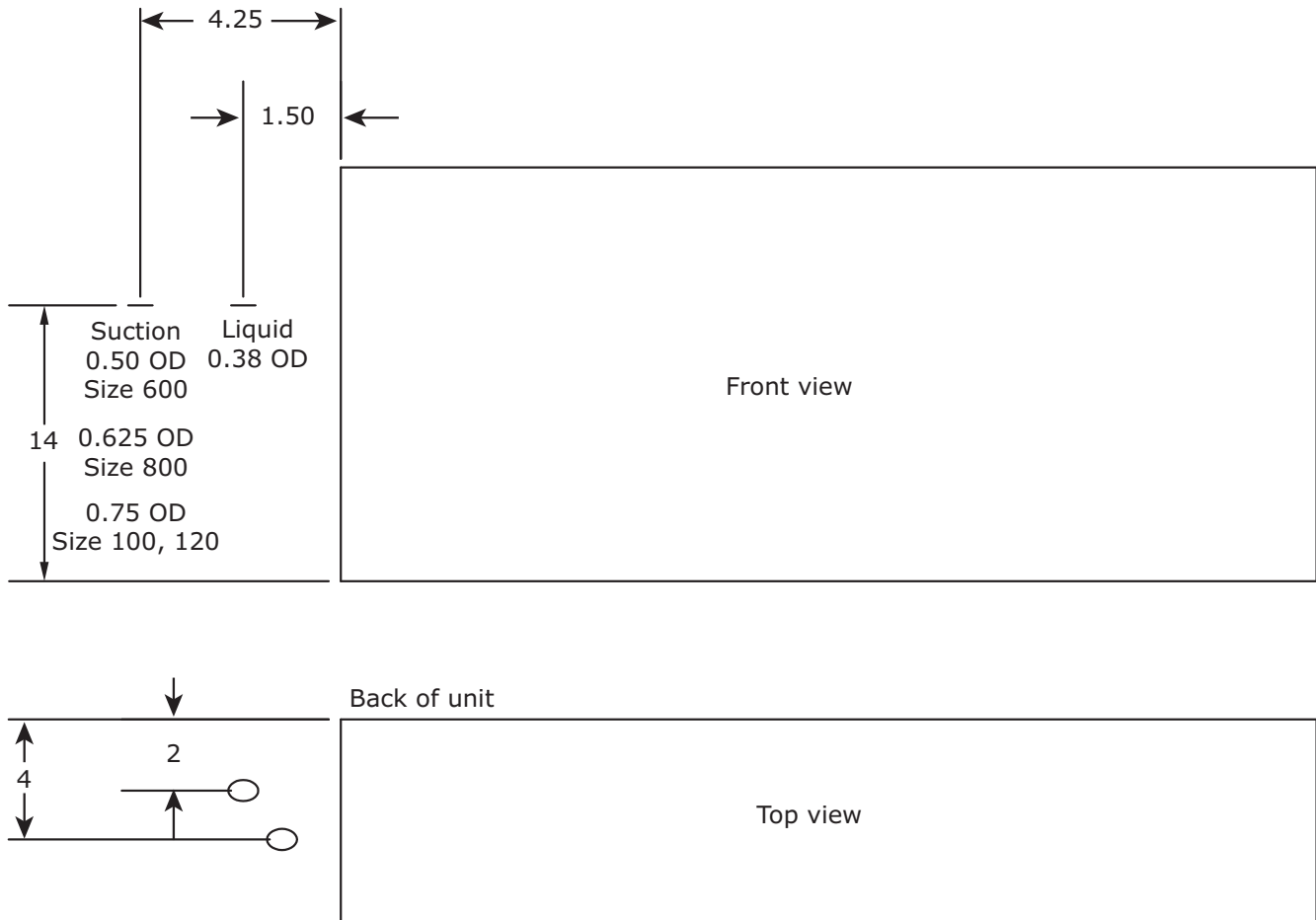

Fresh Air Opening Locations

Horizontal Units

Figure 47. Fresh air openings for horizontal units (models C, D, E, and P (back duct collar only))

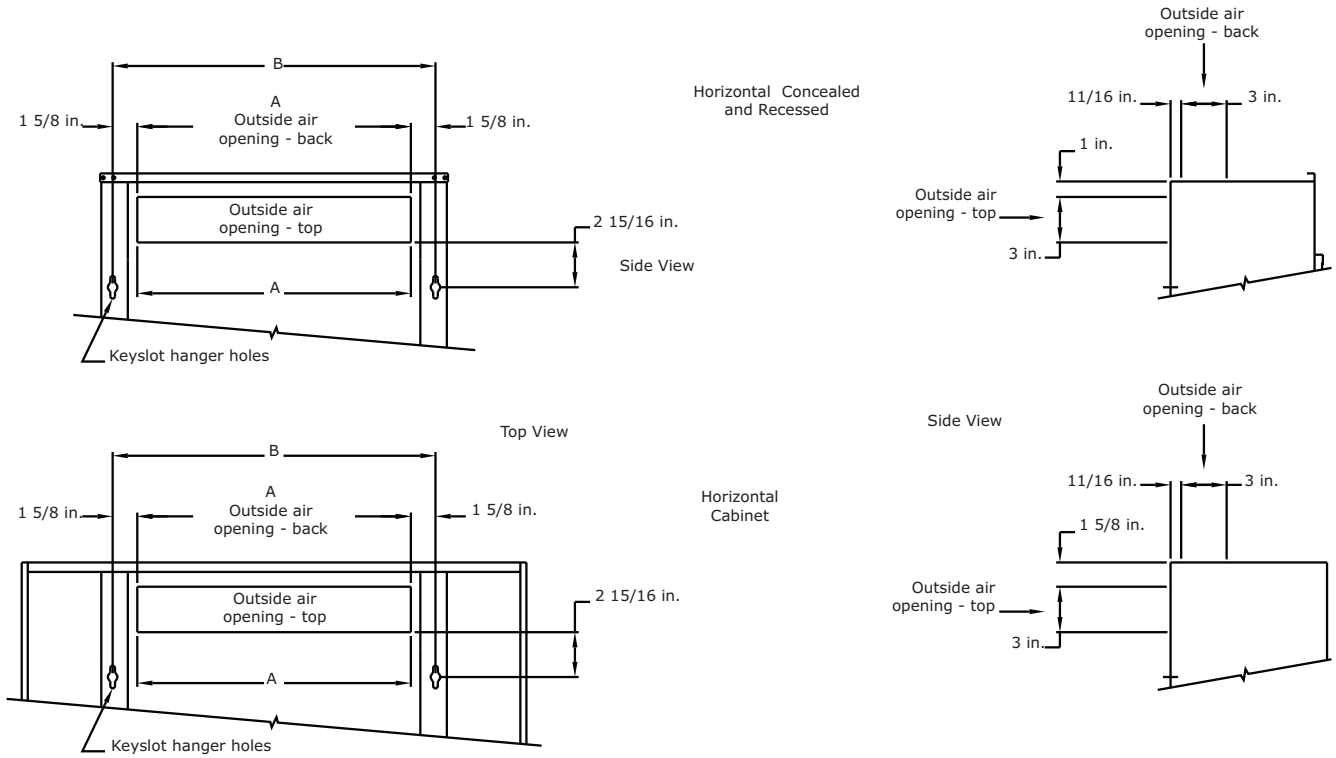

Table 27. Fresh air opening dimensions (inches) for horizontal units

Unit Size	02-03	04	06	08	10-12
A	18	23	32 1/2	41	60
B	21 5/16	26 5/16	35 13/16	44 5/16	63 5/16

Vertical Units

Figure 48. Fresh air openings for vertical units (models A, B, H, J, K, and L)

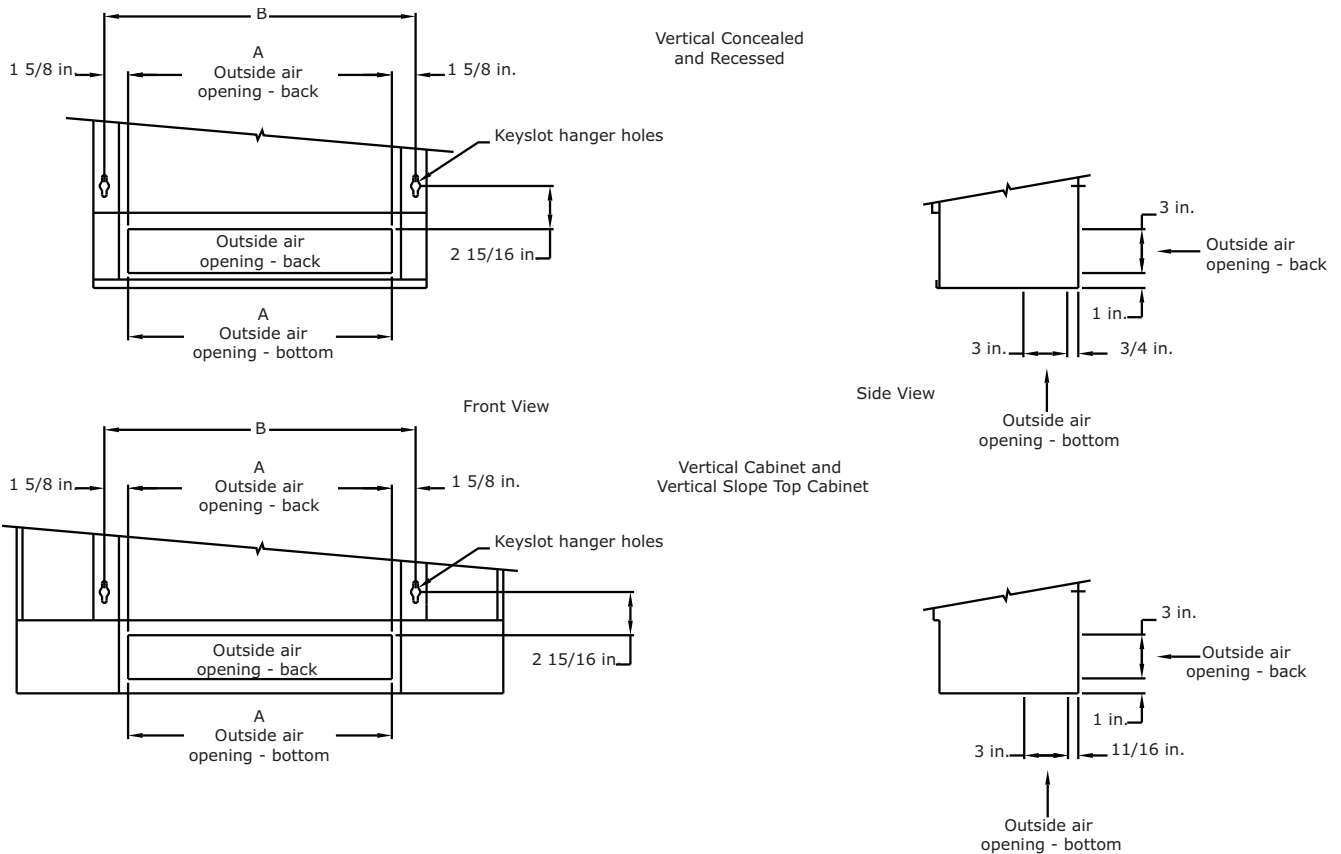

Table 28. Fresh air opening dimensions (inches) for vertical units

Unit Size	02-03	04	06	08	10-12
A	18	23	32 1/2	41	60
B	21 5/16	26 5/16	35 13/16	44 5/16	63 5/16

Components

Wall Box

Figure 49. Wall box

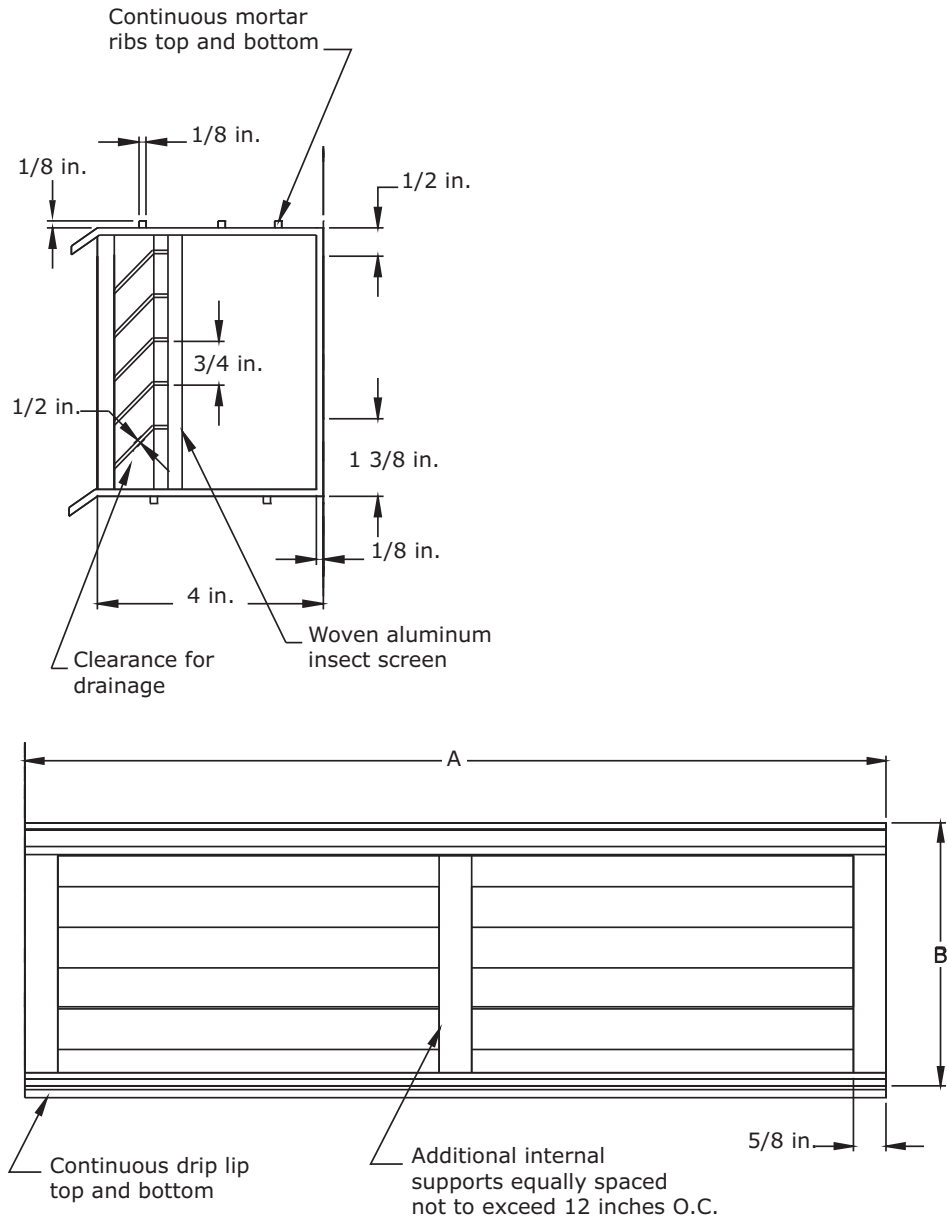

Table 29. Wall box dimensions (inches)

Unit Size (ref. only)	Dimensions A x B	Internal Supports
02-03	24 3/8 x 4 3/4	1
04	24 3/8 x 7 1/2	1
06	33 1/8 x 7 1/2	2
08	37 1/2 x 7 1/2	3
10-12	58 1/4 x 7 1/2	4

Projection Panel

Figure 50. Projection panel

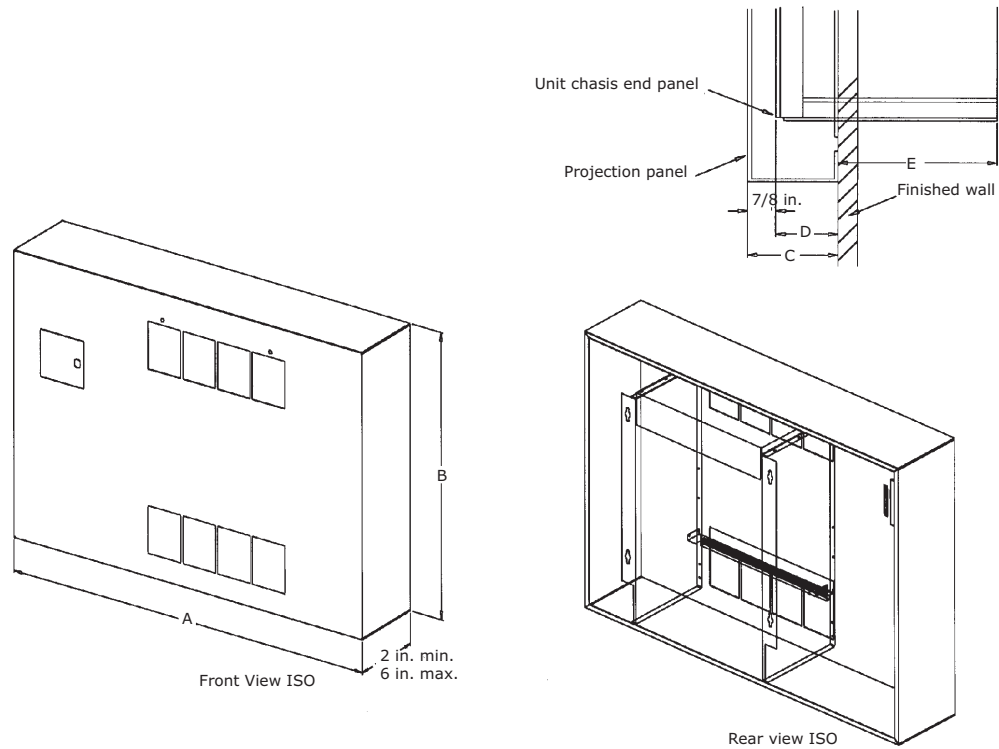

Table 30. Projection panel dimensions (inches)

Unit Size	02-03	04	06	08	10-12
A	47	51	63	65 1/2	89 1/2
B	30	30	30	33 1/2	33 1/2

Table 31. Projection panel dimensions (inches)

Unit Size	All sizes									
C	2	2-1/2	3	3 1/2	4	4 1/2	5	5 1/2	6	2
D	1 1/8	1 5/8	2 1/8	2 5/8	3 1/8	3 5/8	4 1/8	4 5/8	5 1/8	1 1/8
E	8 5/8	8 1/8	7 5/8	7 1/8	6 5/8	6 1/8	5 5/8	5 1/8	4 5/8	8 5/8



Mechanical Specifications

Performance Data

Capacity: Unit capacities are certified under Industry Room Fan Coil Air Conditioner Certification Program in accordance with AHRI Standard 440-2008.

Safety: All standard units are UL listed in the United States and Canada and comply with NFPA 90A requirements.

Construction

All Units

The unit includes a chassis, coil(s), fan wheel(s), fan casing(s), fan board and motor(s). Units also include a noncorrosive, ABS main drain pan, positively sloped in every plane and insulated with closed-cell insulation. Horizontal units and all units with standard piping packages also include a thermoplastic auxiliary drain pan. Steel parts exposed to moisture are galvanized. The fan board assembly and both drain pans are easily removable. The fan board assembly includes a quick-disconnect motor plug. The chassis construction is 18-gauge galvanized steel, and continuous throughout the unit. The unit is acoustically and thermally insulated with closed-cell insulation. All panels are made rigid by channel forming.

Vertical Cabinet and Slope Top Units

Front panel fabrication is 16-gauge galvanized steel. All other panels are 18-gauge galvanized steel. The discharge grille is recessed to resist condensate formation. Hinged access door construction is 20-gauge steel and is flush with top panel.

Horizontal Cabinet Units

All panels are 18-gauge galvanized steel, including the bottom panel. Discharge grille is recessed to resist condensate formation. The hinged access door is flush with front panel. Bottom panels ship with tamperproof screw fasteners and a safety chain.

Concealed/Recessed Units

Exposed panels on recessed units are 18-gauge steel construction and ship separate from the unit. Bottom panels on horizontal recessed models ship standard with tamperproof screw fasteners and a safety chain. Horizontal recessed units feature a telescoping panel to allow the panel to be adjusted to line up flush with the ceiling. The telescoping panel extends 1.25 inches to 2 inches depending on the configuration of airflow.

Low Vertical Unit

Front panels are of 16-gauge galvanized steel. All cabinet parts are made rigid by channel forming. End panel is removable for piping access. Hinged access door construction is 20-gauge steel and flush with top panel.

Unit Finish

All cabinet parts and exposed recessed panels are cleaned, bonderized, phosphatized, and painted with a baked powder finish available in six decorator colors. Standard finish meets ASTM B117 specifications (salt spray test).

Fans

The galvanized metal fan wheels are centrifugal forward-curved and double-width. Fan wheels and housings are corrosion resistant. Fan housing construction is formed sheet metal. Low vertical units utilize an aluminum tangential wheel design.

Motors

All motors are brushless DC (BLDC)/electronically commutated motors (ECM) factory-programmed and run-tested in assembled units. The motor controller is mounted in a touch-safe control box with a built-in integrated user interface and LED tachometer. If adjustments are needed, motor parameters can be adjusted through momentary contact switches accessible without factory service personnel on the motor control board.

Motors will soft-ramp between speeds to lessen the acoustics due to sudden speed changes. Motors can be operated at three speeds or with a field-supplied variable speed controller. The motor will choose the highest speed if there are simultaneous/conflicting speed requests.

All motors have integral thermal overload protection with a maximum ambient operating temperature of 104°F and are permanently lubricated. Motors are capable of starting at 50 percent of rated voltage and operating at 90 percent of rated voltage on all speed settings. Motors can operate up to 10 percent over voltage.

Extended End Pockets

On vertical or horizontal cabinet units, an 8-inch extended end pocket is available on the piping end. On vertical cabinet and vertical slope top units, an 8-inch extended end pocket is available on both the piping and control side.

Tamperproof Locks

Key-operated locking access doors and/or panels will help prevent nuisance tampering with unit and/or controls. Tamper proof locks are available on vertical cabinet, horizontal cabinet, vertical recessed, vertical slope top, and low vertical units.

Leveling Feet

Refrigerator type screw-in bolts to level the unit are available on vertical and low vertical cabinet units.

Controls

Controls options are fan speed control, customer supplied terminal interface, and UC400-B/Symbio™ 400-B. A variety of inputs and outputs are available for the control interface and Tracer® controller option. A disconnect switch (for non-electric heat units), fused transformer, contactor(s), and terminal strip are provided with the control interface and Tracer® controller option.

Customer Supplied Terminal Interface

The control interface is intended to be used with a field-supplied, low-voltage thermostat or controller. The control box contains a relay board which includes a line voltage to 24-volt transformer, quiet contactors (for electric heat units), and an optional disconnect switch. All end devices are wired to a low-voltage terminal block and are run-tested, so the only a power connection and thermostat connection is needed to commission the unit. Changeover sensors and controls are provided whenever a change-over coil is selected. When N.O. valves are selected, inverting relays are provided for use with standard thermostats.

Fan Speed Control

The fan speed control is available with or without the control interface option and is available as wall-mount or unit-mount. The speed control incorporates a 0 to 10 Vdc signal providing limitless control of the motor RPM between the factory set low and high speeds. The control box contains a line voltage to 24-volt transformer, ECM motor controller, and an optional disconnect switch.

Disconnect Switch

A unit mounted disconnect switch is available as a standard option on all units.



Mechanical Specifications

Coils

All water coils are proof-tested at 300 psig (air) and leak-tested at 100 psig (air under water). Maximum main coil working pressure is 300 psig. Maximum entering water temperature is 200°F. Tubes and u-bends are 3/8-inch OD copper. Fins are aluminum and are mechanically bonded to the copper tubes. Coil stub-outs are 5/8-inch OD copper tubing.

Reheat Coils

Reheat coils are available for use with both hot water and steam. Hot water maximum working pressure is 300 psig, and the maximum entering water temperature is 200°F. The steam coil maximum working pressure is 15 psig. The reheat coils are constructed of single circuit 5/8-inch copper tubes with aluminum fins. Piping connections are expanded to accept standard copper tubing 5/8-inch OD.

Electric Heat Coil

The auxiliary electric heating coil is provided as either the total source of heat or auxiliary intermediate season heating. The electric heat coils are located in the preheat position, and are the open-wire type. The coils are a nickel chromium element design. The electric heat operates at the same voltage as the unit, and only a single power connection is necessary.

All units with factory-mounted electric heat are UL-listed and interlocked with the fan motor switch. A call for electric heat operation will turn the fan on. Motors controls are synchronized with fan/valve operation to ensure safe operation and to ensure that two modes of heat are not operating simultaneously. A transformer is supplied on any voltage unit, eliminating the need for field installation of a step-down transformer. Unit-mounted quiet magnetic relays are supplied on all voltages. A high temperature cutout, with both automatic reset and backup single-use, is provided as an integral part of the elements to de-energize the electric heat in the event of malfunction.

Refrigerant Coil

Direct expansion coils contain copper tubes mechanically expanded into evenly spaced aluminum fins. All coils are leak tested at 650 psig. Maximum standard operating conditions are 650 psig at 127°F with R410A. Distributors are sized consistently with capacity of coil. A thermostatic expansion valve (TXV) is factory selected and installed for a wide-range of control to maintain optimum control of superheat. Coils are shipped with a dry nitrogen holding charge.

DX and Heat Pump Coils

Direct expansion coils contain copper tubes mechanically expanded into evenly spaced aluminum fins. All coils are leak tested at 650 psig. Maximum standard operating conditions are 650 psig at 127°F with R410A. Distributors are sized consistently with capacity of coil. A thermostatic expansion valve (TXV) is factory-selected and installed for a wide-range of control to maintain optimum control of superheat. Coils are shipped with a dry nitrogen holding charge.

Filters

Filters are concealed from sight and easily removable. Filters are located behind an integral access door on horizontal type units. Filters are either 1-inch throwaway or 1-inch MERV 8.

Units equipped with 1-inch MERV 8 filters have a rating based on ASHRAE Standard 52.2. The average dust spot efficiency is no less than 35 to 40 percent when tested in accordance with ASHRAE 52.1 atmospheric dust spot method.

Units equipped with 1-inch MERV 13 filters have a rating based on ASHRAE Standard 52.2. The average dust spot efficiency is no less than 90 percent efficiency on 1-3 micron particles and greater than 90 percent efficiency on 3-10 micron particles when tested in accordance with ASHRAE Test Standard 52.2.

Fresh Air Dampers

A fresh air opening with a damper is a factory-installed option. Dampers are constructed of 18-gauge steel. Fresh air is sealed off with gasket material when the damper is set in the closed position. Return and fresh air mixes when the damper is open.

Manual Damper

The manual damper is field-adjustable to allow a 0 to 100% fresh air position.

Auto Two-Position Damper

The auto two-position damper is factory set at 25 percent when open. The damper can be set in the field to allow a zero to 50 percent fresh air position.

Economizer Damper

The economizer damper is accompanied by a factory-installed and wired modulating actuator. The damper is factory set at 25 percent default minimum and 100 percent maximum opening.

Colors

Six decorator colors are available in a baked powder finish. For a color chart, contact your local Trane office for a copy of UNT-SLB017-EN (*Color Selector: Cabinet Heaters, Fan Coils, Unit Ventilators and Water-Source Heat Pump Consoles*).

Components

Quad Grille Outlet

Figure 51. Quad grille outlet



Quad grilles are square multi-directional grilles that allow four different discharge directions by rotating the grilles 90°. The quad grille construction is a black plastic material (NORYL-SE 1-731) with a 15° angle on the discharge louvers. Quad grilles are recessed into the discharge panel to prevent condensation from forming on the grille exterior. Quad grilles are available on all cabinet style units.

Bar Grille Inlet/Outlet

Figure 52. Bar grille outlet

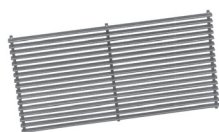

Bar grilles are formed steel grille options available on the discharge of all cabinet units, the return of vertical cabinet, vertical slope tops and low vertical cabinet units. The grilles have a black paint finish with 18-gauge steel construction. The louvers are formed at a 15° angle, and the discharge grilles are recessed to prevent condensate formation on the surface of the grille. The bar grilles are fixed in one discharge direction.

Sub-bases

Figure 53. Sub-base (shown turned on its side)

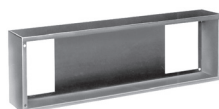

Sub-bases elevate vertical cabinet or slope top cabinet units to a specified height; for example, to reach the bottom of a window sill. The sub-base also provides a cavity through which to run piping underneath the fan coil unit. Sub-bases are 16-gauge steel construction and have the same black paint finish as the base of the unit. The sub-base is available in heights between two inches and seven inches in 1/2-inch increments. The sub-base depth and width is identical to the dimensions of the unit.

Mechanical Specifications

False Backs

Figure 54. False backs



False backs increase the depth of a vertical cabinet unit and provide a cavity through which to run piping behind the fan coil unit. False backs are also an excellent application when installing a unit beneath a window sill that extends out past the front of the unit.

False backs are 18-gauge steel construction and have the same paint finish as the unit. The false back is available in depths between two inches and eight inches in 1-inch increments, with height and width identical to the dimensions of the unit.

Recessing Flanges

Figure 55. Recessing flanges



Recessing flanges have 18-gauge steel construction and are painted the same finish as the unit. Recessing flanges provide an aesthetic architectural border or frame around vertical and horizontal cabinet fan coil units.

Aluminum Wall Boxes

Figure 56. Wall box



Wall boxes have a clear anodized finish and include a single core wire mesh insect screen. The frame is 10-gauge extruded aluminum alloy 6063-T5 construction. Horizontal louvers have 16-gauge extruded aluminum alloy 6063-T5 construction.

Wall boxes ship separate for field installation. A field supplied duct or sleeve from the wall box to the unit fresh air opening is required to provide fresh air. Wall boxes are sized to handle up to 100 percent of nominal air flow.

Projection Panels

Figure 57. Projection panel

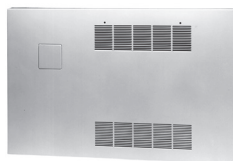

Projection panels allow semi-recessing of vertical recessed units.

Panels are 16-gauge steel construction, painted with a baked powder finish. They are available in projection depths ranging from two inches to six inches in 1/2-inch increments. There is a distance of 7/8 inch between the projection panel and the front of the unit.

Piping Package

All piping packages are proof-tested at 300 psig (air) and leak tested at 100 (air under water.) The maximum working pressure of the interconnecting piping is 300 psig.

For hydronic applications, maximum working temperature is 200 °F except for applications with up to 50% glycol where the limit is 180 °F.

Control valves are mounted in all factory piping packages. All piping packages are factory-installed and come in a variety of options:

- **Basic:** Shut-off ball valve on the supply line. Control valve and shut-off ball valve on the return line.

Mechanical Specifications

- **Basic with manual circuit setter:** Shut-off ball valve on the supply line. Control valve and manual circuit setter on the return line.
- **Deluxe with manual circuit setter:** Union, strainer, P/T port, and shut-off ball valve on the supply line. Union, control valve and manual circuit setter on the return line.
- **Deluxe with auto flow:** Union, strainer, P/T port, and shut-off ball valve on the supply line. Union, control valve, auto flow valve, P/T port and shut-off ball valve on the return line.

Control Valves

Control valves are ball valve designed with zero leakage. The ball valve incorporates self-cleaning technology to provide superior clog resistance. The actuator is easily removable for service without removing the valve body.

Figure 58. Control valve

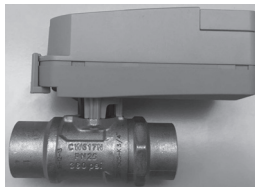

Material	Media Temperature	Working Pressure	Differential Pressure	Close off Pressure
Body - Forged Brass	36°F min	360 psig	40 psig	75 psig
Ball - Chrome Plated Brass	200°F max			
Stem - Brass				
Seats - PTFE				
O-Rings - EPDM (lubricated)				

Table 32. Control valve actuators

Actuator Type	Media Temperature	Ambient Temperature	Power Supply	Power Consumption	Stroke Time
2 Position	36°F min	35°F min	24 Vac 50/60Hz 580	2.5 watts	Variable
Modulating/Analog	200°F max	104°F max		0.3 watts	

End Valves

Each piping package includes a ball valve on the entering water pipe and one of the following end valve on the leaving water pipe:

- Ball valve
- Manual circuit setter
- Auto circuit setter

Ball Valve

Ball valves, also known as stop valves, allow the unit to be cut off for service purposes. These valve handles rotate 90 degrees to a fully open position with a maximum working pressure of 600 psig.

Manual Circuit Setter

A manual circuit setter acts as both a flow setting device and a stop valve. This valve allows water flow through the unit to be set quickly and accurately. The manual circuit setter includes ¼ in. Schrader ports in the valve body. These ports are used to measure the pressure drop across the valve. This pressure drop can be compared to factory supplied curves that relate the pressure drop to a specific flow rate. This valve also has a memory stop that helps find the correct setting quickly.

Figure 59. Manual circuit setter

Material	Temperature	Working Pressure
----------	-------------	------------------

Mechanical Specifications

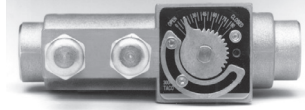

Body - Bronze	250°F max	300 psig max
Seats - Teflon®		
Internal Components - Brass, Teflon®, EPDM		
Schrader Valve Connections - Brass 1/4 in.		
Indicator Plate - Stainless Steel		
Pointer - Die Cast Zinc		

Automatic Flow Control (Auto Flow Valve)

Automatic Flow Control is located on the return line. This device is a non-adjustable in-line flow control valve that maintains the GPM for the unit with a cartridge sized to a specific flow rate.

Figure 60. Auto flow valve

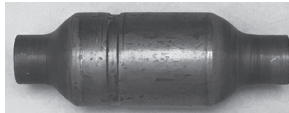

Material	Media Temperature	Working Pressure	Pressure Drop
Valve Body - Copper	32°F min	522 psig	2-80 psig 0.50-5.00 GPM
O-rings - EPDM	225°F max		3-80 psig 5.50-9.00 GPM
Retainer - Stainless Steel			
Diaphragm - EPDM			
Orifice - Polyphenyl sulfone			

Strainer

The strainer is provided with a plug to access the basket. The strainer contains a 20 mesh screen with a working pressure of 300 psig and a maximum water temperature of 210 °F.

P/T Port

P/T Port has the ability to measure temperature or pressure of the line.

Figure 61. P/T Port

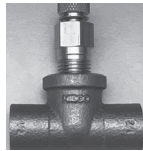

Material	Temperature	Working Pressure
Tee Body - Cast Bronze		
P/T Plug Body - Brass	200°F max	500 psig

Bypass Balance Valve

All three-way control valve packages include a balance fitting in the bypass line to allow flow balancing in the bypass position. The balance valve incorporates both a gland screw and stem for manual flow adjustment. The working pressure of this valve is 400 psig.

Union

Figure 62. Union



Material
Nut—Forged Brass
Body—Copper
Tail—Copper



Notes



The AHRI Certified mark indicates Trane U.S. Inc. participation in the AHRI Certification program. For verification of individual certified products, go to ahridirectory.org.

Trane - by Trane Technologies (NYSE: TT), a global climate innovator - creates comfortable, energy efficient indoor environments for commercial and residential applications. For more information, please visit trane.com or tranetechnologies.com.

Trane has a policy of continuous product and product data improvement and reserves the right to change design and specifications without notice. We are committed to using environmentally conscious print practices.