



Product Catalog

# Trane Rental Services

## Temporary Air-Cooled Chillers



April 2025

TEMP-PRC010A-EN

TRANE  
TECHNOLOGIES™



# Introduction

Read this manual thoroughly before operating or servicing this unit.

## Warnings, Cautions, and Notices

Safety advisories appear throughout this manual as required. Your personal safety and the proper operation of this machine depend upon the strict observance of these precautions.

The three types of advisories are defined as follows:



Indicates a potentially hazardous situation which, if not avoided, could result in death or serious injury.



Indicates a potentially hazardous situation which, if not avoided, could result in minor or moderate injury. It could also be used to alert against unsafe practices.



Indicates a situation that could result in equipment or property-damage only accidents.

## Important Environmental Concerns

Scientific research has shown that certain man-made chemicals can affect the earth's naturally occurring stratospheric ozone layer when released to the atmosphere. In particular, several of the identified chemicals that may affect the ozone layer are refrigerants that contain Chlorine, Fluorine and Carbon (CFCs) and those containing Hydrogen, Chlorine, Fluorine and Carbon (HCFCs). Not all refrigerants containing these compounds have the same potential impact to the environment. Trane advocates the responsible handling of all refrigerants.

## Important Responsible Refrigerant Practices

Trane believes that responsible refrigerant practices are important to the environment, our customers, and the air conditioning industry. All technicians who handle refrigerants must be certified according to local rules. For the USA, the Federal Clean Air Act (Section 608) sets forth the requirements for handling, reclaiming, recovering and recycling of certain refrigerants and the equipment that is used in these service procedures. In addition, some states or municipalities may have additional requirements that must also be adhered to for responsible management of refrigerants. Know the applicable laws and follow them.

### **⚠ WARNING**

#### **Proper Field Wiring and Grounding Required!**

**Failure to follow code could result in death or serious injury.**

**All field wiring MUST be performed by qualified personnel. Improperly installed and grounded field wiring poses FIRE and ELECTROCUTION hazards. To avoid these hazards, you MUST follow requirements for field wiring installation and grounding as described in NEC and your local/state/national electrical codes.**

**⚠ WARNING****Personal Protective Equipment (PPE) Required!**

Failure to wear proper PPE for the job being undertaken could result in death or serious injury. Technicians, in order to protect themselves from potential electrical, mechanical, and chemical hazards, **MUST** follow precautions in this manual and on the tags, stickers, and labels, as well as the instructions below:

- Before installing/servicing this unit, technicians **MUST** put on all PPE required for the work being undertaken (Examples; cut resistant gloves/sleeves, butyl gloves, safety glasses, hard hat/bump cap, fall protection, electrical PPE and arc flash clothing). **ALWAYS** refer to appropriate Safety Data Sheets (SDS) and OSHA guidelines for proper PPE.
- When working with or around hazardous chemicals, **ALWAYS** refer to the appropriate SDS and OSHA/GHS (Global Harmonized System of Classification and Labelling of Chemicals) guidelines for information on allowable personal exposure levels, proper respiratory protection and handling instructions.
- If there is a risk of energized electrical contact, arc, or flash, technicians **MUST** put on all PPE in accordance with OSHA, NFPA 70E, or other country-specific requirements for arc flash protection, **PRIOR** to servicing the unit. **NEVER PERFORM ANY SWITCHING, DISCONNECTING, OR VOLTAGE TESTING WITHOUT PROPER ELECTRICAL PPE AND ARC FLASH CLOTHING. ENSURE ELECTRICAL METERS AND EQUIPMENT ARE PROPERLY RATED FOR INTENDED VOLTAGE.**

**⚠ WARNING****Follow EHS Policies!**

Failure to follow instructions below could result in death or serious injury.

- All Trane personnel must follow the company's Environmental, Health and Safety (EHS) policies when performing work such as hot work, electrical, fall protection, lockout/tagout, refrigerant handling, etc. Where local regulations are more stringent than these policies, those regulations supersede these policies.
- Non-Trane personnel should always follow local regulations.

## Copyright

This document and the information in it are the property of Trane, and may not be used or reproduced in whole or in part without written permission. Trane reserves the right to revise this publication at any time, and to make changes to its content without obligation to notify any person of such revision or change.

## Trademarks

All trademarks referenced in this document are the trademarks of their respective owners.



# Table of Contents

Application Considerations .....	6
Ambient Limitations .....	6
Electrical Connections and Shore Power .....	6
Water Flow Limits Value .....	7
Flows Out of Range .....	7
Entering Water Temperature Limits .....	8
Leaving Water Temperature Limits .....	8
Leaving Water Temperatures Out of Range .....	8
Short Water Loops .....	9
Close Spacing and Clearances .....	9
Acoustics .....	10
Pump Control .....	12
Freeze Protection .....	12
Controls .....	12
10 Ton Portable Chiller .....	13
25 to 120 Ton CGAM .....	16
25 Ton Air-Cooled CGAM .....	16
40 Ton Air-Cooled CGAM .....	20
60 Ton Air-Cooled CGAM .....	25
80 Ton Air-Cooled CGAM .....	30
100 Ton Air-Cooled CGAM .....	35
120 Ton Air-Cooled CGAM .....	40
200 Ton ACSA .....	46
General – RSCA0200F0 .....	47
200 Ton Air-Cooled ACXA .....	50
General – RSCX0200F1 .....	52

80 to 500 Ton RTAA/RTAC .....	55
80 Ton Air-Cooled RTAA .....	55
100 Ton Air-Cooled RTAA .....	57
125 Ton Air-Cooled RTAA .....	60
155 Ton Air-Cooled RTAC .....	63
170 Ton Air-Cooled RTAA .....	69
170 Ton Air-Cooled RTAC .....	71
200 Ton Air-Cooled RTAA .....	76
200 Ton Air-Cooled RTAC .....	78
250 Ton Air-Cooled RTAC .....	84
300 Ton Air-Cooled RTAA .....	90
300 Ton Air-Cooled RTAC .....	92
400 Ton Air-Cooled RTAA .....	98
400 Ton Air-Cooled RTAC .....	101
500 Ton Air-Cooled RTAC .....	107



# Application Considerations

## Ambient Limitations

Trane Rental Services ACSA, ACXA, CGAM, and RTAC units can operate outdoors in a wide range of ambient temperatures. Depending on the product, this allows the chiller to perform from -20°F to 130°F (-18°C to 54°C).

- Trane Rental Services sets and enables a low ambient lockout temperature at 25°F. Modifications to the lockout should only be performed by a Trane technician or with the help of Trane Rental Services Technical Support Group.
- The minimum ambient temperatures are based on wind condition not exceeding 5 mph. Higher wind conditions will result in a drop in head pressure, increasing the minimum starting and operating ambient temperatures.
- To keep the chiller online, the adaptive control microprocessor will stage fans on, modulate electronic expansion valves, and modulate slide valve positions as the chiller approaches a high pressure cutout limit.

Trane Rental Services RSPA chillers can only operate indoors at an ambient temperature of 60°F to 95°F.

**Important:** They cannot be exposed to the elements under any circumstances.

- If there is no place indoors to place the chiller, an enclosure must be placed around the chiller.
- The enclosure must meet clearance requirements and be conditioned to maintain the ambient temperature range this chiller can operate in.

## Electrical Connections and Shore Power

Table 1. Trane rental RTAC power configuration

Unit Size (tons)	Rental RTAC Model	Power Supply Configuration
300 - 400	F0	Single or Dual point
300 - 400	F2	Dual point
500	All	Dual point

Figure 1. Single point configuration

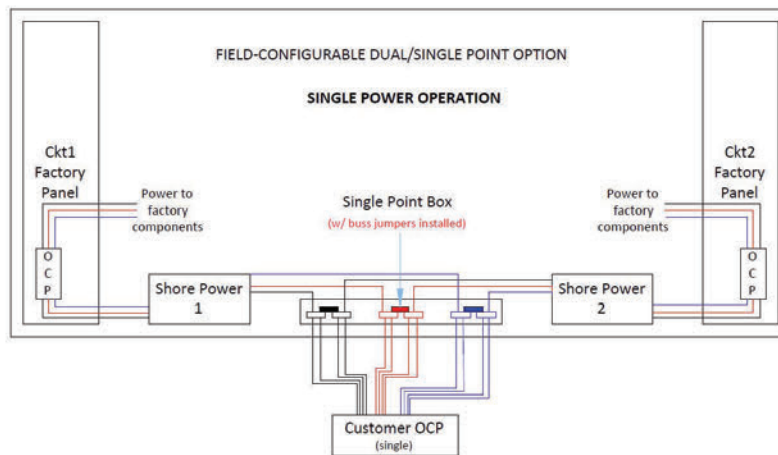

**Figure 2. Dual point configuration**

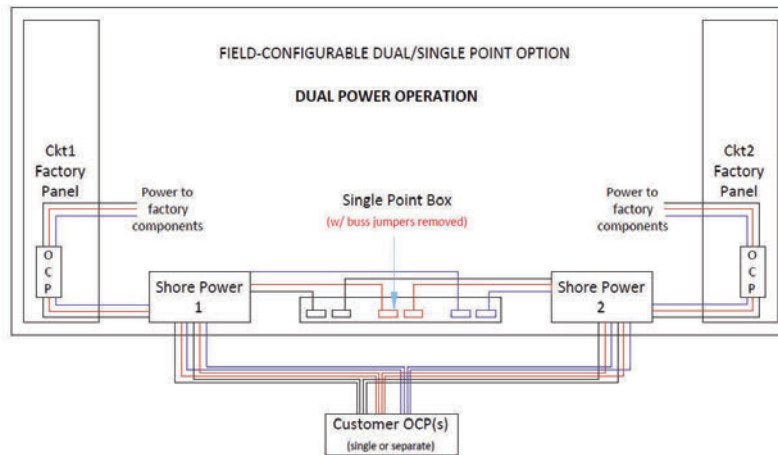

ACSA, ACXA, CGAM, and RTAC chillers include a shore power connection to energize the oil sump heater. Regardless of ambient temperature, this is required to boil refrigerant out of the oil and is required to be energized 24 hours prior to start-up.

The below table lists components powered by the shore power circuit. The circuit itself is powered via a 115V 60 Hz NEMA 5-15P plug on the enclosure, from the building, with an extension cord.

**Table 2. Components powered by shore power circuit**

ACSA/ACXA	CGAM	RTAC <sup>(a)</sup>
Compressor Heaters	Compressor Heaters	Compressor Heaters
Symbio™ 800 Interface	CH530 Interface	Oil Separator Heater
Symbio 800 Controls	CH530 Controls	CH530 Interface
—	Evaporator Heater	CH530 Controls

<sup>(a)</sup> Some units have dual circuits and also have a shore power enclosure for each circuit.

## Water Flow Limits Value

Minimum and maximum flow rates are found under the water flow rates and pressure drops section of the desired chiller listing. Verify flow is within these limits.

Evaporator flow rates below the tabulated values will result in laminar flow causing freeze up problems, scaling, stratification, and poor control. Flow rates exceeding those listed may result in very high pressure drop across the evaporator and excessive tube erosion.

## Flows Out of Range

Many process cooling jobs require evaporator flow rates that fall outside of a rental chiller specifications. A simple piping change can alleviate this problem.

- A plastic injection molding process requires 80 gpm (5.1 l/s) of 50°F (10°C) water and returns that water at 60°F (15.6°C).
- The chiller can operate at these temperatures, but has a minimum flow rate of 120 gpm (7.6 l/s).

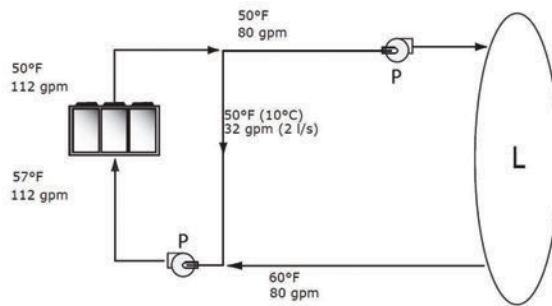

Trane Rental Services offers plate and frame heat exchangers in four tonnage ratings (100, 150, 250, 500). They provide fluid to fluid heat exchange in chilled/hot water applications. If a process requires cooling, but the flow rate is too low or too high for a standard chiller of corresponding tonnage, then the use of a heat exchanger can allow the chiller to operate at a flow rate that meets specification while the customer process can operate at its optimal flow rate.

## Entering Water Temperature Limits

The maximum water temperature that can be circulated through an evaporator when the unit is operating is 75°F (RTAC), 95°F (ACSA/ACXA and CGAM), and 100°F (RSPA).

- On RTAC units, if the return water temperature exceeds 75°F, the compressors will experience a high amperage draw that will trip over-current protection devices and high refrigeration pressure cutouts.
- If the entering water temperature is higher than the maximum allowable temperature, consult Trane Rental Services about implementing a bypass to mix supply water with return water to reduce the return water temperature. Adding a bypass may require additional pumps for balancing the temporary chiller plant layout.

The maximum water temperature that can be circulated through an evaporator when the unit is not operating is 108°F (RTAC) and 125°F (ACSA/ACXA and CGAM).

- If there is a need for a dual process application such as comfort cooling (daytime) and ice storage (usually nighttime), rental chillers may be retrofitted for this purpose.
- Consult Trane Rental Services Engineering prior to performing these tasks.

## Leaving Water Temperature Limits

Trane Rental Services chillers have been selected with a low leaving water option. Low temperature machines produce leaving liquid temperatures less than 40°F (4.4°C). However since the liquid supply temperature setpoint is less than 40°F (4.4°C) (ACSA/ACXA and RTAC), and 42°F (5.5°C) (CGAM), this results in suction temperatures at or below the freezing point of water. A glycol solution is required for all low temperature machines. Consult Trane Rental Services engineering for any performance selection on chillers.

## Leaving Water Temperatures Out of Range

Many process cooling jobs require evaporator flow rates that fall outside of a chiller specifications. Many process cooling jobs require temperature ranges that cannot be met by the published minimum and maximum temperature values for the rental chiller evaporator. A simple piping change can alleviate this problem.

- A laboratory load requires 120 gpm (7.6 l/s) of water entering the process at 85°F (29.4°C) and returning at 95°F (35°C). The accuracy required is better than the cooling tower can give. The selected chiller has adequate capacity, but a maximum leaving chilled water temperature of 65°F (18.3°C).
- In the figure below, both the chiller and process flow rates are equal. This is not necessary. If the chiller had a higher flow rate, there would simply be more water bypassing and mixing with warm water.

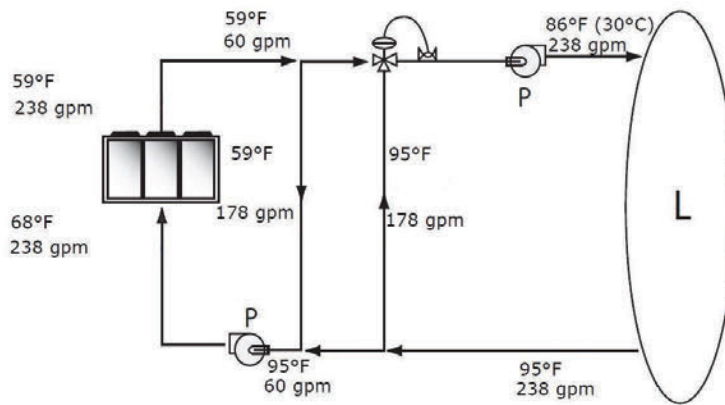

Trane Rental Services offers plate and frame heat exchangers in four tonnage ratings (100, 150, 250, 500). They provide fluid to fluid heat exchange in chilled/hot water applications. They operate in wide temperature ranges (14°F to 250°F) which might allow for standard chiller operation temperatures while customer process can operate at high temperatures needed for proper operation.

## Short Water Loops

Adequate water volume is an important chilled water system design parameter because it provides for stable chilled water temperature control and helps to limit unacceptable short cycling of chiller compressors.

Typically, a 2 minute water loop circulation time is sufficient to prevent short water loop issues. As a guideline, confirm the volume of water in the chilled water loop equals or exceeds two times the evaporator flow rate.

If the installed system volume does not meet the above recommendations, consider the following items to increase the volume of water in the system and reduce the rate of change of the return water temperature.

- A volume buffer tank located in the return water piping.
- Large system supply and return header piping (which also reduces system pressure drop and pump energy use).

## Close Spacing and Clearances

- Allow for unrestricted access to all service points.
- A minimum of 4 feet is recommended for compressor service.
- Provide sufficient clearance for the opening of control panel doors.
- The chiller should be completely open above the fan deck.
- Ducting individual fans is not recommended.

When installation is a concern due to minimal recirculating air and close spacing, consider the following for more than one chiller:

## Application Considerations

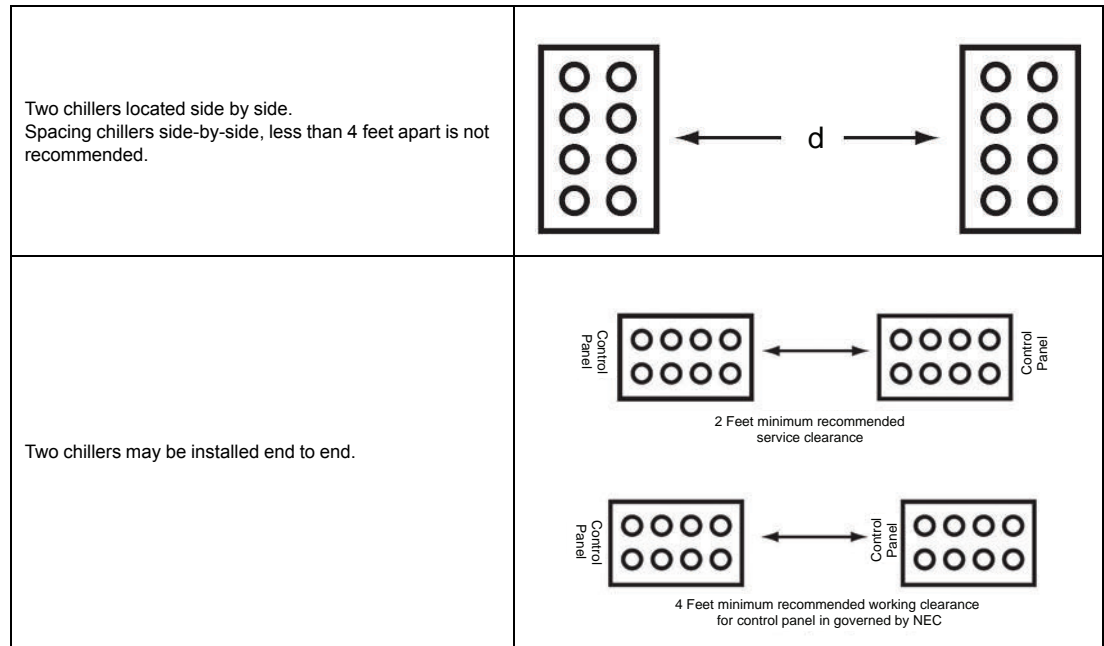

There is no performance effect for any spacing of chillers end to end. Minimum spacing is governed by service clearances and working clearance required by the National Electric Code (NEC) near control panels. A 2-foot clearance is recommended on the end opposite the control panel. Article 110-16 of the NEC requires 3 to 4 feet of working clearance, on the control panel end depending on the actual installed conditions. Refer to the NEC for a detailed discussion of requirements.

In all cases, local codes which require additional clearances will take precedence over these recommendations. Refer to *Series R® Air-Cooled Helical Rotary Liquid Chillers - Installation, Operation, and Maintenance* (RTAC-SVX01\*-EN) and *Close-Spacing and Restricted Airflow Situations Air-Cooled Scroll Chillers - Engineering Bulletin* (CG-PRB011\*-EN) for more information on clearances and close spacing applications.

Trane Rental Services RSPA chillers require a minimum 2-foot clearance at the air intake and a minimum 6-foot clearance at the vertical exhaust air discharge. There must be adequate ventilation to dissipate the rejected heat. The unit must not be placed in non-ventilated areas.

## Acoustics

In order to minimize noise and vibration transmission, locate outdoor unit away from sound sensitive areas.

For rental ACSA and ACXA 60 Hz units, sound pressure levels measured 30 feet from control panel. A-weighted Sound Pressure Level, dBA, ref 20 micro PA.

**Table 3. ACSA/ACXA sound pressure data**

Unit Size (tons)	Percent Load				
	100%	67%	50%	33%	17%
200	72	71	70	67	64

For rental CGAM 60 Hz units with standard super quiet fans, sound pressure levels measured 30 feet from control panel. A-weighted Sound Pressure Level, dBA, ref 20 micro Pa.

**Table 4. CGAM sound pressure data**

Unit Size (tons)	Percent Load			
	100%	75%	50%	25%
25	56	—	55	—
40	58	57	57	54
60	62	62	61	58
80	63	62	61	58
100	62	62	60	58
120	65	64	62	59

Refer to the table below for overall A-weighted sound pressure levels for rental RTAC chillers.

**Table 5. RTAC sound pressure data**

Unit Size (tons)	A-Weighted Sound Pressure Level, dBA, ref 20 micro Pa (60 Hz @ 30 ft.)
155	72.0
170	74.0
200	75.0
250	75.0
300	76.0
400	78.0
500	78.0

Estimations made using this bulletin are considered typical of what may be measured in a free field with a hand-held sound meter, in the absence of a nearby reflective surface.

One of the techniques used in the field to try attenuate sound is through the use of barrier walls. A barrier wall constructed to only 1/2-inch exterior grade plywood gives 10 dBA reduction in sound. Refer to figure below for minimum wall requirements. A minimum distance of 4 feet is recommended, but the chiller may be placed closer than 4 feet to a barrier wall. Some loss of performance will occur.

**Figure 3. Minimum wall requirements**

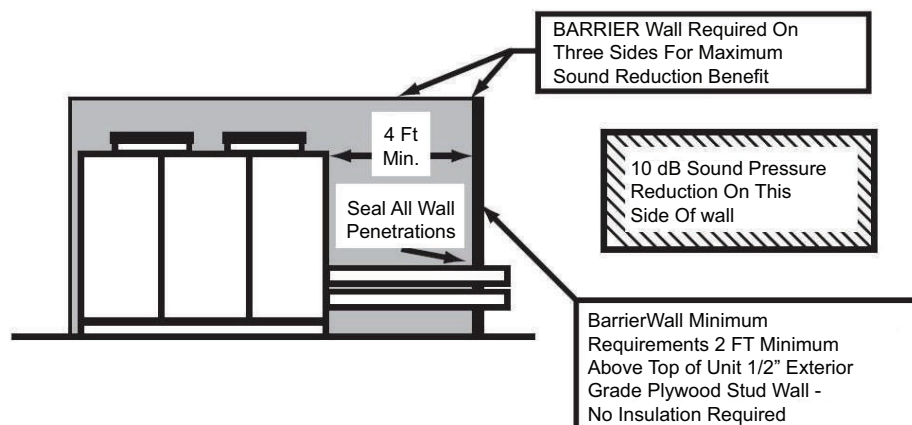



### Pump Control

Trane Rental Services offers a pump that is pre-piped, wired, and integral to the frame of the rental chiller.

The pump contactor is located in the shore power panel and has a control switch with an indication light that will be lit when the pump is running. The pump switch can be used to select between three operating modes: Off, On, and Auto. When the pump switch is in Auto mode, the pump is controlled through the chiller controls. When the pump switch is On, the pump will run until the mode is changed. When the pump switch is Off, the pump will remain off.

Trane Rental Services RTAA style chillers have a pump that are usually installed external to the chiller. RTAA can only be selected in Off/On mode of operation. Contact Trane Rental Services Engineering for more information. The pump electrical connection is usually mandated by the local electrical code.

There are two viable options:

1. Identify an electrical breaker at the site and connect the pump to it.
2. Trane Rental Services also offers I-line panels to connect through lug or cam-lock type connections.

### Freeze Protection

In ambient temperatures between 32°F (0°C) and -20°F (-28°C) it is recommended that a non-freezing, low temperature, corrosion inhibiting, heat transfer fluid be added to the chilled water system. The solution must be strong enough to provide protection against ice formation at the lowest anticipated ambient temperature. As a result of low chilled water setpoints at or below 40°F (4°C), glycol or other antifreeze solution must be used. Trane Rental Services RSPA chillers require at least 30 percent glycol when operating at a chilled water setpoint at or below 48°F. Contact Trane Rental Services Engineering for more information on glycol percentage recommendations.

In addition to using glycol, it is highly recommended that all exposed piping and pumps, integral to the chiller, be heat traced and insulated. Follow recommended guidelines by the heat tracing manufacturer. In low ambient applications, heaters alone will provide protection down to -20°F (-29°C), but will NOT protect the evaporator from freezing as a result of charge migration. It is required that water pump control be used in conjunction with heaters. CH530 controller can start the pump when freezing conditions are detected. For this option the pump must be controlled by the unit and this function must be validated.

### Controls

RTAC and CGAM style chillers include Trane standard DynaView display. Designed to be weatherproofed and made of durable plastic for use as an outdoor device, it is also provided with CH530 control panel. This interface allows the user to access any important information concerning setpoints, active temperatures, modes, electrical data, pressure and diagnostics.

RTAC and CGAM style chillers have external current limit setpoint as well as external chilled water setpoint inputs that accept either 4 to 20 mA or 2 to 10 Vdc signals. This allows for remote flexibility to meet job requirements while not having to learn a complicated control system. The Kestrelview Service Tool must be used to set the input signal type from the factory default from 2 to 10 Vdc to that of 4 to 20 mA current. This tool must also be used to enable or disable the feature if installed.

ACSA and ACXA chillers utilize Trane Symbio™ 800 controls platform. The Symbio 800 controller is a factory-installed, application specific and programmable controller designed to control chillers. A 7-inch user interface features a touch sensitive color screen that provides facility managers at-a-glance operating status, performance monitoring, scheduling changes, and operating adjustments.

ACSA, ACXA, CGAM, and RTAC rental chillers all include BACnet® communication interfaces.



# 10 Ton Portable Chiller

**Table 6. General – RSPA0010F0 (indoor only)**

Labels	Value
Model Number	TempTek CFD 10-A
Nominal Tons	10
Refrigerant	R-410A
Water Connection Size <sup>(a)</sup>	1.5-inch Dixon
Ambient Operating Conditions	60°F to 95°F
Setpoint Limits <sup>(b)</sup>	20°F to 80°F
Number of Electrical Circuits	1
Number of Refrigerant Circuits	1

<sup>(a)</sup> Chiller ships with two, 25-foot sections of 1.5-inch hose with Dixon couplings, one, 1.5-inch NPT pin Dixon fitting, and one, 1.5-inch NPT receptable Dixon fitting. Dixon to Victaulic adapters will need to be sourced in the field to connect to TRS AHU waterlines.

<sup>(b)</sup> When leaving solution is below 48°F, a glycol solution is required.

**Table 7. Electrical data**

Labels	Value
Voltage <sup>(a)</sup>	460V 3-Phase
Frequency	60 Hz
Wire Connection Type <sup>(b)</sup>	8/4 Cable Whip
SCCR	5,000 A
<b>Without Integral Pump</b>	
Minimum Circuit Ampacity (MCA)	32 A
Maximum Overcurrent Protection (MOP)	50 A
Full Load Amps (FLA)	26.6 A
<b>With Integral Pump</b>	
Minimum Circuit Ampacity (MCA)	36 A
Maximum Overcurrent Protection (MOP)	50 A
Full Load Amps (FLA)	30.4 A

**Notes:**

1. For additional electrical information, contact Trane Rental Services.
2. All features and specifications are subject to change without notice or liability.

<sup>(a)</sup> RSPA0010B0AA requires 208V, 3-phase power.

<sup>(b)</sup> Chiller ships with one, 20-foot section of 8/4 cable whip.

**Table 8. Pump data**

Labels	Value
Horsepower	3 HP
Min Flow	24 gpm @ 136 ft.
Max Flow	48 gpm @ 113 ft.



# 10 Ton Portable Chiller

**Table 9. Cooling capacity (10 tons)**

Leaving Water Temp	Glycol (%)	Estimated Capacity (Tons) at 2.4 GPM / Nominal Ton	
		Ambient Air Temp	
		95°F	
60°F	0	10.29	
50°F	0	9.80	
45°F	30	8.82	
40°F	30	7.84	
35°F	30	6.86	
30°F	30	5.88	
25°F	30	4.90	
20°F	40	3.92	

**Table 10. Dimensions and weights**

Labels	Value
<b>RSPA0010B0AA; RSPA0010F0AB<sup>(a)</sup></b>	
Length	4 ft. 8 in.
Width	2 ft. 10 in.
Height	5 ft.
Shipping Weight (lbs)	1,100
Operating Weight (lbs)	1,309
<b>RSPA0010F0AC - RSPA0010F0**</b>	
Length	8 ft.
Width	3 ft. 10 in.
Height	6 ft. 8 in.
Shipping Weight (lbs)	1,500
Operating Weight (lbs)	1,809
Fork Pocket Dimensions	8.125 in. x 3.5 in. x 3 ft. 10 in.
Fork Pocket Center to Center Distance	3 ft. 3.875 in.

**Note:** Lifting device: forklift or crane

<sup>(a)</sup> Units not on a skid.

**Table 11. Installed/operating clearances**

Labels	Value
Air Intake	24 in.
Vertical Exhaust	72 in.

**Note:** Unit must not be placed in non-ventilated areas.

Integral Pump Curve

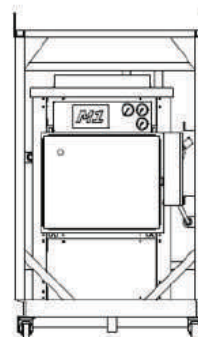
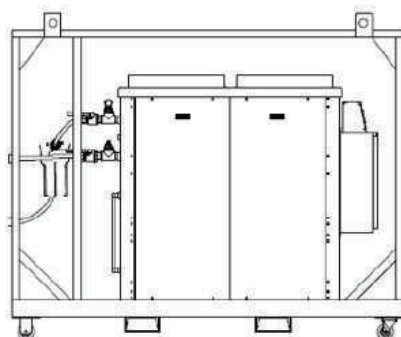
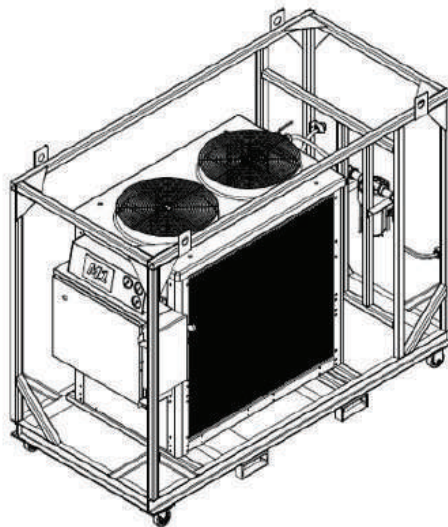
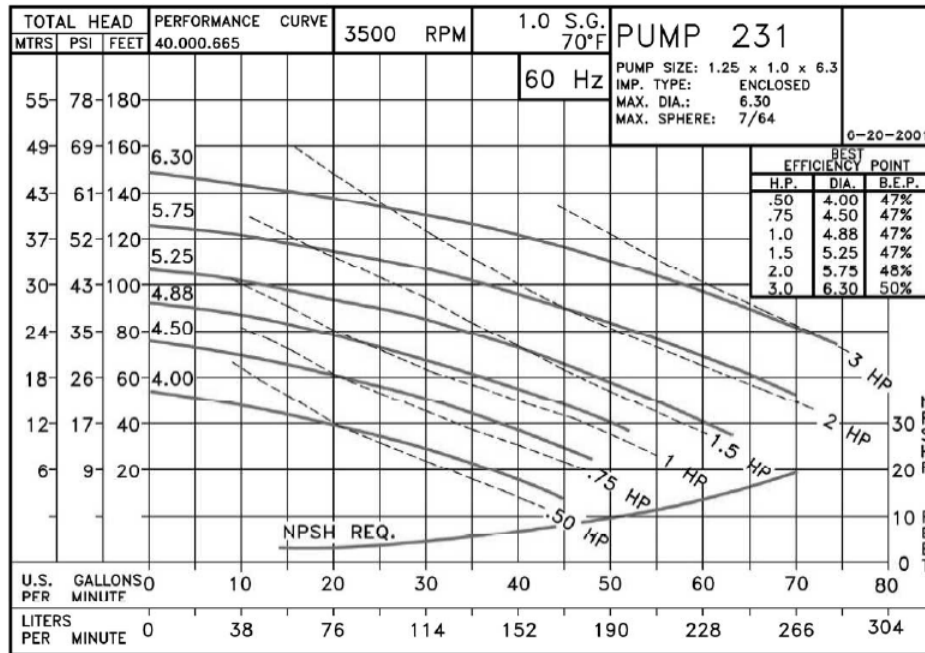



# 25 to 120 Ton CGAM

## 25 Ton Air-Cooled CGAM

**Table 12. General – CSCA0025F0-F2**

Labels	Value
Model Number	CGAM026
Nominal Tons	26
Refrigerant	R-410A
Refrigerant Charge <sup>(a)</sup>	34 lbs
Microchannel Refrigerant Charge <sup>(b)</sup>	22.5 lbs
Water Connection Size	2.5 in. Victaulic
Ambient Operating Conditions	0°F to 125°F
Extreme Ambient Operating Conditions <sup>(c)</sup>	-20°F to 125°F
Chilled Water Setpoint Limits <sup>(d)</sup>	0°F to 65°F
Number of Electrical Circuits	1
Number of Refrigerant Circuits	1

- (a) The listed refrigerant charge is per refrigeration circuit for all round tube and plate fin condenser coils.
- (b) The listed refrigerant charge is per refrigeration circuit for all extreme low ambient microchannel condenser coils.
- (c) For CGAM models with microchannel condenser coils.
- (d) When leaving solution is below 42°F, a glycol solution is required for all low temperature and ice-making applications.

**Table 13. Electrical data**

Labels	Value
Voltage	460V 3-Phase
Frequency	60 Hz
F0 Power Supply Connections <sup>(a)</sup> <sup>(b)</sup>	Lugs or Series 16 Cam-Type Connections
F2 Power Supply Connections <sup>(b)</sup>	Series 16 Cam-Type Connections Only
<b>Without Integral Pump</b>	
Minimum Circuit Ampacity (MCA)	56 A
Maximum Overcurrent Protection (MOP)	75 A
Full Load Amps (FLA)	49 A
<b>With Integral Pump</b>	
Minimum Circuit Ampacity (MCA)	64 A
Maximum Overcurrent Protection (MOP)	80 A
Full Load Amps (FLA)	55 A

**Note:** For additional electrical information, contact Trane Rental Services.

- (a) Maximum wire size lug(s) can accept - 2/0.
- (b) Depending on chiller MCA and wire used, multiple wires per phase may be required.

**Table 14. Pump data**

Labels	Value
Horsepower	5 HP
Min Flow	25 gpm @ 122.2 ft.
Max Flow	104 gpm @ 89.3 ft.

**Note:** Pump is mounted within the chiller frame with a bypass and controlled by the chiller standalone control system if not connected to end user building automation system.

**Table 15. Cooling capacity (25 tons)**

Leaving Water Temp	Propylene Glycol (%)	Estimated Capacity (Tons) at 2.4 GPM / Nominal Ton				
		Ambient Air Temp				
		85°F	95°F	105°F	115°F	125°F
65°F	0	36.6	34.2	31.6	29.1	—
55°F	0	31.9	29.7	27.5	25.2	22.9
45°F	0	27.3	25.5	23.6	21.6	19.6
35°F	10	22.8	21.3	19.7	18.0	16.3
25°F	25	18.6	17.4	16.1	14.7	—
15°F	35	14.8	13.9	12.8	—	—
5°F	40	11.7	11.0	—	—	—

*Note: Actual tons of refrigeration in table above are based on chiller models with round tube and plate fin condenser coils.*

**Table 16. Water flow rates and pressure drops (25 tons)**

Flow Rate (GPM)	Pressure Drop (ft. H <sub>2</sub> O)
30 (min flow)	3.58
40	6.04
50	9.21
60	13.10
70	17.60
80	22.90
89 (max flow)	28.30

*Note: Maximum water side pressure is 150 psi (2.31 ft. H<sub>2</sub>O = 1 psi).*

## General – CSCA0025F0

**Table 17. Dimensions and weights**

Labels	Value
Length	12 ft. 6 in.
Width	4 ft. 11 in.
Height	8 ft. 6 in.
Shipping Weight (lbs)	5,200
Operating Weight (lbs)	5,400
Fork Pocket Dimensions	9.25 in. x 5.25 in. x 4 ft. 2.75 in.
Fork Pocket Center to Center Distance	3 ft.

**Notes:**

1. Lifting device: forklift or crane.
2. All weights and dimensions listed above are subject to change without notice or liability.

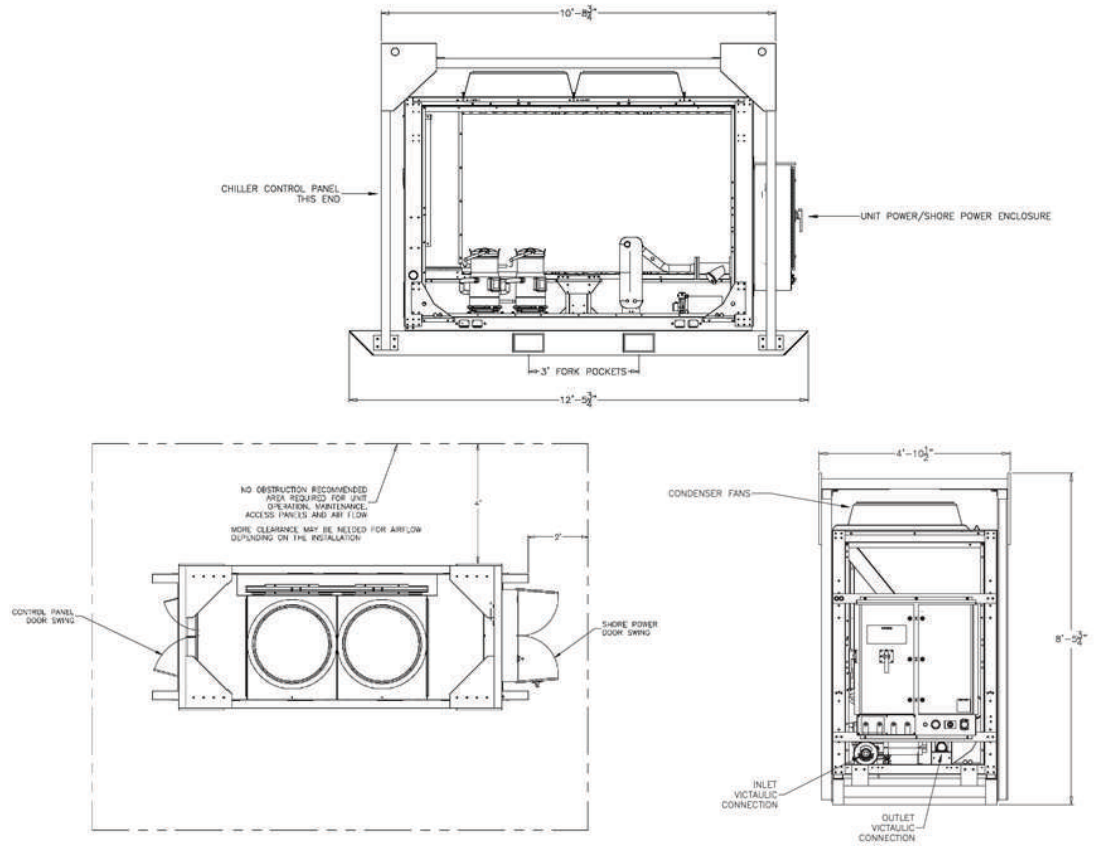
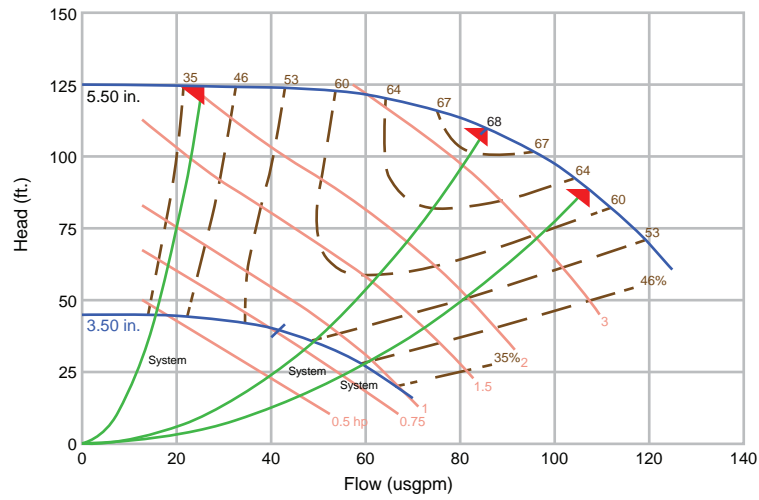

General – CSCA0025F2

Table 18. Dimensions and weights

Labels	Value
Length	13 ft. 4.5 in.
Width	4 ft. 9.75 in.
Height	7 ft. 11.5 in.
Shipping Weight (lbs)	5,000
Operating Weight (lbs)	5,200
Fork Pocket Dimensions	9.25 in. x 5.25 in. x 4 ft. 3 in.
Fork Pocket Center to Center Distance	4 ft. 2 in.

Notes:

1. Lifting device: forklift or crane.
2. All weights and dimensions listed above are subject to change without notice or liability.

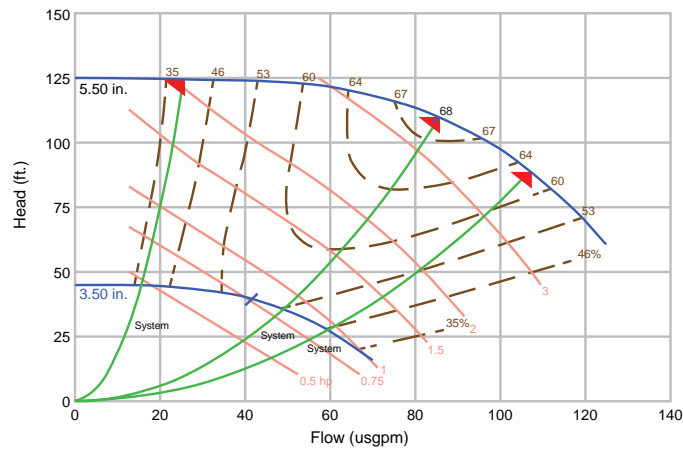

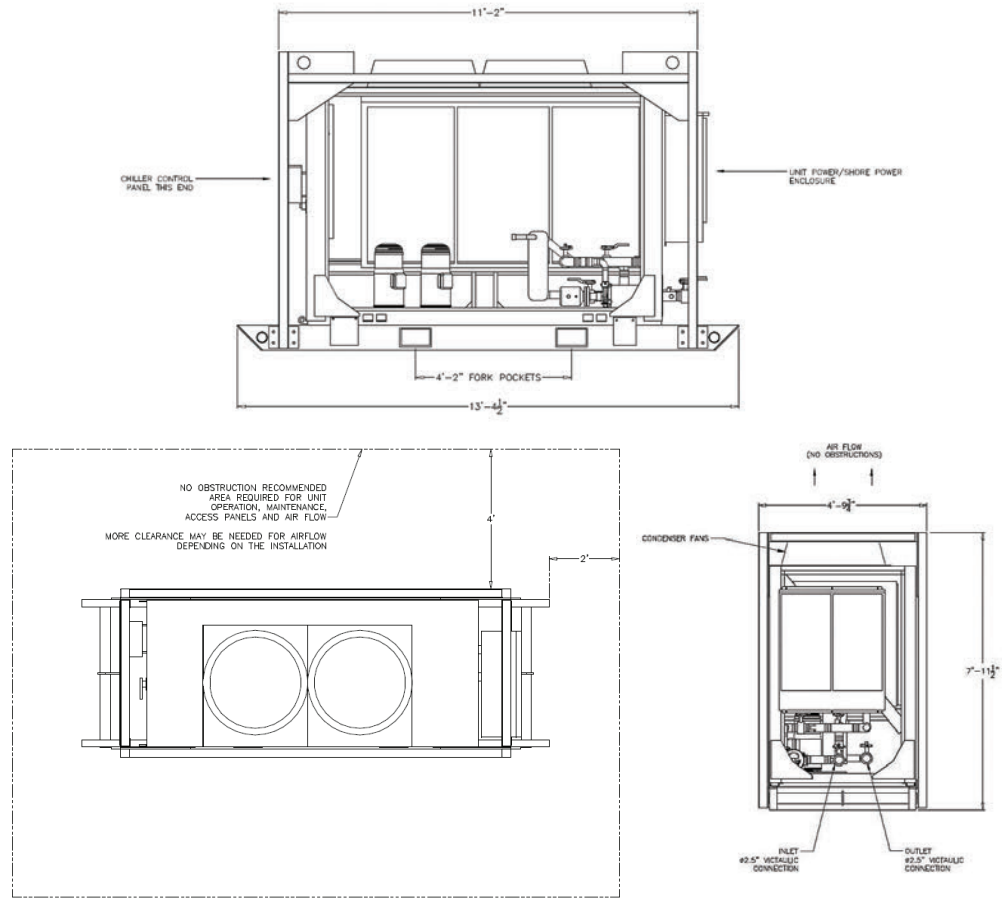

## 40 Ton Air-Cooled CGAM

Table 19. General – CSCA0040F0-F2

Labels	Value
Model Number	CGAM040
Nominal Tons	40
Refrigerant	R-410A
Refrigerant Charge <sup>(a)</sup>	32 lbs
Microchannel Refrigerant Charge <sup>(b)</sup>	19 lbs
Water Connection Size	2.5 in. Victaulic
Ambient Operating Conditions	0°F to 125°F
Extreme Ambient Operating Conditions <sup>(c)</sup>	-20°F to 125°F
Chilled Water Setpoint Limits <sup>(d)</sup>	0°F to 65°F
Number of Electrical Circuits	1
Number of Refrigerant Circuits	2

- (a) The listed refrigerant charge is per refrigeration circuit for all round tube and plate fin condenser coils.
- (b) The listed refrigerant charge is per refrigeration circuit for all extreme low ambient microchannel condenser coils.
- (c) For CGAM models with microchannel condenser coils.
- (d) When leaving solution is below 42°F, a glycol solution is required for all low temperature and ice-making applications.

**Table 20. Electrical data**

Labels	Value
Voltage	460V 3-Phase
Frequency	60 Hz
F0 Power Supply Connections <sup>(a)</sup> <sup>(b)</sup>	Lugs or Series 16 Cam-Type Connections
F2 Power Supply Connections <sup>(b)</sup>	Series 16 Cam-Type Connections Only
<b>Without Integral Pump</b>	
Minimum Circuit Ampacity (MCA)	95 A
Maximum Overcurrent Protection (MOP)	110 A
Full Load Amps (FLA)	89 A
<b>With Integral Pump</b>	
Minimum Circuit Ampacity (MCA)	109 A
Maximum Overcurrent Protection (MOP)	125 A
Full Load Amps (FLA)	103 A

**Note:** For additional electrical information, contact Trane Rental Services.

<sup>(a)</sup> Maximum wire size lug(s) can accept - 2/0.

<sup>(b)</sup> Depending on chiller MCA and wire used, multiple wires per phase may be required.

**Table 21. Pump data**

Labels	Value
Horsepower	10 HP
Min Flow	50 gpm @ 137.7 ft.
Max Flow	201.6 gpm @ 104.1 ft.

**Note:** Pump is mounted within the chiller frame with a bypass and controlled by the chiller standalone control system if not connected to end user building automation system.

**Table 22. Cooling capacity (40 tons)**

Leaving Water Temp	Propylene Glycol (%)	Estimated Capacity (Tons) at 2.4 GPM / Nominal Ton				
		Ambient Air Temp				
		85°F	95°F	105°F	115°F	125°F
65°F	0	57.8	54.2	50.3	46.5	42.6
55°F	0	49.3	46.3	40.0	39.7	36.3
45°F	0	41.3	38.9	36.2	33.3	30.4
35°F	10	33.5	31.5	29.4	27.1	24.7
25°F	25	26.3	24.9	23.2	21.3	—
15°F	35	20.3	19.2	17.9	—	—
5°F	40	15.8	14.8	—	—	—

**Note:** Actual tons of refrigeration in table above are based on chiller models with round tube and plate fin condenser coils.



25 to 120 Ton CGAM

**Table 23. Water flow rates and pressure drops (40 tons)**

Flow Rate (GPM)	Pressure Drop (ft. H <sub>2</sub> O)
46 (min flow)	5.38
50	6.30
60	8.90
70	12.00
80	15.40
90	19.40
100	23.70
110	28.50
120	33.70
130	39.30
136 (max flow)	42.90

*Note: Maximum water side pressure is 150 psi (2.31 ft. H<sub>2</sub>O = 1 psi).*

**General – CSCA0040F0**

**Table 24. Dimensions and weights**

Labels	Value
Length	12 ft. 5 in.
Width	8ft. 1 in.
Height	8 ft. 6 in.
Shipping Weight (lbs)	7,600
Operating Weight (lbs)	7,800
Fork Pocket Dimensions	9.25 in. x 5.25 in. x 7 ft. 4.125 in.
Fork Pocket Center to Center Distance	3 ft.

**Notes:**

1. *Lifting device: forklift or crane.*
2. *All weights and dimensions listed above are subject to change without notice or liability.*

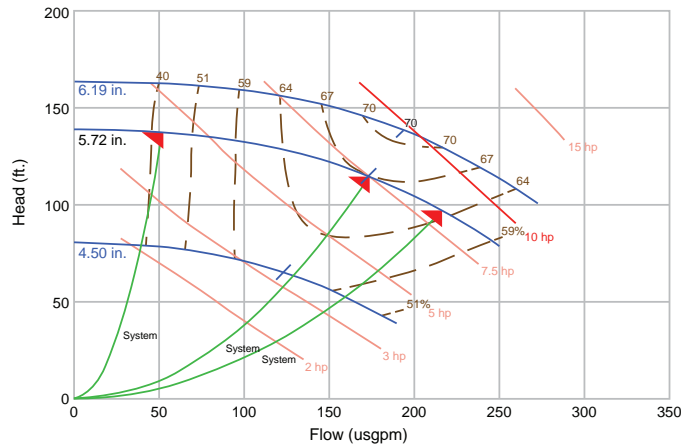

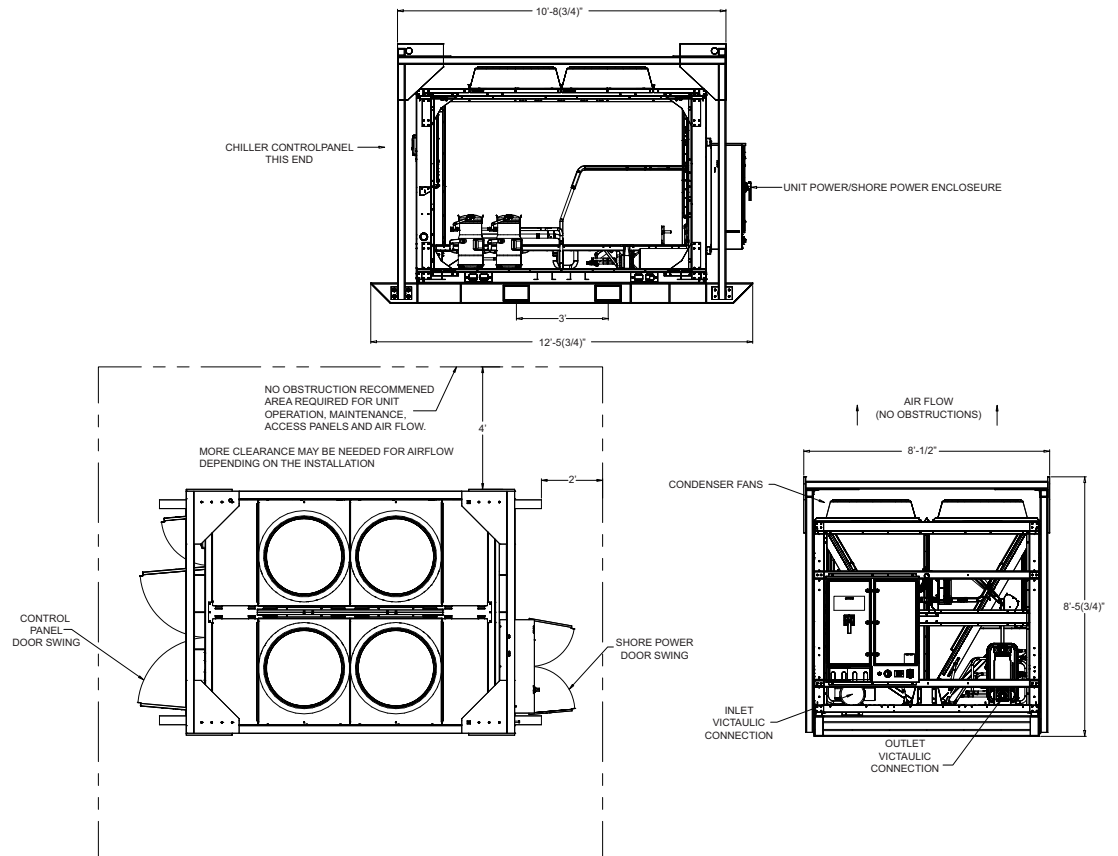

**General – CSCA0040F2**

**Table 25. Dimensions and weights**

Labels	Value
Length	13 ft. 4.5 in.
Width	8 ft.
Height	7 ft. 11.5 in.
Shipping Weight (lbs)	7,000
Operating Weight (lbs)	7,200
Fork Pocket Dimensions	9.25 in. x 5.25 in. x 7 ft. 5 in.
Fork Pocket Center to Center Distance	4 ft. 6 in.

**Notes:**

1. *Lifting device: forklift or crane.*
2. *All weights and dimensions listed above are subject to change without notice or liability.*



## 60 Ton Air-Cooled CGAM

**Table 26. General – CSCA0060F0-F3**

Labels	Value
Model Number	CGAM060
Nominal Tons	60
Refrigerant	R-410A
Refrigerant Charge <sup>(a)</sup>	44 lbs
Microchannel Refrigerant Charge <sup>(b)</sup>	28 lbs
Water Connection Size	4 in. Victaulic
Ambient Operating Conditions	0°F to 125°F
Extreme Ambient Operating Conditions <sup>(c)</sup>	-20°F to 125°F
Chilled Water Setpoint Limits <sup>(d)</sup>	0°F to 65°F
Number of Electrical Circuits	1
Number of Refrigerant Circuits	2

<sup>(a)</sup> The listed refrigerant charge is per refrigeration circuit for all round tube and plate fin condenser coils.

<sup>(b)</sup> The listed refrigerant charge is per refrigeration circuit for all extreme low ambient microchannel condenser coils.

<sup>(c)</sup> For CGAM models with microchannel condenser coils.

<sup>(d)</sup> When leaving solution is below 42°F, a glycol solution is required for all low temperature and ice-making applications.

**Table 27. Electrical data**

Labels	Value
Voltage	460V 3-Phase
Frequency	60 Hz
F0 Power Supply Connections <sup>(a)</sup> <sup>(b)</sup>	Lugs or Series 16 Cam-Type Connections
F2–F3 Power Supply Connections <sup>(b)</sup>	Series 16 Cam-Type Connections Only
<b>Without Integral Pump</b>	
Minimum Circuit Ampacity (MCA)	130 A
Maximum Overcurrent Protection (MOP)	150 A
Full Load Amps (FLA)	124 A
<b>With Integral Pump</b>	
Minimum Circuit Ampacity (MCA)	144 A
Maximum Overcurrent Protection (MOP)	150 A
Full Load Amps (FLA)	136 A

**Note:** For additional electrical information, contact Trane Rental Services.

<sup>(a)</sup> Maximum wire size lug(s) can accept - 350 MCM.

<sup>(b)</sup> Depending on chiller MCA and wire used, multiple wires per phase may be required.

**Table 28. Pump data**

Labels	Value
Horsepower	10 HP
Min Flow	50 gpm @ 137.7 ft.
Max Flow	201.6 gpm @ 104.1 ft.

**Note:** Pump is mounted within the chiller frame with a bypass and controlled by the chiller standalone control system if not connected to end user building automation system.



## 25 to 120 Ton CGAM

**Table 29. Cooling capacity (60 tons)**

Leaving Water Temp	Propylene Glycol (%)	Estimated Capacity (Tons) at 2.4 GPM / Nominal Ton				
		Ambient Air Temp				
		85°F	95°F	105°F	115°F	125°F
65°F	0	85.1	79.8	74.2	68.3	—
55°F	0	73.3	68.8	64.0	59.0	54.0
45°F	0	62.2	58.4	54.3	50.0	45.7
35°F	15	51.3	48.3	44.9	41.4	37.7
25°F	25	41.6	39.2	36.5	33.6	30.6
15°F	35	32.9	31.0	28.8	26.5	—
5°F	45	25.7	24.2	22.5	—	—

*Note: Actual tons of refrigeration in table above are based on chiller models with round tube and plate fin condenser coils.*

**Table 30. Water flow rates and pressure drops (60 tons)**

Flow Rate (GPM)	Pressure Drop (ft. H <sub>2</sub> O)
68 (min flow)	4.57
85	6.99
100	9.51
115	12.40
130	15.60
145	19.20
160	23.20
175	27.50
190	32.20
201 (max flow)	35.90

*Note: Maximum water side pressure is 150 psi (2.31 ft. H<sub>2</sub>O = 1 psi).*

## General – CSCA0060F0

**Table 31. Dimensions and weights**

Labels	Value
Length	15 ft. 6 in.
Width	8 ft. 1 in.
Height	8 ft. 6 in.
Shipping Weight (lbs)	9,000
Operating Weight (lbs)	9,200
Fork Pocket Dimensions	9.25 in. x 5.25 in. x 7 ft. 4.125 in.
Fork Pocket Center to Center Distance	4 ft. 6 in.

**Notes:**

1. Lifting device: forklift or crane.
2. All weights and dimensions listed above are subject to change without notice or liability.

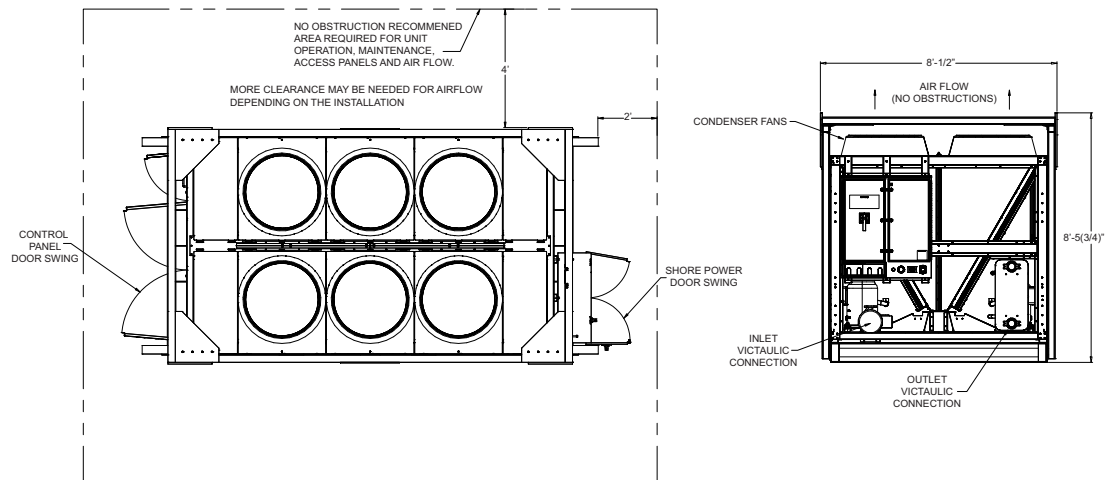
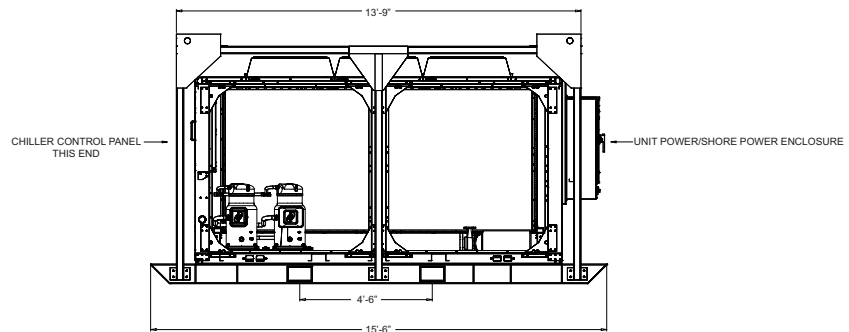
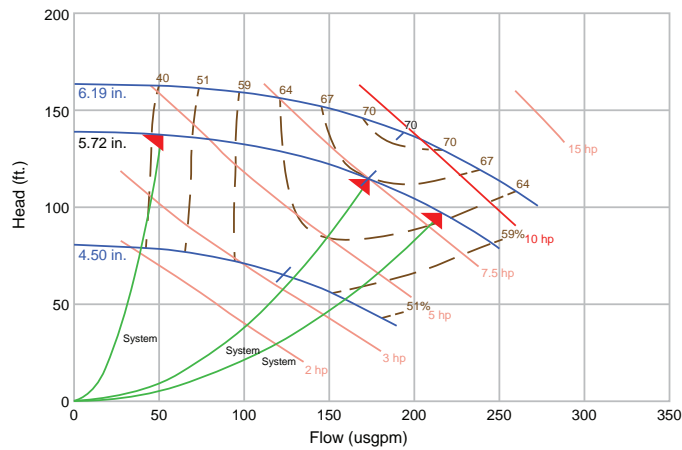

**General – CSCA0060F2**

**Table 32. Dimensions and weights**

Labels	Value
Length	16 ft. 4.5 in.
Width	8 ft.
Height	7 ft. 11.5 in.
Shipping Weight (lbs)	8,500
Operating Weight (lbs)	8,700

**Table 32. Dimensions and weights (continued)**

Labels	Value
Fork Pocket Dimensions	9.25 in. x 5.25 in. x 7 ft. 5 in.
Fork Pocket Center to Center Distance	4 ft. 6 in.

**Notes:**

1. *Lifting device: forklift or crane.*
2. *All weights and dimensions listed above are subject to change without notice or liability.*

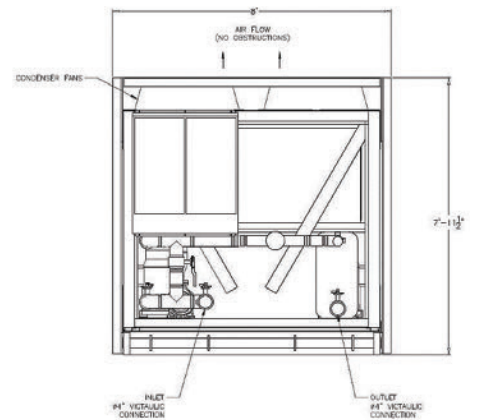
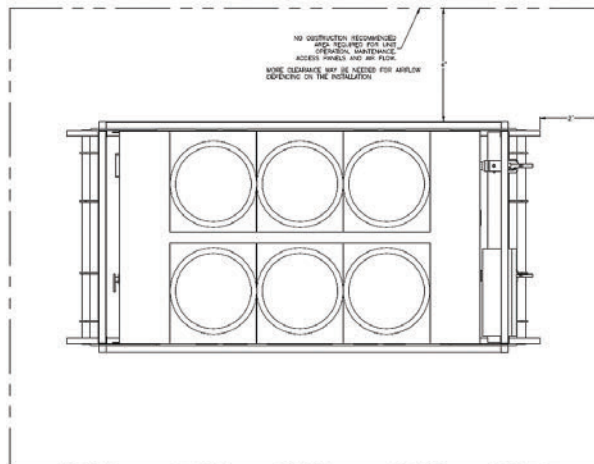
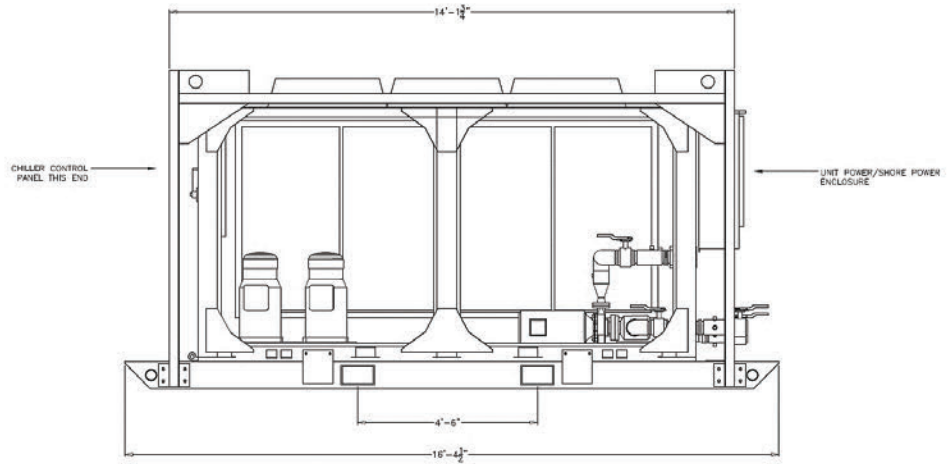
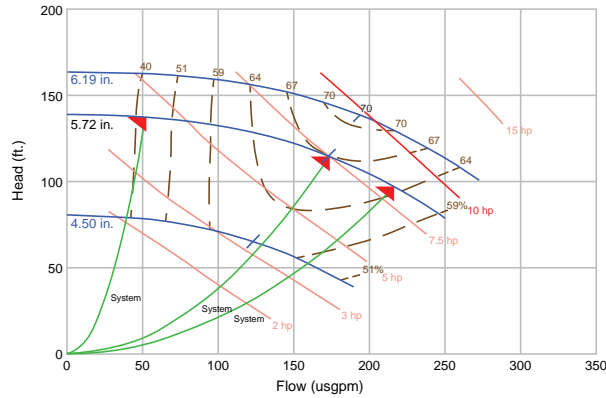

## General – CSCA0060F3

**Table 33. Dimensions and weights**

Labels	Value
Length	16 ft. 4.5 in.
Width	7 ft. 4.5 in.
Height	7 ft. 11 in.
Shipping Weight (lbs)	7,900
Operating Weight (lbs)	8,100
Fork Pocket Dimensions	9.25 in. x 5.25 in. x 7 ft. 5 in.
Fork Pocket Center to Center Distance	4 ft. 6 in.

**Notes:**

1. *Lifting device: forklift or crane.*
2. *All weights and dimensions listed above are subject to change without notice or liability.*

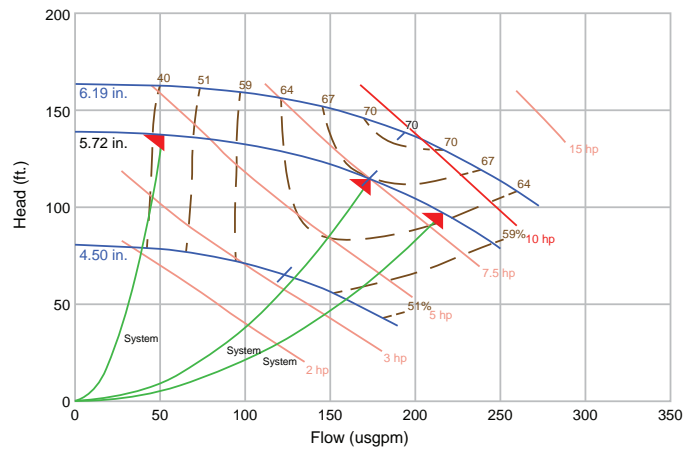

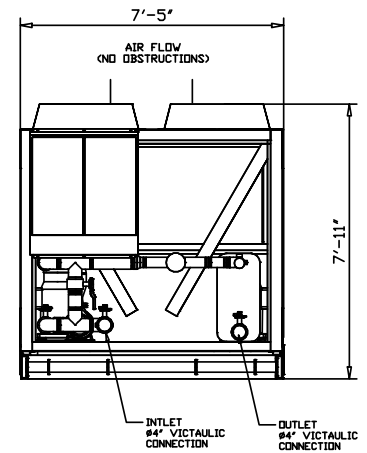
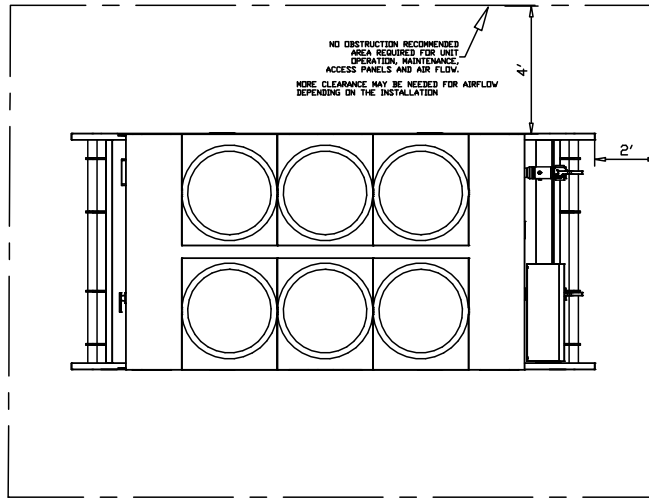
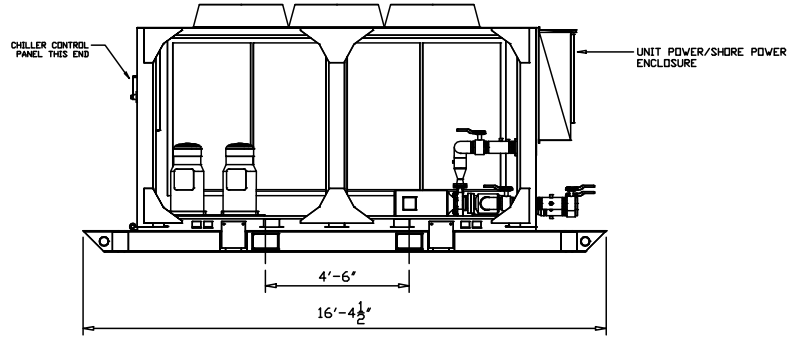

## 80 Ton Air-Cooled CGAM

Table 34. General – CSPA0080F1-F2

Labels	Value
Model Number	CGAM080
Nominal Tons	80
Refrigerant	R-410A
Refrigerant Charge <sup>(a)</sup>	74 lbs
Microchannel Refrigerant Charge <sup>(b)</sup>	45 lbs
Water Connection Size	4 in. Victaulic
Ambient Operating Conditions	0°F to 125°F
Extreme Ambient Operating Conditions <sup>(c)</sup>	-20°F to 125°F
Chilled Water Setpoint Limits <sup>(d)</sup>	0°F to 65°F
Number of Electrical Circuits	1
Number of Refrigerant Circuits	2

- (a) The listed refrigerant charge is per refrigeration circuit for all round tube and plate fin condenser coils.
- (b) The listed refrigerant charge is per refrigeration circuit for all extreme low ambient microchannel condenser coils.
- (c) For CGAM models with microchannel condenser coils.
- (d) When leaving solution is below 42°F, a glycol solution is required for all low temperature and ice-making applications.

**Table 35. Electrical data**

Labels	Value
Voltage	460V 3-Phase
Frequency	60 Hz
F0 Power Supply Connections <sup>(a)</sup> <sup>(b)</sup>	Lugs or Series 16 Cam-Type Connections
F2 Power Supply Connections <sup>(b)</sup>	Series 16 Cam-Type Connections Only
<b>Without Integral Pump</b>	
Minimum Circuit Ampacity (MCA)	162 A
Maximum Overcurrent Protection (MOP)	175 A
Full Load Amps (FLA)	152 A
<b>With Integral Pump</b>	
Minimum Circuit Ampacity (MCA)	189 A
Maximum Overcurrent Protection (MOP)	200 A
Full Load Amps (FLA)	179 A

**Note:** For additional electrical information, contact Trane Rental Services.

<sup>(a)</sup> Maximum wire size lug(s) can accept - 350 MCM.

<sup>(b)</sup> Depending on chiller MCA and wire used, multiple wires per phase may be required.

**Table 36. Pump data**

Labels	Value
Horsepower	20 HP
Min Flow	91 gpm @ 162.9 ft.
Max Flow	376 gpm @ 124.5 ft.

**Note:** Pump is mounted within the chiller frame with a bypass and controlled by the chiller standalone control system if not connected to end user building automation system.

**Table 37. Cooling capacity (80 tons)**

Leaving Water Temp	Propylene Glycol (%)	Estimated Capacity (Tons) at 2.4 GPM / Nominal Ton				
		Ambient Air Temp				
		85°F	95°F	105°F	115°F	125°F
65°F	0	115.6	108.1	100.3	92.5	—
55°F	0	99.9	93.5	86.7	79.9	73.1
45°F	0	84.8	79.5	73.8	67.9	62.0
35°F	15	70.0	65.7	61.0	56.1	51.2
25°F	25	56.6	53.2	49.5	45.5	—
15°F	35	44.6	41.9	39.0	—	—
5°F	45	34.7	32.5	—	—	—

**Note:** Actual tons of refrigeration in table above are based on chiller models with round tube and plate fin condenser coils.



## 25 to 120 Ton CGAM

**Table 38. Water flow rates and pressure drops (80 tons)**

Flow Rate (GPM)	Pressure Drop (ft. H <sub>2</sub> O)
92 (min flow)	4.26
110	5.96
130	8.19
150	10.70
170	13.60
190	16.80
210	20.30
230	24.20
250	28.40
275 (max flow)	34.10

*Note: Maximum water side pressure is 150 psi (2.31 ft. H<sub>2</sub>O = 1 psi).*

## General – CSCA0080F1

**Table 39. Dimensions and weights**

Labels	Value
Length	15 ft. 1 in.
Width	8 ft. 1 in.
Height	8 ft. 6 in.
Shipping Weight (lbs)	10,100
Operating Weight (lbs)	10,300
Fork Pocket Dimensions	9.25 in. x 5.25 in. x 7 ft. 4.75 in.
Fork Pocket Center to Center Distance	4 ft. 6 in.

**Notes:**

1. Lifting device: forklift or crane.
2. All weights and dimensions listed above are subject to change without notice or liability.

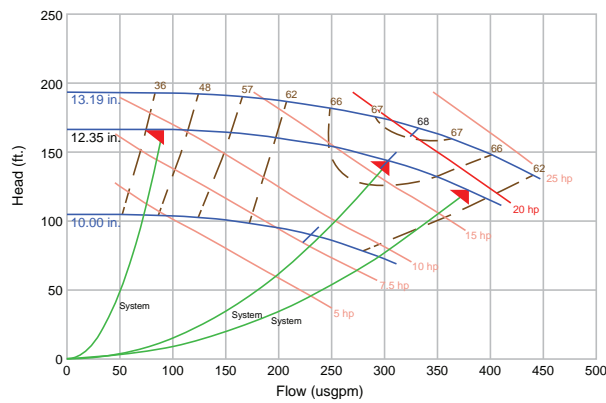

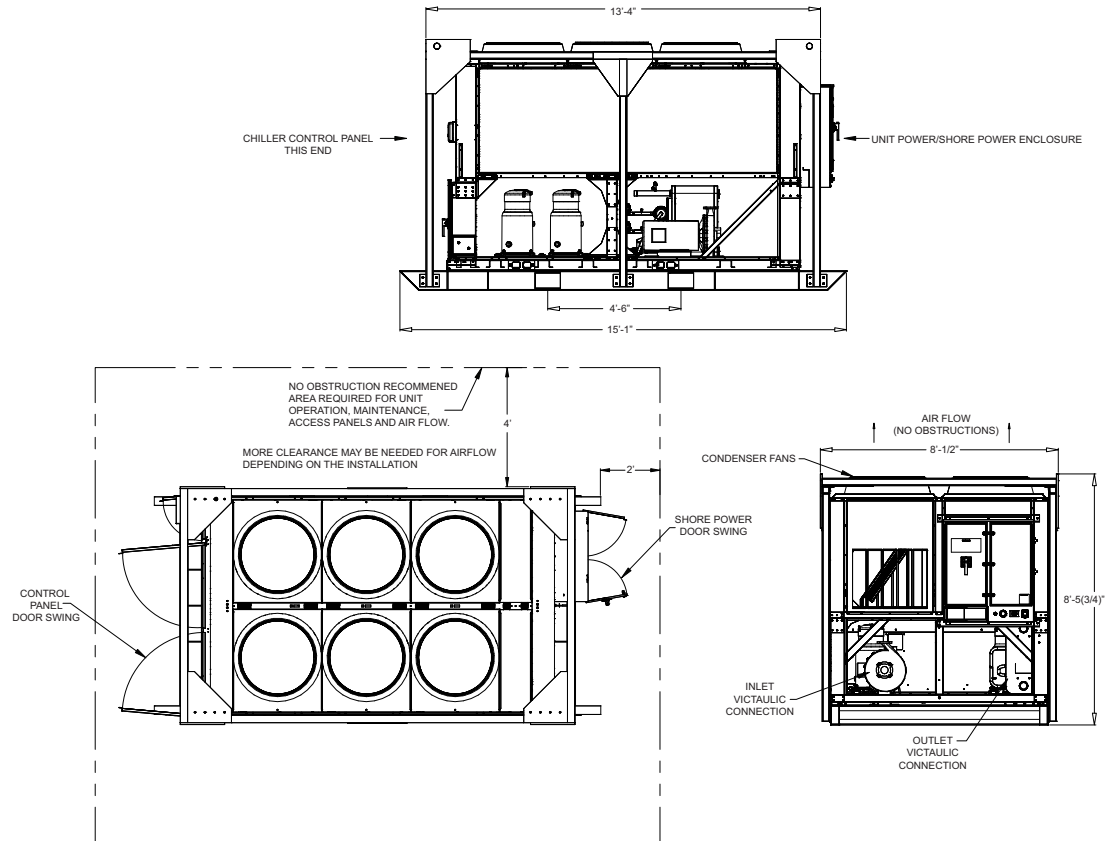

## General – CSCA0080F2

Table 40. Dimensions and weights

Labels	Value
Length	15 ft. 7.5 in.
Width	8 ft. 0.5 in.
Height	8 ft. 6 in.
Shipping Weight (lbs)	9,800
Operating Weight (lbs)	10,000
Fork Pocket Dimensions	9.25 in. x 5.25 in. x 7 ft. 5 in.
Fork Pocket Center to Center Distance	4 ft. 6 in.

**Notes:**

1. Lifting device: forklift or crane.
2. All weights and dimensions listed above are subject to change without notice or liability.



# 25 to 120 Ton CGAM

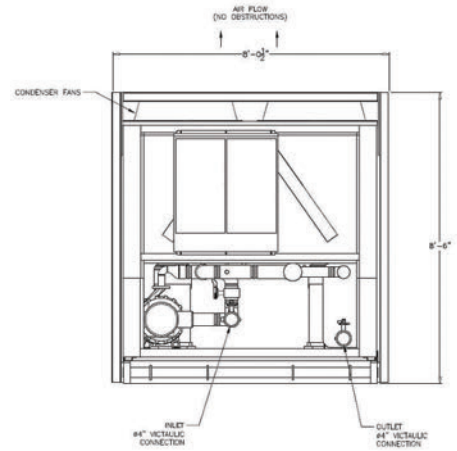
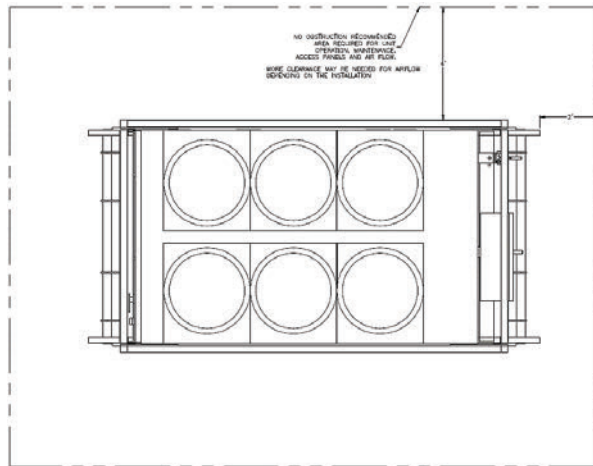
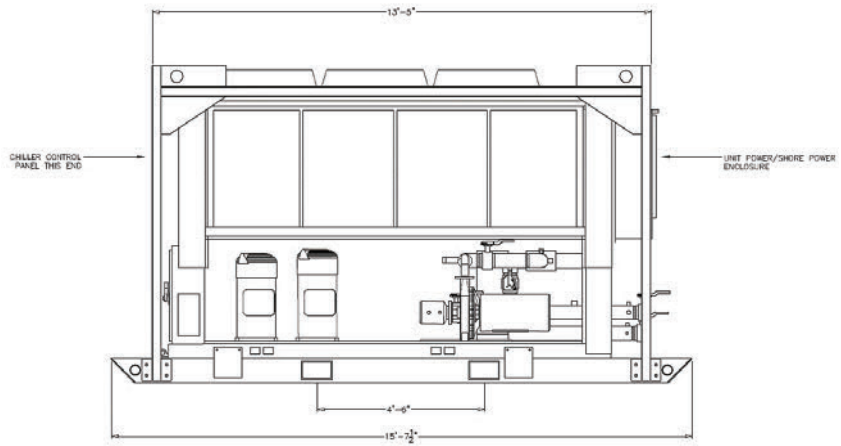
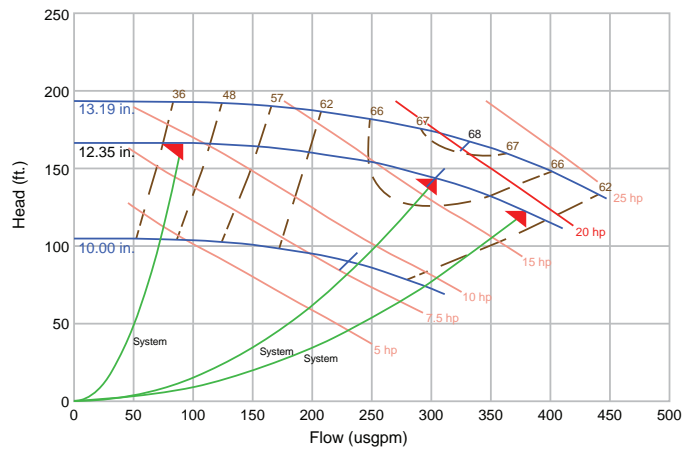

# 100 Ton Air-Cooled CGAM

**Table 41. General – CSCA00100F1-F3**

Labels	Value
Model Number	CGAM100
Nominal Tons	100
Refrigerant	R-410A
Refrigerant Charge <sup>(a)</sup>	90 lbs
Microchannel Refrigerant Charge <sup>(b)</sup>	49 lbs
Water Connection Size	4 in. Victaulic
Ambient Operating Conditions	0°F to 125°F
Extreme Ambient Operating Conditions <sup>(c)</sup>	-20°F to 125°F
Chilled Water Setpoint Limits <sup>(d)</sup>	0°F to 65°F
Number of Electrical Circuits	1
Number of Refrigerant Circuits	2

<sup>(a)</sup> The listed refrigerant charge is per refrigeration circuit for all round tube and plate fin condenser coils.

<sup>(b)</sup> The listed refrigerant charge is per refrigeration circuit for all extreme low ambient microchannel condenser coils.

<sup>(c)</sup> For CGAM models with microchannel condenser coils.

<sup>(d)</sup> When leaving solution is below 42°F, a glycol solution is required for all low temperature and ice-making applications.

**Table 42. Electrical data**

Labels	Value
Voltage	460V 3-Phase
Frequency	60 Hz
F0 Power Supply Connections <sup>(a) (b)</sup>	Lugs or Series 16 Cam-Type Connections
F2–F3 Power Supply Connections <sup>(b)</sup>	Series 16 Cam-Type Connections Only
<b>Without Integral Pump</b>	
Minimum Circuit Ampacity (MCA)	206 A
Maximum Overcurrent Protection (MOP)	225 A
Full Load Amps (FLA)	194 A
<b>With Integral Pump</b>	
Minimum Circuit Ampacity (MCA)	233 A
Maximum Overcurrent Protection (MOP)	250 A
Full Load Amps (FLA)	221 A

**Note:** For additional electrical information, contact Trane Rental Services.

<sup>(a)</sup> Maximum wire size lug(s) can accept - 350 MCM.

<sup>(b)</sup> Depending on chiller MCA and wire used, multiple wires per phase may be required.

**Table 43. Pump data**

Labels	Value
Horsepower	20 HP
Min Flow	91 gpm @ 162.9 ft.
Max Flow	376 gpm @ 124.5 ft.

**Note:** Pump is mounted within the chiller frame with a bypass and controlled by the chiller standalone control system if not connected to end user building automation system.



## 25 to 120 Ton CGAM

**Table 44. Cooling capacity (100 tons)**

Leaving Water Temp	Propylene Glycol (%)	Estimated Capacity (Tons) at 2.4 GPM / Nominal Ton				
		Ambient Air Temp				
		85°F	95°F	105°F	115°F	125°F
65°F	0	146.7	137.0	127.0	117.0	—
55°F	0	126.7	118.4	109.7	100.9	92.1
45°F	0	107.5	100.6	93.2	85.6	78.0
35°F	10	88.9	83.3	77.3	70.9	64.5
25°F	25	71.6	67.2	62.4	57.2	—
15°F	35	56.3	52.8	49.0	—	—
5°F	45	43.6	40.9	—	—	—

*Note: Actual tons of refrigeration in table above are based on chiller models with round tube and plate fin condenser coils.*

**Table 45. Water flow rates and pressure drops (100 tons)**

Flow Rate (GPM)	Pressure Drop (ft. H <sub>2</sub> O)
116 (min flow)	4.20
146	6.51
176	9.30
206	12.60
236	16.30
266	20.60
296	25.30
326	30.50
346 (max flow)	34.30

*Note: Maximum water side pressure is 150 psi (2.31 ft. H<sub>2</sub>O = 1 psi).*

## General – CSCA0100F1

**Table 46. Dimensions and weights**

Labels	Value
Length	17 ft. 8 in.
Width	8 ft. 1 in.
Height	8 ft. 6 in.
Shipping Weight (lbs)	11,200
Operating Weight (lbs)	11,400
Fork Pocket Dimensions	9.25 in. x 5.25 in. x 7 ft. 4.75 in.
Fork Pocket Center to Center Distance	4 ft. 6 in.

**Notes:**

1. Lifting device: forklift or crane.
2. All weights and dimensions listed above are subject to change without notice or liability.

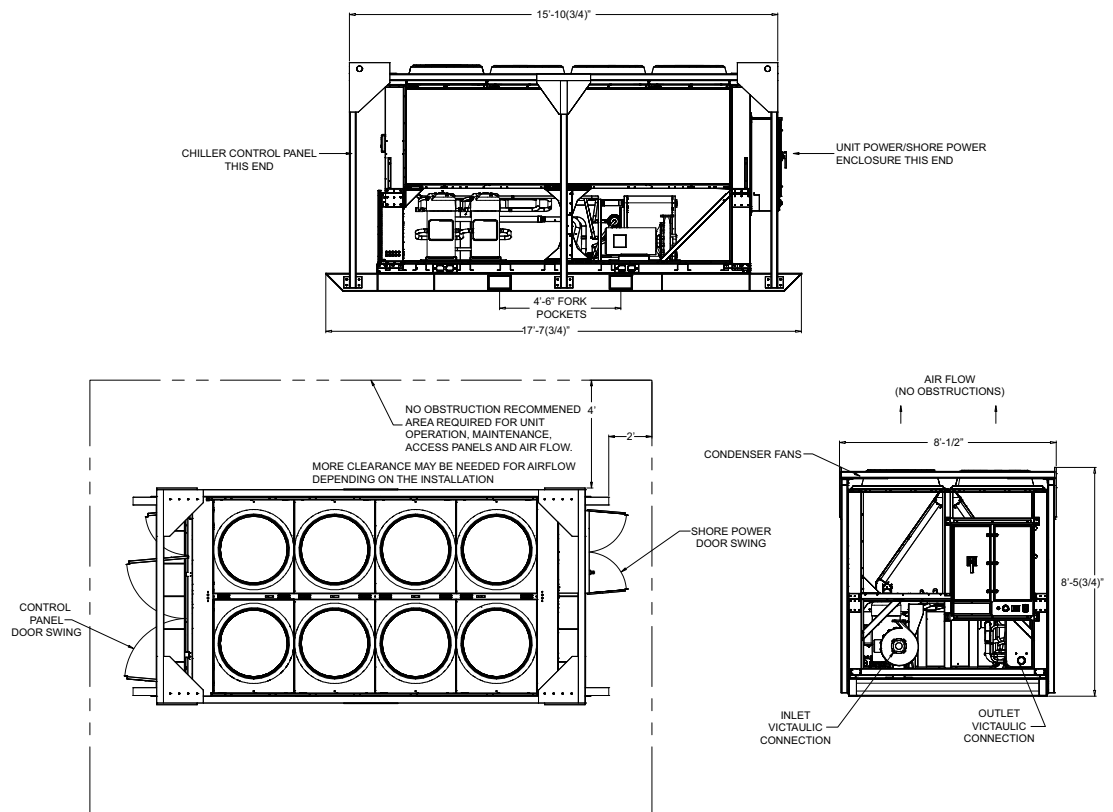
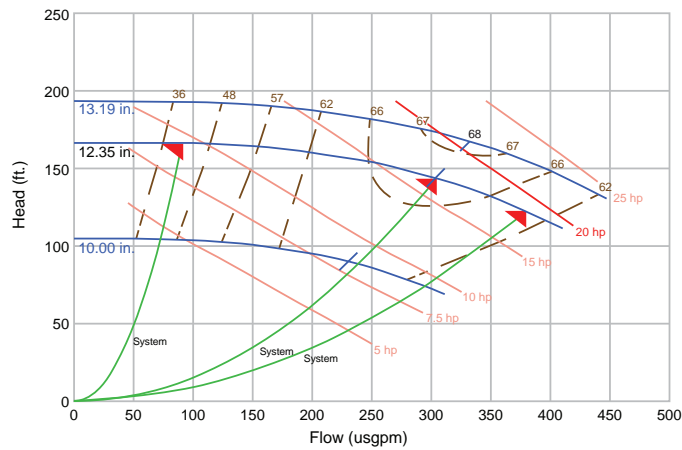

**General – CSCA0100F2**

**Table 47. Dimensions and weights**

Labels	Value
Length	17 ft. 5.5 in.
Width	8 ft. 0.5 in.
Height	8 ft. 6 in.
Shipping Weight (lbs)	12,500
Operating Weight (lbs)	12,700
Fork Pocket Dimensions	9.25 in. x 5.25 in. x 7 ft. 5 in.

**Table 47. Dimensions and weights (continued)**

Labels	Value
Fork Pocket Center to Center Distance	4 ft. 6 in.

**Notes:**

1. Lifting device: forklift or crane.
2. All weights and dimensions listed above are subject to change without notice or liability.

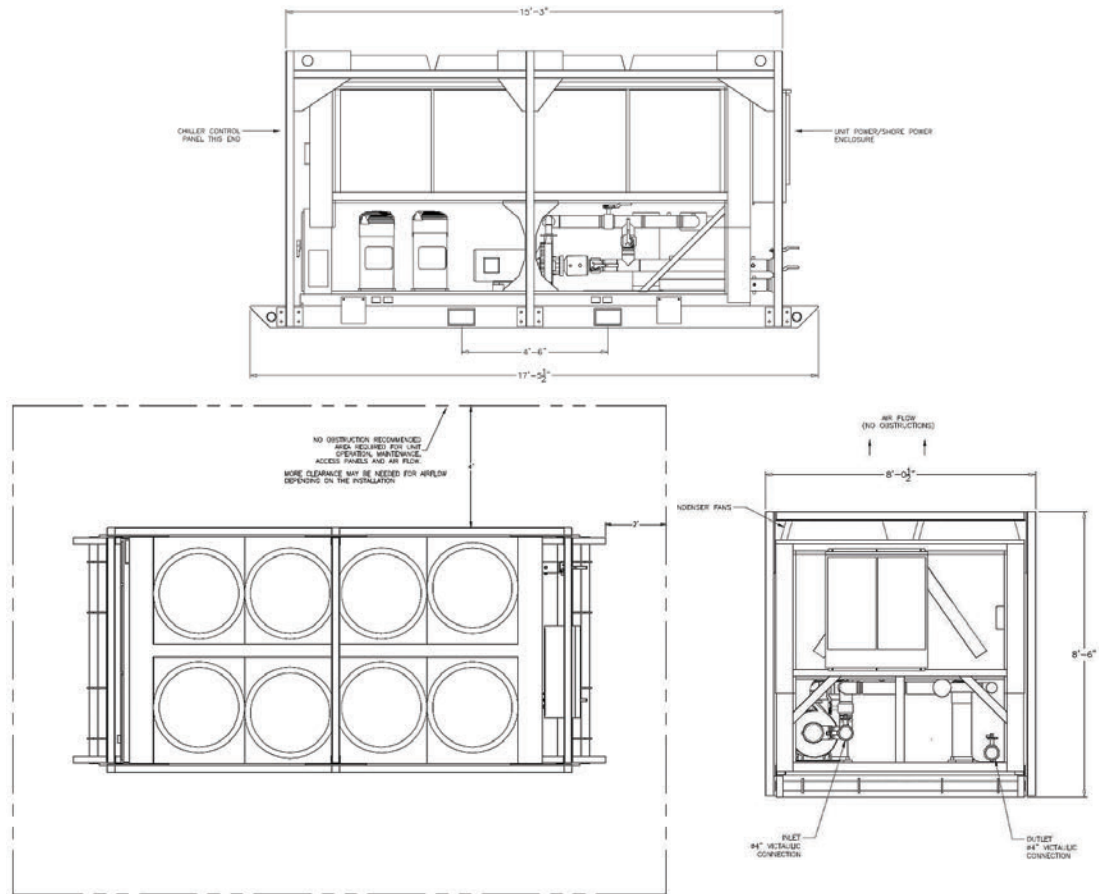
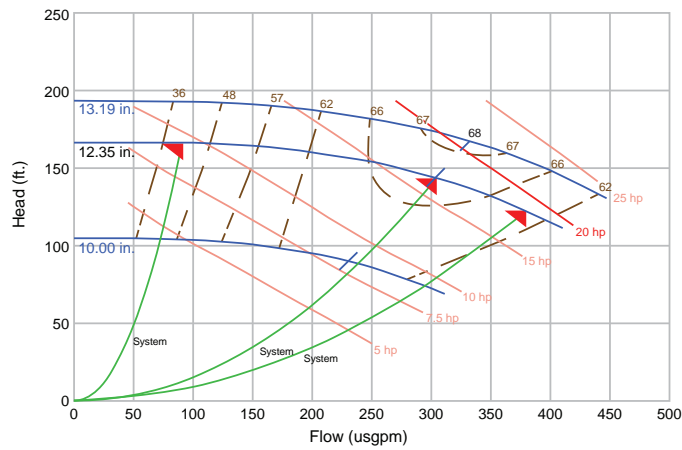

**General – CSCA0100F3**

**Table 48. Dimensions and weights**

Labels	Value
Length	17 ft. 5.5 in.
Width	7 ft. 5 in.
Height	8 ft. 6 in.
Shipping Weight (lbs)	10,000
Operating Weight (lbs)	10,200
Fork Pocket Dimensions	9.25 in. x 5.25 in. x 7 ft. 5 in.
Fork Pocket Center to Center Distance	5 ft.

**Notes:**

1. *Lifting device: forklift or crane.*
2. *All weights and dimensions listed above are subject to change without notice or liability.*

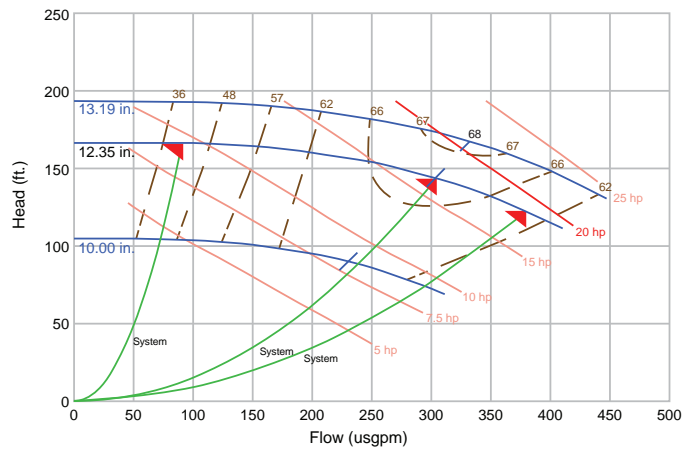



## 25 to 120 Ton CGAM

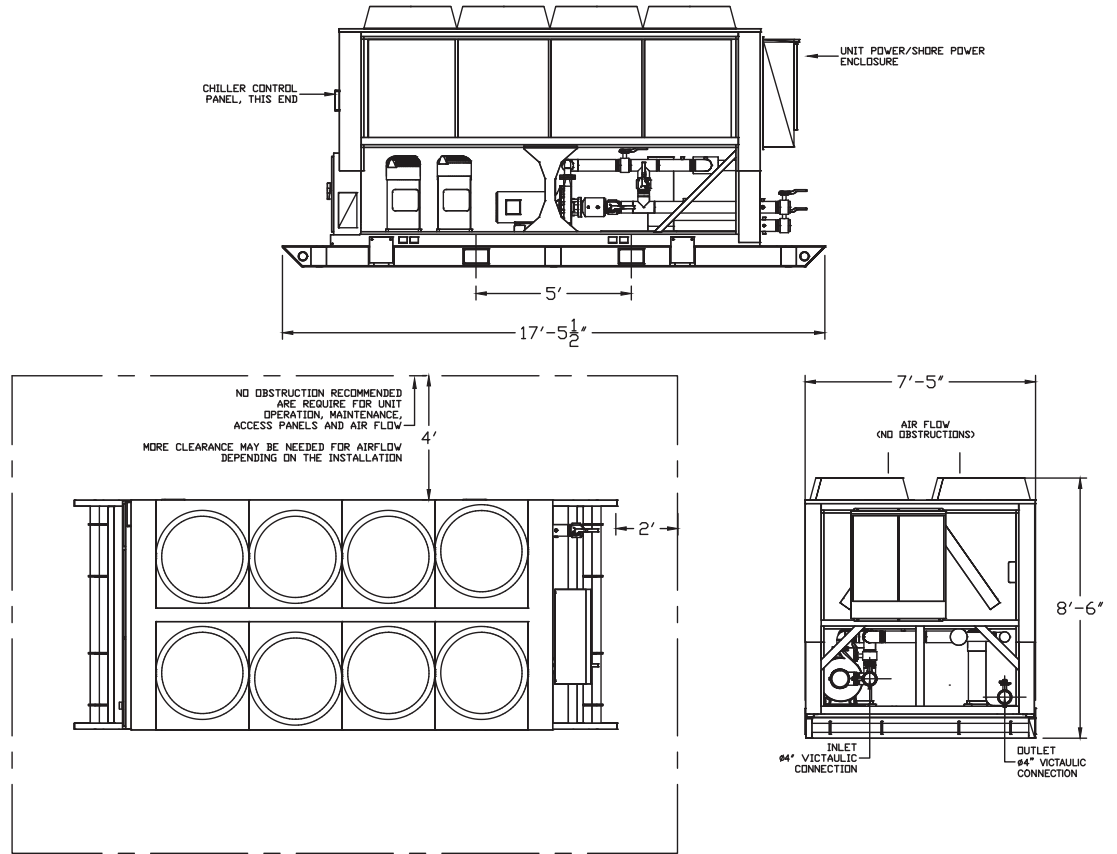

## 120 Ton Air-Cooled CGAM

Table 49. General – CSCA00120F1-F3

Labels	Value
Model Number	CGAM0120
Nominal Tons	120
Refrigerant	R-410A
Refrigerant Charge <sup>(a)</sup>	86 lbs
Microchannel Refrigerant Charge <sup>(b)</sup>	50 lbs
Water Connection Size	6 in. Victaulic
Ambient Operating Conditions	0°F to 125°F
Extreme Ambient Operating Conditions <sup>(c)</sup>	-20°F to 125°F
Chilled Water Setpoint Limits <sup>(d)</sup>	0°F to 65°F
Number of Electrical Circuits	1
Number of Refrigerant Circuits	2

(a) The listed refrigerant charge is per refrigeration circuit for all round tube and plate fin condenser coils.

(b) The listed refrigerant charge is per refrigeration circuit for all extreme low ambient microchannel condenser coils.

(c) For CGAM models with microchannel condenser coils.

(d) When leaving solution is below 42°F, a glycol solution is required for all low temperature and ice-making applications.

**Table 50. Electrical data**

Labels	Value
Voltage	460V 3-Phase
Frequency	60 Hz
F0 Power Supply Connections <sup>(a)</sup> <sup>(b)</sup>	Lugs or Series 16 Cam-Type Connections
F2–F3 Power Supply Connections <sup>(b)</sup>	Series 16 Cam-Type Connections Only
<b>Without Integral Pump</b>	
Minimum Circuit Ampacity (MCA)	244 A
Maximum Overcurrent Protection (MOP)	250 A
Full Load Amps (FLA)	230 A
<b>With Integral Pump</b>	
Minimum Circuit Ampacity (MCA)	271 A
Maximum Overcurrent Protection (MOP)	300 A
Full Load Amps (FLA)	257 A

**Note:** For additional electrical information, contact Trane Rental Services.

<sup>(a)</sup> Maximum wire size lug(s) can accept - 350 MCM.

<sup>(b)</sup> Depending on chiller MCA and wire used, multiple wires per phase may be required.

**Table 51. Pump data**

Labels	Value
Horsepower	20 HP
Min Flow	91 gpm @ 162.9 ft.
Max Flow	376 gpm @ 124.5 ft.

**Note:** Pump is mounted within the chiller frame with a bypass and controlled by the chiller standalone control system if not connected to end user building automation system.

**Table 52. Cooling capacity (120 tons)**

Leaving Water Temp	Propylene Glycol (%)	Estimated Capacity (Tons) at 2.4 GPM / Nominal Ton				
		Ambient Air Temp				
		85°F	95°F	105°F	115°F	125°F
65°F	0	169.7	158.1	146.3	134.6	—
55°F	0	147.5	137.5	127.1	116.7	—
45°F	0	126.1	117.6	108.7	99.6	90.5
35°F	10	104.6	97.7	90.4	82.7	75.1
25°F	25	85.1	79.6	73.7	67.4	—
15°F	35	67.3	63.0	58.3	—	—
5°F	45	52.4	49.1	—	—	—

**Note:** Actual tons of refrigeration in table above are based on chiller models with round tube and plate fin condenser coils.



## 25 to 120 Ton CGAM

**Table 53. Water flow rates and pressure drops (120 tons)**

Flow Rate (GPM)	Pressure Drop (ft. H <sub>2</sub> O)
136 (min flow)	5.03
170	7.72
205	11.10
240	15.00
275	19.50
310	24.60
345	30.30
380	36.60
407 (max flow)	41.90

*Note: Maximum water side pressure is 150 psi (2.31 ft. H<sub>2</sub>O = 1 psi).*

## General – CSCA0120F1

**Table 54. Dimensions and weights**

Labels	Value
Length	17 ft. 8 in.
Width	8 ft. 1 in.
Height	8 ft. 6 in.
Shipping Weight (lbs)	11,200
Operating Weight (lbs)	11,400
Fork Pocket Dimensions	9.25 in. x 5.25 in. x 7 ft. 4.75 in.
Fork Pocket Center to Center Distance	4 ft. 6 in.

**Notes:**

1. *Lifting device: forklift or crane.*
2. *All weights and dimensions listed above are subject to change without notice or liability.*

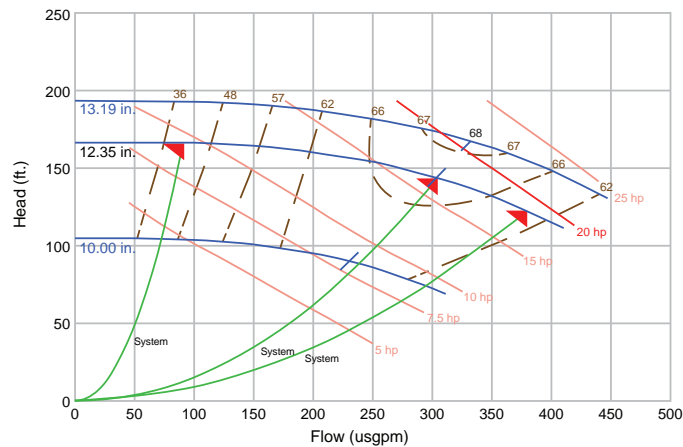

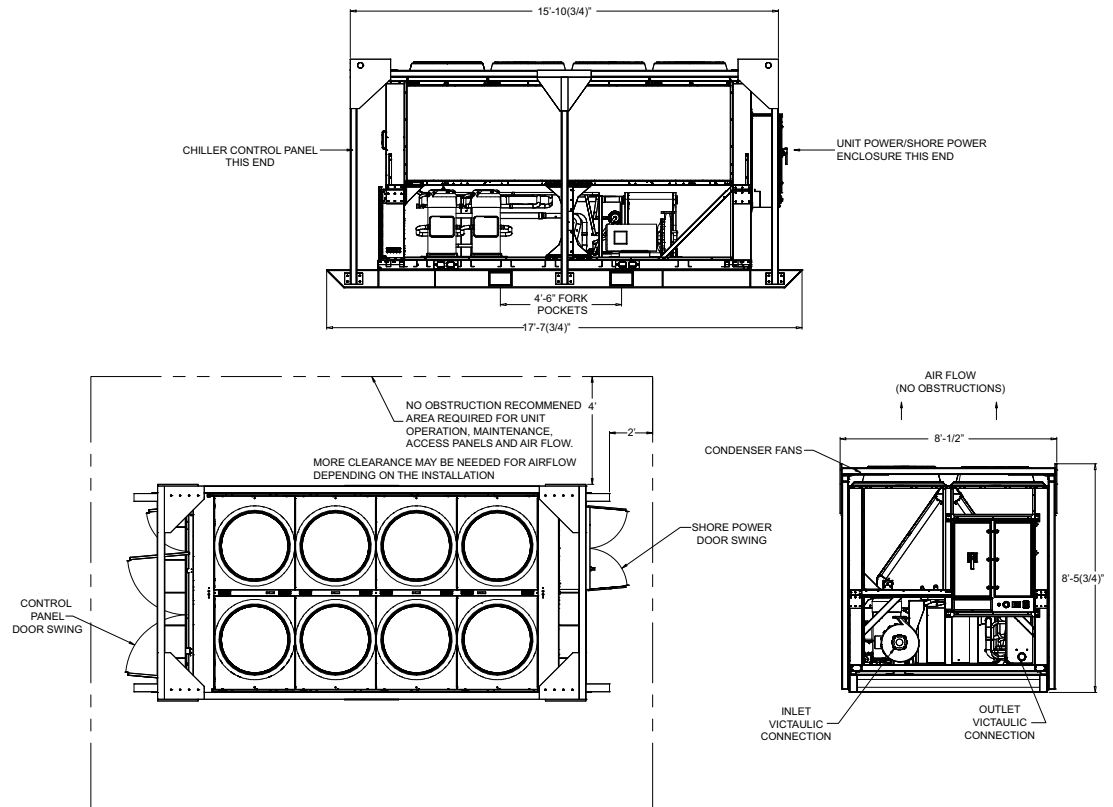

## General – CSCA0120F2

**Table 55. Dimensions and weights**

Labels	Value
Length	17 ft. 5.5 in.
Width	8 ft. 0.5 in.
Height	8 ft. 6 in.
Shipping Weight (lbs)	13,000
Operating Weight (lbs)	13,200
Fork Pocket Dimensions	9.25 in. x 5.25 in. x 7 ft. 5 in.
Fork Pocket Center to Center Distance	4 ft. 6 in.

**Notes:**

1. *Lifting device: forklift or crane.*
2. *All weights and dimensions listed above are subject to change without notice or liability.*

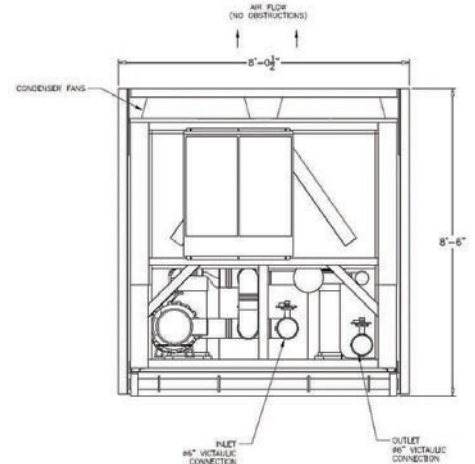
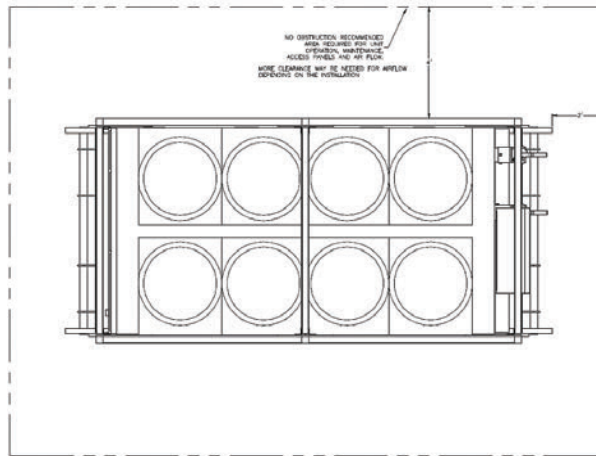
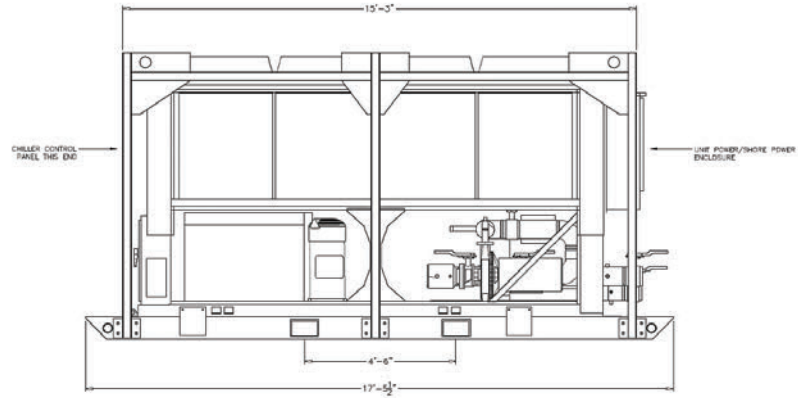
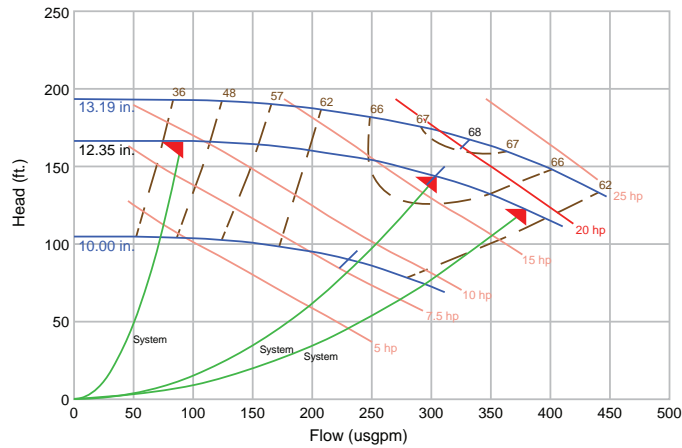

**General – CSCA0120F3**

**Table 56. Dimensions and weights**

Labels	Value
Length	17 ft. 5.5 in.
Width	7 ft. 5 in.
Height	8 ft. 6 in.
Shipping Weight (lbs)	10,500
Operating Weight (lbs)	10,700
Fork Pocket Dimensions	9.25 in. x 5.25 in. x 7 ft. 5 in.

**Table 56. Dimensions and weights (continued)**

Labels	Value
Fork Pocket Center to Center Distance	5 ft.

**Notes:**

1. *Lifting device: forklift or crane.*
2. *All weights and dimensions listed above are subject to change without notice or liability.*

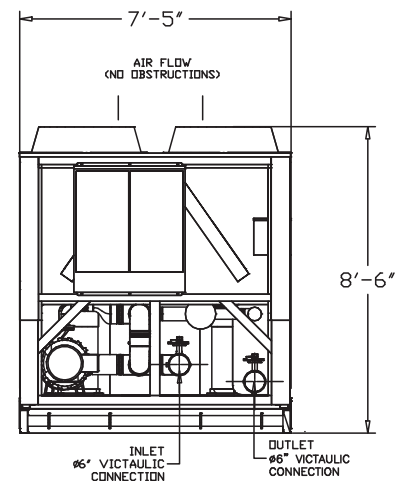
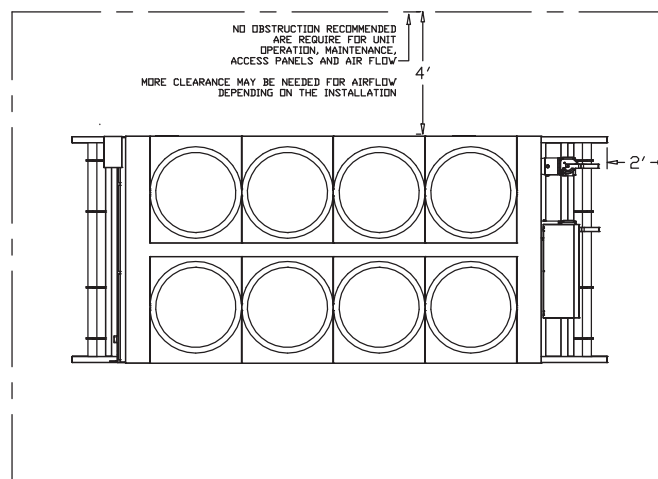
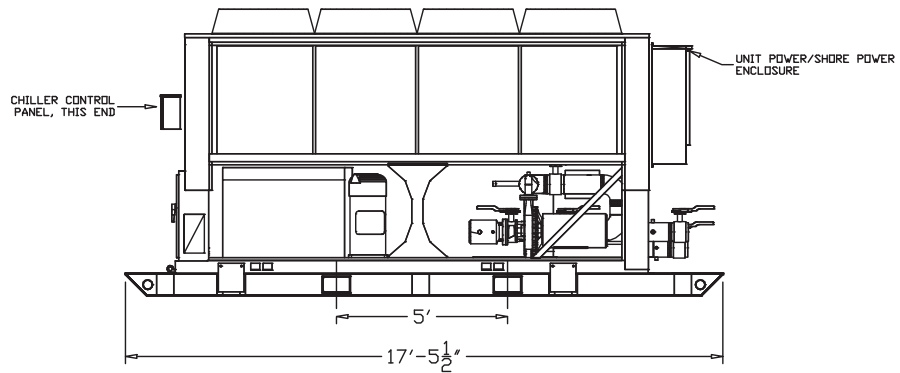
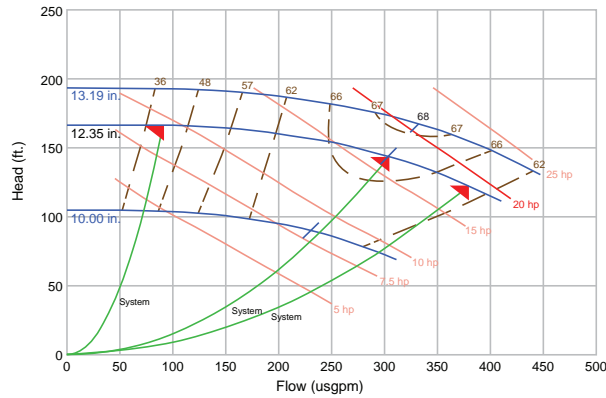



# 200 Ton ACSA

**Table 57. General – RSCA0200F0**

Labels	Value
Model Number	ACSA200
Nominal Tons	200
Refrigerant	R-410A
Refrigerant Charge <sup>(a)</sup>	96/96 lbs
Water Connection Size	6 in. Victaulic
Ambient Operating Conditions	-20°F to 130°F
Chilled Water Setpoint Limits <sup>(b) (c)</sup>	0°F to 68°F
Number of Electrical Circuits	1
Number of Refrigerant Circuits	2

- (a) Data containing information on two circuits is shown as follows: ckt 1/ ckt 2.
- (b) Setpoints only to be used as a guide, selection is required for actual chiller performance.
- (c) When leaving solution is below 42°F, a glycol solution is required for all low temperature and ice-making applications.

**Table 58. Electrical data**

Labels	Value
Voltage	460V 3-Phase
Frequency	60 Hz
Wire Connection Type	Series 16 Cam Type Only
SCCR	5000 A
<b>Without Integral Pump</b>	
Minimum Circuit Ampacity (MCA)	438 A
Maximum Overcurrent Protection (MOP)	500 A
Full Load Amps (FLA)	428 A
<b>With Integral Pump</b>	
Minimum Circuit Ampacity (MCA)	493 A
Maximum Overcurrent Protection (MOP)	500 A
Full Load Amps (FLA)	476 A

**Notes:**

1. For additional electrical information, contact Trane Rental Services.
2. All features and specifications are subject to change without notice or liability.

**Table 59. Pump data**

Labels	Value
Horsepower	40 HP
Min Flow	181 gpm @ 190 ft.
Max Flow	848 gpm @ 119 ft.

**Table 60. Cooling capacity (200 tons)**

Leaving Water Temp	Glycol (%)	Estimated Capacity (Tons) at 2.4 GPM / Nominal Ton			
		Ambient Air Temp			
		65°F	75°F	85°F	95°F
65°F	0	306.9	289.4	271.6	254.0
55°F	0	266.1	251.1	235.9	220.6
45°F	0	227.8	215.4	202.6	189.5
35°F	12	191.0	180.9	170.3	159.4
25°F	25	157.8	149.6	140.9	131.9
15°F	34	128.5	121.9	114.8	107.4
5°F	40	103.3	97.9	92.2	86.1
0°F	42	92.3	87.3	82.1	76.6

**Table 61. Water flow rates and pressure drops (200 tons)**

Flow Rate (GPM)	Pressure Drop (ft. H <sub>2</sub> O)
240 (min flow)	5.23
250	5.63
300	7.86
350	10.40
400	13.30
450	16.50
500	20.00
550	23.90
600	28.10
650	32.50
700	37.30
720 (max flow)	39.30

## General – RSCA0200F0

**Table 62. Dimensions and weights**

Labels	Value
Length	23 ft. 5.5 in.
Width	8 ft. 5 in.
Height	8 ft. 5 in.
Shipping Weight (lbs)	15,020
Operating Weight (lbs)	15,520
Fork Pocket Dimensions	9.5 in. x 4.5 in. x 7 ft. 4 in.
Fork Pocket Center to Center Distance	3 ft. 11 in.

**Note:** Lifting device: forklift or crane.

**Table 63. Installed/operating clearances**

Labels	Value
Front	40 in.
Back	40 in.
Sides	48 in. <sup>(a)</sup>
Top	No Obstructions

(a) Based on no obstructions; contact Trane Rental Services for side-by-side or close spacing applications.

**Single Speed Pump Curve**

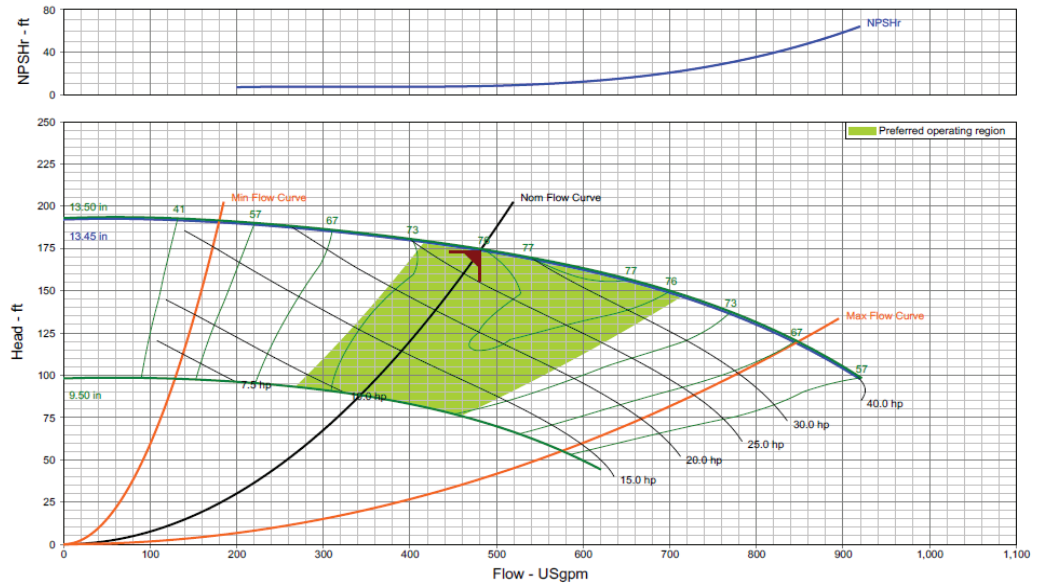

**Multi-Speed Pump Curve**

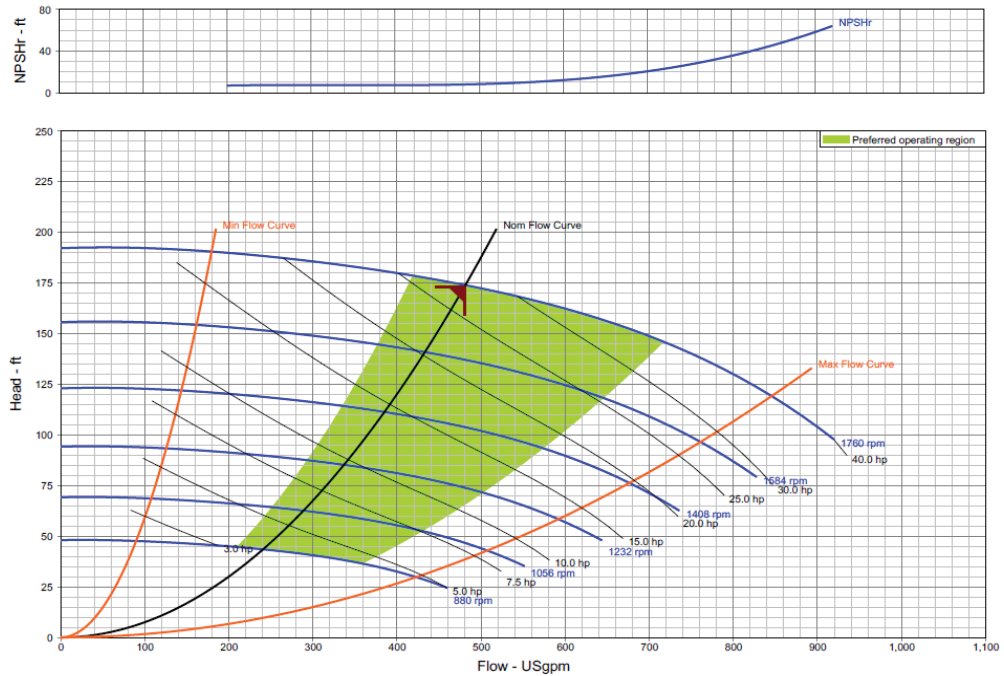

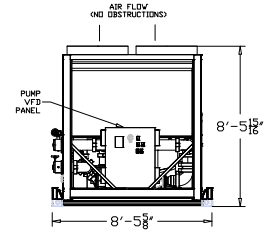
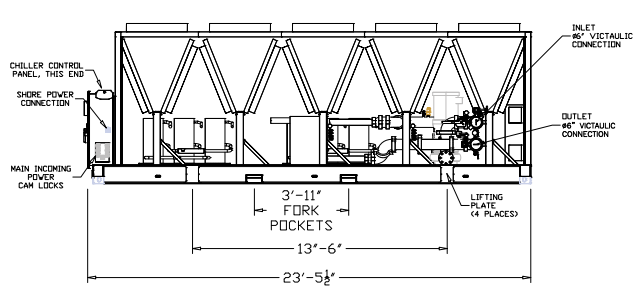
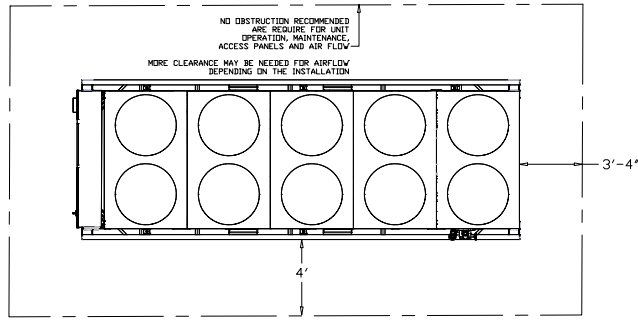



# 200 Ton Air-Cooled ACXA

**Table 64. General – RSCX0200F1**

Labels	Value
Model Number	ACXA200
Nominal Tons	200
Refrigerant	R-454B
Refrigerant Charge <sup>(a)</sup>	163/163 lbs
Water Connection Size	6 in. Victaulic
Cooling Mode Ambient Operating Conditions	–4°F to 125°F
Cooling Mode Setpoint Limits <sup>(b) (c)</sup>	40°F to 68°F
Heating Mode Ambient Operating Conditions	0°F to 95°F
Heating Mode Setpoint Limits <sup>(b)(d)</sup>	68°F to 140°F
Number of Electrical Circuits	1
Number of Refrigerant Circuits	2

- (a) Data containing information on two circuits is shown as follows: ckt 1/ ckt 2.
- (b) Setpoints only to be used as a guide, selection is required for actual chiller performance.
- (c) When leaving solution is below 42°F, a glycol solution is required.
- (d) When leaving solution is below 80°F at full load, at least 25% glycol solution is required.

**Table 65. Electrical data**

Labels	Value
Voltage	460V 3-Phase
Frequency	60 Hz
Wire Connection Type	Series 16 Cam Type Only
SCCR	35,000 A
<b>Without Integral Pump</b>	
Minimum Circuit Ampacity (MCA)	401 A
Maximum Overcurrent Protection (MOP)	500 A
Full Load Amps (FLA)	379 A
<b>With Integral Pump</b>	
Minimum Circuit Ampacity (MCA)	462 A
Maximum Overcurrent Protection (MOP)	500 A
Full Load Amps (FLA)	427 A

**Notes:**

1. For additional electrical information, contact Trane Rental Services.
2. All features and specifications are subject to change without notice or liability.

**Table 66. Pump data**

Labels	Value
Horsepower	40 HP
Min Flow	181 gpm @ 190 ft.
Max Flow	848 gpm @ 119 ft.

**Table 67. Cooling capacity (200 tons)**

Leaving Water Temp	Glycol (%)	Estimated Capacity (Tons) at 2.4 GPM / Nominal Ton			
		Ambient Air Temp			
		65°F	75°F	85°F	95°F
68°F	0	288.6	273.7	258.2	242.3
65°F	0	276.6	262.2	247.4	232.2
60°F	0	256.9	243.5	229.8	215.8
55°F	0	237.8	225.4	212.8	200.0
50°F	0	219.5	208.1	196.5	184.6
45°F	0	202.1	191.5	180.9	170.0
40°F	8	184.8	175.2	165.5	155.7

To have a selection performed to verify performance in a specific application, provide the following information in the format below.

**Table 68. Heating capacity (200 tons)**

Parameter	Value
Fluid Type and Concentration (30% propylene glycol)	—
Ambient Temperature <sup>(a)</sup> (°F / °C)	—
Must have two out of the three below	—
Inlet Temperature (°F / °C)	—
Outlet Temperature (°F / °C)	—
Flow Rate (GPM)	—

<sup>(a)</sup> Ambient dry bulb and wet bulb temperatures are required for a performance selection.

**Table 69. Cooling mode water flow rates and pressure drops**

Flow Rate (GPM)	Pressure Drop (ft. H <sub>2</sub> O)
240 (min flow)	5.23
250	5.60
300	7.81
350	10.40
400	13.20
450	16.40
500	19.90
550	23.80
600	27.90
650	32.40
700	37.10
720 (max flow)	39.10



## 200 Ton Air-Cooled ACXA

**Table 70. Heating mode water flow rates and pressure drops**

Flow Rate (GPM)	Pressure Drop (ft. H <sub>2</sub> O)
240 (min flow)	3.31
250	3.57
300	4.98
350	6.60
400	8.44
450	10.50
500	12.80
550	15.30
600	17.90
650	20.90
700	23.98
720 (max flow)	25.30

## General – RSCX0200F1

**Table 71. Dimensions and weights**

Labels	Value
Length	23 ft. 6 in.
Width	8 ft. 5.625 in.
Height	8 ft. 5.9375 in.
Shipping Weight (lbs)	18,769
Operating Weight (lbs)	19,328
Fork Pocket Dimensions	9.5 in. x 4.5 in.
Fork Pocket Center to Center Distance	3 ft. 11 in.

*Note: Lifting device: forklift or crane.*

**Table 72. Installed/operating clearances**

Labels	Value
Front	40 in.
Back	40 in.
Sides	48 in. <sup>(a)</sup>
Top	No Obstructions

<sup>(a)</sup> Based on no obstructions; contact Trane Rental Services for side-by-side or close spacing applications.

Single Speed Pump Curve

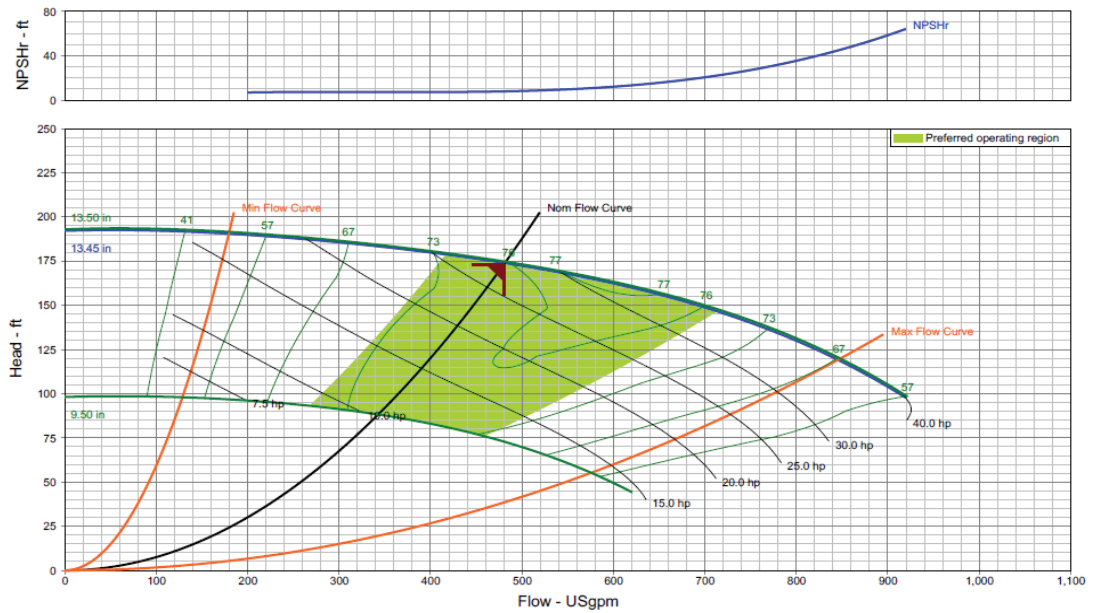

Multi-Speed Pump Curve

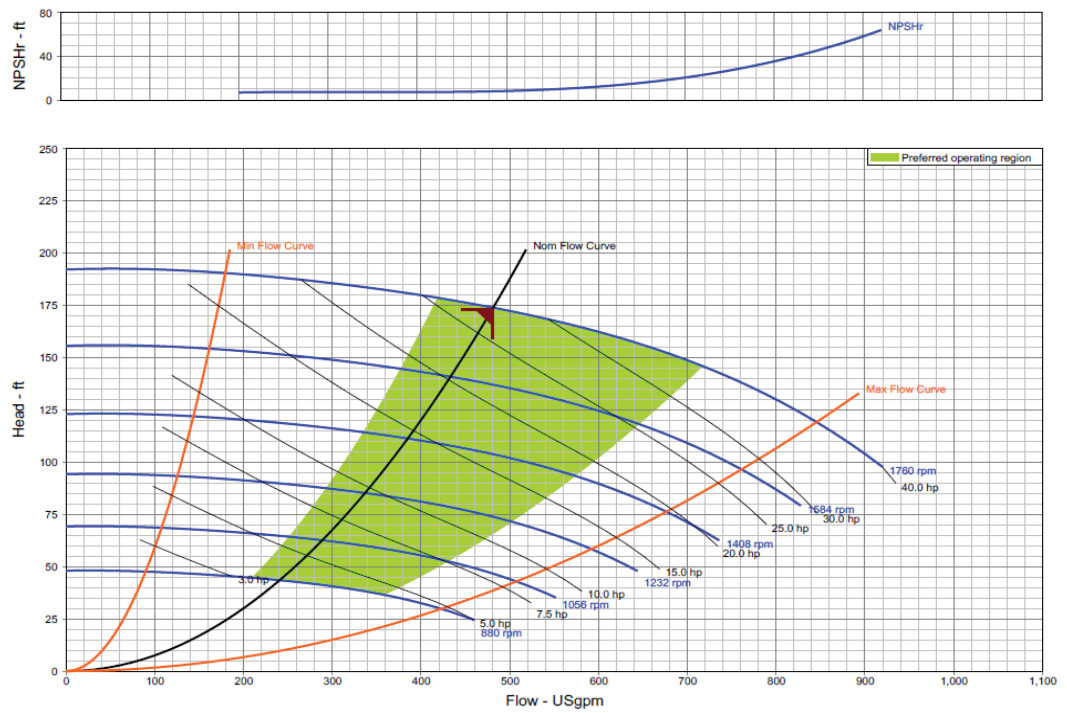



# 200 Ton Air-Cooled ACXA

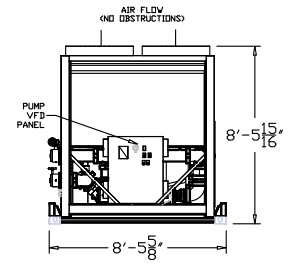
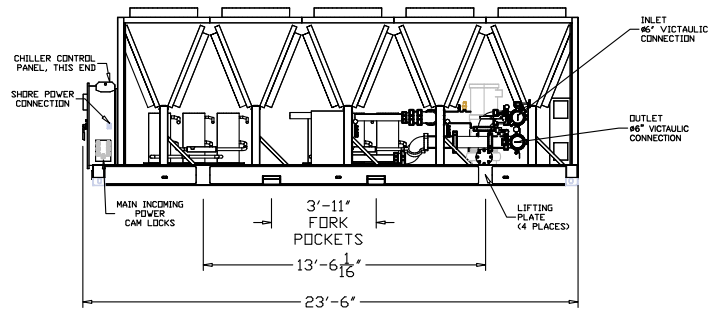
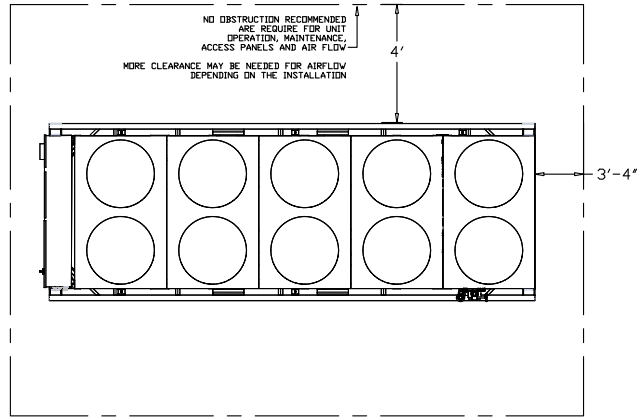



# 80 to 500 Ton RTAA/RTAC

## 80 Ton Air-Cooled RTAA

**Table 73. General – CSCA0080F0 and CSCA0080F1**

Labels	Value
Model Number	RTAA80
Nominal Tons	80
Refrigerant	R-22
Refrigerant Charge	122 lbs
Water Connection Size	4 in.
Ambient Operating Conditions	0°F to 115°F
Chilled Water Setpoint Limits <sup>(a)</sup>	0°F to 65°F
Number of Electrical Circuits	1
Number of Refrigerant Circuits	2

**Note:** Selection is required for actual chiller performance.

<sup>(a)</sup> Setpoints are to be used only as a guide.

**Table 74. Electrical data**

Labels	Value
Voltage	460V 3-Phase
Frequency	60 Hz
Maximum Wire Size Lug(s) can accept <sup>(a)</sup>	250 MCM
<b>Without Integral Pump</b>	
Minimum Circuit Ampacity (MCA)	160 A
Maximum Overcurrent Protection (MOP)	200 A
Full Load Amps (FLA)	144 A
<b>With Integral Pump (CSCA0080F1 Only)</b>	
Minimum Circuit Ampacity (MCA)	185 A
Maximum Overcurrent Protection (MOP)	255 A
Full Load Amps (FLA)	169 A

<sup>(a)</sup> Depending on chiller MCA and wire used, multiple wires per phase may be required.

**Table 75. Pump data<sup>(a)</sup>**

Label	Value
Horsepower	20 HP
Min Flow	90 gpm @ 166.7 ft.
Max Flow	406 gpm @ 109.5 ft.

**Note:** For additional electrical information, contact Trane Rental Services.

<sup>(a)</sup> Pump is mounted within the frame of chiller.



# 80 to 500 Ton RTAA/RTAC

**Table 76. Cooling capacity (tons)**

Leaving Chilled Water Temperature	Outdoor Ambient Temperature		
	85°F	95°F	105°F
44°F	84.5	79.8	74.9

*Note: Contact Trane Rental Services for low temperature applications.*

**Table 77. Water flow rates**

	Minimum	Standard	Maximum
Evaporator Flow	96 gpm	190.9 gpm	288 gpm
Pressure Drop	3.5 ft.	12.3 ft.	27.9 ft.

*Note: Maximum water side pressure is 150 psi (2.31 ft. H<sub>2</sub>O = 1 psi).*

## General – CSCA0080F0 and CSCA0080F1

**Table 78. Dimensions and weights**

Labels	Value
Length	20 ft.
Width	8 ft. 3 in.
Height	8 ft. 5 in.
Shipping Weight <sup>(a)</sup> (lbs)	11,250
Operating Weight (lbs)	11,570

*Note: Lifting device: forklift or crane.*

<sup>(a)</sup> For units with integral pump add 1,000 lb to unit weight.

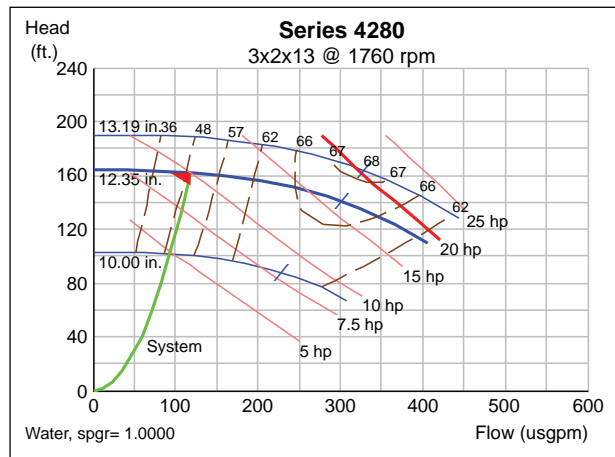

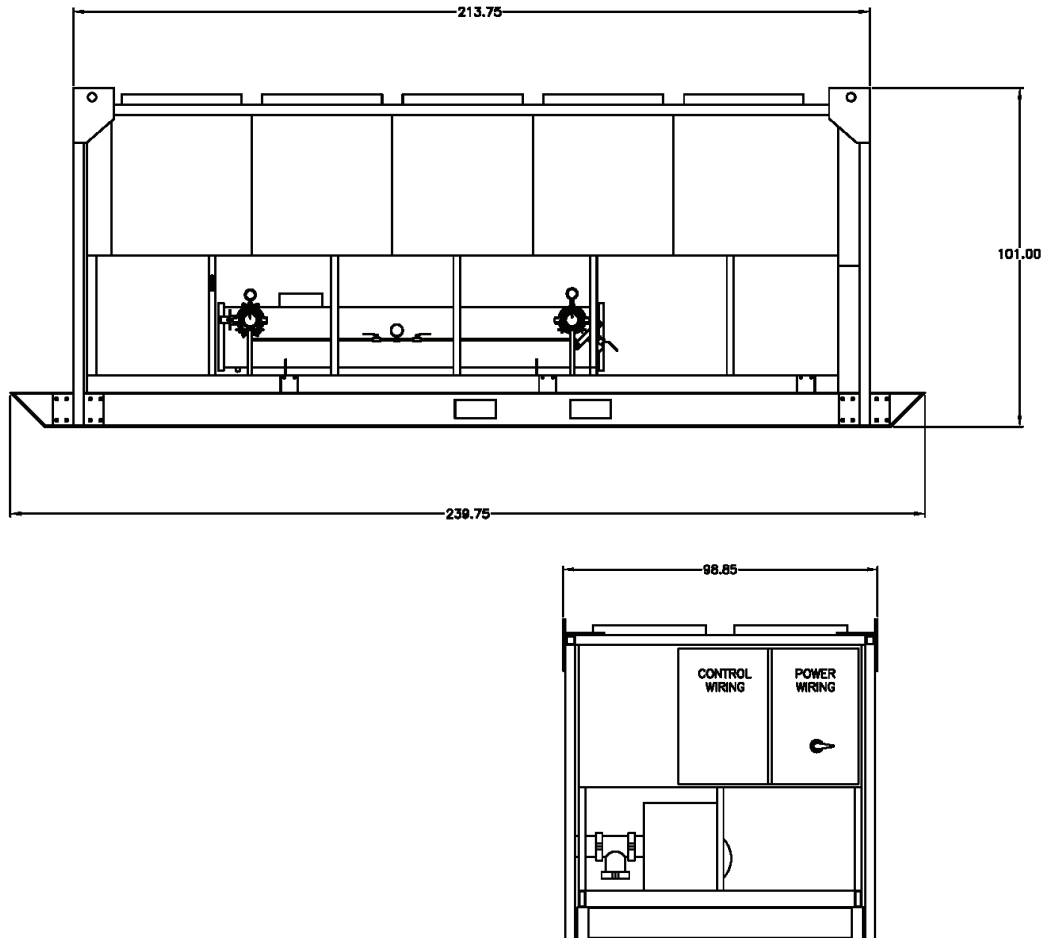

## 100 Ton Air-Cooled RTAA

**Table 79. General – CSCA0100F0 and CSCA0100F1**

Labels	Value
Model Number	RTAA100
Nominal Tons	100
Refrigerant	R-22
Refrigerant Charge	146 lbs
Water Connection Size	4 in.
Ambient Operating Conditions	0°F to 115°F
Chilled Water Setpoint Limits <sup>(a)</sup>	0°F to 65°F
Number of Electrical Circuits	1
Number of Refrigerant Circuits	2

**Note:** Selection is required for actual chiller performance.

<sup>(a)</sup> Setpoints are to be used only as a guide.



## 80 to 500 Ton RTAA/RTAC

**Table 80. Electrical data**

Labels	Value
Voltage	460V 3-Phase
Frequency	60 Hz
Maximum Wire Size Lug(s) can accept <sup>(a)</sup>	250 MCM
<b>Without Integral Pump</b>	
Minimum Circuit Ampacity (MCA)	214 A
Maximum Overcurrent Protection (MOP)	250 A
Full Load Amps (FLA)	193 A
<b>With Integral Pump (CSCA0100F1 Only)</b>	
Minimum Circuit Ampacity (MCA)	239 A
Maximum Overcurrent Protection (MOP)	300 A
Full Load Amps (FLA)	218 A

<sup>(a)</sup> Depending on chiller MCA and wire used, multiple wires per phase may be required.

**Table 81. Pump data<sup>(a)</sup>**

Labels	Value
Horsepower	20 HP
Min Flow	90 gpm @ 166.7 ft.
Max Flow	406 gpm @ 109.5 ft.

**Note:** For additional electrical information contact Trane Rental Services.

<sup>(a)</sup> Pump is mounted within the frame of chiller.

**Table 82. Cooling capacity (tons)**

Leaving Chilled Water Temperature	outdoor Ambient Temperature		
	85°F	95°F	105°F
44°F	106.6	100.6	94.3

**Note:** Contact Trane Rental Services for low temperature applications.

**Table 83. Water flow rates**

	Minimum	Standard	Maximum
Evaporator Flow	120 gpm	240.8 gpm	360 gpm
Pressure Drop	3.9 ft.	14.4 ft.	33 ft.

**Note:** Maximum water side pressure is 150 psi (2.31 ft. H<sub>2</sub>O = 1 psi).

## General – CSCA0100F0 and CSCA0100F1

**Table 84. Dimensions and weights**

Labels	Value
Length	20 ft.
Width	8 ft. 3 in.
Height	8 ft. 5 in.

**Table 84. Dimensions and weights (continued)**

Labels	Value
Shipping Weight <sup>(a)</sup> (lbs)	11,700
Operating Weight (lbs)	11,960

**Note:** Lifting device: forklift or crane.

<sup>(a)</sup> For units with integral pump add 1,000 lb to unit weight.

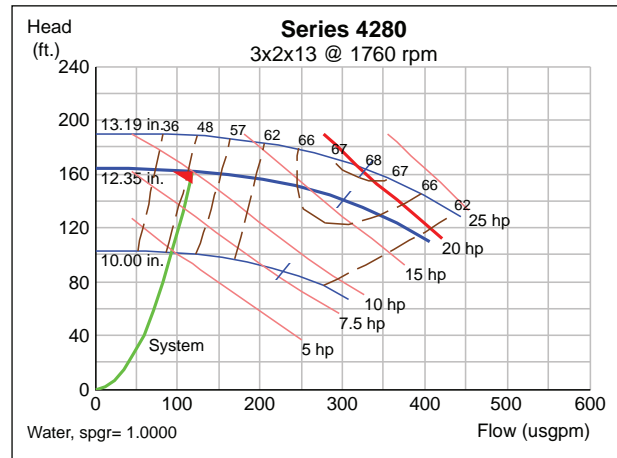

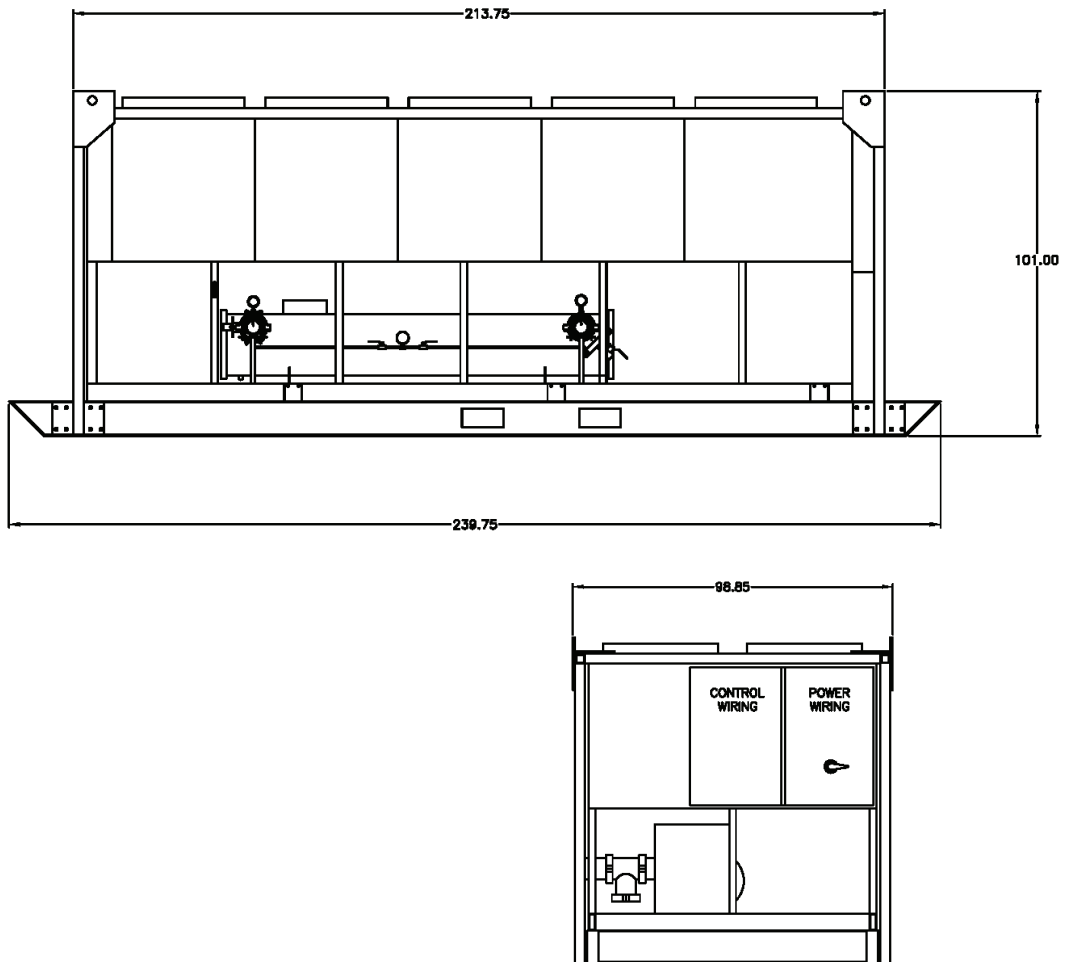

## 125 Ton Air-Cooled RTAA

**Table 85. General – CSCA0125F0 and CSCA0125F1**

Labels	Value
Model Number	RTAA125
Nominal Tons	125
Refrigerant	R-22
Refrigerant Charge	196 lbs
Water Connection Size	6 in.
Ambient Operating Conditions	0°F to 115°F
Chilled Water Setpoint Limits <sup>(a)</sup>	0°F to 65°F
Number of Electrical Circuits	1
Number of Refrigerant Circuits	2

**Note:** Selection is required for actual chiller performance.

<sup>(a)</sup> Setpoints are to be used only as a guide.

**Table 86. Electrical data**

Labels	Value
Voltage	460V 3-Phase
Frequency	60 Hz
Maximum Wire Size Lug(s) can accept <sup>(a)</sup>	250 MCM
<b>Without Integral Pump</b>	
Minimum Circuit Ampacity (MCA)	253 A
Maximum Overcurrent Protection (MOP)	350 A
Full Load Amps (FLA)	227 A
<b>With Integral Pump (CSCA0125F1 Only)</b>	
Minimum Circuit Ampacity (MCA)	278 A
Maximum Overcurrent Protection (MOP)	350 A
Full Load Amps (FLA)	252 A

<sup>(a)</sup> Depending on chiller MCA and wire used, multiple wires per phase may be required.

**Table 87. Pump data<sup>(a)</sup>**

Labels	Value
Horsepower	20 HP
Min Flow	90 gpm @ 166.7 ft.
Max Flow	406 gpm @ 109.5 ft.

**Note:** For additional electrical information contact Trane Rental Services.

<sup>(a)</sup> Pump is mounted within the frame of chiller.

**Table 88. Cooling capacity (tons)**

Leaving Chilled Water Temperature	Outdoor Ambient Temperature		
	85°F	95°F	105°F
44°F	127.3	120.0	112.4

**Note:** Contact Trane Rental Services for low temperature applications.

**Table 89. Water flow rates**

	Minimum	Standard	Maximum
Evaporator Flow	150 gpm	287.2 gpm	450 gpm
Pressure Drop	5.5 ft.	21.3 ft.	47.1 ft.

**Note:** Maximum water side pressure is 150 psi (2.31 ft. H<sub>2</sub>O = 1 psi).

## General – CSCA0125F0 and CSCA0125F1

**Table 90. Dimensions and weights**

Labels	Value
Length	22 ft.
Width	8 ft. 3 in.
Height	8 ft. 5 in.



80 to 500 Ton RTAA/RTAC

**Table 90. Dimensions and weights (continued)**

Labels	Value
Shipping Weight <sup>(a)</sup> (lbs)	12,800
Operating Weight (lbs)	13,170

**Note:** Lifting device: forklift or crane.

<sup>(a)</sup> For units with integral pump add 1,000 lb to unit weight.

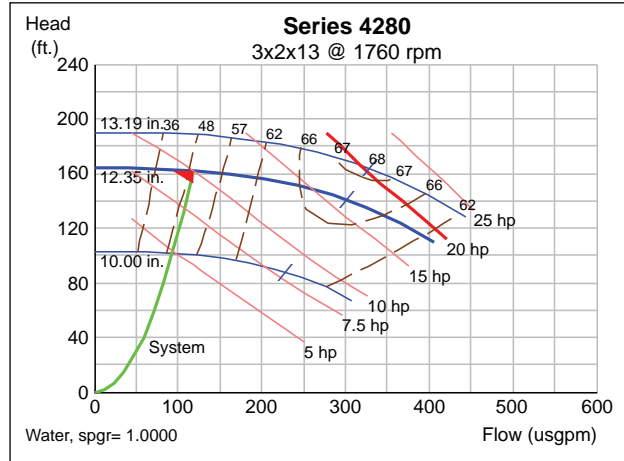

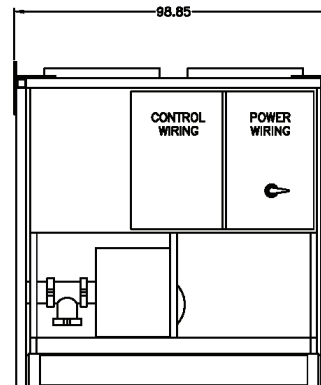
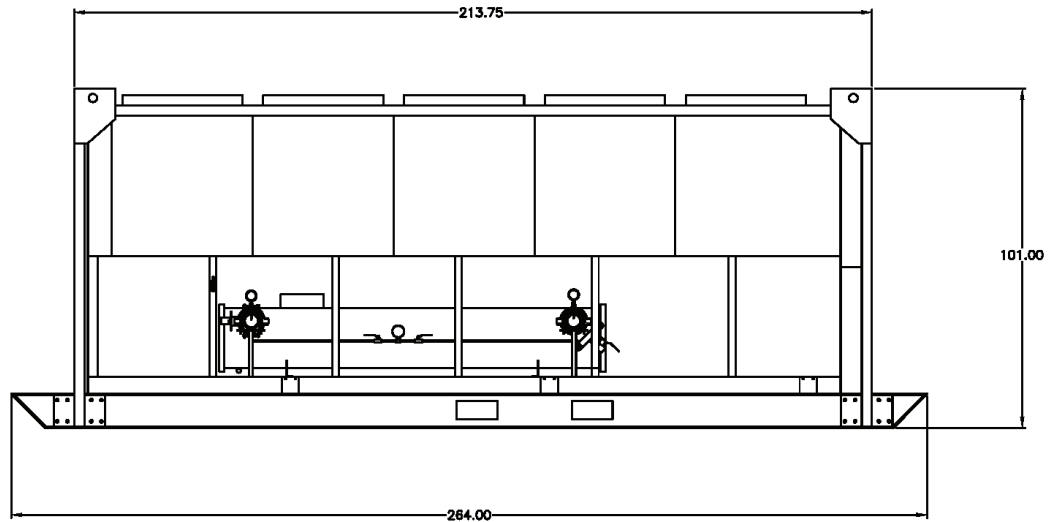

## 155 Ton Air-Cooled RTAC

**Table 91. General – CSCA0155F0-F3**

Labels	Value
Model Number	RTAC155
Nominal Tons	155
Refrigerant	R-134a
Refrigerant Charge <sup>(a)</sup>	175/165 lbs
Water Connection Size	6 in. Victaulic
Ambient Operating Conditions	0°F to 125°F
Chilled Water Setpoint Limits <sup>(b) (c)</sup>	20°F to 65°F
Evaporation Configuration	2 pass
Number of Electrical Circuits	1
Number of Refrigerant Circuits	2

**Note:** Selection is required for actual chiller performance.

- <sup>(a)</sup> Data containing information on two circuits is shown as follows: ckt 1/ ckt 2.
- <sup>(b)</sup> When leaving solution is below 40°F a glycol solution is required for all low temperature and ice-making applications.
- <sup>(c)</sup> Have engineering validate performance for applications that require 60°F and above supply leaving water temperatures.

**Table 92. Electrical data**

Labels	Value
Voltage	460V 3-Phase
Frequency	60 Hz
F0 Power Supply Connections <sup>(a)</sup> <sup>(b)</sup>	Lugs or Series 16 Cam-Type Connections
F2 Power Supply Connections <sup>(a)</sup>	Series 16 Cam-Type Connections Only
<b>Without Integral Pump</b>	
Minimum Circuit Ampacity (MCA)	322 A
Maximum Overcurrent Protection (MOP)	450 A
Full Load Amps (FLA)	289 A
<b>With Integral Pump</b>	
Minimum Circuit Ampacity (MCA)	360 A
Maximum Overcurrent Protection (MOP)	500 A
Full Load Amps (FLA)	326 A

**Note:** For additional electrical information, contact Trane Rental Services.

<sup>(a)</sup> Maximum wire size lug(s) can accept - 2/0.

<sup>(b)</sup> Depending on chiller MCA and wire used, multiple wires per phase may be required.

**Table 93. Pump data – CSCA0155F0<sup>(a)</sup>**

Labels	Value
Horsepower	25 HP
Min Flow	199 gpm @ 129.7 ft.
Max Flow	800 gpm @ 93.1 ft.

<sup>(a)</sup> Pump is mounted within the chiller frame and controlled by the chiller standalone control system if not connected to end user building automation system.

**Table 94. Pump data – CSCA0155F2-F3<sup>(a)</sup>**

Labels	Value
Horsepower	25 HP
Min Flow	146 gpm @ 143 ft.
Max Flow	606 gpm @ 99 ft.

<sup>(a)</sup> Pump is mounted within the chiller frame and controlled by the chiller standalone control system if not connected to end user building automation system.

**Table 95. Cooling capacity (tons)**

Leaving Water Temp	Propylene Glycol (%)	Estimated Capacity (Tons) at 2.4 GPM / Nominal Ton				
		Ambient Air Temp				
		85°F	95°F	105°F	115°F	125°F
60°F	0	215.2	200.5	181.1	156.4	117.4
55°F	0	198.9	185.3	169.7	147.8	115.0
50°F	0	183.0	170.4	156.3	139.5	112.8
45°F	0	167.7	156.0	143.1	128.9	108.8
40°F	0	153.0	142.2	130.4	117.0	101.7

**Table 95. Cooling capacity (tons) (continued)**

Leaving Water Temp	Propylene Glycol (%)	Estimated Capacity (Tons) at 2.4 GPM / Nominal Ton				
		Ambient Air Temp				
		85°F	95°F	105°F	115°F	125°F
35°F	10 <sup>(a)</sup>	138.2	128.3	117.6	105.1	91.9
30°F	20 <sup>(a)</sup>	121.9	113.2	103.6	92.2	80.1
25°F	25 <sup>(a)</sup>	105.1	97.6	89.2	79.0	68.2
20°F	30 <sup>(b)</sup>	97.2	90.0	81.7	71.8	61.3

<sup>(a)</sup> Performance based on using propylene glycol solution for antifreeze protection.

<sup>(b)</sup> Performance based on using ethylene glycol for antifreeze protection.

**Table 96. Water flow rates and pressure drops**

Flow Rate (GPM)	Pressure Drop (ft. H <sub>2</sub> O)
193 (min flow)	3.91
250	6.48
300	9.15
350	12.20
400	15.60
450	19.40
500	23.50
550	28.00
600	32.90
650	38.20
709 (max flow)	44.90

*Note: Maximum water side pressure is 150 psi (2.31 ft. H<sub>2</sub>O = 1 psi).*

## General – CSCA0155F0

**Table 97. Dimensions and weights**

Labels	Value
Length	21 ft. 3 in.
Width	8 ft. 5 in.
Height	8 ft. 6 in.
Shipping Weight (lbs)	16,900
Operating Weight (lbs)	17,200
Fork Pocket Dimensions	9.25 in. x 5.25 in. x 7 ft. 6.5 in.
Fork Pocket Center to Center Distance	4 ft. 6 in.

**Notes:**

1. *Lifting device: forklift or crane.*
2. *All weights and dimensions listed above are subject to change without notice or liability.*

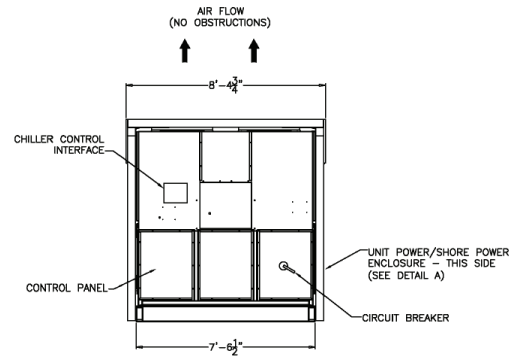
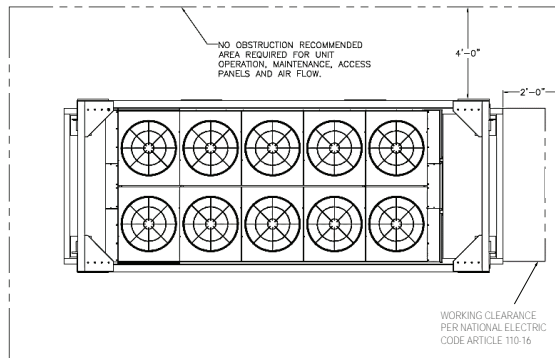
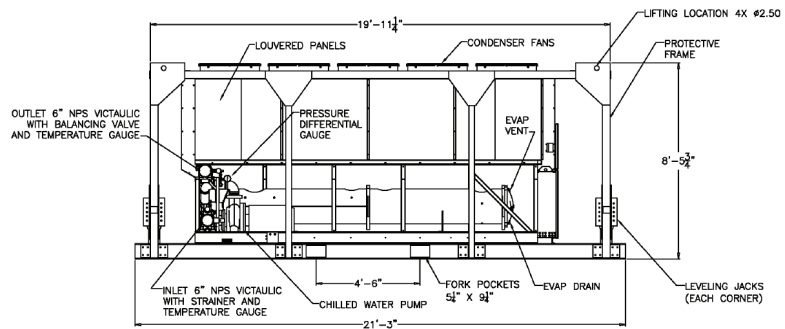
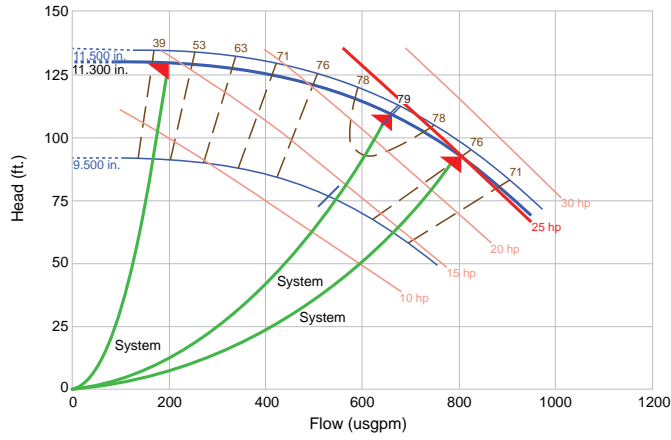

General – CSCA0155F2

Table 98. Dimensions and weights

Labels	Value
Length	21 ft. 2 in.
Shipping Width	8 ft. 4.5 in.
Operating Width (Leveling Jacks Installed)	10 ft. 2 in.
Height	8 ft. 6 in.
Shipping Weight (lbs)	14,600
Operating Weight (lbs)	14,900
Fork Pocket Dimensions	9.25 in. x 5.25 in. x 7 ft. 8 in.

**Table 98. Dimensions and weights (continued)**

Labels	Value
Fork Pocket Center to Center Distance	5 ft.

**Notes:**

1. Lifting device: forklift or crane.
2. All weights and dimensions listed above are subject to change without notice or liability.

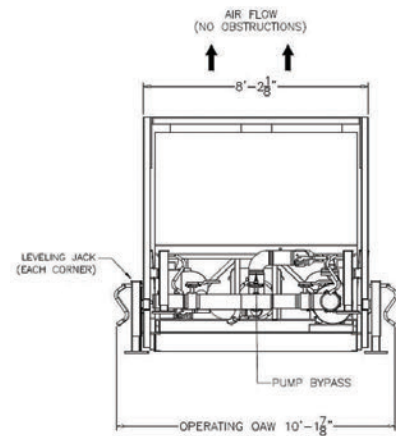
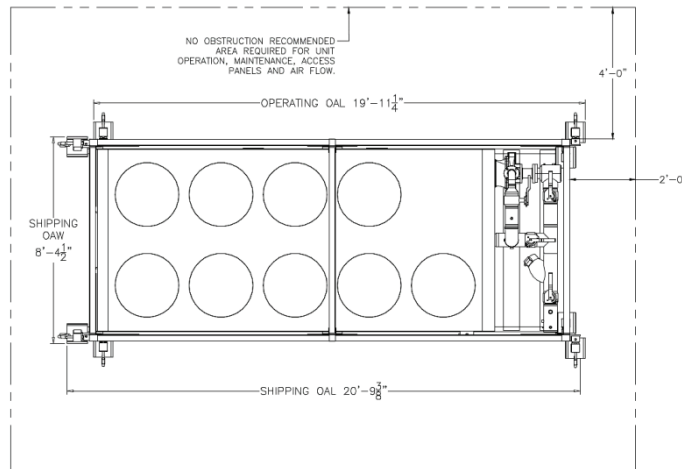
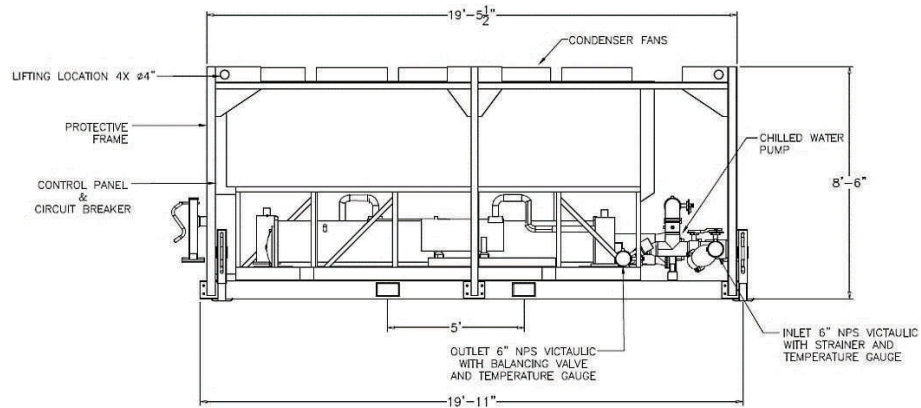
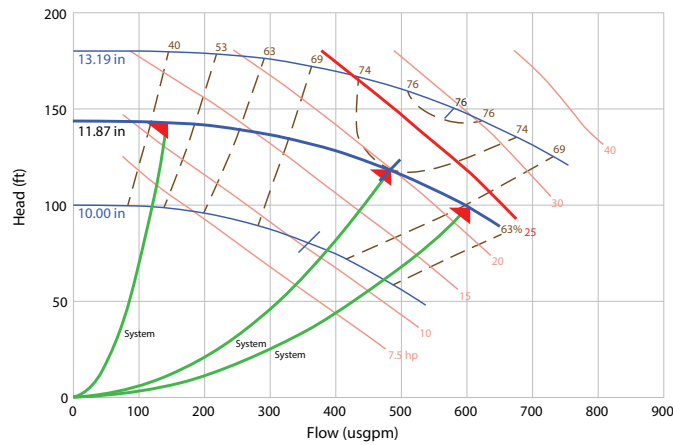



80 to 500 Ton RTAA/RTAC

General – CSCA0155F3

Table 99. Dimensions and weights

Labels	Value
Length	21 ft. 2 in.
Width	8 ft. 4.5 in.
Operating Width (Leveling Jacks Installed)	10 ft. 2 in.
Height	8 ft. 6 in.
Shipping Weight (lbs)	18,000
Operating Weight (lbs)	18,300
Fork Pocket Dimensions	9.25 in. x 5.25 in. x 7 ft. 8 in.
Fork Pocket Center to Center Distance	5 ft.

Notes:

1. Lifting device: forklift or crane.
2. All weights and dimensions listed above are subject to change without notice or liability.

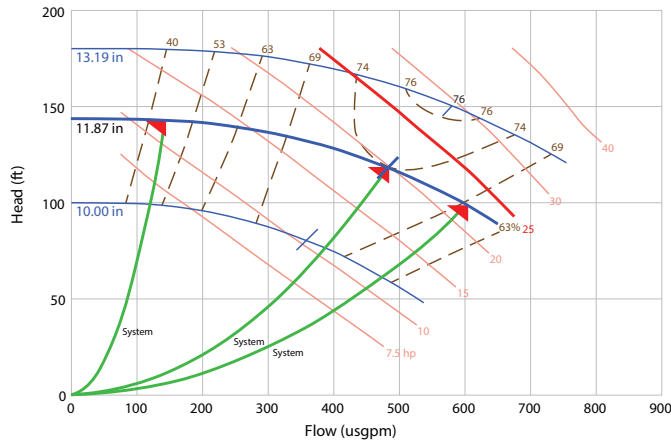

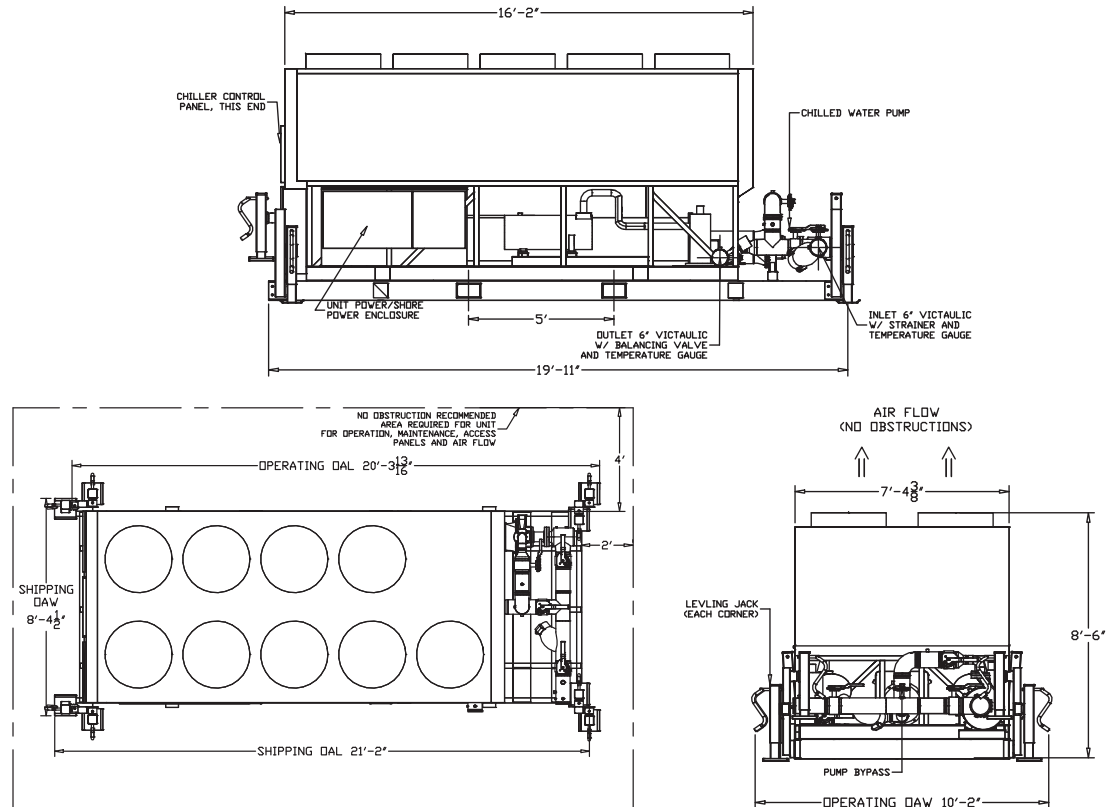

## 170 Ton Air-Cooled RTAA

**Table 100. General – CSCA0170F0**

Labels	Value
Model Number	RTAA170
Nominal Tons	170
Refrigerant	R-22
Refrigerant Charge	300 lbs
Water Connection Size	6 in.
Ambient Operating Conditions	0°F to 115°F
Chilled Water Setpoint Limits <sup>(a)</sup>	0°F to 65°F
Number of Electrical Circuits	1
Number of Refrigerant Circuits	2

**Note:** Selection is required for actual chiller performance.

<sup>(a)</sup> Setpoints are to be used only as a guide.

**Table 101. Electrical data**

Labels	Value
Voltage	460V 3-Phase
Frequency	60 Hz
Maximum Wire Size Lug(s) can accept <sup>(a)</sup>	350 MCM
<b>Without Integral Pump</b>	



## 80 to 500 Ton RTAA/RTAC

**Table 101. Electrical data (continued)**

Labels	Value
Minimum Circuit Ampacity (MCA)	369 A
Maximum Overcurrent Protection (MOP)	500 A
Full Load Amps (FLA)	327 A

**Note:** For additional electrical information, contact Trane Rental Services.

<sup>(a)</sup> Depending on chiller MCA and wire used, multiple wires per phase may be required.

**Table 102. Cooling capacity (tons)**

Leaving Chilled Water Temperature	Outdoor Ambient Temperature		
	85°F	95°F	105°F
44°F	173.8	164.5	154.9

**Note:** Contact Trane Rental Services for low temperature applications.

**Table 103. Water flow rates**

	Minimum	Standard	Maximum
Evaporator Flow	186 gpm	393.5 gpm	612 gpm
Pressure Drop	4.1 ft.	16.0 ft.	38.8 ft.

**Note:** Maximum water side pressure is 150 psi (2.31 ft. H<sub>2</sub>O = 1 psi).

## General – CSCA0170F0

**Table 104. Dimensions and weights**

Labels	Value
Length	25 ft. 7 in.
Width	8 ft. 3 in.
Height	8 ft. 7 in.
Shipping Weight <sup>(a)</sup> (lbs)	16,555
Operating Weight (lbs)	17,130

**Note:** Lifting device: forklift or crane.

<sup>(a)</sup> For units with integral pump add 1,000 lb to unit weight.

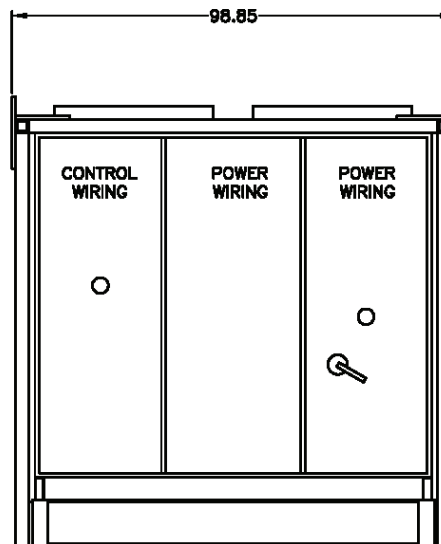
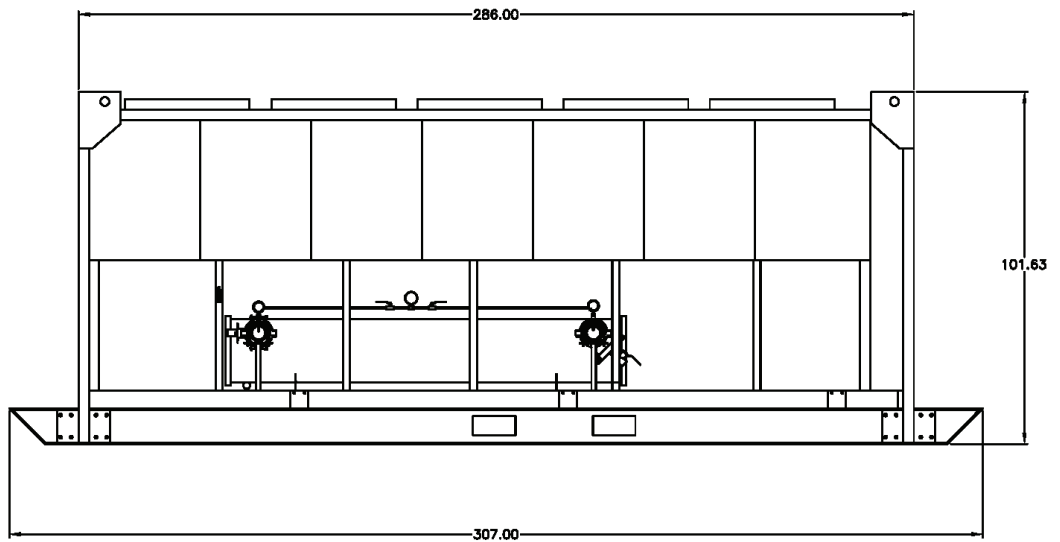

## 170 Ton Air-Cooled RTAC

Table 105. General – CSCA0170F0 and CSCA0170F2

Labels	Value
Model Number	RTAC170
Nominal Tons	170
Refrigerant	R-134a
Refrigerant Charge <sup>(a)</sup>	175/175 lbs
Water Connection Size	6 in. Victaulic
Ambient Operating Conditions	0°F to 125°F
Chilled Water Setpoint Limits <sup>(b)(c)</sup>	20°F to 65°F
Evaporation Configuration	2 pass

**Table 105. General – CSCA0170F0 and CSCA0170F2 (continued)**

Labels	Value
Number of Electrical Circuits	1
Number of Refrigerant Circuits	2

- (a) Data containing information on two circuits is shown as follows: ckt 1/ ckt 2.  
 (b) When leaving solution is below 40°F a glycol solution is required for all low temperature and ice-making applications.  
 (c) Have engineering validate performance for applications that require 60°F and above supply leaving water temperatures.

**Table 106. Electrical data**

Labels	Value
Voltage	460V 3-Phase
Frequency	60 Hz
F0 Power Supply Connections <sup>(a)</sup> <sup>(b)</sup>	Lugs or Series 16 Cam-Type Connections
F2 Power Supply Connections <sup>(a)</sup>	Series 16 Cam-Type Connections Only
<b>Without Integral Pump</b>	
Minimum Circuit Ampacity (MCA)	346 A
Maximum Overcurrent Protection (MOP)	450 A
Full Load Amps (FLA)	311 A
<b>With Integral Pump</b>	
Minimum Circuit Ampacity (MCA)	385 A
Maximum Overcurrent Protection (MOP)	500 A
Full Load Amps (FLA)	350 A

**Note:** For additional electrical information, contact Trane Rental Services.

- (a) Maximum wire size lug(s) can accept - 600 MCM.  
 (b) Depending on chiller MCA and wire used, multiple wires per phase may be required.

**Table 107. Pump data – CSCA0170F0<sup>(a)</sup>**

Labels	Value
Horsepower	25 HP
Min Flow	199 gpm @ 129.7 ft.
Max Flow	800 gpm @ 93.1 ft.

- (a) Pump is mounted within the chiller frame and controlled by the chiller standalone control system if not connected to end user building automation system.

**Table 108. Pump data – CSCA0170F2<sup>(a)</sup>**

Labels	Value
Horsepower	25 HP
Min Flow	146 gpm @ 143 ft.
Max Flow	606 gpm @ 99 ft.

- (a) Pump is mounted within the chiller frame and controlled by the chiller standalone control system if not connected to end user building automation system.

**Table 109. Cooling capacity (tons)**

Leaving Water Temp	Propylene Glycol (%)	Estimated Capacity (Tons) at 2.4 GPM / Nominal Ton				
		Ambient Air Temp				
		85°F	95°F	105°F	115°F	125°F
60°F	0	235.3	219.6	199.5	173.0	129.2
55°F	0	217.5	203.0	186.8	163.9	126.3
50°F	0	200.3	186.8	171.9	155.1	123.5
45°F	0	183.6	171.1	157.5	142.4	120.7
40°F	0	167.7	156.1	143.6	129.4	114.2
35°F	10 <sup>(a)</sup>	151.8	141.1	129.7	116.4	102.4
30°F	20 <sup>(a)</sup>	134.5	125.0	114.8	102.6	89.7
25°F	25 <sup>(a)</sup>	116.6	108.5	99.4	88.5	76.8
20°F	30 <sup>(b)</sup>	107.7	99.9	91.1	80.4	69.1

<sup>(a)</sup> Performance based on using propylene glycol solution for antifreeze protection.

<sup>(b)</sup> Performance based on using ethylene glycol for antifreeze protection.

**Table 110. Water flow rates and pressure drops**

Flow Rate (GPM)	Pressure Drop (ft. H <sub>2</sub> O)
202 (min flow)	3.34
250	5.05
300	7.12
350	9.46
400	12.10
450	14.90
500	18.10
550	21.40
600	25.10
650	29.10
700	33.30
741 (max flow)	37.10

**Note:** Maximum water side pressure is 150 psi (2.31 ft. H<sub>2</sub>O = 1 psi).

## General – CSCA0170F0

**Table 111. Dimensions and weights**

Labels	Value
Length	21 ft. 3 in.
Width	8 ft. 5 in.
Height	8 ft. 6 in.
Shipping Weight (lbs)	18,350
Operating Weight (lbs)	18,700
Fork Pocket Dimensions	9.25 in. x 5.25 in. x 7 ft. 8 in.

**Table 111. Dimensions and weights (continued)**

Labels	Value
Fork Pocket Center to Center Distance	4 ft. 6 in.

**Notes:**

1. Lifting device: forklift or crane.
2. All weights and dimensions listed above are subject to change without notice or liability.

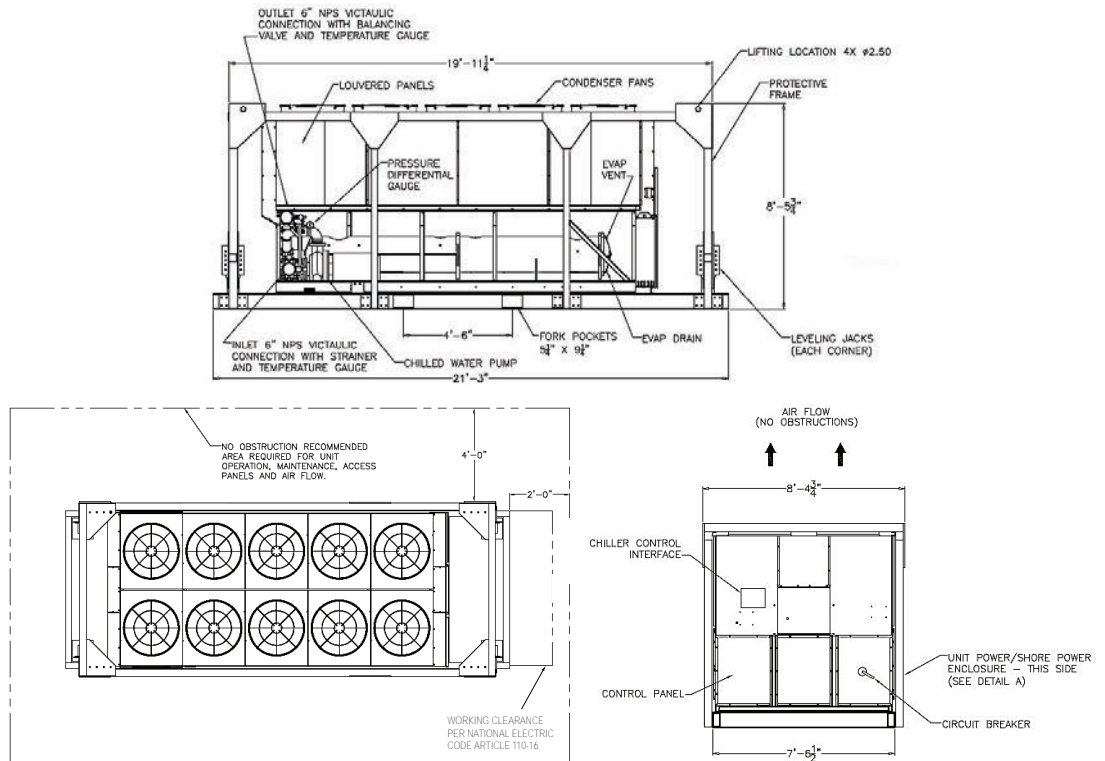
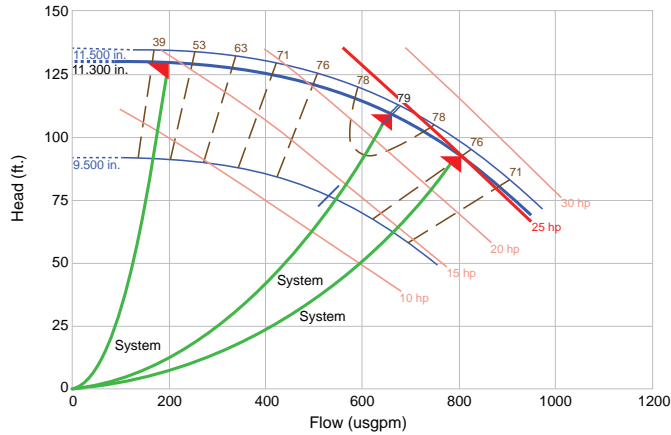

## General – CSCA0170F2

**Table 112. Dimensions and weights**

Labels	Value
Length	21 ft. 2in.
Shipping Width	8 ft. 4.5 in.
Operating Width (Leveling Jacks Installed)	10 ft. 2 in.
Height	8 ft. 6 in.
Shipping Weight (lbs)	16,300
Operating Weight (lbs)	16,650
Fork Pocket Dimensions	9.25 in. x 5.25 in. x 7 ft. 8 in.
Fork Pocket Center to Center Distance	5 ft.

**Notes:**

1. *Lifting device: forklift or crane*
2. *All weights and dimensions listed above are subject to change without notice or liability.*

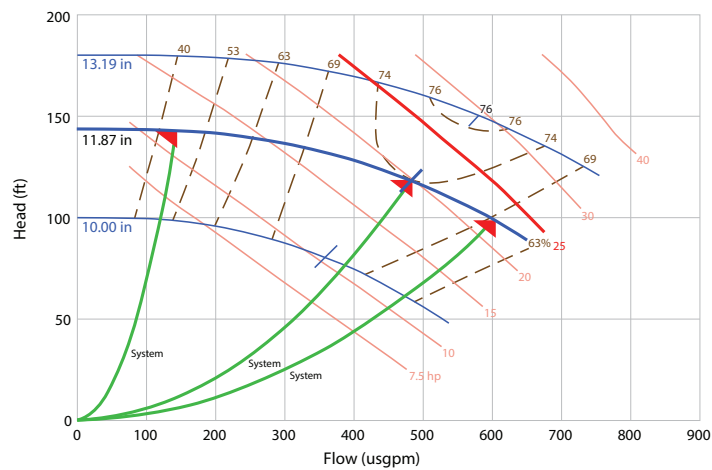



## 80 to 500 Ton RTAA/RTAC

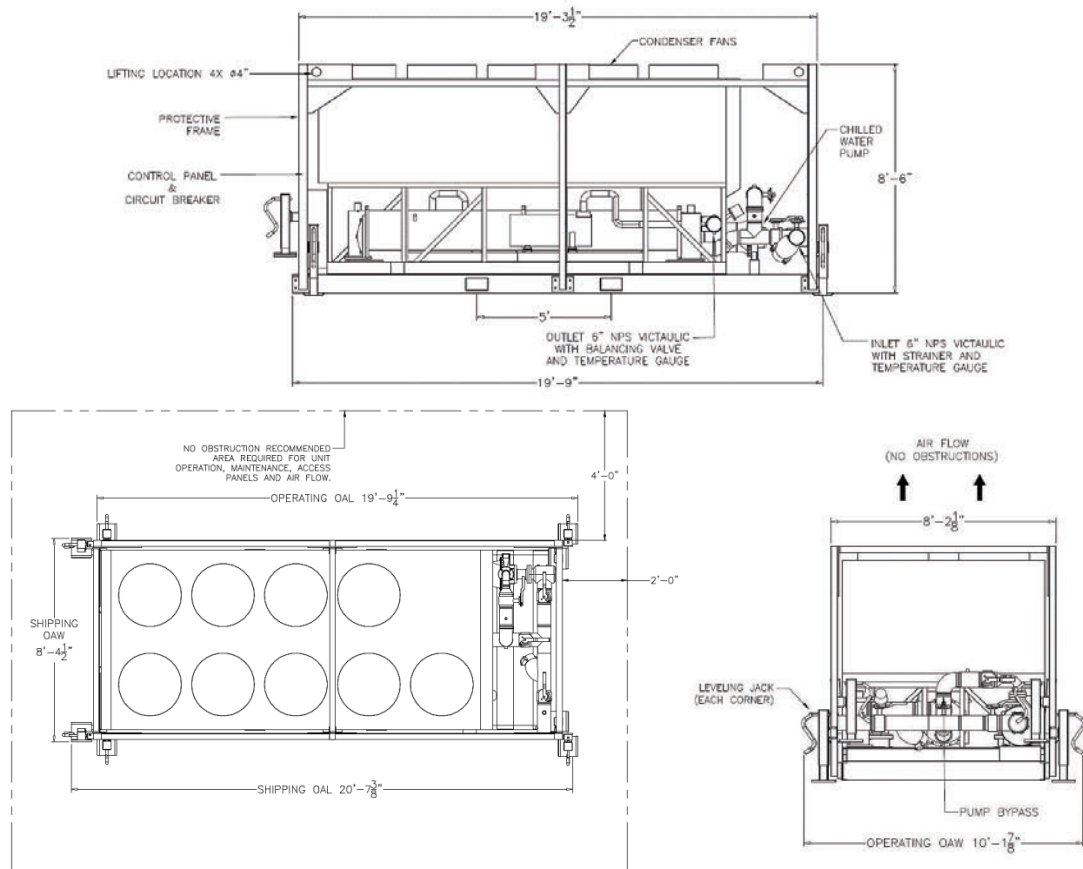

## 200 Ton Air-Cooled RTAA

**Table 113. General – CSCA0200F0**

Labels	Value
Model Number	RTAA200
Nominal Tons	200
Refrigerant	R-22
Refrigerant Charge	340 lbs
Water Connection Size	6 in.
Ambient Operating Conditions	0°F to 125°F
Chilled Water Setpoint Limits <sup>(a)</sup>	0°F to 65°F
Number of Electrical Circuits	1
Number of Refrigerant Circuits	2

**Note:** Selection is required for actual chiller performance.

<sup>(a)</sup> Setpoints are to be used only as a guide.

**Table 114. Electrical data**

Labels	Value
Voltage	460V 3-phase
Frequency	60 Hz

**Table 114. Electrical data (continued)**

Labels	Value
Maximum Wire Size Lug(s) can accept <sup>(a)</sup>	350 MCM
<b>Without Integral Pump</b>	
Minimum Circuit Ampacity (MCA)	406 A
Maximum Overcurrent Protection (MOP)	500 A
Full Load Amps (FLA)	365 A

**Note:** For additional electrical information, contact Trane Rental Services.

<sup>(a)</sup> Depending on chiller MCA and wire used, multiple wires per phase may be required.

**Table 115. Cooling capacity (tons)**

Leaving Chilled Water Temperature	Outdoor Ambient Temperature		
	85°F	95°F	105°F
44°F	198.3	188.3	178.2

**Note:** Contact Trane Rental Services for low temperature applications.

**Table 116. Water flow rates**

	Minimum	Standard	Maximum
Evaporator Flow	222 gpm	450.6 gpm	720 gpm
Pressure Drop	4.5 ft.	16.4 ft.	42.0 ft.

**Note:** Maximum water side pressure is 150 psi (2.31 ft. H<sub>2</sub>O = 1 psi).

## General – CSCA0200F0

**Table 117. Dimensions and weights**

Labels	Value
Length	25 ft. 7 in.
Width	8 ft. 3 in.
Height	8 ft. 6 in.
Shipping Weight <sup>(a)</sup> (lbs)	17,000
Operating Weight (lbs)	17,450

**Note:** Lifting device: forklift or crane.

<sup>(a)</sup> For units with integral pump add 1,000 lb to unit weight.

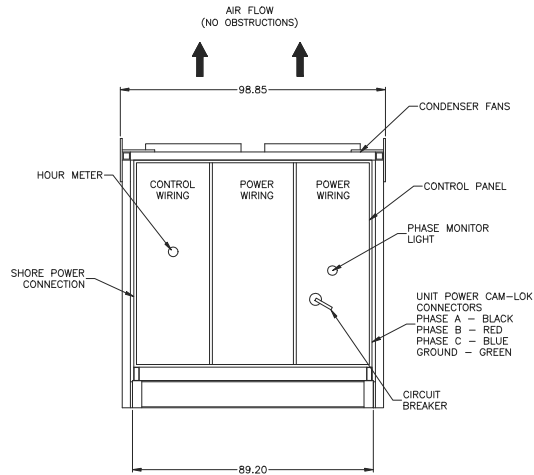
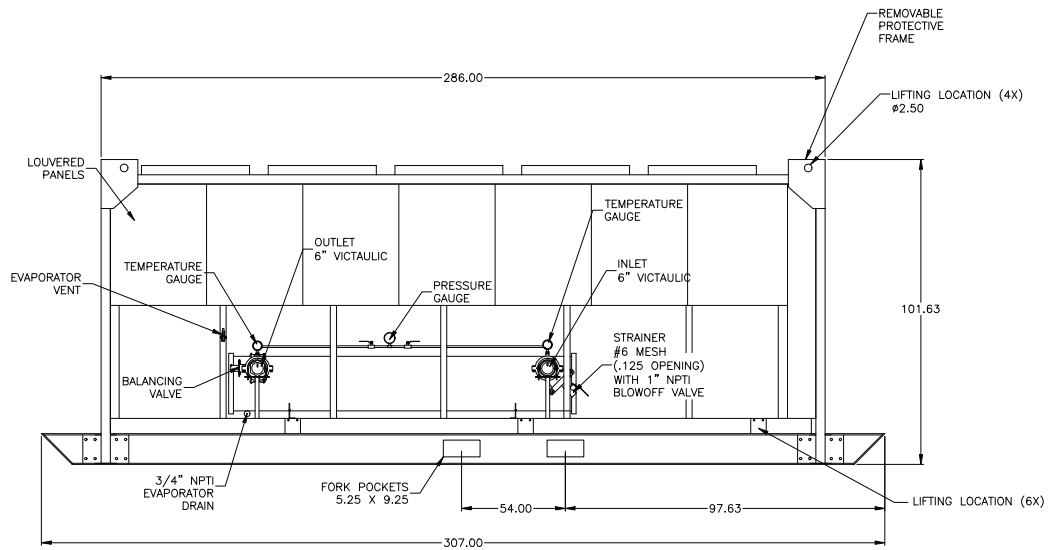

## 200 Ton Air-Cooled RTAC

Table 118. General – CSCA0200F0-F3

Labels	Value
Model Number	RTAC200
Nominal Tons	200
Refrigerant	R-134a
Refrigerant Charge <sup>(a)</sup>	225/225 lbs
Water Connection Size	6 in. Victaulic
Ambient Operating Conditions	0°F to 125°F
Chilled Water Setpoint Limits <sup>(b) (c)</sup>	20°F to 65°F
Evaporation Configuration	2 pass

**Table 118. General – CSCA0200F0-F3 (continued)**

Labels	Value
Number of Electrical Circuits	1
Number of Refrigerant Circuits	2

- (a) Data containing information on two circuits is shown as follows: ckt 1/ ckt 2.  
 (b) When leaving solution is below 40°F a glycol solution is required for all low temperature and ice-making applications.  
 (c) Have engineering validate performance for applications that require 60°F and above supply leaving water temperatures.

**Table 119. Electrical data**

Labels	Value
Voltage	460V 3-phase
Frequency	60 Hz
F0 Power Supply Connections <sup>(a)</sup> <sup>(b)</sup>	Lugs or Series 16 Cam-Type Connections
F2-F3 Power Supply Connections <sup>(b)</sup>	Series 16 Cam-Type Connections Only
<b>Without Integral Pump</b>	
Minimum Circuit Ampacity (MCA)	417 A
Maximum Overcurrent Protection (MOP)	500 A
Full Load Amps (FLA)	375 A
<b>With Integral Pump</b>	
Minimum Circuit Ampacity (MCA)	455 A
Maximum Overcurrent Protection (MOP)	600 A
Full Load Amps (FLA)	413 A

**Note:** For additional electrical information, contact Trane Rental Services.

- (a) Maximum wire size lug(s) can accept - 600 MCM.  
 (b) Depending on chiller MCA and wire used, multiple wires per phase may be required.

**Table 120. Pump data – CSCA0200F0<sup>(a)</sup>**

Labels	Value
Horsepower	25 HP
Min Flow	199 gpm @ 129.7 ft.
Max Flow	800 gpm @ 93.1 ft.

- (a) Pump is mounted within the chiller frame and controlled by the chiller standalone control system if not connected to end user building automation system.

**Table 121. Pump data – CSCA0200F2–F3<sup>(a)</sup>**

Labels	Value
Horsepower	25 HP
Min Flow	146 gpm @ 143 ft.
Max Flow	606 gpm @ 99 ft.

- (a) Pump is mounted within the chiller frame and controlled by the chiller standalone control system if not connected to end user building automation system.



## 80 to 500 Ton RTAA/RTAC

**Table 122. Cooling capacity (tons)**

Leaving Water Temp	Propylene Glycol (%)	Estimated Capacity (Tons) at 2.4 GPM / Nominal Ton				
		Ambient Air Temp				
		85°F	95°F	105°F	115°F	125°F
60°F	0	277.9	258.9	236.7	205.8	152.6
55°F	0	257.5	240.2	220.7	195.3	150.3
50°F	0	237.7	221.7	203.6	184.5	147.2
45°F	0	218.4	203.6	187.1	169.1	143.4
40°F	0	199.8	186.2	171.1	154.3	136.7
35°F	10 <sup>(a)</sup>	181.2	168.8	155.0	139.4	123.0
30°F	20 <sup>(a)</sup>	161.5	150.4	138.0	123.8	108.8
25°F	25 <sup>(a)</sup>	140.9	131.3	120.4	107.8	94.3
20°F	30 <sup>(b)</sup>	129.7	120.6	110.1	97.9	84.9

(a) Performance based on using propylene glycol solution for antifreeze protection.

(b) Performance based on using ethylene glycol for antifreeze protection.

**Table 123. Water flow rates and pressure drops**

Flow Rate (GPM)	Pressure Drop (ft. H <sub>2</sub> O)
217 (min flow)	3.37
300	6.27
350	8.36
400	10.70
450	13.20
500	16.00
550	19.00
600	22.20
650	25.70
700	29.50
750	33.50
796 (max flow)	37.40

*Note: Maximum water side pressure is 150 psi (2.31 ft. H<sub>2</sub>O = 1 psi).*

## General – CSCA0200F0

**Table 124. Dimensions and weights**

Labels	Value
Length	25 ft.
Width	8 ft. 5 in.
Height	8 ft. 6 in.
Shipping Weight (lbs)	16,650
Operating Weight (lbs)	18,333
Fork Pocket Dimensions	9.25 in. x 5.25 in. x 7 ft. 8 in.

**Table 124. Dimensions and weights (continued)**

Labels	Value
Fork Pocket Center to Center Distance	4 ft. 6 in.

**Notes:**

1. Lifting device: forklift or crane.
2. All weights and dimensions listed above are subject to change without notice or liability.

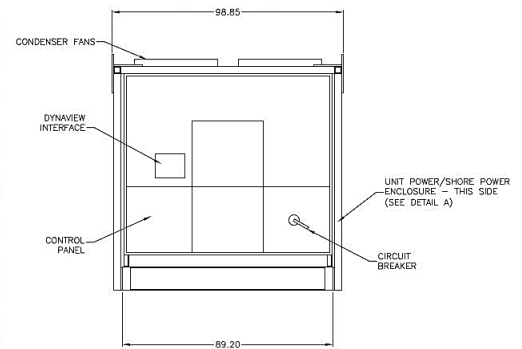
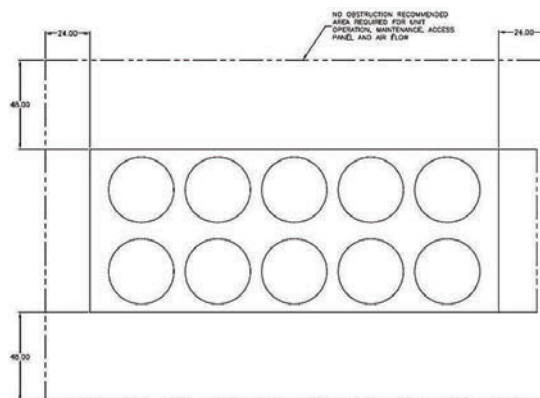
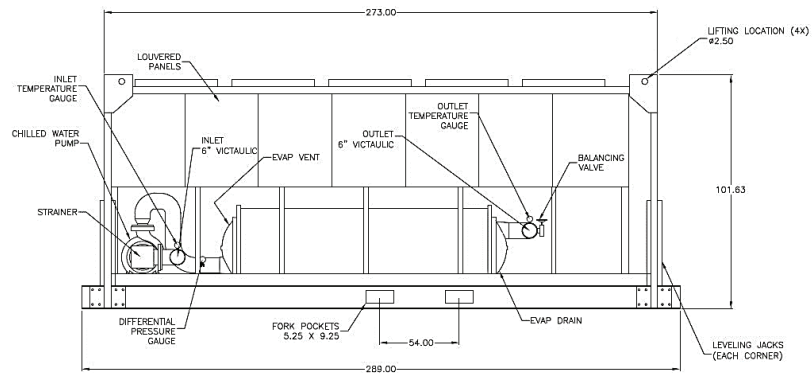
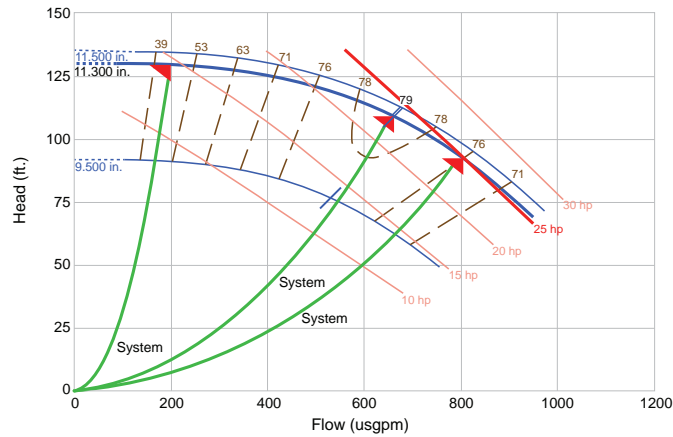



**General – CSCA0200F2**

**Table 125. Dimensions and weights**

Labels	Value
Length	22 ft. 6 in.
Width	8 ft. 4.5 in.
Operating Width (Leveling Jacks Installed)	10 ft. 2 in.
Height	8 ft. 6 in.
Shipping Weight (lbs)	16,800
Operating Weight (lbs)	17,150
Fork Pocket Dimensions	9.25 in. x 5.25 in. x 7 ft. 8 in.
Fork Pocket Center to Center Distance	5 ft.

**Notes:**

1. *Lifting device: forklift or crane.*
2. *All weights and dimensions listed above are subject to change without notice or liability.*

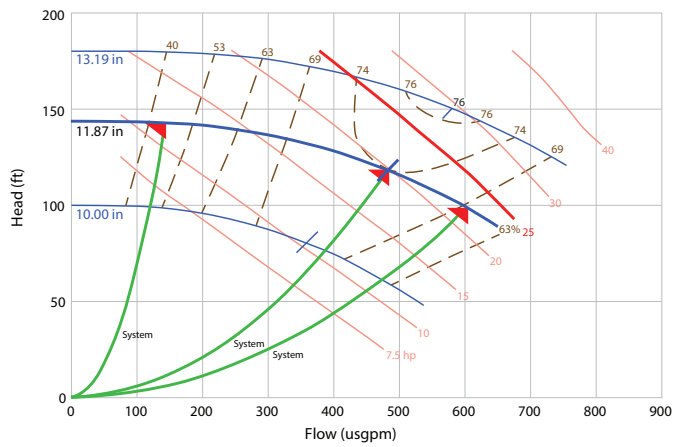

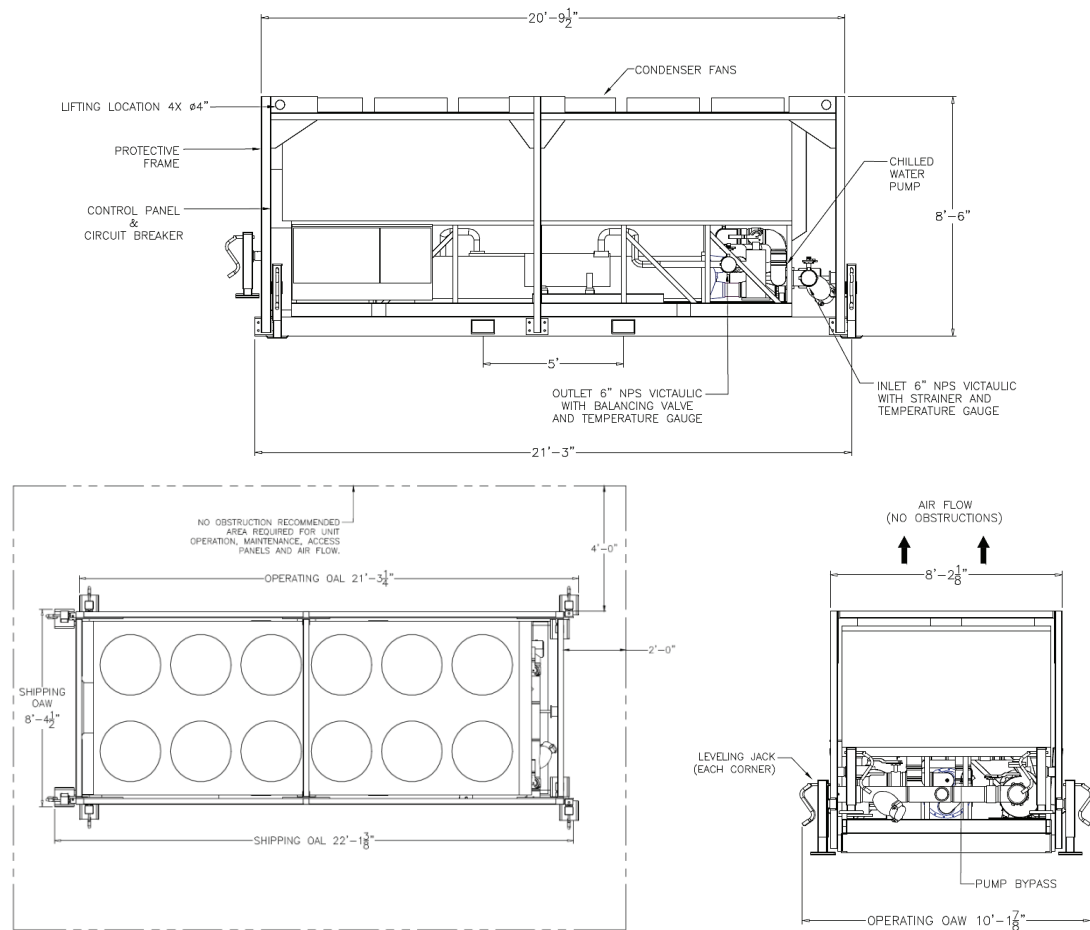

### General – CSCA0200F3

**Table 126. Dimensions and weights**

Labels	Value
Length	22 ft. 6 in.
Width	8 ft. 4.5 in.
Operating Width (Leveling Jacks Installed)	10 ft. 2 in.
Height	8 ft. 6 in.
Shipping Weight (lbs)	20,750
Operating Weight (lbs)	22,400
Fork Pocket Dimensions	9.25 in. x 5.25 in. x 7 ft. 8 in.
Fork Pocket Center to Center Distance	5 ft.

**Notes:**

1. *Lifting device: forklift or crane.*
2. *All weights and dimensions listed above are subject to change without notice or liability.*



## 80 to 500 Ton RTAA/RTAC

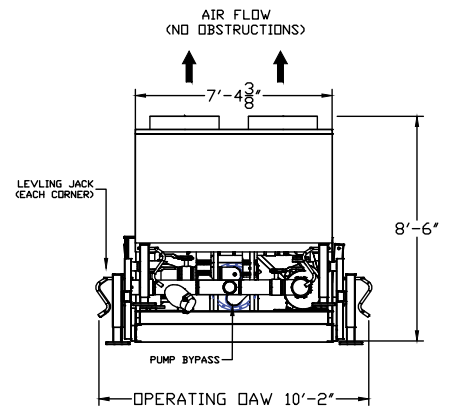
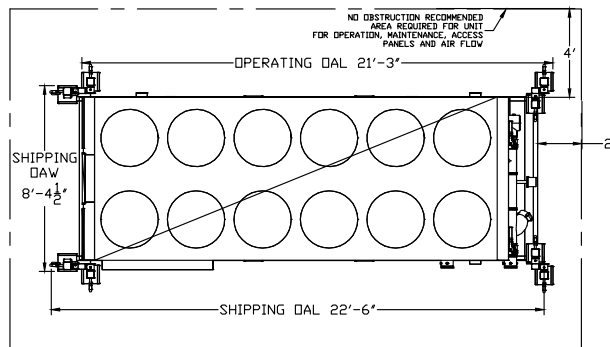
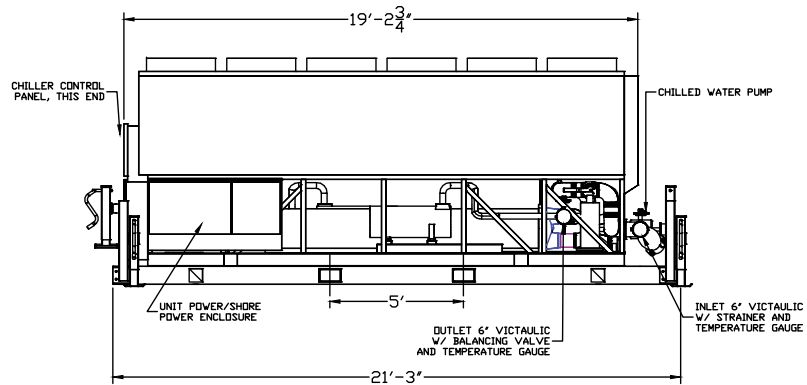
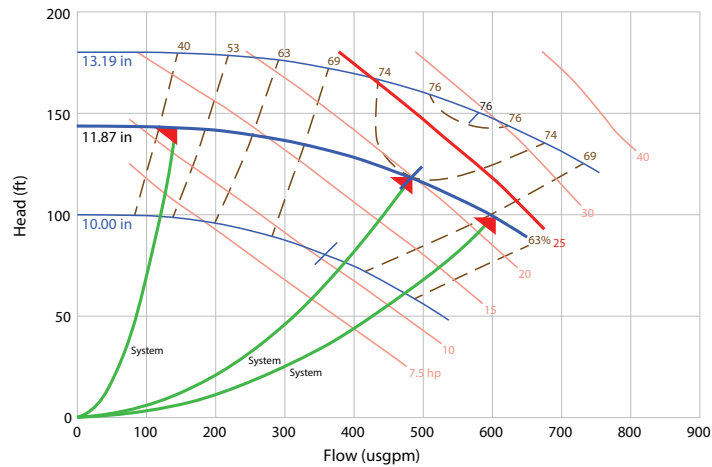

## 250 Ton Air-Cooled RTAC

Table 127. General – CSPA0250F0-F3

Labels	Value
Model Number	RTAC250
Nominal Tons	250
Refrigerant	R-134a
Refrigerant Charge <sup>(a)</sup>	235–235 lbs
Water Connection Size	6 in. Victaulic
Ambient Operating Conditions	0°F to 125°F

**Table 127. General – CSCA0250F0-F3 (continued)**

Labels	Value
Chilled Water Setpoint Limits <sup>(b) (c)</sup>	20°F to 65°F
Evaporation Configuration	2 pass
Number of Electrical Circuits	1
Number of Refrigerant Circuits	2

- (a) Data containing information on two circuits is shown as follows: ckt 1/ ckt 2.  
 (b) When leaving solution is below 40°F a glycol solution is required for all low temperature and ice-making applications.  
 (c) Have engineering validate performance for applications that require 60°F and above supply leaving water temperatures.

**Table 128. Electrical data**

Labels	Value
Voltage	460V 3-Phase
Frequency	60 Hz
F0 Power Supply Connections <sup>(a) (b)</sup>	Lugs or Series 16 Cam-Type Connections
F2-F3 Power Supply Connections <sup>(b)</sup>	Series 16 Cam-Type Connections Only
<b>Without Integral Pump</b>	
Minimum Circuit Ampacity (MCA)	495 A
Maximum Overcurrent Protection (MOP)	600 A
Full Load Amps (FLA)	442 A
<b>With Integral Pump</b>	
Minimum Circuit Ampacity (MCA)	548 A
Maximum Overcurrent Protection (MOP)	700 A
Full Load Amps (FLA)	495 A

**Note:** For additional electrical information, contact Trane Rental Services.

- (a) Maximum wire size lug(s) can accept - 600 MCM.  
 (b) Depending on chiller MCA and wire used, multiple wires per phase may be required.

**Table 129. Pump data – CSCA0250F0<sup>(a)</sup>**

Labels	Value
Horsepower	40 HP
Min Flow	259 gpm @ 116.9 ft.
Max Flow	1253.6 gpm @ 82.7 ft.

- (a) Pump is mounted within the chiller frame and controlled by the chiller standalone control system if not connected to end user building automation system.

**Table 130. Pump data – CSCA0250F2-F3<sup>(a)</sup>**

Labels	Value
Horsepower	30 HP
Min Flow	210 gpm @ 123 ft.
Max Flow	874 gpm @ 84 ft.

- (a) Pump is mounted within the chiller frame and controlled by the chiller standalone control system if not connected to end user building automation system.



## 80 to 500 Ton RTAA/RTAC

**Table 131. Cooling capacity (tons)**

Leaving Water Temp	Propylene Glycol (%)	Estimated Capacity (Tons) at 2.4 GPM / Nominal Ton				
		Ambient Air Temp				
		85°F	95°F	105°F	115°F	125°F
60°F	0	336.0	312.7	279.0	244.2	180.5
55°F	0	310.9	289.9	265.8	231.2	175.4
50°F	0	286.5	267.5	245.8	218.9	172.1
45°F	0	263.0	245.6	226.0	204.8	168.4
40°F	0	240.5	224.5	206.7	187.1	164.3
35°F	10 <sup>(a)</sup>	218.3	203.7	187.6	169.5	150.5
30°F	20 <sup>(a)</sup>	196.4	183.2	168.6	152.1	134.6
25°F	25 <sup>(a)</sup>	174.1	162.4	149.4	134.4	118.5
20°F	30 <sup>(b)</sup>	158.9	148.0	135.7	121.5	106.5

**Note:** Contact Trane Rental Services for low temperature applications.

<sup>(a)</sup> Performance based on using propylene glycol solution for antifreeze protection.

<sup>(b)</sup> Performance based on using ethylene glycol for antifreeze protection.

**Table 132. Water flow rates and pressure drops**

Flow Rate (GPM)	Pressure Drop (ft. H <sub>2</sub> O)
217 (min flow)	3.65
300	6.78
350	9.02
400	11.50
450	14.30
500	17.30
550	20.50
600	24.00
650	27.80
700	31.80
750	36.10
796 (max flow)	40.40

**Note:** Maximum water side pressure is 150 psi (2.31 ft. H<sub>2</sub>O = 1 psi).

## General – CSCA0250F0

**Table 133. Dimensions and weights**

Labels	Value
Length	27 ft. 1 in.
Width	8 ft. 5 in.
Height	8 ft. 6 in.
Shipping Weight (lbs)	18,700
Operating Weight (lbs)	19,300

**Table 133. Dimensions and weights (continued)**

Labels	Value
Fork Pocket Dimensions	9.25 in. x 5.25 in. x 7 ft. 8 in.
Fork Pocket Center to Center Distance	4 ft. 6 in.

**Notes:**

1. Lifting device: forklift or crane.
2. All weights and dimensions listed above are subject to change without notice or liability.

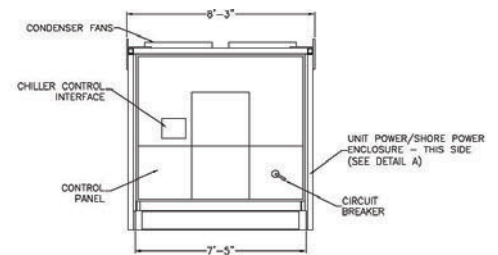
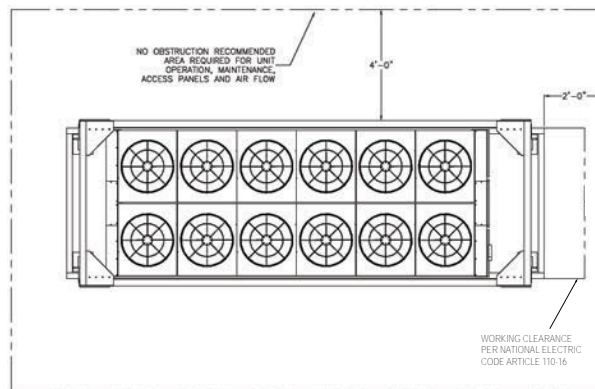
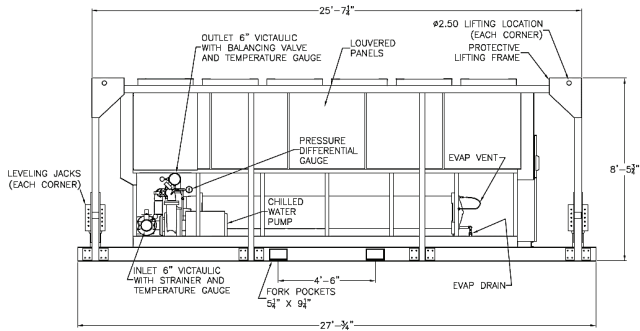
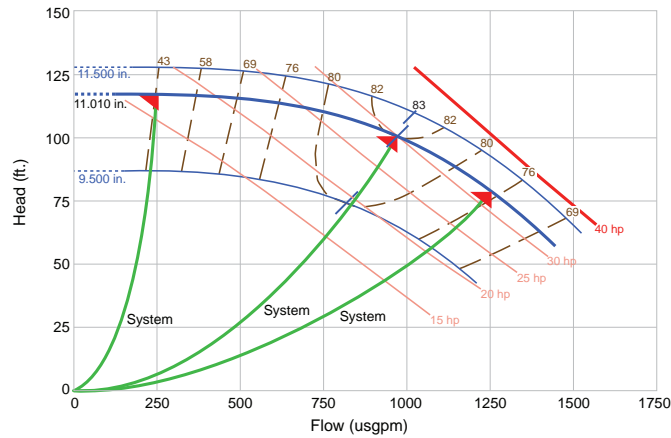



80 to 500 Ton RTAA/RTAC

General – CSCA0250F2

Table 134. Dimensions and weights

Labels	Value
Length	25 ft. 3.25 in.
Width	8 ft. 4.5 in.
Operating Width (Leveling Jacks Installed)	10 ft. 2 in.
Height	8 ft. 6 in.
Shipping Weight (lbs)	24,000
Operating Weight (lbs)	24,600
Fork Pocket Dimensions	9.25 in. x 5.25 in. x 7 ft. 8 in.
Fork Pocket Center to Center Distance	5 ft.

Notes:

1. Lifting device: forklift or crane.
2. All weights and dimensions listed above are subject to change without notice or liability.

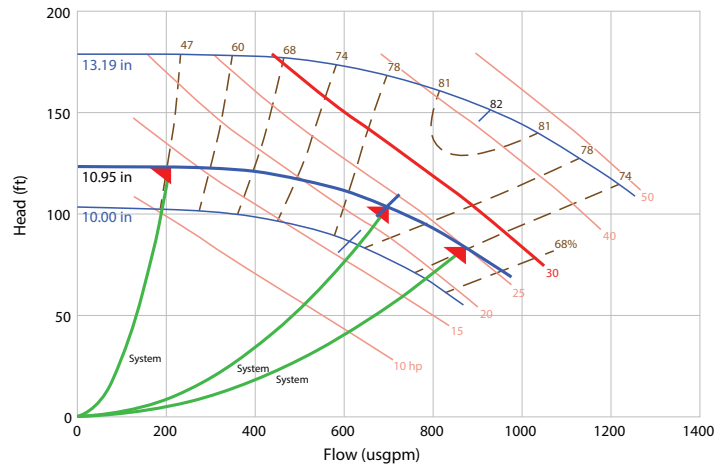

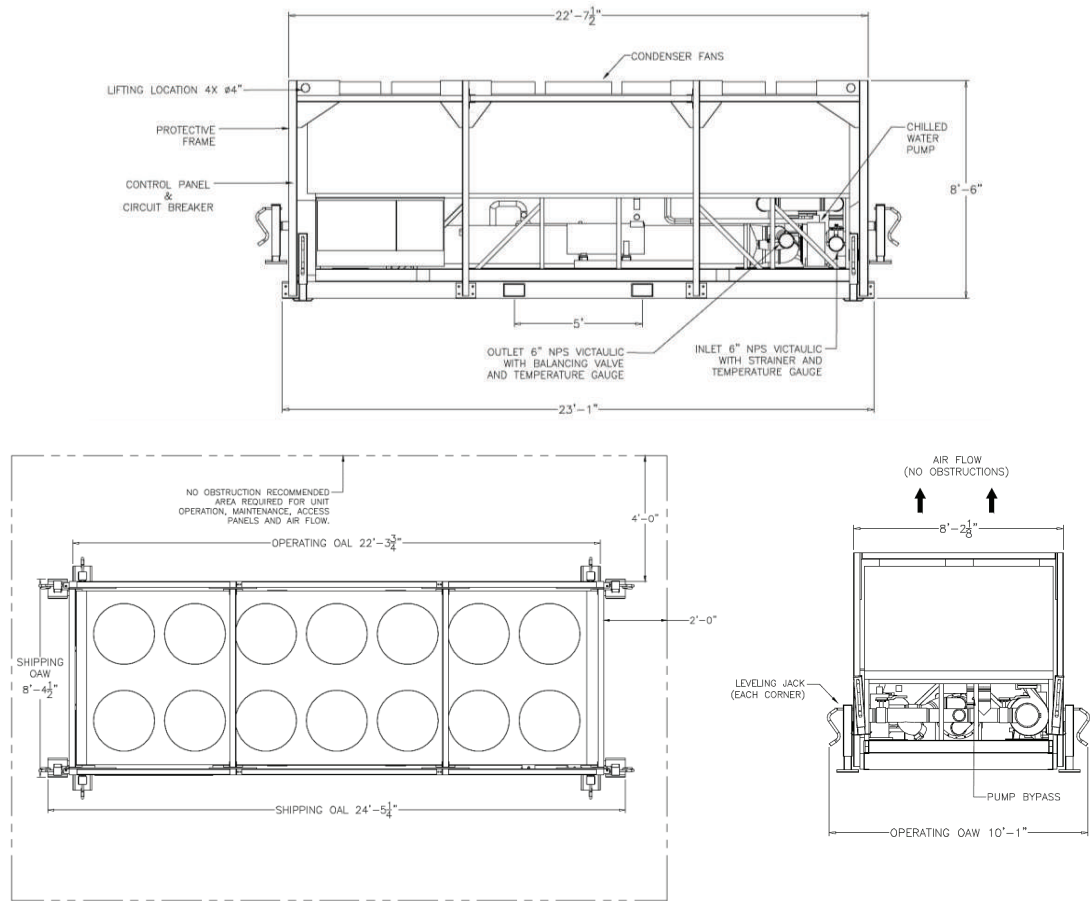

### General – CSCA0250F3

**Table 135. Dimensions and weights**

Labels	Value
Length	25 ft. 3.25 in.
Width	8 ft. 4.5 in.
Operating Width (Leveling Jacks Installed)	10 ft. 2 in.
Height	8 ft. 6 in.
Shipping Weight (lbs)	23,000
Operating Weight (lbs)	23,600
Fork Pocket Dimensions	9.25 in. x 5.25 in. x 7 ft. 8 in.
Fork Pocket Center to Center Distance	5 ft.

**Notes:**

1. *Lifting device: forklift or crane.*
2. *All weights and dimensions listed above are subject to change without notice or liability.*

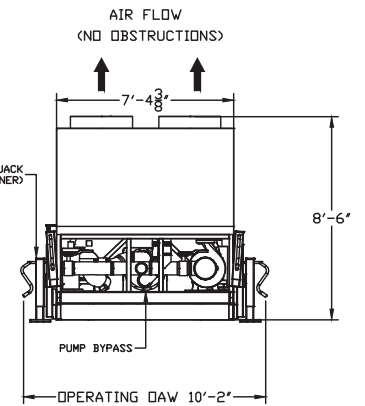
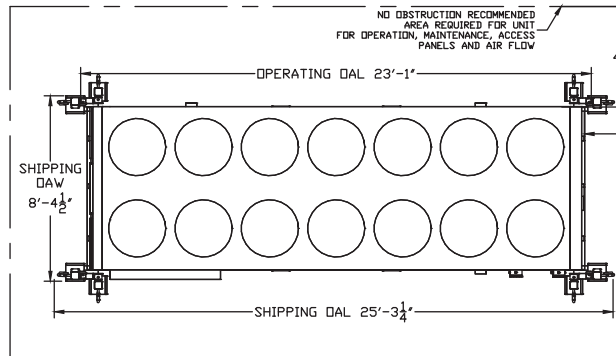
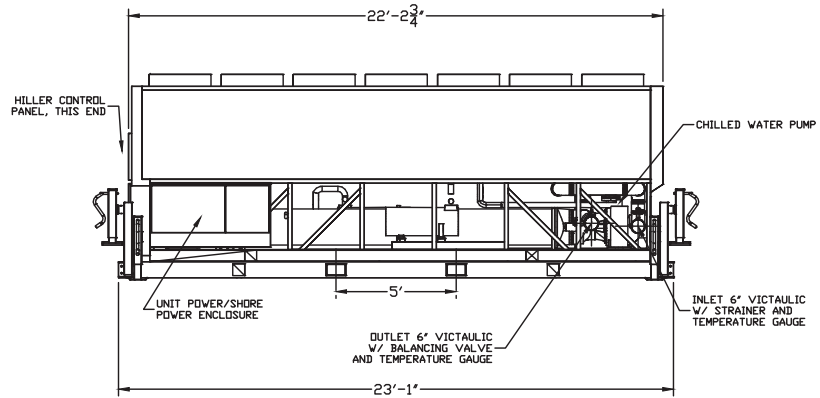
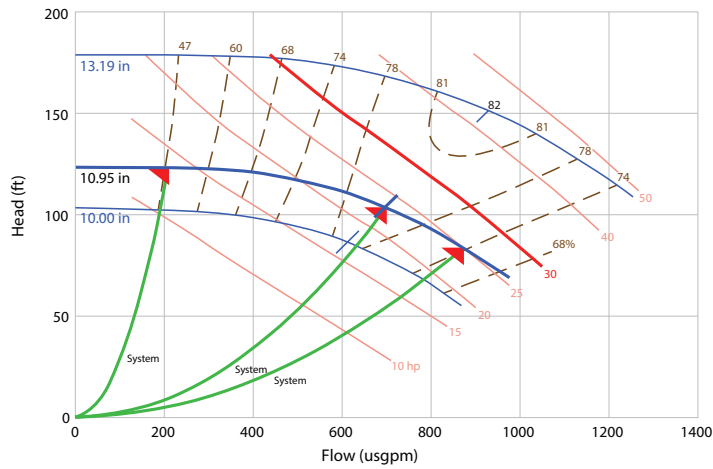

### 300 Ton Air-Cooled RTAA

Table 136. General – CSPA0300F0

Labels	Value
Model Number	RTAA300
Nominal Tons	300
Refrigerant	R-22
Refrigerant Charge <sup>(a)</sup>	540 lbs
Water Connection Size	6 in.
Ambient Operating Conditions	0°F to 125°F

**Table 136. General – CSCA0300F0 (continued)**

Labels	Value
Chilled Water Setpoint Limits <sup>(b) (c)</sup>	0°F to 65°F
Number of Electrical Circuits	1
Number of Refrigerant Circuits	2

<sup>(a)</sup> Setpoints are to be used only as a guide. Selection is required for actual chiller performance.

<sup>(b)</sup> Several of the RTAA300s are permanently set-up for single point electrical connections or dual point electrical connections only. Contact Trane Rental Services with any questions regarding chiller to be supplied.

<sup>(c)</sup> Depending on chiller MCA and wire used, multiple wires per phase may be required.

**Table 137. Electrical data – single point**

Labels	Value
Voltage	460V 3-Phase
Frequency	60 Hz
Maximum Wire Size Lug(s) can accept <sup>(a)</sup>	600 MCM
Minimum Circuit Ampacity (MCA)	589 A
Maximum Overcurrent Protection (MOP)	700 A
Full Load Amps (FLA)	548 A

**Note:** For additional electrical information, contact Trane Rental Services.

<sup>(a)</sup> Depending on chiller MCA and wire used, multiple wires per phase may be required.

**Table 138. Electrical data – dual point**

Labels	Value
Minimum Circuit Ampacity (MCA)	406/224 A
Maximum Overcurrent Protection (MOP)	500/350 A
Full Load Amps (FLA)	365/183 A

**Note:** For additional electrical information, contact Trane Rental Services.

**Table 139. Cooling capacity (tons)**

Leaving Chilled Water Temperature	Outdoor Ambient Temperature		
	85°F	95°F	105°F
44°F	299.8	284.9	269.8

**Note:** Contact Trane Rental Services for low temperature applications.

**Table 140. Water flow rates**

	Minimum	Standard	Maximum
Evaporator Flow	360 gpm	681.7 gpm	1080 gpm
Pressure Drop	6.3 ft.	18.2 ft.	50.1 ft.

**Note:** Maximum water side pressure is 150 psi (2.31 ft. H<sub>2</sub>O = 1 psi).



## 80 to 500 Ton RTAA/RTAC

### General – CSCA0300F0

**Table 141. Dimensions and weights**

	Chiller	Trailer	Overall (Chiller and Trailer)
Length	36 ft. 5 in.	48 ft. 0 in.	48 ft. 0 in.
Width	7 ft. 9 in.	8 ft. 6 in.	8 ft. 6 in.
Height	8 ft. 0 in.	4 ft. 7 in.	12 ft. 7 in.
Shipping Weight <sup>(a)</sup> (lbs)	19,740	14,760	34,500
Operating Weight (lbs)	20,865	—	—

**Note:** Chiller is permanently mounted to trailer.

<sup>(a)</sup> Refer to trailer and overall dimensions

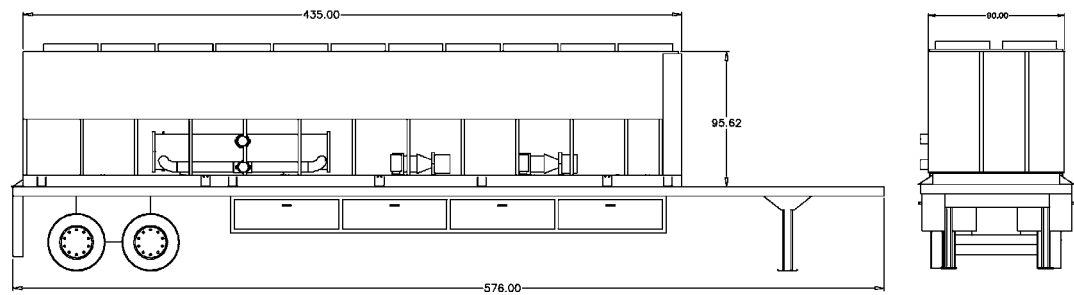

## 300 Ton Air-Cooled RTAC

**Table 142. General – CSCA0300F0**

Labels	Value
Model Number	RTAC300
Nominal Tons	300
Refrigerant	R-134a
Refrigerant Charge <sup>(a)</sup>	415/200 lbs
Water Connection Size	6 in. Victaulic
Ambient Operating Conditions	0°F to 125°F
Chilled Water Setpoint Limits <sup>(b) (c)</sup>	20°F to 65°F
Evaporation Configuration	2 pass
Number of Electrical Circuits	1
Number of Refrigerant Circuits	2

<sup>(a)</sup> Data containing information on two circuits is shown as follows: ckt 1/ ckt 2.

<sup>(b)</sup> When leaving solution is below 40°F a glycol solution is required for all low temperature and ice-making applications.

<sup>(c)</sup> Have engineering validate performance for applications that require 60°F and above supply leaving water temperatures.

**Table 143. Electrical data**

Labels	Value
Voltage	460V 3-phase
Frequency	60 Hz
Maximum Wire Size Lug(s) Can Accept <sup>(a)</sup>	600 MCM
<b>Single Point - With Integral Pump</b>	

**Table 143. Electrical data (continued)**

Labels	Value
Minimum Circuit Ampacity (MCA)	678 A
Maximum Overcurrent Protection (MOP)	800 A
Full Load Amps (FLA)	635 A
<b>Single Point - Without Integral Pump</b>	
Minimum Circuit Ampacity (MCA)	606 A
Maximum Overcurrent Protection (MOP)	700 A
Full Load Amps (FLA)	563 A
<b>Dual Point - With Integral Pump</b>	
Minimum Circuit Ampacity (MCA) (circuit 1/circuit 2)	423/288 A
Maximum Overcurrent Protection (MOP) (circuit 1/circuit 2)	500/450 A
Full Load Amps (FLA) (circuit 1/circuit 2)	377/246 A
<b>Dual Point - Without Integral Pump</b>	
Minimum Circuit Ampacity (MCA) (circuit 1/circuit 2)	423/228 A
Maximum Overcurrent Protection (MOP) (circuit 1/circuit 2)	500/350 A
Full Load Amps (FLA) (circuit 1/circuit 2)	377/186 A

(a) Depending on chiller MCA and wire used, multiple wires per phase may be required.

**Table 144. Pump data – CSCA0300F0<sup>(a)</sup>**

Labels	Value
Horsepower	50 HP
Min Flow	280 gpm @ 161 ft.
Max Flow	1167.5 gpm @ 117 ft.

(a) Pump is mounted within the chiller frame and controlled by the chiller standalone control system if not connected to end user building automation system.

**Table 145. Cooling capacity (tons)**

Leaving Water Temp	Propylene Glycol (%)	Estimated Capacity (Tons) at 2.4 GPM / Nominal Ton				
		Ambient Air Temp				
		85°F	95°F	105°F	115°F	125°F
60°F	0	419.0	389.9	353.7	308.4	225.4
55°F	0	388.3	361.7	332.2	292.0	221.9
50°F	0	358.4	334.0	306.5	277.0	217.4
45°F	0	329.3	307.0	281.5	254.4	212.2
40°F	0	301.3	280.7	257.3	232.0	205.4
35°F	10 <sup>(a)</sup>	273.3	254.5	233.2	209.6	184.9
30°F	20 <sup>(a)</sup>	244.2	227.3	208.1	186.6	163.8
25°F	25 <sup>(a)</sup>	214.0	199.3	182.3	162.9	142.3
20°F	30 <sup>(b)</sup>	196.1	182.3	165.9	147.4	127.7

(a) Performance based on using propylene glycol solution for antifreeze protection.

(b) Performance based on using ethylene glycol for antifreeze protection.



**80 to 500 Ton RTAA/RTAC**

**Table 146. Water flow rates and pressure drops**

Flow Rate (GPM)	Pressure Drop (ft. H <sub>2</sub> O)
400	5.83
500	8.84
600	12.30
700	16.30
800	20.70
900	25.60
1000	31.00
1100	37.00
1134 (max flow)	39.20

*Note: Maximum water side pressure is 150 psi (2.31 ft. H<sub>2</sub>O = 1 psi).*

**General – CSCA0300F0**

**Table 147. Dimensions and weights**

Chiller Only	
Labels	Value
Length	36 ft.
Width	8 ft. 1 in.
Height	8 ft.
Shipping Weight (lbs)	23,400
Operating Weight (lbs)	25,400
Trailer	
Labels	Value
Length	48 ft.
Width	8 ft. 6 in.
Height	5 ft. 0.25 in.
Shipping Weight (lbs)	14,760

**Notes:**

1. *Lifting device: forklift or crane.*
2. *All weights and dimensions listed above are subject to change without notice or liability.*

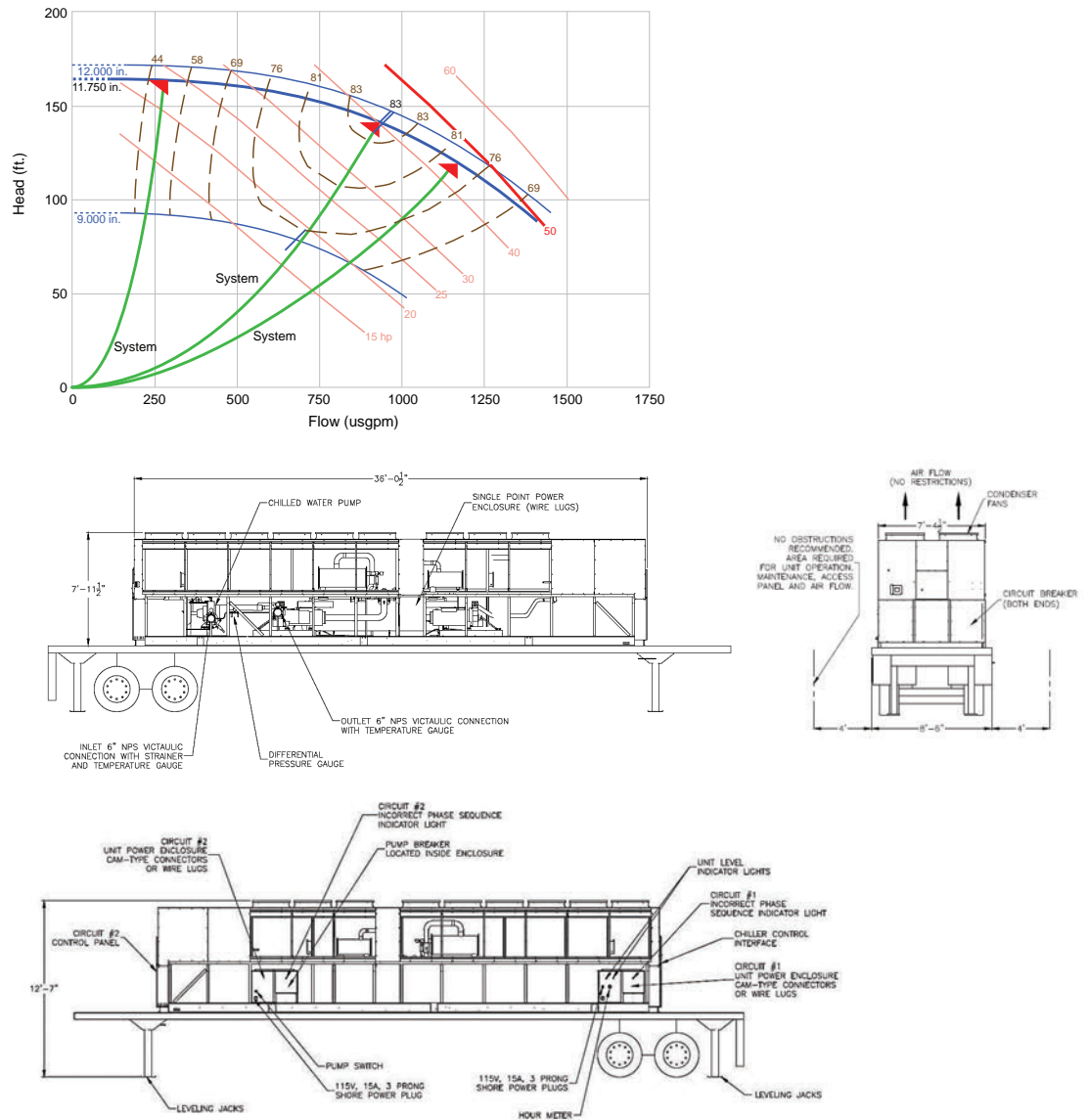
**Table 148. General – CSCA0300F2-F3**

Labels	Value
Model Number	RTAC300
Nominal Tons	300
Refrigerant	R-134a
Refrigerant Charge <sup>(a)</sup>	415/200 lbs
Water Connection Size	6 in. Victaulic
Ambient Operating Conditions	0°F to 125°F
Chilled Water Setpoint Limits <sup>(b) (c)</sup>	20°F to 65°F
Evaporation Configuration	2 pass
Number of Electrical Circuits	1
Number of Refrigerant Circuits	2

(a) Data containing information on two circuits is shown as follows: ckt 1/ ckt 2.

(b) When leaving solution is below 42°F a glycol solution is required for all low temperature and ice-making applications.

(c) Have engineering validate performance for applications that require 60°F and above supply leaving water temperatures.



## 80 to 500 Ton RTAA/RTAC

**Table 149. Electrical data – Dual point only**

Labels	Value
Voltage	460V 3-Phase
Frequency	60 Hz
Power Supply Connections <sup>(a)</sup>	Series 16 Cam-Type Connections Only
<b>Without Integral Pump</b>	
Minimum Circuit Ampacity (MCA) (circuit 1/circuit 2)	482/231 A
Maximum Overcurrent Protection (MOP) (circuit 1/circuit 2)	600/350 A
Full Load Amps (FLA) (circuit 1/circuit 2)	434/185 A
<b>With Integral Pump</b>	
Minimum Circuit Ampacity (MCA) (circuit 1/circuit 2)	417/231 A
Maximum Overcurrent Protection (MOP) (circuit 1/circuit 2)	500/350 A
Full Load Amps (FLA) (circuit 1/circuit 2)	369/185 A

**Note:** For additional electrical information, contact Trane Rental Services.

<sup>(a)</sup> Depending on chiller MCA and wire used, multiple wires per phase may be required.

**Table 150. Pump data – CSCA0300F2-F3<sup>(a)</sup>**

Labels	Value
Horsepower	50 HP
Min Flow	357 gpm @ 142 ft.
Max Flow	1488 gpm @ 84 ft.

<sup>(a)</sup> Pump is mounted within the chiller frame with a bypass and controlled by the chiller standalone control system if not connected to end user building automation system.

**Table 151. Cooling capacity (tons)**

Leaving Water Temp	Propylene Glycol (%)	Estimated Capacity (Tons) at 2.4 GPM / Nominal Ton				
		Ambient Air Temp				
		85°F	95°F	105°F	115°F	125°F
60°F	0	419.0	389.9	353.7	308.4	225.4
55°F	0	388.3	361.7	332.2	292.0	221.9
50°F	0	358.4	334.0	306.5	277.0	217.4
45°F	0	329.3	307.0	281.5	254.4	212.2
40°F	0	301.3	280.7	257.3	232.0	205.4
35°F	10 <sup>(a)</sup>	273.3	254.5	233.2	209.6	184.9
30°F	20 <sup>(a)</sup>	244.2	227.3	208.1	186.6	163.8
25°F	25 <sup>(a)</sup>	214.0	199.3	182.3	162.9	142.3
20°F	30 <sup>(b)</sup>	196.1	182.3	165.9	147.4	127.7

<sup>(a)</sup> Performance based on using propylene glycol solution for antifreeze protection.

<sup>(b)</sup> Performance based on using ethylene glycol for antifreeze protection.

**Table 152. Water flow rates and pressure drops**

Flow Rate (GPM)	Pressure Drop (ft. H <sub>2</sub> O)
309 (min flow)	3.55
400	5.83
500	8.84
600	12.30
700	16.30
800	20.70
900	25.60
1000	31.00
1100	37.00
1134 (max flow)	39.20

*Note: Maximum water side pressure is 150 psi (2.31 ft. H<sub>2</sub>O = 1 psi).*

## General – CSCA0300F2-F3

**Table 153. Dimensions and weights**

Chiller Only	
Labels	Value
Length	36 ft. 2.25 in.
Width	8 ft. 6 in.
Height	8 ft.
Shipping Weight (lbs)	28,000
Operating Weight (lbs)	30,049
Trailer	
Labels	Value
Length	48 ft.
Width	8 ft. 6 in.
Height	5 ft. 0.25 in.
Shipping Weight (lbs)	14,760

**Notes:**

1. *Lifting device: forklift or crane.*
2. *All weights and dimensions listed above are subject to change without notice or liability.*

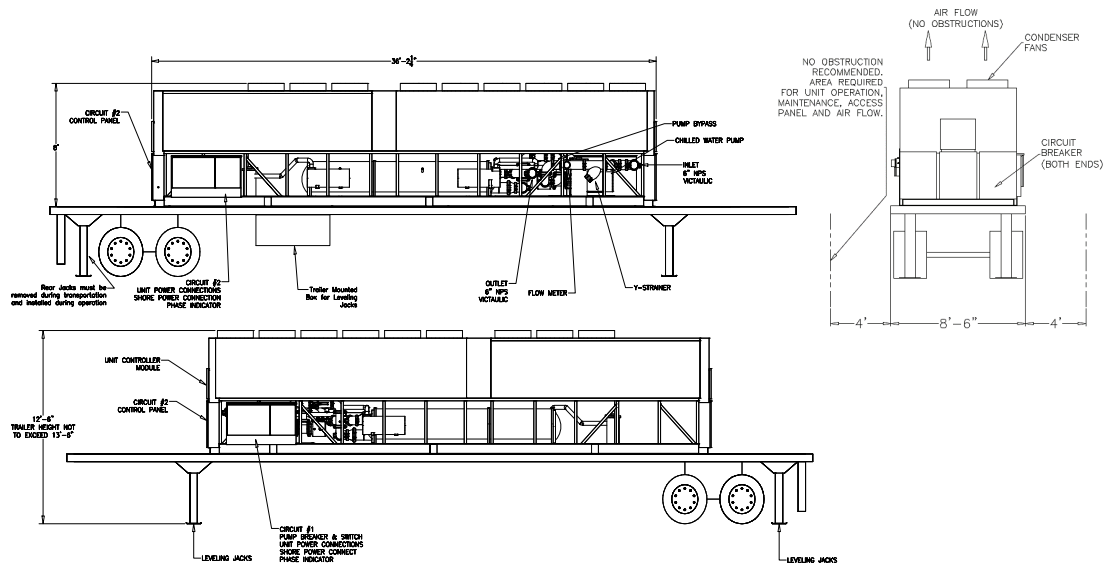
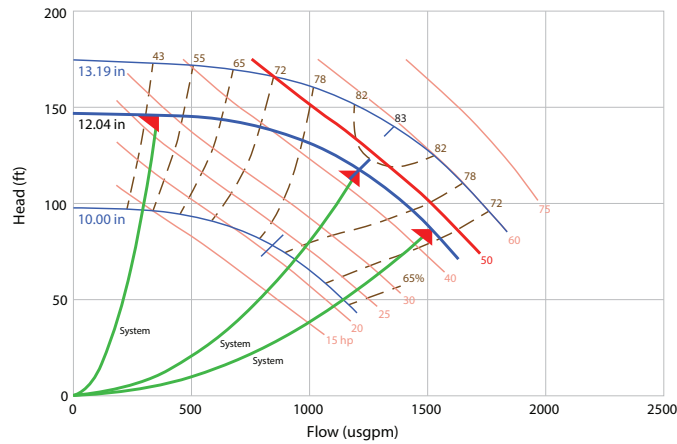

## 400 Ton Air-Cooled RTAA

Table 154. General – CSCA0400F0

Labels	Value
Model Number	RTAA400
Nominal Tons	400
Refrigerant	R-22
Refrigerant Charge	415/415 lbs
Water Connection Size	6 in. Victaulic
Ambient Operating Conditions	0°F to 125°F
Chilled Water Setpoint Limits <sup>(a)</sup>	10°F to 65°F
Number of Electrical Circuits <sup>(b)</sup>	2
Number of Refrigerant Circuits	2

**Note:** Selection is required for actual chiller performance.

- (a) Setpoints are to be used only as a guide.
- (b) Several of the RTAA400s are permanently set-up for single point electrical connections or dual point electrical connections only. Contact Trane Rental Services with any questions regarding chiller to be supplied.

**Table 155. Electrical data – Single point**

Labels	Value
Voltage	460V 3-Phase
Frequency	60 Hz
Maximum Wire Size Lug(s) can accept <sup>(a)</sup>	350 MCM
<b>Single Point - With Integral Pump</b>	
Minimum Circuit Ampacity (MCA)	830 A
Maximum Overcurrent Protection (MOP)	1000 A
Full Load Amps (FLA)	790 A
<b>Single Point - Without Integral Pump</b>	
Minimum Circuit Ampacity (MCA)	774 A
Maximum Overcurrent Protection (MOP)	800 A
Full Load Amps (FLA)	734 A
<b>Dual Point</b>	
Voltage	460V 3-phase
Frequency	60 Hz
Maximum Wire Size Lug(s) can accept <sup>(a)</sup>	600 MCM
<b>Dual Point - With Integral Pump</b>	
Minimum Circuit Ampacity (MCA) (circuit 1/circuit 2)	468/406 A
Maximum Overcurrent Protection (MOP) (circuit 1/circuit 2)	500/500 A
Full Load Amps (FLA) (circuit 1/circuit 2)	424/366 A
<b>Dual Point - Without Integral Pump</b>	
Minimum Circuit Ampacity (MCA) (circuit 1/circuit 2)	406/406 A
Maximum Overcurrent Protection (MOP) (circuit 1/circuit 2)	500/500 A
Full Load Amps (FLA) (circuit 1/circuit 2)	366/366 A

**Note:** For additional electrical information, contact Trane Rental Services.

<sup>(a)</sup> Depending on chiller MCA and wire used, multiple wires per phase may be required.

**Table 156. Pump data<sup>(a)</sup>**

Labels	Value
Horsepower	50 HP
Min Flow	280 gpm @ 161 ft.
Max Flow	1167.5 gpm @ 117 ft.

<sup>(a)</sup> Pump is mounted within the chiller.

**Table 157. Cooling capacity ( tons)**

Leaving Chilled Water Temperature	Outdoor Ambient Temperature		
	85°F	95°F	105°F
44°F	402.2	382.3	362.1

**Note:** Contact Trane Rental Services for low temperature applications.

**Table 158. Water flow rates**

	Minimum	Standard	Maximum
Evaporator Flow	480 gpm	914.8 gpm	1440 gpm
Pressure Drop	7.4 ft.	21.9 ft.	59.6 ft.

*Note: Maximum water side pressure is 150 psi (2.31 ft. H<sub>2</sub>O = 1 psi).*

**General – CSCA0400F0**
**Table 159. Dimensions and weights**

	Chiller <sup>(a)</sup>	Trailer	Overall (Chiller and Trailer)
Length	45 ft. 5 in.	48 ft. 0 in.	48 ft. 0 in.
Width	7 ft. 11 in.	8 ft. 6 in.	8 ft. 6 in.
Height	8 ft. 0 in.	4 ft. 7 in.	12 ft. 7 in.
Shipping Weight (lbs)	25,200	14,760	39,960
Operating Weight (lbs)	26,100	—	—

*Note: Chiller is permanently mounted to trailer.*

<sup>(a)</sup> Refer to trailer and overall dimensions.

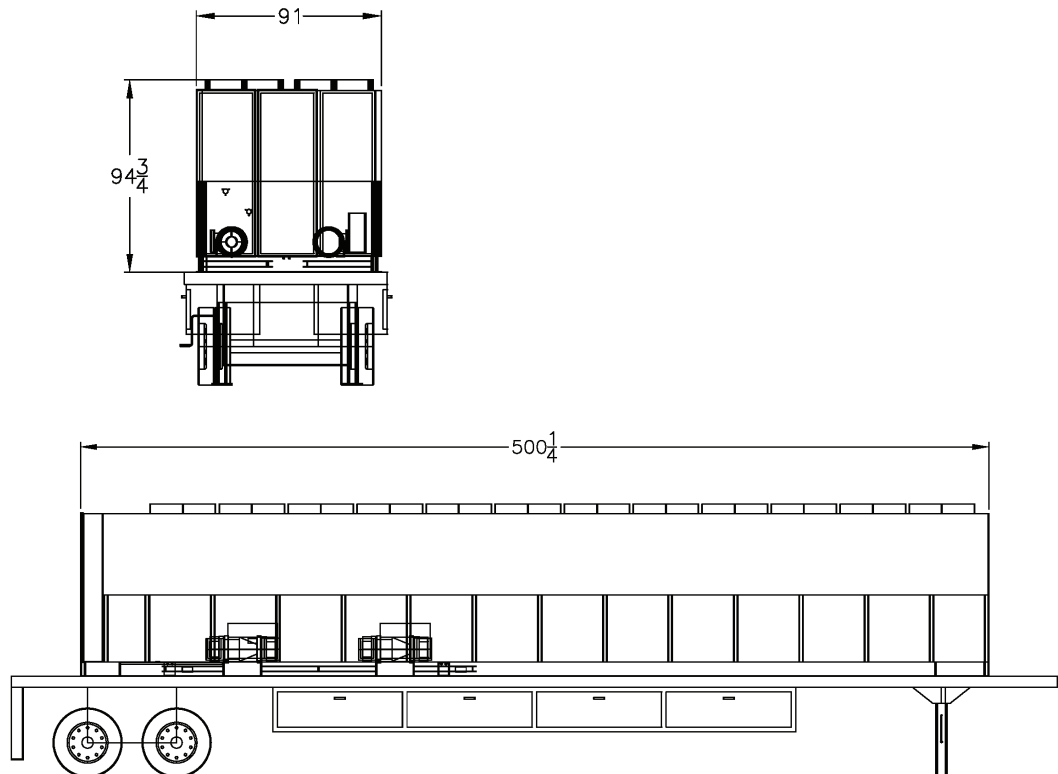

## 400 Ton Air-Cooled RTAC

**Table 160. General – CSCA0400F0**

Labels	Value
Model Number	RTAC400
Nominal Tons	400
Refrigerant	R-134a
Refrigerant Charge <sup>(a)</sup>	415/415 lbs
Water Connection Size	6 in. Victaulic
Ambient Operating Conditions	0°F to 125°F
Chilled Water Setpoint Limits <sup>(b) (c)</sup>	20°F to 65°F
Evaporation Configuration	2 pass
Number of Electrical Circuits	2
Number of Refrigerant Circuits	2

<sup>(a)</sup> Data containing information on two circuits is shown as follows: ckt 1/ ckt 2.

<sup>(b)</sup> When leaving solution is below 40°F a glycol solution is required for all low temperature and ice-making applications.

<sup>(c)</sup> Have engineering validate performance for applications that require 60°F and above supply leaving water temperatures.

**Table 161. Electrical data**

Labels	Value
Voltage	460V 3-Phase
Frequency	60 Hz
Maximum Wire Size Lug(s) Can Accept <sup>(a)</sup>	600 MCM
<b>Single Point - With Integral Pump</b>	
Minimum Circuit Ampacity (MCA)	855 A
Maximum Overcurrent Protection (MOP)	1000 A
Full Load Amps (FLA)	812 A
<b>Single Point - Without Integral Pump</b>	
Minimum Circuit Ampacity (MCA)	792 A
Maximum Overcurrent Protection (MOP)	800 A
Full Load Amps (FLA)	750 A
<b>Dual Point - With Integral Pump</b>	
Minimum Circuit Ampacity (MCA) (circuit 1/circuit 2)	417/474 A
Maximum Overcurrent Protection (MOP) (circuit 1/circuit 2)	500/600 A
Full Load Amps (FLA) (circuit 1/circuit 2)	375/432 A
<b>Dual Point - Without Integral Pump</b>	
Minimum Circuit Ampacity (MCA) (circuit 1/circuit 2)	417/417 A
Maximum Overcurrent Protection (MOP) (circuit 1/circuit 2)	500/500 A
Full Load Amps (FLA) (circuit 1/circuit 2)	375/375 A

**Note:** For additional electrical information, contact Trane Rental Services.

<sup>(a)</sup> Depending on chiller MCA and wire used, multiple wires per phase may be required.



## 80 to 500 Ton RTAA/RTAC

**Table 162. Pump data – CSCA0400F0<sup>(a)</sup>**

Labels	Value
Horsepower	50 HP
Min Flow	280 gpm @ 161 ft.
Max Flow	1167.5 gpm @ 117 ft.

<sup>(a)</sup> Pump is mounted within the chiller frame with a bypass and controlled by the chiller standalone control system if not connected to end user building automation system.

**Table 163. Cooling capacity (tons)**

Leaving Water Temp	Propylene Glycol (%)	Estimated Capacity (Tons) at 2.4 GPM / Nominal Ton				
		Ambient Air Temp				
		85°F	95°F	105°F	115°F	125°F
60°F	0	563.0	523.9	473.0	412.3	299.2
55°F	0	522.3	486.3	447.0	390.8	294.4
50°F	0	482.6	449.7	412.8	371.5	288.4
45°F	0	444.0	414.0	379.6	343.3	281.5
40°F	0	406.6	379.0	347.4	313.5	275.6
35°F	10 <sup>(a)</sup>	369.5	344.2	315.4	283.8	250.6
30°F	20 <sup>(a)</sup>	331.8	309.1	282.9	253.8	223.1
25°F	25 <sup>(a)</sup>	292.9	272.8	249.4	223.1	195.2
20°F	30 <sup>(b)</sup>	267.8	249.0	226.7	201.7	175.1

<sup>(a)</sup> Performance based on using propylene glycol solution for antifreeze protection.

<sup>(b)</sup> Performance based on using ethylene glycol for antifreeze protection.

**Table 164. Water flow rates and pressure drops**

Flow Rate (GPM)	Pressure Drop (ft. H <sub>2</sub> O)
381 (min flow)	3.66
500	6.18
600	8.68
700	11.50
800	14.70
900	18.10
1000	21.90
1100	26.10
1200	30.60
1300	35.40
1396 (max flow)	40.50

**Note:** Maximum water side pressure is 150 psi (2.31 ft. H<sub>2</sub>O = 1 psi).

General – CSCA0400F0

Table 165. Dimensions and weights

Chiller Only	
Labels	Value
Length	39 ft. 8 in.
Width	8 ft. 1 in.
Height	8 ft.
Shipping Weight (lbs)	28,700
Operating Weight (lbs)	30,860
Trailer	
Labels	Value
Length	48 ft.
Width	8 ft. 6 in.
Height	5 ft. 0.25 in.
Shipping Weight (lbs)	14,760

Notes:

1. Lifting device: forklift or crane.
2. All weights and dimensions listed above are subject to change without notice or liability.

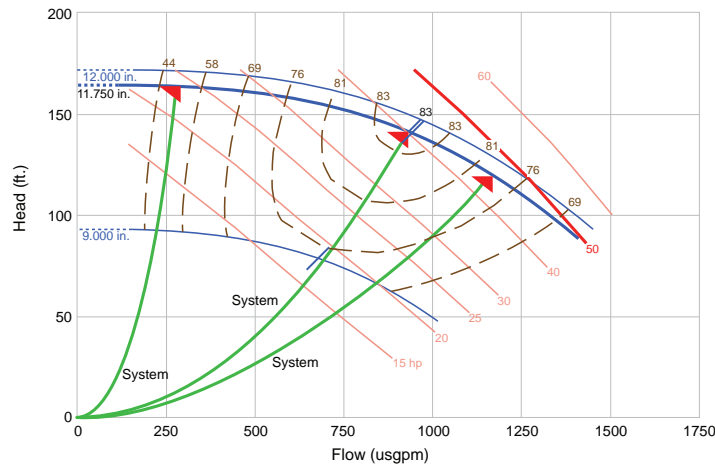

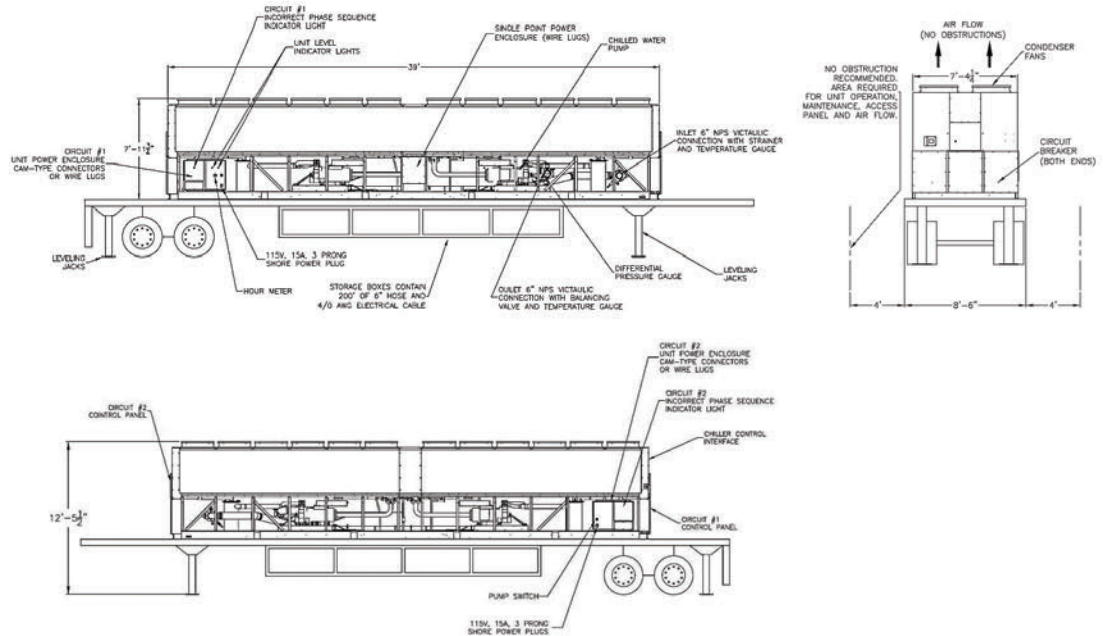

**Table 166. General – CSCA0400F2-F3**

Labels	Value
Model Number	RTAC400
Nominal Tons	400
Refrigerant	R-134a
Refrigerant Charge <sup>(a)</sup>	415/415 lbs
Water Connection Size	6 in. Victaulic
Ambient Operating Conditions	0°F to 125°F
Chilled Water Setpoint Limits <sup>(b) (c)</sup>	20°F to 65°F
Evaporation Configuration	2 pass
Number of Electrical Circuits	2
Number of Refrigerant Circuits	2

- (a) Data containing information on two circuits is shown as follows: ckt 1/ ckt 2.
- (b) When leaving solution is below 42°F a glycol solution is required for all low temperature and ice-making applications.
- (c) Have engineering validate performance for applications that require 60°F and above supply leaving water temperatures.

**Table 167. Electrical data – Dual point only**

Labels	Value
Voltage	460V 3-Phase
Frequency	60 Hz
Power Supply Connections <sup>(a)</sup>	Series 16 Cam-Type Connections Only
<b>With Integral Pump</b>	
Minimum Circuit Ampacity (MCA) (circuit 1/circuit 2)	482/417 A
Maximum Overcurrent Protection (MOP) (circuit 1/circuit 2)	600/500 A
Full Load Amps (FLA) (circuit 1/circuit 2)	434/369 A
<b>Without Integral Pump</b>	

**Table 167. Electrical data – Dual point only (continued)**

Labels	Value
Minimum Circuit Ampacity (MCA) (circuit 1/circuit 2)	417/417 A
Maximum Overcurrent Protection (MOP) (circuit 1/circuit 2)	500/500 A
Full Load Amps (FLA) (circuit 1/circuit 2)	369/369 A

**Note:** For additional electrical information, contact Trane Rental Services.

(a) Depending on chiller MCA and wire used, multiple wires per phase may be required.

**Table 168. Pump data – CSCA0400F2-F3<sup>(a)</sup>**

Labels	Value
Horsepower	50 HP
Min Flow	357 gpm @ 142 ft.
Max Flow	1488 gpm @ 84 ft.

(a) Pump is mounted within the chiller frame with a bypass and controlled by the chiller standalone control system if not connected to end user building automation system.

**Table 169. Cooling capacity (tons)**

Leaving Water Temp	Propylene Glycol (%)	Estimated Capacity (Tons) at 2.4 GPM / Nominal Ton				
		Ambient Air Temp				
		85°F	95°F	105°F	115°F	125°F
60°F	0	563.0	523.9	473.0	412.3	299.2
55°F	0	522.3	486.3	447.0	390.8	294.4
50°F	0	482.6	449.7	412.8	371.5	288.4
45°F	0	444.0	414.0	379.6	343.3	281.5
40°F	0	406.6	379.0	347.4	313.5	275.6
35°F	10 <sup>(a)</sup>	369.5	344.2	315.4	283.8	250.6
30°F	20 <sup>(a)</sup>	331.8	309.1	282.9	253.8	223.1
25°F	25 <sup>(a)</sup>	292.9	272.8	249.4	223.1	195.2
20°F	30 <sup>(b)</sup>	267.8	249.0	226.7	201.7	175.1

(a) Performance based on using propylene glycol solution for antifreeze protection.

(b) Performance based on using ethylene glycol for antifreeze protection.

**Table 170. Water flow rates and pressure drops**

Flow Rate (GPM)	Pressure Drop (ft. H <sub>2</sub> O)
381 (min flow)	3.66
500	6.18
600	8.68
700	11.50
800	14.70
900	18.10
1000	21.90
1100	26.10
1200	30.60



## 80 to 500 Ton RTAA/RTAC

**Table 170. Water flow rates and pressure drops (continued)**

Flow Rate (GPM)	Pressure Drop (ft. H <sub>2</sub> O)
1300	35.40
1396 (max flow)	40.50

*Note: Maximum water side pressure is 150 psi (2.31 ft. H<sub>2</sub>O = 1 psi).*

## General – CSCA0400F2-F3

**Table 171. Dimensions and weights**

Chiller Only	
Labels	Value
Length	39 ft. 2.25 in.
Width	8 ft. 6 in.
Height	8 ft.
Shipping Weight (lbs)	35,800
Operating Weight (lbs)	37,974
Trailer	
Labels	Value
Length	48 ft.
Width	8 ft. 6 in.
Height	5 ft. 0.25 in.
Shipping Weight (lbs)	14,760

**Notes:**

1. Lifting device: forklift or crane.
2. All weights and dimensions listed above are subject to change without notice or liability.

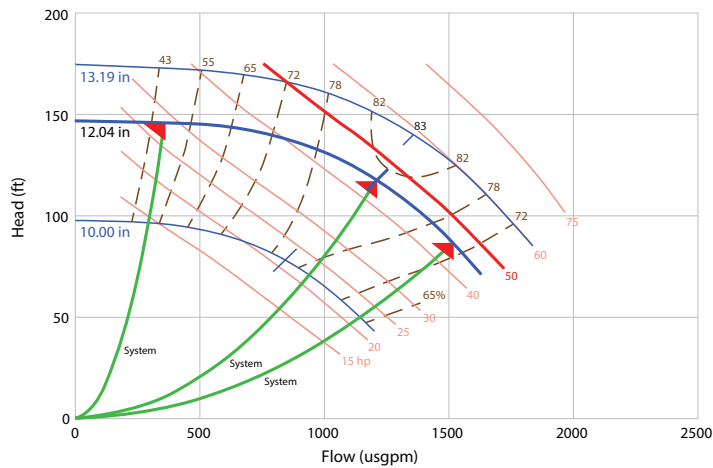

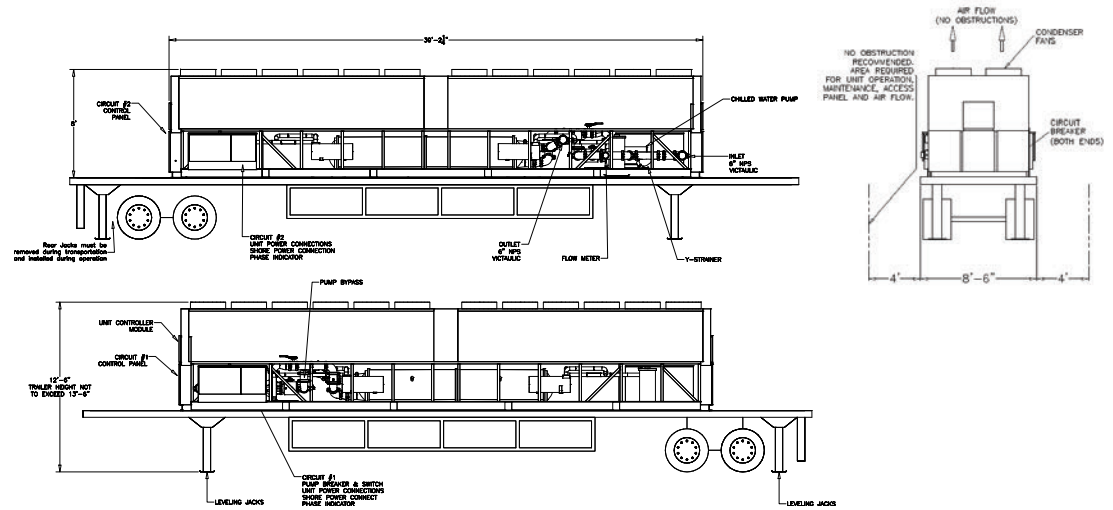

## 500 Ton Air-Cooled RTAC

**Table 172. General – CSCA0500F0-F4**

Labels	Value
Model Number	RTAC500
Nominal Tons	500
Refrigerant	R-134a
Refrigerant Charge <sup>(a)</sup>	460/460 lbs
Water Connection Size	6 in. Victaulic
Ambient Operating Conditions	0°F to 125°F
Chilled Water Setpoint Limits <sup>(b) (c)</sup>	20°F to 65°F
Evaporation Configuration	2 pass
Number of Electrical Circuits	2
Number of Refrigerant Circuits	2

(a) Data containing information on two circuits is shown as follows: ckt 1/ ckt 2.

(b) When leaving solution is below 40°F a glycol solution is required for all low temperature and ice-making applications.

(c) Have engineering validate performance for applications that require 60°F and above supply leaving water temperatures.

**Table 173. Electrical data – dual point only**

Labels	Value
Voltage	460V 3-Phase
Frequency	60 Hz
F0 Power Supply Connections <sup>(a) (b)</sup>	Lugs or Series 16 Cam- Type Connections
F2-F4 Power Supply Connections <sup>(b)</sup>	Series 16 Cam-Type Connections Only
<b>F0 Series Electrical With Integral Pump</b>	
Minimum Circuit Ampacity (MCA) (circuit 1/circuit 2)	495/561 A
Maximum Overcurrent Protection (MOP) (circuit 1/ circuit 2)	600/700 A
Full Load Amps (FLA) (circuit 1/circuit 2)	445/511 A
<b>F0 Series Electrical - Without Integral Pump</b>	
Minimum Circuit Ampacity (MCA) (circuit 1/circuit 2)	495/495 A
Maximum Overcurrent Protection (MOP) (circuit 1/ circuit 2)	600/600 A



## 80 to 500 Ton RTAA/RTAC

**Table 173. Electrical data – dual point only (continued)**

Labels	Value
Full Load Amps (FLA) (circuit 1/circuit 2)	445/445 A
<b>F2-F4 Series Electrical With Integral Pump</b>	
Minimum Circuit Ampacity (MCA) (circuit 1/circuit 2)	560/495 A
Maximum Overcurrent Protection (MOP) (circuit 1/ circuit 2)	700/600 A
Full Load Amps (FLA) (circuit 1/circuit 2)	503/438 A
<b>F2-F4 Series Electrical Without Integral Pump</b>	
Minimum Circuit Ampacity (MCA) (circuit 1/circuit 2)	495/495 A
Maximum Overcurrent Protection (MOP) (circuit 1/ circuit 2)	600/600 A
Full Load Amps (FLA) (circuit 1/circuit 2)	438/438 A

**Note:** For additional electrical information, contact Trane Rental Services.

- (a) Maximum wire size lug(s) can accept - 600 MCM.
- (b) Depending on chiller MCA and wire used, multiple wires per phase may be required.

**Table 174. Pump data – CSCA0500F0<sup>(a)</sup>**

Labels	Value
Horsepower	50 HP
Min Flow	370 gpm @ 142.5 ft.
Max Flow	1543 gpm @ 93.1 ft.

- (a) Pump is mounted within the chiller frame with a bypass and controlled by the chiller standalone control system if not connected to end user building automation system.

**Table 175. Pump data – CSCA0500F2-F4<sup>(a)</sup>**

Labels	Value
Horsepower	50 HP
Min Flow	365 gpm @ 146 ft.
Max Flow	1521 gpm @ 87 ft.

- (a) Pump is mounted within the chiller frame with a bypass and controlled by the chiller standalone control system if not connected to end user building automation system.

**Table 176. Cooling capacity (tons)**

Leaving Water Temp	Propylene Glycol (%)	Estimated Capacity (Tons) at 2.4 GPM / Nominal Ton				
		Ambient Air Temp				
		85°F	95°F	105°F	115°F	125°F
60°F	0	679.0	626.3	556.4	483.4	352.8
55°F	0	629.3	585.5	529.5	462.1	343.4
50°F	0	580.9	541.3	497.4	437.0	335.2
45°F	0	534.0	498.3	457.8	414.1	329.1
40°F	0	488.9	456.5	419.3	379.6	320.4
35°F	10 <sup>(a)</sup>	444.3	414.8	381.0	344.5	305.9
30°F	20 <sup>(a)</sup>	400.6	373.8	343.3	309.8	274.3
25°F	25 <sup>(a)</sup>	356.0	332.2	304.8	274.4	242.2
20°F	30 <sup>(b)</sup>	325.0	302.8	277.0	248.2	217.7

- (a) Performance based on using propylene glycol solution for antifreeze protection.
- (b) Performance based on using ethylene glycol for antifreeze protection.

**Table 177. Water flow rates and pressure drops**

Flow Rate (GPM)	Pressure Drop (ft. H <sub>2</sub> O)
422 (min flow)	3.69
550	6.14
650	8.39
750	10.90
850	13.70
950	16.80
1050	20.10
1150	23.70
1250	27.60
1350	31.80
1450	36.30
1548 (max flow)	41.00

*Note: Maximum water side pressure is 150 psi (2.31 ft. H<sub>2</sub>O = 1 psi).*

## General – CSCA0500F0

**Table 178. Dimensions and weights**

Chiller Only	
Labels	Value
Length	45 ft. 3 in.
Width	8 ft. 1 in.
Height	8 ft.
Shipping Weight (lbs)	31,640
Operating Weight (lbs)	32,990
Trailer	
Labels	Value
Length	48 ft.
Width	8 ft. 6 in.
Height	5 ft. 0.25 in.
Shipping Weight (lbs)	14,760

**Notes:**

1. *Lifting device: forklift or crane.*
2. *All weights and dimensions listed above are subject to change without notice or liability.*



# 80 to 500 Ton RTAA/RTAC

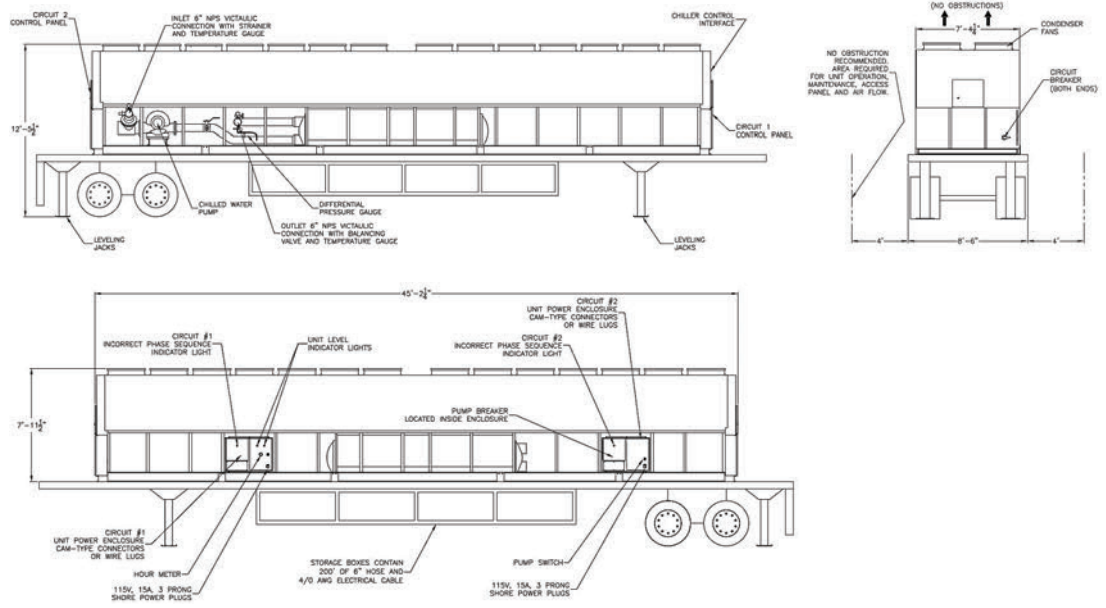
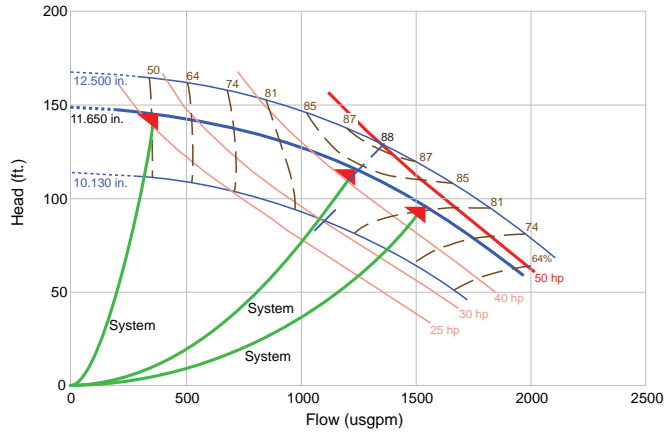

## General – CSCA0500F2-F4

Table 179. Dimensions and weights

Chiller Only	
Labels	Value
Length	45 ft. 2.25 in.
Width	8 ft. 6 in.
Height	8 ft.
Shipping Weight (lbs)	36,000
Operating Weight (lbs)	37,350
Trailer	
Labels	Value
Length	48 ft.
Width	8 ft. 6 in.
Height	5 ft. 0.25 in.

**Table 179. Dimensions and weights (continued)**

Shipping Weight (lbs)	14,760
-----------------------	--------

**Notes:**

1. Lifting device: forklift or crane.
2. All weights and dimensions listed above are subject to change without notice or liability.

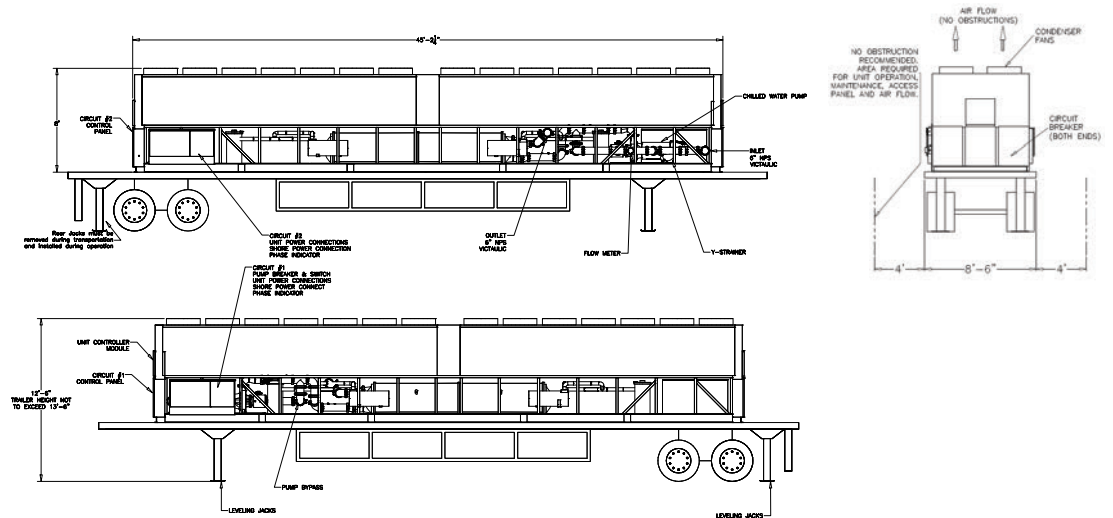
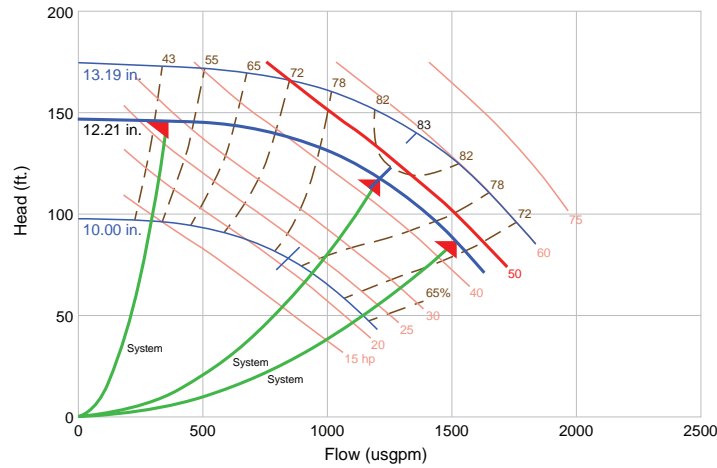

Trane - by Trane Technologies (NYSE: TT), a global innovator - creates comfortable, energy efficient indoor environments for commercial and residential applications. For more information, please visit [trane.com](https://trane.com) or [tranetechnologies.com](https://tranetechnologies.com).

Trane has a policy of continuous product and product data improvements and reserves the right to change design and specifications without notice. We are committed to using environmentally conscious print practices.

TEMP-PRC010A-EN 26 Apr 2025  
CHS-PRB010M-EN (March 2024)

©2025 Trane