



Product Catalog

Trane Rental Services

Packaged DX Air Conditioning





Introduction

Warnings, Cautions, and Notices

Safety advisories appear throughout this manual as required. Your personal safety and the proper operation of this machine depend upon the strict observance of these precautions.

The three types of advisories are defined as follows:

⚠ WARNING	Indicates a potentially hazardous situation which, if not avoided, could result in death or serious injury.
⚠ CAUTION	Indicates a potentially hazardous situation which, if not avoided, could result in minor or moderate injury. It could also be used to alert against unsafe practices.
NOTICE	Indicates a situation that could result in equipment or property-damage only accidents.

Important Environmental Concerns

Scientific research has shown that certain man-made chemicals can affect the earth's naturally occurring stratospheric ozone layer when released to the atmosphere. In particular, several of the identified chemicals that may affect the ozone layer are refrigerants that contain Chlorine, Fluorine and Carbon (CFCs) and those containing Hydrogen, Chlorine, Fluorine and Carbon (HCFCs). Not all refrigerants containing these compounds have the same potential impact to the environment. Trane advocates the responsible handling of all refrigerants.

Important Responsible Refrigerant Practices

Trane believes that responsible refrigerant practices are important to the environment, our customers, and the air conditioning industry. All technicians who handle refrigerants must be certified according to local rules. For the USA, the Federal Clean Air Act (Section 608) sets forth the requirements for handling, reclaiming, recovering and recycling of certain refrigerants and the equipment that is used in these service procedures. In addition, some states or municipalities may have additional requirements that must also be adhered to for responsible management of refrigerants. Know the applicable laws and follow them.

⚠ WARNING
Proper Field Wiring and Grounding Required!
Failure to follow code could result in death or serious injury. All field wiring MUST be performed by qualified personnel. Improperly installed and grounded field wiring poses FIRE and ELECTROCUTION hazards. To avoid these hazards, you MUST follow requirements for field wiring installation and grounding as described in NEC and your local/state/national electrical codes.

⚠ WARNING**Personal Protective Equipment (PPE) Required!**

Failure to wear proper PPE for the job being undertaken could result in death or serious injury. Technicians, in order to protect themselves from potential electrical, mechanical, and chemical hazards, **MUST** follow precautions in this manual and on the tags, stickers, and labels, as well as the instructions below:

- Before installing/servicing this unit, technicians **MUST** put on all PPE required for the work being undertaken (Examples; cut resistant gloves/sleeves, butyl gloves, safety glasses, hard hat/bump cap, fall protection, electrical PPE and arc flash clothing). **ALWAYS** refer to appropriate Safety Data Sheets (SDS) and OSHA guidelines for proper PPE.
- When working with or around hazardous chemicals, **ALWAYS** refer to the appropriate SDS and OSHA/GHS (Global Harmonized System of Classification and Labeling of Chemicals) guidelines for information on allowable personal exposure levels, proper respiratory protection and handling instructions.
- If there is a risk of energized electrical contact, arc, or flash, technicians **MUST** put on all PPE in accordance with OSHA, NFPA 70E, or other country-specific requirements for arc flash protection, **PRIOR** to servicing the unit. **NEVER PERFORM ANY SWITCHING, DISCONNECTING, OR VOLTAGE TESTING WITHOUT PROPER ELECTRICAL PPE AND ARC FLASH CLOTHING. ENSURE ELECTRICAL METERS AND EQUIPMENT ARE PROPERLY RATED FOR INTENDED VOLTAGE.**

⚠ WARNING**Follow EHS Policies!**

Failure to follow instructions below could result in death or serious injury.

- All Trane personnel must follow the company's Environmental, Health and Safety (EHS) policies when performing work such as hot work, electrical, fall protection, lockout/tagout, refrigerant handling, etc. Where local regulations are more stringent than these policies, those regulations supersede these policies.
- Non-Trane personnel should always follow local regulations.

Copyright

This document and the information in it are the property of Trane, and may not be used or reproduced in whole or in part without written permission. Trane reserves the right to revise this publication at any time, and to make changes to its content without obligation to notify any person of such revision or change.

Trademarks

All trademarks referenced in this document are the trademarks of their respective owners.

Revision History

Updated performance data section, electrical data tables 62, 94 (MCA/MOP).



Table of Contents

Overview	5
Application Considerations	6
Ventilation	6
Controls	6
Dehumidification/Reheat	7
Modulating Hot Gas Reheat	7
Flexible Rental Duct	7
Additional Considerations	7
Quick Equipment Overview	8
Voyager™ with Electric Heat	9
Model: CSDX0025F3	9
Model: CSDX0025F4DE-EB	14
Model: CSDX0025F4ED-GL	19
Model: CSDX0025F5	24
Model: RSDX0025F7AA-AK	29
Model: CSDX0035F0	34
Model: CSDX0035F6	39
Model: RSDX0035F6AB-AF	45
Model: CSDX0050F0	50
Model: CSDX0050F4	55
Model: CSDX0050F6	60
Model: RSDX0050F6AA-AJ	66
Model: CSHX0035F3	71
Model: CSHX0035F4	75
Model: RSHX0035F4AA-AO	80
Model: CSHX0050F3	84
Model: CSHX0050F4	88
Model: RSHX0050F4AA-AJ	93
Model: RSHX0080	97



Overview

This catalog should be only be used as a reference for Trane Rental Services Voyager™ air conditioners to determine size limitations, available power, or lifting requirements. Verify the following with Trane Rental Services:

- Dimensions/weights and control options for the specific rental unit before equipment is shipped to a job site.
- Confirm adequate power is available for each Voyager unit.
- If additional information is required, reference the product catalog and/or installation manual.

Contact Trane Rental Services 24/7 for availability of all equipment (including: flex duct, electrical cable, transformers, etc.) prior to obtaining a purchase order from the customer. Equipment is available on a first-come, first-served basis, and can be reserved for three days with a signed Rental Agreement.



Application Considerations

Ventilation

Economizing

Most standard units (CSDX) are equipped with a 0 to 100 percent dry bulb controlled economizer (see “Quick Equipment Overview,” p. 8). A return duct inlet must be left open and a manual damper should be used when introducing fresh air to a machine without an economizer.

100% Outside Air

- Standard units (CSDX) nominally operate to the standard 400 cfm/ton, and can only achieve a 15°F to 25°F temperature differential across the coil, while maintaining a usable external static pressure.
- When the outdoor ambient temperature is high, units cannot provide the discharge air temperatures required to maintain a space at comfortable temperatures.
- High static units (CSHX and RSHX) are nominally designed to provide 200 cfm/ton at a much higher external static pressure.
- They are able to achieve 25°F to 35°F temperature differential across the cooling coil (dependent on latent load).
- This makes them more suitable to maintain typical space temperatures at a relatively high ambient temperature.

Controls

Setpoint

Adjust the CSDX and CSHX setpoint using the unit mounted return air sensor or the provided remote sensor included with a 50 foot lead wire.

Adjust the RSHX0080 setpoint using the unit mounted return air sensor or the supply air sensor with an onboard PLC control.

Another option is to use a remote wireless thermostat. Place this inside the space, up to 100 feet away from the unit.

Communications

If BACnet® or LonTalk® is required on *SDX and *SHX units, contact Trane Rental Services.

RSHX0080 units do not include a remote communications option and are local control only.

Airflow

- 25 ton F3 and F5 units do not have a VFD or an electronic method to modulate cfm.
- 25 ton F4 and F7 feature VFD for VAV/static pressure reset applications.
- 35 to 50 tons F0-F6 feature a VFD for VAV/static pressure reset applications.
- The default static pressure setpoint programmed into the VFD corresponds to the pressure differential between fan discharge pressure and atmospheric pressure.

Note: *Trane Rental Services models are configured as constant volume with fan speed adjustment performed with an on-board setpoint. If VAV mode is required, contact Trane Rental Services.*

- 35 to 50 tons high static units are not suitable for VAV/static reset or to achieve a wide variety of airflows. If a cfm setpoint is programmed, the fan speed will modulate to maintain that cfm, regardless of static pressure. Only the cfm setting can be changed.

Dehumidification/Reheat

All rental packaged units can operate in electric reheat mode (except CSDX0025F5, RSDX0035F6 and RSDX0050F6) see “[Quick Equipment Overview](#),” p. 8. This operating mode includes compressors, fans, and a portion of the electric heat in the unit. This allows the cooling coil to continue condensing moisture out of the supply air, while reheating it to minimize the amount of overcooling of the conditioned space.

Modulating Hot Gas Reheat

- 35 and 50 tons F6 DX units include hot gas reheat.
- The colder the air, the less moisture it contains. With hot gas reheat, hot refrigerant gas leaving the compressor is diverted to a hot gas reheat coil. The cold air leaving the DX coil is reheated to an acceptable temperature and returned as dehumidified air to the facility space.
- Modulating hot gas reheat helps maintain both temperature and humidity levels in cooling mode, while reducing unit operating costs and saving energy.
- Standard modulating hot gas reheat requires a call for cooling to initiate. If there is no call for cooling, and a need for dehumidification, use another electric reheat.

Flexible Rental Duct

Rental duct is not insulated and can gain/lose heat along duct path. When planning the job, consider the length and path of flexible duct. For high static units, excess duct lengths across hot blacktops or roofing can have a negative impact on cooling ability.

The recommended maximum duct lengths for units do not take into consideration existing duct systems. If connecting flex duct to customer duct for additional distribution, consider the specified static pressure needed to push air through. Add this to the friction losses through the flexible duct to determine the total amount of external static pressure required.

Important: *If running return ducts on a high static unit, rental duct is collapsible and may cinch closed if put under high enough negative pressure.*

If collapsing return duct occurs, see the following options:

- Straighten the duct path by pulling duct taut and secure with wire or twine with provided nylon tabs and grommets.
- For turns, consider using hard elbows (not provided).
- Introduce fresh air to reduce the negative pressure in the return section of the unit.

Additional Considerations

For additional information and specific unit considerations, contact Trane Rental Services.



Quick Equipment Overview

	Heat Size and Type	Electric Re-heat	Hot Gas Reheat	Economizer (0-100% Dry Bulb Control)	VFD with VAV Operation	VFD with Constant Volume Operation	Zone Temperature Input Selector
CSDX0025F3	54 kW - Electric	Yes	No	Yes	No	No	Yes
CSDX0025F4	72 kW - Electric	Yes	No	No	Yes	Yes	Yes
CSDX0025F5	200 MBH - Gas	No	No	No	No	No	Yes
RSDX0025F7	72 kW - Electric	Yes	No	No	Yes	Yes	Yes
CSDX0035F0	90 kW - Electric	Yes	No	Yes	Yes	No	No
CSDX0035F6	90 kW - Electric	Yes	Yes	Yes	Yes	Yes	Yes
RSDX0035F6	90 kW - Electric	No	Yes	Yes	Yes	Yes	Yes
CSDX0050F0	108 kW - Electric	Yes	No	Yes	Yes	No	No
CSDX0050F4	108 kW - Electric	Yes	No	Yes	Yes	Yes	Yes
CSDX0050F6	108 kW - Electric	Yes	Yes	Yes	Yes	Yes	Yes
RSDX0050F6	108 kW - Electric	No	Yes	Yes	Yes	Yes	Yes
CSHX0035F3	90 kW - Electric	Yes	No	No	No	Yes	No
CSHX0035F4	90 kW - Electric	Yes	No	Yes	No	Yes	Yes
RSHX0035F4	90 kW - Electric	Yes	No	Yes	No	Yes	Yes
CSHX0050F3	108 kW - Electric	Yes	No	No	No	Yes	No
CSHX0050F4	108 kW - Electric	Yes	No	Yes	No	Yes	Yes
RSHX0050F4	108 kW - Electric	Yes	No	Yes	No	Yes	Yes
RSHX0080F0	162 kW - Electric	Yes	No	No	No	Yes	Yes



Voyager™ with Electric Heat

Model: CSDX0025F3

Features

- 0 to 100 percent Economizer, Dry Bulb Control
- Constant Volume Fan with Field Adjustable Sheave
- Hinged Service Access
- Electric Heat with Reheat Option
- Phase and Under/Over Voltage Protection
- Series 16 Cam Type Electrical Connections
- Unit Mounted Thermostat with Remote Option
- Trane BACnet® Control Interface RS-485 MS/TP and Remote Monitoring Available Upon Request
- Clogged Filter Switch Kit
- Hot Gas Bypass
- Manual Supply Air Dampers
- Two Stage Cooling and Heating
- Low Ambient Operation Down to 0°F
- ReliaTel™ Trane Controls

Table 1. General data - CSDX0025F3

Labels	Value
Nominal Cooling Tons ^(a)	25
Heating Capacity	54 kW
Refrigerant	R-410A
Number of Refrigerant Circuits	2
Number of Compressors	2
Ambient Operating Conditions	0°F – 115°F

(a) Design Conditions: 95°F Ambient, 80°F EDB, 71°F EWB, 400 CFM/Ton.

Table 2. Electrical data – circuit breaker style disconnect - CSDX0025F3

Labels	Value
Number of Electrical Circuits	1
Voltage	460V 3 Phase
Frequency	60 Hz
Wire Connection Type	Series 16 Cam Type Connections or Hardwire (Maximum 350 MCM)
SCCR	5000 A
Minimum Circuit Ampacity (MCA)	101 A
Maximum Overcurrent Protection (MOP)	125 A
Cooling Only FLA	54 A
Heating Only FLA	78.9 A
Electric Reheat (27 kW Electric Heat + All Cooling) FLA	87.9 A



Voyager™ with Electric Heat

Table 3. Airflow data - CSDX0025F3

Labels	Value
Supply Motor	7.5 HP
Nominal CFM	10,000
Minimum/Maximum CFM	7,000 – 11,000
Maximum ESP at Nominal CFM	0.75 in.
Supply Air Connection Qty/Size	(2) 20 in.
Return Air Connection Qty/Size	(2) 20 in.
Merv-7 Throwaway Filter Qty/Size	(6) 20 in. x 20 in. x 2 in.
Maximum Supply/Return Duct Run at Minimum CFM	175 ft.
Maximum Supply/Return Duct Run at Maximum CFM	50 ft.

Table 4. Dimensions and weights - CSDX0025F3

Labels	Value
Length	14 ft. 8.4 in.
Width	8 ft. 6 in.
Height	5 ft. 10 in.
Shipping Weight	4,700 lbs
Fork Pocket Dimensions	9.25 in. x 5.25 in. x 8 ft.
Center to Center Distance of Fork Pockets	63.25 in.

Notes:

- Lifting Device: Forklift or crane.
- Confirm all dimensions and weights with TRS turnkey facility because this data might not match what is listed in this document.
- For additional installation information, see RT-SVX25*-EN.

Table 5. Operating clearances - CSDX0025F3

Labels	Value
Condenser Coil End	4 ft. 0 in.
Economizer End (if equipped)	5 ft. 8 in.
Front (Control Panel)	5 ft. 0 in.
Back (Supply/Return Duct Connections)	3 ft. 0 in.
Top	No Obstructions

Note: Operating clearances are provided based on single machine, above ground. For multiple unit or pit operation, contact Trane Rental Services.

Table 6. External static pressure – CSDX0025F3

External Static Pressure (in H ₂ O)																	
CFM	0.1	0.2	0.3	0.4	0.5	0.6	0.7	0.8	0.9	1.0	1.1	1.2	1.3	1.4	CFM	ESP Subtraction (in H ₂ O) 54 kW Heat	
	7000	-	-	-	-	-	-	-	-	-	-	-	-	-		-	7000
7500	-	-	-	-	-	-	-	-	-	-	-	-	-	-	892	7500	0.11
8000	-	-	-	-	-	-	-	-	-	-	-	-	-	891	911	8000	0.13
8500	-	-	-	-	-	-	-	-	-	-	-	895	913	932	8500	0.14	
9000	-	-	-	-	-	-	-	-	-	887	904	921	938	955	9000	0.15	
9500	-	-	-	-	-	-	-	882	889	915	932	949	965	981	9500	0.16	
10000	-	-	-	-	-	-	896	912	929	945	-	-	-	-	10000	0.18	
10500	-	-	-	-	891	908	-	-	-	-	-	-	-	-	10500	0.19	
11000	-	-	885	-	-	-	-	-	-	-	-	-	-	-	11000	0.22	

Notes:

1. Assumes 2-inch MERV 7 filters (factory provided).
2. Subtract 0.01 inch from ESPs if using 2-inch MERV 13 filters (customer provided).

Table 7. Fan data – CSDX0025F3

Sheave Adjustment	Turns Open					
	6	5	4	3	2	1
Fan RPM	806	844	882	920	958	994



Voyager™ with Electric Heat

Table 8. Gross cooling capacities – CSDX0025F3

Airflow cfm	Ent DB (°F)	Ambient Temperature (°F)																	
		85						95						105					
		Entering Wet Bulb																	
		61		67		73		61		67		73		61		67		73	
MBh	SHC	MBh	SHC	MBh	SHC	MBh	SHC	MBh	SHC	MBh	SHC	MBh	SHC	MBh	SHC	MBh	SHC		
7000	75	257.6	212.0	289.0	165.3	317.0	114.6	245.8	206.4	274.9	159.4	299.4	108.2	233.1	200.6	259.5	153.1	279.6	101.1
	80	257.0	250.5	288.9	204.5	317.1	154.5	245.3	244.2	272.1	198.7	299.5	148.1	232.7	232.3	259.5	192.4	279.8	141.0
	85	259.2	259.1	288.8	243.6	317.2	194.2	249.7	249.7	274.6	237.7	299.7	187.7	239.4	239.4	259.2	231.3	280.1	180.7
	90	273.4	273.4	287.9	282.0	317.2	233.5	263.5	263.5	274.1	273.6	299.8	227.1	252.3	252.3	258.7	258.4	280.4	220.2
8000	75	264.4	228.7	295.5	175.0	321.8	116.8	251.7	223.0	280.5	168.9	302.9	110.1	238.0	216.8	264.2	162.4	281.8	102.7
	80	263.5	262.1	295.4	219.8	322.0	162.4	250.9	250.6	280.4	213.7	303.1	155.7	237.6	237.4	264.1	207.3	282.0	148.3
	85	270.1	270.1	295.0	264.3	322.1	207.6	250.9	250.9	279.9	258.2	303.4	201.0	248.6	248.6	263.6	251.6	282.5	193.7
	90	285.1	285.1	292.4	293.7	322.2	252.7	274.1	274.1	279.3	279.0	303.6	246.1	261.6	261.6	263.6	263.4	282.7	238.7
9000	75	269.4	245.0	300.5	184.4	325.2	118.8	256.0	239.1	284.8	178.2	305.1	111.8	241.7	232.8	267.6	171.5	284.3	104.8
	80	268.4	266.9	300.4	234.8	325.4	170.0	255.7	255.5	284.7	228.6	305.4	163.1	242.3	242.1	267.6	222.1	284.5	156.0
	85	279.4	279.4	299.7	284.7	325.7	221.0	268.4	268.4	283.9	278.5	305.9	214.1	256.1	256.1	267.0	266.2	284.7	206.9
	90	294.7	294.7	299.1	298.8	325.8	271.6	282.6	282.6	284.2	282.0	306.1	264.8	268.8	268.8	269.0	269.0	284.4	257.6
10000	75	273.3	261.1	304.4	193.6	327.7	120.8	259.5	255.0	288.0	187.3	307.8	114.0	244.7	244.0	270.1	180.4	286.4	106.9
	80	273.1	272.9	304.3	249.8	328.0	177.7	260.3	260.3	288.1	243.4	307.8	170.8	248.3	248.3	270.2	236.5	286.7	163.8
	85	287.3	287.3	303.3	302.5	328.3	234.3	275.4	275.4	287.0	286.2	307.9	227.3	262.1	262.1	269.1	268.5	286.9	220.4
	90	302.6	302.6	303.8	303.5	328.2	290.4	289.5	289.5	289.7	289.7	307.7	283.6	274.4	274.4	274.5	274.5	286.4	276.4
11000	75	276.5	275.7	307.6	202.8	330.2	122.9	262.3	261.6	290.6	196.3	310.1	116.2	247.0	246.2	272.1	189.3	288.1	109.1
	80	277.6	277.6	307.6	264.5	330.3	185.5	266.1	266.1	290.6	258.0	310.3	178.8	253.4	253.4	272.0	251.0	288.4	171.5
	85	293.9	293.9	306.1	305.3	331.2	247.7	281.3	281.3	289.1	288.4	310.4	241.0	267.1	267.1	270.8	270.4	288.6	233.8
	90	309.2	309.2	309.4	309.4	330.3	309.3	295.0	295.0	295.2	295.2	309.5	302.3	278.5	278.5	278.7	278.7	288.1	286.9
Airflow cfm	Ent DB (°F)	Ambient Temperature (°F)																	
		115						120						125					
		Entering Wet Bulb																	
		61		67		73		61		67		73		61		67		73	
MBh	SHC	MBh	SHC	MBh	SHC	MBh	SHC	MBh	SHC	MBh	SHC	MBh	SHC	MBh	SHC	MBh	SHC		
7000	75	219.7	194.5	243.0	146.4	258.2	93.6	212.8	191.4	234.3	143.0	247.2	89.8	-	-	-	-	236.0	85.9
	80	219.4	219.2	243.0	185.7	258.2	133.4	212.8	212.5	234.3	182.3	247.5	129.7	-	-	-	-	236.2	125.8
	85	228.2	228.2	242.7	224.7	258.5	173.0	222.2	222.2	234.1	221.2	247.8	169.3	-	-	-	-	236.6	165.5
	90	239.8	239.8	242.5	242.2	258.7	212.5	233.0	233.0	234.1	233.9	247.9	208.7	-	-	-	-	233.8	204.9
8000	75	223.7	209.8	246.5	155.4	260.3	95.4	216.5	207.3	237.3	151.9	244.8	91.5	-	-	227.8	148.2	236.9	87.5
	80	224.1	224.0	246.6	200.4	260.5	140.9	217.8	217.8	237.4	196.8	249.1	137.1	-	-	228.0	193.2	237.3	133.1
	85	236.1	236.1	246.2	243.9	260.9	186.2	229.4	229.4	237.1	236.4	249.6	182.4	-	-	227.6	227.1	238.0	178.6
	90	247.4	247.4	247.6	247.6	260.9	231.2	239.5	239.5	239.7	239.7	249.6	227.3	-	-	231.1	231.1	238.0	223.4
9000	75	226.8	221.7	249.1	164.3	257.8	96.3	214.5	213.9	234.7	159.8	245.1	92.1	-	-	229.5	156.9	-	-
	80	230.0	227.3	249.1	214.9	258.8	148.2	220.4	220.4	234.8	210.7	246.2	144.0	-	-	229.6	207.4	-	-
	85	242.4	239.8	248.5	248.1	259.6	199.7	231.9	231.9	234.3	233.9	247.0	195.5	-	-	229.1	228.7	-	-
	90	252.9	251.0	253.0	253.0	259.8	250.6	241.7	241.7	241.8	241.8	247.3	245.5	-	-	233.9	233.9	-	-
10000	75	229.3	223.8	251.0	173.2	263.2	99.2	221.2	220.7	241.0	169.4	250.7	95.1	213.2	212.8	230.8	165.7	-	-
	80	235.2	232.2	250.9	229.1	263.6	156.2	228.2	228.2	240.9	225.5	251.4	152.2	220.9	220.9	230.7	221.7	-	-
	85	247.3	244.8	250.1	249.6	263.9	212.8	239.1	239.1	240.3	240.0	251.7	208.6	230.3	230.3	230.4	230.4	-	-
	90	256.6	255.0	256.7	256.7	263.7	262.7	246.2	246.2	246.3	246.3	251.6	250.6	236.1	236.1	236.2	236.2	-	-
11000	75	230.8	230.4	252.4	182.0	264.0	101.1	222.7	222.3	242.1	178.2	251.2	97.0	214.6	214.1	-	-	-	-
	80	239.4	239.4	252.2	243.6	264.7	163.8	232.0	232.0	242.0	238.9	252.1	159.2	224.1	224.1	-	-	-	-
	85	251.0	251.0	251.7	251.3	264.9	226.1	242.1	242.1	242.2	242.2	252.4	222.0	232.5	232.5	-	-	-	-
	90	258.7	258.7	258.8	258.8	264.9	263.8	248.7	248.7	248.8	248.8	252.1	251.4	237.7	237.7	-	-	-	-

Notes:

1. All capacities shown are gross and have not considered indoor fan heat. To obtain **NET** cooling capacity subtract indoor fan heat. For indoor fan heat formula, refer to appropriate airflow table notes.
2. MBh = Total Gross Capacity.
3. SHC = Sensible Heat Capacity.

Table 9. Electric heating performance – CSDX0025F3

CFM	Temp Rise (°F)
7000	24.0
8000	21.0
9000	19.0
10000	17.0
11000	15.5

Table 10. Sound data – CSDX0025F3

Sound Path (Hz)	63	125	250	500	1K	2K	4K	8K
Ducted Discharge (dB)	95	88	79	80	80	80	80	74
Ducted Inlet (dB)	93	84	79	70	70	71	71	67
Outdoor Noise (dB)	102	89	93	94	92	87	83	75

Unit Drawings – CSDX0025F3

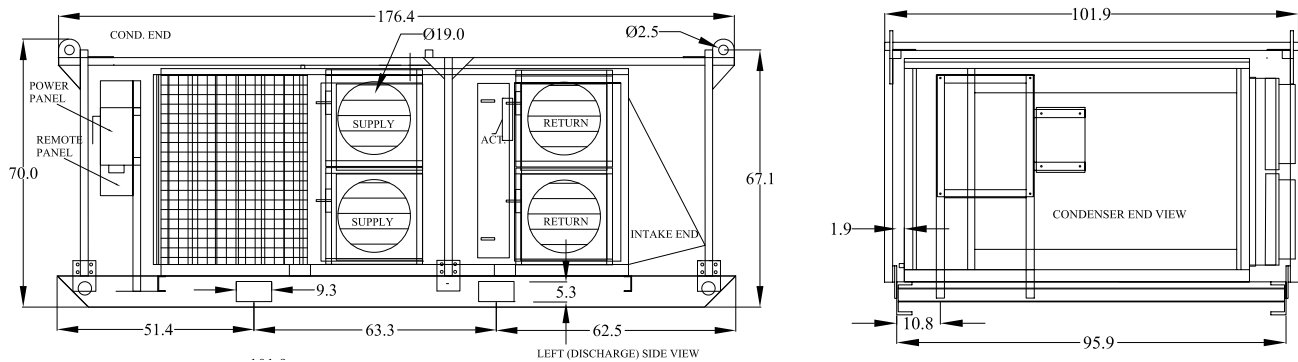



Voyager™ with Electric Heat

Model: CSDX0025F4DE-EB

Features

- Hot Gas Bypass
- Incoming/Outgoing Power Daisy Chain Capable
- Phase and Under/Over Voltage Protection
- ReliaTel™ Trane Controls
- Hinged Service Access
- Electric Heat with Reheat Option
- Series 16 Cam Type Electrical Connections
- Low Ambient Down to 0°F
- Two Stage Cooling and Heating
- Unit Mounted Thermostat with Remote Option
- Blower VFD with across the Line Bypass and Speed Adjustment Potentiometer (VAV Mode Available Upon Request)
- Trane BACnet® Control Interface RS-485 MS/TP (Remote Monitoring Available Upon Request)
- Clogged Filter Switch

Table 11. General data – CSDX0025F4DE-EB

Labels	Value
Nominal Cooling Tons ^(a)	25
Heating Capacity	72 kW
Refrigerant	R-410A
Number of Refrigerant Circuits	2
Number of Compressors	2
Ambient Operating Conditions	0°F – 115°F

(a) Design Conditions: 95°F Ambient, 80°F EDB, 71°F EWB, 400 CFM/Ton.

Table 12. Electrical data – circuit breaker style disconnect – CSDX0025F4DE-EB

Labels	Value
Number of Electrical Circuits	1
Voltage	460V 3 Phase
Frequency	60 Hz
Wire Connection Type	Series 16 Cam Type Only
SCCR	5000 A
Minimum Circuit Ampacity (MCA)	110.9 A
Maximum Overcurrent Protection (MOP)	125 A
Cooling Only FLA	48.9 A
Heating Only FLA	101.5 A
Electric Reheat (36 kW Electric Heat + All Cooling) FLA	94.1 A

Table 13. Airflow data – CSDX0025F4DE-EB

Labels	Value
Supply Motor	7.5 HP
Nominal CFM	10,000
Minimum/Maximum CFM	7,000 – 11,000
Maximum ESP at Nominal CFM	1.25 in.
Supply Air Connection Qty/Size	(2) 20 in.
Return Air Connection Qty/Size	(2) 20 in.
Merv-7 Throwaway Filter Qty/Size	(8) 20 in. x 25 in. x 2 in.
Maximum Supply/Return Duct Run at Minimum CFM	350 ft.
Maximum Supply/Return Duct Run at Maximum CFM	75 ft.

Table 14. Dimensions and weights – CSDX0025F4DE-EB

Labels	Value
Length	10 ft. 11.5 in.
Width	7 ft. 11.625 in.
Height	5 ft. 4.125 in.
Shipping Weight	3,790 lbs
Fork Pocket Dimensions	7.625 in. x 2.625 in.
Center to Center Distance of Fork Pockets	32 in.

Notes:

- Lifting Device: Forklift or crane.
- Confirm all dimensions and weights with TRS turnkey facility because this data might not match what is listed in this document.
- For additional installation information, see RT-SVX25*-EN.

Table 15. Operating clearances – CSDX0025F4DE-EB

Labels	Value
Ends	4 ft.
Front (Control Panel)	5 ft.
Back (Supply/Return Duct Connections)	3 ft.
Top	No Obstructions

Note: Operating clearances are provided based on single machine, above ground. For multiple unit or pit operation, contact Trane Rental Services.

Voyager™ with Electric Heat

Figure 1. Fan curve – CSDX0025F4DE-EB

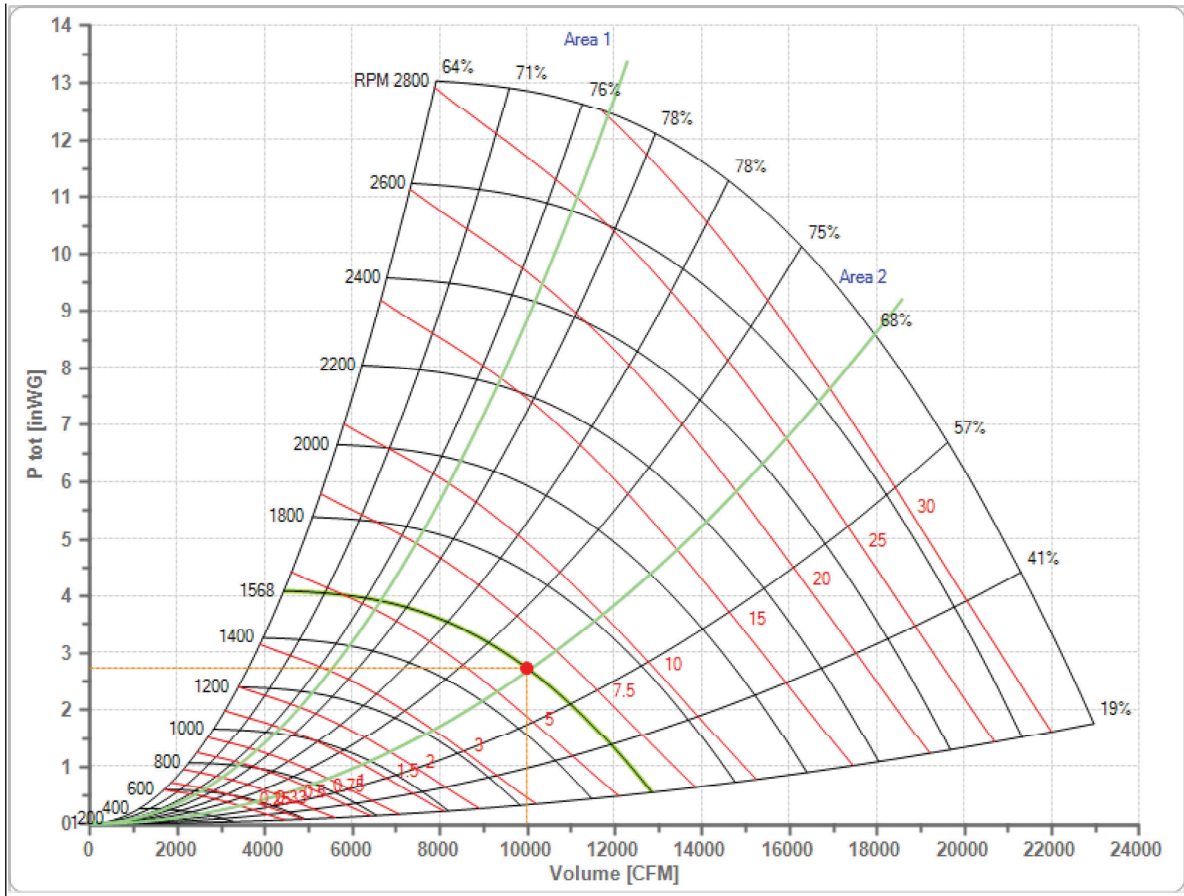

Voyager™ with Electric Heat

Table 16. Gross cooling capacities – CSDX0025F4DE-EB

Airflow cfm	Ent DB (°F)	Ambient Temperature (°F)																	
		85						95						105					
		Entering Wet Bulb																	
		61		67		73		61		67		73		61		67		73	
MBh	SHC	MBh	SHC	MBh	SHC	MBh	SHC	MBh	SHC	MBh	SHC	MBh	SHC	MBh	SHC	MBh	SHC		
7000	75	257.6	212.0	289.0	165.3	317.0	114.6	245.8	206.4	274.9	159.4	299.4	108.2	233.1	200.6	259.5	153.1	279.6	101.1
	80	257.0	250.5	288.9	204.5	317.1	154.5	245.3	244.2	272.1	198.7	299.5	148.1	232.7	232.3	259.5	192.4	279.8	141.0
	85	259.2	259.1	288.8	243.6	317.2	194.2	249.7	249.7	274.6	237.7	299.7	187.7	239.4	239.4	259.2	231.3	280.1	180.7
	90	273.4	273.4	287.9	282.0	317.2	233.5	263.5	263.5	274.1	273.6	299.8	227.1	252.3	252.3	258.7	258.4	280.4	220.2
8000	75	264.4	228.7	295.5	175.0	321.8	116.8	251.7	223.0	280.5	168.9	302.9	110.1	238.0	216.8	264.2	162.4	281.8	102.7
	80	263.5	262.1	295.4	219.8	322.0	162.4	250.9	250.6	280.4	213.7	303.1	155.7	237.6	237.4	264.1	207.3	282.0	148.3
	85	270.1	270.1	295.0	264.3	322.1	207.6	250.9	250.9	279.9	258.2	303.4	201.0	248.6	248.6	263.6	251.6	282.5	193.7
	90	285.1	285.1	292.4	293.7	322.2	252.7	274.1	274.1	279.3	279.0	303.6	246.1	261.6	261.6	263.6	263.4	282.7	238.7
9000	75	269.4	245.0	300.5	184.4	325.2	118.8	256.0	239.1	284.8	178.2	305.1	111.8	241.7	232.8	267.6	171.5	284.3	104.8
	80	268.4	266.9	300.4	234.8	325.4	170.0	255.7	255.5	284.7	228.6	305.4	163.1	242.3	242.1	267.6	222.1	284.5	156.0
	85	279.4	279.4	299.7	284.7	325.7	221.0	268.4	268.4	283.9	278.5	305.9	214.1	256.1	256.1	267.0	266.2	284.7	206.9
	90	294.7	294.7	299.1	298.8	325.8	271.6	282.6	282.6	284.2	282.0	306.1	264.8	268.8	268.8	269.0	269.0	284.4	257.6
10000	75	273.3	261.1	304.4	193.6	327.7	120.8	259.5	255.0	288.0	187.3	307.8	114.0	244.7	244.0	270.1	180.4	286.4	106.9
	80	273.1	272.9	304.3	249.8	328.0	177.7	260.3	260.3	288.1	243.4	307.8	170.8	248.3	248.3	270.2	236.5	286.7	163.8
	85	287.3	287.3	303.3	302.5	328.3	234.3	275.4	275.4	287.0	286.2	307.9	227.3	262.1	262.1	269.1	268.5	286.9	220.4
	90	302.6	302.6	303.8	303.5	328.2	290.4	289.5	289.5	289.7	289.7	307.7	283.6	274.4	274.4	274.5	274.5	286.4	276.4
11000	75	276.5	275.7	307.6	202.8	330.2	122.9	262.3	261.6	290.6	196.3	310.1	116.2	247.0	246.2	272.1	189.3	288.1	109.1
	80	277.6	277.6	307.6	264.5	330.3	185.5	266.1	266.1	290.6	258.0	310.3	178.8	253.4	253.4	272.0	251.0	288.4	171.5
	85	293.9	293.9	306.1	305.3	331.2	247.7	281.3	281.3	289.1	288.4	310.4	241.0	267.1	267.1	270.8	270.4	288.6	233.8
	90	309.2	309.2	309.4	309.4	330.3	309.3	295.0	295.0	295.2	295.2	309.5	302.3	278.5	278.5	278.7	278.7	288.1	286.9
Airflow cfm	Ent DB (°F)	Ambient Temperature (°F)																	
		115						120						125					
		Entering Wet Bulb																	
		61		67		73		61		67		73		61		67		73	
MBh	SHC	MBh	SHC	MBh	SHC	MBh	SHC	MBh	SHC	MBh	SHC	MBh	SHC	MBh	SHC	MBh	SHC		
7000	75	219.7	194.5	243.0	146.4	258.2	93.6	212.8	191.4	234.3	143.0	247.2	89.8	-	-	-	-	236.0	85.9
	80	219.4	219.2	243.0	185.7	258.2	133.4	212.8	212.5	234.3	182.3	247.5	129.7	-	-	-	-	236.2	125.8
	85	228.2	228.2	242.7	224.7	258.5	173.0	222.2	222.2	234.1	221.2	247.8	169.3	-	-	-	-	236.6	165.5
	90	239.8	239.8	242.5	242.2	258.7	212.5	233.0	233.0	234.1	233.9	247.9	208.7	-	-	-	-	233.8	204.9
8000	75	223.7	209.8	246.5	155.4	260.3	95.4	216.5	207.3	237.3	151.9	244.8	91.5	-	-	227.8	148.2	236.9	87.5
	80	224.1	224.0	246.6	200.4	260.5	140.9	217.8	217.8	237.4	196.8	249.1	137.1	-	-	228.0	193.2	237.3	133.1
	85	236.1	236.1	246.2	243.9	260.9	186.2	229.4	229.4	237.1	236.4	249.6	182.4	-	-	227.6	227.1	238.0	178.6
	90	247.4	247.4	247.6	247.6	260.9	231.2	239.5	239.5	239.7	239.7	249.6	227.3	-	-	231.1	231.1	238.0	223.4
9000	75	226.8	221.7	249.1	164.3	257.8	96.3	214.5	213.9	234.7	159.8	245.1	92.1	-	-	229.5	156.9	-	-
	80	230.0	227.3	249.1	214.9	258.8	148.2	220.4	220.4	234.8	210.7	246.2	144.0	-	-	229.6	207.4	-	-
	85	242.4	239.8	248.5	248.1	259.6	199.7	231.9	231.9	234.3	233.9	247.0	195.5	-	-	229.1	228.7	-	-
	90	252.9	251.0	253.0	253.0	259.8	250.6	241.7	241.7	241.8	241.8	247.3	245.5	-	-	233.9	233.9	-	-
10000	75	229.3	223.8	251.0	173.2	263.2	99.2	221.2	220.7	241.0	169.4	250.7	95.1	213.2	212.8	230.8	165.7	-	-
	80	235.2	232.2	250.9	229.1	263.6	156.2	228.2	228.2	240.9	225.5	251.4	152.2	220.9	220.9	230.7	221.7	-	-
	85	247.3	244.8	250.1	249.6	263.9	212.8	239.1	239.1	240.3	240.0	251.7	208.6	230.3	230.3	230.4	230.4	-	-
	90	256.6	255.0	256.7	256.7	263.7	262.7	246.2	246.2	246.3	246.3	251.6	250.6	236.1	236.1	236.2	236.2	-	-
11000	75	230.8	230.4	252.4	182.0	264.0	101.1	222.7	222.3	242.1	178.2	251.2	97.0	214.6	214.1	-	-	-	-
	80	239.4	239.4	252.2	243.6	264.7	163.8	232.0	232.0	242.0	238.9	252.1	159.2	224.1	224.1	-	-	-	-
	85	251.0	251.0	251.7	251.3	264.9	226.1	242.1	242.1	242.2	242.2	252.4	222.0	232.5	232.5	-	-	-	-
	90	258.7	258.7	258.8	258.8	264.9	263.8	248.7	248.7	248.8	248.8	252.1	251.4	237.7	237.7	-	-	-	-

Notes:

1. All capacities shown are gross and have not considered indoor fan heat. To obtain **NET** cooling capacity subtract indoor fan heat. For indoor fan heat formula, refer to appropriate airflow table notes.
2. MBh = Total Gross Capacity.
3. SHC = Sensible Heat Capacity.



Voyager™ with Electric Heat

Table 17. Electric heating performance – CSDX0025F4DE-EB

CFM	Temp Rise (°F)
7000	32.4
8000	28.3
9000	25.2
10000	22.7
11000	20.6

Table 18. Sound data – CSDX0025F4DE-EB

Sound Path (Hz)	63	125	250	500	1K	2K	4K	8K
Ducted Discharge (dB)	94	88	78	80	79	79	79	74
Ducted Inlet (dB)	92	84	78	74	69	71	71	66
Outdoor Noise (dB)	102	89	93	94	92	87	83	75

Unit Drawings – CSDX0025F4DE-EB

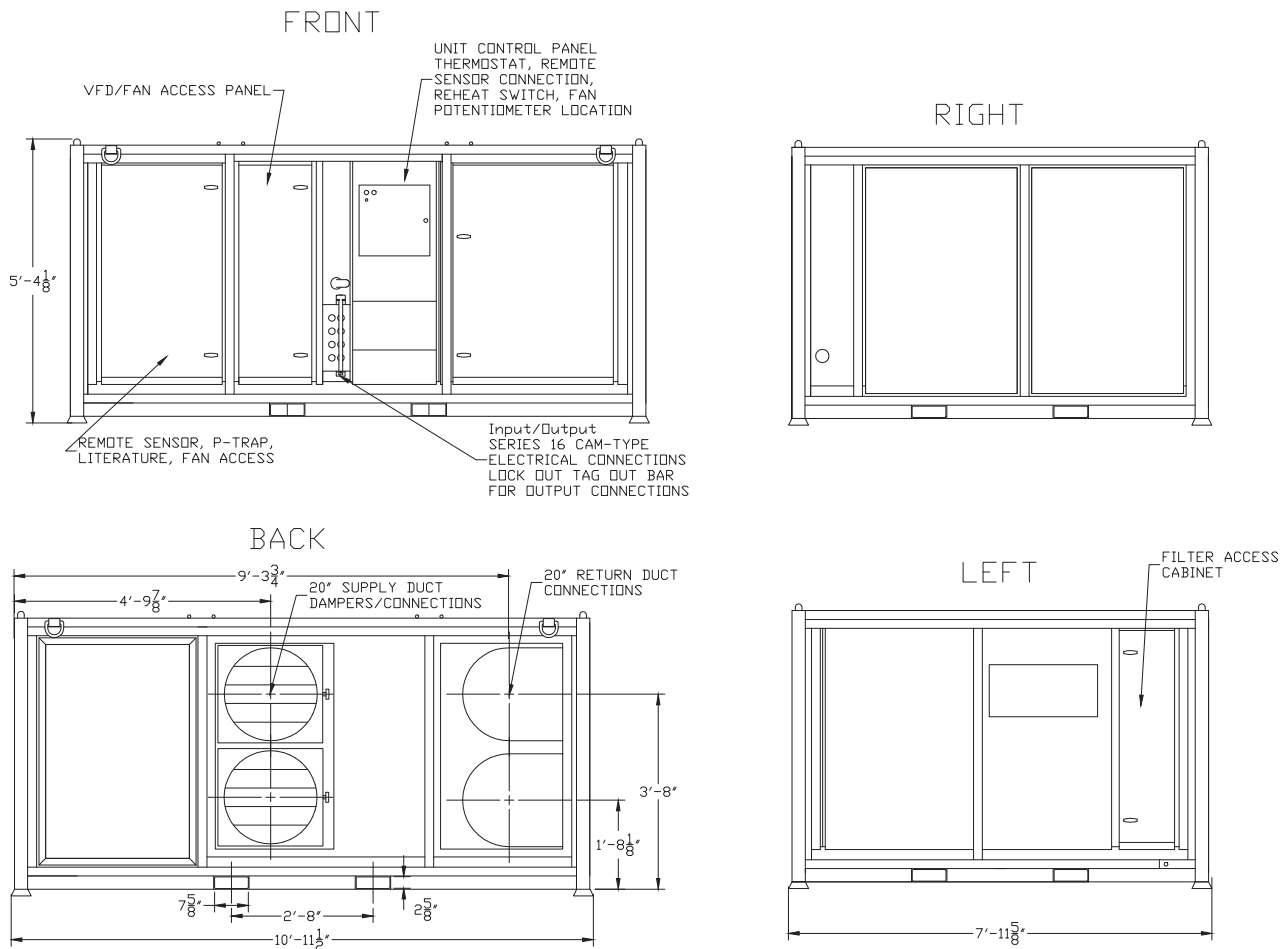

Model: CSDX0025F4ED-GL

Features

- Hot Gas Bypass
- Series 16 Cam Type Electrical Connections
- Incoming/Outgoing Power Daisy Chain Capable
- Phase and Under/Over Voltage Protection
- ReliaTel™ Trane Controls
- Hinged Service Access
- Electric Heat with Reheat Option
- Low Ambient Down to 0°F
- Four Stage Cooling and Two Stage Heating
- Unit Mounted Thermostat with Remote Option
- Blower VFD with Line Bypass and Speed Adjustment Potentiometer (VAV Mode Available Upon Request)
- Trane BACnet® Control Interface RS-485 MS/TP (Remote Monitoring Available Upon Request)
- Clogged Filter Switch

Table 19. General data – CSDX0025F4ED-GL

Labels	Value
Nominal Cooling Tons ^(a)	25
Heating Capacity	72 kW
Refrigerant	R-410A
Refrigerant Charge(Ckt1/Ckt2)	11.8lbs/10.6lbs
Number of Refrigerant Circuits	2
Number of Compressors	2
Ambient Operating Conditions	0°F – 115°F

(a) Design Conditions: 95°F Ambient, 80°F EDB, 71°F EWB, 400 CFM/Ton.

Table 20. Electrical data – circuit breaker style disconnect – CSDX0025F4ED-GL

Labels	Value
Number of Electrical Circuits	1
Voltage	460V 3 Phase
Frequency	60 Hz
Wire Connection Type	Series 16 Cam Type Only
SCCR	5000 A
Minimum Circuit Ampacity (MCA)	111.8 A
Maximum Overcurrent Protection (MOP)	125 A
Cooling Only FLA	50.7 A
Heating Only FLA	101.4 A
Reheat (36kW Electric Heat + All Cooling) FLA	95.9 A



Voyager™ with Electric Heat

Table 21. Airflow data – CSDX0025F4ED-GL

Labels	Value
Supply Motor	7.5 HP
Nominal CFM	10,000
Minimum/Maximum CFM	7,000 – 11,000
Maximum ESP at Nominal CFM	1.25 in.
Supply Air Connection Qty/Size	(2) 20 in.
Return Air Connection Qty/Size	(2) 20 in.
Merv-8 Throwaway Filter Qty/Size	(12) 20 in. x 20 in. x 2 in.
Maximum Supply/Return Duct Run at 7000 CFM	650 ft.
Maximum Supply/Return Duct Run at 10,000 CFM	125 ft.

Table 22. Dimensions and weights – CSDX0025F4ED-GL

Labels	Value
Length	11 ft. 0.25 in.
Width	8 ft. 0.25 in.
Height	6 ft. 3.25 in.
Shipping Weight	3,700 lbs.
Fork Pocket Dimensions	7.625 in. x 3.625 in.
Center to Center Distance of Fork Pockets	32 in.

Notes:

- Lifting Device: Forklift or crane.
- Confirm all dimensions and weights with TRS turnkey facility because this data might not match what is listed in this document.
- For additional installation information, see RT-SVX25*-EN.

Table 23. Operating clearances – CSDX0025F4ED-GL

Labels	Value
Sides	48 in.
Front (Control Panel)	60 in.
Back (Supply/Return)	18 in.
Top	No obstructions

Note: Operating clearances are provided based on single machine, above ground. For multiple unit or pit operation, contact Trane Rental Services.

Figure 2. Fan curve – CSDX0025F4ED-GL

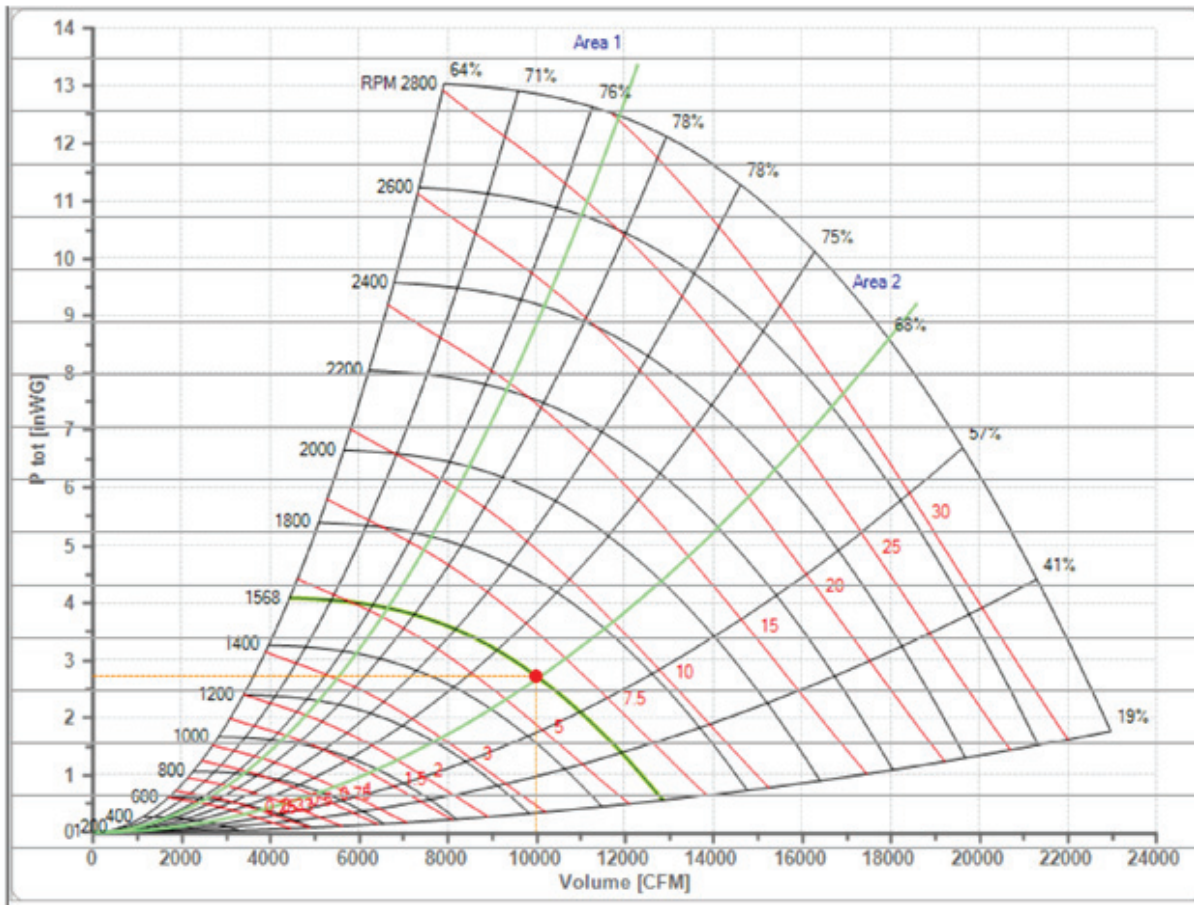

Table 24. Electric heating performance – CSDX0025F4ED-GL

CFM	Temp Rise (°F)
7000	32.4
8000	28.3
9000	25.2
10000	22.7
11000	20.6

Table 25. Sound data – CSDX0025F4ED-GL

CSDX0025F4ED-GL Sound Data								
Sound Path (Hz)	63	125	250	500	1K	2K	4K	8K
Ducted Discharge (dB)	94	88	78	80	79	79	79	74
Ducted Inlet (dB)	92	84	78	74	69	71	71	66
Outdoor Noise (dB)	102	89	93	94	92	87	83	75



Voyager™ with Electric Heat

Table 26. Gross cooling capacities – CSDX0025F4ED-GL

Airflow cfm	Ent DB (°F)	Ambient Temperature (°F)																	
		85						95						105					
		Entering Wet Bulb																	
		61		67		73		61		67		73		61		67		73	
MBh	SHC	MBh	SHC	MBh	SHC	MBh	SHC	MBh	SHC	MBh	SHC	MBh	SHC	MBh	SHC	MBh	SHC		
7000	75	265.0	218.8	289.1	175.7	308.5	103.5	251.6	209.8	273.9	168.5	292.2	98.3	237.1	200.1	257.7	160.6	274.8	92.5
	80	272.6	243.7	290.1	213.7	312.6	162.9	259.1	233.6	275.1	205.1	296.2	156.0	244.6	222.8	259.1	195.8	278.8	148.4
	85	282.6	263.5	295.9	241.5	316.7	204.5	268.8	252.4	280.9	231.7	300.2	196.1	254.0	240.6	264.8	221.2	282.7	187.1
	90	293.9	279.9	304.6	263.0	320.8	234.9	279.7	268.1	289.2	252.2	304.2	225.4	264.4	255.6	272.9	240.8	286.7	215.3
8000	75	273.3	229.9	295.7	185.4	324.1	111.8	259.1	220.1	279.8	177.5	306.4	105.9	243.9	209.7	262.8	168.9	287.8	99.3
	80	281.8	255.9	298.0	224.7	324.2	172.6	267.6	245.0	282.2	215.4	306.7	165.0	252.3	233.5	265.5	205.3	288.3	156.6
	85	292.5	276.6	304.7	253.7	324.2	215.6	278.0	264.7	288.9	243.1	307.0	206.4	262.5	252.2	272.1	231.9	288.7	196.7
	90	304.5	293.8	314.1	276.0	329.2	247.0	289.5	281.2	298.1	264.5	311.9	236.8	273.5	268.0	281.0	252.4	293.6	225.9
9000	75	280.1	239.6	301.0	193.8	327.8	118.7	265.2	229.1	284.3	185.2	309.4	112.0	249.3	218.0	266.6	175.8	290.0	104.7
	80	289.6	266.7	304.4	234.4	329.1	181.0	274.7	255.1	288.0	224.3	310.9	172.6	258.7	242.8	270.5	213.5	291.7	163.6
	85	301.1	288.3	312.1	264.4	330.3	225.2	285.9	275.7	295.6	253.1	312.3	215.4	269.6	262.5	278.1	241.2	293.3	204.9
	90	313.7	306.3	322.3	287.7	336.3	257.8	297.9	293.0	305.5	275.5	318.3	246.8	281.2	279.0	287.7	262.6	299.2	235.1
10000	75	285.6	247.9	304.9	200.8	330.2	124.2	270.0	236.7	287.4	191.4	311.0	116.8	253.3	224.8	269.0	181.3	290.9	108.7
	80	296.1	276.1	309.5	242.7	332.6	188.0	280.4	263.8	292.3	231.9	313.7	178.9	263.6	250.7	274.1	220.3	293.7	169.1
	85	308.3	298.6	318.2	273.8	335.0	233.5	292.3	285.3	300.9	261.7	316.3	222.9	275.3	271.3	282.6	249.0	296.6	211.7
	90	321.4	317.4	329.1	298.0	342.0	267.1	305.0	303.3	311.6	285.0	323.2	255.4	287.5	287.5	293.0	271.4	303.4	243.0
11000	75	289.7	254.9	307.3	206.5	331.1	128.3	273.3	243.0	289.2	196.3	311.2	120.2	255.9	230.3	270.0	185.5	291.5	111.3
	80	301.1	284.2	313.2	249.6	334.7	193.7	284.7	271.1	295.2	238.0	315.1	183.8	267.2	257.3	276.3	225.8	294.4	173.2
	85	314.1	307.6	322.8	281.8	338.3	240.4	297.4	293.5	304.8	269.0	318.9	229.1	279.6	278.8	285.8	255.6	298.4	217.1
	90	327.9	327.1	334.5	306.9	346.3	275.1	310.7	310.7	316.3	293.2	326.8	262.7	292.5	292.5	297.0	278.8	306.2	249.5
Airflow cfm	Ent DB (°F)	Ambient Temperature (°F)																	
		115						120						125					
		Entering Wet Bulb																	
		61		67		73		61		67		73		61		67		73	
MBh	SHC	MBh	SHC	MBh	SHC	MBh	SHC	MBh	SHC	MBh	SHC	MBh	SHC	MBh	SHC	MBh	SHC		
7000	75	221.7	189.7	240.4	152.0	256.4	85.9	213.6	184.3	231.5	147.5	246.8	82.4	205.2	178.7	222.2	142.8	237.0	78.7
	80	229.1	211.3	242.1	185.8	260.3	140.1	220.9	205.2	233.2	180.5	250.7	135.7	212.6	199.1	224.1	175.1	240.8	131.1
	85	238.2	228.2	247.7	210.1	264.2	177.4	229.9	221.7	238.8	204.3	254.6	172.3	221.4	215.1	229.6	198.2	244.7	167.0
	90	248.2	242.4	255.6	228.7	268.1	204.4	239.7	235.5	246.5	222.4	258.4	198.7	230.9	228.5	237.2	215.9	248.5	192.8
8000	75	227.7	198.6	244.9	159.6	268.2	92.0	219.2	192.8	235.5	154.6	258.0	88.1	210.5	186.8	225.9	149.6	247.5	84.0
	80	236.1	221.2	247.7	194.6	268.8	147.6	227.6	214.8	238.5	189.0	258.7	142.8	218.8	208.3	229.0	183.2	248.4	137.9
	85	245.9	239.0	254.3	220.0	269.5	186.2	237.3	232.2	245.0	213.8	259.5	180.8	228.4	225.2	235.5	207.4	249.2	175.1
	90	256.5	254.0	262.9	239.5	274.3	214.3	247.7	246.8	253.5	232.9	264.3	208.2	238.5	238.5	243.9	226.0	254.0	202.0
9000	75	232.4	206.1	247.9	165.7	269.7	96.6	223.5	200.0	238.2	160.5	259.1	92.4	214.4	193.6	228.2	155.0	248.3	87.9
	80	241.7	229.8	252.0	202.0	271.5	153.8	232.8	223.0	242.4	196.0	261.0	148.6	223.7	216.1	232.5	189.9	250.3	143.3
	85	252.3	248.5	259.5	228.5	273.4	193.7	243.3	241.3	249.9	221.9	263.0	187.8	234.1	233.9	240.0	215.2	252.4	181.8
	90	263.5	263.5	268.9	249.0	279.2	222.8	254.3	254.3	259.1	241.9	268.8	216.4	244.8	244.8	249.1	234.7	258.1	209.8
10000	75	235.6	212.3	249.6	170.5	269.8	99.9	226.4	205.7	239.5	164.9	260.5	95.3	217.0	199.0	229.2	159.1	249.2	90.5
	80	245.9	237.0	254.9	208.1	272.8	158.6	236.7	229.9	244.9	201.7	262.0	153.1	227.2	222.6	234.6	195.2	250.9	147.4
	85	257.3	256.6	263.3	235.7	275.9	199.7	247.9	247.9	253.3	228.7	265.1	193.5	238.3	238.3	243.1	221.6	254.1	187.1
	90	269.1	269.1	273.5	257.1	282.7	229.9	259.5	259.5	263.4	249.6	271.9	223.2	249.6	249.6	253.0	242.0	260.9	216.2
11000	75	237.5	217.0	249.9	174.0	271.0	101.8	228.0	210.1	240.5	167.9	261.3	96.8	218.1	203.0	229.8	161.7	252.3	91.6
	80	248.8	242.8	256.3	212.8	274.0	162.0	239.2	235.3	246.0	206.1	263.6	156.1	229.3	227.7	235.4	199.2	253.4	150.1
	85	260.9	260.9	265.8	241.4	277.0	204.4	251.2	251.2	255.4	234.1	265.9	197.9	241.2	241.2	244.8	226.6	254.5	191.1
	90	273.3	273.3	276.7	263.8	284.7	235.7	263.3	263.3	266.2	256.0	273.6	228.5	253.1	253.1	255.4	248.0	262.2	221.2

Notes:

1. All capacities shown are gross and have not considered indoor fan heat. To obtain NET cooling capacity subtract indoor fan heat. For indoor fan heat formula, refer to appropriate airflow table notes.
2. MBh = Total Gross Capacity.
3. SHC = Sensible Heat Capacity.

Unit Drawings – CSDX0025F4ED-GL

Front

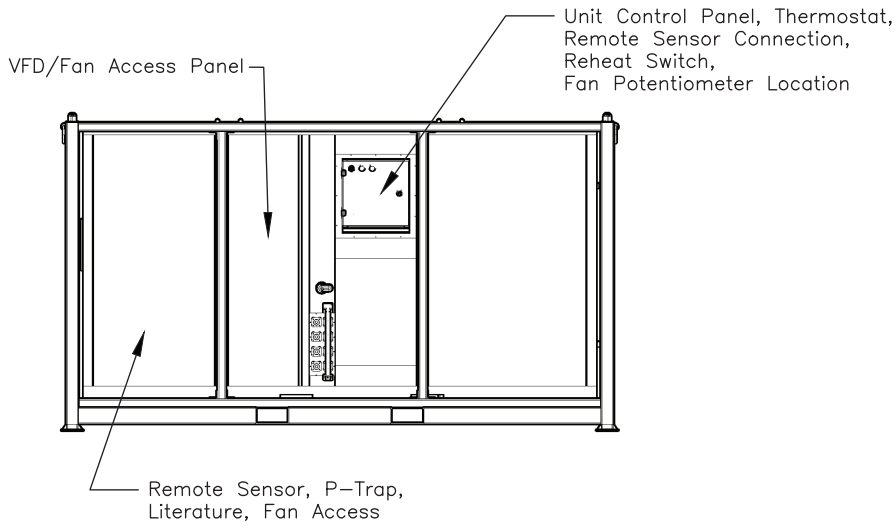

Left

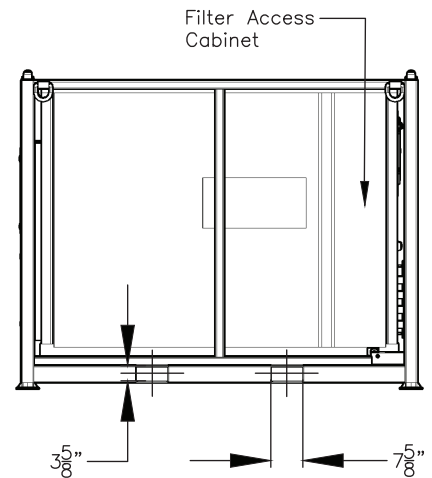

Back

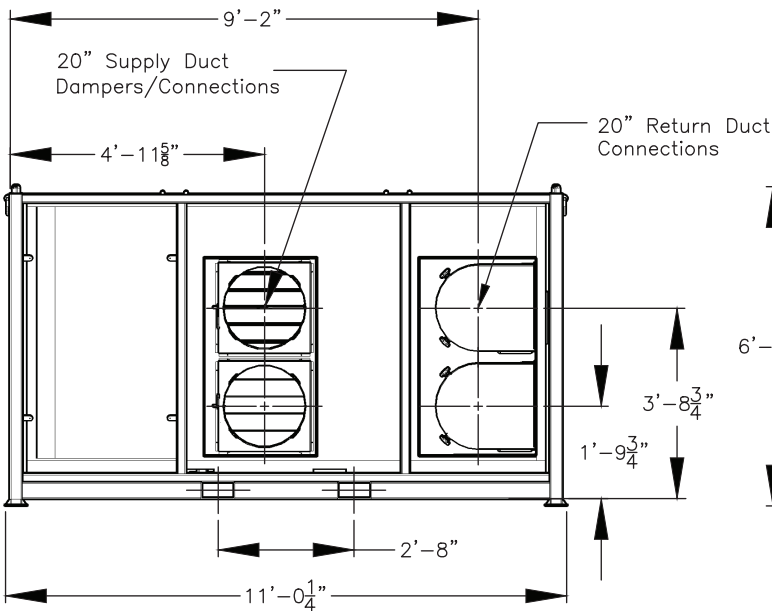

Right

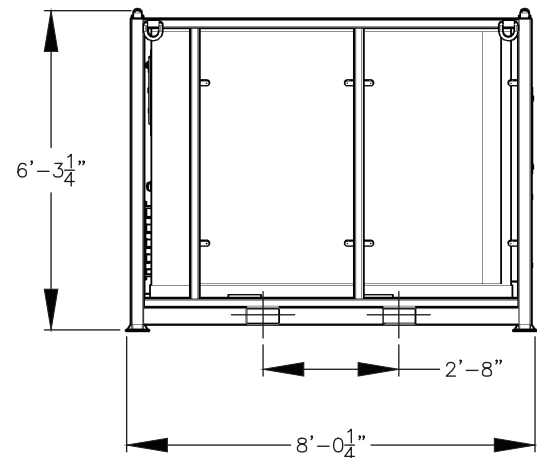



Voyager™ with Electric Heat

Model: CSDX0025F5

Features

- Incoming/Outgoing Power Daisy Chain Capable
- Constant Volume Fan with Field Adjustable Sheave
- Hinged Service Access
- Phase and Under/Over Voltage Protection
- Series 16 Cam Type Electrical Connections
- Unit Mounted Thermostat with Remote Option
- Trane BACnet® Control Interface RS-485 MS/TP and Remote Monitoring Available Upon Request
- Clogged Filter Switch Kit
- Hot Gas Bypass
- Manual Supply Air Dampers
- Two Stage Cooling and Heating
- Low Ambient Operation Down to 0°F

Table 27. General data – CSDX0025F5

Labels	Value
Nominal Cooling Tons ^(a)	25
Heating Capacity (Input/Output) ^{(b) (c)}	250/200 Mbh
Refrigerant	R-410A
Number of Refrigerant Circuits	2
Number of Compressors	2
Ambient Operating Conditions	0°F – 115°F

(a) Design Conditions: 95°F Ambient, 80°F EDB, 71°F EWB, 400 CFM/Ton.

(b) Gas Heat – Machine will come with factory fitted gas valve to orifice plate only. Trane does not provide any gas piping, fittings, regulators required to connect to machine. When gas heat is utilized, Trane start-up is required.

(c) Unit will ship from Trane ready to operate with Natural Gas. LP Kit available for field installation only. Unit must be returned to NG prior to returning the machine to TRS.

Table 28. Electrical data – circuit breaker style disconnect – CSDX0025F5

Labels	Value
Number of Electrical Circuits	1
Voltage	460V 3 Phase
Frequency	60 Hz
Wire Connection Type	Series 16 Cam Type Only
SCCR	5000 A
Minimum Circuit Ampacity (MCA)	58.65 A
Maximum Overcurrent Protection (MOP)	70 A
Cooling Only FLA	54 A
Heating Only FLA	11.8 A

Table 29. Airflow data – CSDX0025F5

Labels	Value
Supply Motor	7.5 HP
Nominal CFM	10,000
Minimum/Maximum CFM	7,000 – 11,000
Maximum ESP at Nominal CFM	0.5 in.
Supply Air Connection Qty/Size	(2) 20 in.
Return Air Connection Qty/Size	(2) 20 in.
Merv-7 Throwaway Filter Qty/Size	(8) 20 in. x 25 in. x 2 in.
Maximum Supply/Return Duct Run at Minimum CFM	175 ft.
Maximum Supply/Return Duct Run at Maximum CFM	50 ft.

Table 30. Dimensions and weights – CSDX0025F5

Labels	Value
Length	10 ft. 11.5 in.
Width	8 ft. 0 in.
Height	5 ft. 1.25 in.
Shipping Weight	3,600 lbs
Fork Pocket Dimensions	7.625 in. x 2.625 in.
Center to Center Distance of Fork Pockets	32 in.

Notes:

- Lifting Device: Forklift or crane.
- Confirm all dimensions and weights with TRS turnkey facility because this data might not match what is listed in this document.
- For additional installation information, see RT-SVX26*-EN.

Table 31. Operating clearances – CSDX0025F5

Labels	Value
Ends	4 ft.
Front (Control Panel)	5 ft.
Back (Supply/Return Duct Connections)	3 ft.
Top	No Obstructions

Note: Operating clearances are provided based on single machine, above ground. For multiple unit or pit operation, contact Trane Rental Services.



Voyager™ with Electric Heat

Table 32. External static pressure – CSDX0025F5

External Static Pressure (Inches of Water)																					
cfm	0.10		0.20		0.30		0.40		0.50		0.60		0.70		0.80		0.90		1.00		
	rpm	bhp	rpm	bhp	rpm	bhp	rpm	bhp	rpm	bhp	rpm	bhp	rpm	bhp	rpm	bhp	rpm	bhp	rpm	bhp	
											7.5-hp Standard Motor and Drive										
7000											694	3.19	716	3.38	738	3.58	760	3.79	783	4.01	
7500									704	3.57	725	3.76	746	3.94	767	4.15	787	4.36	807	4.57	
8000						716	3.99	737	4.19	757	4.39	777	4.59	797	4.80	816	5.02	835	5.24		
8500			705	4.16	728	4.42	750	4.67	770	4.89	790	5.11	808	5.30	827	5.53	846	5.75	864	5.98	
9000	717	4.63	740	4.86	763	5.14	785	5.43	804	5.66	823	5.89	841	6.12	859	6.34	877	6.57			
9500	752	5.38	777	5.68	799	5.97	818	6.23	838	6.50	856	6.76	874	7.00							
10000	791	6.27	814	6.56	834	6.86	854	7.16	872	7.43											
10500	828	7.23	850	7.55	869	7.80															
11000	867	8.33																			

External Static Pressure (Inches of Water)										
cfm	1.10		1.20		1.30		1.40		1.50	
	rpm	bhp	rpm	bhp	rpm	bhp	rpm	bhp	rpm	bhp
7.5-hp Standard Motor and Drive										
7000	805	4.24	827	4.74	849	4.69	869	4.91		
7500	828	4.82	850	5.06	871	5.31				
8000	853	5.46	873	5.72						
8500										
9000										
9500										
10000										
10500										
11000										

Notes:

1. Fan motor heat (MBh) = 3.15 x Fan bhp.
2. Data includes pressure drop due to standard filters and wet coils. No accessories or options are included in pressure drop data.
3. Factory supplied motors, in commercial equipment, are definite purpose motors, specifically designed and tested to operate reliably and continuously at all cataloged conditions. Using the full horsepower range of our fan motors as shown in our tabular data will not result in nuisance tripping or premature motor failure. Our product's warranty will not be affected.



Voyager™ with Electric Heat

Table 34. Gas heating performance – CSDX0025F5

CFM	Temp Rise (°F)
7000	26.3
8000	23.0
9000	20.5
10000	18.4
11000	16.8

Table 35. Sound data – CSDX0025F5

Sound Path (Hz)	63	125	250	500	1K	2K	4K	8K
Ducted Discharge (dB)	94	88	78	80	79	79	79	74
Ducted Inlet (dB)	92	84	78	74	69	71	71	66
Outdoor Noise (dB)	102	89	93	94	92	87	83	75

Unit Drawings – CSDX0025F5

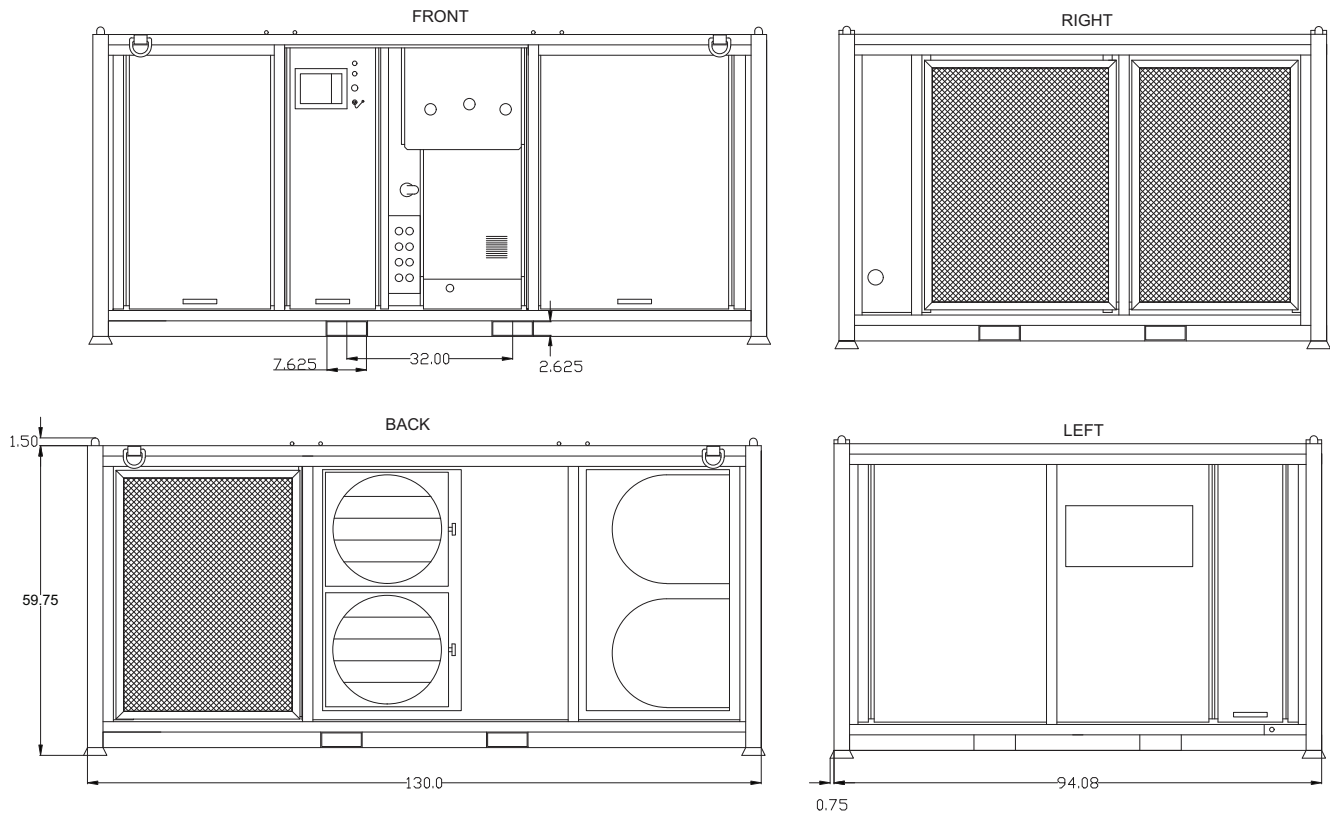

Model: RSDX0025F7AA-AK

Features

- Two Direct Drive Plenum Fans
- Series 16 Cam Type Electrical Connections
- Phase and Under/Over Voltage Protection
- Symbio 700 Trane Controls
- Hinged Service Access
- Electric Heat with Reheat Option
- Low Ambient Down to 0°F
- Four Stage Cooling and Two Stage Heating
- Unit Mounted Thermostat with Remote Option
- Variable Speed Evaporator Fans with EC motors
- Trane BACnet® Control Interface RS-485 MS/TP (Remote Monitoring Available Upon Request)
- Clogged Filter Switch
- RA Humidity Sensor for Dehumidification Electric Reheat

Table 36. General data – RSDX0025F7AA-AK

Labels	Value
Nominal Cooling Tons ^(a)	25
Heating Capacity	72 kW
Refrigerant	R-410A
Refrigerant Charge	38.0 lbs
Number of Refrigerant Circuits	1
Number of Compressors	2
Ambient Operating Conditions	0°F – 125°F

(a) Design Conditions: 95°F Ambient, 80°F EDB, 71°F EWB, 400 CFM/Ton.

Table 37. Electrical data – circuit breaker style disconnect – RSDX0025F7AA-AK

Labels	Value
Number of Electrical Circuits	1
Voltage	460V 3 Phase
Frequency	60 Hz
Wire Connection Type	Series 16 Cam Type Only
SCCR	65 kA
Minimum Circuit Ampacity (MCA)	147 A
Maximum Overcurrent Protection (MOP)	150 A
Cooling Only FLA	54.3 A
Heating + Aux Electric Heat FLA	144.8 A
Reheat (72kW Electric Heat + All Cooling) FLA	99.5 A



Voyager™ with Electric Heat

Table 38. Airflow data – RSDX0025F7AA-AK

Labels	Value
Supply Motor	7.5 HP
Nominal CFM	10,000
Minimum/Maximum CFM	7,500 – 12,000
Maximum ESP at Nominal CFM	1.70 in.
Supply Air Connection Qty/Size	(2) 20 in.
Return Air Connection Qty/Size	(2) 20 in.
Merv-8 Throwaway Filter Qty/Size	(4) 20 in. x 24 in. x 2 in. and (4) 20 in. x 30 in. x 2 in.
Maximum Supply/Return Duct Run at 7500 CFM	500 ft.
Maximum Supply/Return Duct Run at 12,000 CFM	150 ft.

Table 39. Dimensions and weights – RSDX0025F7AA-AK

Labels	Value
Length	11 ft. 6 in.
Width	8 ft. 5 in.
Height	8 ft. 6 in.
Shipping Weight	4,900 lbs
Fork Pocket Dimensions	7.625 in. x 3.625 in.
Center to Center Distance of Fork Pockets	3 ft. 2 in.

Note: Lifting Device: Forklift or crane.

Table 40. Operating clearances – RSDX0025F7AA-AK

Labels	Value
Front (Control Panel)	60 in.
Back Side	36 in.
Left Side (Supply/Return)	68 in.
Right Side (Power Connection)	48 in.
Top	No obstructions

Note: Operating clearances are provided based on single machine, above ground. For multiple unit or pit operation, contact Trane Rental Services.

Figure 3. Fan curve – RSDX0025F7AA-AK

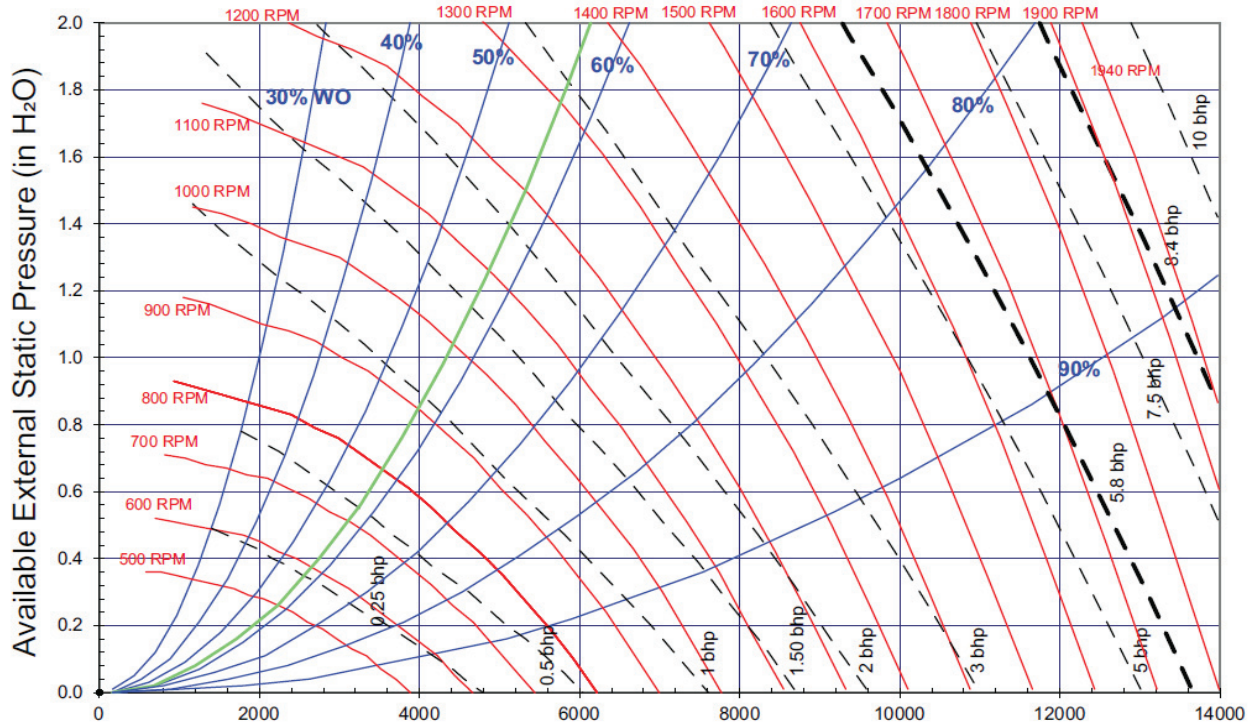

Table 41. Electric heating performance – RSDX0025F7AA-AK

CFM	Temp Rise (°F)
7500	30.35
9000	25.29
10000	22.76
11000	20.69
12000	18.97

Table 42. Sound data – RSDX0025F7AA-AK

Octave Center Frequency (Hz)	63	125	250	500	1K	2K	4K	8K	Overall dBA
	94	90	92	91	88	84	81	75	



Voyager™ with Electric Heat

Table 43. Gross cooling capacities – RSDX0025F7AA-AK

Airflow cfm	Ent DB (°F)	Ambient Temperature (°F)																	
		85						95						105					
		Entering Wet Bulb																	
		61		67		73		61		67		73		61		67		73	
MBh	SHC	MBh	SHC	MBh	SHC	MBh	SHC	MBh	SHC	MBh	SHC	MBh	SHC	MBh	SHC	MBh	SHC		
7500	75	247.4	201.9	273.9	155.7	301.5	107.9	233.5	194.4	258.6	148.2	284.3	100.4	218.8	186.5	242.5	140.4	266.0	92.7
	80	250.4	238.1	275.3	193.8	303.1	146.3	237.0	230.3	260.1	186.3	286.4	138.9	222.9	222.1	244.0	178.5	268.8	131.3
	85	260.5	260.5	276.6	231.8	304.4	184.4	248.4	248.4	261.7	224.4	288.0	177.1	235.4	235.4	245.9	216.7	270.5	169.5
	90	274.9	274.9	280.0	267.7	305.4	222.4	262.5	262.5	265.6	260	289.1	215.2	249.2	249.2	250.6	250.6	271.7	207.6
9000	75	255.6	222.5	281.6	167.6	308.2	111.2	241.2	214.9	265.7	160	290.4	103.8	225.8	207.0	248.8	152.1	271.5	96.0
	80	261.5	261.5	283.1	212.5	310.7	156.6	248.1	248.1	267.3	204.9	293.4	149.1	234.5	234.5	250.5	197.0	275.0	141.4
	85	276.3	276.3	285.7	257.7	312.3	201.6	263.1	263.1	270.3	250.3	295.1	194.2	249.1	249.1	253.9	238.4	276.9	186.5
	90	291.7	291.7	292.4	292.4	313.6	246.4	278.2	278.2	278.3	278.3	296.7	239.1	263.7	263.7	264.1	264.1	278.7	231.5
10000	75	260.2	235.7	285.7	175.2	311.9	113.4	245.5	228.1	269.3	167.5	293.6	105.8	230.0	215.4	252.0	159.6	274.4	98.0
	80	268.7	268.7	287.2	224.4	314.7	163.1	255.6	255.6	271.1	216.8	297.0	155.6	241.4	241.4	254.0	209.0	278.2	147.9
	85	284.8	284.8	290.9	270.6	316.3	212.5	271.1	271.1	275.3	262.5	298.8	205.1	256.4	256.4	258.9	253.9	280.1	197.3
	90	300.8	300.8	301.2	301.2	318.1	261.9	286.7	286.7	287.0	287.0	300.9	254.5	271.5	271.5	271.8	271.8	282.6	246.9
11000	75	264.3	248.5	289.0	182.4	314.9	115.4	249.5	235.9	272.4	174.8	296.3	107.8	233.9	227.1	254.8	166.7	276.7	99.9
	80	275.8	275.8	290.8	236.0	318.1	169.4	262.0	262.0	274.5	228.4	300.0	161.9	247.2	247.2	257.2	220.5	280.9	154.1
	85	292.2	292.2	295.8	285.7	319.7	223	277.9	277.9	280.1	277.5	301.8	215.6	262.7	262.7	263.6	263.6	282.9	207.8
	90	308.6	308.6	308.9	308.9	322.1	276.9	293.9	293.9	294.2	294.2	304.6	269.5	278.2	278.2	278.4	278.4	286.1	261.9
12000	75	268.2	255.8	291.9	189.5	317.4	117.3	253.2	247.3	275.0	181.7	298.6	109.7	237.4	237.4	257.1	173.7	278.6	101.8
	80	281.8	281.8	294.1	247.3	320.9	175.5	267.5	267.5	277.5	239.7	302.5	167.9	252.3	252.3	260.0	231.7	283.2	160.1
	85	298.5	298.5	300.4	300.4	322.6	233.2	283.8	283.8	284.6	284.6	304.4	225.8	268.1	268.1	268.2	268.2	285.2	218.0
	90	315.3	315.3	315.7	315.7	325.7	291.4	300.1	300.1	300.4	300.4	308.0	284.1	283.9	283.9	284.1	384.1	289.3	269.9
Airflow cfm	Ent DB (°F)	Ambient Temperature (°F)																	
		115						125											
		Entering Wet Bulb																	
		61		67		73		61		67		73		61		67		73	
MBh	SHC	MBh	SHC	MBh	SHC	MBh	SHC	MBh	SHC	MBh	SHC	MBh	SHC	MBh	SHC	MBh	SHC		
7500	75	203.0	178.3	225.2	132.2	246.7	84.6	186.2	169.5	206.7	123.5	225.9	76.1						
	80	208.2	208.2	226.8	170.3	250.0	123.3	193.3	193.3	208.4	161.7	229.8	114.8						
	85	221.4	221.4	229.0	208.7	251.9	161.5	206.2	206.2	211.0	196.2	231.7	153.1						
	90	234.8	234.8	235.0	235.0	253.3	199.7	219.1	219.1	219.4	219.4	233.3	191.2						
9000	75	209.6	194.3	230.8	143.8	251.5	87.8	192.5	184.5	211.5	135.1	229.9	79.2						
	80	219.8	219.8	232.7	188.8	255.5	133.4	203.9	203.9	213.7	180.2	234.5	124.8						
	85	234.0	234.0	236.8	229.5	257.5	178.4	217.5	217.5	218.6	218.6	236.6	169.9						
	90	248.1	248.1	248.4	248.4	259.7	223.6	231.1	231.1	231.3	231.3	239.1	215.1						
10000	75	213.7	206.2	233.7	151.2	253.9	89.8	196.3	196.2	214.0	142.4	231.8	81.1						
	80	226.1	226.1	236.0	200.7	258.4	139.8	209.5	209.5	216.5	186.5	237.0	131.2						
	85	240.7	240.7	241.7	241.7	260.4	189.2	223.5	223.5	223.6	223.6	239.1	180.7						
	90	255.2	255.2	255.5	255.5	263.3	239.0	237.4	237.4	237.6	237.6	242.5	224.2						
11000	75	217.4	217.4	236.1	158.4	255.8	91.7	200.0	200.0	216.0	149.5	233.2	82.9						
	80	231.4	231.4	238.9	212.3	260.7	146.0	214.3	214.3	219.3	196.7	239.0	137.3						
	85	246.4	246.4	246.5	246.5	262.8	199.7	228.6	228.6	228.8	228.8	241.3	191.1						
	90	261.3	261.3	261.5	261.5	266.6	247.5	242.7	242.7	243.0	243.0	245.7	237.6						
12000	75	220.9	220.9	238.1	165.3	257.3	93.5	203.7	203.7	217.7	156.3	234.3	84.7						
	80	236.1	236.1	241.5	216.8	262.7	152.0	218.4	218.4	221.8	206.4	240.6	143.3						
	85	251.3	251.3	251.5	251.5	265.0	209.9	232.9	232.9	233.1	233.1	243.3	201.3						
	90	266.4	266.4	266.7	266.7	269.8	260.6	247.3	247.3	247.5	247.5	248.8	248.8						

Notes:

1. All capacities shown are gross and have not considered indoor fan heat. To obtain NET cooling capacity subtract indoor fan heat. For indoor fan heat formula, refer to appropriate airflow table notes.
2. MBh = Total Gross Capacity.
3. SHC = Sensible Heat Capacity.

Table 44. Gross heating capacity – RSDX0025F7AA-AK

Outdoor Temp (°F) 70% RH	Integrated Heating Capacity (MBh/1000) at Indicated Dry Bulb Temp (°F)				Total Power in Kilowatts at Indicated Dry Bulb Temp (°F)			
	60	70	75	80	60	70	75	80
22	167.0	163.5	161.8	160.1	19.1	20.8	21.7	22.7
27	182.0	177.9	176.2	174.3	19.3	21.0	22.0	23.0
32	197.9	193.6	191.2	189.3	19.6	21.3	22.3	23.3
37	213.6	208.8	206.4	204.2	19.8	21.6	22.5	23.5
42	230.0	224.7	222.1	219.5	20.1	21.9	22.8	23.8
47	246.6	240.8	237.9	235.0	20.4	22.1	23.1	24.1
52	263.9	257.5	254.3	251.2	20.6	22.4	23.4	24.4
57	282.2	275.2	271.6	268.1	20.9	22.7	23.7	24.7
62	300.4	292.6	288.7	284.8	21.2	23.0	24.0	25.1
67	318.4	309.8	305.4	301.0	21.5	23.3	24.3	25.4
72	338.1	328.1	323.2	318.2	21.9	23.7	24.7	25.7

Unit Drawings – RSDX0025F7AA-AK

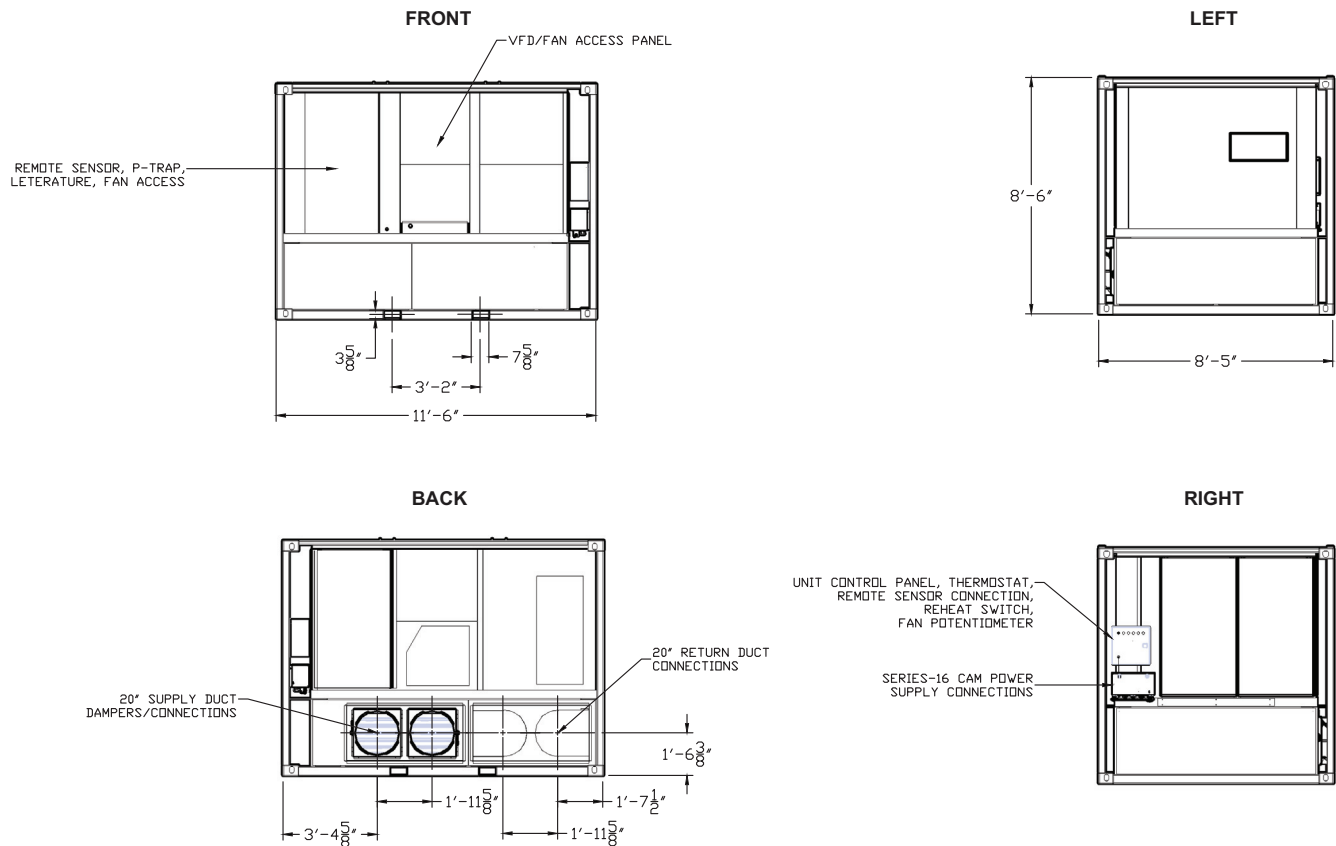



Voyager™ with Electric Heat

Model: CSDX0035F0

Features

- 0 to 100 percent Economizer, Dry Bulb Control
- VAV with VFD and with Bypass
- Hinged Service Access
- Electric Heat with Reheat Option
- Phase and Under/Over Voltage Protection
- Series 16 Cam Type Electrical Connections
- Remote Room Sensor
- Trane BACnet® Control Interface RS-485 MS/TP and Remote Monitoring Available Upon Request
- Clogged Filter Switch Kit
- Hot Gas Bypass
- Manual Supply/Return Air Dampers
- Two Stage Cooling and Heating
- Low Ambient Operation Down to 0°F

Table 45. General data – CSDX0035F0

Labels	Value
Nominal Cooling Tons ^(a)	35
Heating Capacity	90 kW
Refrigerant	R-22/R-410A
Number of Refrigerant Circuits	2
Number of Compressors	2
Ambient Operating Conditions	0°F – 115°F

(a) Design Conditions: 95°F Ambient, 80°F EDB, 71°F EWB, 400 CFM/Ton.

Table 46. Electrical data – circuit breaker style disconnect – CSDX0035F0

Labels	Value
Number of Electrical Circuits	1
Voltage	460V 3 Phase
Frequency	60 Hz
Wire Connection Type	Series 16 Cam Type Connections or Hardwire (Maximum 350 MCM)
SCCR	5000 A
Minimum Circuit Ampacity (MCA)	180.1 A
Maximum Overcurrent Protection (MOP)	200 A
Cooling Only FLA	79 A
Heating Only FLA	131.1 A
Electric Reheat (60 kW Electric Heat + All Cooling) FLA	154.4 A

Table 47. Airflow data – CSDX0035F0

Labels	Value
Supply Motor	15 HP
Nominal CFM	14,000
Minimum/Maximum CFM	10,500 – 14,400
Maximum ESP at Nominal CFM	1.9 in.
Supply Air Connection Qty/Size	(2) 20 in.
Return Air Connection Qty/Size	(2) 20 in.
Merv-7 Throwaway Filter Qty/Size	(16) 16 in. x 20 in. x 2 in.
Maximum Supply/Return Duct Run at Minimum CFM	125 ft.
Maximum Supply/Return Duct Run at Maximum CFM	50 ft.

Table 48. Dimensions and weights – CSDX0035F0

Labels	Value
Length	19 ft. 0 in.
Width	8 ft. 4 in.
Height	7 ft. 2.25 in.
Shipping Weight	7000 lbs
Fork Pocket Dimensions	9.5 in. x 5.5 in. x 94 in.
Center to Center Distance of Fork Pockets	63.5 in.

Notes:

- Lifting Device: Forklift or crane.
- Confirm all dimensions and weights with TRS turnkey facility because this data might not match what is listed in this document.

Table 49. Operating clearances – CSDX0035F0

Labels	Value
Condenser Coil End	8 ft.
Economizer End	6 ft.
Front (Control Panel)	4 ft.
Back (Supply/Return Duct Connections)	4 ft.
Top	No Obstructions

Note: Operating clearances provided are for single unit use only, if multiple units are to be placed next to each other reach out to Trane Rental Services for more information.

Voyager™ with Electric Heat

Figure 4. Fan curve – CSDX0035F0

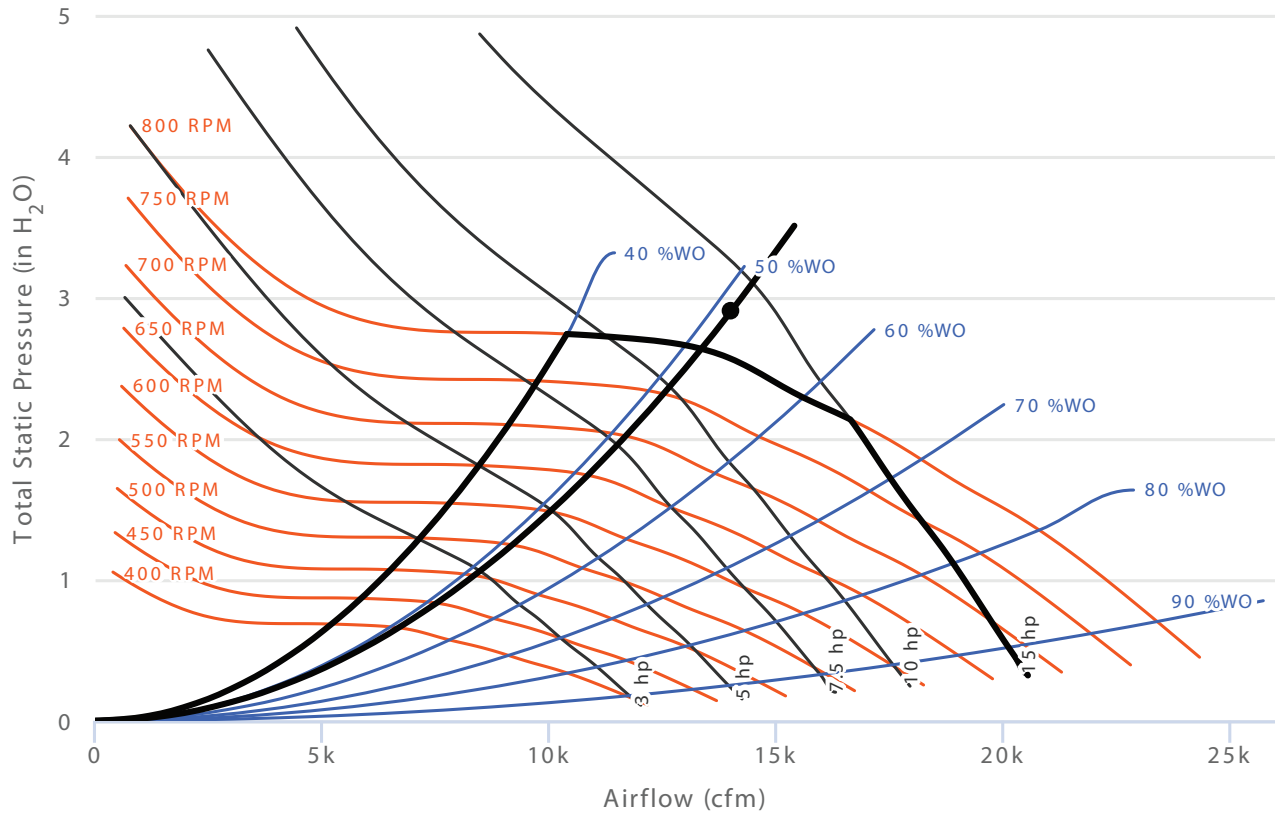

Table 50. Gross cooling capacities – CSDX0035F0

Airflow cfm	EntDB (°F)	Ambient Temperature																	
		85						95						105					
		Entering Wet Bulb						Entering Wet Bulb						Entering Wet Bulb					
		61		67		73		61		67		73		61		67		73	
TGC	SHC	TGC	SHC	TGC	SHC	TGC	SHC	TGC	SHC	TGC	SHC	TGC	SHC	TGC	SHC	TGC	SHC	TGC	SHC
10500	75	375	307	410	238	447	162	355	297	388	227	422	152	334	285	364	216	396	141
	80	381	364	412	293	450	221	361	353	390	282	425	210	340	340	267	269	399	200
	85	397	397	416	349	452	278	379	379	394	337	427	268	359	359	371	325	401	255
	90	417	417	422	406	454	332	399	399	401	394	430	321	378	378	378	378	404	309
12000	75	384	328	418	251	454	166	364	319	395	241	429	155	342	306	371	230	402	144
	80	392	392	421	312	458	232	373	373	398	300	433	222	353	353	374	288	406	211
	85	413	413	426	376	459	295	394	394	404	364	434	283	373	373	379	351	408	271
	90	434	434	434	434	463	357	414	414	414	414	438	345	392	392	392	392	412	333
13000	75	389	342	423	261	458	168	368	333	399	250	433	158	346	318	374	234	405	147
	80	400	400	426	324	462	240	381	381	403	313	436	229	360	360	378	300	409	218
	85	422	422	432	393	464	306	402	402	409	381	439	294	381	381	384	369	411	282
	90	444	444	444	444	468	373	423	423	423	423	443	361	400	400	400	400	416	348
14000	75	394	356	427	270	462	170	373	344	402	254	436	160	350	331	377	241	407	149
	80	408	408	430	337	466	247	388	388	407	325	440	237	367	367	382	312	411	223
	85	431	431	437	410	468	317	410	410	414	398	442	305	388	388	389	385	415	292
	90	456	456	456	456	475	395	434	434	434	434	449	383	410	410	410	410	421	370
14400	75	396	361	428	273	463	171	378	349	404	257	437	161	352	336	378	244	409	150
	80	411	411	432	341	467	250	391	391	408	329	441	239	369	369	383	317	412	225
	85	434	434	439	417	470	321	413	413	416	405	444	309	390	390	390	390	416	296
	90	456	456	456	456	475	395	434	434	434	434	449	383	410	410	410	410	421	370
Airflow cfm	EntDB (°F)	Ambient Temperature (°F)																	
		115																	
		Entering Wet Bulb																	
		61		67		73													
TGC	SHC	TGC	SHC	TGC	SHC														
10500	75	311	272	339	204	367	130												
	80	320	320	341	257	371	188												
	85	338	338	346	312	373	242												
	90	356	356	356	356	376	296												
12000	75	318	291	344	218	372	133												
	80	331	331	348	275	376	199												
	85	350	350	354	338	379	258												
	90	368	368	368	368	383	319												
13000	75	322	304	347	221	375	135												
	80	338	338	352	287	378	204												
	85	357	357	358	355	382	268												
	90	376	376	376	376	387	335												
14000	75	326	317	350	228	377	137												
	80	326	317	350	228	377	137												
	85	344	344	355	298	381	210												
	90	382	382	382	382	390	350												
14400	75	328	322	351	231	378	138												
	80	346	346	356	303	382	212												
	85	365	365	365	365	386	283												
	90	384	384	384	384	391	356												

Notes:

1. All capacities shown are gross and have not considered indoor fan heat.
2. TGC = Total gross capacity.
3. SHC = Sensible heat capacity.



Voyager™ with Electric Heat

Table 51. Electric heating performance – CSDX0035F0

CFM	Temp Rise (°F)
10500	30.1
12000	27.0
13000	25.5
14000	24.2
14400	23.7

Table 52. Sound data – CSDX0035F0

Sound Path (Hz)	63	125	250	500	1K	2K	4K	8K
Ducted Discharge (dB)	87	87	84	86	82	76	72	70
Ducted Inlet (dB)	88	79	73	80	75	70	65	58
Outdoor Noise (dB)	100	96	97	96	93	89	90	83

Unit Drawings – CSDX0035F0

Discharge Side View

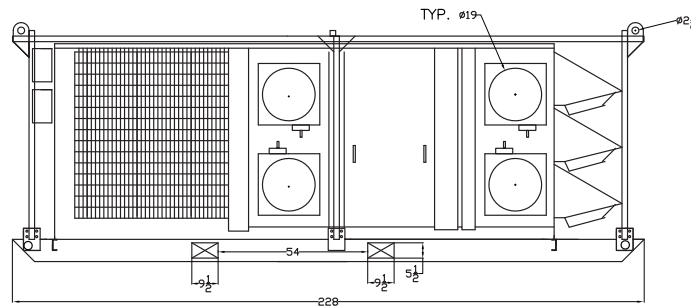

TRANE ELECTRICAL PANEL SIDE OF UNIT

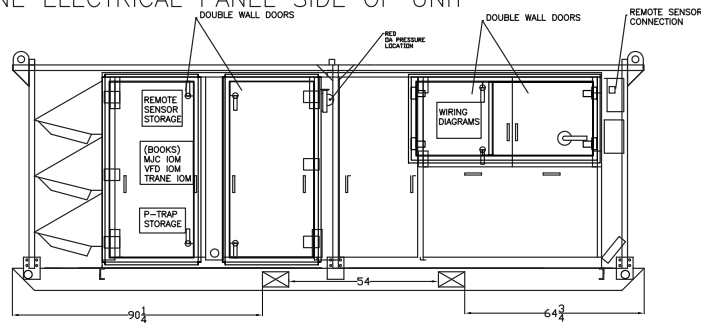

Front View

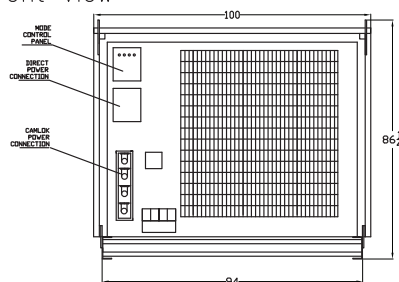

Model: CSDX0035F6

Features

- 0 to 100 percent Economizer, Dry Bulb Control
- Hot Gas Reheat (Performance available upon request)
- Blower VFD with across the Line Bypass and Speed Adjustment Potentiometer (VAV Mode Available Upon Request)
- Hinged Service Access
- Electric Heat with Reheat Option
- Phase and Under/Over Voltage Protection
- Series 16 Cam Type Electrical Connections
- Unit Mounted Thermostat with Remote Option
- Trane BACnet® Control Interface RS-485 MS/TP and Remote Monitoring Available Upon Request
- Clogged Filter Switch Kit
- Hot Gas Bypass
- Manual Supply Air Dampers
- Two Stage Cooling and Heating
- Low Ambient Operation Down to 0°F
- ReliaTel™ Trane Controls

Table 53. General data – CSDX0035F6

Labels	Value
Nominal Cooling Tons ^(a)	35
Heating Capacity	90 kW
Refrigerant	R-410A
Number of Refrigerant Circuits	2
Number of Compressors	2
Ambient Operating Conditions	0°F – 115°F

(a) Design Conditions: 95°F Ambient, 80°F EDB, 69°F EWB, 400 CFM/Ton.

Table 54. Electrical data – circuit breaker style disconnect – CSDX0035F6

Labels	Value
Number of Electrical Circuits	1
Voltage	460V 3 Phase
Frequency	60Hz
Wire Connection Type	Series 16 Cam Type Only
SCCR	5000 A
Minimum Circuit Ampacity (MCA)	180.1 A
Maximum Overcurrent Protection (MOP)	200 A
Cooling Only FLA	79.0 A
Heating Only FLA	131.1 A
Electric Reheat (60 kW Electric Heat + All Cooling) FLA	154.4 A



Voyager™ with Electric Heat

Table 55. Airflow data – CSDX0035F6

Labels	Value
Supply Motor	15 HP
Nominal CFM	14,000
Minimum/Maximum CFM	10,500 – 14,400
Maximum ESP at Nominal CFM	2.48 in.
Supply Air Connection Qty/Size	(2) 20 in.
Return Air Connection Qty/Size	(2) 20 in.
Merv-7 Throwaway Filter Qty/Size	(16) 16 in. x 20 in. x 2 in.
Maximum Supply/Return Duct Run at Minimum CFM	250 ft.
Maximum Supply/Return Duct Run at Maximum CFM	75 ft.

Table 56. Dimensions and weights – CSDX0035F6

Labels	F6CA-CQ	F6CR-DK
Length	18 ft. 4 in.	18 ft. 4 in.
Width	8 ft. 3.625 in.	7 ft. 7.25 in.
Height	7 ft. 4.5 in.	6 ft. 10 in.
Shipping Weight	7,900 lbs	6,420 lbs
Fork Pocket Dimensions	9.5 in. x 5.5 in.	9.5 in. x 5.5 in.
Center to Center Distance of Fork Pockets	60 in.	4 ft. 10.25 in.

Notes:

- Lifting Device: Forklift or crane.
- Confirm all dimensions and weights with TRS turnkey facility because this data might not match what is listed in this document.
- For additional installation information, see RT-SVX34*-EN.

Table 57. Operating clearances – CSDX0035F6

Labels	Value
Condenser Coil End	8 ft.
Economizer End (If equipped)	6 ft.
Front (Control Panel)	4 ft.
Back (Supply/Return Duct Connections)	4 ft.
Top	No Obstructions

Note: Operating clearances provided are for single unit use only, if multiple units are to be placed next to each other reach out to Trane Rental Services for more information.

Figure 5. Fan curve – CSDX0035F6

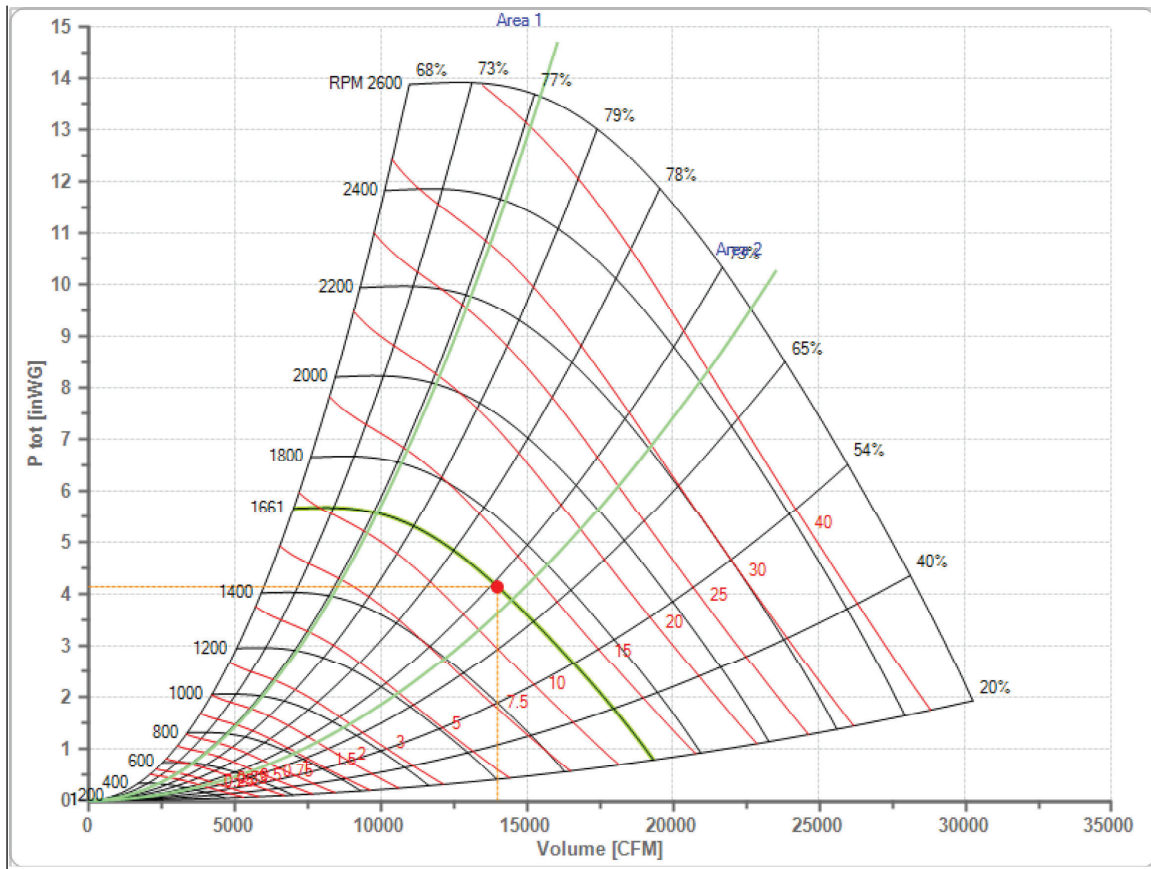



Voyager™ with Electric Heat

Table 58. Gross cooling capacities – CSDX0035F6

Airflow cfm	Ent DB (°F)	Ambient Temperature (°F)																	
		85						95						105					
		Entering Wet Bulb						Entering Wet Bulb						Entering Wet Bulb					
		61		67		73		61		67		73		61		67		73	
		TGC	SHC	TGC	SHC	TGC	SHC	TGC	SHC	TGC	SHC	TGC	SHC	TGC	SHC	TGC	SHC	TGC	SHC
10500	75	375	307	410	238	447	162	355	297	388	227	422	152	334	285	364	216	396	141
	80	381	364	412	293	450	221	361	353	390	282	425	210	340	340	267	269	399	200
	85	397	397	416	349	452	278	379	379	394	337	427	268	359	359	371	325	401	255
	90	417	417	422	406	454	332	399	399	401	394	430	321	378	378	378	378	404	309
12000	75	384	328	418	251	454	166	364	319	395	241	429	155	342	306	371	230	402	144
	80	392	392	421	312	458	232	373	373	398	300	433	222	353	353	374	288	406	211
	85	413	413	426	376	459	295	394	394	404	364	434	283	373	373	379	351	408	271
	90	434	434	434	434	463	357	414	414	414	414	438	345	392	392	392	392	412	333
13000	75	389	342	423	261	458	168	368	333	399	250	433	158	346	318	374	234	405	147
	80	400	400	426	324	462	240	381	381	403	313	436	229	360	360	378	300	409	218
	85	422	422	432	393	464	306	402	402	409	381	439	294	381	381	384	369	411	282
	90	444	444	444	444	468	373	423	423	423	423	443	361	400	400	400	400	416	348
14000	75	394	356	427	270	462	170	373	344	402	254	436	160	350	331	377	241	407	149
	80	408	408	430	337	466	247	388	388	407	325	440	237	367	367	382	312	411	223
	85	431	431	437	410	468	317	410	410	414	398	442	305	388	388	389	385	415	292
	90	456	456	456	456	475	395	434	434	434	434	449	383	410	410	410	410	421	370
14400	75	396	361	428	273	463	171	378	349	404	257	437	161	352	336	378	244	409	150
	80	411	411	432	341	467	250	391	391	408	329	441	239	369	369	383	317	412	225
	85	434	434	439	417	470	321	413	413	416	405	444	309	390	390	390	390	416	296
	90	456	456	456	456	475	395	434	434	434	434	449	383	410	410	410	410	421	370
Airflow cfm	Ent DB (°F)	Ambient Temperature (°F)																	
		115																	
		Entering Wet Bulb																	
		61		67		73		61		67		73		61		67		73	
		TGC	SHC	TGC	SHC	TGC	SHC	TGC	SHC	TGC	SHC	TGC	SHC	TGC	SHC	TGC	SHC	TGC	SHC
10500	75	311	272	339	204	367	130												
	80	320	320	341	257	371	188												
	85	338	338	346	312	373	242												
	90	356	356	356	356	376	296												
12000	75	318	291	344	218	372	133												
	80	331	331	348	275	376	199												
	85	350	350	354	338	379	258												
	90	368	368	368	368	383	319												
13000	75	322	304	347	221	375	135												
	80	338	338	352	287	378	204												
	85	357	357	358	355	382	268												
	90	376	376	376	376	387	335												
14000	75	326	317	350	228	377	137												
	80	326	317	350	228	377	137												
	85	344	344	355	298	381	210												
	90	382	382	382	382	390	350												
14400	75	328	322	351	231	378	138												
	80	346	346	356	303	382	212												
	85	365	365	365	365	386	283												
	90	384	384	384	384	391	356												

Notes:

1. All capacities shown are gross and have not considered indoor fan heat.
2. TGC = Total gross capacity.
3. SHC = Sensible heat capacity.

Table 59. Electric heating performance – CSDX0035F6

CFM	Temp Rise (°F)
10500	30.1
12000	27.0
13000	25.5
14000	24.2
14400	23.7

Table 60. Sound data – CSDX0035F6

Sound Path (Hz)	63	125	250	500	1K	2K	4K	8K
Ducted Discharge (dB)	89	92	95	89	86	79	74	68
Outdoor Noise (dB)	100	96	97	96	93	89	90	83

Unit Drawings – CSDX0035F6CA-CQ

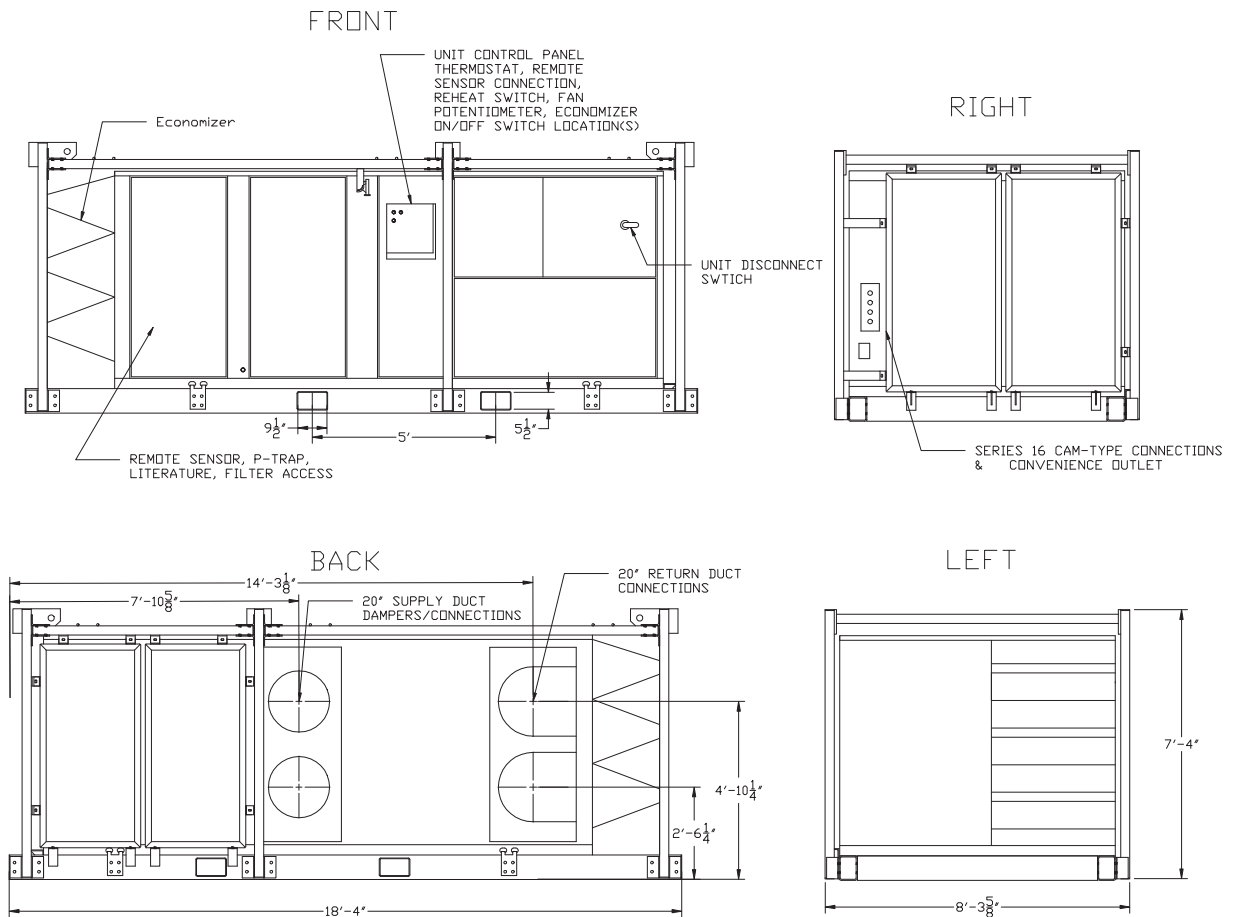



Voyager™ with Electric Heat

Unit Drawings – CSDX0035F6CR-DK

FRONT

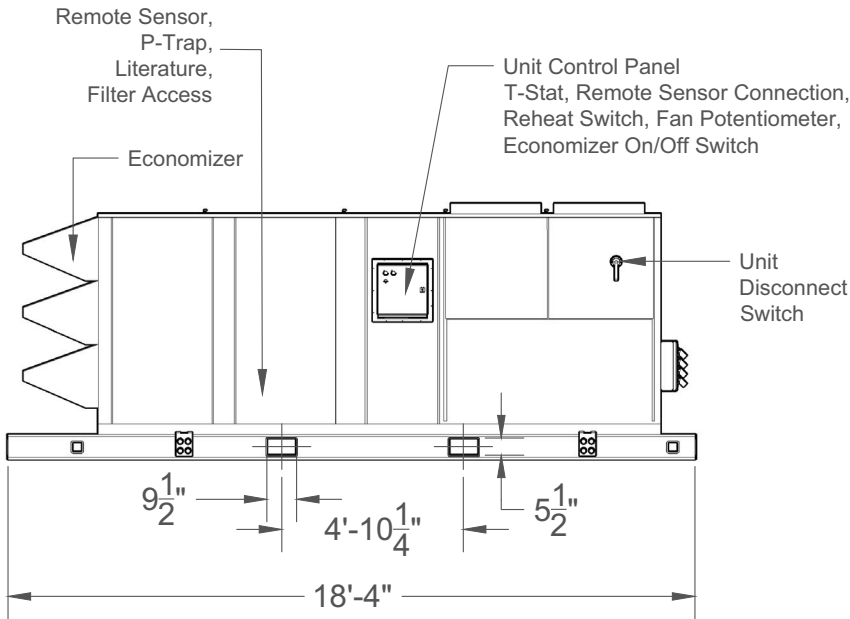

LEFT

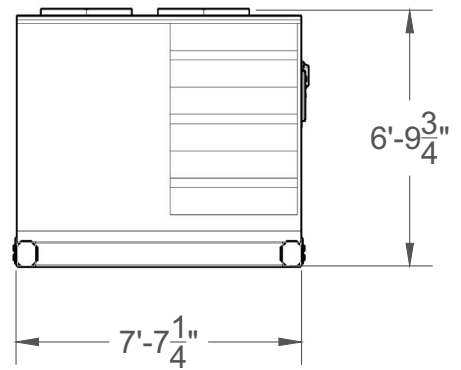

BACK

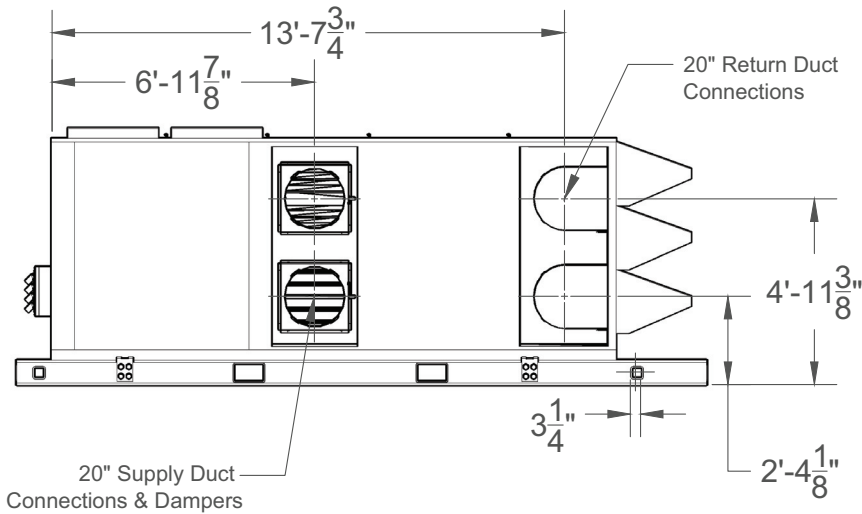

RIGHT

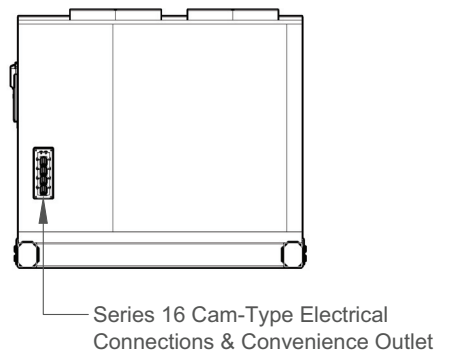

Model: RSDX0035F6AB-AF

Features

- 0 to 100 percent Economizer, Dry Bulb Control
- Hot Gas Reheat (Performance available upon request)
- Blower VFD with Line Bypass and Speed Adjustment Potentiometer (VAV Mode Available Upon Request)
- Hinged Service Access
- Phase and Under/Over Voltage Protection
- Series 16 Cam Type Electrical Connections
- Unit Mounted Thermostat with Remote Option
- Sybmio 700 Trane Controls with BACnet® Interface RS-485 MS/TP (Remote Monitoring Available Upon Request)
- Clogged Filter Switch Kit
- Hot Gas Bypass
- Manual Supply Air Dampers
- Three Stage Cooling and Two Stage Electric Heat
- Low Ambient Operation Down to 0°F

Table 61. General data – RSDX0035F6AB-AF

Labels	Value
Nominal Cooling Tons ^(a)	35
Heating Capacity	90 kW
Refrigerant	R-410A
Refrigerant Charge	41.3lbs
Number of Refrigerant Circuits	1
Number of Compressors	3
Ambient Operating Conditions	0°F – 115°F

(a) Design Conditions: 95°F Ambient, 80°F EDB, 71°F EWB, 400 CFM/Ton.

Table 62. Electrical data – circuit breaker style disconnect – RSDX0035F6AB-AF

Labels	Value
Number of Electrical Circuits	1
Voltage	460V 3 Phase
Frequency	60 Hz
Wire Connection Type	Series 16 Cam Type Only
SCCR	65 kA
Minimum Circuit Ampacity (MCA)	141 A
Maximum Overcurrent Protection (MOP)	150 A
Cooling Only FLA	93.4 A
Heating Only FLA	137.8 A



Voyager™ with Electric Heat

Table 63. Airflow data – RSDX0035F6AB-AF

Labels	Value
Supply Motor	20 HP
Nominal CFM	14,000
Minimum/Maximum CFM	10,500 – 14,400
Maximum ESP at Nominal CFM	2.50 in.
Supply Air Connection Qty/Size	(2) 20 in.
Return Air Connection Qty/Size	(2) 20 in.
Merv-8 Throwaway Filter Qty/Size	(16) 16 in. x 20 in. x 2 in.
Maximum Supply/Return Duct Run at 10,500 CFM	400 ft.
Maximum Supply/Return Duct Run at 14,400 CFM	184 ft.

Table 64. Dimensions and weights – RSDX0035F6AB-AF

Labels	Value
Length	18 ft. 4 in.
Width	7 ft. 7.25 in.
Height	6 ft. 9.75 in.
Shipping Weight	6,580 lbs
Fork Pocket Dimensions	9.5 in. x 5.5 in.
Center to Center Distance of Fork Pockets	4 ft. 10.375 in.

Note: Lifting Device: Forklift or crane.

Table 65. Operating clearances – RSDX0035F6AB-AF

Labels	Value
Condenser Coil End	8 ft.
Economizer End (If equipped)	6 ft.
Front (Control Panel)	4 ft.
Back (Supply/Return Duct Connections)	4 ft.
Top	No obstructions

Note: Operating clearances are provided based on single machine, above ground. For multiple unit or pit operation, contact Trane Rental Services.

Figure 6. Fan curve – RSDX0035F6AB-AF

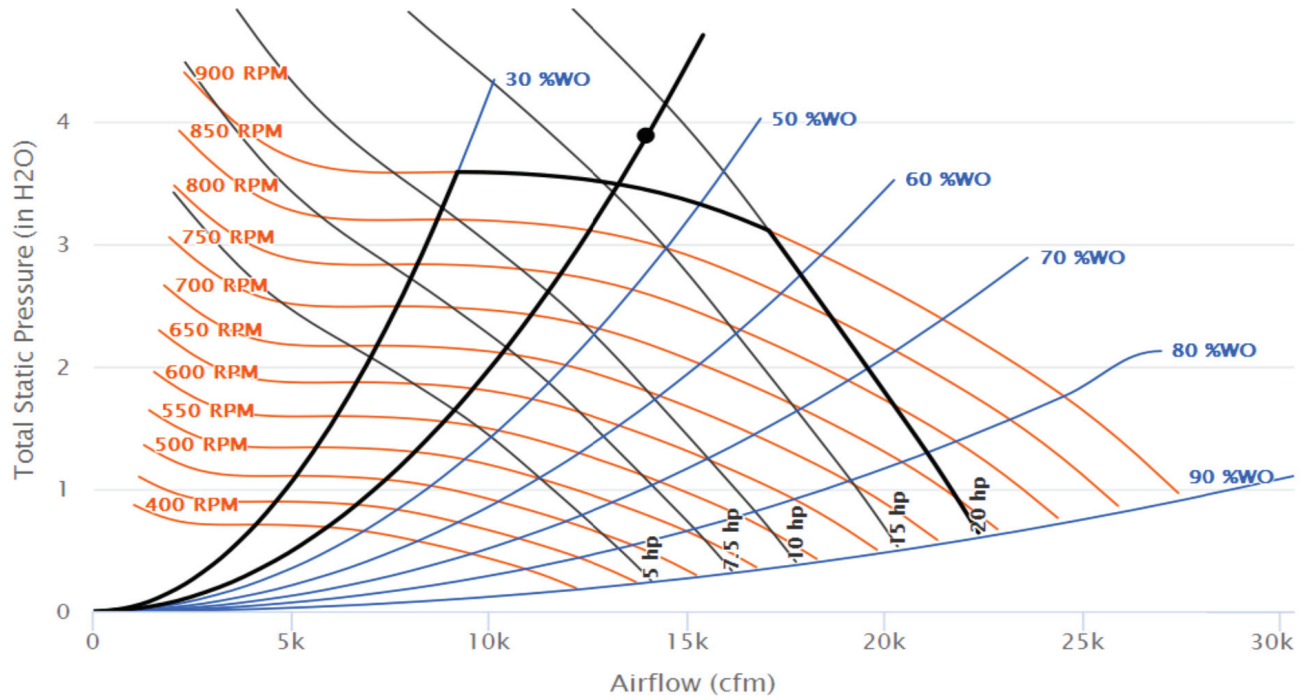



Voyager™ with Electric Heat

Table 66. Gross cooling capacities – RSDX0035F6AB-AF

Airflow cfm	Ent DB (°F)	Ambient Temperature (°F)																	
		85						95						105					
		Entering Wet Bulb																	
		61		67		73		61		67		73		61		67		73	
TGC	SHC	TGC	SHC	TGC	SHC	TGC	SHC	TGC	SHC	TGC	SHC	TGC	SHC	TGC	SHC	TGC	SHC	TGC	SHC
10500	75	375	307	410	238	447	162	355	297	388	277	422	152	334	285	364	216	396	141
	80	381	364	412	293	450	221	361	353	390	282	425	210	340	340	267	269	399	200
	85	397	397	416	349	452	278	379	379	394	337	427	268	359	359	371	325	401	255
	90	417	417	422	406	454	332	399	399	401	394	430	321	378	378	378	378	404	309
12000	75	384	328	418	251	454	166	364	319	395	241	429	155	342	306	371	230	402	144
	80	392	392	421	312	458	232	373	373	398	300	433	222	353	353	374	288	406	211
	85	413	413	426	376	459	295	394	394	404	364	434	283	373	273	379	351	408	271
	90	434	434	434	434	463	357	414	414	414	414	438	345	392	392	392	392	412	333
13000	75	389	342	423	261	458	168	368	333	399	250	433	158	346	318	374	234	405	147
	80	400	400	426	324	462	240	381	381	403	313	436	229	360	360	378	300	409	218
	85	422	422	432	393	464	306	402	402	409	381	439	294	381	381	384	369	411	282
	90	444	444	444	444	468	373	423	423	423	423	443	361	400	400	400	400	416	348
14000	75	394	356	429	270	462	170	373	344	402	254	436	160	350	331	377	241	407	149
	80	408	408	430	337	466	247	388	388	407	325	440	237	367	367	382	312	411	223
	85	431	431	437	410	468	317	410	410	414	398	445	305	388	388	389	385	415	292
	90	456	456	456	456	475	395	434	434	434	434	449	383	410	410	410	410	421	370
14400	75	396	361	428	273	463	171	378	349	404	257	437	161	352	336	378	244	409	150
	80	411	411	432	341	467	250	391	391	408	329	441	239	369	369	383	317	412	225
	85	434	434	439	417	470	321	413	413	416	405	444	309	390	390	390	390	416	296
	90	456	456	456	456	475	395	434	434	434	434	449	383	410	410	410	410	421	370
Airflow cfm	Ent DB (°F)	Ambient Temperature (°F)																	
		115																	
		Entering Wet Bulb																	
		61		67		73		61		67		73		61		67		73	
TGC	SHC	TGC	SHC	TGC	SHC	TGC	SHC	TGC	SHC	TGC	SHC	TGC	SHC	TGC	SHC	TGC	SHC	TGC	SHC
10500	75	311	272	339	204	367	130												
	80	320	320	341	257	371	188												
	85	338	338	346	312	373	242												
	90	356	356	356	356	376	296												
12000	75	318	291	344	218	372	133												
	80	331	331	348	275	376	199												
	85	350	350	354	338	379	258												
	90	368	368	368	368	383	319												
13000	75	322	304	347	221	375	135												
	80	338	338	352	287	378	204												
	85	357	357	358	355	382	268												
	90	376	376	376	376	387	335												
14000	75	326	317	350	228	377	137												
	80	326	317	350	228	377	137												
	85	344	344	355	298	381	210												
	90	382	382	382	382	390	350												
14400	75	328	322	351	231	378	138												
	80	346	346	356	303	382	212												
	85	365	365	365	365	386	283												
	90	384	384	384	384	391	356												

Notes:

1. All capacities shown are gross and have not considered indoor fan heat. To obtain NET cooling capacity subtract indoor fan heat. For indoor fan heat formula, refer to appropriate airflow table notes.
2. TGC = Total Gross Capacity.
3. SHC = Sensible Heat Capacity.

Table 67. Electric heating performance – RSDX0035F6AB-AF

CFM	Temp Rise (°F)
10500	30.1
12000	27.0
13000	25.5
14000	24.2
14400	23.7

Table 68. Sound data – RSDX0035F6AB-AF

Sound Path (Hz)	Octave Center Frequency (Hz)							
	63	125	250	500	1K	2K	4K	8K
Ducted Discharge (dB)	87	87	84	86	86	76	72	74
Ducted Return (dB)	92	79	73	84	79	74	69	62
Outdoor Noise (dB)	100	96	97	96	93	89	90	83

Unit Drawings – RSDX0035F6AB-AF

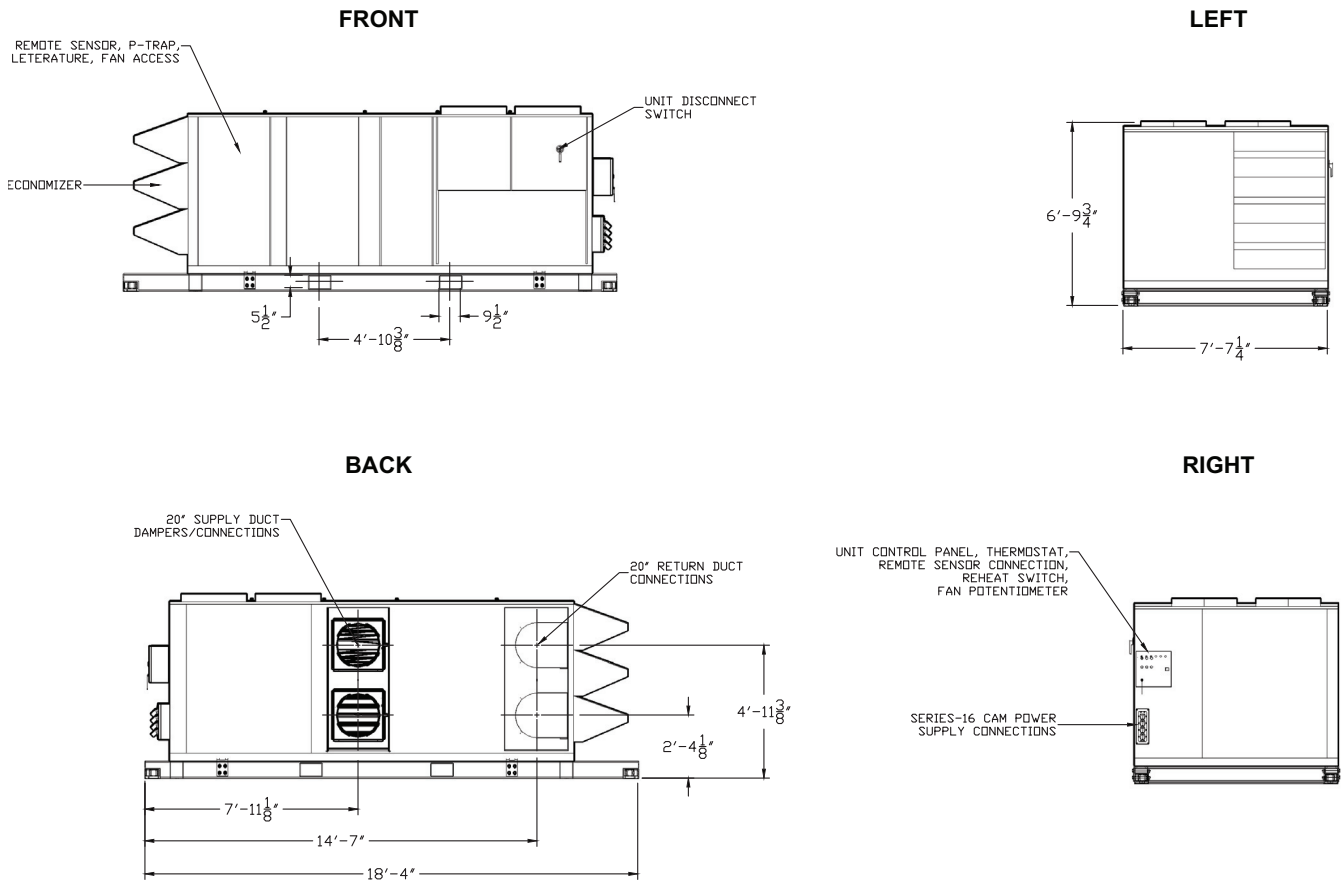



Voyager™ with Electric Heat

Model: CSDX0050F0

Features

- 0 to 100 percent Economizer, Dry Bulb Control
- VAV with VFD and with Bypass
- Hinged Service Access
- Electric Heat w/Reheat Option
- Phase and Under/Over Voltage Protection
- Series 16 Cam Type Electrical Connections
- Remote Room Sensor
- Trane BACnet® Control Interface RS-485 MS/TP and Remote Monitoring Available Upon Request
- Clogged Filter Switch Kit
- Hot Gas Bypass
- Manual Supply/Return Air Dampers
- Three Stage Cooling and Two Stage Heating
- Low Ambient Operation Down to 0°F

Table 69. General data – CSDX0050F0

Labels	Value
Nominal Cooling Tons ^(a)	50
Heating Capacity	108 kW
Refrigerant	R-22/R-410A
Number of Refrigerant Circuits	2
Number of Compressors	3
Ambient Operating Conditions	0°F – 115°F

(a) Design Conditions: 95°F Ambient, 80°F EDB, 67.2°F EWB, 400 CFM/Ton.

Table 70. Electrical data – circuit breaker style disconnect – CSDX0050F0

Labels	Value
Number of Electrical Circuits	1
Voltage	460V 3 Phase
Frequency	60 Hz
Wire Connection Type	Series 16 Cam Type Connections or Hardwire (Maximum 350 MCM)
SCCR	5000 A
Minimum Circuit Ampacity (MCA)	240.5 A
Maximum Overcurrent Protection (MOP)	250 A
Cooling Only FLA	120.6 A
Heating Only FLA	160.4 A
Reheat	211.1 A

Table 71. Airflow data – CSDX0050F0

Labels	Value
Supply Motor	20 HP
Nominal CFM	20,000
Minimum/Maximum CFM	15,000 – 20,000
Maximum ESP at Nominal CFM	0.90 in.
Supply Air Connection Qty/Size	(3) 20 in.
Return Air Connection Qty/Size	(2) 20 in.
Merv-7 Throwaway Filter Qty/Size	(17) 16 in. x 20 in. x 2 in.
Maximum Supply/Return Duct Run at Minimum CFM	75 ft.
Maximum Supply/Return Duct Run at Maximum CFM	25 ft.

Table 72. Dimensions and weights – CSDX0050F0

Labels	Value
Length	23 ft. 6 in.
Width	8 ft. 4 in.
Height	7 ft. 9.25 in.
Shipping Weight	8,300 lbs
Fork Pocket Dimensions	9.5 in. x 5.5 in. x 94 in.
Center to Center Distance of Fork Pockets	63.5 in.

Notes:

- Lifting Device: Forklift or crane.
- Confirm all dimensions and weights with TRS turnkey facility because this data might not match what is listed in this document.
- For additional installation information, see RT-SVX34*-EN.

Table 73. Operating clearances – CSDX0050F0

Labels	Value
Condenser Coil End	8 ft.
Economizer End (if equipped)	6 ft.
Front (Control Panel)	4 ft.
Back (Supply/Return Duct Connections)	4 ft.
Top	No Obstructions

Note: Operating clearances are provided based on single machine, above ground. For multiple unit or pit operation, contact Trane Rental Services.

Voyager™ with Electric Heat

Figure 7. Fan curve – CSDX0050F0

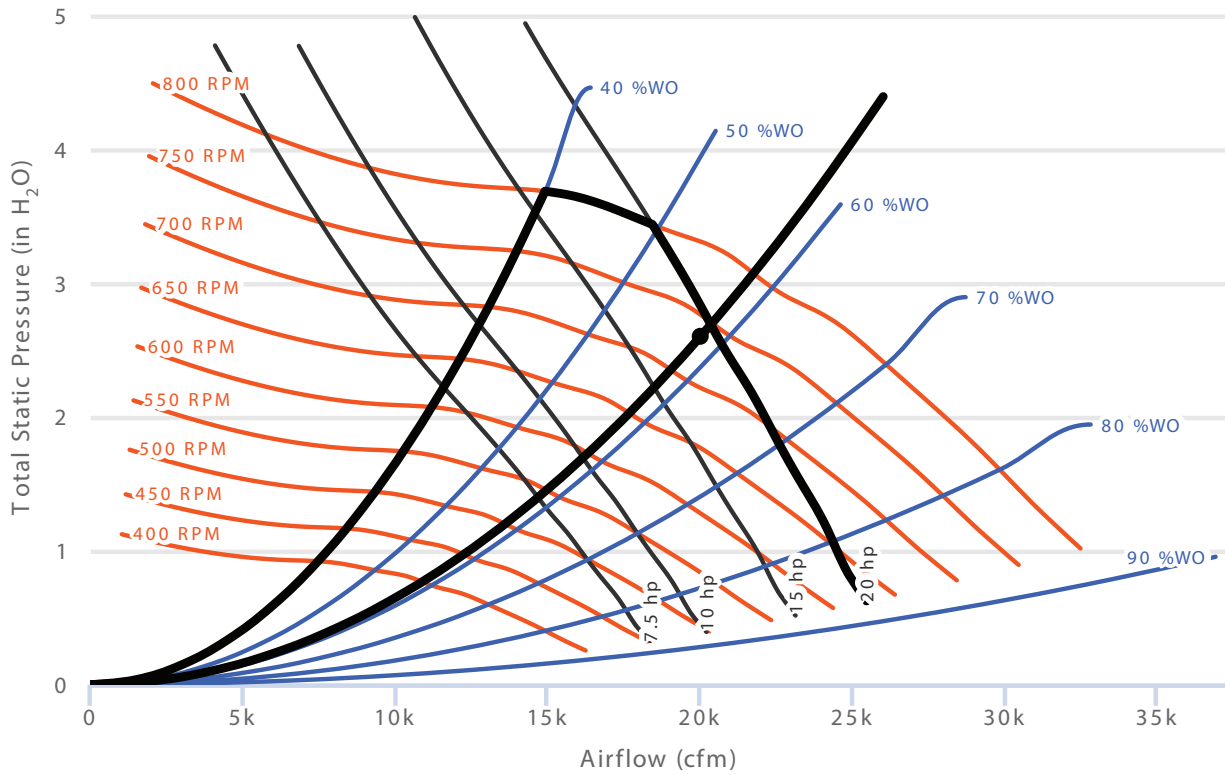

Table 74. Gross cooling capacities – CSDX0050F0

Airflow cfm	Ent DB (°F)	Ambient Temperature (°F)																	
		85						95						105					
		Entering Wet Bulb						Entering Wet Bulb						Entering Wet Bulb					
		61		67		73		61		67		73		61		67		73	
		TGC	SHC	TGC	SHC	TGC	SHC	TGC	SHC	TGC	SHC	TGC	SHC	TGC	SHC	TGC	SHC	TGC	SHC
15000	75	538	438	593	339	650	232	508	421	559	322	612	215	476	402	523	304	572	197
	80	547	522	596	420	654	317	518	504	652	402	617	300	484	484	526	382	577	282
	85	571	571	602	501	657	400	543	543	569	483	620	383	514	514	533	463	579	363
	90	603	603	611	584	660	479	574	574	578	565	623	461	543	543	542	542	584	441
17000	75	552	468	605	359	661	237	520	449	570	341	622	220	487	429	532	323	581	202
	80	562	562	609	446	666	333	534	534	574	428	627	316	503	503	537	408	586	298
	85	595	595	616	538	668	424	565	565	582	519	630	405	534	534	545	499	589	386
	90	627	627	627	627	674	513	597	597	596	596	636	494	564	564	563	563	595	474
18000	75	557	482	610	368	666	240	526	463	574	350	626	222	492	444	536	332	584	205
	80	571	571	614	459	671	341	542	542	579	441	632	323	511	511	542	421	590	305
	85	605	605	622	556	673	435	575	575	588	537	635	416	542	542	551	517	594	397
	90	638	638	638	638	680	529	607	607	606	606	641	510	573	573	572	572	600	490
19000	75	563	496	614	377	670	242	531	477	578	360	630	225	496	457	540	341	587	207
	80	580	580	619	572	675	348	551	551	584	453	636	330	519	519	546	433	591	312
	85	614	614	628	574	678	447	583	583	593	554	639	428	550	550	556	534	598	408
	90	648	648	648	648	685	546	616	616	616	616	646	526	581	581	581	581	605	506
20000	75	568	510	618	387	674	245	535	491	582	369	633	227	501	471	542	344	591	209
	80	589	589	624	485	679	355	558	558	588	465	639	338	526	526	550	445	597	320
	85	623	623	634	591	683	458	592	592	598	572	643	439	558	558	561	551	601	419
	90	657	657	657	657	690	562	624	624	624	624	651	542	589	589	588	588	609	522
Airflow cfm	Ent DB (°F)	Ambient Temperature (°F)																	
		115																	
		Entering Wet Bulb																	
		61		67		73		61		67		73		61		67		73	
		TGC	SHC	TGC	SHC	TGC	SHC	TGC	SHC	TGC	SHC	TGC	SHC	TGC	SHC	TGC	SHC	TGC	SHC
15000	75	441	382	485	286	529	179												
	80	454	454	488	362	535	263												
	85	482	482	495	443	537	342												
	90	509	509	509	509	542	421												
17000	75	451	409	493	304	537	184												
	80	470	470	498	387	543	279												
	85	499	499	506	478	546	365												
	90	528	528	528	528	552	453												
18000	75	456	423	496	313	540	186												
	80	478	478	502	400	544	285												
	85	507	507	511	495	550	376												
	90	536	536	536	536	557	469												
19000	75	460	436	499	315	543	189												
	80	485	485	506	412	547	291												
	85	514	514	514	514	553	386												
	90	544	544	543	543	561	485												
20000	75	464	450	502	323	545	191												
	80	491	491	509	424	550	297												
	85	521	521	521	521	557	397												
	90	550	550	550	550	564	500												

Notes:

1. All capacities shown are gross and have not considered indoor fan heat. To obtain NET cooling capacity subtract indoor fan heat. For indoor fan heat formula, refer to appropriate airflow table notes.
2. TGC = Total Gross Capacity.
3. SHC = Sensible Heat Capacity.



Voyager™ with Electric Heat

Table 75. Electric heating performance – CSDX0050F0

CFM	Temp Rise (°F)
15000	25.6
16000	24.4
18000	22.5
19000	21.8
20000	21.2

Table 76. Sound data – CSDX0050F0

Sound Path (Hz)	63	125	250	500	1K	2K	4K	8K
Ducted Discharge (dB)	99	98	87	89	82	79	75	71
Outdoor Noise (dB)	104	97	96	97	95	93	88	79

Unit Drawings – CSDX0050F0

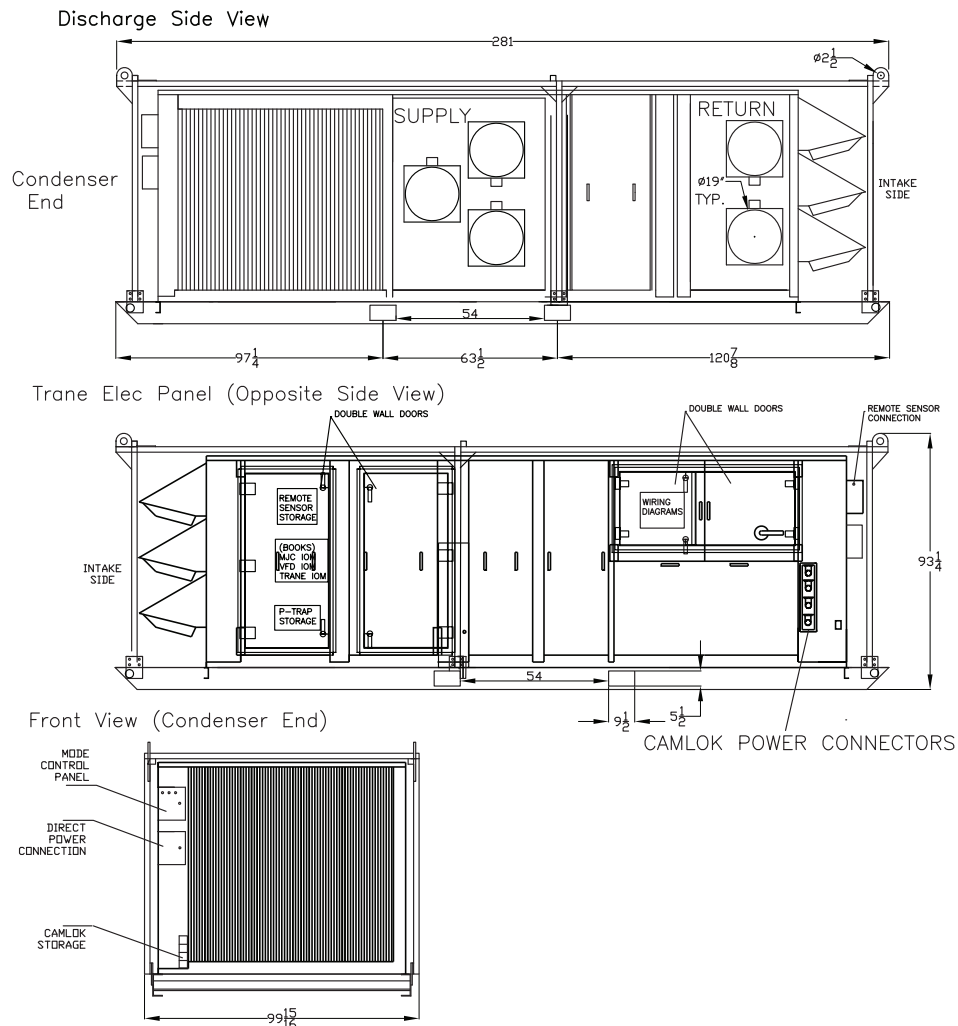

Model: CSDX0050F4

Features

- 0 to 100 percent Economizer, Dry Bulb Control
- Blower VFD with Line Bypass and Speed Adjustment Potentiometer (VAV Mode Available Upon Request)
- Hinged Service Access
- Electric Heat with Reheat Option
- Phase and Under/Over Voltage Protection
- Series 16 Cam Type Electrical Connections
- Unit Mounted Thermostat with Remote Option
- Trane BACnet® Control Interface RS-485 MS/TP and Remote Monitoring Available Upon Request
- Clogged Filter Switch Kit
- Hot Gas Bypass
- Manual Supply Air Dampers
- Three Stage Cooling and Two Stage Heating
- Low Ambient Operation Down to 0°F
- ReliaTel™ Trane Controls

Table 77. General data – CSDX0050F4

Labels	Value
Nominal Cooling Tons ^(a)	50
Heating Capacity	108 kW
Refrigerant	R-410A
Number of Refrigerant Circuits	2
Number of Compressors	3
Ambient Operating Conditions	0°F – 115°F

(a) Design Conditions: 95°F Ambient, 80°F EDB, 67.2°F EWB, 400 CFM/Ton.

Table 78. Electrical data – circuit breaker style disconnect – CSDX0050F4

Labels	Value
Number of Electrical Circuits	1
Voltage	460V 3 Phase
Frequency	60 Hz
Wire Connection Type	Series 16 Cam Type Only
SCCR	5000 A
Minimum Circuit Ampacity (MCA)	232.2 A
Maximum Overcurrent Protection (MOP)	250 A
Cooling Only FLA	112.2 A
Heating Only FLA	160.4 A
Electric Reheat (72 kW Electric Heat + All Cooling) FLA	202.7 A



Voyager™ with Electric Heat

Table 79. Airflow data – CSDX0050F4

Labels	Value
Supply Motor	20 HP
Nominal CFM	20,000
Minimum/Maximum CFM	15,000 – 20,000
Maximum ESP at Nominal CFM	1.52 in.
Supply Air Connection Qty/Size	(4) 20 in.
Return Air Connection Qty/Size	(4) 20 in.
Merv-8 Throwaway Filter Qty/Size	(17) 16 in. x 20 in. x 2 in.
Maximum Supply/Return Duct Run at Minimum CFM	450 ft.
Maximum Supply/Return Duct Run at Maximum CFM	100 ft.

Table 80. Dimensions and weights – CSDX0050F4

Labels	Value
Length	22 ft. 8.875 in.
Width	8 ft. 3.5 in.
Height	7 ft. 11 in.
Shipping Weight	10,360 lbs
Fork Pocket Dimensions	9.5 in. x 5.5 in.
Center to Center Distance of Fork Pockets	60 in.

Notes:

- Lifting Device: Forklift or crane.
- Operating clearances are provided based on single machine, above ground. For multiple unit or pit operation, contact Trane Rental Services.

Table 81. Operating clearances – CSDX0050F4

Labels	Value
Condenser Coil End	8 ft.
Economizer End (if equipped)	6 ft.
Front (Control Panel)	4 ft.
Back (Supply/Return Duct Connections)	4 ft.
Top	No Obstructions

Note: Operating clearances provided are for single unit use only, if multiple units are to be placed next to each other reach out to Trane Rental Services for more information.

Figure 8. Fan curve – CSDX0050F4

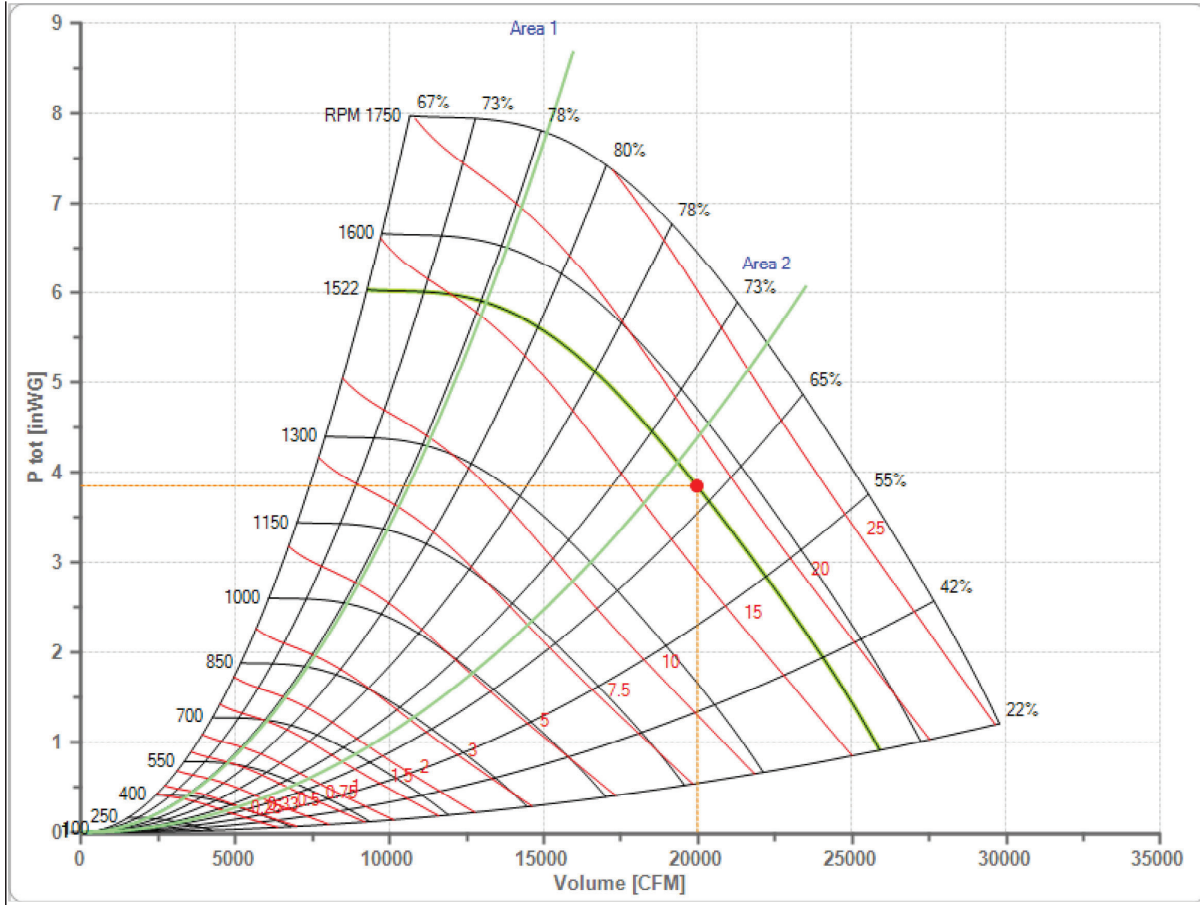



Voyager™ with Electric Heat

Table 82. Gross cooling capacities – CSDX0050F4

Airflow cfm	Ent DB (°F)	Ambient Temperature (°F)																	
		85						95						105					
		Entering Wet Bulb						Entering Wet Bulb						Entering Wet Bulb					
		61		67		73		61		67		73		61		67		73	
TGC	SHC	TGC	SHC	TGC	SHC	TGC	SHC	TGC	SHC	TGC	SHC	TGC	SHC	TGC	SHC	TGC	SHC	TGC	SHC
15000	75	538	438	593	339	650	232	508	421	559	322	612	215	476	402	523	304	572	197
	80	547	522	596	420	654	317	518	504	652	402	617	300	484	484	526	382	577	282
	85	571	571	602	501	657	400	543	543	569	483	620	383	514	514	533	463	579	363
	90	603	603	611	584	660	479	574	574	578	565	623	461	543	543	542	542	584	441
17000	75	552	468	605	359	661	237	520	449	570	341	622	220	487	429	532	323	581	202
	80	562	562	609	446	666	333	534	534	574	428	627	316	503	503	537	408	586	298
	85	595	595	616	538	668	424	565	565	582	519	630	405	534	534	545	499	589	386
	90	627	627	627	627	674	513	597	597	596	596	636	494	564	564	563	563	595	474
18000	75	557	482	610	368	666	240	526	463	574	350	626	222	492	444	536	332	584	205
	80	571	571	614	459	671	341	542	542	579	441	632	323	511	511	542	421	590	305
	85	605	605	622	556	673	435	575	575	588	537	635	416	542	542	551	517	594	397
	90	638	638	638	638	680	529	607	607	606	606	641	510	573	573	572	572	600	490
19000	75	563	496	614	377	670	242	531	477	578	360	630	225	496	457	540	341	587	207
	80	580	580	619	572	675	348	551	551	584	453	636	330	519	519	546	433	591	312
	85	614	614	628	574	678	447	583	583	593	554	639	428	550	550	556	534	598	408
	90	648	648	648	648	685	546	616	616	616	616	646	526	581	581	581	581	605	506
20000	75	568	510	618	387	674	245	535	491	582	369	633	227	501	471	542	344	591	209
	80	589	589	624	485	679	355	558	558	588	465	639	338	526	526	550	445	597	320
	85	623	623	634	591	683	458	592	592	598	572	643	439	558	558	561	551	601	419
	90	657	657	657	657	690	562	624	624	624	624	651	542	589	589	588	588	609	522
Airflow cfm	Ent DB (°F)	Ambient Temperature (°F)																	
		115																	
		Entering Wet Bulb																	
		61		67		73		61		67		73		61		67		73	
TGC	SHC	TGC	SHC	TGC	SHC	TGC	SHC	TGC	SHC	TGC	SHC	TGC	SHC	TGC	SHC	TGC	SHC	TGC	SHC
15000	75	441	382	485	286	529	179												
	80	454	454	488	362	535	263												
	85	482	482	495	443	537	342												
	90	509	509	509	509	542	421												
17000	75	451	409	493	304	537	184												
	80	470	470	498	387	543	279												
	85	499	499	506	478	546	365												
	90	528	528	528	528	552	453												
18000	75	456	423	496	313	540	186												
	80	478	478	502	400	544	285												
	85	507	507	511	495	550	376												
	90	536	536	536	536	557	469												
19000	75	460	436	499	315	543	189												
	80	485	485	506	412	547	291												
	85	514	514	514	514	553	386												
	90	544	544	543	543	561	485												
20000	75	464	450	502	323	545	191												
	80	491	491	509	424	550	297												
	85	521	521	521	521	557	397												
	90	550	550	550	550	564	500												

Note:

1. All capacities shown are gross and have not considered indoor fan heat.
2. TGC = Total gross capacity.
3. SHC = Sensible heat capacity.

Table 83. Electric heating performance – CSDX0050F4

CFM	Temp Rise (°F)
15000	25.6
16000	24.4
18000	22.5
19000	21.8
20000	21.2

Table 84. Sound data – CSDX0050F4

Sound Path (Hz)	63	125	250	500	1K	2K	4K	8K
Ducted Discharge (dB)	99	97	87	88	81	79	74	70
Outdoor Noise (dB)	104	97	96	97	95	93	88	79

Unit Drawings – CSDX0050F4

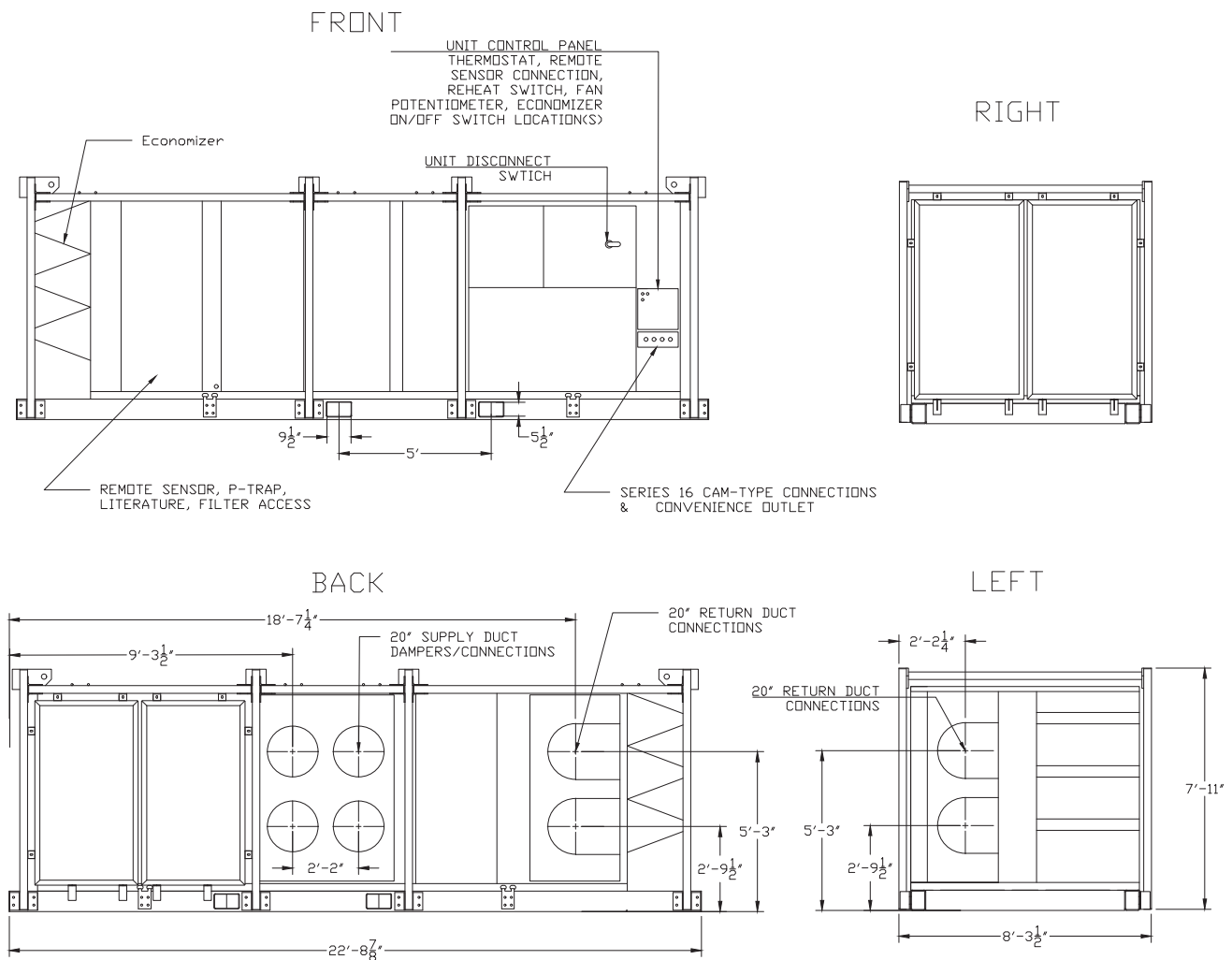



Voyager™ with Electric Heat

Model: CSDX0050F6

Features

- 0 to 100 percent Economizer, Dry Bulb Control
- Hot Gas Reheat (Performance available upon request)
- Blower VFD with Line Bypass and Speed Adjustment Potentiometer (VAV Mode Available Upon Request)
- Hinged Service Access
- Electric Heat with Reheat Option
- Phase and Under/Over Voltage Protection
- Series 16 Cam Type Electrical Connections
- Unit Mounted Thermostat with Remote Option
- Trane BACnet® Control Interface RS-485 MS/TP and Remote Monitoring Available Upon Request
- Clogged Filter Switch Kit
- Hot Gas Bypass
- Manual Supply Air Dampers
- Three Stage Cooling and Two Stage Heating
- Low Ambient Operation Down to 0°F
- ReliaTel™ Trane Controls

Table 85. General data – CSDX0050F6

Labels	Value
Nominal Cooling Tons ^(a)	50
Heating Capacity	108 kW
Refrigerant	R-410A
Number of Refrigerant Circuits	2
Number of Compressors	3
Ambient Operating Conditions	0°F – 115°F

(a) Design Conditions: 95°F Ambient, 80°F EDB, 67.2°F EWB, 400 CFM/Ton.

Table 86. Electrical data – circuit breaker style disconnect – CSDX0050F6

Labels	Value
Number of Electrical Circuits	1
Voltage	460V 3 Phase
Frequency	60 Hz
Wire Connection Type	Series 16 Cam Type Only
SCCR	5000 A
Minimum Circuit Ampacity (MCA)	232.2 A
Maximum Overcurrent Protection (MOP)	250 A
Cooling Only FLA	112.2 A
Heating Only FLA	160.4 A
Electric Reheat (72 kW Electric Heat + All Cooling) FLA	202.7 A

Table 87. Airflow data – CSDX0050F6

Labels	Value
Supply Motor	20 HP
Nominal CFM	20,000
Minimum/Maximum CFM	15,000 – 20,000
Maximum ESP at Nominal CFM	1.52 in.
Supply Air Connection Qty/Size	(4) 20 in.
Return Air Connection Qty/Size	(4) 20 in.
Merv-8 Throwaway Filter Qty/Size	(17) 16 in. x 20 in. x 2 in.
Maximum Supply/Return Duct Run at Minimum CFM	450 ft.
Maximum Supply/Return Duct Run at Maximum CFM	100 ft.

Table 88. Dimensions and weights – CSDX0050F6

Labels	F6DV-EM	F6EN-FL
Length	22 ft. 8.875 in.	22 ft. 9.375 in.
Width	8 ft. 3.5 in.	7 ft. 7.125 in.
Height	7 ft. 11 in.	7 ft. 4.5 in.
Shipping Weight	10,360 lbs	7,980 lbs
Fork Pocket Dimensions	9.5 in. x 5.5 in.	9.5 in. x 5.5 in.
Center to Center Distance of Fork Pockets	60 in.	4 ft. 10.25 in.

Notes:

- Lifting Device: Forklift or crane.
- Operating clearances are provided based on single machine, above ground. For multiple unit or pit operation, contact Trane Rental Services.

Table 89. Operating clearances – CSDX0050F6

Labels	Value
Condenser Coil End	8 ft.
Economizer End (if equipped)	6 ft.
Front (Control Panel)	4 ft.
Back (Supply/Return Duct Connections)	4 ft.
Top	No Obstructions

Note: Operating clearances provided are for single unit use only, if multiple units are to be placed next to each other reach out to Trane Rental Services for more information.

Voyager™ with Electric Heat
Figure 9. Fan curve – CSDX0050F6

Table 90. Gross cooling capacities – CSDX0050F6

Airflow cfm	Ent DB (°F)	Ambient Temperature (°F)																	
		85						95						105					
		Entering Wet Bulb						Entering Wet Bulb						Entering Wet Bulb					
		61		67		73		61		67		73		61		67		73	
TGC	SHC	TGC	SHC	TGC	SHC	TGC	SHC	TGC	SHC	TGC	SHC	TGC	SHC	TGC	SHC	TGC	SHC	TGC	SHC
15000	75	538	438	593	339	650	232	508	421	559	322	612	215	476	402	523	304	572	197
	80	547	522	596	420	654	317	518	504	652	402	617	300	484	484	526	382	577	282
	85	571	571	602	501	657	400	543	543	569	483	620	383	514	514	533	463	579	363
	90	603	603	611	584	660	479	574	574	578	565	623	461	543	543	542	542	584	441
17000	75	552	468	605	359	661	237	520	449	570	341	622	220	487	429	532	323	581	202
	80	562	562	609	446	666	333	534	534	574	428	627	316	503	503	537	408	586	298
	85	595	595	616	538	668	424	565	565	582	519	630	405	534	534	545	499	589	386
	90	627	627	627	627	674	513	597	597	596	596	636	494	564	564	563	563	595	474
18000	75	557	482	610	368	666	240	526	463	574	350	626	222	492	444	536	332	584	205
	80	571	571	614	459	671	341	542	542	579	441	632	323	511	511	542	421	590	305
	85	605	605	622	556	673	435	575	575	588	537	635	416	542	542	551	517	594	397
	90	638	638	638	638	680	529	607	607	606	606	641	510	573	573	572	572	600	490
19000	75	563	496	614	377	670	242	531	477	578	360	630	225	496	457	540	341	587	207
	80	580	580	619	572	675	348	551	551	584	453	636	330	519	519	546	433	591	312
	85	614	614	628	574	678	447	583	583	593	554	639	428	550	550	556	534	598	408
	90	648	648	648	648	685	546	616	616	616	616	646	526	581	581	581	581	605	506
20000	75	568	510	618	387	674	245	535	491	582	369	633	227	501	471	542	344	591	209
	80	589	589	624	485	679	355	558	558	588	465	639	338	526	526	550	445	597	320
	85	623	623	634	591	683	458	592	592	598	572	643	439	558	558	561	551	601	419
	90	657	657	657	657	690	562	624	624	624	624	651	542	589	589	588	588	609	522
Airflow cfm	Ent DB (°F)	Ambient Temperature (°F)																	
		115																	
		Entering Wet Bulb																	
		61		67		73		61		67		73		61		67		73	
TGC	SHC	TGC	SHC	TGC	SHC	TGC	SHC	TGC	SHC	TGC	SHC	TGC	SHC	TGC	SHC	TGC	SHC	TGC	SHC
15000	75	441	382	485	286	529	179												
	80	454	454	488	362	535	263												
	85	482	482	495	443	537	342												
	90	509	509	509	509	542	421												
17000	75	451	409	493	304	537	184												
	80	470	470	498	387	543	279												
	85	499	499	506	478	546	365												
	90	528	528	528	528	552	453												
18000	75	456	423	496	313	540	186												
	80	478	478	502	400	544	285												
	85	507	507	511	495	550	376												
	90	536	536	536	536	557	469												
19000	75	460	436	499	315	543	189												
	80	485	485	506	412	547	291												
	85	514	514	514	514	553	386												
	90	544	544	543	543	561	485												
20000	75	464	450	502	323	545	191												
	80	491	491	509	424	550	297												
	85	521	521	521	521	557	397												
	90	550	550	550	550	564	500												

Note:

1. All capacities shown are gross and have not considered indoor fan heat.
2. TGC = Total gross capacity.
3. SHC = Sensible heat capacity.

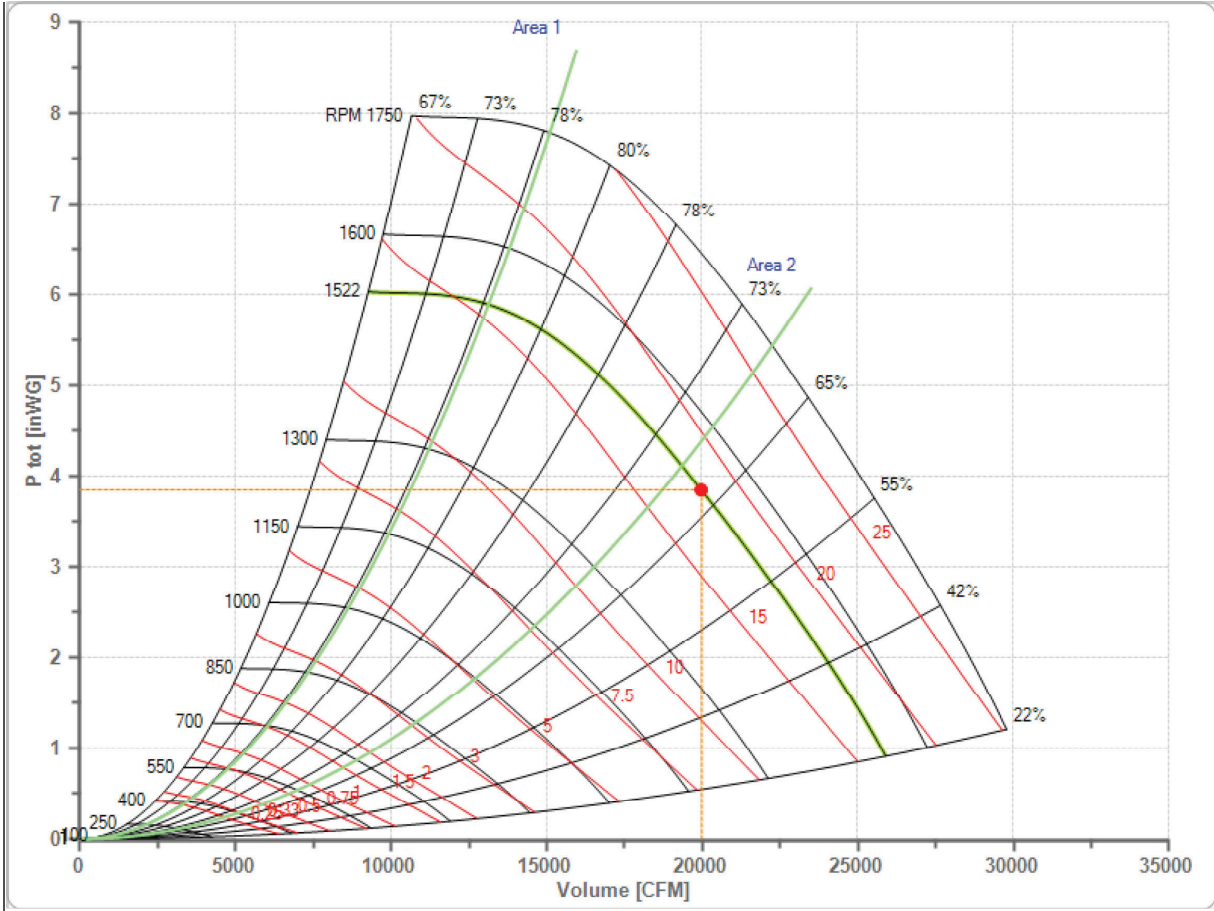
Voyager™ with Electric Heat

Table 91. Electric heating performance – CSDX0050F6

CFM	Temp Rise (°F)
15000	25.6
16000	24.4
18000	22.5
19000	21.8
20000	21.2

Table 92. Sound data – CSDX0050F6

Sound Path (Hz)	63	125	250	500	1K	2K	4K	8K
Ducted Discharge (dB)	99	97	87	88	81	79	74	70
Outdoor Noise (dB)	104	97	96	97	95	93	88	79

Unit Drawings – CSDX0050F6DV-EM

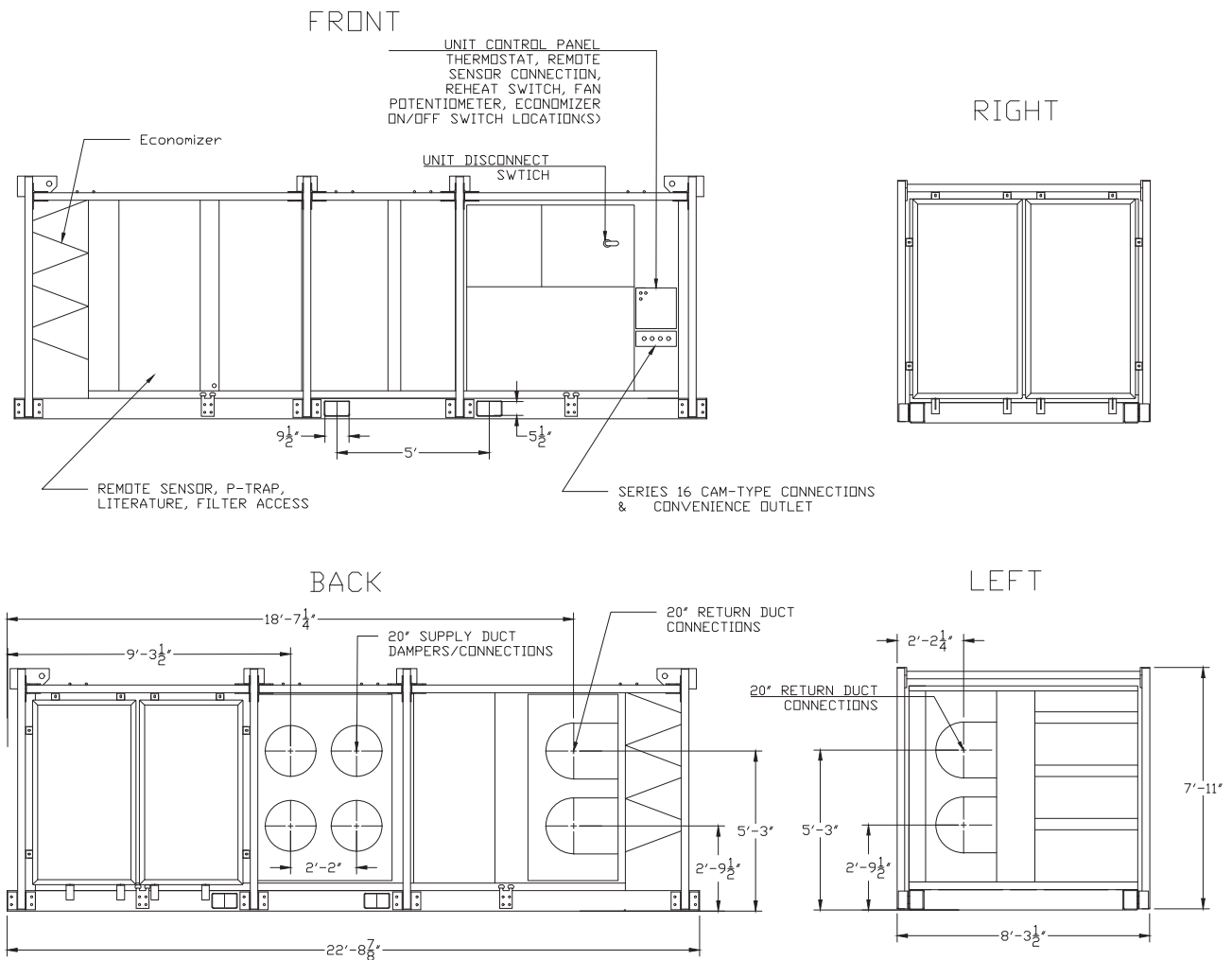

Unit Drawings – CSDX0050F6EN-FL

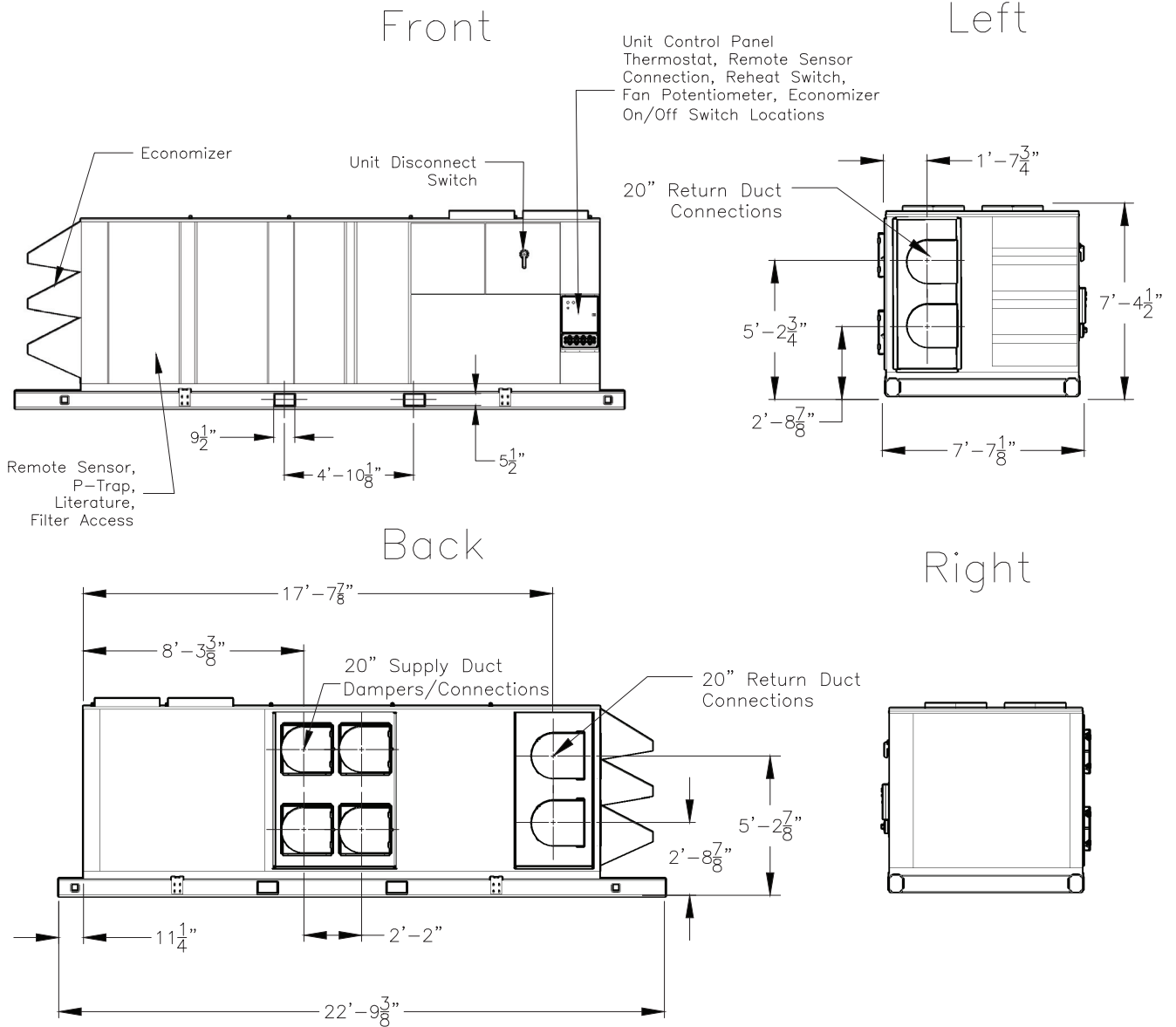



Voyager™ with Electric Heat

Model: RSDX0050F6AA-AJ

Features

- 0 to 100 percent Economizer, Dry Bulb Control
- Hot Gas Reheat (Performance available upon request)
- Blower VFD with Line Bypass and Speed Adjustment Potentiometer (VAV Mode Available Upon Request)
- Hinged Service Access
- Phase and Under/Over Voltage Protection
- Series 16 Cam Type Electrical Connections
- Unit Mounted Thermostat with Remote Option
- Symbio 700 Trane Controls with BACnet® Interface RS-485 MS/TP (Remote Monitoring Available Upon Request)
- Clogged Filter Switch
- Hot Gas Bypass
- Manual Supply Air Dampers
- Three Stage Cooling and Two Stage Electric Heat
- Low Ambient Operation Down to 0°F

Table 93. General data – RSDX0050F6AA-AJ

Labels	Value
Nominal Cooling Tons ^(a)	50
Heating Capacity	108 kW
Refrigerant	R-410A
Refrigerant Charge	61.2 lbs
Number of Refrigerant Circuits	1
Number of Compressors	3
Ambient Operating Conditions	0°F – 115°F

(a) Design Conditions: 95°F Ambient, 80°F EDB, 71°F EWB, 400 CFM/Ton.

Table 94. Electrical data – circuit breaker style disconnect – RSDX0050F6AA-AJ

Labels	Value
Number of Electrical Circuits	1
Voltage	460V 3 Phase
Frequency	60 Hz
Wire Connection Type	Series 16 Cam Type Only
SCCR	65 kA
Minimum Circuit Ampacity (MCA)	170 A
Maximum Overcurrent Protection (MOP)	175 A
Cooling Only FLA	123.2 A
Heating Only FLA	166.2 A

Table 95. Airflow data – RSDX0050F6AA-AJ

Labels	Value
Supply Motor	25 HP
Nominal CFM	20,000
Minimum/Maximum CFM	15,000 – 20,000
Maximum ESP at Nominal CFM	1.70 in.
Supply Air Connection Qty/Size	(4) 20 in.
Return Air Connection Qty/Size	(4) 20 in.
Merv-8 Throwaway Filter Qty/Size	(17) 16 in. x 20 in. x 2 in.
Maximum Supply/Return Duct Run at 15,000 CFM	730 ft.
Maximum Supply/Return Duct Run at 20,000 CFM	270 ft.

Table 96. Dimensions and weights – RSDX0050F6AA-AJ

Labels	Value
Length	18 ft. 4 in.
Width	7 ft. 7.25 in.
Height	6 ft. 9.75 in.
Shipping Weight	8,160 lbs
Fork Pocket Dimensions	9.5 in. x 5.5 in.
Center to Center Distance of Fork Pockets	4 ft. 10.375 in.

Note: Lifting Device: Forklift or crane.

Table 97. Operating clearances – RSDX0050F6AA-AJ

Labels	Value
Condenser Coil End	8 ft.
Economizer End (if equipped)	6 ft.
Front (Control Panel)	4 ft.
Back (Supply/Return Duct Connections)	4 ft.
Top	No Obstructions

Note: Operating clearances provided are for single unit use only, if multiple units are to be placed next to each other reach out to Trane Rental Services for more information.

Voyager™ with Electric Heat
Figure 10. Fan curve – RSDX0050F6AA-AJ

Table 98. Gross cooling capacities – RSDX0050F6AA-AJ

Airflow cfm	Ent DB (°F)	Ambient Temperature (°F)																	
		85						95						105					
		Entering Wet Bulb (°F)																	
		61		67		73		61		67		73		61		67		73	
TGC	SHC	TGC	SHC	TGC	SHC	TGC	SHC	TGC	SHC	TGC	SHC	TGC	SHC	TGC	SHC	TGC	SHC	TGC	SHC
15000	75	538	438	593	339	650	232	508	421	559	322	612	215	476	402	523	304	572	197
	80	547	522	596	420	654	317	518	504	652	402	617	300	484	484	526	382	577	282
	85	571	571	602	501	657	400	543	543	569	483	620	383	514	514	533	463	579	363
	90	603	603	611	584	660	479	574	574	578	565	623	461	543	543	542	542	584	441
17000	75	552	468	605	359	661	237	520	449	570	341	622	220	487	429	532	323	581	202
	80	562	562	609	446	666	333	534	534	574	428	627	316	503	503	537	408	586	298
	85	595	595	616	538	668	424	565	565	582	519	630	405	534	534	545	499	589	386
	90	627	627	627	627	674	513	597	597	596	596	636	494	564	564	563	563	595	474
18000	75	557	482	610	368	666	240	526	463	574	350	626	222	492	444	536	332	584	205
	80	571	571	614	459	671	341	542	542	579	441	632	323	511	511	542	421	590	305
	85	605	605	622	556	673	435	575	575	588	537	635	416	542	542	551	517	594	397
	90	638	638	638	638	680	529	607	607	606	606	641	510	573	573	572	572	600	490
19000	75	563	496	614	377	670	242	531	477	578	360	630	225	496	457	540	341	587	207
	80	580	580	619	572	675	348	551	551	584	453	636	330	519	519	546	433	591	312
	85	614	614	628	574	678	447	583	583	593	554	639	428	550	550	556	534	598	408
	90	648	648	648	648	685	546	616	616	616	616	646	526	581	581	581	581	605	506
20000	75	568	510	618	387	674	245	535	491	582	369	633	227	501	471	542	344	591	209
	80	589	589	624	485	679	355	558	558	588	465	639	338	526	526	550	445	597	320
	85	623	623	634	591	683	458	592	592	598	572	643	439	558	558	561	551	601	419
	90	657	657	657	657	690	562	624	624	624	624	651	542	589	589	588	588	609	522
Airflow cfm	Ent DB (°F)	Ambient Temperature (°F)																	
		115																	
		Entering Wet Bulb (°F)																	
		61		67		73		61		67		73		61		67		73	
TGC	SHC	TGC	SHC	TGC	SHC	TGC	SHC	TGC	SHC	TGC	SHC	TGC	SHC	TGC	SHC	TGC	SHC	TGC	SHC
15000	75	441	382	485	286	529	179												
	80	454	454	488	362	535	263												
	85	482	482	495	443	537	342												
	90	509	509	509	509	542	421												
17000	75	451	409	493	304	537	184												
	80	470	470	498	387	543	279												
	85	499	499	506	478	546	365												
	90	528	528	528	528	552	453												
18000	75	456	423	496	313	540	186												
	80	478	478	502	400	544	285												
	85	507	507	511	495	550	376												
	90	536	536	536	536	557	469												
19000	75	460	436	499	315	543	189												
	80	485	485	506	412	547	291												
	85	514	514	514	514	553	386												
	90	544	544	543	543	561	485												
20000	75	464	450	502	323	545	191												
	80	491	491	509	424	550	297												
	85	521	521	521	521	557	397												
	90	550	550	550	550	564	500												

Note:

1. All capacities shown are gross and have not considered indoor fan heat. To obtain NET cooling capacity subtract indoor fan heat. For indoor fan heat formula, refer to appropriate airflow table notes.
2. TGC = Total gross capacity.
3. SHC = Sensible heat capacity.

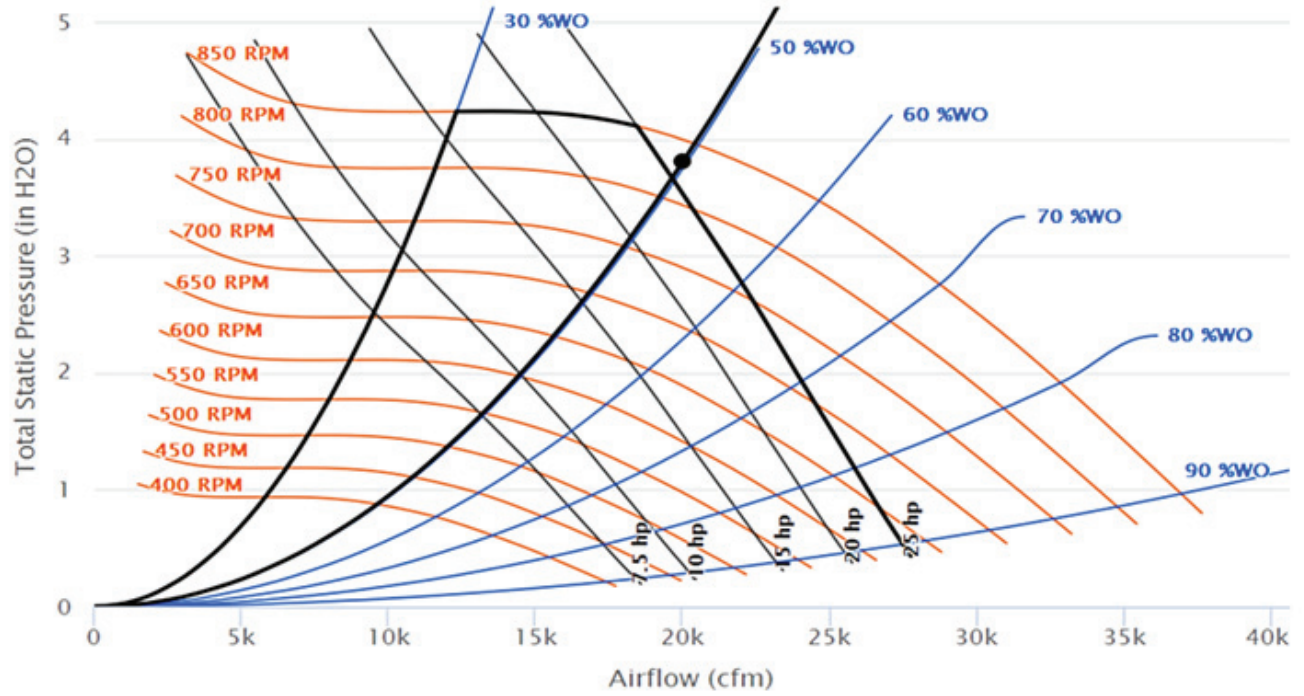

Voyager™ with Electric Heat

Table 99. Electric heating performance – RSDX0050F6AA-AJ

CFM	Temp Rise (°F)
15000	25.6
16000	24.4
18000	22.5
19000	21.8
20000	21.2

Table 100. Sound data – RSDX0050F6AA-AJ

Sound Path (Hz)	Octave Center Frequency (Hz)							
	63	125	250	500	1K	2K	4K	8K
Ducted Discharge (dB)	102	102	90	93	86	82	79	75
Ducted Return (dB)	93	92	85	86	78	80	80	81
Outdoor Noise (dB)	104	97	96	97	95	93	88	79

Unit Drawing – RSDX0050F6AA-AJ

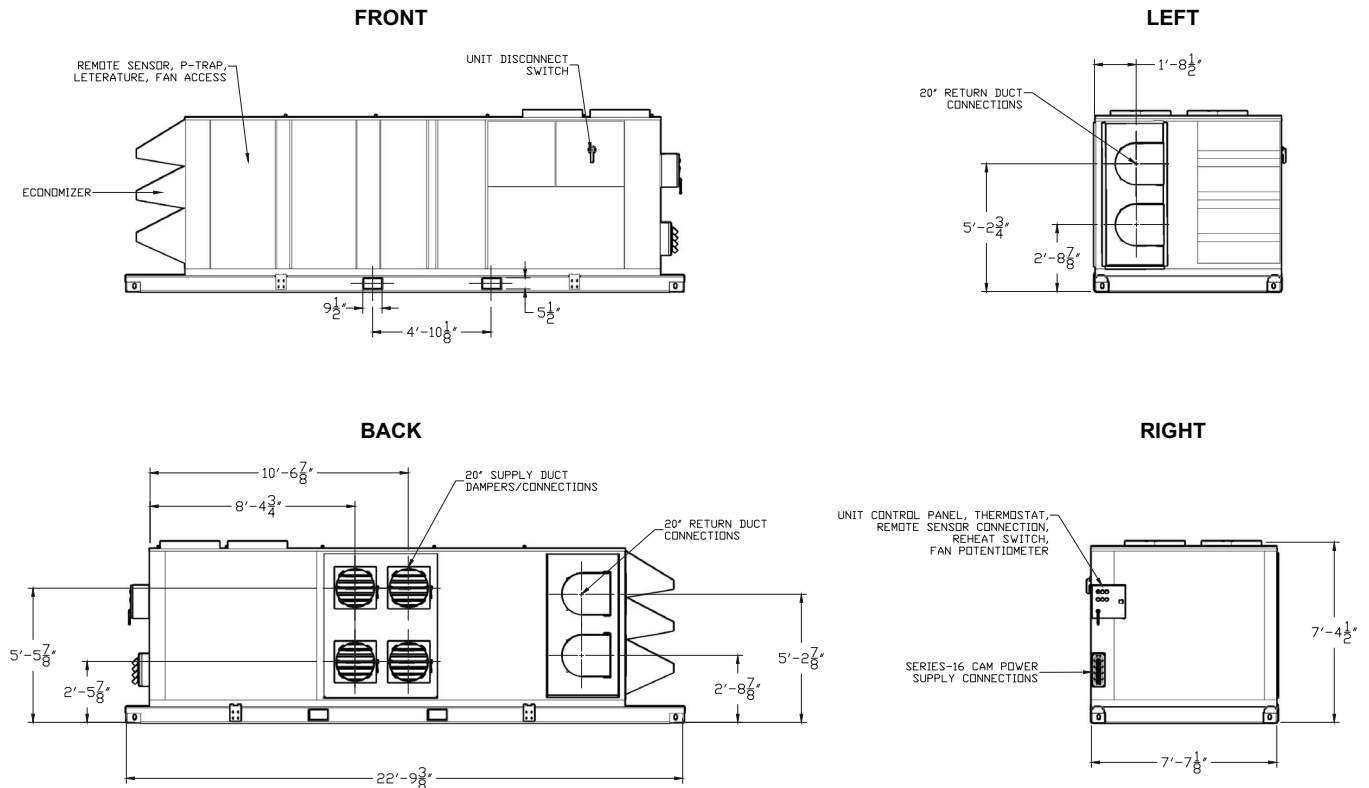

Model: CSHX0035F3

Features

- VFD with Bypass
- Hinged Service Access
- Electric Heat with Reheat Option
- Phase and Under/Over Voltage Protection
- Series 16 Cam Type Electrical Connections
- Remote Room Sensor
- Trane BACnet® Control Interface RS-485 MS/TP and Remote Monitoring Available Upon Request
- Clogged Filter Switch Kit
- Hot Gas Bypass
- Manual Supply/Return Air Dampers
- Two Stage Cooling and Heating
- Low Ambient Operation Down to 0°F
- ReliaTel™ Trane Controls

Table 101. General data – CSHX0035F3

Labels	Value
Nominal Cooling Tons	35
Heating Capacity	90 kW
Refrigerant	R-410A
Number of Refrigerant Circuits	2
Number of Compressors	2
Ambient Operating Conditions	0°F – 115°F

Table 102. Electrical data – circuit breaker style disconnect – CSHX0035F3

Labels	Value
Number of Electrical Circuits	1
Voltage	460V 3 Phase
Frequency	60 Hz
Wire Connection Type	Series 16 Cam Type Connections or Hardwire (Maximum 350 MCM)
SCCR	5000 A
Minimum Circuit Ampacity (MCA)	179.8 A
Maximum Overcurrent Protection (MOP)	200 A
Cooling Only FLA	78.7 A
Heating Only FLA	130.8 A
Electric Reheat (60 kW Electric Heat + All Cooling) FLA	154.1 A



Voyager™ with Electric Heat

Table 103. Airflow data – CSHX0035F3

Labels	Value
Supply Motor	15 HP
Nominal CFM	7,000
Maximum ESP at Nominal CFM	5 in.
Supply Air Connection Qty/Size	(2) 20 in.
Return Air Connection Qty/Size	(2) 20 in.
Mist Eliminator Pre Filter Qty/Size	(6) 20 in. x 20 in. x 1 in.
Merv-7 Throwaway Filter Qty/Size	(6) 20 in. x 20 in. x 2 in.
Maximum Supply/Return Duct Run at Maximum CFM	650 ft.

Table 104. Dimensions and weights – CSHX0035F3

Labels	Value
Length	17 ft. 7.4 in.
Width	8 ft. 4 in.
Height	7 ft. 2.3 in.
Shipping Weight	7,000 lbs
Fork Pocket Dimensions	9.5 in. x 5.5 in. x 94 in.
Center to Center Distance of Fork Pockets	63.5 in.

Notes:

- Lifting Device: Forklift or crane.
- Operating clearances are provided based on single machine, above ground. For multiple unit or pit operation, contact Trane Rental Services.

Table 105. Operating clearances – CSHX0035F3

Labels	Value
Condenser Coil End	8 ft.
Economizer End (if equipped)	6 ft.
Front (Control Panel)	4 ft.
Back (Supply/Return Duct Connections)	4 ft.
Top	No Obstructions

Note: Operating clearances provided are for single unit use only, if multiple units are to be placed next to each other reach out to Trane Rental Services for more information.

Figure 11. Fan curve – CSHX0035F3

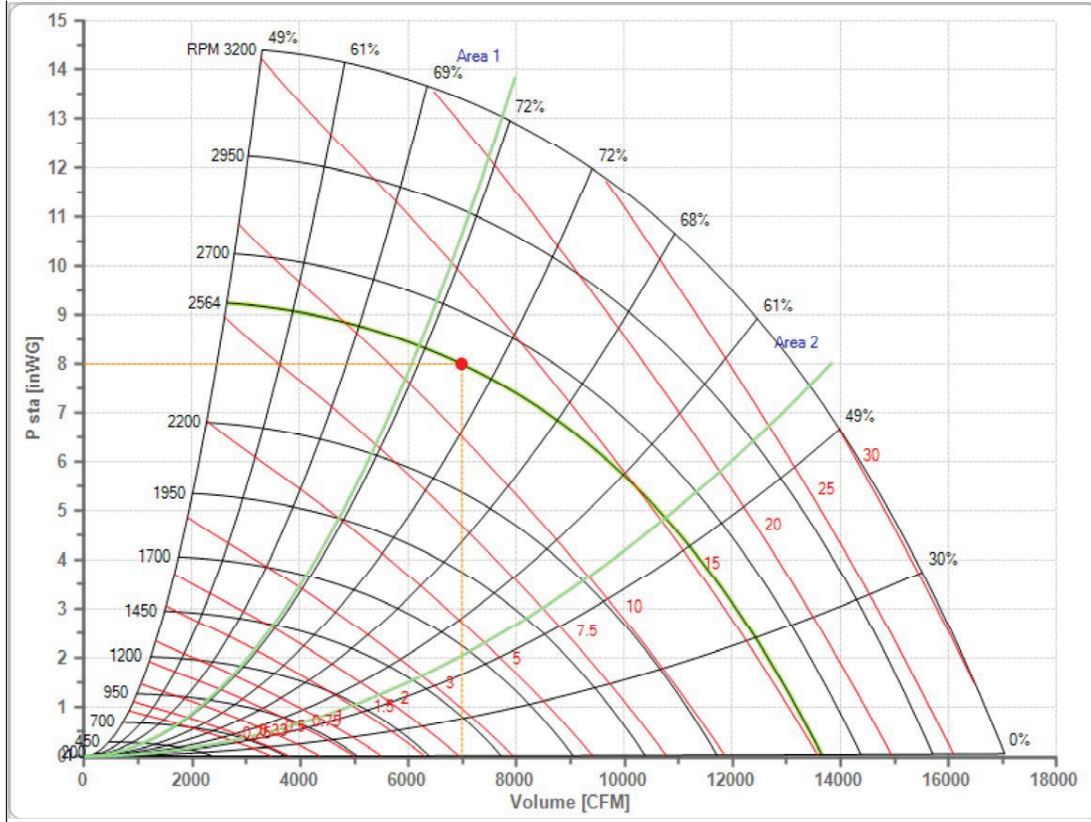

Table 106. Gross cooling capacities – CSHX0035F3

Airflow cfm	Ent DB (°F)	Ambient Temperature (°F)																	
		85						95						105					
		Entering Wet Bulb						Entering Wet Bulb						Entering Wet Bulb					
		61		67		73		61		67		73		61		67		73	
		TGC	SHC	TGC	SHC	TGC	SHC	TGC	SHC	TGC	SHC	TGC	SHC	TGC	SHC	TGC	SHC		
7000	75	N/A	N/A	356	177	408	133	N/A	N/A	348	174	396	127	N/A	N/A	321.3	162	365	115
	80	N/A	N/A	359	218	407	170	N/A	N/A	349	213	396	165	N/A	N/A	323.19	201	365	153
	85	333	307	359	256	404	207	325	302	352	252	396	204	303	289	325	240	365	191
	90	350	346	367	297	N/A	N/A	341	337	360	294	511	290	320	316	334	279	N/A	N/A
Airflow cfm	Ent DB (°F)	Ambient Temperature (°F)																	
		115																	
		Entering Wet Bulb																	
		61		67		73		61		67		73		61		67		73	
		TGC	SHC	TGC	SHC	TGC	SHC	TGC	SHC	TGC	SHC	TGC	SHC	TGC	SHC	TGC	SHC		
7000	75	N/A	N/A	302	153	343	106												
	80	276	239	303	192	343	144												
	85	287	280	306	232	343	183												
	90	305	301	316	271	344	221												

Note:

1. All capacities shown are gross and have not considered indoor fan heat.
2. TGC = Total gross capacity.
3. SHC = Sensible heat capacity.



Voyager™ with Electric Heat

Table 107. Electric heating performance – CSHX0035F3

CFM	Temp Rise (°F)
7000	40

Table 108. Sound data – CSHX0035F3

Sound Path (Hz)	63	125	250	500	1K	2K	4K	8K
Ducted Discharge (dB)	89	95	95	91	91	84	77	71
Outdoor Noise (dB)	100	96	97	96	93	89	90	83

Unit Drawings – CSHX0035F3

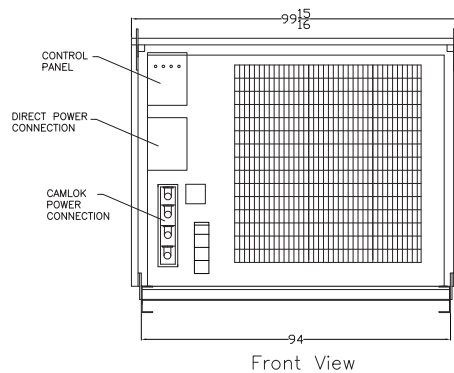
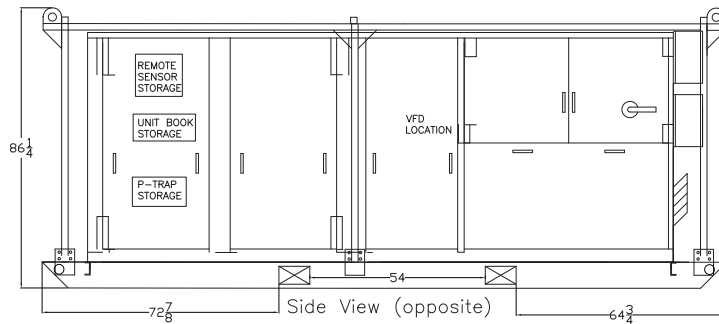
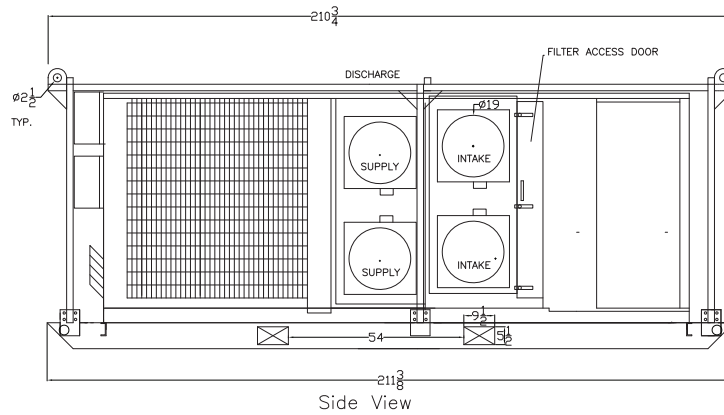

Model: CSHX0035F4

Features

- 0 to 100 percent Economizer, Dry Bulb Control
- Blower VFD with Line bypass
- Hinged Service Access
- Electric Heat with Reheat Option
- Phase and Under/Over Voltage Protection
- Series 16 Cam Type Electrical Connections
- Unit Mounted Thermostat with Remote Option
- Trane BACnet® Control Interface RS-485 MS/TP and Remote Monitoring Available Upon Request
- Clogged Filter Switch Kit
- Hot Gas Bypass
- Manual Supply Air Dampers
- Two Stage Cooling and Heating
- Low Ambient Operation Down to 0°F
- ReliaTel™ Trane Controls

Table 109. General data – CSHX0035F4

Labels	Value
Nominal Cooling Tons	35
Heating Capacity	90 kW
Refrigerant	R-410A
Number of Refrigerant Circuits	2
Number of Compressors	2
Ambient Operating Conditions	0°F – 115°F

Table 110. Electrical data – circuit breaker style disconnect – CSHX0035F4

Labels	Value
Number of Electrical Circuits	1
Voltage	460V 3 Phase
Frequency	60 Hz
Wire Connection Type	Series 16 Cam Type Only
SCCR	5000 A
Minimum Circuit Ampacity (MCA)	180.1 A
Maximum Overcurrent Protection (MOP)	200 A
Cooling Only FLA	79.0 A
Heating Only FLA	131.1 A
Electric Reheat (60 kW Electric Heat + All Cooling) FLA	154.1 A



Voyager™ with Electric Heat

Table 111. Airflow data – CSHX0035F4

Labels	Value
Supply Motor	15 HP
Nominal CFM	7000
Maximum ESP at Nominal CFM	5 in.
Supply Air Connection Qty/Size	(2) 20 in.
Return Air Connection Qty/Size	(2) 20 in.
Merv-7 Throwaway Filter Qty/Size	(16) 16 in. x 20 in. x 2 in.
Maximum Supply/Return Duct Run at Maximum CFM	650 ft.

Table 112. Dimensions and weights – CSHX0035F4

Labels	F4BC-BE	F4BF-BR
Length	18 ft. 4 in.	18 ft. 4 in.
Width	8 ft. 3.625 in.	7 ft. 7.25 in.
Height	7 ft. 4.5 in.	6 ft. 9.75 in.
Shipping Weight	7,900 lbs	6,520 lbs
Fork Pocket Dimensions	9.5 in. x 5.5 in.	9.5 in. x 5.5 in.
Center to Center Distance of Fork Pockets	60 in.	4 ft. 10.25 in.

Notes:

- Lifting Device: Forklift or crane.
- Confirm all dimensions and weights with TRS turnkey facility because this data might not match what is listed in this document.
- For additional installation information, see RT-SVX34*-EN.

Table 113. Operating clearances – CSHX0035F4

Labels	Value
Condenser Coil End	8 ft.
Economizer End (if equipped)	6 ft.
Front (Control Panel)	4 ft.
Back (Supply/Return Duct Connections)	4 ft.
Top	No Obstructions

Note: Operating clearances are provided based on single machine, above ground. For multiple unit or pit operation, contact Trane Rental Services.

Figure 12. Fan curve – CSHX0035F4

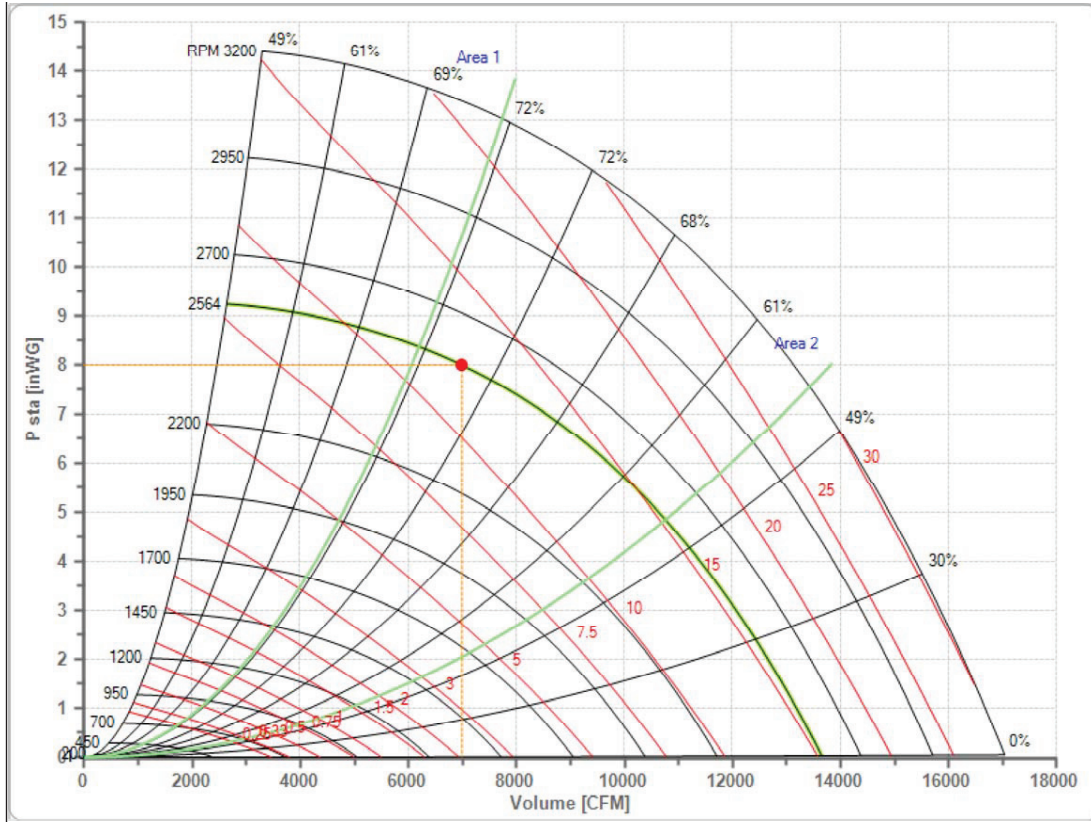

Table 114. Gross cooling capacities – CSHX0035F4

Airflow cfm	Ent DB (°F)	Ambient Temperature (°F)																	
		85						95						105					
		Entering Wet Bulb						Entering Wet Bulb						Entering Wet Bulb					
		61		67		73		61		67		73		61		67		73	
		TGC	SHC	TGC	SHC	TGC	SHC	TGC	SHC	TGC	SHC	TGC	SHC	TGC	SHC	TGC	SHC	TGC	SHC
7000	75	N/A	N/A	356	177	408	133	N/A	N/A	348	174	396	127	N/A	N/A	321.3	162	365	115
	80	N/A	N/A	359	218	407	170	N/A	N/A	349	213	396	165	N/A	N/A	323.19	201	365	153
	85	333	307	359	256	404	207	325	302	352	252	396	204	303	289	325	240	365	191
	90	350	346	367	297	N/A	N/A	341	337	360	294	511	290	320	316	334	279	N/A	N/A
Airflow cfm	Ent DB (°F)	Ambient Temperature (°F)																	
		115																	
		Entering Wet Bulb																	
		61		67		73		61		67		73		61		67		73	
		TGC	SHC	TGC	SHC	TGC	SHC	TGC	SHC	TGC	SHC	TGC	SHC	TGC	SHC	TGC	SHC	TGC	SHC
7000	75	N/A	N/A	302	153	343	106												
	80	276	239	303	192	343	144												
	85	287	280	306	232	343	183												
	90	305	301	316	271	344	221												

Note:

1. All capacities shown are gross and have not considered indoor fan heat.
2. TGC = Total gross capacity.
3. SHC = Sensible heat capacity.



Voyager™ with Electric Heat

Table 115. Electric heating performance – CSHX0035F4

CFM	Temp Rise (°F)
7000	40

Table 116. Sound data – CSHX0035F4

Sound Path (Hz)	63	125	250	500	1K	2K	4K	8K
Ducted Discharge (dB)	89	95	95	91	91	84	77	71
Outdoor Noise (dB)	100	96	97	96	93	89	90	83

Unit Drawings – CSHX0035F4BC-BE

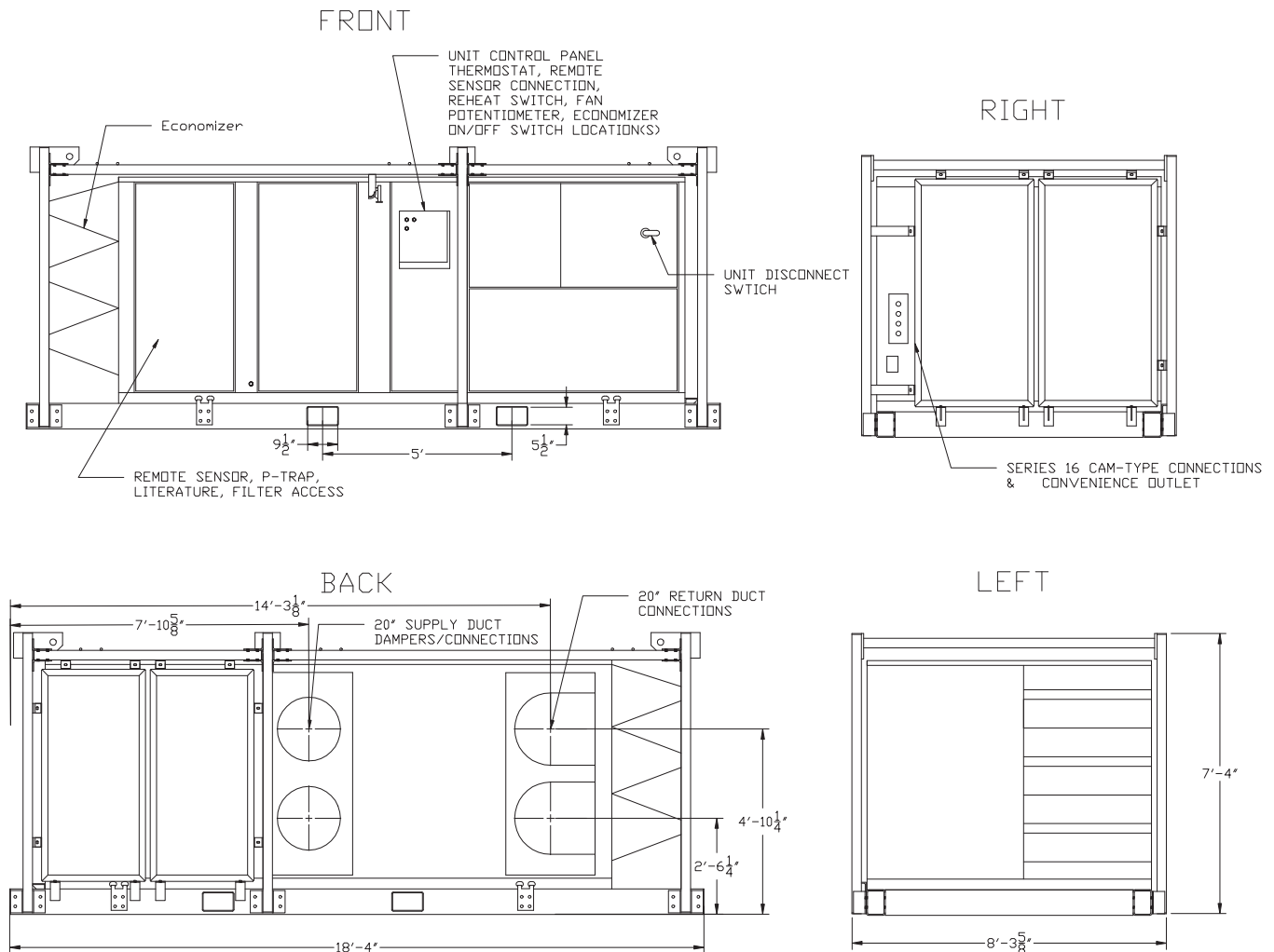

Unit Drawings – CSHX0035F4BF-BR

FRONT

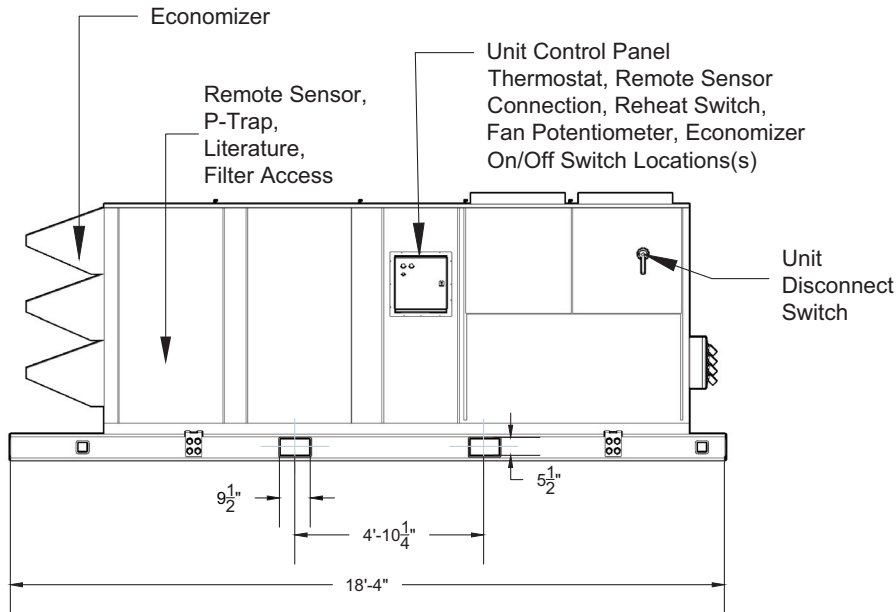

LEFT

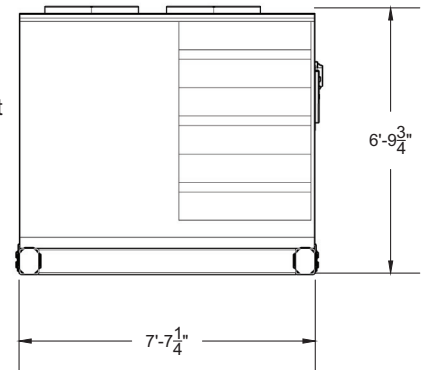

BACK

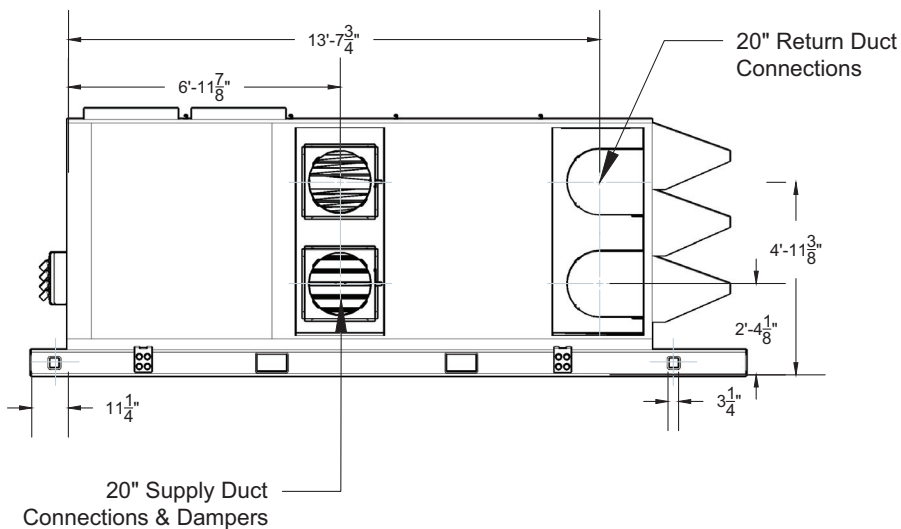

RIGHT

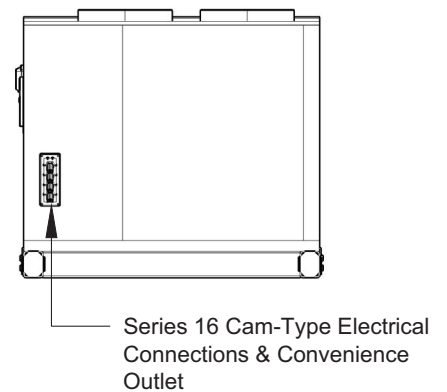



Voyager™ with Electric Heat

Model: RSHX0035F4AA-AO

Features

- 0 to 100 percent Economizer, Dry Bulb Control
- Blower VFD with Line Bypass and Speed Adjustment Potentiometer (VAV Mode Available Upon Request)
- Hinged Service Access
- Phase and Under/Over Voltage Protection
- Series 16 Cam Type Electrical Connections
- Unit Mounted Thermostat with Remote Option
- Symbio 700 Trane Controls with BACnet® Interface RS-485 MS/TP (Remote Monitoring Available Upon Request)
- Clogged Filter Switch Kit
- Hot Gas Bypass
- Manual Supply Air Dampers
- Three Stage Cooling and Two Stage Electric Heat
- Low Ambient Operation Down to 0°F

Table 117. General data – RSHX0035F4AA-AO

Labels	Value
Nominal Cooling Tons ^(a)	35
Heating Capacity	90 kW
Refrigerant	R-410A
Refrigerant Charge	38.3 lbs
Number of Refrigerant Circuits	1
Number of Compressors	3
Ambient Operating Conditions	0°F – 115°F

(a) Design Conditions: 95°F Ambient, 80°F EDB, 71°F EWB, 400 CFM/Ton.

Table 118. Electrical data – circuit breaker style disconnect – RSHX0035F4AA-AO

Labels	Value
Number of Electrical Circuits	1
Voltage	460V 3 Phase
Frequency	60 Hz
Wire Connection Type	Series 16 Cam Type Only
SCCR	65 kA
Minimum Circuit Ampacity (MCA)	193.6 A
Maximum Overcurrent Protection (MOP)	200 A
Cooling Only FLA	93.4 A
Heating Only FLA	137.8 A
Electric Reheat (72 kW Electric Heat + All Cooling) FLA	168.8 A

Table 119. Airflow data – RSHX0035F4AA-AO

Labels	Value
Supply Motor	15 HP
Nominal CFM	7000
Maximum ESP at Nominal CFM	5 in.
Supply Air Connection Qty/Size	(2) 20 in.
Return Air Connection Qty/Size	(2) 20 in.
Merv-8 Throwaway Filter Qty/Size	(16) 16 in. x 20 in. x 2 in.
Maximum Supply/Return Duct Run at Maximum CFM	650 ft.

Table 120. Dimensions and weights – RSHX0035F4AA-AO

Labels	Value
Length	18 ft. 4 in.
Width	7 ft. 7.25 in.
Height	6 ft. 9.75 in.
Shipping Weight	6,580 lbs
Fork Pocket Dimensions	9.5 in. x 5.5 in.
Center to Center Distance of Fork Pockets	4 ft. 10.375 in.

Note: Lifting Device: Forklift or crane.

Table 121. Operating clearances – RSHX0035F4AA-AO

Labels	Value
Condenser Coil End	8 ft.
Economizer End (if equipped)	6 ft.
Front (Control Panel)	4 ft.
Back (Supply/Return Duct Connections)	4 ft.
Top	No Obstructions

Note: Operating clearances are provided based on single machine, above ground. For multiple unit or pit operation, contact Trane Rental Services.



Voyager™ with Electric Heat

Figure 13. Fan curve – RSHX0035F4AA-AO

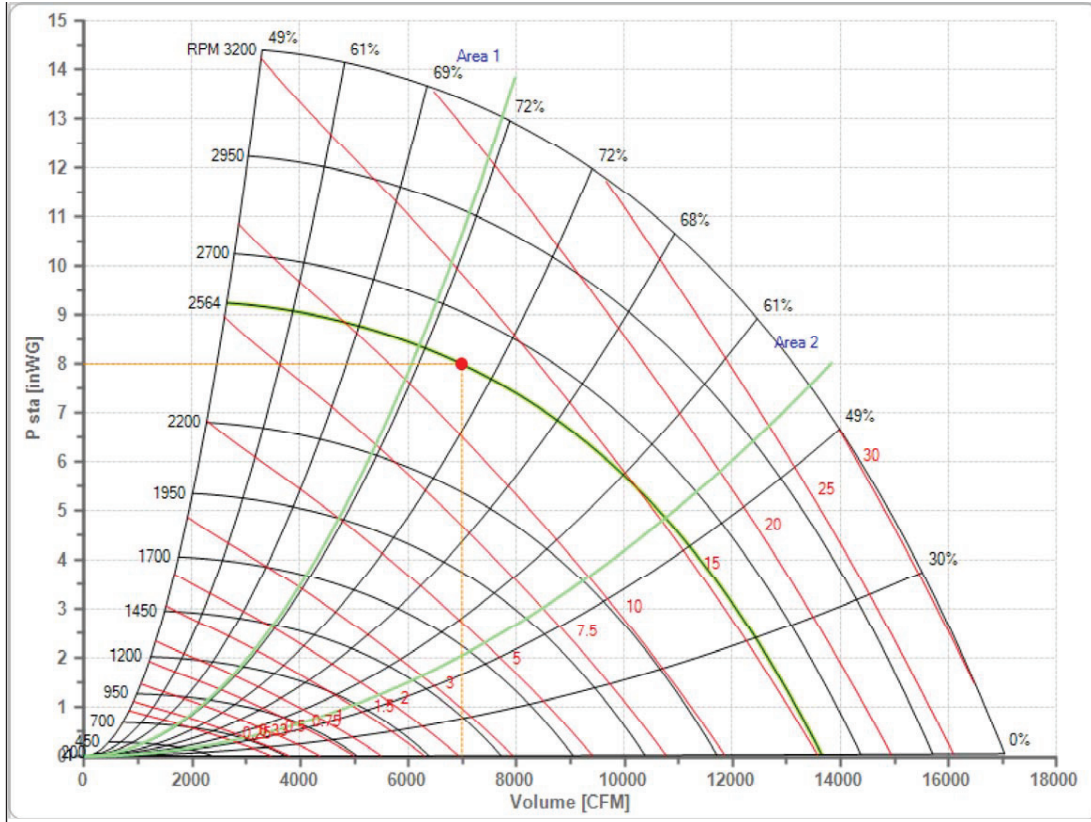

Table 122. Gross cooling capacities – RSHX0035F4AA-AO

Airflow cfm	Ent DB (°F)	Ambient Temperature (°F)																								
		85						95						105												
		Entering Wet Bulb (°F)																								
		61			67			73			61			67			73			61			67			73
TGC	SHC	TGC	SHC	TGC	SHC	TGC	SHC	TGC	SHC	TGC	SHC	TGC	SHC	TGC	SHC	TGC	SHC	TGC	SHC	TGC	SHC	TGC	SHC			
7000	75	N/A	N/A	356	177	408	133	N/A	N/A	348	174	396	127	N/A	N/A	321.3	162	365	115							
	80	N/A	N/A	359	218	407	170	N/A	N/A	349	213	396	165	N/A	N/A	323.19	201	365	153							
	85	333	307	359	256	404	207	325	302	352	252	396	204	303	289	325	240	365	191							
	90	350	346	367	297	N/A	N/A	341	337	360	294	511	290	320	316	334	279	N/A	N/A							
Airflow cfm	Ent DB (°F)	Ambient Temperature (°F)																								
		115																								
		Entering Wet Bulb (°F)																								
		61			67			73			61			67			73									
7000	75	N/A	N/A	302	153	343	106																			
	80	276	239	303	192	343	144																			
	85	287	280	306	232	343	183																			
	90	305	301	316	271	344	221																			

Note:

1. All capacities shown are gross and have not considered indoor fan heat. To obtain NET cooling capacity subtract indoor fan heat. For indoor fan heat formula, refer to appropriate airflow table notes.
2. TGC = Total gross capacity.
3. SHC = Sensible heat capacity.

Table 123. Electric heating performance – RSHX0035F4AA-AO

CFM	Temp Rise (°F)
7000	40

Table 124. Sound data – RSHX0035F4AA-AO

Sound Path (Hz)	63	125	250	500	1K	2K	4K	8K
Ducted Discharge (dB)	89	95	95	91	91	84	77	71
Outdoor Noise (dB)	100	96	97	96	93	89	90	83

Unit Drawing – RSHX0035F4AA-AO

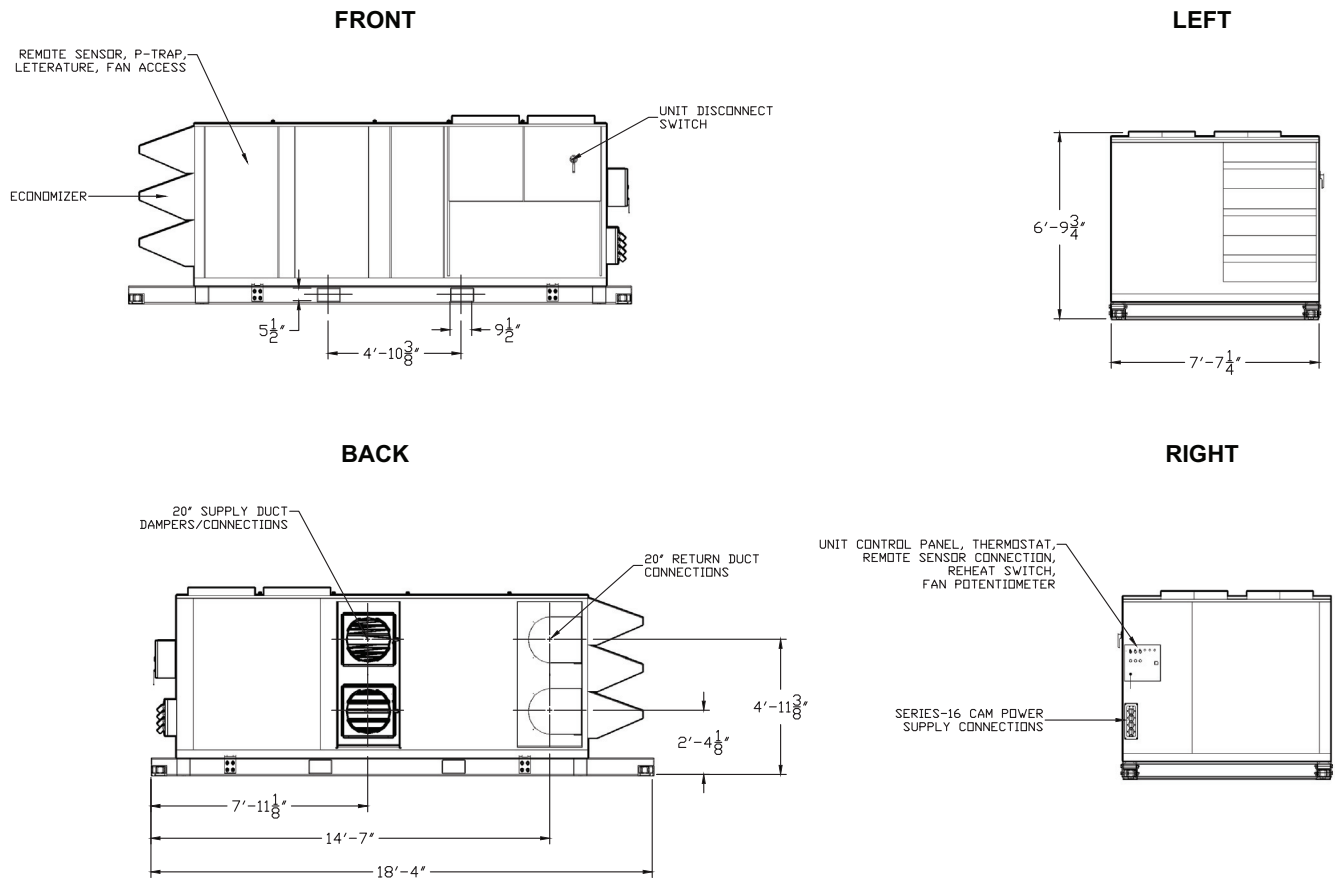



Voyager™ with Electric Heat

Model: CSHX0050F3

Features

- VFD with Bypass
- Hinged Service Access
- Electric Heat with Reheat Option
- Phase and Under/Over Voltage Protection
- Series 16 Cam Type Electrical Connections
- Remote Room Sensor
- Trane BACnet® Control Interface RS-485 MS/TP and Remote Monitoring Available Upon Request
- Clogged Filter Switch Kit
- Hot Gas Bypass
- Manual Supply/Return Air Dampers
- Three Stage Cooling and Two Stage Heating
- Low Ambient Operation Down to 0°F
- ReliaTel™ Trane Controls

Table 125. General data – CSHX0050F3

Labels	Value
Nominal Cooling Tons	50
Heating Capacity	108 kW
Refrigerant	R-410A
Number of Refrigerant Circuits	2
Number of Compressors	3
Ambient Operating Conditions	0°F – 115°F

Table 126. Electrical data – circuit breaker style disconnect – CSHX0050F3

Labels	Value
Number of Electrical Circuits	1
Voltage	460V 3 Phase
Frequency	60 Hz
Wire Connection Type	Series 16 Cam Type Connections or Hardwire (Maximum 350 MCM)
SCCR	5000 A
Minimum Circuit Ampacity (MCA)	240.5 A
Maximum Overcurrent Protection (MOP)	250 A
Cooling Only FLA	120.6 A
Heating Only FLA	160.4 A
Reheat	211.1 A

Table 127. Airflow data – CSHX0050F3

Labels	Value
Supply Motor	20 HP
Nominal CFM	10,000
Maximum ESP at Nominal CFM	5 in.
Supply Air Connection Qty/Size	(3) 20 in.
Return Air Connection Qty/Size	(3 or 2) 20 in.
Mist Eliminator Pre Filter Qty/Size	(4) 16 in. x 20 in. x 1 in. and (4) 16 in. x 25 in. x 1 in.
Merv-7 Throwaway Filter Qty/Size	(4) 16 in. x 20 in. x 2 in. and (4) 16 in. x 25 in. x 2 in.
Maximum Supply/Return Duct Run at Maximum CFM	425 ft.

Table 128. Dimensions and weights – CSHX0050F3

Labels	Value
Length	22 ft. 1 in.
Width	8 ft. 4 in.
Height	7 ft. 9.34 in.
Shipping Weight	8,300 lbs
Fork Pocket Dimensions	9.25 in. x 5.25 in. x 84 in.
Center to Center Distance of Fork Pockets	63.25 in.

Notes:

- Lifting Device: Forklift or crane.
- Confirm all dimensions and weights with TRS turnkey facility because this data might not match what is listed in this document.
- For additional installation information, see RT-SVX34*-EN.

Table 129. Operating clearances – CSHX0050F3

Labels	Value
Condenser Coil End	8 ft.
Economizer End (if equipped)	6 ft.
Front (Control Panel)	4 ft.
Back (Supply/Return Duct Connections)	4 ft.
Top	No Obstructions

Note: Operating clearances are provided based on single machine, above ground. For multiple unit or pit operation, contact Trane Rental Services.

Voyager™ with Electric Heat

Figure 14. Fan curve – CSHX0050F3

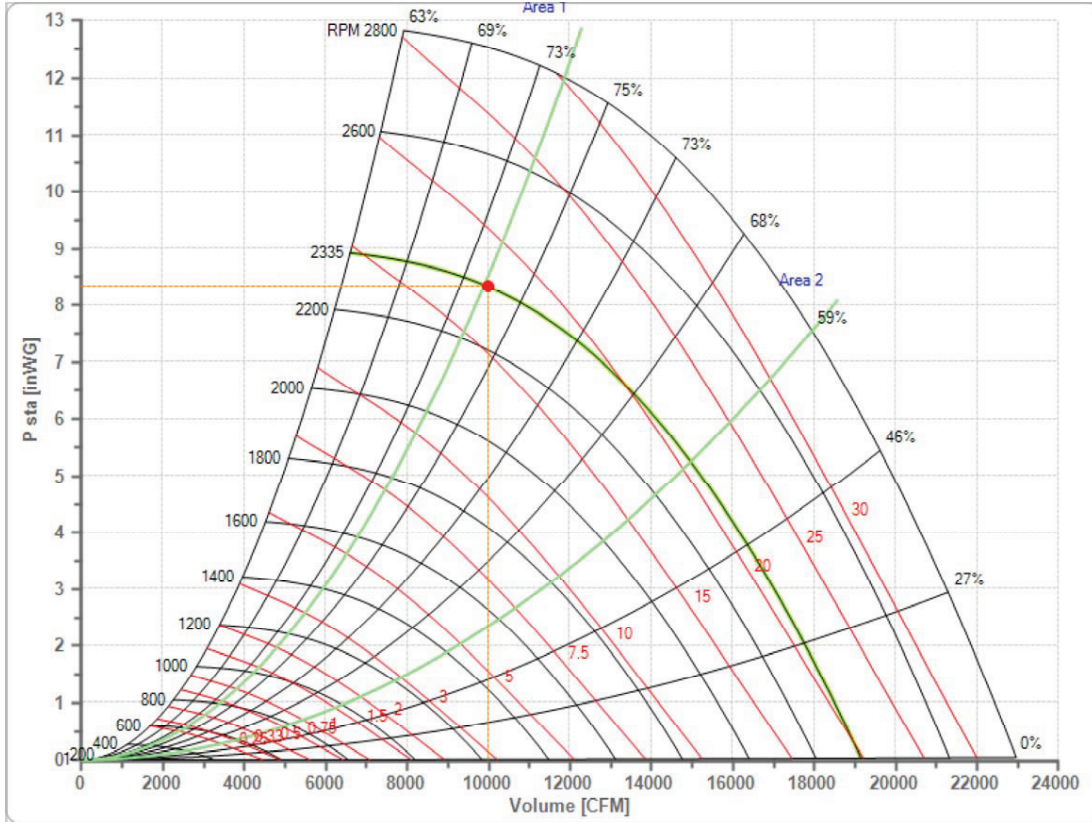

Table 130. Gross cooling capacities – CSHX0050F3

Airflow cfm	Ent DB (°F)	Ambient Temperature (°F)																	
		85						95						105					
		Entering Wet Bulb						Entering Wet Bulb						Entering Wet Bulb					
		61		67		73		61		67		73		61		67		73	
		TGC	SHC	TGC	SHC	TGC	SHC	TGC	SHC	TGC	SHC	TGC	SHC	TGC	SHC	TGC	SHC	TGC	SHC
10000	75	N/A	N/A	518	258	592	192	N/A	N/A	495	247	565	181	N/A	N/A	468	236	535	169
	80	N/A	N/A	520	314	592	247	N/A	N/A	496	868	564	303	N/A	N/A	470	292	535	224
	85	476	439	524	371	592	302	463	432	500	360	565	291	442	420	475	348	536	280
	90	502	499	536	430	N/A	N/A	488	481	513	419	N/A	N/A	468	462	490	407	N/A	N/A
Airflow cfm	Ent DB (°F)	Ambient Temperature (°F)																	
		115																	
		Entering Wet Bulb																	
		61				67				73									
		TGC	SHC	TGC	SHC	TGC	SHC	TGC	SHC	TGC	SHC	TGC	SHC	TGC	SHC	TGC	SHC	TGC	SHC
10000	75	N/A	N/A	442	224	504	158												
	80	399	345	444	280	504	213												
	85	420	408	449	337	505	268												
	90	447	440	464	395	507	324												

- Note:
1. All capacities shown are gross and have not considered indoor fan heat.
 2. TGC = Total gross capacity.
 3. SHC = Sensible heat capacity.

Voyager™ with Electric Heat

Table 131. Electric heating performance – CSHX0050F3

CFM	Temp Rise (°F)
10000	34

Table 132. Sound data – CSHX0050F3

Sound Path (Hz)	63	125	250	500	1K	2K	4K	8K
Ducted Discharge (dB)	99	97	90	93	90	84	76	70
Outdoor Noise (dB)	104	97	96	97	95	93	88	79

Unit Drawings – CSHX0050F3

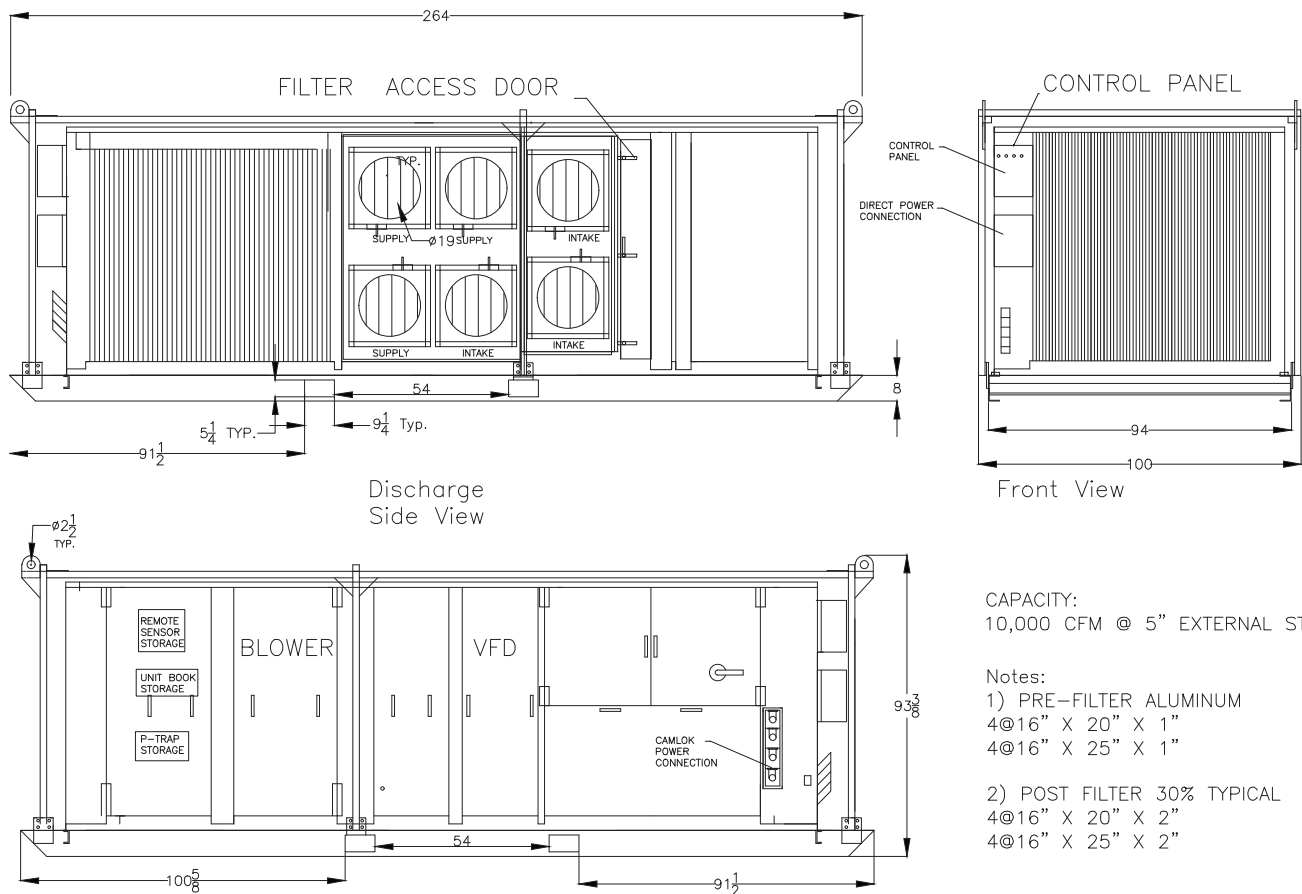

CAPACITY:
10,000 CFM @ 5" EXTERNAL STATIC

- Notes:
- 1) PRE-FILTER ALUMINUM
4@16" X 20" X 1"
4@16" X 25" X 1"
 - 2) POST FILTER 30% TYPICAL
4@16" X 20" X 2"
4@16" X 25" X 2"

- Notes:
- 1) Dimensions shown in inches.
 - 2) Base ends are slanted 45°.
 - 3) Total weight of unit in base and lifting frame is approximately 7500lbs.

Opposite
Side View



Voyager™ with Electric Heat

Model: CSHX0050F4

Features

- 0 to 100 percent Economizer, Dry Bulb Control
- Blower VFD with Line Bypass
- Hinged Service Access
- Electric Heat with Reheat Option
- Phase and Under/Over Voltage Protection
- Series 16 Cam Type Electrical Connections
- Unit Mounted Thermostat with Remote Option
- Trane BACnet® Control Interface RS-485 MS/TP and Remote Monitoring Available Upon Request
- Clogged Filter Switch Kit
- Hot Gas Bypass
- Manual Supply Air Dampers
- Three Stage Cooling and Two Stage Heating
- Low Ambient Operation Down to 0°F
- ReliaTel™ Trane Controls

Table 133. General data – CSHX0050F4

Labels	Value
Nominal Cooling Tons	50
Heating Capacity	108 kW
Refrigerant	R-410A
Number of Refrigerant Circuits	2
Number of Compressors	3
Ambient Operating Conditions	0°F – 115°F

Table 134. Electrical data – circuit breaker style disconnect – CSHX0050F4

Labels	Value
Number of Electrical Circuits	1
Voltage	460V 3 Phase
Frequency	60 Hz
Wire Connection Type	Series 16 Cam Type Only
SCCR	5000 A
Minimum Circuit Ampacity (MCA)	232.2 A
Maximum Overcurrent Protection (MOP)	250 A
Cooling Only FLA	112.2 A
Heating Only FLA	160.4 A
Electric Reheat (72 kW Electric Heat + All Cooling) FLA	202.7 A

Table 135. Airflow data – CSHX0050F4

Labels	Value
Supply Motor	20 HP
Nominal CFM	10,000
Maximum ESP at Nominal CFM	5 in.
Supply Air Connection Qty/Size	(4) 20 in.
Return Air Connection Qty/Size	(4) 20 in.
Merv-8 Throwaway Filter Qty/Size	(17) 16 in. x 20 in. x 2 in.
Maximum Supply/Return Duct Run at Maximum CFM	1250 ft.

Table 136. Dimensions and weights – CSHX0050F4

Labels	F4BT-BW	F4BX-DH
Length	22 ft. 8.875 in.	22 ft. 9.375 in.
Width	8 ft. 3.5 in.	7 ft. 7.125 in.
Height	7 ft. 11 in.	7 ft. 4.5 in.
Shipping Weight	10,360 lbs	8,160 lbs
Fork Pocket Dimensions	9.5 in. x 5.5 in.	9.5 in. x 5.5 in.
Center to Center Distance of Fork Pockets	60 in.	4 ft. 10.125 in.

Notes:

- Lifting Device: Forklift or crane.
- Confirm all dimensions and weights with TRS turnkey facility because this data might not match what is listed in this document.
- For additional installation information, see RT-SVX34*-EN.

Table 137. Operating clearances – CSHX0050F4

Labels	Value
Condenser Coil End	8 ft.
Economizer End (if equipped)	6 ft.
Front (Control Panel)	4 ft.
Back (Supply/Return Duct Connections)	4 ft.
Top	No Obstructions

Note: Operating clearances are provided based on single machine, above ground. For multiple unit or pit operation, contact Trane Rental Services.

Voyager™ with Electric Heat

Figure 15. Fan curve – CSHX0050F4

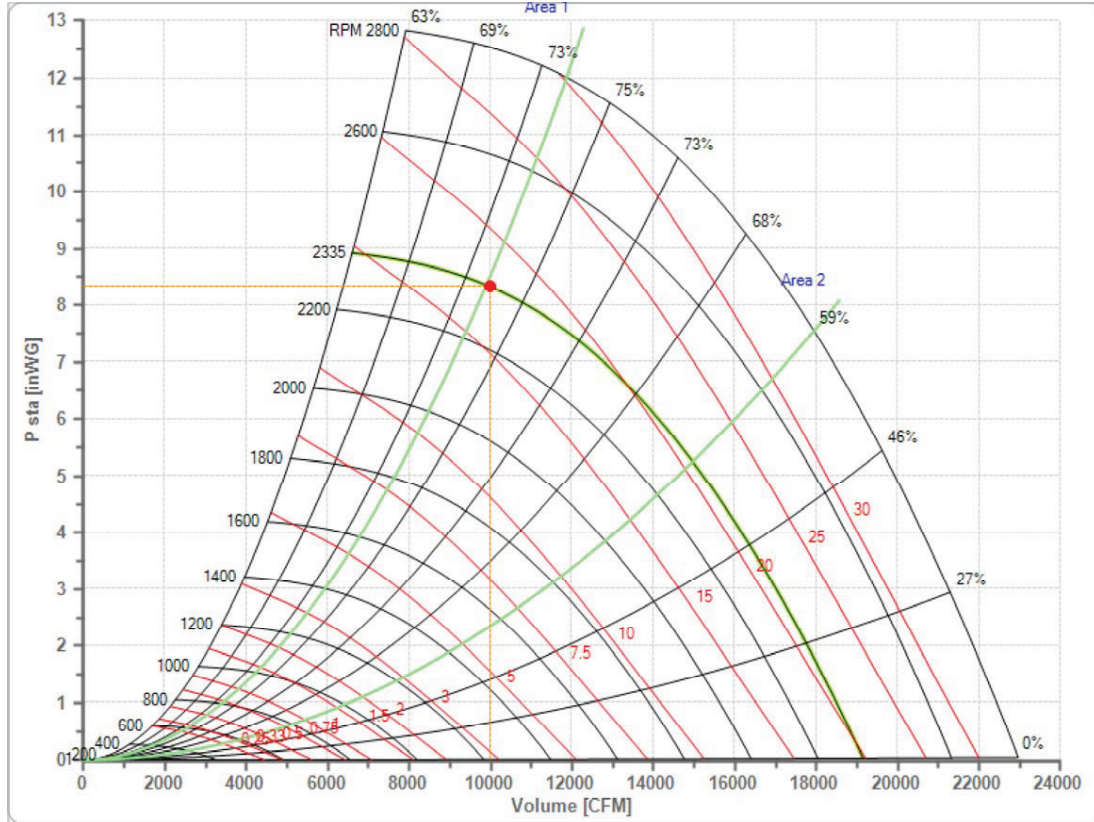

Table 138. Gross cooling capacities – CSHX0050F4

Airflow cfm	Ent DB (°F)	Ambient Temperature (°F)																	
		85						95						105					
		Entering Wet Bulb						Entering Wet Bulb						Entering Wet Bulb					
		61		67		73		61		67		73		61		67		73	
		TGC	SHC	TGC	SHC	TGC	SHC	TGC	SHC	TGC	SHC	TGC	SHC	TGC	SHC	TGC	SHC	TGC	SHC
10000	75	N/A	N/A	518	258	592	192	N/A	N/A	495	247	565	181	N/A	N/A	468	236	535	169
	80	N/A	N/A	520	314	592	247	N/A	N/A	496	868	564	303	N/A	N/A	470	292	535	224
	85	476	439	524	371	592	302	463	432	500	360	565	291	442	420	475	348	536	280
	90	502	499	536	430	N/A	N/A	488	481	513	419	N/A	N/A	468	462	490	407	N/A	N/A
10000	75	Ambient Temperature (°F)																	
		115																	
		Entering Wet Bulb																	
		61		67		73		61		67		73		61		67		73	
		TGC	SHC	TGC	SHC	TGC	SHC	TGC	SHC	TGC	SHC	TGC	SHC	TGC	SHC	TGC	SHC	TGC	SHC
		N/A	N/A	442	224	504	158												
		399	345	444	280	504	213												
		420	408	449	337	505	268												
		447	440	464	395	507	324												

- Note:**
- All capacities shown are gross and have not considered indoor fan heat.
 - TGC = Total gross capacity.
 - SHC = Sensible heat capacity.

Table 139. Electric heating performance – CSHX0050F4

CFM	Temp Rise (°F)
10000	34

Table 140. Sound data – CSHX0050F4

Sound Path (Hz)	63	125	250	500	1K	2K	4K	8K
Ducted Discharge (dB)	99	97	90	93	90	84	76	70
Outdoor Noise (dB)	104	97	96	97	95	93	88	79

Unit Drawings – CSHX0050F4BT-BW

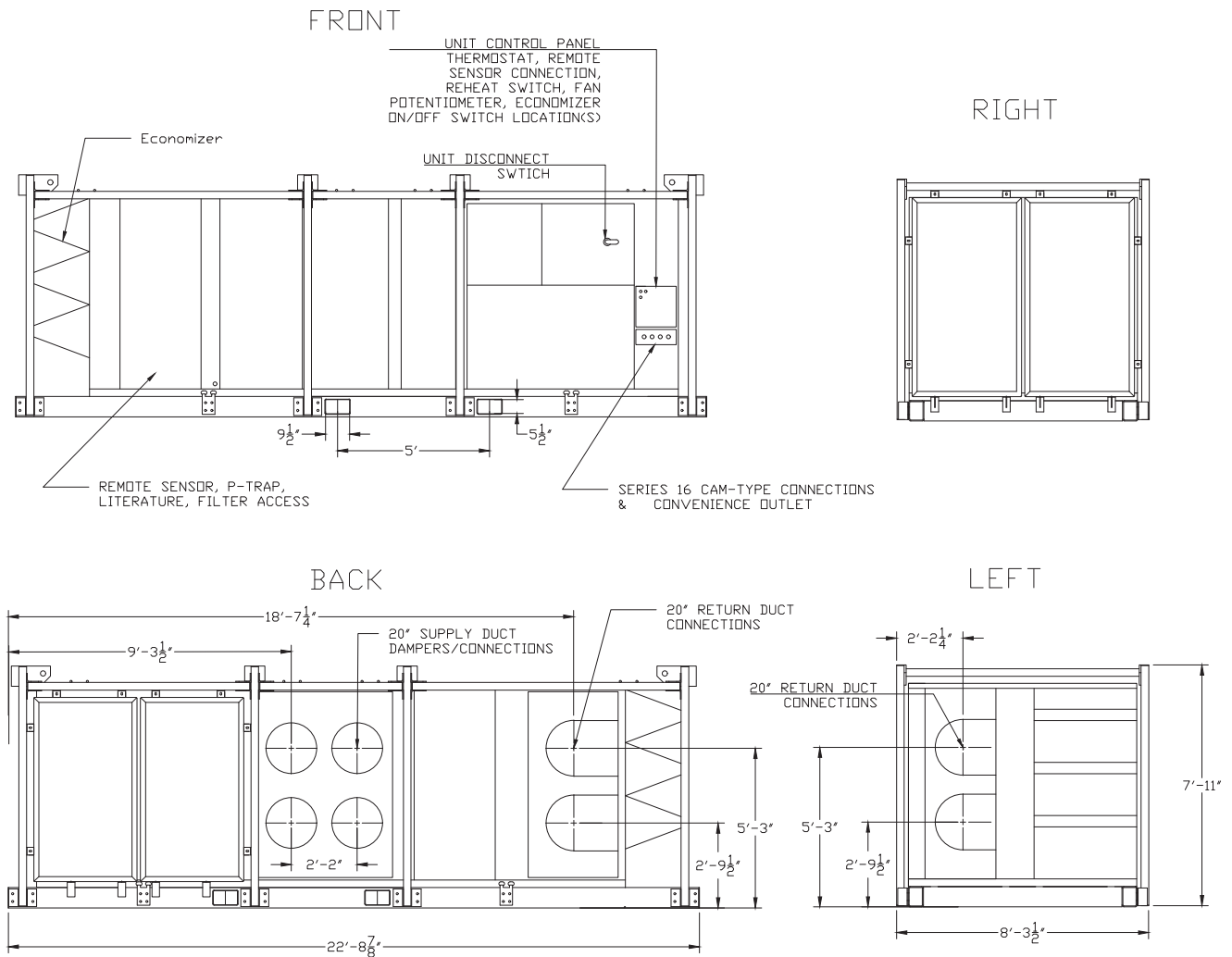

Voyager™ with Electric Heat

Unit Drawings – CSHX0050F4BX-DH

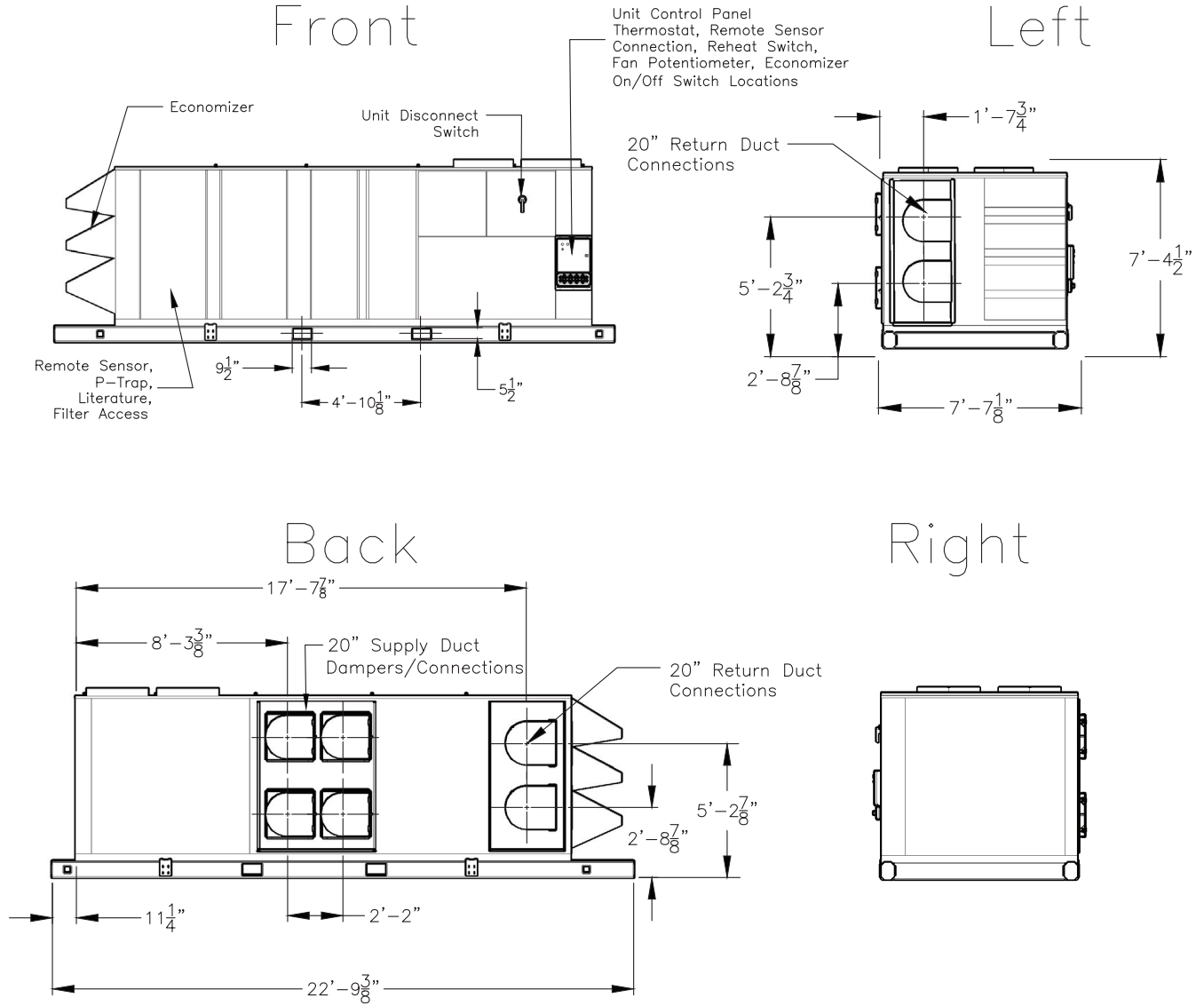

Model: RSHX0050F4AA-AJ

Features

- 0 to 100 percent Economizer, Dry Bulb Control
- Blower VFD with Line Bypass and Speed Adjustment Potentiometer (VAV Mode Available Upon Request)
- Hinged Service Access
- Phase and Under/Over Voltage Protection
- Series 16 Cam Type Electrical Connections
- Unit Mounted Thermostat with Remote Option
- Symbio 700 Trane Controls with BACnet® Interface RS-485 MS/TP (Remote Monitoring Available Upon Request)
- Clogged Filter Switch Kit
- Hot Gas Bypass
- Manual Supply Air Dampers
- Three Stage Cooling and Two Stage Electric Heat
- Low Ambient Operation Down to 0°F

Table 141. General data – RSHX0050F4AA-AJ

Labels	Value
Nominal Cooling Tons ^(a)	50
Heating Capacity	108 kW
Refrigerant	R-410A
Refrigerant Charge	38.3 lbs
Number of Refrigerant Circuits	1
Number of Compressors	3
Ambient Operating Conditions	0°F – 115°F

(a) Design Conditions: 95°F Ambient, 80°F EDB, 71°F EWB, 400 CFM/Ton.

Table 142. Electrical data – circuit breaker style disconnect – RSHX0050F4AA-AJ

Labels	Value
Number of Electrical Circuits	1
Voltage	460V 3 Phase
Frequency	60 Hz
Wire Connection Type	Series 16 Cam Type Only
SCCR	65 kA
Minimum Circuit Ampacity (MCA)	244.2 A
Maximum Overcurrent Protection (MOP)	250 A
Cooling Only FLA	123.2 A
Heating Only FLA	166.2 A
Electric Reheat (72 kW Electric Heat + All Cooling) FLA	213.7 A



Voyager™ with Electric Heat

Table 143. Airflow data – RSHX0050F4AA-AJ

Labels	Value
Supply Motor	20 HP
Nominal CFM	10,000
Maximum ESP at Nominal CFM	5 in.
Supply Air Connection Qty/Size	(4) 20 in.
Return Air Connection Qty/Size	(4) 20 in.
Merv-8 Throwaway Filter Qty/Size	(17) 16 in. x 20 in. x 2 in.
Maximum Supply/Return Duct Run at Maximum CFM	1250 ft.

Table 144. Dimensions and weights – RSHX0050F4AA-AJ

Labels	Value
Length	18 ft. 4 in.
Width	7 ft. 7.25 in.
Height	6 ft. 9.75 in.
Shipping Weight	8,160 lbs
Fork Pocket Dimensions	9.5 in. x 5.5 in.
Center to Center Distance of Fork Pockets	4 ft. 10.375 in.

Note: Lifting Device: Forklift or crane.

Table 145. Operating clearances – RSHX0050F4AA-AJ

Labels	Value
Condenser Coil End	8 ft.
Economizer End (if equipped)	6 ft.
Front (Control Panel)	4 ft.
Back (Supply/Return Duct Connections)	4 ft.
Top	No Obstructions

Note: Operating clearances are provided based on single machine, above ground. For multiple unit or pit operation, contact Trane Rental Services.

Figure 16. Fan curve – RSHX0050F4AA-AJ

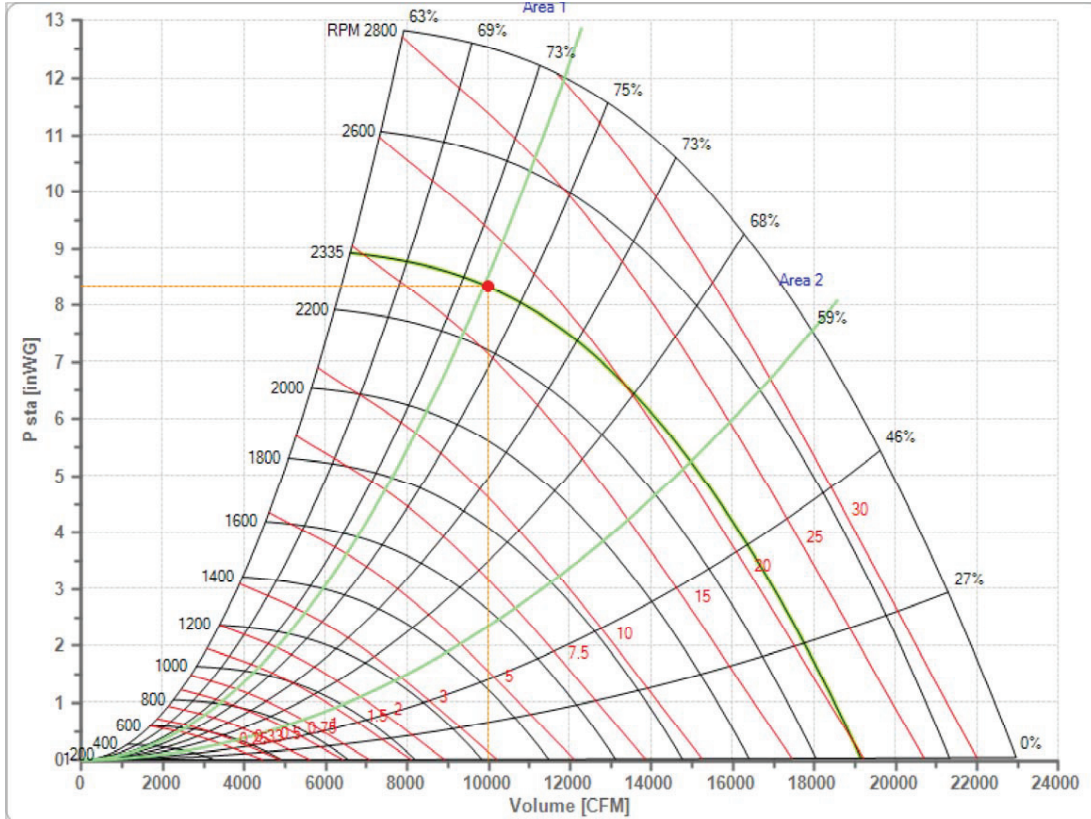

Table 146. Gross cooling capacities – RSHX0050F4AA-AJ

Airflow cfm	Ent DB (°F)	Ambient Temperature (°F)																	
		85						95						105					
		Entering Wet Bulb (°F)																	
		61		67		73		61		67		73		61		67		73	
TGC	SHC	TGC	SHC	TGC	SHC	TGC	SHC	TGC	SHC	TGC	SHC	TGC	SHC	TGC	SHC	TGC	SHC		
10000	75	N/A	N/A	518	258	592	192	N/A	N/A	495	247	565	181	N/A	N/A	468	236	535	169
	80	N/A	N/A	520	314	592	247	N/A	N/A	496	868	564	303	N/A	N/A	470	292	535	224
	85	476	439	524	371	592	302	463	432	500	360	565	291	442	420	475	348	536	280
	90	502	499	536	430	N/A	N/A	488	481	513	419	N/A	N/A	468	462	490	407	N/A	N/A
10000	Ent DB (°F)	Ambient Temperature (°F)																	
		115																	
		Entering Wet Bulb (°F)																	
		61		67		73		61		67		73		61		67		73	
10000	75	N/A	N/A	442	224	504	158												
	80	399	345	444	280	504	213												
	85	420	408	449	337	505	268												
	90	447	440	464	395	507	324												

Note:

1. All capacities shown are gross and have not considered indoor fan heat. To obtain NET cooling capacity subtract indoor fan heat. For indoor fan heat formula, refer to appropriate airflow table notes.
2. TGC = Total gross capacity.
3. SHC = Sensible heat capacity.



Voyager™ with Electric Heat

Table 147. Electric heating performance – RSHX0050F4AA-AJ

CFM	Temp Rise (°F)
10000	34

Table 148. Sound data – RSHX0050F4AA-AJ

Sound Path (Hz)	63	125	250	500	1K	2K	4K	8K
Ducted Discharge (dB)	99	97	90	93	90	84	76	70
Outdoor Noise (dB)	104	97	96	97	95	93	88	79

Unit Drawing – RSHX0050F4AA-AJ

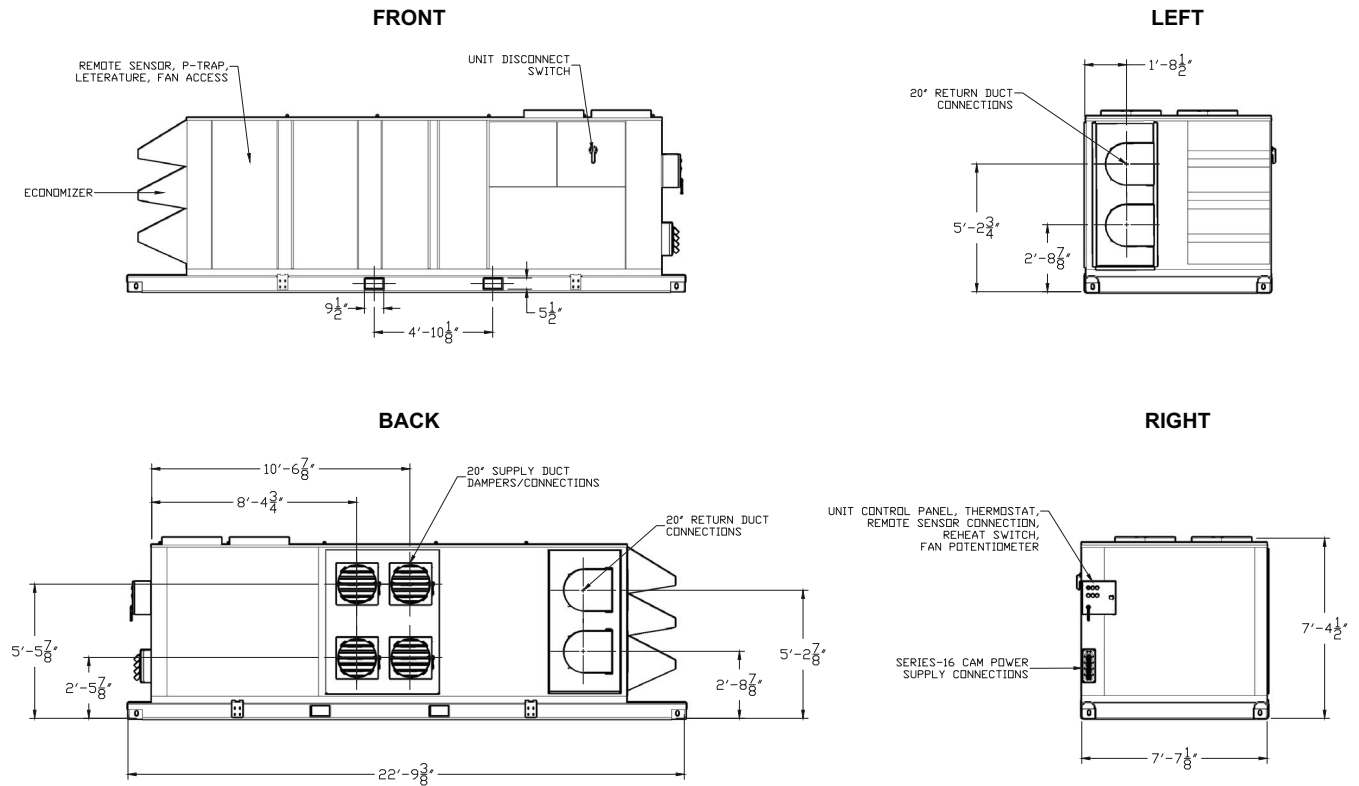

Model: RSHX0080

Features

- Hot Gas Bypass
- Cam Type Electrical Connections
- Electric Heat with Reheat (Dehumidification) Option
- Hydrophilic Condenser and Evaporator Coils
- Phase and Under/Over Voltage Protection
- Remote Wireless Thermostat (Available Upon Request)
- Run Hour Meter
- 120V 6 Amp GFCI Convenience Outlet
- Supply and Condenser Fan VFD's with Bypass
- ETL, UL 1995 and CSA STD C22.2 No.236 Certified

Table 149. General data – RSHX0080

Labels	Value
Nominal Cooling Tons	80
Heating Capacity	162 kW
Refrigerant	R-410A
Number of Refrigerant Circuits	2
Number of Compressors	2
Ambient Operating Conditions	0°F – 105°F

Table 150. Electrical data – circuit breaker style disconnect – RSHX0080

Labels	Value
Number of Electrical Circuits	1
Voltage	460V 3 Phase
Frequency	60 Hz
Wire Connection Type	Series 16 Cam Type Only
SCCR	5000 A
Minimum Circuit Ampacity (MCA)	329 A
Maximum Overcurrent Protection (MOP)	400 A
Cooling Only FLA	147.1 A
Heating Only FLA	237.7 A
Electric Reheat (108 kW Electric Heat + All Cooling) FLA	282.7 A



Voyager™ with Electric Heat

Table 151. Airflow data – RSHX0080

Labels	Value
Supply Motor	30 HP
Nominal CFM	12,800
Minimum/Maximum CFM	4,200 – 17,000
Maximum ESP at Nominal CFM	4.6 in.
Supply Air Connection Qty/Size	(3) 20 in.
Return Air Connection Qty/Size	(4) 20 in.
Merv-8 Throwaway Filter Qty/Size	(8) 16 in. x 25 in. x 2 in.
Maximum Supply/Return Duct Run at Maximum CFM	500 ft.

Table 152. Dimensions and weights – RSHX0080

Labels	Value
Length	13 ft. 0 in.
Width	7 ft. 4 in.
Height	8 ft. 4 in.
Shipping Weight	9,800 lbs
Fork Pocket Dimensions	12 in. x 4.75 in.
Center to Center Distance of Fork Pockets	48 in.

Note: Lifting Device: Forklift or crane.

Table 153. Operating clearances – RSHX0080

Labels	Value
Left End - Opposite Control Panel	8 ft.
Right End - Control Panel	8 ft.
Front - Supply Air Connections	8 ft.
Back - Return Duct Connections	8 ft.
Top	No Obstructions

Note: Operating clearances are provided based on single machine, above ground. For multiple unit or pit operation, contact Trane Rental Services.

Figure 17. Fan curve – RSHX0080

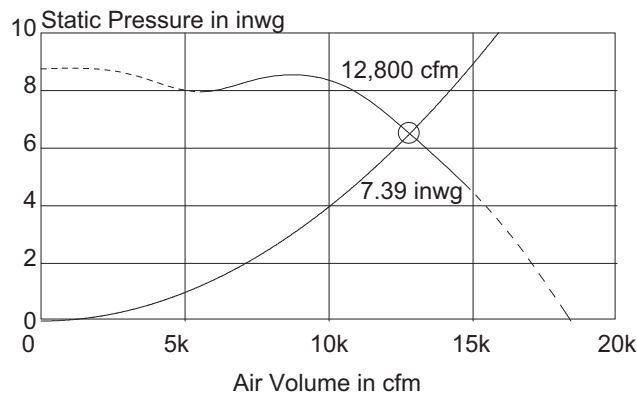
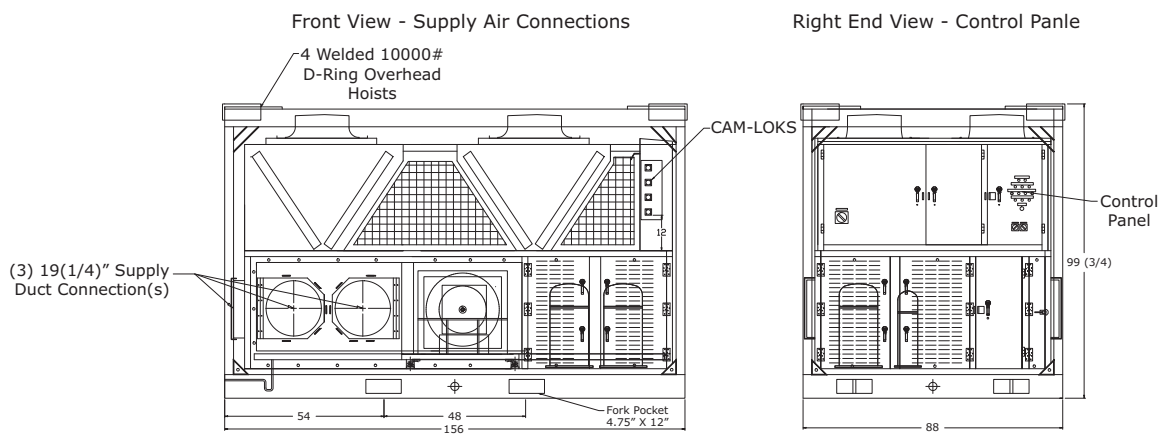

Table 154. Electric heating performance – RSHX0080

CFM	Temp Rise (°F)
8000	35.4
10000	28.3
12800	22.1
15000	18.9
17000	16.7

Unit Drawings – RSHX0080



Plan View Of Evaporator Blower Section Only

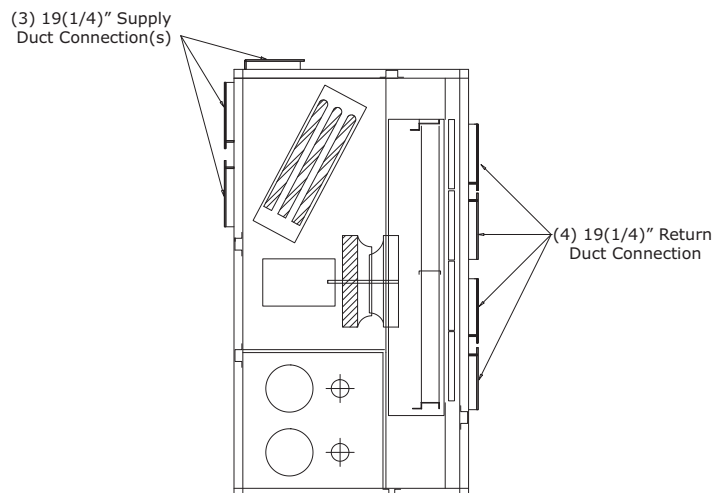

Trane - by Trane Technologies (NYSE: TT), a global climate innovator - creates comfortable, energy efficient indoor environments for commercial and residential applications. For more information, please visit trane.com or tranetechnologies.com.

Trane has a policy of continuous product and product data improvement and reserves the right to change design and specifications without notice. We are committed to using environmentally conscious print practices.