



Product Catalog

Split System Air Conditioners Odyssey™ with Symbio™ Controls

R-22 Dry Charge, Heat Pump Condenser
7.5, 10, 15 and 20 Tons, 60 Hz





Introduction



Odyssey™ Split Systems offer a wide range of options, allowing you to easily match unit tonnage with the right load requirements.

When a project calls for the convenience and cost efficiency of a unitary product, where a rooftop unit isn't right, Odyssey may be the answer. It provides heating and cooling in a split configuration that's unique in its versatility while staying true to our standards for efficiency and reliability. And with the Symbio® digital controller on board, Odyssey introduces smart building capabilities that take service, comfort and sustainability beyond the expected.

With wide network availability, flexible applications, installation ease, built-in reliability and easy servicing, Odyssey will meet any number of customer applications. Add to that Trane's outstanding customer service and you have the formula to make Odyssey the clear choice for continued customer satisfaction.

Wide Network Availability

A broad distribution network provides owners, maintenance personnel, contractors, etc., the means to get their hands on equipment when they need it. Whether it's an emergency replacement or a new construction project in its infancy stages, Odyssey products meet an array of needs at the right time and right price.

Flexible Applications

No matter what the application, Odyssey provides the solution. A broad array of models and tonnages are available with single or dual compressors, single or dual circuits and numerous accessories. Condensing units can be installed on the ground or on a rooftop along with extended piping runs, while air handlers can be free discharge on the ground or horizontally suspended with long duct runs from a ceiling. Should application challenges arise, Odyssey delivers.

Easy to Install

Small footprints and low weights combined with factory installed components like TXVs, filter driers, etc., reduce installation time and cost. Colored connectors and wiring, as well as factory-tested units make Odyssey the right choice.

Built-in Reliability

Keeping in mind that productivity only occurs when equipment is operational, Trane has taken the steps to ensure that Odyssey is up and running. Early indicators such as phase/reversal monitors and loss of

charge protection provide diagnostics which prevent failure and provide years of worry-free service and operation.

Easy to Service

When preventive maintenance or service is required, technicians will find efficient access to both air handlers and condensers. Panels provide complete, easy access coupled with standardized cabinets in which all components are located in proximity. Odyssey's improved design results in minimum service times and costs.

With these capabilities, Odyssey provides customers high efficiency and superior performance for the best all-around value in the market today.

Copyright

This document and the information in it are the property of Trane, and may not be used or reproduced in whole or in part without written permission. Trane reserves the right to revise this publication at any time, and to make changes to its content without obligation to notify any person of such revision or change.

Trademarks

All trademarks referenced in this document are the trademarks of their respective owners.

Revision History

- Updated Accessories chapter.
- Updated Model Number Description chapter.
- Updated General Data chapter.
- Updated Electrical Data chapter.
- Updated Heat Pump chapter.
- Updated Weights chapter.



Table of Contents

Accessories	5
Heat Pump Condenser	5
Model Number Description	6
Heat Pump Condenser	6
General Data	7
Performance Data	8
Electrical Data	12
Heat Pump	13
Weights	16
Heat Pump Condenser	16



Accessories

Heat Pump Condenser

Table 1. TWA accessories

Model	Used With
Rubber Isolators	
BAYISLT005* (black)	TWA0902*A, TWA1202*A
BAYISLT009* (red)	TWA1802*D
BAYISLT010* (green)	TWA2402*D
Steel Spring Isolators	
BAYISLT023* (red)	TWA0902*A, TWA1202*A
BAYISLT024* (black)	TWA1802*D
BAYISLT025* (yellow)	TWA2402*D
Service Valve Kit	
BAYVALV001*	TWA0902*A, TWA1202*A
BAYVALV006*	TWA1802*D, TWA2402*D
Low Ambient — On/Off Fan Control^(a) ^(b)	
BAYLOAMS10* (External Mount, small cabinets) ^(c)	(all voltages) TWA0902*A
BAYLOAMS20* (Internal mount, large cabinets)	(all voltages) TWA1202*A, TWA1802*D, TWA2402*D
LonTalk Communications Interface^(d)	
BAYLTCI005*	All Models
Expansion Module Kit	
BAYMODU002* (XM30)	All Models
BAYMODU004* (XM32)	All Models

^(a) Cycles fan on/off (no modulating).

^(b) When BAYLOAM is used, the Evaporator Defrost Control (EDC) must be disabled in the Symbio 700 controller configuration.

^(c) Kit mounts external to the outdoor unit and operates by sensing ambient temperature and discharge pressure.

^(d) Field installed LonTalk interface requires installation of Symbio control board with Advanced Diagnostics (not included).



Model Number Description

Heat Pump Condenser

Digit 1, 2, 3— Unit Function

TWA = Split System Heat Pump

Digit 4, 5, 6 — Tonnage

090 = 7.5 Tons (60 Hz)

120 = 10 Tons (60 Hz)

180 = 15 Tons (60 Hz)

240 = 20 Tons (60 Hz)

Digit 7 — Refrigerant

2 = R-22

Digit 8 — Voltage

3 = 208-230 Vac - 3 PH (60Hz)

4 = 460 Vac - 3 PH (60Hz)

Digit 9 — Refrigeration Circuit/Stage

A = 1 Compressor/1 Line/1 Stage (Single)

D = 2 Compressors/2 Line/2 Stage (Dual)

Digit 10 — Major Design Sequence

B = Rev B

Digit 11 — Minor Design Sequence

A = Rev A

Digit 12, 13 — Service Digits

**

Digit 14 — Efficiency Generation

A = Generation A

Digit 15 — Controls

S = Symbio™

Digit 16 — None

0 = None

Digit 17 — Coil Protection

1 = Standard Coil w/ Coil Guard

Digit 18, 19, 20 — None

0 = None

Digit 21 — Communications Options

0 = No Option

1 = Advanced Diagnostics and BACnet® BAS

2 = Advanced Diagnostics and LonTalk®
Communications Interface (LCI)

Digit 22 to 40 — None

0 = None



General Data

Table 2. General data for 7.5 - 20 ton heat pump, 60 Hz

	7.5 Tons	10 Tons	15 Tons	20 Tons
	Single Compressor TWA0902*A*	Single Compressor TWA1202*A*	Dual Compressor TWA1802*D*	Dual Compressor TWA2402*D*
Compressor				
Type	Scroll	Scroll	Scroll	Scroll
No./Tons	1/6.9	1/8.6	2/6.9	2/8.6
System Data				
No. Refrigerant Circuits	1	1	2	2
Suction Line Connection (in.) OD	1 3/8	1 3/8	1 3/8	1 3/8
Liquid Line Connection (in.) OD	1/2	1/2	5/8	5/8
Outdoor Coil				
Type	Lanced	Lanced	Lanced	Lanced
Tube Size (in.) OD	0.375	0.375	0.375	0.375
Face Area (sq ft)	19.24	29.02	52.60	52.60
Rows/FPI (Fins per inch)	2/18	2/18	2/18	2/18
Outdoor Fan				
Type	Propeller	Propeller	Propeller	Propeller
No. Used/Diameter (in.)	1/26	1/28	2/28	2/28
Drive Type/No. Speeds	Direct/1	Direct/1	Direct/1	Direct/1
CFM	6,530	9,800	19,500	19,500
No. Motor/HP	1/0.5	1/1	2/1	2/1
Motor RPM	1,100	1,100	1,100	1,100
Shipping Dimensions				
HxWxD (in.)	46.1" x 45.25" x 39"	52.1" x 55" x 42"	51.1" x 96" x 48"	51.1" x 96" x 48"



Performance Data

Table 3. Gross cooling capacities (MBH) 7.5 tons TWA0902*A condensing unit only (IP)

Outdoor Temp (°F)		Suction Temperature (°F)					
		30	35	40	45	50	55
65	Head Press (psig)	161.6	172.5	178.6	185.2	192.0	199.2
	Capacity (Btuh/1000)	75.4	83.5	92.3	101.5	111.1	121.0
	Unit Power (kW)	4.8	5.0	5.1	5.3	5.5	5.6
75	Head Press (psig)	190.7	196.7	203.0	209.7	216.7	224.1
	Capacity (Btuh/1000)	71.3	79.2	87.7	96.4	105.5	114.8
	Unit Power (kW)	5.3	5.5	5.6	5.8	6.0	6.2
85	Head Press (psig)	217.1	223.3	230.0	237.0	244.3	252.0
	Capacity (Btuh/1000)	67.5	75.0	83.0	91.3	99.9	108.8
	Unit Power (kW)	5.8	6.0	6.1	6.3	6.5	6.7
95	Head Press (psig)	246.4	252.9	259.7	266.9	274.5	282.3
	Capacity (Btuh/1000)	63.6	70.8	78.3	86.2	94.4	102.8
	Unit Power (kW)	6.4	6.6	6.7	6.9	7.1	7.3
105	Head Press (psig)	278.2	285.0	292.0	299.4	307.2	315.2
	Capacity (Btuh/1000)	59.7	66.5	73.6	81.0	88.7	96.7
	Unit Power (kW)	7.0	7.2	7.4	7.6	7.8	8.0
115	Head Press (psig)	312.8	319.8	327.1	334.6	342.5	350.7
	Capacity (Btuh/1000)	55.7	62.1	68.9	75.8	83.1	90.5
	Unit Power (kW)	7.7	7.8	8.0	8.2	8.4	8.6
125	Head Press (psig)	350.1	357.3	364.7	372.5	380.5	388.8
	Capacity (Btuh/1000)	51.6	57.7	64.1	70.6	77.3	84.3
	Unit Power (kW)	8.4	8.6	8.7	8.9	9.1	9.3

Note: Performance data calculated at 15°F subcooling and 15°F superheat and does not include capacity loss due to refrigerant lines.

Figure 1. TWA0902*A capacity curve

Capacity Curves - Condensing Unit Only

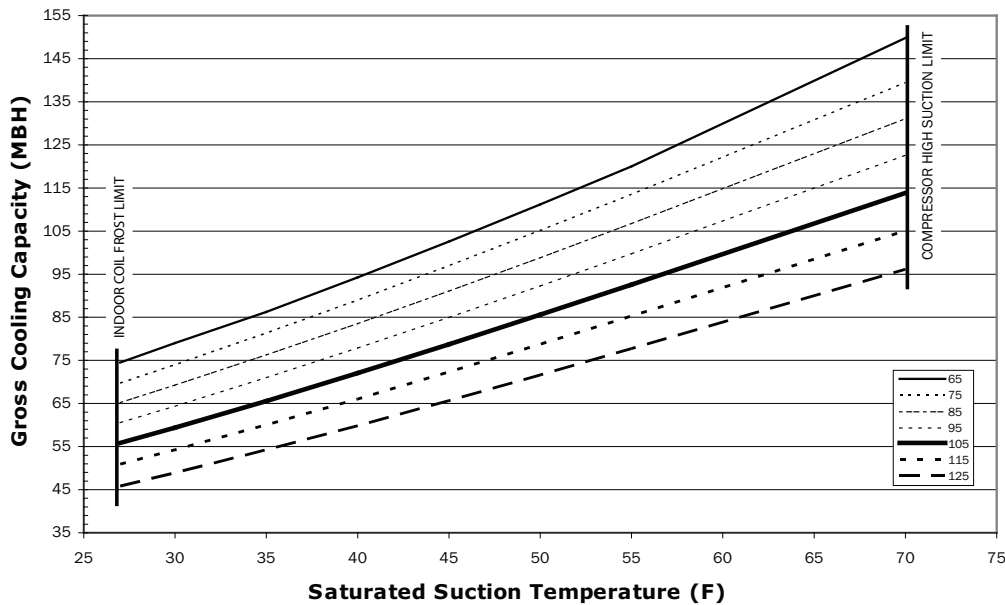
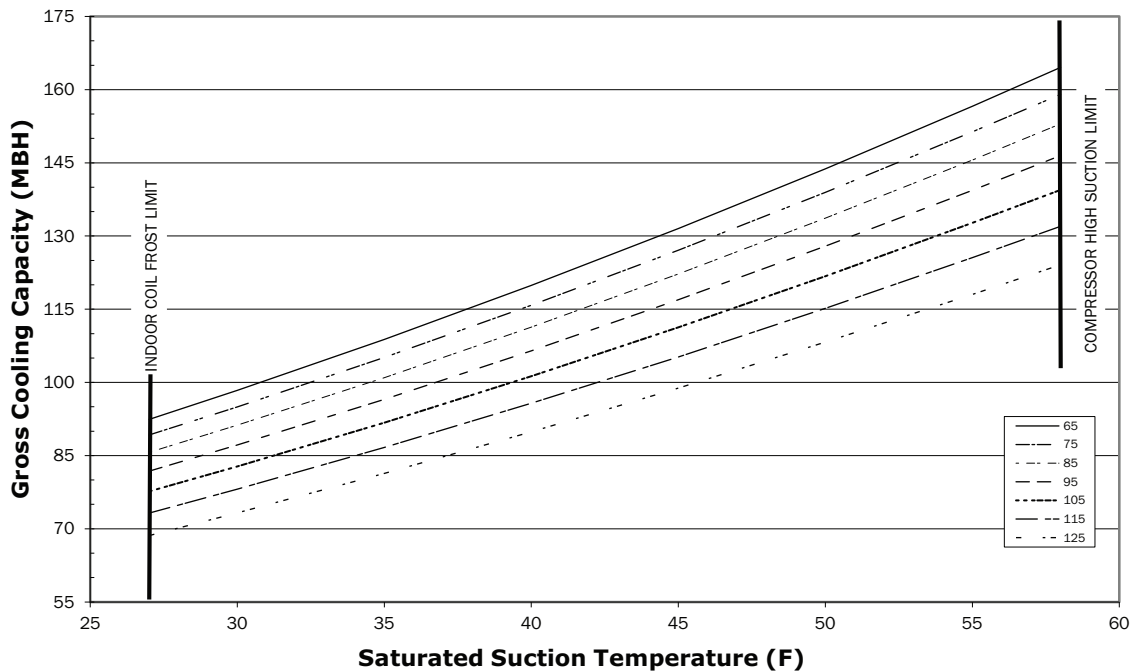

Table 4. Gross cooling capacities (MBH) 10 tons TWA1202*A condensing unit only (IP)

Outdoor Temp (°F)		Suction Temperature (°F)					
		30	35	40	45	50	55
65	Head Press (psig)	166.3	172.1	178.4	185.1	192.3	199.9
	Capacity (Btuh/1000)	98.4	108.8	119.9	131.5	143.8	156.6
	Unit Power (kW)	7.1	7.3	7.5	7.8	8.0	8.3
75	Head Press (psig)	189.0	194.9	201.2	207.9	215.1	222.7
	Capacity (Btuh/1000)	95.0	105.1	115.8	127.1	138.9	151.3
	Unit Power (kW)	7.6	7.8	8.0	8.3	8.5	8.8
85	Head Press (psig)	213.9	219.9	226.3	233.1	240.4	248.1
	Capacity (Btuh/1000)	91.2	101.0	111.3	122.2	133.6	145.6
	Unit Power (kW)	8.1	8.4	8.6	8.8	9.1	9.3
95	Head Press (psig)	241.6	247.7	254.3	261.2	268.5	276.2
	Capacity (Btuh/1000)	87.2	96.5	106.5	117.0	127.9	139.4
	Unit Power (kW)	8.8	9.0	9.2	9.5	9.7	10.0
105	Head Press (psig)	272.0	278.2	284.8	291.7	299.1	306.9
	Capacity (Btuh/1000)	82.8	91.8	101.2	111.3	121.8	132.7
	Unit Power (kW)	9.6	9.8	10.0	10.2	10.5	10.7
115	Head Press (psig)	305.1	311.3	317.9	324.9	332.3	340.1
	Capacity (Btuh/1000)	78.1	86.7	95.7	105.2	115.2	125.6
	Unit Power (kW)	10.4	10.6	10.8	11.0	11.3	11.5
125	Head Press (psig)	340.8	347.1	353.8	360.8	368.2	375.9
	Capacity (Btuh/1000)	73.2	81.3	89.9	98.8	108.2	118.0
	Unit Power (kW)	11.3	11.5	11.7	12.0	12.2	12.4

Note: Performance data calculated at 15°F subcooling and 15°F superheat and does not include capacity loss due to refrigerant lines.

Figure 2. TWA1202*A capacity curves
Capacity Curves - Condensing Unit Only



Performance Data

Table 5. Gross cooling capacities (MBH) 15 tons TWA1802*D condensing unit only (IP)

Outdoor Temp (°F)		Suction Temperature (°F)					
		30	35	40	45	50	55
65	Head Press (psig)	149.9	154.2	158.9	164.0	169.3	175.0
	Capacity (Btuh/1000)	148.9	167.0	186.2	206.9	228.7	251.4
	Unit Power (kW)	10.4	10.6	10.9	11.1	11.4	11.6
75	Head Press (psig)	172.4	176.8	181.5	186.6	192.0	197.6
	Capacity (Btuh/1000)	141.1	158.4	176.8	196.3	217.1	238.9
	Unit Power (kW)	11.3	11.5	11.7	12.0	12.3	12.6
85	Head Press (psig)	197.3	201.8	206.6	211.6	217.0	222.7
	Capacity (Btuh/1000)	133.2	149.7	167.3	185.8	205.4	226.2
	Unit Power (kW)	12.2	12.4	12.7	13.0	13.3	13.6
95	Head Press (psig)	224.8	229.4	234.3	239.5	245.0	250.8
	Capacity (Btuh/1000)	125.1	140.9	157.6	175.4	194.0	213.5
	Unit Power (kW)	13.2	13.5	13.8	14.1	14.4	14.7
105	Head Press (psig)	255.2	259.9	264.9	270.2	275.8	281.6
	Capacity (Btuh/1000)	116.8	131.9	147.9	164.8	182.5	201.0
	Unit Power (kW)	14.4	14.7	15.0	15.3	15.6	15.9
115	Head Press (psig)	288.4	293.2	298.3	303.7	309.3	315.2
	Capacity (Btuh/1000)	108.4	122.8	138.1	154.1	170.9	188.4
	Unit Power (kW)	15.7	15.9	16.2	16.5	16.9	17.2
125	Head Press (psig)	324.5	329.5	334.7	340.1	345.8	351.7
	Capacity (Btuh/1000)	99.9	113.6	128.1	143.3	159.2	175.7
	Unit Power (kW)	17.1	17.3	17.6	17.9	18.2	18.6

Note: Performance data calculated at 15°F subcooling and 15°F superheat and does not include capacity loss due to refrigerant lines.

Figure 3. TWA1802*D capacity curves

Capacity Curves - Condensing Unit Only

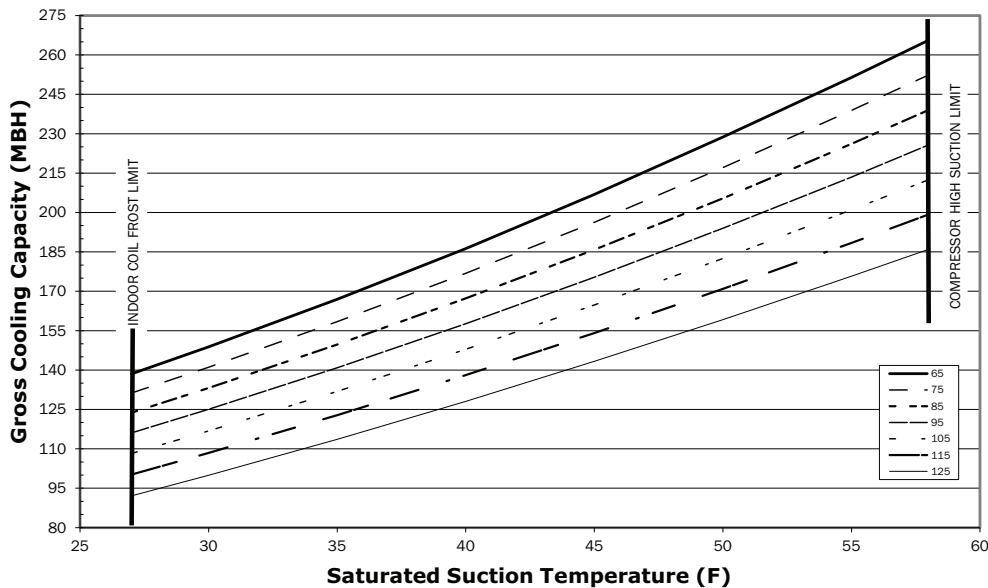
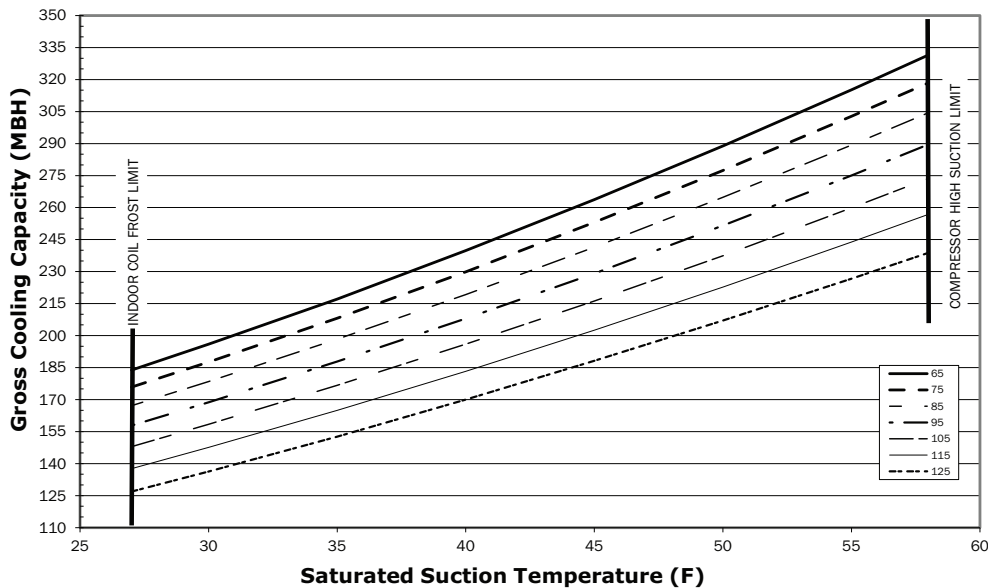

Table 6. Gross cooling capacities (MBH) 20 tons TWA2402*D condensing unit only (IP)

Outdoor Temp (°F)		Suction Temperature (°F)					
		30	35	40	45	50	55
65	Head Press (psig)	164.1	169.9	176.1	182.8	189.9	197.5
	Capacity (Btuh/1000)	196.0	217.1	239.8	263.8	288.9	315.2
	Unit Power (kW)	14.3	14.8	15.2	15.7	16.2	16.8
75	Head Press (psig)	186.5	192.3	198.6	205.3	212.4	219.9
	Capacity (Btuh/1000)	187.6	208.1	229.8	253.0	277.4	302.8
	Unit Power (kW)	15.3	15.7	16.2	16.7	17.2	17.7
85	Head Press (psig)	211.3	217.1	223.4	230.1	237.3	245.0
	Capacity (Btuh/1000)	178.5	198.3	219.2	241.4	264.8	289.3
	Unit Power (kW)	16.4	16.8	17.3	17.8	18.3	18.8
95	Head Press (psig)	238.7	244.7	251.1	257.8	265.1	272.7
	Capacity (Btuh/1000)	168.8	187.8	208.0	229.1	251.6	275.1
	Unit Power (kW)	17.7	18.2	18.6	19.1	19.5	20.0
105	Head Press (psig)	268.9	275.0	281.4	288.2	295.4	303.1
	Capacity (Btuh/1000)	158.4	176.7	195.9	216.2	237.4	259.9
	Unit Power (kW)	19.2	19.6	20.1	20.5	21.0	21.5
115	Head Press (psig)	301.8	307.9	314.4	321.3	328.5	336.2
	Capacity (Btuh/1000)	147.6	164.9	183.3	202.5	222.7	243.8
	Unit Power (kW)	20.9	21.3	21.7	22.2	22.6	23.1
125	Head Press (psig)	337.5	343.7	350.2	357.1	364.1	371.6
	Capacity (Btuh/1000)	136.2	152.7	170.0	188.2	207.1	226.7
	Unit Power (kW)	22.7	23.1	23.5	24.0	24.4	24.8

Note: Performance data calculated at 15°F subcooling and 15°F superheat and does not include capacity loss due to refrigerant lines.

Figure 4. TWA2402*D capacity curves
Capacity Curves - Condensing Unit Only



Electrical Data

Table 7. Electrical characteristics — compressor and condenser fan motors — heat pumps — 60Hz

Tons	Unit Model Number							Condenser Fan Motor				
		Volts	Phase	Compressor 1		Compressor 2		No.	Volts	Phase	Amps	
				RLA	LRA	RLA	LRA				FLA	LRA
				Amps	Amps	Amps	Amps				(Ea.)	(Ea.)
7.5	TWA09023A	208-230	3	22.4	164	N/A	N/A	1	208-230	3	2.3	8.4
	TWA09024A	460	3	10.9	100	N/A	N/A	1	460	3	1.1	4.2
10	TWA12023A	208-230	3	30.1	231	N/A	N/A	1	208-230	3	4.3	19.4
	TWA12024A	460	3	15.5	114	N/A	N/A	1	460	3	2.2	10.1
15	TWA18023D	208-230	3	22.4	164	22.4	164	2	208-230	3	4.3	19.4
	TWA18024D	460	3	10.9	100	10.9	100	2	460	3	2.2	10.1
20	TWA24023D	208-230	3	30.1	231	30.1	231	2	208-230	3	4.3	19.4
	TWA24024D	460	3	15.5	114	15.5	114	2	460	3	2.2	10.1

Note: Electrical characteristics reflect nameplate values and are calculated in accordance with cULus specifications.

Table 8. Unit wiring — heat pumps — 60Hz

Tons	Unit Model Number	Volts	Minimum Circuit Ampacity	Maximum Fuse or Circuit Breaker Size
7.5	TWA09023A	208-230	30	50
	TWA09024A	460	15	25
10	TWA12023A	208-230	42	70
	TWA12024A	460	22	35
15	TWA18023D	208-230	59	80
	TWA18024D	460	29	35
20	TWA24023D	208-230	76	100
	TWA24024D	460	39	50



Heat Pump

Figure 5. 7.5 ton heat pump, single compressor – in (mm)

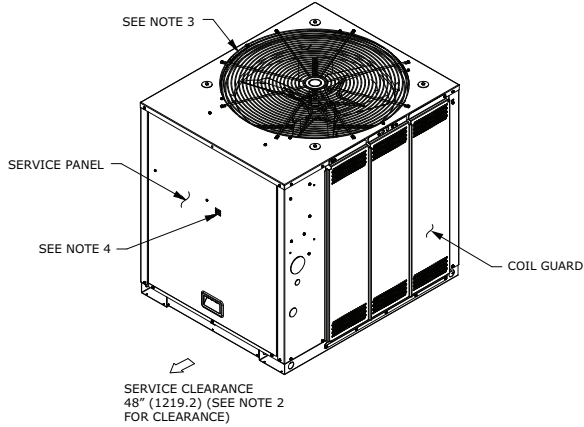

NOTES:

1. ACCESS OPENING IS FOR FIELD INSTALLED BAYLOAM ACCESSORY.
2. MINIMUM CLEARANCE FOR PROPER OPERATION IS 36" (914.4) FROM WALLS, SHRUBBERY, PRIVACY FENCES ETC. MINIMUM CLEARANCE BETWEEN ADJACENT UNITS IS 72" (1828.8). RECOMMENDED SERVICE CLEARANCE 48" (1219.2)
3. TOP DISCHARGE AREA SHOULD BE UNRESTRICTED FOR 100" (2540) MINIMUM. UNIT SHOULD BE PLACED SO ROOF RUN-OFF WATER OR FALLING SNOW FROM ROOF DOES NOT POUR/FALL DIRECTLY ON UNIT
4. OUTDOOR AIR TEMPERATURE SENSOR OPENING (DO NOT BLOCK OPENING)

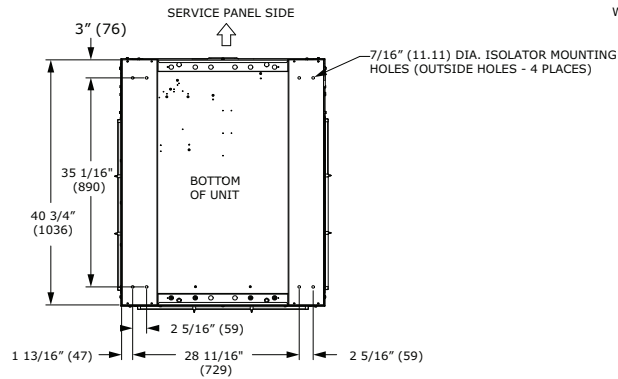
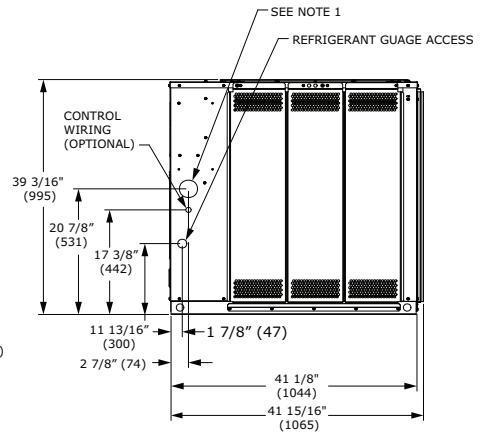
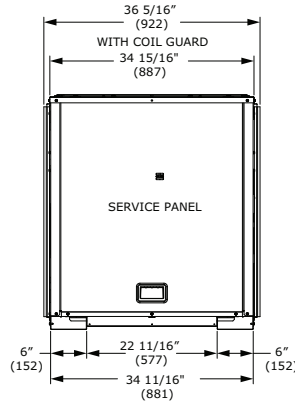
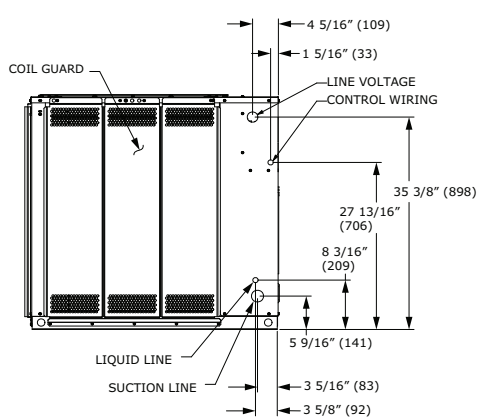



Heat Pump

Figure 6. 10 ton heat pump, single compressor – in (mm)

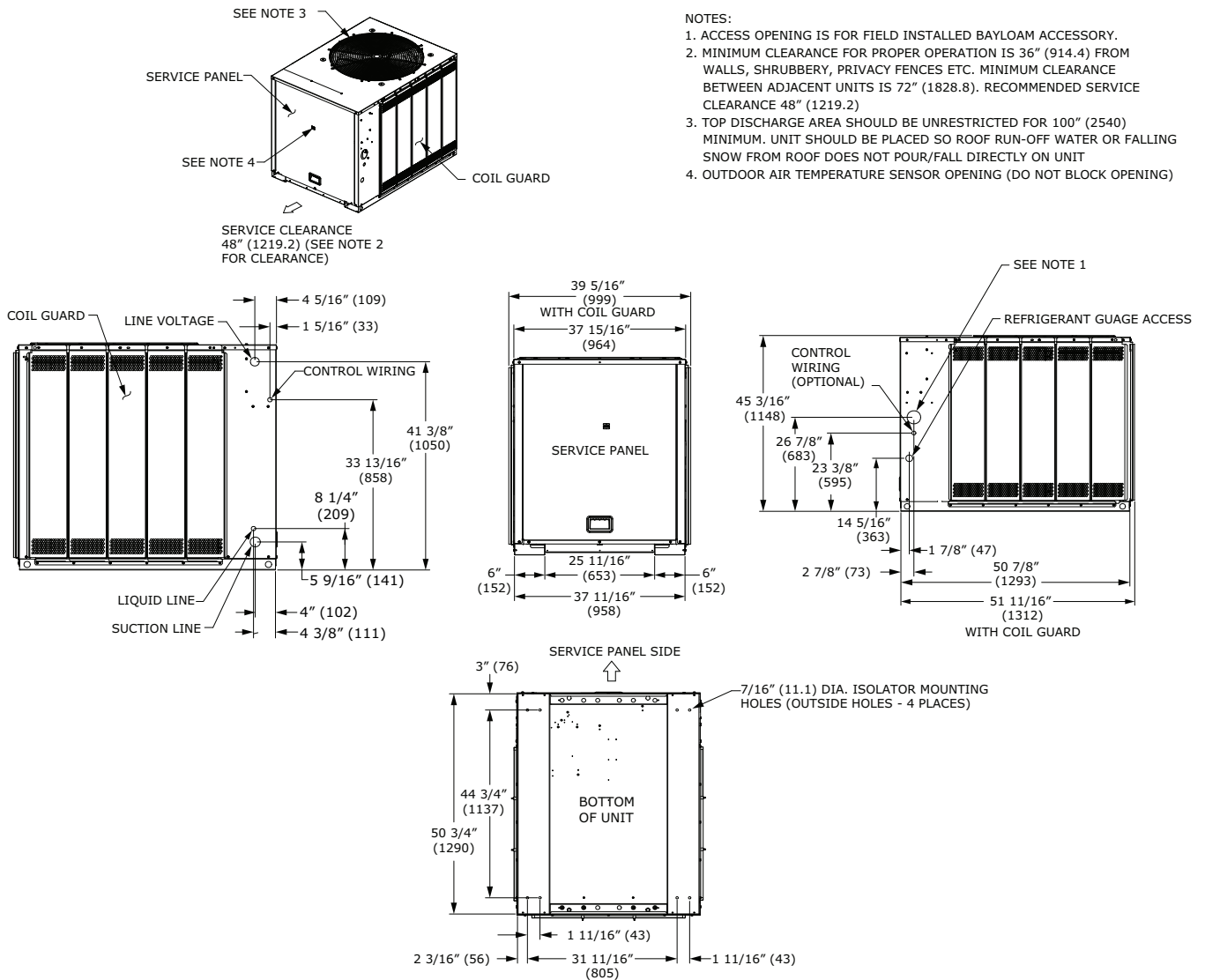
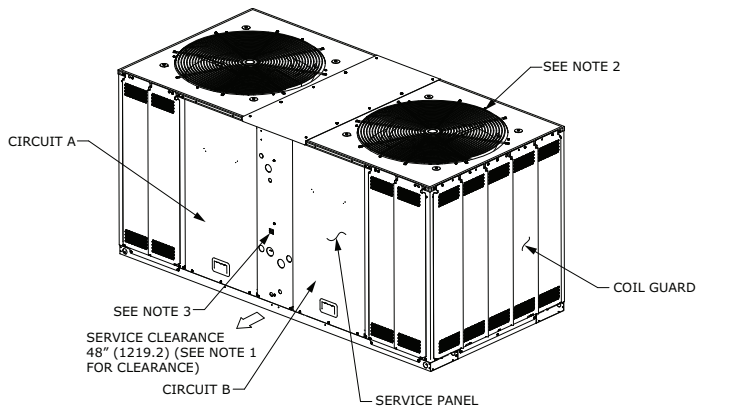
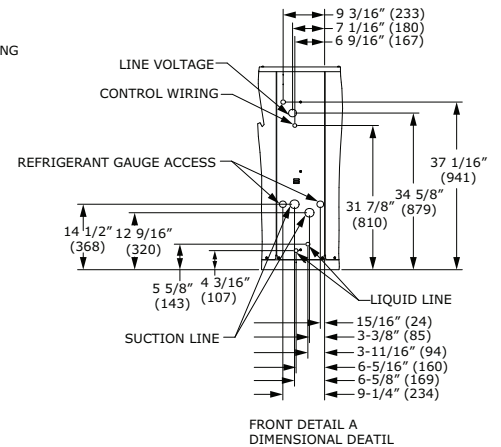
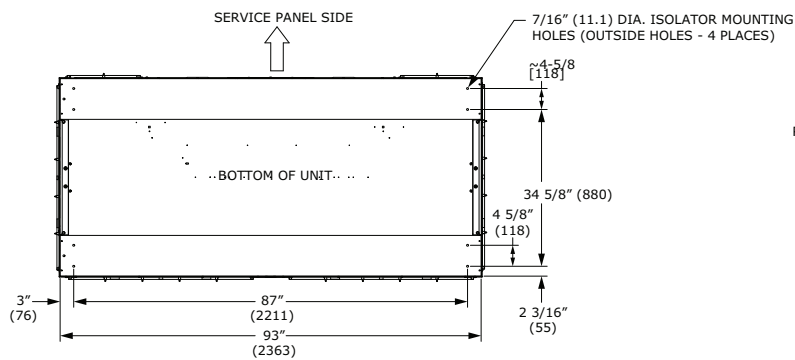
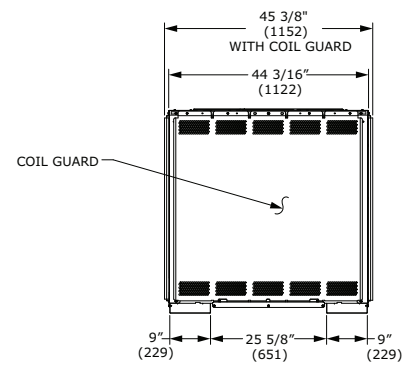
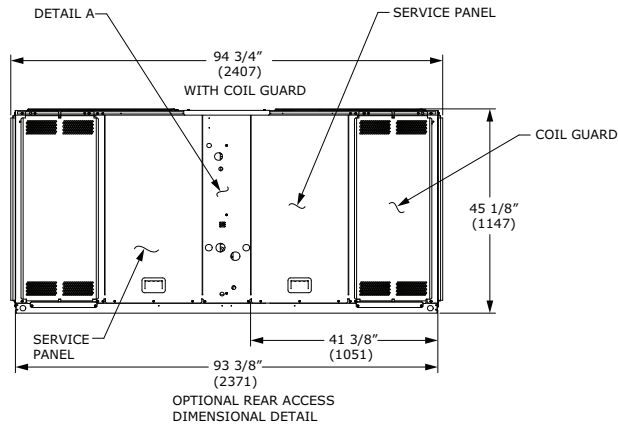

Figure 7. 15, 20 ton heat pump, dual compressor – in (mm)



NOTES:

1. MINIMUM CLEARANCE FOR PROPER OPERATION IS 36" (914.4) FROM WALLS, SHRUBBERY, PRIVACY FENCES ETC. MINIMUM CLEARANCE BETWEEN ADJACENT UNITS IS 72" (1828.8). RECOMMENDED SERVICE CLEARANCE 48" (1219.2)
2. TOP DISCHARGE AREA SHOULD BE UNRESTRICTED FOR 100" (2540) MINIMUM. UNIT SHOULD BE PLACED SO ROOF RUN-OFF WATER OR FALLING SNOW FROM ROOF DOES NOT POUR/FALL DIRECTLY ON UNIT
3. OUTDOOR AIR TEMPERATURE SENSOR OPENING (DO NOT BLOCK OPENING)





Weights

Heat Pump Condenser

Table 9. TWA R-22 unit and corner weights — lbs (60 Hz)

Tons	Model No.	Shipping Max (lbs)	Net Max (lbs)	Corner Weights			
				1	2	3	4
7.5	TWA0902*A	397	360	112	105	74	69
10	TWA1202*A	482	437	110	129	91	107
15	TWA1802*D	920	819	243	240	169	167
20	TWA2402*D	1003	902	273	273	178	178

Figure 8. TWA0902*A, 1202*A

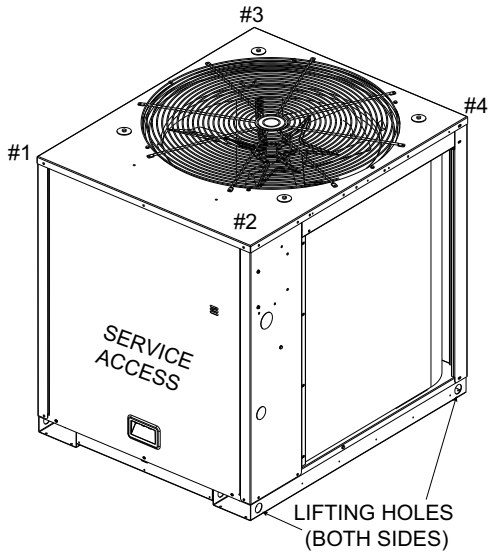
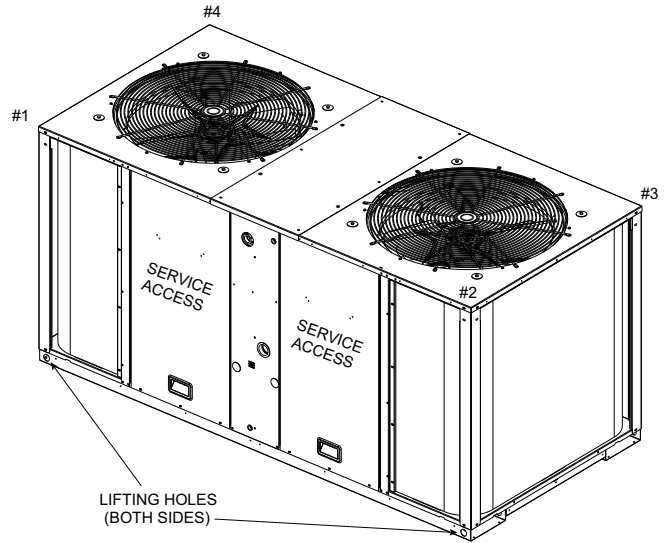

Figure 9. TWA1802*D, TWA2402*D





Notes



Trane - by Trane Technologies (NYSE: TT), a global innovator - creates comfortable, energy efficient indoor environments for commercial and residential applications. For more information, please visit trane.com or tranetechnologies.com.

Trane has a policy of continuous product and product data improvements and reserves the right to change design and specifications without notice. We are committed to using environmentally conscious print practices.

SSP-PRC027L-EN 04 Jun 2022
Supersedes SSP-PRC027K-EN (December 2020)

©2022 Trane