



Product Catalog

IntelliCore™ Split Systems

Cooling Condensers – 20 to 120 Tons

Remote Chillers – 20 to 120 Tons

With Symbio™ 800





Introduction

Trane® 20 to 120 ton air-cooled condensing units are the leaders in the split system marketplace. The vast amount of air handling options along with the remote chiller possibility allows this condensing unit to be used in a wide array of applications. Designed for efficiency, reliability and flexibility, the Trane units have the most advanced design in the industry.

The addition of the Symbio™ 800 controller and TD-7 touch screen user interface provides a high degree of control, superior monitoring capability, and unmatched diagnostic information. The Symbio 800 controller integrates with all common standard building communication protocols, including BACnet® MS/TP, BACnet/IP, and Modbus®. The Trane IntelliCore has the technology and flexibility to bring total comfort to every building space.



Copyright

This document and the information in it are the property of Trane, and may not be used or reproduced in whole or in part without written permission. Trane reserves the right to revise this publication at any time, and to make changes to its content without obligation to notify any person of such revision or change.

Trademarks

All trademarks referenced in this document are the trademarks of their respective owners.

Revision History

- Updated Features and Benefits chapter.
- Added Digit 27 to Model Number Description chapter.
- Updated General data IntelliCore condensing units table in General Information chapter.
- Updated Performance Data chapter.
- Added IntelliCore electrical data (R-410A) table to Installation Electrical chapter.
- Updated figures in Unit Dimensions chapter.
- Updated Unit Weights chapter.



Table of Contents

- Features and Benefits 5
 - Trane 3-D Scroll Compressor 5
 - Additional Features 6
 - 20 to 120 Ton Units 6
- Application Considerations 8
 - Unit Sizing 8
 - Application Assistance and System Matching 8
 - Unit Location 8
 - Leak Detection System (Refrigerant charge greater than 3.91 lb per circuit) 9
 - Effect of Altitude on Capacity 9
 - Ambient Considerations 9
 - Corrosive Atmospheres 9
 - Refrigerant Piping 9
 - Remote Chiller Evaporator 10
- Selection Procedures 11
- Model Number Description 13
- General Data 14
- Performance Data 16
 - 60Hz Units 16
 - 50Hz Units 25



Table of Contents

Controls	39
Symbio 800 Controls	39
System Control	40
Discharge Cooling Temperature Control	40
Coil Frost Protection	41
Chiller Freeze Protection	41
Hot Gas Bypass	41
Compressor Protections	42
Demand Limit	42
Manual Override	42
Rapid Restart	43
Condenser Fan Control	43
Emergency Stop	43
Equipment Stop	43
Refrigerant Leak Detection Input	43
Remote Setpoint	43
User Interface	43
Communication Protocol	44
Electrical	45
Unit Dimensions	48
Unit Weights	76
Mechanical Specifications	77
Air-Cooled Condensing Unit — Model RAUK	77
Options	78



Features and Benefits

Trane 3-D Scroll Compressor

Simple, Reliable Design

The Trane® 3-D™ Scroll provides important reliability and efficiency benefits. The 3-D Scroll allows the orbiting scrolls to touch in all three dimensions, forming a completely enclosed compression chamber which leads to increased efficiency. In addition, the orbiting scrolls only touch with enough force to create a seal; so there is no wear between the scroll plates. The fixed and orbiting scrolls are made of high strength cast iron which results in less thermal distortion, less leakage, and higher efficiencies.



Compressors

IntelliCore Split Systems feature enhanced compressor technology designed to deliver higher efficiency and performance. Compressors perform well under part-load cooling conditions and in system backup applications.

Dual manifolded compressors are available on 20, 25, 30 (R-410A only), 40, 50, and 60 ton models.

20 and 25 ton models with R-454B use two-stage unloading compressors.

Trio manifolded compressors are available on 30 (R-454B only), 80, 100, and 120 ton models.

A minimum of four unit capacity steps is available for all models except 20 to 30 ton R-410A models.

Microchannel Condenser Coil

Microchannel condensing coils are all-aluminum coils with fully-brazed construction. This design reduces risk of leaks and provides increased coil rigidity — making them more rugged on the jobsite. Their flat streamlined tubes with small ports and metallurgical tube-to-fin bond allow for exceptional heat transfer. Microchannel all-aluminum construction provides several additional benefits:

- Light weight (simplifies coil handling)
- Easy to recycle
- Minimize galvanic corrosion



Features and Benefits

Figure 1. Microchannel condenser coil

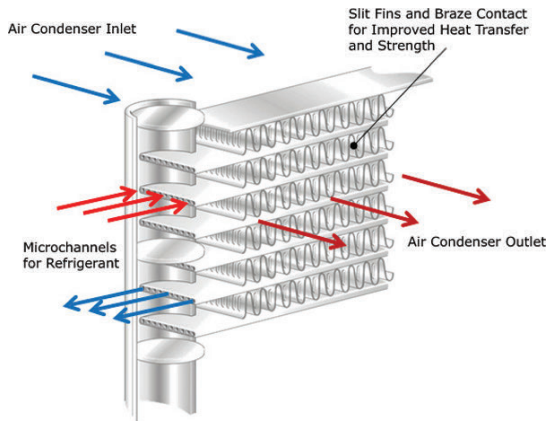

Suction Gas Cooled Motor

Compressor motor efficiency and reliability is further optimized with the latest scroll design. Cool suction gas keeps the motor cooler for longer life and better efficiency.

Proven Design Through Testing and Research

With over twenty five years of development and testing, Trane 3-D Scroll compressors have undergone more than 400,000 hours of laboratory testing and field operation. This work combined with over 25 patents makes Trane the worldwide leader in air conditioning scroll compressor technology.

Voltage Power Supply

Four voltage options are available on IntelliCore™ 20 to 120 ton units: 200, 230, 460, and 575V. 380V/50Hz and 415V/50Hz are available as a design special offering.

Passive Manifolding

Trane offers a parallel manifolding scheme that uses no moving mechanical parts. This feature assures continuous oil return, again providing greater system reliability. And greater reliability means optimal performance over the life of the unit.

Additional Features

Remote Chiller Evaporator Option with Field Installation Kit

This option allows chilled water to be generated remotely from the condensing section.

The EVP controls option includes a remote panel that houses customer connections and a freezestat device.

The accessory kit includes the remote chiller evaporator, with mounting hardware and insulation, water strainer, minimum water flow limit switch and evaporator pipe stubs with couplings. The EVP control option must be selected with this accessory kit.

20 to 120 Ton Units

Standard Features

- Symbio™ 800 controller
 - No system control, Supply Air VAV control, or EVP control
 - Adaptive Control™ algorithms
- Trane® 3-D scroll compressors
- Two-stage compressors (20 and 25 ton R-454B systems)
- Phase loss/reversal/low voltage monitor
- Factory-installed discharge service valves

- Passive manifolding for 3-D scroll compressors
- Standard ambient operating range: 40°F to 125°F (In certain cases 115°F max ambient for EVP chiller)
- Heavy gauge galvanized steel frame
- Louvered panels for coil protection
- Slate gray air-dry paint finish

Optional Features

- Remote chiller evaporator with field installation kit
- Non-fused disconnect switch
- High fault SCCR
- 15A powered convenience outlet
- 20A unpowered convenience outlet
- Low ambient option
- Hot gas bypass to the evaporator inlet
- Suction service valve
- Pressure gauges
- Unit spring isolators
- Neoprene-in-shear isolators
- cULus approval (60 Hz only)
- Quick ship availability
- Extended compressor warranty
- Corrosion protected condenser coil
- Symbio™ 800 controls options include:
 - Integrated economizer with Supply Air VAV Control
 - Rapid restart with Supply Air VAV Control or EVP Control
 - Wi-Fi adapter
 - 7–inch user interface touch display
 - Expansion module
 - BACnet® and Modbus® communication protocol

Quick Ship

Trane® 20 to 120 ton model IntelliCore™ air-cooled condensing units are available with Quick Ship. Trane knows that you want your units on the job site, on time, with the options you need. Quick Ship provides you with the controls and options you need — options like hot gas bypass, isolators and refrigerant gauges. You no longer have to settle for a basic unit requiring many field installed options to meet your job schedule. Now, you can get a customized unit from the factory in record time. Quick ship provides more control over unit selection and scheduling than ever before. Trane wants to make it easy for you to do business with us.



Application Considerations

Certain application constraints should be considered when sizing, selecting and installing Trane® air-cooled condensing units. Unit reliability is dependent upon these considerations. Where your application varies from the guidelines presented, it should be reviewed with the local Trane sales engineer.

Unit Sizing

Unit capacities are listed in the performance data section. Intentionally oversizing a unit to assure adequate capacity is not recommended. Erratic system operation and excessive compressor cycling are often a direct result of an oversized condensing unit. In addition, an oversized unit is usually more expensive to purchase, install and operate. If oversizing is desired, consider using two units.

Application Assistance and System Matching

Trane's large commercial condensing units can be paired with a variety of performance climate changers, custom air handlers, Odyssey™ light commercial air handlers, remote chiller evaporators and much more.

Application guides, which include piping requirements and condenser specifications as well as selection tools, are available for easier system matching and installation.

Contact Trane Sales for further details or specific split system needs.

Unit Location

Foundation

A base or foundation is not required if the selected unit location is level and strong enough to support the unit's operating weight.

Isolation and Sound Emission

Since the environment in which a sound source is located affects sound pressure, unit placement must be carefully evaluated. The most effective form of noise isolation is proper unit location. Units should be placed away from noise sensitive areas.

Structurally transmitted sound can be reduced by using isolators, which are recommended for sound sensitive installations. For maximum isolation effect, the refrigeration lines and electrical conduit should also be isolated and flexible electrical conduit used.

An acoustical engineer should always be consulted on critical applications.

State and local codes on sound emissions should always be considered.

Air Flow Considerations

Unobstructed flow of condenser air is essential for maintaining condensing unit capacity and operating efficiency. When determining unit placement, careful consideration must be given to assure proper air flow across the condenser heat transfer surface. Inadequate air flow will result in warm air recirculation and coil air flow starvation.

- Warm air recirculation occurs when discharge air from the condenser fans is recycled back at the condenser coil inlet.
- Coil starvation occurs when free air flow to the condenser is restricted.

Both warm air recirculation and coil starvation cause reductions in unit efficiency and capacity. In more severe cases, nuisance unit shutdowns will result from excessive head pressures. Accurate estimates of the degree of efficiency and capacity reduction are not possible due to the unpredictable effect of varying winds.

When hot gas bypass is used, reduced head pressure increases the minimum ambient condition for proper operation. In addition, wind tends to further reduce head pressure. Therefore, it is advisable to protect the air-cooled condensing unit from continuous direct winds exceeding 10 miles per hour.

Debris, trash, supplies, etc., should not be allowed to accumulate in the vicinity of the air-cooled condensing unit. Supply air movement may draw debris between coil fins and cause coil starvation. Special consideration should be given to units operating in low ambient temperatures. Condenser coils and fan discharge must be kept free of snow and other obstructions to permit adequate air flow for satisfactory unit operation.

Clearances

Adequate service clearance is required for unit access and maintenance. See “Unit Dimensions,” p. 48 chapter for service clearance recommendations. Local code requirements may take precedence.

Leak Detection System (Refrigerant charge greater than 3.91 lb per circuit)

A Leak Detection System is required per UL-60335-2-40. IntelliCore™ Cooling Condenser Section shall accept an isolated contact closure input suitable for customer connection to hard wire the leak detection system in the paired air handler or mechanical room. If the input opens, compressor operation will be disabled. When the input closes, compressor operation will resume as required.

Effect of Altitude on Capacity

Capacities given in the performance data tables are at sea level. At elevations substantially above sea level, the decreased air density will decrease condenser capacity and, therefore, unit capacity and efficiency. The adjustment factors shown in [Table 2, p. 15](#) can be applied directly to the catalog performance data to determine the unit's adjusted performance.

Ambient Considerations

Start-up and operation at lower ambients requires sufficient head pressure be maintained for proper expansion valve operation. At higher ambients, excessive head pressure may result. Standard operating conditions are 40°F to 125°F in most cases (115°F max ambient for EVP chiller). With a low ambient damper, operation down to 0°F is possible. Minimum ambient temperatures are based on still conditions (winds not exceeding five mph). Greater wind velocities will result in increased minimum operating ambients. Units with hot gas bypass have a minimum operating ambient temperature of 10°F.

For proper operation outside these recommendations, contact the local Trane sales office.

Corrosive Atmospheres

Trane's large condensers are designed and built to industrial standards and will perform to those standards for an extended period depending on the hours of use, the quality of maintenance performed, and the regularity of that maintenance. One factor that can have an adverse effect on unit life is its operation in a corrosive environment. Since the microchannel condenser coil is an all-aluminum design, it provides a high level of corrosion protection on its own. Uncoated, it withstands a salt spray test in accordance with ASTM B117 for 1,000 hours. When condensers are operated in highly corrosive environments, Trane recommends the corrosion protected condenser coil option. This corrosion protection option meets the most stringent testing in the industry, including ASTM B117 Salt Spray test for 6,000 hours and ASTM G85A2 Cyclic Acidified Salt Fog test for 2,400 hours. The acid fog test is the most stringent available today. This coating is added after coil construction covering all tubes, headers, fins and edges. The design provides superior protection from any corrosive agent.

Note: *Field coating is not allowed on microchannel coils.*

The exterior panels are durable enough to withstand a minimum of 672 hours consecutive salt spray application in accordance with standard ASTM B117. All screws are coated with zinc-plus-zinc chromate.

Refrigerant Piping

Split systems can have significantly more refrigerant than packaged systems and thus require controls to reliably manage this excess refrigerant. Each compressor shall have crankcase heaters installed, properly sized to minimize the amount of liquid refrigerant present in the oil sump during off cycles. Additionally, the condensing unit shall have controls to initiate a liquid line solenoid closure when each refrigerant circuit shuts down. To be operational, the liquid line requires a field supplied and installed isolated solenoid valve within 10 feet of the evaporator.

Due to this, special consideration must always be given to oil return. Minimum suction gas velocities must always be maintained for proper oil return. Utilize *Tube Size and Component Selection IntelliCore™ Split Systems (20 to 120 Tons) R-454B Refrigerant Microchannel Condensers Application Guide (SS-APG018*-EN)* and *Tube Size and Component Selection RAUJ Split Systems (20 to 120 Tons) R-410A Refrigerant Microchannel Condensers Application Guide (SS-APG012*-EN)* for proper system design. For special applications, call Clarksville Product Support.

Note: *Under certain conditions, R-410A/R-454B refrigerant can present special challenges with piping and system design.*

Whenever refrigerant line set lengths approach 150 equivalent feet and/or design ambient temperature exceeds 115°F, contact your Trane Account Executive to review application requirements.



Remote Chiller Evaporator

Water Treatment

Using untreated or improperly treated water may result in scaling, erosion, corrosion, and algae or slime buildup in the heat exchanger that will adversely affect system capacity. Proper water treatment must be determined locally and depends on the type of system and local water characteristics. Neither salt nor brackish water is recommended, either will lead to a shortened heat exchanger life. Trane encourages employment of a qualified water treatment specialist, familiar with local water conditions, to assist in the establishment of a proper water treatment program.

Water Flow Limits

The minimum and maximum water flow rates are given in . Water flow rates below the tabulated values will result in laminar flow causing freeze-up problems, scaling, stratification and poor system control. Flow rates exceeding the maximum listed may result in very high pressure drop, erosion of the heat exchanger and damage to the water flow switch.

Water Temperature Limits

IntelliCore™ with remote EVP chiller performance data is based on a water temperature drop of 10°F. Full load chilled water temperature drops from 8 to 14°F may be used as long as minimum and maximum water temperature and minimum and maximum flow rates are not violated. Leaving water temperatures below 42°F require freeze protection down to 15°F. The maximum water temperature that can be circulated through the chiller when the unit is not operating is 125°F. Evaporator damage may result above this temperature.

Short Water Loops

Adequate chilled water system water volume is an important system design parameter because it provides for stable chilled water temperature control and helps limit unacceptable short cycling of chiller compressors. Typically, a five-minute water loop circulation time is sufficient to prevent short water loop issues. Therefore, as a guideline, ensure the volume of water in the chilled water loop equals or exceeds five times the evaporator flow rate. For systems with a rapidly changing load profile the amount of volume should be increased.

Note: Water volumes should be calculated as close as possible to maintain constant water flow through the water loop.

Water Piping

Foreign matter in the chilled water system will increase pressure drop and reduce water flow. Installation of a properly selected strainer is also necessary to prevent debris larger than 0.039" from entering the heat exchanger. All building water piping must be thoroughly flushed before making the final piping connections to the heat exchanger. To reduce heat loss and prevent condensation, insulation should be applied to piping. Expansion tanks are also generally required to accommodate chilled water volume changes.



Selection Procedures

Net capacity curves for the IntelliCore™ condensing units are given in the performance data section. When matched with a coil curve, the resultant point of intersection will be the system design balance point. The design operating suction temperature and capacity can then be read directly from the graph.

Note: *It is usually necessary to account for suction and liquid line losses in the performance. The actual losses are determined by the interconnecting piping.*

To plot the DX evaporator performance curve it is only necessary to obtain gross evaporator capacities for the given entering air conditions and cfm at two different saturated suction temperatures. The Trane Refrigeration Coil Computer Selection Program can be used to conveniently provide the necessary evaporator capacity values at the selected suction temperatures.

Selection Example

The IntelliCore 20 to 120 ton Trane Select Assist (TSA) selection program provides the ability to generate performance output for pre-selected Trane Modular Climate Changer evaporator coils with the condensing units.

To select a condensing unit and evaporator coil not available in the IntelliCore TSA program, the example below can be used to cross-plot an evaporator coil with known performance with the IntelliCore condensing unit.

From the Trane Select Assist program:

R-410A:

- DX Evap Coil = Model Number DFDB42 - 42" X 60" / 4 Row / 144 FPF - FD/Delta-flo E
- Entering Coil Conditions = 80/67 DB/WB and 95°F Ambient - 8500 CFM
- Coil Performance @ 38F SST - 406.49 MBh Total
- Coil Performance @ 45F SST - 293.09 MBh Total
- Balance Point at 95°F Ambient = 370 MBh @ 40.2 SST
- Coils are identical fin series and circuiting on both simulations.

R-454B:

- DX Evap Coil = Model Number DFDB42 - 42" X 60" / 4 Row / 144 FPF - FD/Delta-flo E
- Entering Coil Conditions = 80/67 DB/WB and 95°F Ambient - 8500 CFM
- Coil Performance @ 38F SST - 399.68 MBh Total
- Coil Performance @ 47F SST - 247.37 MBh Total
- Balance Point at 95°F Ambient = 346 MBh @ 41.9 SST
- Coils are identical fin series and circuiting on both simulations.



Selection Procedures

Figure 2. Performance – R-410A 30 ton, 60 Hz

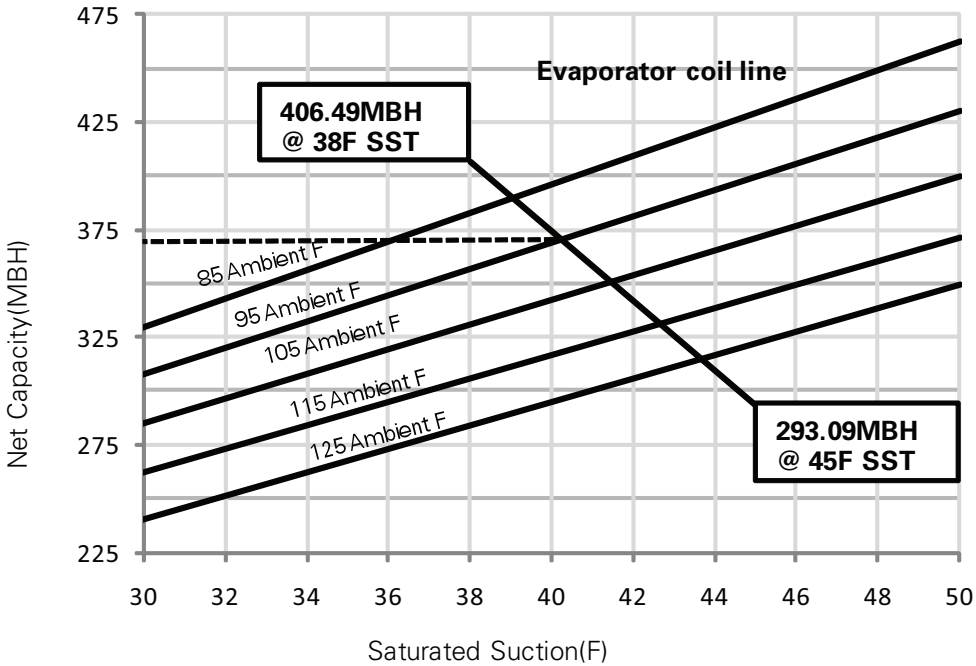
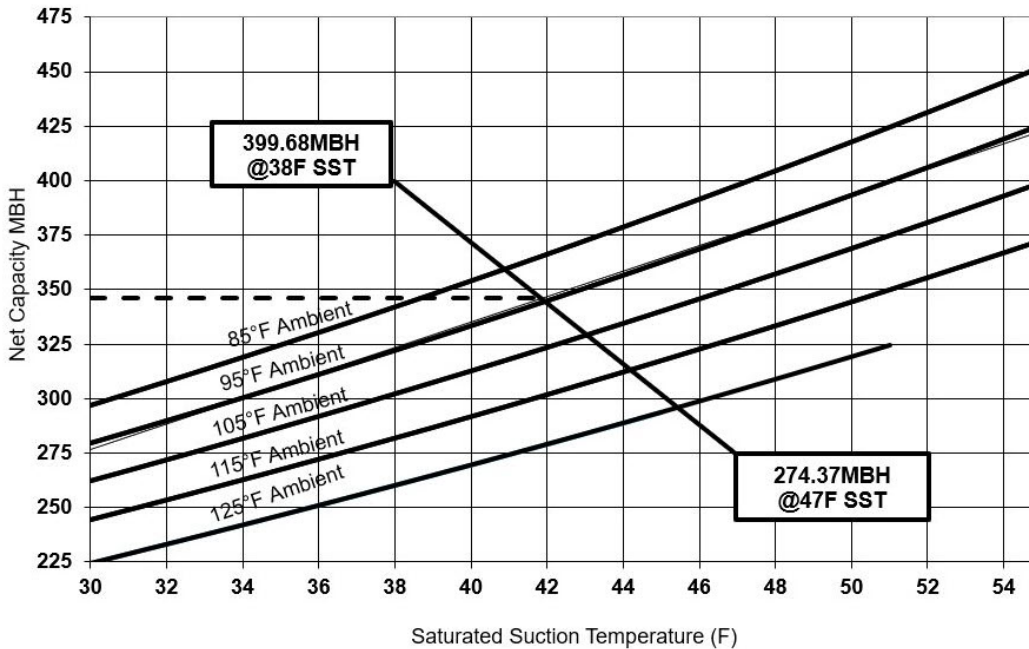

Figure 3. Performance – R-454B 30 ton, 60 Hz



By plotting the two coil performance outputs across the IntelliCore Net Capacity curve at their respective total MBH at the defined saturated suction temperatures and ignoring line losses, we can see that the condenser/evaporator coil combination, at 95 F ambient, provides 346 MBH Net Capacity at 41.9 SST.



Model Number Description

Digit 1 — Unit Type

R = Remote Condenser

Digit 2 — Condenser

A = Air-Cooled

Digit 3 — System Type

U = Upflow

Digit 4 — Development Sequence

K = Fourth

Digit 5, 6, 7 — Nominal Capacity

C20 = 20 Tons

C25 = 25 Tons

C30 = 30 Tons

C40 = 40 Tons

C50 = 50 Tons

C60 = 60 Tons

C80 = 80 Tons

D10 = 100 Tons

D12 = 120 Tons

Digit 8 — Voltage and Start Characteristics

E = 200/60/3

F = 230/60/3

4 = 460/60/3

5 = 575/60/3

* = 380/50/3

* = 415/50/3

Digit 9 — System Controls

B = No System Control

E = Supply Air VAV Control

P = EVP Control

Digit 10 — Design Sequence

Factory Assigned

Digit 11 — Ambient Control

0 = Standard

1 = 0°F (Low Ambient Option)

Digit 12 — Agency Approval

0 = None

3 = cULus (60 Hz only)

Digit 13 — Disconnect Switch

0 = None

A = Unit Mounted Disconnect Switch with Standard Fault SCCR

B = Unit Mounted Disconnect Switch with High Fault SCCR

Digit 14 — Hot-Gas Bypass Valve

0 = None

B = Hot-Gas Bypass Valve

Digit 15 — Suction Service Valve

0 = None

D = Suction Service Valve

Digit 16 — Pressure Gauges

0 = None

F = Pressure Gauges and Piping

Digit 17 — IBC Compliance

0 = None

1 = IBC Compliance

Digit 18 — Corrosion Protected Condenser Coil

0 = None

J = Corrosion Protected Condenser Coil

Digit 19 — Options

0 = None

C = Remote Chiller Evaporator and Install Kit

T = Flow Switch (EVP Control Only)

Digit 20 — Isolators

0 = None

1 = Spring Isolator

2 = Neoprene Isolators

Digit 21 — Powered and Unpowered Convenience Outlet

0 = None

1 = Powered 15A Convenience Outlet

2 = Unpowered 20A Convenience Outlet

Digit 22 — TD-7 and Wi-Fi Adapter

0 = None

1 = Wi-Fi Adapter

2 = TD-7

3 = Wi-Fi Adapter and TD-7

Digit 23 — Communication Protocol

0 = None

1 = BACnet®

2 = Modbus®

Digit 24 — Rapid Restart

0 = None

1 = Rapid Restart

Digit 25 — Integrated Economizer Controls

0 = None

1 = Economizer Control with Dry Bulb

Digit 26 — Expansion Module

0 = None

1 = Expansion Module

Notes:

1. The service digit for each model number contains 26 digits. All 26 digits must be referenced.

2. * = Design special.

Digit 27 — Refrigerant Type

A = R-410A

B = R-454B



General Data

Table 1. General data — IntelliCore condensing units

Unit Size (tons)		20	25	30	40	50	60	80	100	120
Compressor Data										
Type		Scroll								
Number of Refrigerant Circuits		1	1	1	2	2	2	2	2	2
Manifolded Compressor sizes ^(a) :R-410A	Tons	10-10	10-13.5	15-15	10-10	11.5-13.5	15-15	15-15-15	15-15-20	20-20-20
Manifolded Compressor sizes ^(a) :R-454B	Tons	12.8-8.7 ^(b)	15.2-10.2 ^(b)	7.4-11.3-11.3	9.8-11.3	11.3-12.3	14.9-14.9	15-15-15	15-15-20.5	20.5-20.5-20.5
Unit Capacity Steps : R-410A	%	100-50	100-42	100-50	100-75-50-25	100-73-46-23	100-75-50-25	100-83-66-50-33-17	100-80-60-45-30-15	100-83-66-50-33-17
Unit Capacity Steps : R-454B	%	100-82-40-23	100-82-60-40-22	100-75-62-38-25	100-73-46-23	100-74-48-24	100-75-50-25	100-83-66-50-33-17	100-80-59-45-30-15	100-83-66-50-33-17
Condenser Fan Data										
Type/Drive Type		Prop/Direct								
Qty		2	3	3	4	6	6	8	12	12
Diameter	in	26	26	26	26	26	26	26	26	26
Power/motor	hp	1.0	1.0	1.0	1.0	1.0	1.0	1.0	1.0	1.0
Nominal Total Airflow	cfm	14600	20700	20700	26790	36890	40490	56490	73890	76280
Condenser Coil Data										
Type		Microchannel								
Number of Coils		2	2	2	2	2	2	4	4	4
Size	in	42x71	42x71	42x71	59x71	51x96	51x96	59x71	51x96	64x96
Face Area	ft ²	41.4	41.4	41.4	58.2	68.0	68.0	116.4	136.0	170.7
Rows/Fin Per Ft.		1/240	1/240	1/240	1/240	1/240	1/240	1/240	1/240	1/240
Storage Capacity ^(c) : R-410A	lbs	18.7	18.7	18.7	23.5	25	25	47.1	50	62.9
Storage Capacity ^(c) : R-454B	lbs	11.5	11.5	11.5	22.9	23.9	23.9	45.7	47.8	60.2
Refrigerant Data^(d)										
Operating Charge ^(e) : R-410A	lbs	11.9	11.8	11.8	22.7	23.4	23.8	57.1	59.1	65.3
Operating Charge ^(e) : R-454B	lbs	6.8	6.7	8.0	13.8	14.0	14.7	38.2	38.2	41.1
Outdoor Air Temperature for Mechanical Cooling										
Standard Ambient Operating Range ^(f)	°F	40-125	40-125	40-125	40-125	40-125	40-125	40-125	40-125	40-125
Low Ambient Option	°F	0-125	0-125	0-125	0-125	0-125	0-125	0-125	0-125	0-125

^(a) Circuit 1 compressor manifold sizes shown. For units with 2 circuits, compressor manifold set is the same for circuit 1 and 2.

^(b) 2-stage compressor.

^(c) Condenser storage capacity is given at conditions of 95°F outdoor temperature, and 95% full.

^(d) Refer to Refrigerant Piping in the Application Considerations section. Condensing units are shipped with nitrogen holding charge only.

^(e) Operating charge is approximate for condensing unit only, and does not include charge for low side or interconnecting lines. Condensing units are shipped with a nitrogen holding charge only.

^(f) Maximum operating ambient for EVP remote chillers is 115°F.

Table 2. Altitude correction multiplier for capacity

Configuration	Altitude (ft.)				
	2,000	4,000	6,000	8,000	10,000
Condensing Unit Only	0.982	0.960	0.933	0.902	0.866
Condensing Unit / Air Handling Unit Combination	0.983	0.963	0.939	0.911	0.881
Condensing Unit With Evaporator	0.986	0.968	0.947	0.921	0.891



Performance Data

60Hz Units

Figure 4. Performance — RA 20 ton 60 Hz (R-410A)

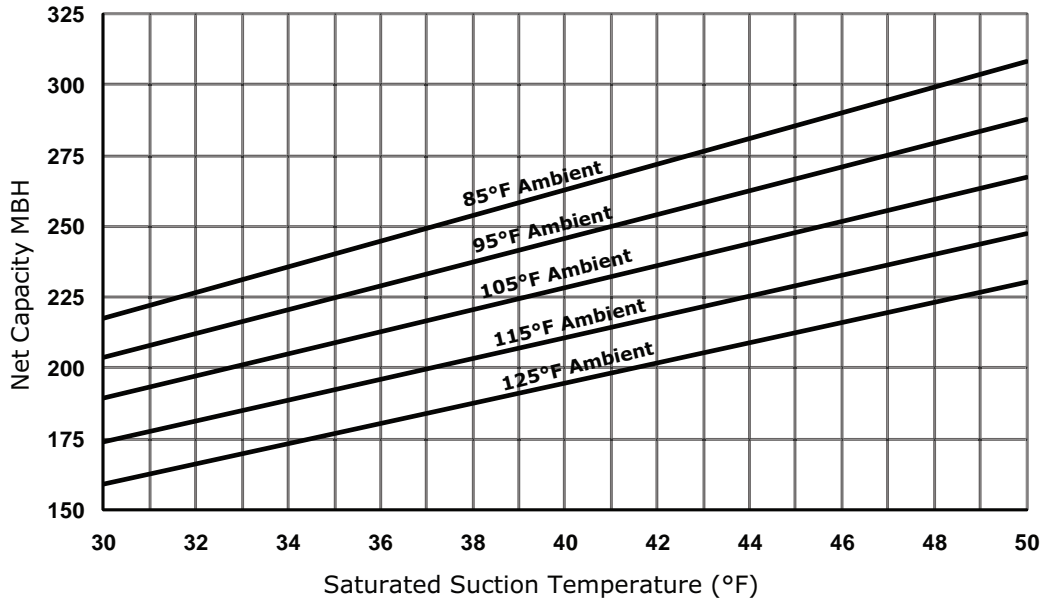

Figure 5. Performance — RA 20 ton 60 Hz (R-454B)

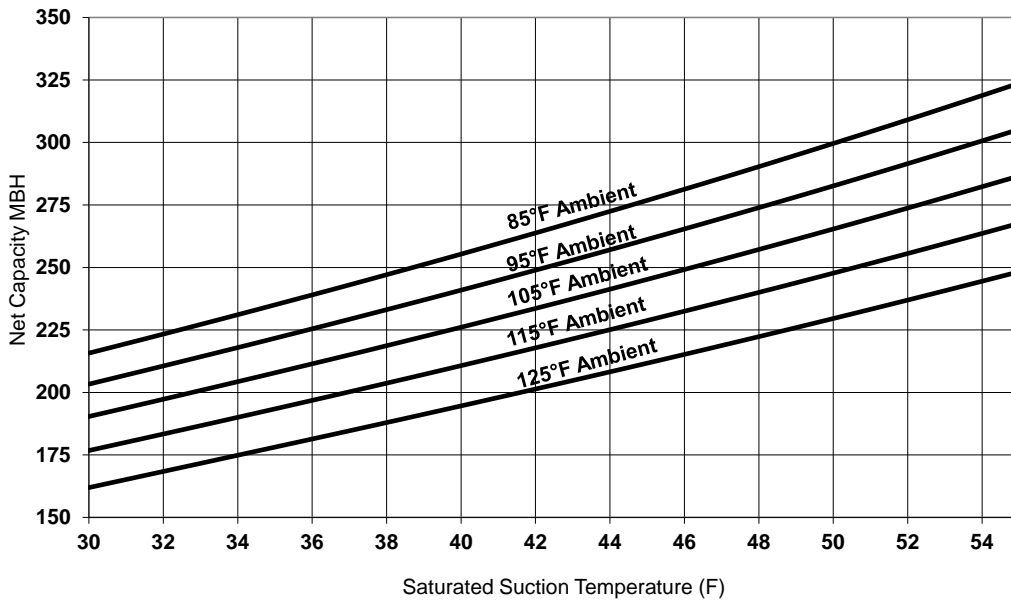

Figure 6. Performance — RA 25 ton 60 Hz (R-410A)

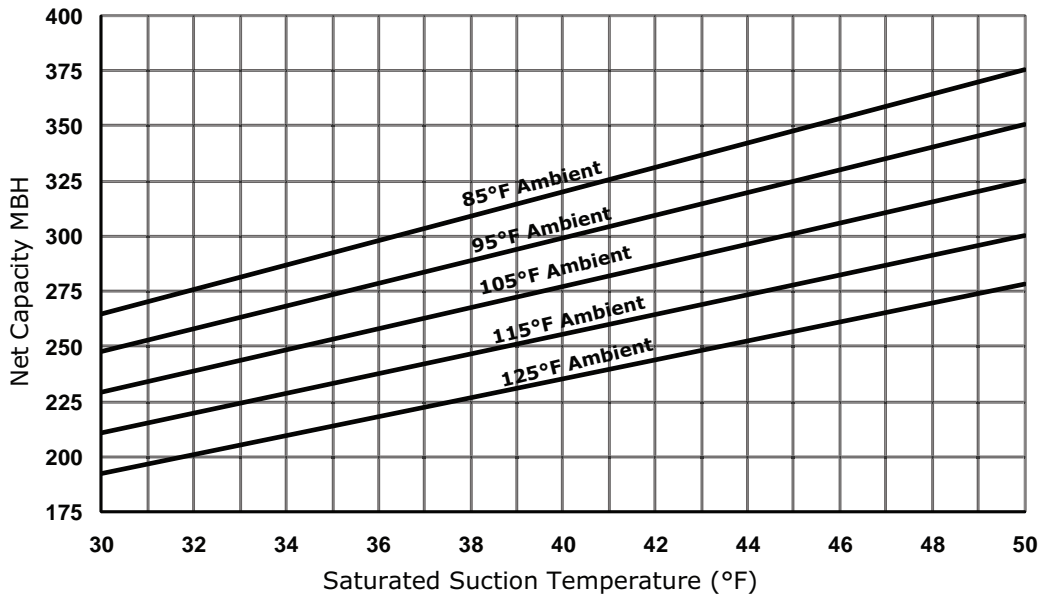
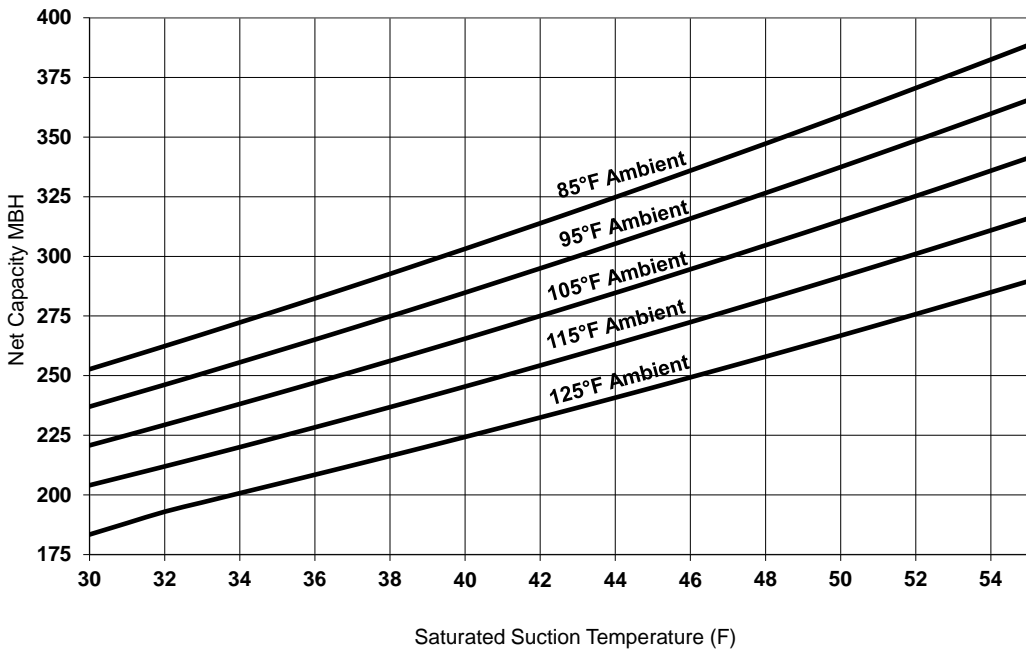

Figure 7. Performance — RA 25 ton 60 Hz (R-454B)





Performance Data

Figure 8. Performance — RA 30 ton 60 Hz (R-410A)

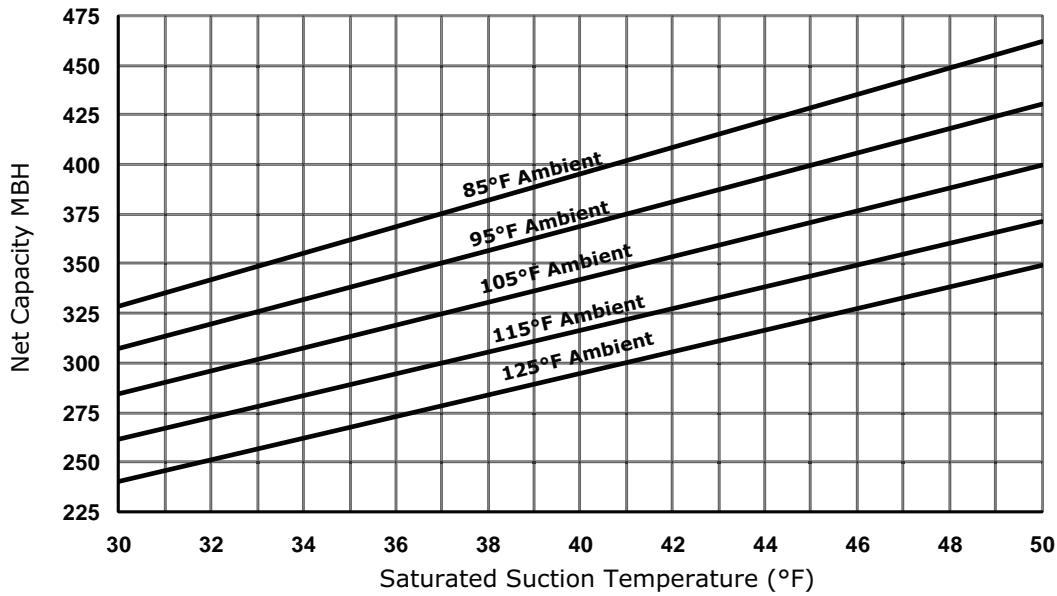

Figure 9. Performance — RA 30 ton 60 Hz (R-454B)

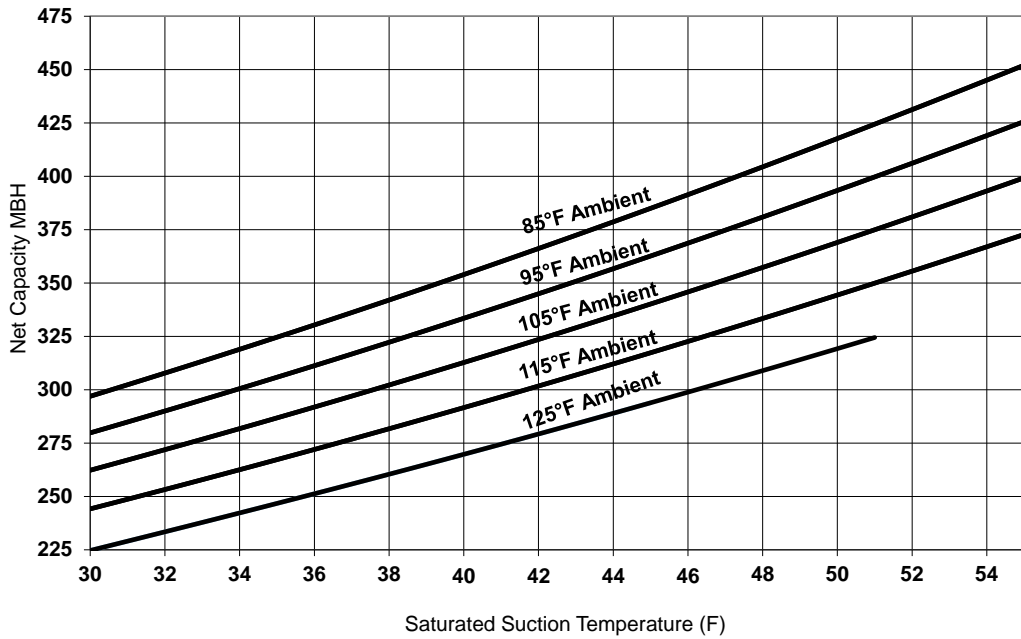

Figure 10. Performance — RA 40 ton 60 Hz (R-410A)

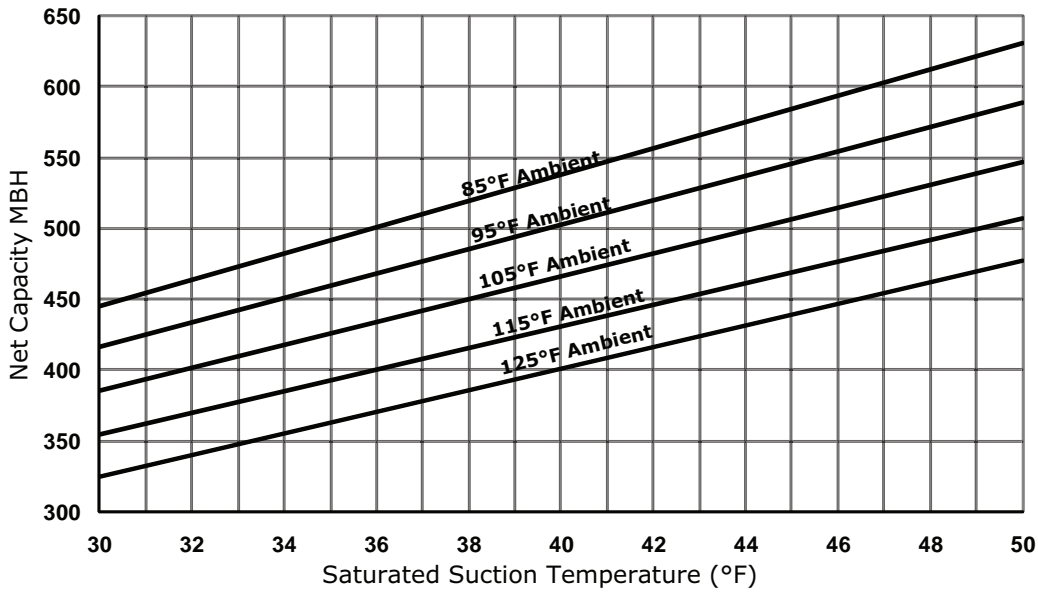
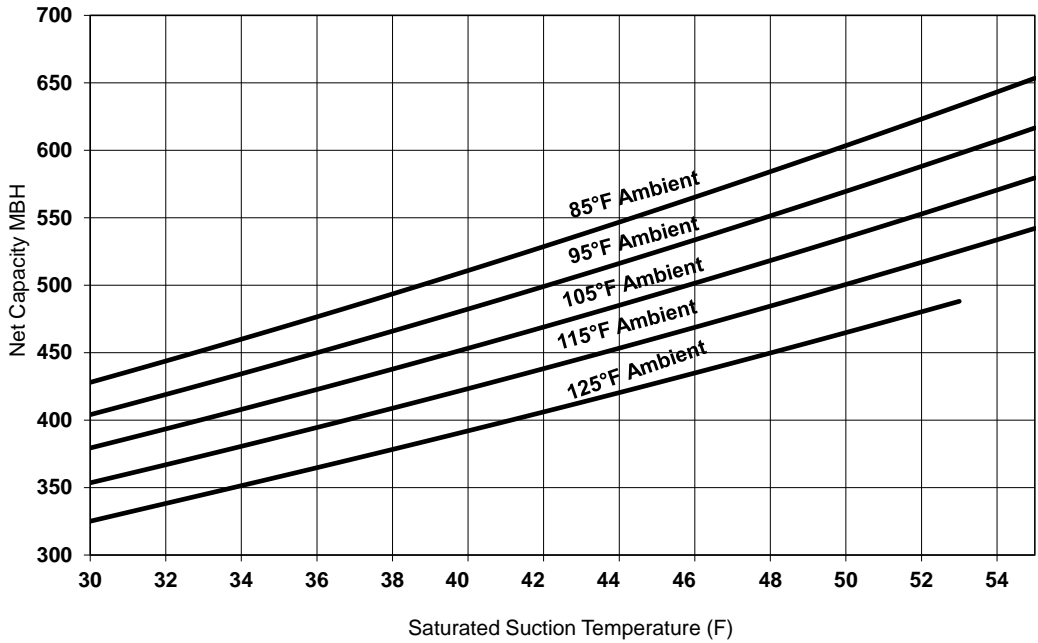

Figure 11. Performance — RA 40 ton 60 Hz (R-454B)





Performance Data

Figure 12. Performance — RA 50 ton 60 Hz (R-410A)

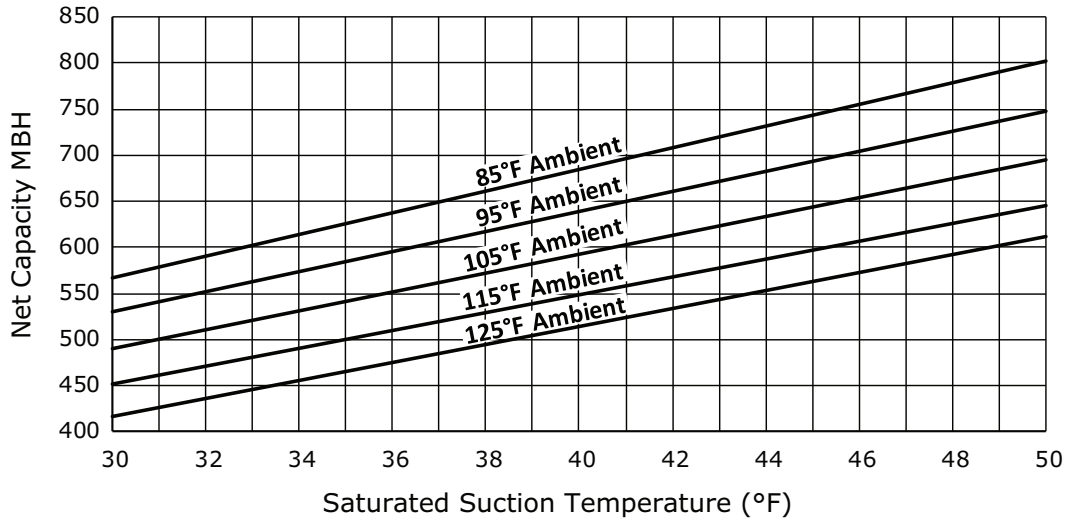

Figure 13. Performance — RA 50 ton 60 Hz (R-454B)

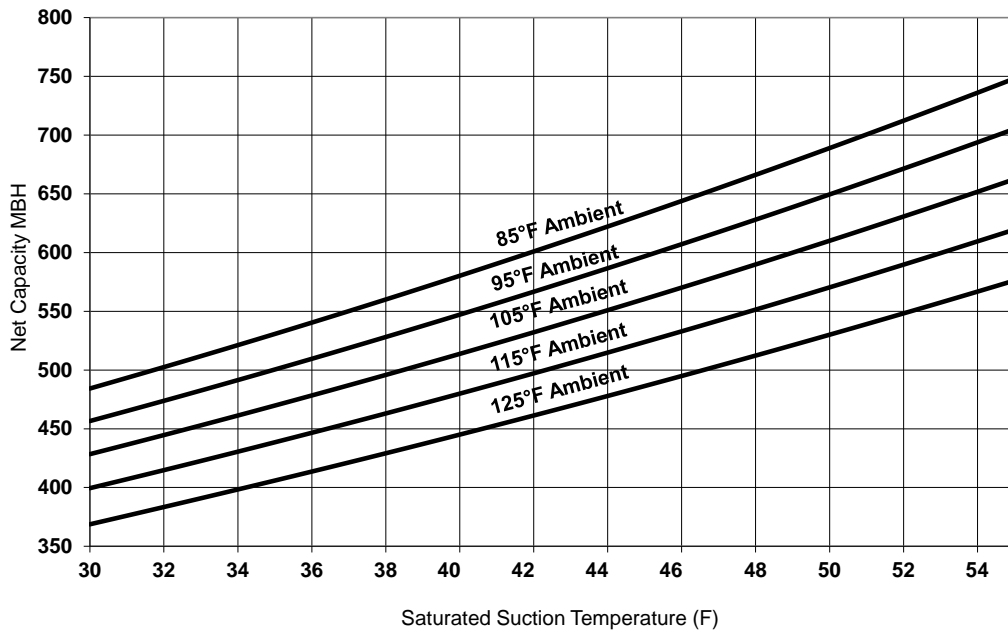

Figure 14. Performance — RA 60 ton 60 Hz (R-410A)

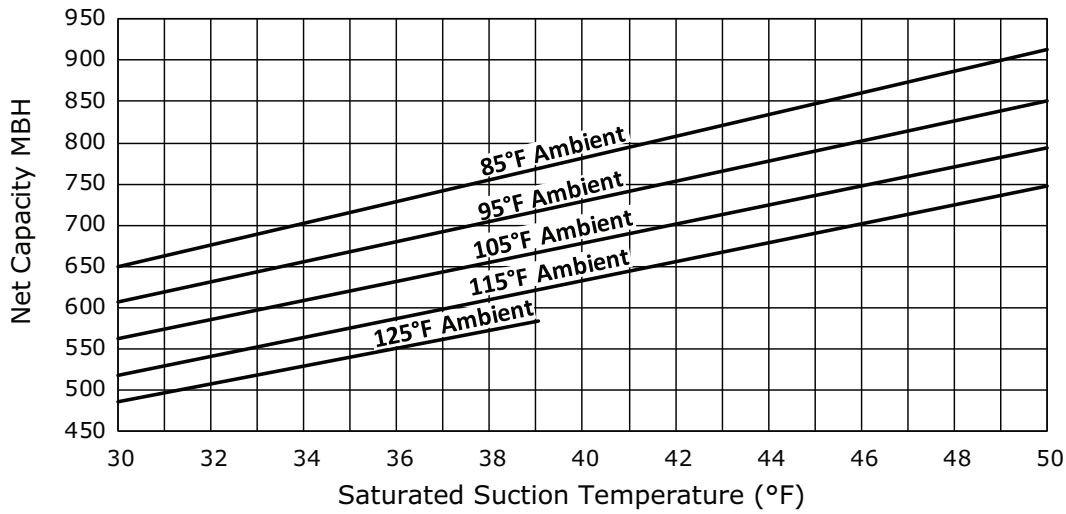
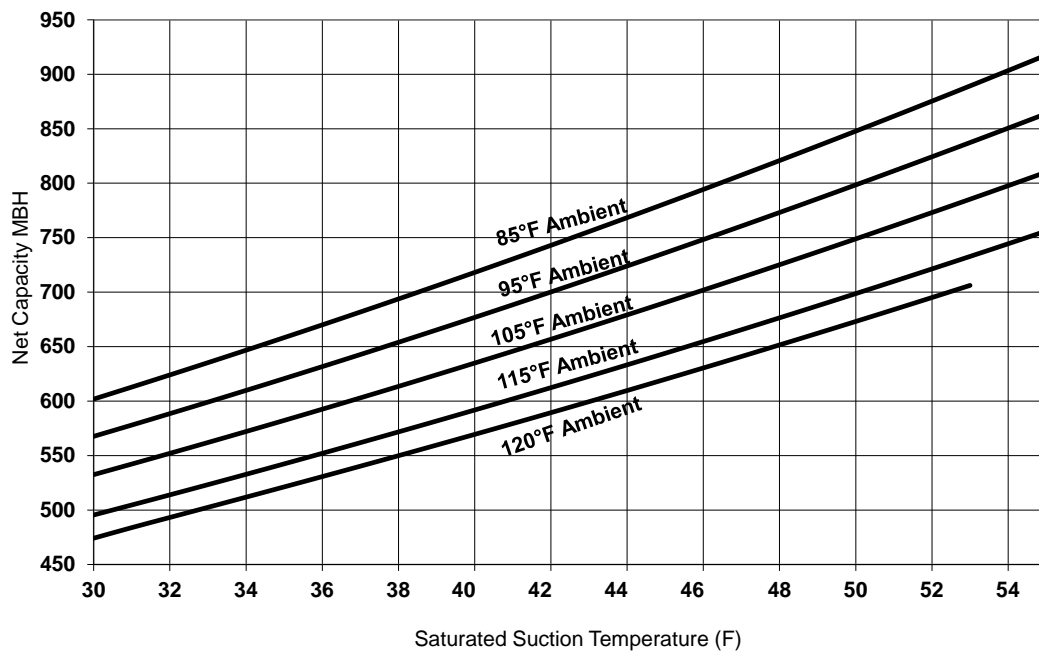

Figure 15. Performance — RA 60 ton 60 Hz (R-454B)





Performance Data

Figure 16. Performance — RA 80 ton 60 Hz (R-410A)

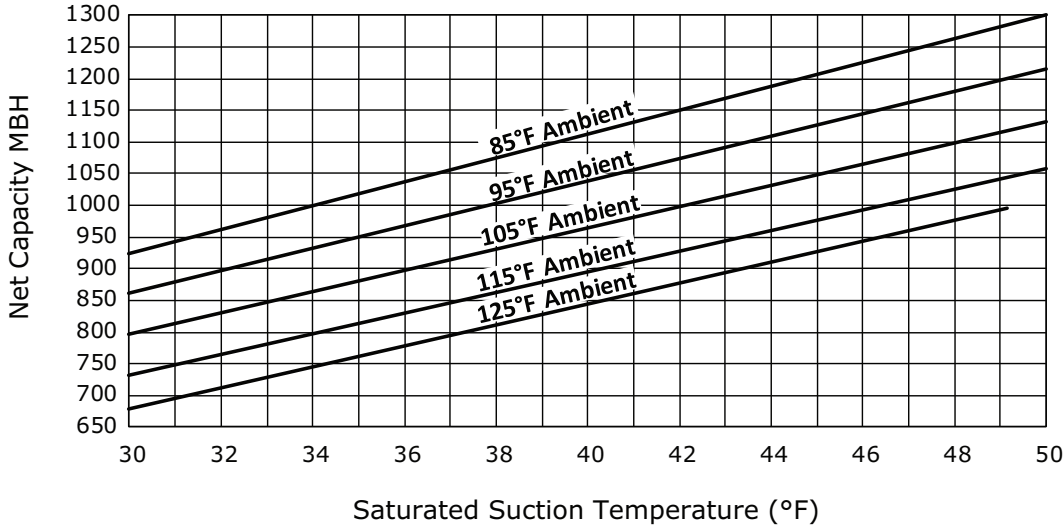

Figure 17. Performance — RA 80 ton 60 Hz (R-454B)

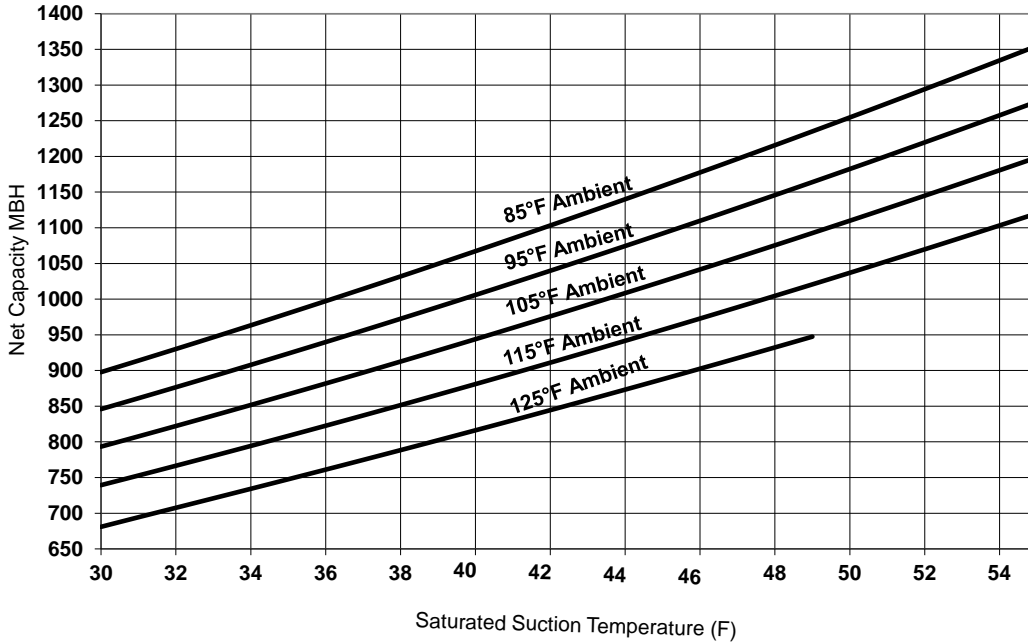

Figure 18. Performance — RA 100 ton 60 Hz (R-410A)

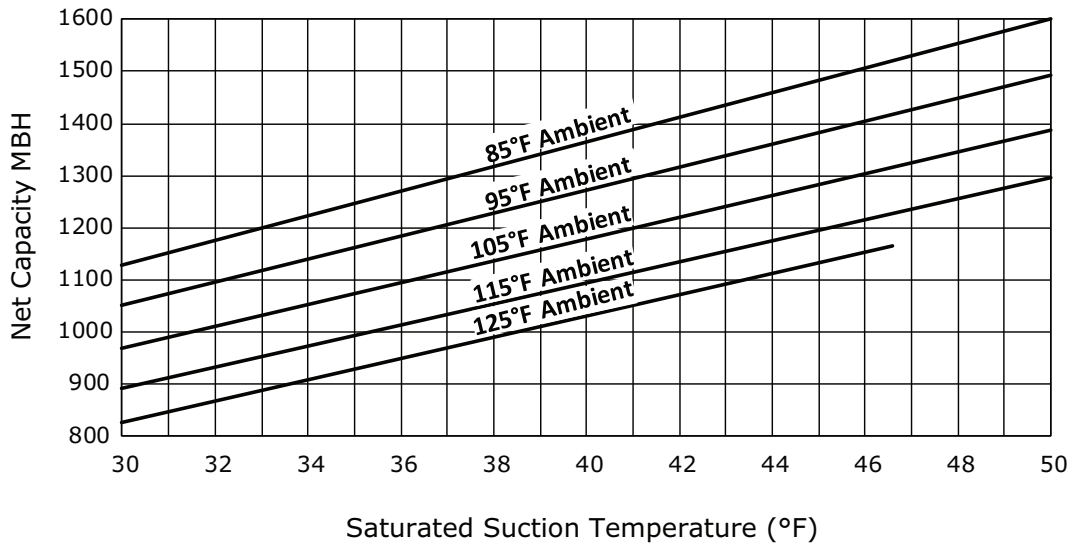
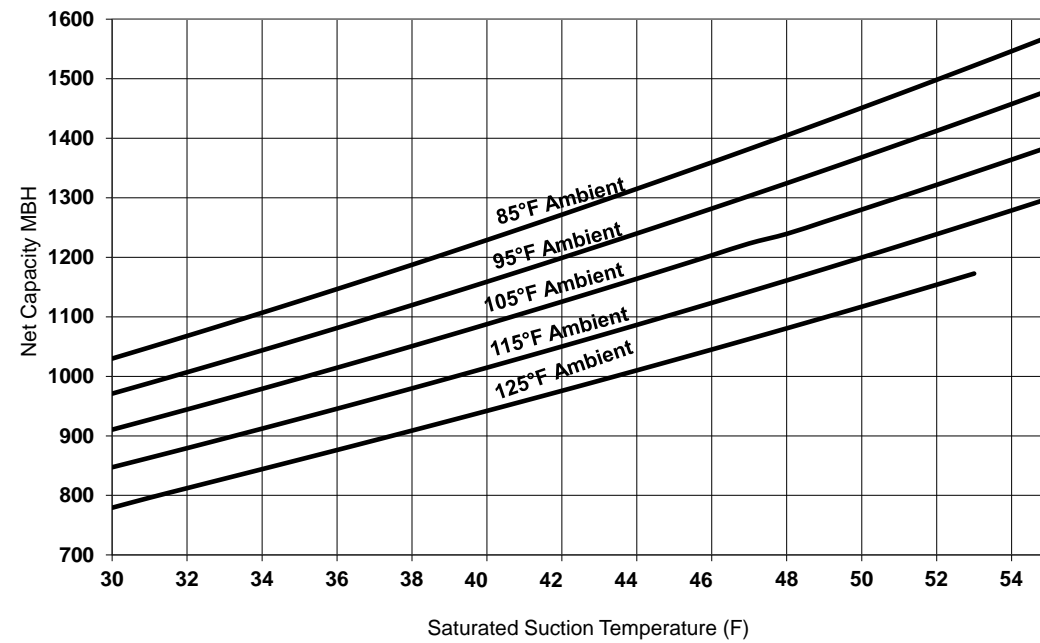

Figure 19. Performance — RA 100 ton 60 Hz (R-454B)





Performance Data

Figure 20. Performance — RA 120 ton 60 Hz (R-410A)

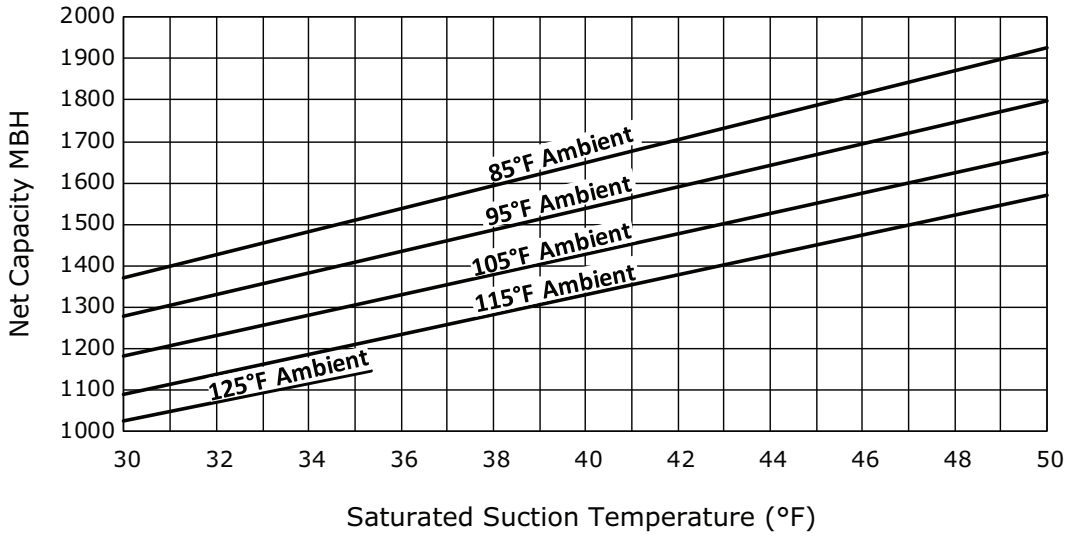
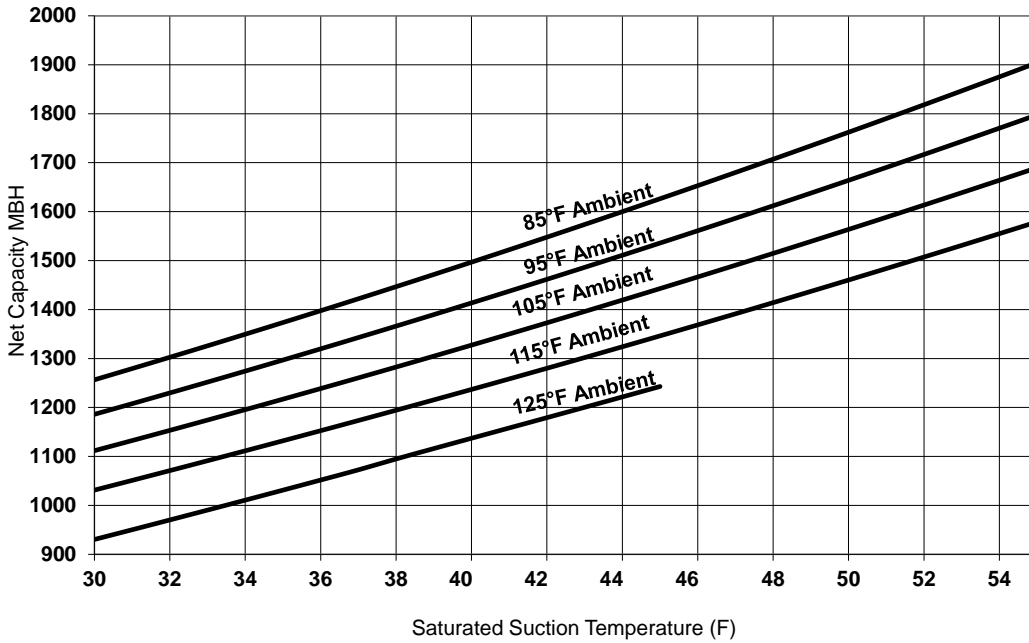

Figure 21. Performance — RA 120 ton 60 Hz (R-454B)



50Hz Units

Figure 22. Performance — RA 20 ton 50 Hz (R-410A)

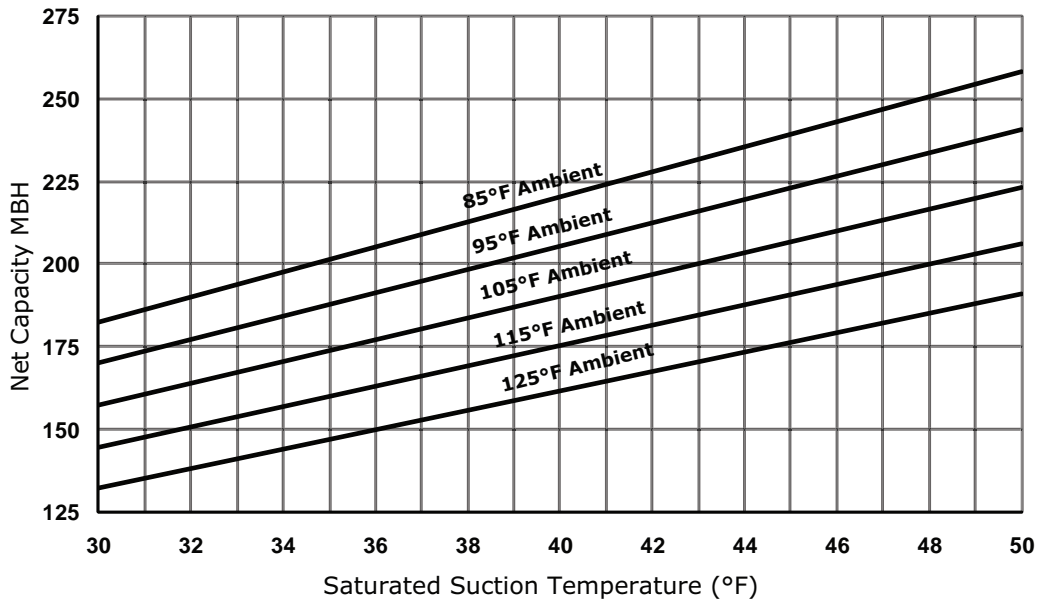
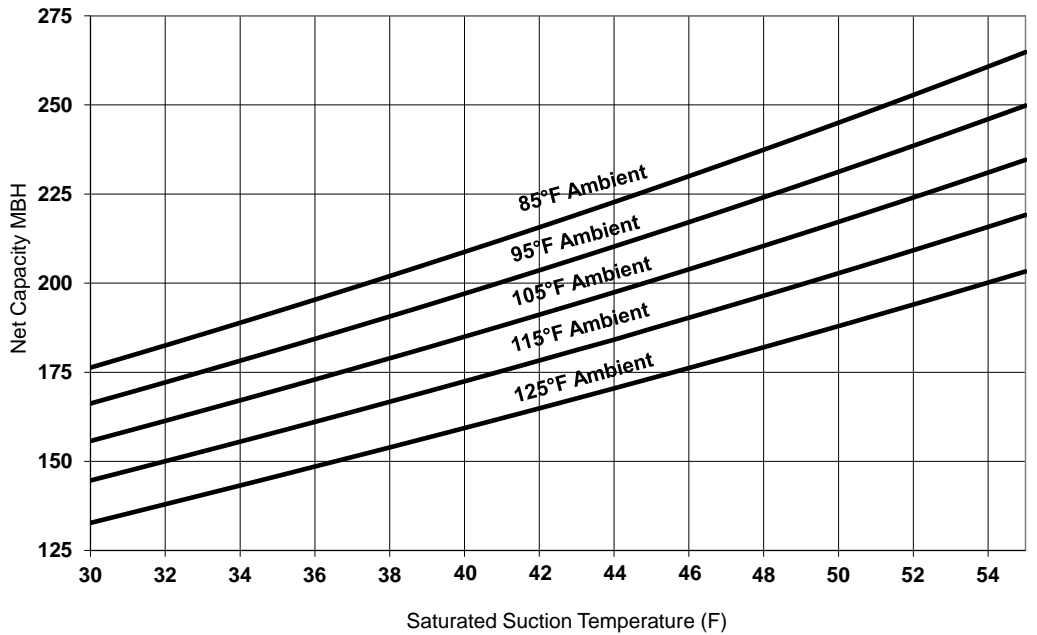

Figure 23. Performance — RA 20 ton 50 Hz (R-454B)





Performance Data

Figure 24. Performance — RA 25 ton 50 Hz (R-410A)

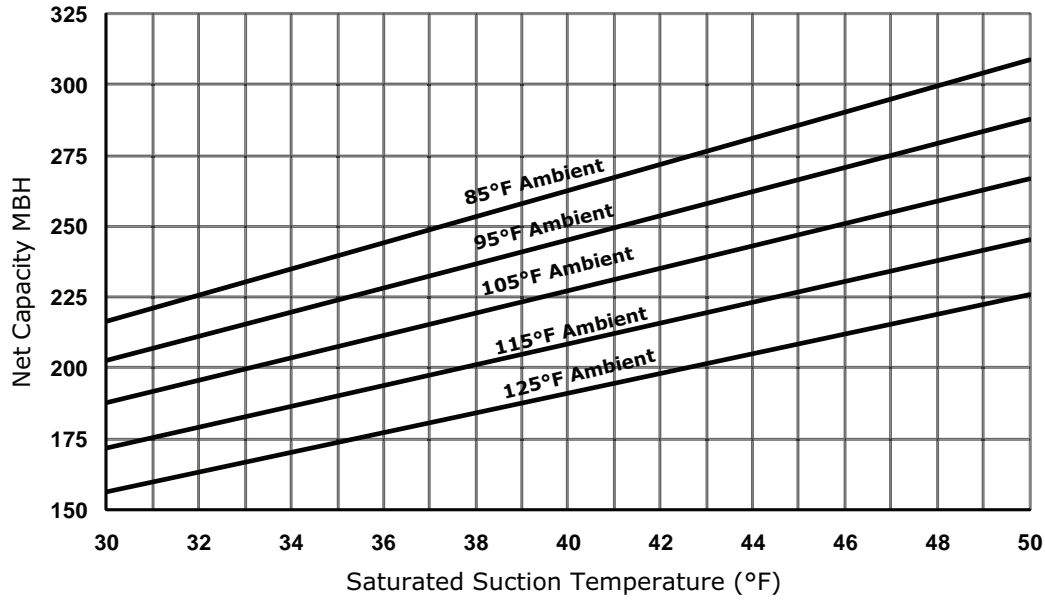

Figure 25. Performance — RA 25 ton 50 Hz (R-454B)

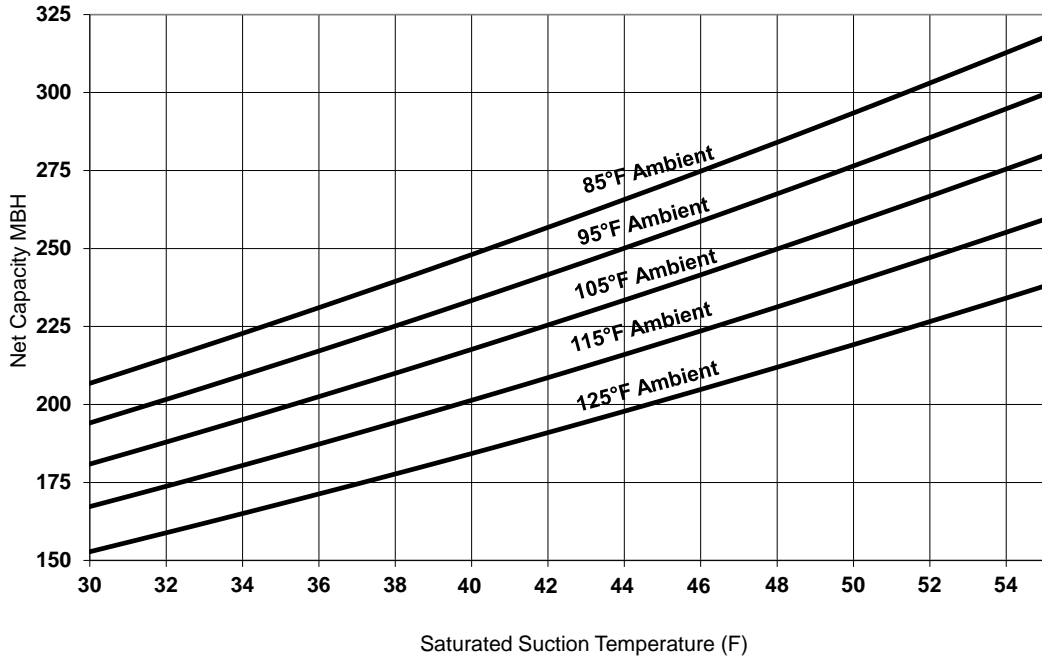

Figure 26. Performance — RA 30 ton 50 Hz (R-410A)

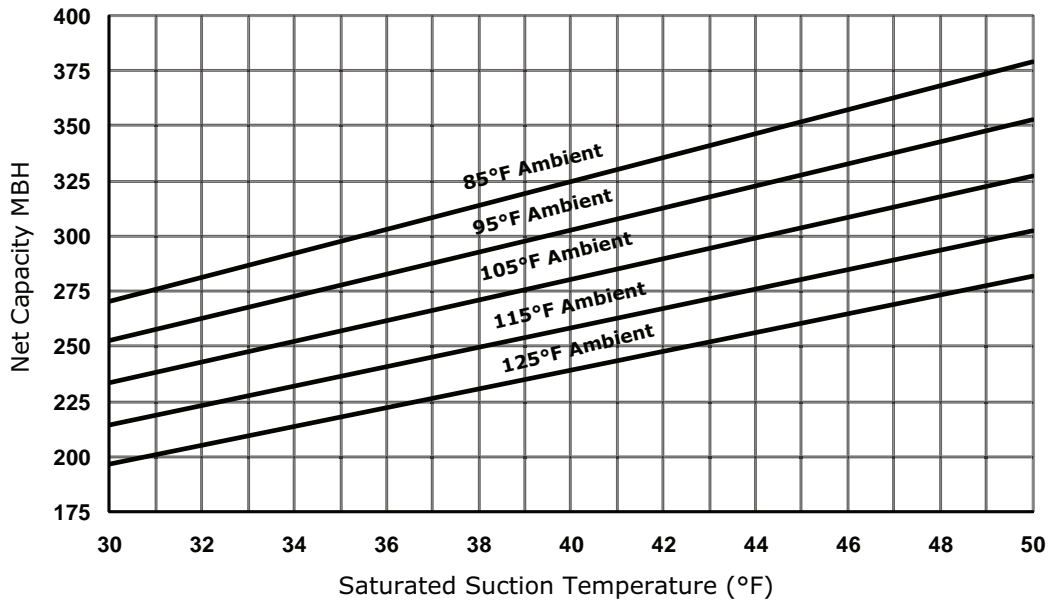
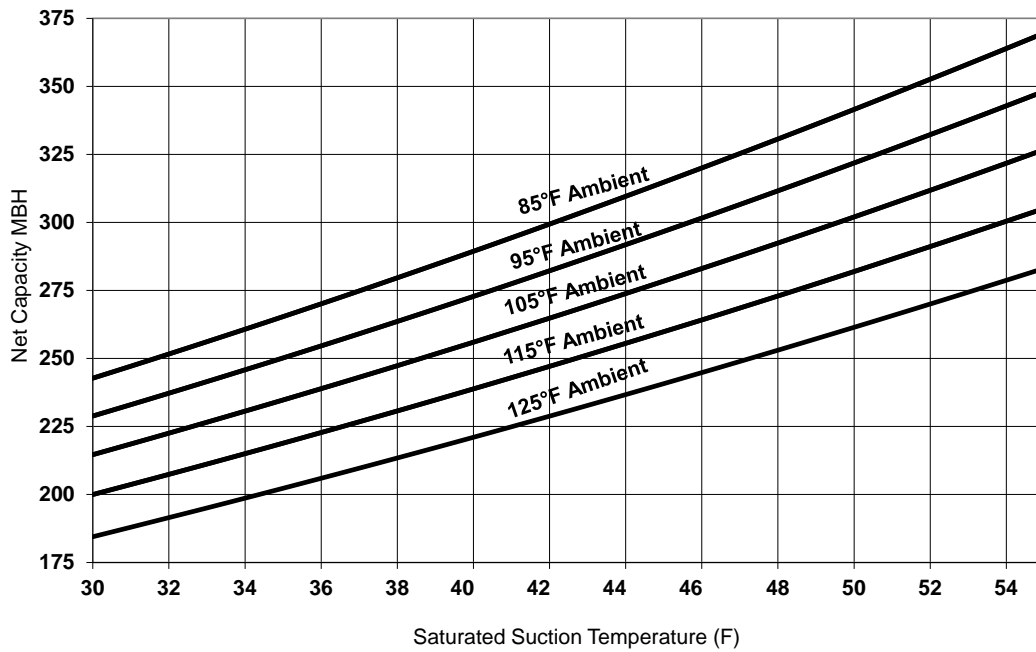

Figure 27. Performance — RA 30 ton 50 Hz (R-454B)





Performance Data

Figure 28. Performance — RA 40 ton 50 Hz (R-410A)

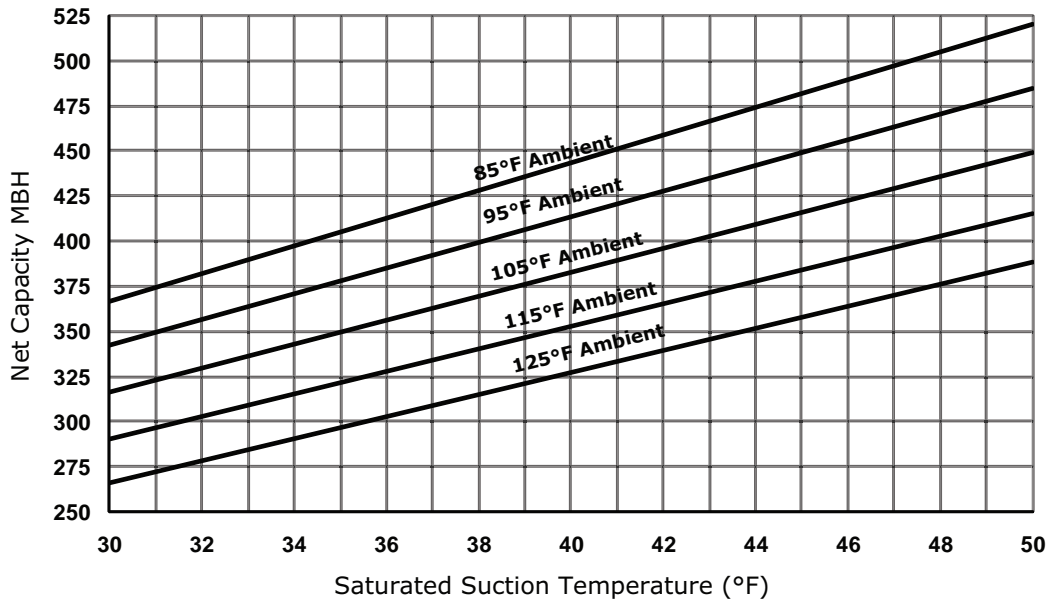

Figure 29. Performance — RA 40 ton 50 Hz (R-454B)

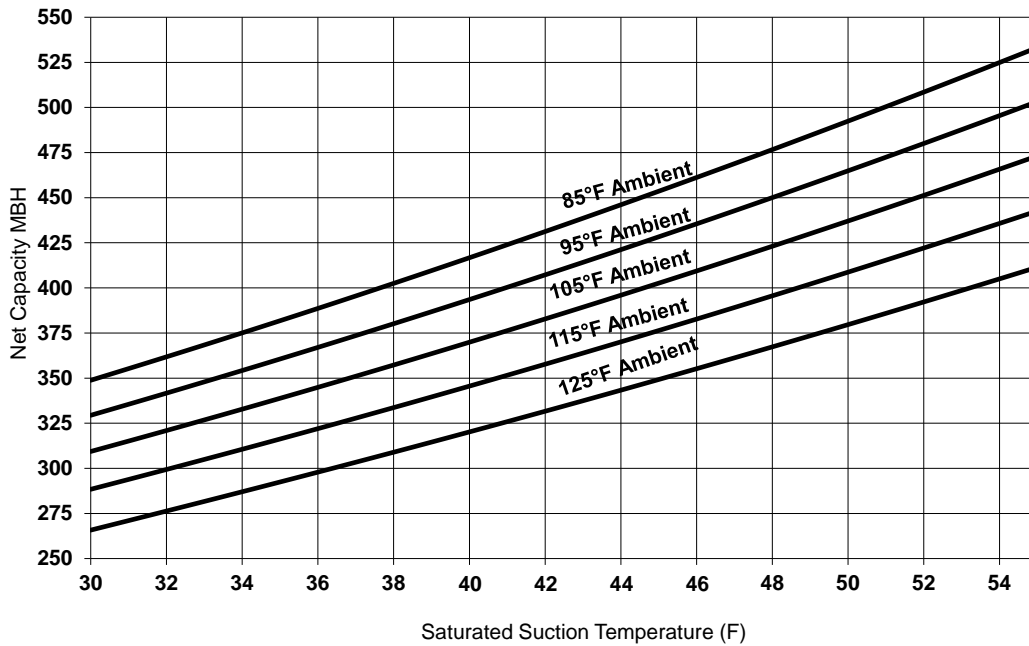

Figure 30. Performance — RA 50 ton 50 Hz (R-410A)

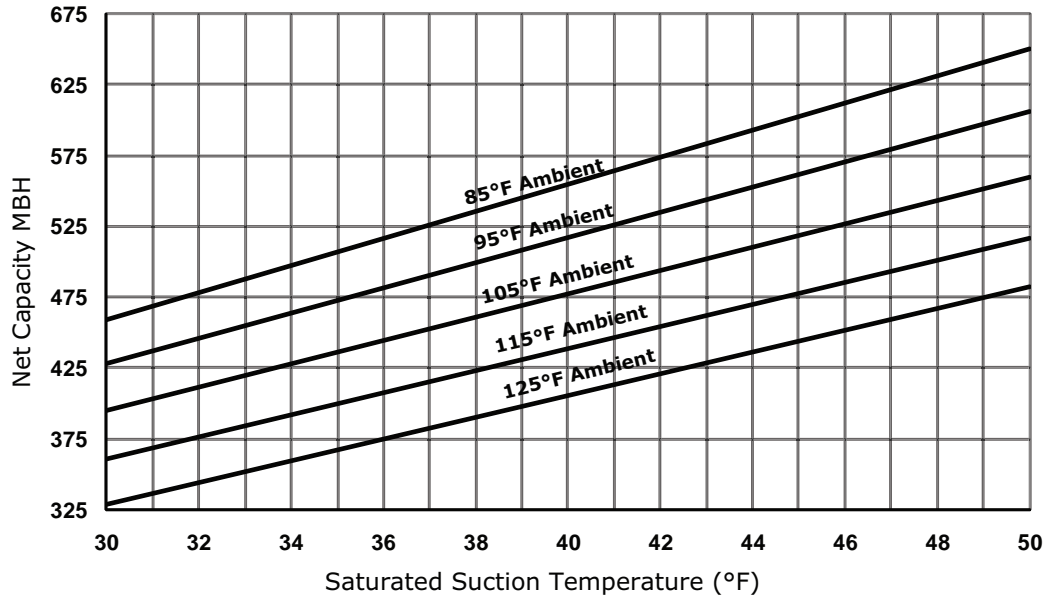
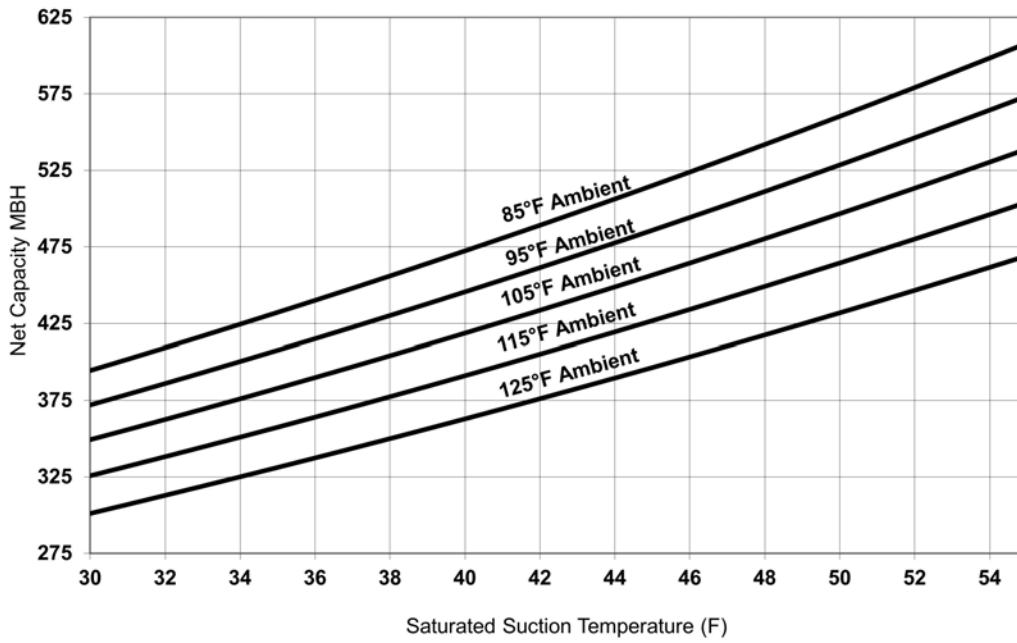

Figure 31. Performance — RA 50 ton 50 Hz (R-454B)





Performance Data

Figure 32. Performance — RA 60 ton 50 Hz (R-410A)

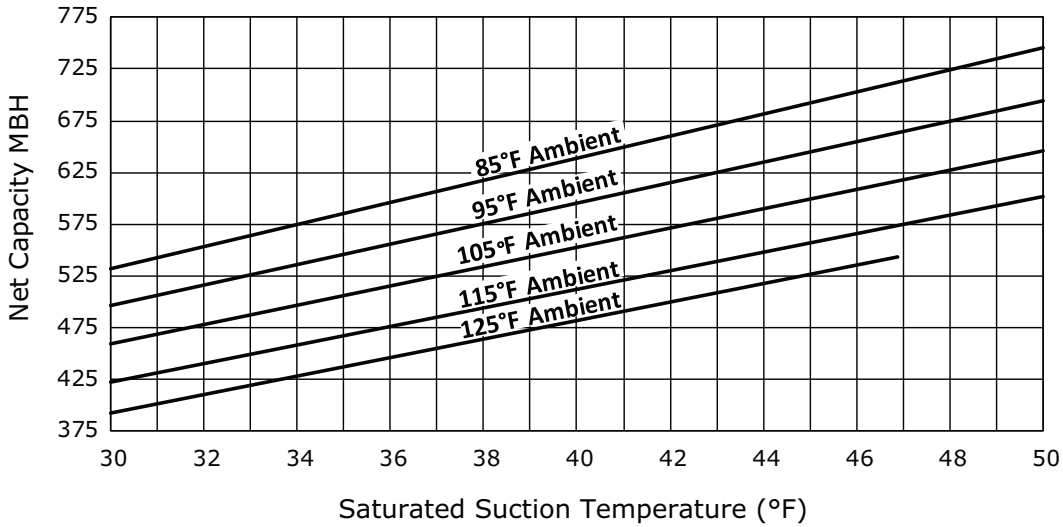

Figure 33. Performance — RA 60 ton 50 Hz (R-454B)

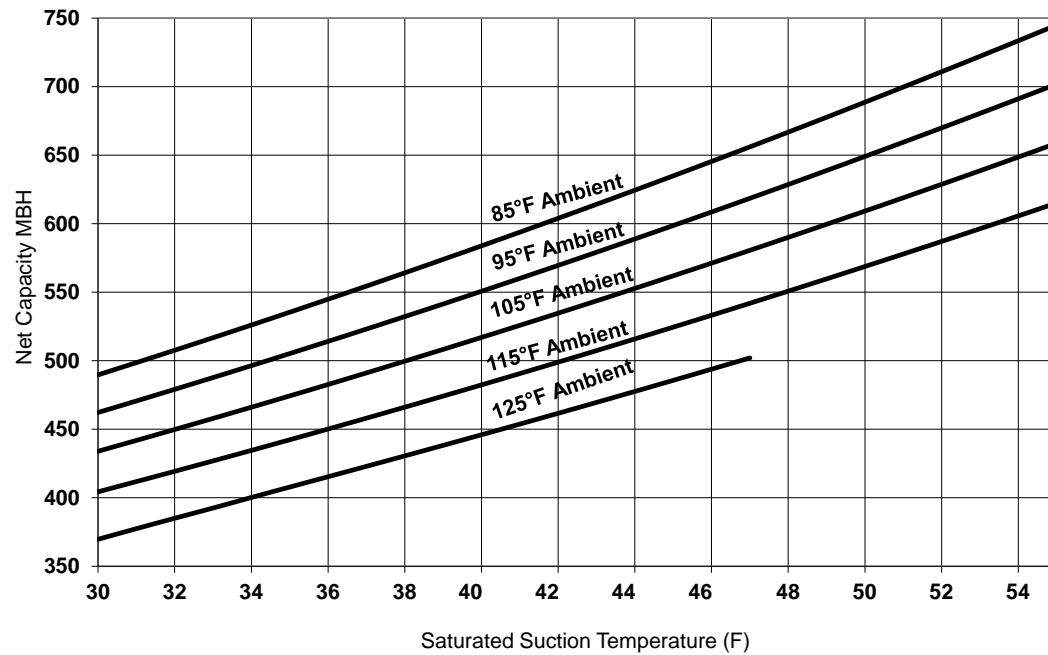

Figure 34. Performance — RA 80 ton 50 Hz (R-410A)

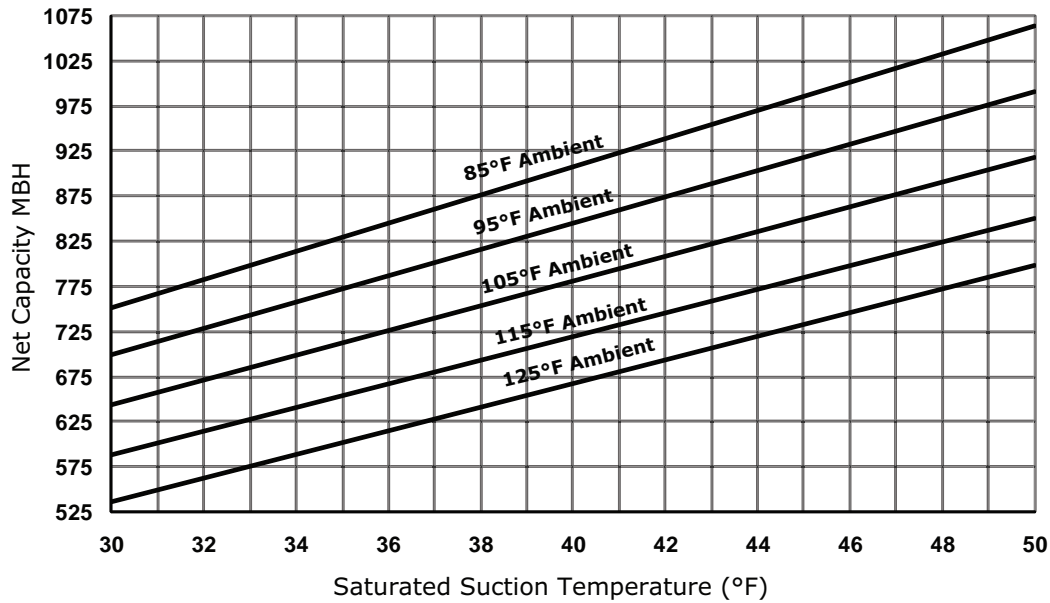
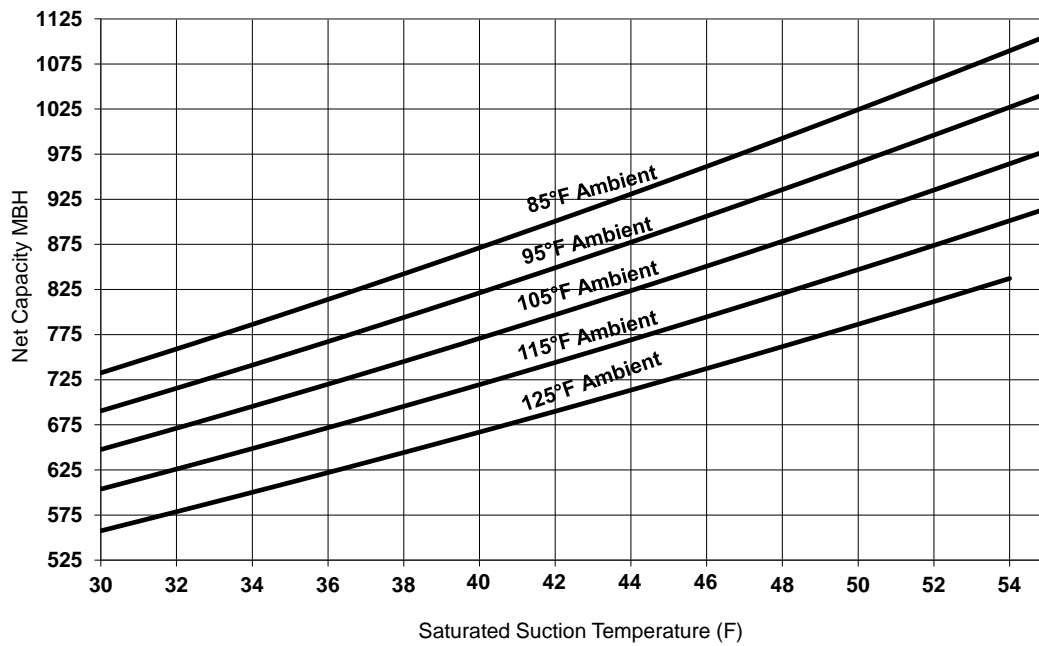

Figure 35. Performance — RA 80 ton 50 Hz (R-454B)





Performance Data

Figure 36. Performance — RA 100 ton 50 Hz (R-410A)

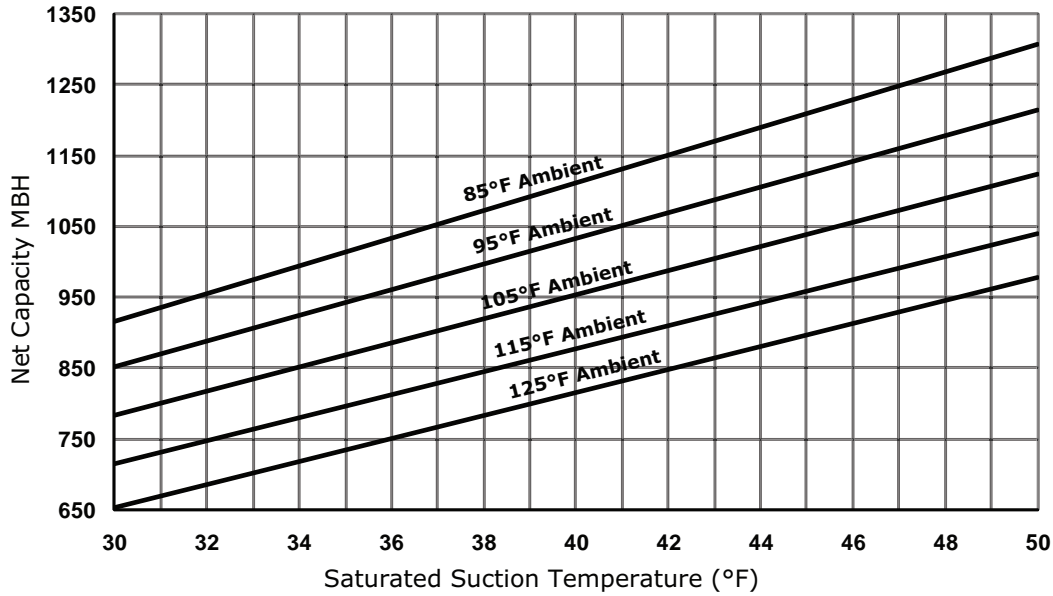

Figure 37. Performance — RA 100 ton 50 Hz (R-454B)

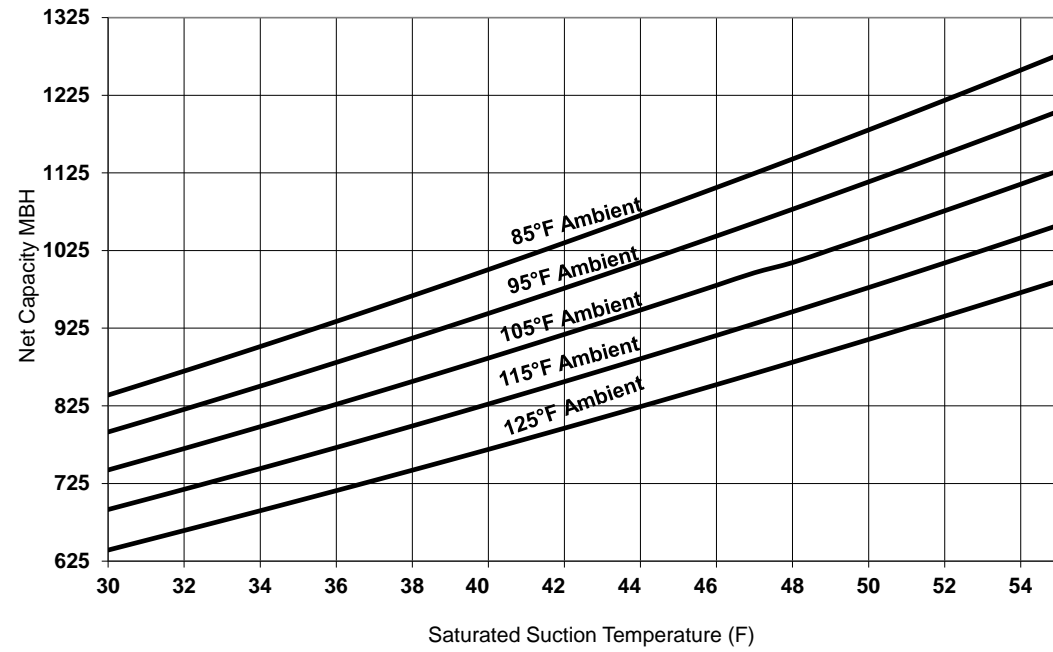

Figure 38. Performance — RA 120 ton 50 Hz (R-410A)

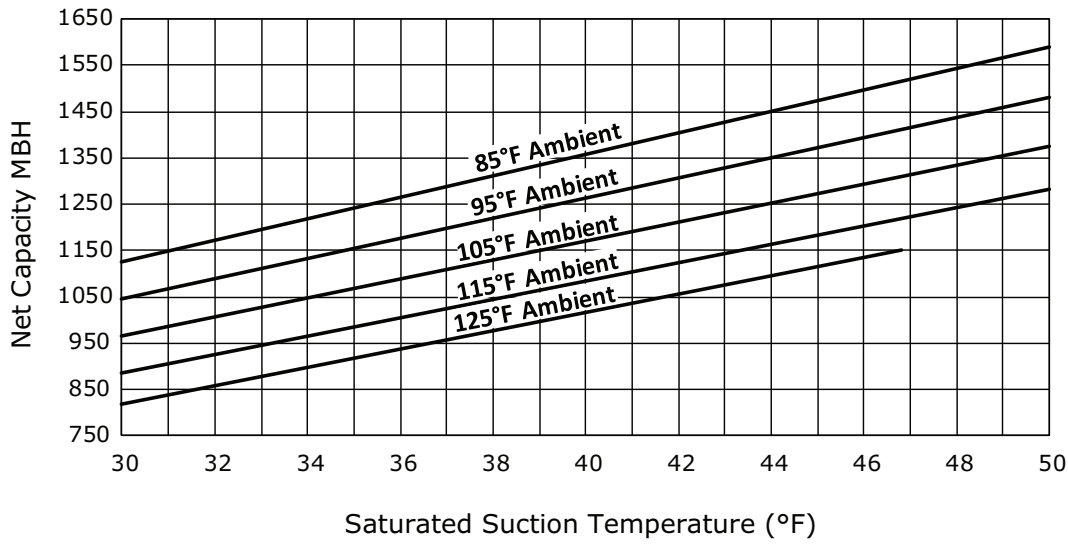
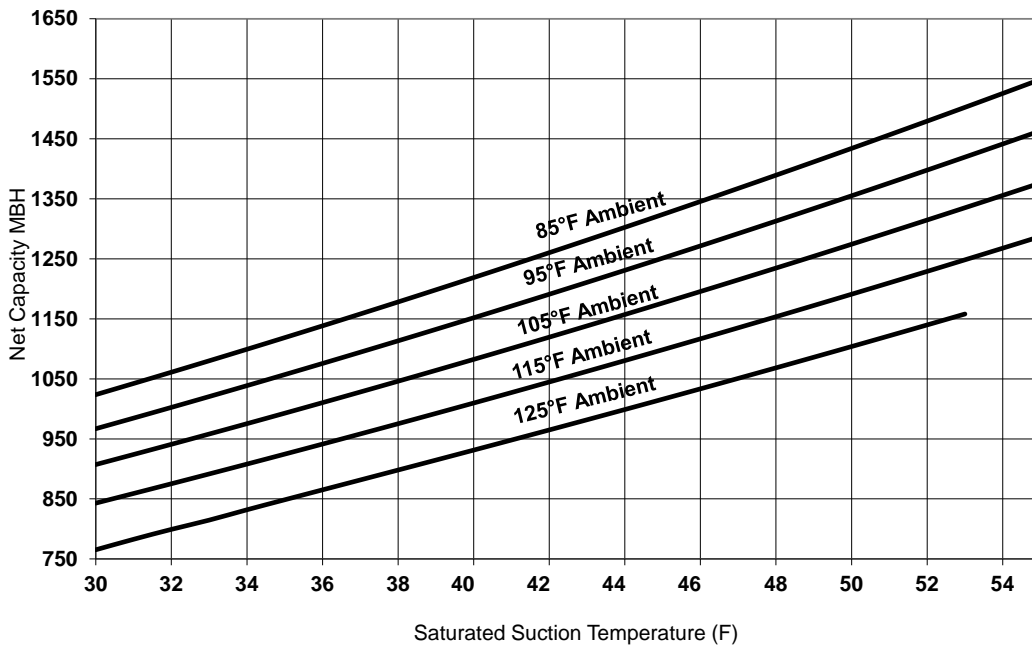

Figure 39. Performance — RA 120 ton 50 Hz (R-454B)





Performance Data

Table 3. System performance — 20 to 120 ton IntelliCore™ with remote EVP chiller

Unit Size (tons)	LWFT (°F)	Entering Condenser Air Temperature (°F)															
		85				95				105				115			
		Capacity (tons)		Compr kW		Capacity (tons)		Compr kW		Capacity (tons)		Compr kW		Capacity (tons)		Compr kW	
		(R-410A)	(R-454B)	(R-410A)	(R-454B)	(R-410A)	(R-454B)	(R-410A)	(R-454B)	(R-410A)	(R-454B)	(R-410A)	(R-454B)	(R-410A)	(R-454B)	(R-410A)	(R-454B)
20	40	18.1	18.8	18.7	17.5	17.1	17.7	20.9	19.4	16.0	16.6	23.4	21.4	14.9	15.4	26.3	23.7
	42	18.8	19.4	18.9	17.8	17.8	18.3	21.1	19.6	16.7	17.2	23.7	21.7	15.6	16.0	26.6	23.9
	44	19.4	20.1	19.1	18.0	18.4	19.0	21.4	19.8	17.2	17.8	23.9	21.9	16.1	16.6	26.8	24.1
	46	20.0	20.8	19.3	18.2	18.9	19.6	21.6	20.0	17.8	18.4	24.1	22.1	16.6	17.1	27.0	24.3
	48	20.7	21.5	19.5	18.4	19.5	20.2	21.8	20.3	18.4	19.0	24.4	22.3	17.1	17.7	27.3	24.5
	50	21.3	22.1	19.7	18.6	20.2	20.9	22.0	20.5	19.0	19.6	24.6	22.5	17.7	18.3	27.5	24.7
25	40	22.2	23.3	21.8	20.5	20.8	21.9	24.4	22.7	19.4	20.5	27.3	25.1	17.9	19.0	30.9	27.7
	42	23.1	24.1	22.1	20.7	21.7	22.7	24.6	22.9	20.2	21.2	27.6	25.3	18.7	19.7	31.1	28.0
	44	23.9	24.9	22.3	21.0	22.5	23.5	24.9	23.1	21.0	22.0	27.9	25.5	19.4	20.4	31.3	28.2
	46	24.8	25.8	22.5	21.2	23.3	24.3	25.2	23.4	21.7	22.7	28.1	25.8	20.0	21.1	31.6	28.4
	48	25.6	26.6	22.8	21.5	24.1	25.1	25.4	23.6	22.4	23.5	28.4	26.0	20.7	21.8	31.9	28.7
	50	26.5	27.5	23.1	21.7	24.9	25.9	25.7	23.9	23.2	24.2	28.7	26.3	21.4	22.5	32.2	28.9
30	40	26.0	28.4	26.8	27.2	24.5	26.8	29.8	29.8	23.0	25.0	33.2	32.7	21.4	23.3	36.9	35.8
	42	27.1	29.4	27.2	27.6	25.5	27.7	30.2	30.2	23.9	25.9	33.5	33.1	22.3	24.1	37.3	36.1
	44	28.0	30.4	27.5	27.9	26.4	28.6	30.5	30.5	24.7	26.8	33.9	33.4	23.0	25.0	37.6	36.5
	46	28.9	31.4	27.8	28.3	27.2	29.6	30.8	30.9	25.5	27.7	34.2	33.8	23.8	25.8	37.9	36.8
	48	29.9	32.4	28.1	28.7	28.2	30.5	31.2	31.3	26.4	28.6	34.6	34.2	24.6	26.7	38.3	37.2
	50	30.9	33.5	28.4	29.0	29.1	31.5	31.5	31.7	27.3	29.5	34.9	34.5	25.4	27.5	38.7	37.6
40	40	36.7	34.0	36.8	38.9	34.8	33.9	41.1	38.9	32.8	33.9	45.9	39.0	30.6	33.8	51.4	39.2
	42	38.4	35.3	37.2	39.3	36.2	35.2	41.5	39.3	34.2	35.2	46.3	39.4	32.0	35.1	51.8	39.6
	44	39.7	36.6	37.6	39.7	37.4	36.5	41.9	39.8	35.4	36.5	46.7	39.9	33.1	36.4	52.2	40.0
	46	41.0	37.9	37.9	40.1	38.7	37.9	42.3	40.2	36.4	37.8	47.1	40.3	34.0	37.7	52.5	40.4
	48	42.4	39.3	38.3	40.6	40.1	39.2	42.7	40.6	37.6	39.2	47.5	40.8	34.3	39.1	52.6	40.9
	50	43.7	40.7	38.6	41.0	41.3	40.6	43.0	41.1	38.9	40.5	47.9	41.2	36.3	40.5	53.4	41.4
50	40	42.4	45.6	39.9	50.1	40.0	45.6	44.5	50.2	37.7	45.5	49.8	50.3	35.3	45.4	55.8	50.5
	42	44.1	47.2	40.3	50.6	41.7	47.2	45.0	50.7	39.3	47.1	50.3	50.9	36.8	47.0	56.3	51.1
	44	45.7	48.9	40.7	51.2	43.1	48.8	45.4	51.3	40.6	48.7	50.7	51.5	38.0	48.6	56.7	51.7
	46	47.3	50.6	41.1	51.8	43.7	50.5	45.6	51.9	41.9	50.4	51.1	52.1	39.1	50.3	57.1	52.3
	48	48.9	52.2	41.5	52.4	46.1	52.2	46.3	52.5	43.3	52.1	51.6	52.7	40.5	51.9	57.6	52.9
	50	50.6	54.0	41.9	53.0	47.7	53.9	46.7	53.2	44.8	53.8	52.1	53.3	41.9	53.6	58.1	53.5

Table 3. System performance — 20 to 120 ton IntelliCore™ with remote EVP chiller (continued)

Unit Size (tons)	LWFT (°F)	Entering Condenser Air Temperature (°F)															
		85				95				105				115			
		Capacity (tons)		Compr kW		Capacity (tons)		Compr kW		Capacity (tons)		Compr kW		Capacity (tons)		Compr kW	
		(R-410A)	(R-454B)	(R-410A)	(R-454B)	(R-410A)	(R-454B)	(R-410A)	(R-454B)	(R-410A)	(R-454B)	(R-410A)	(R-454B)	(R-410A)	(R-454B)	(R-410A)	(R-454B)
60	40	52.4	52.1	54.4	59.6	49.4	52.0	60.7	59.7	46.4	51.9	67.8	59.9	43.2	51.8	76.4	60.1
	42	54.6	53.9	55.1	60.3	51.5	53.8	61.5	60.4	48.3	53.7	68.6	60.6	45.0	53.6	77.0	60.8
	44	56.5	55.7	55.8	61.1	53.2	55.7	62.1	61.2	50.0	55.5	69.3	61.4	46.5	55.4	77.7	61.6
	46	56.7	57.6	55.9	61.8	55.0	57.5	62.9	62.0	51.6	57.4	70.0	62.2	48.0	57.3	78.3	62.4
	48	60.4	59.5	57.2	62.6	56.9	59.4	63.6	62.8	53.3	59.3	70.8	63.0	49.6	59.1	79.0	63.2
	50	62.3	61.5	57.9	63.4	58.7	61.3	64.4	63.6	55.1	61.2	71.6	63.8	51.3	61.0	79.8	64.0
80	40	76.4	72.2	80.5	87.7	72.1	72.1	89.3	87.8	67.8	72.0	99.1	88.1	63.3	71.8	110.4	88.4
	42	79.5	74.8	81.6	88.4	75.0	74.7	90.4	88.7	70.6	74.5	100.4	89.0	65.9	74.4	111.6	89.3
	44	82.2	77.4	82.5	89.3	77.6	77.3	91.5	89.6	72.9	77.1	101.4	89.8	68.1	76.9	112.6	90.2
	46	84.8	80.0	83.4	90.2	80.1	79.9	92.5	90.4	75.2	79.8	102.5	90.7	70.4	79.6	113.7	91.1
	48	87.7	82.7	84.5	91.1	82.8	82.6	93.6	91.4	77.7	82.4	103.6	91.7	72.7	82.2	114.9	92.0
	50	90.4	85.4	85.5	92.0	85.3	85.3	94.6	92.3	80.2	85.1	104.7	92.6	74.8	84.9	116.0	93.0
100	40	90.3	89.9	89.5	102.6	85.2	89.8	99.1	102.8	79.9	89.6	110.1	103.2	74.4	89.4	122.8	103.5
	42	93.9	93.1	90.7	103.7	88.6	93.0	100.4	103.9	83.0	92.8	111.4	104.2	77.3	92.6	124.0	104.6
	44	97.2	96.3	91.8	104.8	91.6	96.2	101.6	105.0	85.9	96.0	112.6	105.4	80.0	95.8	125.2	105.8
	46	100.5	99.6	92.9	105.9	94.7	99.5	102.8	106.1	88.8	99.3	113.8	106.5	82.7	99.1	126.5	106.9
	48	103.8	103.0	94.1	107.0	97.9	102.8	104.0	107.3	91.8	102.6	115.1	107.6	85.5	102.4	127.7	108.1
	50	107.3	106.4	95.3	108.2	101.1	106.2	105.3	108.5	94.8	106.0	116.4	108.9	88.5	105.7	129.1	109.3
120	40	109.5	107.8	107.9	124.9	103.4	107.6	119.7	125.2	97.0	107.5	133.4	125.5	90.2	107.3	150.4	126.0
	42	114.0	111.5	109.4	126.1	107.6	111.4	121.2	126.4	101.0	111.2	135.0	126.8	93.9	111.0	151.6	127.3
	44	117.8	115.4	110.7	127.4	111.3	115.2	122.6	127.7	104.4	115.0	136.3	128.1	97.1	114.7	152.9	128.7
	46	121.8	119.2	112.0	128.8	115.0	119.0	124.0	129.1	108.0	118.8	137.8	129.5	100.5	118.5	154.2	130.0
	48	125.8	123.1	113.4	130.1	118.8	122.9	125.4	130.4	111.6	122.7	139.2	130.9	103.9	122.4	155.6	131.4
	50	129.9	127.1	114.8	131.5	122.7	126.9	126.9	131.9	115.2	126.6	140.8	132.3	107.3	126.3	157.1	132.8

Notes:

1. Leaving water temperature (LWT) below 42°F requires freeze protection to 15°F.
2. 40°F LWT performance includes 20% glycol.

Table 4. Chiller water pressure drop (ft H₂O) – R-410A

Flow (gpm)	Size (tons)									
	20	25	30	40	50	60	80	100	120	
25	3.7	-	-	-	-	-	-	-	-	
30	5.2	3.2	-	-	-	-	-	-	-	
35	6.9	4.2	-	-	-	-	-	-	-	
40	8.8	5.4	3.1	-	-	-	-	-	-	
45	10.9	6.7	3.9	-	-	-	-	-	-	
50	13.3	8.2	4.8	5.3	-	-	-	-	-	
60	18.5	11.4	6.7	7.5	4.1	-	-	-	-	
70	24.6	15.2	8.9	10.1	5.5	-	-	-	-	



Performance Data

Table 4. Chiller water pressure drop (ft H₂O) – R-410A (continued)

Flow (gpm)	Size (tons)								
	20	25	30	40	50	60	80	100	120
80	-	19.4	11.4	13	7.1	5	-	-	-
90	-	24.1	14.2	16.3	8.9	6.3	-	-	-
100	-	-	17.3	19.9	10.9	7.7	4.3	-	-
120	-	-	-	28.3	15.4	10.9	6.1	3.2	-
140	-	-	-	-	20.7	14.6	8.2	4.4	-
160	-	-	-	-	26.7	18.9	10.6	5.6	4.8
180	-	-	-	-	-	23.6	13.2	7.1	6.1
200	-	-	-	-	-	-	16.2	8.7	7.4
240	-	-	-	-	-	-	22.9	12.3	10.6
280	-	-	-	-	-	-	-	16.5	14.2
320	-	-	-	-	-	-	-	21.3	18.3
360	-	-	-	-	-	-	-	26.7	23
400	-	-	-	-	-	-	-	-	28.2

Table 5. Chiller water pressure drop (ft H₂O) – R-454B

Flow (gpm)	Size (tons)								
	20	25	30	40	50	60	80	100	120
25	3.2	—	—	—	—	—	—	—	—
30	4.5	2.8	—	—	—	—	—	—	—
35	6.0	3.7	—	—	—	—	—	—	—
40	7.7	4.7	3.2	—	—	—	—	—	—
45	9.5	5.8	4.0	—	—	—	—	—	—
50	11.6	7.0	4.8	4.2	—	—	—	—	—
60	16.3	9.7	6.8	6.0	4.3	—	—	—	—
70	21.7	12.9	9.0	8.0	5.7	—	—	—	—
80	—	16.4	11.5	10.3	7.4	5.1	—	—	—
90	—	20.4	14.2	12.9	9.2	6.4	—	—	—
100	—	—	17.3	15.7	11.3	7.8	4.3	—	—
120	—	—	—	22.2	15.9	11.0	6.0	3.2	—
140	—	—	—	—	21.4	14.8	8.1	4.2	—
160	—	—	—	—	27.5	19.1	10.4	5.5	4.7
180	—	—	—	—	—	23.9	13.0	6.8	5.8
200	—	—	—	—	—	—	15.9	8.4	7.1
240	—	—	—	—	—	—	22.5	11.8	10.1
280	—	—	—	—	—	—	—	15.8	13.5
320	—	—	—	—	—	—	—	20.4	17.4
360	—	—	—	—	—	—	—	25.5	21.8
400	—	—	—	—	—	—	—	—	26.6

Figure 40. Remote EVP glycol freeze protection

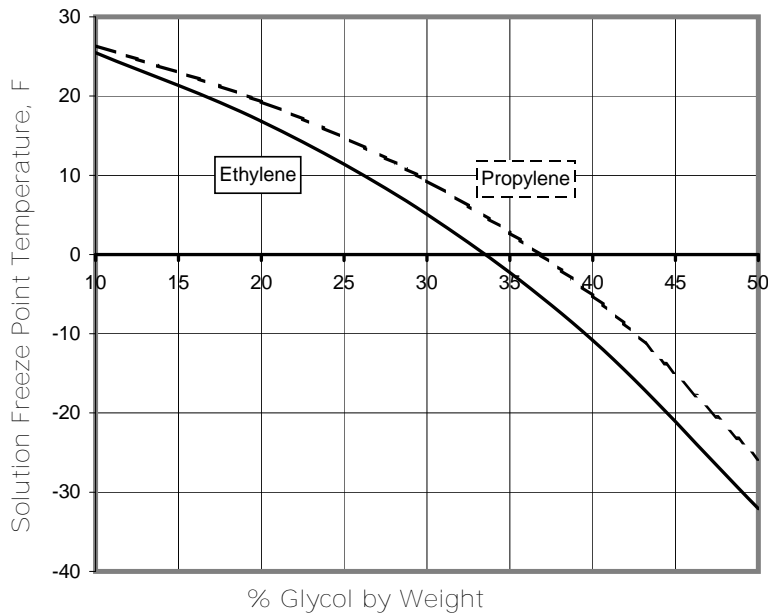
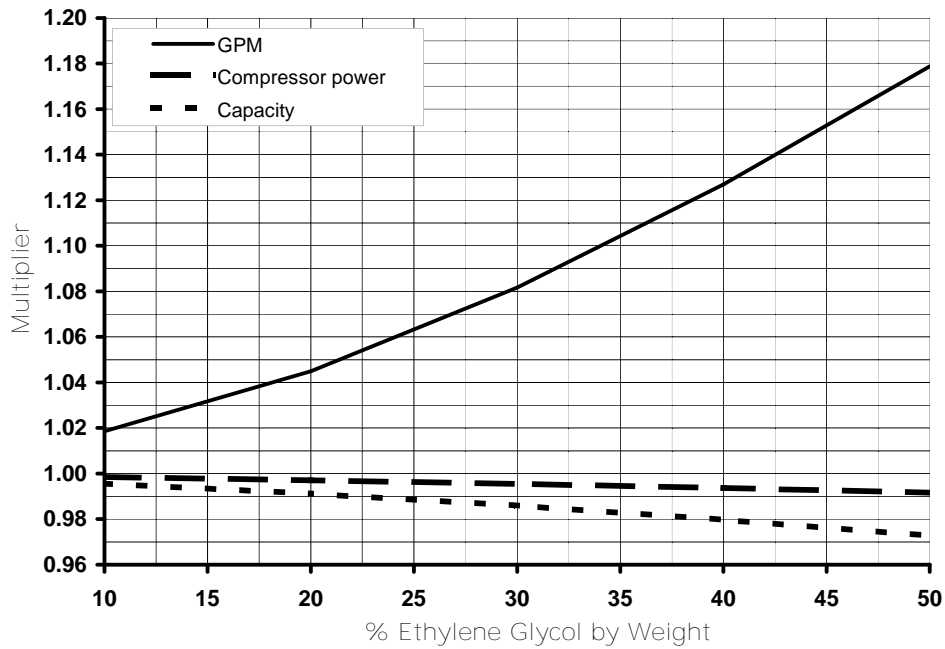
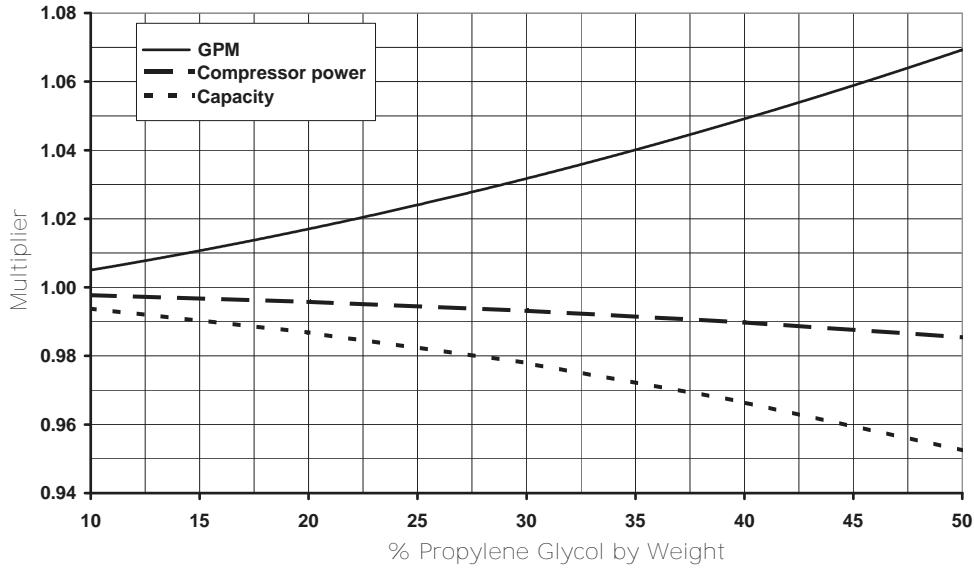

Figure 41. Remote EVP ethylene glycol GPM, capacity, compressor power adjustment



Performance Data
Figure 42. Remote EVP propylene glycol GPM, capacity, compressor power adjustment



Controls

Symbio 800 Controls

Symbio™ 800 controller is a factory-installed, application specific and programmable controller designed to control large-packaged HVAC equipment. Features include automated controller back-up, secure remote connectivity, wireless building communication, mobile device connectivity, and custom programming with expandable I/O (expansion module).

The Symbio 800 controller supports a seven-inch user interface (TD-7) featuring a touch-sensitive color screen that provides facility managers at-a-glance operating status, performance monitoring, scheduling changes, and operating adjustments.

Refer to the Symbio 800 Controller Installation, Operation, and Maintenance manual BAS-SVX080*-EN for Symbio 800 controller specifications.

Features and Benefits

Symbio 800 Standard Features	Benefit
Multiple, open standard protocol support: <ul style="list-style-type: none"> • BACnet MS/TP • BACnet/IP • Modbus RTU • Modbus TCP 	Flexible integration with all common open standard protocols using Trane SC+ or competitive BAS Systems and control.
Common integration strategies and specific equipment points lists	Simplified, lower costs, and uncompromised building integration.
Application specific	Application specific software based on unit model number to reduce project costs and provide superior reliability, comfort, and performance. Ability to upgrade firmware with a simple file transfer.
Smart analytics	Symbio 800 provides data to Trane Intelligence System (TIS) for smart analytics to provide superior reliability through the life of the equipment with minimum downtime.
Data logging	Data log can be used locally or remotely to analyze equipment performance.
Local scheduling	Capable of operating in stand-alone operation without a building automation system as a temporary back-up schedule for ongoing comfort and energy savings.
Reports	Quickly summarizes data for clear understanding and interpretation to enable local monitoring of expected performance and operating efficiency.
Adaptive Control™ algorithms	Pre-empts potential equipment disruptions during rapidly changing conditions – providing consistent equipment performance and building comfort.
SD card backup and restore	Faster, lower cost repairs with reduced downtime.
User security with audit trail support	Flexible and secure access for multiple users allows monitoring, custom report editing, and tracking changes by user.
Multiple language support	Suitable for operation in multiple geographies.



Controls

Symbio 800 Optional Features	Benefits
User interface touch display <ul style="list-style-type: none"> • Display preferences • Intuitive navigation • At-a-glance status • Graphs 	Rugged, seven-inch color touch screen user interface. Easy, touch navigation for viewing data and making operational changes. View dates, times, units (SI, IP), screen brightness, data format, and backlight timeout. Helps operators access data and alarms for quick and accurate response and resolution. Easily readable color display showing key operating parameters of major equipment components. Easily visualize trend data for local troubleshooting and fine-tuning.
Remote Connectivity	Trane Connect™ provides easy, secure option to connect remotely to a Tracer SC+ or directly to user Trane Equipment.
Programmable	Equipment application flexibility and cost-reduced control of nearby equipment.
Expandable I/O	Field or factory installed expansion module for programmable feature. Reduced installation costs and increased installation flexibility.
Wi-Fi Adapter	Enables the operation of wireless service tools for increased technician productivity and Flexibility.

System Control

No System Control

Compressor run request is wired to the terminal strip inside the main control panel. Symbio™ 800 will start compressors based on compressor request once the Interlock has been proven. There is not a prescribed staging sequence. The standard No System Control unit is provided with compressor protections for longer life and reliability.

Supply Air VAV Control

Symbio™ 800 provides dynamic temperature control based on controlling capacity staging to meet the discharge cooling setpoint. The discharge cooling setpoint is adjustable from 40°F to 75°F. The objective is stable discharge air cooling. The discharge temperature sensor ships with the unit for field mounting. The standard Supply Air VAV unit is provided with reliable compressor protections for longer life and reliability.

EVP Control

Symbio™ 800 provides dynamic evaporator leaving water temperature control based on controlling capacity staging to meet the discharge cooling setpoint. The discharge cooling setpoint is adjustable from 10°F to 60°F. The objective is stable leaving water temperature control while minimizing evaporator capacity variation. Control has an adjustable 0-10°F control band using integrated logic and the field installed discharge temperature sensor for chiller freeze protection. The discharge temperature sensor ships with the unit for field mounting. The standard EVP control unit is provided with reliable compressor protections for longer life and reliability.

Discharge Cooling Temperature Control

Cooling Sequence – VAV and EVP

For normal cooling operation, cooling capacity will be staged to meet the calculated discharge cooling setpoint. As the cooling request increases, additional stages will be increased to meet the demand. As the cooling request decreases, compressor operation will be reduced. There are no restrictions concerning time delays other than preventing more than one compressor from turning on at the same time.

If the controller determines that there is a need for compressor staging to meet the calculated discharge cooling setpoint, once interlock proving has been met, the unit will begin to stage compressors accordingly. Compressor staging order is based on unit configuration.

Cooling with Integrated Economizer

The economizer (if available) and mechanical cooling are used to control the discharge air temperature. Only Supply Air VAV units offer Integrated Economizing. The paired air handler will have an outdoor air damper that is manipulated using an actuator.

The outdoor air damper actuator will be wired to a terminal strip in the condenser main control box. The economizer feature will provide 2 to 10 Vdc voltage output from the terminal strip to control the outdoor air damper actuator. The actuator will need to be equipped with feedback to indicate damper position. The capability of cooling using outdoor air is determined by comparing the outdoor air temperature against the Economizer Enable Minimum Outdoor Air Temperature Setpoint.

A call for cooling will modulate the outside air dampers open. The rate of economizer modulation is based on deviation of the discharge air temperature from Economizer Enable Minimum Outdoor Air Temperature Setpoint, that is the further away from setpoint, the faster the outside air damper will open. First stage of mechanical cooling will be allowed to start after the economizer reaches full open.

Note: To meet Title 24 and AHRI requirements, the Economizer must be fully utilized prior to starting mechanical cooling.

If the condenser unit does not include an integrated economizer, mechanical cooling only is used to satisfy cooling requirements.

Discharge Cooling Reset

Discharge Cooling Reset can be used to adjust the Discharge Cooling Setpoint based on outdoor air temperature. Discharge Cooling Reset adjustment is available from the user interface for discharge cooling control.

Outdoor air cooling reset is sometimes used in applications where the outdoor temperature has a large effect on building load. When the outside air temperature is low and the building cooling load is low, the discharge cooling setpoint can be raised, thereby preventing sub-cooling of critical zones. This reset can lower usage of mechanical cooling, thus savings in compressor kW, but an increase in supply fan kW may occur.

Coil Frost Protection

Coil Frost Protection is standard on No System Control and Supply Air VAV Control. Coil Frost Protection reduces the need for hot gas bypass on condensing units. This feature is a circuit level protection that is active when one or more compressors on a circuit are running. Coil Frost Protection has two functions:

- **Coil Frost Limit** — Coil Frost Limit uses the circuit suction saturated temperature to limit loading or unload the circuit capacity to minimize evaporator coil frosting conditions.
- **Frostat™** — Frostat consists of a ship with thermostat for field installation on the suction line. Frostat will deenergize the circuit when the suction line temperature is below 30°F. When the suction line temperature rises above 40°F, the circuit is allowed to reenergize.

Chiller Freeze Protection

Chiller Freeze Protection is standard on EVP Control.

Low Evaporator Water Temperature Protection: The Low Evaporator Water Temperature Protection feature provides evaporator freeze protection based on the discharge water temperature relative to the low water temperature cutout setting. This is a unit level feature where if the discharge temperature falls sufficiently low to risk freezing the unit will shutdown.

Low Refrigerant Temperature Protection: The Low Refrigerant Temperature Protection feature provides protection from cold refrigerant causing localized freezing in stagnant areas of the heat exchanger. This is a circuit level feature where if the suction saturated temperature falls below the low refrigerant temperature cutout setting the circuit will shutdown.

Freezestat™: Freezestat consists of a ship with device that is installed and wired in the remote mounted panel. The device is standard on EVP Control. This is a unit level protection and is active whenever the unit is running. The device has a temperature control switch that opens / closes a set of contacts. The contacts are normally closed and opens as the water temperature falls below the temperature control setpoint.

Hot Gas Bypass

Hot Gas Bypass (HGBP) valves ship with the unit for field installation, when ordered. HGBP is a function that energizes the HGBP solenoid valve and regulates the valve based on the valve's preset pressure setpoint.

The HGBP solenoid valve is controlled via a relay output. To open the valve, control will close the relay which will energize the solenoid. The HGBP solenoid valve is closed when not energized. When the suction pressure is at or above the valve setpoint, the valve remains closed. As suction pressure falls below the valve's adjustable set point, the valve begins to open. The valve will open at a rate proportional to the suction pressure drop, thus maintaining evaporator pressure and preventing coil frost.

Note: Coil Frost Limit and Frostat™ is standard on No System Control and Supply Air VAV units and is recommended in place of hot gas bypass.



Compressor Protections

Compressor Minimum Off Time

For each compressor, when the compressor has been turned OFF for any reason, a timer will be started for that compressor(s). The compressor(s) will not be allowed to be turned back ON until their timer has expired.

Compressor Minimum On Time

Once a compressor has been turned ON a timer will be started for that compressor. The compressor will not be allowed to be turned back OFF until its timer has expired. A normal stop request (Front Panel Stop, normal shutdown diagnostic, or Off mode) will honor the Minimum ON Time and keep the compressor on until the timer expires.

Compressor Interstage Delay

For normal unit operation the timing between stages will be maintained at a minimum of a fixed Interstage Delay time. The compressor control algorithm may request staging to occur beyond three minutes but the time span from one stage turning ON (OFF) until the next compressor stage turning ON(OFF) will be no less than the three-minute Interstage Delay time. Rapid Restart and manual compressor control can override this time.

For No System Control units, the interstage delay will be reduced to 60 seconds, as long as the three- minute off time has been honored

Compressor Lockouts and Inhibits

- **Compressor Lockouts** — Compressor lockouts are typically non-recoverable and require user interaction at the User Interface to clear associated diagnostics that return the compressor(s) to operation.
- **Compressor Inhibits** —Inhibits of compressors are typically recoverable without requiring user interaction. The inhibit of a compressor will be immediate once the request is issued. Inhibits originate from undesirable refrigeration operating conditions and may or may not be associated with a diagnostic event. Once the condition has recovered, the compressor will be un-inhibited and will be available for staging sequences.

Balanced Compressor Starts

For Supply Air VAV and EVP Control, balanced starts are a user-selectable feature through the User Interface available on all units. After each request for compressor operation, the lead refrigeration circuit switches, thereby causing a more equitable or balanced run time among compressors.

Low Ambient Compressor Start Lockout

This function will lock out the compressor if the outdoor air temperature is below the low ambient compressor lock out temperature setpoint. The factory setpoint is 50°F on standard units and 0°F on low ambient units without HGBP and 10°F with HGBP. This setpoint is adjustable at the user interface. Compressors will be locked out when outdoor air temperatures fall below the selected temperature and will be allowed to start again when temperatures rise 5°F above the setpoint.

Low Charge Protection

A refrigerant loss of charge is detected using suction superheat of each circuit. Suction superheat is calculated based on suction temperature and suction saturated temperature. At the touch screen interface, a warning diagnostic is displayed when a low charge has been detected on the circuit but is not critical enough to force a circuit shutdown. When a critical low charge has been detected on the circuit, a circuit shut down is triggered, and a shutdown diagnostic is displayed at the touch screen interface.

Demand Limit

This mode is used to reduce electrical consumption at peak load times. When demand limiting is needed, mechanical cooling operation is either partially or completely disabled to save energy.

Manual Override

Service Manual Override controls provide an override capability of the automatic sequences of valves, dampers, fans, and compressors. Single or multiple, controls may be overridden. All remaining controls set to Auto will enforce the limits to protect the machine from damage. All diagnostics will also be available to protect from machine damage available.

Rapid Restart

The Rapid Restart function is utilized to meet the cooling requirement for applications where the space has a high heat load and requires critical temperature control. This feature is required only for cooling and available on Supply Air VAV and EVP System Control. A typical application is a computer room that has many routers and servers. There will be no assumptions about how long the unit has been OFF so the unit will perform the same startup sequence each occurrence when enabled. The control for Rapid Restart is very aggressive because the loss of cooling capacity, due to a power interruption or extended cooling inhibited time, may cause the space temperature to rise as much as 3 to 4°F per minute.

When power restores normally, or by a backup generator, the cooling capacity must be rapidly restored to help get the space under control. After a Rapid Restart, the unit can subsequently manage the load using normal capacity control.

Condenser Fan Control

Head Pressure Control utilizes a combination of fixed speed condenser fans and an optional low ambient damper on the first fan to control compressor discharge pressure to a desirable level. Discharge pressure, suction pressure and outdoor air temperature are utilized to provide the control. As the condenser fan pressure increases, more stages of fan capacity will be energized to prevent excessively high pressure that could open the high pressure cutout switch. Condenser fan capacity will be decreased to prevent excessively low pressures that could cause low compressor pressure ratio and unstable TXV operation. A unit can have one or two refrigeration circuits. Head pressure control is controlled independently on each circuit.

Low Ambient Damper Control

A single fixed speed fan can provide too much condenser fan capacity during low ambient conditions. A low ambient modulating damper box installed over the stage 1 condenser fan permits operation down to 0°F without hot gas bypass valve and 10°F with hot gas bypass valve by maintaining proper head pressure.

Emergency Stop

Symbio™ 800 shall accept an isolated contact closure input to provide the Emergency Stop Feedback Input function. The contact closure status shall be monitored by a Symbio 800 binary input. Contact closure represents normal operation, and contact opening represents a situation requiring immediate shutdown and lockout of the unit in response to an external event.

Equipment Stop

Symbio™ 800 shall accept an isolated contact closure input suitable for customer connection to request Stop or Auto command modes from a remote device. The contact closure status shall be monitored by a Symbio 800 binary input. Contact closure represents an Auto request, and contact opening represents a Stop request.

Refrigerant Leak Detection Input

Condenser units require a refrigerant leak detector input. The leak sensor will be mounted in the paired air handler unit and hard wired to a terminal strip in the main control panel. Symbio™ 800 shall accept an isolated contact closure input suitable for customer connection to hard wire a leak sensor. The contact closure status shall be monitored by a Symbio 800 binary input. Contact closure represents a unit operation request, and contact opening represents compressor operation disabling.

Remote Setpoint

The remote setpoint input will allow a customer to change the Discharge Cooling Setpoint remotely for Supply Air VAV and EVP Control units. This can be achieved through a 2K potentiometer that is located within the space and wired to the main control box. The setpoint range is 10 to 90°F.

User Interface

A seven-inch user interface features a touch-sensitive color screen that provides operating status, performance monitoring, and scheduling changes, and operating adjustments.



Communication Protocol

BACnet Building Automation Control Network

The BACnet® control network for Symbio™ 800 expands communications from the unit controller network to the Tracer® Ensemble™ or Tracer SC+ building automation system or third party building automation system. Utilizing BACnet, the BAS allows external setpoint and configuration adjustment and monitoring of status and diagnostics. The Symbio 800 utilizes the BACnet defined MS/TP protocol as defined in ASHRAE standard 135-2004. This controller works in standalone mode, with Tracer Ensemble, Tracer SC+ or when connected to a third party building automation system that supports BACnet.

Modbus Building Automation Control Network

The Modbus® control network for Symbio™ 800 expands communications from the unit controller network to the Tracer® Ensemble™ or Tracer SC+ building automation system or third party building automation system. Utilizing Modbus, the BAS allows external setpoint and configuration adjustment and monitoring of status and diagnostics. The Symbio 800 utilizes the Modbus defined RTU/TCP protocol as defined in an ASHRAE standard. This controller works in standalone mode, with Tracer Ensemble, Tracer SC+ or when connected to a third party building automation system that supports Modbus.



Electrical

Note: Local codes may take precedence.

Table 6. IntelliCore electrical data (R-410A)

Unit Size (Ton)	Rated Voltage ^(a)	Condenser Fan Motor ^(b)		CPT Amps	Compressor Motor ^(b)												Unit Characteristics		
		Qty	FLA		RLA				LRA				MCA ^(c)				MOP ^(d)		
					1A	1B	1C	2A	2B	2C	1A	1B	1C	2A	2B	2C			
20	200/60/3	2	4.1	10.0	40.3	40.3	—	—	—	—	—	—	267	267	—	—	—	109	125
	230/60/3	2	4.1	9.0	40.3	40.3	—	—	—	—	—	—	267	267	—	—	—	108	125
	460/60/3	2	1.8	4.5	19.1	19.1	—	—	—	—	—	—	142	142	—	—	—	52	70
25	575/60/3	2	1.4	3.5	15.8	15.8	—	—	—	—	—	—	103	103	—	—	—	42	50
	200/60/3	3	4.1	10.0	40.3	49.5	—	—	—	—	—	—	267	315	—	—	—	125	150
	230/60/3	3	4.1	9.0	40.3	45.6	—	—	—	—	—	—	267	315	—	—	—	119	150
30	460/60/3	3	1.8	4.5	19.1	22.6	—	—	—	—	—	—	142	158	—	—	—	58	70
	575/60/3	3	1.4	3.5	15.8	19.1	—	—	—	—	—	—	103	136	—	—	—	48	60
	200/60/3	3	4.1	10.0	58.1	58.1	—	—	—	—	—	—	345	345	—	—	—	154	200
40	230/60/3	3	4.1	9.0	53.1	53.1	—	—	—	—	—	—	345	345	—	—	—	141	175
	460/60/3	3	1.8	4.5	26.5	26.5	—	—	—	—	—	—	155	155	—	—	—	70	90
	575/60/3	3	1.4	3.5	23.1	23.1	—	—	—	—	—	—	126	126	—	—	—	60	80
50	200/60/3	4	4.1	10.0	40.3	40.3	—	40.3	40.3	40.3	—	—	267	267	—	267	—	198	225
	230/60/3	4	4.1	9.0	40.3	40.3	—	40.3	40.3	40.3	—	—	267	267	—	267	—	197	225
	460/60/3	4	1.8	4.5	19.1	19.1	—	19.1	19.1	19.1	—	—	142	142	—	142	—	93	110
60	575/60/3	4	1.4	3.5	15.8	15.8	—	15.8	15.8	15.8	—	—	103	103	—	103	—	77	90
	200/60/3	6	4.1	10.0	44.8	49.5	—	44.8	49.5	49.5	—	—	304	315	—	304	—	236	250
	230/60/3	6	4.1	9.0	42.3	45.6	—	42.3	45.6	45.6	—	—	304	315	—	304	—	221	250
80	460/60/3	6	1.8	4.5	20.4	22.6	—	20.4	22.6	22.6	—	—	147	158	—	147	—	107	125
	575/60/3	6	1.4	3.5	17.2	19.1	—	17.2	19.1	19.1	—	—	122	136	—	122	—	90	100
	200/60/3	6	4.1	10.0	58.0	58.0	—	58.0	58.0	58.0	—	—	345	345	—	345	—	282	300
60	230/60/3	6	4.1	9.0	53.0	53.0	—	53.0	53.0	53.0	—	—	345	345	—	345	—	259	300
	460/60/3	6	1.8	4.5	26.5	26.5	—	26.5	26.5	26.5	—	—	155	155	—	155	—	128	150
	575/60/3	6	1.4	3.5	23.1	23.1	—	23.1	23.1	23.1	—	—	126	126	—	126	—	111	125
80	200/60/3	8	4.1	10.0	60.0	60.0	60.0	60.0	60.0	60.0	60.0	60.0	320	320	320	320	320	418	450
	230/60/3	8	4.1	9.0	54.8	54.8	54.8	54.8	54.8	54.8	54.8	54.8	320	320	320	320	320	385	400
	460/60/3	8	1.8	4.5	26.7	26.7	26.7	26.7	26.7	26.7	26.7	26.7	160	160	160	160	160	186	200
80	575/60/3	8	1.4	3.5	21.4	21.4	21.4	21.4	21.4	21.4	21.4	21.4	135	135	135	135	135	149	150

Table 6. IntelliCore electrical data (R-410A) (continued)

Unit Size (Ton)	Rated Voltage ^(a)	Condenser Fan Motor ^(b)		CPT Amps	Compressor Motor ^(b)												Unit Characteristics		
		Qty	FLA		RLA						LRA						MCA ^(c)	MOP ^(d)	
					1A	1B	1C	2A	2B	2C	1A	1B	1C	2A	2B	2C			
100	230/60/3	12	4.1	9.0	55.5	55.5	72.5	55.5	55.5	72.5	55.5	320	320	485	320	320	485	444	500
	460/60/3	12	1.8	4.5	27.8	27.8	36.3	27.8	27.8	36.3	27.8	160	160	215	160	160	215	219	250
	575/60/3	12	1.4	3.5	22.2	22.2	29.0	22.2	22.2	29.0	22.2	135	135	175	135	135	175	175	200
120	460/60/3	12	1.8	4.5	36.3	36.3	36.3	36.3	36.3	36.3	36.3	215	215	215	215	215	215	253	300
	575/60/3	12	1.4	3.5	29.0	29.0	29.0	29.0	29.0	29.0	29.0	175	175	175	175	175	175	202	225

^(a) Voltage Utilization Range is +/- 10% of Rated voltage (use range): 200/60/3 (180-220), 230/60/3 (207-253), 460/60/3 (414-506), 575/60/3 (517-633)

^(b) Electrical information is for each individual motor.

^(c) Minimum circuit ampacity (MCA) is 125 percent of the RLA of the largest compressor motor plus the total RLA/FLA of the remaining motors and CPT amps.

^(d) Maximum Overcurrent Protection Device permitted by NEC 440-22 is 225 percent of the RLA of the largest compressor motor plus the total RLA/FLA of the remaining motors and CPT amps.

Table 7. IntelliCore electrical data (R-454B)

Unit Size (Ton)	Rated Voltage ^(a)	Condenser Fan Motor ^(b)		CPT Amps	Compressor Motor ^(b)												Unit Characteristics			
		Qty	FLA		RLA				LRA				MCA ^(c)	MOP ^(d)						
					1A	1B	1C	2A	2B	2C	1A	1B			1C	2A	2B	2C		
20	200/60/3	2	4.1	49.6	34.7	—	—	—	—	—	—	—	336	255	—	—	—	115	150	
	230/60/3	2	4.1	47.3	30.1	—	—	—	—	—	—	—	336	255	—	—	—	107	150	
	460/60/3	2	1.8	21.6	15.1	—	—	—	—	—	—	—	141	123	—	—	—	51	70	
	575/60/3	2	1.4	17.2	12.1	—	—	—	—	—	—	—	109	94	—	—	—	40	50	
25	200/60/3	3	4.1	62.1	40.1	—	—	—	—	—	—	—	386	255	—	—	—	141	200	
	230/60/3	3	4.1	54.0	34.9	—	—	—	—	—	—	—	386	255	—	—	—	124	175	
	460/60/3	3	1.8	27.0	17.4	—	—	—	—	—	—	—	182	140	—	—	—	62	80	
	575/60/3	3	1.4	21.6	14.0	—	—	—	—	—	—	—	131	108	—	—	—	49	70	
30	200/60/3	3	4.1	32.3	46.0	46.0	—	—	—	—	—	—	203	304	304	—	—	159	200	
	230/60/3	3	4.1	29.5	42.3	42.3	—	—	—	—	—	—	203	304	304	—	—	146	175	
	460/60/3	3	1.8	14.7	21.8	21.8	—	—	—	—	—	—	98	147	147	—	—	74	90	
	575/60/3	3	1.4	11.9	17.2	17.2	—	—	—	—	—	—	84	122	122	—	—	59	70	
40	200/60/3	4	4.1	40.5	46.0	—	40.5	46.0	—	—	—	—	267	304	—	267	304	211	250	
	230/60/3	4	4.1	40.3	42.3	—	40.3	42.3	—	—	—	—	267	304	—	267	304	202	225	
	460/60/3	4	1.8	19.1	21.8	—	19.1	21.8	—	—	—	—	142	147	—	142	147	99	110	
	575/60/3	4	1.4	15.8	17.2	—	15.8	17.2	—	—	—	—	103	122	—	103	122	80	90	
50	200/60/3	6	4.1	46.0	47.4	—	46.0	47.4	—	—	—	—	304	315	—	304	315	234	250	
	230/60/3	6	4.1	42.3	45.6	—	42.3	45.6	—	—	—	—	304	315	—	304	315	221	250	
	460/60/3	6	1.8	21.8	21.8	—	21.8	21.8	—	—	—	—	147	158	—	147	158	108	125	
	575/60/3	6	1.4	17.2	19.1	—	17.2	19.1	—	—	—	—	122	136	—	122	136	90	100	
60	200/60/3	6	4.1	62.4	62.4	—	62.4	62.4	—	—	—	—	337	337	—	337	337	300	350	
	230/60/3	6	4.1	56.9	56.9	—	56.9	56.9	—	—	—	—	337	337	—	337	337	276	300	
	460/60/3	6	1.8	28.5	28.5	—	28.5	28.5	—	—	—	—	155	155	—	155	155	137	150	
	575/60/3	6	1.4	23.1	23.1	—	23.1	23.1	—	—	—	—	126	126	—	126	126	111	125	
80	200/60/3	8	4.1	52.2	52.2	52.2	52.2	52.2	52.2	52.2	52.2	52.2	308	308	308	308	308	370	400	
	230/60/3	8	4.1	51.5	51.5	51.5	51.5	51.5	51.5	51.5	51.5	51.5	308	308	308	308	308	364	400	
	460/60/3	8	1.8	25.3	25.3	25.3	25.3	25.3	25.3	25.3	25.3	25.3	160	160	160	160	160	178	200	
	575/60/3	8	1.4	20.3	20.3	20.3	20.3	20.3	20.3	20.3	20.3	20.3	135	135	135	135	135	142	150	
100	200/60/3	12	4.1	52.2	52.2	81.2	52.2	52.2	81.2	52.2	52.2	81.2	308	308	528	308	308	528	451	500
	230/60/3	12	4.1	51.5	51.5	70.6	51.5	51.5	70.6	51.5	51.5	70.6	308	308	528	308	308	528	424	450
	460/60/3	12	1.8	25.3	25.3	35.6	25.3	25.3	35.6	25.3	25.3	35.6	160	160	215	160	160	208	225	
	575/60/3	12	1.4	20.3	20.3	28.5	20.3	20.3	28.5	20.3	20.3	28.5	135	135	175	135	135	166	175	
120	460/60/3	12	1.8	35.6	35.6	35.6	35.6	35.6	35.6	35.6	35.6	35.6	215	215	215	215	215	249	250	
	575/60/3	12	1.4	28.5	28.5	28.5	28.5	28.5	28.5	28.5	28.5	28.5	175	175	175	175	175	199	225	

(a) Voltage Utilization Range is +/- 10% of Rated voltage (use range): 200/60/3 (180-220), 230/60/3 (207-253), 460/60/3 (414-506), 575/60/3 (517-633)
 (b) Electrical information is for each individual motor.
 (c) Minimum circuit ampacity (MCA) is 125 percent of the RLA of the largest compressor motor plus the total RLA/FLA of the remaining motors and CPT amps.
 (d) Maximum Overcurrent Protection Device permitted by NEC 440-22 is 225 percent of the RLA of the largest compressor motor plus the total RLA/FLA of the remaining motors and CPT amps.

Unit Dimensions

Figure 43. Air-cooled condensing unit — 20 ton

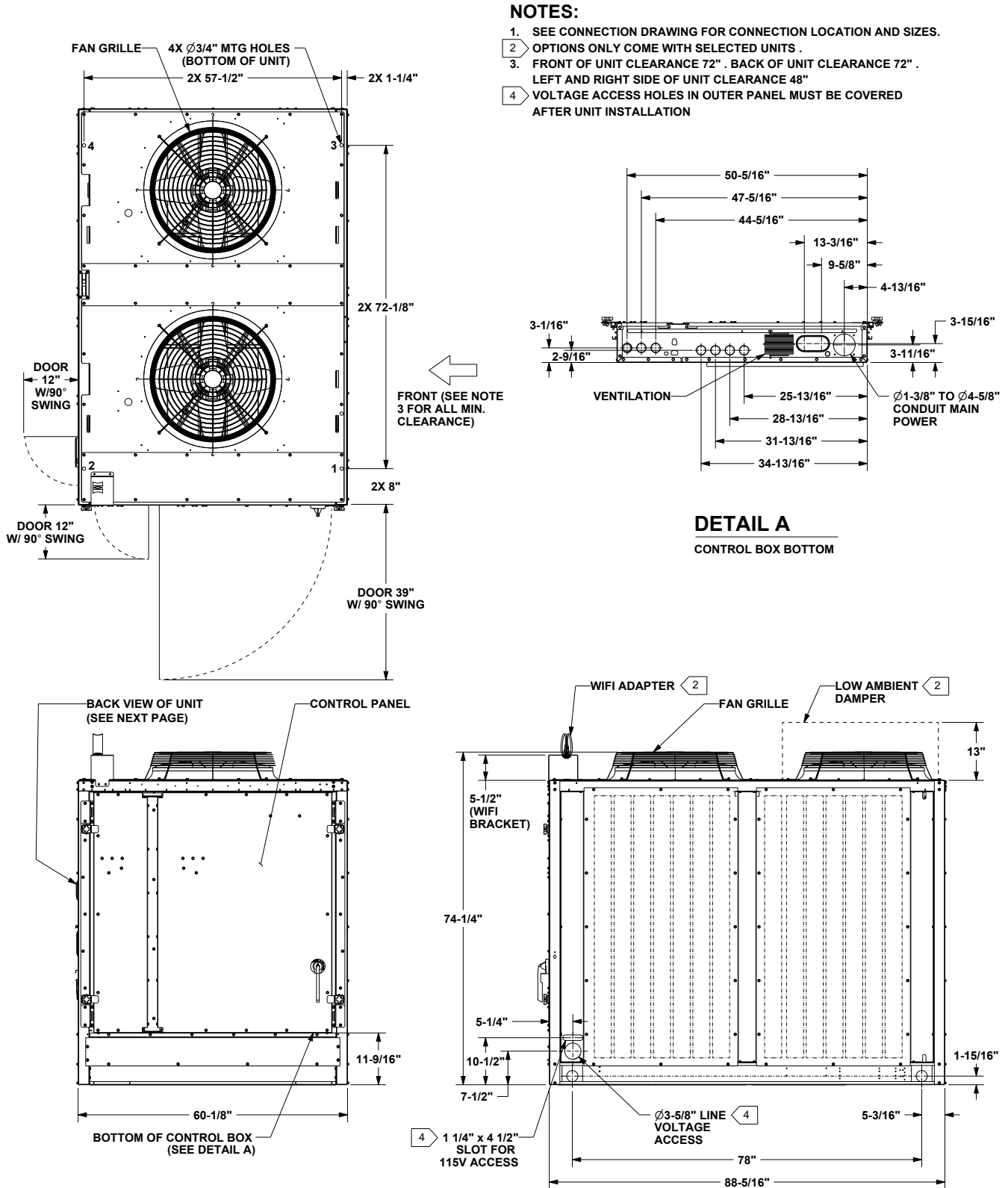
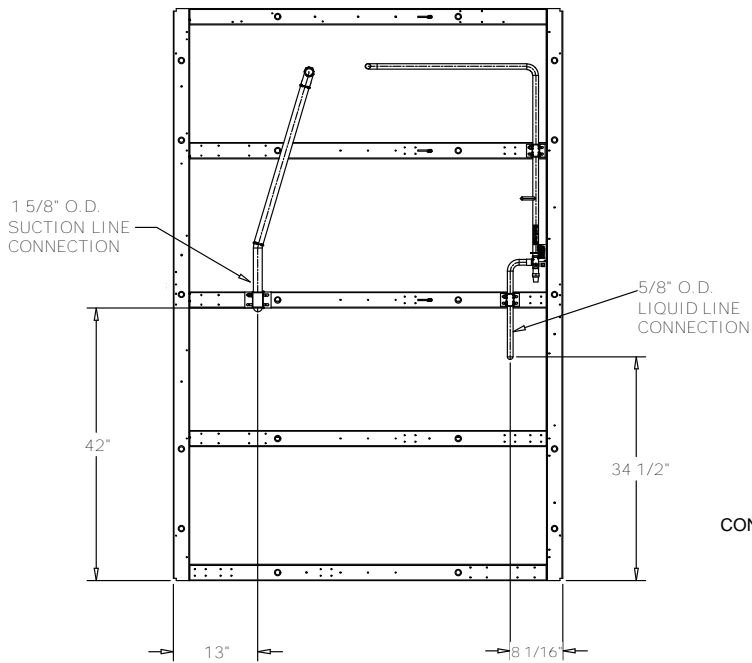

Figure 44. Air-cooled condensing unit connections — 20 ton (R-410A)

CONTROL PANEL SIDE



PLAN VIEW OF UNIT
CONNECTION DRAWING

NOTES:
1. VERIFY WEIGHT, CONNECTION, AND ALL DIMENSION WITH INSTALLER DOCUMENTS BEFORE INSTALLATION

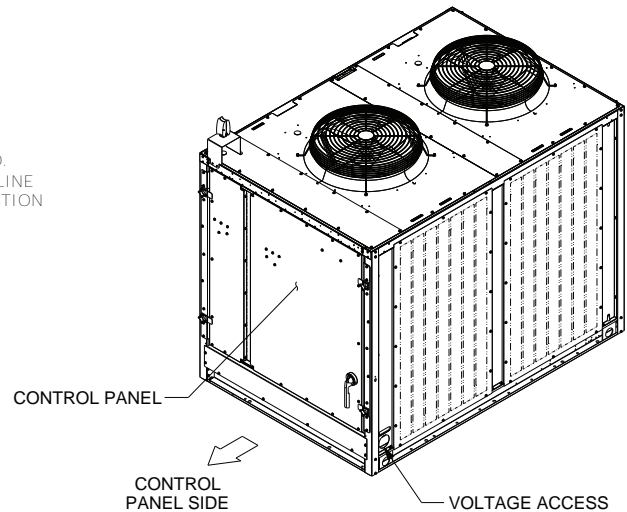

ORIENTATION VIEW OF UNIT
ISOMETRIC DRAWING

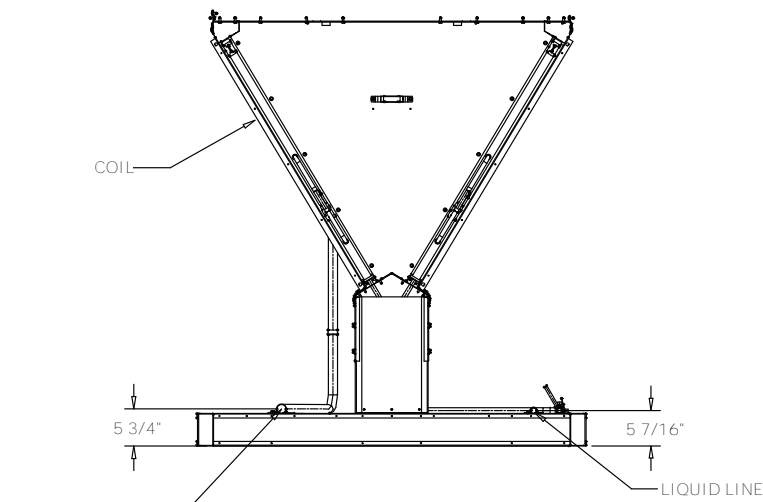

CONTROL PANEL SIDE VIEW OF UNIT
CONNECTION DRAWING

20 TON UNIT

DIMENSIONAL CONNECTION DRAWING



Unit Dimensions

Figure 45. Air-cooled condensing unit connections — 20 ton (R-454B)

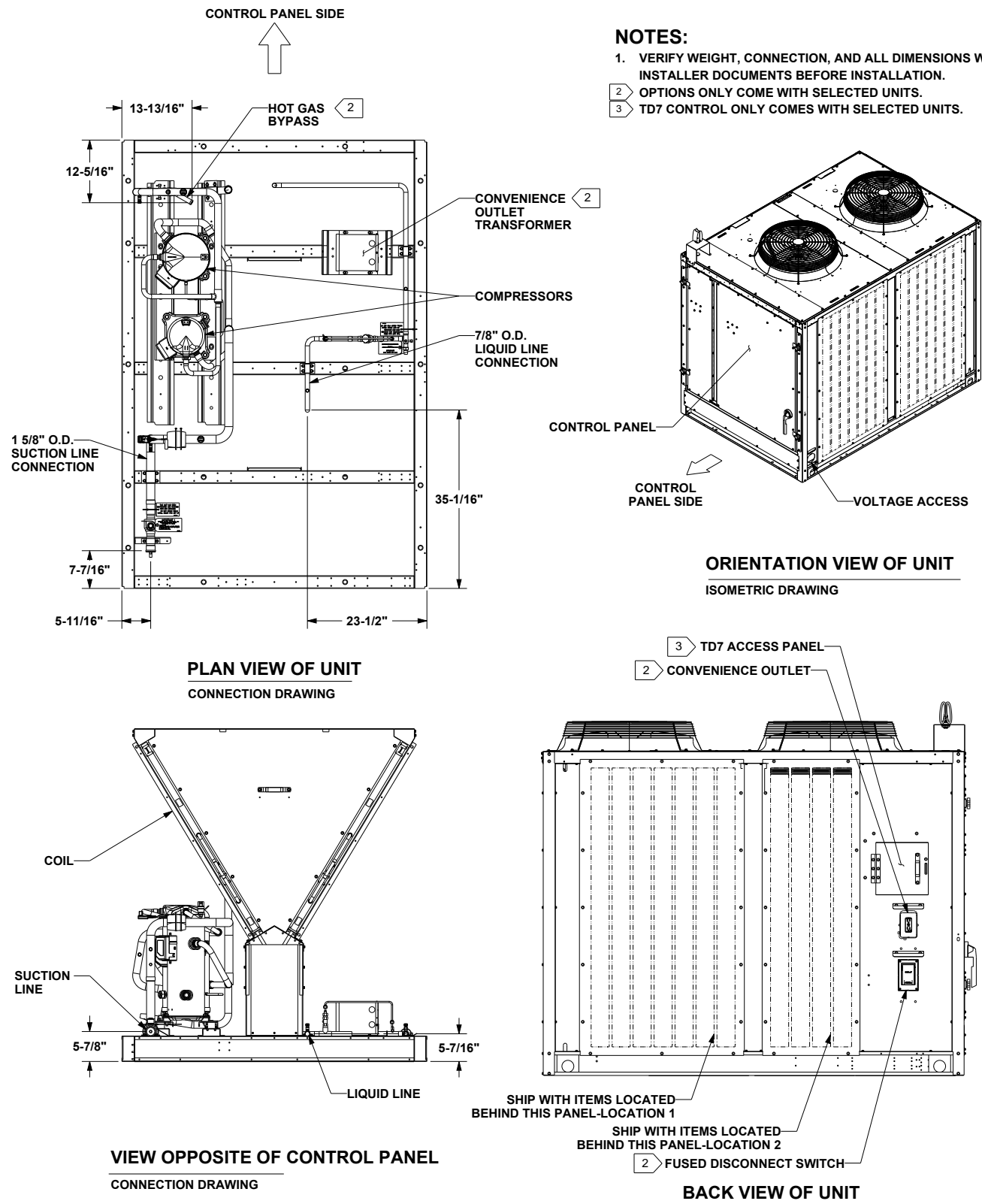

- NOTES:**
1. VERIFY WEIGHT, CONNECTION, AND ALL DIMENSIONS WITH INSTALLER DOCUMENTS BEFORE INSTALLATION.
 2. OPTIONS ONLY COME WITH SELECTED UNITS.
 3. TD7 CONTROL ONLY COMES WITH SELECTED UNITS.

20 TON UNIT

DIMENSION CONNECTION DRAWING

Figure 46. Air-cooled condensing unit — 25 and 30 tons

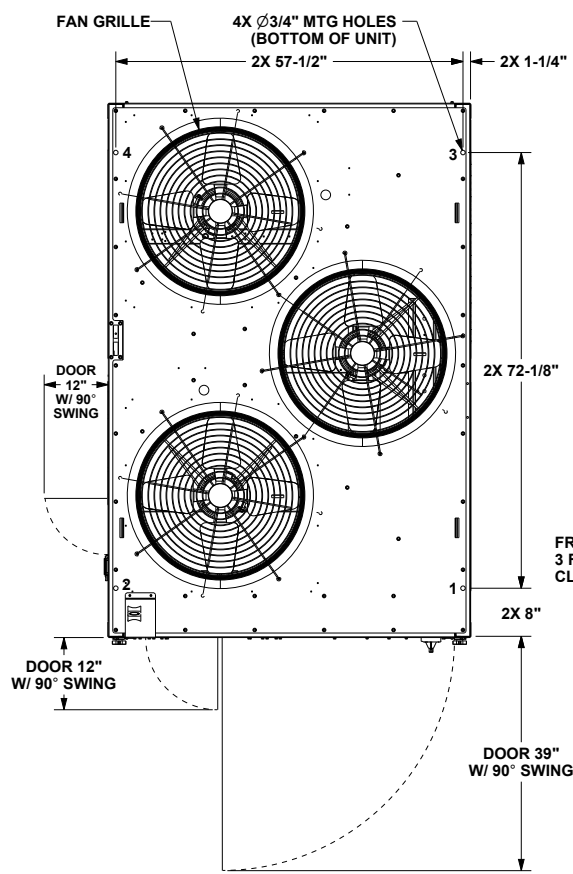

NOTES:

1. SEE CONNECTION DRAWING FOR CONNECTION LOCATION AND SIZES.
2. OPTIONS ONLY COME WITH SELECTED UNITS .
3. FRONT OF 25T AND 30T UNIT CLEARANCE 72" . BACK OF UNIT CLEARANCE 72" . LEFT AND RIGHT SIDE OF 25T AND 30T UNIT CLEARANCE 48"
4. VOLTAGE ACCESS HOLES IN OUTER PANEL MUST BE COVERED AFTER UNIT INSTALLATION

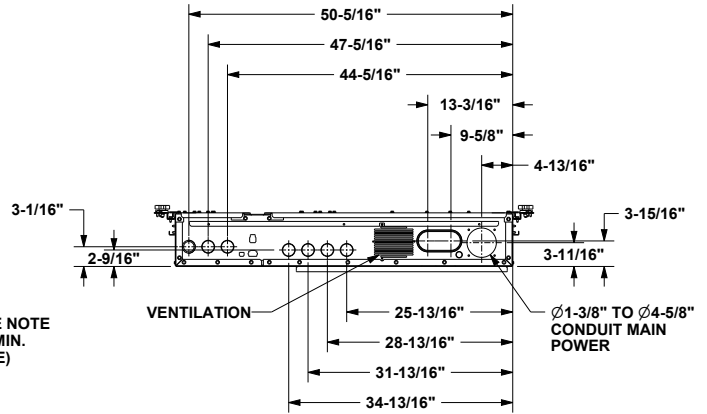

DETAIL A

CONTROL BOX BOTTOM

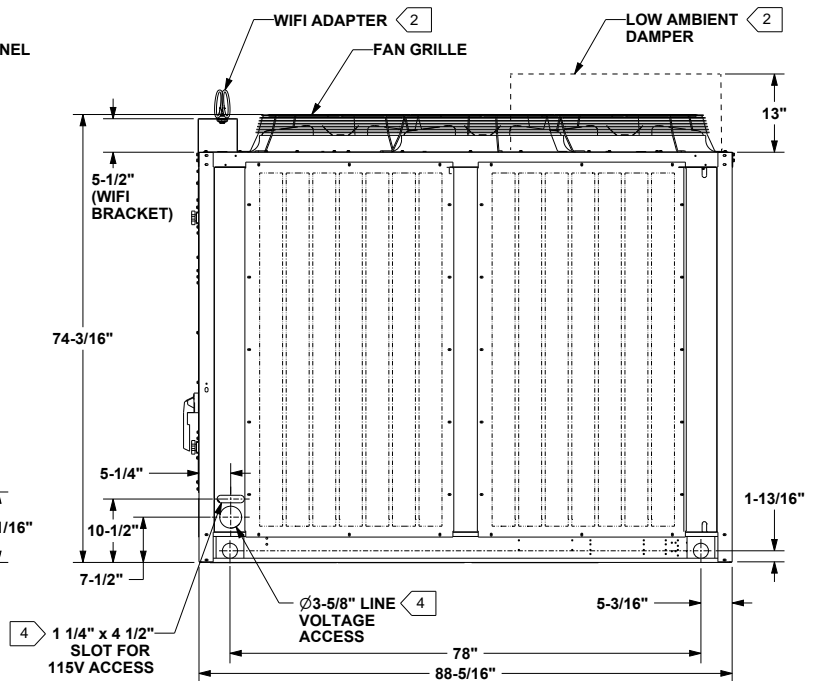
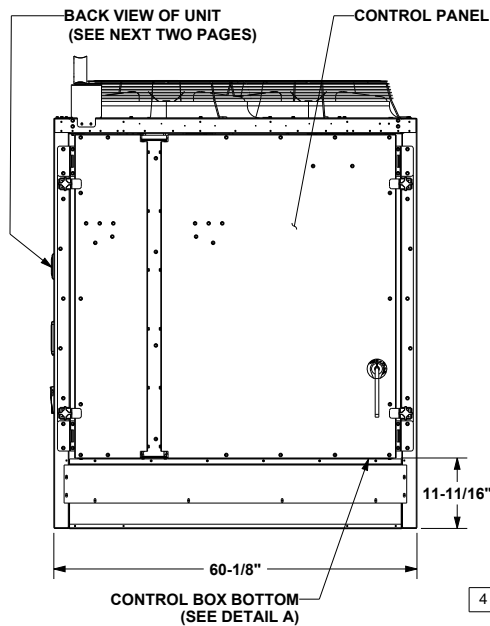



Unit Dimensions

Figure 47. Air-cooled condensing unit connections — 25 and 30 tons (R-410A)

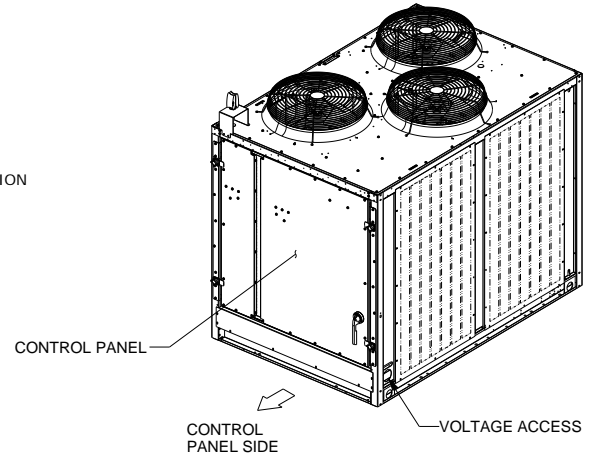
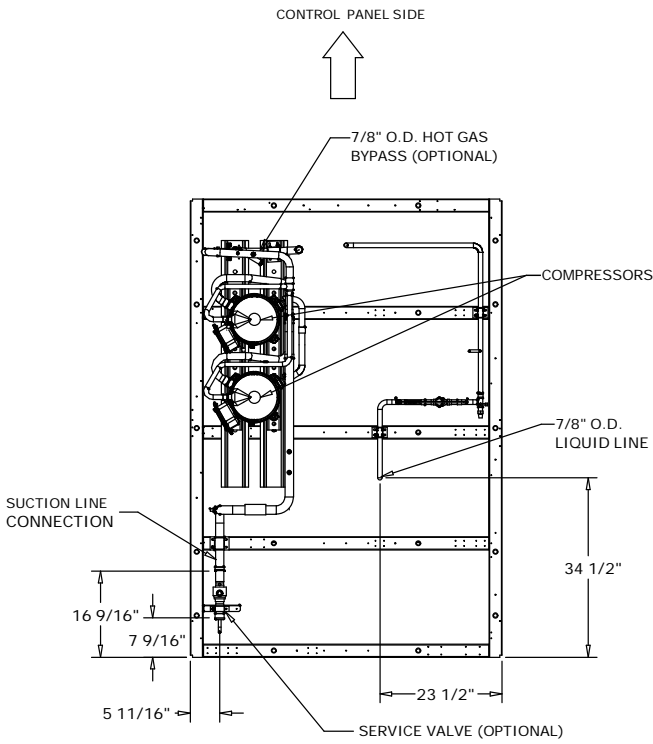

PLAN VIEW OF UNIT
CONNECTION DRAWING

ORIENTATION VIEW OF UNIT
ISOMETRIC DRAWING

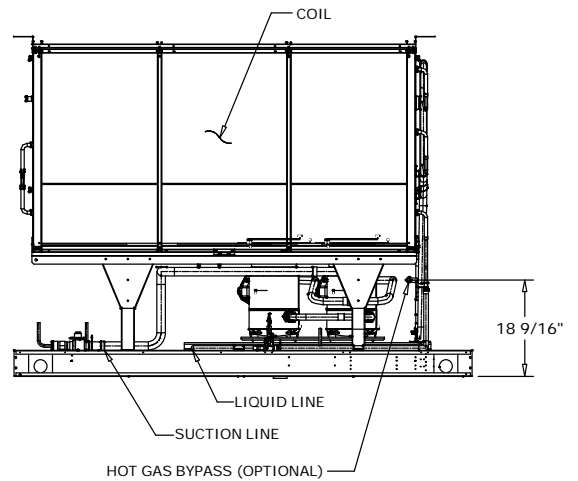
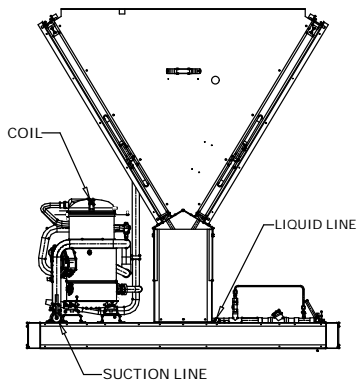

CONTROL PANEL SIDE VIEW OF UNIT
CONNECTION DRAWING

BACK VIEW OF UNIT
CONNECTION DRAWING

Figure 48. Air-cooled condensing unit connections — 25 tons (R-454B)

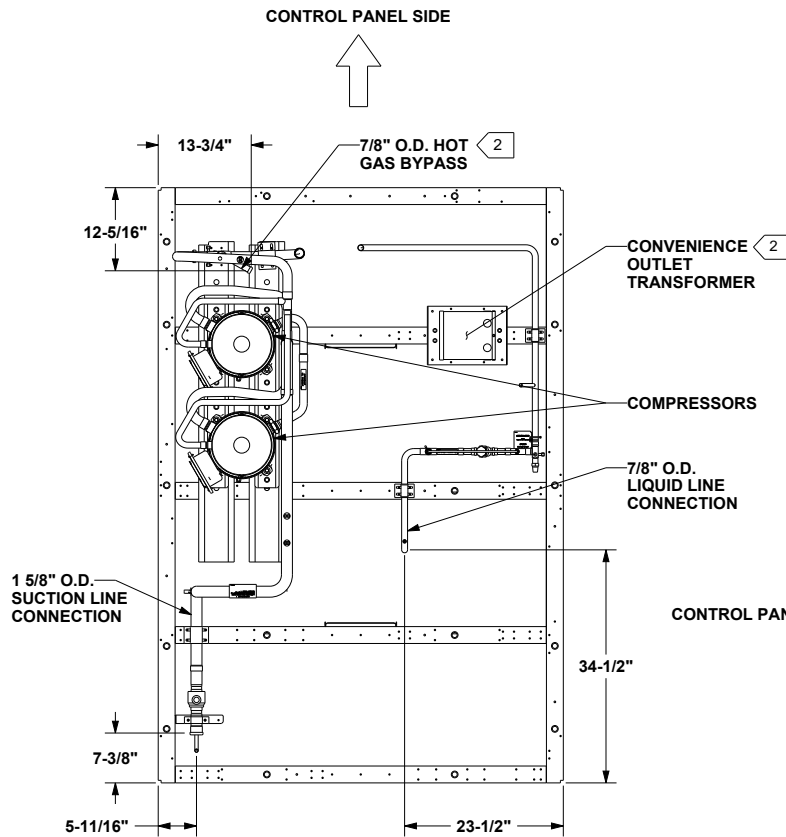

PLAN VIEW OF UNIT
CONNECTION DRAWING

NOTES:

1. VERIFY WEIGHT, CONNECTION, AND ALL DIMENSIONS WITH INSTALLER DOCUMENTS BEFORE INSTALLATION.
2. OPTIONS ONLY COME WITH SELECTED UNITS.
3. TD7 CONTROL ONLY COMES WITH SELECTED UNITS.

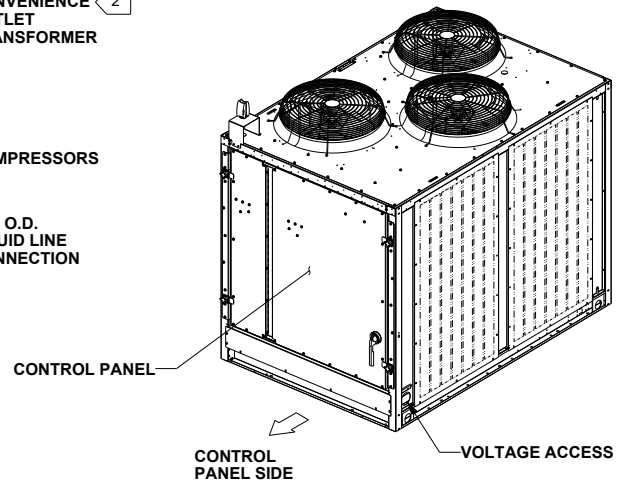

ORIENTATION VIEW OF UNIT
ISOMETRIC DRAWING

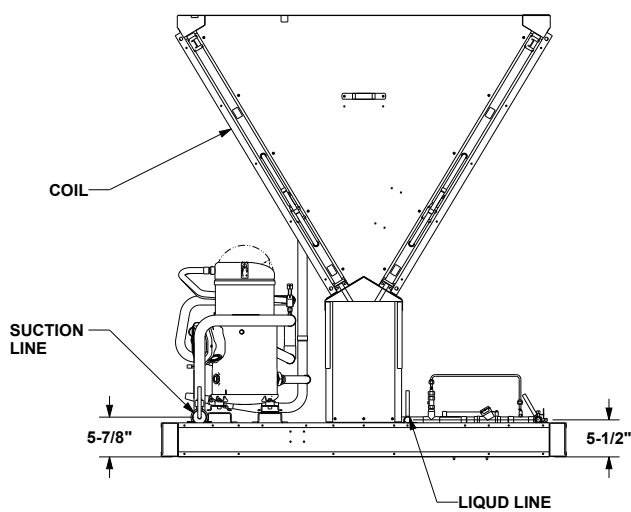

VIEW OPPOSITE OF CONTROL PANEL
CONNECTION DRAWING

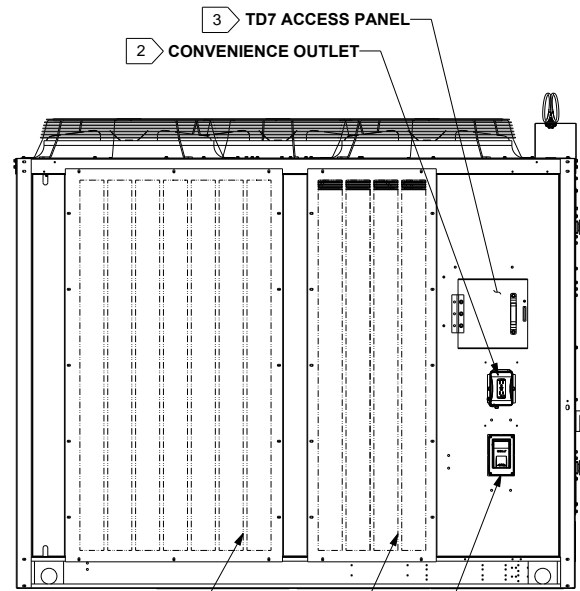

BACK VIEW OF UNIT

25 TON UNIT

DIMENSION CONNECTION DRAWING



Unit Dimensions

Figure 49. Air-cooled condensing unit connections — 30 tons (R-454B)

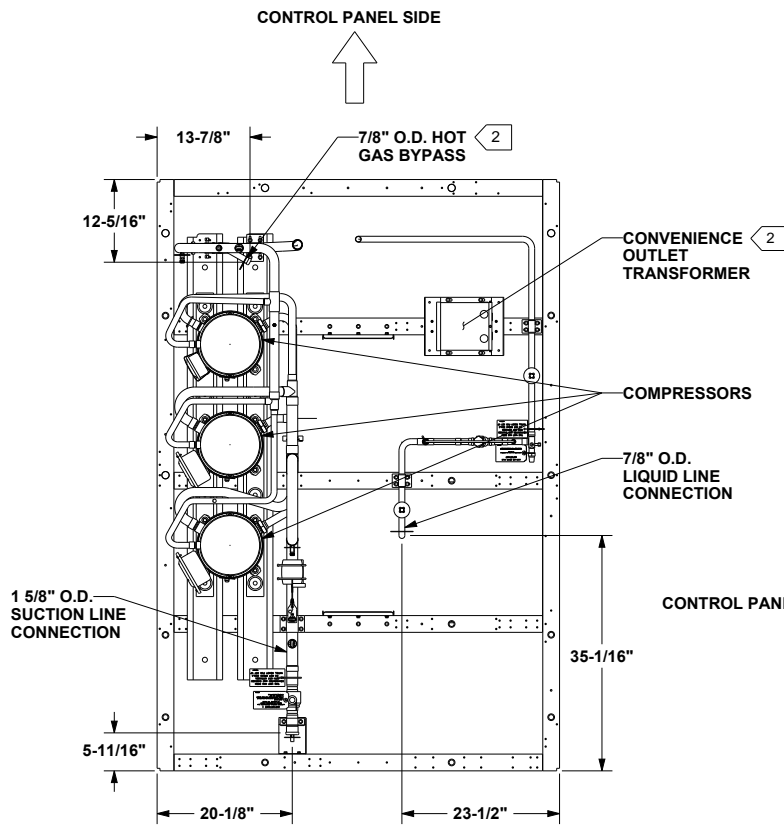

PLAN VIEW OF UNIT
CONNECTION DRAWING

NOTES:

1. VERIFY WEIGHT, CONNECTION, AND ALL DIMENSIONS WITH INSTALLER DOCUMENTS BEFORE INSTALLATION.
2. OPTIONS ONLY COME WITH SELECTED UNITS.
3. TD7 CONTROL ONLY COMES WITH SELECTED UNITS.

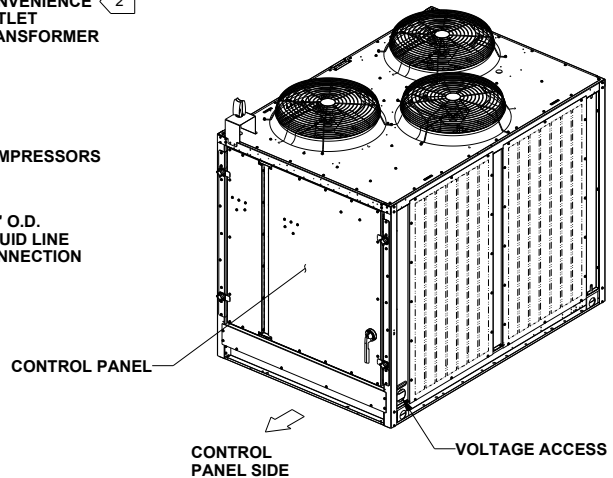

ORIENTATION VIEW OF UNIT
ISOMETRIC DRAWING

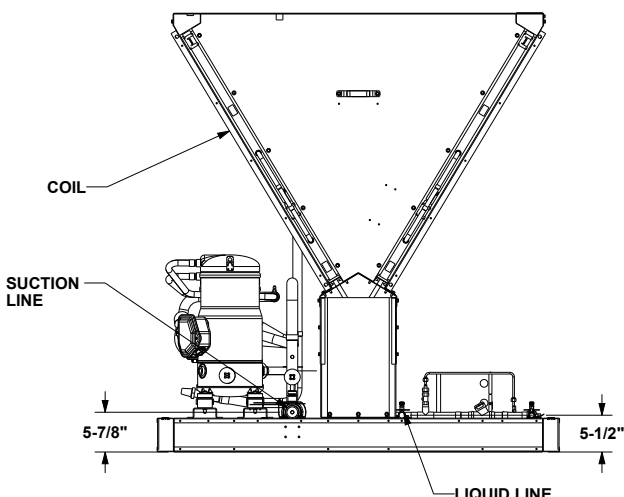

VIEW OPPOSITE OF CONTROL PANEL
CONNECTION DRAWING

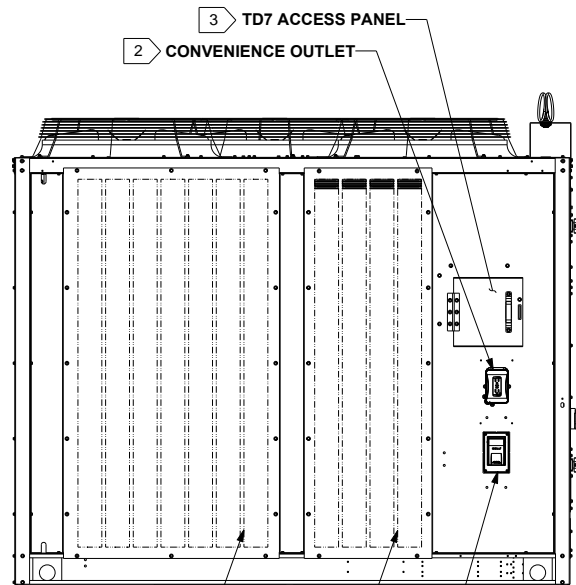

BACK VIEW OF UNIT

30 TON UNIT
DIMENSION CONNECTION DRAWING

Figure 50. Air-cooled condensing unit — 40 ton

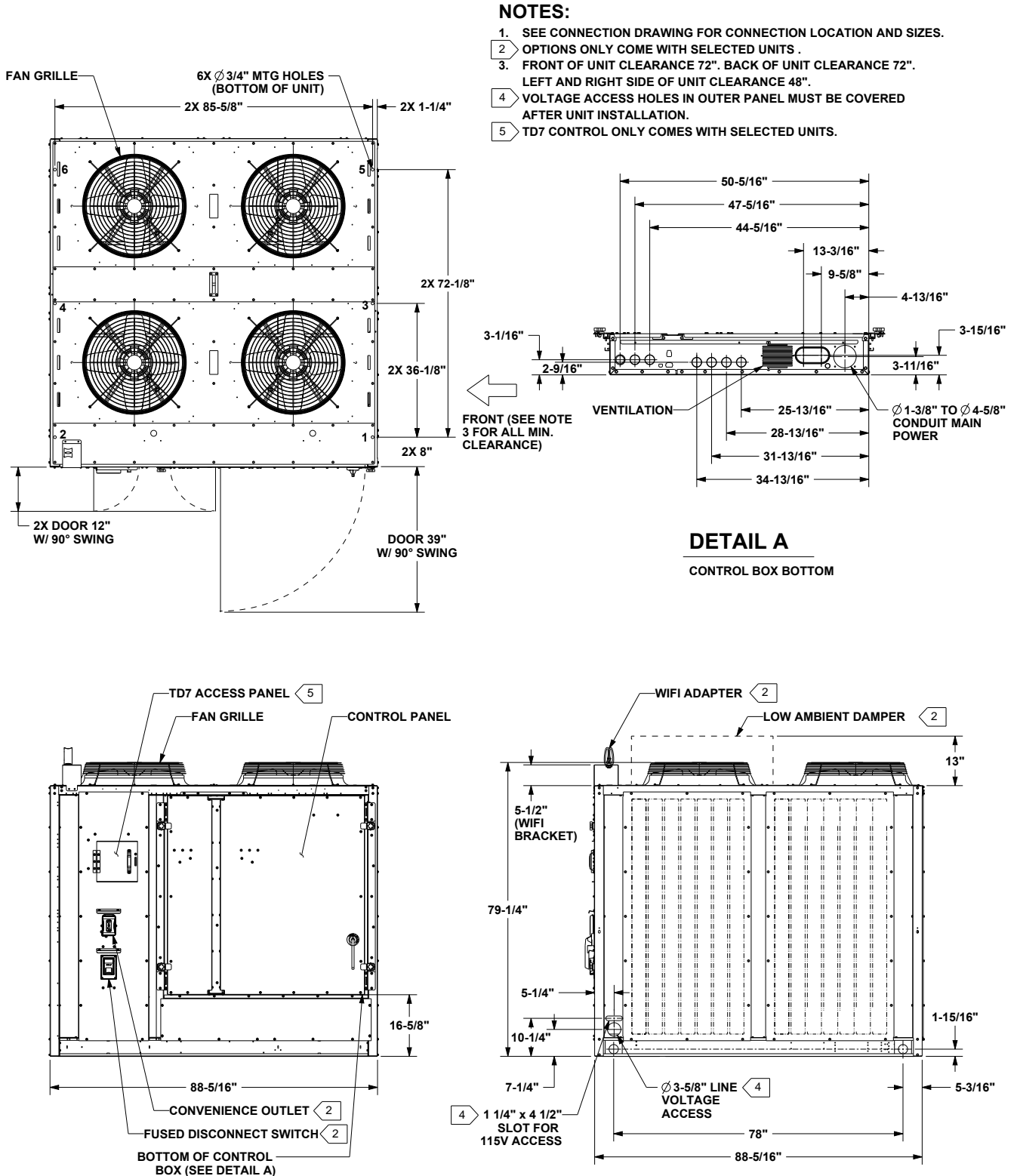



Unit Dimensions

Figure 51. Air-cooled condensing unit connections — 40 ton

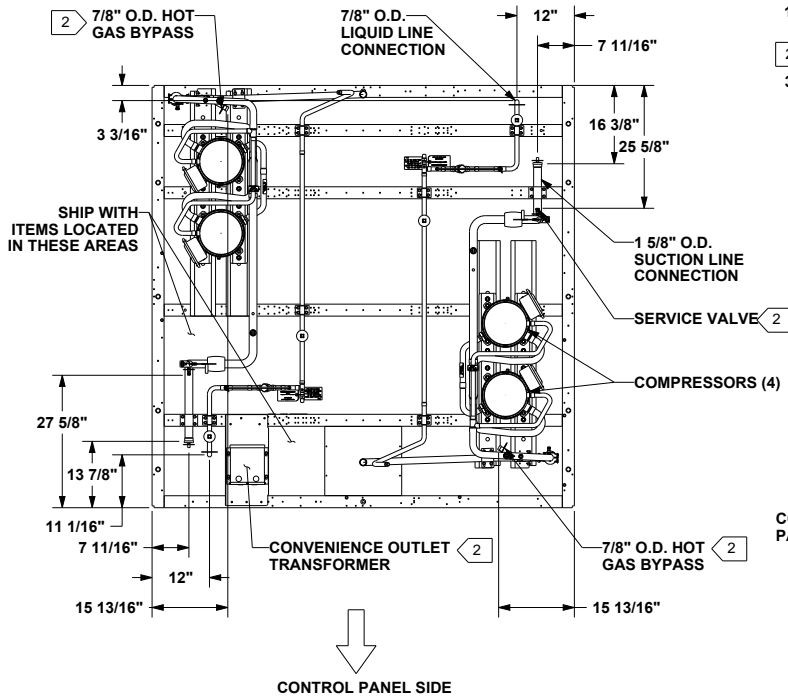

CONTROL PANEL SIDE
PLAN VIEW OF UNIT
 CONNECTION DRAWING

- NOTES:**
1. VERIFY WEIGHT, CONNECTION, AND ALL DIMENSIONS WITH INSTALLER DOCUMENTS BEFORE INSTALLATION.
 2. OPTIONS ONLY COME WITH SELECTED UNITS.
 3. DUAL CIRCUIT UNIT REQUIRES TWO SEPARATE LINE SETS (TWO SUCTION LINES AND TWO LIQUID LINES).

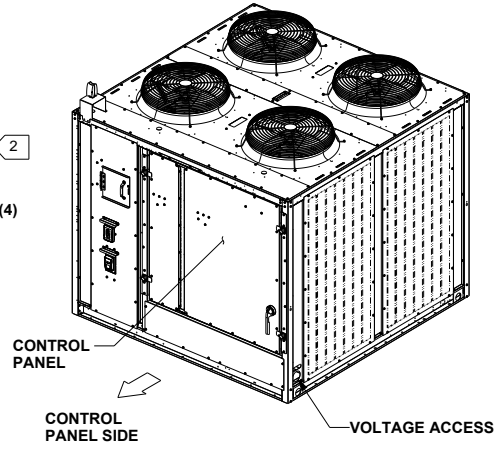

ORIENTATION VIEW OF UNIT
 ISOMETRIC DRAWING

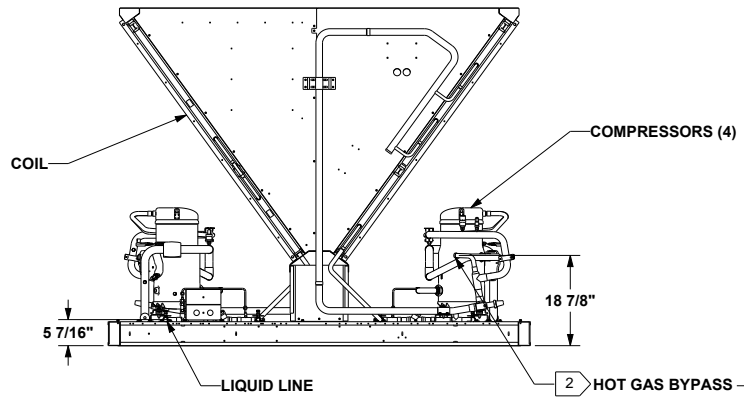

CONTROL PANEL SIDE VIEW OF UNIT
 CONNECTION DRAWING

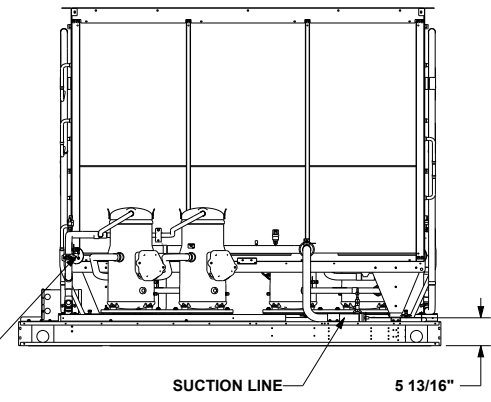

FRONT OF UNIT
 CONNECTION DRAWING

40 TON UNIT
 DIMENSION CONNECTION DRAWING

Figure 52. Air-cooled condensing unit — 50 ton

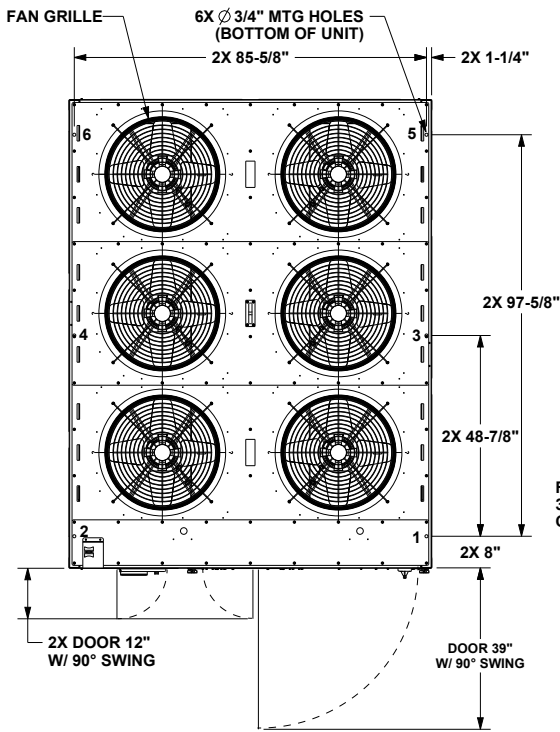

NOTES:

1. SEE CONNECTION DRAWING FOR CONNECTION LOCATION AND SIZES.
2. OPTIONS ONLY COME WITH SELECTED UNITS.
3. FRONT OF UNIT CLEARANCE 72". BACK OF UNIT CLEARANCE 72". LEFT AND RIGHT SIDE OF UNIT CLEARANCE 48".
4. VOLTAGE ACCESS HOLES IN OUTER PANEL MUST BE COVERED AFTER UNIT INSTALLATION.
5. TD7 CONTROL ONLY COMES WITH SELECTED UNITS.

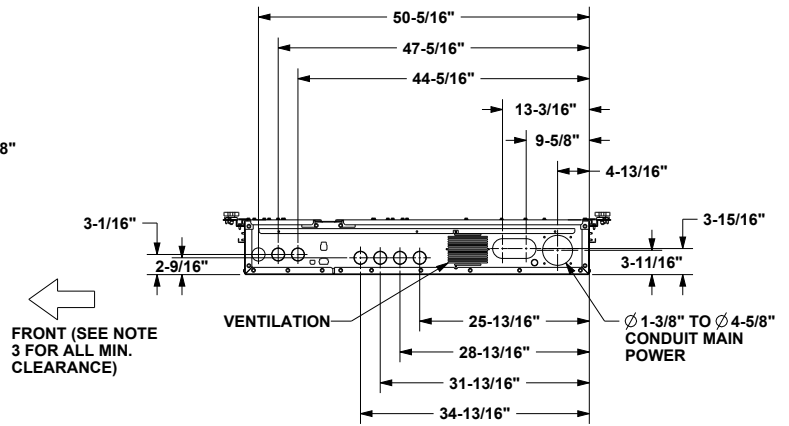

DETAIL A

CONTROL BOX BOTTOM

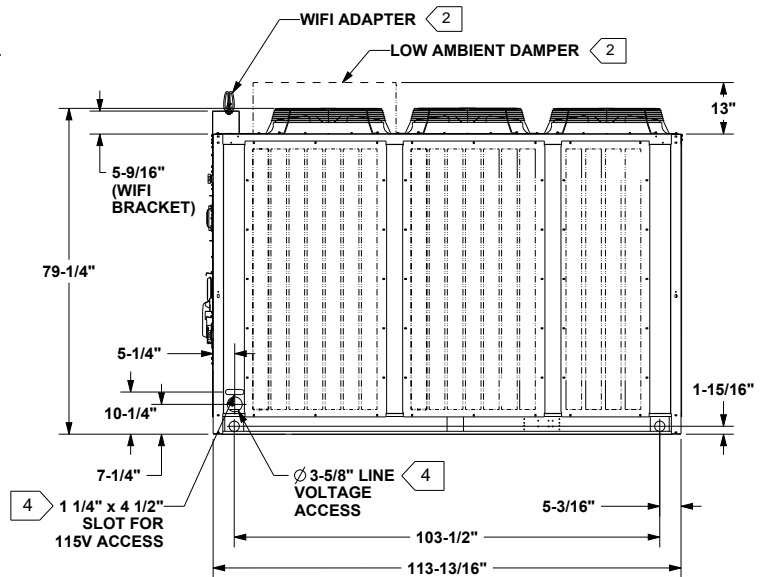
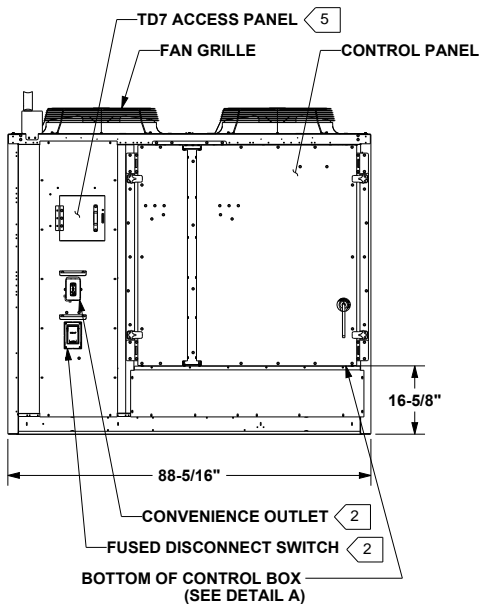



Unit Dimensions

Figure 53. Air-cooled condensing unit connections — 50 ton

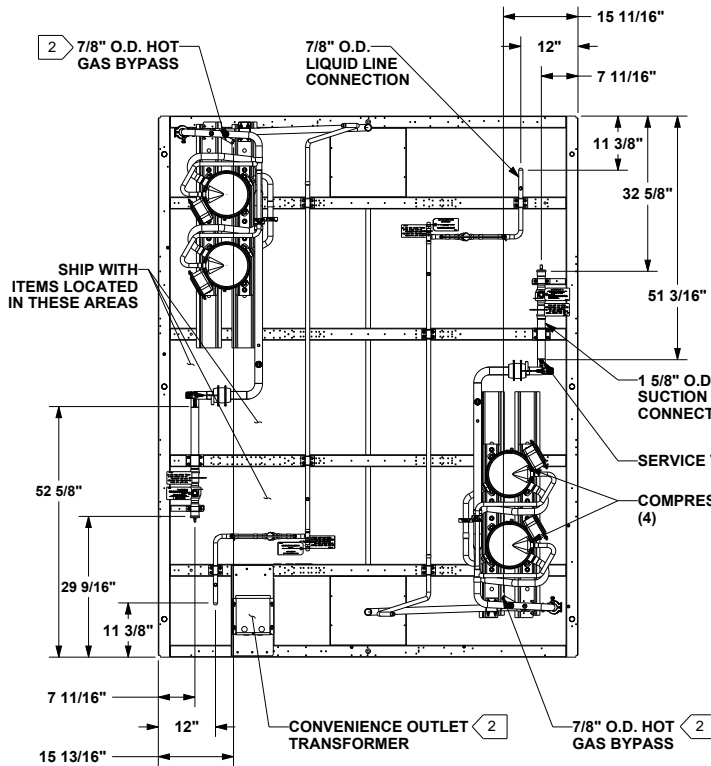

NOTES:

1. VERIFY WEIGHT, CONNECTION, AND ALL DIMENSIONS WITH INSTALLER DOCUMENTS BEFORE INSTALLATION.
2. OPTIONS ONLY COME WITH SELECTED UNITS.
3. DUAL CIRCUIT UNIT REQUIRES TWO SEPARATE LINE SETS (TWO SUCTION LINES AND TWO LIQUID LINES).

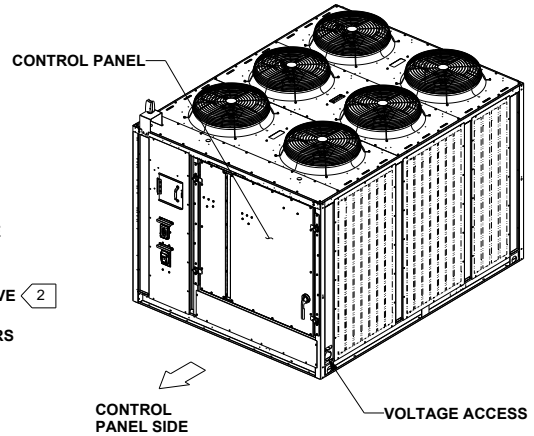

CONTROL PANEL SIDE

PLAN VIEW OF UNIT
CONNECTION DRAWING

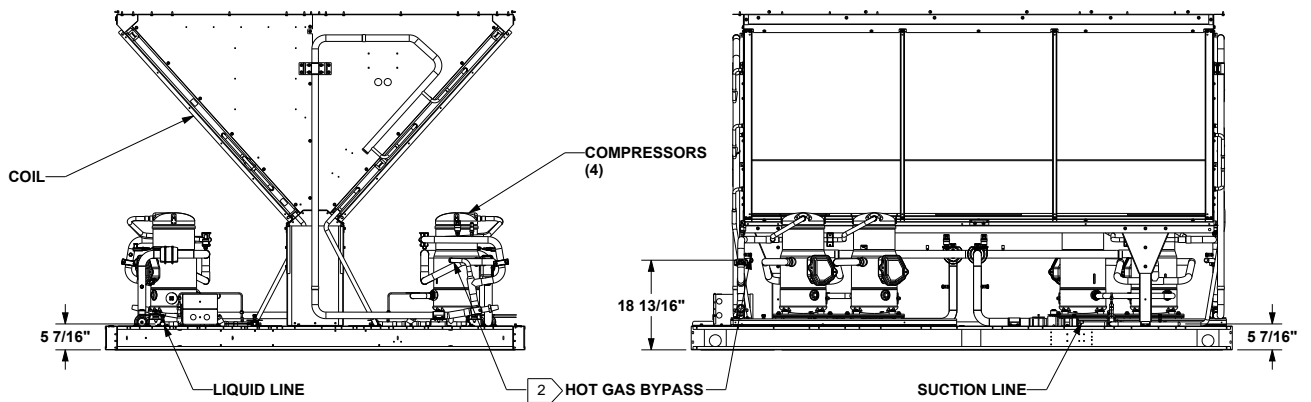

50 TON UNIT

DIMENSION CONNECTION DRAWING

Figure 54. Air-cooled condensing unit — 60 ton

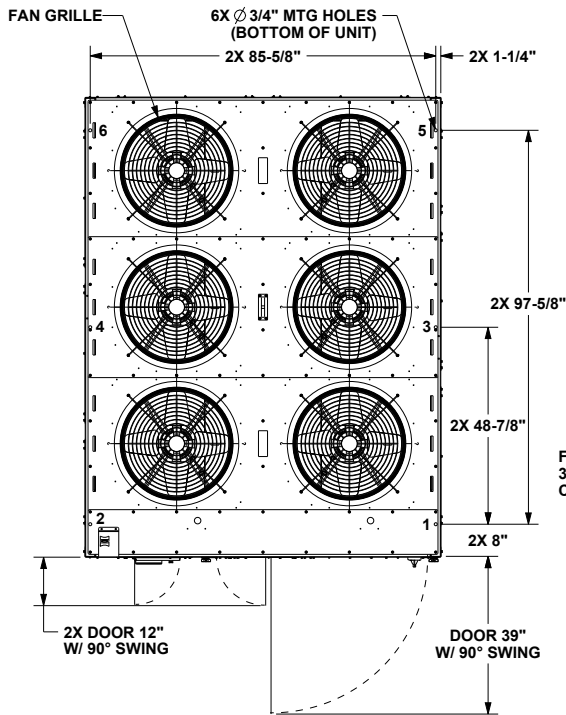

NOTES:

1. SEE CONNECTION DRAWING FOR CONNECTION LOCATION AND SIZES.
2. OPTIONS ONLY COME WITH SELECTED UNITS.
3. FRONT OF UNIT CLEARANCE 72". BACK OF UNIT CLEARANCE 72". LEFT AND RIGHT SIDE OF UNIT CLEARANCE 48".
4. VOLTAGE ACCESS HOLES IN OUTER PANEL MUST BE COVERED AFTER UNIT INSTALLATION.
5. TD7 CONTROL ONLY COMES WITH SELECTED UNITS.

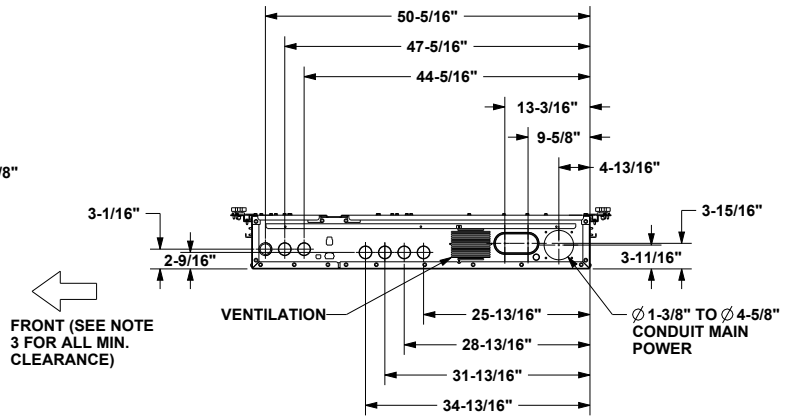

DETAIL A

CONTROL BOX BOTTOM

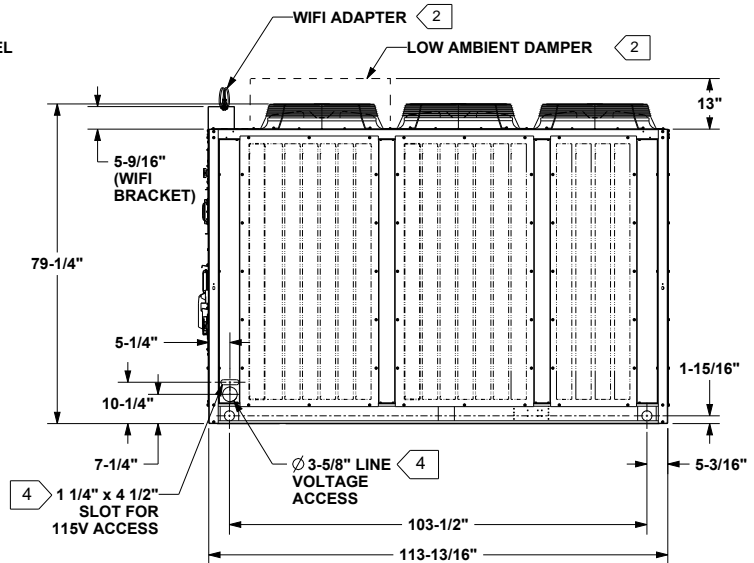
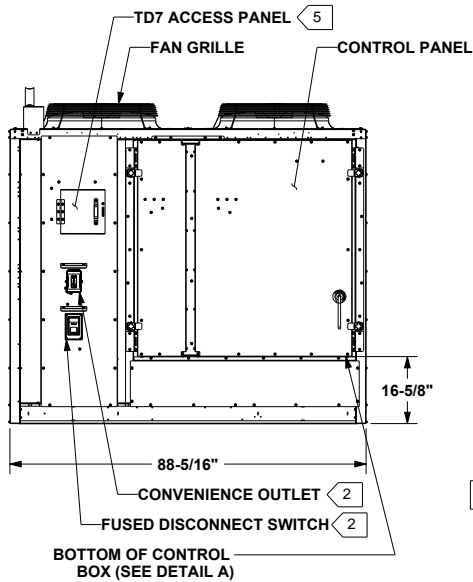



Unit Dimensions

Figure 55. Air-cooled condensing unit connections — 60 ton

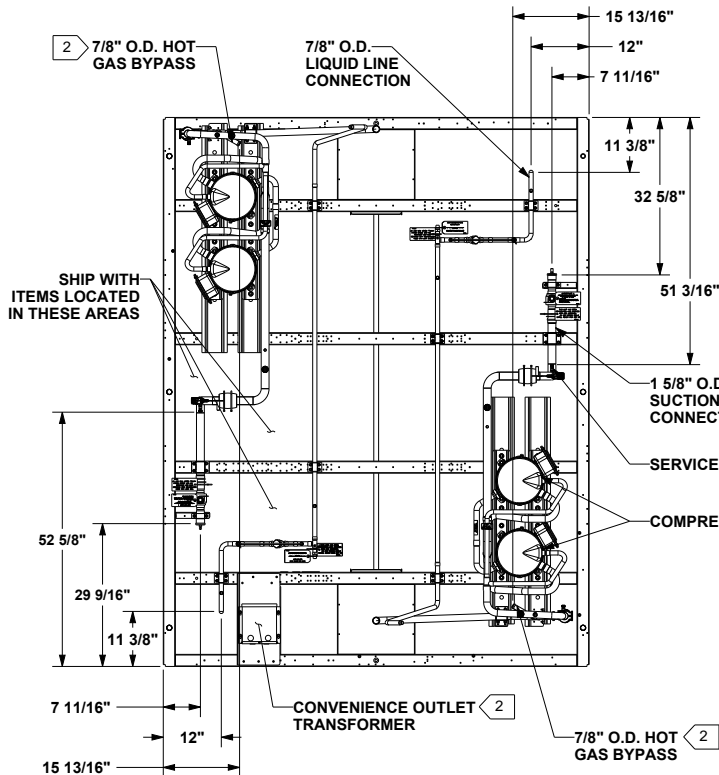

NOTES:

1. VERIFY WEIGHT, CONNECTION, AND ALL DIMENSIONS WITH INSTALLER DOCUMENTS BEFORE INSTALLATION.
2. OPTIONS ONLY COME WITH SELECTED UNITS.
3. DUAL CIRCUIT UNIT REQUIRES TWO SEPARATE LINE SETS (TWO SUCTION LINES AND TWO LIQUID LINES).

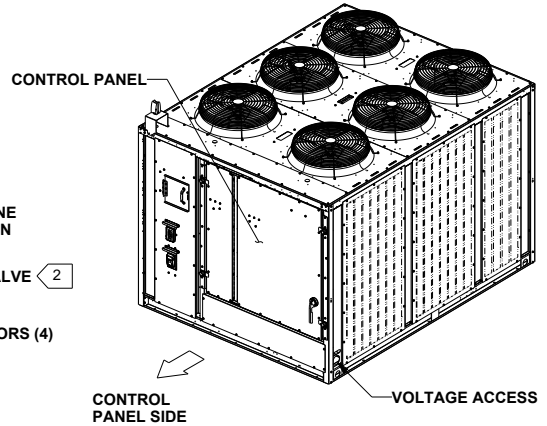

ORIENTATION VIEW OF UNIT
ISOMETRIC DRAWING

CONTROL PANEL SIDE

PLAN VIEW OF UNIT
CONNECTION DRAWING

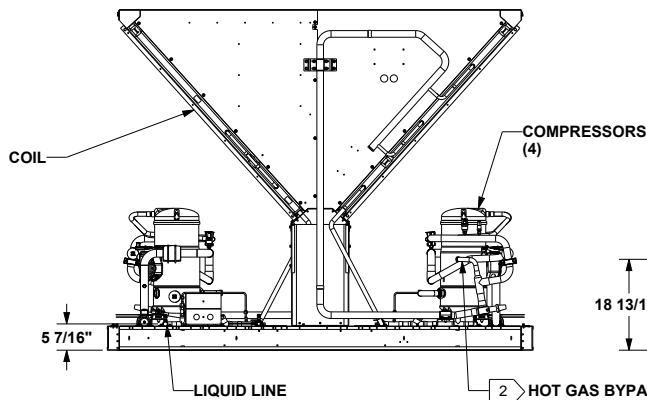

CONTROL PANEL SIDE VIEW OF UNIT
CONNECTION DRAWING

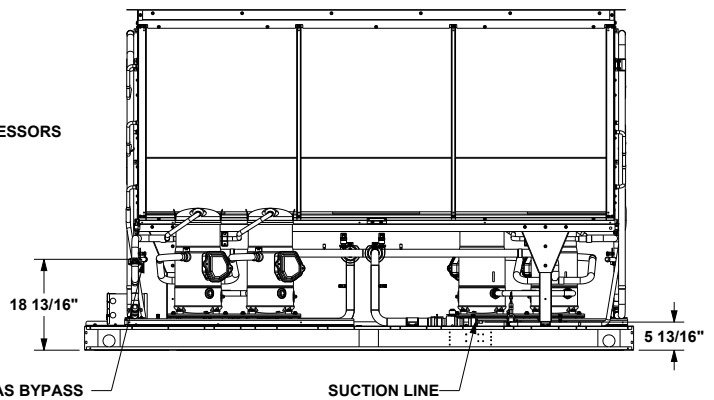

FRONT VIEW OF UNIT
CONNECTION DRAWING

60 TON UNIT
DIMENSION CONNECTION DRAWING

Figure 56. Air-cooled condensing unit — 80 ton

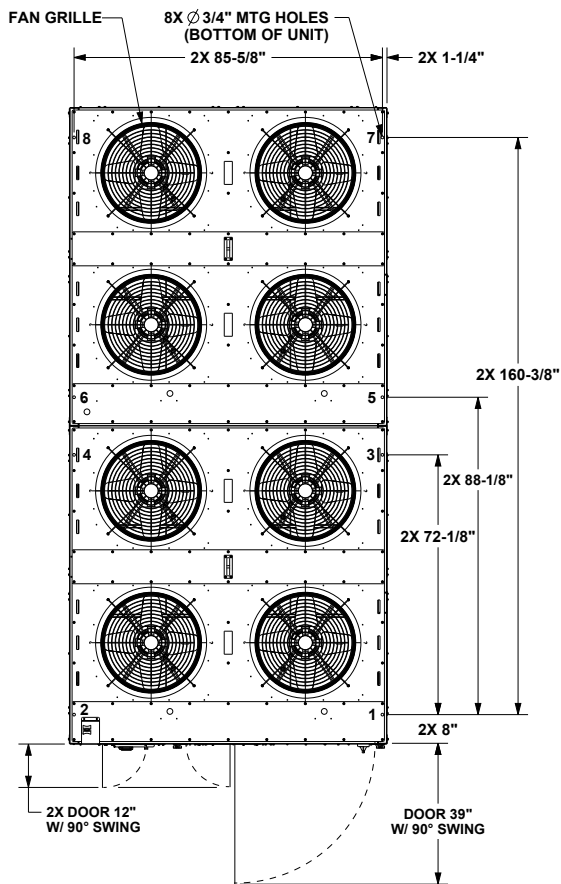

NOTES:

1. SEE CONNECTION DRAWING FOR CONNECTION LOCATION AND SIZES.
2. OPTIONS ONLY COME WITH SELECTED UNITS.
3. FRONT OF UNIT CLEARANCE 72". BACK OF UNIT CLEARANCE 72". LEFT AND RIGHT SIDE OF UNIT CLEARANCE 48".
4. VOLTAGE ACCESS HOLES IN OUTER PANEL MUST BE COVERED AFTER UNIT INSTALLATION.
5. TD7 CONTROL ONLY COMES WITH SELECTED UNITS.

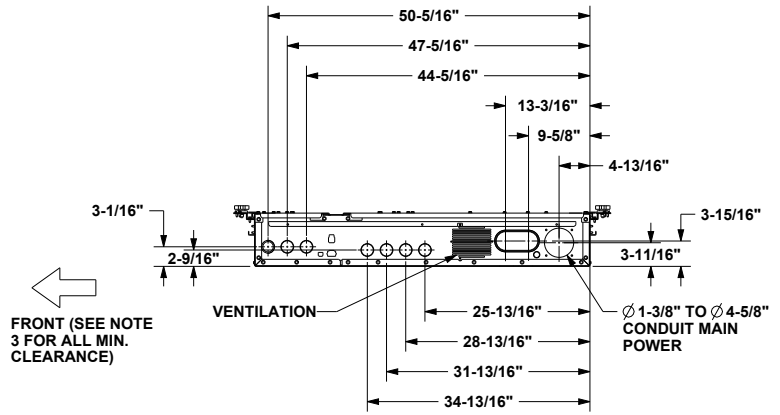

DETAIL A

CONTROL BOX BOTTOM

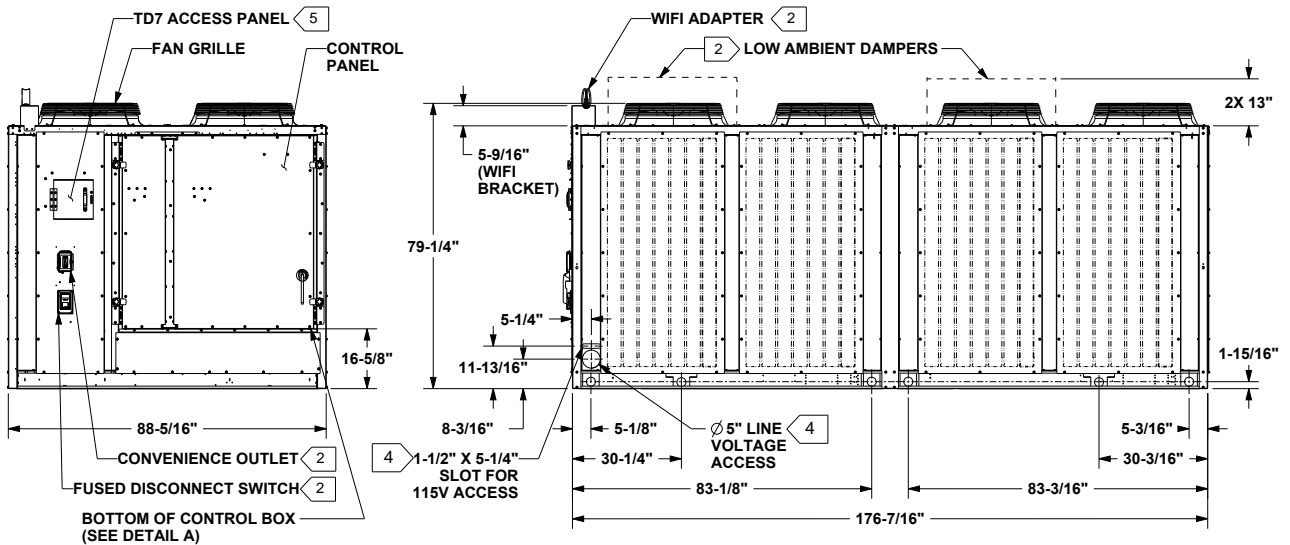



Unit Dimensions

Figure 57. Air-cooled condensing unit connections — 80 ton

NOTES:

1. VERIFY WEIGHT, CONNECTION, AND ALL DIMENSIONS WITH INSTALLER DOCUMENTS BEFORE INSTALLATION.
2. OPTIONS ONLY COME WITH SELECTED UNITS .
3. DUAL CIRCUIT UNIT REQUIRES TWO SEPARATE LINE SETS (TWO SUCTION LINES AND TWO LIQUID LINES).

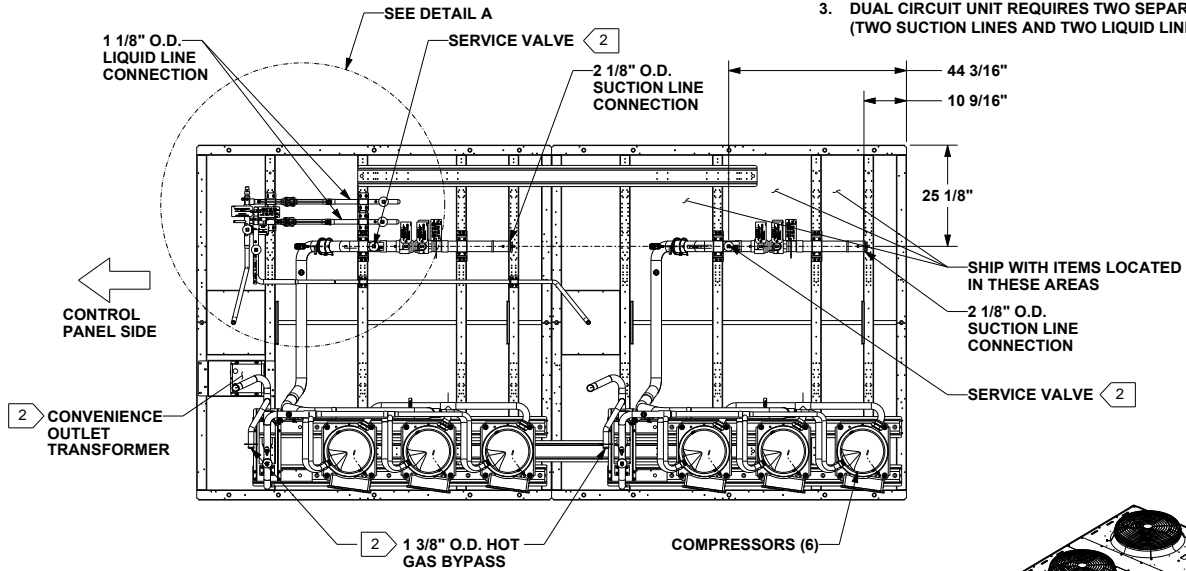

PLAN VIEW OF UNIT CONNECTION DRAWING

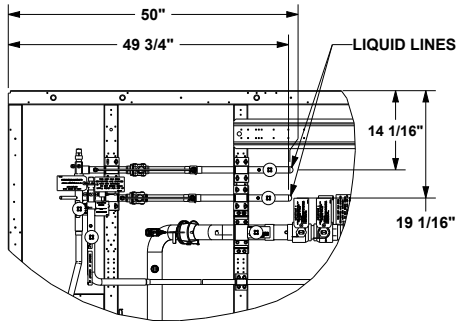

DETAIL A

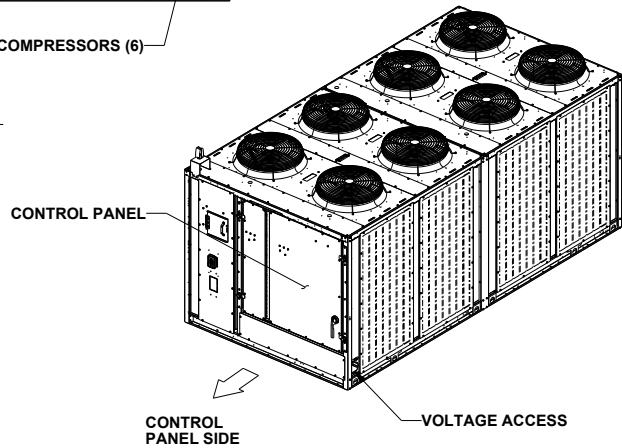

ORIENTATION VIEW OF UNIT ISOMETRIC DRAWING

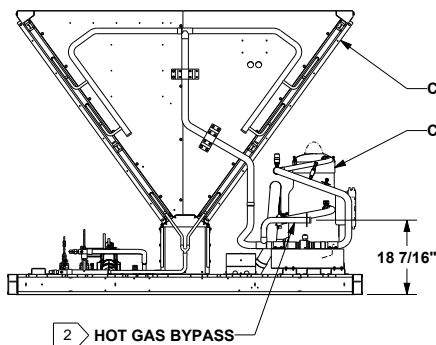

CONTROL PANEL SIDE VIEW OF UNIT CONNECTION DRAWING

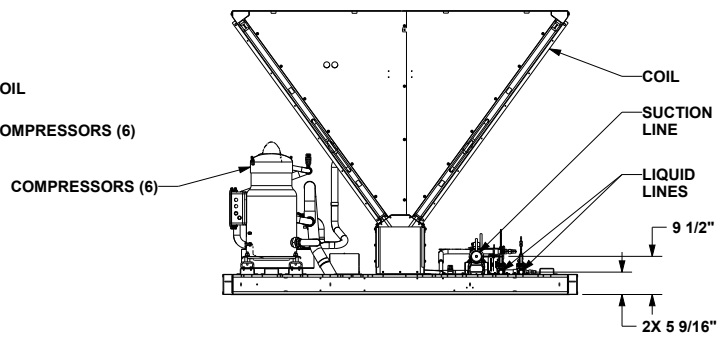

SIDE OPPOSITE OF CONTROL PANEL CONNECTION DRAWING

80 TON UNIT

DIMENSION CONNECTION DRAWING

Figure 58. Air-cooled condensing unit — 100 and 120 tons

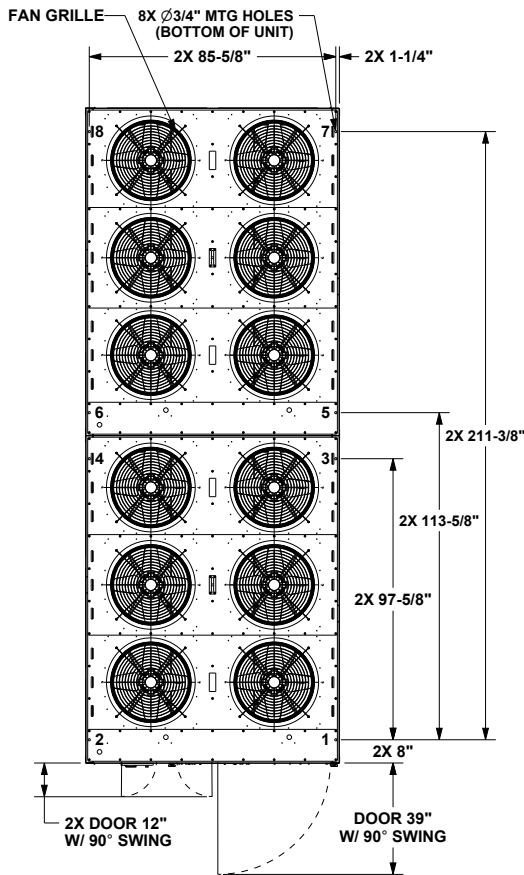

NOTES:

1. SEE CONNECTION DRAWING FOR CONNECTION LOCATION AND SIZES.
2. OPTIONS ONLY COME ON SELECTED UNITS.
3. FRONT AND BACK OF UNIT CLEARANCE 72". LEFT AND RIGHT SIDE OF UNIT CLEARANCE 48"
4. VOLTAGE ACCESS HOLES IN OUTER PANEL MUST BE COVERED AFTER UNIT INSTALLATION

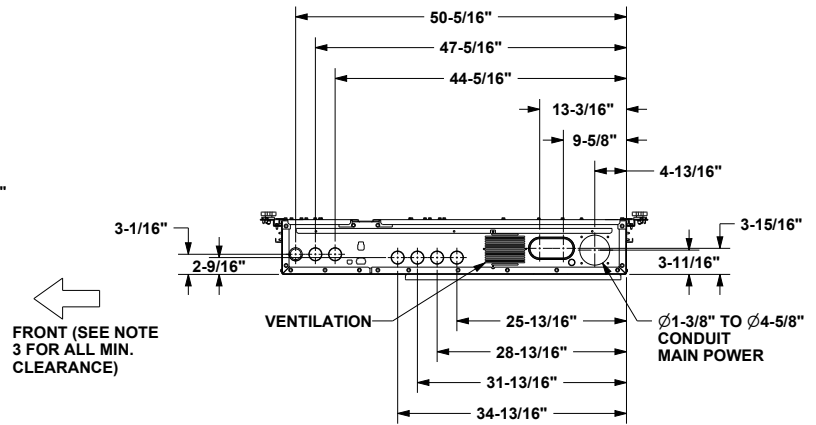

DETAIL A

CONTROL BOX BOTTOM

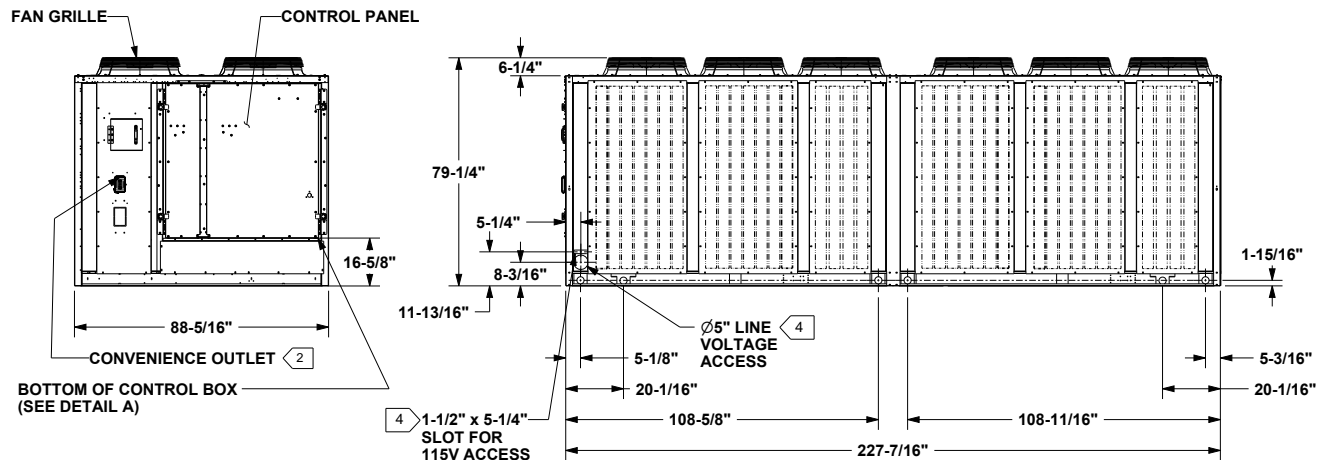



Unit Dimensions

Figure 59. Air-cooled condensing unit connections — 100 and 120 tons

NOTES:

1. VERIFY WEIGHT, CONNECTION, AND ALL DIMENSIONS WITH INSTALLER DOCUMENTS BEFORE INSTALLATION.
2. OPTIONS ONLY COME WITH SELECTED UNITS.
3. DUAL CIRCUIT UNIT REQUIRES TWO SEPARATE LINE SETS (TWO SUCTION LINES AND TWO LIQUID LINES).

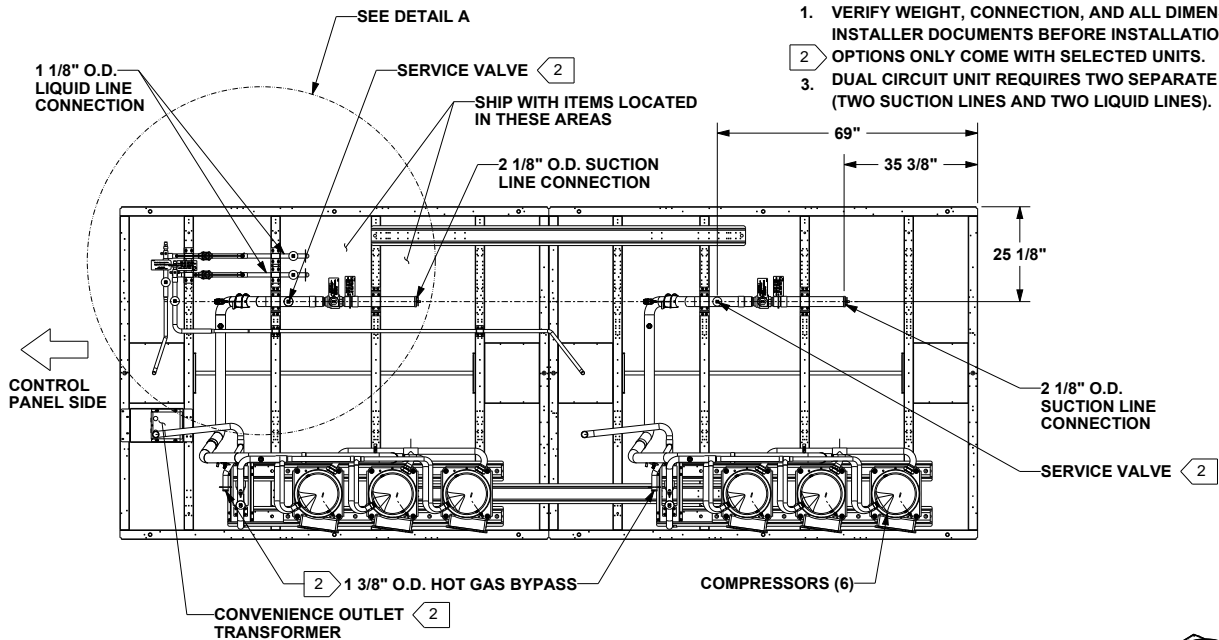

PLAN VIEW OF UNIT CONNECTION DRAWING

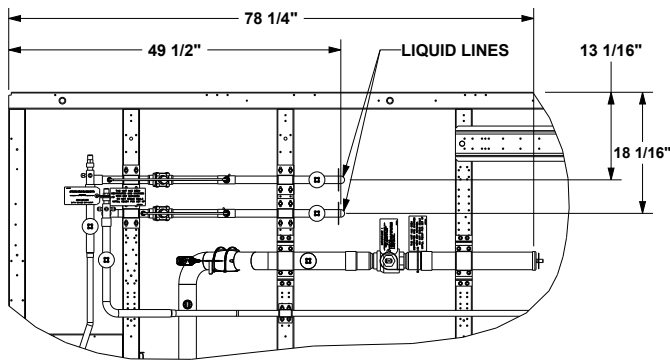

DETAIL A

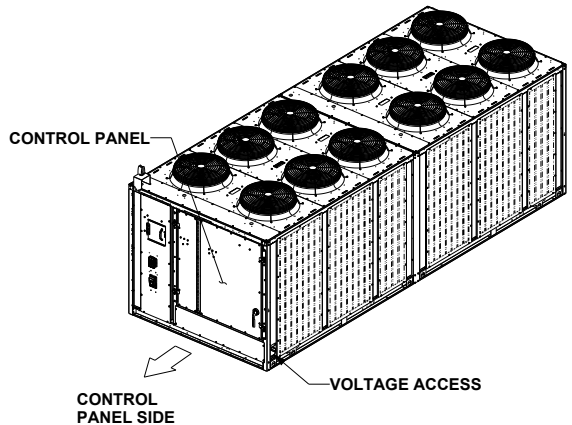

ORIENTATION VIEW OF UNIT ISOMETRIC DRAWING

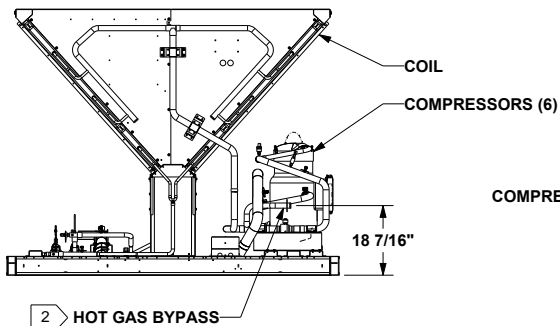

CONTROL PANEL SIDE VIEW OF UNIT CONNECTION DRAWING

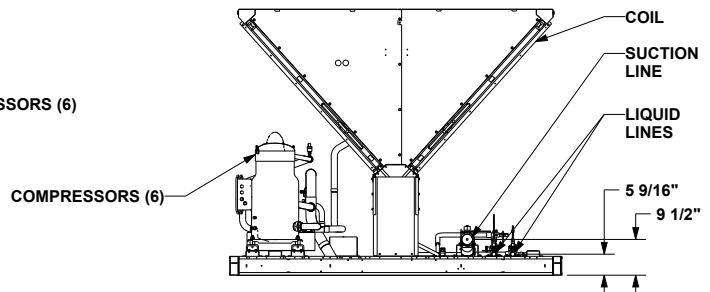

SIDE OPPOSITE OF CONTROL PANEL CONNECTION DRAWING

100 AND 120 TON UNITS
DIMENSION CONNECTION DRAWING

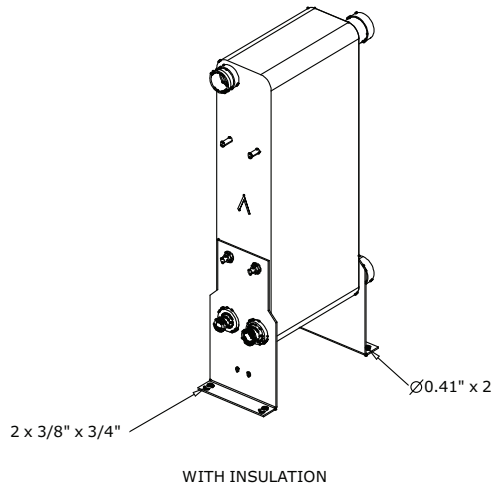
Figure 60. Evaporator chiller — 20 ton

NOTES:

1. THIS HEAT EXCHANGER IS INTENDED FOR INDOOR INSTALLATION ONLY
2. HEAT EXCHANGER MOUNTING LEGS ARE INSTALLED AT JOB SITE WITH SUPPLIED FASTENERS
3. INSULATION SHOULD BE INSTALLED AFTER INSTALLING LEGS & REFRIGERANT TUBING, OR MUST BE ADEQUATELY SHIELDED AGAINST HEAT WHEN BRAZING REFRIGERANT LINES
4. INSTALL INSULATION SIDE PIECES FIRST THEN WRAPPER (MAY REQUIRE TRIMMING)
5. USE VINYL TAPE (FIELD SUPPLIED) TO SEAL INSULATION AFTER INSTALLATION
6. WATER CONNECTIONS ARE GROOVED (VICTAULIC)
7. REFRIGERANT CONNECTIONS ARE STAINLESS STEEL AND REQUIRE SPECIAL BRAZE MATERIALS. SEE IOM BRAZE PROCEDURE.
8. 1/2" X 14 NPT F4 CONNECTION SUPPLIED ON EXT 04 THRU 06 AND 08 10 ONLY BRAZED PLATE HEAT EXCHANGER REMOTE CHILLER EVAPORATOR OPTION

OPTION INCLUDES:

- 1 - BRAZED PLATE HEAT EXCHANGER - SHIPS SEPARATE FROM CONDENSING UNIT
- 1 - INSTALLATION KIT, TO INCLUDE:
 - 2 - MOUNTING BRACKETS
 - 1 - INSULATION KIT
 - 1 - MOUNTING BRACKET & INSULATION KIT INSTALLATION INSTRUCTIONS
- 1 - WATER CONNECTION KIT WITH PIPING STUBS, Y CONNECTOR, STRAINER, VICTAULIC CONNECTIONS WITH GASKETS, WATER FLOW SWITCH
- 1 - WATER CONNECTION KIT INSTALLATION INSTRUCTIONS

INSTALLATION ADDITIONALLY REQUIRES:

- EVP REMOTE PANEL WITH LEAVING WATER TEMPERATURE SENSOR, FREEZE-STAT, AND INSTALLATION INSTRUCTIONS
- 4 - FIELD PROVIDED 7/16" BOLTS FOR SECURING BRAZED PLATE HEAT EXCHANGER TO PERMANENT MOUNTING SURFACE
- 2 - FIELD PROVIDED 1/2" - 14 NPTE PLUGS, STAINLESS STEEL OR PVC
- FIELD PROVIDED TEFLON TAPE FOR SEALING 1/2" PIPE PLUGS
- FIELD PROVIDED WATER STRAINER PLUG OR BLOW DOWN VALVE
- FIELD PROVIDED TEE FOR INSTALLING WATER FLOW SWITCH
- FIELD PROVIDED 2" VINYL TAPE FOR SEALING INSULATION SEAMS

SEE IOM FOR INSTALLATION DETAIL

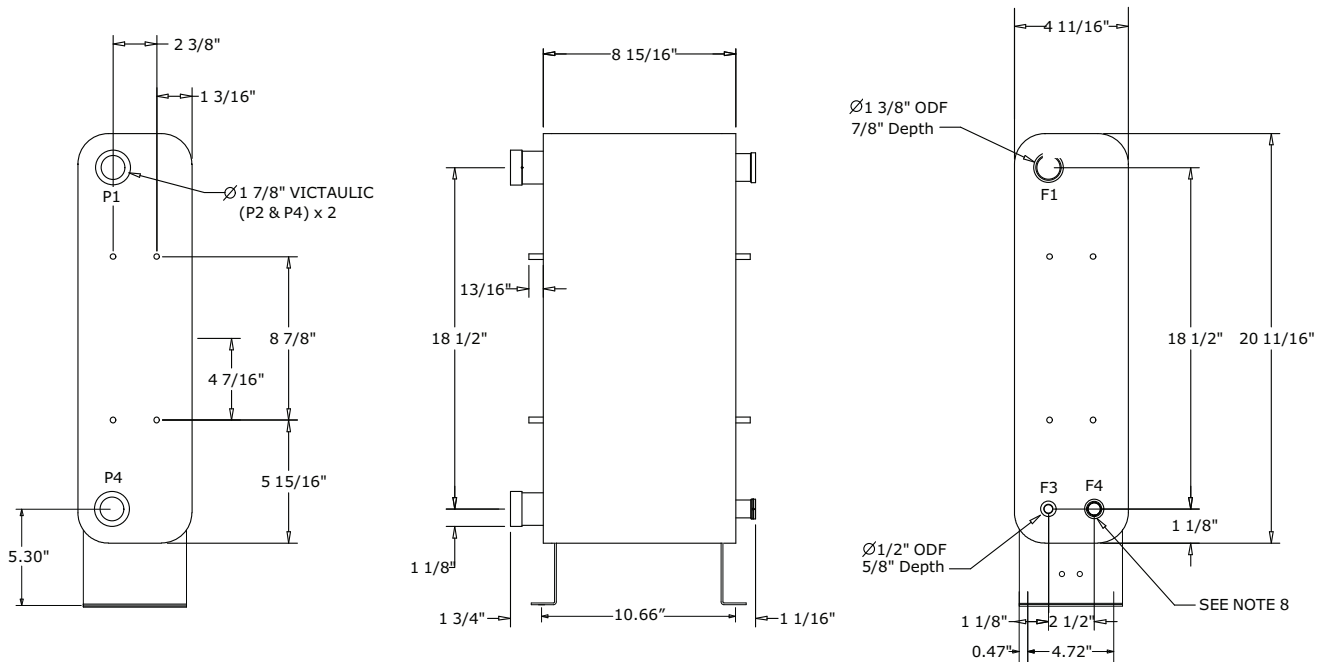

20 TON BRAZED PLATE HEAT EXCHANGER

ACCESSORY DRAWING

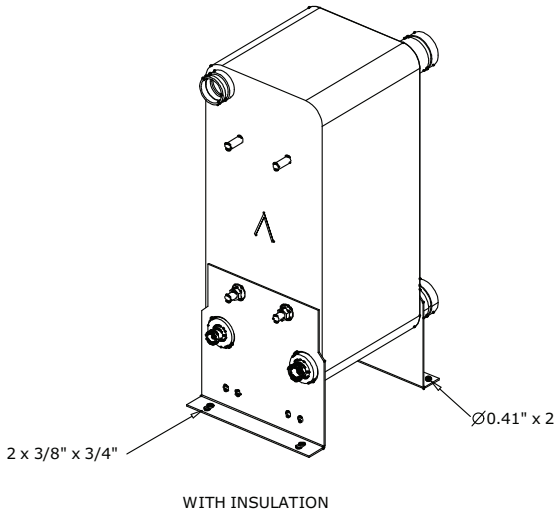

Unit Dimensions

Figure 61. Evaporator chiller — 25 ton



NOTES:

1. THIS HEAT EXCHANGER IS INTENDED FOR INDOOR INSTALLATION ONLY
2. HEAT EXCHANGER MOUNTING LEGS ARE INSTALLED AT JOB SITE WITH SUPPLIED FASTENERS
3. INSULATION SHOULD BE INSTALLED AFTER INSTALLING LEGS & REFRIGERANT TUBING, OR MUST BE ADEQUATELY SHIELDED AGAINST HEAT WHEN BRAZING REFRIGERANT LINES
4. INSTALL INSULATION SIDE PIECES FIRST THEN WRAPPER MAY REQUIRE TRIMMING)
5. USE VINYL TAPE (FIELD SUPPLIED) TO SEAL INSULATION AFTER INSTALLATION
6. WATER CONNECTIONS ARE GROOVED (VICTAULIC)
7. REFRIGERANT CONNECTIONS ARE STAINLESS STEEL AND REQUIRE SPECIAL BRAZE MATERIALS. SEE IOM BRAZE PROCEDURE.
8. 1/2" - 14 NPT F4 CONNECTION SUPPLIED ON EXT'S 05 THRU 08 AND 13 THRU 16 ONLY.

BRAZED PLATE HEAT EXCHANGER REMOTE CHILLER EVAPORATOR OPTION

OPTION INCLUDES:

- 1 - BRAZED PLATE HEAT EXCHANGER - SHIPS SEPARATE FROM CONDENSING UNIT
- 1 - INSTALLATION KIT, TO INCLUDE:
 - 2 - MOUNTING BRACKETS
 - 1 - INSULATION KIT
 - 1 - MOUNTING BRACKET & INSULATION KIT INSTALLATION INSTRUCTIONS
- 1 - WATER CONNECTION KIT WITH PIPING STUBS, Y CONNECTOR, STRAINER, VICTAULIC CONNECTIONS WITH GASKETS, WATER FLOW SWITCH
- 1 - WATER CONNECTION KIT INSTALLATION INSTRUCTIONS

INSTALLATION ADDITIONALLY REQUIRES:

- EVP REMOTE PANEL WITH LEAVING WATER TEMPERATURE SENSOR, FREEZE-STAT, AND INSTALLATION INSTRUCTIONS
- 4 - FIELD PROVIDED 7/16" BOLTS FOR SECURING BRAZED PLATE HEAT EXCHANGER TO PERMANENT MOUNTING SURFACE
- 2 - FIELD PROVIDED 1/2" - 14 NPT PLUGS, STAINLESS STEEL OR PVC
- FIELD PROVIDED TEFLON TAPE FOR SEALING 1/2" PIPE PLUGS
- FIELD PROVIDED WATER STRAINER PLUG OR BLOW DOWN VALVE
- FIELD PROVIDED TEE FOR INSTALLING WATER FLOW SWITCH
- FIELD PROVIDED 2" VINYL TAPE FOR SEALING INSULATION SEAMS

SEE IOM FOR INSTALLATION DETAIL

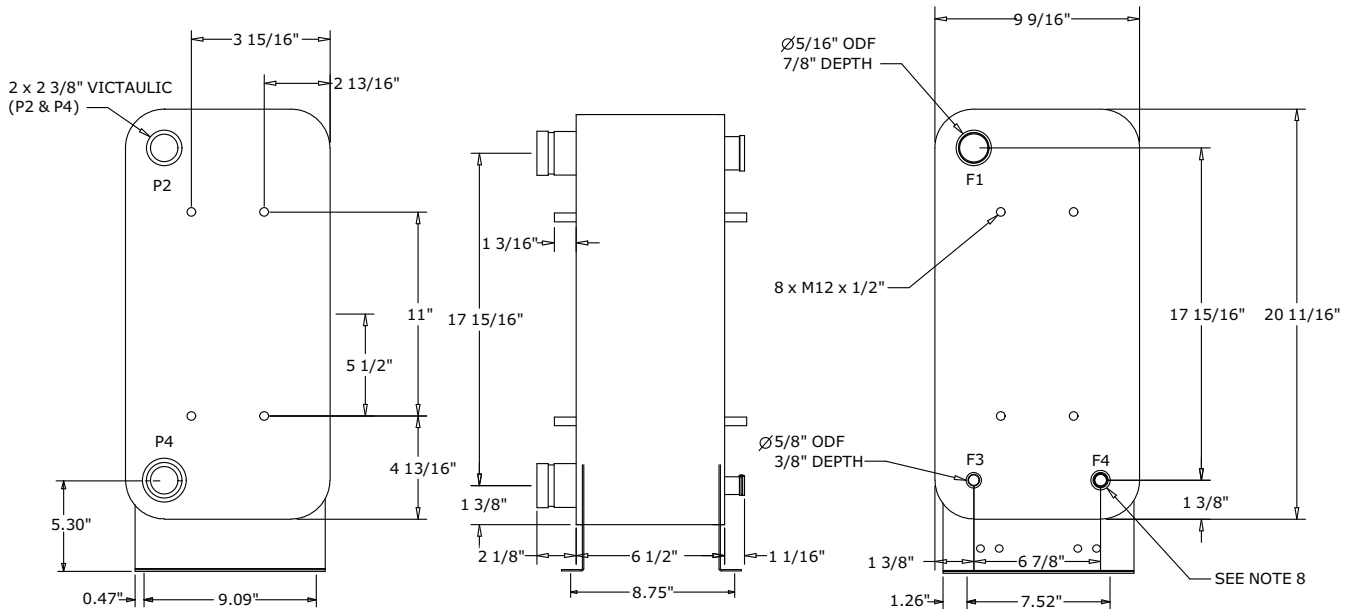

25 TON BRAZED PLATE HEAT EXCHANGER

ACCESSORY DRAWING

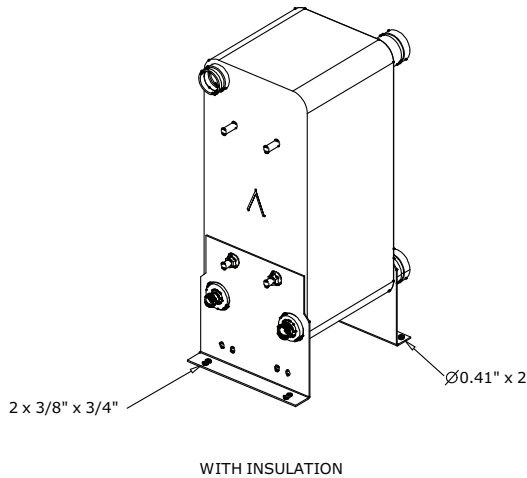
Figure 62. Evaporator chiller — 30 ton (R-410A)

NOTES:

1. THIS HEAT EXCHANGER IS INTENDED FOR INDOOR INSTALLATION ONLY
2. HEAT EXCHANGER MOUNTING LEGS ARE INSTALLED AT JOB SITE WITH SUPPLIED FASTENERS
3. INSULATION SHOULD BE INSTALLED AFTER INSTALLING LEGS & REFRIGERANT TUBING, OR MUST BE ADEQUATELY SHIELDED AGAINST HEAT WHEN BRAZING REFRIGERANT LINES
4. INSTALL INSULATION SIDE PIECES FIRST THEN WRAPPER (MAY REQUIRE TRIMMING)
5. USE VINYL TAPE (FIELD SUPPLIED) TO SEAL INSULATION AFTER INSTALLATION
6. WATER CONNECTIONS ARE GROOVED (VICTAULIC)
7. REFRIGERANT CONNECTIONS ARE STAINLESS STEEL AND REQUIRE SPECIAL BRAZE MATERIALS. SEE IOM BRAZE PROCEDURE.
8. 1/2" - 14 NPT F4 CONNECTION SUPPLIED ON EXT'S 05 THRU 08 AND 13 THRU 16 ONLY.

BRAZED PLATE HEAT EXCHANGER REMOTE CHILLER EVAPORATOR OPTION
OPTION INCLUDES:

- 1 - BRAZED PLATE HEAT EXCHANGER - SHIPS SEPARATE FROM RAUJ CONDENSING UNIT
- 1 - INSTALLATION KIT, TO INCLUDE:
 - 2 - MOUNTING BRACKETS
 - 1 - INSULATION KIT
 - 1 - MOUNTING BRACKET & INSULATION KIT INSTALLATION INSTRUCTIONS
- 1 - WATER CONNECTION KIT WITH PIPING STUBS, Y CONNECTOR, STRAINER, VICTAULIC CONNECTIONS WITH GASKETS, WATER FLOW SWITCH
- 1 - WATER CONNECTION KIT INSTALLATION INSTRUCTIONS

INSTALLATION ADDITIONALLY REQUIRES:

- RAUJ REMOTE EVP CONTROL PANEL WITH LEAVING WATER TEMPERATURE SENSOR, FREEZE-STAT, AND INSTALLATION INSTRUCTIONS - ALL INCLUDED WITH REMOTE EVP CONTROL PANEL
- 4 - FIELD PROVIDED 7/16" BOLTS FOR SECURING BRAZED PLATE HEAT EXCHANGER TO PERMANENT MOUNTING SURFACE
- 2 - FIELD PROVIDED 1/2" - 14 NPTE PLUGS, STAINLESS STEEL OR PVC
- FIELD PROVIDED TEFLON TAPE FOR SEALING 1/2" PIPE PLUGS
- FIELD PROVIDED WATER STRAINER PLUG OR BLOW DOWN VALVE
- FIELD PROVIDED TEE FOR INSTALLING WATER FLOW SWITCH
- FIELD PROVIDED 2" VINYL TAPE FOR SEALING INSULATION SEAMS

SEE IOM FOR INSTALLATION DETAIL

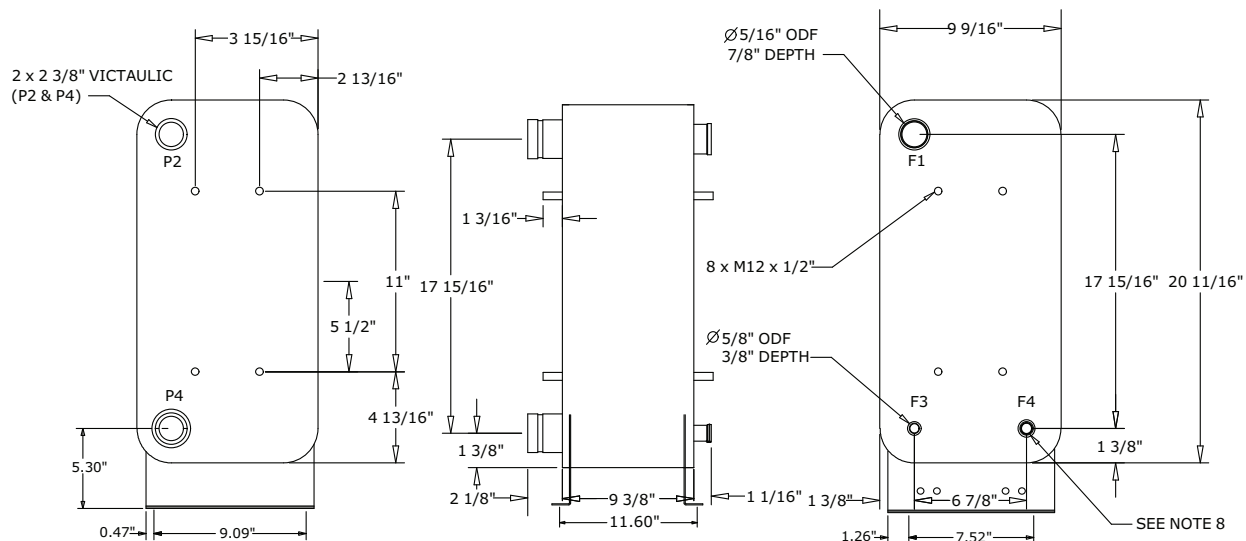

30 TON BRAZED PLATE HEAT EXCHANGER

ACCESSORY DRAWING

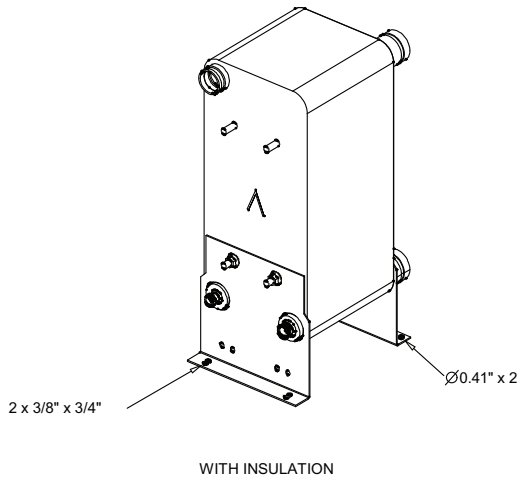

Unit Dimensions

Figure 63. Evaporator chiller — 30 ton (R-454B)



NOTES:

1. THIS HEAT EXCHANGER IS INTENDED FOR INDOOR INSTALLATION ONLY
2. HEAT EXCHANGER MOUNTING LEGS ARE INSTALLED AT JOB SITE WITH SUPPLIED FASTENERS
3. INSULATION SHOULD BE INSTALLED AFTER INSTALLING LEGS & REFRIGERANT TUBING, OR MUST BE ADEQUATELY SHIELDED AGAINST HEAT WHEN BRAZING REFRIGERANT LINES
4. INSTALL INSULATION SIDE PIECES FIRST THEN WRAPPER (MAY REQUIRE TRIMMING)
5. USE VINYL TAPE (FIELD SUPPLIED) TO SEAL INSULATION AFTER INSTALLATION
6. WATER CONNECTIONS ARE GROOVED (VICTAULIC)
7. REFRIGERANT CONNECTIONS ARE STAINLESS STEEL AND REQUIRE SPECIAL BRAZE MATERIALS. SEE IOM BRAZE PROCEDURE.
8. 1/2" - 14 NPT F4 CONNECTION SUPPLIED ON EXT'S 05 THRU 08 AND 13 THRU 16 ONLY.

BRAZED PLATE HEAT EXCHANGER REMOTE CHILLER EVAPORATOR OPTION

OPTION INCLUDES:

- 1 - BRAZED PLATE HEAT EXCHANGER - SHIPS SEPARATE FROM CONDENSING UNIT
- 1 - INSTALLATION KIT, TO INCLUDE:
 - 2 - MOUNTING BRACKETS
 - 1 - INSULATION KIT
 - 1 - MOUNTING BRACKET & INSULATION KIT INSTALLATION INSTRUCTIONS
- 1 - WATER CONNECTION KIT WITH PIPING STUBS, Y CONNECTOR, STRAINER, VICTAULIC CONNECTIONS WITH GASKETS, WATER FLOW SWITCH
- 1 - WATER CONNECTION KIT INSTALLATION INSTRUCTIONS

INSTALLATION ADDITIONALLY REQUIRES:

- EVP REMOTE PANEL WITH LEAVING WATER TEMPERATURE SENSOR, FREEZE-STAT, AND INSTALLATION INSTRUCTIONS
- 4 - FIELD PROVIDED 7/16" BOLTS FOR SECURING BRAZED PLATE HEAT EXCHANGER TO PERMANENT MOUNTING SURFACE
- 2 - FIELD PROVIDED 1/2" - 14 NPTE PLUGS, STAINLESS STEEL OR PVC
- FIELD PROVIDED TEFLON TAPE FOR SEALING 1/2" PIPE PLUGS
- FIELD PROVIDED WATER STRAINER PLUG OR BLOW DOWN VALVE
- FIELD PROVIDED TEE FOR INSTALLING WATER FLOW SWITCH
- FIELD PROVIDED 2" VINYL TAPE FOR SEALING INSULATION SEAMS

SEE IOM FOR INSTALLATION DETAIL

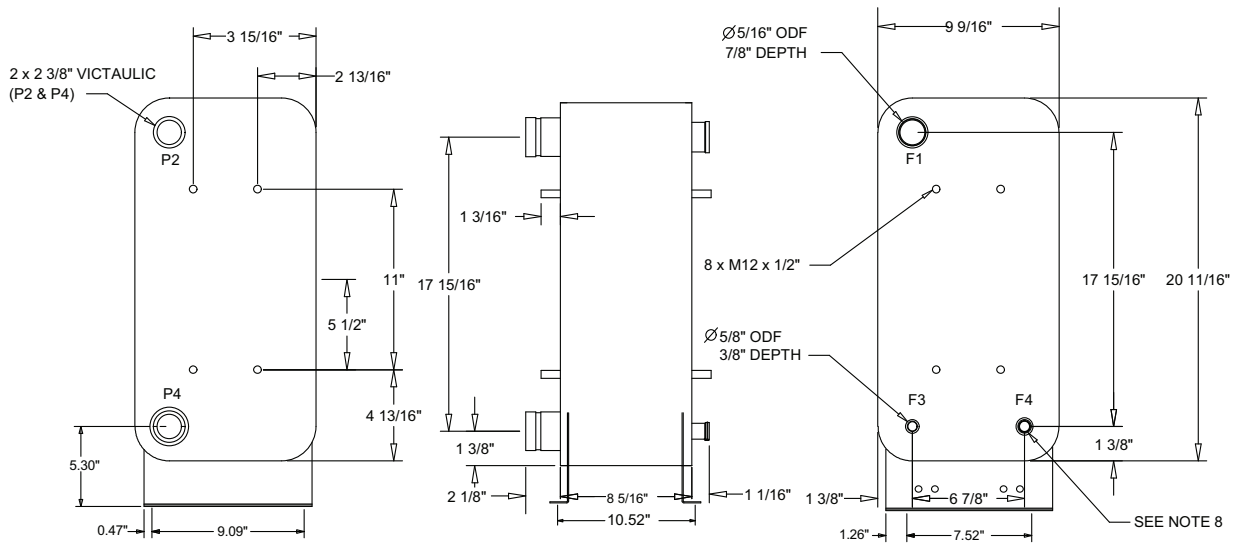

30 TON BRAZED PLATE HEAT EXCHANGER

ACCESSORY DRAWING

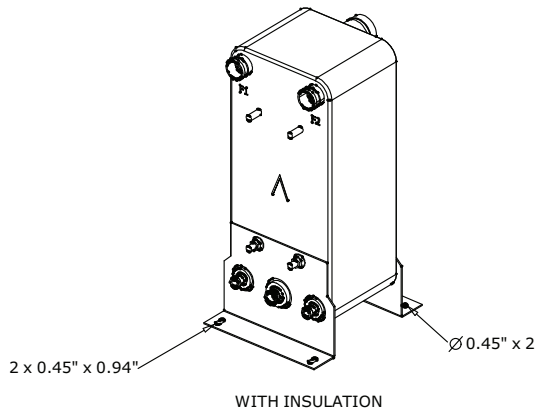
Figure 64. Evaporator chiller — 40 ton (R-410A)

NOTES:

1. THIS HEAT EXCHANGER IS INTENDED FOR INDOOR INSTALLATION ONLY
2. HEAT EXCHANGER MOUNTING LEGS ARE INSTALLED AT JOB SITE WITH SUPPLIED FASTENERS
3. INSULATION SHOULD BE INSTALLED AFTER INSTALLING LEGS & REFRIGERANT TUBING, OR MUST BE ADEQUATELY SHIELDED AGAINST HEAT WHEN BRAZING REFRIGERANT LINES
4. INSTALL INSULATION SIDE PIECES FIRST THEN WRAPPER (MAY REQUIRE TRIMMING)
5. USE VINYL TAPE (FIELD SUPPLIED) TO SEAL INSULATION AFTER INSTALLATION
6. WATER CONNECTIONS ARE GROOVED (VICTAULIC)
7. REFRIGERANT CONNECTIONS ARE STAINLESS STEEL AND REQUIRE SPECIAL BRAZE MATERIALS. SEE IOM BRAZE PROCEDURE.
8. 1/2" NPT F5 CONNECTION SUPPLIED ON EXT'S 04 THRU 06 ONLY
BRAZED PLATE HEAT EXCHANGER REMOTE CHILLER EVAPORATOR OPTION

OPTION INCLUDES:

- 1 - BRAZED PLATE HEAT EXCHANGER - SHIPS SEPARATE FROM RAUJ CONDENSING UNIT
- 1 - INSTALLATION KIT, TO INCLUDE:
 - 2 - MOUNTING BRACKETS
 - 1 - INSULATION KIT
 - 1 - MOUNTING BRACKET & INSULATION KIT INSTALLATION INSTRUCTIONS
- 1 - WATER CONNECTION KIT WITH PIPING STUBS, Y CONNECTOR, STRAINER, VICTAULIC CONNECTIONS WITH GASKETS, WATER FLOW SWITCH
- 1 - WATER CONNECTION KIT INSTALLATION INSTRUCTIONS

INSTALLATION ADDITIONALLY REQUIRES:

- RAUJ REMOTE EVP CONTROL PANEL WITH LEAVING WATER TEMPERATURE SENSOR, FREEZE-STAT, AND INSTALLATION INSTRUCTIONS - ALL INCLUDED WITH REMOTE EVP CONTROL PANEL
- 4 - FIELD PROVIDED 7/16" BOLTS FOR SECURING BRAZED PLATE HEAT EXCHANGER TO PERMANENT MOUNTING SURFACE
- 2 - FIELD PROVIDED 1/2" - 14 NPTE PLUGS, STAINLESS STEEL OR PVC
- FIELD PROVIDED TEFLON TAPE FOR SEALING 1/2" PIPE PLUGS
- FIELD PROVIDED WATER STRAINER PLUG OR BLOW DOWN VALVE
- FIELD PROVIDED TEE FOR INSTALLING WATER FLOW SWITCH
- FIELD PROVIDED 2" VINYL TAPE FOR SEALING INSULATION SEAMS

SEE IOM FOR INSTALLATION DETAIL

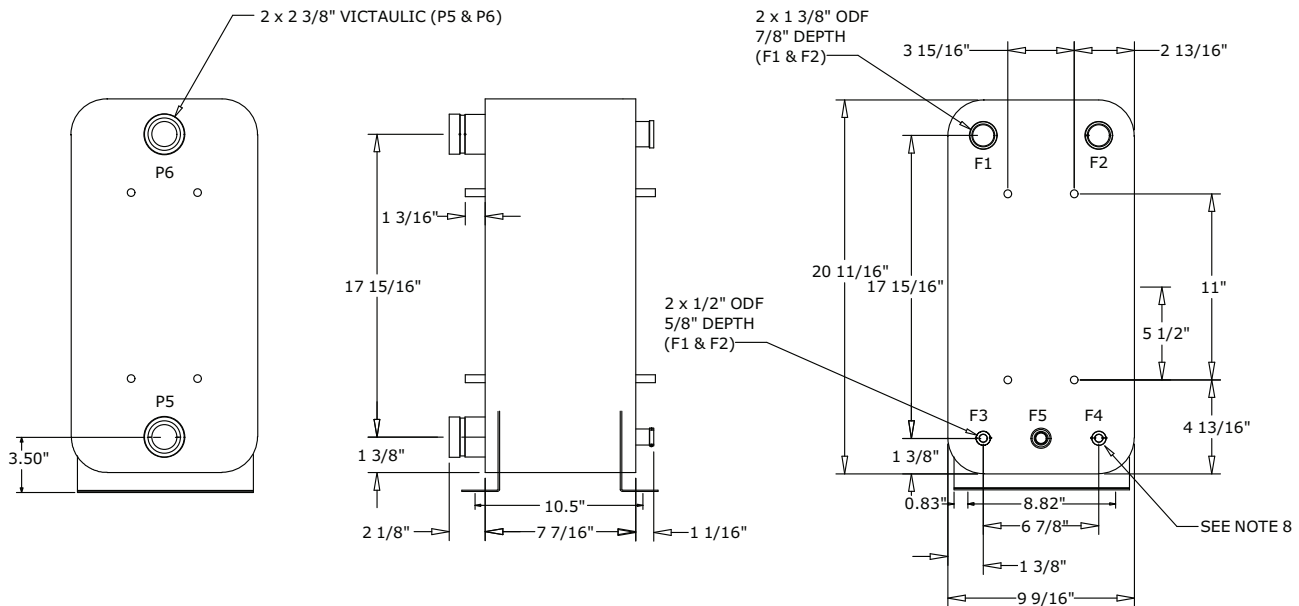

40 TON BRAZED PLATE HEAT EXCHANGER

ACCESSORY DRAWING

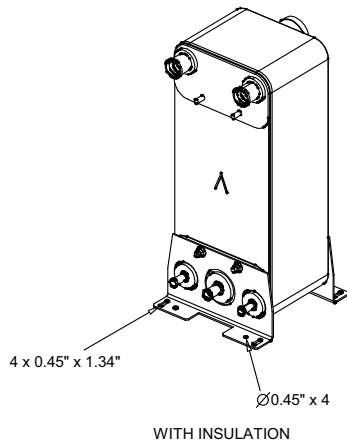

Unit Dimensions

Figure 65. Evaporator chiller — 40 ton (R-454B)



NOTES:

1. THIS HEAT EXCHANGER IS INTENDED FOR INDOOR INSTALLATION ONLY
2. HEAT EXCHANGER MOUNTING LEGS ARE INSTALLED AT JOB SITE WITH SUPPLIED FASTENERS
3. INSULATION SHOULD BE INSTALLED AFTER INSTALLING LEGS & REFRIGERANT TUBING, OR MUST BE ADEQUATELY SHIELDED AGAINST HEAT WHEN BRAZING REFRIGERANT LINES
4. INSTALL INSULATION SIDE PIECES FIRST THEN WRAPPER (MAY REQUIRE TRIMMING)
5. USE VINYL TAPE (FIELD SUPPLIED) TO SEAL INSULATION AFTER INSTALLATION
6. WATER CONNECTIONS ARE GROOVED (VICTAULIC)
7. REFRIGERANT CONNECTIONS ARE STAINLESS STEEL AND REQUIRE SPECIAL BRAZE MATERIALS. SEE IOM BRAZE PROCEDURE.
8. 1/2" - 14 NPT F5 CONNECTION SUPPLIED ON EXT'S 13 THRU 24 AND 37 THRU 48 ONLY.

BRAZED PLATE HEAT EXCHANGER REMOTE CHILLER EVAPORATOR OPTION

OPTION INCLUDES:

- 1 - BRAZED PLATE HEAT EXCHANGER - SHIPS SEPARATE FROM CONDENSING UNIT
- 1 - INSTALLATION KIT, TO INCLUDE:
 - 2 - MOUNTING BRACKETS
 - 1 - INSULATION KIT
 - 1 - MOUNTING BRACKET & INSULATION KIT INSTALLATION INSTRUCTIONS
- 1 - WATER CONNECTION KIT WITH PIPING STUBS, Y CONNECTOR, STRAINER, VICTAULIC CONNECTIONS WITH GASKETS, WATER FLOW SWITCH
- 1 - WATER CONNECTION KIT INSTALLATION INSTRUCTIONS

INSTALLATION ADDITIONALLY REQUIRES:

- EVP REMOTE PANEL WITH LEAVING WATER TEMPERATURE SENSOR, FREEZE-STAT, AND INSTALLATION INSTRUCTIONS
- 4 - FIELD PROVIDED 7/16" BOLTS FOR SECURING BRAZED PLATE HEAT EXCHANGER TO PERMANENT MOUNTING SURFACE
- 2 - FIELD PROVIDED 1/2" - 14 NPTE PLUGS, STAINLESS STEEL OR PVC
- FIELD PROVIDED TEFLON TAPE FOR SEALING 1/2" PIPE PLUGS
- FIELD PROVIDED WATER STRAINER PLUG OR BLOW DOWN VALVE
- FIELD PROVIDED TEE FOR INSTALLING WATER FLOW SWITCH
- FIELD PROVIDED 2" VINYL TAPE FOR SEALING INSULATION SEAMS

SEE IOM FOR INSTALLATION DETAIL

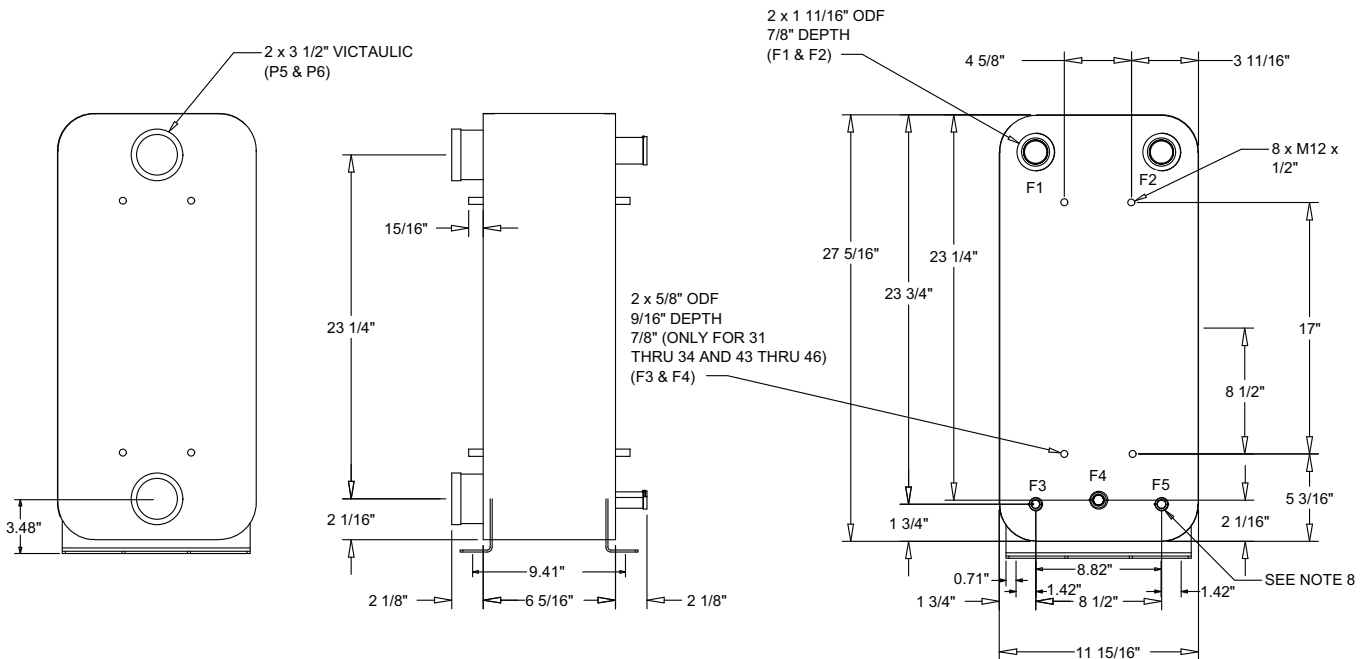

40 TON BRAZED PLATE HEAT EXCHANGER

ACCESSORY DRAWING

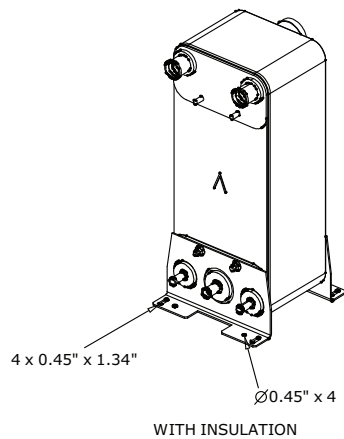
Figure 66. Evaporator chiller — 50 ton

NOTES:

1. THIS HEAT EXCHANGER IS INTENDED FOR INDOOR INSTALLATION ONLY
2. HEAT EXCHANGER MOUNTING LEGS ARE INSTALLED AT JOB SITE WITH SUPPLIED FASTENERS
3. INSULATION SHOULD BE INSTALLED AFTER INSTALLING LEGS & REFRIGERANT TUBING, OR MUST BE ADEQUATELY SHIELDED AGAINST HEAT WHEN BRAZING REFRIGERANT LINES
4. INSTALL INSULATION SIDE PIECES FIRST THEN WRAPPER (MAY REQUIRE TRIMMING)
5. USE VINYL TAPE (FIELD SUPPLIED) TO SEAL INSULATION AFTER INSTALLATION
6. WATER CONNECTIONS ARE GROOVED (VICTAULIC)
7. REFRIGERANT CONNECTIONS ARE STAINLESS STEEL AND REQUIRE SPECIAL BRAZE MATERIALS. SEE IOM BRAZE PROCEDURE.
8. 1/2" - 14 NPT F5 CONNECTION SUPPLIED ON EXT'S 13 THRU 24 AND 37 THRU 48 ONLY.

BRAZED PLATE HEAT EXCHANGER REMOTE CHILLER EVAPORATOR OPTION
OPTION INCLUDES:

- 1 - BRAZED PLATE HEAT EXCHANGER - SHIPS SEPARATE FROM CONDENSING UNIT
- 1 - INSTALLATION KIT, TO INCLUDE:
 - 2 - MOUNTING BRACKETS
 - 1 - INSULATION KIT
 - 1 - MOUNTING BRACKET & INSULATION KIT INSTALLATION INSTRUCTIONS
- 1 - WATER CONNECTION KIT WITH PIPING STUBS, Y CONNECTOR, STRAINER, VICTAULIC CONNECTIONS WITH GASKETS, WATER FLOW SWITCH
- 1 - WATER CONNECTION KIT INSTALLATION INSTRUCTIONS

INSTALLATION ADDITIONALLY REQUIRES:

- EVP REMOTE PANEL WITH LEAVING WATER TEMPERATURE SENSOR, FREEZE-STAT, AND INSTALLATION INSTRUCTIONS
- 4 - FIELD PROVIDED 7/16" BOLTS FOR SECURING BRAZED PLATE HEAT EXCHANGER TO PERMANENT MOUNTING SURFACE
- 2 - FIELD PROVIDED 1/2" - 14 NPTE PLUGS, STAINLESS STEEL OR PVC
- FIELD PROVIDED TEFLON TAPE FOR SEALING 1/2" PIPE PLUGS
- FIELD PROVIDED WATER STRAINER PLUG OR BLOW DOWN VALVE
- FIELD PROVIDED TEE FOR INSTALLING WATER FLOW SWITCH
- FIELD PROVIDED 2" VINYL TAPE FOR SEALING INSULATION SEAMS

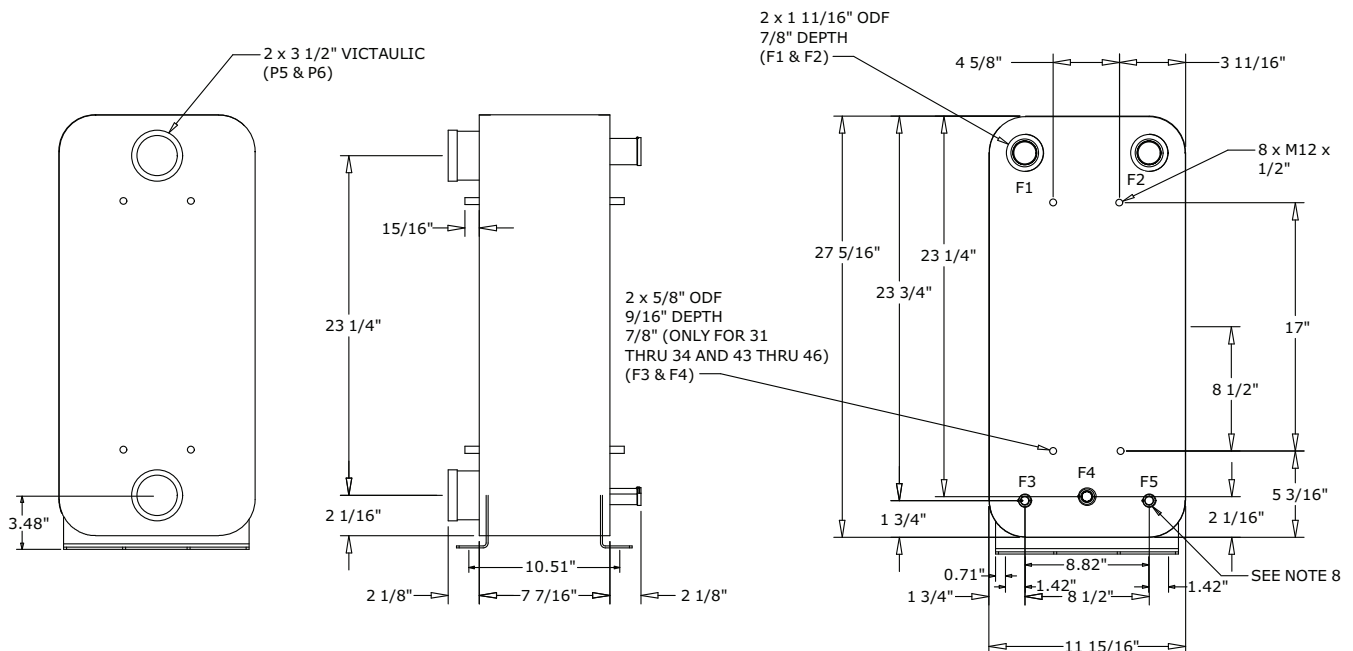
SEE IOM FOR INSTALLATION DETAIL

50 TON BRAZED PLATE HEAT EXCHANGER

ACCESSORY DRAWING

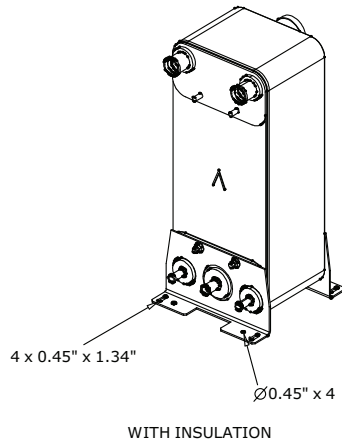

Unit Dimensions

Figure 67. Evaporator chiller — 60 ton



NOTES:

1. THIS HEAT EXCHANGER IS INTENDED FOR INDOOR INSTALLATION ONLY
2. HEAT EXCHANGER MOUNTING LEGS ARE INSTALLED AT JOB SITE WITH SUPPLIED FASTENERS
3. INSULATION SHOULD BE INSTALLED AFTER INSTALLING LEGS & REFRIGERANT TUBING, OR MUST BE ADEQUATELY SHIELDED AGAINST HEAT WHEN BRAZING REFRIGERANT LINES
4. INSTALL INSULATION SIDE PIECES FIRST THEN WRAPPER (MAY REQUIRE TRIMMING)
5. USE VINYL TAPE (FIELD SUPPLIED) TO SEAL INSULATION AFTER INSTALLATION
6. WATER CONNECTIONS ARE GROOVED (VICTAULIC)
7. REFRIGERANT CONNECTIONS ARE STAINLESS STEEL AND REQUIRE SPECIAL BRAZE MATERIALS. SEE IOM BRAZE PROCEDURE.
8. 1/2" - 14 NPT F5 CONNECTION SUPPLIED ON EXT'S 13 THRU 24 AND 37 THRU 48 ONLY.

BRAZED PLATE HEAT EXCHANGER REMOTE CHILLER EVAPORATOR OPTION

OPTION INCLUDES:

- 1 - BRAZED PLATE HEAT EXCHANGER - SHIPS SEPARATE FROM CONDENSING UNIT
- 1 - INSTALLATION KIT, TO INCLUDE:
 - 2 - MOUNTING BRACKETS
 - 1 - INSULATION KIT
 - 1 - MOUNTING BRACKET & INSULATION KIT INSTALLATION INSTRUCTIONS
- 1 - WATER CONNECTION KIT WITH PIPING STUBS, Y CONNECTOR, STRAINER, VICTAULIC CONNECTIONS WITH GASKETS, WATER FLOW SWITCH
- 1 - WATER CONNECTION KIT INSTALLATION INSTRUCTIONS

INSTALLATION ADDITIONALLY REQUIRES:

- EVP REMOTE PANEL WITH LEAVING WATER TEMPERATURE SENSOR, FREEZE-STAT, AND INSTALLATION INSTRUCTIONS
- 4 - FIELD PROVIDED 7/16" BOLTS FOR SECURING BRAZED PLATE HEAT EXCHANGER TO PERMANENT MOUNTING SURFACE
- 2 - FIELD PROVIDED 1/2" - 14 NPTE PLUGS, STAINLESS STEEL OR PVC
- FIELD PROVIDED TEFLON TAPE FOR SEALING 1/2" PIPE PLUGS
- FIELD PROVIDED WATER STRAINER PLUG OR BLOW DOWN VALVE
- FIELD PROVIDED TEE FOR INSTALLING WATER FLOW SWITCH
- FIELD PROVIDED 2" VINYL TAPE FOR SEALING INSULATION SEAMS

SEE IOM FOR INSTALLATION DETAIL

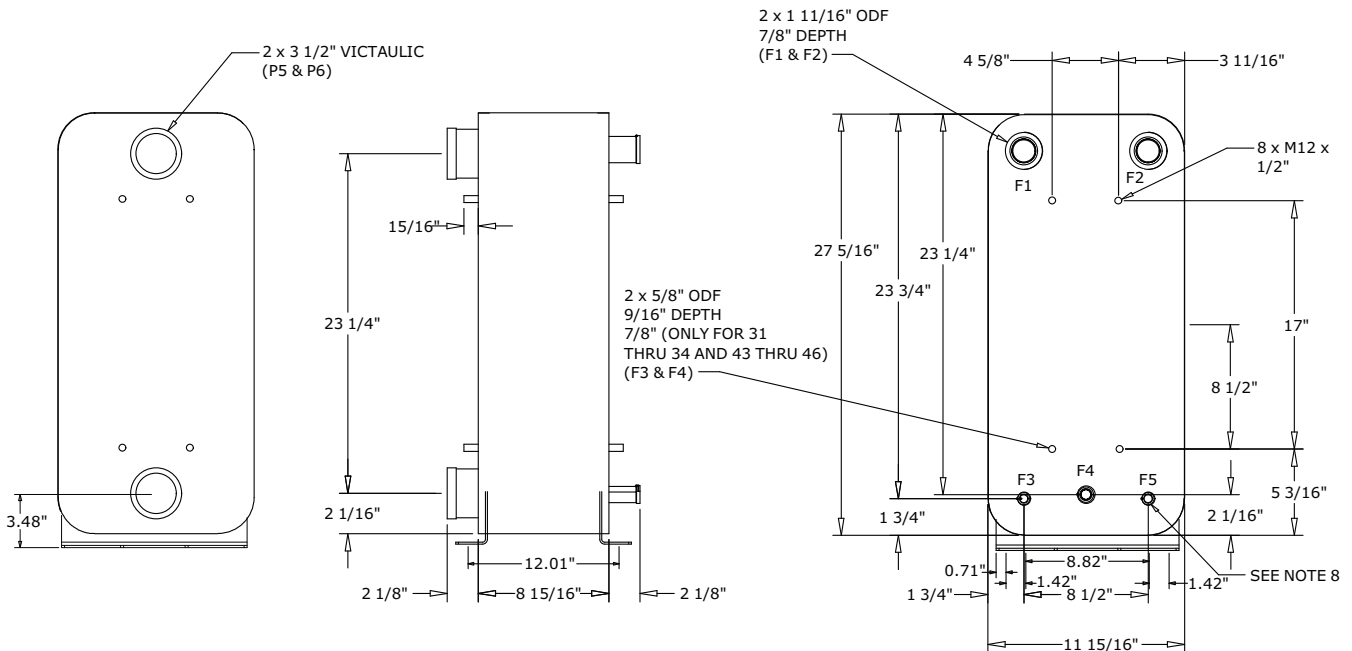

60 TON BRAZED PLATE HEAT EXCHANGER

ACCESSORY DRAWING

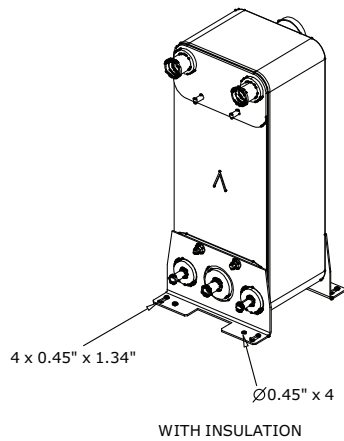
Figure 68. Evaporator chiller — 80 ton

NOTES:

1. THIS HEAT EXCHANGER IS INTENDED FOR INDOOR INSTALLATION ONLY
2. HEAT EXCHANGER MOUNTING LEGS ARE INSTALLED AT JOB SITE WITH SUPPLIED FASTENERS
3. INSULATION SHOULD BE INSTALLED AFTER INSTALLING LEGS & REFRIGERANT TUBING, OR MUST BE ADEQUATELY SHIELDED AGAINST HEAT WHEN BRAZING REFRIGERANT LINES
4. INSTALL INSULATION SIDE PIECES FIRST THEN WRAPPER (MAY REQUIRE TRIMMING)
5. USE VINYL TAPE (FIELD SUPPLIED) TO SEAL INSULATION AFTER INSTALLATION
6. WATER CONNECTIONS ARE GROOVED (VICTAULIC)
7. REFRIGERANT CONNECTIONS ARE STAINLESS STEEL AND REQUIRE SPECIAL BRAZE MATERIALS. SEE IOM BRAZE PROCEDURE.
8. 1/2" - 14 NPT F5 CONNECTION SUPPLIED ON EXT'S 13 THRU 24 AND 37 THRU 48 ONLY.

BRAZED PLATE HEAT EXCHANGER REMOTE CHILLER EVAPORATOR OPTION
OPTION INCLUDES:

1 - BRAZED PLATE HEAT EXCHANGER - SHIPS SEPARATE FROM CONDENSING UNIT

1 - INSTALLATION KIT, TO INCLUDE:

2 - MOUNTING BRACKETS

1 - INSULATION KIT

1 - MOUNTING BRACKET & INSULATION KIT INSTALLATION INSTRUCTIONS

1 - WATER CONNECTION KIT WITH PIPING STUBS, Y CONNECTOR, STRAINER, VICTAULIC CONNECTIONS WITH GASKETS, WATER FLOW SWITCH

1 - WATER CONNECTION KIT INSTALLATION INSTRUCTIONS

INSTALLATION ADDITIONALLY REQUIRES:

EVP REMOTE PANEL WITH LEAVING WATER TEMPERATURE SENSOR, FREEZE-STAT, AND INSTALLATION INSTRUCTIONS

4 - FIELD PROVIDED 7/16" BOLTS FOR SECURING BRAZED PLATE HEAT EXCHANGER TO PERMANENT MOUNTING SURFACE

2 - FIELD PROVIDED 1/2" - 14 NPTE PLUGS, STAINLESS STEEL OR PVC

FIELD PROVIDED TEFLON TAPE FOR SEALING 1/2" PIPE PLUGS

FIELD PROVIDED WATER STRAINER PLUG OR BLOW DOWN VALVE

FIELD PROVIDED TEE FOR INSTALLING WATER FLOW SWITCH

FIELD PROVIDED 2" VINYL TAPE FOR SEALING INSULATION SEAMS

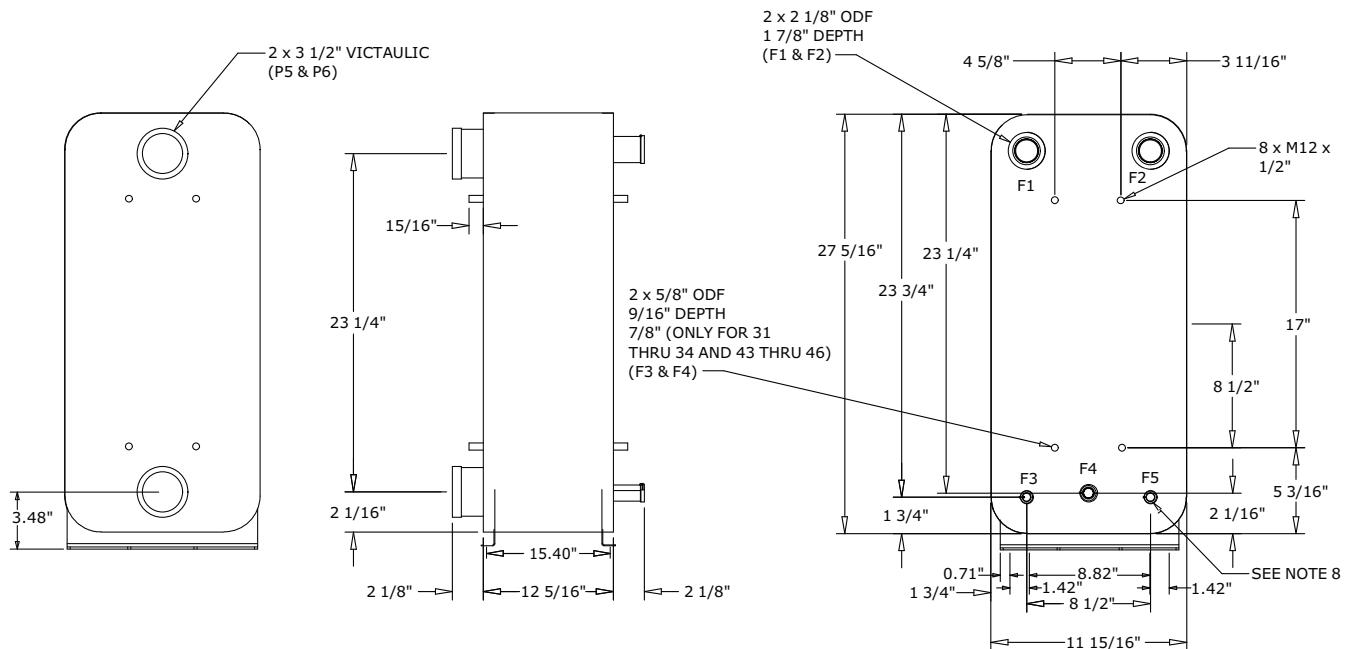
SEE IOM FOR INSTALLATION DETAIL

80 TON BRAZED PLATE HEAT EXCHANGER

ACCESSORY DRAWING

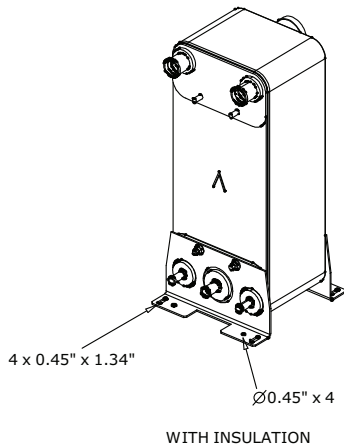

Unit Dimensions

Figure 69. Evaporator chiller — 100 ton



NOTES:

1. THIS HEAT EXCHANGER IS INTENDED FOR INDOOR INSTALLATION ONLY
2. HEAT EXCHANGER MOUNTING LEGS ARE INSTALLED AT JOB SITE WITH SUPPLIED FASTENERS
3. INSULATION SHOULD BE INSTALLED AFTER INSTALLING LEGS & REFRIGERANT TUBING, OR MUST BE ADEQUATELY SHIELDED AGAINST HEAT WHEN BRAZING REFRIGERANT LINES
4. INSTALL INSULATION SIDE PIECES FIRST THEN WRAPPER (MAY REQUIRE TRIMMING)
5. USE VINYL TAPE (FIELD SUPPLIED) TO SEAL INSULATION AFTER INSTALLATION
6. WATER CONNECTIONS ARE GROOVED (VICTAULIC)
7. REFRIGERANT CONNECTIONS ARE STAINLESS STEEL AND REQUIRE SPECIAL BRAZE MATERIALS. SEE IOM BRAZE PROCEDURE.
8. 1/2" - 14 NPT F5 CONNECTION SUPPLIED ON EXT'S 13 THRU 24 AND 37 THRU 48 ONLY.

BRAZED PLATE HEAT EXCHANGER REMOTE CHILLER EVAPORATOR OPTION

OPTION INCLUDES:

- 1 - BRAZED PLATE HEAT EXCHANGER - SHIPS SEPARATE FROM CONDENSING UNIT
- 1 - INSTALLATION KIT, TO INCLUDE:
 - 2 - MOUNTING BRACKETS
 - 1 - INSULATION KIT
 - 1 - MOUNTING BRACKET & INSULATION KIT INSTALLATION INSTRUCTIONS
- 1 - WATER CONNECTION KIT WITH PIPING STUBS, Y CONNECTOR, STRAINER, VICTAULIC CONNECTIONS WITH GASKETS, WATER FLOW SWITCH
- 1 - WATER CONNECTION KIT INSTALLATION INSTRUCTIONS

INSTALLATION ADDITIONALLY REQUIRES:

- EVP REMOTE PANEL WITH LEAVING WATER TEMPERATURE SENSOR, FREEZE-STAT, AND INSTALLATION INSTRUCTIONS
- 4 - FIELD PROVIDED 7/16" BOLTS FOR SECURING BRAZED PLATE HEAT EXCHANGER TO PERMANENT MOUNTING SURFACE
- 2 - FIELD PROVIDED 1/2" - 14 NPT PLUGS, STAINLESS STEEL OR PVC
- FIELD PROVIDED TEFLON TAPE FOR SEALING 1/2" PIPE PLUGS
- FIELD PROVIDED WATER STRAINER PLUG OR BLOW DOWN VALVE
- FIELD PROVIDED TEE FOR INSTALLING WATER FLOW SWITCH
- FIELD PROVIDED 2" VINYL TAPE FOR SEALING INSULATION SEAMS

SEE IOM FOR INSTALLATION DETAIL

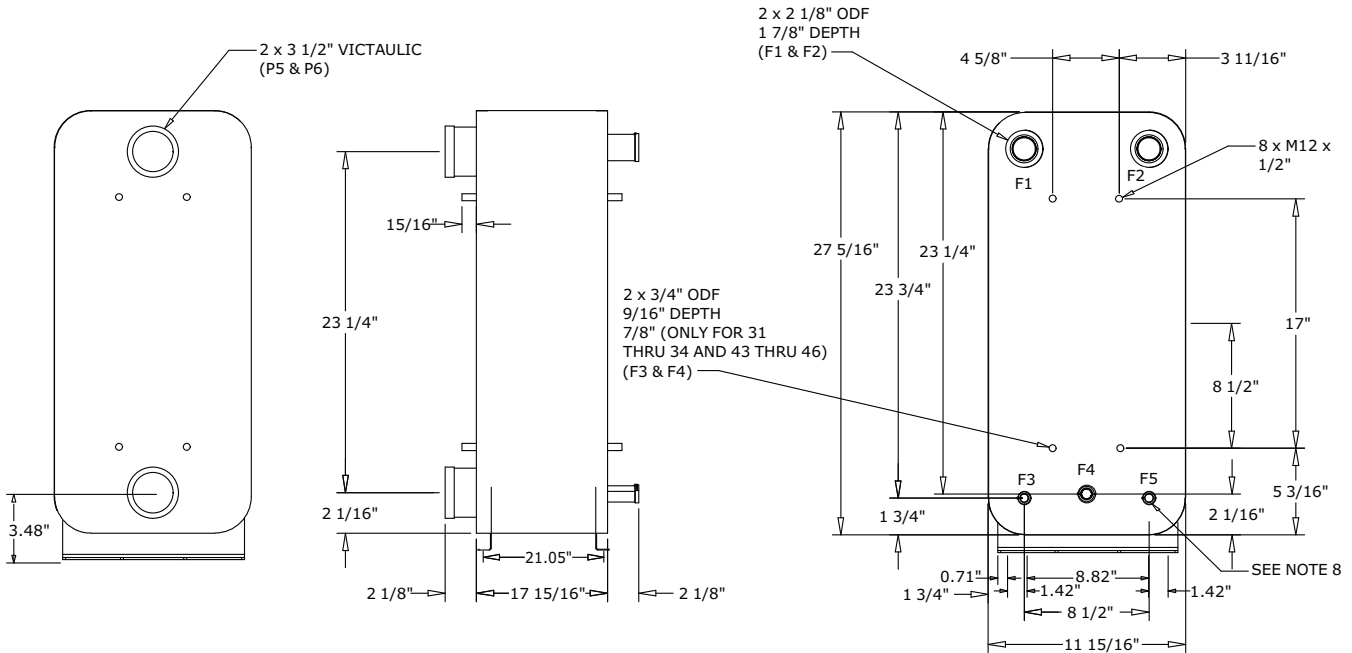

100 TON BRAZED PLATE HEAT EXCHANGER

ACCESSORY DRAWING

Figure 70. Evaporator chiller — 120 ton

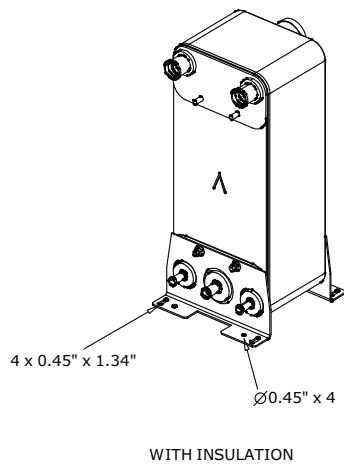

NOTES:

1. THIS HEAT EXCHANGER IS INTENDED FOR INDOOR INSTALLATION ONLY
2. HEAT EXCHANGER MOUNTING LEGS ARE INSTALLED AT JOB SITE WITH SUPPLIED FASTENERS
3. INSULATION SHOULD BE INSTALLED AFTER INSTALLING LEGS & REFRIGERANT TUBING, OR MUST BE ADEQUATELY SHIELDED AGAINST HEAT WHEN BRAZING REFRIGERANT LINES
4. INSTALL INSULATION SIDE PIECES FIRST THEN WRAPPER (MAY REQUIRE TRIMMING)
5. USE VINYL TAPE (FIELD SUPPLIED) TO SEAL INSULATION AFTER INSTALLATION
6. WATER CONNECTIONS ARE GROOVED (VICTAULIC)
7. REFRIGERANT CONNECTIONS ARE STAINLESS STEEL AND REQUIRE SPECIAL BRAZE MATERIALS. SEE IOM BRAZE PROCEDURE.
8. 1/2" - 14 NPT F5 CONNECTION SUPPLIED ON EXT'S 13 THRU 24 AND 37 THRU 48 ONLY.

BRAZED PLATE HEAT EXCHANGER REMOTE CHILLER EVAPORATOR OPTION

OPTION INCLUDES:

- 1 - BRAZED PLATE HEAT EXCHANGER - SHIPS SEPARATE FROM CONDENSING UNIT
- 1 - INSTALLATION KIT, TO INCLUDE:
 - 2 - MOUNTING BRACKETS
 - 1 - INSULATION KIT
 - 1 - MOUNTING BRACKET & INSULATION KIT INSTALLATION INSTRUCTIONS
- 1 - WATER CONNECTION KIT WITH PIPING STUBS, Y CONNECTOR, STRAINER, VICTAULIC CONNECTIONS WITH GASKETS, WATER FLOW SWITCH
- 1 - WATER CONNECTION KIT INSTALLATION INSTRUCTIONS

INSTALLATION ADDITIONALLY REQUIRES:

- EVP REMOTE PANEL WITH LEAVING WATER TEMPERATURE SENSOR, FREEZE-STAT, AND INSTALLATION INSTRUCTIONS
- 4 - FIELD PROVIDED 7/16" BOLTS FOR SECURING BRAZED PLATE HEAT EXCHANGER TO PERMANENT MOUNTING SURFACE
- 2 - FIELD PROVIDED 1/2" - 14 NPTE PLUGS, STAINLESS STEEL OR PVC
- FIELD PROVIDED TEFLON TAPE FOR SEALING 1/2" PIPE PLUGS
- FIELD PROVIDED WATER STRAINER PLUG OR BLOW DOWN VALVE
- FIELD PROVIDED TEE FOR INSTALLING WATER FLOW SWITCH
- FIELD PROVIDED 2" VINYL TAPE FOR SEALING INSULATION SEAMS

SEE IOM FOR INSTALLATION DETAIL

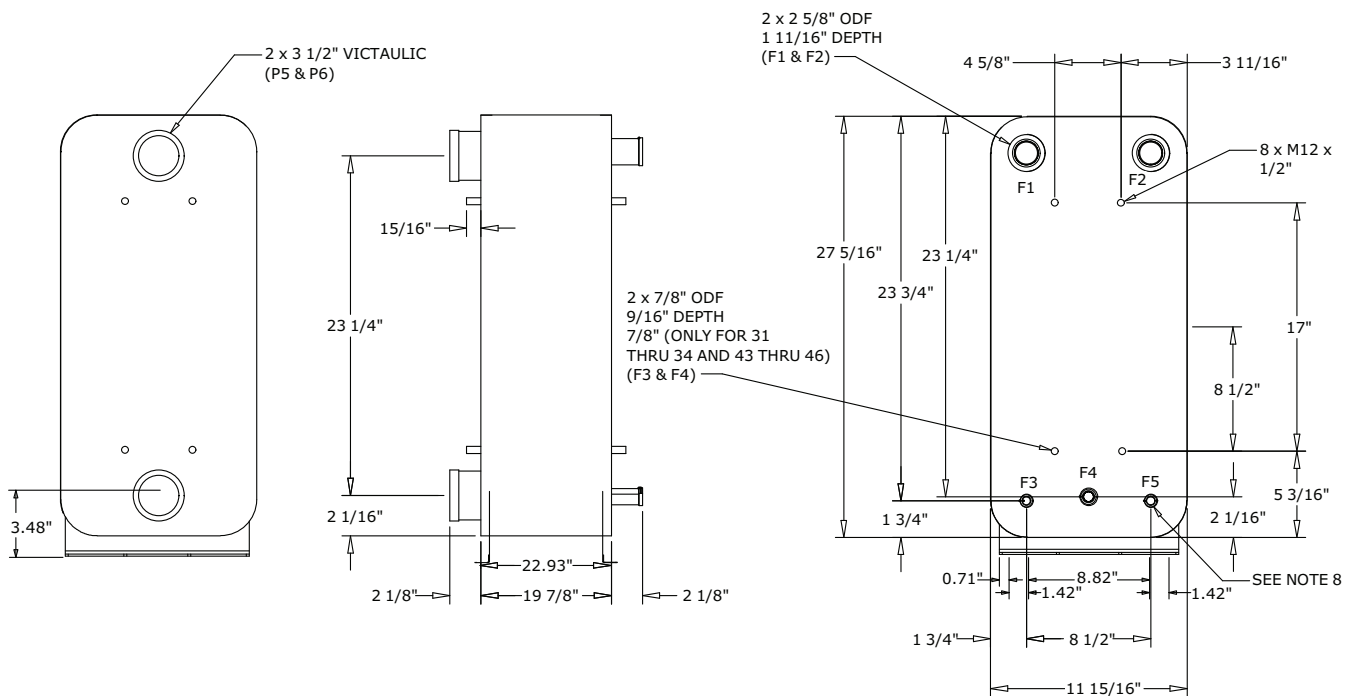

120 TON BRAZED PLATE HEAT EXCHANGER

ACCESSORY DRAWING



Unit Weights

Table 8. IntelliCore condensing unit weights

Unit Size (tons)	Operating Weights (lb) – R-410A	Operating Weights (lb) – R-454B
20	1783	1762
25	1843	1810
30	1875	1989
40	3028	3040
50	3380	3380
60	3355	3375
80	5129	5129
100	5811	5811
120	6310	6310

Table 9. EVP remote chiller weights

Unit Size (tons)	Weights (lbs)			
	Shipping		Operating	
	R-410A	R-454B	R-410A	R-454B
20	54	54	67	67
25	86	86	105	105
30	116	112	144	140
40	92	124	134	176
50	138	138	207	207
60	160	160	245	245
80	212	212	332	332
100	298	298	475	475
120	327	327	524	524



Mechanical Specifications

Air-Cooled Condensing Unit — Model RAUK

General

All air-cooled condensing units shall have scroll compressors and are factory assembled and wired. Each unit shall ship from the factory with a nitrogen holding charge. Units shall be constructed of 14-gauge welded galvanized steel frame with 14 and 16-gauge galvanized steel panels and access doors. Units shall have factory mounted, louvered, full-length steel grilles to protect the condenser coils and piping. Unit surface shall be finished with an air-dry paint. This air-dry paint finish shall be durable enough to withstand a minimum of 672-consecutive-hour salt spray application in accordance with standard ASTM B117.

Refrigeration Circuits

The 20 to 30 ton units shall be single circuit. The 40 to 120 ton units shall be dual circuited.

Symbio 800 Controller

The Symbio™ 800 controller is an application-specific, programmable controller that is factory installed and designed to control packaged HVAC equipment. A seven-inch user interface features a touch-sensitive color screen that provides facility managers with at-a-glance operating status, performance monitoring, scheduling changes, and operating adjustments. Other advanced features include automated controller backup and optional features such as secure remote connectivity, wireless building communications, mobile device connectivity, and custom programming with expandable I/O.

Unit control

Factory shall provide 115-volt control circuit which includes fusing and control power transformer. The unit shall be wired with magnetic contactors for compressor and condenser motors and high pressure cutouts. Charge isolation, reset relay and anti-recycle compressor timer shall be provided. Across-the-line start is standard.

Phase Monitor

The unit shall be equipped with a phase monitor in the control box. The phase monitor shall protect against phase loss, imbalance and reversal of the line voltage.

Compressor

Trane® 3-D™ Scroll compressors shall have a simple mechanical design. Scroll type compression shall provide low vibration. 3-D compressors shall provide a completely enclosed compression chamber with no leakage paths. The compressor shall be suction gas cooled, direct drive, with 3600 RPM hermetic motors. The Scroll compressor shall include a centrifugal oil pump, oil level sight glass, and an oil charging valve.

Split systems can have significantly more refrigerant than packaged systems and thus require controls to reliably manage this excess refrigerant. Each compressor shall have crankcase heaters installed, properly sized to minimize the amount of liquid refrigerant present in the oil sump during off cycles. Additionally, the condensing unit shall have controls to initiate refrigerant Isolation at system shut down on each refrigerant circuit. To be operational, the refrigerant Isolation cycle requires a field-installed isolation solenoid valve on the common liquid line near the evaporator.

Condenser Coils

Condenser coils shall have all aluminum microchannel coils. All coils shall be leak tested at the factory to ensure pressure integrity. The condenser coil shall be pressure tested to 650 psig.

Condenser Fans

All condenser fans shall be vertical discharge, direct drive fans, statically balanced, with aluminum blades and zinc plated steel hubs. Condenser fan motors shall be three-phase motors with permanently lubricated ball bearings, built in current and thermal overload protection and weather-tight slingers over motor bearings.

Leak Detection Sensors

The condenser section shall accept an isolated closure input suitable for customer connection to hard wire the leak detection system in the paired air handler or mechanical room.



Options

BACnet Communication Protocol

Remote condenser controller communication interface shall use the BACnet® protocol with an Ethernet (IEEE 802.3) or RS485 (EIA-485) physical interface and an appropriate data link technology as defined in ANSI®/ASHRAE® Standard 135-2012 (for example, BACnet/IP, BACnet/MSTP). The rooftop controller shall be BTL listed as a BACnet Advanced Application Controller (B-AAC) as defined in ANSI/ASHRAE Standard 135-2012.

Modbus Communication Protocol

The Symbio™ 800 controller shall support standard Modbus® RTU communication protocol through an RS485 two wire communication link. Modbus TCP communication protocol is supported through an Ethernet connection.

Controls Expansion Hardware

Symbio™ 800 offers field applied custom programming controls capability through additional inputs/outputs using XM70 expansion modules.

XM70 shall have 19 universal connections (inputs/outputs) and can be factory or field installed.

Rapid Restart Option

The Rapid Restart option provides immediate startup upon power failure. Rapid Restart shall begin immediately after recovery from a power loss and work by restarting the compressors and supply fan quickly to provide full cooling within three to four minutes.

Low Ambient Control

Low ambient option shall allow operation down to 0°F through the use of fan cycling and head pressure control dampers. The control shall consist of a heavy gauge damper assembly that is modulated by an actuator. The actuator shall be controlled by measured head pressure. All components are factory-mounted.

Non-Fused Unit Disconnect Switch

A non-fused disconnect switch shall be mounted in the control box and provides for interruption of power for servicing the unit. Lugs shall be suitable for copper wires only. No overcurrent or short circuit protection shall be provided for unit by this switch. Option shall include external handle to allow power disconnection without having to open the control box door.

Hot Gas Bypass Valve

The hot gas bypass valve shall modulate hot gas to the inlet of the evaporator when suction pressure falls below the valve adjustable set point. Electronic versions shall be available with control through temperature or pressure. Hot gas bypass valves shall be shipped with the unit for field installation.

(Model: Sporlan, SHGBE-8)

Note: For 40T to 120 ton units, two valves will need to be field installed (1 per circuit). For all other systems, one valve will need to be field installed.

Suction Service Valve

Option shall consist of a refrigerant shutoff valve to isolate the compressor for servicing.

Pressure Gauges

Pressure gauges shall be provided for monitoring suction and discharge pressure. One set shall be provided for each circuit. The gauges shall be ship-with for field installation.

Corrosion Protected Condenser Coil

All Aluminum Microchannel condenser coil protection shall consist of a corrosion resistant coating that shall withstand ASTM B117 Salt Spray test for 6000 hours and ASTM G85 A2 Cyclic Acidified Salt Fog test for 2400 hours. This coating shall be added after coil construction covering all tubes, headers and fin edges, therefore providing optimal protection in more corrosive environments.

Spring Isolation Package

Spring vibration isolators shall be supplied for field installation under the unit base to minimize transmission of unit vibrations. Isolators shall consist of a cast, spring loaded, telescoping housing as the isolation medium. Mountings shall include built-in leveling bolts, resilient inserts that act as centering guides, and ribbed neoprene acoustical pads bonded to the bottom of the isolator. The kit shall include instructions for field installation.

Neoprene Vibration Isolation Package

Neoprene-in shear isolators shall be supplied for field installation under the unit base to minimize transmission of unit vibration. The isolators shall consist of a steel top plate and base completely imbedded in color coded oil-resistant neoprene stock. Mountings shall have a 1/4-inch deflection. The kit shall include instructions for field installation. (Available on 20 to 60 ton units only).

Remote Evaporator Chillers — Model EVP

The remote chiller control option shall include a terminal strip in the main unit control box and a remote mounted panel that is customer installed. The remote chiller accessory kit shall include the evaporator with mounting hardware and insulation, water strainer, minimum water flow limit switch and water side pipe stubs with couplings. The remote chiller accessory kit does not include a leak detection sensor, or related controls. For unit operation a field supplied leak detection sensor and related controls must be provided. The chiller shall be a stainless steel brazed plate heat exchanger designed for up to 150 psig water side working pressure and 430 psig refrigerant working pressure. Chiller mounting shall be intended for non-freezing locations.

Flow Switch

The flow switch shall be provided for applications where the condensing unit is used with a remote evaporator chiller. This option shall be a ship-with item for field installation. The switch shall prohibit compressor start-up and operation, if the water flow through the chiller is not adequate.

Unpowered convenience outlet

Option shall include a factory installed GFCI, 20 amp, 115 volt, 2 plug, unpowered convenience outlet.

Powered convenience outlet

Option shall include a factory installed 15 amp, 115 volt ground fault interrupter convenience outlet with a single point power entry from a factory mounted transformer. Option shall meet NEC 210-63 requirements. This outlet shall include a separate disconnect switch so that the outlet is powered when the unit disconnect switch is off. The unit mounted non-fused disconnect switch option with external handle is required when ordering the convenience outlet.

Unit Interrupt Rating (Short Circuit Current Rating)

A standard SCCR of 5,000 amps shall be applied to the unit enclosure. A high fault SCCR option is available that provides a 65,000A SCCR for 200V, 230V, and 460V units; 35,000A SCCR for 575V units.



Trane - by Trane Technologies (NYSE: TT), a global innovator - creates comfortable, energy efficient indoor environments for commercial and residential applications. For more information, please visit trane.com or tranetechnologies.com.

Trane has a policy of continuous product and product data improvements and reserves the right to change design and specifications without notice. We are committed to using environmentally conscious print practices.

SS-PRC058C-EN 17 Jul 2026
Supersedes SS-PRC058B-EN (May 2025)

©2026 Trane