



Product Catalog

Split System Air Conditioners Odyssey™ with Symbio™ Controls

R-410A Dry Charge, Cooling Condenser
6, 7.5, 10, 12.5, 15, 20 and 25 Tons, 60 Hz





Introduction



Odyssey™ Split Systems offer a wide range of options, allowing you to easily match unit tonnage with the right load requirements.

When a project calls for the convenience and cost efficiency of a unitary product, where a rooftop unit isn't right, Odyssey may be the answer. It provides heating and cooling in a split configuration that's unique in its versatility while staying true to our standards for efficiency and reliability. And with the Symbio® digital controller on board, Odyssey introduces smart building capabilities that take service, comfort and sustainability beyond the expected.

With wide network availability, flexible applications, installation ease, built-in reliability and easy servicing, Odyssey will meet any number of customer applications. Add to that Trane's outstanding customer service and you have the formula to make Odyssey the clear choice for continued customer satisfaction.

Wide Network Availability

A broad distribution network provides owners, maintenance personnel, contractors, etc., the means to get their hands on equipment when they need it. Whether it's an emergency replacement or a new construction project in its infancy stages, Odyssey products meet an array of needs at the right time and right price.

Flexible Applications

No matter what the application, Odyssey provides the solution. A broad array of models and tonnages are available with single or dual compressors, single or dual circuits and numerous accessories. Condensing units can be installed on the ground or on a rooftop along with extended piping runs, while air handlers can be free discharge on the ground or horizontally suspended with long duct runs from a ceiling. Should application challenges arise, Odyssey delivers.

Easy to Install

Small footprints and low weights combined with factory installed components like TXVs, filter driers, etc., reduce installation time and cost. Colored connectors and wiring, as well as factory-tested units make Odyssey the right choice.

Built-in Reliability

Keeping in mind that productivity only occurs when equipment is operational, Trane has taken the steps to ensure that Odyssey is up and running. Early indicators such as phase/reversal monitors and loss of charge protection provide diagnostics which prevent failure and provide years of worry-free service and operation.

Easy to Service

When preventive maintenance or service is required, technicians will find efficient access to both air handlers and condensers. Panels provide complete, easy access coupled with standardized cabinets in which all components are located in proximity. Odyssey's improved design results in minimum service times and costs.

With these capabilities, Odyssey provides customers high efficiency and superior performance for the best all-around value in the market today.

Copyright

This document and the information in it are the property of Trane, and may not be used or reproduced in whole or in part without written permission. Trane reserves the right to revise this publication at any time, and to make changes to its content without obligation to notify any person of such revision or change.

Trademarks

All trademarks referenced in this document are the trademarks of their respective owners.



Table of Contents

Features	6
Split System Overview.....	6
Other Features	7
Standard and Optional Features	7
Standard Controls	11
Additional Controls	12
Accessories	13
Cooling Condenser	13
Air Handler.....	14
Electric Heaters	15
Application Considerations	17
Clearance Requirements	17
180° Blower Rotation.....	17
Low Ambient Cooling.....	17
Selection Procedure	19
Cooling Capacity	19
Heating Capacity	19
Air Delivery	20
Model Number Description	21
Cooling Condenser	21
Air Handler.....	22
General Data	23
Performance Data	30
Gross Cooling Capacities	30
Fan Performance	64
Zone Controls	95
Zone Sensors	95
Conventional Thermostats	95
Electrical Data	96
Cooling Condenser	96
Air Handler.....	98
Jobsite Connections	106
Symbio™ Controls	106

Dimensional Data	108
Cooling Condenser	108
Air Handler	116
Accessories	124
Weights	131
Cooling Condenser	131
Air Handler	132
Mechanical Specifications	135
Condensing Units	135
Air Handlers	138



Features

Split System Overview

Unlike typical split systems on the market, Odyssey offers easy servicing, built-in reliability, ease of installation and outstanding customer service. And because today's owners are very cost-conscious when it comes to service and maintenance, the Odyssey Split System was designed with direct input from service contractors. This valuable information helped to design a product that would get the service person off the job quicker and save the owner money.

Flexible Applications

Odyssey offers outstanding standard features enhanced by a variety of factory and field installed options, multiple control options, rigorously tested proven designs and superior product and technical support. Because of this, Odyssey offers ultimate flexibility. Units are built to order in our standard "shortest in the industry" ship cycle time. Odyssey is available with single, dual and manifolded compressor options. Single compressor outdoor units feature a single refrigeration circuitry, lowering job installation costs by requiring only one set of refrigerant lines.

Equally important, Odyssey offers single refrigerant circuit/capacity unloading models. The unloading units feature dual manifolded scroll compressors with two stages of capacity modulation and a single refrigeration circuit. Dual compressor/dual circuit models give true stand-by protection - if one compressor fails, the second will automatically start-up. Also, the first compressor can be serviced without shutting down the unit since the refrigerant circuits are independent. Dual compressor models also save on energy costs. During light load conditions, only one compressor will operate to save energy.

Factory installed VFD is standard with most units. These 2-Speed and Single Zone VAV (SZVAV) solutions, combined with condensing units that have multiple compressors, provide increased part load performance (IEER) when conditions are not at the max design condition. Additionally, some states have adopted codes that require this type of performance. Odyssey units are built with installation in mind. With a smaller footprint, the outdoor unit takes up less space and weighs less, making its installation more efficient and economical. Our indoor air handlers are built to be installed in confined spaces, fitting through standard doorways and freight elevators.

Unmatched Product Support

One of our finest assets, Trane Sales Representatives are a support group that can assist you with:

- Product
- Application
- Service
- Training
- Special Applications
- Specifications
- Computer Programs and much more

Rigorous Testing

Our units are rigorously rain tested to ensure water integrity. Actual shipping tests are performed to determine packaging requirements. Units are test shipped around the country to determine the best packaging. Factory shake and drop tests are used as part of the package design process to help assure that the unit arrives at the job site in top condition. Rigging tests include lifting a unit into the air and letting it drop one foot, assuring that the lifting lugs and rails hold up under stress. A 100% coil leak test is performed at the factory. The condenser coils are leak tested at 660 psig and evaporators to 450 psig. All parts are inspected at the point of final assembly. Sub-standard parts are identified and rejected immediately. Every unit receives a 100% unit run test before leaving the production line to ensure it lives up to rigorous Trane requirements.

Other Features

Microchannel Condenser Coil

Microchannel condensing coils are all-aluminum coils with fully-brazed construction. This design reduces risk of leaks and provides increased coil rigidity — making them more rugged on the jobsite. Their flat streamlined tubes with small ports and metallurgical tube-to-fin bond allow for exceptional heat transfer. Microchannel all-aluminum construction provides several additional benefits:

- Light weight (simplifies coil handling)
- Easy to recycle
- Minimize galvanic corrosion

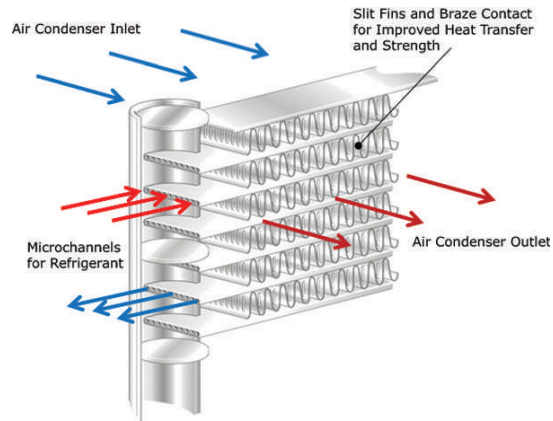

Standard and Optional Features

Figure 1. Compressors

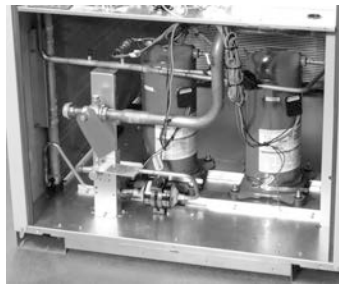
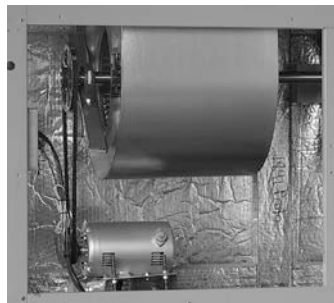

Figure 2. Belt drive motor



2-Speed VFD — A variable frequency drive is used to reduce the supply fan motor speed to 66% of its full capacity during part load cooling conditions.

Airflow Distribution — Odyssey can replace an older machine with old ductwork and, in many cases, improve the comfort through better air distribution.

Anti-Short Cycle Timing — The Symbio™ 700 controller provides a 3 minute minimum “ON” time and 3 minute “OFF” time for compressors to enhance compressor reliability by assuring proper oil return.

Belt Drive Motors — For additional static requirements, Odyssey Split Systems offer standard belt drive motors to meet and exceed a wide range of airflow needs.

Coil Guards — Coil Guards are standard with all condensers. This feature protects the condenser coil from vandalism and/or hail damage.



Colored Connectors and Wiring — Interconnecting wiring between components is standardized using colored and keyed connectors and colored wires, helping to save time and money tracing wires and diagnosing the unit.

Compressors — Odyssey Split Systems contain the best compressor technology available to achieve the highest possible performance. Dual compressors perform very well under part load cooling conditions and system back-up applications. Dual compressors are available on 6-25 ton models and allow for efficient cooling utilizing 2-stages of compressor operation.

Complete Coat™ Microchannel Condenser Coil — This cathodic, epoxy-type electro-disposition coating is formulated for high edge builds and provides excellent resistance and durability in potentially corrosive environments due to alkalies, acids, alcohols, petroleum, seawater, salty air, etc. Available for Microchannel units only.

Convertible Units — The air handlers ship in a horizontal configuration. They can be easily converted to vertical by simply repositioning the drain pan.

Crankcase Heaters — These band heaters provide improved compressor reliability by warming the oil to prevent migration during off-cycles or low ambient conditions.

Dual Sloped Drain Pans — Every Odyssey unit has a non-corrosive, removable, double sloped drain pan that's easy to clean and reversible to allow installation of drain trap in two positions on either side of the unit.

Duct flanges — An optional field installed kit that can save time and money.

Easy Access Low Voltage Connections — Thermostat and other low voltage control wiring connections are made directly to the Symbio 700 and other boards in the system. Screw-type pressure connectors are detachable from the boards for easy connection of control wires – saving cost and time.

Electric Heaters — Electric heat modules are available in a variety of voltages and capacities.

Foil Faced Insulation — All internal air handler surfaces have cleanable foil-faced insulation. All edges are either captured or sealed to ensure insulation fibers do not get into the airstream.

High Static Motor — This high static motor accessory extends the capability of the standard unit.

High and Low Voltage Control Panel — High voltage components and connections are isolated from low voltage and covered with a sheet metal panel. This allows setup and test parameters at the Symbio™ 700 display and the VFD keypad display to be safely viewed and adjusted in the low voltage section of the control panel.

High Pressure Control — All units include High Pressure Control as standard.

Low Ambient Cooling — All Odyssey units have cooling capabilities down to 0°F as standard. At temperatures below 55°F for single compressor units and 40°F for dual compressor units, some reduction in cooling capacity can be expected. When the optional Low Ambient Accessory kit is field installed, the full capacity of the unit is available down to 0°F.

Low Voltage Connections — Low voltage wiring connects directly to the control boards in the unit via detachable connectors. This makes it easy for the installer to attach the wires and then snap the connectors into place.

Phase Monitor/Reversal Protection — Phase monitor shall provide 100% protection for motors and compressors against problems caused by phase loss, phase imbalance, and phase reversal. Phase monitors are equipped with an LED that provides an ON or FAULT indicator.

ID Fan Fail — The Symbio™ 700 controller provides a ID fan fail feature caused by belt failure and motor freewheeling under no load. The Variable Frequency Drive records the motor torque and if below a certain value shuts the unit. Fan Fail error is displayed on controller display.

Quick-Access Panels — Remove a few screws for access to the standardized internal components and wiring.

Single Point Power — A single electrical connection powers the unit.

Single Side Service — Single side service is standard on all units.

Single Zone Variable Air Volume (SZVAV) — A variable frequency drive is used in conjunction with the Symbio™ 700 to provide supply fan motor speed modulation. For SZVAV control, the drive will accelerate or decelerate as required to meet the Zone Cooling demand. In order to maximize energy

savings, the VFD will be held at minimum speed until the load in the zone requires the speed to increase. The supply fan speed will be reduced to a minimum of 58%¹ during ventilation and part load cooling demands, and 80% during full load cooling demands with the ability to fully modulate. The commissioning maximum and minimum airflow points can be easily set by programming these parameters at the display on the Symbio control board.

Standardized Components — Components are placed in the same location on all Odyssey units. Because of these standardized components throughout the Odyssey line, contractors/owners can stock fewer parts.

Symbio™ 700 — Standard on Odyssey condensers, the Symbio™ 700 controller provides exceptional machine control with a focus on system reliability and application flexibility. The Symbio controller provides direct access to the Symbio Service and Installation mobile application for easy setup and troubleshooting with no special tools. A wide range of system integration options (Non-communicating, BACnet®, LonTalk®, etc.) provide options to meet the needs of your application.

Thermal Expansion Valve with Bypass Check Valves — This feature is standard on all indoor units.

Unit Cabinet — The compact cabinet takes up less room and is less costly to ship. The design also ensures water integrity.

¹. 64% for part load and 83% for full load if a max speed of less than 44.5 Hz is desired.



Features

Table 1. Odyssey features – standard and optional

	Standard Features	Options ^(a)	
		Factory Installed	Field Installed
1-year Limited Parts Warranty	X		
5-year Limited Compressor Warranty	X		
2-Speed Variable Frequency Drive		X	
Belt Drive Motors	X		
Coil Guards	X		
Colored Connectors and Wiring	X		
Complete Coat™ Microchannel Condenser Coil		X	
Compressor Discharge Temperature Limit (DTL)	X		
Convertible Airflow	X		
Crankcase Heaters	X		
Easy Access Low Voltage Connections	X		
Electric Heaters			X
Filters	X		
Filters – 2" MERV 13			X
Foil-Faced and Edge Captured Insulation	X		
High Pressure Control	X		
High Static Motor Kit ^(b)			X
Hot Gas Bypass			X
IAQ Dual Sloped and Removable Drain Pans	X		
Low Ambient Cooling			X
Liquid Line Refrigerant Drier	X		
Low Pressure Control	X		
Low Static Motor Kit ^(b)			X
Low Voltage Circuit Protection	X		
Phase Loss/Reversal Monitor	X		
Quick Access Panels	X		
Scroll Compressors	X		
Single Point Power	X		
Single Side Service	X		
Single Zone Variable Air Volume (SZVAV / 2-Speed Fan)		X	
Standardized Components	X		
Symbio™ Controls	X		
Thermal Expansion Valve	X		
Vibration Isolators			X

^(a) Refer to model number description for option availability or contact Product Support.

^(b) Available on constant volume units only. See Accessories chapter for more information.

Standard Controls

Symbio™ 700 Controls

Figure 3. Symbio 700 board



Symbio 700 controls provide unit control for heating, cooling, and ventilating, utilizing input from sensors that measure outdoor and indoor temperature. Symbio also provides outputs for building automation systems and expanded diagnostics. Quality and reliability are enhanced through Symbio control and logic:

- Prevents the unit from short cycling, considerably improving compressor life.
- Ensures the compressor will run for a specific amount of time which allows oil to return for better lubrication, enhancing the reliability of the compressor.
- Reduces the number of components required to operate the unit, reducing possibilities for component failure.

Installation and Service

The Symbio™ 700 control platform provides a user-friendly, onboard interface that makes setup and continued operation easy – or users can take advantage of the Symbio™ Service and Installation Mobile App for setup, troubleshooting, and operation. Both the Symbio onboard user interface and mobile app simplify troubleshooting by displaying active alarms. Symbio eliminates the need for field-installed, anti-short cycle timer and time delay relays. The wiring of the low voltage connections to the unit and zone sensors is simple, making installation easy.

Testing

Symbio™ 700 requires no special tools to run the unit through its paces. Simply navigate to the ‘Service’ section of the user interface or the ‘Utilities’ section of the Symbio™ Service and Installation Mobile App and enter the test section. Here the unit can be placed in the desired operating condition for a pre-determined amount of time supporting troubleshooting efforts in the field. The Symbio 700 will return to normal control when the user exits test mode or when the pre-determined, user-selected Service Test time has expired.

Other Benefits

- Symbio™ 700 built-in anti-shortcycle timer, time delay relay and minimum “on” time control functions are factory tested to assure proper operation.
- Symbio 700 softens electrical “spikes” by staging on fans, compressors and heaters.
- Intelligent Fallback is a benefit to the building occupant. If a component goes astray, the unit will continue to operate at predetermined temperature setpoint.

- Intelligent Anticipation is a standard feature. It functions continuously as Symbio 700 and zone sensor(s) work together in harmony to provide much tighter comfort control than conventional electromechanical thermostats.
- The Symbio 700 design is standardized across the board, ensuring a lower cost to owners.

Additional Controls

VariTrac® Building Automation System — When Trane’s changeover VAV System for light commercial applications is coupled with the unit, it provides the latest in technological advances for comfort management systems and can allow thermostat control in every zone served by VariTrac.

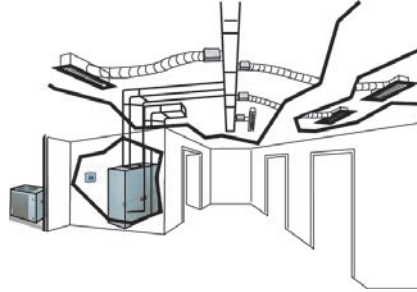

Froststat™ — This control (a standard feature on all air handlers) utilizes a capillary bulb embedded in the face of the evaporator coil which monitors coil temperature to inhibit evaporator icing and protect the compressor. Useful for applications with low leaving air temperatures, low airflow and/or high latent load applications.

LonTalk® Communications Interface — The LonTalk communications interface allows the unit to communicate as a Tracer LON® device or directly with generic LonTalk Network Building Automation System Controls.

BACnet® Communication Interface (BCI) — The BACnet Communication Interface allows the unit to communicate directly with a generic open protocol BACnet MS/TP or IP Network Building Automation Control System.

Zone Sensors/Thermostats— Available in programmable, automatic and manual styles.

Table 2. Odyssey control options – standard and optional

	Standard Features	Options ^(a)	
		Factory Installed	Field Installed
BACnet® Communication Interface (BCI)		X	
Froststat™ - Evaporator Defrost Control (EDC)	X		
LonTalk® Communications Interface (LCI)		X	X
Symbio™ 700 Microprocessor Controls	X		
Thermostat			X
Zone Sensor			X

^(a) Refer to model number description for option availability or contact Product Support.



Accessories

Cooling Condenser

Table 3. TTA accessories

Model	Used With
Universal Hot Gas Bypass Kit	
BAYHGBP010*	All models
Rubber Isolators	
BAYISLT004* (blue)	TTA072, TTA090
BAYISLT005* (black)	TTA120
BAYISLT009* (red)	TTA150, TTA180
BAYISLT010* (green)	TTA240, TTA300
Steel Spring Isolators	
BAYISLT023* (red)	TTA072, TTA090, TTA120**A
BAYISLT024* (black)	TTA120**C/D, TTA150, TTA180
BAYISLT025* (yellow)	TTA240, TTA300
Service Valve Kit	
BAYVALV020*	TTA0724*A, TTA0904*A, TTA1204*A/C
BAYVALV022*	TTA0724*D, TTA0904*D, TTA1204*D
BAYVALV023*	TTA1504*D
BAYVALV024*	TTA1804*D, TTA2404*D
BAYVALV026*	TTA1804*C, TTA2404*C
BAYVALV027*	TTA3004*C
Low Ambient — On/Off Fan Control^{(a) (b)}	
BAYLOAMS10* (External Mount, small cabinets) ^(c)	(all voltages) TTA072, TTA090, TTA120, TTA150
BAYLOAMS20* (Internal mount, large cabinets)	(all voltages) TTA180, TTA240, TTA300
Transducer Kit for Head Pressure Control (BAYLOAMS10*)	
BAYLOTR001* ^(d)	TTA072**D, TTA090**D, TTA120**D, TTA150**D
LonTalk Communications Interface^(e)	
BAYLTCI005*	All Models
Expansion Module Kit	
BAYMODU002* (XM30)	All Models
BAYMODU004* (XM32)	All Models

(a) Cycles fan on/off (no modulating).

(b) When BAYLOAM is used, the Evaporator Defrost Control (EDC) must be disabled in the Symbio 700 controller configuration.

(c) Kit mounts external to the outdoor unit and operates by sensing ambient temperature and discharge pressure.

(d) BAYLOTR001* required when BAYLOAMS10* kits are used with units that have 2 compressors (dual circuit) and 1 condenser fan.

(e) Field installed LonTalk interface requires installation of Symbio control board with Advanced Diagnostics (not included).



Accessories

Air Handler

Table 4. TWE Accessories

Model	Used With
Base (Subbase)	
BAYBASE009*	TWE060
BAYBASE0010*	TWE072, TWE090
BAYBASE0011*	TWE120
BAYBASE0012*	TWE150, TWE180
BAYBASE0013*	TWE240, TWE300
Drip Kit	
BAYDRKT006*	TWE060
BAYDRKT007*	TWE072, TWE090
BAYDRKT008*	TWE120
BAYDRKT009*	TWE150, TWE180
BAYDRKT010*	TWE240, TWE300
Duct Flange Kit	
BAYDUCT010*	TWE051, TWE060, TWE072, TWE076, TWE090, TWE101, TWE120
BAYDUCT020*	TWE126, TWE150, TWE156, TWE180, TWE201, TWE240, TWE251, TWE300
Filters – 2" MERV 13	
BAYFILT006*	TWE060
BAYFILT007*	TWE072, TWE090
BAYFILT008*	TWE120
BAYFILT009*	TWE150, TWE180
BAYFILT010*	TWE240, TWE300
Rubber Isolators^(a) (b) (c)	
BAYISLT004* (Floor — Blue)	TWE060, TWE072, TWE090, TWE120
BAYISLT009* (Floor — Red) ^(d)	TWE150, TWE180
BAYISLT010* (Floor — Green) ^{(d)(a)}	TWE240, TWE300
BAYISLT012* (Suspended —Red/Green)	TWE150, TWE180
BAYISLT013* (Suspended —Red/Green) ^(c)	TWE060
BAYISLT014* (Suspended — Green) ^(c)	TWE072, TWE090
BAYISLT015* (Suspended — Green/Black) ^(c)	TWE120
BAYISLT016* (Suspended —Red/Green)	TWE240, TWE300
Steel Spring Isolators^(b)	
BAYISLT019* (Floor — Red) ^{(c)(a)}	TWE060, TWE072, TWE090, TWE120
BAYISLT021* (Floor — Black) ^{(c)(a)}	TWE150, TWE180
BAYISLT032* (Floor — Black/Yellow) ^{(c)(a)}	TWE240, TWE300
BAYISLT028* (Suspended — Tan)	TWE060
BAYISLT029* (Suspended — Red)	TWE072, TWE090, TWE120
BAYISLT030* (Suspended — Black)	TWE150, TWE180
BAYISLT031* (Suspended — Black/Yellow)	TWE240, TWE300
Plenum^(e)	
BAYPLNM015* (Discharge Plenum & Grille) ^(e)	TWE060
BAYPLNM016* (Discharge Plenum & Grille) ^(e)	TWE072, TWE090
BAYPLNM017* (Discharge Plenum & Grille) ^(e)	TWE120
BAYPLNM018* (Discharge Plenum/Hydronic Coil Plenum & Grille) ^(e)	TWE150, TWE180
BAYPLNM019* (Discharge Plenum/Hydronic Coil Plenum & Grille) ^(e)	TWE240, TWE300
BAYPLNM020* (Hydronic Coil Discharge Plenum & Grille) ^(e)	TWE060
BAYPLNM021* (Hydronic Coil Discharge Plenum & Grille) ^(e)	TWE072, TWE090
BAYPLNM022* (Hydronic Coil Discharge Plenum & Grille) ^(e)	TWE120
BAYPLNM030* (Electric Heat Discharge Plenum & Grille) ^(e)	TWE060
BAYPLNM031* (Electric Heat Discharge Plenum & Grille) ^(e)	TWE072, TWE090

Table 4. TWE Accessories (continued)

Model	Used With
BAYPLNM032* (Electric Heat Discharge Plenum & Grille) ^(e)	TWE120
BAYPLNM033* (Electric Heat Discharge Plenum & Grille) ^(e)	TWE150, TWE180
BAYPLNM034* (Electric Heat Discharge Plenum & Grille) ^(e)	TWE240, TWE300
Return Air Grille	
BAYGRLE001*	TWE060
BAYGRLE002*	TWE072, TWE090
BAYGRLE003*	TWE120
BAYGRLE004*	TWE150, TWE180
BAYGRLE005*	TWE240, TWE300
Symbio™ Options Module Kit	
BAYMODU001*	All TWE units with Digit 15 = 1 and Electric heater installed
Transformer	
BAYTFMR018* - 100 VA Transformer (208-230V)	All TWE072 – TWE300, 208-230V units
BAYTFMR019* - 100 VA Transformer (460V)	All TWE072 – TWE120, 460V units
BAYTFMR020* - 100 VA Transformer (575V)	All TWE072 – TWE120, 575V units
BAYTFMR021* - 100 VA Transformer (400 V)	All TWE072 – TWE120 380V/60 Hz unit
Water Kits	
BAYWATR022* (Steam Coil Enclosure) ^(e)	TWE060
BAYWATR023* (Steam Coil Enclosure) ^(e)	TWE072, TWE090
BAYWATR024* (Steam Coil Enclosure) ^(e)	TWE120
BAYWATR025* (Steam Coil Enclosure) ^(e)	TWE150, TWE180
BAYWATR026* (Steam Coil Enclosure) ^(e)	TWE240, TWE300
BAYWATR027* (Hot Water Coil Enclosure) ^(e)	TWE060
BAYWATR028* (Hot Water Coil Enclosure) ^(e)	TWE072, TWE090
BAYWATR029* (Hot Water Coil Enclosure) ^(e)	TWE120
BAYWATR030* (Hot Water Coil Enclosure) ^(e)	TWE150, TWE180
BAYWATR031* (Hot Water Coil Enclosure) ^(e)	TWE240, TWE300
Wire Kit — 180° Blower Discharge Reversal Kit^(f)	
BAYWRKT002*	TWE060, TWE072, TWE090, TWE120

^(a) Requires use of subbase accessory.

^(b) In units with steam or hot water coils applied vertically or horizontally, check IOM for proper Isolator Kit selection.

^(c) Do not use if blower will operate less than 600 RPM.

^(d) When the air handler is in the vertical position and close proximity trapping of condensate is required, use of subbase is required.

^(e) When installed horizontally, plenum/water coil must be self-supported. When adding vibration isolators, see Isolator Installation Guide (ACC-SVN92*-EN) for isolator and location matrix.

^(f) Cannot be used on TWE150-300, due to motor mount location. Only available with Constant Volume units.

Electric Heaters

Table 5. Electric heaters

Model	Used With
6–10 Ton Electric Heater Selection	
BAYHTRP106* — 4.33/5.76 kW Heater 208/240/1 Phase	TWE060*1, TWE090*1, TWE120*1
BAYHTRS112* — 8.65/11.52 kW Heater 208/240/1 Phase	TWE060*1, TWE090*1, TWE120*1
BAYHTRT117* — 12.98/17.28 kW Heater 208/240/1 Phase	TWE060*1, TWE090*1, TWE120*1
BAYHTRS123* — 17.31/23.04 kW Heater 208/240/1 Phase	TWE060*1, TWE090*1, TWE120*1
BAYHTRP129* — 21.63/28.80 kW Heater 208/240/1 Phase	TWE090*1, TWE120*1
BAYHTRP305* — 3.76/5.00 kW Heater 208/240/3 Phase	TWE060*3 (CV and OS MTR), TWE072*3B, TWE090*3, TWE120*3 (VFD)
BAYHTRS310* — 7.48/9.96 kW Heater 208/240/3 Phase	TWE060*3 (CV and OS MTR), TWE072*3B, TWE090*3, TWE120*3 (VFD)
BAYHTRS315* — 11.24/14.96 kW Heater 208/240/3 Phase	TWE060*3 (CV and OS MTR), TWE072*3B, TWE090*3, TWE120*3 (VFD)
BAYHTRP325* — 18.72/24.92 kW Heater 208/240/3 Phase	TWE060*3 (CV and OS MTR), TWE072*3B, TWE090*3, TWE120*3 (VFD)
BAYHTRP335* — 26.20/34.88 kW Heater 208/240/3 Phase	TWE090*3, TWE120*3 (VFD)



Accessories

Table 5. Electric heaters (continued)

Model	Used With
BAYHTRP405* — 5.00 kW Heater 460/3 Phase	TWE060*4 (CV and OS MTR), TWE072*4*****C/D, TWE090*4*****C/D, TWE120*4*****C/D
BAYHTRS410* — 9.96 kW Heater 460/3 Phase	TWE060*4 (CV and OS MTR), TWE072*4*****C/D, TWE090*4*****C/D, TWE120*4*****C/D
BAYHTRS415* — 14.96 kW Heater 460/3 Phase	TWE060*4 (CV and OS MTR), TWE072*4*****C/D, TWE090*4*****C/D, TWE120*4*****C/D
BAYHTRP425* — 24.92 kW Heater 460/3 Phase	TWE060*4 (CV and OS MTR), TWE072*4*****C/D, TWE090*4*****C/D, TWE120*4*****C/D
BAYHTRP435* — 34.88 kW Heater 460/3 Phase	TWE090*4*****C/D, TWE120*4*****C/D
BAYHTRPW05* — 5 kW Heater 575/3 Phase	TWE060*W (CV and OS MTR), TWE072*W, TWE090*W, TWE120*W (VFD)
BAYHTRSW10* — 9.96 kW Heater 575/3 Phase	TWE060*W (CV and OS MTR), TWE072*W, TWE090*W, TWE120*W (VFD)
BAYHTRSW15* — 14.96 kW Heater 575/3 Phase	TWE060*W (CV and OS MTR), TWE072*W, TWE090*W, TWE120*W (VFD)
BAYHTRPW25* — 24.92 kW Heater 575/3 Phase	TWE060*W (CV and OS MTR), TWE072*W, TWE090*W, TWE120*W (VFD)
BAYHTRPW35* — 34.88 kW Heater 575/3 Phase	TWE090*W, TWE120*W (VFD)
12.5–25 Ton Electric Heater Selection	
BAYHTRT310* — 7.51/10.0 kW Heater 208/230 3 Phase	TWE150*3, TWE180*3, TWE240*3, TWE300*3 (VFD)
BAYHTRR320* — 14.96/19.92 kW Heater 208/230 3 Phase	TWE150*3, TWE180*3, TWE240*3, TWE300*3 (VFD)
BAYHTRR330* — 22.47/29.92 kW Heater 208/230 3 Phase	TWE150*3, TWE180*3, TWE240*3, TWE300*3(VFD)
BAYHTRR350* — 37.44/49.84 kW Heater 208/230 3 Phase	TWE150*3, TWE180*3, TWE240*3, TWE300*3 (VFD)
BAYHTRT410* — 10.0 kW Heater 460/3 Phase	TWE150*4*****C/D, TWE180*4*****C/D, TWE240*4 (VFD), TWE300*4 (VFD)
BAYHTRR420* — 19.92 kW Heater 460/3 Phase	TWE150*4*****C/D, TWE180*4*****C/D, TWE240*4 (VFD), TWE300*4 (VFD)
BAYHTRR430* — 29.92 kW Heater 460/3 Phase	TWE150*4*****C/D, TWE180*4*****C/D, TWE240*4 (VFD), TWE300*4 (VFD)
BAYHTRR450* — 49.84 kW Heater 460/3 Phase	TWE150*4*****C/D, TWE180*4*****C/D, TWE240*4 (VFD), TWE300*4 (VFD)
BAYHTRTW10* — 10.0 kW Heater 575/3 Phase	TWE150*W, TWE180*W, TWE240*W, TWE300*W (VFD)
BAYHTRRW20* — 19.92 kW Heater 575/3 Phase	TWE150*W, TWE180*W, TWE240*W, TWE300*W (VFD)
BAYHTRRW30* — 29.92 kW Heater 575/3 Phase	TWE150*W, TWE180*W, TWE240*W, TWE300*W (VFD)
BAYHTRRW50* — 49.84 kW Heater 575/3 Phase	TWE150*W, TWE180*W, TWE240*W, TWE300*W (VFD)

Note: Electric Heaters not available for 380/60Hz.



Application Considerations

Application of this product should be within the cataloged airflow and performance considerations.

Clearance Requirements

The recommended clearances identified with unit dimensions should be maintained to assure adequate serviceability, maximum capacity and peak operating efficiency. Actual clearances which appear inadequate should be reviewed with the local representative.

180° Blower Rotation

The 5, 6, 7.5, and 10 ton constant volume air handler blower section can be rotated 180° to change the discharge pattern. This modification must be done in the field and requires an additional kit. See unit installation guide.

Low Ambient Cooling

As manufactured, all Odyssey units have cooling capabilities down to 0°F. At temperatures below 55°F for single compressor units and 40°F for dual compressor units, some reduction in cooling capacity can be expected. At this temperature, equipment can provide approximately 60% of the mechanical cooling capacity. When the optional Low Ambient Accessory kit is field installed, the full capacity of the unit is available down to 0°F. When using these units with control systems such as bypass changeover Variable Air Volume, make sure to consider the requirement for a head pressure control to allow low ambient cooling.

Figure 4. Typical split system application

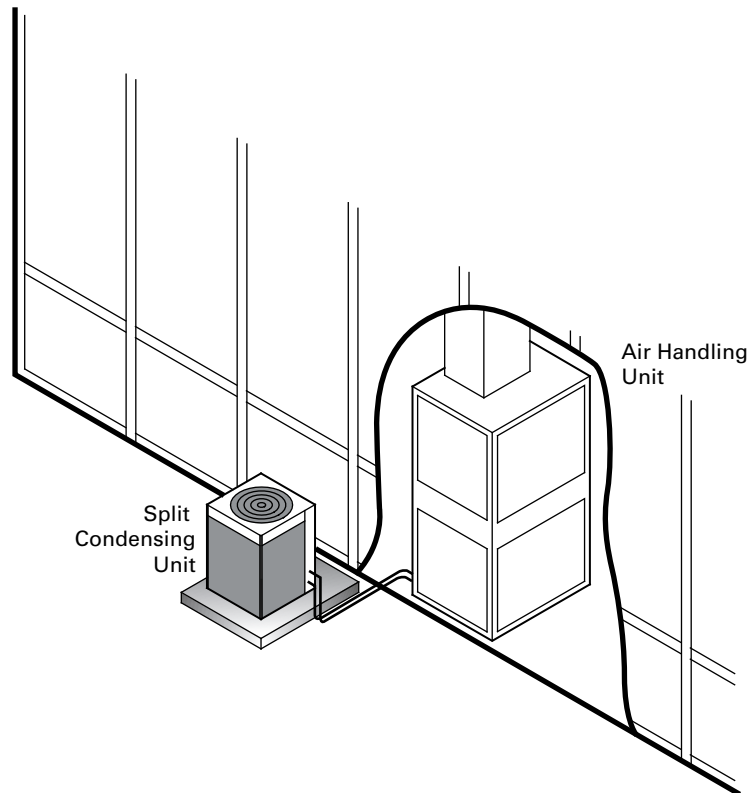

Figure 5. Typical horizontal air handler application

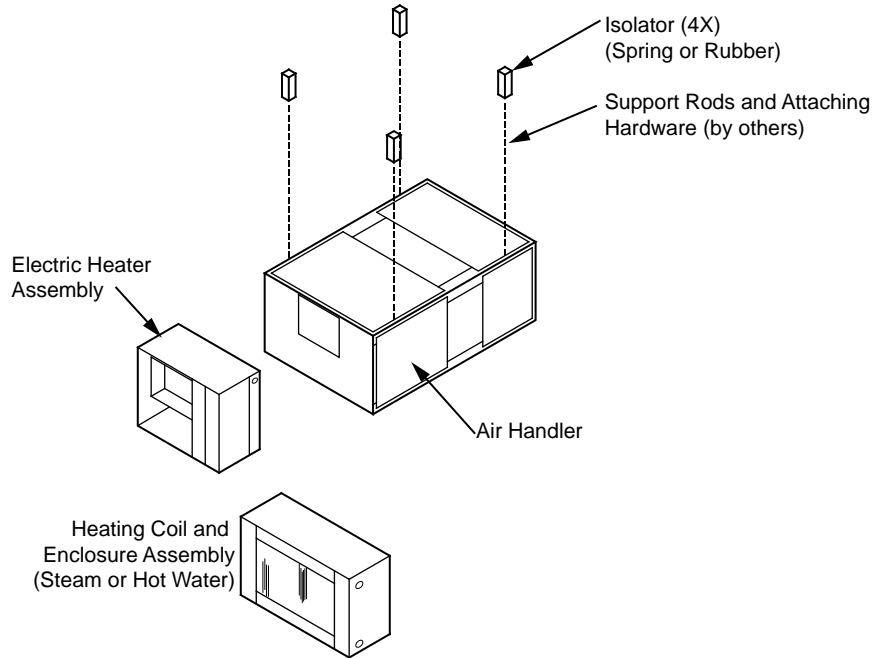
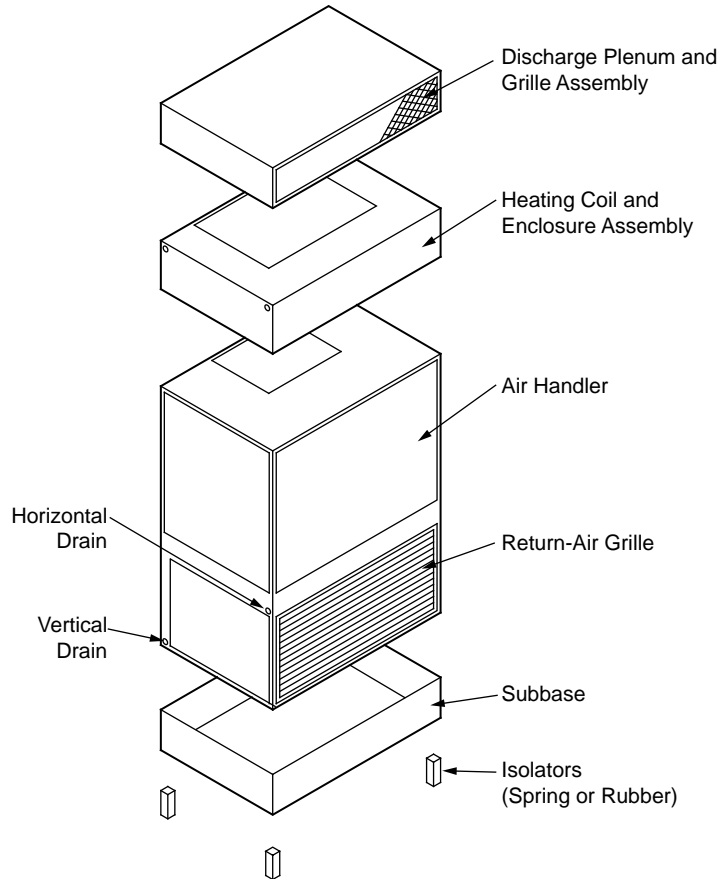

Figure 6. Typical vertical air handler application





Selection Procedure

Cooling Capacity

1. Calculate the building's total and sensible cooling loads at design conditions, using standardized calculation methods.
2. Size the equipment using the gross cooling capacity tables. Match the cooling loads at design conditions. For example, if the following specifies the building cooling requirements:
Electrical Characteristics: 460/60/3
Summer Design Conditions: Entering Evap Coil—80°F DB/67°F WB , Outdoor Ambient—95°F
Total Cooling Load: 86 MBh
Sensible Cooling Load: 60 MBh
Airflow: 3000 cfm
External Static Pressure: 0.77 inches of water gauge
3. Use [Table 15, p. 32](#) to determine that TTA09043A with TWE09043A has a gross cooling capacity of 97.7 MBh and 74.6 MBh sensible capacity at 95°F DB ambient and 3000 cfm with 80°F DB/67° F WB air entering the evaporator.
4. To find the net cooling capacities, fan motor heat must be subtracted. Determine the total unit static pressure:
External Static Duct System: 0.77
Standard Filter: 0.10 in.
Supplementary Electric Heat: 0.23 in.
Total Static Pressure: 1.10 in.

Notes:

- *The Evaporator Fan Performance Table has included the effect of a 1 in. filter already. Therefore, the actual Total Static Pressure is 1.10 - 0.10 = 1.00 in. . With 3000 cfm and 1.00 in., [Table 50, p. 67](#) shows 1.97 Bhp (high static drive kit required).*
- *This formula can be used to calculate Fan Motor Heat:*
$$3.15 \times \text{Bhp} = \text{MBh}$$
$$3.15 \times 1.97 = 6.2 \text{ MBh}$$
$$\text{Net Total Cooling Capacity} = 97.7 \text{ MBh} - 6.2 \text{ MBh} = 91.5 \text{ MBh}$$
$$\text{Net Sensible Cooling Capacity} = 74.6 \text{ MBh} - 6.2 \text{ MBh} = 68.4 \text{ MBh}$$

Heating Capacity

1. Calculate the building heating load using the Trane calculation form or any other standard accepted method.
2. Size the equipment using [Table 66, p. 83](#) to match the heating loads at design conditions. For example, if the following specifies the building heating requirements:
Total Heating Load: 97.0 MBh
Airflow: 2625 cfm
Supplementary Electric Heaters
3. Use [Table 67, p. 84](#) to determine that the 34.88 kW heater has a capacity of 119,045 Btuh.
4. From the Electrical Characteristics table, the 34.88 kW heater at 460V indicates the heater model is BAYHTRP435.



Selection Procedure

Air Delivery

1. The external static pressure drop through the air distribution system is 0.77 inches of water gauge, use [Table 66, p. 83](#) to determine that the static pressure drop through the electric heater is 0.23 inches of water ($0.77 + 0.23 = 1.00$ in.).
2. Enter [Table 50, p. 67](#) for TWE09043A at 2625 cfm and 1.00 static pressure. The high static motor at 995 RPM gives the desired airflow.



Model Number Description

Cooling Condenser

Digit 1, 2, 3 — Unit Function

TTA = Split System Cooling

Digit 4, 5, 6 — Tonnage

072 = 6 Tons (60 Hz)

090 = 7.5 Tons (60 Hz)

120 = 10 Tons (60 Hz)

150 = 12.5 Tons (60 Hz)

180 = 15 Tons (60 Hz)

240 = 20 Tons (60 Hz)

300 = 25 Tons (60Hz)

Digit 7 — Refrigerant

4 = R-410A

Digit 8 — Voltage

3 = 208-230 Vac - 3 PH (60Hz)

4 = 460 Vac - 3 PH (60Hz)

W = 575 Vac - 3 PH (60Hz)

K = 380 Vac - 3 PH (60Hz)

Digit 9 — Refrigeration Circuit/Stage

A = 1 Compressor/1 Line/1 Stage (Single)

C = 2 Compressors/1 Line/2 Stage (Manifold)

D = 2 Compressors/2 Line/2 Stage (Dual)

Digit 10 — Major Design Sequence

A = Rev A

B = Rev B

Digit 11 — Minor Design Sequence

A = Rev A

Digit 12, 13 — Service Digits

**

Digit 14 — Efficiency Generation

A = Generation A

B = Generation B

Digit 15 — Controls

S = Symbio™

Digit 16 — None

0 = None

Digit 17 — Coil Protection

1 = Standard Coil w/ Coil Guard

5 = Complete Coat Condenser Coil with Coil Guard (MCHE)

Digit 18, 19, 20 — None

0 = None

Digit 21 — Communications Options

0 = No Option

1 = Advanced Diagnostics and BACnet® BAS

2 = Advanced Diagnostics and LonTalk® Communications Interface (LCI)

Digit 22 to 40 — None

0 = None



Model Number Description

Air Handler

Digit 1, 2, 3 — Unit Function

TWE = Air Handler

Digit 4, 5, 6— Tonnage

060 = 5 Tons (60 Hz)

072 = 6 Tons (60Hz)

090 = 7.5 Tons (60 Hz)

120 = 10 Tons (60 Hz)

150 = 12.5 Tons (60 Hz)

180 = 15 Tons (60 Hz)

240 = 20 Tons (60 Hz)

300 = 25 Tons (60 Hz)

Digit 7 — Refrigerant

4 = R-410A

Digit 8 — Voltage

1 = 208-230 Vac - 1 PH (60 Hz)

3 = 208-230 Vac - 3 PH (60 Hz)

4 = 460 Vac - 3 PH (60 Hz)

K = 380 Vac - 3 PH (60 Hz)

W = 575 Vac - 3 PH (60 Hz)

Digit 9 — Refrigeration Circuit/Stage

A = Single Circuit

B = Dual Circuit

Digit 10 — Major Design Sequence

A = Rev A

Digit 11 — Minor Design Sequence

A = Rev A

B = Rev B

Digit 12, 13 — Service Digits

**

Digit 14 — Efficiency Generation

A = Generation A

B = Generation B

Digit 15 — Controls

1 = Constant Volume

C = 2 Stage Airflow (Electromechanical Cond Only)

D = 2 Stage Airflow/Single Zone VAV (Symbio Cond Only)

Digit 16 — Indoor Fan Sizes

0 = Standard Motor

4 = High Static – (Oversized Motor for VFD Units)

Digit 17 to 40 — None

0 = None



General Data

Table 6. General data — 6 to 7.5 tons (TTA0724*A*-TTA0904*D*) condensing units — 60 Hz

	6 Tons	6 Tons	7.5 Tons	7.5 Tons
	Single Compressor TTA0724*A*	Dual Compressor TTA0724*D*	Single Compressor TTA0904*A*	Dual Compressor TTA0904*D*
Cooling Performance - Gross Cooling Capacity				
Matched Air Handler	TWE0904*A*	TWE0724*B*	TWE0904*A*	TWE0904*B*
AHRI Rated Airflow	2,400	2,400	3,000	3000
Gross Cooling Capacity - System	78,000	77,000	98,000	96,000
Condensing Unit Only	70,000	68,000	92,000	92,000
AHRI Net Cooling Capacity	76,000	75,000	95,000	93,000
Efficiency				
Matched Air Handler (EER)	11.5	11.5	11.5	11.5
Condensing Unit Only (EER)	13.6	12.0	12.7	12.8
System (IEER) ^(a)	14.8	14.8	14.8	14.8
System kW/Condensing Unit kW	5.5 / 4.9	5.7 / 5.2	8.1 / 7.1	8.0 / 7.0
Compressor				
Type ^(b)	Scroll 1S	Scroll 1S	Scroll 2S	Scroll 2S
No./Tons/Min Stage%/Total Stages	1 / 5.1 / 100 / 1	2 / 2.4 / 50 ^(c) / 2	1 / 6.9 / 67 ^(d) / 2	2 / 3.3 / 67 ^(d) / 2
System Data				
No. Refrigerant Circuits ^(e)	1	2	1	2
Suction Line Connection (in.) OD ^(e)	1 1/8	7/8	1 3/8	1 1/8
Liquid Line Connection (in.) OD ^(e)	1/2	1/2	1/2	1/2
Outdoor Coil				
Type	MCHE	MCHE	MCHE	MCHE
Tube Size OD/Coil Width MCHE (in.)	0.8	0.8	0.8	0.8
Face Area (sq ft)	18.5	17.4	18.5	17.4
Rows/FPI (Fins per inch)	1/23	1/23	1/23	1/23
Outdoor Fan				
Type	Propeller	Propeller	Propeller	Propeller
No. Used/Diameter (in.)	1/26	1/26	1/26	1/26
Drive Type/No. Speeds	Direct/1	Direct/1	Direct/1	Direct/1
CFM	5,700	5,700	5,700	5,700
No. Motor/HP	1/0.5	1/0.5	1/0.5	1/0.5
Motor RPM	1,100	1,100	1,100	1,100
Refrigerant Charge (Field Supplied)				
lbs of R-410A	10.0	7.0 / 7.0	10.4	7.1 / 7.5
Shipping Dimensions				
HxWxD (in.)	45" x 45.25" x 39"	45" x 45.25" x 39"	45" x 45.25" x 39"	45" x 45.25" x 39"

Notes:

- 6 to 10 ton and 20 to 25 ton condensing units are tested in accordance with AHRI Standard 365.
 - 12.5 and 15 ton condensing units are AHRI Certified to AHRI Standard 365.
 - 6 to 20 ton units are AHRI Certified to AHRI Standard 340-360 (I-P). Rating conditions are 95°F outdoor air temperature, 80°F entering dry bulb, 67°F entering wet bulb with 25ft of interconnecting refrigerant piping with minimum external static pressure as determined by rating standard.
 - 25 ton units are tested in accordance with AHRI Standard 340-360.
- (a) For 380V Units, IEER values can differ. Only 1-stage compressors are offered with these units. Please consult the AHRI Directory for IEER performance.
- (b) 1-stage compressor = 1S, 2-stage compressor = 2S
- (c) 1st stage is compressor 1. 2nd stage is compressor 1 and 2.
- (d) All compressors stage to 66% for first stage, then 100% for 2nd stage.
- (e) For line lengths greater than 25ft, refer to refrigerant piping applications manual for line sizing and line length.



General Data

Table 7. General data — 10 to 12.5 tons (TTA1204*D*-TTA1504*D*) condensing units — 60 Hz

	10 Tons	10 Tons	12.5 Tons
	Dual Compressor TTA1204*D*	Manifolded Compressor TTA1204*C*	Dual Compressor TTA1504*D*
Cooling Performance - Gross Cooling Capacity			
Matched Air Handler	TWE1204*B*	TWE1204*A*	TWE1504*B*
AHRI Rated Airflow	4,000 ^(a)	4,000 ^(a)	5,000
Gross Cooling Capacity - System	120,000	126,000	160,000
Condensing Unit Only	112,000	116,000	150,000
AHRI Net Cooling Capacity	116,000	122,000 ^(b)	156,000
Efficiency			
Matched Air Handler (EER)	11.5	11.5	11.2
Condensing Unit Only (EER)	12.7	12.5	12.0
System (IEER) ^(c)	14.8	14.8	14.2
System kW/Condensing Unit kW	9.6 / 8.4	10.0 / 8.8	13.4 / 12.0
Compressor			
Type ^(d)	Scroll 2S	Manifolded Scrolls 1S	Scroll 2S
No./Tons/Min Stage%/Total Stages	2 / 4.1 / 67 ^(e) / 2	2 / 4.3 / 50 ^(f) / 2	2 / 5.6 / 67 ^(e) / 2
System Data			
No. Refrigerant Circuits ^(g)	2	1	2
Suction Line Connection (in.) OD ^(g)	1 1/8	1 3/8	1 1/8
Liquid Line Connection (in.) OD ^(g)	1/2	1/2	1/2
Outdoor Coil			
Type	MCHE	MCHE	MCHE
Tube Size OD/Coil Width MCHE (in.)	0.8	0.8	1.0
Face Area (sq ft)	22.7	23.8	27.0
Rows/FPI (Fins per inch)	1/23	1/23	1/23
Outdoor Fan			
Type	Propeller	Propeller	Propeller
No. Used/Diameter (in.)	1/28	1/28	1/28
Drive Type/No. Speeds	Direct/1	Direct/1	Direct/1
CFM	8,800	8,800	8,800
No. Motor/HP	1/1	1/1	1/1
Motor RPM	1,125	1,125	1,125
Refrigerant Charge (Field Supplied)			
lbs of R-410A	8.2 / 8.4	13.1	10.4/10.4
Shipping Dimensions			
HxWxD (in.)	45" x 55" x 42"	45" x 55" x 42"	52.1" x 55" x 42"

Notes:

1. 6 to 10 ton and 20 to 25 ton condensing units are tested in accordance with AHRI Standard 365.
 2. 12.5 and 15 ton condensing units are AHRI Certified to AHRI Standard 365.
 3. 6 to 20 ton units are AHRI Certified to AHRI Standard 340-360 (I-P). Rating conditions are 95°F outdoor air temperature, 80°F entering dry bulb, 67°F entering wet bulb with 25ft of interconnecting refrigerant piping with minimum external static pressure as determined by rating standard.
 4. 25 ton units are tested in accordance with AHRI Standard 340-360.
- (a) For single phase application, AHRI Rated Airflow will be 3,500
- (b) For single phase application, AHRI Net Cooling Capacity will be 121,000 Btu/hr
- (c) For 380V Units, IEER values can differ. Only 1-stage compressors are offered with these units. Please consult the AHRI Directory for IEER performance.
- (d) 1-stage compressor = 1S, 2-stage compressor = 2S
- (e) All compressors stage to 66% for first stage, then 100% for 2nd stage.
- (f) 1st stage is compressor 1. 2nd stage is compressor 1 and 2.
- (g) For line lengths greater than 25ft, refer to refrigerant piping applications manual for line sizing and line length.

Table 8. General data — 15 to 25 tons (TTA1804*D*-TTA3004*C*) condensing units — 60 Hz

	15 Tons	15 Tons	20 Tons	20 Tons	25 Ton
	Dual Compressor TTA1804*D*	Manifolded Compressor TTA1804*C*	Dual Compressor TTA2404*D*	Manifolded Compressor TTA2404*C*	Manifolded Compressor TTA3004*C*
Cooling Performance - Gross Cooling Capacity					
Matched Air Handler	TWE1804*B*	TWE1804*B*	TWE2404*B*	TWE2404*B*	TWE3004*B*
AHRI Rated Airflow	6,000	6,000	8,000	8,000	8,750
Gross Cooling Capacity - System	198,000	194,000	254,000	258,000	308,000
Condensing Unit Only	190,000	182,000	252,000	266,000	316,000
AHRI Net Cooling Capacity	194,000	188,000	246,000	250,000	296,000
Efficiency					
Matched Air Handler (EER)	11.2	11.2	10.2	10.2	10.1
Condensing Unit Only (EER)	12.7	12.8	12.5	12.1	11.7
System (IEER) ^(a)	14.2	14.2	13.2	13.2	13.2
System kW/Condensing Unit kW	15.8 / 14.2	15.1 / 13.3	21.2 / 18.9	23.4 / 21.2	28.6 / 25.5
Compressor					
Type ^(b)	Scroll 1S	Manifolded Scrolls 1S	Scroll 2S	Manifolded Scroll 1S	Manifolded Scrolls 1S
No./Tons/Min Stage%/Total Stages	2 / 6.9 / 50 ^(c) / 2	2/7.6; 6.8/53 ^(c) / 2	1 / 10.2, 1/8.7 / 67 ^(d) /2	2 / 10.0 / 50 ^(c) / 2	2 / 11.8 / 50 ^(c) / 2
System Data					
No. Refrigerant Circuits ^(e)	2	1	2	1	1
Suction Line Connection (in.) OD ^(e)	1 3/8	1 5/8	1 3/8	1 5/8	2 1/8
Liquid Line Connection (in.) OD ^(e)	1/2	5/8	1/2	5/8	5/8
Outdoor Coil					
Type	MCHE	MCHE	MCHE	MCHE	MCHE
Tube Size OD/Coil Width MCHE (in.)	0.8	0.8	0.8	0.8	1.0
Face Area (sq ft)	44.3	44.3	44.3	44.3	51.3
Rows/FPI (Fins per inch)	1/23	1/23	1/23	1/23	1/23
Outdoor Fan					
Type	Propeller	Propeller	Propeller	Propeller	Propeller
No. Used/Diameter (in.)	2/28	2/28	2/28	2/28	2/28
Drive Type/No. Speeds	Direct/1	Direct/1	Direct/1	Direct/1	Direct/1
CFM	17,000	17,000	17,000	17,000	17,000
No. Motor/HP	2/1	2/1	2/1	2/1	2/1
Motor RPM	1,125	1,125	1,125	1,125	1,125
Refrigerant Charge (Field Supplied)					
lbs of R-410A	11.5 / 11.5	22.5	11.2 / 11.2	23.8	29.8
Shipping Dimensions					
HxWxD (in.)	51.1" x 96" x 48"	51.1" x 96" x 48"	51.1" x 96" x 48"	51.1" x 96" x 48"	57.1" x 96" x 48"

Notes:

- 6 to 10 ton and 20 to 25 ton condensing units are tested in accordance with AHRI Standard 365.
- 12.5 and 15 ton condensing units are AHRI Certified to AHRI Standard 365.
- 6 to 20 ton units are AHRI Certified to AHRI Standard 340-360 (I-P). Rating conditions are 95°F outdoor air temperature, 80°F entering dry bulb, 67°F entering wet bulb with 25ft of interconnecting refrigerant piping with minimum external static pressure as determined by rating standard.
- 25 ton units are tested in accordance with AHRI Standard 340-360.

^(a) For 380V Units, IEER values can differ. Only 1-stage compressors are offered with these units. Please consult the AHRI Directory for IEER performance.

^(b) 1-stage compressor = 1S, 2-stage compressor = 2S

^(c) 1st stage is compressor 1. 2nd stage is compressor 1 and 2.

^(d) All compressors stage to 66% for first stage, then 100% for 2nd stage.

^(e) For line lengths greater than 25ft, refer to refrigerant piping applications manual for line sizing and line length.



General Data

Table 9. General data — 6 to 10 tons (TWE0724*B* - TWE1204*B*) SZVAV and 2-speed VFD air handler - 60hz

	6 Tons	7.5 Tons	7.5 Tons	10 Tons	10 Tons
	Dual Circuit TWE07243B*, 4B*, WB*	Single Circuit TWE09043A*, 4A*, WA*	Dual Circuit TWE09043B*, 4B*, WB*	Single Circuit TWE12043A*, 4A*, WA*	Dual Circuit TWE12043B*, 4B*, WB*
System Data					
No. Refrigerant Circuits	2	1	2	1	2
Suction Line Connection (in.) OD	1-1/8	1-3/8	1-1/8	1-3/8	1-1/8
Liquid Line Connection (in.) OD	1/2	1/2	1/2	1/2	1/2
Indoor Coil					
Type	Lanced/Intertwined	Lanced/Intertwined	Lanced/Intertwined	Lanced/Intertwined	Lanced/Intertwined
Tube Size (in.)	0.375	0.375	0.375	0.375	0.375
Face Area (sq. ft.)	8.1	8.1	8.1	11.2	11.2
Rows/FPI (Fins per inch)	4/14	4/14	4/14	4/14	4/14
Refrigerant Control	Expansion Valve	Expansion Valve	Expansion Valve	Expansion Valve	Expansion Valve
Drain Connection Size (in.)	1 PVC	1 PVC	1 PVC	1 PVC	1 PVC
Indoor Fan					
Type	Centrifugal	Centrifugal	Centrifugal	Centrifugal	Centrifugal
No. Used/Diameter x Width (in.)	1/15x15	1/15x15	1/15x15	1/15x15	1/15x15
Drive Type/No. Speeds	Belt/VFD Variable	Belt/VFD Variable	Belt/VFD Variable	Belt/VFD Variable	Belt/VFD Variable
CFM (Nominal)	2400	3000	3000	4000	4000
No. Motors	1	1	1	1	1
Motor HP - Standard/Oversized	2.0/3.0	2.0/3.0	2.0/3.0	2.0/3.0	2.0/3.0
Motor RPM	1725	1725	1725	1725	1725
Motor Frame Size	56 H	56 H	56 H	56 H	56 H
Filters^(a)					
Type/Furnished	Throwaway/Yes	Throwaway/Yes	Throwaway/Yes	Throwaway/Yes	Throwaway/Yes
(No.)/Size Recommended	(3) 16x25x1	(3) 16x25x1	(3) 16x25x1	(4) 16x25x1	(4) 16x25x1
MERV 13 (No.)/Size Recommended	(3) 16x25x2	(3) 16x25x2	(3) 16x25x2	(4) 16x25x2	(4) 16x25x2
Shipping Dimensions					
HxWxD (in.)	61.2" x 30.5" x 53"	61.2" x 30.5" x 53"	61.2" x 30.5" x 53"	61.2" x 30.5" x 69"	61.2" x 30.5" x 69"

^(a) One inch, throw-away filters shall be standard on TWE060, TWE072, TWE090, TWE120 model air handlers from the factory. The filter rack can be field converted to two inch capability. Two inch, throw-away filters shall be standard on TWE1504*B, TWE1804*B, and TWE2404*B models.

Table 10. General data — 12.5 to 25 tons (TWE1504*B* - TWE3004*B*) SZVAV and 2-speed VFD air handler - 60hz

	12.5 Tons	15 Tons	20 Tons	25 Tons
	Dual Circuit TWE15043B*, 4B*, WB*	Dual Circuit TWE18043B*, 4B*, WB*	Dual Circuit TWE24043B*, 4B*, WB*	Dual Circuit TWE30043B*, 4B*, WB*
System Data				
No. Refrigerant Circuits	2	2	2	2
Suction Line Connection (in.) OD	1-3/8	1-3/8	1-3/8	1-3/8
Liquid Line Connection (in.) OD	1/2	1/2	5/8	5/8
Indoor Coil				
Type	Lanced/Intertwined	Lanced/Intertwined	Lanced/Intertwined	Lanced/Face Split
Tube Size (in.)	0.375	0.375	0.375	0.375
Face Area (sq. ft.)	16.3	16.3	21.7	21.7
Rows/FPI (Fins per inch)	4/14	4/14	3/14	4/14
Refrigerant Control	Expansion Valve	Expansion Valve	Expansion Valve	Expansion Valve
Drain Connection Size (in.)	1 PVC	1 PVC	1 PVC	1 PVC
Indoor Fan				
Type	Centrifugal	Centrifugal	Centrifugal	Centrifugal
No. Used/Diameter x Width (in.)	2/15x15	2/15x15	2/15x15	2/15x15
Drive Type/No. Speeds	Belt/VFD Variable	Belt/VFD Variable	Belt/VFD Variable	Belt/VFD Variable
CFM (Nominal)	5000	6000	8000	8750

Table 10. General data — 12.5 to 25 tons (TWE1504*B* - TWE3004*B*) SZVAV and 2-speed VFD air handler - 60hz (continued)

No. Motors	1	1	1	1
Motor HP - Standard/Oversized	2.0/5.0	3.0/5.0	5.0/7.5	7.5 ^(a)
Motor RPM	1725/3450	1725/3450	3450	3450
Motor Frame Size	56 H	56 H	56 H/184 T	184 T
Filters^(b)				
Type/Furnished	Throwaway/Yes	Throwaway/Yes	Throwaway/Yes	Throwaway/Yes
(No.)/Size Recommended	(8) 15x20x2	(8) 15x20x2	(4) 16x25x2 (4) 16x20x2	(4) 16x25x2 (4) 16x20x2
MERV 13 (No.)/Size Recommended	(8) 15x20x2	(8) 15x20x2	(4) 16x25x2 (4) 16x20x2	(4) 16x25x2 (4) 16x20x2
Shipping Dimensions				
HxWxD (in.)	76.3" x 33.3" x 85"	76.3" x 33.3" x 85"	79.1" x 35.8" x 95"	79.1" x 35.8" x 95"

^(a) Standard motor only

^(b) One inch, throw-away filters shall be standard on TWE060, TWE072, TWE090, TWE120 model air handlers from the factory. The filter rack can be field converted to two inch capability. Two inch, throw-away filters shall be standard on TWE150, TWE180, TWE240, and TWE300 models.

Table 11. General data — 5 to 7.5 tons (TWE0604*A* - TWE0904*B*) constant volume air handler - 60hz

	5 Tons	5 Tons	6 Tons	7.5 Tons	7.5 Tons
System Data					
No. Refrigerant Circuits	1	2	2	1	2
Suction Line Connection (in.) OD	1-1/8	1-1/8	1-1/8	1-3/8	1-1/8
Liquid Line Connection (in.) OD	1/2	1/2	1/2	1/2	1/2
Indoor Coil					
Type	Lanced/Intertwined	Lanced/Intertwined	Lanced/Intertwined	Lanced/Intertwined	Lanced/Intertwined
Tube Size (in.)	0.375	0.375	0.375	0.375	0.375
Face Area (sq. ft.)	5	5	8.1	8.1	8.1
Rows/FPI (Fins per inch)	4/14	4/14	3/14	4/14	4/14
Refrigerant Control	Expansion Valve	Expansion Valve	Expansion Valve	Expansion Valve	Expansion Valve
Drain Connection Size (in.)	1 PVC	1 PVC	1 PVC	1 PVC	1 PVC
Indoor Fan					
Type	Centrifugal	Centrifugal	Centrifugal	Centrifugal	Centrifugal
No. Used/Diameter x Width (in.)	1/12x12	1/12x12	1/15x15	1/15x15	1/15x15
Drive Type/No. Speeds	Belt/Adjustable	Belt/Adjustable	Belt/Adjustable	Belt/Adjustable	Belt/Adjustable
CFM (Nominal)	2000	2000	2400	3000	3000
No. Motors	1	1	1	1	1
Motor HP - Standard/Oversized	0.75/1.5	0.75/1.5	1.5 ^(a)	1.5/2.0 ^(b)	1.5/2.0
Motor RPM	1725	1725	1725	1725	1725
Motor Frame Size	56 H	56 H	56 H	56 H	56 H
Filters^(c)					
Type/Furnished	Throwaway/Yes	Throwaway/Yes	Throwaway/Yes	Throwaway/Yes	Throwaway/Yes
(No.)/Size Recommended	(1) 16x20x1 (1) 20x20x1	(1) 16x20x1 (1) 20x20x1	(3) 16x25x1	(3) 16x25x1	(3) 16x25x1
MERV 13 (No.)/Size Recommended	(1) 16x20x2 (1) 20x20x2	(1) 16x20x2 (1) 20x20x2	(3) 16x25x2	(3) 16x25x2	(3) 16x25x2
Shipping Dimensions					
HxWxD (in.)	55.1" x 27.5" x 43.5"	55.1" x 27.5" x 43.5"	61.2" x 30.5" x 53"	61.2" x 30.5" x 53"	61.2" x 30.5" x 53"

(a) Standard motor only ; 4KB* does not have any oversize motor

(b) 2hp oversized motor for 41A/B only

(c) One inch, throw-away filters shall be standard on TWE060, TWE072, TWE090, TWE120 model air handlers from the factory. The filter rack can be field converted to two inch capability. Two inch, throw-away filters shall be standard on TWE150, TWE180, TWE240 & TWE300 models

Table 12. General data —10 to 25 tons (TWE1204*A* - TWE3004KB*) constant volume air handler - 60hz

	10 Tons	10 Tons	12.5 Tons	15 Tons	20 Tons	25 Tons
System Data						
No. Refrigerant Circuits	1	2	2	2	2	2
Suction Line Connection (in.) OD	1-3/8	1-1/8	1-3/8	1-3/8	1-3/8	1-3/8
Liquid Line Connection (in.) OD	1/2	1/2	1/2	5/8	1/2	5/8
Indoor Coil						
Type	Lanced/Intertwined	Lanced/Intertwined	Lanced/Intertwined	Lanced/Intertwined	Lanced/Intertwined	Lanced/Intertwined
Tube Size (in.)	0.375	0.375	0.375	0.375	0.375	0.375
Face Area (sq. ft.)	11.2	11.2	16.3	16.3	21.7	21.7
Rows/FPI (Fins per inch)	4/14	4/14	4/14	4/14	3/14	4/14
Refrigerant Control	Expansion Valve	Expansion Valve	Expansion Valve	Expansion Valve	Expansion Valve	Expansion Valve
Drain Connection Size (in.)	1 PVC	1 PVC	1 PVC	1 PVC	1 PVC	1 PVC
Indoor Fan						
Type	Centrifugal	Centrifugal	Centrifugal	Centrifugal	Centrifugal	Centrifugal
No. Used/Diameter x Width (in.)	1/15x15	1/15x15	2/15x15	2/15x15	2/15x15	2/15x15
Drive Type/No. Speeds	Belt/Adjustable	Belt/Adjustable	Belt/Adjustable	Belt/VFD Variable	Belt	Belt
CFM (Nominal)	4000	4000	5000	6000	8000	8750
No. Motors	1	1	1	1	1	1
Motor HP - Standard/Oversized	2.0 ^(a)	2.0	2.0 ^(b)	3.0	5.0	7.5
Motor RPM	1725	1725	1725	1725	1725	3450
Motor Frame Size	56 H	56 H	56 H	56 H	56 H	184 T
Filters^(c)						
Type/Furnished	Throwaway/Yes	Throwaway/Yes	Throwaway/Yes	Throwaway/Yes	Throwaway/Yes	Throwaway/Yes
(No.)/Size Recommended	(4) 16x25x1	(4) 16x25x1	(8) 15x20x2	(8) 15x20x2	(4) 16x25x2 (4) 16x20x2	(4) 16x25x2 (4) 16x20x2
MERV 13 (No.)/Size Recommended	(4) 16x25x2	(4) 16x25x2	(8) 15x20x2	(8) 15x20x2	(4) 16x25x2 (4) 16x20x2	(4) 16x25x2 (4) 16x20x2
Shipping Dimensions						
HxWxD (in.)	61.2" x 30.5" x 69"	61.2" x 30.5" x 69"	76.3" x 33.3" x 85"	76.3" x 33.3" x 85"	79.1" x 35.8" x 95"	79.1" x 35.8" x 95"

(a) Standard motor only, 1204 does not have any oversize motor.
 (b) Standard motor only ; 4KB* does not have any oversize motor.
 (c) One inch, throw-away filters shall be standard on TWE060, TWE072, TWE090, TWE120 model air handlers from the factory. The filter rack can be field converted to two inch capability. Two inch, throw-away filters shall be standard on TWE180 and TWE240 models.



Performance Data

Gross Cooling Capacities

Table 13. Gross cooling capacities (MBH) 6 tons TTA0724*A condensing unit with 7.5 tons TWE0904*A air handler (IP)

CFM	Ent DB (° F)	Ambient Temperature (°F)						Ambient Temperature (°F)						Ambient Temperature (°F)					
		85						95						105					
		Entering Wet Bulb (°F)						Entering Wet Bulb (°F)						Entering Wet Bulb (°F)					
		61		67		73		61		67		73		61		67		73	
		MBH	SHC	MBH	SHC	MBH	SHC	MBH	SHC	MBH	SHC	MBH	SHC	MBH	SHC	MBH	SHC	MBH	SHC
2160	75	72.8	61.9	79.9	47.5	87.0	32.0	70.0	60.5	76.8	46.2	83.6	30.8	66.9	59.0	73.3	44.8	80.0	29.5
	80	73.5	73.5	79.8	59.0	86.7	43.9	70.9	70.9	76.7	57.6	83.4	42.7	68.2	68.2	73.3	56.2	79.7	41.4
	85	77.1	77.1	80.0	70.5	86.5	55.6	74.5	74.5	76.9	69.2	83.1	54.3	71.8	71.8	73.6	67.7	79.5	52.9
	90	80.8	80.8	80.8	80.8	86.4	67.0	78.0	78.0	78.2	78.2	83.0	65.8	75.2	75.2	75.3	75.3	79.4	64.4
2400	75	74.2	65.6	81.1	49.7	88.0	32.5	71.3	64.2	77.8	48.4	84.6	31.3	68.1	62.7	74.3	47.0	80.9	30.0
	80	75.7	75.7	81.0	62.3	87.7	45.7	73.1	73.1	77.8	61.0	84.3	44.5	70.4	70.4	74.4	59.5	80.6	43.3
	85	79.5	79.5	81.3	75.2	87.5	58.6	76.8	76.8	78.2	73.8	84.1	57.3	74.0	74.0	74.8	72.4	80.4	55.9
	90	83.1	83.1	83.2	83.2	87.4	71.3	80.3	80.3	80.4	80.4	84.0	70.0	77.3	77.3	77.4	77.4	80.3	68.6
2640	75	75.4	69.3	82.1	51.7	88.8	33.0	72.4	67.9	78.7	50.6	85.4	31.8	69.2	66.4	75.2	48.9	81.6	30.6
	80	77.7	77.7	82.0	65.6	88.6	47.6	75.0	75.0	78.8	64.3	85.1	46.4	72.1	72.1	75.3	62.8	81.3	45.1
	85	81.5	81.5	82.5	79.8	88.3	61.5	78.7	78.7	79.3	78.5	84.8	60.2	75.8	75.8	76.0	76.0	81.1	58.8
	90	85.0	85.0	85.2	85.2	88.2	75.6	82.2	82.2	82.3	82.3	84.8	74.3	79.1	79.1	79.1	79.1	81.1	72.9
2880	75	76.4	72.9	82.9	53.7	89.5	33.5	73.4	71.5	79.5	52.3	86.0	32.4	70.2	70.0	76.0	50.8	82.2	31.1
	80	79.4	79.4	82.9	68.9	89.3	49.4	76.7	76.7	79.6	67.5	85.8	48.3	73.7	73.7	76.1	66.1	81.9	47.0
	85	83.2	83.2	83.5	83.5	88.9	64.4	80.3	80.3	80.5	80.5	85.4	63.1	77.3	77.3	77.3	77.3	81.6	61.7
	90	86.7	86.7	86.8	86.8	89.1	79.9	83.7	83.7	83.8	83.8	85.4	78.5	80.5	80.5	80.5	80.5	81.7	77.1
CFM	Ent DB (° F)	Ambient Temperature (°F)						Ambient Temperature (°F)											
		115						125											
		Entering Wet Bulb (°F)						Entering Wet Bulb (°F)											
		61		67		73		61		67		73							
		MBH	SHC	MBH	SHC	MBH	SHC	MBH	SHC	MBH	SHC	MBH	SHC						
2160	75	63.6	57.4	69.6	43.4	76.2	28.2	60.0	55.7	65.5	41.8	71.8	26.7						
	80	65.4	65.4	69.7	54.7	75.9	40.1	62.2	62.2	65.8	53.0	71.5	38.6						
	85	68.8	68.8	70.1	66.2	75.7	51.5	65.6	65.6	66.2	64.6	71.4	49.9						
	90	72.1	72.1	72.2	72.2	75.6	62.9	68.7	68.7	68.8	68.8	71.4	61.3						
2400	75	64.7	61.1	70.5	45.5	76.9	28.7	61.1	59.4	66.6	43.6	72.6	27.2						
	80	67.4	67.4	70.8	58.0	76.7	41.9	64.1	64.1	66.8	56.3	72.2	40.5						
	85	70.8	70.8	71.3	70.9	76.5	54.4	67.4	67.4	67.5	67.5	72.2	52.8						
	90	74.1	74.1	74.2	74.2	76.4	67.2	70.5	70.5	70.6	70.6	72.2	65.6						
2640	75	65.8	64.8	71.5	47.3	77.6	29.2	62.2	62.2	67.3	45.5	73.1	27.8						
	80	69.0	69.0	71.6	61.3	77.3	43.8	65.6	65.6	67.5	59.6	72.8	42.3						
	85	72.5	72.5	72.6	72.6	77.1	57.3	68.9	68.9	69.0	69.0	72.7	55.7						
	90	75.7	75.7	75.8	75.8	77.1	71.4	72.0	72.0	72.0	72.0	72.8	69.8						
2880	75	66.8	66.8	72.1	49.2	78.2	29.8	63.3	63.3	67.9	47.5	73.6	28.3						
	80	70.5	70.5	72.3	64.5	77.9	45.7	66.9	66.9	68.2	62.8	73.3	44.2						
	85	73.9	73.9	74.0	74.0	77.6	60.3	70.2	70.2	70.3	70.3	73.2	58.6						
	90	77.0	77.0	77.1	77.1	77.7	75.7	73.1	73.1	73.2	73.2	73.4	73.4						

Notes:

1. All capacities shown are gross and have not considered indoor fan heat. To obtain net cooling, subtract indoor fan heat.
2. MBH = Total Gross Capacity, SHC = Sensible Heat Capacity

Table 14. Gross cooling capacities (MBH) 6 tons TTA0724*D condensing unit with 6 tons TWE0724*B air handler (IP)

CFM	Ent DB (°F)	Ambient Temperature (°F)						Ambient Temperature (°F)						Ambient Temperature (°F)					
		85						95						105					
		Entering Wet Bulb (°F)						Entering Wet Bulb (°F)						Entering Wet Bulb (°F)					
		61		67		73		61		67		73		61		67		73	
		MBH	SHC	MBH	SHC	MBH	SHC	MBH	SHC	MBH	SHC	MBH	SHC	MBH	SHC	MBH	SHC	MBH	SHC
2160	75	71.0	61.4	79.2	47.3	88.7	32.6	67.7	59.8	75.4	45.8	84.7	31.2	64.2	58.2	71.4	44.2	80.3	29.6
	80	72.0	72.0	79.1	59.0	88.4	44.6	69.2	69.2	75.5	57.5	84.3	43.2	66.3	66.3	71.5	55.9	80.0	41.6
	85	76.2	76.2	79.5	70.8	88.1	56.5	73.4	73.4	75.9	69.3	84.1	55.0	70.3	70.3	72.0	67.6	79.8	53.4
	90	80.8	80.8	80.8	80.8	88.2	68.2	77.7	77.7	77.8	77.8	84.3	66.7	74.5	74.5	74.6	74.6	80.0	65.1
2400	75	72.5	65.2	80.6	49.6	90.1	33.2	69.1	63.7	76.7	48.1	86.0	31.8	65.5	62.0	72.6	46.5	81.5	30.3
	80	74.6	74.6	80.6	62.6	89.8	46.6	71.7	71.7	76.9	61.0	85.6	45.1	68.5	68.5	72.8	59.3	81.2	43.6
	85	79.0	79.0	81.1	75.7	89.6	59.8	76.0	76.0	77.5	74.2	85.5	58.2	72.8	72.8	73.6	72.5	81.2	56.6
	90	83.6	83.6	83.8	83.8	89.8	72.8	80.5	80.5	80.7	80.7	85.8	71.3	77.2	77.2	77.3	77.3	81.5	69.7
2640	75	73.8	69.1	81.7	51.9	91.3	33.9	70.3	67.5	77.8	50.3	87.0	32.4	66.7	65.8	73.7	48.6	82.4	30.9
	80	76.8	76.8	81.9	66.1	91.0	48.5	73.8	73.8	78.1	64.5	86.7	47.1	70.5	70.5	73.9	62.8	82.1	45.6
	85	81.5	81.5	82.7	80.6	90.9	62.9	78.4	78.4	79.0	78.9	86.7	61.4	75.0	75.0	75.2	75.2	82.2	59.8
	90	86.2	86.2	86.4	86.4	91.2	77.3	83.1	83.1	83.2	83.2	87.1	75.8	79.6	79.6	79.7	79.7	82.7	74.2
2880	75	75.0	72.8	82.8	54.0	92.3	34.5	71.5	71.2	78.8	52.4	87.9	33.0	67.9	67.8	74.5	50.7	83.3	31.5
	80	78.8	78.8	83.0	69.5	92.0	50.5	75.7	75.7	79.1	67.9	87.6	49.0	72.3	72.3	74.9	66.2	83.0	47.4
	85	83.7	83.7	84.1	84.1	92.0	66.1	80.4	80.4	80.6	80.6	87.7	64.5	76.9	76.9	77.0	77.0	83.2	62.9
	90	88.6	88.6	88.7	88.7	92.4	81.8	85.3	85.3	85.4	85.4	88.2	80.3	81.7	81.7	81.8	81.8	83.8	78.7
	Ambient Temperature (°F)						Ambient Temperature (°F)												
	115						125												
	Entering Wet Bulb (°F)						Entering Wet Bulb (°F)												
	61		67		73		61		67		73								
	MBH	SHC	MBH	SHC	MBH	SHC	MBH	SHC	MBH	SHC	MBH	SHC	MBH	SHC	MBH	SHC	MBH	SHC	
2160	60.6	56.5	67.2	42.5	75.6	28.0	-	-	-	-	70.6	26.3							
	63.1	63.1	67.4	54.1	75.2	40.0	-	-	62.9	52.3	70.2	38.3							
	67.0	67.0	68.0	66.0	75.2	51.7	63.5	63.5	64.0	62.8	70.4	49.9							
	71.1	71.1	71.2	71.2	75.5	63.5	67.4	67.4	67.6	67.6	70.7	61.7							
2400	61.8	60.3	68.3	44.7	76.6	28.6	-	-	63.5	42.7	71.5	26.9							
	65.2	65.2	68.6	57.6	76.3	42.0	61.2	61.2	64.1	55.7	71.2	40.2							
	69.3	69.3	69.7	69.1	76.4	54.9	65.6	65.6	65.7	65.7	71.4	53.1							
	73.6	73.6	73.7	73.7	76.8	68.0	69.7	69.7	69.9	69.9	71.9	66.2							
2640	63.0	62.5	69.3	46.8	77.5	29.2	-	-	64.5	44.8	72.2	27.5							
	67.0	67.0	69.6	61.0	77.2	43.8	63.2	63.2	65.1	59.2	72.1	42.0							
	71.3	71.3	71.5	71.5	77.5	58.0	67.5	67.5	67.6	67.6	72.4	56.2							
	75.8	75.8	75.9	75.9	78.0	72.5	71.8	71.8	71.9	71.9	73.0	70.7							
2880	64.3	64.3	70.0	48.8	78.2	29.8	-	-	65.2	46.9	72.8	28.0							
	68.6	68.6	70.5	64.5	78.0	45.6	64.7	64.7	65.9	62.6	72.8	43.7							
	73.1	73.1	73.2	73.2	78.3	61.2	69.1	69.1	69.2	69.2	73.2	59.3							
	77.8	77.8	77.9	77.9	79.1	77.0	73.6	73.6	73.7	73.7	74.2	73.8							

Notes:

- All capacities shown are gross and have not considered indoor fan heat. To obtain net cooling, subtract indoor fan heat.
- MBH = Total Gross Capacity, SHC = Sensible Heat Capacity



Performance Data

Table 15. Gross cooling capacities (MBH) 7.5 tons TTA0904*A condensing unit with 7.5 tons TWE0904*A air handler (IP)

CFM	Ent DB (°F)	Ambient Temperature (°F)						Ambient Temperature (°F)						Ambient Temperature (°F)					
		85						95						105					
		Entering Wet Bulb (°F)						Entering Wet Bulb (°F)						Entering Wet Bulb (°F)					
		61		67		73		61		67		73		61		67		73	
	MBH	SHC	MBH	SHC	MBH	SHC	MBH	SHC	MBH	SHC	MBH	SHC	MBH	SHC	MBH	SHC	MBH	SHC	
2700	75	92.7	77.9	101.4	59.7	109.7	40.1	88.3	75.8	96.6	57.7	104.5	38.2	83.5	73.5	91.3	55.5	98.9	36.2
	80	93.7	92.6	101.4	74.2	109.6	55.0	89.5	89.5	96.6	72.2	104.4	53.1	85.2	85.2	91.4	69.9	98.8	51.1
	85	97.7	97.7	101.8	88.6	109.6	69.8	93.9	93.9	97.1	86.6	104.4	67.9	89.6	89.6	92.0	84.4	98.8	65.8
	90	102.8	102.8	102.8	102.8	109.6	84.2	98.2	98.2	98.4	98.4	104.4	82.2	93.8	93.8	94.0	94.0	98.9	80.1
3000	75	94.4	82.5	102.8	62.3	110.9	40.7	89.9	80.4	97.8	60.3	105.5	38.8	85.0	78.0	92.5	58.2	99.8	36.8
	80	95.9	95.9	102.8	78.4	110.8	57.2	92.0	92.0	98.0	76.3	105.5	55.3	87.7	87.7	92.7	74.0	99.8	53.4
	85	100.6	100.6	103.3	94.4	110.8	73.6	96.6	96.6	98.6	92.3	105.4	71.6	92.1	92.1	93.4	90.1	99.7	69.4
	90	105.1	105.1	105.3	105.3	110.8	89.5	100.9	100.9	101.0	101.0	105.5	87.5	96.3	96.3	96.4	96.4	99.9	85.3
3300	75	95.8	87.1	103.9	65.0	111.8	41.3	91.2	84.9	98.9	63.0	106.4	39.4	86.3	82.6	93.4	60.9	100.6	37.4
	80	98.4	98.4	104.0	82.5	111.8	59.5	94.3	94.3	99.1	80.4	106.4	57.6	89.8	89.8	93.7	78.1	100.6	55.6
	85	103.1	103.1	104.7	100.2	111.7	77.3	98.8	98.8	99.8	98.1	106.3	75.2	94.2	94.2	94.7	94.7	100.5	73.1
	90	107.5	107.5	107.6	107.6	112.1	94.9	103.1	103.1	103.2	103.2	106.5	92.8	98.2	98.2	98.3	98.3	100.7	90.6
3600	75	97.1	91.6	104.9	67.6	112.7	41.9	92.4	89.5	99.8	65.7	107.2	40.0	87.4	87.1	94.2	63.5	101.3	38.0
	80	100.4	100.4	105.0	86.5	112.6	61.7	96.2	96.2	100.0	84.4	107.1	59.9	91.6	91.6	94.6	82.2	101.2	57.9
	85	105.1	105.1	105.9	105.9	112.7	81.0	100.7	100.7	101.1	101.1	107.0	78.9	95.9	95.9	96.0	96.0	101.1	76.7
	90	109.5	109.5	109.6	109.6	113.3	100.3	104.9	104.9	105.0	105.0	107.2	98.1	99.8	99.8	99.9	99.9	101.4	95.9
CFM	Ent DB (°F)	Ambient Temperature (°F)						Ambient Temperature (°F)											
		115						125											
		Entering Wet Bulb (°F)						Entering Wet Bulb (°F)											
		61		67		73		61		67		73							
	MBH	SHC	MBH	SHC	MBH	SHC	MBH	SHC	MBH	SHC	MBH	SHC							
2700	75	78.3	71.0	85.6	53.2	92.7	34.0	72.7	68.3	79.2	50.7	86.0	31.7						
	80	80.7	80.7	85.8	67.5	92.7	48.9	75.6	75.6	79.6	64.9	86.0	46.6						
	85	84.9	84.9	86.4	82.0	92.7	63.4	79.7	79.7	80.4	79.4	86.0	60.9						
	90	88.9	88.9	89.1	89.1	92.8	77.7	83.5	83.5	83.6	83.6	86.2	75.2						
3000	75	79.7	75.5	86.6	55.9	93.6	34.7	73.9	72.8	80.2	53.1	86.7	32.3						
	80	83.0	83.0	86.9	71.6	93.6	51.2	77.7	77.7	80.6	68.9	86.7	48.9						
	85	87.2	87.2	87.8	87.7	93.5	67.1	81.7	81.7	81.8	81.8	86.7	64.5						
	90	91.1	91.1	91.2	91.2	93.7	83.0	85.3	85.3	85.4	85.4	87.0	80.5						
3300	75	80.9	80.1	87.4	58.6	94.3	35.3	75.1	75.1	81.0	55.5	87.4	33.0						
	80	84.9	84.9	87.8	75.7	94.3	53.5	79.4	79.4	81.4	73.0	87.3	51.2						
	85	89.1	89.1	89.2	89.2	94.2	70.7	83.4	83.4	83.4	83.4	87.3	68.2						
	90	92.8	92.8	92.9	92.9	94.4	88.3	86.8	86.8	86.9	86.9	87.6	85.7						
3600	75	82.1	82.1	88.1	61.2	94.9	35.9	76.5	76.5	81.6	58.0	87.9	33.6						
	80	86.5	86.5	88.6	79.7	94.9	55.8	80.8	80.8	82.2	77.0	87.8	53.5						
	85	90.6	90.6	90.7	90.7	94.7	74.4	84.7	84.7	84.8	84.8	87.7	71.8						
	90	94.3	94.3	94.3	94.3	95.1	93.5	88.0	88.0	88.1	88.1	88.3	88.3						

Notes:

1. All capacities shown are gross and have not considered indoor fan heat. To obtain net cooling, subtract indoor fan heat.
2. MBH = Total Gross Capacity, SHC = Sensible Heat Capacity

Table 16. Gross cooling capacities (MBH) 7.5 tons TTA0904*D condensing unit with 7.5 tons TWE0904*B air handler (IP)

CFM	Ent DB (°F)	Ambient Temperature (°F)						Ambient Temperature (°F)						Ambient Temperature (°F)					
		85						95						105					
		Entering Wet Bulb (°F)						Entering Wet Bulb (°F)						Entering Wet Bulb (°F)					
		61		67		73		61		67		73		61		67		73	
		MBH	SHC	MBH	SHC	MBH	SHC	MBH	SHC	MBH	SHC	MBH	SHC	MBH	SHC	MBH	SHC	MBH	SHC
2700	75	91.5	77.8	99.9	59.1	109.3	40.1	87.2	75.8	95.1	57.2	102.7	37.7	82.5	73.7	90.0	55.1	96.9	35.7
	80	92.2	90.8	99.7	73.8	108.0	54.5	88.3	88.2	94.9	71.8	102.4	52.5	84.2	84.2	89.8	69.8	96.7	50.5
	85	96.3	96.3	99.8	88.4	107.8	69.3	92.4	92.4	95.1	86.4	102.2	67.3	88.2	88.2	90.1	84.4	96.4	65.3
	90	102.0	100.9	102.0	100.9	107.6	83.9	96.3	96.3	96.4	96.4	103.4	82.4	91.9	91.9	92.0	92.0	96.4	79.9
3000	75	93.1	82.5	101.1	61.8	109.5	40.3	88.6	80.5	96.2	59.8	103.8	38.3	83.9	78.4	91.0	57.8	97.8	36.3
	80	94.3	94.3	102.5	78.7	110.4	57.2	90.7	90.7	96.0	76.0	103.5	54.8	86.5	86.5	90.9	74.0	97.6	52.8
	85	99.0	99.0	101.2	94.2	109.0	73.2	94.9	94.9	96.4	92.3	103.3	71.2	90.5	90.5	91.3	89.9	97.4	69.2
	90	103.1	103.1	103.3	103.3	109.0	89.5	98.7	98.7	98.9	98.9	103.3	87.5	94.1	94.1	94.2	94.2	97.5	85.4
3300	75	94.4	87.2	103.8	65.0	110.5	40.9	89.9	85.1	97.1	62.4	104.6	38.9	85.1	83.0	91.8	60.4	98.6	36.9
	80	96.9	96.9	101.9	82.2	110.3	59.1	92.8	92.8	97.0	80.2	104.4	57.1	88.4	88.4	91.7	78.2	98.4	55.0
	85	102.6	102.6	102.3	100.1	110.1	77.1	96.9	96.9	97.5	96.6	104.2	75.1	92.3	92.3	92.4	92.3	98.2	73.0
	90	105.7	105.7	105.8	105.8	110.1	95.0	101.0	101.0	101.1	101.1	104.3	93.0	96.1	96.1	96.2	96.2	98.3	90.9
3600	75	95.6	91.8	104.6	67.6	111.4	41.6	91.0	89.8	97.8	65.0	105.4	39.5	86.2	85.3	92.4	63.0	99.2	37.5
	80	98.9	98.9	102.9	86.4	112.3	61.7	94.6	94.6	99.6	85.1	105.2	59.4	90.0	90.0	92.4	82.4	99.0	57.3
	85	103.2	103.2	103.8	103.6	110.9	81.0	98.6	98.6	98.9	98.9	104.9	78.9	93.7	93.7	93.9	93.9	98.8	76.8
	90	107.8	107.8	108.9	108.9	111.2	100.6	103.0	103.0	104.2	104.2	105.2	98.5	97.8	97.8	97.9	97.9	99.1	96.4
CFM	Ent DB (°F)	Ambient Temperature (°F)						Ambient Temperature (°F)											
		115						125											
		Entering Wet Bulb (°F)						Entering Wet Bulb (°F)											
		61		67		73		61		67		73							
		MBH	SHC	MBH	SHC	MBH	SHC	MBH	SHC	MBH	SHC	MBH	SHC						
2700	75	77.8	71.5	84.7	53.1	90.8	33.5	72.6	69.2	78.9	50.8	84.2	31.3						
	80	80.0	80.0	84.5	67.7	90.5	48.4	75.4	75.4	78.8	65.4	84.0	46.2						
	85	83.8	83.8	84.9	82.3	90.3	63.2	78.9	78.9	79.3	77.6	83.8	60.9						
	90	87.1	87.1	87.2	87.2	90.3	77.8	81.9	81.9	81.9	81.9	83.8	75.5						
3000	75	79.0	76.2	85.6	55.7	91.5	34.2	73.7	72.2	79.7	53.5	84.8	31.9						
	80	82.1	82.1	85.5	71.9	91.3	50.7	77.3	77.3	79.7	69.6	84.6	48.4						
	85	85.8	85.8	86.0	85.1	91.1	67.0	80.6	80.6	80.7	80.7	84.3	64.7						
	90	89.0	89.0	89.1	89.1	91.3	83.2	83.4	83.4	83.5	83.5	84.6	81.0						
3300	75	80.1	78.8	86.2	58.3	92.2	34.8	75.0	75.0	80.3	56.0	85.2	32.5						
	80	83.8	83.8	86.2	76.0	92.0	52.9	78.8	78.8	80.4	73.8	85.1	50.7						
	85	87.3	87.3	87.4	87.4	91.8	70.8	81.9	81.9	82.0	82.0	84.9	68.5						
	90	90.8	90.8	90.8	90.8	92.0	88.7	84.8	84.8	84.8	84.8	85.3	83.1						
3600	75	81.3	81.3	86.8	60.8	92.7	35.4	76.3	76.3	80.8	58.5	85.7	33.1						
	80	85.3	85.3	86.9	80.2	92.5	55.2	80.0	80.0	80.9	78.0	85.5	52.9						
	85	88.6	88.6	88.6	88.6	92.3	74.7	84.9	84.9	82.9	82.9	85.4	72.3						
	90	92.2	92.2	92.2	92.2	94.4	91.6	85.9	85.9	85.9	85.9	86.0	86.0						

Notes:

1. All capacities shown are gross and have not considered indoor fan heat. To obtain net cooling, subtract indoor fan heat.
2. MBH = Total Gross Capacity, SHC = Sensible Heat Capacity



Performance Data

Table 17. Gross cooling capacities (MBH) 7.5 tons TTA0904*A condensing unit with 10 tons TWE1204*A air handler (IP)

CFM	Ent DB (°F)	Ambient Temperature (°F)						Ambient Temperature (°F)						Ambient Temperature (°F)					
		85						95						105					
		Entering Wet Bulb (°F)						Entering Wet Bulb (°F)						Entering Wet Bulb (°F)					
		61		67		73		61		67		73		61		67		73	
	MBH	SHC	MBH	SHC	MBH	SHC	MBH	SHC	MBH	SHC	MBH	SHC	MBH	SHC	MBH	SHC	MBH	SHC	
2700	75	94.6	78.9	103.2	60.8	111.4	41.1	90.2	76.8	98.5	58.9	106.5	39.3	85.4	74.5	93.3	56.8	101.2	37.5
	80	95.5	93.6	103.3	75.1	111.4	56.0	91.3	91.3	98.7	73.1	106.5	54.3	86.9	86.9	93.6	70.9	101.1	52.4
	85	99.4	99.4	103.5	89.5	111.3	70.7	95.7	95.7	99.0	87.5	106.4	68.8	91.5	91.5	94.0	85.4	101.1	66.7
	90	104.3	104.1	104.3	104.1	111.4	84.9	99.9	99.9	100.1	100.1	106.3	83.0	95.7	95.7	95.8	95.8	101.0	80.9
3000	75	96.3	83.5	104.7	63.5	112.7	41.7	91.8	81.4	99.9	61.5	107.7	40.0	86.9	79.0	94.5	59.5	102.3	38.1
	80	97.7	97.7	104.7	79.2	112.7	58.3	93.8	93.8	100.0	77.2	107.7	56.6	89.6	89.6	94.8	75.0	102.2	54.8
	85	102.3	102.3	105.0	95.2	112.7	74.3	98.4	98.4	100.5	93.2	107.5	72.3	94.1	94.1	95.4	91.1	102.1	70.3
	90	106.6	106.6	106.8	106.8	113.0	90.3	102.6	102.6	102.7	102.7	107.4	88.2	98.2	98.2	98.3	98.3	102.0	86.1
3300	75	97.7	88.0	105.9	65.9	113.8	42.4	93.2	85.9	101.0	63.9	108.8	40.6	88.2	83.5	95.7	61.6	103.2	38.8
	80	100.1	100.1	105.9	83.2	113.8	60.6	96.2	96.2	101.1	81.2	108.7	58.9	91.7	91.7	95.9	79.0	103.2	57.1
	85	104.7	104.7	106.3	100.8	113.9	78.0	100.7	100.7	101.7	98.9	108.4	75.9	96.2	96.2	96.7	96.7	102.8	73.8
	90	109.0	109.0	109.1	109.1	114.4	95.7	104.8	104.8	104.9	104.9	108.4	93.4	100.2	100.2	100.2	100.2	102.7	91.3
3600	75	98.9	92.5	106.9	68.3	114.8	43.0	94.4	90.3	102.0	66.3	109.6	41.3	89.4	88.0	96.5	64.0	104.0	39.5
	80	102.2	102.2	106.8	87.2	114.7	63.0	98.1	98.1	102.0	85.2	109.6	61.3	93.6	93.6	96.8	83.0	104.0	59.4
	85	106.7	106.7	107.5	106.5	115.0	81.7	102.6	102.6	102.9	102.9	109.0	79.4	97.9	97.9	98.0	98.0	103.4	77.4
	90	111.3	111.3	111.4	111.4	115.6	101.0	106.6	106.6	106.7	106.7	109.4	98.7	101.8	101.8	101.9	101.9	103.4	96.5
CFM	Ent DB (°F)	Ambient Temperature (°F)						Ambient Temperature (°F)											
		115						125											
		Entering Wet Bulb (°F)						Entering Wet Bulb (°F)											
		61		67		73		61		67		73							
	MBH	SHC	MBH	SHC	MBH	SHC	MBH	SHC	MBH	SHC	MBH	SHC							
2700	75	80.1	71.9	87.3	54.5	95.1	35.4	74.4	69.2	80.7	52.0	88.3	33.1						
	80	82.4	82.4	87.9	68.5	95.1	50.4	77.3	77.3	81.6	65.8	88.3	48.1						
	85	86.8	86.8	88.5	83.0	95.1	64.4	81.6	81.6	82.4	80.3	88.5	61.9						
	90	90.9	90.9	91.0	91.0	95.1	78.7	85.5	85.5	85.6	85.6	88.6	76.2						
3000	75	81.5	76.4	88.7	56.7	96.1	36.1	75.7	73.7	82.2	53.9	89.2	33.8						
	80	84.8	84.8	89.1	72.5	96.1	52.7	79.5	79.5	82.7	69.8	89.1	50.4						
	85	89.2	89.2	89.9	88.7	96.0	68.0	83.7	83.7	83.8	83.8	89.3	65.4						
	90	93.2	93.2	93.3	93.3	96.0	83.9	87.5	87.5	87.6	87.6	89.4	81.4						
3300	75	82.7	80.9	89.7	59.1	97.0	36.8	76.9	76.9	83.1	56.2	89.8	34.5						
	80	86.8	86.8	90.1	76.5	96.9	55.1	81.3	81.3	83.6	73.8	89.8	52.8						
	85	91.2	91.2	91.3	91.3	96.7	71.5	85.5	85.5	85.6	85.6	89.9	68.9						
	90	95.0	95.0	95.1	95.1	96.8	89.1	89.1	89.1	89.2	89.2	90.1	86.5						
3600	75	83.9	83.9	90.5	61.4	97.7	37.4	78.3	78.3	83.8	58.6	90.4	35.1						
	80	88.5	88.5	90.9	80.5	97.7	57.4	82.8	82.8	84.4	77.8	90.4	55.1						
	85	92.8	92.8	92.8	92.8	97.3	75.0	86.9	86.9	87.0	87.0	90.5	72.5						
	90	96.4	96.4	96.5	96.5	97.4	94.2	90.4	90.4	90.5	90.5	90.7	90.7						

Notes:

1. All capacities shown are gross and have not considered indoor fan heat. To obtain net cooling, subtract indoor fan heat.
2. MBH = Total Gross Capacity, SHC = Sensible Heat Capacity

Table 18. Gross cooling capacities (MBH) 10 tons TTA1204*D condensing unit with 10 tons TWE1204*B air handler (IP)

CFM	Ent DB (°F)	Ambient Temperature (°F)						Ambient Temperature (°F)						Ambient Temperature (°F)					
		85						95						105					
		Entering Wet Bulb (°F)						Entering Wet Bulb (°F)						Entering Wet Bulb (°F)					
		61		67		73		61		67		73		61		67		73	
		MBH	SHC	MBH	SHC	MBH	SHC	MBH	SHC	MBH	SHC	MBH	SHC	MBH	SHC	MBH	SHC	MBH	SHC
3500	75	111.9	97.9	123.7	74.4	134.3	49.4	107.1	95.7	118.4	72.3	128.8	47.4	102.0	93.5	112.8	70.1	123.0	45.4
	80	113.2	113.2	123.4	93.4	134.0	68.6	109.3	109.3	118.1	91.3	128.6	66.7	105.0	105.0	112.5	89.1	122.7	64.7
	85	119.5	119.5	123.6	112.4	133.8	87.8	115.3	115.3	118.5	110.3	128.3	85.9	110.8	110.8	113.0	108.1	122.5	83.9
	90	125.6	125.6	125.6	125.6	133.6	106.8	121.0	121.0	121.2	121.2	128.1	104.9	116.4	116.4	116.6	116.6	122.3	102.9
4000	75	114.5	105.9	125.9	78.9	136.1	50.4	109.6	103.7	120.4	76.8	130.3	48.4	104.4	101.4	114.7	74.6	124.4	46.4
	80	117.9	117.9	125.6	100.6	135.9	72.4	113.6	113.6	120.2	98.5	130.0	70.5	109.0	109.0	114.5	96.3	124.1	68.5
	85	124.1	124.1	126.2	122.4	135.6	94.4	119.7	119.7	121.0	120.1	129.8	92.4	114.9	114.9	115.5	115.5	123.8	90.4
	90	129.9	129.9	130.0	130.0	135.6	116.1	125.3	125.3	125.4	125.4	129.7	114.0	120.3	120.3	120.5	120.5	123.9	112.0
4400	75	116.3	112.2	127.2	82.5	137.3	51.3	111.3	110.0	121.7	80.4	131.2	49.2	106.0	106.0	115.9	78.2	125.2	47.2
	80	120.9	120.9	127.0	106.3	137.1	75.5	116.4	116.4	121.6	104.2	130.9	73.4	111.6	111.6	115.8	102.0	124.9	71.5
	85	127.1	127.1	128.0	128.0	136.8	99.6	122.5	122.5	122.8	122.8	130.7	97.5	117.5	117.5	117.6	117.6	124.7	95.5
	90	132.6	132.6	132.8	132.8	137.0	123.5	127.9	127.9	128.0	128.0	130.9	121.4	122.7	122.7	122.8	122.8	124.8	119.3
4800	75	117.9	117.9	128.3	86.0	138.3	52.1	112.9	112.9	122.8	83.9	132.1	50.0	107.7	107.7	116.9	81.7	125.9	48.0
	80	123.5	123.5	128.2	112.0	138.0	78.5	118.8	118.8	122.8	109.9	131.8	76.5	113.9	113.9	116.9	107.7	125.6	74.5
	85	129.6	129.6	129.8	129.8	137.8	104.8	124.8	124.8	124.9	124.9	131.5	102.6	119.7	119.7	119.6	119.6	125.3	100.6
	90	135.1	135.1	135.2	135.2	138.1	130.9	129.9	129.9	130.0	130.0	131.9	128.8	124.6	124.6	124.7	124.7	125.7	124.9
CFM	Ent DB (°F)	Ambient Temperature (°F)						Ambient Temperature (°F)											
		115						125											
		Entering Wet Bulb (°F)						Entering Wet Bulb (°F)											
		61		67		73		61		67		73							
		MBH	SHC	MBH	SHC	MBH	SHC	MBH	SHC	MBH	SHC	MBH	SHC						
3500	75	96.7	91.1	106.9	67.8	116.7	43.3	91.1	88.6	100.5	65.4	110.0	41.0						
	80	100.4	100.4	106.7	86.8	116.5	62.6	95.4	95.4	100.4	84.3	109.7	60.3						
	85	106.0	106.0	107.3	105.8	116.2	81.7	100.8	100.8	101.3	101.3	109.4	79.4						
	90	111.4	111.4	111.5	111.5	116.1	100.7	105.9	105.9	106.1	106.1	109.4	98.4						
4000	75	98.9	98.9	108.6	72.3	118.0	44.3	93.4	93.4	102.0	69.9	111.1	42.0						
	80	104.1	104.1	108.5	93.9	117.8	66.3	98.8	98.8	102.1	91.5	110.8	64.1						
	85	109.8	109.8	109.9	109.9	117.5	88.2	104.3	104.3	104.4	104.4	110.6	85.9						
	90	115.0	115.0	115.1	115.1	117.6	109.9	109.2	109.2	109.3	109.3	110.8	107.6						
4400	75	100.8	100.8	109.7	75.9	118.8	45.1	95.3	95.3	103.0	73.4	111.8	42.9						
	80	106.5	106.5	109.7	99.6	118.5	69.4	101.0	101.0	103.2	97.2	111.6	67.1						
	85	112.2	112.2	112.4	112.4	118.2	93.3	106.5	106.5	106.6	106.6	111.3	91.0						
	90	117.2	117.2	117.3	117.3	118.5	116.9	111.2	111.2	111.2	111.2	111.8	111.7						
4800	75	102.6	102.6	110.6	79.4	119.4	45.9	97.2	97.2	103.8	76.9	112.4	43.7						
	80	108.6	108.6	110.8	105.3	119.2	72.4	102.9	102.9	104.2	102.9	112.1	70.1						
	85	114.2	114.2	114.3	114.3	118.9	98.4	108.3	108.3	108.4	108.4	111.9	96.1						
	90	118.9	118.9	119.0	119.0	119.4	118.9	112.7	112.7	112.7	112.7	112.8	112.8						

Notes:

1. All capacities shown are gross and have not considered indoor fan heat. To obtain net cooling, subtract indoor fan heat.
2. MBH = Total Gross Capacity, SHC = Sensible Heat Capacity



Performance Data

Table 19. Gross cooling capacities (MBH) one compressor - 10 tons TTA1204*C condensing unit with 10 tons TWE1204*A air handler (IP)

CFM	Ent DB (°F)	Ambient Temperature (°F)						Ambient Temperature (°F)						Ambient Temperature (°F)					
		85						95						105					
		Entering Wet Bulb (°F)						Entering Wet Bulb (°F)						Entering Wet Bulb (°F)					
		61		67		73		61		67		73		61		67		73	
	MBH	SHC	MBH	SHC	MBH	SHC	MBH	SHC	MBH	SHC	MBH	SHC	MBH	SHC	MBH	SHC	MBH	SHC	
3500	75	71.0	71.0	75.6	55.1	82.5	32.2	68.6	68.6	72.7	53.9	79.2	31.1	66.1	66.1	69.7	52.7	75.6	30.0
	80	75.1	75.1	76.0	73.9	81.9	51.5	72.6	72.6	73.2	72.7	78.5	50.4	70.0	70.0	70.3	70.3	74.9	49.2
	85	79.1	79.1	79.2	79.2	82.0	69.1	76.5	76.5	76.6	76.6	79.0	68.0	73.8	73.8	73.9	73.9	75.9	66.9
	90	82.8	82.8	82.8	82.8	82.8	82.8	80.0	80.0	80.1	80.1	80.2	80.2	77.2	77.2	77.3	77.3	77.4	77.4
4000	75	72.9	72.9	76.5	59.2	83.2	33.3	70.4	70.4	73.6	58.0	79.7	32.2	67.8	67.8	70.5	56.7	75.9	31.0
	80	77.2	77.2	77.2	77.2	82.6	55.3	74.5	74.5	74.6	74.6	79.0	54.2	71.8	71.8	71.9	71.9	75.3	53.0
	85	81.1	81.1	81.1	81.1	82.8	75.3	78.4	78.4	78.5	78.5	79.8	74.2	75.6	75.6	75.7	75.7	76.7	73.0
	90	84.8	84.8	84.9	84.9	85.0	85.0	81.8	81.8	81.9	81.9	81.9	81.9	78.9	78.9	78.9	78.9	79.0	79.0
4400	75	74.2	74.2	77.1	62.4	83.6	34.2	71.6	71.6	74.1	61.2	80.0	33.0	68.9	68.9	71.0	59.9	76.1	31.8
	80	78.5	78.5	78.5	78.5	83.0	58.4	75.8	75.8	75.9	75.9	79.3	57.3	73.0	73.0	73.0	73.0	75.5	56.1
	85	82.3	82.3	82.4	82.4	83.4	80.3	79.6	79.6	79.7	79.7	80.4	79.1	76.7	76.7	76.8	76.8	77.3	77.3
	90	86.3	86.3	86.3	86.3	86.4	86.4	83.1	83.1	83.1	83.1	83.2	83.2	79.9	79.9	80.0	80.0	80.0	80.0
4800	75	75.3	75.3	77.6	65.7	83.9	35.0	72.7	72.7	74.6	64.4	80.2	33.9	69.9	69.9	71.5	63.1	76.3	32.7
	80	79.6	79.6	79.6	79.6	83.2	61.5	76.9	76.9	76.9	76.9	80.9	58.2	74.0	74.0	74.0	74.0	75.6	59.1
	85	83.4	83.4	83.4	83.4	84.0	84.0	80.6	80.6	80.7	80.7	80.7	80.7	77.7	77.7	77.7	77.7	77.8	77.8
	90	87.5	87.5	87.6	87.6	87.6	87.6	84.2	84.2	84.3	84.3	84.3	84.3	80.9	80.9	80.9	80.9	81.0	81.0
CFM	Ent DB (°F)	Ambient Temperature (°F)						Ambient Temperature (°F)											
		115						125											
		Entering Wet Bulb (°F)						Entering Wet Bulb (°F)											
		61		67		73		61		67		73							
	MBH	SHC	MBH	SHC	MBH	SHC	MBH	SHC	MBH	SHC	MBH	SHC							
3500	75	63.5	63.5	66.5	51.3	71.7	28.8	60.7	60.7	63.2	49.9	67.7	27.5						
	80	67.2	67.2	67.3	67.3	71.1	48.0	64.2	64.2	64.3	64.3	67.0	46.8						
	85	70.9	70.9	71.0	71.0	72.6	65.6	67.8	67.8	67.9	67.9	69.0	64.3						
	90	74.3	74.3	74.4	74.4	74.4	74.4	71.1	71.1	71.2	71.2	71.2	71.2						
4000	75	65.0	65.0	67.3	55.3	72.0	29.8	62.1	62.1	63.9	53.9	67.9	28.5						
	80	68.9	68.9	68.9	68.9	71.3	51.8	65.8	65.8	65.8	65.8	67.2	50.6						
	85	72.6	72.6	72.7	72.7	73.4	71.8	69.4	69.4	69.5	69.5	69.9	69.9						
	90	75.9	75.9	75.9	75.9	76.0	76.0	72.6	72.6	72.6	72.6	72.7	72.7						
4400	75	66.1	66.1	67.8	58.5	72.2	30.6	63.0	63.0	64.3	57.0	68.0	29.3						
	80	70.0	70.0	70.1	70.1	71.5	54.9	66.8	66.8	66.9	66.9	67.3	53.6						
	85	73.7	73.7	73.8	73.8	74.0	74.0	70.4	70.4	70.5	70.5	70.5	70.5						
	90	76.9	76.9	76.9	76.9	76.9	76.9	73.5	73.5	73.5	73.5	73.6	73.6						
4800	75	67.0	67.0	68.2	61.7	72.3	31.4	63.8	63.8	64.8	60.1	68.0	30.1						
	80	71.0	71.0	71.0	71.0	71.5	57.9	67.7	67.7	67.7	67.7	67.3	56.6						
	85	74.6	74.6	74.7	74.7	74.7	74.7	71.3	71.3	71.3	71.3	71.4	71.4						
	90	77.6	77.6	77.7	77.7	77.7	77.7	74.2	74.2	74.3	74.3	74.3	74.3						

Notes:

1. All capacities shown are gross and have not considered indoor fan heat. To obtain net cooling, subtract indoor fan heat.
2. MBH = Total Gross Capacity, SHC = Sensible Heat Capacity

Table 20. Gross cooling capacities (MBH) both compressors - 10 tons TTA1204*C condensing unit with 10 tons TWE1204*A air handler (IP)

CFM	Ent DB (°F)	Ambient Temperature (°F)						Ambient Temperature (°F)						Ambient Temperature (°F)					
		85						95						105					
		Entering Wet Bulb (°F)						Entering Wet Bulb (°F)						Entering Wet Bulb (°F)					
		61		67		73		61		67		73		61		67		73	
		MBH	SHC	MBH	SHC	MBH	SHC	MBH	SHC	MBH	SHC	MBH	SHC	MBH	SHC	MBH	SHC	MBH	SHC
3500	75	117.6	100.1	129.0	76.7	139.8	51.3	113.1	97.9	124.1	74.7	134.6	49.5	108.4	95.6	118.9	72.6	129.0	47.5
	80	118.5	118.5	128.7	95.3	139.3	70.6	114.3	114.3	123.8	93.2	134.0	68.7	110.0	110.0	118.6	91.0	128.5	66.8
	85	123.6	123.6	128.6	113.8	138.9	89.7	119.7	119.7	123.8	111.7	133.5	87.6	115.5	115.5	118.7	109.6	128.0	85.5
	90	129.6	129.6	129.6	129.6	138.4	108.1	125.0	125.0	125.2	125.2	133.1	106.0	120.7	120.7	120.9	120.9	127.5	103.9
4000	75	120.3	107.8	131.3	81.2	142.0	52.5	115.7	105.6	126.2	79.2	136.3	50.5	110.8	103.3	120.8	77.1	130.6	48.5
	80	122.4	122.4	131.0	102.2	141.4	74.5	118.4	118.4	125.9	100.1	135.8	72.5	114.1	114.1	120.6	97.8	130.1	70.6
	85	128.3	128.3	131.2	123.5	141.0	95.9	124.1	124.1	126.2	121.4	135.3	93.7	119.6	119.6	121.1	119.2	129.5	91.6
	90	133.7	133.7	133.9	133.9	140.8	117.1	129.3	129.3	129.5	129.5	134.8	114.9	124.7	124.7	124.8	124.8	129.1	112.7
4400	75	122.1	113.9	132.7	84.6	143.5	53.4	117.4	111.7	127.6	82.5	137.4	51.3	112.5	109.4	122.1	80.7	131.6	49.4
	80	125.5	125.5	132.4	107.7	142.9	77.6	121.3	121.3	127.3	105.5	136.9	75.6	116.8	116.8	122.0	103.3	131.1	73.6
	85	131.3	131.3	132.9	131.2	142.5	100.9	126.9	126.9	127.9	127.9	136.3	98.6	122.3	122.3	122.8	122.8	130.4	96.4
	90	136.6	136.6	136.8	136.8	142.5	124.3	132.0	132.0	132.1	132.1	136.2	122.0	127.1	127.1	127.3	127.3	130.1	119.7
4800	75	123.7	119.9	134.0	87.9	144.7	54.3	119.0	117.7	128.8	85.8	138.4	52.2	114.0	114.0	123.1	84.3	132.5	50.2
	80	128.1	128.1	133.6	113.1	144.1	80.7	123.7	123.7	128.5	111.0	137.9	78.7	119.1	119.1	123.1	108.7	132.0	76.7
	85	133.8	133.8	134.5	134.5	143.8	105.9	129.3	129.3	129.5	129.5	137.3	103.5	124.5	124.5	124.6	124.6	131.2	101.3
	90	139.4	139.3	139.5	139.5	143.9	131.6	134.2	134.2	134.3	134.3	137.5	129.2	129.1	129.1	129.2	129.2	131.0	126.8
CFM	Ent DB (°F)	Ambient Temperature (°F)						Ambient Temperature (°F)											
		115						125											
		Entering Wet Bulb (°F)						Entering Wet Bulb (°F)											
		61		67		73		61		67		73							
		MBH	SHC	MBH	SHC	MBH	SHC	MBH	SHC	MBH	SHC	MBH	SHC						
3500	75	103.3	93.2	113.2	70.4	123.1	45.5	97.9	90.6	107.1	68.0	116.6	43.2						
	80	105.6	105.6	113.1	88.6	122.5	64.7	100.8	100.8	107.0	86.0	116.0	62.5						
	85	110.9	110.9	113.3	107.2	122.1	83.3	105.9	105.9	107.4	104.7	115.6	80.8						
	90	116.0	116.0	116.1	116.1	121.6	101.7	110.7	110.7	110.9	110.9	115.2	99.2						
4000	75	105.6	100.8	115.0	74.9	124.6	46.5	100.1	98.2	108.9	71.9	117.9	44.3						
	80	109.5	109.5	115.0	95.5	124.0	68.5	104.4	104.4	108.8	92.9	117.3	66.3						
	85	114.8	114.8	115.6	115.6	123.5	89.3	109.5	109.5	109.7	109.7	116.8	86.8						
	90	119.6	119.6	119.8	119.8	123.1	110.5	114.1	114.1	114.2	114.2	116.5	108.0						
4400	75	107.2	106.9	116.4	77.8	125.5	47.4	101.6	101.6	110.0	75.2	118.8	45.1						
	80	112.0	112.0	116.2	100.9	125.0	71.6	106.7	106.7	110.0	98.3	118.2	69.4						
	85	117.3	117.3	117.4	117.4	124.3	94.2	111.8	111.8	111.9	111.9	117.6	91.7						
	90	121.9	121.9	122.0	122.0	124.0	117.5	116.1	116.1	116.2	116.2	117.4	115.0						
4800	75	108.7	108.7	117.4	81.0	126.3	48.2	103.2	103.2	111.0	78.4	119.5	46.0						
	80	114.2	114.2	117.3	106.3	125.8	74.7	108.7	108.7	111.0	103.7	118.9	72.5						
	85	119.3	119.3	119.4	119.4	125.0	99.0	113.6	113.6	113.7	113.7	118.2	96.5						
	90	123.7	123.7	123.8	123.8	124.8	124.5	117.6	117.6	117.7	117.7	118.2	118.2						

Notes:

- All capacities shown are gross and have not considered indoor fan heat. To obtain net cooling, subtract indoor fan heat.
- MBH = Total Gross Capacity, SHC = Sensible Heat Capacity



Performance Data

Table 21. Gross cooling capacities (MBH) 12.5 tons TTA1504*D condensing unit with 12.5 tons TWE1504*B air handler (IP)

CFM	Ent DB (°F)	Ambient Temperature (°F)						Ambient Temperature (°F)						Ambient Temperature (°F)					
		85						95						105					
		Entering Wet Bulb (°F)						Entering Wet Bulb (°F)						Entering Wet Bulb (°F)					
		61		67		73		61		67		73		61		67		73	
	MBH	SHC	MBH	SHC	MBH	SHC	MBH	SHC	MBH	SHC	MBH	SHC	MBH	SHC	MBH	SHC	MBH	SHC	
4500	75	150.9	129.3	165.1	98.2	177.4	65.1	144.0	126.1	157.7	95.2	169.4	62.3	136.3	122.7	149.4	91.9	160.5	59.2
	80	152.4	150.1	164.8	122.8	177.1	90.0	145.9	145.9	157.3	119.8	169.1	87.2	139.4	139.4	149.1	116.5	160.2	84.1
	85	159.2	159.2	164.9	147.2	176.8	114.7	153.2	153.2	157.6	144.2	168.8	111.9	146.5	146.5	149.5	140.9	159.9	108.8
	90	166.5	166.5	166.5	166.5	176.5	139.3	160.0	160.0	160.2	160.2	168.5	136.5	152.9	152.9	153.1	153.1	159.7	133.4
5000	75	153.5	137.2	167.2	102.6	179.3	66.1	146.5	134.0	159.6	99.6	170.8	63.2	138.7	130.6	151.1	96.4	161.8	60.2
	80	156.4	156.4	166.9	129.9	179.0	93.8	150.3	150.3	159.3	126.9	170.5	90.9	143.5	143.5	150.9	123.6	161.5	87.8
	85	163.8	163.8	167.3	157.1	178.6	121.3	157.5	157.5	159.9	154.1	170.2	118.4	150.4	150.4	151.7	149.1	161.2	115.3
	90	170.6	170.6	170.8	170.8	178.4	148.5	164.0	164.0	164.2	164.2	170.0	145.6	156.6	156.6	156.8	156.8	161.0	142.4
5500	75	155.8	145.1	168.9	107.0	180.8	67.1	148.6	141.9	161.1	104.0	172.0	64.2	140.6	135.8	152.6	100.8	162.7	61.1
	80	160.3	160.3	168.6	136.9	180.5	97.5	153.9	153.9	160.9	133.9	171.7	94.6	146.8	146.8	152.4	130.6	162.4	91.5
	85	167.6	167.6	169.4	166.7	180.2	127.8	161.0	161.0	162.0	158.7	171.4	124.8	153.6	153.6	154.0	153.8	162.1	121.6
	90	174.2	174.2	174.3	174.3	180.1	157.7	167.2	167.2	167.4	167.4	171.4	154.7	159.4	159.4	159.6	159.6	162.1	151.5
6000	75	157.8	152.9	170.2	111.4	182.2	68.2	150.4	146.3	162.4	108.4	173.1	65.2	142.8	141.2	153.7	105.2	163.5	62.0
	80	163.5	163.5	170.0	144.0	181.8	101.4	157.0	157.0	162.3	141.0	172.8	98.3	149.6	149.6	153.7	137.7	163.2	95.2
	85	170.7	170.7	171.3	171.3	181.5	134.3	163.9	163.9	164.1	164.1	172.4	131.2	156.2	156.2	156.3	156.3	162.8	128.0
	90	177.1	177.1	177.3	177.3	181.8	167.0	169.8	169.8	169.9	169.9	172.7	163.9	161.7	161.7	161.7	161.7	163.1	159.6
CFM	Ent DB (°F)	Ambient Temperature (°F)						Ambient Temperature (°F)											
		115						125											
		Entering Wet Bulb (°F)						Entering Wet Bulb (°F)											
		61		67		73		61		67		73							
	MBH	SHC	MBH	SHC	MBH	SHC	MBH	SHC	MBH	SHC	MBH	SHC							
4500	75	128.0	118.9	140.2	88.3	150.8	55.9	118.6	113.3	130.0	84.4	139.9	52.2						
	80	132.2	132.2	140.0	112.8	150.5	80.8	124.0	124.0	129.8	108.8	139.6	77.1						
	85	138.9	138.9	140.6	137.4	150.2	105.5	130.4	130.4	130.9	130.8	139.3	101.8						
	90	145.0	145.0	145.2	145.2	150.0	130.0	136.0	136.0	136.2	136.2	139.3	126.2						
5000	75	130.0	124.8	141.8	92.8	151.8	56.8	121.1	118.8	131.4	88.9	140.8	53.2						
	80	135.9	135.9	141.6	119.9	151.5	84.5	127.3	127.3	131.4	116.0	140.5	80.8						
	85	142.5	142.5	143.0	141.5	151.2	111.9	133.5	133.5	133.6	133.6	140.2	108.1						
	90	148.2	148.2	148.4	148.4	151.2	139.1	138.7	138.7	138.8	138.8	140.1	132.4						
5500	75	132.3	130.3	143.1	97.2	152.7	57.8	123.2	123.2	132.5	93.2	141.5	54.1						
	80	138.9	138.9	143.0	127.0	152.4	88.2	130.0	130.0	132.6	123.0	141.2	84.5						
	85	145.3	145.3	145.5	145.5	152.0	118.2	136.0	136.0	136.0	136.0	140.9	114.5						
	90	150.7	150.7	150.8	150.8	152.0	144.5	140.7	140.7	140.8	140.8	141.2	137.8						
6000	75	133.9	133.9	144.1	101.5	153.3	58.7	125.5	125.5	133.4	97.5	142.1	55.1						
	80	141.4	141.4	144.2	134.1	153.0	91.9	132.2	132.2	133.7	130.1	141.8	88.3						
	85	147.6	147.6	147.3	147.3	152.7	124.6	137.9	137.9	138.0	138.0	141.4	120.9						
	90	152.5	152.5	152.6	152.6	153.1	150.1	142.1	142.1	142.1	142.1	142.2	142.2						

Notes:

1. All capacities shown are gross and have not considered indoor fan heat. To obtain net cooling, subtract indoor fan heat.
2. MBH = Total Gross Capacity, SHC = Sensible Heat Capacity

Table 22. Gross cooling capacities (MBH) 15 tons TTA1804*D condensing unit with 15 tons TWE1804*B air handler (IP)

CFM	Ent DB (°F)	Ambient Temperature (°F)						Ambient Temperature (°F)						Ambient Temperature (°F)					
		85						95						105					
		Entering Wet Bulb (°F)						Entering Wet Bulb (°F)						Entering Wet Bulb (°F)					
		61		67		73		61		67		73		61		67		73	
		MBH	SHC	MBH	SHC	MBH	SHC	MBH	SHC	MBH	SHC	MBH	SHC	MBH	SHC	MBH	SHC	MBH	SHC
5400	75	184.1	155.9	204.3	120.0	224.8	82.1	175.9	152.0	195.4	116.3	215.3	78.7	167.2	147.9	185.8	112.4	205.1	74.9
	80	185.4	181.9	203.8	149.3	224.3	111.8	178.0	176.9	194.9	145.5	214.8	108.3	170.0	170.0	185.4	141.6	204.5	104.6
	85	194.0	194.0	203.8	178.3	223.7	141.4	187.1	187.1	195.1	174.6	214.2	137.9	179.7	179.7	185.8	170.7	204.0	134.2
	90	205.5	202.3	205.5	202.3	223.3	170.7	196.9	196.9	197.6	197.5	213.8	167.1	189.2	189.2	189.5	189.5	203.7	163.4
6000	75	187.7	165.5	207.7	125.6	227.9	83.6	179.4	161.6	198.5	121.9	218.2	80.1	170.4	157.5	188.7	117.9	207.7	76.4
	80	190.4	190.4	207.2	158.1	227.4	116.6	183.3	183.3	198.1	154.3	217.7	113.1	175.6	175.6	188.4	150.3	207.2	109.4
	85	200.6	200.6	207.6	190.5	226.8	149.4	193.4	193.4	198.8	186.8	217.1	146.0	185.6	185.6	189.3	182.8	206.6	142.2
	90	210.8	210.8	211.2	211.2	226.5	181.9	203.4	203.4	203.7	203.7	216.8	178.3	195.4	195.4	195.7	195.7	206.6	174.6
6600	75	190.9	175.0	210.5	131.1	230.5	84.9	182.4	171.1	201.1	127.4	220.6	81.4	173.3	167.0	191.1	123.4	209.9	77.7
	80	195.8	195.8	210.1	166.7	229.9	121.3	188.4	188.4	200.8	162.9	220.0	117.8	180.5	180.5	190.8	158.9	209.4	114.1
	85	206.3	206.3	210.9	202.5	229.3	157.4	198.8	198.8	202.0	198.8	219.5	153.8	190.6	190.6	192.5	192.5	208.9	150.0
	90	216.7	216.7	217.0	217.0	229.1	193.0	209.0	209.0	209.3	209.3	219.4	189.5	200.6	200.6	200.9	200.9	209.0	185.7
7200	75	193.7	184.5	212.8	136.5	232.7	86.3	185.1	180.6	203.3	132.8	222.6	82.8	175.9	175.7	193.0	128.8	211.7	79.1
	80	200.5	200.5	212.5	175.3	232.1	125.9	192.9	192.9	203.0	171.5	222.0	122.5	184.7	184.7	193.0	167.4	211.1	118.7
	85	211.3	211.3	214.0	212.8	231.5	165.2	203.5	203.5	205.0	205.0	221.5	161.6	195.0	195.0	195.6	195.6	210.8	157.8
	90	221.8	221.8	222.1	222.1	231.5	204.1	213.8	213.8	214.0	214.0	221.7	200.6	205.1	205.1	205.3	205.3	211.2	196.8
CFM	Ent DB (°F)	Ambient Temperature (°F)						Ambient Temperature (°F)											
		115						125											
		Entering Wet Bulb (°F)						Entering Wet Bulb (°F)											
		61		67		73		61		67		73							
		MBH	SHC	MBH	SHC	MBH	SHC	MBH	SHC	MBH	SHC	MBH	SHC						
5400	75	157.9	143.6	175.7	108.3	194.1	71.0	148.1	139.0	164.7	103.9	182.5	66.9						
	80	162.2	162.2	175.3	137.4	193.6	100.7	153.8	153.8	164.5	132.9	181.9	96.6						
	85	171.6	171.6	176.0	166.6	193.0	130.3	163.0	163.0	165.6	162.3	181.5	126.1						
	90	181.0	181.0	181.3	181.3	192.9	159.4	172.1	172.1	172.4	172.4	181.5	155.2						
6000	75	161.0	153.1	178.3	113.8	196.5	72.4	151.0	148.6	167.0	109.4	184.6	68.3						
	80	167.5	167.5	178.1	146.0	196.0	105.5	158.7	158.7	167.0	141.6	184.0	101.4						
	85	177.2	177.2	179.4	178.3	195.5	138.2	168.2	168.2	169.2	169.2	183.7	133.9						
	90	186.7	186.7	187.0	187.0	195.6	170.6	177.4	177.4	177.7	177.7	184.0	166.4						
6600	75	163.8	162.6	180.4	119.2	198.5	73.8	153.7	153.0	169.1	114.7	186.3	69.7						
	80	172.0	172.0	180.4	154.7	197.9	110.2	162.9	162.9	169.2	150.2	185.8	106.0						
	85	182.0	182.0	182.7	182.7	197.6	146.0	172.5	172.5	172.8	172.8	185.5	141.7						
	90	191.6	191.6	191.8	191.8	197.9	181.7	181.8	181.8	182.0	182.0	185.0	174.9						
7200	75	166.3	166.1	182.3	124.5	200.1	75.2	156.5	156.5	170.8	119.9	187.7	71.0						
	80	175.9	175.9	182.5	163.2	199.6	114.8	166.5	166.5	171.2	158.7	187.1	110.7						
	85	186.0	186.0	186.3	186.3	199.3	153.8	176.3	176.3	176.5	176.5	187.0	149.5						
	90	195.7	195.7	195.9	195.9	200.0	192.8	185.5	185.5	185.7	185.7	187.5	181.9						

Notes:

1. All capacities shown are gross and have not considered indoor fan heat. To obtain net cooling, subtract indoor fan heat.
2. MBH = Total Gross Capacity, SHC = Sensible Heat Capacity



Performance Data

Table 23. Gross Cooling Capacities (MBH) one compressor - 15 Tons TTA1804*C Condensing Unit with 15 Tons TWE1804*B Air Handler (IP)

CFM	Ent DB (°F)	Ambient Temperature (°F)						Ambient Temperature (°F)						Ambient Temperature (°F)					
		85						95						105					
		Entering Wet Bulb (°F)						Entering Wet Bulb (°F)						Entering Wet Bulb (°F)					
		61		67		73		61		67		73		61		67		73	
		MBH	SHC	MBH	SHC	MBH	SHC	MBH	SHC	MBH	SHC	MBH	SHC	MBH	SHC	MBH	SHC	MBH	SHC
5400	75	121.6	121.6	132.9	92.5	148.0	56.1	116.1	116.1	125.6	89.8	139.8	53.4	110.6	110.6	118.5	87.2	131.9	50.8
	80	129.8	129.8	133.6	122.0	147.9	85.9	123.9	123.9	126.5	119.3	139.7	83.2	118.1	118.1	119.4	117.0	131.8	80.7
	85	138.2	138.2	138.4	138.4	148.0	115.5	131.9	131.9	132.1	132.1	139.9	112.8	125.8	125.8	125.9	125.9	132.0	110.4
	90	146.9	146.9	146.9	146.9	149.2	145.3	140.1	140.1	140.3	140.3	141.4	141.4	133.6	133.6	130.2	130.2	134.1	134.1
6000	75	124.7	124.7	134.4	97.9	149.5	57.5	118.9	118.9	127.0	95.1	141.2	54.8	113.2	113.2	119.7	92.4	133.1	52.2
	80	133.3	133.3	135.5	130.7	149.4	90.6	127.1	127.1	127.2	127.2	141.1	87.9	120.9	120.9	121.1	121.1	133.0	85.3
	85	142.0	142.0	142.1	142.1	149.6	123.5	135.4	135.4	135.6	135.6	141.4	120.8	128.9	128.9	129.1	129.1	133.5	118.2
	90	150.6	150.6	148.2	148.2	151.5	151.5	143.7	143.7	143.9	143.9	144.1	144.1	137.0	137.0	131.6	131.6	137.3	137.3
6600	75	127.5	127.5	135.7	103.1	150.7	58.8	121.4	121.4	128.1	100.3	142.3	56.1	115.4	115.4	120.7	97.9	134.1	53.5
	80	136.3	136.3	136.4	136.4	150.7	95.3	129.8	129.8	129.9	129.9	142.2	92.6	123.4	123.4	123.5	123.5	134.0	90.0
	85	145.2	145.2	145.4	145.4	151.0	131.4	138.4	138.4	138.5	138.5	142.6	129.0	131.6	131.6	131.8	131.8	134.6	126.5
	90	153.9	153.9	154.1	154.1	154.3	154.3	146.8	146.8	146.9	146.9	147.1	147.1	139.8	139.8	132.2	132.2	140.1	140.1
7200	75	129.8	129.8	136.8	108.4	151.8	60.1	123.5	123.5	129.0	105.8	143.2	57.5	117.4	117.4	121.6	103.2	134.9	54.9
	80	138.9	138.9	139.0	139.0	151.7	99.9	132.2	132.2	132.3	132.3	143.1	97.2	125.6	125.6	125.7	125.7	134.8	94.6
	85	148.0	148.0	148.1	148.1	152.2	139.3	140.9	140.9	141.0	141.0	143.8	137.1	134.0	134.0	134.1	134.1	135.7	134.5
	90	156.7	156.7	156.8	156.8	157.0	157.0	149.4	149.4	149.5	149.5	149.6	149.6	142.1	142.1	132.5	132.5	142.4	142.4
CFM	Ent DB (°F)	Ambient Temperature (°F)						Ambient Temperature (°F)											
		115						125											
		Entering Wet Bulb (°F)						Entering Wet Bulb (°F)											
		61		67		73		61		67		73							
		MBH	SHC	MBH	SHC	MBH	SHC	MBH	SHC	MBH	SHC	MBH	SHC						
5400	75	104.9	104.9	111.4	84.5	123.9	48.3	98.9	98.9	104.0	81.9	115.7	45.7						
	80	112.1	112.1	112.8	112.8	123.9	78.1	105.8	105.8	105.9	105.9	115.7	75.5						
	85	119.5	119.5	119.6	119.6	124.1	107.9	112.9	112.9	113.0	113.0	116.2	105.1						
	90	127.0	127.0	122.0	122.0	127.4	127.4	120.1	120.1	113.1	113.1	120.4	120.4						
6000	75	107.3	107.3	112.5	89.9	125.0	49.7	101.0	101.0	105.0	87.3	116.7	47.1						
	80	114.7	114.7	114.8	114.8	124.9	82.8	108.2	108.2	108.3	108.3	116.6	80.2						
	85	122.4	122.4	122.5	122.5	125.4	116.0	115.5	115.5	115.6	115.6	117.4	113.0						
	90	130.1	130.1	122.7	122.7	130.4	130.4	122.9	122.9	123.0	123.0	123.1	123.1						
6600	75	109.3	109.3	113.4	95.3	125.9	51.0	102.9	102.9	105.8	92.6	117.4	48.4						
	80	117.0	117.0	117.1	117.1	125.8	87.4	110.2	110.2	110.3	110.3	117.4	84.8						
	85	124.8	124.8	125.0	125.0	126.8	123.5	117.7	117.7	117.8	117.8	118.6	118.6						
	90	132.7	132.7	123.0	123.0	132.9	132.9	125.2	125.2	125.3	125.3	117.5	117.5						
7200	75	111.1	111.1	114.2	100.6	126.6	52.3	104.5	104.5	106.7	97.5	118.1	49.7						
	80	118.9	118.9	119.0	119.0	126.6	91.9	112.0	112.0	112.0	112.0	118.0	89.5						
	85	127.0	127.0	127.1	127.1	127.2	127.2	119.6	119.6	119.7	119.7	119.5	119.5						
	90	134.9	134.9	123.1	123.1	126.6	126.6	127.2	127.2	127.3	127.3	124.6	124.6						

Notes:

1. All capacities shown are gross and have not considered indoor fan heat. To obtain net cooling, subtract indoor fan heat.
2. MBH = Total Gross Capacity, SHC = Sensible Heat Capacity

Table 24. Gross cooling capacities (MBH) both compressors - 15 tons TTA1804*C condensing unit with 15 tons TWE1804*B air handler (IP)

CFM	Ent DB (°F)	Ambient Temperature (°F)						Ambient Temperature (°F)						Ambient Temperature (°F)							
		85						95						105							
		Entering Wet Bulb (°F)						Entering Wet Bulb (°F)						Entering Wet Bulb (°F)							
		61		67		73		61		67		73		61		67		73			
		MBH	SHC	MBH	SHC	MBH	SHC	MBH	SHC	MBH	SHC	MBH	SHC	MBH	SHC	MBH	SHC	MBH	SHC	MBH	SHC
5400	75	180.2	154.6	200.1	118.5	219.3	80.4	172.1	150.9	191.0	114.8	209.5	77.0	163.7	147.1	181.5	111.1	199.3	73.4		
	80	182.5	182.5	200.0	148.0	219.2	110.2	175.0	175.0	190.9	144.3	209.4	106.8	167.5	167.5	181.5	140.6	199.3	103.2		
	85	191.6	191.6	200.3	177.4	219.1	139.9	184.5	184.5	191.5	173.8	209.4	136.5	177.1	177.1	182.3	170.1	199.2	132.9		
	90	202.8	202.8	202.8	202.8	219.0	169.5	194.3	194.3	194.7	194.7	209.3	166.0	186.7	186.7	187.0	187.0	199.2	162.5		
6000	75	183.7	164.3	203.2	124.0	222.0	81.7	175.4	160.5	193.9	120.3	212.0	78.3	166.7	156.7	184.2	116.6	201.6	74.7		
	80	187.5	187.5	203.2	156.8	221.9	114.8	180.3	180.3	193.8	153.1	211.9	111.4	172.8	172.8	184.1	149.3	201.5	107.8		
	85	197.9	197.9	204.0	189.6	221.8	147.8	190.5	190.5	194.9	186.0	211.9	144.4	182.7	182.7	185.6	182.2	201.5	140.8		
	90	208.2	208.2	208.5	208.5	221.8	180.7	200.5	200.5	200.8	200.8	211.9	177.2	192.4	192.4	192.7	192.7	201.6	173.7		
6600	75	186.8	173.8	205.8	129.5	224.2	83.0	178.3	170.1	196.3	125.8	214.0	79.6	169.4	166.2	186.4	122.0	203.4	76.0		
	80	192.7	192.7	205.8	165.5	224.1	119.4	185.2	185.2	196.2	161.8	213.9	116.0	177.4	177.4	186.4	158.0	203.4	112.4		
	85	203.4	203.4	207.1	201.7	224.0	155.7	195.6	195.6	198.0	198.0	213.9	152.3	187.5	187.5	187.7	187.7	203.3	148.7		
	90	213.7	213.7	213.9	213.9	224.1	191.8	205.6	205.6	205.9	205.9	214.1	188.4	197.2	197.2	197.4	197.4	203.7	184.8		
7200	75	189.5	183.4	208.0	134.9	226.0	84.3	180.9	179.6	198.3	131.2	215.7	80.8	172.0	172.0	188.2	127.4	204.9	77.3		
	80	197.3	197.3	207.9	174.1	225.9	124.0	189.5	189.5	198.3	170.4	215.6	120.6	181.3	181.3	188.4	166.6	204.8	117.0		
	85	208.1	208.1	208.3	208.3	225.8	163.6	200.0	200.0	200.3	200.3	215.5	160.2	191.6	191.6	191.8	191.8	204.8	156.6		
	90	218.3	218.3	218.6	218.6	226.1	202.9	209.9	209.9	210.2	210.2	216.0	199.5	201.1	201.1	201.3	201.3	205.5	195.9		
CFM	Ent DB (°F)	Ambient Temperature (°F)						Ambient Temperature (°F)													
		115						125													
		Entering Wet Bulb (°F)						Entering Wet Bulb (°F)													
		61		67		73		61		67		73									
		MBH	SHC	MBH	SHC	MBH	SHC	MBH	SHC	MBH	SHC	MBH	SHC								
5400	75	154.6	143.0	171.5	107.1	188.6	69.7	144.9	138.7	160.6	102.9	176.8	65.7								
	80	159.8	159.8	171.4	136.6	188.5	99.5	151.4	151.4	160.5	132.4	176.8	95.5								
	85	169.2	169.2	172.6	166.2	188.5	129.2	160.4	160.4	161.9	161.9	176.7	125.2								
	90	178.4	178.4	178.7	178.7	188.6	158.8	169.4	169.4	169.6	169.6	177.0	154.7								
6000	75	157.5	152.6	173.9	112.6	190.7	71.0	147.5	147.5	162.7	108.4	178.7	67.0								
	80	164.7	164.7	173.8	145.4	190.6	104.1	155.9	155.9	162.8	141.1	178.6	100.1								
	85	174.4	174.4	175.8	175.8	190.5	137.1	165.2	165.2	165.4	165.4	178.5	133.1								
	90	183.7	183.7	184.0	184.0	190.9	170.0	174.2	174.2	174.4	174.4	179.1	165.9								
6600	75	160.1	160.1	175.9	118.0	192.3	72.3	150.2	150.2	164.5	113.8	180.2	68.3								
	80	169.0	169.0	176.0	154.0	192.3	108.8	159.7	159.7	164.9	149.7	180.1	104.7								
	85	178.8	178.8	179.0	179.0	192.2	145.1	169.2	169.2	169.4	169.4	180.0	141.0								
	90	188.1	188.1	188.3	188.3	192.9	181.1	178.1	178.1	178.3	178.3	181.0	177.1								
7200	75	162.5	162.5	177.5	123.4	193.7	73.6	153.3	153.3	166.0	119.1	181.4	69.6								
	80	172.6	172.6	177.9	162.6	193.6	113.3	163.1	163.1	166.6	158.4	181.3	109.3								
	85	182.5	182.5	182.7	182.7	193.5	152.9	172.6	172.6	172.8	172.8	181.2	148.8								
	90	191.8	191.8	190.8	190.8	194.6	192.2	181.3	181.3	180.0	180.0	182.7	182.7								

Notes:

1. All capacities shown are gross and have not considered indoor fan heat. To obtain net cooling, subtract indoor fan heat.
2. MBH = Total Gross Capacity, SHC = Sensible Heat Capacity



Performance Data

Table 25. Gross cooling capacities (MBH) 15 tons TTA1804*D condensing unit with 20 tons TWE2404*B air handler (IP)

CFM	Ent DB (°F)	Ambient Temperature (°F)						Ambient Temperature (°F)						Ambient Temperature (°F)					
		85						95						105					
		Entering Wet Bulb (°F)						Entering Wet Bulb (°F)						Entering Wet Bulb (°F)					
		61		67		73		61		67		73		61		67		73	
	MBH	SHC	MBH	SHC	MBH	SHC	MBH	SHC	MBH	SHC	MBH	SHC	MBH	SHC	MBH	SHC	MBH	SHC	
5400	75	183.1	155.8	202.5	119.7	220.9	81.1	175.1	152.1	193.9	116.3	211.9	77.9	166.6	148.1	184.6	112.6	202.2	74.5
	80	184.0	184.0	201.9	149.1	220.4	110.9	176.5	174.6	193.4	145.5	211.4	107.7	168.9	168.9	184.2	141.7	201.6	104.3
	85	191.4	191.4	201.7	177.8	219.9	140.6	184.8	184.8	193.2	174.2	210.9	137.4	177.6	177.6	184.2	170.4	201.1	134.0
	90	202.6	199.8	202.6	199.8	219.4	169.7	193.9	193.9	195.0	195.0	210.4	166.3	186.5	186.5	186.9	186.9	200.7	162.7
6000	75	186.5	165.2	205.6	125.3	223.6	82.4	178.3	161.4	196.8	121.8	214.4	79.2	169.5	157.4	187.3	118.2	204.5	75.8
	80	188.4	188.4	205.1	157.6	223.1	115.6	181.2	181.2	196.4	154.0	213.9	112.4	173.7	173.7	187.0	150.2	203.9	109.0
	85	197.5	197.5	204.9	189.6	222.6	148.5	190.6	190.6	196.4	186.0	213.3	145.3	183.0	183.0	187.3	182.3	203.4	141.7
	90	206.9	206.9	207.4	207.4	222.1	180.5	199.8	199.8	200.0	200.0	212.9	177.2	192.0	192.0	192.3	192.3	203.0	173.6
6600	75	189.3	174.5	208.2	130.8	225.8	83.7	180.9	170.7	199.2	127.3	216.4	80.5	172.1	166.7	189.5	123.6	206.3	77.1
	80	192.9	192.9	207.8	166.1	225.3	120.2	185.8	185.8	198.9	162.4	215.9	117.0	178.2	178.2	189.3	158.6	205.8	113.6
	85	202.8	202.8	207.8	201.4	224.8	156.2	195.5	195.5	199.2	197.8	215.4	152.8	187.7	187.7	190.1	190.1	205.3	149.2
	90	212.1	212.1	212.4	212.4	224.3	191.4	204.7	204.7	204.9	204.9	214.9	188.0	196.6	196.6	196.8	196.8	204.8	184.4
7200	75	191.8	183.8	210.3	136.2	227.6	85.0	183.4	180.0	201.2	132.6	218.1	81.8	174.5	174.5	191.4	128.8	207.9	78.4
	80	197.3	197.3	210.0	174.5	227.1	124.8	190.0	190.0	200.9	170.8	217.6	121.6	182.1	182.1	191.2	166.9	207.3	118.2
	85	207.2	207.2	210.4	210.4	226.6	163.8	199.7	199.7	201.7	201.7	217.1	160.4	191.6	191.6	192.6	192.6	206.8	156.7
	90	216.5	216.5	216.8	216.8	226.0	202.2	208.8	208.8	209.0	209.0	216.5	198.8	200.5	200.5	200.7	200.7	206.4	195.2
CFM	Ent DB (°F)	Ambient Temperature (°F)						Ambient Temperature (°F)											
		115						125											
		Entering Wet Bulb (°F)						Entering Wet Bulb (°F)											
		61		67		73		61		67		73							
	MBH	SHC	MBH	SHC	MBH	SHC	MBH	SHC	MBH	SHC	MBH	SHC							
5400	75	157.6	143.9	174.8	108.7	191.6	70.9	148.2	139.5	164.2	104.6	180.2	67.0						
	80	160.9	160.9	174.4	137.6	191.1	100.7	152.9	152.9	164.0	133.3	179.7	96.8						
	85	169.8	169.8	174.7	166.4	190.6	130.2	161.5	161.5	164.5	162.2	179.2	126.1						
	90	178.5	178.5	178.8	178.8	190.3	158.9	169.8	169.8	170.0	170.0	178.9	154.7						
6000	75	160.4	153.2	177.1	114.3	193.7	72.2	150.8	148.8	166.3	110.0	182.0	68.3						
	80	165.8	165.8	177.0	146.1	193.2	105.4	157.4	157.4	166.3	141.7	181.5	101.5						
	85	174.9	174.9	177.6	177.0	192.7	137.8	166.1	166.1	167.4	167.4	181.1	133.6						
	90	183.6	183.6	183.8	183.8	192.3	169.7	174.4	174.4	174.6	174.6	180.8	165.6						
6600	75	162.9	161.8	179.1	119.5	195.4	73.5	153.2	153.2	168.2	115.1	183.5	69.6						
	80	170.0	170.0	179.1	154.5	194.9	110.0	161.2	161.2	168.1	150.1	183.0	106.1						
	85	179.2	179.2	180.4	180.4	194.4	145.3	170.0	170.0	170.5	170.5	182.6	141.1						
	90	187.9	187.9	188.0	188.0	192.0	180.5	178.2	178.2	178.4	178.4	182.4	176.4						
7200	75	165.2	165.2	180.9	124.6	196.8	74.8	155.8	155.8	169.8	120.2	184.8	70.9						
	80	173.6	173.6	180.9	162.8	196.2	114.7	164.5	164.5	169.7	158.4	184.2	110.6						
	85	182.9	182.9	183.3	183.3	195.8	152.8	173.4	173.4	173.5	173.5	183.8	148.6						
	90	191.4	191.4	191.5	191.5	195.6	191.3	181.3	181.3	181.5	181.5	183.9	183.9						

Notes:

1. All capacities shown are gross and have not considered indoor fan heat. To obtain net cooling, subtract indoor fan heat.
2. MBH = Total Gross Capacity, SHC = Sensible Heat Capacity

Table 26. Gross cooling capacities (MBH) 20 tons TTA2404*D condensing unit with 20 tons TWE2404*B air handler (IP)

CFM	Ent DB (°F)	Ambient Temperature (°F)						Ambient Temperature (°F)						Ambient Temperature (°F)								
		85						95						105								
		Entering Wet Bulb (°F)						Entering Wet Bulb (°F)						Entering Wet Bulb (°F)								
		61		67		73		61		67		73		61		67		73				
		MBH	SHC	MBH	SHC	MBH	SHC	MBH	SHC	MBH	SHC	MBH	SHC	MBH	SHC	MBH	SHC	MBH	SHC	MBH	SHC	
7200	75	236.9	204.7	261.2	156.2	284.0	104.4	227.3	200.2	250.7	152.0	272.6	100.4	217.0	195.4	239.3	147.5	260.2	96.1			
	80	237.6	235.5	260.4	195.5	283.3	144.2	228.6	225.5	250.0	191.1	272.0	140.2	219.2	219.2	238.6	186.4	259.6	135.9			
	85	247.0	247.0	260.1	233.8	282.7	183.9	238.9	238.9	249.7	229.4	271.4	179.9	229.9	229.9	238.4	224.7	258.9	175.6			
	90	261.2	256.0	261.2	256.0	282.1	222.8	250.2	250.2	251.8	250.0	270.7	218.6	240.8	240.8	241.5	241.5	258.3	214.1			
8000	75	241.1	217.2	265.1	163.5	287.6	106.2	231.3	212.7	254.3	159.3	275.6	102.1	220.6	207.8	242.6	154.8	262.9	97.8			
	80	243.2	243.1	264.4	206.9	286.9	150.5	234.3	234.3	253.7	202.5	275.0	146.4	224.8	224.8	242.0	197.7	262.3	142.1			
	85	254.5	254.5	264.1	249.5	286.2	194.6	245.9	245.9	253.5	245.0	274.3	190.5	236.5	236.5	241.9	236.6	261.5	186.0			
	90	266.2	266.2	267.2	267.2	285.7	237.5	257.2	257.2	257.5	257.5	273.8	233.1	247.4	247.4	247.2	247.2	261.0	228.5			
8800	75	244.7	229.6	268.3	170.8	290.6	108.0	234.5	225.0	257.3	166.6	278.3	103.9	223.7	218.8	245.3	162.1	265.1	99.5			
	80	248.5	248.5	267.7	218.1	289.9	156.8	239.9	239.9	256.7	213.7	277.6	152.6	230.5	230.5	244.8	208.9	264.5	148.2			
	85	260.8	260.8	267.5	261.3	289.2	205.1	251.8	251.8	256.7	253.3	276.8	200.7	242.0	242.0	245.1	244.3	263.8	196.0			
	90	272.5	272.5	272.5	272.5	288.8	252.1	263.1	263.1	263.4	263.4	276.4	247.6	252.8	252.8	253.0	253.0	263.2	242.9			
9600	75	247.7	241.3	270.9	178.0	293.1	109.8	237.5	233.7	259.8	173.8	280.5	105.6	226.5	225.4	247.6	169.2	267.1	101.2			
	80	252.9	252.9	270.4	229.3	292.4	163.0	245.0	245.0	259.2	224.9	279.8	158.8	235.2	235.2	247.1	220.0	266.3	154.4			
	85	266.2	266.2	270.5	269.2	291.7	215.3	256.9	256.9	259.6	259.6	279.2	210.9	246.7	246.7	247.8	247.8	265.7	206.1			
	90	277.8	277.8	278.1	278.1	291.3	266.6	268.1	268.1	268.3	268.3	275.9	255.2	257.3	257.3	257.5	257.5	265.2	256.1			
CFM	Ent DB (°F)	Ambient Temperature (°F)						Ambient Temperature (°F)														
		115						125														
		Entering Wet Bulb (°F)						Entering Wet Bulb (°F)														
		61		67		73		61		67		73										
		MBH	SHC	MBH	SHC	MBH	SHC	MBH	SHC	MBH	SHC	MBH	SHC	MBH	SHC	MBH	SHC	MBH	SHC	MBH	SHC	
7200	75	205.9	190.3	227.0	142.7	246.6	91.4	194.2	185.0	213.7	137.6	231.8	86.4									
	80	209.4	209.3	226.4	181.4	246.0	131.3	199.3	199.3	213.1	176.0	231.1	126.2									
	85	220.2	220.2	226.2	219.2	245.2	170.9	209.5	209.5	213.2	209.3	230.4	165.5									
	90	230.6	230.6	230.8	230.8	244.7	209.1	219.2	219.2	219.4	219.4	229.8	203.7									
8000	75	209.3	202.7	230.0	150.0	249.0	93.1	197.3	194.1	216.3	144.8	233.9	88.1									
	80	215.3	215.3	229.4	192.6	248.4	137.4	204.6	204.6	215.8	187.1	233.2	132.4									
	85	226.2	226.2	229.6	227.2	247.6	181.0	214.9	214.9	216.2	214.7	232.5	175.5									
	90	236.5	236.5	236.7	236.7	247.1	223.5	224.4	224.4	224.6	224.6	231.9	218.1									
8800	75	212.2	210.1	232.4	157.2	251.0	94.8	200.0	196.9	218.2	151.7	235.5	89.7									
	80	220.3	220.3	231.9	203.7	250.3	143.5	209.1	209.1	218.0	198.2	234.8	138.5									
	85	231.2	231.2	232.4	231.2	249.6	191.0	219.3	219.3	220.0	220.0	234.1	185.5									
	90	241.3	241.3	241.5	241.5	249.0	237.9	228.6	228.6	228.8	228.8	233.6	227.7									
9600	75	214.8	212.6	234.3	164.0	252.6	96.4	202.9	202.9	220.1	158.4	236.9	91.4									
	80	224.6	224.6	234.0	214.8	251.9	149.7	213.0	213.0	219.8	209.2	236.2	144.6									
	85	235.5	235.5	236.1	236.1	251.2	201.0	223.1	223.1	223.0	223.0	235.5	195.5									
	90	245.4	245.4	245.5	245.5	250.7	245.7	232.0	232.0	232.2	232.2	234.9	228.7									

Notes:

1. All capacities shown are gross and have not considered indoor fan heat. To obtain net cooling, subtract indoor fan heat.
2. MBH = Total Gross Capacity, SHC = Sensible Heat Capacity



Performance Data

Table 27. Gross cooling capacities (MBH) one compressor - 20 tons TTA2404*C condensing unit with 20 tons TWE2404*B air handler (IP)

CFM	Ent DB (°F)	Ambient Temperature (°F)						Ambient Temperature (°F)						Ambient Temperature (°F)					
		85						95						105					
		Entering Wet Bulb (°F)						Entering Wet Bulb (°F)						Entering Wet Bulb (°F)					
		61		67		73		61		67		73		61		67		73	
		MBH	SHC	MBH	SHC	MBH	SHC	MBH	SHC	MBH	SHC	MBH	SHC	MBH	SHC	MBH	SHC	MBH	SHC
7200	75	152.7	152.7	167.3	118.4	182.8	69.9	146.8	146.8	159.9	116.1	175.0	67.3	140.3	140.3	151.4	113.0	166.0	64.4
	80	162.2	162.2	167.7	156.5	182.7	109.1	156.3	156.3	160.5	153.7	174.9	106.6	149.4	149.4	152.3	150.5	166.0	103.7
	85	171.9	171.9	172.0	172.0	182.7	147.2	165.6	165.6	165.8	165.8	174.9	144.5	158.4	158.4	158.5	158.5	166.0	141.4
	90	180.7	180.7	180.7	180.7	183.2	183.2	174.0	174.0	174.1	174.1	175.6	175.6	166.3	166.3	160.9	160.9	167.1	167.1
8000	75	156.1	156.1	169.0	125.8	184.0	71.5	150.2	150.2	161.5	123.1	176.1	69.0	143.4	143.4	152.8	120.0	167.1	66.1
	80	166.1	166.1	169.7	167.6	184.0	115.1	159.9	159.9	162.5	162.5	176.1	112.6	152.7	152.7	154.2	154.2	167.0	109.7
	85	175.8	175.8	175.9	175.9	183.9	157.1	169.2	169.2	169.4	169.4	176.0	154.4	161.7	161.7	161.8	161.8	167.0	151.4
	90	183.8	183.8	180.2	180.2	184.7	184.7	176.8	176.8	172.0	172.0	177.2	177.2	168.7	168.7	162.3	162.3	168.3	168.3
8800	75	159.3	159.3	170.4	132.9	185.0	73.1	153.1	153.1	162.8	130.1	177.1	70.6	146.1	146.1	154.0	127.0	168.0	67.7
	80	169.4	169.4	169.6	169.6	184.9	121.1	163.0	163.0	163.1	163.1	177.0	118.6	155.6	155.6	155.7	155.7	167.9	115.7
	85	178.9	178.9	179.0	179.0	184.7	167.0	172.1	172.1	172.2	172.2	176.8	164.4	164.3	164.3	164.4	164.4	167.8	161.3
	90	186.0	186.0	186.0	186.0	186.1	186.1	178.7	178.7	173.4	173.4	178.6	178.6	170.0	170.0	163.1	163.1	170.0	170.0
9600	75	162.0	162.0	171.6	139.8	185.8	74.8	155.7	155.7	163.9	137.1	177.8	72.2	148.4	148.4	155.0	133.9	168.6	69.4
	80	172.3	172.3	172.4	172.4	185.7	127.1	165.6	165.6	165.7	165.7	177.7	124.6	158.0	158.0	158.1	158.1	168.6	121.7
	85	181.4	181.4	181.4	181.4	185.4	177.0	174.4	174.4	174.5	174.5	177.5	174.3	166.4	166.4	166.4	166.4	168.5	168.5
	90	187.7	187.7	187.8	187.8	187.9	187.9	179.8	179.8	179.9	179.9	180.2	180.2	170.8	170.8	170.8	170.8	170.8	170.8
CFM	Ent DB (°F)	Ambient Temperature (°F)						Ambient Temperature (°F)											
		115						125											
		Entering Wet Bulb (°F)						Entering Wet Bulb (°F)											
		61		67		73		61		67		73							
		MBH	SHC	MBH	SHC	MBH	SHC	MBH	SHC	MBH	SHC	MBH	SHC						
7200	75	132.9	132.9	142.0	109.6	156.0	61.2	124.9	124.9	132.2	106.0	145.3	57.8						
	80	141.6	141.6	143.3	143.3	155.9	100.5	133.3	133.3	133.4	133.4	145.2	97.1						
	85	150.2	150.2	150.3	150.3	156.0	138.0	141.4	141.4	141.5	141.5	145.4	134.4						
	90	157.4	157.4	150.3	150.3	157.6	157.6	147.6	147.6	138.9	138.9	147.7	147.7						
8000	75	135.7	135.7	143.3	116.6	156.9	62.9	127.5	127.5	133.3	113.0	146.1	59.5						
	80	144.7	144.7	144.8	144.8	156.9	106.5	136.0	136.0	136.1	136.1	146.0	103.1						
	85	153.2	153.2	153.3	153.3	157.0	148.0	143.9	143.9	144.0	144.0	146.3	144.3						
	90	159.2	159.2	151.1	151.1	159.3	159.3	148.5	148.5	148.4	148.4	148.4	148.4						
8800	75	138.1	138.1	144.3	123.5	157.7	64.5	129.7	129.7	134.2	119.9	146.8	61.2						
	80	147.2	147.2	147.3	147.3	157.6	112.5	138.3	138.3	138.4	138.4	146.7	109.1						
	85	155.5	155.5	155.5	155.5	157.8	157.8	145.8	145.8	145.9	145.9	145.9	145.9						
	90	159.9	159.9	159.8	159.8	160.4	160.4	148.2	148.2	148.2	148.2	148.2	148.2						
9600	75	140.2	140.2	145.2	130.5	158.3	66.2	131.6	131.6	134.9	126.9	147.3	62.8						
	80	149.4	149.4	149.5	149.5	158.3	118.5	140.2	140.2	140.3	140.3	147.3	115.1						
	85	157.2	157.2	157.2	157.2	157.3	157.3	147.2	147.2	147.2	147.2	146.7	146.7						
	90	160.3	160.3	160.3	160.3	160.4	160.4	148.6	148.6	148.6	148.6	148.6	148.6						

Notes:

1. All capacities shown are gross and have not considered indoor fan heat. To obtain net cooling, subtract indoor fan heat.
2. MBH = Total Gross Capacity, SHC = Sensible Heat Capacity

Table 28. Gross cooling capacities (MBH) both compressors - 20 tons TTA2404*C condensing unit with 20 tons TWE2404*B air handler (IP)

CFM	Ent DB (°F)	Ambient Temperature (°F)						Ambient Temperature (°F)						Ambient Temperature (°F)					
		85						95						105					
		Entering Wet Bulb (°F)						Entering Wet Bulb (°F)						Entering Wet Bulb (°F)					
		61		67		73		61		67		73		61		67		73	
		MBH	SHC	MBH	SHC	MBH	SHC	MBH	SHC	MBH	SHC	MBH	SHC	MBH	SHC	MBH	SHC	MBH	SHC
7200	75	243.0	205.7	266.3	157.0	285.9	104.8	232.9	201.0	254.8	152.3	271.6	99.7	221.3	195.6	241.5	147.1	255.5	94.1
	80	243.6	243.6	266.2	195.8	285.8	144.0	233.9	233.9	254.7	191.1	271.5	138.9	223.0	223.0	241.4	185.8	255.5	133.3
	85	251.9	251.9	266.2	233.9	285.7	183.0	243.2	243.2	254.7	229.1	271.4	178.0	233.0	233.0	241.5	223.6	255.4	172.4
	90	267.0	267.0	267.0	267.0	285.5	221.8	253.9	253.9	256.0	256.0	271.3	216.5	242.7	242.7	243.4	243.4	255.3	210.7
8000	75	247.4	218.1	269.7	164.0	289.3	106.5	236.9	213.3	257.8	159.3	274.3	101.3	224.9	207.8	244.1	153.9	257.8	95.6
	80	248.9	248.9	269.6	207.1	289.2	150.1	239.1	239.1	257.7	202.2	274.2	144.9	228.3	228.3	244.0	196.6	257.7	139.2
	85	259.3	259.3	269.6	249.1	289.2	193.5	249.9	249.9	257.7	244.2	274.2	188.3	238.9	238.9	244.0	238.6	257.6	182.6
	90	270.2	270.2	271.4	271.4	289.0	236.1	259.9	259.9	260.2	260.2	274.1	230.7	247.5	247.5	247.6	247.6	257.6	224.8
8800	75	251.0	230.3	272.4	170.9	292.3	108.2	240.2	225.4	260.1	166.1	276.8	103.0	227.8	219.8	246.0	160.7	259.7	97.2
	80	253.8	253.8	272.3	218.0	292.2	156.1	244.2	244.2	260.0	213.0	276.7	150.9	233.4	233.4	245.9	207.4	259.6	145.1
	85	265.4	265.4	272.3	264.2	292.1	203.9	255.3	255.3	260.0	259.2	276.6	198.6	243.5	243.5	246.2	246.2	259.4	192.6
	90	275.4	275.4	275.6	275.6	292.0	250.5	264.2	264.2	263.9	263.9	276.6	245.0	250.6	250.6	250.8	250.8	259.5	239.0
9600	75	254.1	242.4	274.6	177.7	294.8	109.9	242.9	237.4	261.9	172.9	278.8	104.6	230.2	230.2	247.5	167.4	261.2	98.8
	80	258.8	258.8	274.5	228.8	294.7	162.2	249.1	249.1	261.9	223.7	278.7	156.9	237.7	237.7	247.4	218.0	261.1	151.1
	85	270.2	270.2	274.5	274.5	294.4	214.2	259.6	259.6	262.1	262.1	278.6	208.6	246.9	246.9	248.0	248.0	261.0	202.5
	90	280.1	280.1	280.4	280.4	294.6	264.9	268.2	268.2	268.5	268.5	278.7	259.2	254.4	254.4	254.6	254.6	261.0	253.1
CFM	Ent DB (°F)	Ambient Temperature (°F)						Ambient Temperature (°F)											
		115						125											
		Entering Wet Bulb (°F)						Entering Wet Bulb (°F)											
		61		67		73		61		67		73							
		MBH	SHC	MBH	SHC	MBH	SHC	MBH	SHC	MBH	SHC	MBH	SHC						
7200	75	208.6	189.8	227.1	141.4	238.1	88.1	195.7	183.9	212.1	135.5	220.1	82.0						
	80	211.5	211.5	227.0	179.9	238.1	127.3	200.2	200.2	212.1	173.9	220.1	121.2						
	85	221.6	221.6	227.1	217.7	238.0	166.4	209.3	209.3	212.2	211.6	220.0	160.3						
	90	229.9	229.9	230.0	230.0	237.9	204.4	215.6	215.6	215.6	215.6	219.9	198.0						
8000	75	211.8	201.9	229.2	148.1	239.9	89.6	198.4	195.9	213.7	142.3	221.1	83.4						
	80	216.9	216.9	229.1	190.6	239.8	133.2	205.0	205.0	213.7	184.5	221.1	127.0						
	85	226.5	226.5	229.3	229.3	239.7	176.4	213.1	213.1	214.1	214.1	221.0	169.9						
	90	233.1	233.1	233.2	233.2	239.7	218.5	217.5	217.5	217.6	217.6	220.9	211.8						
8800	75	214.4	213.8	230.7	154.9	241.2	91.1	201.0	201.0	214.9	148.9	221.8	84.7						
	80	221.5	221.5	230.6	201.3	241.1	139.0	208.8	208.8	214.7	195.0	221.8	132.7						
	85	230.1	230.1	231.1	231.1	241.1	186.2	215.5	215.5	215.5	215.5	221.7	179.4						
	90	236.0	236.0	236.1	236.1	241.0	232.5	219.7	219.7	219.8	219.8	221.5	221.5						
9600	75	216.8	216.8	231.8	161.6	242.2	92.5	203.3	203.3	215.7	155.6	222.3	86.1						
	80	225.1	225.1	231.7	211.9	242.1	144.9	211.6	211.6	215.5	205.5	222.2	138.4						
	85	232.5	232.5	232.6	232.6	242.1	195.9	216.5	216.5	216.6	216.6	222.1	189.0						
	90	238.9	238.9	239.0	239.0	242.0	242.0	221.4	221.4	221.4	221.4	221.9	221.9						

Notes:

1. All capacities shown are gross and have not considered indoor fan heat. To obtain net cooling, subtract indoor fan heat.
2. MBH = Total Gross Capacity, SHC = Sensible Heat Capacity



Performance Data

Table 29. Gross cooling capacities (MBH) one compressor - 25 tons TTA3004*C condensing unit with 25 tons TWE3004*B air handler (IP)

CFM	Ent DB (°F)	Ambient Temperature (°F)						Ambient Temperature (°F)						Ambient Temperature (°F)					
		85						95						105					
		Entering Wet Bulb (°F)						Entering Wet Bulb (°F)						Entering Wet Bulb (°F)					
		61		67		73		61		67		73		61		67		73	
		MBH	SHC	MBH	SHC	MBH	SHC	MBH	SHC	MBH	SHC	MBH	SHC	MBH	SHC	MBH	SHC	MBH	SHC
8750	75	180.9	180.9	198.7	144.1	219.4	84.2	174.2	174.2	190.2	140.3	210.0	81.2	166.6	166.6	180.2	137.3	199.2	77.7
	80	192.0	192.0	198.3	190.6	218.5	132.7	185.1	185.1	189.9	187.4	209.1	129.6	177.0	177.0	180.3	180.3	198.3	126.1
	85	203.2	203.2	203.4	203.4	217.8	179.7	195.9	195.9	196.1	196.1	208.4	176.5	187.4	187.4	187.6	187.6	197.7	172.9
	90	214.3	214.3	214.3	214.3	217.8	217.8	206.5	206.5	201.1	201.1	208.8	208.8	197.5	197.5	197.7	197.7	198.6	198.6
10000	75	186.3	186.3	201.5	154.5	221.8	87.0	179.3	179.3	192.5	152.1	212.2	83.9	171.3	171.3	182.4	148.5	201.2	80.4
	80	197.8	197.8	197.9	197.9	220.9	142.4	190.5	190.5	190.6	190.6	211.3	139.3	182.0	182.0	182.1	182.1	200.3	135.8
	85	209.3	209.3	209.4	209.4	220.2	195.9	201.6	201.6	201.7	201.7	210.6	192.7	192.7	192.7	192.8	192.8	199.7	189.0
	90	220.0	220.0	220.2	220.2	221.0	221.0	211.8	211.8	204.3	204.3	212.1	212.1	202.4	202.4	192.5	192.5	201.2	201.2
11000	75	189.9	189.9	203.3	163.2	223.2	89.2	182.7	182.7	194.1	161.1	213.6	86.1	174.4	174.4	183.8	157.4	202.5	82.6
	80	201.7	201.7	201.8	201.8	222.3	150.2	194.1	194.1	194.2	194.2	212.7	147.1	185.3	185.3	185.4	185.4	201.6	143.6
	85	213.3	213.3	213.4	213.4	221.6	208.8	205.3	205.3	205.4	205.4	211.9	205.5	196.1	196.1	196.2	196.2	201.0	201.0
	90	223.6	223.6	223.7	223.7	223.7	223.7	215.0	215.0	205.7	205.7	214.1	214.1	205.2	205.2	205.2	205.2	203.9	203.9
12000	75	193.0	193.0	204.6	173.3	224.4	91.4	185.6	185.6	195.5	170.0	214.7	88.3	177.1	177.1	185.4	164.5	203.5	84.8
	80	205.0	205.0	205.2	205.2	223.6	157.9	197.2	197.2	197.3	197.3	213.8	154.8	188.2	188.2	188.3	188.3	202.6	151.3
	85	216.6	216.6	216.8	216.8	216.9	216.9	208.4	208.4	208.5	208.5	208.6	208.6	198.9	198.9	199.0	199.0	202.2	202.2
	90	226.3	226.3	226.4	226.4	225.6	225.6	217.4	217.4	217.4	217.4	216.5	216.5	207.1	207.0	207.1	207.1	205.9	205.9
CFM	Ent DB (°F)	Ambient Temperature (°F)						Ambient Temperature (°F)											
		115						125											
		Entering Wet Bulb (°F)						Entering Wet Bulb (°F)											
		61		67		73		61		67		73							
		MBH	SHC	MBH	SHC	MBH	SHC	MBH	SHC	MBH	SHC	MBH	SHC						
8750	75	157.9	157.9	169.3	133.3	187.3	73.8	149.0	149.0	158.4	128.1	174.9	69.9						
	80	168.0	168.0	168.1	168.1	186.4	122.2	158.6	158.6	158.7	158.7	174.0	118.3						
	85	177.9	177.9	178.1	178.1	185.8	168.8	168.0	168.0	168.1	168.1	173.5	164.7						
	90	187.5	187.5	187.6	187.6	187.6	187.6	176.7	176.7	165.0	165.0	175.0	175.0						
10000	75	162.1	162.1	171.2	144.5	189.0	76.6	152.8	152.8	159.8	140.4	176.4	72.6						
	80	172.5	172.5	172.6	172.6	188.1	132.0	162.6	162.6	162.8	162.8	175.5	128.0						
	85	182.7	182.7	182.8	182.8	187.7	184.9	172.2	172.2	172.3	172.3	172.4	172.4						
	90	191.6	191.6	191.7	191.7	190.0	190.0	180.0	180.0	180.0	180.0	180.0	180.0						
11000	75	165.0	165.0	172.5	153.4	190.2	78.8	155.4	155.4	160.9	149.3	177.4	74.8						
	80	175.5	175.5	175.6	175.6	189.2	139.7	165.3	165.3	165.4	165.4	176.5	135.8						
	85	185.7	185.7	185.8	185.8	186.0	186.0	174.8	174.8	174.9	174.9	175.0	175.0						
	90	193.8	193.8	193.8	193.8	192.2	192.2	181.3	181.3	181.2	181.2	179.5	179.5						
12000	75	167.5	167.5	173.5	162.2	191.1	81.0	157.6	157.6	161.8	158.1	178.2	77.0						
	80	178.1	178.1	178.2	178.2	190.2	147.5	167.6	167.6	167.7	167.7	177.3	143.5						
	85	188.3	188.3	188.4	188.4	187.6	187.6	177.0	177.0	177.1	177.1	177.6	177.6						
	90	195.0	195.0	179.6	179.6	193.8	193.8	181.5	181.5	181.4	181.4	180.7	180.7						

Notes:

1. All capacities shown are gross and have not considered indoor fan heat. To obtain net cooling, subtract indoor fan heat.
2. MBH = Total Gross Capacity, SHC = Sensible Heat Capacity

Table 30. Gross cooling capacities (MBH) both compressors- 25 tons TTA3004*C condensing unit with 25 tons TWE3004*B air handler (IP)

CFM	Ent DB (°F)	Ambient Temperature (°F)						Ambient Temperature (°F)						Ambient Temperature (°F)					
		85						95						105					
		Entering Wet Bulb (°F)						Entering Wet Bulb (°F)						Entering Wet Bulb (°F)					
		61		67		73		61		67		73		61		67		73	
		MBH	SHC	MBH	SHC	MBH	SHC	MBH	SHC	MBH	SHC	MBH	SHC	MBH	SHC	MBH	SHC	MBH	SHC
8750	75	291.7	250.6	322.8	191.6	349.1	127.9	279.4	244.9	308.8	186.0	332.9	122.2	265.6	238.5	293.2	179.7	314.6	115.7
	80	291.2	291.2	322.0	239.5	348.4	176.3	279.5	279.5	307.8	233.8	332.1	170.6	266.5	266.5	292.2	227.4	313.8	164.2
	85	301.6	301.6	321.3	286.4	347.6	224.6	291.1	291.1	307.3	280.6	331.3	218.8	279.2	279.2	291.7	274.1	313.0	212.4
	90	321.2	321.2	321.2	321.2	346.8	272.2	305.0	305.0	307.9	307.9	330.5	266.3	292.4	292.4	293.3	293.3	312.2	259.6
10000	75	298.7	270.5	329.1	203.2	353.0	130.2	285.8	264.6	314.5	197.5	336.0	124.3	271.3	258.1	298.1	191.1	316.7	117.8
	80	299.5	299.5	328.1	257.6	352.3	185.6	287.7	287.7	313.5	251.7	335.2	179.7	274.3	274.3	297.3	245.1	315.9	173.1
	85	313.5	313.5	327.6	311.2	351.5	240.7	302.2	302.2	313.0	305.2	334.4	234.8	289.3	289.3	296.7	296.7	315.1	228.3
	90	328.0	328.0	329.2	329.2	350.7	294.7	315.8	315.8	315.9	315.9	333.6	288.5	301.8	301.8	302.1	302.1	314.3	281.7
11000	75	303.2	286.3	333.0	212.3	355.2	132.0	289.9	280.3	318.0	206.5	337.6	126.0	275.0	273.6	301.2	200.1	317.7	119.3
	80	305.8	305.8	332.1	271.9	354.4	192.9	293.7	293.7	317.1	265.9	336.8	186.9	282.0	282.0	300.4	259.2	316.9	180.3
	85	321.4	321.4	331.6	330.8	353.7	253.6	309.4	309.4	316.6	316.6	336.1	247.3	295.8	295.8	299.9	299.9	316.2	240.4
	90	335.5	335.5	334.9	334.9	352.8	312.5	322.4	322.4	321.7	321.7	335.1	306.3	307.4	307.4	306.5	306.5	315.1	299.3
12000	75	307.1	301.8	336.2	221.3	357.0	133.8	293.5	293.5	320.8	215.4	338.7	127.7	278.2	278.2	303.7	209.0	318.6	121.0
	80	312.8	312.8	335.4	286.0	356.2	200.3	301.0	301.0	320.0	279.9	337.9	194.2	287.7	287.7	302.9	273.2	317.6	187.5
	85	328.1	328.1	334.8	334.8	355.3	266.0	315.4	315.4	319.5	319.5	337.2	259.7	301.0	301.0	303.0	303.0	316.9	252.6
	90	341.5	341.5	341.8	341.8	354.6	330.5	327.6	327.6	327.8	327.8	336.2	324.1	311.3	311.3	311.4	311.4	315.9	315.9
CFM	Ent DB (°F)	Ambient Temperature (°F)						Ambient Temperature (°F)											
		115						125											
		Entering Wet Bulb (°F)						Entering Wet Bulb (°F)											
		61		67		73		61		67		73							
		MBH	SHC	MBH	SHC	MBH	SHC	MBH	SHC	MBH	SHC	MBH	SHC						
8750	75	251.1	231.8	276.5	173.2	294.8	108.9	238.1	226.0	260.3	166.9	274.7	102.1						
	80	253.3	253.3	275.6	220.6	294.0	157.3	242.3	242.3	259.5	214.1	273.9	150.5						
	85	266.3	266.3	275.1	267.3	293.2	205.5	253.5	253.5	258.9	258.9	273.3	198.7						
	90	278.4	278.4	278.6	278.6	292.3	252.4	264.2	264.2	264.4	264.4	272.2	245.2						
10000	75	256.0	251.2	280.8	184.4	296.0	110.8	242.4	242.4	263.9	178.0	274.9	103.8						
	80	262.3	262.3	280.0	238.2	295.1	166.1	249.8	249.8	263.1	231.5	274.0	159.1						
	85	275.3	275.3	279.4	279.4	294.5	220.9	261.2	261.2	263.1	263.1	273.4	213.5						
	90	286.3	286.3	286.4	286.4	293.4	274.3	269.9	269.9	270.0	270.0	272.0	266.8						
11000	75	259.2	259.2	283.4	193.3	296.3	112.2	245.1	245.1	266.0	186.8	274.9	105.2						
	80	268.3	268.3	282.6	252.2	295.5	173.2	254.7	254.7	265.3	245.4	274.0	166.2						
	85	280.9	280.9	282.7	282.7	294.8	232.9	265.8	265.8	265.9	265.9	273.2	225.5						
	90	290.4	290.4	290.4	290.4	293.5	291.8	271.9	271.9	271.9	271.9	272.0	272.0						
12000	75	262.1	262.1	285.5	202.2	297.0	114.0	247.1	247.1	267.7	195.6	275.1	106.9						
	80	273.3	273.3	284.7	266.1	296.2	180.5	259.1	259.1	267.0	259.2	274.3	173.4						
	85	285.3	285.3	285.6	285.6	295.3	245.2	269.1	269.1	269.2	269.2	273.3	237.7						
	90	292.7	292.7	292.7	292.7	294.3	294.3	271.9	271.9	271.8	271.8	272.2	272.2						

Notes:

1. All capacities shown are gross and have not considered indoor fan heat. To obtain net cooling, subtract indoor fan heat.
2. MBH = Total Gross Capacity, SHC = Sensible Heat Capacity



Performance Data

Table 31. Gross cooling capacities (MBH) 6 tons TTA0724*A condensing unit only (IP)

Outdoor Temp (°F)		Saturated Suction Temperature (°F)					
		30	35	40	45	50	55
65	Head Press (psig)	239.6	243.9	248.3	252.8	257.4	261.9
	Capacity (Btuh/1000)	63.9	70.1	76.9	84.2	92.0	100.5
	Unit Power (kW)	3.6	3.7	3.7	3.7	3.8	3.8
75	Head Press (psig)	276.0	280.4	284.9	289.5	294.2	298.8
	Capacity (Btuh/1000)	60.7	66.7	73.1	79.9	87.4	95.3
	Unit Power (kW)	4.0	4.1	4.1	4.2	4.2	4.3
85	Head Press (psig)	316.1	320.6	325.2	329.8	334.5	339.1
	Capacity (Btuh/1000)	57.5	63.1	69.2	75.7	82.7	90.2
	Unit Power (kW)	4.5	4.5	4.6	4.6	4.7	4.7
95	Head Press (psig)	359.9	364.5	369.2	373.9	378.6	383.2
	Capacity (Btuh/1000)	54.0	59.4	65.1	71.3	77.9	85.0
	Unit Power (kW)	5.0	5.1	5.1	5.1	5.2	5.2
105	Head Press (psig)	407.6	412.3	417.1	421.8	426.4	431.0
	Capacity (Btuh/1000)	50.5	55.6	61.0	66.8	73.1	79.7
	Unit Power (kW)	5.6	5.7	5.7	5.7	5.8	5.8
115	Head Press (psig)	459.4	464.1	468.8	473.5	478.1	482.5
	Capacity (Btuh/1000)	46.8	51.6	56.7	62.3	68.2	74.5
	Unit Power (kW)	6.3	6.4	6.4	6.4	6.4	6.5
125	Head Press (psig)	515.7	520.1	524.6	529.0	533.3	537.4
	Capacity (Btuh/1000)	42.9	47.5	52.4	57.6	63.2	69.2
	Unit Power (kW)	7.1	7.2	7.2	7.2	7.2	7.2

Note: Performance data calculated at 15°F subcooling and 15°F superheat and does not include capacity loss due to refrigerant lines.

Figure 7. TTA0724*A capacity curve

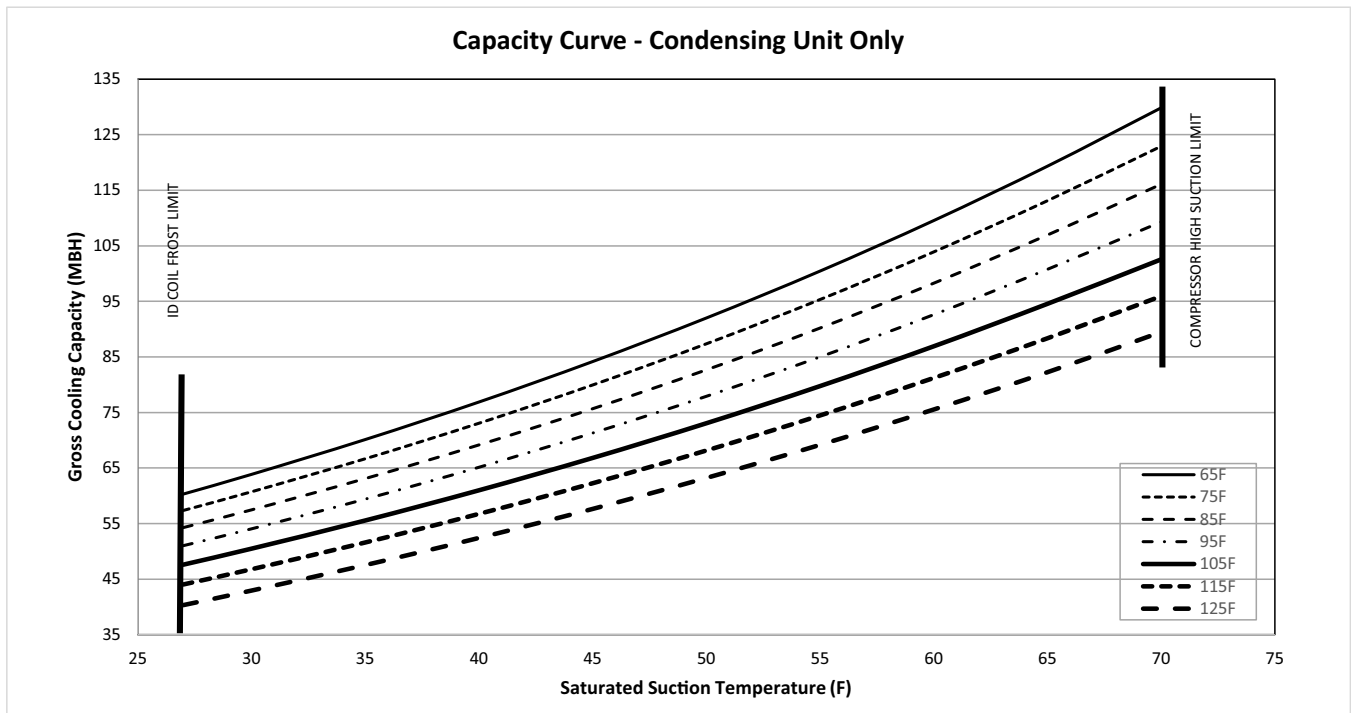
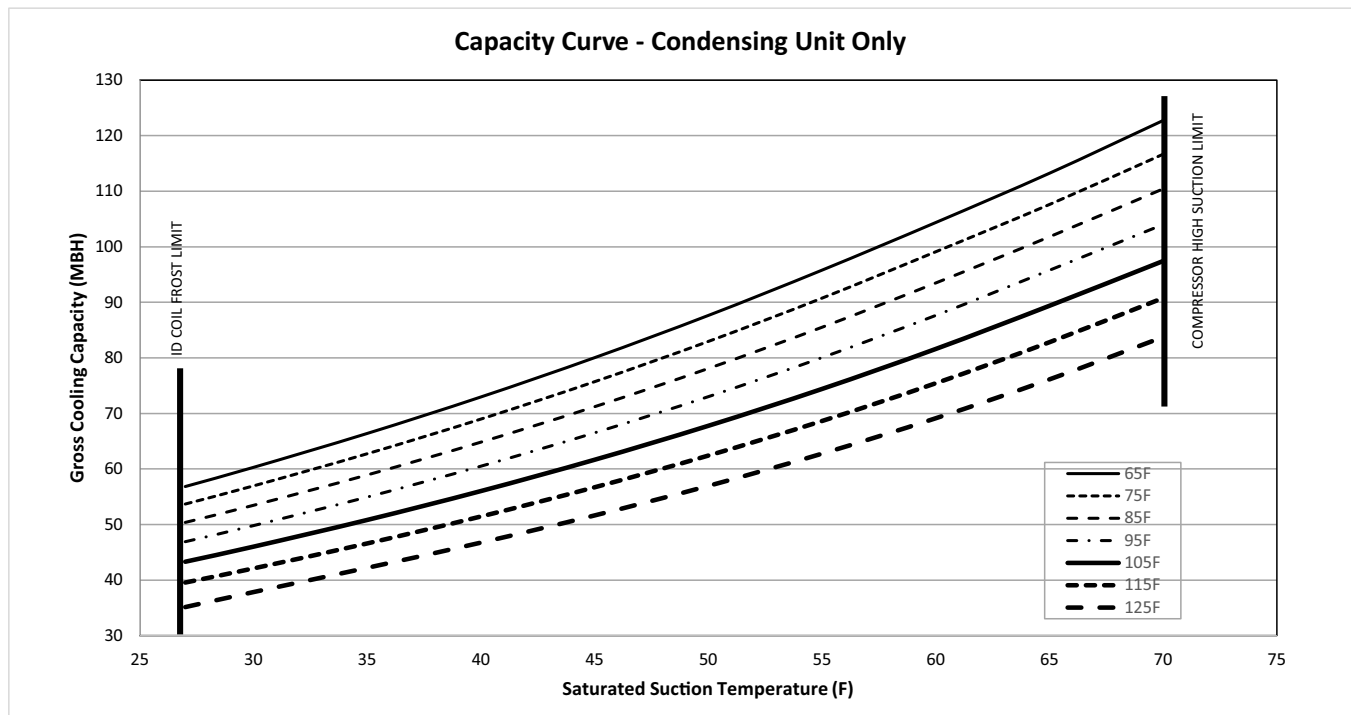

Table 32. Gross cooling capacities (MBH) 6 tons TTA0724*D condensing unit only (IP)

Outdoor Temp (°F)		Saturated Suction Temperature (°F)					
		30	35	40	45	50	55
65	Head Press (psig)	250.1	253.8	257.4	260.7	263.9	266.7
	Capacity (Btuh/1000)	60.3	66.4	73.0	80.0	87.6	95.8
	Unit Power (kW)	3.9	3.9	3.9	3.9	3.9	4.0
75	Head Press (psig)	290.0	294.1	298.0	301.7	305.0	307.8
	Capacity (Btuh/1000)	57.0	62.7	69.0	75.7	83.0	90.8
	Unit Power (kW)	4.4	4.4	4.5	4.5	4.5	4.5
85	Head Press (psig)	333.8	338.5	342.9	346.9	350.4	353.2
	Capacity (Btuh/1000)	53.5	58.9	64.8	71.2	78.1	85.5
	Unit Power (kW)	5.0	5.0	5.0	5.0	5.0	5.0
95	Head Press (psig)	381.7	387.0	391.9	396.5	400.3	403.3
	Capacity (Btuh/1000)	49.8	54.9	60.5	66.5	73.0	80.1
	Unit Power (kW)	5.6	5.6	5.7	5.7	5.7	5.7
105	Head Press (psig)	433.8	439.8	445.5	450.6	454.9	458.2
	Capacity (Btuh/1000)	46.0	50.8	56.0	61.7	67.8	74.4
	Unit Power (kW)	6.3	6.4	6.4	6.4	6.4	6.4
115	Head Press (psig)	490.6	497.1	503.4	509.3	514.2	517.9
	Capacity (Btuh/1000)	42.1	46.6	51.4	56.7	62.4	68.6
	Unit Power (kW)	7.2	7.2	7.2	7.3	7.3	7.3
125	Head Press (psig)	555.7	559.7	566.1	572.4	577.9	582.0
	Capacity (Btuh/1000)	37.8	42.2	46.7	51.6	57.0	62.8
	Unit Power (kW)	8.2	8.2	8.2	8.2	8.2	8.2

Note: Performance data calculated at 15°F subcooling and 15°F superheat and does not include capacity loss due to refrigerant lines.

Figure 8. TTA0724*D capacity curve





Performance Data

Table 33. Gross cooling capacities (MBH) 7.5 tons TTA0904*A condensing unit only (IP)

Outdoor Temp (°F)		Saturated Suction Temperature (°F)					
		30	35	40	45	50	55
65	Head Press (psig)	259.1	265.2	271.4	277.7	284.1	290.5
	Capacity (Btuh/1000)	83.7	92.0	100.9	110.6	121.1	132.4
	Unit Power (kW)	5.1	5.2	5.3	5.4	5.6	5.7
75	Head Press (psig)	296.2	302.4	308.6	315.0	321.3	327.6
	Capacity (Btuh/1000)	79.5	87.4	95.9	105.0	114.9	125.5
	Unit Power (kW)	5.7	5.8	5.9	6.0	6.1	6.2
85	Head Press (psig)	337.0	343.1	349.4	355.7	362.0	368.2
	Capacity (Btuh/1000)	75.3	82.7	90.7	99.3	108.5	118.5
	Unit Power (kW)	6.3	6.4	6.5	6.6	6.7	6.8
95	Head Press (psig)	381.5	387.6	393.8	400.0	406.1	412.2
	Capacity (Btuh/1000)	70.9	77.8	85.3	93.3	102.0	111.3
	Unit Power (kW)	7.0	7.1	7.2	7.2	7.3	7.4
105	Head Press (psig)	429.8	435.8	441.8	447.9	453.8	459.6
	Capacity (Btuh/1000)	66.3	72.8	79.7	87.2	95.3	104.1
	Unit Power (kW)	7.8	7.8	7.9	8.0	8.1	8.2
115	Head Press (psig)	481.8	487.6	493.4	499.1	504.8	510.3
	Capacity (Btuh/1000)	61.6	67.6	74.1	81.1	88.6	96.7
	Unit Power (kW)	8.6	8.7	8.8	8.8	8.9	9.0
125	Head Press (psig)	537.6	542.9	548.2	553.4	558.5	563.4
	Capacity (Btuh/1000)	56.7	62.3	68.3	74.8	81.9	89.4
	Unit Power (kW)	9.6	9.6	9.7	9.7	9.8	9.8

Note: Performance data calculated at 15°F subcooling and 15°F superheat and does not include capacity loss due to refrigerant lines.

Figure 9. TTA0904*A capacity curve

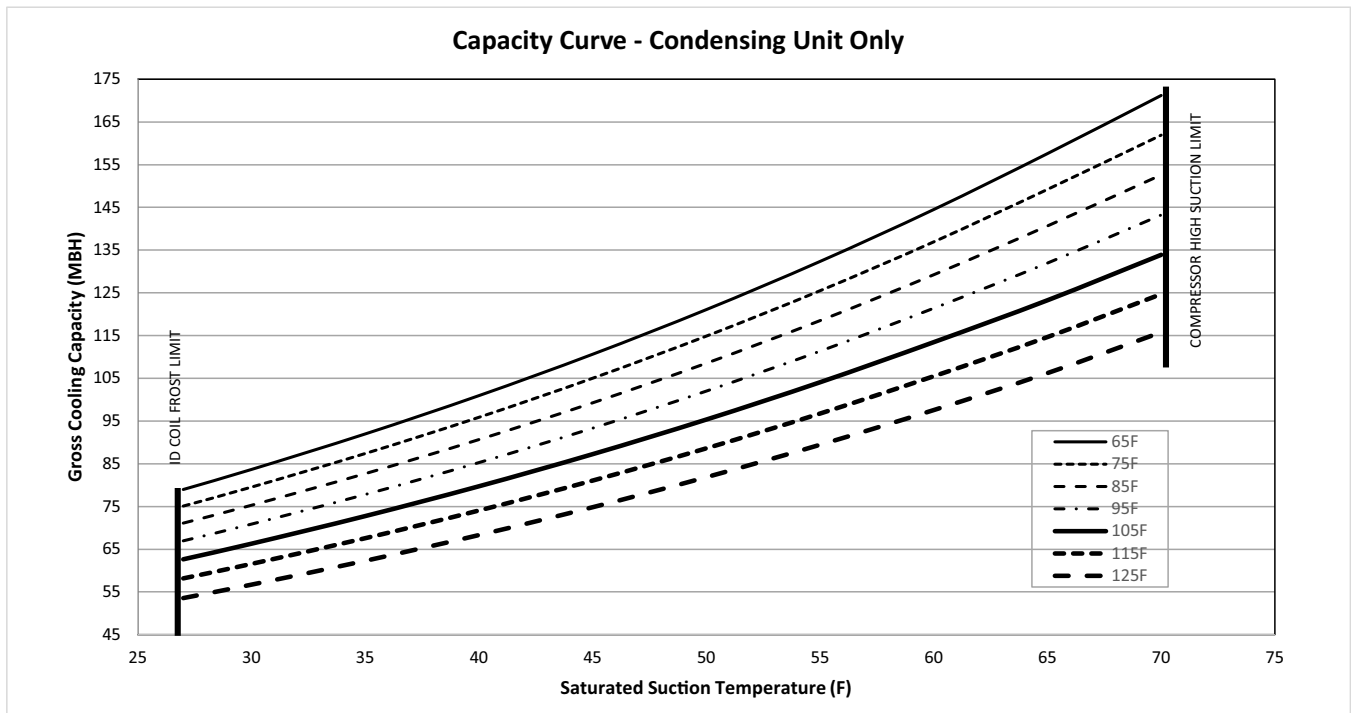
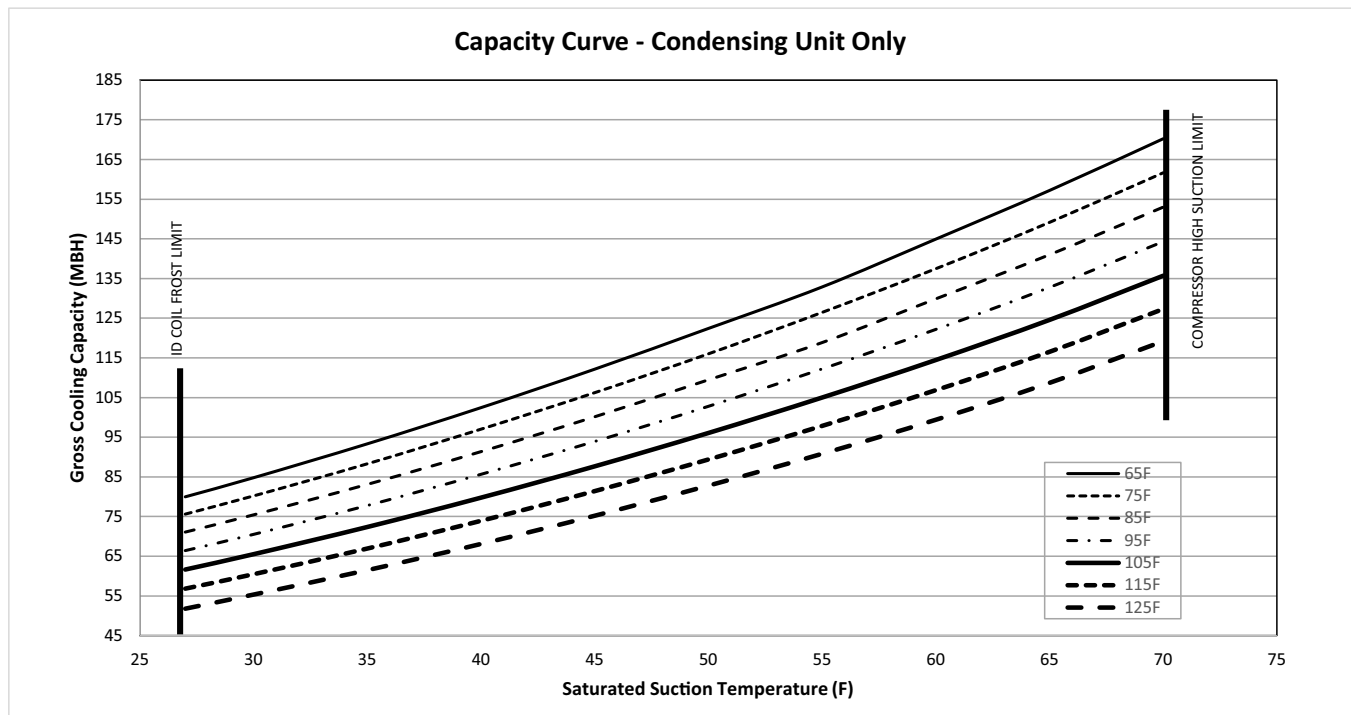

Table 34. Gross cooling capacities (MBH) 7.5 tons TTA0904*D condensing unit only (IP)

Outdoor Temp (°F)		Saturated Suction Temperature (°F)					
		30	35	40	45	50	55
65	Head Press (psig)	263.6	268.1	272.7	278.0	283.8	294.0
	Capacity (Btuh/1000)	84.8	93.3	102.4	112.1	122.4	132.9
	Unit Power (kW)	5.1	5.2	5.2	5.3	5.3	5.4
75	Head Press (psig)	301.1	306.1	310.5	316.2	321.9	326.9
	Capacity (Btuh/1000)	80.2	88.3	97.0	106.2	116.0	126.5
	Unit Power (kW)	5.7	5.7	5.8	5.8	5.9	5.9
85	Head Press (psig)	342.4	347.5	352.3	357.7	363.4	374.5
	Capacity (Btuh/1000)	75.4	83.1	91.4	100.1	109.5	118.9
	Unit Power (kW)	6.3	6.4	6.4	6.5	6.5	6.6
95	Head Press (psig)	387.6	392.7	397.1	403.0	408.5	413.5
	Capacity (Btuh/1000)	70.5	77.8	85.6	93.9	102.8	112.2
	Unit Power (kW)	7.0	7.1	7.1	7.2	7.2	7.3
105	Head Press (psig)	436.5	441.8	446.6	451.9	457.2	462.2
	Capacity (Btuh/1000)	65.5	72.4	79.8	87.7	96.1	105.0
	Unit Power (kW)	7.8	7.9	8.0	8.0	8.1	8.1
115	Head Press (psig)	489.6	494.8	499.5	504.4	509.3	514.2
	Capacity (Btuh/1000)	60.5	66.9	73.9	81.4	89.4	97.8
	Unit Power (kW)	8.8	8.8	8.9	8.9	9.0	9.0
125	Head Press (psig)	548.1	552.2	556.4	560.5	564.6	568.8
	Capacity (Btuh/1000)	55.3	61.5	68.1	75.2	82.8	90.8
	Unit Power (kW)	9.8	9.9	9.9	10.0	10.0	10.0

Note: Performance data calculated at 15°F subcooling and 15°F superheat and does not include capacity loss due to refrigerant lines.

Figure 10. TTA0904*D capacity curve





Performance Data

Table 35. Gross cooling capacities (MBH) 10 tons TTA1204*D condensing unit only (IP)

Outdoor Temp (°F)		Saturated Suction Temperature (°F)					
		30	35	40	45	50	55
65	Head Press (psig)	251.8	256.1	260.1	263.7	266.7	269.3
	Capacity (Btuh/1000)	100.2	110.2	121.0	132.7	145.5	159.4
	Unit Power (kW)	6.5	6.5	6.6	6.7	6.7	6.8
75	Head Press (psig)	289.1	293.5	297.7	301.3	304.3	306.8
	Capacity (Btuh/1000)	95.1	104.6	114.9	126.1	138.2	151.4
	Unit Power (kW)	7.1	7.2	7.2	7.3	7.3	7.3
85	Head Press (psig)	330.1	334.7	338.9	342.5	345.4	347.8
	Capacity (Btuh/1000)	89.8	98.8	108.6	119.2	130.7	143.2
	Unit Power (kW)	7.8	7.9	7.9	8.0	8.0	8.0
95	Head Press (psig)	375.0	379.7	383.9	387.5	390.4	392.7
	Capacity (Btuh/1000)	84.2	92.8	102.1	112.1	123.1	134.9
	Unit Power (kW)	8.7	8.7	8.8	8.8	8.8	8.9
105	Head Press (psig)	423.9	428.8	433.0	436.6	439.3	441.4
	Capacity (Btuh/1000)	78.6	86.7	95.5	105.0	115.3	126.5
	Unit Power (kW)	9.6	9.6	9.7	9.7	9.8	9.8
115	Head Press (psig)	477.2	482.0	486.2	489.6	492.2	494.0
	Capacity (Btuh/1000)	72.9	80.6	88.8	97.8	107.6	118.2
	Unit Power (kW)	10.5	10.6	10.7	10.8	10.8	10.8
125	Head Press (psig)	536.4	539.7	543.6	546.6	548.8	550.1
	Capacity (Btuh/1000)	67.0	74.4	82.2	90.7	99.9	109.9
	Unit Power (kW)	11.6	11.7	11.8	11.8	11.9	11.9

Note: Performance data calculated at 15°F subcooling and 15°F superheat and does not include capacity loss due to refrigerant lines.

Figure 11. TTA1204*D capacity curve

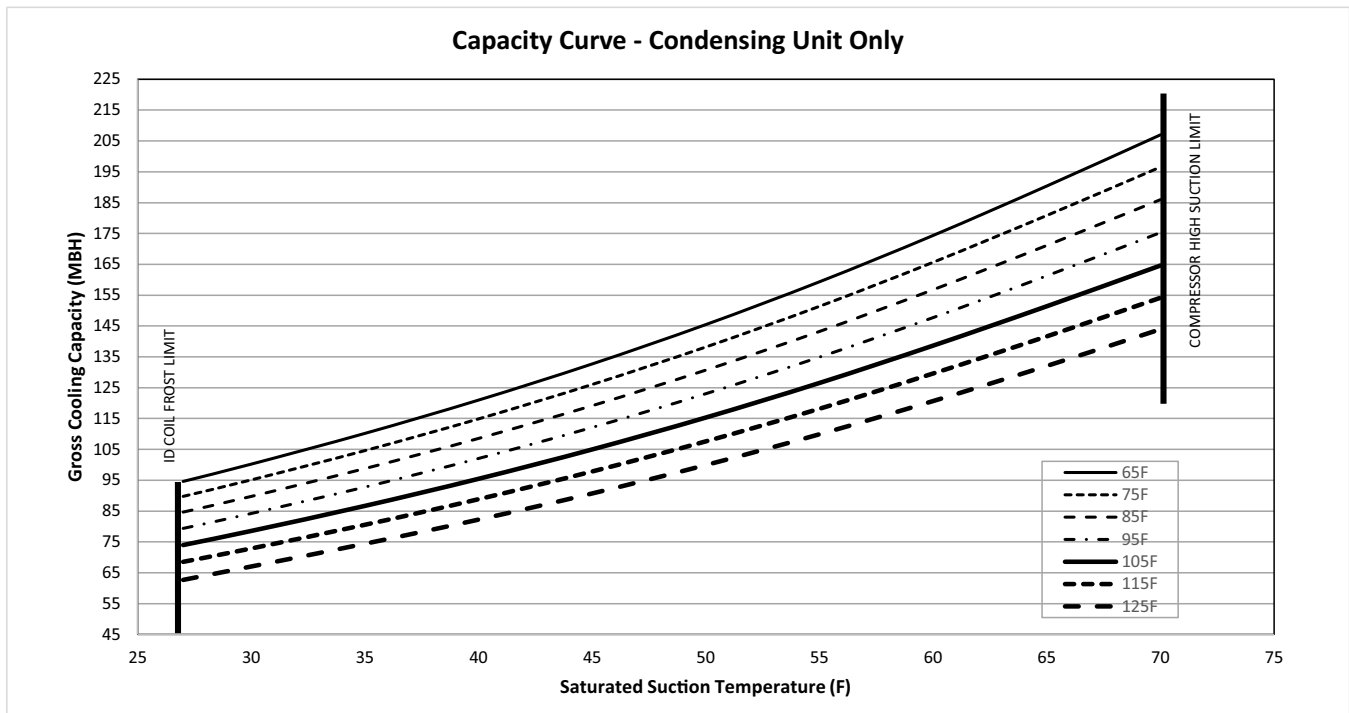
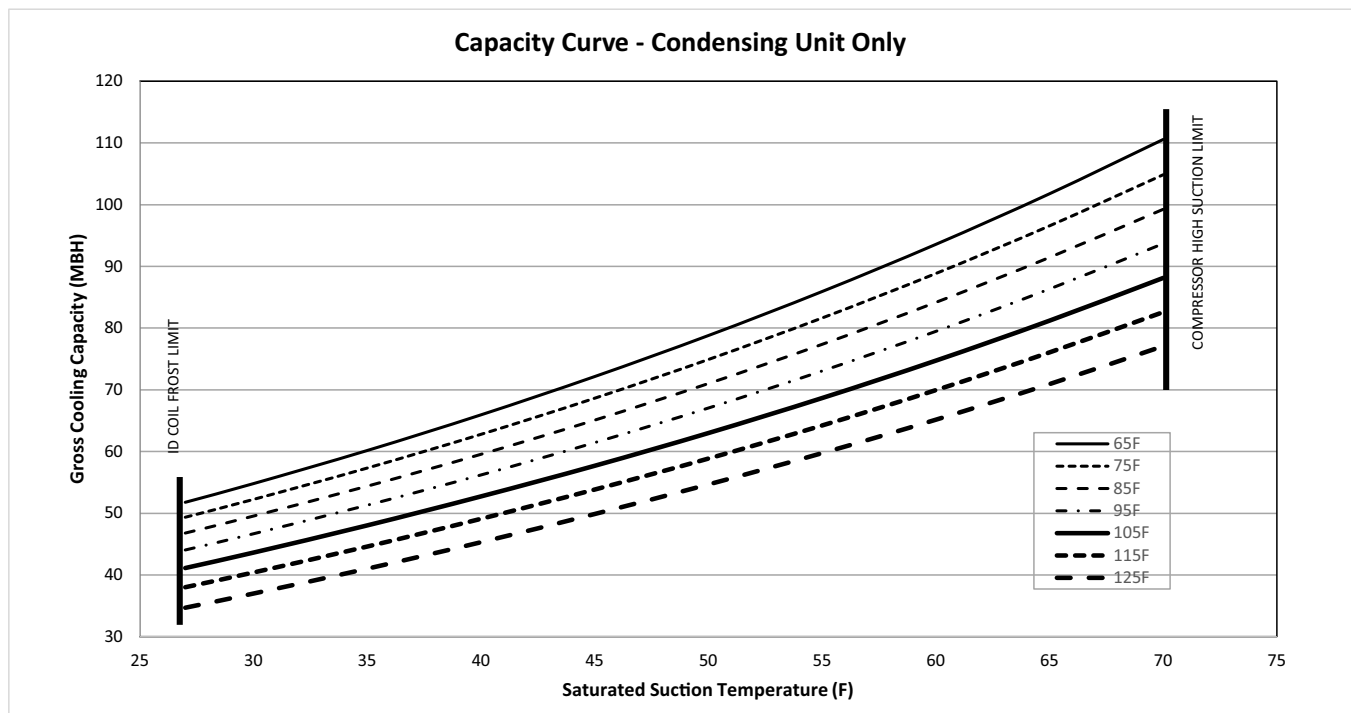

Table 36. Gross cooling capacities (MBH) one compressor - 10 tons TTA1204*C condensing unit only (IP)

Outdoor Temp (°F)		Saturated Suction Temperature (°F)					
		30	35	40	45	50	55
65	Head Press (psig)	222.4	225.2	228.3	231.5	234.9	238.4
	Capacity (Btuh/1000)	54.8	60.2	65.9	72.1	78.8	85.9
	Unit Power (kW)	3.5	3.5	3.6	3.6	3.6	3.6
75	Head Press (psig)	257.9	260.9	264.1	267.4	270.9	274.4
	Capacity (Btuh/1000)	52.2	57.3	62.8	68.6	74.9	81.6
	Unit Power (kW)	3.9	3.9	3.9	3.9	4.0	4.0
85	Head Press (psig)	297.6	300.3	303.6	307.1	310.6	314.1
	Capacity (Btuh/1000)	49.5	54.4	59.5	65.1	71.0	77.4
	Unit Power (kW)	4.2	4.3	4.3	4.3	4.3	4.4
95	Head Press (psig)	341.7	343.9	347.2	350.7	354.3	357.9
	Capacity (Btuh/1000)	46.7	51.3	56.2	61.4	67.0	73.0
	Unit Power (kW)	4.7	4.7	4.7	4.7	4.8	4.8
105	Head Press (psig)	390.4	392.5	395.1	398.6	402.2	405.8
	Capacity (Btuh/1000)	43.6	48.0	52.7	57.7	63.0	68.7
	Unit Power (kW)	5.2	5.2	5.2	5.2	5.2	5.3
115	Head Press (psig)	444.1	446.1	448.1	451.0	454.6	458.0
	Capacity (Btuh/1000)	40.4	44.6	49.1	53.8	58.9	64.2
	Unit Power (kW)	5.8	5.8	5.8	5.8	5.8	5.8
125	Head Press (psig)	503.9	505.4	506.9	508.4	511.2	514.5
	Capacity (Btuh/1000)	37.0	41.0	45.3	49.9	54.7	59.7
	Unit Power (kW)	6.5	6.5	6.4	6.4	6.4	6.4

Note: Performance data calculated at 15°F subcooling and 15°F superheat and does not include capacity loss due to refrigerant lines.

Figure 12. TTA1204*C - one compressor - capacity curve



Performance Data

Table 37. Gross cooling capacities (MBH) both compressors - 10 tons TTA1204*C condensing unit only (IP)

Outdoor Temp (°F)		Saturated Suction Temperature (°F)					
		30	35	40	45	50	55
65	Head Press (psig)	254.3	259.6	264.9	270.2	275.4	280.6
	Capacity (Btuh/1000)	107.7	118.2	129.6	141.9	155.2	169.6
	Unit Power (kW)	6.6	6.7	6.8	6.9	7.0	7.1
75	Head Press (psig)	291.1	296.4	301.8	307.0	312.1	317.1
	Capacity (Btuh/1000)	102.2	112.2	122.9	134.5	147.0	160.4
	Unit Power (kW)	7.3	7.4	7.5	7.6	7.7	7.8
85	Head Press (psig)	331.5	336.9	342.2	347.4	352.4	357.2
	Capacity (Btuh/1000)	96.6	106.0	116.1	127.1	138.8	151.5
	Unit Power (kW)	8.1	8.2	8.3	8.4	8.5	8.6
95	Head Press (psig)	375.6	381.0	386.4	391.5	396.4	401.1
	Capacity (Btuh/1000)	90.7	99.7	109.3	119.6	130.7	142.5
	Unit Power (kW)	9.1	9.1	9.2	9.3	9.4	9.4
105	Head Press (psig)	423.5	429.0	434.3	439.4	444.1	448.6
	Capacity (Btuh/1000)	84.7	93.1	102.2	112.0	122.5	133.6
	Unit Power (kW)	10.1	10.2	10.2	10.3	10.4	10.4
115	Head Press (psig)	475.3	480.7	486.0	490.9	495.5	499.8
	Capacity (Btuh/1000)	78.4	86.5	95.1	104.4	114.3	124.8
	Unit Power (kW)	11.3	11.4	11.4	11.5	11.5	11.6
125	Head Press (psig)	531.1	536.3	541.2	545.8	550.1	554.0
	Capacity (Btuh/1000)	72.0	79.7	88.0	96.8	106.1	116.1
	Unit Power (kW)	12.7	12.7	12.8	12.8	12.8	12.8

Note: Performance data calculated at 15°F subcooling and 15°F superheat and does not include capacity loss due to refrigerant lines.

Figure 13. TTA1204*C - both compressors - capacity curve

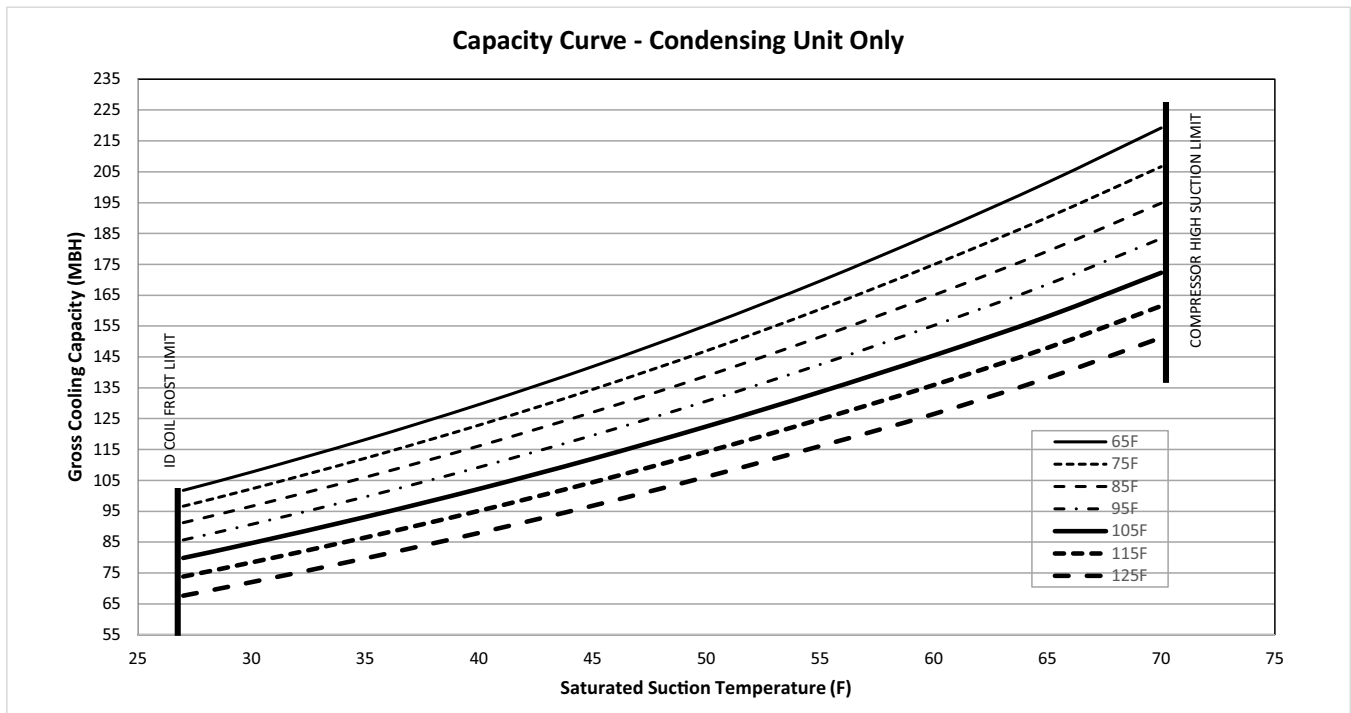
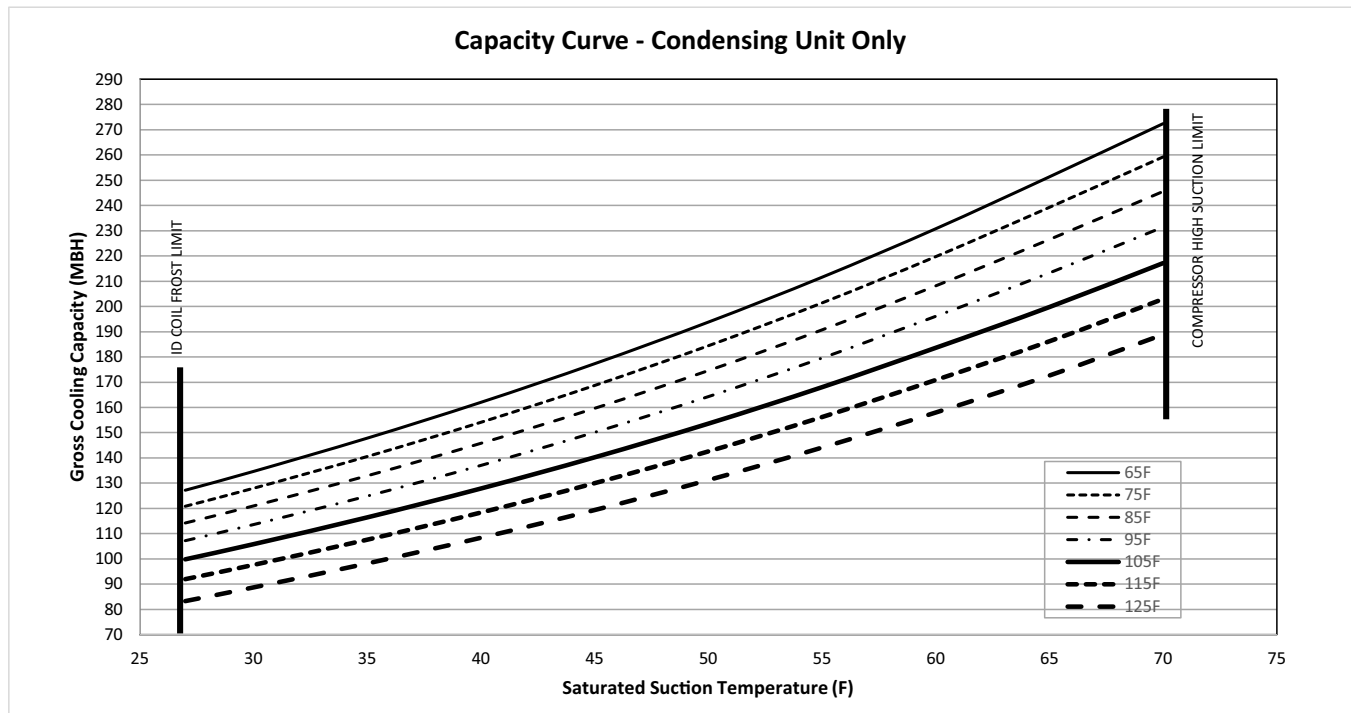

Table 38. Gross cooling capacities (MBH) 12.5 tons TTA1504*D condensing unit only (IP)

Outdoor Temp (°F)		Saturated Suction Temperature (°F)					
		30	35	40	45	50	55
65	Head Press (psig)	263.4	269.0	274.8	280.4	285.9	290.9
	Capacity (Btuh/1000)	134.7	147.8	162.0	177.3	193.8	211.6
	Unit Power (kW)	8.8	9.0	9.1	9.2	9.4	9.6
75	Head Press (psig)	301.6	307.4	313.3	319.1	324.6	329.7
	Capacity (Btuh/1000)	128.0	140.6	154.1	168.7	184.4	201.4
	Unit Power (kW)	9.8	9.9	10.1	10.2	10.3	10.5
85	Head Press (psig)	343.3	349.3	355.3	361.1	366.6	371.7
	Capacity (Btuh/1000)	121.0	132.9	145.8	159.6	174.6	190.7
	Unit Power (kW)	10.9	11.0	11.1	11.3	11.4	11.5
95	Head Press (psig)	388.7	394.7	400.7	406.5	412.0	417.0
	Capacity (Btuh/1000)	113.6	124.9	137.0	150.1	164.3	179.6
	Unit Power (kW)	12.1	12.2	12.4	12.5	12.6	12.7
105	Head Press (psig)	437.7	443.7	449.6	455.3	460.6	465.4
	Capacity (Btuh/1000)	105.8	116.4	127.9	140.2	153.6	168.0
	Unit Power (kW)	13.5	13.6	13.8	13.9	14.0	14.1
115	Head Press (psig)	490.9	496.4	501.9	507.2	512.1	516.6
	Capacity (Btuh/1000)	97.6	107.6	118.4	130.0	142.6	156.2
	Unit Power (kW)	15.0	15.1	15.3	15.4	15.5	15.6
125	Head Press (psig)	550.1	553.9	558.2	562.5	566.6	570.2
	Capacity (Btuh/1000)	88.7	98.2	108.4	119.4	131.2	144.1
	Unit Power (kW)	16.7	16.8	17.0	17.1	17.2	17.3

Note: Performance data calculated at 15°F subcooling and 15°F superheat and does not include capacity loss due to refrigerant lines.

Figure 14. TTA1504*D capacity curve





Performance Data

Table 39. Gross cooling capacities (MBH) 15 tons TTA1804*D condensing unit only (IP)

Outdoor Temp (°F)		Saturated Suction Temperature (°F)					
		30	35	40	45	50	55
65	Head Press (psig)	241.9	245.3	249.7	254.3	259.0	263.9
	Capacity (Btuh/1000)	173.3	189.2	206.1	224.4	244.1	265.3
	Unit Power (kW)	11.1	11.3	11.5	11.7	12.0	12.2
75	Head Press (psig)	278.8	282.3	286.4	291.2	296.0	300.9
	Capacity (Btuh/1000)	165.2	180.5	196.9	214.4	233.3	253.7
	Unit Power (kW)	12.1	12.2	12.4	12.7	12.9	13.2
85	Head Press (psig)	319.5	323.1	326.7	331.6	336.6	341.5
	Capacity (Btuh/1000)	156.4	171.1	186.9	203.7	221.9	241.4
	Unit Power (kW)	13.2	13.4	13.5	13.7	14.0	14.2
95	Head Press (psig)	364.3	367.8	371.4	375.8	380.8	385.8
	Capacity (Btuh/1000)	147.0	161.1	176.3	192.5	209.9	228.6
	Unit Power (kW)	14.5	14.6	14.8	15.0	15.2	15.4
105	Head Press (psig)	413.6	417.0	420.5	424.0	429.1	434.0
	Capacity (Btuh/1000)	137.3	150.7	165.3	180.9	197.5	215.3
	Unit Power (kW)	15.9	16.1	16.2	16.4	16.6	16.8
115	Head Press (psig)	467.9	471.0	474.2	477.4	481.3	486.1
	Capacity (Btuh/1000)	127.3	140.1	154.0	168.9	184.9	201.9
	Unit Power (kW)	17.6	17.7	17.9	18.0	18.1	18.3
125	Head Press (psig)	528.1	530.6	533.0	535.5	538.0	541.8
	Capacity (Btuh/1000)	117.2	129.4	142.6	156.8	172.2	188.5
	Unit Power (kW)	19.6	19.7	19.7	19.8	19.9	20.1

Note: Performance data calculated at 15°F subcooling and 15°F superheat and does not include capacity loss due to refrigerant lines.

Figure 15. TTA1804*D capacity curve

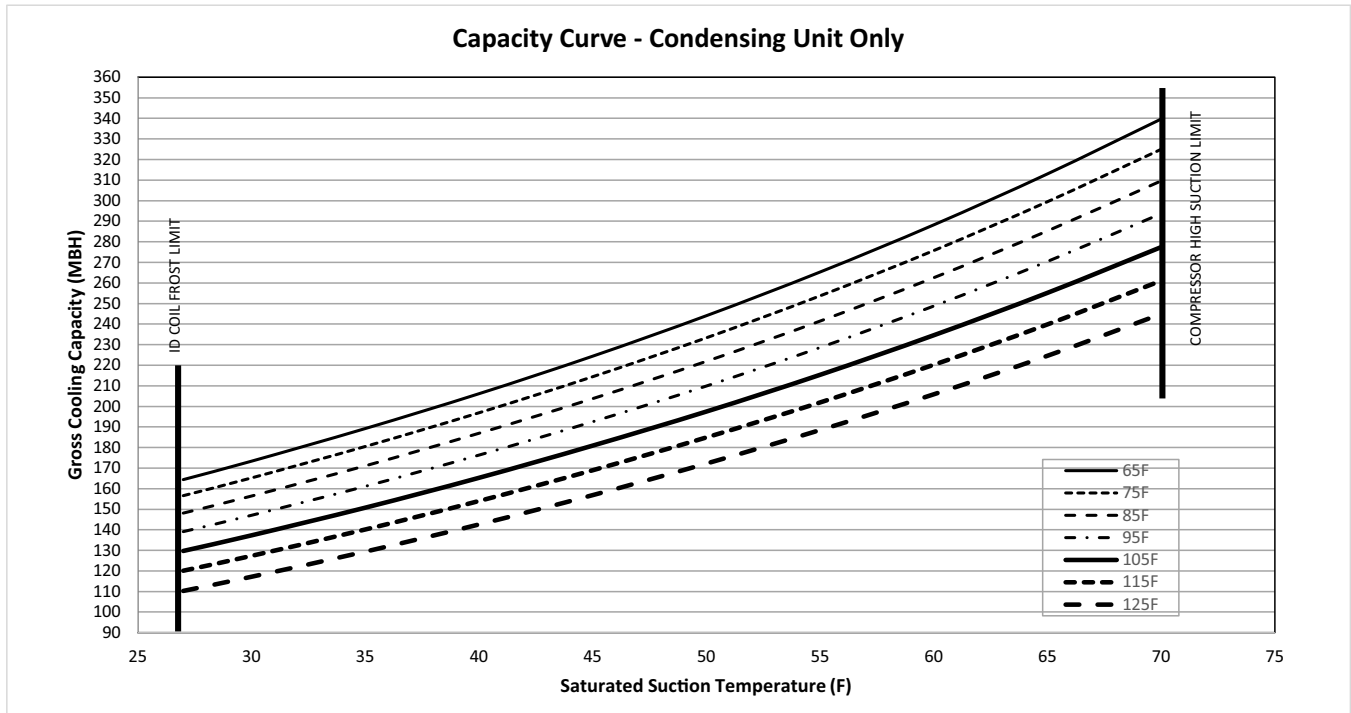
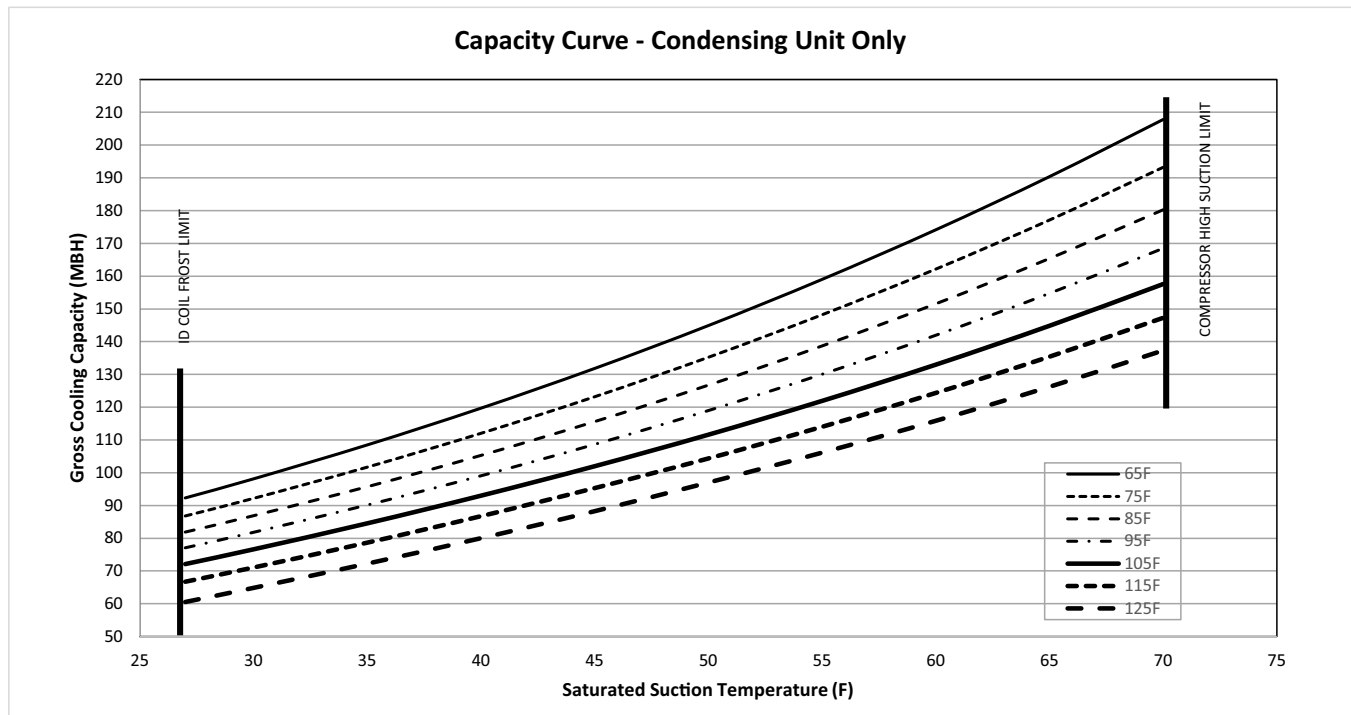

Table 40. Gross cooling capacities (MBH) one compressor - 15 tons TTA1804*C condensing unit only (IP)

Outdoor Temp (°F)		Saturated Suction Temperature (°F)					
		30	35	40	45	50	55
65	Head Press (psig)	218.8	221.6	224.6	227.8	231.3	235.1
	Capacity (Btuh/1000)	98.1	108.5	119.7	131.8	144.9	159.0
	Unit Power (kW)	6.6	6.6	6.7	6.8	6.8	6.9
75	Head Press (psig)	253.7	256.5	259.5	262.8	266.3	270.0
	Capacity (Btuh/1000)	92.2	101.7	112.0	123.2	135.2	148.2
	Unit Power (kW)	7.1	7.1	7.2	7.3	7.3	7.4
85	Head Press (psig)	292.6	295.5	298.5	301.8	305.4	309.1
	Capacity (Btuh/1000)	86.9	95.7	105.3	115.6	126.7	138.7
	Unit Power (kW)	7.6	7.7	7.8	7.8	7.9	8.0
95	Head Press (psig)	336.1	338.7	341.8	345.1	348.7	352.4
	Capacity (Btuh/1000)	81.8	90.1	99.0	108.6	119.0	130.0
	Unit Power (kW)	8.3	8.3	8.4	8.5	8.5	8.6
105	Head Press (psig)	384.7	386.8	389.5	392.9	396.4	400.1
	Capacity (Btuh/1000)	76.6	84.5	93.0	102.0	111.6	121.9
	Unit Power (kW)	9.0	9.0	9.1	9.2	9.3	9.3
115	Head Press (psig)	438.4	440.5	442.6	445.2	448.8	452.4
	Capacity (Btuh/1000)	71.1	78.6	86.7	95.3	104.3	114.0
	Unit Power (kW)	9.8	9.9	9.9	10.0	10.1	10.1
125	Head Press (psig)	498.8	500.2	501.9	503.8	505.7	509.2
	Capacity (Btuh/1000)	64.8	72.2	80.0	88.2	97.0	106.1
	Unit Power (kW)	10.8	10.9	10.9	11.0	11.0	11.1

Note: Performance data calculated at 15°F subcooling and 15°F superheat and does not include capacity loss due to refrigerant lines.

Figure 16. TTA1804*C - one compressor - capacity curve





Performance Data

Table 41. Gross cooling capacities (MBH) both compressors - 15 tons TTA1804*C condensing unit only (IP)

Outdoor Temp (°F)		Saturated Suction Temperature (°F)					
		30	35	40	45	50	55
65	Head Press (psig)	238.7	243.2	247.8	252.6	257.5	262.3
	Capacity (Btuh/1000)	166.9	183.8	202.0	221.7	243.1	266.1
	Unit Power (kW)	10.7	10.8	10.9	11.0	11.1	11.2
75	Head Press (psig)	274.5	279.0	283.7	288.5	293.3	298.1
	Capacity (Btuh/1000)	157.8	173.6	190.7	209.1	229.1	250.6
	Unit Power (kW)	11.6	11.7	11.8	12.0	12.1	12.2
85	Head Press (psig)	314.2	318.8	323.5	328.3	333.0	337.6
	Capacity (Btuh/1000)	149.0	163.9	180.0	197.3	216.0	236.1
	Unit Power (kW)	12.7	12.8	12.9	13.0	13.1	13.2
95	Head Press (psig)	357.8	362.5	367.2	372.0	376.7	381.2
	Capacity (Btuh/1000)	140.2	154.3	169.5	185.8	203.4	222.3
	Unit Power (kW)	13.9	14.0	14.1	14.2	14.3	14.4
105	Head Press (psig)	405.4	410.2	415.0	419.7	424.3	428.7
	Capacity (Btuh/1000)	131.0	144.5	158.9	174.3	190.9	208.8
	Unit Power (kW)	15.2	15.3	15.4	15.6	15.7	15.8
115	Head Press (psig)	457.1	462.0	466.8	471.5	475.9	480.1
	Capacity (Btuh/1000)	121.3	134.2	148.0	162.7	178.5	195.4
	Unit Power (kW)	16.7	16.9	17.0	17.1	17.2	17.2
125	Head Press (psig)	513.1	517.9	522.5	527.0	531.2	535.2
	Capacity (Btuh/1000)	111.0	123.5	136.7	150.8	165.9	182.0
	Unit Power (kW)	18.4	18.5	18.6	18.7	18.8	18.9

Note: Performance data calculated at 15°F subcooling and 15°F superheat and does not include capacity loss due to refrigerant lines.

Figure 17. TTA1804*C - both compressors - capacity curve

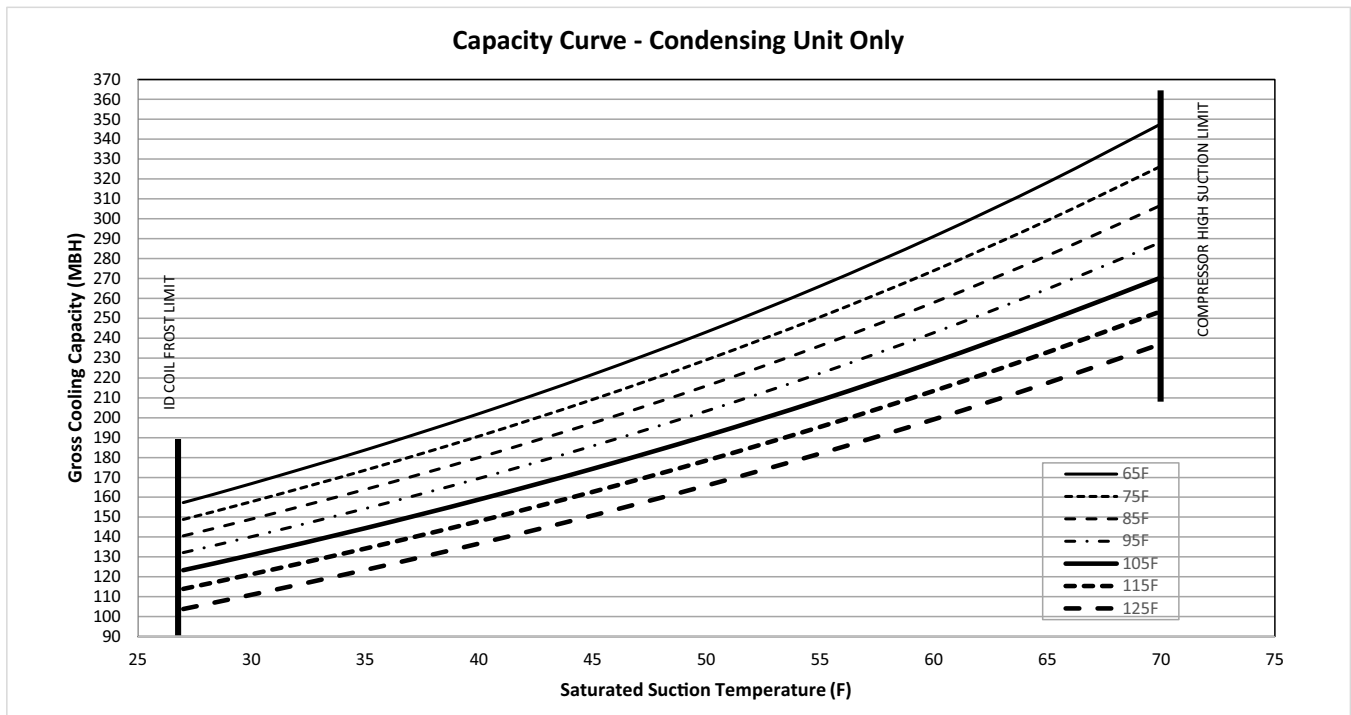
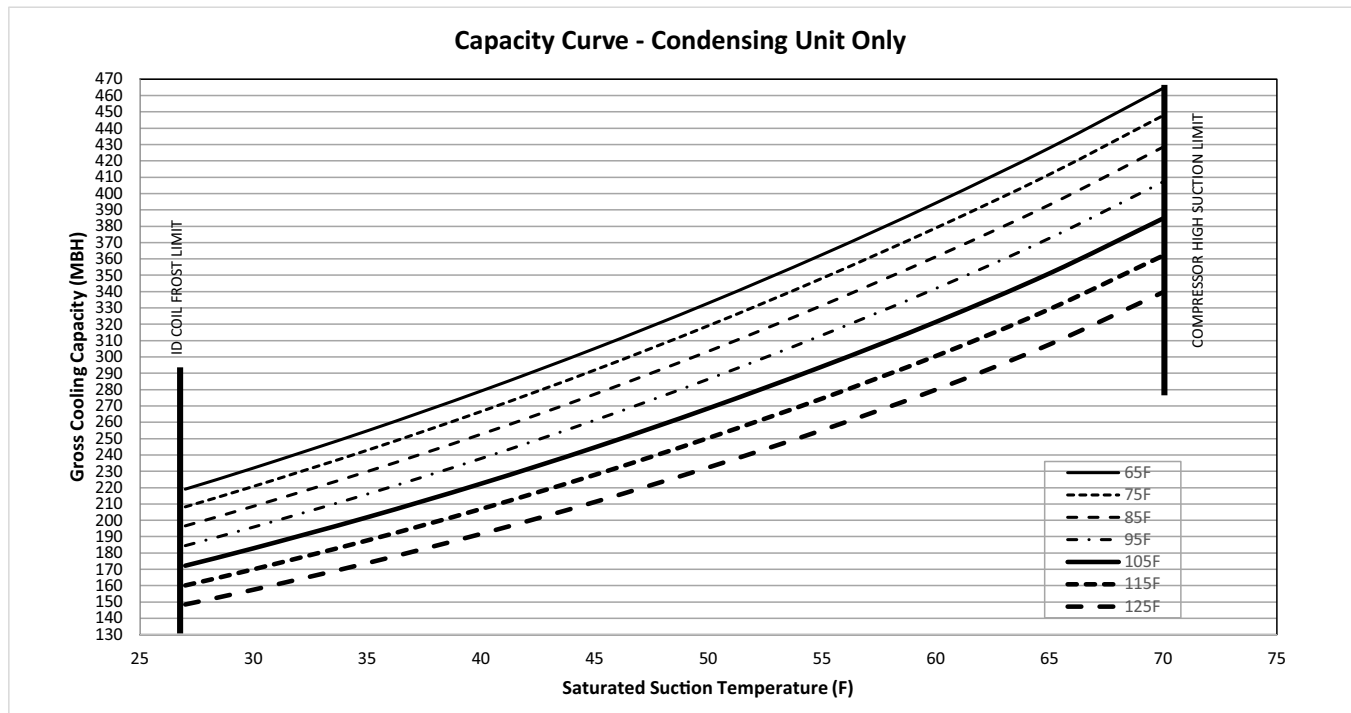

Table 42. Gross cooling capacities (MBH) 20 tons TTA2404*D condensing unit only (IP)

Outdoor Temp (°F)		Saturated Suction Temperature (°F)					
		30	35	40	45	50	55
65	Head Press (psig)	258.5	264.0	269.6	275.0	280.2	285.2
	Capacity (Btuh/1000)	232.0	254.8	279.1	305.1	332.9	362.6
	Unit Power (kW)	14.7	15.1	15.4	15.8	16.1	16.5
75	Head Press (psig)	295.5	301.3	307.0	312.6	318.0	323.1
	Capacity (Btuh/1000)	220.8	242.9	266.6	291.9	319.1	348.1
	Unit Power (kW)	16.1	16.4	16.7	17.0	17.4	17.7
85	Head Press (psig)	335.8	341.8	347.7	353.5	358.9	364.3
	Capacity (Btuh/1000)	208.6	229.8	252.7	277.2	303.4	331.5
	Unit Power (kW)	17.6	17.9	18.2	18.5	18.8	19.1
95	Head Press (psig)	379.9	385.9	391.9	397.7	403.2	408.8
	Capacity (Btuh/1000)	195.8	216.0	237.8	261.2	286.4	313.3
	Unit Power (kW)	19.2	19.6	19.9	20.2	20.4	20.7
105	Head Press (psig)	427.8	433.8	439.7	445.5	450.9	456.8
	Capacity (Btuh/1000)	182.9	201.8	222.4	244.6	268.5	294.1
	Unit Power (kW)	21.1	21.4	21.7	22.0	22.3	22.6
115	Head Press (psig)	479.8	485.6	491.2	496.7	502.0	507.9
	Capacity (Btuh/1000)	170.0	187.7	206.9	227.8	250.4	274.5
	Unit Power (kW)	23.2	23.5	23.8	24.1	24.4	24.6
125	Head Press (psig)	535.9	541.1	546.3	551.3	556.1	561.5
	Capacity (Btuh/1000)	157.5	173.8	191.7	211.2	232.4	255.1
	Unit Power (kW)	25.5	25.8	26.1	26.4	26.6	26.9

Note: Performance data calculated at 15°F subcooling and 15°F superheat and does not include capacity loss due to refrigerant lines.

Figure 18. TTA2404*D capacity curve





Performance Data

Table 43. Gross cooling capacities (MBH) one compressor - 20 tons TTA2404*C condensing unit only (IP)

Outdoor Temp (°F)		Saturated Suction Temperature (°F)					
		30	35	40	45	50	55
65	Head Press (psig)	233.9	235.9	237.7	239.7	243.8	247.6
	Capacity (Btuh/1000)	124.0	137.2	151.4	166.4	181.9	198.3
	Unit Power (kW)	8.6	8.7	8.9	9.0	9.2	9.4
75	Head Press (psig)	272.2	274.0	275.7	277.0	281.0	284.8
	Capacity (Btuh/1000)	119.0	131.6	145.2	159.6	174.5	190.2
	Unit Power (kW)	9.2	9.3	9.4	9.6	9.7	9.9
85	Head Press (psig)	314.7	316.4	317.8	318.8	321.8	325.6
	Capacity (Btuh/1000)	113.1	125.3	138.2	152.0	166.3	181.2
	Unit Power (kW)	9.9	10.0	10.1	10.3	10.4	10.6
95	Head Press (psig)	361.9	363.3	364.3	364.8	366.4	370.1
	Capacity (Btuh/1000)	106.5	118.0	130.3	143.5	157.2	171.3
	Unit Power (kW)	10.8	10.9	11.0	11.1	11.2	11.4
105	Head Press (psig)	414.6	415.3	415.6	415.4	414.9	418.4
	Capacity (Btuh/1000)	98.9	109.8	121.5	134.0	147.3	160.5
	Unit Power (kW)	11.8	11.9	12.0	12.1	12.2	12.3
115	Head Press (psig)	474.3	473.5	472.6	471.2	469.3	470.7
	Capacity (Btuh/1000)	90.4	100.8	111.9	123.8	136.4	149.2
	Unit Power (kW)	13.0	13.1	13.1	13.2	13.2	13.3
125	Head Press (psig)	548.5	542.4	537.8	533.6	529.4	527.0
	Capacity (Btuh/1000)	80.8	91.1	101.8	113.3	125.4	137.9
	Unit Power (kW)	14.6	14.5	14.5	14.4	14.4	14.4

Note: Performance data calculated at 15°F subcooling and 15°F superheat and does not include capacity loss due to refrigerant lines.

Figure 19. TTA2404*C - One compressor - capacity curves

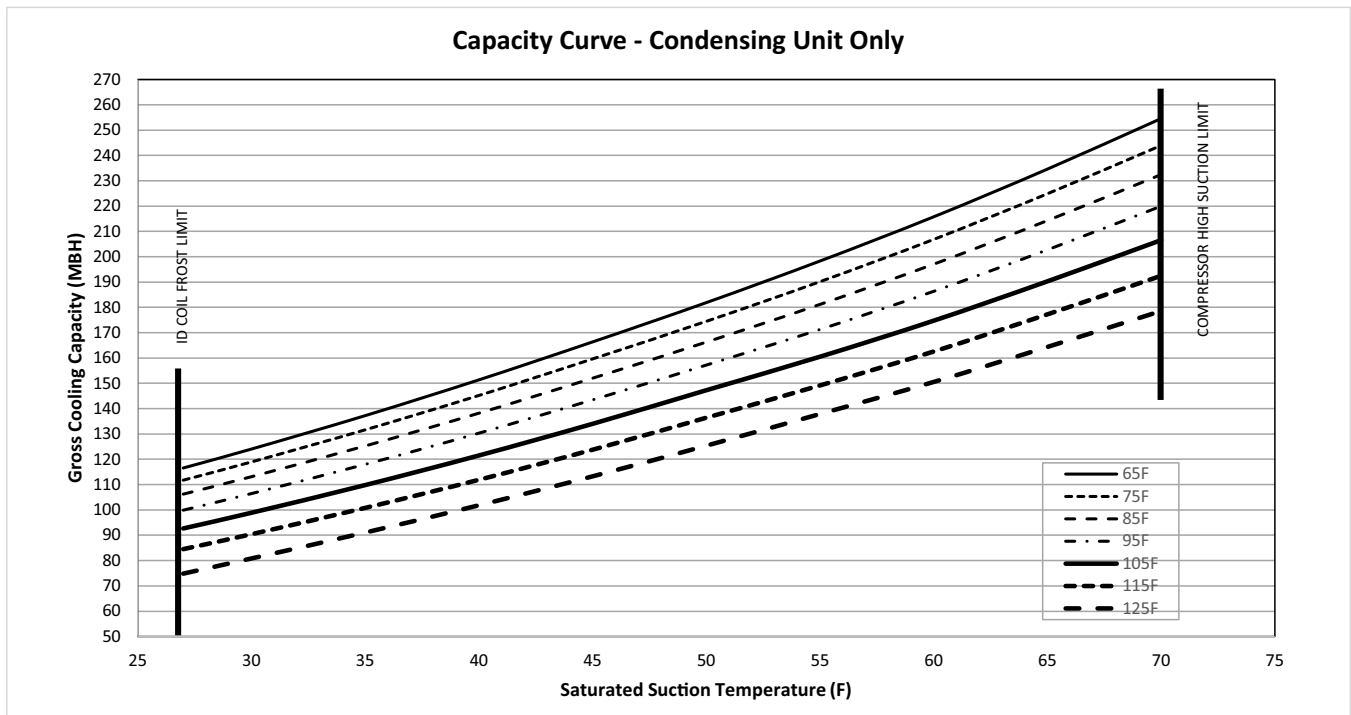
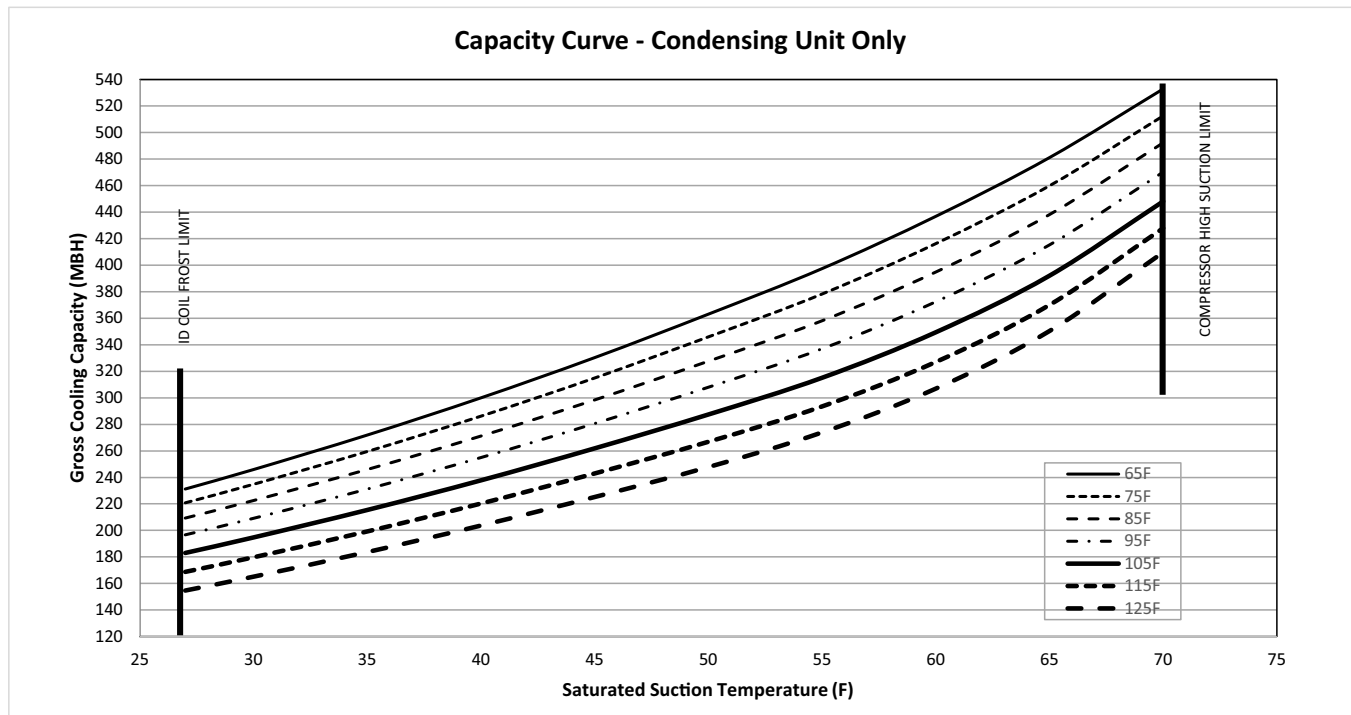

Table 44. Gross cooling capacities (MBH) both compressors - 20 tons TTA2404*C condensing unit only (IP)

Outdoor Temp (°F)		Saturated Suction Temperature (°F)					
		30	35	40	45	50	55
65	Head Press (psig)	265.1	271.0	276.2	280.2	282.8	288.9
	Capacity (Btuh/1000)	245.9	271.9	300.0	330.3	363.1	397.4
	Unit Power (kW)	16.3	16.7	17.1	17.5	17.8	18.3
75	Head Press (psig)	303.0	309.0	314.0	317.8	320.2	326.4
	Capacity (Btuh/1000)	234.8	259.5	286.1	314.9	345.9	378.3
	Unit Power (kW)	17.6	18.0	18.4	18.8	19.1	19.6
85	Head Press (psig)	344.4	350.3	355.1	358.6	360.9	367.3
	Capacity (Btuh/1000)	222.5	245.9	271.2	298.4	327.6	358.1
	Unit Power (kW)	19.2	19.6	20.0	20.3	20.6	21.1
95	Head Press (psig)	389.1	394.9	399.5	402.6	405.2	411.4
	Capacity (Btuh/1000)	209.1	231.2	254.9	280.6	308.0	337.0
	Unit Power (kW)	20.9	21.3	21.7	22.0	22.3	22.7
105	Head Press (psig)	437.3	442.8	447.0	449.8	452.7	458.4
	Capacity (Btuh/1000)	194.7	215.4	237.8	261.9	287.4	315.1
	Unit Power (kW)	22.9	23.3	23.6	23.9	24.1	24.5
115	Head Press (psig)	489.0	494.1	497.9	500.2	503.2	508.0
	Capacity (Btuh/1000)	179.7	199.2	220.3	243.0	266.8	293.5
	Unit Power (kW)	25.1	25.4	25.7	25.9	26.2	26.5
125	Head Press (psig)	544.8	549.3	552.3	554.0	556.8	560.1
	Capacity (Btuh/1000)	165.1	183.7	203.7	225.2	247.8	273.9
	Unit Power (kW)	27.5	27.7	27.9	28.1	28.3	28.6

Note: Performance data calculated at 15°F subcooling and 15°F superheat and does not include capacity loss due to refrigerant lines.

Figure 20. TTA2404*C - both compressors - capacity curves



Performance Data

Table 45. Gross cooling capacities (MBH) one compressor - 25 tons TTA3004*C condensing unit only (IP)

Outdoor Temp (°F)		Saturated Suction Temperature (°F)					
		30	35	40	45	50	55
65	Head Press (psig)	246.4	248.7	250.8	252.6	253.9	256.2
	Capacity (Btuh/1000)	142.4	157.0	172.7	189.5	207.4	226.2
	Unit Power (kW)	10.2	10.3	10.4	10.5	10.6	10.7
75	Head Press (psig)	286.2	288.4	290.3	291.9	292.9	294.3
	Capacity (Btuh/1000)	136.5	150.6	165.8	182.0	199.3	217.5
	Unit Power (kW)	11.0	11.1	11.2	11.3	11.4	11.6
85	Head Press (psig)	330.6	332.5	334.1	335.3	335.8	336.0
	Capacity (Btuh/1000)	129.6	143.2	157.7	173.3	189.9	207.6
	Unit Power (kW)	11.9	12.0	12.2	12.3	12.4	12.5
95	Head Press (psig)	380.2	381.6	382.6	383.1	382.9	382.0
	Capacity (Btuh/1000)	121.7	134.6	148.5	163.4	179.3	196.3
	Unit Power (kW)	13.0	13.1	13.3	13.4	13.5	13.6
105	Head Press (psig)	436.1	436.4	436.3	435.8	434.5	432.5
	Capacity (Btuh/1000)	112.6	124.9	138.1	152.2	167.4	183.7
	Unit Power (kW)	14.3	14.4	14.5	14.6	14.7	14.7
115	Head Press (psig)	501.4	499.1	496.9	494.3	491.3	487.6
	Capacity (Btuh/1000)	102.3	114.1	126.7	140.2	154.7	170.3
	Unit Power (kW)	15.9	15.9	16.0	16.0	16.0	16.1
125	Head Press (psig)	601.8	580.9	570.2	562.1	555.0	548.1
	Capacity (Btuh/1000)	89.3	101.9	114.6	127.9	142.0	157.0
	Unit Power (kW)	18.4	17.9	17.7	17.6	17.5	17.5

Note: Performance data calculated at 15°F subcooling and 15°F superheat and does not include capacity loss due to refrigerant lines.

Figure 21. TTA3004*C - one compressors - capacity curves

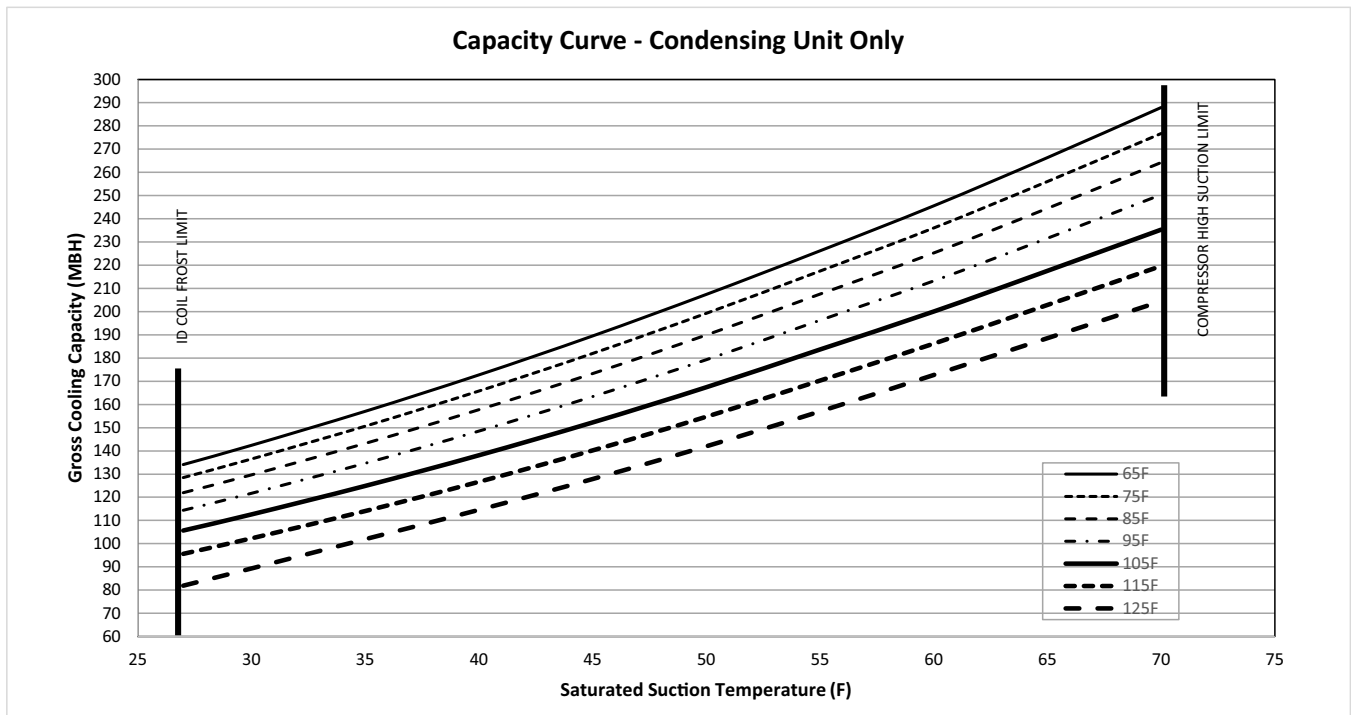
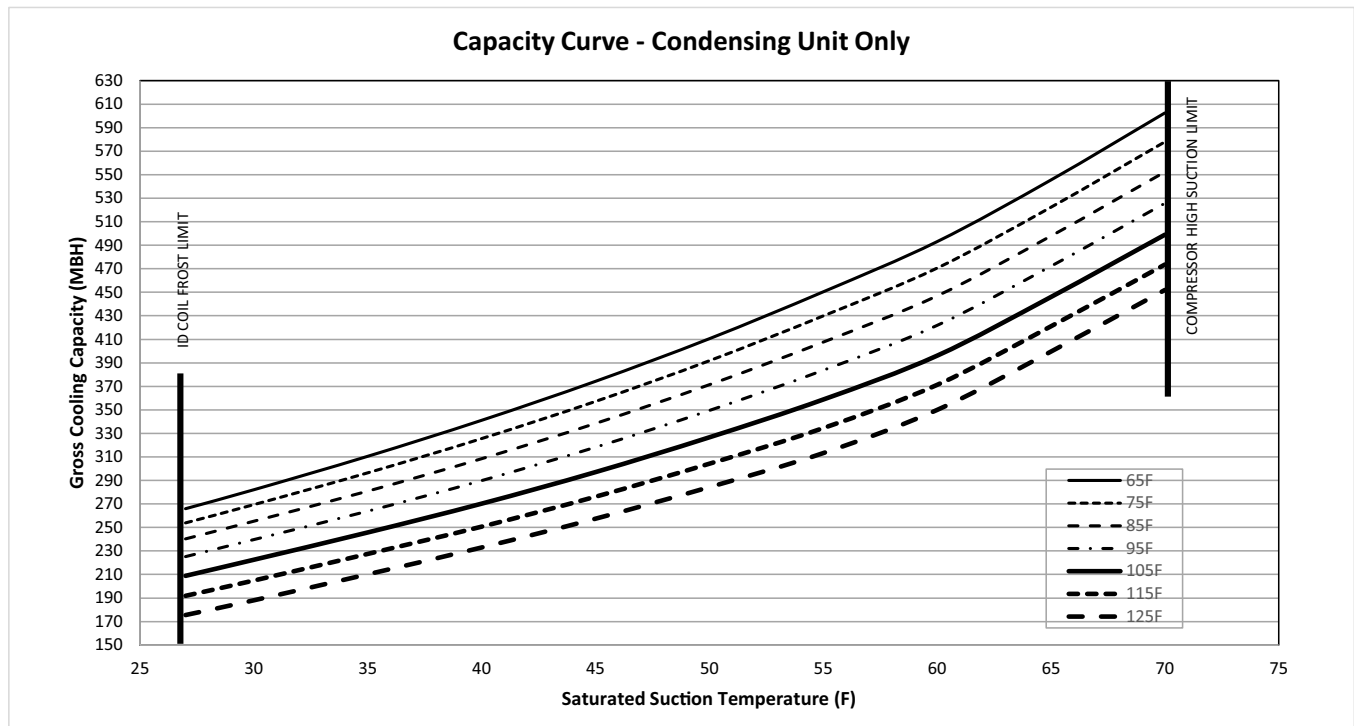

Table 46. Gross cooling capacities (MBH) both compressors - 25 tons TTA3004*C condensing unit only (IP)

Outdoor Temp (°F)		Saturated Suction Temperature (°F)					
		30	35	40	45	50	55
65	Head Press (psig)	279.0	286.9	294.4	300.5	304.5	305.9
	Capacity (Btuh/1000)	282.1	310.5	341.1	374.3	410.5	450.4
	Unit Power (kW)	19.8	20.3	20.8	21.2	21.6	21.8
75	Head Press (psig)	318.0	326.0	333.3	339.2	342.7	343.5
	Capacity (Btuh/1000)	269.4	296.5	325.6	357.2	391.8	429.9
	Unit Power (kW)	21.5	22.0	22.5	23.0	23.3	23.6
85	Head Press (psig)	360.4	368.4	375.5	380.9	383.9	384.3
	Capacity (Btuh/1000)	255.3	280.9	308.5	338.5	371.4	407.6
	Unit Power (kW)	23.4	23.9	24.4	24.9	25.2	25.5
95	Head Press (psig)	406.6	414.0	420.8	425.7	428.0	428.3
	Capacity (Btuh/1000)	239.7	263.9	289.8	318.2	349.5	383.7
	Unit Power (kW)	25.5	26.1	26.6	27.0	27.3	27.6
105	Head Press (psig)	457.6	463.0	469.3	473.5	475.1	475.6
	Capacity (Btuh/1000)	222.5	245.8	270.2	297.1	326.7	358.8
	Unit Power (kW)	28.0	28.4	28.9	29.3	29.6	29.8
115	Head Press (psig)	513.2	515.3	520.9	524.3	525.1	525.6
	Capacity (Btuh/1000)	204.9	227.5	250.7	276.2	304.2	334.5
	Unit Power (kW)	30.7	31.0	31.4	31.8	32.0	32.2
125	Head Press (psig)	575.1	573.6	576.2	578.6	578.3	578.1
	Capacity (Btuh/1000)	188.1	210.2	233.0	257.4	284.3	313.2
	Unit Power (kW)	33.8	33.8	34.1	34.4	34.5	34.7

Note: Performance data calculated at 15°F subcooling and 15°F superheat and does not include capacity loss due to refrigerant lines.

Figure 22. TTA3004*C - both compressors - capacity curves





Performance Data

Fan Performance

Important: Additional external static pressure from accessories must be added to the design static pressure from the accessory pressure tables.

Table 47. Evaporator fan performance —TWE060 — constant volume air handler

External Static Pressure (Inches of Water Gauge)																								
		0.10"		0.20"		0.30"		0.40"		0.50"		0.60"		0.70"		0.80"		0.90"		1.00"		1.10"		
CFM	RPM	BHP	RPM	BHP	RPM	BHP	RPM	BHP	RPM	BHP	RPM	BHP	RPM	BHP	RPM	BHP	RPM	BHP	RPM	BHP	RPM	BHP		
																			3/4 HP Standard Motor			1.5 HP High Static Motor		
1600	—	—	738	0.33	790	0.38	840	0.44	888	0.50	936	0.56	980	0.62	1025	0.69	1070	0.76	1111	0.83	1152	0.91		
1700	719	0.33	771	0.38	821	0.44	869	0.50	914	0.56	959	0.62	1003	0.68	1047	0.75	1089	0.82	1129	0.90	1170	0.98		
1800	756	0.39	804	0.44	853	0.50	898	0.56	942	0.62	985	0.69	1028	0.75	1068	0.82	1109	0.89	1149	0.97	1187	1.05		
1900	792	0.45	838	0.51	884	0.57	928	0.63	971	0.69	1012	0.76	1052	0.83	1092	0.90	1131	0.97	1170	1.05	1207	1.13		
2000	829	0.52	873	0.58	917	0.64	959	0.71	1000	0.77	1040	0.84	1079	0.91	1117	0.98	1155	1.06	1192	1.14	1227	1.21		
2100	866	0.60	908	0.66	950	0.72	991	0.79	1030	0.86	1069	0.93	1106	1.00	1144	1.08	1179	1.15	1215	1.23	1250	1.31		
2200	903	0.68	944	0.74	983	0.81	1023	0.88	1061	0.95	1099	1.02	1134	1.10	1170	1.18	1206	1.26	1241	1.34	1274	1.42		
2300	940	0.78	979	0.84	1017	0.90	1055	0.97	1093	1.05	1129	1.13	1164	1.21	1198	1.28	1232	1.37	1266	1.45	1299	1.53		
2400	978	0.88	1015	0.94	1052	1.01	1089	1.08	1125	1.16	1160	1.24	1194	1.32	1227	1.40	1259	1.48	1292	1.57	—	—		
External Static Pressure (Inches of Water Gauge)																								
		1.20"		1.30"		1.40"																		
CFM	RPM	BHP	RPM	BHP	RPM	BHP	1.5 HP High Static Motor																	
1600	1191	0.99	1229	1.07	1264	1.14																		
1700	1208	1.06	1246	1.14	1281	1.22																		
1800	1226	1.13	1263	1.22	1300	1.30																		
1900	1245	1.21	1281	1.30	1317	1.39																		
2000	1265	1.30	1300	1.39	1335	1.48																		
2100	1285	1.39	1319	1.48	—	—																		
2200	1308	1.50	—	—	—	—																		
2300	—	—	—	—	—	—																		
2400	—	—	—	—	—	—																		

Notes:

1. Data includes pressure drop due to wet coil and 1" filter.
2. Fan motor heat (MBh) = 3.15 x BHP.
3. Check General Data for indoor fan motor HP availability.
4. Factory supplied motors, in commercial equipment, are definite purpose motors, specifically designed and tested to operate reliably and continuously at all cataloged conditions. Using the full horsepower range of our fan motors as shown in our tabular data will not result in nuisance tripping or premature motor failure. Our product's warranty will not be affected.

Table 48. Evaporator fan performance —TWE0724KB — constant volume air handler

External Static Pressure (Inches of Water Gauge)																			
		0.10"		0.20"		0.30"		0.40"		0.50"		0.60"		0.70"		0.80"		0.90"	
CFM	RPM	BHP	RPM	BHP	RPM	BHP	RPM	BHP	RPM	BHP	RPM	BHP	RPM	BHP	RPM	BHP	RPM	BHP	
1.5 HP Standard Motor with Field Supplied Low Static Sheave and Belt							1.5 HP Standard Motor												
1920	456	0.23	518	0.29	578	0.37	635	0.46	688	0.55	737	0.65	782	0.75	824	0.85	863	0.95	
2040	474	0.26	536	0.33	592	0.41	648	0.50	700	0.60	748	0.70	793	0.80	835	0.91	874	1.02	
2160	492	0.30	555	0.38	608	0.46	661	0.55	711	0.65	759	0.75	804	0.86	846	0.97	886	1.08	
2280	512	0.34	574	0.43	625	0.51	675	0.60	724	0.70	771	0.81	815	0.92	857	1.03	896	1.15	
2400	532	0.38	594	0.48	642	0.56	689	0.66	737	0.76	783	0.87	826	0.98	868	1.10	907	1.22	
2520	553	0.43	614	0.54	661	0.63	705	0.72	751	0.82	795	0.94	838	1.05	879	1.18	918	1.30	
2640	575	0.49	634	0.60	679	0.69	722	0.79	765	0.89	809	1.01	850	1.13	891	1.25	929	1.38	
2760	597	0.55	651	0.66	698	0.76	740	0.86	780	0.96	822	1.08	863	1.21	903	1.33	941	1.46	
2880	619	0.62	669	0.73	718	0.84	758	0.94	797	1.05	837	1.16	877	1.29	915	1.42	953	1.55	
External Static Pressure (Inches of Water Gauge)																			
		1.00"		1.10"		1.20"		1.30"		1.40"		1.50"		1.60"					
CFM	RPM	BHP	RPM	BHP	RPM	BHP	RPM	BHP	RPM	BHP	RPM	BHP	RPM	BHP					
1.5 HP Standard Motor with Field Supplied High Static Sheave and Belt																			
1920	900	1.05	934	1.15	967	1.25	998	1.36	1027	1.46	1056	1.56	1082	1.65					
2040	911	1.12	946	1.23	979	1.34	1011	1.45	1041	1.55	1069	1.66	—	—					
2160	923	1.20	958	1.31	991	1.42	1023	1.54	1053	1.65	—	—	—	—					
2280	934	1.27	969	1.39	1003	1.51	1035	1.63	—	—	—	—	—	—					
2400	945	1.35	980	1.47	1014	1.60	1046	1.72	—	—	—	—	—	—					
2520	955	1.43	991	1.56	1025	1.69	—	—	—	—	—	—	—	—					
2640	966	1.51	1002	1.64	—	—	—	—	—	—	—	—	—	—					
2760	978	1.60	—	—	—	—	—	—	—	—	—	—	—	—					
2880	989	1.69	—	—	—	—	—	—	—	—	—	—	—	—					

Notes:

1. Data includes pressure drop due to wet coil and 1" filter.
2. Fan motor heat (MBh) = 3.15 x BHP.
3. Check General Data for indoor fan motor HP availability.
4. For 380/60Hz models: Performance is limited to standard motor CFM/static range. No high static or oversized motors are available.
5. Factory supplied motors, in commercial equipment, are definite purpose motors, specifically designed and tested to operate reliably and continuously at all cataloged conditions. Using the full horsepower range of our fan motors as shown in our tabular data will not result in nuisance tripping or premature motor failure. Our product's warranty will not be affected.

Table 50. Evaporator fan performance —TWE09041B, 4KB — constant volume air handler

External Static Pressure (Inches of Water Gauge)																					
		0.10"		0.20"		0.30"		0.40"		0.50"		0.60"		0.70"		0.80"		0.90"		1.00"	
CFM	RPM	BHP	RPM	BHP	RPM	BHP	RPM	BHP	RPM	BHP	RPM	BHP	RPM	BHP	RPM	BHP	RPM	BHP	RPM	BHP	
		1.5 HP Standard Motor with Field Supplied Sheave and Belt				1.5 HP Standard Motor								1.5 Hp Standard Motor with Field Supplied High Satic Sheave/Belt							
2400	532	0.38	594	0.48	642	0.56	689	0.66	737	0.76	783	0.87	826	0.98	868	1.10	907	1.22	945	1.35	
2550	558	0.45	618	0.55	665	0.64	709	0.74	754	0.84	799	0.95	841	1.07	882	1.19	921	1.32	958	1.45	
2700	587	0.52	643	0.63	689	0.73	731	0.82	773	0.93	816	1.04	857	1.17	897	1.29	935	1.42	972	1.55	
2850	613	0.60	664	0.71	713	0.82	753	0.92	792	1.02	833	1.14	873	1.27	912	1.40	950	1.53	986	1.67	
3000	643	0.70	688	0.80	737	0.92	777	1.03	814	1.14	852	1.25	891	1.38	928	1.51	965	1.65	1001	1.79	
3150	671	0.79	711	0.90	762	1.04	800	1.15	837	1.26	872	1.37	909	1.50	945	1.63	981	1.78	1016	1.92	
3300	701	0.91	736	1.01	786	1.15	824	1.27	860	1.39	894	1.51	928	1.63	963	1.77	998	1.91	1032	2.06	
3450	729	1.03	763	1.13	808	1.27	849	1.41	883	1.53	916	1.65	949	1.78	982	1.91	1015	2.06	1049	2.21	
3600	756	1.15	790	1.26	831	1.40	874	1.56	908	1.69	940	1.81	971	1.94	1002	2.07	1034	2.22	—	—	
External Static Pressure (Inches of Water Gauge)																					
		1.10"		1.20"		1.30"		1.40"		1.50"											
CFM	RPM	BHP	RPM	BHP	RPM	BHP	RPM	BHP	RPM	BHP											
		1.5 Hp Standard Motor with Field Supplied High Satic Sheave/Belt				2 HP High Static Motor															
2400	980	1.47	1014	1.60	1046	1.72	1077	1.85	1107	1.98											
2550	994	1.58	1028	1.71	1060	1.84	1091	1.98	1121	2.11											
2700	1007	1.69	1041	1.83	1074	1.97	1105	2.11	—	—											
2850	1021	1.81	1055	1.95	1087	2.09	1119	2.24	—	—											
3000	1035	1.93	1069	2.08	1101	2.23	—	—	—	—											
3150	1050	2.07	1083	2.22	—	—	—	—	—	—											
3300	1065	2.21	—	—	—	—	—	—	—	—											
3450	—	—	—	—	—	—	—	—	—	—											
3600	—	—	—	—	—	—	—	—	—	—											

Notes:

1. Data includes pressure drop due to wet coil and 1" filter.
2. Fan motor heat (MBh) = 3.15 x BHP.
3. Check General Data for indoor fan motor HP availability.
4. Factory supplied motors, in commercial equipment, are definite purpose motors, specifically designed and tested to operate reliably and continuously at all cataloged conditions. Using the full horsepower range of our fan motors as shown in our tabular data will not result in nuisance tripping or premature motor failure. Our product's warranty will not be affected.
5. For 380/60Hz models: Performance is limited to standard motor CFM/static range. No high static or oversized motors are available.



Performance Data

Table 51. Evaporator fan performance - TWE0904** - 2-speed VFD, SZVAV air handler

		External Static Pressure (Inches of Water Gauge)																												
		0.10"		0.20"		0.30"		0.40"		0.50"		0.60"		0.70"		0.80"		0.90"		1.00"										
CFM	RPM	Hz	BHP	RPM	Hz	BHP	RPM	Hz	BHP	RPM	Hz	BHP	RPM	Hz	BHP	RPM	Hz	BHP	RPM	Hz	BHP	RPM	Hz	BHP	RPM	Hz	BHP			
2 HP Standard Drive																														
2400	532	29	0.38	594	32	0.48	642	34	0.56	689	37	0.66	737	40	0.76	783	42	0.87	826	44	0.98	868	47	1.10	907	49	1.22	945	51	1.35
2550	558	30	0.45	618	33	0.55	665	36	0.64	709	38	0.74	754	40	0.84	799	43	0.95	841	45	1.07	882	47	1.19	921	49	1.32	958	51	1.45
2700	587	31	0.52	643	34	0.63	689	37	0.73	731	39	0.82	773	41	0.93	816	44	1.04	857	46	1.17	897	48	1.29	935	50	1.42	972	52	1.55
2850	613	33	0.60	664	36	0.71	713	38	0.82	753	40	0.92	792	43	1.02	833	45	1.14	873	47	1.27	912	49	1.40	950	51	1.53	986	53	1.67
3000	643	35	0.70	688	37	0.80	737	40	0.92	777	42	1.03	814	44	1.14	852	46	1.25	891	48	1.38	928	50	1.51	965	52	1.65	1001	54	1.79
3150	671	36	0.79	711	38	0.90	762	41	1.04	800	43	1.15	837	45	1.26	872	47	1.37	909	49	1.50	945	51	1.63	981	53	1.78	1016	55	1.92
3300	701	38	0.91	736	40	1.01	786	42	1.15	824	44	1.27	860	46	1.39	894	48	1.51	928	50	1.63	963	52	1.77	998	54	1.91	1032	46	2.06
3450	729	39	1.03	763	41	1.13	808	43	1.27	849	46	1.41	883	47	1.53	916	49	1.65	949	51	1.78	982	53	1.91	1015	45	2.06	1049	46	2.21
3600	756	41	1.15	790	42	1.26	831	45	1.40	874	47	1.56	908	49	1.69	940	42	1.81	971	43	1.94	1002	44	2.07	1034	46	2.22	1066	47	2.37
3 HP High Static Drive																														
External Static Pressure (Inches of Water Gauge)																														
		1.10"		1.20"		1.30"		1.40"		1.50"		1.60"		1.70"		1.80"		1.90"		2.00"										
CFM	RPM	Hz	BHP	RPM	Hz	BHP	RPM	Hz	BHP	RPM	Hz	BHP	RPM	Hz	BHP	RPM	Hz	BHP	RPM	Hz	BHP	RPM	Hz	BHP	RPM	Hz	BHP	RPM	Hz	BHP
2 HP Standard Drive																														
2400	980	53	1.47	1014	54	1.60	1046	56	1.72	1077	58	1.85	1107	59	1.98	1135	50	2.10	1163	51	2.23	1189	53	2.36	1215	54	2.48	1240	55	2.61
2550	994	53	1.58	1028	55	1.71	1060	57	1.84	1091	59	1.98	1121	50	2.11	1150	51	2.25	1178	52	2.38	1204	53	2.51	1230	54	2.65	1256	56	2.78
2700	1007	54	1.69	1041	56	1.83	1074	58	1.97	1105	49	2.11	1135	50	2.25	1164	52	2.39	1192	53	2.53	1219	54	2.67	1245	55	2.82	1271	56	2.96
2850	1021	55	1.81	1055	57	1.95	1087	48	2.09	1119	49	2.24	1149	51	2.39	1178	52	2.54	1206	53	2.69	1234	55	2.84	1260	56	2.99	1285	57	3.14
3000	1035	56	1.93	1069	47	2.08	1101	49	2.23	1132	50	2.38	1162	51	2.54	1192	53	2.69	1220	54	2.85	1247	55	3.00	1274	56	3.16	—	—	—
3150	1050	46	2.07	1083	48	2.22	1115	49	2.37	1146	51	2.53	1176	52	2.69	1205	53	2.85	1233	55	3.01	1261	56	3.17	—	—	—	—	—	—
3300	1065	47	2.21	1097	49	2.36	1129	50	2.52	1160	51	2.68	1190	53	2.85	1219	54	3.01	—	—	—	—	—	—	—	—	—	—	—	—
3450	1081	48	2.36	1113	49	2.52	1144	51	2.68	1174	52	2.85	1204	53	3.02	—	—	—	—	—	—	—	—	—	—	—	—	—	—	—
3600	1098	49	2.53	1129	50	2.69	1159	51	2.86	1189	53	3.02	—	—	—	—	—	—	—	—	—	—	—	—	—	—	—	—	—	
3 HP High Static Drive																														
External Static Pressure (Inches of Water Gauge)																														
		2.10"		2.20"		2.30"																								
CFM	RPM	Hz	BHP	RPM	Hz	BHP	RPM	Hz	BHP																					
2400	1264	56	2.74	1287	57	2.86	1310	58	2.99																					
2550	1280	57	2.92	1304	58	3.05	1327	59	3.19																					
2700	1295	57	3.10	—	—	—	—	—	—																					
2850	—	—	—	—	—	—	—	—	—																					
3000	—	—	—	—	—	—	—	—	—																					
3150	—	—	—	—	—	—	—	—	—																					
3300	—	—	—	—	—	—	—	—	—																					
3450	—	—	—	—	—	—	—	—	—																					
3600	—	—	—	—	—	—	—	—	—																					

Notes:
 1. 2-Speed VFD or SZVAV applications are capable of running below 320 cfm/ton during low speed airflow operation, but "full" airflow must be set to 320 cfm/ton or higher.
 2. Check General Data for indoor fan motor HP availability.
 3. Data includes pressure drop due to wet coil and 1-inch filter.

Table 52. Evaporator fan performance —TWE12041B, 4KB — constant volume air handler

External Static Pressure (Inches of Water Gauge)														
CFM	0.10"		0.20"		0.30"		0.40"		0.50"		0.60"		0.70"	
	RPM	BHP	RPM	BHP	RPM	BHP	RPM	BHP	RPM	BHP	RPM	BHP	RPM	BHP
2 HP Standard Motor														
3200	570	0.60	616	0.69	657	0.80	695	0.90	731	1.00	766	1.10	800	1.21
3400	601	0.71	643	0.80	684	0.92	720	1.02	755	1.13	788	1.24	821	1.35
3600	631	0.84	670	0.92	710	1.04	746	1.16	779	1.27	812	1.39	843	1.50
3800	662	0.98	699	1.06	738	1.19	772	1.31	805	1.43	836	1.55	866	1.67
4000	695	1.14	728	1.21	765	1.34	799	1.47	831	1.60	861	1.72	890	1.85
4200	727	1.31	757	1.38	792	1.50	826	1.65	857	1.78	887	1.91	915	2.05
4400	757	1.49	788	1.58	820	1.69	853	1.84	884	1.98	913	2.12	940	2.26
4600	788	1.69	818	1.78	849	1.89	881	2.04	911	2.20	—	—	—	—
4800	824	1.93	849	2.01	877	2.11	908	2.26	—	—	—	—	—	—
External Static Pressure (Inches of Water Gauge)														
CFM	0.80"		0.90"		1.00"		1.10"		1.20"		1.30"		1.40"	
	RPM	BHP	RPM	BHP	RPM	BHP	RPM	BHP	RPM	BHP	RPM	BHP	RPM	BHP
2 HP Standard Motor with Field Supplied Sheave/Belt														
3200	834	1.33	867	1.45	900	1.58	933	1.70	964	1.83	993	1.96	1022	2.09
3400	854	1.46	886	1.59	917	1.72	947	1.85	978	1.99	1008	2.12	1037	2.26
3600	874	1.62	905	1.74	935	1.87	965	2.01	993	2.15	1023	2.29	—	—
3800	896	1.79	925	1.91	954	2.05	983	2.19	—	—	—	—	—	—
4000	919	1.98	947	2.10	975	2.24	—	—	—	—	—	—	—	—
4200	943	2.18	970	2.31	—	—	—	—	—	—	—	—	—	—
4400	—	—	—	—	—	—	—	—	—	—	—	—	—	—
4600	—	—	—	—	—	—	—	—	—	—	—	—	—	—
4800	—	—	—	—	—	—	—	—	—	—	—	—	—	—

Notes:

1. Data includes pressure drop due to wet coil and 1" filter.
2. Fan motor heat (MBh) = 3.15 x BHP.
3. Check General Data for indoor fan motor HP availability.
4. Factory supplied motors, in commercial equipment, are definite purpose motors, specifically designed and tested to operate reliably and continuously at all cataloged conditions. Using the full horsepower range of our fan motors as shown in our tabular data will not result in nuisance tripping or premature motor failure. Our product's warranty will not be affected.



Performance Data

Table 53. Evaporator fan performance - TWE1204 - 2-speed VFD, SZVAV air handler**

CFM	External Static Pressure (Inches of Water Gauge)																													
	0.10"		0.20"		0.30"		0.40"		0.50"		0.60"		0.70"		0.80"		0.90"		1.00"											
	RPM	Hz	BHP	RPM	Hz	BHP	RPM	Hz	BHP	RPM	Hz	BHP	RPM	Hz	BHP	RPM	Hz	BHP	RPM	Hz	BHP	RPM	Hz	BHP						
2 HP Standard Drive																														
3200	570	37	0.60	616	40	0.69	657	43	0.80	695	45	0.90	731	48	1.00	766	50	1.10	800	52	1.21	834	55	1.33	867	57	1.45	900	59	1.58
3400	601	39	0.71	643	42	0.80	684	45	0.92	720	47	1.02	755	49	1.13	788	52	1.24	821	54	1.35	854	56	1.46	886	58	1.59	917	60	1.72
3600	631	41	0.84	670	44	0.92	710	46	1.04	746	49	1.16	779	51	1.27	812	53	1.39	843	55	1.50	874	57	1.62	905	59	1.74	935	61	1.87
3800	662	43	0.98	699	46	1.06	738	48	1.19	772	50	1.31	805	53	1.43	836	55	1.55	866	57	1.67	896	59	1.79	925	60	1.91	954	62	2.05
4000	695	45	1.14	728	48	1.21	765	50	1.34	799	52	1.47	831	54	1.60	861	56	1.72	890	58	1.85	919	60	1.98	947	61	2.10	975	63	2.24
4200	727	47	1.31	757	50	1.38	792	52	1.50	826	54	1.65	857	56	1.78	887	58	1.91	915	60	2.05	943	62	2.18	970	64	2.31	996	66	2.44
4400	757	49	1.49	788	52	1.58	820	54	1.69	853	56	1.84	884	58	1.98	913	60	2.12	940	62	2.26	967	64	2.40	993	66	2.54	1019	68	2.67
4600	788	52	1.69	818	55	1.78	849	57	1.89	881	58	2.04	911	60	2.20	939	62	2.34	966	64	2.48	992	66	2.63	1018	68	2.78	1042	70	2.92
4800	824	54	1.93	849	57	2.01	877	59	2.11	908	60	2.26	937	62	2.42	966	64	2.58	992	66	2.73	1017	68	2.88	1042	70	3.03	1067	72	3.19
3 HP High Static Drive																														
3200	933	49	1.70	964	51	1.83	993	53	1.96	1022	54	2.09	1050	56	2.22	1077	57	2.36	1103	58	2.49	1128	60	2.62	1152	61	2.75	1176	63	2.88
3400	947	50	1.85	978	52	1.99	1008	53	2.12	1037	55	2.26	1064	56	2.40	1091	58	2.54	1117	59	2.68	1142	60	2.82	1166	62	2.95	1190	64	3.08
3600	965	51	2.01	993	53	2.15	1023	54	2.29	1051	56	2.44	1079	57	2.58	1106	59	2.73	1132	60	2.88	1157	61	3.02	1182	63	3.17	1206	65	3.31
3800	983	52	2.19	1011	54	2.33	1039	55	2.47	1066	56	2.62	1094	58	2.78	1120	59	2.93	1145	60	3.08	1170	62	3.23	1194	64	3.38	1218	66	3.52
4000	1002	53	2.38	1029	54	2.52	1056	56	2.67	1083	57	2.82	1109	59	2.98	1135	60	3.14	1160	61	3.29	1185	63	3.44	1210	65	3.59	1234	67	3.73
4200	1023	54	2.58	1049	56	2.73	1075	57	2.88	1101	58	3.04	1126	60	3.20	1151	61	3.36	1176	62	3.51	1201	64	3.66	1225	66	3.81	1249	68	3.95
4400	1045	55	2.82	1069	57	2.96	1095	58	3.11	1121	59	3.27	1146	60	3.42	1171	61	3.57	1196	62	3.72	1221	64	3.87	1245	66	4.02	1269	68	4.16
4600	1067	56	3.07	1091	58	3.21	1117	59	3.35	1142	60	3.50	1167	61	3.65	1192	62	3.80	1217	63	3.95	1242	64	4.10	1266	66	4.25	1290	68	4.39
4800	1090	57	3.32	1113	59	3.45	1139	60	3.59	1164	61	3.74	1189	62	3.89	1214	63	4.04	1239	64	4.19	1264	65	4.34	1288	67	4.49	1312	69	4.63

Notes:

1. 2-Speed VFD or SZVAV applications are capable of running below 320 cfm/ton during low speed airflow operation, but "full" airflow must be set to 320 cfm/ton or higher.
2. Check General Data for indoor fan motor HP availability.
3. Data includes pressure drop due to wet coil and 1-inch filter.

Table 54. Evaporator fan performance —TWE1504KB — constant volume air handler

																								External Static Pressure (Inches of Water Gauge)																							
		0.10"		0.20"		0.30"		0.40"		0.50"		0.60"		0.70"		0.80"		0.90"		1.00"		1.10"		1.20"																							
CFM	RPM	BHP	RPM	BHP	RPM	BHP	RPM	BHP	RPM	BHP	RPM	BHP	RPM	BHP	RPM	BHP	RPM	BHP	RPM	BHP	RPM	BHP	RPM	BHP																							
												2 HP Standard Motor												2 HP Standard Motor w/Field Supplied Sheave/Belt																							
4000	—	—	—	—	584	0.82	631	0.96	674	1.09	715	1.23	753	1.36	789	1.51	825	1.65	859	1.80	891	1.95	922	2.10																							
4200	—	—	548	0.78	598	0.91	645	1.05	687	1.19	727	1.33	765	1.47	800	1.62	835	1.77	869	1.93	901	2.08	932	2.24																							
4400	—	—	564	0.87	613	1.01	659	1.15	701	1.29	740	1.44	777	1.59	812	1.74	846	1.90	879	2.06	911	2.22	—	—																							
4600	—	—	580	0.96	628	1.11	673	1.26	714	1.41	753	1.56	790	1.72	824	1.88	858	2.03	889	2.19	—	—	—	—																							
4800	548	0.92	597	1.07	643	1.22	687	1.37	728	1.53	766	1.69	802	1.85	837	2.01	870	2.18	—	—	—	—	—	—																							
5000	565	1.02	614	1.18	659	1.34	702	1.49	742	1.66	780	1.82	815	1.99	849	2.16	—	—	—	—	—	—	—	—																							
5200	585	1.14	631	1.30	675	1.46	717	1.63	756	1.80	793	1.97	829	2.14	862	2.31	—	—	—	—	—	—	—	—																							
5400	604	1.27	648	1.43	692	1.60	732	1.77	771	1.94	808	2.12	842	2.30	—	—	—	—	—	—	—	—	—	—																							
5600	622	1.40	666	1.56	708	1.74	748	1.92	786	2.10	822	2.28	—	—	—	—	—	—	—	—	—	—	—	—																							
5800	641	1.54	684	1.71	725	1.90	763	2.08	800	2.26	—	—	—	—	—	—	—	—	—	—	—	—	—	—																							
6000	662	1.70	702	1.88	741	2.06	779	2.25	—	—	—	—	—	—	—	—	—	—	—	—	—	—	—	—																							

Notes:

1. Data includes pressure drop due to wet coil and 2" filter.
2. Fan motor heat (MBh) = 3.15 x BHP.
3. Check General Data for indoor fan motor HP availability.
4. For 380/60Hz models: Performance is limited to standard motor CFM/static range. No high static or oversized motors are available.
5. Factory supplied motors, in commercial equipment, are definite purpose motors, specifically designed and tested to operate reliably and continuously at all cataloged conditions. Using the full horsepower range of our fan motors as shown in our tabular data will not result in nuisance tripping or premature motor failure. Our product's warranty will not be affected.



Performance Data

Table 55. Evaporator fan performance - TWE1504** - 2-speed VFD, SZVAV air handler

CFM	External Static Pressure (Inches of Water Gauge)																													
	0.10"		0.20"		0.30"		0.40"		0.50"		0.60"		0.70"		0.80"		0.90"		1.00"											
	RPM	Hz	BHP	RPM	Hz	BHP	RPM	Hz	BHP	RPM	Hz	BHP	RPM	Hz	BHP	RPM	Hz	BHP	RPM	Hz	BHP	RPM	Hz	BHP	RPM	Hz	BHP			
4000	474	31	0.57	532	35	0.69	584	38	0.82	631	41	0.96	674	44	1.09	715	47	1.23	753	49	1.36	789	52	1.51	825	54	1.65	859	56	1.80
4200	492	32	0.64	548	36	0.78	598	39	0.91	645	42	1.05	687	45	1.19	727	48	1.33	765	50	1.47	800	52	1.62	835	55	1.77	869	57	1.93
4400	510	33	0.73	564	37	0.87	613	40	1.01	659	43	1.15	701	46	1.29	740	48	1.44	777	51	1.59	812	53	1.74	846	55	1.90	879	58	2.06
4600	528	35	0.82	580	38	0.96	628	41	1.11	673	44	1.26	714	47	1.41	753	49	1.56	790	52	1.72	824	54	1.88	858	56	2.03	889	45	2.19
4800	548	36	0.92	597	39	1.07	643	42	1.22	687	45	1.37	728	48	1.53	766	50	1.69	802	53	1.85	837	55	2.01	870	44	2.18	901	45	2.34
5000	565	37	1.02	614	40	1.18	659	43	1.34	702	46	1.49	742	49	1.66	780	51	1.82	815	53	1.99	849	43	2.16	882	44	2.33	913	46	2.50
5200	585	38	1.14	631	41	1.30	675	44	1.46	717	47	1.63	756	50	1.80	793	52	1.97	829	42	2.14	862	43	2.31	894	45	2.49	925	47	2.67
5400	604	40	1.27	648	42	1.43	692	45	1.60	732	48	1.77	771	39	1.94	808	41	2.12	842	42	2.30	875	44	2.48	907	46	2.66	938	47	2.84
5600	622	41	1.40	666	44	1.56	708	46	1.74	748	38	1.92	786	40	2.10	822	41	2.28	856	43	2.46	889	45	2.65	920	46	2.84	950	48	3.02
5800	641	42	1.54	684	45	1.71	725	37	1.90	763	39	2.08	800	40	2.26	836	42	2.45	870	44	2.64	902	46	2.83	933	47	3.02	963	49	3.22
6000	662	33	1.70	702	46	1.88	741	37	2.06	779	39	2.25	816	41	2.44	851	43	2.63	884	45	2.83	916	46	3.03	947	48	3.22	976	49	3.42
External Static Pressure (Inches of Water Gauge)																														
CFM	1.10"		1.20"		1.30"		1.40"		1.50"		1.60"		1.70"		1.80"		1.90"		2.00"											
	RPM	Hz	BHP	RPM	Hz	BHP	RPM	Hz	BHP	RPM	Hz	BHP	RPM	Hz	BHP	RPM	Hz	BHP	RPM	Hz	BHP	RPM	Hz	BHP	RPM	Hz	BHP			
	4000	891	58	1.95	922	60	2.10	951	48	2.25	979	49	2.40	1006	51	2.55	1032	52	2.70	1057	53	2.85	1081	55	3.00	1105	56	3.14	1127	57
4200	901	59	2.08	932	47	2.24	961	48	2.40	990	50	2.55	1017	51	2.71	1043	53	2.87	1068	54	3.03	1093	55	3.18	1116	56	3.34	1139	57	3.49
4400	921	46	2.22	942	47	2.38	971	49	2.55	1000	50	2.71	1027	52	2.88	1053	53	3.04	1079	54	3.21	1103	56	3.37	1127	57	3.53	1150	58	3.70
4600	941	46	2.36	951	48	2.53	981	49	2.70	1010	51	2.87	1037	52	3.05	1064	54	3.22	1089	55	3.39	1114	56	3.56	1138	57	3.74	1161	59	3.90
4800	931	47	2.51	961	48	2.69	991	50	2.86	1020	51	3.04	1047	53	3.22	1074	54	3.40	1099	55	3.58	1124	57	3.76	1148	58	3.94	1172	59	4.12
5000	943	48	2.68	972	49	2.85	1001	50	3.03	1029	52	3.22	1057	53	3.40	1083	55	3.59	1109	56	3.78	1134	57	3.96	1158	58	4.15	1182	60	4.34
5200	955	48	2.85	984	50	3.03	1011	51	3.21	1039	52	3.40	1067	54	3.59	1093	55	3.79	1119	56	3.98	1144	58	4.17	1168	59	4.37	1192	60	4.56
5400	967	49	3.03	996	50	3.22	1023	52	3.40	1050	53	3.59	1077	54	3.79	1103	56	3.99	1129	57	4.19	1154	58	4.39	1178	59	4.59	—	—	—
5600	979	49	3.22	1008	51	3.41	1035	52	3.60	1061	54	3.80	1087	55	3.99	1113	56	4.19	1139	57	4.40	1164	59	4.61	1188	60	4.82	—	—	—
5800	992	50	3.42	1020	51	3.61	1047	53	3.81	1073	54	4.01	1099	55	4.22	1124	57	4.42	1149	58	4.63	1174	59	4.84	1198	60	5.06	—	—	—
6000	1005	51	3.63	1032	52	3.83	1059	53	4.04	1085	55	4.24	1111	56	4.45	1135	57	4.66	1160	58	4.87	1184	60	5.08	—	—	—	—	—	
External Static Pressure (Inches of Water Gauge)																														
CFM	2.10"		2.20"		2.30"																									
	RPM	Hz	BHP	RPM	Hz	BHP	RPM	Hz	BHP																					
	4000	1149	58	3.44	1170	59	3.57	1191	60	3.71																				
4200	1161	59	3.65	1183	60	3.80	—	—	—																					
4400	1173	59	3.86	1194	60	4.02	—	—	—																					
4600	1184	60	4.08	—	—	—	—	—	—																					
4800	1194	60	4.30	—	—	—	—	—	—																					
5000	—	—	—	—	—	—	—	—	—																					
5200	—	—	—	—	—	—	—	—	—																					
5400	—	—	—	—	—	—	—	—	—																					
5600	—	—	—	—	—	—	—	—	—																					
5800	—	—	—	—	—	—	—	—	—																					
6000	—	—	—	—	—	—	—	—	—																					

Notes:
 1. 2-Speed VFD or SZVAV applications are capable of running below 320 cfm/ton during low speed airflow operation, but "full" airflow must be set to 320 cfm/ton or higher.
 2. Check General Data for indoor fan motor HP availability.
 3. Data includes pressure drop due to wet coil and 2-inch filter.

Table 56. Evaporator fan performance —TWE1804KB — constant volume air handler

External Static Pressure (Inches of Water Gauge)																					
		0.10"		0.20"		0.30"		0.40"		0.50"		0.60"		0.70"		0.80"		0.90"		1.00"	
CFM	RPM	BHP	RPM	BHP	RPM	BHP	RPM	BHP	RPM	BHP	RPM	BHP	RPM	BHP	RPM	BHP	RPM	BHP	RPM	BHP	
	3 HP Standard Motor w/ Field Supplied Low Static Sheave/Belt										3 HP Standard Motor w/ Field Supplied High Static Sheave/Belt										
4800	548	0.92	597	1.07	643	1.22	687	1.37	728	1.53	766	1.69	802	1.85	837	2.01	870	2.18	901	2.34	
5100	576	1.08	623	1.24	667	1.40	709	1.56	749	1.72	787	1.89	822	2.06	856	2.23	888	2.41	919	2.58	
5400	604	1.27	648	1.43	692	1.60	732	1.77	771	1.94	808	2.12	842	2.30	875	2.48	907	2.66	938	2.84	
5700	633	1.47	674	1.64	716	1.82	756	2.00	793	2.18	829	2.36	863	2.55	895	2.74	927	2.93	957	3.12	
6000	662	1.70	702	1.88	741	2.06	779	2.25	816	2.44	851	2.63	884	2.83	916	3.03	947	3.22	976	3.42	
6300	690	1.95	728	2.12	767	2.32	804	2.52	839	2.72	873	2.92	905	3.12	937	3.33	—	—	—	—	
6600	721	2.24	757	2.41	793	2.61	828	2.81	863	3.02	896	3.24	928	3.45	—	—	—	—	—	—	
6900	748	2.51	784	2.71	819	2.92	853	3.14	887	3.36	—	—	—	—	—	—	—	—	—	—	
7200	778	2.84	812	3.04	846	3.26	—	—	—	—	—	—	—	—	—	—	—	—	—	—	
External Static Pressure (Inches of Water Gauge)																					
		1.10"		1.20"		1.30"		1.40"		1.50"											
CFM	RPM	BHP	RPM	BHP	RPM	BHP	RPM	BHP	RPM	BHP											
	3 HP Standard Motor w/ Field Supplied High Static Sheave/Belt																				
4800	931	2.51	961	2.69	991	2.86	1020	3.04	1047	3.22											
5100	949	2.76	978	2.94	1006	3.12	1034	3.31	—	—											
5400	967	3.03	996	3.22	1023	3.40	—	—	—	—											
5700	986	3.32	—	—	—	—	—	—	—	—											
6000	—	—	—	—	—	—	—	—	—	—											
6300	—	—	—	—	—	—	—	—	—	—											
6600	—	—	—	—	—	—	—	—	—	—											
6900	—	—	—	—	—	—	—	—	—	—											
7200	—	—	—	—	—	—	—	—	—	—											

Notes:

1. Data includes pressure drop due to wet coil and 2" filter.
2. Fan motor heat (MBh) = 3.15 x BHP.
3. Check General Data for indoor fan motor HP availability.
4. For 380/60Hz models: Performance is limited to standard motor CFM/static range. No high static or oversized motors are available.
5. Factory supplied motors, in commercial equipment, are definite purpose motors, specifically designed and tested to operate reliably and continuously at all cataloged conditions. Using the full horsepower range of our fan motors as shown in our tabular data will not result in nuisance tripping or premature motor failure. Our product's warranty will not be affected.



Performance Data

Table 57. Evaporator fan performance - TWE1804** - 2-speed VFD, SZVAV air handler

CFM	External Static Pressure (Inches of Water Gauge)																							
	0.10"		0.20"		0.30"		0.40"		0.50"		0.60"		0.70"		0.80"									
	RPM	BHP	RPM	Hz	RPM	Hz	RPM	Hz	RPM	Hz	RPM	Hz	RPM	Hz	RPM	Hz								
3 HP Standard Drive																								
4800	548	0.92	38	597	42	1.07	643	45	1.22	687	48	1.37	728	51	1.53	766	54	1.69	802	56	1.85	837	59	2.01
5100	576	1.08	40	623	44	1.24	667	47	1.40	709	50	1.56	749	53	1.72	787	55	1.89	822	58	2.06	856	60	2.23
5400	604	1.27	42	648	46	1.43	692	49	1.60	732	51	1.77	771	54	1.94	808	57	2.12	842	59	2.30	875	61	2.48
5700	633	1.47	44	674	47	1.64	716	50	1.82	756	53	2.00	793	56	2.18	829	58	2.36	863	61	2.55	895	63	2.74
6000	662	1.70	46	702	49	1.88	741	52	2.06	779	55	2.25	816	57	2.44	851	60	2.63	884	63	2.83	916	66	3.03
6300	690	1.95	49	728	51	2.12	767	54	2.32	804	56	2.52	839	59	2.72	873	62	2.92	905	65	3.12	937	68	3.33
6600	721	2.24	51	757	53	2.41	793	56	2.61	828	58	2.81	863	60	3.02	896	63	3.24	928	66	3.45	958	70	3.66
6900	748	2.51	53	784	55	2.71	819	58	2.92	853	61	3.14	887	63	3.36	919	66	3.57	950	69	3.79	980	72	4.02
7200	778	2.84	55	812	57	3.04	846	60	3.26	879	63	3.49	911	66	3.71	943	69	3.95	973	72	4.17	1002	75	4.40
5 HP High Static Drive																								
4800	870	2.18	44	901	45	2.34	931	47	2.51	961	48	2.69	991	50	2.86	1020	51	3.04	1047	53	3.22	1074	54	3.40
5100	888	2.41	45	919	46	2.58	949	48	2.76	978	49	2.94	1006	51	3.12	1034	52	3.31	1062	53	3.50	1088	55	3.69
5400	907	2.66	46	938	47	2.84	967	49	3.03	996	50	3.22	1023	52	3.40	1050	53	3.59	1077	54	3.79	1103	56	3.99
5700	927	2.93	47	957	48	3.12	986	50	3.32	1014	51	3.51	1041	52	3.71	1067	54	3.91	1093	55	4.10	1118	56	4.31
6000	947	3.22	48	976	49	3.42	1005	51	3.63	1032	52	3.83	1059	53	4.04	1085	55	4.24	1111	56	4.45	1135	57	4.66
6300	967	3.54	49	996	50	3.75	1024	52	3.96	1052	53	4.17	1078	54	4.38	1104	56	4.60	1129	57	4.81	1153	58	5.03
6600	988	3.87	50	1016	51	4.09	1044	53	4.31	1071	54	4.53	1097	55	4.75	1123	57	4.98	1147	58	5.20	—	—	—
6900	1009	4.25	51	1037	52	4.47	1065	54	4.69	1091	55	4.92	1117	56	5.16	—	—	—	—	—	—	—	—	—
7200	1031	4.63	52	1059	53	4.86	1085	55	5.10	—	—	—	—	—	—	—	—	—	—	—	—	—	—	—
5 HP High Static Drive																								
4800	1099	3.58	55	1124	57	3.76	1148	58	3.94	1172	59	4.12	1194	60	4.30	—	—	—	—	—	—	—	—	—
5100	1114	3.88	56	1139	57	4.07	1163	59	4.26	1187	60	4.45	—	—	—	—	—	—	—	—	—	—	—	—
5400	1129	4.19	57	1154	58	4.39	1178	59	4.59	—	—	—	—	—	—	—	—	—	—	—	—	—	—	—
5700	1144	4.51	58	1169	59	4.72	1193	60	4.94	—	—	—	—	—	—	—	—	—	—	—	—	—	—	—
6000	1160	4.87	58	1184	60	5.08	—	—	—	—	—	—	—	—	—	—	—	—	—	—	—	—	—	—
6300	—	—	—	—	—	—	—	—	—	—	—	—	—	—	—	—	—	—	—	—	—	—	—	—
6600	—	—	—	—	—	—	—	—	—	—	—	—	—	—	—	—	—	—	—	—	—	—	—	—
6900	—	—	—	—	—	—	—	—	—	—	—	—	—	—	—	—	—	—	—	—	—	—	—	—
7200	—	—	—	—	—	—	—	—	—	—	—	—	—	—	—	—	—	—	—	—	—	—	—	—

- Notes:
- 2-Speed VFD or SZVAV applications are capable of running below 320 cfm/ton during low speed airflow operation, but "full" airflow must be set to 320 cfm/ton or higher.
 - Check General Data for indoor fan motor HP availability.
 - Data includes pressure drop due to wet coil and 2-inch filter.

Table 58. Evaporator fan performance — TWE2404KB — constant volume air handler

External Static Pressure (Inches of Water Gauge)																					
CFM	0.10"		0.20"		0.30"		0.40"		0.50"		0.60"		0.70"		0.80"		0.90"		1.00"		
	RPM	BHP	RPM	BHP	RPM	BHP	RPM	BHP	RPM	BHP	RPM	BHP	RPM	BHP	RPM	BHP	RPM	BHP	RPM	BHP	
5 HP Standard Motor with Field Supplied Low Static Sheave/Belt											5 HP Standard Motor										
6400	619	1.56	656	1.70	691	1.84	724	1.98	756	2.12	786	2.26	816	2.41	845	2.56	873	2.72	900	2.87	
6800	654	1.86	688	2.00	722	2.15	754	2.30	784	2.44	814	2.59	842	2.74	869	2.90	897	3.07	924	3.23	
7200	687	2.17	721	2.34	753	2.49	784	2.65	813	2.81	842	2.96	869	3.12	895	3.29	921	3.46	947	3.62	
7600	721	2.54	754	2.72	784	2.87	814	3.04	843	3.21	870	3.38	896	3.53	922	3.71	947	3.88	972	4.06	
8000	757	2.96	788	3.13	817	3.30	845	3.48	872	3.65	899	3.82	925	4.00	950	4.16	974	4.35	998	4.53	
8400	790	3.37	820	3.57	849	3.76	877	3.95	903	4.13	929	4.32	953	4.49	978	4.67	1002	4.86	1025	5.05	
8800	826	3.88	854	4.07	881	4.26	908	4.46	933	4.65	959	4.85	982	5.04	1006	5.22	1030	5.42	1052	5.61	
9200	863	4.44	889	4.64	915	4.84	939	5.02	965	5.24	989	5.43	1012	5.62	—	—	—	—	—	—	
9600	897	5.01	922	5.20	948	5.44	971	5.63	—	—	—	—	—	—	—	—	—	—	—	—	
External Static Pressure (Inches of Water Gauge)																					
CFM	1.10"		1.20"		1.30"		1.40"		1.50"		1.60"		1.70"		1.80"		1.90"		2.00"		
	RPM	BHP	RPM	BHP	RPM	BHP	RPM	BHP	RPM	BHP	RPM	BHP	RPM	BHP	RPM	BHP	RPM	BHP	RPM	BHP	
5 HP Standard Motor											5 HP Standard Motor with Field Supplied High Static Sheave/Belt										
6400	927	3.03	952	3.19	977	3.34	1001	3.48	1024	3.63	1050	3.80	1075	3.98	1098	4.15	1120	4.31	1139	4.47	
6800	949	3.40	974	3.57	999	3.74	1022	3.90	1045	4.05	1067	4.21	1090	4.36	1114	4.55	1138	4.74	—	—	
7200	972	3.80	997	3.97	1021	4.15	1044	4.34	1067	4.51	1089	4.68	1110	4.84	1131	5.00	—	—	—	—	
7600	996	4.24	1020	4.42	1044	4.60	1067	4.80	1089	4.99	1111	5.18	1132	5.36	—	—	—	—	—	—	
8000	1021	4.72	1044	4.91	1067	5.10	1090	5.29	1112	5.49	1134	5.69	—	—	—	—	—	—	—	—	
8400	1047	5.24	1069	5.43	1091	5.63	—	—	—	—	—	—	—	—	—	—	—	—	—	—	
8800	—	—	—	—	—	—	—	—	—	—	—	—	—	—	—	—	—	—	—	—	
9200	—	—	—	—	—	—	—	—	—	—	—	—	—	—	—	—	—	—	—	—	
9600	—	—	—	—	—	—	—	—	—	—	—	—	—	—	—	—	—	—	—	—	

Notes:

1. Data includes pressure drop due to wet coil and 2" filter.
2. Fan motor heat (MBh) = 3.15 x BHP.
3. Check General Data for indoor fan motor HP availability.
4. For 380/60Hz models: Performance is limited to standard motor CFM/static range. No high static or oversized motors are available.
5. Factory supplied motors, in commercial equipment, are definite purpose motors, specifically designed and tested to operate reliably and continuously at all cataloged conditions. Using the full horsepower range of our fan motors as shown in our tabular data will not result in nuisance tripping or premature motor failure. Our product's warranty will not be affected.



Performance Data

Table 59. Evaporator fan performance - TWE2404** - 2-speed VFD, SZVAV air handler

		External Static Pressure (Inches of Water Gauge)																												
		0.10"		0.20"		0.30"		0.40"		0.50"		0.60"		0.70"		0.80"		0.90"		1.00"										
CFM	RPM	Hz	BHP	RPM	Hz	BHP	RPM	Hz	BHP	RPM	Hz	BHP	RPM	Hz	BHP	RPM	Hz	BHP	RPM	Hz	BHP	RPM	Hz	BHP						
5 HP Standard Drive																														
6400	619	33	1.56	656	35	1.70	691	36	1.84	724	38	1.98	756	40	2.12	786	41	2.26	816	43	2.41	845	45	2.56	873	46	2.72	900	47	2.87
6800	654	34	1.86	688	36	2.00	722	38	2.15	754	40	2.30	784	41	2.44	814	43	2.59	842	44	2.74	869	46	2.90	897	47	3.07	924	49	3.23
7200	687	36	2.17	721	38	2.34	753	40	2.49	784	41	2.65	813	43	2.81	842	44	2.96	869	46	3.12	895	47	3.29	921	49	3.46	947	50	3.62
7600	721	38	2.54	754	40	2.72	784	41	2.87	814	43	3.04	843	44	3.21	870	46	3.38	896	47	3.53	922	49	3.71	947	50	3.88	972	51	4.06
8000	757	40	2.96	788	42	3.13	817	43	3.30	845	45	3.48	872	46	3.65	899	47	3.82	925	49	4.00	950	50	4.16	974	51	4.35	998	53	4.53
8400	790	42	3.37	820	43	3.57	849	45	3.76	877	46	3.95	903	48	4.13	929	49	4.32	953	50	4.49	978	52	4.67	1002	53	4.86	1025	47	5.05
8800	826	38	3.88	854	39	4.07	881	40	4.26	908	41	4.46	933	42	4.65	959	44	4.85	982	45	5.04	1006	46	5.22	1030	47	5.42	1052	48	5.61
9200	863	39	4.44	889	40	4.64	915	42	4.84	939	43	5.02	965	44	5.24	989	45	5.43	1012	46	5.62	1036	47	5.83	1058	48	6.02	1080	49	6.22
9600	897	41	5.01	922	42	5.20	948	43	5.44	971	44	5.63	996	45	5.84	1019	46	6.05	1042	47	6.27	1065	48	6.47	—	—	—	—	—	—
External Static Pressure (Inches of Water Gauge)																														
		1.10"		1.20"		1.30"		1.40"		1.50"		1.60"		1.70"		1.80"		1.90"		2.00"										
CFM	RPM	Hz	BHP	RPM	Hz	BHP	RPM	Hz	BHP	RPM	Hz	BHP	RPM	Hz	BHP	RPM	Hz	BHP	RPM	Hz	BHP	RPM	Hz	BHP						
5 HP Standard Drive																														
6400	927	49	3.03	952	50	3.19	977	51	3.34	1001	53	3.48	1024	54	3.63	1050	55	3.80	1075	57	3.98	1098	50	4.15	1120	51	4.31	1139	52	4.47
6800	949	50	3.40	974	51	3.57	999	53	3.74	1022	54	3.90	1045	55	4.05	1067	56	4.21	1090	50	4.36	1114	51	4.55	1138	52	4.74	1160	53	4.92
7200	972	51	3.80	997	53	3.97	1021	54	4.15	1044	55	4.34	1067	56	4.51	1089	49	4.68	1110	50	4.84	1131	51	5.00	1152	52	5.17	1175	53	5.36
7600	996	52	4.24	1020	54	4.42	1044	55	4.60	1067	56	4.80	1089	57	4.99	1111	50	5.18	1132	51	5.36	1153	52	5.53	1173	53	5.70	1193	54	5.88
8000	1021	54	4.72	1044	55	4.91	1067	48	5.10	1090	50	5.29	1112	51	5.49	1134	52	5.69	1155	52	5.89	1175	53	6.09	1195	54	6.28	1215	55	6.46
8400	1047	48	5.24	1069	49	5.43	1091	50	5.63	1113	51	5.83	1135	52	6.04	1156	53	6.24	1177	53	6.45	1198	54	6.67	1217	55	6.87	1237	56	7.08
8800	1074	49	5.81	1095	50	6.01	1117	51	6.22	1138	52	6.42	1159	53	6.63	1180	54	6.84	1200	55	7.06	1220	55	7.28	1240	56	7.49	1259	57	7.71
9200	1101	50	6.42	1122	51	6.63	1143	52	6.84	1163	53	7.05	1183	54	7.27	1204	55	7.49	1224	56	7.71	—	—	—	—	—	—	—	—	
9600	—	—	—	—	—	—	—	—	—	—	—	—	—	—	—	—	—	—	—	—	—	—	—	—	—	—	—	—	—	
External Static Pressure (Inches of Water Gauge)																														
		2.10"		2.20"		2.30"		2.40"																						
CFM	RPM	Hz	BHP	RPM	Hz	BHP	RPM	Hz	BHP	RPM	Hz	BHP																		
7.5 HP High Static Drive																														
6400	1158	53	4.62	1177	53	4.78	1195	54	4.93	1213	55	5.08																		
6800	1181	54	5.09	1200	55	5.26	1218	55	5.43	1236	56	5.59																		
7200	1198	54	5.56	1220	55	5.76	1240	56	5.95	1259	57	6.13																		
7600	1213	55	6.05	1234	56	6.25	1256	57	6.46	1277	58	6.67																		
8000	1234	56	6.64	1253	57	6.82	1272	58	7.01	1292	59	7.20																		
8400	1256	57	7.28	1275	58	7.48	1293	59	7.66	—	—	—																		
8800	—	—	—	—	—	—	—	—	—	—	—	—																		
9200	—	—	—	—	—	—	—	—	—	—	—	—																		
9600	—	—	—	—	—	—	—	—	—	—	—	—																		

Notes:
 1. 2-Speed VFD or SZVAV applications are capable of running below 320 cfm/ton during low speed airflow operation, but "full" airflow must be set to 320 cfm/ton or higher.
 2. Check General Data for indoor fan motor HP availability.
 3. Data includes pressure drop due to wet coil and 2-inch filter.

Table 60. Evaporator fan performance —TWE3004KB — constant volume air handler

External Static Pressure (Inches of Water Gauge)																				
CFM	0.10"		0.20"		0.30"		0.40"		0.50"		0.60"		0.70"		0.80"		0.90"			
	RPM	BHP	RPM	BHP	RPM	BHP	RPM	BHP	RPM	BHP	RPM	BHP	RPM	BHP	RPM	BHP	RPM	BHP		
	7.5 HP Standard Motor and Low Static Drive Field Supplied Sheave				7.5 HP Standard Motor															
8000	781	3.09	811	3.27	840	3.44	868	3.63	895	3.80	921	3.97	947	4.15	972	4.33	996	4.52		
8500	827	3.69	855	3.87	882	4.05	909	4.25	935	4.43	960	4.62	985	4.81	1008	4.99	1032	5.19		
9000	869	4.31	899	4.57	925	4.75	951	4.95	974	5.13	999	5.34	1023	5.54	1046	5.73	1068	5.93		
9500	918	5.11	940	5.27	967	5.50	992	5.73	1016	5.94	1039	6.14	1062	6.35	1084	6.55	1105	6.75		
10000	959	5.85	988	6.16	1011	6.35	1033	6.55	1056	6.78	1080	7.03	1101	7.22	1123	7.46	1143	7.66		
10500	1006	6.78	1033	7.09	1054	7.28	1076	7.51	1100	7.77	1120	7.96	1141	8.21	1162	8.44	1183	8.69		
11000	1049	7.71	1076	8.06	1097	8.29	1120	8.55	—	—	—	—	—	—	—	—	—	—		
External Static Pressure (Inches of Water Gauge)																				
CFM	1.00"		1.10"		1.20"		1.30"		1.40"		1.50"		1.60"		1.70"		1.80"			
	RPM	BHP	RPM	BHP	RPM	BHP	RPM	BHP	RPM	BHP	RPM	BHP	RPM	BHP	RPM	BHP	RPM	BHP		
	7.5 HP Standard Motor						7.5 HP Standard Motor and High Static Drive Field Supplied Sheave													
8000	1019	4.70	1043	4.89	1066	5.09	1089	5.28	1111	5.48	1133	5.69	1154	5.89	1175	6.08	1195	6.28		
8500	1054	5.38	1076	5.58	1099	5.78	1120	5.98	1142	6.19	1164	6.40	1185	6.62	1205	6.83	1225	7.04		
9000	1091	6.14	1112	6.34	1133	6.55	1154	6.77	1175	6.98	1195	7.20	1216	7.42	1236	7.64	1255	7.86		
9500	1127	6.97	1148	7.19	1168	7.40	1189	7.63	1208	7.85	1228	8.07	1248	8.31	1267	8.53	—	—		
10000	1165	7.89	1185	8.11	1205	8.34	1224	8.56	—	—	—	—	—	—	—	—	—	—		
10500	—	—	—	—	—	—	—	—	—	—	—	—	—	—	—	—	—	—		
11000	—	—	—	—	—	—	—	—	—	—	—	—	—	—	—	—	—	—		
External Static Pressure (Inches of Water Gauge)																				
CFM	1.90"		2.00"		2.10"		2.20"		2.30"		2.40"									
	RPM	BHP	RPM	BHP	RPM	BHP	RPM	BHP	RPM	BHP	RPM	BHP								
	7.5 HP Standard Motor and High Static Drive Field Supplied Sheave																			
8000	1215	6.46	1235	6.65	1254	6.83	1273	7.02	1293	7.22	1314	7.44								
8500	1245	7.26	1264	7.47	1283	7.67	1301	7.86	1319	8.05	1337	8.25								
9000	1275	8.10	1294	8.32	1313	8.56	—	—	—	—	—	—								
9500	—	—	—	—	—	—	—	—	—	—	—	—								
10000	—	—	—	—	—	—	—	—	—	—	—	—								
10500	—	—	—	—	—	—	—	—	—	—	—	—								
11000	—	—	—	—	—	—	—	—	—	—	—	—								

Notes:

1. Data includes pressure drop due to wet coil and 2" filter.
2. Fan motor heat (MBh) = 3.15 x BHP.
3. Check General Data for indoor fan motor HP availability.
4. For 380/60Hz models: Performance is limited to standard motor CFM/static range. No high static or oversized motors are available.
5. Factory supplied motors, in commercial equipment, are definite purpose motors, specifically designed and tested to operate reliably and continuously at all cataloged conditions. Using the full horsepower range of our fan motors as shown in our tabular data will not result in nuisance tripping or premature motor failure. Our product's warranty will not be affected.



Performance Data

Table 61. Evaporator fan performance - TWE3004** - 2-speed VFD, SZVAV air handler

External Static Pressure (Inches of Water Gauge)																								
0.10"		0.20"		0.30"		0.40"		0.50"		0.60"		0.70"		0.80"										
CFM	RPM	Hz	BHP	RPM	Hz	BHP	RPM	Hz	BHP	RPM	Hz	BHP	RPM	Hz	BHP	RPM	Hz	BHP	RPM	Hz				
7.5 HP Standard Drive																								
8000	781	41	3.09	811	42	3.27	840	44	3.44	868	45	3.63	895	47	3.80	921	48	3.97	947	49	4.15	972	51	4.33
8500	827	43	3.69	855	45	3.87	882	46	4.05	909	47	4.25	935	49	4.43	960	50	4.62	985	51	4.81	1008	53	4.99
9000	869	45	4.31	899	47	4.57	925	48	4.75	951	50	4.95	974	51	5.13	999	52	5.34	1023	53	5.54	1046	54	5.73
9500	918	48	5.11	940	49	5.27	967	50	5.50	992	52	5.73	1016	53	5.94	1039	54	6.14	1062	55	6.35	1084	56	6.55
10000	959	50	5.85	988	51	6.16	1011	53	6.35	1033	54	6.55	1056	55	6.78	1080	56	7.03	1101	57	7.22	1123	58	7.46
10500	1006	52	6.78	1033	54	7.09	1054	55	7.28	1076	56	7.51	1100	57	7.77	1120	58	7.96	—	—	—	—	—	—
11000	1049	55	7.71	—	—	—	—	—	—	—	—	—	—	—	—	—	—	—	—	—	—	—	—	—
External Static Pressure (Inches of Water Gauge)																								
0.90"		1.00"		1.10"		1.20"		1.30"		1.40"		1.50"		1.60"										
CFM	RPM	Hz	BHP	RPM	Hz	BHP	RPM	Hz	BHP	RPM	Hz	BHP	RPM	Hz	BHP	RPM	Hz	BHP	RPM	Hz				
7.5 HP Standard Drive																								
8000	996	52	4.52	1019	53	4.70	1043	54	4.89	1066	56	5.09	1089	57	5.28	1111	58	5.48	1133	59	5.69	1154	60	5.89
8500	1032	54	5.19	1054	55	5.38	1076	56	5.58	1099	57	5.78	1120	58	5.98	1142	59	6.19	—	—	—	—	—	—
9000	1068	56	5.93	1091	57	6.14	1112	58	6.34	1133	59	6.55	1154	60	6.77	—	—	—	—	—	—	—	—	—
9500	1105	58	6.75	1127	59	6.97	1148	60	7.19	—	—	—	—	—	—	—	—	—	—	—	—	—	—	—
10000	1143	60	7.66	—	—	—	—	—	—	—	—	—	—	—	—	—	—	—	—	—	—	—	—	—
10500	—	—	—	—	—	—	—	—	—	—	—	—	—	—	—	—	—	—	—	—	—	—	—	—
11000	—	—	—	—	—	—	—	—	—	—	—	—	—	—	—	—	—	—	—	—	—	—	—	—

Notes:

1. 2-Speed VFD or SZVAV applications are capable of running below 320 cfm/ton during low speed airflow operation, but "full" airflow must be set to 320 cfm/ton or higher.
2. Check General Data for indoor fan motor HP availability.
3. Data includes pressure drop due to wet coil and 2-inch filter.

Table 62. Standard fan motors - constant volume air handlers

Model	Motor	Motor Sheave Turns Open	Nominal RPM	Required Field Supplied Components		
				Motor Sheave	Blower Sheave	Belt
TWE060	Standard Motor 0.75 HP	0	1071	N/A	N/A	N/A
		1	1000			
		2	928			
		3	857			
		4	785			
TWE072	Standard Motor 1.5 HP	0	847	N/A	N/A	N/A
		1	791			
		2	734			
		3	678			
		4	621			
TWE072	Standard Motor with Field Supplied Components - 1.5 HP (Low Static)	5	565	Variable Pitch (1.9 - 2.9 Inch Pitch Diameter), 0.625 Inch Bore, Single Groove, Browning 1VP34	Fixed pitch (8.5 Inch Pitch Diameter), 1 Inch Bore, Single Groove, Browning BK95	Browning A52
		6	589			
		1	548			
		2	507			
		3	466			
		4	426			
TWE072	Standard Motor with Field Supplied Components - 1.5 HP (High Static)	5	385	Variable Pitch (3-4 Inch Pitch Diameter), 0.625 Inch Bore, Single Groove, Browning 1VP44	Fixed Pitch (6 Inch Pitch Diameter), 1 Inch Bore, Single Groove, Browning BK70	Browning A50
		6	863			
		1	920			
		2	978			
		3	1035			
		4	1093			
TWE090	Standard Motor 1.5 HP	0	847	N/A	N/A	N/A
		1	791			
		2	734			
		3	678			
		4	621			
TWE090	Standard Motor with Field Supplied Components - 1.5 HP (Low Static)	5	565	Variable Pitch (1.9 - 2.9 Inch Pitch Diameter), 0.625 Inch Bore, Single Groove, Browning 1VP34	Fixed pitch (8.5 Inch Pitch Diameter), 1 Inch Bore, Single Groove, Browning BK95	Browning A52
		6	589			
		1	548			
		2	507			
		3	466			
		4	426			
TWE090	Standard Motor with Field Supplied Components - 1.5 HP (High Static)	5	385	Variable Pitch (3-4 Inch Pitch Diameter), 0.625 Inch Bore, Single Groove, Browning 1VP44	Fixed Pitch (6 Inch Pitch Diameter), 1 Inch Bore, Single Groove, Browning BK70	Browning A50
		6	863			
		1	920			
		2	978			
		3	1035			
		4	1093			
TWE120	Standard Motor 2 HP	0	818	N/A	N/A	N/A
		1	773			
		2	727			
		3	682			
		4	636			
TWE120	Standard Motor with Field Supplied Components - 2 HP (High Static)	5	591	Variable Pitch (3-4 Inch Pitch Diameter), 0.875 Inch Bore, Single Groove, Browning 1VP44	Fixed Pitch (6.7 Inch Pitch Diameter), 1 Inch Bore, Single Groove, Browning AK71	Browning A51
		6	772			
		1	824			
		2	875			
		3	927			
		4	978			
TWE150	Standard Motor 2 HP	0	768	N/A	N/A	N/A
		1	725			
		2	683			
		3	640			
		4	598			
		5	555			



Performance Data

Table 62. Standard fan motors - constant volume air handlers (continued)

Model	Motor	Motor Sheave Turns Open	Nominal RPM	Required Field Supplied Components		
				Motor Sheave	Blower Sheave	Belt
TWE150	Standard Motor with Field Supplied Components 2 HP (High Static)	0	913	Variable Pitch (2.4 - 3.4 Inch Pitch Diameter), 0.875 Inch Bore, Single Groove, Browning 1VL40	Fixed pitch (6.7 Inch Pitch Diameter), 1.4375 Inch Bore, Single Groove, Browning AK71	Browning A55
		1	862			
		2	806			
		3	749			
		4	693			
		5	659			
TWE180	Standard Motor 3 HP	0	845	N/A	N/A	N/A
		1	812			
		2	728			
		3	745			
		4	711			
		5	678			
		6	644			
TWE180	Standard Motor with Field Supplied Components 3 HP (Low Static)	0	649	Variable Pitch (2.4 - 3.4 Inch Pitch Diameter), 0.875 Inch Bore, Single Groove, Browning 1VL40	Fixed Pitch (9.5 Inch Pitch Diameter), 1.4375 Inch Bore, Single Groove, Browning BK105	Browning AX59
		1	613			
		2	557			
		3	500			
		4	444			
		5	469			
TWE180	Standard Motor with Field Supplied Components - 3 HP (High Static)	1	887	Variable Pitch (3.6-4.6 Inch Pitch Diameter), 0.875 Inch Bore, Single Groove, Browning 1VP50	Fixed Pitch (7 Inch Pitch Diameter), 1.4375 Inch Bore, Single Groove, Browning BK80	Browning A58
		2	936			
		3	986			
		4	1035			
		5	1084			
		6	1134			
TWE240	Standard Motor 5 HP	0	966	N/A	N/A	N/A
		1	932			
		2	899			
		3	865			
		4	831			
		5	798			
		6	764			
TWE240	Standard Motor with Field Supplied Components 5 HP (High Static)	1	1119	Variable Pitch (3.4 - 4.4 Inch Pitch Diameter), 1.125 Inch Bore, Single Groove, Browning 1VP50	Fixed Pitch (7.4 Inch Pitch Diameter), 1.4375 Inch Bore, Single Groove, Browning BK80	Browning BX56
		2	1072			
		3	1026			
		4	979			
		5	932			
		6	886			
TWE240	Standard Motor with Field Supplied Components - 5 HP (Low Static)	1	633	Variable Pitch (3.2-4.2 Inch Pitch Diameter), 0.875 Inch Bore, Single Groove, Browning 1VP44	Fixed Pitch (8.9 Inch Pitch Diameter), 1.4375 Inch Bore, Single Groove, Browning BK95	Browning BX58
		2	672			
		3	712			
		4	751			
		5	791			
		6	831			
TWE300	Standard Motor 7.5 HP	0	1068	N/A	N/A	N/A
		1	1016			
		2	964			
		3	912			
		4	859			
		5	807			
TWE300	Standard Motor with Field Supplied Components 7.5 HP (Low Static)	1	717	Variable Pitch (3.2-4.2 inch pitch diameter), 1.125 Inch Bore, Single Groove, Browning 1VL44	Fixed Pitch (15.4 inch pitch diameter), 1.4375 Inch Bore, Single Groove, Browning BK160	Browning BX70
		2	762			
		3	806			
		4	851			
		5	896			
		6	941			

Table 62. Standard fan motors - constant volume air handlers (continued)

Model	Motor	Motor Sheave Turns Open	Nominal RPM	Required Field Supplied Components		
				Motor Sheave	Blower Sheave	Belt
TWE300	Standard Motor with Field Supplied Components 7.5 HP (High Static)	1	1053	Variable Pitch (4.7-5.9 Inch Pitch Diameter), 1.125 Inch Bore, Single Groove, Browning 1VP60	Fixed Pitch (15.4 Inch Pitch Diameter), 1.4375 Inch Bore, Single Groove, Browning BK160	Browning BX72
		2	1098			
		3	1142			
		4	1187			
		5	1232			
		6	1276			
		7	1322			

Table 63. High static fan motors - constant volume air handlers

Model	Motor	Motor Sheave Turns Open	Nominal RPM	Required Field Supplied Components		
				Motor Sheave	Blower Sheave	Belt
TWE060	High Static Motor 1.5 HP	0	1346	N/A	N/A	N/A
		1	1279			
		2	1212			
		3	1144			
		4	1077			
TWE090	High Static Motor 2 HP	0	1094	N/A	N/A	N/A
		1	1039			
		2	984			
		3	930			
		4	875			
		5	820			



Performance Data

Table 64. Discharge plenum and grille assembly throw distance (ft) — air handler (60 Hz)

Tons	Model No.	CFM	Louver Angle Deflection Position			
			Straight	20°	40°	55°
5	TWE0604*A/B	1600	42	31	26	20
		1800	46	37	29	22
		2000	48	43	33	24
		2200	51	50	36	25
		2400	54	57	39	29
6	TWE0724*B	1920	48	33	30	27
		2160	50	38	32	28
		2400	52	43	35	29
		2640	54	47	38	30
		2880	57	51	41	32
7.5	TWE0904*A/B	2400	52	43	35	29
		2700	55	48	38	31
		3000	58	53	42	32
		3300	62	57	46	35
		3600	66	60	50	37
10	TWE1204*A/B	3200	56	46	38	30
		3600	62	51	42	33
		4000	66	57	47	35
		4400	71	62	52	38
		4800	76	67	56	42
12.5	TWE1504*B	4900	47	38	32	25
		5400	52	44	37	29
		6000	57	49	41	32
		6600	61	53	43	34
		7200	65	57	46	35
15	TWE1804*B	4900	47	38	32	25
		5400	52	44	37	29
		6000	57	49	41	32
		6600	61	53	43	34
		7200	65	57	46	35
20	TWE2404*B	6400	56	46	38	30
		7200	62	51	42	33
		8000	66	57	47	35
		8800	71	62	52	38
		9600	76	67	56	42
25	TWE3004*B	8000	66	57	47	35
		9000	72	63	53	39
		10000	78	70	59	43
		11000	84	76	65	46
		12000	90	83	71	50

Notes:

1. Assumes incompressible and adiabatic flow through grille.
2. Throw distance values are based on a terminal velocity of 75 FPM.
3. Throw distance values at other terminal velocities may be established by multiplying throw distances in the table above by throw factor as follows: for 50 FPM terminal velocity, multiply by 1.50 throw factor; for 100 FPM terminal velocity, multiply by 0.75 throw factor; for 150 FPM terminal velocity, multiply by 0.50 throw factor.
4. SZVAV/2-Speed VFD available for 6–25 ton only.

Table 65. Electric heat discharge plenum and grille airflow (CFM) - constant volume air handler (60Hz)

Tons	Unit Model No.	Electric Heater Model No.	Airflow (CFM)	
			Minimum	Maximum
5	TWE06041A, B	BAYHTRT117*	2000	2400
	TWE06043A, B	BAYHTRS315*	2000	2400
	TWE06044A, B	BAYHTRS415*	2000	2400
6	TWE07243B	BAYHTRS315*	2000	2880
	TWE07243B	BAYHTRP325*	2000	2880
	TWE07244B	BAYHTRS415*	2000	2880
	TWE07244B	BAYHTRP425*	2000	2880
7.5	TWE09041A, B	BAYHTRT117*	3000	3600
	TWE09041A, B	BAYHTRS123*	3375	3600
7.5	TWE09043A, B	BAYHTRS315*	2625	3600
	TWE09043A, B	BAYHTRP325*	3000	3600
	TWE09044A, B	BAYHTRS415*	2625	3600
	TWE09044A, B	BAYHTRP425*	2625	3600
10	TWE12041A, B	BAYHTRT117*	3500	4800
	TWE12041A, B	BAYHTRS123*	4000	4800
10	TWE12043A, B	BAYHTRS315*	4000	4800
	TWE12043A, B	BAYHTRP325*	3500	4800
	TWE12044A, 4B	BAYHTRS415*	3500	4800
	TWE12044A, 4B	BAYHTRP425*	3500	4800
12.5	TWE15043B	BAYHTRR330*	5250	6000
	TWE15044B	BAYHTRR430*	5250	6000
15	TWE18043B	BAYHTRR330*	5250	7200
	TWE18044B	BAYHTRR430*	5250	7200
20	TWE24043B	BAYHTRR330*	7000	9600
	TWE24044B	BAYHTRR430*	7000	9600
25	TWE30043B	BAYHTRR330*	8750	12000
	TWE30044B	BAYHTRR430*	8750	12000

Note: SZVAVI/2-Speed VFD available for 6 to 25 ton only.

Table 66. Static pressure drop through accessories (inches of water column) - air handler (60Hz)

Tons	Unit Model No.	CFM	Return Grille	Discharge Plenum & Grille	2" MERV 13 Filter	Electric Heaters (kW)				Hydronic Coils	
						5-10	15-20	25-30	35-50	Steam	Hot Water
5	TWE0604*A/B	1600	0.12	0.21	0.22	0.08	0.08	0.14	—	0.44	0.31
		2000	0.18	0.33	0.29	0.13	0.13	0.19	—	0.62	0.44
		2400	0.28	0.47	0.36	0.19	0.19	0.37	—	0.80	0.59
6	TWE0724*B	1920	0.04	0.20	0.15	0.01	0.03	0.04	0.06	0.31	0.16
		2400	0.08	0.27	0.19	0.03	0.06	0.08	0.12	0.38	0.23
		2880	0.12	0.37	0.24	0.05	0.11	0.15	0.21	0.48	0.31
7.5	TWE0904*A/B	2400	0.08	0.27	0.19	0.03	0.06	0.08	0.12	0.38	0.23
		3000	0.13	0.40	0.25	0.06	0.12	0.17	0.23	0.50	0.33
		3600	0.18	0.58	0.31	0.08	0.16	0.24	0.32	0.66	0.44
10	TWE1204*A/B	3200	0.07	0.43	0.19	0.06	0.13	0.19	0.26	0.42	0.40
		4000	0.11	0.66	0.25	0.10	0.20	0.30	0.40	0.59	0.56
		4800	0.15	0.95	0.31	0.14	0.28	0.42	0.57	0.76	0.75



Performance Data

Table 66. Static pressure drop through accessories (inches of water column) - air handler (60Hz) (continued)

Tons	Unit Model No.	CFM	Return Grille	Discharge Plenum & Grille	2" MERV 13 Filter	Electric Heaters (kW)				Hydronic Coils	
						5-10	15-20	25-30	35-50	Steam	Hot Water
12.5	TWE1504*B	4000	0.06	0.16	0.15	0.02	0.02	0.04	0.08	0.28	0.24
		5000	0.10	0.25	0.20	0.03	0.03	0.08	0.12	0.44	0.38
		6000	0.14	0.36	0.25	0.04	0.05	0.12	0.17	0.64	0.54
15	TWE1804*B	4800	0.09	0.23	0.19	0.03	0.03	0.06	0.08	0.46	0.38
		6000	0.15	0.34	0.25	0.06	0.06	0.12	0.17	0.64	0.54
		7200	0.20	0.49	0.31	0.08	0.08	0.16	0.24	0.82	0.72
20	TWE2404*B	6400	0.11	0.43	0.22	0.06	0.06	0.13	0.19	0.50	0.41
		8000	0.17	0.66	0.29	0.10	0.10	0.20	0.30	0.70	0.58
		9600	0.23	0.95	0.36	0.14	0.14	0.28	0.42	0.89	0.78
25	TWE3004*B	8000	0.17	0.66	0.29	0.10	0.10	0.20	0.30	0.70	0.58
		10000	0.25	1.03	0.37	0.15	0.15	0.30	0.45	0.94	0.83
		12000	0.32	1.49	0.47	0.20	0.20	0.42	0.62	1.16	1.14

Notes:

1. SZVAV/2-Speed VFD available for 6-25 ton only.
2. Return air filter ESP included in Fan Performance Table data.
3. Discharge plenum and grille - at louver opening angle of 42 degrees. For ESP at other angle openings, see accessory installation instructions.

Table 67. Auxiliary electric heat capacity - air handler (60Hz)

Unit Model No.	Total kW	No. of Stages	Stage 1		Stage 2		Total	
			kW Input	BTUH Output	kW Input	BTUH Output	kW Input	BTUH Output
TWE06041A, TWE06041B	5.76	1	5.76	19659	-	-	5.76	19659
	11.52	1	11.52	39318	-	-	11.52	39318
	17.28	1	17.28	58977	-	-	17.28	58977
	23.04	2	11.52	39318	11.52	39318	23.04	78636
TWE06043A, TWE06044A, TWE0604WA, TWE06043B, TWE06044B	5.00	1	5.00	17065	-	-	5.00	17065
	9.96	1	9.96	33993	-	-	9.96	33993
	14.96	1	14.96	51058	-	-	14.96	51058
	24.92	2	14.96	51058	9.96	33993	24.92	85051
TWE07243B, TWE07244B, TWE0724WB	5.00	1	5.00	17065	-	-	5.00	17065
	9.96	1	9.96	33993	-	-	9.96	33993
	14.96	1	14.96	51058	-	-	14.96	51058
	24.92	2	14.96	51058	9.96	33993	24.92	85051
TWE09041A, TWE09041B	5.76	1	5.76	19659	-	-	5.76	19659
	11.52	1	11.52	39318	-	-	11.52	39318
	17.28	1	17.28	58977	-	-	17.28	58977
	23.04	2	11.52	39318	11.52	39318	23.04	78636
	28.80	2	17.28	58977	11.52	39318	28.80	98295
TWE09043A, TWE09043B, TWE0904WA, TWE0904WB	5.00	1	5.00	17065	-	-	5.00	17065
	9.96	1	9.96	33993	-	-	9.96	33993
	14.96	1	14.96	51058	-	-	14.96	51058
	24.92	2	14.96	51058	9.96	33993	24.92	85051
	34.88	2	19.92	67987	14.96	51058	34.88	119045
TWE09043B, TWE09044B, TWE0904WB	5.00	1	5.00	17065	-	-	5.00	17065
	9.96	1	9.96	33993	-	-	9.96	33993
	14.96	1	14.96	51058	-	-	14.96	51058
	24.92	2	14.96	51058	9.96	33993	24.92	85051
	34.88	2	19.92	67987	14.96	51058	34.88	119045
TWE12041A, TWE12041B	5.76	1	5.76	19659	-	-	5.76	19659
	11.52	1	11.52	39318	-	-	11.52	39318
	17.28	1	17.28	58977	-	-	17.28	58977
	23.04	2	11.52	39318	11.52	39318	23.04	78636
	28.80	2	17.28	58977	11.52	39318	28.80	98295

Table 67. Auxiliary electric heat capacity - air handler (60Hz) (continued)

Unit Model No.	Total kW	No. of Stages	Stage 1		Stage 2		Total	
			kW Input	BTUH Output	kW Input	BTUH Output	kW Input	BTUH Output
TWE12043A, TWE1204WA, TWE12044A, TWE12044B, TWE12043B, TWE1204WB	5.00	1	5.00	17065	–	–	5.00	17065
	9.96	1	9.96	33993	–	–	9.96	33993
	14.96	1	14.96	51058	–	–	14.96	51058
	24.92	2	14.96	51058	9.96	33993	24.92	85051
	34.88	2	19.92	67987	14.96	51058	34.88	119045
TWE15043B, TWE1504WB	10.00	1	10.00	34130	–	–	10.00	34130
	19.92	1	19.92	67987	–	–	19.92	67987
	29.92	2	19.92	67987	10.00	34130	29.92	102117
	49.84	2	29.92	102117	19.92	67987	49.84	170104
TWE15043B, TWE15044B, TWE1504WB	10.00	1	10.00	34130	–	–	10.00	34130
	19.92	1	19.92	67987	–	–	19.92	67987
	29.92	2	19.92	67987	10.00	34130	29.92	102117
	49.84	2	29.92	102117	19.92	67987	49.84	170104
TWE18043B, TWE1804WB	10.00	1	10.00	34130	–	–	10.00	34130
	19.92	1	19.92	67987	–	–	19.92	67987
	29.92	2	19.92	67987	10.00	34130	29.92	102117
	49.84	2	29.92	102117	19.92	67987	49.84	170104
TWE18043B, TWE18044B, TWE1804WB	10.00	1	10.00	34130	–	–	10.00	34130
	19.92	1	19.92	67987	–	–	19.92	67987
	29.92	2	19.92	67987	10.00	34130	29.92	102117
	49.84	2	29.92	102117	19.92	67987	49.84	170104
TWE2404*B	10.00	1	10.00	34130	–	–	10.00	34130
	19.92	1	19.92	67987	–	–	19.92	67987
	29.92	2	19.92	67987	10.00	34130	29.92	102117
	49.84	2	29.92	102117	19.92	67987	49.84	170104
TWE3004*B	10.00	1	10.00	34130	–	–	10.00	34130
	19.92	1	19.92	67987	–	–	19.92	67987
	29.92	2	19.92	67987	10.00	34130	29.92	102117
	49.84	2	29.92	102117	19.92	67987	49.84	170104

Notes:

1. Heaters are rated at 240V, 480V, and 600V. For other than rated voltage, capacity = (Voltage/Related Voltage)² x Rated Capacity.
2. SZVAV/2-Speed VFD available for 6–25 ton only.



Performance Data

Table 68. Steam heating coil capacity – air handler steam pressure (PSIG) (60Hz)

Unit Model No.	Airflow (CFM)	EAT (°F)	Steam Pressure (PSIG)														
			2 PSI			5 PSI			10 PSI			15 PSI			25 PSI		
			LAT	MBh	Cond. lb/hr	LAT	MBh	Cond. lb/hr	LAT	MBh	Cond. lb/hr	LAT	MBh	Cond. lb/hr	LAT	MBh	Cond. lb/hr
TWE0604*A, TWE0604*B	1600	40	97	99	103	100	104	108	104	111	117	108	117	124	113	127	136
		60	111	88	91	114	93	97	118	100	105	121	106	112	127	116	124
		80	125	77	80	127	82	85	131	89	94	135	95	101	140	105	112
	2000	40	90	108	112	93	114	118	96	122	128	99	129	136	104	139	149
		60	104	96	100	107	102	106	111	110	115	114	116	123	119	127	136
		80	119	84	87	121	90	93	125	98	102	128	104	110	133	115	123
	2400	40	85	116	120	87	123	127	90	131	137	93	138	146	98	150	160
		60	100	104	107	102	110	114	105	118	124	108	125	132	113	137	146
		80	115	91	94	117	97	100	120	105	110	123	112	118	127	123	132
TWE072*B	1920	40	106	151	157	112	159	165	116	169	178	121	179	189	126	194	207
		60	120	134	139	124	141	147	128	153	160	133	162	172	139	177	189
		80	133	117	121	136	125	131	140	136	143	145	144	152	151	159	170
	2400	40	102	162	168	106	171	177	110	182	191	114	192	203	120	208	222
		60	115	144	149	119	152	158	123	164	172	127	174	184	133	190	203
		80	129	126	130	132	134	140	136	146	153	140	155	164	146	171	183
	2880	40	96	174	180	100	183	190	104	196	205	107	206	218	113	223	239
		60	110	154	159	113	163	170	117	176	184	121	186	197	126	204	218
		80	124	135	140	127	144	150	131	157	164	134	166	176	140	184	197
TWE0904*A, TWE0904*B	2400	40	102	162	168	106	171	177	110	182	191	114	192	203	120	208	222
		60	115	144	149	119	152	158	123	164	172	127	174	184	133	190	203
		80	129	126	130	132	134	140	136	146	153	140	155	164	146	171	183
	3000	40	95	178	183	97	187	194	101	200	209	105	210	222	110	228	244
		60	109	158	163	111	167	174	115	180	188	119	190	201	124	208	222
		80	122	138	143	125	147	153	129	160	168	132	170	180	138	188	201
	3600	40	89	191	197	91	201	208	95	215	225	97	226	239	103	245	262
		60	103	170	175	106	180	187	110	193	203	112	205	216	117	224	239
		80	118	149	154	121	158	164	124	172	180	127	183	194	132	202	216
TWE1204*A, TWE1204*B	3200	40	99	203	210	102	214	222	106	229	240	109	241	254	115	261	279
		60	112	181	187	115	191	199	119	206	216	123	218	230	129	238	255
		80	126	158	164	129	169	175	133	183	192	136	195	206	142	215	230
	4000	40	91	222	229	94	234	243	98	250	262	101	264	278	106	286	306
		60	106	198	204	108	209	217	112	225	236	115	239	252	120	261	279
		80	120	173	179	123	184	192	126	200	210	129	214	226	134	236	252
	4800	40	86	239	246	88	251	261	92	269	282	94	284	299	99	307	329
		60	101	212	219	103	225	233	107	242	254	109	257	271	114	280	300
		80	116	186	192	118	198	206	121	215	226	124	230	243	129	253	271
TWE1504*B	4000	40	103	274	283	106	288	299	111	308	323	115	325	343	121	352	376
		60	116	244	252	119	258	268	124	277	291	128	294	310	134	321	343
		80	129	213	220	132	227	236	137	247	259	141	263	278	147	290	310
	5000	40	95	300	309	98	316	328	102	337	354	106	356	346	111	286	412
		60	109	267	275	112	282	293	116	304	318	119	322	340	125	352	376
		80	123	234	241	126	249	259	130	270	283	133	288	305	139	318	340
	6000	40	90	322	332	92	339	352	96	363	380	99	383	404	104	415	444
		60	104	287	296	107	303	315	110	327	342	113	347	366	118	379	405
		80	119	251	259	121	268	278	125	291	305	128	310	328	133	342	366

Table 68. Steam heating coil capacity – air handler steam pressure (PSIG) (60Hz) (continued)

Unit Model No.	Airflow (CFM)	EAT (°F)	Steam Pressure (PSIG)														
			2 PSI			5 PSI			10 PSI			15 PSI			25 PSI		
			LAT	MBh	Cond. lb/hr	LAT	MBh	Cond. lb/hr	LAT	MBh	Cond. lb/hr	LAT	MBh	Cond. lb/hr	LAT	MBh	Cond. lb/hr
TWE1804*B	4800	40	97	295	304	100	310	322	104	332	348	107	350	369	113	379	406
		60	110	262	271	113	278	288	117	299	313	121	317	334	126	346	370
		80	124	230	237	127	245	254	131	266	279	134	284	299	140	313	334
	6000	40	90	322	332	92	339	352	96	363	380	99	383	404	104	415	444
		60	104	287	296	107	303	315	110	327	343	113	347	366	118	379	405
		80	119	251	259	121	268	278	125	291	305	128	310	328	133	342	366
	7200	40	84	346	356	87	364	378	90	390	408	93	411	434	97	446	477
		60	99	308	318	102	326	338	105	351	368	108	373	393	112	407	435
		80	115	270	278	117	287	299	120	313	327	123	334	352	127	368	394
TWE2404*B	6400	40	95	379	391	97	399	414	102	427	447	105	450	475	110	488	522
		60	109	337	348	111	357	371	115	384	403	119	408	430	124	445	476
		80	123	295	305	125	315	327	129	342	358	133	365	385	138	402	430
	8000	40	88	414	426	90	436	452	94	467	488	97	492	519	102	534	571
		60	102	368	380	105	390	405	108	420	440	111	446	470	116	487	521
		80	117	322	333	120	344	357	123	374	392	126	399	421	131	440	471
	9600	40	83	443	457	85	468	485	88	501	524	91	529	558	95	574	613
		60	98	395	407	100	418	434	103	451	473	106	479	505	110	524	560
		80	113	346	357	115	369	383	119	402	421	121	429	453	125	473	506
TWE3004*B	8000	40	88	414	426	90	436	452	94	467	488	97	492	519	102	534	571
		60	102	368	380	105	390	405	108	420	440	111	446	470	116	487	521
		80	117	322	333	120	344	357	123	374	392	126	399	421	131	440	471
	10000	40	82	450	464	84	475	492	87	509	533	90	537	567	94	583	623
		60	97	401	413	99	425	441	102	459	480	105	487	513	109	532	569
		80	112	352	363	115	375	389	118	408	427	120	436	460	124	481	514
	12000	40	77	479	493	79	509	527	82	546	571	84	577	608	88	627	669
		60	93	430	443	95	456	473	98	492	515	100	523	551	104	572	611
		80	109	377	389	111	402	418	114	438	459	116	468	494	120	517	553

Notes:

1. Type NS Coil, 1 Row, 1" OD, SF Fins, 132 Fins per Foot.
2. SZVAV/2-Speed VFD available for 6–25 ton only.
3. LAT = Leaving Air Temperature (°F)
4. MBh Capacity= BTU/HR/1000
5. Cond. Lb/Hr = Condensate pound per hour



Performance Data

Table 69. Hot water heating coil capacity - air handler (60Hz)

Tons	Unit Model No.	Airflow (CFM)	Enter Air Temp (°F)	Entering Water Temperature (°F)								
				180								
				Water Temperature Drop (°F)								
				20			30			40		
GPM	MBh	LAT	GPM	MBh	LAT	GPM	MBh	LAT				
5	TWE0604*A, TWE0604*B	1600	40	10.9	106.1	101.0	6.6	96.5	96.0	4.5	87.4	90.0
			60	9.0	88.3	111.0	5.4	79.1	106.0	3.6	70.3	100.0
			80	7.2	70.6	121.0	4.2	61.8	116.0	2.7	53.4	111.0
		2000	40	12.3	119.8	95.0	7.4	108.6	90.0	5.0	97.9	851.0
			60	10.2	99.6	106.0	6.1	88.8	101.0	4.0	78.6	96.0
			80	8.1	79.5	117.0	4.7	69.2	112.0	3.0	59.6	107.0
		2400	40	13.5	132.0	91.0	8.1	119.2	86.0	5.5	107.1	811.0
			60	11.2	109.6	102.0	6.6	97.4	97.0	4.4	85.9	931.0
			80	9.0	87.4	114.0	5.2	75.7	109.0	3.3	64.9	105.0
6	TWE072*B	1920	40	15.4	150.3	112.5	9.4	137.6	106.4	6.4	124.9	100.2
			60	12.8	124.9	120.2	7.6	111.3	113.7	5.2	101.5	109.0
			80	10.2	99.6	128.0	6.0	87.8	122.4	3.9	76.1	116.7
		2400	40	17.0	165.9	104.0	10.4	152.3	98.0	7.1	139.2	93.0
			60	14.2	138.4	113.0	8.5	125.2	108.0	5.7	112.5	103.0
			80	11.4	111.1	123.0	6.7	98.3	118.0	4.4	86.1	113.0
		2880	40	18.7	182.5	98.7	11.5	168.4	94.1	7.7	150.3	88.3
			60	15.6	152.3	109.0	9.2	134.7	103.3	6.4	124.9	100.2
			80	12.5	122.0	119.2	7.2	105.4	113.9	4.7	91.7	109.5
7.5	TWE0904*A, TWE0904*B	2400	40	17.0	165.9	104.0	10.4	152.3	98.0	7.1	139.2	93.0
			60	14.2	138.4	113.0	8.5	125.2	108.0	5.7	112.5	103.0
			80	11.4	111.1	123.0	6.7	98.3	118.0	4.4	86.1	113.0
		3000	40	19.3	187.9	98.0	11.7	171.9	93.0	8.0	156.5	88.0
			60	16.1	156.7	108.0	9.6	141.1	103.0	6.4	126.3	991.0
			80	12.9	125.5	119.0	7.5	110.6	114.0	4.9	96.5	110.0
		3600	40	21.2	207.3	93.0	12.9	189.1	88.0	8.8	171.6	84.0
			60	17.7	172.7	104.0	10.6	155.0	100.0	7.1	138.3	95.0
			80	14.2	138.2	115.0	8.3	121.2	111.0	5.4	105.4	107.0
10	TWE1204*A, TWE1204*B	3200	40	24.5	239.1	109.0	14.3	210.0	100.0	9.1	178.7	91.0
			60	20.2	197.3	117.0	11.5	168.4	108.0	6.9	134.8	99.0
			80	15.9	155.6	125.0	8.6	126.1	116.0	4.0	78.7	103.0
		4000	40	27.8	271.7	103.0	16.2	237.5	95.0	10.3	201.9	86.0
			60	22.9	223.8	112.0	13.0	190.3	104.0	7.8	153.3	95.0
			80	18.1	176.2	121.0	9.7	142.6	113.0	5.0	97.3	102.0
		4800	40	30.7	300.0	98.0	17.8	261.3	90.0	11.3	221.7	82.0
			60	25.3	246.9	107.0	14.3	209.1	100.0	8.6	168.9	92.0
			80	19.9	194.0	117.0	10.7	156.7	110.0	5.6	110.2	101.0
12.5	TWE1504*B	4000	40	31.7	318.0	113.3	19.2	287.7	106.3	12.8	256.5	99.1
			60	26.4	264.4	120.9	15.6	234.4	114.0	10.2	203.2	106.9
			80	21.1	210.9	128.6	12.1	181.1	121.7	7.4	148.9	114.3
		5000	40	36.0	360.6	106.5	21.7	325.2	100.0	14.4	288.8	93.3
			60	29.9	299.6	115.3	17.6	264.5	108.8	11.4	228.3	102.1
			80	23.8	238.7	124.0	13.6	203.8	117.6	8.4	167.5	110.9
		6000	40	39.7	397.0	101.0	23.8	357.0	94.9	15.8	316.1	88.6
			60	32.9	329.6	110.7	19.3	290.0	104.6	12.5	249.5	98.3
			80	26.2	262.3	120.3	14.9	223.1	114.3	9.1	182.8	108.1

Table 69. Hot water heating coil capacity - air handler (60Hz) (continued)

Tons	Unit Model No.	Airflow (CFM)	Enter Air Temp (°F)	Entering Water Temperature (°F)								
				180								
				Water Temperature Drop (°F)								
				20			30			40		
GPM	MBh	LAT	GPM	MBh	LAT	GPM	MBh	LAT				
15	TWE1804*B	4800	40	35.2	343.9	106.0	21.2	310.3	100.0	14.1	276.3	93.0
			60	29.3	285.7	115.0	17.2	252.7	108.0	11.2	218.5	102.0
			80	23.3	227.7	124.0	13.3	195.0	117.0	8.2	159.9	111.0
		6000	40	40.0	390.3	100.0	23.9	350.8	94.0	15.9	311.4	88.0
			60	33.3	323.9	110.0	19.5	285.3	104.0	12.6	246.2	98.0
			80	26.4	257.7	120.0	15.0	219.9	114.0	9.2	180.5	108.0
		7200	40	44.2	431.3	95.0	26.4	386.5	89.0	17.5	342.1	84.0
			60	36.6	357.6	106.0	21.4	313.9	100.0	13.8	270.6	95.0
			80	29.1	284.2	116.0	16.5	241.6	111.0	10.1	198.3	105.0
20	TWE2404*B	6400	40	46.8	456.2	106.0	28.4	416.5	100.0	19.3	376.7	94.0
			60	39.0	380.2	115.0	23.3	341.2	109.0	15.4	301.7	103.0
			80	31.2	304.5	124.0	18.2	266.0	118.0	11.6	227.0	113.0
		8000	40	53.0	517.5	100.0	32.1	470.9	94.0	21.7	424.5	89.0
			60	44.2	430.9	110.0	26.3	385.2	104.0	17.4	339.6	99.0
			80	35.3	344.6	120.0	20.5	299.8	115.0	13.0	255.2	109.0
		9600	40	58.6	572.0	94.0	35.4	519.1	90.0	23.9	466.8	85.0
			60	48.8	475.9	106.0	28.9	424.2	101.0	19.1	373.3	96.0
			80	39.0	380.2	116.0	22.5	329.6	112.0	14.3	280.0	107.0
25	TWE3004*B	8000	40	52.0	520.2	100.0	31.6	474.4	94.7	21.4	427.6	89.3
			60	43.3	433.6	110.0	25.9	388.2	104.7	17.1	341.6	99.4
			80	34.7	347.0	120.0	20.1	301.9	114.8	12.8	255.3	109.4
		10000	40	57.9	579.4	93.4	35.1	526.9	88.6	23.7	473.6	83.7
			60	48.2	482.5	104.5	28.7	430.6	99.7	18.9	377.7	94.8
			80	38.5	385.7	115.6	22.3	334.3	110.8	14.1	281.6	106.0
		12000	40	62.8	628.6	88.3	38.0	570.5	83.8	25.6	511.7	79.3
			60	52.3	523.2	100.2	31.0	465.8	95.8	20.4	407.5	91.3
			80	41.7	417.9	112.2	24.1	361.2	107.8	15.2	303.3	103.3



Performance Data

Table 69. Hot water heating coil capacity - air handler (60Hz) (continued)

Tons	Unit Model No.	Airflow (CFM)	Enter Air Temp (°F)	Entering Water Temperature (°F)								
				200								
				Water Temperature Drop (°F)								
				20			30			40		
GPM	MBh	LAT	GPM	MBh	LAT	GPM	MBh	LAT				
5	TWE0604*A, TWE0604*B	1600	40	12.9	124.9	112.0	7.9	115.4	106.0	5.5	106.3	101.0
			60	11.0	107.0	122.0	6.7	97.8	116.0	4.6	88.9	111.0
			80	9.2	89.1	131.0	5.5	80.2	126.0	3.7	71.7	121.0
		2000	40	4.5	141.3	105.0	8.9	130.1	100.0	6.1	119.4	95.0
			60	12.4	120.9	116.0	7.5	110.1	111.0	5.1	99.7	106.0
			80	10.4	100.6	126.0	6.2	90.2	122.0	4.1	80.3	117.0
		2400	40	6.0	155.8	100.0	9.8	143.1	95.0	6.7	131.0	90.0
			60	3.7	133.3	111.0	8.3	120.9	106.0	5.6	109.2	102.0
			80	11.4	110.8	123.0	6.8	98.9	118.0	4.5	87.8	114.0
6	TWE072*B	1920	40	17.9	174.7	124.3	11.2	164.0	119.1	7.9	154.2	114.4
			60	15.6	152.3	133.4	9.6	140.5	127.8	6.5	126.9	121.2
			80	13.0	126.9	141.2	8.0	117.1	136.5	5.4	105.4	130.8
		2400	40	20.0	194.8	115.0	12.4	181.2	110.0	8.6	168.2	105.0
			60	17.2	167.1	124.0	10.6	153.9	119.0	7.2	141.2	114.0
			80	14.4	139.6	134.0	8.7	126.8	129.0	5.9	114.3	124.0
		2880	40	21.9	213.7	108.7	13.7	200.6	104.5	9.6	187.4	100.2
			60	19.0	185.4	119.6	11.7	171.3	115.1	8.0	156.2	110.2
			80	15.8	154.2	129.6	9.7	142.0	125.7	6.5	126.9	120.8
7.5	TWE0904*A, TWE0904*B	2400	40	20.0	194.8	115.0	12.4	181.2	110.0	8.6	168.2	105.0
			60	17.2	167.1	124.0	10.6	153.9	119.0	7.2	141.2	114.0
			80	14.4	139.6	134.0	8.7	126.8	129.0	5.9	114.3	124.0
		3000	40	22.7	220.9	108.0	14.0	204.9	103.0	9.7	189.6	98.0
			60	9.5	189.4	118.0	11.9	173.9	113.0	8.2	159.0	109.0
			80	16.3	158.1	129.0	9.8	143.0	124.0	6.6	128.5	119.0
		3600	40	25.1	244.0	102.0	15.5	225.7	98.0	0.7	208.4	93.0
			60	21.5	209.1	113.0	13.1	191.4	109.0	9.0	174.4	105.0
			80	17.9	174.3	125.0	10.8	157.1	120.0	7.2	140.9	116.0
10	TWE1204*A, TWE1204*B	3200	40	29.3	284.7	122.0	17.6	256.8	114.0	11.7	228.6	106.0
			60	25.0	242.6	130.0	14.7	215.2	122.0	9.6	186.9	114.0
			80	20.6	200.6	138.0	11.9	173.6	130.0	7.4	144.3	122.0
		4000	40	33.4	324.1	115.0	19.9	291.0	107.0	13.3	258.2	99.0
			60	28.4	275.8	124.0	16.7	243.6	116.0	10.8	211.0	109.0
			80	23.4	227.7	132.0	13.4	196.2	125.0	8.4	163.2	118.0
		4800	40	36.9	358.3	109.0	22.0	320.7	102.0	14.6	283.7	94.0
			60	31.4	304.7	118.0	18.4	268.1	111.0	11.9	231.6	104.0
			80	25.9	251.3	128.0	14.8	215.6	121.0	9.2	179.4	114.0
12.5	TWE1504*B	4000	40	37.3	374.5	126.3	23.0	345.9	119.7	15.8	316.5	113.0
			60	32.0	320.9	134.0	19.4	292.5	127.4	13.1	263.1	120.7
			80	26.6	267.4	141.6	15.9	293.1	135.1	10.5	209.7	128.3
		5000	40	42.4	425.4	118.5	26.0	391.7	112.2	17.8	357.2	105.9
			60	36.3	364.3	127.2	22.0	330.8	121.0	14.8	296.5	114.7
			80	30.2	303.2	135.9	17.9	269.9	129.8	11.8	235.8	123.5
		6000	40	46.7	468.8	112.0	28.6	430.6	106.2	19.5	391.7	100.2
			60	40.0	401.2	121.7	24.2	363.3	115.8	16.2	324.8	109.9
			80	33.2	333.6	131.3	19.7	296.1	125.5	12.9	257.8	119.6

Table 69. Hot water heating coil capacity - air handler (60Hz) (continued)

Tons	Unit Model No.	Airflow (CFM)	Enter Air Temp (°F)	Entering Water Temperature (°F)								
				200								
				Water Temperature Drop (°F)								
				20			30			40		
GPM	MBh	LAT	GPM	MBh	LAT	GPM	MBh	LAT				
15	TWE1804*B	4800	40	41.8	406.0	118.0	25.6	373.4	112.0	17.5	341.0	105.0
			60	35.8	347.5	127.0	21.6	315.4	121.0	14.6	283.4	114.0
			80	29.8	289.1	135.0	17.7	257.6	129.0	11.6	225.7	123.0
		6000	40	7.5	461.4	111.0	29.0	423.0	105.0	19.8	385.0	99.0
			60	40.6	394.6	121.0	24.5	356.9	115.0	16.4	319.6	109.0
			80	33.8	327.9	130.0	19.9	291.0	125.0	13.1	254.3	119.0
		7200	40	52.5	510.4	105.0	32.0	466.7	100.0	21.8	423.8	94.0
			60	44.9	436.3	116.0	27.0	393.5	110.0	18.0	351.4	105.0
			80	37.3	362.2	126.0	22.0	320.5	121.0	14.3	279.5	116.0
20	TWE2404*B	6400	40	55.2	536.5	117.0	34.1	497.8	112.0	23.6	459.4	106.0
			60	47.4	460.2	126.0	28.9	422.1	121.0	19.7	384.2	115.0
			80	39.5	384.0	135.0	23.8	346.5	130.0	15.9	308.9	124.0
		8000	40	62.7	609.2	110.0	38.6	563.8	105.0	26.6	518.8	100.0
			60	53.8	522.2	120.0	32.7	477.6	115.0	22.2	433.3	110.0
			80	44.8	435.4	130.0	26.8	391.5	125.0	17.9	347.9	120.0
		9600	40	69.4	673.9	105.0	42.7	622.3	100.0	29.3	571.5	95.0
			60	59.4	577.4	115.0	36.1	526.8	111.0	24.5	476.7	106.0
			80	49.5	481.0	126.0	29.6	431.4	121.0	19.6	382.6	117.0
25	TWE3004*B	8000	40	60.9	611.5	110.5	37.7	567.6	105.4	26.1	523.0	100.3
			60	52.3	524.6	120.5	32.0	481.1	115.5	21.8	436.7	110.3
			80	43.6	437.8	130.5	26.2	394.6	125.5	17.5	350.3	120.4
		10000	40	67.9	681.6	102.9	42.0	631.2	98.2	28.9	580.2	93.5
			60	58.2	584.4	113.9	35.5	534.5	109.3	24.1	483.9	104.6
			80	48.6	487.4	124.9	29.1	437.9	120.4	19.3	387.5	115.7
		12000	40	73.7	740.0	96.9	45.5	684.0	92.6	31.3	627.7	88.2
			60	63.2	634.2	108.7	38.5	578.9	104.5	26.1	523.0	100.2
			80	52.7	528.6	120.6	31.5	473.8	116.4	20.9	418.3	112.1



Performance Data

Table 69. Hot water heating coil capacity - air handler (60Hz) (continued)

Tons	Unit Model No.	Airflow (CFM)	Enter Air Temp (°F)	Entering Water Temperature (°F)								
				210								
				Water Temperature Drop (°F)								
				20			30			40		
GPM	MBh	LAT	GPM	MBh	LAT	GPM	MBh	LAT				
5	TWE0604*A, TWE0604*B	1600	40	13.9	134.3	117.0	8.6	124.8	112.0	6.0	115.8	107.0
			60	12.0	116.3	127.0	7.4	107.1	122.0	5.1	98.3	117.0
			80	10.2	98.4	137.0	6.1	89.5	132.0	4.2	80.9	127.0
		2000	40	15.7	152.0	110.0	9.7	140.9	105.0	6.7	130.2	100.0
			60	13.6	131.6	121.0	8.3	120.7	116.0	5.7	110.5	111.0
			80	11.5	111.2	131.0	6.9	100.7	126.0	4.7	90.7	122.0
		2400	40	17.3	167.7	104.0	10.6	155.0	99.0	7.4	142.9	95.0
			60	15.0	145.1	116.0	9.1	132.8	111.0	6.2	121.0	106.0
			80	12.6	122.6	127.0	7.6	110.6	122.0	5.1	99.3	118.0
6	TWE072*B	1920	40	19.5	190.3	131.8	12.0	175.7	124.7	8.5	165.9	120.0
			60	16.8	164.0	139.1	10.4	152.3	133.4	7.3	142.5	128.7
			80	14.5	141.5	148.2	8.8	128.8	142.1	5.9	115.2	135.5
		2400	40	21.6	209.2	120.0	13.4	195.7	115.0	9.4	182.7	110.0
			60	18.7	181.5	130.0	11.6	168.3	125.0	8.0	155.6	120.0
			80	15.9	153.9	139.0	9.7	141.0	134.0	6.6	128.6	129.0
		2880	40	23.9	233.3	115.0	14.7	215.2	109.2	10.3	201.1	104.6
			60	20.6	201.1	124.6	12.7	185.9	119.8	8.8	171.8	115.2
			80	17.7	172.8	135.5	10.6	155.2	129.9	7.1	138.6	124.6
7.5	TWE0904*A, TWE0904*B	2400	40	21.6	209.2	120.0	13.4	195.7	115.0	9.4	182.7	110.0
			60	18.7	181.5	130.0	11.6	168.3	125.0	8.0	155.6	120.0
			80	15.9	153.9	139.0	9.7	141.0	134.0	6.6	128.6	129.0
		3000	40	24.5	237.4	113.0	15.2	221.5	108.0	10.6	206.2	103.0
			60	21.2	205.8	123.0	13.1	190.3	118.0	9.0	175.4	114.0
			80	18.0	174.4	134.0	10.9	159.2	129.0	7.4	144.7	124.0
		3600	40	27.1	262.3	107.0	16.8	244.1	102.0	11.7	226.8	98.0
			60	23.4	227.3	118.0	14.4	209.6	114.0	9.9	192.6	109.0
			80	19.8	192.4	129.0	12.0	175.2	125.0	8.2	158.7	121.0
10	TWE1204*A, TWE1204*B	3200	40	31.7	307.4	129.0	19.2	279.9	121.0	13.0	252.6	113.0
			60	27.4	265.1	136.0	16.4	238.2	129.0	10.9	211.0	121.0
			80	23.0	223.0	144.0	13.5	196.5	137.0	8.7	169.1	129.0
		4000	40	36.1	350.2	121.0	21.8	317.6	113.0	14.7	285.5	106.0
			60	31.1	301.7	130.0	18.5	269.9	122.0	12.3	238.2	115.0
			80	26.1	253.4	138.0	15.3	222.3	131.0	9.8	190.8	124.0
		4800	40	40.0	387.4	114.0	24.1	350.3	107.0	16.2	313.9	100.0
			60	34.4	333.6	124.0	20.4	297.3	117.0	13.5	261.7	110.0
			80	28.9	279.9	134.0	16.8	244.6	127.0	10.8	209.5	120.0
12.5	TWE1504*B	4000	40	40.1	402.7	132.8	24.9	374.7	126.4	17.2	346.1	119.8
			60	34.7	349.1	140.5	21.3	321.3	134.1	14.6	292.7	127.5
			80	29.4	295.5	148.1	17.8	267.8	141.7	11.9	239.2	135.1
		5000	40	45.5	457.6	124.4	28.2	424.6	118.3	19.5	391.0	112.1
			60	39.4	396.4	133.1	24.1	363.7	127.1	16.5	330.2	120.9
			80	33.4	335.3	141.8	20.1	302.7	135.8	13.4	269.4	129.7
		6000	40	50.2	504.5	117.5	31.0	467.1	111.8	21.4	429.1	105.9
			60	43.5	436.8	127.1	26.5	399.7	121.4	18.0	362.0	115.6
			80	36.7	369.2	136.7	22.1	332.4	131.1	14.7	294.9	125.3

Table 69. Hot water heating coil capacity - air handler (60Hz) (continued)

Tons	Unit Model No.	Airflow (CFM)	Enter Air Temp (°F)	Entering Water Temperature (°F)								
				210								
				Water Temperature Drop (°F)								
				20			30			40		
GPM	MBh	LAT	GPM	MBh	LAT	GPM	MBh	LAT				
15	TWE1804*B	4800	40	45.1	437.0	124.0	27.8	404.7	118.0	19.2	372.9	112.0
			60	39.0	378.3	133.0	23.8	346.6	127.0	16.2	315.2	120.0
			80	33.0	319.8	141.0	19.8	288.6	135.0	13.3	257.5	129.0
		6000	40	51.3	496.8	116.0	31.5	458.9	110.0	21.7	421.5	105.0
			60	44.4	429.9	126.0	27.0	392.6	120.0	18.3	355.8	115.0
			80	37.5	363.0	136.0	22.4	326.5	130.0	14.9	290.3	125.0
		7200	40	56.7	549.8	110.0	34.8	506.7	105.0	23.9	464.3	99.0
			60	49.1	475.5	121.0	29.8	433.1	115.0	20.2	391.5	110.0
			80	41.4	401.3	131.0	24.7	359.8	126.0	16.4	319.0	121.0
20	TWE2404*B	6400	40	59.5	576.5	123.0	37.0	538.3	118.0	25.8	500.5	112.0
			60	51.6	500.0	132.0	31.8	462.4	127.0	21.9	425.0	121.0
			80	43.7	423.7	141.0	26.6	386.6	136.0	18.0	349.7	130.0
		8000	40	67.6	654.9	115.0	41.9	610.0	110.0	29.1	565.7	105.0
			60	58.6	567.8	125.0	36.0	523.6	120.0	24.7	479.9	115.0
			80	49.6	480.7	135.0	30.0	437.3	130.0	20.3	394.2	125.0
		9600	40	74.8	724.6	110.0	46.3	673.8	105.0	32.1	623.6	100.0
			60	64.8	628.0	120.0	39.7	578.0	115.0	27.2	528.4	111.0
			80	54.8	531.4	131.0	33.1	482.2	126.0	22.3	433.5	122.0
25	TWE3004*B	8000	40	65.4	656.9	115.7	40.7	613.8	110.8	28.4	570.1	105.7
			60	56.7	569.9	125.7	35.0	527.2	120.8	24.1	483.8	115.8
			80	48.1	483.1	135.7	29.3	440.6	130.8	19.8	397.3	125.8
		10000	40	72.9	732.5	107.5	45.3	683.0	103.0	31.5	633.0	98.4
			60	63.2	635.2	118.6	38.9	586.2	114.1	26.7	536.5	109.5
			80	53.5	538.0	129.6	32.5	489.4	125.1	21.9	440.0	120.6
		12000	40	79.2	795.5	101.1	49.2	740.5	96.9	34.1	685.1	92.7
			60	68.6	689.5	113.0	42.2	635.1	108.8	28.9	580.3	104.6
			80	58.1	583.7	124.9	35.2	529.9	120.7	23.7	475.4	116.5

Notes:

1. SZVAV/2-Speed VFD available for 6–25 ton only.
2. GPM = Gallons Per Minute
3. MBh Capacity: BTU/HR/1000
4. LAT = Leaving Air Temperature (°F)

Table 70. Hot water heating coil - water side pressure drop @ 180°F entering water temperature - air handler (60Hz)

Tons	Unit Model No.	Gallons Per Minute (GPM)																		
		2	4	6	8	10	12	14	16	18	20	22	24	26	28	30	32	34	36	38
		Pressure Drop (Ft. of Water)																		
5	TWE0604*A/B	0.02	0.07	0.15	0.26	0.40	0.56	0.75	0.97	1.22	1.49	1.78	-	-	-	-	-	-	-	
6	TWE0724*B	-	-	0.06	0.11	0.16	0.23	0.30	0.39	0.48	0.58	0.70	0.82	0.95	1.09	1.24	1.40	1.57	-	
7.5	TWE0904*A,B	-	-	0.06	0.11	0.16	0.23	0.30	0.39	0.48	0.58	0.70	0.82	0.95	1.09	1.24	1.40	1.57	-	
10	TWE1204*A,B	-	-	-	0.06	0.09	0.13	0.17	0.22	0.27	0.33	0.39	0.46	0.54	0.62	0.70	0.79	0.89	0.99	
12.5	TWE1504*B	-	-	-	-	0.11	0.15	0.20	0.26	0.32	0.39	0.47	0.55	0.64	0.73	0.83	0.94	1.05	1.17	
15	TWE1804*B	-	-	-	-	0.11	0.15	0.20	0.26	0.32	0.39	0.47	0.55	0.64	0.73	0.83	0.94	1.05	1.17	
20	TWE2404*B	-	-	-	-	-	0.17	0.23	0.30	0.37	0.45	0.53	0.63	0.72	0.83	0.94	1.06	1.19	1.32	
25	TWE3004*B	-	-	-	-	-	0.17	0.23	0.30	0.37	0.45	0.53	0.63	0.72	0.83	0.94	1.06	1.19	1.32	
Tons	Unit Model No.	Gallons Per Minute (GPM)																		
		40	42	44	46	48	50	52	54	56	58	60	62	64	66	68	70	72	74	76
		Pressure Drop (Ft. of Water)																		
5	TWE0604*A/B	-	-	-	-	-	-	-	-	-	-	-	-	-	-	-	-	-	-	
6	TWE0724*B	-	-	-	-	-	-	-	-	-	-	-	-	-	-	-	-	-	-	



Performance Data

Table 70. Hot water heating coil - water side pressure drop @ 180°F entering water temperature - air handler (60Hz) (continued)

Tons	Unit Model No.	Gallons Per Minute (GPM)																		
		40	42	44	46	48	50	52	54	56	58	60	62	64	66	68	70	72	74	76
		Pressure Drop (Ft. of Water)																		
7.5	TWE0904*A,B	-	-	-	-	-	-	-	-	-	-	-	-	-	-	-	-	-	-	-
10	TWE1204*A,B	1.21	1.32	1.44	1.57	1.70	1.84	-	-	-	-	-	-	-	-	-	-	-	-	-
12.5	TWE1504*B	1.42	1.56	1.70	1.85	2.00	2.16	2.33	2.50	2.67	2.86	3.04	3.24	3.44	3.64	3.85	4.07	-	-	-
15	TWE1804*B	1.42	1.56	1.70	1.85	2.00	2.16	2.33	2.50	2.67	2.86	3.04	3.24	3.44	3.64	3.85	4.07	-	-	-
20	TWE2404*B	1.61	1.76	1.92	2.09	2.26	2.44	2.63	2.82	3.02	3.22	3.43	3.65	3.87	4.10	4.34	4.58	4.83	5.08	5.34
25	TWE3004*B	1.61	1.76	1.92	2.09	2.26	2.44	2.63	2.82	3.02	3.22	3.43	3.65	3.87	4.10	4.34	4.58	4.83	5.08	5.34

Note: SZVAV/2-Speed VFD available for 6-25 ton only.



Zone Controls

Zone Sensors

Zone Sensors are the building occupant's comfort control devices. Zone sensors are required for SZVAV applications. The following zone sensor options are available for units with Symbio 700 control.

Manual Changeover	Heat, Cool or Off System Switch. Fan Auto or Off Switch. One temperature setpoint lever.
Manual/Automatic Changeover	Auto, Heat, Cool or Off System Switch. Fan Auto or Off Switch. Two temperature setpoint levers.
Manual/Automatic Changeover	Auto, Heat, Cool or Off System Switch. Fan Auto or Off Switch. Two temperature setpoint levers.
Integrated Comfort™ System	Sensor(s) available with optional temperature adjustment and override buttons to provide central control through a Trane Integrated Comfort™ system.
Remote Sensor	Sensor(s) available for all zone sensors to provide remote sensing capabilities.

Conventional Thermostats

Note: All thermostats may be used with Symbio 700 units.

Non-Programmable Thermostats	
TCONT102* (1H/1C) Common terminal not required	Auto-changeover Backlit Display and Keys Filter Reminder Keypad Lock
TCONT103* (2H/1C) Common terminal required	Auto-changeover Backlit Display & Keys Filter Reminder Keypad Lock Outdoor Temp Sensor Available
TCONT402* (3H/2C) Common terminal required	Auto-changeover Backlit Display & Keys Filter Reminder Keypad Lock Outdoor Temp Sensor Included
Programmable Thermostats	
TCONT202* (1H/1C) Common terminal preferred, not required	5/2 or 5/1/1 Programming Actual and Setpoint temps displayed simultaneously
TCONT203* (4H/2C) Common terminal preferred, not required	5/2 or 5/1/1 Programming Actual and Setpoint temps displayed simultaneously
TCONT302* (4H/2C) Common terminal preferred, not required	Interactive touchscreen Large display Real time clock
TCONT303* (4H/2C) Humidity Sensor Common terminal preferred, not required	Interactive touchscreen Large display Real time clock Built-in humidity sensor



Electrical Data

Cooling Condenser

Table 71. Electrical characteristics — compressor and condenser fan motors — 60 Hz

Tons	Unit Model Number	Compressor Motors						Condenser Fan Motor				
		Volts	Phase	Compressor 1		Compressor 2		No.	Volts	Phase	Amps	
				Amps		Amps					FLA (Ea.)	LRA (Ea.)
				RLA	LRA	RLA	LRA					
6	TTA07243A	208-230	3	19.6	136	N/A	N/A	1	208-230	3	2.3	8.4
	TTA07244A	460	3	8.2	66	N/A	N/A	1	460	3	1.1	4.2
	TTA0724WA	575	3	6.6	55	N/A	N/A	1	575	3	1.0	3.6
	TTA0724KA	380	3	10.3	83	N/A	N/A	1	380	3	1.4	5.2
6	TTA07243D	208-230	3	9.0	71	9.0	71	1	208-230	3	2.3	8.4
	TTA07244D	460	3	5.7	38	5.7	38	1	460	3	1.1	4.2
	TTA0724WD	575	3	3.8	37	3.8	37	1	575	3	1.0	3.6
	TTA0724KD	380	3	5.5	45	5.5	45	1	380	3	1.4	5.2
7.5	TTA09043A	208-230	3	26.9	164	N/A	N/A	1	208-230	3	2.3	8.4
	TTA09044A	460	3	12.0	94	N/A	N/A	1	460	3	1.1	4.2
	TTA0904WA	575	3	9.0	65	N/A	N/A	1	575	3	1.0	3.6
	TTA0904KA	380	3	13.9	94	N/A	N/A	1	380	3	1.4	5.2
7.5	TTA09043D	208-230	3	14.0	83	14.0	83	1	208-230	3	2.3	8.4
	TTA09044D	460	3	6.4	41	6.4	41	1	460	3	1.1	4.2
	TTA0904WD	575	3	4.6	33	4.6	33	1	575	3	1.0	3.6
	TTA0904KD	380	3	7.6	52	7.6	52	1	380	3	1.4	5.2
10	TTA12043D	208-230	3	16.2	110	16.2	110	1	208-230	3	4.3	19.4
	TTA12044D	460	3	7.6	52	7.6	52	1	460	3	2.2	10.1
	TTA1204WD	575	3	5.3	39	5.3	39	1	575	3	1.8	8.0
	TTA1204KD	380	3	8.5	66	8.5	66	1	380	3	2.6	11.9
10	TTA12043C	208-230	3	16.0	110	16.0	110	1	208-230	3	4.3	19.4
	TTA12044C	460	3	7.8	52	7.8	52	1	460	3	2.2	10.1
	TTA1204WC	575	3	5.7	39	5.7	39	1	575	3	1.8	8.0
12.5	TTA15043D	208-230	3	20.3	167	20.3	167	1	208-230	3	4.3	19.4
	TTA15044D	460	3	9.9	69	9.9	69	1	460	3	2.2	10.1
	TTA1504WD	575	3	7.6	55	7.6	55	1	575	3	1.8	8.0
	TTA1504KD	380	3	11.3	88	11.3	88	1	380	3	2.6	11.9
15	TTA18043D	208-230	3	25.0	164	25.0	164	2	208-230	3	4.3	19.4
	TTA18044D	460	3	12.2	100	12.2	100	2	460	3	2.2	10.1
	TTA1804WD	575	3	9.2	78	9.2	78	2	575	3	1.8	8.0
	TTA1804KD	380	3	13.9	94	13.9	94	2	380	3	2.6	11.9
15	TTA18043C	208-230	3	27.6	191	22.4	149	2	208-230	3	4.3	19.4
	TTA18044C	460	3	12.8	100	10.6	75	2	460	3	2.2	10.1
	TTA1804WC	575	3	9.6	78	7.7	54	2	575	3	1.8	8.0
	TTA1804KC	380	3	15.4	123	11.3	88	2	380	3	2.6	11.9
20	TTA24043D	208-230	3	35.4	240	32.6	240	2	208-230	3	4.3	19.4
	TTA24044D	460	3	16.5	140	14.8	130	2	460	3	2.2	10.1
	TTA2404WD	575	3	12.9	108	11.1	94	2	575	3	1.8	8.0
	TTA2404KD	380	3	21.2	152	16.0	135	2	380	3	2.6	11.9
20	TTA24043C	208-230	3	39.1	267	39.1	267	2	208-230	3	4.3	19.4
	TTA24044C	460	3	18.6	142	18.6	142	2	460	3	2.2	10.1
	TTA2404WC	575	3	15.4	103	15.4	103	2	575	3	1.8	8.0
	TTA2404KC	380	3	22.4	160	22.4	160	2	380	3	2.6	11.9
25	TTA30043C	208-230	3	41.0	304	41.0	304	2	208-230	3	4.3	19.4
	TTA30044C	460	3	19.4	147	19.4	147	2	460	3	2.2	10.1
	TTA3004WC	575	3	16.7	122	16.7	122	2	575	3	1.8	8.0
	TTA3004KC	380	3	23.8	168	23.8	168	2	380	3	2.6	11.9

Note: Electrical characteristics reflect nameplate values and are calculated in accordance with cULus specifications.

Table 72. Unit wiring — condensing units — 60 Hz

Tons	Unit Model Number	Volts	Minimum Circuit Ampacity	Maximum Fuse or Circuit Breaker Size
6	TTA07243A	187-253	27	45
	TTA07244A	414-506	11	15
	TTA0724WA	518-632	9	15
	TTA0724KA	342-418	14	20
6	TTA07243D	187-253	23	30
	TTA07244D	414-506	14	15
	TTA0724WD	518-632	10	15
	TTA0724KD	342-418	14	15
7.5	TTA09043A	187-253	36	60
	TTA09044A	414-506	16	25
	TTA0904WA	518-632	12	20
	TTA0904KA	342-418	19	30
7.5	TTA09043D	187-253	34	45
	TTA09044D	414-506	16	20
	TTA0904WD	518-632	11	15
	TTA0904KD	342-418	19	25
10	TTA12043D	187-253	41	50
	TTA12044D	414-506	19	25
	TTA1204WD	518-632	14	15
	TTA1204KD	342-418	22	30
10	TTA12043C	187-253	40	50
	TTA12044C	414-506	20	25
	TTA1204WC	518-632	15	20
12.5	TTA15043D	187-253	50	70
	TTA15044D	414-506	25	30
	TTA1504WD	518-632	19	25
	TTA1504KD	342-418	28	35
15	TTA18043D	187-253	74	100
	TTA18044D	414-506	32	40
	TTA1804WD	518-632	24	30
	TTA1804KD	342-418	36	50
15	TTA18043C	187-253	66	90
	TTA18044C	414-506	31	40
	TTA1804WC	518-632	23	30
	TTA1804KC	342-418	36	50
20	TTA24043D	187-253	85	110
	TTA24044D	414-506	40	50
	TTA2404WD	518-632	31	40
	TTA2404KD	342-418	48	60
20	TTA24043C	187-253	97	125
	TTA24044C	414-506	46	60
	TTA2404WC	518-632	38	50
	TTA2404KC	342-418	56	70
25	TTA30043C	187-253	101	125
	TTA30044C	414-506	48	60
	TTA3004WC	518-632	41	50
	TTA3004KC	342-418	59	80



Electrical Data

Air Handler

Table 73. Voltage operating range (all air handlers)

Model Number: Digit 8	Electrical Characteristics	Unit Operating Voltage Range
1	208-230/60/1	187-253
3	208-230/60/3	187-253
4	460/60/3	414-506
W	575/60/3	518-632
K	380/60/3	342-418

Table 74. Electrical characteristics — 5 to 25 ton standard motor — 60 Hz constant volume air handler

Tons	Unit Model Number	Standard Evaporator Fan Motor							
		No.	Volts	Phase	HP	Amps		MCA	MOP
						FLA	LRA		
5	TWE06041A/B	1	208-230	1	0.75	6.0	43.0	8	15
	TWE06043A/B	1	208-230	3	0.75	2.8	13.0	4	15
	TWE0604KA	1	380	3	0.75	1.9	12	2	15
	TWE06044A/B	1	460	3	0.75	1.4	6.0	2	15
	TWE0604WA	1	575	3	0.75	1.4	5.0	2	15
6	TWE072KB	1	380	3	1.5	3	20	4	15
7.5	TWE09041A/B	1	208-230	1	1.5	7.5	53.0	9	15
	TWE0904KA/B	1	380	3	2	3.0	20.0	4	15
10	TWE12041A/B	1	208-230	1	2	10.5	48.0	13	20
	TWE1204KA/B	1	380	3	2.0	3.7	28.0	5	15
12.5	TWE1504KB	1	380	3	2	3.7	28.0	5	15
15	TWE1804KB	1	380	3	3	5.6	49.0	7	15
20	TWE2404KB	1	380	3	5	9.1	64.0	11	20
25	TWE3004KB	1	380	3	7.5	10.7	76.0	13	20

Table 75. Electrical characteristics — 5 to 25 ton high static motor — 60 Hz constant volume air handler

Tons	Unit Model Number	High Static Evaporator Fan Motor							
		No.	Volts	Phase	HP	Amps		MCA	MOP
						FLA	LRA		
5	TWE06041A/B	1	208-230	1	1.5	7.5	53.0	9	15
	TWE06043A/B	1	208-230	3	1.5	6.4	33.0	8	15
	TWE0604KA	N/A	N/A	N/A	N/A	N/A	N/A	N/A	N/A
	TWE06044A/B	1	460	3	1.5	3.0	17.0	4	15
	TWE0604WA	1	575	3	1.5	1.9	14.0	2	15
7.5	TWE09041A/B	1	208-230	1	2	10.5	48.0	13	20
	TWE09043A/B	N/A	N/A	N/A	N/A	N/A	N/A	N/A	N/A
	TWE0904KA/B	N/A	N/A	N/A	N/A	N/A	N/A	N/A	N/A
	TWE09044A/B	N/A	N/A	N/A	N/A	N/A	N/A	N/A	N/A
	TWE0904WA/B	N/A	N/A	N/A	N/A	N/A	N/A	N/A	N/A

Table 76. Electrical characteristics — standard and oversized motors — 6 to 25 ton SZVAV and 2-Speed VFD air handler — 60 Hz

Tons	Unit Model Number	Standard Evaporator Fan Motor								Oversized Evaporator Fan Motor							
		No.	Volts	Phase	HP	Amps		MCA	MOP	No.	Volts	Phase	HP	Amps		MCA	MOP
						FLA	LRA							FLA	LRA		
6	TWE07243B	1	208-230	3	2	6.8	54.0	8	15	1	208-230	3	3	10.0	74.0	13	20
	TWE07244B	1	460	3	2	3.3	27.2	4	15	1	460	3	3	4.9	37.0	6	15
	TWE0724WB	1	575	3	2	2.5	18.0	3	15	1	575	3	3	3.9	35.0	5	15
7.5	TWE09043A/B	1	208-230	3	2	6.8	54.0	8	15	1	208-230	3	3	10.0	74.0	13	20
	TWE09044A/B	1	460	3	2	3.3	27.2	4	15	1	460	3	3	4.9	37.0	6	15
	TWE0904WA/B	1	575	3	2	2.5	18.0	3	15	1	575	3	3	3.9	35.0	5	15
10	TWE12043A/B	1	208-230	3	2	6.8	54.0	8	15	1	208-230	3	3	10.0	74.0	13	20
	TWE12044A/B	1	460	3	2	3.3	27.0	4	15	1	460	3	3	4.9	37.0	6	15
	TWE1204WA/B	1	575	3	2	2.5	18.0	3	15	1	575	3	3	3.9	35.0	5	15
12.5	TWE15043B	1	208-230	3	2	6.8	54.0	8	15	1	208-230	3	5	15.1	105.0	19	30
	TWE15044B	1	460	3	2	3.3	27.0	4	15	1	460	3	5	7.1	52.0	9	15
	TWE1504WB	1	575	3	2	2.5	18.0	3	15	1	575	3	5	5.7	46.0	7	15
15	TWE18043B	1	208-230	3	3	10.0	74.0	13	20	1	208-230	3	5	15.1	105.0	19	30
	TWE18044B	1	460	3	3	4.9	37.0	6	15	1	460	3	5	7.1	52.0	9	15
	TWE1804WB	1	575	3	3	3.9	35.0	5	15	1	575	3	5	5.7	46.0	7	15
20	TWE24043B	1	208-230	3	5	15.1	105.0	19	30	1	208-230	3	7.5	22.8	141.0	29	50
	TWE24044B	1	460	3	5	7.1	52.0	9	15	1	460	3	7.5	10.0	62.0	12	20
	TWE2404WB	1	575	3	5	5.7	46.0	7	15	1	575	3	7.5	8.2	60.0	10	15
25	TWE30043B	1	208-230	3	7.5	22.8	141.0	29	50	N/A	N/A	N/A	N/A	N/A	N/A	N/A	N/A
	TWE30044B	1	460	3	7.5	10.0	62.0	12	20	N/A	N/A	N/A	N/A	N/A	N/A	N/A	N/A
	TWE3004WB	1	575	3	7.5	8.2	60.0	10	15	N/A	N/A	N/A	N/A	N/A	N/A	N/A	N/A

Table 77. Unit wiring with electric heat (single point connection) — 5 to 25 ton constant volume air handlers — 60 Hz

Tons	Used With	Heater Model Number	Heater kW Rating	Unit Power Supply	Control Stages	Standard Evap Motor		High Static Evap Motor	
						MCA	MOP	MCA	MOP
5	TWE06041A/B	BAYHTRP106*	4.33	208/1/60	1	34	35	35	40
		BAYHTRS112*	8.65		1	59	60	61	70
		BAYHTRT117*	12.98		1	86	90	87	90
		BAYHTRS123*	17.31		2	111	125	113	125
5	TWE06041A/B	BAYHTRP106*	5.76	230/1/60	1	38	40	39	40
		BAYHTRS112*	11.52		1	68	70	69	70
		BAYHTRT117*	17.28		1	98	100	99	100
		BAYHTRS123*	23.04		2	128	150	129	150
5	TWE06043A/B	BAYHTRP305*	3.76	208/3/60	1	17	20	21	25
		BAYHTRS310*	7.48		1	29	30	34	35
		BAYHTRS315*	11.24		1	43	45	47	50
		BAYHTRP325*	18.72		2	69	70	73	80
5	TWE06043A/B	BAYHTRP305*	5	230/3/60	1	19	20	23	25
		BAYHTRS310*	9.96		1	33	35	37	40
		BAYHTRS315*	14.96		1	49	50	53	60
		BAYHTRP325*	24.92		2	79	80	83	90
5	TWE06044A/B	BAYHTRP405*	5	460/3/60	1	9	15	11	15
		BAYHTRS410*	9.96		1	17	20	19	20
		BAYHTRS415*	14.96		1	24	25	26	30
		BAYHTRP425*	24.92		2	39	40	41	45



Electrical Data

Table 77. Unit wiring with electric heat (single point connection) — 5 to 25 ton constant volume air handlers — 60 Hz (continued)

Tons	Used With	Heater Model Number	Heater kW Rating	Unit Power Supply	Control Stages	Standard Evap Motor		High Static Evap Motor	
						MCA	MOP	MCA	MOP
5	TWE0604WA	BAYHTRPW05*	5	575/3/60	1	8	15	8	15
		BAYHTRSW10*	9.96		1	14	15	14	15
		BAYHTRSW15*	14.96		1	20	20	20	25
		BAYHTRPW25*	24.92		2	32	35	32	35
7.5	TWE09041A/B	BAYHTRP106*	4.33	208/1/60	1	35	40	39	40
		BAYHTRS112*	8.65		1	61	70	65	70
		BAYHTRT117*	12.98		1	87	90	91	100
		BAYHTRS123*	17.31		2	113	125	117	125
		BAYHTRP129*	21.63		2	139	150	143	150
7.5	TWE09041A/B	BAYHTRP106*	5.76	230/1/60	1	39	40	43	45
		BAYHTRS112*	11.52		1	69	70	73	80
		BAYHTRT117*	17.28		1	99	100	103	110
		BAYHTRS123*	23.04		2	129	150	133	150
		BAYHTRP129*	28.8		2	159	175	163	175
10	TWE12041A/B	BAYHTRP106*	4.33	208/1/60	1	37	40	N/A	N/A
		BAYHTRS112*	8.65		1	63	70	N/A	N/A
		BAYHTRT117*	12.98		1	89	90	N/A	N/A
		BAYHTRS123*	17.31		2	115	125	N/A	N/A
		BAYHTRP129*	21.63		2	141	150	N/A	N/A
10	TWE12041A/B	BAYHTRP106*	5.76	230/1/60	1	41	45	N/A	N/A
		BAYHTRS112*	11.52		1	71	80	N/A	N/A
		BAYHTRT117*	17.28		1	101	110	N/A	N/A
		BAYHTRS123*	23.04		2	131	150	N/A	N/A
		BAYHTRP129*	28.8		2	161	175	N/A	N/A

Table 78. Unit wiring with electric heat (single point connection) — 6 to 25 ton SZVAV and 2-Speed VFD air handlers — 60 Hz

Tons	Used With	Heater Model Number	Heater KW Rating	Unit Power Supply	Control Stages	MCA	Maximum Fuse or Circuit Breaker Size
6	TWE07243*****BC0, D0	BAYHTRP305*	3.76	208/3/60	1	22	25
		BAYHTRS310*	7.48		1	34	35
		BAYHTRS315*	11.24		1	48	50
		BAYHTRP325*	18.72		2	74	80
6	TWE07243*****BC0, D0	BAYHTRP305*	5.00	230/3/60	1	24	25
		BAYHTRS310*	9.96		1	38	40
		BAYHTRS315*	14.96		1	54	60
		BAYHTRP325*	24.92		2	84	90
6	TWE07243*****BC4, D4	BAYHTRP305*	3.76	208/3/60	1	26	30
		BAYHTRS310*	7.48		1	38	40
		BAYHTRS315*	11.24		1	52	60
		BAYHTRP325*	18.72		2	78	80
6	TWE07243*****BC4, D4	BAYHTRP305*	5.00	230/3/60	1	28	30
		BAYHTRS310*	9.96		1	42	45
		BAYHTRS315*	14.96		1	58	60
		BAYHTRP325*	24.92		2	88	90

Table 78. Unit wiring with electric heat (single point connection) — 6 to 25 ton SZVAV and 2-Speed VFD air handlers — 60 Hz (continued)

Tons	Used With	Heater Model Number	Heater KW Rating	Unit Power Supply	Control Stages	MCA	Maximum Fuse or Circuit Breaker Size
6	TWE07244*****BC0, D0	BAYHTRP405*	5.00	460/3/60	1	12	15
		BAYHTRS410*	9.96		1	19	20
		BAYHTRS415*	14.96		1	27	30
		BAYHTRP425*	24.92		2	42	45
6	TWE07244*****BC4, D4	BAYHTRP405*	5.00	460/3/60	1	14	15
		BAYHTRS410*	9.96		1	21	25
		BAYHTRS415*	14.96		1	29	30
		BAYHTRP425*	24.92		2	44	45
6	TWE0724W*****BC0, D0	BAYHTRPW05*	5.00	575/3/60	1	9	15
		BAYHTRSW10*	9.96		1	15	20
		BAYHTRSW15*	14.96		1	21	25
		BAYHTRPW25*	24.92		2	33	35
6	TWE0724W*****BC4, D4	BAYHTRPW05*	5.00	575/3/60	1	11	15
		BAYHTRSW10*	9.96		1	17	20
		BAYHTRSW15*	14.96		1	23	25
		BAYHTRPW25*	24.92		2	35	35
7.5	TWE09043*****BC0, D0	BAYHTRP305*	3.76	208/3/60	1	22	25
		BAYHTRS310*	7.48		1	34	35
		BAYHTRS315*	11.24		1	48	50
		BAYHTRP325*	18.72		2	74	80
		BAYHTRP335*	26.20		2	100	100
7.5	TWE09043*****BC0, D0	BAYHTRP305*	5.00	230/3/60	1	24	25
		BAYHTRS310*	9.96		1	38	40
		BAYHTRS315*	14.96		1	54	60
		BAYHTRP325*	24.92		2	84	90
		BAYHTRP335*	34.88		2	113	125
7.5	TWE09043*****BC4, D4	BAYHTRP305*	3.76	208/3/60	1	26	30
		BAYHTRS310*	7.48		1	38	40
		BAYHTRS315*	11.24		1	52	60
		BAYHTRP325*	18.72		2	78	80
		BAYHTRP335*	26.20		2	104	110
7.5	TWE09043*****BC4, D4	BAYHTRP305*	5.00	230/3/60	1	28	30
		BAYHTRS310*	9.96		1	42	45
		BAYHTRS315*	14.96		1	58	60
		BAYHTRP325*	24.92		2	88	90
		BAYHTRP335*	34.88		2	118	125
7.5	TWE09044*****BC0, D0	BAYHTRP405*	5.00	460/3/60	1	12	15
		BAYHTRS410*	9.96		1	19	20
		BAYHTRS415*	14.96		1	27	30
		BAYHTRP425*	24.92		2	42	45
		BAYHTRP435*	34.88		2	57	60
7.5	TWE09044*****BC4, D4	BAYHTRP405*	5.00	460/3/60	1	14	15
		BAYHTRS410*	9.96		1	21	25
		BAYHTRS415*	14.96		1	29	30
		BAYHTRP425*	24.92		2	44	45
		BAYHTRP435*	34.88		2	59	60



Electrical Data

Table 78. Unit wiring with electric heat (single point connection) — 6 to 25 ton SZVAV and 2-Speed VFD air handlers — 60 Hz (continued)

Tons	Used With	Heater Model Number	Heater KW Rating	Unit Power Supply	Control Stages	MCA	Maximum Fuse or Circuit Breaker Size
7.5	TWE0904W*****BC0, D0	BAYHTRPW05*	5.00	575/3/60	1	9	15
		BAYHTRSW10*	9.96		1	15	20
		BAYHTRSW15*	14.96		1	21	25
		BAYHTRPW25*	24.92		2	33	35
		BAYHTRPW35*	34.88		2	45	50
7.5	TWE0904W*****BC4, D4	BAYHTRPW05*	5.00	575/3/60	1	11	15
		BAYHTRSW10*	9.96		1	17	20
		BAYHTRSW15*	14.96		1	23	25
		BAYHTRPW25*	24.92		2	35	35
		BAYHTRPW35*	34.88		2	47	50
10	TWE12043*****BC0, D0	BAYHTRP305*	3.76	208/3/60	1	22	25
		BAYHTRS310*	7.48		1	34	35
		BAYHTRS315*	11.24		1	48	50
		BAYHTRP325*	18.72		2	74	80
		BAYHTRP335*	26.20		2	100	100
10	TWE12043*****BC0, D0	BAYHTRP305*	5.00	230/3/60	1	24	25
		BAYHTRS310*	9.96		1	38	40
		BAYHTRS315*	14.96		1	54	60
		BAYHTRP325*	24.92		2	84	90
		BAYHTRP335*	34.88		2	113	125
10	TWE12043*****BC4, D4	BAYHTRP305*	3.76	208/3/60	1	26	30
		BAYHTRS310*	7.48		1	38	40
		BAYHTRS315*	11.24		1	52	60
		BAYHTRP325*	18.72		2	78	80
		BAYHTRP335*	26.20		2	104	110
10	TWE12043*****BC4, D4	BAYHTRP305*	5.00	230/3/60	1	28	30
		BAYHTRS310*	9.96		1	42	45
		BAYHTRS315*	14.96		1	58	60
		BAYHTRP325*	24.92		2	88	90
		BAYHTRP335*	34.88		2	118	125
10	TWE12044*****BC0, D0	BAYHTRP405*	5.00	460/3/60	1	12	15
		BAYHTRS410*	9.96		1	19	20
		BAYHTRS415*	14.96		1	27	30
		BAYHTRP425*	24.92		2	42	45
		BAYHTRP435*	34.88		2	57	60
10	TWE12044*****BC4, D4	BAYHTRP405*	5.00	460/3/60	1	14	15
		BAYHTRS410*	9.96		1	21	25
		BAYHTRS415*	14.96		1	29	30
		BAYHTRP425*	24.92		2	44	45
		BAYHTRP435*	34.88		2	59	60
10	TWE1204W*****BC0, D0	BAYHTRPW05*	5.00	575/3/60	1	9	15
		BAYHTRSW10*	9.96		1	15	20
		BAYHTRSW15*	14.96		1	21	25
		BAYHTRPW25*	24.92		2	33	35
		BAYHTPW35*	34.88		2	45	50

Table 78. Unit wiring with electric heat (single point connection) — 6 to 25 ton SZVAV and 2-Speed VFD air handlers — 60 Hz (continued)

Tons	Used With	Heater Model Number	Heater KW Rating	Unit Power Supply	Control Stages	MCA	Maximum Fuse or Circuit Breaker Size
10	TWE1204W*****BC4, D4	BAYHTRPW05*	5.00	575/3/60	1	11	15
		BAYHTRSW10*	9.96		1	17	20
		BAYHTRSW15*	14.96		1	23	25
		BAYHTRPW25*	24.92		2	35	35
		BAYHTRPW35*	34.88		2	47	50
12.5	TWE15043*****BC0, D0	BAYHTRT310*	7.51	208/3/60	1	35	35
		BAYHTRR320*	14.96		1	60	70
		BAYHTRR330*	22.47		2	87	90
		BAYHTRR350*	37.44		2	139	150
12.5	TWE15043*****BC0, D0	BAYHTRT310*	10.00	230/3/60	1	39	40
		BAYHTRR320*	19.92		1	68	70
		BAYHTRR330*	29.92		2	99	100
		BAYHTRR350*	49.84		2	159	175
12.5	TWE15043*****BC4, D4	BAYHTRT310*	7.51	208/3/60	1	45	50
		BAYHTRR320*	14.96		1	71	80
		BAYHTRR330*	22.47		2	97	100
		BAYHTRR350*	37.44		2	149	150
12.5	TWE15043*****BC4, D4	BAYHTRT310*	10.00	230/3/60	1	49	50
		BAYHTRR320*	19.92		1	79	80
		BAYHTRR330*	29.92		2	109	110
		BAYHTRR350*	49.84		2	169	175
12.5	TWE15044*****BC0, D0	BAYHTRT410*	10.00	460/3/60	1	19	20
		BAYHTRR420*	19.92		1	34	35
		BAYHTRR430*	29.92		2	49	50
		BAYHTRR450*	49.84		2	79	80
12.5	TWE15044*****BC4, D4	BAYHTRT410*	10.00	460/3/60	1	24	25
		BAYHTRR420*	19.92		1	39	40
		BAYHTRR430*	29.92		2	54	60
		BAYHTRR450*	49.84		2	84	90
12.5	TWE1504W*****BC0, D0	BAYHTRTW10*	10.00	575/3/60	1	15	20
		BAYHTRRW20*	19.92		1	27	30
		BAYHTRRW30*	29.92		2	39	40
		BAYHTRRW50*	49.84		2	63	70
12.5	TWE1504W*****BC4, D4	BAYHTRTW10*	10.00	575/3/60	1	19	20
		BAYHTRRW20*	19.92		1	31	35
		BAYHTRRW30*	29.92		2	43	45
		BAYHTRRW50*	49.84		2	67	70
15	TWE18043*****BC0, D0	BAYHTRT310*	7.51	208/3/60	1	39	40
		BAYHTRR320*	14.96		1	64	70
		BAYHTRR330*	22.47		2	91	100
		BAYHTRR350*	37.44		2	143	150
15	TWE18043*****BC0, D0	BAYHTRT310*	10.00	230/3/60	1	43	45
		BAYHTRR320*	19.92		1	72	80
		BAYHTRR330*	29.92		2	103	110
		BAYHTRR350*	49.84		2	163	175



Electrical Data

Table 78. Unit wiring with electric heat (single point connection) — 6 to 25 ton SZVAV and 2-Speed VFD air handlers — 60 Hz (continued)

Tons	Used With	Heater Model Number	Heater KW Rating	Unit Power Supply	Control Stages	MCA	Maximum Fuse or Circuit Breaker Size
15	TWE18043*****BC4, D4	BAYHTRT310*	7.51	208/3/60	1	45	50
		BAYHTRR320*	14.96		1	71	80
		BAYHTRR330*	22.47		2	97	100
		BAYHTRR350*	37.44		2	149	150
15	TWE18043*****BC4, D4	BAYHTRT310*	10.00	230/3/60	1	49	50
		BAYHTRR320*	19.92		1	79	80
		BAYHTRR330*	29.92		2	109	110
		BAYHTRR350*	49.84		2	169	175
15	TWE18044*****BC0, D0	BAYHTRT410*	10.00	460/3/60	1	21	25
		BAYHTRR420*	19.92		1	36	40
		BAYHTRR430*	29.92		2	51	60
		BAYHTRR450*	49.84		2	81	90
15	TWE18044*****BC4, D4	BAYHTRT410*	10.00	460/3/60	1	24	25
		BAYHTRR420*	19.92		1	39	40
		BAYHTRR430*	29.92		2	54	60
		BAYHTRR450*	49.84		2	84	90
15	TWE1804W*****BC0, D0	BAYHTRTW10*	10.00	575/3/60	1	17	20
		BAYHTRRW20*	19.92		1	29	30
		BAYHTRRW30*	29.92		2	41	45
		BAYHTRRW50*	49.84		2	65	70
15	TWE1804W*****BC4, D4	BAYHTRTW10*	10.00	575/3/60	1	19	20
		BAYHTRRW20*	19.92		1	31	35
		BAYHTRRW30*	29.92		2	43	45
		BAYHTRRW50*	49.84		2	67	70
20	TWE24043*****BC0, D0	BAYHTRT310*	7.51	208/3/60	1	45	50
		BAYHTRR320*	14.96		1	71	80
		BAYHTRR330*	22.47		2	97	100
		BAYHTRR350*	37.44		2	149	150
20	TWE24043*****BC0, D0	BAYHTRT310*	10.00	230/3/60	1	49	50
		BAYHTRR320*	19.92		1	79	80
		BAYHTRR330*	29.92		2	109	110
		BAYHTRR350*	49.84		2	169	175
20	TWE24043*****BC4, D4	BAYHTRT310*	7.51	208/3/60	1	55	70
		BAYHTRR320*	14.96		1	80	90
		BAYHTRR330*	22.47		2	107	110
		BAYHTRR350*	37.44		2	159	175
20	TWE24043*****BC4, D4	BAYHTRT310*	10.00	230/3/60	1	59	70
		BAYHTRR320*	19.92		1	88	90
		BAYHTRR330*	29.92		2	119	125
		BAYHTRR350*	49.84		2	179	200
20	TWE24044*****BC0, D0	BAYHTRT410*	10.00	460/3/60	1	24	25
		BAYHTRR420*	19.92		1	39	40
		BAYHTRR430*	29.92		2	54	60
		BAYHTRR450*	49.84		2	84	90

Table 78. Unit wiring with electric heat (single point connection) — 6 to 25 ton SZVAV and 2-Speed VFD air handlers — 60 Hz (continued)

Tons	Used With	Heater Model Number	Heater KW Rating	Unit Power Supply	Control Stages	MCA	Maximum Fuse or Circuit Breaker Size
20	TWE24044*****BC4, D4	BAYHTRT410*	10.00	460/3/60	1	28	30
		BAYHTRR420*	19.92		1	42	45
		BAYHTRR430*	29.92		2	58	60
		BAYHTRR450*	49.84		2	87	90
20	TWE2404W*****BC0, D0	BAYHTRTW10*	10.00	575/3/60	1	19	20
		BAYHTRRW20*	19.92		1	31	35
		BAYHTRRW30*	29.92		2	43	45
		BAYHTRRW50*	49.84		2	67	70
20	TWE2404W*****BC4, D4	BAYHTRTW10*	10.00	575/3/60	1	22	25
		BAYHTRRW20*	19.92		1	34	35
		BAYHTRRW30*	29.92		2	46	50
		BAYHTRRW50*	49.84		2	70	80
25	TWE30043*****BC0, D0	BAYHTRT310*	7.51	208/3/60	1	55	70
		BAYHTRR320*	14.96		1	80	90
		BAYHTRR330*	22.47		2	107	110
		BAYHTRR350*	37.44		2	159	175
25	TWE30043*****BC0, D0	BAYHTRT310*	10.00	230/3/60	1	59	70
		BAYHTRR320*	19.92		1	88	90
		BAYHTRR330*	29.92		2	119	125
		BAYHTRR350*	49.84		2	179	200
25	TWE30044*****BC0, D0	BAYHTRT410*	10.00	460/3/60	1	28	30
		BAYHTRR420*	19.92		1	42	45
		BAYHTRR430*	29.92		2	58	60
		BAYHTRR450*	49.84		2	87	90
25	TWE3004W*****BC0, D0	BAYHTRTW10*	10.00	575/3/60	1	22	25
		BAYHTRRW20*	19.92		1	34	35
		BAYHTRRW30*	29.92		2	46	50
		BAYHTRRW50*	49.84		2	70	80

Jobsite Connections

Symbio™ Controls

Wiring shown with dashed lines is to be furnished and installed by the customer. All customer supplied wiring must be copper only and must conform to NEC and local electrical codes. Codes may require line of sight between disconnect switch and unit.

Figure 23. Symbio™ jobsite connections

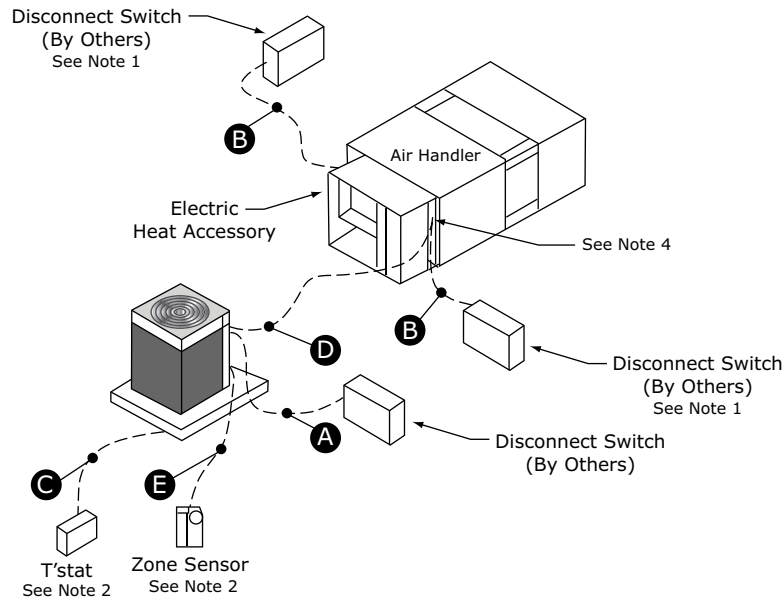

Communication signal wires require shielded twisted pairs.

Use Comlink cable with a PVC jacket, 18/1 PR, stranded shield, 25 PF/FT plenum rated for the field communication signal wiring.

Notes:

1. When electric heater accessory is used, single point power entry or dual point power entry is field optional. Single point power entry option is through electric heater only.
2. *Choose only one of the following; Thermostat, Mechanical Zone Sensor, Programmable Zone Sensor Panel or BAS Zone Sensor.
3. **

⚠ WARNING

Electrical Shock Hazard!

Failure to follow instructions below could result in death or serious injury. Properly connect the system's oversized protective earthing (grounding) terminal(s).

4. Once power wire connections are complete inside the air handler control box, seal the sheet metal entry points of the control box by using parts (neoprene gasket, grommet, and plug) shipped along with the air handler unit package.
5. For detailed controls wiring instructions, see Split System Air Conditioners Odyssey™ with Symbio™ Controls Wiring and Start-Up Installation Guide (SS-SVN016*-EN).

Important: For the EDC switch to be functional and thereby facilitate reliable unit operation, make the EDC connections from the indoor to the outdoor control boxes.

Table 79. Recommended thermostat wire size

Wire Size	Maximum Wire Length
(Gauge)	Physical distance between Unit & T'stat
22	30 Feet
20	50 Feet
18	75 Feet
16	125 Feet
14	200 Feet

Table 80. Zone sensor module wiring

Distance from Unit to Control	Recommended Wire Size
0-150 feet (0-45.7 m)	22 gauge (0.33 mm ²)
151-240 feet (46-73.1 m)	20 gauge (0.50 mm ²)
241-305 feet (73.5-117.3 m)	18 gauge (0.75 mm ²)
386-610 feet (117.7-185.9 m)	16 gauge (1.31 mm ²)
611-970 feet (186.2-295.7 m)	14 gauge (2.08 mm ²)



Dimensional Data

Cooling Condenser

Figure 24. 6, 7.5 ton condensing, single compressor – in (mm)

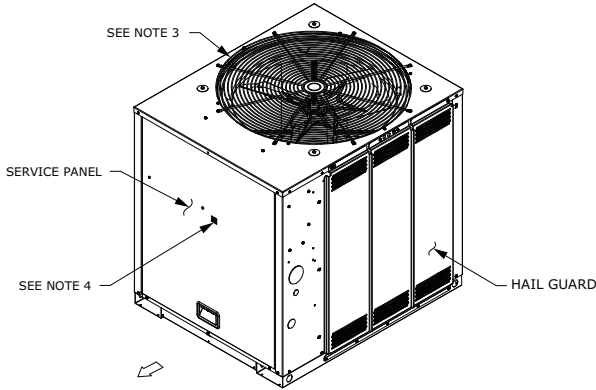

NOTES:

1. ACCESS OPENING IS FOR FIELD INSTALLED BAYLOAM ACCESSORY.
2. MINIMUM CLEARANCE FOR PROPER OPERATION IS 36" (914.4) FROM WALLS, SHRUBBERY, PRIVACY FENCES ETC. MINIMUM CLEARANCE BETWEEN ADJACENT UNITS IS 72" (1828.8). RECOMMENDED SERVICE CLEARANCE 48" (1219.2)
3. TOP DISCHARGE AREA SHOULD BE UNRESTRICTED FOR 100" (2540) MINIMUM. UNIT SHOULD BE PLACED SO ROOF RUN-OFF WATER OR FALLING SNOW FROM ROOF DOES NOT POUR/FALL DIRECTLY ON UNIT
4. OUTDOOR AIR TEMPERATURE SENSOR OPENING (DO NOT BLOCK OPENING)

SERVICE CLEARANCE
48" (1219.2) (SEE NOTE 2
FOR CLEARANCE)

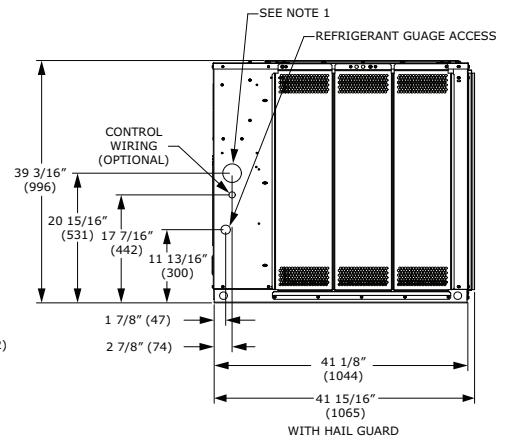
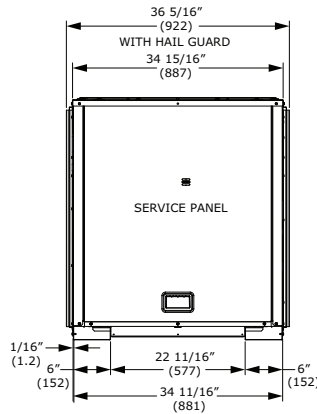
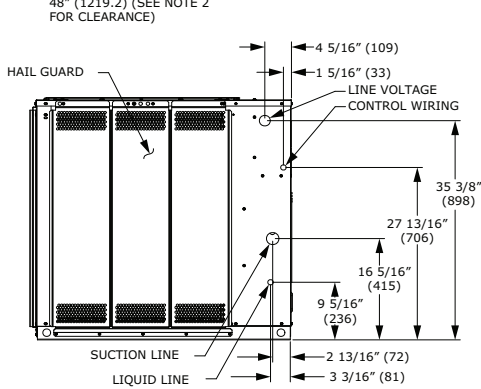

SERVICE PANEL SIDE

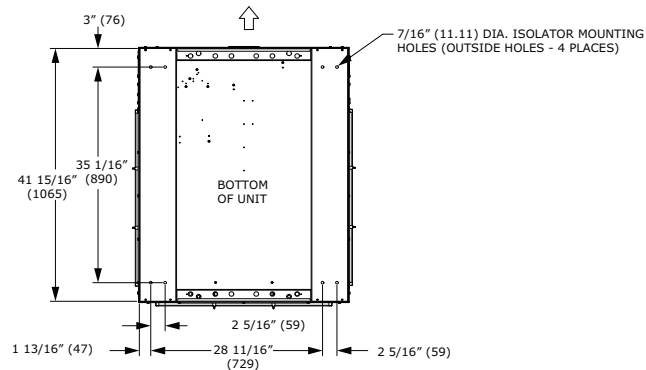
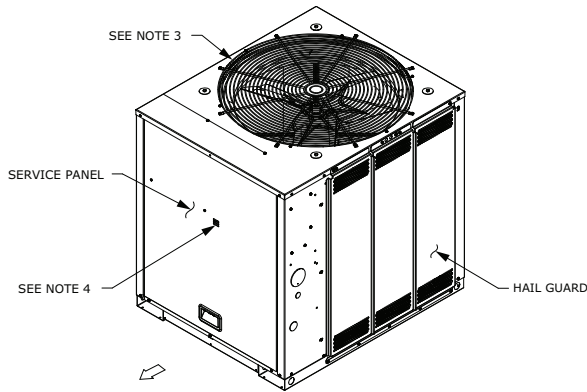

Figure 25. 6, 7.5 ton condensing, dual compressor – in (mm)



NOTES:

1. ACCESS OPENING IS FOR FIELD INSTALLED BAYLOAM ACCESSORY.
2. MINIMUM CLEARANCE FOR PROPER OPERATION IS 36" (914.4) FROM WALLS, SHRUBBERY, PRIVACY FENCES ETC. MINIMUM CLEARANCE BETWEEN ADJACENT UNITS IS 72" (1828.8). RECOMMENDED SERVICE CLEARANCE 48" (1219.2)
3. TOP DISCHARGE AREA SHOULD BE UNRESTRICTED FOR 100" (2540) MINIMUM. UNIT SHOULD BE PLACED SO ROOF RUN-OFF WATER OR FALLING SNOW FROM ROOF DOES NOT POUR/FALL DIRECTLY ON UNIT
4. OUTDOOR AIR TEMPERATURE SENSOR OPENING (DO NOT BLOCK OPENING)

SERVICE CLEARANCE
48" (1219.2) (SEE NOTE 2
FOR CLEARANCE)

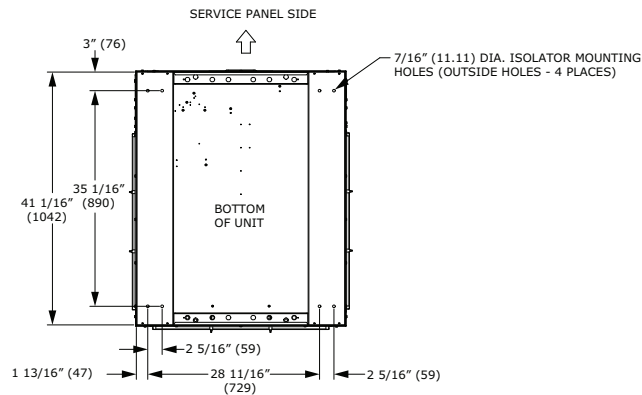
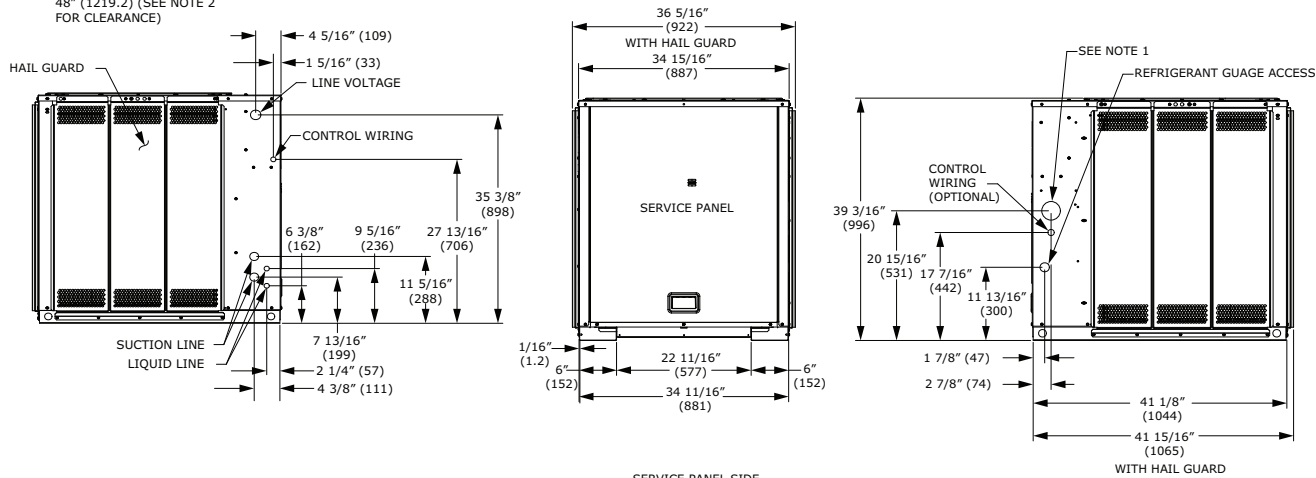

Figure 26. 10 ton condensing, manifolded compressor – in (mm)

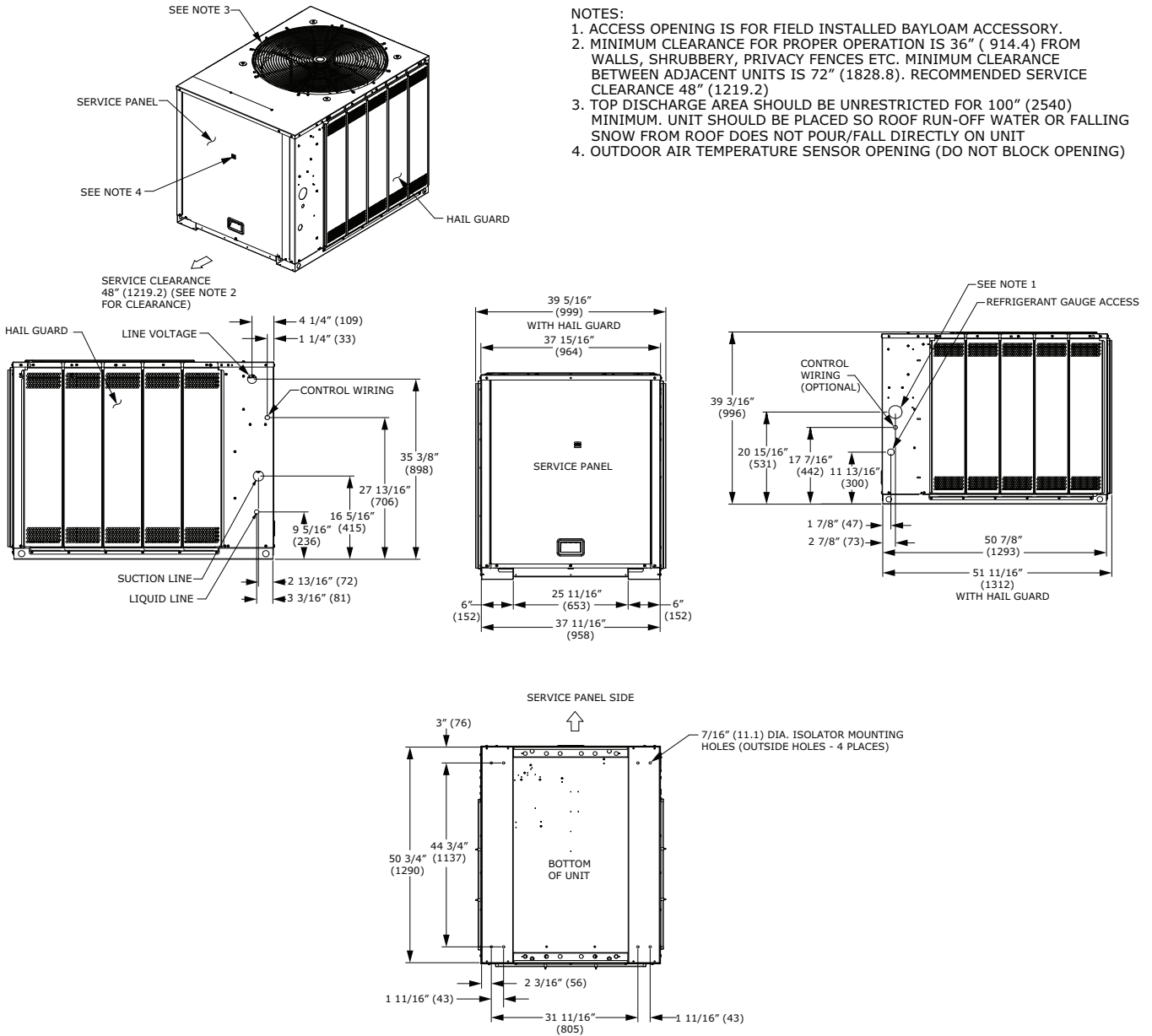
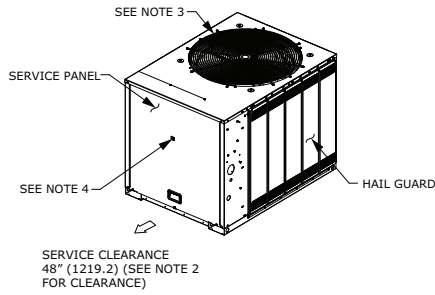
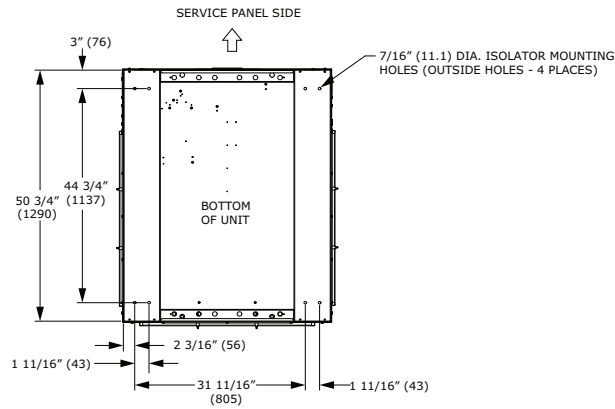
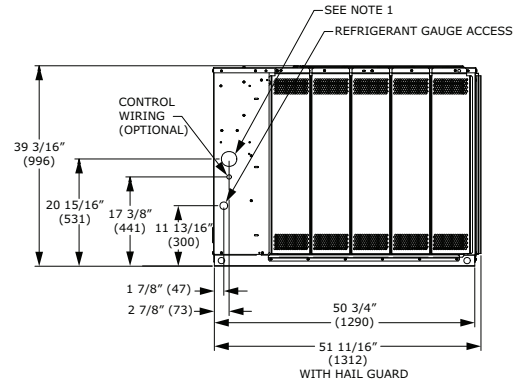
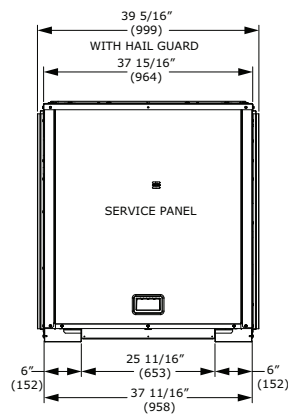
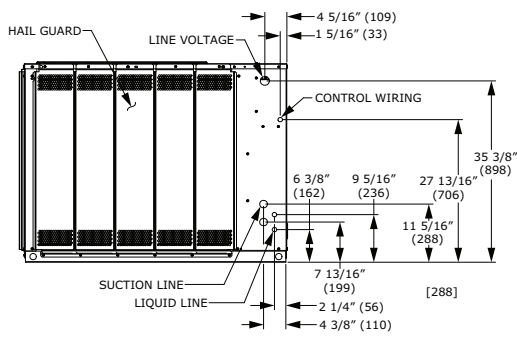

Figure 27. 10 ton condensing, dual compressor – in (mm)



NOTES:

1. ACCESS OPENING IS FOR FIELD INSTALLED BAYLOAM ACCESSORY.
2. MINIMUM CLEARANCE FOR PROPER OPERATION IS 36" (914.4) FROM WALLS, SHRUBBERY, PRIVACY FENCES ETC. MINIMUM CLEARANCE BETWEEN ADJACENT UNITS IS 72" (1828.8). RECOMMENDED SERVICE CLEARANCE 48" (1219.2)
3. TOP DISCHARGE AREA SHOULD BE UNRESTRICTED FOR 100" (2540) MINIMUM. UNIT SHOULD BE PLACED SO ROOF RUN-OFF WATER OR FALLING SNOW FROM ROOF DOES NOT POUR/FALL DIRECTLY ON UNIT
4. OUTDOOR AIR TEMPERATURE SENSOR OPENING (DO NOT BLOCK OPENING)



Dimensional Data

Figure 28. 12.5 ton condensing, dual compressor – in (mm)

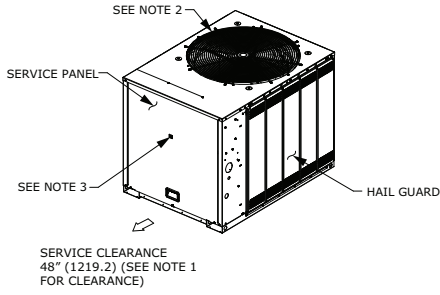

NOTES:

1. MINIMUM CLEARANCE FOR PROPER OPERATION IS 36" (914.4) FROM WALLS, SHRUBBERY, PRIVACY FENCES ETC. MINIMUM CLEARANCE BETWEEN ADJACENT UNITS IS 72" (1828.8). RECOMMENDED SERVICE CLEARANCE 48" (1219.2)
2. TOP DISCHARGE AREA SHOULD BE UNRESTRICTED FOR 100" (2540) MINIMUM. UNIT SHOULD BE PLACED SO ROOF RUN-OFF WATER OR FALLING SNOW FROM ROOF DOES NOT POUR/FALL DIRECTLY ON UNIT
3. OUTDOOR AIR TEMPERATURE SENSOR OPENING (DO NOT BLOCK OPENING)

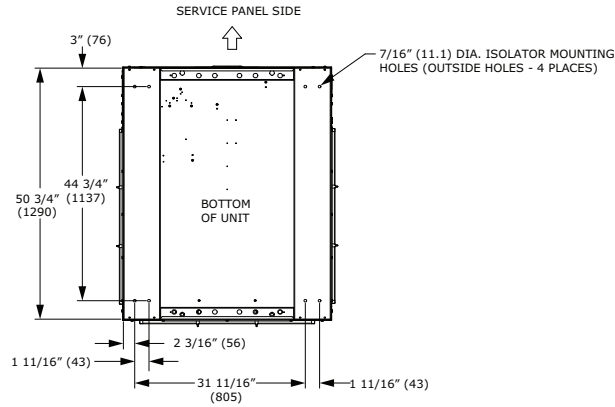
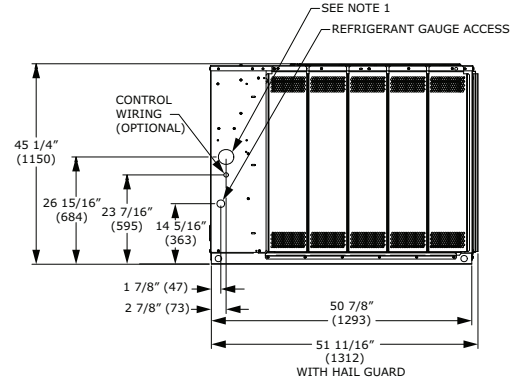
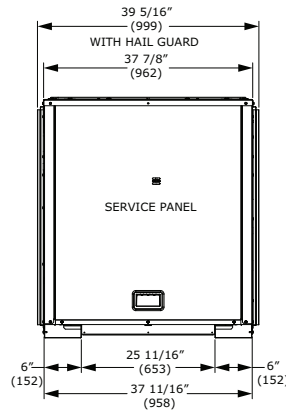
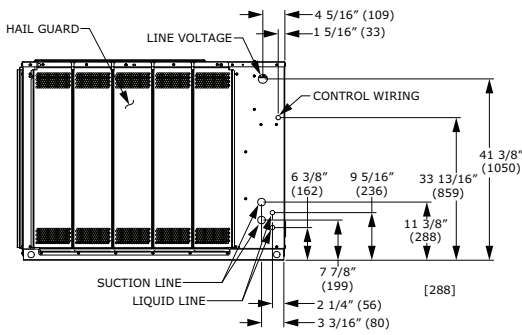
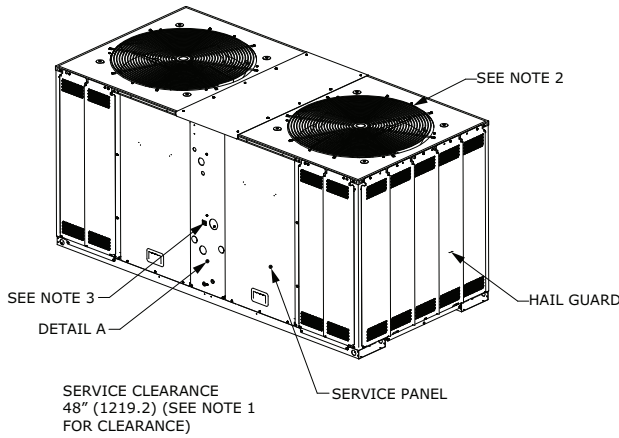
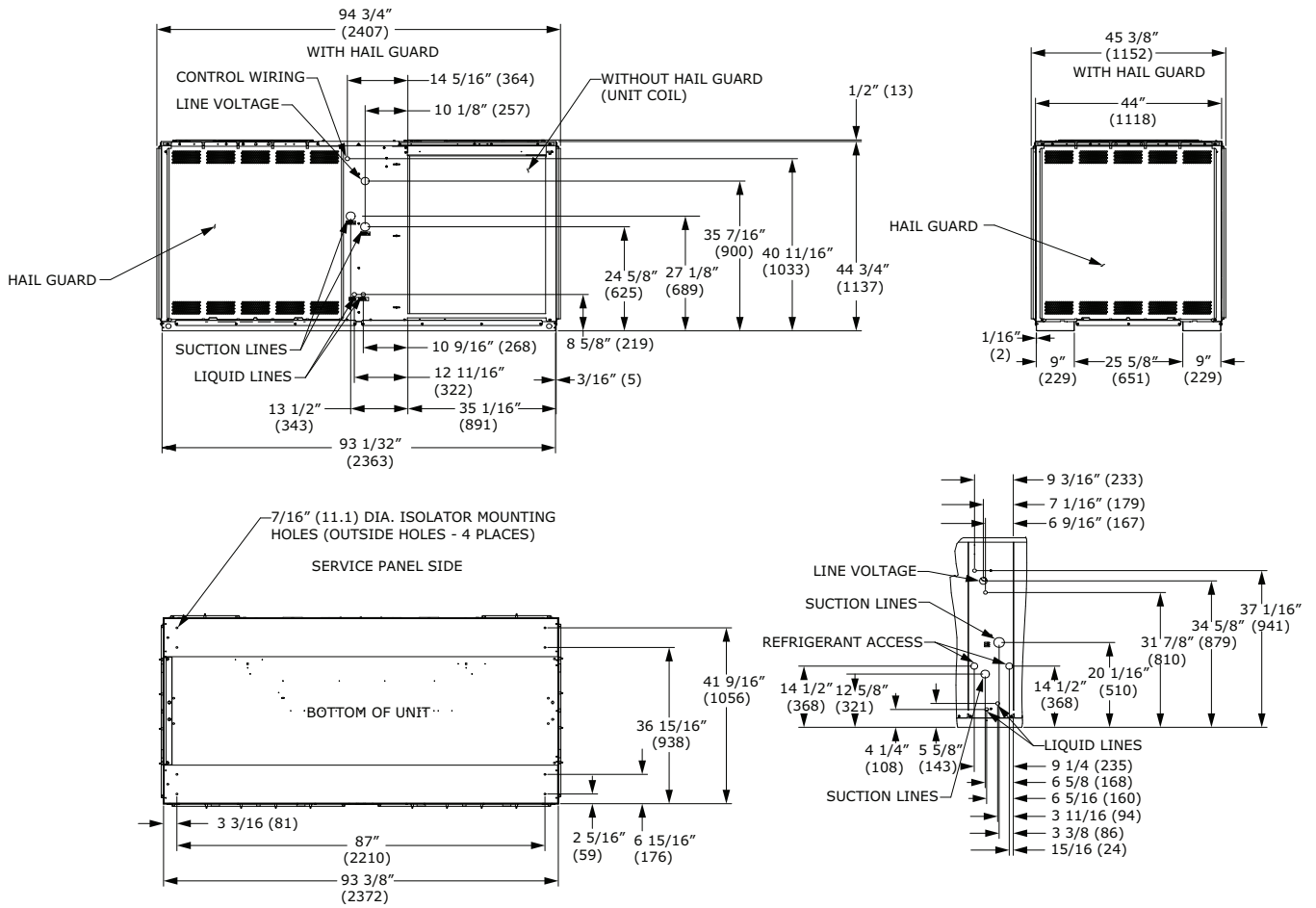

Figure 29. 15, 20 ton condensing, dual compressor – in (mm)



NOTES:

1. MINIMUM CLEARANCE FOR PROPER OPERATION IS 36" (914.4) FROM WALLS, SHRUBBERY, PRIVACY FENCES ETC. MINIMUM CLEARANCE BETWEEN ADJACENT UNITS IS 72" (1828.8). RECOMMENDED SERVICE CLEARANCE 48" (1219.2)
2. TOP DISCHARGE AREA SHOULD BE UNRESTRICTED FOR 100" (2540) MINIMUM. UNIT SHOULD BE PLACED SO ROOF RUN-OFF WATER OR FALLING SNOW FROM ROOF DOES NOT POUR/FALL DIRECTLY ON UNIT
3. OUTDOOR AIR TEMPERATURE SENSOR OPENING (DO NOT BLOCK OPENING)





Dimensional Data

Figure 30. 15, 20 ton condensing, manifolded compressor – in (mm)

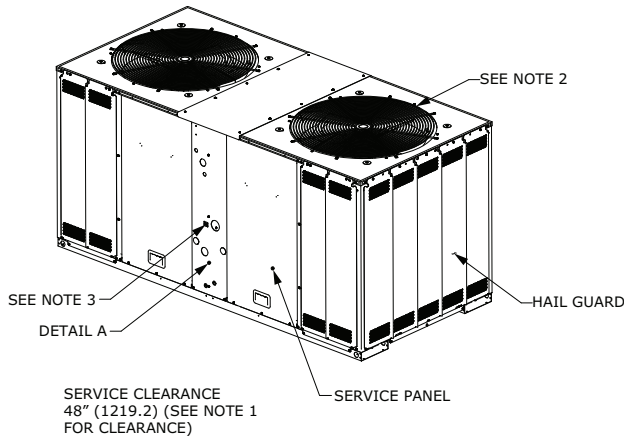

NOTES:

1. MINIMUM CLEARANCE FOR PROPER OPERATION IS 36" (914.4) FROM WALLS, SHRUBBERY, PRIVACY FENCES ETC. MINIMUM CLEARANCE BETWEEN ADJACENT UNITS IS 72" (1828.8). RECOMMENDED SERVICE CLEARANCE 48" (1219.2)
2. TOP DISCHARGE AREA SHOULD BE UNRESTRICTED FOR 100" (2540) MINIMUM. UNIT SHOULD BE PLACED SO ROOF RUN-OFF WATER OR FALLING SNOW FROM ROOF DOES NOT POUR/FALL DIRECTLY ON UNIT
3. OUTDOOR AIR TEMPERATURE SENSOR OPENING (DO NOT BLOCK OPENING)

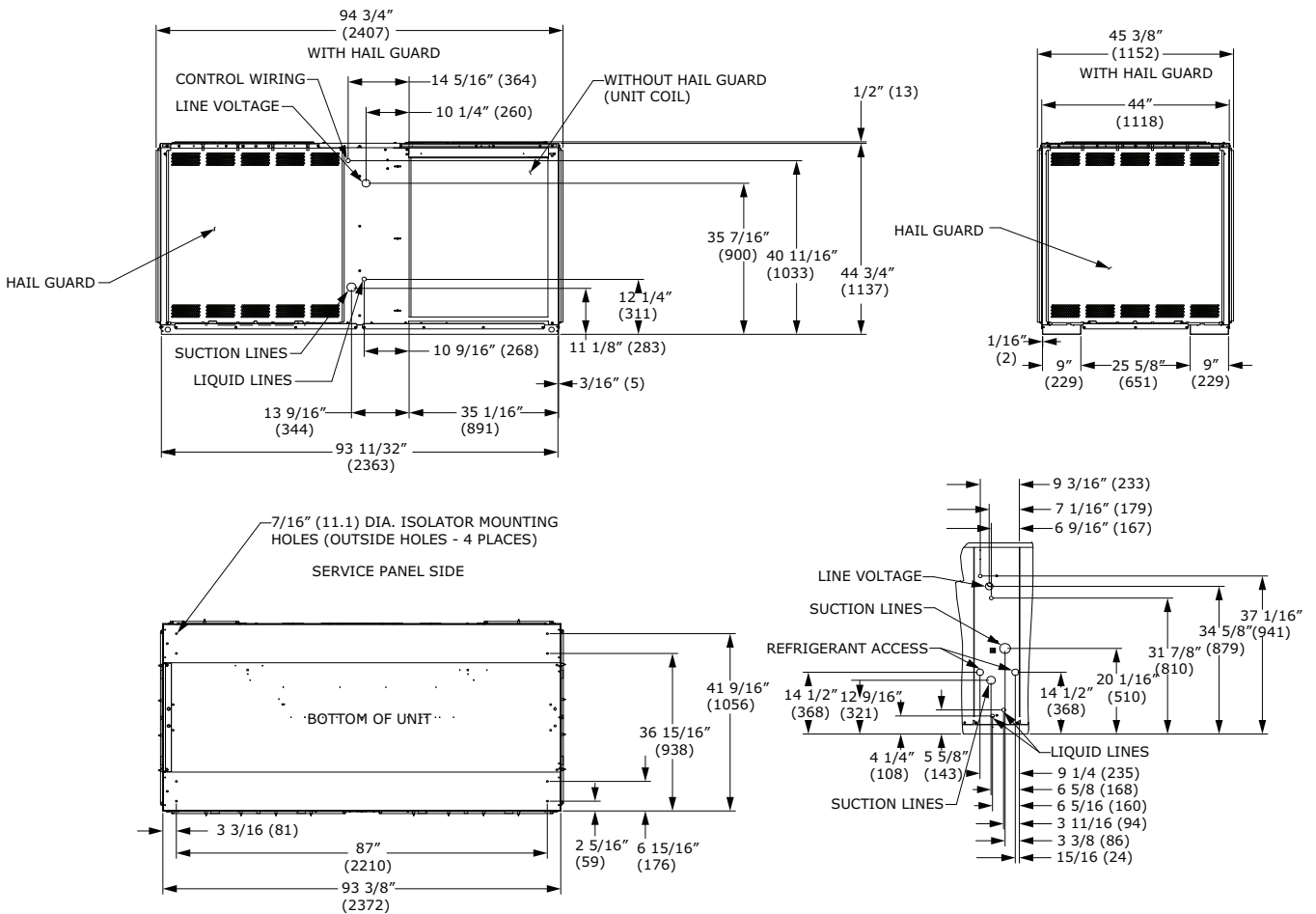
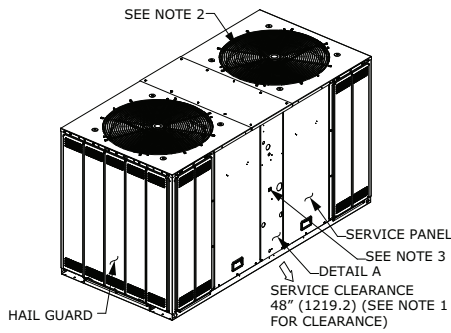
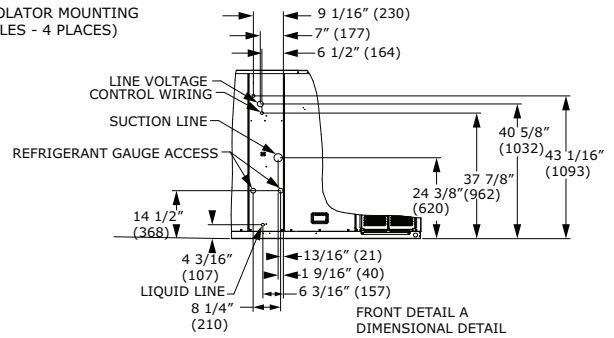
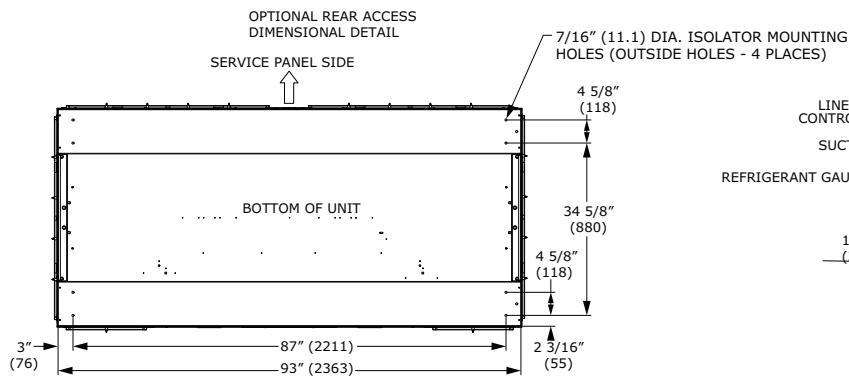
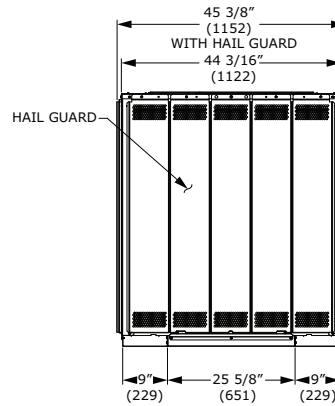
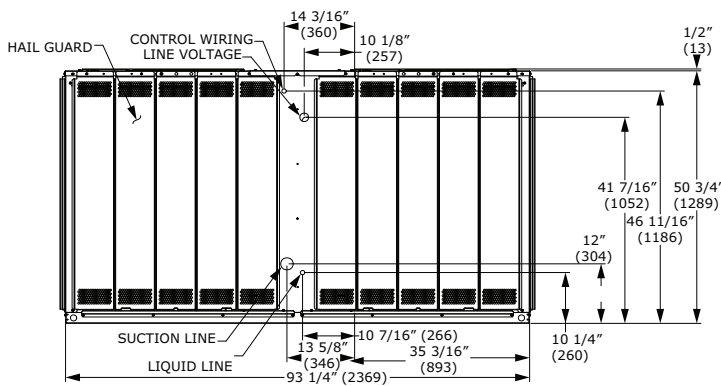

Figure 31. 25 ton condensing, manifolded compressor – in (mm)



NOTES:

1. MINIMUM CLEARANCE FOR PROPER OPERATION IS 36" (914.4) FROM WALLS, SHRUBBERY, PRIVACY FENCES ETC. MINIMUM CLEARANCE BETWEEN ADJACENT UNITS IS 72" (1828.8). RECOMMENDED SERVICE CLEARANCE 48" (1219.2)
2. TOP DISCHARGE AREA SHOULD BE UNRESTRICTED FOR 100" (2540) MINIMUM. UNIT SHOULD BE PLACED SO ROOF RUN-OFF WATER OR FALLING SNOW FROM ROOF DOES NOT POUR/FALL DIRECTLY ON UNIT
3. OUTDOOR AIR TEMPERATURE SENSOR OPENING (DO NOT BLOCK OPENING)



Air Handler

Figure 32. 5 ton air handler, single circuit – in. (mm)

Note: Duct flange is a field-installed accessory.

NOTES:

1. PANEL DEPTH 1/2" (12.7) (TYP. ALL PANELS).
2. REMOVABLE DRAIN PAN AND ATTACHED DRAIN CONNECTION MAY BE INSTALLED ON END OF UNIT IN EITHER THE VERTICAL OR HORIZONTAL CONFIGURATION, PLASTIC DRAIN PAN ACCESS PLATE ON THE END OF UNIT OPPOSITE DRAIN CONNECTION MUST BE REMOVED TO SLIDE DRAIN PAN OUT OF UNIT FOR CLEANING. ACCESS PLATE MUST BE RE-INSTALLED AFTER SLIDING DRAIN PAN BACK INTO UNIT.
3. IF PERIODIC DRAIN PAN CLEANING IS REQUIRED, ALLOW ROOM FOR PARTIAL REMOVAL OF DRAIN PAN CONNECTION AT END OF UNIT.
4. 1" (25.4) FEMALE SCHED. 40 (10.2) PVC PIPE DRAIN CONNECTION VERTICAL CONFIGURATION.
5. 1" (25.4) FEMALE SCHED. 40 (10.2) PVC PIPE DRAIN CONNECTION HORIZONTAL CONFIGURATION.

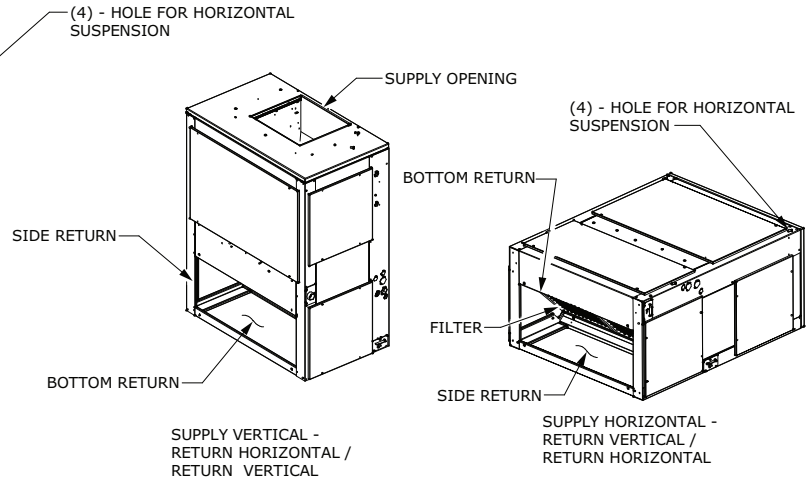
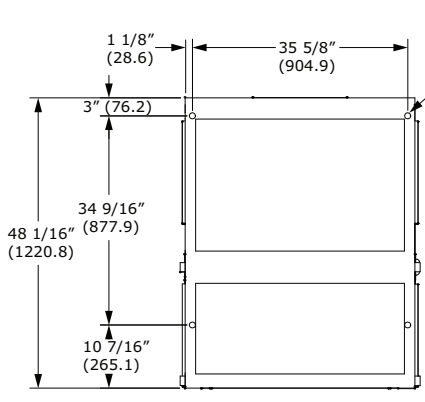
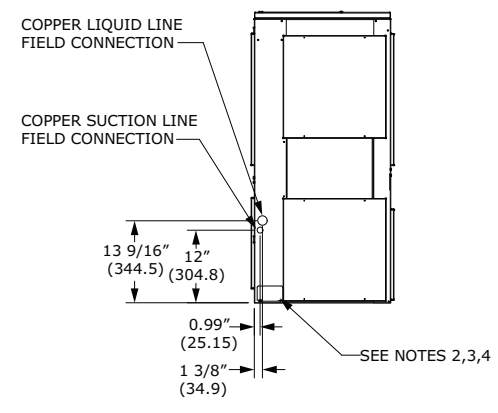
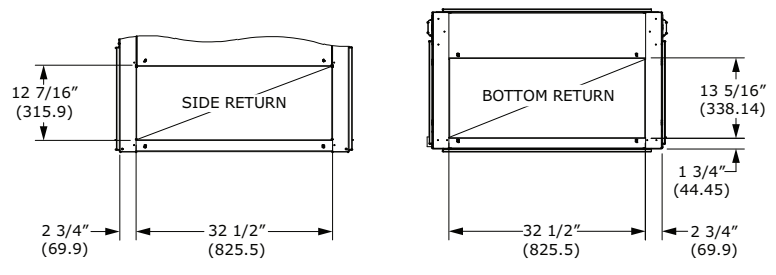
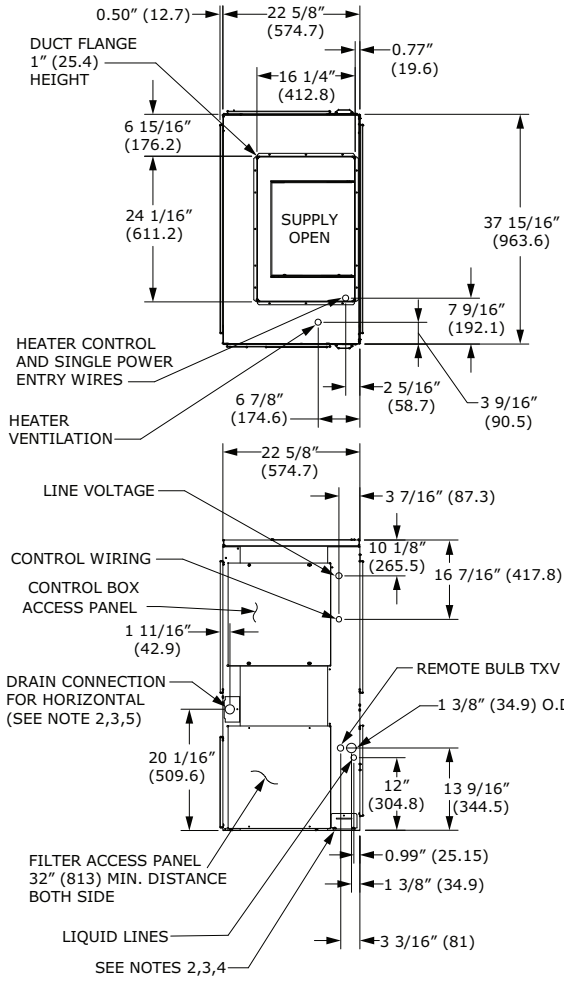
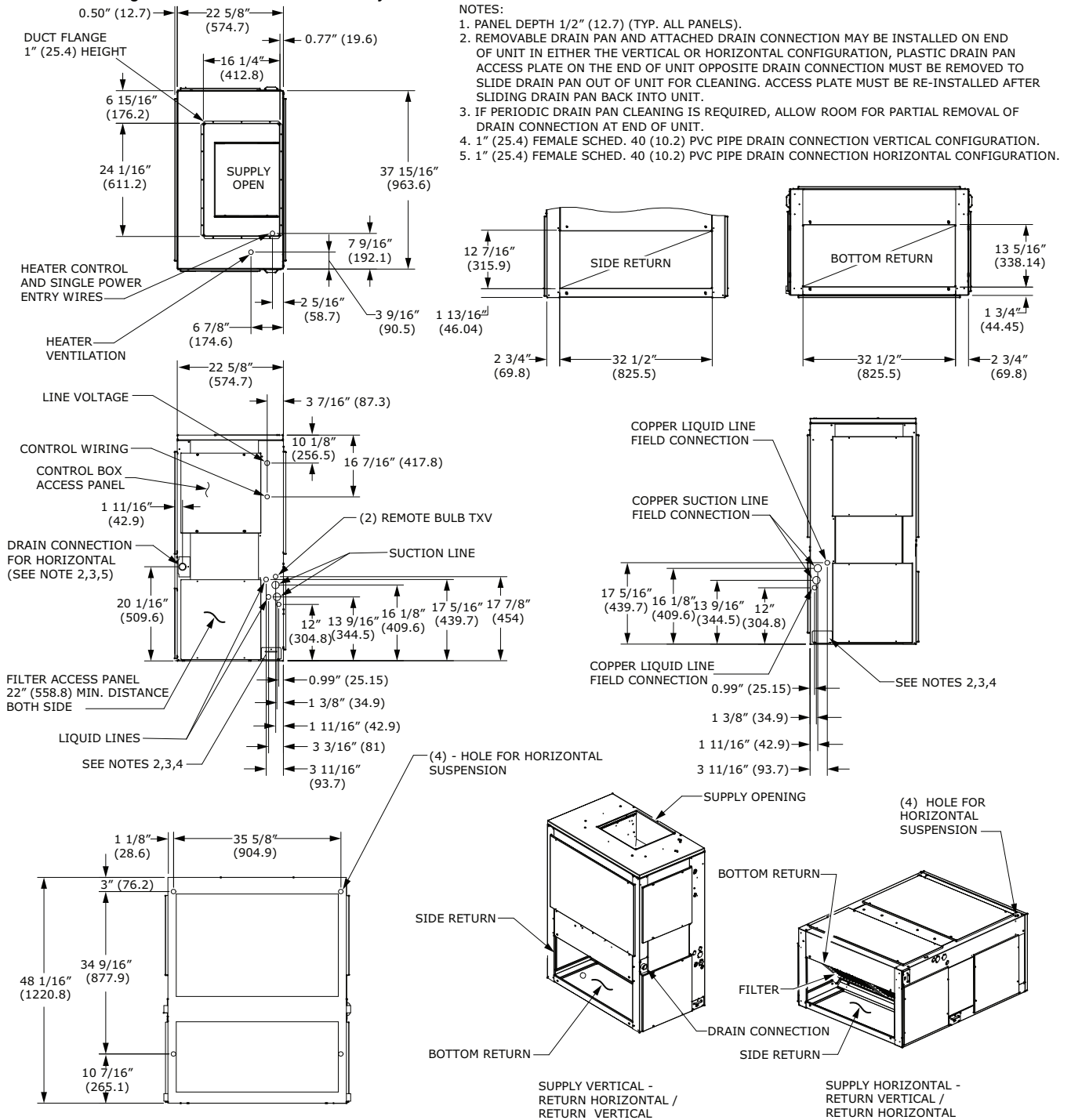

Figure 33. 5 ton air handler, dual circuit – in. (mm)

Note: Duct flange is a field-installed accessory.



Dimensional Data

Figure 34. 7.5 ton air handler, single circuit – in. (mm)

Note: Duct flange is a field-installed accessory.

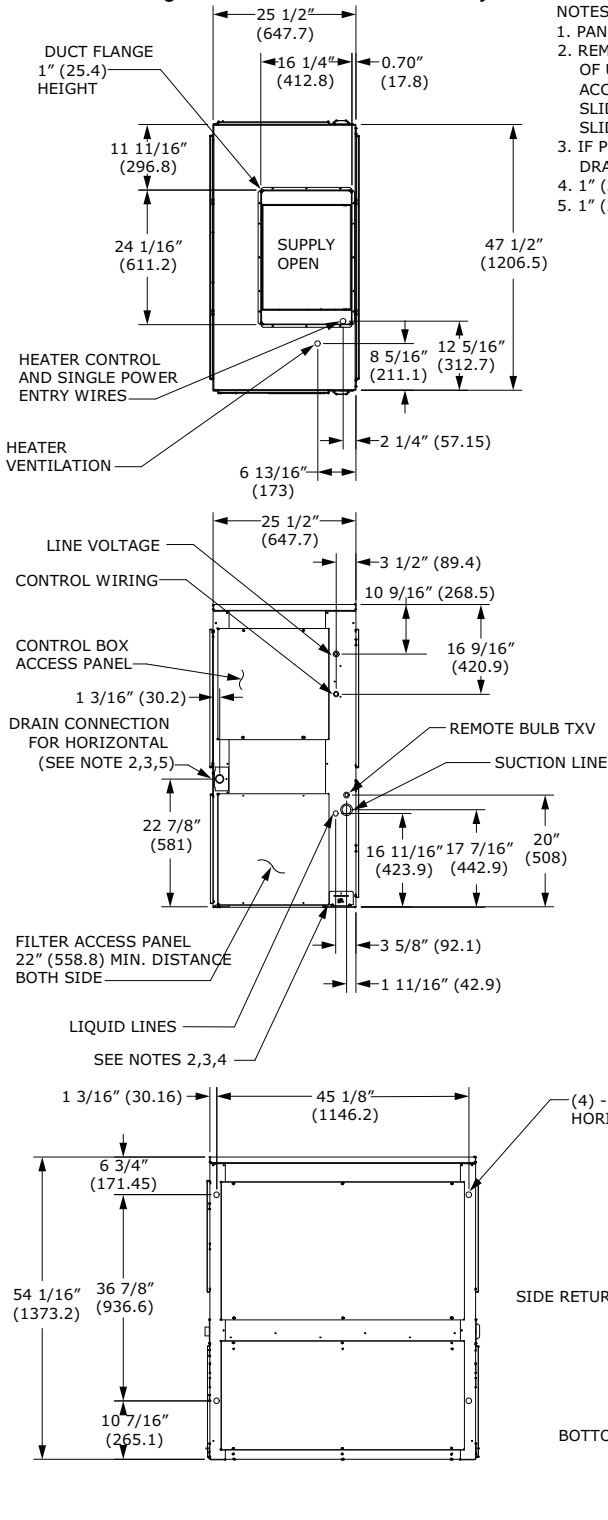

NOTES:

1. PANEL DEPTH 1/2" (12.7) (TYP. ALL PANELS).
2. REMOVABLE DRAIN PAN AND ATTACHED DRAIN CONNECTION MAY BE INSTALLED ON END OF UNIT IN EITHER THE VERTICAL OR HORIZONTAL CONFIGURATION, PLASTIC DRAIN PAN ACCESS PLATE ON THE END OF UNIT OPPOSITE DRAIN CONNECTION MUST BE REMOVED TO SLIDE DRAIN PAN OUT OF UNIT FOR CLEANING. ACCESS PLATE MUST BE RE-INSTALLED AFTER SLIDING DRAIN PAN BACK INTO UNIT.
3. IF PERIODIC DRAIN PAN CLEANING IS REQUIRED, ALLOW ROOM FOR PARTIAL REMOVAL OF DRAIN PAN CONNECTION AT END OF UNIT.
4. 1" (25.4) FEMALE SCHED. 40 (10.2) PVC PIPE DRAIN CONNECTION VERTICAL CONFIGURATION.
5. 1" (25.4) FEMALE SCHED. 40 (10.2) PVC PIPE DRAIN CONNECTION HORIZONTAL CONFIGURATION.

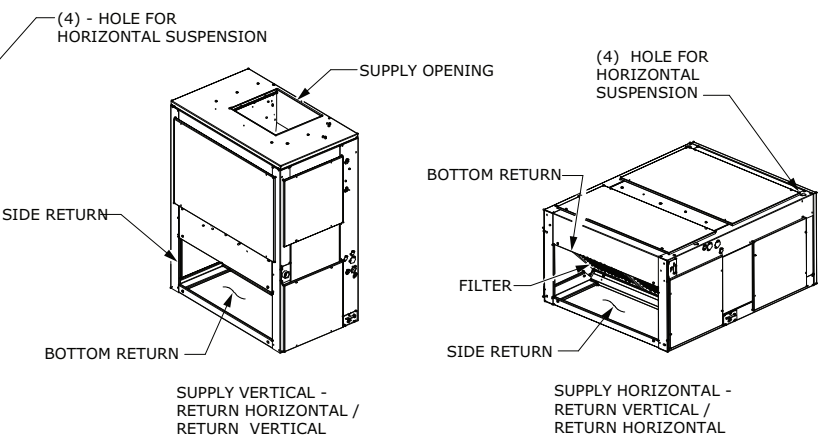
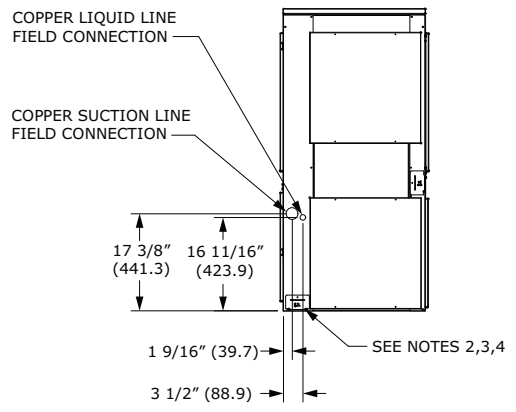
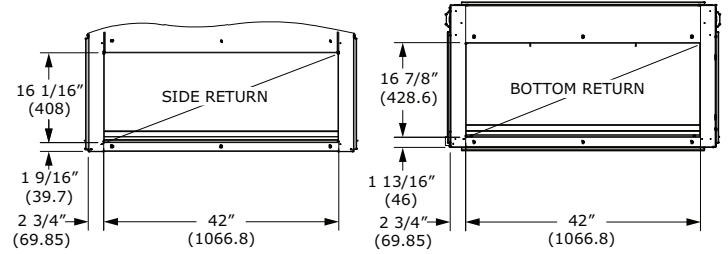
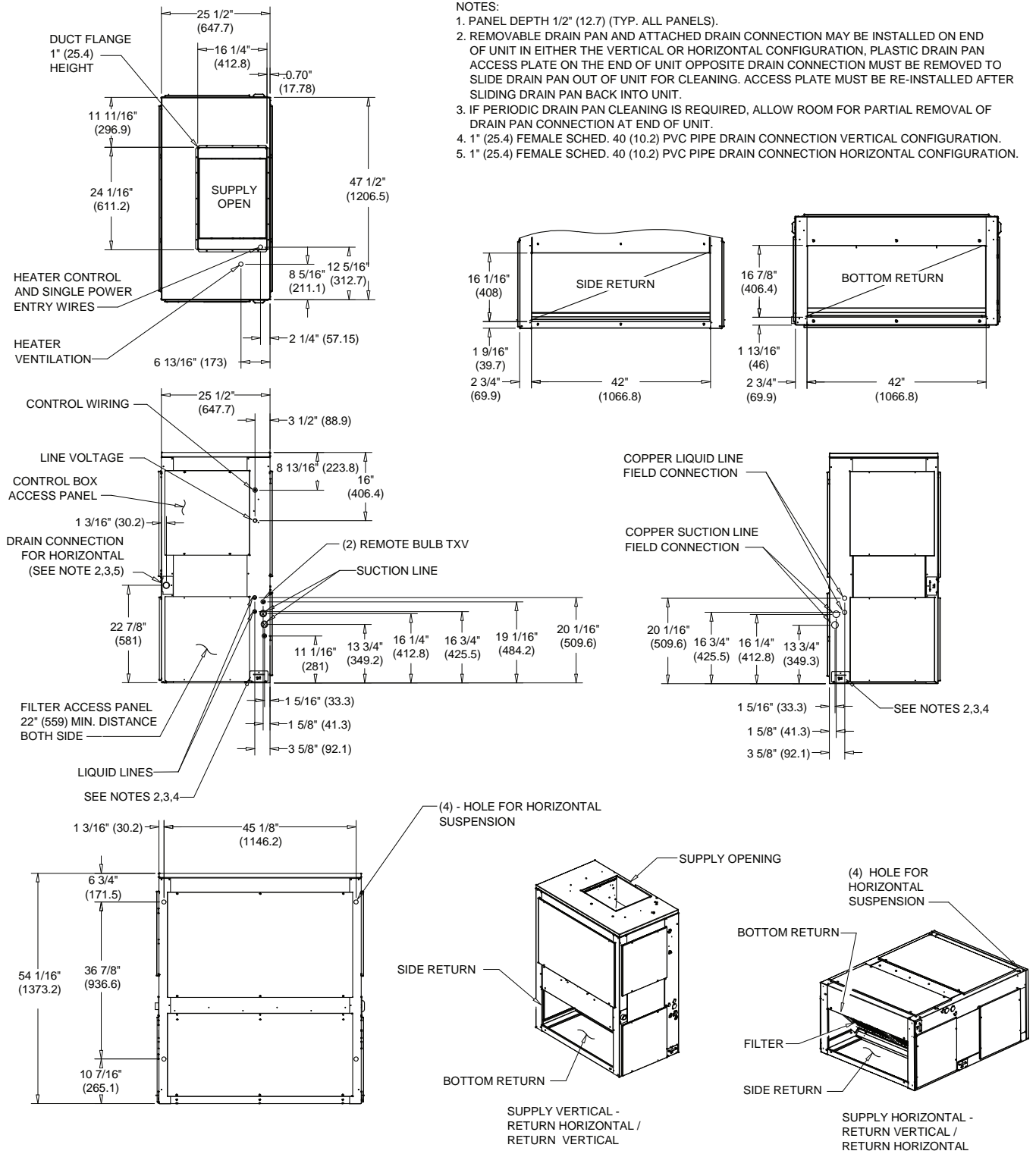

Figure 35. 6, 7.5 ton air handler, dual circuit – in. (mm)

Note: Duct flange is a field-installed accessory.



Dimensional Data

Figure 36. 10 ton air handler, single circuit – in. (mm)

Note: Duct flange is a field-installed accessory.

NOTES:

1. PANEL DEPTH 1/2" (12.7) (TYP. ALL PANELS).
2. REMOVABLE DRAIN PAN AND ATTACHED DRAIN CONNECTION MAY BE INSTALLED ON END OF UNIT IN EITHER THE VERTICAL OR HORIZONTAL CONFIGURATION, PLASTIC DRAIN PAN ACCESS PLATE ON THE END OF UNIT OPPOSITE DRAIN CONNECTION MUST BE REMOVED TO SLIDE DRAIN PAN OUT OF UNIT FOR CLEANING. ACCESS PLATE MUST BE RE-INSTALLED AFTER SLIDING DRAIN PAN BACK INTO UNIT.
3. IF PERIODIC DRAIN PAN CLEANING IS REQUIRED, ALLOW ROOM FOR PARTIAL REMOVAL OF DRAIN PAN CONNECTION AT END OF UNIT.
4. 1" (25.4) FEMALE SCHED. 40 (10.2) PVC PIPE DRAIN CONNECTION VERTICAL CONFIGURATION.
5. 1" (25.4) FEMALE SCHED. 40 (10.2) PVC PIPE DRAIN CONNECTION HORIZONTAL CONFIGURATION.

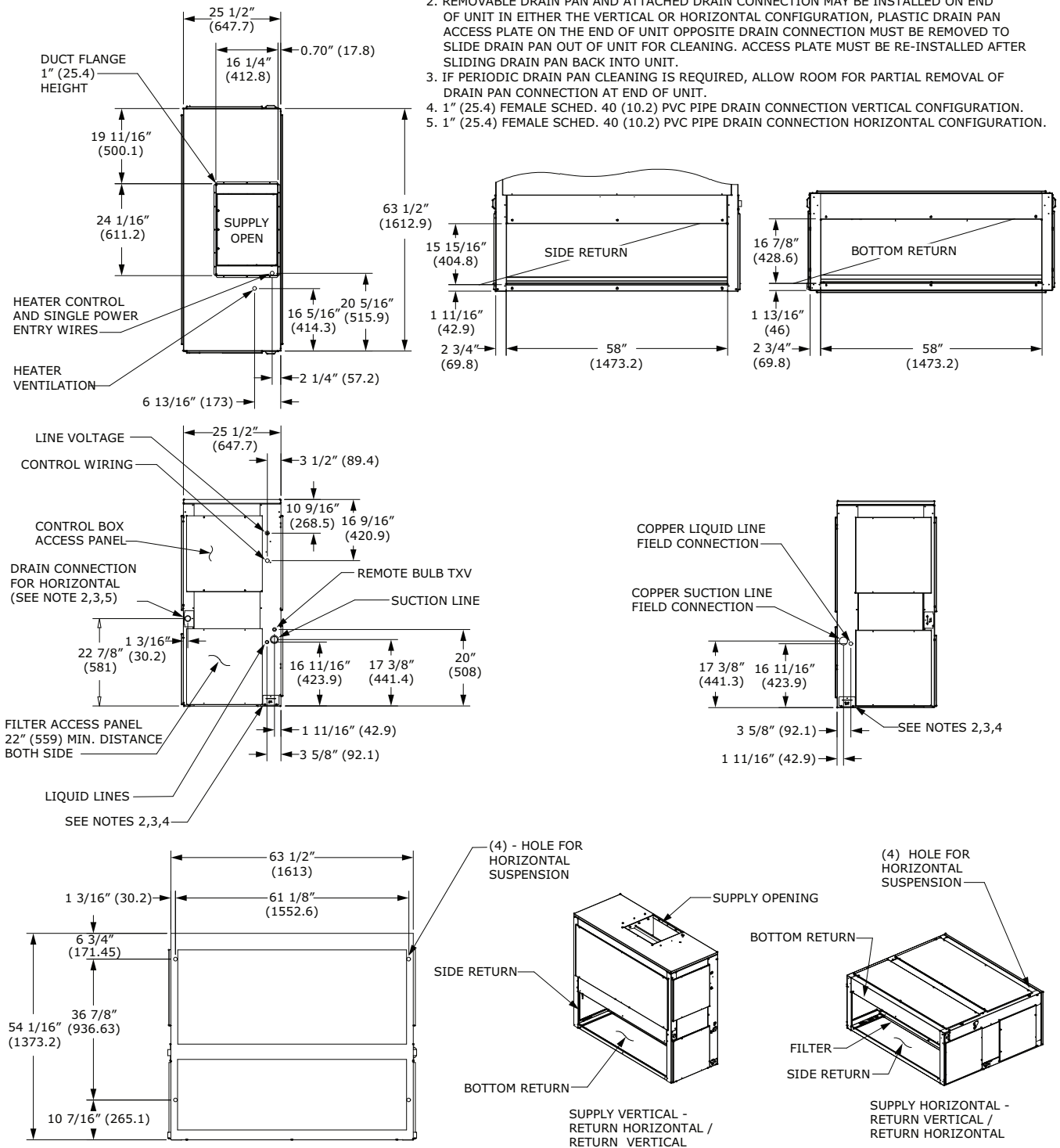
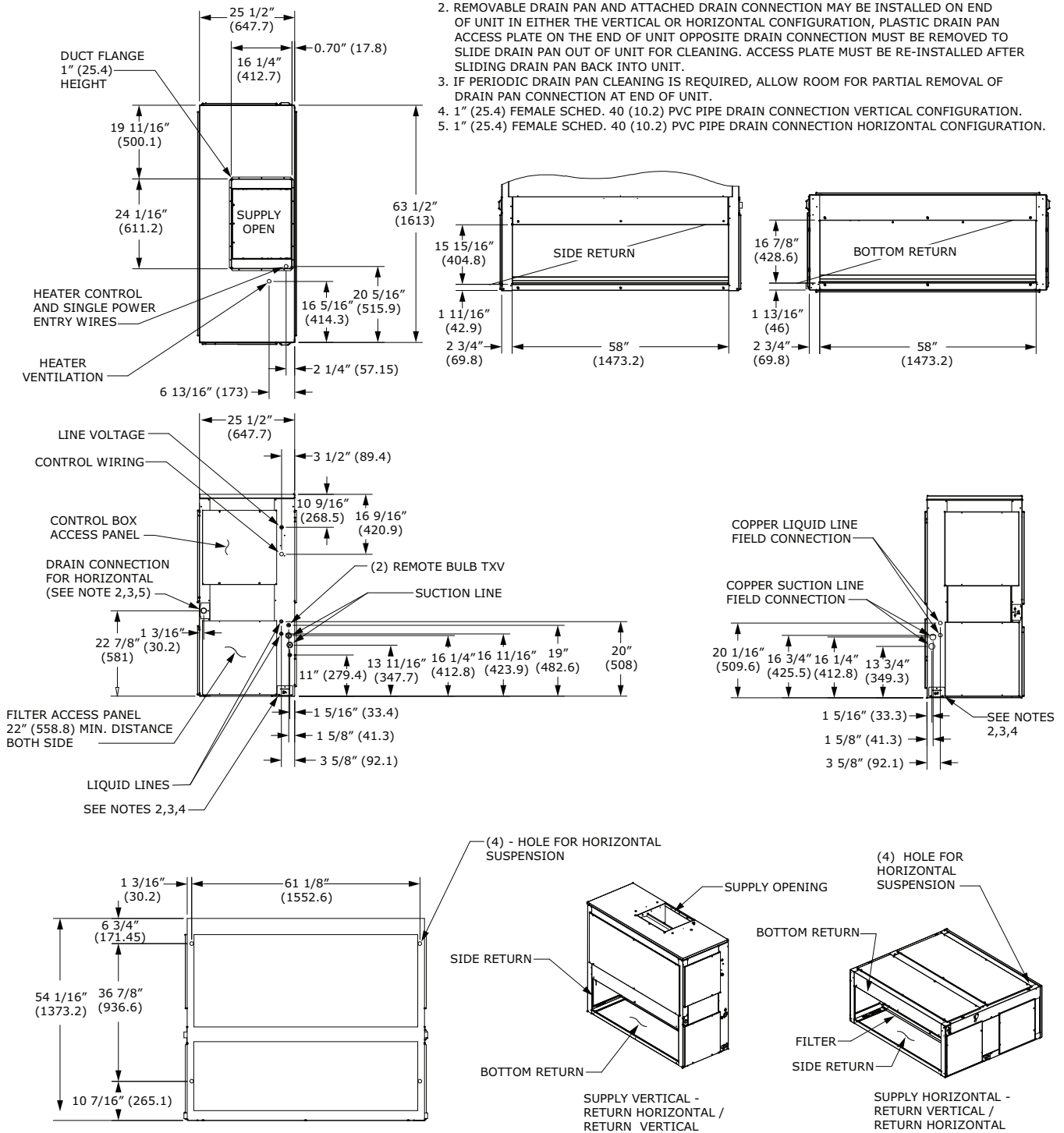

Figure 37. 10 ton air handler, dual circuit – in. (mm)

Note: Duct flange is a field-installed accessory.

NOTES:

1. PANEL DEPTH 1/2" (12.7) (TYP. ALL PANELS).
2. REMOVABLE DRAIN PAN AND ATTACHED DRAIN CONNECTION MAY BE INSTALLED ON END OF UNIT IN EITHER THE VERTICAL OR HORIZONTAL CONFIGURATION, PLASTIC DRAIN PAN ACCESS PLATE ON THE END OF UNIT OPPOSITE DRAIN CONNECTION MUST BE REMOVED TO SLIDE DRAIN PAN OUT OF UNIT FOR CLEANING. ACCESS PLATE MUST BE RE-INSTALLED AFTER SLIDING DRAIN PAN BACK INTO UNIT.
3. IF PERIODIC DRAIN PAN CLEANING IS REQUIRED, ALLOW ROOM FOR PARTIAL REMOVAL OF DRAIN PAN CONNECTION AT END OF UNIT.
4. 1" (25.4) FEMALE SCHED. 40 (10.2) PVC PIPE DRAIN CONNECTION VERTICAL CONFIGURATION.
5. 1" (25.4) FEMALE SCHED. 40 (10.2) PVC PIPE DRAIN CONNECTION HORIZONTAL CONFIGURATION.



Dimensional Data

Figure 38. 12.5, 15 ton air handler, dual circuit – in. (mm)

Note: Duct flange is a field-installed accessory.

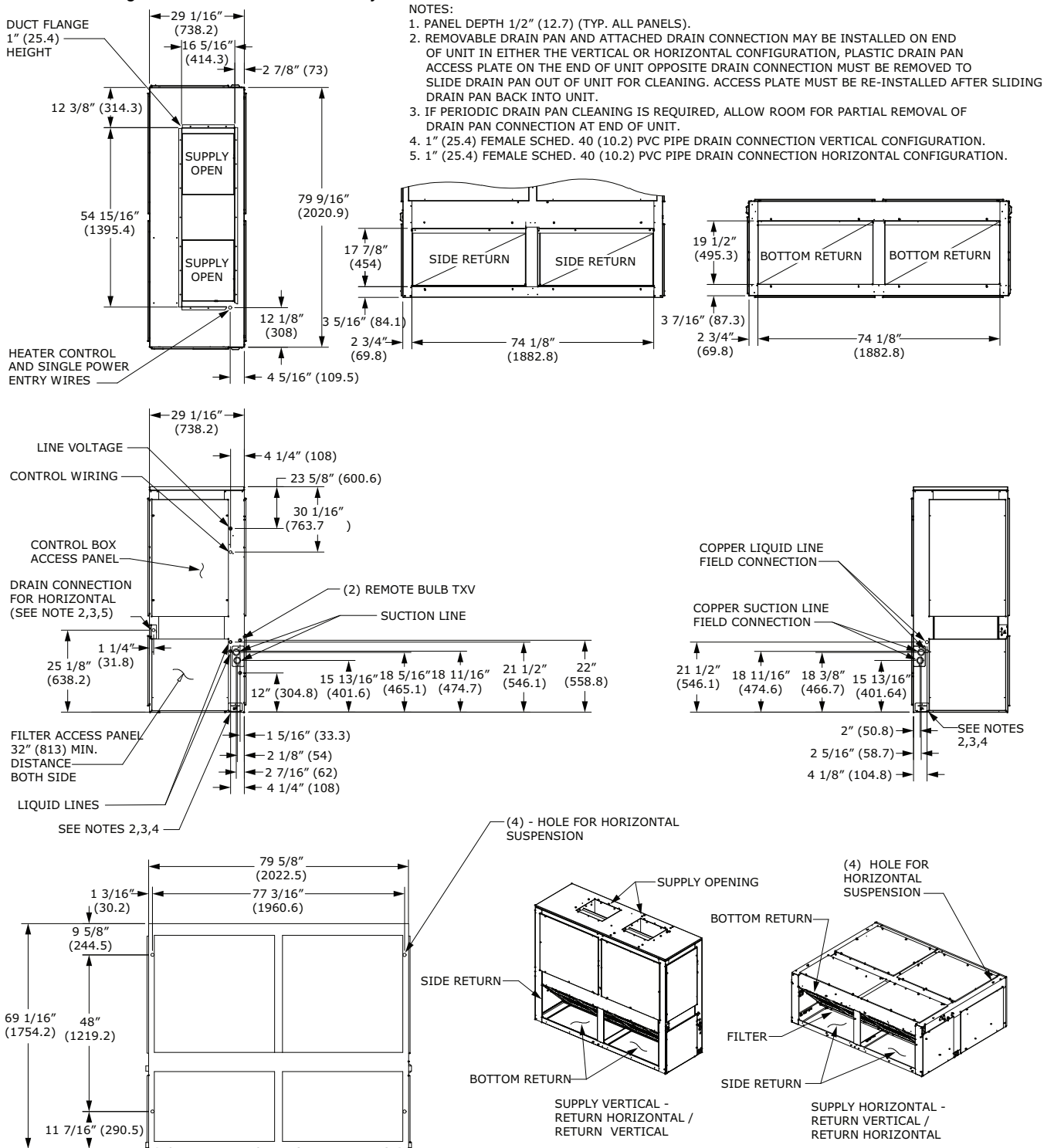
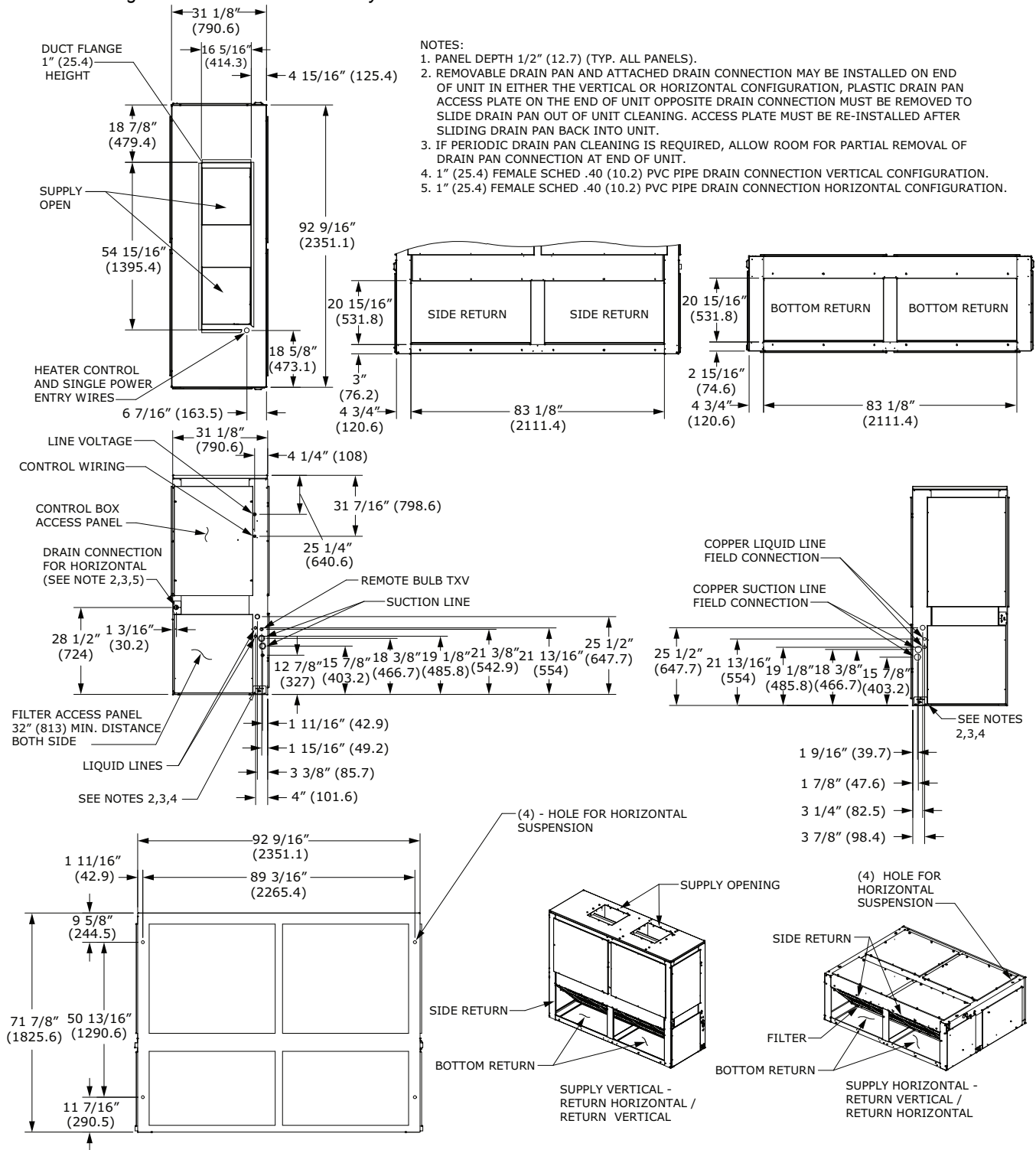

Figure 39. 20, 25 ton air handler, dual circuit – in. (mm)

Note: Duct flange is a field-installed accessory.



Accessories

Figure 40. Rubber isolator accessory dimensions

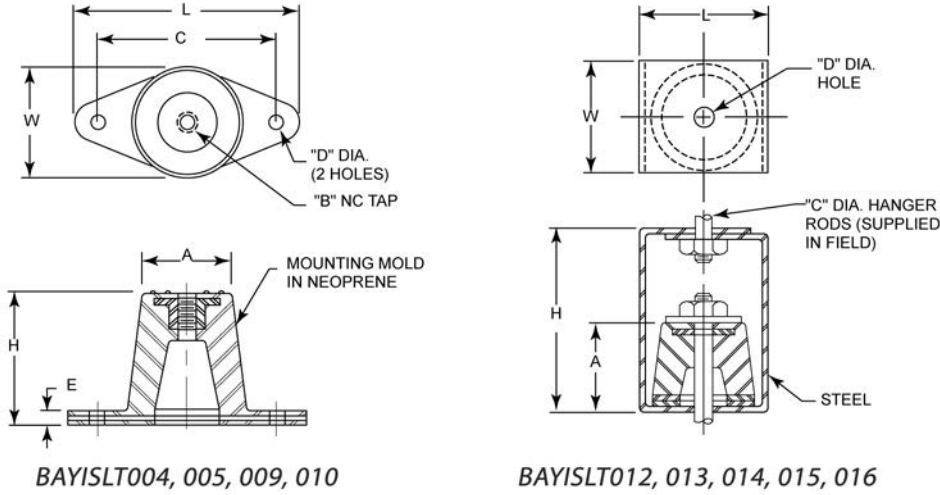

BAYISLT004, 005, 009, 010

BAYISLT012, 013, 014, 015, 016

Table 81. Rubber isolator accessory dimensions – in (mm)

Model No.	L	W	H	A	B	C	D	E
BAYISLT004	3-1/8 (79.375)	1-3/4 (44.45)	1-1/4 (31.75)	1-1/4 (31.75)	3/8 (9.525)	2-3/8 (60.325)	3/8 (9.525)	1/4 (6.35)
BAYISLT005	3-7/8 (98.425)	2-3/8 (60.325)	1-3/4 (44.45)	1-3/4 (44.45)	3/8 (9.525)	3 (76.2)	3/8 (9.525)	1/4 (6.35)
BAYISLT009	3-7/8 (98.425)	2-3/8 (60.325)	1-3/4 (44.45)	1-3/4 (44.45)	3/8 (9.525)	3 (76.2)	3/8 (9.525)	1/4 (6.35)
BAYISLT010	3-7/8 (98.425)	2-3/8 (60.325)	1-3/4 (44.45)	1-3/4 (44.45)	3/8 (9.525)	3 (76.2)	3/8 (9.525)	1/4 (6.35)
BAYISLT013	2-1/4 (57.15)	2 (50.8)	3 (76.2)	1-3/8 (34.925)	3/4 (19.05)	3/8 (9.525)	1/2 (12.7)	—
BAYISLT014	2-1/4 (57.15)	2 (50.8)	3 (76.2)	1-3/8 (34.925)	3/4 (19.05)	3/8 (9.525)	1/2 (12.7)	—
BAYISLT015	2-1/4 (57.15)	2 (50.8)	3 (76.2)	1-3/8 (34.925)	3/4 (19.05)	3/8 (9.525)	1/2 (12.7)	—
BAYISLT012	3 (76.2)	2-1/4 (57.15)	4-1/2 (114.3)	1-7/8 (47.625)	1/4 (6.35)	5/8 (15.875)	3/4 (19.05)	—
BAYISLT015 ^(a)	3 (76.2)	2-1/4 (57.15)	4-1/2 (114.3)	1-7/8 (47.625)	1/4 (6.35)	5/8 (15.875)	3/4 (19.05)	—
BAYISLT016	3 (76.2)	2-1/4 (57.15)	4-1/2 (114.3)	1-7/8 (47.625)	1/4 (6.35)	5/8 (15.875)	3/4 (19.05)	—

Note: BAYISLT015 contains a quantity 2 of the 2-1/4 x 2 x 3 isolators and quantity of 3 of the 3 x 2-1/4 x 4-1/2 isolators.

Figure 41. Spring isolator accessory dimensions – in (mm)

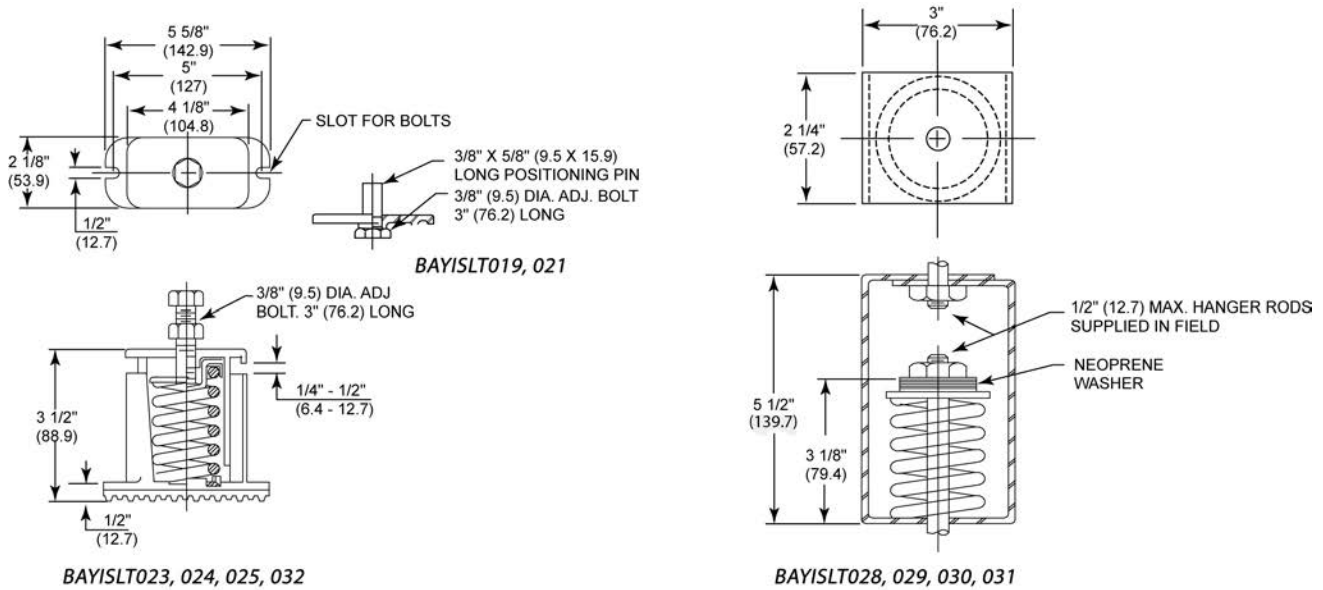
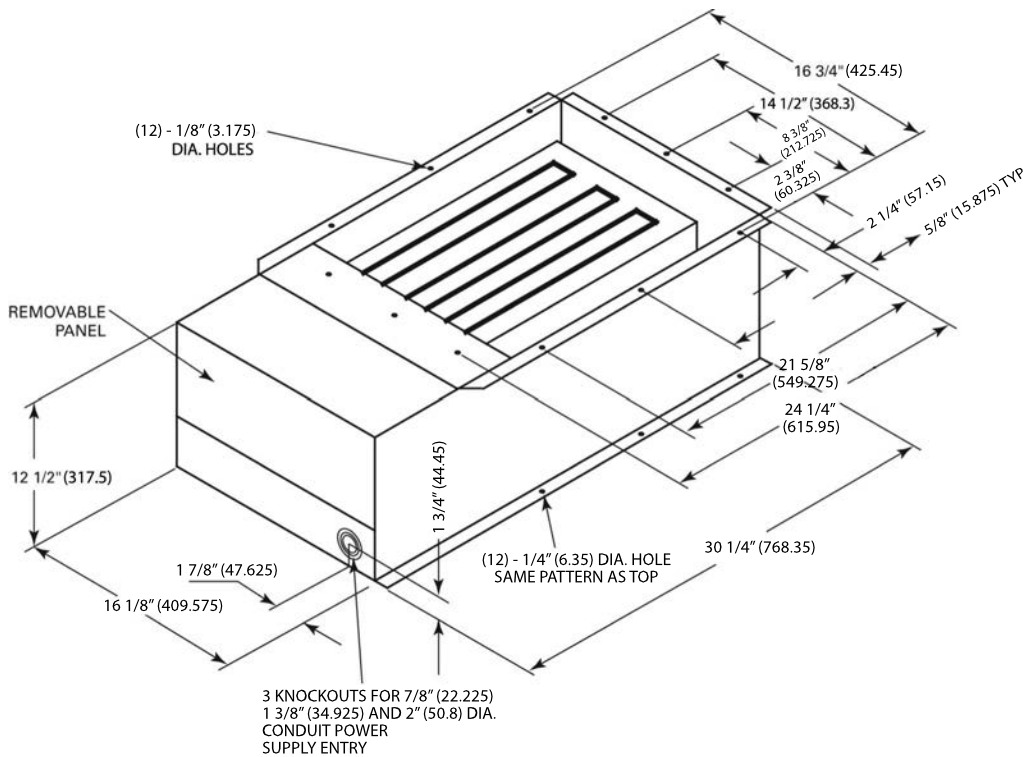

Figure 42. Electric heater accessory for 5-10 ton air handlers – in (mm)





Dimensional Data

Figure 43. Electric heater accessory for 12.5-25 ton air handlers – in (mm)

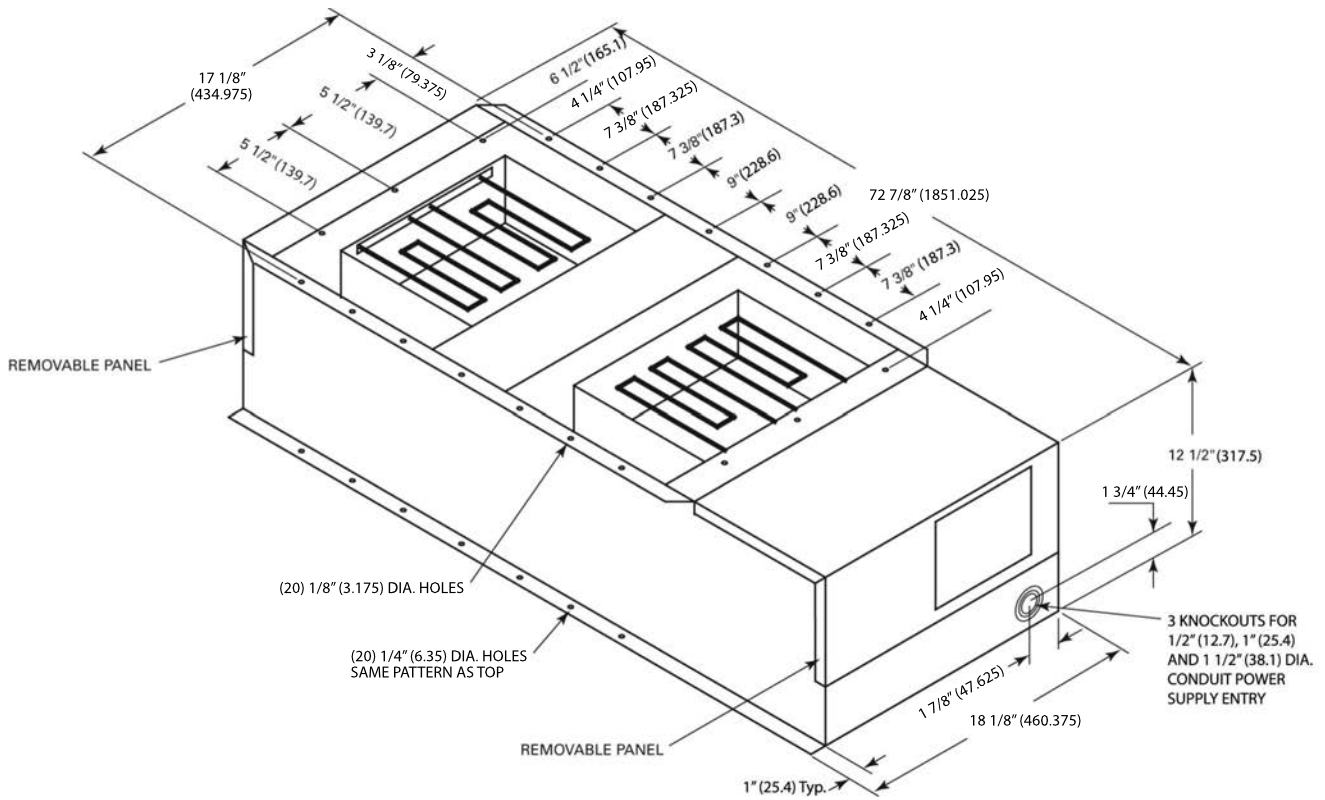
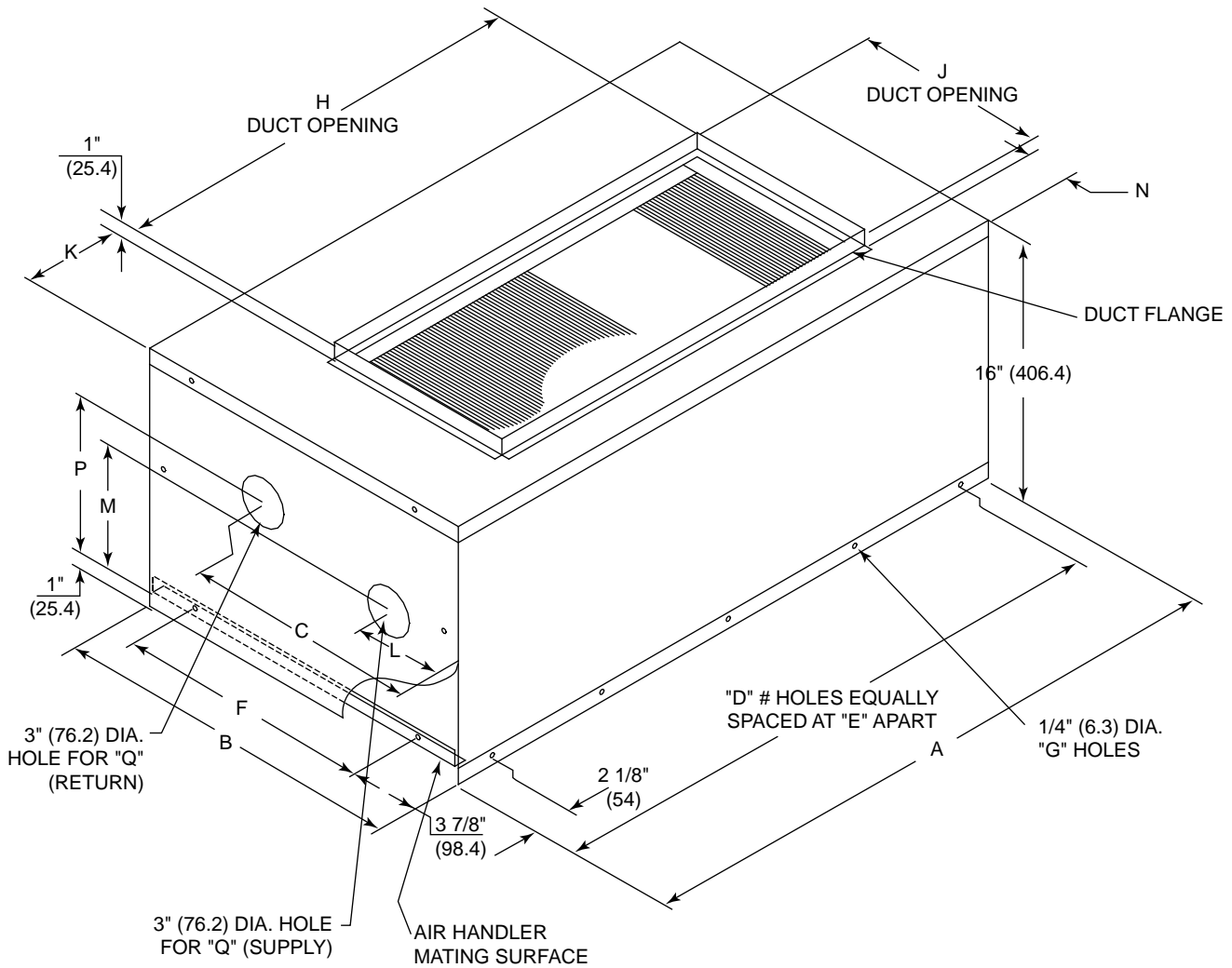

Figure 44. Hot water coil accessory – in (mm)

Note: Duct flange available as kit. See accessories chapter for details.

Table 82. Hot water coil accessory – in (mm)

Model No.	A	B	C	D	E	F	G	H
BAYWATR027	38.14 (969)	22.74 (576)	13.74 (349)	5 (127)	9 (229)	13.65 (347)	16 (406)	26 (660)
BAYWATR028	47.74 (1213)	25.74 (654)	15.95 (405)	5 (127)	10.84 (275)	17.17 (436)	16 (406)	30 (762)
BAYWATR029	63.84 (1621)	25.74 (654)	15.95 (405)	6 (152)	11.84 (301)	17.16 (436)	18 (457)	36 (914)
BAYWATR030	79.74 (2025)	29.18 (741)	14.36 (365)	8 (203)	10.85 (276)	19.67 (500)	22 (559)	51 (1295)
BAYWATR031	92.74 (2356)	31.24 (793)	16.48 (419)	8 (203)	10.85 (276)	19.67 (500)	22 (559)	64 (1626)
Model No.	J	K	L	M	N	P	Q	
BAYWATR027	12 (305)	6 (152)	4.94 (125)	7.79 (198)	2.88 (73)	10.24 (260)	2 NPT (51) NPTI	
BAYWATR028	18 (457)	8.88 (225)	8.45 (215)	10.27 (261)	2.88 (73)	7.77 (197)	2.5 NPTI (64) NPTI	
BAYWATR029	18 (457)	13.88 (352)	8.45 (215)	10.03 (255)	2.88 (73)	7.58 (192)	2.5 NPTI (64) NPTI	
BAYWATR030	18 (457)	14.25 (362)	6.86 (174)	9.91 (252)	1.88 (48)	7.41 (188)	2.5 NPTI (64) NPTI	

Dimensional Data

Table 82. Hot water coil accessory – in (mm) (continued)

Model No.	J	K	L	M	N	P	Q
BAYWATR031	18 (457)	14.25 (362)	8.98 (228)	9.88 (251)	3.75 (95)	7.38 (187)	2.5 NPTI (64) NPTI

Note: Hot Water Coil Dimensions - inches (millimeters)

Figure 45. Steam coil accessory – in (mm)

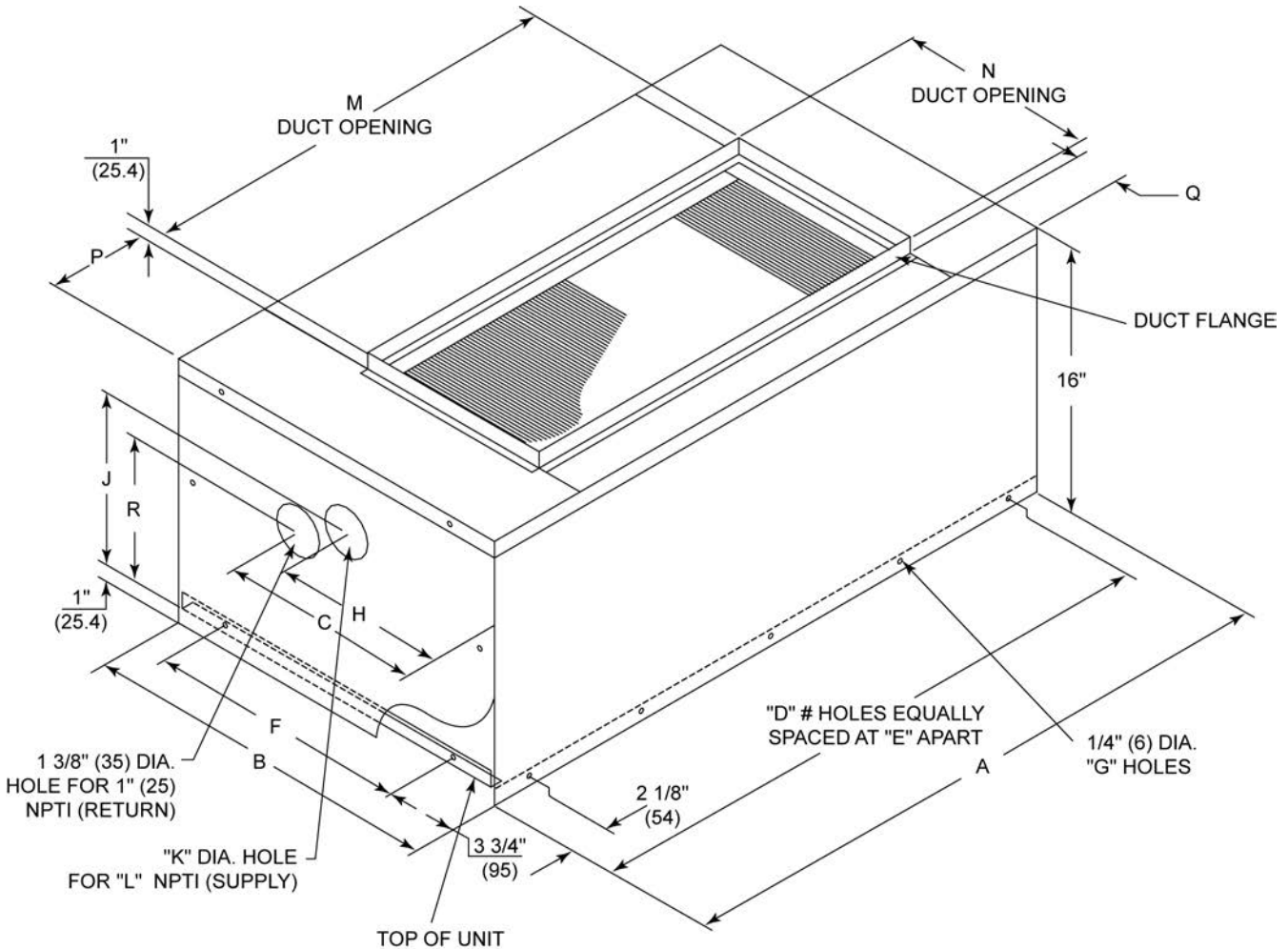

Note: Duct flange available as kit. See accessories chapter for details.

Table 83. Steam coil accessory – in (mm)

Model No.	A	B	C	D	E	F	G	H	J	K
BAYWATR022	38.14 (969)	22.74 (577)	14.32 (364)	5 (127)	9 (229)	13.67 (347)	16 (406)	10.88 (276)	11.17 (284)	2 (51)
BAYWATR023	47.74 (1212)	25.74 (654)	20.14 (511)	5 (127)	10.84 (275)	17.17 (436)	16 (406)	10.88 (276)	11.17 (284)	2 (51)
BAYWATR024	63.84 (1621)	25.74 (654)	20.14 (511)	6 (152)	11.87 (301)	17.16 (436)	18 (457)	13.70 (348)	10.57 (268)	2.5 (64)
BAYWATR025	79.74 (2025)	29.18 (741)	18.55 (471)	8 (203)	10.85 (275)	19.67 (500)	22 (559)	12.11 (308)	10.05 (255)	2.5 (64)
BAYWATR026	92.74 (2355)	31.24 (793)	20.67 (525)	8 (203)	10.85 (275)	19.67 (500)	22 (559)	14.23 (361)	10.01 (254)	2.5 (64)

Table 83. Steam coil accessory – in (mm) (continued)

Model No.	L	M	N	P	Q	R
BAYWATR022	1.5 (38)	26 (660)	12 (305)	6 (152)	2.87 (73)	9.95 (253)
BAYWATR023	2 (51)	30 (762)	18 (457)	8.87 (225)	2.87 (73)	9.95 (253)
BAYWATR024	2 (51)	36 (914)	18 (457)	13.87 (352)	2.87 (73)	9.13 (232)
BAYWATR025	2 (51)	51 (1295)	18 (457)	14.12 (359)	1.87 (48)	8.61 (219)
BAYWATR026	2 (51)	64 (1626)	18 (457)	14.12 (359)	3.75 (95)	8.58 (218)

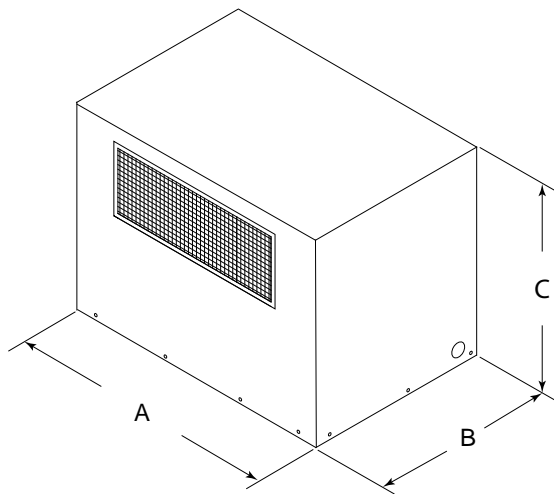
Figure 46. Discharge plenum and grille accessory

Table 84. Discharge plenum and grille dimensions – no heat – in (mm)

Unit	Model No. ^(a)	A	B	C
TWE060	BAYPLNM015	37.94 (963.6)	21.94 (557.2)	28 (711.2)
TWE072, TWE090	BAYPLNM016	47.5 (1206.5)	24.99 (634.7)	28 (711.2)
TWE120	BAYPLNM017	63.5 (1612.9)	24.99 (634.7)	28 (711.2)
TWE180	BAYPLNM018 ^(b)	79.5 (2019.3)	27.63 (701.8)	22 (558.8)
TWE240, TWE300	BAYPLNM019 ^(b)	92.5 (2349.5)	30.43 (772.9)	24 (609.6)
TWE060	BAYPLNM020	37.91 (962.9)	21.91 (556.5)	14.75 (374.65)
TWE090	BAYPLNM021	47.5 (1206.5)	24.99 (634.7)	14.75 (374.65)
TWE120	BAYPLNM022	63.5 (1612.9)	24.99 (634.7)	14.75 (374.65)

^(a) When installed horizontally, plenum/water coil must be self-supported.

^(b) For use with hydronic heat or no heat.

Dimensional Data

Figure 47. Discharge plenum and grille accessory

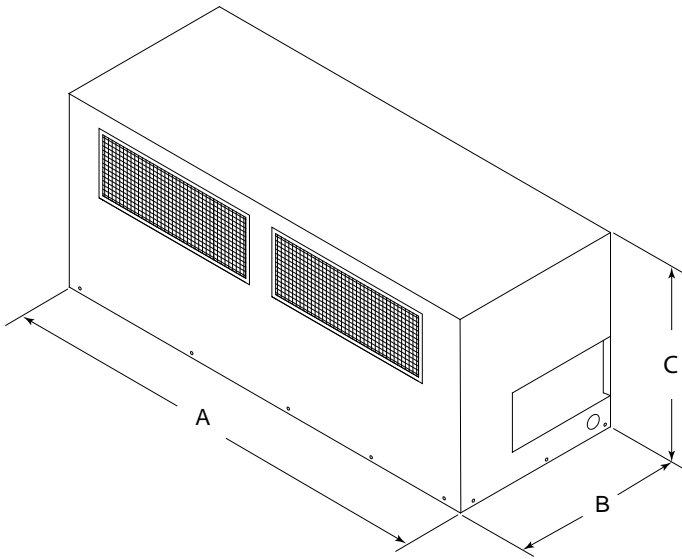

Table 85. Discharge plenum and grille dimensions (for use with electric heat) – in (mm)

Tons	Model No.	A	B	C
TWE060	BAYPLNM030	38.07 (967)	22.69 (576.3)	29.05 (738)
TWE072, TWE090	BAYPLNM031	47.86 (1216)	25.69 (652.5)	29.05 (738)
TWE120	BAYPLNM032	63.86 (1622)	25.69 (652.5)	29.05 (738)
TWE150, TWE180	BAYPLNM033	80.14 (2036)	29.10 (739.1)	35.11 (892)
TWE240, TWE300	BAYPLNM034	92.96 (2361)	31.10 (789.9)	35.05 (890)

Figure 48. Subbase accessory – in (mm)

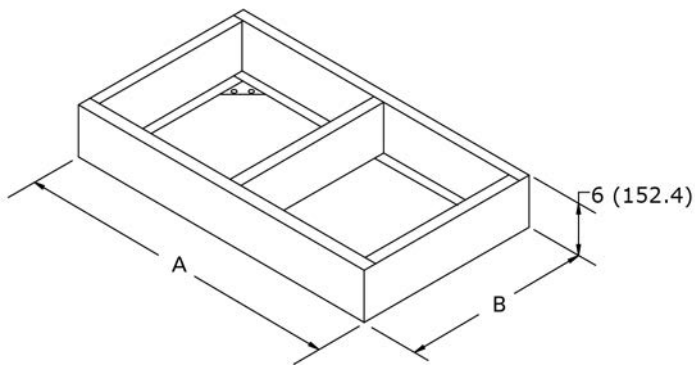

Table 86. Subbase dimensions – in (mm)

Tons	Model No.	A	B
TWE060	BAYBASE009	38 (965.2)	22.63 (574.8)
TWE072, TWE090	BAYBASE010	47.5 (1206.5)	25.51 (648.0)
TWE120	BAYBASE011	63.5 (1612.9)	25.52 (648.2)
TWE150,TWE180	BAYBASE012	79.5 (2019.3)	29.04 (737.6)
TWE240, TWE300	BAYBASE013	92.5 (2349.5)	31.14 (791.0)



Weights

Cooling Condenser

Table 87. TTA R-410A unit and corner weights — lbs (60 Hz)

Tons	Model No.	Shipping Max (lbs)	Net Max (lbs)	Corner Weights			
				1	2	3	4
6	TTA0724*A	324	287	84	89	55	59
	TTA0724*D	344	307	97	89	64	57
7.5	TTA0904*A	342	305	87	94	59	65
	TTA0904*D	380	343	107	100	70	66
10	TTA1204*D	436	391	113	112	84	82
	TTA1204*C	473	428	127	127	87	87
12.5	TTA150*D	504	459	138	137	92	92
15	TTA1804*D	806	705	194	195	158	158
	TTA1804*C	806	705	192	192	161	160
20	TTA2404*D	872	771	214	214	171	172
	TTA2404*C	879	778	218	220	169	171
25	TTA3004*C	1013	912	258	260	196	198

Figure 49. TTA072, 090, 120, 150

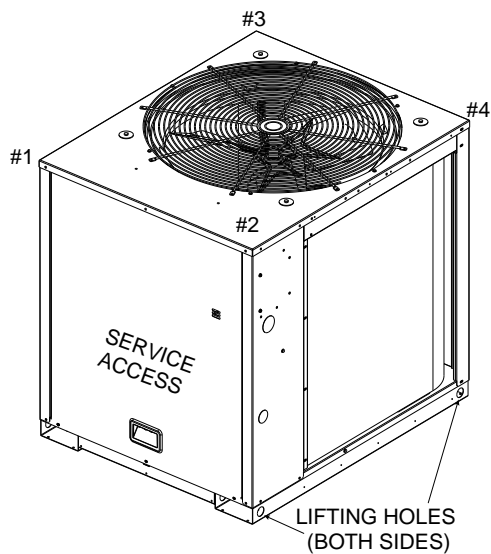
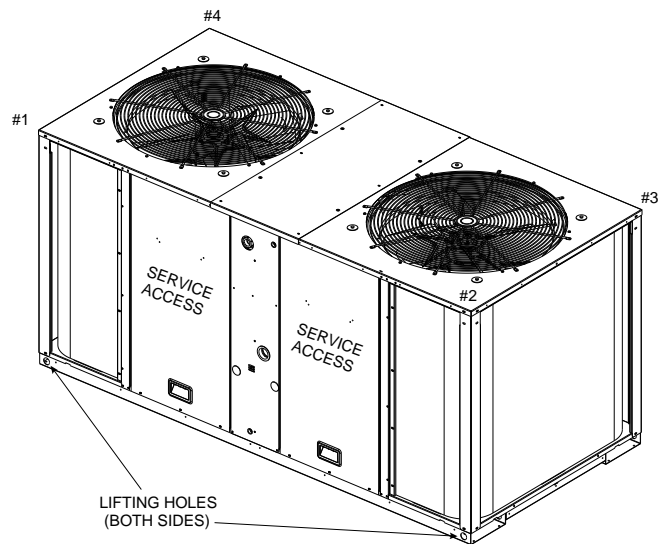

Figure 50. TTA180, 240, 300



Air Handler

Table 88. Constant volume air handler (TWE) — unit and corner weights - (60 Hz)

Tons	Model Number	Shipping Max (lbs)	Net Max (lbs)	Corner Weights - Vertical				Corner Weights - Horizontal			
				1	2	3	4	1	2	3	4
5	TWE0604(3,4,W,1,K)A TWE0604(3,4,1)B	285	232	55	71	51	55	54	67	50	61
6	TWE0724KB	385	323	67	99	75	82	56	92	87	88
7.5	TWE0904(1, K)A/B	385	323	67	99	75	82	56	92	87	88
10	TWE1204(1, K)A/B	441	393	77	121	110	85	79	118	77	119
12.5	TWE1504KB	753	676	168	192	181	135	196	164	145	171
15	TWE1804KB	752	675	167	192	181	135	196	163	145	171
20	TWE2404KB	912	818	258	168	161	231	256	181	146	235
25	TWE3004KB	993	899	211	229	184	275	272	176	228	223

Table 89. SZVAV and 2-Speed VFD air handler (TWE) — unit and corner weights - (60 Hz)

Tons	Model Number	Shipping Max (lbs)	Net Max (lbs)	Corner Weights - Vertical				Corner Weights - Horizontal			
				1	2	3	4	1	2	3	4
6	TWE0724*B	398	336	70	102	78	86	59	95	90	92
7.5	TWE0904*A/B	398	336	70	102	78	86	59	95	90	92
10	TWE1204*A/B	454	406	80	124	113	89	82	121	80	123
12.5	TWE1504*B	766	689	171	195	184	139	199	167	148	175
15	TWE1804*B	765	688	170	195	184	139	199	166	148	175
20	TWE2404*B	925	831	261	171	164	235	259	184	149	239
25	TWE3004*B	1015	921	217	235	189	280	278	182	233	228

Figure 51. Vertical — TWE060, 072, 090, 120

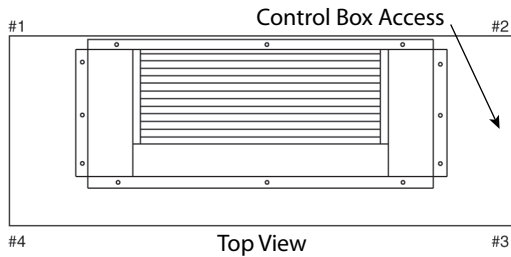

Figure 52. Vertical — TWE150, 180, 240, 300

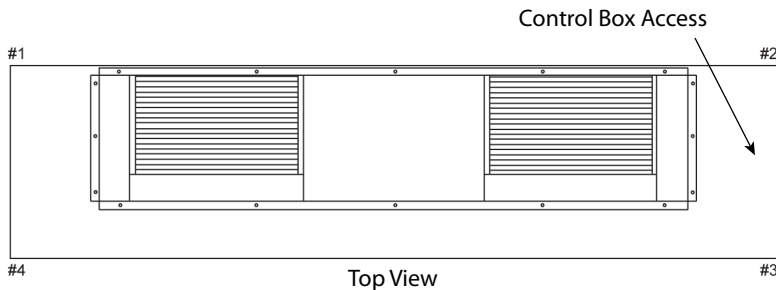

Figure 53. Horizontal — TWE060, 072, 090, 120

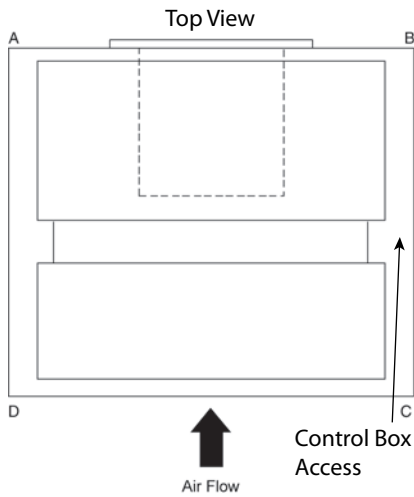
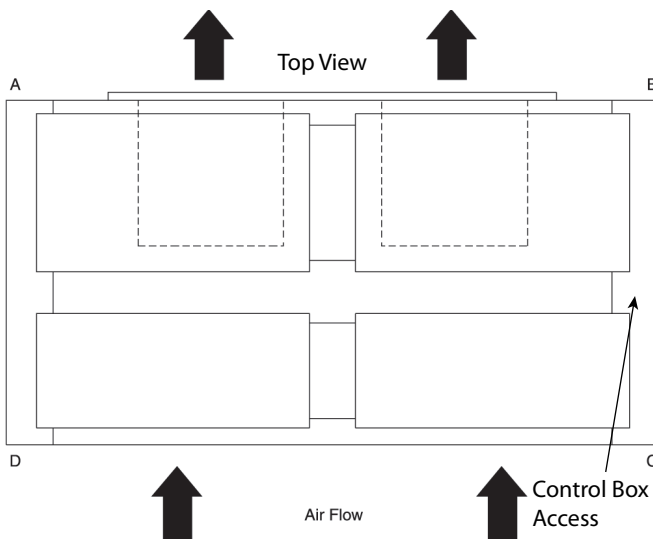

Figure 54. Horizontal — TWE150, 180, 240, 300



Accessories

Table 90. Accessory weights (net lbs.)

Unit Used w/ Tons	Hot Water Coil	Steam Coil	Discharge Plenum and Grille with Hydronic Heat	Discharge Plenum and Grille without Heat	Discharge Plenum and Grille with Electric Heat	Return Air Grille	Electric Heat Min/Max	Subbase	Oversized Motor	RIS Isolator Floor Mount
6	116	131	78	73	160	5	27/45	19.4	48	2
7.5	116	131	78	73	160	5	27/45	19.4	48	2
10	165	148	97	92	195	7	27/45	23.5	50	2
12.5	211	234	—	230	235	10	79/100	28.4	80	2
15	211	234	—	230	235	10	79/100	28.4	80	2
20	242	261	—	145	265	12	79/100	31.7	88	2
25	242	261	—	145	265	12	79/100	31.7	—	2



Weights

Table 90. Accessory weights (net lbs.) (continued)

Unit Used w/ Tons	RIS Isolator Suspended Mount	Steel Spring Isolator Floor Mount	Steel Spring Isolator Suspended Mount	Hail Guard	Control Transformer	Sensors	Expansion Module	Low Ambient	Service Valve
6	6	12	6	21	4	1	13	13	5
7.5	6	12	6	21	4	1	13	13	5
10	7	12	6	28	4	1	13	13	5
12.5	7	12	6	33	4	1	13	13	5
15	7	12	6	55	4	1	2	2	5
20	9	12	6	55	4	1	2	2	5
25	9	12	6	71	4	1	2	2	5



Mechanical Specifications

Condensing Units

Standard Features

General

- Weatherproofed steel mounting/lifting rails
- Hermetic scroll compressors
- Microchannel condenser coils
- Fans and motors
- Standard operating range 50-125°F (min. 0°F with low ambient accessory)
- Nitrogen holding charge
- Certified and rated in accordance with AHRI and DOE standards
- Certified to UL 1995
- Capacities and efficiencies for split systems are rated within the scope of the Air-Conditioning, Heating, and Refrigeration Institute (AHRI) certification program and display the AHRI Standard 340-360 (I-P) mark. This standard applies to units between 65,000 and 250,000 btu/hr.
- Capacities and efficiencies for split system cooling condensers are rated within the scope of the Air-Conditioning, Heating, and Refrigeration Institute (AHRI) certification program and display the AHRI Standard 365 (I-P) mark. This standard applies to cooling units between 135,000 and 250,000 btu/hr.

Casing

- Zinc coated, heavy gauge, galvanized steel
- Weather resistant baked enamel finish
- Meets ASTM B117, 672 hour salt spray test
- Removable single side maintenance access panels
- Lifting handles in maintenance access panels
- Unit base provisions for forklift and/or crane lifting

Refrigeration System - Single Compressor (TTA072**A, TTA090**A)

- Single refrigeration circuit with integral subcooling circuit
- Single direct drive hermetic scroll compressor
- Suction gas-cooled motor w/ $\pm 10\%$ voltage utilization range of unit nameplate voltage
- Crankcase heater
- Internal temperature and current sensitive motor overloads
- No compressor suction and/or discharge valves (reduced vibration/sound)
- Factory installed liquid line filter drier
- Phase loss/reverse rotation monitor
- External high pressure cutout device
- External low pressure cutout device
- Evaporator defrost control
- Loss of charge protection (discharge temperature limit)

Refrigeration System - Dual Compressor (TTA072**D, TTA090**D, TTA120**D, TTA150**D, TTA180**D, TTA240**D)

- Two (2) separate and independent refrigerant circuits
- Each refrigeration circuit equipped with integral subcooling circuit
- Front or rear refrigerant line connections (TTA180**D/240**D)
- Two (2) direct drive hermetic scroll compressor
- Suction gas-cooled motors w/ $\pm 10\%$ voltage utilization range of unit nameplate voltage
- Crankcase Heaters
- Internal temperature and current sensitive motor overloads
- Factory installed liquid line filter driers
- Phase loss/reverse rotation monitor



Mechanical Specifications

- No compressor suction and/or discharge valves (reduced vibration/sound)
- External high pressure cutout devices
- External low pressure cutout devices
- Evaporator defrost control
- Loss of charge protection (discharge temperature limits)

Refrigeration System - Dual Manifolded Compressors (TTA120C, TTA180**C, TTA240**C, TTA300**C)**

- Single refrigerant circuit with integral subcooling circuit
- Two (2) direct drive hermetic scroll compressor
- Suction gas-cooled motors w/ \pm 10% voltage utilization range of unit nameplate voltage
- Crankcase Heaters
- Internal temperature and current sensitive motor overloads
- No compressor suction and/or discharge valves (reduced vibration/sound)
- Factory installed liquid line filter drier
- Phase loss/reverse rotation monitor
- External high pressure cutout devices
- External low pressure cutout devices
- Evaporator defrost control
- Loss of charge protection (discharge line thermostats)
- Front or rear refrigerant line connections (TTA 180**C/240**C/300**C only)

Condenser Coil (Microchannel)

- Microchannel coils burst tested by the manufacturer
- Coils shall be leak tested to ensure the pressure integrity
- Factory pressure and leak tested to 660 psig
- Perforated steel hail guards available (factory installed option or field installed accessory)

Condenser Fan

- 26-inch or 28-inch propeller fan(s)
- Direct drive
- Statically and dynamically balanced

Condenser Motor(s)

- Permanently lubricated totally enclosed or open construction
- Built-in current and thermal overloads
- Ball or sleeve bearing type

Controls

- Centralized microprocessor
- Indoor and outdoor temperature sensors drive algorithms, making decisions for all heating, cooling, and ventilation
- Integrated anti-short cycle timer
- Integrated time delay between compressors
- Completely internally wired
- Colored and keyed connectors and colored wires
- Contactor pressure lugs or terminal block
- Unit external mounting location for disconnect device
- Single point power entry
- Front or rear electrical connections (TTA 180**C/D, 240**C/D, 300**C only)

Coil Guards

- Condenser coil protection from hail, vandals, etc.
- Perforated, painted galvanized steel
- Factory installed

Factory Installed Options

Complete Coat™ Microchannel Condenser Coil

- Available on Microchannel units only
- Cathodic, epoxy-type, electro-disposition coating formulated for high edge build
- Coating provides excellent resistance and durability to corrosive effects of alkalis, acids, alcohols, petroleum, seawater, salty air and other corrosive environments

BACnet Communication Options

- BACnet MS/TP -BACnet IP
- Allows unit communication with Trane or generic BACnet building automation controls

Advanced Diagnostics and LonTalk Communication Interface

- Factory or field installed
- Allows unit communication as a Tracer Lon® device
- Allows unit communication with generic LonTalk® Network building automation controls

Field Installed Options

Low Ambient (Fan ON/OFF)

- Provides unit cooling operation to outdoor ambient of 0°F
- Low cost solution
- Discharge pressure controls condenser fan operation

Service Valves

- Liquid line service valve (with gauge port)
- Suction line service valve (with gauge port)

Vibration Isolators

- Neoprene-in-shear or spring flex choice
- Reduce vibration transmission to building structures, equipment, and adjacent spaces
- Reduce noise transmission to building structures, equipment, and adjacent spaces

Hot Gas Bypass

- Provides capacity modulation solution

Zone Sensor

- Interfaces with microprocessor units
- Manual or automatic programmable
- System malfunction lights
- Remote sensor options

Thermostat

- 1H/1C available
- 2H/1C available
- Manual or automatic changeover available
- Programmable and non-programmable solutions available

LonTalk Communication Interface

- Factory or field installed
- Allows unit communication as a Tracer Lon® device
- Allows unit communication with generic LonTalk® Network building automation controls



Air Handlers

Standard Features

General

- Completely factory assembled
- Convertible for horizontal or vertical configuration
- Convertible for cooling only or heat pump application
- Convertible for left or right external connections (refrigerant and/or electrical)
- Convertible for front or bottom air return
- Nitrogen holding charge
- Certified to UL 1995 for indoor blower coil units

Casing

- Zinc coated, heavy gauge, galvanized steel
- Weather resistant baked enamel finish
- Access panels with captive screws
- Completely insulated with foil faced, cleanable, fire retardant, permanent, odorless glass fiber material
- Captured or sealed insulation edges
- Electrical connection bushings or plugs
- Refrigerant connection bushings or plugs
- Withstand elevated internal static pressure

Refrigeration System

- Single or dual circuit
- Distributor(s)
- Thermal expansion valves (TXVs)

Evaporator Coil

- 3/8" internally enhanced copper tube mechanically bonded to lanced aluminum plate fins
- Factory pressure and leak tested to 449 psig.
- Draw-through airflow
- Dual circuits are interlaced/intertwined
- Double sloped, removable, cleanable, composite drain pan
- Four drain pan positions

Indoor Fan

- Double inlet, double width, forward curved, centrifugal type fan
- Dual fans on 12.5 to 25 ton air handlers
- Adjustable belt drive
- Permanently lubricated bearings

Indoor Motor

- Adjustable motor sheaves (constant volume units)
- Fixed motor sheaves (SZVAV and 2-Speed VFD)
- Thermal overload protection
- Permanently lubricated bearings
- Meet energy policy of 1992 (EPACT)
- Optional oversized motors for high static applications

Controls

- Completely internally wired
- Colored and keyed connectors, colored wires
- Magnetic indoor fan contactor
- Detachable low voltage connectors

- Single point power entry
- Evaporator defrost control

Filters

- Access from side coil panels
- Filters slide on rack
- One inch (1"), throwaway filters on 5 to 10 ton units
- Filter rack convertible to two inch (2") capability on 5 to 10 ton units
- Two inch (2"), throwaway filters on 12.5 to 25 ton units

Factory Installed Options**Constant Volume Airflow**

Factory installed high static motor available

2-Speed VFD Control (Pairing with Legacy Electromechanical Condensers)

- 2-Speed airflow
- Variable Frequency Drive (VFD)
- Motor soft start — avoids start up belt noise and increases belt life
- Programmable keypad accessible outside of airstream
- VFD rated motor
- Factory installed high static motor available

Single Zone Variable Air Volume / 2-Speed Airflow

- Variable Frequency Drive (VFD)
- Motor soft start — avoids start up belt noise and increases belt life
- Programmable VFD keypad accessible outside of airstream
- Airflow adjustment via display/keypad on Symbio™ 700 controller in condenser
- Discharge air sensor
- Symbio 700 Options Module
- VFD rated motor
- Factory installed oversized motor available

Field Installed Options**Electric Heaters**

- Heavy duty nickel chromium elements
- Agency approved
- Installs directly on fan discharge
- One or two stage control (dependent upon capacity)
- Single point power entry
- Terminal strip connections
- 460V Heaters
 - Internally wye connected
 - Automatic line break high limit controls with secondary single action disc limits
- 230V Heaters
 - Internally delta connected
 - Automatic reset of high limit controls through pilot duty with secondary backup fuse links

Hydronic Heat Coils

- One row steam
- Two row hot water
- Installs directly on fan discharge
- Heavy gauge sheet metal casing matches air handler
- Convertible for horizontal or vertical configurations



Mechanical Specifications

Discharge Plenums and Grilles

- Vertical, free discharge applications
- Heavy gauge sheet metal casing matches air handler
- Satin-finished, 4-way adjustable louver grilles

Return Air Grilles

- Vertical, free discharge applications
- Satin-finished, non-adjustable louver grilles
- Replaces front lower access panel

Mounting Sub-Base

- Vertical floor mount configuration requirement
- Heavy gauge sheet metal casing matches air handler
- Provides additional clearance for condensate drain trapping
- Required when isolators are used

Vibration Isolators

- Neoprene-in-shear or spring flex choice
- Floor or suspended applications
- Reduce vibration transmission to building structures, equipment, and adjacent spaces
- Reduce noise transmission to building structures, equipment, and adjacent spaces

Oversize Motors

- High static applications
- Motor, sheaves, belt included

Filters

- 2 inch, MERV 13 high efficiency filters



Notes



The AHRI Certified mark indicates Trane U.S. Inc. participation in the AHRI Certification program. For verification of individual certified products, go to ahrirectory.org.

Trane - by Trane Technologies (NYSE: TT), a global innovator - creates comfortable, energy efficient indoor environments for commercial and residential applications. For more information, please visit trane.com or tranetechnologies.com.

Trane has a policy of continuous product and product data improvements and reserves the right to change design and specifications without notice. We are committed to using environmentally conscious print practices.