



Product Catalog

# Split System Air Conditioners Odyssey™ with Symbio™ Controls

Heat Pump Condenser, 6 to 25 Tons, 60Hz

Air Handler, 5 to 25 Tons, 60Hz





# Introduction



Odyssey™ Split Systems offer a wide range of options, allowing you to easily match unit tonnage with the right load requirements.

When a project calls for the convenience and cost efficiency of a unitary product, where a rooftop unit isn't right, Odyssey may be the answer. It provides heating and cooling in a split configuration that's unique in its versatility while staying true to our standards for efficiency and reliability. And with the Symbio® digital controller on board, Odyssey introduces smart building capabilities that take service, comfort and sustainability beyond the expected.

With wide network availability, flexible applications, installation ease, built-in reliability and easy servicing, Odyssey will meet any number of customer applications. Add to that outstanding customer service and you have the formula to make Odyssey the clear choice for continued customer satisfaction.

## Wide Network Availability

A broad distribution network provides owners, maintenance personnel, contractors, etc., the means to get their hands on equipment when they need it. Whether it's an emergency replacement or a new construction project in its infancy stages, Odyssey products meet an array of needs at the right time and right price.

## Flexible Applications

No matter what the application, Odyssey provides the solution. A broad array of models and tonnages are available with single or dual compressors, single or dual circuits and numerous accessories. Condensing units can be installed on the ground or on a rooftop along with extended piping runs, while air handlers can be free discharge on the ground or horizontally suspended with long duct runs from a ceiling. Should application challenges arise, Odyssey delivers.

## Easy to Install

Small footprints and low weights combined with factory installed components like TXVs, filter driers, etc., reduce installation time and cost. Colored connectors and wiring, as well as factory-tested units make Odyssey the right choice.

## Built-in Reliability

Keeping in mind that productivity only occurs when equipment is operational, Trane has taken the steps to ensure that Odyssey is up and running. Early indicators such as phase/reversal monitors and loss of charge protection provide diagnostics which prevent failure and provide years of worry-free service and operation.

## Easy to Service

When preventive maintenance or service is required, technicians will find efficient access to both air handlers and condensers. Panels provide complete, easy access coupled with standardized cabinets in which all components are located in proximity. Odyssey's improved design results in minimum service times and costs.

With these capabilities, Odyssey provides customers high efficiency and superior performance for the best all-around value in the market today.

## Copyright

This document and the information in it are the property of Trane, and may not be used or reproduced in whole or in part without written permission. Trane reserves the right to revise this publication at any time, and to make changes to its content without obligation to notify any person of such revision or change.

## Trademarks

All trademarks referenced in this document are the trademarks of their respective owners.

## Revision History

- Updated digit 4, 5, 6 – tonnage to add 12.5 and 25 tons in Model Number Description chapter.
- Updated tables in General Data chapter.
- Added 12.5 ton and 25 ton tables in Performance Data chapter.
- Updated tables in Electrical Data chapter.
- Updated Recommended thermostat wire size table in Jobsite Connections chapter.
- Updated tonnage values in Dimensional Data chapter.
- Updated tables in Weights chapter.



# Table of Contents

- Features ..... 6
  - Split System Overview ..... 6
  - Standard and Optional Features ..... 7
  - Standard Controls ..... 10
  - Additional Controls ..... 11
- Accessories ..... 12
  - Heat Pump Condenser ..... 12
  - Air Handler ..... 12
  - Electric Heaters ..... 14
- Application Considerations ..... 16
  - Clearance Requirements ..... 16
  - Low Ambient Cooling ..... 16
  - A2L Application Considerations ..... 18
  - Leak Detection System (Refrigerant charge greater than 3.91 lb per circuit) ..... 20
- Selection Procedure ..... 21
  - Cooling Capacity ..... 21
  - Heating Capacity ..... 21
  - Air Delivery ..... 22
- Model Number Description ..... 23
  - Heat Pump Condenser ..... 23
  - Air Handler ..... 23
- General Data ..... 24
- Performance Data ..... 29
  - Gross Cooling Capacities ..... 29
  - Gross Heating Capacities ..... 49
  - Fan Performance ..... 53
- Zone Controls ..... 77
  - Zone Sensors ..... 77
  - Conventional Thermostats ..... 77
- Electrical Data ..... 78
  - Heat Pump Condenser ..... 78
  - Air Handler ..... 79
- Jobsite Connections ..... 88
  - Symbio™ Controls ..... 88

Dimensional Data .....	90
Heat Pump .....	90
Air Handler .....	96
Accessories .....	104
Weights .....	111
Heat Pump Condenser .....	111
Air Handler .....	111
Mechanical Specifications .....	115
Condensing Units .....	115
Air Handlers .....	117



# Features

## Split System Overview

Unlike typical split systems on the market, Odyssey offers easy servicing, built-in reliability, ease of installation and outstanding customer service. And because today's owners are very cost-conscious when it comes to service and maintenance, the Odyssey Split System was designed with direct input from service contractors. This valuable information helped to design a product that would get the service person off the job quicker and save the owner money.

## Flexible Applications

Odyssey offers outstanding standard features enhanced by a variety of factory and field installed options, multiple control options, rigorously tested proven designs and superior product and technical support. Because of this, Odyssey offers ultimate flexibility. Units are built to order in our standard "shortest in the industry" ship cycle time. Odyssey is available with single, dual and manifolded compressor options. Single compressor outdoor units feature a single refrigeration circuitry, lowering job installation costs by requiring only one set of refrigerant lines.

Equally important, Odyssey offers single refrigerant circuit/capacity unloading models. The unloading units feature dual manifolded scroll compressors with two stages of capacity modulation and a single refrigeration circuit. Dual compressor/dual circuit models give true stand-by protection - if one compressor fails, the second will automatically start-up. Also, the first compressor can be serviced without shutting down the unit since the refrigerant circuits are independent. Dual compressor models also save on energy costs. During light load conditions, only one compressor will operate to save energy.

Factory installed VFD is standard with most units. These 2-Speed and Single Zone VAV (SZVAV) solutions, combined with condensing units that have multiple compressors, provide increased part load performance (IEER) when conditions are not at the max design condition. Additionally, some states have adopted codes that require this type of performance. Odyssey units are built with installation in mind. With a smaller footprint, the outdoor unit takes up less space and weighs less, making its installation more efficient and economical. Our indoor air handlers are built to be installed in confined spaces, fitting through standard doorways and freight elevators.

## Unmatched Product Support

One of our finest assets, Trane Sales Representatives are a support group that can assist you with:

- Product
- Application
- Service
- Training
- Special Applications
- Specifications
- Computer Programs and much more

## Rigorous Testing

Our units are rigorously rain tested to ensure water integrity. Actual shipping tests are performed to determine packaging requirements. Units are test shipped around the country to determine the best packaging. Factory shake and drop tests are used as part of the package design process to help assure that the unit arrives at the job site in top condition. Rigging tests include lifting a unit into the air and letting it drop one foot, assuring that the lifting lugs and rails hold up under stress. A 100% coil leak test is performed at the factory. The condenser coils are leak tested at 660 psig and evaporators to 450 psig. All parts are inspected at the point of final assembly. Sub-standard parts are identified and rejected immediately. Every unit receives a 100% unit run test before leaving the production line to ensure it lives up to rigorous Trane requirements.

## Standard and Optional Features

Figure 1. Compressors

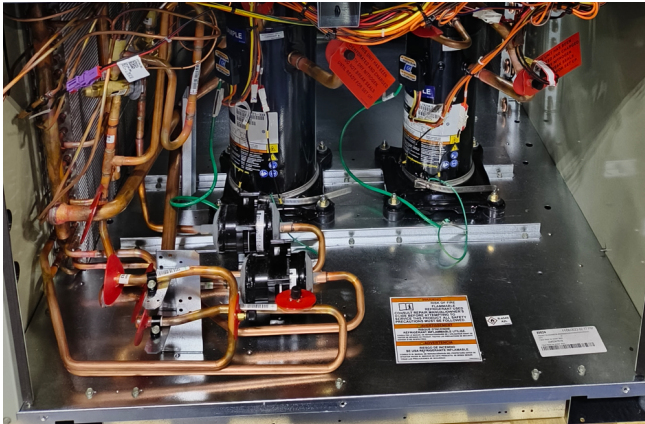
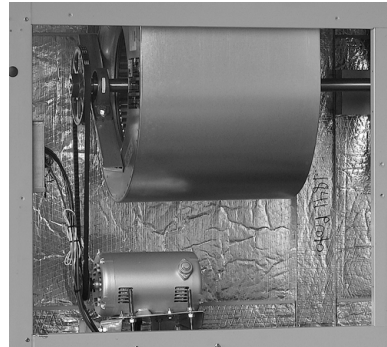

Figure 2. Belt drive motor



**Airflow Distribution** — Odyssey can replace an older machine with old ductwork and, in many cases, improve the comfort through better air distribution.

**Anti-Short Cycle Timing** — The Symbio™ 700 controller provides a 3 minute minimum “ON” time and 3 minute “OFF” time for compressors to enhance compressor reliability by assuring proper oil return.

**Belt Drive Motors** — For additional static requirements, Odyssey Split Systems offer standard belt drive motors to meet and exceed a wide range of airflow needs.

**Black Epoxy Pre-Coated Condenser Coils** — The pre-coated coils are an economical option for protection in mildly corrosive environments.

**Coil Guards** — Coil Guards are optional with all condensers. This feature protects the condenser coil from vandalism and/or hail damage.

**Colored Connectors and Wiring** — Interconnecting wiring between components is standardized using colored and keyed connectors and colored wires, helping to save time and money tracing wires and diagnosing the unit.

**Compressors** — Odyssey Split Systems contain the best compressor technology available to achieve the highest possible performance. Dual compressors perform very well under part load cooling conditions and system back-up applications. Dual compressors are available on 6 to 25 ton models and allow for efficient cooling utilizing 2-stages of compressor operation.

**Convertible Units** — The air handlers ship in a horizontal configuration. They can be easily converted to vertical by simply repositioning the drain pan.

**Crankcase Heaters** — These band heaters provide improved compressor reliability by warming the oil to prevent migration during off-cycles or low ambient conditions.

**Dual Sloped Drain Pans** — Every Odyssey unit has a non-corrosive, removable, double sloped drain pan that’s easy to clean and reversible to allow installation of drain trap in two positions on either side of the unit.

**Duct flanges** — An optional field installed kit that can save time and money.

**Easy Access Low Voltage Connections** — Thermostat and other low voltage control wiring connections are made directly to the Symbio 700 and other boards in the system. Screw-type pressure connectors are detachable from the boards for easy connection of control wires – saving cost and time.

**Electric Heaters** — Electric heat modules are available in a variety of voltages and capacities.

**Foil Faced Insulation** — All internal air handler surfaces have cleanable foil-faced insulation. All edges are either captured or sealed to ensure insulation fibers do not get into the airstream.

**Heat Pump Fan Fail Consideration** — For SZVAV/2-Speed units: In the event that airflow is not available during heating operation, a bi-metallic switch is mounted on the VFD bracket to turn off the compressors and prevent overheating of the motor and VFD.

**High Static Motor** — This high static motor accessory extends the capability of the standard unit.



## Features

---

**High and Low Voltage Control Panel** — High voltage components and connections are isolated from low voltage and covered with a sheet metal panel. This allows setup and test parameters at the Symbio™ 700 display and the VFD keypad display to be safely viewed and adjusted in the low voltage section of the control panel.

**High Pressure Control** — All units include High Pressure Control as standard.

**Leak Detection System** — The leak detection system consists of one or more refrigerant detection sensors. When the system detects a leak, the following mitigation actions will be initiated until refrigerant has not been detected for at least 5 minutes:

- Energize the supply fan(s) to deliver a required minimum amount of circulation airflow.
- Disable compressor operation.
- Provide an output signal to fully open all zoning dampers, such as VAV boxes.
- Provide an output to energize additional mechanical ventilation (if needed).
- Units without airflow proving will disable electric heat sources.

Building fire and smoke systems may override this function.

If the refrigerant sensor has a fault, is at the end of its life, or is disconnected, the unit will initiate the mitigation actions.

Mitigation actions may be verified by disconnecting the sensor.

The refrigerant sensors do not need service. Use only Trane-approved sensors when replacement is required.

**Low Ambient Cooling** — All Odyssey units have cooling capabilities down to 50°F. When the Optional Low Ambient accessory kit is field installed, can extend operation down to 0°F.

**Low Voltage Connections** — Low voltage wiring connects directly to the control boards in the unit via detachable connectors. This makes it easy for the installer to attach the wires and then snap the connectors into place.

**Phase Monitor/Reversal Protection** — Phase monitor shall provide 100% protection for motors and compressors against problems caused by phase loss, phase imbalance, and phase reversal. Phase monitors are equipped with an LED that provides an ON or FAULT indicator.

**ID Fan Fail** — The Symbio™ 700 controller provides a ID fan fail feature caused by belt failure and motor freewheeling under no load. The Variable Frequency Drive records the motor torque and if below a certain value shuts the unit. Fan Fail error is displayed on controller display.

**Quick-Access Panels** — Remove a few screws for access to the standardized internal components and wiring.

**Single Point Power** — A single electrical connection powers the unit.

**Single Side Service** — Single side service is standard on all units.

**Single Zone Variable Air Volume (SZVAV)** — A variable frequency drive is used in conjunction with the Symbio™ 700 to provide supply fan motor speed modulation. For SZVAV control, the drive will accelerate or decelerate as required to meet the Zone Cooling demand. In order to maximize energy savings, the VFD will be held at minimum speed until the load in the zone requires the speed to increase. The supply fan speed will be reduced to a minimum of 58%<sup>1</sup> during ventilation and part load cooling demands, and 80% during full load cooling demands with the ability to fully modulate. The commissioning maximum and minimum airflow points can be easily set by programming these parameters at the display on the Symbio control board.

**Standardized Components** — Components are placed in the same location on all Odyssey units. Because of these standardized components throughout the Odyssey line, contractors/owners can stock fewer parts.

**Symbio™ 700** — Standard on Odyssey condensers, the Symbio™ 700 controller provides exceptional machine control with a focus on system reliability and application flexibility. The Symbio controller provides direct access to the Symbio Service and Installation mobile application for easy setup and troubleshooting with no special tools. A wide range of system integration options (Non-communicating, BACnet®, LonTalk®, etc.) provide options to meet the needs of your application.

**Thermal Expansion Valve with Bypass Check Valves** — This feature is standard on all indoor units.

**Unit Cabinet** — The compact cabinet takes up less room and is less costly to ship. The design also ensures water integrity.

**Leak Detection System** — Trane's Leak Detection System (LDS) consists of one or more refrigerant detection sensors and is required in ducted HVAC systems that have more than 4 lbs of A2L refrigerant charge, per safety standard UL 60335-2-40. For any units with more than 4 lbs of charge in a circuit, Trane will factory-install an LDS. Having the leak detector installed in the factory by the manufacturer on applicable units reduces the risk of improper installation in the field as well as bypassing the added cost in the field for installation, leading to peace of mind that the right solution has been applied to your unit.

---

<sup>1</sup>. 64% for part load and 83% for full load if a max speed of less than 44.5 Hz is desired.

**Table 1. Odyssey features – standard and optional**

	Standard Features	Options <sup>(a)</sup>	
		Factory Installed	Field Installed
1-year Limited Parts Warranty	X		
5-year Limited Compressor Warranty	X		
Belt Drive Motors	X		
Black Epoxy Pre-Coated Coils		X	
Coil Guards		X	X
Colored Connectors and Wiring	X		
Compressor Discharge Temperature Limit (DTL)	X		
Convertible Airflow	X		
Crankcase Heaters	X		
Easy Access Low Voltage Connections	X		
Electric Heaters			X
Filters	X		
Filters – 2" MERV 13			X
Foil-Faced and Edge Captured Insulation	X		
High Pressure Control	X		
High Static Motor Kit <sup>(b)</sup>			X
IAQ Dual Sloped and Removable Drain Pans	X		
Leak Detection System	X		
Low Ambient Cooling			X
Liquid Line Refrigerant Drier	X		
Low Pressure Control	X		
Low Static Motor Kit			X
Low Voltage Circuit Protection	X		
Phase Loss/Reversal Monitor	X		
Quick Access Panels	X		
Scroll Compressors	X		
Single Point Power	X		
Single Side Service	X		
Single Zone Variable Air Volume (SZVAV / 2-Speed Fan)		X	
Standardized Components	X		
Symbio™ Controls	X		
Thermal Expansion Valve	X		
Vibration Isolators			X

<sup>(a)</sup> Refer to model number description for option availability or contact Product Support.

<sup>(b)</sup> Available on constant volume units only. See Accessories chapter for more information.



## Standard Controls

### Symbio™ 700 Controls

Figure 3. Symbio 700 board

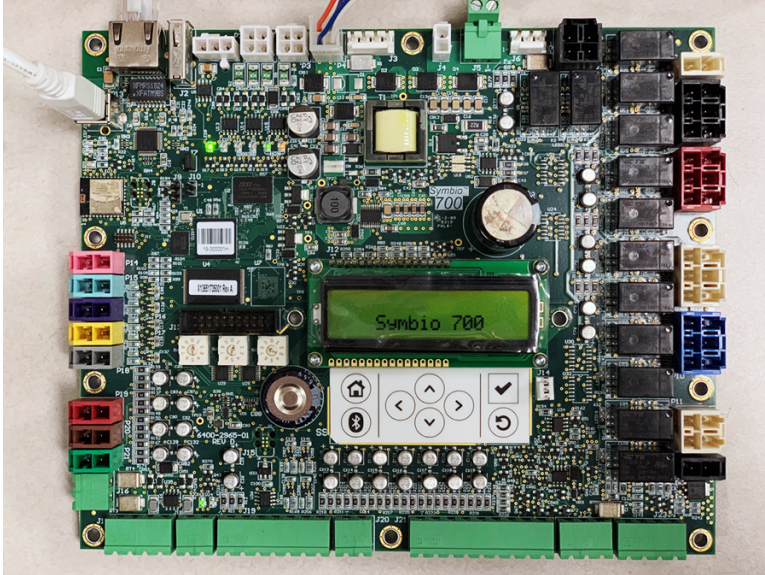

Symbio 700 controls provide unit control for heating, cooling, and ventilating, utilizing input from sensors that measure outdoor and indoor temperature. Symbio also provides outputs for building automation systems and expanded diagnostics. Quality and reliability are enhanced through Symbio control and logic:

- Prevents the unit from short cycling, considerably improving compressor life.
- Ensures the compressor will run for a specific amount of time which allows oil to return for better lubrication, enhancing the reliability of the compressor.
- Provides refrigerant leak detection system and mitigation response when refrigerant is detected as required by the UL 60335-2-40 standard.
- Reduces the number of components required to operate the unit, reducing possibilities for component failure.

### Installation and Service

The Symbio™ 700 control platform provides a user-friendly, onboard interface that makes setup and continued operation easy – or users can take advantage of the Symbio™ Service and Installation Mobile App for setup, troubleshooting, and operation. Both the Symbio onboard user interface and mobile app simplify troubleshooting by displaying active alarms. Symbio eliminates the need for field-installed, anti-short cycle timer and time delay relays. The wiring of the low voltage connections to the unit and zone sensors is simple, making installation easy.

### Testing

Symbio™ 700 requires no special tools to run the unit through its paces. Simply navigate to the 'Service' section of the user interface or the 'Utilities' section of the Symbio™ Service and Installation Mobile App and enter the test section. Here the unit can be placed in the desired operating condition for a pre-determined amount of time supporting troubleshooting efforts in the field. The Symbio 700 will return to normal control when the user exits test mode or when the pre-determined, user-selected Service Test time has expired.

### Other Benefits

- Symbio™ 700 built-in anti-shortcycle timer, time delay relay and minimum "on" time control functions are factory tested to assure proper operation.
- Symbio 700 softens electrical "spikes" by staging on fans, compressors and heaters.
- Intelligent Fallback is a benefit to the building occupant. If a component goes astray, the unit will continue to operate at predetermined temperature setpoint.

- Intelligent Anticipation is a standard feature. It functions continuously as Symbio 700 and zone sensor(s) work together in harmony to provide much tighter comfort control than conventional electromechanical thermostats.
- The Symbio 700 design is standardized across the board, ensuring a lower cost to owners.

## Additional Controls

**VariTrac® Building Automation System** — When Trane's changeover VAV System for light commercial applications is coupled with the unit, it provides the latest in technological advances for comfort management systems and can allow thermostat control in every zone served by VariTrac.

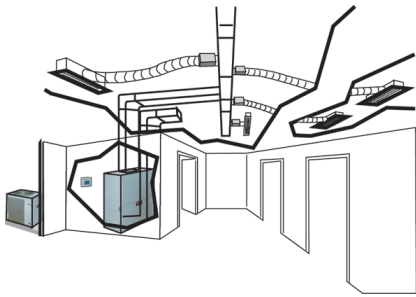

**Froststat™** — This control (a standard feature on all air handlers) utilizes a capillary bulb embedded in the face of the evaporator coil which monitors coil temperature to inhibit evaporator icing and protect the compressor. Useful for applications with low leaving air temperatures, low airflow and/or high latent load applications.

**LonTalk® Communications Interface** — The LonTalk communications interface allows the unit to communicate as a Tracer LON® device or directly with generic LonTalk Network Building Automation System Controls.

**BACnet® Communication Interface (BCI)** — The BACnet Communication Interface allows the unit to communicate directly with a generic open protocol BACnet MS/TP or IP Network Building Automation Control System.

**Zone Sensors/Thermostats**— Available in programmable, automatic and manual styles.

**Table 2. Odyssey control options – standard and optional**

	Standard Features	Options <sup>(a)</sup>	
		Factory Installed	Field Installed
BACnet® Communication Interface (BCI)	—	X	—
Froststat™ - Evaporator Defrost Control (EDC)	X	—	—
LonTalk® Communications Interface (LCI)	—	X	X
Symbio™ 700 Microprocessor Controls	X	—	—
Thermostat	—	—	X
Zone Sensor	—	—	X

<sup>(a)</sup> Refer to model number description for option availability or contact Product Support.



# Accessories

## Heat Pump Condenser

**Table 3. TWA accessories**

Model	Used With
<b>Rubber Isolators</b>	
BAYISLT005* (black)	TWA072, TWA090, TWA120
BAYISLT009* (red)	TWA150, TWA180
BAYISLT010* (green)	TWA240, TWA300
<b>Steel Spring Isolators</b>	
BAYISLT023* (red)	TWA072, TWA090, TWA120
BAYISLT024* (black)	TWA150, TWA180
BAYISLT025* (yellow)	TWA240, TWA300
<b>Service Valve Kit</b>	
BAYVALV020*	TWA072K*A, TWA120K*A
BAYVALV021*	TWA090K*A
BAYVALV022*	TWA072K*D, TWA090K*D, TWA120K*D, TWA150K*D
BAYVALV025*	TWA180K*D, TWA240K*D, TWA300K*D
<b>Low Ambient — On/Off Fan Control<sup>(a)</sup> <sup>(b)</sup></b>	
BAYLOAMS10* (External Mount, small cabinets) <sup>(c)</sup>	(all voltages) TWA072, TWA090, TWA120, TWA150
BAYLOAMS20* (Internal mount, large cabinets)	(all voltages) TWA180, TWA240, TWA300
<b>Transducer Kit for Head Pressure Control (BAYLOAMS10*)</b>	
BAYLOTR001* <sup>(d)</sup>	TWA072**D, TWA090**D, TWA120**D, TWA150**D
<b>LonTalk Communications Interface<sup>(e)</sup></b>	
BAYLTCI005*	All Models
<b>Expansion Module Kit</b>	
BAYMODU002* (XM30)	All Models
BAYMODU004* (XM32)	All Models
<b>Coil (Hail/Vandal) Guard</b>	
BAYGARD068A	TWA072**A, TWA090**A
BAYGARD064A	TWA072**D, TWA090**D
BAYGARD065A	TWA120, TWA150K*D
BAYGARD066A	TWA180, TWA240
BAYGARD067B	TWA300K*D

<sup>(a)</sup> Cycles fan on/off (no modulating).

<sup>(b)</sup> When BAYLOAM is used, the Evaporator Defrost Control (EDC) must be disabled in the Symbio 700 controller configuration.

<sup>(c)</sup> Kit mounts external to the outdoor unit and operates by sensing ambient temperature and discharge pressure.

<sup>(d)</sup> BAYLOTR001\* required when BAYLOAMS10\* kits are used with units that have 2 compressors (dual circuit) and 1 condenser fan.

<sup>(e)</sup> Field installed LonTalk interface requires installation of Symbio control board with Advanced Diagnostics (not included).

## Air Handler

**Table 4. TWE Accessories**

Model	Used With
<b>Base (Subbase)</b>	
BAYBASE009*	TWE060
BAYBASE0010*	TWE072, TWE090
BAYBASE0011*	TWE120
BAYBASE0012*	TWE150, TWE180
BAYBASE0013*	TWE240, TWE300
<b>Drip Kit</b>	
BAYDRKT006*	TWE060

**Table 4. TWE Accessories (continued)**

Model	Used With
BAYDRKT007*	TWE072, TWE090
BAYDRKT008*	TWE120
BAYDRKT009*	TWE150, TWE180
BAYDRKT010*	TWE240, TWE300
<b>Duct Flange Kit</b>	
BAYDUCT010*	TWE051, TWE060, TWE072, TWE076, TWE090, TWE101, TWE120
BAYDUCT020*	TWE126, TWE150, TWE156, TWE180, TWE201, TWE240, TWE251, TWE300
<b>Filters – 2" MERV 13</b>	
BAYFILT006*	TWE060
BAYFILT007*	TWE072, TWE090
BAYFILT008*	TWE120
BAYFILT009*	TWE150, TWE180
BAYFILT010*	TWE240, TWE300
<b>Rubber Isolators<sup>(a) (b) (c)</sup></b>	
BAYISLT004* (Floor — Blue)	TWE060, TWE072, TWE090, TWE120
BAYISLT009* (Floor — Red) <sup>(d)</sup>	TWE150, TWE180
BAYISLT010* (Floor — Green)	TWE240, TWE300
BAYISLT012* (Suspended — Red/Green)	TWE150, TWE180
BAYISLT013* (Suspended — Red/Green)	TWE060
BAYISLT014* (Suspended — Green)	TWE072, TWE090
BAYISLT015* (Suspended — Green/Black)	TWE120
BAYISLT016* (Suspended — Red/Green)	TWE240, TWE300
<b>Steel Spring Isolators</b>	
BAYISLT019* (Floor — Red)	TWE060, TWE072, TWE090, TWE120
BAYISLT021* (Floor — Black)	TWE150, TWE180
BAYISLT032* (Floor — Black/Yellow)	TWE240, TWE300
BAYISLT028* (Suspended — Tan)	TWE060
BAYISLT029* (Suspended — Red)	TWE072, TWE090, TWE120
BAYISLT030* (Suspended — Black)	TWE150, TWE180
BAYISLT031* (Suspended — Black/Yellow)	TWE240, TWE300
<b>Plenum<sup>(e)</sup></b>	
BAYPLNM015* (Discharge Plenum and Grille)	TWE060
BAYPLNM016* (Discharge Plenum and Grille)	TWE072, TWE090
BAYPLNM017* (Discharge Plenum and Grille)	TWE120
BAYPLNM018* (Discharge Plenum/Hydronic Coil Plenum and Grille)	TWE150, TWE180
BAYPLNM019* (Discharge Plenum/Hydronic Coil Plenum and Grille)	TWE240, TWE300
BAYPLNM020* (Hydronic Coil Discharge Plenum and Grille)	TWE060
BAYPLNM021* (Hydronic Coil Discharge Plenum and Grille)	TWE072, TWE090
BAYPLNM022* (Hydronic Coil Discharge Plenum and Grille)	TWE120
BAYPLNM030* (Electric Heat Discharge Plenum and Grille)	TWE060
BAYPLNM031* (Electric Heat Discharge Plenum and Grille)	TWE072, TWE090
BAYPLNM032* (Electric Heat Discharge Plenum and Grille)	TWE120
BAYPLNM033* (Electric Heat Discharge Plenum and Grille)	TWE150, TWE180
BAYPLNM034* (Electric Heat Discharge Plenum and Grille)	TWE240, TWE300
<b>Return Air Grille</b>	
BAYGRLE001*	TWE060
BAYGRLE002*	TWE072, TWE090
BAYGRLE003*	TWE120
BAYGRLE004*	TWE150, TWE180



## Accessories

**Table 4. TWE Accessories (continued)**

Model	Used With
BAYGRLE005*	TWE240, TWE300
<b>Symbio™ Indoor Options Module Kit</b>	
BAYMODU001*	All TWE units with Digit 15 = 1 and Electric heater installed
<b>Transformer</b>	
BAYTFMR018* - 100 VA Transformer (208-230V)	All TWE072 – TWE300, 208-230V units
BAYTFMR019* - 100 VA Transformer (460V)	All TWE072 – TWE300, 460V units
BAYTFMR020* - 100 VA Transformer (575V)	All TWE072 – TWE300, 575V units
<b>Water Kits</b>	
BAYWATR022* (Steam Coil Enclosure)	TWE060
BAYWATR023* (Steam Coil Enclosure)	TWE072, TWE090
BAYWATR024* (Steam Coil Enclosure)	TWE120
BAYWATR025* (Steam Coil Enclosure)	TWE150, TWE180
BAYWATR026* (Steam Coil Enclosure)	TWE240, TWE300
BAYWATR027* (Hot Water Coil Enclosure)	TWE060
BAYWATR028* (Hot Water Coil Enclosure)	TWE072, TWE090
BAYWATR029* (Hot Water Coil Enclosure)	TWE120
BAYWATR030* (Hot Water Coil Enclosure)	TWE150, TWE180
BAYWATR031* (Hot Water Coil Enclosure)	TWE240, TWE300

- (a) Requires use of subbase accessory.
- (b) In units with steam or hot water coils applied vertically or horizontally, check IOM for proper Isolator Kit selection.
- (c) Do not use if blower will operate less than 600 RPM.
- (d) When the air handler is in the vertical position and close proximity trapping of condensate is required, use of subbase is required.
- (e) When installed horizontally, plenum/water coil must be self-supported. When adding vibration isolators, see Isolator Installation Guide (ACC-SVN92\*-EN) for isolator and location matrix.

**Note:** See HUB case DOC-209462 for high-static and low-static drive kits (available only for constant volume air handlers).

## Electric Heaters

**Table 5. Electric heaters**

Model	Used With
<b>6 to 10 Ton Electric Heater Selection</b>	
BAYHTRP106* — 4.33/5.76 kW Heater 208/240/1 Phase	TWE060*1, TWE090*1, TWE120*1
BAYHTRS112* — 8.65/11.52 kW Heater 208/240/1 Phase	TWE060*1, TWE090*1, TWE120*1
BAYHTRT117* — 12.98/17.28 kW Heater 208/240/1 Phase	TWE060*1, TWE090*1, TWE120*1
BAYHTRS123* — 17.31/23.04 kW Heater 208/240/1 Phase	TWE060*1, TWE090*1, TWE120*1
BAYHTRP129* — 21.63/28.80 kW Heater 208/240/1 Phase	TWE090*1, TWE120*1
BAYHTRP305* — 3.76/5.00 kW Heater 208/240/3 Phase	TWE060*3 (CV and OS MTR), TWE072*3B, TWE090*3, TWE120*3 (VFD)
BAYHTRS310* — 7.48/9.96 kW Heater 208/240/3 Phase	TWE060*3 (CV and OS MTR), TWE072*3B, TWE090*3, TWE120*3 (VFD)
BAYHTRS315* — 11.24/14.96 kW Heater 208/240/3 Phase	TWE060*3 (CV and OS MTR), TWE072*3B, TWE090*3, TWE120*3 (VFD)
BAYHTRP325* — 18.72/24.92 kW Heater 208/240/3 Phase	TWE060*3 (CV and OS MTR), TWE072*3B, TWE090*3, TWE120*3 (VFD)
BAYHTRP335* — 26.20/34.88 kW Heater 208/240/3 Phase	TWE090*3, TWE120*3 (VFD)
BAYHTRP405* — 5.00 kW Heater 460/3 Phase	TWE060*4 (CV and OS MTR), TWE072*4*****C/D, TWE090*4*****C/D, TWE120*4*****C/D
BAYHTRS410* — 9.96 kW Heater 460/3 Phase	TWE060*4 (CV and OS MTR), TWE072*4*****C/D, TWE090*4*****C/D, TWE120*4*****C/D
BAYHTRS415* — 14.96 kW Heater 460/3 Phase	TWE060*4 (CV and OS MTR), TWE072*4*****C/D, TWE090*4*****C/D, TWE120*4*****C/D

**Table 5. Electric heaters (continued)**

Model	Used With
BAYHTRP425* — 24.92 kW Heater 460/3 Phase	TWE060*4 (CV and OS MTR), TWE072*4*****C/D, TWE090*4*****C/D, TWE120*4*****C/D
BAYHTRP435* — 34.88 kW Heater 460/3 Phase	TWE090*4*****C/D, TWE120*4*****C/D
BAYHTRPW05* — 5 kW Heater 575/3 Phase	TWE060*W (CV and OS MTR), TWE072*W, TWE090*W, TWE120*W (VFD)
BAYHTRSW10* — 9.96 kW Heater 575/3 Phase	TWE060*W (CV and OS MTR), TWE072*W, TWE090*W, TWE120*W (VFD)
BAYHTRSW15* — 14.96 kW Heater 575/3 Phase	TWE060*W (CV and OS MTR), TWE072*W, TWE090*W, TWE120*W (VFD)
BAYHTRPW25* — 24.92 kW Heater 575/3 Phase	TWE060*W (CV and OS MTR), TWE072*W, TWE090*W, TWE120*W (VFD)
BAYHTRPW35* — 34.88 kW Heater 575/3 Phase	TWE090*W, TWE120*W (VFD)
<b>12.5 to 25 Ton Electric Heater Selection</b>	
BAYHTRT310* — 7.51/10.0 kW Heater 208/230 3 Phase	TWE 150*3, TWE180*3, TWE240*3, TWE300*3 (VFD)
BAYHTRR320* — 14.96/19.92 kW Heater 208/230 3 Phase	TWE 150*3, TWE180*3, TWE240*3, TWE300*3 (VFD)
BAYHTRR330* — 22.47/29.92 kW Heater 208/230 3 Phase	TWE 150*3, TWE180*3, TWE240*3, TWE300*3 (VFD)
BAYHTRR350* — 37.44/49.84 kW Heater 208/230 3 Phase	TWE 150*3, TWE180*3, TWE240*3, TWE300*3 (VFD)
BAYHTRT410* — 10.0 kW Heater 460/3 Phase	TWE150*4*****C/D, TWE180*4*****C/D, TWE240*4(VFD), TWE300*4 (VFD)
BAYHTRR420* — 19.92 kW Heater 460/3 Phase	TWE150*4*****C/D, TWE180*4*****C/D, TWE240*4(VFD), TWE300*4 (VFD)
BAYHTRR430* — 29.92 kW Heater 460/3 Phase	TWE150*4*****C/D, TWE180*4*****C/D, TWE240*4(VFD), TWE300*4 (VFD)
BAYHTRR450* — 49.84 kW Heater 460/3 Phase	TWE150*4*****C/D, TWE180*4*****C/D, TWE240*4(VFD), TWE300*4 (VFD)
BAYHTRTW10* — 10.0 kW Heater 575/3 Phase	TWE150*W, TWE180*W, TWE240*W, TWE300*W (VFD)
BAYHTRRW20* — 19.92 kW Heater 575/3 Phase	TWE150*W, TWE180*W, TWE240*W, TWE300*W (VFD)
BAYHTRRW30* — 29.92 kW Heater 575/3 Phase	TWE150*W, TWE180*W, TWE240*W, TWE300*W (VFD)
BAYHTRRW50* — 49.84 kW Heater 575/3 Phase	TWE150*W, TWE180*W, TWE240*W, TWE300*W (VFD)

**Note:** Electric Heaters not available for 380/60Hz.



# Application Considerations

Application of this product should be within the cataloged airflow and performance considerations.

## Clearance Requirements

The recommended clearances identified with unit dimensions should be maintained to assure adequate serviceability, maximum capacity and peak operating efficiency. Actual clearances which appear inadequate should be reviewed with the local representative.

## Low Ambient Cooling

All Odyssey units have cooling capabilities down to 50°F. When the Optional Low Ambient accessory kit is field installed, can extend operation down to 0°F. When using these units with control systems such as bypass changeover Variable Air Volume, make sure to consider the requirement for a head pressure control to allow low ambient cooling.

Figure 4. Typical split system application

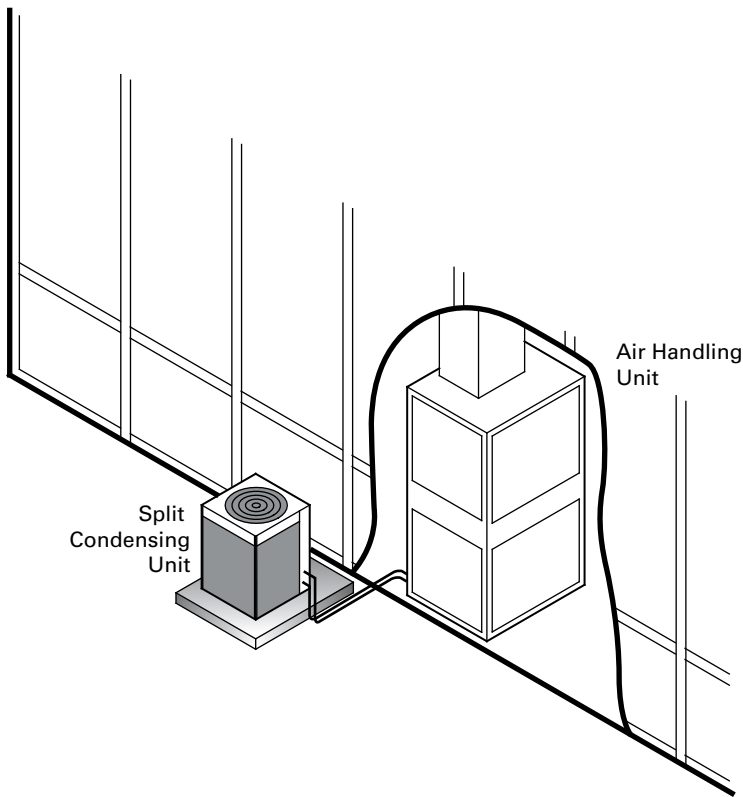

Figure 5. Typical horizontal air handler application

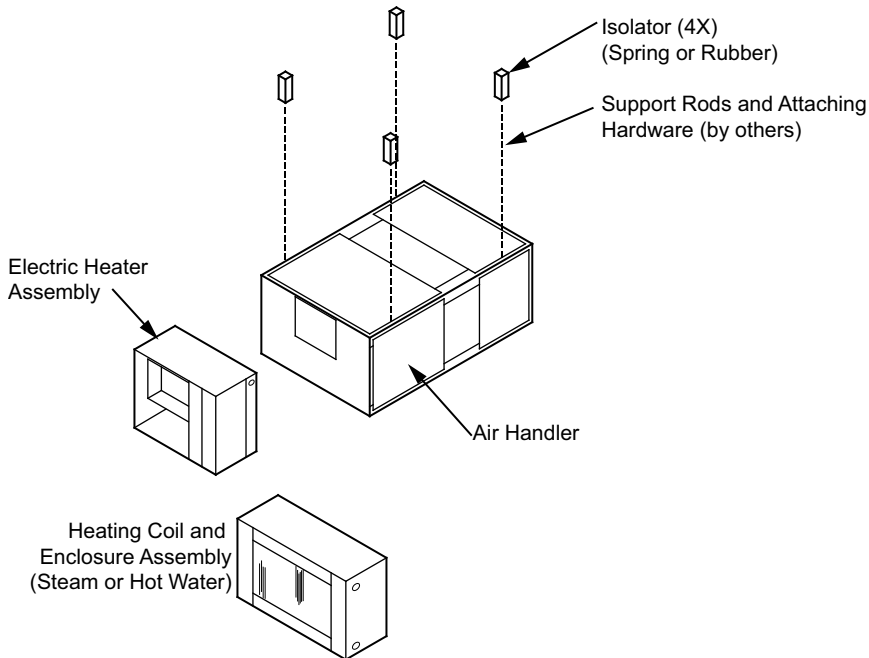
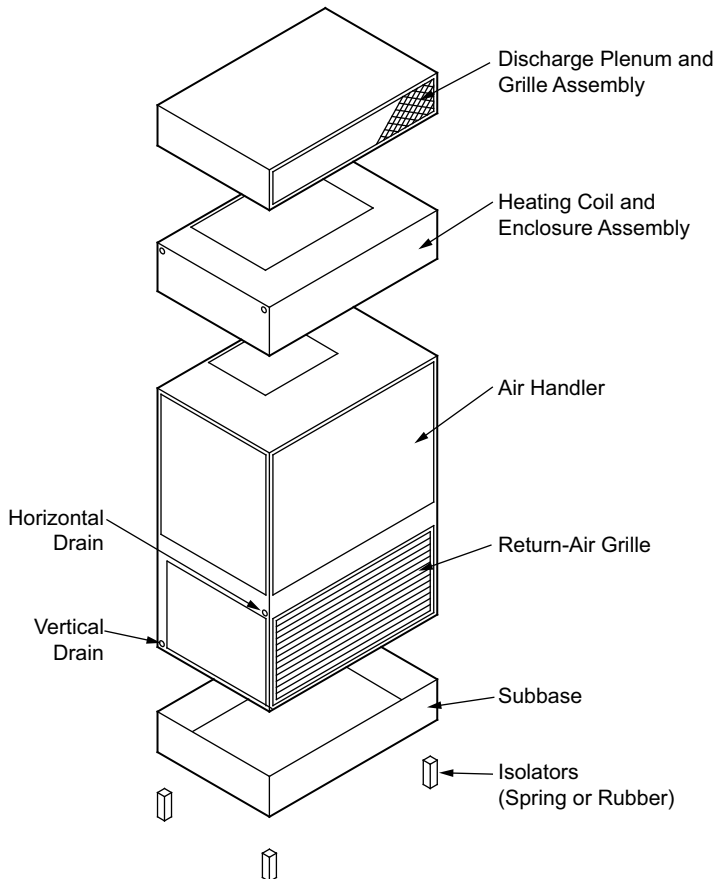

Figure 6. Typical vertical air handler application





### A2L Application Considerations

This product is listed to UL standard 60335-2-40, Household and Similar Electrical Appliances – Safety – Part 2-40: Particular Requirements for Electrical Heat Pumps, Air-Conditioners and Dehumidifiers, which defines safe design and use strategies for equipment using A2L refrigerants. This standard limits the refrigerant concentration in a space in the event of a refrigerant leak. To meet the requirements, the UL standard defines minimum room area, refrigerant charge limit, minimum circulation airflow and/or ventilation airflow requirements, and limits the use of ignition sources in spaces. The standard may require a unit refrigerant leak detection system.

For equipment with R-454B and charge amounts less than or equal to 3.91 lbs per circuit, this UL standard does not prescribe a room area limit and does not require a refrigerant leak detection system or any circulation airflow or ventilation airflow mitigation strategies. However, ignition sources in ductwork must be evaluated.

Depending on the application, a specific requirement of ANSI/ASHRAE Standard 15, Safety Standard for Refrigeration Systems, could be more stringent than UL 60335-2-40 requirements. See *Refrigeration Systems and Machinery Rooms Application Considerations for Compliance with ASHRAE® Standard 15-2022 Application Engineering Manual (APP-APM001\*-EN)* for more information.

#### Minimum Room Area Limits (Refrigerant charge greater than 3.91 lb per circuit)

Equipment with R-454B charge amounts greater than 3.91 lb per circuit may require additional circulation or ventilation airflow mitigation strategies. In this case, two minimum room area ( $A_{min}$ ) thresholds:

- The first threshold defines when equipment serving a single room is required to provide circulation airflow, either continuous or activated by a leak detection system. A ducted system requires circulation airflow unless the smallest room it serves is larger than the adjusted  $A_{min}$  threshold. This product contains a leak detection system if a circuit charge is greater than 3.91 lbs. As a result, no further leak detection system evaluation is required.
- The second threshold defines when additional ventilation airflow is required. If the room area, A or TA, is below the adjusted  $A_{min}$  or  $TA_{min}$  threshold, additional ventilation is required to remove refrigerant in the event of a leak. Refer to UL 60335-2-40 Clause GG.8 and ANSI/ASHRAE Standard 15 Section 7 for natural and mechanical ventilation requirements. For minimum room area, see equipment nameplate or unit Installation, Operation, and Maintenance (IOM) manual.

#### Minimum Room Area Limits (Refrigerant charge greater than 3.91 lb per circuit)

Equipment with R-454B charge amounts greater than 3.91 lb per circuit may require additional circulation or ventilation airflow mitigation strategies. In this case, there are two minimum room area ( $A_{min}$ ) thresholds.

- The first threshold defines when equipment serving a single room is required to provide circulation airflow, either continuous or activated by a leak detection system. A ducted system requires circulation airflow unless the smallest room it serves is larger than the adjusted  $A_{min}$  threshold. This product contains a leak detection system if a circuit charge is greater than 3.91 lbs. As a result, no further leak detection system evaluation is needed.
- The second threshold defines when additional ventilation airflow is required. If the room area, A or TA, is below the adjusted  $A_{min}$  or  $TA_{min}$  threshold, additional ventilation is required to remove refrigerant in the event of a leak. Refer to UL 60335-2-40 Clause GG.8 and ANSI/ASHRAE Standard 15 Section 7 for natural and mechanical ventilation requirements. See equipment nameplate and table below for minimum room area.

Split systems minimum room area requirements need to be determined after final field charging. Use the following figures and the largest final circuit charge to determine the systems  $A_{min}$  value. Record the final charge value on the label provided on the condensing unit.

Figure 7. Charge vs min room area (IP)

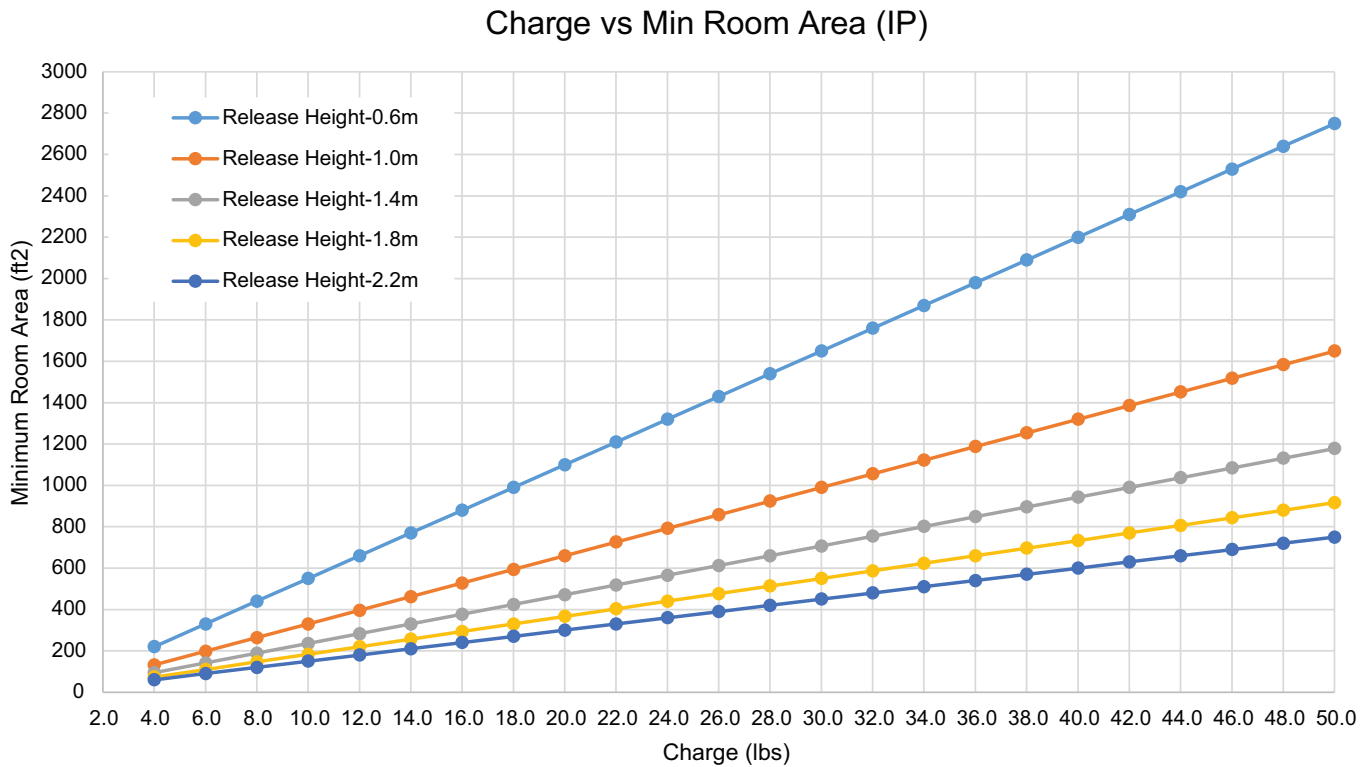
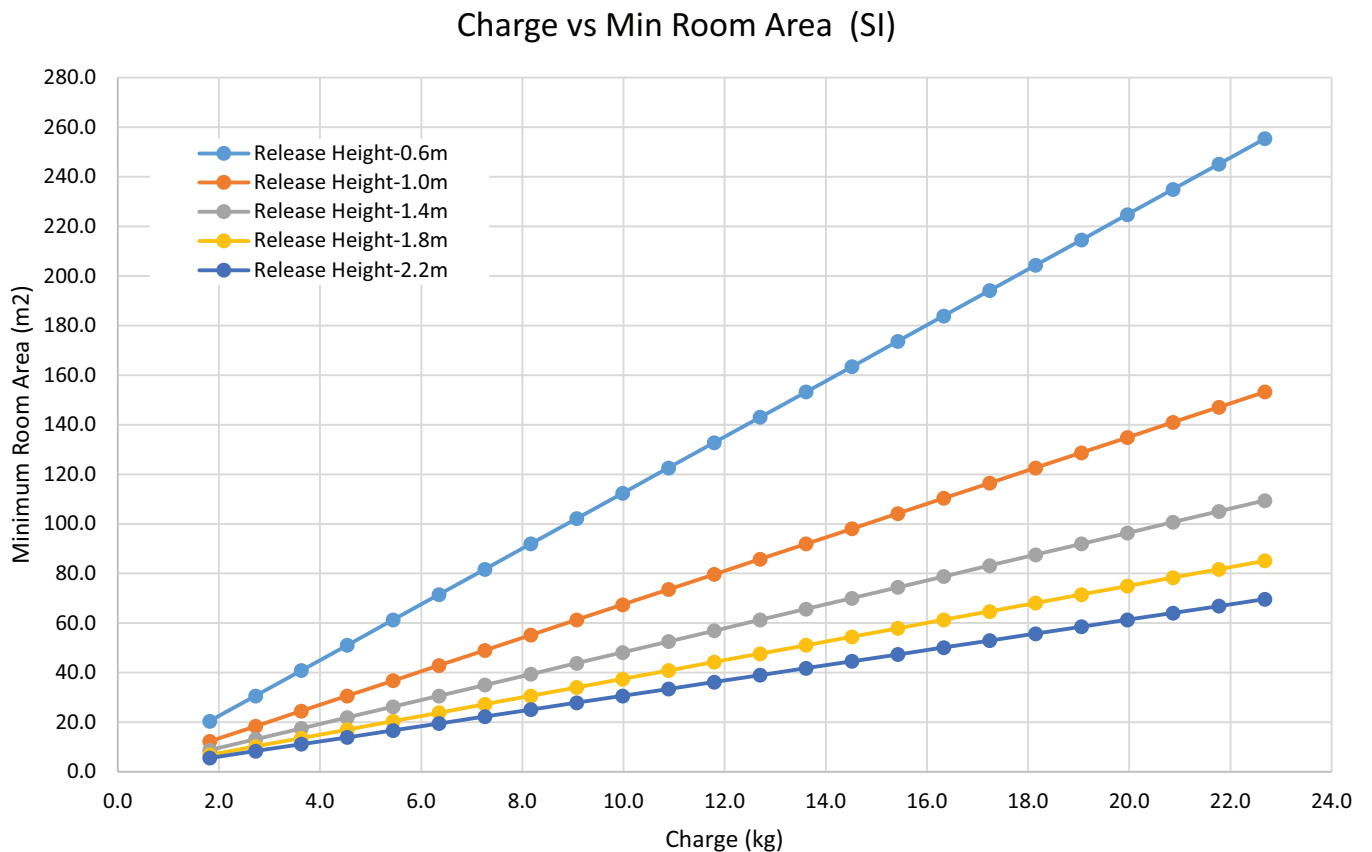

Figure 8. Charge vs min room area (SI)





## Application Considerations

Release height is the vertical distance from the floor to the lowest point in a space refrigerant would leak from first. The minimum value is 0.6 m from the floor. This point is typically the bottom of free return openings or supply diffusers. For fully ducted units, the release height is 2.2 meters.

### Minimum Room Area ( $A_{min}$ ) Adjustments

- **Altitude:** The  $A_{min}$  threshold changes with altitude. Multiple the altitude adjustment factor in the following table by  $A_{min}$  shown on the unit nameplate or in the Installation, Operation, and Maintenance (IOM) manual.

**Table 6. Altitude adjustment factor**

Altitude (ft)	Sea Level to 2000	2001 to 4000	4001 to 6000	6001 to 8000	8001 to 10000	10001 to 12000	12001 to 14000	14001 to 15000	Over 15000
$A_{min}$ Adjustment	1	1.05	1.11	1.17	1.24	1.32	1.41	1.51	1.57

- **Height :**  $A_{min}$  can be adjusted if the unit is installed in a room at a height higher than the minimum height shown on the unit. Multiply  $A_{min}$  by the ratio of the unit minimum release height (in meters) / actual release height (in meters).
- **Institutional Occupancies:** For institutional occupancies, ASHRAE Standard 15 applies an additional adjustment factor, FOCC, to the amount of charge allowed in a space. To calculate the adjusted  $A_{min}$  for institutional occupancies, divide the  $A_{min}$  on the nameplate by 0.5.

### Determining Room Area (A or TA)

The room area (A) is the room area enclosed by the projection to the floor of the walls, partitions, and doors of the space that the equipment serves. For ducted systems, total room area (TA) of all rooms connected by ducts, may be used instead of A.

Rooms connected by drop ceilings only are not considered a single room.

Rooms on the same floor of the building, and connected by an open passageway, can be considered part of the same room if the passageway is a permanent opening, extends to the floor and is intended for people to walk through.

Adjacent rooms on the same floor of the building and connected by permanent openings in the walls and/or doors between rooms (including gaps between the wall and the floor), can be considered part of the same room if the openings meet the following criteria.

- The opening is permanent and cannot be closed.
- Openings extending to the floor, such as door gaps, need to be at least 20 mm above the floor covering surface.
- Natural ventilations opening areas must meet the requirements of ANSIASHRAE Standard 15-2022, Section 7.2.3.2.

Rooms that are connected by a mechanical ventilation system can be considered a single room area if the mechanical ventilation system meets the requirements of ANSIASHRAE Standard 15-2022, Section 7.6.4.

## Leak Detection System (Refrigerant charge greater than 3.91 lb per circuit)

The leak detection system consists of one or more refrigerant detection sensors. When the system detects a leak, the following mitigation actions will be initiated until refrigerant has not been detected for at least 5 minutes:

- Energize the supply fan(s) to deliver a required minimum amount of circulation airflow.
- Disable compressor operation.
- Provide an output signal that can be used to fully open zone dampers and/or VAV boxes and disable electric heat in VAV boxes.
- Provide an output signal that can be used to energize additional mechanical ventilation (if needed).
- Units without airflow proving will disable electric heat sources.

Building fire and smoke systems may override this function.

If the refrigerant sensor has a fault, is at the end of its life, or is disconnected, the unit will initiate the mitigation actions. Mitigation actions may be verified by disconnecting the sensor.

The refrigerant sensors do not need service. Use only manufacturer-approved sensors when replacement is required.



# Selection Procedure

## Cooling Capacity

1. Calculate the buildings total and sensible cooling loads at design conditions, using standardized calculation methods.
2. Size the equipment using the gross cooling capacity tables. Match the cooling loads at design conditions. For example, if the following specifies the building cooling requirements:

Electrical Characteristics: 460/60/3

Summer Design Conditions: Entering Evap Coil—80°F DB/67°F WB, Outdoor Ambient—95°F

Total Cooling Load: 82 MBh

Sensible Cooling Load: 60 MBh

Airflow: 3000 cfm

External Static Pressure: 0.77 inches of water gauge

3. Use [Table 14, p. 31](#) to determine that TWA090K3A with TWE090K3A has a gross cooling capacity of 96.4 and 75.5 sensible capacity at 95°F DB ambient and 3000 cfm with 80°F DB/67° F WB air entering the evaporator.
4. To find the net cooling capacities, fan motor heat must be subtracted. Determine the total unit static pressure:

External Static Duct System: 0.77

Standard Filter: 0.10 in.

Supplementary Electric Heat: 0.23 in.

Total Static Pressure: 1.10 in.

### Notes:

- *The Evaporator Fan Performance Table has included the effect of a 1 in. filter already. Therefore, the actual Total Static Pressure is  $1.10 - 0.10 = 1.00$  in. With 3000 cfm and 1.00 in., [Table 45, p. 57](#) shows 1.79 Bhp (factory installed high static motor required).*
- *This formula can be used to calculate Fan Motor Heat:*  
 $3.15 \times \text{Bhp} = \text{MBh}$   
 $3.15 \times 1.79 = 5.64 \text{ MBh}$   
 $\text{Net Total Cooling Capacity} = 96.4 \text{ MBh} - 5.64 \text{ MBh} = 90.76 \text{ MBh}$   
 $\text{Net Sensible Cooling Capacity} = 75.5 \text{ MBh} - 5.64 \text{ MBh} = 69.86 \text{ MBh}$

## Heating Capacity

1. Calculate the building heating load using the Trane calculation form or any other standard accepted method.
2. Size the equipment using [Table 56, p. 66](#) to match the heating loads at design conditions. For example, if the following specifies the building heating requirements:

Total Heating Load: 95.0 MBh

Outdoor Ambient (Winter): 17°F DB

Indoor Return Temperature: 70°F DB

Airflow: 2625 cfm

3. [Table 35, p. 50](#) indicates the mechanical heating portion of the heat pump will provide 54.3 MBh for the winter design conditions. Full heat load must be carried by the supplementary heater in the unlikely event the heat pump malfunctions. From [Table 57, p. 67](#), the 34.88 kW heater at 460V has a capacity of 119,045. From the 34.88 kW heater at 460V indicates the heater model is BAYHTRP435.



## Selection Procedure

---

### Air Delivery

1. The external static pressure drop through the air distribution system is 0.77 inches of water gauge, use [Table 56, p. 66](#) to determine that the static pressure drop through the electric heater is 0.23 inches of water ( $0.77 + 0.23 = 1.00$  in.).
2. Enter [Table 45, p. 57](#) for TWE090K3A at 2625 cfm and 1.00 static pressure. The high static motor at 965 RPM gives the desired airflow.



# Model Number Description

## Heat Pump Condenser

### Digit 1, 2, 3 — Unit Function

TWA = Split System Heat Pump

### Digit 4, 5, 6 — Tonnage

072 = 6 Tons (60 Hz)  
090 = 7.5 Tons (60 Hz)  
120 = 10 Tons (60 Hz)  
150 = 12.5 Tons (60 Hz)  
180 = 15 Tons (60 Hz)  
240 = 20 Tons (60 Hz)  
300 = 25 Tons (60 Hz)

### Digit 7 — Refrigerant

K = R-454B

### Digit 8 — Voltage

3 = 208-230 Vac - 3 PH (60Hz)  
4 = 460 Vac - 3 PH (60Hz)  
W = 575 Vac - 3 PH (60Hz)

### Digit 9 — Refrigeration Circuit/Stage

A = 1 Compressor/1 Line/1 Stage (Single)  
D = 2 Compressors/2 Line/2 Stage (Dual)

### Digit 10 — Major Design Sequence

A = Rev A

### Digit 11 — Minor Design Sequence

A = Rev A

### Digit 12, 13 — Service Digits

\*\*

### Digit 14 — Efficiency Generation

B = Generation B

### Digit 15 — Controls

S = Symbio™

### Digit 16 — None

0 = None

### Digit 17 — Coil Protection

0 = Standard Coil  
1 = Standard Coil w/ Coil Guard  
2 = Black Epoxy Pre-Coated Condenser Coil (FIN/TUBE)  
3 = Black Epoxy Pre-Coated Condenser Coil with Coil Guard (FIN/TUBE)

### Digit 18, 19, 20 — None

0 = None

### Digit 21 — Communications Options

0 = No Option  
1 = Advanced Diagnostics and BACnet® BAS  
2 = Advanced Diagnostics and LonTalk® Communications Interface (LCI)

### Digit 22 to 40 — None

0 = None

## Air Handler

### Digit 1, 2, 3 — Unit Function

TWE = Air Handler

### Digit 4, 5, 6 — Tonnage

060 = 5 Tons (60 Hz)  
072 = 6 Tons (60Hz)  
090 = 7.5 Tons (60 Hz)  
120 = 10 Tons (60 Hz)  
150 = 12.5 Tons (60 Hz)  
180 = 15 Tons (60 Hz)  
240 = 20 Tons (60 Hz)  
300 = 25 Tons (60 Hz)

### Digit 7 — Refrigerant

K = R-454B

### Digit 8 — Voltage

1 = 208-230 Vac - 1 PH (60 Hz)  
3 = 208-230 Vac - 3 PH (60 Hz)  
4 = 460 Vac - 3 PH (60 Hz)  
W = 575 Vac - 3 PH (60Hz)

### Digit 9 — Refrigeration Circuit/Stage

A = Single Circuit  
B = Dual Circuit

### Digit 10 — Major Design Sequence

A = Rev A

### Digit 11 — Minor Design Sequence

A = Rev A  
B = Rev B

### Digit 12, 13 — Service Digits

\*\*

### Digit 14 — Efficiency Generation

B = Generation B

### Digit 15 — Controls

1 = Constant Volume  
C = 2 Speed Airflow<sup>(a)</sup>  
D = SZVAV (not for 24V T-stat)  
<sup>(a)</sup> 2-Speed units can be controlled by a thermostat, eliminating the need for communication wire between the outdoor unit and indoor unit. This limits functionality. See *Split System Air Conditioners Odyssey™ with Symbio™ Controls R-454B Wiring and Start-Up - Installation Guide* (SS-SVN017\*-EN) for details.

### Digit 16 — Indoor Fan Sizes

0 = Standard Motor  
4 = High Static

### Digit 17 to 40 — None

0 = None

<sup>(a)</sup> 2-Speed units can be controlled by a thermostat, eliminating the need for communication wire between the outdoor unit and indoor unit. This limits functionality. See *Split System Air Conditioners Odyssey™ with Symbio™ Controls R-454B Wiring and Start-Up - Installation Guide*(SS-SVN017\*-EN) for details.



# General Data

**Table 7. General data for 6 to 7.5 ton (TWA072K\*A\*-TWA090K\*D\*) heat pump units, 60 Hz**

	6 Tons Single Comp TWA072K*A*	6 Tons Dual Comp TWA072K*D*	7.5 Tons Single Comp TWA090K*A*	7.5 Tons Dual Comp TWA090K*D*
<b>Cooling Performance - Gross Cooling Capacity</b>				
Matched Air Handler	TWE090K*A*	TWE072K*B*	TWE090K*A*	TWE090K*B*
AHRI Rated Airflow	2100	2400	2625	3000
Gross Cooling Capacity - System	80000	83000	94000	104000
AHRI Net Cooling Capacity	79000	81000	92000	101000
<b>Efficiency</b>				
Matched Air Handler (EER)	11.3	11.2	11	11.2
System (IEER)	14.1	14.1	14.1	14.1
System kW	6.3	6	8	7.8
<b>Heating Performance - AHRI Htg/Matched AH</b>				
High Temperature Capacity	67000	67000	81000	87000
System kW/COP	5.4 / 3.4	5.2 / 3.4	6.6 / 3.4	6.8 / 3.4
Low Temperature Capacity	36000	37000	42000	44000
System kW/COP	4.6 / 2.25	4.9 / 2.25	5.55 / 2.25	5.80 / 2.25
<b>Compressor</b>				
Type <sup>(a)</sup>	Scroll 1S	Scroll1S	Scroll 2S	Scroll 1S
No./Tons/Min Stage %/Total Stages	1/5.6 / 100 / 1	2/3;2.4; / 55 <sup>(b)</sup> / 2	1/6.9 / 66 <sup>(c)</sup> / 2	2/3.5 / 50 <sup>(b)</sup> / 2
<b>System Data</b>				
No. Refrigerant Circuits <sup>(d)</sup>	1	2	1	2
Suction Line Connection (in.) OD <sup>(d)</sup>	1 3/8	1 1/8	1 3/8	1 1/8
Liquid Line Connection (in.) OD <sup>(d)</sup>	1/2	1/2	5/8	1/2
<b>Outdoor Coil</b>				
Type / Tube Size (in.) OD	Lanced / 0.375	Lanced / 0.375	Lanced / 0.375	Lanced / 0.375
Face Area (sq ft)	19.24	19.24	19.24	23.96
Rows/FPI (Fins per inch)	2/18	2/18	2/18	2/18
<b>Outdoor Fan</b>				
Type	Propeller	Propeller	Propeller	Propeller
No. Used/Diameter (in.)	1/26	1/26	1/26	1/26
Drive Type/No. Speeds	Direct/1	Direct/1	Direct/1	Direct/1
CFM	5800	5500	5800	5500
No. Motor/HP	1/0.5	1/0.5	1/0.5	1/0.5
Motor RPM	1100	1100	1100	1100
<b>Refrigerant Charge (Field Supplied)</b>				
lbs of R-454B	17.3	9.1/9.5	16.2	9.3/9.6
<b>Shipping Dimensions</b>				
HxWxD (in.)	45 x 45.25 x 39	45 x 55 x 42	45 x 45.25 x 39	45 x 55 x 42

**Notes:**

1. Condensing units are tested in accordance with AHRI Standard 365.
2. Units are AHRI Certified to AHRI Standard 340-360 (I-P)-2007. Rating conditions are 95°F outdoor air temperature, 80°F entering dry bulb, 67°F entering wet bulb with 25ft of interconnecting refrigerant piping with minimum external static pressure as determined by rating standard.

<sup>(a)</sup> 1-stage compressor = 1S, 2-stage compressor = 2S.

<sup>(b)</sup> 1st stage cooling is compressor 1. 2nd stage is compressor 1 and 2. In Heating mode, both the compressors will run.

<sup>(c)</sup> All compressors stage to 66% for first stage cooling, then 100% for second stage cooling. In Heating mode all compressors will run at 100%.

<sup>(d)</sup> For line lengths of 25ft or less, refer to the Installation, Operation, and Maintenance Manual for pipe sizing. For line lengths greater than 25ft, see *Split System Air Conditioners Odyssey™ Tube Size and Component Selection TTA and TWA (6-25 Tons) Application Guide (SS-APG017\*-EN)* for pipe sizing.

**Table 8. General data for 10 to 25 ton (TWA120K\*A\*-TWA300K\*D\*) heat pump units, 60 Hz**

	10 Tons	10 Tons	12.5 Tons	15 Tons	20 Tons	25 Tons
	Single Comp TWA120K*A*	Dual Comp TWA120K*D*	Dual Comp TWA150K*D*	Dual Comp TWA180K*D*	Dual Comp TWA240K*D*	Dual Comp TWA300K*D*
<b>Cooling Performance - Gross Cooling Capacity</b>						
Matched Air Handler	TWE120K*A*	TWE120K*B*	TWE150K*B*	TWE180K*B*	TWE240K*B*	TWE300K*B*
AHRI Rated Airflow	4000	4000	5000	6000	8000	10000
Gross Cooling Capacity - System	129000	130000	156000	200000	266000	300000
AHRI Net Cooling Capacity	125000	126000	152000	194000	258000	282000
<b>Efficiency</b>						
Matched Air Handler (EER)	11.3	11.2	10.6	10.8	10	9.5
System (IEER)	14.1	14.1	13.5	13.5	12.5	12.5
System kW	10.5	10.3	13.67	16.2	23.9	28.783
<b>Heating Performance - AHRI Htg/Matched AH</b>						
High Temperature Capacity	105000	108000	123000	176000	244000	262000
System kW/COP	8.8 / 3.4	8.9 / 3.4	10.8 / 3.3	15.00 / 3.3	21.2 / 3.2	24/3.2
Low Temperature Capacity	60000	65000	83000	105000	142000	182000
System kW/COP	7.9 / 2.25	8.4 / 2.25	10.2 / 2.05	13.6 / 2.05	18.6 / 2.05	21.93/2.05
<b>Compressor</b>						
Type <sup>(a)</sup>	Scroll 2S	Scroll 2S	Scroll 1S	Scroll 1S	Scroll 1S	Scroll 1S
No./Tons/Min Stage %/Total Stages	1/8.7 / 67 <sup>(b)</sup> / 2	2/4.3 / 67 <sup>(b)</sup> / 2	2/6.1/50 <sup>(c)</sup> /2	2/6.9 / 50 <sup>(c)</sup> / 2	2/10.1 / 50 <sup>(c)</sup> / 2	2/11.8 / 50 <sup>(c)</sup> / 2
<b>System Data</b>						
No. Refrigerant Circuits <sup>(d)</sup>	1	2	2	2	2	2
Suction Line Connection (in.) OD <sup>(d)</sup>	1 3/8	1 1/8	1 1/8	1 3/8	1 3/8	1 3/8
Liquid Line Connection (in.) OD <sup>(d)</sup>	1/2	1/2	1/2	5/8	5/8	5/8
<b>Outdoor Coil</b>						
Type / Tube Size (in.) OD	Lanced / 0.375	Lanced / 0.375	Lanced / 0.375	Lanced / 0.375	Lanced / 0.375	Lanced / 0.376
Face Area (sq ft)	29.02	29.02	29.02	52.6	52.6	60.5
Rows/FPI (Fins per inch)	2/18	2/18	2/18	2/18	2/18	2/18
<b>Outdoor Fan</b>						
Type	Propeller	Propeller	Propeller	Propeller	Propeller	Propeller
No. Used/Diameter (in.)	1/28	1/28	1/28	2/28	2/28	2/28
Drive Type/No. Speeds	Direct/1	Direct/1	Direct/1	Direct/1	Direct/1	Direct/1
CFM	8900	8900	8900	17500	17500	17500
No. Motor/HP	1/1	1/1	1/1	2/1	2/1	2/1
Motor RPM	1125	1125	1125	1125	1125	1125
<b>Refrigerant Charge (Field Supplied)</b>						
lbs of R-454B	23.2	12.6/12.6	12.7/12.7	21.2/21.2	19.9/19.9	23/23
<b>Shipping Dimensions</b>						
HxWxD (in.)	52.1 x 55 x 42	52.1 x 55 x 42	52.1 x 55 x 42	51.1 x 96 x 48	51.1 x 96 x 48	57.1 x 96 x 48

**Notes:**

1. Condensing units are tested in accordance with AHRI Standard 365.
2. Units are AHRI Certified to AHRI Standard 340-360 (I-P)-2007. Rating conditions are 95°F outdoor air temperature, 80°F entering dry bulb, 67°F entering wet bulb with 25ft of interconnecting refrigerant piping with minimum external static pressure as determined by rating standard.

<sup>(a)</sup> 1-stage compressor = 1S, 2-stage compressor = 2S.

<sup>(b)</sup> All compressors stage to 66% for first stage cooling, then 100% for second stage cooling. In Heating mode all compressors will run at 100%.

<sup>(c)</sup> 1st stage cooling is compressor 1. 2nd stage is compressor 1 and 2. In Heating mode, both the compressors will run.

<sup>(d)</sup> For line lengths of 25 ft or less, refer to the Installation, Operation, and Maintenance Manual for pipe sizing. For line lengths greater than 25ft, see *Split System Air Conditioners Odyssey™ Tube Size and Component Selection TTA and TWA (6-25 Tons) Application Guide (SS-APG017\*-EN)* for pipe sizing

**Table 9. General data - 6 to 10 tons (TWE072K\*B\* - TWE120K\*B\*) SZVAV and 2-speed VFD air handler - 60Hz**

	6 Tons	7.5 Tons	7.5 Tons	10 Tons	10 Tons
	Dual Circuit TWE072K3B*, 4B*, WB*	Single Circuit TWE090K3A*, 4A*, WA*	Dual Circuit TWE090K3B*, 4B*, WB*	Single Circuit TWE120K3A*, 4A*, WA*	Dual Circuit TWE120K3B*, 4B*, WB*
<b>System Data</b>					
No. Refrigerant Circuits	2	1	2	1	2



**General Data**

**Table 9. General data - 6 to 10 tons (TWE072K\*B\* - TWE120K\*B\*) SZVAV and 2-speed VFD air handler - 60Hz (continued)**

	6 Tons	7.5 Tons	7.5 Tons	10 Tons	10 Tons
	Dual Circuit TWE072K3B*, 4B*, WB*	Single Circuit TWE090K3A*, 4A*, WA*	Dual Circuit TWE090K3B*, 4B*, WB*	Single Circuit TWE120K3A*, 4A*, WA*	Dual Circuit TWE120K3B*, 4B*, WB*
Suction Line Connection (in.) OD	1-1/8	1-3/8	1-1/8	1-3/8	1-1/8
Liquid Line Connection (in.) OD	1/2	1/2	1/2	1/2	1/2
<b>Indoor Coil</b>					
Type	Lanced/Intertwined	Lanced/Intertwined	Lanced/Intertwined	Lanced/Intertwined	Lanced/Intertwined
Tube Size (in.)	0.375	0.375	0.375	0.375	0.375
Face Area (sq. ft.)	8.1	8.1	8.1	11.2	11.2
Rows/FPI (Fins per inch)	4/14	4/14	4/14	4/14	4/14
Refrigerant Control	Expansion Valve	Expansion Valve	Expansion Valve	Expansion Valve	Expansion Valve
Drain Connection Size (in.)	1 PVC	1 PVC	1 PVC	1 PVC	1 PVC
<b>Indoor Fan</b>					
Type	Centrifugal	Centrifugal	Centrifugal	Centrifugal	Centrifugal
No. Used/Diameter x Width (in.)	1/15x15	1/15x15	1/15x15	1/15x15	1/15x15
Drive Type/No. Speeds	Belt/VFD Variable	Belt/VFD Variable	Belt/VFD Variable	Belt/VFD Variable	Belt/VFD Variable
CFM (Nominal)	2400	2625	3000	4000	4000
No. Motors	1	1	1	1	1
Motor HP - Standard/Oversized	2.0/3.0	2.0/3.0	2.0/3.0	2.0/3.0	2.0/3.0
Motor RPM	1725	1725	1725	1725	1725
Motor Frame Size	56 H	56 H	56 H	56 H	56 H
<b>Filters<sup>(a)</sup></b>					
Type/Furnished	Throwaway/Yes	Throwaway/Yes	Throwaway/Yes	Throwaway/Yes	Throwaway/Yes
(No.)/Size Recommended	(3) 16x25x1	(3) 16x25x1	(3) 16x25x1	(4) 16x25x1	(4) 16x25x1
MERV 13 (No.)/Size Recommended	(3) 16x25x2	(3) 16x25x2	(3) 16x25x2	(4) 16x25x2	(4) 16x25x2
<b>Shipping Dimensions</b>					
HxWxD (in.)	61.2" x 30.5" x 53"	61.2" x 30.5" x 53"	61.2" x 30.5" x 53"	61.2" x 30.5" x 69"	61.2" x 30.5" x 69"

<sup>(a)</sup> One inch, throw-away filters shall be standard on TWE060, TWE072, TWE090, TWE120 model air handlers from the factory. The filter rack can be field converted to two inch capability. Two inch, throw-away filters shall be standard on TWE180 and TWE240 models.

**Table 10. General data - 12.5 to 25 tons (TWE150K\*B\* - TWE300K\*B\*) SZVAV and 2-speed VFD air handler - 60Hz**

	12.5 Tons	15 Tons	20 Tons	25 Tons
	Dual Circuit TWE150K3B*, 4B*, WB*	Dual Circuit TWE180K3B*, 4B*, WB*	Dual Circuit TWE240K3B*, 4B*, WB*	Dual Circuit TWE300K3B*, 4B*, WB*
<b>System Data</b>				
No. Refrigerant Circuits	2	2	2	2
Suction Line Connection (in.) OD	1-3/8	1-3/8	1-3/8	1-3/8
Liquid Line Connection (in.) OD	1/2	1/2	5/8	5/8
<b>Indoor Coil</b>				
Type	Lanced/Intertwined	Lanced/Intertwined	Lanced/Intertwined	Lanced/Intertwined
Tube Size (in.)	0.375	0.375	0.375	0.375
Face Area (sq. ft.)	16.3	16.3	21.7	21.7
Rows/FPI (Fins per inch)	4/14	4/14	3/14	4/14
Refrigerant Control	Expansion Valve	Expansion Valve	Expansion Valve	Expansion Valve
Drain Connection Size (in.)	1 PVC	1 PVC	1 PVC	1 PVC
<b>Indoor Fan</b>				
Type	Centrifugal	Centrifugal	Centrifugal	Centrifugal
No. Used/Diameter x Width (in.)	2/15x15	2/15x15	2/15x15	2/15x15
Drive Type/No. Speeds	Belt/VFD Variable	Belt/VFD Variable	Belt/VFD Variable	Belt/VFD Variable
CFM (Nominal)	5000	6000	8000	10000

**Table 10. General data - 12.5 to 25 tons (TWE150K\*B\* - TWE300K\*B\*) SZVAV and 2-speed VFD air handler - 60Hz (continued)**

	<b>12.5 Tons</b>	<b>15 Tons</b>	<b>20 Tons</b>	<b>25 Tons</b>
	<b>Dual Circuit TWE150K3B*, 4B*, WB*</b>	<b>Dual Circuit TWE180K3B*, 4B*, WB*</b>	<b>Dual Circuit TWE240K3B*, 4B*, WB*</b>	<b>Dual Circuit TWE300K3B*, 4B*, WB*</b>
No. Motors	1	1	1	1
Motor HP - Standard/Oversized	2.0/5.0	3.0/5.0	5.0/7.5	7.5/10
Motor RPM	1725/3450	1725/3450	3450	3450
Motor Frame Size	56 H	56 H	56 H/184 T	184 T/ 215 T
<b>Filters<sup>(a)</sup></b>				
Type/Furnished	Throwaway/Yes	Throwaway/Yes	Throwaway/Yes	Throwaway/Yes
(No.)/Size Recommended	(8) 15x20x2	(8) 15x20x2	(4) 16x25x2 (4) 16x20x2	(4) 16x25x2 (4) 16x20x2
MERV 13 (No.)/Size Recommended	(8) 15x20x2	(8) 15x20x2	(4) 16x25x2 (4) 16x20x2	(4) 16x25x2 (4) 16x20x2
<b>Shipping Dimensions</b>				
HxWxD (in.)	76.3 x 33.3 x 85	76.3 x 33.3 x 85	79.1 x 35.8 x 95	79.1 x 35.8 x 95

<sup>(a)</sup> One inch, throw-away filters shall be standard on TWE060, TWE072, TWE090, TWE120 model air handlers from the factory. The filter rack can be field converted to two inch capability. Two inch, throw-away filters shall be standard on TWE180 and TWE240 models.



General Data

Table 11. 5 to 10 tons (TWE060K\*A - TWE120K\*B\*) constant volume air handler - 60Hz

	5 Tons	5 Tons	7.5 Tons	7.5 Tons	7.5 Tons	10 Tons	10 Tons
<b>System Data</b>	Single Circuit TWE060K3A*, 4A*, 1A*, WA*	Dual Circuit TWE060K3B*, 4B*, 1B*, WB*	Single Circuit TWE090K1A*	Single Circuit TWE090K1A*	Dual Circuit TWE090K1B*	Single Circuit TWE120K1A*	Dual Circuit TWE120K1B*
No. Refrigerant Circuits	1	2	1	1	2	1	2
Suction Line Connection (in.) OD	1-1/8	1-1/8	1-3/8	1-3/8	1-1/8	1-3/8	1-1/8
Liquid Line Connection (in.) OD	1/2	1/2	1/2	1/2	1/2	1/2	1/2
<b>Indoor Coil</b>							
Type	Lanced/Intertwined	Lanced/Intertwined	Lanced/Intertwined	Lanced/Intertwined	Lanced/Intertwined	Lanced/Intertwined	Lanced/Intertwined
Tube Size (in.)	0.375	0.375	0.375	0.375	0.375	0.375	0.375
Face Area (sq. ft.)	5	5	8.1	8.1	8.1	11.2	11.2
Rows/FPI (Fins per inch)	4/14	4/14	4/14	4/14	4/14	4/14	4/14
Refrigerant Control	Expansion Valve	Expansion Valve	Expansion Valve	Expansion Valve	Expansion Valve	Expansion Valve	Expansion Valve
Drain Connection Size (in.)	1 PVC	1 PVC	1 PVC	1 PVC	1 PVC	1 PVC	1 PVC
<b>Indoor Fan</b>							
Type	Centrifugal	Centrifugal	Centrifugal	Centrifugal	Centrifugal	Centrifugal	Centrifugal
No. Used/Diameter x Width (in.)	1/12x12	1/12x12	1/15x15	1/15x15	1/15x15	1/15x15	1/15x15
Drive Type/No. Speeds	Belt/Adjustable	Belt/Adjustable	Belt/Adjustable	Belt/Adjustable	Belt/Adjustable	Belt/Adjustable	Belt/Adjustable
CFM (Nominal)	2000	2000	2625	2625	3000	4000	4000
No. Motors	1	1	1	1	1	1	1
Motor HP - Standard/Oversized	0.75/1.5	0.75/1.5	1.5/2.0	1.5/2.0	1.5/2.0	2.0 <sup>(a)</sup>	2.0 <sup>(a)</sup>
Motor RPM	1725	1725	1725	1725	1725	1725	1725
Motor Frame Size	56 H	56 H	56 H	56 H	56 H	56 H	56 H
<b>Filters<sup>(b)</sup></b>							
Type/Furnished	Throwaway/Yes	Throwaway/Yes	Throwaway/Yes	Throwaway/Yes	Throwaway/Yes	Throwaway/Yes	Throwaway/Yes
(No./)Size Recommended	(1) 16x20x1 (1) 20x20x1	(1) 16x20x1 (1) 20x20x1	(3) 16x25x1	(3) 16x25x1	(3) 16x25x1	(4) 16x25x1	(4) 16x25x1
MERV 13 (No./)Size Recommended	(1) 16x20x2 (1) 20x20x2	(1) 16x20x2 (1) 20x20x2	(3) 16x25x2	(3) 16x25x2	(3) 16x25x2	(4) 16x25x2	(4) 16x25x2
<b>Shipping Dimensions</b>							
HxWxD (in.)	55.1" x 27.5" x 43.5"	55.1" x 27.5" x 43.5"	61.2" x 30.5" x 53"	61.2" x 30.5" x 53"	61.2" x 30.5" x 53"	61.2" x 30.5" x 69"	61.2" x 30.5" x 69"

<sup>(a)</sup> Standard motor only. 120K1 does not have any oversize motor.

<sup>(b)</sup> One inch, throw-away filters shall be standard from the factory. The filter rack can be field converted to two inch capability.



# Performance Data

## Gross Cooling Capacities

Table 12. Gross cooling capacities (MBh) 6 tons TWA072K\*A heat pump with 7.5 tons TWE090K\*A air handler (IP)

CFM	Ent DB (°F)	Ambient Temperature (°F)						Ambient Temperature (°F)						Ambient Temperature (°F)					
		85						95						105					
		Entering Wet Bulb (°F)						Entering Wet Bulb (°F)						Entering Wet Bulb (°F)					
		61		67		73		61		67		73		61		67		73	
		MBH	SHC	MBH	SHC	MBH	SHC	MBH	SHC	MBH	SHC	MBH	SHC	MBH	SHC	MBH	SHC	MBH	SHC
2100	75	76.0	62.3	83.7	48.8	93.1	34.3	72.6	60.6	79.7	47.1	88.7	32.8	69.1	58.8	76.0	45.3	84.0	31.1
	80	76.8	73.7	84.3	59.9	92.9	45.9	73.5	72.1	80.5	58.2	88.5	44.3	70.2	70.2	76.5	56.4	83.8	42.7
	85	80.3	80.3	84.7	71.1	93.2	57.2	77.4	77.4	81.0	69.5	88.9	55.5	74.3	74.3	77.1	67.7	84.5	53.7
	90	85.6	82.6	85.6	82.6	93.6	68.4	81.6	81.6	82.0	81.0	89.4	66.8	78.4	78.4	78.5	78.5	85.0	65.0
2400	75	78.0	67.0	85.8	51.3	94.8	35.1	74.5	65.2	81.8	49.6	90.2	33.5	70.8	63.4	77.6	47.7	85.2	31.8
	80	79.5	79.5	86.3	64.1	94.6	48.3	76.6	76.6	82.4	62.4	89.9	46.7	73.3	73.3	78.2	60.5	85.0	45.0
	85	84.1	84.1	87.0	77.1	95.2	61.0	81.0	81.0	83.1	75.4	90.8	59.3	77.6	77.6	79.0	73.6	86.2	57.5
	90	88.7	88.7	88.8	88.8	95.7	73.9	85.4	85.4	85.6	85.6	91.4	72.2	82.0	82.0	82.1	82.1	86.8	70.4
2640	75	79.4	70.6	87.1	53.4	95.9	35.7	75.8	68.9	83.0	51.6	91.0	34.0	72.0	67.0	78.7	49.7	85.9	32.3
	80	82.0	82.0	87.7	67.4	95.7	50.2	78.8	78.8	83.6	65.7	90.8	48.6	75.4	75.4	79.4	63.8	86.6	46.4
	85	86.7	86.7	88.5	81.8	96.6	64.0	83.4	83.4	84.6	80.1	92.1	62.3	79.9	79.9	80.5	78.3	87.4	60.4
	90	91.5	91.5	91.7	91.7	97.2	78.3	88.1	88.1	88.2	88.2	92.7	76.6	84.4	84.4	84.5	84.5	88.0	74.7
2880	75	80.6	74.3	88.2	55.3	96.7	36.2	77.0	72.5	84.0	53.5	91.7	34.5	73.1	70.6	79.6	51.6	86.5	32.8
	80	84.1	84.1	88.8	70.7	97.1	51.7	80.8	80.8	84.7	69.0	92.4	49.9	77.2	77.2	80.4	67.1	87.5	48.0
	85	89.0	89.0	90.0	86.5	97.8	67.0	85.5	85.5	86.0	84.7	93.1	65.2	81.9	81.9	82.0	82.0	88.3	63.4
	90	94.0	94.0	94.1	94.1	98.5	82.6	90.4	90.4	90.5	90.5	93.9	80.9	86.5	86.5	86.6	86.6	89.2	79.0
CFM	Ent DB (°F)	Ambient Temperature (°F)						Ambient Temperature (°F)											
		115						125											
		Entering Wet Bulb (°F)						Entering Wet Bulb (°F)											
		61		67		73		61		67		73							
		MBH	SHC	MBH	SHC	MBH	SHC	MBH	SHC	MBH	SHC	MBH	SHC						
2100	75	65.3	57.0	71.7	43.4	79.0	29.4	61.3	55.0	67.2	41.3	73.5	27.5						
	80	67.1	67.1	72.3	54.5	78.8	40.9	63.6	63.6	67.9	52.6	73.4	39.1						
	85	71.0	71.0	73.0	65.9	79.9	51.9	67.4	67.4	68.6	64.0	74.9	49.9						
	90	75.0	75.0	75.1	75.1	80.4	63.2	71.2	71.2	71.4	71.4	75.5	61.2						
2400	75	66.9	61.5	73.2	45.8	79.9	30.0	62.8	59.5	68.5	43.7	74.3	28.2						
	80	69.9	69.9	73.9	58.6	80.6	42.8	66.2	66.2	69.3	56.6	75.5	40.7						
	85	74.0	74.0	74.8	71.7	81.4	55.6	70.2	70.2	70.4	69.8	76.3	53.5						
	90	78.3	78.3	78.4	78.4	82.0	68.6	74.2	74.2	74.3	74.3	77.0	66.6						
2640	75	68.1	65.1	74.2	47.7	80.5	30.5	63.9	63.0	69.3	45.5	74.7	28.7						
	80	71.8	71.8	74.9	61.9	81.6	44.4	67.9	67.9	70.2	59.8	76.3	42.2						
	85	76.1	76.1	76.3	76.3	82.4	58.5	72.1	72.1	72.2	72.2	77.2	56.4						
	90	80.5	80.5	80.6	80.6	83.2	72.9	76.2	76.2	76.4	76.4	78.0	70.9						
2880	75	69.2	68.7	75.0	49.5	80.9	31.0	65.1	65.1	70.0	47.3	75.0	29.2						
	80	73.5	73.5	75.8	65.1	82.4	45.9	69.4	69.4	71.1	63.0	77.0	43.7						
	85	77.9	77.9	78.0	78.0	83.3	61.4	73.7	73.7	73.8	73.8	78.0	59.3						
	90	82.4	82.4	82.6	82.6	84.2	77.1	78.0	78.0	78.1	78.1	79.0	75.1						

**Notes:**

1. All capacities shown are gross and have not considered indoor fan heat. To obtain net cooling, subtract indoor fan heat.
2. MBh = Total Gross Capacity, SHC = Sensible Heat Capacity



**Performance Data**

**Table 13. Gross cooling capacities (MBh) 6 tons TWA072K\*D heat pump with 6 tons TWE072K\*B air handler (IP)**

CFM	Ent DB (°F)	Ambient Temperature (°F)						Ambient Temperature (°F)						Ambient Temperature (°F)					
		85						95						105					
		Entering Wet Bulb (°F)						Entering Wet Bulb (°F)						Entering Wet Bulb (°F)					
		61		67		73		61		67		73		61		67		73	
		MBH	SHC	MBH	SHC	MBH	SHC	MBH	SHC	MBH	SHC	MBH	SHC	MBH	SHC	MBH	SHC	MBH	SHC
2160	75	75.0	62.7	83.0	48.8	92.7	34.2	72.9	61.7	80.6	47.8	89.8	33.2	70.6	60.5	77.9	46.6	86.6	32.1
	80	76.4	73.4	83.7	60.4	92.7	46.2	74.5	71.9	81.3	59.4	89.8	45.2	72.4	70.4	78.6	58.2	86.7	44.0
	85	80.4	80.4	84.4	72.2	93.2	57.9	78.6	78.6	82.0	71.1	90.4	56.8	76.5	76.5	79.4	70.0	87.4	55.7
	90	86.1	82.5	86.1	82.5	93.8	69.6	83.1	83.1	83.9	81.0	91.1	68.6	81.0	81.0	81.6	79.3	88.1	67.4
2400	75	76.6	66.4	84.6	50.9	94.0	34.9	74.4	65.4	82.1	49.8	91.0	33.8	72.0	64.2	79.3	48.6	87.6	32.7
	80	78.7	77.4	85.3	63.8	94.2	48.1	76.8	76.0	82.8	62.8	91.3	47.0	74.6	74.5	80.1	61.6	88.0	45.8
	85	83.4	83.4	86.2	77.0	94.9	61.0	81.5	81.5	83.8	75.9	92.0	59.9	79.3	79.3	81.1	74.7	88.9	58.7
	90	88.4	88.4	88.7	87.4	95.7	74.1	86.3	86.3	86.5	85.9	92.7	73.0	84.0	84.0	84.1	84.1	89.7	71.8
2640	75	78.0	70.2	85.9	53.0	95.1	35.4	75.8	69.1	83.3	51.9	91.9	34.4	73.3	67.9	80.4	50.6	88.5	33.2
	80	81.0	81.0	86.7	67.2	95.5	49.9	79.1	79.1	84.2	66.1	92.4	48.8	76.9	76.9	81.3	64.9	89.2	47.5
	85	86.1	86.1	87.9	81.7	96.4	64.1	84.0	84.0	85.4	80.5	93.3	62.9	81.7	81.7	82.9	78.1	90.2	61.7
	90	91.3	91.3	91.4	91.4	97.2	78.5	89.1	89.1	89.2	89.2	94.2	77.4	86.6	86.6	86.8	86.8	91.1	76.2
2880	75	79.3	73.9	87.0	55.0	96.0	36.0	77.1	72.8	84.4	53.9	92.7	34.9	74.6	70.7	81.4	52.6	89.1	33.7
	80	83.2	83.2	87.9	70.6	96.6	51.7	81.1	81.1	85.3	69.5	93.4	50.4	78.8	78.8	82.4	68.2	90.3	49.2
	85	88.5	88.5	89.6	85.3	97.6	67.2	86.3	86.3	87.2	83.3	94.4	66.0	83.8	83.8	84.5	81.5	91.3	64.8
	90	93.8	93.8	94.0	94.0	98.6	82.9	91.5	91.5	91.7	91.7	95.5	81.7	88.9	88.9	89.1	89.1	92.3	80.5
CFM	Ent DB (°F)	Ambient Temperature (°F)						Ambient Temperature (°F)											
		115						125											
		Entering Wet Bulb (°F)						Entering Wet Bulb (°F)											
		61		67		73		61		67		73							
		MBH	SHC	MBH	SHC	MBH	SHC	MBH	SHC	MBH	SHC	MBH	SHC						
2160	75	68.1	59.3	75.1	45.4	83.2	30.9	65.4	58.0	72.1	44.0	79.5	29.7						
	80	70.1	68.7	75.9	57.0	83.5	42.8	67.7	67.0	72.9	55.7	80.0	41.5						
	85	74.3	74.3	76.7	68.8	84.3	54.4	72.0	72.0	73.8	67.5	80.9	53.1						
	90	78.7	78.7	79.1	77.6	85.0	66.2	76.2	76.2	76.4	75.9	81.6	64.9						
2400	75	69.5	63.0	76.4	47.4	84.1	31.5	66.8	61.7	73.3	46.0	80.3	30.2						
	80	72.4	72.4	77.2	60.3	84.7	44.6	70.0	70.0	74.1	59.0	81.2	43.2						
	85	77.0	77.0	78.4	73.1	85.7	57.5	74.4	74.4	75.6	70.8	82.2	56.1						
	90	81.6	81.6	81.7	81.7	86.5	70.6	78.9	78.9	79.1	79.1	83.0	69.2						
2640	75	70.8	66.4	77.5	49.3	84.8	32.0	68.2	64.1	74.3	47.9	80.9	30.7						
	80	74.5	74.5	78.4	63.6	85.9	46.2	72.0	72.0	75.2	62.3	82.2	44.8						
	85	79.2	79.2	80.2	76.2	86.8	60.5	76.6	76.6	77.2	74.1	83.3	59.1						
	90	84.0	84.0	84.2	84.2	87.8	74.9	81.3	81.3	81.4	81.4	84.3	73.6						
2880	75	72.1	68.6	78.4	51.3	85.4	32.5	69.4	66.6	75.1	49.8	81.3	31.2						
	80	76.4	76.4	79.4	66.9	86.8	47.9	73.7	73.7	76.2	65.6	83.1	46.4						
	85	81.3	81.3	81.7	79.5	87.8	63.4	78.5	78.5	78.7	77.5	84.2	62.0						
	90	86.2	86.2	86.4	86.4	89.0	79.3	83.3	83.3	83.4	83.4	85.4	77.9						

**Notes:**

1. All capacities shown are gross and have not considered indoor fan heat. To obtain net cooling, subtract indoor fan heat.
2. MBh = Total Gross Capacity, SHC = Sensible Heat Capacity

**Table 14. Gross cooling capacities (MBh) 7.5 tons TWA090K\*A heat pump with 7.5 tons TWE090K\*A air handler (IP)**

CFM	Ent DB (°F)	Ambient Temperature (°F)						Ambient Temperature (°F)						Ambient Temperature (°F)					
		85						95						105					
		Entering Wet Bulb (°F)						Entering Wet Bulb (°F)						Entering Wet Bulb (°F)					
		61		67		73		61		67		73		61		67		73	
		MBH	SHC	MBH	SHC	MBH	SHC	MBH	SHC	MBH	SHC	MBH	SHC	MBH	SHC	MBH	SHC	MBH	SHC
2625	75	89.8	75.5	98.6	58.2	108.7	40.0	85.8	73.6	94.1	56.4	103.7	38.2	81.5	71.5	89.2	54.4	98.5	36.3
	80	91.0	89.8	98.9	72.2	108.6	54.4	87.2	87.2	94.4	70.3	103.6	52.6	83.5	83.5	89.8	68.2	98.3	50.8
	85	95.5	95.5	99.4	86.2	108.6	68.6	91.9	91.9	95.1	84.3	103.7	66.7	88.2	88.2	90.4	82.4	98.6	64.8
	90	100.8	100.6	100.8	100.6	108.9	82.6	96.7	96.7	96.9	96.9	104.1	80.7	92.8	92.8	93.0	93.0	99.0	78.8
3000	75	92.0	81.3	100.5	61.6	110.5	40.8	87.8	79.3	95.7	59.7	105.4	39.0	83.4	77.2	91.0	57.5	99.9	37.2
	80	94.4	94.4	101.0	77.4	110.4	57.3	90.7	90.7	96.4	75.5	105.2	55.5	86.8	86.8	91.5	73.4	99.8	53.7
	85	99.5	99.5	101.8	93.6	110.6	73.3	95.7	95.7	97.3	91.7	105.6	71.4	91.7	91.7	92.6	89.7	100.3	69.4
	90	104.6	104.6	104.8	104.8	111.1	89.4	100.7	100.7	100.9	100.9	106.1	87.5	96.6	96.6	96.7	96.7	100.9	85.6
3300	75	93.4	85.8	101.8	64.1	111.7	41.5	89.2	83.8	97.1	62.1	106.4	39.7	84.7	81.7	92.1	60.0	100.9	37.9
	80	96.9	96.9	102.3	81.6	111.6	59.6	93.1	93.1	97.6	79.6	106.3	57.8	89.0	89.0	92.7	77.5	100.7	56.0
	85	102.2	102.2	103.4	99.4	111.9	77.1	98.3	98.3	98.9	97.5	106.8	75.2	94.1	94.1	94.3	94.3	101.4	73.2
	90	107.6	107.6	107.7	107.7	112.5	94.8	103.5	103.5	103.6	103.6	107.4	92.9	99.1	99.1	99.3	99.3	102.2	91.0
3600	75	94.7	90.4	102.9	66.6	112.7	42.2	90.4	88.4	98.1	64.5	107.3	40.4	86.0	86.0	93.0	62.4	101.6	38.5
	80	99.1	99.1	103.5	85.7	112.5	61.9	95.2	95.2	98.7	83.7	107.1	60.2	91.0	91.0	93.7	81.6	101.5	58.3
	85	104.6	104.6	105.1	105.1	113.0	80.9	100.5	100.5	100.6	100.6	107.8	78.9	96.1	96.1	96.3	96.3	102.3	76.9
	90	110.1	110.1	110.3	110.3	113.8	100.2	105.8	105.8	106.0	106.0	108.6	98.3	101.3	101.3	101.5	101.5	103.3	96.3
CFM	Ent DB (°F)	Ambient Temperature (°F)						Ambient Temperature (°F)											
		115						120											
		Entering Wet Bulb (°F)						Entering Wet Bulb (°F)											
		61		67		73		61		67		73							
		MBH	SHC	MBH	SHC	MBH	SHC	MBH	SHC	MBH	SHC	MBH	SHC						
2625	75	77.0	69.3	84.4	52.3	93.0	34.4	74.7	68.2	81.8	51.2	90.1	33.5						
	80	79.6	79.6	84.9	66.1	92.8	48.9	77.6	77.6	82.3	65.1	90.0	47.9						
	85	84.2	84.2	85.6	80.3	93.3	62.7	82.1	82.1	83.2	79.2	90.5	61.7						
	90	88.7	88.7	88.9	88.9	93.8	76.8	86.6	86.6	86.7	86.7	91.0	75.7						
3000	75	78.8	75.0	85.9	55.4	94.3	35.3	76.4	73.9	83.3	54.2	91.3	34.3						
	80	82.7	82.7	86.5	71.3	94.1	51.8	80.5	80.5	83.9	70.2	91.1	50.8						
	85	87.4	87.4	87.8	87.6	94.8	67.4	85.2	85.2	85.3	85.3	92.0	66.3						
	90	92.2	92.2	92.4	92.4	95.5	83.5	89.9	89.9	90.1	90.1	92.7	82.5						
3300	75	80.1	79.5	86.9	57.8	95.0	35.9	77.7	77.7	84.2	56.7	92.0	35.0						
	80	84.7	84.7	87.6	75.4	94.9	54.1	82.5	82.5	84.9	74.3	91.9	53.1						
	85	89.7	89.7	89.8	89.8	95.8	71.1	87.3	87.3	87.4	87.4	92.9	70.0						
	90	94.6	94.6	94.7	94.7	96.7	88.9	92.2	92.2	92.3	92.3	93.8	87.8						
3600	75	81.5	81.5	87.7	60.2	95.7	36.6	79.3	79.3	85.0	59.1	92.6	35.6						
	80	86.5	86.5	88.6	79.5	95.5	56.4	84.2	84.2	85.9	78.3	92.5	55.4						
	85	91.6	91.6	91.7	91.7	96.7	74.8	89.2	89.2	89.3	89.3	93.8	73.7						
	90	96.6	96.6	96.7	96.7	97.8	94.3	94.1	94.1	94.2	94.2	95.0	93.2						

**Notes:**

1. All capacities shown are gross and have not considered indoor fan heat. To obtain net cooling, subtract indoor fan heat.
2. MBh = Total Gross Capacity, SHC = Sensible Heat Capacity



**Performance Data**

**Table 15. Gross cooling capacities (MBh) 7.5 tons TWA090K\*D heat pump with 7.5 tons TWE090K\*B air handler (IP)**

CFM	Ent DB (°F)	Ambient Temperature (°F)						Ambient Temperature (°F)						Ambient Temperature (°F)					
		85						95						105					
		Entering Wet Bulb (°F)						Entering Wet Bulb (°F)						Entering Wet Bulb (°F)					
		61		67		73		61		67		73		61		67		73	
		MBH	SHC	MBH	SHC	MBH	SHC	MBH	SHC	MBH	SHC	MBH	SHC	MBH	SHC	MBH	SHC	MBH	SHC
2700	75	94.0	78.2	103.7	61.0	115.5	42.6	91.8	77.2	101.1	59.8	112.3	41.4	89.1	75.9	97.7	58.3	108.4	40.1
	80	95.3	93.0	104.5	75.3	115.5	57.5	93.2	92.0	101.9	74.1	112.2	56.3	90.8	90.0	98.5	72.7	108.4	54.9
	85	100.3	100.3	105.4	89.8	115.9	72.0	98.3	98.3	102.8	88.7	112.8	70.8	95.7	95.7	99.5	87.2	109.0	69.3
	90	106.9	104.7	106.9	104.7	116.6	86.5	103.8	103.8	104.4	103.4	113.5	85.3	101.1	101.1	101.5	100.6	109.8	83.8
3000	75	95.9	82.9	105.6	63.6	117.2	43.3	93.6	81.8	102.9	62.4	113.8	42.2	90.9	80.5	99.4	60.9	109.8	40.8
	80	98.1	98.1	106.5	79.5	117.2	59.9	96.0	96.0	103.7	78.3	113.8	58.7	93.4	93.4	100.3	76.8	109.8	57.3
	85	103.9	103.9	107.5	95.7	117.9	75.9	101.8	101.8	104.8	94.6	114.7	74.6	99.0	99.0	101.5	93.1	110.8	73.1
	90	109.9	109.9	110.1	110.1	118.7	92.0	107.5	107.5	107.7	107.7	115.5	90.7	104.7	104.7	104.9	104.9	111.7	89.3
3300	75	97.6	87.5	107.3	66.1	118.6	44.0	95.3	86.3	104.4	64.9	115.1	42.9	92.4	85.0	100.8	63.4	110.9	41.5
	80	101.0	101.0	108.2	83.7	118.6	62.2	98.9	98.9	105.3	82.5	115.3	60.9	96.1	96.1	101.8	81.0	111.3	59.4
	85	107.1	107.1	109.5	101.6	119.6	79.6	104.8	104.8	106.7	100.4	116.2	78.4	101.9	101.9	103.3	98.9	112.2	76.8
	90	113.3	113.3	113.5	113.5	120.6	97.5	110.8	110.8	111.0	111.0	117.2	96.2	107.8	107.8	108.0	108.0	113.2	94.7
3600	75	99.2	92.0	108.6	68.6	119.7	44.7	96.7	90.9	105.7	67.4	116.1	43.5	93.5	89.3	102.0	65.8	111.8	42.1
	80	103.6	103.6	109.6	87.8	120.0	64.3	101.4	101.4	106.7	86.6	116.6	63.0	98.5	98.5	103.1	85.1	112.5	61.4
	85	109.9	109.9	111.3	107.5	121.1	83.4	107.5	107.5	108.4	106.2	117.6	82.1	104.5	104.5	105.0	104.2	113.5	80.6
	90	116.3	116.3	116.5	116.5	122.2	102.9	113.7	113.7	113.9	113.9	118.7	101.6	110.5	110.5	110.7	110.7	114.6	100.0
CFM	Ent DB (°F)	Ambient Temperature (°F)						Ambient Temperature (°F)											
		115						125											
		Entering Wet Bulb (°F)						Entering Wet Bulb (°F)											
		61		67		73		61		67		73							
		MBH	SHC	MBH	SHC	MBH	SHC	MBH	SHC	MBH	SHC	MBH	SHC						
2700	75	86.0	74.3	94.2	56.8	104.2	38.6	82.3	72.5	90.2	55.1	99.5	37.0						
	80	87.8	87.6	95.1	71.2	104.2	53.5	84.8	84.8	91.1	69.4	99.6	51.8						
	85	93.0	93.0	96.1	85.8	105.0	67.8	89.8	89.8	92.1	84.0	100.6	66.0						
	90	98.3	98.3	98.4	98.4	105.8	82.3	94.9	94.9	95.1	95.1	101.4	80.6						
3000	75	87.4	78.8	95.8	59.3	105.4	39.3	83.8	77.1	91.7	57.5	100.5	37.7						
	80	90.7	90.7	96.7	75.3	105.7	55.7	87.5	87.5	92.6	73.5	101.0	53.8						
	85	96.2	96.2	98.0	91.6	106.7	71.5	92.8	92.8	93.9	89.9	102.0	69.7						
	90	101.6	101.6	101.8	101.8	107.5	87.7	98.1	98.1	98.2	98.2	103.0	85.9						
3300	75	88.9	83.3	97.1	61.7	106.4	40.0	85.2	81.6	92.8	59.9	101.3	38.3						
	80	93.2	93.2	98.1	79.4	107.0	57.7	89.8	89.8	93.9	77.6	102.2	55.9						
	85	98.8	98.8	99.7	97.4	108.0	75.2	95.3	95.3	95.7	94.3	103.3	73.4						
	90	104.5	104.5	104.7	104.7	109.0	93.1	100.8	100.8	100.9	100.9	104.4	91.3						
3600	75	90.3	87.8	98.2	64.2	107.2	40.6	86.6	85.4	93.8	62.3	101.9	38.9						
	80	95.4	95.4	99.3	83.5	108.1	59.7	91.9	91.9	95.0	81.6	103.3	57.9						
	85	101.2	101.2	101.5	101.0	109.2	78.9	97.5	97.5	97.6	97.6	104.4	77.1						
	90	107.0	107.0	107.2	107.2	110.4	98.4	103.1	103.1	103.3	103.3	105.6	96.6						

**Notes:**

1. All capacities shown are gross and have not considered indoor fan heat. To obtain net cooling, subtract indoor fan heat.
2. MBh = Total Gross Capacity, SHC = Sensible Heat Capacity

**Table 16. Gross cooling capacities (MBh) 10 tons TWA120K\*A heat pump with 10 tons TWE120K\*A air handler (IP)**

CFM	Ent DB (°F)	Ambient Temperature (°F)						Ambient Temperature (°F)						Ambient Temperature (°F)					
		85						95						105					
		Entering Wet Bulb (°F)						Entering Wet Bulb (°F)						Entering Wet Bulb (°F)					
		61		67		73		61		67		73		61		67		73	
		MBH	SHC	MBH	SHC	MBH	SHC	MBH	SHC	MBH	SHC	MBH	SHC	MBH	SHC	MBH	SHC	MBH	SHC
3600	75	119.6	101.2	131.0	77.8	144.1	53.7	115.0	98.9	125.7	75.4	137.7	51.5	110.0	96.4	120.1	72.8	130.7	49.1
	80	121.5	121.1	132.2	96.9	143.7	73.5	117.3	117.3	127.0	94.5	137.2	71.4	113.1	113.1	121.4	92.0	132.0	68.3
	85	128.2	128.2	133.3	116.4	145.9	92.3	124.1	124.1	128.2	114.1	140.0	89.9	119.6	119.6	122.7	111.6	133.8	87.3
	90	135.6	135.6	135.6	135.6	146.9	111.7	130.9	130.9	131.1	131.1	141.1	109.4	126.2	126.2	126.5	126.5	134.9	106.8
4000	75	121.9	107.3	133.2	81.0	145.6	54.6	117.1	104.8	127.8	78.5	138.9	52.3	112.1	102.3	121.9	75.8	131.7	50.0
	80	125.4	125.4	134.5	102.4	145.2	76.7	121.2	121.2	129.2	99.9	140.5	73.5	116.6	116.6	123.4	97.3	134.0	70.8
	85	132.6	132.6	136.0	124.2	148.3	97.2	128.3	128.3	130.7	121.8	142.3	94.8	123.5	123.5	125.1	119.2	135.9	92.1
	90	140.0	140.0	140.2	140.2	149.4	118.9	135.4	135.4	135.7	135.7	143.5	116.5	130.5	130.5	130.7	130.7	137.1	113.9
4400	75	124.0	113.2	135.1	84.1	146.7	55.4	119.1	110.7	129.5	81.6	139.8	53.2	114.0	108.1	123.5	78.8	132.3	50.8
	80	129.0	129.0	136.6	107.8	148.6	78.6	124.5	124.5	131.1	105.3	142.4	76.1	119.7	119.7	125.2	102.6	135.6	73.3
	85	136.5	136.5	138.4	131.9	150.4	102.1	131.9	131.9	133.1	129.4	144.2	99.6	126.9	126.9	127.5	126.8	137.6	96.9
	90	144.2	144.2	144.4	144.4	151.7	126.0	139.4	139.4	139.6	139.6	145.6	123.6	134.1	134.1	134.4	134.4	139.1	121.0
4800	75	125.9	119.1	136.7	87.2	147.5	56.2	120.9	116.6	131.0	84.6	140.4	54.0	115.7	113.9	124.8	81.7	132.9	51.5
	80	132.1	132.1	138.3	113.1	150.3	81.2	127.5	127.5	132.7	110.6	143.9	78.6	122.5	122.5	126.7	107.9	137.0	75.7
	85	139.9	139.9	140.7	139.5	152.1	106.9	135.1	135.1	135.4	135.4	145.8	104.4	129.9	129.9	130.0	130.0	139.1	101.6
	90	147.9	147.9	148.1	148.1	153.6	133.1	142.8	142.8	143.1	143.1	147.5	130.7	137.4	137.4	137.6	137.6	140.9	128.0
CFM	Ent DB (°F)	Ambient Temperature (°F)						Ambient Temperature (°F)											
		115						125											
		Entering Wet Bulb (°F)						Entering Wet Bulb (°F)											
		61		67		73		61		67		73							
		MBH	SHC	MBH	SHC	MBH	SHC	MBH	SHC	MBH	SHC	MBH	SHC						
3600	75	104.7	93.7	114.0	70.0	123.3	46.7	99.0	90.8	107.4	66.9	115.2	44.0						
	80	108.4	108.4	115.5	89.3	125.2	65.5	104.8	104.8	109.0	86.3	117.9	62.4						
	85	114.7	114.7	116.8	108.9	127.1	84.6	109.4	109.4	110.5	106.0	119.9	81.6						
	90	121.1	121.1	121.4	121.4	128.3	104.1	115.5	115.5	115.7	115.7	121.1	101.2						
4000	75	106.7	99.5	115.7	72.9	124.0	47.5	100.9	96.5	108.9	69.7	115.7	44.8						
	80	111.7	111.7	117.3	94.5	127.0	67.9	106.3	106.3	110.7	91.5	119.5	64.7						
	85	118.3	118.3	119.2	116.5	129.0	89.3	112.7	112.7	112.9	112.9	121.6	86.2						
	90	125.1	125.1	125.3	125.3	130.3	111.2	119.1	119.1	119.3	119.3	123.0	108.2						
4400	75	108.5	105.3	117.1	75.8	124.5	48.2	102.6	102.2	110.2	72.5	116.1	45.6						
	80	114.6	114.6	118.9	99.7	128.5	70.2	108.9	108.9	112.2	96.6	120.7	66.9						
	85	121.4	121.4	121.6	121.6	130.6	94.0	115.5	115.5	115.6	115.6	123.0	90.8						
	90	128.5	128.5	128.7	128.7	132.2	118.2	122.2	122.2	122.4	122.4	124.7	115.1						
4800	75	110.2	110.2	118.3	78.6	124.9	49.0	104.3	104.3	111.2	75.2	116.4	46.3						
	80	117.1	117.1	120.3	104.9	129.7	72.5	111.1	111.1	113.5	101.7	121.8	69.1						
	85	124.2	124.2	124.3	124.3	131.9	98.6	117.9	117.9	118.1	118.1	124.2	95.4						
	90	131.4	131.4	131.6	131.6	133.8	125.1	124.9	124.9	125.1	125.1	126.3	122.0						

**Notes:**

1. All capacities shown are gross and have not considered indoor fan heat. To obtain net cooling, subtract indoor fan heat.
2. MBh = Total Gross Capacity, SHC = Sensible Heat Capacity



**Performance Data**

**Table 17. Gross cooling capacities (MBh) 10 tons TWA120K\*D heat pump with 10 tons TWE120K\*B air handler (IP)**

CFM	Ent DB (°F)	Ambient Temperature (°F)						Ambient Temperature (°F)						Ambient Temperature (°F)					
		85						95						105					
		Entering Wet Bulb (°F)						Entering Wet Bulb (°F)						Entering Wet Bulb (°F)					
		61		67		73		61		67		73		61		67		73	
		MBH	SHC	MBH	SHC	MBH	SHC	MBH	SHC	MBH	SHC	MBH	SHC	MBH	SHC	MBH	SHC	MBH	SHC
3600	75	121.2	103.1	133.9	79.5	148.7	54.7	115.6	100.5	127.5	76.9	141.7	52.2	109.9	97.8	121.1	74.3	134.4	49.7
	80	123.0	122.9	134.3	98.9	148.4	74.6	118.1	118.1	128.0	96.2	141.4	72.1	113.2	113.2	121.6	93.5	134.1	69.6
	85	129.8	129.8	135.1	118.4	148.4	94.3	124.9	124.9	128.9	115.8	141.5	91.7	119.8	119.8	122.6	113.1	134.4	89.0
	90	137.2	137.2	137.2	137.2	148.9	113.7	131.8	131.8	132.0	132.0	142.1	111.1	126.5	126.5	126.7	126.7	135.0	108.5
4000	75	123.6	109.4	136.1	83.2	150.8	55.7	117.8	106.7	129.6	80.5	143.6	53.2	112.0	104.0	123.0	77.7	136.1	50.6
	80	127.0	127.0	136.6	104.6	150.6	77.8	122.0	122.0	130.2	101.9	143.3	75.3	116.8	116.8	123.6	99.2	135.8	72.7
	85	134.3	134.3	137.7	126.4	150.7	99.5	129.1	129.1	131.4	123.8	143.7	96.8	123.7	123.7	125.1	121.1	136.4	94.1
	90	141.7	141.7	141.9	141.9	151.4	121.1	136.3	136.3	136.6	136.6	144.4	118.5	130.7	130.7	130.9	130.9	137.2	115.8
4400	75	125.7	115.7	138.0	86.7	152.6	56.6	119.8	112.9	131.3	83.9	145.2	54.1	113.8	110.2	124.5	81.1	137.4	51.5
	80	130.7	130.7	138.6	110.3	152.3	81.0	125.4	125.4	132.0	107.6	144.9	78.4	120.0	120.0	125.3	104.8	137.4	75.7
	85	138.2	138.2	140.1	134.4	152.7	104.6	132.8	132.8	133.8	131.7	145.5	102.0	127.1	127.1	127.5	127.5	138.0	99.2
	90	145.9	145.9	146.1	146.1	153.5	128.5	140.3	140.3	140.5	140.5	146.4	125.9	134.4	134.4	134.6	134.6	139.0	123.2
4800	75	127.6	121.9	139.6	90.1	154.1	57.6	121.6	119.1	132.8	87.3	146.5	55.0	115.7	115.7	125.8	84.5	138.6	52.4
	80	133.8	133.8	140.3	115.9	153.8	84.1	128.4	128.4	133.6	113.2	146.4	81.4	122.7	122.7	126.8	110.4	138.7	78.6
	85	141.7	141.7	142.5	142.2	154.4	109.8	136.0	136.0	136.2	136.2	147.0	107.1	130.1	130.1	130.3	130.3	139.4	104.3
	90	149.6	149.6	149.8	149.8	155.4	135.9	143.8	143.8	144.0	144.0	148.2	133.3	137.6	137.6	137.8	137.8	140.8	130.6
CFM	Ent DB (°F)	Ambient Temperature (°F)						Ambient Temperature (°F)											
		115						125											
		Entering Wet Bulb (°F)						Entering Wet Bulb (°F)											
		61		67		73		61		67		73							
		MBH	SHC	MBH	SHC	MBH	SHC	MBH	SHC	MBH	SHC	MBH	SHC						
3600	75	104.1	95.1	114.6	71.5	126.9	47.1	98.5	92.4	108.0	68.8	119.3	44.5						
	80	108.2	108.2	115.1	90.8	126.6	67.0	103.1	103.1	108.6	88.1	119.2	64.3						
	85	114.6	114.6	116.3	110.4	127.2	86.3	109.2	109.2	110.0	107.8	119.8	83.5						
	90	121.0	121.0	121.3	121.3	127.8	105.8	115.4	115.4	115.6	115.6	120.6	103.1						
4000	75	106.1	101.2	116.2	74.9	128.4	48.0	100.3	98.5	109.5	72.1	120.6	45.4						
	80	111.5	111.5	116.9	96.4	128.3	70.0	106.2	106.2	110.3	93.6	120.8	67.2						
	85	118.2	118.2	118.7	118.4	128.9	91.4	112.5	112.5	112.7	112.7	121.4	88.6						
	90	125.0	125.0	125.2	125.2	129.8	113.1	119.0	119.0	119.2	119.2	122.4	110.4						
4400	75	108.0	107.4	117.6	78.3	129.6	48.9	102.3	102.3	110.7	75.4	121.5	46.3						
	80	114.4	114.4	118.5	102.0	129.8	72.9	108.8	108.8	111.7	99.2	122.0	70.0						
	85	121.3	121.3	121.5	121.5	130.4	96.5	115.4	115.4	115.5	115.5	122.8	93.7						
	90	128.3	128.3	128.5	128.5	131.6	120.5	122.1	122.1	122.3	122.3	124.1	117.7						
4800	75	109.9	109.9	118.8	81.6	130.5	49.8	104.4	104.4	111.8	78.7	122.3	47.2						
	80	117.0	117.0	119.9	107.6	131.0	75.7	111.1	111.1	113.0	104.7	123.1	72.8						
	85	124.1	124.1	124.2	124.2	131.7	101.5	117.9	117.9	118.0	118.0	123.9	98.7						
	90	131.3	131.3	131.5	131.5	133.3	127.8	124.8	124.8	124.9	124.9	125.7	125.0						

**Notes:**

1. All capacities shown are gross and have not considered indoor fan heat. To obtain net cooling, subtract indoor fan heat.
2. MBh = Total Gross Capacity, SHC = Sensible Heat Capacity

**Table 18. Gross cooling capacities (MBh) 12.5 tons TWA150K\*D heat pump with 12.5 tons TWE150K\*B air handler (IP)**

CFM	Ent DB (°F)	Ambient Temperature (°F)						Ambient Temperature (°F)						Ambient Temperature (°F)					
		85						95						105					
		Entering Wet Bulb (°F)						Entering Wet Bulb (°F)						Entering Wet Bulb (°F)					
		61		67		73		61		67		73		61		67		73	
		MBH	SHC	MBH	SHC	MBH	SHC	MBH	SHC	MBH	SHC	MBH	SHC	MBH	SHC	MBH	SHC	MBH	SHC
4500	75	145.6	126.3	161.3	96.6	178.4	65.6	139.0	123.3	153.9	93.7	170.2	62.7	132.0	120.0	146.0	90.6	161.6	59.7
	80	148.0	148.0	161.2	120.9	178.1	90.3	142.4	142.4	153.9	117.9	169.9	87.5	136.4	136.4	146.2	114.7	161.3	84.5
	85	156.2	156.2	161.8	145.2	177.8	115.0	150.5	150.5	154.7	142.3	169.7	112.1	144.3	144.3	147.1	139.1	161.2	108.9
	90	164.9	164.9	164.9	164.9	178.0	139.2	158.6	158.6	158.9	158.9	170.0	136.3	152.2	152.2	152.5	152.5	161.5	133.2
5000	75	148.3	134.2	163.7	101.2	180.9	66.8	141.6	131.1	156.1	98.3	172.5	63.9	134.5	127.9	148.1	95.1	163.6	60.9
	80	152.7	152.7	163.8	128.1	180.6	94.3	146.9	146.9	156.3	125.1	172.2	91.4	140.7	140.7	148.4	121.8	163.3	88.4
	85	161.4	161.4	164.9	155.2	180.4	121.6	155.3	155.3	157.6	152.3	172.0	118.6	148.8	148.8	149.9	148.9	163.3	115.4
	90	170.1	170.1	170.3	170.3	180.8	148.5	163.8	163.8	164.0	164.0	172.5	145.5	157.0	157.0	157.2	157.2	163.8	142.4
5500	75	150.7	142.0	165.8	105.8	183.0	68.0	143.9	138.9	158.0	102.7	174.3	65.0	136.7	135.7	149.9	99.4	165.2	62.0
	80	157.0	157.0	166.1	135.2	182.6	98.3	150.9	150.9	158.4	132.1	174.0	95.3	144.3	144.3	150.3	128.9	164.9	92.3
	85	165.9	165.9	167.6	165.2	182.5	128.1	159.5	159.5	160.3	160.3	173.9	125.0	152.7	152.7	153.0	153.0	165.0	121.8
	90	174.9	174.9	175.1	175.1	183.1	157.8	168.2	168.2	168.5	168.5	174.7	154.8	161.1	161.1	161.4	161.4	165.8	151.6
6000	75	152.9	149.8	167.6	110.1	184.7	69.1	146.1	145.9	159.7	107.0	175.8	66.2	139.0	139.0	151.3	103.7	166.6	63.1
	80	160.7	160.7	168.0	142.3	184.3	102.2	154.3	154.3	160.2	139.2	175.5	99.2	147.5	147.5	152.0	136.0	166.3	96.1
	85	169.9	169.9	170.4	170.4	184.3	134.5	163.2	163.2	163.4	163.4	175.6	131.4	156.2	156.2	156.3	156.3	166.5	128.2
	90	179.1	179.1	179.3	179.3	185.2	167.1	172.1	172.1	172.3	172.3	176.6	164.0	164.7	164.7	164.9	164.9	167.7	160.9
CFM	Ent DB (°F)	Ambient Temperature (°F)						Ambient Temperature (°F)											
		115						120											
		Entering Wet Bulb (°F)						Entering Wet Bulb (°F)											
		61		67		73		61		67		73							
		MBH	SHC	MBH	SHC	MBH	SHC	MBH	SHC	MBH	SHC	MBH	SHC						
4500	75	124.6	116.6	137.6	87.3	152.4	56.6	120.7	114.8	133.3	85.5	147.6	54.9						
	80	130.0	130.0	137.9	111.3	152.1	81.3	126.5	126.5	133.6	109.6	147.3	79.7						
	85	137.6	137.6	139.1	135.8	152.1	105.7	134.1	134.1	135.0	133.9	147.4	103.9						
	90	145.3	145.3	145.5	145.5	152.6	129.9	141.6	141.6	141.8	141.8	147.9	128.2						
5000	75	126.9	124.4	139.6	91.7	154.2	57.7	123.0	122.4	135.1	89.8	149.3	56.1						
	80	133.9	133.9	140.0	118.4	153.9	85.3	130.3	130.3	135.6	116.7	148.9	83.6						
	85	141.8	141.8	142.3	142.1	154.0	112.1	138.1	138.1	138.3	138.3	149.2	110.4						
	90	149.7	149.7	149.9	149.9	154.7	139.2	145.9	145.9	146.1	146.1	149.9	137.5						
5500	75	129.2	129.2	141.1	95.9	155.6	58.8	125.5	125.5	136.6	94.1	150.6	57.2						
	80	137.3	137.3	141.7	125.5	155.4	89.1	133.5	133.5	137.3	123.7	150.4	87.3						
	85	145.4	145.4	145.6	145.6	155.6	118.5	141.5	141.5	141.7	141.7	150.7	116.7						
	90	153.5	153.5	153.7	153.7	156.6	148.4	149.5	149.5	149.7	149.7	151.8	146.7						
6000	75	131.9	131.9	142.5	100.2	156.8	60.0	128.2	128.2	137.8	98.3	151.7	58.3						
	80	140.2	140.2	143.3	132.5	156.7	92.7	136.4	136.4	138.8	130.7	151.6	90.9						
	85	148.6	148.6	148.7	148.7	157.0	124.9	144.5	144.5	144.7	144.7	152.0	123.1						
	90	156.8	156.8	157.0	157.0	158.4	157.2	152.6	152.6	152.8	152.8	153.6	153.6						

**Notes:**

- All capacities shown are gross and have not considered indoor fan heat. To obtain net cooling, subtract indoor fan heat.
- MBh = Total Gross Capacity, SHC = Sensible Heat Capacity



**Performance Data**

**Table 19. Gross cooling capacities (MBh) 15 tons TWA180K\*D heat pump with 15 tons TWE180K\*B air handler (IP)**

CFM	Ent DB (°F)	Ambient Temperature (°F)						Ambient Temperature (°F)						Ambient Temperature (°F)					
		85						95						105					
		Entering Wet Bulb (°F)						Entering Wet Bulb (°F)						Entering Wet Bulb (°F)					
		61		67		73		61		67		73		61		67		73	
		MBH	SHC	MBH	SHC	MBH	SHC	MBH	SHC	MBH	SHC	MBH	SHC	MBH	SHC	MBH	SHC	MBH	SHC
5400	75	184.7	155.1	203.2	120.3	225.9	83.4	177.3	151.4	194.8	116.5	215.9	79.9	169.4	147.4	185.9	112.4	205.3	76.3
	80	187.2	184.7	204.8	148.9	225.5	113.3	180.1	180.1	196.4	145.2	215.5	109.9	172.9	172.9	187.6	141.2	205.1	106.0
	85	196.4	196.4	206.2	178.1	226.6	142.3	189.9	189.9	198.0	174.4	217.3	138.6	182.9	182.9	189.4	170.5	207.5	134.6
	90	208.9	207.8	208.9	207.8	227.8	171.3	200.4	200.4	201.4	200.3	218.6	167.6	193.2	193.2	193.6	193.6	208.9	163.7
6000	75	188.5	164.3	207.0	125.4	229.0	84.9	180.8	160.5	198.2	121.5	218.6	81.4	172.7	156.5	189.0	117.3	207.5	77.6
	80	192.3	192.3	208.6	157.3	228.4	118.1	185.6	185.6	200.0	153.5	218.7	114.3	178.5	178.5	190.9	149.4	208.4	110.2
	85	203.2	203.2	210.4	189.9	230.6	149.9	196.4	196.4	202.0	186.1	221.0	146.1	189.1	189.1	193.1	182.2	210.9	142.1
	90	214.5	214.5	214.9	214.9	231.9	182.3	207.4	207.4	207.8	207.8	222.5	178.5	199.8	199.8	200.2	200.2	212.5	174.6
6600	75	191.8	173.5	210.1	130.4	231.4	86.3	183.9	169.6	201.1	126.4	220.6	82.7	175.6	165.4	191.7	122.1	209.1	78.9
	80	197.7	197.7	211.8	165.7	231.7	122.4	190.8	190.8	203.0	161.8	221.7	118.4	183.4	183.4	193.7	157.6	211.2	114.2
	85	209.3	209.3	214.1	201.6	233.9	157.5	202.1	202.1	205.5	197.8	224.1	153.6	194.4	194.4	196.5	193.8	213.7	149.5
	90	221.1	221.1	221.4	221.4	235.5	193.2	213.6	213.6	214.0	214.0	225.8	189.4	205.6	205.6	205.9	205.9	215.6	185.4
7200	75	194.7	182.5	212.8	135.3	233.4	87.6	186.6	178.5	203.6	131.2	222.2	84.0	178.2	174.3	193.9	126.8	210.3	80.2
	80	202.6	202.6	214.6	173.9	234.5	126.6	195.4	195.4	205.6	169.9	224.3	122.5	187.7	187.7	196.1	165.7	213.6	118.2
	85	214.6	214.6	217.5	213.3	236.7	165.0	207.1	207.1	208.8	208.8	226.7	161.0	199.1	199.1	199.8	199.8	216.1	156.8
	90	226.9	226.9	227.2	227.2	238.5	204.1	219.1	219.1	219.4	219.4	228.7	200.2	210.7	210.7	211.0	211.0	218.3	196.1
CFM	Ent DB (°F)	Ambient Temperature (°F)						Ambient Temperature (°F)											
		115						125											
		Entering Wet Bulb (°F)						Entering Wet Bulb (°F)											
		61		67		73		61		67		73							
		MBH	SHC	MBH	SHC	MBH	SHC	MBH	SHC	MBH	SHC	MBH	SHC						
5400	75	161.0	143.2	176.3	108.1	193.8	72.4	152.0	138.6	166.2	103.4	181.3	68.3						
	80	165.6	165.6	178.3	137.0	194.5	101.8	157.8	157.8	168.3	132.4	183.2	97.1						
	85	175.5	175.5	180.2	166.3	197.1	130.4	167.3	167.3	170.4	161.9	186.0	125.8						
	90	185.5	185.5	185.8	185.8	198.7	159.6	177.1	177.1	177.4	177.4	187.7	155.2						
6000	75	164.0	152.1	179.2	112.9	195.5	73.7	154.8	147.5	168.7	108.0	182.6	69.5						
	80	170.8	170.8	181.3	145.1	197.6	105.8	162.6	162.6	171.0	140.5	185.9	101.0						
	85	181.2	181.2	183.7	177.9	200.2	137.7	172.6	172.6	173.8	173.3	188.8	133.1						
	90	191.7	191.7	192.0	192.0	202.0	170.4	182.8	182.8	183.0	183.0	190.7	165.8						
6600	75	166.8	161.0	181.6	117.5	196.7	74.9	157.4	156.2	170.9	112.6	183.5	70.7						
	80	175.4	175.4	183.9	153.2	200.1	109.7	166.7	166.7	173.4	148.4	188.2	104.8						
	85	186.1	186.1	187.1	187.1	202.8	145.1	177.1	177.1	177.4	177.4	191.1	140.3						
	90	197.0	197.0	197.3	197.3	204.8	181.1	187.7	187.7	188.0	188.0	193.4	176.5						
7200	75	169.3	169.3	183.7	122.1	197.6	76.2	160.0	160.0	172.7	117.0	184.1	71.9						
	80	179.4	179.4	186.1	161.2	202.2	113.5	170.4	170.4	175.4	156.4	190.1	108.5						
	85	190.5	190.5	190.7	190.7	205.0	152.3	181.1	181.1	181.3	181.3	193.1	147.5						
	90	201.8	201.8	202.0	202.0	207.4	191.8	192.0	192.0	192.3	192.3	195.8	187.1						

**Notes:**

1. All capacities shown are gross and have not considered indoor fan heat. To obtain net cooling, subtract indoor fan heat.
2. MBh = Total Gross Capacity, SHC = Sensible Heat Capacity

**Table 20. Gross cooling capacities (MBh) 20 tons TWA240K\*D heat pump with 20 tons TWE240K\*B air handler (IP)**

CFM	Ent DB (°F)	Ambient Temperature (°F)						Ambient Temperature (°F)						Ambient Temperature (°F)					
		85						95						105					
		Entering Wet Bulb (°F)						Entering Wet Bulb (°F)						Entering Wet Bulb (°F)					
		61		67		73		61		67		73		61		67		73	
		MBH	SHC	MBH	SHC	MBH	SHC	MBH	SHC	MBH	SHC	MBH	SHC	MBH	SHC	MBH	SHC	MBH	SHC
7200	75	247.0	209.0	274.2	161.2	303.2	111.2	237.7	204.6	263.6	157.0	290.8	106.7	227.8	200.0	252.6	152.5	278.8	102.5
	80	247.5	247.3	272.9	200.2	301.6	150.5	238.6	238.6	262.4	195.8	289.7	146.3	229.4	229.4	251.5	191.2	277.6	142.0
	85	256.1	256.1	272.3	238.3	300.9	190.1	248.2	248.2	261.8	233.9	288.5	185.7	239.9	239.9	250.9	229.4	276.5	181.4
	90	273.4	273.4	273.4	273.4	299.3	228.6	260.5	260.5	263.4	263.4	287.8	224.3	251.8	251.8	253.3	253.3	275.2	219.6
8000	75	251.5	221.6	278.9	168.8	308.0	113.3	241.9	217.1	267.9	164.5	295.6	108.9	231.7	212.5	256.5	160.0	282.8	104.5
	80	253.1	253.1	277.7	211.8	306.8	157.2	244.1	244.1	266.8	207.3	294.4	152.9	234.9	234.9	255.5	202.7	281.6	148.5
	85	264.5	264.5	276.9	254.2	305.6	201.0	256.2	256.2	266.3	249.9	293.1	196.6	247.4	247.4	255.3	245.3	280.2	192.0
	90	277.6	277.6	279.6	279.6	304.1	243.6	268.9	268.9	269.6	269.6	292.3	239.2	259.5	259.5	259.9	259.9	279.6	234.6
8800	75	255.6	234.2	282.9	176.3	312.0	115.3	245.4	229.5	271.6	171.9	299.3	110.9	235.2	224.9	259.8	167.3	286.1	106.4
	80	258.6	258.6	281.8	223.3	310.8	163.7	249.9	249.9	270.6	218.8	298.1	159.3	241.2	241.2	258.9	214.1	284.9	154.8
	85	271.9	271.9	281.4	270.2	309.3	211.7	263.1	263.1	270.5	265.8	296.7	207.1	253.8	253.8	259.2	259.2	283.6	202.4
	90	285.4	285.4	286.0	286.0	308.7	258.6	276.0	276.0	276.3	276.3	296.1	254.1	266.5	266.5	266.8	266.8	282.9	249.4
9600	75	259.0	246.5	286.3	183.6	315.4	117.2	248.9	242.0	274.4	179.1	302.4	112.8	238.5	237.3	262.3	174.5	288.4	108.2
	80	264.5	264.5	285.3	234.8	314.2	170.1	255.8	255.8	273.8	230.2	301.2	165.7	246.6	246.6	261.7	225.3	287.2	161.0
	85	278.4	278.4	285.3	285.3	312.9	222.2	269.2	269.2	274.2	274.2	299.9	217.5	259.4	259.4	262.8	262.8	286.5	212.8
	90	292.1	292.1	292.4	292.4	312.2	273.4	282.4	282.4	282.7	282.7	299.2	268.8	272.5	272.5	272.8	272.8	285.4	263.9
CFM	Ent DB (°F)	Ambient Temperature (°F)						Ambient Temperature (°F)											
		115						120											
		Entering Wet Bulb (°F)						Entering Wet Bulb (°F)											
		61		67		73		61		67		73							
		MBH	SHC	MBH	SHC	MBH	SHC	MBH	SHC	MBH	SHC	MBH	SHC						
7200	75	218.0	195.5	241.1	148.0	265.8	97.9	213.0	193.2	235.1	145.6	259.1	95.6						
	80	220.2	220.2	240.1	186.5	264.6	137.5	215.7	215.7	234.2	184.1	257.9	135.2						
	85	231.1	231.1	239.8	224.8	263.3	176.8	226.2	226.2	234.1	222.4	256.5	174.4						
	90	242.6	242.6	242.9	242.9	262.6	215.0	237.7	237.7	238.0	238.0	256.0	212.6						
8000	75	221.6	207.8	244.6	155.4	269.3	99.9	216.3	205.4	238.5	153.0	262.4	97.5						
	80	226.1	226.1	243.8	197.9	268.2	143.9	221.6	221.6	237.7	195.4	261.2	141.5						
	85	238.1	238.1	243.9	240.6	266.9	187.2	233.2	233.2	238.0	238.0	260.0	184.7						
	90	249.7	249.7	250.1	250.1	266.2	229.8	244.7	244.7	244.8	244.8	259.4	227.3						
8800	75	224.9	220.2	247.4	162.6	271.9	101.7	219.5	217.8	241.0	160.2	264.8	99.3						
	80	231.8	231.8	246.8	209.2	270.7	150.1	226.8	226.8	240.6	206.7	263.6	147.7						
	85	244.1	244.1	247.5	247.5	269.9	197.6	239.0	239.0	241.4	241.4	262.9	195.1						
	90	256.2	256.2	256.2	256.2	268.9	244.3	250.5	250.5	250.8	250.8	261.8	241.8						
9600	75	227.8	227.8	249.8	169.5	274.4	103.5	222.3	222.3	243.5	167.1	267.1	101.1						
	80	236.9	236.9	249.2	220.4	273.2	156.4	231.9	231.9	243.1	217.9	265.9	154.0						
	85	249.3	249.3	251.0	251.0	272.1	207.7	244.0	244.0	245.0	245.0	264.9	205.2						
	90	261.7	261.7	262.0	262.0	271.6	259.0	256.1	256.1	256.3	256.3	264.5	256.5						

**Notes:**

- All capacities shown are gross and have not considered indoor fan heat. To obtain net cooling, subtract indoor fan heat.
- MBh = Total Gross Capacity, SHC = Sensible Heat Capacity



**Performance Data**

**Table 21. Gross cooling capacities (MBh) 25 tons TWA300K\*D heat pump with 25 tons TWE300K\*B air handler (IP)**

CFM	Ent DB (°F)	Ambient Temperature (°F)						Ambient Temperature (°F)						Ambient Temperature (°F)					
		85						95						105					
		Entering Wet Bulb (°F)						Entering Wet Bulb (°F)						Entering Wet Bulb (°F)					
		61		67		73		61		67		73		61		67		73	
		MBH	SHC	MBH	SHC	MBH	SHC	MBH	SHC	MBH	SHC	MBH	SHC	MBH	SHC	MBH	SHC	MBH	SHC
9000	75	278.9	245.7	306.9	187.2	339.1	125.2	267.8	240.3	294.1	181.9	324.4	120.1	255.9	234.6	280.2	176.1	308.0	114.5
	80	283.4	283.4	308.2	234.9	339.0	175.0	273.4	273.4	295.5	229.5	323.8	169.7	262.6	262.6	281.9	223.7	307.7	164.3
	85	298.3	298.3	309.8	283.2	339.4	223.4	288.3	288.3	297.4	277.8	325.0	217.9	277.3	277.3	284.0	272.1	309.1	211.9
	90	315.1	315.1	315.1	315.1	340.6	271.4	303.5	303.5	304.0	304.0	326.1	265.9	292.1	292.1	292.5	292.5	310.8	260.1
9500	75	281.5	253.3	309.4	191.7	341.4	126.4	270.2	247.9	296.2	186.2	326.4	121.2	258.1	242.2	282.3	180.3	309.8	115.7
	80	287.3	287.3	310.7	241.9	341.3	179.0	277.1	277.1	297.8	236.4	325.9	173.8	266.5	266.5	283.9	230.5	309.6	167.9
	85	302.9	302.9	312.7	292.9	342.0	229.8	292.6	292.6	300.0	287.5	327.3	224.2	281.4	281.4	286.5	281.7	311.2	218.1
	90	319.1	319.1	319.6	319.6	343.1	280.5	308.2	308.2	308.6	308.6	328.5	274.9	296.3	296.3	296.7	296.7	313.0	269.1
10000	75	283.9	260.9	311.5	195.9	343.5	127.6	272.4	255.5	298.3	190.4	328.2	122.4	260.2	249.7	284.2	184.4	311.4	116.8
	80	291.0	291.0	313.0	248.9	343.4	182.9	281.0	281.0	299.9	243.3	327.9	177.5	270.0	270.0	285.8	237.4	311.3	171.5
	85	307.3	307.3	315.3	302.7	344.3	236.1	296.7	296.7	302.5	297.2	329.2	230.4	285.1	285.1	288.8	288.6	313.6	224.5
	90	323.6	323.6	324.1	324.1	345.4	289.5	312.4	312.4	312.9	312.9	330.7	283.9	300.3	300.3	300.6	300.6	315.0	278.0
10500	75	286.1	268.5	313.6	200.1	345.5	128.7	274.5	263.0	300.3	194.5	329.9	123.5	262.2	257.2	286.0	188.5	312.8	117.9
	80	294.9	294.9	315.2	255.8	344.9	186.6	284.5	284.5	301.8	250.1	329.8	181.2	273.3	273.3	287.6	244.2	312.8	175.2
	85	311.3	311.3	317.8	312.4	346.5	242.4	300.4	300.4	304.9	304.4	331.4	236.7	288.6	288.6	291.1	291.1	315.3	230.7
	90	328.0	328.0	328.4	328.4	347.6	298.5	316.5	316.5	316.8	316.8	332.7	292.9	303.9	303.9	304.3	304.3	316.9	287.0
CFM	Ent DB (°F)	Ambient Temperature (°F)						Ambient Temperature (°F)											
		115						120											
		Entering Wet Bulb (°F)						Entering Wet Bulb (°F)											
		61		67		73		61		67		73							
		MBH	SHC	MBH	SHC	MBH	SHC	MBH	SHC	MBH	SHC	MBH	SHC						
9000	75	243.2	228.6	265.6	169.9	291.1	108.8	236.4	225.3	257.9	166.6	282.0	105.8						
	80	251.5	251.5	267.3	217.4	291.0	158.2	245.4	245.4	259.5	214.1	282.2	155.0						
	85	265.5	265.5	269.8	265.9	292.7	205.6	259.1	259.1	262.3	260.9	284.0	202.3						
	90	279.4	279.4	279.8	279.8	294.0	253.7	272.7	272.7	273.1	273.1	285.4	250.4						
9500	75	245.2	236.0	267.5	174.0	292.6	109.9	238.4	232.8	259.6	170.6	283.4	106.9						
	80	254.9	254.9	269.1	224.2	292.5	161.8	248.7	248.7	261.3	220.9	283.7	158.5						
	85	269.2	269.2	272.2	272.2	294.5	211.8	262.6	262.6	264.6	264.6	285.7	208.4						
	90	283.4	283.4	283.7	283.7	296.0	262.6	276.4	276.4	276.8	276.8	287.3	259.3						
10000	75	247.2	243.5	269.2	178.0	293.9	111.0	240.3	238.6	261.2	174.6	284.6	108.0						
	80	258.1	258.1	270.8	231.0	294.2	165.3	251.7	251.7	262.9	227.7	285.3	161.9						
	85	272.6	272.6	274.5	274.5	296.2	217.9	265.8	265.8	266.9	266.9	287.0	214.4						
	90	287.0	287.0	287.3	287.3	296.5	271.0	279.9	279.9	280.2	280.2	289.0	268.2						
10500	75	249.0	248.3	270.7	182.1	295.1	112.1	242.1	242.1	262.7	178.6	285.7	109.1						
	80	261.1	261.1	272.4	237.8	295.7	168.7	254.6	254.6	264.5	234.4	286.7	165.3						
	85	275.7	275.7	276.7	276.7	297.7	224.0	268.9	268.9	269.4	269.4	288.0	220.4						
	90	290.3	290.3	290.6	290.6	299.5	280.4	283.0	283.0	283.3	283.3	290.6	277.0						

**Notes:**

1. All capacities shown are gross and have not considered indoor fan heat. To obtain net cooling, subtract indoor fan heat.
2. MBh = Total Gross Capacity, SHC = Sensible Heat Capacity

**Table 22. Gross cooling capacities (MBh) 6 tons TWA072K\*A condensing unit only (IP)**

Outdoor Temp (°F)		Saturation Suction Temperature (°F)					
		30	35	40	45	50	55
65	Head Press (psig)	237.2	243.4	249.9	256.8	264.1	271.8
	Capacity (Btuh/1000)	65.5	71.9	78.8	86.1	94.0	102.3
	Unit Power (kW)	4.0	4.0	4.0	4.1	4.1	4.1
75	Head Press (psig)	272.8	279.4	286.4	293.8	301.5	309.5
	Capacity (Btuh/1000)	62.5	68.6	75.1	82.1	89.5	97.5
	Unit Power (kW)	4.4	4.5	4.6	4.6	4.7	4.7
85	Head Press (psig)	312.0	319.0	326.4	334.1	342.2	350.6
	Capacity (Btuh/1000)	59.3	65.2	71.4	78.0	85.0	92.6
	Unit Power (kW)	4.9	5.0	5.1	5.2	5.2	5.3
95	Head Press (psig)	354.8	362.2	369.9	378.0	386.4	395.1
	Capacity (Btuh/1000)	56.1	61.6	67.5	73.8	80.5	87.6
	Unit Power (kW)	5.5	5.6	5.7	5.8	5.9	5.9
105	Head Press (psig)	401.3	409.0	417.0	425.4	434.0	443.0
	Capacity (Btuh/1000)	52.8	58.0	63.6	69.5	75.8	82.6
	Unit Power (kW)	6.1	6.2	6.3	6.4	6.5	6.6
115	Head Press (psig)	451.5	459.5	467.8	476.4	485.3	494.4
	Capacity (Btuh/1000)	49.2	54.2	59.5	65.1	71.0	77.4
	Unit Power (kW)	6.8	6.9	7.0	7.1	7.3	7.4
125	Head Press (psig)	505.6	513.9	522.4	531.1	540.0	549.2
	Capacity (Btuh/1000)	45.6	50.2	55.2	60.5	66.1	72.1
	Unit Power (kW)	7.6	7.7	7.8	7.9	8.0	8.2

Note: Performance data calculated at 15°F subcooling and 15°F superheat and does not include capacity loss due to refrigerant lines.

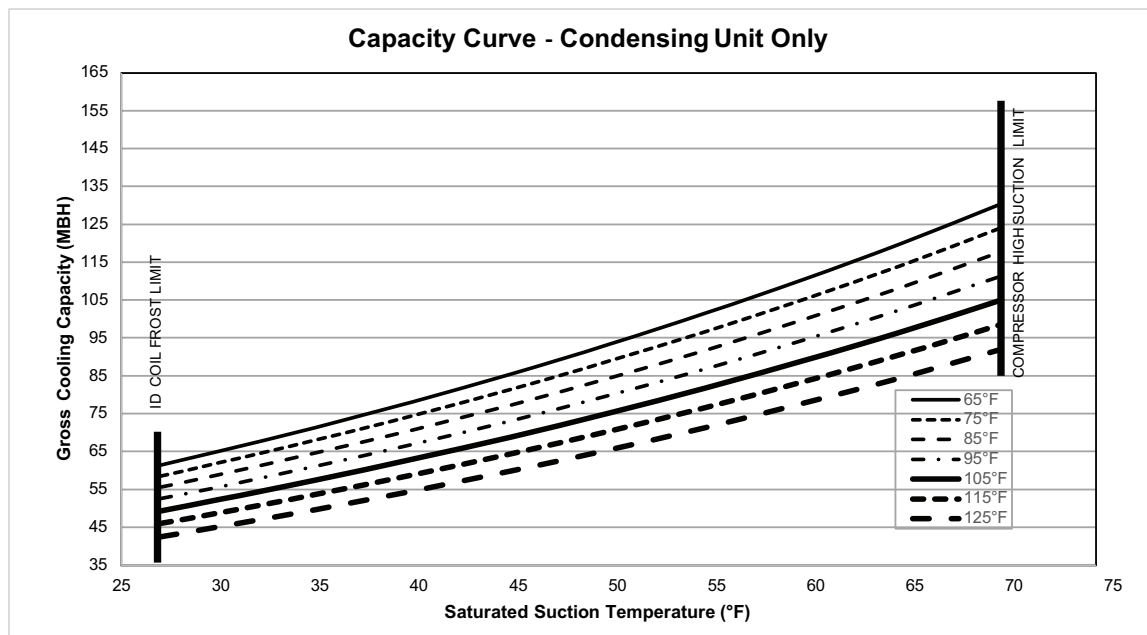
**Figure 9. TWA072K\*A capacity curves**



## Performance Data

**Table 23. Gross cooling capacities (MBh) 6 tons TWA072K\*D condensing unit only (IP)**

Outdoor Temp (°F)		Saturation Suction Temperature (°F)					
		30	35	40	45	50	55
65	Head Press (psig)	224.5	229.9	235.7	241.9	248.0	255.0
	Capacity (Btuh/1000)	64.2	70.5	77.2	84.4	92.2	100.4
	Unit Power (kW)	3.7	3.8	3.8	3.8	3.8	3.9
75	Head Press (psig)	259.1	264.9	271.0	277.1	284.0	292.2
	Capacity (Btuh/1000)	61.3	67.3	73.8	80.7	88.0	95.7
	Unit Power (kW)	4.2	4.2	4.2	4.3	4.3	4.4
85	Head Press (psig)	297.3	303.4	309.5	316.3	324.3	332.2
	Capacity (Btuh/1000)	58.3	64.0	70.2	76.7	83.6	91.0
	Unit Power (kW)	4.7	4.7	4.7	4.8	4.8	4.9
95	Head Press (psig)	339.1	345.5	352.0	359.7	367.5	375.7
	Capacity (Btuh/1000)	55.0	60.4	66.3	72.5	79.1	86.2
	Unit Power (kW)	5.2	5.3	5.3	5.4	5.4	5.5
105	Head Press (psig)	384.5	391.0	398.1	406.2	414.3	422.8
	Capacity (Btuh/1000)	51.4	56.7	62.3	68.2	74.5	81.2
	Unit Power (kW)	5.9	5.9	6.0	6.1	6.1	6.2
115	Head Press (psig)	433.6	440.5	448.4	456.3	464.7	473.5
	Capacity (Btuh/1000)	47.7	52.8	58.1	63.8	69.8	76.1
	Unit Power (kW)	6.7	6.7	6.8	6.8	6.9	6.9
125	Head Press (psig)	486.4	494.1	502.0	510.2	518.8	527.8
	Capacity (Btuh/1000)	43.8	48.6	53.7	59.1	64.8	70.8
	Unit Power (kW)	7.5	7.6	7.6	7.7	7.7	7.8

Note: Performance data calculated at 15°F subcooling and 15°F superheat and does not include capacity loss due to refrigerant lines.

**Figure 10. TWA072K\*D capacity curves**

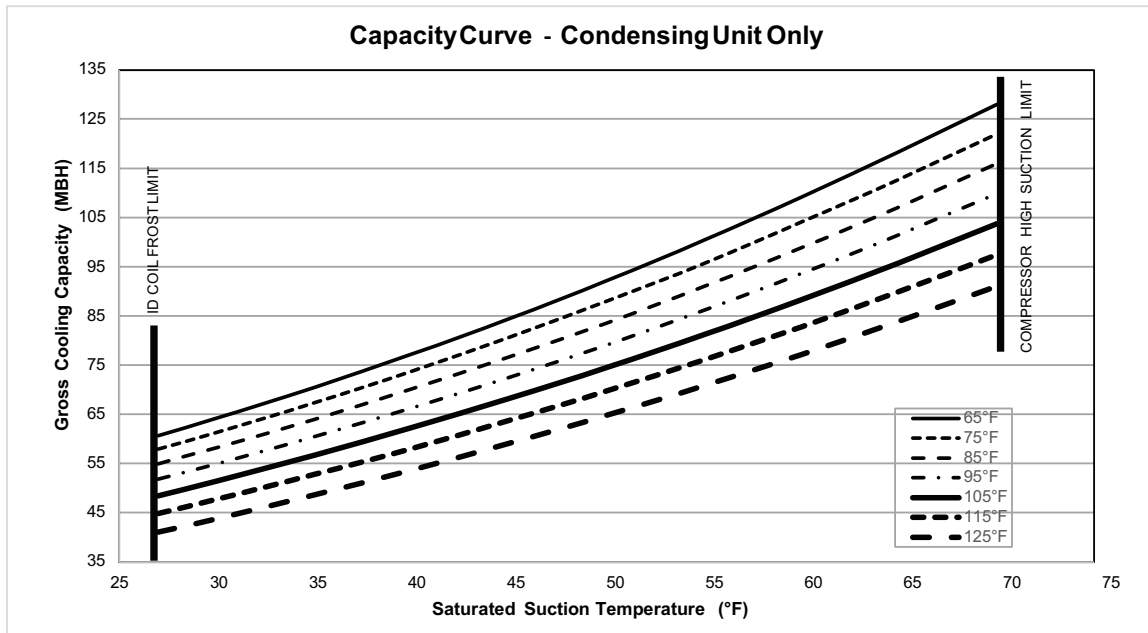

**Table 24. Gross cooling capacities (MBh) 7.5 tons TWA090K\*A condensing unit only (IP)**

Outdoor Temp (°F)		Saturation Suction Temperature (°F)					
		30	35	40	45	50	55
65	Head Press (psig)	245.6	252.7	260.3	268.4	276.9	286.0
	Capacity (Btuh/1000)	79.9	87.7	95.9	104.5	113.8	123.6
	Unit Power (kW)	5.0	5.1	5.2	5.4	5.5	5.7
75	Head Press (psig)	281.3	288.8	296.8	305.3	314.2	323.7
	Capacity (Btuh/1000)	76.2	83.5	91.3	99.6	108.5	117.9
	Unit Power (kW)	5.5	5.6	5.7	5.9	6.1	6.2
85	Head Press (psig)	320.3	328.2	336.6	345.4	354.8	364.7
	Capacity (Btuh/1000)	72.2	79.2	86.7	94.6	103.1	112.2
	Unit Power (kW)	6.1	6.2	6.3	6.5	6.6	6.8
95	Head Press (psig)	362.7	371.0	379.7	389.0	398.8	409.1
	Capacity (Btuh/1000)	68.1	74.8	81.9	89.6	97.7	106.4
	Unit Power (kW)	6.7	6.8	7.0	7.1	7.3	7.5
105	Head Press (psig)	408.3	417.0	426.2	435.9	446.0	456.6
	Capacity (Btuh/1000)	63.7	70.2	77.0	84.3	92.2	100.6
	Unit Power (kW)	7.4	7.5	7.7	7.9	8.0	8.2
115	Head Press (psig)	457.3	466.5	476.0	486.1	496.6	507.6
	Capacity (Btuh/1000)	59.2	65.3	71.9	78.9	86.5	94.6
	Unit Power (kW)	8.2	8.3	8.5	8.7	8.8	9.0
120	Head Press (psig)	483.1	492.5	502.2	512.4	523.1	534.2
	Capacity (Btuh/1000)	56.8	62.8	69.3	76.2	83.6	91.5
	Unit Power (kW)	8.6	8.8	8.9	9.1	9.3	9.5

Note: Performance data calculated at 15°F subcooling and 15°F superheat and does not include capacity loss due to refrigerant lines.

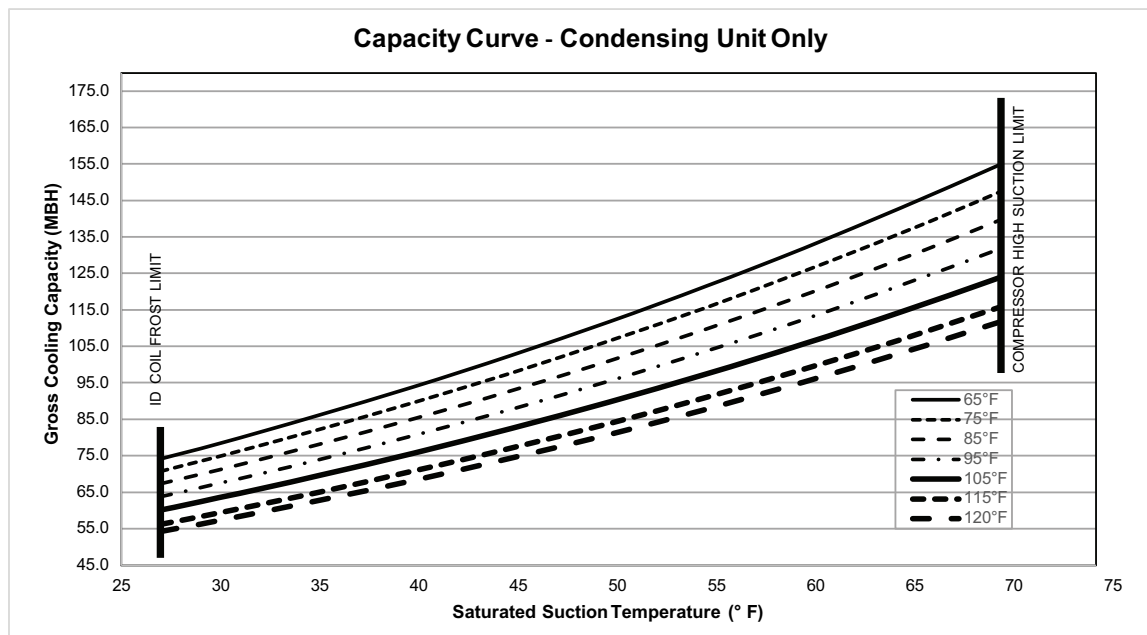
**Figure 11. TWA090K\*A capacity curves**



**Performance Data**

**Table 25. Gross cooling capacities (MBh) 7.5 tons TWA090K\*D condensing unit only (IP)**

Outdoor Temp (°F)		Saturation Suction Temperature (°F)					
		30	35	40	45	50	55
65	Head Press (psig)	233.2	239.1	246.3	252.9	260.2	268.3
	Capacity (Btuh/1000)	83.4	91.5	100.0	109.2	119.0	129.4
	Unit Power (kW)	4.8	4.8	4.9	4.9	5.0	5.0
75	Head Press (psig)	267.7	274.9	282.2	288.6	296.9	305.3
	Capacity (Btuh/1000)	79.5	87.2	95.4	104.4	113.6	123.5
	Unit Power (kW)	5.3	5.4	5.5	5.5	5.6	5.6
85	Head Press (psig)	306.0	313.7	321.4	328.4	336.7	347.3
	Capacity (Btuh/1000)	75.4	82.8	90.6	99.1	108.0	117.0
	Unit Power (kW)	6.0	6.1	6.1	6.2	6.3	6.4
95	Head Press (psig)	348.3	355.8	362.6	372.4	381.3	390.6
	Capacity (Btuh/1000)	71.0	78.0	85.7	93.4	101.7	110.5
	Unit Power (kW)	6.7	6.8	6.9	7.0	7.1	7.2
105	Head Press (psig)	393.2	401.1	409.5	416.8	427.3	436.8
	Capacity (Btuh/1000)	66.2	72.9	79.9	87.6	95.2	103.5
	Unit Power (kW)	7.6	7.7	7.8	7.8	8.0	8.1
115	Head Press (psig)	441.3	448.3	458.1	466.9	474.4	485.7
	Capacity (Btuh/1000)	61.0	67.5	74.0	81.0	88.6	96.2
	Unit Power (kW)	8.6	8.7	8.8	8.9	8.9	9.1
125	Head Press (psig)	492.3	499.6	507.9	518.3	525.9	536.9
	Capacity (Btuh/1000)	55.4	61.5	67.8	74.3	81.4	88.5
	Unit Power (kW)	9.8	9.8	9.8	10.0	10.0	10.2

Note: Performance data calculated at 15°F subcooling and 15°F superheat and does not include capacity loss due to refrigerant lines.

**Figure 12. TWA090K\*D capacity curves**

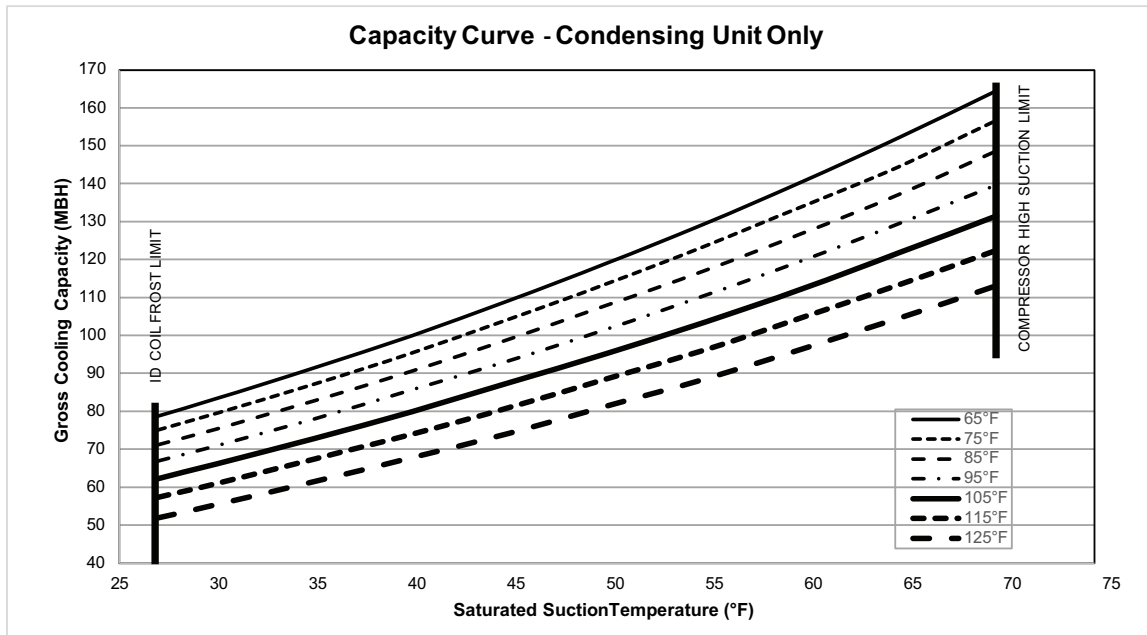

**Table 26. Gross cooling capacities (MBh) 10 tons TWA120K\*A condensing unit only (IP)**

Outdoor Temp (°F)		Saturation Suction Temperature (°F)					
		30	35	40	45	50	55
65	Head Press (psig)	241.8	248.4	255.5	263.2	271.4	280.2
	Capacity (Btuh/1000)	100.1	109.5	119.7	130.5	142.1	154.6
	Unit Power (kW)	6.5	6.7	6.9	7.1	7.3	7.5
75	Head Press (psig)	277.1	284.2	291.8	299.8	308.4	317.6
	Capacity (Btuh/1000)	95.7	104.8	114.5	124.9	136.1	148.1
	Unit Power (kW)	7.1	7.3	7.5	7.7	7.8	8.1
85	Head Press (psig)	316	323.5	331.4	339.8	348.8	358.2
	Capacity (Btuh/1000)	91.1	99.8	109.1	119.1	129.9	141.4
	Unit Power (kW)	7.8	8	8.1	8.3	8.5	8.7
95	Head Press (psig)	358.6	366.4	374.6	383.3	392.5	402.3
	Capacity (Btuh/1000)	86.4	94.7	103.6	113.1	123.3	134.3
	Unit Power (kW)	8.5	8.7	8.9	9.1	9.3	9.5
105	Head Press (psig)	404.9	412.9	421.3	430.3	439.7	449.6
	Capacity (Btuh/1000)	81.6	89.4	97.8	106.8	116.5	126.9
	Unit Power (kW)	9.4	9.6	9.8	10	10.1	10.3
115	Head Press (psig)	454.8	463	471.6	480.8	490.3	500.4
	Capacity (Btuh/1000)	76.5	83.9	91.8	100.3	109.4	119.3
	Unit Power (kW)	10.3	10.5	10.7	10.9	11.1	11.3
125	Head Press (psig)	508.7	517	525.7	534.8	544.4	554.4
	Capacity (Btuh/1000)	71.2	78.1	85.5	93.5	102.1	111.3
	Unit Power (kW)	11.4	11.6	11.8	12	12.2	12.4

Note: Performance data calculated at 15°F subcooling and 15°F superheat and does not include capacity loss due to refrigerant lines.

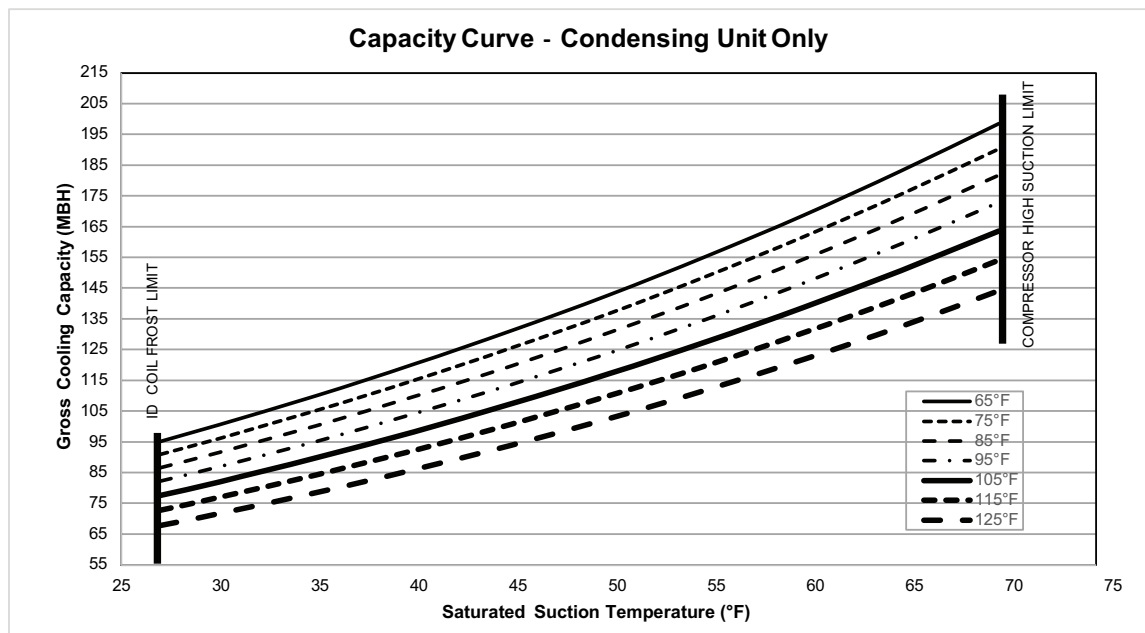
**Figure 13. TWA120K\*A capacity curves**



**Performance Data**

**Table 27. Gross cooling capacities (MBh) 10 tons TWA120K\*D condensing unit only (IP)**

Outdoor Temp (°F)		Saturation Suction Temperature (°F)					
		30	35	40	45	50	55
65	Head Press (psig)	232.1	238.1	244.5	251.4	258.8	266.9
	Capacity (Btuh/1000)	101.4	111.4	122.3	134.0	146.5	160.0
	Unit Power (kW)	8.5	8.6	8.8	8.9	9.1	9.3
75	Head Press (psig)	267.3	273.5	280.2	287.5	295.2	303.5
	Capacity (Btuh/1000)	97.4	106.8	117.0	128.1	139.9	152.7
	Unit Power (kW)	9.3	9.5	9.6	9.8	10.0	10.2
85	Head Press (psig)	305.8	312.3	319.3	326.9	334.9	343.4
	Capacity (Btuh/1000)	92.6	101.6	111.3	121.7	132.9	145.0
	Unit Power (kW)	10.3	10.4	10.6	10.7	10.9	11.2
95	Head Press (psig)	347.8	354.6	362.0	369.8	378.1	386.9
	Capacity (Btuh/1000)	87.4	96.0	105.2	115.1	125.7	137.2
	Unit Power (kW)	11.4	11.5	11.7	11.8	12.1	12.3
105	Head Press (psig)	393.5	400.7	408.3	416.4	424.9	434.0
	Capacity (Btuh/1000)	82.0	90.2	98.9	108.4	118.5	129.3
	Unit Power (kW)	12.6	12.8	12.9	13.1	13.3	13.5
115	Head Press (psig)	443.1	450.7	458.6	467.0	475.8	485.1
	Capacity (Btuh/1000)	76.5	84.3	92.6	101.6	111.2	121.5
	Unit Power (kW)	14.1	14.2	14.4	14.6	14.8	15.0
125	Head Press (psig)	497.2	505.1	513.3	521.9	531.0	540.4
	Capacity (Btuh/1000)	70.9	78.4	86.4	94.9	104.0	113.8
	Unit Power (kW)	15.7	15.9	16.1	16.2	16.4	16.6

Note: Performance data calculated at 15°F subcooling and 15°F superheat and does not include capacity loss due to refrigerant lines.

**Figure 14. TWA120K\*D capacity curves**

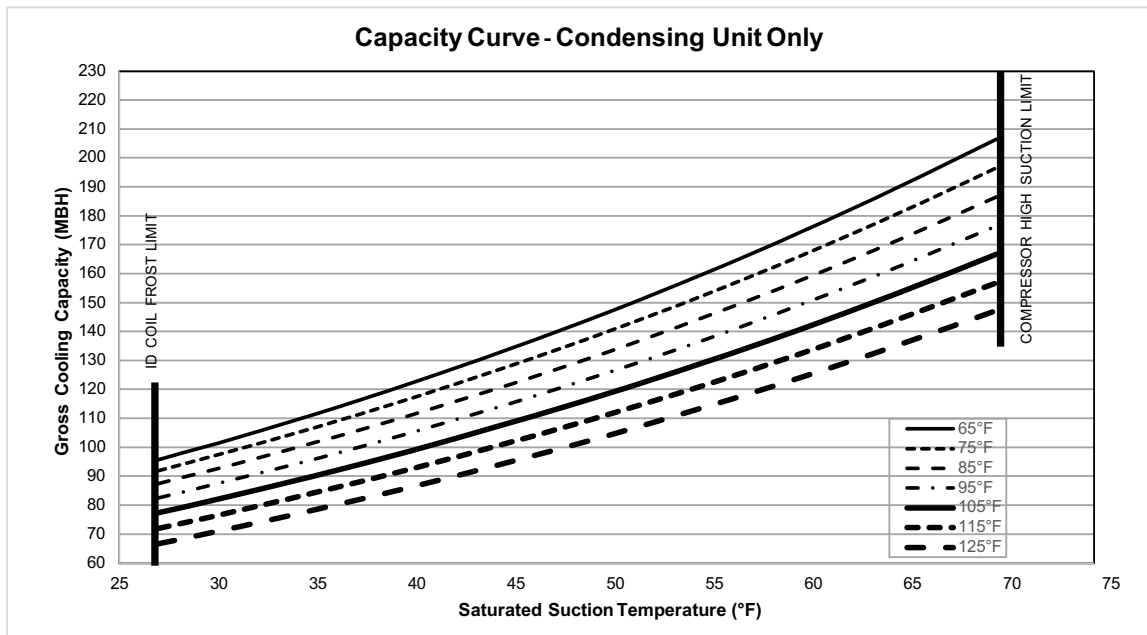

**Table 28. Gross cooling capacities (MBh) 12.5 tons TWA150K\*D condensing unit only (IP)**

Outdoor Temp (°F)		Saturation Suction Temperature (°F)					
		30	35	40	45	50	55
65	Head Press (psig)	244.8	252.1	259.8	268.1	276.8	285.9
	Capacity (Btuh/1000)	127.2	140.7	155.1	170.3	186.3	203.0
	Unit Power (kW)	8.4	8.5	8.6	8.7	8.9	9.0
75	Head Press (psig)	280.2	288.0	296.2	304.9	313.9	323.4
	Capacity (Btuh/1000)	120.4	133.3	146.9	161.4	176.6	192.3
	Unit Power (kW)	9.5	9.6	9.7	9.9	10.0	10.1
85	Head Press (psig)	319.0	327.3	335.9	345.0	354.5	364.3
	Capacity (Btuh/1000)	113.4	125.6	138.7	152.4	166.7	181.6
	Unit Power (kW)	10.7	10.8	11.0	11.1	11.2	11.4
95	Head Press (psig)	361.2	370.0	379.1	388.5	398.4	408.6
	Capacity (Btuh/1000)	106.0	117.7	130.0	143.1	156.6	170.7
	Unit Power (kW)	12.1	12.2	12.3	12.5	12.6	12.8
105	Head Press (psig)	406.7	415.9	425.4	435.3	445.5	456.0
	Capacity (Btuh/1000)	98.1	109.2	121.0	133.3	146.2	159.5
	Unit Power (kW)	13.5	13.7	13.9	14.0	14.2	14.3
115	Head Press (psig)	455.3	465.0	475.0	485.4	496.0	506.8
	Capacity (Btuh/1000)	89.6	100.2	111.4	123.1	135.2	147.8
	Unit Power (kW)	15.2	15.3	15.5	15.7	15.9	16.0
120	Head Press (psig)	480.8	490.8	501.0	511.6	522.3	533.3
	Capacity (Btuh/1000)	85.1	95.5	106.4	117.8	129.6	141.8
	Unit Power (kW)	16.0	16.2	16.4	16.6	16.8	16.9

Note: Performance data calculated at 15°F subcooling and 15°F superheat and does not include capacity loss due to refrigerant lines.

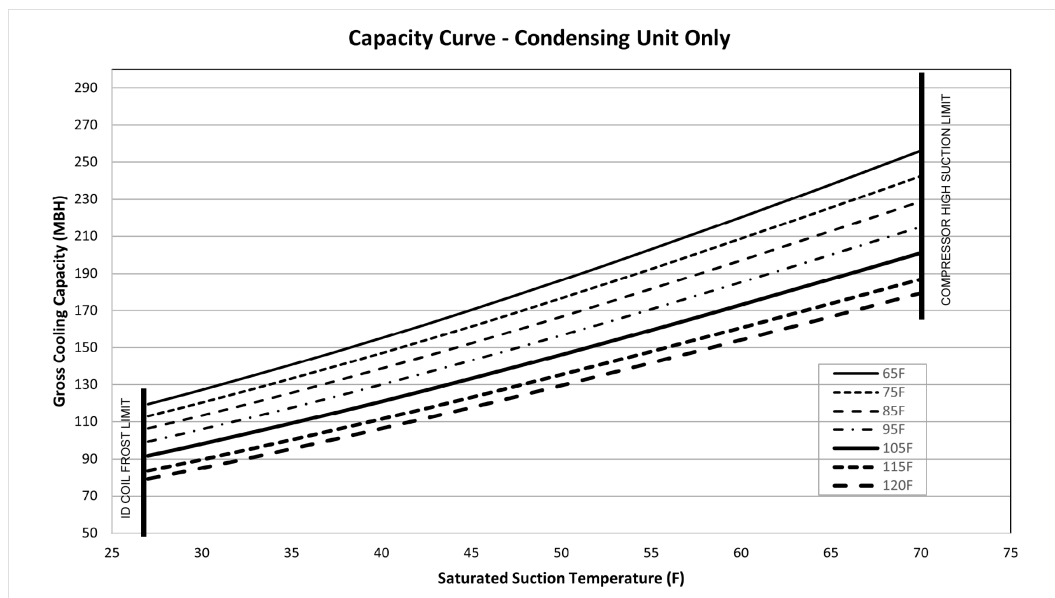
**Figure 15. TWA150KD capacity curves**



**Performance Data**

**Table 29. Gross cooling capacities (MBh) 15 tons TWA180K\*D condensing unit only (IP)**

Outdoor Temp (°F)		Saturation Suction Temperature (°F)					
		30	35	40	45	50	55
65	Head Press (psig)	224.7	229.7	235.0	240.7	246.6	252.7
	Capacity (Btuh/1000)	164.4	180.6	197.9	216.4	236.1	257.2
	Unit Power (kW)	10.4	10.4	10.5	10.6	10.6	10.6
75	Head Press (psig)	258.8	264.2	269.9	275.9	282.1	288.7
	Capacity (Btuh/1000)	156.8	172.2	188.8	206.5	225.4	245.5
	Unit Power (kW)	11.4	11.5	11.6	11.7	11.8	11.9
85	Head Press (psig)	296.6	302.4	308.3	314.6	321.2	328.0
	Capacity (Btuh/1000)	148.9	163.7	179.5	196.4	214.4	233.6
	Unit Power (kW)	12.6	12.7	12.9	13.0	13.1	13.2
95	Head Press (psig)	338.1	344.1	350.4	357.0	363.8	370.9
	Capacity (Btuh/1000)	140.7	154.9	169.9	186.1	203.2	221.5
	Unit Power (kW)	13.9	14.0	14.2	14.4	14.5	14.7
105	Head Press (psig)	383.4	389.6	396.2	403.0	410.1	417.4
	Capacity (Btuh/1000)	132.3	145.7	160.1	175.5	191.8	209.2
	Unit Power (kW)	15.3	15.5	15.7	15.9	16.0	16.2
115	Head Press (psig)	432.5	439.0	445.8	452.8	460.1	467.6
	Capacity (Btuh/1000)	123.5	136.3	150.0	164.6	180.1	196.7
	Unit Power (kW)	16.9	17.1	17.3	17.5	17.7	17.9
125	Head Press (psig)	485.7	492.5	499.4	506.6	514.0	521.6
	Capacity (Btuh/1000)	114.4	126.5	139.5	153.3	168.1	183.8
	Unit Power (kW)	18.7	18.9	19.1	19.3	19.5	19.7

Note: Performance data calculated at 15°F subcooling and 15°F superheat and does not include capacity loss due to refrigerant lines.

**Figure 16. TWA180K\*D capacity curves**

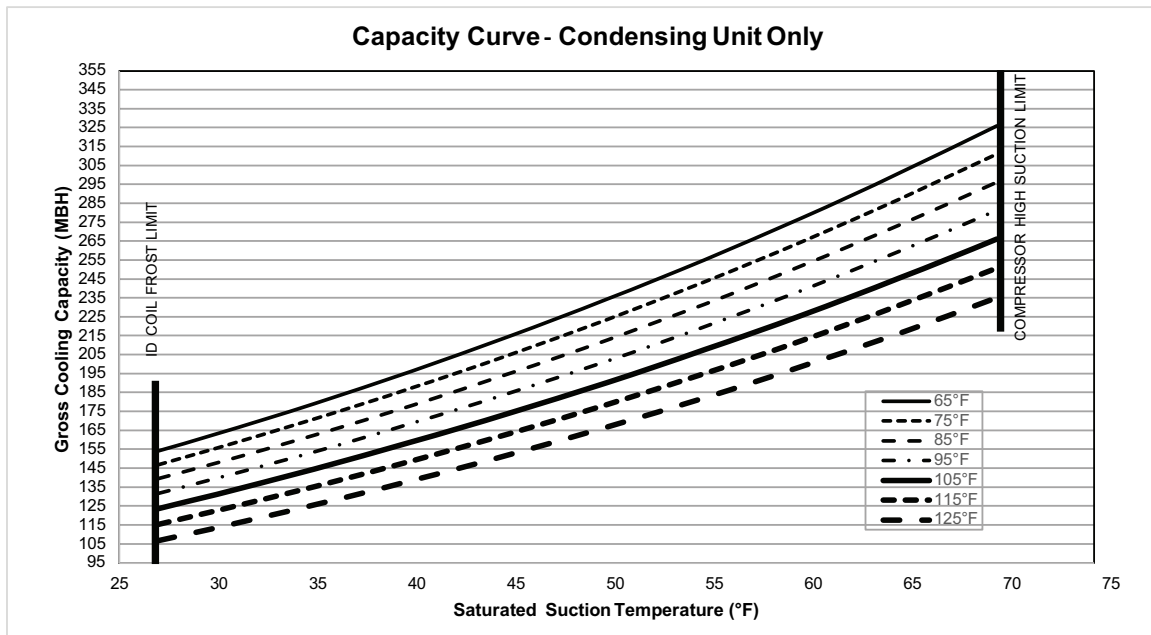

**Table 30. Gross cooling capacities (MBh) 20 tons TWA240K\*D condensing unit only (IP)**

Outdoor Temp (°F)		Saturation Suction Temperature (°F)					
		30	35	40	45	50	55
65	Head Press (psig)	243.7	250.3	257.6	265.4	272.8	282.7
	Capacity (Btuh/1000)	239.0	261.7	286.1	312.2	340.6	370.4
	Unit Power (kW)	19.9	20.2	20.4	20.7	20.9	21.2
75	Head Press (psig)	278.9	285.9	293.6	301.8	310.5	319.7
	Capacity (Btuh/1000)	227.2	248.7	271.7	296.5	323.1	351.9
	Unit Power (kW)	22.1	22.4	22.8	23.1	23.5	23.8
85	Head Press (psig)	317.5	325.0	333.0	341.5	350.6	360.1
	Capacity (Btuh/1000)	215.3	235.6	257.4	280.9	306.2	333.5
	Unit Power (kW)	24.4	24.9	25.3	25.7	26.2	26.6
95	Head Press (psig)	359.7	367.6	375.9	384.7	393.5	404.1
	Capacity (Btuh/1000)	203.4	222.6	243.2	265.4	289.4	315.0
	Unit Power (kW)	27.0	27.5	28.0	28.5	29.0	29.5
105	Head Press (psig)	405.8	413.8	422.4	431.4	441.2	451.6
	Capacity (Btuh/1000)	191.6	209.7	229.2	250.2	272.7	296.9
	Unit Power (kW)	29.8	30.4	30.9	31.5	32.1	32.7
115	Head Press (psig)	455.6	463.8	472.8	482.3	492.0	502.0
	Capacity (Btuh/1000)	179.8	196.9	215.2	234.8	256.2	279.3
	Unit Power (kW)	32.8	33.5	34.1	34.8	35.4	36.0
120	Head Press (psig)	481.9	490.2	499.2	508.7	518.4	528.4
	Capacity (Btuh/1000)	174.0	190.6	208.3	227.4	248.1	270.6
	Unit Power (kW)	34.5	35.1	35.8	36.4	37.1	37.7

Note: Performance data calculated at 15°F subcooling and 15°F superheat and does not include capacity loss due to refrigerant lines.

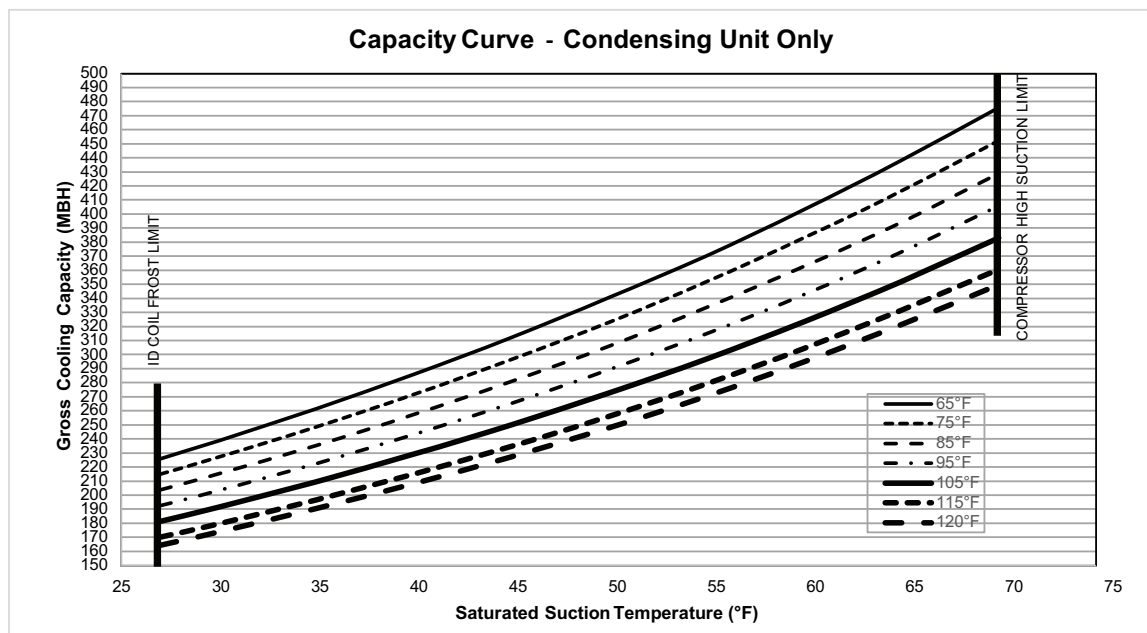
**Figure 17. TWA240K\*D capacity curves**



## Performance Data

**Table 31. Gross cooling capacities (MBh) 25 tons TWA300K\*D condensing unit only (IP)**

Outdoor Temp (°F)		Saturated Suction Temperature (°F)					
		30	35	40	45	50	55
65	Head Press (psig)	257.0	264.5	272.4	280.7	289.4	298.3
	Capacity (Btuh/1000)	263.1	289.0	316.5	345.6	376.1	407.9
	Unit Power (kW)	16.9	17.1	17.4	17.7	17.9	18.1
75	Head Press (psig)	293.9	301.9	310.2	318.9	327.9	337.1
	Capacity (Btuh/1000)	250.3	274.9	300.9	328.5	357.3	387.2
	Unit Power (kW)	18.7	19.0	19.3	19.6	20.0	20.2
85	Head Press (psig)	334.3	342.7	351.3	360.4	369.6	379.1
	Capacity (Btuh/1000)	237.1	260.3	284.9	310.9	338.1	366.2
	Unit Power (kW)	20.7	21.0	21.4	21.8	22.1	22.5
95	Head Press (psig)	378.3	386.9	395.9	405.2	414.6	424.3
	Capacity (Btuh/1000)	223.4	245.3	268.5	292.9	318.3	344.6
	Unit Power (kW)	22.8	23.3	23.7	24.1	24.5	24.9
105	Head Press (psig)	425.8	434.7	443.9	453.3	463.0	472.7
	Capacity (Btuh/1000)	209.2	229.8	251.5	274.3	298.1	322.6
	Unit Power (kW)	25.2	25.7	26.1	26.6	27.0	27.4
115	Head Press (psig)	477.0	486.1	495.5	505.0	514.7	524.4
	Capacity (Btuh/1000)	194.5	213.7	234.0	255.2	277.3	300.0
	Unit Power (kW)	27.8	28.3	28.8	29.2	29.7	30.2
120	Head Press (psig)	532.1	541.2	550.6	560.1	569.7	579.2
	Capacity (Btuh/1000)	179.2	197.0	215.8	235.4	255.8	276.7
	Unit Power (kW)	30.6	31.1	31.6	32.1	32.6	33.0

Note: Performance data calculated at 15°F subcooling and 15°F superheat and does not include capacity loss due to refrigerant lines.

**Figure 18. TWA300KD capacity curve**

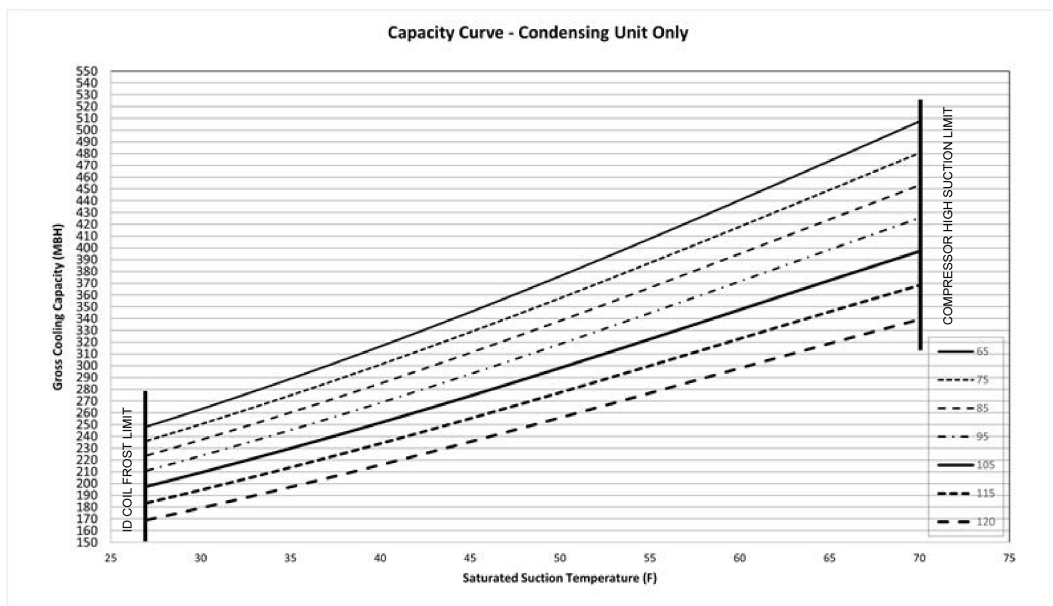

## Gross Heating Capacities

**Table 32. Gross heating capacities (MBH) 6 tons TWA072K\*A heat pump with 7.5 tons TWE090K\*A air handler at 2100 CFM (IP)**

Outdoor Temp (°F)	Integrated Heating Capacity (MBH) at Indicated Indoor Dry Bulb Temp (°F)				Total Power (kW) at Indicated Indoor Dry Bulb Temp (°F)			
	60	70	75	80	60	70	75	80
-8	23.9	23.8	24.0	23.7	4.2	4.7	4.9	5.2
-3	27.4	27.1	27.0	27.0	4.3	4.7	5.0	5.3
2	31.2	30.9	30.7	30.7	4.4	4.8	5.1	5.3
7	34.5	34.3	34.3	34.2	4.5	4.9	5.1	5.4
12	38.2	37.7	37.5	37.4	4.5	5.0	5.3	5.5
17	41.9	41.3	41.1	40.9	4.6	5.1	5.4	5.6
22	45.8	45.1	44.8	44.6	4.7	5.2	5.5	5.7
27	49.9	49.0	48.6	48.2	4.8	5.3	5.6	5.9
32	54.2	53.0	52.5	52.1	4.9	5.4	5.7	6.0
37	58.1	57.0	56.5	55.9	5.0	5.5	5.8	6.1
42	62.4	61.1	60.4	59.8	5.1	5.6	5.9	6.2
47	66.8	65.3	64.5	63.8	5.2	5.8	6.1	6.4
52	71.4	69.7	68.8	67.9	5.3	5.9	6.2	6.5
57	76.2	74.2	73.3	72.3	5.4	6.0	6.3	6.6
62	81.3	79.0	77.8	76.7	5.6	6.1	6.5	6.8
67	86.8	83.9	82.6	81.2	5.7	6.3	6.6	6.9
72	92.1	89.1	87.6	86.0	5.8	6.4	6.7	7.1

**Notes:**

1. Net heating capacity and power include indoor fan heat at AHRI ESP. To obtain net heating at other conditions, subtract fan heat at this condition and add fan heat at new condition.
2. Integrated heating capacities and power include the effects of defrost in the frost region. All heating capacities and power are at 70% outdoor relative humidity and demand defrost cycle.

**Table 33. Gross heating capacities (MBH) 6 tons TWA072K\*D heat pump with 6 tons TWE072K\*B air handler at 2400 CFM (IP)**

Outdoor Temp (°F)	Integrated Heating Capacity (MBH) at Indicated Indoor Dry Bulb Temp (°F)				Total Power (kW) at Indicated Indoor Dry Bulb Temp (°F)			
	60	70	75	80	60	70	75	80
-8	22.0	20.9	20.6	19.8	4.5	5.0	5.2	5.5
-3	25.4	24.5	24.0	23.4	4.5	5.0	5.3	5.6
2	28.8	27.9	27.4	26.9	4.6	5.1	5.3	5.6
7	32.3	31.5	31.0	30.4	4.6	5.1	5.4	5.7
12	36.1	35.1	34.6	34.1	4.7	5.2	5.5	5.8
17	39.9	38.9	38.4	37.8	4.7	5.3	5.5	5.8
22	44.0	42.9	42.3	41.7	4.8	5.3	5.6	5.9
27	48.2	47.0	46.4	45.8	4.9	5.4	5.7	6.0
32	52.7	51.3	50.7	50.0	5.0	5.5	5.8	6.1
37	57.2	55.8	55.1	54.2	5.0	5.6	6.0	6.2
42	61.8	60.2	59.4	58.7	5.1	5.7	6.0	6.3
47	66.8	65.0	64.2	63.3	5.2	5.8	6.1	6.4
52	72.3	70.1	69.2	68.2	5.3	5.9	6.2	6.5
57	77.9	75.8	74.7	73.4	5.4	6.0	6.3	6.6
62	83.7	81.4	79.9	78.8	5.5	6.1	6.4	6.8
67	90.4	87.3	85.6	84.4	5.7	6.3	6.6	6.9
72	96.1	92.9	91.5	90.2	5.8	6.4	6.7	7.1

**Notes:**

1. Net heating capacity and power include indoor fan heat at AHRI ESP. To obtain net heating at other conditions, subtract fan heat at this condition and add fan heat at new condition.
2. Integrated heating capacities and power include the effects of defrost in the frost region. All heating capacities and power are at 70% outdoor relative humidity and demand defrost cycle.



## Performance Data

**Table 34. Gross heating capacities (MBH) 7.5 tons TWA090K\*A heat pump with 7.5 tons TWE090K\*A air handler at 2625 CFM (IP)**

Outdoor Temp (°F)	Integrated Heating Capacity (MBH) at Indicated Indoor Dry Bulb Temp (°F)				Total Power (kW) at Indicated Indoor Dry Bulb Temp (°F)			
	60	70	75	80	60	70	75	80
-8	24.7	26.4	27.1	27.7	6.0	6.4	6.7	6.9
-3	29.3	30.6	31.3	31.7	5.9	6.4	6.6	6.9
2	33.8	35.1	35.4	35.5	5.9	6.4	6.6	6.9
7	38.6	39.4	39.6	39.5	5.8	6.4	6.6	6.9
12	43.0	43.5	43.6	43.7	5.9	6.4	6.7	7.0
17	47.9	48.0	48.1	48.1	5.9	6.4	6.7	7.0
22	52.9	52.8	52.7	52.6	5.9	6.5	6.8	7.1
27	58.0	57.7	57.6	57.3	6.0	6.5	6.8	7.2
32	63.4	62.9	62.6	62.3	6.0	6.6	6.9	7.3
37	68.7	68.0	67.6	67.2	6.1	6.7	7.0	7.4
42	74.2	73.2	72.7	72.2	6.2	6.8	7.2	7.5
47	79.8	78.6	78.0	77.4	6.4	7.0	7.3	7.7
52	85.7	84.3	83.6	82.9	6.5	7.1	7.5	7.8
57	92.2	90.5	89.7	88.9	6.7	7.3	7.7	8.0
62	99.0	97.0	96.1	95.2	6.9	7.5	7.9	8.3
67	106.1	103.9	102.8	101.8	7.1	7.8	8.1	8.5
72	113.4	110.9	109.7	108.5	7.4	8.0	8.4	8.8

**Notes:**

1. Net heating capacity and power include indoor fan heat at AHRI ESP. To obtain net heating at other conditions, subtract fan heat at this condition and add fan heat at new condition.
2. Integrated heating capacities and power include the effects of defrost in the frost region. All heating capacities and power are at 70% outdoor relative humidity and demand defrost cycle.

**Table 35. Gross heating capacities (MBH) 7.5 tons TWA090K\*D heat pump with 7.5 tons TWE090K\*B air handler at 3000 CFM (IP)**

Outdoor Temp (°F)	Integrated Heating Capacity (MBH) at Indicated Indoor Dry Bulb Temp (°F)				Total Power (kW) at Indicated Indoor Dry Bulb Temp (°F)			
	60	70	75	80	60	70	75	80
-8	30.5	28.6	27.8	27.0	5.6	6.2	6.6	7.1
-3	34.9	33.2	32.5	31.9	5.7	6.4	6.7	7.2
2	39.3	37.8	37.2	36.6	5.8	6.5	6.9	7.3
7	43.8	42.3	41.8	41.3	5.9	6.6	7.0	7.4
12	48.4	46.9	46.4	45.9	6.0	6.7	7.1	7.5
17	53.1	51.7	51.1	50.6	6.1	6.8	7.2	7.6
22	58.1	56.6	56.0	55.5	6.2	6.9	7.3	7.7
27	63.3	61.7	61.1	60.5	6.3	7.0	7.4	7.8
32	68.7	67.1	66.4	65.7	6.4	7.1	7.5	7.9
37	74.1	72.5	71.8	71.0	6.4	7.2	7.6	8.1
42	80.0	78.2	77.4	76.5	6.6	7.4	7.8	8.2
47	86.0	84.1	83.1	82.2	6.8	7.5	7.9	8.3
52	92.5	90.3	89.2	88.2	6.9	7.6	8.0	8.5
57	99.2	96.8	95.6	94.4	7.0	7.8	8.2	8.7
62	106.2	103.6	102.3	100.8	7.2	8.0	8.4	8.9
67	113.5	110.6	109.1	107.7	7.3	8.2	8.6	9.1
72	121.2	117.9	116.3	114.3	7.5	8.4	8.8	9.3

**Notes:**

1. Net heating capacity and power include indoor fan heat at AHRI ESP. To obtain net heating at other conditions, subtract fan heat at this condition and add fan heat at new condition.
2. Integrated heating capacities and power include the effects of defrost in the frost region. All heating capacities and power are at 70% outdoor relative humidity and demand defrost cycle.

**Table 36. Gross heating capacities (MBH) 10 tons TWA120K\*A heat pump with 10 tons TWE120K\*A air handler at 4000 CFM (IP)**

Outdoor Temp (°F)	Integrated Heating Capacity (MBH) at Indicated Indoor Dry Bulb Temp (°F)				Total Power (kW) at Indicated Indoor Dry Bulb Temp (°F)			
	60	70	75	80	60	70	75	80
-8	32.9	32.9	33.1	33.3	6.9	7.5	7.8	8.0
-3	38.3	38.2	38.3	38.5	7.0	7.6	7.8	8.1
2	44.8	44.6	44.6	44.6	7.0	7.6	7.9	8.2

**Table 36. Gross heating capacities (MBH)10 tons TWA120K\*A heat pump with 10 tons TWE120K\*A air handler at 4000 CFM (IP) (continued)**

Outdoor Temp (°F)	Integrated Heating Capacity (MBH) at Indicated Indoor Dry Bulb Temp (°F)				Total Power (kW) at Indicated Indoor Dry Bulb Temp (°F)			
	60	70	75	80	60	70	75	80
7	50.6	50.2	50.1	50.1	7.1	7.7	8.0	8.4
12	56.4	55.8	55.6	55.5	7.2	7.8	8.2	8.5
17	62.4	61.6	61.3	61.1	7.3	8.0	8.3	8.7
22	68.5	67.5	67.2	66.9	7.4	8.1	8.5	8.8
27	74.8	73.7	73.2	72.8	7.6	8.2	8.6	9.0
32	81.4	80.1	79.5	79.0	7.7	8.4	8.8	9.2
37	88.0	86.5	85.8	85.2	7.9	8.6	8.9	9.3
42	94.8	93.0	92.2	91.5	8.0	8.7	9.1	9.5
47	101.7	99.8	98.8	97.9	8.2	8.9	9.3	9.7
52	103.4	106.8	106.7	104.6	8.2	9.1	9.5	9.9
57	116.6	114.1	112.9	111.7	8.6	9.3	9.7	10.1
62	125.3	121.9	121.1	119.6	8.8	9.6	10.0	10.4
67	134.0	130.8	129.2	127.6	9.1	9.8	10.2	10.6
72	142.4	138.6	136.7	134.8	9.3	10.0	10.4	10.9

**Notes:**

1. Net heating capacity and power include indoor fan heat at AHRI ESP. To obtain net heating at other conditions, subtract fan heat at this condition and add fan heat at new condition.
2. Integrated heating capacities and power include the effects of defrost in the frost region. All heating capacities and power are at 70% outdoor relative humidity and demand defrost cycle.

**Table 37. Gross heating capacities (MBH)10 tons TWA120K\*D heat pump with 10 tons TWE120K\*B air handler at 4000 CFM (IP)**

Outdoor Temp (°F)	Integrated Heating Capacity (MBH) at Indicated Indoor Dry Bulb Temp (°F)				Total Power (kW) at Indicated Indoor Dry Bulb Temp (°F)			
	60	70	75	80	60	70	75	80
-8	36.1	36.2	36.6	37.2	7.4	7.8	8.1	8.3
-3	41.2	41.5	41.6	41.9	7.5	8.0	8.2	8.5
2	46.7	46.6	46.7	46.7	7.6	8.1	8.4	8.7
7	52.3	52.0	51.9	51.9	7.6	8.2	8.5	8.9
12	57.8	57.2	57.0	56.9	7.7	8.4	8.7	9.0
17	63.8	63.0	62.6	62.4	7.8	8.5	8.8	9.2
22	70.2	69.1	68.6	68.2	7.9	8.6	9.0	9.4
27	76.9	75.5	74.9	74.4	8.0	8.7	9.1	9.5
32	84.0	82.3	81.6	80.9	8.1	8.9	9.3	9.7
37	91.0	89.1	88.2	87.4	8.2	9.0	9.4	9.8
42	98.2	96.0	95.0	94.1	8.3	9.1	9.6	10.0
47	105.6	103.3	102.1	101.0	8.5	9.3	9.7	10.2
52	113.7	111.1	109.8	108.5	8.6	9.5	9.9	10.4
57	122.2	119.2	117.7	116.5	8.8	9.7	10.1	10.6
62	131.2	127.6	125.9	124.3	9.0	9.9	10.3	10.8
67	140.1	136.4	134.5	132.7	9.2	10.1	10.5	11.0
72	149.5	145.4	143.4	141.3	9.5	10.3	10.8	11.3

**Notes:**

1. Net heating capacity and power include indoor fan heat at AHRI ESP. To obtain net heating at other conditions, subtract fan heat at this condition and add fan heat at new condition.
2. Integrated heating capacities and power include the effects of defrost in the frost region. All heating capacities and power are at 70% outdoor relative humidity and demand defrost cycle.

**Table 38. Gross heating capacities (MBH) 12.5 tons TWA150K\*D heat pump with 12.5 tons TWE150K\*B air handler at 5000 CFM (IP)**

Outdoor Temp (°F)	Integrated Heating Capacity (MBH) at Indicated Indoor Dry Bulb Temp (°F)				Total Power (kW) at Indicated Indoor Dry Bulb Temp (°F)			
	60	70	75	80	60	70	75	80
-8	45.2	45.6	45.6	—	8.7	9.7	10.2	—
-3	50.8	51.1	51.1	51.1	8.8	9.8	10.3	10.8
2	56.8	56.8	56.7	56.7	8.8	9.8	10.4	10.9
7	62.5	62.4	62.2	62.3	8.9	9.9	10.5	11.0
12	68.8	68.4	68.2	68.1	9.0	10.0	10.6	11.1



## Performance Data

**Table 38. Gross heating capacities (MBH) 12.5 tons TWA150K\*D heat pump with 12.5 tons TWE150K\*B air handler at 5000 CFM (IP) (continued)**

Outdoor Temp (°F)	Integrated Heating Capacity (MBH) at Indicated Indoor Dry Bulb Temp (°F)				Total Power (kW) at Indicated Indoor Dry Bulb Temp (°F)			
	60	70	75	80	60	70	75	80
17	75.3	74.7	74.4	74.2	9.1	10.1	10.7	11.2
22	82.2	81.2	80.8	80.5	9.1	10.2	10.8	11.4
27	89.3	88.1	87.6	87.2	9.2	10.3	10.9	11.5
32	97.1	95.5	94.9	94.3	9.3	10.4	11.0	11.6
37	104.8	102.9	102.2	101.5	9.4	10.5	11.1	11.7
42	112.8	110.7	109.5	108.6	9.6	10.7	11.2	11.9
47	120.9	118.3	117.1	116.0	9.7	10.8	11.4	12.0
52	129.4	126.5	125.1	123.9	9.8	10.9	11.5	12.1
57	138.9	136.0	134.1	132.7	9.9	11.1	11.6	12.3
62	148.8	144.9	143.1	141.3	10.1	11.2	11.8	12.4
67	159.4	154.9	152.5	150.3	10.2	11.4	12.0	12.6
72	170.1	164.8	162.3	159.8	10.4	11.5	12.1	12.8

**Notes:**

1. Net heating capacity and power include indoor fan heat at AHRI ESP. To obtain net heating at other conditions, subtract fan heat at this condition and add fan heat at new condition.
2. Integrated heating capacities and power include the effects of defrost in the frost region. All heating capacities and power are at 70% outdoor relative humidity and demand defrost cycle.

**Table 39. Gross heating capacities (MBH) 15 tons TWA180K\*D heat pump with 15 tons TWE180K\*B air handler at 6000 CFM (IP)**

Outdoor Temp (°F)	Integrated Heating Capacity (MBH) at Indicated Indoor Dry Bulb Temp (°F)				Total Power (kW) at Indicated Indoor Dry Bulb Temp (°F)			
	60	70	75	80	60	70	75	80
-8	56.9	56.8	57.1	57.6	11.7	12.8	13.4	14.1
-3	66.0	66.4	66.4	65.6	11.9	13.0	13.6	14.3
2	76.0	75.6	75.4	75.4	12.1	13.3	13.9	14.6
7	85.7	84.9	84.7	84.5	12.4	13.5	14.1	14.8
12	95.2	94.2	93.8	93.5	12.6	13.8	14.4	15.1
17	105.3	104.0	103.5	103.1	12.9	14.0	14.6	15.3
22	115.8	114.2	113.5	113.0	13.1	14.3	14.9	15.6
27	126.8	125.0	124.1	123.4	13.3	14.5	15.1	15.8
32	138.1	135.8	134.8	133.9	13.6	14.8	15.5	16.2
37	149.3	146.8	145.5	144.4	13.8	15.1	15.7	16.5
42	160.7	157.6	156.2	155.3	14.0	15.3	16.0	16.7
47	172.8	169.4	167.9	166.4	14.3	15.6	16.3	17.0
52	185.0	181.4	179.6	177.9	14.6	15.9	16.6	17.4
57	198.2	193.9	191.9	189.9	14.9	16.2	16.9	17.7
62	212.9	208.0	205.7	203.2	15.2	16.6	17.3	18.1
67	227.9	222.4	219.7	217.0	15.6	17.0	17.7	18.5
72	243.4	237.4	234.3	231.4	16.0	17.4	18.2	19.0

**Notes:**

1. Net heating capacity and power include indoor fan heat at AHRI ESP. To obtain net heating at other conditions, subtract fan heat at this condition and add fan heat at new condition.
2. Integrated heating capacities and power include the effects of defrost in the frost region. All heating capacities and power are at 70% outdoor relative humidity and demand defrost cycle.

**Table 40. Gross heating capacities (MBH) 20 tons TWA240K\*D heat pump with 20 tons TWE240K\*B air handler at 8000 CFM (IP)**

Outdoor Temp (°F)	Integrated Heating Capacity (MBH) at Indicated Indoor Dry Bulb Temp (°F)				Total Power (kW) at Indicated Indoor Dry Bulb Temp (°F)			
	60	70	75	80	60	70	75	80
-8	85.5	85.9	86.8	87.2	16.2	17.8	18.6	19.5
-3	97.8	98.3	98.6	99.1	16.6	18.1	19.0	19.9
2	110.2	110.2	110.3	110.5	16.9	18.5	19.3	20.2
7	121.5	121.0	120.9	120.9	17.2	18.8	19.7	20.6
12	135.6	133.5	133.1	132.9	17.6	19.2	20.1	21.0
17	147.9	146.3	145.8	145.3	17.9	19.6	20.5	21.4
22	161.7	159.6	158.8	158.1	18.3	20.0	20.9	21.9
27	176.0	173.4	172.4	171.4	18.7	20.4	21.4	22.3
32	191.0	188.0	186.7	185.4	19.1	20.9	21.8	22.8

**Table 40. Gross heating capacities (MBH) 20 tons TWA240K\*D heat pump with 20 tons TWE240K\*B air handler at 8000 CFM (IP) (continued)**

Outdoor Temp (°F)	Integrated Heating Capacity (MBH) at Indicated Indoor Dry Bulb Temp (°F)				Total Power (kW) at Indicated Indoor Dry Bulb Temp (°F)			
	60	70	75	80	60	70	75	80
37	206.5	202.9	201.4	199.9	19.5	21.3	22.3	23.3
42	222.3	218.2	216.2	214.5	19.9	21.8	22.8	23.9
47	238.7	234.0	231.8	229.7	20.4	22.3	23.3	24.4
52	256.0	250.6	248.1	245.7	20.9	22.8	23.9	25.0
57	273.9	267.8	265.7	262.9	21.3	23.4	24.5	25.6
62	293.4	286.6	283.3	280.2	21.9	24.0	25.1	26.2
67	313.2	305.5	301.9	298.3	22.5	24.6	25.7	26.9
72	333.9	325.3	321.2	315.1	23.1	25.3	26.4	27.5

**Notes:**

1. Net heating capacity and power include indoor fan heat at AHRI ESP. To obtain net heating at other conditions, subtract fan heat at this condition and add fan heat at new condition.
2. Integrated heating capacities and power include the effects of defrost in the frost region. All heating capacities and power are at 70% outdoor relative humidity and demand defrost cycle.

**Table 41. Gross heating capacities (MBH) 25 tons TWA300K\*D heat pump with 25 tons TWE300K\*B air handler at 10000 CFM (IP)**

Outdoor Temp (°F)	Integrated Heating Capacity (MBH) at Indicated Indoor Dry Bulb Temp (°F)				Total Power (kW) at Indicated Indoor Dry Bulb Temp (°F)			
	60	70	75	80	60	70	75	80
-8	101.2	101.7	101.7	101.9	18.9	20.5	21.3	22.2
-3	113.3	112.4	112.3	112.3	19.1	20.7	21.6	22.5
2	124.6	123.4	123.1	123.0	19.4	21.0	21.9	22.8
7	135.3	133.8	133.5	133.2	19.7	21.3	22.2	23.2
12	147.7	146.0	145.3	144.8	20.0	21.6	22.5	23.5
17	160.8	158.3	157.3	156.6	20.2	21.9	22.9	23.8
22	173.8	170.9	169.6	168.6	20.5	22.2	23.2	24.2
27	187.8	184.3	182.9	181.6	20.8	22.6	23.5	24.5
32	202.4	198.7	197.1	195.6	21.1	22.9	23.9	24.9
37	217.4	213.1	211.2	209.4	21.4	23.3	24.3	25.3
42	232.8	228.1	225.8	223.4	21.7	23.6	24.6	25.7
47	249.0	243.5	240.8	238.0	22.0	24.0	25.0	26.1
52	266.7	260.3	256.3	253.2	22.4	24.4	25.4	26.5
57	285.7	278.4	274.7	271.1	22.8	24.8	25.8	26.9
62	302.5	293.8	289.5	285.3	23.1	25.1	26.2	27.3
67	322.2	312.1	307.1	302.2	23.5	25.5	26.6	27.7
72	346.1	331.6	325.7	320.0	24.0	25.9	27.0	28.2

**Notes:**

1. Net heating capacity and power include indoor fan heat at AHRI ESP. To obtain net heating at other conditions, subtract fan heat at this condition and add fan heat at new condition.
2. Integrated heating capacities and power include the effects of defrost in the frost region. All heating capacities and power are at 70% outdoor relative humidity and demand defrost cycle.

## Fan Performance

**Important:** Additional external static pressure from accessories must be added to the design static pressure from the accessory pressure tables.



## Performance Data

**Table 42. Evaporator fan performance —TWE060 — constant volume air handler**

External Static Pressure (Inches of Water Gauge)																								
		0.10"		0.20"		0.30"		0.40"		0.50"		0.60"		0.70"		0.80"		0.90"		1.00"		1.10"		
CFM	RPM	BHP	RPM	BHP	RPM	BHP	RPM	BHP	RPM	BHP	RPM	BHP	RPM	BHP	RPM	BHP	RPM	BHP	RPM	BHP	RPM	BHP		
																			<b>3/4 HP Standard Motor</b>			<b>1.5 HP High Static Motor</b>		
1600	—	—	738	0.33	790	0.38	840	0.44	888	0.50	936	0.56	980	0.62	1025	0.69	1070	0.76	1111	0.83	1152	0.91		
1700	719	0.33	771	0.38	821	0.44	869	0.50	914	0.56	959	0.62	1003	0.68	1047	0.75	1089	0.82	1129	0.90	1170	0.98		
1800	756	0.39	804	0.44	853	0.50	898	0.56	942	0.62	985	0.69	1028	0.75	1068	0.82	1109	0.89	1149	0.97	1187	1.05		
1900	792	0.45	838	0.51	884	0.57	928	0.63	971	0.69	1012	0.76	1052	0.83	1092	0.90	1131	0.97	1170	1.05	1207	1.13		
2000	829	0.52	873	0.58	917	0.64	959	0.71	1000	0.77	1040	0.84	1079	0.91	1117	0.98	1155	1.06	1192	1.14	1227	1.21		
2100	866	0.60	908	0.66	950	0.72	991	0.79	1030	0.86	1069	0.93	1106	1.00	1144	1.08	1179	1.15	1215	1.23	1250	1.31		
2200	903	0.68	944	0.74	983	0.81	1023	0.88	1061	0.95	1099	1.02	1134	1.10	1170	1.18	1206	1.26	1241	1.34	1274	1.42		
2300	940	0.78	979	0.84	1017	0.90	1055	0.97	1093	1.05	1129	1.13	1164	1.21	1198	1.28	1232	1.37	1266	1.45	1299	1.53		
2400	978	0.88	1015	0.94	1052	1.01	1089	1.08	1125	1.16	1160	1.24	1194	1.32	1227	1.40	1259	1.48	1292	1.57	—	—		
External Static Pressure (Inches of Water Gauge)																								
		1.20"		1.30"		1.40"																		
CFM	RPM	BHP	RPM	BHP	RPM	BHP																		
<b>1.5 HP High Static Motor</b>																								
1600	1191	0.99	1229	1.07	1264	1.14																		
1700	1208	1.06	1246	1.14	1281	1.22																		
1800	1226	1.13	1263	1.22	1300	1.30																		
1900	1245	1.21	1281	1.30	1317	1.39																		
2000	1265	1.30	1300	1.39	1335	1.48																		
2100	1285	1.39	1319	1.48	—	—																		
2200	1308	1.50	—	—	—	—																		
2300	—	—	—	—	—	—																		
2400	—	—	—	—	—	—																		

**Notes:**

1. Data includes pressure drop due to wet coil and 1" filter.
2. Fan motor heat (MBh) = 3.15 x BHP.
3. Check General Data for indoor fan motor HP availability.
4. Factory supplied motors, in commercial equipment, are definite purpose motors, specifically designed and tested to operate reliably and continuously at all cataloged conditions. Using the full horsepower range of our fan motors as shown in our tabular data will not result in nuisance tripping or premature motor failure. Our product's warranty will not be affected.
5. Field supplied high static motor.

**Table 43. Evaporator fan performance - TWE072\*\* - 2-speed VFD, SZVAV air handler**

External Static Pressure (Inches of Water Gauge)																															
0.10"		0.20"		0.30"		0.40"		0.50"		0.60"		0.70"		0.80"		0.90"		1.00"													
CFM	RPM	Hz	BHP	RPM	Hz	BHP	RPM	Hz	BHP	RPM	Hz	BHP	RPM	Hz	BHP	RPM	Hz	BHP	RPM	Hz	BHP										
<b>2 HP Standard Drive</b>																															
1920	—	—	—	—	—	—	—	—	635	40	0.46	688	44	0.55	737	47	0.65	782	50	0.75	824	52	0.85	863	55	0.95	900	57	1.05		
2040	—	—	—	—	—	592	38	0.41	648	41	0.50	700	44	0.60	748	47	0.70	793	50	0.80	835	53	0.91	874	56	1.02	911	58	1.12		
2160	—	—	—	—	—	608	39	0.46	661	42	0.55	711	45	0.65	759	48	0.75	804	51	0.86	846	54	0.97	886	56	1.08	923	59	1.20		
2280	—	—	—	—	—	625	40	0.51	675	43	0.60	724	46	0.70	771	49	0.81	815	52	0.92	857	54	1.03	896	57	1.15	934	59	1.27		
2400	—	—	—	—	594	38	0.48	642	41	0.56	689	44	0.66	737	47	0.76	783	50	0.87	826	52	0.98	868	55	1.10	907	58	1.22	945	60	1.35
2520	—	—	—	—	614	39	0.54	661	42	0.63	705	45	0.72	751	48	0.82	795	51	0.94	838	53	1.05	879	56	1.18	918	58	1.30	955	42	1.43
2640	—	—	—	—	634	40	0.60	679	43	0.69	722	46	0.79	765	49	0.89	809	51	1.01	850	54	1.13	891	57	1.25	929	59	1.38	966	43	1.51
2760	597	38	0.55	651	41	0.66	698	44	0.76	740	47	0.86	780	50	0.96	822	52	1.08	863	55	1.21	903	57	1.33	941	60	1.46	978	43	1.60	
2880	619	39	0.62	669	42	0.73	718	46	0.84	758	48	0.94	797	51	1.05	837	53	1.16	877	56	1.29	915	58	1.42	953	42	1.55	989	44	1.69	
<b>External Static Pressure (Inches of Water Gauge)</b>																															
1.10"		1.20"		1.30"		1.40"		1.50"		1.60"		1.70"		1.80"		1.90"		2.00"													
CFM	RPM	Hz	BHP	RPM	Hz	BHP	RPM	Hz	BHP	RPM	Hz	BHP	RPM	Hz	BHP	RPM	Hz	BHP	RPM	Hz	BHP										
<b>2 HP Standard Drive</b>																															
1920	934	59	1.15	967	43	1.25	998	44	1.36	1027	45	1.46	1056	47	1.56	1082	48	1.65	1108	49	1.75	1132	50	1.84	1156	51	1.94	1179	52	2.03	
2040	946	60	1.23	979	43	1.34	1011	45	1.45	1041	46	1.55	1069	47	1.66	1097	49	1.77	1124	50	1.87	1148	51	1.98	1172	52	2.08	1195	53	2.18	
2160	958	42	1.31	991	44	1.42	1023	45	1.54	1053	47	1.65	1082	48	1.77	1110	49	1.88	1137	50	1.99	1163	51	2.11	1188	53	2.22	1212	54	2.33	
2280	969	43	1.39	1003	44	1.51	1035	46	1.63	1065	47	1.75	1095	48	1.87	1123	50	1.99	1150	51	2.11	1176	52	2.23	1202	53	2.35	1226	54	2.47	
2400	980	43	1.47	1014	45	1.60	1046	46	1.72	1077	48	1.85	1107	49	1.98	1135	50	2.10	1163	51	2.23	1189	53	2.36	1215	54	2.48	1240	55	2.61	
2520	991	44	1.56	1025	45	1.69	1057	47	1.82	1088	48	1.95	1118	49	2.08	1147	51	2.22	1175	52	2.35	1202	53	2.48	1227	54	2.61	1252	55	2.75	
2640	1002	44	1.64	1036	46	1.78	1068	47	1.92	1099	49	2.05	1130	50	2.19	1158	51	2.33	1186	52	2.47	1213	54	2.61	1240	55	2.75	1265	56	2.89	
2760	1013	45	1.74	1046	46	1.87	1079	48	2.02	1111	49	2.16	1140	50	2.30	1170	52	2.45	1198	53	2.59	1225	54	2.74	1251	55	2.89	1277	56	3.03	
2880	1024	45	1.83	1057	47	1.97	1090	48	2.12	1121	50	2.27	1151	51	2.42	1181	52	2.57	1209	53	2.72	1236	55	2.87	1263	56	3.02	1288	57	3.17	
<b>External Static Pressure (Inches of Water Gauge)</b>																															
2.10"		2.20"		2.30"		2.40"																									
CFM	RPM	Hz	BHP	RPM	Hz	BHP	RPM	Hz	BHP	RPM	Hz	BHP																			
<b>3 HP High Static Drive</b>																															
1920	1202	53	2.13	1224	54	2.23	1246	55	2.33	1267	56	2.42																			
2040	1218	54	2.28	1240	55	2.38	1262	56	2.48	1283	57	2.59																			
2160	1234	55	2.43	1257	56	2.54	1278	57	2.65	1299	57	2.75																			
2280	1250	55	2.59	1273	56	2.71	1295	57	2.82	1316	58	2.93																			
2400	1264	56	2.74	1287	57	2.86	1310	58	2.99	1332	59	3.11																			
2520	1277	56	2.88	1300	58	3.01	1324	59	3.15	—	—	—																			
2640	1289	57	3.03	1313	58	3.17	—	—	—	—	—	—																			
2760	1302	58	3.18	—	—	—	—	—	—	—	—	—																			
2880	—	—	—	—	—	—	—	—	—	—	—	—																			

**Notes:**  
 1. 2-Speed VFD or SZVAV applications are capable of running below 320 cfm/ton during low speed airflow operation, but "full" airflow must be set to 320 cfm/ton or higher.  
 2. Check General Data for indoor fan motor HP availability.  
 3. Data includes pressure drop due to wet coil and 1-inch filter.



## Performance Data

**Table 44. Evaporator fan performance —TWE090K1B — constant volume air handler**

External Static Pressure (Inches of Water Gauge)																					
		0.10"		0.20"		0.30"		0.40"		0.50"		0.60"		0.70"		0.80"		0.90"		1.00"	
CFM	RPM	BHP	RPM	BHP	RPM	BHP	RPM	BHP	RPM	BHP	RPM	BHP	RPM	BHP	RPM	BHP	RPM	BHP	RPM	BHP	
	<b>1.5 HP Standard Motor with Field Supplied Sheave and Belt</b>				<b>1.5 HP Standard Motor</b>								<b>1.5 Hp Standard Motor with Field Supplied High Satic Sheave/Belt</b>								
2400	532	0.38	594	0.48	642	0.56	689	0.66	737	0.76	783	0.87	826	0.98	868	1.10	907	1.22	945	1.35	
2550	558	0.45	618	0.55	665	0.64	709	0.74	754	0.84	799	0.95	841	1.07	882	1.19	921	1.32	958	1.45	
2700	587	0.52	643	0.63	689	0.73	731	0.82	773	0.93	816	1.04	857	1.17	897	1.29	935	1.42	972	1.55	
2850	613	0.60	664	0.71	713	0.82	753	0.92	792	1.02	833	1.14	873	1.27	912	1.40	950	1.53	986	1.67	
3000	643	0.70	688	0.80	737	0.92	777	1.03	814	1.14	852	1.25	891	1.38	928	1.51	965	1.65	1001	1.79	
3150	671	0.79	711	0.90	762	1.04	800	1.15	837	1.26	872	1.37	909	1.50	945	1.63	981	1.78	1016	1.92	
3300	701	0.91	736	1.01	786	1.15	824	1.27	860	1.39	894	1.51	928	1.63	963	1.77	998	1.91	1032	2.06	
3450	729	1.03	763	1.13	808	1.27	849	1.41	883	1.53	916	1.65	949	1.78	982	1.91	1015	2.06	1049	2.21	
3600	756	1.15	790	1.26	831	1.40	874	1.56	908	1.69	940	1.81	971	1.94	1002	2.07	1034	2.22	—	—	
External Static Pressure (Inches of Water Gauge)																					
		1.10"		1.20"		1.30"		1.40"		1.50"											
CFM	RPM	BHP	RPM	BHP	RPM	BHP	RPM	BHP	RPM	BHP											
	<b>1.5 Hp Standard Motor with Field Supplied High Satic Sheave/Belt</b>				<b>2 HP High Static Motor</b>																
2400	980	1.47	1014	1.60	1046	1.72	1077	1.85	1107	1.98											
2550	994	1.58	1028	1.71	1060	1.84	1091	1.98	1121	2.11											
2700	1007	1.69	1041	1.83	1074	1.97	1105	2.11	—	—											
2850	1021	1.81	1055	1.95	1087	2.09	1119	2.24	—	—											
3000	1035	1.93	1069	2.08	1101	2.23	—	—	—	—											
3150	1050	2.07	1083	2.22	—	—	—	—	—	—											
3300	1065	2.21	—	—	—	—	—	—	—	—											
3450	—	—	—	—	—	—	—	—	—	—											
3600	—	—	—	—	—	—	—	—	—	—											

**Notes:**

1. Data includes pressure drop due to wet coil and 1" filter.
2. Fan motor heat (MBh) = 3.15 x BHP.
3. Check General Data for indoor fan motor HP availability.
4. Factory supplied motors, in commercial equipment, are definite purpose motors, specifically designed and tested to operate reliably and continuously at all cataloged conditions. Using the full horsepower range of our fan motors as shown in our tabular data will not result in nuisance tripping or premature motor failure. Our product's warranty will not be affected.

**Table 45. Evaporator fan performance - TWE090K\*\* - 2-speed VFD, SZVAV air handler**

CFM		External Static Pressure (Inches of Water Gauge)																												
		0.10"		0.20"		0.30"		0.40"		0.50"		0.60"		0.70"		0.80"		0.90"		1.00"										
RPM	Hz	BHP	RPM	Hz	BHP	RPM	Hz	BHP	RPM	Hz	BHP	RPM	Hz	BHP	RPM	Hz	BHP	RPM	Hz	BHP	RPM	Hz	BHP	RPM	Hz	BHP				
<b>2 HP Standard Drive</b>																														
2400	—	—	—	—	—	642	39	0.56	689	42	0.66	737	44	0.76	783	47	0.87	826	50	0.98	868	52	1.10	907	55	1.22	945	57	1.35	
2550	—	—	618	38	0.55	665	40	0.64	709	43	0.74	754	45	0.84	799	48	0.95	841	51	1.07	882	53	1.19	921	55	1.32	958	58	1.45	
2700	—	—	643	39	0.63	689	41	0.73	731	44	0.82	773	47	0.93	816	49	1.04	857	52	1.17	897	54	1.29	935	56	1.42	972	59	1.55	
2850	—	—	664	40	0.71	713	43	0.82	753	45	0.92	792	48	1.02	833	50	1.14	873	53	1.27	912	55	1.40	950	57	1.53	986	59	1.67	
3000	643	39	0.70	688	41	0.80	737	44	0.92	777	47	1.03	814	49	1.14	852	51	1.25	891	54	1.38	928	56	1.51	965	58	1.65	1001	44	1.79
3150	671	40	0.79	711	43	0.90	762	46	1.04	800	48	1.15	837	50	1.26	872	53	1.37	909	55	1.50	945	57	1.63	981	59	1.78	1016	45	1.92
3300	701	42	0.91	736	44	1.01	786	47	1.15	824	50	1.27	860	52	1.39	894	54	1.51	928	56	1.63	963	58	1.77	998	60	1.91	1032	46	2.06
3450	729	44	1.03	763	46	1.13	808	49	1.27	849	51	1.41	883	53	1.53	916	55	1.65	949	57	1.78	982	59	1.91	1015	45	2.06	1049	46	2.21
3600	756	46	1.15	790	48	1.26	831	50	1.40	874	53	1.56	908	55	1.69	940	42	1.81	971	43	1.94	1002	44	2.07	1034	46	2.22	1066	47	2.37
<b>External Static Pressure (Inches of Water Gauge)</b>																														
CFM		1.10"		1.20"		1.30"		1.40"		1.50"		1.60"		1.70"		1.80"		1.90"		2.00"										
		RPM	Hz	BHP	RPM	Hz	BHP	RPM	Hz	BHP	RPM	Hz	BHP	RPM	Hz	BHP	RPM	Hz	BHP	RPM	Hz	BHP								
<b>3 HP High Static Drive</b>																														
2400	980	59	1.47	1014	45	1.60	1046	46	1.72	1077	48	1.85	1107	49	1.98	1135	50	2.10	1163	51	2.23	1189	53	2.36	1215	54	2.48	1240	55	2.61
2550	994	60	1.58	1028	45	1.71	1060	47	1.84	1091	48	1.98	1121	50	2.11	1150	51	2.25	1178	52	2.38	1204	53	2.51	1230	54	2.65	1256	56	2.78
2700	1007	45	1.69	1041	46	1.83	1074	48	1.97	1105	49	2.11	1135	50	2.25	1164	52	2.39	1192	53	2.53	1219	54	2.67	1245	55	2.82	1271	56	2.96
2850	1021	45	1.81	1055	47	1.95	1087	48	2.09	1119	49	2.24	1149	51	2.39	1178	52	2.54	1206	53	2.69	1234	55	2.84	1260	56	2.99	1285	57	3.14
3000	1035	46	1.93	1069	47	2.08	1101	49	2.23	1132	50	2.38	1162	51	2.54	1192	53	2.69	1220	54	2.85	1247	55	3.00	1274	56	3.16	—	—	—
3150	1050	46	2.07	1083	48	2.22	1115	49	2.37	1146	51	2.53	1176	52	2.69	1205	53	2.85	1233	55	3.01	1261	56	3.17	—	—	—	—	—	
3300	1065	47	2.21	1097	49	2.36	1129	50	2.52	1160	51	2.68	1190	53	2.85	1219	54	3.01	—	—	—	—	—	—	—	—	—	—	—	
3450	1081	48	2.36	1113	49	2.52	1144	51	2.68	1174	52	2.85	1204	53	3.02	—	—	—	—	—	—	—	—	—	—	—	—	—	—	
3600	1098	49	2.53	1129	50	2.69	1159	51	2.86	1189	53	3.02	—	—	—	—	—	—	—	—	—	—	—	—	—	—	—	—	—	
<b>External Static Pressure (Inches of Water Gauge)</b>																														
CFM		2.10"		2.20"		2.30"																								
		RPM	Hz	BHP	RPM	Hz	BHP	RPM	Hz	BHP																				
<b>3 HP High Static Drive</b>																														
2400	1264	56	2.74	1287	57	2.86	1310	58	2.99	—	—	—	—	—	—	—	—	—	—	—	—	—	—	—	—	—	—	—	—	
2550	1280	57	2.92	1304	58	3.05	1327	59	3.19	—	—	—	—	—	—	—	—	—	—	—	—	—	—	—	—	—	—	—	—	
2700	1295	57	3.10	—	—	—	—	—	—	—	—	—	—	—	—	—	—	—	—	—	—	—	—	—	—	—	—	—	—	
2850	—	—	—	—	—	—	—	—	—	—	—	—	—	—	—	—	—	—	—	—	—	—	—	—	—	—	—	—	—	
3000	—	—	—	—	—	—	—	—	—	—	—	—	—	—	—	—	—	—	—	—	—	—	—	—	—	—	—	—	—	
3150	—	—	—	—	—	—	—	—	—	—	—	—	—	—	—	—	—	—	—	—	—	—	—	—	—	—	—	—	—	
3300	—	—	—	—	—	—	—	—	—	—	—	—	—	—	—	—	—	—	—	—	—	—	—	—	—	—	—	—	—	
3450	—	—	—	—	—	—	—	—	—	—	—	—	—	—	—	—	—	—	—	—	—	—	—	—	—	—	—	—	—	
3600	—	—	—	—	—	—	—	—	—	—	—	—	—	—	—	—	—	—	—	—	—	—	—	—	—	—	—	—	—	

**Notes:**  
 1. 2-Speed VFD or SZVAV applications are capable of running below 320 cfm/ton during low speed airflow operation, but "full" airflow must be set to 320 cfm/ton or higher.  
 2. Check General Data for indoor fan motor HP availability.  
 3. Data includes pressure drop due to wet coil and 1-inch filter.



## Performance Data

**Table 46. Evaporator fan performance —TWE120K1B — constant volume air handler**

External Static Pressure (Inches of Water Gauge)														
CFM	0.10"		0.20"		0.30"		0.40"		0.50"		0.60"		0.70"	
	RPM	BHP	RPM	BHP	RPM	BHP	RPM	BHP	RPM	BHP	RPM	BHP	RPM	BHP
<b>2 HP Standard Motor</b>														
3200	570	0.60	616	0.69	657	0.80	695	0.90	731	1.00	766	1.10	800	1.21
3400	601	0.71	643	0.80	684	0.92	720	1.02	755	1.13	788	1.24	821	1.35
3600	631	0.84	670	0.92	710	1.04	746	1.16	779	1.27	812	1.39	843	1.50
3800	662	0.98	699	1.06	738	1.19	772	1.31	805	1.43	836	1.55	866	1.67
4000	695	1.14	728	1.21	765	1.34	799	1.47	831	1.60	861	1.72	890	1.85
4200	727	1.31	757	1.38	792	1.50	826	1.65	857	1.78	887	1.91	915	2.05
4400	757	1.49	788	1.58	820	1.69	853	1.84	884	1.98	913	2.12	940	2.26
4600	788	1.69	818	1.78	849	1.89	881	2.04	911	2.20	—	—	—	—
4800	824	1.93	849	2.01	877	2.11	908	2.26	—	—	—	—	—	—
<b>External Static Pressure (Inches of Water Gauge)</b>														
CFM	0.80"		0.90"		1.00"		1.10"		1.20"		1.30"		1.40"	
	RPM	BHP	RPM	BHP	RPM	BHP	RPM	BHP	RPM	BHP	RPM	BHP	RPM	BHP
<b>2 HP Standard Motor with Field Supplied Sheave/Belt</b>														
3200	834	1.33	867	1.45	900	1.58	933	1.70	964	1.83	993	1.96	1022	2.09
3400	854	1.46	886	1.59	917	1.72	947	1.85	978	1.99	1008	2.12	1037	2.26
3600	874	1.62	905	1.74	935	1.87	965	2.01	993	2.15	1023	2.29	—	—
3800	896	1.79	925	1.91	954	2.05	983	2.19	—	—	—	—	—	—
4000	919	1.98	947	2.10	975	2.24	—	—	—	—	—	—	—	—
4200	943	2.18	970	2.31	—	—	—	—	—	—	—	—	—	—
4400	—	—	—	—	—	—	—	—	—	—	—	—	—	—
4600	—	—	—	—	—	—	—	—	—	—	—	—	—	—
4800	—	—	—	—	—	—	—	—	—	—	—	—	—	—

**Notes:**

1. Data includes pressure drop due to wet coil and 1" filter.
2. Fan motor heat (MBh) = 3.15 x BHP.
3. Check General Data for indoor fan motor HP availability.
4. Factory supplied motors, in commercial equipment, are definite purpose motors, specifically designed and tested to operate reliably and continuously at all cataloged conditions. Using the full horsepower range of our fan motors as shown in our tabular data will not result in nuisance tripping or premature motor failure. Our product's warranty will not be affected.

**Table 47. Evaporator fan performance - TWE120K\*\* - 2-speed VFD, SZVAV air handler**

CFM		External Static Pressure (Inches of Water Gauge)																												
		0.10"		0.20"		0.30"		0.40"		0.50"		0.60"		0.70"		0.80"		0.90"		1.00"										
RPM	Hz	BHP	RPM	Hz	BHP	RPM	Hz	BHP	RPM	Hz	BHP	RPM	Hz	BHP	RPM	Hz	BHP	RPM	Hz	BHP	RPM	Hz	BHP	RPM	Hz	BHP	RPM	Hz	BHP	
<b>2 HP Standard Drive</b>																														
3200	570	37	0.60	616	40	0.69	657	43	0.80	695	45	0.90	731	48	1.00	766	50	1.10	800	52	1.21	834	55	1.33	867	57	1.45	900	59	1.58
3400	601	39	0.71	643	42	0.80	684	45	0.92	720	47	1.02	755	49	1.13	788	52	1.24	821	54	1.35	854	56	1.46	886	58	1.59	917	60	1.72
3600	631	41	0.84	670	44	0.92	710	46	1.04	746	49	1.16	779	51	1.27	812	53	1.39	843	55	1.50	874	57	1.62	905	59	1.74	935	49	1.87
3800	662	43	0.98	699	46	1.06	738	48	1.19	772	50	1.31	805	53	1.43	836	55	1.55	866	57	1.67	896	59	1.79	925	60	1.91	954	51	2.05
4000	695	45	1.14	728	48	1.21	765	50	1.34	799	52	1.47	831	54	1.60	861	56	1.72	890	58	1.85	919	60	1.98	947	50	2.10	975	52	2.24
4200	727	47	1.31	757	50	1.38	792	52	1.50	826	54	1.65	857	56	1.78	887	58	1.91	915	60	2.05	943	50	2.18	970	51	2.31	996	53	2.44
4400	757	49	1.49	788	52	1.58	820	54	1.69	853	56	1.84	884	58	1.98	913	48	2.12	940	50	2.26	967	51	2.40	993	53	2.54	1019	54	2.67
4600	788	52	1.69	818	53	1.78	849	55	1.89	881	58	2.04	911	48	2.20	939	50	2.34	966	51	2.48	992	53	2.63	1018	54	2.78	1042	55	2.92
4800	824	54	1.93	849	55	2.01	877	57	2.11	908	48	2.26	937	50	2.42	966	51	2.58	992	53	2.73	1017	54	2.88	1042	55	3.03	1067	56	3.19
<b>3 HP High Static Drive</b>																														
3200	933	49	1.70	964	51	1.83	993	53	1.96	1022	54	2.09	1050	56	2.22	1077	57	2.36	1103	58	2.49	1128	60	2.62						
3400	947	50	1.85	978	52	1.99	1008	53	2.12	1037	55	2.26	1064	56	2.40	1091	58	2.54	1117	59	2.68	1142	60	2.82						
3600	965	51	2.01	993	53	2.15	1023	54	2.29	1051	56	2.44	1079	57	2.58	1106	59	2.73	1132	60	2.88									
3800	983	52	2.19	1011	54	2.33	1039	55	2.47	1066	56	2.62	1094	58	2.78	1120	59	2.93												
4000	1002	53	2.38	1029	54	2.52	1056	56	2.67	1083	57	2.82	1109	59	2.98	1135	60	3.14												
4200	1023	54	2.58	1049	56	2.73	1075	57	2.88	1101	58	3.04	1126	60	3.20															
4400	1045	55	2.82	1069	57	2.96	1095	58	3.11																					
4600	1067	56	3.07	1091	58	3.21																								
4800	—	—	—	—	—	—	—	—	—	—	—	—	—	—	—	—	—	—	—	—	—	—	—	—	—	—	—	—	—	

**Notes:**

1. 2-Speed VFD or SZVAV applications are capable of running below 320 cfm/ton during low speed airflow operation, but "full" airflow must be set to 320 cfm/ton or higher.
2. Check General Data for indoor fan motor HP availability.
3. Data includes pressure drop due to wet coil and 1-inch filter.



Performance Data

Table 48. Evaporator fan performance - TWE150K\*\* - 2-Speed VFD, SZVAV air handler

CFM		External Static Pressure (Inches of Water Gauge)																														
		0.10"		0.20"		0.30"		0.40"		0.50"		0.60"		0.70"		0.80"		0.90"		1.00"												
RPM	Hz	BHP	RPM	Hz	BHP	RPM	Hz	BHP	RPM	Hz	BHP	RPM	Hz	BHP	RPM	Hz	BHP	RPM	Hz	BHP	RPM	Hz	BHP	RPM	Hz	BHP	RPM	Hz	BHP	RPM	Hz	BHP
2 HP Standard Drive																																
4000	474	31	0.57	532	35	0.69	584	38	0.82	631	41	0.96	674	44	1.09	715	47	1.23	753	49	1.36	789	52	1.51	825	54	1.65	859	56	1.80		
4200	492	32	0.64	548	36	0.78	598	39	0.91	645	42	1.05	687	45	1.19	727	48	1.33	765	50	1.47	800	52	1.62	835	55	1.77	869	57	1.93		
4400	510	33	0.73	564	37	0.87	613	40	1.01	659	43	1.15	701	46	1.29	740	48	1.44	777	51	1.59	812	53	1.74	846	55	1.90	879	58	2.06		
4600	528	35	0.82	580	38	0.96	628	41	1.11	673	44	1.26	714	47	1.41	753	49	1.56	790	52	1.72	824	54	1.88	858	56	2.03	889	45	2.19		
4800	548	36	0.92	597	39	1.07	643	42	1.22	687	45	1.37	728	48	1.53	766	50	1.69	802	53	1.85	837	55	2.01	870	44	2.18	901	45	2.34		
5000	565	37	1.02	614	40	1.18	659	43	1.34	702	46	1.49	742	49	1.66	780	51	1.82	815	53	1.99	849	43	2.16	882	44	2.33	913	46	2.50		
5200	585	38	1.14	631	41	1.30	675	44	1.46	717	47	1.63	756	50	1.80	793	52	1.97	829	42	2.14	862	43	2.31	894	45	2.49	925	47	2.67		
5400	604	40	1.27	648	42	1.43	692	45	1.60	732	48	1.77	771	39	1.94	808	41	2.12	842	42	2.30	875	44	2.48	907	46	2.66	938	47	2.84		
5600	622	41	1.40	666	44	1.56	708	46	1.74	748	38	1.92	786	40	2.10	822	41	2.28	856	43	2.46	889	45	2.65	920	46	2.84	950	48	3.02		
5800	641	42	1.54	684	45	1.71	725	37	1.90	763	39	2.08	800	40	2.26	836	42	2.45	870	44	2.64	902	46	2.83	933	47	3.02	963	49	3.22		
6000	662	33	1.70	702	46	1.88	741	37	2.06	779	39	2.25	816	41	2.44	851	43	2.63	884	45	2.83	916	46	3.03	947	48	3.22	976	49	3.42		
5 HP High Static Drive																																
4000	891	58	1.95	922	60	2.10	951	48	2.25	979	49	2.40	1006	51	2.55	1032	52	2.70	1057	53	2.85	1081	55	3.00	1105	56	3.14	1127	57	3.29		
4200	901	59	2.08	932	47	2.24	961	48	2.40	990	50	2.55	1017	51	2.71	1043	53	2.87	1068	54	3.03	1093	55	3.18	1116	56	3.34	1139	57	3.49		
4400	911	46	2.22	942	47	2.38	971	49	2.55	1000	50	2.71	1027	52	2.88	1053	53	3.04	1079	54	3.21	1103	56	3.37	1127	57	3.53	1150	58	3.70		
4600	921	46	2.36	951	48	2.53	981	49	2.70	1010	51	2.87	1037	52	3.05	1064	54	3.22	1089	55	3.39	1114	56	3.56	1138	57	3.74	1161	59	3.90		
4800	931	47	2.51	961	48	2.69	991	50	2.86	1020	51	3.04	1047	53	3.22	1074	54	3.40	1099	55	3.58	1124	57	3.76	1148	58	3.94	1172	59	4.12		
5000	943	48	2.68	972	49	2.85	1001	50	3.03	1029	52	3.22	1057	53	3.40	1083	55	3.59	1109	56	3.78	1134	57	3.96	1158	58	4.15	1182	60	4.34		
5200	955	48	2.85	984	50	3.03	1011	51	3.21	1039	52	3.40	1067	54	3.59	1093	55	3.79	1119	56	3.98	1144	58	4.17	1168	59	4.37	1192	60	4.56		
5400	967	49	3.03	996	50	3.22	1023	52	3.40	1050	53	3.59	1077	54	3.79	1103	56	3.99	1129	57	4.19	1154	58	4.39	1178	59	4.59	—	—	—		
5600	979	49	3.22	1008	51	3.41	1035	52	3.60	1061	54	3.80	1087	55	3.99	1113	56	4.19	1139	57	4.40	1164	59	4.61	1188	60	4.82	—	—	—		
5800	992	50	3.42	1020	51	3.61	1047	53	3.81	1073	54	4.01	1099	55	4.22	1124	57	4.42	1149	58	4.63	1174	59	4.84	1198	60	5.06	—	—	—		
6000	1005	51	3.63	1032	52	3.83	1059	53	4.04	1085	55	4.24	1111	56	4.45	1135	57	4.66	1160	58	4.87	1184	60	5.08	—	—	—	—	—	—		
2 HP Standard Drive																																
4000	891	58	1.95	922	60	2.10	951	48	2.25	979	49	2.40	1006	51	2.55	1032	52	2.70	1057	53	2.85	1081	55	3.00	1105	56	3.14	1127	57	3.29		
4200	901	59	2.08	932	47	2.24	961	48	2.40	990	50	2.55	1017	51	2.71	1043	53	2.87	1068	54	3.03	1093	55	3.18	1116	56	3.34	1139	57	3.49		
4400	911	46	2.22	942	47	2.38	971	49	2.55	1000	50	2.71	1027	52	2.88	1053	53	3.04	1079	54	3.21	1103	56	3.37	1127	57	3.53	1150	58	3.70		
4600	921	46	2.36	951	48	2.53	981	49	2.70	1010	51	2.87	1037	52	3.05	1064	54	3.22	1089	55	3.39	1114	56	3.56	1138	57	3.74	1161	59	3.90		
4800	931	47	2.51	961	48	2.69	991	50	2.86	1020	51	3.04	1047	53	3.22	1074	54	3.40	1099	55	3.58	1124	57	3.76	1148	58	3.94	1172	59	4.12		
5000	943	48	2.68	972	49	2.85	1001	50	3.03	1029	52	3.22	1057	53	3.40	1083	55	3.59	1109	56	3.78	1134	57	3.96	1158	58	4.15	1182	60	4.34		
5200	955	48	2.85	984	50	3.03	1011	51	3.21	1039	52	3.40	1067	54	3.59	1093	55	3.79	1119	56	3.98	1144	58	4.17	1168	59	4.37	1192	60	4.56		
5400	967	49	3.03	996	50	3.22	1023	52	3.40	1050	53	3.59	1077	54	3.79	1103	56	3.99	1129	57	4.19	1154	58	4.39	1178	59	4.59	—	—	—		
5600	979	49	3.22	1008	51	3.41	1035	52	3.60	1061	54	3.80	1087	55	3.99	1113	56	4.19	1139	57	4.40	1164	59	4.61	1188	60	4.82	—	—	—		
5800	992	50	3.42	1020	51	3.61	1047	53	3.81	1073	54	4.01	1099	55	4.22	1124	57	4.42	1149	58	4.63	1174	59	4.84	1198	60	5.06	—	—	—		
6000	1005	51	3.63	1032	52	3.83	1059	53	4.04	1085	55	4.24	1111	56	4.45	1135	57	4.66	1160	58	4.87	1184	60	5.08	—	—	—	—	—	—		
5 HP High Static Drive																																
4000	1149	58	3.44	1170	59	3.57	1191	60	3.71	—	—	—	—	—	—	—	—	—	—	—	—	—	—	—	—	—	—	—	—	—		
4200	1161	59	3.65	1183	60	3.80	—	—	—	—	—	—	—	—	—	—	—	—	—	—	—	—	—	—	—	—	—	—	—	—	—	
4400	1173	59	3.86	1194	60	4.02	—	—	—	—	—	—	—	—	—	—	—	—	—	—	—	—	—	—	—	—	—	—	—	—	—	
4600	1184	60	4.08	—	—	—	—	—	—	—	—	—	—	—	—	—	—	—	—	—	—	—	—	—	—	—	—	—	—	—	—	
4800	1194	60	4.30	—	—	—	—	—	—	—	—	—	—	—	—	—	—	—	—	—	—	—	—	—	—	—	—	—	—	—	—	
5000	—	—	—	—	—	—	—	—	—	—	—	—	—	—	—	—	—	—	—	—	—	—	—	—	—	—	—	—	—	—	—	
5200	—	—	—	—	—	—	—	—	—	—	—	—	—	—	—	—	—	—	—	—	—	—	—	—	—	—	—	—	—	—	—	
5400	—	—	—	—	—	—	—	—	—	—	—	—	—	—	—	—	—	—	—	—	—	—	—	—	—	—	—	—	—	—	—	
5600	—	—	—	—	—	—	—	—	—	—	—	—	—	—	—	—	—	—	—	—	—	—	—	—	—	—	—	—	—	—	—	
5800	—	—	—	—	—	—	—	—	—	—	—	—	—	—	—	—	—	—	—	—	—	—	—	—	—	—	—	—	—	—	—	
6000	—	—	—	—	—	—	—	—	—	—	—	—	—	—	—	—	—	—	—	—	—	—	—	—	—	—	—	—	—	—	—	

Notes:  
 1. 2-Speed VFD or SZVAV applications are capable of running below 320 cfm/ton during low speed airflow operation, but "full" airflow must be set to 320 cfm/ton or higher.  
 2. Check General Data for indoor fan motor HP availability.  
 3. Data includes pressure drop due to wet coil and 2-inch filter.

**Table 49. Evaporator fan performance - TWE180K\*\* - 2-speed VFD, SZVAV air handler**

External Static Pressure (Inches of Water Gauge)																								
CFM	0.10"			0.20"			0.30"			0.40"			0.50"			0.60"			0.70"			0.80"		
	RPM	BHP	Hz	RPM	BHP	Hz	RPM	BHP	Hz	RPM	BHP	Hz	RPM	BHP	Hz	RPM	BHP	Hz	RPM	BHP	Hz	RPM	BHP	Hz
3 HP Standard Drive																								
4800	548	38	0.92	597	42	1.07	643	45	1.22	687	48	1.37	728	51	1.53	766	54	1.69	802	56	1.85	837	59	2.01
5100	576	40	1.08	623	44	1.24	667	47	1.40	709	50	1.56	749	53	1.72	787	55	1.89	822	58	2.06	856	60	2.23
5400	604	42	1.27	648	46	1.43	692	49	1.60	732	51	1.77	771	54	1.94	808	57	2.12	842	59	2.30	875	61	2.48
5700	633	44	1.47	674	47	1.64	716	50	1.82	756	53	2.00	793	56	2.18	829	58	2.36	863	61	2.55	895	63	2.74
6000	662	46	1.70	702	49	1.88	741	52	2.06	779	55	2.25	816	57	2.44	851	60	2.63	884	63	2.83	916	66	3.03
6300	690	49	1.95	728	51	2.12	767	54	2.32	804	56	2.52	839	59	2.72	873	62	2.92	905	65	3.12	937	68	3.33
6600	721	51	2.24	757	53	2.41	793	56	2.61	828	58	2.81	863	61	3.02	896	64	3.24	928	67	3.45	958	70	3.66
6900	748	53	2.51	784	55	2.71	819	58	2.92	853	61	3.14	887	64	3.36	919	67	3.57	950	70	3.79	980	73	4.02
7200	778	55	2.84	812	57	3.04	846	60	3.26	879	63	3.49	911	66	3.71	943	69	3.95	973	72	4.17	1002	75	4.40
5 HP High Static Drive																								
External Static Pressure (Inches of Water Gauge)																								
CFM	0.90"			1.00"			1.10"			1.20"			1.30"			1.40"			1.50"			1.60"		
	RPM	BHP	Hz	RPM	BHP	Hz	RPM	BHP	Hz	RPM	BHP	Hz	RPM	BHP	Hz	RPM	BHP	Hz	RPM	BHP	Hz	RPM	BHP	Hz
4800	870	44	2.18	901	45	2.34	931	47	2.51	961	48	2.69	991	50	2.86	1020	51	3.04	1047	53	3.22	1074	54	3.40
5100	888	45	2.41	919	46	2.58	949	48	2.76	978	49	2.94	1006	51	3.12	1034	52	3.31	1062	53	3.50	1088	55	3.69
5400	907	46	2.66	938	47	2.84	967	49	3.03	996	50	3.22	1023	52	3.40	1050	53	3.59	1077	54	3.79	1103	56	3.99
5700	927	47	2.93	957	48	3.12	986	50	3.32	1014	51	3.51	1041	52	3.71	1067	54	3.91	1093	55	4.10	1118	56	4.31
6000	947	48	3.22	976	49	3.42	1005	51	3.63	1032	52	3.83	1059	53	4.04	1085	55	4.24	1111	56	4.45	1135	57	4.66
6300	967	49	3.54	996	50	3.75	1024	52	3.96	1052	53	4.17	1078	54	4.38	1104	56	4.60	1129	57	4.81	1153	58	5.03
6600	988	50	3.87	1016	51	4.09	1044	53	4.31	1071	54	4.53	1097	55	4.75	1123	57	4.98	1147	58	5.20	—	—	—
6900	1009	51	4.25	1037	52	4.47	1065	54	4.69	1091	55	4.92	1117	56	5.16	—	—	—	—	—	—	—	—	—
7200	1031	52	4.63	1059	53	4.86	1085	55	5.10	—	—	—	—	—	—	—	—	—	—	—	—	—	—	
External Static Pressure (Inches of Water Gauge)																								
CFM	1.70"			1.80"			1.90"			2.00"			2.10"											
	RPM	BHP	Hz	RPM	BHP	Hz	RPM	BHP	Hz	RPM	BHP	Hz	RPM	BHP	Hz									
5 HP High Static Drive																								
4800	1099	55	3.58	1124	57	3.76	1148	58	3.94	1172	59	4.12	1194	60	4.30									
5100	1114	56	3.88	1139	57	4.07	1163	59	4.26	1187	60	4.45	—	—	—									
5400	1129	57	4.19	1154	58	4.39	1178	59	4.59	—	—	—	—	—	—									
5700	1144	58	4.51	1169	59	4.72	1193	60	4.94	—	—	—	—	—	—									
6000	1160	58	4.87	1184	60	5.08	—	—	—	—	—	—	—	—	—									
6300	—	—	—	—	—	—	—	—	—	—	—	—	—	—	—									
6600	—	—	—	—	—	—	—	—	—	—	—	—	—	—	—									
6900	—	—	—	—	—	—	—	—	—	—	—	—	—	—	—									
7200	—	—	—	—	—	—	—	—	—	—	—	—	—	—	—									

**Notes:**  
 1. 2-Speed VFD or SZVAV applications are capable of running below 320 cfm/ton during low speed airflow operation, but "full" airflow must be set to 320 cfm/ton or higher.  
 2. Check General Data for indoor fan motor HP availability.  
 3. Data includes pressure drop due to wet coil and 2-inch filter.



Performance Data

Table 50. Evaporator fan performance - TWE240K\*\* - 2-speed VFD, SZVAV air handler

CFM		External Static Pressure (Inches of Water Gauge)																												
		0.10"		0.20"		0.30"		0.40"		0.50"		0.60"		0.70"		0.80"		0.90"		1.00"										
RPM	Hz	BHP	RPM	Hz	BHP	RPM	Hz	BHP	RPM	Hz	BHP	RPM	Hz	BHP	RPM	Hz	BHP	RPM	Hz	BHP	RPM	Hz	BHP	RPM	Hz	BHP	RPM	Hz	BHP	
5 HP Standard Drive																														
6400	619	33	1.56	656	35	1.70	691	36	1.84	724	38	1.98	756	40	2.12	786	41	2.26	816	43	2.41	845	45	2.56	873	46	2.72	900	47	2.87
6800	654	34	1.86	688	36	2.00	722	38	2.15	754	40	2.30	784	41	2.44	814	43	2.59	842	44	2.74	869	46	2.90	897	47	3.07	924	49	3.23
7200	687	36	2.17	721	38	2.34	753	40	2.49	784	41	2.65	813	43	2.81	842	44	2.96	869	46	3.12	895	47	3.29	921	49	3.46	947	50	3.62
7600	721	38	2.54	754	40	2.72	784	41	2.87	814	43	3.04	843	44	3.21	870	46	3.38	896	47	3.53	922	49	3.71	947	50	3.88	972	51	4.06
8000	757	40	2.96	788	42	3.13	817	43	3.30	845	45	3.48	872	46	3.65	899	47	3.82	925	49	4.00	950	50	4.16	974	51	4.35	998	53	4.53
8400	790	42	3.37	820	43	3.57	849	45	3.76	877	46	3.95	903	48	4.13	929	49	4.32	953	50	4.49	978	52	4.67	1002	53	4.86	1025	47	5.05
8800	826	38	3.88	854	39	4.07	881	40	4.26	908	41	4.46	933	42	4.65	959	44	4.85	982	45	5.04	1006	46	5.22	1030	47	5.42	1052	48	5.61
9200	863	39	4.44	889	40	4.64	915	42	4.84	939	43	5.02	965	44	5.24	989	45	5.43	1012	46	5.62	1036	47	5.83	1058	48	6.02	1080	49	6.22
9600	897	41	5.01	922	42	5.20	948	43	5.44	971	44	5.63	996	45	5.84	1019	46	6.05	1042	47	6.27	1065	48	6.47	—	—	—	—	—	—
External Static Pressure (Inches of Water Gauge)																														
5 HP Standard Drive																														
6400	927	49	3.03	952	50	3.19	977	51	3.34	1001	53	3.48	1024	54	3.63	1050	55	3.80	1075	57	3.98	1098	50	4.15	1120	51	4.31	1139	52	4.47
6800	949	50	3.40	974	51	3.57	999	53	3.74	1022	54	3.90	1045	55	4.05	1067	56	4.21	1090	50	4.36	1114	51	4.55	1138	52	4.74	1160	53	4.92
7200	972	51	3.80	997	53	3.97	1021	54	4.15	1044	55	4.34	1067	56	4.51	1089	49	4.68	1110	50	4.84	1131	51	5.00	1152	52	5.17	1175	53	5.36
7600	996	52	4.24	1020	54	4.42	1044	55	4.60	1067	56	4.80	1089	57	4.99	1111	50	5.18	1132	51	5.36	1153	52	5.53	1173	53	5.70	1193	54	5.88
8000	1021	54	4.72	1044	55	4.91	1067	48	5.10	1090	50	5.29	1112	51	5.49	1134	52	5.69	1155	52	5.89	1175	53	6.09	1195	54	6.28	1215	55	6.46
8400	1047	48	5.24	1069	49	5.43	1091	50	5.63	1113	51	5.83	1135	52	6.04	1156	53	6.24	1177	53	6.45	1198	54	6.67	1217	55	6.87	1237	56	7.08
8800	1074	49	5.81	1095	50	6.01	1117	51	6.22	1138	52	6.42	1159	53	6.63	1180	54	6.84	1200	55	7.06	1220	55	7.28	1240	56	7.49	1259	57	7.71
9200	1101	50	6.42	1122	51	6.63	1143	52	6.84	1163	53	7.05	1183	54	7.27	1204	55	7.49	1224	56	7.71	—	—	—	—	—	—	—	—	
9600	—	—	—	—	—	—	—	—	—	—	—	—	—	—	—	—	—	—	—	—	—	—	—	—	—	—	—	—	—	
External Static Pressure (Inches of Water Gauge)																														
7.5 HP High Static Drive																														
6400	1158	53	4.62	1177	53	4.78	1195	54	4.93	1213	55	5.08	—	—	—	—	—	—	—	—	—	—	—	—	—	—	—	—	—	
6800	1181	54	5.09	1200	55	5.26	1218	55	5.43	1236	56	5.59	—	—	—	—	—	—	—	—	—	—	—	—	—	—	—	—	—	
7200	1198	54	5.56	1220	55	5.76	1240	56	5.95	1259	57	6.13	—	—	—	—	—	—	—	—	—	—	—	—	—	—	—	—	—	
7600	1213	55	6.05	1234	56	6.25	1256	57	6.46	1277	58	6.67	—	—	—	—	—	—	—	—	—	—	—	—	—	—	—	—	—	
8000	1234	56	6.64	1253	57	6.82	1272	58	7.01	1292	59	7.20	—	—	—	—	—	—	—	—	—	—	—	—	—	—	—	—	—	
8400	1256	57	7.28	1275	58	7.48	1293	59	7.66	—	—	—	—	—	—	—	—	—	—	—	—	—	—	—	—	—	—	—	—	
8800	—	—	—	—	—	—	—	—	—	—	—	—	—	—	—	—	—	—	—	—	—	—	—	—	—	—	—	—	—	
9200	—	—	—	—	—	—	—	—	—	—	—	—	—	—	—	—	—	—	—	—	—	—	—	—	—	—	—	—	—	
9600	—	—	—	—	—	—	—	—	—	—	—	—	—	—	—	—	—	—	—	—	—	—	—	—	—	—	—	—	—	

Notes:  
 1. 2-Speed VFD or SZVAV applications are capable of running below 320 cfm/ton during low speed airflow operation, but "full" airflow must be set to 320 cfm/ton or higher.  
 2. Check General Data for indoor fan motor HP availability.  
 3. Data includes pressure drop due to wet coil and 2-inch filter.

**Table 51. Evaporator fan performance - TWE300K\*\* - 2-Speed VFD, SZVAV air handler**

		External Static Pressure (Inches of Water Gauge)																						
		0.10"		0.20"		0.30"		0.40"		0.50"		0.60"		0.70"		0.80"								
CFM	RPM	Hz	BHP	RPM	Hz	BHP	RPM	Hz	BHP	RPM	Hz	BHP	RPM	Hz	BHP	RPM	Hz	BHP						
7.5 HP Standard Drive																								
8000	780	41	2.96	811	42	3.14	837	44	3.27	863	45	3.41	889	46	3.56	915	48	3.77	942	49	4.02	967	50	4.27
8500	824	43	3.53	855	45	3.72	880	46	3.86	904	47	4.01	928	48	4.16	953	50	4.33	978	51	4.58	1003	52	4.85
9000	870	45	4.18	900	47	4.40	923	48	4.53	947	49	4.69	969	50	4.84	992	52	5.01	1016	53	5.21	1039	54	5.47
9500	918	48	4.94	941	49	5.08	969	50	5.30	989	52	5.44	1009	53	5.58	1032	54	5.76	1054	55	5.94	1077	56	6.18
10000	966	50	5.78	989	51	5.94	1012	53	6.13	1032	54	6.27	1053	55	6.45	1073	56	6.61	1093	57	6.77	1114	58	6.98
10500	1012	53	6.68	1033	54	6.82	1055	55	7.00	1076	56	7.19	1096	57	7.37									
11000	1055	55	7.58																					
11500																								
12000																								
External Static Pressure (Inches of Water Gauge)																								
		0.90"		1.00"		1.10"		1.20"		1.30"		1.40"		1.50"		1.60"								
CFM	RPM	Hz	BHP	RPM	Hz	BHP	RPM	Hz	BHP	RPM	Hz	BHP	RPM	Hz	BHP	RPM	Hz	BHP						
7.5 HP Standard Drive																								
8000	993	52	4.43	1017	53	4.55	1041	54	4.64	1065	55	4.78	1088	57	4.96	1111	58	5.16	1134	59	5.36	1156	60	5.57
8500	1027	54	5.12	1051	55	5.30	1074	56	5.41	1097	57	5.53	1119	58	5.64	1142	59	5.82	1163	43	6.01	1185	44	6.23
9000	1062	55	5.76	1086	57	6.05	1108	58	6.24	1130	59	6.39	1152	60	6.50	1173	43	6.62	1194	44	6.77	1215	45	6.97
9500	1098	57	6.46	1121	58	6.77	1143	60	7.08	1165	43	7.31	1186	44	7.47	1206	44	7.60	1227	45	7.73	1247	46	7.85
10000	1135	59	7.23	1157	43	7.54	1178	43	7.87	1199	44	8.19	1220	45	8.47	1240	46	8.65	1259	46	8.79	1279	47	8.93
10500																								
11000																								
11500																								
12000																								
External Static Pressure (Inches of Water Gauge)																								
		1.7		1.8		1.9		2		2.1		2.2		2.3		2.4								
CFM	RPM	Hz	BHP	RPM	Hz	BHP	RPM	Hz	BHP	RPM	Hz	BHP	RPM	Hz	BHP	RPM	Hz	BHP						
10 HP High Static Drive																								
8000	1178	43	5.79	1199	44	5.99	1220	45	6.19	1241	46	6.40	1262	47	6.61	1282	47	6.81	1302	48	7.03	1321	49	7.24
8500	1206	44	6.44	1227	45	6.67	1248	46	6.90	1268	47	7.11	1288	48	7.33	1307	48	7.55	1327	49	7.77	1346	50	7.98
9000	1236	46	7.18	1256	46	7.40	1276	47	7.64	1295	48	7.87	1315	49	8.11	1334	49	8.34	1353	50	8.57	1372	51	8.80
9500	1266	47	8.03	1286	47	8.24	1306	48	8.46	1325	49	8.69	1344	50	8.93	1362	50	9.19	1381	51	9.44	1399	52	9.68
10000	1298	48	9.05	1317	49	9.19	1336	49	9.40	1355	50	9.62	1373	51	9.86									
10500																								
11000																								
11500																								
12000																								

**Notes:**  
 1. 2-Speed VFD or SZVAV applications are capable of running below 320 cfm/ton during low speed airflow operation, but "full" airflow must be set to 320 cfm/ton or higher.  
 2. Check General Data for indoor fan motor HP availability.  
 3. Data includes pressure drop due to wet coil and 2-inch filter.



## Performance Data

**Table 52. Standard fan motors - constant volume air handlers**

Model	Motor	Motor Sheave Turns Open	Nominal RPM	Required Field Supplied Components		
				Motor Sheave	Blower Sheave	Belt
TWE060	Standard Motor 0.75 HP	0	1071	N/A	N/A	N/A
		1	1000			
		2	928			
		3	857			
		4	785			
5	714					
TWE090	Standard Motor 1.5 HP	0	847	N/A	N/A	N/A
		1	791			
		2	734			
		3	678			
		4	621			
5	565					
TWE090	Standard Motor with Field Supplied Components - 1.5 HP (Low Static)	1	406	Variable Pitch (2.0 - 3.0 Inch Pitch Diameter), 0.625 Inch Bore, Single Groove, Browning 1VP34	Fixed pitch (8.5 Inch Pitch Diameter), 1 Inch Bore, Single Groove, Browning BK95	Browning A52
		2	446			
		3	487			
		4	528			
		5	568			
		6	609			
TWE090	Standard Motor with Field Supplied Components - 1.5 HP (High Static)	1	863	Variable Pitch (3-4 Inch Pitch Diameter), 0.625 Inch Bore, Single Groove, Browning 1VP44	Fixed Pitch (6 Inch Pitch Diameter), 1 Inch Bore, Single Groove, Browning BK70	Browning A50
		2	920			
		3	978			
		4	1035			
		5	1093			
		6	1150			
TWE120	Standard Motor 2 HP	0	818	N/A	N/A	N/A
		1	773			
		2	727			
		3	682			
		4	636			
5	591					
TWE120	Standard Motor with Field Supplied Components - 2 HP (High Static)	1	772	Variable Pitch (3-4 Inch Pitch Diameter), 0.875 Inch Bore, Single Groove, Browning 1VP44	Fixed Pitch (6.7 Inch Pitch Diameter), 1 Inch Bore, Single Groove, Browning AK71	Browning A51
		2	824			
		3	875			
		4	927			
		5	978			
		6	1030			

**Table 53. High static fan motors - constant volume air handlers**

Model	Motor	Motor Sheave Turns Open	Nominal RPM	Required Field Supplied Components		
				Motor Sheave	Blower Sheave	Belt
TWE060	High Static Motor 1.5 HP	0	1346	N/A	N/A	N/A
		1	1279			
		2	1212			
		3	1144			
		4	1077			
5	1010					
TWE090	High Static Motor 2 HP	0	1094	N/A	N/A	N/A
		1	1039			
		2	984			
		3	930			
		4	875			
5	820					

**Table 54. Discharge plenum and grille assembly throw distance (ft) – air handler (60 Hz)**

Tons	Model No.	CFM	Louver Angle Deflection Position			
			Straight	20°	40°	55°
5	TWE060K*A/B	1600	42	31	26	20
		1800	46	37	29	22
		2000	48	43	33	24
		2200	51	50	36	25
		2400	54	57	39	29
6	TWE072K*B	1920	48	33	30	27
		2160	50	38	32	28
		2400	52	43	35	29
		2640	54	47	38	30
		2880	57	51	41	32
7.5	TWE090K*A/B	2400	52	43	35	29
		2700	55	48	38	31
		3000	58	53	42	32
		3300	62	57	46	35
		3600	66	60	50	37
10	TWE120K*A/B	3200	56	46	38	30
		3600	62	51	42	33
		4000	66	57	47	35
		4400	71	62	52	38
		4800	76	67	56	42
12.5	TWE150K*B	4900	47	38	32	25
		5400	52	44	37	29
		6000	57	49	41	32
		6600	61	53	43	34
		7200	65	57	46	35
15	TWE180K*B	4900	47	38	32	25
		5400	52	44	37	29
		6000	57	49	41	32
		6600	61	53	43	34
		7200	65	57	46	35
20	TWE240K*B	6400	56	46	38	30
		7200	62	51	42	33
		8000	66	57	47	35
		8800	71	62	52	38
		9600	76	67	56	42
25	TWE300K*B	8000	66	57	47	35
		9000	72	63	53	39
		10000	78	70	59	43
		11000	84	76	65	46
		12000	90	83	71	50

**Notes:**

1. Assumes incompressible and adiabatic flow through grille.
2. Throw distance values are based on a terminal velocity of 75 FPM.
3. Throw distance values at other terminal velocities may be established by multiplying throw distances in the table above by throw factor as follows: for 50 FPM terminal velocity, multiply by 1.50 throw factor; for 100 FPM terminal velocity, multiply by 0.75 throw factor; for 150 FPM terminal velocity, multiply by 0.50 throw factor.
4. SZVAV/2-Speed VFD available for 6 to 25 ton only.



**Performance Data**

**Table 55. Electric heat discharge plenum and grille airflow (CFM) – constant volume air handler (60Hz)**

Tons	Unit Model No.	Electric Heater Model No.	Airflow (CFM)	
			Minimum	Maximum
5	TWE060K1A, B	BAYHTRT117*	2000	2400
	TWE060K3A, B	BAYHTRS315*	2000	2400
	TWE060K4A, B	BAYHTRS415*	2000	2400
6	TWE072K3B	BAYHTRS315*	2000	2880
	TWE072K3B	BAYHTRP325*	2000	2880
	TWE072K4B	BAYHTRS415*	2000	2880
	TWE072K4B	BAYHTRP425*	2000	2880
7.5	TWE090K1A, B	BAYHTRT117*	3000	3600
	TWE090K1A, B	BAYHTRS123*	3375	3600
7.5	TWE090K3A, B	BAYHTRS315*	2625	3600
	TWE090K3A, B	BAYHTRP325*	3000	3600
	TWE090K4A, B	BAYHTRS415*	2625	3600
	TWE090K4A, B	BAYHTRP425*	2625	3600
10	TWE120K1A, B	BAYHTRT117*	3500	4800
	TWE120K1A, B	BAYHTRS123*	4000	4800
10	TWE120K3A, B	BAYHTRS315*	4000	4800
	TWE120K3A, B	BAYHTRP325*	3500	4800
	TWE120K4A, B	BAYHTRS415*	3500	4800
	TWE120K4A, B	BAYHTRP425*	3500	4800
12.5	TWE150K3B	BAYHTRR330*	5250	6000
	TWE150K4B	BAYHTRR430*	5250	6000
15	TWE180K3B	BAYHTRR330*	5250	7200
	TWE180K4B	BAYHTRR430*	5250	7200
20	TWE240K3B	BAYHTRR330*	7000	9600
	TWE240K4B	BAYHTRR430*	7000	9600
25	TWE300K3B	BAYHTRR330*	8750	12000
	TWE300K4B	BAYHTRR430*	8750	12000

Note: SZVAV/2-Speed VFD available for 6 to 25 ton only.

**Table 56. Static pressure drop through accessories (inches of water column) – air handler (60Hz)**

Tons	Unit Model No.	CFM	Return Grille	Discharge Plenum and Grille	2" MERV 13 Filter	Electric Heaters (kW)				Hydronic Coils	
						5 to 10	15 to 20	25 to 30	35 to 50	Steam	Hot Water
5	TWE060K*A/B	1600	0.12	0.21	0.22	0.08	0.08	0.14	—	0.44	0.31
		2000	0.18	0.33	0.29	0.13	0.13	0.19	—	0.62	0.44
		2400	0.28	0.47	0.36	0.19	0.19	0.37	—	0.80	0.59
6	TWE072K*B	1920	0.04	0.20	0.15	0.01	0.03	0.04	0.06	0.31	0.16
		2400	0.08	0.27	0.19	0.03	0.06	0.08	0.12	0.38	0.23
		2880	0.12	0.37	0.24	0.05	0.11	0.15	0.21	0.48	0.31
7.5	TWE090K*A/B	2400	0.08	0.27	0.19	0.03	0.06	0.08	0.12	0.38	0.23
		3000	0.13	0.40	0.25	0.06	0.12	0.17	0.23	0.50	0.33
		3600	0.18	0.58	0.31	0.08	0.16	0.24	0.32	0.66	0.44
10	TWE120K*A/B	3200	0.07	0.43	0.19	0.06	0.13	0.19	0.26	0.42	0.40
		4000	0.11	0.66	0.25	0.10	0.20	0.30	0.40	0.59	0.56
		4800	0.15	0.95	0.31	0.14	0.28	0.42	0.57	0.76	0.75
12.5	TWE150K*B	4000	0.06	0.16	0.15	0.02	0.02	0.04	0.08	0.28	0.24
		5000	0.10	0.25	0.20	0.03	0.03	0.08	0.12	0.44	0.38
		6000	0.14	0.36	0.25	0.04	0.05	0.12	0.17	0.64	0.54
15	TWE180K*B	4800	0.09	0.23	0.19	0.03	0.03	0.06	0.08	0.46	0.38
		6000	0.15	0.34	0.25	0.06	0.06	0.12	0.17	0.64	0.54
		7200	0.20	0.49	0.31	0.08	0.08	0.16	0.24	0.82	0.72

**Table 56. Static pressure drop through accessories (inches of water column) – air handler (60Hz) (continued)**

Tons	Unit Model No.	CFM	Return Grille	Discharge Plenum and Grille	2" MERV 13 Filter	Electric Heaters (kW)				Hydronic Coils	
						5 to 10	15 to 20	25 to 30	35 to 50	Steam	Hot Water
20	TWE240K*B	6400	0.11	0.43	0.22	0.06	0.06	0.13	0.19	0.50	0.41
		8000	0.17	0.66	0.29	0.10	0.10	0.20	0.30	0.70	0.58
		9600	0.23	0.95	0.36	0.14	0.14	0.28	0.42	0.89	0.78
25	TWE300K*B	8000	0.17	0.66	0.29	0.10	0.10	0.20	0.30	0.70	0.58
		10000	0.25	1.03	0.37	0.15	0.15	0.30	0.45	0.94	0.83
		12000	0.32	1.49	0.47	0.20	0.20	0.42	0.62	1.16	1.14

**Notes:**

1. SZVAV/2-Speed VFD available for 6 to 25 ton only.
2. Return air filter ESP included in Fan Performance Table data.
3. Discharge plenum and grille - at louver opening angle of 42 degrees. For ESP at other angle openings, see accessory installation instructions.

**Table 57. Auxiliary electric heat capacity – air handler (60Hz)**

Unit Model No.	Total kW	No. of Stages	Stage 1		Stage 2		Total	
			kW Input	BTUH Output	kW Input	BTUH Output	kW Input	BTUH Output
TWE060K1A, TWE060K1B	5.76	1	5.76	19659	—	—	5.76	19659
	11.52	1	11.52	39318	—	—	11.52	39318
	17.28	1	17.28	58977	—	—	17.28	58977
	23.04	2	11.52	39318	11.52	39318	23.04	78636
TWE060K3A, TWE060K4A, TWE060KWA, TWE060K3B, TWE060K4B, TWE072K3B, TWE072K4B, TWE072KWB	5.00	1	5.00	17065	—	—	5.00	17065
	9.96	1	9.96	33993	—	—	9.96	33993
	14.96	1	14.96	51058	—	—	14.96	51058
	24.92	2	14.96	51058	9.96	33993	24.92	85051
TWE090K1A, TWE090K1B, TWE120K1A, TWE120K1B	5.76	1	5.76	19659	—	—	5.76	19659
	11.52	1	11.52	39318	—	—	11.52	39318
	17.28	1	17.28	58977	—	—	17.28	58977
	23.04	2	11.52	39318	11.52	39318	23.04	78636
	28.80	2	17.28	58977	11.52	39318	28.80	98295
TWE090K3A, TWE090K3B, TWE090KWA, TWE090K3B, TWE090K4B, TWE090KWB, TWE120K3A, TWE120K4A, TWE120KWA, TWE120K3B, TWE120K4B, TWE120KWB	5.00	1	5.00	17065	—	—	5.00	17065
	9.96	1	9.96	33993	—	—	9.96	33993
	14.96	1	14.96	51058	—	—	14.96	51058
	24.92	2	14.96	51058	9.96	33993	24.92	85051
	34.88	2	19.92	67987	14.96	51058	34.88	119045
TWE150K3B, TWE150K4B, TWE150KWB, TWE180K3B, TWE180K4B, TWE180KWB	10.00	1	10.00	34130	—	—	10.00	34130
	19.92	1	19.92	67987	—	—	19.92	67987
	29.92	2	19.92	67987	10.00	34130	29.92	102117
	49.84	2	29.92	102117	19.92	67987	49.84	170104
TWE240K*B, TWE300K*B	10.00	1	10.00	34130	—	—	10.00	34130
	19.92	1	19.92	67987	—	—	19.92	67987
	29.92	2	19.92	67987	10.00	34130	29.92	102117
	49.84	2	29.92	102117	19.92	67987	49.84	170104

**Notes:**

1. Heaters are rated at 240V, 480V, and 600V. For other than rated voltage, capacity = (Voltage/Related Voltage)<sup>2</sup> x Rated Capacity.
2. SZVAV/2-Speed VFD available for 6 to 25 ton only.



**Performance Data**

**Table 58. Steam heating coil capacity – air handler steam pressure (PSIG) (60Hz)**

Unit Model No.	Airflow (CFM)	EAT (°F)	Steam Pressure (PSIG)														
			2 PSI			5 PSI			10 PSI			15 PSI			25 PSI		
			LAT	MBh	Cond. lb/hr	LAT	MBh	Cond. lb/hr	LAT	MBh	Cond. lb/hr	LAT	MBh	Cond. lb/hr	LAT	MBh	Cond. lb/hr
TWE060K*A, TWE060K*B	1600	40	97	99	103	100	104	108	104	111	117	108	117	124	113	127	136
		60	111	88	91	114	93	97	118	100	105	121	106	112	127	116	124
		80	125	77	80	127	82	85	131	89	94	135	95	101	140	105	112
	2000	40	90	108	112	93	114	118	96	122	128	99	129	136	104	139	149
		60	104	96	100	107	102	106	111	110	115	114	116	123	119	127	136
		80	119	84	87	121	90	93	125	98	102	128	104	110	133	115	123
	2400	40	85	116	120	87	123	127	90	131	137	93	138	146	98	150	160
		60	100	104	107	102	110	114	105	118	124	108	125	132	113	137	146
		80	115	91	94	117	97	100	120	105	110	123	112	118	127	123	132
TWE072K*B	1920	40	106	151	157	112	159	165	116	169	178	121	179	189	126	194	207
		60	120	134	139	124	141	147	128	153	160	133	162	172	139	177	189
		80	133	117	121	136	125	131	140	136	143	145	144	152	151	159	170
	2400	40	102	162	168	106	171	177	110	182	191	114	192	203	120	208	222
		60	115	144	149	119	152	158	123	164	172	127	174	184	133	190	203
		80	129	126	130	132	134	140	136	146	153	140	155	164	146	171	183
	2880	40	96	174	180	100	183	190	104	196	205	107	206	218	113	223	239
		60	110	154	159	113	163	170	117	176	184	121	186	197	126	204	218
		80	124	135	140	127	144	150	131	157	164	134	166	176	140	184	197
TWE090K*A, TWE090K*B	2400	40	102	162	168	106	171	177	110	182	191	114	192	203	120	208	222
		60	115	144	149	119	152	158	123	164	172	127	174	184	133	190	203
		80	129	126	130	132	134	140	136	146	153	140	155	164	146	171	183
	3000	40	95	178	183	97	187	194	101	200	209	105	210	222	110	228	244
		60	109	158	163	111	167	174	115	180	188	119	190	201	124	208	222
		80	122	138	143	125	147	153	129	160	168	132	170	180	138	188	201
	3600	40	89	191	197	91	201	208	95	215	225	97	226	239	103	245	262
		60	103	170	175	106	180	187	110	193	203	112	205	216	117	224	239
		80	118	149	154	121	158	164	124	172	180	127	183	194	132	202	216
TWE120K*A, TWE120K*B	3200	40	99	203	210	102	214	222	106	229	240	109	241	254	115	261	279
		60	112	181	187	115	191	199	119	206	216	123	218	230	129	238	255
		80	126	158	164	129	169	175	133	183	192	136	195	206	142	215	230
	4000	40	91	222	229	94	234	243	98	250	262	101	264	278	106	286	306
		60	106	198	204	108	209	217	112	225	236	115	239	252	120	261	279
		80	120	173	179	123	184	192	126	200	210	129	214	226	134	236	252
	4800	40	86	239	246	88	251	261	92	269	282	94	284	299	99	307	329
		60	101	212	219	103	225	233	107	242	254	109	257	271	114	280	300
		80	116	186	192	118	198	206	121	215	226	124	230	243	129	253	271
TWE150K*B	4000	40	103	274	283	106	288	299	111	308	323	115	325	343	121	352	376
		60	116	244	252	119	258	268	124	277	291	128	294	310	134	321	343
		80	129	213	220	132	227	236	137	247	259	141	263	278	147	290	310
	5000	40	95	300	309	98	316	328	102	337	354	106	356	346	111	286	412
		60	109	267	275	112	282	293	116	304	318	119	322	340	125	352	376
		80	123	234	241	126	249	259	130	270	283	133	288	305	139	318	340
	6000	40	90	322	332	92	339	352	96	363	380	99	383	404	104	415	444
		60	104	287	296	107	303	315	110	327	342	113	347	366	118	379	405
		80	119	251	259	121	268	278	125	291	305	128	310	328	133	342	366

**Table 58. Steam heating coil capacity – air handler steam pressure (PSIG) (60Hz) (continued)**

Unit Model No.	Airflow (CFM)	EAT (°F)	Steam Pressure (PSIG)														
			2 PSI			5 PSI			10 PSI			15 PSI			25 PSI		
			LAT	MBh	Cond. lb/hr	LAT	MBh	Cond. lb/hr	LAT	MBh	Cond. lb/hr	LAT	MBh	Cond. lb/hr	LAT	MBh	Cond. lb/hr
TWE180K*B	4800	40	97	295	304	100	310	322	104	332	348	107	350	369	113	379	406
		60	110	262	271	113	278	288	117	299	313	121	317	334	126	346	370
		80	124	230	237	127	245	254	131	266	279	134	284	299	140	313	334
	6000	40	90	322	332	92	339	352	96	363	380	99	383	404	104	415	444
		60	104	287	296	107	303	315	110	327	343	113	347	366	118	379	405
		80	119	251	259	121	268	278	125	291	305	128	310	328	133	342	366
	7200	40	84	346	356	87	364	378	90	390	408	93	411	434	97	446	477
		60	99	308	318	102	326	338	105	351	368	108	373	393	112	407	435
		80	115	270	278	117	287	299	120	313	327	123	334	352	127	368	394
TWE240K*B	6400	40	95	379	391	97	399	414	102	427	447	105	450	475	110	488	522
		60	109	337	348	111	357	371	115	384	403	119	408	430	124	445	476
		80	123	295	305	125	315	327	129	342	358	133	365	385	138	402	430
	8000	40	88	414	426	90	436	452	94	467	488	97	492	519	102	534	571
		60	102	368	380	105	390	405	108	420	440	111	446	470	116	487	521
		80	117	322	333	120	344	357	123	374	392	126	399	421	131	440	471
	9600	40	83	443	457	85	468	485	88	501	524	91	529	558	95	574	613
		60	98	395	407	100	418	434	103	451	473	106	479	505	110	524	560
		80	113	346	357	115	369	383	119	402	421	121	429	453	125	473	506
TWE300K*B	8000	40	88	414	426	90	436	452	94	467	488	97	492	519	102	534	571
		60	102	368	380	105	390	405	108	420	440	111	446	470	116	487	521
		80	117	322	333	120	344	357	123	374	392	126	399	421	131	440	471
	10000	40	82	450	464	84	475	492	87	509	533	90	537	567	94	583	623
		60	97	401	413	99	425	441	102	459	480	105	487	513	109	532	569
		80	112	352	363	115	375	389	118	408	427	120	436	460	124	481	514
	12000	40	77	479	493	79	509	527	82	546	571	84	577	608	88	627	669
		60	93	430	443	95	456	473	98	492	515	100	523	551	104	572	611
		80	109	377	389	111	402	418	114	438	459	116	468	494	120	517	553

**Notes:**

1. Type NS Coil, 1 Row, 1" OD, SF Fins, 132 Fins per Foot.
2. SZVAV/2-Speed VFD available for 6 to 25 ton only.
3. LAT = Leaving Air Temperature (°F)
4. MBh Capacity= BTU/HR/1000
5. Cond. Lb/Hr = Condensate pound per hour



**Performance Data**

**Table 59. Hot water heating coil capacity – air handler (60Hz)**

Tons	Unit Model No.	Airflow (CFM)	Enter Air Temp (°F)	Entering Water Temperature (°F)								
				180								
				Water Temperature Drop (°F)								
				20			30			40		
GPM	MBh	LAT	GPM	MBh	LAT	GPM	MBh	LAT				
5	TWE060K*A, TWE060K*B	1600	40	10.9	106.1	101.0	6.6	96.5	96.0	4.5	87.4	90.0
			60	9.0	88.3	111.0	5.4	79.1	106.0	3.6	70.3	100.0
			80	7.2	70.6	121.0	4.2	61.8	116.0	2.7	53.4	111.0
		2000	40	12.3	119.8	95.0	7.4	108.6	90.0	5.0	97.9	851.0
			60	10.2	99.6	106.0	6.1	88.8	101.0	4.0	78.6	96.0
			80	8.1	79.5	117.0	4.7	69.2	112.0	3.0	59.6	107.0
		2400	40	13.5	132.0	91.0	8.1	119.2	86.0	5.5	107.1	811.0
			60	11.2	109.6	102.0	6.6	97.4	97.0	4.4	85.9	931.0
			80	9.0	87.4	114.0	5.2	75.7	109.0	3.3	64.9	105.0
6	TWE072K*B	1920	40	15.4	150.3	112.5	9.4	137.6	106.4	6.4	124.9	100.2
			60	12.8	124.9	120.2	7.6	111.3	113.7	5.2	101.5	109.0
			80	10.2	99.6	128.0	6.0	87.8	122.4	3.9	76.1	116.7
		2400	40	17.0	165.9	104.0	10.4	152.3	98.0	7.1	139.2	93.0
			60	14.2	138.4	113.0	8.5	125.2	108.0	5.7	112.5	103.0
			80	11.4	111.1	123.0	6.7	98.3	118.0	4.4	86.1	113.0
		2880	40	18.7	182.5	98.7	11.5	168.4	94.1	7.7	150.3	88.3
			60	15.6	152.3	109.0	9.2	134.7	103.3	6.4	124.9	100.2
			80	12.5	122.0	119.2	7.2	105.4	113.9	4.7	91.7	109.5
7.5	TWE090K*A, TWE090K*B	2400	40	17.0	165.9	104.0	10.4	152.3	98.0	7.1	139.2	93.0
			60	14.2	138.4	113.0	8.5	125.2	108.0	5.7	112.5	103.0
			80	11.4	111.1	123.0	6.7	98.3	118.0	4.4	86.1	113.0
		3000	40	19.3	187.9	98.0	11.7	171.9	93.0	8.0	156.5	88.0
			60	16.1	156.7	108.0	9.6	141.1	103.0	6.4	126.3	991.0
			80	12.9	125.5	119.0	7.5	110.6	114.0	4.9	96.5	110.0
		3600	40	21.2	207.3	93.0	12.9	189.1	88.0	8.8	171.6	84.0
			60	17.7	172.7	104.0	10.6	155.0	100.0	7.1	138.3	95.0
			80	14.2	138.2	115.0	8.3	121.2	111.0	5.4	105.4	107.0
10	TWE120K*A, TWE120K*B	3200	40	24.5	239.1	109.0	14.3	210.0	100.0	9.1	178.7	91.0
			60	20.2	197.3	117.0	11.5	168.4	108.0	6.9	134.8	99.0
			80	15.9	155.6	125.0	8.6	126.1	116.0	4.0	78.7	103.0
		4000	40	27.8	271.7	103.0	16.2	237.5	95.0	10.3	201.9	86.0
			60	22.9	223.8	112.0	13.0	190.3	104.0	7.8	153.3	95.0
			80	18.1	176.2	121.0	9.7	142.6	113.0	5.0	97.3	102.0
		4800	40	30.7	300.0	98.0	17.8	261.3	90.0	11.3	221.7	82.0
			60	25.3	246.9	107.0	14.3	209.1	100.0	8.6	168.9	92.0
			80	19.9	194.0	117.0	10.7	156.7	110.0	5.6	110.2	101.0
12.5	TWE150K*B	4000	40	31.7	318.0	113.3	19.2	287.7	106.3	12.8	256.5	99.1
			60	26.4	264.4	120.9	15.6	234.4	114.0	10.2	203.2	106.9
			80	21.1	210.9	128.6	12.1	181.1	121.7	7.4	148.9	114.3
		5000	40	36.0	360.6	106.5	21.7	325.2	100.0	14.4	288.8	93.3
			60	29.9	299.6	115.3	17.6	264.5	108.8	11.4	228.3	102.1
			80	23.8	238.7	124.0	13.6	203.8	117.6	8.4	167.5	110.9
		6000	40	39.7	397.0	101.0	23.8	357.0	94.9	15.8	316.1	88.6
			60	32.9	329.6	110.7	19.3	290.0	104.6	12.5	249.5	98.3
			80	26.2	262.3	120.3	14.9	223.1	114.3	9.1	182.8	108.1

**Table 59. Hot water heating coil capacity – air handler (60Hz) (continued)**

Tons	Unit Model No.	Airflow (CFM)	Enter Air Temp (°F)	Entering Water Temperature (°F)								
				180								
				Water Temperature Drop (°F)								
				20			30			40		
GPM	MBh	LAT	GPM	MBh	LAT	GPM	MBh	LAT				
15	TWE180K*B	4800	40	35.2	343.9	106.0	21.2	310.3	100.0	14.1	276.3	93.0
			60	29.3	285.7	115.0	17.2	252.7	108.0	11.2	218.5	102.0
			80	23.3	227.7	124.0	13.3	195.0	117.0	8.2	159.9	111.0
		6000	40	40.0	390.3	100.0	23.9	350.8	94.0	15.9	311.4	88.4
			60	33.3	323.9	110.0	19.5	285.3	104.0	12.6	246.2	98.0
			80	26.4	257.7	120.0	15.0	219.9	114.0	9.2	180.5	108.0
		7200	40	44.2	431.3	95.0	26.4	386.5	89.0	17.5	342.1	84.0
			60	36.6	357.6	106.0	21.4	313.9	100.0	13.8	270.6	95.0
			80	29.1	284.2	116.0	16.5	241.6	111.0	10.1	198.3	105.0
20	TWE2404K	6400	40	46.8	456.2	106.0	28.4	416.5	100.0	19.3	376.7	94.0
			60	39.0	380.2	115.0	23.3	341.2	109.0	15.4	301.7	103.0
			80	31.2	304.5	124.0	18.2	266.0	118.0	11.6	227.0	113.0
		8000	40	53.0	517.5	100.0	32.1	470.9	94.0	21.7	424.5	89.0
			60	44.2	430.9	110.0	26.3	385.2	104.0	17.4	339.6	99.0
			80	35.3	344.6	120.0	20.5	299.8	115.0	13.0	255.2	109.0
		9600	40	58.6	572.0	94.0	35.4	519.1	90.0	23.9	466.8	85.0
			60	48.8	475.9	106.0	28.9	424.2	101.0	19.1	373.3	96.0
			80	39.0	380.2	116.0	22.5	329.6	112.0	14.3	280.0	107.0
25	TWE300K*B	8000	40	52.0	520.2	100.0	31.6	474.4	94.7	21.4	427.6	89.3
			60	43.3	433.6	110.0	25.9	388.2	104.7	17.1	341.6	99.4
			80	34.7	347.0	120.0	20.1	301.9	114.8	12.8	255.3	109.4
		10000	40	57.9	579.4	93.4	35.1	526.9	88.6	23.7	473.6	83.7
			60	48.2	482.5	104.5	28.7	430.6	99.7	18.9	377.7	94.8
			80	38.5	385.7	115.6	22.3	334.3	110.8	14.1	281.6	106.0
		12000	40	62.8	628.6	88.3	38.0	570.5	83.8	25.6	511.7	79.3
			60	52.3	523.2	100.2	31.0	465.8	95.8	20.4	407.5	91.3
			80	41.7	417.9	112.2	24.1	361.2	107.8	15.2	303.3	103.3



**Performance Data**

**Table 59. Hot water heating coil capacity – air handler (60Hz) (continued)**

Tons	Unit Model No.	Airflow (CFM)	Enter Air Temp (°F)	Entering Water Temperature (°F)								
				200								
				Water Temperature Drop (°F)								
				20			30			40		
GPM	MBh	LAT	GPM	MBh	LAT	GPM	MBh	LAT				
5	TWE060K*A, TWE060K*B	1600	40	12.9	124.9	112.0	7.9	115.4	106.0	5.5	106.3	101.0
			60	11.0	107.0	122.0	6.7	97.8	116.0	4.6	88.9	111.0
			80	9.2	89.1	131.0	5.5	80.2	126.0	3.7	71.7	121.0
		2000	40	4.5	141.3	105.0	8.9	130.1	100.0	6.1	119.4	95.0
			60	12.4	120.9	116.0	7.5	110.1	111.0	5.1	99.7	106.0
			80	10.4	100.6	126.0	6.2	90.2	122.0	4.1	80.3	117.0
		2400	40	6.0	155.8	100.0	9.8	143.1	95.0	6.7	131.0	90.0
			60	3.7	133.3	111.0	8.3	120.9	106.0	5.6	109.2	102.0
			80	11.4	110.8	123.0	6.8	98.9	118.0	4.5	87.8	114.0
6	TWE072K*B	1920	40	17.9	174.7	124.3	11.2	164.0	119.1	7.9	154.2	114.4
			60	15.6	152.3	133.4	9.6	140.5	127.8	6.5	126.9	121.2
			80	13.0	126.9	141.2	8.0	117.1	136.5	5.4	105.4	130.8
		2400	40	20.0	194.8	115.0	12.4	181.2	110.0	8.6	168.2	105.0
			60	17.2	167.1	124.0	10.6	153.9	119.0	7.2	141.2	114.0
			80	14.4	139.6	134.0	8.7	126.8	129.0	5.9	114.3	124.0
		2880	40	21.9	213.7	108.7	13.7	200.6	104.5	9.6	187.4	100.2
			60	19.0	185.4	119.6	11.7	171.3	115.1	8.0	156.2	110.2
			80	15.8	154.2	129.6	9.7	142.0	125.7	6.5	126.9	120.8
7.5	TWE090K*A, TWE090K*B	2400	40	20.0	194.8	115.0	12.4	181.2	110.0	8.6	168.2	105.0
			60	17.2	167.1	124.0	10.6	153.9	119.0	7.2	141.2	114.0
			80	14.4	139.6	134.0	8.7	126.8	129.0	5.9	114.3	124.0
		3000	40	22.7	220.9	108.0	14.0	204.9	103.0	9.7	189.6	98.0
			60	9.5	189.4	118.0	11.9	173.9	113.0	8.2	159.0	109.0
			80	16.3	158.1	129.0	9.8	143.0	124.0	6.6	128.5	119.0
		3600	40	25.1	244.0	102.0	15.5	225.7	98.0	0.7	208.4	93.0
			60	21.5	209.1	113.0	13.1	191.4	109.0	9.0	174.4	105.0
			80	17.9	174.3	125.0	10.8	157.1	120.0	7.2	140.9	116.0
10	TWE120K*A, TWE120K*B	3200	40	29.3	284.7	122.0	17.6	256.8	114.0	11.7	228.6	106.0
			60	25.0	242.6	130.0	14.7	215.2	122.0	9.6	186.9	114.0
			80	20.6	200.6	138.0	11.9	173.6	130.0	7.4	144.3	122.0
		4000	40	33.4	324.1	115.0	19.9	291.0	107.0	13.3	258.2	99.0
			60	28.4	275.8	124.0	16.7	243.6	116.0	10.8	211.0	109.0
			80	23.4	227.7	132.0	13.4	196.2	125.0	8.4	163.2	118.0
		4800	40	36.9	358.3	109.0	22.0	320.7	102.0	14.6	283.7	94.0
			60	31.4	304.7	118.0	18.4	268.1	111.0	11.9	231.6	104.0
			80	25.9	251.3	128.0	14.8	215.6	121.0	9.2	179.4	114.0
12.5	TWE150K*B	4000	40	37.3	374.5	126.3	23.0	345.9	119.7	15.8	316.5	113.0
			60	32.0	320.9	134.0	19.4	292.5	127.4	13.1	263.1	120.7
			80	26.6	267.4	141.6	15.9	243.1	135.1	10.5	209.7	128.3
		5000	40	42.4	425.4	118.5	26.0	391.7	112.2	17.8	357.2	105.9
			60	36.3	364.3	127.2	22.0	330.8	121.0	14.8	296.5	114.7
			80	30.2	303.2	135.9	17.9	269.9	129.8	11.8	235.8	123.5
		6000	40	46.7	468.8	112.0	28.6	430.6	106.2	19.5	391.7	100.2
			60	40.0	401.2	121.7	24.2	363.3	115.8	16.2	324.8	109.9
			80	33.2	333.6	131.3	19.7	296.1	125.5	12.9	257.8	119.6

**Table 59. Hot water heating coil capacity – air handler (60Hz) (continued)**

Tons	Unit Model No.	Airflow (CFM)	Enter Air Temp (°F)	Entering Water Temperature (°F)								
				200								
				Water Temperature Drop (°F)								
				20			30			40		
GPM	MBh	LAT	GPM	MBh	LAT	GPM	MBh	LAT				
15	TWE180K*B	4800	40	41.8	406.0	118.0	25.6	373.4	112.0	17.5	341.0	105.0
			60	35.8	347.5	127.0	21.6	315.4	121.0	14.6	283.4	114.0
			80	29.8	289.1	135.0	17.7	257.6	129.0	11.6	225.7	123.0
		6000	40	7.5	461.4	111.0	29.0	423.0	105.0	19.8	385.0	99.0
			60	40.6	394.6	121.0	24.5	356.9	115.0	16.4	319.6	109.0
			80	33.8	327.9	130.0	19.9	291.0	125.0	13.1	254.3	119.0
		7200	40	52.5	510.4	105.0	32.0	466.7	100.0	21.8	423.8	94.0
			60	44.9	436.3	116.0	27.0	393.5	110.0	18.0	351.4	105.0
			80	37.3	362.2	126.0	22.0	320.5	121.0	14.3	279.5	116.0
20	TWE2404K	6400	40	55.2	536.5	117.0	34.1	497.8	112.0	23.6	459.4	106.0
			60	47.4	460.2	126.0	28.9	422.1	121.0	19.7	384.2	115.0
			80	39.5	384.0	135.0	23.8	346.5	130.0	15.9	308.9	124.0
		8000	40	62.7	609.2	110.0	38.6	563.8	105.0	26.6	518.8	100.0
			60	53.8	522.2	120.0	32.7	477.6	115.0	22.2	433.3	110.0
			80	44.8	435.4	130.0	26.8	391.5	125.0	17.9	347.9	120.0
		9600	40	69.4	673.9	105.0	42.7	622.3	100.0	29.3	571.5	95.0
			60	59.4	577.4	115.0	36.1	526.8	111.0	24.5	476.7	106.0
			80	49.5	481.0	126.0	29.6	431.4	121.0	19.6	382.6	117.0
25	TWE300K*B	8000	40	60.9	611.5	110.5	37.7	567.6	105.4	26.1	523.0	100.3
			60	52.3	524.6	120.5	32.0	481.1	115.5	21.8	436.7	110.3
			80	43.6	437.8	130.5	26.2	394.6	125.5	17.5	350.3	120.4
		10000	40	67.9	681.6	102.9	42.0	631.2	98.2	28.9	580.2	93.5
			60	58.2	584.4	113.9	35.5	534.5	109.3	24.1	483.9	104.6
			80	48.6	487.4	124.9	29.1	437.9	120.4	19.3	387.5	115.7
		12000	40	73.7	740.0	96.9	45.5	684.0	92.6	31.3	627.7	88.2
			60	63.2	634.2	108.7	38.5	578.9	104.5	26.1	523.0	100.2
			80	52.7	528.6	120.6	31.5	473.8	116.4	20.9	418.3	112.1



**Performance Data**

**Table 59. Hot water heating coil capacity – air handler (60Hz) (continued)**

Tons	Unit Model No.	Airflow (CFM)	Enter Air Temp (°F)	Entering Water Temperature (°F)								
				210								
				Water Temperature Drop (°F)								
				20			30			40		
GPM	MBh	LAT	GPM	MBh	LAT	GPM	MBh	LAT				
5	TWE060K*A, TWE060K*B	1600	40	13.9	134.3	117.0	8.6	124.8	112.0	6.0	115.8	107.0
			60	12.0	116.3	127.0	7.4	107.1	122.0	5.1	98.3	117.0
			80	10.2	98.4	137.0	6.1	89.5	132.0	4.2	80.9	127.0
		2000	40	15.7	152.0	110.0	9.7	140.9	105.0	6.7	130.2	100.0
			60	13.6	131.6	121.0	8.3	120.7	116.0	5.7	110.5	111.0
			80	11.5	111.2	131.0	6.9	100.7	126.0	4.7	90.7	122.0
		2400	40	17.3	167.7	104.0	10.6	155.0	99.0	7.4	142.9	95.0
			60	15.0	145.1	116.0	9.1	132.8	111.0	6.2	121.0	106.0
			80	12.6	122.6	127.0	7.6	110.6	122.0	5.1	99.3	118.0
6	TWE072K*B	1920	40	19.5	190.3	131.8	12.0	175.7	124.7	8.5	165.9	120.0
			60	16.8	164.0	139.1	10.4	152.3	133.4	7.3	142.5	128.7
			80	14.5	141.5	148.2	8.8	128.8	142.1	5.9	115.2	135.5
		2400	40	21.6	209.2	120.0	13.4	195.7	115.0	9.4	182.7	110.0
			60	18.7	181.5	130.0	11.6	168.3	125.0	8.0	155.6	120.0
			80	15.9	153.9	139.0	9.7	141.0	134.0	6.6	128.6	129.0
		2880	40	23.9	233.3	115.0	14.7	215.2	109.2	10.3	201.1	104.6
			60	20.6	201.1	124.6	12.7	185.9	119.8	8.8	171.8	115.2
			80	17.7	172.8	135.5	10.6	155.2	129.9	7.1	138.6	124.6
7.5	TWE090K*A, TWE090K*B	2400	40	21.6	209.2	120.0	13.4	195.7	115.0	9.4	182.7	110.0
			60	18.7	181.5	130.0	11.6	168.3	125.0	8.0	155.6	120.0
			80	15.9	153.9	139.0	9.7	141.0	134.0	6.6	128.6	129.0
		3000	40	24.5	237.4	113.0	15.2	221.5	108.0	10.6	206.2	103.0
			60	21.2	205.8	123.0	13.1	190.3	118.0	9.0	175.4	114.0
			80	18.0	174.4	134.0	10.9	159.2	129.0	7.4	144.7	124.0
		3600	40	27.1	262.3	107.0	16.8	244.1	102.0	11.7	226.8	98.0
			60	23.4	227.3	118.0	14.4	209.6	114.0	9.9	192.6	109.0
			80	19.8	192.4	129.0	12.0	175.2	125.0	8.2	158.7	121.0
10	TWE120K*A, TWE120K*B	3200	40	31.7	307.4	129.0	19.2	279.9	121.0	13.0	252.6	113.0
			60	27.4	265.1	136.0	16.4	238.2	129.0	10.9	211.0	121.0
			80	23.0	223.0	144.0	13.5	196.5	137.0	8.7	169.1	129.0
		4000	40	36.1	350.2	121.0	21.8	317.6	113.0	14.7	285.5	106.0
			60	31.1	301.7	130.0	18.5	269.9	122.0	12.3	238.2	115.0
			80	26.1	253.4	138.0	15.3	222.3	131.0	9.8	190.8	124.0
		4800	40	40.0	387.4	114.0	24.1	350.3	107.0	16.2	313.9	100.0
			60	34.4	333.6	124.0	20.4	297.3	117.0	13.5	261.7	110.0
			80	28.9	279.9	134.0	16.8	244.6	127.0	10.8	209.5	120.0
12.5	TWE150K*B	4000	40	40.1	402.7	132.8	24.9	374.7	126.4	17.2	346.1	119.8
			60	34.7	349.1	140.5	21.3	321.3	134.1	14.6	292.7	127.5
			80	29.4	295.5	148.1	17.8	267.8	141.7	11.9	239.2	135.1
		5000	40	45.5	457.6	124.4	28.2	424.6	118.3	19.5	391.0	112.1
			60	39.4	396.4	133.1	24.1	363.7	127.1	16.5	330.2	120.9
			80	33.4	335.3	141.8	20.1	302.7	135.8	13.4	269.4	129.7
		6000	40	50.2	504.5	117.5	31.0	467.1	111.8	21.4	429.1	105.9
			60	43.5	436.8	127.1	26.5	399.7	121.4	18.0	362.0	115.6
			80	36.7	369.2	136.7	22.1	332.4	131.1	14.7	294.9	125.3

**Table 59. Hot water heating coil capacity – air handler (60Hz) (continued)**

Tons	Unit Model No.	Airflow (CFM)	Enter Air Temp (°F)	Entering Water Temperature (°F)								
				210								
				Water Temperature Drop (°F)								
				20			30			40		
GPM	MBh	LAT	GPM	MBh	LAT	GPM	MBh	LAT				
15	TWE180K*B	4800	40	45.1	437.0	124.0	27.8	404.7	118.0	19.2	372.9	112.0
			60	39.0	378.3	133.0	23.8	346.6	127.0	16.2	315.2	120.0
			80	33.0	319.8	141.0	19.8	288.6	135.0	13.3	257.5	129.0
		6000	40	51.3	496.8	116.0	31.5	458.9	110.0	21.7	421.5	105.0
			60	44.4	429.9	126.0	27.0	392.6	120.0	18.3	355.8	115.0
			80	37.5	363.0	136.0	22.4	326.5	130.0	14.9	290.3	125.0
		7200	40	56.7	549.8	110.0	34.8	506.7	105.0	23.9	464.3	99.0
			60	49.1	475.5	121.0	29.8	433.1	115.0	20.2	391.5	110.0
			80	41.4	401.3	131.0	24.7	359.8	126.0	16.4	319.0	121.0
20	TWE2404K	6400	40	59.5	576.5	123.0	37.0	538.3	118.0	25.8	500.5	112.0
			60	51.6	500.0	132.0	31.8	462.4	127.0	21.9	425.0	121.0
			80	43.7	423.7	141.0	26.6	386.6	136.0	18.0	349.7	130.0
		8000	40	67.6	654.9	115.0	41.9	610.0	110.0	29.1	565.7	105.0
			60	58.6	567.8	125.0	36.0	523.6	120.0	24.7	479.9	115.0
			80	49.6	480.7	135.0	30.0	437.3	130.0	20.3	394.2	125.0
		9600	40	74.8	724.6	110.0	46.3	673.8	105.0	32.1	623.6	100.0
			60	64.8	628.0	120.0	39.7	578.0	115.0	27.2	528.4	111.0
			80	54.8	531.4	131.0	33.1	482.2	126.0	22.3	433.5	122.0
25	TWE300K*B	8000	40	65.4	656.9	115.7	40.7	613.8	110.8	28.4	570.1	105.7
			60	56.7	569.9	125.7	35.0	527.2	120.8	24.1	483.8	115.8
			80	48.1	483.1	135.7	29.3	440.6	130.8	19.8	397.3	125.8
		10000	40	72.9	732.5	107.5	45.3	683.0	103.0	31.5	633.0	98.4
			60	63.2	635.2	118.6	38.9	586.2	114.1	26.7	536.5	109.5
			80	53.5	538.0	129.6	32.5	489.4	125.1	21.9	440.0	120.6
		12000	40	79.2	795.5	101.1	49.2	740.5	96.9	34.1	685.1	92.7
			60	68.6	689.5	113.0	42.2	635.1	108.8	28.9	580.3	104.6
			80	58.1	583.7	124.9	35.2	529.9	120.7	23.7	475.4	116.5

**Notes:**

1. SZVAV/2-Speed VFD available for 6 to 25 ton only.
2. GPM = Gallons Per Minute
3. MBh Capacity: BTU/HR/1000
4. LAT = Leaving Air Temperature (°F)

**Table 60. Hot water heating coil - water side pressure drop @ 180°F entering water temperature - air handler (60Hz)**

Tons	Unit Model No.	Gallons Per Minute (GPM)																		
		2	4	6	8	10	12	14	16	18	20	22	24	26	28	30	32	34	36	38
		Pressure Drop (Ft. of Water)																		
5	TWE060K*A,B	0.02	0.07	0.15	0.26	0.40	0.56	0.75	0.97	1.22	1.49	1.78	8.12	—	—	—	—	—	—	
6	TWE072K*B	—	—	0.06	0.11	0.16	0.23	0.30	0.39	0.48	0.58	0.70	0.82	0.95	1.09	1.24	1.40	1.57	—	
7.5	TWE090K*A,B	—	—	0.06	0.11	0.16	0.23	0.30	0.39	0.48	0.58	0.70	0.82	0.95	1.09	1.24	1.40	1.57	—	
10	TWE120K*A,B	—	—	—	0.06	0.09	0.13	0.17	0.22	0.27	0.33	0.39	0.46	0.54	0.62	0.70	0.79	0.89	0.99	
12.5	TWE150K*B	—	—	—	—	0.11	0.15	0.20	0.26	0.32	0.39	0.47	0.55	0.64	0.73	0.83	0.94	1.05	1.17	
15	TWE180K*B	—	—	—	—	0.11	0.15	0.20	0.26	0.32	0.39	0.47	0.55	0.64	0.73	0.83	0.94	1.05	1.17	
20	TWE240K*B	—	—	—	—	—	0.17	0.23	0.30	0.37	0.45	0.53	0.63	0.72	0.83	0.94	1.06	1.19	1.32	
25	TWE300K*B	—	—	—	—	—	0.17	0.23	0.30	0.37	0.45	0.53	0.63	0.72	0.83	0.94	1.06	1.19	1.32	
Tons	Unit Model No.	Gallons Per Minute (GPM)																		
		40	42	44	46	48	50	52	54	56	58	60	62	64	66	68	70	72	74	76
		Pressure Drop (Ft. of Water)																		
5	TWE060K*A,B	—	—	—	—	—	—	—	—	—	—	—	—	—	—	—	—	—	—	
6	TWE072K*B	—	—	—	—	—	—	—	—	—	—	—	—	—	—	—	—	—	—	
7.5	TWE090K*A,B	—	—	—	—	—	—	—	—	—	—	—	—	—	—	—	—	—	—	
10	TWE120K*A,B	1.21	1.32	1.44	1.57	1.70	1.84	—	—	—	—	—	—	—	—	—	—	—	—	
12.5	TWE150K*B	1.42	1.56	1.70	1.85	2.00	2.16	2.33	2.50	2.67	2.86	3.04	3.24	3.44	3.64	3.85	4.07	—	—	
15	TWE180K*B	1.42	1.56	1.70	1.85	2.00	2.16	2.33	2.50	2.67	2.86	3.04	3.24	3.44	3.64	3.85	4.07	—	—	



## Performance Data

**Table 60. Hot water heating coil - water side pressure drop @ 180°F entering water temperature - air handler (60Hz) (continued)**

Tons	Unit Model No.	Gallons Per Minute (GPM)																		
		40	42	44	46	48	50	52	54	56	58	60	62	64	66	68	70	72	74	76
		Pressure Drop (Ft. of Water)																		
20	TWE240K*B	1.61	1.76	1.92	2.09	2.26	2.44	2.63	2.82	3.02	3.22	3.43	3.65	3.87	4.10	4.34	4.58	4.83	5.08	5.34
25	TWE300K*B	1.61	1.76	1.92	2.09	2.26	2.44	2.63	2.82	3.02	3.22	3.43	3.65	3.87	4.10	4.34	4.58	4.83	5.08	5.34

**Note:** SZVAV/2-Speed VFD available for 6 to 25 ton only.



# Zone Controls

## Zone Sensors

Zone Sensors are the building occupant's comfort control devices. Zone sensors are required for SZVAV applications. The following zone sensor options are available for units with Symbio 700 control.

<b>Manual Changeover</b>	Heat, Cool or Off System Switch. Fan Auto or Off Switch. One temperature setpoint lever.
<b>Manual/Automatic Changeover</b>	Auto, Heat, Cool or Off System Switch. Fan Auto or Off Switch. Two temperature setpoint levers.
<b>Manual/Automatic Changeover</b>	Auto, Heat, Cool or Off System Switch. Fan Auto or Off Switch. Two temperature setpoint levers.
<b>Integrated Comfort™ System</b>	Sensor(s) available with optional temperature adjustment and override buttons to provide central control through a Trane Integrated Comfort™ system.
<b>Remote Sensor</b>	Sensor(s) available for all zone sensors to provide remote sensing capabilities.

## Conventional Thermostats

**Note:** All thermostats may be used with Symbio 700 units.

<b>Non-Programmable Thermostats</b>	
TCONT102* (1H/1C) Common terminal not required	Auto-changeover Backlit Display and Keys Filter Reminder Keypad Lock
TCONT103* (2H/1C) Common terminal required	Auto-changeover Backlit Display & Keys Filter Reminder Keypad Lock Outdoor Temp Sensor Available
TCONT402* (3H/2C) Common terminal required	Auto-changeover Backlit Display & Keys Filter Reminder Keypad Lock Outdoor Temp Sensor Included
<b>Programmable Thermostats</b>	
TCONT202* (1H/1C) Common terminal preferred, not required	5/2 or 5/1/1 Programming Actual and Setpoint temps displayed simultaneously
TCONT203* (4H/2C) Common terminal preferred, not required	5/2 or 5/1/1 Programming Actual and Setpoint temps displayed simultaneously
TCONT302* (4H/2C) Common terminal preferred, not required	Interactive touchscreen Large display Real time clock
TCONT303* (4H/2C) Humidity Sensor Common terminal preferred, not required	Interactive touchscreen Large display Real time clock Built-in humidity sensor



# Electrical Data

## Heat Pump Condenser

**Table 61. Electrical characteristics — compressor and condenser fan motors — heat pumps — 60Hz**

Tons	Unit Model Number	Compressor Motors						Condenser Fan Motor				
		Volts	Phase	Compressor 1		Compressor 2		No.	Volts	Phase	Amps	
				Amps		Amps					FLA (Ea.)	LRA (Ea.)
				RLA	LRA	RLA	LRA					
6	TWA072K3A	208-230	3	25.8	166	—	—	1	208-230	3	2.3	8.4
	TWA072K4A	460	3	10.2	75	—	—	1	460	3	1.1	4.2
	TWA072KWA	575	3	8.3	54	—	—	1	575	3	1.0	3.6
6	TWA072K3D	208-230	3	14.8	103	13.2	98	1	208-230	3	2.3	8.4
	TWA072K4D	460	3	6.7	50	5.9	44	1	460	3	1.1	4.2
	TWA072KWD	575	3	5.9	41	5.2	27	1	575	3	1.0	3.6
7.5	TWA090K3A	208-230	3	27.1	179	—	—	1	208-230	3	2.3	8.4
	TWA090K4A	460	3	11.3	95	—	—	1	460	3	1.1	4.2
	TWA090KWA	575	3	10.6	65	—	—	1	575	3	1.0	3.6
7.5	TWA090K3D	208-230	3	13.8	120	13.8	120	1	208-230	3	2.3	8.4
	TWA090K4D	460	3	7.0	49	7.0	49	1	460	3	1.1	4.2
	TWA090KWD	575	3	6.7	41	6.7	41	1	575	3	1.0	3.6
10	TWA120K3A	208-230	3	31.1	255	—	—	1	208-230	3	4.3	19.4
	TWA120K4A	460	3	16.2	123	—	—	1	460	3	2.2	10.1
	TWA120KWA	575	3	13.2	94	—	—	1	575	3	1.8	8.0
10	TWA120K3D	208-230	3	14.6	150	14.6	150	1	208-230	3	4.3	19.4
	TWA120K4D	460	3	7.9	58	7.9	58	1	460	3	2.2	10.1
	TWA120KWD	575	3	6.7	48	6.7	48	1	575	3	1.8	8.0
12.5	TWA150K3D	208-230	3	24.4	180	24.4	180	1	208-230	3	4.3	19.4
	TWA150K4D	460	3	10.6	75	10.6	75	1	460	3	2.2	10.1
	TWA150KWD	575	3	8.6	60	8.6	60	1	575	3	1.8	8.0
15	TWA180K3D	208-230	3	28.5	179	28.5	179	2	208-230	3	4.3	19.4
	TWA180K4D	460	3	11.9	103	11.9	103	2	460	3	2.2	10.1
	TWA180KWD	575	3	10.4	78	10.4	78	2	575	3	1.8	8.0
20	TWA240K3D	208-230	3	36.8	255	36.8	255	2	208-230	3	4.3	19.4
	TWA240K4D	460	3	17.8	140	17.8	140	2	460	3	2.2	10.1
	TWA240KWD	575	3	13.6	108	13.6	108	2	575	3	1.8	8.0
25	TWA300K3D	208-230	3	42.3	304	42.3	304	2	208-230	3	4.3	19.4
	TWA300K4D	460	3	24.4	147	24.4	147	2	460	3	2.2	10.1
	TWA300KWD	575	3	16.7	122	16.7	122	2	575	3	1.8	8.0

**Note:** Electrical characteristics reflect nameplate values and are calculated in accordance with cULus specifications.

**Table 62. Unit wiring — heat pumps — 60Hz**

Tons	Unit Model Number	Volts	Minimum Circuit Ampacity	Maximum Fuse or Circuit Breaker Size
6	TWA072K3A	187-253	36	60
	TWA072K4A	414-506	15	25
	TWA072KWA	518-632	13	20
6	TWA072K3D	187-253	35	45
	TWA072K4D	414-506	17	20
	TWA072KWD	518-632	15	20

**Table 62. Unit wiring — heat pumps — 60Hz (continued)**

Tons	Unit Model Number	Volts	Minimum Circuit Ampacity	Maximum Fuse or Circuit Breaker Size
7.5	TWA090K3A	187-253	38	60
	TWA090K4A	414-506	17	25
	TWA090KWA	518-632	16	25
7.5	TWA090K3D	187-253	35	45
	TWA090K4D	414-506	18	20
	TWA090KWD	518-632	18	20
10	TWA120K3A	187-253	45	70
	TWA120K4A	414-506	24	35
	TWA120KWA	518-632	20	30
10	TWA120K3D	187-253	39	50
	TWA120K4D	414-506	21	25
	TWA120KWD	518-632	18	20
12.5	TWA150K3D	187-253	61	80
	TWA150K4D	414-506	28	35
	TWA150KWD	518-632	23	30
15	TWA180K3D	187-253	74	100
	TWA180K4D	414-506	33	40
	TWA180KWD	518-632	28	35
20	TWA240K3D	187-253	93	125
	TWA240K4D	414-506	46	60
	TWA240KWD	518-632	36	45
25	TWA300K3D	187-253	105	125
	TWA300K4D	414-506	61	80
	TWA300KWD	518-632	43	50

## Air Handler

**Table 63. Voltage operating range (all air handlers)**

Model Number: Digit 8	Electrical Characteristics	Unit Operating Voltage Range
1	208-230/60/1	187-253
3	208-230/60/3	187-253
4	460/60/3	414-506
W	575/60/3	518-632

**Table 64. Electrical characteristics — 5 to 10 ton standard motor — 60 Hz constant volume air handler**

Tons	Unit Model Number	Standard Evaporator Fan Motor							
		No.	Volts	Phase	HP	Amps		MCA	MOP
						FLA	LRA		
5	TWE060K1A/B	1	208-230	1	0.75	6.0	43.0	8	15
	TWE060K3A/B	1	208-230	3	0.75	2.8	13.0	4	15
	TWE060K4A/B	1	460	3	0.75	1.4	6.0	2	15
	TWE060KWA	1	575	3	0.75	1.4	5.0	2	15
7.5	TWE090K1A/B	1	208-230	1	1.5	7.5	53.0	10	15
10	TWE120K1A/B	1	208-230	1	2	10.5	48.0	14	20

**Notes:**

- For additional information contact product support.
- (TWE072K3B, TWE090K3A/B, TWE120K3A/B, TWE150K3B and TWE180K3B are field wired for 460V.



## Electrical Data

**Table 65. Electrical characteristics — 5 to 20 ton high static motor — 60 Hz constant volume air handler**

Tons	Unit Model Number	High Static Evaporator Fan Motor							
		No.	Volts	Phase	HP	Amps		MCA	MOP
						FLA	LRA		
5	TWE060K1A/B	1	208-230	1	1.5	7.5	53.0	10	15
	TWE060K3A/B	1	208-230	3	1.5	6.4	33.0	8	15
	TWE060K4A/B	1	460	3	1.5	3.0	17.0	4	15
	TWE060KWA	1	575	3	1.5	1.9	14.0	3	15
7.5	TWE090K1A/B	1	208-230	1	2	10.5	48.0	14	20

**Table 66. Electrical characteristics — standard and oversized motors — 6 to 25 ton SZVAV and 2-Speed VFD air handler — 60 Hz**

Tons	Unit Model Number	Standard Evaporator Fan Motor								Oversized Evaporator Fan Motor							
		No.	Volts	Phase	HP	Amps		MCA	MOP	No.	Volts	Phase	HP	Amps		MCA	MOP
						FLA	LRA							FLA	LRA		
6	TWE072K3B	1	208-230	3	2	6.8	54.0	9	15	1	208-230	3	3	10.0	74.0	13	20
	TWE072K4B	1	460	3	2	3.3	27.2	5	15	1	460	3	3	4.9	37.0	7	15
	TWE072KWB	1	575	3	2	2.5	18.0	4	15	1	575	3	3	3.9	35.0	5	15
7.5	TWE090K3A/B	1	208-230	3	2	6.8	54.0	9	15	1	208-230	3	3	10.0	74.0	13	20
	TWE090K4A/B	1	460	3	2	3.3	27.2	5	15	1	460	3	3	4.9	37.0	7	15
	TWE090KWA/B	1	575	3	2	2.5	18.0	4	15	1	575	3	3	3.9	35.0	5	15
10	TWE120K3A/B	1	208-230	3	2	6.8	54.0	9	15	1	208-230	3	3	10.0	74.0	13	20
	TWE120K4A/B	1	460	3	2	3.3	27.0	5	15	1	460	3	3	4.9	37.0	7	15
	TWE120KWA/B	1	575	3	2	2.5	18.0	4	15	1	575	3	3	3.9	35.0	5	15
12.5	TWE150K3B	1	208-230	3	2	6.8	54.0	9	15	1	208-230	3	5	15.1	105.0	19	30
	TWE150K4B	1	460	3	2	3.3	27.0	5	15	1	460	3	5	7.1	52.0	9	15
	TWE150KWB	1	575	3	2	2.5	18.0	4	15	1	575	3	5	5.7	46.0	8	15
15	TWE180K3B	1	208-230	3	3	10.0	74.0	13	20	1	208-230	3	5	15.1	105.0	19	30
	TWE180K4B	1	460	3	3	4.9	37.0	7	15	1	460	3	5	7.1	52.0	9	15
	TWE180KWB	1	575	3	3	3.9	35.0	5	15	1	575	3	5	5.7	46.0	8	15
20	TWE240K3B	1	208-230	3	5	15.1	105.0	19	30	1	208-230	3	7.5	22.8	141.0	29	50
	TWE240K4B	1	460	3	5	7.1	52.0	9	15	1	460	3	7.5	10.0	62.0	13	20
	TWE240KWB	1	575	3	5	5.7	46.0	8	15	1	575	3	7.5	8.2	60.0	11	15
25	TWE300K3B	1	208-230	3	7.5	22.8	141.0	29	50	1	208-230	3	10	25.2	177.0	32	50
	TWE300K4B	1	460	3	7.5	10.0	62.0	13	20	1	460	3	10	12.6	88.0	16	25
	TWE300KWB	1	575	3	7.5	8.2	60.0	11	15	1	575	3	10	10.1	71.0	13	20

**Note:** For additional information contact product support.

**Table 67. Unit wiring with electric heat (single point connection) — 5 to 20 ton constant volume air handlers — 60 Hz**

Tons	Used With	Heater Model Number	Heater kW Rating	Unit Power Supply	Control Stages	Standard Evap Motor		High Static Evap Motor	
						MCA	MOP	MCA	MOP
5	TWE060K1A/B	BAYHTRP106*	4.33	208/1/60	1	34	35	36	40
		BAYHTRS112*	8.65		1	60	60	62	70
		BAYHTRT117*	12.98		1	86	90	88	90
		BAYHTRS123*	17.31		2	112	125	114	125
5	TWE060K1A/B	BAYHTRP106*	5.76	230/1/60	1	38	40	40	40
		BAYHTRS112*	11.52		1	68	70	70	70
		BAYHTRT117*	17.28		1	98	100	100	100
		BAYHTRS123*	23.04		2	128	150	130	150
5	TWE060K3A/B	BAYHTRP305*	3.76	208/3/60	1	17	20	22	25
		BAYHTRS310*	7.48		1	30	30	34	35
		BAYHTRS315*	11.24		1	43	45	48	50
		BAYHTRP325*	18.72		2	69	70	74	80
5	TWE060K3A/B	BAYHTRP305*	5	230/3/60	1	19	20	24	25
		BAYHTRS310*	9.96		1	34	35	38	40
		BAYHTRS315*	14.96		1	49	50	54	60
		BAYHTRP325*	24.92		2	79	80	84	90
5	TWE060K4A/B	BAYHTRP405*	5	460/3/60	1	10	15	12	15
		BAYHTRS410*	9.96		1	17	20	19	20
		BAYHTRS415*	14.96		1	25	25	27	30
		BAYHTRP425*	24.92		2	40	40	42	45
5	TWE060KWA	BAYHTRPW05*	5	575/3/60	1	8	15	9	15
		BAYHTRSW10*	9.96		1	14	15	15	15
		BAYHTRSW15*	14.96		1	20	20	21	25
		BAYHTRPW25*	24.92		2	32	35	33	35
7.5	TWE090K1A/B	BAYHTRP106*	4.33	208/1/60	1	36	40	40	40
		BAYHTRS112*	8.65		1	62	70	66	70
		BAYHTRT117*	12.98		1	88	90	92	100
		BAYHTRS123*	17.31		2	114	125	118	125
		BAYHTRP129*	21.63		2	140	150	144	150
7.5	TWE090K1A/B	BAYHTRP106*	5.76	230/1/60	1	40	40	44	45
		BAYHTRS112*	11.52		1	70	70	74	80
		BAYHTRT117*	17.28		1	100	100	104	110
		BAYHTRS123*	23.04		2	130	150	134	150
		BAYHTRP129*	28.8		2	160	175	164	175
10	TWE120K1A/B	BAYHTRP106*	4.33	208/1/60	1	40	40	N/A	N/A
		BAYHTRS112*	8.65		1	66	70	N/A	N/A
		BAYHTRT117*	12.98		1	92	100	N/A	N/A
		BAYHTRS123*	17.31		2	118	125	N/A	N/A
		BAYHTRP129*	21.63		2	144	150	N/A	N/A
10	TWE120K1A/B	BAYHTRP106*	5.76	230/1/60	1	44	45	N/A	N/A
		BAYHTRS112*	11.52		1	74	80	N/A	N/A
		BAYHTRT117*	17.28		1	104	110	N/A	N/A
		BAYHTRS123*	23.04		2	134	150	N/A	N/A
		BAYHTRP129*	28.8		2	164	175	N/A	N/A

**Notes:**

1. kW ratings are at: 208/240V for 208-230V air handlers; 480V for 460V air handlers; 600V for 575V air handlers. For other than rated voltage, capacity = (voltage/rated voltage)<sup>2</sup> x rated capacity.
2. Any power supply and circuits must be wired and protected in accordance with local codes.
3. Electric heat not available with 380/60 Hz models.



**Electrical Data**

**Table 68. Unit wiring with electric heat (single point connection) — 6 to 25 ton SZVAV and 2-Speed VFD air handlers — 60 Hz**

Tons	Used With	Heater Model Number	Heater KW Rating	Unit Power Supply	Control Stages	MCA	Maximum Fuse or Circuit Breaker Size
6	TWE072K3*****BC0, D0	BAYHTRP305*	3.76	208/3/60	1	22	25
		BAYHTRS310*	7.48		1	35	35
		BAYHTRS315*	11.24		1	48	50
		BAYHTRP325*	18.72		2	74	80
6	TWE072K3*****BC0, D0	BAYHTRP305*	5.00	230/3/60	1	24	25
		BAYHTRS310*	9.96		1	39	40
		BAYHTRS315*	14.96		1	54	60
		BAYHTRP325*	24.92		2	84	90
6	TWE072K3*****BC4, D4	BAYHTRP305*	3.76	208/3/60	1	26	30
		BAYHTRS310*	7.48		1	39	40
		BAYHTRS315*	11.24		1	52	60
		BAYHTRP325*	18.72		2	78	80
6	TWE072K3*****BC4, D4	BAYHTRP305*	5.00	230/3/60	1	28	30
		BAYHTRS310*	9.96		1	43	45
		BAYHTRS315*	14.96		1	58	60
		BAYHTRP325*	24.92		2	88	90
6	TWE072K4*****BC0, D0	BAYHTRP405*	5.00	460/3/60	1	12	15
		BAYHTRS410*	9.96		1	20	20
		BAYHTRS415*	14.96		1	27	30
		BAYHTRP425*	24.92		2	42	45
6	TWE072K4*****BC4, D4	BAYHTRP405*	5.00	460/3/60	1	14	15
		BAYHTRS410*	9.96		1	22	25
		BAYHTRS415*	14.96		1	29	30
		BAYHTRP425*	24.92		2	44	45
6	TWE072KW*****BC0, D0	BAYHTRPW05*	5.00	575/3/60	1	10	15
		BAYHTRSW10*	9.96		1	16	20
		BAYHTRSW15*	14.96		1	22	25
		BAYHTRPW25*	24.92		2	34	35
6	TWE072KW*****BC4, D4	BAYHTRPW05*	5.00	575/3/60	1	11	15
		BAYHTRSW10*	9.96		1	17	20
		BAYHTRSW15*	14.96		1	23	25
		BAYHTRPW25*	24.92		2	35	35
7.5	TWE090K3*****BC0, D0	BAYHTRP305*	3.76	208/3/60	1	22	25
		BAYHTRS310*	7.48		1	35	35
		BAYHTRS315*	11.24		1	48	50
		BAYHTRP325*	18.72		2	74	80
		BAYHTRP335*	26.20		2	100	100
7.5	TWE090K3*****BC0, D0	BAYHTRP305*	5.00	230/3/60	1	24	25
		BAYHTRS310*	9.96		1	39	40
		BAYHTRS315*	14.96		1	54	60
		BAYHTRP325*	24.92		2	84	90
		BAYHTRP335*	34.88		2	114	125
7.5	TWE090K3*****BC4, D4	BAYHTRP305*	3.76	208/3/60	1	26	30
		BAYHTRS310*	7.48		1	39	40
		BAYHTRS315*	11.24		1	52	60
		BAYHTRP325*	18.72		2	78	80
		BAYHTRP335*	26.20		2	104	110

**Table 68. Unit wiring with electric heat (single point connection) — 6 to 25 ton SZVAV and 2-Speed VFD air handlers — 60 Hz (continued)**

Tons	Used With	Heater Model Number	Heater KW Rating	Unit Power Supply	Control Stages	MCA	Maximum Fuse or Circuit Breaker Size
7.5	TWE090K3*****BC4, D4	BAYHTRP305*	5.00	230/3/60	1	28	30
		BAYHTRS310*	9.96		1	43	45
		BAYHTRS315*	14.96		1	58	60
		BAYHTRP325*	24.92		2	88	90
		BAYHTRP335*	34.88		2	118	125
7.5	TWE090K4*****BC0, D0	BAYHTRP405*	5.00	460/3/60	1	12	15
		BAYHTRS410*	9.96		1	20	20
		BAYHTRS415*	14.96		1	27	30
		BAYHTRP425*	24.92		2	42	45
		BAYHTRP435*	34.88		2	57	60
7.5	TWE090K4*****BC4, D4	BAYHTRP405*	5.00	460/3/60	1	14	15
		BAYHTRS410*	9.96		1	22	25
		BAYHTRS415*	14.96		1	29	30
		BAYHTRP425*	24.92		2	44	45
		BAYHTRP435*	34.88		2	59	60
7.5	TWE090KW*****BC0, D0	BAYHTRPW05*	5.00	575/3/60	1	10	15
		BAYHTRSW10*	9.96		1	16	20
		BAYHTRSW15*	14.96		1	22	25
		BAYHTRPW25*	24.92		2	34	35
		BAYHTRPW35*	34.88		2	46	50
7.5	TWE090KW*****BC4, D4	BAYHTRPW05*	5.00	575/3/60	1	11	15
		BAYHTRSW10*	9.96		1	17	20
		BAYHTRSW15*	14.96		1	23	25
		BAYHTRPW25*	24.92		2	35	35
		BAYHTRPW35*	34.88		2	47	50
10	TWE120K3*****BC0, D0	BAYHTRP305*	3.76	208/3/60	1	22	25
		BAYHTRS310*	7.48		1	35	35
		BAYHTRS315*	11.24		1	48	50
		BAYHTRP325*	18.72		2	74	80
		BAYHTRP335*	26.20		2	100	100
10	TWE120K3*****BC0, D0	BAYHTRP305*	5.00	230/3/60	1	24	25
		BAYHTRS310*	9.96		1	39	40
		BAYHTRS315*	14.96		1	54	60
		BAYHTRP325*	24.92		2	84	90
		BAYHTRP335*	34.88		2	114	125
10	TWE120K3*****BC4, D4	BAYHTRP305*	3.76	208/3/60	1	26	30
		BAYHTRS310*	7.48		1	39	40
		BAYHTRS315*	11.24		1	52	60
		BAYHTRP325*	18.72		2	78	80
		BAYHTRP335*	26.20		2	104	110
10	TWE120K3*****BC4, D4	BAYHTRP305*	5.00	230/3/60	1	28	30
		BAYHTRS310*	9.96		1	43	45
		BAYHTRS315*	14.96		1	58	60
		BAYHTRP325*	24.92		2	88	90
		BAYHTRP335*	34.88		2	118	125



**Electrical Data**

**Table 68. Unit wiring with electric heat (single point connection) — 6 to 25 ton SZVAV and 2-Speed VFD air handlers — 60 Hz (continued)**

Tons	Used With	Heater Model Number	Heater KW Rating	Unit Power Supply	Control Stages	MCA	Maximum Fuse or Circuit Breaker Size
10	TWE120K4*****BC0, D0	BAYHTRP405*	5.00	460/3/60	1	12	15
		BAYHTRS410*	9.96		1	20	20
		BAYHTRS415*	14.96		1	27	30
		BAYHTRP425*	24.92		2	42	45
		BAYHTRP435*	34.88		2	57	60
10	TWE120K4*****BC4, D4	BAYHTRP405*	5.00	460/3/60	1	14	15
		BAYHTRS410*	9.96		1	22	25
		BAYHTRS415*	14.96		1	29	30
		BAYHTRP425*	24.92		2	44	45
		BAYHTRP435*	34.88		2	59	60
10	TWE120KW*****BC0, D0	BAYHTRPW05*	5.00	575/3/60	1	10	15
		BAYHTRSW10*	9.96		1	16	20
		BAYHTRSW15*	14.96		1	22	25
		BAYHTRPW25*	24.92		2	34	35
		BAYHTRPW35*	34.88		2	46	50
10	TWE120KW*****BC4, D4	BAYHTRPW05*	5.00	575/3/60	1	11	15
		BAYHTRSW10*	9.96		1	17	20
		BAYHTRSW15*	14.96		1	23	25
		BAYHTRPW25*	24.92		2	35	35
		BAYHTRPW35*	34.88		2	47	50
12.5	TWE150K3*****BC0, D0	BAYHTRT310*	7.51	208/3/60	1	35	35
		BAYHTRR320*	14.96		1	61	70
		BAYHTRR330*	22.47		2	87	90
		BAYHTRR350*	37.44		2	139	150
12.5	TWE150K3*****BC0, D0	BAYHTRT310*	10.00	230/3/60	1	39	40
		BAYHTRR320*	19.92		1	69	70
		BAYHTRR330*	29.92		2	99	100
		BAYHTRR350*	49.84		2	159	175
12.5	TWE150K3*****BC4, D4	BAYHTRT310*	7.51	208/3/60	1	45	50
		BAYHTRR320*	14.96		1	71	80
		BAYHTRR330*	22.47		2	97	100
		BAYHTRR350*	37.44		2	149	150
12.5	TWE150K3*****BC4, D4	BAYHTRT310*	10.00	230/3/60	1	49	50
		BAYHTRR320*	19.92		1	79	80
		BAYHTRR330*	29.92		2	109	110
		BAYHTRR350*	49.84		2	169	175
12.5	TWE150K4*****BC0, D0	BAYHTRT410*	10.00	460/3/60	1	20	20
		BAYHTRR420*	19.92		1	35	35
		BAYHTRR430*	29.92		2	50	50
		BAYHTRR450*	49.84		2	80	80
12.5	TWE150K4*****BC4, D4	BAYHTRT410*	10.00	460/3/60	1	24	25
		BAYHTRR420*	19.92		1	39	40
		BAYHTRR430*	29.92		2	54	60
		BAYHTRR450*	49.84		2	84	90

**Table 68. Unit wiring with electric heat (single point connection) — 6 to 25 ton SZVAV and 2-Speed VFD air handlers — 60 Hz (continued)**

Tons	Used With	Heater Model Number	Heater KW Rating	Unit Power Supply	Control Stages	MCA	Maximum Fuse or Circuit Breaker Size
12.5	TWE150KW*****BC0, D0	BAYHTRTW10*	10.00	575/3/60	1	16	20
		BAYHTRRW20*	19.92		1	28	30
		BAYHTRRW30*	29.92		2	40	40
		BAYHTRRW50*	49.84		2	64	70
12.5	TWE150KW*****BC4, D4	BAYHTRTW10*	10.00	575/3/60	1	20	20
		BAYHTRRW20*	19.92		1	32	35
		BAYHTRRW30*	29.92		2	44	45
		BAYHTRRW50*	49.84		2	68	70
15	TWE180K3*****BC0, D0	BAYHTRT310*	7.51	208/3/60	1	39	40
		BAYHTRR320*	14.96		1	65	70
		BAYHTRR330*	22.47		2	91	100
		BAYHTRR350*	37.44		2	143	150
15	TWE180K3*****BC0, D0	BAYHTRT310*	10.00	230/3/60	1	43	45
		BAYHTRR320*	19.92		1	73	80
		BAYHTRR330*	29.92		2	103	110
		BAYHTRR350*	49.84		2	163	175
15	TWE180K3*****BC4, D4	BAYHTRT310*	7.51	208/3/60	1	45	50
		BAYHTRR320*	14.96		1	71	80
		BAYHTRR330*	22.47		2	97	100
		BAYHTRR350*	37.44		2	149	150
15	TWE180K3*****BC4, D4	BAYHTRT310*	10.00	230/3/60	1	49	50
		BAYHTRR320*	19.92		1	79	80
		BAYHTRR330*	29.92		2	109	110
		BAYHTRR350*	49.84		2	169	175
15	TWE180K4*****BC0, D0	BAYHTRT410*	10.00	460/3/60	1	22	25
		BAYHTRR420*	19.92		1	37	40
		BAYHTRR430*	29.92		2	52	60
		BAYHTRR450*	49.84		2	82	90
15	TWE180K4*****BC4, D4	BAYHTRT410*	10.00	460/3/60	1	24	25
		BAYHTRR420*	19.92		1	39	40
		BAYHTRR430*	29.92		2	54	60
		BAYHTRR450*	49.84		2	84	90
15	TWE180KW*****BC0, D0	BAYHTRTW10*	10.00	575/3/60	1	17	20
		BAYHTRRW20*	19.92		1	29	30
		BAYHTRRW30*	29.92		2	41	45
		BAYHTRRW50*	49.84		2	65	70
15	TWE180KW*****BC4, D4	BAYHTRTW10*	10.00	575/3/60	1	20	20
		BAYHTRRW20*	19.92		1	32	35
		BAYHTRRW30*	29.92		2	44	45
		BAYHTRRW50*	49.84		2	68	70
20	TWE240K3*****BC0, D0	BAYHTRT310*	7.51	208/3/60	1	45	50
		BAYHTRR320*	14.96		1	71	80
		BAYHTRR330*	22.47		2	97	100
		BAYHTRR350*	37.44		2	149	150
20	TWE240K3*****BC0, D0	BAYHTRT310*	10.00	230/3/60	1	49	50
		BAYHTRR320*	19.92		1	79	80
		BAYHTRR330*	29.92		2	109	110
		BAYHTRR350*	49.84		2	169	175



**Electrical Data**

**Table 68. Unit wiring with electric heat (single point connection) — 6 to 25 ton SZVAV and 2-Speed VFD air handlers — 60 Hz (continued)**

Tons	Used With	Heater Model Number	Heater KW Rating	Unit Power Supply	Control Stages	MCA	Maximum Fuse or Circuit Breaker Size
20	TWE240K3*****BC4, D4	BAYHTRT310*	7.51	208/3/60	1	55	70
		BAYHTRR320*	14.96		1	81	90
		BAYHTRR330*	22.47		2	107	110
		BAYHTRR350*	37.44		2	159	175
20	TWE240K3*****BC4, D4	BAYHTRT310*	10.00	230/3/60	1	59	70
		BAYHTRR320*	19.92		1	89	90
		BAYHTRR330*	29.92		2	119	125
		BAYHTRR350*	49.84		2	179	200
20	TWE240K4*****BC0, D0	BAYHTRT410*	10.00	460/3/60	1	24	25
		BAYHTRR420*	19.92		1	39	40
		BAYHTRR430*	29.92		2	54	60
		BAYHTRR450*	49.84		2	84	90
20	TWE240K4*****BC4, D4	BAYHTRT410*	10.00	460/3/60	1	28	30
		BAYHTRR420*	19.92		1	43	45
		BAYHTRR430*	29.92		2	58	60
		BAYHTRR450*	49.84		2	88	90
20	TWE240KW*****BC0, D0	BAYHTRTW10*	10.00	575/3/60	1	20	20
		BAYHTRRW20*	19.92		1	32	35
		BAYHTRRW30*	29.92		2	44	45
		BAYHTRRW50*	49.84		2	68	70
20	TWE240KW*****BC4, D4	BAYHTRTW10*	10.00	575/3/60	1	23	25
		BAYHTRRW20*	19.92		1	35	35
		BAYHTRRW30*	29.92		2	47	50
		BAYHTRRW50*	49.84		2	71	80
25	TWE300K3*****BC0, D0	BAYHTRT310*	7.51	208/3/60	1	55	70
		BAYHTRR320*	14.96		1	81	90
		BAYHTRR330*	22.47		2	107	110
		BAYHTRR350*	37.44		2	159	175
25	TWE300K3*****BC0, D0	BAYHTRT310*	10.00	230/3/60	1	59	70
		BAYHTRR320*	19.92		1	89	90
		BAYHTRR330*	29.92		2	119	125
		BAYHTRR350*	49.84		2	179	200
25	TWE300K3*****BC4, D4	BAYHTRT310*	7.51	208/3/60	1	58	70
		BAYHTRR320*	14.96		1	84	90
		BAYHTRR330*	22.47		2	110	110
		BAYHTRR350*	37.44		2	162	175
25	TWE300K3*****BC4, D4	BAYHTRT310*	10.00	230/3/60	1	62	80
		BAYHTRR320*	19.92		1	92	100
		BAYHTRR330*	29.92		2	122	125
		BAYHTRR350*	49.84		2	182	200
25	TWE300K4*****BC0, D0	BAYHTRT410*	10.00	460/3/60	1	28	30
		BAYHTRR420*	19.92		1	43	45
		BAYHTRR430*	29.92		2	58	60
		BAYHTRR450*	49.84		2	88	90
25	TWE300K4*****BC4, D4	BAYHTRT410*	10.00	460/3/60	1	31	40
		BAYHTRR420*	19.92		1	46	50
		BAYHTRR430*	29.92		2	61	70
		BAYHTRR450*	49.84		2	91	100

**Table 68. Unit wiring with electric heat (single point connection) — 6 to 25 ton SZVAV and 2-Speed VFD air handlers — 60 Hz (continued)**

Tons	Used With	Heater Model Number	Heater KW Rating	Unit Power Supply	Control Stages	MCA	Maximum Fuse or Circuit Breaker Size
25	TWE300KW*****BC0, D0	BAYHTRTW10*	10.00	575/3/60	1	23	25
		BAYHTRRW20*	19.92		1	35	35
		BAYHTRRW30*	29.92		2	47	50
		BAYHTRRW50*	49.84		2	71	80
25	TWE300KW*****BC0, D4	BAYHTRTW10*	10.00	575/3/60	1	25	30
		BAYHTRRW20*	19.92		1	37	40
		BAYHTRRW30*	29.92		2	49	50
		BAYHTRRW50*	49.84		2	73	80

# Jobsite Connections

## Symbio™ Controls

Wiring shown with dashed lines is to be furnished and installed by the customer. All customer supplied wiring must be copper only and must conform to NEC and local electrical codes. Codes may require line of sight between disconnect switch and unit.

**Figure 19. Symbio™ jobsite connections**

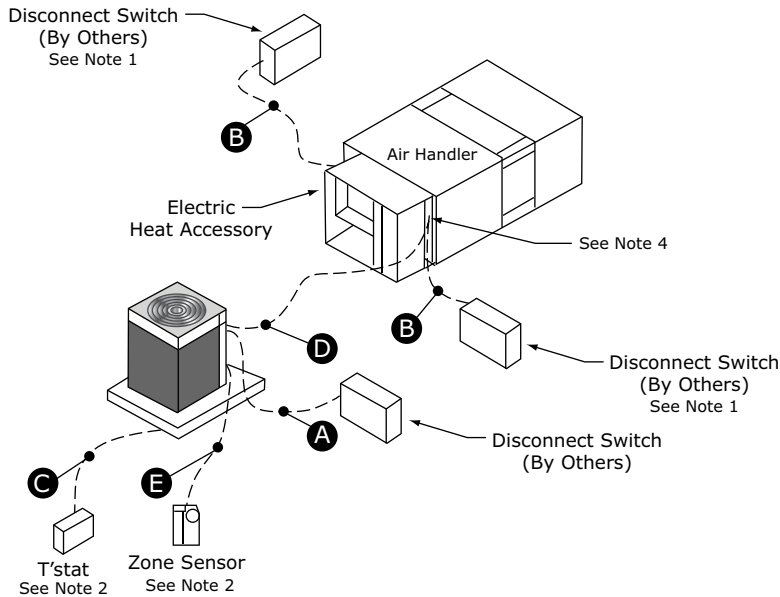

### Power Wires

- A. 3 wires, line voltage for 3 phase, 1 grounding wire\*\*
- B. 3 wires, line voltage for 3 phase, (2 wires for single phase) 1 grounding wire\*\*

### Control Wires

- C. Heat Pump thermostat: 6 to 9 wires depending on T'stat options and stages of cooling and heating
- D. Wiring between indoor and outdoor unit: 5 to 11 wires depending on unit control options\*
- E. Zone Sensor: 4 to 7 wires depending on zone sensor model\*

### Communication signal wires require shielded twisted pairs.

Use Comlink cable with a PVC jacket, 18/1 PR, stranded shield, 25 PF/FT plenum rated for the field communication signal wiring.

**Notes:**

1. When electric heater accessory is used, single point power entry or dual point power entry is field optional. Single point power entry option is through electric heater only.
2. \*Choose only one of the following; Thermostat, Mechanical Zone Sensor, Programmable Zone Sensor Panel or BAS Zone Sensor.
3. \*\*

**⚠ WARNING**

**Electrical Shock Hazard!**  
**Failure to follow instructions below could result in death or serious injury.**  
**Properly connect the system's oversized protective earthing (grounding) terminal(s).**

4. Once power wire connections are complete inside the air handler control box, seal the sheet metal entry points of the control box by using parts (neoprene gasket, grommet, and plug) shipped along with the air handler unit package.
5. For detailed controls wiring instructions, see Split System Air Conditioners Odyssey™ with Symbio™ Controls Wiring and Start-Up Installation Guide (SS-SVN017\*-EN)

**Important:** For the EDC switch to be functional and thereby facilitate reliable unit operation, make the EDC connections from the indoor to the outdoor control boxes.

**Table 69. Recommended thermostat wire size**

Wire Size (Gauge)	Maximum Wire Length Physical distance between Unit and T'stat
22	30 Feet
20	50 Feet
18	75 Feet
16	125 Feet
14	200 Feet
12	250 Feet

**Table 70. Zone sensor module wiring**

Distance from Unit to Control	Recommended Wire Size
0-150 feet (0-45.7 m)	22 gauge (0.33 mm <sup>2</sup> )
151-240 feet (46-73.1 m)	20 gauge (0.50 mm <sup>2</sup> )
241-305 feet (73.5-117.3 m)	18 gauge (0.75 mm <sup>2</sup> )
386-610 feet (117.7-185.9 m)	16 gauge (1.31 mm <sup>2</sup> )
611-970 feet (186.2-295.7 m)	14 gauge ( 2.08 mm <sup>2</sup> )



# Dimensional Data

## Heat Pump

Figure 20. 6-7.5 ton heat pump, single compressor – in (mm)

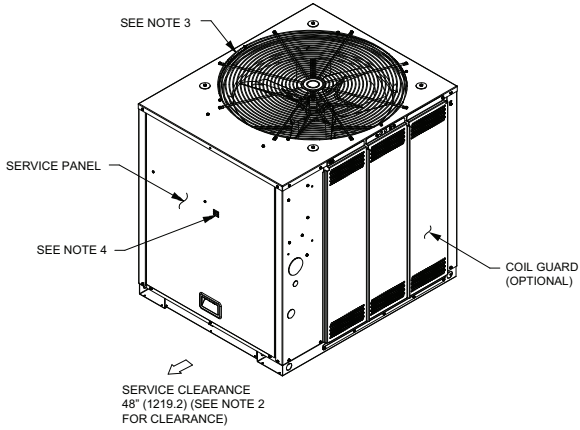

NOTES:

1. ACCESS OPENING IS FOR FIELD INSTALLED BAYLOAM ACCESSORY.
2. MINIMUM CLEARANCE FOR PROPER OPERATION IS 36" (914.4) FROM WALLS, SHRUBBERY, PRIVACY FENCES ETC. MINIMUM CLEARANCE BETWEEN ADJACENT UNITS IS 72" (1828.8). RECOMMENDED SERVICE CLEARANCE 48" (1219.2)
3. TOP DISCHARGE AREA SHOULD BE UNRESTRICTED FOR 100' (2540) MINIMUM. UNIT SHOULD BE PLACED SO ROOF RUN-OFF WATER OR FALLING SNOW FROM ROOF DOES NOT POUR/FALL DIRECTLY ON UNIT
4. OUTDOOR AIR TEMPERATURE SENSOR OPENING (DO NOT BLOCK OPENING)

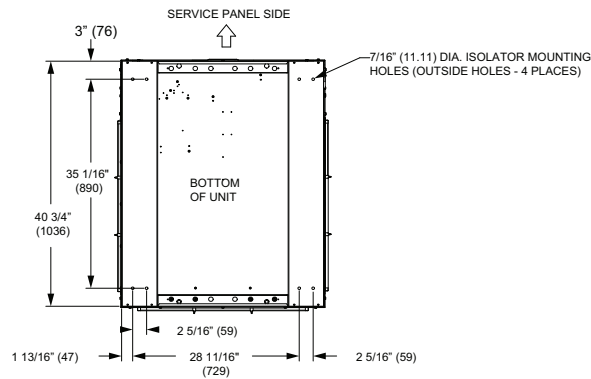
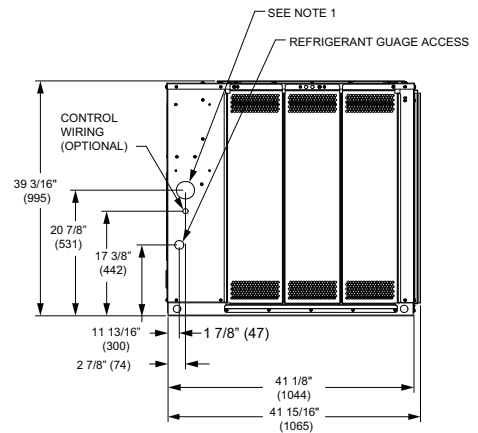
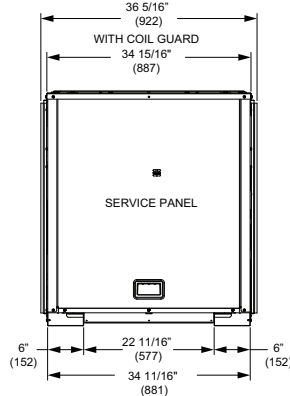
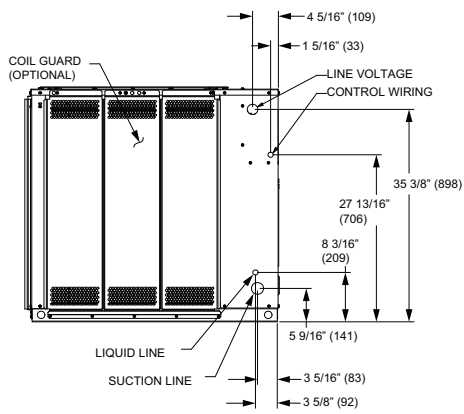
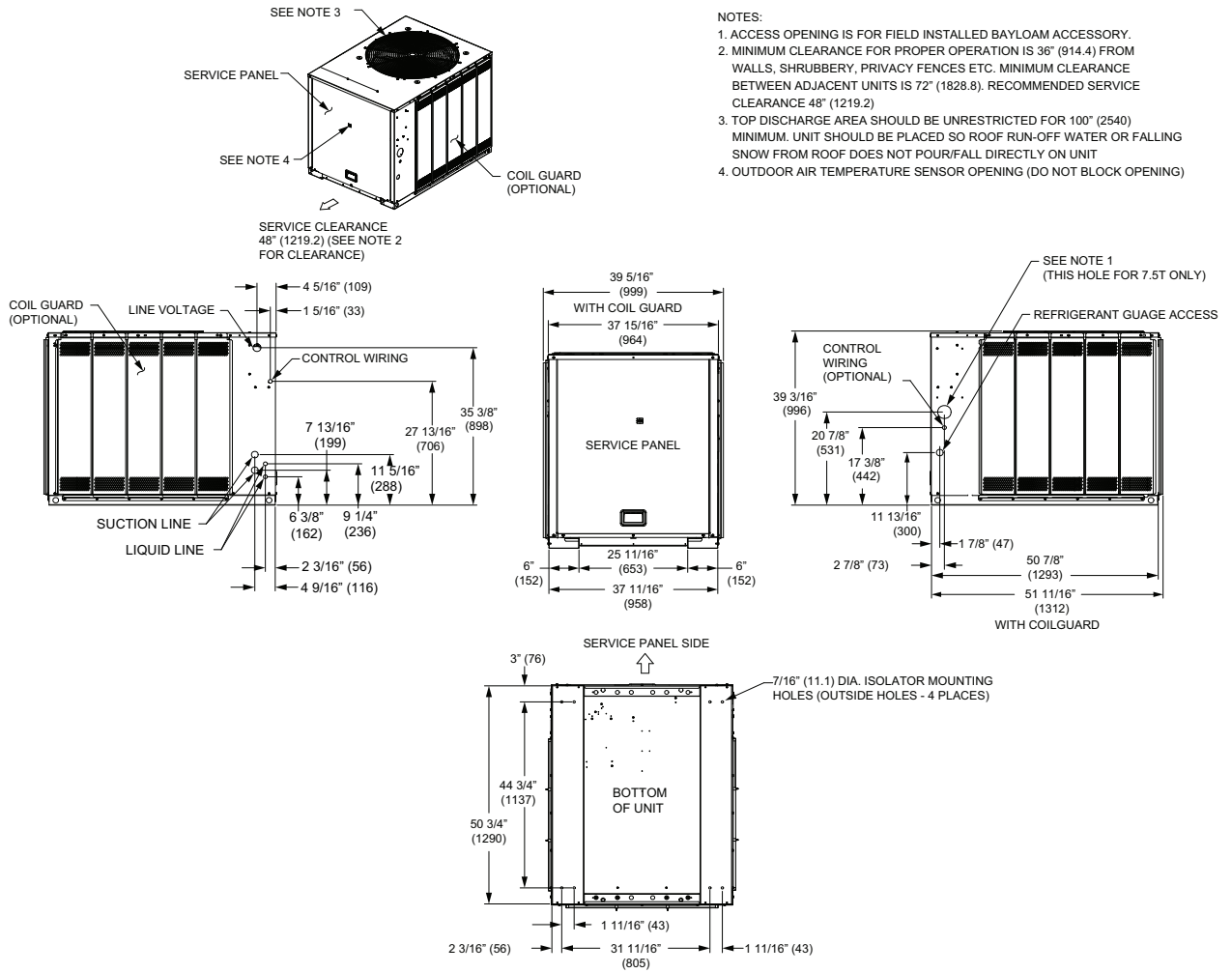

Figure 21. 6-7.5 ton heat pump, dual compressor – in (mm)





# Dimensional Data

**Figure 22. 10 ton heat pump, single compressor – in (mm)**

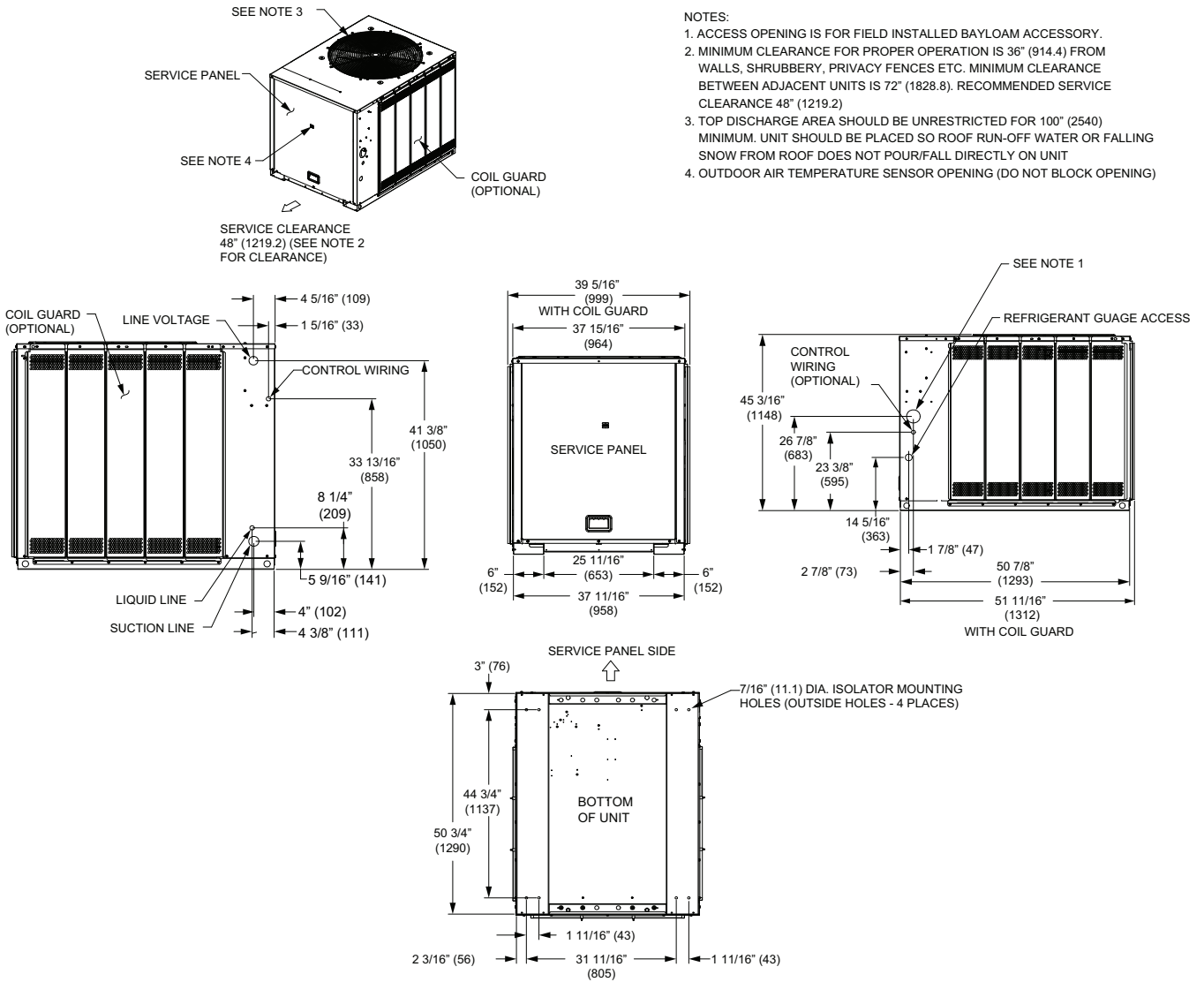

**Figure 23. 10 and 12.5 ton heat pump, dual compressor – in (mm)**

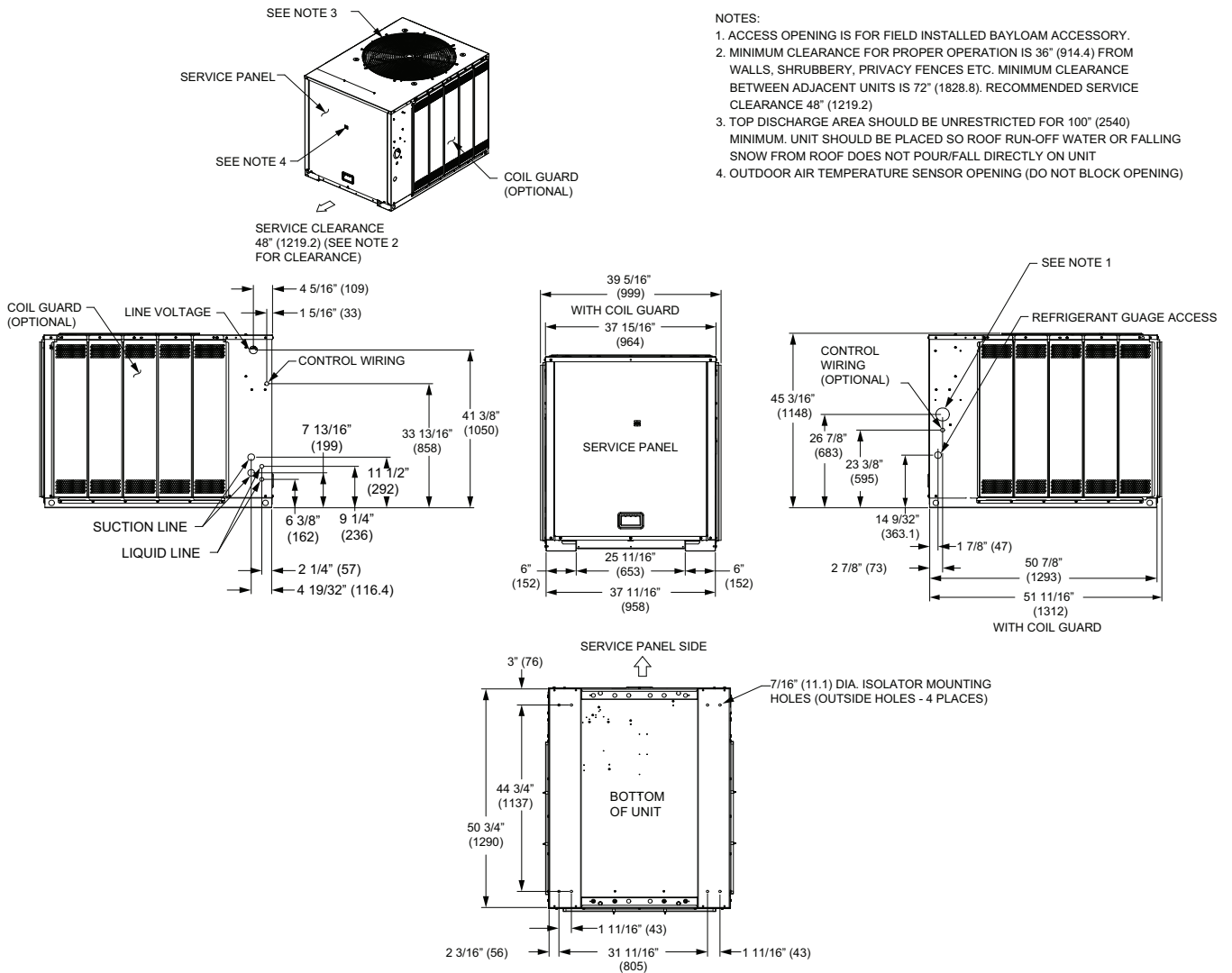

**Figure 24. 15, 20 ton heat pump, dual compressor – in (mm)**

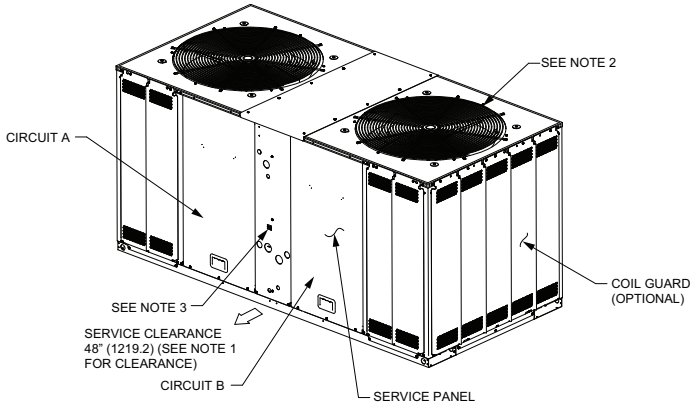

**NOTES:**

1. MINIMUM CLEARANCE FOR PROPER OPERATION IS 36" (914.4) FROM WALLS, SHRUBBERY, PRIVACY FENCES ETC. MINIMUM CLEARANCE BETWEEN ADJACENT UNITS IS 72" (1828.8). RECOMMENDED SERVICE CLEARANCE 48" (1219.2)
2. TOP DISCHARGE AREA SHOULD BE UNRESTRICTED FOR 100' (2540) MINIMUM. UNIT SHOULD BE PLACED SO ROOF RUN-OFF WATER OR FALLING SNOW FROM ROOF DOES NOT POUR/FALL DIRECTLY ON UNIT
3. OUTDOOR AIR TEMPERATURE SENSOR OPENING (DO NOT BLOCK OPENING)

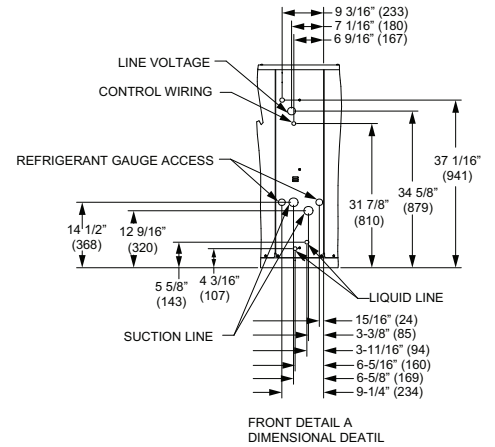
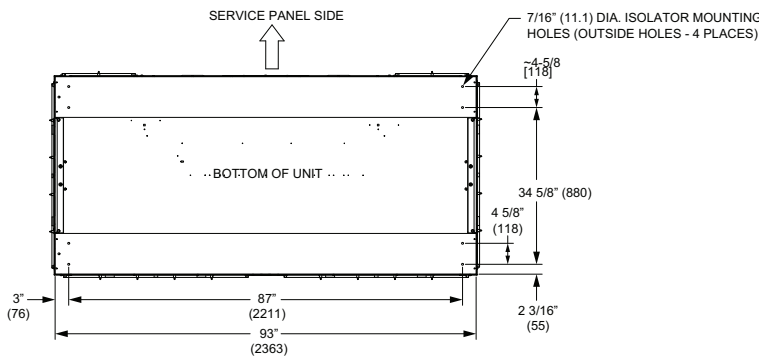
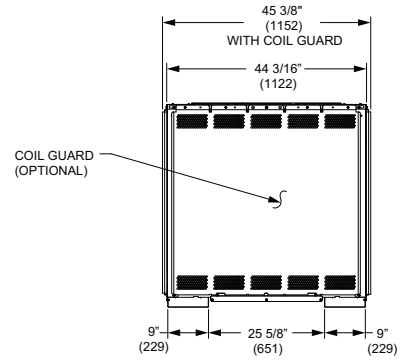
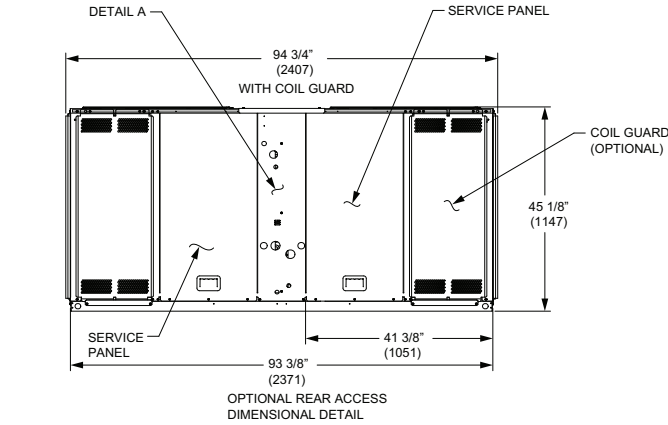
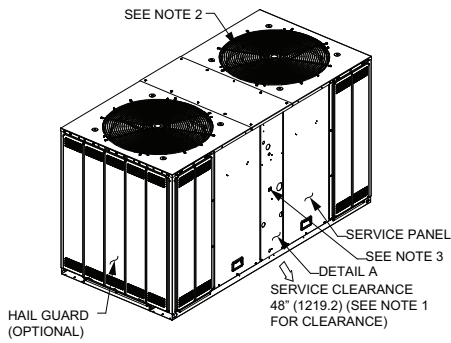
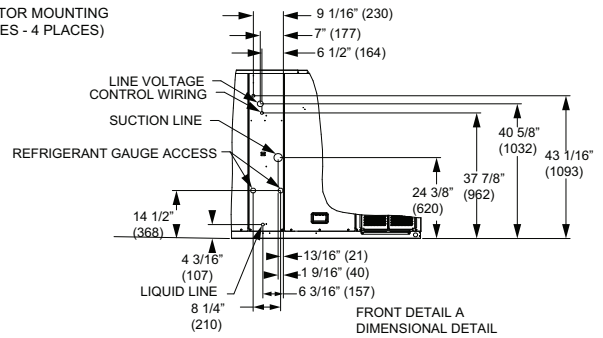
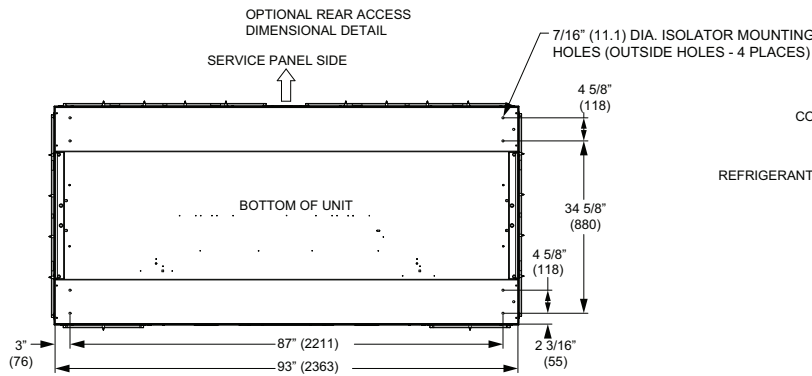
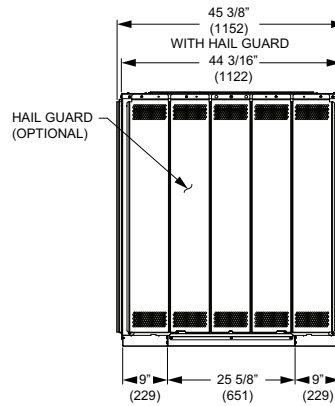
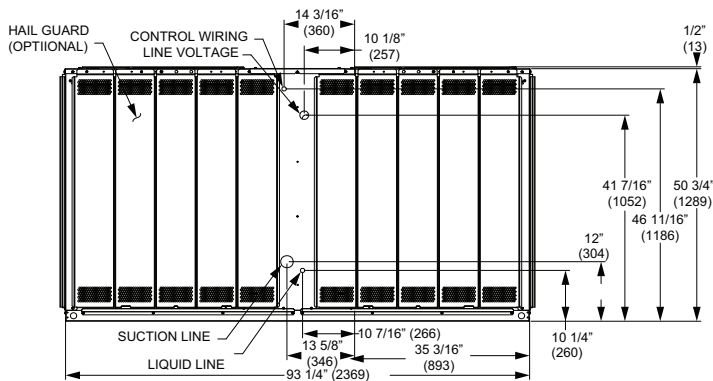

Figure 25. 25 ton condensing, manifolded compressor – in (mm)



NOTES:

1. MINIMUM CLEARANCE FOR PROPER OPERATION IS 36" (914.4) FROM WALLS, SHRUBBERY, PRIVACY FENCES ETC. MINIMUM CLEARANCE BETWEEN ADJACENT UNITS IS 72" (1828.8). RECOMMENDED SERVICE CLEARANCE 48" (1219.2)
2. TOP DISCHARGE AREA SHOULD BE UNRESTRICTED FOR 100" (2540) MINIMUM. UNIT SHOULD BE PLACED SO ROOF RUN-OFF WATER OR FALLING SNOW FROM ROOF DOES NOT POUR/FALL DIRECTLY ON UNIT
3. OUTDOOR AIR TEMPERATURE SENSOR OPENING (DO NOT BLOCK OPENING)



# Air Handler

**Figure 26. 5 ton air handler, single circuit – in. (mm)**

*Note: Duct flange is a field-installed accessory.*

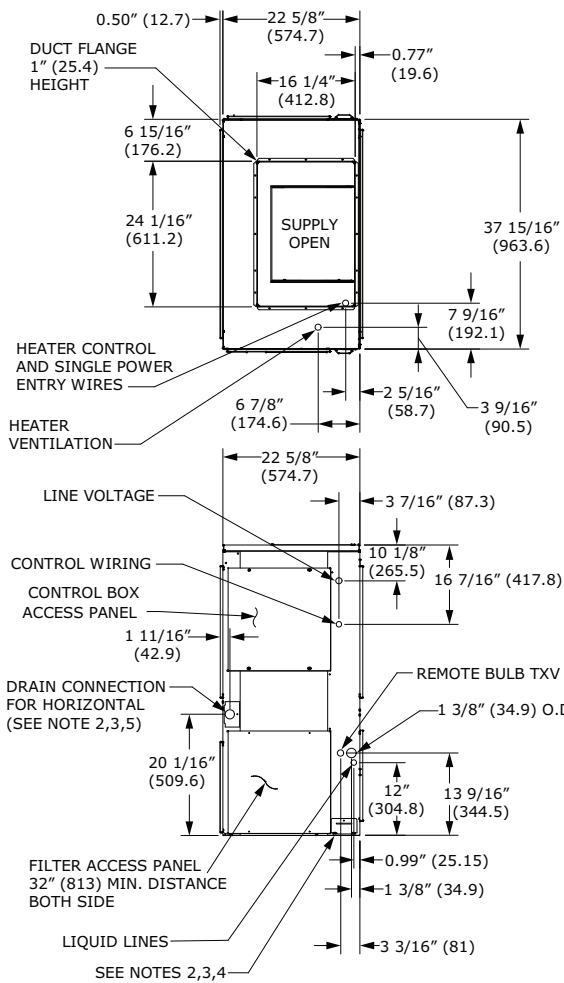

**NOTES:**

1. PANEL DEPTH 1/2" (12.7) (TYP. ALL PANELS).
2. REMOVABLE DRAIN PAN AND ATTACHED DRAIN CONNECTION MAY BE INSTALLED ON END OF UNIT IN EITHER THE VERTICAL OR HORIZONTAL CONFIGURATION, PLASTIC DRAIN PAN ACCESS PLATE ON THE END OF UNIT OPPOSITE DRAIN CONNECTION MUST BE REMOVED TO SLIDE DRAIN PAN OUT OF UNIT FOR CLEANING. ACCESS PLATE MUST BE RE-INSTALLED AFTER SLIDING DRAIN PAN BACK INTO UNIT.
3. IF PERIODIC DRAIN PAN CLEANING IS REQUIRED, ALLOW ROOM FOR PARTIAL REMOVAL OF DRAIN PAN CONNECTION AT END OF UNIT.
4. 1" (25.4) FEMALE SCHED. 40 (10.2) PVC PIPE DRAIN CONNECTION VERTICAL CONFIGURATION.
5. 1" (25.4) FEMALE SCHED. 40 (10.2) PVC PIPE DRAIN CONNECTION HORIZONTAL CONFIGURATION.

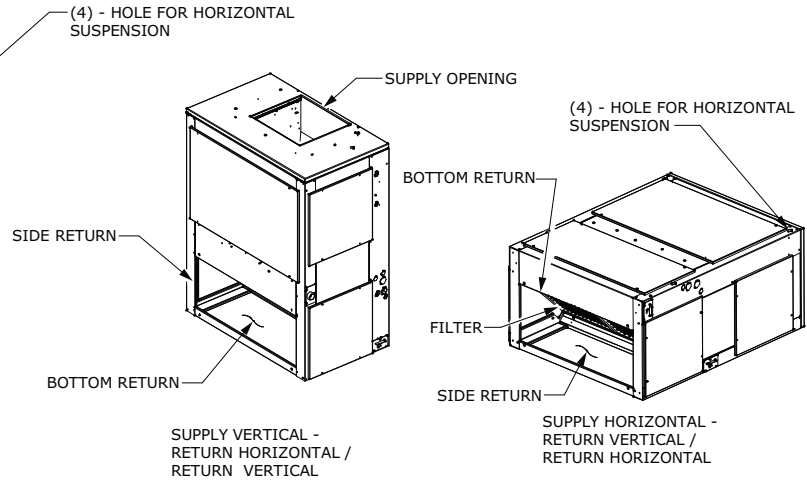
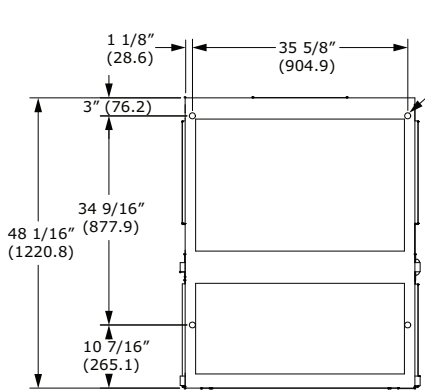
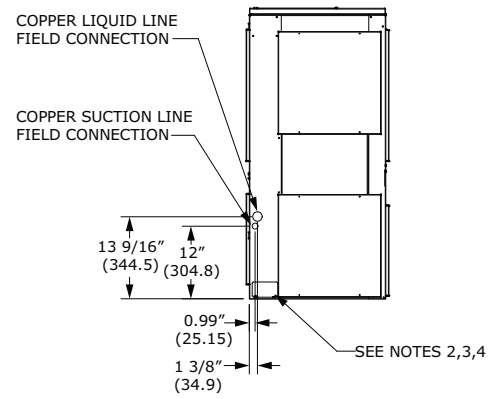
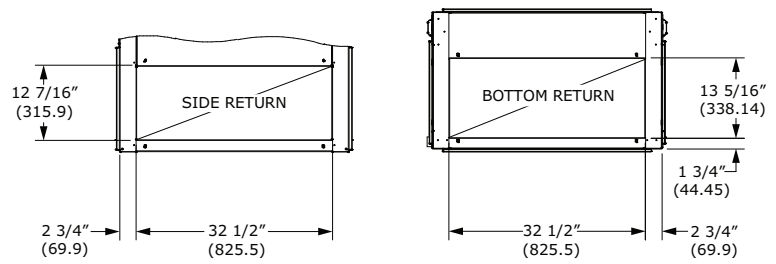

**Figure 27. 5 ton air handler, dual circuit – in. (mm)**

**Note: Duct flange is a field-installed accessory.**

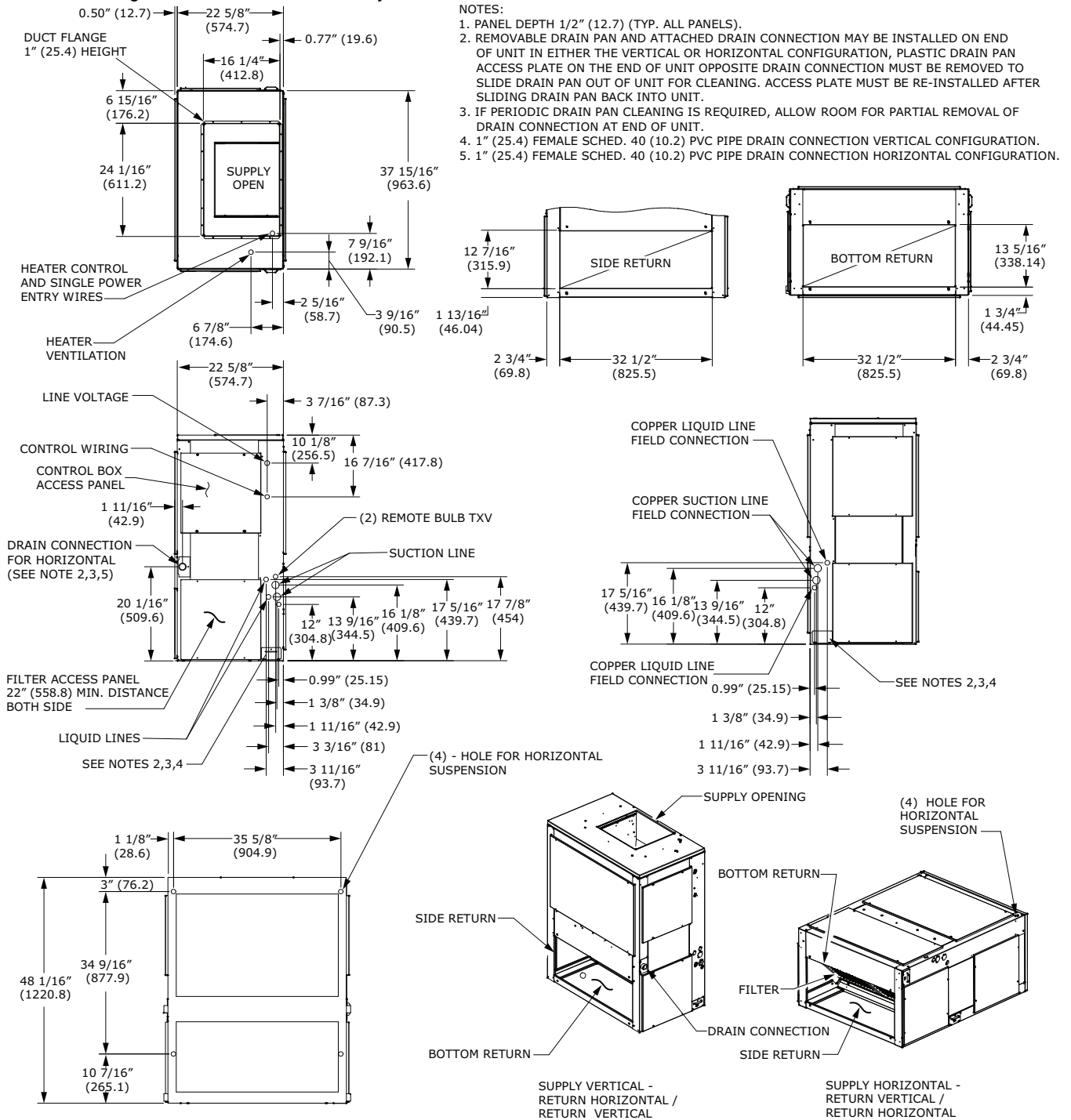

# Dimensional Data

**Figure 28. 7.5 ton air handler, single circuit – in. (mm)**

*Note: Duct flange is a field-installed accessory.*

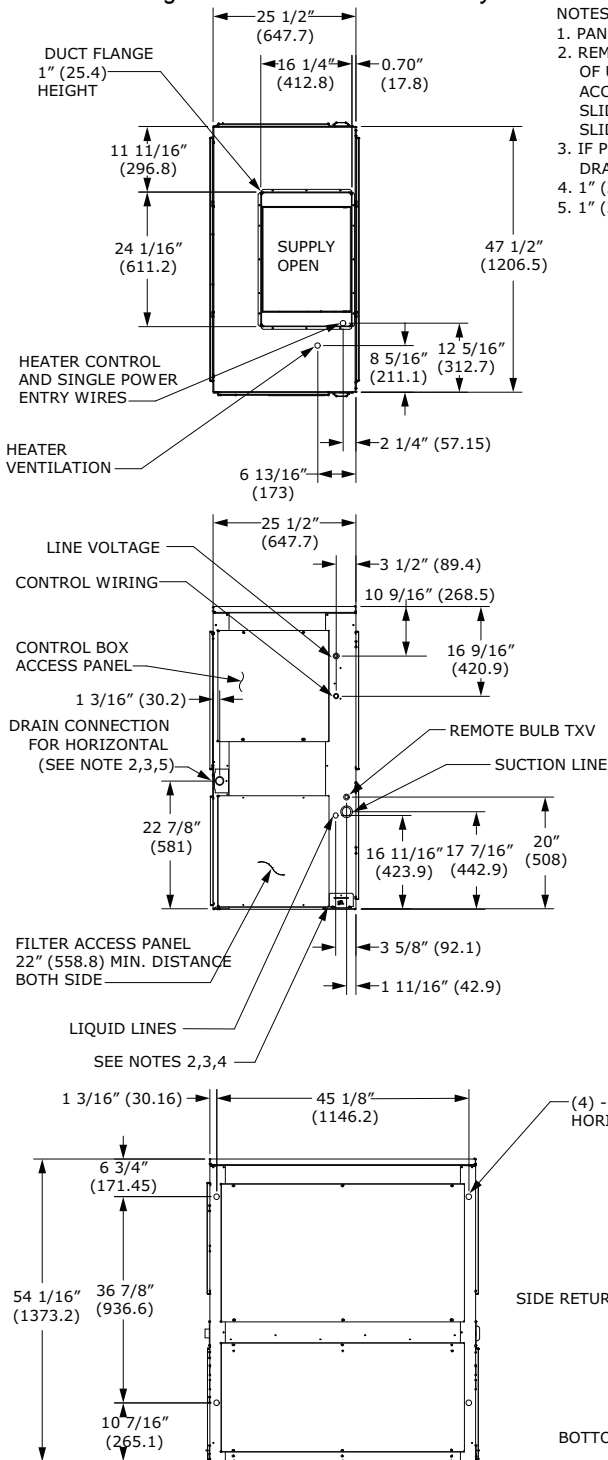

**NOTES:**

1. PANEL DEPTH 1/2" (12.7) (TYP. ALL PANELS).
2. REMOVABLE DRAIN PAN AND ATTACHED DRAIN CONNECTION MAY BE INSTALLED ON END OF UNIT IN EITHER THE VERTICAL OR HORIZONTAL CONFIGURATION, PLASTIC DRAIN PAN ACCESS PLATE ON THE END OF UNIT OPPOSITE DRAIN CONNECTION MUST BE REMOVED TO SLIDE DRAIN PAN OUT OF UNIT FOR CLEANING. ACCESS PLATE MUST BE RE-INSTALLED AFTER SLIDING DRAIN PAN BACK INTO UNIT.
3. IF PERIODIC DRAIN PAN CLEANING IS REQUIRED, ALLOW ROOM FOR PARTIAL REMOVAL OF DRAIN PAN CONNECTION AT END OF UNIT.
4. 1" (25.4) FEMALE SCHED. 40 (10.2) PVC PIPE DRAIN CONNECTION VERTICAL CONFIGURATION.
5. 1" (25.4) FEMALE SCHED. 40 (10.2) PVC PIPE DRAIN CONNECTION HORIZONTAL CONFIGURATION.

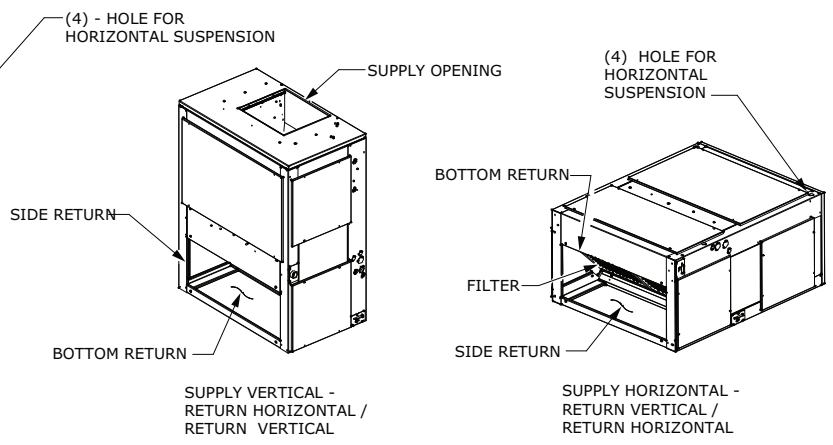
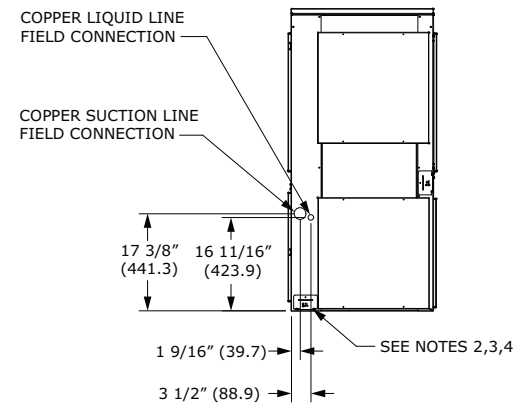
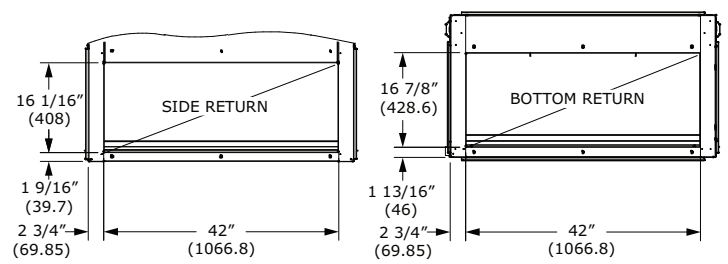



# Dimensional Data

**Figure 30. 10 ton air handler, single circuit – in. (mm)**

*Note: Duct flange is a field-installed accessory.*

**NOTES:**

1. PANEL DEPTH 1/2" (12.7) (TYP. ALL PANELS).
2. REMOVABLE DRAIN PAN AND ATTACHED DRAIN CONNECTION MAY BE INSTALLED ON END OF UNIT IN EITHER THE VERTICAL OR HORIZONTAL CONFIGURATION, PLASTIC DRAIN PAN ACCESS PLATE ON THE END OF UNIT OPPOSITE DRAIN CONNECTION MUST BE REMOVED TO SLIDE DRAIN PAN OUT OF UNIT FOR CLEANING. ACCESS PLATE MUST BE RE-INSTALLED AFTER SLIDING DRAIN PAN BACK INTO UNIT.
3. IF PERIODIC DRAIN PAN CLEANING IS REQUIRED, ALLOW ROOM FOR PARTIAL REMOVAL OF DRAIN PAN CONNECTION AT END OF UNIT.
4. 1" (25.4) FEMALE SCHED. 40 (10.2) PVC PIPE DRAIN CONNECTION VERTICAL CONFIGURATION.
5. 1" (25.4) FEMALE SCHED. 40 (10.2) PVC PIPE DRAIN CONNECTION HORIZONTAL CONFIGURATION.

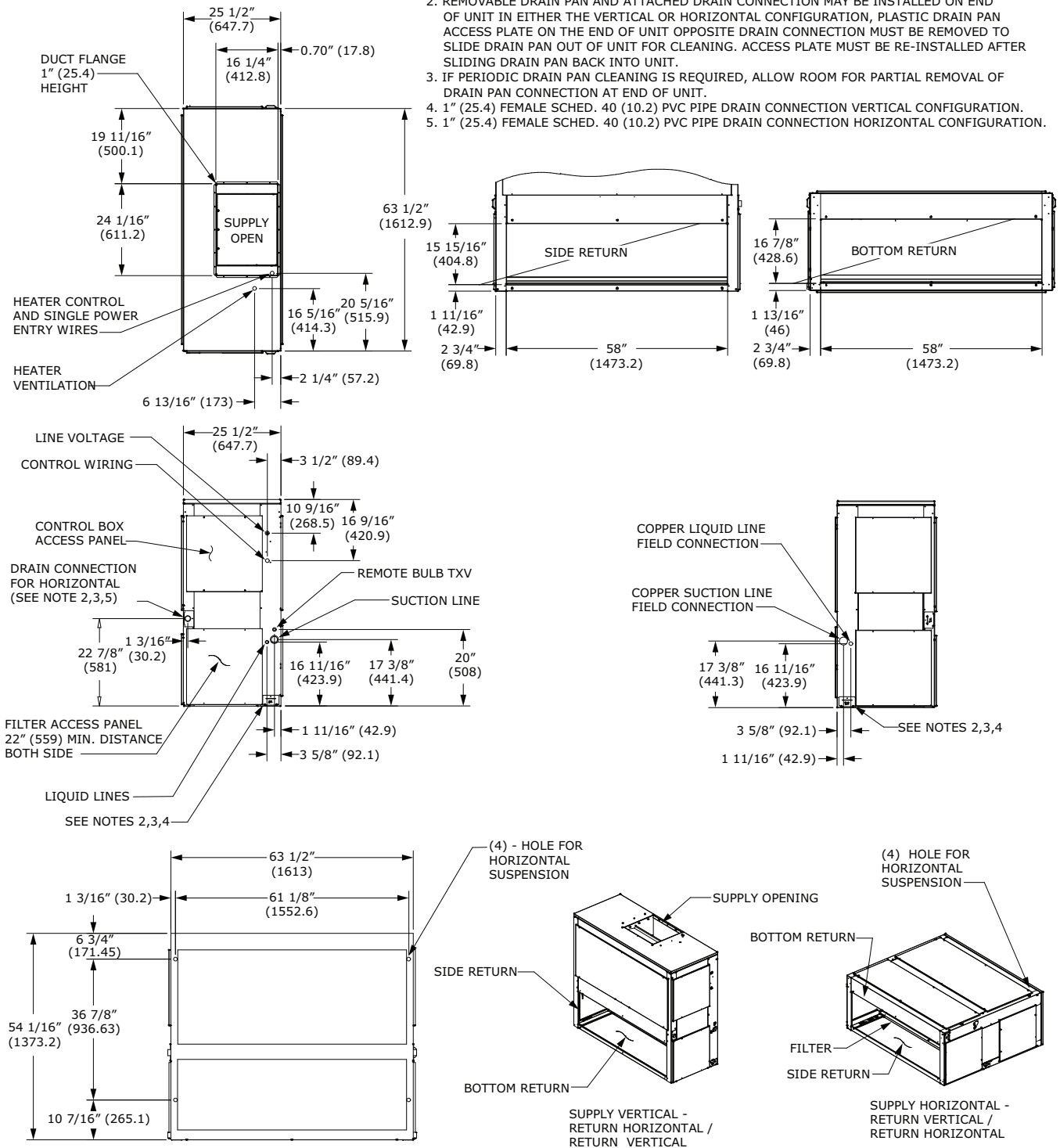
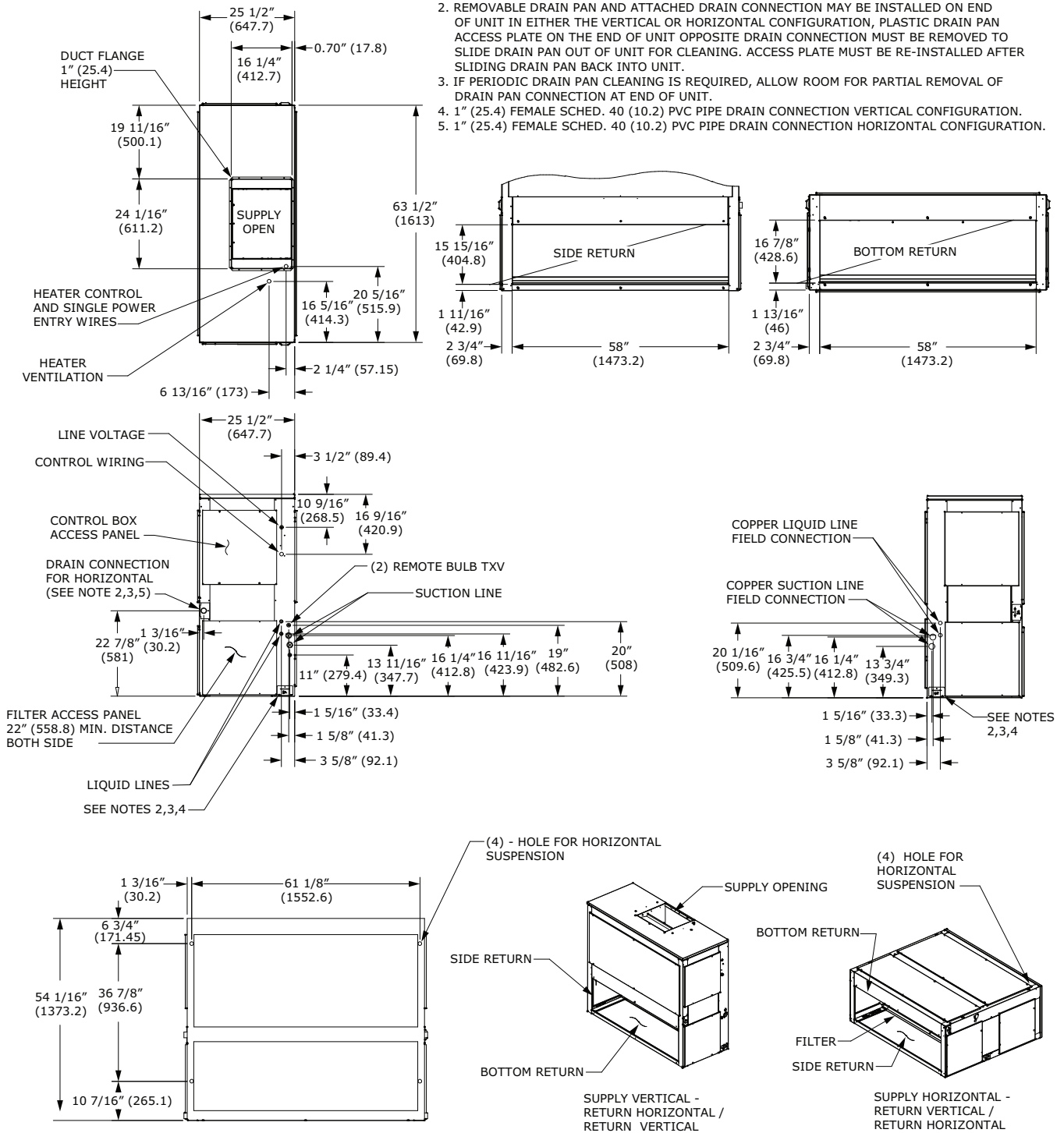

**Figure 31. 10 ton air handler, dual circuit – in. (mm)**

*Note: Duct flange is a field-installed accessory.*

**NOTES:**

1. PANEL DEPTH 1/2" (12.7) (TYP. ALL PANELS).
2. REMOVABLE DRAIN PAN AND ATTACHED DRAIN CONNECTION MAY BE INSTALLED ON END OF UNIT IN EITHER THE VERTICAL OR HORIZONTAL CONFIGURATION, PLASTIC DRAIN PAN ACCESS PLATE ON THE END OF UNIT OPPOSITE DRAIN CONNECTION MUST BE REMOVED TO SLIDE DRAIN PAN OUT OF UNIT FOR CLEANING. ACCESS PLATE MUST BE RE-INSTALLED AFTER SLIDING DRAIN PAN BACK INTO UNIT.
3. IF PERIODIC DRAIN PAN CLEANING IS REQUIRED, ALLOW ROOM FOR PARTIAL REMOVAL OF DRAIN PAN CONNECTION AT END OF UNIT.
4. 1" (25.4) FEMALE SCHED. 40 (10.2) PVC PIPE DRAIN CONNECTION VERTICAL CONFIGURATION.
5. 1" (25.4) FEMALE SCHED. 40 (10.2) PVC PIPE DRAIN CONNECTION HORIZONTAL CONFIGURATION.



# Dimensional Data

**Figure 32. 12.5 and 15 ton air handler, dual circuit – in. (mm)**

**Note: Duct flange is a field-installed accessory.**

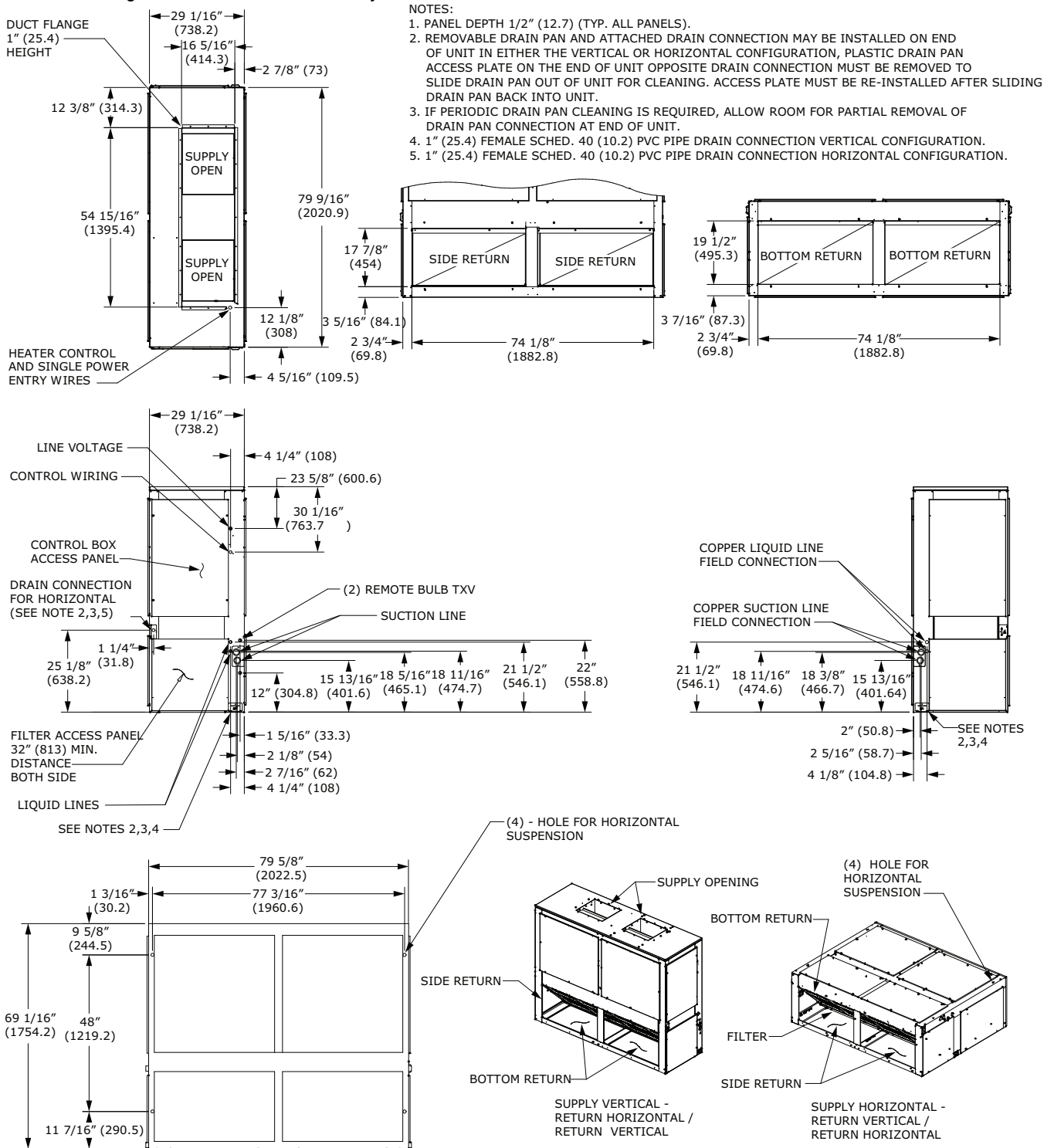

**Figure 33. 20 and 25 ton air handler, dual circuit – in. (mm)**

*Note: Duct flange is a field-installed accessory.*

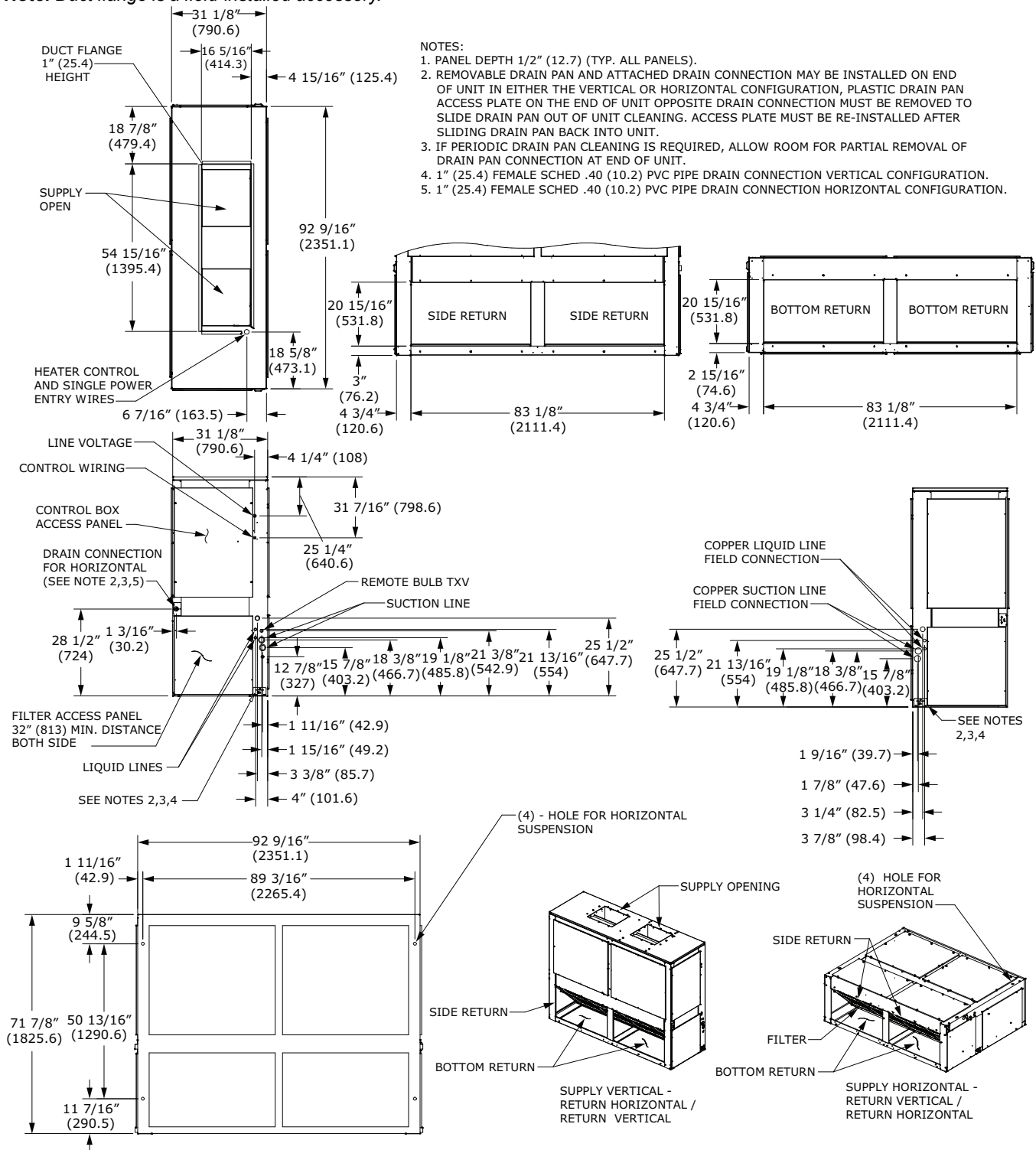

## Accessories

Figure 34. Rubber isolator accessory dimensions

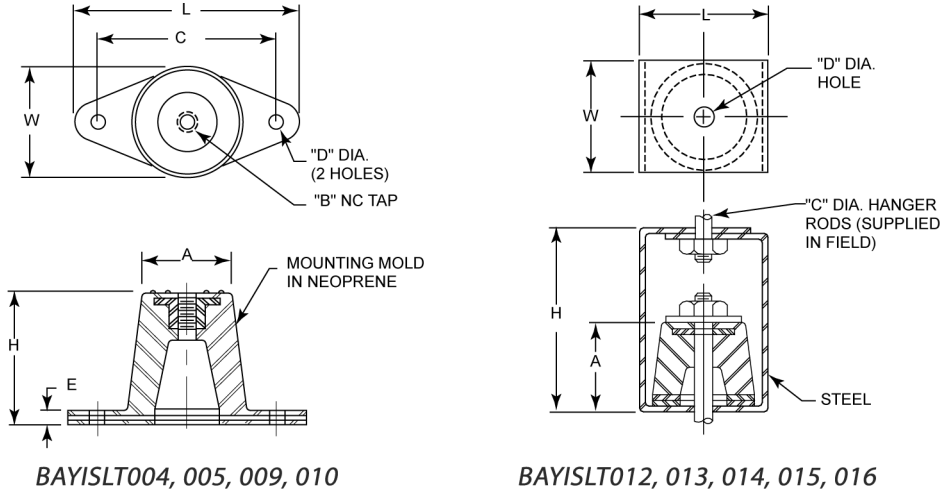

Table 71. Rubber isolator accessory dimensions – in (mm)

Model No.	L	W	H	A	B	C	D	E
BAYISLT004	3-1/8 (79.375)	1-3/4 (44.45)	1-1/4 (31.75)	1-1/4 (31.75)	3/8 (9.525)	2-3/8 (60.325)	3/8 (9.525)	1/4 (6.35)
BAYISLT005	3-7/8 (98.425)	2-3/8 (60.325)	1-3/4 (44.45)	1-3/4 (44.45)	3/8 (9.525)	3 (76.2)	3/8 (9.525)	1/4 (6.35)
BAYISLT009	3-7/8 (98.425)	2-3/8 (60.325)	1-3/4 (44.45)	1-3/4 (44.45)	3/8 (9.525)	3 (76.2)	3/8 (9.525)	1/4 (6.35)
BAYISLT010	3-7/8 (98.425)	2-3/8 (60.325)	1-3/4 (44.45)	1-3/4 (44.45)	3/8 (9.525)	3 (76.2)	3/8 (9.525)	1/4 (6.35)
BAYISLT013	2-1/4 (57.15)	2 (50.8)	3 (76.2)	1-3/8 (34.925)	3/4 (19.05)	3/8 (9.525)	1/2 (12.7)	—
BAYISLT014	2-1/4 (57.15)	2 (50.8)	3 (76.2)	1-3/8 (34.925)	3/4 (19.05)	3/8 (9.525)	1/2 (12.7)	—
BAYISLT015	2-1/4 (57.15)	2 (50.8)	3 (76.2)	1-3/8 (34.925)	3/4 (19.05)	3/8 (9.525)	1/2 (12.7)	—
BAYISLT012	3 (76.2)	2-1/4 (57.15)	4-1/2 (114.3)	1-7/8 (47.625)	1/4 (6.35)	5/8 (15.875)	3/4 (19.05)	—
BAYISLT015 <sup>(a)</sup>	3 (76.2)	2-1/4 (57.15)	4-1/2 (114.3)	1-7/8 (47.625)	1/4 (6.35)	5/8 (15.875)	3/4 (19.05)	—
BAYISLT016	3 (76.2)	2-1/4 (57.15)	4-1/2 (114.3)	1-7/8 (47.625)	1/4 (6.35)	5/8 (15.875)	3/4 (19.05)	—

**Note:** BAYISLT015 contains a quantity 2 of the 2-1/4 x 2 x 3 isolators and quantity of 3 of the 3 x 2-1/4 x 4-1/2 isolators.

Figure 35. Spring isolator accessory dimensions – in (mm)

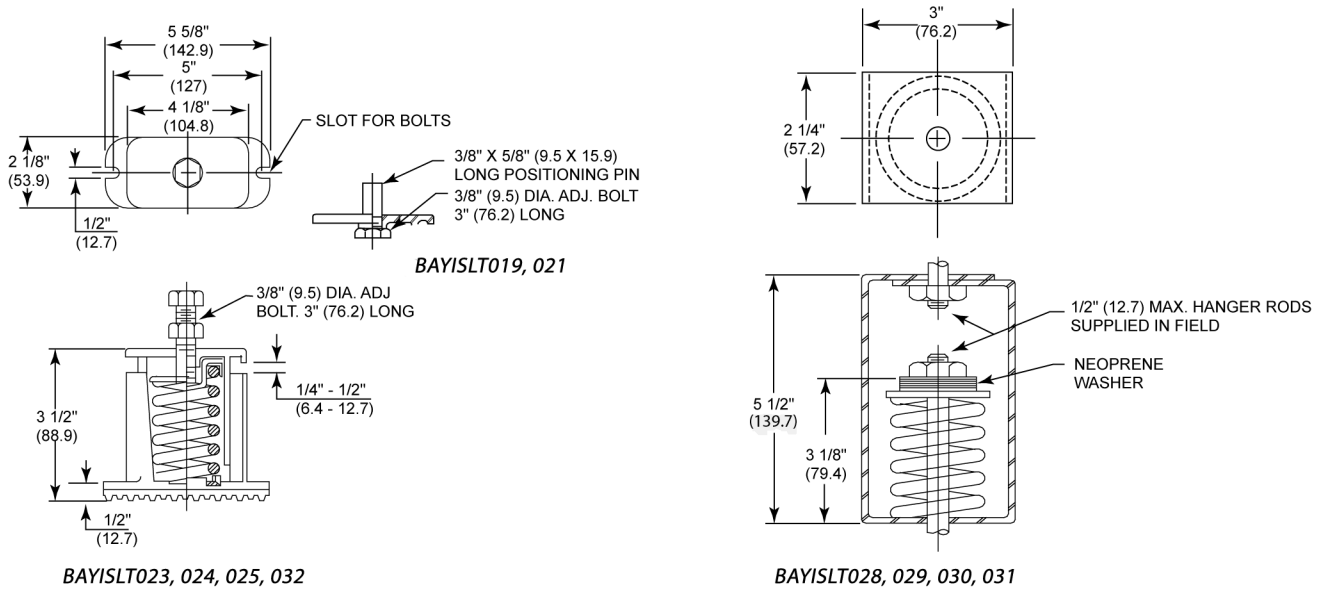
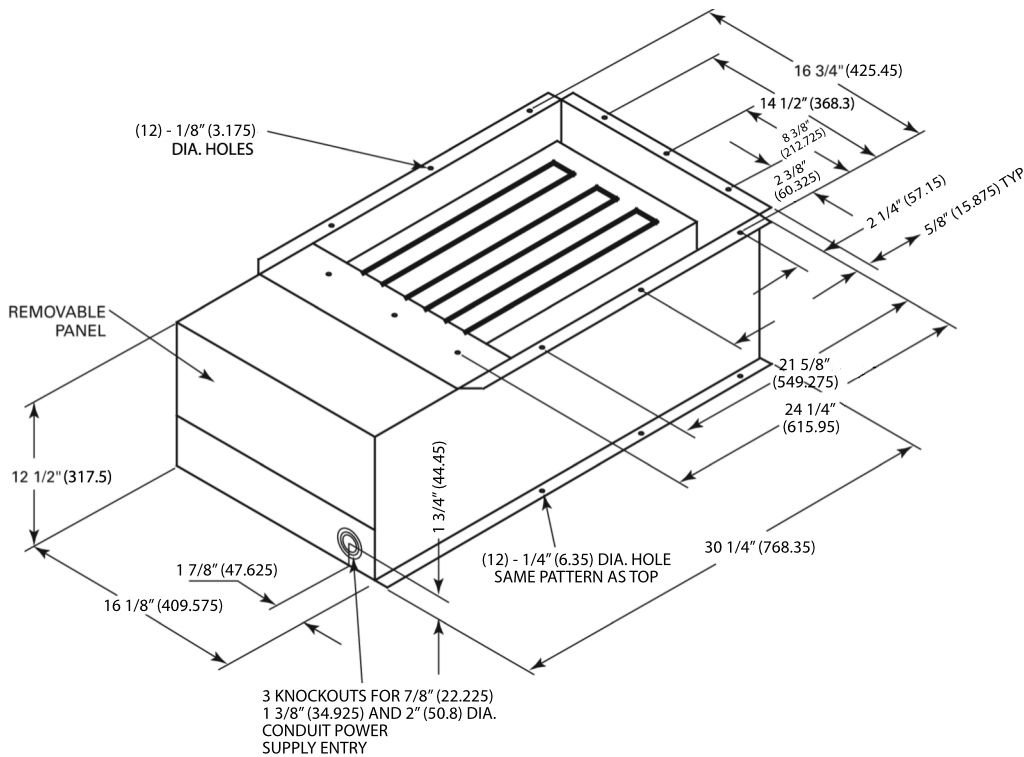

Figure 36. Electric heater accessory for 5-10 ton air handlers – in (mm)





## Dimensional Data

Figure 37. Electric heater accessory for 12.5-25 ton air handlers – in (mm)

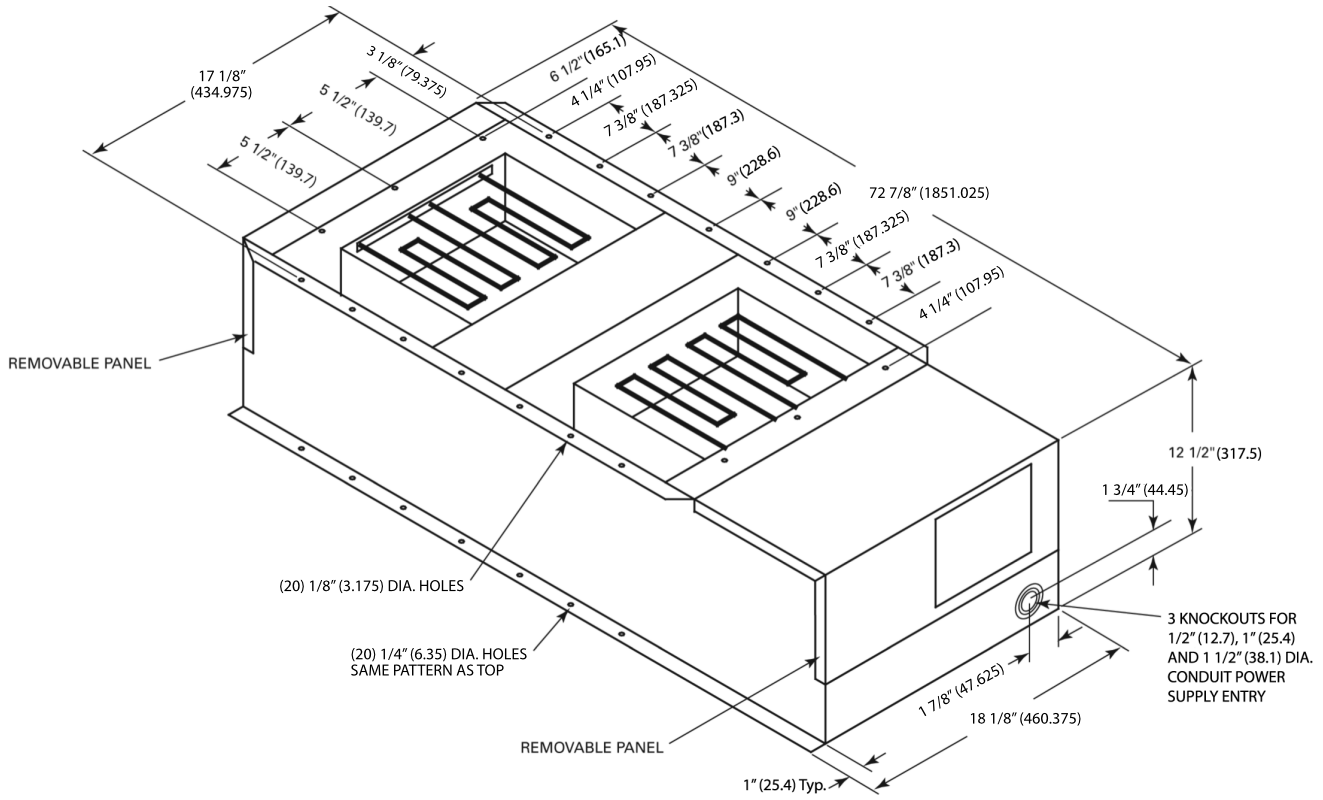

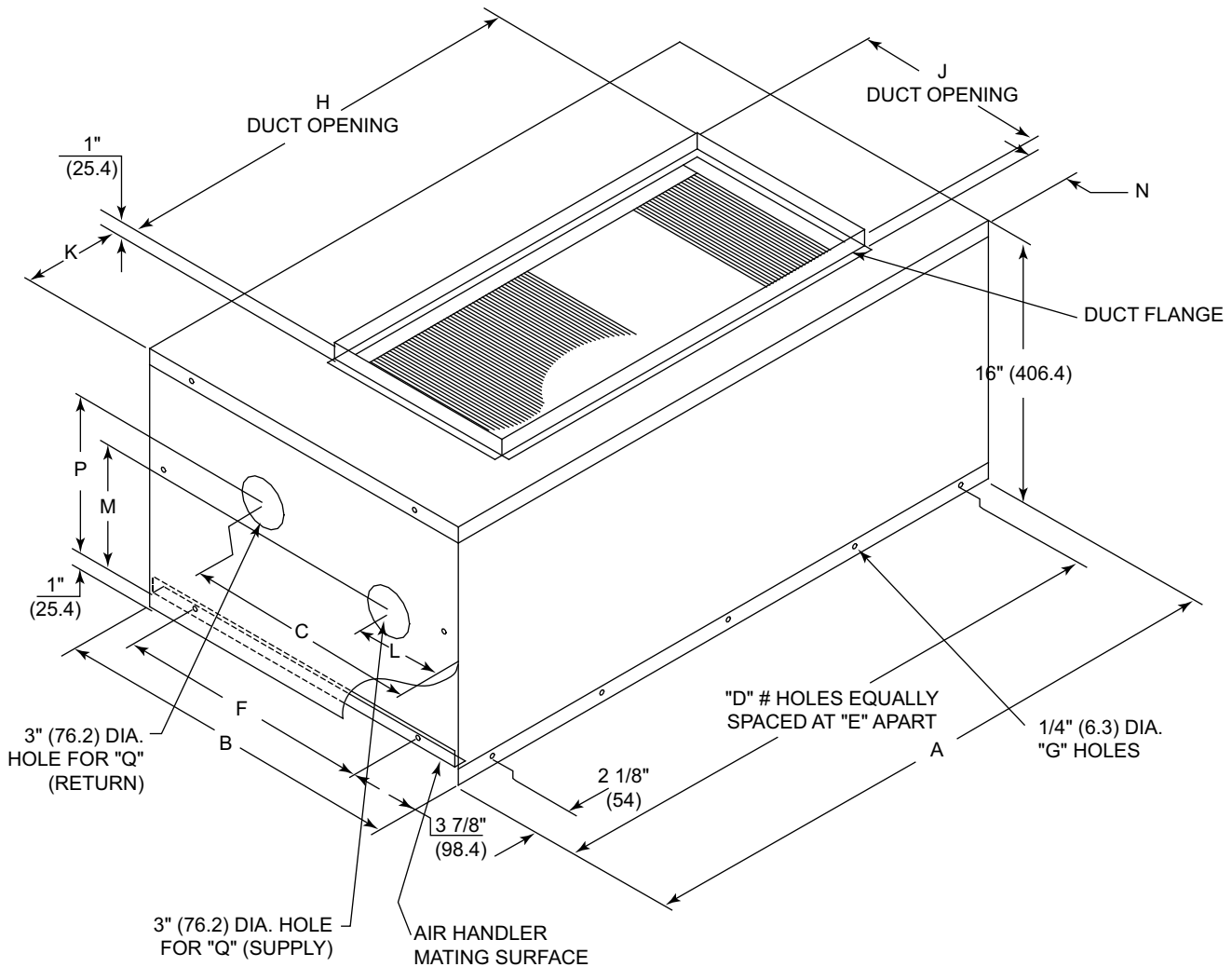
**Figure 38. Hot water coil accessory – in (mm)**

**Note:** Duct flange available as kit. See accessories chapter for details.

**Table 72. Hot water coil accessory – in (mm)**

Model No.	A	B	C	D	E	F	G	H
BAYWATR027	38.14 (969)	22.74 (576)	13.74 (349)	5 (127)	9 (229)	13.65 (347)	16 (406)	26 (660)
BAYWATR028	47.74 (1213)	25.74 (654)	15.95 (405)	5 (127)	10.84 (275)	17.17 (436)	16 (406)	30 (762)
BAYWATR029	63.84 (1621)	25.74 (654)	15.95 (405)	6 (152)	11.84 (301)	17.16 (436)	18 (457)	36 (914)
BAYWATR030	79.74 (2025)	29.18 (741)	14.36 (365)	8 (203)	10.85 (276)	19.67 (500)	22 (559)	51 (1295)
BAYWATR031	92.74 (2356)	31.24 (793)	16.48 (419)	8 (203)	10.85 (276)	19.67 (500)	22 (559)	64 (1626)
Model No.	J	K	L	M	N	P	Q	
BAYWATR027	12 (305)	6 (152)	4.94 (125)	7.79 (198)	2.88 (73)	10.24 (260)	2 NPT (51) NPTI	
BAYWATR028	18 (457)	8.88 (225)	8.45 (215)	10.27 (261)	2.88 (73)	7.77 (197)	2.5 NPTI (64) NPTI	
BAYWATR029	18 (457)	13.88 (352)	8.45 (215)	10.03 (255)	2.88 (73)	7.58 (192)	2.5 NPTI (64) NPTI	
BAYWATR030	18 (457)	14.25 (362)	6.86 (174)	9.91 (252)	1.88 (48)	7.41 (188)	2.5 NPTI (64) NPTI	

## Dimensional Data

**Table 72. Hot water coil accessory – in (mm) (continued)**

Model No.	J	K	L	M	N	P	Q
BAYWATR031	18 (457)	14.25 (362)	8.98 (228)	9.88 (251)	3.75 (95)	7.38 (187)	2.5 NPTI (64) NPTI

Note: Hot Water Coil Dimensions - inches (millimeters)

**Figure 39. Steam coil accessory – in (mm)**

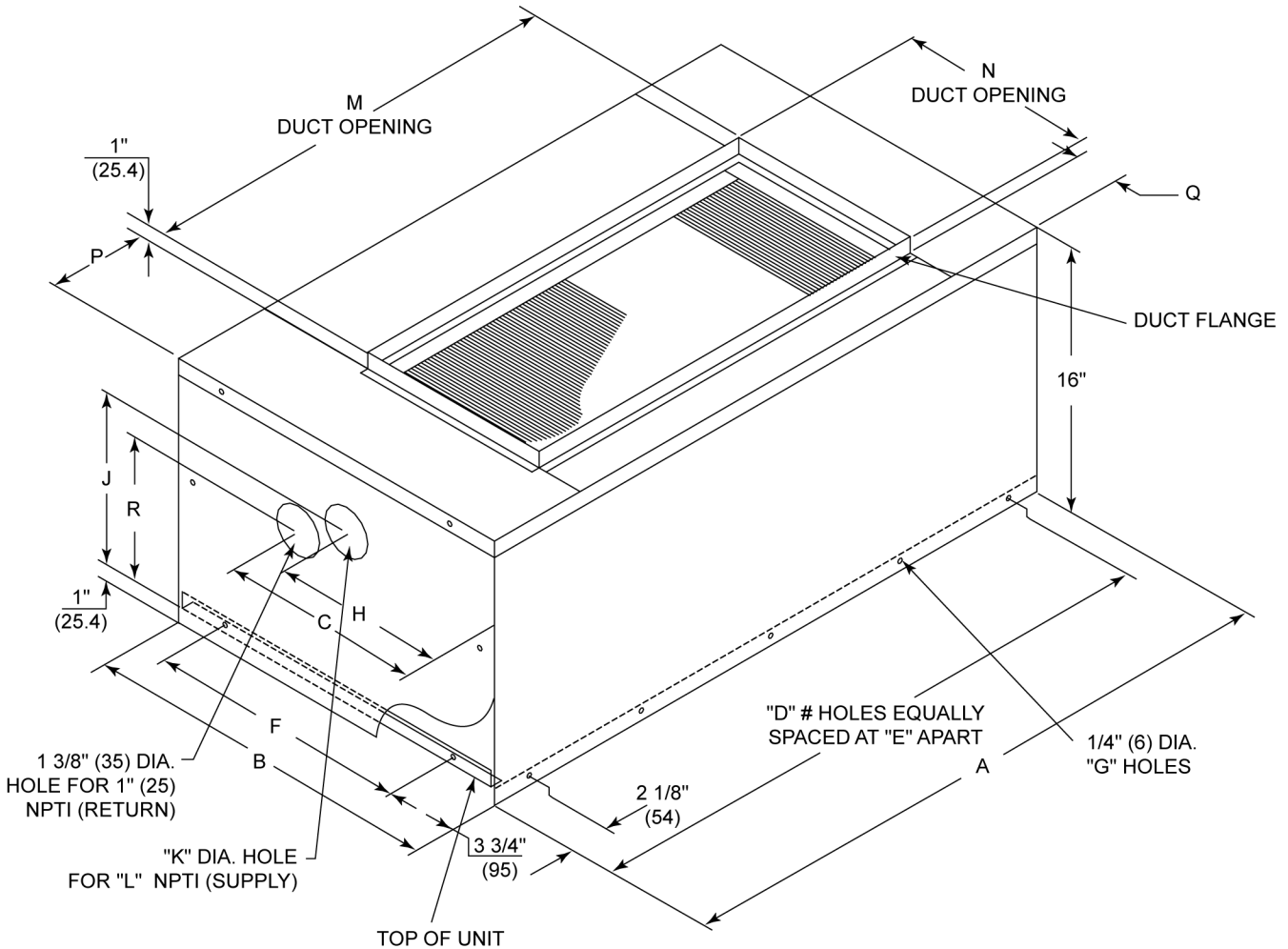

Note: Duct flange available as kit. See accessories chapter for details.

**Table 73. Steam coil accessory – in (mm)**

Model No.	A	B	C	D	E	F	G	H	J	K
BAYWATR022	38.14 (969)	22.74 (577)	14.32 (364)	5 (127)	9 (229)	13.67 (347)	16 (406)	10.88 (276)	11.17 (284)	2 (51)
BAYWATR023	47.74 (1212)	25.74 (654)	20.14 (511)	5 (127)	10.84 (275)	17.17 (436)	16 (406)	10.88 (276)	11.17 (284)	2 (51)
BAYWATR024	63.84 (1621)	25.74 (654)	20.14 (511)	6 (152)	11.87 (301)	17.16 (436)	18 (457)	13.70 (348)	10.57 (268)	2.5 (64)
BAYWATR025	79.74 (2025)	29.18 (741)	18.55 (471)	8 (203)	10.85 (275)	19.67 (500)	22 (559)	12.11 (308)	10.05 (255)	2.5 (64)
BAYWATR026	92.74 (2355)	31.24 (793)	20.67 (525)	8 (203)	10.85 (275)	19.67 (500)	22 (559)	14.23 (361)	10.01 (254)	2.5 (64)

**Table 73. Steam coil accessory – in (mm) (continued)**

Model No.	L	M	N	P	Q	R
BAYWATR022	1.5 (38)	26 (660)	12 (305)	6 (152)	2.87 (73)	9.95 (253)
BAYWATR023	2 (51)	30 (762)	18 (457)	8.87 (225)	2.87 (73)	9.95 (253)
BAYWATR024	2 (51)	36 (914)	18 (457)	13.87 (352)	2.87 (73)	9.13 (232)
BAYWATR025	2 (51)	51 (1295)	18 (457)	14.12 (359)	1.87 (48)	8.61 (219)
BAYWATR026	2 (51)	64 (1626)	18 (457)	14.12 (359)	3.75 (95)	8.58 (218)

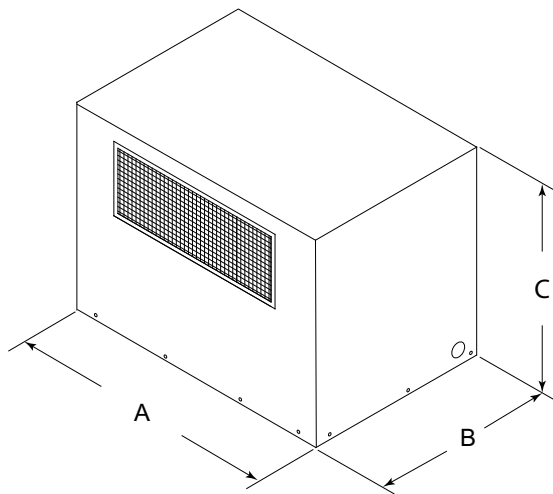
**Figure 40. Discharge plenum and grille accessory**

**Table 74. Discharge plenum and grille dimensions – no heat – in (mm)**

Unit	Model No. <sup>(a)</sup>	A	B	C
TWE060	BAYPLNM015	37.94 (963.6)	21.94 (557.2)	28 (711.2)
TWE072, TWE090	BAYPLNM016	47.5 (1206.5)	24.99 (634.7)	28 (711.2)
TWE120	BAYPLNM017	63.5 (1612.9)	24.99 (634.7)	28 (711.2)
TWE150, TWE180	BAYPLNM018 <sup>(b)</sup>	79.5 (2019.3)	27.63 (701.8)	22 (558.8)
TWE240, TWE300	BAYPLNM019 <sup>(b)</sup>	92.5 (2349.5)	30.43 (772.9)	24 (609.6)

<sup>(a)</sup> When installed horizontally, plenum/water coil must be self-supported.

<sup>(b)</sup> For use with hydronic heat or no heat.

## Dimensional Data

**Figure 41. Discharge plenum and grille accessory**

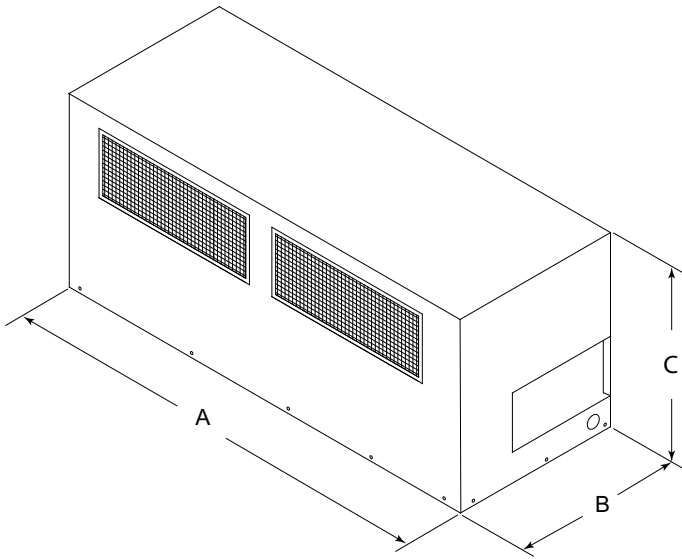

**Table 75. Discharge plenum and grille dimensions (for use with electric heat) – in (mm)**

Tons	Model No.	A	B	C
TWE060	BAYPLNM030	38.07 (967)	22.69 (576.3)	29.05 (738)
TWE072, TWE090	BAYPLNM031	47.86 (1216)	25.69 (652.5)	29.05 (738)
TWE120	BAYPLNM032	63.86 (1622)	25.69 (652.5)	29.05 (738)
TWE150, TWE180	BAYPLNM033	80.14 (2036)	29.10 (739.1)	35.11 (892)
TWE240, TWE300	BAYPLNM034	92.96 (2361)	31.10 (789.9)	35.05 (890)

**Figure 42. Subbase accessory – in (mm)**

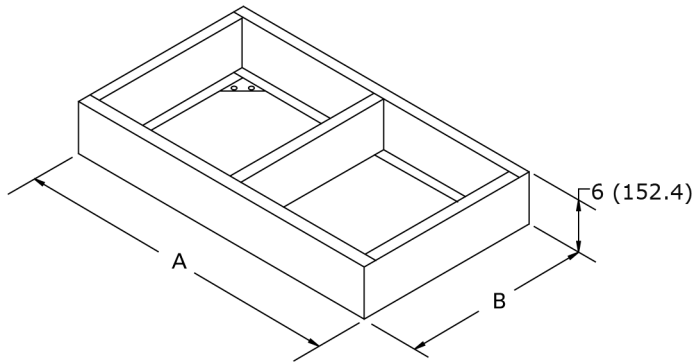

**Table 76. Subbase dimensions – in (mm)**

Tons	Model No.	A	B
TWE060	BAYBASE009	38 (965.2)	22.63 (574.8)
TWE072, TWE090	BAYBASE010	47.5 (1206.5)	25.51 (648.0)
TWE120	BAYBASE011	63.5 (1612.9)	25.52 (648.2)
TWE150, TWE180	BAYBASE012	79.5 (2019.3)	29.04 (737.6)
TWE240, TWE300	BAYBASE013	92.5 (2349.5)	31.14 (791.0)



# Weights

## Heat Pump Condenser

Table 77. TWA R-454B unit and corner weights — lbs (60 Hz)

Tons	Model No.	Shipping Max (lbs)	Net Max (lbs)	Corner Weights			
				1	2	3	4
6	TWA072K*A	360	325	112	83	56	76
	TWA072K*D	434	395	138	94	100	65
7.5	TWA090K*A	395	363	90	128	66	80
	TWA090K*D	484	445	156	105	113	73
10	TWA120K*A	495	440	156	103	110	72
	TWA120K*D	487	448	157	106	113	74
12.5	TWA150K*D	550	498	172	121	122	83
15	TWA180K*D	874	782	242	172	202	169
20	TWA240K*D	1004	914	274	287	160	196
25	TWA300K*D	1070	980	291	303	176	213

Figure 43. TWA072, 090, 120, 150

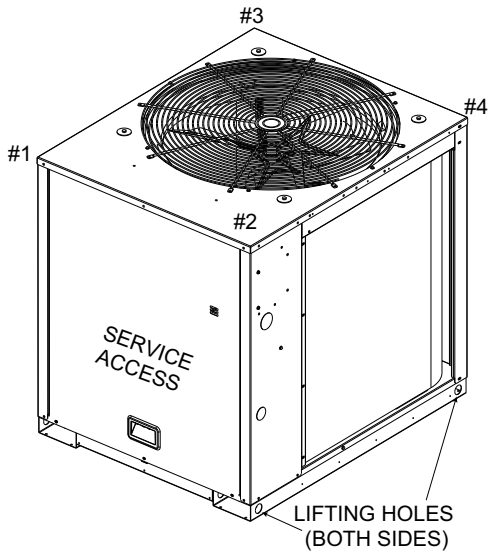
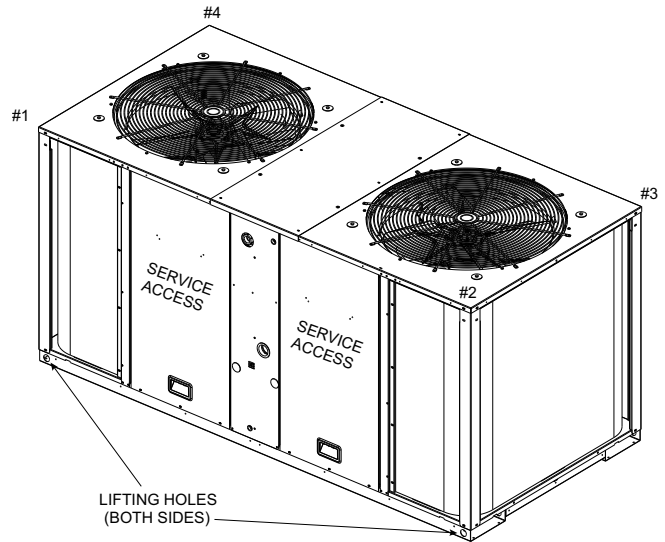

Figure 44. TWA180, 240, 300



## Air Handler

Table 78. Constant volume air handler (TWE) — unit and corner weights - (60 Hz)

Tons	Model Number	Shipping Max (lbs)	Net Max (lbs)	Corner Weights - Vertical				Corner Weights - Horizontal			
				1	2	3	4	1	2	3	4
5	TWE060K(3,4,W,1)A	285	232	55	71	51	55	54	67	50	61
	TWE060K(3,4)B										
7.5	TWE090K(1), A/B	385	323	67	99	75	82	56	92	87	88
10	TWE120K(1)A/B	441	393	77	121	110	85	79	118	77	119



# Weights

**Table 79. SZVAV and 2-Speed VFD air handler (TWE) — unit and corner weights - (60 Hz)**

Tons	Model Number	Shipping Max (lbs)	Net Max (lbs)	Corner Weights - Vertical				Corner Weights - Horizontal			
				1	2	3	4	1	2	3	4
6	TWE072K*B	398	336	70	102	78	86	59	95	90	92
7.5	TWE090K*A/B	398	336	70	102	78	86	59	95	90	92
10	TWE120K*A/B	454	406	80	124	113	89	82	121	80	123
12.5	TWE150K*B	766	689	171	195	184	139	199	167	148	175
15	TWE180K*B	765	688	170	195	184	139	199	166	148	175
20	TWE240K*B	925	831	261	171	164	235	259	184	149	239
25	TWE300K*B	1015	921	217	235	189	280	278	182	233	228

**Figure 45. Vertical — TWE060, 072, 090, 120**

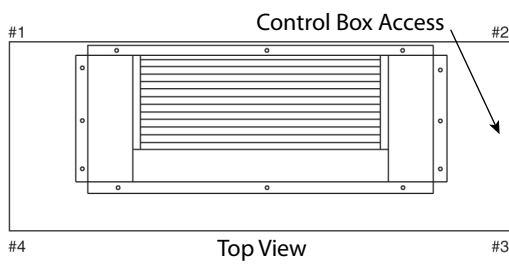

**Figure 46. Vertical — TWE150, 180, 240, 300**

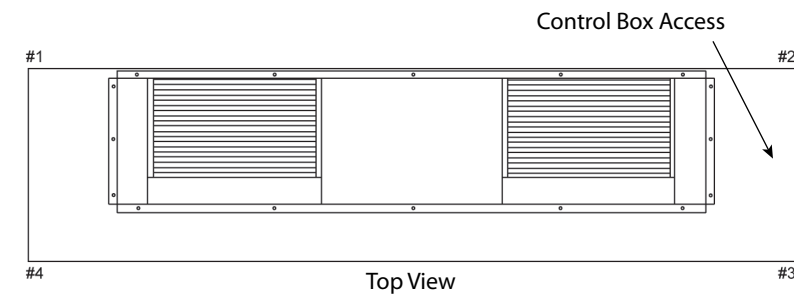

**Figure 47. Horizontal — TWE060, 072, 090, 120**

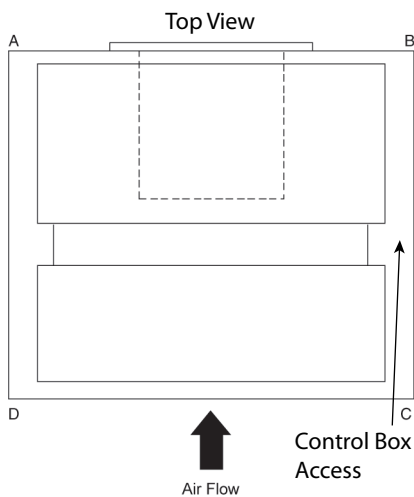

**Figure 48. Horizontal — TWE150, 180, 240, 300**

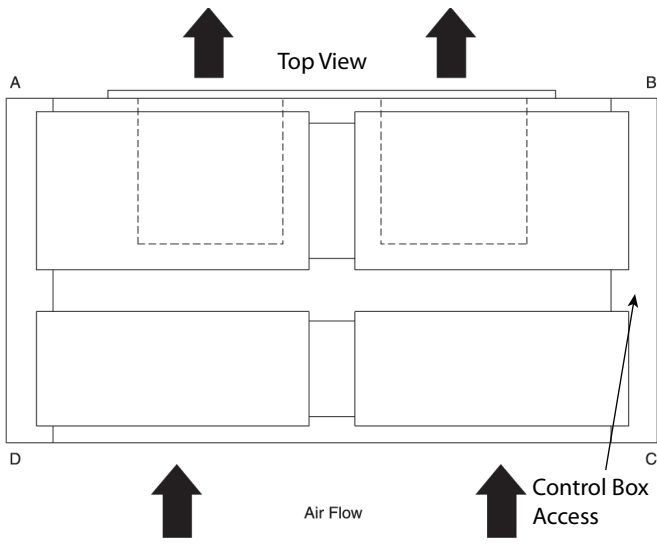



## Weights

### Accessories

Table 80. Accessory weights (net lbs.)

Unit Used w/ Tons	Hot Water Coil	Steam Coil	Discharge Plenum and Grille with Hydronic Heat	Discharge Plenum and Grille without Heat	Discharge Plenum and Grille with Electric Heat	Return Air Grille	Electric Heat Min/Max	Subbase	Oversized Motor	RIS Isolator Floor Mount
6	116	131	78	73	160	5	27/45	19.4	48	2
7.5	116	131	78	73	160	5	27/45	19.4	48	2
10	165	148	97	92	195	7	27/45	23.5	50	2
12.5	211	234	—	230	235	10	79/100	28.4	80	2
15	211	234	—	230	235	10	79/100	28.4	80	2
20	242	261	—	145	265	12	79/100	31.7	88	2
25	242	261	—	145	265	12	79/100	31.7	129	2
Unit Used w/ Tons	RIS Isolator Suspended Mount	Steel Spring Isolator Floor Mount	Steel Spring Isolator Suspended Mount	Hail Guard	Control Transformer	Sensors	Expansion Module	Low Ambient	Service Valve	
6	6	12	6	21	4	1	13	13	5	
7.5	6	12	6	21	4	1	13	13	5	
10	7	12	6	28	4	1	13	13	5	
12.5	7	12	6	28	4	1	13	13	5	
15	7	12	6	55	4	1	2	2	5	
20	9	12	6	55	4	1	2	2	5	
25	9	12	6	71	4	1	2	2	5	



# Mechanical Specifications

## Condensing Units

### Standard Features

#### General

- Weatherproofed steel mounting/lifting rails
- Hermetic scroll compressors
- Plate fin condenser coils
- Fans and motors
- Standard operating range 50-125°F (min. 0°F with low ambient accessory)
- Nitrogen holding charge
- Certified and rated in accordance with AHRI and DOE standards
- Certified to UL 60335-2-40
- Capacities and efficiencies for split systems are rated within the scope of the Air-Conditioning, Heating, and Refrigeration Institute (AHRI) certification program and display the AHRI Standard 340-360 (I-P) mark. This standard applies to units between 65,000 and 250,000 btu/hr.

#### Casing

- Zinc coated, heavy gauge, galvanized steel
- Weather resistant baked enamel finish
- Meets ASTM B117, 672 hour salt spray test
- Removable single side maintenance access panels
- Lifting handles in maintenance access panels
- Unit base provisions for forklift and/or crane lifting

#### Refrigeration System - Single Compressor (TWA072\*\*A, TWA090\*\*A, TWA120\*\*A)

- Single refrigeration circuit with integral subcooling circuit
- Single direct drive hermetic scroll compressor
- Suction gas-cooled motor w/  $\pm 10\%$  voltage utilization range of unit nameplate voltage
- Reversing valve
- Crankcase heater
- Internal temperature and current sensitive motor overloads
- No compressor suction and/or discharge valves (reduced vibration/sound)
- Factory installed liquid line filter drier
- Phase loss/reverse rotation monitor
- External high pressure cutout device
- External low pressure cutout device
- Evaporator defrost control
- Loss of charge protection (discharge temperature limit)

#### Refrigeration System - Dual Compressor (TWA072\*\*D, TWA090\*\*D, TWA120\*\*D, TWA150\*\*D, TWA180\*\*D, TWA240\*\*D, TWA300\*\*D)

- Two (2) separate and independent refrigerant circuits
- Each refrigeration circuit equipped with integral subcooling circuit
- Two (2) direct drive hermetic scroll compressor
- Suction gas-cooled motors w/  $\pm 10\%$  voltage utilization range of unit nameplate voltage
- Reversing valves
- Crankcase Heaters
- Internal temperature and current sensitive motor overloads
- Factory installed liquid line filter driers
- Phase loss/reverse rotation monitor
- No compressor suction and/or discharge valves (reduced vibration/sound)
- External high pressure cutout devices



## Mechanical Specifications

---

- External low pressure cutout devices
- Evaporator defrost control
- Loss of charge protection (discharge temperature limits)

### Condenser Coil (Fin and Tube)

- 3/8-inch internally enhanced copper tube
- Mechanically bonded to lanced aluminum plate fins
- Factory pressure and leak tested to 660 psig
- Perforated steel hail guards available

### Condenser Fan

- 26-inch or 28-inch propeller fan(s)
- Direct drive
- Statically and dynamically balanced

### Condenser Motor(s)

- Permanently lubricated totally enclosed or open construction
- Built-in current and thermal overloads
- Ball or sleeve bearing type

### Controls

- Centralized microprocessor
- Indoor and outdoor temperature sensors drive algorithms, making decisions for all heating, cooling, and ventilation
- Integrated anti-short cycle timer
- Integrated time delay between compressors
- Completely internally wired
- Colored and keyed connectors and colored wires
- Contactor pressure lugs or terminal block
- Unit external mounting location for disconnect device
- Single point power entry

### Coil Guards

- Condenser coil protection from hail, vandals, etc.
- Perforated, painted galvanized steel
- Factory or field installed

### Factory Installed Options

#### Black Epoxy Coated Condenser Coil (Fin and Tube)

- Thermoset vinyl coating
- Bonded to aluminum fin stock (prior to fin-stamping process)
- Economical protectant in mildly corrosive environments

#### BACnet Communication Options

- BACnet MS/TP -BACnet IP
- Allows unit communication with Trane or generic BACnet building automation controls

#### Advanced Diagnostics and LonTalk Communication Interface

- Factory or field installed
- Allows unit communication as a Tracer Lon® device
- Allows unit communication with generic LonTalk® Network building automation controls

### Field Installed Options

#### Low Ambient (Fan ON/OFF)

- Provides unit cooling operation to outdoor ambient of 0°F
- Low cost solution

- Discharge pressure controls condenser fan operation

**Service Valves**

- Liquid line service valve (with gauge port)
- Suction line service valve (with gauge port)

**Vibration Isolators**

- Neoprene-in-shear or spring flex choice
- Reduce vibration transmission to building structures, equipment, and adjacent spaces
- Reduce noise transmission to building structures, equipment, and adjacent spaces

**Zone Sensor**

- Interfaces with microprocessor units
- Manual or automatic programmable
- System malfunction lights
- Remote sensor options

**Thermostat**

- 1H/1C available
- 2H/1C available
- Manual or automatic changeover available
- Programmable and non-programmable solutions available

**LonTalk Communication Interface**

- Factory or field installed
- Allows unit communication as a Tracer Lon® device
- Allows unit communication with generic LonTalk® Network building automation controls

**Air Handlers****Standard Features****General**

- Completely factory assembled
- Convertible for horizontal or vertical configuration
- Convertible for cooling only or heat pump application
- Convertible for left or right external connections (refrigerant and/or electrical)
- Convertible for front or bottom air return
- Nitrogen holding charge
- Certified to UL60335-2-40 for indoor blower coil units

**Casing**

- Zinc coated, heavy gauge, galvanized steel
- Weather resistant baked enamel finish
- Access panels with captive screws
- Completely insulated with foil faced, cleanable, fire retardant, permanent, odorless glass fiber material
- Captured or sealed insulation edges
- Electrical connection bushings or plugs
- Refrigerant connection bushings or plugs
- Withstand elevated internal static pressure

**Refrigeration System**

- Single or dual circuit
- Distributor(s)
- Thermal expansion valves (TXVs)



## Mechanical Specifications

---

### Evaporator Coil

- 3/8-inch internally enhanced copper tube mechanically bonded to lanced aluminum plate fins
- Factory pressure and leak tested to 449 psig.
- Draw-through airflow
- Dual circuits are interlaced/intertwined
- Double sloped, removable, cleanable, composite drain pan
- Four drain pan positions

### Indoor Fan

- Double inlet, double width, forward curved, centrifugal type fan
- Dual fans on 15 to 20 ton air handlers
- Adjustable belt drive
- Permanently lubricated bearings

### Indoor Motor

- Adjustable motor sheaves (constant volume units)
- Fixed motor sheaves (SZVAV and 2-Speed VFD)
- Thermal overload protection
- Permanently lubricated bearings
- Meet energy policy of 1992 (EPACT)
- Optional oversized motors for high static applications

### Controls

- Completely internally wired
- Colored and keyed connectors, colored wires
- Magnetic indoor fan contactor
- Detachable low voltage connectors
- Single point power entry
- Evaporator defrost control

### Filters

- Access from side coil panels
- Filters slide on rack
- One inch (1"), throwaway filters on 5 to 10 ton units
- Filter rack convertible to two inch (2") capability on 5 to 10 ton units
- Two inch (2"), throwaway filters on 15 to 20 ton units

### Leak Detection System

- Added as per safety standard UL 60335-2-40
- Two refrigerant detection sensors are present
- Reduces the risk of improper installation in the field as well as bypassing the added cost in the field for installation.

## Factory Installed Options

### Constant Volume Airflow

Factory installed high static motor available

### 2-Speed VFD Control

- 2-Speed airflow
- Variable Frequency Drive (VFD)
- Motor soft start — avoids start up belt noise and increases belt life
- Programmable keypad accessible outside of airstream
- VFD rated motor
- Factory installed high static motor available

### Single Zone Variable Air Volume/2-Speed Airflow

- Variable Frequency Drive (VFD)
- Motor soft start — avoids start up belt noise and increases belt life
- Programmable VFD keypad accessible outside of airstream
- Airflow adjustment via display/keypad on Symbio™ 700 controller in condenser
- Discharge air sensor
- Symbio 700 Options Module
- VFD rated motor
- Factory installed oversized motor available

## Field Installed Options

### Electric Heaters

- Heavy duty nickel chromium elements
- Agency approved
- Installs directly on fan discharge
- One or two stage control (dependent upon capacity)
- Single point power entry
- Terminal strip connections
- 460V Heaters
  - Internally wye connected
  - Automatic line break high limit controls with secondary single action disc limits
- 230V Heaters
  - Internally delta connected
  - Automatic reset of high limit controls through pilot duty with secondary backup fuse links

### Hydronic Heat Coils

- One row steam
- Two row hot water
- Installs directly on fan discharge
- Heavy gauge sheet metal casing matches air handler
- Convertible for horizontal or vertical configurations

### Discharge Plenums and Grilles

- Vertical, free discharge applications
- Heavy gauge sheet metal casing matches air handler
- Satin-finished, 4-way adjustable louver grilles

### Return Air Grilles

- Vertical, free discharge applications
- Satin-finished, non-adjustable louver grilles
- Replaces front lower access panel



## Mechanical Specifications

---

### Mounting Sub-Base

- Vertical floor mount configuration requirement
- Heavy gauge sheet metal casing matches air handler
- Provides additional clearance for condensate drain trapping
- Required when isolators are used

### Vibration Isolators

- Neoprene-in-shear or spring flex choice
- Floor or suspended applications
- Reduce vibration transmission to building structures, equipment, and adjacent spaces
- Reduce noise transmission to building structures, equipment, and adjacent spaces

### Oversize Motors

- High static applications
- Motor, sheaves, belt included

### Filters

- 2 inch, MERV 13 high efficiency filters





**Notes**

---





The AHRI Certified mark indicates Trane U.S. Inc. participation in the AHRI Certification program. For verification of individual certified products, go to [ahridirectory.org](http://ahridirectory.org).

Trane - by Trane Technologies (NYSE: TT), a global innovator - creates comfortable, energy efficient indoor environments for commercial and residential applications. For more information, please visit [trane.com](http://trane.com) or [tranetechnologies.com](http://tranetechnologies.com).

Trane has a policy of continuous product and product data improvements and reserves the right to change design and specifications without notice. We are committed to using environmentally conscious print practices.