



Product Catalog

# Split System Air Conditioners Odyssey™ with Symbio™ Controls

Cooling Condenser, 6 to 25 Tons, 60Hz

Air Handler, 5 to 25 Tons, 60Hz





# Introduction



Odyssey™ Split Systems offer a wide range of options, allowing you to easily match unit tonnage with the right load requirements.

When a project calls for the convenience and cost efficiency of a unitary product, where a rooftop unit isn't right, Odyssey may be the answer. It provides heating and cooling in a split configuration that's unique in its versatility while staying true to our standards for efficiency and reliability. And with the Symbio® digital controller on board, Odyssey introduces smart building capabilities that take service, comfort and sustainability beyond the expected.

With wide network availability, flexible applications, installation ease, built-in reliability and easy servicing, Odyssey will meet any number of customer applications. Add to that outstanding customer service and you have the formula to make Odyssey the clear choice for continued customer satisfaction.

## Wide Network Availability

A broad distribution network provides owners, maintenance personnel, contractors, etc., the means to get their hands on equipment when they need it. Whether it's an emergency replacement or a new construction project in its infancy stages, Odyssey products meet an array of needs at the right time and right price.

## Flexible Applications

No matter what the application, Odyssey provides the solution. A broad array of models and tonnages are available with single or dual compressors, single or dual circuits and numerous accessories. Condensing units can be installed on the ground or on a rooftop along with extended piping runs, while air handlers can be free discharge on the ground or horizontally suspended with long duct runs from a ceiling. Should application challenges arise, Odyssey delivers.

## Easy to Install

Small footprints and low weights combined with factory installed components like TXVs, filter driers, etc., reduce installation time and cost. Colored connectors and wiring, as well as factory-tested units make Odyssey the right choice.

## Built-in Reliability

Keeping in mind that productivity only occurs when equipment is operational, Trane has taken the steps to ensure that Odyssey is up and running. Early indicators such as phase/reversal monitors and loss of charge protection provide diagnostics which prevent failure and provide years of worry-free service and operation.

## Easy to Service

When preventive maintenance or service is required, technicians will find efficient access to both air handlers and condensers. Panels provide complete, easy access coupled with standardized cabinets in which all components are located in proximity. Odyssey's improved design results in minimum service times and costs.

With these capabilities, Odyssey provides customers high efficiency and superior performance for the best all-around value in the market today.

## Copyright

This document and the information in it are the property of Trane, and may not be used or reproduced in whole or in part without written permission. Trane reserves the right to revise this publication at any time, and to make changes to its content without obligation to notify any person of such revision or change.

## Trademarks

All trademarks referenced in this document are the trademarks of their respective owners.

## Revision History

- Added 575V data in Accessories, Model Number Description, and Electrical Data chapters.
- Updated 6 to 10 tons (TWE072K\*B\* – TWE120K\*B\*) SZVAV and 2-speed VFD air handler table in general data chapter.
- Updated gross cooling capacities in performance data chapter.



# Table of Contents

Features .....	6
Split System Overview.....	6
Other Features .....	7
Standard and Optional Features .....	7
Standard Controls .....	11
Additional Controls .....	12
Accessories .....	13
Cooling Condenser .....	13
Air Handler.....	14
Electric Heaters .....	16
Application Considerations .....	17
Clearance Requirements .....	17
Low Ambient Cooling.....	17
A2L Application Considerations.....	19
Leak Detection System(Refrigerant charge greater than 3.91 lb per circuit) .....	21
Selection Procedure .....	23
Cooling Capacity .....	23
Heating Capacity .....	23
Air Delivery .....	23
Model Number Description .....	24
Cooling Condenser .....	24
Air Handler.....	25
General Data .....	26
Performance Data .....	32
Gross Cooling Capacities .....	32
Fan Performance .....	65
Zone Controls .....	89
Zone Sensors .....	89
Conventional Thermostats .....	89
Electrical Data .....	90
Cooling Condenser .....	90
Air Handler.....	91
Jobsite Connections .....	101
Symbio™ Controls .....	101



Dimensional Data .....	103
Cooling Condenser .....	103
Air Handler .....	111
Accessories .....	119
Weights .....	126
Cooling Condenser .....	126
Air Handler .....	127
Mechanical Specifications .....	130
Condensing Units .....	130
Air Handlers .....	133



# Features

## Split System Overview

Unlike typical split systems on the market, Odyssey offers easy servicing, built-in reliability, ease of installation and outstanding customer service. And because today's owners are very cost-conscious when it comes to service and maintenance, the Odyssey Split System was designed with direct input from service contractors. This valuable information helped to design a product that would get the service person off the job quicker and save the owner money.

## Flexible Applications

Odyssey offers outstanding standard features enhanced by a variety of factory and field installed options, multiple control options, rigorously tested proven designs and superior product and technical support. Because of this, Odyssey offers ultimate flexibility. Units are built to order in our standard "shortest in the industry" ship cycle time. Odyssey is available with single, dual and manifolded compressor options. Single compressor outdoor units feature a single refrigeration circuitry, lowering job installation costs by requiring only one set of refrigerant lines.

Equally important, Odyssey offers single refrigerant circuit/capacity unloading models. The unloading units feature dual manifolded scroll compressors with two stages of capacity modulation and a single refrigeration circuit. Dual compressor/dual circuit models give true stand-by protection - if one compressor fails, the second will automatically start-up. Also, the first compressor can be serviced without shutting down the unit since the refrigerant circuits are independent. Dual compressor models also save on energy costs. During light load conditions, only one compressor will operate to save energy.

Factory installed VFD is standard with most units. These 2-Speed and Single Zone VAV (SZVAV) solutions, combined with condensing units that have multiple compressors, provide increased part load performance (IEER) when conditions are not at the max design condition. Additionally, some states have adopted codes that require this type of performance. Odyssey units are built with installation in mind. With a smaller footprint, the outdoor unit takes up less space and weighs less, making its installation more efficient and economical. Our indoor air handlers are built to be installed in confined spaces, fitting through standard doorways and freight elevators.

## Unmatched Product Support

One of our finest assets, Trane Sales Representatives are a support group that can assist you with:

- Product
- Application
- Service
- Training
- Special Applications
- Specifications
- Computer Programs and much more

## Rigorous Testing

Our units are rigorously rain tested to ensure water integrity. Actual shipping tests are performed to determine packaging requirements. Units are test shipped around the country to determine the best packaging. Factory shake and drop tests are used as part of the package design process to help assure that the unit arrives at the job site in top condition. Rigging tests include lifting a unit into the air and letting it drop one foot, assuring that the lifting lugs and rails hold up under stress. A 100% coil leak test is performed at the factory. The condenser coils are leak tested at 660 psig and evaporators to 450 psig. All parts are inspected at the point of final assembly. Sub-standard parts are identified and rejected immediately. Every unit receives a 100% unit run test before leaving the production line to ensure it lives up to rigorous Trane requirements.

## Other Features

### Microchannel Condenser Coil

Microchannel condensing coils are all-aluminum coils with fully-brazed construction. This design reduces risk of leaks and provides increased coil rigidity — making them more rugged on the jobsite. Their flat streamlined tubes with small ports and metallurgical tube-to-fin bond allow for exceptional heat transfer. Microchannel all-aluminum construction provides several additional benefits:

- Light weight (simplifies coil handling)
- Easy to recycle
- Minimize galvanic corrosion

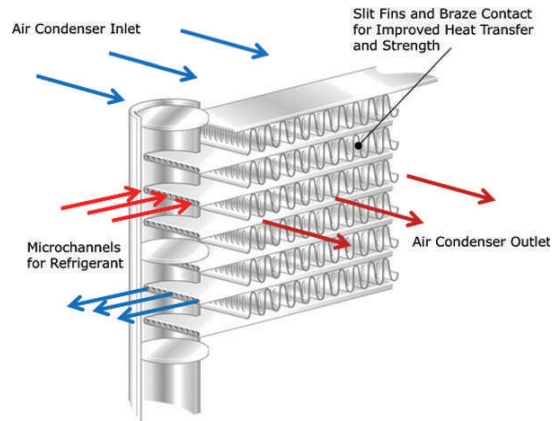

## Standard and Optional Features

Figure 1. Compressors

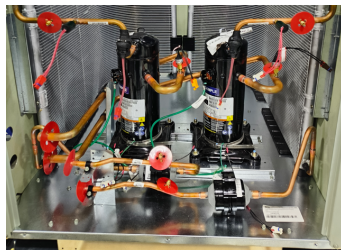
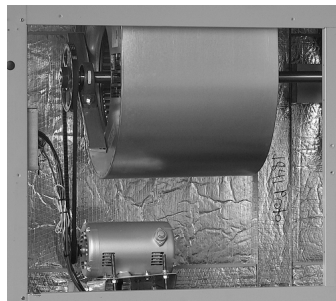

Figure 2. Belt drive motor



**2-Speed VFD** — A variable frequency drive is used to reduce the supply fan motor speed to 66% of its full capacity during part load cooling conditions.

**Airflow Distribution** — Odyssey can replace an older machine with old ductwork and, in many cases, improve the comfort through better air distribution.

**Anti-Short Cycle Timing** — The Symbio™ 700 controller provides a 3 minute minimum “ON” time and 3 minute “OFF” time for compressors to enhance compressor reliability by assuring proper oil return.

**Belt Drive Motors** — For additional static requirements, Odyssey Split Systems offer standard belt drive motors to meet and exceed a wide range of airflow needs.

**Coil Guards** — Coil Guards are optional with all condensers. This feature protects the condenser coil from vandalism and/or hail damage.



**Colored Connectors and Wiring** — Interconnecting wiring between components is standardized using colored and keyed connectors and colored wires, helping to save time and money tracing wires and diagnosing the unit.

**Compressors** — Odyssey Split Systems contain the best compressor technology available to achieve the highest possible performance. Dual compressors perform very well under part load cooling conditions and system back-up applications. Dual compressors are available on 6-25 ton models and allow for efficient cooling utilizing 2-stages of compressor operation.

**Complete Coat™ Microchannel Condenser Coil** — This cathodic, epoxy-type electro-disposition coating is formulated for high edge builds and provides excellent resistance and durability in potentially corrosive environments due to alkalis, acids, alcohols, petroleum, seawater, salty air, etc. Available for Microchannel units only.

**Convertible Units** — The air handlers ship in a horizontal configuration. They can be easily converted to vertical by simply repositioning the drain pan.

**Crankcase Heaters** — These band heaters provide improved compressor reliability by warming the oil to prevent migration during off-cycles or low ambient conditions.

**Dual Sloped Drain Pans** — Every Odyssey unit has a non-corrosive, removable, double sloped drain pan that's easy to clean and reversible to allow installation of drain trap in two positions on either side of the unit.

**Duct flanges** — An optional field installed kit that can save time and money.

**Easy Access Low Voltage Connections** — Thermostat and other low voltage control wiring connections are made directly to the Symbio 700 and other boards in the system. Screw-type pressure connectors are detachable from the boards for easy connection of control wires – saving cost and time.

**Electric Heaters** — Electric heat modules are available in a variety of voltages and capacities.

**Foil Faced Insulation** — All internal air handler surfaces have cleanable foil-faced insulation. All edges are either captured or sealed to ensure insulation fibers do not get into the airstream.

**High Static Motor** — This high static motor accessory extends the capability of the standard unit.

**High and Low Voltage Control Panel** — High voltage components and connections are isolated from low voltage and covered with a sheet metal panel. This allows setup and test parameters at the Symbio™ 700 display and the VFD keypad display to be safely viewed and adjusted in the low voltage section of the control panel.

**High Pressure Control** — All units include High Pressure Control as standard.

**Low Ambient Cooling** — All Odyssey units have cooling capabilities down to 0°F as standard. At temperatures below 50°F, some reduction in cooling capacity can be expected. When the optional Low Ambient Accessory kit is field installed, the full capacity of the unit is available down to 0°F.

**Low Voltage Connections** — Low voltage wiring connects directly to the control boards in the unit via detachable connectors. This makes it easy for the installer to attach the wires and then snap the connectors into place.

**Phase Monitor/Reversal Protection** — Phase monitor shall provide 100% protection for motors and compressors against problems caused by phase loss, phase imbalance, and phase reversal. Phase monitors are equipped with an LED that provides an ON or FAULT indicator.

**ID Fan Fail** — The Symbio™ 700 controller provides a ID fan fail feature caused by belt failure and motor freewheeling under no load. The Variable Frequency Drive records the motor torque and if below a certain value shuts the unit. Fan Fail error is displayed on controller display.

**Quick-Access Panels** — Remove a few screws for access to the standardized internal components and wiring.

**Single Point Power** — A single electrical connection powers the unit.

**Single Side Service** — Single side service is standard on all units.

**Single Zone Variable Air Volume (SZVAV)** — A variable frequency drive is used in conjunction with the Symbio™ 700 to provide supply fan motor speed modulation. For SZVAV control, the drive will accelerate or decelerate as required to meet the Zone Cooling demand. In order to maximize energy savings, the VFD will be held at minimum speed until the load in the zone requires the speed to

increase. The supply fan speed will be reduced to a minimum of 58%<sup>1</sup> during ventilation and part load cooling demands, and 80% during full load cooling demands with the ability to fully modulate. The commissioning maximum and minimum airflow points can be easily set by programming these parameters at the display on the Symbio control board.

**Standardized Components** — Components are placed in the same location on all Odyssey units. Because of these standardized components throughout the Odyssey line, contractors/owners can stock fewer parts.

**Symbio™ 700** — Standard on Odyssey condensers, the Symbio™ 700 controller provides exceptional machine control with a focus on system reliability and application flexibility. The Symbio controller provides direct access to the Symbio Service and Installation mobile application for easy setup and troubleshooting with no special tools. A wide range of system integration options (Non-communicating, BACnet®, LonTalk®, etc.) provide options to meet the needs of your application.

**Thermal Expansion Valve with Bypass Check Valves** — This feature is standard on all indoor units.

**Unit Cabinet** — The compact cabinet takes up less room and is less costly to ship. The design also ensures water integrity.

**Leak Detection System** — Trane's Leak Detection System (LDS) consists of one or more refrigerant detection sensors and is required in ducted HVAC systems that have more than 4 lbs of A2L refrigerant charge, per safety standard UL 60335-2-40. For any units with more than 4 lbs of charge in a circuit, Trane will factory-install an LDS. Having the leak detector installed in the factory by the manufacturer on applicable units reduces the risk of improper installation in the field as well as bypassing the added cost in the field for installation, leading to peace of mind that the right solution has been applied to your unit.

---

<sup>1</sup>. 64% for part load and 83% for full load if a max speed of less than 44.5 Hz is desired.



## Features

**Table 1. Odyssey features – standard and optional**

	Standard Features	Options <sup>(a)</sup>	
		Factory Installed	Field Installed
1-year Limited Parts Warranty	X		
5-year Limited Compressor Warranty	X		
2-Speed Variable Frequency Drive		X	
Belt Drive Motors	X		
Coil Guards		X	X
Colored Connectors and Wiring	X		
Complete Coat™ Microchannel Condenser Coil		X	
Compressor Discharge Temperature Limit (DTL)	X		
Convertible Airflow	X		
Crankcase Heaters	X		
Easy Access Low Voltage Connections	X		
Electric Heaters			X
Filters	X		
Filters – 2" MERV 13			X
Foil-Faced and Edge Captured Insulation	X		
High Pressure Control	X		
High Static Motor Kit <sup>(b)</sup>			X
Hot Gas Bypass			X
IAQ Dual Sloped and Removable Drain Pans	X		
Leak Detection System	X		
Low Ambient Cooling			X
Liquid Line Refrigerant Drier	X		
Low Pressure Control	X		
Low Static Motor Kit			X
Low Voltage Circuit Protection	X		
Phase Loss/Reversal Monitor	X		
Quick Access Panels	X		
Scroll Compressors	X		
Single Point Power	X		
Single Side Service	X		
Single Zone Variable Air Volume (SZVAV / 2-Speed Fan)		X	
Standardized Components	X		
Symbio™ Controls	X		
Thermal Expansion Valve	X		
Vibration Isolators			X

<sup>(a)</sup> Refer to model number description for option availability or contact Product Support.

<sup>(b)</sup> Available on constant volume units only. See Accessories chapter for more information.

## Standard Controls

### Symbio™ 700 Controls

Figure 3. Symbio 700 board

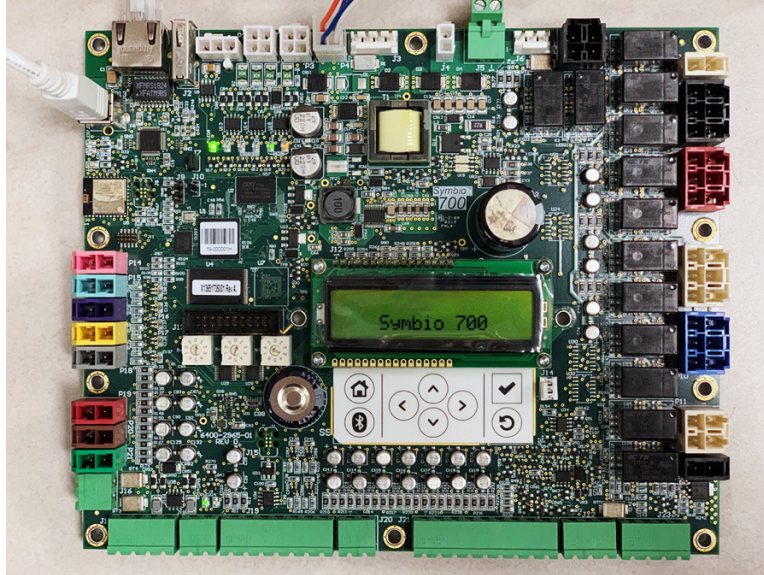

Symbio 700 controls provide unit control for heating, cooling, and ventilating, utilizing input from sensors that measure outdoor and indoor temperature. Symbio also provides outputs for building automation systems and expanded diagnostics. Quality and reliability are enhanced through Symbio control and logic:

- Prevents the unit from short cycling, considerably improving compressor life.
- Ensures the compressor will run for a specific amount of time which allows oil to return for better lubrication, enhancing the reliability of the compressor.
- Provides refrigerant leak detection system and mitigation response when refrigerant is detected as required by the UL 60335-2-40 standard.
- Reduces the number of components required to operate the unit, reducing possibilities for component failure.

### Installation and Service

The Symbio™ 700 control platform provides a user-friendly, onboard interface that makes setup and continued operation easy – or users can take advantage of the Symbio™ Service and Installation Mobile App for setup, troubleshooting, and operation. Both the Symbio onboard user interface and mobile app simplify troubleshooting by displaying active alarms. Symbio eliminates the need for field-installed, anti-short cycle timer and time delay relays. The wiring of the low voltage connections to the unit and zone sensors is simple, making installation easy.

### Testing

Symbio™ 700 requires no special tools to run the unit through its paces. Simply navigate to the ‘Service’ section of the user interface or the ‘Utilities’ section of the Symbio™ Service and Installation Mobile App and enter the test section. Here the unit can be placed in the desired operating condition for a pre-determined amount of time supporting troubleshooting efforts in the field. The Symbio 700 will return to normal control when the user exits test mode or when the pre-determined, user-selected Service Test time has expired.

### Other Benefits

- Symbio™ 700 built-in anti-shortcycle timer, time delay relay and minimum “on” time control functions are factory tested to assure proper operation.
- Symbio 700 softens electrical “spikes” by staging on fans, compressors and heaters.

- Intelligent Fallback is a benefit to the building occupant. If a component goes astray, the unit will continue to operate at predetermined temperature setpoint.
- Intelligent Anticipation is a standard feature. It functions continuously as Symbio 700 and zone sensor(s) work together in harmony to provide much tighter comfort control than conventional electromechanical thermostats.
- The Symbio 700 design is standardized across the board, ensuring a lower cost to owners.

## Additional Controls

**VariTrac® Building Automation System** — When Trane’s changeover VAV System for light commercial applications is coupled with the unit, it provides the latest in technological advances for comfort management systems and can allow thermostat control in every zone served by VariTrac.

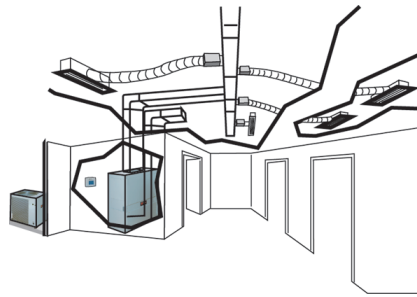

**Froststat™** — This control (a standard feature on all air handlers) utilizes a capillary bulb embedded in the face of the evaporator coil which monitors coil temperature to inhibit evaporator icing and protect the compressor. Useful for applications with low leaving air temperatures, low airflow and/or high latent load applications.

**LonTalk® Communications Interface** — The LonTalk communications interface allows the unit to communicate as a Tracer LON® device or directly with generic LonTalk Network Building Automation System Controls.

**BACnet® Communication Interface (BCI)** — The BACnet Communication Interface allows the unit to communicate directly with a generic open protocol BACnet MS/TP or IP Network Building Automation Control System.

**Zone Sensors/Thermostats**— Available in programmable, automatic and manual styles.

**Table 2. Odyssey control options – standard and optional**

	Standard Features	Options <sup>(a)</sup>	
		Factory Installed	Field Installed
BACnet® Communication Interface (BCI)		X	
Froststat™ - Evaporator Defrost Control (EDC)	X		
LonTalk® Communications Interface (LCI)		X	X
Symbio™ 700 Microprocessor Controls	X		
Thermostat			X
Zone Sensor			X

<sup>(a)</sup> Refer to model number description for option availability or contact Product Support.





# Accessories

## Cooling Condenser

**Table 3. TTA accessories**

Model	Used With
<b>Universal Hot Gas Bypass Kit</b>	
BAYHGBP011*	All models
<b>Rubber Isolators</b>	
BAYISLT004* (blue)	TTA072, TTA090
BAYISLT005* (black)	TTA120
BAYISLT009* (red)	TTA150, TTA180
BAYISLT010* (green)	TTA240, TTA300
<b>Steel Spring Isolators</b>	
BAYISLT023* (red)	TTA072, TTA090, TTA120**A
BAYISLT024* (black)	TTA120**C/D, TTA150, TTA180
BAYISLT025* (yellow)	TTA240, TTA300
<b>Service Valve Kit</b>	
BAYVALV020*	TTA072K*A, TTA090K*A, TTA120K*C
BAYVALV022*	TTA072K*D, TTA090K*D, TTA120K*D
BAYVALV023*	TTA150K*D
BAYVALV024*	TTA180K*D, TTA240K*D
BAYVALV026*	TTA180K*C, TTA240K*C
BAYVALV027*	TTA300K*C
<b>Low Ambient — On/Off Fan Control<sup>(a) (b)</sup></b>	
BAYLOAMS10* (External Mount, small cabinets) <sup>(c)</sup>	(all voltages) TTA072, TTA090, TTA120, TTA150
BAYLOAMS20* (Internal mount, large cabinets)	(all voltages) TTA180, TTA240, TTA300
<b>Transducer Kit for Head Pressure Control (BAYLOAMS10*)</b>	
BAYLOTR001* <sup>(d)</sup>	TTA072**D, TTA090**D, TTA120**D, TTA150**D
<b>LonTalk Communications Interface<sup>(e)</sup></b>	
BAYLTCI005*	All Models
<b>Expansion Module Kit</b>	
BAYMODU002* (XM30)	All Models
BAYMODU004* (XM32)	All Models
<b>Coil (Hail/Vandal) Guard</b>	
BAYGARD068A	TTA072, TTA090
BAYGARD064A	TTA120
BAYGARD065A	TTA150
BAYGARD066A	TTA180, TTA240
BAYGARD067A	TTA300

(a) Cycles fan on/off (no modulating).

(b) When BAYLOAM is used, the Evaporator Defrost Control (EDC) must be disabled in the Symbio 700 controller configuration.

(c) Kit mounts external to the outdoor unit and operates by sensing ambient temperature and discharge pressure.

(d) BAYLOTR001\* required when BAYLOAMS10\* kits are used with units that have 2 compressors (dual circuit) and 1 condenser fan.

(e) Field installed LonTalk interface requires installation of Symbio control board with Advanced Diagnostics (not included).



## Accessories

# Air Handler

**Table 4. TWE Accessories**

Model	Used With
<b>Base (Subbase)</b>	
BAYBASE009*	TWE060
BAYBASE0010*	TWE072, TWE090
BAYBASE0011*	TWE120
BAYBASE0012*	TWE150, TWE180
BAYBASE0013*	TWE240, TWE300
<b>Drip Kit</b>	
BAYDRKT006*	TWE060
BAYDRKT007*	TWE072, TWE090
BAYDRKT008*	TWE120
BAYDRKT009*	TWE150, TWE180
BAYDRKT010*	TWE240, TWE300
<b>Duct Flange Kit</b>	
BAYDUCT010*	TWE051, TWE060, TWE072, TWE076, TWE090, TWE101, TWE120
BAYDUCT020*	TWE126, TWE150, TWE156, TWE180, TWE201, TWE240, TWE251, TWE300
<b>Filters – 2" MERV 13</b>	
BAYFILT006*	TWE060
BAYFILT007*	TWE072, TWE090
BAYFILT008*	TWE120
BAYFILT009*	TWE150, TWE180
BAYFILT010*	TWE240, TWE300
<b>Rubber Isolators<sup>(a) (b) (c)</sup></b>	
BAYISLT004* (Floor — Blue)	TWE060, TWE072, TWE090, TWE120
BAYISLT009* (Floor — Red) <sup>(d)</sup>	TWE150, TWE180
BAYISLT010* (Floor — Green) <sup>(d)(a)</sup>	TWE240, TWE300
BAYISLT012* (Suspended —Red/Green)	TWE150, TWE180
BAYISLT013* (Suspended —Red/Green) <sup>(c)</sup>	TWE060
BAYISLT014* (Suspended — Green) <sup>(c)</sup>	TWE072, TWE090
BAYISLT015* (Suspended — Green/Black) <sup>(c)</sup>	TWE120
BAYISLT016* (Suspended —Red/Green)	TWE240, TWE300
<b>Steel Spring Isolators<sup>(b)</sup></b>	
BAYISLT019* (Floor — Red) <sup>(c)(a)</sup>	TWE060, TWE072, TWE090, TWE120
BAYISLT021* (Floor — Black) <sup>(c)(a)</sup>	TWE150, TWE180
BAYISLT032* (Floor — Black/Yellow) <sup>(c)(a)</sup>	TWE240, TWE300
BAYISLT028* (Suspended — Tan)	TWE060
BAYISLT029* (Suspended — Red)	TWE072, TWE090, TWE120
BAYISLT030* (Suspended — Black)	TWE150, TWE180
BAYISLT031* (Suspended — Black/Yellow)	TWE240, TWE300
<b>Plenum<sup>(e)</sup></b>	
BAYPLNM015* (Discharge Plenum & Grille) <sup>(e)</sup>	TWE060
BAYPLNM016* (Discharge Plenum & Grille) <sup>(e)</sup>	TWE072, TWE090
BAYPLNM017* (Discharge Plenum & Grille) <sup>(e)</sup>	TWE120
BAYPLNM018* (Discharge Plenum/Hydronic Coil Plenum & Grille) <sup>(e)</sup>	TWE150, TWE180
BAYPLNM019* (Discharge Plenum/Hydronic Coil Plenum & Grille) <sup>(e)</sup>	TWE240, TWE300
BAYPLNM020* (Hydronic Coil Discharge Plenum & Grille) <sup>(e)</sup>	TWE060
BAYPLNM021* (Hydronic Coil Discharge Plenum & Grille) <sup>(e)</sup>	TWE072, TWE090
BAYPLNM022* (Hydronic Coil Discharge Plenum & Grille) <sup>(e)</sup>	TWE120
BAYPLNM030* (Electric Heat Discharge Plenum & Grille) <sup>(e)</sup>	TWE060
BAYPLNM031* (Electric Heat Discharge Plenum & Grille) <sup>(e)</sup>	TWE072, TWE090

**Table 4. TWE Accessories (continued)**

Model	Used With
BAYPLNM032* (Electric Heat Discharge Plenum & Grille) <sup>(e)</sup>	TWE120
BAYPLNM033* (Electric Heat Discharge Plenum & Grille) <sup>(e)</sup>	TWE150, TWE180
BAYPLNM034* (Electric Heat Discharge Plenum & Grille) <sup>(e)</sup>	TWE240, TWE300
<b>Return Air Grille</b>	
BAYGRLE001*	TWE060
BAYGRLE002*	TWE072, TWE090
BAYGRLE003*	TWE120
BAYGRLE004*	TWE150, TWE180
BAYGRLE005*	TWE240, TWE300
<b>Symbio™ Indoor Options Module Kit</b>	
BAYMODU001*	All TWE units with Digit 15 = 1 and Electric heater installed
<b>Transformer</b>	
BAYTFMR018* - 100 VA Transformer (208-230V)	All TWE072 – TWE300, 208-230V units
BAYTFMR019* - 100 VA Transformer (460V)	All TWE072 – TWE120, 460V units
BAYTFMR020* - 100 VA Transformer (575V)	All TWE072 – TWE120, 575V units
<b>Water Kits</b>	
BAYWATR022* (Steam Coil Enclosure) <sup>(e)</sup>	TWE060
BAYWATR023* (Steam Coil Enclosure) <sup>(e)</sup>	TWE072, TWE090
BAYWATR024* (Steam Coil Enclosure) <sup>(e)</sup>	TWE120
BAYWATR025* (Steam Coil Enclosure) <sup>(e)</sup>	TWE150, TWE180
BAYWATR026* (Steam Coil Enclosure) <sup>(e)</sup>	TWE240, TWE300
BAYWATR027* (Hot Water Coil Enclosure) <sup>(e)</sup>	TWE060
BAYWATR028* (Hot Water Coil Enclosure) <sup>(e)</sup>	TWE072, TWE090
BAYWATR029* (Hot Water Coil Enclosure) <sup>(e)</sup>	TWE120
BAYWATR030* (Hot Water Coil Enclosure) <sup>(e)</sup>	TWE150, TWE180
BAYWATR031* (Hot Water Coil Enclosure) <sup>(e)</sup>	TWE240, TWE300

<sup>(a)</sup> Requires use of subbase accessory.

<sup>(b)</sup> In units with steam or hot water coils applied vertically or horizontally, check IOM for proper Isolator Kit selection.

<sup>(c)</sup> Do not use if blower will operate less than 600 RPM.

<sup>(d)</sup> When the air handler is in the vertical position and close proximity trapping of condensate is required, use of subbase is required.

<sup>(e)</sup> When installed horizontally, plenum/water coil must be self-supported. When adding vibration isolators, see *Vibration Mounting for Split Systems Installation Instructions* (ACC-SVN92\*-EN) for isolator and location matrix.

**Note:** See HUB case DOC-209462 for high-static and low-static drive kits (available only for constant volume air handlers).



**Accessories**

## Electric Heaters

**Table 5. Electric heaters**

Model	Used With
<b>6 to 10 Ton Electric Heater Selection</b>	
BAYHTRP106* — 4.33/5.76 kW Heater 208/240/1 Phase	TWE060*1, TWE090*1, TWE120*1
BAYHTRS112* — 8.65/11.52 kW Heater 208/240/1 Phase	TWE060*1, TWE090*1, TWE120*1
BAYHTRT117* — 12.98/17.28 kW Heater 208/240/1 Phase	TWE060*1, TWE090*1, TWE120*1
BAYHTRS123* — 17.31/23.04 kW Heater 208/240/1 Phase	TWE060*1, TWE090*1, TWE120*1
BAYHTRP129* — 21.63/28.80 kW Heater 208/240/1 Phase	TWE090*1, TWE120*1
BAYHTRP305* — 3.76/5.00 kW Heater 208/240/3 Phase	TWE060*3 (CV AND OS MTR), TWE072*3B, TWE090*3, TWE120*3 (VFD)
BAYHTRS310* — 7.48/9.96 kW Heater 208/240/3 Phase	TWE060*3 (CV AND OS MTR), TWE072*3B, TWE090*3, TWE120*3 (VFD)
BAYHTRS315* — 11.24/14.96 kW Heater 208/240/3 Phase	TWE060*3 (CV AND OS MTR), TWE072*3B, TWE090*3, TWE120*3 (VFD)
BAYHTRP325* — 18.72/24.92 kW Heater 208/240/3 Phase	TWE060*3 (CV AND OS MTR), TWE072*3B, TWE090*3, TWE120*3 (VFD)
BAYHTRP335* — 26.20/34.88 kW Heater 208/240/3 Phase	TWE090*3, TWE120*3 (VFD)
BAYHTRP405* — 5.00 kW Heater 460/3 Phase	TWE060*4 (CV AND OS MTR), TWE072*4*****C/D, TWE090*4*****C/D, TWE120*4*****C/D
BAYHTRS410* — 9.96 kW Heater 460/3 Phase	TWE060*4 (CV AND OS MTR), TWE072*4*****C/D, TWE090*4*****C/D, TWE120*4*****C/D
BAYHTRS415* — 14.96 kW Heater 460/3 Phase	TWE060*4 (CV AND OS MTR), TWE072*4*****C/D, TWE090*4*****C/D, TWE120*4*****C/D
BAYHTRP425* — 24.92 kW Heater 460/3 Phase	TWE060*4 (CV AND OS MTR), TWE072*4*****C/D, TWE090*4*****C/D, TWE120*4*****C/D
BAYHTRP435* — 34.88 kW Heater 460/3 Phase	TWE090*4*****C/D, TWE120*4*****C/D
BAYHTRPW05* — 5 kW Heater 575/3 Phase	TWE060*W (CV AND OS MTR), TWE072*W, TWE090*W, TWE120*W (VFD)
BAYHTRSW10* — 9.96 kW Heater 575/3 Phase	TWE060*W (CV AND OS MTR), TWE072*W, TWE090*W, TWE120*W (VFD)
BAYHTRSW15* — 14.96 kW Heater 575/3 Phase	TWE060*W (CV AND OS MTR), TWE072*W, TWE090*W, TWE120*W (VFD)
BAYHTRPW25* — 24.92 kW Heater 575/3 Phase	TWE060*W (CV AND OS MTR), TWE072*W, TWE090*W, TWE120*W (VFD)
BAYHTRPW35* — 34.88 kW Heater 575/3 Phase	TWE090*W, TWE120*W (VFD)
<b>12.5 to 25 Ton Electric Heater Selection</b>	
BAYHTRT310* — 7.51/10.0 kW Heater 208/230 3 Phase	TWE150*3, TWE180*3, TWE240*3, TWE300*3 (VFD)
BAYHTRR320* — 14.96/19.92 kW Heater 208/230 3 Phase	TWE150*3, TWE180*3, TWE240*3, TWE300*3 (VFD)
BAYHTRR330* — 22.47/29.92 kW Heater 208/230 3 Phase	TWE150*3, TWE180*3, TWE240*3, TWE300*3 (VFD)
BAYHTRR350* — 37.44/49.84 kW Heater 208/230 3 Phase	TWE150*3, TWE180*3, TWE240*3, TWE300*3 (VFD)
BAYHTRT410* — 10.0 kW Heater 460/3 Phase	TWE150*4*****C/D, TWE180*4*****C/D, TWE240*4 (VFD), TWE300*4 (VFD)
BAYHTRR420* — 19.92 kW Heater 460/3 Phase	TWE150*4*****C/D, TWE180*4*****C/D, TWE240*4 (VFD), TWE300*4 (VFD)
BAYHTRR430* — 29.92 kW Heater 460/3 Phase	TWE150*4*****C/D, TWE180*4*****C/D, TWE240*4 (VFD), TWE300*4 (VFD)
BAYHTRR450* — 49.84 kW Heater 460/3 Phase	TWE150*4*****C/D, TWE180*4*****C/D, TWE240*4 (VFD), TWE300*4 (VFD)
BAYHTRTW10* — 10.0 kW Heater 575/3 Phase	TWE150*W, TWE180*W, TWE240*W, TWE300*W (VFD)
BAYHTRRW20* — 19.92 kW Heater 575/3 Phase	TWE150*W, TWE180*W, TWE240*W, TWE300*W (VFD)
BAYHTRRW30* — 29.92 kW Heater 575/3 Phase	TWE150*W, TWE180*W, TWE240*W, TWE300*W (VFD)
BAYHTRRW50* — 49.84 kW Heater 575/3 Phase	TWE150*W, TWE180*W, TWE240*W, TWE300*W (VFD)

**Note:** Electric Heaters not available for 380/60Hz.



# Application Considerations

Application of this product should be within the cataloged airflow and performance considerations.

## Clearance Requirements

The recommended clearances identified with unit dimensions should be maintained to assure adequate serviceability, maximum capacity and peak operating efficiency. Actual clearances which appear inadequate should be reviewed with the local representative.

## Low Ambient Cooling

As manufactured, all Odyssey units have cooling capabilities down to 0°F. At temperatures below 50°F, some reduction in cooling capacity can be expected. When the optional Low Ambient Accessory kit is field installed, the full capacity of the unit is available down to 0°F. When using these units with control systems such as bypass changeover Variable Air Volume, make sure to consider the requirement for a head pressure control to allow low ambient cooling.

**Figure 4. Typical split system application**

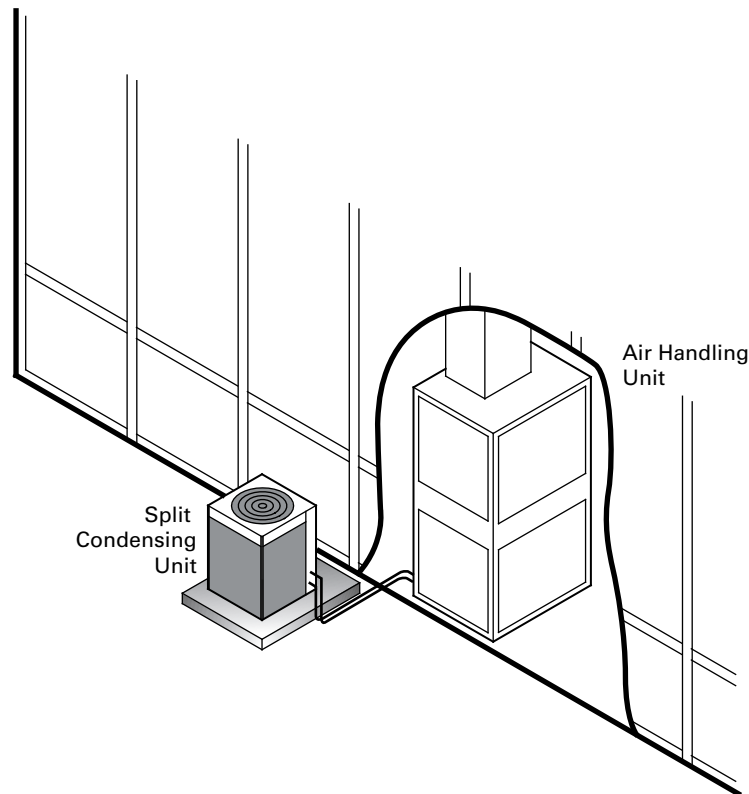

**Figure 5. Typical horizontal air handler application**

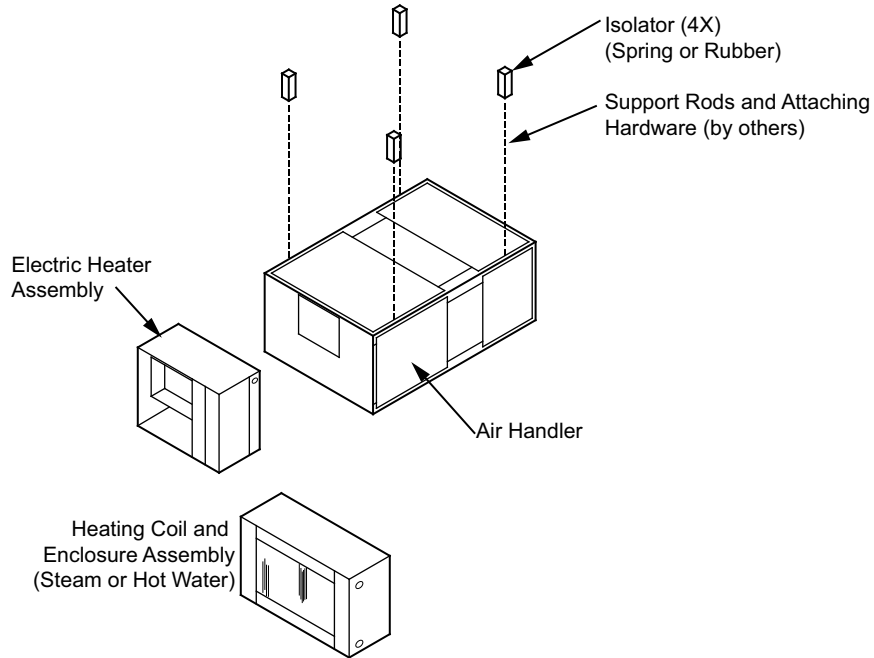

**Figure 6. Typical vertical air handler application**

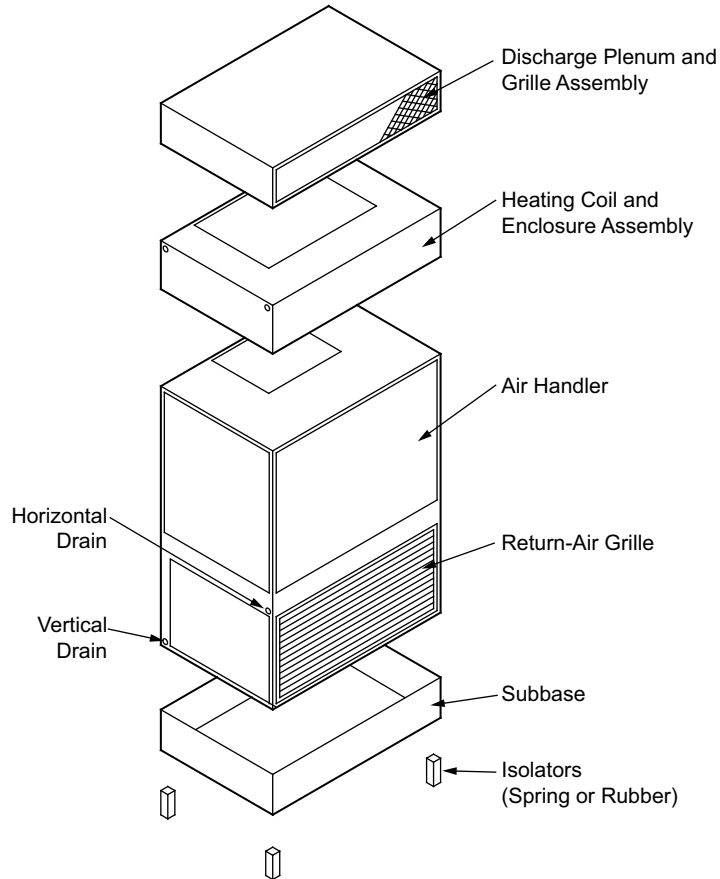

## A2L Application Considerations

This product is listed to UL standard 60335-2-40, Household and Similar Electrical Appliances – Safety – Part 2-40: Particular Requirements for Electrical Heat Pumps, Air-Conditioners and Dehumidifiers, which defines safe design and use strategies for equipment using A2L refrigerants. This standard limits the refrigerant concentration in a space in the event of a refrigerant leak. To meet the requirements, the UL standard defines minimum room area, refrigerant charge limit, minimum circulation airflow and/or ventilation airflow requirements, and limits the use of ignition sources in spaces. The standard may require a unit refrigerant leak detection system.

For equipment with R-454B and charge amounts less than or equal to 3.91 lbs per circuit, this UL standard does not prescribe a room area limit and does not require a refrigerant leak detection system or any circulation airflow or ventilation airflow mitigation strategies. However, ignition sources in ductwork must be evaluated.

Depending on the application, a specific requirement of ANSI/ASHRAE Standard 15, Safety Standard for Refrigeration Systems, could be more stringent than UL 60335-2-40 requirements. See *Refrigeration Systems and Machinery Rooms Application Considerations for Compliance with ASHRAE® Standard 15-2022 Application Engineering Manual (APP-APM001\*-EN)* for more information.

### Minimum Room Area Limits (Refrigerant charge greater than 3.91 lb per circuit)

Equipment with R-454B charge amounts greater than 3.91 lb per circuit may require additional circulation or ventilation airflow mitigation strategies. In this case, two minimum room area ( $A_{min}$ ) thresholds:

- The first threshold defines when equipment serving a single room is required to provide circulation airflow, either continuous or activated by a leak detection system. A ducted system requires circulation airflow unless the smallest room it serves is larger than the adjusted  $A_{min}$  threshold. This product contains a leak detection system if a circuit charge is greater than 3.91 lbs. As a result, no further leak detection system evaluation is required.
- The second threshold defines when additional ventilation airflow is required. If the room area,  $A$  or  $TA$ , is below the adjusted  $A_{min}$  or  $TA_{min}$  threshold, additional ventilation is required to remove refrigerant in the event of a leak. Refer to UL 60335-2-40 Clause GG.8 and ANSI/ASHRAE Standard 15 Section 7 for natural and mechanical ventilation requirements. For minimum room area, see equipment nameplate or unit Installation, Operation, and Maintenance (IOM) manual.

### Minimum Room Area Limits (Refrigerant charge greater than 3.91 lb per circuit)

Equipment with R-454B charge amounts greater than 3.91 lb per circuit may require additional circulation or ventilation airflow mitigation strategies. In this case, there are two minimum room area ( $A_{min}$ ) thresholds.

- The first threshold defines when equipment serving a single room is required to provide circulation airflow, either continuous or activated by a leak detection system. A ducted system requires circulation airflow unless the smallest room it serves is larger than the adjusted  $A_{min}$  threshold. This product contains a leak detection system if a circuit charge is greater than 3.91 lbs. As a result, no further leak detection system evaluation is needed.
- The second threshold defines when additional ventilation airflow is required. If the room area,  $A$  or  $TA$ , is below the adjusted  $A_{min}$  or  $TA_{min}$  threshold, additional ventilation is required to remove refrigerant in the event of a leak. Refer to UL 60335-2-40 Clause GG.8 and ANSI/ASHRAE Standard 15 Section 7 for natural and mechanical ventilation requirements. See equipment nameplate and table below for minimum room area.

Split systems minimum room area requirements need to be determined after final field charging. Use the following figures and the largest final circuit charge to determine the systems  $A_{min}$  value. Record the final charge value on the label provided on the condensing unit.

Figure 7. Charge vs min room area (IP)

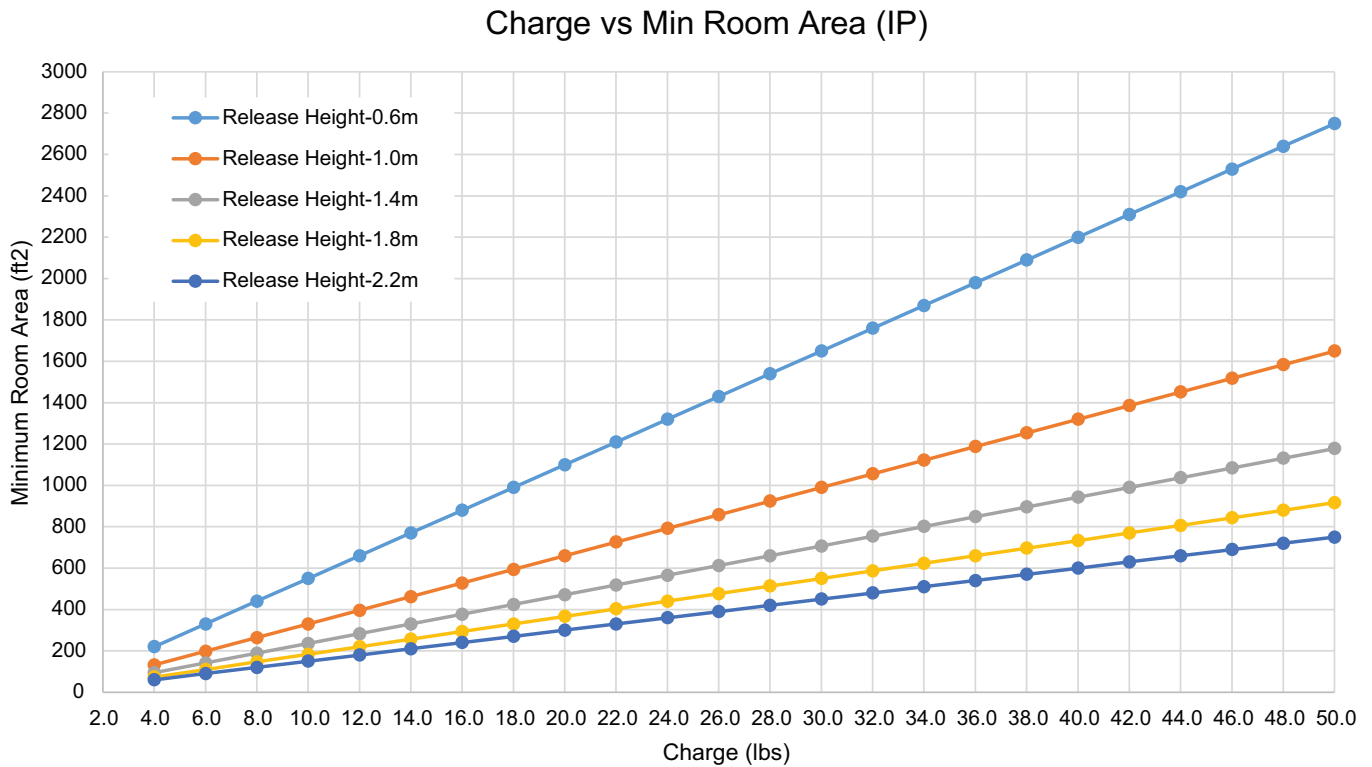
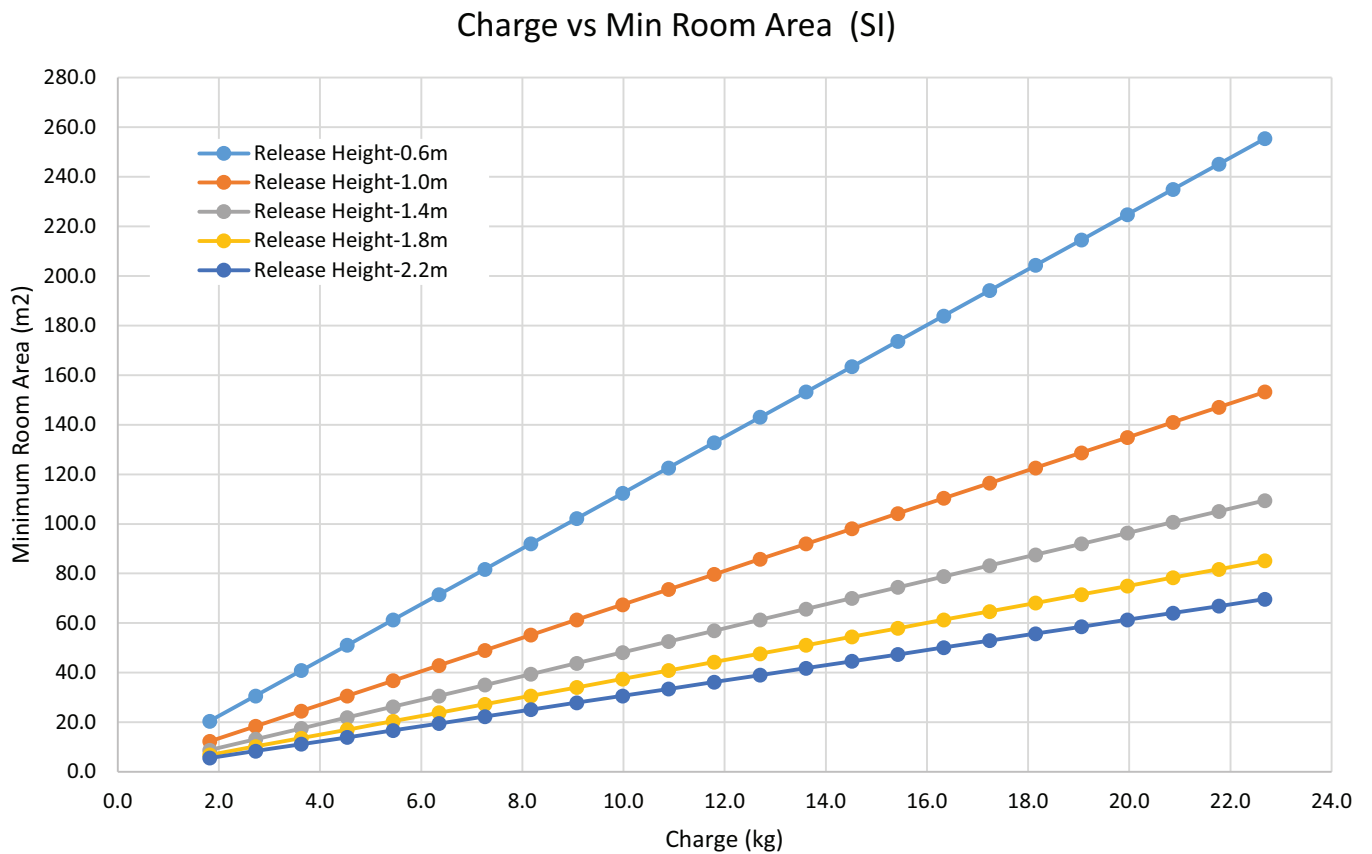

Figure 8. Charge vs min room area (SI)





Release height is the vertical distance from the floor to the lowest point in a space refrigerant would leak from first. The minimum value is 0.6 m from the floor. This point is typically the bottom of free return openings or supply diffusers. For fully ducted units, the release height is 2.2 meters.

### Minimum Room Area ( $A_{min}$ ) Adjustments

- **Altitude:** The  $A_{min}$  threshold changes with altitude. Multiple the altitude adjustment factor in the following table by  $A_{min}$  shown on the unit nameplate or in the Installation, Operation, and Maintenance (IOM) manual.

**Table 6. Altitude adjustment factor**

Altitude (ft)	Sea Level to 2000	2001 to 4000	4001 to 6000	6001 to 8000	8001 to 10000	10001 to 12000	12001 to 14000	14001 to 15000	Over 15000
$A_{min}$ Adjustment	1	1.05	1.11	1.17	1.24	1.32	1.41	1.51	1.57

- **Height :**  $A_{min}$  can be adjusted if the unit is installed in a room at a height higher than the minimum height shown on the unit. Multiply  $A_{min}$  by the ratio of the unit minimum release height (in meters) / actual release height (in meters).
- **Institutional Occupancies:** For institutional occupancies, ASHRAE Standard 15 applies an additional adjustment factor, FOCC, to the amount of charge allowed in a space. To calculate the adjusted  $A_{min}$  for institutional occupancies, divide the  $A_{min}$  on the nameplate by 0.5.

### Determining Room Area (A or TA)

The room area (A) is the room area enclosed by the projection to the floor of the walls, partitions, and doors of the space that the equipment serves. For ducted systems, total room area (TA) of all rooms connected by ducts, may be used instead of A.

Rooms connected by drop ceilings only are not considered a single room.

Rooms on the same floor of the building, and connected by an open passageway, can be considered part of the same room if the passageway is a permanent opening, extends to the floor and is intended for people to walk through.

Adjacent rooms on the same floor of the building and connected by permanent openings in the walls and/or doors between rooms (including gaps between the wall and the floor), can be considered part of the same room if the openings meet the following criteria.

- The opening is permanent and cannot be closed.
- Openings extending to the floor, such as door gaps, need to be at least 20 mm above the floor covering surface.
- Natural ventilations opening areas must meet the requirements of ANSI/ASHRAE Standard 15-2022, Section 7.2.3.2.

Rooms that are connected by a mechanical ventilation system can be considered a single room area if the mechanical ventilation system meets the requirements of ANSI/ASHRAE Standard 15-2022, Section 7.6.4.

### Leak Detection System (Refrigerant charge greater than 3.91 lb per circuit)

The leak detection system consists of one or more refrigerant detection sensors. When the system detects a leak, the following mitigation actions will be initiated until refrigerant has not been detected for at least 5 minutes:

- Energize the supply fan(s) to deliver a required minimum amount of circulation airflow.
- Disable compressor operation.
- Provide an output signal to fully open all zoning dampers, such as VAV boxes.
- Provide an output to energize additional mechanical ventilation (if needed).
- Units without airflow proving will disable electric heat sources.



## Application Considerations

---

Building fire and smoke systems may override this function.

If the refrigerant sensor has a fault, is at the end of its life, or is disconnected, the unit will initiate the mitigation actions. Mitigation actions may be verified by disconnecting the sensor.

The refrigerant sensors do not need service. Use only manufacturer-approved sensors when replacement is required.



# Selection Procedure

## Cooling Capacity

1. Calculate the building's total and sensible cooling loads at design conditions, using standardized calculation methods.
2. Size the equipment using the gross cooling capacity tables. Match the cooling loads at design conditions. For example, if the following specifies the building cooling requirements:  
Electrical Characteristics: 460/60/3  
Summer Design Conditions: Entering Evap Coil—80°F DB/67°F WB, Outdoor Ambient—95°F  
Total Cooling Load: 86 MBh  
Sensible Cooling Load: 60 MBh  
Airflow: 3000 cfm  
External Static Pressure: 0.77 inches of water gauge
3. Use [Table 15, p. 34](#) to determine that TTA090K3A with TWE090K3A has a gross cooling capacity of 99.7 MBh and 76.3 MBh sensible capacity at 95°F DB ambient and 3000 cfm with 80°F DB/67° F WB air entering the evaporator.
4. To find the net cooling capacities, fan motor heat must be subtracted. Determine the total unit static pressure:  
External Static Duct System: 0.77  
Standard Filter: 0.10 in.  
Supplementary Electric Heat: 0.23 in.  
Total Static Pressure: 1.10 in.

### Notes:

- *The Evaporator Fan Performance Table has included the effect of a 1 in. filter already. Therefore, the actual Total Static Pressure is 1.10 - 0.10 = 1.00 in. With 3000 cfm and 1.00 in., [Table 48, p. 68](#) shows 1.79 Bhp (factory installed high static motor required).*
- *This formula can be used to calculate Fan Motor Heat:*  
$$3.15 \times \text{Bhp} = \text{MBh}$$
$$3.15 \times 1.79 = 5.64 \text{ MBh}$$
$$\text{Net Total Cooling Capacity} = 99.7 - 5.64 = 94.1 \text{ MBh}$$
$$\text{Net Sensible Cooling Capacity} = 76.3 - 5.64 = 70.7 \text{ MBh}$$

## Heating Capacity

1. Calculate the building heating load using the Trane calculation form or any other standard accepted method.
2. Size the equipment using [Table 59, p. 78](#) to match the heating loads at design conditions. For example, if the following specifies the building heating requirements:  
Total Heating Load: 97.0 MBh  
Airflow: 2625 cfm  
Supplementary Electric Heaters
3. Use [Table 60, p. 79](#) to determine that the 34.88 kW heater has a capacity of 119,045 Btuh.
4. From the Electrical Characteristics table, the 34.88 kW heater at 460V indicates the heater model is BAYHTRP435.

## Air Delivery

1. The external static pressure drop through the air distribution system is 0.77 inches of water gauge, use [Table 59, p. 78](#) to determine that the static pressure drop through the electric heater is 0.23 inches of water (0.77 + 0.23 = 1.00 in.).
2. Enter [Table 48, p. 68](#) for TWE090K3A at 2625 cfm and 1.00 static pressure. The high static motor at 965 RPM gives the desired airflow.



# Model Number Description

## Cooling Condenser

### Digit 1, 2, 3 — Unit Function

TTA = Split System Cooling

### Digit 4, 5, 6 — Tonnage

072 = 6 Tons (60 Hz)

090 = 7.5 Tons (60 Hz)

120 = 10 Tons (60 Hz)

150 = 12.5 Tons (60 Hz)

180 = 15 Tons (60 Hz)

240 = 20 Tons (60 Hz)

300 = 25 Tons (60Hz)

### Digit 7 — Refrigerant

K = R-454B

### Digit 8 — Voltage

3 = 208-230 Vac - 3 PH (60Hz)

4 = 460 Vac - 3 PH (60Hz)

W = 575 Vac - 3 PH (60Hz)

### Digit 9 — Refrigeration Circuit/Stage

A = 1 Compressor/1 Line/1 Stage (Single)

C = 2 Compressors/1 Line/2 Stage (Manifold)

D = 2 Compressors/2 Line/2 Stage (Dual)

### Digit 10 — Major Design Sequence

A = Rev A

### Digit 11 — Minor Design Sequence

A = Rev A

### Digit 12, 13 — Service Digits

\*\*

### Digit 14 — Efficiency Generation

B = Generation B

### Digit 15 — Controls

S = Symbio™

### Digit 16 — None

0 = None

### Digit 17 — Coil Protection

0 = Standard Coil

1 = Standard Coil w/ Coil Guard

4 = Complete Coat Condenser Coil (MCHE)

5 = Complete Coat Condenser Coil with Coil Guard (MCHE)

### Digit 18, 19, 20 — None

0 = None

### Digit 21 — Communications Options

0 = No Option

1 = Advanced Diagnostics and BACnet® BAS

2 = Advanced Diagnostics and LonTalk® Communications Interface (LCI)

### Digit 22 to 40 — None

0 = None

# Air Handler

### Digit 1, 2, 3 — Unit Function

**TWE** = Air Handler

### Digit 4, 5, 6 — Tonnage

**060** = 5 Tons (60 Hz)

**072** = 6 Tons (60 Hz)

**090** = 7.5 Tons (60 Hz)

**120** = 10 Tons (60 Hz)

**150** = 12.5 Tons (60 Hz)

**180** = 15 Tons (60 Hz)

**240** = 20 Tons (60 Hz)

**300** = 25 Tons (60 Hz)

### Digit 7 — Refrigerant

**K** = R-454B

### Digit 8 — Voltage

**1** = 208-230 Vac - 1 PH (60 Hz)

**3** = 208-230 Vac - 3 PH (60 Hz)

**4** = 460 Vac - 3 PH (60 Hz)

**W** = 575 Vac - 3 PH (60 Hz)

### Digit 9 — Refrigeration Circuit/Stage

**A** = Single Circuit

**B** = Dual Circuit

### Digit 10 — Major Design Sequence

**A** = Rev A

### Digit 11 — Minor Design Sequence

**A** = Rev A

### Digit 12, 13 — Service Digits

\*\*

### Digit 14 — Efficiency Generation

**B** = Generation B

### Digit 15 — Controls

**1** = Constant Volume

**C** = 2-Speed Airflow<sup>(a)</sup>

**D** =SZVAV (not for 24V T-stat)

<sup>(a)</sup> 2-Speed units can be controlled by a thermostat, eliminating the need for communication wire between the outdoor unit and indoor unit. This limits functionality. See *Split System Air Conditioners Odyssey™ with Symbio™ Controls R-454B Wiring and Start-Up Installation Guide* (SS-SVN017\*-EN) for details.

### Digit 16 — Indoor Fan Sizes

**0** = Standard Motor

**4** = High Static – (Oversized Motor for VFD Units)

### Digit 17 to 40 — None

**0** = None

<sup>(a)</sup> 2-Speed units can be controlled by a thermostat, eliminating the need for communication wire between the outdoor unit and indoor unit. This limits functionality. See *Split System Air Conditioners Odyssey™ with Symbio™ Controls R-454B Wiring and Start-Up Installation Guide* (SS-SVN017\*-EN) for details.



# General Data

**Table 7. General data – 6 to 7.5 tons (TTA072K\*A\*-TTA090K\*D\*) condensing units – 60 Hz**

	6 Tons	6 Tons	7.5 Tons	7.5 Tons
	Single Compressor TTA072K*A*	Dual Compressor TTA072K*D*	Single Compressor TTA090K*A*	Dual Compressor TTA090K*D*
<b>Cooling Performance - Gross Cooling Capacity</b>				
Matched Air Handler	TWE090K*A*	TWE072K*B*	TWE090K*A*	TWE090K*B*
AHRI Rated Airflow	2,400	2,400	3,000	3000
Gross Cooling Capacity - System	78,000	77,000	99,000	98,000
AHRI Net Cooling Capacity	76,000	75,000	97,000	96,000
<b>Efficiency</b>				
Matched Air Handler (EER)	11.5	11.5	11.5	11.5
System (IEER)	14.8	14.8	14.8	14.8
System kW	5.7	5.6	8.3	7.7
<b>Compressor</b>				
Type <sup>(a)</sup>	Scroll 1S	Scroll 1S	Scroll 2S	Scroll 2S
No./Tons/Min Stage%/Total Stages	1 / 5.1 / 100 / 1	2 / 2.4 / 50 <sup>(b)</sup> / 2	1 / 6.9 / 67 <sup>(c)</sup> / 2	2 / 3.3 / 67 <sup>(c)</sup> / 2
<b>System Data</b>				
No. Refrigerant Circuits <sup>(d)</sup>	1	2	1	2
Suction Line Connection (in.) OD <sup>(d)</sup>	1 1/8	7/8	1 3/8	1 1/8
Liquid Line Connection (in.) OD <sup>(d)</sup>	1/2	1/2	1/2	1/2
<b>Outdoor Coil</b>				
Type	MCHE	MCHE	MCHE	MCHE
Tube Size OD/Coil Width MCHE (in.)	0.8	0.8	0.8	0.8
Face Area (sq ft)	18.5	17.4	18.5	17.4
Rows/FPI (Fins per inch)	1/23	1/23	1/23	1/23
<b>Outdoor Fan</b>				
Type	Propeller	Propeller	Propeller	Propeller
No. Used/Diameter (in.)	1/26	1/26	1/26	1/26
Drive Type/No. Speeds	Direct/1	Direct/1	Direct/1	Direct/1
CFM	5,700	5,700	5,700	5,700
No. Motor/HP	1/0.5	1/0.5	1/0.5	1/0.5
Motor RPM	1,100	1,100	1,100	1,100
<b>Refrigerant Charge (Field Supplied)</b>				
lbs of R-454B	8.6	6.3 / 6.3	8.7	6/6.1
<b>Shipping Dimensions</b>				
HxWxD (in.)	45" x 45.25" x 39"	45" x 45.25" x 39"	45" x 45.25" x 39"	45" x 45.25" x 39"

**Notes:**

- All condensing units are tested in accordance with AHRI Standard 365.
  - 6 - 20 ton units are AHRI Certified to AHRI Standard 340-360 (I-P). Rating conditions are 95°F outdoor air temperature, 80°F entering dry bulb, 67°F entering wet bulb with 25ft of interconnecting refrigerant piping with minimum external static. pressure as determined by rating standard.
  - 25 ton units are tested in accordance with AHRI Standard 340-360.
- (a) 1-stage compressor = 1S, 2-stage compressor = 2S.  
 (b) 1st stage is compressor 1. 2nd stage is compressor 1 and 2.  
 (c) All compressors stage to 66% for first stage, then 100% for second stage.  
 (d) For line lengths greater than 25ft, refer to refrigerant piping applications manual for line sizing and line length.

**Table 8. General data – 10 to 12.5 tons (TTA120K\*D\*-TTA150K\*D\*) condensing units – 60 Hz**

	10 Tons	10 Tons	12.5 Tons
	Dual Compressor TTA120K*D*	Manifolded Compressor TTA120K*C*	Dual Compressor TTA150K*D*
<b>Cooling Performance - Gross Cooling Capacity</b>			
Matched Air Handler	TWE120K*B*	TWE120K*A*	TWE150K*B*
AHRI Rated Airflow	4,000 <sup>(a)</sup>	4,000	5,000
Gross Cooling Capacity - System	125,000	129,000	160,000
AHRI Net Cooling Capacity	121,000	125,000	156,000
<b>Efficiency</b>			
Matched Air Handler (EER)	11.5	11.5	11.2
System (IEER)	14.8	14.8	14.2
System kW	9.8	10.3	13.8
<b>Compressor</b>			
Type <sup>(b)</sup>	Scroll 2S	Manifolded Scrolls 1S	Scroll 2S
No./Tons/Min Stage%/Total Stages	2 / 4.1 / 67 <sup>(c)</sup> / 2	2 / 4.3 / 50 <sup>(d)</sup> / 2	2 / 5.6 / 67 <sup>(e)</sup> / 2
<b>System Data</b>			
No. Refrigerant Circuits <sup>(e)</sup>	2	1	2
Suction Line Connection (in.) OD <sup>(e)</sup>	1 1/8	1 3/8	1 1/8
Liquid Line Connection (in.) OD <sup>(e)</sup>	1/2	1/2	1/2
<b>Outdoor Coil</b>			
Type	MCHE	MCHE	MCHE
Tube Size OD/Coil Width MCHE (in.)	0.8	0.8	1.0
Face Area (sq ft)	22.7	23.8	27.0
Rows/FPI (Fins per inch)	1/23	1/23	1/23
<b>Outdoor Fan</b>			
Type	Propeller	Propeller	Propeller
No. Used/Diameter (in.)	1/28	1/28	1/28
Drive Type/No. Speeds	Direct/1	Direct/1	Direct/1
CFM	8,800	8,800	8,800
No. Motor/HP	1/1	1/1	1/1
Motor RPM	1,125	1,125	1,125
<b>Refrigerant Charge (Field Supplied)</b>			
lbs of R-454B	7/7.5	11.1	8.6/8.4
<b>Shipping Dimensions</b>			
HxWxD (in.)	45" x 55" x 42"	45" x 55" x 42"	52.1" x 55" x 42"

**Notes:**

- All condensing units are tested in accordance with AHRI Standard 365.
  - 6 - 20 ton units are AHRI Certified to AHRI Standard 340-360 (I-P). Rating conditions are 95°F outdoor air temperature, 80°F entering dry bulb, 67°F entering wet bulb with 25ft of interconnecting refrigerant piping with minimum external static pressure as determined by rating standard.
  - 25 ton units are tested in accordance with AHRI Standard 340-360.
- (a) For single phase application, AHRI Rated Airflow will be 3,800.
- (b) 1-stage compressor = 1S, 2-stage compressor = 2S.
- (c) All compressors stage to 66% for first stage, then 100% for second stage.
- (d) 1st stage is compressor 1. 2nd stage is compressor 1 and 2.
- (e) For line lengths greater than 25ft, refer to refrigerant piping applications manual for line sizing and line length.



## General Data

**Table 9. General data – 15 to 25 tons (TTA180K\*D\*-TTA300K\*C\*) condensing units – 60 Hz**

	15 Tons	15 Tons	20 Tons	20 Tons	25 Ton
	Dual Compressor TTA180K*D*	Manifolded Compressor TTA180K*C*	Dual Compressor TTA240K*D*	Manifolded Compressor TTA240K*C*	Manifolded Compressor TTA300K*C*
<b>Cooling Performance - Gross Cooling Capacity</b>					
Matched Air Handler	TWE180K*B*	TWE180K*B*	TWE240K*B*	TWE240K*B*	TWE300K*B*
AHRI Rated Airflow	6,000	6,000	8,000	8,000	8,750
Gross Cooling Capacity - System	200,000	196,000	254,000	252,000	306,000
AHRI Net Cooling Capacity	196,000	190,000	246,000	244,000	294,000
<b>Efficiency</b>					
Matched Air Handler (EER)	11.2	11.2	10.2	10.2	10.1
System (IEER)	14.2	14.2	13.2	13.2	13.2
System kW	15.7	15	21.6	22.5	29.1
<b>Compressor</b>					
Type <sup>(a)</sup>	Scroll 1S	Manifolded Scrolls 1S	Scroll 2S	Manifolded Scroll 1S	Manifolded Scrolls 1S
No./Tons/Min Stage%/Total Stages	2 / 6.9 / 50 <sup>(b)</sup> / 2	2/7.6; 5.6 /58 <sup>(b)</sup> / 2	1 / 10.2, 1/8.7 / 67 <sup>(c)</sup> /2	2 / 9.8;9.4 / 51 <sup>(b)</sup> / 2	2 / 12.1;11 / 52 <sup>(b)</sup> / 2
<b>System Data</b>					
No. Refrigerant Circuits <sup>(d)</sup>	2	1	2	1	1
Suction Line Connection (in.) OD <sup>(d)</sup>	1 3/8	1 5/8	1 3/8	1 5/8	2 1/8
Liquid Line Connection (in.) OD <sup>(d)</sup>	1/2	5/8	1/2	5/8	5/8
<b>Outdoor Coil</b>					
Type	MCHE	MCHE	MCHE	MCHE	MCHE
Tube Size OD/Coil Width MCHE (in.)	0.8	0.8	0.8	0.8	1.0
Face Area (sq ft)	44.3	44.3	44.3	44.3	51.3
Rows/FPI (Fins per inch)	1/23	1/23	1/23	1/23	1/23
<b>Outdoor Fan</b>					
Type	Propeller	Propeller	Propeller	Propeller	Propeller
No. Used/Diameter (in.)	2/28	2/28	2/28	2/28	2/28
Drive Type/No. Speeds	Direct/1	Direct/1	Direct/1	Direct/1	Direct/1
CFM	17,000	17,000	17,000	17,000	17,000
No. Motor/HP	2/1	2/1	2/1	2/1	2/1
Motor RPM	1,125	1,125	1,125	1,125	1,125
<b>Refrigerant Charge (Field Supplied)</b>					
lbs of R-454B	9.4/9.4	18.5	9.9/9.7	19.4	25.6
<b>Shipping Dimensions</b>					
HxWxD (in.)	51.1" x 96" x 48"	51.1" x 96" x 48"	51.1" x 96" x 48"	51.1" x 96" x 48"	57.1" x 96" x 48"

**Notes:**

- All condensing units are tested in accordance with AHRI Standard 365.
- 6 - 20 ton units are AHRI Certified to AHRI Standard 340-360 (I-P). Rating conditions are 95°F outdoor air temperature, 80°F entering dry bulb, 67°F entering wet bulb with 25ft of interconnecting refrigerant piping with minimum external static. pressure as determined by rating standard.
- 25 ton units are tested in accordance with AHRI Standard 340-360.

<sup>(a)</sup> 1-stage compressor = 1S, 2-stage compressor = 2S.

<sup>(b)</sup> 1st stage is compressor 1. 2nd stage is compressor 1 and 2.

<sup>(c)</sup> All compressors stage to 66% for first stage, then 100% for second stage.

<sup>(d)</sup> For line lengths greater than 25ft, refer to refrigerant piping applications manual for line sizing and line length.



**Table 10. General data – 6 to 10 tons (TWE072K\*B\* – TWE120K\*B\*) SZVAV and 2-speed VFD air handler – 60hz**

	6 Tons	7.5 Tons	7.5 Tons	10 Tons	10 Tons
	Dual Circuit TWE072K3B*, 4B*, WB*	Single Circuit TWE090K3A*, 4A*, WA*	Dual Circuit TWE090K3B*, 4B*, WB*	Single Circuit TWE120K3A*, 4A*, WA*	Dual Circuit TWE120K3B*, 4B*, WB*
<b>System Data</b>					
No. Refrigerant Circuits	2	1	2	1	2
Suction Line Connection (in.) OD	1-1/8	1-3/8	1-1/8	1-3/8	1-1/8
Liquid Line Connection (in.) OD	1/2	1/2	1/2	1/2	1/2
<b>Indoor Coil</b>					
Type	Lanced/Intertwined	Lanced/Intertwined	Lanced/Intertwined	Lanced/Intertwined	Lanced/Intertwined
Tube Size (in.)	0.375	0.375	0.375	0.375	0.375
Face Area (sq. ft.)	8.1	8.1	8.1	11.2	11.2
Rows/FPI (Fins per inch)	4/14	4/14	4/14	4/14	4/14
Refrigerant Control	Expansion Valve	Expansion Valve	Expansion Valve	Expansion Valve	Expansion Valve
Drain Connection Size (in.)	1 PVC	1 PVC	1 PVC	1 PVC	1 PVC
<b>Indoor Fan</b>					
Type	Centrifugal	Centrifugal	Centrifugal	Centrifugal	Centrifugal
No. Used/Diameter x Width (in.)	1/15x15	1/15x15	1/15x15	1/15x15	1/15x15
Drive Type/No. Speeds	Belt/VFD Variable	Belt/VFD Variable	Belt/VFD Variable	Belt/VFD Variable	Belt/VFD Variable
CFM (Nominal)	2400	3000	3000	4000	4000
No. Motors	1	1	1	1	1
Motor HP - Standard/Oversized	2.0/3.0	2.0/3.0	2.0/3.0	2.0/3.0	2.0/3.0
Motor RPM	1725	1725	1725	1725	1725
Motor Frame Size	56 H	56 H	56 H	56 H	56 H
<b>Filters<sup>(a)</sup></b>					
Type/Furnished	Throwaway/Yes	Throwaway/Yes	Throwaway/Yes	Throwaway/Yes	Throwaway/Yes
(No.)/Size Recommended	(3) 16x25x1	(3) 16x25x1	(3) 16x25x1	(4) 16x25x1	(4) 16x25x1
MERV 13 (No.)/Size Recommended	(3) 16x25x2	(3) 16x25x2	(3) 16x25x2	(4) 16x25x2	(4) 16x25x2
<b>Shipping Dimensions</b>					
HxWxD (in.)	61.2" x 30.5" x 53"	61.2" x 30.5" x 53"	61.2" x 30.5" x 53"	61.2" x 30.5" x 69"	61.2" x 30.5" x 69"

<sup>(a)</sup> One inch, throw-away filters shall be standard on TWE060, TWE072, TWE090, TWE120 model air handlers from the factory. The filter rack can be field converted to two inch capability. Two inch, throw-away filters shall be standard on TWE150, TWE180, TWE240, and TWE300 models.



## General Data

**Table 11. General data – 12.5 to 25 tons (TWE150K\*B\* – TWE300K\*B\*) SZVAV and 2-speed VFD air handler – 60hz**

	12.5 Tons	15 Tons	20 Tons	25 Tons
	Dual Circuit TWE150K3B*, 4B*, WB*	Dual Circuit TWE180K3B*, 4B*, WB*	Dual Circuit TWE240K3B*, 4B*, WB*	Dual Circuit TWE300K3B*, 4B*, WB*
<b>System Data</b>				
No. Refrigerant Circuits	2	2	2	2
Suction Line Connection (in.) OD	1-3/8	1-3/8	1-3/8	1-3/8
Liquid Line Connection (in.) OD	1/2	1/2	5/8	5/8
<b>Indoor Coil</b>				
Type	Lanced/Intertwined	Lanced/Intertwined	Lanced/Intertwined	Lanced/Face Split
Tube Size (in.)	0.375	0.375	0.375	0.375
Face Area (sq. ft.)	16.3	16.3	21.7	21.7
Rows/FPI (Fins per inch)	4/14	4/14	3/14	4/14
Refrigerant Control	Expansion Valve	Expansion Valve	Expansion Valve	Expansion Valve
Drain Connection Size (in.)	1 PVC	1 PVC	1 PVC	1 PVC
<b>Indoor Fan</b>				
Type	Centrifugal	Centrifugal	Centrifugal	Centrifugal
No. Used/Diameter x Width (in.)	2/15x15	2/15x15	2/15x15	2/15x15
Drive Type/No. Speeds	Belt/VFD Variable	Belt/VFD Variable	Belt/VFD Variable	Belt/VFD Variable
CFM (Nominal)	5000	6000	8000	8750
No. Motors	1	1	1	1
Motor HP - Standard/Oversized	2.0/5.0	3.0/5.0	5.0/7.5	7.5/10
Motor RPM	1725/3450	1725/3450	3450	3450
Motor Frame Size	56 H	56 H	56 H/184 T	184 T/ 215 T
<b>Filters<sup>(a)</sup></b>				
Type/Furnished	Throwaway/Yes	Throwaway/Yes	Throwaway/Yes	Throwaway/Yes
(No.)/Size Recommended	(8) 15x20x2	(8) 15x20x2	(4) 16x25x2 (4) 16x20x2	(4) 16x25x2 (4) 16x20x2
MERV 13 (No.)/Size Recommended	(8) 15x20x2	(8) 15x20x2	(4) 16x25x2 (4) 16x20x2	(4) 16x25x2 (4) 16x20x2
<b>Shipping Dimensions</b>				
HxWxD (in.)	76.3" x 33.3" x 85"	76.3" x 33.3" x 85"	79.1" x 35.8" x 95"	79.1" x 35.8" x 95"

<sup>(a)</sup> One inch, throw-away filters shall be standard on TWE060, TWE072, TWE090, TWE120 model air handlers from the factory. The filter rack can be field converted to two inch capability. Two inch, throw-away filters shall be standard on TWE150, TWE180, TWE240, and TWE300 models.

**Table 12. General data – 5 to 10 tons (TWE060K\*A\* – TWE120K\*B\*) constant volume air handler – 60hz**

	5 Tons	5 Tons	7.5 Tons	7.5 Tons	10 Tons	10 Tons
	Single Circuit TWE060K3A*, 4A*, 1A*, WA*	Dual Circuit TWE060K3B*, 4B*, 1B*, WB*	Single Circuit TWE090K1A*	Dual Circuit TWE090K1B*	Single Circuit TWE120K1A*	Dual Circuit TWE120K1B*
<b>System Data</b>						
No. Refrigerant Circuits	1	2	1	2	1	2
Suction Line Connection (in.) OD	1-1/8	1-1/8	1-3/8	1-1/8	1-3/8	1-1/8
Liquid Line Connection (in.) OD	1/2	1/2	1/2	1/2	1/2	1/2
<b>Indoor Coil</b>						
Type	Lanced/ Intertwined	Lanced/ Intertwined	Lanced/ Intertwined	Lanced/ Intertwined	Lanced/ Intertwined	Lanced/ Intertwined
Tube Size (in.)	0.375	0.375	0.375	0.375	0.375	0.375
Face Area (sq. ft.)	5	5	8.1	8.1	11.2	11.2
Rows/FPI (Fins per inch)	4/14	4/14	4/14	4/14	4/14	4/14
Refrigerant Control	Expansion Valve	Expansion Valve	Expansion Valve	Expansion Valve	Expansion Valve	Expansion Valve
Drain Connection Size (in.)	1 PVC	1 PVC	1 PVC	1 PVC	1 PVC	1 PVC
<b>Indoor Fan</b>						
Type	Centrifugal	Centrifugal	Centrifugal	Centrifugal	Centrifugal	Centrifugal
No. Used/Diameter x Width (in.)	1/12x12	1/12x12	1/15x15	1/15x15	1/15x15	1/15x15
Drive Type/No. Speeds	Belt/Adjustable	Belt/Adjustable	Belt/Adjustable	Belt/Adjustable	Belt/Adjustable	Belt/Adjustable
CFM (Nominal)	2000	2000	3000	3000	4000	4000
No. Motors	1	1	1	1	1	1
Motor HP - Standard/Oversized	0.75/1.5	0.75/1.5	1.5/2.0	1.5/2.0	2.0 <sup>(a)</sup>	2.0 <sup>(a)</sup>
Motor RPM	1725	1725	1725	1725	1725	1725
Motor Frame Size	56 H	56 H	56 H	56 H	56 H	56 H
<b>Filters<sup>(b)</sup></b>						
Type/Furnished	Throwaway/Yes	Throwaway/Yes	Throwaway/Yes		Throwaway/Yes	Throwaway/Yes
(No.)/Size Recommended	(1) 16x20x1 (1) 20x20x1	(1) 16x20x1 (1) 20x20x1	(3) 16x25x1	(3) 16x25x1	(4) 16x25x1	(4) 16x25x1
MERV 13 (No.)/Size Recommended	(1) 16x20x2 (1) 20x20x2	(1) 16x20x2 (1) 20x20x2	(3) 16x25x2	(3) 16x25x2	(4) 16x25x2	(4) 16x25x2
<b>Shipping Dimensions</b>						
HxWxD (in.)	55.1" x 27.5" x 43.5"	55.1" x 27.5" x 43.5"	61.2" x 30.5" x 53"	61.2" x 30.5" x 53"	61.2" x 30.5" x 69"	61.2" x 30.5" x 69"

<sup>(a)</sup> Standard motor only, 120K1 does not have any oversize motor.

<sup>(b)</sup> One inch, throw-away filters shall be standard from the factory. The filter rack can be field converted to two inch capability.



# Performance Data

## Gross Cooling Capacities

Table 13. Gross cooling capacities (MBH) 6 tons TTA072K\*A condensing unit with 7.5 tons TWE090K\*A air handler (IP)

CFM	Ent DB (°F)	Ambient Temperature (°F)						Ambient Temperature (°F)						Ambient Temperature (°F)					
		85						95						105					
		Entering Wet Bulb (°F)						Entering Wet Bulb (°F)						Entering Wet Bulb (°F)					
		61		67		73		61		67		73		61		67		73	
		MBH	SHC	MBH	SHC	MBH	SHC	MBH	SHC	MBH	SHC	MBH	SHC	MBH	SHC	MBH	SHC	MBH	SHC
2160	75	72.5	60.8	79.4	46.7	87.2	31.5	69.5	59.1	76.0	45.2	83.7	30.1	66.3	57.4	72.3	43.6	79.8	28.6
	80	73.5	72.6	79.8	58.0	87.1	43.5	70.7	70.7	76.6	56.4	83.6	42.1	68.0	68.0	73.2	54.7	79.7	40.6
	85	77.3	77.3	80.3	69.6	87.2	54.8	74.6	74.6	77.1	68.0	83.8	53.3	71.8	71.8	73.8	66.4	80.1	51.7
	90	81.3	81.3	81.3	81.3	87.4	66.3	78.5	78.5	78.6	78.6	84.0	64.8	75.6	75.6	75.7	75.7	80.4	63.2
2400	75	73.9	64.4	80.8	48.6	88.4	32.1	70.8	62.8	77.4	47.0	84.7	30.7	67.6	61.1	73.9	45.2	80.7	29.2
	80	75.7	75.7	81.1	61.3	88.2	45.4	73.0	73.0	77.8	59.7	84.6	44.0	70.2	70.2	74.4	58.0	80.6	42.5
	85	79.8	79.8	81.7	74.2	88.4	57.7	77.0	77.0	78.5	72.7	84.9	56.2	74.1	74.1	75.1	71.0	81.2	54.6
	90	83.7	83.7	83.9	83.9	88.6	70.5	80.9	80.9	81.0	81.0	85.1	69.0	77.9	77.9	78.0	78.0	81.4	67.4
2640	75	75.1	68.1	81.8	50.5	89.3	32.7	72.0	66.4	78.4	48.9	85.5	31.3	68.7	64.7	74.8	47.2	81.4	29.8
	80	77.8	77.8	82.2	64.5	89.3	46.9	75.0	75.0	78.9	62.9	85.7	45.3	72.1	72.1	75.3	61.3	81.3	44.4
	85	81.9	81.9	82.9	78.8	89.3	60.6	79.1	79.1	79.7	77.3	85.8	59.1	76.1	76.1	76.3	75.6	82.0	57.5
	90	85.9	85.9	86.0	86.0	89.6	74.7	83.0	83.0	83.1	83.1	86.1	73.2	79.9	79.9	80.0	80.0	82.3	71.6
2880	75	76.2	71.7	82.7	52.5	90.1	33.3	73.0	70.0	79.3	50.8	86.2	31.9	69.8	68.2	75.6	49.0	82.0	30.3
	80	79.6	79.6	83.1	67.8	90.1	48.4	76.7	76.7	79.7	66.2	86.5	46.9	73.7	73.7	76.2	64.5	82.6	45.1
	85	83.8	83.8	84.1	83.4	90.1	63.5	80.8	80.8	81.0	81.0	86.5	62.0	77.7	77.7	77.8	77.8	82.7	60.3
	90	87.8	87.8	87.9	87.9	90.4	79.0	84.8	84.8	84.9	84.9	86.9	77.5	81.5	81.5	81.6	81.6	83.1	75.9
CFM	Ent DB (°F)	Ambient Temperature (°F)						Ambient Temperature (°F)											
		115						125											
		Entering Wet Bulb (°F)						Entering Wet Bulb (°F)											
		61		67		73		61		67		73							
		MBH	SHC	MBH	SHC	MBH	SHC	MBH	SHC	MBH	SHC	MBH	SHC						
2160	75	62.9	55.6	69.0	41.5	75.6	27.0	59.3	53.6	64.9	39.5	71.0	25.2						
	80	65.0	65.0	69.6	53.0	75.5	39.0	61.8	61.8	65.5	51.0	70.9	37.2						
	85	68.8	68.8	70.2	64.7	76.2	49.9	65.4	65.4	66.3	62.7	71.9	48.1						
	90	72.5	72.5	72.6	72.6	76.5	61.5	69.0	69.0	69.1	69.1	72.3	59.7						
2400	75	64.1	59.2	70.1	43.4	76.4	27.6	60.4	57.2	65.9	41.3	71.6	25.8						
	80	67.1	67.1	70.6	56.2	76.9	40.2	63.7	63.7	66.5	54.2	72.4	38.2						
	85	70.9	70.9	71.5	69.3	77.2	52.8	67.4	67.4	67.6	67.3	72.8	50.9						
	90	74.7	74.7	74.8	74.8	77.5	65.7	71.0	71.0	71.1	71.1	73.2	63.9						
2640	75	65.2	62.8	70.9	45.3	77.0	28.1	61.5	60.8	66.7	43.2	72.0	26.3						
	80	68.8	68.8	71.5	59.4	77.7	41.8	65.3	65.3	67.4	57.4	73.1	39.8						
	85	72.8	72.8	72.8	72.8	78.0	55.7	69.1	69.1	69.2	69.2	73.6	53.8						
	90	76.5	76.5	76.6	76.6	78.4	69.9	72.7	72.7	72.8	72.8	74.1	68.1						
2880	75	66.3	66.3	71.6	47.1	77.4	28.7	62.6	62.6	67.3	45.0	72.3	26.8						
	80	70.3	70.3	72.3	62.6	78.4	43.3	66.7	66.7	68.1	60.6	73.8	41.3						
	85	74.3	74.3	74.4	74.4	78.6	58.6	70.5	70.5	70.6	70.6	74.2	56.6						
	90	78.1	78.1	78.2	78.2	79.2	74.1	74.2	74.2	74.3	74.3	74.8	72.2						

**Table 14. Gross cooling capacities (MBH) 6 tons TTA072K\*D condensing unit with 6 tons TWE072K\*B air handler (IP)**

CFM	Ent DB (° F)	Ambient Temperature (°F)						Ambient Temperature (°F)						Ambient Temperature (°F)					
		85						95						105					
		Entering Wet Bulb (°F)						Entering Wet Bulb (°F)						Entering Wet Bulb (°F)					
		61		67		73		61		67		73		61		67		73	
		MBH	SHC	MBH	SHC	MBH	SHC	MBH	SHC	MBH	SHC	MBH	SHC	MBH	SHC	MBH	SHC		
2160	75	71.0	60.4	78.5	46.5	87.5	32.0	67.6	58.6	74.7	44.7	83.1	30.3	63.8	56.7	70.6	42.8	78.4	28.6
	80	72.4	72.3	79.2	58.1	87.4	44.0	69.5	69.5	75.5	56.4	83.2	42.3	66.3	66.3	71.4	54.5	78.8	40.5
	85	76.9	76.9	80.0	69.9	88.1	55.6	73.9	73.9	76.3	68.2	84.0	53.9	70.7	70.7	72.4	66.4	79.8	52.1
	90	81.6	81.3	81.6	81.3	88.8	67.4	78.3	78.3	78.5	78.5	84.7	65.7	75.1	75.1	75.3	75.3	80.5	63.9
2400	75	72.5	64.2	79.9	48.6	88.6	32.6	69.0	62.4	76.0	46.8	84.1	30.9	65.1	60.4	71.8	44.8	79.2	29.2
	80	75.0	75.0	80.7	61.5	88.8	45.8	72.0	72.0	76.8	59.8	84.6	44.1	68.6	68.6	72.8	57.9	80.1	42.2
	85	79.7	79.7	81.7	74.7	89.6	58.7	76.6	76.6	77.9	73.0	85.5	57.0	73.2	73.2	74.0	71.2	81.1	55.2
	90	84.5	84.5	84.6	84.6	90.3	71.8	81.2	81.2	81.4	81.4	86.2	70.1	77.8	77.8	78.0	78.0	81.9	68.3
2640	75	73.8	67.9	81.1	50.6	89.5	33.2	70.2	66.1	77.1	48.8	84.8	31.5	66.4	64.1	72.8	46.8	79.8	29.7
	80	77.3	77.3	81.9	64.9	90.1	47.6	74.1	74.1	78.0	63.1	85.7	45.8	70.7	70.7	73.9	61.2	81.2	43.9
	85	82.2	82.2	83.2	79.5	90.9	61.8	78.9	78.9	79.4	77.8	86.6	60.0	75.4	75.4	75.6	75.6	82.2	58.2
	90	87.1	87.1	87.3	87.3	91.7	76.2	83.8	83.8	83.9	83.9	87.6	74.5	80.2	80.2	80.4	80.4	83.2	72.7
2880	75	75.0	71.6	82.1	52.6	90.2	33.7	71.4	69.7	78.0	50.7	85.4	32.0	67.6	67.5	73.7	48.7	80.2	30.2
	80	79.3	79.3	83.0	68.3	91.1	49.3	76.0	76.0	79.0	66.5	86.7	47.4	72.4	72.4	74.9	64.5	82.1	45.5
	85	84.4	84.4	84.7	84.3	92.0	64.8	81.0	81.0	81.0	81.0	87.7	63.1	77.4	77.4	77.5	77.5	83.1	61.2
	90	89.5	89.5	89.6	89.6	92.9	80.6	86.0	86.0	86.2	86.2	88.7	78.9	82.3	82.3	82.5	82.5	84.3	77.1
CFM	Ent DB (° F)	Ambient Temperature (°F)						Ambient Temperature (°F)											
		115						125											
		Entering Wet Bulb (°F)						Entering Wet Bulb (°F)											
		61		67		73		61		67		73							
		MBH	SHC	MBH	SHC	MBH	SHC	MBH	SHC	MBH	SHC	MBH	SHC						
2160	75	59.8	54.7	66.2	40.7	73.3	26.7	55.6	52.5	61.5	38.5	67.7	24.7						
	80	62.9	62.9	67.1	52.5	74.1	38.5	59.2	59.2	62.6	50.4	69.1	36.4						
	85	67.2	67.2	68.2	64.5	75.2	50.2	63.4	63.4	63.8	62.4	70.3	48.1						
	90	71.6	71.6	71.7	71.7	76.0	62.1	67.8	67.8	67.9	67.9	71.2	60.1						
2400	75	61.1	58.4	67.3	42.7	73.8	27.3	56.9	56.2	62.5	40.5	68.1	25.3						
	80	65.0	65.0	68.3	55.9	75.3	40.2	61.2	61.2	63.7	53.7	70.2	38.0						
	85	69.6	69.6	69.8	69.3	76.5	53.2	65.7	65.7	65.7	65.7	71.5	51.2						
	90	74.2	74.2	74.3	74.3	77.4	66.5	70.2	70.2	70.4	70.4	72.6	64.5						
2640	75	62.3	62.0	68.2	44.6	74.2	27.8	58.3	58.3	63.4	42.4	68.3	25.7						
	80	66.9	66.9	69.4	59.2	76.3	41.8	62.9	62.9	64.7	57.0	71.1	39.6						
	85	71.7	71.7	71.8	71.8	77.5	56.3	67.6	67.6	67.7	67.7	72.4	54.2						
	90	76.5	76.5	76.6	76.6	78.6	70.9	72.4	72.4	72.5	72.5	73.8	68.9						
2880	75	63.7	63.7	69.0	46.6	74.5	28.3	59.7	59.7	64.1	44.2	68.5	26.2						
	80	68.6	68.6	70.4	62.5	77.1	43.4	64.5	64.5	65.6	60.3	71.8	41.1						
	85	73.5	73.5	73.6	73.6	78.4	59.2	69.3	69.3	69.4	69.4	73.3	57.1						
	90	78.4	78.4	78.6	78.6	79.7	75.2	74.2	74.2	74.3	74.3	74.9	73.2						

**Notes:**

1. All capacities shown are gross and have not considered indoor fan heat. To obtain net cooling, subtract indoor fan heat.
2. MBH = Total Gross Capacity, SHC = Sensible Heat Capacity



**Performance Data**

**Table 15. Gross cooling capacities (MBH) 7.5 tons TTA090K\*A condensing unit with 7.5 tons TWE090K\*A air handler (IP)**

CFM	Ent DB (°F)	Ambient Temperature (°F)						Ambient Temperature (°F)						Ambient Temperature (°F)					
		85						95						105					
		Entering Wet Bulb (°F)						Entering Wet Bulb (°F)						Entering Wet Bulb (°F)					
		61		67		73		61		67		73		61		67		73	
	MBH	SHC	MBH	SHC	MBH	SHC	MBH	SHC	MBH	SHC	MBH	SHC	MBH	SHC	MBH	SHC	MBH	SHC	
2700	75	93.4	77.8	102.0	60.0	111.3	40.8	89.5	75.8	97.7	58.3	106.8	39.2	85.3	73.7	93.1	56.4	102.1	37.5
	80	94.5	92.4	102.4	74.1	111.2	55.7	90.8	90.5	98.3	72.3	106.8	54.1	87.0	87.0	93.8	70.3	102.0	52.4
	85	98.8	98.8	102.9	88.5	111.3	70.0	95.5	95.5	98.9	86.7	107.0	68.3	91.9	91.9	94.5	84.8	102.3	66.4
	90	104.1	103.2	104.1	103.2	111.5	84.3	100.2	100.2	100.3	100.3	107.2	82.6	96.5	96.5	96.7	96.7	102.7	80.7
3000	75	95.1	82.3	103.5	62.5	112.6	41.5	91.1	80.3	99.3	60.6	108.1	39.9	86.9	78.2	94.7	58.6	103.3	38.2
	80	96.9	96.9	103.9	78.2	112.6	58.0	93.5	93.5	99.7	76.3	108.1	56.4	89.8	89.8	95.2	74.4	103.2	54.7
	85	101.9	101.9	104.6	94.2	112.7	73.6	98.4	98.4	100.5	92.4	115.5	74.8	94.7	94.7	96.1	90.5	103.6	70.0
	90	106.7	106.7	106.9	106.9	113.0	89.5	103.2	103.2	103.3	103.3	108.6	87.8	99.3	99.3	99.5	99.5	104.0	86.0
3300	75	96.6	86.8	104.8	64.9	113.8	42.2	92.5	84.8	100.5	63.0	109.2	40.6	88.2	82.7	95.8	61.0	104.2	38.9
	80	99.5	99.5	105.2	82.2	113.7	60.3	95.9	95.9	101.0	80.4	109.1	58.7	92.1	92.1	96.4	78.4	104.2	57.1
	85	104.5	104.5	106.1	99.9	113.8	77.3	100.9	100.9	102.0	98.1	109.4	75.5	97.0	97.0	97.6	96.2	104.6	73.6
	90	109.4	109.4	109.5	109.5	114.4	94.8	105.7	105.7	105.8	105.8	109.8	93.0	101.7	101.7	101.9	101.9	105.1	91.2
3600	75	97.8	91.2	105.9	67.3	114.7	42.8	93.8	89.2	101.5	65.4	110.1	41.3	89.5	87.1	96.8	63.3	105.0	39.6
	80	101.6	101.6	106.3	86.2	114.7	62.7	98.0	98.0	102.0	84.4	110.0	61.1	94.1	94.1	97.4	82.4	105.0	59.4
	85	106.7	106.7	107.5	105.6	114.8	80.8	103.0	103.0	103.4	103.4	110.3	79.1	99.0	99.0	99.1	99.1	105.5	77.2
	90	111.6	111.6	111.8	111.8	115.6	100.2	107.8	107.8	108.0	108.0	110.8	98.3	103.8	103.8	103.9	103.9	106.0	96.4
CFM	Ent DB (°F)	Ambient Temperature (°F)						Ambient Temperature (°F)											
		115						125											
		Entering Wet Bulb (°F)						Entering Wet Bulb (°F)											
		61		67		73		61		67		73							
	MBH	SHC	MBH	SHC	MBH	SHC	MBH	SHC	MBH	SHC	MBH	SHC							
2700	75	80.8	71.5	88.5	54.0	96.9	35.7	75.9	69.1	83.2	51.6	91.1	33.8						
	80	83.2	83.2	89.1	68.2	96.8	50.6	79.0	79.0	83.9	65.9	91.1	48.6						
	85	87.9	87.9	89.9	82.7	97.3	64.4	83.7	83.7	84.8	80.4	91.9	62.3						
	90	92.5	92.5	92.6	92.6	97.7	78.8	88.1	88.1	88.3	88.3	92.4	76.6						
3000	75	82.3	76.0	89.8	56.4	97.9	36.4	77.3	73.5	84.4	54.0	92.0	34.4						
	80	85.8	85.8	90.4	72.2	97.9	52.9	81.4	81.4	85.2	69.9	92.0	50.9						
	85	90.6	90.6	91.4	88.4	98.5	68.0	86.1	86.1	86.5	86.1	93.0	65.8						
	90	95.2	95.2	95.3	95.3	98.9	84.0	90.7	90.7	90.8	90.8	93.5	81.8						
3300	75	83.6	80.4	90.8	58.7	98.8	37.1	78.7	77.9	85.4	56.3	92.7	35.1						
	80	87.9	87.9	91.5	76.2	98.7	55.2	83.4	83.4	86.2	73.9	92.7	53.3						
	85	92.8	92.8	93.0	93.0	99.4	71.6	88.2	88.2	88.3	88.3	93.9	69.4						
	90	97.4	97.4	97.5	97.5	100.0	89.2	92.7	92.7	92.8	92.8	94.5	87.1						
3600	75	84.9	84.8	91.7	61.1	99.5	37.8	80.0	80.0	86.2	58.6	93.3	35.8						
	80	89.8	89.8	92.5	80.2	100.0	56.3	85.1	85.1	87.1	77.8	93.3	55.6						
	85	94.7	94.7	94.8	94.8	100.2	75.1	90.0	90.0	90.1	90.1	94.6	72.9						
	90	99.3	99.3	99.4	99.4	100.9	94.4	94.5	94.5	94.6	94.6	95.5	92.2						

**Notes:**

1. All capacities shown are gross and have not considered indoor fan heat. To obtain net cooling, subtract indoor fan heat.
2. MBH = Total Gross Capacity, SHC = Sensible Heat Capacity

**Table 16. Gross cooling capacities (MBH) 7.5 tons TTA090K\*D condensing unit with 7.5 tons TWE090K\*B air handler (IP)**

CFM	Ent DB (°F)	Ambient Temperature (°F)						Ambient Temperature (°F)						Ambient Temperature (°F)					
		85						95						105					
		Entering Wet Bulb (°F)						Entering Wet Bulb (°F)						Entering Wet Bulb (°F)					
		61		67		73		61		67		73		61		67		73	
		MBH	SHC	MBH	SHC	MBH	SHC	MBH	SHC	MBH	SHC	MBH	SHC	MBH	SHC	MBH	SHC	MBH	SHC
2700	75	92.9	77.7	101.2	59.9	110.4	40.7	89.1	75.8	97.0	58.0	105.5	39.0	85.0	73.8	92.4	56.0	100.4	37.2
	80	93.9	92.4	101.5	74.0	110.2	55.6	90.3	90.2	97.3	72.1	106.9	54.4	86.7	86.7	92.8	70.1	100.3	52.0
	85	98.2	98.2	101.9	88.3	110.5	69.9	94.8	94.8	97.8	86.5	105.6	68.0	91.1	91.1	93.4	84.6	100.5	66.0
	90	103.1	102.3	103.1	102.3	110.8	84.2	100.4	100.4	99.4	99.4	106.0	82.3	95.4	95.4	95.5	95.5	100.9	80.4
3000	75	94.6	82.2	102.7	62.3	111.8	41.4	90.6	80.3	98.4	60.4	106.7	39.6	86.4	78.3	93.7	58.3	101.4	37.9
	80	96.4	96.4	104.3	78.6	112.7	58.3	93.0	93.0	98.7	76.1	106.6	56.0	89.2	89.2	94.1	74.1	101.4	54.0
	85	101.2	101.2	103.6	94.1	112.0	73.6	98.7	98.7	100.7	92.8	107.0	71.6	93.7	93.7	94.9	90.2	101.8	69.6
	90	106.0	106.0	106.2	106.2	116.3	91.1	102.2	102.2	102.3	102.3	107.4	87.7	98.0	98.0	98.2	98.2	102.2	85.6
3300	75	96.0	86.7	105.2	65.2	112.8	42.0	92.0	84.8	99.5	62.8	107.6	40.3	87.7	82.7	94.7	60.7	102.3	38.5
	80	98.9	98.9	104.2	82.0	112.8	60.0	95.3	95.3	99.9	80.1	107.7	58.0	91.4	91.4	95.2	78.1	102.4	55.9
	85	103.7	103.7	105.2	99.8	113.2	77.2	100.0	100.0	100.8	97.9	108.1	75.3	95.9	95.9	96.3	95.5	102.8	73.2
	90	108.8	108.8	111.8	111.8	114.7	95.2	104.8	104.8	104.9	104.9	108.7	92.9	100.4	100.4	100.5	100.5	103.3	90.9
3600	75	99.7	92.3	105.0	67.0	113.7	42.7	93.2	89.2	100.5	65.1	108.4	40.9	88.9	87.1	95.6	63.0	102.9	39.2
	80	101.0	101.0	105.4	86.1	113.5	62.5	97.3	97.3	100.9	84.1	108.7	59.9	93.2	93.2	96.1	82.1	103.2	57.8
	85	106.0	106.0	106.7	105.5	115.2	81.2	102.0	102.0	102.3	102.3	109.1	78.9	97.7	97.7	97.8	97.8	103.6	76.7
	90	111.2	111.2	112.2	112.2	114.9	100.2	107.0	107.0	107.1	107.1	109.8	98.2	102.4	102.4	102.5	102.5	104.4	96.1
CFM	Ent DB (°F)	Ambient Temperature (°F)						Ambient Temperature (°F)											
		115						125											
		Entering Wet Bulb (°F)						Entering Wet Bulb (°F)											
		61		67		73		61		67		73							
		MBH	SHC	MBH	SHC	MBH	SHC	MBH	SHC	MBH	SHC	MBH	SHC						
2700	75	80.5	71.6	87.5	53.8	94.8	35.3	75.5	69.2	82.1	51.4	88.7	33.3						
	80	82.8	82.8	87.9	68.0	94.9	49.9	78.5	78.5	82.6	65.6	89.0	47.5						
	85	87.1	87.1	88.5	82.4	95.1	63.8	82.6	82.6	83.3	80.1	89.3	61.5						
	90	91.1	91.1	91.3	91.3	95.4	78.2	86.4	86.4	86.5	86.5	89.6	75.9						
3000	75	81.9	76.1	88.6	56.1	95.7	36.0	76.8	73.6	83.1	53.7	89.5	34.0						
	80	85.1	85.1	89.1	71.9	95.9	51.8	80.6	80.6	83.6	69.5	89.9	49.4						
	85	89.4	89.4	90.0	88.1	96.1	67.4	84.7	84.7	84.8	84.4	90.2	65.0						
	90	93.5	93.5	93.6	93.6	96.6	83.4	88.5	88.5	88.6	88.6	90.5	81.1						
3300	75	83.1	80.5	89.6	58.4	96.4	36.6	78.1	77.9	83.9	55.9	90.1	34.6						
	80	87.1	87.1	90.1	75.9	96.8	53.7	82.4	82.4	84.5	73.5	90.7	51.2						
	85	91.4	91.4	91.5	91.5	97.0	70.9	86.4	86.4	86.5	86.5	90.9	68.5						
	90	95.6	95.6	95.7	95.7	97.6	88.7	90.3	90.3	90.4	90.4	91.5	86.3						
3600	75	84.3	84.3	90.3	60.7	98.8	37.8	79.4	79.4	84.6	58.1	90.5	35.2						
	80	88.7	88.7	90.9	79.8	99.3	56.3	83.8	83.8	85.3	77.3	91.3	53.0						
	85	93.1	93.1	93.2	93.2	97.8	74.5	87.9	87.9	88.0	88.0	91.5	72.0						
	90	97.4	97.4	97.5	97.5	98.6	93.9	91.9	91.9	92.0	92.0	92.4	91.1						

**Notes:**

1. All capacities shown are gross and have not considered indoor fan heat. To obtain net cooling, subtract indoor fan heat.
2. MBH = Total Gross Capacity, SHC = Sensible Heat Capacity



**Performance Data**

**Table 17. Gross cooling capacities (MBH) 10 tons TTA120K\*D condensing unit with 10 tons TWE120K\*B air handler (IP)**

CFM	Ent DB (°F)	Ambient Temperature (°F)						Ambient Temperature (°F)						Ambient Temperature (°F)					
		85						95						105					
		Entering Wet Bulb (°F)						Entering Wet Bulb (°F)						Entering Wet Bulb (°F)					
		61		67		73		61		67		73		61		67		73	
	MBH	SHC	MBH	SHC	MBH	SHC	MBH	SHC	MBH	SHC	MBH	SHC	MBH	SHC	MBH	SHC	MBH	SHC	
3500	75	116.1	99.0	127.7	76.2	140.9	52.0	110.8	96.4	122.0	73.7	134.8	49.9	105.5	93.8	116.1	71.1	128.1	47.6
	80	117.9	117.9	128.2	94.7	140.5	71.3	113.3	113.3	122.6	92.2	134.3	69.2	108.8	108.8	116.8	89.7	128.0	66.7
	85	124.3	124.3	128.9	113.5	140.7	89.9	119.8	119.8	123.4	111.2	134.8	87.6	115.1	115.1	117.7	108.7	128.6	85.1
	90	131.0	130.8	131.0	130.8	140.9	108.5	126.2	126.2	126.5	126.5	135.2	106.3	121.4	121.4	121.7	121.7	129.0	103.9
4000	75	119.0	106.7	130.4	80.4	143.1	53.2	113.6	104.1	124.5	77.9	136.8	51.1	108.1	101.4	118.4	75.2	129.8	48.7
	80	122.7	122.7	130.9	101.6	142.9	75.1	118.1	118.1	125.2	99.2	136.8	72.7	113.2	113.2	119.2	96.6	130.2	70.2
	85	129.5	129.5	132.0	123.3	143.1	96.1	124.8	124.8	126.4	120.9	137.2	93.8	119.8	119.8	120.7	118.4	130.8	91.3
	90	136.2	136.2	136.4	136.4	143.5	117.5	131.4	131.4	131.6	131.6	137.7	115.3	126.3	126.3	126.5	126.5	131.4	112.9
4400	75	120.9	112.7	132.1	83.7	144.6	54.1	115.5	110.1	126.1	81.1	138.1	52.0	110.0	107.5	119.9	78.4	130.9	49.6
	80	126.0	126.0	132.7	107.1	144.4	78.2	121.2	121.2	126.9	104.7	138.3	75.4	116.2	116.2	120.8	102.0	131.7	72.8
	85	133.0	133.0	134.2	131.1	144.7	101.0	128.1	128.1	128.7	128.4	138.7	98.7	123.0	123.0	123.1	123.1	132.2	96.2
	90	139.8	139.8	140.0	140.0	145.1	124.6	134.9	134.9	135.0	135.0	139.3	122.4	129.6	129.6	129.8	129.8	133.0	120.0
4800	75	122.7	118.8	133.5	86.9	145.8	55.0	117.3	116.2	127.4	84.3	139.1	52.9	111.8	111.8	121.1	81.6	131.7	50.5
	80	128.9	128.9	134.2	112.6	145.9	80.5	124.0	124.0	128.3	110.1	139.6	78.1	118.8	118.8	122.2	107.5	132.9	75.5
	85	136.0	136.0	136.3	136.3	146.0	105.9	131.0	131.0	131.1	131.1	140.0	103.6	125.7	125.7	125.8	125.8	133.4	101.1
	90	142.8	142.8	143.0	143.0	146.8	131.8	137.8	137.8	138.0	138.0	140.8	129.6	132.4	132.4	132.5	132.5	134.5	127.2
CFM	Ent DB (°F)	Ambient Temperature (°F)						Ambient Temperature (°F)											
		115						120											
		Entering Wet Bulb (°F)						Entering Wet Bulb (°F)											
		61		67		73		61		67		73							
	MBH	SHC	MBH	SHC	MBH	SHC	MBH	SHC	MBH	SHC	MBH	SHC							
3500	75	100.2	91.2	110.1	68.4	121.1	45.2	95.0	88.7	103.9	65.7	113.7	42.8						
	80	104.1	104.1	110.8	87.1	121.3	64.1	99.4	99.4	104.8	84.4	114.5	61.4						
	85	110.3	110.3	111.9	106.1	122.1	82.6	105.3	105.3	106.1	103.6	115.4	80.0						
	90	116.4	116.4	116.6	116.6	122.6	101.5	111.2	111.2	111.4	111.4	116.0	98.9						
4000	75	102.6	98.8	112.1	72.5	122.5	46.3	100.0	97.5	105.7	69.6	114.8	43.8						
	80	108.2	108.2	113.0	93.9	123.4	67.5	103.1	103.1	106.8	91.2	116.4	64.7						
	85	114.6	114.6	114.9	114.9	124.2	88.7	109.3	109.3	109.4	109.4	117.3	86.1						
	90	121.0	121.0	121.2	121.2	124.9	110.4	115.4	115.4	115.6	115.6	118.2	107.8						
4400	75	104.5	104.5	113.5	75.6	123.3	47.2	99.3	99.3	106.9	72.8	115.4	44.7						
	80	111.0	111.0	114.5	99.4	124.8	70.1	105.6	105.6	108.2	96.6	117.6	67.3						
	85	117.6	117.6	117.7	117.7	125.5	93.6	112.0	112.0	112.1	112.1	118.5	90.9						
	90	124.0	124.0	124.2	124.2	126.5	117.5	118.2	118.2	118.4	118.4	119.7	114.9						
4800	75	106.5	106.5	114.5	78.7	123.9	48.0	101.3	101.3	107.9	75.8	115.9	45.5						
	80	113.3	113.3	115.9	104.8	125.9	72.7	107.8	107.8	109.4	101.9	118.6	69.8						
	85	120.1	120.1	120.2	120.2	126.6	98.5	114.3	114.3	114.4	114.4	119.6	95.7						
	90	126.6	126.6	126.8	126.8	128.0	124.6	120.6	120.6	120.8	120.7	121.2	121.2						

**Notes:**

1. All capacities shown are gross and have not considered indoor fan heat. To obtain net cooling, subtract indoor fan heat.
2. MBH = Total Gross Capacity, SHC = Sensible Heat Capacity



**Table 18. Gross cooling capacities (MBH) – one compressor – 10 tons TTA120K\*C condensing unit with 10 tons TWE120K\*A air handler (IP)**

CFM	Ent DB (°F)	Ambient Temperature (°F)						Ambient Temperature (°F)						Ambient Temperature (°F)					
		85						95						105					
		Entering Wet Bulb (°F)						Entering Wet Bulb (°F)						Entering Wet Bulb (°F)					
		61		67		73		61		67		73		61		67		73	
		MBH	SHC	MBH	SHC	MBH	SHC	MBH	SHC	MBH	SHC	MBH	SHC	MBH	SHC	MBH	SHC	MBH	SHC
3500	75	71.7	71.7	75.5	53.8	79.6	31.7	69.0	69.0	72.3	52.3	75.7	30.4	66.1	66.1	68.9	50.7	71.5	29.1
	80	76.2	76.2	76.7	73.0	82.6	49.2	73.4	73.4	73.7	71.6	79.1	47.7	70.4	70.4	70.5	70.1	75.4	46.1
	85	80.7	80.7	80.8	80.8	83.4	68.3	77.9	77.9	77.9	77.9	80.1	67.0	74.8	74.8	74.8	74.8	76.5	65.6
	90	85.1	85.1	85.1	85.1	85.2	85.2	82.1	82.1	82.2	82.2	82.3	82.3	79.0	79.0	79.1	79.1	79.2	79.2
4000	75	73.6	73.6	76.4	57.6	79.8	32.6	70.8	70.8	73.2	56.0	75.8	31.4	67.7	67.7	69.7	54.3	71.6	30.0
	80	78.3	78.3	78.3	78.3	83.5	52.3	75.4	75.4	75.4	75.4	80.0	50.8	72.3	72.3	72.3	72.3	76.2	49.1
	85	82.9	82.9	83.0	83.0	84.4	74.3	79.9	79.9	80.0	80.0	81.1	73.0	76.7	76.7	76.8	76.8	77.6	71.5
	90	87.2	87.2	87.3	87.3	87.4	87.4	84.3	84.3	84.3	84.3	84.4	84.4	81.0	81.0	81.1	81.1	81.2	81.2
4400	75	74.9	74.9	77.0	60.5	79.9	33.4	72.0	72.0	73.7	58.9	75.9	32.2	68.8	68.8	70.2	57.2	71.6	30.8
	80	79.7	79.7	79.8	79.8	84.1	54.8	76.7	76.7	76.7	76.7	75.4	56.3	73.4	73.4	73.5	73.5	76.7	51.4
	85	84.4	84.4	84.4	84.4	85.2	79.1	81.3	81.3	81.4	81.4	81.9	77.7	78.0	78.0	78.1	78.1	78.4	76.1
	90	88.6	88.6	88.7	88.7	88.8	88.8	85.6	85.6	85.7	85.7	85.8	85.8	82.3	82.3	82.4	82.4	82.5	82.5
4800	75	75.9	75.9	77.6	63.5	79.9	34.2	72.9	72.9	74.3	61.8	75.9	32.9	69.7	69.7	70.7	60.0	71.6	31.6
	80	80.9	80.9	80.9	80.9	84.6	57.3	77.8	77.8	77.8	77.8	80.9	55.6	74.4	74.4	74.5	74.5	77.1	53.7
	85	85.6	85.6	85.6	85.6	86.0	83.8	82.5	82.5	82.5	82.5	82.7	82.3	79.1	79.1	79.1	79.1	79.2	79.2
	90	89.8	89.8	89.9	89.9	90.0	90.0	86.8	86.8	86.9	86.9	86.9	86.9	83.4	83.4	83.5	83.5	83.5	83.5
CFM	Ent DB (°F)	Ambient Temperature (°F)						Ambient Temperature (°F)											
		115						120											
		Entering Wet Bulb (°F)						Entering Wet Bulb (°F)											
		61		67		73		61		67		73							
		MBH	SHC	MBH	SHC	MBH	SHC	MBH	SHC	MBH	SHC	MBH	SHC						
3500	75	63.0	63.0	65.2	49.0	66.9	27.6	61.3	61.3	63.3	48.0	64.4	26.8						
	80	67.2	67.2	67.2	67.2	71.4	44.4	65.5	65.5	65.5	65.5	69.3	43.4						
	85	71.4	71.4	71.5	71.5	72.7	64.0	69.6	69.6	69.7	69.7	70.7	63.2						
	90	75.6	75.6	75.7	75.7	75.8	75.8	73.8	73.8	73.9	73.9	73.9	73.9						
4000	75	64.4	64.4	66.0	52.5	66.9	28.6	62.7	62.7	64.0	51.5	62.2	27.1						
	80	68.9	68.9	68.9	68.9	72.1	47.2	67.1	67.1	67.1	67.1	64.0	49.7						
	85	73.2	73.2	73.3	73.3	73.8	69.8	71.4	71.4	71.4	71.4	71.8	68.9						
	90	77.5	77.5	77.6	77.6	77.7	77.7	75.6	75.6	75.7	75.7	75.8	75.8						
4400	75	65.4	65.4	66.5	55.2	66.8	29.3	63.6	63.6	64.5	54.1	62.1	27.8						
	80	69.9	69.9	70.0	70.0	66.5	53.5	68.0	68.0	68.1	68.1	63.8	52.6						
	85	74.4	74.4	74.5	74.5	74.6	74.4	72.5	72.5	72.6	72.6	72.6	72.6						
	90	78.8	78.8	78.8	78.8	78.9	78.9	76.8	76.8	76.9	76.9	76.9	76.9						
4800	75	66.2	66.2	66.9	57.9	66.7	30.0	64.3	64.3	64.9	56.7	61.9	28.5						
	80	70.8	70.8	70.8	70.8	66.4	56.4	68.9	68.9	68.9	68.9	63.6	55.6						
	85	75.4	75.4	75.5	75.5	75.5	75.5	73.5	73.5	73.5	73.5	73.5	73.5						
	90	79.8	79.8	79.8	79.8	79.9	79.9	77.8	77.8	77.9	77.9	77.9	77.9						

**Notes:**

1. All capacities shown are gross and have not considered indoor fan heat. To obtain net cooling, subtract indoor fan heat.
2. MBH = Total Gross Capacity, SHC = Sensible Heat Capacity



**Performance Data**

**Table 19. Gross cooling capacities (MBH) – both compressors – 10 tons TTA120K\*C condensing unit with 10 tons TWE120K\*A air handler (IP)**

CFM	Ent DB (°F)	Ambient Temperature (°F)						Ambient Temperature (°F)						Ambient Temperature (°F)					
		85						95						105					
		Entering Wet Bulb (°F)						Entering Wet Bulb (°F)						Entering Wet Bulb (°F)					
		61		67		73		61		67		73		61		67		73	
		MBH	SHC	MBH	SHC	MBH	SHC	MBH	SHC	MBH	SHC	MBH	SHC	MBH	SHC	MBH	SHC	MBH	SHC
3500	75	119.6	100.2	131.1	77.5	144.3	53.1	114.7	97.8	125.5	75.2	138.4	51.0	109.4	95.1	120.1	72.4	132.0	48.7
	80	121.1	119.3	131.8	95.8	143.9	72.3	116.6	116.6	126.5	93.5	138.1	70.2	112.1	112.1	120.8	90.9	131.6	67.9
	85	127.3	127.3	132.5	114.5	144.0	90.8	123.1	123.1	127.3	112.2	138.5	88.5	118.4	118.4	121.6	109.7	132.3	86.1
	90	134.1	133.6	134.1	133.6	144.3	109.3	129.4	129.4	129.6	129.6	138.8	107.1	124.6	124.6	124.9	124.9	132.8	104.7
4000	75	122.6	107.9	134.0	81.6	146.5	54.2	117.6	105.4	128.5	79.2	140.5	52.1	112.1	102.7	122.4	76.5	133.8	49.9
	80	125.9	125.9	134.6	102.7	146.2	76.2	121.5	121.5	129.2	100.3	140.1	74.1	116.7	116.7	123.2	97.7	133.4	71.8
	85	132.7	132.7	135.5	124.2	146.5	96.9	128.2	128.2	130.3	121.9	140.8	94.7	123.3	123.3	124.6	119.4	134.5	92.2
	90	139.3	139.3	139.5	139.5	146.9	118.2	134.7	134.7	134.9	134.9	141.3	116.0	129.7	129.7	129.9	129.9	135.1	113.6
4400	75	124.6	113.9	135.7	84.9	148.0	55.1	119.5	111.4	130.1	82.4	141.8	53.0	114.0	108.7	123.9	79.7	134.8	50.7
	80	129.4	129.4	136.4	108.2	147.9	78.8	124.8	124.8	130.9	105.8	142.0	76.4	119.8	119.8	124.9	103.2	135.4	73.9
	85	136.3	136.3	137.7	131.9	148.1	101.8	131.6	131.6	132.5	129.6	142.3	99.5	126.5	126.5	126.8	126.8	135.9	97.0
	90	142.9	142.9	143.1	143.1	148.6	125.3	138.2	138.2	138.4	138.4	142.9	123.1	132.9	132.9	133.1	133.1	136.7	120.7
4800	75	126.5	119.9	137.2	88.1	149.2	56.0	121.3	117.4	131.5	85.6	142.8	53.9	115.8	114.7	125.2	82.9	135.7	51.6
	80	132.4	132.4	137.9	113.6	149.3	81.4	127.7	127.7	132.3	111.2	143.2	79.1	122.5	122.5	126.3	108.5	136.6	76.5
	85	139.3	139.3	139.8	139.6	149.4	106.6	134.6	134.6	134.7	134.7	143.6	104.4	129.3	129.3	129.4	129.4	137.1	101.9
	90	146.0	146.0	146.2	146.2	150.0	132.3	141.1	141.1	141.3	141.3	144.3	130.1	135.7	135.7	135.9	135.9	138.1	127.7
CFM	Ent DB (°F)	Ambient Temperature (°F)						Ambient Temperature (°F)											
		115						120											
		Entering Wet Bulb (°F)						Entering Wet Bulb (°F)											
		61		67		73		61		67		73							
		MBH	SHC	MBH	SHC	MBH	SHC	MBH	SHC	MBH	SHC	MBH	SHC						
3500	75	103.6	92.3	113.7	69.6	124.8	46.2	100.5	90.8	110.3	68.1	120.9	44.9						
	80	107.1	107.1	114.5	88.1	124.4	65.4	104.4	104.4	111.1	86.7	120.5	64.1						
	85	113.3	113.3	115.5	107.0	125.6	83.4	110.6	110.6	112.2	105.6	122.1	82.0						
	90	119.4	119.4	119.6	119.6	126.2	102.2	116.6	116.6	116.8	116.8	122.7	100.8						
4000	75	106.1	99.8	115.8	73.6	126.3	47.3	103.0	98.3	112.3	72.1	122.2	46.0						
	80	111.4	111.4	116.8	94.9	127.0	68.5	108.6	108.6	113.4	93.4	123.3	67.0						
	85	117.9	117.9	118.4	116.7	127.7	89.5	114.9	114.9	115.2	115.2	124.1	88.1						
	90	124.1	124.1	124.3	124.3	128.4	111.0	121.1	121.1	121.3	121.3	124.8	109.6						
4400	75	108.0	105.8	117.2	76.8	127.1	48.2	104.9	104.3	113.7	75.2	123.0	46.8						
	80	114.3	114.3	118.3	100.3	128.3	71.1	111.4	111.4	114.8	98.8	124.5	69.6						
	85	120.9	120.9	121.1	121.1	129.1	94.4	117.9	117.9	118.0	118.0	125.4	92.9						
	90	127.2	127.2	127.4	127.4	130.0	118.1	124.1	124.1	124.3	124.3	126.4	116.7						
4800	75	109.9	109.9	118.4	79.9	127.7	49.0	107.0	107.0	114.8	78.3	123.5	47.6						
	80	116.8	116.8	119.6	105.7	129.5	73.7	113.8	113.8	116.2	104.2	125.6	72.1						
	85	123.5	123.5	123.6	123.6	130.2	99.2	120.4	120.4	120.5	120.5	126.5	97.7						
	90	129.8	129.8	130.0	130.0	131.3	125.1	126.7	126.7	126.8	126.8	127.8	123.7						

**Notes:**

1. All capacities shown are gross and have not considered indoor fan heat. To obtain net cooling, subtract indoor fan heat.
2. MBH = Total Gross Capacity, SHC = Sensible Heat Capacity

**Table 20. Gross cooling capacities (MBH) 12.5 tons TTA150K\*D condensing unit with 12.5 tons TWE150K\*B air handler (IP)**

CFM	Ent DB (°F)	Ambient Temperature (°F)						Ambient Temperature (°F)						Ambient Temperature (°F)					
		85						95						105					
		Entering Wet Bulb (°F)						Entering Wet Bulb (°F)						Entering Wet Bulb (°F)					
		61		67		73		61		67		73		61		67		73	
		MBH	SHC	MBH	SHC	MBH	SHC	MBH	SHC	MBH	SHC	MBH	SHC	MBH	SHC	MBH	SHC	MBH	SHC
4500	75	150.2	127.8	164.5	98.2	179.6	66.4	144.0	124.8	157.7	95.2	172.2	63.8	137.2	121.5	150.1	91.9	163.9	61.0
	80	152.2	150.1	164.8	121.8	179.3	91.2	146.5	146.5	158.1	118.9	171.9	88.7	140.6	140.6	150.6	115.7	163.7	85.6
	85	159.5	159.5	165.4	145.9	179.2	115.0	154.2	154.2	158.8	143.1	172.0	112.2	148.1	148.1	151.5	139.9	164.0	109.1
	90	167.7	166.8	167.7	166.8	179.2	138.9	161.6	161.6	161.9	161.9	172.1	136.1	155.3	155.3	155.6	155.6	164.1	133.0
5000	75	152.9	135.4	167.0	102.3	181.8	67.5	146.6	132.4	160.0	99.3	174.2	64.9	139.6	129.0	152.3	95.9	165.7	62.1
	80	156.5	156.5	167.3	128.7	181.5	95.1	151.0	151.0	160.4	125.7	174.0	92.2	144.8	144.8	152.8	122.5	165.7	89.0
	85	164.4	164.4	168.1	155.6	181.4	121.1	158.8	158.8	161.4	152.7	174.0	118.3	152.4	152.4	154.0	149.5	165.8	115.1
	90	172.1	172.1	172.4	172.4	181.4	147.7	166.3	166.3	166.5	166.5	174.2	145.0	159.7	159.7	159.9	159.9	166.1	141.9
5500	75	155.3	143.0	169.0	106.4	183.6	68.7	148.9	139.9	161.9	103.3	175.8	66.1	141.8	136.5	154.0	99.9	167.1	63.3
	80	160.5	160.5	169.3	135.5	183.4	98.4	154.8	154.8	162.4	132.5	175.7	95.5	148.4	148.4	154.6	129.2	167.3	92.2
	85	168.6	168.6	170.5	165.2	183.1	127.2	162.7	162.7	163.8	162.1	175.6	124.3	156.1	156.1	156.6	155.3	167.3	121.1
	90	176.3	176.3	176.6	176.6	183.3	156.6	170.3	170.3	170.5	170.5	175.9	153.8	163.4	163.4	163.6	163.6	167.7	150.7
6000	75	157.4	150.5	170.8	110.4	185.2	69.8	150.9	147.4	163.5	107.3	177.2	67.2	143.8	143.1	155.5	103.8	168.3	64.4
	80	164.0	164.0	171.1	142.2	184.9	101.8	158.1	158.1	164.0	139.2	177.2	98.8	151.4	151.4	156.2	135.9	168.7	95.5
	85	172.1	172.1	172.8	172.6	184.6	133.2	166.0	166.0	166.4	166.4	177.0	130.3	159.2	159.2	159.4	159.4	168.6	127.1
	90	179.9	179.9	180.1	180.1	185.1	165.5	173.6	173.6	173.7	173.7	177.4	162.6	166.4	166.4	166.6	166.6	169.1	159.4
CFM	Ent DB (°F)	Ambient Temperature (°F)						Ambient Temperature (°F)											
		115						125											
		Entering Wet Bulb (°F)						Entering Wet Bulb (°F)											
		61		67		73		61		67		73							
		MBH	SHC	MBH	SHC	MBH	SHC	MBH	SHC	MBH	SHC	MBH	SHC						
4500	75	129.6	117.8	141.7	88.2	154.5	57.8	121.3	113.8	132.4	84.1	144.0	54.4						
	80	134.0	134.0	142.4	112.1	154.6	82.1	126.7	126.7	133.3	108.1	144.7	78.1						
	85	141.3	141.3	143.4	136.4	155.0	105.6	133.7	133.7	134.6	132.5	145.2	101.8						
	90	148.3	148.3	148.5	148.5	155.3	129.6	140.5	140.5	140.7	140.7	145.7	125.9						
5000	75	131.9	125.3	143.7	92.2	156.0	59.0	123.5	121.3	134.2	88.0	145.1	55.5						
	80	137.9	137.9	144.4	118.8	156.5	85.3	130.2	130.2	135.1	114.8	146.4	81.3						
	85	145.3	145.3	145.9	144.6	156.7	111.6	137.3	137.3	137.5	137.5	146.8	107.7						
	90	152.3	152.3	152.5	152.5	157.1	138.4	144.1	144.1	144.3	144.3	147.3	134.7						
5500	75	134.0	132.6	145.3	96.1	157.2	60.1	125.8	125.6	135.6	91.9	146.0	56.5						
	80	141.2	141.2	146.0	125.5	158.0	88.5	133.2	133.2	136.6	121.5	147.7	84.5						
	85	148.6	148.6	148.8	148.8	158.1	117.6	140.4	140.4	140.5	140.5	148.1	113.7						
	90	155.7	155.7	155.8	155.8	158.6	147.2	147.1	147.1	147.3	147.3	148.8	143.4						
6000	75	136.2	136.2	146.6	100.0	158.1	61.2	128.1	128.1	136.8	95.7	146.7	57.6						
	80	144.0	144.0	147.5	132.2	159.2	91.7	135.7	135.7	138.0	128.1	148.8	87.5						
	85	151.5	151.5	151.6	151.6	159.3	123.5	143.0	143.0	143.1	143.1	149.1	119.6						
	90	158.5	158.5	158.6	158.6	160.1	156.0	149.7	149.7	149.8	149.8	150.4	148.3						

**Notes:**

- All capacities shown are gross and have not considered indoor fan heat. To obtain net cooling, subtract indoor fan heat.
- MBH = Total Gross Capacity, SHC = Sensible Heat Capacity



**Performance Data**

**Table 21. Gross cooling capacities (MBH) 15 tons TTA180K\*D condensing unit with 15 tons TWE180K\*B air handler (IP)**

CFM	Ent DB (°F)	Ambient Temperature (°F)						Ambient Temperature (°F)						Ambient Temperature (°F)					
		85						95						105					
		Entering Wet Bulb (°F)						Entering Wet Bulb (°F)						Entering Wet Bulb (°F)					
		61		67		73		61		67		73		61		67		73	
		MBH	SHC	MBH	SHC	MBH	SHC	MBH	SHC	MBH	SHC	MBH	SHC	MBH	SHC	MBH	SHC	MBH	SHC
5400	75	185.9	155.6	205.8	120.8	227.9	83.5	178.4	151.9	197.3	117.2	218.7	80.1	170.4	148.0	188.2	113.4	208.9	76.6
	80	187.8	184.9	205.9	149.4	227.3	113.1	180.7	180.7	197.6	145.7	218.1	109.7	173.3	173.3	188.8	141.8	208.3	106.2
	85	196.6	196.6	206.7	178.2	226.9	142.4	190.1	190.1	198.5	174.5	217.9	138.8	183.2	183.2	189.9	170.7	208.3	135.0
	90	208.8	207.6	208.8	207.6	227.1	170.9	200.3	200.3	201.2	200.1	218.2	167.4	193.2	193.2	193.6	193.6	208.8	163.7
6000	75	189.7	165.0	209.1	126.4	231.3	85.0	182.0	161.2	200.5	122.6	221.8	81.6	173.8	157.2	191.4	118.6	211.7	78.0
	80	192.9	192.9	209.6	157.9	230.7	117.9	186.1	186.1	201.1	154.2	221.2	114.5	179.1	179.1	192.1	150.2	211.1	111.0
	85	203.5	203.5	210.7	190.0	230.5	150.0	196.7	196.7	202.4	186.4	221.3	146.4	189.4	189.4	193.6	182.5	211.5	142.6
	90	214.2	214.2	214.5	214.5	230.8	181.9	207.2	207.2	207.6	207.6	221.7	178.3	199.7	199.7	200.0	200.0	212.0	174.5
6600	75	193.0	174.3	212.2	131.6	234.0	86.4	185.1	170.5	203.4	127.7	224.4	83.0	176.7	166.4	194.1	123.7	214.0	79.5
	80	198.4	198.4	212.7	166.3	233.4	122.7	191.5	191.5	204.1	162.5	223.8	119.3	184.1	184.1	194.9	158.6	213.4	115.5
	85	209.5	209.5	214.3	201.8	233.4	157.6	202.4	202.4	205.8	198.1	224.1	154.0	194.8	194.8	196.9	194.2	214.0	150.1
	90	220.5	220.5	220.8	220.8	233.9	192.7	213.2	213.2	213.5	213.5	224.6	189.2	205.3	205.3	205.6	205.6	214.8	185.4
7200	75	195.9	183.5	214.9	136.6	236.3	87.8	187.9	179.6	205.9	132.8	226.5	84.4	179.4	175.5	196.3	128.6	215.9	80.8
	80	203.3	203.3	215.4	174.7	235.7	127.4	196.1	196.1	206.6	170.9	225.9	123.7	188.5	188.5	197.2	166.8	215.6	119.7
	85	214.7	214.7	217.5	213.5	235.9	165.1	207.3	207.3	209.0	209.0	226.4	161.5	199.4	199.4	200.1	200.1	216.2	157.6
	90	225.9	225.9	226.2	226.2	236.5	203.6	218.3	218.3	218.6	218.6	227.2	200.0	210.2	210.2	210.5	210.5	217.2	196.2
CFM	Ent DB (°F)	Ambient Temperature (°F)						Ambient Temperature (°F)											
		115						125											
		Entering Wet Bulb (°F)						Entering Wet Bulb (°F)											
		61		67		73		61		67		73							
		MBH	SHC	MBH	SHC	MBH	SHC	MBH	SHC	MBH	SHC	MBH	SHC						
5400	75	161.9	143.8	178.7	109.3	198.2	72.8	152.8	139.3	168.6	104.8	186.6	68.8						
	80	166.1	166.1	179.5	137.7	197.7	102.4	158.3	158.3	169.5	133.2	186.0	98.4						
	85	175.8	175.8	180.7	166.6	198.1	131.0	167.7	167.7	170.9	162.3	187.1	126.6						
	90	185.5	185.5	185.8	185.8	198.7	159.7	177.1	177.1	177.4	177.4	187.8	155.4						
6000	75	165.1	153.0	181.6	114.3	200.7	74.2	155.8	148.5	171.2	109.8	188.7	70.2						
	80	171.5	171.5	182.5	146.0	200.1	107.1	163.3	163.3	172.2	141.5	188.7	102.6						
	85	181.6	181.6	184.3	178.4	201.0	138.5	173.0	173.0	174.3	173.8	189.7	134.1						
	90	191.6	191.6	191.9	191.9	201.7	170.5	182.8	182.8	183.1	183.1	190.6	166.2						
6600	75	167.9	162.1	184.1	119.3	202.7	75.6	158.5	157.5	173.4	114.6	190.3	71.5						
	80	176.2	176.2	185.1	154.3	202.6	111.3	167.6	167.6	174.6	149.7	190.9	106.7						
	85	186.6	186.6	187.6	187.6	203.3	146.0	177.6	177.6	178.0	178.0	191.8	141.5						
	90	196.9	196.9	197.1	197.1	204.3	181.3	187.6	187.6	187.9	187.9	193.0	176.9						
7200	75	170.5	170.4	186.1	124.2	204.3	77.0	161.2	161.2	175.2	119.5	191.7	72.9						
	80	180.3	180.3	187.3	162.5	204.6	115.4	171.3	171.3	176.6	157.9	192.8	110.8						
	85	190.9	190.9	191.1	191.1	205.3	153.4	181.6	181.6	181.9	181.9	193.7	148.9						
	90	201.4	201.4	201.6	201.6	206.6	192.1	191.8	191.8	192.0	192.0	195.2	187.7						

**Notes:**

1. All capacities shown are gross and have not considered indoor fan heat. To obtain net cooling, subtract indoor fan heat.
2. MBH = Total Gross Capacity, SHC = Sensible Heat Capacity

**Table 22. Gross Cooling Capacities (MBH) – one compressor – 15 Tons TTA180K\*C condensing unit with 15 Tons TWE180K\*B Air Handler (IP)**

CFM	Ent DB (°F)	Ambient Temperature (°F)						Ambient Temperature (°F)						Ambient Temperature (°F)					
		85						95						105					
		Entering Wet Bulb (°F)						Entering Wet Bulb (°F)						Entering Wet Bulb (°F)					
		61		67		73		61		67		73		61		67		73	
		MBH	SHC	MBH	SHC	MBH	SHC	MBH	SHC	MBH	SHC	MBH	SHC	MBH	SHC	MBH	SHC	MBH	SHC
5400	75	121.3	121.3	131.1	89.7	141.8	54.9	117.0	117.0	125.5	87.2	134.8	52.7	112.2	112.2	119.6	84.6	127.4	50.4
	80	129.3	129.3	132.6	119.1	144.9	83.1	124.7	124.7	127.1	116.8	138.7	80.6	119.7	119.7	121.4	114.3	132.1	78.0
	85	137.4	137.4	137.6	137.6	146.0	112.4	132.6	132.6	132.8	132.8	140.0	110.1	127.4	127.4	127.6	127.6	133.6	107.6
	90	145.8	145.8	145.8	145.8	147.6	142.0	140.6	140.6	140.8	140.8	141.9	139.8	135.3	135.3	135.4	135.4	135.9	135.9
6000	75	124.4	124.4	132.6	94.4	142.4	56.1	119.7	119.7	126.9	91.9	135.2	53.8	114.7	114.7	120.9	89.2	127.7	51.5
	80	132.6	132.6	134.5	127.3	146.4	87.1	127.8	127.8	129.0	124.9	140.1	84.6	122.6	122.6	123.2	122.3	133.4	81.8
	85	141.0	141.0	141.2	141.2	147.6	119.8	136.0	136.0	136.1	136.1	141.6	117.5	130.6	130.6	130.7	130.7	135.1	115.0
	90	149.3	149.3	149.5	149.5	150.0	150.0	144.2	144.2	144.3	144.3	144.5	144.5	138.6	138.6	138.8	138.8	139.0	139.0
6600	75	126.9	126.9	133.9	99.2	142.8	57.3	122.1	122.1	128.1	96.6	135.5	55.0	116.9	116.9	121.9	93.8	127.9	52.7
	80	135.4	135.4	136.3	135.4	147.7	91.1	130.4	130.4	130.8	130.8	135.1	91.5	125.0	125.0	125.1	125.1	127.5	89.1
	85	144.0	144.0	144.2	144.2	149.1	127.2	138.8	138.8	139.0	139.0	142.9	124.8	133.2	133.2	133.4	133.4	136.5	122.3
	90	152.5	152.5	152.7	152.7	152.8	152.8	147.2	147.2	147.4	147.4	147.5	147.5	141.5	141.5	141.6	141.6	141.8	141.8
7200	75	129.1	129.1	135.0	103.9	143.0	58.4	124.1	124.1	129.1	101.2	135.7	56.2	118.8	118.8	122.9	98.3	128.1	53.9
	80	137.8	137.8	138.0	138.0	142.6	98.2	132.6	132.6	132.8	132.8	135.3	95.9	127.1	127.1	127.2	127.2	127.7	93.6
	85	146.7	146.7	146.8	146.8	150.3	134.6	141.3	141.3	141.4	141.4	144.2	132.2	135.5	135.5	135.7	135.7	137.7	129.5
	90	155.3	155.3	155.4	155.4	155.6	155.6	149.8	149.8	150.0	150.0	150.1	150.1	144.0	144.0	144.1	144.1	144.2	144.2
CFM	Ent DB (°F)	Ambient Temperature (°F)						Ambient Temperature (°F)											
		115						125											
		Entering Wet Bulb (°F)						Entering Wet Bulb (°F)											
		61		67		73		61		67		73							
		MBH	SHC	MBH	SHC	MBH	SHC	MBH	SHC	MBH	SHC	MBH	SHC						
5400	75	107.0	107.0	113.3	81.7	119.6	47.9	101.4	101.4	106.5	78.6	111.3	45.3						
	80	114.3	114.3	115.3	111.6	125.1	75.1	108.4	108.4	108.8	108.6	117.5	71.9						
	85	121.8	121.8	122.0	122.0	126.8	105.0	115.7	115.7	115.8	115.8	119.5	102.0						
	90	129.5	129.5	129.6	129.6	129.7	129.7	123.1	123.1	123.2	123.2	123.4	123.4						
6000	75	109.4	109.4	114.4	86.2	119.9	49.1	103.5	103.5	107.5	82.9	111.4	46.5						
	80	116.9	116.9	117.2	117.2	126.2	78.8	110.8	110.8	110.9	110.9	111.0	79.6						
	85	124.7	124.7	124.9	124.9	128.2	112.2	118.3	118.3	118.5	118.5	120.8	109.2						
	90	132.6	132.6	132.7	132.7	132.9	132.9	126.0	126.0	126.1	126.1	126.3	126.3						
6600	75	111.3	111.3	115.4	90.7	120.0	50.3	105.2	105.2	108.4	87.2	111.4	47.6						
	80	119.2	119.2	119.3	119.3	119.6	86.7	112.8	112.8	112.9	112.9	111.1	84.1						
	85	127.2	127.2	127.3	127.3	129.5	119.5	120.6	120.6	120.7	120.7	122.1	116.4						
	90	135.3	135.3	135.4	135.4	135.5	135.5	128.4	128.4	128.5	128.5	128.7	128.7						
7200	75	113.0	113.0	116.3	95.1	120.1	51.4	106.7	106.7	109.2	91.5	111.5	48.8						
	80	121.1	121.1	121.2	121.2	119.7	91.2	114.5	114.5	114.6	114.6	111.1	88.6						
	85	129.3	129.3	129.4	129.4	130.7	126.7	122.5	122.5	122.6	122.6	123.2	123.2						
	90	137.5	137.5	105.9	105.9	137.8	137.8	130.5	130.5	130.6	130.6	130.7	130.7						

**Notes:**

1. All capacities shown are gross and have not considered indoor fan heat. To obtain net cooling, subtract indoor fan heat.
2. MBH = Total Gross Capacity, SHC = Sensible Heat Capacity



**Performance Data**

**Table 23. Gross cooling capacities (MBH) – both compressors – 15 tons TTA180K\*C condensing unit with 15 tons TWE180K\*B air handler (IP)**

CFM	Ent DB (°F)	Ambient Temperature (°F)						Ambient Temperature (°F)						Ambient Temperature (°F)					
		85						95						105					
		Entering Wet Bulb (°F)						Entering Wet Bulb (°F)						Entering Wet Bulb (°F)					
		61		67		73		61		67		73		61		67		73	
	MBH	SHC	MBH	SHC	MBH	SHC	MBH	SHC	MBH	SHC	MBH	SHC	MBH	SHC	MBH	SHC	MBH	SHC	
5400	75	181.5	154.0	200.0	118.8	220.6	81.2	174.5	150.6	192.0	115.6	212.1	78.2	167.0	147.0	183.3	112.2	202.7	74.9
	80	183.8	183.5	200.5	147.5	220.2	110.9	177.3	177.3	192.8	144.1	211.7	107.9	170.7	170.7	184.5	140.5	202.4	104.7
	85	193.0	193.0	201.5	176.4	220.1	140.2	187.0	187.0	193.9	173.1	211.8	136.9	180.4	180.4	185.8	169.6	202.8	133.4
	90	204.0	204.0	204.0	204.0	220.5	168.9	196.8	196.8	197.2	197.2	212.3	165.7	190.0	190.0	190.3	190.3	203.4	162.3
6000	75	185.0	163.3	203.0	124.4	223.6	82.6	177.9	159.8	194.8	121.1	214.8	79.6	170.2	156.1	185.8	117.7	205.2	76.3
	80	189.0	189.0	203.8	155.9	223.2	115.7	182.8	182.8	196.0	152.5	214.4	112.7	176.1	176.1	187.5	148.8	204.8	109.4
	85	199.4	199.4	205.2	188.2	223.3	147.7	193.0	193.0	197.5	184.9	214.8	144.5	186.1	186.1	189.2	181.3	205.6	140.9
	90	209.7	209.7	210.1	210.1	223.8	179.7	203.2	203.2	203.5	203.5	215.4	176.6	196.0	196.0	196.3	196.3	206.3	173.1
6600	75	188.1	172.5	206.0	129.2	226.0	84.0	180.8	169.0	197.8	125.8	217.0	81.0	172.9	165.3	188.9	122.0	207.2	77.7
	80	194.2	194.2	206.7	164.2	225.7	120.4	187.8	187.8	198.6	160.8	216.7	117.4	180.8	180.8	190.0	157.1	206.8	114.1
	85	204.9	204.9	208.5	199.9	225.9	155.2	198.3	198.3	200.7	196.6	217.3	151.9	191.0	191.0	192.4	192.4	207.9	148.4
	90	215.5	215.5	215.8	215.8	226.5	190.6	208.7	208.7	208.9	208.9	218.1	187.4	201.2	201.2	201.4	201.4	208.8	183.9
7200	75	190.8	181.6	208.3	134.3	228.1	85.4	183.4	178.1	200.0	130.7	218.9	82.3	175.5	174.3	191.0	126.9	208.8	79.0
	80	198.8	198.8	209.1	172.5	227.7	125.1	192.1	192.1	201.0	169.1	218.5	122.1	184.8	184.8	192.2	165.3	208.5	118.8
	85	209.7	209.7	211.5	211.5	228.1	162.7	202.8	202.8	203.8	203.8	219.3	159.4	195.3	195.3	195.6	195.6	209.8	155.8
	90	220.4	220.4	220.7	220.7	228.9	201.3	213.4	213.4	213.6	213.6	220.3	198.1	205.6	205.6	205.8	205.8	211.0	194.6
CFM	Ent DB (°F)	Ambient Temperature (°F)						Ambient Temperature (°F)											
		115						125											
		Entering Wet Bulb (°F)						Entering Wet Bulb (°F)											
		61		67		73		61		67		73							
	MBH	SHC	MBH	SHC	MBH	SHC	MBH	SHC	MBH	SHC	MBH	SHC							
5400	75	158.9	143.0	173.8	108.5	192.5	71.4	150.0	138.7	164.5	103.6	181.1	67.5						
	80	163.7	163.7	175.5	136.6	192.1	101.2	156.0	156.0	165.7	132.3	180.7	97.3						
	85	173.1	173.1	177.0	165.8	193.0	129.6	165.1	165.1	167.4	161.6	182.2	125.4						
	90	182.5	182.5	182.8	182.8	193.8	158.5	174.2	174.2	174.5	174.5	183.1	154.4						
6000	75	161.8	152.1	177.2	113.0	194.6	72.8	152.8	147.8	166.9	108.5	182.8	68.9						
	80	168.7	168.7	178.2	144.9	194.3	105.9	160.6	160.6	168.2	140.6	182.5	102.0						
	85	178.5	178.5	180.3	177.5	195.6	137.1	170.0	170.0	170.7	170.7	184.5	132.8						
	90	188.2	188.2	188.4	188.4	196.5	169.3	179.4	179.4	179.7	179.7	185.7	165.2						
6600	75	164.5	161.2	179.4	117.9	196.3	74.1	155.4	155.4	168.9	113.4	184.2	70.2						
	80	173.1	173.1	180.6	153.1	196.0	110.6	164.6	164.6	170.3	148.7	183.9	106.6						
	85	183.1	183.1	183.5	183.5	197.7	144.5	174.3	174.3	174.5	174.5	186.5	140.2						
	90	193.0	193.0	193.2	193.2	198.8	180.1	183.8	183.8	184.0	184.0	187.9	175.9						
7200	75	167.0	167.0	181.2	122.7	197.7	75.4	158.0	158.0	170.6	118.1	185.3	71.5						
	80	176.8	176.8	182.6	161.3	197.4	115.2	168.0	168.0	172.2	156.9	184.9	111.3						
	85	187.1	187.1	187.3	187.3	199.5	151.9	177.9	177.9	178.1	178.1	188.1	147.6						
	90	197.1	197.1	197.3	197.3	200.9	190.8	187.6	187.6	187.8	187.8	189.9	186.6						

**Notes:**

1. All capacities shown are gross and have not considered indoor fan heat. To obtain net cooling, subtract indoor fan heat.
2. MBH = Total Gross Capacity, SHC = Sensible Heat Capacity

**Table 24. Gross cooling capacities (MBH) 20 tons TTA240K\*D condensing unit with 20 tons TWE240K\*B air handler (IP)**

CFM	Ent DB (°F)	Ambient Temperature (°F)						Ambient Temperature (°F)						Ambient Temperature (°F)									
		85						95						105									
		Entering Wet Bulb (°F)						Entering Wet Bulb (°F)						Entering Wet Bulb (°F)									
		61		67		73		61		67		73		61		67		73					
		MBH	SHC	MBH	SHC	MBH	SHC	MBH	SHC	MBH	SHC	MBH	SHC	MBH	SHC	MBH	SHC	MBH	SHC	MBH	SHC		
7200	75	235.1	202.3	259.4	155.3	284.5	104.5	226.3	198.1	249.7	151.4	274.5	101.0	216.4	193.3	238.7	146.8	262.5	96.8				
	80	236.6	233.9	259.1	193.5	283.9	144.2	228.3	227.2	249.7	189.4	273.9	140.7	219.3	219.3	238.8	184.7	261.9	136.5				
	85	246.3	246.3	259.2	231.5	283.4	183.3	238.9	238.9	249.9	227.5	273.2	179.5	230.3	230.3	239.1	222.8	261.4	175.0				
	90	261.2	255.9	261.2	255.9	283.2	221.3	250.8	250.8	252.7	250.6	273.3	217.5	241.9	241.9	242.9	242.9	261.5	213.0				
8000	75	239.3	214.6	263.3	162.5	288.3	106.4	230.3	210.3	253.6	158.5	278.0	102.9	220.1	205.5	242.0	153.8	265.8	98.7				
	80	242.3	242.3	263.3	204.7	287.7	150.6	234.1	234.1	253.7	200.5	277.4	147.0	224.9	224.9	242.5	195.8	265.2	142.8				
	85	253.8	253.8	263.5	247.0	287.1	193.5	246.1	246.1	254.0	243.0	277.0	189.6	237.1	237.1	243.1	236.2	264.9	185.0				
	90	266.2	266.2	267.5	267.5	287.1	235.7	258.3	258.3	258.9	258.9	276.9	231.9	249.0	249.0	249.0	249.0	264.9	227.3				
8800	75	243.0	226.8	266.7	169.6	291.4	108.3	233.8	222.5	256.6	165.4	281.0	104.7	223.4	217.0	245.1	160.6	268.5	100.5				
	80	247.6	247.6	266.8	215.8	290.8	156.8	239.4	239.4	257.0	211.6	280.3	153.2	230.7	230.7	245.5	206.8	267.8	148.8				
	85	260.3	260.3	267.2	259.2	290.4	203.5	252.3	252.3	257.7	252.5	280.1	199.6	243.0	242.9	246.7	244.9	267.8	195.0				
	90	272.9	272.9	273.1	273.1	290.3	250.1	264.7	264.7	265.0	265.0	280.0	246.2	255.0	255.0	255.3	255.3	267.7	241.6				
9600	75	246.1	238.2	269.5	176.3	294.1	110.1	236.8	231.4	259.5	172.2	283.5	106.5	226.3	224.0	247.7	167.3	270.8	102.3				
	80	252.7	252.7	269.7	226.8	293.4	162.9	244.9	244.9	259.7	222.6	282.8	159.2	235.5	235.5	248.1	217.7	269.9	154.8				
	85	266.0	266.0	270.6	267.8	293.1	213.5	257.7	257.7	261.1	260.9	282.7	209.6	248.0	248.0	250.0	250.0	270.2	204.9				
	90	278.7	278.7	279.0	279.0	293.2	264.5	270.3	270.3	270.6	270.6	282.6	260.5	260.3	260.5	260.5	260.5	270.2	255.9				
CFM	Ent DB (°F)	Ambient Temperature (°F)						Ambient Temperature (°F)															
		115						125															
		Entering Wet Bulb (°F)						Entering Wet Bulb (°F)															
		61		67		73		61		67		73											
		MBH	SHC	MBH	SHC	MBH	SHC	MBH	SHC	MBH	SHC	MBH	SHC	MBH	SHC	MBH	SHC	MBH	SHC	MBH	SHC	MBH	SHC
7200	75	205.5	188.1	225.9	141.7	248.8	92.0	193.5	182.4	212.4	135.9	233.4	86.8										
	80	209.4	209.4	226.5	179.4	248.2	131.7	199.0	199.0	212.9	173.6	232.6	126.4										
	85	220.6	220.6	227.1	217.6	247.9	169.8	209.6	209.6	213.8	210.2	232.8	164.0										
	90	231.7	231.7	231.9	231.9	247.9	207.8	220.3	220.3	220.6	220.6	232.9	202.1										
8000	75	208.9	200.2	229.3	148.5	251.7	93.9	196.7	193.5	215.3	142.5	236.0	88.6										
	80	215.3	215.3	229.8	190.4	251.0	137.9	204.4	204.4	215.7	184.4	235.0	132.2										
	85	226.8	226.8	230.8	227.9	251.0	179.7	215.3	215.3	217.4	217.4	235.6	173.9										
	90	238.3	238.3	238.5	238.5	251.0	222.1	226.2	226.2	226.4	226.4	235.7	216.3										
8800	75	212.0	209.1	232.1	155.1	254.2	95.7	199.6	199.6	217.7	149.1	238.1	90.4										
	80	220.4	220.4	232.5	201.3	253.2	143.8	208.9	208.9	218.2	195.3	237.4	137.8										
	85	232.2	232.2	234.3	234.3	253.6	189.6	220.2	220.2	221.1	221.1	237.8	183.7										
	90	243.8	243.8	244.1	244.1	253.6	236.3	231.2	231.2	231.4	231.4	238.1	230.5										
9600	75	214.8	214.8	234.4	161.7	256.2	97.5	202.3	202.3	219.7	155.5	239.8	92.2										
	80	224.9	224.9	234.8	212.2	255.5	149.4	213.0	213.0	220.3	206.1	239.4	143.3										
	85	236.9	236.9	237.9	237.9	255.7	199.5	224.4	224.4	224.6	224.5	239.7	193.5										
	90	248.6	248.6	248.9	248.9	256.0	248.3	235.5	235.5	235.7	235.7	240.3	238.5										

**Notes:**

1. All capacities shown are gross and have not considered indoor fan heat. To obtain net cooling, subtract indoor fan heat.
2. MBH = Total Gross Capacity, SHC = Sensible Heat Capacity



**Performance Data**

**Table 25. Gross cooling capacities (MBH) – one compressor – 20 tons TTA240K\*C condensing unit with 20 tons TWE240K\*B air handler (IP)**

CFM	Ent DB (°F)	Ambient Temperature (°F)						Ambient Temperature (°F)						Ambient Temperature (°F)					
		85						95						105					
		Entering Wet Bulb (°F)						Entering Wet Bulb (°F)						Entering Wet Bulb (°F)					
		61		67		73		61		67		73		61		67		73	
		MBH	SHC	MBH	SHC	MBH	SHC	MBH	SHC	MBH	SHC	MBH	SHC	MBH	SHC	MBH	SHC	MBH	SHC
7200	75	149.1	149.1	161.9	115.1	177.1	68.6	143.3	143.3	154.8	112.0	168.6	65.9	137.5	137.5	147.3	108.7	159.6	63.0
	80	158.8	158.8	163.1	153.7	176.8	108.4	152.9	152.9	156.2	150.8	168.3	105.6	146.6	146.6	149.0	147.6	159.3	102.8
	85	168.5	168.5	168.6	168.6	178.8	144.6	162.3	162.3	162.5	162.5	171.1	141.7	155.8	155.8	155.9	155.9	163.2	138.7
	90	177.8	177.8	177.8	177.8	180.1	180.1	171.2	171.2	171.4	171.4	172.8	172.8	164.4	164.4	164.5	164.5	165.2	165.2
8000	75	152.6	152.6	163.7	121.5	178.3	70.3	146.7	146.7	156.4	118.4	169.6	67.5	140.4	140.4	148.8	115.1	160.3	64.6
	80	162.5	162.5	165.2	164.6	178.0	114.5	156.4	156.4	156.5	156.5	169.2	111.8	149.8	149.8	149.9	149.9	159.9	108.9
	85	172.3	172.3	172.4	172.4	180.4	154.4	165.9	165.9	166.0	166.0	172.7	151.5	159.1	159.1	159.2	159.2	164.6	148.4
	90	181.3	181.3	181.5	181.5	182.2	182.2	174.7	174.7	174.8	174.8	175.0	175.0	167.6	167.6	167.7	167.7	167.6	167.6
8800	75	155.5	155.5	165.2	128.0	179.2	72.0	149.4	149.4	157.8	124.7	170.2	69.2	142.9	142.9	150.0	121.3	160.7	66.3
	80	165.6	165.6	165.8	165.8	178.9	120.7	159.3	159.3	159.4	159.4	169.9	117.9	152.5	152.5	152.6	152.6	160.4	114.9
	85	175.5	175.5	175.6	175.6	181.7	164.2	168.9	168.9	169.0	169.0	174.0	161.3	161.9	161.9	162.0	162.0	165.9	158.1
	90	184.3	184.3	184.4	184.4	184.4	184.4	177.4	177.4	177.5	177.5	177.5	177.5	170.1	170.1	170.2	170.2	170.3	170.3
9600	75	158.0	158.0	166.4	134.3	179.9	73.7	151.7	151.7	158.9	131.1	170.7	70.9	145.1	145.1	151.1	127.6	161.1	67.9
	80	168.3	168.3	168.4	168.4	179.6	126.8	161.8	161.8	161.9	161.9	170.4	123.9	154.9	154.9	155.0	155.0	160.7	121.0
	85	178.2	178.2	178.3	178.3	182.9	174.0	171.4	171.4	171.5	171.5	175.1	171.0	164.2	164.2	164.3	164.3	164.4	164.4
	90	186.7	186.7	186.8	186.8	186.9	186.9	179.6	179.6	179.7	179.7	179.8	179.8	172.1	172.1	172.1	172.1	172.2	172.2
CFM	Ent DB (°F)	Ambient Temperature (°F)						Ambient Temperature (°F)											
		115						125											
		Entering Wet Bulb (°F)						Entering Wet Bulb (°F)											
		61		67		73		61		67		73							
		MBH	SHC	MBH	SHC	MBH	SHC	MBH	SHC	MBH	SHC	MBH	SHC						
7200	75	131.1	131.1	139.4	105.3	149.9	59.9	124.2	124.2	131.0	101.5	139.7	56.7						
	80	139.9	139.9	141.4	141.4	149.6	99.7	132.7	132.7	132.8	132.8	139.4	96.5						
	85	148.8	148.8	148.9	148.9	154.7	135.4	141.2	141.2	141.3	141.3	145.7	131.9						
	90	157.1	157.1	157.2	157.2	157.3	157.3	149.1	149.1	149.2	149.2	149.3	149.3						
8000	75	133.8	133.8	140.8	111.5	150.4	61.6	126.6	126.6	132.2	107.6	140.0	58.3						
	80	142.9	142.9	143.0	143.0	150.1	105.8	135.4	135.4	135.5	135.5	139.7	102.6						
	85	151.8	151.8	151.9	151.9	156.1	145.1	144.0	144.0	144.1	144.1	147.0	141.5						
	90	159.9	159.9	160.0	160.0	160.1	160.1	151.6	151.6	123.9	123.9	151.7	151.7						
8800	75	136.1	136.1	141.9	117.7	150.7	63.2	128.7	128.7	133.3	113.7	140.2	59.9						
	80	145.4	145.4	145.5	145.5	150.4	111.8	137.6	137.6	137.7	137.7	139.9	108.6						
	85	154.4	154.4	154.5	154.5	157.3	154.7	146.3	146.3	146.3	146.3	146.4	146.4						
	90	162.2	162.2	162.2	162.2	162.3	162.3	153.5	153.5	153.6	153.6	153.6	153.6						
9600	75	138.1	138.1	142.9	123.8	151.0	64.8	130.5	130.5	134.2	119.7	140.4	61.5						
	80	147.5	147.5	147.6	147.6	150.6	117.9	139.6	139.6	139.6	139.6	140.1	114.6						
	85	156.5	156.5	156.6	156.6	156.7	156.7	148.2	148.2	148.2	148.2	148.3	148.3						
	90	163.9	163.9	134.0	134.0	164.0	164.0	155.0	155.0	155.0	155.0	155.1	155.1						

**Notes:**

1. All capacities shown are gross and have not considered indoor fan heat. To obtain net cooling, subtract indoor fan heat.
2. MBH = Total Gross Capacity, SHC = Sensible Heat Capacity



**Table 26. Gross cooling capacities (MBH) – both compressors – 20 tons TTA240K\*C condensing unit with 20 tons TWE240K\*B air handler (IP)**

CFM	Ent DB (°F)	Ambient Temperature (°F)						Ambient Temperature (°F)						Ambient Temperature (°F)					
		85						95						105					
		Entering Wet Bulb (°F)						Entering Wet Bulb (°F)						Entering Wet Bulb (°F)					
		61		67		73		61		67		73		61		67		73	
		MBH	SHC	MBH	SHC	MBH	SHC	MBH	SHC	MBH	SHC	MBH	SHC	MBH	SHC	MBH	SHC	MBH	SHC
7200	75	236.3	202.7	258.6	154.8	279.3	102.5	227.1	198.2	248.4	150.6	267.3	98.3	217.1	193.4	237.2	146.1	254.6	93.8
	80	238.0	238.0	258.5	193.0	279.1	142.3	229.2	229.2	248.4	188.6	267.0	138.0	219.9	219.9	237.4	183.8	254.4	133.6
	85	247.1	247.1	258.7	231.0	278.7	181.4	239.1	239.1	248.6	226.6	266.8	176.8	230.2	230.2	237.8	221.9	254.1	172.0
	90	260.7	260.7	260.7	260.7	279.2	219.5	249.8	249.8	251.1	251.1	267.0	214.8	240.4	240.4	240.7	240.7	253.9	212.7
8000	75	240.2	214.8	262.1	161.9	282.8	104.4	230.8	210.3	251.5	157.8	270.1	99.9	220.6	205.4	240.0	153.3	256.6	95.3
	80	243.0	243.0	262.1	204.0	282.6	148.6	234.2	234.2	251.7	199.5	269.9	144.2	225.1	225.1	240.3	194.6	256.4	139.5
	85	254.0	254.0	262.4	246.3	282.4	191.5	245.5	245.5	252.1	241.9	269.9	186.7	236.2	236.2	241.0	237.0	256.5	181.6
	90	265.1	265.1	265.6	265.6	282.8	233.9	256.0	256.0	256.1	256.1	270.2	229.0	245.9	245.9	246.1	246.1	256.7	223.9
8800	75	243.5	226.9	264.8	168.7	285.8	106.2	233.9	222.3	254.1	164.9	272.6	101.7	223.6	217.4	242.4	159.3	258.7	97.0
	80	247.9	247.9	265.0	214.8	285.5	154.8	239.6	239.6	254.3	210.2	272.4	150.4	230.4	230.4	242.6	205.3	258.5	145.7
	85	259.8	259.8	265.6	261.5	285.6	201.5	250.9	250.9	255.1	255.1	272.5	196.5	241.0	241.0	243.7	243.7	258.7	191.3
	90	270.6	270.6	270.9	270.9	286.1	248.3	261.0	261.0	261.2	261.2	273.0	243.3	250.2	250.2	250.4	250.4	259.2	238.1
9600	75	246.5	238.9	267.3	175.3	288.4	108.0	236.8	234.2	256.3	170.7	274.8	103.5	226.3	226.3	244.4	165.7	260.5	98.7
	80	253.1	253.1	267.4	225.6	288.2	161.1	244.3	244.3	256.5	221.0	274.5	156.5	234.6	234.6	244.5	216.0	260.3	151.8
	85	264.7	264.7	268.3	268.3	288.4	211.5	255.4	255.4	257.7	257.7	275.0	206.5	245.0	245.0	246.1	246.1	260.9	201.1
	90	275.6	275.6	275.8	275.8	288.9	262.6	265.2	265.2	265.4	265.4	275.5	257.6	253.9	253.9	254.1	254.1	261.5	252.3
CFM	Ent DB (°F)	Ambient Temperature (°F)						Ambient Temperature (°F)											
		115						125											
		Entering Wet Bulb (°F)						Entering Wet Bulb (°F)											
		61		67		73		61		67		73							
		MBH	SHC	MBH	SHC	MBH	SHC	MBH	SHC	MBH	SHC	MBH	SHC						
7200	75	206.4	188.2	225.1	141.4	241.0	89.1	194.9	182.7	211.9	135.5	226.2	84.1						
	80	210.0	210.0	225.4	178.6	240.8	128.9	200.0	200.0	212.4	173.0	225.9	123.9						
	85	220.5	220.5	226.0	216.8	240.5	166.7	209.7	209.7	213.2	211.2	225.5	160.9						
	90	229.9	229.9	230.1	230.1	240.1	204.4	218.1	218.1	218.3	218.3	225.1	198.7						
8000	75	209.7	200.2	227.6	148.5	242.7	90.6	197.9	194.6	214.3	141.9	227.6	85.6						
	80	215.6	215.6	227.3	192.2	242.5	134.8	204.9	204.9	214.6	183.6	227.3	129.8						
	85	225.8	225.8	228.9	228.9	242.2	176.1	214.3	214.3	215.8	215.8	226.8	170.2						
	90	234.7	234.7	234.8	234.8	242.3	218.4	221.9	221.9	222.0	222.0	226.9	212.5						
8800	75	212.5	212.1	229.6	155.5	244.1	92.1	200.6	200.6	215.8	150.3	228.7	87.1						
	80	220.2	220.2	229.3	203.6	243.8	140.8	209.0	209.0	216.3	194.2	228.5	135.8						
	85	230.1	230.1	231.4	231.4	244.0	185.7	217.9	217.9	218.2	218.2	228.2	179.7						
	90	238.2	238.2	238.2	238.2	244.6	232.5	224.6	224.6	224.7	224.7	228.8	226.5						
9600	75	215.1	215.1	231.3	162.5	245.5	93.8	203.0	203.0	217.7	154.4	229.7	88.6						
	80	224.0	224.0	231.0	215.1	245.3	146.9	212.3	212.3	217.8	204.7	229.4	141.8						
	85	233.5	233.5	233.8	233.8	245.8	195.5	220.7	220.7	220.8	220.8	229.6	189.3						
	90	241.5	241.5	241.6	241.6	246.6	246.6	227.7	227.7	227.9	227.9	230.5	230.5						

**Notes:**

- All capacities shown are gross and have not considered indoor fan heat. To obtain net cooling, subtract indoor fan heat.
- MBH = Total Gross Capacity, SHC = Sensible Heat Capacity



**Performance Data**

**Table 27. Gross cooling capacities (MBH) – one compressor – 25 tons TTA300K\*C condensing unit with 25 tons TWE300K\*B air handler (IP)**

CFM	Ent DB (°F)	Ambient Temperature (°F)						Ambient Temperature (°F)						Ambient Temperature (°F)						
		85						95						105						
		Entering Wet Bulb (°F)						Entering Wet Bulb (°F)						Entering Wet Bulb (°F)						
		61		67		73		61		67		73		61		67		73		
		MBH	SHC	MBH	SHC	MBH	SHC	MBH	SHC	MBH	SHC	MBH	SHC	MBH	SHC	MBH	SHC	MBH	SHC	
8750	75	181.5	181.5	199.1	141.8	220.8	85.0	176.8	176.8	193.2	139.4	213.7	82.8	171.9	171.9	186.9	136.9	206.1	80.4	
	80	192.9	192.9	199.4	188.5	219.6	133.1	188.1	188.1	193.6	186.1	212.5	130.9	183.1	183.1	187.5	183.6	204.9	128.5	
	85	204.7	204.7	204.9	204.9	220.8	178.1	199.6	199.6	199.8	199.8	214.0	175.7	194.2	194.2	194.4	194.4	206.9	173.2	
	90	217.0	217.0	217.0	217.0	221.7	221.7	211.3	211.3	211.5	211.5	215.1	215.1	205.6	205.6	205.8	205.8	208.4	208.4	
10000	75	186.8	186.8	202.0	152.2	223.2	87.9	182.1	182.1	195.9	149.8	215.9	85.6	177.0	177.0	189.5	147.1	208.0	83.1	
	80	198.8	198.8	199.0	199.0	222.0	142.9	193.8	193.8	194.0	194.0	214.6	140.6	188.4	188.4	188.6	188.6	206.8	138.2	
	85	211.2	211.2	211.4	211.4	223.8	193.9	205.8	205.8	206.0	206.0	216.9	191.5	200.1	200.1	200.2	200.2	209.6	188.9	
	90	223.8	223.8	224.0	224.0	225.9	225.9	218.0	218.0	218.2	218.2	219.3	219.3	212.0	212.0	212.1	212.1	212.6	212.6	
11000	75	190.5	190.5	204.0	160.5	224.8	90.1	185.6	185.6	197.7	158.0	217.2	87.8	180.3	180.3	191.1	155.3	209.1	85.3	
	80	202.9	202.9	203.0	203.0	223.5	150.7	197.6	197.6	197.8	197.8	215.9	148.3	192.0	192.0	192.2	192.2	207.8	145.9	
	85	215.6	215.6	215.8	215.8	225.9	206.5	210.0	210.0	210.2	210.2	218.8	204.0	204.0	204.0	204.0	204.2	204.2	211.5	201.4
	90	228.5	228.5	228.7	228.7	229.2	229.2	222.5	222.5	222.7	222.7	222.7	222.7	216.2	216.2	216.4	216.4	216.3	216.3	
12000	75	193.7	193.7	205.6	168.7	226.0	92.3	188.6	188.6	199.3	166.2	218.2	89.9	183.2	183.2	192.6	163.4	209.9	87.4	
	80	206.4	206.4	206.6	206.6	224.7	158.4	201.0	201.0	201.1	201.1	216.9	156.0	195.2	195.2	195.3	195.3	208.6	153.5	
	85	219.5	219.5	219.6	219.6	227.7	219.1	213.7	213.7	213.8	213.8	220.5	216.5	207.5	207.5	207.6	207.6	207.8	207.8	
	90	232.7	232.7	232.8	232.8	232.7	232.7	226.4	226.4	226.6	226.6	226.8	226.8	219.9	219.9	220.0	220.0	220.2	220.2	
CFM	Ent DB (°F)	Ambient Temperature (°F)						Ambient Temperature (°F)												
		115						120												
		Entering Wet Bulb (°F)						Entering Wet Bulb (°F)												
		61		67		73		61		67		73								
		MBH	SHC	MBH	SHC	MBH	SHC	MBH	SHC	MBH	SHC	MBH	SHC							
8750	75	167.3	167.3	180.5	134.3	198.4	78.0	164.7	164.7	177.2	132.9	194.3	76.7							
	80	177.8	177.8	181.3	181.1	197.1	126.1	175.1	175.1	178.0	178.0	193.1	124.8							
	85	188.6	188.6	188.8	188.8	199.5	170.5	185.7	185.7	185.8	185.8	195.8	169.1							
	90	199.6	199.6	199.8	199.8	201.4	201.4	196.5	196.5	196.7	196.7	197.8	197.8							
10000	75	171.9	171.9	182.9	144.5	199.9	80.6	169.1	169.1	179.5	143.1	195.7	79.4							
	80	182.8	182.8	183.0	183.0	198.7	135.7	179.9	179.9	180.0	180.0	194.4	134.4							
	85	194.1	194.1	194.2	194.2	202.1	186.2	191.0	191.0	191.1	191.1	198.3	184.8							
	90	205.6	205.6	205.7	205.7	205.7	205.7	202.2	202.2	202.4	202.4	202.3	202.3							
11000	75	174.9	174.9	184.4	152.6	200.8	82.8	172.1	172.1	181.0	151.1	196.5	81.4							
	80	186.2	186.2	186.3	186.3	199.5	143.3	183.2	183.2	183.3	183.3	195.2	142.0							
	85	197.8	197.8	197.9	197.9	203.9	198.7	194.6	194.6	194.7	194.7	200.0	197.2							
	90	209.6	209.6	209.7	209.7	209.9	209.9	206.1	206.1	206.2	206.2	206.4	206.4							
12000	75	177.6	177.6	185.8	160.6	201.4	84.8	174.7	174.7	182.2	159.2	197.0	83.5							
	80	189.2	189.2	189.3	189.3	200.1	150.9	186.1	186.1	186.2	186.2	195.7	149.6							
	85	201.0	201.0	201.2	201.2	201.3	201.3	197.7	197.7	197.8	197.8	197.9	197.9							
	90	213.0	213.0	213.1	213.1	197.7	197.7	209.4	209.4	209.5	209.5	193.3	193.3							

**Notes:**

1. All capacities shown are gross and have not considered indoor fan heat. To obtain net cooling, subtract indoor fan heat.
2. MBH = Total Gross Capacity, SHC = Sensible Heat Capacity

**Table 28. Gross cooling capacities (MBH) – both compressors – 25 tons TTA300K\*C condensing unit with 25 tons TWE300K\*B air handler (IP)**

CFM	Ent DB (°F)	Ambient Temperature (°F)						Ambient Temperature (°F)						Ambient Temperature (°F)					
		85						95						105					
		Entering Wet Bulb (°F)						Entering Wet Bulb (°F)						Entering Wet Bulb (°F)					
		61		67		73		61		67		73		61		67		73	
		MBH	SHC	MBH	SHC	MBH	SHC	MBH	SHC	MBH	SHC	MBH	SHC	MBH	SHC	MBH	SHC	MBH	SHC
8750	75	285.8	246.4	317.2	189.5	350.2	128.7	277.4	242.4	307.4	185.6	339.1	124.8	268.4	238.1	297.1	181.5	327.4	120.7
	80	286.6	286.6	316.2	236.0	349.1	176.8	278.6	278.6	306.6	231.9	338.0	172.9	270.0	270.0	296.4	227.6	326.3	168.8
	85	297.5	297.5	316.0	282.2	347.5	224.4	290.3	290.3	306.4	278.1	336.5	220.2	282.5	282.5	296.1	273.8	324.9	215.9
	90	317.3	317.3	317.3	317.3	347.4	270.6	304.9	304.9	308.2	308.2	336.4	266.5	296.7	296.7	298.6	298.6	324.8	262.1
10000	75	292.6	265.8	323.9	201.2	356.6	131.8	283.7	261.7	313.6	197.2	345.0	127.8	274.3	257.3	302.8	193.1	332.8	123.7
	80	294.9	294.9	323.2	253.9	355.5	186.8	286.7	286.7	313.1	249.6	343.9	182.9	278.3	278.3	302.4	245.2	331.7	178.7
	85	309.5	309.5	322.9	306.8	354.3	240.5	301.7	301.7	312.8	302.6	342.8	236.3	293.3	293.3	302.4	298.2	330.7	231.8
	90	325.1	325.1	326.3	326.3	354.0	293.5	316.9	316.9	317.2	317.2	342.5	289.2	308.0	308.0	308.0	308.0	330.4	284.7
11000	75	297.0	281.2	327.7	210.1	360.7	134.2	287.9	277.0	317.6	206.4	348.9	130.2	278.2	272.5	306.5	202.2	336.3	126.0
	80	301.3	301.3	327.8	268.0	359.7	194.8	293.4	293.4	317.3	263.7	347.8	190.8	285.6	285.6	306.3	259.1	335.2	186.6
	85	317.7	317.7	327.6	326.3	358.6	253.3	309.5	309.5	317.5	317.5	346.8	249.0	300.7	300.7	306.8	306.8	334.4	244.4
	90	333.7	333.7	333.6	333.6	358.3	311.6	325.0	325.0	325.3	325.3	346.5	307.3	315.6	315.6	316.0	316.0	334.0	302.7
12000	75	300.9	296.4	331.6	218.8	364.1	136.5	291.6	291.6	321.1	215.6	352.1	132.5	281.8	281.8	309.6	209.8	339.2	128.3
	80	308.5	308.5	331.7	282.0	363.1	202.7	300.3	300.3	321.0	277.6	351.0	198.6	291.7	291.7	309.7	273.0	338.1	194.4
	85	324.9	324.9	332.0	332.0	362.3	266.0	316.3	316.3	321.6	321.6	350.2	261.6	307.1	307.1	310.8	310.8	337.5	257.0
	90	341.2	341.2	341.5	341.5	361.9	329.7	332.0	332.0	332.3	332.3	349.8	325.3	322.3	322.3	322.5	322.5	337.0	320.7
CFM	Ent DB (°F)	Ambient Temperature (°F)						Ambient Temperature (°F)											
		115						120											
		Entering Wet Bulb (°F)						Entering Wet Bulb (°F)											
		61		67		73		61		67		73							
		MBH	SHC	MBH	SHC	MBH	SHC	MBH	SHC	MBH	SHC	MBH	SHC						
8750	75	258.8	233.6	286.0	177.1	314.8	116.3	253.7	231.2	280.1	174.8	308.1	114.0						
	80	261.0	261.0	285.4	223.0	313.7	164.4	256.4	256.4	279.6	220.6	307.0	162.1						
	85	274.1	274.1	285.2	269.2	312.5	211.2	269.6	269.6	279.5	266.8	305.9	208.7						
	90	287.8	287.8	288.5	288.5	312.3	257.4	283.0	283.0	283.2	283.2	305.6	254.9						
10000	75	264.2	252.6	291.2	188.6	319.7	119.3	258.9	250.2	285.0	186.3	312.8	116.9						
	80	269.8	269.8	291.0	240.5	318.6	174.3	265.5	265.5	284.9	238.0	311.6	172.0						
	85	284.3	284.3	291.2	291.2	317.7	227.0	279.4	279.4	285.3	285.3	310.9	224.5						
	90	298.4	298.4	298.7	298.7	317.4	279.9	293.2	293.2	293.6	293.6	310.5	277.4						
11000	75	268.0	267.8	294.6	197.7	322.9	121.6	262.7	262.7	288.3	195.4	315.8	119.2						
	80	276.6	276.6	294.6	254.3	321.7	182.1	271.8	271.8	288.4	251.8	314.6	179.8						
	85	291.1	291.1	295.4	295.4	321.1	239.6	286.0	286.0	289.4	289.4	314.0	237.0						
	90	305.5	305.5	305.8	305.8	320.6	297.9	300.1	300.1	300.3	300.3	313.6	295.3						
12000	75	271.5	271.5	297.4	206.8	325.5	123.8	266.0	266.0	291.0	204.4	318.3	121.4						
	80	282.3	282.3	297.6	268.1	324.4	189.9	277.3	277.3	291.3	265.5	317.1	187.6						
	85	297.1	297.1	299.2	299.2	323.9	252.0	291.8	291.8	293.2	293.2	316.7	249.4						
	90	311.6	311.6	311.9	311.9	323.4	315.8	305.9	305.9	306.2	306.2	316.2	313.2						

**Notes:**

1. All capacities shown are gross and have not considered indoor fan heat. To obtain net cooling, subtract indoor fan heat.
2. MBH = Total Gross Capacity, SHC = Sensible Heat Capacity



## Performance Data

**Table 29. Gross cooling capacities (MBH) 6 tons TTA072K\*A condensing unit only (IP)**

Outdoor Temp (°F)		Saturated Suction Temperature (°F)					
		30	35	40	45	50	55
65	Head Press (psig)	224.8	229.1	233.7	238.5	243.6	249.0
	Capacity (Btuh/1000)	60.7	66.8	73.3	80.4	87.9	96.0
	Unit Power (kW)	3.5	3.6	3.6	3.7	3.7	3.7
75	Head Press (psig)	258.9	263.4	268.2	273.2	278.5	284.0
	Capacity (Btuh/1000)	57.8	63.6	69.8	76.5	83.6	91.3
	Unit Power (kW)	3.9	4.0	4.0	4.0	4.1	4.1
85	Head Press (psig)	296.7	301.4	306.3	311.5	316.9	322.6
	Capacity (Btuh/1000)	54.9	60.5	66.4	72.7	79.5	86.7
	Unit Power (kW)	4.4	4.4	4.5	4.5	4.6	4.6
95	Head Press (psig)	338.2	343.1	348.2	353.6	359.1	364.9
	Capacity (Btuh/1000)	52.1	57.3	63.0	69.0	75.4	82.3
	Unit Power (kW)	4.9	4.9	5.0	5.0	5.1	5.1
105	Head Press (psig)	383.6	388.7	394.0	399.5	405.2	411.1
	Capacity (Btuh/1000)	49.1	54.1	59.5	65.2	71.3	77.8
	Unit Power (kW)	5.4	5.5	5.5	5.6	5.6	5.7
115	Head Press (psig)	433.0	438.2	443.6	449.2	455.0	461.0
	Capacity (Btuh/1000)	46.1	50.8	55.9	61.3	67.1	73.3
	Unit Power (kW)	6.0	6.1	6.2	6.2	6.3	6.3
125	Head Press (psig)	486.6	491.8	497.2	502.8	508.6	514.6
	Capacity (Btuh/1000)	42.8	47.3	52.2	57.3	62.8	68.6
	Unit Power (kW)	6.7	6.8	6.8	6.9	7.0	7.0

Note: Performance data calculated at 15°F subcooling and 15°F superheat and does not include capacity loss due to refrigerant lines.

**Figure 9. TTA072K\*A capacity curve**

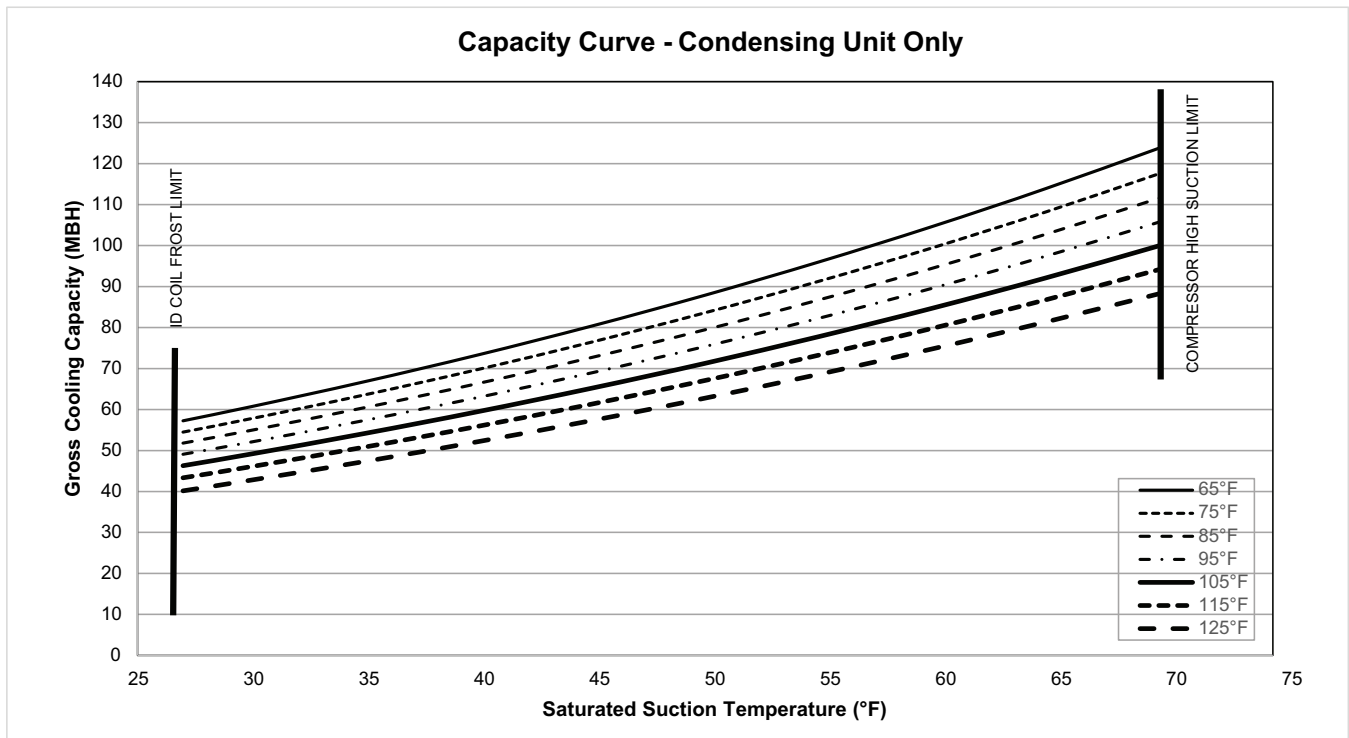

**Table 30. Gross cooling capacities (MBH) 6 tons TTA072K\*D condensing unit only (IP)**

Outdoor Temp (°F)		Saturated Suction Temperature (°F)					
		30	35	40	45	50	55
65	Head Press (psig)	247.0	251.2	255.5	260.0	264.5	269.2
	Capacity (Btuh/1000)	56.5	62.2	68.3	74.8	81.9	89.5
	Unit Power (kW)	3.7	3.7	3.7	3.7	3.7	3.7
75	Head Press (psig)	286.5	291.1	295.8	300.7	305.5	310.4
	Capacity (Btuh/1000)	53.6	59.0	64.8	71.0	77.7	84.9
	Unit Power (kW)	4.2	4.2	4.2	4.2	4.2	4.2
85	Head Press (psig)	329.8	335.0	340.3	345.6	350.9	356.0
	Capacity (Btuh/1000)	50.4	55.5	61.0	66.9	73.3	80.1
	Unit Power (kW)	4.7	4.7	4.7	4.8	4.8	4.8
95	Head Press (psig)	377.0	382.9	388.8	394.8	400.7	406.3
	Capacity (Btuh/1000)	46.9	51.8	57.0	62.6	68.7	75.2
	Unit Power (kW)	5.3	5.3	5.4	5.4	5.4	5.4
105	Head Press (psig)	428.1	434.8	441.6	448.4	455.0	461.3
	Capacity (Btuh/1000)	43.2	47.9	52.9	58.2	63.9	70.1
	Unit Power (kW)	6.0	6.1	6.1	6.1	6.1	6.1
115	Head Press (psig)	484.8	491.6	499.0	506.6	514.0	521.1
	Capacity (Btuh/1000)	39.2	43.7	48.5	53.6	59.0	64.9
	Unit Power (kW)	6.9	6.9	6.9	7.0	7.0	7.0
125	Head Press (psig)	553.6	556.1	562.6	570.3	578.3	586.1
	Capacity (Btuh/1000)	34.5	39.2	43.9	48.8	53.9	59.4
	Unit Power (kW)	8.0	7.9	7.9	7.9	7.9	7.9

Note: Performance data calculated at 15°F subcooling and 15°F superheat and does not include capacity loss due to refrigerant lines.

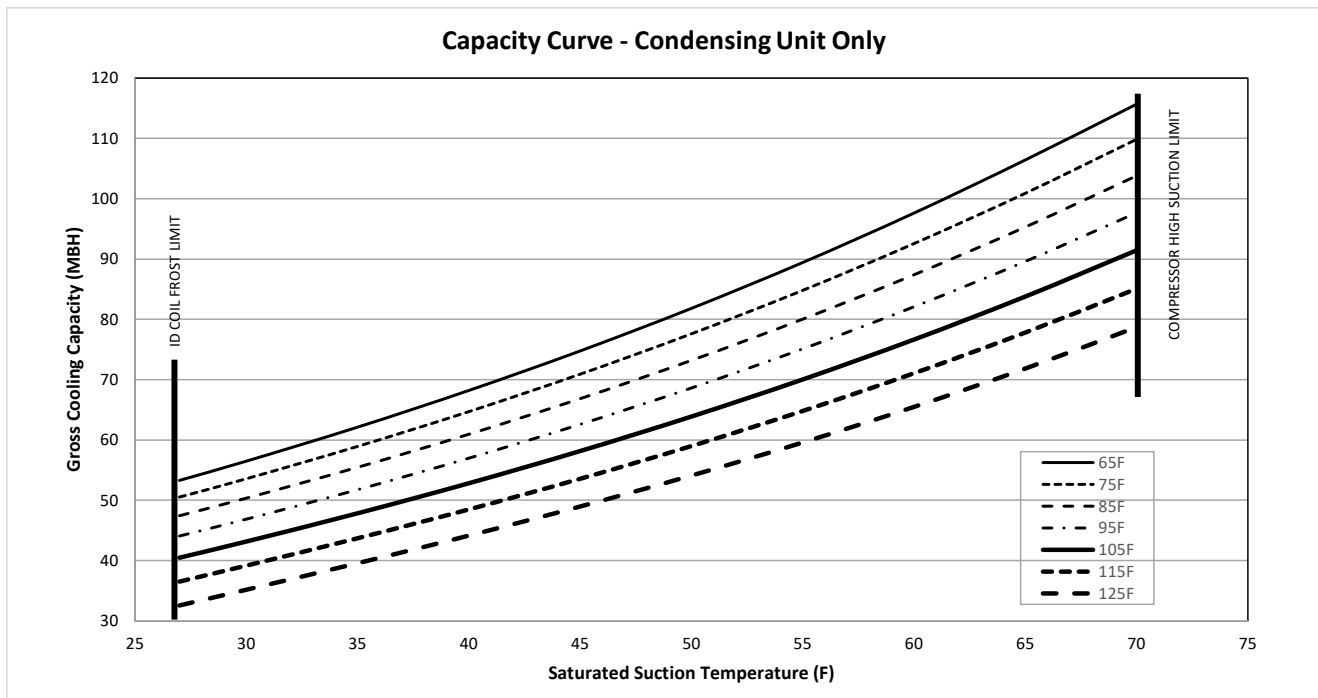
**Figure 10. TTA072K\*D capacity curve**



**Performance Data**

**Table 31. Gross cooling capacities (MBH) 7.5 tons TTA090K\*A condensing unit only (IP)**

Outdoor Temp (°F)		Saturated Suction Temperature (°F)					
		30	35	40	45	50	55
65	Head Press (psig)	243.8	249.7	255.9	262.4	269.3	276.4
	Capacity (Btuh/1000)	78.3	86.0	94.3	103.1	112.6	122.8
	Unit Power (kW)	5.1	5.2	5.3	5.5	5.6	5.7
75	Head Press (psig)	278.9	284.9	291.3	298.0	304.9	312.2
	Capacity (Btuh/1000)	74.7	82.0	89.9	98.3	107.3	116.9
	Unit Power (kW)	5.7	5.8	5.9	6.0	6.1	6.2
85	Head Press (psig)	317.5	323.7	330.2	336.9	344.0	351.3
	Capacity (Btuh/1000)	71.1	78.0	85.4	93.3	101.8	110.9
	Unit Power (kW)	6.3	6.4	6.5	6.6	6.7	6.8
95	Head Press (psig)	359.7	366.0	372.6	379.4	386.5	393.8
	Capacity (Btuh/1000)	67.3	73.8	80.7	88.2	96.2	104.7
	Unit Power (kW)	7.0	7.1	7.2	7.3	7.4	7.5
105	Head Press (psig)	405.8	412.1	418.7	425.5	432.6	439.9
	Capacity (Btuh/1000)	63.4	69.4	76.0	82.9	90.4	98.5
	Unit Power (kW)	7.8	7.9	8.0	8.1	8.2	8.3
115	Head Press (psig)	455.7	461.9	468.5	475.2	482.2	489.3
	Capacity (Btuh/1000)	59.2	64.9	71.0	77.5	84.5	92.0
	Unit Power (kW)	8.6	8.7	8.8	8.9	9.0	9.1
125	Head Press (psig)	509.8	515.7	522.0	528.4	535.1	541.9
	Capacity (Btuh/1000)	54.9	60.2	65.9	72.0	78.5	85.5
	Unit Power (kW)	9.6	9.7	9.8	9.8	9.9	10.0

Note: Performance data calculated at 15°F subcooling and 15°F superheat and does not include capacity loss due to refrigerant lines.

**Figure 11. TTA090K\*A capacity curve**

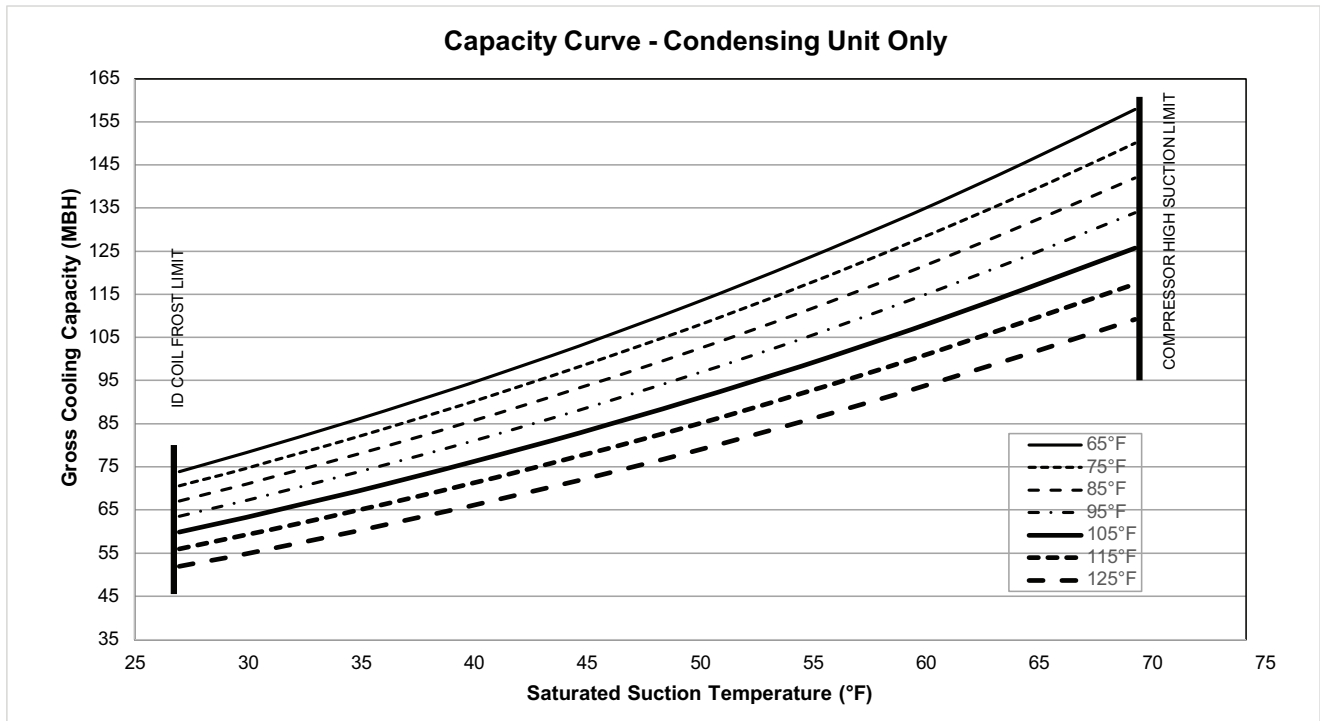
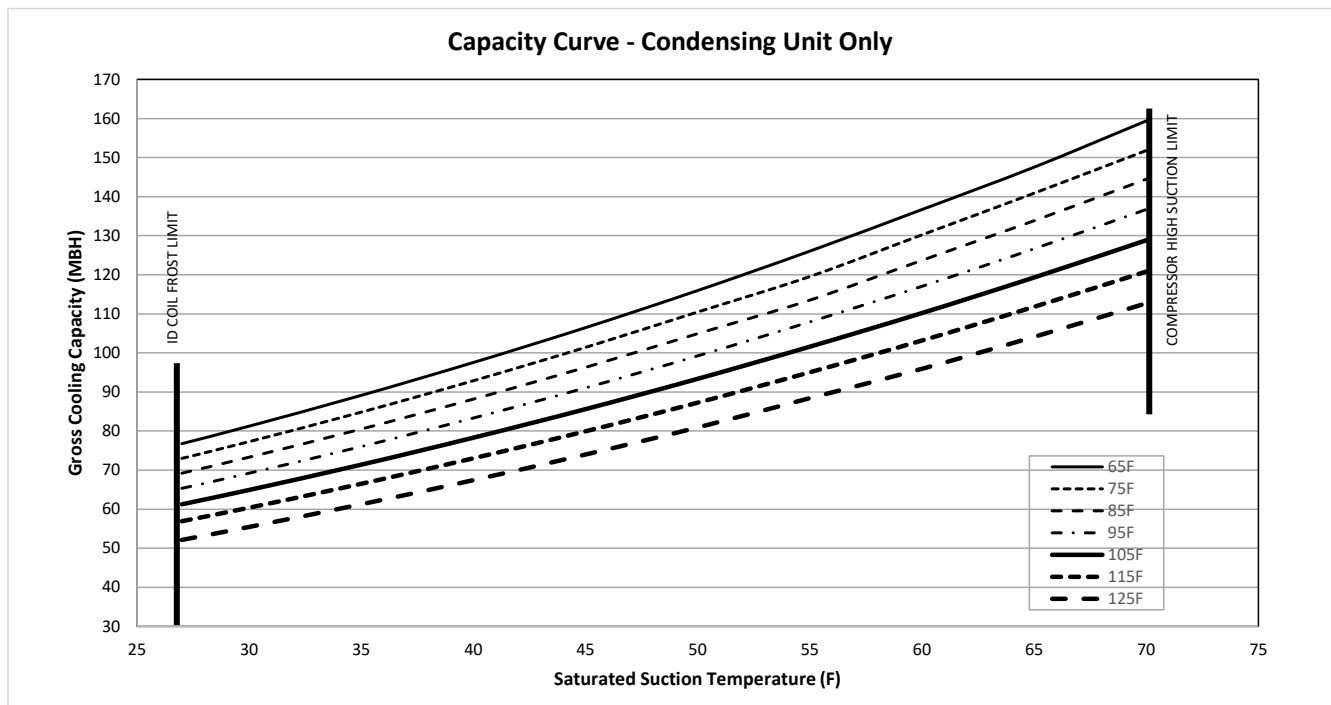

**Table 32. Gross cooling capacities (MBH) 7.5 tons TTA090K\*D condensing unit only (IP)**

Outdoor Temp (°F)		Saturated Suction Temperature (°F)					
		30	35	40	45	50	55
65	Head Press (psig)	240.4	245.5	250.9	257.0	263.0	269.0
	Capacity (Btuh/1000)	81.3	89.1	97.6	106.5	116.0	126.0
	Unit Power (kW)	4.8	4.9	4.9	5.0	5.1	5.1
75	Head Press (psig)	275.9	281.2	286.8	293.0	299.3	310.9
	Capacity (Btuh/1000)	77.3	84.8	92.9	101.4	110.5	119.5
	Unit Power (kW)	5.3	5.4	5.5	5.5	5.6	5.7
85	Head Press (psig)	315.0	320.4	326.3	332.6	339.1	351.5
	Capacity (Btuh/1000)	73.3	80.5	88.2	96.3	104.9	113.5
	Unit Power (kW)	5.9	6.0	6.1	6.1	6.2	6.4
95	Head Press (psig)	357.8	363.7	369.4	375.9	382.5	389.0
	Capacity (Btuh/1000)	69.2	76.0	83.3	91.1	99.3	107.9
	Unit Power (kW)	6.6	6.7	6.8	6.8	6.9	7.0
105	Head Press (psig)	404.4	410.3	416.3	422.9	429.5	436.1
	Capacity (Btuh/1000)	64.9	71.4	78.3	85.6	93.4	101.6
	Unit Power (kW)	7.4	7.5	7.5	7.6	7.7	7.8
115	Head Press (psig)	455.1	460.9	466.9	473.4	480.1	486.7
	Capacity (Btuh/1000)	60.4	66.5	73.0	79.9	87.3	95.0
	Unit Power (kW)	8.2	8.3	8.4	8.5	8.6	8.7
125	Head Press (psig)	511.0	516.1	521.8	527.7	534.2	549.4
	Capacity (Btuh/1000)	55.5	61.3	67.4	74.0	80.9	88.4
	Unit Power (kW)	9.2	9.3	9.4	9.5	9.5	9.8

Note: Performance data calculated at 15°F subcooling and 15°F superheat and does not include capacity loss due to refrigerant lines.

**Figure 12. TTA090K\*D capacity curve**





**Performance Data**

**Table 33. Gross cooling capacities (MBH) 10 tons TTA120K\*D condensing unit only (IP)**

Outdoor Temp (°F)		Saturated Suction Temperature (°F)					
		30	35	40	45	50	55
65	Head Press (psig)	233.2	237.4	241.8	246.4	251.1	255.9
	Capacity (Btuh/1000)	97.6	107.2	117.5	128.6	140.5	153.3
	Unit Power (kW)	6.1	6.1	6.2	6.3	6.4	6.6
75	Head Press (psig)	268.6	273.1	277.7	282.5	287.4	292.3
	Capacity (Btuh/1000)	93.0	102.2	112.0	122.6	133.9	146.1
	Unit Power (kW)	6.8	6.8	6.9	6.9	7.0	7.2
85	Head Press (psig)	307.5	312.2	317.1	322.1	327.1	332.1
	Capacity (Btuh/1000)	88.2	97.0	106.4	116.4	127.3	138.8
	Unit Power (kW)	7.5	7.5	7.6	7.7	7.7	7.8
95	Head Press (psig)	350.0	355.0	360.2	365.4	370.5	375.7
	Capacity (Btuh/1000)	83.3	91.6	100.6	110.2	120.5	131.5
	Unit Power (kW)	8.3	8.3	8.4	8.4	8.5	8.6
105	Head Press (psig)	396.6	401.8	407.2	412.5	417.8	423.1
	Capacity (Btuh/1000)	78.2	86.2	94.8	103.9	113.7	124.1
	Unit Power (kW)	9.1	9.2	9.3	9.3	9.4	9.5
115	Head Press (psig)	447.3	452.8	458.3	463.7	469.1	474.5
	Capacity (Btuh/1000)	73.2	80.8	88.9	97.6	106.8	116.7
	Unit Power (kW)	10.0	10.1	10.2	10.3	10.4	10.5
125	Head Press (psig)	502.9	508.4	513.7	519.1	524.5	529.8
	Capacity (Btuh/1000)	68.0	75.3	83.0	91.2	99.9	109.3
	Unit Power (kW)	11.1	11.2	11.3	11.4	11.5	11.6

Note: Performance data calculated at 15°F subcooling and 15°F superheat and does not include capacity loss due to refrigerant lines.

**Figure 13. TTA120K\*D capacity curve**

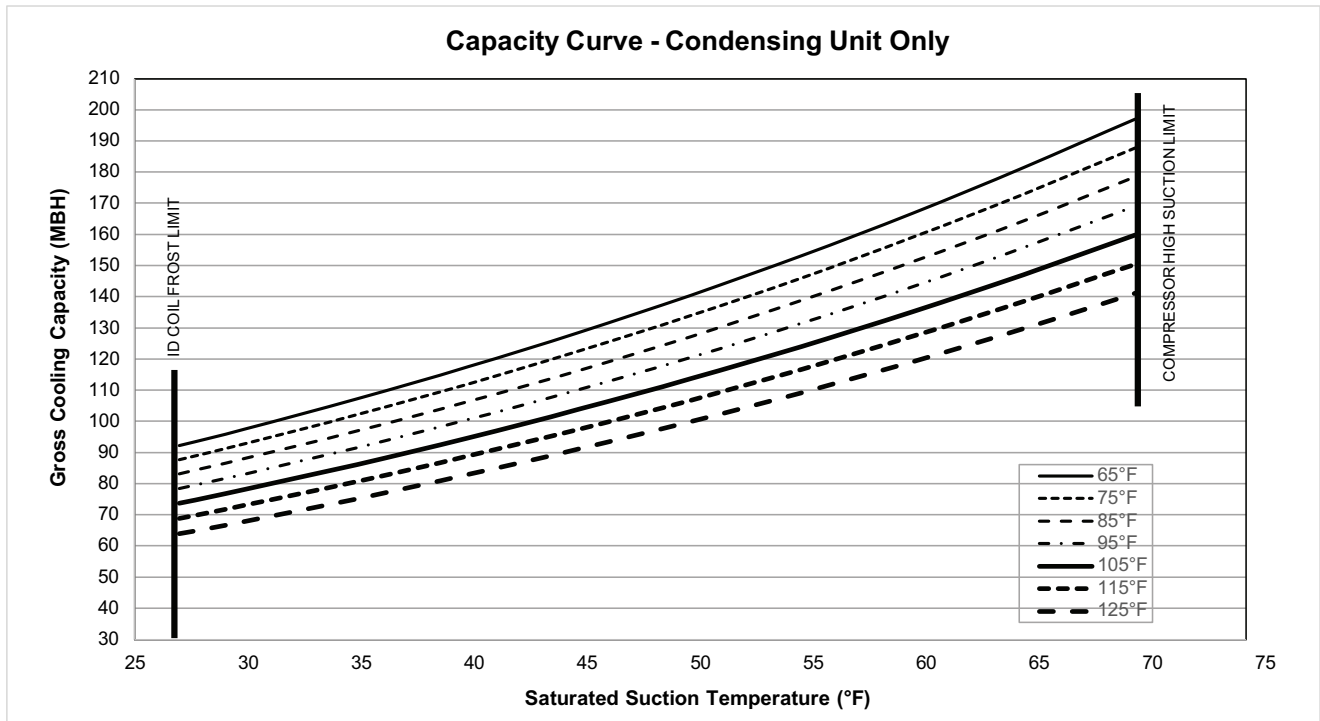
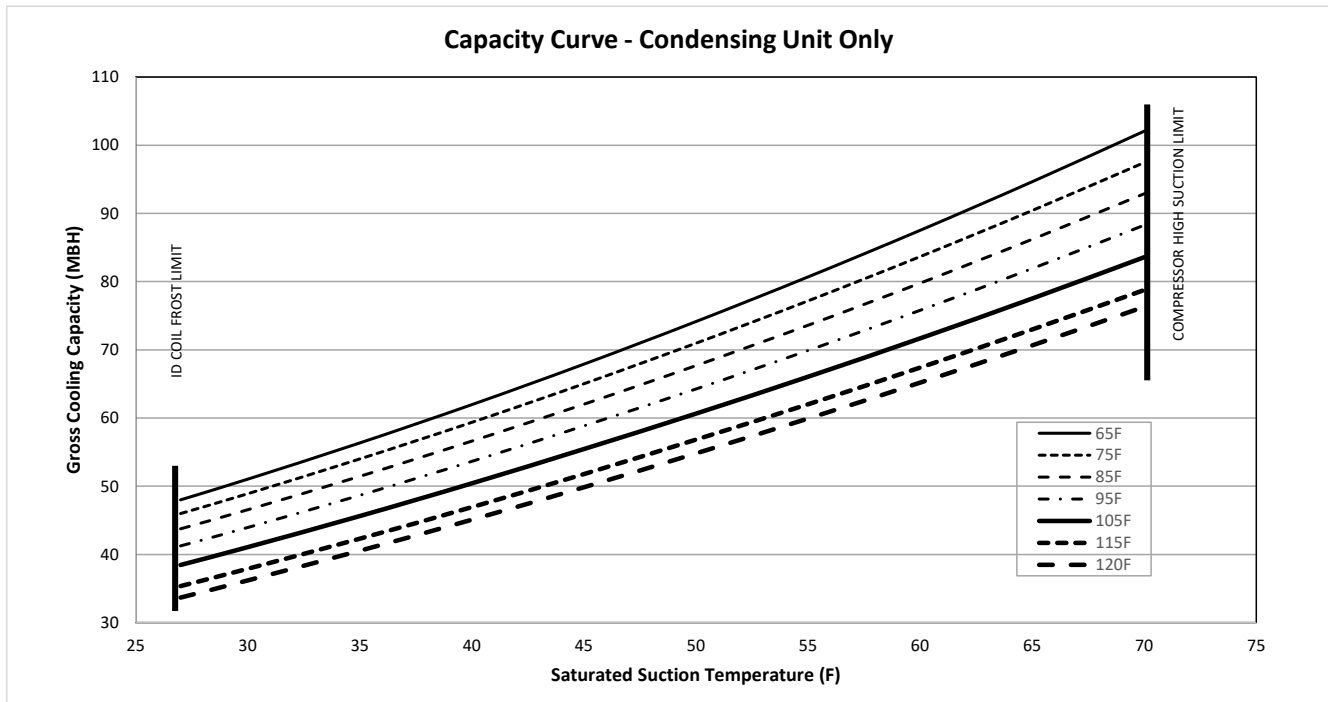



**Table 34. Gross cooling capacities (MBH) – one compressor – 10 tons TTA120K\*C condensing unit only (IP)**

Outdoor Temp (°F)		Saturated Suction Temperature (°F)					
		30	35	40	45	50	55
65	Head Press (psig)	209.4	212.3	215.7	219.3	223.1	227.1
	Capacity (Btuh/1000)	51.0	56.3	62.0	67.9	74.1	80.7
	Unit Power (kW)	3.3	3.3	3.3	3.3	3.3	3.3
75	Head Press (psig)	243.5	246.3	249.7	253.5	257.5	261.7
	Capacity (Btuh/1000)	48.9	54.0	59.4	65.0	71.0	77.2
	Unit Power (kW)	3.6	3.6	3.6	3.6	3.6	3.6
85	Head Press (psig)	281.3	284.1	287.4	291.4	295.6	300.0
	Capacity (Btuh/1000)	46.6	51.5	56.6	62.0	67.7	73.6
	Unit Power (kW)	3.9	3.9	3.9	3.9	3.9	4.0
95	Head Press (psig)	323.0	326.1	329.2	333.1	337.5	342.0
	Capacity (Btuh/1000)	44.0	48.7	53.6	58.8	64.3	69.9
	Unit Power (kW)	4.4	4.4	4.4	4.4	4.4	4.4
105	Head Press (psig)	369.0	372.2	375.5	378.9	383.4	388.1
	Capacity (Btuh/1000)	41.1	45.6	50.4	55.5	60.6	66.1
	Unit Power (kW)	4.9	4.9	4.9	4.9	4.9	4.9
115	Head Press (psig)	419.5	422.8	426.2	429.7	433.4	438.3
	Capacity (Btuh/1000)	37.9	42.3	46.9	51.8	56.8	62.0
	Unit Power (kW)	5.5	5.4	5.4	5.4	5.4	5.5
120	Head Press (psig)	446.7	449.9	453.4	456.9	460.5	464.9
	Capacity (Btuh/1000)	36.2	40.5	45.1	49.8	54.8	59.9
	Unit Power (kW)	5.8	5.8	5.8	5.7	5.7	5.8

Note: Performance data calculated at 15°F subcooling and 15°F superheat and does not include capacity loss due to refrigerant lines.

**Figure 14. TTA120K\*C – one compressor – capacity curve**



**Performance Data**

**Table 35. Gross cooling capacities (MBH) – both compressors – 10 tons TTA120K\*C condensing unit only (IP)**

Outdoor Temp (°F)		Saturated Suction Temperature (°F)					
		30	35	40	45	50	55
65	Head Press (psig)	242.0	248.5	255.3	262.3	269.5	276.8
	Capacity (Btuh/1000)	99.8	110.0	120.8	132.2	144.2	156.9
	Unit Power (kW)	6.2	6.3	6.3	6.4	6.5	6.6
75	Head Press (psig)	277.2	284.0	291.0	298.2	305.6	313.0
	Capacity (Btuh/1000)	95.1	104.8	115.1	126.0	137.4	149.4
	Unit Power (kW)	6.9	7.0	7.0	7.1	7.2	7.3
85	Head Press (psig)	315.6	322.7	330.0	337.5	345.1	352.7
	Capacity (Btuh/1000)	90.1	99.4	109.2	119.5	130.4	141.8
	Unit Power (kW)	7.7	7.8	7.8	7.9	8.0	8.1
95	Head Press (psig)	357.4	364.8	372.4	380.2	387.9	395.7
	Capacity (Btuh/1000)	84.6	93.6	103.0	112.8	123.2	134.1
	Unit Power (kW)	8.6	8.7	8.8	8.9	9.0	9.1
105	Head Press (psig)	402.5	410.3	418.2	426.2	434.2	442.1
	Capacity (Btuh/1000)	78.8	87.4	96.4	105.8	115.8	126.1
	Unit Power (kW)	9.7	9.8	9.8	9.9	10.0	10.2
115	Head Press (psig)	451.1	459.1	467.3	475.6	483.8	491.8
	Capacity (Btuh/1000)	72.5	80.8	89.5	98.6	108.1	118.0
	Unit Power (kW)	10.9	10.9	11.0	11.1	11.2	11.3
120	Head Press (psig)	476.8	484.9	493.2	501.5	509.8	517.8
	Capacity (Btuh/1000)	69.3	77.4	85.9	94.8	104.1	113.8
	Unit Power (kW)	11.5	11.6	11.7	11.8	11.9	12.0

Note: Performance data calculated at 15°F subcooling and 15°F superheat and does not include capacity loss due to refrigerant lines.

**Figure 15. TTA120K\*C – both compressors – capacity curve**

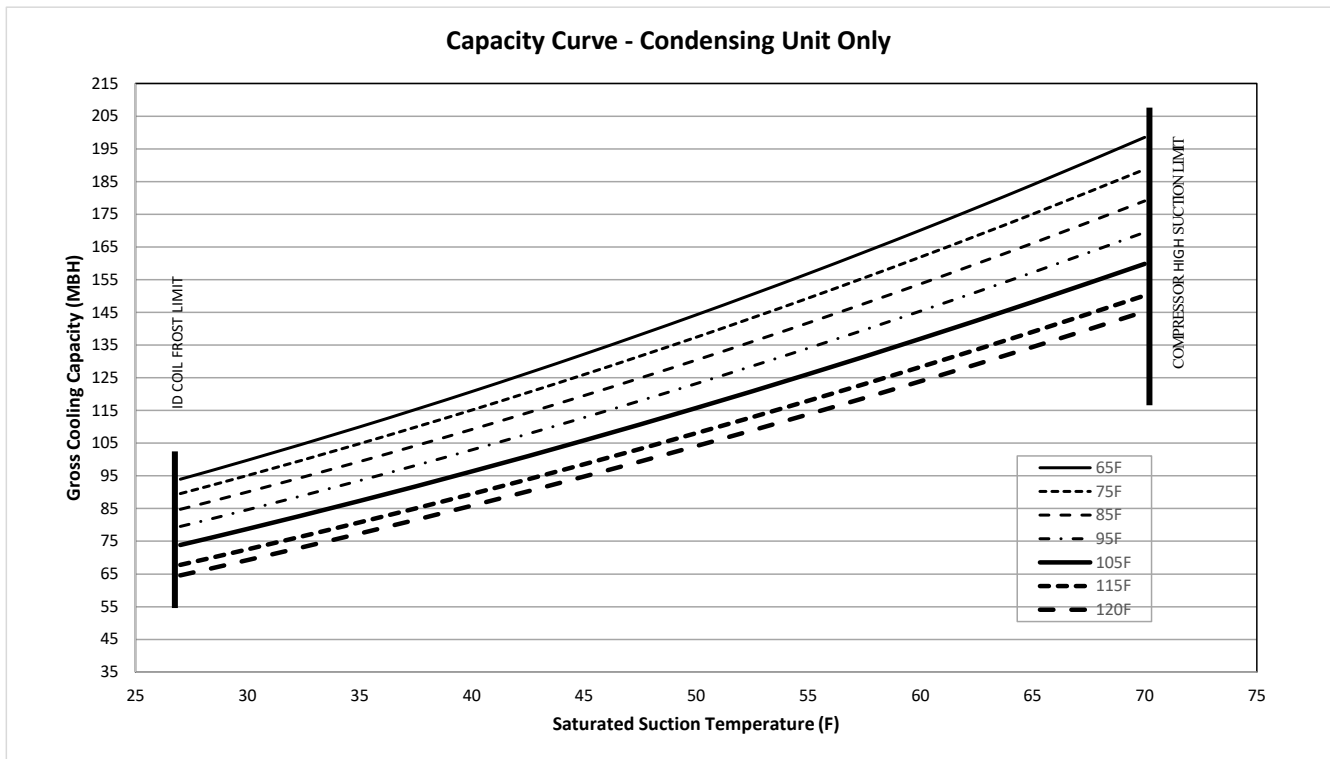

**Table 36. Gross cooling capacities (MBH) 12.5 tons TTA150K\*D condensing unit only (IP)**

Outdoor Temp (°F)		Saturated Suction Temperature (°F)					
		30	35	40	45	50	55
65	Head Press (psig)	249.2	254.6	260.3	266.3	272.4	278.7
	Capacity (Btuh/1000)	126.7	139.0	152.3	166.5	181.8	198.1
	Unit Power (kW)	8.6	8.7	8.9	9.0	9.2	9.4
75	Head Press (psig)	285.5	291.2	297.1	303.2	309.6	316.1
	Capacity (Btuh/1000)	120.8	132.7	145.4	159.0	173.6	189.2
	Unit Power (kW)	9.5	9.7	9.8	9.9	10.1	10.3
85	Head Press (psig)	325.3	331.1	337.2	343.5	350.1	356.8
	Capacity (Btuh/1000)	114.7	126.0	138.2	151.1	165.0	179.9
	Unit Power (kW)	10.6	10.7	10.9	11.0	11.2	11.3
95	Head Press (psig)	368.6	374.5	380.7	387.2	393.9	400.7
	Capacity (Btuh/1000)	108.3	119.0	130.5	142.9	156.0	170.1
	Unit Power (kW)	11.8	11.9	12.1	12.2	12.4	12.6
105	Head Press (psig)	415.5	421.4	427.7	434.2	440.9	447.8
	Capacity (Btuh/1000)	101.5	111.6	122.5	134.1	146.6	159.9
	Unit Power (kW)	13.1	13.3	13.5	13.6	13.8	14.0
115	Head Press (psig)	466.7	472.2	478.2	484.6	491.2	498.0
	Capacity (Btuh/1000)	94.2	103.7	114.0	125.0	136.7	149.3
	Unit Power (kW)	14.6	14.8	15.0	15.1	15.3	15.5
125	Head Press (psig)	524.6	528.3	533.3	539.0	545.1	551.4
	Capacity (Btuh/1000)	86.0	95.2	104.9	115.2	126.3	138.1
	Unit Power (kW)	16.4	16.5	16.7	16.8	17.0	17.2

Note: Performance data calculated at 15°F subcooling and 15°F superheat and does not include capacity loss due to refrigerant lines.

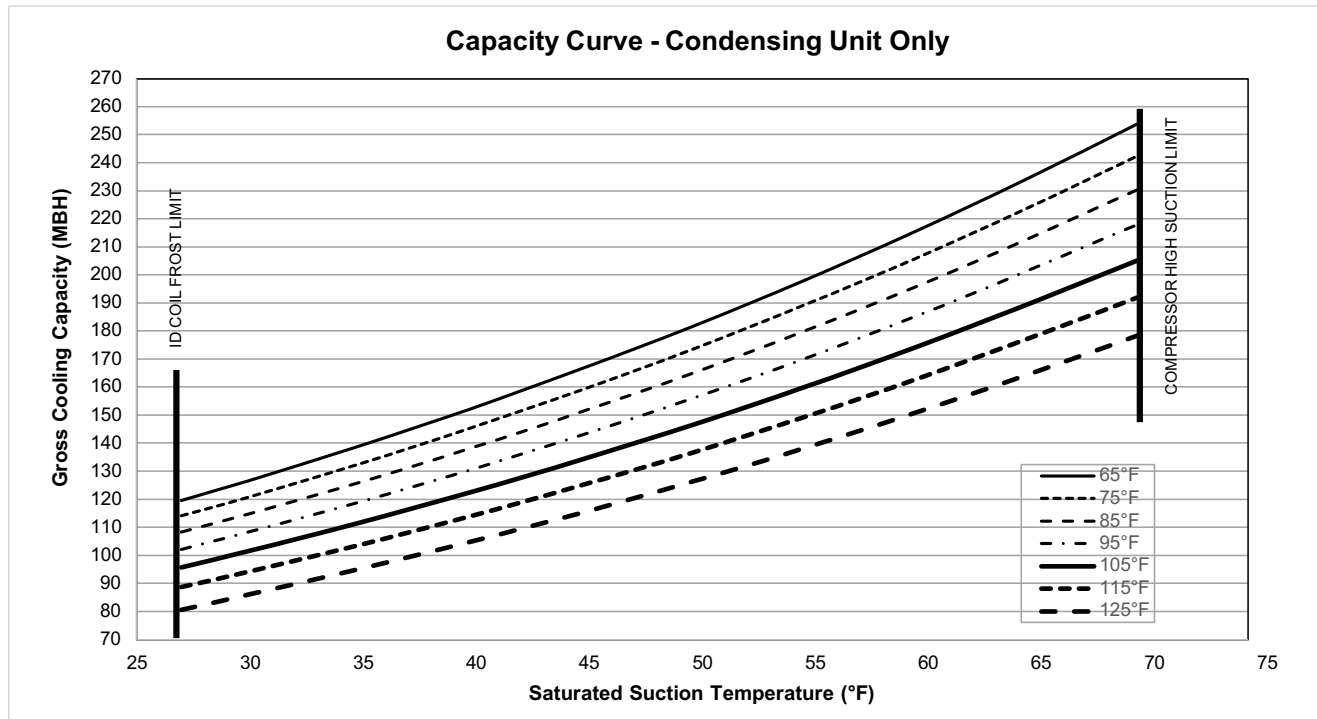
**Figure 16. TTA150K\*D capacity curve**



## Performance Data

**Table 37. Gross cooling capacities (MBH) 15 tons TTA180K\*D condensing unit only (IP)**

Outdoor Temp (°F)		Saturated Suction Temperature (°F)					
		30	35	40	45	50	55
65	Head Press (psig)	226.4	230.9	235.6	240.6	245.8	251.2
	Capacity (Btuh/1000)	164.5	180.9	198.5	217.3	237.4	258.9
	Unit Power (kW)	10.2	10.2	10.3	10.3	10.4	10.4
75	Head Press (psig)	260.3	265.0	270.0	275.1	280.5	286.0
	Capacity (Btuh/1000)	156.8	172.5	189.3	207.3	226.5	247.0
	Unit Power (kW)	11.2	11.3	11.4	11.5	11.5	11.6
85	Head Press (psig)	297.8	302.7	307.8	313.2	318.7	324.4
	Capacity (Btuh/1000)	148.9	163.9	179.9	197.1	215.4	235.0
	Unit Power (kW)	12.4	12.5	12.6	12.7	12.8	12.9
95	Head Press (psig)	339.0	344.1	349.4	354.9	360.6	366.4
	Capacity (Btuh/1000)	140.7	155.0	170.3	186.7	204.2	222.8
	Unit Power (kW)	13.7	13.8	14.0	14.1	14.2	14.3
105	Head Press (psig)	384.1	389.3	394.8	400.4	406.2	412.1
	Capacity (Btuh/1000)	132.2	145.9	160.5	176.0	192.7	210.4
	Unit Power (kW)	15.2	15.3	15.4	15.6	15.7	15.8
115	Head Press (psig)	433.2	438.5	444.1	449.8	455.6	461.6
	Capacity (Btuh/1000)	123.4	136.4	150.3	165.1	180.9	197.8
	Unit Power (kW)	16.8	16.9	17.1	17.2	17.3	17.5
125	Head Press (psig)	486.5	491.9	497.4	503.2	509.0	514.8
	Capacity (Btuh/1000)	114.2	126.6	139.8	153.8	168.8	184.8
	Unit Power (kW)	18.6	18.7	18.9	19.0	19.1	19.3

Note: Performance data calculated at 15°F subcooling and 15°F superheat and does not include capacity loss due to refrigerant lines.

**Figure 17. TTA180K\*D capacity curve**

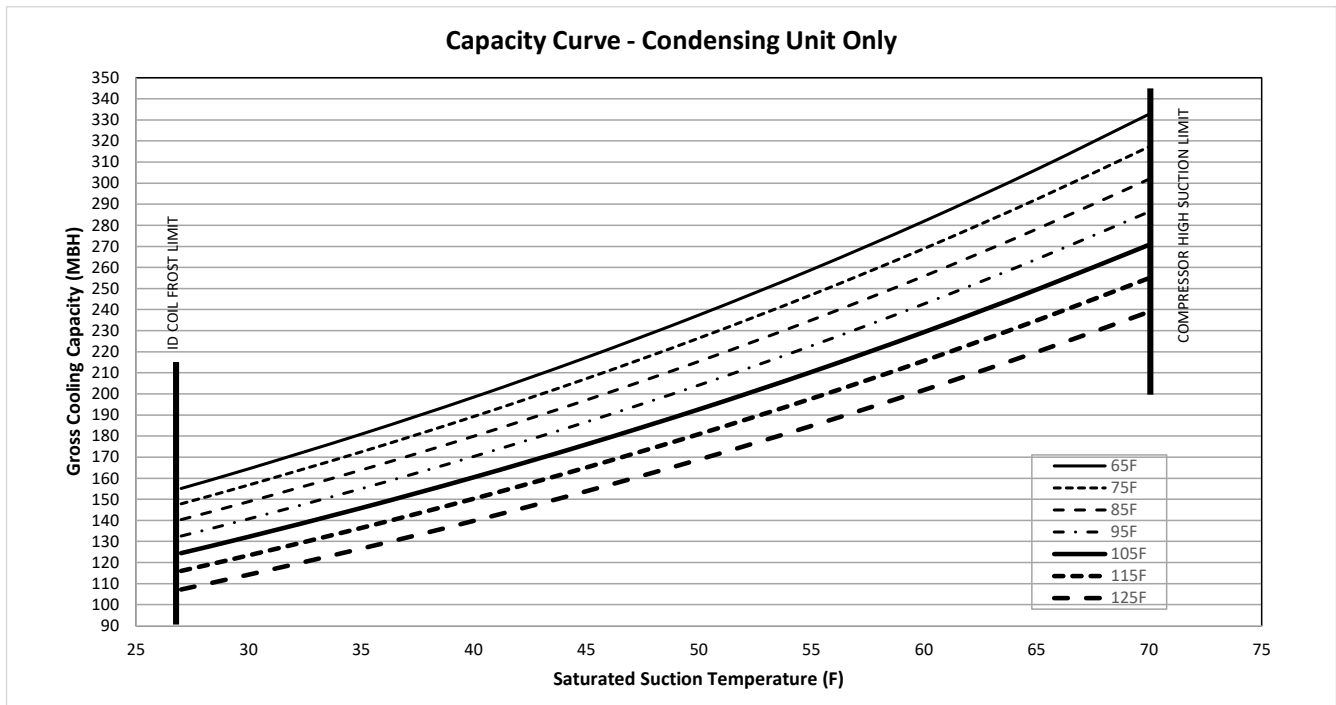
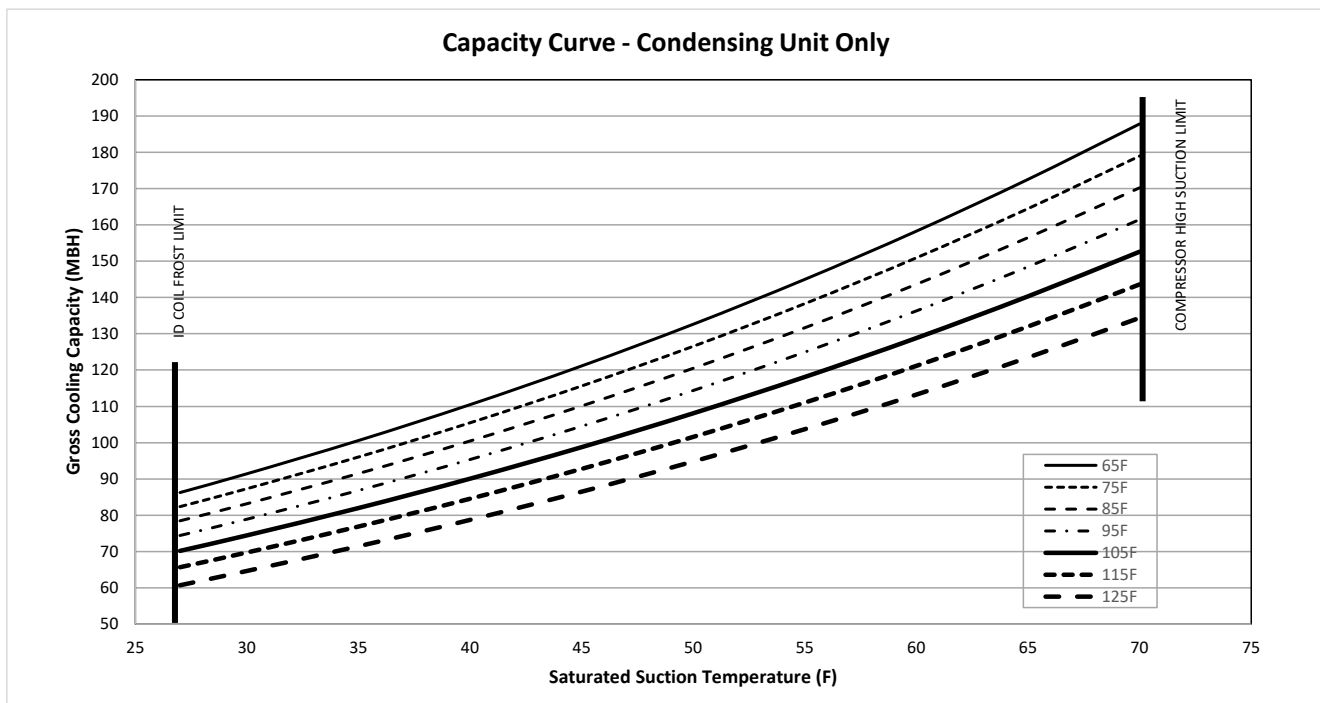

**Table 38. Gross cooling capacities (MBH) – one compressor – 15 tons TTA180K\*C condensing unit only (IP)**

Outdoor Temp (°F)		Saturated Suction Temperature (°F)					
		30	35	40	45	50	55
65	Head Press (psig)	205.7	208.2	210.9	213.9	217.1	220.6
	Capacity (Btuh/1000)	91.4	100.6	110.5	121.1	132.6	145.0
	Unit Power (kW)	5.9	5.9	5.8	5.8	5.8	5.7
75	Head Press (psig)	238.9	241.5	244.3	247.5	250.9	254.5
	Capacity (Btuh/1000)	87.3	96.1	105.5	115.6	126.6	138.3
	Unit Power (kW)	6.4	6.4	6.4	6.4	6.4	6.4
85	Head Press (psig)	275.8	278.6	281.6	284.9	288.4	292.1
	Capacity (Btuh/1000)	83.2	91.5	100.5	110.1	120.5	131.7
	Unit Power (kW)	7.0	7.0	7.1	7.1	7.1	7.1
95	Head Press (psig)	316.8	319.6	322.7	326.0	329.7	333.6
	Capacity (Btuh/1000)	78.9	86.8	95.4	104.5	114.4	125.0
	Unit Power (kW)	7.7	7.7	7.7	7.8	7.8	7.8
105	Head Press (psig)	361.7	364.6	367.8	371.3	375.1	379.1
	Capacity (Btuh/1000)	74.5	82.0	90.1	98.8	108.1	118.1
	Unit Power (kW)	8.4	8.5	8.5	8.5	8.6	8.6
115	Head Press (psig)	411.0	414.0	417.3	420.8	424.6	428.7
	Capacity (Btuh/1000)	69.7	76.9	84.5	92.8	101.6	111.0
	Unit Power (kW)	9.3	9.3	9.4	9.4	9.4	9.5
125	Head Press (psig)	465.6	468.1	471.2	474.8	478.6	482.6
	Capacity (Btuh/1000)	64.6	71.5	78.7	86.5	94.8	103.7
	Unit Power (kW)	10.2	10.2	10.3	10.3	10.4	10.4

Note: Performance data calculated at 15°F subcooling and 15°F superheat and does not include capacity loss due to refrigerant lines.

**Figure 18. TTA180K\*C – one compressor – capacity curve**





## Performance Data

**Table 39. Gross cooling capacities (MBH) – both compressors – 15 tons TTA180K\*C condensing unit only (IP)**

Outdoor Temp (°F)		Saturated Suction Temperature (°F)					
		30	35	40	45	50	55
65	Head Press (psig)	225.8	230.3	235.2	240.4	245.8	251.6
	Capacity (Btuh/1000)	157.3	173.0	189.8	207.9	227.3	248.2
	Unit Power (kW)	9.5	9.6	9.6	9.7	9.7	9.7
75	Head Press (psig)	260.0	264.7	269.8	275.2	280.8	286.7
	Capacity (Btuh/1000)	150.6	165.6	181.6	198.8	217.4	237.2
	Unit Power (kW)	10.6	10.6	10.7	10.8	10.8	10.9
85	Head Press (psig)	297.8	302.7	308.0	313.5	319.3	325.2
	Capacity (Btuh/1000)	143.7	158.0	173.3	189.7	207.3	226.2
	Unit Power (kW)	11.7	11.8	11.9	12.0	12.1	12.1
95	Head Press (psig)	339.3	344.4	349.8	355.5	361.4	367.4
	Capacity (Btuh/1000)	136.5	150.1	164.6	180.2	197.0	214.9
	Unit Power (kW)	12.9	13.0	13.2	13.3	13.4	13.5
105	Head Press (psig)	384.6	389.9	395.4	401.2	407.2	413.2
	Capacity (Btuh/1000)	128.9	141.8	155.6	170.4	186.3	203.3
	Unit Power (kW)	14.3	14.4	14.6	14.7	14.9	15.0
115	Head Press (psig)	433.9	439.3	444.9	450.7	456.7	462.7
	Capacity (Btuh/1000)	120.8	133.1	146.3	160.3	175.4	191.5
	Unit Power (kW)	15.8	16.0	16.1	16.3	16.4	16.6
125	Head Press (psig)	487.6	492.9	498.4	504.1	510.0	515.9
	Capacity (Btuh/1000)	112.3	124.0	136.5	149.8	164.1	179.4
	Unit Power (kW)	17.5	17.7	17.8	18.0	18.1	18.3

**Note:** Performance data calculated at 15°F subcooling and 15°F superheat and does not include capacity loss due to refrigerant lines.

Figure 19. TTA180K\*C – both compressors – capacity curve

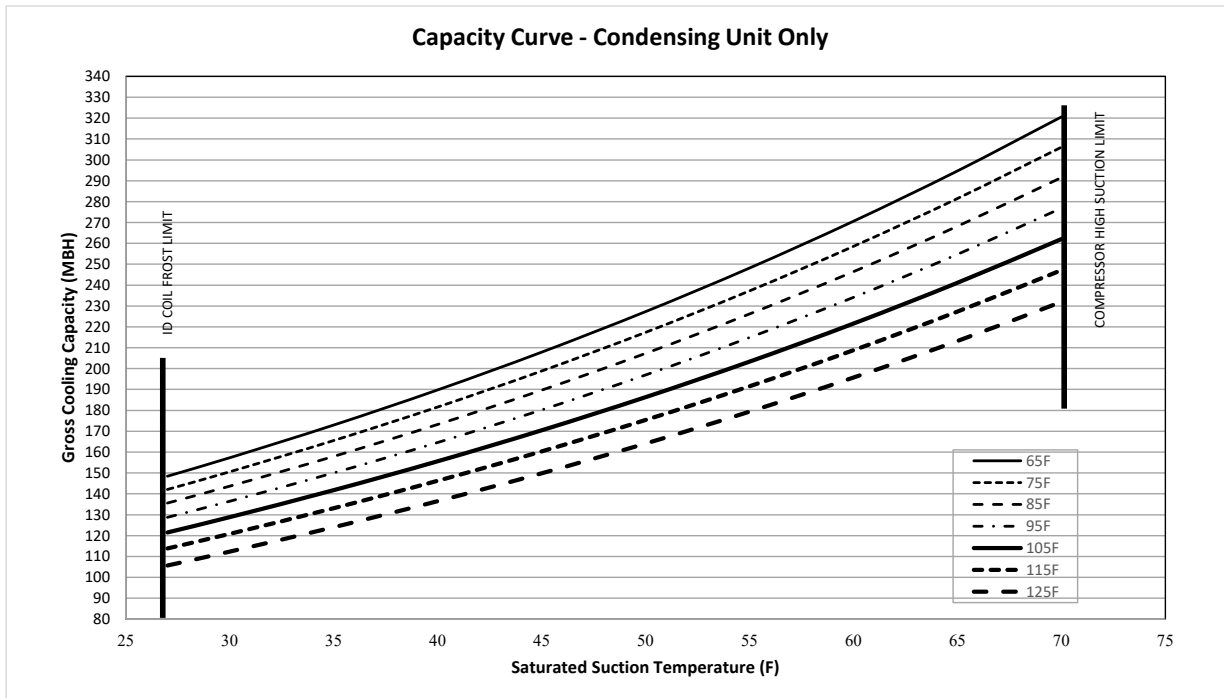



## Performance Data

**Table 40. Gross cooling capacities (MBH) 20 tons TTA240K\*D condensing unit only (IP)**

Outdoor Temp (°F)		Saturated Suction Temperature (°F)					
		30	35	40	45	50	55
65	Head Press (psig)	245.1	251.0	257.2	263.5	269.9	276.3
	Capacity (Btuh/1000)	216.4	237.1	259.2	282.7	307.7	334.4
	Unit Power (kW)	13.8	14.1	14.4	14.7	15.0	15.3
75	Head Press (psig)	280.4	286.9	293.7	300.6	307.6	314.7
	Capacity (Btuh/1000)	206.8	227.4	249.5	273.0	298.1	324.9
	Unit Power (kW)	15.1	15.4	15.8	16.1	16.5	16.8
85	Head Press (psig)	318.9	325.9	333.0	340.3	347.8	355.3
	Capacity (Btuh/1000)	196.0	216.1	237.6	260.5	285.1	311.4
	Unit Power (kW)	16.6	17.0	17.3	17.7	18.0	18.4
95	Head Press (psig)	361.0	368.1	375.5	383.0	390.7	398.5
	Capacity (Btuh/1000)	184.7	203.7	224.2	246.2	269.8	295.1
	Unit Power (kW)	18.3	18.7	19.1	19.4	19.8	20.2
105	Head Press (psig)	406.7	413.8	421.2	428.8	436.6	444.4
	Capacity (Btuh/1000)	173.1	190.7	209.9	230.5	252.8	276.8
	Unit Power (kW)	20.2	20.6	21.0	21.4	21.8	22.2
115	Head Press (psig)	456.5	463.3	470.5	477.9	485.6	493.3
	Capacity (Btuh/1000)	161.5	177.5	195.0	214.1	234.9	257.4
	Unit Power (kW)	22.4	22.8	23.2	23.5	23.9	24.3
125	Head Press (psig)	510.7	516.8	523.4	530.4	537.6	545.0
	Capacity (Btuh/1000)	150.2	164.2	179.9	197.3	216.3	237.1
	Unit Power (kW)	24.8	25.2	25.6	25.9	26.3	26.7

Note: Performance data calculated at 15°F subcooling and 15°F superheat and does not include capacity loss due to refrigerant lines.

**Figure 20. TTA240K\*D capacity curve**

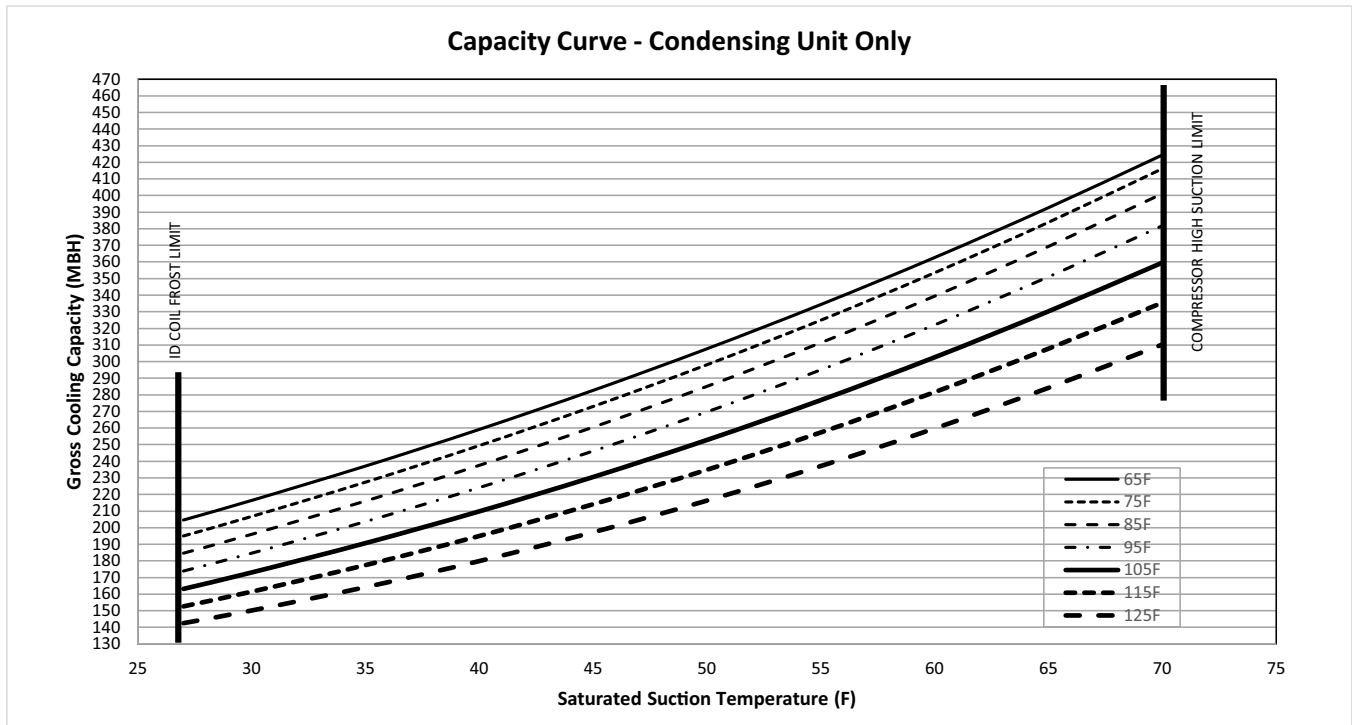
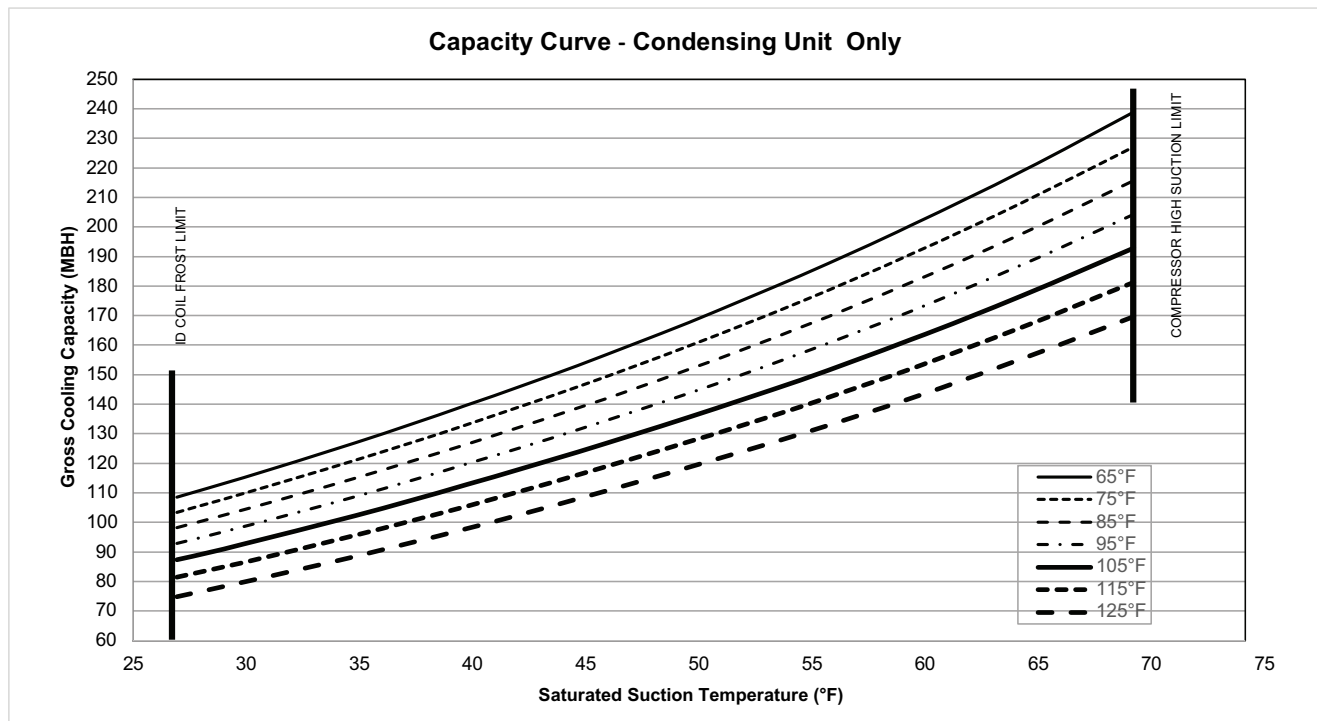



**Table 41. Gross cooling capacities (MBH) – one compressor – 20 tons TTA240K\*C condensing unit only (IP)**

Outdoor Temp (°F)		Saturated Suction Temperature (°F)					
		30	35	40	45	50	55
65	Head Press (psig)	216.5	219.0	222.6	226.8	231.3	235.6
	Capacity (Btuh/1000)	115.3	127.1	139.7	153.2	167.8	183.6
	Unit Power (kW)	7.6	7.6	7.5	7.5	7.5	7.5
75	Head Press (psig)	251.1	253.6	256.8	261.1	265.6	270.2
	Capacity (Btuh/1000)	109.8	121.0	133.1	146.0	159.8	174.8
	Unit Power (kW)	8.3	8.3	8.3	8.4	8.4	8.4
85	Head Press (psig)	289.7	292.1	294.6	299.0	303.7	308.4
	Capacity (Btuh/1000)	104.3	115.0	126.5	138.7	151.8	166.0
	Unit Power (kW)	9.1	9.2	9.2	9.2	9.2	9.3
95	Head Press (psig)	332.4	334.7	337.1	340.9	345.6	350.3
	Capacity (Btuh/1000)	98.7	108.8	119.7	131.4	143.8	157.2
	Unit Power (kW)	10.0	10.1	10.1	10.1	10.2	10.2
105	Head Press (psig)	379.8	382.0	384.1	386.8	391.6	396.3
	Capacity (Btuh/1000)	92.8	102.4	112.8	123.9	135.6	148.3
	Unit Power (kW)	11.0	11.1	11.1	11.2	11.2	11.3
115	Head Press (psig)	432.2	434.1	436.0	437.8	441.7	446.3
	Capacity (Btuh/1000)	86.6	95.7	105.5	116.2	127.3	139.2
	Unit Power (kW)	12.2	12.2	12.3	12.3	12.4	12.4
125	Head Press (psig)	491.6	492.4	493.4	494.4	496.1	500.5
	Capacity (Btuh/1000)	79.9	88.6	97.9	108.0	118.8	130.0
	Unit Power (kW)	13.5	13.5	13.6	13.6	13.6	13.7

Note: Performance data calculated at 15°F subcooling and 15°F superheat and does not include capacity loss due to refrigerant lines.

**Figure 21. TTA240K\*C – one compressor – capacity curve**



**Performance Data**

**Table 42. Gross cooling capacities (MBH) – both compressors – 20 tons TTA240K\*C condensing unit only (IP)**

Outdoor Temp (°F)		Saturated Suction Temperature (°F)					
		30	35	40	45	50	55
65	Head Press (psig)	251.9	258.5	265.1	271.3	276.8	281.5
	Capacity (Btuh/1000)	219.7	241.5	265.1	290.9	319.1	350.1
	Unit Power (kW)	14.8	15.0	15.2	15.3	15.4	15.4
75	Head Press (psig)	287.1	293.8	300.4	306.5	311.9	316.3
	Capacity (Btuh/1000)	209.2	229.9	252.4	276.8	303.6	333.0
	Unit Power (kW)	16.3	16.5	16.7	16.9	17.0	17.0
85	Head Press (psig)	325.8	332.6	339.1	345.1	350.3	354.4
	Capacity (Btuh/1000)	198.6	218.2	239.5	262.7	288.1	315.9
	Unit Power (kW)	17.9	18.2	18.4	18.6	18.7	18.8
95	Head Press (psig)	368.1	374.9	381.4	387.2	392.2	396.0
	Capacity (Btuh/1000)	187.7	206.3	226.5	248.5	272.6	298.9
	Unit Power (kW)	19.7	20.0	20.2	20.4	20.6	20.7
105	Head Press (psig)	414.1	420.8	427.2	432.8	437.5	441.0
	Capacity (Btuh/1000)	176.4	194.1	213.3	234.1	256.9	281.8
	Unit Power (kW)	21.7	22.0	22.2	22.5	22.6	22.7
115	Head Press (psig)	463.9	470.4	476.5	481.9	486.2	489.6
	Capacity (Btuh/1000)	164.8	181.6	199.7	219.5	241.1	264.6
	Unit Power (kW)	23.9	24.2	24.4	24.7	24.8	24.9
125	Head Press (psig)	517.7	524.0	529.6	534.5	538.3	541.7
	Capacity (Btuh/1000)	152.8	168.6	185.9	204.6	225.0	247.2
	Unit Power (kW)	26.3	26.6	26.8	27.0	27.2	27.3

Note: Performance data calculated at 15°F subcooling and 15°F superheat and does not include capacity loss due to refrigerant lines.

**Figure 22. TTA240K\*C – both compressors – capacity curve**

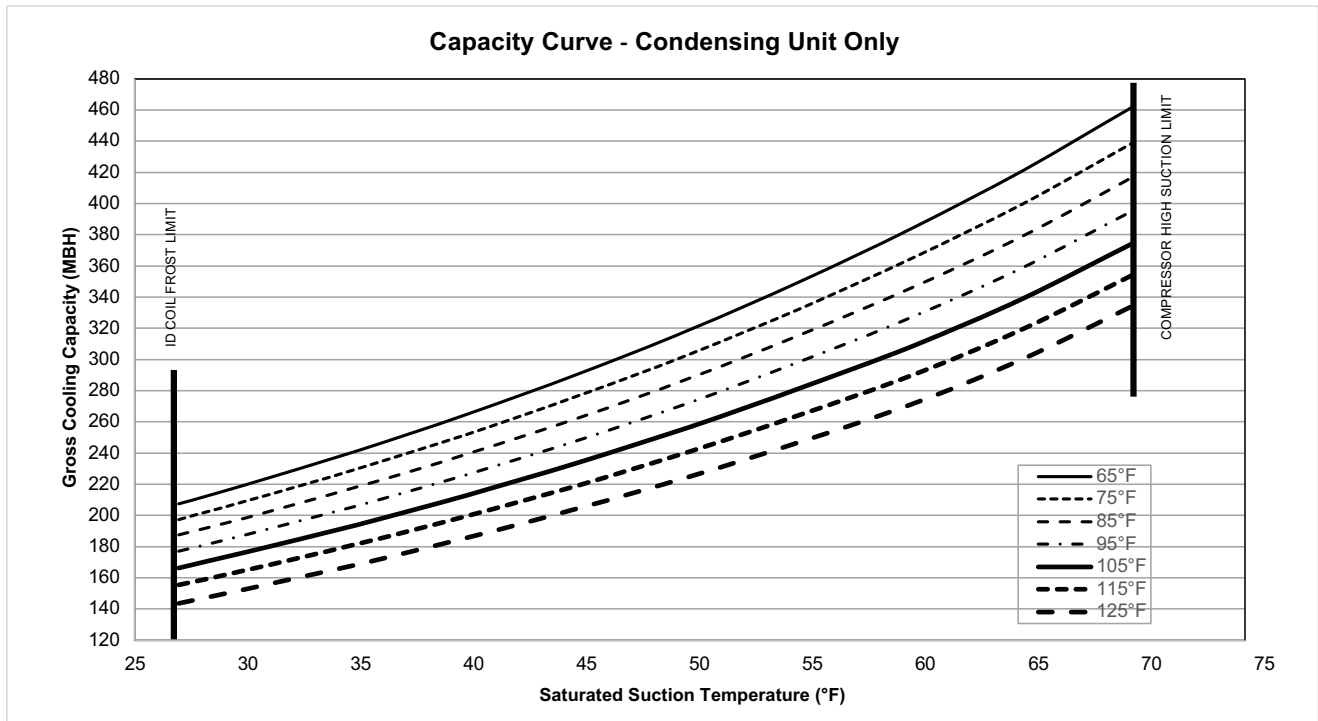

**Table 43. Gross cooling capacities (MBH) – one compressor – 25 tons TTA300K\*C condensing unit only (IP)**

Outdoor Temp (°F)		Saturated Suction Temperature (°F)					
		30	35	40	45	50	55
65	Head Press (psig)	223.5	226.7	231.0	235.8	240.8	246.2
	Capacity (Btuh/1000)	144.7	159.2	174.6	191.2	209.0	228.1
	Unit Power (kW)	9.3	9.3	9.4	9.4	9.4	9.5
75	Head Press (psig)	258.9	262.1	265.9	270.9	276.2	281.7
	Capacity (Btuh/1000)	138.0	151.8	166.7	182.5	199.5	217.7
	Unit Power (kW)	10.2	10.3	10.3	10.4	10.5	10.5
85	Head Press (psig)	298.3	301.6	305.0	309.6	315.1	320.9
	Capacity (Btuh/1000)	131.0	144.2	158.5	173.6	189.8	207.2
	Unit Power (kW)	11.2	11.3	11.4	11.5	11.5	11.6
95	Head Press (psig)	342.0	345.3	348.8	352.4	358.0	364.0
	Capacity (Btuh/1000)	123.7	136.3	149.9	164.5	179.9	196.4
	Unit Power (kW)	12.4	12.5	12.5	12.6	12.7	12.8
105	Head Press (psig)	390.6	393.8	397.2	400.7	405.0	411.1
	Capacity (Btuh/1000)	116.3	128.2	141.1	155.0	169.9	185.5
	Unit Power (kW)	13.7	13.8	13.9	13.9	14.0	14.2
115	Head Press (psig)	444.8	447.6	450.8	454.1	457.6	462.4
	Capacity (Btuh/1000)	108.6	119.9	132.1	145.3	159.5	174.5
	Unit Power (kW)	15.2	15.2	15.3	15.4	15.5	15.6
120	Head Press (psig)	474.5	476.9	479.7	482.8	486.1	489.6
	Capacity (Btuh/1000)	104.6	115.7	127.5	140.4	154.1	168.9
	Unit Power (kW)	16.0	16.1	16.2	16.2	16.3	16.4

Note: Performance data calculated at 15°F subcooling and 15°F superheat and does not include capacity loss due to refrigerant lines.

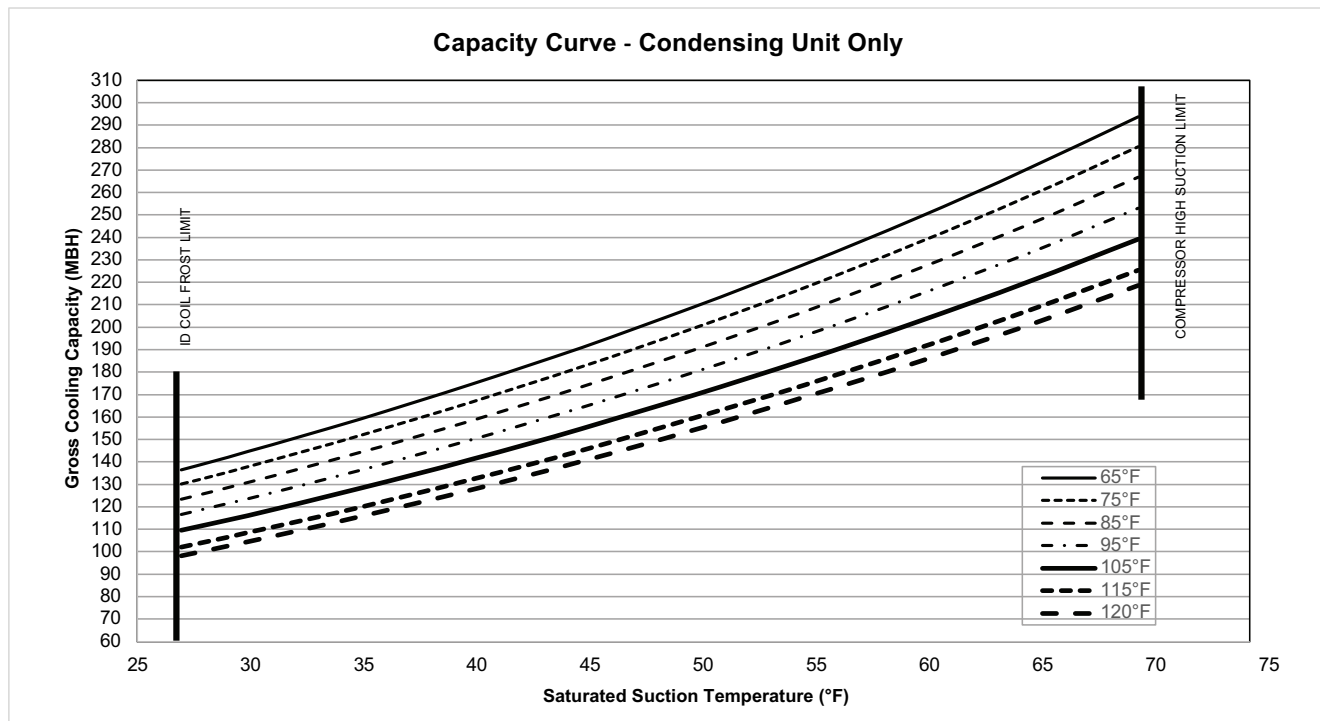
**Figure 23. TTA300K\*C – one compressor – capacity curve**



**Performance Data**

**Table 44. Gross cooling capacities (MBH) – both compressors – 25 tons TTA300K\*C condensing unit only (IP)**

Outdoor Temp (°F)		Saturated Suction Temperature (°F)					
		30	35	40	45	50	55
65	Head Press (psig)	262.4	269.9	277.7	285.6	293.3	300.8
	Capacity (Btuh/1000)	264.1	289.6	317.1	346.8	378.9	413.9
	Unit Power (kW)	18.0	18.3	18.6	18.9	19.1	19.3
75	Head Press (psig)	298.6	306.4	314.3	322.4	330.2	337.7
	Capacity (Btuh/1000)	251.0	275.2	301.4	329.6	360.1	393.3
	Unit Power (kW)	19.9	20.2	20.5	20.9	21.2	21.4
85	Head Press (psig)	338.3	346.3	354.5	362.6	370.5	377.9
	Capacity (Btuh/1000)	237.7	260.7	285.5	312.3	341.3	372.7
	Unit Power (kW)	21.9	22.3	22.7	23.0	23.3	23.6
95	Head Press (psig)	381.8	389.9	398.2	406.3	414.2	421.5
	Capacity (Btuh/1000)	224.2	246.0	269.5	294.8	322.3	352.1
	Unit Power (kW)	24.1	24.6	25.0	25.4	25.7	26.0
105	Head Press (psig)	429.0	437.2	445.5	453.6	461.4	468.5
	Capacity (Btuh/1000)	210.5	231.1	253.3	277.2	303.2	331.5
	Unit Power (kW)	26.6	27.1	27.5	27.9	28.3	28.6
115	Head Press (psig)	480.1	488.3	496.5	504.4	511.9	518.8
	Capacity (Btuh/1000)	196.5	215.9	236.8	259.5	284.1	310.8
	Unit Power (kW)	29.3	29.8	30.3	30.7	31.1	31.4
120	Head Press (psig)	507.3	515.4	523.4	531.2	538.5	545.1
	Capacity (Btuh/1000)	189.4	208.2	228.5	250.5	274.4	300.4
	Unit Power (kW)	30.8	31.3	31.7	32.2	32.5	32.9

Note: Performance data calculated at 15°F subcooling and 15°F superheat and does not include capacity loss due to refrigerant lines.

**Figure 24. TTA300K\*C – both compressors – capacity curve**

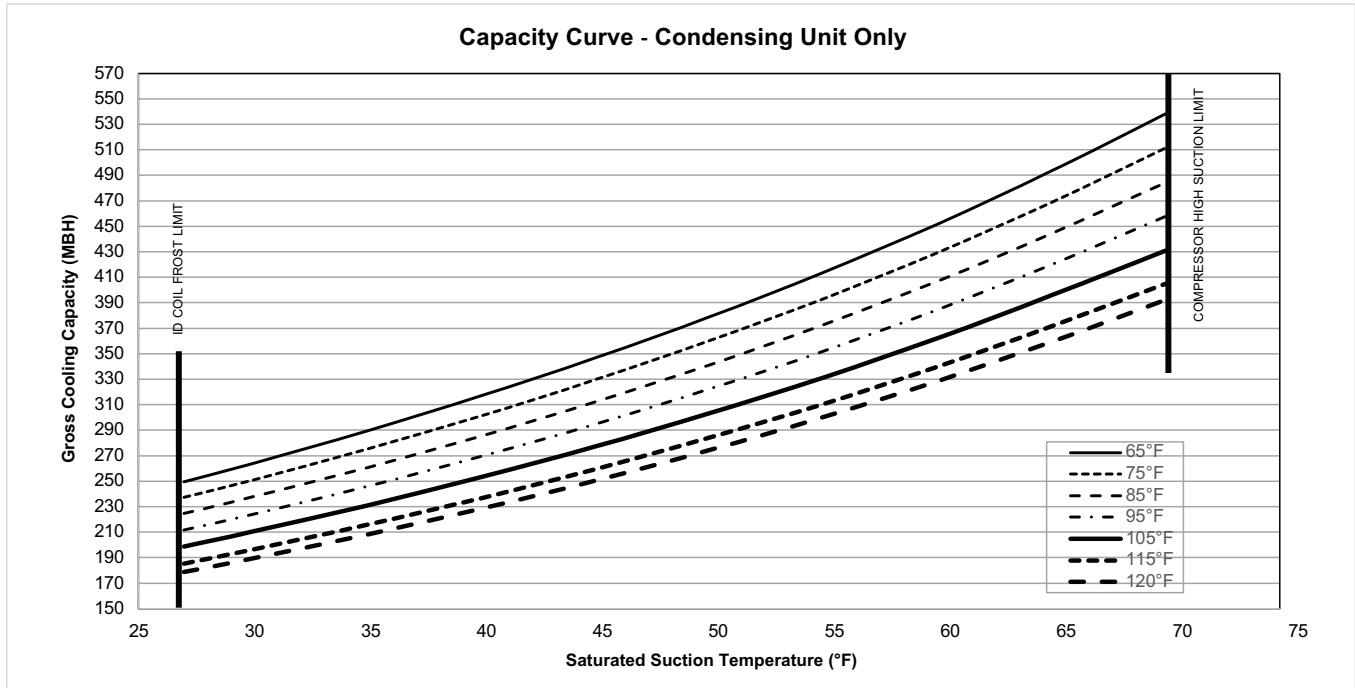

# Fan Performance

**Important:** Additional external static pressure from accessories must be added to the design static pressure from the accessory pressure tables.

**Table 45. Evaporator fan performance – TWE060 – constant volume air handler**

External Static Pressure (Inches of Water Gauge)																								
		0.10"		0.20"		0.30"		0.40"		0.50"		0.60"		0.70"		0.80"		0.90"		1.00"		1.10"		
CFM	RPM	BHP	RPM	BHP	RPM	BHP	RPM	BHP	RPM	BHP	RPM	BHP	RPM	BHP	RPM	BHP	RPM	BHP	RPM	BHP	RPM	BHP		
																			<b>3/4 HP Standard Motor</b>			<b>1.5 HP High Static Motor</b>		
1600	—	—	738	0.33	790	0.38	840	0.44	888	0.50	936	0.56	980	0.62	1025	0.69	1070	0.76	1111	0.83	1152	0.91		
1700	719	0.33	771	0.38	821	0.44	869	0.50	914	0.56	959	0.62	1003	0.68	1047	0.75	1089	0.82	1129	0.90	1170	0.98		
1800	756	0.39	804	0.44	853	0.50	898	0.56	942	0.62	985	0.69	1028	0.75	1068	0.82	1109	0.89	1149	0.97	1187	1.05		
1900	792	0.45	838	0.51	884	0.57	928	0.63	971	0.69	1012	0.76	1052	0.83	1092	0.90	1131	0.97	1170	1.05	1207	1.13		
2000	829	0.52	873	0.58	917	0.64	959	0.71	1000	0.77	1040	0.84	1079	0.91	1117	0.98	1155	1.06	1192	1.14	1227	1.21		
2100	866	0.60	908	0.66	950	0.72	991	0.79	1030	0.86	1069	0.93	1106	1.00	1144	1.08	1179	1.15	1215	1.23	1250	1.31		
2200	903	0.68	944	0.74	983	0.81	1023	0.88	1061	0.95	1099	1.02	1134	1.10	1170	1.18	1206	1.26	1241	1.34	1274	1.42		
2300	940	0.78	979	0.84	1017	0.90	1055	0.97	1093	1.05	1129	1.13	1164	1.21	1198	1.28	1232	1.37	1266	1.45	1299	1.53		
2400	978	0.88	1015	0.94	1052	1.01	1089	1.08	1125	1.16	1160	1.24	1194	1.32	1227	1.40	1259	1.48	1292	1.57	—	—		
External Static Pressure (Inches of Water Gauge)																								
		1.20"		1.30"		1.40"																		
CFM	RPM	BHP	RPM	BHP	RPM	BHP	<b>1.5 HP High Static Motor</b>																	
1600	1191	0.99	1229	1.07	1264	1.14																		
1700	1208	1.06	1246	1.14	1281	1.22																		
1800	1226	1.13	1263	1.22	1300	1.30																		
1900	1245	1.21	1281	1.30	1317	1.39																		
2000	1265	1.30	1300	1.39	1335	1.48																		
2100	1285	1.39	1319	1.48	—	—																		
2200	1308	1.50	—	—	—	—																		
2300	—	—	—	—	—	—																		
2400	—	—	—	—	—	—																		

**Notes:**

1. Data includes pressure drop due to wet coil and 1" filter.
2. Fan motor heat (MBh) = 3.15 x BHP.
3. Check General Data for indoor fan motor HP availability.
4. Factory supplied motors, in commercial equipment, are definite purpose motors, specifically designed and tested to operate reliably and continuously at all cataloged conditions. Using the full horsepower range of our fan motors as shown in our tabular data will not result in nuisance tripping or premature motor failure. Our product's warranty will not be affected.
5. Field supplied High Static Motor.



Performance Data

Table 46. Evaporator fan performance – TWE072K\*\* – 2-speed VFD, SZVAV air handler

CFM		External Static Pressure (Inches of Water Gauge)																													
		0.10"		0.20"		0.30"		0.40"		0.50"		0.60"		0.70"		0.80"		0.90"		1.00"											
RPM	BHP	RPM	BHP	RPM	BHP	RPM	BHP	RPM	BHP	RPM	BHP	RPM	BHP	RPM	BHP	RPM	BHP	RPM	BHP	RPM	BHP										
2 HP Standard Drive																															
1920	—	—	—	—	—	—	—	635	40	0.46	688	44	0.55	737	47	0.65	782	50	0.75	824	52	0.85	863	55	0.95	900	57	1.05			
2040	—	—	—	—	—	592	38	0.41	648	41	0.50	700	44	0.60	748	47	0.70	793	50	0.80	835	53	0.91	874	56	1.02	911	58	1.12		
2160	—	—	—	—	—	608	39	0.46	661	42	0.55	711	45	0.65	759	48	0.75	804	51	0.86	846	54	0.97	886	56	1.08	923	59	1.20		
2280	—	—	—	—	—	625	40	0.51	675	43	0.60	724	46	0.70	771	49	0.81	815	52	0.92	857	54	1.03	896	57	1.15	934	59	1.27		
2400	—	—	—	—	594	38	0.48	642	41	0.56	689	44	0.66	737	47	0.76	783	50	0.87	826	52	0.98	868	55	1.10	907	58	1.22	945	60	1.35
2520	—	—	—	—	614	39	0.54	661	42	0.63	705	45	0.72	751	48	0.82	795	51	0.94	838	53	1.05	879	56	1.18	918	58	1.30	955	42	1.43
2640	—	—	—	—	634	40	0.60	679	43	0.69	722	46	0.79	765	49	0.89	809	51	1.01	850	54	1.13	891	57	1.25	929	59	1.38	966	43	1.51
2760	597	38	0.55	651	41	0.66	698	44	0.76	740	47	0.86	780	50	0.96	822	52	1.08	863	55	1.21	903	57	1.33	941	60	1.46	978	43	1.60	
2880	619	39	0.62	669	42	0.73	718	46	0.84	758	48	0.94	797	51	1.05	837	53	1.16	877	56	1.29	915	58	1.42	953	42	1.55	989	44	1.69	
3 HP High Static Drive																															
1920	934	59	1.15	967	43	1.25	998	44	1.36	1027	45	1.46	1056	47	1.56	1082	48	1.65	1108	49	1.75	1132	50	1.84	1156	51	1.94	1179	52	2.03	
2040	946	60	1.23	979	43	1.34	1011	45	1.45	1041	46	1.55	1069	47	1.66	1097	49	1.77	1124	50	1.87	1148	51	1.98	1172	52	2.08	1195	53	2.18	
2160	958	42	1.31	991	44	1.42	1023	45	1.54	1053	47	1.65	1082	48	1.77	1110	49	1.88	1137	50	1.99	1163	51	2.11	1188	53	2.22	1212	54	2.33	
2280	969	43	1.39	1003	44	1.51	1035	46	1.63	1065	47	1.75	1095	48	1.87	1123	50	1.99	1150	51	2.11	1176	52	2.23	1202	53	2.35	1226	54	2.47	
2400	980	43	1.47	1014	45	1.60	1046	46	1.72	1077	48	1.85	1107	49	1.98	1135	50	2.10	1163	51	2.23	1189	53	2.36	1215	54	2.48	1240	55	2.61	
2520	991	44	1.56	1025	45	1.69	1057	47	1.82	1088	48	1.95	1118	49	2.08	1147	51	2.22	1175	52	2.35	1202	53	2.48	1227	54	2.61	1252	55	2.75	
2640	1002	44	1.64	1036	46	1.78	1068	47	1.92	1099	49	2.05	1130	50	2.19	1158	51	2.33	1186	52	2.47	1213	54	2.61	1240	55	2.75	1265	56	2.89	
2760	1013	45	1.74	1046	46	1.87	1079	48	2.02	1111	49	2.16	1140	50	2.30	1170	52	2.45	1198	53	2.59	1225	54	2.74	1251	55	2.89	1277	56	3.03	
2880	1024	45	1.83	1057	47	1.97	1090	48	2.12	1121	50	2.27	1151	51	2.42	1181	52	2.57	1209	53	2.72	1236	55	2.87	1263	56	3.02	1288	57	3.17	
2.40"																															
External Static Pressure (Inches of Water Gauge)																															
CFM		2.10"		2.20"		2.30"		2.40"																							
		RPM	BHP	RPM	BHP	RPM	BHP	RPM	BHP																						
3 HP High Static Drive																															
1920	1202	53	2.13	1224	54	2.23	1246	55	2.33	1267	56	2.42	—	—	—	—	—	—	—	—	—	—	—	—	—	—	—	—	—	—	
2040	1218	54	2.28	1240	55	2.38	1262	56	2.48	1283	57	2.59	—	—	—	—	—	—	—	—	—	—	—	—	—	—	—	—	—	—	
2160	1234	55	2.43	1257	56	2.54	1278	57	2.65	1299	57	2.75	—	—	—	—	—	—	—	—	—	—	—	—	—	—	—	—	—	—	
2280	1250	55	2.59	1273	56	2.71	1295	57	2.82	1316	58	2.93	—	—	—	—	—	—	—	—	—	—	—	—	—	—	—	—	—	—	
2400	1264	56	2.74	1287	57	2.86	1310	58	2.99	1332	59	3.11	—	—	—	—	—	—	—	—	—	—	—	—	—	—	—	—	—	—	
2520	1277	56	2.88	1300	58	3.01	1324	59	3.15	—	—	—	—	—	—	—	—	—	—	—	—	—	—	—	—	—	—	—	—	—	
2640	1289	57	3.03	1313	58	3.17	—	—	—	—	—	—	—	—	—	—	—	—	—	—	—	—	—	—	—	—	—	—	—	—	
2760	1302	58	3.18	—	—	—	—	—	—	—	—	—	—	—	—	—	—	—	—	—	—	—	—	—	—	—	—	—	—	—	
2880	—	—	—	—	—	—	—	—	—	—	—	—	—	—	—	—	—	—	—	—	—	—	—	—	—	—	—	—	—	—	

Notes:  
 1. 2-Speed VFD or SZVAV applications are capable of running below 320 cfm/ton during low speed airflow operation, but "full" airflow must be set to 320 cfm/ton or higher.  
 2. Check General Data for indoor fan motor HP availability.  
 3. Data includes pressure drop due to wet coil and 1-inch filter.

**Table 47. Evaporator fan performance – TWE090K1B – constant volume air handler**

External Static Pressure (Inches of Water Gauge)																				
CFM	0.10"		0.20"		0.30"		0.40"		0.50"		0.60"		0.70"		0.80"		0.90"		1.00"	
	RPM	BHP	RPM	BHP	RPM	BHP	RPM	BHP	RPM	BHP	RPM	BHP	RPM	BHP	RPM	BHP	RPM	BHP	RPM	BHP
	<b>1.5 HP Standard Motor with Field Supplied Sheave and Belt</b>				<b>1.5 HP Standard Motor</b>								<b>1.5 Hp Standard Motor with Field Supplied High Satic Sheave/Belt</b>							
2400	532	0.38	594	0.48	642	0.56	689	0.66	737	0.76	783	0.87	826	0.98	868	1.10	907	1.22	945	1.35
2550	558	0.45	618	0.55	665	0.64	709	0.74	754	0.84	799	0.95	841	1.07	882	1.19	921	1.32	958	1.45
2700	587	0.52	643	0.63	689	0.73	731	0.82	773	0.93	816	1.04	857	1.17	897	1.29	935	1.42	972	1.55
2850	613	0.60	664	0.71	713	0.82	753	0.92	792	1.02	833	1.14	873	1.27	912	1.40	950	1.53	986	1.67
3000	643	0.70	688	0.80	737	0.92	777	1.03	814	1.14	852	1.25	891	1.38	928	1.51	965	1.65	1001	1.79
3150	671	0.79	711	0.90	762	1.04	800	1.15	837	1.26	872	1.37	909	1.50	945	1.63	981	1.78	1016	1.92
3300	701	0.91	736	1.01	786	1.15	824	1.27	860	1.39	894	1.51	928	1.63	963	1.77	998	1.91	1032	2.06
3450	729	1.03	763	1.13	808	1.27	849	1.41	883	1.53	916	1.65	949	1.78	982	1.91	1015	2.06	1049	2.21
3600	756	1.15	790	1.26	831	1.40	874	1.56	908	1.69	940	1.81	971	1.94	1002	2.07	1034	2.22	—	—
External Static Pressure (Inches of Water Gauge)																				
CFM	1.10"		1.20"		1.30"		1.40"		1.50"											
	RPM	BHP	RPM	BHP	RPM	BHP	RPM	BHP	RPM	BHP										
	<b>1.5 Hp Standard Motor with Field Supplied High Satic Sheave/Belt</b>				<b>2 HP High Static Motor</b>															
2400	980	1.47	1014	1.60	1046	1.72	1077	1.85	1107	1.98										
2550	994	1.58	1028	1.71	1060	1.84	1091	1.98	1121	2.11										
2700	1007	1.69	1041	1.83	1074	1.97	1105	2.11	—	—										
2850	1021	1.81	1055	1.95	1087	2.09	1119	2.24	—	—										
3000	1035	1.93	1069	2.08	1101	2.23	—	—	—	—										
3150	1050	2.07	1083	2.22	—	—	—	—	—	—										
3300	1065	2.21	—	—	—	—	—	—	—	—										
3450	—	—	—	—	—	—	—	—	—	—										
3600	—	—	—	—	—	—	—	—	—	—										

**Notes:**

1. Data includes pressure drop due to wet coil and 1" filter.
2. Fan motor heat (MBh) = 3.15 x BHP.
3. Check General Data for indoor fan motor HP availability.
4. Factory supplied motors, in commercial equipment, are definite purpose motors, specifically designed and tested to operate reliably and continuously at all cataloged conditions. Using the full horsepower range of our fan motors as shown in our tabular data will not result in nuisance tripping or premature motor failure. Our product's warranty will not be affected.





**Table 49. Evaporator fan performance – TWE120K1B – constant volume air handler**

External Static Pressure (Inches of Water Gauge)														
CFM	0.10"		0.20"		0.30"		0.40"		0.50"		0.60"		0.70"	
	RPM	BHP	RPM	BHP	RPM	BHP	RPM	BHP	RPM	BHP	RPM	BHP	RPM	BHP
<b>2 HP Standard Motor</b>														
3200	570	0.60	616	0.69	657	0.80	695	0.90	731	1.00	766	1.10	800	1.21
3400	601	0.71	643	0.80	684	0.92	720	1.02	755	1.13	788	1.24	821	1.35
3600	631	0.84	670	0.92	710	1.04	746	1.16	779	1.27	812	1.39	843	1.50
3800	662	0.98	699	1.06	738	1.19	772	1.31	805	1.43	836	1.55	866	1.67
4000	695	1.14	728	1.21	765	1.34	799	1.47	831	1.60	861	1.72	890	1.85
4200	727	1.31	757	1.38	792	1.50	826	1.65	857	1.78	887	1.91	915	2.05
4400	757	1.49	788	1.58	820	1.69	853	1.84	884	1.98	913	2.12	940	2.26
4600	788	1.69	818	1.78	849	1.89	881	2.04	911	2.20	—	—	—	—
4800	824	1.93	849	2.01	877	2.11	908	2.26	—	—	—	—	—	—
External Static Pressure (Inches of Water Gauge)														
CFM	0.80"		0.90"		1.00"		1.10"		1.20"		1.30"		1.40"	
	RPM	BHP	RPM	BHP	RPM	BHP	RPM	BHP	RPM	BHP	RPM	BHP	RPM	BHP
<b>2 HP Standard Motor with Field Supplied Sheave/Belt</b>														
3200	834	1.33	867	1.45	900	1.58	933	1.70	964	1.83	993	1.96	1022	2.09
3400	854	1.46	886	1.59	917	1.72	947	1.85	978	1.99	1008	2.12	1037	2.26
3600	874	1.62	905	1.74	935	1.87	965	2.01	993	2.15	1023	2.29	—	—
3800	896	1.79	925	1.91	954	2.05	983	2.19	—	—	—	—	—	—
4000	919	1.98	947	2.10	975	2.24	—	—	—	—	—	—	—	—
4200	943	2.18	970	2.31	—	—	—	—	—	—	—	—	—	—
4400	—	—	—	—	—	—	—	—	—	—	—	—	—	—
4600	—	—	—	—	—	—	—	—	—	—	—	—	—	—
4800	—	—	—	—	—	—	—	—	—	—	—	—	—	—

**Notes:**

1. Data includes pressure drop due to wet coil and 1" filter.
2. Fan motor heat (MBh) = 3.15 x BHP.
3. Check General Data for indoor fan motor HP availability.
4. Factory supplied motors, in commercial equipment, are definite purpose motors, specifically designed and tested to operate reliably and continuously at all cataloged conditions. Using the full horsepower range of our fan motors as shown in our tabular data will not result in nuisance tripping or premature motor failure. Our product's warranty will not be affected.

**Table 50. Evaporator fan performance - TWE120K\*\* - 2-speed VFD, SZVAV air handler**

CFM		External Static Pressure (Inches of Water Gauge)																												
		0.10"		0.20"		0.30"		0.40"		0.50"		0.60"		0.70"		0.80"		0.90"		1.00"										
RPM	Hz	BHP	RPM	Hz	BHP	RPM	Hz	BHP	RPM	Hz	BHP	RPM	Hz	BHP	RPM	Hz	BHP	RPM	Hz	BHP	RPM	Hz	BHP	RPM	Hz	BHP				
<b>2 HP Standard Drive</b>																														
3200	570	37	0.60	616	40	0.69	657	43	0.80	695	45	0.90	731	48	1.00	766	50	1.10	800	52	1.21	834	55	1.33	867	57	1.45	900	59	1.58
3400	601	39	0.71	643	42	0.80	684	45	0.92	720	47	1.02	755	49	1.13	788	52	1.24	821	54	1.35	854	56	1.46	886	58	1.59	917	60	1.72
3600	631	41	0.84	670	44	0.92	710	46	1.04	746	49	1.16	779	51	1.27	812	53	1.39	843	55	1.50	874	57	1.62	905	59	1.74	935	49	1.87
3800	662	43	0.98	699	46	1.06	738	48	1.19	772	50	1.31	805	53	1.43	836	55	1.55	866	57	1.67	896	59	1.79	925	60	1.91	954	51	2.05
4000	695	45	1.14	728	48	1.21	765	50	1.34	799	52	1.47	831	54	1.60	861	56	1.72	890	58	1.85	919	60	1.98	947	50	2.10	975	52	2.24
4200	727	47	1.31	757	50	1.38	792	52	1.50	826	54	1.65	857	56	1.78	887	58	1.91	915	60	2.05	943	50	2.18	970	51	2.31	996	53	2.44
4400	757	49	1.49	788	52	1.58	820	54	1.69	853	56	1.84	884	58	1.98	913	48	2.12	940	50	2.26	967	51	2.40	993	53	2.54	1019	54	2.67
4600	788	52	1.69	818	53	1.78	849	55	1.89	881	58	2.04	911	48	2.20	939	50	2.34	966	51	2.48	992	53	2.63	1018	54	2.78	1042	55	2.92
4800	824	54	1.93	849	55	2.01	877	57	2.11	908	48	2.26	937	50	2.42	966	51	2.58	992	53	2.73	1017	54	2.88	1042	55	3.03	1067	56	3.19
<b>3 HP High Static Drive</b>																														
3200	933	49	1.70	964	51	1.83	993	53	1.96	1022	54	2.09	1050	56	2.22	1077	57	2.36	1103	58	2.49	1128	60	2.62	1142	60	2.82	1157	59	2.92
3400	947	50	1.85	978	52	1.99	1008	53	2.12	1037	55	2.26	1064	56	2.40	1091	58	2.54	1117	59	2.68	1142	60	2.82	1157	59	2.92	1172	60	3.02
3600	965	51	2.01	993	53	2.15	1023	54	2.29	1051	56	2.44	1079	57	2.58	1106	59	2.73	1132	60	2.88	1157	60	3.02	1172	60	3.17	1187	60	3.27
3800	983	52	2.19	1011	54	2.33	1039	55	2.47	1066	56	2.62	1094	58	2.78	1120	59	2.93	1145	60	3.08	1170	60	3.23	1195	60	3.38	1220	60	3.53
4000	1002	53	2.38	1029	54	2.52	1056	56	2.67	1083	57	2.82	1109	59	2.98	1135	60	3.14	1160	60	3.30	1185	60	3.45	1210	60	3.60	1235	60	3.75
4200	1023	54	2.58	1049	56	2.73	1075	57	2.88	1101	58	3.04	1126	60	3.20	1151	60	3.36	1176	60	3.52	1201	60	3.68	1226	60	3.84	1251	60	3.99
4400	1045	55	2.82	1069	57	2.96	1095	58	3.11	1121	58	3.27	1146	60	3.43	1171	60	3.59	1196	60	3.75	1221	60	3.91	1246	60	4.07	1271	60	4.23
4600	1067	56	3.07	1091	58	3.21	1117	59	3.36	1143	59	3.52	1168	60	3.68	1193	60	3.84	1218	60	4.00	1243	60	4.16	1268	60	4.32	1293	60	4.48
4800	1090	57	3.33	1113	59	3.47	1139	60	3.61	1165	60	3.77	1191	60	3.93	1217	60	4.09	1243	60	4.25	1269	60	4.41	1295	60	4.57	1321	60	4.73

**Notes:**

1. 2-Speed VFD or SZVAV applications are capable of running below 320 cfm/ton during low speed airflow operation, but "full" airflow must be set to 320 cfm/ton or higher.
2. Check General Data for indoor fan motor HP availability.
3. Data includes pressure drop due to wet coil and 1-inch filter.

**Table 51. Evaporator fan performance - TWE150K\*\* - 2-speed VFD, SZVAV air handler**

CFM		External Static Pressure (Inches of Water Gauge)																												
		0.10"		0.20"		0.30"		0.40"		0.50"		0.60"		0.70"		0.80"		0.90"		1.00"										
RPM	Hz	BHP	RPM	Hz	BHP	RPM	Hz	BHP	RPM	Hz	BHP	RPM	Hz	BHP	RPM	Hz	BHP	RPM	Hz	BHP	RPM	Hz	BHP	RPM	Hz	BHP	RPM	Hz	BHP	
2 HP Standard Drive																														
4000	474	31	0.57	532	35	0.69	584	38	0.82	631	41	0.96	674	44	1.09	715	47	1.23	753	49	1.36	789	52	1.51	825	54	1.65	859	56	1.80
4200	492	32	0.64	548	36	0.78	598	39	0.91	645	42	1.05	687	45	1.19	727	48	1.33	765	50	1.47	800	52	1.62	835	55	1.77	869	57	1.93
4400	510	33	0.73	564	37	0.87	613	40	1.01	659	43	1.15	701	46	1.29	740	48	1.44	777	51	1.59	812	53	1.74	846	55	1.90	879	58	2.06
4600	528	35	0.82	580	38	0.96	628	41	1.11	673	44	1.26	714	47	1.41	753	49	1.56	790	52	1.72	824	54	1.88	858	56	2.03	889	45	2.19
4800	548	36	0.92	597	39	1.07	643	42	1.22	687	45	1.37	728	48	1.53	766	50	1.69	802	53	1.85	837	55	2.01	870	44	2.18	901	45	2.34
5000	565	37	1.02	614	40	1.18	659	43	1.34	702	46	1.49	742	49	1.66	780	51	1.82	815	53	1.99	849	43	2.16	882	44	2.33	913	46	2.50
5200	585	38	1.14	631	41	1.30	675	44	1.46	717	47	1.63	756	50	1.80	793	52	1.97	829	42	2.14	862	43	2.31	894	45	2.49	925	47	2.67
5400	604	40	1.27	648	42	1.43	692	45	1.60	732	48	1.77	771	39	1.94	808	41	2.12	842	42	2.30	875	44	2.48	907	46	2.66	938	47	2.84
5600	622	41	1.40	666	44	1.56	708	46	1.74	748	38	1.92	786	40	2.10	822	41	2.28	856	43	2.46	889	45	2.65	920	46	2.84	950	48	3.02
5800	641	42	1.54	684	45	1.71	725	37	1.90	763	39	2.08	800	40	2.26	836	42	2.45	870	44	2.64	902	46	2.83	933	47	3.02	963	49	3.22
6000	662	33	1.70	702	46	1.88	741	37	2.06	779	39	2.25	816	41	2.44	851	43	2.63	884	45	2.83	916	46	3.03	947	48	3.22	976	49	3.42
5 HP High Static Drive																														
4000	891	58	1.95	922	60	2.10	951	48	2.25	979	49	2.40	1006	51	2.55	1032	52	2.70	1057	53	2.85	1081	55	3.00	1105	56	3.14	1127	57	3.29
4200	901	59	2.08	932	47	2.24	961	48	2.40	990	50	2.55	1017	51	2.71	1043	53	2.87	1068	54	3.03	1093	55	3.18	1116	56	3.34	1139	57	3.49
4400	921	46	2.22	942	47	2.38	971	49	2.55	1000	50	2.71	1027	52	2.88	1053	53	3.04	1079	54	3.21	1103	56	3.37	1127	57	3.53	1150	58	3.70
4600	941	46	2.36	951	48	2.53	981	49	2.70	1010	51	2.87	1037	52	3.05	1064	54	3.22	1089	55	3.39	1114	56	3.56	1138	57	3.74	1161	59	3.90
4800	931	47	2.51	961	48	2.69	991	50	2.86	1020	51	3.04	1047	53	3.22	1074	54	3.40	1099	55	3.58	1124	57	3.76	1148	58	3.94	1172	59	4.12
5000	943	48	2.68	972	49	2.85	1001	50	3.03	1029	52	3.22	1057	53	3.40	1083	55	3.59	1109	56	3.78	1134	57	3.96	1158	58	4.15	1182	60	4.34
5200	955	48	2.85	984	50	3.03	1011	51	3.21	1039	52	3.40	1067	54	3.59	1093	55	3.79	1119	56	3.98	1144	58	4.17	1168	59	4.37	1192	60	4.56
5400	967	49	3.03	996	50	3.22	1023	52	3.40	1050	53	3.59	1077	54	3.79	1103	56	3.99	1129	57	4.19	1154	58	4.39	1178	59	4.59	—	—	—
5600	979	49	3.22	1008	51	3.41	1035	52	3.60	1061	54	3.80	1087	55	3.99	1113	56	4.19	1139	57	4.40	1164	59	4.61	1188	60	4.82	—	—	—
5800	992	50	3.42	1020	51	3.61	1047	53	3.81	1073	54	4.01	1099	55	4.22	1124	57	4.42	1149	58	4.63	1174	59	4.84	1198	60	5.06	—	—	—
6000	1005	51	3.63	1032	52	3.83	1059	53	4.04	1085	55	4.24	1111	56	4.45	1135	57	4.66	1160	58	4.87	1184	60	5.08	—	—	—	—	—	—
2 HP Standard Drive																														
4000	891	58	1.95	922	60	2.10	951	48	2.25	979	49	2.40	1006	51	2.55	1032	52	2.70	1057	53	2.85	1081	55	3.00	1105	56	3.14	1127	57	3.29
4200	901	59	2.08	932	47	2.24	961	48	2.40	990	50	2.55	1017	51	2.71	1043	53	2.87	1068	54	3.03	1093	55	3.18	1116	56	3.34	1139	57	3.49
4400	921	46	2.22	942	47	2.38	971	49	2.55	1000	50	2.71	1027	52	2.88	1053	53	3.04	1079	54	3.21	1103	56	3.37	1127	57	3.53	1150	58	3.70
4600	941	46	2.36	951	48	2.53	981	49	2.70	1010	51	2.87	1037	52	3.05	1064	54	3.22	1089	55	3.39	1114	56	3.56	1138	57	3.74	1161	59	3.90
4800	931	47	2.51	961	48	2.69	991	50	2.86	1020	51	3.04	1047	53	3.22	1074	54	3.40	1099	55	3.58	1124	57	3.76	1148	58	3.94	1172	59	4.12
5000	943	48	2.68	972	49	2.85	1001	50	3.03	1029	52	3.22	1057	53	3.40	1083	55	3.59	1109	56	3.78	1134	57	3.96	1158	58	4.15	1182	60	4.34
5200	955	48	2.85	984	50	3.03	1011	51	3.21	1039	52	3.40	1067	54	3.59	1093	55	3.79	1119	56	3.98	1144	58	4.17	1168	59	4.37	1192	60	4.56
5400	967	49	3.03	996	50	3.22	1023	52	3.40	1050	53	3.59	1077	54	3.79	1103	56	3.99	1129	57	4.19	1154	58	4.39	1178	59	4.59	—	—	—
5600	979	49	3.22	1008	51	3.41	1035	52	3.60	1061	54	3.80	1087	55	3.99	1113	56	4.19	1139	57	4.40	1164	59	4.61	1188	60	4.82	—	—	—
5800	992	50	3.42	1020	51	3.61	1047	53	3.81	1073	54	4.01	1099	55	4.22	1124	57	4.42	1149	58	4.63	1174	59	4.84	1198	60	5.06	—	—	—
6000	1005	51	3.63	1032	52	3.83	1059	53	4.04	1085	55	4.24	1111	56	4.45	1135	57	4.66	1160	58	4.87	1184	60	5.08	—	—	—	—	—	—
5 HP High Static Drive																														
4000	1149	58	3.44	1170	59	3.57	1191	60	3.71	—	—	—	—	—	—	—	—	—	—	—	—	—	—	—	—	—	—	—	—	
4200	1161	59	3.65	1183	60	3.80	—	—	—	—	—	—	—	—	—	—	—	—	—	—	—	—	—	—	—	—	—	—	—	
4400	1173	59	3.86	1194	60	4.02	—	—	—	—	—	—	—	—	—	—	—	—	—	—	—	—	—	—	—	—	—	—	—	
4600	1184	60	4.08	—	—	—	—	—	—	—	—	—	—	—	—	—	—	—	—	—	—	—	—	—	—	—	—	—	—	
4800	1194	60	4.30	—	—	—	—	—	—	—	—	—	—	—	—	—	—	—	—	—	—	—	—	—	—	—	—	—	—	
5000	—	—	—	—	—	—	—	—	—	—	—	—	—	—	—	—	—	—	—	—	—	—	—	—	—	—	—	—	—	
5200	—	—	—	—	—	—	—	—	—	—	—	—	—	—	—	—	—	—	—	—	—	—	—	—	—	—	—	—	—	
5400	—	—	—	—	—	—	—	—	—	—	—	—	—	—	—	—	—	—	—	—	—	—	—	—	—	—	—	—	—	
5600	—	—	—	—	—	—	—	—	—	—	—	—	—	—	—	—	—	—	—	—	—	—	—	—	—	—	—	—	—	
5800	—	—	—	—	—	—	—	—	—	—	—	—	—	—	—	—	—	—	—	—	—	—	—	—	—	—	—	—	—	
6000	—	—	—	—	—	—	—	—	—	—	—	—	—	—	—	—	—	—	—	—	—	—	—	—	—	—	—	—	—	

Notes:  
 1. 2-Speed VFD or SZVAV applications are capable of running below 320 cfm/ton during low speed airflow operation, but "full" airflow must be set to 320 cfm/ton or higher.  
 2. Check General Data for indoor fan motor HP availability.  
 3. Data includes pressure drop due to wet coil and 2-inch filter.



Performance Data

Table 52. Evaporator fan performance - TWE180K\*\* - 2-speed VFD, SZVAV air handler

CFM	External Static Pressure (Inches of Water Gauge)																								
	0.10"		0.20"		0.30"		0.40"		0.50"		0.60"		0.70"		0.80"										
	RPM	BHP	RPM	Hz	RPM	Hz	RPM	Hz	RPM	Hz	RPM	Hz	RPM	Hz	RPM	Hz									
3 HP Standard Drive																									
4800	548	38	0.92	597	42	1.07	643	45	1.22	687	48	1.37	728	51	1.53	766	54	1.69	802	56	1.85	837	59	2.01	
5100	576	40	1.08	623	44	1.24	667	47	1.40	709	50	1.56	749	53	1.72	787	55	1.89	822	58	2.06	856	60	2.23	
5400	604	42	1.27	648	46	1.43	692	49	1.60	732	51	1.77	771	54	1.94	808	57	2.12	842	59	2.30	875	61	2.48	
5700	633	44	1.47	674	47	1.64	716	50	1.82	756	53	2.00	793	56	2.18	829	58	2.36	863	61	2.55	895	63	2.74	
6000	662	46	1.70	702	49	1.88	741	52	2.06	779	55	2.25	816	57	2.44	851	60	2.63	884	63	2.83	916	66	3.03	
6300	690	49	1.95	728	51	2.12	767	54	2.32	804	56	2.52	839	59	2.72	873	62	2.92	905	65	3.12	937	68	3.33	
6600	721	51	2.24	757	53	2.41	793	56	2.61	828	58	2.81	863	61	3.02	896	64	3.24	928	67	3.45	958	70	3.66	
6900	748	53	2.51	784	55	2.71	819	58	2.92	853	61	3.14	887	64	3.36	919	67	3.57	950	70	3.79	980	73	4.02	
7200	778	55	2.84	812	57	3.04	846	60	3.26	879	63	3.49	911	66	3.71	943	69	3.95	973	72	4.17	1002	75	4.40	
5 HP High Static Drive																									
4800	870	44	2.18	901	45	2.34	931	47	2.51	961	48	2.69	991	50	2.86	1020	51	3.04	1047	53	3.22	1074	54	3.40	
5100	888	45	2.41	919	46	2.58	949	48	2.76	978	49	2.94	1006	51	3.12	1034	52	3.31	1062	53	3.50	1088	55	3.69	
5400	907	46	2.66	938	47	2.84	967	49	3.03	996	50	3.22	1023	52	3.40	1050	53	3.59	1077	54	3.79	1103	56	3.99	
5700	927	47	2.93	957	48	3.12	986	50	3.32	1014	51	3.51	1041	52	3.71	1067	54	3.91	1093	55	4.10	1118	56	4.31	
6000	947	48	3.22	976	49	3.42	1005	51	3.63	1032	52	3.83	1059	53	4.04	1085	55	4.24	1111	56	4.45	1135	57	4.66	
6300	967	49	3.54	996	50	3.75	1024	52	3.96	1052	53	4.17	1078	54	4.38	1104	56	4.60	1129	57	4.81	1153	58	5.03	
6600	988	50	3.87	1016	51	4.09	1044	53	4.31	1071	54	4.53	1097	55	4.75	1123	57	4.98	1147	58	5.20	—	—	—	
6900	1009	51	4.25	1037	52	4.47	1065	54	4.69	1091	55	4.92	1117	56	5.16	—	—	—	—	—	—	—	—	—	
7200	1031	52	4.63	1059	53	4.86	1085	55	5.10	—	—	—	—	—	—	—	—	—	—	—	—	—	—	—	
External Static Pressure (Inches of Water Gauge)																									
5 HP High Static Drive																									
4800	1099	55	3.58	1124	57	3.76	1148	58	3.94	1172	59	4.12	1194	60	4.30	—	—	—	—	—	—	—	—	—	—
5100	1114	56	3.88	1139	57	4.07	1163	59	4.26	1187	60	4.45	—	—	—	—	—	—	—	—	—	—	—	—	—
5400	1129	57	4.19	1154	58	4.39	1178	59	4.59	—	—	—	—	—	—	—	—	—	—	—	—	—	—	—	—
5700	1144	58	4.51	1169	59	4.72	1193	60	4.94	—	—	—	—	—	—	—	—	—	—	—	—	—	—	—	—
6000	1160	58	4.87	1184	60	5.08	—	—	—	—	—	—	—	—	—	—	—	—	—	—	—	—	—	—	—
6300	—	—	—	—	—	—	—	—	—	—	—	—	—	—	—	—	—	—	—	—	—	—	—	—	—
6600	—	—	—	—	—	—	—	—	—	—	—	—	—	—	—	—	—	—	—	—	—	—	—	—	—
6900	—	—	—	—	—	—	—	—	—	—	—	—	—	—	—	—	—	—	—	—	—	—	—	—	—
7200	—	—	—	—	—	—	—	—	—	—	—	—	—	—	—	—	—	—	—	—	—	—	—	—	—

- Notes:
- 2-Speed VFD or SZVAV applications are capable of running below 320 cfm/ton during low speed airflow operation, but "full" airflow must be set to 320 cfm/ton or higher.
  - Check General Data for indoor fan motor HP availability.
  - Data includes pressure drop due to wet coil and 2-inch filter.

**Table 53. Evaporator fan performance - TWE240K\*\* - 2-speed VFD, SZVAV air handler**

CFM		External Static Pressure (Inches of Water Gauge)																												
		0.10"		0.20"		0.30"		0.40"		0.50"		0.60"		0.70"		0.80"		0.90"		1.00"										
RPM	Hz	BHP	RPM	Hz	BHP	RPM	Hz	BHP	RPM	Hz	BHP	RPM	Hz	BHP	RPM	Hz	BHP	RPM	Hz	BHP	RPM	Hz	BHP	RPM	Hz	BHP	RPM	Hz	BHP	
5 HP Standard Drive																														
6400	619	33	1.56	656	35	1.70	691	36	1.84	724	38	1.98	756	40	2.12	786	41	2.26	816	43	2.41	845	45	2.56	873	46	2.72	900	47	2.87
6800	654	34	1.86	688	36	2.00	722	38	2.15	754	40	2.30	784	41	2.44	814	43	2.59	842	44	2.74	869	46	2.90	897	47	3.07	924	49	3.23
7200	687	36	2.17	721	38	2.34	753	40	2.49	784	41	2.65	813	43	2.81	842	44	2.96	869	46	3.12	895	47	3.29	921	49	3.46	947	50	3.62
7600	721	38	2.54	754	40	2.72	784	41	2.87	814	43	3.04	843	44	3.21	870	46	3.38	896	47	3.53	922	49	3.71	947	50	3.88	972	51	4.06
8000	757	40	2.96	788	42	3.13	817	43	3.30	845	45	3.48	872	46	3.65	899	47	3.82	925	49	4.00	950	50	4.16	974	51	4.35	998	53	4.53
8400	790	42	3.37	820	43	3.57	849	45	3.76	877	46	3.95	903	48	4.13	929	49	4.32	953	50	4.49	978	52	4.67	1002	53	4.86	1025	47	5.05
8800	826	38	3.88	854	39	4.07	881	40	4.26	908	41	4.46	933	42	4.65	959	44	4.85	982	45	5.04	1006	46	5.22	1030	47	5.42	1052	48	5.61
9200	863	39	4.44	889	40	4.64	915	42	4.84	939	43	5.02	965	44	5.24	989	45	5.43	1012	46	5.62	1036	47	5.83	1058	48	6.02	1080	49	6.22
9600	897	41	5.01	922	42	5.20	948	43	5.44	971	44	5.63	996	45	5.84	1019	46	6.05	1042	47	6.27	1065	48	6.47	—	—	—	—	—	—
External Static Pressure (Inches of Water Gauge)																														
5 HP Standard Drive																														
6400	927	49	3.03	952	50	3.19	977	51	3.34	1001	53	3.48	1024	54	3.63	1050	55	3.80	1075	57	3.98	1098	50	4.15	1120	51	4.31	1139	52	4.47
6800	949	50	3.40	974	51	3.57	999	53	3.74	1022	54	3.90	1045	55	4.05	1067	56	4.21	1090	50	4.36	1114	51	4.55	1138	52	4.74	1160	53	4.92
7200	972	51	3.80	997	53	3.97	1021	54	4.15	1044	55	4.34	1067	56	4.51	1089	49	4.68	1110	50	4.84	1131	51	5.00	1152	52	5.17	1175	53	5.36
7600	996	52	4.24	1020	54	4.42	1044	55	4.60	1067	56	4.80	1089	57	4.99	1111	50	5.18	1132	51	5.36	1153	52	5.53	1173	53	5.70	1193	54	5.88
8000	1021	54	4.72	1044	55	4.91	1067	48	5.10	1090	50	5.29	1112	51	5.49	1134	52	5.69	1155	52	5.89	1175	53	6.09	1195	54	6.28	1215	55	6.46
8400	1047	48	5.24	1069	49	5.43	1091	50	5.63	1113	51	5.83	1135	52	6.04	1156	53	6.24	1177	53	6.45	1198	54	6.67	1217	55	6.87	1237	56	7.08
8800	1074	49	5.81	1095	50	6.01	1117	51	6.22	1138	52	6.42	1159	53	6.63	1180	54	6.84	1200	55	7.06	1220	55	7.28	1240	56	7.49	1259	57	7.71
9200	1101	50	6.42	1122	51	6.63	1143	52	6.84	1163	53	7.05	1183	54	7.27	1204	55	7.49	1224	56	7.71	—	—	—	—	—	—	—	—	
9600	—	—	—	—	—	—	—	—	—	—	—	—	—	—	—	—	—	—	—	—	—	—	—	—	—	—	—	—	—	
External Static Pressure (Inches of Water Gauge)																														
7.5 HP High Static Drive																														
6400	1158	53	4.62	1177	53	4.78	1195	54	4.93	1213	55	5.08	—	—	—	—	—	—	—	—	—	—	—	—	—	—	—	—	—	
6800	1181	54	5.09	1200	55	5.26	1218	55	5.43	1236	56	5.59	—	—	—	—	—	—	—	—	—	—	—	—	—	—	—	—	—	
7200	1198	54	5.56	1220	55	5.76	1240	56	5.95	1259	57	6.13	—	—	—	—	—	—	—	—	—	—	—	—	—	—	—	—	—	
7600	1213	55	6.05	1234	56	6.25	1256	57	6.46	1277	58	6.67	—	—	—	—	—	—	—	—	—	—	—	—	—	—	—	—	—	
8000	1234	56	6.64	1253	57	6.82	1272	58	7.01	1292	59	7.20	—	—	—	—	—	—	—	—	—	—	—	—	—	—	—	—	—	
8400	1256	57	7.28	1275	58	7.48	1293	59	7.66	—	—	—	—	—	—	—	—	—	—	—	—	—	—	—	—	—	—	—	—	
8800	—	—	—	—	—	—	—	—	—	—	—	—	—	—	—	—	—	—	—	—	—	—	—	—	—	—	—	—	—	
9200	—	—	—	—	—	—	—	—	—	—	—	—	—	—	—	—	—	—	—	—	—	—	—	—	—	—	—	—	—	
9600	—	—	—	—	—	—	—	—	—	—	—	—	—	—	—	—	—	—	—	—	—	—	—	—	—	—	—	—	—	

**Notes:**  
 1. 2-Speed VFD or SZVAV applications are capable of running below 320 cfm/ton during low speed airflow operation, but "full" airflow must be set to 320 cfm/ton or higher.  
 2. Check General Data for indoor fan motor HP availability.  
 3. Data includes pressure drop due to wet coil and 2-inch filter.



Performance Data

Table 54. Evaporator fan performance - TWE300K\*\* - 2-speed VFD, SZVAV air handler

CFM		External Static Pressure (Inches of Water Gauge)																						
		0.10"		0.20"		0.30"		0.40"		0.50"		0.60"		0.70"		0.80"								
RPM	Hz	BHP	RPM	Hz	BHP	RPM	Hz	BHP	RPM	Hz	BHP	RPM	Hz	BHP	RPM	Hz	BHP	RPM	Hz	BHP				
7.5 HP Standard Drive																								
8000	780	41	2.96	811	42	3.14	837	44	3.27	863	45	3.41	889	46	3.56	915	48	3.77	942	49	4.02	967	50	4.27
8500	824	43	3.53	855	45	3.72	880	46	3.86	904	47	4.01	928	48	4.16	953	50	4.33	978	51	4.58	1003	52	4.85
9000	870	45	4.18	900	47	4.40	923	48	4.53	947	49	4.69	969	50	4.84	992	52	5.01	1016	53	5.21	1039	54	5.47
9500	918	48	4.94	941	49	5.08	969	50	5.30	989	52	5.44	1009	53	5.58	1032	54	5.76	1054	55	5.94	1077	56	6.18
10000	966	50	5.78	989	51	5.94	1012	53	6.13	1032	54	6.27	1053	55	6.45	1073	56	6.61	1093	57	6.77	1114	58	6.98
10500	1012	53	6.68	1033	54	6.82	1055	55	7.00	1076	56	7.19	1096	57	7.37	1115	41	7.56	1134	42	7.72	1154	43	7.92
11000	1055	55	7.58	1078	40	7.81	1098	41	7.98	1119	41	8.17	1138	42	8.36	1157	43	8.55	1175	43	8.75	1194	44	8.94
11500	1103	41	8.69	1122	41	8.87	1143	42	9.08	1165	43	9.33	1181	44	9.46	1200	44	9.69	1218	45	9.89	—	—	—
12000	1143	42	9.71	1165	43	9.97	—	—	—	—	—	—	—	—	—	—	—	—	—	—	—	—	—	
External Static Pressure (Inches of Water Gauge)																								
CFM		0.90"		1.00"		1.10"		1.20"		1.30"		1.40"		1.50"		1.60"								
		RPM	Hz	BHP	RPM	Hz	BHP	RPM	Hz	BHP	RPM	Hz	BHP	RPM	Hz	BHP	RPM	Hz	BHP					
7.5 HP Standard Drive																								
8000	993	52	4.43	1017	53	4.55	1041	54	4.64	1065	55	4.78	1088	57	4.96	1111	58	5.16	1134	59	5.36	1156	60	5.57
8500	1027	54	5.12	1051	55	5.30	1074	56	5.41	1097	57	5.53	1119	58	5.64	1142	59	5.82	1163	43	6.01	1185	44	6.23
9000	1062	55	5.76	1086	57	6.05	1108	58	6.24	1130	59	6.39	1152	60	6.50	1173	43	6.62	1194	44	6.77	1215	45	6.97
9500	1098	57	6.46	1121	58	6.77	1143	60	7.08	1165	43	7.31	1186	44	7.47	1206	44	7.60	1227	45	7.73	1247	46	7.85
10000	1135	59	7.23	1157	43	7.54	1178	43	7.87	1199	44	8.19	1220	45	8.47	1240	46	8.65	1259	46	8.79	1279	47	8.93
10500	1174	43	8.13	1194	44	8.40	1214	45	8.73	1235	46	9.07	1255	46	9.41	1274	47	9.73	1293	48	9.93	—	—	—
11000	1213	45	9.16	1232	45	9.39	1251	46	9.67	—	—	—	—	—	—	—	—	—	—	—	—	—	—	
11500	—	—	—	—	—	—	—	—	—	—	—	—	—	—	—	—	—	—	—	—	—	—	—	
12000	—	—	—	—	—	—	—	—	—	—	—	—	—	—	—	—	—	—	—	—	—	—	—	
External Static Pressure (Inches of Water Gauge)																								
CFM		1.7		1.8		1.9		2		2.1		2.2		2.3		2.4								
		RPM	Hz	BHP	RPM	Hz	BHP	RPM	Hz	BHP	RPM	Hz	BHP	RPM	Hz	BHP	RPM	Hz	BHP					
10 HP High Static Drive																								
8000	1178	43	5.79	1199	44	5.99	1220	45	6.19	1241	46	6.40	1262	47	6.61	1282	47	6.81	1302	48	7.03	1321	49	7.24
8500	1206	44	6.44	1227	45	6.67	1248	46	6.90	1268	47	7.11	1288	48	7.33	1307	48	7.55	1327	49	7.77	1346	50	7.98
9000	1236	46	7.18	1256	46	7.40	1276	47	7.64	1295	48	7.87	1315	49	8.11	1334	49	8.34	1353	50	8.57	1372	51	8.80
9500	1266	47	8.03	1286	47	8.24	1306	48	8.46	1325	49	8.69	1344	50	8.93	1362	50	9.19	1381	51	9.44	1399	52	9.68
10000	1298	48	9.05	1317	49	9.19	1336	49	9.40	1355	50	9.62	1373	51	9.86	—	—	—	—	—	—	—	—	—
10500	—	—	—	—	—	—	—	—	—	—	—	—	—	—	—	—	—	—	—	—	—	—	—	
11000	—	—	—	—	—	—	—	—	—	—	—	—	—	—	—	—	—	—	—	—	—	—	—	
11500	—	—	—	—	—	—	—	—	—	—	—	—	—	—	—	—	—	—	—	—	—	—	—	
12000	—	—	—	—	—	—	—	—	—	—	—	—	—	—	—	—	—	—	—	—	—	—	—	

Notes:  
 1. 2-Speed VFD or SZVAV applications are capable of running below 320 cfm/ton during low speed airflow operation, but "full" airflow must be set to 320 cfm/ton or higher.  
 2. Check General Data for indoor fan motor HP availability.  
 3. Data includes pressure drop due to wet coil and 2-inch filter.

**Table 55. Standard fan motors – constant volume air handlers**

Model	Motor	Motor Sheave Turns Open	Nominal RPM	Required Field Supplied Components		
				Motor Sheave	Blower Sheave	Belt
TWE060	Standard Motor 0.75 HP	0	1071	N/A	N/A	N/A
		1	1000			
		2	928			
		3	857			
		4	785			
5	714					
TWE090	Standard Motor 1.5 HP	0	847	N/A	N/A	N/A
		1	791			
		2	734			
		3	678			
		4	621			
5	565					
TWE090	Standard Motor with Field Supplied Components - 1.5 HP (Low Static)	1	589	Variable Pitch (1.9 - 2.9 Inch Pitch Diameter), 0.625 Inch Bore, Single Groove, Browning 1VP34	Fixed pitch (8.5 Inch Pitch Diameter), 1 Inch Bore, Single Groove, Browning BK95	Browning A52
		2	548			
		3	507			
		4	466			
		5	426			
		6	385			
TWE090	Standard Motor with Field Supplied Components - 1.5 HP (High Static)	1	863	Variable Pitch (3-4 Inch Pitch Diameter), 0.625 Inch Bore, Single Groove, Browning 1VP44	Fixed Pitch (6 Inch Pitch Diameter), 1 Inch Bore, Single Groove, Browning BK70	Browning A50
		2	920			
		3	978			
		4	1035			
		5	1093			
		6	1150			
TWE120	Standard Motor 2 HP	0	818	N/A	N/A	N/A
		1	773			
		2	727			
		3	682			
		4	636			
5	591					
TWE120	Standard Motor with Field Supplied Components - 2 HP (High Static)	1	772	Variable Pitch (3-4 Inch Pitch Diameter), 0.875 Inch Bore, Single Groove, Browning 1VP44	Fixed Pitch (6.7 Inch Pitch Diameter), 1 Inch Bore, Single Groove, Browning AK71	Browning A51
		2	824			
		3	875			
		4	927			
		5	978			
		6	1030			



**Performance Data**

**Table 56. High static fan motors – constant volume air handlers**

Model	Motor	Motor Sheave Turns Open	Nominal RPM	Required Field Supplied Components		
				Motor Sheave	Blower Sheave	Belt
TWE060	High Static Motor 1.5 HP	0	1346	N/A	N/A	N/A
		1	1279			
		2	1212			
		3	1144			
		4	1077			
		5	1010			
TWE090	High Static Motor 2 HP	0	1094	N/A	N/A	N/A
		1	1039			
		2	984			
		3	930			
		4	875			
		5	820			



**Table 57. Discharge plenum and grille assembly throw distance (ft) – air handler (60 Hz)**

Tons	Model No.	CFM	Louver Angle Deflection Position			
			Straight	20°	40°	55°
5	TWE060K*A/B	1600	42	31	26	20
		1800	46	37	29	22
		2000	48	43	33	24
		2200	51	50	36	25
		2400	54	57	39	29
6	TWE072K*B	1920	48	33	30	27
		2160	50	38	32	28
		2400	52	43	35	29
		2640	54	47	38	30
		2880	57	51	41	32
7.5	TWE090K*A/B	2400	52	43	35	29
		2700	55	48	38	31
		3000	58	53	42	32
		3300	62	57	46	35
		3600	66	60	50	37
10	TWE120K*A/B	3200	56	46	38	30
		3600	62	51	42	33
		4000	66	57	47	35
		4400	71	62	52	38
		4800	76	67	56	42
12.5	TWE150K*B	4900	47	38	32	25
		5400	52	44	37	29
		6000	57	49	41	32
		6600	61	53	43	34
		7200	65	57	46	35
15	TWE180K*B	4900	47	38	32	25
		5400	52	44	37	29
		6000	57	49	41	32
		6600	61	53	43	34
		7200	65	57	46	35
20	TWE240K*B	6400	56	46	38	30
		7200	62	51	42	33
		8000	66	57	47	35
		8800	71	62	52	38
		9600	76	67	56	42
25	TWE300K*B	8000	66	57	47	35
		9000	72	63	53	39
		10000	78	70	59	43
		11000	84	76	65	46
		12000	90	83	71	50

**Notes:**

1. Assumes incompressible and adiabatic flow through grille.
2. Throw distance values are based on a terminal velocity of 75 FPM.
3. Throw distance values at other terminal velocities may be established by multiplying throw distances in the table above by throw factor as follows: for 50 FPM terminal velocity, multiply by 1.50 throw factor; for 100 FPM terminal velocity, multiply by 0.75 throw factor; for 150 FPM terminal velocity, multiply by 0.50 throw factor.
4. SZVAV/2-Speed VFD available for 6 to 25 ton only.



**Performance Data**

**Table 58. Electric heat discharge plenum and grille airflow (CFM) – constant volume air handler (60Hz)**

Tons	Unit Model No.	Electric Heater Model No.	Airflow (CFM)	
			Minimum	Maximum
5	TWE060K1A, B	BAYHTRT117*	2000	2400
	TWE060K3A, B	BAYHTRS315*	2000	2400
	TWE060K4A, B	BAYHTRS415*	2000	2400
6	TWE072K3B	BAYHTRS315*	2000	2880
	TWE072K3B	BAYHTRP325*	2000	2880
	TWE072K4B	BAYHTRS415*	2000	2880
	TWE072K4B	BAYHTRP425*	2000	2880
7.5	TWE090K1A, B	BAYHTRT117*	3000	3600
	TWE090K1A, B	BAYHTRS123*	3375	3600
7.5	TWE090K3A, B	BAYHTRS315*	2625	3600
	TWE090K3A, B	BAYHTRP325*	3000	3600
	TWE090K4A, B	BAYHTRS415*	2625	3600
	TWE090K4A, B	BAYHTRP425*	2625	3600
10	TWE120K1A, B	BAYHTRT117*	3500	4800
	TWE120K1A, B	BAYHTRS123*	4000	4800
10	TWE120K3A, B	BAYHTRS315*	4000	4800
	TWE120K3A, B	BAYHTRP325*	3500	4800
	TWE120K4A, B	BAYHTRS415*	3500	4800
	TWE120K4A, B	BAYHTRP425*	3500	4800
12.5	TWE150K3B	BAYHTRR330*	5250	6000
	TWE150K4B	BAYHTRR430*	5250	6000
15	TWE180K3B	BAYHTRR330*	5250	7200
	TWE180K4B	BAYHTRR430*	5250	7200
20	TWE240K3B	BAYHTRR330*	7000	9600
	TWE240K4B	BAYHTRR430*	7000	9600
25	TWE300K3B	BAYHTRR330*	8750	12000
	TWE300K4B	BAYHTRR430*	8750	12000

Note: SZVAV/2-Speed VFD available for 6 to 25 ton only.

**Table 59. Static pressure drop through accessories (inches of water column) – air handler (60Hz)**

Tons	Unit Model No.	CFM	Return Grille	Discharge Plenum and Grille	2" MERV 13 Filter	Electric Heaters (kW)				Hydronic Coils	
						5 to 10	15 to 20	25 to 30	35 to 50	Steam	Hot Water
5	TWE060K*A/B	1600	0.12	0.21	0.22	0.08	0.08	0.14	—	0.44	0.31
		2000	0.18	0.33	0.29	0.13	0.13	0.19	—	0.62	0.44
		2400	0.28	0.47	0.36	0.19	0.19	0.37	—	0.80	0.59
6	TWE072K*B	1920	0.04	0.20	0.15	0.01	0.03	0.04	0.06	0.31	0.16
		2400	0.08	0.27	0.19	0.03	0.06	0.08	0.12	0.38	0.23
		2880	0.12	0.37	0.24	0.05	0.11	0.15	0.21	0.48	0.31
7.5	TWE090K*A/B	2400	0.08	0.27	0.19	0.03	0.06	0.08	0.12	0.38	0.23
		3000	0.13	0.40	0.25	0.06	0.12	0.17	0.23	0.50	0.33
		3600	0.18	0.58	0.31	0.08	0.16	0.24	0.32	0.66	0.44
10	TWE120K*A/B	3200	0.07	0.43	0.19	0.06	0.13	0.19	0.26	0.42	0.40
		4000	0.11	0.66	0.25	0.10	0.20	0.30	0.40	0.59	0.56
		4800	0.15	0.95	0.31	0.14	0.28	0.42	0.57	0.76	0.75
12.5	TWE150K*B	4000	0.06	0.16	0.15	0.02	0.02	0.04	0.08	0.28	0.24
		5000	0.10	0.25	0.20	0.03	0.03	0.08	0.12	0.44	0.38
		6000	0.14	0.36	0.25	0.04	0.05	0.12	0.17	0.64	0.54
15	TWE180K*B	4800	0.09	0.23	0.19	0.03	0.03	0.06	0.08	0.46	0.38
		6000	0.15	0.34	0.25	0.06	0.06	0.12	0.17	0.64	0.54
		7200	0.20	0.49	0.31	0.08	0.08	0.16	0.24	0.82	0.72

**Table 59. Static pressure drop through accessories (inches of water column) – air handler (60Hz) (continued)**

Tons	Unit Model No.	CFM	Return Grille	Discharge Plenum and Grille	2" MERV 13 Filter	Electric Heaters (kW)				Hydronic Coils	
						5 to 10	15 to 20	25 to 30	35 to 50	Steam	Hot Water
20	TWE240K*B	6400	0.11	0.43	0.22	0.06	0.06	0.13	0.19	0.50	0.41
		8000	0.17	0.66	0.29	0.10	0.10	0.20	0.30	0.70	0.58
		9600	0.23	0.95	0.36	0.14	0.14	0.28	0.42	0.89	0.78
25	TWE300K*B	8000	0.17	0.66	0.29	0.10	0.10	0.20	0.30	0.70	0.58
		10000	0.25	1.03	0.37	0.15	0.15	0.30	0.45	0.94	0.83
		12000	0.32	1.49	0.47	0.20	0.20	0.42	0.62	1.16	1.14

**Notes:**

1. SZVAV/2-Speed VFD available for 6 to 25 ton only.
2. Return air filter ESP included in Fan Performance Table data.
3. Discharge plenum and grille - at louver opening angle of 42 degrees. For ESP at other angle openings, see accessory installation instructions.

**Table 60. Auxiliary electric heat capacity – air handler (60Hz)**

Unit Model No.	Total kW	No. of Stages	Stage 1		Stage 2		Total	
			kW Input	BTUH Output	kW Input	BTUH Output	kW Input	BTUH Output
TWE060K1A, TWE060K1B	5.76	1	5.76	19659	–	–	5.76	19659
	11.52	1	11.52	39318	–	–	11.52	39318
	17.28	1	17.28	58977	–	–	17.28	58977
	23.04	2	11.52	39318	11.52	39318	23.04	78636
TWE060K3A, TWE060K4A, TWE060KWA, TWE060K3B, TWE060K4B, TWE072K3B, TWE072K4B, TWE072KWB	5.00	1	5.00	17065	–	–	5.00	17065
	9.96	1	9.96	33993	–	–	9.96	33993
	14.96	1	14.96	51058	–	–	14.96	51058
	24.92	2	14.96	51058	9.96	33993	24.92	85051
TWE090K1A, TWE090K1B, TWE120K1A, TWE120K1B	5.76	1	5.76	19659	–	–	5.76	19659
	11.52	1	11.52	39318	–	–	11.52	39318
	17.28	1	17.28	58977	–	–	17.28	58977
	23.04	2	11.52	39318	11.52	39318	23.04	78636
	28.80	2	17.28	58977	11.52	39318	28.80	98295
TWE090K3A, TWE090K3B, TWE090KWA, TWE090K3B, TWE090K4B, TWE090KWB, TWE120K3A, TWE120K4A, TWE120KWA, TWE120K3B, TWE120K4B, TWE120KWB	5.00	1	5.00	17065	–	–	5.00	17065
	9.96	1	9.96	33993	–	–	9.96	33993
	14.96	1	14.96	51058	–	–	14.96	51058
	24.92	2	14.96	51058	9.96	33993	24.92	85051
	34.88	2	19.92	67987	14.96	51058	34.88	119045
	10.00	1	10.00	34130	–	–	10.00	34130
TWE150K3B, TWE150K4B, TWE150KWB, TWE180K3B, TWE180K4B, TWE180KWB	19.92	1	19.92	67987	–	–	19.92	67987
	29.92	2	19.92	67987	10.00	34130	29.92	102117
	49.84	2	29.92	102117	19.92	67987	49.84	170104
TWE240K*B, TWE300K*B	10.00	1	10.00	34130	–	–	10.00	34130
	19.92	1	19.92	67987	–	–	19.92	67987
	29.92	2	19.92	67987	10.00	34130	29.92	102117
	49.84	2	29.92	102117	19.92	67987	49.84	170104

**Notes:**

1. Heaters are rated at 240V, 480V, and 600V. For other than rated voltage, capacity = (Voltage/Related Voltage)<sup>2</sup> x Rated Capacity.
2. SZVAV/2-Speed VFD available for 6 to 25 ton only.



**Performance Data**

**Table 61. Steam heating coil capacity – air handler steam pressure (PSIG) (60Hz)**

Unit Model No.	Airflow (CFM)	EAT (°F)	Steam Pressure (PSIG)														
			2 PSI			5 PSI			10 PSI			15 PSI			25 PSI		
			LAT	MBh	Cond. lb/hr	LAT	MBh	Cond. lb/hr	LAT	MBh	Cond. lb/hr	LAT	MBh	Cond. lb/hr	LAT	MBh	Cond. lb/hr
TWE060K*A, TWE060K*B	1600	40	97	99	103	100	104	108	104	111	117	108	117	124	113	127	136
		60	111	88	91	114	93	97	118	100	105	121	106	112	127	116	124
		80	125	77	80	127	82	85	131	89	94	135	95	101	140	105	112
	2000	40	90	108	112	93	114	118	96	122	128	99	129	136	104	139	149
		60	104	96	100	107	102	106	111	110	115	114	116	123	119	127	136
		80	119	84	87	121	90	93	125	98	102	128	104	110	133	115	123
	2400	40	85	116	120	87	123	127	90	131	137	93	138	146	98	150	160
		60	100	104	107	102	110	114	105	118	124	108	125	132	113	137	146
		80	115	91	94	117	97	100	120	105	110	123	112	118	127	123	132
TWE072K*B	1920	40	106	151	157	112	159	165	116	169	178	121	179	189	126	194	207
		60	120	134	139	124	141	147	128	153	160	133	162	172	139	177	189
		80	133	117	121	136	125	131	140	136	143	145	144	152	151	159	170
	2400	40	102	162	168	106	171	177	110	182	191	114	192	203	120	208	222
		60	115	144	149	119	152	158	123	164	172	127	174	184	133	190	203
		80	129	126	130	132	134	140	136	146	153	140	155	164	146	171	183
	2880	40	96	174	180	100	183	190	104	196	205	107	206	218	113	223	239
		60	110	154	159	113	163	170	117	176	184	121	186	197	126	204	218
		80	124	135	140	127	144	150	131	157	164	134	166	176	140	184	197
TWE090K*A, TWE090K*B	2400	40	102	162	168	106	171	177	110	182	191	114	192	203	120	208	222
		60	115	144	149	119	152	158	123	164	172	127	174	184	133	190	203
		80	129	126	130	132	134	140	136	146	153	140	155	164	146	171	183
	3000	40	95	178	183	97	187	194	101	200	209	105	210	222	110	228	244
		60	109	158	163	111	167	174	115	180	188	119	190	201	124	208	222
		80	122	138	143	125	147	153	129	160	168	132	170	180	138	188	201
	3600	40	89	191	197	91	201	208	95	215	225	97	226	239	103	245	262
		60	103	170	175	106	180	187	110	193	203	112	205	216	117	224	239
		80	118	149	154	121	158	164	124	172	180	127	183	194	132	202	216
TWE120K*A, TWE120K*B	3200	40	99	203	210	102	214	222	106	229	240	109	241	254	115	261	279
		60	112	181	187	115	191	199	119	206	216	123	218	230	129	238	255
		80	126	158	164	129	169	175	133	183	192	136	195	206	142	215	230
	4000	40	91	222	229	94	234	243	98	250	262	101	264	278	106	286	306
		60	106	198	204	108	209	217	112	225	236	115	239	252	120	261	279
		80	120	173	179	123	184	192	126	200	210	129	214	226	134	236	252
	4800	40	86	239	246	88	251	261	92	269	282	94	284	299	99	307	329
		60	101	212	219	103	225	233	107	242	254	109	257	271	114	280	300
		80	116	186	192	118	198	206	121	215	226	124	230	243	129	253	271
TWE150K*B	4000	40	103	274	283	106	288	299	111	308	323	115	325	343	121	352	376
		60	116	244	252	119	258	268	124	277	291	128	294	310	134	321	343
		80	129	213	220	132	227	236	137	247	259	141	263	278	147	290	310
	5000	40	95	300	309	98	316	328	102	337	354	106	356	346	111	286	412
		60	109	267	275	112	282	293	116	304	318	119	322	340	125	352	376
		80	123	234	241	126	249	259	130	270	283	133	288	305	139	318	340
	6000	40	90	322	332	92	339	352	96	363	380	99	383	404	104	415	444
		60	104	287	296	107	303	315	110	327	342	113	347	366	118	379	405
		80	119	251	259	121	268	278	125	291	305	128	310	328	133	342	366

**Table 61. Steam heating coil capacity – air handler steam pressure (PSIG) (60Hz) (continued)**

Unit Model No.	Airflow (CFM)	EAT (°F)	Steam Pressure (PSIG)														
			2 PSI			5 PSI			10 PSI			15 PSI			25 PSI		
			LAT	MBh	Cond. lb/hr	LAT	MBh	Cond. lb/hr	LAT	MBh	Cond. lb/hr	LAT	MBh	Cond. lb/hr	LAT	MBh	Cond. lb/hr
TWE180K*B	4800	40	97	295	304	100	310	322	104	332	348	107	350	369	113	379	406
		60	110	262	271	113	278	288	117	299	313	121	317	334	126	346	370
		80	124	230	237	127	245	254	131	266	279	134	284	299	140	313	334
	6000	40	90	322	332	92	339	352	96	363	380	99	383	404	104	415	444
		60	104	287	296	107	303	315	110	327	343	113	347	366	118	379	405
		80	119	251	259	121	268	278	125	291	305	128	310	328	133	342	366
	7200	40	84	346	356	87	364	378	90	390	408	93	411	434	97	446	477
		60	99	308	318	102	326	338	105	351	368	108	373	393	112	407	435
		80	115	270	278	117	287	299	120	313	327	123	334	352	127	368	394
TWE240K*B	6400	40	95	379	391	97	399	414	102	427	447	105	450	475	110	488	522
		60	109	337	348	111	357	371	115	384	403	119	408	430	124	445	476
		80	123	295	305	125	315	327	129	342	358	133	365	385	138	402	430
	8000	40	88	414	426	90	436	452	94	467	488	97	492	519	102	534	571
		60	102	368	380	105	390	405	108	420	440	111	446	470	116	487	521
		80	117	322	333	120	344	357	123	374	392	126	399	421	131	440	471
	9600	40	83	443	457	85	468	485	88	501	524	91	529	558	95	574	613
		60	98	395	407	100	418	434	103	451	473	106	479	505	110	524	560
		80	113	346	357	115	369	383	119	402	421	121	429	453	125	473	506
TWE300K*B	8000	40	88	414	426	90	436	452	94	467	488	97	492	519	102	534	571
		60	102	368	380	105	390	405	108	420	440	111	446	470	116	487	521
		80	117	322	333	120	344	357	123	374	392	126	399	421	131	440	471
	10000	40	82	450	464	84	475	492	87	509	533	90	537	567	94	583	623
		60	97	401	413	99	425	441	102	459	480	105	487	513	109	532	569
		80	112	352	363	115	375	389	118	408	427	120	436	460	124	481	514
	12000	40	77	479	493	79	509	527	82	546	571	84	577	608	88	627	669
		60	93	430	443	95	456	473	98	492	515	100	523	551	104	572	611
		80	109	377	389	111	402	418	114	438	459	116	468	494	120	517	553

**Notes:**

1. Type NS Coil, 1 Row, 1" OD, SF Fins, 132 Fins per Foot.
2. SZVAV/2-Speed VFD available for 6 to 25 ton only.
3. LAT = Leaving Air Temperature (°F)
4. MBh Capacity= BTU/HR/1000
5. Cond. Lb/Hr = Condensate pound per hour



**Performance Data**

**Table 62. Hot water heating coil capacity – air handler (60Hz)**

Tons	Unit Model No.	Airflow (CFM)	Enter Air Temp (°F)	Entering Water Temperature (°F)								
				180								
				Water Temperature Drop (°F)								
				20			30			40		
GPM	MBh	LAT	GPM	MBh	LAT	GPM	MBh	LAT				
5	TWE060K*A, TWE060K*B	1600	40	10.9	106.1	101.0	6.6	96.5	96.0	4.5	87.4	90.0
			60	9.0	88.3	111.0	5.4	79.1	106.0	3.6	70.3	100.0
			80	7.2	70.6	121.0	4.2	61.8	116.0	2.7	53.4	111.0
		2000	40	12.3	119.8	95.0	7.4	108.6	90.0	5.0	97.9	851.0
			60	10.2	99.6	106.0	6.1	88.8	101.0	4.0	78.6	96.0
			80	8.1	79.5	117.0	4.7	69.2	112.0	3.0	59.6	107.0
		2400	40	13.5	132.0	91.0	8.1	119.2	86.0	5.5	107.1	811.0
			60	11.2	109.6	102.0	6.6	97.4	97.0	4.4	85.9	931.0
			80	9.0	87.4	114.0	5.2	75.7	109.0	3.3	64.9	105.0
6	TWE072K*B	1920	40	15.4	150.3	112.5	9.4	137.6	106.4	6.4	124.9	100.2
			60	12.8	124.9	120.2	7.6	111.3	113.7	5.2	101.5	109.0
			80	10.2	99.6	128.0	6.0	87.8	122.4	3.9	76.1	116.7
		2400	40	17.0	165.9	104.0	10.4	152.3	98.0	7.1	139.2	93.0
			60	14.2	138.4	113.0	8.5	125.2	108.0	5.7	112.5	103.0
			80	11.4	111.1	123.0	6.7	98.3	118.0	4.4	86.1	113.0
		2880	40	18.7	182.5	98.7	11.5	168.4	94.1	7.7	150.3	88.3
			60	15.6	152.3	109.0	9.2	134.7	103.3	6.4	124.9	100.2
			80	12.5	122.0	119.2	7.2	105.4	113.9	4.7	91.7	109.5
7.5	TWE090K*A, TWE090K*B	2400	40	17.0	165.9	104.0	10.4	152.3	98.0	7.1	139.2	93.0
			60	14.2	138.4	113.0	8.5	125.2	108.0	5.7	112.5	103.0
			80	11.4	111.1	123.0	6.7	98.3	118.0	4.4	86.1	113.0
		3000	40	19.3	187.9	98.0	11.7	171.9	93.0	8.0	156.5	88.0
			60	16.1	156.7	108.0	9.6	141.1	103.0	6.4	126.3	991.0
			80	12.9	125.5	119.0	7.5	110.6	114.0	4.9	96.5	110.0
		3600	40	21.2	207.3	93.0	12.9	189.1	88.0	8.8	171.6	84.0
			60	17.7	172.7	104.0	10.6	155.0	100.0	7.1	138.3	95.0
			80	14.2	138.2	115.0	8.3	121.2	111.0	5.4	105.4	107.0
10	TWE120K*A, TWE120K*B	3200	40	24.5	239.1	109.0	14.3	210.0	100.0	9.1	178.7	91.0
			60	20.2	197.3	117.0	11.5	168.4	108.0	6.9	134.8	99.0
			80	15.9	155.6	125.0	8.6	126.1	116.0	4.0	78.7	103.0
		4000	40	27.8	271.7	103.0	16.2	237.5	95.0	10.3	201.9	86.0
			60	22.9	223.8	112.0	13.0	190.3	104.0	7.8	153.3	95.0
			80	18.1	176.2	121.0	9.7	142.6	113.0	5.0	97.3	102.0
		4800	40	30.7	300.0	98.0	17.8	261.3	90.0	11.3	221.7	82.0
			60	25.3	246.9	107.0	14.3	209.1	100.0	8.6	168.9	92.0
			80	19.9	194.0	117.0	10.7	156.7	110.0	5.6	110.2	101.0
12.5	TWE150K*B	4000	40	31.7	318.0	113.3	19.2	287.7	106.3	12.8	256.5	99.1
			60	26.4	264.4	120.9	15.6	234.4	114.0	10.2	203.2	106.9
			80	21.1	210.9	128.6	12.1	181.1	121.7	7.4	148.9	114.3
		5000	40	36.0	360.6	106.5	21.7	325.2	100.0	14.4	288.8	93.3
			60	29.9	299.6	115.3	17.6	264.5	108.8	11.4	228.3	102.1
			80	23.8	238.7	124.0	13.6	203.8	117.6	8.4	167.5	110.9
		6000	40	39.7	397.0	101.0	23.8	357.0	94.9	15.8	316.1	88.6
			60	32.9	329.6	110.7	19.3	290.0	104.6	12.5	249.5	98.3
			80	26.2	262.3	120.3	14.9	223.1	114.3	9.1	182.8	108.1

**Table 62. Hot water heating coil capacity – air handler (60Hz) (continued)**

Tons	Unit Model No.	Airflow (CFM)	Enter Air Temp (°F)	Entering Water Temperature (°F)								
				180								
				Water Temperature Drop (°F)								
				20			30			40		
GPM	MBh	LAT	GPM	MBh	LAT	GPM	MBh	LAT				
15	TWE180K*B	4800	40	35.2	343.9	106.0	21.2	310.3	100.0	14.1	276.3	93.0
			60	29.3	285.7	115.0	17.2	252.7	108.0	11.2	218.5	102.0
			80	23.3	227.7	124.0	13.3	195.0	117.0	8.2	159.9	111.0
		6000	40	40.0	390.3	100.0	23.9	350.8	94.0	15.9	311.4	88.4
			60	33.3	323.9	110.0	19.5	285.3	104.0	12.6	246.2	98.0
			80	26.4	257.7	120.0	15.0	219.9	114.0	9.2	180.5	108.0
		7200	40	44.2	431.3	95.0	26.4	386.5	89.0	17.5	342.1	84.0
			60	36.6	357.6	106.0	21.4	313.9	100.0	13.8	270.6	95.0
			80	29.1	284.2	116.0	16.5	241.6	111.0	10.1	198.3	105.0
20	TWE2404K	6400	40	46.8	456.2	106.0	28.4	416.5	100.0	19.3	376.7	94.0
			60	39.0	380.2	115.0	23.3	341.2	109.0	15.4	301.7	103.0
			80	31.2	304.5	124.0	18.2	266.0	118.0	11.6	227.0	113.0
		8000	40	53.0	517.5	100.0	32.1	470.9	94.0	21.7	424.5	89.0
			60	44.2	430.9	110.0	26.3	385.2	104.0	17.4	339.6	99.0
			80	35.3	344.6	120.0	20.5	299.8	115.0	13.0	255.2	109.0
		9600	40	58.6	572.0	94.0	35.4	519.1	90.0	23.9	466.8	85.0
			60	48.8	475.9	106.0	28.9	424.2	101.0	19.1	373.3	96.0
			80	39.0	380.2	116.0	22.5	329.6	112.0	14.3	280.0	107.0
25	TWE300K*B	8000	40	52.0	520.2	100.0	31.6	474.4	94.7	21.4	427.6	89.3
			60	43.3	433.6	110.0	25.9	388.2	104.7	17.1	341.6	99.4
			80	34.7	347.0	120.0	20.1	301.9	114.8	12.8	255.3	109.4
		10000	40	57.9	579.4	93.4	35.1	526.9	88.6	23.7	473.6	83.7
			60	48.2	482.5	104.5	28.7	430.6	99.7	18.9	377.7	94.8
			80	38.5	385.7	115.6	22.3	334.3	110.8	14.1	281.6	106.0
		12000	40	62.8	628.6	88.3	38.0	570.5	83.8	25.6	511.7	79.3
			60	52.3	523.2	100.2	31.0	465.8	95.8	20.4	407.5	91.3
			80	41.7	417.9	112.2	24.1	361.2	107.8	15.2	303.3	103.3



**Performance Data**

**Table 62. Hot water heating coil capacity – air handler (60Hz) (continued)**

Tons	Unit Model No.	Airflow (CFM)	Enter Air Temp (°F)	Entering Water Temperature (°F)								
				200								
				Water Temperature Drop (°F)								
				20			30			40		
GPM	MBh	LAT	GPM	MBh	LAT	GPM	MBh	LAT				
5	TWE060K*A, TWE060K*B	1600	40	12.9	124.9	112.0	7.9	115.4	106.0	5.5	106.3	101.0
			60	11.0	107.0	122.0	6.7	97.8	116.0	4.6	88.9	111.0
			80	9.2	89.1	131.0	5.5	80.2	126.0	3.7	71.7	121.0
		2000	40	4.5	141.3	105.0	8.9	130.1	100.0	6.1	119.4	95.0
			60	12.4	120.9	116.0	7.5	110.1	111.0	5.1	99.7	106.0
			80	10.4	100.6	126.0	6.2	90.2	122.0	4.1	80.3	117.0
		2400	40	6.0	155.8	100.0	9.8	143.1	95.0	6.7	131.0	90.0
			60	3.7	133.3	111.0	8.3	120.9	106.0	5.6	109.2	102.0
			80	11.4	110.8	123.0	6.8	98.9	118.0	4.5	87.8	114.0
6	TWE072K*B	1920	40	17.9	174.7	124.3	11.2	164.0	119.1	7.9	154.2	114.4
			60	15.6	152.3	133.4	9.6	140.5	127.8	6.5	126.9	121.2
			80	13.0	126.9	141.2	8.0	117.1	136.5	5.4	105.4	130.8
		2400	40	20.0	194.8	115.0	12.4	181.2	110.0	8.6	168.2	105.0
			60	17.2	167.1	124.0	10.6	153.9	119.0	7.2	141.2	114.0
			80	14.4	139.6	134.0	8.7	126.8	129.0	5.9	114.3	124.0
		2880	40	21.9	213.7	108.7	13.7	200.6	104.5	9.6	187.4	100.2
			60	19.0	185.4	119.6	11.7	171.3	115.1	8.0	156.2	110.2
			80	15.8	154.2	129.6	9.7	142.0	125.7	6.5	126.9	120.8
7.5	TWE090K*A, TWE090K*B	2400	40	20.0	194.8	115.0	12.4	181.2	110.0	8.6	168.2	105.0
			60	17.2	167.1	124.0	10.6	153.9	119.0	7.2	141.2	114.0
			80	14.4	139.6	134.0	8.7	126.8	129.0	5.9	114.3	124.0
		3000	40	22.7	220.9	108.0	14.0	204.9	103.0	9.7	189.6	98.0
			60	9.5	189.4	118.0	11.9	173.9	113.0	8.2	159.0	109.0
			80	16.3	158.1	129.0	9.8	143.0	124.0	6.6	128.5	119.0
		3600	40	25.1	244.0	102.0	15.5	225.7	98.0	0.7	208.4	93.0
			60	21.5	209.1	113.0	13.1	191.4	109.0	9.0	174.4	105.0
			80	17.9	174.3	125.0	10.8	157.1	120.0	7.2	140.9	116.0
10	TWE120K*A, TWE120K*B	3200	40	29.3	284.7	122.0	17.6	256.8	114.0	11.7	228.6	106.0
			60	25.0	242.6	130.0	14.7	215.2	122.0	9.6	186.9	114.0
			80	20.6	200.6	138.0	11.9	173.6	130.0	7.4	144.3	122.0
		4000	40	33.4	324.1	115.0	19.9	291.0	107.0	13.3	258.2	99.0
			60	28.4	275.8	124.0	16.7	243.6	116.0	10.8	211.0	109.0
			80	23.4	227.7	132.0	13.4	196.2	125.0	8.4	163.2	118.0
		4800	40	36.9	358.3	109.0	22.0	320.7	102.0	14.6	283.7	94.0
			60	31.4	304.7	118.0	18.4	268.1	111.0	11.9	231.6	104.0
			80	25.9	251.3	128.0	14.8	215.6	121.0	9.2	179.4	114.0
12.5	TWE150K*B	4000	40	37.3	374.5	126.3	23.0	345.9	119.7	15.8	316.5	113.0
			60	32.0	320.9	134.0	19.4	292.5	127.4	13.1	263.1	120.7
			80	26.6	267.4	141.6	15.9	243.1	135.1	10.5	209.7	128.3
		5000	40	42.4	425.4	118.5	26.0	391.7	112.2	17.8	357.2	105.9
			60	36.3	364.3	127.2	22.0	330.8	121.0	14.8	296.5	114.7
			80	30.2	303.2	135.9	17.9	269.9	129.8	11.8	235.8	123.5
		6000	40	46.7	468.8	112.0	28.6	430.6	106.2	19.5	391.7	100.2
			60	40.0	401.2	121.7	24.2	363.3	115.8	16.2	324.8	109.9
			80	33.2	333.6	131.3	19.7	296.1	125.5	12.9	257.8	119.6



**Table 62. Hot water heating coil capacity – air handler (60Hz) (continued)**

Tons	Unit Model No.	Airflow (CFM)	Enter Air Temp (°F)	Entering Water Temperature (°F)								
				200								
				Water Temperature Drop (°F)								
				20			30			40		
GPM	MBh	LAT	GPM	MBh	LAT	GPM	MBh	LAT				
15	TWE180K*B	4800	40	41.8	406.0	118.0	25.6	373.4	112.0	17.5	341.0	105.0
			60	35.8	347.5	127.0	21.6	315.4	121.0	14.6	283.4	114.0
			80	29.8	289.1	135.0	17.7	257.6	129.0	11.6	225.7	123.0
		6000	40	7.5	461.4	111.0	29.0	423.0	105.0	19.8	385.0	99.0
			60	40.6	394.6	121.0	24.5	356.9	115.0	16.4	319.6	109.0
			80	33.8	327.9	130.0	19.9	291.0	125.0	13.1	254.3	119.0
		7200	40	52.5	510.4	105.0	32.0	466.7	100.0	21.8	423.8	94.0
			60	44.9	436.3	116.0	27.0	393.5	110.0	18.0	351.4	105.0
			80	37.3	362.2	126.0	22.0	320.5	121.0	14.3	279.5	116.0
20	TWE2404K	6400	40	55.2	536.5	117.0	34.1	497.8	112.0	23.6	459.4	106.0
			60	47.4	460.2	126.0	28.9	422.1	121.0	19.7	384.2	115.0
			80	39.5	384.0	135.0	23.8	346.5	130.0	15.9	308.9	124.0
		8000	40	62.7	609.2	110.0	38.6	563.8	105.0	26.6	518.8	100.0
			60	53.8	522.2	120.0	32.7	477.6	115.0	22.2	433.3	110.0
			80	44.8	435.4	130.0	26.8	391.5	125.0	17.9	347.9	120.0
		9600	40	69.4	673.9	105.0	42.7	622.3	100.0	29.3	571.5	95.0
			60	59.4	577.4	115.0	36.1	526.8	111.0	24.5	476.7	106.0
			80	49.5	481.0	126.0	29.6	431.4	121.0	19.6	382.6	117.0
25	TWE300K*B	8000	40	60.9	611.5	110.5	37.7	567.6	105.4	26.1	523.0	100.3
			60	52.3	524.6	120.5	32.0	481.1	115.5	21.8	436.7	110.3
			80	43.6	437.8	130.5	26.2	394.6	125.5	17.5	350.3	120.4
		10000	40	67.9	681.6	102.9	42.0	631.2	98.2	28.9	580.2	93.5
			60	58.2	584.4	113.9	35.5	534.5	109.3	24.1	483.9	104.6
			80	48.6	487.4	124.9	29.1	437.9	120.4	19.3	387.5	115.7
		12000	40	73.7	740.0	96.9	45.5	684.0	92.6	31.3	627.7	88.2
			60	63.2	634.2	108.7	38.5	578.9	104.5	26.1	523.0	100.2
			80	52.7	528.6	120.6	31.5	473.8	116.4	20.9	418.3	112.1



**Performance Data**

**Table 62. Hot water heating coil capacity – air handler (60Hz) (continued)**

Tons	Unit Model No.	Airflow (CFM)	Enter Air Temp (°F)	Entering Water Temperature (°F)								
				210								
				Water Temperature Drop (°F)								
				20			30			40		
GPM	MBh	LAT	GPM	MBh	LAT	GPM	MBh	LAT				
5	TWE060K*A, TWE060K*B	1600	40	13.9	134.3	117.0	8.6	124.8	112.0	6.0	115.8	107.0
			60	12.0	116.3	127.0	7.4	107.1	122.0	5.1	98.3	117.0
			80	10.2	98.4	137.0	6.1	89.5	132.0	4.2	80.9	127.0
		2000	40	15.7	152.0	110.0	9.7	140.9	105.0	6.7	130.2	100.0
			60	13.6	131.6	121.0	8.3	120.7	116.0	5.7	110.5	111.0
			80	11.5	111.2	131.0	6.9	100.7	126.0	4.7	90.7	122.0
		2400	40	17.3	167.7	104.0	10.6	155.0	99.0	7.4	142.9	95.0
			60	15.0	145.1	116.0	9.1	132.8	111.0	6.2	121.0	106.0
			80	12.6	122.6	127.0	7.6	110.6	122.0	5.1	99.3	118.0
6	TWE072K*B	1920	40	19.5	190.3	131.8	12.0	175.7	124.7	8.5	165.9	120.0
			60	16.8	164.0	139.1	10.4	152.3	133.4	7.3	142.5	128.7
			80	14.5	141.5	148.2	8.8	128.8	142.1	5.9	115.2	135.5
		2400	40	21.6	209.2	120.0	13.4	195.7	115.0	9.4	182.7	110.0
			60	18.7	181.5	130.0	11.6	168.3	125.0	8.0	155.6	120.0
			80	15.9	153.9	139.0	9.7	141.0	134.0	6.6	128.6	129.0
		2880	40	23.9	233.3	115.0	14.7	215.2	109.2	10.3	201.1	104.6
			60	20.6	201.1	124.6	12.7	185.9	119.8	8.8	171.8	115.2
			80	17.7	172.8	135.5	10.6	155.2	129.9	7.1	138.6	124.6
7.5	TWE090K*A, TWE090K*B	2400	40	21.6	209.2	120.0	13.4	195.7	115.0	9.4	182.7	110.0
			60	18.7	181.5	130.0	11.6	168.3	125.0	8.0	155.6	120.0
			80	15.9	153.9	139.0	9.7	141.0	134.0	6.6	128.6	129.0
		3000	40	24.5	237.4	113.0	15.2	221.5	108.0	10.6	206.2	103.0
			60	21.2	205.8	123.0	13.1	190.3	118.0	9.0	175.4	114.0
			80	18.0	174.4	134.0	10.9	159.2	129.0	7.4	144.7	124.0
		3600	40	27.1	262.3	107.0	16.8	244.1	102.0	11.7	226.8	98.0
			60	23.4	227.3	118.0	14.4	209.6	114.0	9.9	192.6	109.0
			80	19.8	192.4	129.0	12.0	175.2	125.0	8.2	158.7	121.0
10	TWE120K*A, TWE120K*B	3200	40	31.7	307.4	129.0	19.2	279.9	121.0	13.0	252.6	113.0
			60	27.4	265.1	136.0	16.4	238.2	129.0	10.9	211.0	121.0
			80	23.0	223.0	144.0	13.5	196.5	137.0	8.7	169.1	129.0
		4000	40	36.1	350.2	121.0	21.8	317.6	113.0	14.7	285.5	106.0
			60	31.1	301.7	130.0	18.5	269.9	122.0	12.3	238.2	115.0
			80	26.1	253.4	138.0	15.3	222.3	131.0	9.8	190.8	124.0
		4800	40	40.0	387.4	114.0	24.1	350.3	107.0	16.2	313.9	100.0
			60	34.4	333.6	124.0	20.4	297.3	117.0	13.5	261.7	110.0
			80	28.9	279.9	134.0	16.8	244.6	127.0	10.8	209.5	120.0
12.5	TWE150K*B	4000	40	40.1	402.7	132.8	24.9	374.7	126.4	17.2	346.1	119.8
			60	34.7	349.1	140.5	21.3	321.3	134.1	14.6	292.7	127.5
			80	29.4	295.5	148.1	17.8	267.8	141.7	11.9	239.2	135.1
		5000	40	45.5	457.6	124.4	28.2	424.6	118.3	19.5	391.0	112.1
			60	39.4	396.4	133.1	24.1	363.7	127.1	16.5	330.2	120.9
			80	33.4	335.3	141.8	20.1	302.7	135.8	13.4	269.4	129.7
		6000	40	50.2	504.5	117.5	31.0	467.1	111.8	21.4	429.1	105.9
			60	43.5	436.8	127.1	26.5	399.7	121.4	18.0	362.0	115.6
			80	36.7	369.2	136.7	22.1	332.4	131.1	14.7	294.9	125.3

**Table 62. Hot water heating coil capacity – air handler (60Hz) (continued)**

Tons	Unit Model No.	Airflow (CFM)	Enter Air Temp (°F)	Entering Water Temperature (°F)								
				210								
				Water Temperature Drop (°F)								
				20			30			40		
GPM	MBh	LAT	GPM	MBh	LAT	GPM	MBh	LAT				
15	TWE180K*B	4800	40	45.1	437.0	124.0	27.8	404.7	118.0	19.2	372.9	112.0
			60	39.0	378.3	133.0	23.8	346.6	127.0	16.2	315.2	120.0
			80	33.0	319.8	141.0	19.8	288.6	135.0	13.3	257.5	129.0
		6000	40	51.3	496.8	116.0	31.5	458.9	110.0	21.7	421.5	105.0
			60	44.4	429.9	126.0	27.0	392.6	120.0	18.3	355.8	115.0
			80	37.5	363.0	136.0	22.4	326.5	130.0	14.9	290.3	125.0
		7200	40	56.7	549.8	110.0	34.8	506.7	105.0	23.9	464.3	99.0
			60	49.1	475.5	121.0	29.8	433.1	115.0	20.2	391.5	110.0
			80	41.4	401.3	131.0	24.7	359.8	126.0	16.4	319.0	121.0
20	TWE2404K	6400	40	59.5	576.5	123.0	37.0	538.3	118.0	25.8	500.5	112.0
			60	51.6	500.0	132.0	31.8	462.4	127.0	21.9	425.0	121.0
			80	43.7	423.7	141.0	26.6	386.6	136.0	18.0	349.7	130.0
		8000	40	67.6	654.9	115.0	41.9	610.0	110.0	29.1	565.7	105.0
			60	58.6	567.8	125.0	36.0	523.6	120.0	24.7	479.9	115.0
			80	49.6	480.7	135.0	30.0	437.3	130.0	20.3	394.2	125.0
		9600	40	74.8	724.6	110.0	46.3	673.8	105.0	32.1	623.6	100.0
			60	64.8	628.0	120.0	39.7	578.0	115.0	27.2	528.4	111.0
			80	54.8	531.4	131.0	33.1	482.2	126.0	22.3	433.5	122.0
25	TWE300K*B	8000	40	65.4	656.9	115.7	40.7	613.8	110.8	28.4	570.1	105.7
			60	56.7	569.9	125.7	35.0	527.2	120.8	24.1	483.8	115.8
			80	48.1	483.1	135.7	29.3	440.6	130.8	19.8	397.3	125.8
		10000	40	72.9	732.5	107.5	45.3	683.0	103.0	31.5	633.0	98.4
			60	63.2	635.2	118.6	38.9	586.2	114.1	26.7	536.5	109.5
			80	53.5	538.0	129.6	32.5	489.4	125.1	21.9	440.0	120.6
		12000	40	79.2	795.5	101.1	49.2	740.5	96.9	34.1	685.1	92.7
			60	68.6	689.5	113.0	42.2	635.1	108.8	28.9	580.3	104.6
			80	58.1	583.7	124.9	35.2	529.9	120.7	23.7	475.4	116.5

**Notes:**

1. SZVAV/2-Speed VFD available for 6 to 25 ton only.
2. GPM = Gallons Per Minute
3. MBh Capacity: BTU/HR/1000
4. LAT = Leaving Air Temperature (°F)



**Performance Data**

**Table 63. Hot water heating coil - water side pressure drop @ 180°F entering water temperature - air handler (60Hz)**

Tons	Unit Model No.	Gallons Per Minute (GPM)																		
		2	4	6	8	10	12	14	16	18	20	22	24	26	28	30	32	34	36	38
		<b>Pressure Drop (Ft. of Water)</b>																		
5	TWE060K*A,B	0.02	0.07	0.15	0.26	0.40	0.56	0.75	0.97	1.22	1.49	1.78	-	-	-	-	-	-	-	-
6	TWE072K*B	-	-	0.06	0.11	0.16	0.23	0.30	0.39	0.48	0.58	0.70	0.82	0.95	1.09	1.24	1.40	1.57	-	-
7.5	TWE090K*A,B	-	-	0.06	0.11	0.16	0.23	0.30	0.39	0.48	0.58	0.70	0.82	0.95	1.09	1.24	1.40	1.57	-	-
10	TWE120K*A,B	-	-	-	0.06	0.09	0.13	0.17	0.22	0.27	0.33	0.39	0.46	0.54	0.62	0.70	0.79	0.89	0.99	1.10
12.5	TWE150K*B	-	-	-	-	0.11	0.15	0.20	0.26	0.32	0.39	0.47	0.55	0.64	0.73	0.83	0.94	1.05	1.17	1.29
15	TWE180K*B	-	-	-	-	0.11	0.15	0.20	0.26	0.32	0.39	0.47	0.55	0.64	0.73	0.83	0.94	1.05	1.17	1.29
20	TWE240K*B	-	-	-	-	-	0.17	0.23	0.30	0.37	0.45	0.53	0.63	0.72	0.83	0.94	1.06	1.19	1.32	1.46
25	TWE300K*B	-	-	-	-	-	0.17	0.23	0.30	0.37	0.45	0.53	0.63	0.72	0.83	0.94	1.06	1.19	1.32	1.46
Tons	Unit Model No.	Gallons Per Minute (GPM)																		
		40	42	44	46	48	50	52	54	56	58	60	62	64	66	68	70	72	74	76
		<b>Pressure Drop (Ft. of Water)</b>																		
5	TWE060K*A,B	-	-	-	-	-	-	-	-	-	-	-	-	-	-	-	-	-	-	-
6	TWE072K*B	-	-	-	-	-	-	-	-	-	-	-	-	-	-	-	-	-	-	-
7.5	TWE090K*A,B	-	-	-	-	-	-	-	-	-	-	-	-	-	-	-	-	-	-	-
10	TWE120K*A,B	1.21	1.32	1.44	1.57	1.70	1.84	-	-	-	-	-	-	-	-	-	-	-	-	-
12.5	TWE150K*B	1.42	1.56	1.70	1.85	2.00	2.16	2.33	2.50	2.67	2.86	3.04	3.24	3.44	3.64	3.85	4.07	-	-	-
15	TWE180K*B	1.42	1.56	1.70	1.85	2.00	2.16	2.33	2.50	2.67	2.86	3.04	3.24	3.44	3.64	3.85	4.07	-	-	-
20	TWE240K*B	1.61	1.76	1.92	2.09	2.26	2.44	2.63	2.82	3.02	3.22	3.43	3.65	3.87	4.10	4.34	4.58	4.83	5.08	5.34
25	TWE300K*B	1.61	1.76	1.92	2.09	2.26	2.44	2.63	2.82	3.02	3.22	3.43	3.65	3.87	4.10	4.34	4.58	4.83	5.08	5.34

Note: SZVAVI/2-Speed VFD available for 6 to 25 ton only.



# Zone Controls

## Zone Sensors

Zone Sensors are the building occupant's comfort control devices. Zone sensors are required for SZVAV applications. The following zone sensor options are available for units with Symbio 700 control.

<b>Manual Changeover</b>	Heat, Cool or Off System Switch. Fan Auto or Off Switch. One temperature setpoint lever.
<b>Manual/Automatic Changeover</b>	Auto, Heat, Cool or Off System Switch. Fan Auto or Off Switch. Two temperature setpoint levers.
<b>Manual/Automatic Changeover</b>	Auto, Heat, Cool or Off System Switch. Fan Auto or Off Switch. Two temperature setpoint levers.
<b>Integrated Comfort™ System</b>	Sensor(s) available with optional temperature adjustment and override buttons to provide central control through a Trane Integrated Comfort™ system.
<b>Remote Sensor</b>	Sensor(s) available for all zone sensors to provide remote sensing capabilities.

## Conventional Thermostats

*Note: All thermostats may be used with Symbio 700 units.*

<b>Non-Programmable Thermostats</b>	
TCONT102* (1H/1C) Common terminal not required	Auto-changeover Backlit Display and Keys Filter Reminder Keypad Lock
TCONT103* (2H/1C) Common terminal required	Auto-changeover Backlit Display & Keys Filter Reminder Keypad Lock Outdoor Temp Sensor Available
TCONT402* (3H/2C) Common terminal required	Auto-changeover Backlit Display & Keys Filter Reminder Keypad Lock Outdoor Temp Sensor Included
<b>Programmable Thermostats</b>	
TCONT202* (1H/1C) Common terminal preferred, not required	5/2 or 5/1/1 Programming Actual and Setpoint temps displayed simultaneously
TCONT203* (4H/2C) Common terminal preferred, not required	5/2 or 5/1/1 Programming Actual and Setpoint temps displayed simultaneously
TCONT302* (4H/2C) Common terminal preferred, not required	Interactive touchscreen Large display Real time clock
TCONT303* (4H/2C) Humidity Sensor Common terminal preferred, not required	Interactive touchscreen Large display Real time clock Built-in humidity sensor



# Electrical Data

## Cooling Condenser

Table 64. Electrical characteristics — compressor and condenser fan motors — 60 Hz

Tons	Unit Model Number	Compressor Motors						Condenser Fan Motor				
		Volts	Phase	Compressor 1		Compressor 2		No.	Volts	Phase	Amps	
				Amps		Amps					FLA (Ea.)	LRA (Ea.)
				RLA	LRA	RLA	LRA					
6	TTA072K3A	208-230	3	21.8	157	N/A	N/A	1	208-230	3	2.3	8.4
	TTA072K4A	460	3	10.5	75	N/A	N/A	1	460	3	1.1	4.2
	TTA072KWA	575	3	7.9	48	N/A	N/A	1	575	3	1.0	3.6
6	TTA072K3D	208-230	3	13.2	98	13.2	98	1	208-230	3	2.3	8.4
	TTA072K4D	460	3	5.9	44	5.9	44	1	460	3	1.1	4.2
	TTA072KWD	575	3	5.2	27	5.2	27	1	575	3	1.0	3.6
7.5	TTA090K3A	208-230	3	27.1	179	N/A	N/A	1	208-230	3	2.3	8.4
	TTA090K4A	460	3	11.3	95	N/A	N/A	1	460	3	1.1	4.2
	TTA090KWA	575	3	10.6	65	N/A	N/A	1	575	3	1.0	3.6
7.5	TTA090K3D	208-230	3	13.8	112	13.8	112	1	208-230	3	2.3	8.4
	TTA090K4D	460	3	7.0	62	7.0	62	1	460	3	1.1	4.2
	TTA090KWD	575	3	5.6	39	5.6	39	1	575	3	1.0	3.6
10	TTA120K3D	208-230	3	16.1	150	16.1	150	1	208-230	3	4.3	19.4
	TTA120K4D	460	3	7.3	58	7.3	58	1	460	3	2.2	10.1
	TTA120KWD	575	3	6.7	48	6.7	48	1	575	3	1.8	8.0
10	TTA120K3C	208-230	3	16.5	156	16.5	156	1	208-230	3	4.3	19.4
	TTA120K4C	460	3	8.1	69	8.1	69	1	460	3	2.2	10.1
	TTA120KWC	575	3	7.4	48	7.4	48	1	575	3	1.8	8.0
12.5	TTA150K3D	208-230	3	26.8	142	26.8	142	1	208-230	3	4.3	19.4
	TTA150K4D	460	3	11.0	73	11.0	73	1	460	3	2.2	10.1
	TTA150KWD	575	3	9.0	55	9.0	55	1	575	3	1.8	8.0
15	TTA180K3D	208-230	3	28.5	179	28.5	179	2	208-230	3	4.3	19.4
	TTA180K4D	460	3	11.9	103	11.9	103	2	460	3	2.2	10.1
	TTA180KWD	575	3	10.4	78	10.4	78	2	575	3	1.8	8.0
15	TTA180K3C	208-230	3	29.5	208	25.8	166	2	208-230	3	4.3	19.4
	TTA180K4C	460	3	14.4	100	10.2	75	2	460	3	2.2	10.1
	TTA180KWC	575	3	10.4	78	8.3	54	2	575	3	1.8	8.0
20	TTA240K3D	208-230	3	36.7	255	31.1	255	2	208-230	3	4.3	19.4
	TTA240K4D	460	3	18.0	140	16.2	123	2	460	3	2.2	10.1
	TTA240KWD	575	3	14.4	108	13.2	94	2	575	3	1.8	8.0
20	TTA240K3C	208-230	3	45.1	267	45.1	267	2	208-230	3	4.3	19.4
	TTA240K4C	460	3	21.5	142	21.5	142	2	460	3	2.2	10.1
	TTA240KWC	575	3	17.8	103	17.8	103	2	575	3	1.8	8.0
25	TTA300K3C	208-230	3	45.4	315	42.3	304	2	208-230	3	4.3	19.4
	TTA300K4C	460	3	24.4	158	24.4	147	2	460	3	2.2	10.1
	TTA300KWC	575	3	16.4	136	15.4	122	2	575	3	1.8	8.0

Note: Electrical characteristics reflect nameplate values and are calculated in accordance with cULus specifications.

**Table 65. Unit wiring — condensing units — 60 Hz**

Tons	Unit Model Number	Volts	Minimum Circuit Ampacity	Maximum Fuse or Circuit Breaker Size
6	TTA072K3A	187-253	31	50
	TTA072K4A	414-506	16	25
	TTA072KWA	518-632	12	15
6	TTA072K3D	187-253	33	45
	TTA072K4D	414-506	16	20
	TTA072KWD	518-632	14	15
7.5	TTA090K3A	187-253	38	60
	TTA090K4A	414-506	17	25
	TTA090KWA	518-632	16	25
7.5	TTA090K3D	187-253	35	45
	TTA090K4D	414-506	18	20
	TTA090KWD	518-632	15	20
10	TTA120K3D	187-253	42	50
	TTA120K4D	414-506	20	25
	TTA120KWD	518-632	18	20
10	TTA120K3C	187-253	43	50
	TTA120K4C	414-506	22	25
	TTA120KWC	518-632	20	25
12.5	TTA150K3D	187-253	66	90
	TTA150K4D	414-506	28	35
	TTA150KWD	518-632	24	30
15	TTA180K3D	187-253	74	100
	TTA180K4D	414-506	33	40
	TTA180KWD	518-632	28	35
15	TTA180K3C	187-253	73	100
	TTA180K4C	414-506	34	45
	TTA180KWC	518-632	26	35
20	TTA240K3D	187-253	87	110
	TTA240K4D	414-506	45	60
	TTA240KWD	518-632	36	50
20	TTA240K3C	187-253	112	150
	TTA240K4C	414-506	54	70
	TTA240KWC	518-632	45	60
25	TTA300K3C	187-253	109	150
	TTA300K4C	414-506	61	80
	TTA300KWC	518-632	41	50

## Air Handler

**Table 66. Voltage operating range (all air handlers)**

Model Number: Digit 8	Electrical Characteristics	Unit Operating Voltage Range
1	208-230/60/1	187-253
3	208-230/60/3	187-253



## Electrical Data

**Table 66. Voltage operating range (all air handlers) (continued)**

Model Number: Digit 8	Electrical Characteristics	Unit Operating Voltage Range
4	460/60/3	414-506
W	575/60/3	518-632

**Table 67. Electrical characteristics — 5 to 10 ton standard motor — 60 Hz constant volume air handler**

Tons	Unit Model Number	Standard Evaporator Fan Motor							
		No.	Volts	Phase	HP	Amps		MCA	MOP
						FLA	LRA		
5	TWE060K1A/B	1	208-230	1	0.75	6.0	43.0	8	15
	TWE060K3A/B	1	208-230	3	0.75	2.8	13.0	4	15
	TWE060K4A/B	1	460	3	0.75	1.4	6.0	2	15
	TWE060KWA	1	575	3	0.75	1.4	5.0	2	15
7.5	TWE090K1A/B	1	208-230	1	1.5	7.5	53.0	10	15
10	TWE120K1A/B	1	208-230	1	2	10.5	48.0	14	20

**Notes:**

- For additional information contact product support.
- (TWE072K3B, TWE090K3A/B, TWE120K3A/B, TWE150K3B and TWE180K3B are field wired for 460V.

**Table 68. Electrical characteristics — 5 to 25 ton high static motor — 60 Hz constant volume air handler**

Tons	Unit Model Number	High Static Evaporator Fan Motor							
		No.	Volts	Phase	HP	Amps		MCA	MOP
						FLA	LRA		
5	TWE060K1A/B	1	208-230	1	1.5	7.5	53.0	10	15
	TWE060K3A/B	1	208-230	3	1.5	6.4	33.0	8	15
	TWE060K4A/B	1	460	3	1.5	3.0	17.0	4	15
	TWE060KWA	1	575	3	1.5	1.9	14.0	3	15
7.5	TWE090K1A/B	1	208-230	1	2	10.5	48.0	14	20
	TWE090K3A/B	N/A	N/A	N/A	N/A	N/A	N/A	N/A	N/A
	TWE090K4A/B	N/A	N/A	N/A	N/A	N/A	N/A	N/A	N/A

**Notes:**

- For additional information contact product support.
- TWE072K3B, TWE090K3A/B, TWE120K3A/B, TWE150K3B and TWE180K3B are field wired for 460V.

**Table 69. Electrical characteristics — standard and oversized motors — 6 to 25 ton SZVAV and 2-Speed VFD air handler — 60 Hz**

Tons	Unit Model Number	Standard Evaporator Fan Motor								Oversized Evaporator Fan Motor							
		No.	Volts	Phase	HP	Amps		MCA	MOP	No.	Volts	Phase	HP	Amps		MCA	MOP
						FLA	LRA							FLA	LRA		
6	TWE072K3B	1	208-230	3	2	6.8	54.0	9	15	1	208-230	3	3	10.0	74.0	13	20
	TWE072K4B	1	460	3	2	3.3	27.2	5	15	1	460	3	3	4.9	37.0	7	15
	TWE072KWB	1	575	3	2	2.5	18.0	4	15	1	575	3	3	3.9	35.0	5	15
7.5	TWE090K3A/B	1	208-230	3	2	6.8	54.0	9	15	1	208-230	3	3	10.0	74.0	13	20
	TWE090K4A/B	1	460	3	2	3.3	27.2	5	15	1	460	3	3	4.9	37.0	7	15
	TWE090KWA/B	1	575	3	2	2.5	18.0	4	15	1	575	3	3	3.9	35.0	5	15
10	TWE120K3A/B	1	208-230	3	2	6.8	54.0	9	15	1	208-230	3	3	10.0	74.0	13	20
	TWE120K4A/B	1	460	3	2	3.3	27.0	5	15	1	460	3	3	4.9	37.0	7	15
	TWE120KWA/B	1	575	3	2	2.5	18.0	4	15	1	575	3	3	3.9	35.0	5	15



**Table 69. Electrical characteristics — standard and oversized motors — 6 to 25 ton SZVAV and 2-Speed VFD air handler — 60 Hz (continued)**

Tons	Unit Model Number	Standard Evaporator Fan Motor								Oversized Evaporator Fan Motor							
		No.	Volts	Phase	HP	Amps		MCA	MOP	No.	Volts	Phase	HP	Amps		MCA	MOP
						FLA	LRA							FLA	LRA		
12.5	TWE150K3B	1	208-230	3	2	6.8	54.0	9	15	1	208-230	3	5	15.1	105.0	19	30
	TWE150K4B	1	460	3	2	3.3	27.0	5	15	1	460	3	5	7.1	52.0	9	15
	TWE150KWB	1	575	3	2	2.5	18.0	4	15	1	575	3	5	5.7	46.0	8	15
15	TWE180K3B	1	208-230	3	3	10.0	74.0	13	20	1	208-230	3	5	15.1	105.0	19	30
	TWE180K4B	1	460	3	3	4.9	37.0	7	15	1	460	3	5	7.1	52.0	9	15
	TWE180KWB	1	575	3	3	3.9	35.0	5	15	1	575	3	5	5.7	46.0	8	15
20	TWE240K3B	1	208-230	3	5	15.1	105.0	19	30	1	208-230	3	7.5	22.8	141.0	29	50
	TWE240K4B	1	460	3	5	7.1	52.0	9	15	1	460	3	7.5	10.0	62.0	13	20
	TWE240KWB	1	575	3	5	5.7	46.0	8	15	1	575	3	7.5	8.2	60.0	11	15
25	TWE300K3B	1	208-230	3	7.5	22.8	141.0	29	50	1	208-230	3	10	25.2	177.0	32	50
	TWE300K4B	1	460	3	7.5	10.0	62.0	13	20	1	460	3	10	12.6	88.0	16	25
	TWE300KWB	1	575	3	7.5	8.2	60.0	11	15	1	575	3	10	10.1	71.0	13	20

Note: For additional information contact product support.

**Table 70. Unit wiring with electric heat (single point connection) — 5 to 25 ton constant volume air handlers — 60 Hz**

Tons	Used With	Heater Model Number	Heater kW Rating	Unit Power Supply	Control Stages	Standard Evap Motor		High Static Evap Motor	
						MCA	MOP	MCA	MOP
5	TWE060K1A/B	BAYHTRP106*	4.33	208/1/60	1	34	35	36	40
		BAYHTRS112*	8.65		1	60	60	62	70
		BAYHTRT117*	12.98		1	86	90	88	90
		BAYHTRS123*	17.31		2	112	125	114	125
5	TWE060K1A/B	BAYHTRP106*	5.76	230/1/60	1	38	40	40	40
		BAYHTRS112*	11.52		1	68	70	70	70
		BAYHTRT117*	17.28		1	98	100	100	100
		BAYHTRS123*	23.04		2	128	150	130	150
5	TWE060K3A/B	BAYHTRP305*	3.76	208/3/60	1	17	20	22	25
		BAYHTRS310*	7.48		1	30	30	34	35
		BAYHTRS315*	11.24		1	43	45	48	50
		BAYHTRP325*	18.72		2	69	70	74	80
5	TWE060K3A/B	BAYHTRP305*	5	230/3/60	1	19	20	24	25
		BAYHTRS310*	9.96		1	34	35	38	40
		BAYHTRS315*	14.96		1	49	50	54	60
		BAYHTRP325*	24.92		2	79	80	84	90
5	TWE060K4A/B	BAYHTRP405*	5	460/3/60	1	10	15	12	15
		BAYHTRS410*	9.96		1	17	20	19	20
		BAYHTRS415*	14.96		1	25	25	27	30
		BAYHTRP425*	24.92		2	40	40	42	45
5	TWE060KWA	BAYHTRPW05*	5	575/3/60	1	8	15	9	15
		BAYHTRSW10*	9.96		1	14	15	15	15
		BAYHTRSW15*	14.96		1	20	20	21	25
		BAYHTRPW25*	24.92		2	32	35	33	35



**Electrical Data**

**Table 70. Unit wiring with electric heat (single point connection) — 5 to 25 ton constant volume air handlers — 60 Hz (continued)**

Tons	Used With	Heater Model Number	Heater kW Rating	Unit Power Supply	Control Stages	Standard Evap Motor		High Static Evap Motor	
						MCA	MOP	MCA	MOP
7.5	TWE090K1A/B	BAYHTRP106*	4.33	208/1/60	1	36	40	40	40
		BAYHTRS112*	8.65		1	62	70	66	70
		BAYHTRT117*	12.98		1	88	90	92	100
		BAYHTRS123*	17.31		2	114	125	118	125
		BAYHTRP129*	21.63		2	140	150	144	150
7.5	TWE090K1A/B	BAYHTRP106*	5.76	230/1/60	1	40	40	44	45
		BAYHTRS112*	11.52		1	70	70	74	80
		BAYHTRT117*	17.28		1	100	100	104	110
		BAYHTRS123*	23.04		2	130	150	134	150
		BAYHTRP129*	28.8		2	160	175	164	175
10	TWE120K1A/B	BAYHTRP106*	4.33	208/1/60	1	40	40	N/A	N/A
		BAYHTRS112*	8.65		1	66	70	N/A	N/A
		BAYHTRT117*	12.98		1	92	100	N/A	N/A
		BAYHTRS123*	17.31		2	118	125	N/A	N/A
		BAYHTRP129*	21.63		2	144	150	N/A	N/A
10	TWE120K1A/B	BAYHTRP106*	5.76	230/1/60	1	44	45	N/A	N/A
		BAYHTRS112*	11.52		1	74	80	N/A	N/A
		BAYHTRT117*	17.28		1	104	110	N/A	N/A
		BAYHTRS123*	23.04		2	134	150	N/A	N/A
		BAYHTRP129*	28.8		2	164	175	N/A	N/A

**Notes:**

1. kW ratings are at: 208/240V for 208-230V air handlers; 480V for 460V air handlers; 600V for 575V air handlers. For other than rated voltage, capacity = (voltage/rated voltage)<sup>2</sup> x rated capacity.
2. Any power supply and circuits must be wired and protected in accordance with local codes.
3. Electric heat not available with 380/60 Hz models.

**Table 71. Unit wiring with electric heat (single point connection) — 6 to 25 ton SZVAV and 2-Speed VFD air handlers — 60 Hz**

Tons	Used With	Heater Model Number	Heater KW Rating	Unit Power Supply	Control Stages	MCA	Maximum Fuse or Circuit Breaker Size
6	TWE072K3*****BC0, D0	BAYHTRP305*	3.76	208/3/60	1	22	25
		BAYHTRS310*	7.48		1	35	35
		BAYHTRS315*	11.24		1	48	50
		BAYHTRP325*	18.72		2	74	80
6	TWE072K3*****BC0, D0	BAYHTRP305*	5.00	230/3/60	1	24	25
		BAYHTRS310*	9.96		1	39	40
		BAYHTRS315*	14.96		1	54	60
		BAYHTRP325*	24.92		2	84	90
6	TWE072K3*****BC4, D4	BAYHTRP305*	3.76	208/3/60	1	26	30
		BAYHTRS310*	7.48		1	39	40
		BAYHTRS315*	11.24		1	52	60
		BAYHTRP325*	18.72		2	78	80
6	TWE072K3*****BC4, D4	BAYHTRP305*	5.00	230/3/60	1	28	30
		BAYHTRS310*	9.96		1	43	45
		BAYHTRS315*	14.96		1	58	60
		BAYHTRP325*	24.92		2	88	90

**Table 71. Unit wiring with electric heat (single point connection) — 6 to 25 ton SZVAV and 2-Speed VFD air handlers — 60 Hz (continued)**

Tons	Used With	Heater Model Number	Heater KW Rating	Unit Power Supply	Control Stages	MCA	Maximum Fuse or Circuit Breaker Size
6	TWE072K4*****BC0, D0	BAYHTRP405*	5.00	460/3/60	1	12	15
		BAYHTRS410*	9.96		1	20	20
		BAYHTRS415*	14.96		1	27	30
		BAYHTRP425*	24.92		2	42	45
6	TWE072K4*****BC4, D4	BAYHTRP405*	5.00	460/3/60	1	14	15
		BAYHTRS410*	9.96		1	22	25
		BAYHTRS415*	14.96		1	29	30
		BAYHTRP425*	24.92		2	44	45
6	TWE072KW*****BC0, D0	BAYHTRPW05*	5.00	575/3/60	1	10	15
		BAYHTRSW10*	9.96		1	16	20
		BAYHTRSW15*	14.96		1	22	25
		BAYHTRPW25*	24.92		2	34	35
6	TWE072KW*****BC4, D4	BAYHTRPW05*	5.00	575/3/60	1	11	15
		BAYHTRSW10*	9.96		1	17	20
		BAYHTRSW15*	14.96		1	23	25
		BAYHTRPW25*	24.92		2	35	35
7.5	TWE090K3*****BC0, D0	BAYHTRP305*	3.76	208/3/60	1	22	25
		BAYHTRS310*	7.48		1	35	35
		BAYHTRS315*	11.24		1	48	50
		BAYHTRP325*	18.72		2	74	80
		BAYHTRP335*	26.20		2	100	100
7.5	TWE090K3*****BC0, D0	BAYHTRP305*	5.00	230/3/60	1	24	25
		BAYHTRS310*	9.96		1	39	40
		BAYHTRS315*	14.96		1	54	60
		BAYHTRP325*	24.92		2	84	90
		BAYHTRP335*	34.88		2	114	125
7.5	TWE090K3*****BC4, D4	BAYHTRP305*	3.76	208/3/60	1	26	30
		BAYHTRS310*	7.48		1	39	40
		BAYHTRS315*	11.24		1	52	60
		BAYHTRP325*	18.72		2	78	80
		BAYHTRP335*	26.20		2	104	110
7.5	TWE090K3*****BC4, D4	BAYHTRP305*	5.00	230/3/60	1	28	30
		BAYHTRS310*	9.96		1	43	45
		BAYHTRS315*	14.96		1	58	60
		BAYHTRP325*	24.92		2	88	90
		BAYHTRP335*	34.88		2	118	125
7.5	TWE090K4*****BC0, D0	BAYHTRP405*	5.00	460/3/60	1	12	15
		BAYHTRS410*	9.96		1	20	20
		BAYHTRS415*	14.96		1	27	30
		BAYHTRP425*	24.92		2	42	45
		BAYHTRP435*	34.88		2	57	60



**Electrical Data**

**Table 71. Unit wiring with electric heat (single point connection) — 6 to 25 ton SZVAV and 2-Speed VFD air handlers — 60 Hz (continued)**

Tons	Used With	Heater Model Number	Heater KW Rating	Unit Power Supply	Control Stages	MCA	Maximum Fuse or Circuit Breaker Size
7.5	TWE090K4*****BC4, D4	BAYHTRP405*	5.00	460/3/60	1	14	15
		BAYHTRS410*	9.96		1	22	25
		BAYHTRS415*	14.96		1	29	30
		BAYHTRP425*	24.92		2	44	45
		BAYHTRP435*	34.88		2	59	60
7.5	TWE090KW*****BC0, D0	BAYHTRPW05*	5.00	575/3/60	1	10	15
		BAYHTRSW10*	9.96		1	16	20
		BAYHTRSW15*	14.96		1	22	25
		BAYHTRPW25*	24.92		2	34	35
		BAYHTRPW35*	34.88		2	46	50
7.5	TWE090KW*****BC4, D4	BAYHTRPW05*	5.00	575/3/60	1	11	15
		BAYHTRSW10*	9.96		1	17	20
		BAYHTRSW15*	14.96		1	23	25
		BAYHTRPW25*	24.92		2	35	35
		BAYHTRPW35*	34.88		2	47	50
10	TWE120K3*****BC0, D0	BAYHTRP305*	3.76	208/3/60	1	22	25
		BAYHTRS310*	7.48		1	35	35
		BAYHTRS315*	11.24		1	48	50
		BAYHTRP325*	18.72		2	74	80
		BAYHTRP335*	26.20		2	100	100
10	TWE120K3*****BC0, D0	BAYHTRP305*	5.00	230/3/60	1	24	25
		BAYHTRS310*	9.96		1	39	40
		BAYHTRS315*	14.96		1	54	60
		BAYHTRP325*	24.92		2	84	90
		BAYHTRP335*	34.88		2	114	125
10	TWE120K3*****BC4, D4	BAYHTRP305*	3.76	208/3/60	1	26	30
		BAYHTRS310*	7.48		1	39	40
		BAYHTRS315*	11.24		1	52	60
		BAYHTRP325*	18.72		2	78	80
		BAYHTRP335*	26.20		2	104	110
10	TWE120K3*****BC4, D4	BAYHTRP305*	5.00	230/3/60	1	28	30
		BAYHTRS310*	9.96		1	43	45
		BAYHTRS315*	14.96		1	58	60
		BAYHTRP325*	24.92		2	88	90
		BAYHTRP335*	34.88		2	118	125
10	TWE120K4*****BC0, D0	BAYHTRP405*	5.00	460/3/60	1	12	15
		BAYHTRS410*	9.96		1	20	20
		BAYHTRS415*	14.96		1	27	30
		BAYHTRP425*	24.92		2	42	45
		BAYHTRP435*	34.88		2	57	60

**Table 71. Unit wiring with electric heat (single point connection) — 6 to 25 ton SZVAV and 2-Speed VFD air handlers — 60 Hz (continued)**

Tons	Used With	Heater Model Number	Heater KW Rating	Unit Power Supply	Control Stages	MCA	Maximum Fuse or Circuit Breaker Size
10	TWE120K4*****BC4, D4	BAYHTRP405*	5.00	460/3/60	1	14	15
		BAYHTRS410*	9.96		1	22	25
		BAYHTRS415*	14.96		1	29	30
		BAYHTRP425*	24.92		2	44	45
		BAYHTRP435*	34.88		2	59	60
10	TWE120KW*****BC0, D0	BAYHTRPW05*	5.00	575/3/60	1	10	15
		BAYHTRSW10*	9.96		1	16	20
		BAYHTRSW15*	14.96		1	22	25
		BAYHTRPW25*	24.92		2	34	35
		BAYHTRPW35*	34.88		2	46	50
10	TWE120KW*****BC4, D4	BAYHTRPW05*	5.00	575/3/60	1	11	15
		BAYHTRSW10*	9.96		1	17	20
		BAYHTRSW15*	14.96		1	23	25
		BAYHTRPW25*	24.92		2	35	35
		BAYHTRPW35*	34.88		2	47	50
12.5	TWE150K3*****BC0, D0	BAYHTRT310*	7.51	208/3/60	1	35	35
		BAYHTRR320*	14.96		1	61	70
		BAYHTRR330*	22.47		2	87	90
		BAYHTRR350*	37.44		2	139	150
12.5	TWE150K3*****BC0, D0	BAYHTRT310*	10.00	230/3/60	1	39	40
		BAYHTRR320*	19.92		1	69	70
		BAYHTRR330*	29.92		2	99	100
		BAYHTRR350*	49.84		2	159	175
12.5	TWE150K3*****BC4, D4	BAYHTRT310*	7.51	208/3/60	1	45	50
		BAYHTRR320*	14.96		1	71	80
		BAYHTRR330*	22.47		2	97	100
		BAYHTRR350*	37.44		2	149	150
12.5	TWE150K3*****BC4, D4	BAYHTRT310*	10.00	230/3/60	1	49	50
		BAYHTRR320*	19.92		1	79	80
		BAYHTRR330*	29.92		2	109	110
		BAYHTRR350*	49.84		2	169	175
12.5	TWE150K4*****BC0, D0	BAYHTRT410*	10.00	460/3/60	1	20	20
		BAYHTRR420*	19.92		1	35	35
		BAYHTRR430*	29.92		2	50	50
		BAYHTRR450*	49.84		2	80	80
12.5	TWE150K4*****BC4, D4	BAYHTRT410*	10.00	460/3/60	1	24	25
		BAYHTRR420*	19.92		1	39	40
		BAYHTRR430*	29.92		2	54	60
		BAYHTRR450*	49.84		2	84	90



**Electrical Data**

**Table 71. Unit wiring with electric heat (single point connection) — 6 to 25 ton SZVAV and 2-Speed VFD air handlers — 60 Hz (continued)**

Tons	Used With	Heater Model Number	Heater KW Rating	Unit Power Supply	Control Stages	MCA	Maximum Fuse or Circuit Breaker Size
12.5	TWE150KW*****BC0, D0	BAYHTRTW10*	10.00	575/3/60	1	16	20
		BAYHTRRW20*	19.92		1	28	30
		BAYHTRRW30*	29.92		2	40	40
		BAYHTRRW50*	49.84		2	64	70
12.5	TWE150KW*****BC4, D4	BAYHTRTW10*	10.00	575/3/60	1	20	20
		BAYHTRRW20*	19.92		1	32	35
		BAYHTRRW30*	29.92		2	44	45
		BAYHTRRW50*	49.84		2	68	70
15	TWE180K3*****BC0, D0	BAYHTRT310*	7.51	208/3/60	1	39	40
		BAYHTRR320*	14.96		1	65	70
		BAYHTRR330*	22.47		2	91	100
		BAYHTRR350*	37.44		2	143	150
15	TWE180K3*****BC0, D0	BAYHTRT310*	10.00	230/3/60	1	43	45
		BAYHTRR320*	19.92		1	73	80
		BAYHTRR330*	29.92		2	103	110
		BAYHTRR350*	49.84		2	163	175
15	TWE180K3*****BC4, D4	BAYHTRT310*	7.51	208/3/60	1	45	50
		BAYHTRR320*	14.96		1	71	80
		BAYHTRR330*	22.47		2	97	100
		BAYHTRR350*	37.44		2	149	150
15	TWE180K3*****BC4, D4	BAYHTRT310*	10.00	230/3/60	1	49	50
		BAYHTRR320*	19.92		1	79	80
		BAYHTRR330*	29.92		2	109	110
		BAYHTRR350*	49.84		2	169	175
15	TWE180K4*****BC0, D0	BAYHTRT410*	10.00	460/3/60	1	22	25
		BAYHTRR420*	19.92		1	37	40
		BAYHTRR430*	29.92		2	52	60
		BAYHTRR450*	49.84		2	82	90
15	TWE180K4*****BC4, D4	BAYHTRT410*	10.00	460/3/60	1	24	25
		BAYHTRR420*	19.92		1	39	40
		BAYHTRR430*	29.92		2	54	60
		BAYHTRR450*	49.84		2	84	90
15	TWE180KW*****BC0, D0	BAYHTRTW10*	10.00	575/3/60	1	17	20
		BAYHTRRW20*	19.92		1	29	30
		BAYHTRRW30*	29.92		2	41	45
		BAYHTRRW50*	49.84		2	65	70
15	TWE180KW*****BC4, D4	BAYHTRTW10*	10.00	575/3/60	1	20	20
		BAYHTRRW20*	19.92		1	32	35
		BAYHTRRW30*	29.92		2	44	45
		BAYHTRRW50*	49.84		2	68	70

**Table 71. Unit wiring with electric heat (single point connection) — 6 to 25 ton SZVAV and 2-Speed VFD air handlers — 60 Hz (continued)**

Tons	Used With	Heater Model Number	Heater KW Rating	Unit Power Supply	Control Stages	MCA	Maximum Fuse or Circuit Breaker Size
20	TWE240K3*****BC0, D0	BAYHTRT310*	7.51	208/3/60	1	45	50
		BAYHTRR320*	14.96		1	71	80
		BAYHTRR330*	22.47		2	97	100
		BAYHTRR350*	37.44		2	149	150
20	TWE240K3*****BC0, D0	BAYHTRT310*	10.00	230/3/60	1	49	50
		BAYHTRR320*	19.92		1	79	80
		BAYHTRR330*	29.92		2	109	110
		BAYHTRR350*	49.84		2	169	175
20	TWE240K3*****BC4, D4	BAYHTRT310*	7.51	208/3/60	1	55	70
		BAYHTRR320*	14.96		1	81	90
		BAYHTRR330*	22.47		2	107	110
		BAYHTRR350*	37.44		2	159	175
20	TWE240K3*****BC4, D4	BAYHTRT310*	10.00	230/3/60	1	59	70
		BAYHTRR320*	19.92		1	89	90
		BAYHTRR330*	29.92		2	119	125
		BAYHTRR350*	49.84		2	179	200
20	TWE240K4*****BC0, D0	BAYHTRT410*	10.00	460/3/60	1	24	25
		BAYHTRR420*	19.92		1	39	40
		BAYHTRR430*	29.92		2	54	60
		BAYHTRR450*	49.84		2	84	90
20	TWE240K4*****BC4, D4	BAYHTRT410*	10.00	460/3/60	1	28	30
		BAYHTRR420*	19.92		1	43	45
		BAYHTRR430*	29.92		2	58	60
		BAYHTRR450*	49.84		2	88	90
20	TWE240KW*****BC0, D0	BAYHTRTW10*	10.00	575/3/60	1	20	20
		BAYHTRRW20*	19.92		1	32	35
		BAYHTRRW30*	29.92		2	44	45
		BAYHTRRW50*	49.84		2	68	70
20	TWE240KW*****BC4, D4	BAYHTRTW10*	10.00	575/3/60	1	23	25
		BAYHTRRW20*	19.92		1	35	35
		BAYHTRRW30*	29.92		2	47	50
		BAYHTRRW50*	49.84		2	71	80
25	TWE300K3*****BC0, D0	BAYHTRT310*	7.51	208/3/60	1	55	70
		BAYHTRR320*	14.96		1	81	90
		BAYHTRR330*	22.47		2	107	110
		BAYHTRR350*	37.44		2	159	175
25	TWE300K3*****BC0, D0	BAYHTRT310*	10.00	230/3/60	1	59	70
		BAYHTRR320*	19.92		1	89	90
		BAYHTRR330*	29.92		2	119	125
		BAYHTRR350*	49.84		2	179	200



**Electrical Data**

**Table 71. Unit wiring with electric heat (single point connection) — 6 to 25 ton SZVAV and 2-Speed VFD air handlers — 60 Hz (continued)**

Tons	Used With	Heater Model Number	Heater KW Rating	Unit Power Supply	Control Stages	MCA	Maximum Fuse or Circuit Breaker Size
25	TWE300K3*****BC4, D4	BAYHTRT310*	7.51	208/3/60	1	58	70
		BAYHTRR320*	14.96		1	84	90
		BAYHTRR330*	22.47		2	110	110
		BAYHTRR350*	37.44		2	162	175
25	TWE300K3*****BC4, D4	BAYHTRT310*	10.00	230/3/60	1	62	80
		BAYHTRR320*	19.92		1	92	100
		BAYHTRR330*	29.92		2	122	125
		BAYHTRR350*	49.84		2	182	200
25	TWE300K4*****BC0, D0	BAYHTRT410*	10.00	460/3/60	1	28	30
		BAYHTRR420*	19.92		1	43	45
		BAYHTRR430*	29.92		2	58	60
		BAYHTRR450*	49.84		2	88	90
25	TWE300K4*****BC4, D4	BAYHTRT410*	10.00	460/3/60	1	31	40
		BAYHTRR420*	19.92		1	46	50
		BAYHTRR430*	29.92		2	61	70
		BAYHTRR450*	49.84		2	91	100
25	TWE300KW*****BC0, D0	BAYHTRTW10*	10.00	575/3/60	1	23	25
		BAYHTRRW20*	19.92		1	35	35
		BAYHTRRW30*	29.92		2	47	50
		BAYHTRRW50*	49.84		2	71	80
25	TWE300KW*****BC0, D4	BAYHTRTW10*	10.00	575/3/60	1	25	30
		BAYHTRRW20*	19.92		1	37	40
		BAYHTRRW30*	29.92		2	49	50
		BAYHTRRW50*	49.84		2	73	80

**Notes:**

1. kW ratings are at: 208/240V for 208-230V air handlers; 480V for 460V air handlers; 600V for 575V air handlers. For other than rated voltage, capacity = (voltage/rated voltage)<sup>2</sup> x rated capacity.
2. Any power supply and circuits must be wired and protected in accordance with local codes.
3. Electric heat not available with 380/60 Hz models.





# Jobsite Connections

## Symbio™ Controls

Wiring shown with dashed lines is to be furnished and installed by the customer. All customer supplied wiring must be copper only and must conform to NEC and local electrical codes. Codes may require line of sight between disconnect switch and unit.

**Figure 25. Symbio™ jobsite connections**

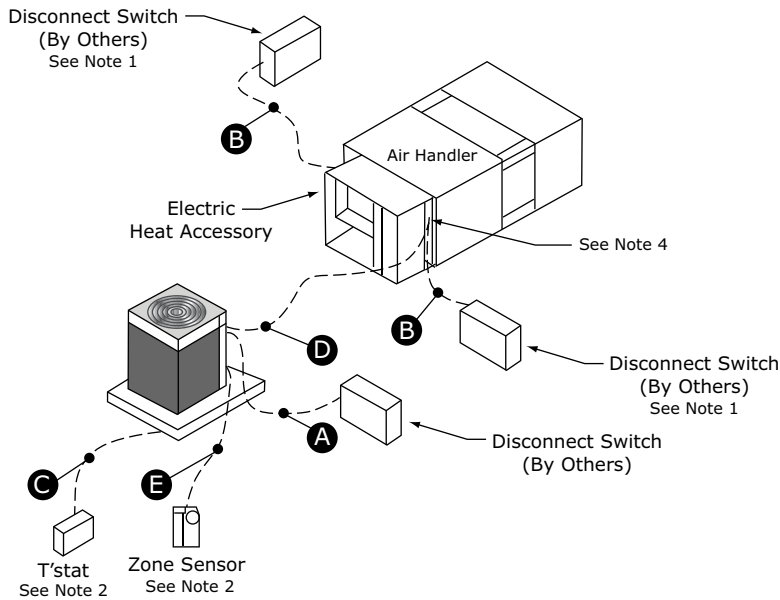

### Power Wires

- A. 3 wires, line voltage for 3 phase, 1 grounding wire\*\*
- B. 3 wires, line voltage for 3 phase, (2 wires for single phase) 1 grounding wire\*\*

### Control Wires

- C. Cooling only (or Cooling with Heat) thermostat: 4 to 7 wires depending on stages of cooling and electric heat
- D. Wiring between indoor and outdoor unit: 5 to 11 wires depending on unit control options\*
- E. Zone Sensor: 4 to 7 wires depending on zone sensor model\*

**Communication signal wires require shielded twisted pairs.**

Use Comlink cable with a PVC jacket, 18/1 PR, stranded shield, 25 PF/FT plenum rated for the field communication signal wiring.

**Notes:**

1. When electric heater accessory is used, single point power entry or dual point power entry is field optional. Single point power entry option is through electric heater only.
2. \*Choose only one of the following; Thermostat, Mechanical Zone Sensor, Programmable Zone Sensor Panel or BAS Zone Sensor.
3. \*\*

**⚠ WARNING**

**Electrical Shock Hazard!**  
*Failure to follow instructions below could result in death or serious injury.  
 Properly connect the system's oversized protective earthing (grounding) terminal(s).*

4. Once power wire connections are complete inside the air handler control box, seal the sheet metal entry points of the control box by using parts (neoprene gasket, grommet, and plug) shipped along with the air handler unit package.
5. For detailed controls wiring instructions, see Split System Air Conditioners Odyssey™ with Symbio™ Controls R-454B Wiring and Start-Up - Installation Guide (SS-SVN017\*-EN).

**Important:** For the EDC switch to be functional and thereby facilitate reliable unit operation, make the EDC connections from the indoor to the outdoor control boxes.

**Table 72. Recommended thermostat wire size**

Wire Size (Gauge)	Maximum Wire Length Physical distance between Unit & T'stat
22	30 Feet
20	50 Feet
18	75 Feet
16	125 Feet
14	200 Feet

**Table 73. Zone sensor module wiring**

Distance from Unit to Control	Recommended Wire Size
0-150 feet (0-45.7 m)	22 gauge (0.33 mm <sup>2</sup> )
151-240 feet (46-73.1 m)	20 gauge (0.50 mm <sup>2</sup> )
241-305 feet (73.5-117.3 m)	18 gauge (0.75 mm <sup>2</sup> )
386-610 feet (117.7-185.9 m)	16 gauge (1.31 mm <sup>2</sup> )
611-970 feet (186.2-295.7 m)	14 gauge ( 2.08 mm <sup>2</sup> )



# Dimensional Data

## Cooling Condenser

Figure 26. 6, 7.5 ton condensing, single compressor – in (mm)

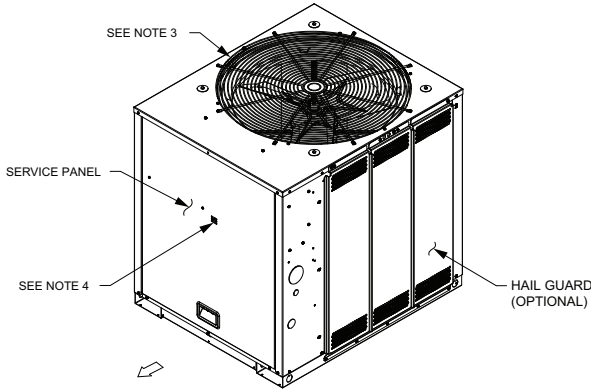

**NOTES:**

1. ACCESS OPENING IS FOR FIELD INSTALLED BAYLOAM ACCESSORY.
2. MINIMUM CLEARANCE FOR PROPER OPERATION IS 36" (914.4) FROM WALLS, SHRUBBERY, PRIVACY FENCES ETC. MINIMUM CLEARANCE BETWEEN ADJACENT UNITS IS 72" (1828.8). RECOMMENDED SERVICE CLEARANCE 48" (1219.2)
3. TOP DISCHARGE AREA SHOULD BE UNRESTRICTED FOR 100" (2540) MINIMUM. UNIT SHOULD BE PLACED SO ROOF RUN-OFF WATER OR FALLING SNOW FROM ROOF DOES NOT POUR/FALL DIRECTLY ON UNIT
4. OUTDOOR AIR TEMPERATURE SENSOR OPENING (DO NOT BLOCK OPENING)

SERVICE CLEARANCE  
48" (1219.2) (SEE NOTE 2  
FOR CLEARANCE)

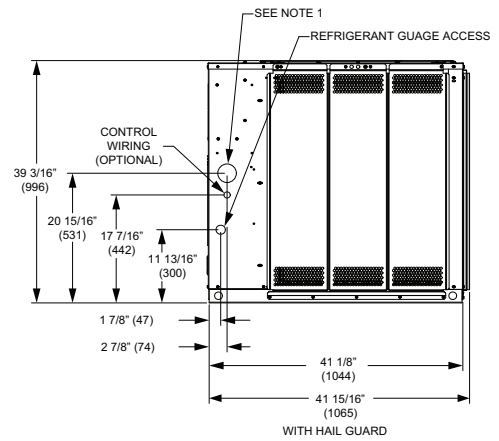
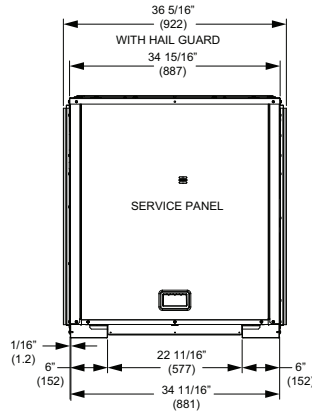
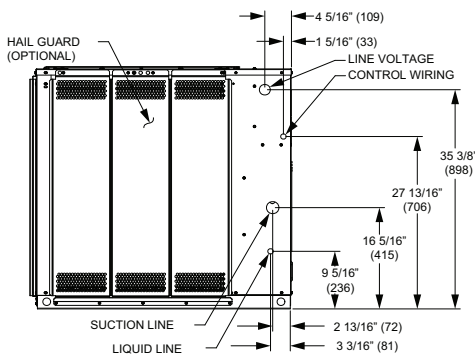

SERVICE PANEL SIDE

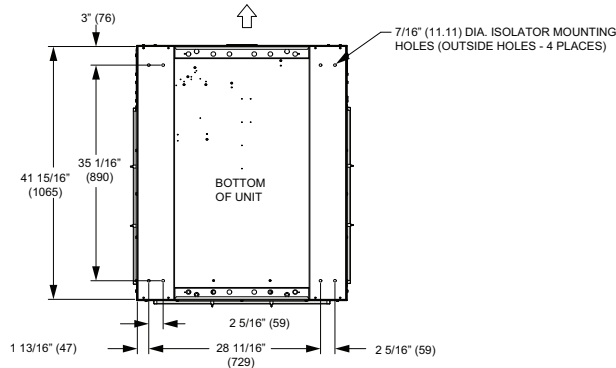



# Dimensional Data

Figure 27. 6, 7.5 ton condensing, dual compressor – in (mm)

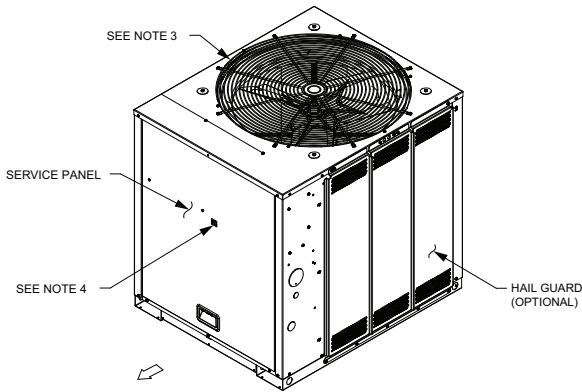

NOTES:

1. ACCESS OPENING IS FOR FIELD INSTALLED BAYLOAM ACCESSORY.
2. MINIMUM CLEARANCE FOR PROPER OPERATION IS 36" (914.4) FROM WALLS, SHRUBBERY, PRIVACY FENCES ETC. MINIMUM CLEARANCE BETWEEN ADJACENT UNITS IS 72" (1828.8). RECOMMENDED SERVICE CLEARANCE 48" (1219.2)
3. TOP DISCHARGE AREA SHOULD BE UNRESTRICTED FOR 100' (2540) MINIMUM. UNIT SHOULD BE PLACED SO ROOF RUN-OFF WATER OR FALLING SNOW FROM ROOF DOES NOT POUR/FALL DIRECTLY ON UNIT
4. OUTDOOR AIR TEMPERATURE SENSOR OPENING (DO NOT BLOCK OPENING)

SERVICE CLEARANCE  
48" (1219.2) (SEE NOTE 2  
FOR CLEARANCE)

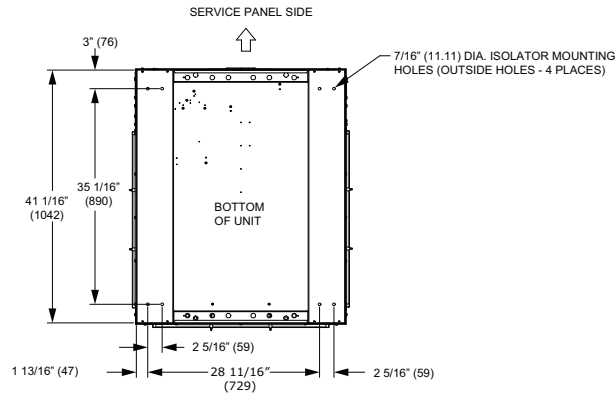
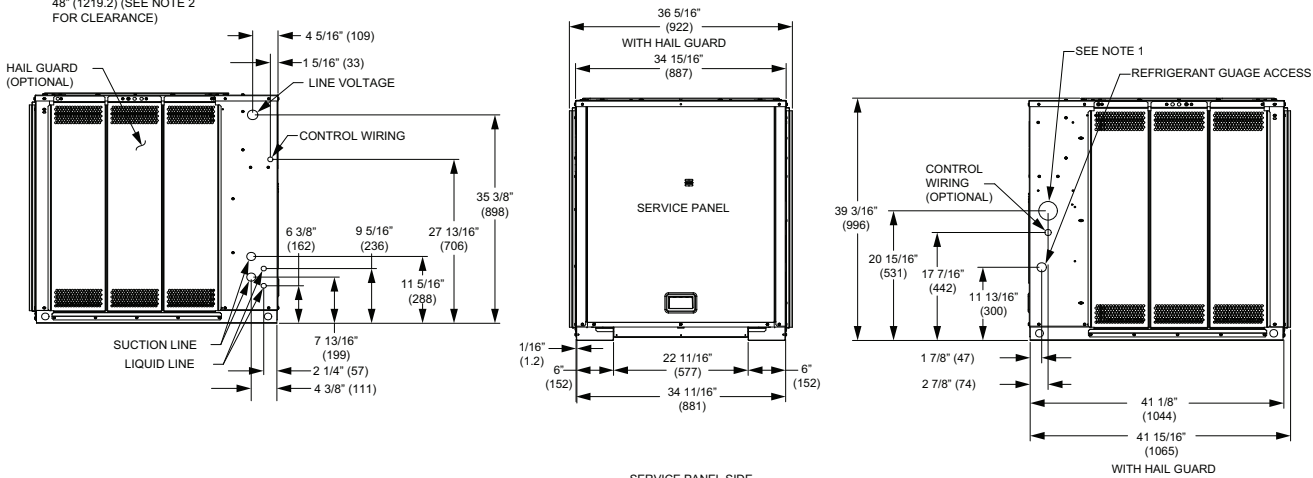
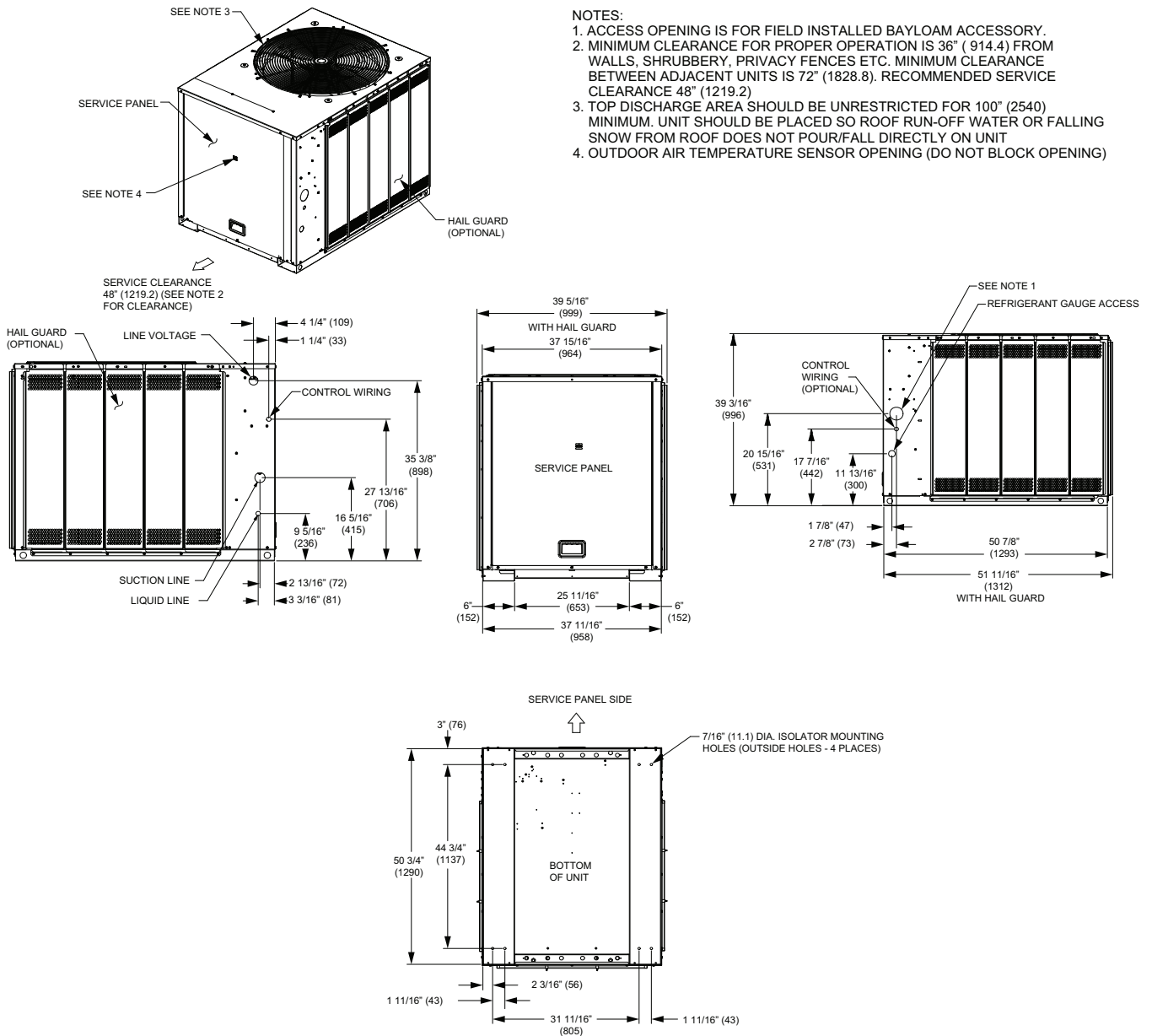
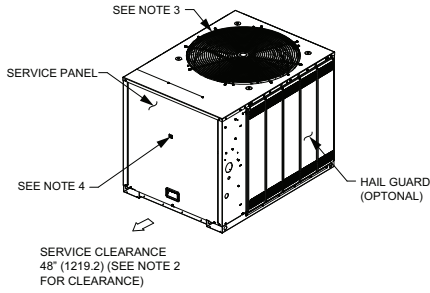

Figure 28. 10 ton condensing, manifolded compressor – in (mm)



**Figure 29. 10 ton condensing, dual compressor – in (mm)**



**NOTES:**

1. ACCESS OPENING IS FOR FIELD INSTALLED BAYLOAM ACCESSORY.
2. MINIMUM CLEARANCE FOR PROPER OPERATION IS 36" ( 914.4) FROM WALLS, SHRUBBERY, PRIVACY FENCES ETC. MINIMUM CLEARANCE BETWEEN ADJACENT UNITS IS 72" (1828.8). RECOMMENDED SERVICE CLEARANCE 48" (1219.2)
3. TOP DISCHARGE AREA SHOULD BE UNRESTRICTED FOR 100" (2540) MINIMUM. UNIT SHOULD BE PLACED SO ROOF RUN-OFF WATER OR FALLING SNOW FROM ROOF DOES NOT POUR/FALL DIRECTLY ON UNIT
4. OUTDOOR AIR TEMPERATURE SENSOR OPENING (DO NOT BLOCK OPENING)

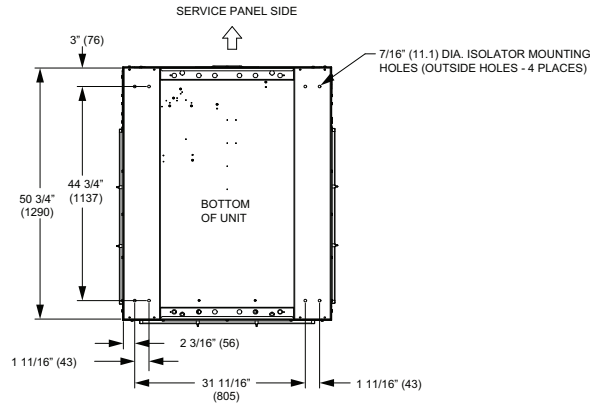
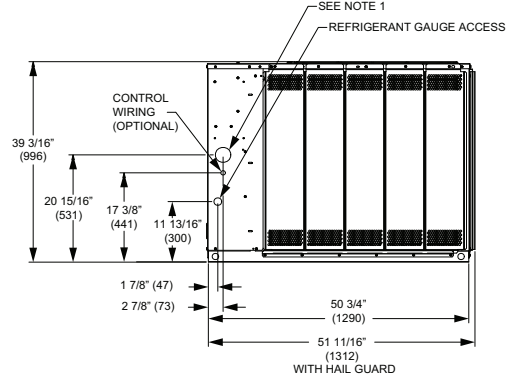
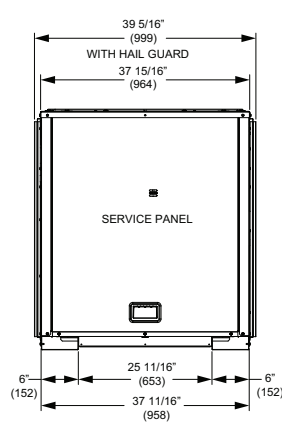
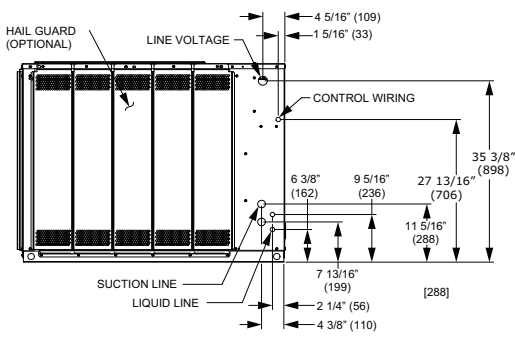
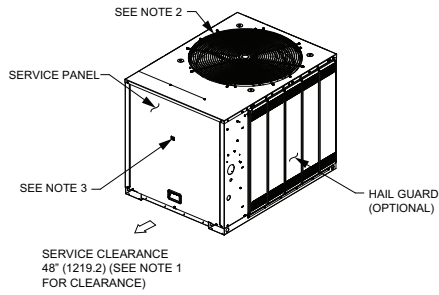
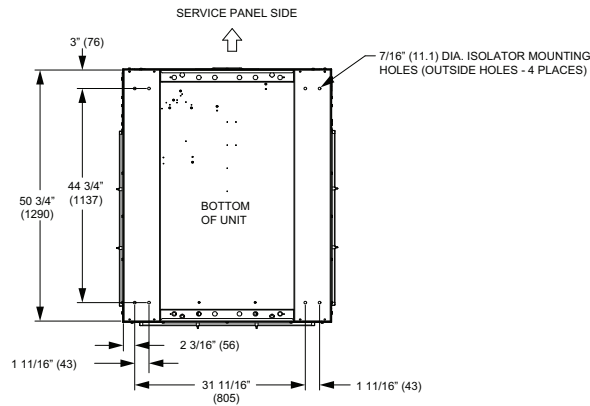
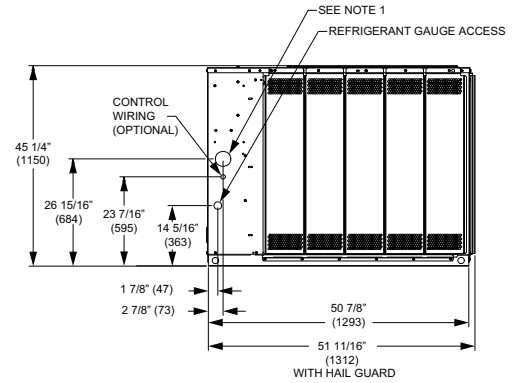
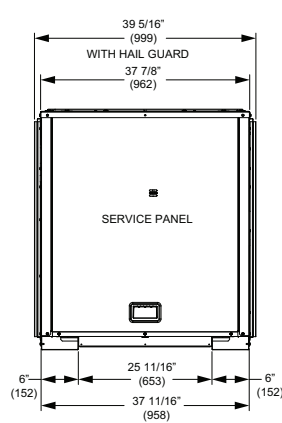
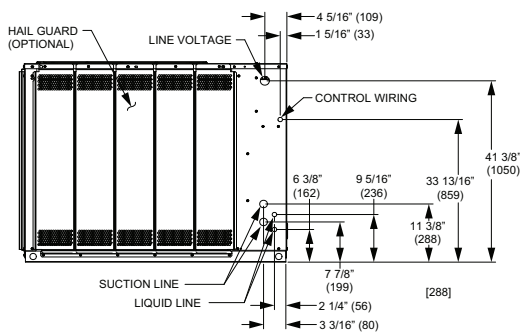

Figure 30. 12.5 ton condensing, dual compressor – in (mm)



NOTES:

1. MINIMUM CLEARANCE FOR PROPER OPERATION IS 36" ( 914.4) FROM WALLS, SHRUBBERY, PRIVACY FENCES ETC. MINIMUM CLEARANCE BETWEEN ADJACENT UNITS IS 72" (1828.8). RECOMMENDED SERVICE CLEARANCE 48" (1219.2)
2. TOP DISCHARGE AREA SHOULD BE UNRESTRICTED FOR 100" (2540) MINIMUM. UNIT SHOULD BE PLACED SO ROOF RUN-OFF WATER OR FALLING SNOW FROM ROOF DOES NOT POUR/FALL DIRECTLY ON UNIT
3. OUTDOOR AIR TEMPERATURE SENSOR OPENING (DO NOT BLOCK OPENING)



# Dimensional Data

Figure 31. 15, 20 ton condensing, dual compressor – in (mm)

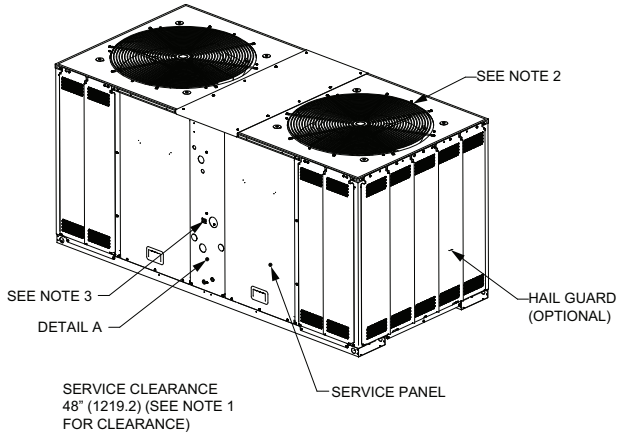

NOTES:

1. MINIMUM CLEARANCE FOR PROPER OPERATION IS 36" (914.4) FROM WALLS, SHRUBBERY, PRIVACY FENCES ETC. MINIMUM CLEARANCE BETWEEN ADJACENT UNITS IS 72" (1828.8). RECOMMENDED SERVICE CLEARANCE 48" (1219.2)
2. TOP DISCHARGE AREA SHOULD BE UNRESTRICTED FOR 100" (2540) MINIMUM. UNIT SHOULD BE PLACED SO ROOF RUN-OFF WATER OR FALLING SNOW FROM ROOF DOES NOT POUR/FALL DIRECTLY ON UNIT
3. OUTDOOR AIR TEMPERATURE SENSOR OPENING (DO NOT BLOCK OPENING)

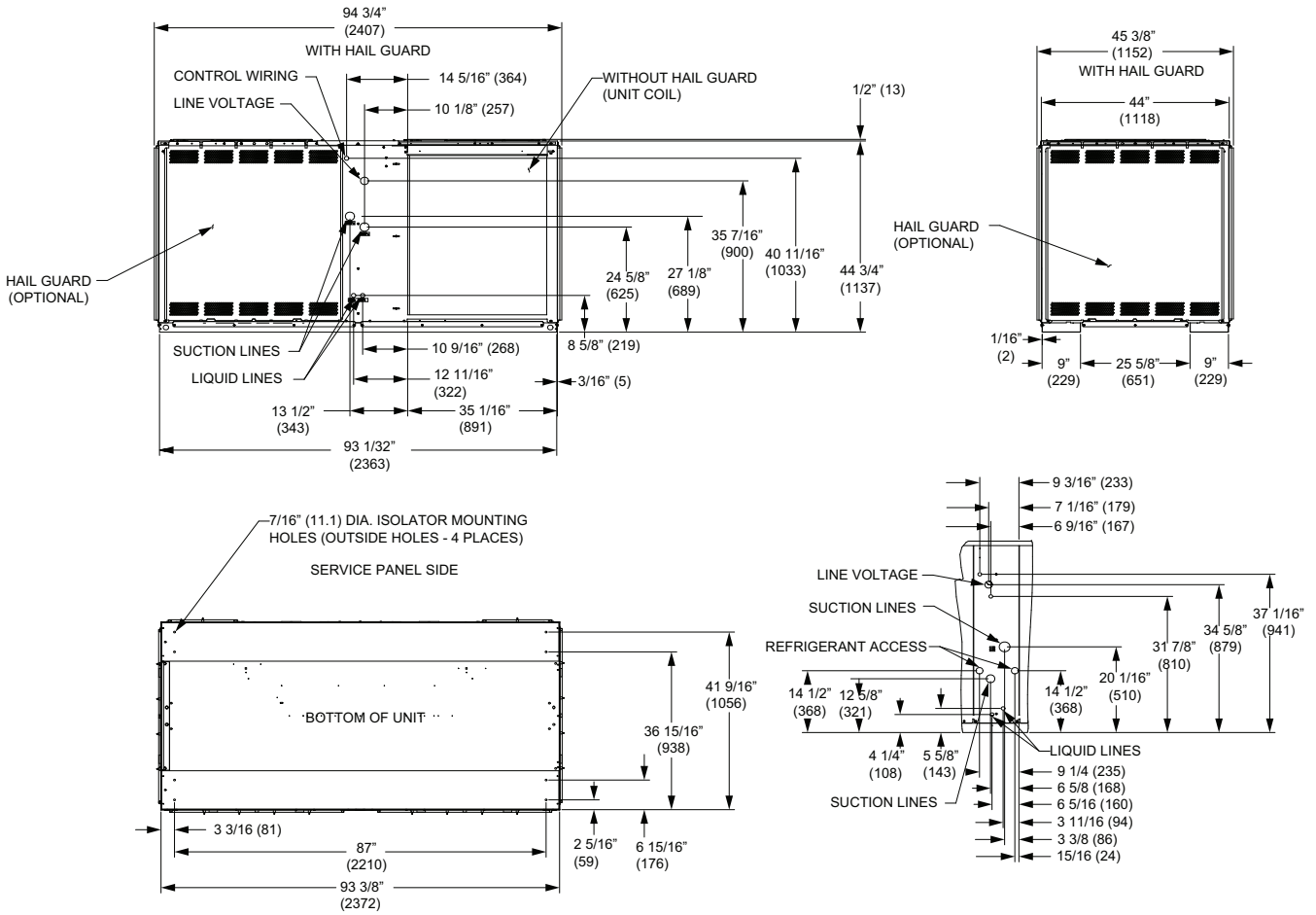
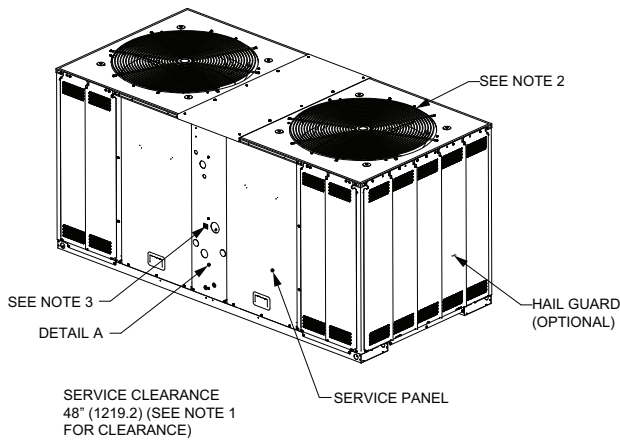

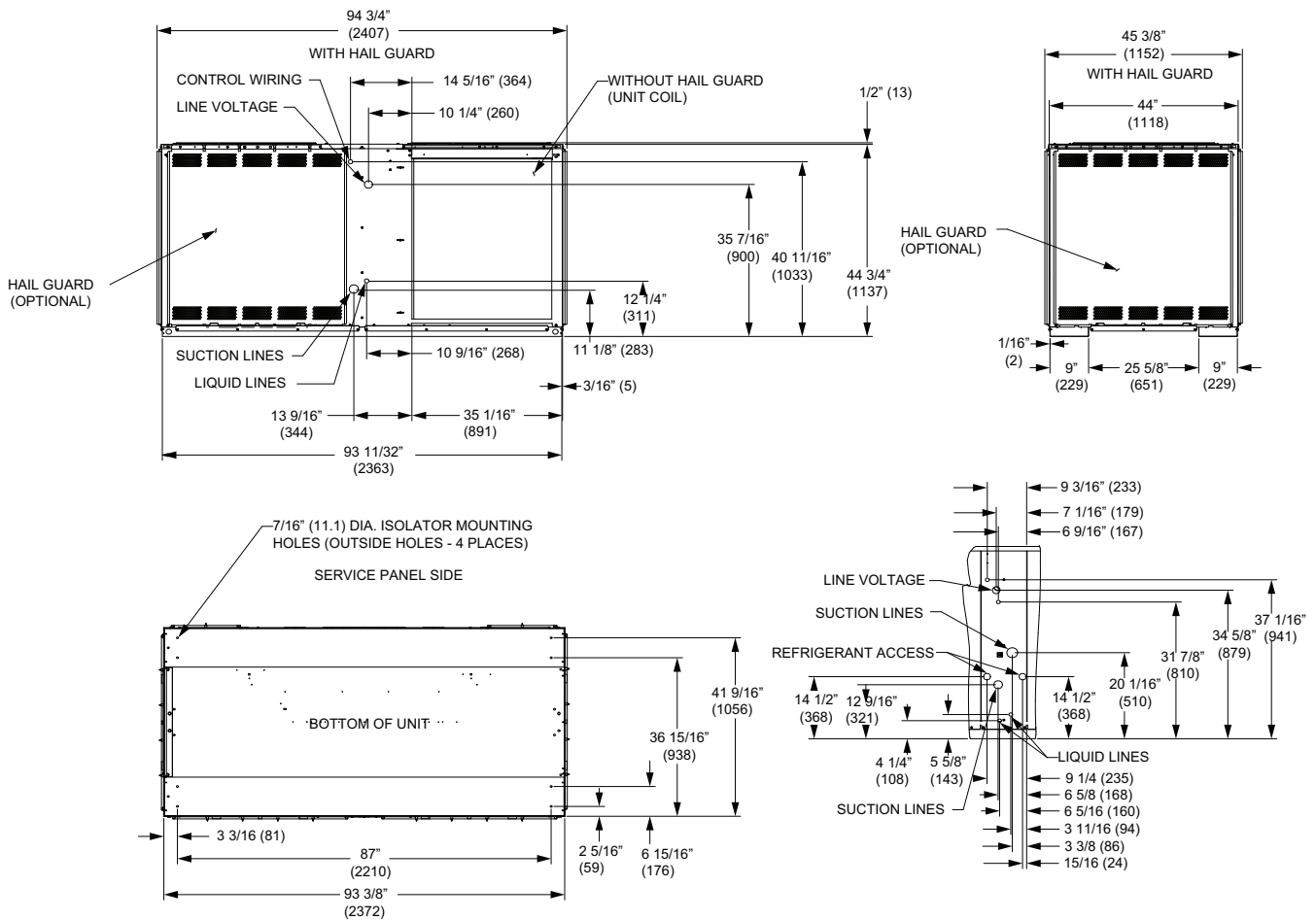

Figure 32. 15, 20 ton condensing, manifolded compressor – in (mm)



NOTES:

1. MINIMUM CLEARANCE FOR PROPER OPERATION IS 36" (914.4) FROM WALLS, SHRUBBERY, PRIVACY FENCES ETC. MINIMUM CLEARANCE BETWEEN ADJACENT UNITS IS 72" (1828.8). RECOMMENDED SERVICE CLEARANCE 48" (1219.2)
2. TOP DISCHARGE AREA SHOULD BE UNRESTRICTED FOR 100' (2540) MINIMUM. UNIT SHOULD BE PLACED SO ROOF RUN-OFF WATER OR FALLING SNOW FROM ROOF DOES NOT POUR/FALL DIRECTLY ON UNIT
3. OUTDOOR AIR TEMPERATURE SENSOR OPENING (DO NOT BLOCK OPENING)





# Dimensional Data

**Figure 33. 25 ton condensing, manifolded compressor – in (mm)**

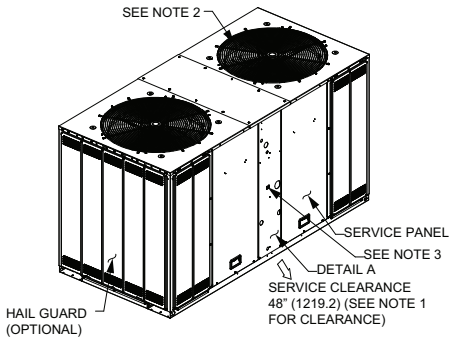

**NOTES:**

1. MINIMUM CLEARANCE FOR PROPER OPERATION IS 36" (914.4) FROM WALLS, SHRUBBERY, PRIVACY FENCES ETC. MINIMUM CLEARANCE BETWEEN ADJACENT UNITS IS 72" (1828.8). RECOMMENDED SERVICE CLEARANCE 48" (1219.2)
2. TOP DISCHARGE AREA SHOULD BE UNRESTRICTED FOR 100' (2540) MINIMUM. UNIT SHOULD BE PLACED SO ROOF RUN-OFF WATER OR FALLING SNOW FROM ROOF DOES NOT POUR/FALL DIRECTLY ON UNIT
3. OUTDOOR AIR TEMPERATURE SENSOR OPENING (DO NOT BLOCK OPENING)

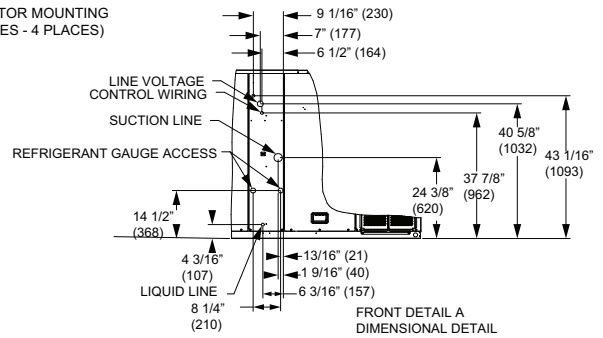
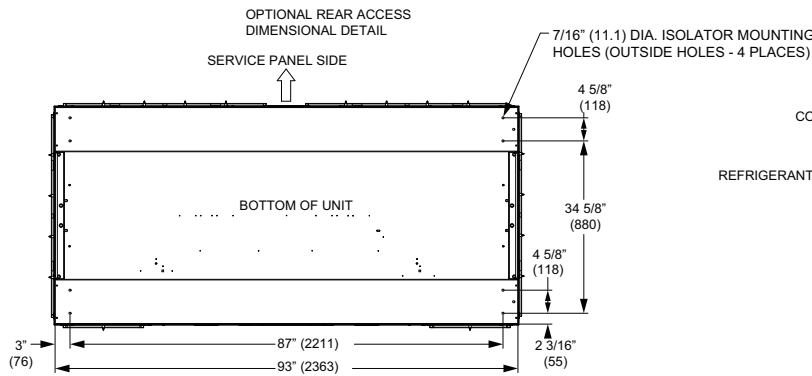
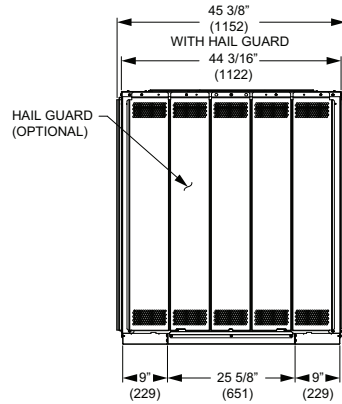
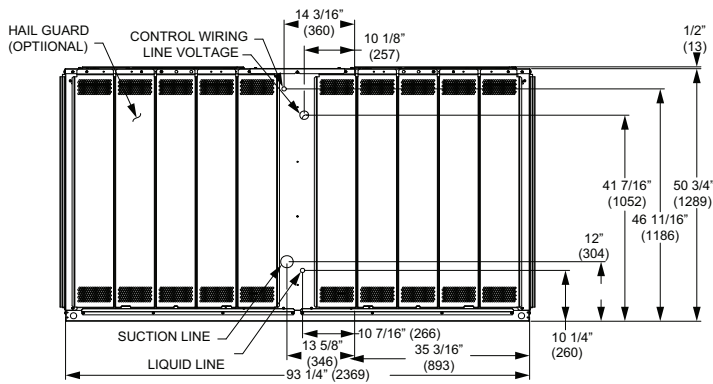

# Air Handler

**Figure 34. 5 ton air handler, single circuit – in. (mm)**

*Note: Duct flange is a field-installed accessory.*

**NOTES:**

1. PANEL DEPTH 1/2" (12.7) (TYP. ALL PANELS).
2. REMOVABLE DRAIN PAN AND ATTACHED DRAIN CONNECTION MAY BE INSTALLED ON END OF UNIT IN EITHER THE VERTICAL OR HORIZONTAL CONFIGURATION, PLASTIC DRAIN PAN ACCESS PLATE ON THE END OF UNIT OPPOSITE DRAIN CONNECTION MUST BE REMOVED TO SLIDE DRAIN PAN OUT OF UNIT FOR CLEANING. ACCESS PLATE MUST BE RE-INSTALLED AFTER SLIDING DRAIN PAN BACK INTO UNIT.
3. IF PERIODIC DRAIN PAN CLEANING IS REQUIRED, ALLOW ROOM FOR PARTIAL REMOVAL OF DRAIN PAN CONNECTION AT END OF UNIT.
4. 1" (25.4) FEMALE SCHED. 40 (10.2) PVC PIPE DRAIN CONNECTION VERTICAL CONFIGURATION.
5. 1" (25.4) FEMALE SCHED. 40 (10.2) PVC PIPE DRAIN CONNECTION HORIZONTAL CONFIGURATION.

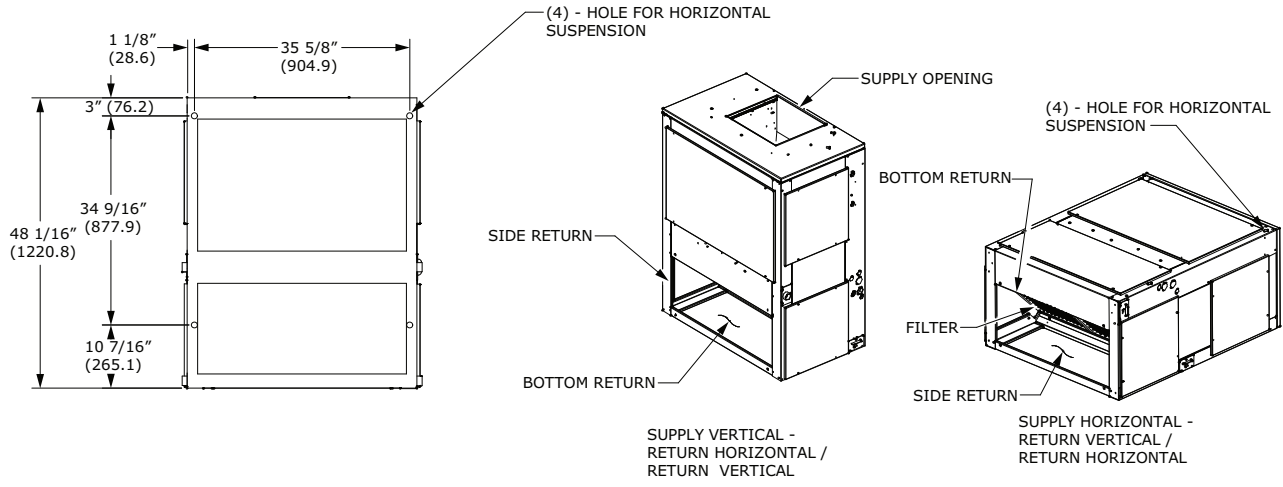
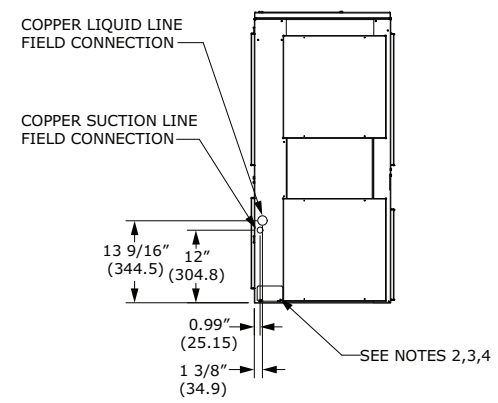
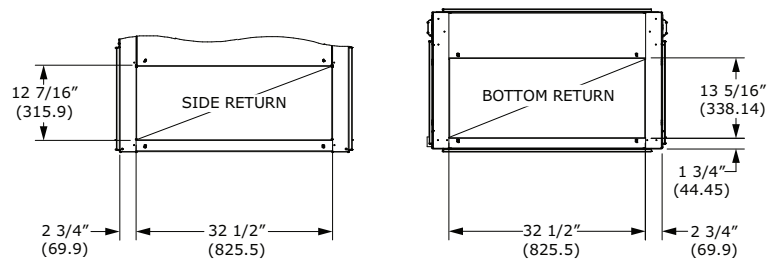
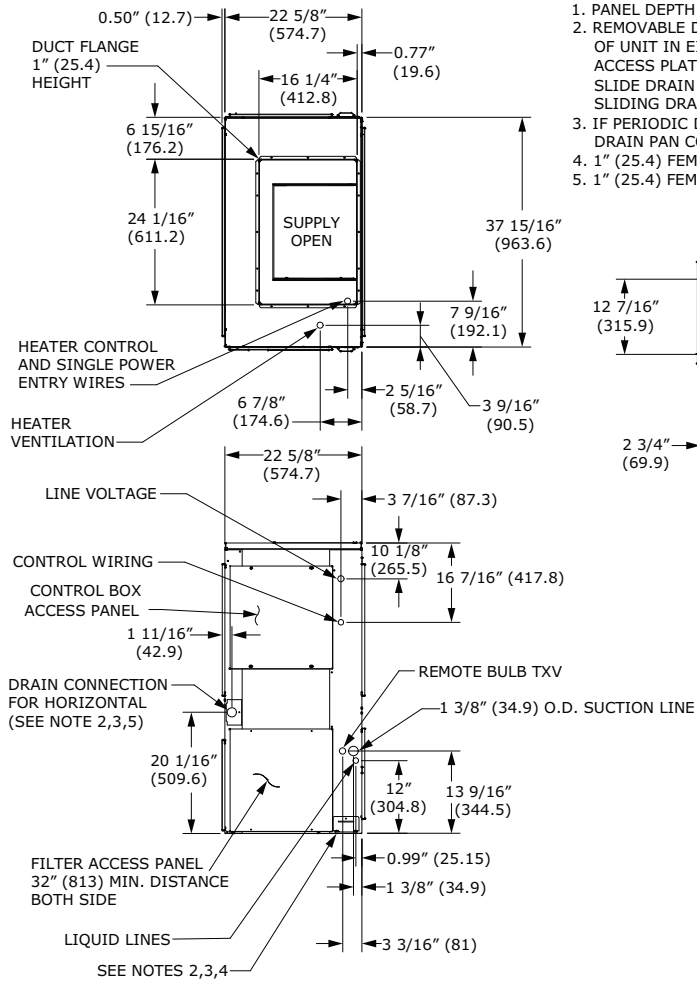

**Figure 35. 5 ton air handler, dual circuit – in. (mm)**

**Note: Duct flange is a field-installed accessory.**

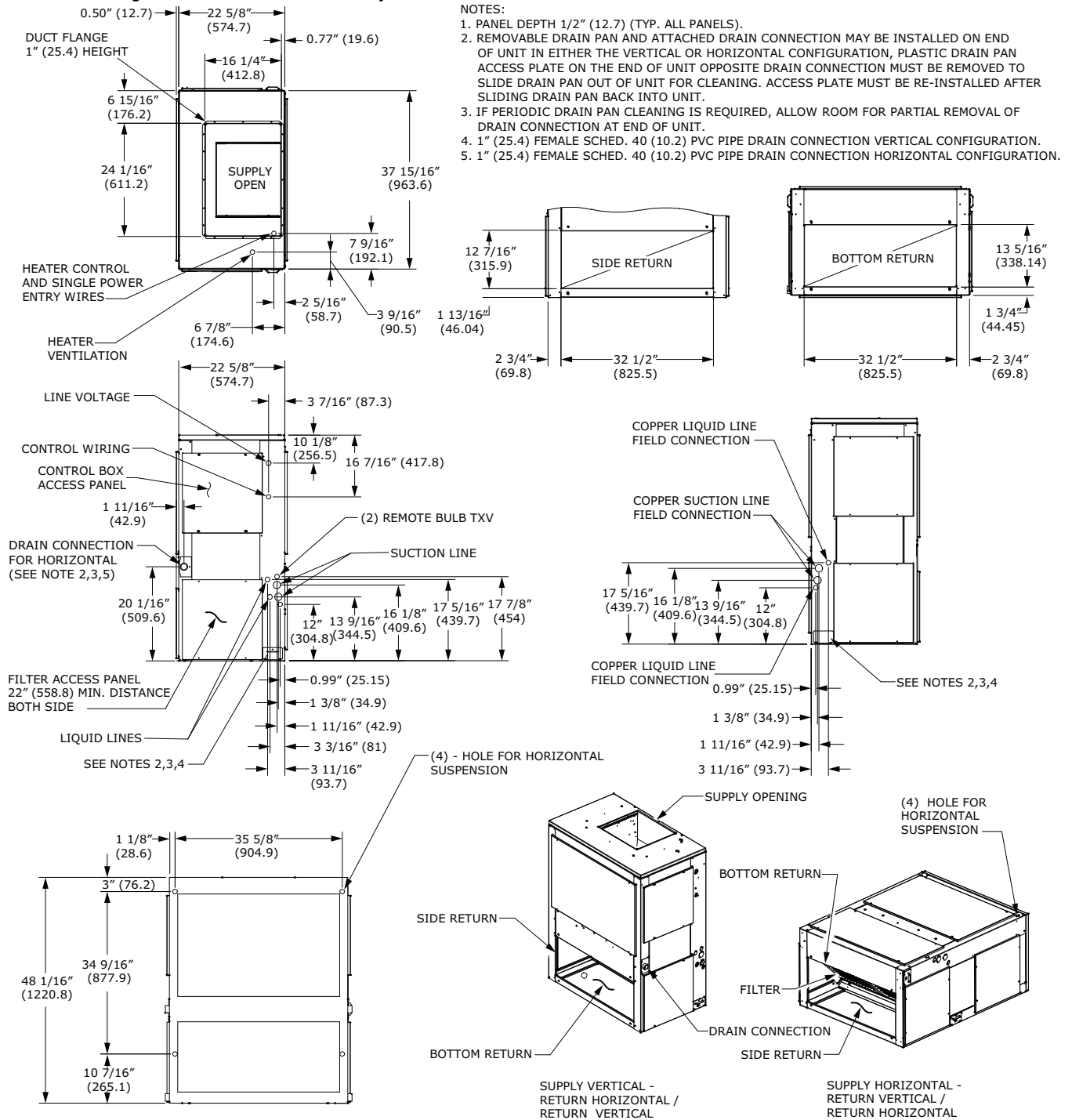

**Figure 36. 7.5 ton air handler, single circuit – in. (mm)**

**Note: Duct flange is a field-installed accessory.**

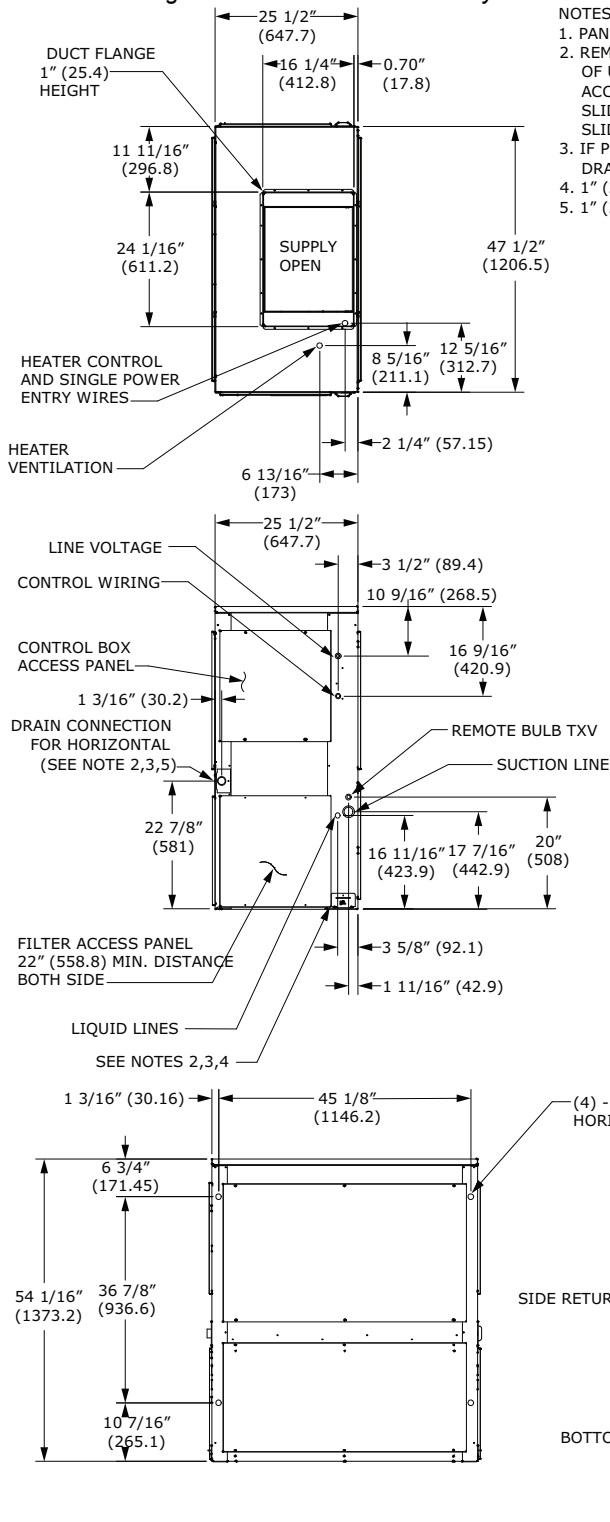

**NOTES:**

1. PANEL DEPTH 1/2" (12.7) (TYP. ALL PANELS).
2. REMOVABLE DRAIN PAN AND ATTACHED DRAIN CONNECTION MAY BE INSTALLED ON END OF UNIT IN EITHER THE VERTICAL OR HORIZONTAL CONFIGURATION, PLASTIC DRAIN PAN ACCESS PLATE ON THE END OF UNIT OPPOSITE DRAIN CONNECTION MUST BE REMOVED TO SLIDE DRAIN PAN OUT OF UNIT FOR CLEANING. ACCESS PLATE MUST BE RE-INSTALLED AFTER SLIDING DRAIN PAN BACK INTO UNIT.
3. IF PERIODIC DRAIN PAN CLEANING IS REQUIRED, ALLOW ROOM FOR PARTIAL REMOVAL OF DRAIN PAN CONNECTION AT END OF UNIT.
4. 1" (25.4) FEMALE SCHED. 40 (10.2) PVC PIPE DRAIN CONNECTION VERTICAL CONFIGURATION.
5. 1" (25.4) FEMALE SCHED. 40 (10.2) PVC PIPE DRAIN CONNECTION HORIZONTAL CONFIGURATION.

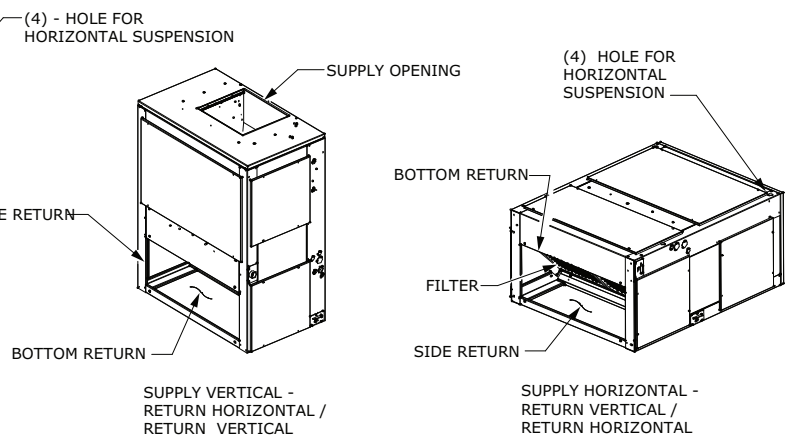
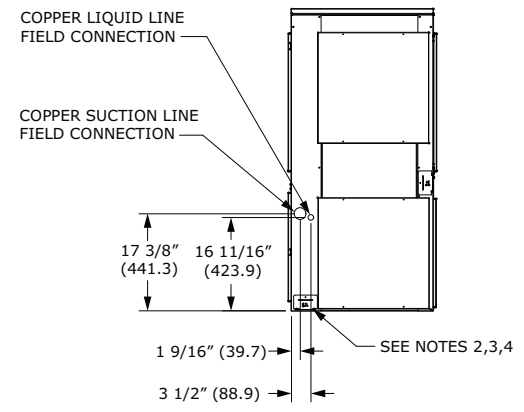
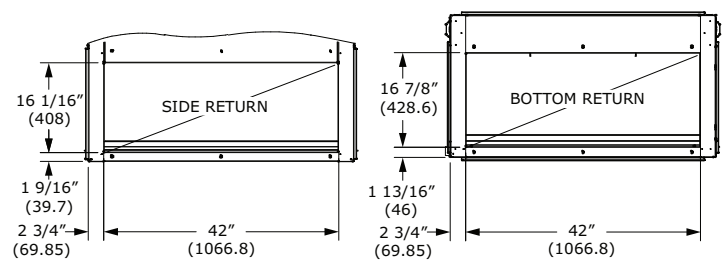

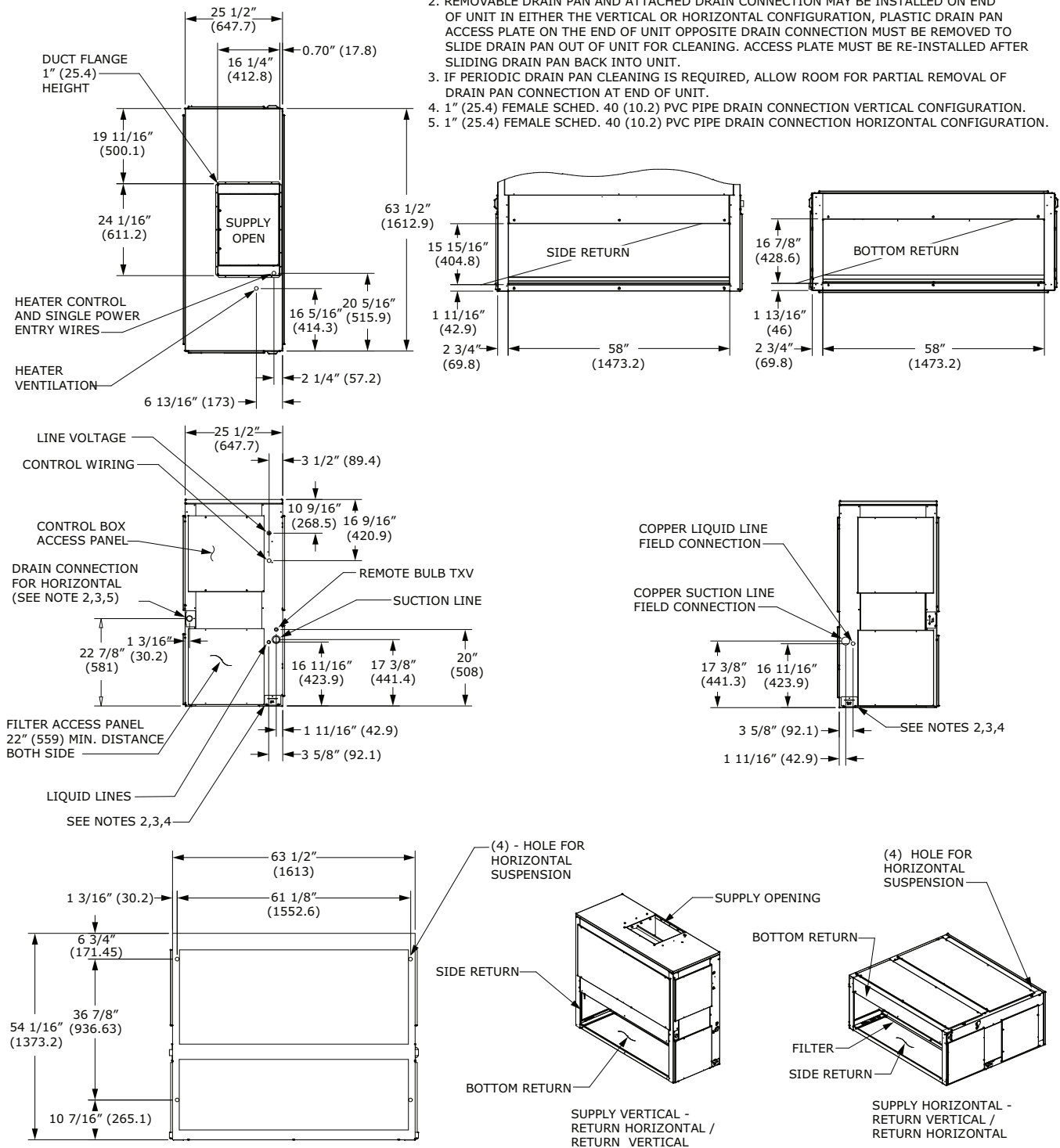

**Figure 38. 10 ton air handler, single circuit – in. (mm)**

*Note: Duct flange is a field-installed accessory.*

**NOTES:**

1. PANEL DEPTH 1/2" (12.7) (TYP. ALL PANELS).
2. REMOVABLE DRAIN PAN AND ATTACHED DRAIN CONNECTION MAY BE INSTALLED ON END OF UNIT IN EITHER THE VERTICAL OR HORIZONTAL CONFIGURATION, PLASTIC DRAIN PAN ACCESS PLATE ON THE END OF UNIT OPPOSITE DRAIN CONNECTION MUST BE REMOVED TO SLIDE DRAIN PAN OUT OF UNIT FOR CLEANING. ACCESS PLATE MUST BE RE-INSTALLED AFTER SLIDING DRAIN PAN BACK INTO UNIT.
3. IF PERIODIC DRAIN PAN CLEANING IS REQUIRED, ALLOW ROOM FOR PARTIAL REMOVAL OF DRAIN PAN CONNECTION AT END OF UNIT.
4. 1" (25.4) FEMALE SCHED. 40 (10.2) PVC PIPE DRAIN CONNECTION VERTICAL CONFIGURATION.
5. 1" (25.4) FEMALE SCHED. 40 (10.2) PVC PIPE DRAIN CONNECTION HORIZONTAL CONFIGURATION.

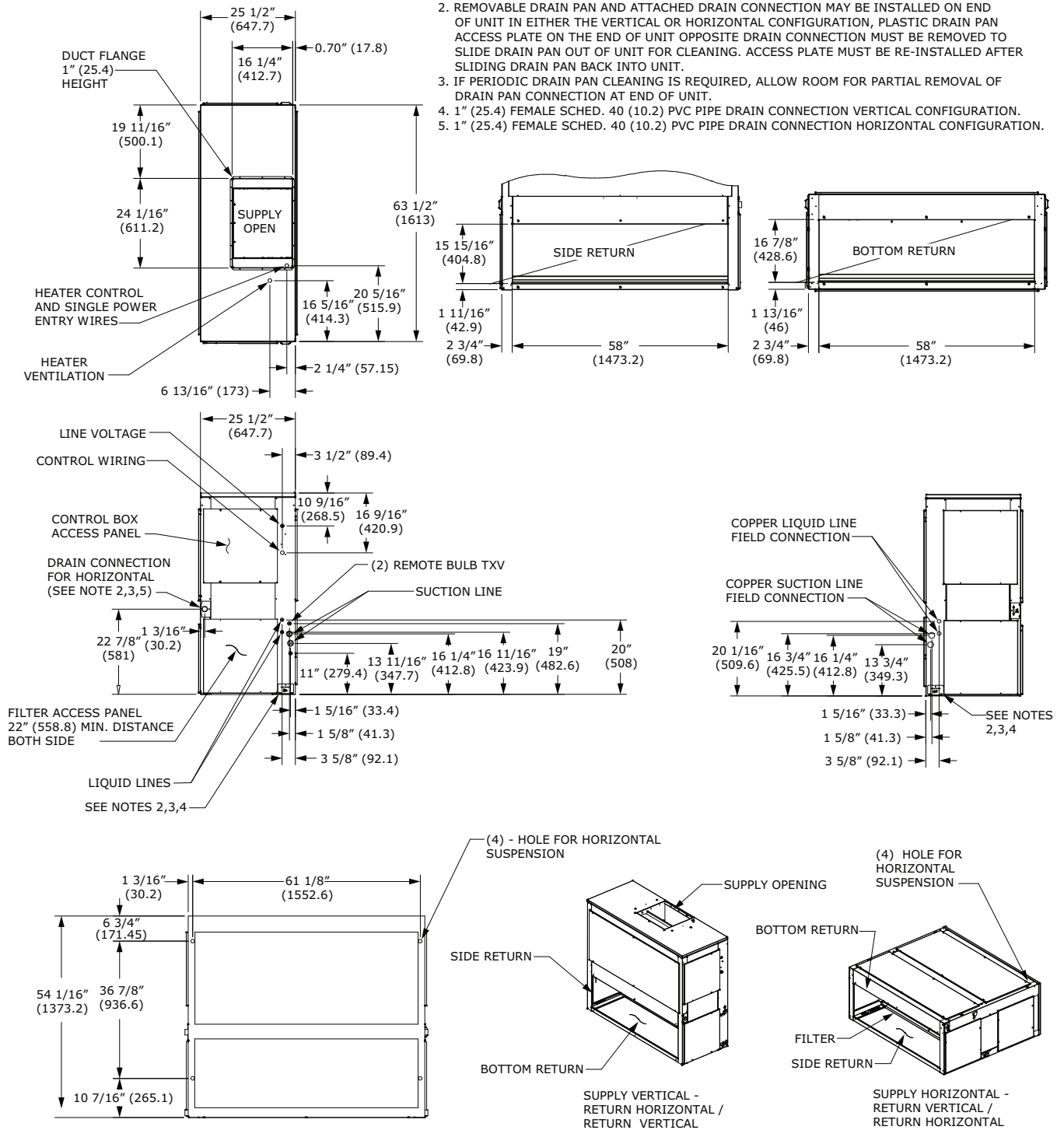

**Figure 39. 10 ton air handler, dual circuit – in. (mm)**

*Note: Duct flange is a field-installed accessory.*

**NOTES:**

1. PANEL DEPTH 1/2" (12.7) (TYP. ALL PANELS).
2. REMOVABLE DRAIN PAN AND ATTACHED DRAIN CONNECTION MAY BE INSTALLED ON END OF UNIT IN EITHER THE VERTICAL OR HORIZONTAL CONFIGURATION, PLASTIC DRAIN PAN ACCESS PLATE ON THE END OF UNIT OPPOSITE DRAIN CONNECTION MUST BE REMOVED TO SLIDE DRAIN PAN OUT OF UNIT FOR CLEANING. ACCESS PLATE MUST BE RE-INSTALLED AFTER SLIDING DRAIN PAN BACK INTO UNIT.
3. IF PERIODIC DRAIN PAN CLEANING IS REQUIRED, ALLOW ROOM FOR PARTIAL REMOVAL OF DRAIN PAN CONNECTION AT END OF UNIT.
4. 1" (25.4) FEMALE SCHED. 40 (10.2) PVC PIPE DRAIN CONNECTION VERTICAL CONFIGURATION.
5. 1" (25.4) FEMALE SCHED. 40 (10.2) PVC PIPE DRAIN CONNECTION HORIZONTAL CONFIGURATION.





**Figure 40. 12.5, 15 ton air handler, dual circuit – in. (mm)**

**Note:** Duct flange is a field-installed accessory.

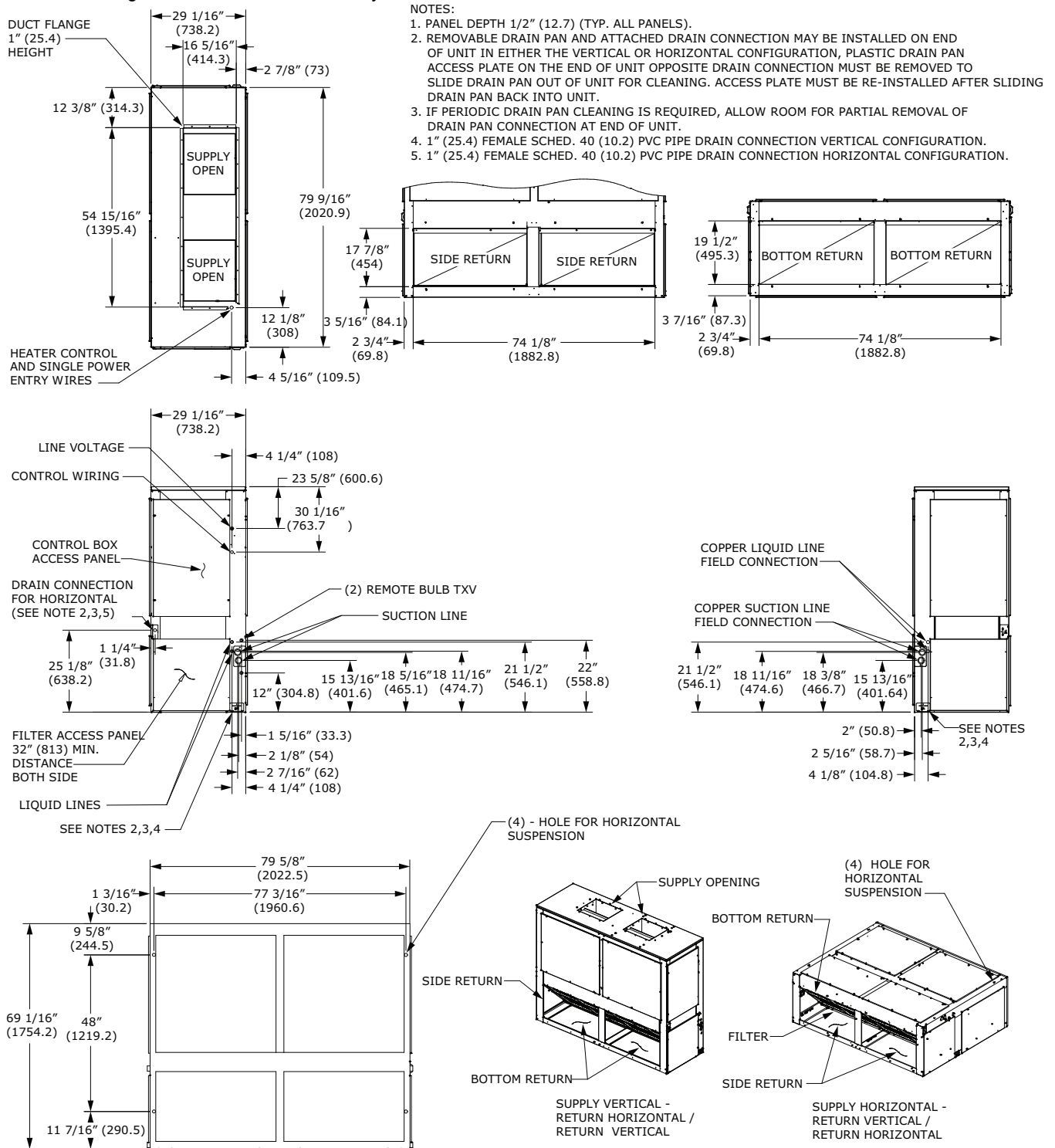

# Dimensional Data

**Figure 41. 20, 25 ton air handler, dual circuit – in. (mm)**

*Note: Duct flange is a field-installed accessory.*

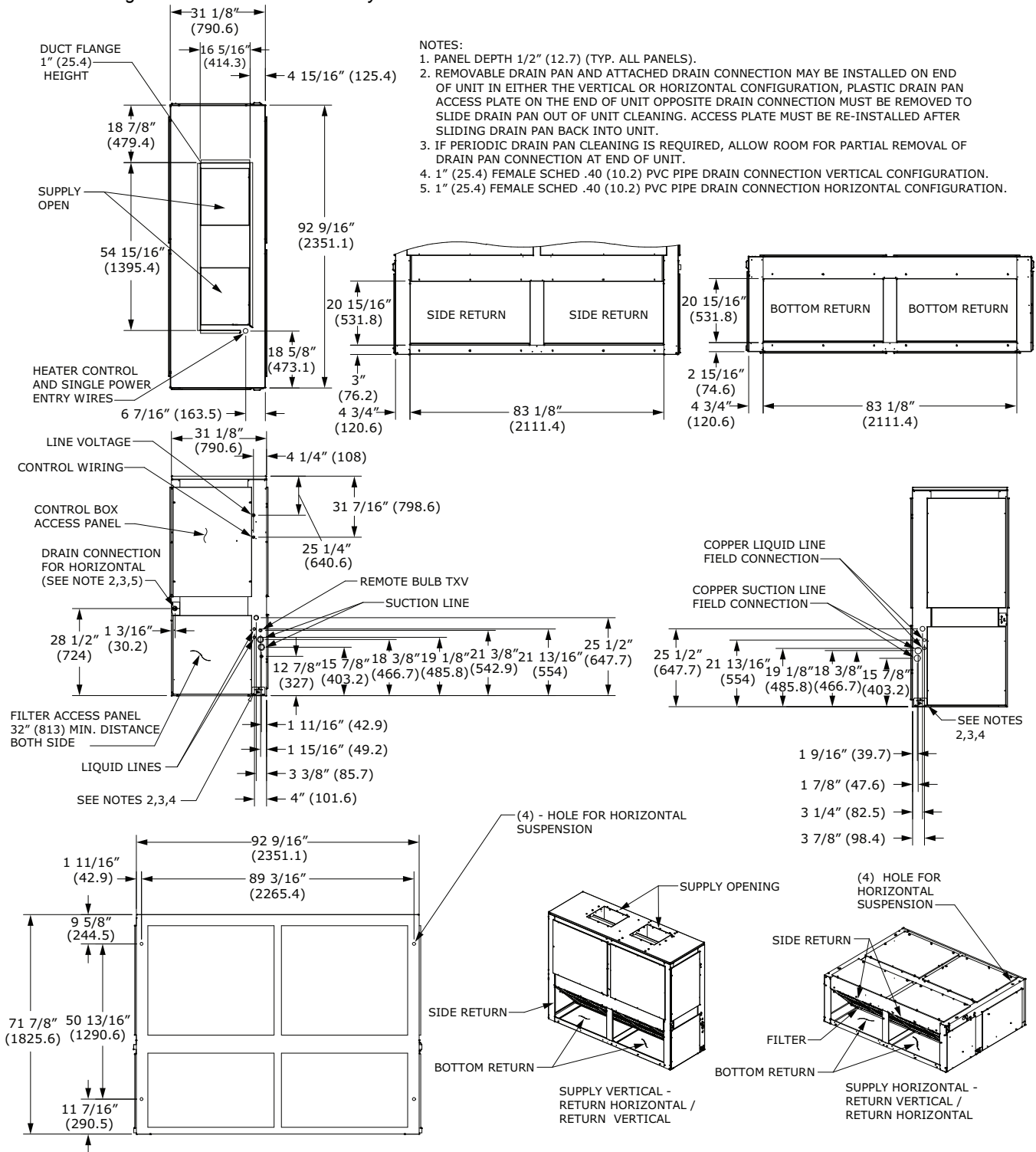

## Accessories

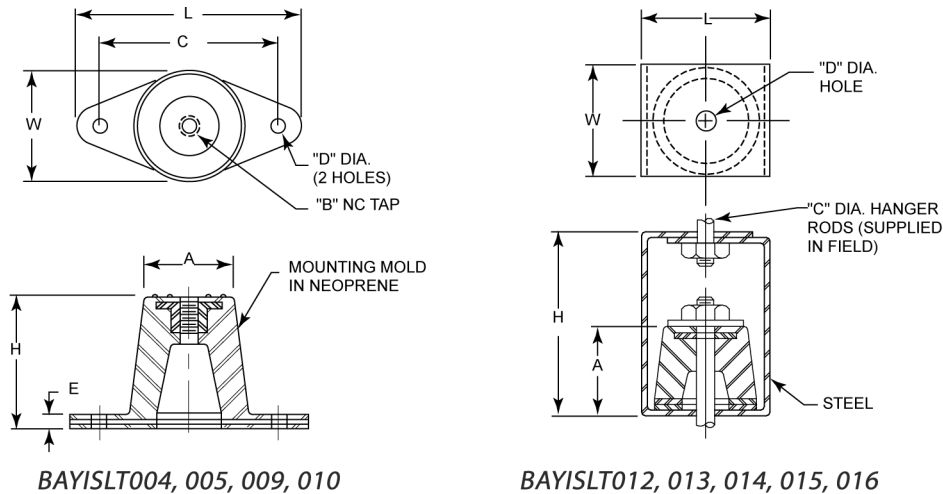
**Figure 42. Rubber isolator accessory dimensions**

**Table 74. Rubber isolator accessory dimensions – in (mm)**

Model No.	L	W	H	A	B	C	D	E
BAYISLT004	3-1/8 (79.375)	1-3/4 (44.45)	1-1/4 (31.75)	1-1/4 (31.75)	3/8 (9.525)	2-3/8 (60.325)	3/8 (9.525)	1/4 (6.35)
BAYISLT005	3-7/8 (98.425)	2-3/8 (60.325)	1-3/4 (44.45)	1-3/4 (44.45)	3/8 (9.525)	3 (76.2)	3/8 (9.525)	1/4 (6.35)
BAYISLT009	3-7/8 (98.425)	2-3/8 (60.325)	1-3/4 (44.45)	1-3/4 (44.45)	3/8 (9.525)	3 (76.2)	3/8 (9.525)	1/4 (6.35)
BAYISLT010	3-7/8 (98.425)	2-3/8 (60.325)	1-3/4 (44.45)	1-3/4 (44.45)	3/8 (9.525)	3 (76.2)	3/8 (9.525)	1/4 (6.35)
BAYISLT013	2-1/4 (57.15)	2 (50.8)	3 (76.2)	1-3/8 (34.925)	3/4 (19.05)	3/8 (9.525)	1/2 (12.7)	—
BAYISLT014	2-1/4 (57.15)	2 (50.8)	3 (76.2)	1-3/8 (34.925)	3/4 (19.05)	3/8 (9.525)	1/2 (12.7)	—
BAYISLT015	2-1/4 (57.15)	2 (50.8)	3 (76.2)	1-3/8 (34.925)	3/4 (19.05)	3/8 (9.525)	1/2 (12.7)	—
BAYISLT012	3 (76.2)	2-1/4 (57.15)	4-1/2 (114.3)	1-7/8 (47.625)	1/4 (6.35)	5/8 (15.875)	3/4 (19.05)	—
BAYISLT015 <sup>(a)</sup>	3 (76.2)	2-1/4 (57.15)	4-1/2 (114.3)	1-7/8 (47.625)	1/4 (6.35)	5/8 (15.875)	3/4 (19.05)	—
BAYISLT016	3 (76.2)	2-1/4 (57.15)	4-1/2 (114.3)	1-7/8 (47.625)	1/4 (6.35)	5/8 (15.875)	3/4 (19.05)	—

**Note:** BAYISLT015 contains a quantity 2 of the 2-1/4 x 2 x 3 isolators and quantity of 3 of the 3 x 2-1/4 x 4-1/2 isolators.

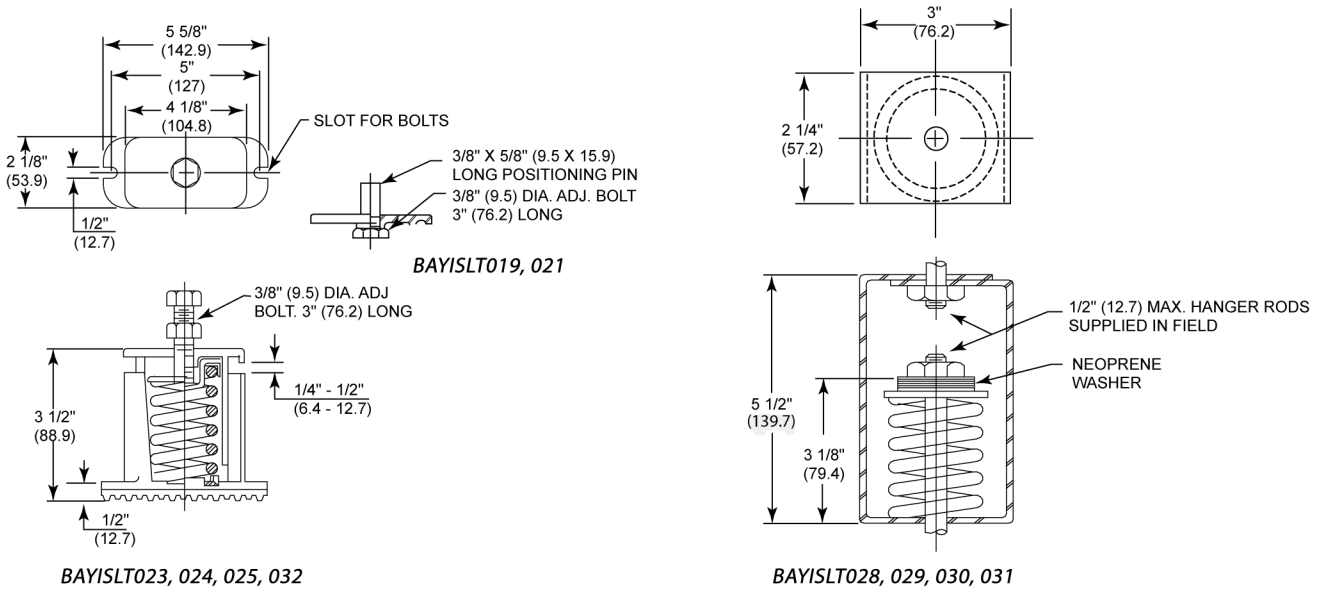
**Figure 43. Spring isolator accessory dimensions – in (mm)**



**Figure 44. Electric heater accessory for 5-10 ton air handlers – in (mm)**

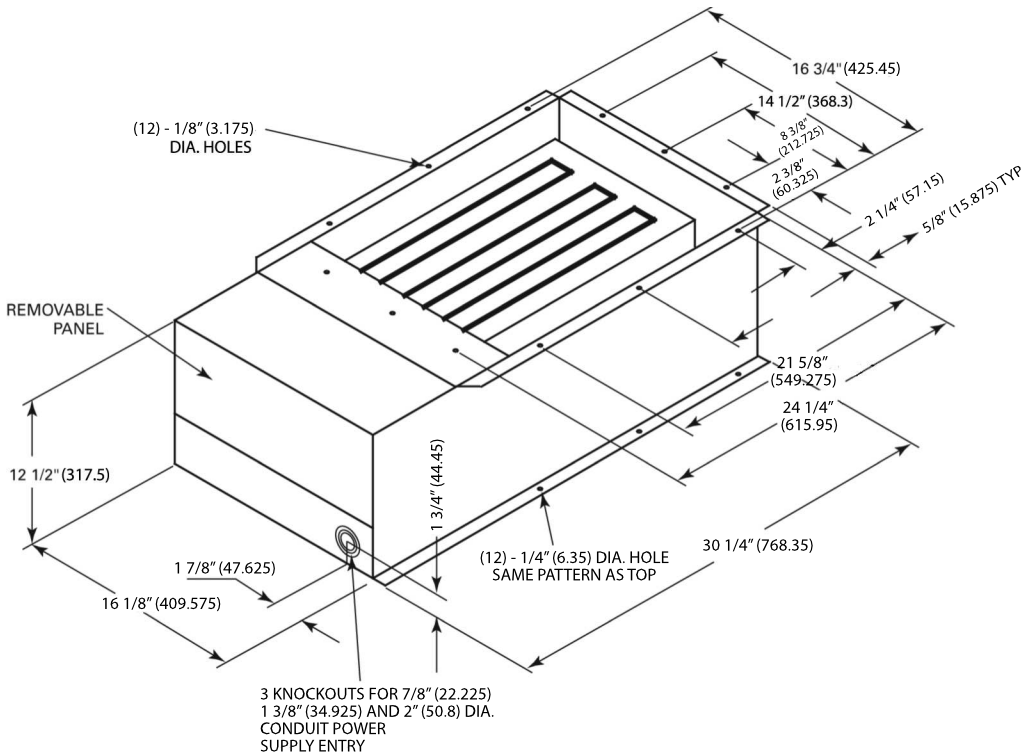
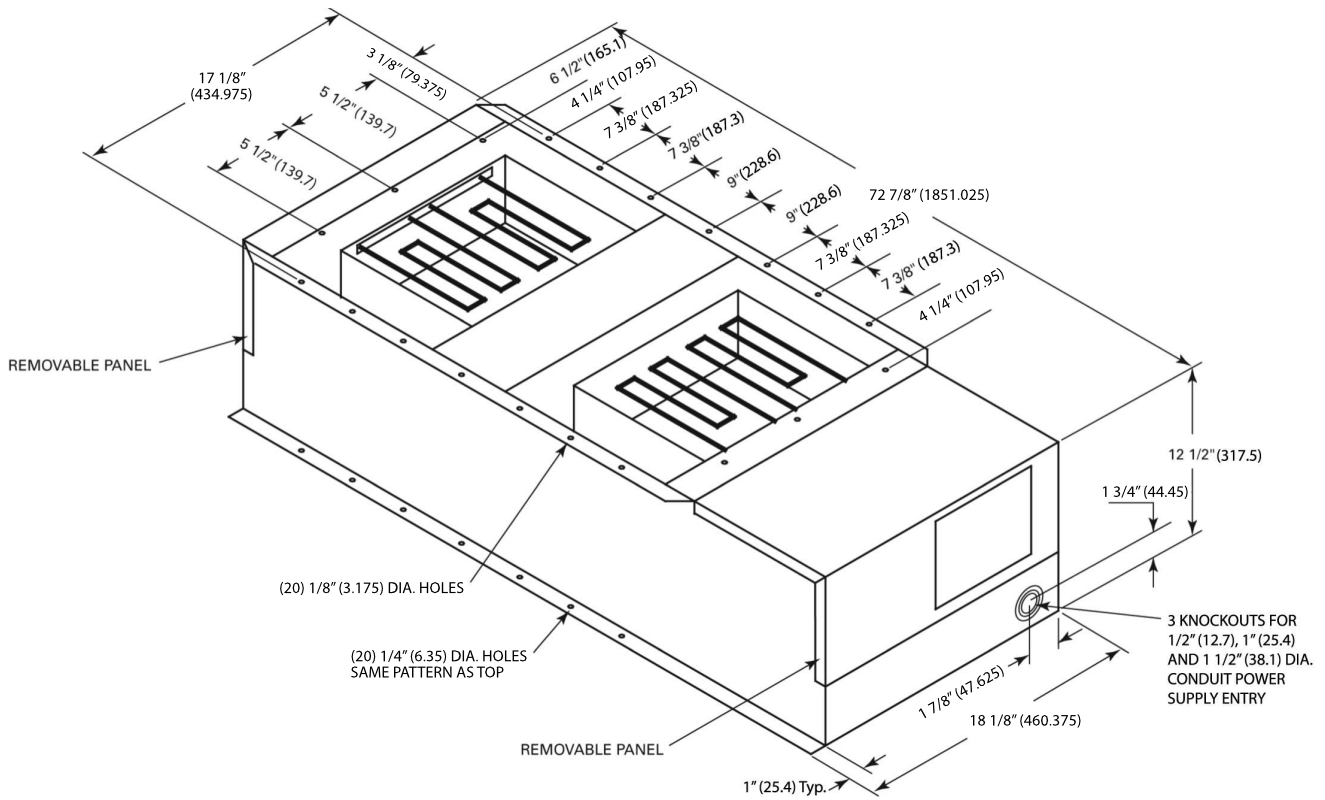
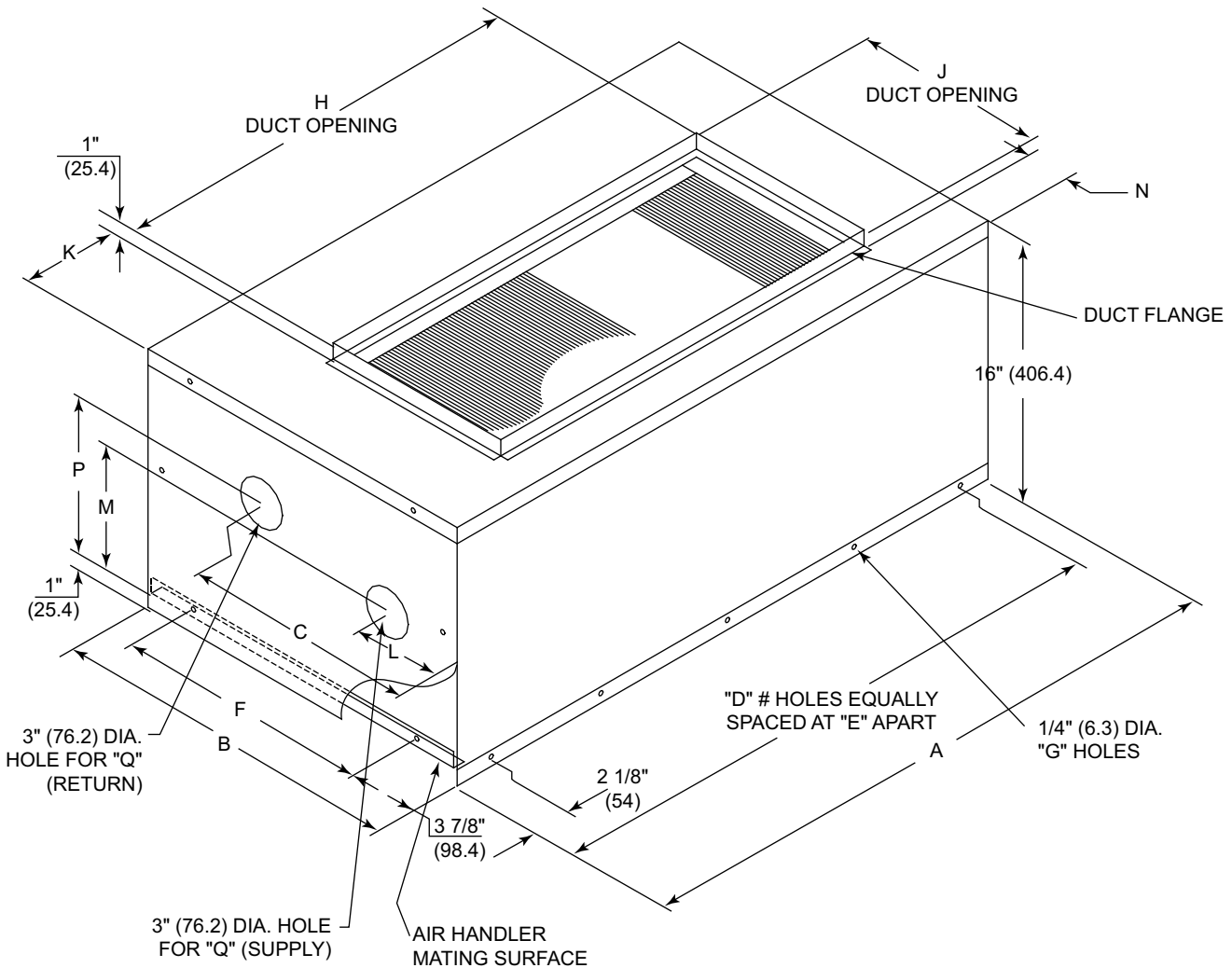

Figure 45. Electric heater accessory for 12.5-25 ton air handlers – in (mm)



## Dimensional Data

Figure 46. Hot water coil accessory – in (mm)



**Note:** Duct flange available as kit. See accessories chapter for details.

Table 75. Hot water coil accessory – in (mm)

Model No.	A	B	C	D	E	F	G	H
BAYWATR027	38.14 (969)	22.74 (576)	13.74 (349)	5 (127)	9 (229)	13.65 (347)	16 (406)	26 (660)
BAYWATR028	47.74 (1213)	25.74 (654)	15.95 (405)	5 (127)	10.84 (275)	17.17 (436)	16 (406)	30 (762)
BAYWATR029	63.84 (1621)	25.74 (654)	15.95 (405)	6 (152)	11.84 (301)	17.16 (436)	18 (457)	36 (914)
BAYWATR030	79.74 (2025)	29.18 (741)	14.36 (365)	8 (203)	10.85 (276)	19.67 (500)	22 (559)	51 (1295)
BAYWATR031	92.74 (2356)	31.24 (793)	16.48 (419)	8 (203)	10.85 (276)	19.67 (500)	22 (559)	64 (1626)
Model No.	J	K	L	M	N	P	Q	
BAYWATR027	12 (305)	6 (152)	4.94 (125)	7.79 (198)	2.88 (73)	10.24 (260)	2 NPT (51) NPTI	
BAYWATR028	18 (457)	8.88 (225)	8.45 (215)	10.27 (261)	2.88 (73)	7.77 (197)	2.5 NPTI (64) NPTI	
BAYWATR029	18 (457)	13.88 (352)	8.45 (215)	10.03 (255)	2.88 (73)	7.58 (192)	2.5 NPTI (64) NPTI	
BAYWATR030	18 (457)	14.25 (362)	6.86 (174)	9.91 (252)	1.88 (48)	7.41 (188)	2.5 NPTI (64) NPTI	

**Table 75. Hot water coil accessory – in (mm) (continued)**

Model No.	J	K	L	M	N	P	Q
BAYWATR031	18 (457)	14.25 (362)	8.98 (228)	9.88 (251)	3.75 (95)	7.38 (187)	2.5 NPTI (64) NPTI

Note: Hot Water Coil Dimensions - inches (millimeters)

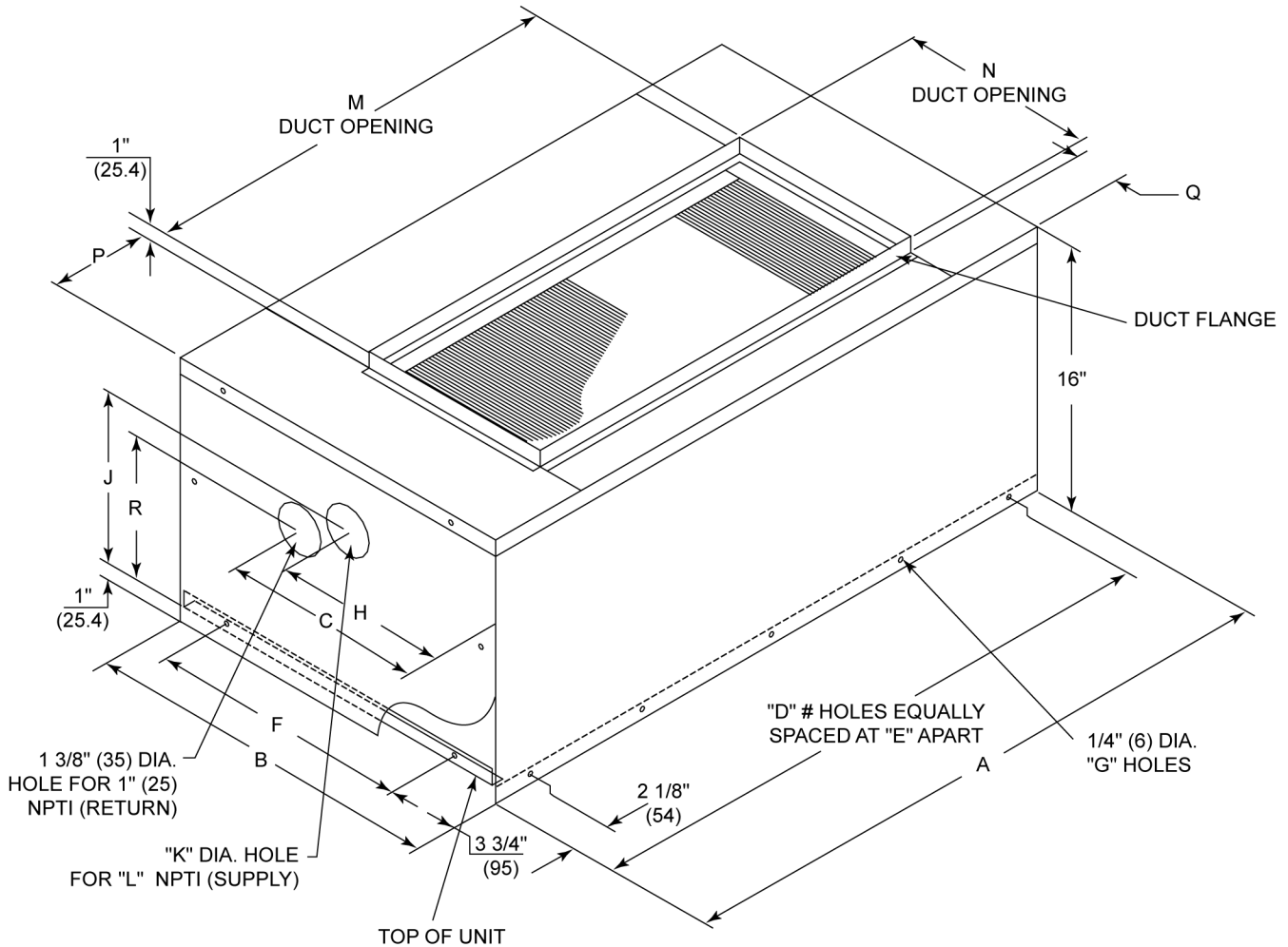
**Figure 47. Steam coil accessory – in (mm)**

Note: Duct flange available as kit. See accessories chapter for details.

**Table 76. Steam coil accessory – in (mm)**

Model No.	A	B	C	D	E	F	G	H	J	K
BAYWATR022	38.14 (969)	22.74 (577)	14.32 (364)	5 (127)	9 (229)	13.67 (347)	16 (406)	10.88 (276)	11.17 (284)	2 (51)
BAYWATR023	47.74 (1212)	25.74 (654)	20.14 (511)	5 (127)	10.84 (275)	17.17 (436)	16 (406)	10.88 (276)	11.17 (284)	2 (51)
BAYWATR024	63.84 (1621)	25.74 (654)	20.14 (511)	6 (152)	11.87 (301)	17.16 (436)	18 (457)	13.70 (348)	10.57 (268)	2.5 (64)
BAYWATR025	79.74 (2025)	29.18 (741)	18.55 (471)	8 (203)	10.85 (275)	19.67 (500)	22 (559)	12.11 (308)	10.05 (255)	2.5 (64)
BAYWATR026	92.74 (2355)	31.24 (793)	20.67 (525)	8 (203)	10.85 (275)	19.67 (500)	22 (559)	14.23 (361)	10.01 (254)	2.5 (64)

## Dimensional Data

**Table 76. Steam coil accessory – in (mm) (continued)**

Model No.	L	M	N	P	Q	R
BAYWATR022	1.5 (38)	26 (660)	12 (305)	6 (152)	2.87 (73)	9.95 (253)
BAYWATR023	2 (51)	30 (762)	18 (457)	8.87 (225)	2.87 (73)	9.95 (253)
BAYWATR024	2 (51)	36 (914)	18 (457)	13.87 (352)	2.87 (73)	9.13 (232)
BAYWATR025	2 (51)	51 (1295)	18 (457)	14.12 (359)	1.87 (48)	8.61 (219)
BAYWATR026	2 (51)	64 (1626)	18 (457)	14.12 (359)	3.75 (95)	8.58 (218)

**Figure 48. Discharge plenum and grille accessory**

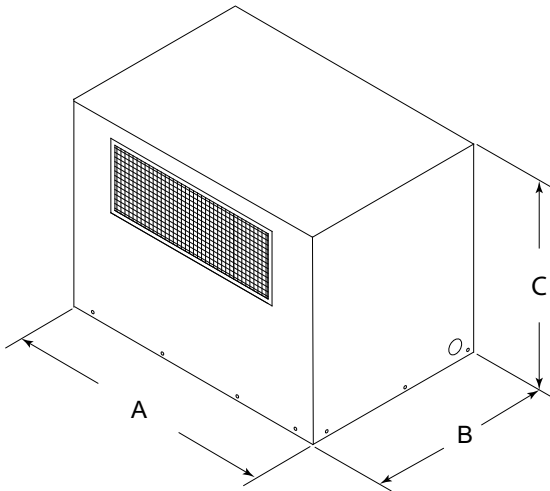

**Table 77. Discharge plenum and grille dimensions – no heat – in (mm)**

Unit	Model No. <sup>(a)</sup>	A	B	C
TWE060	BAYPLNM015	37.94 (963.6)	21.94 (557.2)	28 (711.2)
TWE072, TWE090	BAYPLNM016	47.5 (1206.5)	24.99 (634.7)	28 (711.2)
TWE120	BAYPLNM017	63.5 (1612.9)	24.99 (634.7)	28 (711.2)
TWE180	BAYPLNM018 <sup>(b)</sup>	79.5 (2019.3)	27.63 (701.8)	22 (558.8)
TWE240, TWE300	BAYPLNM019 <sup>(b)</sup>	92.5 (2349.5)	30.43 (772.9)	24 (609.6)
TWE060	BAYPLNM020	37.91 (962.9)	21.91 (556.5)	14.75 (374.65)
TWE090	BAYPLNM021	47.5 (1206.5)	24.99 (634.7)	14.75 (374.65)
TWE120	BAYPLNM022	63.5 (1612.9)	24.99 (634.7)	14.75 (374.65)

<sup>(a)</sup> When installed horizontally, plenum/water coil must be self-supported.

<sup>(b)</sup> For use with hydronic heat or no heat.

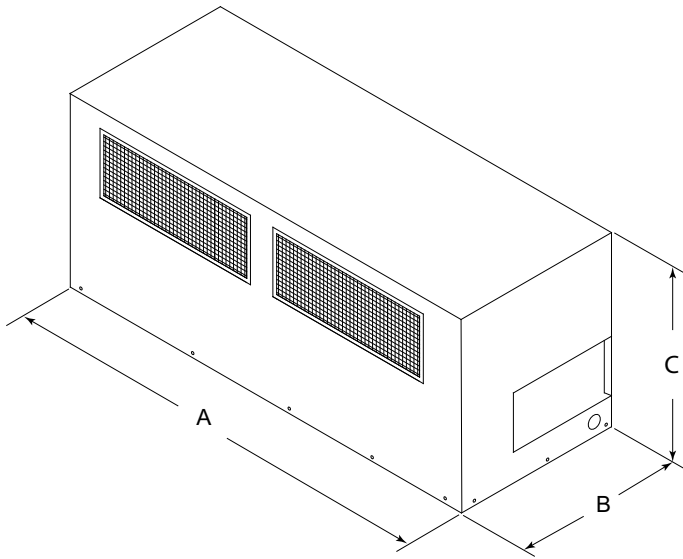

**Figure 49. Discharge plenum and grille accessory**

**Table 78. Discharge plenum and grille dimensions (for use with electric heat) – in (mm)**

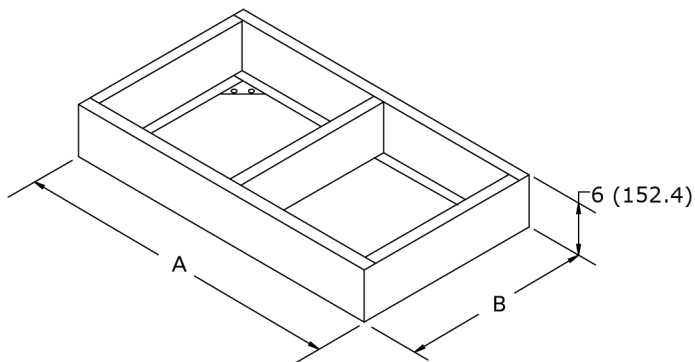
Tons	Model No.	A	B	C
TWE060	BAYPLNM030	38.07 (967)	22.69 (576.3)	29.05 (738)
TWE072, TWE090	BAYPLNM031	47.86 (1216)	25.69 (652.5)	29.05 (738)
TWE120	BAYPLNM032	63.86 (1622)	25.69 (652.5)	29.05 (738)
TWE150, TWE180	BAYPLNM033	80.14 (2036)	29.10 (739.1)	35.11 (892)
TWE240, TWE300	BAYPLNM034	92.96 (2361)	31.10 (789.9)	35.05 (890)

**Figure 50. Subbase accessory – in (mm)**

**Table 79. Subbase dimensions – in (mm)**

Tons	Model No.	A	B
TWE060	BAYBASE009	38 (965.2)	22.63 (574.8)
TWE072, TWE090	BAYBASE010	47.5 (1206.5)	25.51 (648.0)
TWE120	BAYBASE011	63.5 (1612.9)	25.52 (648.2)
TWE150,TWE180	BAYBASE012	79.5 (2019.3)	29.04 (737.6)
TWE240, TWE300	BAYBASE013	92.5 (2349.5)	31.14 (791.0)

# Weights

## Cooling Condenser

Table 80. TTA R-454B unit and corner weights — lbs (60 Hz)

Tons	Model No.	Shipping Max (lbs)	Net Max (lbs)	Corner Weights			
				1	2	3	4
6	TTA072K*A	324	288	84	89	55	59
	TTA072K*D	348	316	100	92	66	59
7.5	TTA090K*A	342	309	88	95	60	66
	TTA090K*D	399	367	114	107	75	71
10	TTA120K*D	443	404	117	116	87	85
	TTA120K*C	473	433	128	128	88	88
12.5	TTA150K*D	504	454	136	136	91	91
15	TTA180K*D	806	715	197	198	160	160
	TTA180K*C	806	707	193	193	161	160
20	TTA240K*D	872	755	210	210	167	168
	TTA240K*C	892	802	225	227	174	176
25	TTA300K*C	1020	930	263	265	200	202

Figure 51. TTA072, 090, 120, 150

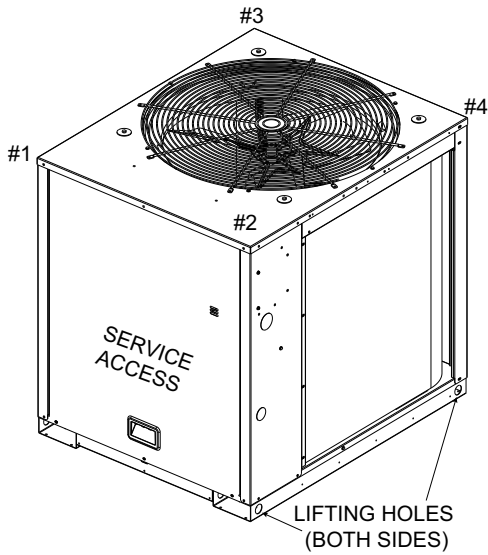
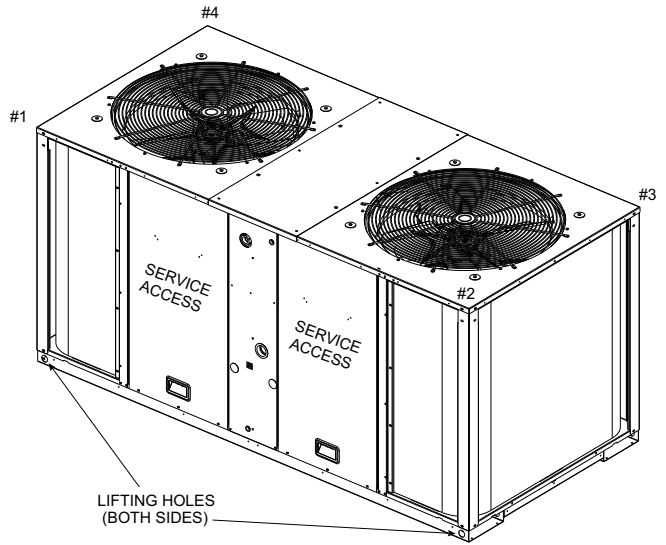

Figure 52. TTA180, 240, 300



# Air Handler

**Table 81. Constant volume air handler (TWE)— unit and corner weights - (60 Hz)**

Tons	Model Number	Shipping Max (lbs)	Net Max (lbs)	Corner Weights - Vertical				Corner Weights - Horizontal			
				1	2	3	4	1	2	3	4
5	TWE060K(3,4,W, 1)A TWE060K(3,4, 1)B	285	232	55	71	51	55	54	67	50	61
7.5	TWE090K(1)A/B	385	323	67	99	75	82	56	92	87	88
10	TWE120K(1)A/B	441	393	77	121	110	85	79	118	77	119

**Table 82. SZVAV and 2-Speed VFD air handler (TWE) — unit and corner weights - lbs (60 Hz)**

Tons	Model Number	Shipping Max (lbs)	Net Max (lbs)	Corner Weights - Vertical				Corner Weights - Horizontal			
				1	2	3	4	1	2	3	4
6	TWE072K*B	398	336	70	102	78	86	59	95	90	92
7.5	TWE090K*A/B	398	336	70	102	78	86	59	95	90	92
10	TWE120K*A/B	454	406	80	124	113	89	82	121	80	123
12.5	TWE150K*B	766	689	171	195	184	139	199	167	148	175
15	TWE180K*B	765	688	170	195	184	139	199	166	148	175
20	TWE240K*B	925	831	261	171	164	235	259	184	149	239
25	TWE300K*B	1015	921	217	235	189	280	278	182	233	228

**Figure 53. Vertical — TWE060, 072, 090, 120**

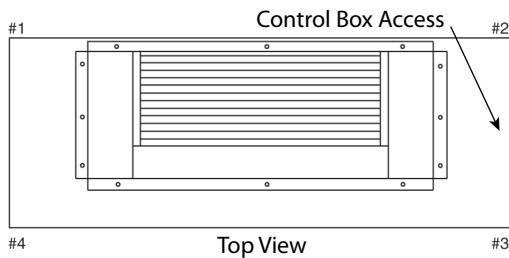

**Figure 54. Vertical — TWE150, 180, 240, 300**

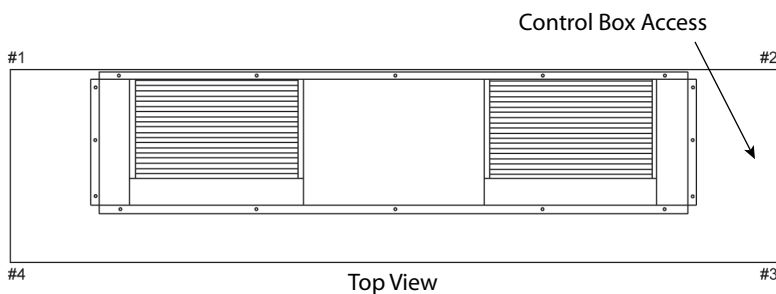

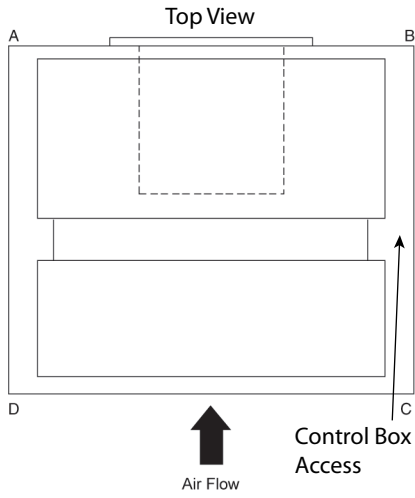
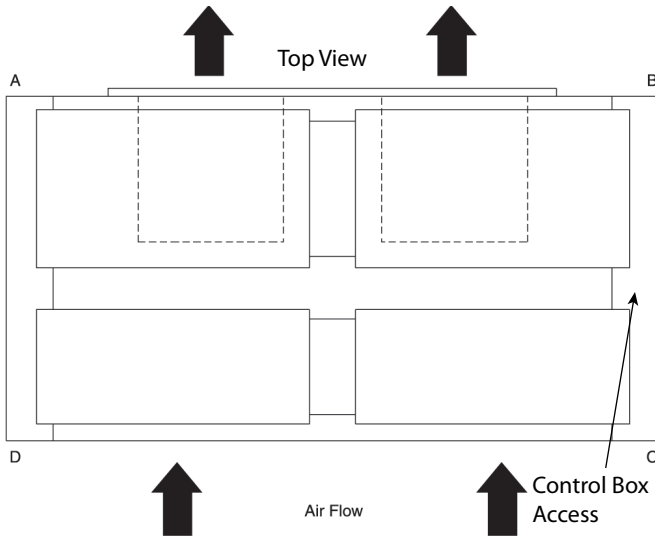
**Figure 55. Horizontal — TWE060, 072, 090, 120****Figure 56. Horizontal — TWE150, 180, 240, 300**

## Accessories

Table 83. Accessory weights (net lbs.)

Unit Used w/ Tons	Hot Water Coil	Steam Coil	Discharge Plenum and Grille with Hydronic Heat	Discharge Plenum and Grille without Heat	Discharge Plenum and Grille with Electric Heat	Return Air Grille	Electric Heat Min/Max	Subbase	Oversized Motor	RIS Isolator Floor Mount
6	116	131	78	73	160	5	27/45	19.4	48	2
7.5	116	131	78	73	160	5	27/45	19.4	48	2
10	165	148	97	92	195	7	27/45	23.5	50	2
12.5	211	234	—	230	235	10	79/100	28.4	80	2
15	211	234	—	230	235	10	79/100	28.4	80	2
20	242	261	—	145	265	12	79/100	31.7	88	2
25	242	261	—	145	265	12	79/100	31.7	129	2
Unit Used w/ Tons	RIS Isolator Suspended Mount	Steel Spring Isolator Floor Mount	Steel Spring Isolator Suspended Mount	Hail Guard	Control Transformer	Sensors	Expansion Module	Low Ambient	Service Valve	
6	6	12	6	21	4	1	13	13	5	
7.5	6	12	6	21	4	1	13	13	5	
10	7	12	6	28	4	1	13	13	5	
12.5	7	12	6	33	4	1	13	13	5	
15	7	12	6	55	4	1	2	2	5	
20	9	12	6	55	4	1	2	2	5	
25	9	12	6	71	4	1	2	2	5	



# Mechanical Specifications

## Condensing Units

### Standard Features

#### General

- Weatherproofed steel mounting/lifting rails
- Hermetic scroll compressors
- Microchannel condenser coils
- Fans and motors
- Standard operating range 50-125°F (min. 0°F with low ambient accessory)
- Nitrogen holding charge
- Certified and rated in accordance with AHRI and DOE standards
- Certified to UL 60335-2-40
- Capacities and efficiencies for split systems are rated within the scope of the Air-Conditioning, Heating, and Refrigeration Institute (AHRI) certification program and display the AHRI Standard 340-360 (I-P) mark. This standard applies to units between 65,000 and 250,000 btu/hr.

#### Casing

- Zinc coated, heavy gauge, galvanized steel
- Weather resistant baked enamel finish
- Meets ASTM B117, 672 hour salt spray test
- Removable single side maintenance access panels
- Lifting handles in maintenance access panels
- Unit base provisions for forklift and/or crane lifting

#### Refrigeration System - Single Compressor (TTA072\*\*A, TTA090\*\*A)

- Single refrigeration circuit with integral subcooling circuit
- Single direct drive hermetic scroll compressor
- Suction gas-cooled motor w/  $\pm$  10% voltage utilization range of unit nameplate voltage
- Crankcase heater
- Internal temperature and current sensitive motor overloads
- No compressor suction and/or discharge valves (reduced vibration/sound)
- Factory installed liquid line filter drier
- Phase loss/reverse rotation monitor
- External high pressure cutout device
- External low pressure cutout device
- Evaporator defrost control
- Loss of charge protection (discharge temperature limit)

#### Refrigeration System - Dual Compressor (TTA072\*\*D, TTA090\*\*D, TTA120\*\*D, TTA150\*\*D, TTA180\*\*D, TTA240\*\*D)

- Two (2) separate and independent refrigerant circuits
- Each refrigeration circuit equipped with integral subcooling circuit
- Front or rear refrigerant line connections (TTA180\*\*D/240\*\*D)
- Two (2) direct drive hermetic scroll compressor
- Suction gas-cooled motors w/  $\pm$  10% voltage utilization range of unit nameplate voltage
- Crankcase Heaters
- Internal temperature and current sensitive motor overloads
- Factory installed liquid line filter driers
- Phase loss/reverse rotation monitor
- No compressor suction and/or discharge valves (reduced vibration/sound)
- External high pressure cutout devices
- External low pressure cutout devices

- Evaporator defrost control
- Loss of charge protection (discharge temperature limits)

**Refrigeration System - Dual Manifolded Compressors (TTA120\*\*C, TTA180\*\*C, TTA240\*\*C, TTA300\*\*C)**

- Single refrigerant circuit with integral subcooling circuit
- Two (2) direct drive hermetic scroll compressor
- Suction gas-cooled motors w/  $\pm$  10% voltage utilization range of unit nameplate voltage
- Crankcase Heaters
- Internal temperature and current sensitive motor overloads
- No compressor suction and/or discharge valves (reduced vibration/sound)
- Factory installed liquid line filter drier
- Phase loss/reverse rotation monitor
- External high pressure cutout devices
- External low pressure cutout devices
- Evaporator defrost control
- Loss of charge protection (discharge line thermostats)
- Front or rear refrigerant line connections (TTA 180\*\*C/240\*\*C/300\*\*C only)

**Condenser Coil (Microchannel)**

- Microchannel coils burst tested by the manufacturer
- Coils shall be leak tested to ensure the pressure integrity
- Factory pressure and leak tested to 660 psig
- Perforated steel hail guards available

**Condenser Fan**

- 26-inch or 28-inch propeller fan(s)
- Direct drive
- Statically and dynamically balanced

**Condenser Motor(s)**

- Permanently lubricated totally enclosed or open construction
- Built-in current and thermal overloads
- Ball or sleeve bearing type

**Controls**

- Centralized microprocessor
- Indoor and outdoor temperature sensors drive algorithms, making decisions for all heating, cooling, and ventilation
- Integrated anti-short cycle timer
- Integrated time delay between compressors
- Completely internally wired
- Colored and keyed connectors and colored wires
- Contactor pressure lugs or terminal block
- Unit external mounting location for disconnect device
- Single point power entry
- Front or rear electrical connections (TTA 180\*\*C/D, 240\*\*C/D, 300\*\*C only)

**Coil Guards**

- Condenser coil protection from hail, vandals, etc.
- Perforated, painted galvanized steel
- Factory or field installed



## Mechanical Specifications

---

### Factory Installed Options

#### Complete Coat™ Microchannel Condenser Coil

- Available on Microchannel units only
- Cathodic, epoxy-type, electro-disposition coating formulated for high edge build
- Coating provides excellent resistance and durability to corrosive effects of alkalis, acids, alcohols, petroleum, seawater, salty air and other corrosive environments

#### BACnet Communication Options

- BACnet MS/TP -BACnet IP
- Allows unit communication with Trane or generic BACnet building automation controls

#### Advanced Diagnostics and LonTalk Communication Interface

- Factory or field installed
- Allows unit communication as a Tracer Lon® device
- Allows unit communication with generic LonTalk® Network building automation controls

### Field Installed Options

#### Low Ambient (Fan ON/OFF)

- Provides unit cooling operation to outdoor ambient of 0°F
- Low cost solution
- Discharge pressure controls condenser fan operation

#### Service Valves

- Liquid line service valve (with gauge port)
- Suction line service valve (with gauge port)

#### Vibration Isolators

- Neoprene-in-shear or spring flex choice
- Reduce vibration transmission to building structures, equipment, and adjacent spaces
- Reduce noise transmission to building structures, equipment, and adjacent spaces

#### Hot Gas Bypass

Provides capacity modulation solution

#### Zone Sensor

- Interfaces with microprocessor units
- Manual or automatic programmable
- System malfunction lights
- Remote sensor options

#### Thermostat

- 1H/1C available
- 2H/1C available
- Manual or automatic changeover available
- Programmable and non-programmable solutions available

#### LonTalk Communication Interface

- Factory or field installed
- Allows unit communication as a Tracer Lon® device
- Allows unit communication with generic LonTalk® Network building automation controls



## Air Handlers

### Standard Features

#### General

- Completely factory assembled
- Convertible for horizontal or vertical configuration
- Convertible for cooling only or heat pump application
- Convertible for left or right external connections (refrigerant and/or electrical)
- Convertible for front or bottom air return
- Nitrogen holding charge
- Certified to UL60335-2-40 for indoor blower coil units

#### Casing

- Zinc coated, heavy gauge, galvanized steel
- Weather resistant baked enamel finish
- Access panels with captive screws
- Completely insulated with foil faced, cleanable, fire retardant, permanent, odorless glass fiber material
- Captured or sealed insulation edges
- Electrical connection bushings or plugs
- Refrigerant connection bushings or plugs
- Withstand elevated internal static pressure

#### Refrigeration System

- Single or dual circuit
- Distributor(s)
- Thermal expansion valves (TXVs)

#### Evaporator Coil

- 3/8-inch internally enhanced copper tube mechanically bonded to lanced aluminum plate fins
- Factory pressure and leak tested to 449 psig.
- Draw-through airflow
- Dual circuits are interlaced/intertwined
- Double sloped, removable, cleanable, composite drain pan
- Four drain pan positions

#### Indoor Fan

- Double inlet, double width, forward curved, centrifugal type fan
- Dual fans on 12.5 to 25 ton air handlers
- Adjustable belt drive
- Permanently lubricated bearings

#### Indoor Motor

- Adjustable motor sheaves (constant volume units)
- Fixed motor sheaves (SZVAV and 2-Speed VFD)
- Thermal overload protection
- Permanently lubricated bearings
- Meet energy policy of 1992 (EPACT)
- Optional oversized motors for high static applications

#### Controls

- Completely internally wired
- Colored and keyed connectors, colored wires
- Magnetic indoor fan contactor
- Detachable low voltage connectors



## Mechanical Specifications

---

- Single point power entry
- Evaporator defrost control

### Filters

- Access from side coil panels
- Filters slide on rack
- One inch (1-inch), throwaway filters on 5 to 10 ton units
- Filter rack convertible to two inch (2-inch) capability on 5 to 10 ton units
- Two inch (2-inch), throwaway filters on 12.5 to 25 ton units

### Leak Detection System

- Added as per safety standard UL 60335-2-40.
- Two refrigerant detection sensors are present .
- Reduces the risk of improper installation in the field as well as bypassing the added cost in the field for installation.

## Factory Installed Options

### Constant Volume Airflow

Factory installed high static motor available

### 2-Speed VFD Control

- 2-Speed airflow
- Variable Frequency Drive (VFD)
- Motor soft start — avoids start up belt noise and increases belt life
- Programmable keypad accessible outside of airstream
- VFD rated motor
- Factory installed high static motor available

### Single Zone Variable Air Volume / 2-Speed Airflow

- Variable Frequency Drive (VFD)
- Motor soft start — avoids start up belt noise and increases belt life
- Programmable VFD keypad accessible outside of airstream
- Airflow adjustment via display/keypad on Symbio™ 700 controller in condenser
- Discharge air sensor
- Symbio 700 Options Module
- VFD rated motor
- Factory installed oversized motor available

## Field Installed Options

### Electric Heaters

- Heavy duty nickel chromium elements
- Agency approved
- Installs directly on fan discharge
- One or two stage control (dependent upon capacity)
- Single point power entry
- Terminal strip connections
- 460V Heaters
  - Internally wye connected
  - Automatic line break high limit controls with secondary single action disc limits
- 230V Heaters
  - Internally delta connected
  - Automatic reset of high limit controls through pilot duty with secondary backup fuse links

**Hydronic Heat Coils**

- One row steam
- Two row hot water
- Installs directly on fan discharge
- Heavy gauge sheet metal casing matches air handler
- Convertible for horizontal or vertical configurations

**Discharge Plenums and Grilles**

- Vertical, free discharge applications
- Heavy gauge sheet metal casing matches air handler
- Satin-finished, 4-way adjustable louver grilles

**Return Air Grilles**

- Vertical, free discharge applications
- Satin-finished, non-adjustable louver grilles
- Replaces front lower access panel

**Mounting Sub-Base**

- Vertical floor mount configuration requirement
- Heavy gauge sheet metal casing matches air handler
- Provides additional clearance for condensate drain trapping
- Required when isolators are used

**Vibration Isolators**

- Neoprene-in-shear or spring flex choice
- Floor or suspended applications
- Reduce vibration transmission to building structures, equipment, and adjacent spaces
- Reduce noise transmission to building structures, equipment, and adjacent spaces

**Oversize Motors**

- High static applications
- Motor, sheaves, belt included

**Filters**

2 inch, MERV 13 high efficiency filters

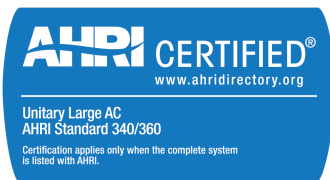

The AHRI Certified mark indicates Trane U.S. Inc. participation in the AHRI Certification program. For verification of individual certified products, go to [ahridirectory.org](http://ahridirectory.org).

Trane - by Trane Technologies (NYSE: TT), a global innovator - creates comfortable, energy efficient indoor environments for commercial and residential applications. For more information, please visit [trane.com](http://trane.com) or [tranetechnologies.com](http://tranetechnologies.com).

Trane has a policy of continuous product and product data improvements and reserves the right to change design and specifications without notice. We are committed to using environmentally conscious print practices.