



Product Catalog

Split System

Cooling Condensers — 20 to 120 Tons

Remote Chillers — 20 to 120 Tons





Introduction

Trane® 20 to 120 ton air-cooled condensing units are the leaders in the split system marketplace. The vast amount of air handling options along with the remote chiller possibility allows this condensing unit to be used in a wide array of applications. Designed for efficiency, reliability and flexibility, the Trane units have the most advanced design in the industry.



Copyright

This document and the information in it are the property of Trane, and may not be used or reproduced in whole or in part without written permission. Trane reserves the right to revise this publication at any time, and to make changes to its content without obligation to notify any person of such revision or change.

Trademarks

All trademarks referenced in this document are the trademarks of their respective owners.

Revision History

- Updated Features and Benefits and Mechanical Specification chapter.
- New system controls options added in Controls chapter.



Table of Contents

- Features and Benefits 4
 - Trane 3-D Scroll Compressor 4
 - Additional Features 5
 - 20 to 120 Ton Units 5
- Application Considerations 7
 - Unit Sizing 7
 - Application Assistance and System Matching 7
 - Unit Location 7
 - Effect of Altitude on Capacity 8
 - Ambient Considerations 8
 - Corrosive Atmospheres 8
 - Coil Frost Protection 8
 - Refrigerant Piping 9
 - Seismic Requirements 9
 - Remote Chiller Evaporator 9
- Selection Procedures 11
- Model Number Description 12
 - 20 to 60 Ton Units 12
 - 80 to 120 Ton Units 13
- General Data 14
- Performance Data 16
 - 60Hz Units 16
 - 50Hz Units 20
- Controls 29
 - System Control Options 29
 - Low Ambient Control Option 29
 - Miscellaneous Options 30
- Electrical 31
- Unit Dimensions 33
- Unit Weights 56
- Mechanical Specifications 57
 - Air-Cooled Condensing Unit — Model RAUJ 57
 - Options 58

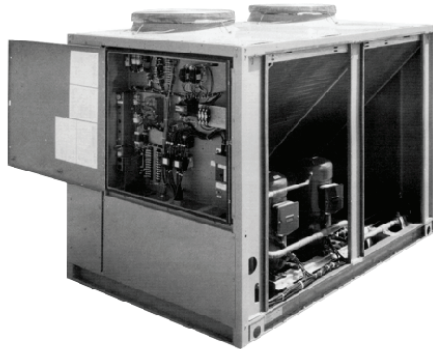


Features and Benefits

Trane 3-D Scroll Compressor

Simple, Reliable Design

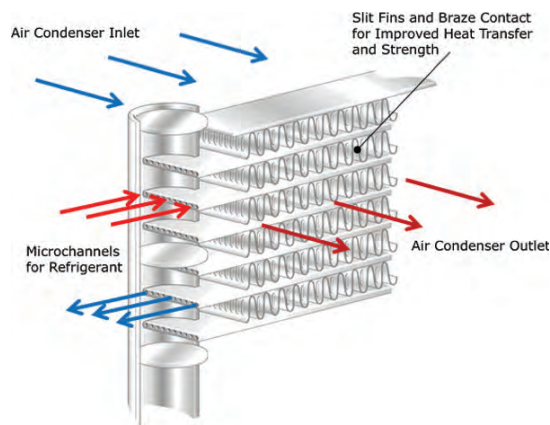
The Trane® 3-D™ Scroll provides important reliability and efficiency benefits. The 3-D Scroll allows the orbiting scrolls to touch in all three dimensions, forming a completely enclosed compression chamber which leads to increased efficiency. In addition, the orbiting scrolls only touch with enough force to create a seal; so there is no wear between the scroll plates. The fixed and orbiting scrolls are made of high strength cast iron which results in less thermal distortion, less leakage, and higher efficiencies.



Microchannel Condenser Coil

Microchannel condensing coils are all-aluminum coils with fully-brazed construction. This design reduces risk of leaks and provides increased coil rigidity — making them more rugged on the jobsite. Their flat streamlined tubes with small ports and metallurgical tube-to-fin bond allow for exceptional heat transfer. Microchannel all-aluminum construction provides several additional benefits:

- Light weight (simplifies coil handling)
- Easy to recycle
- Minimize galvanic corrosion



Suction Gas Cooled Motor

Compressor motor efficiency and reliability is further optimized with the latest scroll design. Cool suction gas keeps the motor cooler for longer life and better efficiency.

Proven Design Through Testing and Research

With over twenty five years of development and testing, Trane 3-D Scroll compressors have undergone more than 400,000 hours of laboratory testing and field operation. This work combined with over 25 patents makes Trane the worldwide leader in air conditioning scroll compressor technology.

Voltage Power Supply

Four voltage options are available on RAUJ 20 to 120 ton units: 200, 230, 460 and 575V.

Passive Manifolding

Trane offers a parallel manifolding scheme that uses no moving mechanical parts. This feature assures continuous oil return, again providing greater system reliability. And greater reliability means optimal performance over the life of the unit.

Additional Features

System Control Options

In addition to “no system control” option, Trane offers two system control options, each using solid-state electronics. These options allow the unit to be ordered with the controls needed, saving field installation costs.

Coil Frost Protection

Trane offers Froststat™ with the VAV system control option on the 20 to 120 ton units. Froststat is the industry’s most reliable method of coil frost protection and assures that your system will provide energy efficient comfort at part load conditions.

Remote Chiller Evaporator Option with Field Installation Kit

This option allows chilled water to be generated remotely from the condensing section.

The EVP controls option includes a unit controller, discharge water temperature sensor and water freeze-stat.

The accessory kit includes the remote chiller evaporator, with mounting hardware and insulation, water strainer, minimum water flow limit switch and evaporator pipe stubs with couplings. The EVP control option must be selected with this accessory kit.

20 to 120 Ton Units

Standard Features

- Trane® 3-D scroll compressors
- Phase loss/reversal/low voltage monitor
- Factory-installed discharge service valves
- Passive manifolding for 3-D scroll compressors
- Standard ambient operating range: 40°F to 125°F (In certain cases 115°F max ambient for EVP chiller)
- Heavy gauge galvanized steel frame
- Louvered panels for coil protection
- Slate gray air-dry paint finish

Optional Features

- Remote chiller evaporator with field installation kit
- Non-fused disconnect
- Convenience outlet
- Low ambient option



Features and Benefits

- Hot gas bypass to the evaporator inlet
- Suction service valve
- Pressure gauges
- Return air sensor
- Unit spring isolators
- Neoprene-in-shear isolators
- cULus approval (60 Hz only)
- Quick ship availability
- Extended compressor warranty
- Corrosion protected condenser coil
- Controls options include:
 - Factory installed VAV, EVP, and No controls
 - Field installed DDC controls kit (VAV and EVP)

Quick Ship

Trane® 20 to 120 ton model RAUJ air-cooled condensing units are available with Quick Ship. Trane knows that you want your units on the job site, on time, with the options you need. Quick Ship provides you with the controls and options you need — options like hot gas bypass, isolators and refrigerant gauges. You no longer have to settle for a basic unit requiring many field installed options to meet your job schedule. Now, you can get a customized unit from the factory in record time. Quick ship provides more control over unit selection and scheduling than ever before. Trane wants to make it easy for you to do business with us.



Application Considerations

Certain application constraints should be considered when sizing, selecting and installing Trane® air-cooled condensing units. Unit reliability is dependent upon these considerations. Where your application varies from the guidelines presented, it should be reviewed with the local Trane sales engineer.

Unit Sizing

Unit capacities are listed in the performance data section. Intentionally oversizing a unit to assure adequate capacity is not recommended. Erratic system operation and excessive compressor cycling are often a direct result of an oversized condensing unit. In addition, an oversized unit is usually more expensive to purchase, install and operate. If oversizing is desired, consider using two units.

Application Assistance and System Matching

Trane's large commercial condensing units can be paired with a variety of performance climate changers, custom air handlers, Odyssey™ light commercial air handlers, remote chiller evaporators and much more.

Application guides, which include piping requirements and condenser specifications as well as selection tools, are available for easier system matching and installation.

Contact Trane Sales for further details or specific split system needs.

Unit Location

Foundation

A base or foundation is not required if the selected unit location is level and strong enough to support the unit's operating weight.

Isolation and Sound Emission

Since the environment in which a sound source is located affects sound pressure, unit placement must be carefully evaluated. The most effective form of noise isolation is proper unit location. Units should be placed away from noise sensitive areas.

Structurally transmitted sound can be reduced by using isolators, which are recommended for sound sensitive installations. For maximum isolation effect, the refrigeration lines and electrical conduit should also be isolated and flexible electrical conduit used.

An acoustical engineer should always be consulted on critical applications.

State and local codes on sound emissions should always be considered.

Air Flow Considerations

Unobstructed flow of condenser air is essential for maintaining condensing unit capacity and operating efficiency. When determining unit placement, careful consideration must be given to assure proper air flow across the condenser heat transfer surface. Inadequate air flow will result in warm air recirculation and coil air flow starvation.

- Warm air recirculation occurs when discharge air from the condenser fans is recycled back at the condenser coil inlet.
- Coil starvation occurs when free air flow to the condenser is restricted.

Both warm air recirculation and coil starvation cause reductions in unit efficiency and capacity. In more severe cases, nuisance unit shutdowns will result from excessive head pressures. Accurate estimates of the degree of efficiency and capacity reduction are not possible due to the unpredictable effect of varying winds.

When hot gas bypass is used, reduced head pressure increases the minimum ambient condition for proper operation. In addition, wind tends to further reduce head pressure. Therefore, it is advisable to protect the air-cooled condensing unit from continuous direct winds exceeding 10 miles per hour.



Application Considerations

Debris, trash, supplies, etc., should not be allowed to accumulate in the vicinity of the air-cooled condensing unit. Supply air movement may draw debris between coil fins and cause coil starvation. Special consideration should be given to units operating in low ambient temperatures. Condenser coils and fan discharge must be kept free of snow and other obstructions to permit adequate air flow for satisfactory unit operation.

Clearances

Adequate service clearance is required for unit access and maintenance. See Dimensions chapter for service clearance recommendations. Local code requirements may take precedence.

Effect of Altitude on Capacity

Capacities given in the performance data tables are at sea level. At elevations substantially above sea level, the decreased air density will decrease condenser capacity and, therefore, unit capacity and efficiency. The adjustment factors shown in , p. 14 can be applied directly to the catalog performance data to determine the unit's adjusted performance.

Ambient Considerations

Start-up and operation at lower ambients requires sufficient head pressure be maintained for proper expansion valve operation. At higher ambients, excessive head pressure may result. Standard operating conditions are 40°F to 125°F in most cases (115°F max ambient for EVP chiller). With a low ambient damper, operation down to 0°F is possible. Minimum ambient temperatures are based on still conditions (winds not exceeding five mph). Greater wind velocities will result in increased minimum operating ambients. Units with hot gas bypass have a minimum operating ambient temperature of 10°F.

For proper operation outside these recommendations, contact the local Trane sales office.

Corrosive Atmospheres

Trane's large condensers are designed and built to industrial standards and will perform to those standards for an extended period depending on the hours of use, the quality of maintenance performed, and the regularity of that maintenance. One factor that can have an adverse effect on unit life is its operation in a corrosive environment. Since the microchannel condenser coil is an all-aluminum design, it provides a high level of corrosion protection on its own. Uncoated, it withstands a salt spray test in accordance with ASTM B117 for 1,000 hours. When condensers are operated in highly corrosive environments, Trane recommends the corrosion protected condenser coil option. This corrosion protection option meets the most stringent testing in the industry, including ASTM B117 Salt Spray test for 6,000 hours and ASTM G85A2 Cyclic Acidified Salt Fog test for 2,400 hours. The acid fog test is the most stringent available today. This coating is added after coil construction covering all tubes, headers, fins and edges. The design provides superior protection from any corrosive agent.

Note: *Field coating is not allowed on microchannel coils.*

The exterior panels are durable enough to withstand a minimum of 672 hours consecutive salt spray application in accordance with standard ASTM B117. All screws are coated with zinc-plus-zinc chromate.

Coil Frost Protection

Frostat™ is standard on condensing units when the VAV option is ordered. Frostat consists of a ship-with thermostat for field installation on the suction line. A timer is also factory-installed to avoid short cycling. Frostat cycles the compressor off when the suction line is below 30°F.

When hot gas valves must be used on 20 to 120 ton units, they can be ordered as a miscellaneous option. The 20 to 30 ton units require one valve; 40 to 60 ton units also require one valve except when no system control option is selected; this option requires two valves. The 80 to 120 ton units require one valve when Supply Air VAV control is selected. Two valves are required on all other 80 to 120 ton control options.

Refrigerant Piping

Split systems can have significantly more refrigerant than packaged systems and thus require controls to reliably manage this excess refrigerant. Each compressor shall have crankcase heaters installed, properly sized to minimize the amount of liquid refrigerant present in the oil sump during off cycles. Additionally, the condensing unit shall have controls to initiate a liquid line solenoid closure when each refrigerant circuit shuts down. To be operational, the liquid line requires a field supplied and installed isolated solenoid valve within 10 feet of the evaporator.

Due to this, special consideration must always be given to oil return. Minimum suction gas velocities must always be maintained for proper oil return. Utilize Tube Size and Component Selection application guide SS-APG012-EN for proper system design. For special applications, call Clarksville Product Support.

Note: *Under certain conditions, R-410A refrigerant can present special challenges with piping and system design. Whenever refrigerant line set lengths approach 150 equivalent feet and/or design ambient temperature exceeds 115°F, contact your Trane Account Executive to review application requirements.*

Seismic Requirements

Certain RAUJ Units are seismically certified in accordance with the International Building Code (IBC) 2009, IBC 2012, California Building Code (CBC) 2010, CBC 2013, American Society of Civil Engineers (ASCE), Minimum Design Loads for Buildings and Other Structures, ASCE 7-05, and ASCE 7-10. The current certification is in accordance with OSHPD Preapproval procedure.

Test criteria ICC-ES AC 156: Sds = 2.2, z/h = 1.0

IBC: International Building Code (IBC) 2009, IBC 2012

OSHPD: California Building Code (CBC) 2010, CBC 2013

Contact your Trane representative for more detail.

Remote Chiller Evaporator

Water Treatment

Using untreated or improperly treated water may result in scaling, erosion, corrosion, and algae or slime buildup in the heat exchanger that will adversely affect system capacity. Proper water treatment must be determined locally and depends on the type of system and local water characteristics. Neither salt nor brackish water is recommended, either will lead to a shortened heat exchanger life. Trane encourages employment of a qualified water treatment specialist, familiar with local water conditions, to assist in the establishment of a proper water treatment program.

Water Flow Limits

The minimum and maximum water flow rates are given in [Table 1, p. 14](#). Water flow rates below the tabulated values will result in laminar flow causing freeze-up problems, scaling, stratification and poor system control. Flow rates exceeding the maximum listed may result in very high pressure drop, erosion of the heat exchanger and damage to the water flow switch.

Water Temperature Limits

RAUJ with remote EVP chiller performance data is based on a water temperature drop of 10°F. Full load chilled water temperature drops from 8 to 14°F may be used as long as minimum and maximum water temperature and minimum and maximum flow rates are not violated. Leaving water temperatures below 42°F require freeze protection down to 15°F. The maximum water temperature that can be circulated through the chiller when the unit is not operating is 125°F. Evaporator damage may result above this temperature.

Short Water Loops

Adequate chilled water system water volume is an important system design parameter because it provides for stable chilled water temperature control and helps limit unacceptable short cycling of chiller compressors. Typically, a five-minute water loop circulation time is sufficient to prevent short water loop



Application Considerations

issues. Therefore, as a guideline, ensure the volume of water in the chilled water loop equals or exceeds five times the evaporator flow rate. For systems with a rapidly changing load profile the amount of volume should be increased.

Note: *Water volumes should be calculated as close as possible to maintain constant water flow through the water loop.*

Water Piping

Foreign matter in the chilled water system will increase pressure drop and reduce water flow. Installation of a properly selected strainer is also necessary to prevent debris larger than 0.039" from entering the heat exchanger. All building water piping must be thoroughly flushed before making the final piping connections to the heat exchanger. To reduce heat loss and prevent condensation, insulation should be applied to piping. Expansion tanks are also generally required to accommodate chilled water volume changes.



Selection Procedures

Net capacity curves for the RAUJ condensing units are given in the performance data section. When matched with a coil curve, the resultant point of intersection will be the system design balance point. The design operating suction temperature and capacity can then be read directly from the graph.

Note: *It is usually necessary to account for suction and liquid line losses in the performance. The actual losses are determined by the interconnecting piping.*

To plot the DX evaporator performance curve it is only necessary to obtain gross evaporator capacities for the given entering air conditions and cfm at two different saturated suction temperatures. The Trane Refrigeration Coil Computer Selection Program can be used to conveniently provide the necessary evaporator capacity values at the selected suction temperatures.

Selection Example

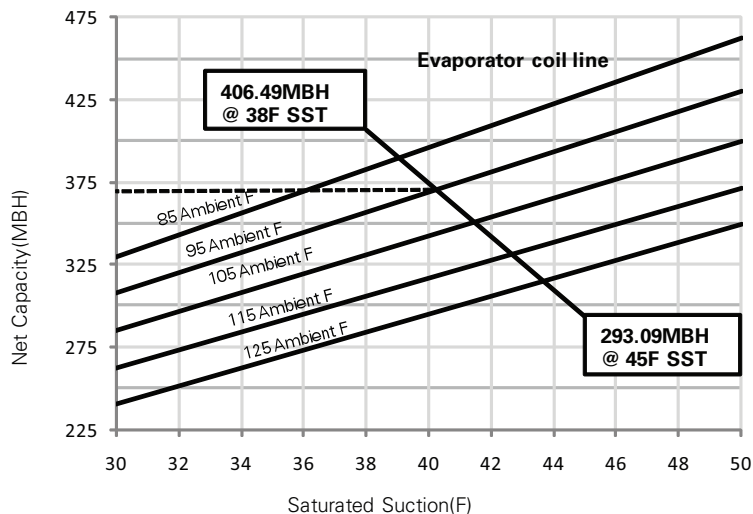
The RAUJ 20 to 120 ton TOPSS™ selection program provides the ability to generate performance output for pre-selected Trane Modular Climate Changer evaporator coils with the RAUJ condensing units.

To select a condensing unit and evaporator coil not available in the RAUJ TOPSS™ program, the example below can be used to cross-plot an evaporator coil with known performance with the RAUJ condensing unit

From the Trane Refrigeration Coil Computer Selection Program:

- DX Evap Coil = Model Number DFDB42 - 42" X 60" / 4 Row / 144 FPF - FD/Delta-flo E
- Entering Coil Conditions = 80/67 DB/WB and 95°F Ambient - 8500 CFM
- Coil Performance @ 38F SST - 406.49 MBh Total
- Coil Performance @ 45F SST - 293.09 MBh Total
- Balance Point at 95°F Ambient = 370 MBh @ 40.2 SST
- Coils are identical fin series and circuiting on both simulations.

Figure 1. Performance - RAUJ 30 ton (60 Hz)



By plotting the two coil performance outputs across the RAUJC30 Net Capacity curve at their respective total MBH at the defined saturated suction temperatures and ignoring line losses,, we can see that the condenser/evaporator coil combination, at 95 F ambient, provides 370 MBH Net Capacity at 40.2 SST.



Model Number Description

20 to 60 Ton Units

Digit 1 — Unit Type

R = Remote Condenser

Digit 2 — Condenser

A = Air-Cooled

Digit 3 — System Type

U = Upflow

Digit 4 — Development Sequence

J = Third

Digit 5, 6, 7 — Nominal Capacity

C20 = 20 Tons

C25 = 25 Tons

C30 = 30 Tons

C40 = 40 Tons

C50 = 50 Tons

C60 = 60 Tons

Digit 8 — Voltage and Start Characteristics

D = 415/50/3 XL

E = 200/60/3 XL

F = 230/60/3 XL

4 = 460/60/3 XL

5 = 575/60/3 XL

9 = 380/50/3 XL

Digit 9 — System Controls

B = No System Control

E = Supply Air VAV Control

P = EVP Control

Digit 10 — Design Sequence

Factory Assigned

Digit 11 — Ambient Control

0 = Standard

1 = 0°F (Low Ambient Dampers)

Digit 12 — Agency Approval

0 = None

3 = cULus (60 Hz only)

Digit 13 — Disconnect Switch

0 = None

A = Non-Fused Disconnect Switch

Digit 14 — Hot-Gas Bypass Valve

0 = None

B = Hot-Gas Bypass Valve

Digit 15 — Suction Service Valve

0 = None

D = Suction Service Valve

Digit 16 — Pressure Gauges

0 = None

F = Pressure Gauges and Piping

Digit 17 — Return Air Sensor

0 = None

G = Return Air Sensor

Digit 18 — Corrosion Protected Condenser Coil

0 = None

J = Corrosion Protected Condenser Coil

Digit 19 — Options

0 = None

C = Remote Chiller Evaporator and Install Kit

T = Flow Switch (EVP Control Only)

Digit 20 — Isolators

1 = Spring Isolator

2 = Neoprene Isolators

Note: The service digit for each model number contains 20 digits. All 20 digits must be referenced.

80 to 120 Ton Units

Digit 1 — Unit Type

R = Remote Condenser

Digit 2 — Condenser

A = Air-Cooled

Digit 3 — System Type

U = Upflow

Digit 4 — Development Sequence

J = Third

Digit 5, 6, 7 — Nominal Capacity

C80 = 80 Tons

D10 = 100 Tons

D12 = 120 Tons

Digit 8 — Voltage and Start Characteristics

E = 200/60/3 XL

F = 230/60/3 XL

4 = 460/60/3 XL

5 = 575/60/3 XL

* = 380/50/3 XL

* = 415/50/3 XL

Digit 9 — System Controls

B = No System Control

E = Supply Air VAV Control

P = EVP Control

Digit 10 — Design Sequence

Factory Assigned

Digit 11 — Ambient Control

0 = Standard

1 = 0°F (Low Ambient Dampers)

Digit 12 — Agency Approval

0 = None

3 = cULus (60 Hz only)

Digit 13 — Circuits

2 = Dual

Digit 14 — Hot-Gas Bypass Valve

0 = None

B = Hot-Gas Bypass Valve

Digit 15 — Suction Service Valve

0 = None

D = Suction Service Valve

Digit 16 — Pressure Gauges

0 = None

F = Pressure Gauges and Piping

Digit 17 — Corrosion Protected Condenser Coil

0 = None

J = Corrosion Protected Condenser Coil

Digit 18 — Isolators

0 = None

1 = Spring Isolator

Digit 19 —

C = Remote Chiller Evap and Install Kit

3 = Flow Switch (EVP Controls Only)

Notes:

1. The service digit for each model number contains 19 digits. All 19 digits must be referenced.
2. * = Design special.



General Data

Table 1. General data — RAUJ condensing units

Unit Size (tons)		20	25	30	40	50	60	80	100	120
Compressor Data										
Type		Scroll								
Number of Refrigerant Circuits		1	1	1	2	2	2	2	2	2
Manifolded Compressor sizes ^(a)	Tons	10-10	10-13.5	15-15	10-10	11.5-13.5	15-15	15-15-15	15-15-20	20-20-20
Unit Capacity Steps	%	100-50	100-42	100-50	100-75-50-25	100-73-46-23	100-75-50-25	100-83-66-50-33-17	100-80-60-45-30-15	100-83-66-50-33-17
Condenser Fan Data										
Type/Drive Type		Prop/Direct								
Qty		2	3	3	4	6	6	8	12	12
Diameter	in	26	26	26	26	26	26	26	26	26
Power/motor	hp	1.0	1.0	1.0	1.0	1.0	1.0	1.0	1.0	1.0
Nominal Total Airflow	cfm	14600	20700	20700	26790	36890	40490	56490	73890	76280
Condenser Coil Data										
Type		Microchannel								
Number of Coils		2	2	2	2	2	2	4	4	4
Size	in	42x71	42x71	42x71	59x71	51x96	51x96	59x71	51x96	64x96
Face Area	ft ²	41.4	41.4	41.4	58.2	68.0	68.0	116.4	136.0	170.7
Rows/Fin Per Ft.		1/240	1/240	1/240	1/240	1/240	1/240	1/240	1/240	1/240
Storage Capacity ^(b)	lbs	18.7	18.7	18.7	23.5	25.0	25.0	47.1	50.0	62.9
Refrigerant Data^(c)										
Type		R-410A								
Operating Charge ^(d)	lbs	11.9	11.8	11.8	22.7	23.4	23.8	57.1	59.1	65.3
Outdoor Air Temperature for Mechanical Cooling										
Standard Ambient Operating Range ^(e)	°F	40-125	40-125	40-125	40-125	40-125	40-125	40-125	40-125	40-125
Low Ambient Option	°F	0-125	0-125	0-125	0-125	0-125	0-125	0-125	0-125	0-125

^(a) Circuit 1 compressor manifold sizes shown. For units with 2 circuits, compressor manifold set is the same for circuit 1 and 2.

^(b) Condenser storage capacity is given at conditions of 95°F outdoor temperature, and 95% full.

^(c) Refer to Refrigerant Piping in the Application Considerations section. Condensing units are shipped with nitrogen holding charge only.

^(d) Operating charge is approximate for condensing unit only, and does not include charge for low side or interconnecting lines. Condensing units are shipped with a nitrogen holding charge only.

^(e) Maximum operating ambient for EVP remote chillers is 115°F.

Table 2. Altitude correction multiplier for capacity

Configuration	Altitude (ft.)				
	2,000	4,000	6,000	8,000	10,000
Condensing Unit Only	0.982	0.960	0.933	0.902	0.866
Condensing Unit / Air Handling Unit Combination	0.983	0.963	0.939	0.911	0.881
Condensing Unit With Evaporator	0.986	0.968	0.947	0.921	0.891



Performance Data

60Hz Units

Figure 2. Performance — RAUJ 20 ton 60 Hz

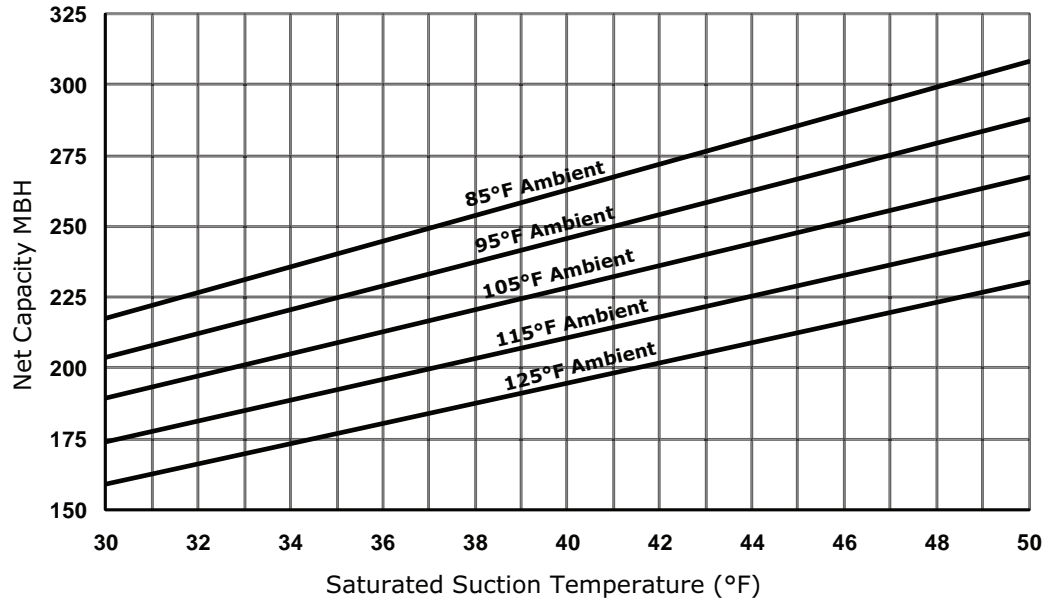


Figure 3. Performance — RAUJ 25 ton 60 Hz

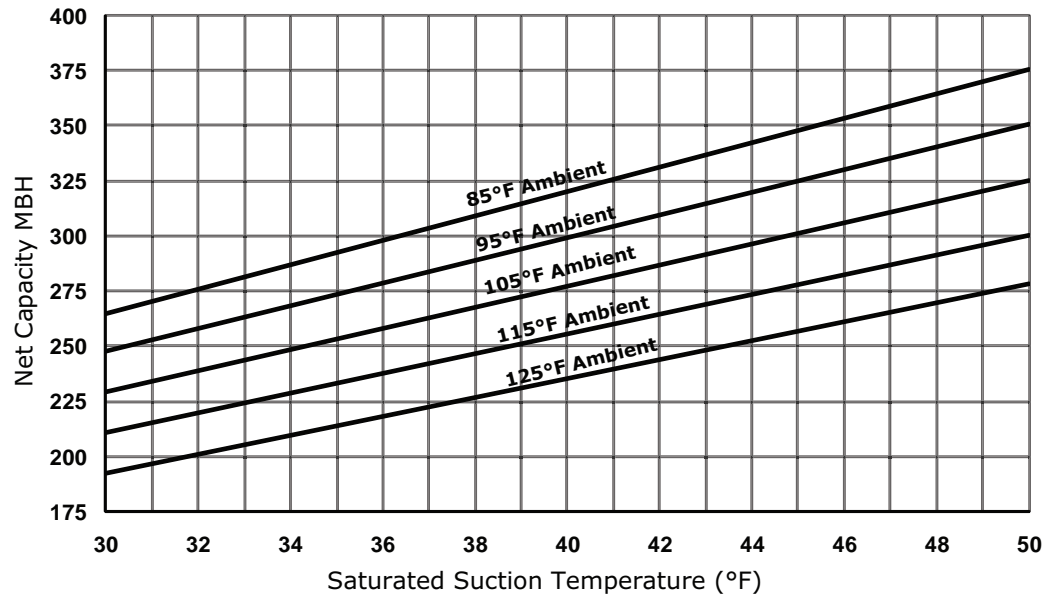


Figure 4. Performance — RAUJ 30 ton 60 Hz

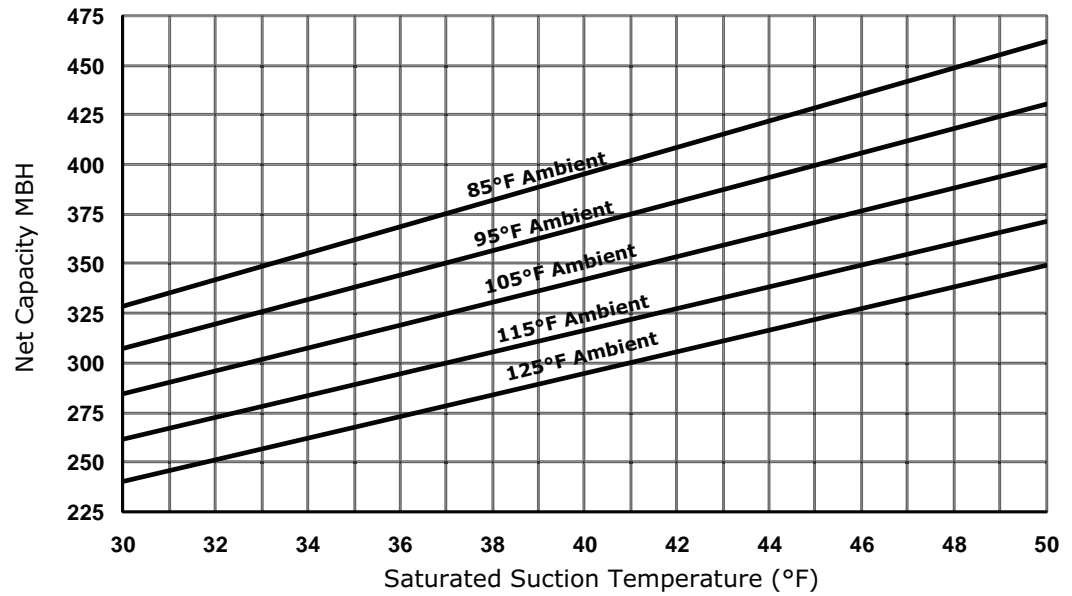


Figure 5. Performance — RAUJ 40 ton 60 Hz

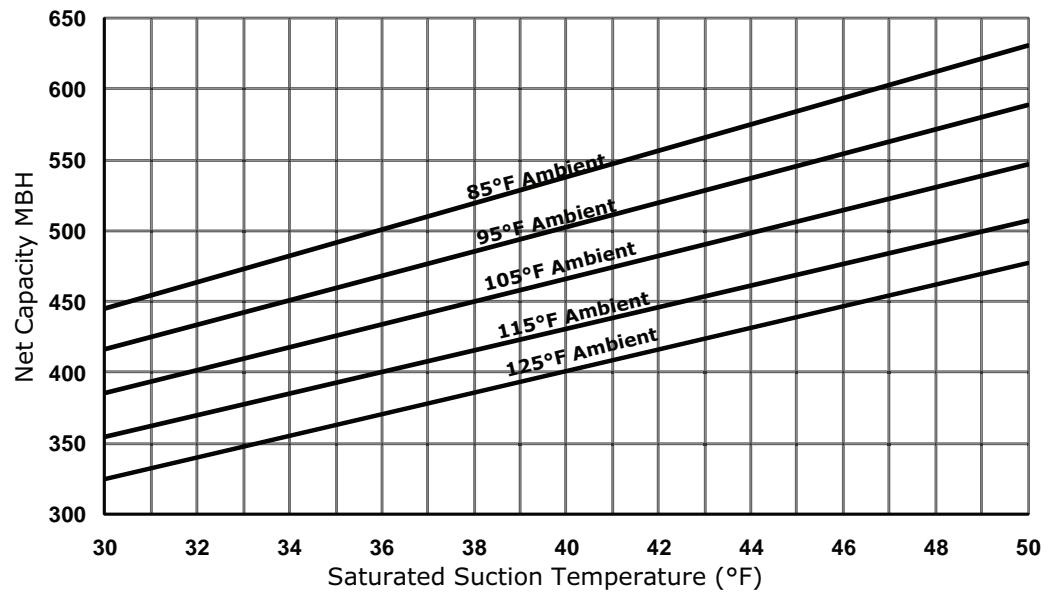


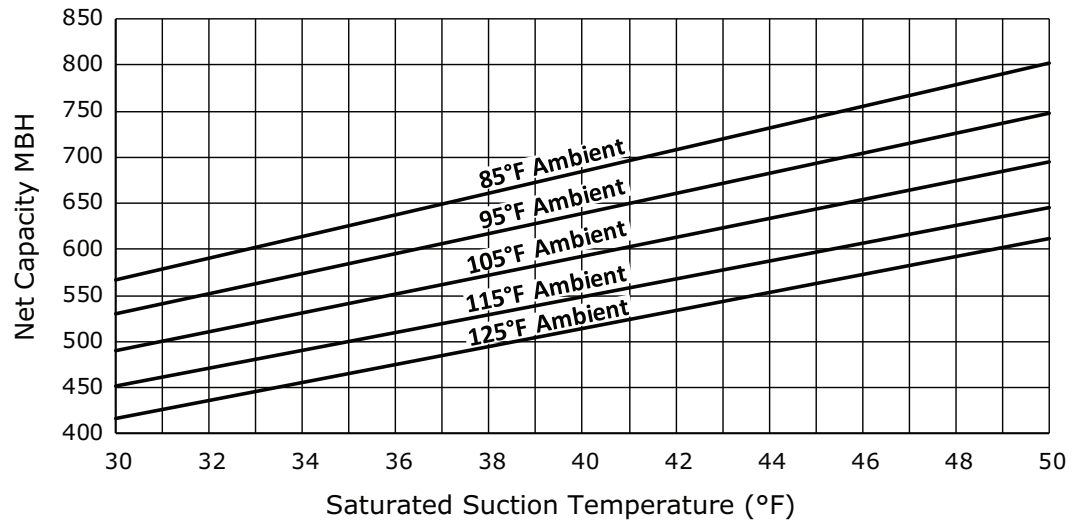
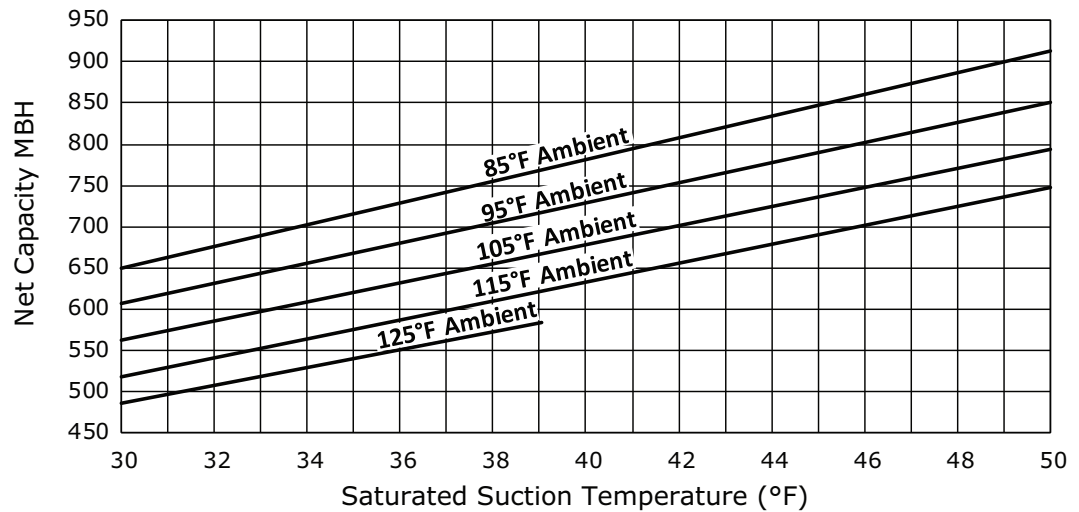
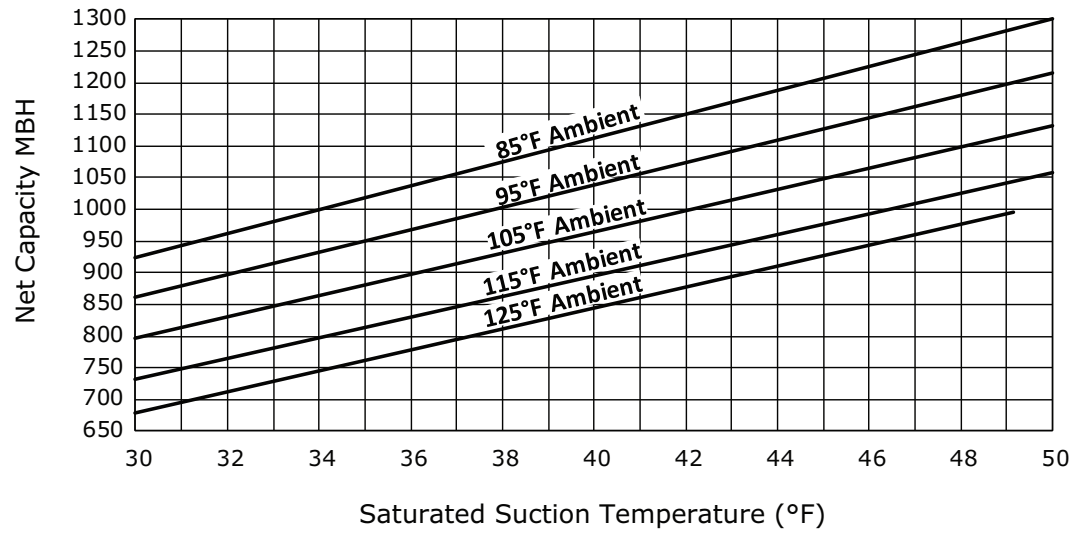
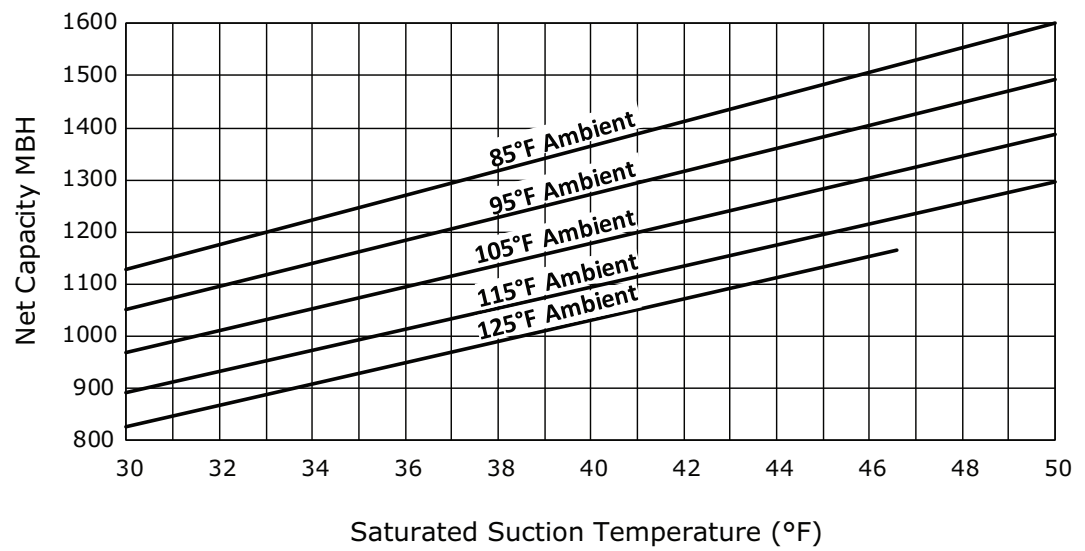
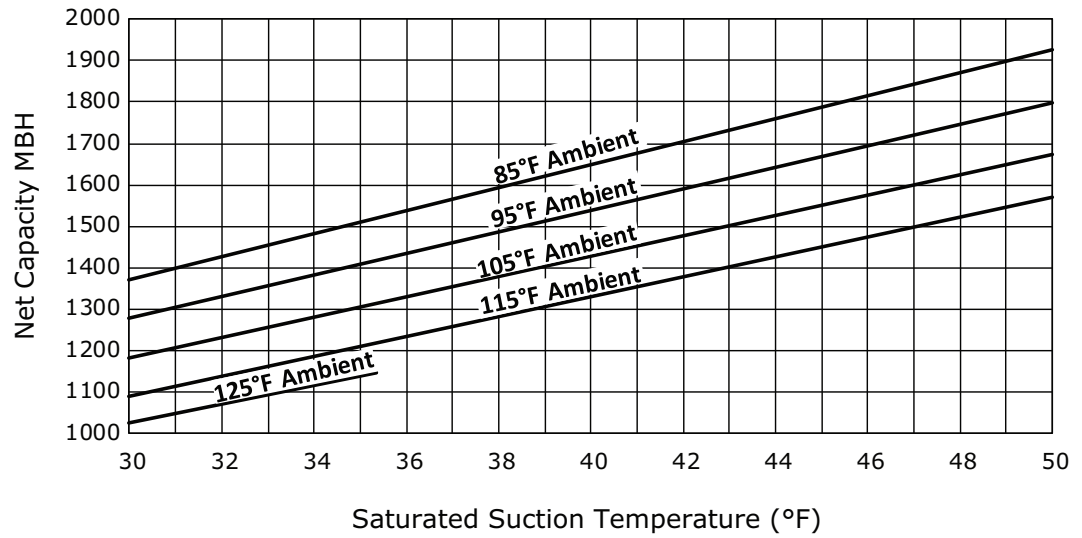
Figure 6. Performance — RAUJ 50 ton 60 Hz

Figure 7. Performance — RAUJ 60 ton 60 Hz


Figure 8. Performance — RAUJ 80 ton 60 Hz

Figure 9. Performance — RAUJ 100 ton 60 Hz




Performance Data

Figure 10. Performance — RAUJ 120 ton 60 Hz



50Hz Units

Figure 11. Performance — RAUJ 20 ton 50 Hz

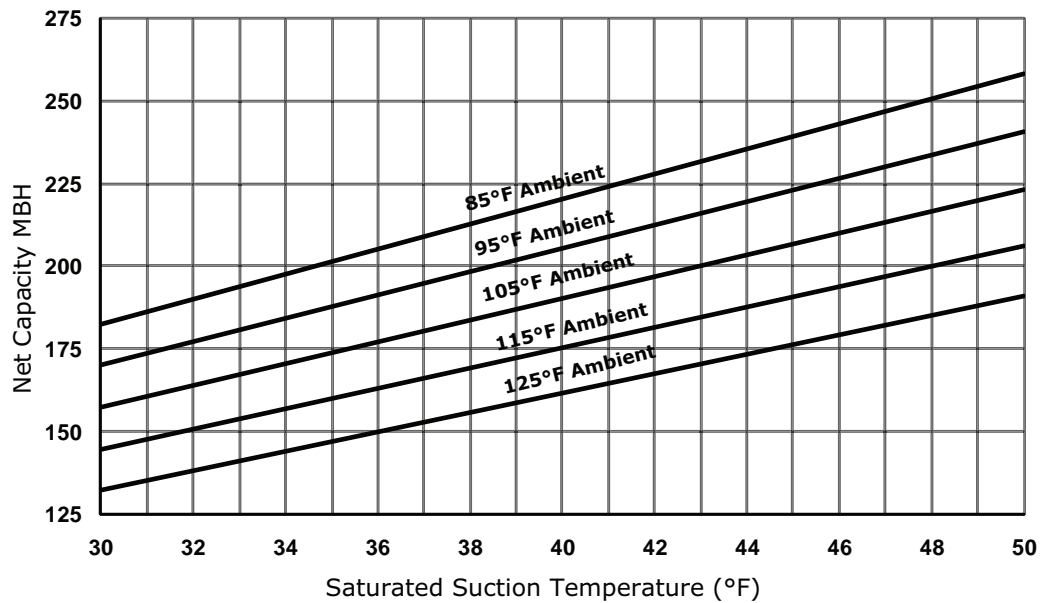


Figure 12. Performance — RAUJ 25 ton 50 Hz

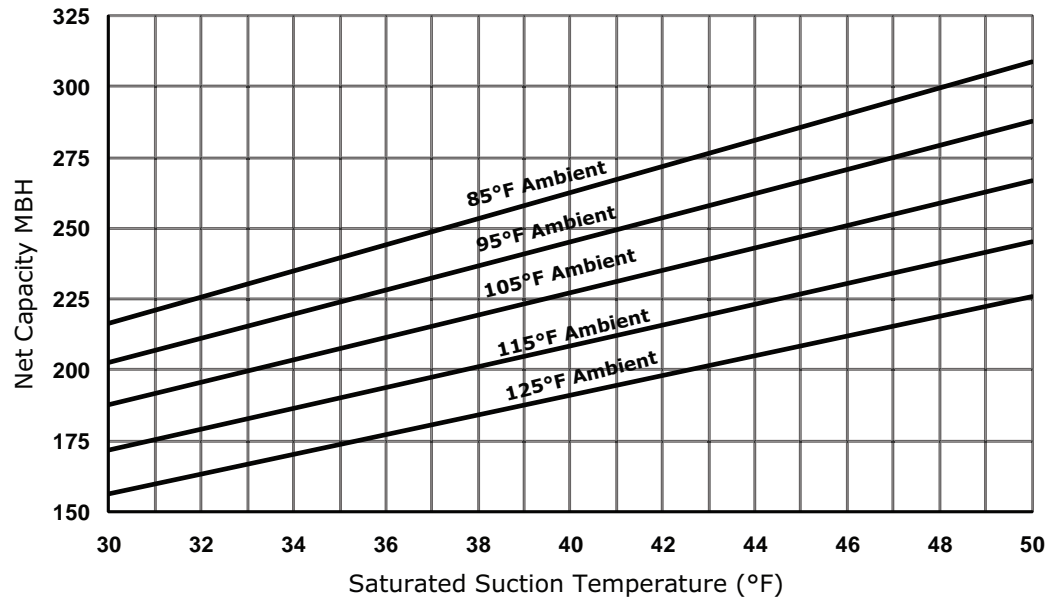


Figure 13. Performance — RAUJ 30 ton 50 Hz

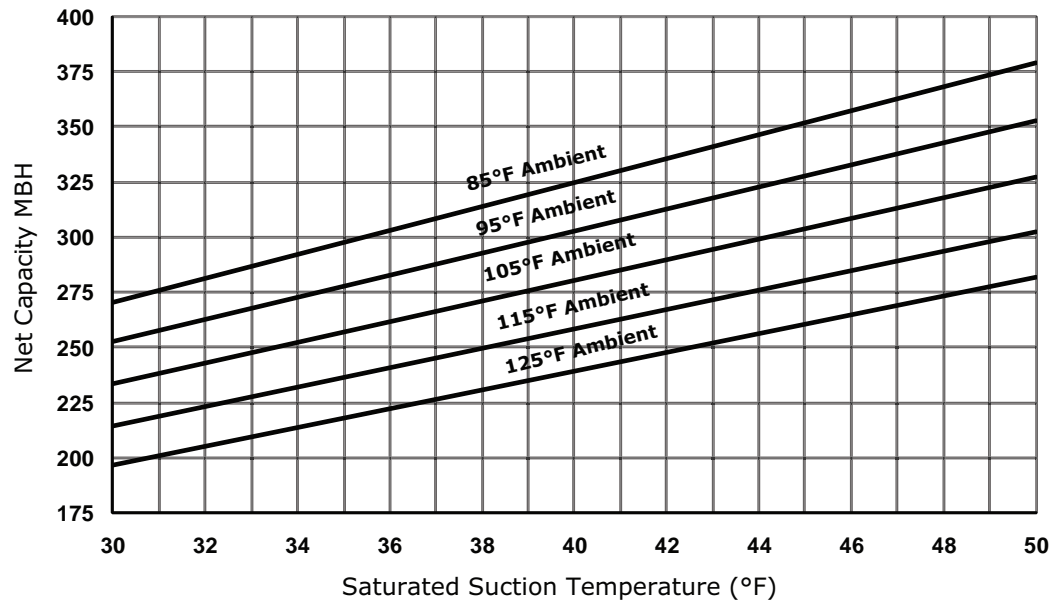


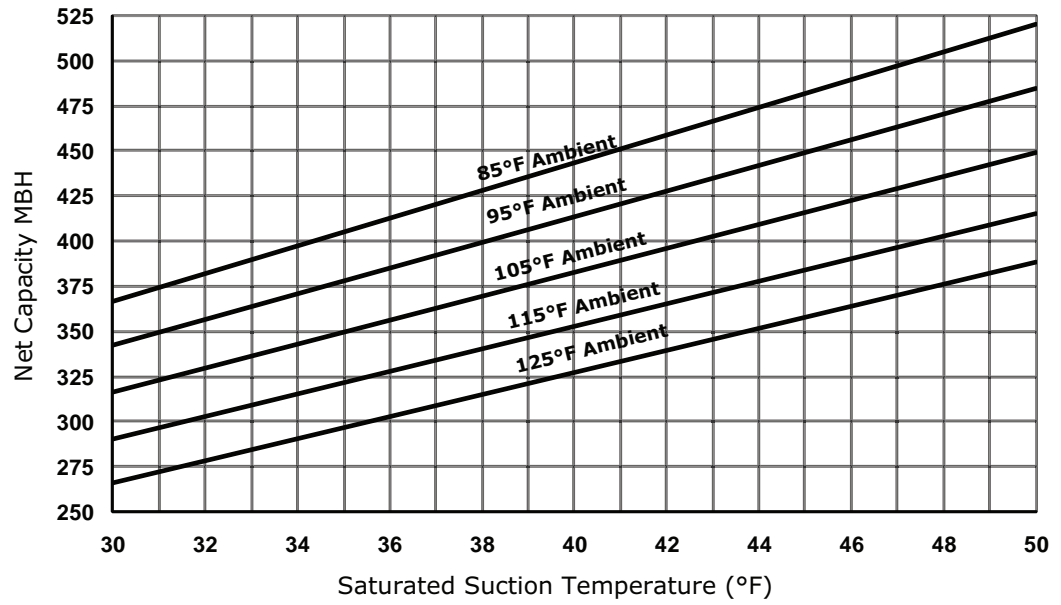
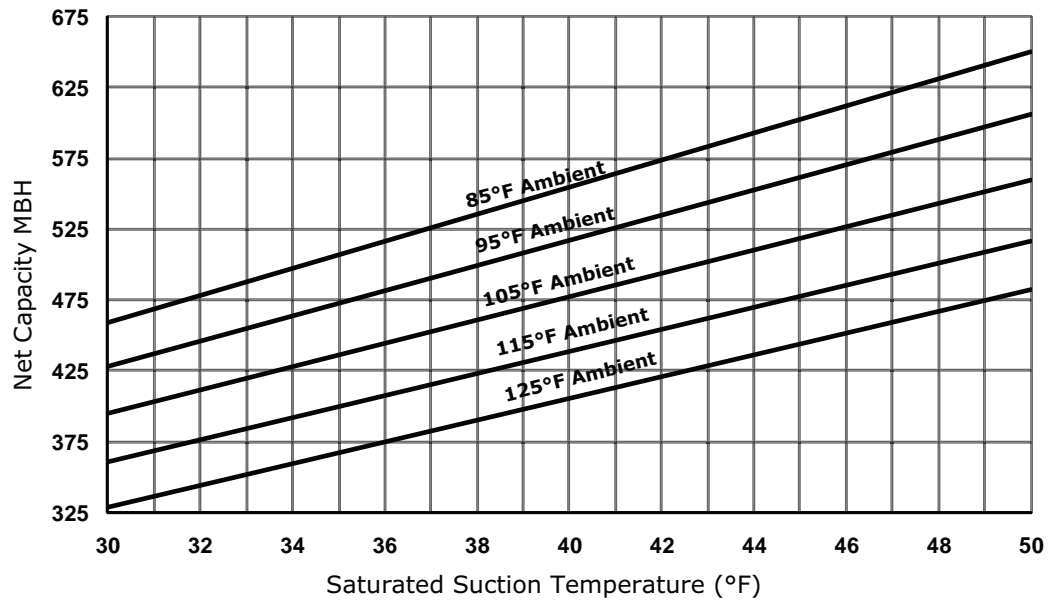
Figure 14. Performance — RAUJ 40 ton 50 Hz

Figure 15. Performance — RAUJ 50 ton 50 Hz


Figure 16. Performance — RAUJ 60 ton 50 Hz

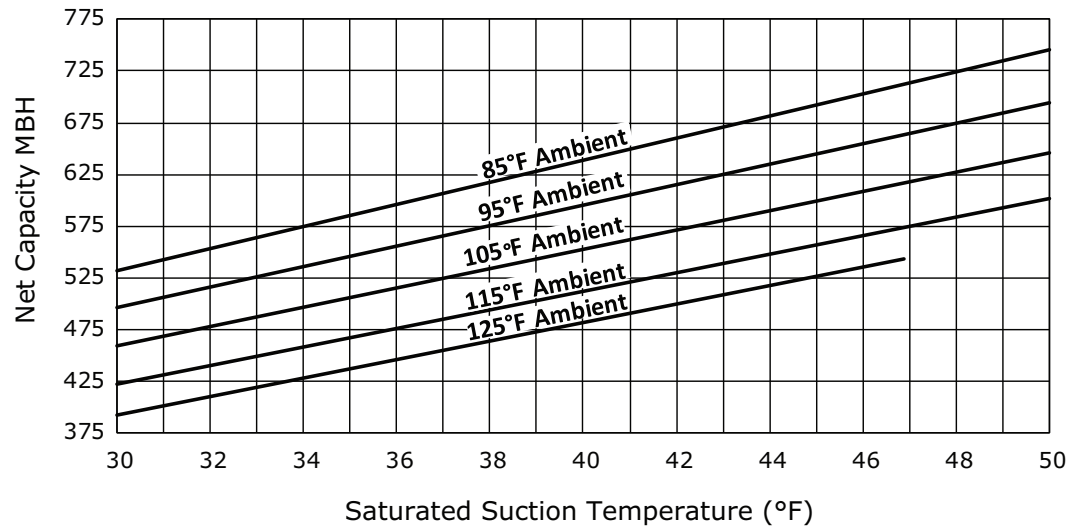


Figure 17. Performance — RAUJ 80 ton 50 Hz

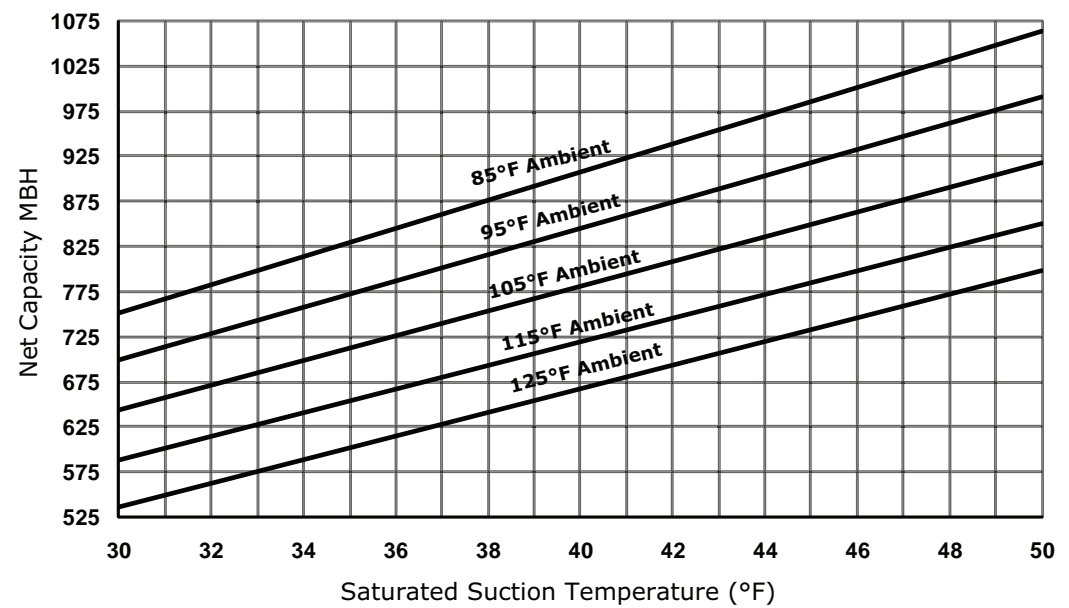


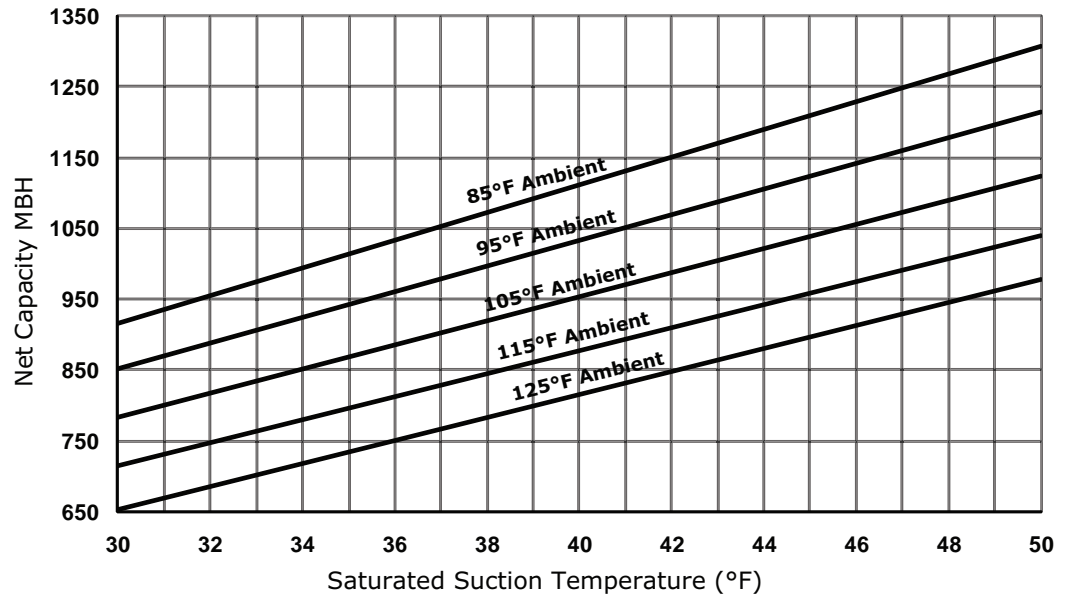
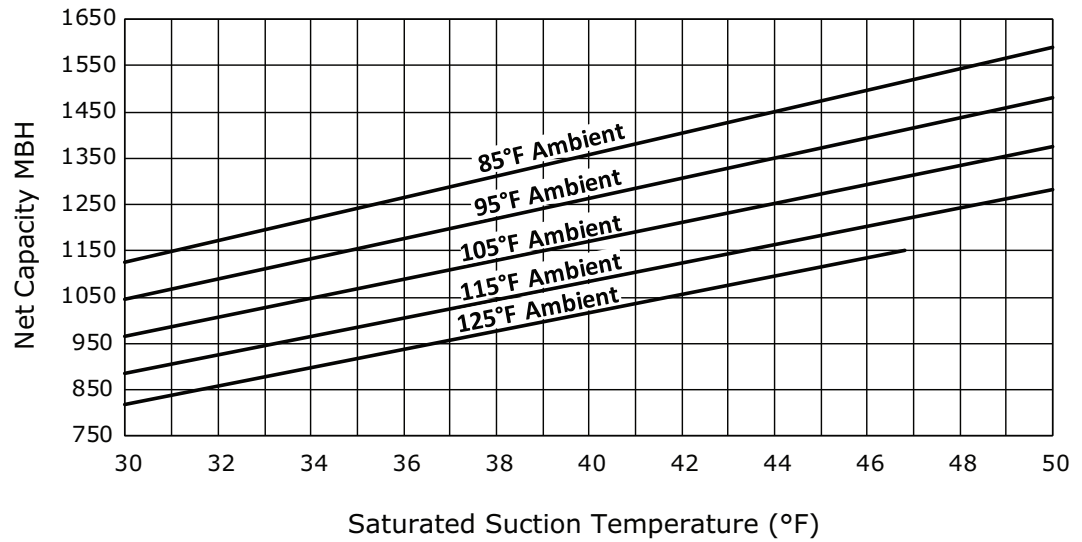
Figure 18. Performance — RAUJ 100 ton 50 Hz

Figure 19. Performance — RAUJ 120 ton 50 Hz


Table 3. System performance — 20 to 120 ton RAUJ with remote EVP chiller

Unit Size (tons)	LWFT (°F)	Entering Condenser Air Temperature (°F)							
		85		95		105		115	
		Capacity (tons)	Compr kW	Capacity (tons)	Compr kW	Capacity (tons)	Compr kW	Capacity (tons)	Compr kW
20	40	18.8	17.5	17.7	19.4	16.6	21.4	15.4	23.7
	42	19.4	17.8	18.3	19.6	17.2	21.7	16.0	23.9
	44	20.1	18.0	19.0	19.8	17.8	21.9	16.6	24.1
	46	20.8	18.2	19.6	20.0	18.4	22.1	17.1	24.3
	48	21.5	18.4	20.2	20.3	19.0	22.3	17.7	24.5
	50	22.1	18.6	20.9	20.5	19.6	22.5	18.3	24.7
25	40	23.3	20.5	21.9	22.7	20.5	25.1	19.0	27.7
	42	24.1	20.7	22.7	22.9	21.2	25.3	19.7	28.0
	44	24.9	21.0	23.5	23.1	22.0	25.5	20.4	28.2
	46	25.8	21.2	24.3	23.4	22.7	25.8	21.1	28.4
	48	26.6	21.5	25.1	23.6	23.5	26.0	21.8	28.7
	50	27.5	21.7	25.9	23.9	24.2	26.3	22.5	28.9
30	40	28.4	27.2	26.8	29.8	25.0	32.7	23.3	35.8
	42	29.4	27.6	27.7	30.2	25.9	33.1	24.1	36.1
	44	30.4	27.9	28.6	30.5	26.8	33.4	25.0	36.5
	46	31.4	28.3	29.6	30.9	27.7	33.8	25.8	36.8
	48	32.4	28.7	30.5	31.3	28.6	34.2	26.7	37.2
	50	33.5	29.0	31.5	31.7	29.5	34.5	27.5	37.6
40	40	34.0	38.9	33.9	38.9	33.9	39.0	33.8	39.2
	42	35.3	39.3	35.2	39.3	35.2	39.4	35.1	39.6
	44	36.6	39.7	36.5	39.8	36.5	39.9	36.4	40.0
	46	37.9	40.1	37.9	40.2	37.8	40.3	37.7	40.4
	48	39.3	40.6	39.2	40.6	39.2	40.8	39.1	40.9
	50	40.7	41.0	40.6	41.1	40.5	41.2	40.5	41.4
50	40	45.6	50.1	45.6	50.2	45.5	50.3	45.4	50.5
	42	47.2	50.6	47.2	50.7	47.1	50.9	47.0	51.1
	44	48.9	51.2	48.8	51.3	48.7	51.5	48.6	51.7
	46	50.6	51.8	50.5	51.9	50.4	52.1	50.3	52.3
	48	52.2	52.4	52.2	52.5	52.1	52.7	51.9	52.9
	50	54.0	53.0	53.9	53.2	53.8	53.3	53.6	53.5
60	40	52.1	59.6	52.0	59.7	51.9	59.9	51.8	60.1
	42	53.9	60.3	53.8	60.4	53.7	60.6	53.6	60.8
	44	55.7	61.1	55.7	61.2	55.5	61.4	55.4	61.6
	46	57.6	61.8	57.5	62.0	57.4	62.2	57.3	62.4
	48	59.5	62.6	59.4	62.8	59.3	63.0	59.1	63.2
	50	61.5	63.4	61.3	63.6	61.2	63.8	61.0	64.0



Performance Data

Table 3. System performance — 20 to 120 ton RAUJ with remote EVP chiller (continued)

Unit Size (tons)	LWFT (°F)	Entering Condenser Air Temperature (°F)							
		85		95		105		115	
		Capacity (tons)	Compr kW	Capacity (tons)	Compr kW	Capacity (tons)	Compr kW	Capacity (tons)	Compr kW
80	40	72.2	87.7	72.1	87.8	72.0	88.1	71.8	88.4
	42	74.8	88.4	74.7	88.7	74.5	89.0	74.4	89.3
	44	77.4	89.3	77.3	89.6	77.1	89.8	76.9	90.2
	46	80.0	90.2	79.9	90.4	79.8	90.7	79.6	91.1
	48	82.7	91.1	82.6	91.4	82.4	91.7	82.2	92.0
	50	85.4	92.0	85.3	92.3	85.1	92.6	84.9	93.0
100	40	89.9	102.6	89.8	102.8	89.6	103.2	89.4	103.5
	42	93.1	103.7	93.0	103.9	92.8	104.2	92.6	104.6
	44	96.3	104.8	96.2	105.0	96.0	105.4	95.8	105.8
	46	99.6	105.9	99.5	106.1	99.3	106.5	99.1	106.9
	48	103.0	107.0	102.8	107.3	102.6	107.6	102.4	108.1
	50	106.4	108.2	106.2	108.5	106.0	108.9	105.7	109.3
120	40	107.8	124.9	107.6	125.2	107.5	125.5	107.3	126.0
	42	111.5	126.1	111.4	126.4	111.2	126.8	111.0	127.3
	44	115.4	127.4	115.2	127.7	115.0	128.1	114.7	128.7
	46	119.2	128.8	119.0	129.1	118.8	129.5	118.5	130.0
	48	123.1	130.1	122.9	130.4	122.7	130.9	122.4	131.4
	50	127.1	131.5	126.9	131.9	126.6	132.3	126.3	132.8

Notes:

1. Performance data at 10°F water temperature drop and 60 Hz.
2. Leaving water temperature (LWT) below 42°F requires freeze protection to 15°F.
3. 40°F LWT performance includes 20% glycol

Table 4. Chiller water pressure drop (ft H₂O)

Flow(gpm)	Size (tons)								
	20	25	30	40	50	60	80	100	120
25	3.7	-	-	-	-	-	-	-	-
30	5.2	3.2	-	-	-	-	-	-	-
35	6.9	4.2	-	-	-	-	-	-	-
40	8.8	5.4	3.1	-	-	-	-	-	-
45	10.9	6.7	3.9	-	-	-	-	-	-
50	13.3	8.2	4.8	5.3	-	-	-	-	-
60	18.5	11.4	6.7	7.5	4.1	-	-	-	-
70	24.6	15.2	8.9	10.1	5.5	-	-	-	-
80	-	19.4	11.4	13	7.1	5	-	-	-
90	-	24.1	14.2	16.3	8.9	6.3	-	-	-
100	-	-	17.3	19.9	10.9	7.7	4.3	-	-
120	-	-	-	28.3	15.4	10.9	6.1	3.2	-
140	-	-	-	-	20.7	14.6	8.2	4.4	-

Table 4. Chiller water pressure drop (ft H₂O) (continued)

Flow(gpm)	Size (tons)								
	20	25	30	40	50	60	80	100	120
160	-	-	-	-	26.7	18.9	10.6	5.6	4.8
180	-	-	-	-	-	23.6	13.2	7.1	6.1
200	-	-	-	-	-	-	16.2	8.7	7.4
240	-	-	-	-	-	-	22.9	12.3	10.6
280	-	-	-	-	-	-	-	16.5	14.2
320	-	-	-	-	-	-	-	21.3	18.3
360	-	-	-	-	-	-	-	26.7	23
400	-	-	-	-	-	-	-	-	28.2

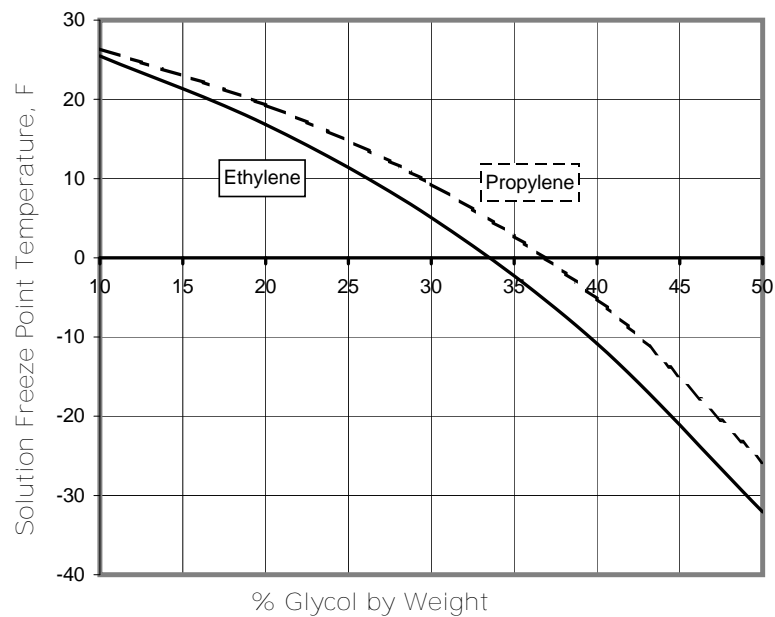
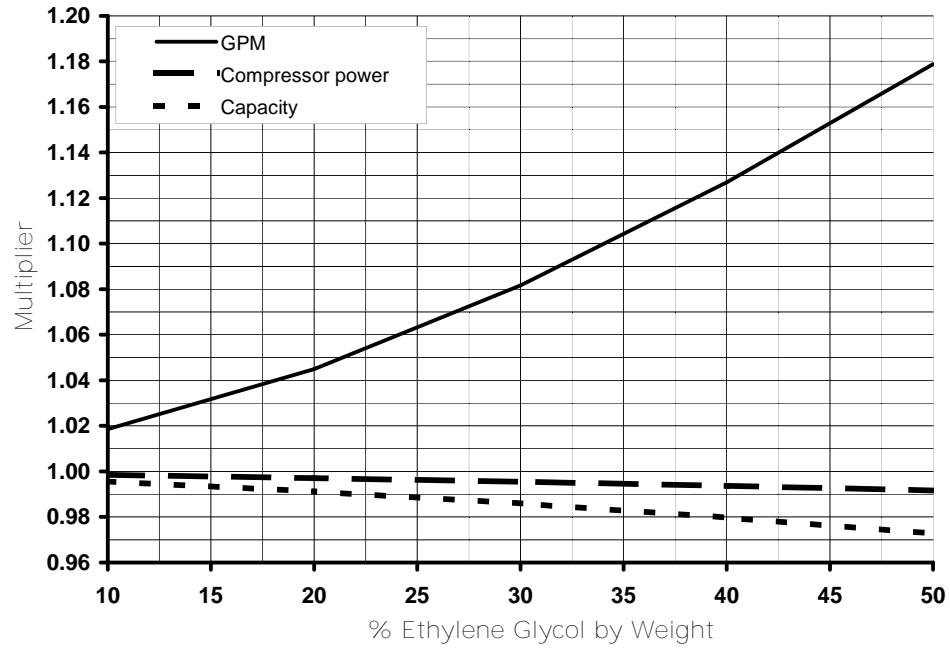
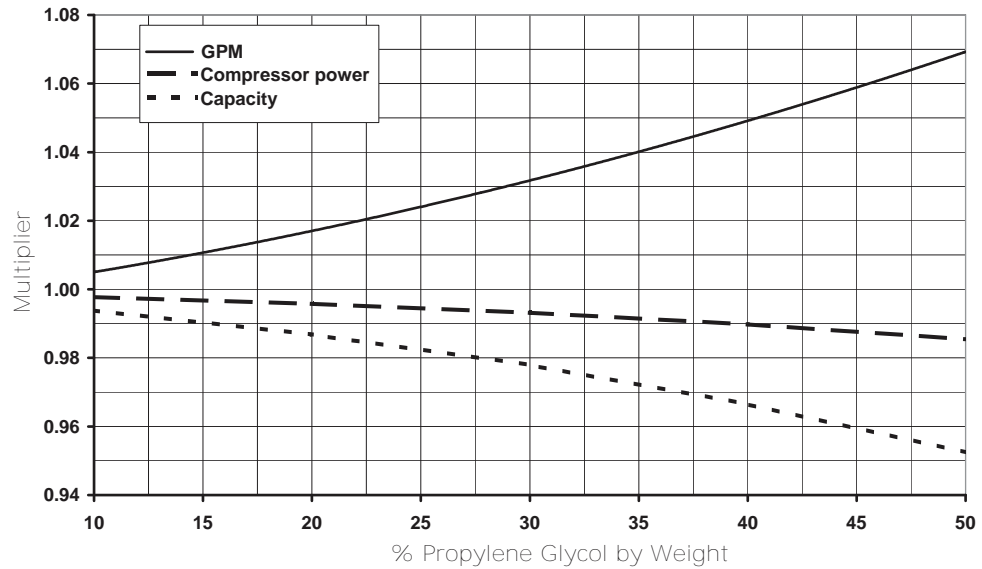
Figure 20. Remote EVP glycol freeze protection


Figure 21. Remote EVP ethylene glycol GPM, capacity, compressor power adjustment

Figure 22. Remote EVP propylene glycol GPM, capacity, compressor power adjustment




Controls

System Control Options

Select one of the following control options to meet your application requirements.

No System Control

Provides the compressors wired to a terminal strip inside the control panel. The temperature controller must be field provided and installed. The 20, 25 and 30 ton sizes have two capacity steps. The 40, 50 and 60 ton sizes have four steps available. The 80, 100, and 120 ton sizes have six steps available.

EVP Chiller Control

Consists of an interface panel in the main unit control box and a remote mounted control box that is customer installed. The remote mounted box contains the Honeywell W7100G controller. The water chiller controller has an adjustable 0-10°F control band using integrating logic, built-in fixed-off timers and field installed discharge water temperature sensors for control and chiller freeze protection. Pumpdown is provided. Lead-lag and multiple chiller control are not provided. There are two capacity steps on 20, 25 and 30 ton sizes, four capacity steps on 40, 50 and 60 ton sizes and six capacity steps on 80, 100 and 120 ton sizes.

Supply Air VAV Control

Provides a Honeywell W7100A control system. This option is for use with shut-off VAV or other applications requiring control of supply air temperature. The control provides a voltage output for interface with field supplied components to provide simultaneous economizer operation. The discharge air sensor ships with the unit for field mounting. The standard VAV unit is provided with reliable coil frost protection in the form of Trane's proven and patented Froststat™. Froststat™ is used in place of hot gas bypass.

UC600 Controller with Cooling Discharge Air Temperature Control (AHU) Kit — Field Installed

Upon receiving a field provided dry contact closure of being enabled by the communicating BAS, the UC600 shall control compressors to cooling discharge air temperature setpoint. Cooling discharge air temperature setpoint shall be an analog value that can be adjusted with Tracer TU or through BACnet communication. A duct discharge air temperature sensor shall be factory provided for field installation.

UC600 Controller with Cooling Leaving Water Temperature Control (Chiller) Kit — Field Installed

Upon receiving a field provided dry contact closure of being enabled by the communicating BAS, the UC600 shall control compressors to leaving water temperature setpoint. Leaving water temperature setpoint shall be an analog value that can be adjusted with Tracer TU or through BACnet communication. If leaving water temperature is at or below 36°F, the unit controller shall go into freeze protection lockout.

Low Ambient Control Option

Standard

Unit start-up and operation down to approximately 40°F at minimum compressor load.

Low Ambient

Factory-installed head pressure control damper assembly permits operation down to 0°F by maintaining proper head pressure. Ten minute timer is standard for protection against nuisance trips.



Miscellaneous Options

Disconnect

Non-fused unit disconnect switch is mounted in the control box and provides for interruption of power for servicing the unit. Lugs are suitable for copper wires only. No overcurrent or short circuit protection is provided for the unit by this switch.

Hot Gas Bypass Valves

Hot gas bypass valves are stocked and shipped with the unit for field installation. When suction pressure falls below the valve adjustable set point, the valve modulates hot gas to the inlet of the evaporator.

Note: *Frostat™ is standard on VAV units and is recommended in place of hot gas bypass.*



Electrical

Note: Local codes may take precedence.

Table 5. RAUJ electrical data

Unit Size (ton)	Rated Voltage ^(a)	Condenser Fan Motor ^(b)		CPT Amps	Compressor Motor ^(b)						Unit Characteristics		
		Qty	FLA		Qty	RLA			LRA			MCA ^(c)	MOP ^(d)
						1A/2A	1B/2B	1C/2C	1A/2A	1B/2B	1C/2C		
20	200/60/3XL	2	4.1	2	41.4	41.4	-	267	267	-	102	125	
	230/60/3XL	2	4.1	2	35.5	35.5	-	267	267	-	89	110	
	460/60/3XL	2	1.8	2	18.6	18.6	-	142	142	-	45	60	
	575/60/3XL	2	1.4	2	15.8	15.8	-	103	103	-	38	50	
	380/415/50/3XL	2	1.7	2	18.6	18.6	-	142	142	-	46	60	
25	200/60/3XL	3	4.1	2	41.4	52	-	267	315	-	120	150	
	230/60/3XL	3	4.1	2	35.5	46.9	-	267	315	-	108	150	
	460/60/3XL	3	1.8	2	18.6	22.2	-	142	158	-	52	70	
	575/60/3XL	3	1.4	2	15.8	19.2	-	103	136	-	45	60	
	380/415/50/3XL	3	1.7	2	18.6	22.2	-	142	158	-	52	70	
30	200/60/3XL	3	4.1	2	56.9	56.9	-	351	351	-	141	175	
	230/60/3XL	3	4.1	2	48.8	48.8	-	351	351	-	123	150	
	460/60/3XL	3	1.8	2	25.5	25.5	-	197	197	-	63	80	
	575/60/3XL	3	1.4	2	23.1	23.1	-	146	146	-	56	70	
	380/415/50/3XL	3	1.7	2	25.5	25.5	-	197	197	-	63	80	
40	200/60/3XL	4	4.1	4	41.4	41.4	-	267	267	-	195	225	
	230/60/3XL	4	4.1	4	35.5	35.5	-	267	267	-	169	200	
	460/60/3XL	4	1.8	4	18.6	18.6	-	142	142	-	87	100	
	575/60/3XL	4	1.4	4	15.8	15.8	-	103	103	-	73	80	
	380/415/50/3XL	4	1.7	4	18.6	18.6	-	142	142	-	86	100	
50	200/60/3XL	6	4.1	4	47	52	-	304	315	-	238	250	
	230/60/3XL	6	4.1	4	42.3	46.9	-	304	315	-	217	250	
	460/60/3XL	6	1.8	4	20.2	22.2	-	147	158	-	102	110	
	575/60/3XL	6	1.4	4	17.1	19.2	-	122	136	-	86	100	
	380/415/50/3XL	6	1.7	4	20.2	22.2	-	147	158	-	101	110	

Table 5. RAUJ electrical data (continued)

Unit Size (ton)	Rated Voltage ^(a)	Condenser Fan Motor ^(b)		CPT Amps	Compressor Motor ^(b)								Unit Characteristics	
		Qty	FLA		Qty	RLA			LRA			MCA ^(c)	MOP ^(d)	
						1A/2A	1B/2B	1C/2C	1A/2A	1B/2B	1C/2C			
60	200/60/3XL	6	4.1	3	4	56.9	56.9	-	351	351	-	269	300	
	230/60/3XL	6	4.1	2	4	48.8	48.8	-	351	351	-	234	250	
	460/60/3XL	6	1.8	1	4	25.5	25.5	-	197	197	-	120	125	
	575/60/3XL	6	1.4	1	4	23.1	23.1	-	146	146	-	107	125	
	380/415/50/3XL	6	1.7	1	4	25.4	25.4	-	197	197	-	119	125	
80	200/60/3XL	8	4.1	4	6	60.5	60.5	60.5	320	320	320	415	450	
	230/60/3XL	8	4.1	3	6	52	52	52	320	320	320	361	400	
	460/60/3XL	8	1.8	2	6	25.4	25.4	25.4	160	160	160	175	200	
	575/60/3XL	8	1.4	1	6	20.3	20.3	20.3	135	135	135	139	150	
100	200/60/3XL	12	4.1	4	6	60.5	60.5	83.9	320	320	485	484	500	
	230/60/3XL	12	4.1	3	6	52	52	74.5	320	320	485	428	500	
	460/60/3XL	12	1.8	2	6	25.4	25.4	37.2	160	160	215	209	225	
	575/60/3XL	12	1.4	1	6	20.3	20.3	29.8	135	135	175	166	175	
120	200/60/3XL	12	4.1	4	6	83.9	83.9	83.9	485	485	485	578	600	
	230/60/3XL	12	4.1	3	6	74.5	74.5	74.5	485	485	485	518	600	
	460/60/3XL	12	1.8	2	6	37.2	37.2	37.2	215	215	215	256	300	
	575/60/3XL	12	1.4	1	6	29.8	29.8	29.8	175	175	175	205	225	

^(a) Voltage Utilization Range is +/- 10% of Rated voltage (use range): 200/60/3 (180-220), 230/60/3 (208-254), 460/60/3 (414-506), 575/60/3 (516-633), 380/50/3 (342-418), 415/50/3 (373-456)

^(b) Electrical information is for each individual motor.

^(c) Minimum circuit ampacity (MCA) is 125 percent of the RLA of one compressor motor plus the total RLA of the remaining motors.

^(d) Maximum Overcurrent Protection Device permitted by NEC 440-22 is 225 percent of the RLA of one compressor motor plus the total RLA of the remaining motors.

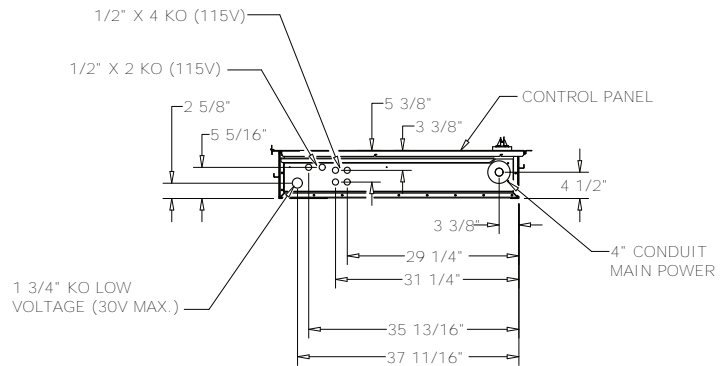
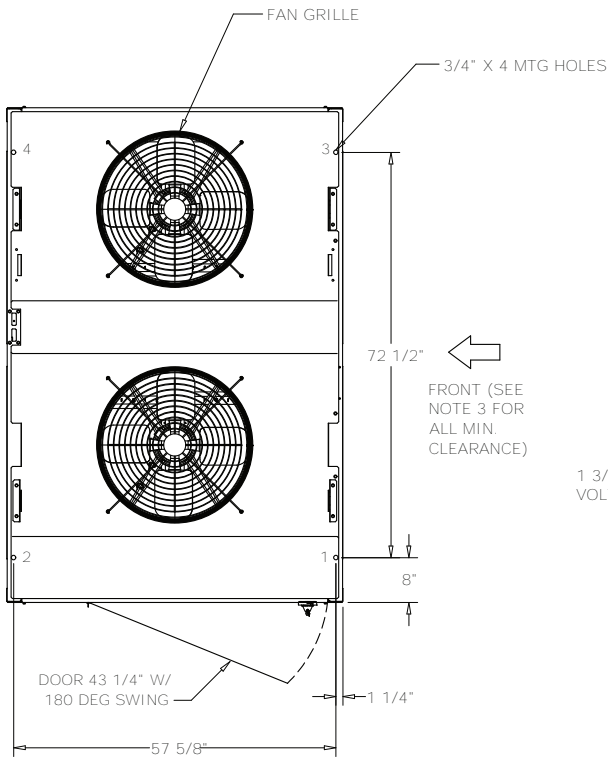


Unit Dimensions

Figure 23. Air-cooled condensing unit — 20 ton

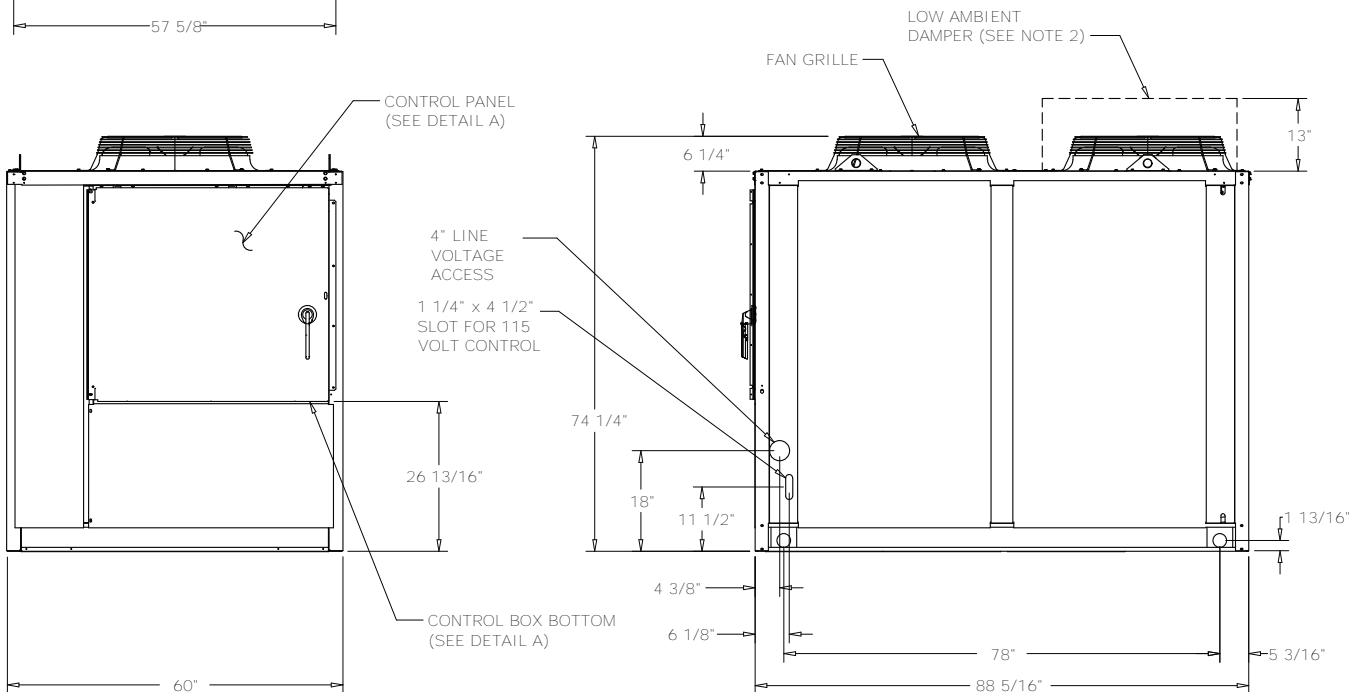
NOTES:

1. SEE CONNECTION DRAWING FOR CONNECTION LOCATION AND SIZES.
2. LOW AMBIENT DAMPER ONLY COMES WITH SELECTED UNIT .
3. FRONT OF UNIT CLEARANCE 72" . BACK OF UNIT CLEARANCE 72" . LEFT AND RIGHT SIDE OF UNIT CLEARANCE 42" .



DETAIL A

CONTROL BOX BOTTOM





Unit Dimensions

Figure 24. Air-cooled condensing unit connections — 20 ton

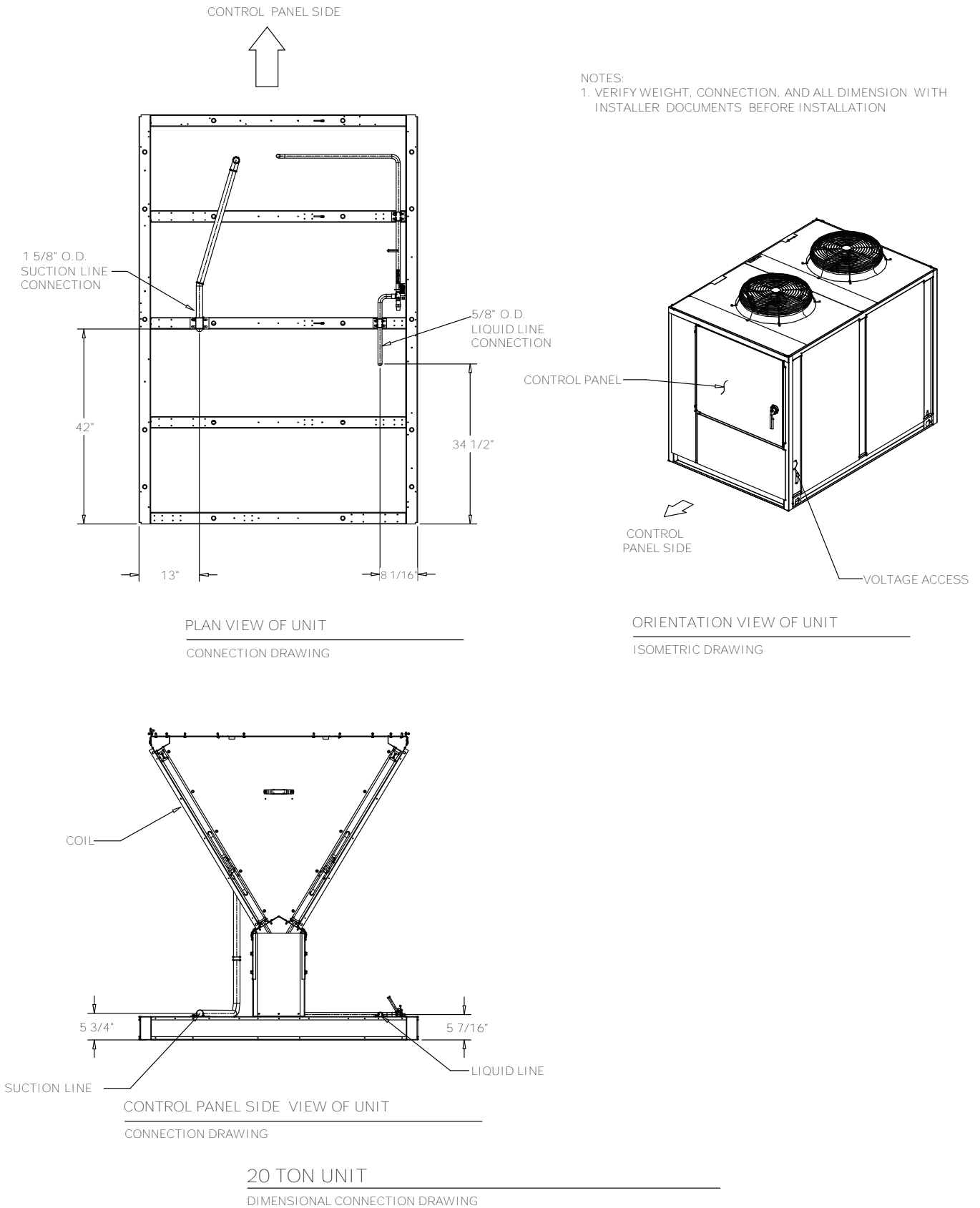
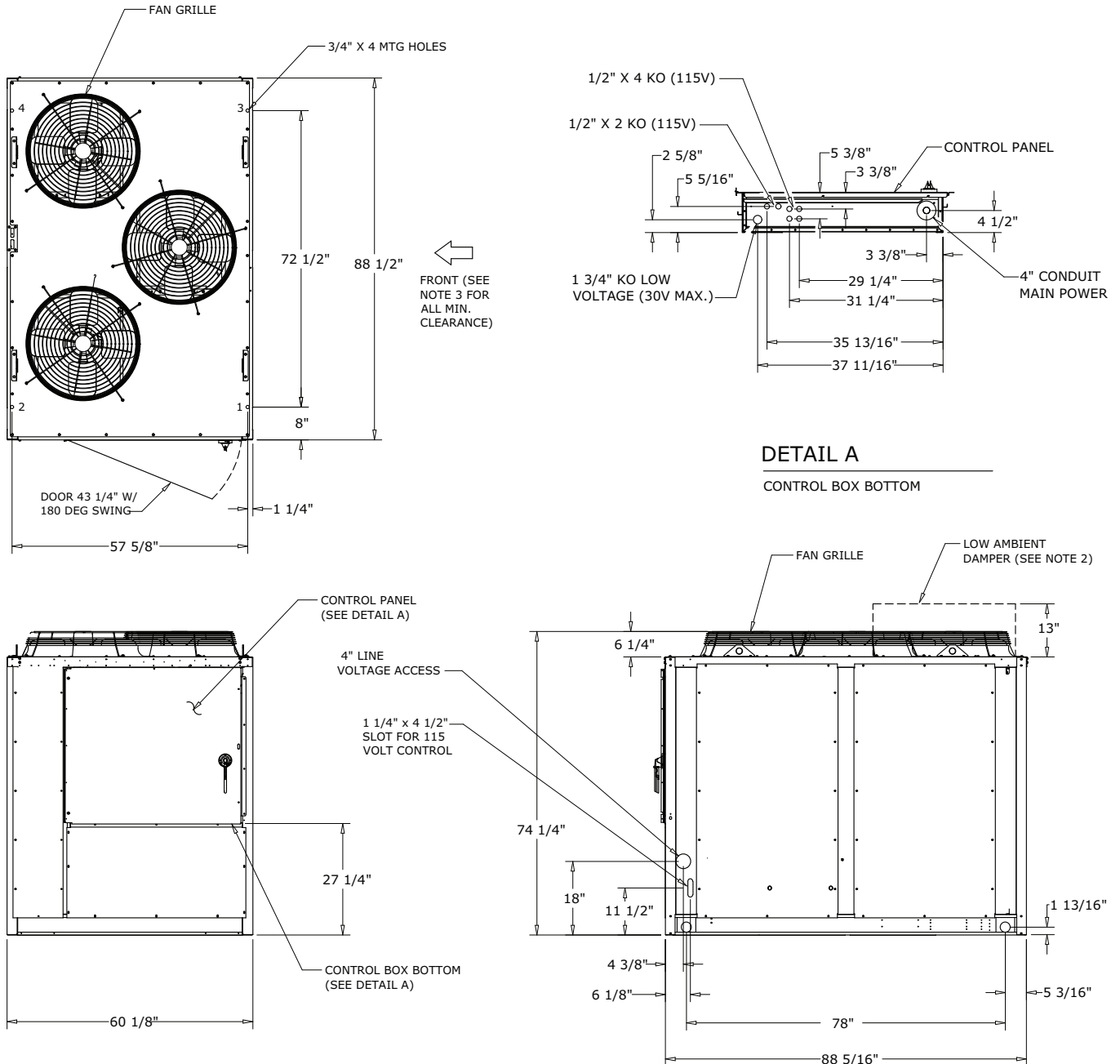


Figure 25. Air-cooled condensing unit — 25 and 30 tons

NOTES:

1. SEE CONNECTION DRAWING FOR CONNECTION LOCATION AND SIZES.
2. LOW AMBIENT DAMPER ONLY COMES WITH SELECTED UNIT .
3. FRONT OF 20 AND 30 UNIT CLEARANCE 72" . BACK OF UNIT CLEARANCE 72". LEFT AND RIGHT SIDE OF 20 AND 30 UNIT CLEARANCE 42".

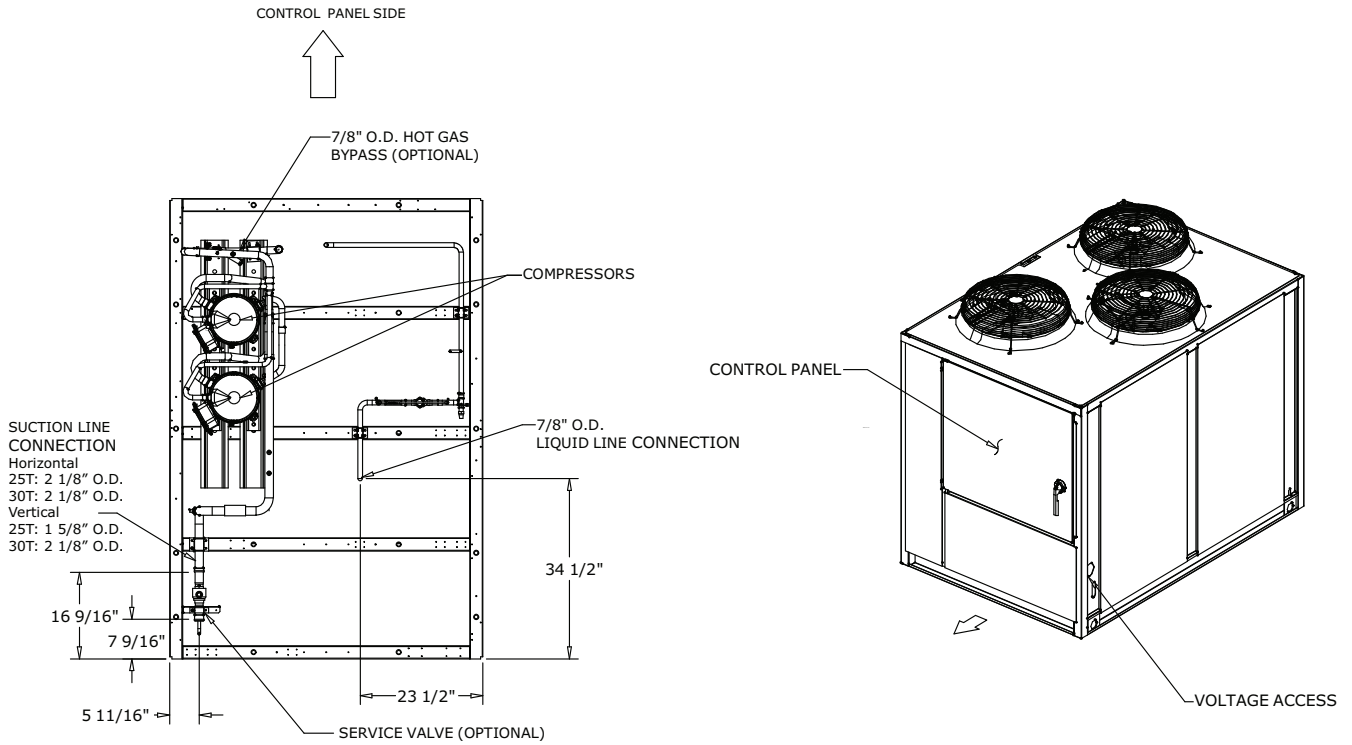




Unit Dimensions

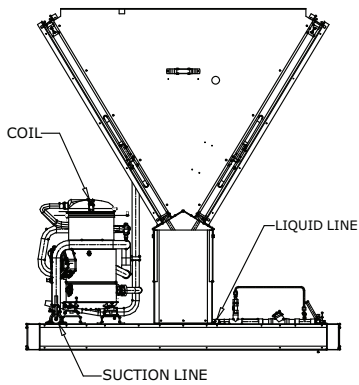
Figure 26. Air-cooled condensing unit connections — 25 and 30 tons

NOTES:
1. VERIFY WEIGHT, CONNECTION, AND ALL DIMENSION WITH INSTALLER DOCUMENTS BEFORE INSTALLATION

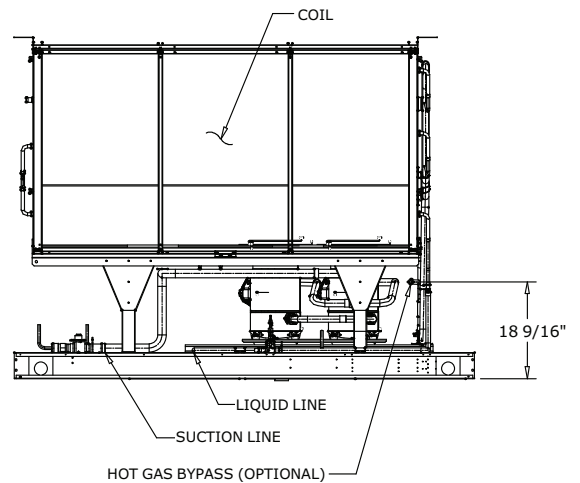


PLAN VIEW OF UNIT
CONNECTION DRAWING

ORIENTATION VIEW OF UNIT
ISOMETRIC DRAWING



CONTROL PANEL SIDE VIEW OF UNIT
CONNECTION DRAWING

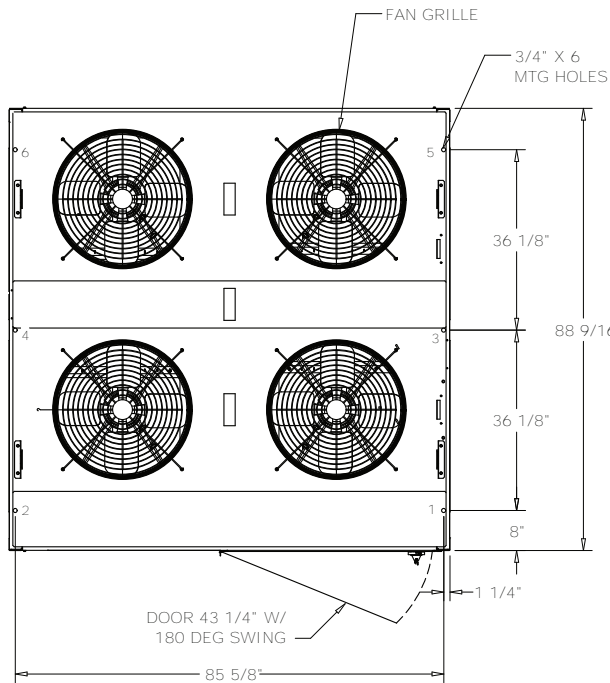


BACK VIEW OF UNIT
CONNECTION DRAWING

25 - 30 TON UNIT

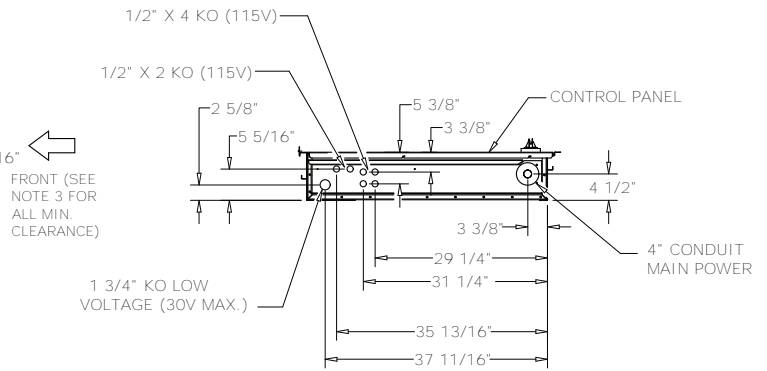
DIMENSIONAL CONNECTION DRAWING

Figure 27. Air-cooled condensing unit — 40 ton



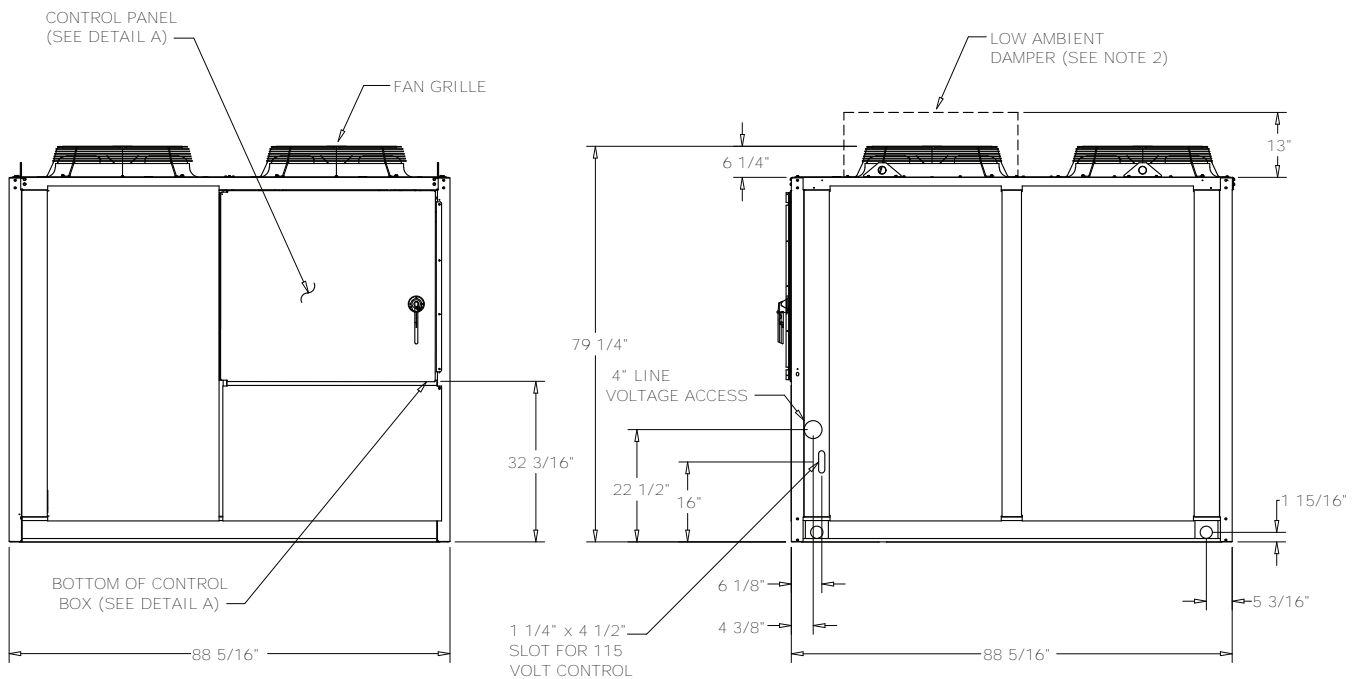
NOTES:

1. SEE CONNECTION DRAWING FOR CONNECTION LOCATION AND SIZES.
2. LOW AMBIENT DAMPER ONLY COMES WITH SELECTED UNIT .
3. FRONT AND BACK OF UNIT CLEARANCE 72" . LEFT AND RIGHT SIDE OF UNIT CLEARANCE 42" .



DETAIL A

BOTTOM OF CONTROL BOX

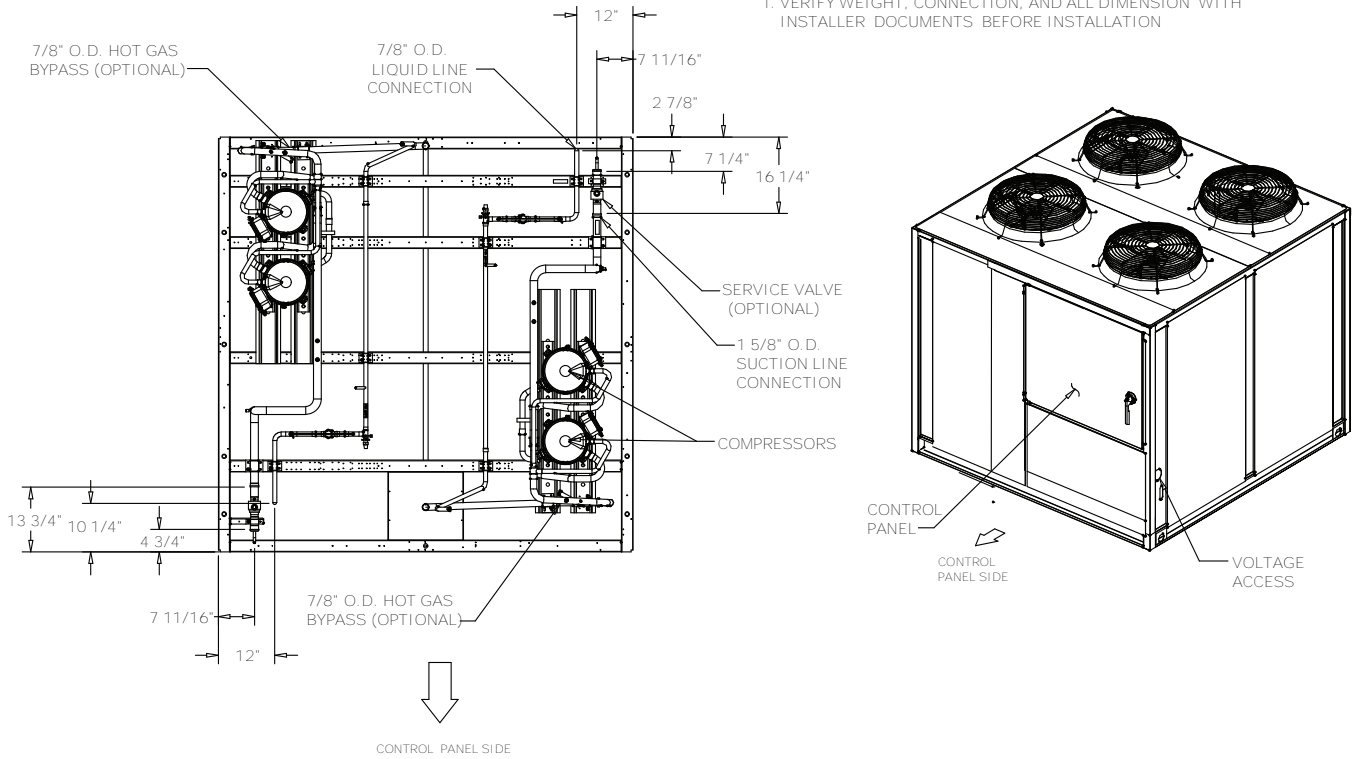




Unit Dimensions

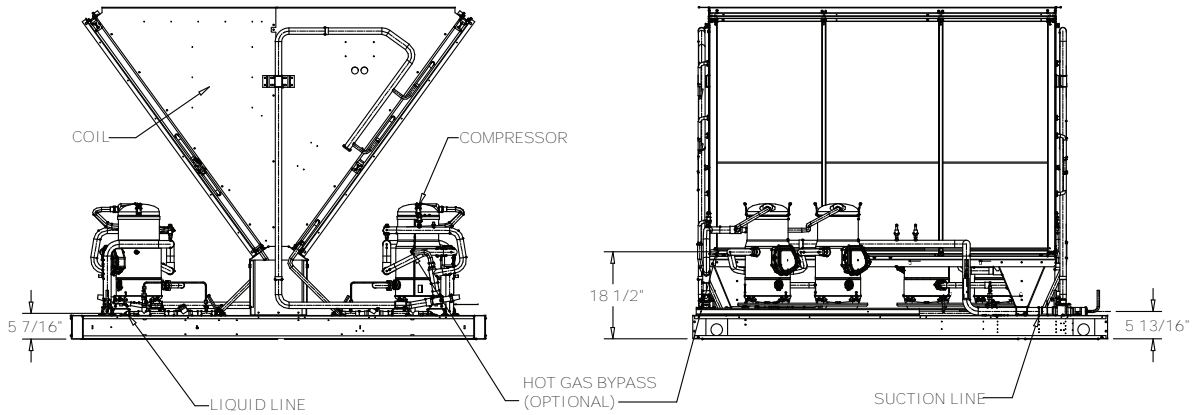
Figure 28. Air-cooled condensing unit connections — 40 ton

NOTES:
 1. VERIFY WEIGHT, CONNECTION, AND ALL DIMENSION WITH INSTALLER DOCUMENTS BEFORE INSTALLATION



PLAN VIEW OF UNIT
 CONNECTION DRAWING

ORIENTATION VIEW OF UNIT
 ISOMETRIC DRAWING



CONTROL PANEL SIDE VIEW OF UNIT
 CONNECTION DRAWING

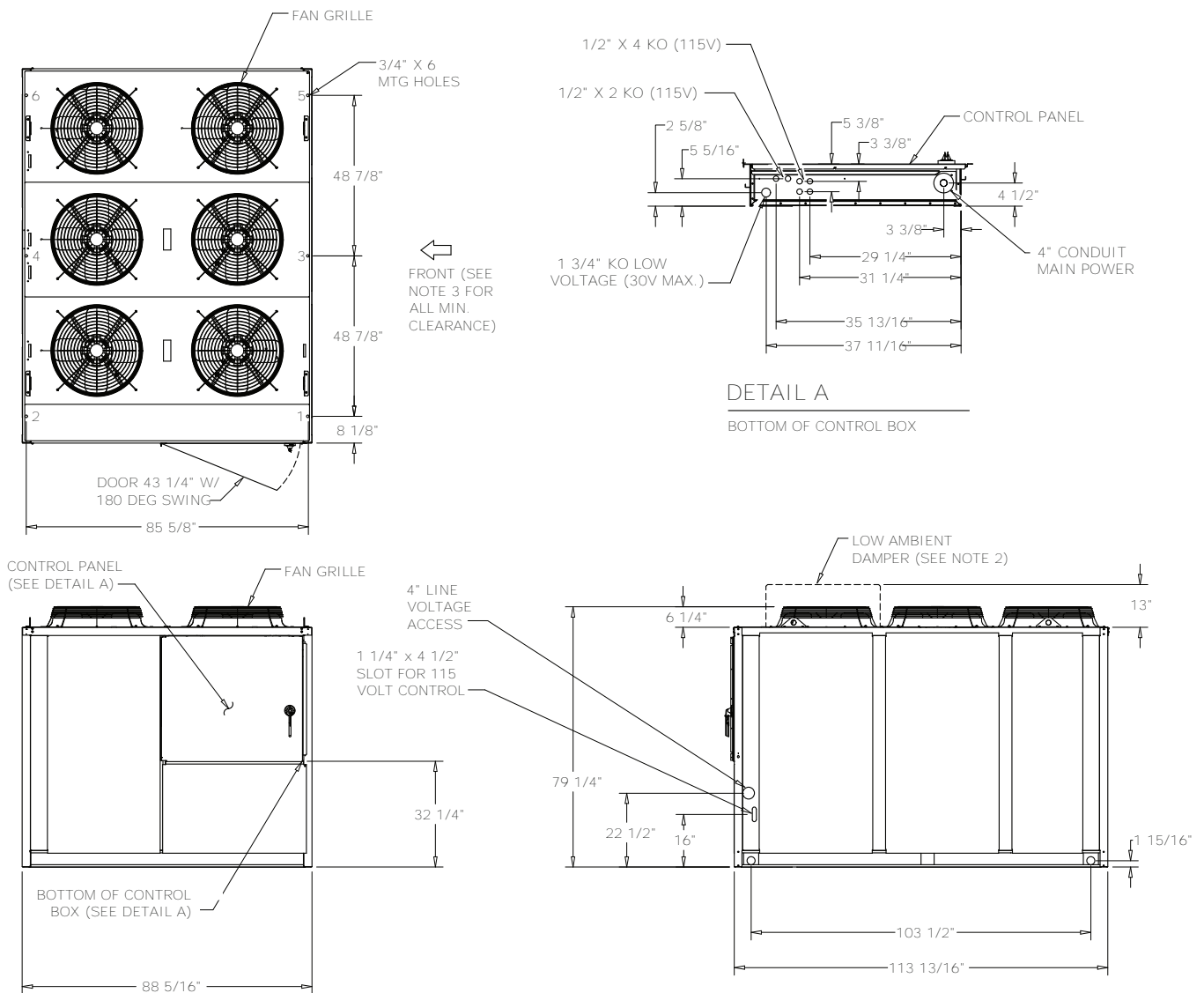
BACK VIEW OF UNIT
 CONNECTION DRAWING

40 TON UNIT
 DIMENSIONAL CONNECTION DRAWING

Figure 29. Air-cooled condensing unit — 50 ton

NOTES:

1. SEE CONNECTION DRAWING FOR CONNECTION LOCATION AND SIZES.
2. LOW AMBIENT DAMPER ONLY COMES WITH SELECTED UNIT .
3. FRONT AND BACK OF UNIT CLEARANCE 72" . LEFT AND RIGHT SIDE OF UNIT CLEARANCE 42" .

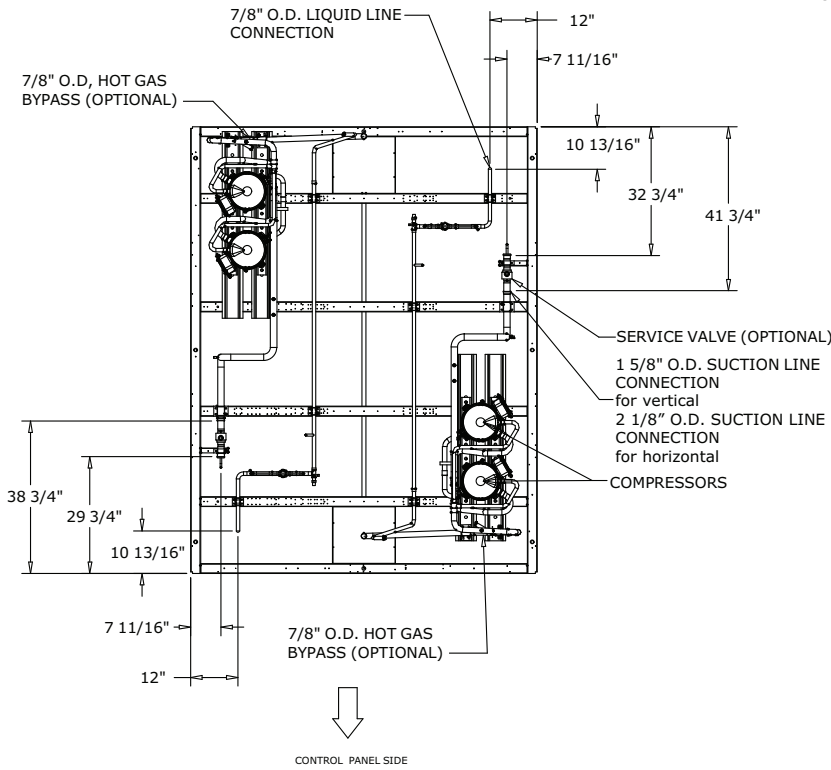




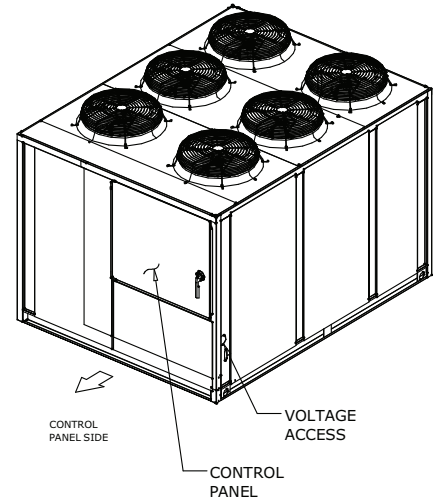
Unit Dimensions

Figure 30. Air-cooled condensing unit connections — 50 ton

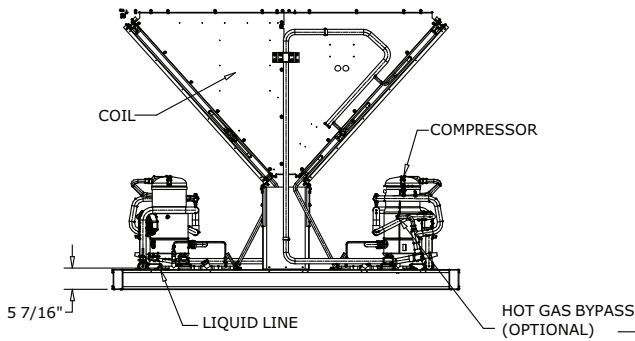
NOTES:
1. VERIFY WEIGHT, CONNECTION, AND ALL DIMENSION WITH INSTALLER DOCUMENTS BEFORE INSTALLATION



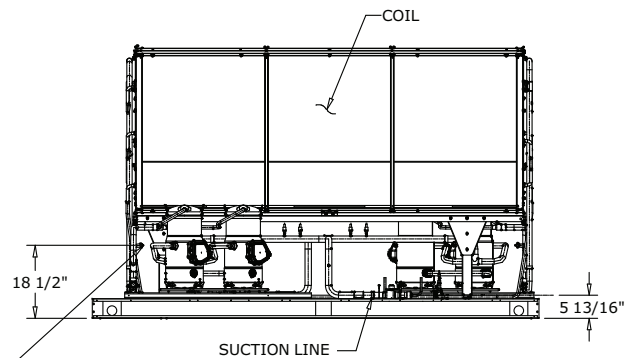
PLAN VIEW OF UNIT
CONNECTION DRAWING



ORIENTATION VIEW OF UNIT
ISOMETRIC DRAWING



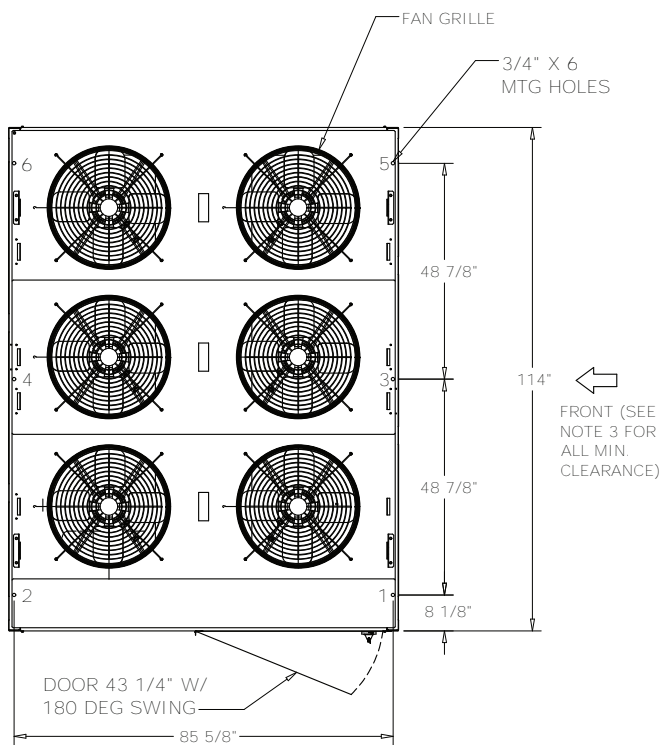
CONTROL PANEL SIDE VIEW OF UNIT
CONNECTION DRAWING



BACK VIEW OF UNIT
CONNECTION DRAWING

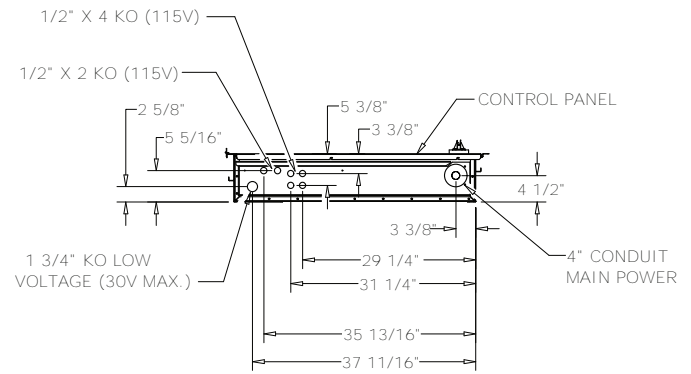
50 TON UNIT
DIMENSIONAL CONNECTION DRAWING

Figure 31. Air-cooled condensing unit — 60 ton

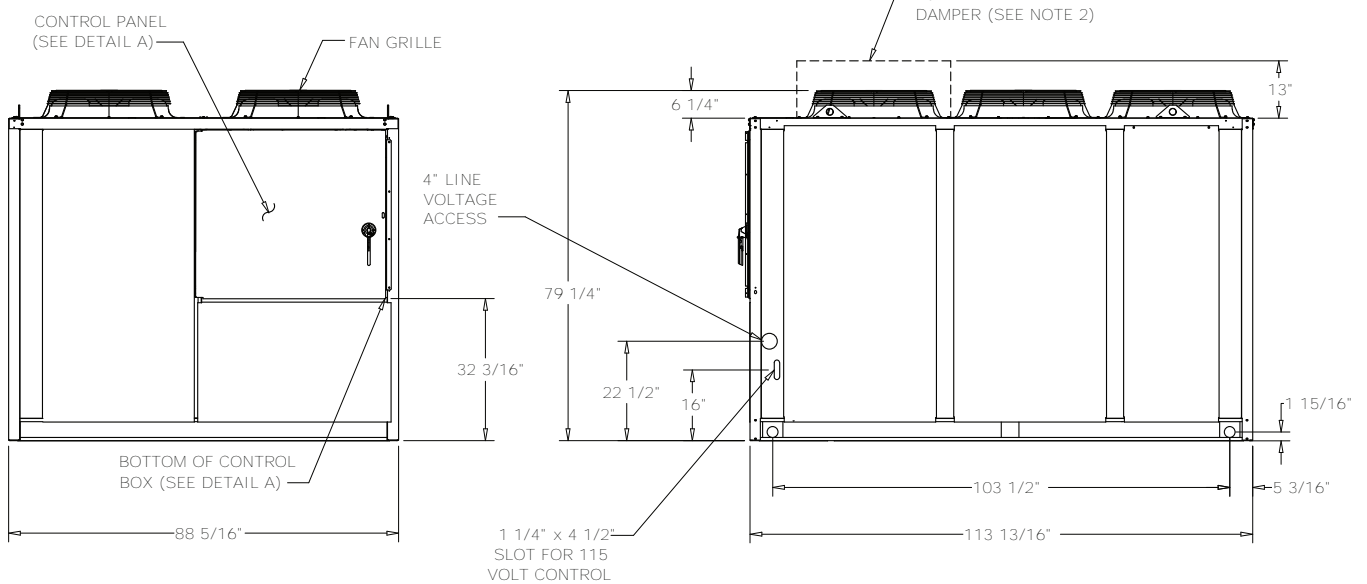


NOTES:

1. SEE CONNECTION DRAWING FOR CONNECTION LOCATION AND SIZES.
2. LOW AMBIENT DAMPER ONLY COMES WITH SELECTED UNIT.
3. FRONT AND BACK OF UNIT CLEARANCE 72". LEFT AND RIGHT SIDE OF UNIT CLEARANCE 42".



DETAIL A
BOTTOM OF CONTROL BOX

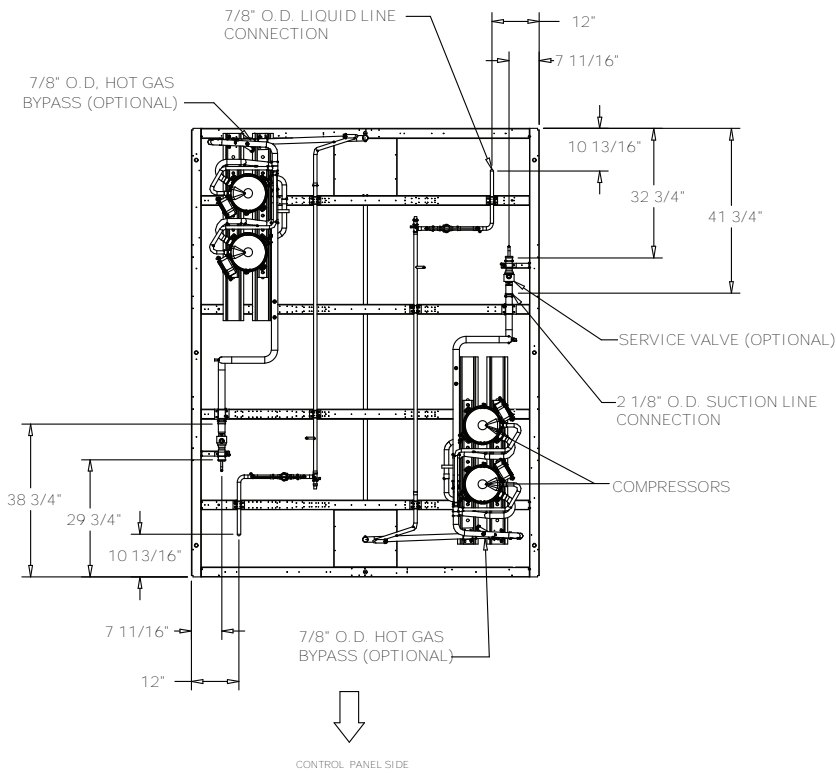




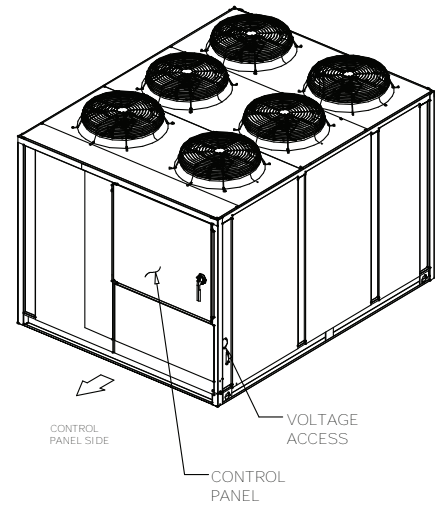
Unit Dimensions

Figure 32. Air-cooled condensing unit connections — 60 ton

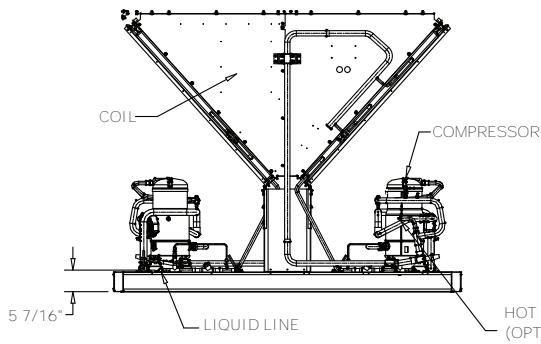
NOTES:
1. VERIFY WEIGHT, CONNECTION, AND ALL DIMENSION WITH INSTALLER DOCUMENTS BEFORE INSTALLATION



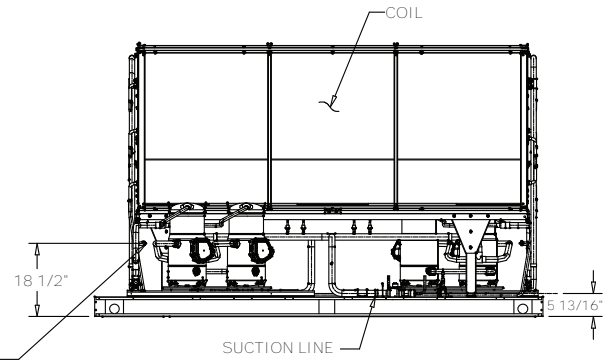
PLAN VIEW OF UNIT
CONNECTION DRAWING



ORIENTATION VIEW OF UNIT
ISOMETRIC DRAWING



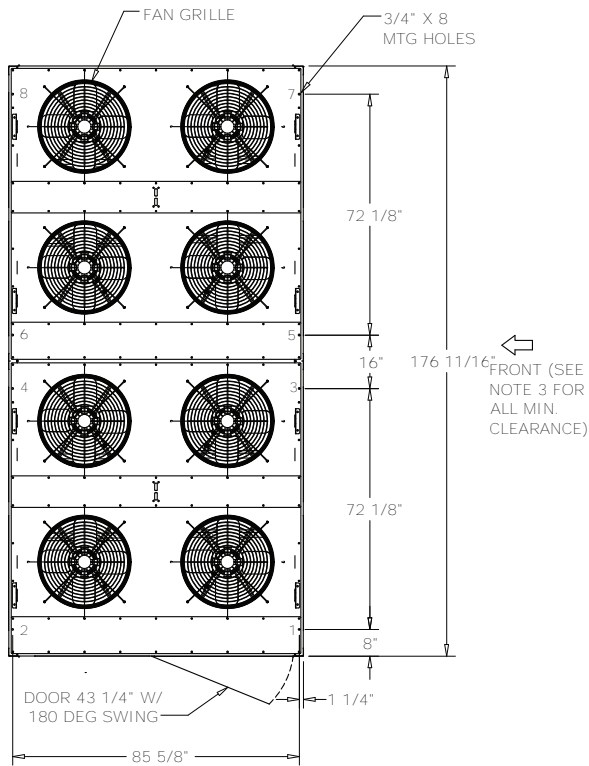
CONTROL PANEL SIDE VIEW OF UNIT
CONNECTION DRAWING



BACK VIEW OF UNIT
CONNECTION DRAWING

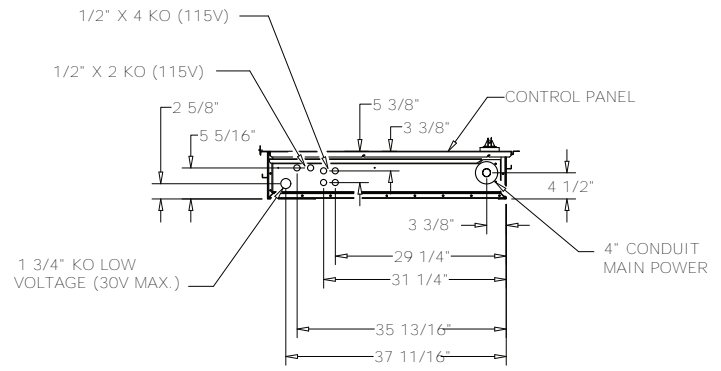
60 TON UNIT
DIMENSIONAL CONNECTION DRAWING

Figure 33. Air-cooled condensing unit — 80 ton



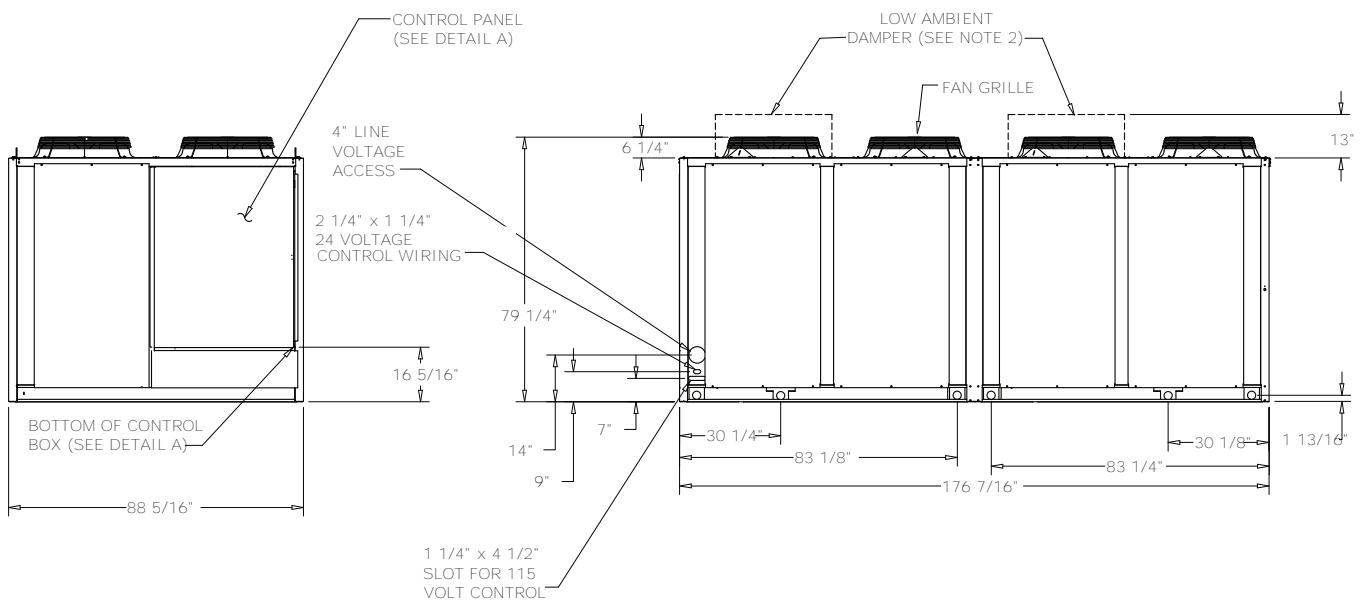
NOTES:

1. SEE CONNECTION DRAWING FOR CONNECTION LOCATION AND SIZES.
2. LOW AMBIENT DAMPER ONLY COMES WITH SELECTED UNIT.
3. FRONT AND BACK OF UNIT CLEARANCE 96". LEFT AND RIGHT SIDE OF UNIT CLEARANCE 48".



DETAIL A

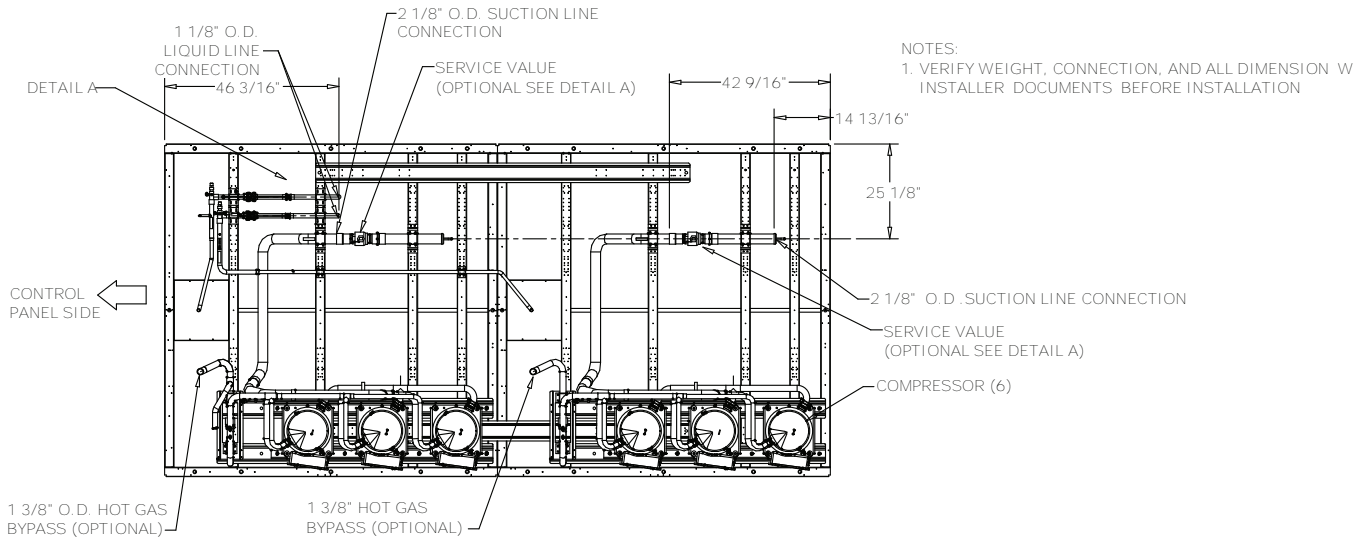
DIMENSIONAL DETAIL



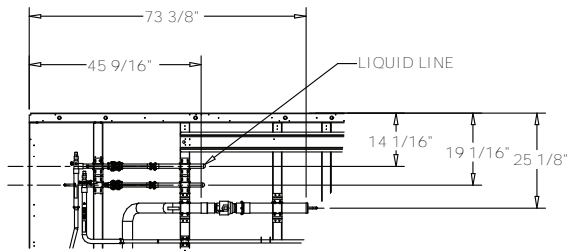


Unit Dimensions

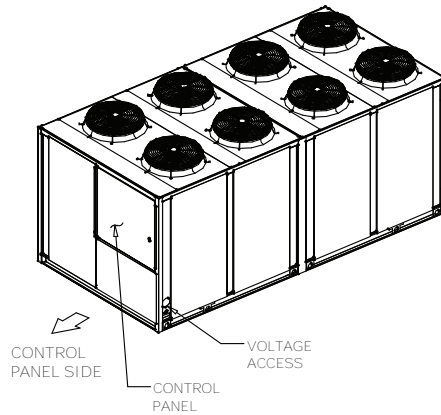
Figure 34. Air-cooled condensing unit connections — 80 ton



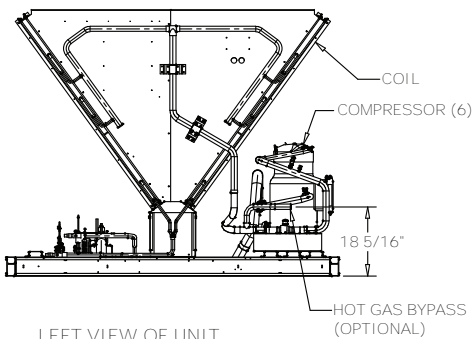
PLAN VIEW OF UNIT
 CONNECTION DRAWING



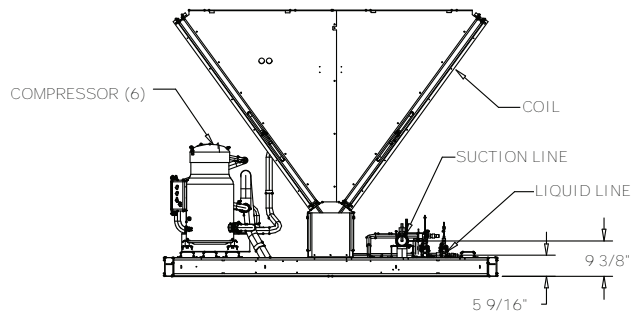
DETAIL A
 DETAIL DRAWING



ORIENTATION VIEW OF UNIT
 ISOMETRIC DRAWING



LEFT VIEW OF UNIT
 CONNECTION DRAWING



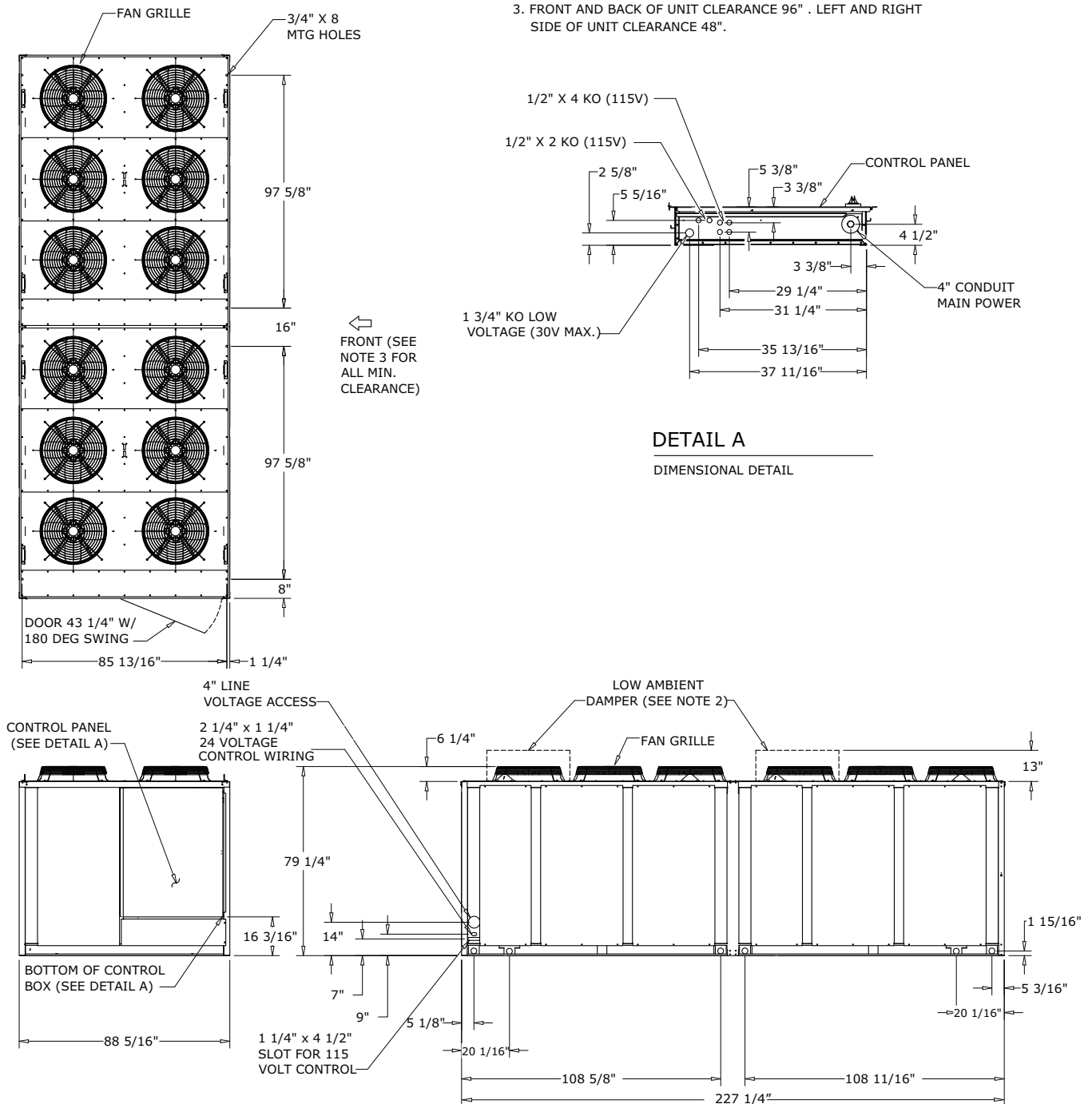
CONTROL PANEL SIDE VIEW OF UNIT
 CONNECTION DRAWING

80 TON UNIT
 DIMENSIONAL CONNECTION DRAWING

Figure 35. Air-cooled condensing unit — 100 and 120 tons

NOTES:

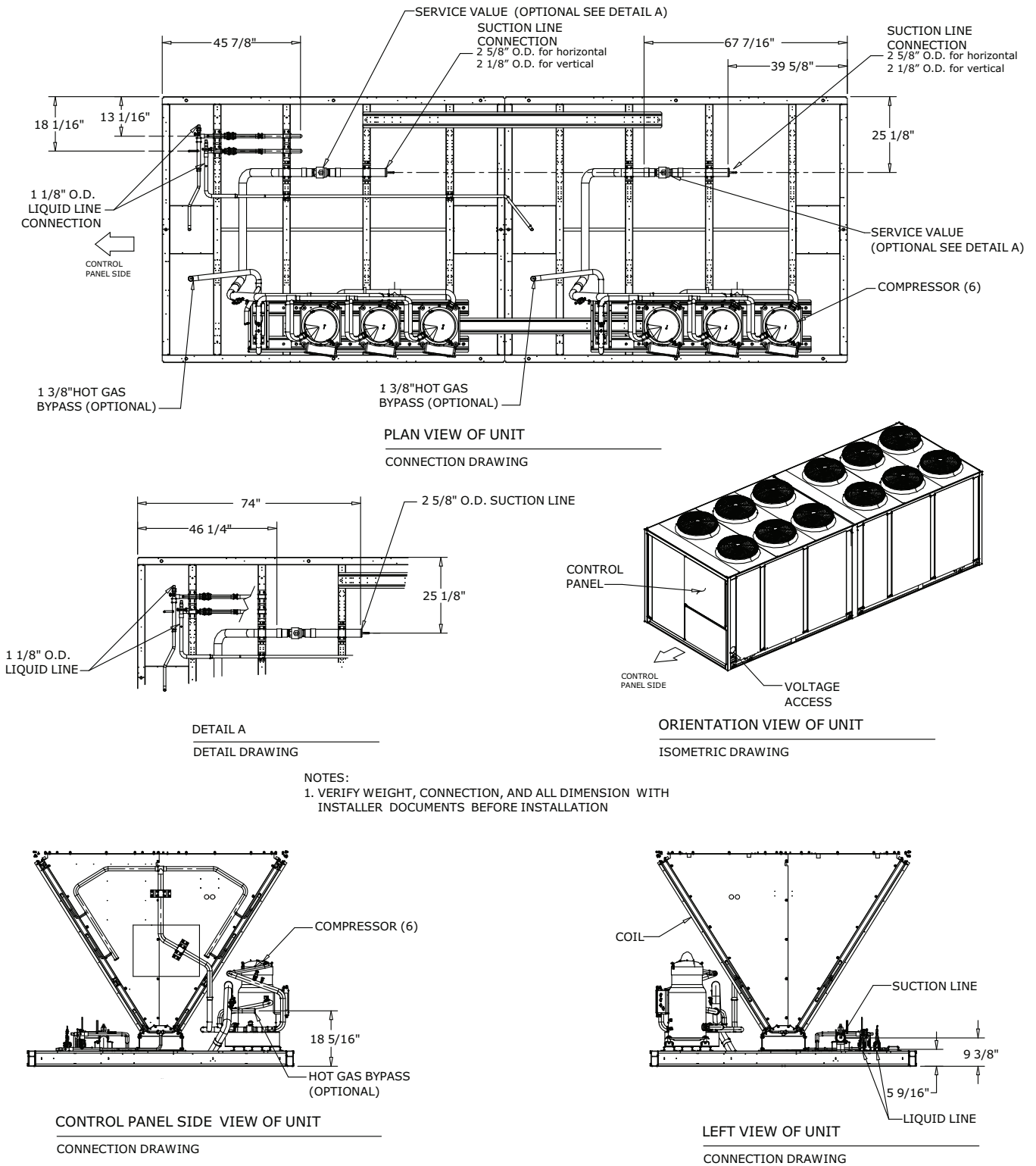
1. SEE CONNECTION DRAWING FOR CONNECTION LOCATION AND SIZES.
2. LOW AMBIENT DAMPER ONLY COMES WITH SELECTED UNIT .
3. FRONT AND BACK OF UNIT CLEARANCE 96" . LEFT AND RIGHT SIDE OF UNIT CLEARANCE 48" .



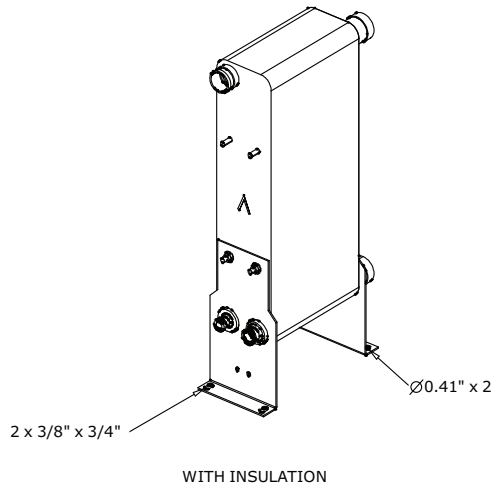


Unit Dimensions

Figure 36. Air-cooled condensing unit connections — 100 and 120 tons



100 - 120 TON UNIT DIMENSIONAL CONNECTION DRAWING

Figure 37. Evaporator chiller — 20 ton

NOTES:

1. THIS HEAT EXCHANGER IS INTENDED FOR INDOOR INSTALLATION ONLY
2. HEAT EXCHANGER MOUNTING LEGS ARE INSTALLED AT JOB SITE WITH SUPPLIED FASTENERS
3. INSULATION SHOULD BE INSTALLED AFTER INSTALLING LEGS & REFRIGERANT TUBING, OR MUST BE ADEQUATELY SHIELDED AGAINST HEAT WHEN BRAZING REFRIGERANT LINES
4. INSTALL INSULATION SIDE PIECES FIRST THEN WRAPPER (MAY REQUIRE TRIMMING)
5. USE VINYL TAPE (FIELD SUPPLIED) TO SEAL INSULATION AFTER INSTALLATION
6. WATER CONNECTIONS ARE GROOVED (VICTAULIC)
7. REFRIGERANT CONNECTIONS ARE STAINLESS STEEL AND REQUIRE SPECIAL BRAZE MATERIALS. SEE IOM BRAZE PROCEDURE.
8. 1/2" X 14 NPT F4 CONNECTION SUPPLIED ON EXT 04 THRU 06 AND 08 10 ONLY BRAZED PLATE HEAT EXCHANGER REMOTE CHILLER EVAPORATOR OPTION

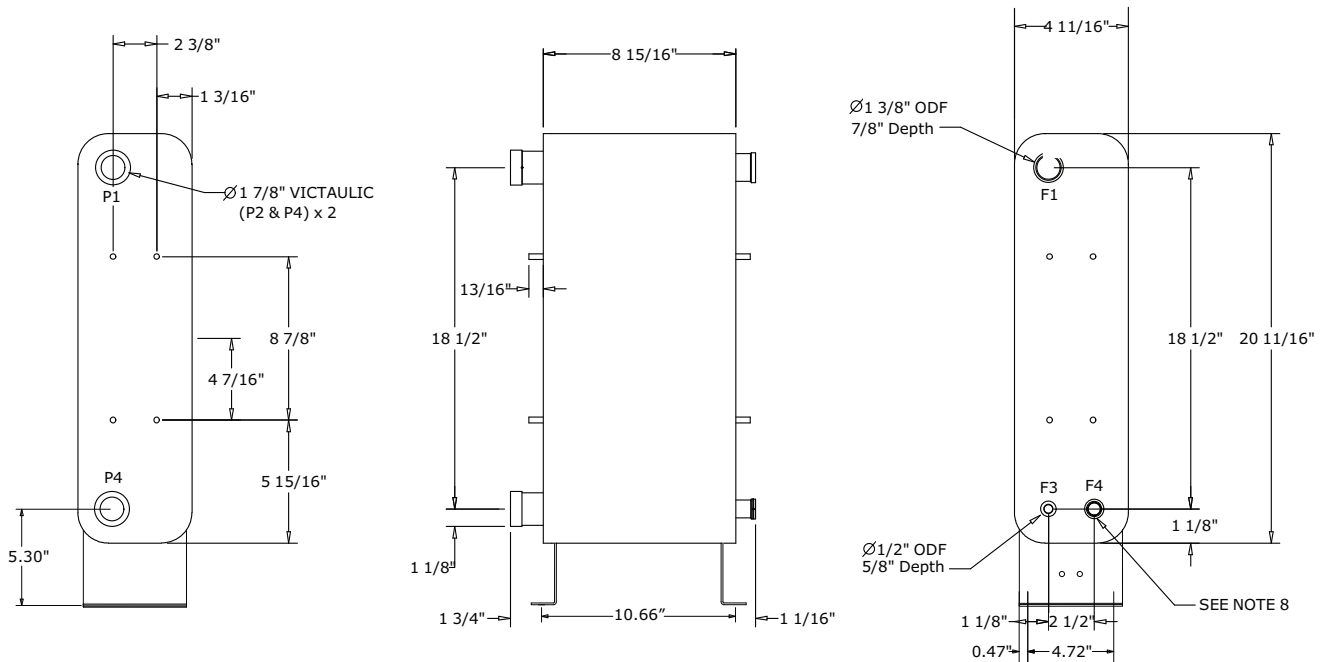
OPTION INCLUDES:

- 1 - BRAZED PLATE HEAT EXCHANGER - SHIPS SEPARATE FROM RAUJ CONDENSING UNIT
- 1 - INSTALLATION KIT, TO INCLUDE:
 - 2 - MOUNTING BRACKETS
 - 1 - INSULATION KIT
 - 1 - MOUNTING BRACKET & INSULATION KIT INSTALLATION INSTRUCTIONS
 - 1 - WATER CONNECTION KIT WITH PIPING STUBS, Y CONNECTOR, STRAINER, VICTAULIC CONNECTIONS WITH GASKETS, WATER FLOW SWITCH
 - 1 - WATER CONNECTION KIT INSTALLATION INSTRUCTIONS

INSTALLATION ADDITIONALLY REQUIRES:

- RAUJ REMOTE EVP CONTROL PANEL WITH LEAVING WATER TEMPERATURE SENSOR, FREEZE-STAT, AND INSTALLATION INSTRUCTIONS - ALL INCLUDED WITH REMOTE EVP CONTROL PANEL
- 4 - FIELD PROVIDED 7/16" BOLTS FOR SECURING BRAZED PLATE HEAT EXCHANGER TO PERMANENT MOUNTING SURFACE
- 2 - FIELD PROVIDED 1/2" - 14 NPTE PLUGS, STAINLESS STEEL OR PVC
- FIELD PROVIDED TEFLON TAPE FOR SEALING 1/2" PIPE PLUGS
- FIELD PROVIDED WATER STRAINER PLUG OR BLOW DOWN VALVE
- FIELD PROVIDED TEE FOR INSTALLING WATER FLOW SWITCH
- FIELD PROVIDED 2" VINYL TAPE FOR SEALING INSULATION SEAMS

SEE IOM FOR INSTALLATION DETAIL

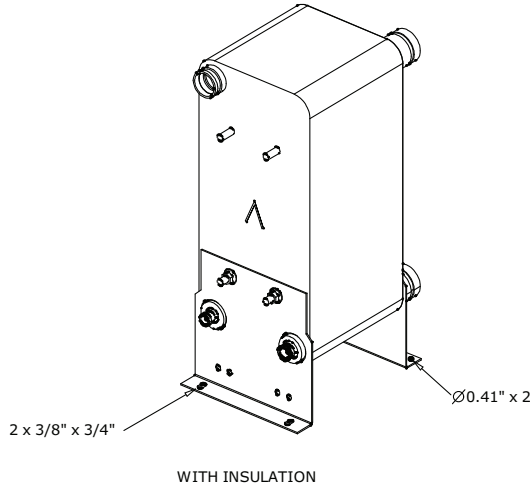

20 TON BRAZED PLATE HEAT EXCHANGER

ACCESSORY DRAWING



Unit Dimensions

Figure 38. Evaporator chiller — 25 ton



NOTES:

1. THIS HEAT EXCHANGER IS INTENDED FOR INDOOR INSTALLATION ONLY
2. HEAT EXCHANGER MOUNTING LEGS ARE INSTALLED AT JOB SITE WITH SUPPLIED FASTENERS
3. INSULATION SHOULD BE INSTALLED AFTER INSTALLING LEGS & REFRIGERANT TUBING, OR MUST BE ADEQUATELY SHIELDED AGAINST HEAT WHEN BRAZING REFRIGERANT LINES
4. INSTALL INSULATION SIDE PIECES FIRST THEN WRAPPER (MAY REQUIRE TRIMMING)
5. USE VINYL TAPE (FIELD SUPPLIED) TO SEAL INSULATION AFTER INSTALLATION
6. WATER CONNECTIONS ARE GROOVED (VICTAULIC)
7. REFRIGERANT CONNECTIONS ARE STAINLESS STEEL AND REQUIRE SPECIAL BRAZE MATERIALS. SEE IOM BRAZE PROCEDURE.
8. 1/2" - 14 NPT F4 CONNECTION SUPPLIED ON EXT'S 05 THRU 08 AND 13 THRU 16 ONLY.

BRAZED PLATE HEAT EXCHANGER REMOTE CHILLER EVAPORATOR OPTION

OPTION INCLUDES:

- 1 - BRAZED PLATE HEAT EXCHANGER - SHIPS SEPARATE FROM RAUJ CONDENSING UNIT

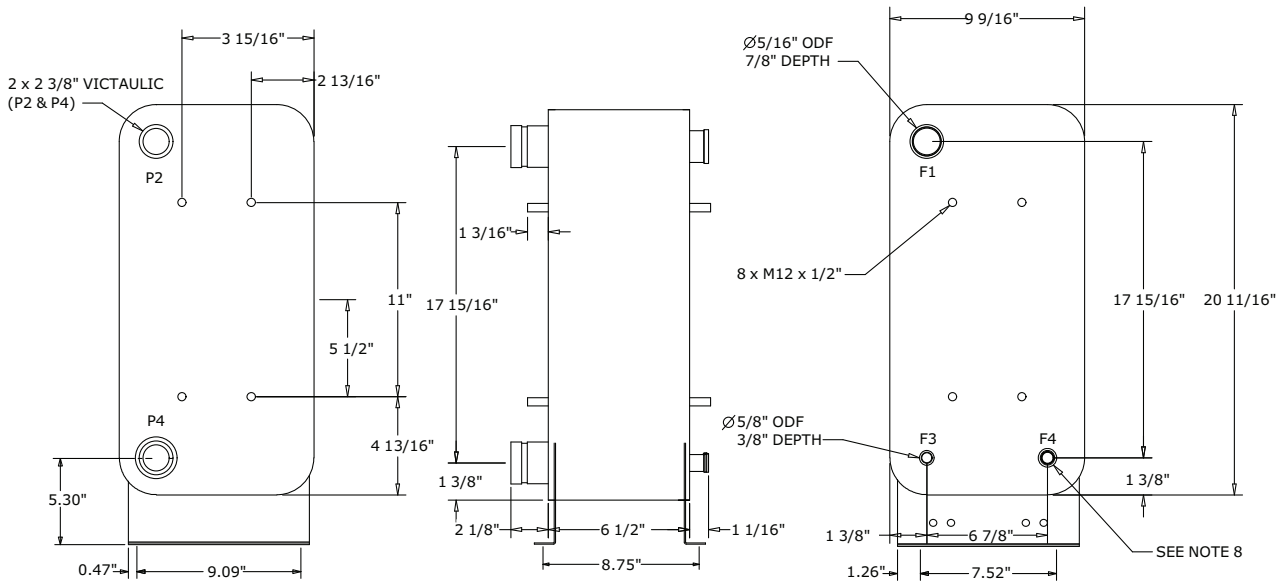
1 - INSTALLATION KIT, TO INCLUDE:

- 2 - MOUNTING BRACKETS
- 1 - INSULATION KIT
- 1 - MOUNTING BRACKET & INSULATION KIT INSTALLATION INSTRUCTIONS
- 1 - WATER CONNECTION KIT WITH PIPING STUBS, Y CONNECTOR, STRAINER, VICTAULIC CONNECTIONS WITH GASKETS, WATER FLOW SWITCH
- 1 - WATER CONNECTION KIT INSTALLATION INSTRUCTIONS

INSTALLATION ADDITIONALLY REQUIRES:

- RAUJ REMOTE EVP CONTROL PANEL WITH LEAVING WATER TEMPERATURE SENSOR, FREEZE-STAT, AND INSTALLATION INSTRUCTIONS - ALL INCLUDED WITH REMOTE EVP CONTROL PANEL
- 4 - FIELD PROVIDED 7/16" BOLTS FOR SECURING BRAZED PLATE HEAT EXCHANGER TO PERMANENT MOUNTING SURFACE
 - 2 - FIELD PROVIDED 1/2" - 14 NPT PLUGS, STAINLESS STEEL OR PVC
- FIELD PROVIDED TEFLON TAPE FOR SEALING 1/2" PIPE PLUGS
 FIELD PROVIDED WATER STRAINER PLUG OR BLOW DOWN VALVE
 FIELD PROVIDED TEE FOR INSTALLING WATER FLOW SWITCH
 FIELD PROVIDED 2" VINYL TAPE FOR SEALING INSULATION SEAMS

SEE IOM FOR INSTALLATION DETAIL



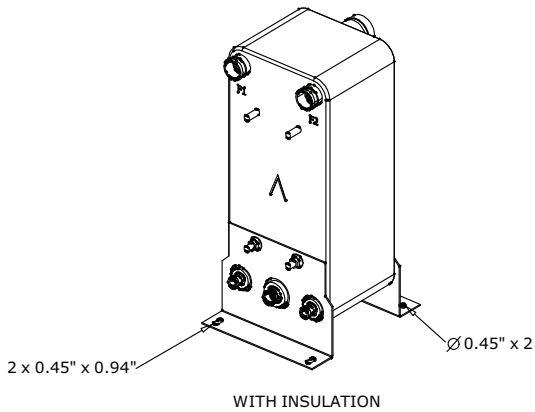
25 TON BRAZED PLATE HEAT EXCHANGER

ACCESSORY DRAWING



Unit Dimensions

Figure 40. Evaporator chiller — 40 ton



NOTES:

1. THIS HEAT EXCHANGER IS INTENDED FOR INDOOR INSTALLATION ONLY
2. HEAT EXCHANGER MOUNTING LEGS ARE INSTALLED AT JOB SITE WITH SUPPLIED FASTENERS
3. INSULATION SHOULD BE INSTALLED AFTER INSTALLING LEGS & REFRIGERANT TUBING, OR MUST BE ADEQUATELY SHIELDED AGAINST HEAT WHEN BRAZING REFRIGERANT LINES
4. INSTALL INSULATION SIDE PIECES FIRST THEN WRAPPER (MAY REQUIRE TRIMMING)
5. USE VINYL TAPE (FIELD SUPPLIED) TO SEAL INSULATION AFTER INSTALLATION
6. WATER CONNECTIONS ARE GROOVED (VICTAULIC)
7. REFRIGERANT CONNECTIONS ARE STAINLESS STEEL AND REQUIRE SPECIAL BRAZE MATERIALS. SEE IOM BRAZE PROCEDURE.
8. 1/2" NPT F5 CONNECTION SUPPLIED ON EXT'S 04 THRU 06 ONLY BRAZED PLATE HEAT EXCHANGER REMOTE CHILLER EVAPORATOR OPTION

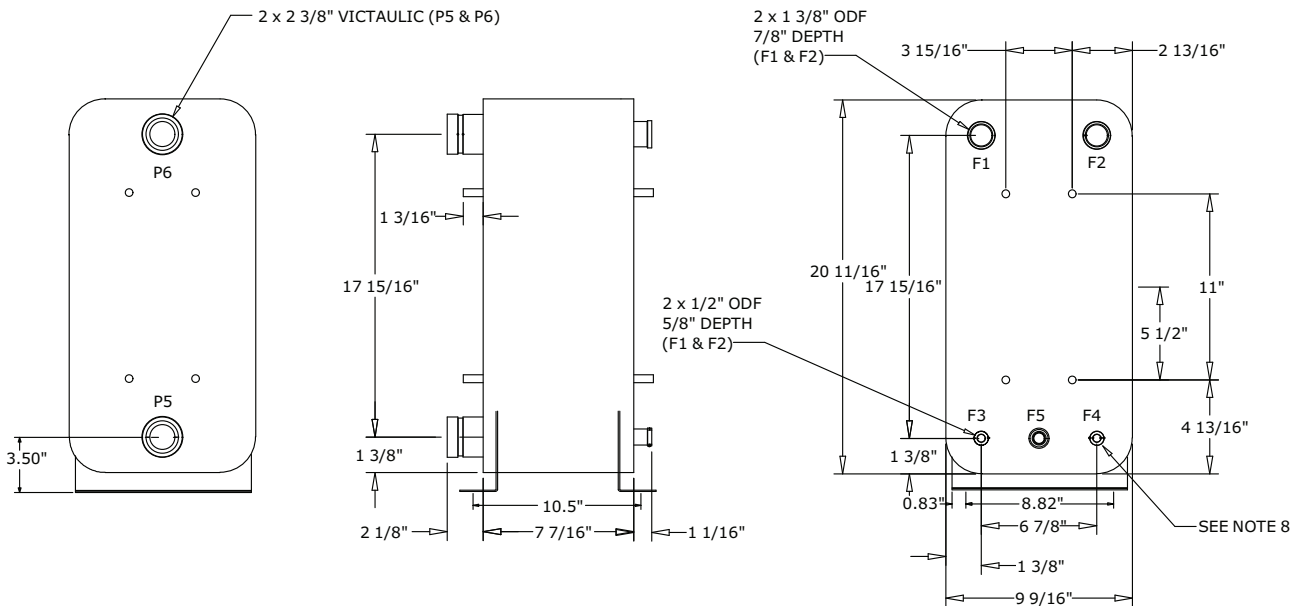
OPTION INCLUDES:

- 1 - BRAZED PLATE HEAT EXCHANGER - SHIPS SEPARATE FROM RAUJ CONDENSING UNIT
- 1 - INSTALLATION KIT, TO INCLUDE:
 - 2 - MOUNTING BRACKETS
 - 1 - INSULATION KIT
 - 1 - MOUNTING BRACKET & INSULATION KIT INSTALLATION INSTRUCTIONS
- 1 - WATER CONNECTION KIT WITH PIPING STUBS, Y CONNECTOR, STRAINER, VICTAULIC CONNECTIONS WITH GASKETS, WATER FLOW SWITCH
- 1 - WATER CONNECTION KIT INSTALLATION INSTRUCTIONS

INSTALLATION ADDITIONALLY REQUIRES:

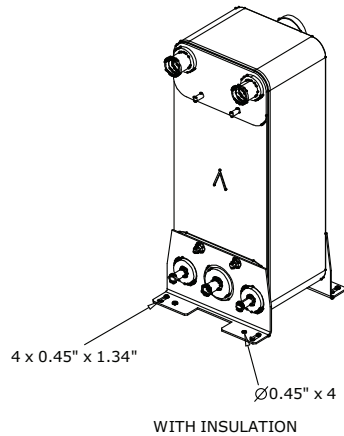
- RAUJ REMOTE EVP CONTROL PANEL WITH LEAVING WATER TEMPERATURE SENSOR, FREEZE-STAT, AND INSTALLATION INSTRUCTIONS - ALL INCLUDED WITH REMOTE EVP CONTROL PANEL
- 4 - FIELD PROVIDED 7/16" BOLTS FOR SECURING BRAZED PLATE HEAT EXCHANGER TO PERMANENT MOUNTING SURFACE
- 2 - FIELD PROVIDED 1/2" - 14 NPTE PLUGS, STAINLESS STEEL OR PVC
- FIELD PROVIDED TEFLON TAPE FOR SEALING 1/2" PIPE PLUGS
- FIELD PROVIDED WATER STRAINER PLUG OR BLOW DOWN VALVE
- FIELD PROVIDED TEE FOR INSTALLING WATER FLOW SWITCH
- FIELD PROVIDED 2" VINYL TAPE FOR SEALING INSULATION SEAMS

SEE IOM FOR INSTALLATION DETAIL



40 TON BRAZED PLATE HEAT EXCHANGER

ACCESSORY DRAWING

Figure 41. Evaporator chiller — 50 ton

NOTES:

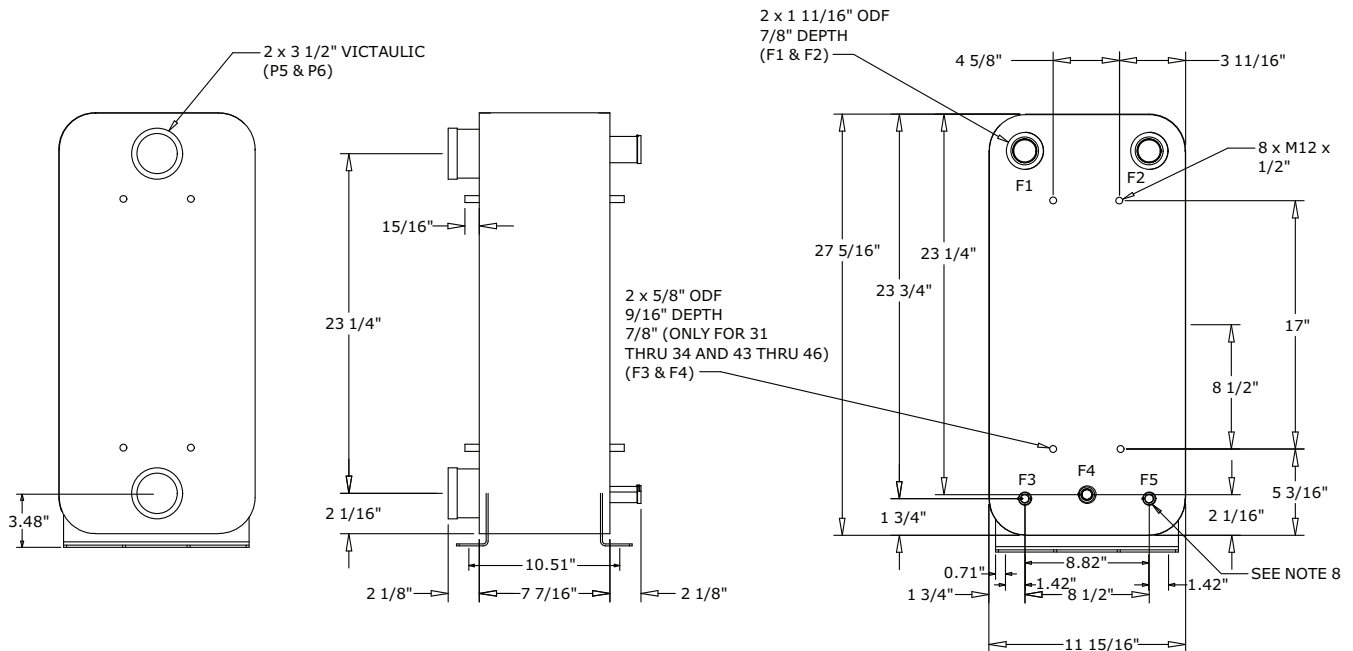
1. THIS HEAT EXCHANGER IS INTENDED FOR INDOOR INSTALLATION ONLY
2. HEAT EXCHANGER MOUNTING LEGS ARE INSTALLED AT JOB SITE WITH SUPPLIED FASTENERS
3. INSULATION SHOULD BE INSTALLED AFTER INSTALLING LEGS & REFRIGERANT TUBING, OR MUST BE ADEQUATELY SHIELDED AGAINST HEAT WHEN BRAZING REFRIGERANT LINES
4. INSTALL INSULATION SIDE PIECES FIRST THEN WRAPPER (MAY REQUIRE TRIMMING)
5. USE VINYL TAPE (FIELD SUPPLIED) TO SEAL INSULATION AFTER INSTALLATION
6. WATER CONNECTIONS ARE GROOVED (VICTAULIC)
7. REFRIGERANT CONNECTIONS ARE STAINLESS STEEL AND REQUIRE SPECIAL BRAZE MATERIALS. SEE IOM BRAZE PROCEDURE.
8. 1/2" - 14 NPT F5 CONNECTION SUPPLIED ON EXT'S 13 THRU 24 AND 37 THRU 48 ONLY.

BRAZED PLATE HEAT EXCHANGER REMOTE CHILLER EVAPORATOR OPTION
OPTION INCLUDES:

- 1 - BRAZED PLATE HEAT EXCHANGER - SHIPS SEPARATE FROM RAUJ CONDENSING UNIT
- 1 - INSTALLATION KIT, TO INCLUDE:
 - 2 - MOUNTING BRACKETS
 - 1 - INSULATION KIT
 - 1 - MOUNTING BRACKET & INSULATION KIT INSTALLATION INSTRUCTIONS
- 1 - WATER CONNECTION KIT WITH PIPING STUBS, Y CONNECTOR, STRAINER, VICTAULIC CONNECTIONS WITH GASKETS, WATER FLOW SWITCH
- 1 - WATER CONNECTION KIT INSTALLATION INSTRUCTIONS

INSTALLATION ADDITIONALLY REQUIRES:

- RAUJ REMOTE EVP CONTROL PANEL WITH LEAVING WATER TEMPERATURE SENSOR, FREEZE-STAT, AND INSTALLATION INSTRUCTIONS - ALL INCLUDED WITH REMOTE EVP CONTROL PANEL
- 4 - FIELD PROVIDED 7/16" BOLTS FOR SECURING BRAZED PLATE HEAT EXCHANGER TO PERMANENT MOUNTING SURFACE
- 2 - FIELD PROVIDED 1/2" - 14 NPT PLUGS, STAINLESS STEEL OR PVC
- FIELD PROVIDED TEFLON TAPE FOR SEALING 1/2" PIPE PLUGS
- FIELD PROVIDED WATER STRAINER PLUG OR BLOW DOWN VALVE
- FIELD PROVIDED TEE FOR INSTALLING WATER FLOW SWITCH
- FIELD PROVIDED 2" VINYL TAPE FOR SEALING INSULATION SEAMS

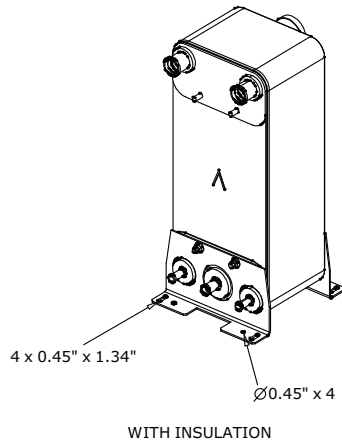
SEE IOM FOR INSTALLATION DETAIL

50 TON BRAZED PLATE HEAT EXCHANGER

ACCESSORY DRAWING



Unit Dimensions

Figure 42. Evaporator chiller — 60 ton



NOTES:

1. THIS HEAT EXCHANGER IS INTENDED FOR INDOOR INSTALLATION ONLY
2. HEAT EXCHANGER MOUNTING LEGS ARE INSTALLED AT JOB SITE WITH SUPPLIED FASTENERS
3. INSULATION SHOULD BE INSTALLED AFTER INSTALLING LEGS & REFRIGERANT TUBING, OR MUST BE ADEQUATELY SHIELDED AGAINST HEAT WHEN BRAZING REFRIGERANT LINES
4. INSTALL INSULATION SIDE PIECES FIRST THEN WRAPPER (MAY REQUIRE TRIMMING)
5. USE VINYL TAPE (FIELD SUPPLIED) TO SEAL INSULATION AFTER INSTALLATION
6. WATER CONNECTIONS ARE GROOVED (VICTAULIC)
7. REFRIGERANT CONNECTIONS ARE STAINLESS STEEL AND REQUIRE SPECIAL BRAZE MATERIALS. SEE IOM BRAZE PROCEDURE.
8. 1/2" - 14 NPT F5 CONNECTION SUPPLIED ON EXT'S 13 THRU 24 AND 37 THRU 48 ONLY.

BRAZED PLATE HEAT EXCHANGER REMOTE CHILLER EVAPORATOR OPTION

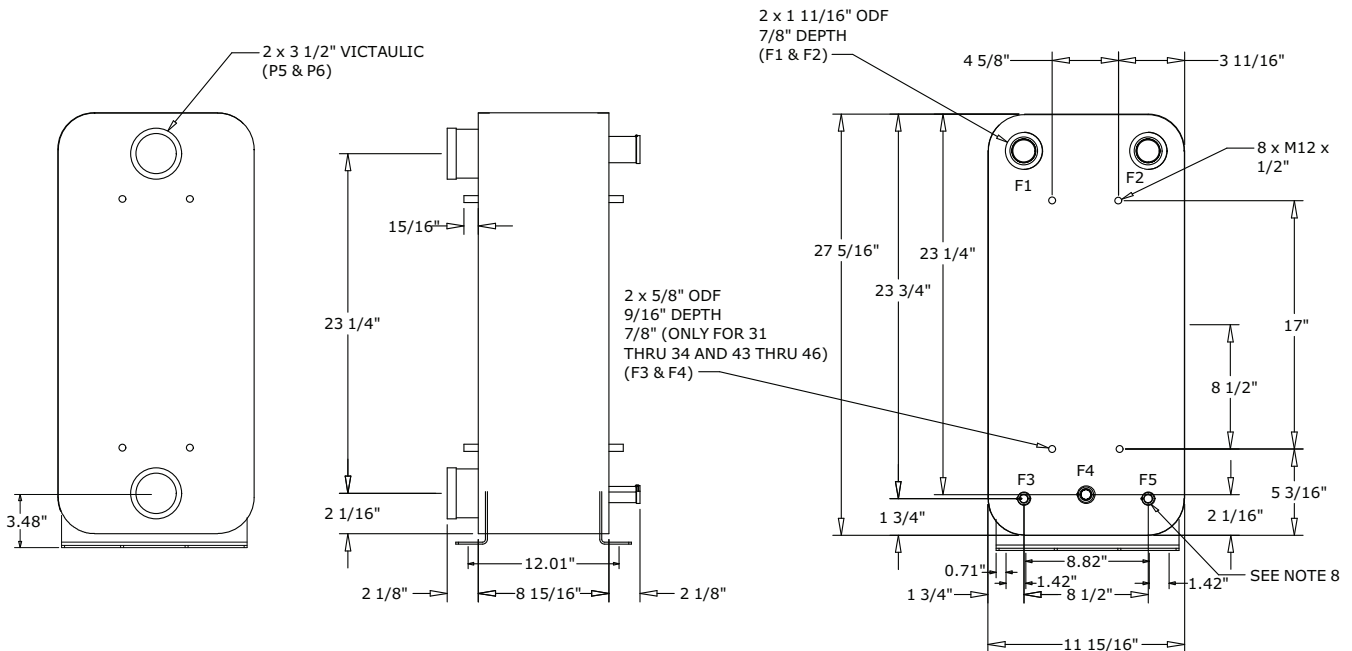
OPTION INCLUDES:

- 1 - BRAZED PLATE HEAT EXCHANGER - SHIPS SEPARATE FROM RAUJ CONDENSING UNIT
- 1 - INSTALLATION KIT, TO INCLUDE:
 - 2 - MOUNTING BRACKETS
 - 1 - INSULATION KIT
 - 1 - MOUNTING BRACKET & INSULATION KIT INSTALLATION INSTRUCTIONS
- 1 - WATER CONNECTION KIT WITH PIPING STUBS, Y CONNECTOR, STRAINER, VICTAULIC CONNECTIONS WITH GASKETS, WATER FLOW SWITCH
- 1 - WATER CONNECTION KIT INSTALLATION INSTRUCTIONS

INSTALLATION ADDITIONALLY REQUIRES:

- RAUJ REMOTE EVP CONTROL PANEL WITH LEAVING WATER TEMPERATURE SENSOR, FREEZE-STAT, AND INSTALLATION INSTRUCTIONS - ALL INCLUDED WITH REMOTE EVP CONTROL PANEL
- 4 - FIELD PROVIDED 7/16" BOLTS FOR SECURING BRAZED PLATE HEAT EXCHANGER TO PERMANENT MOUNTING SURFACE
- 2 - FIELD PROVIDED 1/2" - 14 NPT PLUGS, STAINLESS STEEL OR PVC
- FIELD PROVIDED TEFLON TAPE FOR SEALING 1/2" PIPE PLUGS
- FIELD PROVIDED WATER STRAINER PLUG OR BLOW DOWN VALVE
- FIELD PROVIDED TEE FOR INSTALLING WATER FLOW SWITCH
- FIELD PROVIDED 2" VINYL TAPE FOR SEALING INSULATION SEAMS

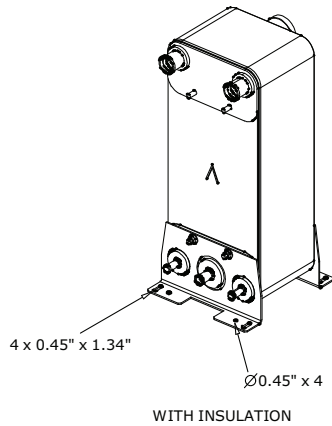
SEE IOM FOR INSTALLATION DETAIL



60 TON BRAZED PLATE HEAT EXCHANGER

ACCESSORY DRAWING

Figure 43. Evaporator chiller — 80 ton



NOTES:

1. THIS HEAT EXCHANGER IS INTENDED FOR INDOOR INSTALLATION ONLY
2. HEAT EXCHANGER MOUNTING LEGS ARE INSTALLED AT JOB SITE WITH SUPPLIED FASTENERS
3. INSULATION SHOULD BE INSTALLED AFTER INSTALLING LEGS & REFRIGERANT TUBING, OR MUST BE ADEQUATELY SHIELDED AGAINST HEAT WHEN BRAZING REFRIGERANT LINES
4. INSTALL INSULATION SIDE PIECES FIRST THEN WRAPPER (MAY REQUIRE TRIMMING)
5. USE VINYL TAPE (FIELD SUPPLIED) TO SEAL INSULATION AFTER INSTALLATION
6. WATER CONNECTIONS ARE GROOVED (VICTAULIC)
7. REFRIGERANT CONNECTIONS ARE STAINLESS STEEL AND REQUIRE SPECIAL BRAZE MATERIALS. SEE IOM BRAZE PROCEDURE.
8. 1/2" - 14 NPT F5 CONNECTION SUPPLIED ON EXT'S 13 THRU 24 AND 37 THRU 48 ONLY.

BRAZED PLATE HEAT EXCHANGER REMOTE CHILLER EVAPORATOR OPTION

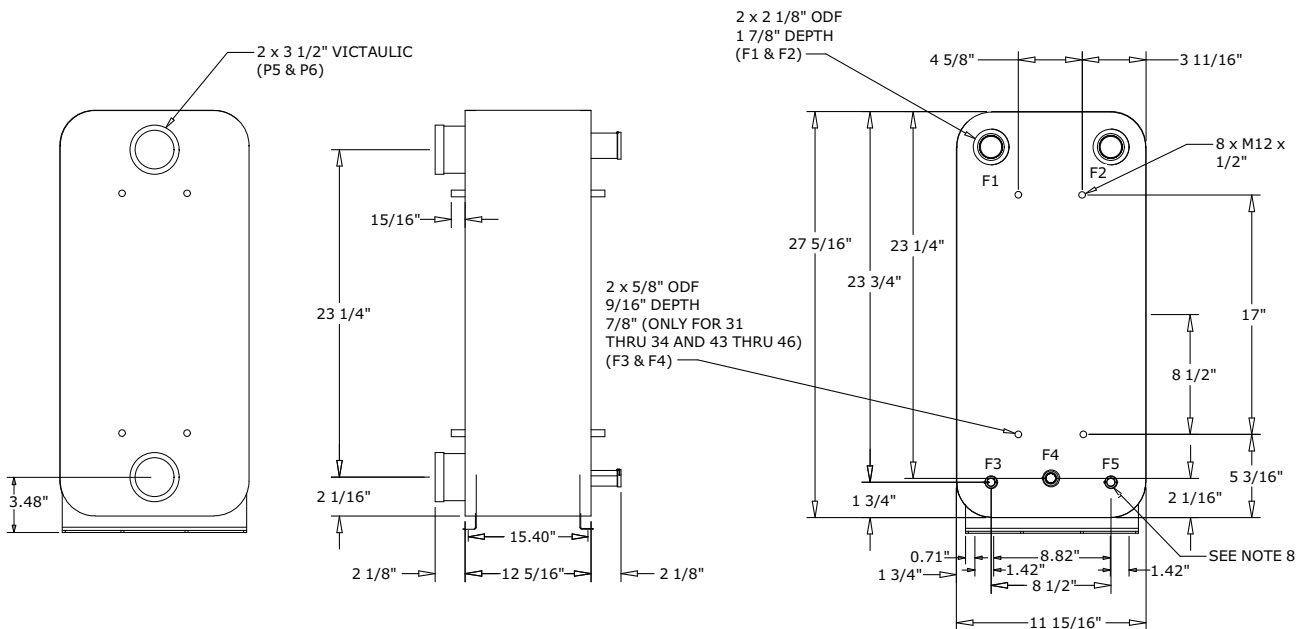
OPTION INCLUDES:

- 1 - BRAZED PLATE HEAT EXCHANGER - SHIPS SEPARATE FROM RAUJ CONDENSING UNIT
- 1 - INSTALLATION KIT, TO INCLUDE:
 - 2 - MOUNTING BRACKETS
 - 1 - INSULATION KIT
 - 1 - MOUNTING BRACKET & INSULATION KIT INSTALLATION INSTRUCTIONS
- 1 - WATER CONNECTION KIT WITH PIPING STUBS, Y CONNECTOR, STRAINER, VICTAULIC CONNECTIONS WITH GASKETS, WATER FLOW SWITCH
- 1 - WATER CONNECTION KIT INSTALLATION INSTRUCTIONS

INSTALLATION ADDITIONALLY REQUIRES:

- RAUJ REMOTE EVP CONTROL PANEL WITH LEAVING WATER TEMPERATURE SENSOR, FREEZE-STAT, AND INSTALLATION INSTRUCTIONS - ALL INCLUDED WITH REMOTE EVP CONTROL PANEL
- 4 - FIELD PROVIDED 7/16" BOLTS FOR SECURING BRAZED PLATE HEAT EXCHANGER TO PERMANENT MOUNTING SURFACE
- 2 - FIELD PROVIDED 1/2" - 14 NPT PLUGS, STAINLESS STEEL OR PVC
- FIELD PROVIDED TEFLON TAPE FOR SEALING 1/2" PIPE PLUGS
- FIELD PROVIDED WATER STRAINER PLUG OR BLOW DOWN VALVE
- FIELD PROVIDED TEE FOR INSTALLING WATER FLOW SWITCH
- FIELD PROVIDED 2" VINYL TAPE FOR SEALING INSULATION SEAMS

SEE IOM FOR INSTALLATION DETAIL



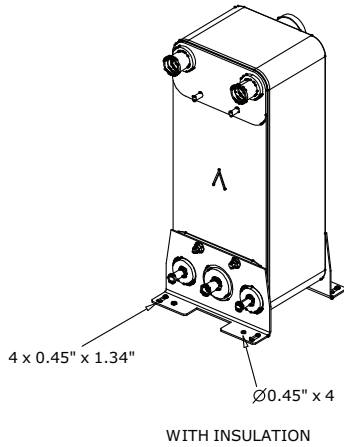
80 TON BRAZED PLATE HEAT EXCHANGER

ACCESSORY DRAWING



Unit Dimensions

Figure 44. Evaporator chiller — 100 ton



NOTES:

1. THIS HEAT EXCHANGER IS INTENDED FOR INDOOR INSTALLATION ONLY
2. HEAT EXCHANGER MOUNTING LEGS ARE INSTALLED AT JOB SITE WITH SUPPLIED FASTENERS
3. INSULATION SHOULD BE INSTALLED AFTER INSTALLING LEGS & REFRIGERANT TUBING, OR MUST BE ADEQUATELY SHIELDED AGAINST HEAT WHEN BRAZING REFRIGERANT LINES
4. INSTALL INSULATION SIDE PIECES FIRST THEN WRAPPER (MAY REQUIRE TRIMMING)
5. USE VINYL TAPE (FIELD SUPPLIED) TO SEAL INSULATION AFTER INSTALLATION
6. WATER CONNECTIONS ARE GROOVED (VICTAULIC)
7. REFRIGERANT CONNECTIONS ARE STAINLESS STEEL AND REQUIRE SPECIAL BRAZE MATERIALS. SEE IOM BRAZE PROCEDURE.
8. 1/2" - 14 NPT F5 CONNECTION SUPPLIED ON EXT'S 13 THRU 24 AND 37 THRU 48 ONLY.

BRAZED PLATE HEAT EXCHANGER REMOTE CHILLER EVAPORATOR OPTION

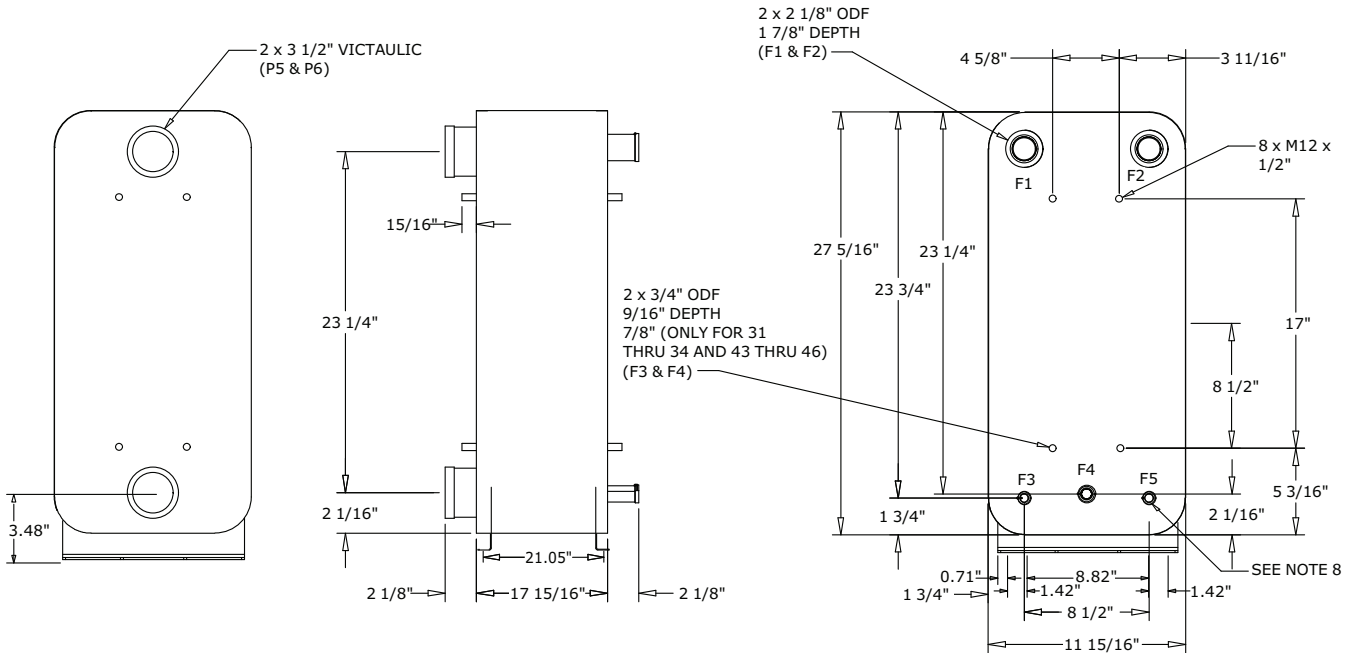
OPTION INCLUDES:

- 1 - BRAZED PLATE HEAT EXCHANGER - SHIPS SEPARATE FROM RAUJ CONDENSING UNIT
- 1 - INSTALLATION KIT, TO INCLUDE:
 - 2 - MOUNTING BRACKETS
 - 1 - INSULATION KIT
 - 1 - MOUNTING BRACKET & INSULATION KIT INSTALLATION INSTRUCTIONS
- 1 - WATER CONNECTION KIT WITH PIPING STUBS, Y CONNECTOR, STRAINER, VICTAULIC CONNECTIONS WITH GASKETS, WATER FLOW SWITCH
- 1 - WATER CONNECTION KIT INSTALLATION INSTRUCTIONS

INSTALLATION ADDITIONALLY REQUIRES:

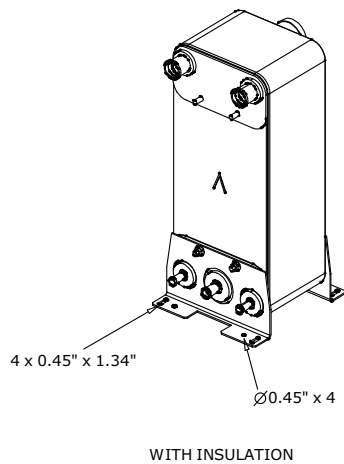
- RAUJ REMOTE EVP CONTROL PANEL WITH LEAVING WATER TEMPERATURE SENSOR, FREEZE-STAT, AND INSTALLATION INSTRUCTIONS - ALL INCLUDED WITH REMOTE EVP CONTROL PANEL
- 4 - FIELD PROVIDED 7/16" BOLTS FOR SECURING BRAZED PLATE HEAT EXCHANGER TO PERMANENT MOUNTING SURFACE
- 2 - FIELD PROVIDED 1/2" - 14 NPT PLUGS, STAINLESS STEEL OR PVC
- FIELD PROVIDED TEFLON TAPE FOR SEALING 1/2" PIPE PLUGS
- FIELD PROVIDED WATER STRAINER PLUG OR BLOW DOWN VALVE
- FIELD PROVIDED TEE FOR INSTALLING WATER FLOW SWITCH
- FIELD PROVIDED 2" VINYL TAPE FOR SEALING INSULATION SEAMS

SEE IOM FOR INSTALLATION DETAIL



100 TON BRAZED PLATE HEAT EXCHANGER

ACCESSORY DRAWING

Figure 45. Evaporator chiller — 120 ton

NOTES:

1. THIS HEAT EXCHANGER IS INTENDED FOR INDOOR INSTALLATION ONLY
2. HEAT EXCHANGER MOUNTING LEGS ARE INSTALLED AT JOB SITE WITH SUPPLIED FASTENERS
3. INSULATION SHOULD BE INSTALLED AFTER INSTALLING LEGS & REFRIGERANT TUBING, OR MUST BE ADEQUATELY SHIELDED AGAINST HEAT WHEN BRAZING REFRIGERANT LINES
4. INSTALL INSULATION SIDE PIECES FIRST THEN WRAPPER (MAY REQUIRE TRIMMING)
5. USE VINYL TAPE (FIELD SUPPLIED) TO SEAL INSULATION AFTER INSTALLATION
6. WATER CONNECTIONS ARE GROOVED (VICTAULIC)
7. REFRIGERANT CONNECTIONS ARE STAINLESS STEEL AND REQUIRE SPECIAL BRAZE MATERIALS. SEE IOM BRAZE PROCEDURE.
8. 1/2" - 14 NPT F5 CONNECTION SUPPLIED ON EXT'S 13 THRU 24 AND 37 THRU 48 ONLY.

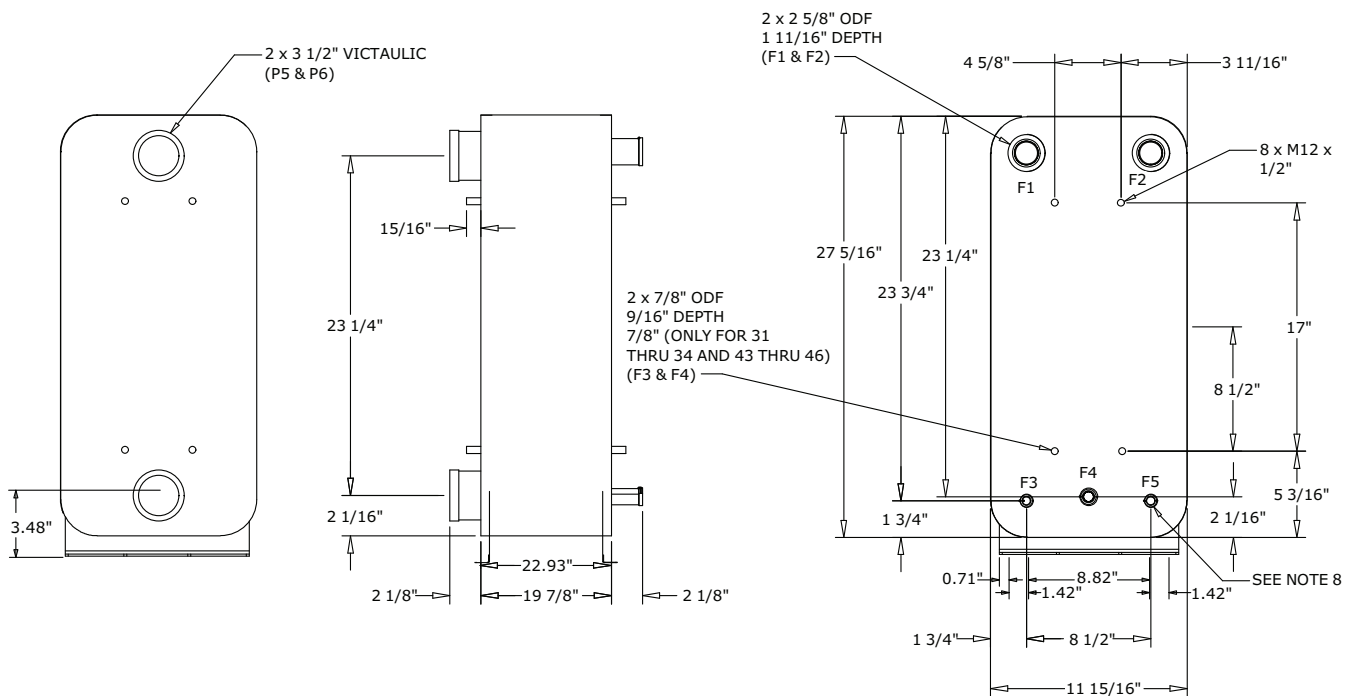
BRAZED PLATE HEAT EXCHANGER REMOTE CHILLER EVAPORATOR OPTION
OPTION INCLUDES:

- 1 - BRAZED PLATE HEAT EXCHANGER - SHIPS SEPARATE FROM RAUJ CONDENSING UNIT
- 1 - INSTALLATION KIT, TO INCLUDE:
 - 2 - MOUNTING BRACKETS
 - 1 - INSULATION KIT
 - 1 - MOUNTING BRACKET & INSULATION KIT INSTALLATION INSTRUCTIONS
- 1 - WATER CONNECTION KIT WITH PIPING STUBS, Y CONNECTOR, STRAINER, VICTAULIC CONNECTIONS WITH GASKETS, WATER FLOW SWITCH
- 1 - WATER CONNECTION KIT INSTALLATION INSTRUCTIONS

INSTALLATION ADDITIONALLY REQUIRES:

- 1 - RAUJ REMOTE EVP CONTROL PANEL WITH LEAVING WATER TEMPERATURE SENSOR, FREEZE-STAT, AND INSTALLATION INSTRUCTIONS - ALL INCLUDED WITH REMOTE EVP CONTROL PANEL
- 4 - FIELD PROVIDED 7/16" BOLTS FOR SECURING BRAZED PLATE HEAT EXCHANGER TO PERMANENT MOUNTING SURFACE
- 2 - FIELD PROVIDED 1/2" - 14 NPT PLUGS, STAINLESS STEEL OR PVC
- FIELD PROVIDED TEFLON TAPE FOR SEALING 1/2" PIPE PLUGS
- FIELD PROVIDED WATER STRAINER PLUG OR BLOW DOWN VALVE
- FIELD PROVIDED TEE FOR INSTALLING WATER FLOW SWITCH
- FIELD PROVIDED 2" VINYL TAPE FOR SEALING INSULATION SEAMS

SEE IOM FOR INSTALLATION DETAIL


120 TON BRAZED PLATE HEAT EXCHANGER

ACCESSORY DRAWING



Unit Weights

Table 6. RAUJ condensing unit weights

Unit Size (tons)	Weights (lbs)	
	Shipping	Operating
20	1548	1573
25	1598	1623
30	1598	1623
40	2482	2532
50	2826	2868
60	2803	2853
80	4870	4940
100	5539	5622
120	5995	6121

Table 7. EVP remote chiller weights

Unit Size (tons)	Weights (lbs)	
	Shipping	Operating
20	54	67
25	86	105
30	116	144
40	92	134
50	138	207
60	160	245
80	212	332
100	298	475
120	327	524



Mechanical Specifications

Air-Cooled Condensing Unit — Model RAUJ

General

All air-cooled condensing units shall have scroll compressors and are factory assembled and wired. Each unit shall ship from the factory with a nitrogen holding charge. Units shall be constructed of 14-gauge welded galvanized steel frame with 14 and 16-gauge galvanized steel panels and access doors. Units shall have factory mounted, louvered, full-length steel grilles to protect the condenser coils and piping. Unit surface shall be phosphatized and finished with an air-dry paint. This air-dry paint finish shall be durable enough to withstand a minimum of 672-consecutive-hour salt spray application in accordance with standard ASTM B117.

Refrigeration Circuits

The 20 to 30 ton units shall be single circuit with two steps of capacity. The 40 to 60 ton units shall be dual circuited with four capacity steps. Each circuit shall have two compressors piped in parallel. The 80, 100, and 120 ton sizes shall have two circuits with six capacity steps. Each circuit shall have three compressors piped in parallel.

Unit control

Factory shall provide 115-volt control circuit which includes fusing and control power transformer. The unit shall be wired with magnetic contactors for compressor and condenser motors, three-leg solid-state compressor overload protection, and high/low pressure cutouts. Charge isolation, reset relay and anti-recycle compressor timer shall be provided. Across-the-line start is standard.

Phase Monitor

The unit shall be equipped with a phase monitor in the control box. The phase monitor shall protect against phase loss, imbalance and reversal of the line voltage.

Compressor

Trane® 3-D™ Scroll compressors shall have a simple mechanical design. Scroll type compression shall provide low vibration. 3-D compressors shall provide a completely enclosed compression chamber with no leakage paths. The compressor shall be suction gas cooled, direct drive, with 3600 RPM hermetic motors. The Scroll compressor shall include a centrifugal oil pump, oil level sight glass, and an oil charging valve.

Split systems can have significantly more refrigerant than packaged systems and thus require controls to reliably manage this excess refrigerant. Each compressor shall have crankcase heaters installed, properly sized to minimize the amount of liquid refrigerant present in the oil sump during off cycles. Additionally, the condensing unit shall have controls to initiate refrigerant Isolation at system shut down on each refrigerant circuit. To be operational, the refrigerant Isolation cycle requires a field-installed isolation solenoid valve on the common liquid line near the evaporator.

Condenser Coils

Condenser coils shall have all aluminum microchannel coils. All coils shall be leak tested at the factory to ensure pressure integrity. The condenser coil shall be pressure tested to 650 psig.

Condenser Fans

All condenser fans shall be vertical discharge, direct drive fans, statically balanced, with aluminum blades and zinc plated steel hubs. Condenser fan motors shall be three-phase motors with permanently lubricated ball bearings, built in current and thermal overload protection and weather-tight slingers over motor bearings.



Options

Low Ambient Control

Low ambient option shall allow operation down to 0°F through the use of fan cycling and head pressure control dampers. The control shall consist of a heavy gauge damper assembly that is modulated by an actuator. The actuator shall be controlled by a low ambient control module. All components are factory-mounted.

Non-Fused Unit Disconnect Switch

A non-fused disconnect switch shall be mounted in the control box and provides for interruption of power for servicing the unit. Lugs shall be suitable for copper wires only. No overcurrent or short circuit protection shall be provided for unit by this switch. Option shall include external handle to allow power disconnection without having to open the control box door.

Hot Gas Bypass Valve

The hot gas bypass valve shall modulate hot gas to the inlet of the evaporator when suction pressure falls below the valve adjustable set point. Electronic versions shall be available with control through temperature or pressure. Hot gas bypass valves shall be shipped with the unit for field installation. (Model: Sporlan, SHGBE-8)

Note: For 40T to 120 ton units with No Control and CV systems, two valves will need be field installed (1 per circuit) to enable use of lead/lag. For all other systems, one valve will need to be field installed.

Suction Service Valve

Option shall consist of a refrigerant shutoff valve to isolate the compressor for servicing.

Pressure Gauges

Pressure gauges shall be provided for monitoring suction and discharge pressure. One set shall be provided for each circuit. The gauges shall be ship-with for field installation.

Corrosion Protected Condenser Coil

All Aluminum Microchannel condenser coil protection shall consist of a corrosion resistant coating that shall withstand ASTM B117 Salt Spray test for 6000 hours and ASTM G85 A2 Cyclic Acidified Salt Fog test for 2400 hours. This coating shall be added after coil construction covering all tubes, headers and fin edges, therefore providing optimal protection in more corrosive environments.

Spring Isolation Package

Spring vibration isolators shall be supplied for field installation under the unit base to minimize transmission of unit vibrations. Isolators shall consist of a cast, spring loaded, telescoping housing as the isolation medium. Mountings shall include built-in leveling bolts, resilient inserts that act as centering guides, and ribbed neoprene acoustical pads bonded to the bottom of the isolator. The kit shall include instructions for field installation.

Neoprene Vibration Isolation Package

Neoprene-in shear isolators shall be supplied for field installation under the unit base to minimize transmission of unit vibration. The isolators shall consist of a steel top plate and base completely imbedded in color coded oil-resistant neoprene stock. Mountings shall have a 1/4-inch deflection. The kit shall include instructions for field installation. (Available on 20 to 60 ton units only).

Remote Evaporator Chillers — Model EVP

The remote chiller control option shall include an interface panel in the main unit control box and a remote mounted control box that is customer installed. The remote mounted box shall contain the Honeywell W7100G controller. The chiller controller shall have an adjustable 0-10°F control band with integrating logic, built in fixed-off timers and field installed discharge water temperature sensors for control and chiller freeze protection. There are two capacity steps on 20, 25 and 30 ton sizes, four

capacity steps on 40, 50 and 60 ton sizes and six capacity steps on 80, 100 and 120 ton sizes. The remote chiller accessory kit shall include the evaporator with mounting hardware and insulation, water strainer, minimum water flow limit switch and water side pipe stubs with couplings. The chiller shall be a stainless steel brazed plate heat exchanger designed for up to 150 psig water side working pressure and 430 psig refrigerant working pressure. Chiller mounting shall be intended for non-freezing locations.

Flow Switch

The flow switch shall be provided for applications where the condensing unit is used with a remote evaporator chiller. This option shall be a ship-with item for field installation. The switch shall prohibit compressor start-up and operation, if the water flow through the chiller is not adequate.

Unpowered convenience outlet

Option shall include a factory installed GFCI, 15amp, 115 volt, 2 plug, unpowered convenience outlet.

Powered convenience outlet

Option shall include a factory installed 15 amp, 115 volt ground fault interrupter convenience outlet with a single point power entry from a factory mounted transformer. Optional shall meet NEC 210-63 requirements. This outlet shall include a separate disconnect switch so that the outlet is powered when the unit disconnect switch is off. The unit mounted non-fused disconnect switch option with external handle is required when ordering the convenience outlet.



Trane - by Trane Technologies (NYSE: TT), a global innovator - creates comfortable, energy efficient indoor environments for commercial and residential applications. For more information, please visit trane.com or tranetechnologies.com.

Trane has a policy of continuous product and product data improvements and reserves the right to change design and specifications without notice. We are committed to using environmentally conscious print practices.

SS-PRC030M-EN 15 Oct 2022
Supersedes SS-PRC030L-EN (July 2021)

©2022 Trane