



Installation, Operation, and Maintenance

Packaged Rooftop Air Conditioners

Horizon Flex Unit Light Commercial

- Cooling, Gas/Electric

10 to 15 Tons, 60 Hz



Model: HAE

Important: Proper execution of the tasks outlined in this Installation, Operation, and Maintenance manual require and assume the technician has been certified as a start up technician for the Trane Horizon Flex unit. This includes working knowledge of the Tracer TU program.

⚠ SAFETY WARNING

Only qualified personnel should install and service the equipment. The installation, starting up, and servicing of heating, ventilating, and air-conditioning equipment can be hazardous and requires specific knowledge and training. Improperly installed, adjusted or altered equipment by an unqualified person could result in death or serious injury. When working on the equipment, observe all precautions in the literature and on the tags, stickers, and labels that are attached to the equipment.

⚠ AVERTISSEMENT DE SÉCURITÉ

L'installation et l'entretien de cet équipement doivent être assurés exclusivement par du personnel qualifié. L'installation, la mise en service et l'entretien d'équipements de chauffage, de ventilation et de climatisation (CVC) présentent un danger et requièrent des connaissances et une formation spécifiques. Une installation, un réglage ou une modification inappropriés d'un équipement par une personne non qualifiée peut provoquer des blessures graves, voire la mort. Lors de toute intervention sur l'équipement, respectez les consignes de sécurité figurant dans la documentation, ainsi que sur les pictogrammes, autocollants et étiquettes apposés sur l'équipement.



Introduction

Read this manual thoroughly before operating or servicing this unit.

Warnings, Cautions, and Notices

Safety advisories appear throughout this manual as required. Your personal safety and the proper operation of this machine depend upon the strict observance of these precautions.

The three types of advisories are defined as follows:

⚠ WARNING Indicates a potentially hazardous situation which, if not avoided, could result in death or serious injury.

⚠ CAUTION Indicates a potentially hazardous situation which, if not avoided, could result in minor or moderate injury. It could also be used to alert against unsafe practices.

NOTICE Indicates a situation that could result in equipment or property-damage only accidents.

Important Environmental Concerns

Scientific research has shown that certain man-made chemicals can affect the earth's naturally occurring stratospheric ozone layer when released to the atmosphere. In particular, several of the identified chemicals that may affect the ozone layer are refrigerants that contain Chlorine, Fluorine and Carbon (CFCs) and those containing Hydrogen, Chlorine, Fluorine and Carbon (HCFCs). Not all refrigerants containing these compounds have the same potential impact to the environment. Trane advocates the responsible handling of all refrigerants.

Important Responsible Refrigerant Practices

Trane believes that responsible refrigerant practices are important to the environment, our customers, and the air conditioning industry. All technicians who handle refrigerants must be certified. The Federal Clean Air Act (Section 608) sets forth the requirements for handling, reclaiming, recovering and recycling of certain refrigerants and the equipment that is used in these service procedures. In addition, some states or municipalities may have additional requirements that must also be adhered to for responsible management of refrigerants. Know the applicable laws and follow them.

⚠ WARNING

Proper Field Wiring and Grounding Required!

Failure to follow code could result in death or serious injury.

All field wiring **MUST** be performed by qualified personnel. Improperly installed and grounded field wiring poses **FIRE** and **ELECTROCUTION** hazards. To avoid these hazards, you **MUST** follow requirements for field wiring installation and grounding as described in **NEC** and your local/state/national electrical codes.

⚠ AVERTISSEMENT

Câblage sur site et mise à la terre corrects nécessaires!

Le non-respect de la réglementation peut entraîner des blessures graves, voire mortelles. Il est **IMPÉRATIF** de confier l'ensemble du câblage sur site à un électricien qualifié. Un câblage sur site mal installé ou mal mis à la terre constitue des risques **D'INCENDIE** et **D'ÉLECTROCUTION**. Pour éviter ces risques, il est **IMPÉRATIF** de respecter les obligations en matière de pose de câblage sur site et de mise à la terre tel que stipulé dans les règles du **NEC** et dans les réglementations électriques locales/nationales.

⚠ WARNING**Personal Protective Equipment (PPE) Required!**

Failure to wear proper PPE for the job being undertaken could result in death or serious injury. Technicians, in order to protect themselves from potential electrical, mechanical, and chemical hazards, **MUST** follow precautions in this manual and on the tags, stickers, and labels, as well as the instructions below:

- Before installing/servicing this unit, technicians **MUST** put on all PPE required for the work being undertaken (Examples; cut resistant gloves/sleeves, butyl gloves, safety glasses, hard hat/bump cap, fall protection, electrical PPE and arc flash clothing). **ALWAYS** refer to appropriate Safety Data Sheets (SDS) and OSHA guidelines for proper PPE.
- When working with or around hazardous chemicals, **ALWAYS** refer to the appropriate SDS and OSHA/GHS (Global Harmonized System of Classification and Labeling of Chemicals) guidelines for information on allowable personal exposure levels, proper respiratory protection and handling instructions.
- If there is a risk of energized electrical contact, arc, or flash, technicians **MUST** put on all PPE in accordance with OSHA, NFPA 70E, or other country-specific requirements for arc flash protection, **PRIOR** to servicing the unit. **NEVER PERFORM ANY SWITCHING, DISCONNECTING, OR VOLTAGE TESTING WITHOUT PROPER ELECTRICAL PPE AND ARC FLASH CLOTHING. ENSURE ELECTRICAL METERS AND EQUIPMENT ARE PROPERLY RATED FOR INTENDED VOLTAGE.**

⚠ AVERTISSEMENT**Équipements de protection individuelle (EPI) obligatoires!**

En cas d'équipement de protection individuelle inadapté au travail entrepris, les techniciens s'exposent à des risques de blessures graves voire mortelles. Afin de se prémunir d'éventuels risques électriques, mécaniques et chimiques, les techniciens **DOIVENT** respecter les consignes préconisées dans le présent manuel, sur les étiquettes et les autocollants, ainsi que les instructions suivantes:

- Avant d'installer/réparer cette unité, les techniciens doivent **IMPÉRATIVEMENT** porter tout l'équipement de protection individuelle (EPI) recommandé pour le travail entrepris (exemples : gants/manchons résistants aux coupures, gants en caoutchouc butyl, lunettes de protection, casque de chantier/antichoc, protection contre les chutes, EPI pour travaux électriques et vêtements de protection contre les arcs électriques). Consulter **SYSTÉMATIQUEMENT** les fiches de données de sécurité et les directives de l'OSHA pour connaître la liste des EPI adaptés.
- Lors d'une intervention avec ou à proximité de produits chimiques dangereux, consulter **SYSTÉMATIQUEMENT** les fiches de données de sécurité appropriées et les directives de l'OSHA/du SGH (système général harmonisé de classification et d'étiquetage des produits chimiques) afin d'obtenir des renseignements sur les niveaux admissibles d'exposition personnelle, la protection respiratoire adaptée et les recommandations de manipulation.
- En cas de risque d'éclair, d'arc électrique ou de contact électrique avec un équipement électrique sous tension, et **AVANT** de réparer l'unité, les techniciens doivent **IMPÉRATIVEMENT** porter tout l'équipement de protection individuelle (EPI) conformément à l'OSHA, à la norme NFPA 70E ou à toute autre exigence propre au pays pour la protection contre les arcs électriques. **NE JAMAIS COMMUTER, DÉBRANCHER ou EFFECTUER DE TEST DE TENSION SANS PORTER UN EPI POUR TRAVAUX ÉLECTRIQUES OU UN VÊTEMENT DE PROTECTION APPROPRIÉ CONTRE LES ARCS ÉLECTRIQUES. IL CONVIENT DE S'ASSURER QUE LES COMPTEURS ET ÉQUIPEMENTS ÉLECTRIQUES CORRESPONDENT À LA TENSION NOMINALE PRÉVUE.**

⚠ WARNING**Follow EHS Policies!**

Failure to follow instructions below could result in death or serious injury.

- All Trane personnel must follow the company's Environmental, Health and Safety (EHS) policies when performing work such as hot work, electrical, fall protection, lockout/tagout, refrigerant handling, etc. Where local regulations are more stringent than these policies, those regulations supersede these policies.
- Non-Trane personnel should always follow local regulations.

⚠ AVERTISSEMENT**Respecter les politiques EHS !**

Lenon-respect des consignes suivantes peut être à l'origine de blessures graves, voire mortelles.

- Tous les membres du personnel externes à l'entreprise sont tenus de respecter les règles établies par l'entreprise en matière d'environnement, de santé et de sécurité (EHS) lors d'une intervention, notamment en cas de travail à chaud, risque de choc électrique et de chute, procédures de verrouillage / déclassement, manipulation de fluide frigorigène, etc. Si les réglementations locales sont plus strictes que les règles imposées par le groupe, elles deviennent prioritaires.
- Le personnel extérieur à l'entreprise est, quant à lui, systématiquement tenu d'observer les réglementations en vigueur à l'échelle locale.

⚠ WARNING**Hazard of Explosion or Fire!**

Failure to follow instructions could result in death or serious injury and equipment or property damage.

Do not store or use gasoline or other flammable vapors and liquids in the vicinity of this or any other appliance.

IF YOU SMELL GAS, follow instructions below:

- Do not try to light any appliance.
- Do not touch any electrical switch.
- Do not use any phone in your building.
- Open windows and doors.
- Alert others and evacuate building immediately.
- From a phone outside of the building, immediately call your gas supplier. Follow the gas supplier's instructions. If you cannot reach your gas supplier, call the fire department.

⚠ WARNING**Hazardous Voltage w/Capacitors!**

Failure to disconnect power and discharge capacitors before servicing could result in death or serious injury. Disconnect all electric power, including remote disconnects and discharge all motor start/run capacitors before servicing. Follow proper lockout/tagout procedures to ensure the power cannot be inadvertently energized. For variable frequency drives or other energy storing components provided by Trane or others, refer to the appropriate manufacturer's literature for allowable waiting periods for discharge of capacitors. Verify with a CAT III or IV voltmeter rated per NFPA 70E that all capacitors have discharged.

⚠ WARNING**Refrigerant under High Pressure!**

Failure to follow instructions below could result in an explosion which could result in death or serious injury or equipment damage.

System contains refrigerant under high pressure. Recover refrigerant to relieve pressure before opening the system. See unit nameplate for refrigerant type. Do not use non-approved refrigerants, refrigerant substitutes, or refrigerant additives.

⚠ AVERTISSEMENT**Fluide frigorigène sous haute pression!**

Tout manquement aux instructions indiquées ci-dessous peut provoquer une explosion pouvant causer des blessures graves voire mortelles ou des dommages matériels. Le système contient de l'huile et du fluide frigorigène sous haute pression. Avant d'ouvrir le circuit, récupérez le fluide frigorigène pour éliminer toute pression dans le circuit. Consultez la plaque constructeur de l'unité pour connaître le type de fluide frigorigène employé. Utilisez uniquement des fluides frigorigènes, substitués et additifs agréés.

⚠ WARNING**Explosion Hazard and Deadly Gases!**

Failure to follow all proper safe refrigerant handling practices could result in death or serious injury. Never solder, braze or weld on refrigerant lines or any unit components that are above atmospheric pressure or where refrigerant may be present. Always remove refrigerant by following the guidelines established by the EPA Federal Clean Air Act or other state or local codes as appropriate. After refrigerant removal, use dry nitrogen to bring system back to atmospheric pressure before opening system for repairs. Mixtures of refrigerants and air under pressure may become combustible in the presence of an ignition source leading to an explosion. Excessive heat from soldering, brazing or welding with refrigerant vapors present can form highly toxic gases and extremely corrosive acids.

⚠ AVERTISSEMENT**Risque d'explosion et gaz mortels!**

Le non-respect de toutes les consignes de manipulation des fluides frigorigènes peut entraîner la mort ou des blessures graves. N'effectuez en aucune circonstance des opérations de brasage ou de soudage sur des conduites de fluide frigorigène ou des composants de l'unité sous pression ou pouvant contenir du fluide frigorigène. Récupérez systématiquement le fluide frigorigène en respectant les directives de la loi américaine sur la propreté de l'air (Agence fédérale pour l'environnement) ou toute autre réglementation nationale ou locale en vigueur. Après la récupération du fluide frigorigène, utilisez de l'azote déshydraté pour ramener le système à la pression atmosphérique avant de l'ouvrir pour procéder aux réparations. Les mélanges de fluide frigorigène et d'air sous pression peuvent devenir combustibles en présence d'une source d'inflammation et provoquer une explosion. La chaleur excessive découlant de travaux de soudage ou de brasage associée à la présence de vapeurs de fluide frigorigène peut entraîner la formation de gaz hautement toxiques et d'acides extrêmement corrosifs.

⚠ WARNING**Hazard of Explosion and Deadly Gases!**

Failure to follow instructions could result in death or serious injury.

If you smell gas:

1. Open windows.
2. Don't touch electrical switches.
3. Extinguish any open flame.
4. Immediately call your gas supplier.

⚠ AVERTISSEMENT**Risque d'explosion et gaz mortels!**

Le non-respect de toutes les consignes de sécurité ci-dessous peut entraîner la mort ou des blessures graves.

Si vous sentez une odeur de gaz:

1. Ouvrez les fenêtres.
2. Ne touches à aucun interrupteur.
3. Éteignez toute flamme nue.
4. Avertissez immédiatement votre fournisseur de gaz.

⚠ WARNING**Hazardous Service Procedures!**

Improper installation, adjustment, alteration, service or maintenance can cause property damage, injury or death. Read the installation, operating and maintenance instructions thoroughly before installing or servicing this equipment.

⚠ AVERTISSEMENT**Procédures d'entretien dangereuses!**

Une installation, un réglage, une modification, une réparation ou un entretien incorrect peut entraîner des dommages matériels, des blessures ou la mort. Lisez attentivement les instructions d'installation, de fonctionnement et d'entretien avant de procéder à l'installation ou à l'entretien de cet équipement.

⚠ WARNING**Hazard of Explosion and Deadly Gases!**

Failure to follow instructions could result in death or serious injury.

The use and storage of gasoline or other flammable vapors and liquids in open containers in the vicinity of this appliance is hazardous.

⚠ AVERTISSEMENT**Risque d'explosion et gaz mortels!**

Le non-respect de toutes les consignes de sécurité ci-dessous peut entraîner la mort ou des blessures graves.

Il est dangereux d'utiliser ou d'entreposer de l'essence ou autres liquides ou vapeurs inflammables dans des récipients ouverts à proximité de cet appareil.

⚠ WARNING**R-454B Flammable A2L Refrigerant!**

Failure to use proper equipment or components as described below could result in equipment failure, and possibly fire, which could result in death, serious injury, or equipment damage.

The equipment described in this manual uses R-454B refrigerant which is flammable (A2L). Use **ONLY** R-454B rated service equipment and components. For specific handling concerns with R-454B, contact your local representative.

Copyright

This document and the information in it are the property of Trane, and may not be used or reproduced in whole or in part without written permission. Trane reserves the right to revise this publication at any time, and to make changes to its content without obligation to notify any person of such revision or change.

Trademarks

All trademarks referenced in this document are the trademarks of their respective owners.

Product Safety Information

This appliance is not intended for use by persons (including children) with reduced physical, sensory or mental capabilities, or lack of experience and knowledge, unless they have been given supervision or instruction concerning use of the appliance by a person responsible for their safety.

Children should be supervised to ensure that they do not play with the appliance.

Maximum altitude of use is 10,000 feet.

This appliance incorporates an earth connection for functional purposes only.



Table of Contents

Model Number Descriptions	9	Decommissioning	17
General Information	11	A2L Application Considerations	17
Overview of Manual	11	Ignition Sources in Ductwork	17
Model Number Description	11	Ignition Sources in Unit	17
Unit Nameplate	11	Unventilated Areas	17
Compressor Nameplate	11	Minimum Room Area Limits (Refrigerant charge greater than 3.91 lb per circuit)	18
Unit Description	11	Minimum Room Area (A_{min}) Adjustments	18
Indoor Fan Failure Input	11	Determining Room Area (A or TA)	19
Refrigerant Circuits	11	Refrigeration Detection System (RDS)	19
Low Pressure Control for Variable Speed Compressors	11	Unit Clearances, Curb Dimensions, and Dimensional Data	20
High Pressure Control for Variable Speed Compressors	11	HAE Units	20
Low Pressure Control ReliaTel™ Control	11	Unit Clearances	20
High Pressure Control ReliaTel™ Control	12	Curb Dimensions	21
Space Temperature / RH Sensor (Optional)	12	Dimensional Data	22
High Temperature Sensor	12	Unit Weight and Rigging	26
Relative Humidity Sensor	12	Unit Weight	26
Control Input (Occupied / Unoccupied)	12	Rigging	27
Hot Gas Reheat	12	Installation	28
Manual Outdoor Air Hood with Damper and Filters	12	Ductwork	28
Modulating Indirect Fired Gas Burner	12	General Unit Requirements	28
Through the Base Electrical with Disconnect Switch	12	Main Electrical Power Requirements	29
Hinged Access Doors	12	Condensate Drain Configuration	29
2-Stage Electric Heat	12	Filter Installation	29
Phase Monitor	13	Field Installed Power Wiring	29
Unit Inspection	13	Main Unit Power	31
First Aid Measures	14	Standard Wiring	31
Storage	14	Voltage Imbalance	32
Unit Clearances	14	Electrical Phasing (Three-Phase Motors)	32
A2L Information	15	Compressor Crankcase Heaters	33
A2L Work Procedures	15	Main Unit Display and Microprocessor Controller	33
Servicing	15	Field-Installed Control Wiring	33
Ignition Source Mitigation	15	Control Power Transformer	34
Leak Detection	16	Controls Using 24 Vac	34
Refrigerant Removal and Evacuation	16	Controls Using DC Analog Input/Output (Standard Low Voltage Multiconductor)	
Refrigerant Charging	16		



Table of Contents

Wire)	34	Motor Data	64
DC Conductors	35	Compressor Data	65
Factory-Provided Sensors	36	Actuators	65
Pre-Start Check List	37	Refrigeration Start-Up	66
System Configuration and Pre-Start	38	Test Procedures	66
Start-Up	41	Indirect Fired Gas Heat Start-Up	67
Refrigeration System Setup	41	Gas Pressure Settings (Modulating)	67
Indirect Fired Gas Heating		Gas Pressure Settings (Two Stage)	67
Start-Up	41	Electric Heat Start-Up	67
Start-Up Procedure	42	Programming	68
Start-Up Procedure for Two Stage Gas heat	43	Generate Point Summary Report	68
Safety Controls	46	Final Notes	68
Manual Outside Air Damper Adjustment Instruc-		Notes	69
tions	47		
Maintenance	49		
Monthly Maintenance	49		
Filters	49		
Supply/Return Air Smoke Detector			
Maintenance	49		
Cooling Season	49		
Heating Season	49		
Condensate Drain	50		
Condenser Coil Cleaning	50		
ERV Wheel Maintenance	51		
Final Process	51		
General Data	53		
Refrigeration Circuit Data	54		
Alarms and Troubleshooting	55		
Microprocessor Control and Faults	55		
RTRM System LED Diagnostic Indicator . .	55		
System Alarms	56		
Sensor Failure Alarm Display	56		
Appendix	58		
Horizon Flex Filter	58		
Field Installation of			
Factory-Provided Sensors	59		
Start-Up Form Trane® Horizon™ Flex	63		
Pre-Start-Up Checklist	63		
Phase Monitor Setup	64		
Voltages	64		



Model Number Descriptions

Digit 1, 2 – Unit Type

HA = HA

Digit 3 – Cabinet Size

E = 1500–6000 cfm

Digit 4 – Major Design Sequence

A = REV 1
B = REV 1.1

Digit 5, 6, 7 – Normal Gross Cooling Capacity (MBh)

010 = 10 Tons High Efficiency
012 = 12 Tons High Efficiency
015 = 15 Tons High Efficiency

Digit 8 – Airflow Configuration

A = Vertical Discharge/No Return
C = Vertical Discharge/Vertical Return

Digit 9 – Voltage Selection

1 = 208/60/3
2 = 230/60/3
3 = 460/60/3
4 = 575/60/3

Digit 10 – Not Used

Digit 11 – Indoor Coil Type

C = DX 4-Row

Digit 12 – Reheat

0 = No Reheat
A = Fin and Tube Modulating HGRH

Digit 13 – Compressor

B = Digital Scroll–1st Circuit Only
D = eFlexTM–1st Circuit
G = Two-Stage Scroll Compressors

Digit 14 – Outdoor Coil

2 = Air Cooled Microchannel

Digit 15 – Refrigerant Capacity Control

0 = None
G = Low GWP Refrigerant and No RCC Valve

Digit 16 – Heat Type (Primary)

0 = No Heat
A = Indirect Fired NG (IF) - 80% Efficiency - 439 SS
B = Indirect Fired NG (IF) - 81% Efficiency - 439 SS
D = Indirect Fired LP (IF) - 80% Efficiency - 439 SS
E = Indirect Fired LP (IF) - 81% Efficiency - 439 SS
H = Electric - Staged
L = Indirect Fired NG (IF) - 81% Efficiency - ALZ
M = Indirect Fired LP (IF) - 81% Efficiency - ALZ

Digit 17 – Gas Heat Capacity – Primary

0 = No Gas Heat
F = 200 MBh
H = 300 MBh
K = 400 MBh

Digit 18 – Heat Type – Secondary

0 = No Secondary Heat
4 = Electric–Staged

Digit 19 – Electric Heat Capacity – Secondary

0 = No Secondary Heat
B = 10 kW (8kW@208V)
D = 20 kW (16kW@208V)
F = 28 kW (23 @208V)
S = 38 kW (31 @208V)

Digit 20 – Not Used

Digit 21 – Supply Fan Motor

A = 1 hp–1800 rpm
B = 1 hp–3600 rpm
C = 1.5 hp–1800 rpm
D = 1.5 hp–3600 rpm
E = 2 hp–1800 rpm
F = 2 hp–3600 rpm
G = 3 hp–1800 rpm
H = 3 hp–3600 rpm
J = 5 hp–1800 rpm
K = 5 hp–3600 rpm
L = 7.5 hp–1800 rpm
M = 7.5 hp–3600 rpm
N = 10 hp–1800 rpm
P = 10 hp–3600 rpm

Digit 22 – Supply Fan Motor Type

1 = Direct Drive with VFD
3 = Direct Drive with Shaft Grounding Ring with VFD

Digit 23, 24 – Supply Fan Wheel Diameter

AC = 14-inch Wheel
AG = 18-inch Wheel
AL = 22-inch Wheel

Digit 25 – Exhaust Fan Motor

0 = No Powered Exhaust
A = 1 hp–1800 rpm
B = 1 hp–3600 rpm
C = 1.5 hp–1800 rpm
D = 1.5 hp–3600 rpm
E = 2 hp–1800 rpm
F = 2 hp–3600 rpm
G = 3 hp–1800 rpm
H = 3 hp–3600 rpm
J = 5 hp–1800 rpm
K = 5 hp–3600 rpm
L = 7.5 hp–1800 rpm
M = 7.5 hp–3600 rpm

Digit 26 – Exhaust Fan Motor Type

0 = No Powered Exhaust
1 = Direct Drive with VFD
3 = Direct Drive with Shaft Grounding Ring with VFD

Digit 27, 28 – Exhaust Fan Wheel Diameter

00 = No Powered Exhaust
AC = 14 in. Wheel
AG = 18 in. Wheel

Digit 29 – Air Flow Monitoring

0 = No Piezo Ring
1 = Supply Fan Piezo Ring
2 = Exhaust Fan Piezo Ring
3 = Supply Fan Piezo Ring and Exhaust Fan Piezo Ring

Digit 30 – Not Used

Digit 31 – Unit Controls

1 = Trane PPS Space Control
2 = Trane PPS Discharge Air Control
3 = Trane PPS Multi-Zone VAV
4 = Trane PPS Single-Zone VAV

Digit 32 – Building Interface

1 = BACnet®

Digit 33 – Filter Options

A = A MERV-8, 30%-With Filter Status Switch
B = MERV-13, 80% With Filter Status Switch
C = MERV-14, 95% With Filter Status Switch
D = MERV-8 30%, MERV-13 80% With Filter Status Switch
F = MERV-8, 30%-Without Filter Status Switch
G = MERV-13, 80%-Without Filter Status Switch
H = MERV-14, 95%-Without Filter Status Switch
J = MERV-8 30%, MERV-13 80% Without Filter Status Switch

Digit 34 – Energy Recovery

0 = No Energy Recovery
1 = ERV – Composite Construction with Bypass for Frost Protection
2 = ERV – Composite Construction with Frost Protection with VFD
3 = ERV – Aluminum Construction with Bypass for Frost Protection
4 = ERV – Aluminum Construction with Frost Protection with VFD

Digit 35 – Energy Recovery Option, Purge

0 = No Purge
1 = Purge

Digit 36 – Energy Recovery Wheel Size

0 = No ERV
A = 30 in. Dia.
B = 36 in. Dia.
C = 41 in. Dia.
D = 46 in. Dia.

Digit 37 – Energy Recovery Option, Rotation Sensor

0 = No Rotation Sensor

Digit 38 – Damper Options

3 = Modulating OA and RA Dampers With Economizer
5 = Manual OA Damper



Model Number Descriptions

Digit 39 – Exhaust Dampers

- 0 = No Exhaust Dampers
- A = Gravity Dampers

Digit 40 – Not Used

Digit 41 – Electrical Options

- 0 = Terminal Block–No Factory Installed Disconnect
- A = Non-Fused Disconnect
- B = Fused Disconnect Switch
- C = 65 SCCR Electrical Rating w/Non-Fused Disconnect
- D = 65 SCCR Electrical Rating w/Fused Disconnect
- E = 65 KAIC Electrical Rating w/Non-Fused Disconnect
- F = 65 KAIC Electrical Rating w/Fused Disconnect

Digit 42 – Corrosive Environment Package

- 0 = No Corrosive Package
- A = Eco Coated Coils
- C = S/S Coil Casing

Digit 43 – Outdoor Air Monitoring

- 0 = No Outdoor Air Monitoring

Digit 44 – Condenser Fan Options

- A = Standard Condenser Fan

Digit 45 – Compressor Sound Blankets and Sound Attenuation

- 0 = No Sound Attenuation Package
- A = Compressor Sound Blankets

Digit 46 – Smoke Detector-Field Installed

- 0 = No Smoke Detector
- 4 = Supply Smoke Detector
- 5 = Return Smoke Detector
- 6 = Supply and Return Smoke Detector

Digit 47 – Hailguards

- 0 = No Hailguards
- A = Hailguards

Digit 48 – Service Lights

- 0 = No Service Lights
- A = Supply Fan Section Service Light
- B = Exhaust Fan Section Service Light
- C = Supply and Exhaust Fan Section Service Light

Digit 49 – UV Lights

- 0 = No UV Lights

Digit 50 – Not Used

Digit 51 – Unit Installation Location

- A = Outdoor

Digit 52 – Convenience Outlet

- 0 = No Convenience Outlet
- A = Convenience Outlet

Digit 53 – Controls Display

- 0 = No Display
- 1 = TD7 Factory Installed
- 2 = TD7 Remote Mounted

Digit 54 – Cooling Controls

- 0 = Standard Control
- A = ReliaTel™

Digit 55 – Face and Bypass on Indoor Coil

- 0 = No Face and Bypass

Digit 56 – Thermostat

- 0 = No Thermostat
- 1 = Thumbwheel Thermostat

Digit 57 – Altitude

- 0 = Sea Level to 1000 Feet
- 1 = 1001 to 2000 Feet
- 2 = 2001 to 3000 Feet
- 3 = 3001 to 4000 Feet
- 4 = 4001 to 5000 Feet
- 5 = 5001 to 6000 Feet
- 6 = 6001 to 7000 Feet
- 7 = Above 7000 Feet

Digit 58 – Condensate Overflow Switch

- 0 = No Condensate Overflow Switch
- A = Condensate Overflow Switch

Digit 59 – Froststat

- 0 = No Froststat

Digit 60 – Not Used

Digit 61 – Outdoor Coil Fluid Type

- 0 = None

Digit 62 – Minimum Damper Leakage

- 0 = Standard
- 1 = Class 1A

Digit 63, 64– UC600 Hardware Template

- 00 = Prior to Hardware Template
- AA = Flex v2.0

Digit 65– Electric Heat Capacity-Primary

- 0 = No Electric Heat
- E = 24kW (19.6kW@208V)
- J = 48kW (39kW@208V)
- L = 68kW (55.6kW@208V)
- N = 99kW (81kW@208V)

Digit 66– Hot Water Coil Design - Primary

- 0 = No Hot Water Heat

Digit 67– Gas Heat Cap-Secondary

- 0 = No Secondary Gas Heat

Digit 68, 96– Reserved for Future Use



General Information

Overview of Manual

Note: *One copy of this document ships inside the control panel of each unit and is customer property. It must be retained by the unit's maintenance personnel.*

This booklet describes proper installation, operation, and maintenance procedures for air cooled systems. By carefully reviewing the information within this manual and following the instructions, the risk of improper operation and/or component damage will be minimized.

It is important that periodic maintenance be performed to help assure trouble free operation. A maintenance schedule is provided at the end of this manual. Should equipment failure occur, contact a qualified service organization with qualified, experienced HVAC technicians to properly diagnose and repair this equipment.

Model Number Description

All products are identified by a multiple-character model number that precisely identifies a particular type of unit. An explanation of the alphanumeric identification code is provided (refer to "Model Number Descriptions," p. 9). Its use will enable the owner/operator, installing contractors, and service engineers to define the operation, specific components, and other options for any specific unit.

When ordering replacement parts or requesting service, be sure to refer to the specific model number and serial number printed on the unit nameplate.

Unit Nameplate

A Mylar® unit nameplate is located on the unit's corner support next to the control box. It includes the unit model number, serial number, electrical characteristics, refrigerant charge, as well as other pertinent unit data.

Compressor Nameplate

The nameplate for the compressors are located on the side of the compressor.

Unit Description

Before shipment, each unit is leak tested, dehydrated, charged with refrigerant and compressor oil, and run tested for proper control operation.

The condenser coils are Microchannel.

Direct-drive, vertical discharge condenser fans are provided with built-in thermal overload protection.

The Main Unit Display and ReliaTel™ Control Module (RTRM) are microelectronic control systems. The acronym RTRM is used extensively throughout this document when referring to the control system network. The RTRM is for refrigeration safety control, not for main unit controls.

The Main Unit Display and the RTRM are mounted in the Main Control Panel. The Main Unit Display and RTRM receive information from sensors and customer binary contacts to satisfy the applicable request for ventilation, cooling, dehumidification and heating.

Indoor Fan Failure Input

The Indoor Fan Failure Switch (IFFS) is connected to verify indoor fan operation.

When there is a call for the indoor fan to be energized, the differential pressure switch, connected to the Main Unit Display, must prove airflow within 2 minutes or the Main Unit Display will shut off all mechanical operations, lock the system out and send a diagnostic alarm to the Unit Display. The system will remain locked out until a reset is initiated through the main unit controller via the Alarm Reset Function on the Unit Display.

Refrigerant Circuits

For 10 to 15 ton units, one refrigerant circuit shall incorporate a standard 4-row coil. Each circuit shall have thermal expansion valves (TXVs), service pressure ports, and refrigerant line filter driers as standard. An area will be provided for replacement suction line driers.

Low Pressure Control for Variable Speed Compressors

The compressor low pressure cutout is wired in series with high pressure cutout, high discharge temperature cutout, and wired to timed safety relay. The timed safety relay is connected to the compressor safety relay, which feeds power to the compressor contactor coil. Anytime this circuit is opened during compressor operation, the compressor for that circuit is immediately turned Off. The compressor will not be allowed to restart for a minimum of 3 minutes should the contacts close from an open state.

High Pressure Control for Variable Speed Compressors

The compressor high pressure cutout is wired in series with low pressure cutout, high discharge temperature cutout, and wired to timed safety relay. The timed safety relay is connected to the compressor safety relay, which feeds power to the compressor contactor coil. Anytime this circuit is opened during compressor operation, the compressor for that circuit is immediately turned Off. The compressor will not be allowed to restart for a minimum of 3 minutes should the contacts close from an open state.

Low Pressure Control ReliaTel™ Control

This input incorporates the Compressor Low Pressure Switch (CLP1). On a call for compressor operation, there is a CLP1 bypass delay where CLP1 is ignored. If there is a low charge condition or low pressure condition due to extreme cold ambient conditions, the unit is allowed to run for the delay



General Information

period to build up pressure. If the outdoor air temperature is less than 40°, the delay will be set to 60 seconds. When the outdoor temperature is between 40° and 49.9° the delay will be set to 30 seconds. For any outdoor temperature 50° and above, there will be no CLP1 bypass delay.

Anytime this circuit is opened during normal compressor operation, the compressors for that circuit are immediately turned Off. The compressors will not be allowed to restart for a minimum of 3 minutes should the contacts close from an open state. If the contacts are still open after the 3 minute wait or the contacts open before 3 consecutive minutes of operation, the compressor will continue to shut off. If after 4 attempts to operate, CLP1 contacts are open, then the unit will be locked out requiring a manual restart. If the compressor operates for 3 consecutive minutes or the call for cooling stops, then the counter resets.

High Pressure Control ReliaTel™ Control

The compressor high pressure controls (CHP1) are wired to the main power of the RTRM. If CHP1 opens, the RTRM board loses power and will not allow any compressor operation for 3 minutes should the contacts close from an open state. If there are 3 attempts to operate unsuccessfully, the unit will shut down requiring a manual restart by resetting BV36 Alarm Reset in the unit's software.

Space Temperature / RH Sensor (Optional)

Field installed, wall mounted combination temperature/humidity sensor (BAYSENS036A) to control space cooling, heating and dew point.

High Temperature Sensor

Discharge Air Temperature Lockout is displayed when the Discharge Air Temperature Local is [above 128°F, below 35°F] for a duration of 10 minutes. The diagnostic is manual reset using Alarm Reset.

Relative Humidity Sensor

This factory installed combination return air sensor located in the return air path is designed to sense relative humidity for use by the microprocessor controller to make required ventilation, cooling, dehumidification and heating decisions.

Note: *Optional Outdoor Air sensor will be used in combination with return air sensor to control temperature and humidity.*

Control Input (Occupied / Unoccupied)

Terminals are provided on the terminal strip labeled OAUTS for a field installed dry contact or switch closure to put the unit in the Occupied or Unoccupied modes.

Hot Gas Reheat

This option shall consist of a hot-gas reheat coil located on the leaving air side of the evaporator.

Manual Outdoor Air Hood with Damper and Filters

Manual outdoor air damper can be adjusted from 0% up to 50% outdoor air. The unit is shipped at 0% outdoor air (sealed with gasket and secured with screws) and must be adjusted during start-up for desired outdoor air percentage. The unit can be factory-provided with an optional modulating outdoor air/return air combo damper that is controlled by an actuator.

Modulating Indirect Fired Gas Burner

The unit will have fully modulating, stainless steel high turndown, indirect fired gas heat or 2-stage aluminized gas heat. The stainless steel heating section will include high turndown burners and a stainless steel tubular heat exchanger. The heat exchanger will be constructed of type 439 stainless steel with a tubular design capable of draining internal condensate. External flue to be constructed of type 430 stainless steel.

The aluminized gas heating section will include 2-stage control and aluminum steel tubular heat exchanger.

Units will be suitable for use with natural gas or Liquid Propane (LP) gas.

Through the Base Electrical with Disconnect Switch

Factory installed 3-pole, molded case disconnect switch with provisions for through the base electrical connections will be included. The disconnect switch, with integral overcurrent circuit breaker, will be installed in the unit in a water tight enclosure with access through a hinged door. Factory wiring will be provided from the switch to the unit high voltage terminal block. The switch will be UL/CSA agency recognized.

Hinged Access Doors

Hinged access doors will be factory-installed.

2-Stage Electric Heat

The unit may have optional 2-stage controlled electric heat. The primary heating section will include open coil heating elements, automatic and manual cut-outs, low voltage controls, air proving switch, maximum 48 amps per circuit and fusing for heaters over 48 amps. For ductwork installation, refer to "Ductwork," p. 28.

Phase Monitor

Figure 1. Macromatic phase monitor

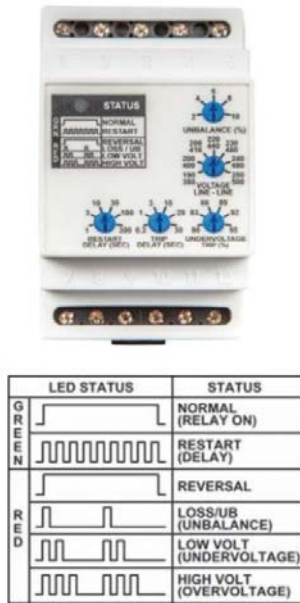

Figure 2. Time Mark phase monitor



Unit Inspection

⚠ WARNING

Fiberglass Wool!

Product may contain fiberglass wool. Disturbing the insulation in this product during installation, maintenance or repair will expose you to airborne particles of glass wool fibers and ceramic fibers known to the state of California to cause cancer through inhalation. Glass wool fibers may also cause respiratory, skin or eye irritation.

⚠ AVERTISSEMENT

Laine de verre!

Le produit peut contenir de la laine de verre. Des interventions inappropriées sur l'isolation de ce produit pendant les opérations d'installation, d'entretien ou de réparation vous exposent à des particules aériennes de fibres de verre ou de fibres céramiques, responsables selon la législation américaine (état de Californie) de risques de cancers par inhalation. Les fibres de verre peuvent aussi provoquer des phénomènes d'irritation au niveau du système respiratoire, de la peau ou des yeux.

As soon as the unit arrives at the job site:

- Verify that the nameplate data matches the data on the sales order and bill of lading (including electrical data).
- Verify that the power supply complies with the unit nameplate specifications.
- Visually inspect the exterior of the unit, including the roof, for signs of shipping damage.
- Visually inspect the internal components for shipping damage as soon as possible after delivery and before it is stored. Do *not* walk on the sheet metal base pans.
- If concealed damage is discovered, notify the carrier's terminal of damage immediately by phone and by mail. Concealed damage must be reported within 15 days.

Request an immediate joint inspection of the damage by the carrier and the consignee. Do not remove damaged material from the receiving location. Take photos of the damage, if possible. The owner must provide reasonable evidence that the damage did not occur after delivery.

- Notify the appropriate sales representative before installing or repairing a damaged unit.

- Avoid breathing fiberglass dust.
- Use a NIOSH approved dust/mist respirator.
- Avoid contact with the skin or eyes. Wear long-sleeved, loose-fitting clothing, gloves, and eye protection.
- Wash clothes separately from other clothing: rinse washer thoroughly.



General Information

- Operations such as sawing, blowing, tear-out, and spraying may generate fiber concentrations requiring additional respiratory protection. Use the appropriate NIOSH approved respiration in these situations.

First Aid Measures

Eye Contact

Flush eyes with water to remove dust. If symptoms persist, seek medical attention.

Skin Contact

Wash affected areas gently with soap and warm water after handling.

Storage

Take precautions to prevent condensate from forming inside the unit's electrical compartments and motors if:

- the unit is stored before it is installed; or,
- the unit is set on the roof curb, and temporary heat is provided in the building. Isolate all side panel service entrances and base pan openings (e.g., conduit holes, S/A and R/A openings, and flue openings) from the ambient air until the unit is ready for start-up.

Note: *Do not use the unit's heater for temporary heat without first completing the start-up procedure detailed in "Start-Up," p. 41.*

The manufacturer will not assume any responsibility for equipment damage resulting from condensate accumulation on the unit's electrical and/or mechanical components.

Unit Clearances

"Unit Clearances, Curb Dimensions, and Dimensional Data," p. 20 contains figures that illustrate the minimum operating and service clearances for either a single or multiple unit installation. These clearances are the minimum distances necessary to assure adequate serviceability, cataloged unit capacity, and peak operating efficiency.

Providing less than the recommended clearances may result in condenser coil starvation, "short-circuiting" of exhaust or recirculation of hot condenser air.



A2L Information

A2L Work Procedures

⚠ WARNING

Risk of Fire — Flammable Refrigerant!

Failure to follow instructions below could result in death or serious injury, and equipment damage.

- To be repaired only by trained service personnel.
- Do not puncture refrigerant tubing.
- Dispose of properly in accordance with federal or local regulations.

⚠ WARNING

Refrigerant under High Pressure!

Failure to follow instructions below could result in an explosion which could result in death or serious injury or equipment damage.

System contains refrigerant under high pressure. Recover refrigerant to relieve pressure before opening the system. See unit nameplate for refrigerant type. Do not use non-approved refrigerants, refrigerant substitutes, or refrigerant additives.

⚠ WARNING

Hazardous Voltage!

Failure to disconnect power before servicing could result in death or serious injury.

Disconnect all electric power, including remote disconnects before servicing. Follow proper lockout/tagout procedures to ensure the power can not be inadvertently energized. Verify that no power is present with a voltmeter.

The units described in this manual use R-454B refrigerant. Use ONLY R-454B rated service equipment or components with these units. For specific handling concerns with R-454B, contact your local Trane representative.

Installation, repair, removal, or disposal should be performed by trained service personnel.

At all times, Trane's maintenance and service guidelines shall be followed. If in doubt, contact Trane technical support for assistance.

Serviceing

Prior to initiating work on equipment, check the area with an appropriate refrigerant detector. Ensure the service personnel are properly trained regarding work in potentially toxic or flammable atmospheres. Ensure that the leak detection equipment being used is suitable for use with all applicable refrigerants, i.e. non-sparking, adequately sealed, or

intrinsically safe. Be aware that the refrigerant does not contain an odor.

If any hot work is to be conducted on the refrigerating equipment or any associated parts, appropriate fire extinguishing equipment shall be available on hand. A dry powder or CO2 fire extinguisher should be located adjacent to the charging area.

At all times, Trane's maintenance and service guidelines shall be followed. If in doubt, contact Trane technical support for assistance.

All maintenance staff and others working in the local area shall be instructed on the nature of the work being carried out. Work in confined spaces shall be avoided.

Ignition Source Mitigation

Do not use any sources of ignition when working on the refrigeration system.

Keep all ignition sources, including cigarette smoking, away from the site of installation, repair, removal or disposal, during which refrigerant can potentially be released to the surrounding space.

Survey the area around the equipment before initiating work to ensure no flammable hazards or ignition risks are present.

"No Smoking" signs shall be displayed.

Do not use devices that can be a source of ignition to accelerate defrosting of components. Use only defrost and cleaning procedures recommended by Trane. Do not pierce or burn.

Ventilation

Ensure that the area is in the open or that it is adequately ventilated before breaking into the system or conducting any hot work. A degree of ventilation shall continue during the period that the work is carried out. The ventilation should safely disperse any released refrigerant and preferably expel it externally into the atmosphere. If present, check that the ventilation system, including outlets, are operating adequately and are not obstructed.

Refrigerating Equipment

Refrigerant piping or components should not be installed in locations where substances which may corrode them are present.

Check that equipment hazard markings are visible and legible. Replace them if they are not.

For equipment using secondary fluids, like water or glycol, check that refrigerant is not present in the secondary fluid loop before conducting any hot work.

Electrical Devices

Do not apply power to the circuit if a fault exists which compromises safety. If the fault cannot be corrected immediately, but it is necessary to continue operation, an adequate temporary solution shall be used. This shall be



A2L Information

reported to the owner of the equipment, so all parties are advised.

Initial safety checks shall include:

- Cabling is not subject to wear, corrosion, excessive pressure, vibration, sharp edges, or any other adverse environmental effects. Account for the effects of aging or continual vibration from sources such as compressors or fans.
- Capacitors are discharged. This shall be done in a safe manner to avoid possibility of sparking.
- No live electrical components and wiring are exposed while charging, recovering, or purging the system.
- Verify continuity of earth bonding.
- Replace electrical components with Trane replacement parts, or those meeting the same ratings and qualified for flame arrest protection, UL LZGH2 category.

Leak Detection

Never use an open flame to detect leaks. A halide torch should not be used. Use only approved leak detection methods per this instruction manual.

The following leak detection methods are deemed acceptable for all refrigerant systems.

Electronic leak detectors may be used to detect refrigerant leaks but, in the case of flammable refrigerants, the sensitivity may not be adequate, or may need re-calibration. (Detection equipment shall be calibrated in a refrigerant-free area.) Ensure that the detector is not a potential source of ignition and is suitable for the refrigerant used. Leak detection equipment shall be set at a percentage of the LFL gas (25% maximum) is confirmed.

Leak detection fluids are also suitable for use with most refrigerants but the use of detergents containing chlorine shall be avoided as the chlorine may react with the refrigerant and corrode the copper pipe-work.

Examples of leak detection fluids are:

- Bubble method
- Fluorescent method agents

If a leak is suspected, all naked flames shall be removed/ extinguished.

If a refrigerant leak is found which requires brazing, all refrigerant shall be recovered from the system, or isolated (by means of shut off valves) in a part of the system remote from the leak.

Refrigerant Removal and Evacuation

When breaking into the refrigerant circuit to make repairs –or for any other purpose – conventional procedures shall be used. However, for flammable refrigerants it is important that best practice be followed, since flammability is a consideration.

The following procedure shall be adhered to:

1. Safely remove refrigerant following local and national regulations.

2. Evacuate.
3. Purge the circuit with inert gas.
4. Evacuate (optional for A2L).
5. Continuously flush or purge with inert gas when using flame to open circuit.
6. Open the circuit.

Prior to refrigerant removal, open all appropriate valves, including solenoid and electronic expansion valves (EXVs). Use control settings, where available. When not available, manually open all electronically controlled valves using acceptable service procedures.

The recovery equipment shall be in good working order with instructions available. Equipment shall be suitable for the recovery of the flammable refrigerant. For specific handling concerns, contact the manufacturer. Ensure all hose connections are checked for tightness to avoid refrigerant leaks.

The refrigerant shall be recovered into the correct recovery cylinders if venting is not allowed by local and national codes. Do not mix refrigerants in recovery unit and especially not in cylinders.

Refrigerant recovery unit should be purged with an inert gas after each use or before using with a different refrigerant Class – for example, A2L to A1.

If compressors or compressor oils are to be removed, ensure that they have been evacuated to an acceptable level to make certain that flammable refrigerant does not remain within the lubricant. The compressor body shall not be heated by an open flame or other ignition sources to accelerate this process. When oil is drained from a system, it shall be carried out safely.

The system shall be purged with oxygen-free nitrogen to render the appliance safe for flammable refrigerants. This process might need to be repeated several times. Compressed air or oxygen shall not be used for purging refrigerant systems.

The system shall be vented down to atmospheric pressure to enable work to take place.

The outlet for the vacuum pump shall not be close to any potential ignition sources, and ventilation shall be available.

Refrigerant Charging

In addition to conventional charging procedures, the following requirements shall be followed.

- Ensure that contamination of different refrigerants does not occur when using charging equipment.
- Hoses or lines shall be as short as possible to minimize the amount of refrigerant contained in them.
- Cylinders shall be kept in an appropriate position according to the instructions.
- Ensure that the refrigerating system is earthed prior to charging the system with refrigerant.
- Label the system when charging is complete (if not already).

- Extreme care shall be taken not to overfill the refrigerating system.

Prior to recharging the system, it shall be pressure-tested with the appropriate purging gas. The system shall be leak-tested on completion of charging but prior to commissioning. A follow up leak test shall be carried out prior to leaving the site.

Prior to refrigerant charging, open all appropriate valves, including solenoid and electronic expansion valves (EXVs). Use control settings, where available. When not available, manually open all electronically controlled valves using acceptable service procedures.

Decommissioning

Before carrying out the decommissioning procedure, it is essential that the trained service personnel is completely familiar with the equipment and all its details. It is recommended good practice that all refrigerants are recovered safely. Prior to the task being carried out, an oil and refrigerant sample shall be taken in case analysis is required prior to re-use of recovered refrigerant. It is essential that electrical power is available before the task is commenced.

1. Become familiar with the equipment and its operation.
2. Isolate system electrically.
3. Before attempting the procedure, ensure that:
 - a. Mechanical handling equipment is available, if required, for handling refrigerant cylinders.
 - b. All personal protective equipment is available and being used correctly.
 - c. The recovery process is supervised at all times by a competent person.
 - d. Recovery equipment and cylinders conform to the appropriate standards.
4. Pump down refrigerant system, if possible.
5. If a vacuum is not possible, make a manifold so that refrigerant can be removed from various parts of the system.
6. Make sure that cylinder is situated on the scales before recovery takes place.
7. Start the recovery machine and operate in accordance with instructions.
8. Do not overfill cylinders (no more than 80% volume liquid charge).
9. Do not exceed the maximum working pressure of the cylinder, even temporarily.
10. When the cylinders have been filled correctly and the process completed, make sure that the cylinders and the equipment are removed from site promptly and all isolation valves on the equipment are closed off.
11. Recovered refrigerant shall not be charged into another refrigerating system unless it has been cleaned and checked. When equipment has been decommissioned, attach a signed label which includes the date of decommissioning.
12. When equipment has been decommissioned, attach a signed label which includes the date of decommissioning.

A2L Application Considerations

This product is listed to UL standard 60335-2-40, Household and Similar Electrical Appliances – Safety –Part 2-40: Particular Requirements for Electrical Heat Pumps, Air-Conditioners and Dehumidifiers, which defines safe design and use strategies for equipment using A2L refrigerants. This standard limits the refrigerant concentration in a space in the event of a refrigerant leak. To meet the requirements, the UL standard defines minimum room area, refrigerant charge limit, minimum circulation airflow and/or ventilation airflow requirements, and limits the use of ignition sources in spaces. The standard may require a unit refrigerant leak detection system.

For equipment with R-454B and charge amounts less than or equal to 3.91 lbs per circuit, this UL standard does not prescribe a room area limit and does not require a refrigerant leak detection system or any circulation airflow or ventilation airflow mitigation strategies.

Depending on the application, a specific requirement of ANSI/ASHRAE Standard 15, Safety Standard for Refrigeration Systems, could be more stringent than UL 60335-2-40 requirements. See *Refrigeration Systems and Machinery Rooms Application Considerations for Compliance with ASHRAE® Standard 15-2022 Application Engineering Manual (APP-APM001*-EN)* for more information.

Ignition Sources in Ductwork

Do not install open flames in the ductwork. Hot surfaces exceeding 700°C (1290°F) should not be installed in the ductwork unless the average airflow velocity is not less than 1.0 m/s (200 ft/min) across the heater and proof of airflow is verified before system is energized.

Electric heaters can exceed the surface temperature limit if airflow distribution is poor, or insufficient airflow is provided over the heater.

Surface temperatures of most gas heaters do not exceed the surface temperature limits due to ANSI construction requirements.

Ignition Sources in Unit

This UL-listed unit does not contain any ignition sources. All potential ignition sources, (including factory or field installed accessory electric heaters, gas heaters, relays, and contactors) were evaluated during product UL listing.

Unventilated Areas

Any unventilated area where equipment is installed with a charge of greater than 3.91 lb per circuit shall be constructed so that should any refrigerant leak, it will not stagnate to create a fire or explosion hazard.

Should the equipment be installed via an air duct system to one or more rooms with an area less than the minimum area



A2L Information

as shown in Table 1, that room shall be without continuously operating open flames (e.g. an operating gas appliance) or other potential ignition sources (e.g. an operating electric heater, hot surfaces). A flame-producing device may be installed in the same space if the device is provided with an effective flame arrest.

Horizon Flex units all have a refrigerant detection system installed, thus false ceilings or drop ceilings may be used as a return air plenum as long as any external connections are also provided with a sensor immediately below the return air plenum duct joint.

Minimum Room Area Limits (Refrigerant charge greater than 3.91 lb per circuit)

Equipment with R-454B charge amounts greater than 3.91 lb per circuit may require additional circulation or ventilation airflow mitigation strategies. In this case, two minimum room area (A_{min}) thresholds:

- The first threshold defines when equipment serving a single room is required to provide circulation airflow, either continuous or activated by a leak detection system. A ducted system requires circulation airflow unless the smallest room it serves is larger than the adjusted A_{min} threshold. This product contains a leak detection system if a circuit charge is greater than 3.91 lbs. As a result, no further leak detection system evaluation is required.
- The second threshold defines when additional ventilation airflow is required. If the room area, A or TA , is below the adjusted A_{min} or TA_{min} threshold, additional ventilation is required to remove refrigerant in the event of a leak. Refer to UL 60335-2-40 Clause GG.8 and ANSIASHRAE

Table 3. Altitude adjustment factor

Altitude (ft)	Sea Level to 2000	2001 to 4000	4001 to 6000	6001 to 8000	8001 to 10000	10001 to 12000	12001 to 14000	14001 to 15000	Over 15000
A_{min} Adjustment	1	1.05	1.11	1.17	1.24	1.32	1.41	1.51	1.57

In addition, A_{min} can be adjusted if the unit is installed in a room at a height that is higher than the minimum height shown on the unit. To adjust A_{min} , multiply by the ratio of the unit minimum release height (in meters) / actual release height (in meters). Use 0.6 m in the ratio for unit minimum installation heights less than or equal to 0.6 m.

For institutional occupancies, ASHRAE Standard 15 applies an additional adjustment factor F_{occ} to the amount of a charge allowed in a space. To calculate the adjusted A_{min} for institutional occupancies, multiply the A_{min} on the nameplate by two.

EXAMPLE 1: 20 Ton Packaged Rooftop Multi-Zone VAV System Serving an Institutional Occupancy Space

Standard 15 Section 7 for natural and mechanical ventilation requirements.

Table 1. Minimum room area

Model Description	Tonnage	Minimum Room Area ^a Minimum Circulation Airflow ^b				
HAE*	010	10	286	ft ²	28	m ²
			514	CFM	873	m ³ /hr
	012	12	301	ft ²	28	m ²
			541	CFM	919	m ³ /hr
	015	15	331	ft ²	31	m ²
			595	CFM	1011	m ³ /hr

Table 2. Maximum refrigerant charges

Model Description	Tonnage	Maximum Single Circuit Refrigerant Charge, lb (kg)	
HAE*	10	19	(9)
	12	20	(9)
	15	22	(10)

Minimum Room Area (A_{min}) Adjustments

Use equation below to adjust the minimum room area, as applicable, based on the unit's installation height, altitude, and occupancy level it serves.

$$A_{min,adj} = \text{Nameplate } A_{min} \times \text{Altitude Adj} \times \text{Height Adj} \times F_{occ}$$

Multiply the altitude adjustment factor in the table below by A_{min} listed on the unit nameplate.

The packaged unit serves 7600 ft² of a nursing home located at an altitude of 4000 ft. The unit has two equally charged 10 ton refrigeration circuits. Each circuit has 12 lbs of refrigerant with a minimum room area requirement of 180 ft² with a 2.2 m release height.

$$TA_{min,adj} = 180 \text{ ft}^2 \times 1.05 \times 2 = 378 \text{ ft}^2$$

No additional ventilation is required.

EXAMPLE 2: 10 Ton Split System Serving a Single Commercial Occupancy Space

The split system serves a 1500 ft² manufacturing space at 5000 ft altitude. The final installed charge of the single circuit

10 ton unit is 20 lb. The unit has an open return with a release height of 1 m and ducted supply air. The unit A_{min} is 660 ft².

$$A_{min,adj} = 660 \text{ ft}^2 \times 1.11 = 733 \text{ ft}^2$$

No additional ventilation is required.

Determining Room Area (A or TA)

The room area (A) is the room area enclosed by the projection to the floor of the walls, partitions, and doors of the space that the equipment serves. For ducted systems, total room area (TA) of all rooms connected by ducts, may be used instead of A.

Rooms connected by drop ceilings only are not considered a single room.

Rooms on the same floor of the building, and connected by an open passageway, can be considered part of the same room if the passageway is a permanent opening, extends to the floor and is intended for people to walk through.

Adjacent rooms on the same floor of the building and connected by permanent openings in the walls and/or doors between rooms (including gaps between the wall and the floor), can be considered part of the same room if the openings meet the following criteria.

- The opening is permanent and cannot be closed.
- Openings extending to the floor, such as door gaps, need to be at least 20mm above the floor covering surface.
- Natural ventilations opening areas must meet the requirements of ANSIASHRAE Standard 15-2022, Section 7.2.3.2.

Rooms that are connected by a mechanical ventilation system can be considered a single room area if the mechanical ventilation system meets the requirements of ANSIASHRAE Standard 15-2022, Section 7.6.4.

Refrigeration Detection System (RDS)

The refrigerant detection system consists of one or more refrigerant detection sensors. When the system detects a refrigerant leak, the following mitigation actions will be initiated. Once refrigerant is no longer detected, mitigation will continue for 5 minutes. The 5-minute timer operation is performed by the sensor.

- If a leak is detected in the airstream, energize the supply fan(s) to deliver a required minimum amount of circulation airflow for dilution of refrigerant.
- Disable heater operation.
- Disable compressor operation.
- Provide an output status signal to fully open all zoning dampers, such as VAV boxes or fire dampers. This output status is to be used as a 24VAC trigger for a 24VAC compatible relay coil being utilized for power transmission

to audible alarms, visual alarms, and additional mechanical ventilation for units installed indoors. Refer to [Figure 22, p. 35](#) for details on where to land wires for refrigerant detection system mitigation status. See [Figure 3, p. 19](#) for an example schematic on how this status should be used.

Figure 3. Refrigerant Detection System example schematic

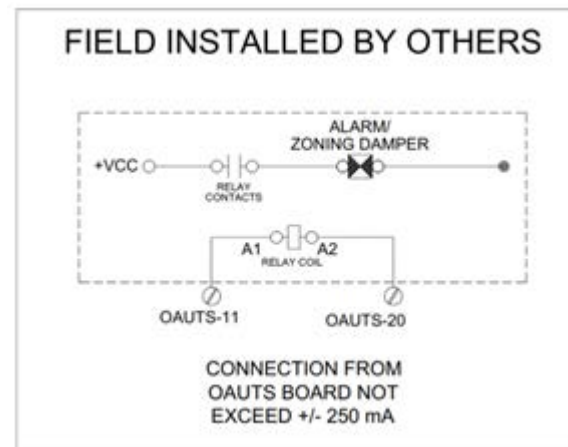

Important: Only connect a relay coil to this output. Do not source more than 500ma from this circuit.

Building or unit fire and smoke detection systems will override the refrigerant leak detection system operation and will shut the unit down.

If the refrigerant sensor has a fault, is at the end of its life, or is disconnected, the unit will initiate the mitigation actions. If the sensor is determined to be in a fault where the output signal is out of range or at the end of its life, it will require replacement.

Mitigation actions can be verified by disconnecting the sensor. Upon reconnection, the unit will immediately be in normal state and the 5-minute period of continued mitigation will not occur since the timer operation is performed by the sensor.

The refrigerant sensors do not need service. Use only manufacturer approved sensors when replacement is required.



Unit Clearances, Curb Dimensions, and Dimensional Data

⚠ WARNING

Combustible Materials!

Failure to maintain proper clearance between the unit heat exchanger, vent surfaces and combustible materials could cause a fire which could result in death or serious injury or property damage. Refer to unit nameplate and installation instructions for proper clearances.

⚠ AVERTISSEMENT

Matériaux combustibles!

Tout manquement à l'obligation de maintenir une distance appropriée entre l'échangeur de chaleur de l'unité, les surfaces de ventilation et les matériaux combustibles peut provoquer un incendie pouvant résulter en des blessures corporelles graves, voire mortelles, ou des dommages matériels. Reportez-vous à la plaque signalétique de l'unité et aux instructions d'installation pour connaître les distances appropriées.

HAE Units

Unit Clearances

Figure 4. Installation clearances for units with no powered exhaust or ERV, in. (cm)

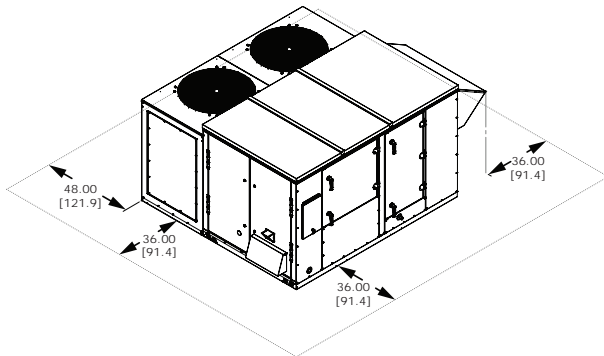
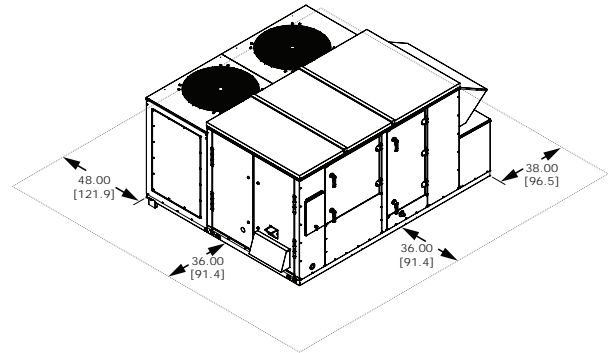
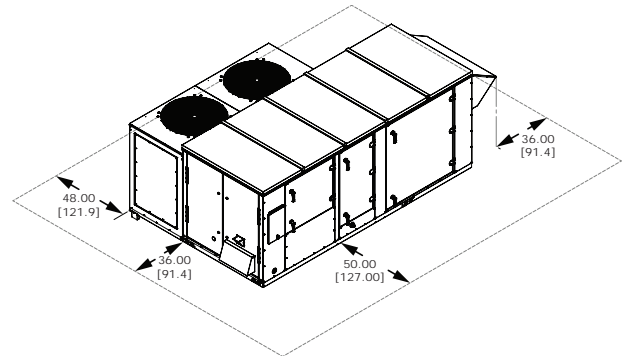

Figure 5. Installation clearances for unit with powered exhaust but no ERV, in. (cm)



Note: 72-inch (182.9 cm) clearance is required above the condenser fans.

Figure 6. Installation clearances for unit with ERV, in. (cm)



Note: 72-inch (182.9 cm) clearance is required above the condenser fans.

Figure 7. Unit to unit clearance, in. (cm)

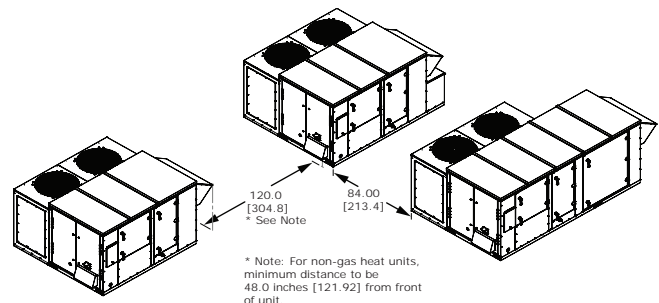

Curb Dimensions

Figure 8. Unit curb data for HAE cabinet with no powered exhaust or ERV, in. (cm)

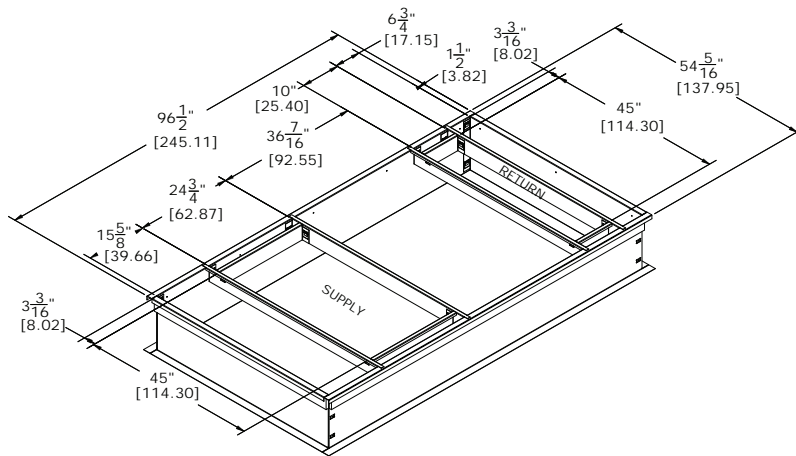

Figure 9. Unit curb data for HAE cabinet with powered exhaust but no ERV, in. (cm)

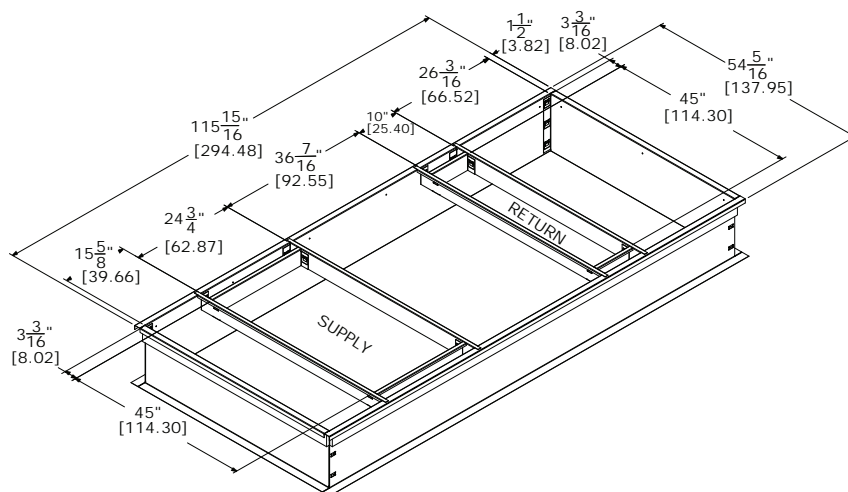
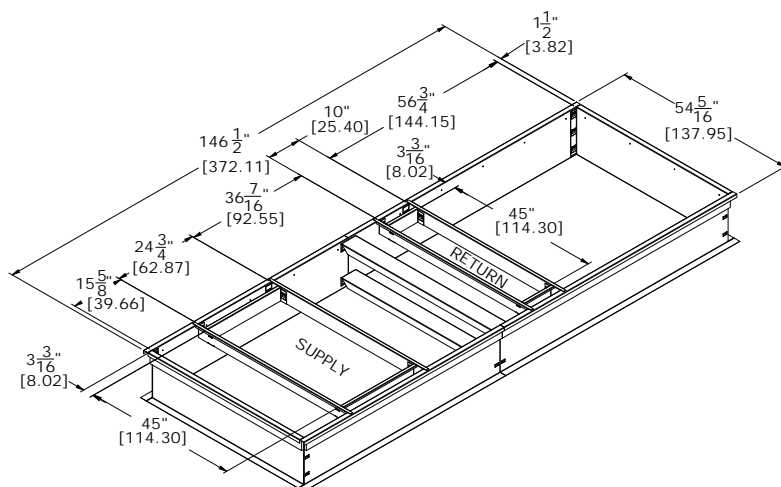

Figure 10. Unit curb data for HAE cabinet with ERV, in. (cm)





Unit Clearances, Curb Dimensions, and Dimensional Data

Dimensional Data

Figure 11. Unit dimensional data for HAE unit with no powered exhaust or ERV, in. (cm)

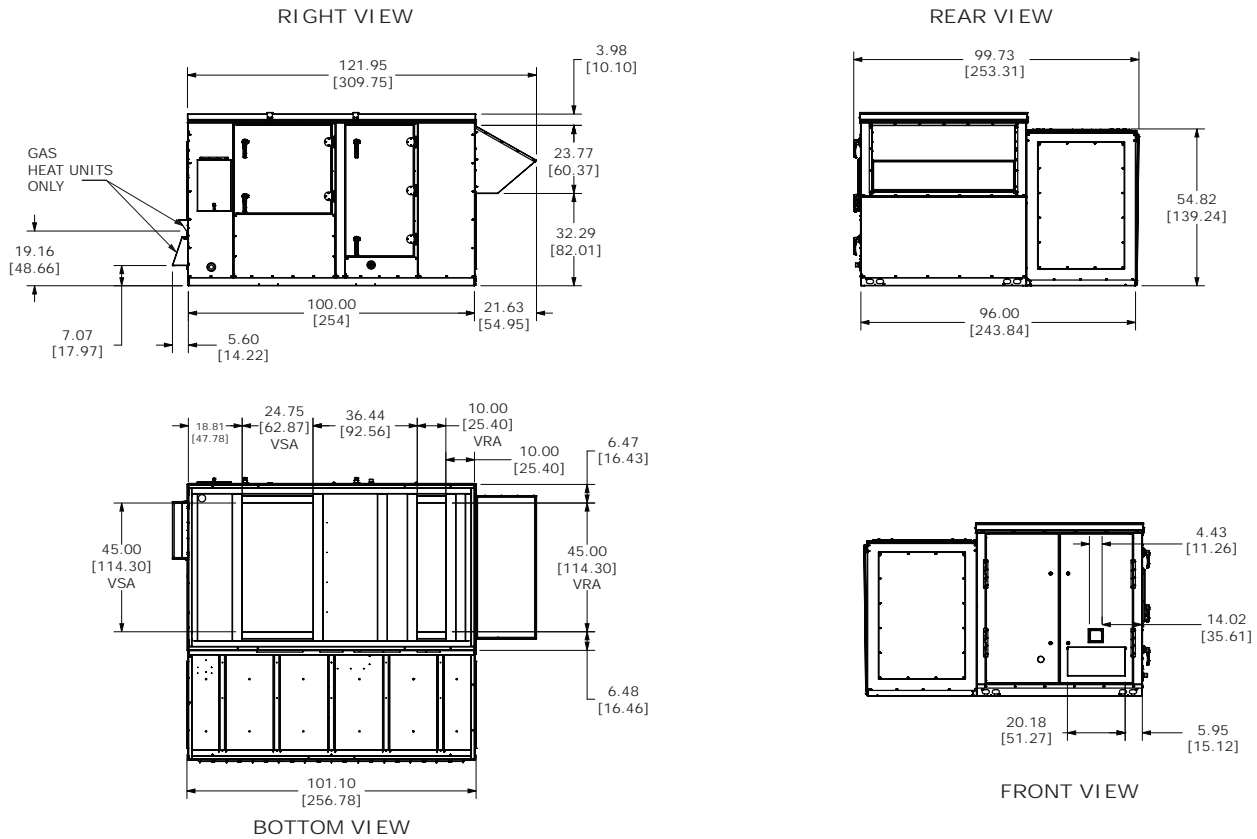

Unit Clearances, Curb Dimensions, and Dimensional Data

Figure 12. Unit dimensional data for HAE cabinet with powered exhaust but no ERV, in. (cm)

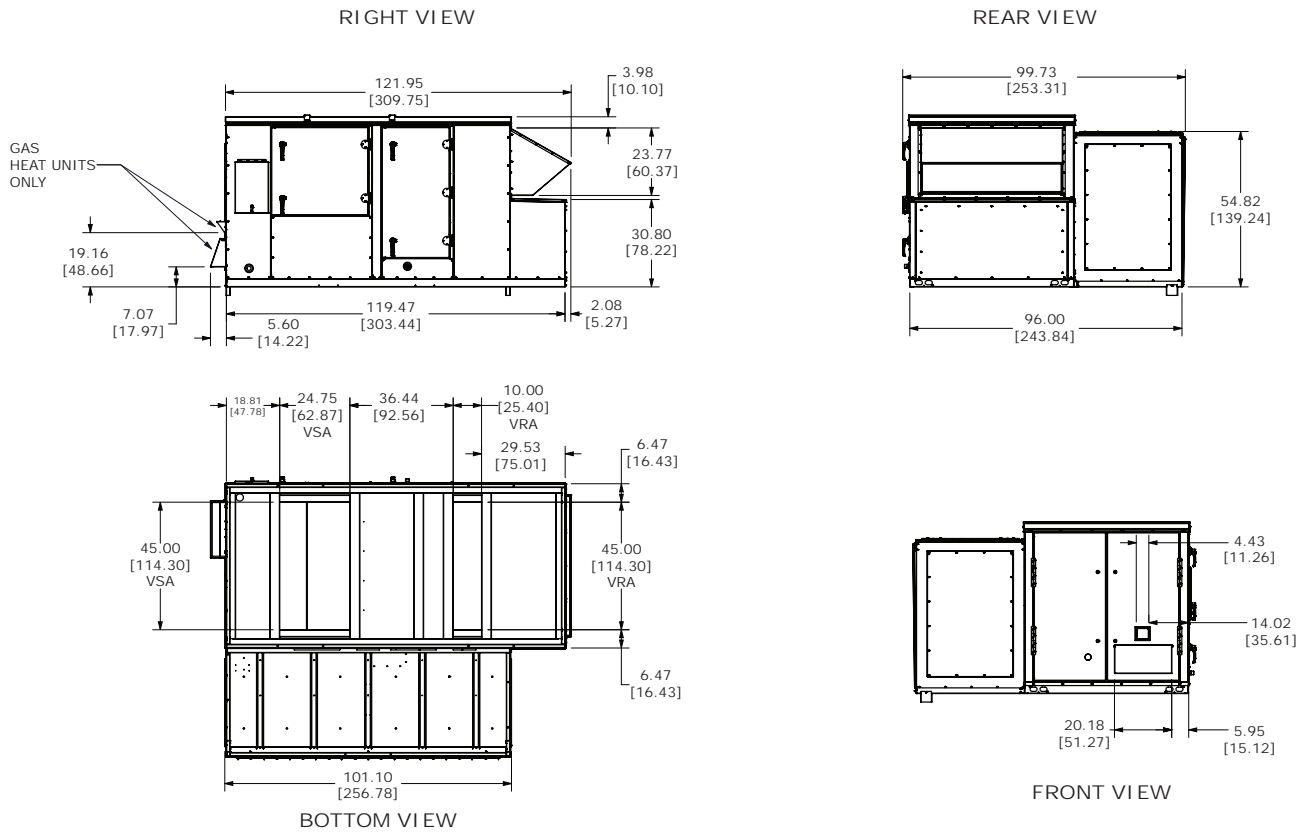



Unit Clearances, Curb Dimensions, and Dimensional Data

Figure 13. Unit dimensional data for HAE cabinet with ERV and collapsible inlet, in. (cm)

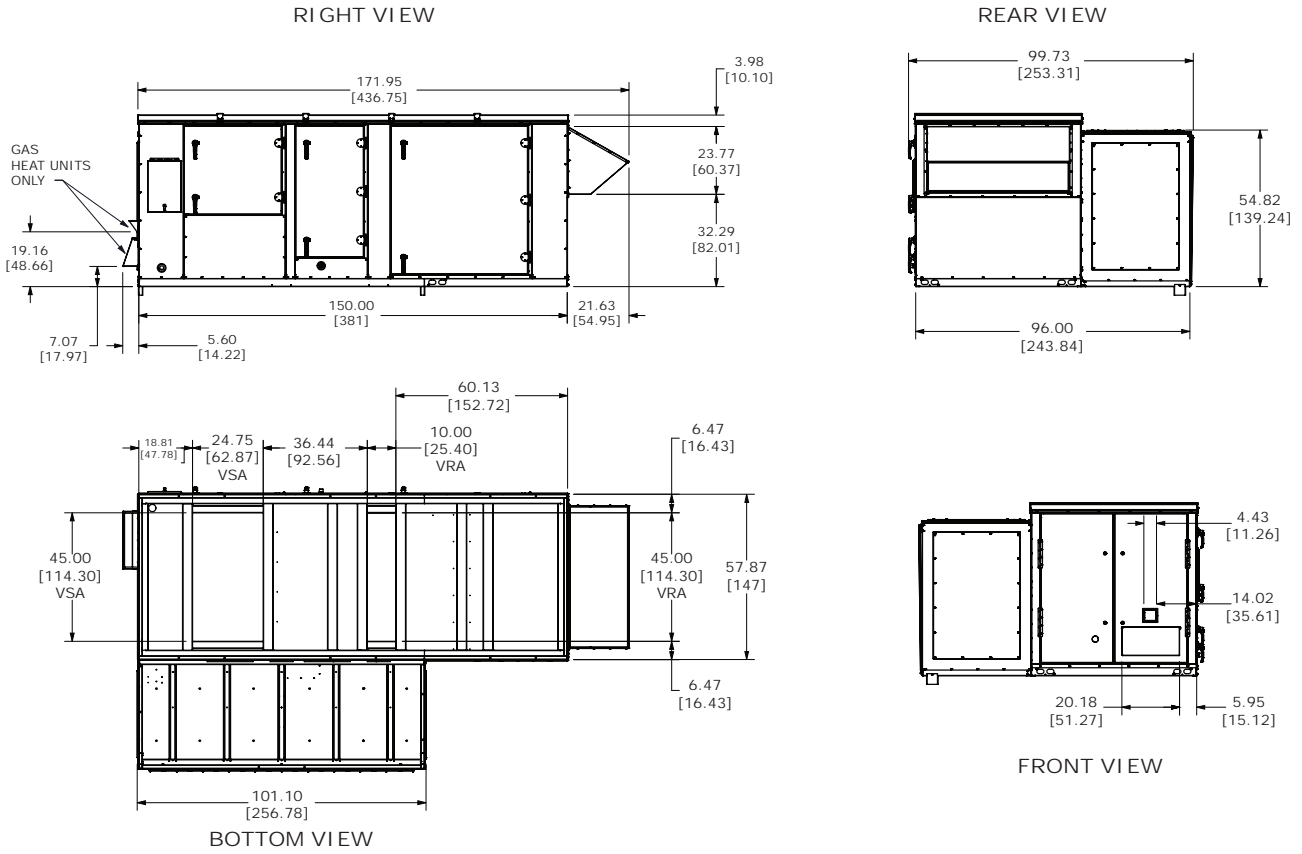

Unit Clearances, Curb Dimensions, and Dimensional Data

Figure 14. Unit dimensional data for HAE cabinet with ERV and fixed inlet

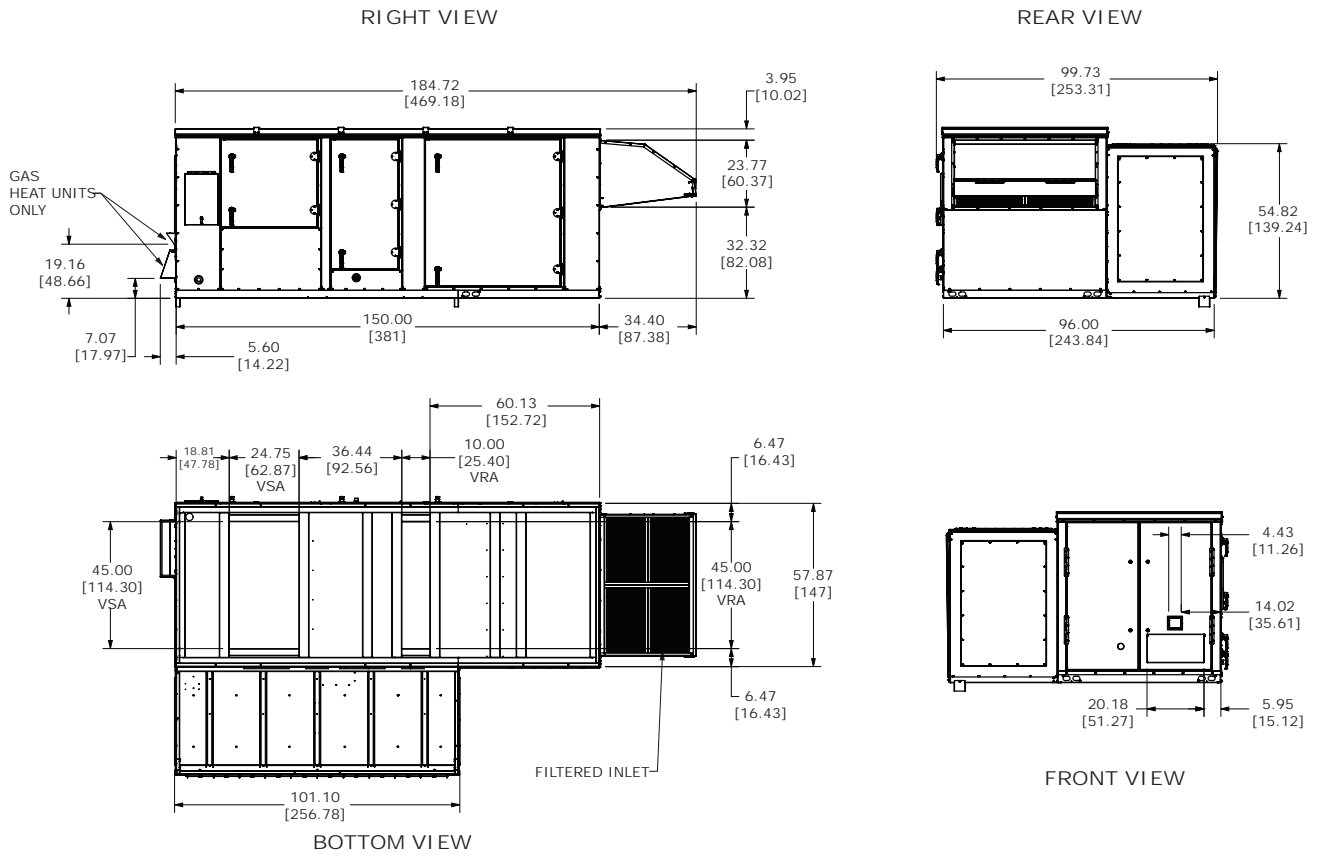



Unit Weight and Rigging

⚠ WARNING

Heavy Objects!

Failure to follow instructions below or properly lift unit could result in unit dropping and possibly crushing operator/technician which could result in death or serious injury, and equipment or property-only damage. Ensure that all the lifting equipment used is properly rated for the weight of the unit being lifted. Each of the cables (chains or slings), hooks, and shackles used to lift the unit must be capable of supporting the entire weight of the unit. Lifting cables (chains or slings) may not be of the same length. Adjust as necessary for even unit lift.

⚠ AVERTISSEMENT

Objets lourds!

Le non-respect des instructions ci-dessous ou un levage inapproprié de l'unité peut provoquer sa chute voire écraser l'opérateur/le technicien, ce qui peut occasionner des blessures graves voire mortelles, et éventuellement endommager l'équipement ou provoquer des dégâts matériels. Assurez-vous que l'équipement de levage utilisé est adapté au poids de l'unité à soulever. Chaque câble (chaîne ou élingue), crochet ou manille utilisé pour le levage de l'unité doit être assez robuste pour supporter le poids total de l'unité. Les câbles, chaînes ou élingues de levage ne doivent pas être de longueur identique. Procédez au réglage afin de soulever l'unité de manière équilibrée.

⚠ WARNING

Improper Unit Lift!

Failure to properly lift unit in a LEVEL position could result in unit dropping and possibly crushing operator/technician which could result in death or serious injury, and equipment or property-only damage. Test lift unit approximately 24 inches (61 cm) to verify proper center of gravity lift point. To avoid dropping of unit, reposition lifting point if unit is not level.

⚠ AVERTISSEMENT

Levage inapproprié de l'unité!

Le non-respect des instructions ci-dessous ou un levage inapproprié de l'unité peut provoquer sa chute voire écraser l'opérateur/le technicien, ce qui peut occasionner des blessures graves voire mortelles, et éventuellement endommager l'équipement ou provoquer des dégâts matériels. Faites un test de levage de l'unité d'environ 60 cm (24 po) afin de vérifier que le point de levage correspond au centre de gravité de l'appareil. Pour éviter une chute de celle-ci, ajustez son point de levage si elle n'est pas à l'horizontale.

Unit Weight

Table 4. Typical unit weight, center of gravity, and corner weights - air cooled units

Cabinet Type	Weight (lbs)		Center of Gravity (in.)		Corner weight (% of total weight)			
	Min	Max	Length	Width	Corner A	Corner B	Corner C	Corner D
Primary Cabinet	1794	3134	46	43	42	31	15	12
Primary Cabinet with Power Exhaust only	2038	3590	50	41	39	32	11	18
Primary Cabinet with ERV	2501	4391	68	39	35	33	11	21

Rigging

Figure 15. Four-point lift (HAE cabinet with no exhaust fan or ERV)

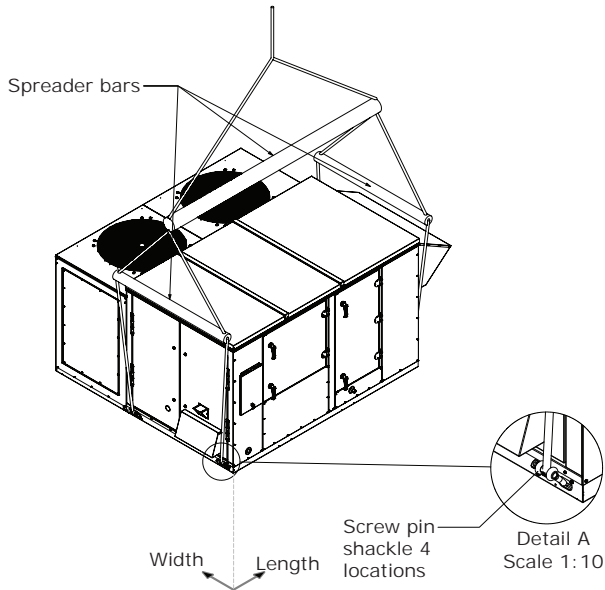

Figure 16. Four-point lift (HAE cabinet with exhaust fan and no ERV)

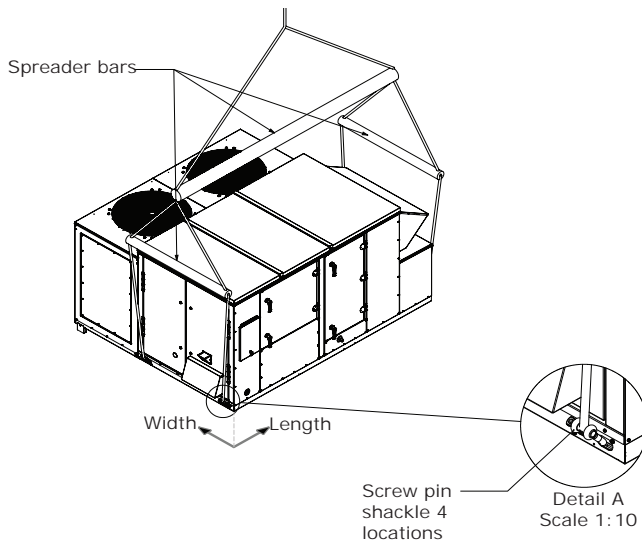
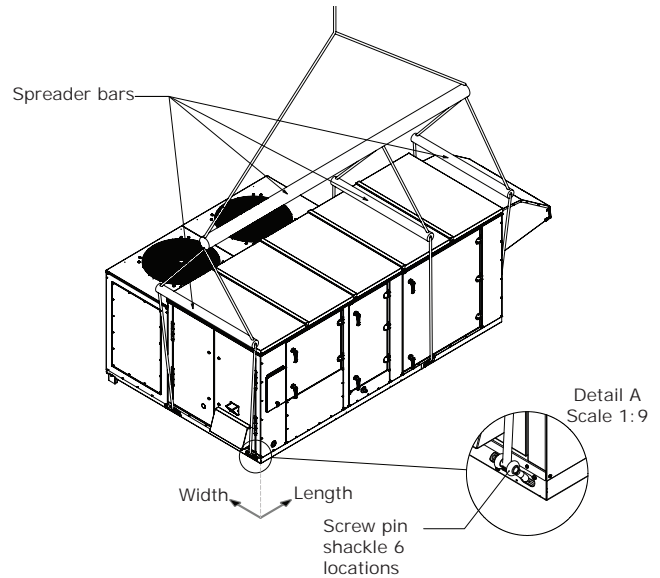

Figure 17. Six-point lift (HAE cabinet with ERV section)



Before proceeding, refer to [Figure 15 - Figure 17, p. 27](#) for rigging drawing.

1. Rig the unit as shown in [Figure 15 - Figure 17, p. 27](#). Attach adequate strength lifting slings to all lifting brackets in the unit base rail. Do not use cables, chains, or slings except as shown.
2. Install a lifting bar, as shown in [Figure 15 - Figure 17, p. 27](#), to protect the unit and to facilitate a uniform lift. The minimum distance between the lifting hook and the top of the unit should be 7 feet.
3. Test-lift the unit to ensure it is properly rigged and balanced, make any necessary rigging adjustments.
4. Lift the unit and position it into place. Remove fork pockets prior to setting on the curb.
5. Downflow units; align the base rail of the unit with the curb rail while lowering the unit onto the curb. Make sure that the gasket on the curb is not damaged while positioning the unit.

Installation

⚠ WARNING

Hazardous Service Procedures!

Failure to follow all precautions in this manual and on the tags, stickers, and labels could result in death or serious injury.

Technicians, in order to protect themselves from potential electrical, mechanical, and chemical hazards, **MUST** follow precautions in this manual and on the tags, stickers, and labels, as well as the following instructions: Unless specified otherwise, disconnect all electrical power including remote disconnect and discharge all energy storing devices such as capacitors before servicing. Follow proper lockout/tagout procedures to ensure the power can not be inadvertently energized. When necessary to work with live electrical components, have a qualified licensed electrician or other individual who has been trained in handling live electrical components perform these tasks.

⚠ AVERTISSEMENT

Procédures d'entretien dangereuses!

Le non-respect de toutes les précautions contenues dans ce manuel ainsi que sur les étiquettes et les autocollants peut entraîner des blessures graves voire mortelles.

Les techniciens, afin d'être protégés des éventuels risques électriques, mécaniques et chimiques, **DOIVENT** suivre les précautions contenues dans ce manuel, sur les étiquettes et les autocollants, ainsi que les instructions suivantes : Sauf indication contraire, coupez toute l'alimentation électrique y compris les disjoncteurs à distance et déchargez tous les dispositifs de stockage d'énergie comme les condensateurs avant l'entretien. Respectez les procédures de verrouillage et d'étiquetage appropriées pour éviter tout risque de remise sous tension accidentelle. S'il est nécessaire de travailler avec des composants électriques sous tension, demandez à un électricien qualifié et agréé ou à une autre personne ayant la formation nécessaire pour manipuler des composants électriques sous tension d'exécuter ces tâches.

Ductwork

Elbows with turning vanes or splitters are recommended to minimize air noise due to turbulence and to reduce static pressure.

When attaching the ductwork to the unit, provide a water-tight flexible connector at the unit to prevent operating sounds from transmitting through the ductwork.

All outdoor ductwork between the unit and the structure should be weather proofed after installation is completed.

Note: For sound consideration, cut holes in the roof deck only for the ductwork penetrations. Do not cut out the roof

deck within the entire curb perimeter. All duct work must be installed and connected to top of roof curb before the unit is set on curb.

If a Curb Accessory Kit is not used:

1. Be sure to use flexible duct connections at the unit.
2. Gaskets must be installed around the curb perimeter flange and the supply and return air opening flanges.

Figure 18. Primary heating position

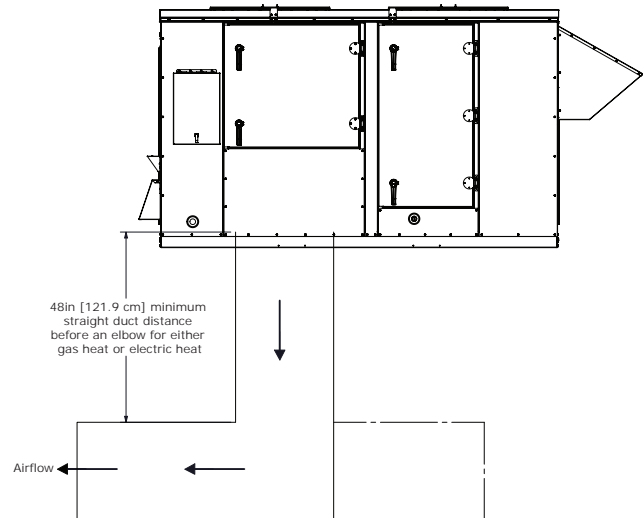

Electric Heat

Bottom discharge units with open coil electric heater in primary heat location requires discharge ductwork with 90 degree elbow. The ductwork must have a minimum of 48 inches straight length before elbow as shown in Figure above. Ductwork must have a 1-inch clearance from combustible materials or be covered with 1 inch non-combustible insulation. These are MANDATORY installation requirements.

General Unit Requirements

The checklist listed below is a summary of the steps required to successfully install a commercial unit. This checklist is intended to acquaint the installing personnel with what is required in the installation process. **It does not replace the detailed instructions called out in the applicable sections of this manual.**

- Check the unit for shipping damage and material shortage. File a freight claim and notify appropriate sales representative if damage or shortage is discovered.
- Verify that the unit nameplate model, options, and voltage are correct.
- Verify that the installation location of the unit will provide the required clearance for proper operation.

- ❑ Assemble and install the roof curb (if applicable). Refer to the latest edition of the curb installers guide that ships with each curb kit. Check curb for level installation; if not level, shim as required.
- ❑ Rigging unit (refer to “Unit Weight and Rigging,” p. 26).
- ❑ Set the unit onto the curb; check for level.
- ❑ Ensure unit-to-curb seal is tight and without buckles or cracks.
- ❑ Install and connect proper condensate drain line to the evaporator condensate pan drain connection (see Figure 19, p. 29).
- ❑ When installed, the appliance must be electrically grounded in accordance with local codes, or in the absence of local codes, with the National Electrical Code, ANSI/NFPA 70, and/or the Canadian Electrical Code, CSA C22.1, if an external electrical source is utilized.

Main Electrical Power Requirements

- ❑ Verify that the power supply complies with the unit nameplate specifications.
- ❑ Inspect all control panel components; tighten any loose connections.
- ❑ Connect properly sized and protected power supply wiring to a field-supplied/-installed disconnect switch and to the main power terminal block (HTB1) in the unit control panel.
- ❑ Connect properly-sized earth ground.

Note: All field-installed wiring must comply with NEC and applicable local codes.

Condensate Drain Configuration

Horizon Flex units are selected based on dehumidification capability. As such, condensate can form at a high rate. Therefore, the Horizon Flex drain pan and condensate line are sized and designed accordingly. However, an often-overlooked element of proper condensate drainage is proper P-Trap and drain line sizing and installation. An incorrectly-designed and -installed P-Trap can restrict condensate flow or cause water in the condensate drain pan to “spit” or “geyser” which may cause condensate overflow. Carefully install and trap the drain pan to ensure adequate condensate removal under all conditions.

An evaporator condensate drain connection is provided on each unit. Refer to Figure 21, p. 30 for the appropriate drain location.

A condensate trap must be installed at the unit due to the drain connection being on the “negative pressure” side of the fan. Install the P-Trap using the guidelines in Figure 19.

Pitch drain lines connected to P-Trap at least 1/2-inch for every 10 feet of horizontal run to assure proper condensate flow. Do not allow the horizontal run to sag causing a possible double-

trap condition which could result in condensate backup due to “air lock”.

Figure 19. Condensate trap installation

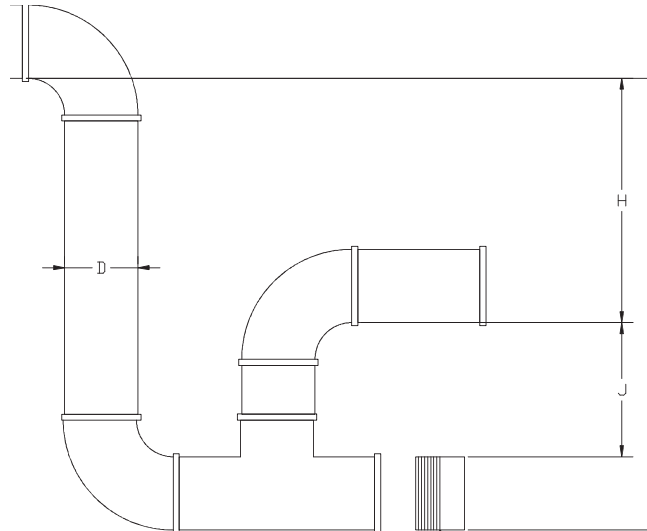

D = Pipe diameter; refer to Figure 21, p. 30 for correct pipe diameter
H = Internal static pressure (in wg) +1 inch
J = H x 0.5
L = H + J + D

Notes:

1. Pitch drain at least 1/2-inch per 10 feet horizontal run.
2. Condensate drain pan will not drain properly if P-trap is not primed and of adequate height to allow for cabinet operating negative pressure.

Filter Installation

Filters accessible through evaporator coil compartment door and or ERV wheel compartment door. Filter type, size, and quantity are determined by selected filter option and unit size.

Note: Do not operate the unit without filters.

Field Installed Power Wiring

⚠ WARNING

Proper Field Wiring and Grounding Required!

Failure to follow code could result in death or serious injury.

All field wiring MUST be performed by qualified personnel. Improperly installed and grounded field wiring poses FIRE and ELECTROCUTION hazards. To avoid these hazards, you MUST follow requirements for field wiring installation and grounding as described in NEC and your local/state/national electrical codes.

⚠️ AVERTISSEMENT

Câblage sur site et mise à la terre corrects nécessaires!

Le non-respect de la réglementation peut entraîner des blessures graves, voire mortelles. Il est **IMPÉRATIF** de confier l'ensemble du câblage sur site à un électricien qualifié. Un câblage sur site mal installé ou mal mis à la terre constitue des risques D'INCENDIE et D'ÉLECTROCUTION. Pour éviter ces risques, il est **IMPÉRATIF** de respecter les obligations en matière de pose de câblage sur site et de mise à la terre tel que stipulé dans les règles du NEC et dans les réglementations électriques locales/nationales.

An overall dimensional layout for the standard field installed wiring entrance into the unit is illustrated in [Figure 21, p. 30](#). To ensure that the unit's supply power wiring is properly sized and installed, refer to the following guidelines.

Figure 20. HAE power entrance

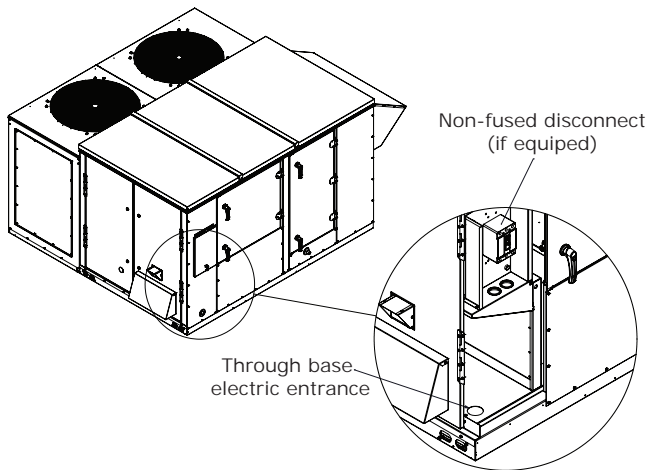
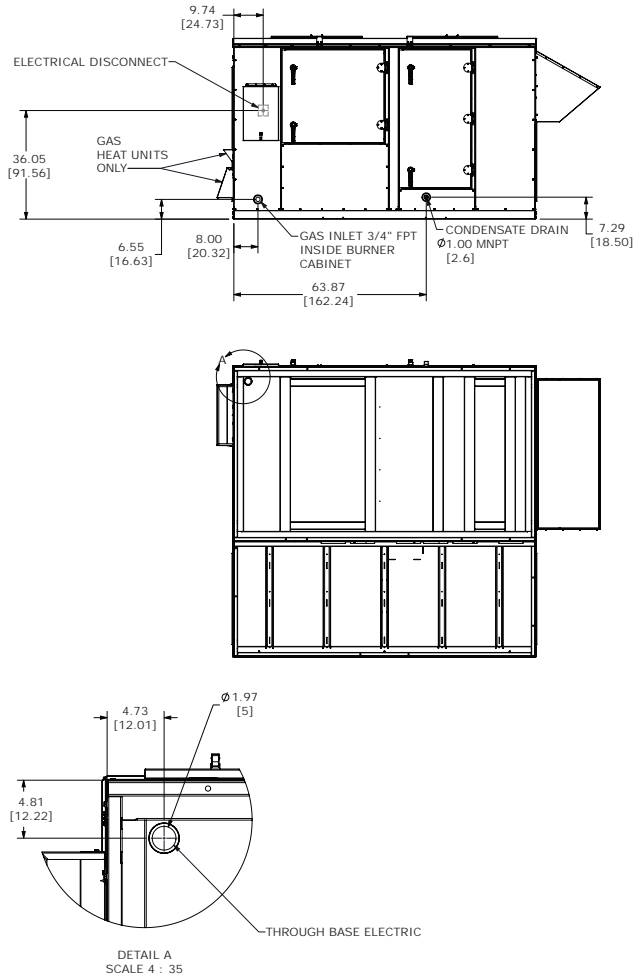

Figure 21. HAE utility connections, in. (cm)



Note: All field installed wiring must conform to NEC guidelines as well as State and Local codes.

Verify that the power supply available is compatible with the unit's nameplate ratings. The available supply power must be within 10 percent of the rated voltage stamped on the nameplate. Use only copper conductors to connect the power supply to the unit.

Main Unit Power

⚠ WARNING

Hazardous Voltage!

Failure to disconnect power before servicing could result in death or serious injury. Disconnect all electric power, including remote disconnects before servicing. Follow proper lockout/tagout procedures to ensure the power can not be inadvertently energized. Verify that no power is present with a voltmeter.

⚠ AVERTISSEMENT

Risque d'électrocution!

Le non-respect de cette consigne peut entraîner des blessures graves, voire mortelles. Avant toute intervention, coupez l'alimentation électrique, y compris aux sectionneurs à distance. Suivez scrupuleusement les procédures de verrouillage/mise hors service préconisées pour empêcher tout rétablissement accidentel de l'alimentation électrique.

NOTICE

Use Copper Conductors Only!

Failure to use copper conductors could result in equipment damage as the equipment was not designed or qualified to accept other types of conductors.

Standard Wiring

⚠ WARNING

Proper Field Wiring and Grounding Required!

Failure to follow code could result in death or serious injury. All field wiring **MUST** be performed by qualified personnel. Improperly installed and grounded field wiring poses **FIRE** and **ELECTROCUTION** hazards. To avoid these hazards, you **MUST** follow requirements for field wiring installation and grounding as described in **NEC** and your local/state/national electrical codes.

⚠ AVERTISSEMENT

Câblage sur site et mise à la terre corrects nécessaires!

Le non-respect de la réglementation peut entraîner des blessures graves, voire mortelles. Il est **IMPÉRATIF** de confier l'ensemble du câblage sur site à un électricien qualifié. Un câblage sur site mal installé ou mal mis à la terre constitue des risques **D'INCENDIE** et **D'ÉLECTROCUTION**. Pour éviter ces risques, il est **IMPÉRATIF** de respecter les obligations en matière de pose de câblage sur site et de mise à la terre tel que stipulé dans les règles du **NEC** et dans les réglementations électriques locales/nationales.

The electrical service must be protected from over current and short circuit conditions in accordance with NEC requirements. Protection devices must be sized according to the electrical data on the nameplate.

1. Location of the applicable electrical service entrance is illustrated in [Figure 21, p. 30](#). Complete the unit's power wiring connections onto either; the main terminal block HTB1 inside the unit control panel, the factory mounted non-fused disconnect switch (UCD) or circuit breaker (UCB), or the electric heat non-fused disconnect switch. Refer to the customer connection diagram that shipped with the unit for specific termination points.
2. Provide proper grounding for the unit in accordance with local and national codes.

Use the following checklist in conjunction with the checklist in "[General Unit Requirements](#)," p. 28 to ensure that the unit is properly installed and ready for operation.

- Verify that the correct size and number of filters are in place.
- Inspect the interior of the unit for tools and debris and install all panels in preparation for starting the unit.
- Check all electrical connections for tightness and "point of termination" accuracy.
- Verify condenser airflow is unobstructed.
- Verify that the condenser and indoor fans turn freely without rubbing and are properly tightened on the shafts.
- Check motor mounting bolts and inlet cone for tightness. Free spin wheel by hand to check for proper alignment of motor, wheel, and inlet cone. Record motor nameplate amps at unit-rated voltage.
- Check proper indoor fan wheel rotation. Wheel housing will be marked to indicate direction of proper rotation.
- With access doors closed and secured, operate blower at 100 percent speed. Check amp readout of amps output to indoor fan at VFD display to confirm operation within motor amp capacity.



Voltage Imbalance

⚠ WARNING

Live Electrical Components!

Failure to follow all electrical safety precautions when exposed to live electrical components could result in death or serious injury.

When it is necessary to work with live electrical components, have a qualified licensed electrician or other individual who has been properly trained in handling live electrical components perform these tasks.

⚠ AVERTISSEMENT

Composants électriques sous tension!

Le non-respect de toutes les consignes de sécurité lors de la manipulation de composants électriques sous tension peut entraîner des blessures graves, voire mortelles. S'il est nécessaire de travailler avec des composants électriques sous tension, demandez à un électricien qualifié et agréé ou à une autre personne ayant la formation nécessaire pour manipuler des composants électriques sous tension d'exécuter ces tâches.

Three phase electrical power to the unit must meet stringent requirements for the unit to operate properly. Measure each leg (phase-to-phase) of the power supply. Each reading must fall within the utilization range stamped on the unit nameplate. If any of the readings do not fall within the proper tolerances, notify the power company to correct this situation before operating the unit.

Excessive three phase voltage imbalance between phases will cause motors to overheat and eventually fail. The maximum allowable voltage imbalance is 2.0 percent. Measure and record the voltage between phases 1, 2, and 3 and calculate the amount of imbalance as follows:

$$\% \text{ Voltage Imbalance} = 100 \times \frac{AV - VD}{AV} \text{ where;}$$

$$AV \text{ (Average Voltage)} = \frac{\text{Volt 1} + \text{Volt 2} + \text{Volt 3}}{3}$$

V1, V2, V3 = Line Voltage Readings

VD = Line Voltage reading that deviates the farthest from the average voltage.

Example: If the voltage readings of the supply power measured 221, 230, and 227, the average volts would be:

$$\frac{221 + 230 + 227}{3} = 226 \text{ Avg.}$$

VD (reading farthest from average) = 221

The percentage of Imbalance equals:

$$100 \times \frac{226 - 221}{226} = 2.2\%$$

The 2.2 percent imbalance in this example exceeds the maximum allowable imbalance of 2.0 percent. This much imbalance between phases can equal as much as a 20 percent current imbalance with a resulting increase in motor winding temperatures that will decrease motor life. If the voltage imbalance is over 2.0 percent, notify the proper agencies to correct the voltage problem before operating this equipment.

Electrical Phasing (Three-Phase Motors)

⚠ WARNING

Live Electrical Components!

Failure to follow all electrical safety precautions when exposed to live electrical components could result in death or serious injury.

When it is necessary to work with live electrical components, have a qualified licensed electrician or other individual who has been properly trained in handling live electrical components perform these tasks.

⚠ AVERTISSEMENT

Composants électriques sous tension!

Le non-respect de toutes les consignes de sécurité lors de la manipulation de composants électriques sous tension peut entraîner des blessures graves, voire mortelles. S'il est nécessaire de travailler avec des composants électriques sous tension, demandez à un électricien qualifié et agréé ou à une autre personne ayant la formation nécessaire pour manipuler des composants électriques sous tension d'exécuter ces tâches.

The compressor motor(s) and the supply fan motor are internally connected for the proper rotation when the incoming power supply is phased as A to L1, B to L2, and C to L3.

Proper electrical supply phasing can be quickly determined and corrected before starting the unit by using an instrument such as an Associated Research Model 45 Phase Sequence Indicator and following these steps:

- Turn off the main source feeding power to the unit field-supplied or factory-installed main disconnect device (switch or circuit breaker).
- Close the unit disconnect device cover, leaving disconnect switch in the off position, and turn main source power on.

- Observe the ABC and CBA phase indicator lights on the face of the sequencer. The ABC indicator light will glow if the phase is ABC. If the CBA indicator light glows, turn main source power off and then open the unit main disconnect device cover and reverse any two power wires.
- Restore the main source power and recheck the phasing. If the phasing is correct, turn main source power off then open the unit main disconnect device cover, remove the phase sequence indicator, reinstall disconnect device cover and, leaving disconnect device in the off position, turn main power source to unit on.

Compressor Crankcase Heaters

⚠ WARNING

Live Electrical Components!

Failure to follow all electrical safety precautions when exposed to live electrical components could result in death or serious injury.

When it is necessary to work with live electrical components, have a qualified licensed electrician or other individual who has been properly trained in handling live electrical components perform these tasks.

⚠ AVERTISSEMENT

Composants électriques sous tension!

Le non-respect de toutes les consignes de sécurité lors de la manipulation de composants électriques sous tension peut entraîner des blessures graves, voire mortelles. S'il est nécessaire de travailler avec des composants électriques sous tension, demandez à un électricien qualifié et agréé ou à une autre personne ayant la formation nécessaire pour manipuler des composants électriques sous tension d'exécuter ces tâches.

To prevent injury or death from electrocution, it is the responsibility of the technician to recognize this hazard and use extreme care when performing service procedures with the electrical power energized.

Each compressor shall be equipped with a crankcase heater. The proper operation of the crankcase heater is important to maintain an elevated compressor oil temperature during the "Off" cycle to reduce oil foaming during compressor starts. Oil foaming occurs when refrigerant condenses in the compressor and mixes with the oil. In lower ambient conditions, refrigerant migration to the compressor could increase.

Note: Variable speed compressor will not be equipped with crank case heater.

When the compressor starts, the sudden reduction in crankcase pressure causes the liquid refrigerant to boil rapidly causing the oil to foam. This condition could damage compressor bearings due to reduced lubrication and could cause compressor mechanical failures.

Before initial start up, or if main power has been off for an extended period of time, compressor crankcase heater(s) should be operated for a minimum of 8 hours prior to compressor operation. With main power OFF, remove jumper between OAUTS terminals 9 and 10 (E-Stop). Turn main power to energize crankcase heater(s). At end of warm up period turn main power off, install 9-10 jumper, turn main power on, and resume normal operation.

Following crankcase heater warm-up, turn main power disconnect off, and install jumper on E-Stop terminals 9 and 10.

Turn Main disconnect "On".

Main Unit Display and Microprocessor Controller

When first powered On, the controls perform self-diagnostic initialization to check that all internal controls are functional. The status LED located on the Main Unit Display and the Green System LED located on the RTRM module are turned On within one second of power-up if internal operation is okay.

Field-Installed Control Wiring

⚠ WARNING

Proper Field Wiring and Grounding Required!

Failure to follow code could result in death or serious injury.

All field wiring MUST be performed by qualified personnel. Improperly installed and grounded field wiring poses FIRE and ELECTROCUTION hazards. To avoid these hazards, you MUST follow requirements for field wiring installation and grounding as described in NEC and your local/state/national electrical codes.

⚠ AVERTISSEMENT

Câblage sur site et mise à la terre corrects nécessaires!

Le non-respect de la réglementation peut entraîner des blessures graves, voire mortelles. Il est IMPÉRATIF d confier l'ensemble du câblage sur site à un électricien qualifié. Un câblage sur site mal installé ou mal mis à la terre constitue des risques D'INCENDIE et D'ÉLECTROCUTION. Pour éviter ces risques, il est IMPÉRATIF de respecter les obligations en matière de pose de câblage sur site et de mise à la terre tel que stipulé dans les règles du NEC et dans les réglementations électriques locales/nationales.

An overall layout of the various control options available with the required number of conductors for each control device is illustrated in [Figure 22, p. 35](#).

Note: All field wiring must conform to NEC guidelines as well as state and local codes.

Control Power Transformer

⚠ WARNING

Hazardous Voltage!

Failure to disconnect power before servicing could result in death or serious injury. Disconnect all electric power, including remote disconnects before servicing. Follow proper lockout/tagout procedures to ensure the power can not be inadvertently energized. Verify that no power is present with a voltmeter.

⚠ AVERTISSEMENT

Risque d'électrocution!

Le non-respect de cette consigne peut entraîner des blessures graves, voire mortelles. Avant toute intervention, coupez l'alimentation électrique, y compris aux sectionneurs à distance. Suivez scrupuleusement les procédures de verrouillage/mise hors service préconisées pour empêcher tout rétablissement accidentel de l'alimentation électrique.

The 24-volt control power transformers are to be used only with the accessories called out in this manual.

Controls Using 24 Vac

⚠ WARNING

Hazardous Voltage!

Failure to disconnect power before servicing could result in death or serious injury. Disconnect all electric power, including remote disconnects before servicing. Follow proper lockout/tagout procedures to ensure the power can not be inadvertently energized. Verify that no power is present with a voltmeter.

⚠ AVERTISSEMENT

Risque d'électrocution!

Le non-respect de cette consigne peut entraîner des blessures graves, voire mortelles. Avant toute intervention, coupez l'alimentation électrique, y compris aux sectionneurs à distance. Suivez scrupuleusement les procédures de verrouillage/mise hors service préconisées pour empêcher tout rétablissement accidentel de l'alimentation électrique.

NOTICE

Use Copper Conductors Only!

Failure to use copper conductors could result in equipment damage as the equipment was not designed or qualified to accept other types of conductors.

Before installing any connecting wiring, refer to [Figure 21, p. 30](#) for the electrical access locations provided on the unit and [Table 5](#) for AC conductor sizing guidelines, and:

1. Use copper conductors unless otherwise specified.
2. Ensure that the AC control wiring between the controls and the unit's termination point does not exceed three (3) ohms/ conductor for the length of the run.

Note: Resistance in excess of 3 ohms per conductor may cause component failure due to insufficient AC voltage supply.

3. Be sure to check all loads and conductors for grounds, shorts, and mis-wiring.
4. Do not run the AC low-voltage wiring in the same conduit with the high-voltage power wiring.

Table 5. 24 Vac conductors

Distance from Unit to Control	Recommended Wire Size
000–460 feet 000–140 m	18 gauge 0.75 mm ²
461–732 feet 104–223 m	16 gauge 1 mm ²

Controls Using DC Analog Input/Output (Standard Low Voltage Multiconductor Wire)

⚠ WARNING

Hazardous Voltage!

Failure to disconnect power before servicing could result in death or serious injury. Disconnect all electric power, including remote disconnects before servicing. Follow proper lockout/tagout procedures to ensure the power can not be inadvertently energized. Verify that no power is present with a voltmeter.

⚠ AVERTISSEMENT

Risque d'électrocution!

Le non-respect de cette consigne peut entraîner des blessures graves, voire mortelles. Avant toute intervention, coupez l'alimentation électrique, y compris aux sectionneurs à distance. Suivez scrupuleusement les procédures de verrouillage/mise hors service préconisées pour empêcher tout rétablissement accidentel de l'alimentation électrique.

Before installing any connecting wiring between the unit and components utilizing a DC analog input/output signal, refer to [Figure 21, p. 30](#) for the electrical access locations provided on the unit.

1. [Table 6](#) lists the conductor sizing guidelines that must be followed when interconnecting the DC binary output devices and the system components utilizing a DC analog input/output signal to the unit.

Note: Resistance in excess of 2.5 ohms per conductor can cause deviations in the accuracy of the controls.

2. Ensure that the wiring between controls and the unit's termination point does not exceed 2.5 ohms/conductor for the length of the run.
3. Do not run the electrical wires transporting DC signals in or around conduit housing high voltage wires.

DC Conductors

Table 6. Zone sensor module wiring

Distance from Unit to Control	Recommended Wire Size
000–150 feet 0–45.7 m	22 gauge 0.33 mm ²
151–240 feet 46–73.1 m	20 gauge 0.50 mm ²
241–385 feet 73.5–117.3 m	18 gauge 0.75 mm ²
386–610 feet 117.7–185.9 m	16 gauge 1.3 mm ²
611–970 feet 186.2–295.7 m	14 gauge 2.0 mm ²

Figure 22. OAUTS connection

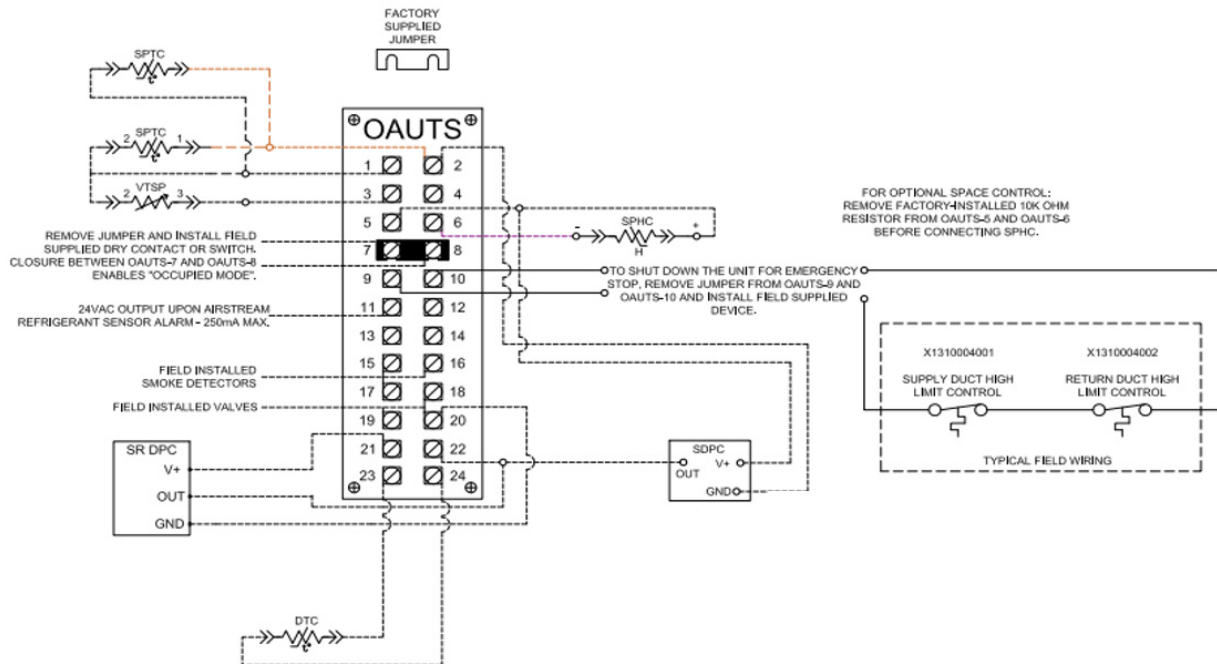

Table 7. OAUTS connection

Part Number	Name	Description
VELSEN-0021 TE-DFG-B1244-00	DTC	Discharge Air Temperature Sensor
VELCON-0976 BA/ZPM-SR-ST-D	SDPC	Supply Duct Pressure Sensor
VELSEN-0024 BAYSENS036A	SPHC	Space Humidity Sensor
VELSEN-0024 BAYSENS036A	SPTC	Space Temperature Sensor
VELCON-0976 BA/ZPM-SR-ST-D	SR DPC	Return Duct Pressure Sensor
VELSEN-0049 BAYSENS074A	VTSP	Thumbwheel Potentiometer



Factory-Provided Sensors

A discharge temperature sensor (VELSEN-0021) will be factory-provided for field installation in the supply duct. Refer to [Figure 36, p. 59](#) for installation instructions.

If space control is selected, a combination space temperature/humidity sensor (BAYSENS036A) will be factory-provided for field installation in the space. Refer to [Figure 37, p. 60](#) for installation instructions.

If multi-zone VAV control is selected, a static pressure sensor (VELCON-0976) will be factory-provided for field installation in the supply duct or space. Refer to [Figure 38, p. 61](#) for installation instructions.

If modulating OA/RA dampers w/economizer and an exhaust fan are selected, a duct static pressure sensor (VELCON-0976) will be factory-provided for field installation in the return duct. Refer to [Figure 39, p. 62](#) for installation instructions.



Pre-Start Check List

Task	Initial	Date
1. Voltage is present and landed at equipment.		
2. Gas piping is complete and landed at each component. Inlet gas pressure to be between 7 in. wc and 14 in. wc.		
3. Field installed sensors installed. Refer to "Factory-Provided Sensors," p. 36 for list of sensors that may be required.		
4. Control wiring installed and landed.		
5. Accessories installed.		
6. Ductwork installed (all runs in place, final tie in complete).		
7. Drain lines installed and properly terminated.		
8. Start-up appointment with Trane service technician set and confirmed.		

Notes:

- *Check list must be completed and returned to Trane before start-up is scheduled.*
- *Start-up must be performed by a Trane technician with Tracer® TU program.*
- *Contractor to furnish access to equipment (ladder, lift, or roof access).*



System Configuration and Pre-Start

The following procedure must be completed prior to performing the start-up procedure in *“Start-Up,” p. 41*. This section describes procedures to navigate the various displays on the Unit Display and configure the Outdoor Air Unit Main Unit Display system setpoints and operating parameters.

Important: *This section is intended to provide guidelines for navigation through the remote operator display screens. The unit is configured at the factory with the default settings as described in sequence of operation and the details concerning setup and operating setpoints.*

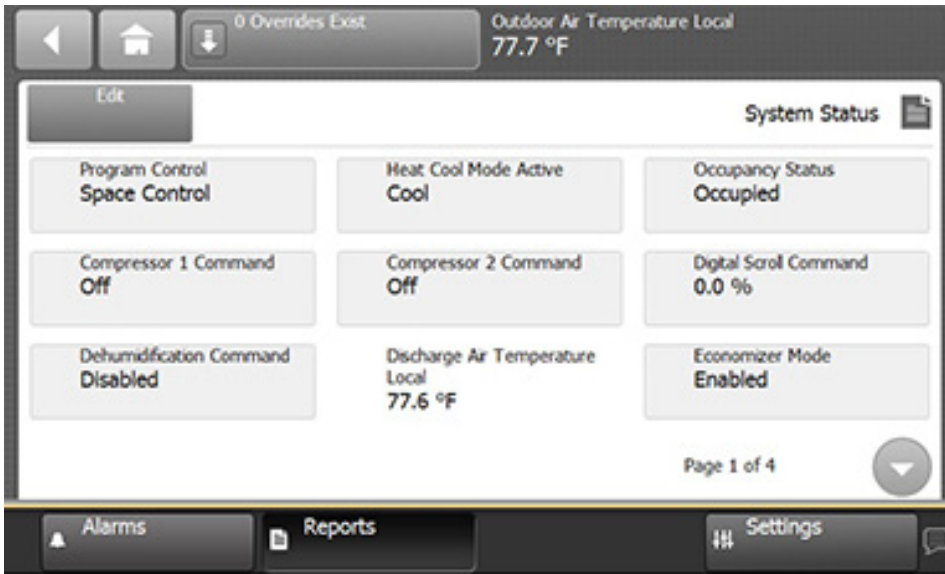

Table 8. Menu descriptions

Screen	Menu	Point List	Min/Inactive	Default	Max/Active	BAS Point?	
Alarms	Active Alarms	List of all active alarms					
	All Alarms	List of all previous alarms					
Reports (continued on next page)	Custom Graphics	*NOT USED*					
	System Status	Program Control	Discharge Air Control	Space Control	Space Control	Y	
		Heat Cool Mode Active	Heat	–	Cool	N	
		Occupancy Status	Occupied Unoccupied Occupied Bypass Occupied Standby Unknown				Y
		Compressor 1 Command	Off	–	On	N	
		Compressor 2 Command	Off	–	On	N	
		Compressor 3 Command	Off	–	On	N	
		Compressor 4 Command	Off	–	On	N	
		Digital Scroll Command	0%	–	100%	N	
		Dehumidification Command	Disabled	–	Enabled	N	
		Discharge Air Temperature Local	Analog Input				
		Economizer Mode	Disabled	–	Enabled	N	
		Evap Leaving Temp Local	Analog Input				
		Heat Capacity	0%	–	100%	N	
		Heating Output Command	0%	–	100%	N	
		Heat 1 Command	Off	–	On	N	
		Heat 2 Command	Off	–	On	N	
		Heat 3 Command	Off	–	On	N	
		Inducer Command	Off	–	On	N	
		Gas Valve Status	Binary Input				
		HGRH Command	0%	–	100%	N	
		Outdoor/Return Air Damper Command	Closed	–	Open	N	
		OAD Position Local	Binary Input				
		Outdoor Air Relative Humidity Local	Analog Input				
		Outdoor Air Temperature Local	Analog Input				
		Space Dewpoint Active	Analog Input				
		Space Temperature Local	Analog Input				
		Supply Fan Start Stop Command	Off	–	Off	N	
		Filter Status	Clean	–	Dirty	N	
		System Lockout	Normal	Normal	Lockout	N	
		UNOCC Cooling Mode	Off	–	On	N	
		UNOCC Dehumid Mode	Off	–	On	N	
		UNOCC Heating Mode	Off	–	On	N	
		ERV Command	Disable	–	Enable	N	
		ERV Leaving Air Temperature Local	Analog Input				
		PEVFD Command	0%	80%	100%	Y	
		Discharge Airflow Local	Analog Input				
		ERV Leaving Air Humidity Local	Analog Input				
		Circuit 1 Reversing Valve ^(a)	Disabled	–	Enabled	N	
		Circuit 2 Reversing Valve ^(a)	Disabled	–	Enabled	N	
		Condenser Fan Command ^(a)	Disabled	–	Enabled	N	
		OA/RA Damper Position Command	0%	–	100%	N	



System Configuration and Pre-Start

Table 8. Menu descriptions (continued)

Screen	Menu	Point List	Min/Inactive	Default	Max/Active	BAS Point?	
Reports (continued from previous page)	System Setpoints	DAT High Temp Cutout	100°F	125°F	150°F	Y	
		DAT Low Temp Cutout	35°F	35°F	50°F	Y	
		DAT Temp Cutout Time	10 min.	10 min.	25 min.	Y	
		Discharge Air Cooling Setpoint	55°F	55°F	75°F	Y	
		Discharge Air Heating Setpoint	65°F	85°F	90°F	Y	
		ERV Wheel Frost Cutout Setpoint	32°F	34°F	40°F	Y	
		EVAP Leaving Temp Setpoint	45°F	53°F	70°F	Y	
		IVFD Signal	50%	100%	100%	Y	
		Maximum Discharge Air Temperature	70°F	90°F	100°F	Y	
		Minimum Discharge Air Cooling Setpoint	40°F	50°F	65°F	Y	
		Minimum Discharge Air Heating Setpoint	50°F	55°F	60°F	Y	
		Maximum OA Damper Position	0%	100%	100%	Y	
		Minimum OA Damper Position	0%	100%	100%	Y	
		Occupied Space Cooling Setpoint	65°F	74°F	90°F	Y	
		Occupied Space Heating Setpoint	60°F	70°F	75°F	Y	
		Outdoor Air Cooling Setpoint (OACS)	70°F	75°F	85°F	Y	
		Outdoor Air Dewpoint Setpoint (OADS)	49°F	58°F	65°F	Y	
		Outdoor Air Heating Setpoint (OAHS)	40°F	70°F	70°F	Y	
		PEVFD Setpoint	0%	80%	100%	Y	
		Space Dewpoint Setpoint (SPDS)	50°F	59°F	68°F	Y	
	UNOCC Space Cooling Setpoint	60°F	80°F	90°F	Y		
	UNOCC Space Dewpoint Setpoint	49°F	65°F	68°F	Y		
	UNOCC Space Heating Setpoint	50°F	60°F	70°F	Y		
	System Setup	Program Control		Discharge Air Control	Space Control	Space Control	Y
		Compressor Count		0	0	2	N
		Heater Count		0	0	2	N
		Split Manifold Burner		Not Installed	Installed	Installed	N
		ERV Option		Not Installed	Installed	Installed	N
		Powered Exhaust Option		Not Installed	Installed	Installed	N
		Space Temp/Humidity Sensor Installed		Not Installed	Installed	Installed	N
		Heat Type		No Heat Gas Heat Electric Heat Other			N
		Alarm Reset		Off	Off	On	Y
		Auxiliary Heating Mode ^(a)		Disabled	-	Enabled	N
	Supply Fan Failure Reset		Off	Off	On	Y	
	Override Summary	List of active overrides - same as selecting Override button at top of screen					
All Point Report	List of all points (AO/AI/BO/BI/MS/etc ...) in the configuration file						
About	Controller Name listed is the version of the program installed in the UC600						
Expansion Modules	Provides status of expansion modules						
TGP2 Programs	List of all TGP2 programs loaded on the UC600						
Data Graphs	*NOT USED*						
Settings	Schedules - Refer to UC600 IOM for scheduling functions						
	Display Preferences						
	Language						
	Date and Time						
	Clean Touchscreen						

(a) Circuit 1 Reversing Valve, Circuit 2 Reversing Valve, and Auxiliary Heating Mode are only provided with ASHP units.



Start-Up

Note: Refer to “Start-Up Form Trane® Horizon™ Flex,” p. 63 for a copy of the start-up form.

Refrigeration System Setup

Upon start-up, refrigeration charge should be verified on each circuit by checking superheat and subcooling. Superheat should be measured at the suction line port nearest the compressor. Subcooling should be measured at the liquid line port nearest the TXV. All compressors on the circuit should be on at 100% when checking superheat and subcooling. It should be in range of 13-17°F for subcooling and 10-12°F for super heat. Record superheat and subcooling readings on the start-up form. If readings do not fall within the desired ranges, charge or TXV adjustments may need to be made.

Indirect Fired Gas Heating Start-Up

⚠ WARNING

Hazardous Service Procedures!

Failure to follow all precautions in this manual and on the tags, stickers, and labels could result in death or serious injury.

Technicians, in order to protect themselves from potential electrical, mechanical, and chemical hazards, **MUST** follow precautions in this manual and on the tags, stickers, and labels, as well as the following instructions: Unless specified otherwise, disconnect all electrical power including remote disconnect and discharge all energy storing devices such as capacitors before servicing. Follow proper lockout/tagout procedures to ensure the power can not be inadvertently energized. When necessary to work with live electrical components, have a qualified licensed electrician or other individual who has been trained in handling live electrical components perform these tasks.

⚠ AVERTISSEMENT

Procédures d'entretien dangereuses!

Le non-respect de toutes les précautions contenues dans ce manuel ainsi que sur les étiquettes et les autocollants peut entraîner des blessures graves voire mortelles.

Les techniciens, afin d'être protégés des éventuels risques électriques, mécaniques et chimiques, **DOIVENT** suivre les précautions contenues dans ce manuel, sur les étiquettes et les autocollants, ainsi que les instructions suivantes : Sauf indication contraire, coupez toute l'alimentation électrique y compris les disjoncteurs à distance et déchargez tous les dispositifs de stockage d'énergie comme les condensateurs avant l'entretien. Respectez les procédures de verrouillage et d'étiquetage appropriées pour éviter tout risque de remise sous tension accidentelle. S'il est nécessaire de travailler avec des composants électriques sous tension, demandez à un électricien qualifié et agréé ou à une autre personne ayant la formation nécessaire pour manipuler des composants électriques sous tension d'exécuter ces tâches.

Notes:

1. Installation of units with gas must conform with local building codes. In the absence of local building codes, installation must conform to the National Fuel Gas code, ANSI Z223.1 or in Canada, CAN/CGA-B149 Installation codes.
2. This furnace module does not have a pilot. It is equipped with a direct spark ignition device that automatically lights the gas burner. DO NOT attempt to light burners by hand.

⚠ WARNING

Explosion Hazard!

Failure to follow safe leak test procedures below could result in death or serious injury or equipment or property-only-damage.

Never use an open flame to detect gas leaks. Use a leak test solution for leak testing.

⚠ AVERTISSEMENT

Risque d'explosion!

Le non-respect des procédures d'essai d'étanchéité sûres recommandées pourrait provoquer des accidents graves, voire mortels, ou des dommages matériels. Ne vérifiez **JAMAIS** la présence de fuites de gaz avec une flamme nue. Vous devez **IMPÉRATIVEMENT** utiliser une solution de test d'étanchéité pour vérifier l'étanchéité.

3. BEFORE OPERATING, leak test all gas piping up to heater gas valve. Smell around the unit area for gas. If gas is smelled, do NOT attempt to place heater in operation until source of gas leak is identified and corrected.



Start-Up

- Use only hand force to operate the gas control lever to the ON position. NEVER use tools. If lever does not operate by hand, replace gas valve prior to starting the unit. Forcing or attempting to repair the gas valve may result in fire or explosion.
- Do not attempt to operate unit, if there is indication that any part or control has been under water. Any control or component that has been under water must be replaced prior to trying to start the unit.
- Installation is to be adjusted to obtain a temperature rise within the range specified on the unit heater rating plate.

Tools Required

- Voltage Meter (μ A)
- Amp Meter
- Gas Manometer (2)
- Temperature Probe
- Small Refrigeration Screwdriver
- 5/16-in. Nut Driver
- 3/16-in. Allen Wrench
- 3/32-in. Allen Wrench
- 1/8-in. NPT barbed pressure taps (3)
- 1/2-in. Open End Wrench

Start-Up Procedure

1. Check Inlet Gas Pressure

Check to insure the gas pressure supplied to the unit is within the pressure requirement listed on the nameplate. DO NOT expose gas controls to pressures above 1/2 psi (14 in. wc). The gas supply line should be installed with an external manual shutoff and pressure tap.

2. Verify Indoor Fan Failure Switch Operation

Indoor Fan Failure Switch (IFFS) is located in the unit electrical control compartment above the heater. Indoor fan failure switch will fail if not proven within 30 seconds of call for indoor fan-ON.

All unit air filters must be clean before proceeding to properly complete this verification.

Important: *If the unit air filters are not clean, unit performance could be affected. Remove and clean or replace air filters as required prior to proceeding with the burner pressure testing.*

In the event that the pressure switch fails to operate, check the pick-up tubes to be certain that the tubes are not obstructed and confirm that the tube connections to IFFS are tight and secure.

3. Confirm Gas Flow at Unit

⚠ WARNING

Hazardous Voltage and Gas!

Failure to turn off gas or disconnect power before servicing could result in an explosion or electrocution which could result in death or serious injury. Turn off the gas supply and disconnect all electric power, including remote disconnects, before servicing the unit. Follow proper lockout/tagout procedures to ensure the power can not be inadvertently energized.

⚠ AVERTISSEMENT

Tension dangereuse et présence de gaz!

Le non-respect de l'obligation de couper le gaz ou l'alimentation électrique avant de procéder à une opération d'entretien peut entraîner une explosion ou une électrocution pouvant résulter en des blessures graves, voire mortelles. Avant toute intervention sur l'unité, couper l'approvisionnement en gaz et l'ensemble de l'alimentation électrique, y compris les disjoncteurs à distance. Suivez scrupuleusement les procédures de verrouillage/mise hors service préconisées pour empêcher tout rétablissement accidentel de l'alimentation électrique.

Open door to unit vestibule housing the gas heater. Move gas control lever to OFF position. Remove 1/8-inch pressure taps (see [Figure 24, p. 46](#)) from both modulating and on-off sections of the split heater manifold. Install a barbed fitting in both 1/8-in. tapped holes for connection to individual gas manometers.

Note: *There is a third 1/8-in. gas pressure tap located in the pipe connecting the main valve/regulator and modulating valve. Maximum pressure into modulating valve is 5-in. The On-Off gas valve includes a regulator adjustment device that is located on the top of the valve. Use this device to regulate valve output to modulating valve as required.*

Wait 5 minutes for any gas to clear. If you smell gas, see [Step 2](#) and correct leak. If you do not smell gas or have corrected any leaks, go to [Step 4](#).

4. Burner Starting Sequence and Burner Ignition

[Figure 24, p. 46](#) illustrates indirect fired gas furnace components.

5. Main Gas Supply

Turn manual gas cock ON.

6. Split Manifold High Fire and Burner Test

Open all manual gas valves. Turn power on at unit's main disconnect switch. Open gas supply manual shut-off valve. Using unit display (or computer with Trane Tracer TU), proceed to System Status Display and Override all Compressor stages OFF, Disable Dehumidification, Disable Economizer Mode, Disable ERV. If two heaters are installed, test heating with split manifold first by overriding

burner 2 OFF. Override heating Output Command to 100.0 percent if one heater is installed and to 49 percent if two heaters are installed. Override Heat Cool Mode Active to Heat. This will enable call for heat to split manifold heater. Depending on outdoor air temperature, at time of start-up, heater high limit temperature may be exceeded causing limit switch to trip. Limit switch is auto-reset. Limit switch must be jumpered out of the circuit if OA temperature dictates.

With limit switch closed, the draft inducer will run on high speed for 10 seconds for proof of high and low airflow switch closure, then begin a 30-second pre-purge period. At the end of the pre-purge the direct spark will be energized and On-Off gas valve will open for a 5-second ignition trial. Following successful ignition, the inducer remains on high for 10-second flame stabilization, followed by 30-second warm up. Should the flame go out or the burner fail to light, an ignition retry will initiate following a 15-second inter-purge period.

Following successful ignition, manifold pressure should be 1.2 in. wc during the warm-up period. The manifold pressure will rise to 3.5 in. wc at 100 percent firing rate. Following these sequences to check low fire gas pressure for modulating section, reduce Heating Output Command to 0 percent. Inducer speed will reduce to low speed. Correct gas pressure for modulating manifold section of heater at 0 percent output signal or low fire will be 0.25 - 0.30 in. wc. For modulating sections, the outlet gas pressure from main/regulator valve into the modulating valve is 5-in. wc.

Main On-Off valves in 1/2-in gas line require 3/32-inch Allen wrench to adjust outlet gas pressure. Valves in 3/4-inch gas line require flat blade screwdriver to adjust outlet gas pressure. Following these sequences, inducer speed will reduce to low speed and will now be speed-controlled by the heater controller based on gas input to burners.

With heating command at 100 percent and with a single split manifold heater installed, the On-Off section of the heater will require the modulating section to prove ON before the On-Off section will enable. Inducer speed high at all times the On-Off section is in ignition sequence or firing. On-Off section sequence includes a 1-second ignition pre-purge followed by 4-second ignition trial. Ignition or flame failure will be followed by 30-second inter-purge for two ignition retry then 5-minute lockout period if both retry attempts fail. Correct manifold gas pressure for On-Off heater section is 3.5 in. wc.

For units including an additional separate On-Off heater, set heat command output to 49 percent to run modulating heater start-up. When complete with modulating heater start-up, increase heat output command to 100 percent to start up the second heater.

High Fire and Low Fire Adjustment

To adjust high fire or low fire setting, please refer to EXA STAR Modulating Valve document. This document will ship with all gas heat units.

Failure to Ignite

- On the initial start-up, or after unit has been off long periods of time, the first ignition trial may be unsuccessful due to need to purge air from manifold at start-up.
- If ignition does not occur on the first trial, the gas and spark are shut-off by the ignition control and the control enters an inter-purge period of 15 seconds, during which the draft inducer continues to run.
- At the end of the inter-purge period, another trial for ignition will be initiated.
- Control will initiate up to three ignition trials on a call for heat before lockout of control occurs.
- Control can be brought out of lockout by cycling call for heat at the Main Unit Display.

Prior to completing the start-up, check the appearance of the main burner flame. Refer to [Figure 23, p. 45](#) for flame characteristics of properly adjusted natural gas systems.

Start-Up Procedure for Two Stage Gas heat

1. Check Inlet Gas Pressure

Check to insure the gas pressure supplied to the unit is within the pressure requirement listed on the nameplate. DO NOT expose gas controls to pressures above 1/2 psi (14 in. wc). The gas supply line should be installed with an external manual shutoff and pressure tap.

2. Verify Indoor Fan Failure Switch Operation

Indoor Fan Failure Switch (IFFS) is located in the unit electrical control compartment above the heater. Indoor fan failure switch will fail if not proven within 30 seconds of call for indoor fan-ON.

All unit air filters must be clean before proceeding to properly complete this verification.

Important: *If the unit air filters are not clean, unit performance could be affected. Remove and clean or replace air filters as required prior to proceeding with the burner pressure testing.*

In the event that the pressure switch fails to operate, check the pick-up tubes to be certain that the tubes are not obstructed and confirm that the tube connections to IFFS are tight and secure.

3. Confirm Gas Flow at Unit

WARNING

Hazardous Voltage and Gas!

Failure to turn off gas or disconnect power before servicing could result in an explosion or electrocution which could result in death or serious injury. Turn off the gas supply and disconnect all electric power, including remote disconnects, before servicing the unit. Follow proper lockout/tagout procedures to ensure the power can not be inadvertently energized.

⚠ AVERTISSEMENT**Tension dangereuse et présence de gaz!**

Le non-respect de l'obligation de couper le gaz ou l'alimentation électrique avant de procéder à une opération d'entretien peut entraîner une explosion ou une électrocution pouvant résulter en des blessures graves, voire mortelles. Avant toute intervention sur l'unité, couper l'approvisionnement en gaz et l'ensemble de l'alimentation électrique, y compris les disjoncteurs à distance. Suivez scrupuleusement les procédures de verrouillage/mise hors service préconisées pour empêcher tout rétablissement accidentel de l'alimentation électrique.

Open door to unit vestibule housing the gas heater. Move gas control lever to OFF position. Remove 1/8-in. pressure taps (see [Figure 24, p. 46](#)) heater manifold. Install a barbed fitting in both 1/8-in. tapped holes for connection to individual gas manometers.

Wait 5 minutes for any gas to clear. If you smell gas, see [Step 2](#) and correct leak. If you do not smell gas or have corrected any leaks, go to [Step 4](#).

4. Burner Starting Sequence and Burner Ignition

[Figure 24, p. 46](#) illustrates indirect fired gas furnace components.

5. Main Gas Supply

Turn manual gas cock ON.

6. Two Stage Fire and Burner Test

Open all manual gas valves. Turn power on at unit's main disconnect switch. Open gas supply manual shut-off valve. Using unit display (or computer with Trane Tracer TU), proceed to System Status Display and Override all Compressor stages OFF, Disable Dehumidification, Disable Economizer Mode, Disable ERV. Override Heat Cool Mode Active to Heat. This will enable call for heat to the heater. Depending on outdoor air temperature, at time of start-up, heater high limit temperature may be exceeded causing limit switch to trip. Limit switch is auto-reset. Limit switch must be jumpered out of the circuit if OA temperature dictates.

With limit switch closed, the draft inducer will run on high speed for 10 seconds for proof of high and low airflow switch closure, then begin a 30-second pre-purge period. At the end of the pre-purge the direct spark will be energized and On-Off gas valve will open for a 5-second ignition trial. Following successful ignition, the inducer remains on high for 10-second flame stabilization, followed by 30-second warm up. Should the flame go out or the burner fail to light, an ignition retry will initiate following a 15-second inter-purge period.

Following successful ignition, manifold pressure should be 1.2 in. wc during the warm-up period. The manifold pressure will decrease to 3.5 in. wc at high firing rate. Following these sequences to check high fire gas pressure, turn Heat 2 Command to On. Inducer speed will

increase to high speed. Correct gas pressure for heater at low fire will be 0.40 in. wc.

Main On-Off valves in 1/2-in. gas line require 3/32-in. Allen wrench to adjust outlet gas pressure. Valves in 3/4-in. gas line require flat blade screwdriver to adjust outlet gas pressure.

High Fire and Low Fire Adjustment

To adjust high fire or low fire setting, please refer to EXA STAR Two Stage Valve document. This document will ship with all gas heat units.

Failure to Ignite

- On the initial start-up, or after unit has been off long periods of time, the first ignition trial may be unsuccessful due to need to purge air from manifold at start-up.
- If ignition does not occur on the first trial, the gas and spark are shut-off by the ignition control and the control enters an inter-purge period of 15 seconds, during which the draft inducer continues to run.
- At the end of the inter-purge period, another trial for ignition will be initiated.
- Control will initiate up to three ignition trials on a call for heat before lockout of control occurs.
- Control can be brought out of lockout by cycling call for heat at the Main Unit Display.

Prior to completing the start-up, check the appearance of the main burner flame. Refer to [Figure 23, p. 45](#) for flame characteristics of properly adjusted natural gas systems.

Figure 23. Flame characteristics of properly-adjusted natural gas systems

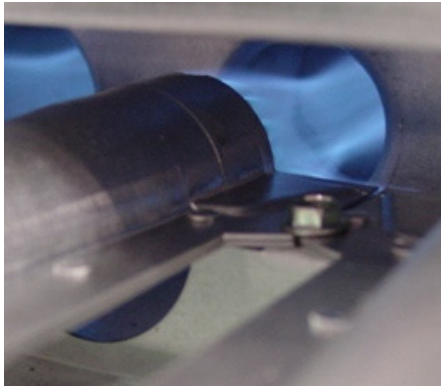

Burner flame at start-up: 1.2-in. wc manifold pressure draft inducer—high speed

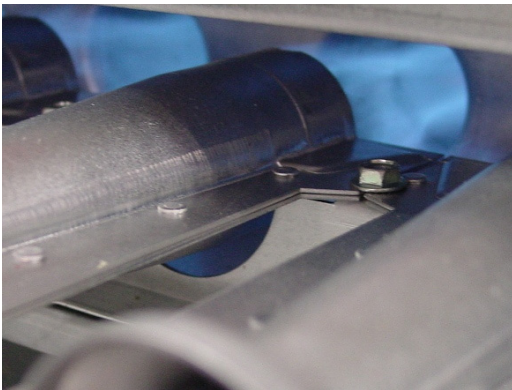

Burner flame at high fire: 3.5-in. wc manifold pressure draft inducer—high speed

Main burner flame

- The burner flame should be predominately blue in color and well defined and centered at the tube entry as shown in [Figure 23](#). Distorted flame or yellow tipping of natural gas flame, or a long yellow flame on propane, may be caused by lint and dirt accumulation inside burner or at burner ports, at air inlet between burner and manifold pipe, or debris in the main burner orifice. Soft brush or vacuum clean affected areas.
- Poorly defined, substantially yellow flames, or flames that appear lazy, indicate poor air supply to burners or excessive burner input. Verify gas supply type and manifold pressure with rating plate.
- Poor air supply can be caused by obstructions or blockage in heat exchanger tubes or vent discharge pipe. Inspect and clean as necessary to eliminate blockage. Vacuum any dirt or loose debris. Clean heat exchanger tubes with stiff brush. Poor flame characteristics can also be caused by flue gas recirculation into combustion air supply. If surrounding buildings or prevailing winds cause recirculation, a flue extension may be required to prevent recirculation.

Contact manufacturer prior to making any flue adjustments.

- Reduced air delivery can also be the result of inducer fan blade slippage, dirt accumulation in the fan blade or low voltage to draft inducer motor. Inspect draft fan assembly and be sure fan blade is secure to motor shaft. Check line voltage to heater.

7. Flame Sensor Current Check

NOTICE

Meter Damage!

Measuring voltage with meter connect to a circuit could result in meter damage. Do NOT measure voltage with meter connected to a circuit.

Flame current is the current which passes through the flame from the sensor to ground. A flame signal of 0.5 to 1.0 microamp (μA) is marginal. For dependable operation, a flame signal of greater than 1.0 μA is required. To measure flame current, connect a meter capable of reading micro-amp current so the flame signal will be read thru the meter's COM and μA connections. The meter should read greater than 1.0 μA .

Note: *If the meter reads below "0" on scale, meter leads are reversed; disconnect power and reconnect meter leads for proper polarity.*

Figure 24. Indirect fired gas furnace components (modulating gas heat components)

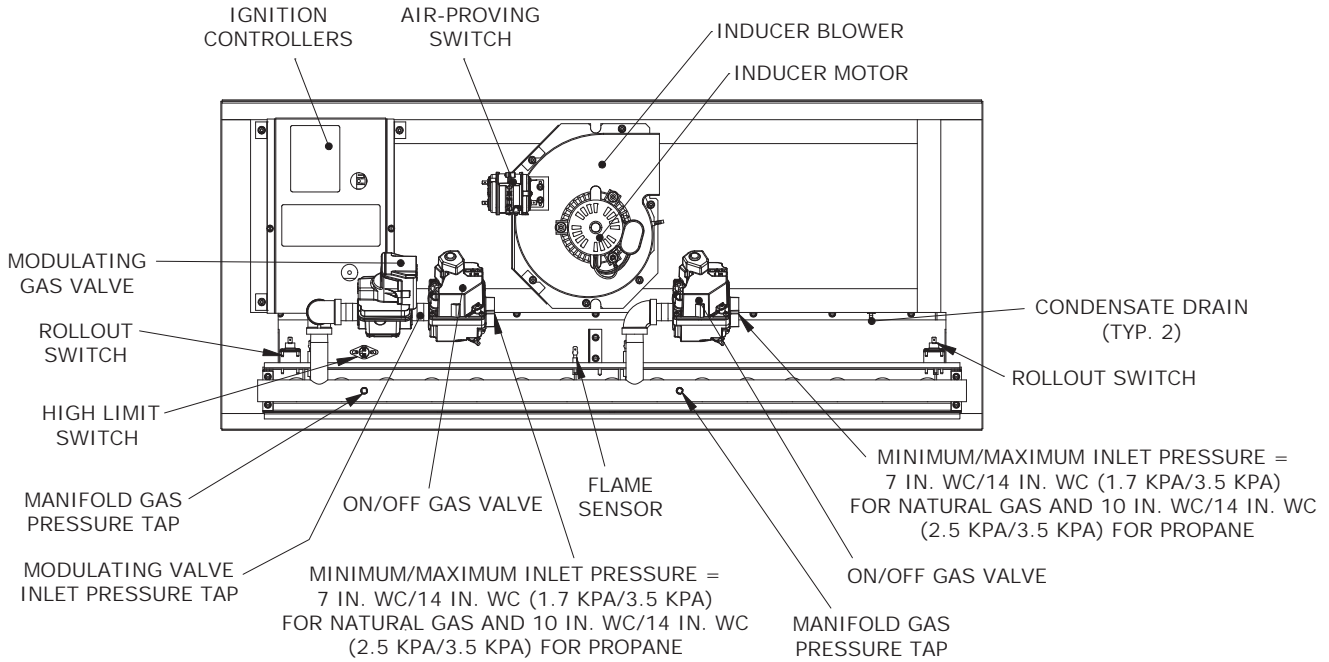
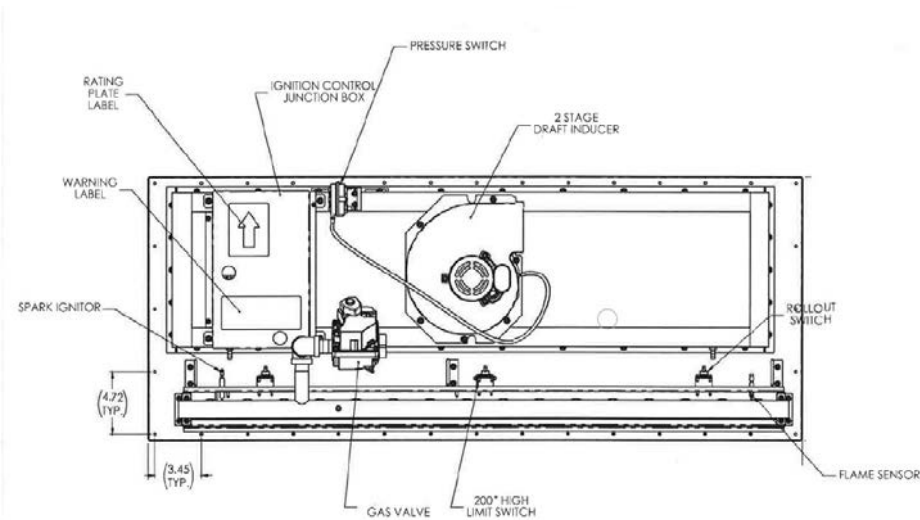

Figure 25. Two stage gas heat components



Safety Controls

Air Pressure Switch

An air pressure switch is provided as part of the control system to verify airflow through draft inducer by monitoring the difference in pressure between the draft inducer and the atmosphere. If sufficient negative pressure is not present, indicating lack of proper air movement through heat exchanger, the switch opens shutting off gas supply through the ignition control module. On units with two speed draft inducer operation, a dual air pressure switch is used, monitoring high

and low speed pressures. The air pressure switches have fixed settings and are not adjustable.

Rollout Switch (Manual Reset)

The furnace module is equipped with manual reset rollout switch(es) in the event of burner flame rollout. The switch will open on temperature rise and shut-off gas supply through the ignition control module. Flame rollout can be caused by insufficient airflow for the burner firing rate (high gas pressure), blockage of the vent system or in the heat exchanger. The furnace module should not be placed back in operation until the cause of rollout condition is identified and corrected. The

rollout switch can be reset by pressing the button on top of the switch.

High Limit Switch

The furnace module is equipped with a fixed temperature high limit switch mounted on the vestibule panel that shuts off gas to the heater through the ignition control module in the event of reduced airflow over the heat exchanger tubes. Reduced airflow can be caused by indoor fan failure, dirty or blocked filters, or restriction of the air inlet or outlet to the unit. The high limit switch will automatically reset when the air temperature drops to approximately 30°F below the limit setpoint. Determine the cause of the reduced air flow and correct.

Note: *Horizon Flex units employ Beckett HMG gas heaters and field conversion kits, and will be provided by Beckett as needed. For more information, contact technical support.*

Manual Outside Air Damper Adjustment Instructions

1. Remove the screws as shown in [Figure 26](#), [Figure 27](#), and [Figure 28](#).

Figure 26. Screws removal

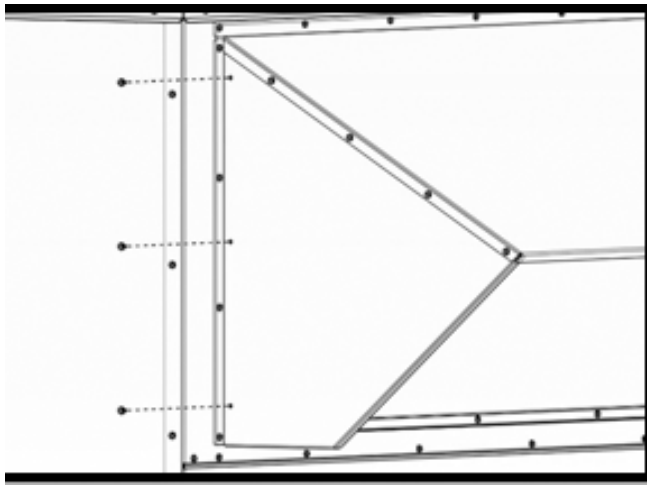

Figure 27. Screws removal

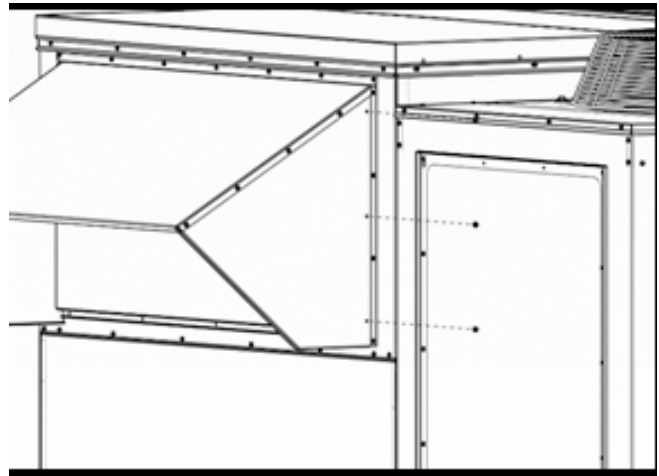
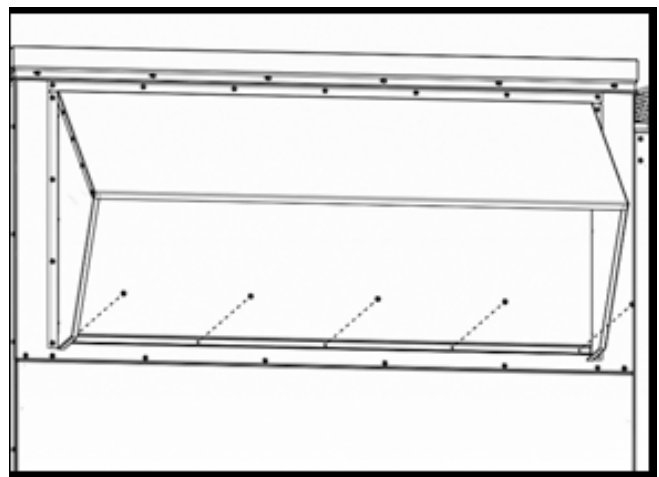
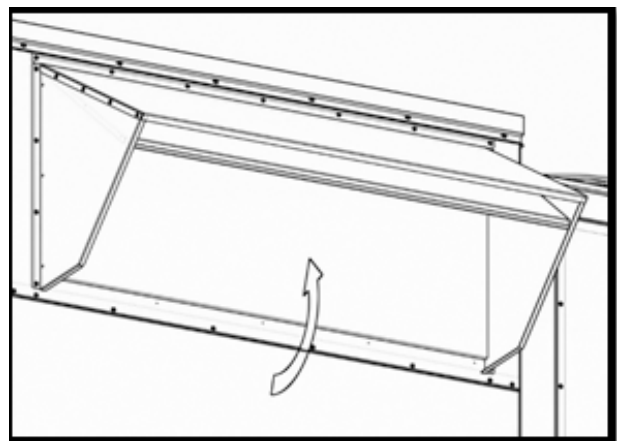

Figure 28. Screws removal



2. Open the damper to desired position as shown in [Figure 29](#).

Figure 29. Damper position



Start-Up

3. Secure the damper at desired position with screws on each side as shown in [Figure 30](#) and [Figure 31](#).

Figure 30. Damper position with screws

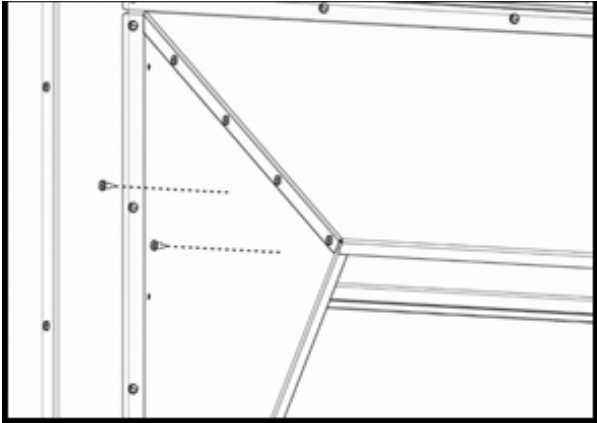
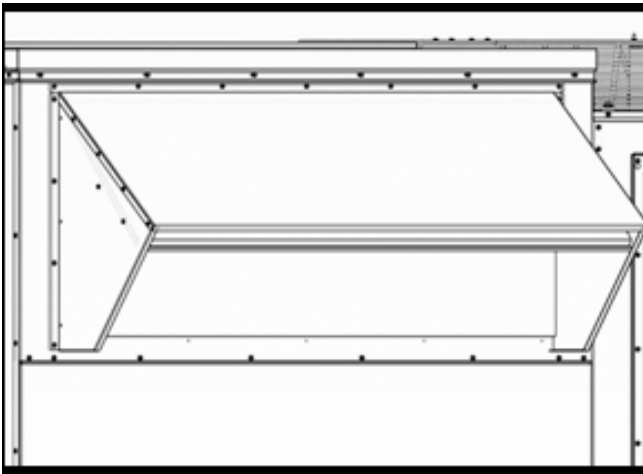

Figure 31. Securing damper at desired position





Maintenance

Make sure all personnel are standing clear of the unit before proceeding. The system components will start when the power is applied.

Monthly Maintenance

Before completing the following checks, turn the unit OFF and lock the main power disconnect switch open.

⚠ WARNING

Hazardous Voltage!

Failure to disconnect power before servicing could result in death or serious injury.

Disconnect all electric power, including remote disconnects before servicing. Follow proper lockout/tagout procedures to ensure the power can not be inadvertently energized. Verify that no power is present with a voltmeter.

⚠ AVERTISSEMENT

Risque d'électrocution!

Le non-respect de cette consigne peut entraîner des blessures graves, voire mortelles. Avant toute intervention, coupez l'alimentation électrique, y compris aux sectionneurs à distance. Suivez scrupuleusement les procédures de verrouillage/mise hors service préconisées pour empêcher tout rétablissement accidentel de l'alimentation électrique.

Filters

Return air filter inspections should take place regularly to ensure proper airflow. Dirty/clogged filters are a leading cause of poor performance. Filter replacement is dependent on the application environment and may require a more frequent replacement if the conditions are prone to cause build-up.

At a minimum, filters should be inspected and replaced as needed every three months. Refer to "Horizon Flex Filter" in "Appendix," p. 58 for exact replacement dimensions.

Note: Do not operate the unit without filters.

Supply/Return Air Smoke Detector Maintenance

Airflow through the unit is affected by the amount of dirt and debris accumulated on the indoor coil and filters.

To insure that airflow through the unit is adequate for proper sampling by the return air smoke detector, complete adherence to the maintenance procedures, including recommended intervals between filter changes, and coil cleaning is required.

Periodic checks and maintenance procedures must be performed on the smoke detector to insure that it will function properly.

For detailed instructions concerning these checks and procedures, refer to the appropriate section(s) of the smoke detector Installation and Maintenance Instructions provided with the literature package for this unit.

Cooling Season

- Check the unit's drain pans and condensate piping to ensure that there are no blockages.
- Inspect the evaporator and condenser coils for dirt, bent fins, etc. If the coils appear dirty, clean them according to the instructions described in "Condenser Coil Cleaning," p. 50.
- Manually rotate the condenser fan(s) to ensure free movement and check motor bearings for wear. Verify that all of the fan mounting hardware is tight.
- Inspect the O/A-R/A damper hinges and pins to ensure that all moving parts are securely mounted. Keep the blades clean as necessary.
- Verify that all damper linkages move freely; lubricate with white grease, if necessary.
- Check supply fan motor bearings; repair or replace the motor as necessary.
- Check the fan shaft bearings for wear. Replace the bearings as necessary.
- Verify that all wire terminal connections are tight.
- Remove any corrosion present on the exterior surfaces of the unit and repaint these areas.
- Generally inspect the unit for unusual conditions (e.g., loose access panels, leaking piping connections, etc.).
- Make sure that all retaining screws are reinstalled in the unit access panels once these checks are complete.
- Check the condition of the gasket around access doors. These gaskets must fit correctly and be in good condition to prevent air/water leaks.
- With the unit running, check and record the: ambient temperature; compressor suction and discharge pressures (each circuit); superheat (each circuit); Record this data on an "operator's maintenance log" like the one shown in Table 9, p. 52. If the operating pressures indicate a refrigerant shortage, measure the system superheat.

Note: Do not release refrigerant to the atmosphere! If adding or removing refrigerant is required, the service technician must comply with all federal, state and local laws.

Heating Season

- Inspect the unit's air filters. If necessary, clean or replace them.
- Check supply fan motor bearings; repair or replace the motor as necessary.



Maintenance

- Inspect both the main unit control panel and heat section control box for loose electrical components and terminal connections, as well as damaged wire insulation. Make any necessary repairs.
- Verify that the electric heat system operates properly.

Condensate Drain

Regular cleaning of the drain pan and condensate line will prevent debris collection and microbial growth from poor drainage. Build-up in the drain pan or p-trap would prevent adequate condensate removal impacting unit performance and can potentially cause water damage due to condensate accumulating within the unit.

To confirm proper condensate drain pipe setup, refer to ["Condensate Drain Configuration,"](#) p. 29.

Condenser Coil Cleaning

Regular coil maintenance, including annual cleaning, enhances the unit's operating efficiency by minimizing: compressor head pressure and amperage draw; evaporator water carryover; fan brake horsepower, due to increase static pressure losses; airflow reduction.

At least once each year, or more often if the unit is located in an unclean environment, clean the condenser coils using the instructions outlined below. Be sure to follow these instructions as closely as possible to avoid damaging the coils.

Microchannel (MCHE) Coils

NOTICE

Coil Damage!

Failure to follow instructions below could result in coil damage.

DO NOT use any detergents with microchannel condenser coils.

Use pressurized water or air ONLY, with pressure no greater than 600psi.

For additional information regarding the proper microchannel coil cleaning procedure, refer to service bulletin RT-SVB83-EN.*

Due to the soft material and thin walls of the MCHE coils, the traditional field maintenance method recommended for Round Tube Plate Fin (RTPF) coils does not apply to microchannel coils.

Moreover, chemical cleaners are a risk factor to MCHE due to the material of the coil. The manufacturer does not recommend the use of chemical cleaners to clean microchannel coils. Using chemical cleaners could lead to warranty claims being further evaluated for validity and failure analysis.

The recommended cleaning method for microchannel condenser coils is pressurized water or air with a non-pinpoint nozzle and an ECU of at least 180 with pressure no greater than 600 psi. To minimize the risk of coil damage, approach the cleaning of the coil with the pressure washer aimed perpendicular to the face of the coil during cleaning. Optimum

clearance between the sprayer nozzle and the microchannel coil is 1-inch to 3-inch.

⚠ WARNING

Hazardous Chemicals!

Failure to follow all safety instructions below could result in death or serious injury. Coil cleaning agents can be either acidic or highly alkaline and can burn severely if contact with skin occurs. Handle chemical carefully and avoid contact with skin. ALWAYS wear Personal Protective Equipment (PPE) including goggles or face shield, chemical resistant gloves, boots, apron or suit as required. For personal safety refer to the cleaning agent manufacturer's Materials Safety Data Sheet and follow all recommended safe handling practices.

⚠ AVERTISSEMENT

Produits chimiques dangereux!

Le non-respect de toutes les consignes de sécurité indiquées ci-après pourrait entraîner des blessures graves voire mortelles. Les agents de nettoyage pour serpentin peuvent être soit acides, soit fortement alcalins et peuvent entraîner des brûlures graves au contact de la peau. Manipulez les produits chimiques avec prudence et évitez tout contact avec la peau. Portez TOUJOURS un équipement de protection individuel (EPI), y compris des lunettes ou un masque facial, des gants résistant aux produits chimiques, des bottes, un tablier ou une combinaison conformément aux exigences. Pour la sécurité personnelle, voir les fiches de données de sécurité du fabricant pour l'agent de nettoyage et suivre toutes les pratiques de manipulation préconisées.

1. Remove enough panels from the unit to gain access to the coil.
2. Protect all electrical devices such as motors and controllers from any over spray.
3. Straighten any bent coil fins with a fin comb.

⚠ WARNING

Hazardous Pressures!

Failure to follow safety precautions below could result in coil bursting, which could result in death or serious injury. Coils contain refrigerant under pressure. When cleaning coils, maintain coil cleaning solution temperature under 150°F to avoid excessive pressure in the coil.

⚠ AVERTISSEMENT**Pressions dangereuses!**

Tout manquement aux consignes de sécurité préconisées ci-dessous risquerait d'entraîner un éclatement du serpentin susceptible de provoquer des blessures graves voire mortelles. Les serpentins contiennent du fluide frigorigène sous pression. Lors du nettoyage des serpentins, maintenez la température de l'agent de nettoyage pour serpentin à moins de 65,5 °C (150 °F) pour éviter toute pression excessive dans le serpentin.

4. Mix the detergent with water according to the manufacturer's instructions. If desired, heat the solution BUT DO NOT EXCEED 150°F maximum to improve its cleansing capability.
5. Pour the cleaning solution into the sprayer. If a high-pressure sprayer is used:
 - a. do not allow sprayer pressure to exceed 600 psi.
 - b. confirm that the minimum nozzle spray angle is 15°.
 - c. maintain a minimum clearance of 6-inches between the sprayer nozzle and the coil.
 - d. spray the solution perpendicular (at 90°) to the coil face.
6. Spray the leaving-airflow side of the coil first; then spray the opposite side of the coil. Allow the cleaning solution to stand on the coil for five minutes.
7. Rinse both sides of the coil with cool, clean water.
8. Inspect both sides of the coil; if it still appears to be dirty, repeat [Step 6](#) and [Step 7](#).
9. Reinstall all of the components and panels removed in [Step 1](#) and any protective covers installed in [Step 2](#).

ERV Wheel Maintenance

If the unit's ERV wheel will remain stationary for an extended period of time, even if only in storage, a manual turning should take place every 6 months. This is to avoid the risk of motor grease evaporating from lack of operation.

The energy recovery wheel and components should be inspected twice a year at a minimum or more often depending on the environment. For best performance, the following items should be inspected:

- There is no damage to the wheel or segments.
- The segments are secured with retaining latches closed.
- The wheels spins freely by hand in clockwise direction (viewed from pulley side).
- The energy transfer media is not excessively dirty or covered with build-up.
- Diameter seals are properly located and secured. The seal should just touch the energy transfer media surface.

Final Process

For future reference, you may find it helpful to record the unit data requested below in the blanks provided.



Maintenance

(1) Complete Unit Model Number:

(2) Unit Serial Number:

– connection(s)

(3) Wiring Diagram Numbers (from unit control panel)

– schematic(s)

Table 9. Sample maintenance log

Date	Current Ambient Temp F/C	Refrigerant Circuit #1						Refrigerant Circuit #2					
		Compr. Oil Level	Suct. Press. Psig/kPa	Disch. Press Psig/kPa	Liquid Press Psig/kPa	Super-heat F/C	Sub-cool F/C	Compr. Oil Level	Suct. Press. Psig/kPa	Disch. Press Psig/kPa	Liquid Press Psig/kPa	Super-heat F/C	Sub-cool F/C
		- ok - low						- ok - low					
		- ok - low						- ok - low					
		- ok - low						- ok - low					
		- ok - low						- ok - low					
		- ok - low						- ok - low					
		- ok - low						- ok - low					
		- ok - low						- ok - low					
		- ok - low						- ok - low					
		- ok - low						- ok - low					
		- ok - low						- ok - low					
		- ok - low						- ok - low					
		- ok - low						- ok - low					



General Data

Table 10. General data-cooling 10 to 15 tons standard efficiency

	10 Tons Downflow	12 Tons Downflow Units	15 Tons Downflow Units
Cooling Performance ^(a) Staged Compressor (4 ROW)			
Gross Cooling Capacity (No Heat - Electric Heat / Gas Heat)	121,000	144,000	176,000
EER ^(b) (No Heat - Electric Heat / Gas Heat)	11.2/11.0	11.0/10.8	11.0/10.8
Nominal Airflow CFM / AHRI Rated CFM	4000/3500	4800/4500	6000/4800
AHRI Net Cooling Capacity (No Heat - Electric Heat / Gas Heat)	121,000	144,000	176,000
Integrated Energy Efficiency Ratio (IEER) ^(c) (No Heat - Electric Heat / Gas Heat)	14.8/14.6	14.2/14	14.2/14
Compressor Number/Type	2/Scroll	2/Scroll	2/Scroll
Cooling Performance^(a) Variable Speed Compressor (4 ROW)			
Gross Cooling Capacity (No Heat - Electric Heat / Gas Heat)	121,000	144,000	176,000
EER ^(b) (No Heat - Electric Heat / Gas Heat)	11.2/11.0	11.0/10.8	11.0/10.8
Nominal Airflow CFM / AHRI Rated CFM	4000/3500	4800/4500	6000/4800
AHRI Net Cooling Capacity (No Heat - Electric Heat / Gas Heat)	121,000	144,000	176,000
Integrated Energy Efficiency Ratio (IEER) ^(c) (No Heat - Electric Heat / Gas Heat)	14.8/14.6	14.2/14	14.2/14
Compressor Number/Type	1/Scroll	1/Scroll	1/Scroll
Outdoor Fan			
Type	Propeller	Propeller	Propeller
Number Used/Diameter (in.)	2/30	2/30	2/30
Drive Type/No. Speeds	Direct/1	Direct/1	Direct/1
cfm	17,270	17,270	17,270
Number Motors/hp	2/1.0	2/1.0	2/1.0
Motor rpm	1,140	1,140	1,140
Indoor Fan			
Type	BI	BI	BI
Number Used/Diameter (in.)	1/(14-22)	1/(14-22)	1/(14-22)
Drive Type/No. Speeds	Direct Drive with VFD	Direct Drive with VFD	Direct Drive with VFD
Filters			
Type ^(d)	MERV8	MERV8	MERV8
Number Size Recommended	(2) 20x24x2 (2) 24x24x2	(2) 20x24x2 (2) 24x24x2	(2) 20x24x2 (2) 24x24x2
Refrigerant Charge^(e)			
Staged Scroll	16lb	17lb	19lb
Variable Speed	15lb	16lb	17lb

(a) Cooling Performance is rated at 95°F ambient, 80°F entering dry bulb, 67°F entering wet bulb. Gross capacity does not include the effect of fan motor heat. AHRI capacity is net and includes the effect of fan motor heat. Certified in accordance with the Unitary Large Equipment Certification Program, which is based on AHRI Standard 340/360.

(b) EER is rated at AHRI conditions and in accordance with AHRI Standard 340/360.

(c) Integrated Energy Efficiency Ratio (IEER) is rated in accordance with AHRI standard 340/360.

(d) MERV 13, MERV 14, and MERV 8 and 13 are selectable options.

(e) Base charge increased by 3lbs. for units selected with hot gas reheat.

Refrigeration Circuit Data

Figure 32. Refrigeration diagram: Tandem compressor without reheat

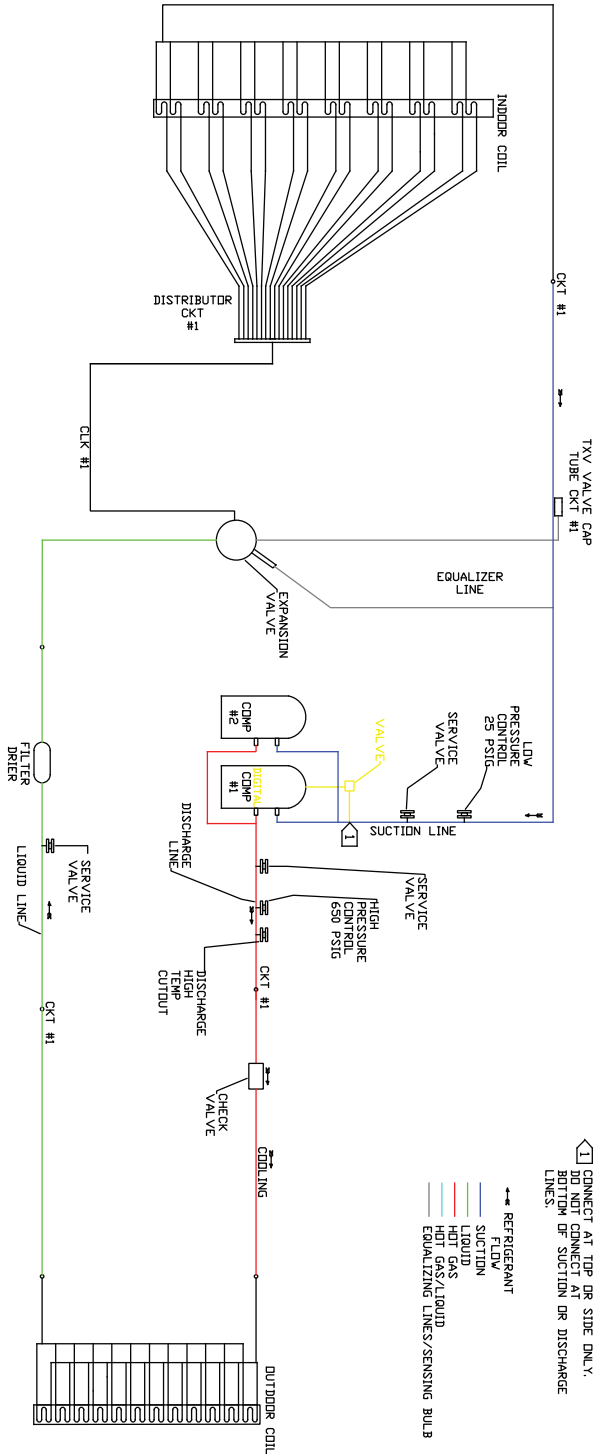
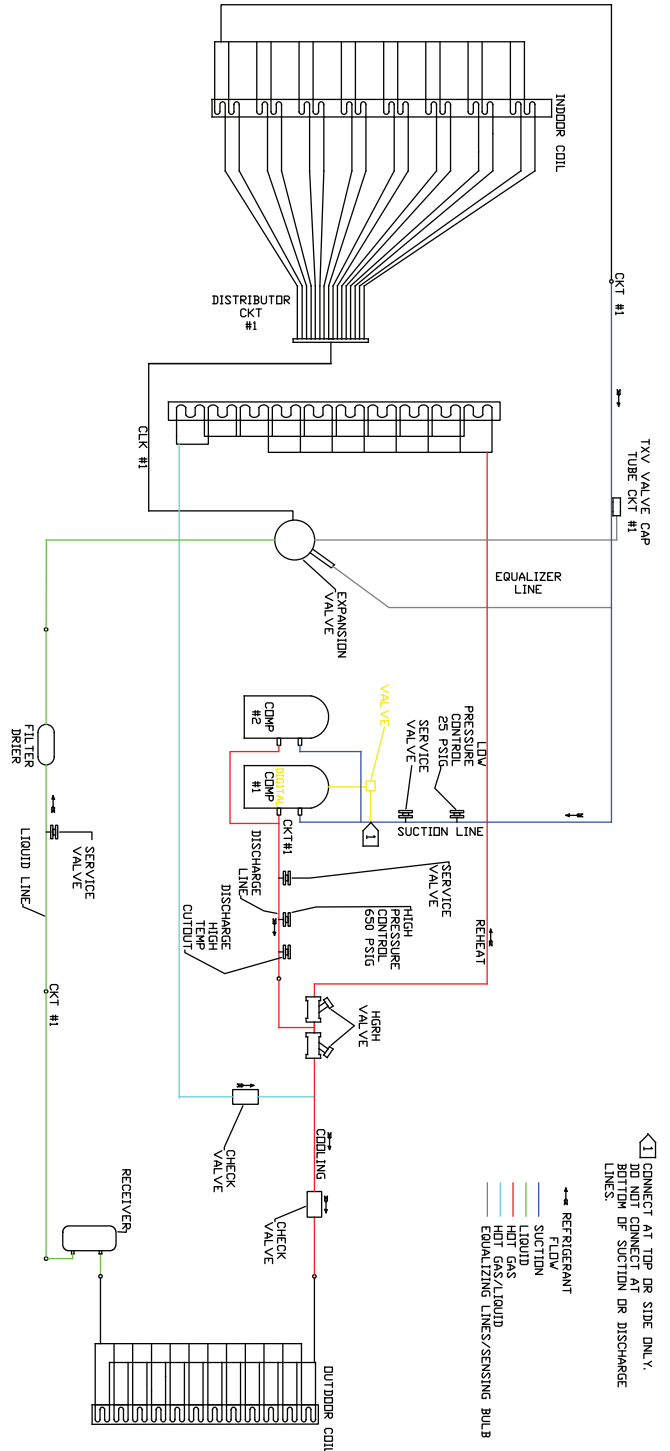

Figure 33. Refrigeration diagram: Tandem compressor with reheat





Alarms and Troubleshooting

⚠ WARNING

Hazardous Service Procedures!

Failure to follow all precautions in this manual and on the tags, stickers, and labels could result in death or serious injury. Technicians, in order to protect themselves from potential electrical, mechanical, and chemical hazards, **MUST** follow precautions in this manual and on the tags, stickers, and labels, as well as the following instructions: Unless specified otherwise, disconnect all electrical power including remote disconnect and discharge all energy storing devices such as capacitors before servicing. Follow proper lockout/tagout procedures to ensure the power can not be inadvertently energized. When necessary to work with live electrical components, have a qualified licensed electrician or other individual who has been trained in handling live electrical components perform these tasks.

⚠ AVERTISSEMENT

Procédures d'entretien dangereuses!

Le non-respect de toutes les précautions contenues dans ce manuel ainsi que sur les étiquettes et les autocollants peut entraîner des blessures graves voire mortelles. Les techniciens, afin d'être protégés des éventuels risques électriques, mécaniques et chimiques, **DOIVENT** suivre les précautions contenues dans ce manuel, sur les étiquettes et les autocollants, ainsi que les instructions suivantes : Sauf indication contraire, coupez toute l'alimentation électrique y compris les disjoncteurs à distance et déchargez tous les dispositifs de stockage d'énergie comme les condensateurs avant l'entretien. Respectez les procédures de verrouillage et d'étiquetage appropriées pour éviter tout risque de remise sous tension accidentelle. S'il est nécessaire de travailler avec des composants électriques sous tension, demandez à un électricien qualifié et agréé ou à une autre personne ayant la formation nécessaire pour manipuler des composants électriques sous tension d'exécuter ces tâches.

Microprocessor Control and Faults

The Main Unit Display and RTRM provide service personnel with unit diagnostics and system status information.

Table 11. ReliaTel™ LED functions

ReliaTel™ Refrigeration Module (RTRM)	
Green System LED	On: normal operation (slight flickering is normal)
	Off: no power, board failure
	One blink: emergency stop open when attempting test mode
	Two flashes every 2 seconds: indicates a diagnostic is present (v4.0 or higher)
	Continuous 0.25 second blink: test mode

RTRM System LED Diagnostic Indicator

On RTRM version 4.0 or higher, the green system LED on the RTRM module provides a quick visual indication of the presence of certain diagnostics. If the green LED on the RTRM is blinking with two 0.25 second blinks every two seconds, one or more of the following diagnostics is present:

- Manual Compressor Lockout
- 10k Ohm Resistor Failure

To check for compressor lockout, see below. Additional details on compressor pressure control can be found in [“General Information,” p. 11.](#)

- **Low Pressure Control Reliatel Control (CLP1) Failure:** CLP1 has opened during the 3 minute minimum on time during 4 consecutive compressor starts. Verify CLP1 by testing voltage between J1-8 and J1-2 terminals on the RTRM and ground. If 24Vac is present, CLP1 is not tripped. If no voltage is present, CLP1 is tripped. Low Pressure Switch opens at 25PSIG and closes at 41PSIG.
- **High Pressure Control Reliatel Control (CHP1) Failure:** CHP1 has opened due to high pressure in the discharge line. Green System LED being OFF is an indication that CHP1 has opened. Verify CHP1 by testing voltage between J1-12 and ground on the RTRM. If 24Vac is present, CHP1 is not tripped. If no voltage is present, one of the following has occurred. Use schematic in [Figure 34, p. 56](#) for reference to this circuit:
 - CHP1 has opened.
 - The Phase Monitor has opened.
 - Contacts 9 and 10 on the OAUTS board have opened. Fire alarms are commonly wired to contacts 9 and 10 and should be checked if this connection is opened.
 - Smoke detectors are tripped.

Figure 34. CHP1 failure

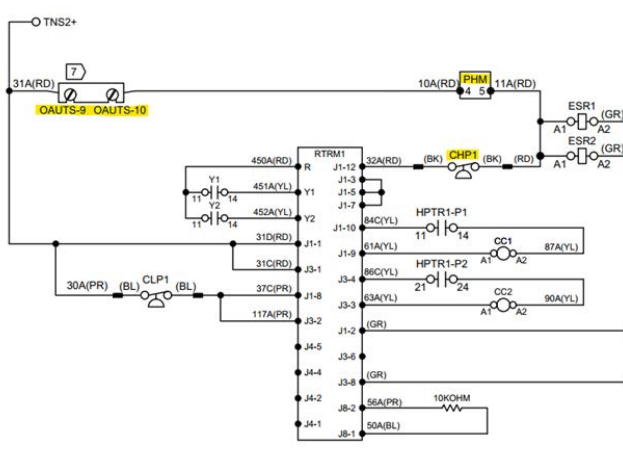

- 10k Ohm Resistor Failure**
 10k ohm resistor is open or shorted. Verify resistor by testing voltage at terminal J8-2. Voltage should read between 4.9Vdc and 0.385Vdc. If voltage reading is out of range, verify all wiring of the resistor and check wiring connections at terminals J8-2 and J8-1. If all wiring appears correct, verify resistance of the resistor by the connector from the RTRM and checking resistance across both leads. Resistance should read nearly exactly 10ohms. Use below schematic for reference:

Figure 35. 10k Ohm resistor failure

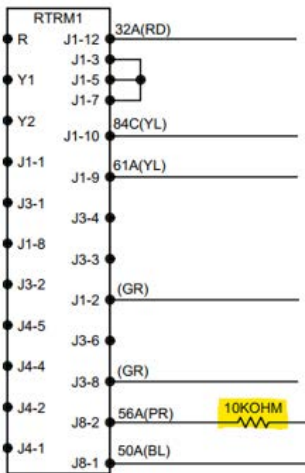

System Alarms

The main Unit Display has built in alarms to help the operator troubleshoot system failures. This section will describe these alarms and provide a guide to troubleshooting the all unit operating modes.

Comprehensive system alarms and diagnostics are accessed through the Alarms icon at the unit display discussed later in

the section, or through Tracer TU programming on connected computer. Sensor failures may be viewed through the Alarms icon.

If an alarm is present, the main indicator light on the UC600 will blink red. If the optional unit display is installed, the Alarm icon on the display will register ALARM, illuminate red and flash.

Important: The space temperature sensor (SPTC) and space relative humidity sensor (SPHC) will read failed if they are not connected; they will Alarm as "In Fault."

Sensor Failure Alarm Display

Press the Alarm button on the Home display of the Unit Display to display system sensor status as described in [Table 12](#) and [Table 13, p. 57](#).

Table 12. Horizon Flex UC600 alarms

Point	Diagnostic	Possible Cause
1	Indoor Fan Failure	VFD not operating
		Outdoor and/or Return Air Dampers not Operating Properly
		Indoor Fan Motor Failure
		Indoor Fan Failure Switch IFFS (pressure) Failure
		IFFS Tubing damaged or not properly connected
	Refer to start-up procedure	
6	Discharge Air Temp Source Failure	Failed sensor or improper sensor installation
8	Fire Shutdown	BAS ONLY
10	Low Temp Lockout	Heat Overridden OFF
		Compressor(s) Overridden ON
		Setpoint Failures Incorrect
		DAT sensor malfunction
	Reference Table 13, p. 57 for heat failure issues	
11	Space Temp Source Failure	BAS communication down Failed sensor or improper sensor installation
13	OA Temp Source Failure	BAS communication down
		Failed sensor or improper sensor installation
14	OA Humidity Source Failure	BAS communication down
		Failed sensor or improper sensor installation Humidity Wiring is polarity sensitive
15	High Temp Lockout	Heat Overridden ON
		Low discharge air volume
		Dirty air filters
		High gas heater manifold pressure
		OA/RA damper position incorrect High temp limit not properly installed or wired DAT sensor malfunction
17	System Lockout	Check all Alarms
		External safety device failed open
19	Space RH Source Failure	BAS communication down
		Failed sensor or improper sensor installation
		Humidity Wiring is polarity sensitive

Table 12. Horizon Flex UC600 alarms (continued)

Point	Diagnostic	Possible Cause
32	ERV Leaving Air Condition Failure	Temperature sensor
		Incorrectly installed or connect RH or Temp sensor
42	Heat Failure	Applies to 5:1 and 10:1 Gas Heaters Only
		Trips after heat command "ON" and no GV status offer 1 minute
		Refer to unit "Service Facts" heat control LED status legend
		No gas, low gas pressure or high gas pressure to unit
		Unit Manual shutoffs closed
		Heater inducer failure
		Heat relay failure
		Loose or incorrect wiring

Table 13. Horizon Flex UC600 troubleshooting

Trouble	Possible Cause
ERV Will Not Run	ERV leaving air temp below 34°F low temp cutout
	Interlocked with Exhaust fan if exhaust is not running ERV will be OFF
Unit Trips Heater High Limit	High fire gas manifold pressure too high
	Supply fan speed too low
	Dirty or clogged filters
	Restricted discharge air duct
	Temperature of air entering heater too high
	Defective high limit

Table 13. Horizon Flex UC600 troubleshooting

Trouble	Possible Cause
Unit Not Running	No power supply to unit disconnect switch
	Power disconnect tripped
	Lockout alarm mode
	Emergency Stop condition exists
	Unit in Unoccupied mode
	Discharge air sensor failed or not installed and connected to unit
No Heat	No gas supply to unit
	Unit manual gas valve(s) closed
	Heater high limit tripped
	Heat relay not energized
	Conditions do not warrant call for heat
	Heater control module malfunction
	Roll out switch trip
	Main gas on-off switch OFF
	Inducer fan failure
Heater air proving switch not making or failed	
No Compressor	Compressor limit switch(es) open
	Compressor relay not energized or failed
	Conditions do not warrant call for cooling or dehumidification
Wide Discharge Temp Swings	Discharge air sensor position must be at least 4 ft.-0 in. away from unit outlet
	Min and Max gas heater manifold pressures not set correctly
Space too Hot, Cold or Humid	Setpoints not adjusted properly
	Space sensors not correctly located or wired
	Malfunctioning space sensor
IFM or PEX VFD OC Trip	Overcurrent alarm requires max Hz setting on VFD be checked and set to not exceed motor nameplate amps
EX VFD only run to Min HZ Setting	If supplied with RA pressure transducer and modulating damper setup is not installed or properly wired.



Appendix

Horizon Flex Filter

Table 14. Horizon Flex filters

Evaporator	Thickness	MERV	Qty	Height	Width
	2	8,13	2	20	24
	2	8,13	2	24	24
	4	14	2	20	24
ERV Module	Return Air				
	Thickness	MERV	Qty	Height	Width
	2	8	4	18	24
	Outside Air				
	Thickness	MERV	Qty	Height	Width
	2	8	4	18	24
Filter Inlet Hood	Thickness	Material	Qty	Height	Width
	2	Aluminum Mesh	4	16	25
	Thickness	MERV	Qty	Height	Width
2	8	4	16	25	

Note: Filter inlet hood is only provided on units with an electric preheater. Bird screens are installed in non-preheater units.

Field Installation of Factory-Provided Sensors

Figure 36. VELSEN-0021 discharge air temperature sensor installation instructions

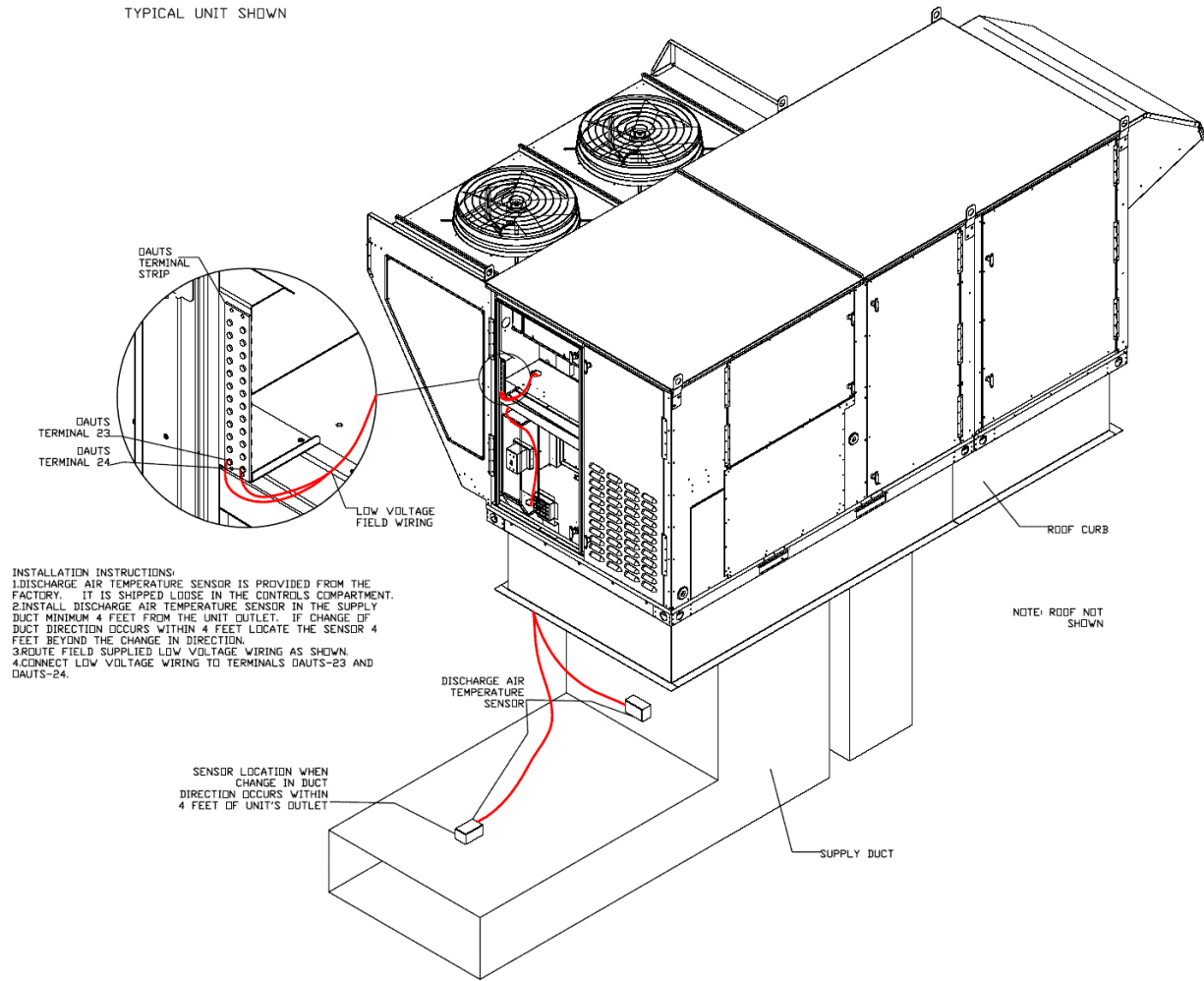
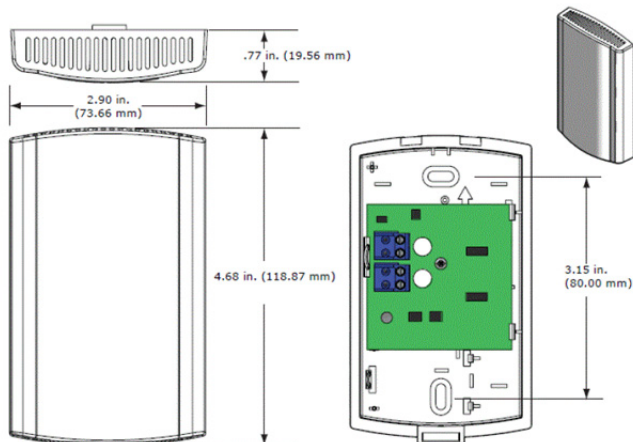

Figure 37. BAYSENS036A space temperature/humidity sensor installation instructions

Sensor Specifications

Accuracy:	±3% RH over 20–95% RH at 77°F (25°C). Includes hysteresis, linearity, and repeatability.
Operating temperature range:	From -20°F to 140°F (-29°C to 60°C)
Supply voltage:	18-36 Vdc
Drift rate:	Less than 1% per year
Operating measurement range:	0-99% RH, noncondensing
Sensing element:	Polymer capacitive
Output characteristics:	4-20 mA for 0-100% RH (<i>X13790486010 is 20- mA for 0-100% RH</i>)
Repeatability:	0.5% RH
Hysteresis:	Less than 1% RH
Sensitivity:	0.1% RH
Storage temperature:	From -85°F to 158°F (-65°C to 70°C)
Thermistor resistance:	10 kΩ at 77°F
Temperature accuracy:	±0.36°F (±0.2°C)

Sensor Dimensions and Locating Best Practices



Mounting

Proper location of the **room humidity sensor** is important to ensure accurate measurement. Place the sensor in an area of the room with good air circulation.

Places to avoid when locating the sensor:

- Locations subject to draft from windows, doors, or diffusers
- Surfaces with an uncooled or unheated area behind them, such as an outside wall or the wall of an unoccupied store room
- Near heat sources, such as radiant heat from the sun, heat from appliances, or heat from concealed pipes or chimneys
- Dead spots behind doors, draperies, or in corners
- Walls having excessive vibration
- Corrosive environments such as near swimming pools or in hospital rooms

To mount the **room humidity sensor**, first choose a flat interior surface that is approximately 54 inches (1.4 m) from the floor and then:

1. Remove sensor cover by pressing on the thumb tab at the bottom of the enclosure. Tilt the cover forward and raise it over the top of the back plate.
2. Feed the wires through the base.
3. Attach sensor to drywall or plaster (hardware not included with the sensor).
Note: For a 2 × 4 junction box, mount the sensor using two #6-32 screws.
4. Connect the controller wires to the terminals on the sensor (refer to the next section about wiring).
5. Replace cover by engaging tab hinges on top of the unit and then push to snap in place.

Figure 38. MZVAV DSPS document

INSTALLATION INSTRUCTIONS FOR (BAPI) OR (BELIMO) SUPPLY DUCT STATIC PRESSURE TRANSDUCER (SDPC)

GENERAL:
SDPC IS USED TO CONTROL SUPPLY FAN SPEED BASED ON STATIC PRESSURE. DEFAULT FOR SDPC IS 0-2" WC TO 0-10VDC. ANY OTHER SETTING MUST BE RE-CONFIGURED WITHIN THE MAIN UNIT CONTROLLER.

IF A DUCT STATIC PRESSURE GREATER THAN 1.5"WC IS DESIRED, IT'S RECOMMENDED TO INCREASE THE RANGE OF THE TRANSDUCER AND RE-CONFIGURE THE MAIN UNIT CONTROLLER.

INSTALLATION:

1. VERIFY DIP SWITCH AND DIAL SETTINGS ACCORDING TO CHART BELOW.
2. MOUNT TRANSDUCER ON THE EXTERIOR OF THE DUCT AT LEAST 4 FT FROM THE UNIT.
3. INSTALL SAMPLING TUBE ONTO THE DUCT AND CONNECT TUBING TO PORT "H" ON TRANSDUCER.
4. LEAVE PORT "L" ON TRANSDUCER OPEN.
5. RUN WIRING FROM THE TRANSDUCER TO THE FIELD WIRING TERMINAL (OAUITS) STRIP USING COPPER CONDUCTORS ONLY.
6. LAND THE WIRING ON FIELD WIRING TERMINAL STRIP ACCORDING TO THE CHART BELOW.

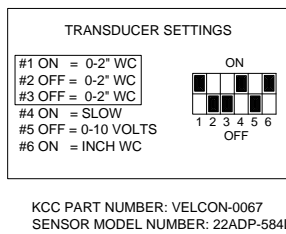
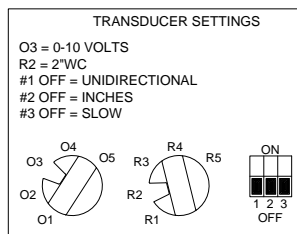

KCC PART NUMBER: VELCON-0976
SENSOR MODEL NUMBER: BAZPM-SR-ST-D

LINES 74 ON UNIT WIRING DIAGRAM

LINES 74 ON UNIT WIRING DIAGRAM

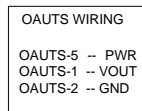
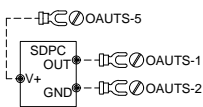

OAUITS FIELD WIRING TERMINAL STRIP

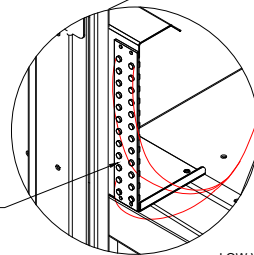

LOW VOLTAGE FIELD WIRING

TYPICAL DUCT INSTALLATION

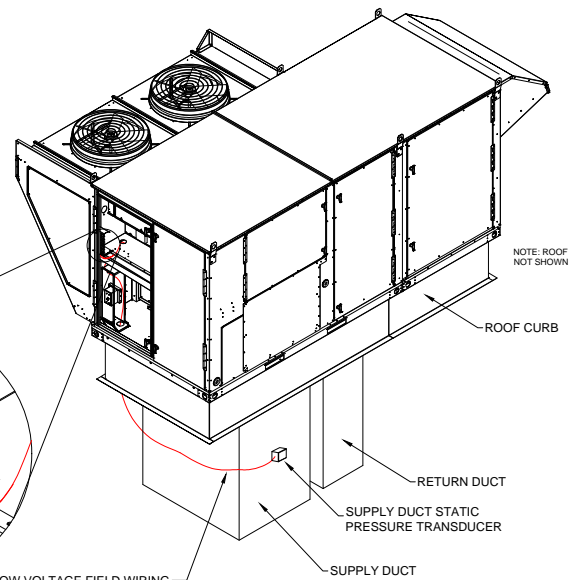

UPDATED 12/13/2021
REV. D

Figure 39. Installation instructions for modulating OA/RA dampers w/economizer and an exhaust fan

GENERAL:

RDSPC IS USED TO CONTROL EXHAUST FAN SPEED BASED ON STATIC PRESSURE. DEFAULT FOR RDSPC IS 0-2" WC TO 0-10VDC. ANY OTHER SETTING MUST BE CHANGED WITHIN THE MAIN UNIT CONTROLLER.

FACTORY SUPPLIED TRANSDUCER IS NOT RECOMMENDED FOR CONTROLLING TO SPACE PRESSURE. IF SPACE PRESSURE CONTROL IS DESIRED, USE A TRANSDUCER WITH A RANGE OF -0.5 TO 5" WC FOR PROPER OPERATION AND RE-CONFIGURE THE MAIN UNIT CONTROLLER.

INSTALLATION:

1. VERIFY DIP SWITCH AND DIAL SETTINGS ACCORDING TO CHART BELOW.
2. MOUNT TRANSDUCER ON THE EXTERIOR OF THE DUCT AT LEAST 4 FT FROM THE UNIT.
3. INSTALL SAMPLING TUBE ONTO THE DUCT AND CONNECT TUBING TO PORT "L" ON TRANSDUCER.
4. LEAVE PORT "H" ON TRANSDUCER OPEN.
5. RUN WIRING FROM THE TRANSDUCER TO THE FIELD WIRING TERMINAL (OAU5) STRIP USING COPPER CONDUCTORS ONLY.
6. LAND THE WIRING ON FIELD WIRING TERMINAL STRIP ACCORDING TO THE CHART BELOW.

KCC PART NUMBER: VELCON-0976
SENSOR MODEL NUMBER: BA/2FM-SR-ST-D

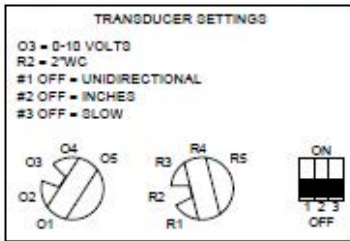

KCC PART NUMBER: VELCON-0067
SENSOR MODEL NUMBER: 22ADP-584L

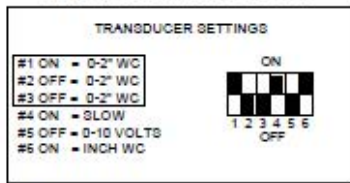

OAU5 WIRING
OAU5-21 - PWR
OAU5-22 - VOUT
OAU5-20 - GND

LINES 54 ON UNIT WIRING DIAGRAM

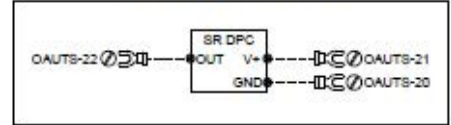

TYPICAL DUCT INSTALLATION

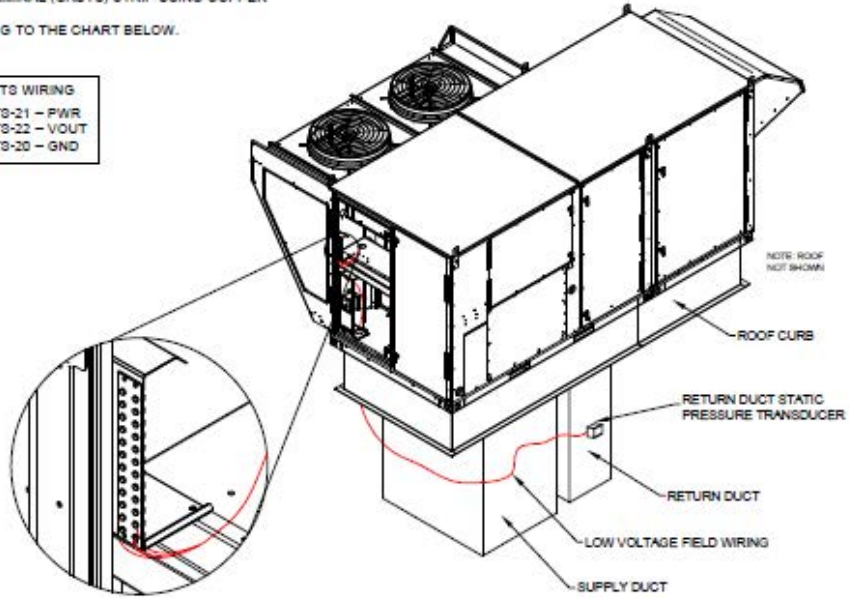

UPDATED 12/1/2021
REV. D



Start-Up Form Trane[®] Horizon[™] Flex

Job Name	
Unit Serial Number	
Unit Tag	
Technician Name	
Trane Office	
Horizon Tech Training Completed	
Start-up Date	

To obtain a digital copy of the latest version of this form, click [here](#) or contact the factory. For questions or concerns, the factory can be reached at (502) 493-5757, (800) 382-2872 or techsupport1@kccmfg.com.

This start-up form is for Horizon Flex units.

Pre-Start-Up Checklist

- Check for visible shipping damage.
- Unit is level.
- All fans spin freely.
- All electrical connections are tight.
- Interior cabinet inspected for damage or loose components.
- All field installed devices are installed.
- Clearances meet minimum requirements in IOM.
- Condensate drains and P-Traps installed.
- All doors open freely.
- Wiring schematics installed on front doors.
- Gas piping is complete and landed at unit (if applicable).

Phase Monitor Setup

- Verify voltage on phase monitor matches incoming voltage to the unit.

Time Mark:

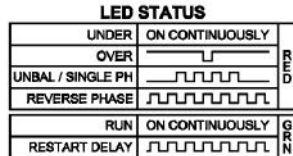

- Verify phase unbalance on phase monitor (phase unbalance should be set to 3%).

Macromatic:

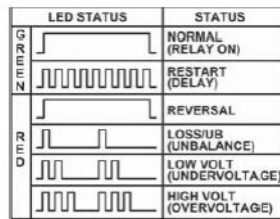

Voltages

Rated voltage	Measured	Recommended
Voltage L1-L2		Voltage +/- 10%
Voltage L1-L3		Voltage +/- 10%
Voltage L2-L3		Voltage +/- 10%
Voltage L1-G		--
Voltage L2-G		--
Voltage L3-G		--
TNS2 Secondary Voltage		22-28

Motor Data

Motor	Rated FLA	Running FLA		
		L1	L2	L3
Supply Fan 1				
Supply Fan 2				
Exhaust Fan 1				
Exhaust Fan 2				

Motor	Rated FLA	Running FLA		
		L1	L2	L3
Condenser Fan 1				
Condenser Fan 2				
Condenser Fan 3				
Condenser Fan 4				
Condenser Fan 5				
Condenser Fan 6				
Energy Wheel				

Compressor Data

	Rated RLA	Running Amps		
Compressor 1				
Compressor 2				
Compressor 3				
Compressor 4				
Compressor 5				
Compressor 6				

Actuators

Outdoor Air Damper Actuator	2-Position or 2-10 VDC	<input type="checkbox"/>
Return Air Damper Actuator	2-Position or 2-10 VDC	<input type="checkbox"/>
Exhaust Damper Actuator(s)	2-Position	<input type="checkbox"/>
Split Exhaust/Return Damper Actuator	2-Position	<input type="checkbox"/>
Outdoor Air ERV Bypass Damper Actuator	2-10 VDC	<input type="checkbox"/>
Exhaust Air ERV Bypass Damper Actuator	2-10 VDC	<input type="checkbox"/>
WSHP Water Valve Actuator(s)	2-10 VDC	<input type="checkbox"/>
Chilled Water/Hot Water Actuator (Field Installed)	--	<input type="checkbox"/>



Refrigeration Start-Up

Cooling start-up can only be completed if the outdoor air temperature is above 50°F. If outdoor air temperature is below 50°F, cooling start-up can be performed with 100% return air to confirm operation if return air conditions are above 50°F. Otherwise, a bump test is recommended to verify compressor operation. Please note in the comments if only a bump test is performed.

Note: Contact Tech Support at 502-493-5757 if SC > 20 or SH > 30. Contact Tech Support before adjusting charge.

Test Procedures

1. Tandem or trio circuits must have all compressors on and digital scroll/variable speed commands set to 100%.
2. Purge the hot gas reheat coil (if installed) by setting the hot gas reheat command to 100%* for one minute, and then immediately to 0%.
3. Allow the head pressure control to modulate the condenser fans freely.
4. Record measurements under the Cooling section once the system has settled.
5. Heat pumps: Switch reversing valve to heating; repeat steps for heating mode. Record measurements under the Heating section.
6. Repeat above steps for Circuit 2 (if applicable).

Check this box if test data below is with both circuits in operation.	<input type="checkbox"/>
Check this box if cooling start-up performed using 100% return air.	<input type="checkbox"/>

		Circuit 1		Circuit 2	
		Cooling	Heating	Cooling	Heating
Outdoor Temp (°F)					
Outdoor RH (%)					
Suction Line	Pressure (PSI)				
	Sat. Temp (°F)				
	Temp (°F)				
	Superheat (°F)				
Liquid Line	Pressure (PSI)				
	Sat. Temp (°F)				
	Temp (°F)				
	Subcooling (°F)				
Evaporator Leaving Temp (°F)					
WSHP Only	Entering Water Temp (°F)				
	Leaving Water Temp (°F)				
	Water Coil Pressure Drop (PSI)				

Expectations: The subcooling varies depending on conditions and mode of operation. For example, during dehumidification mode the head pressure setting is higher to improve reheat capacity and will generally have higher subcooling during testing because the hot gas reheat is manually being closed.

Indirect Fired Gas Heat Start-Up

Note: High limit trips may occur after extended operation during high ambient temperatures.

Gas Pressure Settings (Modulating)

	Measured Pressure	Natural Gas Settings	Propane Settings	
Incoming to Unit		7 - 14	11 - 14	in.H ₂ O
Between On/Off and Mod. Valve		5	10.5	in.H ₂ O
Stage 1 Modulating (Low Fire)		0.4*	0.6 - 2*	in.H ₂ O
Stage 1 Manifold (High Fire)		3.5	8	in.H ₂ O
Stage 2 Manifold		3.5	8	in.H ₂ O
Stage 3 Manifold		3.5	8	in.H ₂ O

*Gas quality varies from site to site. Set the minimum fire gas pressures to the lowest possible pressure so that a consistent, quality flame is present. Verify that the flame remains of high quality by modulating the signal up and down after releasing control back to the program.

Gas Pressure Settings (Two Stage)

	Measured Pressure	Natural Gas Settings	Propane Settings	
Incoming to Unit		7 - 14	11 - 14	in.H ₂ O
Stage 1 Modulating (Low Fire)		1.1	2.5	in.H ₂ O
Stage 1 Manifold (High Fire)		3.5	8	in.H ₂ O

Electric Heat Start-Up

	Rated Amps	Running Amps		
Electric Primary Heater				
Electric Pre-Heater				



Programming

Generate Point Summary Report

Generate a Point Summary Report using Tracer® TU and include it along with the start-up report. The point summary report includes any configuration settings made between shipping and start-up.

Note: *Setpoints are pre-set at the factory using submittal data but may require field adjustments to achieve desired operation.*

Generate this report by going to **Reports > Point Summary Report**. None of the checkboxes need to be selected for the popup window.

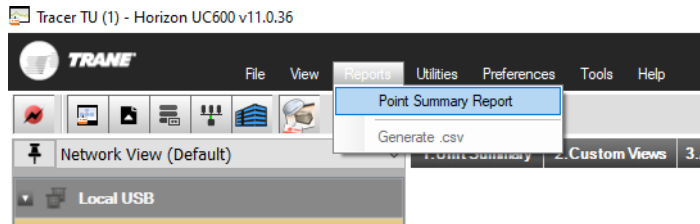

Final Notes

Is there something missing or do you have recommendations on improvements?

Note here if the outdoor air temperature is too low for cooling testing.

Submit completed form and points summary to Horizonstartup@kccmfg.com

Include serial number and job name in subject of email.

If changes were made to the factory program or program control type changed, include the backup program in the email.



Notes

Trane - by Trane Technologies (NYSE: TT), a global climate innovator - creates comfortable, energy efficient indoor environments for commercial and residential applications. For more information, please visit trane.com or tranetechnologies.com.

Trane has a policy of continuous product and product data improvement and reserves the right to change design and specifications without notice. We are committed to using environmentally conscious print practices.