



Product Catalog

Foundation™ Packaged Rooftop Units

Cooling and Gas/Electric
7.5 to 12.5 Tons, 60 Hz





Introduction

Packaged Rooftop Air Conditioners

Figure 1. Packaged rooftop air conditioner

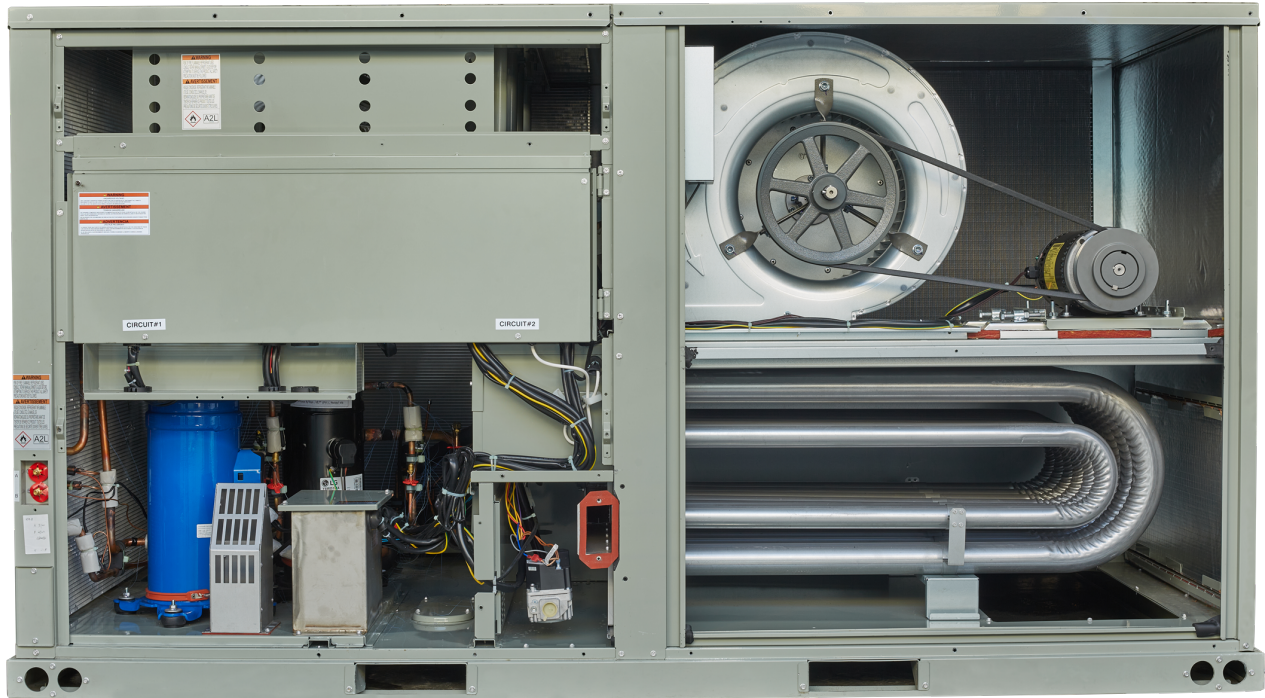

Through the years, Trane has designed and developed the most complete line of Packaged Rooftop products available in the market today.

Customers demanded a product that provided exceptional reliability, was easy to install, and was competitively priced.

Trane listened and is proud to introduce the new Foundation™ Light Commercial rooftop unit. With Foundation, Trane continues to provide the highest standards in quality and reliability, comfort, performance, and ease of installation. light commercial products.

Copyright

This document and the information in it are the property of Trane, and may not be used or reproduced in whole or in part without written permission. Trane reserves the right to revise this publication at any time, and to make changes to its content without obligation to notify any person of such revision or change.

Trademarks

All trademarks referenced in this document are the trademarks of their respective owners.

Revision History

Updated to include 575V information across the document.



Table of Contents

- Features and Benefits 4
 - Standard and Optional Features 4
 - Accessories 5
 - Outstanding Standard Features 6
 - Variety of Options 8
- Application Considerations 11
 - A2L Application Considerations 11
 - Leak Detection System (Refrigerant charge greater than 3.91 lb per circuit) 12
- Selection Procedure 13
 - Cooling Capacity 13
 - Heating Capacity 14
 - Air Delivery Selection 14
- Model Number Description 15
- General Data 16
- Performance Data 21
 - Gross Cooling Capacities 21
 - Evaporator Fan Performance 25
- Controls 42
 - Economizer Controls 42
 - Thermostats 42
- Electrical Data 43
- Jobsite Connections 46
- Dimensional Data 47
- Weights 51
- Mechanical Specifications 53
 - General 53
 - Standard Features 53
 - Factory Installed Options 54
 - Field Installed Options 54



Features and Benefits

Foundation™ has features and benefits that make it first class in the light commercial rooftop market. Designed with input from field contractors and technicians, its convertible airflow and ease of installation are outstanding.

Standard and Optional Features

	Standard	Options ^(a)	
		Factory Installed	Field Installed
1-year Limited Parts Warranty	X		
5-year Limited Compressor Warranty	X		
5-year Limited Heat Exchanger Warranty	X		
5K SCCR	X		
Barometric Relief Damper			X
Belt Drive Motors	X		
CO ₂ sensor - Demand Control Ventilation (DCV)			X
Colored Connectors and Wiring	X		
Compressor Discharge Temperature Limit (DTL)	X		
Condensate Overflow Switch			X
Convertible Airflow	X		
Easy Access Low Voltage Connections	X		
Economizer (Downflow)			X
Electric Heaters			X
Filters	X		
Hail/Vandal Guards			X
High Pressure Control	X		
High Static Motor Kit ^(b)		X	
Insulation - 1/2-inch, 1-lb Density	X		
Leak Detection System	X		
Liquid Line Refrigerant Drier	X		
Low Ambient Cooling	X		
Low Leak Economizer			X
Low Pressure Control	X		
Low Voltage Circuit Protection	X		
LP Conversion Kit	X		
Manual Outside Air Damper			X
Motorized 2-Position Damper			X
Phase Loss/Reversal Monitor	X		
Powered Exhaust			X
Quick Access Panels	X		
Remote Potentiometer			X
Scroll Compressors	X		
Single Point Power	X		

	Standard	Options ^(a)	
		Factory Installed	Field Installed
Single Side Service	X		
Electronic Expansion Valve	X ^(c)		
Through-the-base electrical & gas connection provisions	X		

^(a) Refer to model number description for option availability or contact Product Support.

^(b) Available on constant volume units only. See Accessories chapter for more information.

^(c) Fixed orifice

Accessories

Note: Accessory availability is dependent on unit configuration. Some accessories may require additional accessories/options for full functionality. For more information, contact product support.

BAYKIT	Description
BAYCURB310*	Roof Curb
BAYBARO310*	Barometric Relief
BAYECON310*	0-100% Economizer, Dry Bulb Downflow
BAYECON311*	0-100% Economizer, Dry Bulb Horizontal
BAYECON355*	Low Leak Econ w/FDD Dry Bulb Downflow
BAYECON356*	Low Leak Econ w/FDD Dry Bulb Horizontal
BAYDMPR310*	Motorized outside damper 0-50%
BAYDMPR311*	Manual outside damper 0-25%
BAYPWRX310*	Power Exhaust 208/230V Downflow
BAYPWRX311*	Power Exhaust 460V Downflow
BAYPWRX313*	Power Exhaust 208/230V Horizontal
BAYPWRX314*	Power Exhaust 460V Horizontal
BAYPWRX312*	Power Exhaust 575V Downflow
BAYPWRX315*	Power Exhaust 575V Horizontal
BAYGARD312A	7.5-12.5 Condenser Hail Guard
BAYCOSW311*	Condensate overflow switch
BAYHAKT310*	Hi Alt NG
BAYASCT001	Comp short cycle timer
BAYLSDR310*	Low Static Drive
BAYCO2K300*	Wall mount CO2 kit
BAYCO2K301*	Duct mount CO2 kit
BAYSTAT023*	Remote potentiometer
BAYSEN30ATEMPA	Remote Wired ODT sensor
ZZSENSAL0300AA	Remote Wired IDT sensor
TCONT302AS42DA	3H/2C 7day programmable touchscreen Thermostat
BAYSTAT814 ^{*(a)}	Pivot Smart thermostat electromechanical
BAYSTAT150*	2H/2C digital display programmable thermostat
BAYSTAT152*	3H/2C programmable touchscreen thermostat



Features and Benefits

BAYKIT	Description
BAYSTAT300*	BACnet thermostat
BAYSTAT400*	T24 Thermostat
BAYHTMA310 ^(a)	10.4kW electric heater
BAYHTMA315 ^(a)	16kW electric heater
BAYHTMA325 ^(a)	25kW electric heater
BAYHTMA332 ^(a)	32kW electric heater
BAYHTMA341 ^(a)	41kW electric heater
BAYHTMA350 ^(a)	50kW electric heater
BAYHTMA410 ^(a)	10.4kW electric heater
BAYHTMA415 ^(a)	16kW electric heater
BAYHTMA425 ^(a)	25kW electric heater
BAYHTMA432 ^(a)	32kW electric heater
BAYHTMA441 ^(a)	41kW electric heater
BAYHTMA450 ^(a)	50kW electric heater

^(a) Not applicable to A revision. Applies only to B or later.

Outstanding Standard Features

Colored And Numbered Wiring

Save time and money tracing wires and diagnosing the unit.

Compressors

Foundation® contains the best compressor technology available to achieve the highest possible performance.

Controls – Electromechanical

This 24-volt control includes the control transformer and contactor pressure lugs for power wiring.

Convertible Units

Foundation® 7.5 to 12.5 ton units ship in the downflow configuration. Their convertible design makes it easy to convert them to a horizontal airflow configuration without an additional kit.¹

Efficiency

Product efficiencies meet the requirements of ASHRAE 90.1 - 2022.

Easy Access Low Voltage Terminal Board

Foundation® Low Voltage Terminal Board is mounted outside the main electrical control cabinet. It is extremely easy to locate and attach the thermostat control wiring and also test operation of all unit functions. This is another cost and time saving installation feature.

Insulation

All panels in the evaporator section of the unit have foil-faced, glass fiber insulation. All base panels have foil-faced, glass fiber insulation. All edges are either captured or sealed to ensure no insulation fibers get into the airstream.

Heat Exchanger

The cabinet features a tubular heat exchanger in heat capacities – all available for vertical and horizontal discharge directions. The heat exchanger is fabricated using aluminized steel burners and corrosion-resistant, aluminized steel tubes as standard on

¹ The 7.5 ton unit requires a conversion kit.

all models. As part of the heat exchanger assembly, an induced draft blower is used to pull the gas mixture through the burner tubes. A direct spark ignition system, which doubles as a safety device to prove the flame, is used to ignite the gas mixture.

Leak Detection System

The Leak Detection System (LDS) consists of one or more refrigerant detection sensors and is required in ducted HVAC systems that have more than 3.91 lbs of A2L refrigerant charge, per safety standard UL 60335-2-40. For any units with more than 3.91 lbs of charge in a circuit, an LDS will be factory-installed. Having the leak detector installed in the factory by the manufacturer on applicable units reduces the risk of improper installation in the field as well as bypassing the added cost in the field for installation, leading to peace of mind that the right solution has been applied to your unit.

Locking Safety Device with Anti-Short Cycle Timer

This device monitors compressor safety switch trips to prevent short cycling, protecting the compressor. A manual reset is required after a fourth safety switch trip.

Low Ambient Cooling

All Foundation units have cooling capabilities down to 0°F as standard.

Low Voltage Connections

The wiring of the low voltage connections to the unit and the thermostat is as simple as R-R, G-G, Y-Y, and W-W. This simplified system makes it easy for the installer to wire.

Microchannel Condenser Coil

Microchannel condensing coils are all-aluminum coils with fully-brazed construction. This design reduces risk of leaks and provides increased coil rigidity — making them more rugged on the jobsite. Their flat streamlined tubes with small ports and metallurgical tube-to-fin bond allow for exceptional heat transfer. Microchannel all-aluminum construction provides several additional benefits:

- Light weight (simplifies coil handling)
- Easy to recycle
- Minimize galvanic corrosion

Figure 2. Microchannel condenser coil

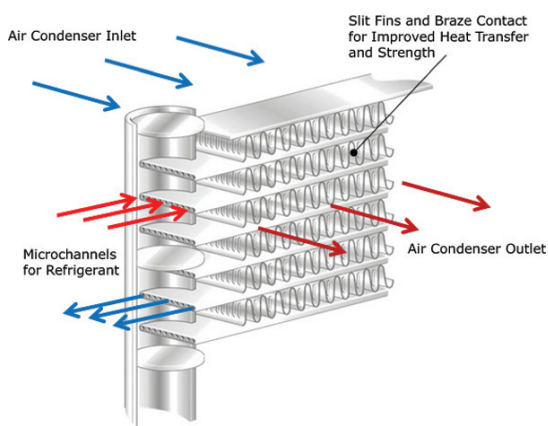

Motors

All indoor fan motors are belt drive as standard.

Pressure Cutouts

Low and high pressure cutouts are standard on all Foundation™ models.

Quick-Access Panels

Remove screws (four or fewer) for access to the standardized internal components and wiring.



Features and Benefits

Quick-Adjust Fan Motor Mounting Plate

With the quick-adjust slider plate, the belt and sheaves can be quickly adjusted without moving the mounted fan motor. This results in reduced time spent on routine maintenance.

Single Point Power

A single electrical connection powers the unit and all on-board options.

Single Side Service

Single side service is standard on all units.

Sloped Drain Pans

Every Foundation® unit has a non-corrosive, sloped drain pan made of rigid PVC - standard on all units.

LP Conversion Kit

LP kits are provided as standard with each GDK 090-150 unit for conversion of gas heat units from natural gas to propane.

Variety of Options

Factory Installed Options

Oversized Motors

Multi-speed only – Factory installed oversized motors are available for high static applications.

Field Installed Options

Condensate Overflow Switch

In the event the condensate drain becomes clogged, a condensate overflow switch is available for unit shutdown. This option protects the unit from water overflowing from the drain pan and entering the base of the unit.

CO₂ Sensor - Demand Control Ventilation (DCV)

Demand-controlled ventilation (DCV) is a control strategy that responds to the actual demand (need) for ventilation by regulating the rate at which the HVAC system brings outdoor air into the building. A CO₂ sensor measures the concentration (parts per million, ppm) of CO₂ in the air. As the CO₂ concentration changes, the outside air damper modulates to meet the current ventilation needs of the zone. DCV is a passive system; direct control of the indoor fan is not possible with standard or low leak economizers. The CO₂ sensor kit is available as a field installed accessory.

Economizer

Economizers may be equipped with dry bulb.

Electric Heaters

Electric heat is available as a field installed option.

Low Leak Economizer with Fault Detection and Diagnostics

This economizer meets the damper leakage requirements for ASHRAE 90.2, IECC, and California Title 24 standards (3 cfm/ft² at 1.0 in. w.g. for outside air dampers and 3 cfm/ft² for return dampers).

Manual Outside Air Damper

A 0-33 percent manual air damper is available.

Motorized Outside Air Damper

A 0–33 percent motorized outside air dampers is available.

Power Exhaust

This option is available on downflow and horizontal units and provides exhaust of the return air to maintain proper building pressurization. This is an excellent option for relieving most building overpressurization problems.

Barometric Relief

Designed to be used on horizontal configuration only. The downflow economizers have a barometric relief built into the economizer.

This product line offers an optional barometric relief damper for use in conjunction with economizer option. This accessory consists of gravity dampers which open with increased pressure. As building pressure increases, the pressure in the unit return air section also increases, opening the dampers and relieving the conditioned space.

Notes:

- *The effectiveness of barometric relief damper during economizing operation is system related.*
- *Pressure drop of the return air system should be considered to control building pressurization.*

Remote Potentiometer

When installed in the economizer control circuitry, this accessory provides a method to remotely adjust the minimum damper position (available with BAYECON310* BAYECON311*).

Roof Curbs

Available for downflow units. Only one roof curb for all 7.5 to 12.5 ton Foundation® units simplifies curb selection.

Thermostats

Available in programmable and non-programmable.

Through-the-Base Electrical Utility Access

An electrical service entrance shall be provided allowing access for both control and main power connections inside the curb and through the base of the unit. This option will allow for field installation of liquid-tight conduit and an external field installed disconnect switch.

Factory provided through the base openings simplify wiring and piping. Because these utility openings frequently minimize the number of roof penetrations, the integrity of roofing materials is enhanced.

Tool-less Hail Guards

Tool-less, hail protection quality coil guards shall be field-installed for condenser coil protection. This option protects the condenser coil from vandalism and/or hail damage.

Other Benefits

Easy to Install, Service and Maintain

Because today's owners are very cost-conscious when it comes to service and maintenance, Foundation was designed with direct input from service contractors. This valuable information helped to design a product that would get the service technician off the job quicker and save the owner money. Foundation does this by offering outstanding standard features enhanced by a variety of factory and field installed options, multiple control options, rigorously tested proven designs and superior product and technical support.

Outstanding Flexibility

The Foundation 7.5-12.5 ton units match the footprint of specific Carrier WeatherMaker™ units.

Rigorous Testing

All of Foundation's designs were rigorously rain tested at the factory to ensure water integrity. Each part of the top overlaps in such a way that water cannot leak into the unit. These overlapped edges are gasketed and sealed to ensure superior water integrity.

Actual shipping tests were performed to determine packaging requirements. Factory shake tests were used as part of the package design process to help assure that the unit arrives at the job site in top condition.

All parts are inspected at the point of final assembly. Sub-standard parts are identified and rejected immediately. Every unit receives a 100% unit run test before leaving the production line to make sure it lives up to rigorous requirements.

Unmatched Support

Trane Sales Representatives are a Support Group that can assist you with:

- Product



Features and Benefits

- Special Applications
- Application
- Specifications
- Service
- Computer Programs and much more
- Training



Application Considerations

A2L Application Considerations

This product is listed to UL standard 60335-2-40, Household and Similar Electrical Appliances – Safety – Part 2-40: Particular Requirements for Electrical Heat Pumps, Air-Conditioners and Dehumidifiers, which defines safe design and use strategies for equipment using A2L refrigerants. This standard limits the refrigerant concentration in a space in the event of a refrigerant leak. To meet the requirements, the UL standard defines minimum room area, refrigerant charge limit, minimum circulation airflow and/or ventilation airflow requirements, and limits the use of ignition sources in spaces. The standard may require a unit refrigerant leak detection system.

For equipment with R-454B and charge amounts less than or equal to 3.91 lbs per circuit, this UL standard does not prescribe a room area limit and does not require a refrigerant leak detection system or any circulation airflow or ventilation airflow mitigation strategies. However, ignition sources in ductwork must be evaluated.

Depending on the application, a specific requirement of ANSI/ASHRAE Standard 15, Safety Standard for Refrigeration Systems, could be more stringent than UL 60335-2-40 requirements. See *Refrigeration Systems and Machinery Rooms Application Considerations for Compliance with ASHRAE® Standard 15-2022 Application Engineering Manual (APP-APM001*-EN)* for more information.

Minimum Room Area Limits (Refrigerant charge greater than 3.91 lb per circuit)

Equipment with R-454B charge amounts greater than 3.91 lb per circuit may require additional circulation or ventilation airflow mitigation strategies. In this case, two minimum room area (A_{min}) thresholds:

- The first threshold defines when equipment serving a single room is required to provide circulation airflow, either continuous or activated by a leak detection system. A ducted system requires circulation airflow unless the smallest room it serves is larger than the adjusted A_{min} threshold. This product contains a leak detection system if a circuit charge is greater than 3.91 lbs. As a result, no further leak detection system evaluation is required.
- The second threshold defines when additional ventilation airflow is required. If the room area, A or TA, is below the adjusted A_{min} or TA_{min} threshold, additional ventilation is required to remove refrigerant in the event of a leak. Refer to UL 60335-2-40 Clause GG.8 and ANSI/ASHRAE Standard 15 Section 7 for natural and mechanical ventilation requirements. For minimum room area, see equipment nameplate or unit Installation, Operation, and Maintenance (IOM) manual.

Minimum Room Area (A_{min}) Adjustments

- **Altitude:** The A_{min} threshold changes with altitude. Multiple the altitude adjustment factor in the following table by A_{min} shown on the unit nameplate or in the Installation, Operation, and Maintenance (IOM) manual.

Table 1. Altitude adjustment factor

Altitude (ft)	Sea Level to 2000	2001 to 4000	4001 to 6000	6001 to 8000	8001 to 10000	10001 to 12000	12001 to 14000	14001 to 15000	Over 15000
A_{min} Adjustment	1	1.05	1.11	1.17	1.24	1.32	1.41	1.51	1.57

- **Height :** A_{min} can be adjusted if the unit is installed in a room at a height higher than the minimum height shown on the unit. Multiply A_{min} by the ratio of the unit minimum release height (in meters) / actual release height (in meters).
- **Institutional Occupancies:** For institutional occupancies, ASHRAE Standard 15 applies an additional adjustment factor, FOCC, to the amount of charge allowed in a space. To calculate the adjusted A_{min} for institutional occupancies, divide the A_{min} on the nameplate by 0.5.

Determining Room Area (A or TA)

The room area (A) is the room area enclosed by the projection to the floor of the walls, partitions, and doors of the space that the equipment serves. For ducted systems, total room area (TA) of all rooms connected by ducts, may be used instead of A.

Rooms connected by drop ceilings only are not considered a single room.

Rooms on the same floor of the building, and connected by an open passageway, can be considered part of the same room if the passageway is a permanent opening, extends to the floor and is intended for people to walk through.



Application Considerations

Adjacent rooms on the same floor of the building and connected by permanent openings in the walls and/or doors between rooms (including gaps between the wall and the floor), can be considered part of the same room if the openings meet the following criteria.

- The opening is permanent and cannot be closed.
- Openings extending to the floor, such as door gaps, need to be at least 20 mm above the floor covering surface.
- Natural ventilations opening areas must meet the requirements of ANSI/ASHRAE Standard 15-2022, Section 7.2.3.2.

Rooms that are connected by a mechanical ventilation system can be considered a single room area if the mechanical ventilation system meets the requirements of ANSI/ASHRAE Standard 15-2022, Section 7.6.4.

Leak Detection System (Refrigerant charge greater than 3.91 lb per circuit)

The leak detection system consists of one or more refrigerant detection sensors. When the system detects a leak, the following mitigation actions will be initiated until refrigerant has not been detected for at least 5 minutes:

- Energize the supply fan(s) to deliver a required minimum amount of circulation airflow.
- Disable compressor operation.
- Provide an output signal that can be used to fully open zone dampers and/or VAV boxes and disable electric heat in VAV boxes.
- Provide an output signal that can be used to energize additional mechanical ventilation (if needed).
- Units without airflow proving will disable electric heat sources.

Building fire and smoke systems may override this function.

If the refrigerant sensor has a fault, is at the end of its life, or is disconnected, the unit will initiate the mitigation actions. Mitigation actions may be verified by disconnecting the sensor.

The refrigerant sensors do not need service. Use only manufacturer-approved sensors when replacement is required.



Selection Procedure

Cooling Capacity

1. Calculate the building's total and sensible cooling loads for the building at design conditions. Use the following calculation methods or any other standard accepted method.

Factors used in unit selection:

- Total Cooling Load: 120 MBh
- Sensible Cooling Load: 96 MBh
- Airflow: 4000 cfm
- Electrical Characteristics: 460/60/3
- Summer Design Conditions: Entering Evaporator Coil: 80°F DB/67°F WB
- Outdoor Ambient: 95°F
- External Static Pressure: 0.38 in. wg
- Rooftop – Downflow configuration
- Accessories: Roof Curb, Electric Heat

2. As a starting point, a rough determination must be made of the size of the unit. The final selection will be made after examining the performance at the given conditions. Divide the total cooling load by nominal Btuh per ton (12 MBh per ton); then round up to the nearest unit size.

$$120 \text{ MBh} / 12 \text{ MBh} = 10 \text{ Tons}$$

3. GDK120A has a gross cooling capacity of 121.8 MBh and 97.7 MBh sensible capacity at 4000 cfm and 95 DB outdoor ambient with 80 DB, 67 WB air entering the evaporator. See [Table 9, p. 23](#).

Note: Find capacity at intermediate conditions not in the table.

When design conditions are between two numbers that are in the capacity table, interpolation is required to approximate the capacity.

Note: Extrapolation outside of the table conditions is not recommended.

4. In order to select the correct unit which meets the building's requirements, the fan motor heat must be deducted from the gross cooling capacity. The amount of heat that the fan motor generates is dependent on the effort by the motor - cfm and static pressure. To determine the total unit static pressure you add the external static pressure to the additional static related by the added features:

External Static Duct System	0.38 wg
Standard Filter 2 in. See .	0.05 wg
Electric Heater Size kW See .	0.07 wg
Total Static Pressure	0.47 wg

Note: Reference heating capacity section on this page for determination of heater size. No additional static add for gas/heat exchanger.

Note: The Evaporator Fan Performance [Table 33, p. 34](#) has already accounted for the pressure drop for standard filters and wet coils. Therefore, the actual total static pressure is $0.47 - 0.05 = 0.42 \text{ wg}$.

With 4000 cfm and 0.42 wg., [Table 33, p. 34](#) shows 1.85 bhp for this unit.

$$3\text{-hp fan motor heat (MBh)} = 2.90 \times \text{fan bhp} + 0.4750$$

$$2.90 \times 1.85 + 0.4750 = 5.84 \text{ MBh}$$

Now subtract the fan motor heat from the gross cooling capacity of the unit:

$$\text{Net Total Cooling Capacity} = 122.1 \text{ MBh} - 5.84 = 116.26 \text{ MBh.}$$

$$\text{Net Sensible Cooling Capacity} = 96.3 \text{ MBh} - 5.84 = 90.46 \text{ MBh.}$$



Selection Procedure

5. Compare your resulting capacities to the building load. If the performance will not meet the required load of the building's total or sensible cooling load, try a selection at the next higher size unit.

Heating Capacity

Note: Heating capacity procedures DIFFER for cooling (E) and gas/electric (G) units.

1. Calculate the building heating load.
2. Size the system heating capacity to match the calculated building heating load. The following are building heating requirements:
 - 460 volt/3 phase Power Supply
 - Total heating load of 100.0 MBh
 - 4000 cfm

The electric heat accessory capacities are listed in . From the table, a 32 kW heater will deliver 109.2 MBh at 480 volts. In order to determine capacity at 460 volts, the heater voltage correction factor from [Table 49, p. 41](#) must be used. Therefore, $109.2 \text{ MBh} \times 0.92$ (voltage correction factor) = 102.6 MBh.

Gas/electric: Fuel natural gas total heating load of 100 MBh. shows 125 MBh and 180 MBh input models. The output capacities of these furnaces are 100 MBh and 144 MBh respectively. The low heat model with 100 MBh output best matches the building requirements.

Air Delivery Selection

External static pressure drop through the air distribution system has been calculated to be 0.38 inches of water. The 32 kW heater is 0.04 inches of water (0.38 + 0.04). Enter input for a EDK120A4E0 at 4000 cfm and 0.42 static pressure. The standard motor will give the desired airflow at 752 rpm and rated bhp of 1.85. See [Table 33, p. 34](#).



Model Number Description

Digit 1 — Unit Type

E = Packaged Cooling, Electric Heat
G = Packaged Gas/Electric

Digit 2 — Efficiency

D = Standard Efficiency

Digit 3 — Airflow Configuration/Refrigerant

K = R-454B

Digit 4, 5, 6 — Nominal Gross Cooling Capacity (MBh)

090 = 7.5 Tons
102 = 8.5 Tons
120 = 10 Tons
150 = 12.5 Tons

Digit 7 — Major Design Sequence

A = Rev A

Digit 8 — Voltage Selection

3 = 208-230/60/3
4 = 460/60/3
W = 575/60/3

Digit 9 — Unit Controls

E = Electromechanical

Digit 10 — Heating Capacity

0 = Cooling Only (field installed electric heat)
H = Gas Heat - High
L = Gas Heat - Low
M = Gas Heat - Medium

Note: The 575V models are only available with high gas.

Digit 11— Minor Design Sequence

A = Rev A

Digit 12, 13 — Service Sequence

00 = None

Digit 14 — Fresh Air Selection

0 = No Fresh Air Options

Note: Fresh air options are available as field installed accessories.

Digit 15 — Supply Fan/Drive Type/Motor

7 = Multi-Speed Standard Motor
9 = Multi-Speed Oversized Motor

Digit 16 — Unit

M = Medium Foundation

Digit 17 — Condenser Coil Protection

0 = Standard Coil

Digit 18 — Through The Base Provisions

0 = No Through the Base Provisions

Digit 19 — Disconnect Switch

0 = No Disconnect/No Circuit Breaker

Digit 20 to 24

Not Used



General Data

Table 2. General data – 7.5 to 12.5 tons – 208/230V

	7.5 Ton	8.5 Ton	10 Ton	12.5 Ton
	E/GDK090	E/GDK102	E/GDK120	E/GDK150
Cooling Performance^(a)				
Gross Cooling Capacity	90000	110000	120000	146000
EER (Downflow/Horizontal)	11.6	11.2	11.2	11.0
Nominal Airflow CFM / AHRI Rated CFM	3200/3200 (EDK)	3700/3700 (EDK)	4000/4000 (EDK)	4600/4600 (EDK)
	3000/3000 (GDK)	3500/3500 (GDK)	3600/3600 (GDK)	4000/4000 (GDK)
AHRI Net Cooling Capacity	86000	104000	114000	140000
Integrated Energy Efficiency Ratio (IEER)	14.8/14.6	14.8/14.6	14.8/14.6	14.2/14.0
Percent Capacity @ part load (Stage 1/Stage 2)	60/100	56/100	57/100	60/100
System Power (kW)	7.41	9.29	10.18	12.73
Compressor				
Number/Type	2 / Scrolls	2 / Scrolls	2 / Scrolls	2 / Scrolls
Stage(s)				
Circuit A	Single	Two Stage	Two Stage	Single
Circuit B	Single	Single	Single	Two Stage
Oil Type				
	POE	POE	POE	POE
Oil/Charge (oz)				
Circuit A	43.3 ± 0.7oz	43.3 ± 0.7oz	43.3 ± 0.7oz	1.57 L ± 0.7oz
Circuit B	25 ± 0.7oz	43.3 ± 0.7oz	1.57 L ± 0.7oz	43.3 ± 0.7oz
Compressor Refrigerant Piping Size (in.)				
Circuit A	7/8 / 1/2	7/8 / 1/2	7/8 / 1/2	7/8 / 1/2
Circuit B	3/4/1/2	7/8 / 1/2	7/8 / 1/2	7/8 / 1/2
Sound				
Outdoor Sound Rating (BELS)	8.4	8.4	8.4	8.9
Outdoor Coil				
Type	Microchannel	Microchannel	Microchannel	Microchannel
Coil Width (in.) (System A + System B)	0.63+0.63	0.81+1.0	0.81+1.0	1.26+1.26
Face Area (sq. ft.)	27.38	27.38	27.38	27.38
Rows/FPI	1/23	1/23	1/23	1/23
Indoor Coil				
Type	Microchannel	Microchannel	Microchannel	Microchannel
Coil Width (in.) Tube Size (in.) ID	0.79	0.79	1.26	1.26
Face Area (sq. ft.)	27.38	27.38	27.38	27.38
Rows/FPI	1/23	1/23	1/23	1/23
Refrigerant Control	EXV	EXV	EXV	EXV
Drain Connection Number/Size (in.)	1 / 3/4 PVC Pipe Socket	1 / 3/4 PVC Pipe Socket	1 / 3/4 PVC Pipe Socket	1 / 3/4 PVC Pipe Socket
Outdoor Fan				
Type	Propeller	Propeller	Propeller	Propeller
Number Used/Diameter (in.)	2 / 23-1/2	2 / 23-1/2	2 / 23-1/2	2 / 23-1/2
Drive Type/No. Speeds	Direct / 18	Direct / 18	Direct / 18	Direct / 18
cfm	8400	8300	8300	9500
Number Motors/hp	2 / 1/3 HP	2 / 1/3 HP	2 / 1/3 HP	2 / 1/3 HP
Motor rpm Max.	960	960	960	1070
Indoor Fan				
Type	FC Centrifugal	FC Centrifugal	FC Centrifugal	FC Centrifugal
Number Used/Diameter (in.)	1 / 15x15	1 / 15x15	1 / 15x15	1 / 15x15
Drive Type/No. Speeds	Belt / 2 VFD	Belt / 2 VFD	Belt / 2 VFD	Belt / 2 VFD
Number Motors	1	1	1	1
Motor hp (Standard/Oversized)	2.0 / 3.0	2.0 / 5.0	3.0 / 5.0	3.0 / 5.0
Motor rpm (Standard/Oversized)	1725	1725	1725	1725
Motor Frame Size (Standard/Oversized)	56 / 56	56 / 56	56 / 56	56 / 56
Filters				

Table 2. General data – 7.5 to 12.5 tons – 208/230V (continued)

	7.5 Ton	8.5 Ton	10 Ton	12.5 Ton
	E/GDK090	E/GDK102	E/GDK120	E/GDK150
Cooling Performance^(a)				
Type Furnished	Throwaway	Throwaway	Throwaway	Throwaway
Number Size Recommended	(4) 20x20x2	(4) 20x20x2	(4) 20x20x2	(4) 20x20x2
Refrigerant Charge (lbs) (R-454B)^(b)				
Circuit A	3.75lbs	4.30lbs	5.07lbs	6.83lbs
Circuit B	3.09lbs	3.86lbs	4.41lbs	5.51lbs

^(a) Units are AHRI Certified to AHRI Standard 340-360 (I-P). Rating conditions are 95°F outdoor air temperature, 80°F entering dry bulb, 67°F entering wet bulb with minimum external static pressure as determined by rating standard.

^(b) Refrigerant charge is an approximate value. For a more precise value, see unit nameplate and service instructions.

Table 3. General data – 7.5 to 12.5 tons – 460V

	7.5 Ton	8.5 Ton	10 Ton	12.5 Ton
	E/GDK090	E/GDK102	E/GDK120	E/GDK150
Cooling Performance^(a)				
Gross Cooling Capacity	90000	110000	120000	146000
EER (Downflow/Horizontal)	11.6	11.2	11.2	11.0
Nominal Airflow CFM / AHRI Rated CFM	3200/3200 (EDK)	3700/3700 (EDK)	4000/4000 (EDK)	4600/4600 (EDK)
	3000/3000 (GDK)	3500/3500 (GDK)	3600/3600 (GDK)	4000/4000 (GDK)
AHRI Net Cooling Capacity	86000	104000	114000	140000
Integrated Energy Efficiency Ratio (IEER)	14.8/14.6	14.8/14.6	14.8/14.6	14.2/14.0
Percent Capacity @ part load (Stage 1/Stage 2)	60/100	56/100	57/100	60/100
System Power (kW)	7.41	9.29	10.18	12.73
Compressor				
Number/Type	2 / Scrolls	2 / Scrolls	2 / Scrolls	2 / Scrolls
Stage(s)				
Circuit A	Single	Two Stage	Two Stage	Single
Circuit B	Single	Single	Single	Two Stage
Oil Type				
Oil/Charge				
Circuit A	43.3 ± 0.7oz	43.3 ± 0.7oz	43.3 ± 0.7oz	1.57 L ± 0.7oz
Circuit B	25 ± 0.7oz	43.3 ± 0.7oz	1.57 L ± 0.7oz	43.3 ± 0.7oz
Compressor Refrigerant Piping Size (in.)				
Circuit A	7/8/ 1/2	7/8/ 1/2	7/8/ 1/2	7/8/ 1/2
Circuit B	3/4/1/2	7/8/ 1/2	7/8/ 1/2	7/8/ 1/2
Sound				
Outdoor Sound Rating (BELS)	8.4	8.4	8.4	8.9
Outdoor Coil				
Type	Microchannel	Microchannel	Microchannel	Microchannel
Coil Width (in.) (System A + System B)	0.63+0.63	0.81+1.0	0.81+1.0	1.26+1.26
Face Area (sq. ft.)	27.38	27.38	27.38	27.38
Rows/FPI	1/23	1/23	1/23	1/23
Indoor Coil				
Type	Microchannel	Microchannel	Microchannel	Microchannel
Coil Width (in.) Tube Size (in.) ID	0.79	0.79	1.26	1.26
Face Area (sq. ft.)	27.38	27.38	27.38	27.38
Rows/FPI	1/23	1/23	1/23	1/23
Refrigerant Control	EXV	EXV	EXV	EXV
Drain Connection Number/Size (in.)	1 / 3/4 PVC Pipe Socket	1 / 3/4 PVC Pipe Socket	1 / 3/4 PVC Pipe Socket	1 / 3/4 PVC Pipe Socket
Outdoor Fan				
Type	Propeller	Propeller	Propeller	Propeller
Number Used/Diameter (in.)	2 / 23-1/2	2 / 23-1/2	2 / 23-1/2	2 / 23-1/2
Drive Type/No. Speeds	Direct / 18	Direct / 18	Direct / 18	Direct / 18
cfm	8400	8300	8300	9500
Number Motors/hp	2 / 1/3HP	2 / 1/3HP	2 / 1/3HP	2 / 3/4HP



General Data

Table 3. General data – 7.5 to 12.5 tons – 460V (continued)

	7.5 Ton	8.5 Ton	10 Ton	12.5 Ton
	E/GDK090	E/GDK102	E/GDK120	E/GDK150
Cooling Performance^(a)				
Motor rpm Max.	960	960	960	1070
Indoor Fan				
Type	FC Centrifugal	FC Centrifugal	FC Centrifugal	FC Centrifugal
Number Used/Diameter (in.)	1 / 15X15	1 / 15X15	1 / 15X15	1 / 15X15
Drive Type/No. Speeds	Belt / 2 VFD	Belt / 2 VFD	Belt / 2 VFD	Belt / 2 VFD
Number Motors	1	1	1	1
Motor hp (Standard/Oversized)	2.0 / 3.0	2.0 / 5.0	3.0 / 5.0	3.0 / 5.0
Motor rpm (Standard/Oversized)	1725	1725	1725	1725
Motor Frame Size (Standard/Oversized)	56/56	56/56	56/56	56/56
Filters				
Type Furnished	Throwaway	Throwaway	Throwaway	Throwaway
Number Size Recommended	(4) 20x20x2	(4) 20x20x2	(4) 20x20x2	(4) 20x20x2
Refrigerant Charge (lbs) (R-454B)^(b)				
Circuit A	3.75	4.3	5.07	6.83
Circuit B	3.09	3.86	4.41	5.51

^(a) Units are AHRI Certified to AHRI Standard 340-360 (I-P). Rating conditions are 95°F outdoor air temperature, 80°F entering dry bulb, 67°F entering wet bulb with minimum external static pressure as determined by rating standard.

^(b) Refrigerant charge is an approximate value. For a more precise value, see unit nameplate and service instructions.

Table 4. General data – 7.5 to 12.5 tons – 575V

	7.5 Ton	8.5 Ton	10 Ton	12.5 Ton
	GDK090	GDK102	GDK120	GDK150
Cooling Performance^(a)				
Gross Cooling Capacity	90000	110000	120000	146000
EER (Downflow/Horizontal)	11.6	11.2	11.2	11.0
Nominal Airflow CFM / AHRI Rated CFM	3000	3500	3600	4000
AHRI Net Cooling Capacity	86000	104000	114000	140000
Integrated Energy Efficiency Ratio (IEER)	14.6	14.6	14.6	14.0
Percent Capacity @ part load (Stage 1/Stage 2)	60/100	56/100	57/100	60/100
System Power (kW)	7.41	9.29	10.18	12.73
Compressor				
Number/Type	2 / Scrolls	2 / Scrolls	2 / Scrolls	2 / Scrolls
Stage(s)				
Circuit A	Single	Two Stage	Two Stage	Single
Circuit B	Single	Single	Single	Two Stage
Oil Type				
Oil/Charge (oz)				
Circuit A	43.3 ± 0.7oz	43.3 ± 0.7oz	43.3 ± 0.7oz	1.57 L ± 0.7oz
Circuit B	25 ± 0.7oz	43.3 ± 0.7oz	1.57 L ± 0.7oz	43.3 ± 0.7oz
Compressor Refrigerant Piping Size (in.)				
Circuit A	7/8 / 1/2	7/8 / 1/2	7/8 / 1/2	7/8 / 1/2
Circuit B	3/4 / 1/2	7/8 / 1/2	7/8 / 1/2	7/8 / 1/2
Sound				
Outdoor Sound Rating (BELS)	8.4	8.4	8.4	8.9
Outdoor Coil				
Type	Microchannel	Microchannel	Microchannel	Microchannel
Coil Width (in.) (System A + System B)	0.63+0.63	0.81+1.0	0.81+1.0	1.26+1.26
Face Area (sq. ft.)	27.38	27.38	27.38	27.38
Rows/FPI	1/23	1/23	1/23	1/23
Indoor Coil				
Type	Microchannel	Microchannel	Microchannel	Microchannel
Coil Width (in.) Tube Size (in.) ID	0.79	0.79	1.26	1.26
Face Area (sq. ft.)	12.88	12.88	12.88	12.88

Table 4. General data – 7.5 to 12.5 tons – 575V (continued)

	7.5 Ton	8.5 Ton	10 Ton	12.5 Ton
	GDK090	GDK102	GDK120	GDK150
Rows/FPI	1/20	1/20	1/20	1/20
Refrigerant Control	EXV	EXV	EXV	EXV
Drain Connection Number/Size (in.)	1 / 3/4 PVC Pipe Socket	1 / 3/4 PVC Pipe Socket	1 / 3/4 PVC Pipe Socket	1 / 3/4 PVC Pipe Socket
Outdoor Fan				
Type	Propeller	Propeller	Propeller	Propeller
Number Used/Diameter (in.)	2 / 23-1/2	2 / 23-1/2	2 / 23-1/2	2 / 23-1/2
Drive Type/No. Speeds	Direct / 18	Direct / 18	Direct / 18	Direct / 18
cfm	8400	8300	8300	9500
Number Motors/hp	2 / 1/3HP	2 / 1/3HP	2 / 1/3HP	2 / 3/4HP
Motor rpm Max.	960	960	960	1070
Indoor Fan				
Type	FC Centrifugal	FC Centrifugal	FC Centrifugal	FC Centrifugal
Number Used/Diameter (in.)	1 / 15X15	1 / 15X15	1 / 15X15	1 / 15X15
Drive Type/No. Speeds	Belt / 2 VFD	Belt / 2 VFD	Belt / 2 VFD	Belt / 2 VFD
Number Motors	1	1	1	1
Motor hp (Standard/Oversized)	2.0 / 3.0	2.0 / 5.0	3.0 / 5.0	3.0 / 5.0
Motor rpm (Standard/Oversized)	1725	1725	1725	1725
Motor Frame Size (Standard/Oversized)	56/56	56/56	56/56	56/56
Filters				
Type Furnished	Throwaway	Throwaway	Throwaway	Throwaway
Number Size Recommended	(4) 20x20x2	(4) 20x20x2	(4) 20x20x2	(4) 20x20x2
Refrigerant Charge (lbs) (R-454B)^(b)				
Circuit A	3.75lbs	4.30lbs	5.07lbs	6.83lbs
Circuit B	3.09lbs	3.86lbs	4.41lbs	5.51lbs

^(a) Units are AHRI Certified to AHRI Standard 340-360 (I-P) . Rating conditions are 95°F outdoor air temperature, 80°F entering dry bulb, 67°F entering wet bulb with minimum external static pressure as determined by rating standard.

^(b) Refrigerant charge is an approximate value. For a more precise value, see unit nameplate and service instructions.

Table 5. General data – heating performance – 7.5 to 12.5 tons (208/230V and 460V)

	Heating Performance ^(a)					
	7.5 to 8.5 Tons			10 to 12.5 Tons		
	Low	Medium	High	Low	Medium	High
Heating Models						
Heating Input (Btu/h)	125000	180000	225000	180000	225000	250000
1 st Stage (Btu)	87500	126000	157500	126000	157500	200000
Heating Output (Btu/h)	100000	144000	180000	144000	180000	200000
1 st Stage (Btu)	70000	100000	125000	100000	125000	160000
Steady State Efficiency %	81%	81%	81%	81%	81%	81%
No. Burners	3	5	6	5	6	6
No. Stages	2	2	2	2	2	2
Gas Supply Line Pressure (in. wc)						
Natural Gas (minimum/maximum)	4.5 / 14.0	4.5 / 14.0	4.5 / 14.0	4.5 / 14.0	4.5 / 14.0	4.5 / 14.0
LP (minimum/maximum)	11.0/14.0	11.0/14.0	11.0/14.0	11.0/14.0	11.0/14.0	11.0/14.0
Gas Connection Pipe Size (in.)	1/2	1/2	3/4	1/2	3/4	3/4

^(a) Heating Performance limit settings and rating data were established and approved under laboratory test conditions using American National Standards Institute standards (ANSI). Ratings shown are for elevations up to 2000 feet. For elevations above 2000 feet, ratings should be reduced at the rate of 4% for each 1000 feet above sea level.

Table 6. General data – heating performance – 7.5 to 12.5 tons (575V)

	Heating Performance ^(a)	
	7.5 to 8.5 Tons	10 to 12.5 Tons
	High	High
Heating Models		
Heating Input (Btu/h)	225000	250000



General Data

Table 6. General data – heating performance – 7.5 to 12.5 tons (575V) (continued)

	Heating Performance ^(a)	
	7.5 to 8.5 Tons	10 to 12.5 Tons
1 st Stage (Btu)	157500	200000
Heating Output (Btu/h)	180000	200000
1 st Stage (Btu)	125000	160000
Steady State Efficiency %	81%	81%
No. Burners	6	6
No. Stages	2	2
Gas Supply Line Pressure (in. wc)		
Natural Gas (minimum/maximum)	4.5 / 14.0	4.5 / 14.0
LP (minimum/maximum)	11.0/14.0	11.0/14.0
Gas Connection Pipe Size (in.)	3/4	3/4

^(a) Heating Performance limit settings and rating data were established and approved under laboratory test conditions using American National Standards Institute standards (ANSI). Ratings shown are for elevations up to 2000 feet. For elevations above 2000 feet, ratings should be reduced at the rate of 4% for each 1000 feet above sea level.



Performance Data

Gross Cooling Capacities

Table 7. Gross cooling capacities 7.5 tons

CFM	Ent DB (° F)	Ambient Temperature (°F)						Ambient Temperature (°F)						Ambient Temperature (°F)					
		85						95						105					
		Entering Wet Bulb Temp (°F)						Entering Wet Bulb Temp (°F)						Entering Wet Bulb Temp (°F)					
		61		67		73		61		67		73		61		67		73	
		MBh	SHC	MBh	SHC	MBh	SHC	MBh	SHC	MBh	SHC	MBh	SHC	MBh	SHC	MBh	SHC	MBh	SHC
2400	75	81.4	55.6	90.9	47.0	100.6	35.9	73.3	53.6	85.5	43.8	92.8	36.0	67.0	50.2	76.4	41.9	86.2	34.3
	80	81.6	68.8	91.2	58.1	100.9	49.1	73.5	64.8	85.7	56.5	92.7	43.4	67.2	59.3	76.6	53.9	86.2	44.8
	85	82.0	77.1	91.5	64.9	101.0	61.5	73.9	71.1	86.2	64.9	93.7	53.0	67.6	64.5	77.1	62.0	87.2	50.7
	90	82.8	78.6	92.4	67.8	101.8	64.1	74.8	74.8	87.3	68.9	94.7	56.2	68.4	68.4	78.0	65.9	88.1	53.9
2700	75	84.6	57.0	94.1	46.5	103.9	39.4	76.3	58.7	88.7	48.0	96.2	41.8	69.9	54.9	79.5	45.9	89.6	42.4
	80	84.8	75.0	94.4	63.3	104.3	53.4	76.5	70.7	89.0	61.6	96.3	49.4	70.1	64.6	79.7	58.8	89.7	43.6
	85	85.3	79.5	94.9	70.9	104.7	67.3	77.0	75.4	89.5	70.7	96.7	57.8	70.7	69.1	80.3	67.7	90.0	55.1
	90	86.1	82.1	95.8	75.2	105.2	71.0	78.0	78.0	90.6	73.7	98.3	68.0	71.5	71.5	81.3	67.3	91.6	59.6
3000	75	85.0	65.5	94.6	56.5	104.4	44.9	76.7	62.9	89.1	52.7	96.7	49.4	70.2	58.7	79.9	50.1	90.0	47.1
	80	85.2	79.6	94.9	68.4	104.8	58.9	76.9	74.9	89.4	66.4	96.8	54.5	70.5	68.4	80.1	63.1	90.1	48.3
	85	85.7	84.2	95.4	76.0	105.2	72.9	77.4	77.4	89.9	75.6	97.2	62.9	71.1	71.1	80.7	68.9	90.4	59.9
	90	86.5	86.5	96.3	80.4	105.7	76.7	78.4	78.4	91.1	75.9	98.8	73.3	71.9	71.9	81.7	68.4	92.1	64.5
3300	75	85.9	71.7	95.6	60.6	105.7	46.3	77.3	68.8	90.0	56.4	97.7	34.1	70.8	64.6	80.6	53.9	90.9	32.9
	80	86.2	76.4	96.1	73.7	106.2	62.4	77.8	77.8	90.4	71.7	98.4	65.3	71.2	71.2	81.0	68.7	91.6	62.5
	85	87.0	82.7	97.0	73.6	106.9	68.3	78.6	78.6	91.4	83.2	99.3	86.6	71.8	71.8	81.8	79.5	92.4	82.8
	90	87.6	83.2	97.7	78.9	107.5	71.9	79.4	79.4	92.4	83.4	99.3	99.3	72.6	72.6	82.7	82.7	92.4	92.4

CFM	Ent DB (° F)	Ambient Temperature (°F)						Ambient Temperature (°F)						Ambient Temperature (°F)					
		115						120						125					
		Entering Wet Bulb Temp (°F)						Entering Wet Bulb Temp (°F)						Entering Wet Bulb Temp (°F)					
		61		67		73		61		67		73		61		67		73	
		MBh	SHC	MBh	SHC	MBh	SHC	MBh	SHC	MBh	SHC	MBh	SHC	MBh	SHC	MBh	SHC	MBh	SHC
2400	75	57.6	47.2	67.9	40.6	77.7	33.2	49.1	44.0	62.7	42.5	71.6	32.3	26.9	24.1	32.9	23.8	37.5	19.8
	80	57.8	51.0	68.0	49.5	77.8	39.1	49.5	48.0	62.8	44.5	71.9	42.8	27.1	24.3	33.0	23.7	37.7	22.1
	85	58.1	56.7	68.4	53.2	78.6	48.9	49.9	63.2	45.5	72.7	44.3	27.3	27.3	33.2	25.6	38.1	24.7	
	90	58.8	58.8	69.2	56.4	79.5	52.1	50.4	50.4	63.9	48.6	73.4	43.6	27.6	27.6	33.6	26.2	38.5	25.3
2700	75	60.4	51.7	70.8	44.6	81.0	35.7	51.8	51.4	65.5	47.0	75.0	40.1	29.4	26.7	35.4	26.3	40.3	24.6
	80	60.6	55.7	71.0	49.9	81.3	42.3	52.1	51.8	65.8	47.4	75.2	41.2	29.5	29.0	35.5	26.9	40.4	25.3
	85	61.0	59.3	71.5	55.6	81.7	47.8	52.5	52.0	66.2	48.2	75.4	44.4	29.7	29.3	35.7	27.2	40.5	25.4
	90	61.7	61.7	72.3	57.0	82.4	50.0	53.2	53.2	67.0	51.5	76.7	46.0	30.0	30.0	36.1	28.4	41.2	25.8
3000	75	60.7	55.0	71.2	48.4	81.4	40.0	52.1	54.2	65.8	50.6	75.4	44.1	29.5	28.3	35.6	27.2	40.5	26.7
	80	60.9	59.0	71.4	53.8	81.7	46.6	52.4	54.7	66.1	50.9	75.6	45.2	29.6	29.6	35.7	27.8	40.6	27.0
	85	61.3	61.3	71.9	59.5	82.1	52.2	52.8	52.8	66.5	50.5	75.8	48.5	29.8	29.8	35.9	28.0	40.7	27.2
	90	62.0	62.0	72.7	60.9	82.8	54.4	53.5	53.5	67.3	51.8	77.1	47.7	30.2	30.2	36.3	28.4	41.4	27.6
3300	75	61.1	61.1	71.7	52.4	82.2	41.0	55.1	55.1	66.4	54.8	76.7	46.7	30.7	30.7	35.5	29.0	40.7	28.0
	80	61.4	61.4	72.1	66.7	82.6	60.2	55.3	55.3	66.7	53.5	76.6	51.2	30.8	30.8	35.6	29.3	40.8	28.2
	85	61.9	61.9	72.8	72.8	83.3	76.3	55.6	55.6	67.3	54.0	77.4	51.9	31.0	31.0	36.0	29.2	41.1	28.5
	90	62.3	62.3	73.5	73.5	83.9	83.9	56.2	56.2	68.0	54.6	77.2	51.8	31.3	31.3	36.3	29.5	41.1	28.6

Notes:

1. All capacities shown are gross and have not considered indoor fan heat. To obtain NET cooling capacity subtract indoor fan heat. For indoor fan heat formula, refer to appropriate airflow table notes.
2. MBh = Total gross capacity
3. SHC = Sensible heat capacity
4. Ambient Temperature above 120°F, the system B shuts down.



Performance Data

Table 8. Gross cooling capacities 8.5 tons

CFM	Ent DB (°F)	Ambient Temperature (°F)						Ambient Temperature (°F)						Ambient Temperature (°F)					
		85						95						105					
		Entering Wet Bulb Temp (°F)						Entering Wet Bulb Temp (°F)						Entering Wet Bulb Temp (°F)					
		61		67		73		61		67		73		61		67		73	
		MBh	SHC	MBh	SHC	MBh	SHC	MBh	SHC	MBh	SHC	MBh	SHC	MBh	SHC	MBh	SHC	MBh	SHC
2700	75	98.8	81.6	110.3	70.5	121.4	57.0	90.9	65.2	104.2	55.2	115.8	44.6	86.0	62.0	99.4	52.4	110.1	43.8
	80	99.1	84.5	110.5	72.9	121.7	60.4	91.2	83.7	104.4	70.4	115.7	53.6	86.2	79.5	99.6	66.9	110.2	56.7
	85	99.5	94.3	110.9	81.2	121.9	75.3	92.4	90.8	105.0	80.5	116.9	64.9	87.3	85.8	100.2	76.4	111.3	63.8
	90	100.4	96.1	112.0	84.7	122.8	74.5	93.5	92.0	106.2	85.4	118.1	68.8	88.4	86.8	101.4	81.1	112.5	67.8
3050	75	100.6	75.0	112.1	64.8	123.3	48.9	92.2	70.8	105.9	60.1	117.9	54.5	86.9	68.0	101.1	58.0	112.2	54.4
	80	100.8	91.7	112.4	79.1	123.8	65.6	92.4	91.7	106.3	76.4	118.0	55.9	86.3	86.3	101.4	73.2	112.3	56.4
	85	101.4	97.1	113.0	88.3	124.2	69.6	92.8	91.6	106.9	86.4	118.5	70.4	87.0	87.0	102.1	83.5	112.7	70.7
	90	102.3	98.0	114.0	90.2	124.9	75.3	95.3	94.1	108.2	88.3	120.5	81.6	90.1	89.0	103.3	85.7	114.6	80.4
3400	75	101.9	81.8	113.8	72.1	125.1	55.9	92.6	77.2	107.7	66.8	119.6	50.1	87.6	73.2	103.0	63.1	114.1	48.8
	80	101.8	99.1	114.2	86.5	125.7	72.7	92.3	92.3	108.1	83.6	120.1	67.8	87.3	87.3	103.3	79.2	114.6	67.0
	85	102.5	99.6	115.1	94.3	126.3	85.7	93.2	93.2	109.1	86.8	120.9	74.5	87.9	87.9	104.2	84.3	115.3	74.3
	90	104.1	100.3	116.1	96.1	127.0	86.8	96.8	96.8	110.0	88.5	121.9	79.1	91.7	91.7	105.1	86.0	116.2	78.9
3750	75	102.4	88.2	115.8	78.2	127.4	59.7	92.7	82.3	109.4	72.7	117.0	43.7	86.8	77.6	104.5	69.3	111.7	44.2
	80	103.4	102.2	116.3	93.7	128.0	78.2	93.9	93.9	109.9	88.5	122.6	82.2	87.9	87.9	104.9	84.2	116.6	79.0
	85	103.6	101.3	117.4	92.2	128.8	83.2	93.7	93.7	111.1	90.3	123.7	84.1	88.3	88.3	106.0	87.5	117.6	79.7
	90	106.1	104.9	118.2	102.8	129.4	92.8	99.0	99.0	112.2	93.3	123.6	84.0	93.6	93.6	107.1	88.0	117.7	79.9
CFM	Ent DB (°F)	Ambient Temperature (°F)						Ambient Temperature (°F)						Ambient Temperature (°F)					
		115						120						125					
		Entering Wet Bulb Temp (°F)						Entering Wet Bulb Temp (°F)						Entering Wet Bulb Temp (°F)					
		61		67		73		61		67		73		61		67		73	
		MBh	SHC	MBh	SHC	MBh	SHC	MBh	SHC	MBh	SHC	MBh	SHC	MBh	SHC	MBh	SHC	MBh	SHC
2700	75	76.7	60.0	88.0	51.6	100.3	42.7	73.6	63.7	82.3	58.6	96.0	41.2	36.9	33.2	44.5	29.9	47.5	25.0
	80	76.9	75.4	88.1	65.8	100.4	50.0	74.1	66.7	82.5	60.2	96.3	43.4	37.1	35.6	44.6	33.2	47.7	27.1
	85	77.4	77.4	88.6	75.3	101.4	62.2	75.5	75.5	82.9	65.4	97.4	56.5	37.4	36.0	44.9	34.0	48.1	30.1
	90	78.9	78.9	89.7	70.9	102.5	66.2	76.2	76.2	84.8	66.7	98.4	60.0	38.4	37.0	45.3	35.3	48.6	32.4
3050	75	77.6	66.2	89.5	57.3	102.2	46.6	74.8	73.3	84.3	63.3	98.3	54.5	37.2	35.1	45.5	33.2	48.7	30.3
	80	77.4	77.3	89.8	72.1	102.5	54.9	74.8	73.5	83.6	64.9	97.8	56.4	37.4	37.3	45.7	36.1	48.8	31.6
	85	78.0	77.8	90.4	73.3	103.0	60.9	77.0	75.2	84.3	67.3	98.8	57.2	37.8	37.8	45.9	36.5	48.9	33.4
	90	80.4	80.0	91.2	74.2	103.9	61.8	77.8	76.6	86.6	69.7	100.5	59.6	39.4	39.4	46.3	37.1	49.7	34.2
3400	75	77.2	70.1	89.4	61.1	104.0	50.1	76.0	62.7	83.8	57.2	98.7	46.1	37.2	35.3	46.6	34.1	48.6	28.4
	80	78.2	78.2	90.9	72.1	104.5	63.1	77.2	70.5	84.7	66.8	99.1	61.6	37.9	37.9	46.7	36.5	50.1	30.3
	85	78.9	78.9	92.3	73.7	105.1	66.5	80.3	80.3	84.6	67.5	101.2	63.8	38.2	38.2	47.1	37.1	50.4	31.0
	90	82.1	82.1	93.1	74.9	105.9	68.4	81.0	81.0	88.4	70.8	101.9	65.0	40.2	40.2	47.4	38.0	50.6	31.6
3750	75	77.7	77.6	88.9	65.7	102.9	53.5	78.5	67.9	84.6	62.7	100.0	56.7	37.6	37.6	46.7	34.6	47.5	25.6
	80	78.7	78.7	89.8	70.3	106.4	64.2	79.6	74.5	85.4	65.4	100.0	61.2	38.2	38.2	47.2	35.4	48.1	28.0
	85	78.1	78.1	94.0	74.3	107.3	65.9	83.5	83.5	85.5	69.4	103.6	66.4	38.9	38.9	48.1	37.1	51.7	31.3
	90	81.2	81.2	94.7	76.7	107.6	68.0	84.3	84.3	90.0	74.1	103.2	68.9	39.8	39.8	48.7	38.6	51.9	31.9

Notes:

1. All capacities shown are gross and have not considered indoor fan heat. To obtain NET cooling capacity subtract indoor fan heat. For indoor fan heat formula, refer to appropriate airflow table notes.
2. MBh = Total gross capacity
3. SHC = Sensible heat capacity
4. Ambient Temperature above 120°F, the system B shuts down.

Table 9. Gross cooling capacities 10 tons

CFM	Ent DB (° F)	Ambient Temperature (°F)						Ambient Temperature (°F)						Ambient Temperature (°F)					
		85						95						105					
		Entering Wet Bulb Temp (°F)						Entering Wet Bulb Temp (°F)						Entering Wet Bulb Temp (°F)					
		61		67		73		61		67		73		61		67		73	
		MBh	SHC	MBh	SHC	MBh	SHC	MBh	SHC	MBh	SHC	MBh	SHC	MBh	SHC	MBh	SHC		
3200	75	111.0	80.0	121.0	72.3	133.9	44.4	107.0	69.6	116.9	63.1	128.6	43.0	95.7	61.9	104.5	56.1	118.5	39.0
	80	111.2	99.7	121.5	90.3	134.1	61.6	107.6	91.2	117.6	82.6	130.1	53.2	96.2	81.0	105.1	73.4	119.8	52.2
	85	111.9	111.9	121.7	101.2	134.5	78.3	108.2	105.4	118.6	95.7	130.7	65.1	96.9	93.7	105.5	84.6	120.4	59.0
	90	112.3	112.3	122.7	105.6	135.1	98.9	109.0	109.0	119.1	101.1	131.5	69.0	97.5	97.5	106.5	89.9	121.1	62.6
3600	75	113.7	88.2	123.0	79.2	136.0	49.0	110.4	77.5	118.9	69.3	131.4	53.8	98.5	68.6	106.4	61.6	121.1	48.8
	80	114.2	109.6	123.4	98.3	136.5	67.4	110.7	100.4	119.3	89.9	131.6	55.4	98.9	89.1	106.7	79.9	121.7	50.5
	85	114.5	114.5	124.1	101.7	137.0	85.7	111.0	111.0	120.1	100.3	132.1	70.9	99.2	99.2	107.5	92.5	122.7	64.9
	90	114.8	114.8	125.3	104.4	137.8	92.1	111.4	111.4	121.6	103.4	134.5	84.1	99.7	99.7	108.9	95.2	123.9	76.3
4000	75	116.6	96.7	125.5	86.6	138.7	53.9	112.7	84.6	121.3	75.8	134.0	47.2	101.1	75.5	108.7	67.5	123.5	43.0
	80	117.0	117.0	126.0	106.8	139.3	73.6	113.2	109.2	121.8	97.7	134.6	67.4	101.5	97.3	109.1	87.0	124.1	61.2
	85	117.4	117.4	127.0	100.2	140.0	93.6	113.7	113.7	122.9	101.0	135.5	88.0	101.9	101.9	110.1	89.9	124.9	79.9
	90	117.9	117.9	128.1	102.9	140.8	99.1	114.0	114.0	124.4	103.4	136.7	94.9	102.1	102.1	111.4	91.9	126.0	85.9
4400	75	119.2	105.6	128.2	94.8	141.6	59.2	115.2	92.4	123.9	82.9	137.5	42.2	103.5	82.6	111.2	74.0	126.1	38.3
	80	119.7	119.7	129.1	100.7	142.3	80.4	115.9	115.9	124.5	106.3	137.8	81.7	104.0	104.0	111.7	88.1	127.2	74.4
	85	120.2	120.2	130.1	102.8	143.2	93.5	116.8	116.8	125.9	99.7	139.1	92.1	104.7	104.7	112.9	92.1	127.9	87.2
	90	120.8	120.8	131.1	107.4	144.0	102.4	117.1	117.1	127.4	104.5	140.0	99.7	105.0	105.0	114.1	93.7	128.3	88.5
CFM	Ent DB (° F)	Ambient Temperature (°F)						Ambient Temperature (°F)						Ambient Temperature (°F)					
		115						120						125					
		Entering Wet Bulb Temp (°F)						Entering Wet Bulb Temp (°F)						Entering Wet Bulb Temp (°F)					
		61		67		73		61		67		73		61		67		73	
		MBh	SHC	MBh	SHC	MBh	SHC	MBh	SHC	MBh	SHC	MBh	SHC	MBh	SHC	MBh	SHC		
3200	75	87.0	57.9	95.0	52.3	109.2	35.8	84.3	62.1	90.0	54.0	104.0	47.0	40.0	37.1	42.7	31.8	49.4	25.1
	80	87.5	75.7	95.6	68.5	110.4	43.0	84.5	81.0	90.7	70.9	104.4	66.9	40.4	39.1	43.2	34.7	49.6	27.2
	85	88.2	87.6	95.8	79.0	111.0	54.2	85.1	85.1	90.9	72.0	105.6	69.4	40.5	40.5	43.6	35.1	50.2	29.2
	90	88.6	88.6	96.8	83.9	111.6	57.6	85.2	85.2	91.1	72.3	106.8	65.1	40.8	40.8	43.7	35.3	50.8	30.5
3600	75	90.1	64.5	96.8	57.7	111.6	38.8	86.4	68.4	92.6	56.8	106.8	46.6	41.2	33.0	44.6	27.8	51.1	22.7
	80	90.4	83.7	97.1	74.6	112.0	46.4	86.9	86.9	93.0	73.4	107.0	67.5	41.6	41.6	44.7	36.5	51.2	32.8
	85	90.6	90.6	97.8	86.4	112.6	62.2	87.1	87.1	93.3	74.2	107.4	69.9	41.8	41.8	44.9	37.0	51.4	34.7
	90	90.7	90.7	99.0	88.0	113.6	74.3	87.3	87.3	93.6	76.8	109.4	72.1	42.0	42.0	45.2	37.4	52.4	40.9
4000	75	92.2	70.7	99.0	63.3	114.0	42.3	90.5	76.7	94.8	64.7	109.6	55.4	43.9	37.7	46.3	31.5	52.9	28.5
	80	92.6	91.2	99.4	81.4	114.5	56.4	90.9	90.9	95.2	78.8	110.4	71.5	44.4	41.2	46.5	36.5	53.0	34.9
	85	92.9	92.9	100.3	82.3	115.3	73.6	91.3	91.3	95.6	79.3	110.7	71.8	44.5	44.5	46.9	37.1	53.4	36.0
	90	93.0	93.0	101.4	84.1	116.2	78.9	91.6	91.6	96.0	79.8	111.3	75.7	44.7	44.7	47.3	38.3	53.9	36.8
4400	75	94.5	77.4	101.4	69.4	116.6	46.1	95.2	86.2	97.2	70.0	113.4	51.4	46.8	42.9	48.1	35.4	55.5	26.3
	80	95.0	95.0	101.9	88.7	117.2	68.3	95.7	90.7	97.8	77.5	113.6	66.1	47.2	45.2	48.2	39.1	55.6	32.7
	85	95.5	95.5	103.0	84.2	118.2	81.2	96.0	96.0	98.1	79.0	113.9	69.6	47.4	47.4	48.3	39.7	56.5	35.2
	90	95.9	95.9	104.0	85.6	119.0	83.2	96.2	96.2	98.6	81.0	114.1	71.4	47.5	47.5	48.8	40.8	56.6	35.9

Notes:

1. All capacities shown are gross and have not considered indoor fan heat. To obtain NET cooling capacity subtract indoor fan heat. For indoor fan heat formula, refer to appropriate airflow table notes.
2. MBh = Total gross capacity
3. SHC = Sensible heat capacity
4. Ambient Temperature above 120°F, the system B shuts down.



Performance Data

Table 10. Gross cooling capacities 12.5 tons

CFM	Ent DB (° F)	Ambient Temperature (°F)						Ambient Temperature (°F)						Ambient Temperature (°F)					
		85						95						105					
		Entering Wet Bulb Temp (°F)						Entering Wet Bulb Temp (°F)						Entering Wet Bulb Temp (°F)					
		61		67		73		61		67		73		61		67		73	
		MBh	SHC	MBh	SHC	MBh	SHC	MBh	SHC	MBh	SHC	MBh	SHC	MBh	SHC	MBh	SHC		
4000	75	131.3	109.0	147.6	85.7	163.2	57.6	128.1	108.1	143.0	84.2	154.7	54.5	119.8	104.3	128.5	77.7	144.6	50.6
	80	131.7	131.5	147.9	108.6	163.5	79.8	128.5	123.2	143.2	107.5	155.1	77.1	120.1	116.4	128.8	100.6	144.8	72.8
	85	132.3	132.3	148.3	115.7	163.8	91.1	128.8	128.8	143.5	114.2	155.3	92.5	120.5	120.5	129.1	102.5	145.0	92.9
	90	132.6	132.6	148.7	117.2	164.2	99.7	128.9	128.9	143.8	113.9	155.5	96.5	120.7	120.7	129.6	105.1	145.2	94.9
4500	75	134.7	122.0	151.1	95.9	167.0	64.8	131.4	121.1	146.5	94.3	158.7	70.2	122.8	116.1	131.8	86.9	148.5	64.7
	80	135.1	135.1	151.5	120.9	167.4	88.9	131.8	131.8	146.8	119.7	159.6	81.9	123.1	123.1	132.1	111.6	148.7	70.8
	85	136.0	136.0	152.2	118.2	168.2	97.9	132.3	132.3	147.3	118.3	158.3	106.1	123.9	123.9	132.6	107.6	147.8	91.8
	90	136.3	136.3	152.6	124.1	168.3	102.9	132.4	132.4	147.5	118.6	159.9	107.5	124.0	124.0	133.1	109.8	149.2	94.5
5000	75	138.1	134.8	154.7	106.2	170.9	71.9	134.6	133.5	149.9	104.2	162.4	60.8	126.0	124.9	135.1	96.4	152.1	56.7
	80	138.6	138.6	155.3	125.1	171.5	98.1	135.3	135.3	150.4	119.7	163.8	101.9	126.5	126.5	135.6	107.1	153.0	88.2
	85	139.8	139.8	156.4	127.3	172.5	102.6	136.0	136.0	151.3	121.8	163.1	104.5	126.9	126.9	136.4	109.0	152.4	89.8
	90	139.9	139.9	156.6	129.4	172.6	106.8	136.1	136.1	151.5	123.2	163.0	106.0	127.5	127.5	136.8	111.5	152.3	92.3
5500	75	141.6	140.1	158.4	117.3	174.9	79.5	138.0	136.6	153.5	115.0	166.2	53.0	129.3	128.1	138.5	106.5	155.6	49.7
	80	142.3	142.3	159.1	125.4	175.6	108.1	139.0	139.0	154.1	121.6	168.3	95.9	129.9	129.9	139.1	107.7	157.3	96.2
	85	143.1	143.1	160.4	128.2	176.9	110.9	139.2	139.2	155.4	124.2	168.1	100.5	130.5	130.5	140.3	110.6	157.2	97.2
	90	143.7	143.7	160.7	131.0	177.0	113.5	139.8	139.8	155.6	126.7	166.2	100.4	131.0	131.0	140.4	111.1	155.4	96.4
CFM	Ent DB (° F)	Ambient Temperature (°F)						Ambient Temperature (°F)						Ambient Temperature (°F)					
		115						120						125					
		Entering Wet Bulb Temp (°F)						Entering Wet Bulb Temp (°F)						Entering Wet Bulb Temp (°F)					
		61		67		73		61		67		73		61		67		73	
		MBh	SHC	MBh	SHC	MBh	SHC	MBh	SHC	MBh	SHC	MBh	SHC	MBh	SHC	MBh	SHC		
4000	75	104.7	98.6	121.3	73.4	131.2	44.1	100.1	96.7	113.3	70.0	127.8	44.2	53.8	51.8	61.4	47.9	70.3	30.3
	80	105.0	105.0	121.5	97.4	131.6	68.0	100.3	100.3	113.6	93.2	128.1	66.0	54.0	54.0	61.6	47.4	70.5	44.0
	85	105.2	105.2	121.7	96.9	131.9	79.3	100.5	100.5	113.8	90.3	128.3	79.4	54.3	54.3	61.9	50.2	70.8	46.4
	90	105.5	105.5	122.0	99.2	132.1	82.4	100.8	100.8	114.1	91.1	128.5	81.1	54.5	54.5	62.1	50.8	71.1	47.2
4500	75	107.5	105.0	124.3	82.2	135.0	48.4	102.7	101.4	116.2	78.0	131.6	56.6	55.9	55.0	63.5	49.9	72.9	38.7
	80	107.8	107.8	124.7	100.4	135.6	74.9	102.9	102.9	116.8	94.6	131.9	84.4	56.0	56.0	63.9	51.1	73.1	47.0
	85	108.2	108.2	125.0	101.8	135.1	85.1	103.1	103.1	116.9	95.1	131.0	85.3	56.3	56.3	64.2	52.0	73.4	49.1
	90	108.5	108.5	125.3	103.4	135.0	85.9	103.8	103.8	117.4	96.5	132.3	87.6	56.7	56.7	64.4	53.4	73.7	49.1
5000	75	110.5	109.0	127.6	91.3	138.5	52.8	108.8	107.6	119.4	86.8	136.0	50.4	59.7	58.2	65.9	46.8	75.7	35.2
	80	110.9	110.9	128.1	100.4	139.3	84.4	109.1	108.5	120.0	96.3	135.7	71.4	59.8	59.8	66.2	51.0	75.8	44.4
	85	111.5	111.3	128.7	102.2	139.5	85.9	109.3	109.3	120.5	96.9	135.3	79.4	60.1	60.1	66.7	52.9	75.8	47.5
	90	111.8	111.8	128.9	104.5	139.7	87.3	109.8	109.8	120.8	98.7	135.0	80.9	60.4	60.4	66.9	54.3	75.8	48.4
5500	75	113.6	112.3	130.9	100.9	142.0	58.3	115.3	113.6	122.7	93.8	139.2	44.5	63.4	62.3	68.3	52.2	78.2	32.0
	80	114.1	114.1	131.6	103.9	143.0	81.4	115.6	115.6	123.3	96.6	139.6	87.1	63.8	63.8	68.7	53.8	78.5	48.2
	85	114.9	114.9	132.5	105.5	142.9	84.6	115.7	115.7	124.1	98.6	139.7	88.7	64.1	64.1	69.3	55.6	78.8	49.0
	90	115.1	115.1	132.5	107.5	142.5	87.7	116.0	116.0	124.2	100.5	137.8	88.8	64.3	64.3	69.4	56.5	78.0	50.2

Notes:

1. All capacities shown are gross and have not considered indoor fan heat. To obtain NET cooling capacity subtract indoor fan heat. For indoor fan heat formula, refer to appropriate airflow table notes.
2. MBh = Total gross capacity
3. SHC = Sensible heat capacity
4. Ambient Temperature above 120°F, the system B shuts down.

Evaporator Fan Performance

Table 11. Belt drive evaporator fan performance - 7.5 tons with low gas heat - GDK090A(3, 4)EL -downflow airflow

External Static Pressure (Inches of Water)																				
CFM	0.1		0.2		0.3		0.4		0.5		0.6		0.7		0.8		0.9		1.0	
	RPM	BHP	RPM	BHP	RPM	BHP	RPM	BHP	RPM	BHP	RPM	BHP	RPM	BHP	RPM	BHP	RPM	BHP	RPM	BHP
	Low Airflow Kit												Standard Motor							
2400	-	-	-	-	-	-	575	0.92	612	0.99	651	1.13	678	1.20	707	1.23	723	1.29	749	1.41
2700	-	-	-	-	574	0.94	606	1.01	643	1.11	679	1.26	706	1.43	736	1.49	755	1.45	779	1.57
3000	-	-	574	1.03	600	1.15	631	1.21	667	1.32	710	1.39	731	1.53	755	1.65	777	1.77	807	1.90
3300	562	1.18	593	1.22	627	1.30	665	1.38	710	1.51	736	1.65	760	1.76	790	1.89	810	2.05	832	2.18
External Static Pressure (Inches of Water)																				
CFM	1.1		1.2		1.3		1.4		1.5		1.6		1.7		1.8		1.9		2.0	
	RPM	BHP	RPM	BHP	RPM	BHP	RPM	BHP	RPM	BHP	RPM	BHP	RPM	BHP	RPM	BHP	RPM	BHP	RPM	BHP
	Standard Motor								High Static (oversize) Motor											
2400	775	1.62	798	1.58	830	1.69	852	1.81	875	1.97	899	2.07	924	2.2	945	2.29	971	2.40	994	2.50
2700	805	1.68	836	1.81	861	1.95	884	2.06	907	2.17	929	2.28	952	2.41	974	2.50	996	2.59	1019	2.70
3000	829	2.02	850	2.17	875	2.28	896	2.41	918	2.52	939	2.63	963	2.73	985	2.84	1008	2.96	1031	3.05
3300	854	2.32	878	2.45	898	2.58	920	2.70	943	2.81	966	2.91	989	3.02	-	-	-	-	-	-

Table 12. Belt drive evaporator fan performance - 7.5 tons with low gas heat - GDK090A(3, 4)EL - horizontal airflow

External Static Pressure (Inches of Water)																				
CFM	0.1		0.2		0.3		0.4		0.5		0.6		0.7		0.8		0.9		1.0	
	RPM	BHP	RPM	BHP	RPM	BHP	RPM	BHP	RPM	BHP	RPM	BHP	RPM	BHP	RPM	BHP	RPM	BHP	RPM	BHP
	Low Airflow Kit												Standard Motor							
2400	-	-	-	-	-	-	586	1.00	623	1.07	663	1.22	691	1.30	720	1.33	737	1.40	763	1.53
2700	-	-	-	-	585	1.00	617	1.08	655	1.18	692	1.34	719	1.52	750	1.59	769	1.54	794	1.67
3000	-	-	585	1.09	611	1.21	643	1.28	679	1.39	723	1.47	745	1.61	769	1.74	791	1.87	822	2.00
3300	572	1.24	604	1.28	639	1.36	677	1.45	723	1.58	750	1.73	774	1.85	805	1.98	825	2.15	848	2.29
External Static Pressure (Inches of Water)																				
CFM	1.1		1.2		1.3		1.4		1.5		1.6		1.7		1.8		1.9		2.0	
	RPM	BHP	RPM	BHP	RPM	BHP	RPM	BHP	RPM	BHP	RPM	BHP	RPM	BHP	RPM	BHP	RPM	BHP	RPM	BHP
	Standard Motor								High Static (oversize) Motor											
2400	789	1.75	813	1.71	845	1.83	868	1.96	891	2.13	916	2.24	941	2.38	963	2.48	989	2.60	1013	2.70
2700	820	1.79	852	1.93	877	2.08	900	2.19	924	2.31	946	2.43	970	2.56	992	2.66	1015	2.76	1038	2.87
3000	844	2.13	866	2.29	891	2.41	913	2.54	935	2.66	957	2.77	981	2.88	1003	3.00	1027	3.12	1050	3.22
3300	870	2.43	894	2.57	915	2.7	937	2.83	961	2.95	984	3.05	1007	3.17	-	-	-	-	-	-



Performance Data

Table 13. Belt drive evaporator fan performance - 7.5 tons with med gas heat - GDK090A(3, 4)EM -downflow airflow

External Static Pressure (Inches of Water)																				
CFM	0.1		0.2		0.3		0.4		0.5		0.6		0.7		0.8		0.9		1.0	
	RPM	BHP	RPM	BHP	RPM	BHP	RPM	BHP	RPM	BHP	RPM	BHP	RPM	BHP	RPM	BHP	RPM	BHP	RPM	BHP
Low Airflow Kit													Standard Motor							
2400	-	-	-	-	554	0.94	584	0.98	622	1.05	661	1.21	689	1.28	718	1.31	736	1.37	761	1.51
2700	-	-	558	0.95	584	1.00	615	1.06	654	1.17	690	1.33	717	1.51	748	1.57	767	1.53	792	1.66
3000	546	1.09	584	1.08	610	1.21	642	1.26	677	1.38	721	1.46	744	1.59	768	1.72	789	1.85	820	1.98
3300	570	1.23	603	1.27	638	1.35	676	1.44	722	1.57	747	1.71	772	1.84	803	1.97	823	2.13	846	2.27
External Static Pressure (Inches of Water)																				
CFM	1.1		1.2		1.3		1.4		1.5		1.6		1.7		1.8		1.9		2.0	
	RPM	BHP	RPM	BHP	RPM	BHP	RPM	BHP	RPM	BHP	RPM	BHP	RPM	BHP	RPM	BHP	RPM	BHP	RPM	BHP
Standard Motor							High Static (oversize) Motor													
2400	788	1.73	811	1.68	843	1.80	866	1.93	889	2.11	913	2.22	939	2.35	961	2.44	986	2.56	1011	2.66
2700	818	1.77	849	1.91	874	2.06	898	2.17	921	2.29	944	2.40	967	2.53	990	2.63	1013	2.74	1036	2.84
3000	841	2.11	864	2.28	889	2.39	911	2.52	933	2.64	954	2.75	978	2.86	1003	2.97	-	-	-	-
3300	869	2.41	892	2.56	913	2.68	935	2.81	959	2.92	990	3.04	-	-	-	-	-	-	-	-

Table 14. Belt drive evaporator fan performance - 7.5 tons with med gas heat - GDK090A(3, 4)EM - horizontal airflow

External Static Pressure (Inches of Water)																				
CFM	0.1		0.2		0.3		0.4		0.5		0.6		0.7		0.8		0.9		1.0	
	RPM	BHP	RPM	BHP	RPM	BHP	RPM	BHP	RPM	BHP	RPM	BHP	RPM	BHP	RPM	BHP	RPM	BHP	RPM	BHP
Low Airflow Kit													Standard Motor							
2400	-	-	-	-	564	1.01	595	1.06	633	1.13	673	1.30	702	1.38	731	1.41	749	1.48	775	1.63
2700	-	-	568	1.01	594	1.06	626	1.13	665	1.24	702	1.41	729	1.60	761	1.67	780	1.62	806	1.76
3000	555	1.15	593	1.14	620	1.27	652	1.33	688	1.45	733	1.54	756	1.68	780	1.81	802	1.95	833	2.09
3300	579	1.29	612	1.33	648	1.41	686	1.51	733	1.64	759	1.79	784	1.93	815	2.06	836	2.23	859	2.38
External Static Pressure (Inches of Water)																				
CFM	1.1		1.2		1.3		1.4		1.5		1.6		1.7		1.8		1.9		2.0	
	RPM	BHP	RPM	BHP	RPM	BHP	RPM	BHP	RPM	BHP	RPM	BHP	RPM	BHP	RPM	BHP	RPM	BHP	RPM	BHP
Standard Motor							High Static (oversize) Motor													
2400	802	1.86	826	1.81	858	1.94	882	2.08	905	2.27	930	2.39	956	2.53	978	2.63	1004	2.76	1029	2.86
2700	832	1.88	864	2.03	889	2.19	913	2.30	937	2.43	960	2.55	984	2.69	1007	2.79	1030	2.91	1054	3.02
3000	855	2.22	878	2.40	903	2.52	926	2.66	948	2.78	970	2.90	994	3.01	-	-	-	-	-	-
3300	882	2.52	906	2.68	927	2.81	949	2.94	974	3.06	-	-	-	-	-	-	-	-	-	-

Table 15. Belt drive evaporator fan performance - 7.5 tons with high gas heat - GDK090A(3, 4, W)EH - downflow airflow

External Static Pressure (Inches of Water)																				
CFM	0.1		0.2		0.3		0.4		0.5		0.6		0.7		0.8		0.9		1.0	
	RPM	BHP	RPM	BHP	RPM	BHP	RPM	BHP	RPM	BHP	RPM	BHP	RPM	BHP	RPM	BHP	RPM	BHP	RPM	BHP
Low Airflow Kit													Standard Motor							
2400	-	-	531	0.90	561	0.98	592	1.03	630	1.10	670	1.25	698	1.33	727	1.37	745	1.43	770	1.57
2700	535	1.00	566	1.07	591	1.03	623	1.10	662	1.20	699	1.36	726	1.55	758	1.62	777	1.58	802	1.71

Table 15. Belt drive evaporator fan performance - 7.5 tons with high gas heat - GDK090A(3, 4, W)EH - downflow airflow (continued)

External Static Pressure (Inches of Water)																				
CFM	0.1		0.2		0.3		0.4		0.5		0.6		0.7		0.8		0.9		1.0	
	RPM	BHP	RPM	BHP	RPM	BHP	RPM	BHP	RPM	BHP	RPM	BHP	RPM	BHP	RPM	BHP	RPM	BHP	RPM	BHP
	Low Airflow Kit												Standard Motor							
3000	553	1.13	590	1.17	617	1.23	649	1.30	685	1.41	729	1.50	752	1.63	776	1.77	799	1.91	830	2.04
3300	576	1.26	609	1.31	644	1.37	682	1.48	729	1.6	756	1.76	780	1.88	811	2.01	831	2.19	854	2.33

External Static Pressure (Inches of Water)																					
CFM	1.1		1.2		1.3		1.4		1.5		1.6		1.7		1.8		1.9		2.0		
	RPM	BHP	RPM	BHP	RPM	BHP	RPM	BHP	RPM	BHP	RPM	BHP	RPM	BHP	RPM	BHP	RPM	BHP	RPM	BHP	
	Standard Motor								High Static (oversize) Motor												
2400	798	1.79	821	1.75	854	1.88	877	2.01	900	2.19	925	2.30	951	2.44	973	2.54	999	2.67	1024	2.77	
2700	828	1.84	860	1.98	885	2.13	909	2.24	933	2.36	956	2.49	979	2.62	1002	2.71	1025	2.82	-	-	
3000	851	2.17	874	2.33	899	2.46	921	2.59	943	2.71	966	2.83	990	2.94	-	-	-	-	-	-	
3300	877	2.46	900	2.62	922	2.75	943	2.87	-	-	-	-	-	-	-	-	-	-	-	-	

Table 16. Belt drive evaporator fan performance - 7.5 tons with high gas heat - GDK090A(3, 4, W)EH - horizontal airflow

External Static Pressure (Inches of Water)																				
CFM	0.1		0.2		0.3		0.4		0.5		0.6		0.7		0.8		0.9		1.0	
	RPM	BHP	RPM	BHP	RPM	BHP	RPM	BHP	RPM	BHP	RPM	BHP	RPM	BHP	RPM	BHP	RPM	BHP	RPM	BHP
	Low Airflow Kit												Standard Motor							
2400	-	-	541	0.97	571	1.05	603	1.11	641	1.18	682	1.35	711	1.43	740	1.47	758	1.54	784	1.69
2700	544	1.06	576	1.14	601	1.09	634	1.17	673	1.28	711	1.45	738	1.65	771	1.72	790	1.68	816	1.82
3000	562	1.19	599	1.23	627	1.30	659	1.37	696	1.49	741	1.58	764	1.72	788	1.87	812	2.01	843	2.15
3300	585	1.32	619	1.37	655	1.44	693	1.55	741	1.68	768	1.84	793	1.97	824	2.11	845	2.29	868	2.44

External Static Pressure (Inches of Water)																					
CFM	1.1		1.2		1.3		1.4		1.5		1.6		1.7		1.8		1.9		2.0		
	RPM	BHP	RPM	BHP	RPM	BHP	RPM	BHP	RPM	BHP	RPM	BHP	RPM	BHP	RPM	BHP	RPM	BHP	RPM	BHP	
	Standard Motor								High Static (oversize) Motor												
2400	812	1.93	836	1.88	869	2.02	893	2.16	916	2.36	942	2.48	968	2.63	990	2.73	1017	2.87	1042	2.98	
2700	842	1.95	875	2.10	900	2.26	924	2.38	949	2.51	972	2.64	996	2.78	1019	2.88	1042	3.00	-	-	
3000	865	2.29	888	2.46	913	2.59	936	2.73	958	2.86	982	2.98	1006	3.10	-	-	-	-	-	-	
3300	891	2.58	915	2.74	937	2.88	959	3.01	-	-	-	-	-	-	-	-	-	-	-	-	

Table 17. Belt drive evaporator fan performance - 7.5 tons cooling only - EDK090A(3, 4)E0 - downflow airflow

External Static Pressure (Inches of Water)																				
CFM	0.1		0.2		0.3		0.4		0.5		0.6		0.7		0.8		0.9		1.0	
	RPM	BHP	RPM	BHP	RPM	BHP	RPM	BHP	RPM	BHP	RPM	BHP	RPM	BHP	RPM	BHP	RPM	BHP	RPM	BHP
	Low Airflow Kit												Standard Motor							
2400	-	-	-	-	-	-	560	0.84	596	0.89	634	1.02	660	1.09	688	1.12	705	1.17	729	1.28
2700	-	-	-	-	561	0.87	591	0.93	628	1.01	663	1.15	689	1.31	719	1.37	737	1.33	761	1.44



Performance Data

Table 17. Belt drive evaporator fan performance - 7.5 tons cooling only - EDK090A(3, 4)E0 - downflow airflow (continued)

3000	-	-	561	0.95	586	1.05	617	1.11	651	1.20	693	1.28	715	1.39	738	1.50	759	1.62	789	1.73
3300	550	1.11	581	1.15	614	1.22	651	1.30	695	1.42	721	1.55	744	1.67	774	1.78	793	1.93	815	2.06

External Static Pressure (Inches of Water)

		1.1		1.2		1.3		1.4		1.5		1.6		1.7		1.8		1.9		2.0	
CFM		RPM	BHP	RPM	BHP	RPM	BHP	RPM	BHP	RPM	BHP	RPM	BHP	RPM	BHP	RPM	BHP	RPM	BHP	RPM	BHP
Standard Motor										High Static (oversize) Motor											
755	1.47	777	1.43	808	1.53	830	1.64	852	1.79	875	1.88	900	1.99	921	2.07	945	2.18	969	2.26		
786	1.54	816	1.67	840	1.80	863	1.89	885	1.99	907	2.09	929	2.21	951	2.29	973	2.38	995	2.48		
809	1.85	831	1.99	855	2.09	876	2.20	897	2.31	918	2.40	941	2.50	963	2.60	985	2.71	1006	2.82		
837	2.18	859	2.31	880	2.43	900	2.54	924	2.65	946	2.74	968	2.85	1001	2.97	-	-	-	-		

Table 18. Belt drive evaporator fan performance - 7.5 tons cooling only - EDK090A(3, 4)E0 - horizontal airflow

External Static Pressure (Inches of Water)

		0.1		0.2		0.3		0.4		0.5		0.6		0.7		0.8		0.9		1.0	
CFM		RPM	BHP	RPM	BHP	RPM	BHP	RPM	BHP	RPM	BHP	RPM	BHP	RPM	BHP	RPM	BHP	RPM	BHP	RPM	BHP
Low Airflow Kit										Standard Motor											
2400	-	-	-	-	-	-	-	571	0.91	607	0.97	646	1.11	673	1.18	701	1.21	718	1.27	743	1.39
2700	-	-	-	-	571	0.93	602	1.00	639	1.09	675	1.24	701	1.41	732	1.47	750	1.52	775	1.64	
3000	-	-	571	1.00	597	1.11	628	1.17	663	1.27	706	1.37	728	1.49	751	1.62	773	1.74	803	1.86	
3300	559	1.17	591	1.21	625	1.28	662	1.37	707	1.49	733	1.63	757	1.75	787	1.87	807	2.03	829	2.16	

External Static Pressure (Inches of Water)

		1.1		1.2		1.3		1.4		1.5		1.6		1.7		1.8		1.9		2.0	
CFM		RPM	BHP	RPM	BHP	RPM	BHP	RPM	BHP	RPM	BHP	RPM	BHP	RPM	BHP	RPM	BHP	RPM	BHP	RPM	BHP
Standard Motor										High Static (oversize) Motor											
2400	769	1.59	792	1.72	823	1.84	846	1.97	868	2.15	892	2.26	917	2.39	938	2.50	963	2.61	987	2.72	
2700	800	1.76	831	1.89	855	2.04	878	2.15	901	2.26	923	2.38	946	2.51	968	2.61	990	2.71	1013	2.82	
3000	824	1.99	846	2.14	870	2.25	892	2.37	913	2.48	935	2.59	958	2.69	980	2.80	1003	2.91	1024	3.03	
3300	851	2.29	874	2.43	895	2.55	916	2.67	940	2.78	962	2.88	985	2.99	-	-	-	-	-	-	

Table 19. Belt drive evaporator fan performance - 8.5 tons with low gas heat - GDK102A(3, 4)EL - downflow airflow

External Static Pressure (Inches of Water)

		0.1		0.2		0.3		0.4		0.5		0.6		0.7		0.8		0.9		1.0	
CFM		RPM	BHP	RPM	BHP	RPM	BHP	RPM	BHP	RPM	BHP	RPM	BHP	RPM	BHP	RPM	BHP	RPM	BHP	RPM	BHP
Low Airflow Kit										Standard Motor											
2700	-	-	-	-	575	0.93	606	1	643	1.1	680	1.24	706	1.41	737	1.48	755	1.43	780	1.55	
3050	-	-	581	1.04	607	1.15	638	1.21	674	1.32	718	1.39	739	1.53	764	1.66	786	1.78	816	1.90	
3400	580	1.21	612	1.25	647	1.33	686	1.41	733	1.55	761	1.69	784	1.81	816	1.94	836	2.10	859	2.24	
3750	636	1.34	673	1.38	711	1.47	753	1.57	805	1.71	835	1.86	862	1.99	896	2.14	918	2.32	943	2.47	

Table 19. Belt drive evaporator fan performance - 8.5 tons with low gas heat - GDK102A(3, 4)EL - downflow airflow (continued)

External Static Pressure (Inches of Water)																				
CFM	1.1		1.2		1.3		1.4		1.5		1.6		1.7		1.8		1.9		2.0	
	RPM	BHP	RPM	BHP	RPM	BHP	RPM	BHP	RPM	BHP	RPM	BHP	RPM	BHP	RPM	BHP	RPM	BHP	RPM	BHP
	Standard Motor										High Static (oversize) Motor									
2700	805	1.66	837	1.79	861	1.93	884	2.03	908	2.15	929	2.26	953	2.38	974	2.47	997	2.56	1020	2.67
3050	838	2.02	860	2.17	885	2.29	906	2.42	928	2.53	951	2.64	974	2.74	996	2.85	1019	2.97	1043	3.06
3400	882	2.37	906	2.51	927	2.64	950	2.76	974	2.87	995	2.97	1015	3.07	1037	3.17	1061	3.25	1078	3.35
3750	968	2.62	995	2.77	1018	2.91	1043	3.05	1069	3.18	1088	3.31	1104	3.41	1134	3.51	1154	3.64	1175	3.73

Table 20. Belt drive evaporator fan performance - 8.5 tons with low gas heat - GDK102A(3, 4)EL - horizontal airflow

External Static Pressure (Inches of Water)																				
CFM	0.1		0.2		0.3		0.4		0.5		0.6		0.7		0.8		0.9		1.0	
	RPM	BHP	RPM	BHP	RPM	BHP	RPM	BHP	RPM	BHP	RPM	BHP	RPM	BHP	RPM	BHP	RPM	BHP	RPM	BHP
	Low Airflow Kit										Standard Motor									
2700	-	-	-	-	585	1	617	1.08	655	1.18	692	1.34	719	1.52	750	1.59	769	1.54	794	1.67
3050	-	-	591	1.1	617	1.22	649	1.29	686	1.40	730	1.48	752	1.63	777	1.76	799	1.89	830	2.02
3400	589	1.28	622	1.32	658	1.40	697	1.49	745	1.63	773	1.78	797	1.91	829	2.04	850	2.21	873	2.36
3750	646	1.40	683	1.45	722	1.54	765	1.64	817	1.79	848	1.95	875	2.09	910	2.24	932	2.43	958	2.59

External Static Pressure (Inches of Water)																				
CFM	1.1		1.2		1.3		1.4		1.5		1.6		1.7		1.8		1.9		2.0	
	RPM	BHP	RPM	BHP	RPM	BHP	RPM	BHP	RPM	BHP	RPM	BHP	RPM	BHP	RPM	BHP	RPM	BHP	RPM	BHP
	Standard Motor										High Static (oversize) Motor									
2700	820	1.79	852	1.93	877	2.08	900	2.19	924	2.31	946	2.43	970	2.56	992	2.66	1015	2.76	1038	2.87
3050	852	2.15	875	2.31	900	2.43	922	2.57	944	2.69	967	2.80	991	2.91	1013	3.03	1037	3.15	1061	3.25
3400	896	2.50	921	2.65	942	2.78	965	2.91	990	3.04	1014	3.14	1037	3.27	1068	3.34	1084	3.43	1101	3.54
3750	983	2.75	1010	2.90	1034	3.05	1059	3.20	1086	3.33	1112	3.45	1138	3.58	1153	3.72	1165	3.81	1175	3.91

Table 21. Belt drive evaporator fan performance - 8.5 tons with med gas heat - GDK102A(3,4)EM - downflow airflow

External Static Pressure (Inches of Water)																				
CFM	0.1		0.2		0.3		0.4		0.5		0.6		0.7		0.8		0.9		1.0	
	RPM	BHP	RPM	BHP	RPM	BHP	RPM	BHP	RPM	BHP	RPM	BHP	RPM	BHP	RPM	BHP	RPM	BHP	RPM	BHP
	Low Airflow Kit										Standard Motor									
2700	-	-	558	0.94	583	0.98	615	1.05	653	1.15	689	1.31	716	1.49	747	1.55	766	1.50	792	1.63
3050	552	1.09	589	1.08	615	1.2	648	1.26	683	1.37	727	1.47	751	1.60	775	1.72	796	1.85	827	1.99
3400	586	1.26	620	1.3	656	1.38	696	1.48	743	1.60	769	1.75	795	1.89	826	2.01	847	2.18	871	2.32
3750	644	1.39	681	1.43	721	1.52	763	1.63	815	1.77	845	1.93	872	2.08	907	2.22	931	2.41	956	2.57

External Static Pressure (Inches of Water)																				
CFM	1.1		1.2		1.3		1.4		1.5		1.6		1.7		1.8		1.9		2.0	
	RPM	BHP	RPM	BHP	RPM	BHP	RPM	BHP	RPM	BHP	RPM	BHP	RPM	BHP	RPM	BHP	RPM	BHP	RPM	BHP
	Standard Motor										High Static (oversize) Motor									
2700	817	1.75	849	1.89	873	2.03	897	2.14	920	2.26	943	2.37	966	2.50	989	2.59	1012	2.70	1035	2.80
3050	849	2.11	872	2.28	897	2.45	919	2.58	941	2.69	963	2.81	987	2.92	1011	3.02	1031	3.11	1052	3.19



Performance Data

Table 21. Belt drive evaporator fan performance - 8.5 tons with med gas heat - GDK102A(3,4)EM - downflow airflow (continued)

		External Static Pressure (Inches of Water)																			
		1.1		1.2		1.3		1.4		1.5		1.6		1.7		1.8		1.9		2.0	
CFM		RPM	BHP	RPM	BHP	RPM	BHP	RPM	BHP	RPM	BHP	RPM	BHP	RPM	BHP	RPM	BHP	RPM	BHP	RPM	BHP
		Standard Motor						High Static (oversize) Motor													
3400		893	2.47	918	2.62	940	2.74	961	2.88	981	2.99	1000	3.07	1021	3.16	1042	3.26	1065	3.35	1084	3.45
3750		982	2.72	1008	2.89	1032	3.04	1056	3.17	1082	3.30	1104	3.44	1123	3.52	1142	3.63	1163	3.73	1112	3.83

Table 22. Belt drive evaporator fan performance - 8.5 tons with med gas heat - GDK102A(3, 4)EM- horizontal airflow

		External Static Pressure (Inches of Water)																			
		0.1		0.2		0.3		0.4		0.5		0.6		0.7		0.8		0.9		1.0	
CFM		RPM	BHP	RPM	BHP	RPM	BHP	RPM	BHP	RPM	BHP	RPM	BHP	RPM	BHP	RPM	BHP	RPM	BHP	RPM	BHP
		Low Airflow Kit										Standard Motor									
2700		-	-	568	1.01	594	1.06	626	1.13	665	1.24	702	1.41	729	1.60	761	1.67	780	1.62	806	1.76
3050		561	1.16	599	1.15	626	1.28	659	1.34	695	1.46	740	1.56	764	1.70	788	1.83	810	1.97	841	2.11
3400		596	1.33	630	1.37	667	1.45	707	1.56	755	1.69	782	1.84	808	1.99	839	2.12	861	2.30	885	2.45
3750		654	1.46	692	1.50	732	1.59	775	1.71	828	1.85	858	2.02	886	2.18	921	2.33	945	2.52	971	2.69
		External Static Pressure (Inches of Water)																			
		1.1		1.2		1.3		1.4		1.5		1.6		1.7		1.8		1.9		2.0	
CFM		RPM	BHP	RPM	BHP	RPM	BHP	RPM	BHP	RPM	BHP	RPM	BHP	RPM	BHP	RPM	BHP	RPM	BHP	RPM	BHP
		Standard Motor						High Static (oversize) Motor													
2700		832	1.88	864	2.03	889	2.19	913	2.30	937	2.43	960	2.55	984	2.69	1007	2.79	1030	2.91	1054	3.02
3050		864	2.24	887	2.42	912	2.60	935	2.74	957	2.86	980	2.99	1004	3.10	1028	3.21	1049	3.30	1070	3.39
3400		908	2.60	933	2.76	955	2.89	977	3.03	997	3.15	1016	3.24	1038	3.33	1059	3.44	1082	3.53	1102	3.64
3750		997	2.85	1024	3.03	1048	3.18	1072	3.32	1099	3.46	1121	3.60	1140	3.69	1160	3.80	1181	3.91	1129	4.01

Table 23. Belt drive evaporator fan performance - 8.5 tons with high gas heat - GDK102A(3, 4, W)EH - downflow airflow

		External Static Pressure (Inches of Water)																			
		0.1		0.2		0.3		0.4		0.5		0.6		0.7		0.8		0.9		1.0	
CFM		RPM	BHP	RPM	BHP	RPM	BHP	RPM	BHP	RPM	BHP	RPM	BHP	RPM	BHP	RPM	BHP	RPM	BHP	RPM	BHP
		Low Airflow Kit										Standard Motor									
2700		534	0.98	566	1.06	590	1.01	623	1.09	661	1.19	698	1.35	725	1.53	757	1.6	776	1.56	801	1.69
3050		558	1.13	595	1.17	622	1.23	655	1.3	691	1.41	735	1.51	759	1.64	783	1.78	806	1.91	837	2.04
3400		593	1.29	628	1.34	664	1.4	703	1.52	751	1.64	778	1.8	804	1.93	835	2.06	856	2.24	880	2.38
3750		651	1.42	688	1.48	729	1.56	771	1.67	824	1.81	855	1.99	882	2.13	917	2.28	940	2.51	966	2.63
		External Static Pressure (Inches of Water)																			
		1.1		1.2		1.3		1.4		1.5		1.6		1.7		1.8		1.9		2.0	
CFM		RPM	BHP	RPM	BHP	RPM	BHP	RPM	BHP	RPM	BHP	RPM	BHP	RPM	BHP	RPM	BHP	RPM	BHP	RPM	BHP
		Standard Motor						High Static (oversize) Motor													
2700		827	1.81	859	1.95	884	2.1	908	2.21	932	2.33	955	2.45	978	2.58	1001	2.67	1023	2.79	1044	2.89
3050		859	2.17	882	2.33	906	2.47	929	2.6	952	2.72	975	2.83	999	2.95	1021	3.07	1042	3.16	1063	3.27
3400		903	2.52	927	2.68	950	2.82	972	2.94	990	3.07	1011	3.19	1031	3.3	1052	3.41	1073	3.51	1093	3.58
3750		992	2.79	1018	2.96	1043	3.1	1067	3.25	1090	3.38	1111	3.55	1072	3.65	1093	3.72	1114	3.8	1134	3.91

Table 24. Belt drive evaporator fan performance - 8.5 tons with high gas heat - GDK102A(3, 4, W)EH - horizontal airflow

CFM	0.1		0.2		0.3		0.4		0.5		0.6		0.7		0.8		0.9		1.0	
	RPM	BHP	RPM	BHP	RPM	BHP	RPM	BHP	RPM	BHP	RPM	BHP	RPM	BHP	RPM	BHP	RPM	BHP	RPM	BHP
	Low Airflow Kit								Standard Motor											
2700	544	1.06	576	1.14	601	1.09	634	1.17	673	1.28	711	1.45	738	1.65	771	1.72	790	1.68	816	1.82
3050	568	1.2	605	1.24	633	1.31	666	1.38	703	1.5	748	1.6	772	1.74	796	1.89	820	2.03	851	2.17
3400	603	1.36	638	1.41	675	1.48	714	1.6	763	1.73	791	1.9	817	2.03	849	2.17	870	2.3	894	2.42
3750	661	1.49	699	1.55	740	1.63	783	1.75	837	1.9	868	2.08	896	2.23	931	2.38	955	2.59	981	2.76
CFM	1.1		1.2		1.3		1.4		1.5		1.6		1.7		1.8		1.9		2.0	
	RPM	BHP	RPM	BHP	RPM	BHP	RPM	BHP	RPM	BHP	RPM	BHP	RPM	BHP	RPM	BHP	RPM	BHP	RPM	BHP
	Standard Motor				High Static (oversize) Motor															
2700	842	1.95	875	2.1	900	2.26	924	2.38	949	2.51	972	2.64	996	2.78	1019	2.88	1042	3	1063	3.11
3050	874	2.31	897	2.48	922	2.62	945	2.76	968	2.89	992	3.01	1016	3.13	1039	3.26	1060	3.36	1081	3.47
3400	918	2.66	942	2.82	965	2.97	988	3.1	1006	3.24	1027	3.36	1048	3.48	1069	3.59	1090	3.7	1111	3.77
3750	1007	2.92	1034	3.1	1059	3.25	1084	3.4	1107	3.54	1128	3.72	1089	3.82	1110	3.9	1131	3.98	1152	4.1

Table 25. Belt drive evaporator fan performance - 8.5 tons cooling only - EDK102A(3, 4)E0 - downflow airflow

External Static Pressure (Inches of Water)																				
CFM	0.1		0.2		0.3		0.4		0.5		0.6		0.7		0.8		0.9		1.0	
	RPM	BHP	RPM	BHP	RPM	BHP	RPM	BHP	RPM	BHP	RPM	BHP	RPM	BHP	RPM	BHP	RPM	BHP	RPM	BHP
	Low Airflow Kit								Standard Motor											
2700	-	-	-	-	577	0.94	608	1.01	645	1.10	682	1.25	708	1.42	739	1.48	758	1.44	783	1.57
3050	-	-	577	1.01	603	1.12	634	1.18	670	1.28	720	1.26	740	1.36	764	1.49	783	1.65	803	1.78
3400	576	1.2	609	1.24	644	1.32	682	1.43	716	1.48	741	1.63	763	1.78	786	1.94	809	2.09	833	2.34
3750	621	1.30	657	1.35	694	1.60	719	1.73	735	1.85	760	1.99	783	2.14	804	2.40	828	2.56	850	2.70
External Static Pressure (Inches of Water)																				
CFM	1.1		1.2		1.3		1.4		1.5		1.6		1.7		1.8		1.9		2.0	
	RPM	BHP	RPM	BHP	RPM	BHP	RPM	BHP	RPM	BHP	RPM	BHP	RPM	BHP	RPM	BHP	RPM	BHP	RPM	BHP
	Standard Motor								High Static (oversize) Motor											
2700	808	1.68	839	1.81	864	1.95	887	2.05	910	2.16	932	2.27	955	2.39	978	2.48	1000	2.59	1023	2.69
3050	829	2.03	850	2.15	875	2.26	893	2.36	916	2.46	936	2.57	961	2.66	983	2.75	1005	2.84	1026	2.93
3400	857	2.48	878	2.61	897	2.72	921	2.83	942	2.93	964	3.02	981	3.11	1003	3.21	1018	3.30	1040	3.39
3750	873	2.82	894	2.94	912	3.05	928	3.16	949	3.26	967	3.36	988	3.46	1006	3.56	1027	3.66	1044	3.75

Table 26. Belt drive evaporator fan performance - 8.5 tons cooling only - EDK102A(3, 4)E0 - horizontal airflow

External Static Pressure (Inches of Water)																				
CFM	0.1		0.2		0.3		0.4		0.5		0.6		0.7		0.8		0.9		1.0	
	RPM	BHP	RPM	BHP	RPM	BHP	RPM	BHP	RPM	BHP	RPM	BHP	RPM	BHP	RPM	BHP	RPM	BHP	RPM	BHP
	Low Airflow Kit								Standard Motor											
2700	-	-	-	-	571	0.93	602	1.00	639	1.09	675	1.24	701	1.41	732	1.47	750	1.43	775	1.55
3050	-	-	571	1	597	1.11	628	1.17	663	1.27	713	1.25	733	1.35	756	1.48	775	1.63	795	1.76
3400	570	1.19	603	1.23	638	1.31	675	1.42	709	1.47	734	1.61	755	1.76	778	1.92	801	2.07	825	2.32
3750	615	1.29	650	1.34	687	1.58	712	1.71	728	1.83	752	1.97	775	2.12	796	2.38	820	2.53	842	2.67



Performance Data

Table 26. Belt drive evaporator fan performance - 8.5 tons cooling only - EDK102A(3, 4)E0 - horizontal airflow (continued)

External Static Pressure (Inches of Water)																					
		1.1		1.2		1.3		1.4		1.5		1.6		1.7		1.8		1.9		2.0	
CFM	RPM	BHP	RPM	BHP	RPM	BHP	RPM	BHP	RPM	BHP	RPM	BHP	RPM	BHP	RPM	BHP	RPM	BHP	RPM	BHP	
	Standard Motor										High Static (oversize) Motor										
2700	800	1.66	831	1.79	855	1.93	878	2.03	901	2.14	923	2.25	946	2.37	968	2.46	990	2.56	1013	2.66	
3050	821	2.01	842	2.13	866	2.24	884	2.34	907	2.44	927	2.54	951	2.63	973	2.72	995	2.81	1016	2.90	
3400	849	2.46	869	2.58	888	2.69	912	2.80	933	2.90	954	2.99	971	3.08	993	3.18	1008	3.27	1030	3.36	
3750	864	2.79	885	2.91	903	3.02	919	3.13	940	3.23	957	3.33	978	3.43	996	3.52	1017	3.62	1034	3.71	

Table 27. Belt drive evaporator fan performance - 10 tons with low gas heat - GDK120A(3, 4, W)EL - downflow airflow

External Static Pressure (Inches of Water)																					
		0.1		0.2		0.3		0.4		0.5		0.6		0.7		0.8		0.9		1.0	
CFM	RPM	BHP	RPM	BHP	RPM	BHP	RPM	BHP	RPM	BHP	RPM	BHP	RPM	BHP	RPM	BHP	RPM	BHP	RPM	BHP	
	Low Airflow Kit										Standard Motor										
3200	-	-	-	-	-	-	-	-	737	1.34	761	1.49	785	1.64	809	1.79	833	1.94	857	2.09	
3600	-	-	-	-	739	1.46	760	1.58	782	1.72	804	1.86	828	2.02	851	2.18	875	2.34	906	2.64	
4000	737	1.59	760	1.71	782	1.86	805	1.99	828	2.13	851	2.29	874	2.45	903	2.78	924	2.94	945	3.09	
4400	780	2.03	805	2.18	830	2.33	854	2.49	876	2.65	902	2.96	923	3.11	944	3.24	965	3.39	986	3.52	

External Static Pressure (Inches of Water)																					
		1.1		1.2		1.3		1.4		1.5		1.6		1.7		1.8		1.9		2.0	
CFM	RPM	BHP	RPM	BHP	RPM	BHP	RPM	BHP	RPM	BHP	RPM	BHP	RPM	BHP	RPM	BHP	RPM	BHP	RPM	BHP	
	Standard Motor										High Static (oversize) Motor										
3200	879	2.21	910	2.46	931	2.54	952	2.66	973	2.79	994	2.91	1015	3.03	1036	3.16	1057	3.28	1078	3.39	
3600	927	2.79	948	2.93	969	3.03	990	3.14	1011	3.26	1032	3.36	1053	3.44	1074	3.53	1095	3.61	1116	3.68	
4000	966	3.23	987	3.34	1008	3.44	1031	3.53	1052	3.63	1072	3.72	1093	3.81	1116	3.88	1137	3.96	1159	4.06	
4400	1007	3.66	1028	3.76	1049	3.86	1071	3.96	1092	4.06	1113	4.14	1135	4.24	1156	4.32	1178	4.42	1201	4.48	

Table 28. Belt drive evaporator fan performance - 10 tons with low gas heat - GDK120A(3, 4)EL - horizontal airflow

External Static Pressure (Inches of Water)																					
		0.1		0.2		0.3		0.4		0.5		0.6		0.7		0.8		0.9		1.0	
CFM	RPM	BHP	RPM	BHP	RPM	BHP	RPM	BHP	RPM	BHP	RPM	BHP	RPM	BHP	RPM	BHP	RPM	BHP	RPM	BHP	
	Low Airflow Kit										Standard Motor										
3200	-	-	-	-	-	-	729	1.36	753	1.51	777	1.66	801	1.81	825	1.96	849	2.11	873	2.26	
3600	-	-	733	1.52	755	1.62	776	1.75	798	1.89	820	2.03	844	2.19	867	2.35	891	2.53	922	2.81	
4000	753	1.76	776	1.88	798	2.02	821	2.16	844	2.31	867	2.45	892	2.61	919	2.95	940	3.11	961	3.26	
4400	796	2.21	821	2.35	846	2.51	866	2.67	887	2.84	918	3.13	939	3.28	960	3.42	981	3.56	1002	3.69	

External Static Pressure (Inches of Water)																					
		1.1		1.2		1.3		1.4		1.5		1.6		1.7		1.8		1.9		2.0	
CFM	RPM	BHP	RPM	BHP	RPM	BHP	RPM	BHP	RPM	BHP	RPM	BHP	RPM	BHP	RPM	BHP	RPM	BHP	RPM	BHP	
	Standard Motor										High Static (oversize) Motor										
3200	905	2.49	926	2.61	947	2.72	968	2.83	989	2.96	1010	3.08	1031	3.2	1052	3.33	1073	3.45	1094	3.56	
3600	943	2.96	964	3.09	985	3.22	1006	3.32	1027	3.43	1048	3.53	1069	3.62	1090	3.69	1111	3.78	1132	3.85	

Table 28. Belt drive evaporator fan performance - 10 tons with low gas heat - GDK120A(3, 4)EL - horizontal airflow (continued)

CFM	External Static Pressure (Inches of Water)																			
	1.1		1.2		1.3		1.4		1.5		1.6		1.7		1.8		1.9		2.0	
	RPM	BHP	RPM	BHP	RPM	BHP	RPM	BHP	RPM	BHP	RPM	BHP	RPM	BHP	RPM	BHP	RPM	BHP	RPM	BHP
4000	982	3.39	1003	3.51	1024	3.61	1045	3.69	1066	3.81	1087	3.89	1108	3.97	1129	4.05	1150	4.13	1171	4.22
4400	1023	3.82	1044	3.93	1065	4.03	1086	4.13	1107	4.23	1128	4.32	1149	4.41	1170	4.49	1191	4.57	1212	4.65

Table 29. Belt drive evaporator fan performance - 10 tons with med gas heat - GDK120A(3, 4)EM- downflow airflow

CFM	External Static Pressure (Inches of Water)																			
	0.1		0.2		0.3		0.4		0.5		0.6		0.7		0.8		0.9		1.0	
	RPM	BHP	RPM	BHP	RPM	BHP	RPM	BHP	RPM	BHP	RPM	BHP	RPM	BHP	RPM	BHP	RPM	BHP	RPM	BHP
	Low Airflow Kit										Standard Motor									
3200	-	-	-	-	711	1.35	738	1.44	762	1.59	786	1.74	810	1.89	834	2.04	858	2.19	882	2.34
3600	-	-	742	1.59	764	1.71	785	1.83	807	1.97	829	2.11	853	2.27	876	2.43	910	2.73	931	2.89
4000	762	1.84	785	1.96	807	2.11	830	2.24	853	2.38	876	2.54	907	2.87	928	3.03	949	3.19	970	3.34
4400	805	2.28	830	2.43	855	2.58	879	2.75	906	3.06	927	3.21	948	3.36	969	3.49	990	3.64	1011	3.77

CFM	External Static Pressure (Inches of Water)																			
	1.1		1.2		1.3		1.4		1.5		1.6		1.7		1.8		1.9		2.0	
	RPM	BHP	RPM	BHP	RPM	BHP	RPM	BHP	RPM	BHP	RPM	BHP	RPM	BHP	RPM	BHP	RPM	BHP	RPM	BHP
	Standard Motor										High Static (oversize) Motor									
3200	914	2.57	935	2.71	956	2.79	977	2.91	998	3.04	1019	3.16	1040	3.28	1061	3.41	1082	3.53	1103	3.64
3600	952	3.04	973	3.18	994	3.28	1015	3.39	1036	3.51	1057	3.61	1078	3.69	1099	3.78	1120	3.86	1141	3.93
4000	991	3.48	1012	3.59	1033	3.69	1054	3.78	1075	3.88	1096	3.97	1117	4.05	1138	4.13	1159	4.21	1180	4.31
4400	1032	3.91	1053	4.01	1074	4.11	1095	4.21	1116	4.31	1137	4.39	1158	4.49	1179	4.57	1200	4.65	1221	4.73

Table 30. Belt drive evaporator fan performance - 10 tons with med gas heat - GDK120A(3, 4)EM - horizontal airflow

CFM	External Static Pressure (Inches of Water)																			
	0.1		0.2		0.3		0.4		0.5		0.6		0.7		0.8		0.9		1.0	
	RPM	BHP	RPM	BHP	RPM	BHP	RPM	BHP	RPM	BHP	RPM	BHP	RPM	BHP	RPM	BHP	RPM	BHP	RPM	BHP
	Low Airflow Kit										Standard Motor									
3200	-	-	712	1.48	734	1.58	754	1.68	778	1.77	802	1.92	826	2.07	850	2.22	874	2.37	898	2.52
3600	736	1.67	758	1.78	780	1.88	801	2.01	823	2.15	845	2.29	869	2.45	892	2.61	926	2.91	947	3.07
4000	778	2.02	801	2.14	823	2.28	846	2.42	869	2.56	902	2.88	923	3.05	944	3.21	965	3.37	986	3.52
4400	821	2.46	846	2.61	871	2.76	901	3.08	922	3.24	943	3.39	964	3.54	985	3.68	1006	3.82	1027	3.95

CFM	External Static Pressure (Inches of Water)																			
	1.1		1.2		1.3		1.4		1.5		1.6		1.7		1.8		1.9		2.0	
	RPM	BHP	RPM	BHP	RPM	BHP	RPM	BHP	RPM	BHP	RPM	BHP	RPM	BHP	RPM	BHP	RPM	BHP	RPM	BHP
	Standard Motor										High Static (oversize) Motor									
3200	930	2.75	951	2.88	972	2.98	993	3.09	1014	3.22	1035	3.34	1056	3.46	1077	3.59	1098	3.71	1119	3.82
3600	968	3.22	989	3.35	1010	3.47	1031	3.58	1052	3.69	1073	3.79	1094	3.88	1115	3.96	1136	4.04	1157	4.11
4000	1007	3.66	1028	3.77	1049	3.87	1070	3.96	1091	4.06	1112	4.15	1133	4.23	1154	4.31	1175	4.39	1196	4.48
4400	1048	4.08	1069	4.19	1090	4.29	1111	4.39	1132	4.49	1153	4.58	1174	4.67	1195	4.75	1216	4.83	1237	4.91



Performance Data

Table 31. Belt drive evaporator fan performance - 10 tons with high gas heat - GDK120A(3, 4, W)EH - downflow airflow

External Static Pressure (Inches of Water)																				
CFM	0.1		0.2		0.3		0.4		0.5		0.6		0.7		0.8		0.9		1.0	
	RPM	BHP	RPM	BHP	RPM	BHP	RPM	BHP	RPM	BHP	RPM	BHP	RPM	BHP	RPM	BHP	RPM	BHP	RPM	BHP
	Low Airflow Kit										Standard Motor									
3200	-	-	-	-	711	1.35	738	1.44	762	1.59	786	1.74	810	1.89	834	2.04	858	2.19	882	2.34
3600	-	-	742	1.59	764	1.71	785	1.83	807	1.97	829	2.11	853	2.27	876	2.43	910	2.73	931	2.89
4000	762	1.84	785	1.96	807	2.11	830	2.24	853	2.38	876	2.54	907	2.87	928	3.03	949	3.19	970	3.34
4400	805	2.28	830	2.43	855	2.58	879	2.75	906	3.06	927	3.21	948	3.36	969	3.49	990	3.64	1011	3.77
External Static Pressure (Inches of Water)																				
CFM	1.1		1.2		1.3		1.4		1.5		1.6		1.7		1.8		1.9		2.0	
	RPM	BHP	RPM	BHP	RPM	BHP	RPM	BHP	RPM	BHP	RPM	BHP	RPM	BHP	RPM	BHP	RPM	BHP	RPM	BHP
	Standard Motor						High Static (oversize) Motor													
3200	914	2.57	935	2.71	956	2.79	977	2.91	998	3.04	1019	3.16	1040	3.28	1061	3.41	1082	3.53	1103	3.64
3600	952	3.04	973	3.18	994	3.28	1015	3.39	1036	3.51	1057	3.61	1078	3.69	1099	3.78	1120	3.86	1141	3.93
4000	991	3.48	1012	3.59	1033	3.69	1054	3.78	1075	3.88	1096	3.97	1117	4.05	1138	4.13	1159	4.21	1180	4.31
4400	1032	3.91	1053	4.01	1074	4.11	1095	4.21	1116	4.31	1137	4.39	1158	4.49	1179	4.57	1200	4.65	1221	4.73

Table 32. Belt drive evaporator fan performance - 10 tons with high gas heat - GDK120A(3, 4, W)EH - horizontal airflow

External Static Pressure (Inches of Water)																				
CFM	0.1		0.2		0.3		0.4		0.5		0.6		0.7		0.8		0.9		1.0	
	RPM	BHP	RPM	BHP	RPM	BHP	RPM	BHP	RPM	BHP	RPM	BHP	RPM	BHP	RPM	BHP	RPM	BHP	RPM	BHP
	Low Airflow Kit										Standard Motor									
3200	-	-	712	1.48	734	1.58	754	1.68	778	1.77	802	1.92	826	2.07	850	2.22	874	2.37	898	2.52
3600	736	1.67	758	1.78	780	1.88	801	2.01	823	2.15	845	2.29	869	2.45	892	2.61	926	2.91	947	3.07
4000	778	2.02	801	2.14	823	2.28	846	2.42	869	2.56	902	2.68	923	2.85	944	3.01	965	3.17	986	3.32
4400	821	2.46	846	2.61	871	2.76	901	3.08	922	3.24	943	3.39	964	3.54	985	3.68	1006	3.82	1027	3.95
External Static Pressure (Inches of Water)																				
CFM	1.1		1.2		1.3		1.4		1.5		1.6		1.7		1.8		1.9		2.0	
	RPM	BHP	RPM	BHP	RPM	BHP	RPM	BHP	RPM	BHP	RPM	BHP	RPM	BHP	RPM	BHP	RPM	BHP	RPM	BHP
	Standard Motor						High Static (oversize) Motor													
3200	930	2.75	951	2.88	972	2.98	993	3.09	1014	3.22	1035	3.34	1056	3.46	1077	3.59	1098	3.71	1119	3.82
3600	968	3.22	989	3.35	1010	3.47	1031	3.58	1052	3.69	1073	3.79	1094	3.88	1115	3.96	1136	4.04	1157	4.11
4000	1007	3.66	1028	3.77	1049	3.87	1070	3.96	1091	4.06	1112	4.15	1133	4.23	1154	4.31	1175	4.39	1196	4.48
4400	1048	4.08	1069	4.19	1090	4.29	1111	4.39	1132	4.49	1153	4.58	1174	4.67	1195	4.75	1216	4.83	1237	4.91

Table 33. Belt drive evaporator fan performance - 10 tons cooling only - EDK120A(3, 4)EO - downflow airflow

External Static Pressure (Inches of Water)																				
CFM	0.1		0.2		0.3		0.4		0.5		0.6		0.7		0.8		0.9		1.0	
	RPM	BHP	RPM	BHP	RPM	BHP	RPM	BHP	RPM	BHP	RPM	BHP	RPM	BHP	RPM	BHP	RPM	BHP	RPM	BHP
	Low Airflow Kit																			
3200	-	-	-	-	-	-	-	-	-	-	-	-	758	1.55	782	1.69	807	1.84	833	2.01
3600	-	-	-	-	-	-	-	-	736	1.55	770	1.83	798	1.95	820	2.09	845	2.26	870	2.41

Table 33. Belt drive evaporator fan performance - 10 tons cooling only - EDK120A(3, 4)EO - downflow airflow (continued)

External Static Pressure (Inches of Water)																					
CFM	0.1		0.2		0.3		0.4		0.5		0.6		0.7		0.8		0.9		1.0		
	RPM	BHP	RPM	BHP	RPM	BHP	RPM	BHP	RPM	BHP	RPM	BHP	RPM	BHP	RPM	BHP	RPM	BHP	RPM	BHP	
4000	-	-	-	-	724	1.74	752	1.85	782	2.06	809	2.21	836	2.37	860	2.54	882	2.71	914	2.99	
4400	717	1.94	745	2.08	772	2.19	799	2.34	825	2.47	852	2.63	876	2.79	909	3.08	934	3.24	958	3.39	

External Static Pressure (Inches of Water)																					
CFM	1.1		1.2		1.3		1.4		1.5		1.6		1.7		1.8		1.9		2.0		
	RPM	BHP	RPM	BHP	RPM	BHP	RPM	BHP	RPM	BHP	RPM	BHP	RPM	BHP	RPM	BHP	RPM	BHP	RPM	BHP	
Standard Motor																				High Static (oversize) Motor	
3200	858	2.17	881	2.34	913	2.62	936	2.74	959	2.85	982	2.96	1005	3.07	1028	3.17	1051	3.27	1074	3.37	
3600	896	2.59	926	2.84	949	2.96	972	3.08	995	3.19	1018	3.3	1041	3.41	1064	3.51	1087	3.61	1110	3.71	
4000	939	3.14	962	3.27	985	3.39	1008	3.51	1031	3.62	1054	3.72	1077	3.82	1100	3.92	1123	4.02	1146	4.12	
4400	981	3.52	1004	3.65	1027	3.77	1050	3.89	1073	3.99	1096	4.11	1119	4.22	1142	4.32	1165	4.42	1188	4.52	

Table 34. Belt drive evaporator fan performance - 10 tons cooling only - EDK120A(3, 4)EO - horizontal airflow

External Static Pressure (Inches of Water)																					
CFM	0.1		0.2		0.3		0.4		0.5		0.6		0.7		0.8		0.9		1.0		
	RPM	BHP	RPM	BHP	RPM	BHP	RPM	BHP	RPM	BHP	RPM	BHP	RPM	BHP	RPM	BHP	RPM	BHP	RPM	BHP	
Low Airflow Kit																					
3200	-	-	-	-	-	-	-	-	-	-	747	1.61	774	1.73	798	1.87	823	2.02	849	2.18	
3600	-	-	-	-	-	-	-	-	752	1.73	786	2.01	814	2.13	836	2.28	861	2.44	886	2.59	
4000	-	-	717	1.72	742	1.85	768	2.03	798	2.24	825	2.39	852	2.55	876	2.72	898	2.89	930	3.16	
4400	735	2.17	761	2.26	788	2.38	815	2.52	841	2.65	868	2.81	892	2.97	925	3.15	950	3.33	974	3.51	

External Static Pressure (Inches of Water)																					
CFM	1.1		1.2		1.3		1.4		1.5		1.6		1.7		1.8		1.9		2.0		
	RPM	BHP	RPM	BHP	RPM	BHP	RPM	BHP	RPM	BHP	RPM	BHP	RPM	BHP	RPM	BHP	RPM	BHP	RPM	BHP	
Standard Motor																				High Static (oversize) Motor	
3200	874	2.35	897	2.52	929	2.79	952	2.91	975	3.02	998	3.13	1021	3.24	1044	3.34	1067	3.44	1090	3.54	
3600	919	2.87	942	3.01	965	3.13	988	3.25	1011	3.36	1034	3.47	1057	3.58	1080	3.68	1103	3.78	1126	3.88	
4000	955	3.31	978	3.44	1001	3.56	1024	3.68	1047	3.79	1070	3.89	1093	3.99	1116	4.09	1139	4.19	1162	4.29	
4400	997	3.69	1020	3.82	1043	3.94	1066	4.06	1089	4.17	1112	4.28	1135	4.39	1158	4.49	1181	4.59	1204	4.69	

Table 35. Belt drive evaporator fan performance - 12.5 tons with low heat heat - GDK150A(3, 4)EL - downflow airflow

External Static Pressure (Inches of Water)																					
CFM	0.1		0.2		0.3		0.4		0.5		0.6		0.7		0.8		0.9		1.0		
	RPM	BHP	RPM	BHP	RPM	BHP	RPM	BHP	RPM	BHP	RPM	BHP	RPM	BHP	RPM	BHP	RPM	BHP	RPM	BHP	
Standard Motor																					
4000	-	-	-	-	-	-	793	2.09	820	2.24	847	2.38	873	2.52	899	2.66	924	2.77	949	2.89	
4500	-	-	791	2.23	816	2.41	842	2.58	869	2.76	897	2.91	925	3.19	951	3.37	977	3.53	1002	3.69	
5000	822	2.56	848	2.76	874	2.93	899	3.26	924	3.41	950	3.59	976	3.77	1001	3.96	1028	4.11	1056	4.27	
5500	873	2.99	899	3.31	925	3.46	950	3.63	975	3.81	999	3.99	1024	4.17	1049	4.36	1075	4.53	1101	4.71	



Performance Data

Table 35. Belt drive evaporator fan performance - 12.5 tons with low heat heat - GDK150A(3, 4)EL - downflow airflow (continued)

External Static Pressure (Inches of Water)																					
CFM	1.1		1.2		1.3		1.4		1.5		1.6		1.7		1.8		1.9		2.0		
	RPM	BHP	RPM	BHP	RPM	BHP	RPM	BHP	RPM	BHP	RPM	BHP	RPM	BHP	RPM	BHP	RPM	BHP	RPM	BHP	
High Static (oversize) Motor																					
4000	973	3.12	997	3.26	1020	3.37	1043	3.48	1065	3.59	1087	3.73	1108	3.86	1129	3.97	1149	4.09	1169	4.18	
4500	1026	3.86	1050	4.01	1073	4.16	1095	4.31	1117	4.44	1141	4.56	1166	4.64	1191	4.72	1213	4.79	1235	4.86	
5000	1083	4.42	1109	4.57	1135	4.72	1160	4.87	1185	5.02	1212	5.18	1236	5.33	-	-	-	-	-	-	
5500	1125	4.89	1149	5.07	1181	5.22	1204	5.34	1228	5.49	-	-	-	-	-	-	-	-	-	-	

Table 36. Belt drive evaporator fan performance - 12.5 tons with low gas heat - GDK150A(3, 4)EL - horizontal airflow

External Static Pressure (Inches of Water)																					
CFM	0.1		0.2		0.3		0.4		0.5		0.6		0.7		0.8		0.9		1.0		
	RPM	BHP	RPM	BHP	RPM	BHP	RPM	BHP	RPM	BHP	RPM	BHP	RPM	BHP	RPM	BHP	RPM	BHP	RPM	BHP	
Standard Motor																					
4000	-	-	-	-	773	2.03	801	2.18	828	2.33	855	2.47	881	2.61	907	2.74	932	2.86	957	2.98	
4500	-	-	799	2.32	824	2.51	850	2.67	877	2.84	905	3.02	933	3.28	959	3.46	985	3.62	1010	3.78	
5000	830	2.65	856	2.84	882	3.02	915	3.34	932	3.52	958	3.68	984	3.86	1009	4.04	1036	4.21	1064	4.36	
5500	881	3.08	916	3.41	937	3.54	958	3.72	983	3.89	1007	4.08	1032	4.26	1057	4.44	1083	4.62	1109	4.79	
External Static Pressure (Inches of Water)																					
CFM	1.1		1.2		1.3		1.4		1.5		1.6		1.7		1.8		1.9		2.0		
	RPM	BHP	RPM	BHP	RPM	BHP	RPM	BHP	RPM	BHP	RPM	BHP	RPM	BHP	RPM	BHP	RPM	BHP	RPM	BHP	
High Static (oversize) Motor																					
4000	981	3.21	1005	3.34	1028	3.46	1051	3.57	1073	3.68	1095	3.82	1116	3.94	1137	4.06	1157	4.18	1177	4.27	
4500	1034	3.94	1058	4.12	1081	4.25	1103	4.40	1125	4.53	1149	4.64	1174	4.73	1199	4.81	1221	4.88	1243	4.94	
5000	1091	4.51	1117	4.66	1143	4.81	1168	4.96	1193	5.11	1218	5.24	-	-	-	-	-	-	-	-	
5500	1133	4.98	1157	5.16	1183	5.29	1211	5.42	-	-	-	-	-	-	-	-	-	-	-	-	

Table 37. Belt drive evaporator fan performance - 12.5 tons with med gas heat - GDK150A(3, 4)EM- downflow airflow

External Static Pressure (Inches of Water)																					
CFM	0.1		0.2		0.3		0.4		0.5		0.6		0.7		0.8		0.9		1.0		
	RPM	BHP	RPM	BHP	RPM	BHP	RPM	BHP	RPM	BHP	RPM	BHP	RPM	BHP	RPM	BHP	RPM	BHP	RPM	BHP	
Standard Motor																					
4000	-	-	-	-	783	2.09	811	2.24	838	2.39	865	2.53	891	2.67	917	2.81	942	2.92	967	3.04	
4500	-	-	809	2.38	834	2.56	860	2.73	887	2.91	915	3.06	943	3.34	969	3.52	995	3.68	1020	3.84	
5000	840	2.71	866	2.91	892	3.08	917	3.41	942	3.56	968	3.74	994	3.92	1019	4.11	1046	4.26	1074	4.42	
5500	891	3.14	917	3.46	943	3.61	968	3.78	993	3.96	1017	4.14	1042	4.32	1067	4.51	1093	4.68	1119	4.86	
External Static Pressure (Inches of Water)																					
CFM	1.1		1.2		1.3		1.4		1.5		1.6		1.7		1.8		1.9		2.0		
	RPM	BHP	RPM	BHP	RPM	BHP	RPM	BHP	RPM	BHP	RPM	BHP	RPM	BHP	RPM	BHP	RPM	BHP	RPM	BHP	
High Static (oversize) Motor																					
4000	991	3.27	1015	3.41	1038	3.52	1061	3.63	1083	3.74	1105	3.88	1126	4.01	1147	4.12	1167	4.24	1187	4.33	
4500	1044	4.01	1068	4.16	1091	4.31	1113	4.46	1135	4.59	1159	4.71	1184	4.79	1209	4.87	1231	4.94	1253	5.01	

Table 37. Belt drive evaporator fan performance - 12.5 tons with med gas heat - GDK150A(3, 4)EM- downflow airflow (continued)

External Static Pressure (Inches of Water)																				
CFM	1.1		1.2		1.3		1.4		1.5		1.6		1.7		1.8		1.9		2.0	
	RPM	BHP	RPM	BHP	RPM	BHP	RPM	BHP	RPM	BHP	RPM	BHP	RPM	BHP	RPM	BHP	RPM	BHP	RPM	BHP
5000	1101	4.57	1127	4.72	1153	4.87	1178	5.02	1203	5.17	1230	5.33	-	-	-	-	-	-	-	-
5500	1143	5.04	1167	5.22	1199	5.37	1222	5.49	-	-	-	-	-	-	-	-	-	-	-	-

Table 38. Belt drive evaporator fan performance - 12.5 tons with med gas heat - GDK150A(3, 4)EM - horizontal airflow

External Static Pressure (Inches of Water)																				
CFM	0.1		0.2		0.3		0.4		0.5		0.6		0.7		0.8		0.9		1.0	
	RPM	BHP	RPM	BHP	RPM	BHP	RPM	BHP	RPM	BHP	RPM	BHP	RPM	BHP	RPM	BHP	RPM	BHP	RPM	BHP
Standard Motor																				
4000	749	1.91	770	2.07	798	2.24	826	2.39	853	2.54	880	2.68	906	2.82	932	2.95	957	3.07	982	3.19
4500	802	2.35	824	2.53	849	2.71	875	2.88	902	3.05	930	3.21	958	3.49	984	3.67	1010	3.83	1035	3.99
5000	855	2.86	881	3.05	907	3.23	932	3.55	957	3.71	983	3.89	1009	4.07	1034	4.25	1061	4.41	1089	4.57
5500	906	3.29	932	3.61	958	3.75	983	3.93	1008	4.11	1032	4.29	1057	4.47	1082	4.65	1108	4.83	1134	5.01
External Static Pressure (Inches of Water)																				
CFM	1.1		1.2		1.3		1.4		1.5		1.6		1.7		1.8		1.9		2.0	
	RPM	BHP	RPM	BHP	RPM	BHP	RPM	BHP	RPM	BHP	RPM	BHP	RPM	BHP	RPM	BHP	RPM	BHP	RPM	BHP
High Static (oversize) Motor																				
4000	1006	3.42	1030	3.55	1053	3.67	1076	3.78	1098	3.89	1120	4.03	1141	4.15	1162	4.27	1182	4.39	1202	4.48
4500	1059	4.15	1083	4.31	1106	4.46	1128	4.61	1150	4.74	1174	4.85	1199	4.94	1224	5.02	1246	5.09	1268	5.15
5000	1116	4.72	1142	4.87	1168	5.02	1193	5.17	1218	5.32	-	-	-	-	-	-	-	-	-	-
5500	1158	5.19	1182	5.37	-	-	-	-	-	-	-	-	-	-	-	-	-	-	-	-

Table 39. Belt drive evaporator fan performance - 12.5 tons with high gas heat - GDK150A(3, 4, W)EH - downflow airflow

External Static Pressure (Inches of Water)																				
CFM	0.1		0.2		0.3		0.4		0.5		0.6		0.7		0.8		0.9		1.0	
	RPM	BHP	RPM	BHP	RPM	BHP	RPM	BHP	RPM	BHP	RPM	BHP	RPM	BHP	RPM	BHP	RPM	BHP	RPM	BHP
Standard Motor																				
4000	-	-	-	-	783	2.09	811	2.24	838	2.39	865	2.53	891	2.67	917	2.81	942	2.92	967	3.04
4500	-	-	809	2.38	834	2.56	860	2.73	887	2.91	915	3.06	943	3.34	969	3.52	995	3.68	1020	3.84
5000	840	2.71	866	2.91	892	3.08	917	3.41	942	3.56	968	3.74	994	3.92	1019	4.11	1046	4.26	1074	4.42
5500	891	3.14	917	3.46	943	3.61	968	3.78	993	3.96	1017	4.14	1042	4.32	1067	4.51	1093	4.68	1119	4.86
External Static Pressure (Inches of Water)																				
CFM	1.1		1.2		1.3		1.4		1.5		1.6		1.7		1.8		1.9		2.0	
	RPM	BHP	RPM	BHP	RPM	BHP	RPM	BHP	RPM	BHP	RPM	BHP	RPM	BHP	RPM	BHP	RPM	BHP	RPM	BHP
High Static (oversize) Motor																				
4000	991	3.27	1015	3.41	1038	3.52	1061	3.63	1083	3.74	1105	3.88	1126	4.01	1147	4.12	1167	4.24	1187	4.33
4500	1044	4.01	1068	4.16	1091	4.31	1113	4.46	1135	4.59	1159	4.71	1184	4.79	1209	4.87	1231	4.94	1253	5.01
5000	1101	4.57	1127	4.72	1153	4.87	1178	5.02	1203	5.17	1230	5.33	-	-	-	-	-	-	-	-
5500	1143	5.04	1167	5.22	1199	5.37	1222	5.49	-	-	-	-	-	-	-	-	-	-	-	-



Performance Data

Table 40. Belt drive evaporator fan performance - 12.5 tons with high gas heat - GDK150A(3, 4, W)EH - horizontal airflow

External Static Pressure (Inches of Water)																				
	0.1		0.2		0.3		0.4		0.5		0.6		0.7		0.8		0.9		1.0	
CFM	RPM	BHP	RPM	BHP	RPM	BHP	RPM	BHP	RPM	BHP	RPM	BHP	RPM	BHP	RPM	BHP	RPM	BHP	RPM	BHP
Standard Motor																				
4000	749	1.91	770	2.07	798	2.24	826	2.39	853	2.54	880	2.68	906	2.82	932	2.95	957	3.07	982	3.19
4500	802	2.35	824	2.53	849	2.71	875	2.88	902	3.05	930	3.21	958	3.49	984	3.67	1010	3.83	1035	3.99
5000	855	2.86	881	3.05	907	3.23	932	3.55	957	3.71	983	3.89	1009	4.07	1034	4.25	1061	4.41	1089	4.57
5500	906	3.29	932	3.61	958	3.75	983	3.93	1008	4.11	1032	4.29	1057	4.47	1082	4.65	1108	4.83	1134	5.01
External Static Pressure (Inches of Water)																				
	1.1		1.2		1.3		1.4		1.5		1.6		1.7		1.8		1.9		2.0	
CFM	RPM	BHP	RPM	BHP	RPM	BHP	RPM	BHP	RPM	BHP	RPM	BHP	RPM	BHP	RPM	BHP	RPM	BHP	RPM	BHP
High Static (oversize) Motor																				
4000	1006	3.42	1030	3.55	1053	3.67	1076	3.78	1098	3.89	1120	4.03	1141	4.15	1162	4.27	1182	4.39	1202	4.48
4500	1059	4.15	1083	4.31	1106	4.46	1128	4.61	1150	4.74	1174	4.85	1199	4.94	1224	5.02	1246	5.09	1268	5.15
5000	1116	4.72	1142	4.87	1168	5.02	1193	5.17	1218	5.32	-	-	-	-	-	-	-	-	-	-
5500	1158	5.19	1182	5.37	-	-	-	-	-	-	-	-	-	-	-	-	-	-	-	-

Table 41. Belt drive evaporator fan performance - 12.5 tons cooling only - EDK150A(3, 4)E0 - downflow airflow

External Static Pressure (Inches of Water)																				
	0.1		0.2		0.3		0.4		0.5		0.6		0.7		0.8		0.9		1.0	
CFM	RPM	BHP	RPM	BHP	RPM	BHP	RPM	BHP	RPM	BHP	RPM	BHP	RPM	BHP	RPM	BHP	RPM	BHP	RPM	BHP
Standard Motor																				
4000	-	-	-	-	-	-	-	-	769	2.06	790	2.23	811	2.38	833	2.57	856	2.74	879	2.91
4500	-	-	759	2.12	787	2.35	808	2.52	829	2.69	851	2.86	874	3.03	906	3.31	929	3.46	952	3.58
5000	807	2.52	828	2.68	854	2.85	871	3.02	903	3.31	928	3.46	952	3.62	976	3.78	999	3.93	1022	4.07
5500	870	2.99	882	3.15	914	3.43	937	3.59	960	3.75	983	3.91	1006	4.06	1029	4.22	1052	4.38	1075	4.52
External Static Pressure (Inches of Water)																				
	1.1		1.2		1.3		1.4		1.5		1.6		1.7		1.8		1.9		2.0	
CFM	RPM	BHP	RPM	BHP	RPM	BHP	RPM	BHP	RPM	BHP	RPM	BHP	RPM	BHP	RPM	BHP	RPM	BHP	RPM	BHP
High Static (oversize) Motor																				
4000	911	3.19	932	3.33	952	3.45	972	3.56	992	3.66	1011	3.76	1030	3.86	1050	3.95	1071	4.04	1094	4.14
4500	974	3.74	995	3.88	1015	4.01	1035	4.11	1055	4.21	1074	4.31	1093	4.41	1113	4.51	1134	4.59	1157	4.69
5000	1044	4.21	1065	4.34	1085	4.46	1105	4.58	1125	4.68	1144	4.78	1163	4.88	1183	4.98	1204	5.08	1227	5.18
5500	1097	4.66	1118	4.79	1138	4.91	1158	5.02	1178	5.12	1197	5.22	1216	5.32	-	-	-	-	-	-

Table 42. Belt drive evaporator fan performance - 12.5 tons cooling only - EDK150A(3, 4)E0 - horizontal airflow

External Static Pressure (Inches of Water)																				
	0.1		0.2		0.3		0.4		0.5		0.6		0.7		0.8		0.9		1.0	
CFM	RPM	BHP	RPM	BHP	RPM	BHP	RPM	BHP	RPM	BHP	RPM	BHP	RPM	BHP	RPM	BHP	RPM	BHP	RPM	BHP
Standard Motor																				
4000	-	-	-	-	-	-	763	2.02	798	2.24	825	2.39	852	2.55	876	2.72	898	2.89	930	3.16
4500	-	-	775	2.25	803	2.48	824	2.65	845	2.82	867	2.99	890	3.16	922	3.44	945	3.59	968	3.73

Table 42. Belt drive evaporator fan performance - 12.5 tons cooling only - EDK150A(3, 4)E0 - horizontal airflow (continued)

External Static Pressure (Inches of Water)																					
CFM	0.1		0.2		0.3		0.4		0.5		0.6		0.7		0.8		0.9		1.0		
	RPM	BHP	RPM	BHP	RPM	BHP	RPM	BHP	RPM	BHP	RPM	BHP	RPM	BHP	RPM	BHP	RPM	BHP	RPM	BHP	
5000	823	2.65	844	2.81	870	2.98	887	3.15	919	3.43	944	3.59	968	3.75	992	3.91	1015	4.06	1038	4.2	
5500	886	3.12	898	3.28	930	3.56	953	3.72	976	3.88	999	4.04	1022	4.19	1045	4.35	1068	4.51	1091	4.65	

External Static Pressure (Inches of Water)																					
CFM	1.1		1.2		1.3		1.4		1.5		1.6		1.7		1.8		1.9		2.0		
	RPM	BHP	RPM	BHP	RPM	BHP	RPM	BHP	RPM	BHP	RPM	BHP	RPM	BHP	RPM	BHP	RPM	BHP	RPM	BHP	
	Standard Motor				High Static (oversize) Motor																
4000	955	3.31	978	3.44	1001	3.56	1024	3.68	1047	3.79	1070	3.89	1093	3.99	1116	4.09	1139	4.19	1162	4.29	
4500	990	3.87	1011	4.01	1031	4.13	1051	4.24	1071	4.34	1090	4.44	1109	4.54	1129	4.63	1150	4.72	1173	4.82	
5000	1060	4.34	1081	4.47	1101	4.59	1121	4.71	1141	4.81	1160	4.91	1179	5.01	1199	5.11	1220	5.21	1243	5.31	
5500	1113	4.79	1134	4.92	1154	5.04	1174	5.15	1194	5.25	1213	5.35	1232	5.45	-	-	-	-	-	-	

Table 43. Low airflow kit and drive/fan speed (rpm)

Tons	Unit Model Number	Fan Sheave	6 Turns Open	5 Turns Open	4 Turns Open	3 Turns Open	2 Turns Open	1 Turn Open	Closed
7.5	EDK090	15-15	570	594	617	641	665	688	712
	GDK090								
8.5	EDK102	15-15	570	594	617	641	665	688	712
	GDK102								
10	EDK120	15-15	717	741	765	789	813	837	861
	GDK120								
12.5	EDK150	—	—	—	—	—	—	—	—
	GDK150	—	—	—	—	—	—	—	—

Note: Factory Set at closed.

Table 44. Standard motor and drive/fan speed (rpm)

Tons	Unit Model Number	Fan Sheave	6 Turns Open	5 Turns Open	4 Turns Open	3 Turns Open	2 Turns Open	1 Turn Open	Closed
7.5	EDK090	15-15	713	730	753	776	800	823	846
	GDK090								
8.5	EDK102	15-15	728	757	786	815	843	872	901
	GDK102								
10	EDK120	15-15	862	901	934	967	1001	1034	1067
	GDK120								
12.5	EDK150	15-15	763	795	827	859	891	923	955
	GDK150								

Note: Factory Set at closed.

Table 45. High Static (Oversize) motor and drive/fan speed (rpm)

Tons	Unit Model Number	Fan Sheave	6 Turn Open	5 Turn Open	4 Turn Open	3 Turn Open	2 Turn Open	1 Turn Open	Closed
7.5	EDK090	15-15	848	874	906	938	970	1002	1034
	GDK090								
8.5	EDK102	15-15	848	874	906	938	970	1002	1034
	GDK102								



Performance Data

Table 45. High Static (Oversize) motor and drive/fan speed (rpm) (continued)

Tons	Unit Model Number	Fan Sheave	6 Turn Open	5 Turn Open	4 Turn Open	3 Turn Open	2 Turn Open	1 Turn Open	Closed
10	EDK120	15-15	917	965	1013	1061	1108	1156	1204
	GDK120								
12.5	EDK150	15-15	930	982	1034	1086	1139	1191	1243
	GDK150								

Note: 10 tons and 12.5 tons factory set at 4 turns open; 7.5 tons and 8.5 tons factory set as closed.

Table 46. Static pressure drop through accessories (inches water column)

Tons	Unit Model Number	Cfm	Standard Filters	Standard Economizer	Electric Heater (not applicable to 575V)					
					10.4	16	25	32	41	50
7.5	E/GDK090A (Downflow)	2400	0.01	—	0.005	0.005	0.005	0.01	0.01	—
		3000	0.03	—	0.01	0.01	0.01	0.02	0.02	—
		3375	0.04	—	0.015	0.015	0.015	0.03	0.03	—
	E/GDK090A (Horizontal)	2400	0.01	—	0.005	0.005	0.005	0.01	0.01	—
		3000	0.03	—	0.01	0.01	0.01	0.02	0.02	—
		3375	0.04	—	0.015	0.015	0.015	0.03	0.03	—
8.5	E/GDK102A (Downflow)	2720	0.02	—	0.01	0.01	0.01	0.02	0.02	—
		3400	0.04	—	0.015	0.015	0.015	0.03	0.03	—
		3825	0.05	—	0.02	0.02	0.02	0.04	0.04	—
	E/GDK102A (Horizontal)	2720	0.02	—	0.01	0.01	0.01	0.02	0.02	—
		3400	0.04	—	0.015	0.015	0.015	0.03	0.03	—
		3825	0.05	—	0.02	0.02	0.02	0.04	0.04	—
10	E/GDK120A (Downflow)	3200	0.03	—	0.015	0.015	—	0.03	0.03	0.03
		4000	0.05	—	0.02	0.02	—	0.04	0.04	0.04
		4500	0.07	—	0.025	0.025	—	0.05	0.05	0.05
	E/GDK120A (Horizontal)	3200	0.03	—	0.015	0.015	—	0.03	0.03	0.03
		4000	0.05	—	0.02	0.02	—	0.04	0.04	0.04
		4500	0.07	—	0.025	0.025	—	0.05	0.05	0.05
12.5	E/GDK150A (Downflow)	4000	0.05	—	0.02	0.02	—	0.04	0.04	0.04
		5000	0.07	—	0.03	0.03	—	0.06	0.06	0.06
		5625	0.09	—	0.035	0.035	—	0.07	0.07	0.07
	E/GDK150A (Horizontal)	4000	0.05	—	0.02	0.02	—	0.04	0.04	0.04
		5000	0.07	—	0.03	0.03	—	0.06	0.06	0.06
		5625	0.09	—	0.035	0.035	—	0.07	0.07	0.07

Table 47. Gas fired heating capacities

Tons	Gas Heat Option	Heating Input(MBh) ^(a)	Heating Output(MBh) ^(a)	Air Temp Rise
7.5	Low, Medium, or High ^(b)	125/87.5	100/70	15-45
		180/126	144/100	20-65
		225/157.5	180/125	25-70
8.5	Low, Medium, or High ^(b)	125/87.5	100/70	15-45
		180/126	144/100	20-65
		225/157.5	180/125	25-70
10	Low, Medium, or High ^(b)	180/125	144/100	20-50
		225/157.5	180/125	25-60
		250/200	200/160	30-65
12.5	Low, Medium, or High ^(b)	180/125	144/100	15-50
		225/157.5	180/125	20-60
		250/200	200/160	25-65

^(a) For two stage heaters (input or output), second stage is total heating capacity. Second stage/first stage.

^(b) The 575V models are only available with high gas.

Table 48. Auxiliary electric heat capacity – 208/230V and 460V

Tons	Unit Model Number ^(a)	Ton ^(b)		No. of Stages	Stage 1		Stage 2	
		kW	MBh		kW	MBh	kW	MBh
		Input ^(c)	Output		Input	Output	Input	Output
7.5	BAYHTMA*10B ^(d)	10.4	35.490	1	10.4	35.490	—	—
	BAYHTMA*15B ^(d)	16	54.590	1	16	54.590	—	—
	BAYHTMA*25B ^(d)	25	85.300	1	25	85.300	—	—
	BAYHTMA*32B ^(d)	32	109.190	2	16	54.590	16	54.590
	BAYHTMA*41B ^(d)	41	139.900	2	25	85.300	16	54.590
8.5	BAYHTMA*10B ^(d)	10.4	35.490	1	10.4	35.490	—	—
	BAYHTMA*15B ^(d)	16	54.590	1	16	54.590	—	—
	BAYHTMA*25B ^(d)	25	85.300	1	25	85.300	—	—
	BAYHTMA*32B ^(d)	32	109.190	2	16	54.590	16	54.590
	BAYHTMA*41B ^(d)	41	139.900	2	25	85.300	16	54.590
10	BAYHTMA*10B ^(d)	10.4	35.490	1	10.4	35.490	—	—
	BAYHTMA*15B ^(d)	16	54.590	1	16	54.590	—	—
	BAYHTMA*32B ^(d)	32	109.190	2	16	54.590	16	54.590
	BAYHTMA*41B ^(d)	41	139.900	2	25	85.300	16	54.590
	BAYHTMA*50B ^(d)	50	170.610	2	25	85.300	25	85.300
12.5	BAYHTMA*10B ^(d)	10.4	35.490	1	10.4	35.490	—	—
	BAYHTMA*15B ^(d)	16	54.590	1	16	54.590	—	—
	BAYHTMA*32B ^(d)	32	109.190	2	16	54.590	16	54.590
	BAYHTMA*41B ^(d)	41	139.900	2	25	85.300	16	54.590
	BAYHTMA*50B ^(d)	50	170.610	2	25	85.300	25	85.300

^(a) * = 3 (208-230V) or 4 (460V)

^(b) Heaters are rated at 240V, 480V, and 600V. For other than rated voltage, CAP = (voltage/rated voltage)² x rated cap.

^(c) For all input/output categories, does not include fan power or heat.

^(d) Applies to B or later revision.

Table 49. Electric heater voltage correction factors (applicable to auxiliary heat capacity) – 208/230V and 460V

Nominal Voltage	Distribution Voltage	Capacity Multiplier
240	208	0.75
	230	0.92
	240	1

Table 50. Air temperature rise across electric heaters(°F) – 208/230V and 460V

kW	Stages	7.5 Ton 3000 cfm	8.5 Ton 3400 cfm	10 Ton 4000 cfm	12.5 Ton 5000 cfm
10.4	1	10.7	9.9	8.2	6.8
16	1	14.6	13.8	12.6	10.9
25	1	22.4	22.4	—	—
32	2	28.2	27.1	25.3	22.9
41	2	37.5	35.6	32.4	30.1
50	2	—	—	39.5	37



Controls

Economizer Controls

The standard equipment offering is a fixed dry bulb changeover control.

Remote Potentiometer

Minimum position setting of economizer can be remotely adjusted with this accessory.

Thermostats

Model #	Type	Stages	Display Type	Features
TCONT302AS42DA	Programmable	4H/2C	Touchscreen	Common preferred, not required 2/ 2 AA battery power
BAYSTAT814	Touchscreen	3H/2C	Touchscreen	Remote access via Pivot Mobile App
BAYSTAT300	Programmable	3H/2C	Backlit Display and Keys	BACnet MS-TP enabled



Electrical Data

Table 51. Unit wiring with cooling only (no electric heat) or gas heat

TONS	Unit Model Number	Unit Operating Voltage Range	Standard Indoor Fan Motor		Oversized Indoor Fan Motor	
			Minimum Circuit Ampacity ^(a)	Maximum Fuse Size or Maximum Circuit Breaker	Minimum Circuit Ampacity	Maximum Fuse Size or Maximum Circuit Breaker
7.5	GDK090A	208-230	35	45	39	50
8.5	GDK102A	208-230	38	45	45	50
10	GDK120A	208-230	45	60	52	60
12.5	GDK150A	208-230	62	80	64	80
7.5	GDK090A	460	18	20	25	30
8.5	GDK102A	460	20	25	27	30
10	GDK120A	460	28	30	29	35
12.5	GDK150A	460	35	45	35	45
7.5	GDK090A	575	13	15	18	20
8.5	GDK102A	575	15	15	20	20
10	GDK120A	575	23	25	24	30
12.5	GDK150A	575	27	35	29	35

^(a) For Standard and Oversized Indoor Fan Motor, values do not include power exhaust accessory.

Table 52. Unit wiring with electric heat (single point connection)

Tons	Unit Model Number	Heater kW Rating	Control Stages	Standard Indoor Fan Motor		Oversized Indoor Fan Motor	
				Minimum Circuit Ampacity	Maximum Fuse Size or Maximum Circuit Breaker	Minimum Circuit Ampacity	Maximum Fuse Size or Maximum Circuit Breaker
208/230 Volts Three Phase							
7.5	BAYHTMA341 ^{*(a)}	41	2	116/133	125/150	122/139	125/150
	BAYHTMA332 ^{*(a)}	32	2	93/106	100/110	99/112	100/125
	BAYHTMA325 ^{*(a)}	25	1	75/85	80/90	81/91	90/100
	BAYHTMA315 ^{*(a)}	15	1	51/58	60	57/64	60/70
	BAYHTMA310 ^{*(a)}	10	1	37/41	45	43/47	50
8.5	BAYHTMA341 ^{*(a)}	41	2	116/133	125/150	126/142	150
	BAYHTMA332 ^{*(a)}	32	2	93/106	100/110	102/115	110/125
	BAYHTMA325 ^{*(a)}	25	1	75/85	80/90	84/94	90/100
	BAYHTMA315 ^{*(a)}	15	1	51/58	60	60/67	60/70
	BAYHTMA310 ^{*(a)}	10	1	38/41	45/45	46/50	50/50
10	BAYHTMA350 ^{*(a)}	50	2	146/136	150	149/139	150
	BAYHTMA341 ^{*(a)}	41	2	122/139	125/150	126/142	150
	BAYHTMA332 ^{*(a)}	32	2	99/112	100/125	102/115	110/125
	BAYHTMA315 ^{*(a)}	15	1	57/64	60/70	60/67	60/70
	BAYHTMA310 ^{*(a)}	10	1	50/50	60/60	52/52	60/60
12.5	BAYHTMA350 ^{*(a)}	50	2	146/136	150	149/139	150
	BAYHTMA341 ^{*(a)}	41	2	122/139	125/150	126/142	150
	BAYHTMA332 ^{*(a)}	32	2	99/112	100/125	102/115	110/125
	BAYHTMA315 ^{*(a)}	15	1	62/64	80	64/67	80/80
	BAYHTMA310 ^{*(a)}	10	1	62/62	80	64/64	80/80
460 Volts Three Phase							
7.5	BAYHTMA441 ^{*(a)}	41	2	70	70	76	80
	BAYHTMA433 ^{*(a)}	33	2	57	60	63	70
	BAYHTMA425 ^{*(a)}	25	1	44	45	50	50
	BAYHTMA416 ^{*(a)}	16	1	31	35	37	40
	BAYHTMA414 ^{*(a)}	14	1	27	30	33	35
8.5	BAYHTMA441 ^{*(a)}	41	2	70	70	78	80
	BAYHTMA433 ^{*(a)}	33	2	57	60	65	70
	BAYHTMA425 ^{*(a)}	25	1	44	45	52	60
	BAYHTMA416 ^{*(a)}	16	1	31	35	39	40
	BAYHTMA414 ^{*(a)}	14	1	27	30	35	40



Electrical Data

Table 52. Unit wiring with electric heat (single point connection) (continued)

Tons	Unit Model Number	Heater kW Rating	Control Stages	Standard Indoor Fan Motor		Oversized Indoor Fan Motor	
				Minimum Circuit Ampacity	Maximum Fuse Size or Maximum Circuit Breaker	Minimum Circuit Ampacity	Maximum Fuse Size or Maximum Circuit Breaker
10	BAYHTMA450*(a)	50	2	74	80	76	80
	BAYHTMA441*(a)	41	2	76	80	78	80
	BAYHTMA433*(a)	33	2	63	70	65	70
	BAYHTMA416*(a)	16	1	37	40	39	40
	BAYHTMA414*(a)	14	1	33	35	35	40
12.5	BAYHTMA450*(a)	50	2	74	80	76	80
	BAYHTMA441*(a)	41	2	76	80	78	80
	BAYHTMA433*(a)	33	2	63	70	65	70
	BAYHTMA416*(a)	16	1	37	45	39	45
	BAYHTMA414*(a)	14	1	35	45	37	45

(a) Not applicable to A revision. Applies only to B or later.

Table 53. Electrical characteristics – compressor motor and condenser motor

TONS	Unit Model Number	Compressor Motors						Condenser Fan Motors			
		No.	Volts	Phase	rpm	Amps ^(a)		No.	Phase	hp	Amps
						RLA	LRA				FLA
7.5	E/GDK090A	2	208-230	3	3500	12.0/9.0	123/70	2	3	1/3	1.5
8.5	E/GDK102A	2	208-230	3	3500	12.1/12.0	93/123	2	3	1/3	1.5
10	E/GDK120A	2	208-230	3	3500	12.1/17.6	93/120	2	3	1/3	1.5
12.5	E/GDK150A	2	208-230	3	3500	22.4/12.1	190/93	2	3	3/4	4.5
7.5	E/GDK090A	2	460	3	3500	6.3/4.1	60/39	2	3	1/3	0.87
8.5	E/GDK102A	2	460	3	3500	6.5/6.3	60/60	2	3	1/3	0.87
10	E/GDK120A	2	460	3	3500	6.5/8.3	60/70	2	3	1/3	0.87
12.5	E/GDK150A	2	460	3	3500	12.2/6.5	87/60	2	3	3/4	2.0
7.5	GDK090A	2	575	3	3500	4.4/3.3	41/29	2	3	1/3	0.87
8.5	GDK090A	2	575	3	3500	5.1/4.4	41/41	2	3	1/3	0.87
10	GDK090A	2	575	3	3500	5.1/7.4	41/53	2	3	1/3	0.87
12.5	GDK090A	2	575	3	3500	9.6/5.1	62/41	2	3	3/4	2.0

(a) For Compressor Motors and Condenser Fan Motors: Amp draw for each motor; multiply value by number of motors to determine total amps.

Table 54. Electrical characteristics – evaporator fan motor

TONS	Unit Model Number	Standard Evaporator Fan Motor					Oversized Evaporator Fan Motor				
		No.	Volts	Phase	hp	Amps	No.	Volts	Phase	hp	Amps
						FLA					FLA
7.5	GDK090A	1	203-230	3	2	7.2	1	203-230	3	3	12
8.5	GDK102A	1	203-230	3	2	7.2	1	203-230	3	5	14.6
10	GDK120A	1	203-230	3	3	12	1	203-230	3	5	14.6
12.5	GDK150A	1	203-230	3	3	12	1	203-230	3	5	14.6
7.5	GDK090A	1	460/575	3	2	3.5	1	460/575	3	3	8.7
8.5	GDK102A	1	460/575	3	2	3.5	1	460/575	3	5	10.3
10	GDK120A	1	460/575	3	3	8.7	1	460/575	3	5	10.3
12.5	GDK150A	1	460/575	3	3	8.7	1	460/575	3	5	10.3

Table 55. Electrical characteristics – combustion blower motor (gas heat units)

TONS	Unit Model Number	Combustion Blower Motor				Amps
		No.	Volts	Phase	rpm	FLA
7.5	GDK090	1	208/230	1	2100	1.2
8.5	GDK105	1	208/230	1	2100	1.2
10	GDK120	1	208/230	1	2100	1.2
12.5	GDK150	1	208/230	1	2100	1.2
7.5	GDK090	1	460/575	1	2100	1.3
8.5	GDK105	1	460/575	1	2100	1.3

Table 55. Electrical characteristics – combustion blower motor (gas heat units) (continued)

TONS	Unit Model Number	Combustion Blower Motor				
		No.	Volts	Phase	rpm	Amps
						FLA
10	GDK120	1	460/575	1	2100	1.3
12.5	GDK150	1	460/575	1	2100	1.3



Jobsite Connections

Table 56. Typical number of wires

Thermostats	
A	3 Wires, 24V, Cooling only 4 Wires 24V, with Electric Heat
B	3 Power Wires + 1 Ground Wire (three phase)

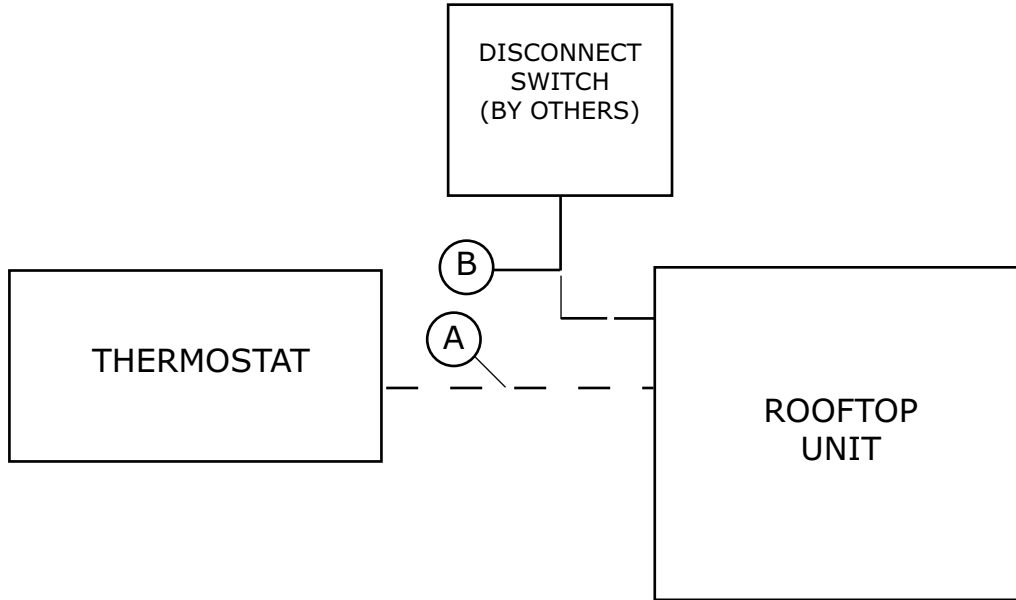

Notes:

- For specific wiring information, see the installation instructions.
- All wiring except power wire is low voltage.
- All customer supplied wiring to be copper and must conform to applicable electrical codes and local electric codes. Wiring shown dotted is to be furnished and installed by the customer.

Dimensional Data

Figure 3. Typical installation clearance for single and multiple unit applications (in inches)

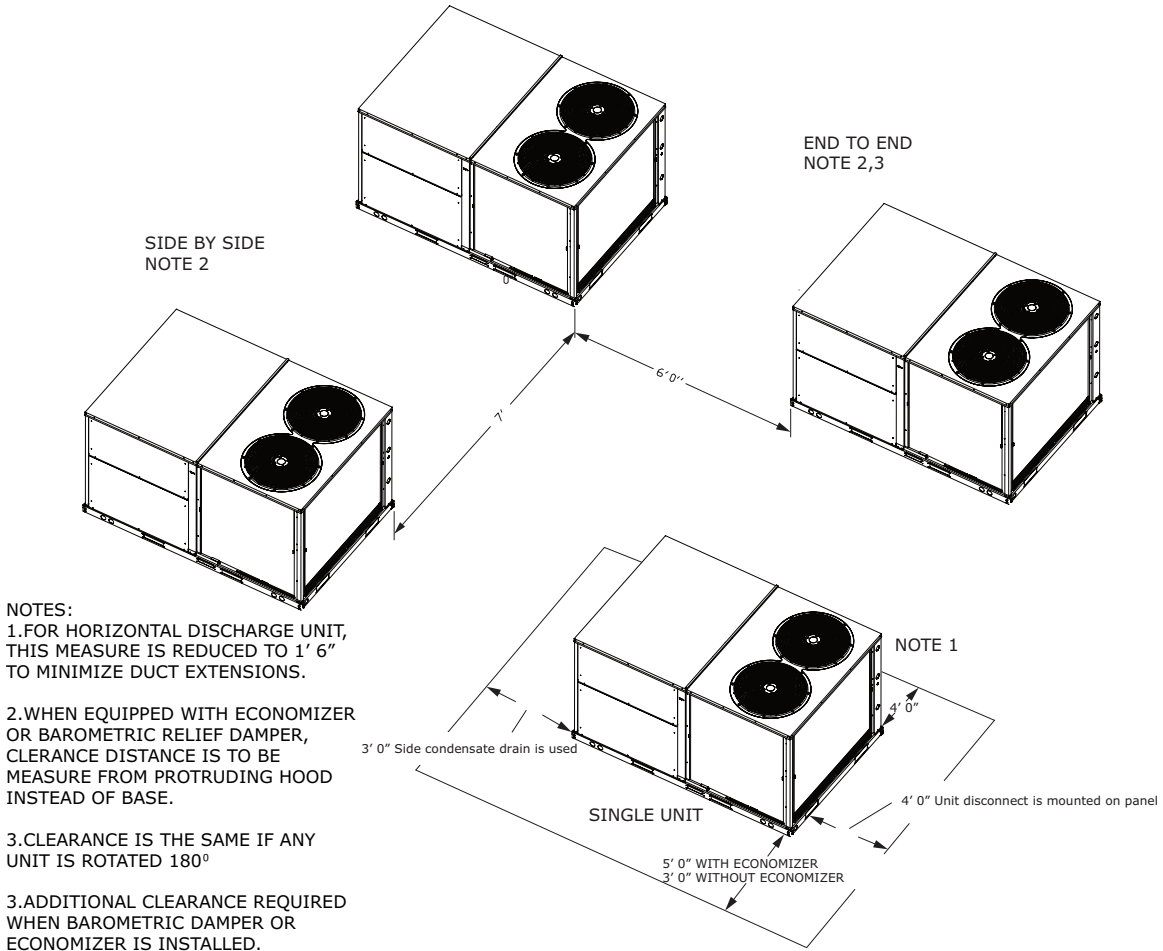

Figure 4. Cooling with optional electrical heat and gas/electric units — overview

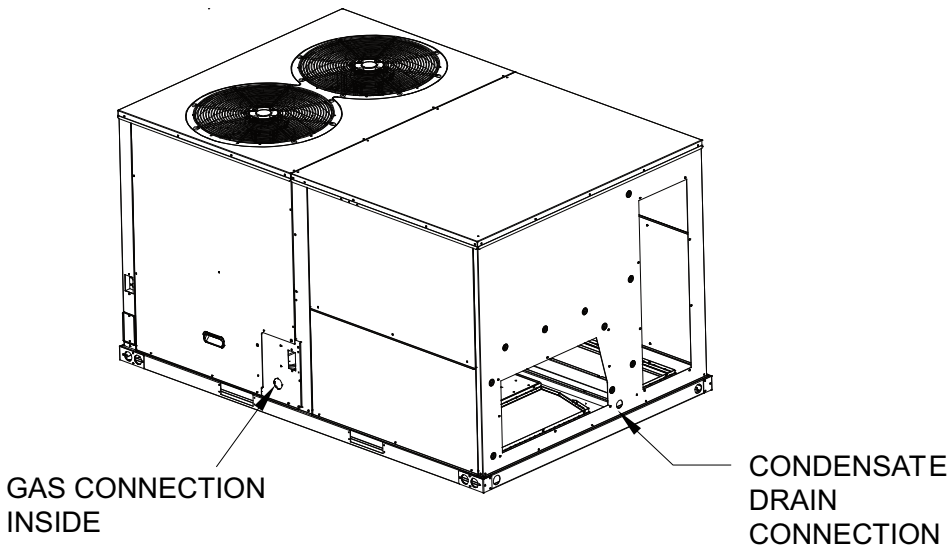

Figure 5. Cooling with optional electrical heat and gas/electric units — overview

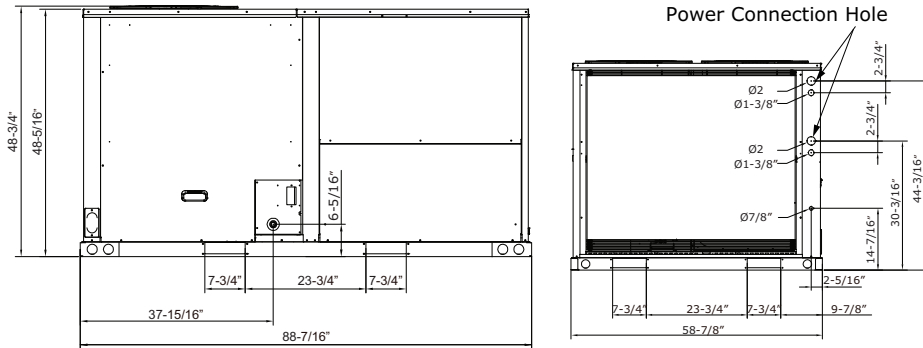
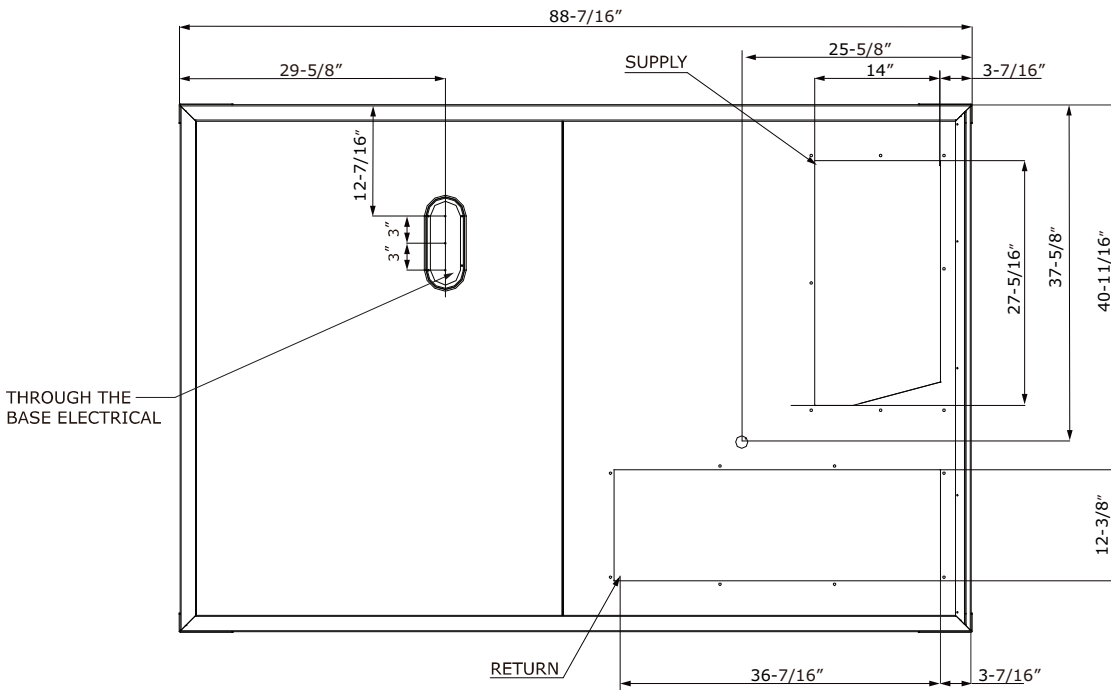

Figure 6. Cooling with optional electrical heat and gas/electric units — bottom view (in inches)



- NOTES:
 1. THROUGH THE BASE GAS AND ELECTRICAL IS NOT STANDARD ON ALL UNITS.
 2. VERIFY WEIGHT, CONNECTION, AND ALL DIMENSION WITH INSTALLER DOCUMENTS BEFORE INSTALLATION.

Figure 7. Cooling with optional electrical heat and gas/electric units — back view (horizontal configuration) (in inches)

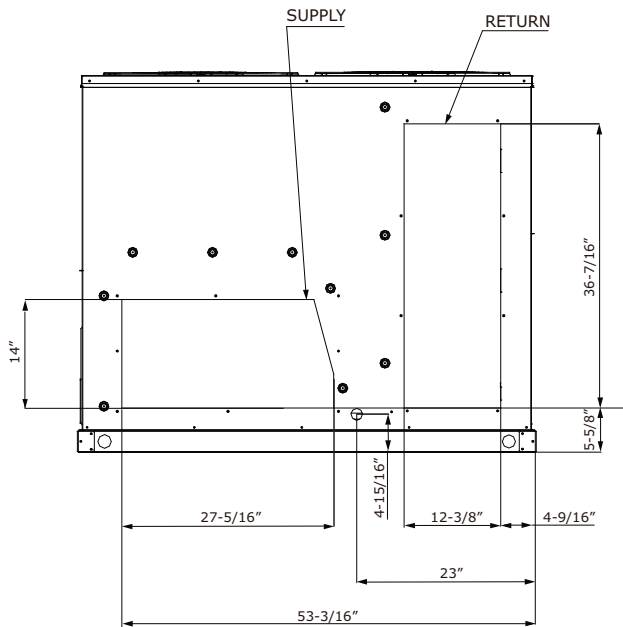
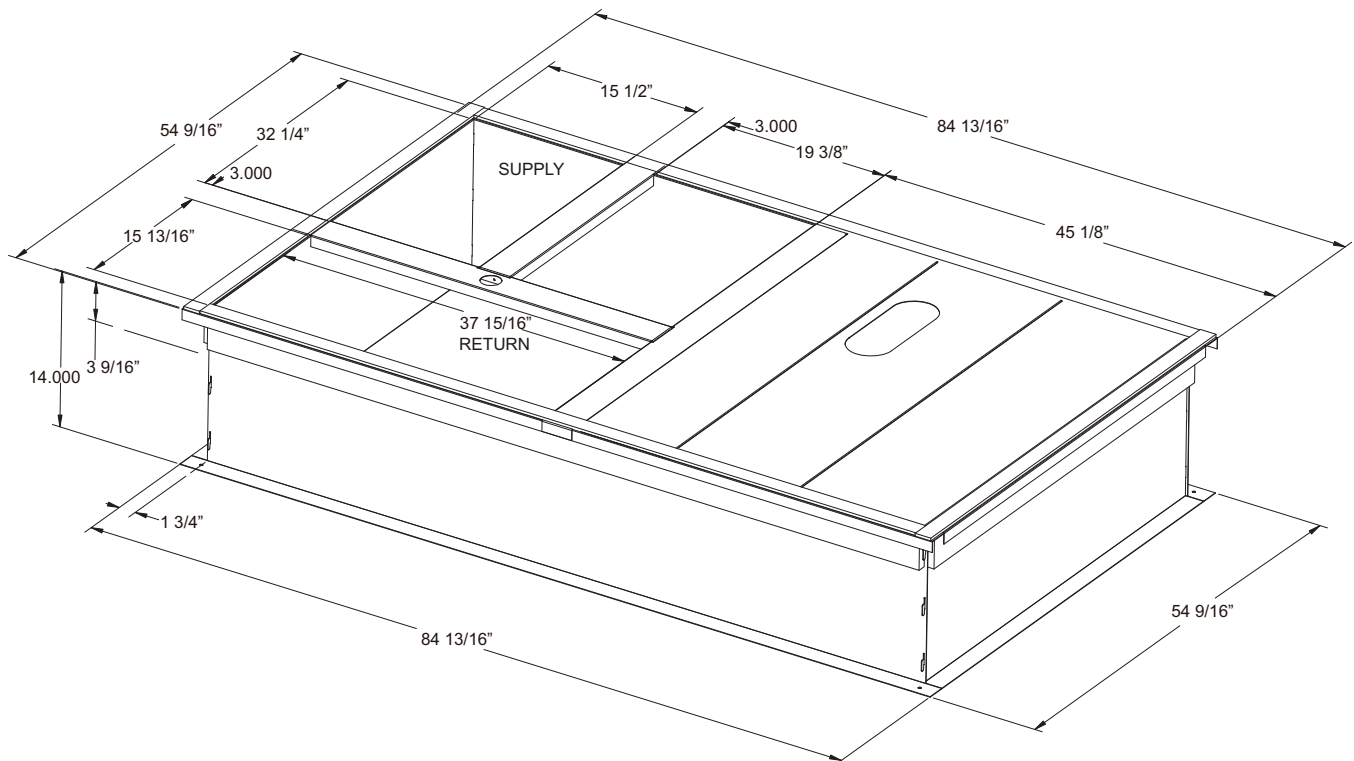

Figure 8. Cooling with optional electric heat and gas/electric models — roof curb (in inches)





Dimensional Data

Figure 9. Cooling with optional electric heat and gas/electric models — downflow unit clearance (in inches)

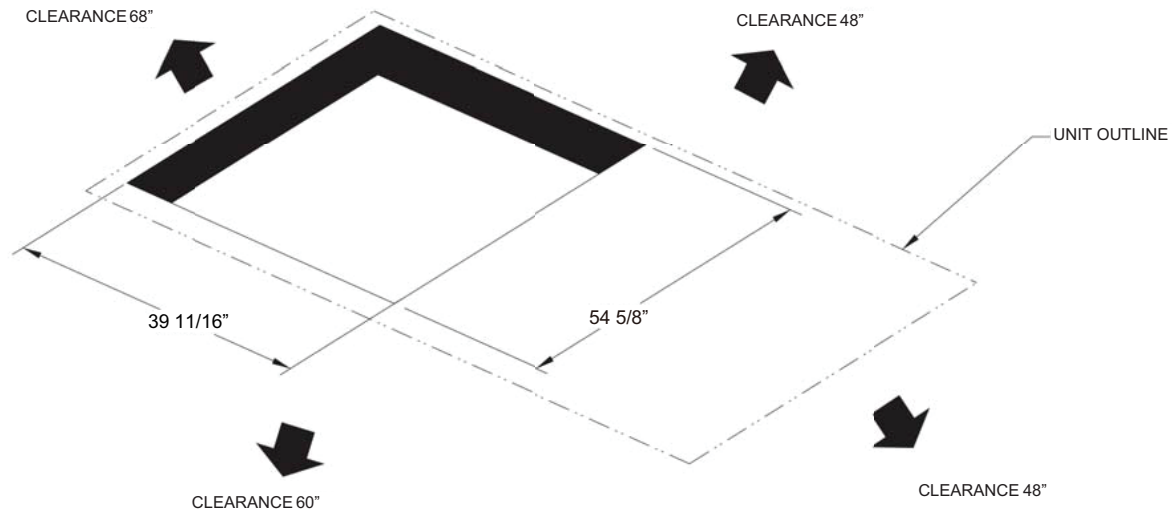



Weights

Table 57. Maximum unit and corner weights (lb) and center of gravity dimensions (in.)

Voltage	Tons	Unit Model No.	Weights (lb) ^(a) , ^(b)		Corner Weights ^(c)				Center of Gravity (in.)	
			Shipping	Net	A	B	C	D	Length	Width
208/230V and 460V	7.5	GDK090A	1087	1025	247	246	265	267	44	33
	8.5	GDK102A	1124	1063	254	246	275	287	43	35
	10	GDK120A	1157	1096	289	242	257	317	38	33
	12.5	GDK150A	1237	1175	306	257	278	344	38	34
	7.5	EDK090A	979	917	221	220	237	238	44	33
	8.5	EDK102A	1016	955	228	221	247	258	43	35
	10	EDK120A	1047	985	260	217	231	284	38	33
	12.5	EDK150A	1127	1065	277	233	252	311	38	34
575V	7.5	GDK090A	1136	1074	255	254	278	286	42	35
	8.5	GDK102A	1173	1112	268	256	288	298	41	37
	10	GDK120A	1207	1145	298	250	268	328	36	35
	12.5	GDK150A	1297	1235	318	267	289	359	36	36

^(a) Weights are approximate. Horizontal and downflow unit and corner weights may vary slightly.

^(b) Weights do not include additional factory or field installed options/accessories.

^(c) Corner weights are given for information only. 7.5 to 12.5 ton models must be supported continuously by a curb or equivalent frame support.

Note: To calculate additional weight for accessories, see *Accessory net weights table*.

Table 58. Accessory net weight (lb) – 208V/380V and 460V

Accessories	Model #	Net weight (lb)			
		E/GDK090	E/GDK102	E/GDK120	E/GDK150
Electric Heaters					
10 kW (240V)	BAYHTMA310B	19.4	19.4	19.4	19.4
16 kW (240V)	BAYHTMA315B	20	20	20	20
25 kW (240V)	BAYHTMA325B	20.5	20.5	20.5	20.5
32 kW (240V)	BAYHTMA332B	24.4	24.4	24.4	24.4
41 kW (240V)	BAYHTMA341B	24.8	24.8	24.8	24.8
50 kW (240V)	BAYHTMA350B	25.2	25.2	25.2	25.2
Oversized Motor					
2 HP (230 / 460)	—	37.5	37.5	—	—
3 HP (230 / 460)	—	45.0	—	45.0	45.0
5 HP (230 / 460)	—	—	53.0	53.0	53.0
External Vent Hood		2.8			

Figure 10. Center of gravity/corner weights

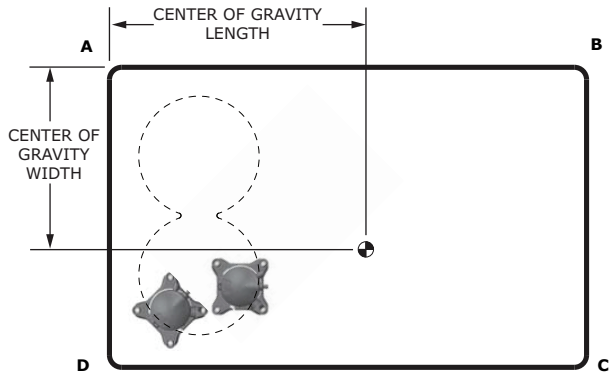



Mechanical Specifications

General

- Packaged rooftop units cooling, heating capacities, and efficiencies are AHRI Certified within scope of AHRI Standard (I-P) and ANSI Z21.47 and 10 CFR Part 431 pertaining to Commercial Warm Air Furnaces
- Packaged rooftop units are dedicated downflow or horizontal airflow
- Operating range between 125°F and 40°F in cooling standard from the factory
- Factory assembled, internally wired, fully charged with R-454B, and 100 percent run tested to check cooling operation, fan and blower rotation, and control sequence before leaving the factory
- Colored and numbered wiring internal to the unit for simplified identification
- Units ETL listed and labeled, classified in accordance UL 60335-2-40 4th edition.

Standard Features

Casing

- Zinc coated, heavy gauge, galvanized steel
- Weather-resistant baked enamel finish on phosphatized exterior surfaces
- Meets ASTM B117, 672 hour salt spray test
- Removable single side maintenance access panels
- Lifting handles in maintenance access panels (can be removed and reinstalled by removing no more than 11 fasteners while providing a water and air tight seal)
- Exposed vertical panels and top covers in the indoor air section shall be insulated with a 1/2-inch, 1-pound density foil-faced, fire-resistant, permanent, odorless, glass fiber material
- Base of unit shall be insulated with 1/2-inch, 1-pound density, foil-faced, glass fiber material
- Base pan shall have no penetrations within the perimeter of the curb other than the raised 1 1/8-inch high downflow supply/return openings to provide an added water integrity precaution, if the condensate drain backs up
- Downflow unit's base pan shall have no penetrations within the perimeter of the curb other than the raised 1 1/8-inch high supply/return openings to provide an added water integrity precaution, if the condensate drain backs up
- Base of unit shall have provisions for forklift and crane lifting

Compressors

- All units have direct-drive, hermetic, scroll type compressors with centrifugal type oil pumps
- Suction gas-cooled motor with voltage utilization range of plus or minus 10 percent of unit nameplate voltage
- Internal overloads standard with scroll compressors
- All models have phase monitors and Low and High Pressure Controls as standard

Evaporator and Condenser Coils

- Microchannel coils burst tested by manufacturer
- Microchannel condenser coils standard on all units
- Coils leak tested to ensure the pressure integrity
- Evaporator coil and condenser coil leak tested to 225 psig and pressure tested to 450 psig
- Sloped condensate drain pans are standard

Filters

Two inch standard filters shall be factory supplied on all units.

Gas Heat Section

- Progressive tubular heat exchanger, stainless steel burners and corrosion resistant steel
- Induced draft combustion blower shall be used to pull the combustion products through the firing tubes
- Heater shall use a direct spark ignition (DSI) system
- On initial call for heat, the combustion blower shall purge the heat exchanger for 20 seconds before ignition



Mechanical Specifications

- After three unsuccessful ignition attempts, entire heating system shall be locked out until manually reset at the thermostat/zone sensor
- Units shall be suitable for use with natural gas or propane (field-installed kit)

Indoor Fan

- Belt driven, FC centrifugal fans with adjustable motor sheaves
- Motors thermally protected
- Oversized motors available for high static application
- Indoor fan motors meet the U.S. Energy Policy Act of 1992 (EPACT)

Locking Safety Device

- Pressure switch monitoring allows for lockout in a situation where the switch is opened
- By monitoring the Y input as well as the pressure switches, advanced decision making can be made to identify situations where faults/errors occur

Outdoor Fans

- Outdoor fan shall be externally drive, statically and dynamically balanced, draw-through in the vertical discharge position.
- Fan motor(s) shall be permanently lubricated and shall have current overload protection.

Refrigerant Circuits

- Each refrigerant circuit shall have a fixed orifice, service pressure ports, and refrigerant line filter driers factory installed as standard
- An area shall be provided for replacement suction line driers

Refrigerant Pressure Control

All units include High and Low Pressure Cutouts as standard.

Unit Top

The top cover shall be double hemmed and gasket sealed to prevent water leakage.

Factory Installed Options

Multi-Speed Indoor Fan System

Incorporates a multi-speed fan control to change the speed of the fan to 70% of full airflow based off of compressor stages

Oversized Motors

Oversized motors shall be available as a factory option for High Static applications.

Field Installed Options

Condensate Overflow Switch

This option shall shut the unit down in the event that a clogged condensate drain line prevents proper condensate removal from the unit.

Demand Control Ventilation with CO₂ Sensor

- CO₂ sensor shall have the ability to monitor the concentration (parts per million, ppm) of CO₂ (Carbon Dioxide) in the air
- As the CO₂ concentration changes, the outside air damper modulates to meet the current ventilation needs of the zone

Economizer (Standard) — Downflow

- Assembly includes fully modulating 0–100% motor and dampers, barometric relief, minimum position setting, preset linkage, wiring harness with plug, fixed dry bulb and spring return actuator

- Barometric relief damper shall provide a pressure operated damper that shall be gravity closing and shall prohibit entrance of outside air during the equipment “off” cycle

Economizer — Horizontal

The horizontal economizer shall contain the same features as the downflow economizer with the exception of barometric relief.

Electric Heaters

- Electric heat modules will be available for installation within the basic unit.
- Elements will be made of heavy-duty nickel chromium elements internally – delta connected for 240 volt; wye connected for 139 volt.
- Power assemblies provide single-point connection.
- Electric heat modules will be UL listed or CSA certified.

Hail Guards

Tool-less, hail protection quality coil guards are available for condenser coil protection.

Leak Detection Sensors

Unit shall be furnished with a leak detection system from the factory when a circuit refrigerant charge exceeds 3.91 lbs. The leak detection system shall consist of one or more refrigerant detection sensors. When the system detects a leak, the unit controller shall initiate mitigation actions.

Low Leak Economizer with Fault Detection & Diagnostics – Downflow

- Controller shall have the capability to provide the value of each sensor used in controlling the economizer operation
- System status is also indicated for the following conditions:
 - Free cooling available
 - Economizer enabled
 - Compressor enabled
 - Heating Enabled
 - Mixed air low limit cycle active
- Fault Detection and Diagnostic system detects the following faults:
 - Air temperature sensor failure/fault
 - Not economizing when conditions indicate system should be economizing
 - Economizing when conditions indicate system should not be economizing
 - Dampers are not modulating
 - Excessive amounts of outside air are being introduced through the economizer
- Fault Detection and Diagnostic system is certified by the California Energy Commission as meeting requirements of California Title 24 120.2(i)1 through 120.2(i)8 in accordance with Section 100(h)

Manual Outside Air Damper

Manually set outdoor air dampers shall provide up to 50% outside air.

Motorized Outside Air Damper

- Outdoor air dampers shall open to set position when indoor fan starts
- Damper shall close to the full closed position when indoor fan shuts down

Powered Exhaust

The powered exhaust shall provide exhaust of return air, when using an economizer, to maintain better building pressurization.



Mechanical Specifications

Remote Potentiometer

The minimum position setting of the economizer shall be adjusted with this accessory.

Through-the-Base Gas Piping

- Unit shall include a standard through the base gas provision
- Option shall have all piping necessary including, black steel, manual gas shut-off valve, elbows, and union
- Manual shutoff valve shall include a 1/8-inch NPT pressure tap
- Assembly will require minor field labor to install (Gas/Electric Only)

Through-the-Base Utilities Access

- Electrical service entrance shall be provided allowing electrical access for both control and main power connections inside the curb and through the base of the unit
- Option shall allow for field installation of liquid-tight conduit and an external field installed disconnect switch



Notes

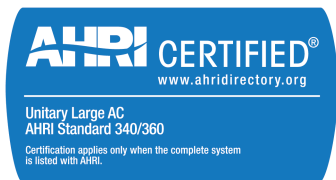

The AHRI Certified mark indicates Trane U.S. Inc. participation in the AHRI Certification program. For verification of individual certified products, go to ahridirectory.org.

Trane - by Trane Technologies (NYSE: TT), a global innovator - creates comfortable, energy efficient indoor environments for commercial and residential applications. For more information, please visit trane.com or tranetechnologies.com.

Trane has a policy of continuous product and product data improvements and reserves the right to change design and specifications without notice. We are committed to using environmentally conscious print practices.