



Product Catalog

# Packaged Rooftop Air Conditioners Voyager™ 3 with Symbio™ 700 Controls

eStage™

27.5 to 50 Tons - 60 Hz

22.9 to 41.7 Tons (81-148 kW) - 50 Hz





# Introduction

## Packaged Rooftop Air Conditioners

Through the years, Trane has designed and developed the most complete line of Packaged Rooftop products available in the market today. Trane was the first to introduce the Micro—microelectronic unit controls—and has continued to improve and revolutionize this design concept.

The ReliaTel™ control platform offered the same great features and functionality as the original Micro, with additional benefits. Now with the Symbio™ digital controller on board, Voyager 3 features smart building capabilities that take the service, comfort, and sustainability beyond the expected.

The Voyager™ 3 line offers 27.5 to 50 ton, 60 Hz and 23 to 42 ton 50 Hz models. Both 50 and 60 Hz models come in a choice of five sizes to meet the changing demands of the commercial rooftop market.

Trane customers demand products that provide exceptional reliability, meet stringent performance requirements, and are competitively priced. Trane delivers with Voyager 3.

Voyager 3 features cutting edge technologies: reliable 3-D™ Scroll compressors, eStage™ for premium efficiency, Trane engineered Symbio™ controls, computer-aided run testing, and Integrated Comfort™ Systems.

So, whether you're a contractor, the engineer, or an owner you can be certain Voyager Products are built to meet your needs.

It's Hard To Stop A Trane®.



## Copyright

This document and the information in it are the property of Trane, and may not be used or reproduced in whole or in part without written permission. Trane reserves the right to revise this publication at any time, and to make changes to its content without obligation to notify any person of such revision or change.

## Trademarks

All trademarks referenced in this document are the trademarks of their respective owners.

## Revision History

Updates to:

- Model Number Description
- General Data chapter
- Performance Data chapter
- Weights chapter



# Table of Contents

Features and Benefits .....	6
Standard Features .....	6
Optional Features .....	6
Outstanding Optional Features .....	7
Quality and Reliability .....	10
Unmatched Product Support .....	13
Application Considerations .....	14
60/50 Hz Units .....	14
A2L Application Considerations .....	17
Leak Detection System (Refrigerant charge greater than 3.91 lb per circuit) .....	18
Selection Procedure .....	20
60 Hz Units .....	20
50 Hz Units .....	23
Model Number Description .....	26
60 Hz Description .....	26
50 Hz Description .....	28
General Data .....	30
Performance Adjustment Factors .....	38
Performance Data (60 Hz Units) .....	40
Performance Data (50 Hz Units) .....	54
Controls .....	76
Enhanced BAS Integration and Connectivity .....	76
Secure Remote Connectivity with Trane Connect .....	76
Serviceability .....	76
Flexibility .....	78
Economizer Controls .....	79
Zone Sensors .....	79
Air-Fi Wireless Communicating Zone Sensors .....	80
Thermostats .....	81
Electrical Data .....	82
Electrical Service Sizing .....	82
Dimensional Data .....	90
Fresh Air, Power Exhaust Hoods .....	90

Weights .....	97
Mechanical Specifications .....	100
General .....	100
Outside Air .....	102
Exhaust Air .....	102
Miscellaneous Unit Options .....	103



# Features and Benefits

## Standard Features

- R-454B refrigerant optimized design
- Factory installed Symbio™ 700 controls with Advanced Diagnostic capabilities
- Variable frequency drive
- Compressor lead-lag
- Crankcase heaters
- Emergency stop input
- Froststat™ coil frost protection on all units
- Occupied-Unoccupied switching
- Phase monitor
- Temperature discharge limit (TDL)
- Timed override activation
- FC supply fans
- Supply airflow proving
- Supply air overpressurization protection on VAV units
- Dedicated downflow, horizontal, or mixed airflow configurations
- Trane 3-D™ Scroll compressors
- Two inch standard efficiency filters
- Sloped condensate drain pan
- Cleanable, IAQ-enhancing, foil faced insulation on all interior surfaces exposed to the unit air stream
- cULus listing on standard options
- Discharge air temperature sensor
- Leak detection system

## Optional Features

### Cabinet

- Factory or field installed condenser coil guards
- Factory or field installed condenser hail guards
- Hinged service access
- Downflow/upflow, horizontal, or mixed airflow configurations
- Sloped stainless steel evaporator coil drain pans

### Controls

- Statitrac™ direct space pressure control
- Trane Air Quality Traq™ (outside air measurement)
- BACnet Communication Interface (BCI)
- LonTalk® Communication Interface (LCI)
- Air-Fi™ Wireless Communications Interface (WCI)
- CO<sub>2</sub> sensors for space comfort control (SCC) or discharge air control (DAC)
- Ventilation override
- Condensate Overflow Switch
- Symbio 700 Expansion Modules

- Leak Detection System (LDS) and mitigation response, per safety standard UL 60335-2-40

## **Electrical**

- Factory mounted disconnect with external handle (non-fused)
- Factory powered or field powered 15A GFI convenience outlet
- High Fault SCCR
- Through-the-base electrical provision

## **Filtration**

- MERV 8 high efficiency 2" or 4" throwaway filters
- MERV 14 high efficiency 4" filters
- Clogged filter switch

## **Heat**

- Natural Gas or LP (kit) heat with two stage and modulating options
- Natural gas and LP elevation kits
- Stainless steel heat exchanger (gas heat only)
- Electric heat

## **Mechanical**

- Multi-speed, VAV, or SZ VAV Control
- Motors with Internal Shaft Grounding Ring
- 50% fresh air tracking power exhaust
- 100% fresh air tracking power exhaust
- 50% power exhaust
- 100% power exhaust
- Ultra low leak power exhaust
- Barometric relief
- Economizer with differential (comparative) enthalpy control
- Economizer with dry bulb control
- Economizer with reference enthalpy control
- Ultra low leak economizer with Fault Detection and Diagnostics (FDD)
- Manual fresh air damper
- Economizer with differential dry bulb control

## **Refrigeration**

- Corrosion protected condenser coil
- Modulating hot gas reheat
- Service valves

## **Outstanding Optional Features**

### **Single Zone VAV (SZVAV)**

Single Zone VAV (SZVAV) is designed for use in single zone applications such as gymnasiums, auditoriums, manufacturing facilities, retail box stores, and any large open spaces where there is a diversity in the load profile. It is an ideal replacement to "yesterday's" constant-volume (CV) systems, as it reduces operating costs while improving occupant comfort.



## Features and Benefits

---

SZVAV systems combine Trane application, control and system integration knowledge to exactly match fan speed with cooling and heating loads, regardless of the operating condition. Trane algorithms meet and/or exceed ASHRAE 90.1 SZVAV energy-saving recommendations and those of CA Title 24. The result is an optimized balance between zone temperature control and system energy savings. Depending on your specific application, energy savings can be as much as 20+%.

*Note: Building system modeling in energy simulation software such as TRACE is recommended to evaluate performance improvements for your application.*

SZVAV is fully integrated into the control system. It provides the simplest and fastest commissioning in the industry through proven factory-installed, wired, and tested system controllers. All control modules, logic boards and sensors are factory installed and tested to ensure the highest quality and most reliable system available. This means no special programming of algorithms, or hunting at the jobsite for field installed sensors, boards, etc. SZVAV is a quick and simple solution for many applications and is available from your most trusted rooftop VAV system solution provider -Trane.

## Zoned Rooftop Systems

Trane Zoned Rooftop Systems combine:

- Voyager 3 packaged rooftop units with Symbio™ controls
- VAV terminal units (in multiple-zone system configurations)
- Tracer Concierge® control system
- (Optional) Air-Fi® Wireless controls

Zoned Rooftop Systems are pre-engineered systems that deliver cost effective comfort, energy efficiency and are easy to install and operate. The system types range from single-zone to multiple-zone configurations with various options for airflow modulation, cooling and heating, and ventilation control. Trane® Zoned Rooftop Systems provide customers with affordable options for small buildings, to increase comfort and efficiency, while simplifying maintenance. For more details, see APP-PRC009\*-EN.

## Power Exhaust

Provides exhaust of the return air when using an economizer to maintain proper building pressurization. Great for relieving most building over pressurization problems.

## Fresh Air Tracking Power Exhaust Option

Provides exhaust of the return air to maintain proper building pressurization by proportionally controlling the exhaust air to the economizer dampers; in other words, the exhaust damper “tracks” the outside air damper position.

## Statitrac™ Direct Space Building Pressurization Control

Trane's Statitrac™ control is a highly accurate and efficient method of maintaining building pressure control with a large rooftop air conditioner. Statitrac space pressure control turns the exhaust fans on and modulates exhaust dampers to maintain space pressure within the space pressure deadband. Proper building pressurization eliminates annoying door whistling, doors standing open, and odors from other zones.



## Downflow and Horizontal Economizers

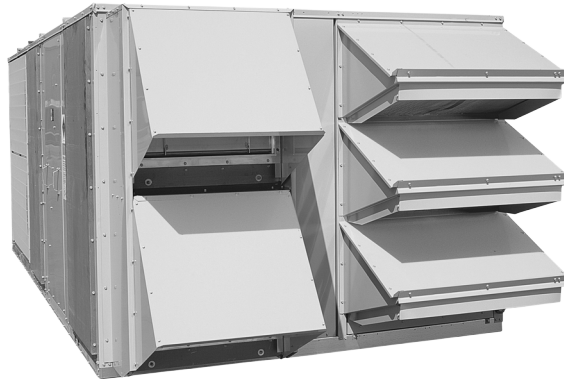

The economizers come with four control options: dry bulb temperature, comparative enthalpy, reference enthalpy, and differential dry bulb temperature. The photo shows the three fresh air hoods on the horizontal discharge configuration.

## Trane Air Quality (Traq™) Outside Air Measurement System

Trane Air Quality (Traq) outside air measurement system uses velocity pressure sensing rings to measure airflow in the outside air opening from 40 cfm/ton to maximum airflow. Measurement accuracy is at least  $\pm 15\%$ , meeting requirements of LEED IE Q Credit 1.

## Modulating Hot Gas Reheat

By its very nature, the colder the air, the less moisture it contains. With hot gas reheat, hot refrigerant gas leaving the compressor is diverted to a hot gas reheat coil. The cold air leaving the DX coil is then reheated to an acceptable temperature and returned as dehumidified air to the facility space. The modulation of the hot gas reheat helps maintain both temperature and humidity levels in cooling mode, while reducing unit operating costs and saving energy.

**Figure 1. Hot gas reheat**

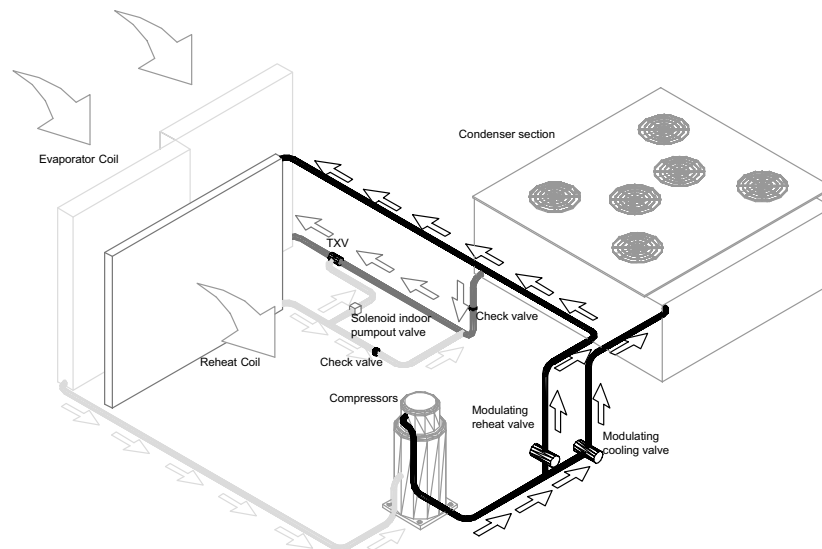

## Condenser Guards

Two options for condenser guards are available: standard guards and hail (louvered) guards. Condenser hail guards protect the unit condenser coil from hail, debris damage, and vandalism.



## Features and Benefits

---

### Trane Factory Built Roof Curbs

Available for all units.

### Motor Shaft Grounding Ring

Motors with internal Shaft grounding rings can be used with VFDs to provide a conductive discharge path away from the motor bearings to ground. Not available with 25HP motor.

### Stainless Steel Sloped Drain Pans

The non-porous, stainless steel surface on these drain pans avoids the harboring of dirt and bacteria, while discouraging microbial growth and helping to promote indoor air quality. The material is easy to clean, long lasting, and extremely durable, thus minimizing drain pan deterioration and premature leakage. The stainless steel drain pans are sloped, allowing for easy and fast water exit.

### Condensate Overflow Switch

A condensate overflow switch is available to shut the unit down in the event that the condensate drain becomes clogged. This option protects the unit from water overflowing from the drain pan and entering the base of the unit.

### eStage™ - Standard and High Efficiency Units

Through compressor staging on a single circuit, this option allows units to have a maximum 25% load at the first stage allowing the unit to meet Title 24, along with providing increased full load and part load unit efficiency.

## Quality and Reliability

### Easy to Install, Service and Maintain

Because today's owners are very cost-conscious when it comes to service and maintenance, this unit was designed with direct input from service contractors. This valuable information helped to design a product that would get the service technician off the job quicker and save the owner money. This product line offers outstanding standard features enhanced by a variety of factory and field installed options, multiple control options, rigorously tested proven designs and superior product and technical support.

### Rigorous Testing

Our units are rigorously rain tested to ensure water integrity. Actual shipping tests are performed to determine packaging requirements. Units are test shipped around the country to determine the best packaging. Factory shake tests are used as part of the package design process to help assure that the unit arrives at the job site in top condition. Rigging tests include lifting a unit into the air and letting it drop one foot, assuring that the lifting lugs and rails hold up under stress. A 100% coil leak test is performed at the factory. The condenser coils are leak tested at 660 psig and evaporators to 450 psig. All parts are inspected at the point of final assembly. Sub-standard parts are identified and rejected immediately. Every unit receives a 100% unit run test before leaving the production line to ensure it lives up to rigorous Trane requirements.

### Conversionless Units

The dedicated design units require no panel removal or alteration time to convert the airflow discharge in the field—a major cost savings during installation.

Horizontal units come complete with duct flanges so the contractor doesn't have to field fabricate them. These duct flanges are a time and cost saver.

### Tubular Heat Exchanger (Gas Heat Only)

The Voyager™ tubular gas heat exchangers are available in both low and high heat capacities with the ability to burn natural gas as standard and LP with a field-installed kit. All gas heat configurations are offered in either two stage or 10:1 modulating operation. Turndown on modulating furnaces with LP fuel will be limited to 6:1 for the equivalent 10:1 natural gas furnace.

Each heat exchanger is fabricated using stainless steel burners and corrosion-resistant aluminized steel tubes as standard on all two-stage models, with options for a complete stainless steel construction. Modulating heat is only offered with a complete stainless steel construction.

This assortment of configurations provides a suitable solution for a variety of applications. All Voyager™ tubular gas heat exchangers are tested under ANSI Z83.8/CSA 2.6 and meet the 2023 Department of Energy efficiency code for 81% steady state efficiency. Integral to the heat exchanger assembly, an induced draft blower is used to pull the gas mixture through the burner tubes. A direct spark ignition system, which doubles as a safety device to prove the flame, is used to ignite the gas mixture.

### Low Ambient Cooling

All units have cooling capabilities down to 0°F as standard.

### Microchannel Condenser Coil

Microchannel condensing coils are all-aluminum coils with fully-brazed construction. This design reduces risk of leaks and provides increased coil rigidity — making them more rugged on the jobsite. Their flat streamlined tubes with small ports and metallurgical tube-to-fin bond allow for exceptional heat transfer. Microchannel all-aluminum construction provides several additional benefits:

- Light weight (simplifies coil handling)
- Easy to recycle
- Minimize galvanic corrosion

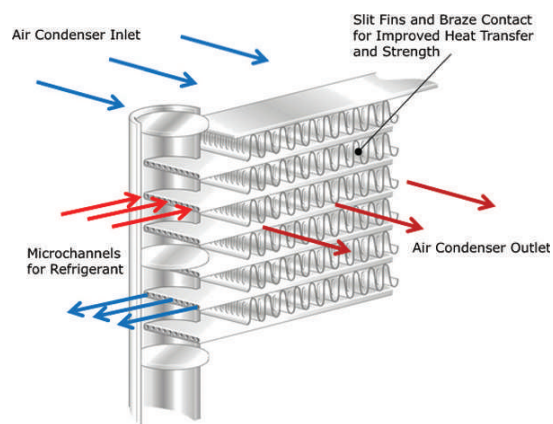

### Leak Detection Sensors

Unit shall be furnished with a leak detection system from the factory when a circuit refrigerant charge exceeds 4 lbs. The leak detection system shall consist of one or more refrigerant detection sensors. When the system detects a leak, the unit controller shall initiate mitigation actions.

### Symbio Controls

#### Enhanced BAS Integration and Connectivity

- Open standard communications
  - BACnet® over Zigbee (Air-Fi Wireless)
  - BACnet MS/TP
  - BACnet IP
  - Modbus™ RTU
  - Modbus TCP/IP
  - LonTalk®
- Securely access, troubleshoot, and monitor equipment from anywhere via Trane Connect™

#### Serviceability



## Features and Benefits

---

- Wireless mobile app interface (iPhone and Android) to simplify startup/service
- On-board user interface
- Data Trending
- Real-time, clear language diagnostics
- Historical alarm logs
- Backup and Restore functionality to reduce commissioning and service time

### Flexibility

- Future-ready upgradable software, supporting changing codes and new sequences of operation
- Standard, consistent pre-engineered applications that meet industry standards
- Built-in Schedules (requires Tracer® TU)
- Expandable inputs and outputs (requires Tracer TU)
- Ability to add custom programmed sequences (requires Tracer TU)

## Phase Monitor

This unit features a three-phase line monitor module that protects against phase loss, phase reversal and phase unbalance. It is intended to protect compressors from reverse rotation. It has an operating input voltage range of 190–600 Vac, and LED indicators for “**ON**” and “**FAULT**”. There are no field adjustments and the module will automatically reset from a fault condition.

## Supply Airflow Proving

Fan status is checked through the VFD. Any alarms sent to the Symbio board disable all unit functions and a diagnostic will be annunciated on the onboard user interface and/or mobile app.

## Pressure Cutouts

Low and high pressure cutouts are standard on all models.

## Single Point Power

A single electrical connection powers the unit.

## Sloped Drain Pans

Every unit has a non-corrosive, sloped drain pan made of pre-painted steel and standard on all units.

## Temperature Discharge Limit (TDL)

A bi-metal element discharge line thermostat is installed as a standard feature on the discharge line of each system. This standard feature provides extra protection to the compressors against high discharge temperatures in case of loss of charge, extremely high ambient and other conditions which could drive the discharge temperature higher.

## Variable Frequency Drives (VFD)

Variable Frequency Drives are factory installed and tested to provide supply fan motor speed modulation, as well as modulating gas heat. VFD's on the supply fan, as compared to inlet guide vanes or discharge dampers, are quieter, more efficient, and are eligible for utility rebates. The VFD's are available with or without a bypass option. Bypass control will simply provide full nominal airflow in the event of drive failure.

Modulating gas heat models with VFD's allow tighter space temperature control with less temperature swing.

## **Unmatched Product Support**

Our Sales Representatives are a support group that can assist you with:

- Product
- Application
- Service
- Training
- Special Applications
- Specifications
- Computer Programs and more



# Application Considerations

## 60/50 Hz Units

### Exhaust Air Options

When is it necessary to provide building exhaust?

Whenever an outdoor air economizer is used, a building generally requires an exhaust system. The purpose of the exhaust system is to exhaust the proper amount of air to prevent over or under-pressurization of the building.

A building may have all or part of its exhaust system in the rooftop unit. Often, a building provides exhaust external to the air conditioning equipment. This external exhaust must be considered when selecting the rooftop exhaust system.

Voyager™ 3 rooftop units offer four types of exhaust systems:

- 50% or 100% Power exhaust fan
- 50% or 100% Fresh Air Tracking Power Exhaust Fan(s)
- 100% Power Exhaust with Statitrac™ Building Pressure Control
- Barometric relief dampers

### Application Recommendations

#### Power Exhaust Fan (with or without Fresh Air Tracking)

The exhaust fan option is either a single fan for exhausting approximately half of the air-moving capabilities of the supply fan system or dual fans for 100% exhaust. Either exhaust capability arrangement is configured as an on/off non-modulating exhaust or an on/off exhaust with an actuator controlled damper to track the position of the fresh air damper.

For non-100% air applications, the 50% non-tracking power exhaust fan generally should not be selected for more than 40 to 50% of design supply airflow. Since it is an on/off non-modulating fan, it does not vary exhaust cfm with the amount of outside air entering the building. Therefore, if selected for more than 40 to 50% of supply airflow, the building may become under pressurized when economizer operation is allowing lesser amounts of outdoor air into the building. If, however, building pressure is not of a critical nature, the non-modulating exhaust fan may be sized for more than 50% of design supply airflow. Consult (60Hz) or [Table 48, p. 75](#) (50Hz) for specific exhaust fan capabilities with Voyager 3 units.

#### 100% Power Exhaust with Statitrac™ Building Pressure Control

This control is available only with 100% power exhaust. The exhaust dampers are modulated in response to building pressure. Statitrac, a differential pressure control system, uses a differential pressure transducer to compare indoor building pressure to atmospheric pressure. The exhaust fans are turned on when required to lower building static pressure to setpoint. The Statitrac control system then modulates the exhaust dampers to control the building pressure to within the adjustable, specified deadband that is set at the RTVM board. Economizer and return air dampers are modulated independent of the exhaust dampers based on ventilation control and economizer cooling requests. Statitrac can only lower building pressure; it cannot raise it. To lower building pressure, Statitrac exhausts air from the space using the power exhaust. To raise building pressure, more air must be supplied to the space, as with economizer operation. Additional relief, such as a bathroom exhaust fan or relief fan, as well as other units serving the space, will affect building pressure and must be taken into account.

#### Barometric Relief Dampers

Barometric relief dampers consist of gravity dampers which open with increased building pressure. As the building pressure increases, the pressure in the unit return section also increases, opening the dampers and relieving air. Barometric relief may be used to provide relief for single story buildings with no return ductwork and exhaust requirements less than 25%.

## Altitude Corrections

The rooftop performance tables and curves of this catalog are based on standard air (.075 lbs/ft). If the rooftop airflow requirements are at other than standard conditions (sea level), an air density correction is needed to project accurate unit performance.

Figure 3, p. 39 shows the air density ratio at various temperatures and elevations. Trane rooftops are designed to operate between 40° and 90°F leaving air temperature.

The procedure to use when selecting a supply or exhaust fan on a rooftop for elevations and temperatures other than standard is as follows:

1. First, determine the air density ratio using Figure 3, p. 39.
2. Divide the static pressure at the nonstandard condition by the air density ratio to obtain the corrected static pressure.
3. Use the actual cfm and the corrected static pressure to determine the fan rpm and bhp from the rooftop performance tables or curves.
4. The fan rpm is correct as selected.
5. Bhp must be multiplied by the air density ratio to obtain the actual operating bhp.

In order to better illustrate this procedure, the following examples are used:

### 60 Hz

Consider a 30 ton rooftop unit that is to deliver 11,000 actual cfm at 1.50 inches total static pressure (tsp), 55°F leaving air temperature, at an elevation of 5,000 ft.

- From Figure 3, p. 39, the air density ratio is 0.86.
- $Tsp = 1.50 \text{ inches} / 0.86 = 1.74 \text{ inches tsp}$ .
- From the performance tables: a 30 ton rooftop will deliver 11,000 cfm at 1.74 inches tsp at 632 rpm and 6.2 bhp.
- The rpm is correct as selected — 632 rpm.
- $Bhp = 6.2 \times 0.86 = 5.33$ .

Compressor MBh, SHR, and kW should be calculated at standard and then converted to actual using the correction factors in Table 9, p. 39. Apply these factors to the capacities selected at standard cfm so as to correct for the reduced mass flow rate across the condenser.

Heat selections other than gas heat will not be affected by altitude. Nominal gas capacity (output) should be multiplied by the factors given in Table 10, p. 39 before calculating the heating supply air temperature.

### 50 Hz

Consider a 29 ton (105 kW) rooftop unit that is to deliver 9,160 actual cfm (4323 L/s) at 1.50 inches total static pressure (tsp) (38 mm, 373 Pa), 55°F (12.8°C) leaving air temperature, at an elevation of 5,000 ft (1524 m).

- From Figure 3, p. 39, the air density ratio is 0.86.
- $Tsp = 1.50 \text{ inches} / 0.86 = 1.74 \text{ inches tsp}$ .  $374 / .86 = 434 \text{ Pa}$ .
- From the performance tables: a 29-ton (105 kW) rooftop will deliver 9,160 cfm at 1.74 inches tsp (4323 L/s at 434 Pa) at 618 rpm and 4.96 bhp (3.7 kW).
- The rpm is correct as selected – 618 rpm.
- $Bhp = 4.96 \times 0.86 = 4.27 \text{ bhp actual}$ .  $kW = 3.7 \times 0.86 = 3.18 \text{ kW}$

Compressor MBh, SHR, and kW should be calculated at standard and then converted to actual using the correction factors in Table 9, p. 39. Apply these factors to the capacities selected at standard cfm so as to correct for the reduced mass flow rate across the condenser.

Heat selections other than gas heat will not be affected by altitude.

## Acoustical Considerations

Proper placement of rooftops is critical to reducing transmitted sound levels to the building. The ideal time to make provisions to reduce sound transmissions is during the design phase. The most



## Application Considerations

---

economical means of avoiding an acoustical problem is to place the rooftop(s) away from acoustically critical areas. If possible, rooftops should not be located directly above areas such as: offices, conference rooms, executive office areas and classrooms. Instead, ideal locations might be over corridors, utility rooms, toilets or other areas where higher sound levels directly below the unit(s) are acceptable.

Several basic guidelines for unit placement should be followed to minimize sound transmission through the building structure:

- Never cantilever the compressor end of the unit. A structural cross member must support this end of the unit.
- Locate the unit center of gravity which is close to, or over, a column or main support beam.
- If the roof structure is very light, roof joists must be replaced by a structural shape in the critical areas described above.
- If several units are to be placed on one span, they should be staggered to reduce deflection over that span.

It is impossible to totally quantify the effect of building structure on sound transmission, since this depends on the response of the roof and building members to the sound and vibration of the unit components. However, the guidelines listed above are experience- proven guidelines which will help reduce sound transmissions.

## Clearance Requirements

The recommended clearances identified with unit dimensions should be maintained to assure adequate serviceability, maximum capacity and peak operating efficiency. A reduction in unit clearance could result in condenser coil starvation or warm condenser air recirculation. If the clearances shown are not possible on a particular job, consider the following:

- Do the clearances available allow for major service work such as changing compressors or coils?
- Do the clearances available allow for proper outside air intake, exhaust air removal and condenser airflow?
- If screening around the unit is being used, is there a possibility of air recirculation from the exhaust to the outside air intake or from condenser exhaust to condenser intake?

Actual clearances which appear inadequate should be reviewed with a local Trane sales engineer. When two or more units are to be placed side by side, the distance between the units should be increased to 150% of the recommended single unit clearance. The units should also be staggered for two reasons:

- To reduce span deflection if more than one unit is placed on a single span. Reducing deflection discourages sound transmission.
- To assure proper diffusion of exhaust air before contact with the outside air intake of adjacent unit.

## Duct Design

It is important to note that the rated capacities of the rooftop can be met only if the rooftop is properly installed in the field. A well designed duct system is essential in meeting these capacities.

The satisfactory distribution of air throughout the system requires that there be an unrestricted and uniform airflow from the rooftop discharge duct. This discharge section should be straight for at least several duct diameters to allow the conversion of fan energy from velocity pressure to static pressure.

When job conditions dictate elbows be installed near the rooftop outlet, the loss of capacity and static pressure may be reduced through proper direction of the bend in the elbow. The high velocity side of the rooftop outlet should be directed at the outside radius of the elbow rather than the inside.

## Modulating Hot Gas Reheat

Often supply fan VAV modulation or staged compressor control sufficient in handling building humidity in a wide range of indoor load conditions. Applications where non-peak load conditions can be dominated by latent loads are candidates for the Hot Gas Reheat option. This includes many applications subject to ASHRAE Standard 62 requirements.



When a Hot Gas Reheat coil is energized, it increases the air temperature after exiting the evaporator coil. While this provides dehumidification, this is not a dehumidifier. The main function of the Packaged RTU is to provide zone temperature control. For times when dehumidification is needed, the hot gas reheat will be energized.

Applications which should be investigated before using the standard modulating hot gas reheat option, and will require additional investigation include the following:

- Process applications
- Units utilized as a make-up air or 100% outside air units
- Zones with dramatically varying load conditions (sanctuaries, locker rooms, gymnasiums, etc.)

The Modulating Hot Gas Reheat standard option is available on 60Hz units only. Generally, the standard Modulating Hot Gas Reheat option requires a call for cooling to initiate. If there is no call for cooling, and there is a desire for dehumidification, another solution will need to be investigated. The IntelliPak™ packaged rooftop systems include non-standard solutions which can be considered for these types of applications.

## Natural Gas Heating Considerations

Trane offers heavy gauge 409 stainless steel throughout the construction of UL recognized, natural gas tubular exchangers. These heat exchangers can be applied with confidence, particularly with full modulation control, when mixed air temperatures are below 50°F, and low ambient temperatures can cause condensation to form on the heat exchanger. The Voyager™ natural gas heat exchangers are not recommended for applications with mixed air conditions entering the heat exchanger below 30°F to ensure adequate leaving air heating temperature.

## A2L Application Considerations

This product is listed to UL standard 60335-2-40, Household and Similar Electrical Appliances – Safety – Part 2-40: Particular Requirements for Electrical Heat Pumps, Air-Conditioners and Dehumidifiers, which defines safe design and use strategies for equipment using A2L refrigerants. This standard limits the refrigerant concentration in a space in the event of a refrigerant leak. To meet the requirements, the UL standard defines minimum room area, refrigerant charge limit, minimum circulation airflow and/or ventilation airflow requirements, and limits the use of ignition sources in spaces. The standard may require a unit refrigerant leak detection system.

For equipment with R-454B and charge amounts less than or equal to 3.91 lbs per circuit, this UL standard does not prescribe a room area limit and does not require a refrigerant leak detection system or any circulation airflow or ventilation airflow mitigation strategies. However, ignition sources in ductwork must be evaluated.

Depending on the application, a specific requirement of ANSI/ASHRAE Standard 15, Safety Standard for Refrigeration Systems, could be more stringent than UL 60335-2-40 requirements. See *Refrigeration Systems and Machinery Rooms Application Considerations for Compliance with ASHRAE® Standard 15-2022 Application Engineering Manual (APP-APM001\*-EN)* for more information.

## Minimum Room Area Limits (Refrigerant charge greater than 3.91 lb per circuit)

Equipment with R-454B charge amounts greater than 3.91 lb per circuit may require additional circulation or ventilation airflow mitigation strategies. In this case, two minimum room area ( $A_{min}$ ) thresholds:

- The first threshold defines when equipment serving a single room is required to provide circulation airflow, either continuous or activated by a leak detection system. A ducted system requires circulation airflow unless the smallest room it serves is larger than the adjusted  $A_{min}$  threshold. This product contains a leak detection system if a circuit charge is greater than 3.91 lbs. As a result, no further leak detection system evaluation is required.
- The second threshold defines when additional ventilation airflow is required. If the room area,  $A$  or  $TA$ , is below the adjusted  $A_{min}$  or  $TA_{min}$  threshold, additional ventilation is required to remove refrigerant in the event of a leak. Refer to UL 60335-2-40 Clause GG.8 and ANSI/ASHRAE Standard 15 Section 7 for natural and mechanical ventilation requirements. For minimum room area, see equipment nameplate or unit Installation, Operation, and Maintenance (IOM) manual.



## Application Considerations

### Minimum Room Area ( $A_{min}$ ) Adjustments

- **Altitude:** The  $A_{min}$  threshold changes with altitude. Multiple the altitude adjustment factor in the following table by  $A_{min}$  shown on the unit nameplate or in the Installation, Operation, and Maintenance (IOM) manual.

Table 1. Altitude adjustment factor

Altitude (ft)	Sea Level to 2000	2001 to 4000	4001 to 6000	6001 to 8000	8001 to 10000	10001 to 12000	12001 to 14000	14001 to 15000	Over 15000
$A_{min}$ Adjustment	1	1.05	1.11	1.17	1.24	1.32	1.41	1.51	1.57

- **Height :**  $A_{min}$  can be adjusted if the unit is installed in a room at a height higher than the minimum height shown on the unit. Multiply  $A_{min}$  by the ratio of the unit minimum release height (in meters) / actual release height (in meters).
- **Institutional Occupancies:** For institutional occupancies, ASHRAE Standard 15 applies an additional adjustment factor, FOCC, to the amount of charge allowed in a space. To calculate the adjusted  $A_{min}$  for institutional occupancies, divide the  $A_{min}$  on the nameplate by 0.5.

### Determining Room Area (A or TA)

The room area (A) is the room area enclosed by the projection to the floor of the walls, partitions, and doors of the space that the equipment serves. For ducted systems, total room area (TA) of all rooms connected by ducts, may be used instead of A.

Rooms connected by drop ceilings only are not considered a single room.

Rooms on the same floor of the building, and connected by an open passageway, can be considered part of the same room if the passageway is a permanent opening, extends to the floor and is intended for people to walk through.

Adjacent rooms on the same floor of the building and connected by permanent openings in the walls and/or doors between rooms (including gaps between the wall and the floor), can be considered part of the same room if the openings meet the following criteria.

- The opening is permanent and cannot be closed.
- Openings extending to the floor, such as door gaps, need to be at least 20 mm above the floor covering surface.
- Natural ventilations opening areas must meet the requirements of ANSI\ASHRAE Standard 15-2022, Section 7.2.3.2.

Rooms that are connected by a mechanical ventilation system can be considered a single room area if the mechanical ventilation system meets the requirements of ANSI\ASHRAE Standard 15-2022, Section 7.6.4.

### Leak Detection System (Refrigerant charge greater than 3.91 lb per circuit)

The leak detection system consists of one or more refrigerant detection sensors. When the system detects a leak, the following mitigation actions will be initiated until refrigerant has not been detected for at least 5 minutes:

- Energize the supply fan(s) to deliver a required minimum amount of circulation airflow.
- Disable compressor operation.
- Provide an output signal that can be used to fully open zone dampers and/or VAV boxes and disable electric heat in VAV boxes.
- Provide an output signal that can be used to energize additional mechanical ventilation (if needed).
- Units without airflow proving will disable electric heat sources.

Building fire and smoke systems may override this function.

If the refrigerant sensor has a fault, is at the end of its life, or is disconnected, the unit will initiate the mitigation actions. Mitigation actions may be verified by disconnecting the sensor.

The refrigerant sensors do not need service. Use only manufacturer-approved sensors when replacement is required.



# Selection Procedure

## 60 Hz Units

Five basic areas:

- Cooling capacity
- Heating capacity
- Air delivery
- Unit electrical requirements
- Unit designation

### Cooling Capacity Selection

- Summer design conditions — 95 DB/76 WB, 95°F entering air to condenser.
- Summer room design conditions — 76 DB/66 WB.
- Total peak cooling load — 321 MBh (26.75 tons).
- Total peak supply cfm — 12000 cfm.
- External static pressure — 1.2 inches.
- Return air temperatures — 80 DB/66 WB.
- Return air cfm — 10800 cfm.
- Outside air ventilation cfm and load — 1200 cfm and 18.23 MBh (1.52 tons).
- Unit accessories include:
  - Aluminized heat exchanger — high heat module.
  - 2" hi-efficiency throwaway filters.
  - Economizer.

#### Step 1 — Determine Nominal Capacity

A summation of the peak cooling load and the outside air ventilation load shows: 26.75 tons + 1.52 tons = 28.27 required unit capacity. From , 30-ton unit capacity at 80 DB/67 WB, 95°F entering the condenser and 12,000 total peak supply cfm, is 353 MBh (29.4 tons). Thus, a nominal 30 ton unit is selected.

#### Step 2 — Determine Supply Fan and Exhaust Fan BHP

Having selected a nominal 30 ton unit, the supply fan and exhaust fan motor bhp must be determined.

Determine unit static pressure at design supply cfm (see ):

External static pressure = 1.20 inches

Heat exchanger = High Heat: 0.14 inches

High efficiency filter 2"= 0.23 inches

Indoor coil = 0.34 inches

Economizer = 0.07 inches

Unit total static pressure = 1.98 inches

Using total cfm of 12000 and total static pressure of 1.98 inches, shows 7.78 bhp with 676 rpm.

#### Step 3 — Determine Evaporator Coil Entering Air Conditions

- Mixed air dry bulb temperature determination:

Using the minimum percent of OA (1,200 cfm ÷ 12,000 cfm = 10 percent), determine the mixture dry bulb to the evaporator.  $RADB + \%OA (OADB - RADB) = 80 + (0.10) (95 - 80) = 80 + 1.5 = 81.5^\circ\text{F}$

- Approximate wet bulb mixture temperature:

$RAWB + OA (OAWB - RAWB) = 66 + (0.10) (76-66) = 66 + 1 = 67^\circ\text{F}$ .

A psychrometric chart can be used to more accurately determine the mixture temperature to the evaporator coil.

#### **Step 4 — Determine Total Required Unit Cooling Capacity**

Required capacity = total peak load + O.A. load + supply air fan motor heat. From [Figure 2, p. 23](#), the supply air fan motor heat for 7.78 bhp = 22.1 MBh. Capacity = 321 + 18.23 + 22.1 = 361.3 MBh (30.1 tons)

#### **Step 5 — Determine Unit Capacity**

From , unit capacity at 81.5 DB. 67 WB entering the evaporator, 12000 supply air cfm, 95°F entering the condenser is 355 MBh (29.6 tons) 290 sensible MBh.

#### **Step 6 — Determine Leaving Air Temperature**

Unit sensible heat capacity, corrected for supply air fan motor heat 290 - 22.1 = 267.9 MBh.

Supply air dry bulb temperature difference = 267.9 MBh ÷ (1.085 x 12,000 cfm) = 20.6°F.

Supply air dry bulb: 81.5 - 20.6 = 60.9.

Unit enthalpy difference = 355 ÷ (4.5 x 12,000) = 6.57 Btu/lb.

Btu/lb leaving enthalpy = h (ent WB) = 31.62 Btu/lb.

Leaving enthalpy = 31.62 Btu/lb - 6.57 Btu/lb = 25.1 Btu/lb.

From [Table 8, p. 38](#), the leaving air wet bulb temperature corresponding to an enthalpy of 25.1 Btu/lb = 58°F.

Leaving air temperatures = 60.9°F/58°F

### **Heating Capacity Selection**

- Winter outdoor design conditions — 0°F.
- Total return air temperature — 72°F.
- Winter outside air minimum ventilation load and cfm — 1,200 cfm and 87.2 MBh.
- Peak heating load 225 MBh.

#### **Utilizing Unit Selection in the Cooling Capacity Procedure**

Mixed air temperature = RADB + %O.A. (OADB - RADB) = 72 + (0.10) (0-72) = 64.8°F.

Supply air fan motor heat temperature rise = 20,600 BTU ÷ (1.085 x 12,000) cfm = 1.6°F.

Mixed air temperature entering heat module = 64.8 + 1.6 = 66.4°F.

Total winter heating load = peak heating + ventilation load - total fan motor heat = 225 + 87.2 - 22.1 = 290.1 MBh.

#### **Electric Heating System**

Unit operating on 480/60/3 power supply. From , 90 kw may be selected for a nominal 30-ton unit operating on 480-volt power. The high heat module — 90 KW or 307 MBh will satisfy the winter heating load of 290.1 MBh.

shows an air temperature rise of 23.6°F for 12,000 cfm through the 90 kw heat module.

Unit supply temperature at design heating conditions = mixed air temperature + air temperature rise = 66.4 + 23.6 = 90°F.

#### **Natural Gas Heating System**

Assume natural gas supply — 1000 Btu/ft<sup>3</sup>. From select the high heat module (486 MBh output) to satisfy 290.1 at unit cfm.

also shows air temperature rise of 37.3°F for 12,000 cfm through heating module.

Unit supply temperature design heating conditions = mixed air temperature + air temperature rise = 66.4 + 37.3 = 103.7°F.



### Modulating Hot Gas Reheat Selection

**Note:** Please note that hot gas reheat operation will not be allowed when there is a call for cooling or heating.

Utilize the Trane Select Assist selection program or contact a local Trane sales office to calculate leaving unit air temperature, latent capacity, reheat sensible capacity, leaving unit dew point, and moisture removal when the unit is in hot gas reheat operation.

The hot gas reheat Trane Select Assist selection requires the following customer input values: supply fan airflow, ambient air temperatures, entering air temperatures, and a desired reheat set point temperature. If the conditions provided are not within the reheat operating envelope an error will be generated in the Trane Select Assist program. If the reheat set point is not obtainable at the provided conditions the customer will be required to make adjustments to the conditions or change the reheat set point value.

### Air Delivery Procedure

Supply air fan bhp and rpm selection. Unit supply air fan performance shown in includes pressure drops for dampers and casing losses. Static pressure drops of accessory components such as heating systems, and filters if used, must be added to external unit static pressure for total static pressure determination.

Supply fan performance curve includes internal resistance of rooftop. For total static pressure determination, system external static must be added to appropriate component static pressure drops (evaporator coil, filters, optional economizer, optional heating system, optional cooling only extended casing).

The supply air fan motor selected in the previous cooling capacity determination example was 7.78 bhp with 676 rpm. Thus, the supply fan motor selected is 7.5 hp.

To select the drive, refer for a 30-ton unit. Select the appropriate drive for the applicable rpm range. Drive selection letter C with a range of 650 rpm, is required for 676 rpm. Where altitude is significantly above sea level, use [Table 9, p. 39](#), [Table 10, p. 39](#) and [Figure 3, p. 39](#) for applicable correction factors.

### Unit Electrical Requirements

Selection procedures for electrical requirements for wire sizing amps, maximum fuse sizing and dual element fuses are given in the electrical service selection of this catalog.

### Unit Designation

After determining specific unit characteristics utilizing the selection procedure and additional job information, the complete unit model number can be developed using the model number nomenclature page.

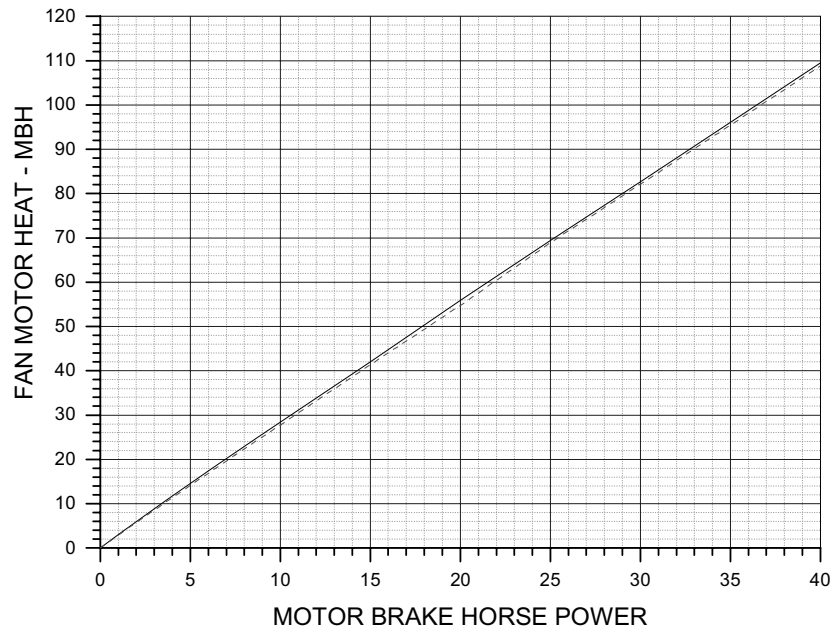
**Figure 2. Fan motor heat**

## 50 Hz Units

Five basic areas:

- Cooling capacity
- Heating capacity
- Air delivery
- Unit electrical requirements
- Unit designation

### Cooling Capacity Selection

- Summer design conditions – 95 DB/76 WB (35/24.4°C), 95°F (35°C) entering air to condenser.
- Summer room design conditions – 76 DB/66 WB (24.4/18.9°C).
- Total peak cooling load – 270 MBh (79 kW) (22.5 tons).
- Total peak supply cfm – 10,000 cfm (4720 L/s).
- External static pressure – 1.24 inches wc (310 Pa).
- Return air temperatures – 80 DB/66°F WB (26.7/18.9°C).
- Return air cfm – 3540 cfm (1671 L/s).
- Outside air ventilation cfm and load – 1000 cfm and 15.19 MBh (1.27 tons or 4.45 kW) 472 L/s.
- Unit accessories include:
  - Aluminized heat exchanger – high heat module.
  - 2" Hi-efficiency throwaway filters.
  - Exhaust fan.
  - Economizer cycle.

#### Step 1 — Determine Nominal Capacity

A summation of the peak cooling load and the outside air ventilation load shows: 22.5 tons + 1.27 tons = 23.77 (79 kW + 4.45 kW = 83.45) required unit capacity. From , 25.4 ton (89 kW) unit capacity at 80 DB/ 67 WB (27/19°C), 95°F entering the condenser and 10,000 total peak supply cfm (4720 L/s) is 297 MBh (24.75 tons).

### Step 2 — Determine Supply Fan and Exhaust Fan BHP

Having selected the correct unit, the supply fan and exhaust fan motor bhp must be determined:

Using , determine unit static pressure at design supply cfm:

External static pressure = 1.24 inches (310 Pa)

Heat exchanger = 0.12 inches (30 Pa)

High efficiency filter 2" (50 mm) = 0.18 inches (45 Pa)

Economizer = 0.07 inches (17 Pa)

Unit total static pressure = 1.61 inches (402 Pa)

Using total cfm of 10,000 (4720 L/s) and total static pressure of 1.61 inches (41 mm), refer to [Figure 6, p. 71](#). It shows 5.11 bhp (3.8 kW) with 601 rpm.

### Step 3 — Determine Evaporator Coil Entering Air Conditions

- Mixed air dry bulb temperature determination:

Using the minimum percent of OA (1,000 cfm ÷ 10,000 cfm = 10 percent), determine the mixture dry bulb to the evaporator.  $RADB + \% OA (OADB - RADB) = 80 + (0.10) (95 - 80) = 80 + 1.5 = 81.5^\circ F (26.7 + 1.5 = 28^\circ C)$ .

- Approximate Wet Bulb Mixture Temperature:

$RAWB + OA (OAWB - RAWB) = 66 + (0.10) (76-66) = 68 + 1 = 67^\circ F$ .

A psychrometric chart can be used to more accurately determine the mixture temperature to the evaporator coil.

### Step 4 — Determine Total Required Unit Cooling Capacity

Required capacity = total peak load + O.A. load + supply air fan motor heat. From , the supply air fan motor heat for 5.11 bhp = 14 MBh. Capacity = 270 + 15 + 14 = 299 MBh (89 kW)

### Step 5 — Determine Unit Capacity

From unit capacity at 81.5 DB/67 WB entering the evaporator, 10,000 supply air cfm, 95°F (35°C) entering the condenser about 298 MBh (87 kW) with 243 MBh (71.1 kW) sensible.

### Step 6 — Determine Leaving Air Temperature

Unit sensible heat capacity, corrected for supply air fan motor heat 243 - 14 = 229 MBh (67 kW).

Supply air dry bulb temperature difference =  $229 \text{ MBh} \div (1.085 \times 10,000 \text{ cfm}) = 21.1^\circ F (-6.1^\circ C)$

Supply air dry bulb:  $81.5 - 21.1 = 60.4 (15.8^\circ C)$

Unit enthalpy difference =  $298 \div (4.5 \times 10,000) = 6.62$

Btu/lb leaving enthalpy = h (ent WB) = 31.62

Leaving enthalpy = 31.62 Btu/lb - 6.62 Btu/lb = 25 Btu/lb.

From [Table 8, p. 38](#) the leaving air wet bulb temperature corresponding to an enthalpy of 25 Btu/lb = 57.8°F (14.3°C).

Leaving air temperatures = 60.4 DB/57.8 WB (15.8/14.3°C).

## Heating Capacity Selection

- Winter outdoor design conditions – 0°F (-17.8°C).
- Total return air temperature – 72°F (22.2°C).
- Winter outside air minimum ventilation load and cfm – 1,000 cfm and 87.2 MBh.
- Peak heating load 150 MBh.

### Utilizing Unit selection in the Cooling Capacity Procedure

Mixed air temperature =  $RADB + \% O.A. (OADB - RADB) = 72 + (0.10) (0-72) = 64.8^\circ F$ .

Supply air fan motor heat temperature rise =  $20,600 \text{ Btu} \div (1.085 \times 10,000) \text{ cfm} = 1.9^\circ F$ .

Mixed air temperature entering heat module =  $64.8 + 1.9 = 66.7^\circ F$ .



Total winter heating load = peak heating + ventilation load - total fan motor heat =  $150 + 87.2 - 14 = 223.2$  MBh.

### **Electric Heating System**

Unit operating on 415 power supply. From , kW may be selected for TE\*305 unit to satisfy the winter heating load. The 67 kW module will do the job.

This table also shows an air temperature rise of 21.2°F for 10,000 cfm through the 67 kW heat module.

Unit supply temperature at design heating conditions = mixed air temperature + air temperature rise =  $66.7 + 21.2 = 87.9$ °F.

### **Air Delivery Procedure**

Supply air fan bhp and rpm selection. Unit supply air fan performance shown in [Figure 6, p. 71](#) and [Figure 7, p. 71](#) includes pressure drops for dampers and casing losses. Static pressure drops of accessory components such as heating systems, and filters if used, must be added to external unit static pressure for total static pressure determination.

The supply air fan motor selected in the previous cooling capacity determination example was 5.11 bhp with 601 rpm. Thus, the supply fan motor selected is 7.5 hp.

To select the drive, enter for a 25.4 unit. Select the appropriate drive for the applicable rpm range. Drive selection letter D with a range of 583 rpm, is required for 601 rpm. Where altitude is significantly above sea level, use [Table 9, p. 39](#), [Table 10, p. 39](#) and [Figure 3, p. 39](#) for applicable correction factors.

### **Unit Electrical Requirements**

Selection procedures for electrical requirements for wire sizing amps, maximum fuse sizing and dual element fuses are given in the electrical service selection of this catalog.

### **Unit Designation**

After determining specific unit characteristics utilizing the selection procedure and additional job information, the complete unit model number can be developed using the model number nomenclature page.



# Model Number Description

## 60 Hz Description

### Digit 1, 2 — Unit Function

TC = DX Cooling, No Heat  
TE = DX Cooling, Electric Heat  
YC = DX Cooling, Natural Gas Heat

### Digit 3 — Unit Airflow Design

D = Downflow Supply and Upflow Return  
H = Horizontal Supply and Horizontal Return  
F = Horizontal Supply and Upflow Return  
R = Downflow Supply and Horizontal Return

### Digit 4, 5, 6 — Nominal Cooling Capacity

330 = 27.5 Tons  
360 = 30 Tons  
420 = 35 Tons  
480 = 40 Tons  
600 = 50 Tons

### Digit 7 — Major Development Sequence

D = R-454B Refrigerant + Symbio 700

### Digit 8 — Power Supply<sup>1</sup>

E = 208/60/3  
F = 230/60/3  
4 = 460/60/3  
5 = 575/60/3

### Digit 9 — Heating Capacity<sup>2</sup>

0 = No Heat (TC Only)  
L = Low Heat (YC Only)  
H = High Heat (YC Only)  
J = Low Heat-Stainless Steel Gas Heat Exchanger (YC Only)  
K = High Heat-Stainless Steel Gas Heat Exchangers (YC Only)  
M = Low Heat-Stainless Steel Gas Heat Exchanger w/ Modulating Control (27.5-35 Tons YC only)  
P = High Heat-Stainless Steel Gas Heat Exchangers w/ Modulating Control (27.5-35 Tons YC Only)  
R = Low Heat-Stainless Steel Gas Heat Exchanger w/ Modulating Control (40-50 Tons YC Only)  
T = High Heat-Stainless Steel Gas Heat Exchangers w/ Modulating Control (40-50 Tons YC Only)

**Note:** When second digit is "E" for Electric Heat, the following values apply in the ninth digit.

A = 36 kW (27 kW for 208V)  
B = 54 kW (41 kW for 208V)  
C = 72 kW  
D = 90 kW  
E = 108 kW

### Digit 10 — Design Sequence

\* = Current

**Note:** Sequence may be any letter A through Z, or any digit 1 through 9.

### Digit 11 — Exhaust<sup>4</sup>

0 = None  
1 = Barometric Relief (Available w/ Economizer only)  
2 = 100% Power Exhaust Fan (Available w/ Economizer Only)  
3 = 50% Power Exhaust Fan (Available w/ Economizer Only)  
4 = 100% Fresh Air Tracking Power Exhaust Fan (Available w/ Economizer Only)  
5 = 50% Fresh Air Tracking Power Exhaust Fan (Available w/ Economizer Only)  
6 = 100% Power Exhaust w/ Statitrac™  
7 = 100% Power Exhaust Fan w/ Ultra Low Leak Exhaust Damper (Available w/ Economizer Only)  
8 = 50% Power Exhaust Fan w/ Ultra Low Leak Exhaust Damper (Available w/ Economizer Only)  
9 = 100% Power Exhaust w/ Ultra Low Leak Exhaust Damper w/ Statitrac™

### Digit 12 — Filter

A = 2" MERV 4, Std Eff, Throwaway Filters  
B = 2" MERV 8, High Eff, Throwaway Filters  
C = 4" MERV 8, High Eff, Throwaway Filters  
D = 4" MERV 14, High Eff, Throwaway Filters

### Digit 13 — Supply Fan Motor, HP

1 = 7.5 HP  
2 = 10 HP  
3 = 15 HP  
4 = 20 HP  
9 = 25 HP

### Digit 14 — Supply Air Fan Drive Selections

A = 550 RPM  
B = 600 RPM  
C = 650 RPM  
D = 700 RPM  
E = 750 RPM  
G = 800 RPM  
H = 500 RPM  
J = 525 RPM  
K = 575 RPM  
L = 625 RPM  
M = 675 RPM  
N = 725 RPM  
P = 775 RPM  
Q = 825 RPM  
R = 850 RPM  
S = 900 RPM

### Digit 15 — Outside Air Selection

A = No Outside Air  
B = 0-25% Manual Damper  
C = 0-100% Economizer, Dry Bulb Control  
D = 0-100% Economizer, Reference Enthalpy Control  
E = 0-100% Economizer, Differential Enthalpy Control  
F = "C" Option and Low Leak Fresh Air Damper  
G = "D" Option and Low Leak Fresh Air Damper  
H = "E" Option and Low Leak Fresh Air Damper  
J = "C" Option and Ultra Low Leak Outside Air Damper  
K = "D" Option and Ultra Low Leak Outside Air Damper  
L = "E" Option and Ultra Low Leak Outside Air Damper  
1 = Option "C" with Traq  
2 = Option "D" with Traq  
3 = Option "E" with Traq  
4 = Option "F" with Traq  
5 = Option "G" with Traq  
6 = Option "H" with Traq  
7 = Option "C" with Traq w/ Ultra Low Leak Outside Air Damper  
8 = Option "D" with Traq w/ Ultra Low Leak Outside Air Damper  
9 = Option "E" with Traq w/ Ultra Low Leak Outside Air Damper

### Digit 16 — System Control

8 = Multi-speed Fan  
E = Multi-speed Fan w/ Bypass  
F = Multi-speed Fan w/ Motor Shaft Grounding Ring  
G = Multi-speed Fan w/ Bypass & Motor Shaft Grounding Ring  
4 = VAV Supply Air Temperature Control  
5 = VAV Supply Air Temperature Control w/Bypass  
A = VAV Supply Air Temperature Control w/ Motor Shaft Grounding Ring  
B = VAV Supply Air Temperature Control w/ Bypass & Motor Shaft Grounding Ring

6 = Single Zone VAV  
7 = Single Zone VAV w/ Bypass  
C = Single Zone VAV w/ Motor Shaft Grounding Ring  
D = Single Zone VAV w/ Bypass & Motor Shaft Grounding Ring

**Note:** Zone sensors are not included with option and must be ordered as a separate accessory.

**Note:** Shaft Grounding ring not available with 25HP motor.

## Model Number Description

### Miscellaneous Options

#### Digit 17

0 = No Service Valves  
A = Service Valves

*Discharge service valves are standard and included in all units.*

#### Digit 18

B = Through the Base Electrical Provision

#### Digit 19

C = Non-Fused Disconnect Switch w/ External Handle

#### Digit 20

D = Factory-Powered 15A GFI Convenience Outlet and Non-Fused Disconnect Switch w/ External Handle

#### Digit 21

E = Field-Powered 15A GFI Convenience Outlet

#### Digit 22

\* = Unused Digit

#### Digit 23

G = Ventilation Override

#### Digit 24

H = Hinged Service Access

#### Digit 25

H = Condenser Louvered Hail Guards  
J = Condenser Coil Guards (standard)

#### Digit 26

0 = None  
K = Advanced Control and LonTalk Comm (LCI)  
B = Advanced Control and BACnet/Modbus Comm (BCI)  
A = Advanced Control and AirFi Wireless (WCI)

#### Digit 27

0 = 5kA SCCR  
D = High Fault 65kA SCCR Disconnect<sup>5</sup>  
E = High Fault 65kA SCCR Disconnect w/Powered Convenience Outlet<sup>5</sup>

#### Digit 28

0 = Standard Drain Pan  
M = Stainless Steel Drain Pan  
1 = Standard Drain Pan w/ Condensate Overflow Switch  
2 = Stainless Steel Drain Pan w/ Condensate Overflow Switch

#### Digit 29 — Efficiency/ Condenser Coil Options

0 = Standard Efficiency Unit (eStage)  
J = Standard Efficiency Unit (eStage) w/ Corrosion Protected Condenser Coil  
K = High Efficiency Unit (eStage)  
L = High Efficiency Unit (eStage) w/ Corrosion Protected Condenser Coil

#### Digit 30 — Not used

#### Digit 31 — Miscellaneous Options

P = Discharge Temperature Sensor  
R = Clogged Filter Switch

#### Digit 32 — Modulating Hot Gas Reheat Option

T = Modulating Hot Gas Reheat

#### Digit 33 — Control Expansion Modules

0 = None  
A = Symbio 700 XM- 30 Expansion Module  
B = Symbio 700 XM- 32 Expansion Module  
C = Symbio 700 XM- 30 & XM-32 Expansion Modules  
D = Symbio 700 XM- 30 & XM-30 Expansion Modules  
E = Symbio 700 XM- 32 & XM-32 Expansion Modules

#### Model Number Notes

##### Notes:

1. All voltages are across the line starting only.
2. Electric Heat KW ratings are based upon voltage ratings of 208/240/480/ 600 V. For a 240 V heater derated to 208 V, the resulting kW rating decreases from 36 kW to 27 kW, and from 54 kW to 41 kW. Voltage offerings are shown in following table (see Table 22, p. 56 for additional information).
3. The service digit for each model number contains 33 digits; all 33 digits must be referenced.
4. Ventilation override exhaust mode is not available for the exhaust fan with fresh air tracking power exhaust. VOM is available for the exhaust fan without fresh air tracking power exhaust.
5. 575 VAC option is 25kA.

Tons	Elec. Heater Rated Volt.	KW				
		27/36	41/54	72	90	108
27.5 to 35	208	x	x			
	240	x	x			
	480	x	x	x	x	
40 and 50	600		x	x	x	
	208		x			
	240		x			
	480		x	x	x	x
	600		x	x	x	x



# Model Number Description

## 50 Hz Description

### Digit 1, 2 — Unit Function

**TC** = DX Cooling, No Heat  
**TE** = DX Cooling, Electric Heat

### Digit 3 — Unit Airflow Design

**D** = Downflow Supply and Upflow Return  
**H** = Horizontal Supply and Horizontal Return  
**F** = Horizontal Supply and Upflow Return  
**R** = Downflow Supply and Horizontal Return

### Digit 4, 5, 6 — Nominal Cooling Capacity

**275** = 22.9 Tons (82 kW)  
**305** = 25.4 Tons (89 kW)  
**350** = 29.2 Tons (105 kW)  
**400** = 33.3 Tons (120 kW)  
**500** = 41.7 Tons (148 kW)

### Digit 7 — Major Development Sequence

**D** = R-454B Refrigerant + Symbio 700

### Digit 8 — Power Supply<sup>1</sup>

**C** = 380/50/3  
**D** = 415/50/3

### Digit 9 — Heating Capacity<sup>2</sup>

*Note: When second digit is "E" for Electric Heat, the following values apply in the ninth digit.*

**380V / 415V**

**A** = 23 kW / 27 kW  
**B** = 34 kW / 40 kW  
**C** = 45 kW / 54 kW  
**D** = 56 kW / 67 kW  
**E** = 68 kW / 81 kW

### Digit 10 — Design Sequence

\* = Current

*Note: Sequence may be any letter A through Z, or any digit 1 through 9.*

### Digit 11 — Exhaust<sup>4</sup>

**0** = None  
**1** = Barometric Relief (Available w/ Economizer only)  
**2** = 100% Power Exhaust Fan (Available w/ Economizer Only)  
**3** = 50% Power Exhaust Fan (Available w/ Economizer Only)  
**4** = 100% Fresh Air Tracking Power Exhaust Fan (Available w/ Economizer Only)  
**5** = 50% Fresh Air Tracking Power Exhaust Fan (Available w/ Economizer Only)  
**6** = 100% Power Exhaust w/ Statitrac™  
**7** = 100% Power Exhaust Fan w/ Ultra Low Leak Exhaust Damper (Available w/ Economizer Only)  
**8** = 50% Power Exhaust Fan w/ Ultra Low Leak Exhaust Damper (Available w/ Economizer Only)  
**9** = 100% Power Exhaust w/ Ultra Low Leak Exhaust Damper w/ Statitrac™

### Digit 12 — Filter

**A** = 2" (51mm) MERV 4, Std Eff, Throwaway Filters  
**B** = 2" MERV (51mm) 8, High Eff, Throwaway Filters  
**C** = 4" (102mm) MERV 8, High Eff, Throwaway Filters  
**D** = 4" (102mm) MERV 14, High Eff, Throwaway Filters

### Digit 13 — Supply Fan Motor, HP

**1** = 7.5 HP (5.6 kW)  
**2** = 10 HP (7.5 kW)  
**3** = 15 HP (10 kW)  
**4** = 20 HP (15 kW)

### Digit 14 — Supply Air Fan Drive Selections

**A** = 458 RPM  
**B** = 500 RPM  
**C** = 541 RPM  
**D** = 583 RPM  
**E** = 625 RPM  
**G** = 664 RPM  
**H** = 417 RPM  
**J** = 437 RPM  
**K** = 479 RPM  
**L** = 521 RPM  
**M** = 562 RPM  
**N** = 604 RPM  
**P** = 646 RPM  
**R** = 708 RPM

### Digit 15 — Outside Air Selection

**A** = No Outside Air  
**B** = 0-25% Manual Damper  
**C** = 0-100% Economizer, Dry Bulb Control  
**D** = 0-100% Economizer, Reference Enthalpy Control  
**E** = 0-100% Economizer, Differential Enthalpy Control  
**F** = "C" Option and Low Leak Fresh Air Damper  
**G** = "D" Option and Low Leak Fresh Air Damper  
**H** = "E" Option and Low Leak Fresh Air Damper  
**J** = "C" Option and Ultra Low Leak Outside Air Damper  
**K** = "D" Option and Ultra Low Leak Outside Air Damper  
**L** = "E" Option and Ultra Low Leak Outside Air Damper  
**1** = Option "C" with Traq  
**2** = Option "D" with Traq  
**3** = Option "E" with Traq  
**4** = Option "F" with Traq  
**5** = Option "G" with Traq  
**6** = Option "H" with Traq  
**7** = Option "C" with Traq w/ Ultra Low Leak Outside Air Damper  
**8** = Option "D" with Traq w/ Ultra Low Leak Outside Air Damper  
**9** = Option "E" with Traq w/ Ultra Low Leak Outside Air Damper

### Digit 16 — System Control

**8** = Multi-speed Fan  
**E** = Multi-speed Fan w/ Bypass  
**F** = Multi-speed Fan w/ Motor Shaft Grounding Ring  
**G** = Multi-speed Fan w/ Bypass & Motor Shaft Grounding Ring  
**4** = VAV Supply Air Temperature Control  
**5** = VAV Supply Air Temperature Control w/Bypass  
**A** = VAV Supply Air Temperature Control w/ Motor Shaft Grounding Ring  
**B** = VAV Supply Air Temperature Control w/ Bypass & Motor Shaft Grounding Ring  
**6** = Single Zone VAV  
**7** = Single Zone VAV w/ Bypass  
**C** = Single Zone VAV w/ Motor Shaft Grounding Ring  
**D** = Single Zone VAV w/ Bypass & Motor Shaft Grounding Ring

*Note: Zone sensors are not included with option and must be ordered as a separate accessory.*

**Miscellaneous Options****Digit 17**

**0** = No Service Valves

**A** = Service Valves

*Discharge service valves are standard and included in all units.*

**Digit 18**

**B** = Through the Base Electrical Provision

**Digit 19**

**C** = Non-Fused Disconnect Switch w/ External Handle

**Digit 20**

\* = Unused Digit

**Digit 21**

\* = Unused Digit

**Digit 22**

\* = Unused Digit

**Digit 23**

**G** = Ventilation Override

**Digit 24**

**H** = Hinged Service Access

**Digit 25**

**H** = Condenser Louvered Hail Guards

**J** = Condenser Coil Guards (standard)

**Digit 26**

**0** = None

**K** = Advanced Control and LonTalk Comm (LCI)

**B** = Advanced Control and BACnet/Modbus Comm (BCI)

**A** = Advanced Control and AirFi Wireless (WCI)

**Digit 27**

**0** = 5kA SCCR

**D** = High Fault 65kA SCCR Disconnect

**Digit 28**

**0** = Standard Drain Pan

**M** = Stainless Steel Drain Pan

**1** = Standard Drain Pan w/ Condensate Overflow Switch

**2** = Stainless Steel Drain Pan w/ Condensate Overflow Switch

**Digit 29 — Efficiency/ Condenser Coil Options**

**0** = Standard Efficiency (eStage) Unit

**J** = Standard Efficiency (eStage) Unit with Corrosion Protected Condenser Coil

**K** = High Efficiency Unit (eStage)

**L** = High Efficiency Unit (eStage) with Corrosion Protected Condenser Coil

**Digit 30 — Not used****Digit 31 — Miscellaneous Options**

**P** = Discharge Temperature Sensor

**R** = Clogged Filter Switch

**Digit 32**

\* = Unused Digit

**Digit 33 — Control Expansion Modules**

**0** = None

**A** = Symbio 700 XM- 30 Expansion Module

**B** = Symbio 700 XM- 32 Expansion Module

**C** = Symbio 700 XM- 30 & XM-32 Expansion Modules

**D** = Symbio 700 XM- 30 & XM-30 Expansion Modules

**E** = Symbio 700 XM- 32 & XM-32 Expansion Modules

**Model Number Notes****Notes:**

1. All voltages are across the line starting only.
2. Electric Heat KW ratings are based upon voltage ratings of 380/415 V. Heaters A, B, C, D are used with 22.9-29.2 ton (82-105 kW) units only and heaters B, C, D, E are used with 33.3-41.7 ton (120-148 kW) units only.
3. The service digit for each model number contains 33 digits; all 33 digits must be referenced.
4. Ventilation override exhaust mode is not available for the exhaust fan with fresh air tracking power exhaust. VOM is available for the exhaust fan without fresh air tracking power exhaust.



# General Data

**Table 2. General data - 27.5 - 35 tons (60 Hz)**

	27.5 Tons				30 Tons				35 Tons			
<b>Cooling Performance<sup>(a) (b)</sup></b>												
Net Capacity/EER/IEER (Multi-speed)/IEER (VAV) - Std Efficiency	CLG:326000/11.0/15.2/15.4 EH:326000/11.0/15.2/15.4 GH(Low):324000/10.8/14.9/15.2 GH(High):324000/10.8/14.8/15.0				CLG:354000/10.8/15.4/15.6 EH:354000/10.8/15.3/15.6 GH(Low):352000/10.6/15.1/15.4 GH(High):352000/10.7/15.0/15.3				CLG:390000/10.5/15.2/15.4 EH:388000/10.5/15.1/15.4 GH(Low):386000/10.2/14.7/15.1 GH(High):388000/10.3/14.7/15.1			
Net Capacity/EER/IEER (Multi-speed)/IEER (VAV) - High Efficiency	CLG:340000/12.0/17.0/17.2 EH:340000/11.9/16.9/17.1 GH(Low):338000/11.7/16.7/16.9 GH(High):340000/11.7/16.4/16.7				CLG:374000/11.8/17.3/17.5 EH:374000/11.7/17.2/17.4 GH(Low):372000/11.5/16.9/17.2 GH(High):372000/11.6/16.8/17.1				CLG:400000/11.4/16.9/17.1 EH:400000/11.3/16.8/17.1 GH(Low):400000/11.0/16.4/16.8 GH(High):400000/11.2/16.4/16.8			
	<b>Two Stage</b>		<b>Modulating</b>		<b>Two Stage</b>		<b>Modulating</b>		<b>Two Stage</b>		<b>Modulating</b>	
<b>Natural Gas Heat<sup>(c) (d)</sup></b>	<b>Low</b>	<b>High</b>	<b>Low</b>	<b>High</b>	<b>Low</b>	<b>High</b>	<b>Low</b>	<b>High</b>	<b>Low</b>	<b>High</b>	<b>Low</b>	<b>High</b>
Heating Input (BTUH)	350000	600000	350000	600000	350000	600000	350000	600000	350000	600000	350000	600000
Heating Output (BTUH)	283500	486000	283500	486000	283500	486000	283500	486000	283500	486000	283500	486000
Steady State Efficiency (%) <sup>(e)</sup>	81	81	81	81	81	81	81	81	81	81	81	81
No. Burners	1	1	1	1	1	1	1	1	1	1	1	1
No. Stages/Turn down rate	2	2	10:1	10:1	2	2	10:1	10:1	2	2	10:1	10:1
<b>Electric Heat</b>												
kW Range <sup>(f)</sup>	27-90				27-90				27-90			
Capacity Steps	2				2				2			
<b>Compressor - Std Efficiency</b>												
Qty/Type/Refrigerant/Circuits	3/Scroll/R-454B/1				3/Scroll/R-454B/1				3/Scroll/R-454B/1			
Size (Nominal)	6/9/9				6/11/11				7/11/11			
Unit Capacity Steps (%)	100/76/62/38/24				100/78/61/39/22				100/75/63/38/25			
<b>Compressor - High Efficiency</b>												
Qty/Type/Refrigerant/Circuits	3/Scroll/R-454B/1				3/Scroll/R-454B/1				3/Scroll/R-454B/1			
Size (Nominal)	6/9/9				6/11/11				7/11/11			
Unit Capacity Steps (%)	100/76/62/38/24				100/78/61/39/22				100/75/63/38/25			
<b>Outdoor Coil - Std Efficiency</b>												
Type	Microchannel				Microchannel				Microchannel			
Face Area (sq. ft.)	49.9				49.9				49.9			
Rows	1				1				1			
<b>Outdoor Coil - High Efficiency</b>												
Type	Microchannel				Microchannel				Microchannel			
Face Area (sq. ft.)	49.9				49.9				49.9			
Rows	2				2				2			
<b>Indoor Coil - Std Efficiency</b>												
Tube Size (in.) OD	3/8				3/8				3/8			
Face Area (sq. ft.)	31.7				31.7				31.7			
Rows/Fins Per Foot	4/180				4/180				4/180			
Refrigerant Control	TXV				TXV				TXV			
No. of Circuits	1				1				1			
Drain Connection No./Size (in)	1/1.25				1/1.25				1/1.25			
Type	PVC				PVC				PVC			
<b>Indoor Coil - High Efficiency</b>												
Tube Size (in.) OD	3/8				3/8				3/8			
Face Area (sq. ft.)	31.7				31.7				31.7			
Rows/Fins Per Foot	5/180				5/180				5/180			
Refrigerant Control	TXV				TXV				TXV			
No. of Circuits	1				1				1			
Drain Connection No./Size (in)	1/1.25				1/1.25				1/1.25			
Type	PVC				PVC				PVC			
<b>Outdoor Fan Type</b>												
No. Used/Diameter	Propeller 3/28.00				Propeller 3/28.00				Propeller 3/28.00			

**Table 2. General data - 27.5 - 35 tons (60 Hz) (continued)**

	<b>27.5 Tons</b>	<b>30 Tons</b>	<b>35 Tons</b>
Drive Type/No. Speeds	Direct/1	Direct/1	Direct/1
CFM	21,200	21,200	21,200
No. Motors/HP/RPM	3/1.0/1140	3/1.0/1140	3/1.0/1140
<b>Indoor Fan Type</b>	FC	FC	FC
No. Used	1	1	1
Diameter/Width (in)	22.38/22.00	22.38/22.00	22.38/22.00
Drive Type/No. Speeds	Belt/1	Belt/1	Belt/1
No. Motors/HP Range	1/7.50-15.00	1/7.50-15.00	1/7.50/10.00-20.00
CFM Range <sup>(g)</sup>	8250-12100	9000-13200	10500-15400
<b>Exhaust Fan Type</b>	Propeller	Propeller	Propeller
Diameter (in)	26.00	26.00	26.00
Drive Type/No. Speeds/Motor Frame Size	Direct/1/56	Direct/1/56	Direct/1/56
Motor HP/RPM	1.0/1140	1.0/1140	1.0/1140
<b>Filters - Type Furnished</b>	Throwaway	Throwaway	Throwaway
No./ Recommended Size (in) <sup>(h)</sup>	16/16x20x2	16/16x20x2	16/16x20x2
<b>Min. Outside Air Temp for Mechanical Cooling</b>	0°F	0°F	0°F
<b>Refrigerant Charge - Std Efficiency (Pounds of R-454B)</b>			
Standard	31.0	31.0	31.0
Optional Hot Gas Reheat	33.4	33.4	33.4
<b>Refrigerant Charge - High Efficiency (Pounds of R-454B)</b>			
Standard	39.0	39.0	39.0
Optional Hot Gas Reheat	41.4	41.4	41.4

- (a) Cooling performance is rated at 95°F ambient, 80°F entering dry bulb, 67°F entering wet bulb. Gross capacity does not include the effect of fan motor heat. AHRI capacity is net and includes the effect of fan motor heat. Units are suitable for operation to ±20% of nominal cfm. Units are certified in accordance with the Unitary Air-Conditioner Equipment certification program, which is based on AHRI Standard 340/360.
- (b) EER and/or IEER are rated at AHRI conditions and in accordance with DOE test procedures. For simplified verification of your specific unit EER/IEER, and capacity at operating conditions, it is strongly recommended that a TSA (Trane Select Assist) report be run.
- (c) Heating Performance limit settings and rating data were established and approved under laboratory test conditions using American National Standards Institute standards. Ratings shown are for elevations up to 4,500 feet.
- (d) Standard gas furnaces: Second Stage is total heating capacity—Second Stage/First Stage; Modulating gas furnaces: High Fire is total heating capacity— High Fire/Low Fire.
- (e) Heating Performance is AHRI and DOE certified
- (f) Maximum KW @ 208V = 41, @ 240V = 54.
- (g) Cooling only CFM range.
- (h) Filter dimensions listed are nominal. For actual filter and rack sizes see the Unit Installation, Operation, Maintenance Guide.



## General Data

**Table 3. General data — 40 & 50 tons (60 Hz)**

	40 Tons				50 Tons			
<b>Cooling Performance<sup>(a)</sup> (b)</b>								
Net Capacity/EER/IEER (Multi-speed)/IEER (VAV) - Std Efficiency	CLG:455000/11.4/15.8/16.1 EH:455000/11.3/15.6/16.0 GH(Low):455000/11.2/15.4/15.8 GH(High):450000/11.0/15.1/15.6				CLG:525000/10.5/15.0/15.3 EH:525000/10.4/14.8/15.1 GH(Low):520000/10.2/14.6/14.9 GH(High):520000/10.0/14.2/14.5			
Net Capacity/EER/IEER (Multi-speed)/IEER (VAV) - High Efficiency	CLG: 455000/11.4/16.5/16.9 EH: 455000/11.3/16.4/16.8 GH(Low): 455000/11.2/16.2/16.6 GH(High): 450000/11.0/15.9/16.4				CLG: 525000/10.5/15.8/16.1 EH: 525000/10.4/15.7/16.0 GH(Low): 520000/10.2/15.3/15.6 GH(High): 520000/10.0/15.0/15.3			
<b>Natural Gas Heat<sup>(c)</sup> (d)</b>	<b>Two Stage</b>		<b>Modulating</b>		<b>Two Stage</b>		<b>Modulating</b>	
	<b>Low</b>	<b>High</b>	<b>Low</b>	<b>High</b>	<b>Low</b>	<b>High</b>	<b>Low</b>	<b>High</b>
Heating Input (BTUH)	400000	800000	400000	800000	400000	800000	400000	800000
Heating Output (BTUH)	324000	648000	324000	648000	324000	648000	324000	648000
Steady State Efficiency (%) <sup>(e)</sup>	81	81	81	81	81	81	81	81
No. Burners	1	2	1	2	1	2	1	2
No. Stages/Turn down rate	2	2	10:1	10:1	2	2	10:1	10:1
<b>Electric Heat</b>								
kW Range <sup>(f)</sup>	41-108				41-108			
Capacity Steps	2				2			
<b>Compressor - Std Efficiency</b>								
Qty/Type/Refrigerant/Circuits	3/Scroll/R-454B/1				3/Scroll/R-454B/1			
Size (Nominal)	8/13/13				10/15/15			
Unit Capacity Steps (%)	100/76/62/38/24				100/75/62/38/25			
<b>Compressor - High Efficiency</b>								
Qty/Type/Refrigerant/Circuits	3/Scroll/R-454B/1				3/Scroll/R-454B/1			
Size (Nominal)	8/13/13				10/15/15			
Unit Capacity Steps (%)	100/76/62/38/24				100/75/62/38/25			
<b>Outdoor Coil - Std Efficiency</b>								
Type	Microchannel				Microchannel			
Face Area (sq. ft.)	65.4				65.4			
Rows	2				2			
<b>Outdoor Coil - High Efficiency</b>								
Type	Microchannel				Microchannel			
Face Area (sq. ft.)	65.4				65.4			
Rows	2				2			
<b>Indoor Coil - Std Efficiency</b>								
Tube Size (in.) OD	3/8				3/8			
Face Area (sq. ft.)	36.7				36.7			
Rows/Fins Per Foot	5/180				5/180			
Refrigerant Control	TXV				TXV			
No. of Circuits	1				1			
Drain Connection No./Size (in)	1/1.25				1/1.25			
Type	PVC				PVC			
<b>Indoor Coil - High Efficiency</b>								
Tube Size (in.) OD	3/8				3/8			
Face Area (sq. ft.)	36.7				36.7			
Rows/Fins Per Foot	5/180				5/180			
Refrigerant Control	TXV				TXV			
No. of Circuits	1				1			
Drain Connection No./Size (in)	1/1.25				1/1.25			
Type	PVC				PVC			
<b>Outdoor Fan Type</b>	Propeller				Propeller			
No. Used/Diameter	4/28.00				4/28.00			
Drive Type/No. Speeds	Direct/1				Direct/1			
CFM	28,900				28,900			
No. Motors/HP/RPM	4/1.0/1140				4/1.0/1140			
<b>Indoor Fan Type</b>	FC				FC			
No. Used	1				1			



**Table 3. General data — 40 & 50 tons (60 Hz) (continued)**

	40 Tons	50 Tons
Diameter/Width (in)	25.00/25.00	25.00/25.00
Drive Type/No. Speeds	Belt/1	Belt/1
No. Motors/HP Range	1/10.00-20.00	1/10.00/15.00-25.00
CFM Range <sup>(g)</sup>	12000-17600	15000-22000
<b>Exhaust Fan Type</b>	Propeller	Propeller
Diameter (in)	28.00	28.00
Drive Type/No. Speeds/Motor Frame Size	Direct/1/56	Direct/1/56
Motor HP/RPM	1.5/1140	1.5/1140
<b>Filters - Type Furnished</b>	Throwaway	Throwaway
No./ Recommended Size (in) <sup>(h)</sup>	17/16x20x2	17/16x20x2
<b>Min. Outside Air Temp for Mechanical Cooling</b>	0°F	0°F
<b>Refrigerant Charge - Std and High Efficiency (Pounds of R-454B)</b>		
Standard	57.2	57.2
Optional Hot Gas Reheat	62.9	62.5

- (a) Cooling performance is rated at 95°F ambient, 80°F entering dry bulb, 67°F entering wet bulb. Gross capacity does not include the effect of fan motor heat. AHRI capacity is net and includes the effect of fan motor heat. Units are suitable for operation to ±20% of nominal cfm. Units are certified in accordance with the Unitary Air-Conditioner Equipment certification program, which is based on AHRI Standard 340/360.
- (b) EER and/or IEER are rated at AHRI conditions and in accordance with DOE test procedures. For simplified verification of your specific unit EER/IEER, and capacity at operating conditions, it is strongly recommended that a TSA (Trane Select Assist) report be run.
- (c) Heating Performance limit settings and rating data were established and approved under laboratory test conditions using American National Standards Institute standards. Ratings shown are for elevations up to 4,500 feet.
- (d) Standard gas furnaces: Second Stage is total heating capacity—Second Stage/First Stage; Modulating gas furnaces: High Fire is total heating capacity— High Fire/Low Fire.
- (e) Heating Performance is AHRI and DOE certified
- (f) Maximum KW @ 208V = 41, @ 240V = 54.
- (g) Cooling only CFM range.
- (h) Filter dimensions listed are nominal. For actual filter and rack sizes see the Unit Installation, Operation, Maintenance Guide.

**Table 4. Economizer outdoor air damper leakage (of rated airflow) (60 Hz)**

	Delta P Across Dampers (in. WC)	
	0.5 (In.)	1.0 (In.)
<b>Standard</b>	1.5%	2.5%
<b>Low Leak</b>	0.5%	1.0%
<b>Ultra Low Leak</b>	0.0%	0.1%

**Notes:**

- Standard and Low Leak data based on tests completed in accordance with AMCA Standard 500.
- Ultra Low Leak dampers are rated AMCA class 1A; leak rate = 3 CFM per sq-ft face area at 1.0" WC.



## General Data

**Table 5. General data — 22.9 - 29.2 tons (50 Hz)**

	TC*275 (22.9 Tons)	TC*305 (25.4 Tons)	TC*350 (29.2 Tons)
<b>Cooling Performance<sup>(a)</sup></b>			
Nominal Gross Capacity- Std Efficiency	285,000 (83.5 kW)	309,000 (90.5 kW)	343,000 (100.5 kW)
Nominal Gross Capacity- High Efficiency	301,000 (88.2 kW)	332,000 (97.3 kW)	357,000 (104.6 kW)
<b>Compressor - Std Efficiency</b>			
Qty/Type/Refrigerant/Circuits	3/Scroll/R-454B/1	3/Scroll/R-454B/1	3/Scroll/R-454B/1
Size (Nominal)	6/9/9	6/11/11	7/11/11
Unit Capacity Steps (%)	100/76/62/38/24	100/78/61/39/22	100/75/63/38/25
<b>Compressor - High Efficiency, eStage</b>			
Qty/Type/Refrigerant/Circuits	3/Scroll/R-454B/1	3/Scroll/R-454B/1	3/Scroll/R-454B/1
Size (Nominal)	6/9/9	6/11/11	7/11/11
Unit Capacity Steps (%)	100/76/62/38/24	100/78/61/39/22	100/75/63/38/25
<b>Outdoor Coil - Std Efficiency</b>			
Type	Microchannel	Microchannel	Microchannel
Face Area (sq. ft.)	49.9 (4.6)	49.9 (4.6)	49.9 (4.6)
Rows	1	1	1
<b>Outdoor Coil - High Efficiency</b>			
Type	Microchannel	Microchannel	Microchannel
Face Area (sq. ft.)	49.9 (4.6)	49.9 (4.6)	49.9 (4.6)
Rows	2	2	2
<b>Indoor Coil - Std Efficiency</b>			
Tube Size OD - in. (mm)	0.375 (9.5)	0.375 (9.5)	0.375 (9.5)
Face Area - sq. ft (sq. m)	31.7 (2.9)	31.7 (2.9)	31.7 (2.9)
Rows/Fins Per Foot	4/180	4/180	4/180
Refrigerant Control	TXV	TXV	TXV
Drain Connection No./Size - in (mm)	1/1.25 (1/32)	1/1.25 (1/32)	1/1.25 (1/32)
<b>Indoor Coil - High Efficiency</b>			
Tube Size OD - in. (mm)	0.375 (9.5)	0.375 (9.5)	0.375 (9.5)
Face Area - sq. ft (sq. m)	31.7 (2.9)	31.7 (2.9)	31.7 (2.9)
Rows/Fins Per Foot	5/180	5/180	5/180
Refrigerant Control	TXV	TXV	TXV
Drain Connection No./Size - in (mm)	1/1.25 (1/32)	1/1.25 (1/32)	1/1.25 (1/32)
<b>Outdoor Fan Type</b>			
Type	Propeller	Propeller	Propeller
No. Used	3	3	3
Diameter - in. (mm)	28.0 (711)	28.0 (711)	28.0 (711)
Drive Type/No. Speeds	Direct/1	Direct/1	Direct/1
CFM (L/s)	17,100 (8070)	17,100 (8070)	17,100 (8070)
No. Motors (RPM)	3 (950)	3 (950)	3 (950)
Motors - HP (kW)	0.75 (0.56)	0.75 (0.56)	0.75 (0.56)
<b>Indoor Fan Type/No. Used</b>			
Type/No. Used	FC/1	FC/1	FC/1
Diameter - in. (mm)	22.4 (568)	22.4 (568)	22.4 (568)
Width - in. (mm)	22.0 (559)	22.0 (559)	22.0 (559)
Drive Type	Belt	Belt	Belt
No. Speeds/No. Motors	1/1	1/1	1/1
Motors - HP (kW)	7.5-10(5.6-7.5)	7.5-15 (5.6-10)	7.5-15 (5.6-10)
<b>Exhaust Fan Type</b>			
Type	Propeller	Propeller	Propeller
Diameter - in. (mm)	26.00 (660)	26.00 (660)	26.00 (660)
Drive Type/No. Speeds/Motor Frame Size	Direct/1/56	Direct/1/56	Direct/1/56
Motor - HP (kW)/RPM	0.75 (0.56)/950	0.75 (0.56)/950	0.75 (0.56)/950
<b>Filters - Type Furnished</b>			
Type	Throwaway	Throwaway	Throwaway
No.	16	16	16
Recommended Size - in (mm)	16 x 20 x 2 (406 x 508 x 51)	16 x 20 x 2 (406 x 508 x 51)	16 x 20 x 2 (406 x 508 x 51)
<b>Refrigerant Charge - Std Efficiency (Pounds of R-454B)</b>			
Standard	31.0	31.0	31.0
Optional Hot Gas Reheat	33.4	33.4	33.4

**Table 5. General data — 22.9 - 29.2 tons (50 Hz) (continued)**

	TC*275 (22.9 Tons)	TC*305 (25.4 Tons)	TC*350 (29.2 Tons)
<b>Refrigerant Charge - High Efficiency (Pounds of R-454B)</b>			
Standard	39.0	39.0	39.0
Optional Hot Gas Reheat	41.4	41.4	41.4

<sup>(a)</sup> Cooling performance is rated at 95°F (35°C) ambient, 80°F (27°C) entering dry bulb, 67°F (19°C) entering wet bulb. Gross capacity does not include the effect of fan motor heat.



## General Data

**Table 6. General data — 33.3 and 41.7 tons (50 Hz)**

	TC*400 (33.3 Tons)	TC*500 (41.7 Tons)
<b>Cooling Performance<sup>(a)</sup></b>		
Nominal Gross Capacity- Std and High Efficiency	408,000 (119.5 kW)	476,000 (139.5 kW)
<b>Compressor - Std Efficiency</b>		
Qty/Type/Refrigerant/Circuits	3/Scroll/R-454B/1	3/Scroll/R-454B/1
Size (Nominal)	8/13/13	10/15/15
Unit Capacity Steps (%)	100/76/62/38/24	100/75/62/38/25
<b>Compressor - High Efficiency</b>		
Qty/Type/Refrigerant/Circuits	3/Scroll/R-454B/1	3/Scroll/R-454B/1
Size (Nominal)	8/13/13	10/15/15
Unit Capacity Steps (%)	100/76/62/38/24	100/75/62/38/25
<b>Outdoor Coil - Std Efficiency</b>		
Type	Microchannel	Microchannel
Face Area - sq. ft. (sq. m)	65.4 (6.1)	65.4 (6.1)
Rows	2	2
<b>Outdoor Coil - High Efficiency</b>		
Type	Microchannel	Microchannel
Face Area (sq. ft.)	65.4 (6.1)	65.4 (6.1)
Rows	2	2
<b>Indoor Coil - Std Efficiency</b>		
Tube Size OD - in. (mm)	0.375 (9.5)	0.375 (9.5)
Face Area - sq. ft (sq. m)	36.7 (3.4)	36.7 (3.4)
Rows/Fins Per Foot	5/180	5/180
Refrigerant Control	TXV	TXV
Drain Connection No./Size - in (mm)	1/1.25 (1/32)	1/1.25 (1/32)
<b>Indoor Coil - High Efficiency</b>		
Tube Size OD - in. (mm)	0.375 (9.5)	0.375 (9.5)
Face Area - sq. ft (sq. m)	36.7 (3.4)	36.7 (3.4)
Rows/Fins Per Foot	5/180	5/180
Refrigerant Control	TXV	TXV
Drain Connection No./Size - in (mm)	1/1.25 (1/32)	1/1.25 (1/32)
<b>Outdoor Fan Type</b>	Propeller	Propeller
No. Used	4	4
Diameter - in. (mm)	28.0 (711)	28.0 (711)
Drive Type/No. Speeds	Direct/1	Direct/1
CFM (L/s)	24,900 (11750)	24,900 (11750)
No. Motors (RPM)	4 (950)	4 (950)
Motors - HP (kW)	0.75 (0.56)	0.75 (0.56)
<b>Indoor Fan Type/No. Used</b>	FC/1	FC/1
Diameter - in. (mm)	25.0 (635)	25.0 (635)
Width - in. (mm)	25.0 (635)	25.0 (635)
Drive Type	Belt	Belt
No. Speeds/No. Motors	1/1	1/1
Motors - HP (kW)	10.0-15.0 (7.5-10.0)	10.0-20.0 (7.5-15.0)
<b>Exhaust Fan Type</b>	Propeller	Propeller
Diameter - in. (mm)	28.00 (711)	28.00 (711)
Drive Type/No. Speeds/Motor Frame Size	Direct/1/56	Direct/1/56
Motor - HP (kW)/RPM	1.0 (0.75)/950	1.0 (0.75)/950
<b>Filters - Type Furnished</b>	Throwaway	Throwaway
No.	17	17
Recommended Size - in (mm)	16 x 20 x 2 (406 x 508 x 51)	16 x 20 x 2 (406 x 508 x 51)
<b>Refrigerant Charge - Std and High Efficiency (Pounds of R-454B)</b>		
Standard	57.2	57.2
Optional Hot Gas Reheat	62.9	62.5

<sup>(a)</sup> Cooling performance is rated at 95°F (35°C) ambient, 80°F (27°C) entering dry bulb, 67°F (19°C) entering wet bulb. Gross capacity does not include the effect of fan motor heat.

**Table 7. Economizer outdoor air damper leakage (of rated airflow) (50 Hz)**

	Delta P Across Dampers (in. WC)	
	0.5 (In.)	1.0 (In.)
<b>Standard</b>	1.5%	2.5%
<b>Low Leak</b>	0.5%	1.0%
<b>Ultra Low Leak</b>	0.0%	0.1%

**Notes:**

1. Standard and Low Leak data based on tests completed in accordance with AMCA Standard 500.
2. Ultra Low Leak dampers are rated AMCA class 1A; leak rate = 3 CFM per sq-ft face area at 1.0" WC.



# Performance Adjustment Factors

Table 8. Enthalpy of saturated air

Wet Bulb Temperature		Btu Per lb
°F	°C	
40	4.4	15.23
41	5.0	15.70
42	5.5	16.17
43	6.1	16.66
44	6.7	17.15
45	7.2	17.65
46	7.8	18.16
47	8.3	18.68
48	8.9	19.21
49	9.4	19.75
50	10.0	20.30
51	10.6	20.86
52	11.1	21.44
53	11.7	22.02
54	12.2	22.62
55	12.8	23.22
56	13.3	23.84
57	13.9	24.48
58	14.4	25.12
59	15.0	25.78
60	15.6	26.46
61	16.1	27.15
62	16.7	27.85
63	17.2	28.57
64	17.8	29.31
65	18.3	30.06
66	18.9	30.83
67	19.4	31.62
68	20.0	32.42
69	20.6	33.25
70	21.1	34.09
71	21.7	34.95
72	22.2	35.83
73	22.8	36.74
74	23.3	37.66
75	23.9	38.61

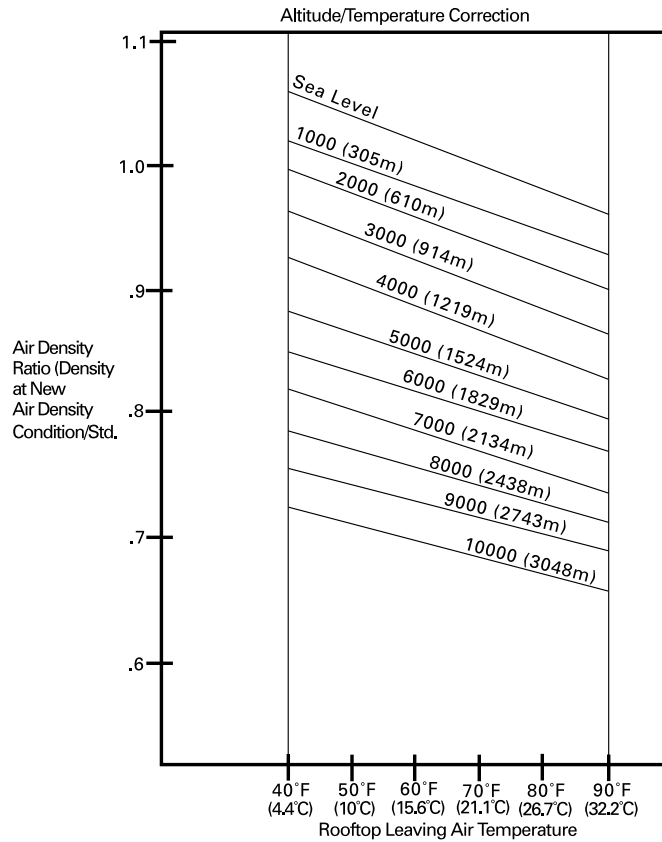
**Figure 3. Air density ratios**

**Table 9. Cooling capacity altitude correction factors**

	Altitude ft. (m)							
	Sea Level	1000 (304.8)	2000 (609.6)	3000 (914.4)	4000 (1219.2)	5000 (1524.0)	6000 (1828.8)	7000 (2133.6)
Cooling Capacity Multiplier	1.00	0.99	0.99	0.98	0.97	0.96	0.95	0.94
KW Correction Multiplier (Compressors)	1.00	1.01	1.02	1.03	1.04	1.05	1.06	1.07
SHR Correction Multiplier	1.00	0.98	0.95	0.93	0.91	0.89	0.87	0.85
Maximum Condenser Ambient	115°F (46.1°C)	114°F (45.6°C)	113°F (45.0°C)	112°F (44.4°C)	111°F (43.9°C)	110°F (43.3°C)	109°F (42.8°C)	108°F (42.2°C)

Note: SHR = Sensible Heat Ratio.

**Table 10. Gas heating capacity altitude correction factors**

	Altitude ft. (m)								
	Sea Level To 2000 (Sea Level To 609.6)	2000 To 2999 (609.6 To 914.1)	3000 To 3999 (914.4 To 1218.9)	4000 To 4999 (1219.2 To 1523.7)	5000 To 5999 (1524.0 To 1828.5)	6000 To 6999 (1828.8 To 2133.3)	7000 To 7999 (2133.6 To 2438.1)	8000 To 8999 (2438.4 To 2742.9)	9000 To 9999 (2743.2 To 3047.7)
Capacity Multiplier	1.00	0.96	0.92	0.88	0.84	0.80	0.76	0.72	0.68



# Performance Data (60 Hz Units)

Table 11. 27.5 ton standard efficiency, gross cooling capacities (MBh)—60 Hz

CFM	Ent DB (°F)	Ambient Temperature (°F)						Ambient Temperature (°F)						Ambient Temperature (°F)					
		85						95						105					
		Entering Wet Bulb Temp (°F)						Entering Wet Bulb Temp (°F)						Entering Wet Bulb Temp (°F)					
		61		67		73		61		67		73		61		67		73	
		TGC	SHC	TGC	SHC	TGC	SHC	TGC	SHC	TGC	SHC	TGC	SHC	TGC	SHC	TGC	SHC		
8000	75	310	243	346	191	380	136	295	234	329	183	362	128	278	225	311	174	342	120
	80	311	284	347	234	382	180	297	275	331	226	363	172	281	267	313	218	344	163
	85	318	318	348	277	382	223	306	306	331	269	364	215	292	292	314	261	345	206
	90	336	336	349	319	383	266	323	323	333	310	365	258	309	309	316	301	345	250
9300	75	321	264	357	204	389	140	305	256	339	196	370	132	288	244	320	187	349	123
	80	324	312	358	254	391	190	308	303	340	246	371	182	292	292	322	237	351	173
	85	338	338	359	304	391	240	324	324	342	293	372	232	309	309	323	284	351	223
	90	356	356	362	351	391	290	342	342	345	343	372	282	327	327	327	327	352	273
10400	75	328	280	364	214	395	143	312	271	345	206	375	135	294	261	326	197	354	126
	80	333	333	365	270	396	199	318	318	347	262	376	190	303	303	327	253	355	182
	85	351	351	366	323	396	255	337	337	349	314	376	246	321	321	330	305	355	238
	90	370	370	371	371	396	310	355	355	355	355	376	302	338	338	339	339	356	289
11000	75	332	289	367	220	397	144	315	280	348	211	377	136	297	270	329	203	356	127
	80	338	338	368	279	398	203	324	324	349	271	378	195	308	308	330	258	357	186
	85	358	358	370	335	398	262	343	343	352	326	378	254	327	327	333	316	357	245
	90	376	376	377	377	398	321	360	360	361	361	378	309	343	343	344	344	357	299
12100	75	338	305	372	230	401	147	321	296	353	221	381	139	303	286	333	212	359	130
	80	348	348	373	291	402	212	333	333	354	282	381	203	317	317	334	272	359	195
	85	368	368	375	355	401	276	352	352	357	346	381	268	335	335	338	337	359	259
	90	386	386	386	386	401	336	369	369	369	369	381	327	351	351	351	351	359	318
CFM	Ent DB (°F)	Ambient Temperature (°F)						Ambient Temperature (°F)						Ambient Temperature (°F)					
		115						115						115					
		Entering Wet Bulb Temp (°F)						Entering Wet Bulb Temp (°F)						Entering Wet Bulb Temp (°F)					
		61		67		73		61		67		73		61		67		73	
		TGC	SHC	TGC	SHC	TGC	SHC	TGC	SHC	TGC	SHC	TGC	SHC	TGC	SHC	TGC	SHC		
8000	75	261	216	292	165	321	111												
	80	264	257	294	208	323	154												
	85	278	278	295	252	324	197												
	90	294	294	298	292	324	241												
9300	75	270	235	300	178	327	114												
	80	276	276	302	228	329	164												
	85	293	293	304	274	329	214												
	90	310	310	311	311	330	264												
10400	75	276	251	305	188	331	117												
	80	286	286	307	240	332	173												
	85	277	277	310	295	332	228												
	90	320	320	321	321	333	279												
11000	75	279	260	308	193	333	118												
	80	291	291	309	248	334	177												
	85	309	309	312	306	334	236												
	90	324	324	325	325	334	289												
12100	75	284	276	311	203	335	121												
	80	300	300	313	262	337	186												
	85	317	317	317	317	337	250												
	90	330	330	331	331	337	307												

**Notes:**

1. All capacities shown are gross and have not considered indoor fan heat. To obtain net cooling, subtract indoor fan heat.
2. TGC = Total gross capacity.
3. SHC = Sensible heat capacity.



**Table 12. 27.5 ton high efficiency, gross cooling capacities (MBh)—60 Hz**

CFM	Ent DB (°F)	Ambient Temperature (°F)						Ambient Temperature (°F)						Ambient Temperature (°F)					
		85						95						105					
		Entering Wet Bulb Temp (°F)						Entering Wet Bulb Temp (°F)						Entering Wet Bulb Temp (°F)					
		61		67		73		61		67		73		61		67		73	
TGC	SHC	TGC	SHC	TGC	SHC	TGC	SHC	TGC	SHC	TGC	SHC	TGC	SHC	TGC	SHC	TGC	SHC		
8000	75	323	251	362	199	402	144	307	242	344	190	382	136	290	233	326	181	362	127
	80	324	293	363	243	404	189	309	285	345	234	384	180	292	275	327	225	364	171
	85	331	331	364	286	405	233	318	318	346	278	386	224	304	304	328	269	365	216
	90	349	349	365	329	405	277	336	336	348	321	386	268	322	322	330	311	366	260
9300	75	335	273	374	212	413	148	318	264	355	203	392	140	300	253	336	194	371	131
	80	337	322	375	263	415	200	321	313	357	254	395	191	304	304	337	245	374	182
	85	352	352	376	314	416	251	338	338	358	304	396	243	322	322	339	295	375	234
	90	372	372	379	364	417	302	357	357	361	355	397	294	342	342	343	343	376	285
10400	75	343	290	382	223	420	152	326	280	363	214	399	143	308	271	343	205	377	134
	80	347	346	383	280	423	209	331	331	364	271	402	201	316	316	344	262	380	191
	85	367	367	385	335	424	266	352	352	367	326	403	258	336	336	347	317	381	249
	90	388	388	390	390	424	324	373	373	374	374	404	315	356	356	357	357	382	306
11000	75	347	299	386	229	424	153	329	290	366	220	402	144	311	280	346	210	379	135
	80	353	353	387	289	426	214	338	338	368	280	405	205	322	322	347	271	383	196
	85	375	375	389	347	427	275	359	359	371	338	406	266	342	342	350	328	384	257
	90	396	396	397	397	427	335	380	380	381	381	407	326	363	363	364	364	385	314
12100	75	353	316	392	239	429	156	335	307	372	230	407	147	317	297	351	221	383	138
	80	364	364	393	306	431	223	349	349	373	294	410	214	332	332	353	284	387	205
	85	387	387	396	369	432	289	371	371	377	360	411	281	353	353	357	350	388	272
	90	409	409	409	409	433	353	392	392	392	392	412	344	374	374	374	374	389	334
8000	Ent DB (°F)	Ambient Temperature (°F)						Ambient Temperature (°F)						Ambient Temperature (°F)					
		115						115						115					
		Entering Wet Bulb Temp (°F)						Entering Wet Bulb Temp (°F)						Entering Wet Bulb Temp (°F)					
		61		67		73		61		67		73		61		67		73	
CFM	TGC	SHC	TGC	SHC	TGC	SHC	TGC	SHC	TGC	SHC	TGC	SHC	TGC	SHC	TGC	SHC	TGC	SHC	
8000	75	273	224	306	172	339	117												
	80	275	266	308	216	342	162												
	85	289	289	309	260	344	206												
	90	307	307	311	302	345	250												
9300	75	282	243	315	184	347	121												
	80	288	288	317	236	351	173												
	85	306	306	319	285	352	224												
	90	325	325	326	326	353	275												
10400	75	289	260	321	195	353	124												
	80	299	299	323	252	356	182												
	85	319	319	326	306	357	239												
	90	338	338	339	339	359	294												
11000	75	292	270	324	201	355	126												
	80	305	305	326	258	359	187												
	85	325	325	329	318	360	247												
	90	344	344	345	345	361	304												
12100	75	297	286	328	211	358	128												
	80	314	314	331	273	363	195												
	85	335	335	335	335	363	258												
	90	354	354	354	354	365	324												

**Notes:**

1. All capacities shown are gross and have not considered indoor fan heat. To obtain net cooling, subtract indoor fan heat.
2. TGC = Total gross capacity.
3. SHC = Sensible heat capacity.



**Performance Data (60 Hz Units)**

**Table 13. 30 ton standard efficiency, gross cooling capacities (Mbh)—60 Hz**

CFM	Ent DB (°F)	Ambient Temperature (°F)						Ambient Temperature (°F)						Ambient Temperature (°F)					
		85						95						105					
		Entering Wet Bulb Temp (°F)						Entering Wet Bulb Temp (°F)						Entering Wet Bulb Temp (°F)					
		61		67		73		61		67		73		61		67		73	
		TGC	SHC	TGC	SHC	TGC	SHC	TGC	SHC	TGC	SHC	TGC	SHC	TGC	SHC	TGC	SHC		
9000	75	341	269	378	211	413	148	325	260	361	202	393	139	307	251	342	193	371	130
	80	342	315	379	259	413	196	327	307	362	250	393	188	310	297	343	241	372	178
	85	351	351	380	307	413	244	338	338	363	298	394	236	323	323	344	289	372	227
	90	370	370	382	353	414	292	356	356	365	344	394	284	341	341	346	335	372	275
10000	75	350	289	387	222	420	151	333	280	369	213	399	142	315	268	349	204	377	133
	80	353	341	388	276	420	205	337	332	370	268	399	197	320	320	350	258	377	187
	85	368	368	389	331	420	260	353	353	371	320	399	251	338	338	351	310	376	242
	90	387	387	392	383	419	314	372	372	374	374	399	305	355	355	355	355	376	296
11400	75	358	306	394	233	425	153	341	296	375	224	404	145	322	286	355	215	381	136
	80	362	362	395	294	424	214	347	347	376	285	403	205	331	331	355	276	380	196
	85	382	382	396	352	425	275	366	366	377	342	403	266	349	349	357	333	379	256
	90	400	400	401	401	426	336	384	384	384	384	403	327	365	365	366	366	380	314
12000	75	361	315	397	238	427	155	344	305	378	229	406	146	325	295	357	220	381	137
	80	368	368	398	302	427	219	352	352	378	293	405	210	336	336	358	284	381	200
	85	388	388	399	363	427	283	372	372	380	353	405	274	354	354	360	344	381	264
	90	406	406	406	406	428	347	389	389	389	389	406	334	369	369	370	370	381	324
13200	75	367	333	402	249	431	158	350	323	382	240	408	149	331	313	361	231	383	140
	80	378	378	402	319	431	228	362	362	383	307	408	218	345	345	362	296	383	209
	85	398	398	404	385	432	298	381	381	385	376	408	289	362	362	364	364	384	279
	90	415	415	415	415	433	365	396	396	397	397	409	355	376	376	376	376	385	344
CFM	Ent DB (°F)	Ambient Temperature (°F)						Ambient Temperature (°F)						Ambient Temperature (°F)					
		115						115						115					
		Entering Wet Bulb Temp (°F)						Entering Wet Bulb Temp (°F)						Entering Wet Bulb Temp (°F)					
		61		67		73		61		67		73		61		67		73	
		TGC	SHC	TGC	SHC	TGC	SHC	TGC	SHC	TGC	SHC	TGC	SHC	TGC	SHC	TGC	SHC		
9000	75	289	241	321	183	348	121												
	80	292	287	322	231	348	169												
	85	307	307	323	279	349	217												
	90	324	324	326	325	349	265												
10000	75	296	258	327	194	352	124												
	80	302	302	328	249	352	177												
	85	320	320	330	300	352	232												
	90	336	336	337	337	352	286												
11400	75	302	276	332	205	355	126												
	80	313	313	333	266	355	186												
	85	331	331	335	322	355	247												
	90	345	345	345	345	356	303												
12000	75	305	285	334	210	356	127												
	80	318	318	335	270	356	190												
	85	335	335	338	333	356	254												
	90	348	348	348	348	356	313												
13200	75	310	302	338	221	358	130												
	80	326	326	339	286	358	199												
	85	342	342	342	342	358	264												
	90	352	352	353	353	358	333												

**Notes:**

1. All capacities shown are gross and have not considered indoor fan heat. To obtain net cooling, subtract indoor fan heat.
2. TGC = Total gross capacity.
3. SHC = Sensible heat capacity.

**Table 14. 30 ton high efficiency, gross cooling capacities (Mbh)—60 Hz**

CFM	Ent DB (°F)	Ambient Temperature (°F)						Ambient Temperature (°F)						Ambient Temperature (°F)					
		85						95						105					
		Entering Wet Bulb Temp (°F)						Entering Wet Bulb Temp (°F)						Entering Wet Bulb Temp (°F)					
		61		67		73		61		67		73		61		67		73	
TGC	SHC	TGC	SHC	TGC	SHC	TGC	SHC	TGC	SHC	TGC	SHC	TGC	SHC	TGC	SHC	TGC	SHC		
9000	75	358	280	401	221	444	159	341	271	382	212	423	150	324	262	362	203	400	141
	80	359	328	402	271	445	209	343	319	383	262	424	200	326	309	363	252	402	191
	85	368	368	403	320	446	259	354	354	384	311	425	250	339	339	365	302	403	241
	90	389	389	404	369	446	309	375	375	386	359	426	300	359	359	367	350	404	290
10200	75	368	301	412	234	453	163	351	291	392	224	431	154	332	280	371	215	408	144
	80	371	355	413	290	455	219	354	346	393	281	433	210	336	336	373	271	410	201
	85	387	387	414	346	455	276	372	372	395	337	434	267	356	356	374	325	411	257
	90	409	409	417	400	456	332	394	394	398	391	435	323	377	377	378	378	412	313
11400	75	377	319	420	246	461	166	359	309	400	236	438	157	340	299	378	226	414	147
	80	382	381	421	308	462	229	365	365	401	299	440	220	349	349	380	289	416	210
	85	404	404	423	369	463	292	388	388	403	359	441	283	371	371	382	349	417	273
	90	427	427	428	428	463	355	410	410	411	411	441	346	392	392	393	393	418	336
12000	75	381	328	424	251	464	168	363	319	403	242	441	159	343	308	381	232	417	149
	80	388	388	425	317	465	234	372	372	405	308	443	225	355	355	383	298	419	215
	85	411	411	427	381	465	300	395	395	407	371	443	291	377	377	386	361	419	281
	90	434	434	435	435	466	366	417	417	418	418	444	357	398	398	399	399	420	344
13200	75	389	347	430	263	469	171	370	337	409	253	446	162	350	327	387	243	421	152
	80	400	400	432	335	470	243	384	384	411	323	448	234	366	366	388	312	423	225
	85	424	424	435	404	470	316	407	407	414	394	448	307	388	388	392	384	423	297
	90	447	447	448	448	471	385	429	429	430	430	448	375	409	409	410	410	424	365
	Ent DB (°F)	Ambient Temperature (°F)						Ambient Temperature (°F)						Ambient Temperature (°F)					
		115						115						115					
		Entering Wet Bulb Temp (°F)						Entering Wet Bulb Temp (°F)						Entering Wet Bulb Temp (°F)					
		61		67		73		61		67		73		61		67		73	
CFM	(°F)	TGC	SHC	TGC	SHC	TGC	SHC	TGC	SHC	TGC	SHC	TGC	SHC	TGC	SHC	TGC	SHC		
9000	75	304	252	341	193	376	131												
	80	307	299	342	242	378	181												
	85	323	323	343	292	380	231												
	90	342	342	346	339	380	280												
10200	75	313	269	349	204	383	134												
	80	319	319	350	261	385	191												
	85	339	339	352	314	386	247												
	90	359	359	360	360	387	303												
11400	75	320	288	355	216	388	137												
	80	331	331	357	279	391	200												
	85	352	352	360	338	391	263												
	90	372	372	373	373	392	322												
12000	75	323	297	358	221	391	139												
	80	337	337	360	284	393	205												
	85	358	358	363	350	393	271												
	90	378	378	378	378	394	333												
13200	75	328	315	362	233	394	142												
	80	347	347	365	301	396	214												
	85	368	368	369	369	397	287												
	90	387	387	388	388	397	354												

**Notes:**

1. All capacities shown are gross and have not considered indoor fan heat. To obtain net cooling, subtract indoor fan heat.
2. TGC = Total gross capacity.
3. SHC = Sensible heat capacity.



**Performance Data (60 Hz Units)**

**Table 15. 35 ton standard efficiency, gross cooling capacities (Mbh)—60 Hz**

CFM	Ent DB (°F)	Ambient Temperature (°F)						Ambient Temperature (°F)						Ambient Temperature (°F)					
		85						95						105					
		Entering Wet Bulb Temp (°F)						Entering Wet Bulb Temp (°F)						Entering Wet Bulb Temp (°F)					
		61		67		73		61		67		73		61		67		73	
TGC	SHC	TGC	SHC	TGC	SHC	TGC	SHC	TGC	SHC	TGC	SHC	TGC	SHC	TGC	SHC	TGC	SHC		
10500	75	380	308	421	238	458	164	361	298	401	229	435	155	341	288	379	219	410	145
	80	383	362	422	295	458	221	365	352	402	286	435	212	345	342	380	275	411	202
	85	396	396	423	352	459	278	380	380	403	342	436	269	363	363	381	330	411	259
	90	417	417	425	406	459	335	400	400	406	396	436	325	382	382	385	385	412	315
11900	75	390	331	430	252	465	168	370	318	409	242	441	158	350	307	386	231	416	148
	80	394	392	431	316	465	232	376	376	410	306	441	222	357	357	387	296	416	212
	85	414	414	432	377	465	296	397	397	411	367	441	286	378	378	389	356	416	276
	90	434	434	436	436	465	360	416	416	417	417	441	351	397	397	397	397	416	340
13300	75	398	350	437	264	470	171	378	339	415	254	446	161	357	328	391	244	420	151
	80	406	406	438	336	470	242	389	389	416	326	445	233	370	370	392	316	419	222
	85	428	428	440	404	469	314	410	410	418	393	445	304	390	390	395	382	419	294
	90	448	448	448	448	469	385	429	429	429	429	445	376	407	407	408	408	419	360
14000	75	402	360	440	271	472	172	381	350	417	261	448	163	360	339	394	250	422	153
	80	412	412	440	346	471	247	394	394	418	336	447	238	375	375	395	321	421	228
	85	434	434	443	417	471	323	415	415	421	407	446	313	395	395	398	395	420	303
	90	453	453	454	454	471	394	433	433	434	434	446	383	411	411	411	411	420	372
15400	75	408	381	444	283	476	175	387	371	422	273	451	166	366	359	397	263	425	156
	80	423	423	445	362	476	258	404	404	423	351	450	248	384	384	399	340	425	238
	85	444	444	448	443	476	341	425	425	426	426	450	331	403	403	403	403	425	321
	90	462	462	463	463	476	418	441	441	441	441	450	407	417	417	417	417	426	396
10500	Ent DB (°F)	Ambient Temperature (°F)						Ambient Temperature (°F)						Ambient Temperature (°F)					
		115						115						115					
		Entering Wet Bulb Temp (°F)						Entering Wet Bulb Temp (°F)						Entering Wet Bulb Temp (°F)					
		61		67		73		61		67		73		61		67		73	
CFM		TGC	SHC	TGC	SHC	TGC	SHC	TGC	SHC	TGC	SHC	TGC	SHC	TGC	SHC	TGC	SHC		
10500	75	320	274	355	208	384	134												
	80	325	325	356	265	385	191												
	85	344	344	358	318	385	248												
	90	363	363	363	363	385	304												
11900	75	328	296	361	221	389	138												
	80	338	338	362	285	389	201												
	85	358	358	365	345	388	266												
	90	375	375	375	375	389	325												
13300	75	334	316	366	233	393	141												
	80	349	349	367	300	393	212												
	85	368	368	371	371	393	283												
	90	383	383	384	384	393	349												
14000	75	337	327	368	239	394	142												
	80	354	354	370	309	394	217												
	85	373	373	373	373	394	292												
	90	386	386	387	387	394	360												
15400	75	343	343	372	252	397	145												
	80	362	362	373	328	397	227												
	85	379	379	380	380	397	303												
	90	390	390	390	390	398	383												

**Notes:**

1. All capacities shown are gross and have not considered indoor fan heat. To obtain net cooling, subtract indoor fan heat.
2. TGC = Total gross capacity.
3. SHC = Sensible heat capacity.

**Table 16. 35 ton high efficiency, gross cooling capacities (Mbh)—60 Hz**

CFM	Ent DB (°F)	Ambient Temperature (°F)						Ambient Temperature (°F)						Ambient Temperature (°F)					
		85						95						105					
		Entering Wet Bulb Temp (°F)						Entering Wet Bulb Temp (°F)						Entering Wet Bulb Temp (°F)					
		61		67		73		61		67		73		61		67		73	
TGC	SHC	TGC	SHC	TGC	SHC	TGC	SHC	TGC	SHC	TGC	SHC	TGC	SHC	TGC	SHC	TGC	SHC		
10500	75	391	314	433	244	471	169	372	304	412	234	448	160	351	293	390	223	423	150
	80	393	369	434	301	472	227	374	359	413	291	449	217	355	348	391	281	424	207
	85	406	406	435	358	472	284	390	390	414	348	449	274	373	373	392	336	424	264
	90	428	428	437	413	472	341	411	411	417	403	449	331	393	393	395	392	424	321
11900	75	401	337	443	257	479	173	381	324	421	247	455	163	360	313	397	237	429	153
	80	405	399	443	322	479	237	386	386	422	312	455	228	367	367	398	301	429	217
	85	425	425	445	384	479	302	408	408	423	374	454	292	389	389	400	363	428	282
	90	446	446	448	448	478	367	428	428	429	429	455	357	408	408	409	409	429	346
13300	75	410	357	450	270	485	176	389	346	427	260	461	167	368	334	403	249	434	156
	80	418	418	451	342	484	248	400	400	428	332	459	238	380	380	404	318	433	228
	85	440	440	453	411	484	320	422	422	430	401	459	310	401	401	407	389	432	300
	90	461	461	461	461	484	393	441	441	441	441	459	379	419	419	419	419	432	367
14000	75	414	367	453	276	488	178	393	357	430	266	463	168	371	345	406	256	437	158
	80	424	424	454	353	486	253	406	406	431	339	461	243	386	386	407	328	435	233
	85	447	447	456	424	486	329	427	427	433	414	460	319	407	407	410	403	433	309
	90	466	466	467	467	487	402	446	446	446	446	461	391	423	423	424	424	434	379
15400	75	420	389	458	289	493	181	399	378	435	279	467	172	377	366	410	268	440	161
	80	436	436	459	369	491	264	416	416	436	358	465	254	396	396	411	346	438	244
	85	458	458	462	451	491	348	437	437	439	439	464	337	415	415	416	416	436	327
	90	476	476	476	476	492	426	454	454	454	454	466	415	430	430	430	430	437	403
10500	75	330	280	365	212	396	139												
	80	334	334	366	270	396	195												
	85	354	354	368	324	396	252												
	90	372	372	373	373	396	310												
11900	75	338	301	372	225	401	142												
	80	348	348	373	290	401	206												
	85	368	368	375	351	400	270												
	90	385	385	386	386	400	331												
13300	75	345	322	377	238	406	145												
	80	360	360	378	306	406	217												
	85	379	379	381	377	406	288												
	90	394	394	395	395	406	355												
14000	75	348	333	379	244	408	147												
	80	364	364	381	315	408	222												
	85	383	383	384	384	408	292												
	90	397	397	398	398	408	367												
15400	75	352	352	383	257	411	151												
	80	373	373	384	333	411	232												
	85	391	391	391	391	411	308												
	90	403	403	403	403	411	391												

**Notes:**

1. All capacities shown are gross and have not considered indoor fan heat. To obtain net cooling, subtract indoor fan heat.
2. TGC = Total gross capacity.
3. SHC = Sensible heat capacity.



**Performance Data (60 Hz Units)**

**Table 17. 40 ton standard and high efficiency, gross cooling capacities (Mbh)—60 Hz**

CFM	Ent DB (°F)	Ambient Temperature (°F)						Ambient Temperature (°F)						Ambient Temperature (°F)					
		85						95						105					
		Entering Wet Bulb Temp (°F)						Entering Wet Bulb Temp (°F)						Entering Wet Bulb Temp (°F)					
		61		67		73		61		67		73		61		67		73	
		TGC	SHC	TGC	SHC	TGC	SHC	TGC	SHC	TGC	SHC	TGC	SHC	TGC	SHC	TGC	SHC		
12000	75	440	354	493	276	545	195	417	341	468	264	516	183	392	325	441	251	487	170
	80	443	417	495	343	551	263	421	404	470	330	523	250	397	390	444	317	494	237
	85	460	460	497	408	554	329	440	440	472	396	527	317	420	420	446	379	497	304
	90	487	487	500	471	556	395	467	467	476	458	529	383	446	446	451	445	499	370
13600	75	452	377	505	293	556	200	428	364	479	280	527	187	403	350	452	267	496	174
	80	458	452	508	367	564	277	435	435	482	355	535	264	413	413	454	342	505	251
	85	483	483	510	438	567	352	462	462	485	425	539	339	440	440	458	411	508	326
	90	512	512	516	512	569	427	491	491	492	492	541	414	468	468	469	469	511	401
15200	75	463	402	515	308	565	205	439	389	489	295	534	192	413	374	460	282	502	179
	80	473	473	518	392	575	290	452	452	491	379	545	278	429	429	463	360	513	264
	85	503	503	522	470	578	374	481	481	496	456	548	362	458	458	468	442	517	349
	90	533	533	534	534	580	458	511	511	512	512	551	440	487	487	488	488	520	426
16000	75	468	415	520	316	569	207	443	401	492	303	537	194	417	386	463	289	504	181
	80	481	481	523	404	579	297	459	459	495	385	549	284	436	436	467	370	516	271
	85	512	512	527	486	582	385	489	489	501	472	552	373	466	466	473	458	520	359
	90	543	543	544	544	584	468	520	520	521	521	555	454	495	495	496	496	524	440
17600	75	476	439	527	331	574	211	451	425	499	318	541	198	424	410	469	304	508	184
	80	496	496	531	421	586	310	474	474	503	407	555	297	449	449	474	392	522	284
	85	528	528	537	517	590	407	505	505	510	503	559	395	480	480	482	482	526	372
	90	560	560	561	561	593	496	536	536	537	537	563	483	510	510	511	511	531	468
12000	75	Ambient Temperature (°F)						Ambient Temperature (°F)						Ambient Temperature (°F)					
		115						115						115					
		Entering Wet Bulb Temp (°F)						Entering Wet Bulb Temp (°F)						Entering Wet Bulb Temp (°F)					
		61		67		73		61		67		73		61		67		73	
12000	75	366	310	412	237	455	156	366	310	412	237	455	156	366	310	412	237	455	156
	80	372	372	415	303	463	224	372	372	415	303	463	224	372	372	415	303	463	224
	85	397	397	418	365	466	290	397	397	418	365	466	290	397	397	418	365	466	290
	90	423	423	424	424	468	356	423	423	424	424	468	356	423	423	424	424	468	356
13600	75	376	335	422	253	463	161	376	335	422	253	463	161	376	335	422	253	463	161
	80	390	390	425	328	472	237	390	390	425	328	472	237	390	390	425	328	472	237
	85	417	417	429	397	476	313	417	417	429	397	476	313	417	417	429	397	476	313
	90	444	444	445	445	478	382	444	444	445	445	478	382	444	444	445	445	478	382
15200	75	385	359	429	268	467	165	385	359	429	268	467	165	385	359	429	268	467	165
	80	405	405	433	344	479	250	405	405	433	344	479	250	405	405	433	344	479	250
	85	433	433	439	428	483	335	433	433	439	428	483	335	433	433	439	428	483	335
	90	461	461	462	462	487	411	461	461	462	462	487	411	461	461	462	462	487	411
16000	75	389	371	432	275	469	167	389	371	432	275	469	167	389	371	432	275	469	167
	80	411	411	437	355	482	257	411	411	437	355	482	257	411	411	437	355	482	257
	85	440	440	444	443	487	346	440	440	444	443	487	346	440	440	444	443	487	346
	90	469	469	470	470	491	425	469	469	470	470	491	425	469	469	470	470	491	425
17600	75	396	394	435	278	471	170	396	394	435	278	471	170	396	394	435	278	471	170
	80	424	424	443	376	487	270	424	424	443	376	487	270	424	424	443	376	487	270
	85	453	453	454	454	492	356	453	453	454	454	492	356	453	453	454	454	492	356
	90	482	482	483	483	498	453	482	482	483	483	498	453	482	482	483	483	498	453

**Notes:**

1. All capacities shown are gross and have not considered indoor fan heat. To obtain net cooling, subtract indoor fan heat.
2. TGC = Total gross capacity.
3. SHC = Sensible heat capacity.

**Table 18. 50 ton standard and high efficiency, gross cooling capacities (MBh)—60 Hz**

CFM	Ent DB (°F)	Ambient Temperature (°F)						Ambient Temperature (°F)						Ambient Temperature (°F)					
		85						95						105					
		Entering Wet Bulb Temp (°F)						Entering Wet Bulb Temp (°F)						Entering Wet Bulb Temp (°F)					
		61		67		73		61		67		73		61		67		73	
		TGC	SHC	TGC	SHC	TGC	SHC	TGC	SHC	TGC	SHC	TGC	SHC	TGC	SHC	TGC	SHC		
15000	75	519	430	579	332	637	228	493	416	550	318	605	214	465	399	519	303	570	200
	80	524	510	580	414	639	311	498	495	551	400	607	297	472	472	521	385	573	283
	85	549	549	582	496	640	394	526	526	554	480	609	380	502	502	523	464	575	366
	90	580	580	587	575	641	476	557	557	560	560	610	462	531	531	532	532	576	448
17000	75	532	460	591	351	648	233	505	445	561	337	614	220	477	430	529	322	579	205
	80	541	541	593	444	650	327	518	518	563	430	617	314	492	492	531	415	582	299
	85	574	574	596	534	651	421	550	550	567	519	619	407	523	523	535	504	584	393
	90	606	606	607	607	651	514	581	581	582	582	620	500	553	553	554	554	585	486
19000	75	544	491	602	370	656	238	516	476	570	356	622	225	486	460	537	341	586	210
	80	561	561	603	474	658	343	536	536	573	460	625	329	510	510	540	440	589	315
	85	595	595	608	573	659	447	569	569	578	558	626	434	541	541	546	543	590	419
	90	626	626	627	627	660	547	600	600	601	601	627	532	571	571	572	572	592	517
20000	75	549	507	606	379	660	241	520	492	574	365	626	227	491	476	541	350	589	212
	80	570	570	608	489	662	351	545	545	577	469	628	337	517	517	544	453	592	323
	85	604	604	613	593	662	461	577	577	583	578	629	447	549	549	551	551	593	433
	90	635	635	636	636	664	564	608	608	609	609	631	550	578	578	579	579	595	535
22000	75	558	537	613	398	666	246	529	522	581	383	631	232	499	499	547	368	594	217
	80	586	586	615	512	668	367	559	559	584	497	634	353	531	531	550	481	597	338
	85	619	619	622	622	668	487	592	592	593	593	634	474	563	563	563	563	598	451
	90	650	650	651	651	670	600	622	622	623	623	636	585	591	591	591	591	600	570
CFM	Ent DB (°F)	Ambient Temperature (°F)						Ambient Temperature (°F)						Ambient Temperature (°F)					
		115						115						115					
		Entering Wet Bulb Temp (°F)						Entering Wet Bulb Temp (°F)						Entering Wet Bulb Temp (°F)					
		61		67		73		61		67		73		61		67		73	
		TGC	SHC	TGC	SHC	TGC	SHC	TGC	SHC	TGC	SHC	TGC	SHC	TGC	SHC	TGC	SHC		
15000	75	436	383	485	288	533	185												
	80	447	447	487	370	537	268												
	85	475	475	491	448	538	351												
	90	504	504	505	505	540	433												
17000	75	446	414	495	306	541	190												
	80	465	465	497	400	545	284												
	85	495	495	502	488	546	377												
	90	524	524	524	524	548	465												
19000	75	455	444	502	325	547	195												
	80	481	481	505	423	551	300												
	85	511	511	512	512	552	404												
	90	539	539	540	540	554	501												
20000	75	459	459	505	334	550	197												
	80	488	488	509	437	553	307												
	85	518	518	519	519	554	417												
	90	546	546	546	546	557	518												
22000	75	468	468	510	352	554	202												
	80	500	500	515	464	558	323												
	85	530	530	531	531	559	434												
	90	556	556	557	557	561	553												

**Notes:**

1. All capacities shown are gross and have not considered indoor fan heat. To obtain net cooling, subtract indoor fan heat.
2. TGC = Total gross capacity.
3. SHC = Sensible heat capacity.



## Performance Data (60 Hz Units)

**Table 19. Electric heat air temperature rise—60 Hz**

KW Input	Total MBH	CFM														
		8000	9000	1000-0	1100-0	1200-0	1300-0	1400-0	1500-0	1600-0	1700-0	1800-0	1900-0	2000-0	2100-0	2200-0
36	123	14.2	12.6	11.3	10.3	9.5	8.7	8.1	7.6	—	—	—	—	—	—	—
54	184	21.3	18.9	17.0	15.5	14.2	13.1	12.2	11.3	10.6	10.0	9.5	9.0	8.5	8.1	7.7
72	246	28.4	25.2	22.7	20.6	18.9	17.4	16.2	15.1	14.2	13.3	12.6	11.9	11.3	10.8	10.3
90	307	35.4	31.5	28.4	25.8	23.6	21.8	20.3	18.9	17.7	16.7	15.8	14.9	14.2	13.5	12.9
108	369	—	—	—	—	28.4	26.2	24.3	22.7	21.3	20.0	18.9	17.9	17.0	16.2	15.5

**Table 20. Available electric heat KW ranges—60 Hz**

Nominal Unit Size Tons	Electric Heat Rated Voltage			
	208	240	480	600
27.5	27-41	36-54	36-90	54-90
30.0	27-41	36-54	36-90	54-90
35.0	27-41	36-54	36-90	54-90
40.0	41	54	54-108	54-108
50.0	41	54	54-108	54-108

**Notes:**

1. kW ranges in this table are based on heater operating at 208, 240, 480, and 600 volts.
2. For other than rated voltage, kW = (Applied Voltage/Rate Voltage)<sup>2</sup> x Rated kW.
3. Electric heaters up to 54 kW are single element heaters, those above 54 kW are dual element heaters.

**Table 21. Gas input/output ranges—60 Hz**

Tonnage	Gas Type	Heat option	Two-Stage <sup>(a)</sup>		Modulating		Air Temp. Rise (°F)
			Input (MBh)	Output (MBh)	Input Range (MBh)	Output Range (MBh)	
27.5 - 35	Natural	Low	350/263	284/213	35-350	28-284	10-40
		High	600/396	486/321	60-600	49-486	25-55
40-50		Low	400/300	324/243	40-400	32-324	5-35
		High	800/600	648/486	80-800	65-648	20-50
27.5 - 35	LP	Low	350/263	284/213	58-350	47-284	10-40
		High	600/396	486/321	86-515 <sup>(b)</sup>	70-417 <sup>(b)</sup>	25-55
40-50		Low	400/300	324/243	67-400	54-324	5-35
		High	800/600	648/486	133-800	108-648	20-50

<sup>(a)</sup> Second stage/ first stage

<sup>(b)</sup> The 600MBH Mod option derates to 515MBH

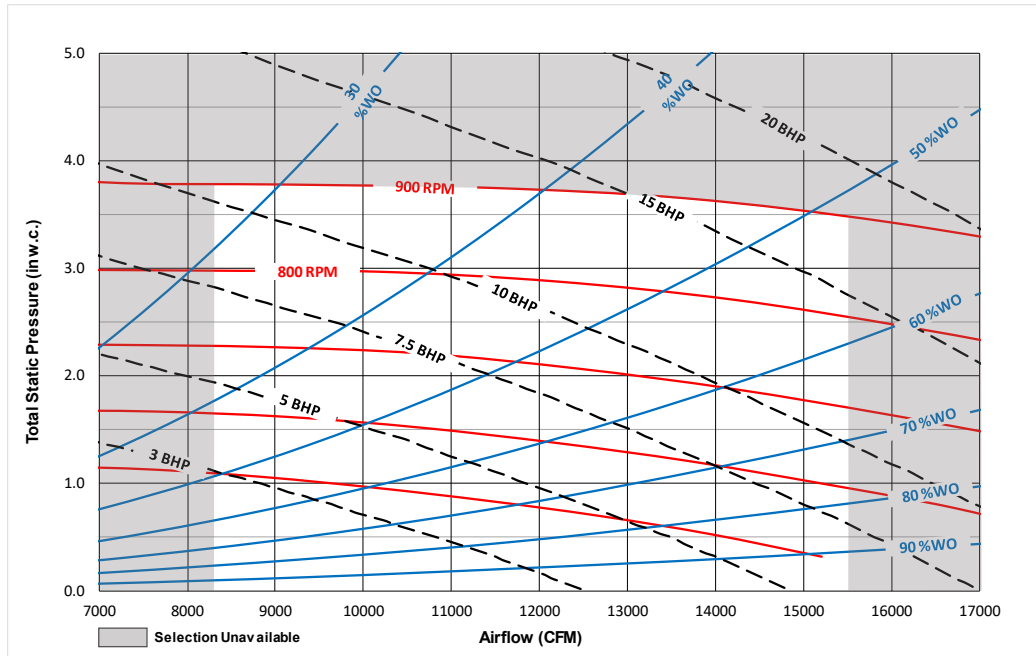

**Figure 4. Rooftop supply fan performance - 27.5, 30, and 35 tons - forward curved**

**Notes:**

- Supply fan performance curve includes internal resistance of rooftop. For total static pressure determination, system external static must be added to appropriate component (evaporator coil, filters) static pressure drops.
- Static pressure drops from the supply fan to the space (optional heat + curb + supply ESP) cannot exceed 3.0 in w.c.
- Curve can show combined operating min/max for multiple tonnages. Refer to general data for appropriate operating parameters such as motor horsepower and airflow ranges.
- Shaded areas represent unavailable selections. Contact your local Trane representative for more information on selections in these shaded regions.
- Max RPM is indicated on curve and RPM values are in increments of 100RPM unless otherwise shown.
- Catalog curves represent fan data corrected to the following standard conditions: 70°F dry bulb temperature, barometric pressure of 14.696 psia, and an air density of 0.075 lb/ft<sup>3</sup>. Utilize Trane Select Assist™ to generate fan curves for unit-specific operating temperatures and elevations.

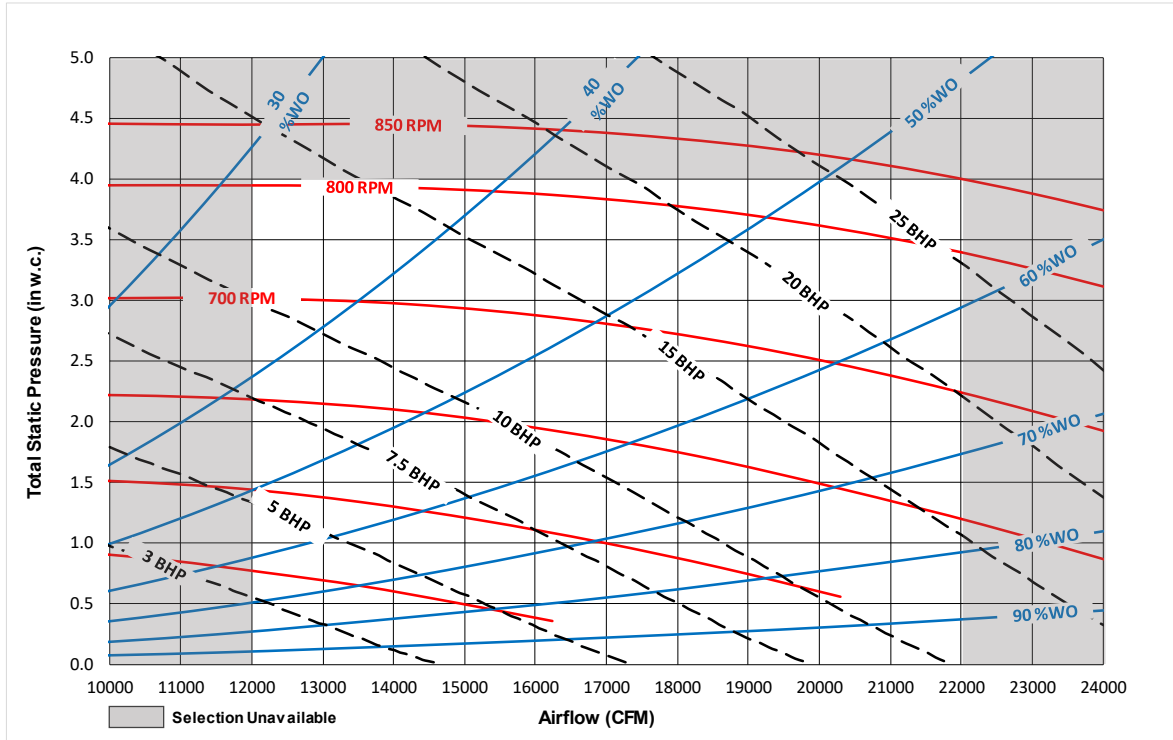

## Performance Data (60 Hz Units)

Figure 5. Rooftop supply fan performance - 40 and 50 tons - forward curved



**Notes:**

- Supply fan performance curve includes internal resistance of rooftop. For total static pressure determination, system external static must be added to appropriate component (evaporator coil, filters) static pressure drops.
- Static pressure drops from the supply fan to the space (optional heat + curb + supply ESP) cannot exceed 3.0 in w.c.
- Curve can show combined operating min/max for multiple tonnages. Refer to general data for appropriate operating parameters such as motor horsepower and airflow ranges.
- Shaded areas represent unavailable selections. Contact your local Trane representative for more information on selections in these shaded regions.
- Max RPM is indicated on curve and RPM values are in increments of 100RPM unless otherwise shown.
- Catalog curves represent fan data corrected to the following standard conditions: 70°F dry bulb temperature, barometric pressure of 14.696 psia, and an air density of 0.075 lb/ft<sup>3</sup>. Utilize Trane Select Assist™ to generate fan curves for unit-specific operating temperatures and elevations.

**Notes:**

- Supply fan performance curve includes internal resistance of rooftop. For total static pressure determination, system external static must be added to appropriate component static pressure drops (evaporator coil, filters, optional economizer, optional heating system)
- The diagrams above show airflow rates (CFM) at sea level.

**Table 22. Component static pressure drops (in. W.G.) — 60 Hz**

Nom. Tons	CFM Std Air	Heating System				Standard Efficiency ID Coil		High Efficiency ID Coil		Filters				Econo- mizer	Hot Gas Reheat Coil
		Gas Heat		Electric Heat		Dry	Wet	Dry	Wet	Throw- away 2"	MERV 8 High Eff		MERV 14 High Eff 4"		
		Low	High	1 Ele- ment	2 Ele- ments						2"	2"			
27.5	8000	0.26	0.23	0.05	0.06	0.16	0.25	0.20	0.31	0.07	0.10	0.09	0.24	0.04	0.08
	9000	0.34	0.25	0.07	0.07	0.19	0.29	0.24	0.36	0.08	0.11	0.11	0.28	0.04	0.10
	10000	0.42	0.26	0.08	0.09	0.23	0.35	0.29	0.43	0.09	0.12	0.12	0.32	0.05	0.12
	11000	0.50	0.28	0.10	0.11	0.27	0.40	0.34	0.49	0.11	0.13	0.14	0.37	0.06	0.14
	12000	0.60	0.29	0.12	0.13	0.31	0.45	0.39	0.56	0.12	0.15	0.16	0.41	0.07	0.17
30	9000	0.34	0.25	0.07	0.07	0.19	0.29	0.24	0.36	0.08	0.11	0.11	0.28	0.04	0.10
	10000	0.42	0.26	0.08	0.09	0.23	0.35	0.29	0.43	0.09	0.12	0.12	0.32	0.05	0.12
	11000	0.50	0.28	0.10	0.11	0.27	0.40	0.34	0.49	0.11	0.13	0.14	0.37	0.06	0.14
	12000	0.60	0.29	0.12	0.13	0.31	0.45	0.39	0.56	0.12	0.15	0.16	0.41	0.07	0.17
	13000	0.71	0.31	0.14	0.15	0.36	0.51	0.44	0.63	0.14	0.16	0.18	0.46	0.09	0.20
35	10500	0.46	0.27	0.09	0.10	0.25	0.37	0.31	0.46	0.10	0.13	0.13	0.35	0.06	0.13
	11500	0.55	0.29	0.11	0.12	0.29	0.42	0.36	0.53	0.11	0.14	0.15	0.39	0.07	0.16
	12500	0.65	0.30	0.13	0.14	0.33	0.48	0.41	0.60	0.13	0.16	0.17	0.44	0.08	0.18
	13500	0.76	0.32	0.15	0.16	0.38	0.53	0.48	0.66	0.15	0.17	0.19	0.49	0.10	0.22
	14500	0.88	0.33	0.18	0.19	0.42	0.59	0.53	0.74	0.16	0.19	0.21	0.54	0.11	0.25
15400	1.00	0.35	0.20	0.21	0.46	0.64	0.57	0.80	0.18	0.21	0.23	0.59	0.12	0.28	
40	12000	0.27	0.49	0.08	0.13	0.30	0.45	0.30	0.45	0.14	0.14	0.14	0.38	0.07	0.06
	13000	0.30	0.54	0.10	0.15	0.35	0.51	0.35	0.51	0.15	0.15	0.16	0.43	0.08	0.07
	14000	0.33	0.59	0.11	0.18	0.39	0.58	0.39	0.58	0.17	0.17	0.18	0.47	0.09	0.08
	15000	0.37	0.64	0.13	0.20	0.44	0.63	0.44	0.63	0.18	0.18	0.20	0.52	0.10	0.09
	16000	0.40	0.70	0.15	0.23	0.49	0.69	0.49	0.69	0.20	0.20	0.22	0.57	0.11	0.10
17000	0.43	0.75	0.17	0.26	0.54	0.75	0.54	0.75	0.22	0.22	0.25	0.62	0.12	0.11	
50	15000	0.37	0.64	0.13	0.20	0.44	0.63	0.44	0.63	0.18	0.18	0.20	0.52	0.10	0.09
	16000	0.40	0.70	0.15	0.23	0.49	0.69	0.49	0.69	0.20	0.20	0.22	0.57	0.11	0.10
	17000	0.43	0.75	0.17	0.26	0.54	0.75	0.54	0.75	0.22	0.22	0.25	0.62	0.12	0.11
	18000	0.47	0.80	0.19	0.29	0.59	0.82	0.59	0.82	0.24	0.24	0.27	0.67	0.14	0.13
	19000	0.50	0.85	0.21	0.32	0.65	0.89	0.65	0.89	0.26	0.26	0.30	0.73	0.16	0.14
	20000	0.54	0.91	0.23	0.36	0.71	0.96	0.71	0.96	0.29	0.29	0.33	0.79	0.18	0.16
	21000	0.58	0.96	0.25	0.39	0.76	1.03	0.76	1.03	0.31	0.31	0.36	0.85	0.21	0.18
22000	0.62	1.01	0.27	0.42	0.82	1.09	0.82	1.09	0.34	0.34	0.39	0.91	0.24	0.20	

**Note:** Static pressure drops of accessory components must be added to external static pressure to enter fan selection tables.



**Performance Data (60 Hz Units)**

**Table 23. Supply air fan drive selections—60 Hz**

Nominal Tons	7.5 HP		10 HP		15 HP		20 HP		25 HP	
	RPM	Drive No.	RPM	Drive No.	RPM	Drive No.	RPM	Drive No.	RPM	Drive No.
27.5	550	A								
	600	B								
	650	C								
			700	D						
			750	E						
			800	G	800	G				
30					850	R				
	550	A								
	600	B								
	650	C								
			700	D						
			750	E	750	E				
35					800	G				
					850	R				
					900	S				
	600	B								
			650	C	700	D				
			700	D	750	E				
40			750	E	800	G				
					850	R	850	R		
							900	S		
			500	H						
			525	J						
			575	K						
50					625	L				
					675	M				
					725	N	725	N		
							775	P		
							800	G		
			525	J						
50			575	K						
					625	L				
					675	M	675	M		
					725	N	725	N	725	N
							775	P	775	P
									825	Q

**Table 24. Power exhaust fan performance—27.5-35 ton—60 Hz**

	Power Exhaust Selection			
	50%		100%	
	Damper Open Position			
	min	max	min	max
Return Duct Static (in. wc)	CFM			
0.0	3812	6866	7624	13742
0.1	3497	5296	6995	10591
0.2	3190	4458	6325	9000
0.3	2884	3812	5768	7635
0.4	2621	3359	5241	6719
0.5	2342	2885	4683	5771

**Note:** These values are the minimum and maximum positions for non-tracking power exhaust. Fresh air tracking and Statitrac options can fully close the exhaust dampers in their operation, and are thus able to reach lower airflows. Statitrac requires 100% power exhaust.

**Table 25. Power exhaust fan performance—40-50—60 Hz**

	Power Exhaust Selection			
	50%		100%	
	Damper Open Position			
	min	max	min	max
Return Duct Static (in. wc)	CFM			
0.0	4854	8035	9708	16069
0.1	4575	7410	9151	14820
0.2	4262	6450	8552	13496
0.3	4011	6027	8021	12054
0.4	3718	5526	7436	11051
0.5	3467	5186	6933	10373

**Note:** These values are the minimum and maximum positions for non-tracking power exhaust. Fresh air tracking and Statitrac options can fully close the exhaust dampers in their operation, and are thus able to reach lower airflows. Statitrac requires 100% power exhaust.



# Performance Data (50 Hz Units)

Table 26. 22.9 ton standard efficiency, gross cooling capacities (MBh) — 50 Hz

ID Airflow CFM	Ent DB (°F)	Ambient Temperature (°F)						Ambient Temperature (°F)						Ambient Temperature (°F)					
		85						95						105					
		Entering Wet Bulb Temp (°F)						Entering Wet Bulb Temp (°F)						Entering Wet Bulb Temp (°F)					
		61		67		73		61		67		73		61		67		73	
TGC	SHC	TGC	SHC	TGC	SHC	TGC	SHC	TGC	SHC	TGC	SHC	TGC	SHC	TGC	SHC	TGC	SHC		
6900	75	256	203	285	159	313	112	242	196	271	151	297	105	228	188	255	144	280	97
	80	257	239	286	196	315	149	244	231	272	189	299	142	230	223	257	181	282	135
	85	265	265	287	233	315	186	254	254	273	226	300	179	242	242	258	218	283	172
	90	280	280	288	268	316	223	268	268	275	261	300	216	256	256	260	253	283	209
7700	75	262	216	291	167	318	114	248	207	276	159	302	107	233	199	261	152	284	99
	80	265	256	292	208	320	156	251	248	278	201	303	148	237	237	262	193	286	141
	85	277	277	293	248	320	197	265	265	279	240	304	190	252	252	263	232	287	182
	90	292	292	296	289	320	238	280	280	282	281	304	231	267	267	267	267	287	224
8700	75	269	230	298	176	324	117	254	222	282	169	307	109	239	214	266	161	289	102
	80	273	273	299	223	325	163	260	260	283	216	308	156	247	247	267	208	290	149
	85	289	289	300	267	325	210	276	276	285	259	308	203	263	263	269	251	290	195
	90	304	304	305	305	325	257	291	291	292	292	308	247	277	277	278	278	290	238
9100	75	271	236	300	180	325	118	256	228	284	172	308	110	242	220	268	165	290	103
	80	277	277	301	229	326	166	264	264	285	221	309	159	251	251	269	211	291	152
	85	293	293	302	275	326	215	280	280	287	267	309	208	267	267	271	259	291	200
	90	308	308	309	309	326	264	295	295	295	295	309	253	281	281	281	281	291	245
10000	75	276	250	304	188	329	120	261	242	288	181	311	113	246	233	271	173	293	105
	80	285	285	305	239	329	173	272	272	289	231	312	166	258	258	272	222	294	159
	85	302	302	307	292	329	227	288	288	292	284	311	219	274	274	275	275	293	212
	90	316	316	317	317	329	276	302	302	302	302	311	268	286	286	287	287	293	260
ID Airflow CFM	Ent DB (°F)	Ambient Temperature (°F)						Ambient Temperature (°F)						Ambient Temperature (°F)					
		115						115						115					
		Entering Wet Bulb Temp (°F)						Entering Wet Bulb Temp (°F)						Entering Wet Bulb Temp (°F)					
		61		67		73		61		67		73		61		67		73	
TGC	SHC	TGC	SHC	TGC	SHC	TGC	SHC	TGC	SHC	TGC	SHC	TGC	SHC	TGC	SHC	TGC	SHC		
6900	75	213	178	239	136	262	90												
	80	216	215	240	173	264	127												
	85	229	229	242	209	265	164												
	90	243	243	244	244	265	201												
7700	75	218	190	244	144	266	92												
	80	224	224	245	185	268	133												
	85	239	239	247	224	268	174												
	90	253	253	253	253	268	216												
8700	75	224	205	248	153	269	94												
	80	234	234	250	197	271	141												
	85	248	248	252	243	271	187												
	90	262	262	262	262	271	230												
9100	75	226	211	250	157	271	95												
	80	237	237	251	202	272	144												
	85	252	252	254	250	272	192												
	90	264	264	265	265	272	236												
10000	75	230	224	253	165	273	97												
	80	244	244	255	213	274	151												
	85	258	258	258	258	273	198												
	90	269	269	269	269	274	251												

**Notes:**

1. All capacities shown are gross and have not considered indoor fan heat. To obtain net cooling, subtract indoor fan heat.
2. TGC = Total gross capacity.
3. SHC = Sensible heat capacity.

**Table 27. 22.9 ton high efficiency, gross cooling capacities (MBh) — 50 Hz**

ID	Airflow CFM	Ent DB (°F)	Ambient Temperature (°F)						Ambient Temperature (°F)						Ambient Temperature (°F)					
			85						95						105					
			Entering Wet Bulb Temp (°F)						Entering Wet Bulb Temp (°F)						Entering Wet Bulb Temp (°F)					
			61		67		73		61		67		73		61		67		73	
TGC	SHC	TGC	SHC	TGC	SHC	TGC	SHC	TGC	SHC	TGC	SHC	TGC	SHC	TGC	SHC	TGC	SHC			
6900	75	266	210	299	165	332	118	253	202	284	157	315	111	238	194	268	150	297	103	
	80	268	247	300	203	333	157	254	239	285	195	317	149	240	231	269	188	299	141	
	85	275	275	300	241	334	195	264	264	286	233	318	187	252	252	270	226	300	180	
	90	291	291	302	278	335	233	280	280	287	270	319	225	267	267	272	262	301	218	
7700	75	273	223	306	173	338	121	259	216	290	166	321	113	244	206	274	158	302	105	
	80	275	264	307	216	340	164	262	257	291	208	323	156	247	247	275	200	305	148	
	85	288	288	308	258	341	206	276	276	293	250	324	199	263	263	276	241	306	191	
	90	305	305	310	299	341	248	292	292	295	291	325	241	279	279	280	280	307	233	
8700	75	281	239	313	183	345	124	266	231	297	176	327	116	251	222	280	167	308	108	
	80	284	284	314	231	347	172	272	272	298	223	329	164	258	258	281	215	310	156	
	85	302	302	316	277	347	220	289	289	300	269	330	212	275	275	283	261	311	204	
	90	319	319	320	320	348	268	306	306	307	307	331	260	292	292	293	293	312	250	
9100	75	283	245	316	187	347	125	269	237	299	179	329	117	253	228	282	171	309	109	
	80	289	289	317	237	349	175	276	276	300	229	331	168	262	262	283	219	312	160	
	85	307	307	319	285	350	225	294	294	303	277	332	218	280	280	286	269	313	210	
	90	325	325	325	325	350	275	311	311	312	312	333	266	296	296	297	297	314	257	
10000	75	289	259	321	196	351	127	273	251	304	188	333	120	258	242	286	180	313	112	
	80	298	298	322	249	353	182	285	285	305	241	335	175	271	271	288	232	316	167	
	85	317	317	324	303	353	237	303	303	308	295	336	230	288	288	291	287	316	222	
	90	335	335	336	336	354	290	321	321	321	321	337	282	305	305	306	306	317	273	
ID	Airflow CFM	Ent DB (°F)	Ambient Temperature (°F)						Ambient Temperature (°F)						Ambient Temperature (°F)					
			115						115						115					
			Entering Wet Bulb Temp (°F)						Entering Wet Bulb Temp (°F)						Entering Wet Bulb Temp (°F)					
			61		67		73		61		67		73		61		67		73	
TGC	SHC	TGC	SHC	TGC	SHC	TGC	SHC	TGC	SHC	TGC	SHC	TGC	SHC	TGC	SHC	TGC	SHC			
6900	75	223	186	251	141	278	95													
	80	225	223	252	179	281	133													
	85	239	239	253	216	282	172													
	90	254	254	255	254	283	210													
7700	75	229	198	256	149	283	97													
	80	234	234	257	192	286	140													
	85	249	249	259	232	287	183													
	90	265	265	266	266	288	225													
8700	75	235	213	262	159	288	100													
	80	244	244	263	205	291	148													
	85	261	261	266	252	291	196													
	90	277	277	277	277	293	242													
9100	75	237	220	263	163	289	101													
	80	248	248	265	210	292	151													
	85	265	265	268	260	293	202													
	90	281	281	281	281	294	249													
10000	75	241	233	267	171	291	103													
	80	255	255	269	223	295	159													
	85	273	273	273	273	296	210													
	90	288	288	289	289	297	265													

**Notes:**

1. All capacities shown are gross and have not considered indoor fan heat. To obtain net cooling, subtract indoor fan heat.
2. TGC = Total gross capacity.
3. SHC = Sensible heat capacity.



**Performance Data (50 Hz Units)**

**Table 28. 82 kw (22.9 ton) standard efficiency, gross cooling capacities (kw) — 50 Hz**

ID	Airflow L/s	Ent DB (°C)	Ambient Temperature (°C)						Ambient Temperature (°C)						Ambient Temperature (°C)					
			29.4						35						40.6					
			Entering Wet Bulb Temp (°C)						Entering Wet Bulb Temp (°C)						Entering Wet Bulb Temp (°C)					
			16.1		19.4		22.8		16.1		19.4		22.8		16.1		19.4		22.8	
		TGC	SHC	TGC	SHC	TGC	SHC	TGC	SHC	TGC	SHC	TGC	SHC	TGC	SHC	TGC	SHC			
3256	23.9	75.0	59.5	83.5	46.5	91.8	32.7	70.9	57.3	79.3	44.4	87.1	30.7	66.8	55.1	74.9	42.2	82.1	28.5	
	26.7	75.4	70.0	83.8	57.4	92.2	43.7	71.5	67.7	79.6	55.3	87.6	41.6	67.5	65.4	75.2	53.1	82.7	39.5	
	29.4	77.7	77.7	84.0	68.3	92.4	54.6	74.3	74.3	79.9	66.2	87.8	52.6	70.9	70.9	75.5	64.0	82.9	50.4	
	32.2	82.0	82.0	84.5	78.7	92.5	65.5	78.7	78.7	80.5	76.5	87.9	63.4	75.1	75.1	76.2	74.3	83.0	61.3	
3634	23.9	76.8	63.4	85.4	48.8	93.3	33.4	72.6	60.7	81.0	46.7	88.5	31.3	68.4	58.3	76.4	44.5	83.4	29.2	
	26.7	77.5	75.0	85.7	61.0	93.7	45.6	73.5	72.7	81.4	58.9	88.9	43.5	69.4	69.4	76.8	56.6	83.9	41.3	
	29.4	81.0	81.0	86.0	72.6	93.8	57.7	77.6	77.6	81.7	70.4	89.1	55.6	73.9	73.9	77.2	68.1	84.0	53.4	
	32.2	85.5	85.5	86.7	84.6	93.9	69.8	82.0	82.0	82.5	82.4	89.2	67.7	78.2	78.2	78.4	78.4	84.1	65.6	
4106	23.9	78.8	67.5	87.2	51.6	94.8	34.2	74.5	65.1	82.7	49.4	89.9	32.1	70.2	62.7	77.9	47.2	84.6	29.9	
	26.7	79.9	79.9	87.5	65.3	95.1	47.8	76.2	76.2	83.0	63.2	90.2	45.7	72.5	72.5	78.2	60.9	85.0	43.6	
	29.4	84.6	84.6	88.0	78.3	95.1	61.5	81.0	81.0	83.6	76.0	90.2	59.4	77.1	77.1	78.9	73.7	85.0	57.2	
	32.2	89.2	89.2	89.3	89.3	95.2	75.2	85.4	85.4	85.5	85.5	90.3	72.3	81.2	81.2	81.4	81.4	85.1	69.9	
4295	23.9	79.5	69.3	87.8	52.7	95.3	34.5	75.2	66.9	83.3	50.5	90.3	32.4	70.8	64.5	78.4	48.3	85.0	30.2	
	26.7	81.1	81.1	88.1	67.0	95.6	48.7	77.4	77.4	83.6	64.9	90.6	46.6	73.6	73.6	78.8	61.7	85.4	44.5	
	29.4	85.9	85.9	88.6	80.5	95.5	63.0	82.1	82.1	84.2	78.2	90.6	60.9	78.1	78.1	79.5	75.9	85.3	58.7	
	32.2	90.4	90.4	90.6	90.6	95.5	77.3	86.5	86.5	86.6	86.6	90.6	74.2	82.2	82.2	82.3	82.3	85.3	71.8	
4719	23.9	80.9	73.2	89.0	55.1	96.4	35.1	76.5	70.8	84.3	52.9	91.2	33.0	72.1	68.4	79.4	50.7	85.8	30.9	
	26.7	83.5	83.5	89.3	69.9	96.5	50.7	79.7	79.7	84.7	67.6	91.4	48.6	75.7	75.7	79.8	65.2	86.1	46.5	
	29.4	88.4	88.4	90.0	85.5	96.3	66.4	84.5	84.5	85.5	83.2	91.3	64.3	80.2	80.2	80.7	80.7	85.9	62.1	
	32.2	92.7	92.7	92.8	92.8	96.4	80.9	88.5	88.5	88.6	88.6	91.2	78.6	84.0	84.0	84.0	84.0	85.8	76.1	
ID	Airflow L/s	Ent DB (°C)	Ambient Temperature (°C)						Ambient Temperature (°C)						Ambient Temperature (°C)					
			46.1						46.1						46.1					
			Entering Wet Bulb Temp (°C)						Entering Wet Bulb Temp (°C)						Entering Wet Bulb Temp (°C)					
			16.1		19.4		22.8		16.1		19.4		22.8		16.1		19.4		22.8	
		TGC	SHC	TGC	SHC	TGC	SHC	TGC	SHC	TGC	SHC	TGC	SHC	TGC	SHC	TGC	SHC			
3256	23.9	62.4	52.2	70.1	39.9	76.8	26.3													
	26.7	63.3	63.0	70.5	50.8	77.4	37.2													
	29.4	67.2	67.2	70.8	61.1	77.6	48.1													
	32.2	71.3	71.3	71.6	71.6	77.7	59.0													
3634	23.9	64.0	55.8	71.5	42.1	77.9	26.9													
	26.7	65.6	65.6	71.8	54.3	78.4	39.0													
	29.4	70.0	70.0	72.3	65.6	78.5	51.1													
	32.2	74.1	74.1	74.2	74.2	78.6	63.2													
4106	23.9	65.6	60.2	72.8	44.8	79.0	27.6													
	26.7	68.4	68.4	73.2	57.6	79.4	41.3													
	29.4	72.8	72.8	73.9	71.2	79.3	54.9													
	32.2	76.7	76.7	76.8	76.8	79.4	67.3													
4295	23.9	66.2	61.9	73.2	45.9	79.3	27.9													
	26.7	69.4	69.4	73.7	59.1	79.7	42.1													
	29.4	73.8	73.8	74.5	73.3	79.6	56.4													
	32.2	77.5	77.5	77.6	77.6	79.6	69.2													
4719	23.9	67.4	65.8	74.0	48.3	79.9	28.6													
	26.7	71.4	71.4	74.6	62.6	80.3	44.2													
	29.4	75.6	75.6	75.7	75.7	80.2	58.2													
	32.2	78.9	78.9	78.9	78.9	80.3	73.5													

**Notes:**

1. All capacities shown are gross and have not considered indoor fan heat. To obtain net cooling, subtract indoor fan heat.
2. TGC = Total gross capacity.
3. SHC = Sensible heat capacity.



**Table 29. 85 kw (22.9 ton) high efficiency, gross cooling capacities (kw) — 50 Hz**

ID	Airflow L/s	Ent DB (°C)	Ambient Temperature (°C)						Ambient Temperature (°C)						Ambient Temperature (°C)					
			29.4						35						40.6					
			Entering Wet Bulb Temp (°C)						Entering Wet Bulb Temp (°C)						Entering Wet Bulb Temp (°C)					
			16.1		19.4		22.8		16.1		19.4		22.8		16.1		19.4		22.8	
		TGC	SHC	TGC	SHC	TGC	SHC	TGC	SHC	TGC	SHC	TGC	SHC	TGC	SHC	TGC	SHC			
3256	23.9	78.1	61.5	87.5	48.3	97.2	34.6	74.1	59.3	83.1	46.1	92.3	32.4	69.9	57.0	78.4	43.8	87.0	30.2	
	26.7	78.4	72.3	87.8	59.5	97.7	45.9	74.6	70.0	83.4	57.3	92.8	43.7	70.4	67.7	78.8	55.0	87.7	41.4	
	29.4	80.6	80.6	88.0	70.6	97.9	57.1	77.3	77.3	83.7	68.4	93.2	54.9	73.8	73.8	79.1	66.1	88.0	52.6	
	32.2	85.3	85.3	88.4	81.4	98.1	68.2	81.9	81.9	84.2	79.2	93.4	66.0	78.3	78.3	79.6	76.8	88.3	63.8	
3634	23.9	80.1	65.5	89.7	50.8	99.1	35.4	76.0	63.3	85.1	48.5	94.0	33.2	71.6	60.5	80.2	46.2	88.6	30.9	
	26.7	80.7	77.5	90.0	63.2	99.7	47.9	76.7	75.2	85.4	61.0	94.7	45.7	72.4	72.4	80.6	58.6	89.4	43.4	
	29.4	84.4	84.4	90.3	75.6	99.9	60.4	80.8	80.8	85.7	73.4	95.0	58.2	77.1	77.1	81.0	70.6	89.7	55.9	
	32.2	89.3	89.3	90.9	87.6	100.1	72.8	85.7	85.7	86.5	85.3	95.2	70.6	81.8	81.8	82.0	82.0	89.9	68.3	
4106	23.9	82.2	70.0	91.8	53.7	101.0	36.3	78.0	67.6	87.0	51.4	95.7	34.0	73.5	65.1	82.0	49.1	90.2	31.7	
	26.7	83.2	83.2	92.1	67.7	101.6	50.4	79.6	79.6	87.4	65.5	96.5	48.2	75.7	75.7	82.4	63.1	91.0	45.9	
	29.4	88.4	88.4	92.6	81.3	101.8	64.4	84.7	84.7	87.9	78.9	96.7	62.2	80.7	80.7	83.0	76.5	91.3	59.9	
	32.2	93.6	93.6	93.8	93.8	102.0	78.4	89.8	89.8	90.0	90.0	96.9	76.2	85.6	85.6	85.8	85.8	91.5	73.4	
4295	23.9	83.0	71.8	92.6	54.9	101.6	36.6	78.7	69.4	87.7	52.6	96.3	34.4	74.2	67.0	82.6	50.2	90.7	32.0	
	26.7	84.6	84.6	92.9	69.5	102.3	51.3	80.9	80.9	88.1	67.3	97.1	49.1	76.9	76.9	83.0	64.3	91.5	46.8	
	29.4	89.9	89.9	93.4	83.6	102.4	66.0	86.1	86.1	88.7	81.3	97.3	63.8	81.9	81.9	83.7	78.8	91.8	61.5	
	32.2	95.2	95.2	95.4	95.4	102.6	80.6	91.2	91.2	91.4	91.4	97.5	77.9	86.9	86.9	87.1	87.1	92.0	75.5	
4719	23.9	84.6	76.0	94.0	57.4	102.9	37.3	80.1	73.5	89.0	55.1	97.5	35.1	75.5	71.0	83.7	52.7	91.6	32.7	
	26.7	87.4	87.4	94.3	72.9	103.5	53.5	83.5	83.5	89.4	70.5	98.2	51.3	79.3	79.3	84.3	68.0	92.5	48.9	
	29.4	92.9	92.9	95.1	88.8	103.6	69.5	88.9	88.9	90.3	86.5	98.4	67.4	84.5	84.5	85.2	84.0	92.7	65.0	
	32.2	98.2	98.2	98.4	98.4	103.8	84.9	94.0	94.0	94.2	94.2	98.6	82.6	89.5	89.5	89.6	89.6	93.0	80.1	
ID	Airflow L/s	Ent DB (°C)	Ambient Temperature (°C)						Ambient Temperature (°C)						Ambient Temperature (°C)					
			46.1						46.1						46.1					
			Entering Wet Bulb Temp (°C)						Entering Wet Bulb Temp (°C)						Entering Wet Bulb Temp (°C)					
			16.1		19.4		22.8		16.1		19.4		22.8		16.1		19.4		22.8	
		TGC	SHC	TGC	SHC	TGC	SHC	TGC	SHC	TGC	SHC	TGC	SHC	TGC	SHC	TGC	SHC			
3256	23.9	65.4	54.6	73.5	41.5	81.5	27.8													
	26.7	66.1	65.2	73.8	52.6	82.3	39.1													
	29.4	70.0	70.0	74.2	63.4	82.6	50.3													
	32.2	74.4	74.4	74.9	74.4	82.8	61.4													
3634	23.9	67.0	58.0	75.1	43.8	82.9	28.5													
	26.7	68.5	68.5	75.4	56.2	83.7	41.1													
	29.4	73.1	73.1	75.9	68.1	84.1	53.5													
	32.2	77.7	77.7	77.8	77.8	84.3	65.9													
4106	23.9	68.8	62.6	76.7	46.6	84.3	29.3													
	26.7	71.6	71.6	77.0	60.0	85.2	43.4													
	29.4	76.4	76.4	77.8	73.9	85.4	57.5													
	32.2	81.1	81.1	81.2	81.2	85.7	70.8													
4295	23.9	69.4	64.4	77.2	47.7	84.7	29.6													
	26.7	72.7	72.7	77.6	61.7	85.6	44.4													
	29.4	77.5	77.5	78.5	76.2	85.9	59.1													
	32.2	82.3	82.3	82.4	82.4	86.2	72.9													
4719	23.9	70.6	68.4	78.2	50.2	85.4	30.3													
	26.7	74.9	74.9	78.8	65.3	86.5	46.5													
	29.4	79.9	79.9	80.0	80.0	86.7	61.6													
	32.2	84.5	84.5	84.7	84.7	87.1	77.5													

**Notes:**

1. All capacities shown are gross and have not considered indoor fan heat. To obtain net cooling, subtract indoor fan heat.
2. TGC = Total gross capacity.
3. SHC = Sensible heat capacity.



**Performance Data (50 Hz Units)**

**Table 30. 25.4 ton standard efficiency, gross cooling capacities (MBh) — 50 Hz**

ID	Airflow CFM	Ent DB (°F)	Ambient Temperature (°F)						Ambient Temperature (°F)						Ambient Temperature (°F)					
			85						95						105					
			Entering Wet Bulb Temp (°F)						Entering Wet Bulb Temp (°F)						Entering Wet Bulb Temp (°F)					
			61		67		73		61		67		73		61		67		73	
TGC	SHC	TGC	SHC	TGC	SHC	TGC	SHC	TGC	SHC	TGC	SHC	TGC	SHC	TGC	SHC	TGC	SHC			
7500	75	278	221	310	172	339	121	265	213	295	165	322	113	250	205	279	157	303	105	
	80	280	259	311	213	339	161	267	252	296	205	322	153	252	244	280	197	304	145	
	85	288	288	312	253	339	201	277	277	297	245	322	193	264	264	281	237	304	185	
	90	304	304	313	291	339	241	292	292	298	284	322	233	279	279	283	275	304	225	
8500	75	286	237	317	182	344	123	272	230	302	174	327	116	257	220	285	166	308	108	
	80	289	281	318	227	344	168	275	273	303	220	327	161	261	261	286	212	308	153	
	85	302	302	319	273	344	214	290	290	304	263	326	206	276	276	287	255	307	198	
	90	318	318	321	316	344	259	305	305	306	306	326	251	291	291	291	291	307	243	
9500	75	293	251	323	191	349	125	278	243	307	184	331	118	263	235	289	175	311	110	
	80	297	297	324	242	348	176	284	284	308	234	330	168	271	271	290	226	310	160	
	85	314	314	325	290	349	227	300	300	309	282	330	219	286	286	292	274	310	211	
	90	329	329	330	330	350	278	315	315	315	315	331	270	299	299	300	300	311	258	
10000	75	296	259	325	196	351	127	281	251	309	188	332	119	265	242	291	180	313	111	
	80	302	302	326	249	351	180	289	289	310	241	331	172	275	275	292	230	311	164	
	85	319	319	328	299	351	233	305	305	311	291	332	225	290	290	294	283	311	217	
	90	334	334	334	334	352	287	319	319	319	319	333	276	302	302	303	303	312	267	
11000	75	301	274	329	205	354	129	286	266	313	197	335	121	270	257	295	189	314	114	
	80	311	311	330	260	354	187	297	297	313	252	334	179	282	282	295	243	314	171	
	85	327	327	332	318	355	246	313	313	315	310	335	238	297	297	298	298	314	230	
	90	341	341	341	341	356	301	325	325	325	325	336	293	307	307	308	308	315	283	
ID	Airflow CFM	Ent DB (°F)	Ambient Temperature (°F)																	
			115																	
			Entering Wet Bulb Temp (°F)																	
			61		67		73													
TGC	SHC	TGC	SHC	TGC	SHC															
7500	75	234	197	261	149	284	97													
	80	237	235	262	189	284	137													
	85	251	251	263	227	284	177													
	90	265	265	266	266	284	217													
8500	75	241	211	267	158	288	100													
	80	247	247	268	203	287	144													
	85	262	262	269	246	287	189													
	90	275	275	275	275	286	235													
9500	75	246	226	271	167	289	102													
	80	256	256	272	215	289	152													
	85	270	270	273	264	289	202													
	90	282	282	282	282	289	249													
10000	75	248	233	272	171	292	103													
	80	259	259	273	221	290	155													
	85	274	274	275	274	290	208													
	90	284	284	284	284	290	257													
11000	75	252	248	275	180	292	105													
	80	266	266	276	234	292	162													
	85	279	279	279	279	292	216													
	90	288	288	288	288	292	274													

**Notes:**

1. All capacities shown are gross and have not considered indoor fan heat. To obtain net cooling, subtract indoor fan heat.
2. TGC = Total gross capacity.
3. SHC = Sensible heat capacity.

**Table 31. 25.4 ton high efficiency, gross cooling capacities (MBh) — 50 Hz**

ID	Airflow CFM	Ent DB (°F)	Ambient Temperature (°F)						Ambient Temperature (°F)						Ambient Temperature (°F)					
			85						95						105					
			Entering Wet Bulb Temp (°F)						Entering Wet Bulb Temp (°F)						Entering Wet Bulb Temp (°F)					
			61		67		73		61		67		73		61		67		73	
TGC	SHC	TGC	SHC	TGC	SHC	TGC	SHC	TGC	SHC	TGC	SHC	TGC	SHC	TGC	SHC	TGC	SHC			
7500	75	293	230	329	181	364	130	279	222	313	174	346	122	264	214	296	165	327	114	
	80	294	270	330	223	365	172	280	262	314	215	348	164	266	254	297	207	329	156	
	85	302	302	330	264	366	213	290	290	315	256	349	205	278	278	298	248	330	197	
	90	320	320	332	304	367	254	308	308	316	296	349	247	294	294	300	288	331	238	
8500	75	302	247	338	192	372	133	287	239	321	184	353	125	271	229	303	175	334	117	
	80	304	293	339	239	373	180	290	284	322	231	355	172	274	274	305	222	336	164	
	85	318	318	340	285	374	227	306	306	323	276	356	219	292	292	306	267	336	211	
	90	337	337	342	330	374	274	323	323	326	322	356	266	309	309	310	310	337	258	
9500	75	309	263	345	202	378	136	294	254	328	194	359	128	278	245	309	185	339	120	
	80	313	313	346	254	379	188	300	300	329	246	361	180	286	286	311	237	340	172	
	85	332	332	348	304	380	240	318	318	331	296	361	233	304	304	313	287	341	224	
	90	351	351	352	352	380	293	337	337	337	337	362	285	321	321	322	322	342	274	
10000	75	313	271	348	207	381	137	297	262	330	198	361	129	280	253	312	190	341	121	
	80	319	319	349	262	382	192	305	305	332	253	363	184	291	291	313	243	343	176	
	85	338	338	351	314	382	247	324	324	334	306	363	239	309	309	316	297	343	231	
	90	357	357	358	358	382	302	342	342	343	343	364	292	327	327	327	327	343	283	
11000	75	319	286	353	216	385	140	303	277	335	208	366	132	286	268	316	199	344	123	
	80	329	329	354	274	386	200	315	315	337	266	367	192	300	300	318	256	346	184	
	85	349	349	357	334	386	260	334	334	339	325	367	253	318	318	321	316	346	244	
	90	368	368	368	368	386	318	352	352	353	353	367	309	335	335	336	336	346	300	
ID	Airflow CFM	Ent DB (°F)	Ambient Temperature (°F)						Ambient Temperature (°F)						Ambient Temperature (°F)					
			115						115						115					
			Entering Wet Bulb Temp (°F)						Entering Wet Bulb Temp (°F)						Entering Wet Bulb Temp (°F)					
			61		67		73		61		67		73		61		67		73	
TGC	SHC	TGC	SHC	TGC	SHC	TGC	SHC	TGC	SHC	TGC	SHC	TGC	SHC	TGC	SHC	TGC	SHC			
7500	75	248	206	278	157	307	105													
	80	250	245	279	198	309	147													
	85	264	264	280	239	310	188													
	90	280	280	283	279	310	230													
8500	75	255	220	285	166	312	108													
	80	260	260	286	213	315	155													
	85	277	277	287	258	315	202													
	90	294	294	294	294	316	249													
9500	75	260	236	290	176	317	111													
	80	270	270	291	226	319	163													
	85	288	288	294	278	319	215													
	90	305	305	305	305	320	265													
10000	75	263	244	292	181	319	112													
	80	275	275	293	233	321	167													
	85	293	293	296	288	321	222													
	90	309	309	310	310	321	273													
11000	75	268	259	295	190	322	115													
	80	283	283	298	247	324	175													
	85	301	301	302	302	324	231													
	90	316	316	317	317	324	291													

**Notes:**

1. All capacities shown are gross and have not considered indoor fan heat. To obtain net cooling, subtract indoor fan heat.
2. TGC = Total gross capacity.
3. SHC = Sensible heat capacity.



**Performance Data (50 Hz Units)**

**Table 32. 86 kw (25.4 ton) standard efficiency, gross cooling capacities (kw)— 50 Hz**

ID	Airflow L/s	Ent DB (°C)	Ambient Temperature (°C)						Ambient Temperature (°C)						Ambient Temperature (°C)					
			29.4						35						40.6					
			Entering Wet Bulb Temp (°C)						Entering Wet Bulb Temp (°C)						Entering Wet Bulb Temp (°C)					
			16.1		19.4		22.8		16.1		19.4		22.8		16.1		19.4		22.8	
		TGC	SHC	TGC	SHC	TGC	SHC	TGC	SHC	TGC	SHC	TGC	SHC	TGC	SHC	TGC	SHC			
3540	23.9	81.6	64.7	90.9	50.5	99.2	35.4	77.6	62.5	86.5	48.4	94.2	33.2	73.3	60.2	81.8	46.0	88.9	30.9	
	26.7	82.0	76.0	91.1	62.3	99.3	47.1	78.2	73.8	86.7	60.1	94.4	44.9	74.0	71.4	82.0	57.8	89.0	42.6	
	29.4	84.4	84.4	91.3	74.0	99.4	58.9	81.1	81.1	87.0	71.9	94.5	56.7	77.4	77.4	82.3	69.6	89.1	54.4	
	32.2	89.1	89.1	91.7	85.3	99.4	70.6	85.6	85.6	87.5	83.1	94.5	68.4	81.8	81.8	82.9	80.7	89.1	66.1	
4012	23.9	83.9	69.5	93.0	53.4	100.9	36.1	79.7	67.3	88.4	51.1	95.7	33.9	75.3	64.4	83.5	48.8	90.2	31.6	
	26.7	84.7	82.3	93.3	66.7	100.9	49.3	80.6	80.0	88.7	64.4	95.7	47.1	76.4	76.4	83.8	62.1	90.2	44.8	
	29.4	88.5	88.5	93.5	80.0	100.8	62.6	84.9	84.9	89.0	77.2	95.7	60.4	81.0	81.0	84.1	74.7	90.1	58.0	
	32.2	93.2	93.2	94.2	92.6	100.9	75.9	89.4	89.4	89.8	89.8	95.7	73.6	85.2	85.2	85.4	85.4	90.0	71.3	
4483	23.9	85.8	73.7	94.7	56.0	102.2	36.8	81.5	71.3	89.9	53.8	96.9	34.6	77.0	68.8	84.8	51.4	91.3	32.3	
	26.7	87.0	87.0	94.9	70.9	102.1	51.5	83.3	83.3	90.1	68.7	96.6	49.2	79.3	79.3	85.1	66.3	90.9	46.9	
	29.4	91.9	91.9	95.3	85.0	102.3	66.5	88.1	88.1	90.6	82.7	96.7	64.1	83.8	83.8	85.6	80.2	90.8	61.7	
	32.2	96.5	96.5	96.6	96.6	102.4	81.3	92.3	92.3	92.4	92.4	96.9	79.0	87.7	87.7	87.8	87.8	91.0	75.7	
4719	23.9	86.7	75.9	95.4	57.4	102.8	37.1	82.3	73.5	90.6	55.1	97.4	34.9	77.7	71.0	85.4	52.7	91.7	32.6	
	26.7	88.4	88.4	95.6	73.0	102.7	52.7	84.6	84.6	90.7	70.7	97.1	50.3	80.5	80.5	85.6	67.6	91.2	48.0	
	29.4	93.4	93.4	96.0	87.8	102.9	68.4	89.4	89.4	91.2	85.4	97.2	66.0	85.0	85.0	86.2	82.9	91.2	63.6	
	32.2	97.8	97.8	97.9	97.9	103.1	84.1	93.5	93.5	93.6	93.6	97.5	80.8	88.6	88.6	88.7	88.7	91.4	78.1	
5191	23.9	88.2	80.3	96.6	60.0	103.8	37.8	83.8	77.8	91.6	57.7	98.3	35.6	79.0	75.3	86.3	55.3	91.9	33.3	
	26.7	91.0	91.0	96.7	76.3	103.8	54.9	87.0	87.0	91.8	73.9	98.0	52.6	82.7	82.7	86.6	71.3	91.9	50.1	
	29.4	95.9	95.9	97.2	93.2	104.0	72.2	91.6	91.6	92.4	90.8	98.1	69.8	87.0	87.0	87.2	87.2	92.0	67.3	
	32.2	99.8	99.8	99.9	99.9	104.2	88.3	95.1	95.1	95.3	95.3	98.4	85.8	90.1	90.1	90.1	90.1	92.2	83.1	
ID	Airflow L/s	Ent DB (°C)	Ambient Temperature (°C)																	
			46.1																	
			Entering Wet Bulb Temp (°C)																	
			16.1		19.4		22.8								16.1		19.4		22.8	
		TGC	SHC	TGC	SHC	TGC	SHC					TGC	SHC	TGC	SHC	TGC	SHC			
3540	23.9	68.7	57.7	76.6	43.6	83.2	28.5													
	26.7	69.5	68.9	76.9	55.4	83.2	40.2													
	29.4	73.4	73.4	77.2	66.6	83.2	51.9													
	32.2	77.6	77.6	77.9	77.9	83.3	63.6													
4012	23.9	70.5	61.8	78.2	46.3	84.3	29.2													
	26.7	72.3	72.3	78.4	59.6	84.1	42.3													
	29.4	76.7	76.7	78.8	72.1	84.0	55.5													
	32.2	80.5	80.5	80.7	80.7	84.0	68.8													
4483	23.9	72.1	66.1	79.3	48.9	84.8	29.8													
	26.7	74.9	74.9	79.6	63.0	84.8	44.4													
	29.4	79.2	79.2	80.1	77.5	84.6	59.2													
	32.2	82.6	82.6	82.6	82.6	84.7	72.9													
4719	23.9	72.8	68.3	79.8	50.2	85.6	30.2													
	26.7	76.0	76.0	80.1	64.8	85.0	45.5													
	29.4	80.2	80.2	80.7	80.2	84.9	61.0													
	32.2	83.3	83.3	83.3	83.3	85.1	75.3													
5191	23.9	74.0	72.6	80.6	52.8	85.5	30.9													
	26.7	78.0	78.0	80.9	68.6	85.5	47.6													
	29.4	81.8	81.8	81.9	81.9	85.5	63.4													
	32.2	84.4	84.4	84.5	84.5	85.6	80.2													

**Notes:**

1. All capacities shown are gross and have not considered indoor fan heat. To obtain net cooling, subtract indoor fan heat.
2. TGC = Total gross capacity.
3. SHC = Sensible heat capacity.

**Table 33. 90 kw (25.4 ton) high efficiency, gross cooling capacities (kw)— 50 Hz**

ID	Airflow L/s	Ent DB (°C)	Ambient Temperature (°C)						Ambient Temperature (°C)						Ambient Temperature (°C)					
			29.4						35						40.6					
			Entering Wet Bulb Temp (°C)						Entering Wet Bulb Temp (°C)						Entering Wet Bulb Temp (°C)					
			16.1		19.4		22.8		16.1		19.4		22.8		16.1		19.4		22.8	
		TGC	SHC	TGC	SHC	TGC	SHC	TGC	SHC	TGC	SHC	TGC	SHC	TGC	SHC	TGC	SHC			
3540	23.9	85.9	67.4	96.3	53.2	106.7	38.1	81.7	65.2	91.7	50.9	101.5	35.8	77.3	62.8	86.7	48.4	95.9	33.4	
	26.7	86.3	79.2	96.6	65.3	107.1	50.3	82.2	76.9	92.0	63.0	102.0	48.0	77.9	74.5	87.1	60.6	96.5	45.6	
	29.4	88.6	88.6	96.9	77.4	107.3	62.5	85.1	85.1	92.3	75.1	102.2	60.2	81.4	81.4	87.4	72.7	96.7	57.8	
	32.2	93.7	93.7	97.3	89.1	107.4	74.5	90.2	90.2	92.7	86.8	102.4	72.3	86.3	86.3	87.9	84.3	96.9	69.9	
4012	23.9	88.5	72.5	99.0	56.2	109.0	39.0	84.1	70.1	94.1	53.8	103.6	36.7	79.5	67.3	88.9	51.4	97.8	34.2	
	26.7	89.2	85.8	99.3	69.9	109.4	52.8	84.9	83.4	94.4	67.6	104.1	50.5	80.4	80.4	89.3	65.1	98.4	48.0	
	29.4	93.3	93.3	99.6	83.7	109.6	66.5	89.5	89.5	94.8	80.9	104.3	64.2	85.5	85.5	89.7	78.3	98.6	61.8	
	32.2	98.7	98.7	100.3	96.8	109.7	80.2	94.8	94.8	95.6	94.5	104.4	77.9	90.6	90.6	90.8	90.8	98.7	75.5	
4483	23.9	90.7	77.0	101.1	59.1	110.8	39.8	86.1	74.5	96.0	56.7	105.2	37.5	81.3	71.9	90.7	54.2	99.3	35.0	
	26.7	91.8	91.8	101.4	74.4	111.2	55.2	87.8	87.8	96.3	72.1	105.7	52.9	83.7	83.7	91.0	69.6	99.8	50.4	
	29.4	97.3	97.3	101.8	89.2	111.2	70.5	93.3	93.3	96.9	86.7	105.8	68.2	89.0	89.0	91.7	84.2	99.9	65.7	
	32.2	102.9	102.9	103.1	103.1	111.4	85.8	98.7	98.7	98.9	98.9	106.0	83.5	94.2	94.2	94.4	94.4	100.1	80.4	
4719	23.9	91.6	79.3	102.0	60.5	111.6	40.2	87.0	76.8	96.8	58.1	105.9	37.9	82.2	74.1	91.4	55.6	99.9	35.4	
	26.7	93.4	93.4	102.3	76.7	111.9	56.3	89.4	89.4	97.2	74.3	106.4	54.0	85.2	85.2	91.7	71.1	100.4	51.6	
	29.4	99.1	99.1	102.8	92.1	111.9	72.4	95.0	95.0	97.8	89.6	106.4	70.1	90.6	90.6	92.5	87.0	100.5	67.7	
	32.2	104.7	104.7	104.9	104.9	112.0	88.5	100.4	100.4	100.6	100.6	106.6	85.6	95.7	95.7	95.9	95.9	100.7	83.0	
5191	23.9	93.4	83.9	103.5	63.3	112.9	41.0	88.7	81.3	98.2	60.9	107.2	38.7	83.7	78.7	92.6	58.4	101.0	36.2	
	26.7	96.5	96.5	103.8	80.4	113.1	58.7	92.3	92.3	98.6	77.9	107.5	56.3	87.8	87.8	93.1	75.2	101.4	53.9	
	29.4	102.3	102.3	104.6	97.9	113.1	76.3	98.0	98.0	99.5	95.4	107.5	74.0	93.3	93.3	94.1	92.8	101.4	71.6	
	32.2	107.8	107.8	107.9	107.9	113.2	93.2	103.2	103.2	103.4	103.4	107.6	90.7	98.3	98.3	98.4	98.4	101.5	88.1	
ID	Airflow L/s	Ent DB (°C)	Ambient Temperature (°C)																	
			46.1																	
			Entering Wet Bulb Temp (°C)																	
			16.1		19.4		22.8								16.1		19.4		22.8	
		TGC	SHC	TGC	SHC	TGC	SHC													
3540	23.9	72.6	60.2	81.4	45.9	89.9	30.8													
	26.7	73.3	71.9	81.8	58.0	90.5	43.1													
	29.4	77.3	77.3	82.1	70.1	90.8	55.2													
	32.2	82.1	82.1	82.8	81.7	91.0	67.3													
4012	23.9	74.6	64.6	83.4	48.8	91.6	31.7													
	26.7	76.2	76.2	83.7	62.5	92.2	45.5													
	29.4	81.2	81.2	84.2	75.6	92.4	59.2													
	32.2	86.1	86.1	86.2	86.2	92.6	72.9													
4483	23.9	76.3	69.1	84.9	51.6	92.9	32.5													
	26.7	79.2	79.2	85.3	66.3	93.4	47.8													
	29.4	84.4	84.4	86.0	81.4	93.5	63.1													
	32.2	89.2	89.2	89.4	89.4	93.7	77.6													
4719	23.9	77.0	71.4	85.5	53.0	93.4	32.8													
	26.7	80.6	80.6	86.0	68.3	93.9	49.0													
	29.4	85.8	85.8	86.8	84.3	94.0	65.1													
	32.2	90.6	90.6	90.7	90.7	94.2	80.1													
5191	23.9	78.4	75.8	86.6	55.7	94.3	33.6													
	26.7	83.0	83.0	87.2	72.3	94.8	51.3													
	29.4	88.2	88.2	88.4	88.4	94.8	67.8													
	32.2	92.8	92.8	92.9	92.9	94.9	85.2													

**Notes:**

1. All capacities shown are gross and have not considered indoor fan heat. To obtain net cooling, subtract indoor fan heat.
2. TGC = Total gross capacity.
3. SHC = Sensible heat capacity.



**Performance Data (50 Hz Units)**

**Table 34. 29.2 ton standard efficiency, gross cooling capacities (MBh) —50 Hz**

ID Airflow CFM	Ent DB (°F)	Ambient Temperature (°F)						Ambient Temperature (°F)						Ambient Temperature (°F)					
		85						95						105					
		Entering Wet Bulb Temp (°F)						Entering Wet Bulb Temp (°F)						Entering Wet Bulb Temp (°F)					
		61		67		73		61		67		73		61		67		73	
TGC	SHC	TGC	SHC	TGC	SHC	TGC	SHC	TGC	SHC	TGC	SHC	TGC	SHC	TGC	SHC	TGC	SHC		
8750	75	311	253	346	196	376	134	296	245	328	187	357	126	279	236	310	179	336	118
	80	314	299	347	243	377	182	298	290	329	235	357	174	282	281	311	226	337	165
	85	326	326	347	290	377	229	312	312	330	282	358	221	298	298	312	271	337	212
	90	343	343	350	335	377	276	329	329	333	327	358	268	314	314	315	315	337	259
9900	75	319	272	353	207	382	137	303	261	335	198	362	129	286	252	316	189	341	120
	80	323	323	354	260	382	190	308	308	336	252	362	182	293	293	317	243	340	173
	85	340	340	355	311	382	244	326	326	337	302	362	236	310	310	318	293	340	227
	90	358	358	359	359	382	297	342	342	343	343	362	289	326	326	326	326	340	280
11000	75	326	287	358	217	386	140	309	278	340	208	366	131	291	268	320	199	343	123
	80	333	333	359	276	385	199	318	318	341	267	365	190	302	302	321	255	343	182
	85	352	352	361	332	385	258	336	336	343	323	364	249	319	319	323	314	344	241
	90	368	368	369	369	385	314	352	352	352	352	364	305	334	334	334	334	344	295
11600	75	329	296	361	222	388	141	312	287	342	213	367	133	294	277	322	205	343	124
	80	339	339	362	285	387	203	323	323	343	273	366	195	307	307	323	263	343	186
	85	357	357	364	343	386	265	341	341	345	334	366	257	324	324	326	325	343	248
	90	373	373	373	373	387	324	356	356	356	356	366	315	337	337	337	337	343	305
12800	75	335	314	365	233	392	144	317	305	346	224	371	136	299	295	325	215	346	127
	80	348	348	366	298	390	212	332	332	347	289	369	204	315	315	327	279	346	195
	85	366	366	368	366	390	281	349	349	350	350	368	272	331	331	331	331	345	263
	90	380	380	380	380	391	345	362	362	362	362	369	336	341	341	341	341	346	326
ID Airflow CFM	Ent DB (°F)	Ambient Temperature (°F)						Ambient Temperature (°F)						Ambient Temperature (°F)					
		115						115						115					
		Entering Wet Bulb Temp (°F)						Entering Wet Bulb Temp (°F)						Entering Wet Bulb Temp (°F)					
		61		67		73		61		67		73		61		67		73	
TGC	SHC	TGC	SHC	TGC	SHC	TGC	SHC	TGC	SHC	TGC	SHC	TGC	SHC	TGC	SHC	TGC	SHC		
8750	75	261	224	290	169	314	109												
	80	265	265	291	217	314	156												
	85	282	282	292	261	314	203												
	90	297	297	298	298	314	250												
9900	75	267	242	295	180	317	111												
	80	277	277	296	233	317	164												
	85	293	293	298	283	317	217												
	90	307	307	307	307	317	267												
11000	75	272	258	299	190	321	114												
	80	285	285	300	245	320	172												
	85	301	301	303	303	319	231												
	90	313	313	314	314	321	285												
11600	75	275	267	300	195	322	115												
	80	289	289	302	253	322	177												
	85	305	305	305	305	322	239												
	90	316	316	316	316	322	295												
12800	75	280	280	303	206	321	118												
	80	296	296	305	269	321	186												
	85	310	310	311	311	321	247												
	90	319	319	319	319	321	315												

**Notes:**

1. All capacities shown are gross and have not considered indoor fan heat. To obtain net cooling, subtract indoor fan heat.
2. TGC = Total gross capacity.
3. SHC = Sensible heat capacity.

**Table 35. 29.2 ton high efficiency , gross cooling capacities (MBh) — 50 Hz**

ID	Airflow CFM	Ent DB (°F)	Ambient Temperature (°F)						Ambient Temperature (°F)						Ambient Temperature (°F)					
			85						95						105					
			Entering Wet Bulb Temp (°F)						Entering Wet Bulb Temp (°F)						Entering Wet Bulb Temp (°F)					
			61		67		73		61		67		73		61		67		73	
TGC	SHC	TGC	SHC	TGC	SHC	TGC	SHC	TGC	SHC	TGC	SHC	TGC	SHC	TGC	SHC	TGC	SHC			
8750	75	321	258	356	200	387	138	304	250	338	192	367	130	287	240	319	183	346	121	
	80	323	304	357	248	387	186	307	296	339	239	367	178	290	286	320	230	346	169	
	85	334	334	357	296	387	234	320	320	340	287	367	225	305	305	321	276	346	216	
	90	352	352	359	341	387	281	338	338	342	333	368	273	322	322	323	323	346	264	
9900	75	329	276	363	211	393	141	312	267	345	202	373	133	294	257	325	193	350	124	
	80	332	329	364	265	393	195	316	316	346	256	372	186	301	301	326	247	350	177	
	85	350	350	365	317	392	248	335	335	347	308	372	240	318	318	327	298	350	231	
	90	367	367	368	368	392	302	351	351	352	352	372	294	334	334	335	335	350	282	
11000	75	336	293	369	221	398	144	319	284	350	213	377	136	300	274	329	203	352	127	
	80	343	343	370	281	397	203	327	327	351	272	376	194	311	311	330	260	352	186	
	85	361	361	371	338	396	262	346	346	352	329	375	254	328	328	332	319	352	245	
	90	378	378	379	379	396	320	361	361	362	362	375	310	343	343	343	343	352	301	
11600	75	339	302	372	227	400	145	322	293	352	218	379	137	303	283	332	209	354	128	
	80	348	348	372	290	398	207	333	333	353	278	378	199	316	316	333	268	354	190	
	85	367	367	374	349	398	270	351	351	355	340	376	262	333	333	335	330	354	253	
	90	383	383	383	383	399	330	365	365	366	366	377	321	346	346	346	346	354	311	
12800	75	345	320	376	238	404	148	327	311	356	229	380	140	308	301	335	220	356	131	
	80	358	358	377	304	402	217	342	342	357	294	380	208	324	324	336	284	356	199	
	85	376	376	379	372	402	286	359	359	360	360	380	277	340	340	340	340	356	263	
	90	390	390	391	391	403	351	372	372	372	372	381	342	351	351	351	351	357	332	
ID	Airflow CFM	Ent DB (°F)	Ambient Temperature (°F)						Ambient Temperature (°F)						Ambient Temperature (°F)					
			115						115						115					
			Entering Wet Bulb Temp (°F)						Entering Wet Bulb Temp (°F)						Entering Wet Bulb Temp (°F)					
			61		67		73		61		67		73		61		67		73	
TGC	SHC	TGC	SHC	TGC	SHC	TGC	SHC	TGC	SHC	TGC	SHC	TGC	SHC	TGC	SHC	TGC	SHC			
8750	75	269	229	298	173	323	112													
	80	273	273	299	221	323	159													
	85	289	289	300	266	323	206													
	90	305	305	305	305	323	254													
9900	75	275	247	303	184	327	115													
	80	284	284	304	238	326	168													
	85	301	301	306	288	326	221													
	90	315	315	315	315	326	272													
11000	75	281	263	307	194	327	117													
	80	293	293	308	250	327	176													
	85	309	309	311	309	327	235													
	90	321	321	322	322	327	290													
11600	75	283	272	309	199	329	119													
	80	298	298	310	258	329	180													
	85	313	313	313	313	329	243													
	90	324	324	324	324	329	300													
12800	75	287	287	312	205	331	122													
	80	305	305	314	273	331	190													
	85	319	319	319	319	331	252													
	90	328	328	329	329	331	321													

**Notes:**

1. All capacities shown are gross and have not considered indoor fan heat. To obtain net cooling, subtract indoor fan heat.
2. TGC = Total gross capacity.
3. SHC = Sensible heat capacity.



**Performance Data (50 Hz Units)**

**Table 36. 97 kw (29.2 ton) standard efficiency, gross cooling capacities (kw)— 50 Hz**

ID	Airflow L/s	Ent DB (°C)	Ambient Temperature (°C)						Ambient Temperature (°C)						Ambient Temperature (°C)					
			29.4						35						40.6					
			Entering Wet Bulb Temp (°C)						Entering Wet Bulb Temp (°C)						Entering Wet Bulb Temp (°C)					
			16.1		19.4		22.8		16.1		19.4		22.8		16.1		19.4		22.8	
		TGC	SHC	TGC	SHC	TGC	SHC	TGC	SHC	TGC	SHC	TGC	SHC	TGC	SHC	TGC	SHC	TGC	SHC	
4130	23.9	91.3	74.2	101.3	57.4	110.2	39.4	86.6	71.7	96.2	54.9	104.5	37.0	81.7	69.1	90.8	52.3	98.5	34.5	
	26.7	92.0	87.5	101.6	71.3	110.4	53.3	87.4	85.0	96.5	68.8	104.7	50.9	82.7	82.4	91.1	66.2	98.6	48.3	
	29.4	95.5	95.5	101.8	85.1	110.4	67.1	91.5	91.5	96.8	82.6	104.8	64.7	87.2	87.2	91.4	79.5	98.7	62.2	
	32.2	100.6	100.6	102.4	98.3	110.5	81.0	96.5	96.5	97.5	95.8	104.8	78.5	92.0	92.0	92.3	92.3	98.7	76.0	
4672	23.9	93.6	79.7	103.5	60.6	111.9	40.2	88.8	76.6	98.2	58.1	106.0	37.8	83.7	73.8	92.5	55.5	99.8	35.3	
	26.7	94.7	94.7	103.7	76.2	111.9	55.8	90.2	90.2	98.4	73.7	106.1	53.4	85.8	85.8	92.8	71.1	99.8	50.8	
	29.4	99.7	99.7	104.0	91.2	111.8	71.5	95.5	95.5	98.9	88.6	106.0	69.0	90.9	90.9	93.3	85.9	99.7	66.4	
	32.2	104.8	104.8	105.1	105.1	111.8	87.1	100.3	100.3	100.5	100.5	106.0	84.7	95.4	95.4	95.5	95.5	99.7	82.1	
5191	23.9	95.5	84.1	105.0	63.5	113.1	41.0	90.6	81.5	99.6	61.0	107.2	38.5	85.4	78.7	93.8	58.4	100.6	36.0	
	26.7	97.6	97.6	105.2	80.9	113.0	58.2	93.3	93.3	99.8	78.4	107.0	55.8	88.7	88.7	94.0	74.9	100.6	53.2	
	29.4	103.0	103.0	105.8	97.3	112.8	75.5	98.5	98.5	100.4	94.7	106.8	73.1	93.6	93.6	94.7	91.9	100.8	70.5	
	32.2	107.9	107.9	108.0	108.0	112.8	92.0	103.1	103.1	103.2	103.2	106.8	89.4	97.8	97.8	97.9	97.9	100.8	86.6	
5475	23.9	96.5	86.8	105.8	65.1	113.7	41.4	91.5	84.1	100.2	62.6	107.7	38.9	86.2	81.3	94.4	59.9	100.6	36.4	
	26.7	99.2	99.2	106.0	83.4	113.4	59.5	94.8	94.8	100.5	80.0	107.4	57.1	90.0	90.0	94.7	77.2	100.6	54.5	
	29.4	104.6	104.6	106.6	100.6	113.2	77.8	99.9	99.9	101.2	98.0	107.2	75.3	94.9	94.9	95.4	95.2	100.6	72.7	
	32.2	109.3	109.3	109.4	109.4	113.5	95.1	104.3	104.3	104.4	104.4	107.2	92.4	98.7	98.7	98.8	98.8	100.6	89.5	
6041	23.9	98.1	92.1	107.0	68.2	114.8	42.2	93.0	89.3	101.3	65.7	108.6	39.7	87.6	86.5	95.3	63.1	101.5	37.2	
	26.7	102.0	102.0	107.2	87.3	114.2	62.1	97.3	97.3	101.6	84.6	108.1	59.7	92.3	92.3	95.7	81.8	101.5	57.1	
	29.4	107.2	107.2	108.0	107.2	114.3	82.4	102.3	102.3	102.5	102.5	107.8	79.8	96.9	96.9	97.0	97.0	101.1	77.2	
	32.2	111.4	111.4	111.5	111.5	114.6	101.2	106.1	106.1	106.1	106.1	108.2	98.4	100.0	100.0	100.1	100.1	101.3	95.5	
ID	Airflow L/s	Ent DB (°C)	Ambient Temperature (°C)						Ambient Temperature (°C)						Ambient Temperature (°C)					
			46.1						46.1						46.1					
			Entering Wet Bulb Temp (°C)						Entering Wet Bulb Temp (°C)						Entering Wet Bulb Temp (°C)					
			16.1		19.4		22.8		16.1		19.4		22.8		16.1		19.4		22.8	
		TGC	SHC	TGC	SHC	TGC	SHC	TGC	SHC	TGC	SHC	TGC	SHC	TGC	SHC	TGC	SHC	TGC	SHC	
4130	23.9	76.4	65.8	84.9	49.6	92.0	31.8													
	26.7	77.8	77.8	85.2	63.5	92.1	45.6													
	29.4	82.6	82.6	85.6	76.6	92.1	59.5													
	32.2	87.1	87.1	87.2	87.2	92.2	73.3													
4672	23.9	78.3	70.9	86.4	52.7	92.9	32.6													
	26.7	81.1	81.1	86.7	68.4	93.0	48.1													
	29.4	85.8	85.8	87.3	83.0	92.9	63.7													
	32.2	90.0	90.0	90.1	90.1	92.9	78.3													
5191	23.9	79.8	75.7	87.6	55.6	94.0	33.4													
	26.7	83.6	83.6	87.9	71.9	93.7	50.5													
	29.4	88.2	88.2	88.7	88.7	93.4	67.8													
	32.2	91.8	91.8	91.9	91.9	94.0	83.6													
5475	23.9	80.6	78.3	88.1	57.2	94.5	33.8													
	26.7	84.8	84.8	88.4	74.2	94.5	51.8													
	29.4	89.3	89.3	89.4	89.4	94.5	70.0													
	32.2	92.5	92.5	92.6	92.6	94.5	86.5													
6041	23.9	82.0	82.0	88.9	60.3	94.0	34.6													
	26.7	86.9	86.9	89.3	78.7	94.0	54.4													
	29.4	91.0	91.0	91.0	91.0	94.0	72.5													
	32.2	93.4	93.4	93.5	93.5	94.0	92.3													

**Notes:**

1. All capacities shown are gross and have not considered indoor fan heat. To obtain net cooling, subtract indoor fan heat.
2. TGC = Total gross capacity.
3. SHC = Sensible heat capacity.



**Table 37. 102 kw (29.2 ton) high efficiency, gross cooling capacities (kw) — 50 Hz**

ID	Airflow L/s	Ent DB (°C)	Ambient Temperature (°C)						Ambient Temperature (°C)						Ambient Temperature (°C)					
			29.4						35						40.6					
			Entering Wet Bulb Temp (°C)						Entering Wet Bulb Temp (°C)						Entering Wet Bulb Temp (°C)					
			16.1		19.4		22.8		16.1		19.4		22.8		16.1		19.4		22.8	
		TGC	SHC	TGC	SHC	TGC	SHC	TGC	SHC	TGC	SHC	TGC	SHC	TGC	SHC	TGC	SHC	TGC	SHC	
4130	23.9	94.0	75.7	104.3	58.7	113.4	40.6	89.2	73.1	99.0	56.2	107.6	38.1	84.1	70.5	93.4	53.5	101.4	35.5	
	26.7	94.6	89.2	104.5	72.7	113.5	54.5	89.9	86.6	99.3	70.1	107.7	52.0	84.9	83.9	93.7	67.5	101.5	49.4	
	29.4	98.0	98.0	104.7	86.6	113.4	68.4	93.9	93.9	99.6	84.1	107.7	66.0	89.5	89.5	94.0	81.0	101.5	63.3	
	32.2	103.2	103.2	105.3	100.1	113.4	82.4	99.0	99.0	100.2	97.5	107.7	79.9	94.4	94.4	94.6	94.6	101.5	77.3	
4672	23.9	96.4	80.8	106.5	61.9	115.2	41.4	91.5	78.1	101.0	59.3	109.3	39.0	86.2	75.3	95.2	56.7	102.6	36.4	
	26.7	97.4	96.5	106.7	77.7	115.1	57.1	92.7	92.7	101.3	75.1	109.1	54.6	88.2	88.2	95.5	72.5	102.7	51.9	
	29.4	102.4	102.4	107.0	92.9	114.9	72.8	98.1	98.1	101.7	90.3	109.0	70.3	93.3	93.3	95.9	87.5	102.6	67.7	
	32.2	107.6	107.6	107.9	107.9	114.9	88.5	103.0	103.0	103.2	103.2	109.0	86.1	97.9	97.9	98.1	98.1	102.6	82.7	
5191	23.9	98.4	85.8	108.2	64.9	116.6	42.2	93.4	83.1	102.5	62.3	110.6	39.7	88.0	80.2	96.6	59.6	103.2	37.1	
	26.7	100.4	100.4	108.3	82.4	116.2	59.5	96.0	96.0	102.8	79.8	110.2	57.0	91.2	91.2	96.8	76.3	103.2	54.4	
	29.4	105.9	105.9	108.8	99.1	116.0	76.9	101.3	101.3	103.3	96.4	109.9	74.4	96.2	96.2	97.4	93.6	103.3	71.8	
	32.2	110.8	110.8	110.9	110.9	116.2	93.7	105.9	105.9	106.0	106.0	109.9	91.0	100.4	100.4	100.5	100.5	103.2	88.1	
5475	23.9	99.4	88.5	108.9	66.5	117.3	42.6	94.3	85.8	103.2	63.9	111.2	40.2	88.8	82.9	97.2	61.2	103.7	37.6	
	26.7	102.1	102.1	109.1	85.0	116.8	60.8	97.5	97.5	103.5	81.5	110.6	58.3	92.6	92.6	97.5	78.6	103.7	55.7	
	29.4	107.5	107.5	109.6	102.4	116.6	79.2	102.7	102.7	104.1	99.7	110.3	76.7	97.5	97.5	98.1	96.9	103.7	74.0	
	32.2	112.2	112.2	112.3	112.3	116.9	96.8	107.1	107.1	107.2	107.2	110.5	94.1	101.4	101.4	101.5	101.5	103.7	91.1	
6041	23.9	101.1	93.8	110.2	69.6	118.5	43.5	95.8	91.0	104.4	67.1	111.2	41.1	90.3	88.1	98.2	64.3	104.3	38.5	
	26.7	105.0	105.0	110.4	89.0	117.7	63.5	100.2	100.2	104.7	86.2	111.2	61.0	95.0	95.0	98.5	83.3	104.3	58.4	
	29.4	110.2	110.2	111.0	109.0	117.8	83.9	105.2	105.2	105.4	105.4	111.2	81.3	99.6	99.6	99.7	99.7	104.3	77.1	
	32.2	114.4	114.4	114.5	114.5	118.2	103.0	109.0	109.0	109.1	109.1	111.6	100.2	102.8	102.8	102.9	102.9	104.6	97.2	
ID	Airflow L/s	Ent DB (°C)	Ambient Temperature (°C)																	
			46.1																	
			Entering Wet Bulb Temp (°C)																	
			16.1		19.4		22.8								16.1		19.4		22.8	
		TGC	SHC	TGC	SHC	TGC	SHC													
4130	23.9	78.7	67.1	87.3	50.7	94.6	32.8													
	26.7	79.9	79.9	87.6	64.7	94.6	46.6													
	29.4	84.7	84.7	88.0	78.0	94.6	60.5													
	32.2	89.2	89.2	89.4	89.4	94.6	74.4													
4672	23.9	80.7	72.3	88.9	53.8	95.4	33.6													
	26.7	83.3	83.3	89.2	69.6	95.4	49.1													
	29.4	88.1	88.1	89.7	84.4	95.4	64.8													
	32.2	92.3	92.3	92.4	92.4	95.4	79.6													
5191	23.9	82.2	77.2	90.1	56.7	97.0	34.4													
	26.7	86.0	86.0	90.4	73.2	96.4	51.6													
	29.4	90.6	90.6	91.0	90.5	96.1	69.0													
	32.2	94.2	94.2	94.3	94.3	96.0	85.0													
5475	23.9	83.0	79.8	90.6	58.3	96.4	34.8													
	26.7	87.2	87.2	91.0	75.5	96.4	52.9													
	29.4	91.7	91.7	91.8	91.8	96.4	71.2													
	32.2	94.9	94.9	95.0	95.0	96.4	88.0													
6041	23.9	84.2	84.2	91.5	60.0	96.9	35.8													
	26.7	89.3	89.3	91.9	80.1	96.9	55.6													
	29.4	93.4	93.4	93.5	93.5	96.9	73.8													
	32.2	96.3	96.3	96.4	96.4	97.1	94.0													

**Notes:**

1. All capacities shown are gross and have not considered indoor fan heat. To obtain net cooling, subtract indoor fan heat.
2. TGC = Total gross capacity.
3. SHC = Sensible heat capacity.



**Performance Data (50 Hz Units)**

**Table 38. 33.3 ton standard and high efficiency, gross cooling capacities (MBh) —50 Hz**

ID	Airflow CFM	Ent DB (°F)	Ambient Temperature (°F)						Ambient Temperature (°F)						Ambient Temperature (°F)					
			85						95						105					
			Entering Wet Bulb Temp (°F)						Entering Wet Bulb Temp (°F)						Entering Wet Bulb Temp (°F)					
			61		67		73		61		67		73		61		67		73	
TGC	SHC	TGC	SHC	TGC	SHC	TGC	SHC	TGC	SHC	TGC	SHC	TGC	SHC	TGC	SHC	TGC	SHC			
10000	75	360	291	404	226	447	159	340	279	383	215	422	148	319	265	360	204	397	137	
	80	363	343	406	282	453	215	344	331	385	271	429	204	323	320	362	259	404	193	
	85	378	378	408	336	455	271	361	361	386	323	432	260	343	343	364	311	407	249	
	90	400	400	411	388	457	326	384	384	390	377	433	315	365	365	368	366	409	304	
11300	75	370	310	414	240	456	163	350	298	392	229	431	152	328	285	368	217	405	141	
	80	375	371	416	302	463	227	355	355	394	291	439	216	337	337	371	279	413	204	
	85	397	397	419	361	466	289	379	379	397	349	442	278	360	360	374	337	416	267	
	90	421	421	424	422	467	352	402	402	403	403	443	341	383	383	384	384	418	329	
12600	75	379	330	423	252	463	167	358	318	399	241	437	156	336	305	375	229	409	144	
	80	388	388	425	322	472	238	370	370	402	306	446	227	350	350	378	293	419	215	
	85	413	413	428	386	475	308	394	394	406	375	449	297	374	374	382	362	423	285	
	90	438	438	439	439	476	373	419	419	420	420	452	361	398	398	399	399	425	349	
13300	75	383	341	426	259	466	169	362	329	403	248	439	158	339	316	377	236	411	146	
	80	395	395	429	328	476	244	376	376	405	316	450	233	357	357	381	303	422	221	
	85	421	421	433	400	478	317	402	402	410	388	453	306	381	381	386	376	426	295	
	90	447	447	448	448	480	386	427	427	428	428	455	374	406	406	407	407	429	361	
14600	75	390	360	432	271	470	172	369	348	408	260	442	161	346	335	380	239	413	149	
	80	407	407	436	346	481	255	388	388	412	333	455	243	367	367	387	320	426	231	
	85	434	434	441	426	484	335	414	414	418	414	458	317	393	393	394	394	431	304	
	90	461	461	462	462	487	409	440	440	441	441	462	397	418	418	419	419	435	384	
ID	Airflow CFM	Ent DB (°F)	Ambient Temperature (°F)						Ambient Temperature (°F)						Ambient Temperature (°F)					
			115						115						115					
			Entering Wet Bulb Temp (°F)						Entering Wet Bulb Temp (°F)						Entering Wet Bulb Temp (°F)					
			61		67		73		61		67		73		61		67		73	
TGC	SHC	TGC	SHC	TGC	SHC	TGC	SHC	TGC	SHC	TGC	SHC	TGC	SHC	TGC	SHC	TGC	SHC			
10000	75	297	252	335	192	370	125													
	80	302	302	338	247	378	181													
	85	324	324	340	298	380	237													
	90	346	346	347	347	382	292													
11300	75	305	272	343	205	376	129													
	80	317	317	345	262	385	192													
	85	340	340	349	324	388	255													
	90	362	362	363	363	390	313													
12600	75	312	292	348	217	379	132													
	80	329	329	352	280	390	203													
	85	353	353	357	349	394	273													
	90	376	376	377	377	397	336													
13300	75	316	302	350	223	380	133													
	80	335	335	355	290	393	209													
	85	359	359	361	361	397	275													
	90	383	383	384	384	401	348													
14600	75	322	321	353	225	381	136													
	80	345	345	361	307	396	219													
	85	370	370	370	370	402	290													
	90	394	394	395	395	406	371													

**Notes:**

1. All capacities shown are gross and have not considered indoor fan heat. To obtain net cooling, subtract indoor fan heat.
2. TGC = Total gross capacity.
3. SHC = Sensible heat capacity.

**Table 39. 117 kW (33.3 ton) standard and high efficiency — 50 Hz**

ID	Airflow L/s	Ent DB (°C)	Ambient Temperature (°C)						Ambient Temperature (°C)						Ambient Temperature (°C)					
			29.4						35						40.6					
			Entering Wet Bulb Temp (°C)						Entering Wet Bulb Temp (°C)						Entering Wet Bulb Temp (°C)					
			16.1		19.4		22.8		16.1		19.4		22.8		16.1		19.4		22.8	
		TGC	SHC	TGC	SHC	TGC	SHC	TGC	SHC	TGC	SHC	TGC	SHC	TGC	SHC	TGC	SHC	TGC	SHC	
4719	23.9	105.6	85.2	118.5	66.4	131.0	46.6	99.7	81.9	112.2	63.1	123.8	43.4	93.5	77.7	105.4	59.8	116.4	40.1	
	26.7	106.4	100.5	119.0	82.5	132.7	63.1	100.8	97.2	112.8	79.3	125.8	59.9	94.8	93.6	106.1	75.9	118.4	56.6	
	29.4	110.7	110.7	119.4	98.6	133.5	79.4	105.8	105.8	113.2	94.7	126.6	76.2	100.6	100.6	106.7	91.2	119.2	72.8	
	32.2	117.3	117.3	120.3	113.8	133.9	95.5	112.4	112.4	114.3	110.6	127.0	92.3	107.1	107.1	108.0	107.2	119.7	89.0	
5333	23.9	108.5	90.8	121.5	70.2	133.7	47.8	102.5	87.3	114.9	67.0	126.3	44.6	96.2	83.6	107.9	63.5	118.6	41.2	
	26.7	109.9	108.8	122.1	88.5	135.8	66.5	104.1	104.1	115.6	85.2	128.6	63.3	98.7	98.7	108.6	81.8	120.9	59.9	
	29.4	116.2	116.2	122.7	105.7	136.6	84.8	111.0	111.0	116.4	102.3	129.4	81.6	105.5	105.5	109.6	98.7	121.8	78.2	
	32.2	123.3	123.3	124.2	123.8	137.0	103.0	118.0	118.0	118.2	118.2	129.9	99.8	112.3	112.3	112.5	112.5	122.4	96.5	
5947	23.9	111.1	96.7	123.8	74.0	135.8	49.0	104.9	93.2	117.0	70.7	128.0	45.6	98.4	89.4	109.8	67.2	119.9	42.2	
	26.7	113.6	113.6	124.5	94.3	138.3	69.8	108.3	108.3	117.7	89.7	130.8	66.5	102.6	102.6	110.7	86.0	122.8	63.1	
	29.4	121.0	121.0	125.6	113.3	139.1	90.2	115.5	115.5	118.9	109.8	131.7	86.9	109.7	109.7	112.0	106.2	123.8	83.5	
	32.2	128.5	128.5	128.7	128.7	139.6	109.3	122.8	122.8	123.1	123.1	132.3	105.9	116.8	116.8	117.0	117.0	124.7	102.2	
6277	23.9	112.3	99.9	124.9	76.0	136.6	49.5	106.1	96.3	118.0	72.6	128.7	46.2	99.5	92.5	110.6	69.1	120.4	42.7	
	26.7	115.8	115.8	125.6	96.1	139.4	71.5	110.3	110.3	118.8	92.5	131.8	68.2	104.5	104.5	111.7	88.8	123.7	64.7	
	29.4	123.3	123.3	126.9	117.3	140.2	93.0	117.7	117.7	120.2	113.8	132.7	89.8	111.7	111.7	113.2	110.2	124.8	86.3	
	32.2	131.0	131.0	131.2	131.2	140.8	113.0	125.2	125.2	125.4	125.4	133.5	109.5	119.0	119.0	119.2	119.2	125.7	105.9	
6890	23.9	114.4	105.7	126.6	79.6	137.7	50.4	108.0	102.0	119.5	76.2	129.5	47.1	101.3	98.2	111.5	70.1	120.9	43.6	
	26.7	119.4	119.4	127.7	101.3	141.1	74.6	113.7	113.7	120.7	97.7	133.3	71.3	107.6	107.6	113.4	93.9	125.0	67.8	
	29.4	127.2	127.2	129.3	124.8	142.0	98.2	121.3	121.3	122.5	121.2	134.2	93.0	115.0	115.0	115.3	115.3	126.2	89.1	
	32.2	135.1	135.1	135.4	135.4	142.8	119.8	129.1	129.1	129.3	129.3	135.4	116.4	122.6	122.6	122.8	122.8	127.4	112.7	
ID	Airflow L/s	Ent DB (°C)	Ambient Temperature (°C)						Ambient Temperature (°C)						Ambient Temperature (°C)					
			46.1						46.1						46.1					
			Entering Wet Bulb Temp (°C)						Entering Wet Bulb Temp (°C)						Entering Wet Bulb Temp (°C)					
			16.1		19.4		22.8		16.1		19.4		22.8		16.1		19.4		22.8	
		TGC	SHC	TGC	SHC	TGC	SHC	TGC	SHC	TGC	SHC	TGC	SHC	TGC	SHC	TGC	SHC	TGC	SHC	
4719	23.9	87.0	73.9	98.2	56.2	108.6	36.6													
	26.7	88.6	88.6	98.9	72.4	110.7	53.1													
	29.4	94.9	94.9	99.7	87.5	111.4	69.4													
	32.2	101.3	101.3	101.6	101.6	112.0	85.5													
5333	23.9	89.4	79.8	100.4	60.0	110.3	37.7													
	26.7	92.9	92.9	101.1	76.9	112.8	56.4													
	29.4	99.5	99.5	102.4	95.0	113.7	74.7													
	32.2	106.2	106.2	106.4	106.4	114.4	91.6													
5947	23.9	91.5	85.5	102.0	63.6	111.2	38.6													
	26.7	96.5	96.5	103.2	82.1	114.4	59.5													
	29.4	103.5	103.5	104.7	102.4	115.5	80.0													
	32.2	110.3	110.3	110.5	110.5	116.5	98.4													
6277	23.9	92.5	88.6	102.7	65.5	111.5	39.1													
	26.7	98.2	98.2	104.1	84.9	115.1	61.2													
	29.4	105.3	105.3	105.9	105.9	116.2	80.6													
	32.2	112.3	112.3	112.5	112.5	117.5	102.1													
6890	23.9	94.2	94.2	103.6	65.9	111.7	39.9													
	26.7	101.1	101.1	105.7	89.9	116.1	64.2													
	29.4	108.4	108.4	108.6	108.6	117.7	85.1													
	32.2	115.6	115.6	115.8	115.8	119.0	108.8													

**Notes:**

1. All capacities shown are gross and have not considered indoor fan heat. To obtain net cooling, subtract indoor fan heat.
2. TGC = Total gross capacity.
3. SHC = Sensible heat capacity.



## Performance Data (50 Hz Units)

**Table 40. 41.7 ton standard and high efficiency, gross cooling capacities (MBh) — 50 Hz**

ID	Airflow CFM	Ent DB (°F)	Ambient Temperature (°F)						Ambient Temperature (°F)						Ambient Temperature (°F)					
			85						95						105					
			Entering Wet Bulb Temp (°F)						Entering Wet Bulb Temp (°F)						Entering Wet Bulb Temp (°F)					
			61		67		73		61		67		73		61		67		73	
TGC	SHC	TGC	SHC	TGC	SHC	TGC	SHC	TGC	SHC	TGC	SHC	TGC	SHC	TGC	SHC	TGC	SHC			
12500	75	426	354	476	273	524	187	404	342	451	260	496	175	380	327	425	247	467	162	
	80	431	421	478	341	526	256	409	408	453	329	499	244	387	387	426	316	470	231	
	85	452	452	479	410	527	324	433	433	455	395	500	313	412	412	429	382	471	300	
	90	478	478	483	476	527	393	458	458	460	460	501	381	436	436	437	437	472	369	
14100	75	437	378	486	288	533	191	414	365	460	276	504	179	389	352	433	263	474	166	
	80	445	445	488	366	535	269	425	425	462	353	507	257	403	403	435	340	477	244	
	85	472	472	490	440	535	346	451	451	465	427	508	334	429	429	438	414	478	322	
	90	499	499	500	500	536	423	477	477	478	478	509	412	454	454	455	455	479	395	
15800	75	447	405	495	304	540	195	423	392	468	292	511	183	398	378	440	279	480	170	
	80	462	462	496	391	542	282	441	441	470	375	513	270	418	418	442	361	483	258	
	85	490	490	500	473	542	369	468	468	475	460	514	357	444	444	447	447	484	344	
	90	517	517	517	517	543	451	494	494	495	495	515	439	469	469	470	470	485	425	
16600	75	451	417	498	312	543	197	427	404	471	299	514	185	401	390	443	286	483	172	
	80	469	469	500	399	544	288	447	447	474	386	516	277	424	424	445	372	485	264	
	85	497	497	504	489	545	379	475	475	479	476	516	368	451	451	451	451	486	355	
	90	524	524	524	524	546	465	500	500	501	501	518	453	475	475	475	475	487	439	
18300	75	459	443	504	327	549	202	434	430	477	315	519	189	409	409	448	302	487	177	
	80	483	483	507	422	550	302	460	460	480	409	521	290	436	436	451	395	489	277	
	85	511	511	512	512	549	402	488	488	488	488	521	390	462	462	463	463	490	370	
	90	536	536	537	537	551	495	512	512	512	512	522	483	485	485	485	485	492	469	
ID	Airflow CFM	Ent DB (°F)	Ambient Temperature (°F)						Ambient Temperature (°F)						Ambient Temperature (°F)					
			115						115						115					
			Entering Wet Bulb Temp (°F)						Entering Wet Bulb Temp (°F)						Entering Wet Bulb Temp (°F)					
			61		67		73		61		67		73		61		67		73	
TGC	SHC	TGC	SHC	TGC	SHC	TGC	SHC	TGC	SHC	TGC	SHC	TGC	SHC	TGC	SHC	TGC	SHC			
12500	75	355	313	396	234	436	149													
	80	365	365	398	303	439	218													
	85	389	389	401	368	440	287													
	90	413	413	413	413	441	356													
14100	75	363	337	404	249	442	153													
	80	380	380	406	323	445	231													
	85	405	405	410	399	446	308													
	90	428	428	429	429	448	381													
15800	75	371	363	410	265	447	157													
	80	393	393	413	346	450	244													
	85	419	419	419	419	451	331													
	90	442	442	442	442	453	411													
16600	75	374	374	412	272	449	159													
	80	399	399	415	357	452	250													
	85	424	424	425	425	453	336													
	90	447	447	447	447	455	425													
18300	75	383	383	417	288	452	163													
	80	410	410	421	380	456	264													
	85	434	434	435	435	457	356													
	90	455	455	456	456	458	455													

**Notes:**

1. All capacities shown are gross and have not considered indoor fan heat. To obtain net cooling, subtract indoor fan heat.
2. TGC = Total gross capacity.
3. SHC = Sensible heat capacity.

**Table 41. 138 kW (41.7 ton) standard and high efficiency, gross cooling capacities (kw)— 50 Hz**

ID	Airflow L/s	Ent DB (°C)	Ambient Temperature (°C)						Ambient Temperature (°C)						Ambient Temperature (°C)					
			29.4						35						40.6					
			Entering Wet Bulb Temp (°C)						Entering Wet Bulb Temp (°C)						Entering Wet Bulb Temp (°C)					
			16.1		19.4		22.8		16.1		19.4		22.8		16.1		19.4		22.8	
		TGC	SHC	TGC	SHC	TGC	SHC	TGC	SHC	TGC	SHC	TGC	SHC	TGC	SHC	TGC	SHC			
5899	23.9	125.0	103.9	139.5	79.9	153.5	54.7	118.3	100.2	132.2	76.3	145.5	51.2	111.4	95.8	124.4	72.5	136.9	47.5	
	26.7	126.2	123.3	140.0	100.0	154.1	74.9	119.8	119.6	132.7	96.4	146.2	71.5	113.3	113.3	124.9	92.7	137.7	67.8	
	29.4	132.5	132.5	140.4	120.1	154.4	95.1	126.8	126.8	133.3	115.9	146.6	91.6	120.6	120.6	125.6	112.0	138.1	88.0	
	32.2	140.2	140.2	141.7	139.5	154.5	115.2	134.3	134.3	134.8	134.8	146.8	111.8	127.9	127.9	128.1	128.1	138.4	108.1	
6654	23.9	128.1	110.9	142.5	84.5	156.1	56.0	121.3	107.0	135.0	80.8	147.9	52.4	114.1	103.1	126.9	77.0	139.0	48.7	
	26.7	130.4	130.4	143.0	107.2	156.7	78.7	124.5	124.5	135.4	103.5	148.6	75.2	118.1	118.1	127.4	99.7	139.8	71.5	
	29.4	138.4	138.4	143.7	128.9	156.8	101.4	132.3	132.3	136.4	125.2	148.9	98.0	125.8	125.8	128.5	121.2	140.1	94.3	
	32.2	146.2	146.2	146.5	146.5	157.0	124.1	139.9	139.9	140.2	140.2	149.1	120.7	133.1	133.1	133.3	133.3	140.5	115.9	
7457	23.9	131.0	118.7	145.0	89.2	158.3	57.2	123.9	114.8	137.3	85.5	149.8	53.7	116.5	110.7	129.0	81.7	140.8	50.0	
	26.7	135.4	135.4	145.5	114.6	158.8	82.7	129.2	129.2	137.8	109.8	150.5	79.2	122.5	122.5	129.6	105.8	141.6	75.5	
	29.4	143.6	143.6	146.6	138.7	158.8	108.1	137.2	137.2	139.1	134.9	150.7	104.6	130.3	130.3	131.1	131.0	141.8	100.9	
	32.2	151.4	151.4	151.6	151.6	159.1	132.2	144.7	144.7	145.0	145.0	151.0	128.6	137.4	137.4	137.6	137.6	142.2	124.7	
7834	23.9	132.2	122.3	146.0	91.4	159.2	57.8	125.1	118.4	138.2	87.7	150.6	54.3	117.6	114.3	129.8	83.8	141.5	50.6	
	26.7	137.5	137.5	146.5	116.9	159.6	84.5	131.1	131.1	138.8	113.1	151.3	81.0	124.3	124.3	130.5	109.0	142.2	77.3	
	29.4	145.8	145.8	147.8	143.3	159.6	111.2	139.2	139.2	140.3	139.5	151.4	107.7	132.1	132.1	132.3	132.3	142.4	104.0	
	32.2	153.4	153.4	153.7	153.7	159.9	136.4	146.6	146.6	146.8	146.8	151.8	132.7	139.1	139.1	139.3	139.3	142.9	128.8	
8637	23.9	134.5	129.9	147.9	96.0	160.8	59.1	127.3	126.0	139.8	92.3	152.1	55.5	119.7	119.7	131.2	88.4	142.7	51.8	
	26.7	141.5	141.5	148.5	123.8	161.1	88.4	134.8	134.8	140.6	119.9	152.6	84.9	127.7	127.7	132.2	115.8	143.5	81.2	
	29.4	149.7	149.7	150.2	150.2	161.0	117.8	142.9	142.9	143.1	143.1	152.6	114.4	135.4	135.4	135.6	135.6	143.6	108.6	
	32.2	157.1	157.1	157.3	157.3	161.4	145.2	150.0	150.0	150.2	150.2	153.1	141.5	142.1	142.1	142.3	142.3	144.1	137.5	
ID	Airflow L/s	Ent DB (°C)	Ambient Temperature (°C)																	
			46.1																	
			Entering Wet Bulb Temp (°C)																	
			16.1		19.4		22.8								16.1		19.4		22.8	
		TGC	SHC	TGC	SHC	TGC	SHC													
5899	23.9	104.0	91.7	116.1	68.6	127.7	43.6													
	26.7	107.0	107.0	116.6	88.7	128.6	63.9													
	29.4	114.0	114.0	117.5	107.9	129.0	84.1													
	32.2	120.9	120.9	121.1	121.1	129.3	104.2													
6654	23.9	106.5	98.9	118.3	73.0	129.6	44.8													
	26.7	111.3	111.3	118.9	94.6	130.5	67.6													
	29.4	118.7	118.7	120.1	117.1	130.8	90.4													
	32.2	125.6	125.6	125.8	125.8	131.2	111.7													
7457	23.9	108.7	106.5	120.1	77.6	131.1	46.1													
	26.7	115.3	115.3	120.9	101.5	132.0	71.6													
	29.4	122.7	122.7	122.9	122.9	132.2	97.0													
	32.2	129.4	129.4	129.6	129.6	132.7	120.5													
7834	23.9	109.7	109.7	120.8	79.8	131.6	46.6													
	26.7	117.0	117.0	121.7	104.7	132.6	73.4													
	29.4	124.4	124.4	124.5	124.5	132.8	98.3													
	32.2	130.9	130.9	131.1	131.1	133.3	124.6													
8637	23.9	112.1	112.1	122.1	84.3	132.6	47.8													
	26.7	120.0	120.0	123.3	111.4	133.7	77.3													
	29.4	127.3	127.3	127.5	127.5	133.8	104.2													
	32.2	133.4	133.4	133.5	133.5	134.3	133.2													

**Notes:**

1. All capacities shown are gross and have not considered indoor fan heat. To obtain net cooling, subtract indoor fan heat.
2. TGC = Total gross capacity.
3. SHC = Sensible heat capacity.



## Performance Data (50 Hz Units)

**Table 42. Electric heat air temperature rise (°F) (I-P)—50 Hz**

KW Input	Total MBH	CFM												
		7000	8000	9000	10000	11000	12000	13000	14000	15000	16000	17000	18000	19000
26.9	92	12.1	10.6	9.4	8.5	7.7	7.1	—	—	—	—	—	—	—
40.4	138	18.2	15.9	14.1	12.7	11.6	10.6	9.8	9.1	8.5	8.0	7.5	7.1	6.7
53.8	184	24.2	21.2	18.8	16.9	15.4	14.1	13.0	12.1	11.3	10.6	10.0	9.4	8.9
67.3	230	30.3	26.5	23.6	21.2	19.3	17.7	16.3	15.1	14.1	13.2	12.5	11.8	11.2
80.7	275	—	—	—	25.4	23.1	21.2	19.6	18.2	16.9	15.9	15.0	14.1	13.4

**Notes:**

1. Air temperature rise = (KW x 3413)/(scfm x 1.085).
2. All heaters on constant volume units provide 2 increments of capacity.
3. Air temperature rise in this table are based on heater operating at 415 volts.

**Table 43. Electric heat air temperature rise (°C) (SI)—50 Hz**

KW Input	L/S												
	3300	3780	4250	4720	5190	5660	6140	6610	7080	7550	8020	8500	8970
26.9	6.8	5.9	5.3	4.7	4.3	4.0	—	—	—	—	—	—	—
40.4	10.2	8.9	7.9	7.1	6.5	5.9	5.5	5.1	4.8	4.5	4.2	4.0	3.8
53.8	13.6	11.9	10.5	9.5	8.6	7.9	7.3	6.8	6.3	5.9	5.6	5.3	5.0
67.3	17.0	14.8	13.2	11.9	10.8	9.9	9.1	8.5	7.9	7.4	7.0	6.6	6.3
80.7	—	—	—	14.2	13.0	11.9	11.0	10.2	9.5	8.9	8.4	7.9	7.5

**Notes:**

1. Air temperature rise in this table are based on heater operating at 415 volts.
2. All heaters on constant volume units provide 2 increments of capacity.

**Table 44. Available electric heat KW ranges—50 Hz**

Nominal Unit Size Tons	Nominal Voltage (V)	
	380	415
22.9	23–56	27–67
25.0	23–56	27–67
29.2	23–56	27–67
33.3	34–68	40–81
42.7	34–68	40–81

**Note:** kW ranges in this table are based on heater operating at nominal voltages 380 or 415.

Figure 6. Supply fan performance – 22.9-29.1 tons

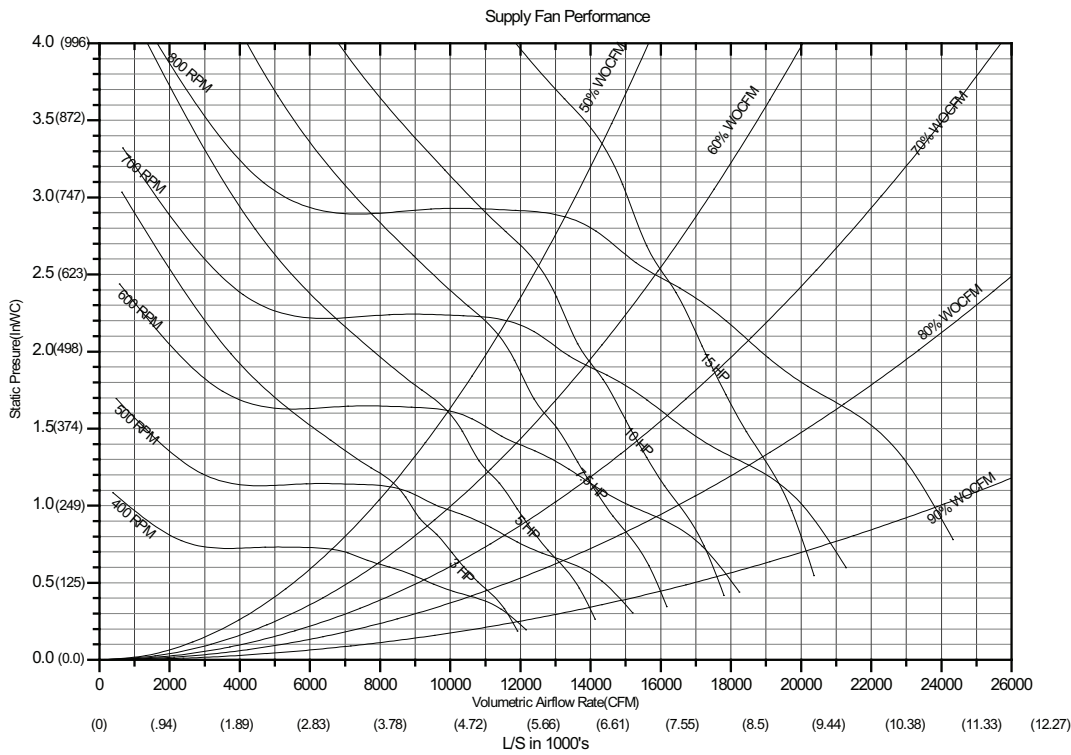
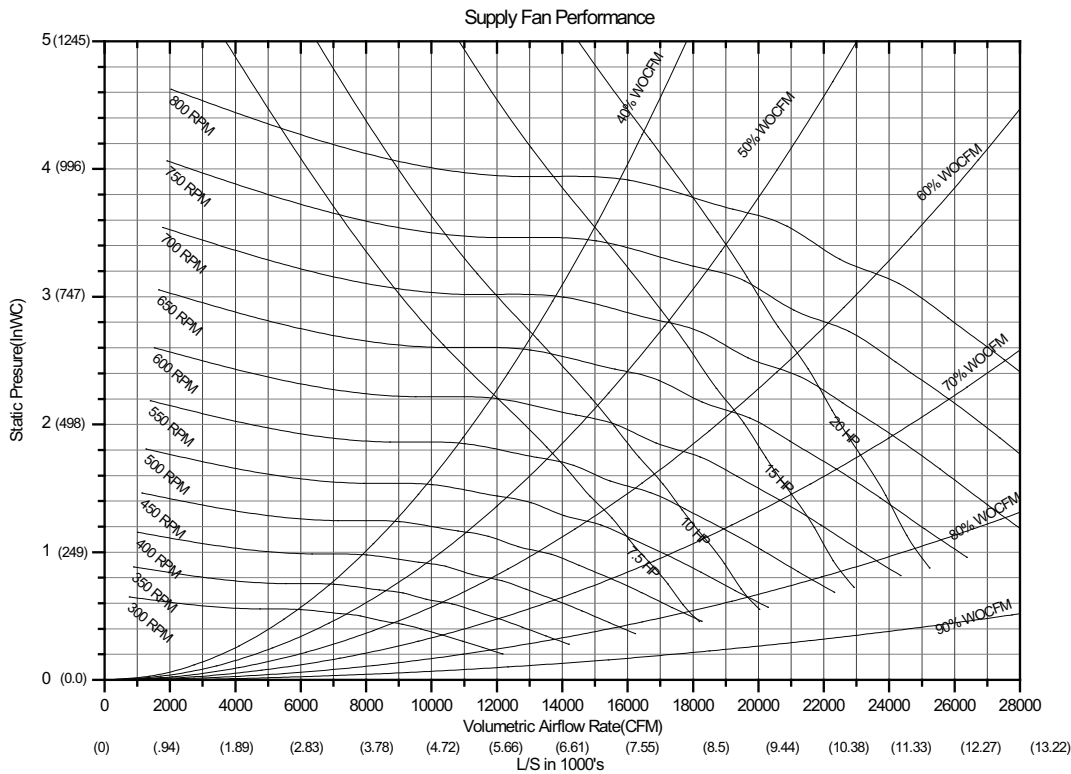

Figure 7. Supply fan performance – 33.3 and 41.7 tons (I-P)





**Performance Data (50 Hz Units)**

**Table 45. Component static pressure drops – in. wg (I-P)**

Nom. Tons	CFM Std Air	Heating System				Standard Efficiency ID Coil		High Efficiency ID Coil		Filters				Econo-mizer	Hot Gas Reheat Coil
		Gas Heat		Electric Heat		Dry	Wet	Dry	Wet	Throw-away 2"	MERV 8 High Eff		MERV 14 High Eff 4"		
		Low	High	1 Element	2 Elements						2"	2"			
23 (80)	6670	–	–	0.04	0.05	0.12	0.19	0.15	0.24	0.05	0.08	0.07	0.19	0.03	0.05
	7500	–	–	0.06	0.06	0.15	0.23	0.18	0.29	0.06	0.09	0.08	0.22	0.04	0.07
	8330	–	–	0.07	0.08	0.17	0.27	0.21	0.33	0.07	0.10	0.10	0.26	0.05	0.08
	9170	–	–	0.08	0.09	0.20	0.31	0.25	0.38	0.08	0.11	0.11	0.29	0.06	0.10
	10000	–	–	0.10	0.11	0.23	0.35	0.29	0.43	0.09	0.12	0.12	0.32	0.07	0.12
25 (88)	7500	–	–	0.06	0.06	0.15	0.23	0.18	0.29	0.06	0.09	0.08	0.22	0.04	0.07
	8330	–	–	0.07	0.08	0.17	0.27	0.21	0.33	0.07	0.10	0.10	0.26	0.05	0.08
	9170	–	–	0.08	0.09	0.20	0.31	0.25	0.38	0.08	0.11	0.11	0.29	0.06	0.10
	10000	–	–	0.10	0.11	0.23	0.35	0.29	0.43	0.09	0.12	0.12	0.32	0.07	0.12
29 (103)	8750	–	–	0.08	0.08	0.18	0.28	0.23	0.35	0.08	0.11	0.10	0.27	0.05	0.09
	9580	–	–	0.09	0.10	0.21	0.32	0.26	0.40	0.09	0.12	0.11	0.31	0.06	0.11
	11200	–	–	0.13	0.14	0.28	0.41	0.35	0.51	0.11	0.14	0.14	0.38	0.08	0.15
	12100	–	–	0.15	0.16	0.31	0.46	0.39	0.58	0.12	0.15	0.16	0.42	0.09	0.17
	12800	–	–	0.16	0.18	0.34	0.50	0.42	0.62	0.13	0.16	0.17	0.45	0.10	0.19
33 (118)	10000	–	–	0.07	0.11	0.23	0.35	0.23	0.35	0.08	0.11	0.11	0.30	0.07	0.04
	10800	–	–	0.08	0.13	0.25	0.39	0.25	0.39	0.09	0.12	0.12	0.33	0.08	0.05
	11700	–	–	0.10	0.15	0.29	0.44	0.29	0.44	0.11	0.13	0.14	0.37	0.09	0.05
	12500	–	–	0.11	0.17	0.33	0.49	0.33	0.49	0.12	0.14	0.15	0.40	0.10	0.06
	13300	–	–	0.12	0.19	0.36	0.53	0.36	0.53	0.13	0.16	0.17	0.44	0.11	0.07
14200	–	–	0.14	0.22	0.40	0.58	0.40	0.58	0.14	0.17	0.18	0.48	0.12	0.08	
42 (146)	12500	–	–	0.11	0.17	0.33	0.48	0.33	0.48	0.12	0.14	0.15	0.40	0.10	0.06
	13300	–	–	0.12	0.19	0.36	0.53	0.36	0.53	0.13	0.16	0.17	0.44	0.11	0.07
	14200	–	–	0.16	0.24	0.40	0.58	0.40	0.58	0.14	0.17	0.18	0.48	0.12	0.08
	15800	–	–	0.18	0.27	0.48	0.68	0.48	0.68	0.17	0.20	0.22	0.56	0.14	0.10
	16700	–	–	0.20	0.30	0.53	0.74	0.53	0.74	0.18	0.21	0.24	0.61	0.16	0.11
18300	–	–	0.23	0.35	0.61	0.84	0.61	0.84	0.21	0.25	0.28	0.69	0.18	0.13	

**Note:** Static pressure drops of accessory components must be added to external static pressure to enter fan performance tables.



**Table 46. Supply air fan drive selections—50 Hz**

Nominal Tons (kW)	7.5 HP (5.6 kW)		10 HP (7.5 kW)		15 HP (10 kW)		20 HP (15 kW)	
	RPM	Drive No.	RPM	Drive No.	RPM	Drive No.	RPM	Drive No.
23 (80)	498	A						
	500	B						
	541	C						
			583	D				
			625	E				
25 (88)	458	A						
	500	B						
	541	C						
			583	D				
			625	E				
					664	G		
29 (103)	500	B						
			541	C				
			583	D				
			625	E				
					664	G		
					708	R		
33 (108)			417	H				
			437	J				
			479	K				
					521	L		
					562	M		
					604	N		
42 (146)			437	J				
			479	K				
						521	L	
					562	M		
					604	N		
							604	N
							646	P



**Performance Data (50 Hz Units)**

**Table 47. Power exhaust fan performance—22.9-29.2 tons—50 Hz**

	Power Exhaust Selection			
	50%		100%	
	Damper Open Position			
	min	max	min	max
Return Duct Static (Pa)	L/s			
0.0	1499	2701	2999	5405
24.9	1375	2083	2751	4166
49.8	1255	1753	2488	3540
74.7	1134	1499	2269	3003
99.6	1031	1321	2061	2643
124.5	921	1135	1842	2270

**Table 48. Power exhaust fan performance—33.3-41.7 tons—50 Hz**

	Power Exhaust Selection			
	50%		100%	
	Damper Open Position			
	min	max	min	max
Return Duct Static (Pa)	L/s			
0.0	1909	3160	3818	6321
24.9	1800	2915	3599	5829
49.8	1676	2537	3364	5308
74.7	1577	2371	3155	4741
99.6	1462	2173	2925	4347
124.5	1364	2040	2727	4080

**Note:** These values are the minimum and maximum positions for non-tracking power exhaust. Fresh air tracking and Statitrac options can fully close the exhaust dampers in their operation, and are thus able to reach lower airflows. Statitrac requires 100% power exhaust.



## Controls

### Enhanced BAS Integration and Connectivity

- Symbio™ 700 integrates seamlessly with Tracer® Synchrony and Tracer Ensemble® to deliver optimized building automation and building management features and functions.
- Easily integrate with open standard protocols to connect seamlessly to a Building Automation System (BAS).
- Digit 21 must equal 1, 2, or 3 for communication support.

### BACnet Communications

Symbio™ 700 includes native BACnet® communications which allows the unit to communicate directly with a Tracer® or other BAS via open protocol BACnet MS/TP or IP.

### Modbus Communications

Symbio™ 700 includes native Modbus communications which allows the unit to communicate directly with a Tracer® or other BAS via open protocol Modbus™ RTU or TCP/IP.

### LonTalk Communications

The optional LonTalk® communications module allows the unit to communicate directly with a Tracer® or other BAS via open protocol LonTalk.

### Air-Fi Wireless Communications

The optional Air-Fi® communications module allows the unit to communicate directly with a Tracer® or other BAS via open protocol BACnet over Zigbee wireless.

### Secure Remote Connectivity with Trane Connect

The Symbio™ controller enables secure remote connectivity via Trane Connect® to Trane Intelligent Services and remote monitoring. Trane Connect provides anywhere/anytime access to monitor and manage with secure remote access and connectivity options through a multitude of platforms.

## Serviceability

### Symbio Service and Installation Mobile App

The Symbio™ Service and Installation mobile app is accessible through mobile devices (phones and tablets) via Bluetooth connectivity or via Trane Connect. The intuitive mobile app feels natural to technicians and operators. They will quickly be able to view equipment status and alarms, perform start-up tasks, change configurations, test the equipment's performance in specific modes—and much more. Free for download from App Store (Apple iOS) and Google Play (Android devices).

To download the Symbio Service and Installation Mobile App use the links below or scan the code with your mobile phone camera.

[Apple download link \(https://apps.apple.com/us/app/symbio-service-installation/id1309310176\)](https://apps.apple.com/us/app/symbio-service-installation/id1309310176)

[Google Play \(Android\) download link \(https://play.google.com/store/apps/details?id=com.trane.mobileservicetool\)](https://play.google.com/store/apps/details?id=com.trane.mobileservicetool)

Figure 8. Scan code



Figure 9. Symbio service and installation mobile app

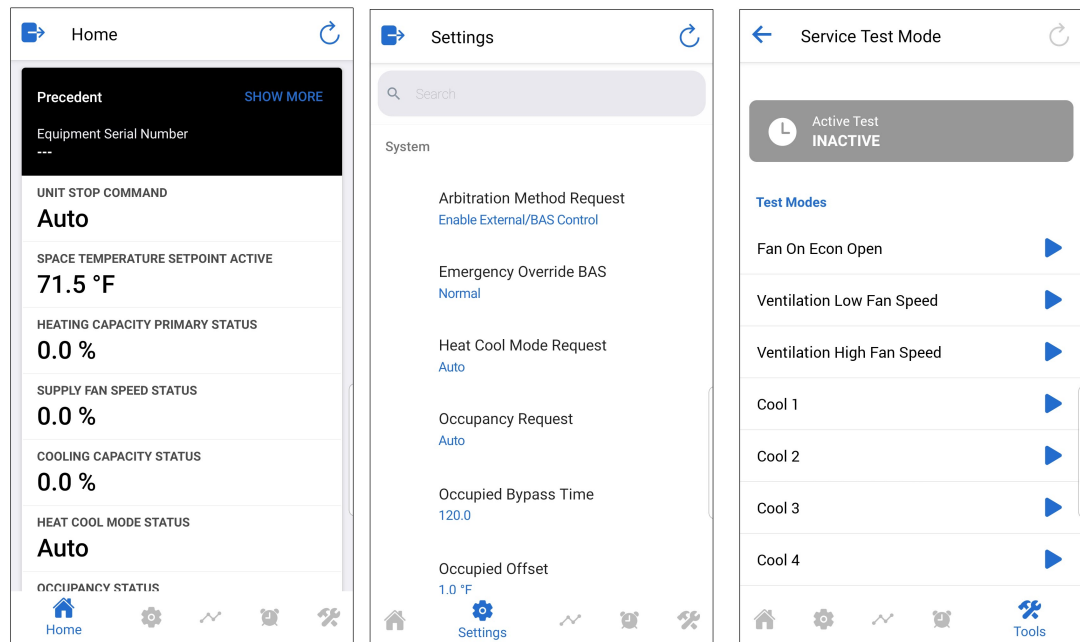

## Onboard User Interface

An integrated onboard user interface that makes setup and continued operation easy. It provides real time operational performance, status, data, and alarms. It also allows the user to interact with, service, troubleshoot, and control their equipment without additional service software tools or when a mobile interface is not available.

**Figure 10. Onboard user interface**

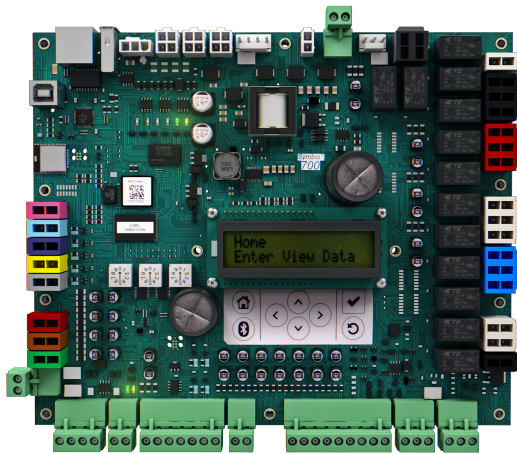

## Service Test Mode

Symbio™ 700 requires no special tools to run the unit through its paces. Simply navigate to the ‘Service’ section of the on-board user interface or the ‘Tools’ section of the Symbio Service and Installation Mobile App and enter the ‘Service Test Mode’ section. Here the unit can be placed in the desired operating condition for a pre-determined amount of time supporting troubleshooting efforts in the field. The Symbio 700 will return to normal control when the user exits test mode or when the pre-determined, user-selected Service Test time has expired.

## Symbio 700 Controls with Upgradeable Software

Equipment and systems feature engineered, tested, and proven applications that meet industry energy standards and provide the flexibility to customize and update over the life of the equipment. Professional operational algorithms are embedded within the Symbio™ 700 controller at the factory. Symbio 700 standardizes each equipment unit to maintain standards for comfort, efficiency, and air quality, without additional field programming. Symbio 700 provides the flexibility over the life of the equipment to meet changing customer needs and/or industry standards.

## Flexibility

### Expansion Modules

- XM30 – Provides 4 universal inputs or analog outputs
- XM32 – Provides 4 binary outputs

### Field Programming via TGP2

- Control ancillary equipment
- Custom sequences

### TGP2 and XM Limitations

- Programs will only have access to available BACnet® points. (Ensures system reliability.)
- TGP2 programs will not have direct I/O control access for factory components. (Compressors will not be able to be directly controlled On/Off without going through factory provided protection sequences.)
- Onboard I/O will not be available to custom applied TGP2 programs. If additional I/O is required for a new control loop, a separate expansion module will be required.
- I/O will be limited to a maximum combination of 2 XM modules. Only XM30 or XM32 modules are supported by the Symbio™ 700.

## Economizer Controls

Four options for economizer control are available: Dry Bulb Temperature, Comparative Enthalpy, Reference Enthalpy, and Differential Dry Bulb Temperature.

### Dry Bulb Temperature Control

The dry bulb system measures outdoor temperature comparing it to the economizer enable setpoint. If the outdoor temperature is below the economizer enable setpoint, the economizer will operate freely. This system is best suited for arid regions where the humidity levels of outside air would not be detrimental to building comfort and indoor air quality.

### Comparative Enthalpy Control

The comparative enthalpy system measures the temperature and humidity of both return air and outside air to determine which source has lower enthalpy. This system allows true comparison of outdoor air and return air enthalpy by measurement of outdoor air and return air temperature and humidity.

### Reference Enthalpy Control

The reference enthalpy system compares outdoor air temperature and humidity to the economizer enthalpy enable setpoint. If outdoor air temperature and humidity are below the economizer enthalpy enable setpoint, the economizer will operate freely. This system provides more sophisticated control where outdoor air humidity levels may not be acceptable for building comfort and indoor air quality.

### Differential Dry Bulb Temperature Control

The differential dry bulb system measures the temperature of both return air and outside air to determine when to economize. If outdoor air temperature is below the return air temperature minus a differential, the economizer will operate freely. This system is best suited for arid regions where the humidity levels of outside air would not be detrimental to building comfort and indoor air quality.

## Zone Sensors

Zone Temperature Only

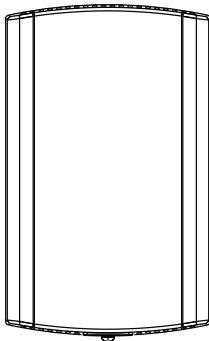

**BAYSENS077**

Provides temperature input only. Can be used as a secondary remote temperature input for thermostats.

Integrated Comfort™ System

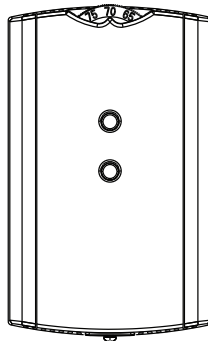

**BAYSENS073 / BAYSENS074 / BAYSENS075**

Sensor(s) available with optional temperature adjustment and override buttons to provide central control through a Tracer system.

Wired Display Sensor

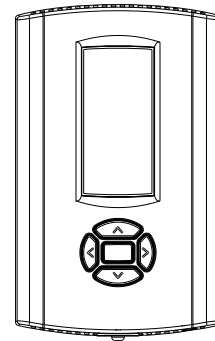

**BAYSENS135**

Temperature sensor with LCD display. Offers dual temperature setpoint, auto/on fan control and Heat/Cool/Auto/Off system control and a lockable setting with oF or oC indicators.

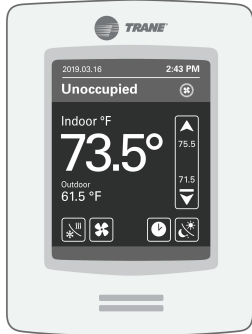
**Touchscreen Digital Display Communicating Sensor**

**BAYSENS800**

Uses BACnet® MS/TP link to communicate zone temperature and setpoints. Auto, Heat, Cool or Off System Switch. Fan Auto or On Switch. 7-day programmable thermostat with night setback.

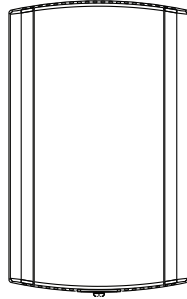
**Note:** Not compatible with VAV units. Requires BACnet communications.

**Wired CO<sub>2</sub> Sensor**

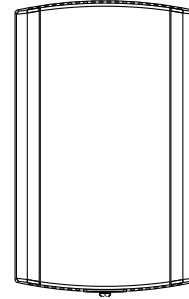
The maintenance-free temperature and carbon dioxide (CO<sub>2</sub>) sensor is primarily used for demand control ventilation applications.

**Wired Zone Temperature and Humidity Sensor**

**BAYSENS036**

Measures temperature and relative humidity. Relative humidity input is used to control activation of dehumidification.

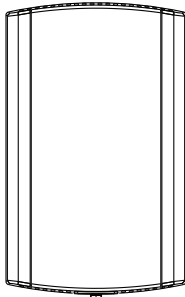
## Air-Fi Wireless Communicating Zone Sensors

**Wireless Zone Temperature Only**

**BAYSENS203**

Measures temperature and optional humidity (with WCS-SH) for use in public spaces where no local user interface is preferred.

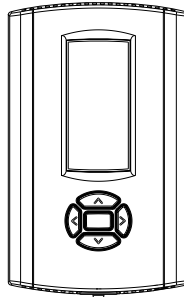
**Note:** Requires BACnet communications.

**Wireless Zone Temperature Display Sensor**

**BAYSENS202**

Measures temperature and optional humidity (with WCS-SH). Easy-to-use interface for clear and simple monitoring and control. Display can be configured for any Trane system or to meet the customer's preference.

**Note:** Requires BACnet communications.

**Wireless Temperature, Occupancy, and CO<sub>2</sub> Sensor**
**BAYCO2K200**

Zone sensor for temperature, occupancy and CO<sub>2</sub> with optional humidity (with WCS-SH).

**Note:** Requires BACnet Communications.

**Wireless Temperature and Occupancy Sensor**
**BAYSENS154**

Zone sensor for temperature and occupancy, optional humidity (with WCS-SH).

**Note:** Requires BACnet Communications.



# Thermostats

Digital Display Programmable Thermostat (3H/2C)

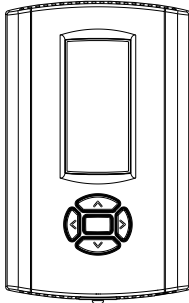

**BAYSTAT150**

Three Heat/Two Cool Auto changeover digital display thermostat. 7-day programmable thermostat with night setback.

**Note:** Not compatible with VAV units.

Digital Display Programmable Thermostat (1H/1C)

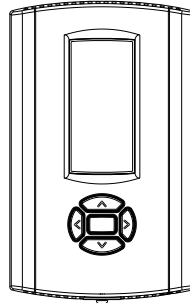

**BAYSTAT151**

One Heat/One Cool Auto changeover digital display thermostat.

**Note:** Not compatible with VAV units.

Digital Display Thermostat (3H/2C)

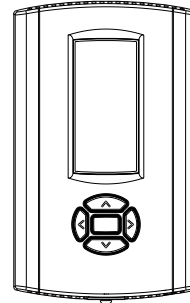

**BAYSTAT155**

Three Heat/Two Cool Auto changeover display thermostat.

**Note:** Not compatible with VAV units.

Pivot® Web Enabled Smart Thermostat (3H/2C)

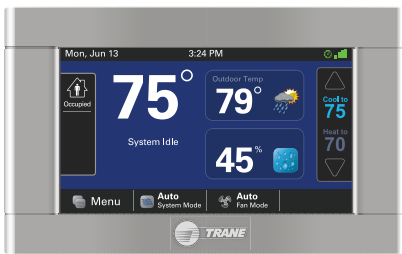

**BAYSTAT814**

Our Pivot Smart Thermostat system is great for commercial buildings. With its intuitive touchscreen and customizable display, it is easy for occupants to use. The Trane Pivot mobile app enables users to control multiple buildings remotely, making changes in seconds to all systems.

**Note:** Not compatible with VAV units.

Touchscreen Programmable Thermostat with Relative Humidity Sensor (3H/2C)



**BAYSTAT152**

Three Heat, Two Cool digital display thermostat with built-in humidity control. This thermostat combines both humidity and temperature into one.

**Note:** Not compatible with VAV units.



# Electrical Data

## Electrical Service Sizing

To correctly size electrical service wiring for your unit, find the appropriate calculations listed below. Each type of unit has its own set of calculations for MCA (Minimum Circuit Ampacity), MOP (Maximum Overcurrent Protection), and RDE (Recommended Dual Element fuse size). Read the load definitions that follow and then find the appropriate set of calculations based on your unit type.

Set 1 is for cooling only and cooling with gas heat units, and set 2 is for cooling with electric heat units.

Load Definitions: (To determine load values, see the Electrical Service Sizing Data Tables.)

LOAD1 = CURRENT OF THE LARGEST MOTOR (COMPRESSOR OR FAN MOTOR)

LOAD2 = SUM OF THE CURRENTS OF ALL REMAINING MOTORS

LOAD3 = CURRENT OF ELECTRIC HEATERS

LOAD4 = ANY OTHER LOAD RATED AT 1 AMP OR MORE

### Set 1. Cooling Only Rooftop Units and Cooling with Gas Heat Rooftop Units

$$\text{MCA} = (1.25 \times \text{LOAD1}) + \text{LOAD2} + \text{LOAD4}$$

$$\text{MOP} = (2.25 \times \text{LOAD1}) + \text{LOAD2} + \text{LOAD4}$$

Select a fuse rating equal to the MOP value. If the MOP value does not equal a standard fuse size as listed in NEC 240-6, select the next lower standard fuse rating.

**Note:** If selected MOP is less than the MCA, then reselect the lowest standard maximum fuse size which is equal to or larger than the MCA, provided the reselected fuse size does not exceed 800 amps.

$$\text{RDE} = (1.5 \times \text{LOAD1}) + \text{LOAD2} + \text{LOAD4}$$

Select a fuse rating equal to the RDE value. If the RDE value does not equal a standard fuse size as listed in NEC 240-6, select the next higher standard fuse rating.

**Note:** If the selected RDE is greater than the selected MOP value, then reselect the RDE value to equal the MOP value.

Keep in mind when determining LOADS that crankcase heaters are disabled in the cooling mode.

$$\text{DSS} = 1.15 \times (\text{LOAD1} + \text{LOAD2} + \text{LOAD4})$$

Select a disconnect switch size equal to or larger than the DSS value calculated.

### Set 2. Rooftop Units with Electric Heat

To arrive at the correct MCA, MOP, and RDE values for these units, you must perform two sets of calculations. First calculate the MCA, MOP, and RDE values as if the unit was in cooling mode (use the equations given in Set 1). Then calculate the MCA, MOP, and RDE values as if the unit was in the heating mode as follows.

**Note:** Keep in mind when determining LOADS that the compressors and condenser fans don't run while the unit is in the heating mode and crankcase heaters are disabled in the cooling mode.

- For units using heaters less than 50 kw:  $\text{MCA} = 1.25 \times (\text{LOAD1} + \text{LOAD2} + \text{LOAD4}) + (1.25 \times \text{LOAD3})$
- For units using heaters equal to or greater than 50 kw:  $\text{MCA} = 1.25 \times (\text{LOAD1} + \text{LOAD2} + \text{LOAD4}) + \text{LOAD3}$

The nameplate MCA value will be the larger of the cooling mode MCA value or the heating mode MCA value calculated above.

$$\text{MOP} = (2.25 \times \text{LOAD1}) + \text{LOAD2} + \text{LOAD3} + \text{LOAD4}$$

The selection MOP value will be the larger of the cooling mode MOP value or the heating mode MOP value calculated above.

Select a fuse rating equal to the MOP value. If the MOP value does not equal a standard fuse size as listed in NEC 240-6, select the next lower standard fuse rating.

**Note:** If selected MOP is less than the MCA, then reselect the lowest standard maximum fuse size which is equal to or larger than the MCA, provided the reselected fuse size does not exceed 800 amps. If 125% of the current rating of the electric heater load is greater than the computed MOP, the next higher standard rating is selected based off of 125% of the current rating of the electric heater load.

$$RDE = (1.5 \times \text{LOAD1}) + \text{LOAD2} + \text{LOAD3} + \text{LOAD4}$$

The selection RDE value will be the larger of the cooling mode RDE value or the heating mode RDE value calculated above.

Select a fuse rating equal to the RDE value. If the RDE value does not equal a standard fuse size as listed in NEC 240-6, select the next higher standard fuse rating.

**Note:** If the selected RDE is greater than the selected MOP value, then reselect the RDE value to equal the MOP value.

$$DSS = 1.15 \times (\text{LOAD1} + \text{LOAD2} + \text{LOAD3} + \text{LOAD4})$$

**Note:** Keep in mind when determining LOADS that the compressors and condenser fans don't run while the unit is in the heating mode.

The selection DSS value will be the larger of the cooling mode DSS or the heating mode DSS calculated above.

Select a disconnect switch size equal to or larger than the DSS value calculated.

**Table 49. 27.5 - 35 ton electrical service sizing data—60 Hz**

Model	Elec. Specs	Allowable Voltage Range	Compressor Std Eff			Compressor High Eff, eStage			Fan Motors								
			No/Ton	RLA (Ea.)	LRA (Ea.)	No/Ton	RLA (Ea.)	LRA (Ea.)	Supply			Condenser			Exhaust		
									HP	FLA	No	HP	FLA (Ea.)	50% No.	100% No.	HP	FLA (Ea.)
TC/TE/ YC*330	208/60/3	187-229	1/6, 2/9	27.7,40.3	203, 267	1/6, 2/9	27.7,40.3	203, 267	7.5, 10.0, 15.0	22.8, 25.2, 43.0	3	1.0	4.4	1	2	1.0	4.4
	230/60/3	207-253	1/6, 2/9	27.7,40.3	203, 267	1/6, 2/9	27.7,40.3	203, 267	7.5, 10.0, 15.0	19.6, 25.2, 36.0	3	1.0	4.4	1	2	1.0	4.4
	460/60/3	414-506	1/6, 2/9	14.5,19.1	98, 142	1/6, 2/9	14.5,19.1	98, 142	7.5, 10.0, 15.0	9.8, 12.6, 18.0	3	1.0	2.2	1	2	1.0	2.2
TC/TE/ YC*360	575/60/3	517-633	1/6, 2/9	12.5,15.8	84, 103	1/6, 2/9	12.5,15.8	84, 103	7.5, 10.0, 15.0	7.8, 10.1, 15.0	3	1.0	1.5	1	2	1.0	1.5
	208/60/3	187-229	1/6, 2/10	27.7,42.3	203, 304	1/6, 2/10	27.7,42.3	203, 304	7.5, 10.0, 15.0	22.8, 25.2, 43.0	3	1.0	4.4	1	2	1.0	4.4
	230/60/3	207-253	1/6, 2/10	27.7,42.3	203, 304	1/6, 2/10	27.7,42.3	203, 304	7.5, 10.0, 15.0	19.6, 25.2, 36.0	3	1.0	4.4	1	2	1.0	4.4
TC/TE/ YC*420	460/60/3	414-506	1/6, 2/10	14.5,19.8	98, 147	1/6, 2/10	14.5,19.8	98, 147	7.5, 10.0, 15.0	9.8, 12.6, 18.0	3	1.0	2.2	1	2	1.0	2.2
	575/60/3	517-633	1/6, 2/10	12.5,17.2	84, 122	1/6, 2/10	12.5,17.2	84, 122	7.5, 10.0, 15.0	7.8, 10.1, 15.0	3	1.0	1.5	1	2	1.0	1.5
	208/60/3	187-229	1/6, 2/11	29.3,42.5	203, 304	1/7, 2/11	29.3,42.5	203, 304	7.5, 10.0, 15.0, 20.0	22.8, 25.2, 43.0, 56.1	3	1.0	4.4	1	2	1.0	4.4
TC/TE/ YC*420	230/60/3	207-253	1/6, 2/11	29.3,42.5	203, 304	1/7, 2/11	29.3,42.5	203, 304	7.5, 10.0, 15.0, 20.0	19.6, 25.2, 36.0, 49.4	3	1.0	4.4	1	2	1.0	4.4
	460/60/3	414-506	1/6, 2/11	14.5,21.8	98, 147	1/7, 2/11	14.5,21.8	98, 147	7.5, 10.0, 15.0, 20.0	9.8, 12.6, 18.0, 24.7	3	1.0	2.2	1	2	1.0	2.2
	575/60/3	517-633	1/6, 2/11	11.9,17.2	84, 122	1/7, 2/11	11.9,17.2	84, 122	7.5, 10.0, 15.0, 20.0	7.8, 10.1, 15.0, 19.5	3	1.0	1.5	1	2	1.0	1.5

**Notes:**

1. All customer wiring and devices must be installed in accordance with local and national electrical codes.
2. 100% Power Exhaust is with or without Statitrac™.

**Table 50. 40 and 50 ton electrical service sizing data—60 Hz**

Model	Elec. Specs	Allowable Voltage Range	Compressor Std Eff			Compressor High Eff, eStage			Fan Motors								
			No/Ton	RLA (Ea.)	LRA (Ea.)	No/Ton	RLA (Ea.)	LRA (Ea.)	Supply		Condenser		Exhaust				
									HP	FLA	No	HP	FLA (Ea.)	50% No.	100% No.	HP	FLA (Ea.)
TC/TE/ YC*480	208/60/3	187-229	1/8, 2/13	32.2,45.9	267, 319	1/8, 2/13	32.2,45.9	267, 319	10.0, 15.0, 20.0	25.2, 43.0, 56.1	4	1.0	4.4	1	2	1.5	5.4
	230/60/3	207-253	1/8, 2/13	32.2,45.9	267, 319	1/8, 2/13	32.2,45.9	267, 319	10.0, 15.0, 20.0	25.2, 36.0, 49.4	4	1.0	4.4	1	2	1.5	5.4
	460/60/3	414-506	1/8, 2/13	15.6,22.5	142, 158	1/8, 2/13	15.6,22.5	142, 158	10.0, 15.0, 20.0	12.6, 18.0, 24.7	4	1.0	2.2	1	2	1.5	2.7
TC/TE/ YC*600	575/60/3	517-633	1/8, 2/13	14.5,19.1	103, 136	1/8, 2/13	14.5,19.1	103, 136	10.0, 15.0, 20.0	10.1, 15.0, 19.5	4	1.0	1.5	1	2	1.5	2.2
	208/60/3	187-229	1/10, 2/15	40.3,56.0	267, 337	1/10, 2/15	40.3,57.9	267, 337	10.0, 15.0, 20.0, 25.0	25.2, 43.0, 56.1, 70.0	4	1.0	4.4	1	2	1.5	5.4
	230/60/3	207-253	1/10, 2/15	40.3,56.0	267, 337	1/10, 2/15	40.3,57.9	267, 337	10.0, 15.0, 20.0, 25.0	25.2, 36.0, 49.4, 61.0	4	1.0	4.4	1	2	1.5	5.4
TC/TE/ YC*600	460/60/3	414-506	1/10, 2/15	19.1,27.6	142, 155	1/10, 2/15	20.5,31.7	142, 155	10.0, 15.0, 20.0, 25.0	12.6, 18.0, 24.7, 30.5	4	1.0	2.2	1	2	1.5	2.7
	575/60/3	517-633	1/10, 2/15	15.8,23.1	103, 126	1/10, 2/15	15.8,23.1	103, 126	10.0, 15.0, 20.0, 25.0	10.1, 15.0, 19.5, 24.5	4	1.0	1.5	1	2	1.5	2.2

**Notes:**

1. All customer wiring and devices must be installed in accordance with local and national electrical codes.
2. 100% Power Exhaust is with or without Statitrac™.



## Electrical Data

**Table 51. Electrical service sizing data—miscellaneous load —60 Hz**

Nominal Unit Size (Tons)	FLA Add Unit Voltage			
	200	230	460	575
27.5 - 35	1	1	1	1
40, 50	1	1	1	1

*Note: Miscellaneous Load values are active during heating and cooling mode operation.*

**Table 52. Electrical service sizing data — electric heat module (electric heat only)—60 Hz**

Models: TE(D,H,F,R) 330—600 Electric Heat FLA						
Nominal Unit Size (Tons)	Nominal Unit Voltage	KW Heater				
		36 FLA	54 FLA	72 FLA	90 FLA	108 FLA
27.5-35	208	74.9	112.4	—	—	—
	230	86.6	129.9	—	—	—
	460	43.3	65.0	86.6	108.3	—
	575	—	52.0	69.3	86.6	—
40- 50	208	—	112.4	—	—	—
	230	—	129.9	—	—	—
	460	—	65.0	86.6	108.3	129.9
	575	—	52.0	69.3	86.6	103.9

*Note: All FLA in this table are based on heater operating at 208, 240, 480, and 600 volts.*

**Table 53. Electrical service sizing data, 275–350 units 50 Hz**

Model	Elec. Specs	Compressor Std Eff						Compressor High Eff, eStage						Fan Motors					
		No/Ton		RLA (Ea.)	LRA (Ea.)	No/Ton	RLA (Ea.)	LRA (Ea.)	Supply		Condenser		Exhaust						
		1/6, 2/9	1/6, 2/9	14.5,19.1	98, 142	1/6, 2/9	14.5,19.1	98, 142	HP (kW)	FLA	No	HP (kW)	FLA (Ea.)	50% No.	100% No.	HP (kW)	FLA (Ea.)		
TC/TE/ YC*275	380-415/50/ 3	1/6, 2/9	1/6, 2/9	14.5,19.1	98, 142	1/6, 2/9	14.5,19.1	98, 142	7.5 (5.6), 10 (6.8), 15 (10.5)	12.1/11.5, 15.2/14.6, 22.0/23.0	3	0.75 (0.56)	4.4	1.00	2.00	0.75 (0.56)	1.70		
TC/TE/ YC*305	380-415/50/ 3	1/6, 2/10	1/6, 2/10	14.5,19.8	98, 147	1/6, 2/10	14.5,19.8	98, 147	7.5 (5.6), 10 (6.8), 15 (10.5)	12.1/11.5, 15.2/14.6, 22.0/23.0	3	0.75 (0.56)	4.4	1	2	0.75 (0.56)	1.7		
TC/TE/ YC*350	380-415/50/ 3	1/6, 2/11	1/6, 2/11	14.5,21.8	98, 147	1/7, 2/11	14.5,21.8	98, 147	7.5 (5.6), 10 (6.8), 15 (10.5)	12.1/11.5, 15.2/14.6, 22.0/23.0	3	0.75 (0.56)	4.4	1	2	0.75 (0.56)	1.7		

All customer wiring and devices must be installed in accordance with local and national electrical codes.

Allowable voltage range for the 380V unit is 342-418V, allowable voltage range for the 415V unit is 373-456.

100% Power Exhaust is with or without Statitrac™.

**Table 54. Electrical service sizing data, 400 and 500 units 50 Hz**

Model	Elec. Specs	Compressor Std Eff				Compressor High Eff, eStage				Fan Motors									
		No/Ton	RLA (Ea.)	LRA (Ea.)	No/Ton	RLA (Ea.)	LRA (Ea.)	No/Ton	FLA (Ea.)	No	HP (kW)	FLA (Ea.)	50% No.		100% No.		HP (kW)	FLA (Ea.)	
TC/TE/ YC*400	380-415/50/ 3	1/8, 2/13	15.6,22.5	142, 158	1/8, 2/13	15.6,22.5	142, 158	1/8, 2/13	15.6,22.5	142, 158	10 (6.8), 15 (10.5)	15.2/14.6, 22.0/23.0	4	0.75 (0.56)	4.4	1	2	1.0 (0.75)	2.5
TC/TE/ YC*500	380-415/50/ 3	1/10, 2/15	19.1,27.6	142, 155	1/10, 2/15	19.1,27.6	142, 155	1/10, 2/15	19.1,27.6	142, 155	10 (6.8), 15 (10.5), 20 (12.8)	15.2/14.6, 22.0/23.0, 28.0/28.0	4	0.75 (0.56)	4.4	1	2	1.0 (0.75)	2.5

All customer wiring and devices must be installed in accordance with local and national electrical codes.  
 Allowable voltage range for the 380V unit is 342-418V, allowable voltage range for the 415V unit is 373-456.  
 100% Power Exhaust is with or without Statitrac™.



**Table 55. Electrical service sizing data — miscellaneous load — 50 Hz**

Nominal Unit Size	FLA Add Unit Voltage	
	380	415
23 - 29	1	1
33 - 42	1	1

*Note: Miscellaneous Load values are active during heating and cooling mode operation.*

**Table 56. Electrical service sizing data – electric heat module (electric heat units only) — 50 Hz**

Models: TE(D,H,F,R) 275 thru 500 Electric Heat FLA						
Nominal Unit Size (Tons)	Nominal Unit Voltage	KW Heater (380/415V)				
		23/27	34/40	45/54	56/67	68/81
23-29	380	34.5	51.1	68.9	85.5	–
	415	37.6	55.6	75.1	93.2	–
33, 42	380	–	51.1	68.9	85.5	103.4
	415	–	55.6	75.1	93.2	112.7

*Note: All FLA in this table are based on heater operating at 380 or 415 volts as shown above.*

# Dimensional Data

## Fresh Air, Power Exhaust Hoods

Figure 11. Side view showing fresh air and power exhaust hoods for downflow return

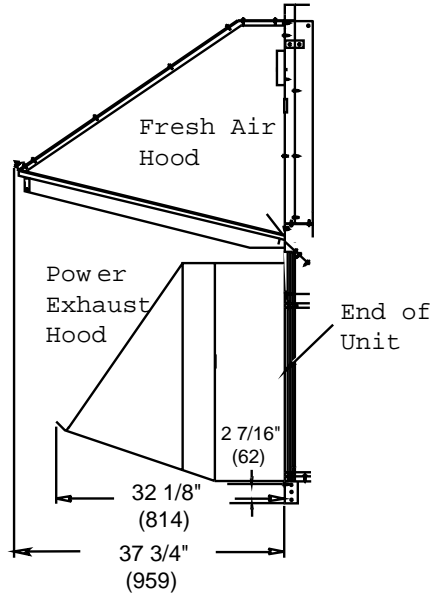
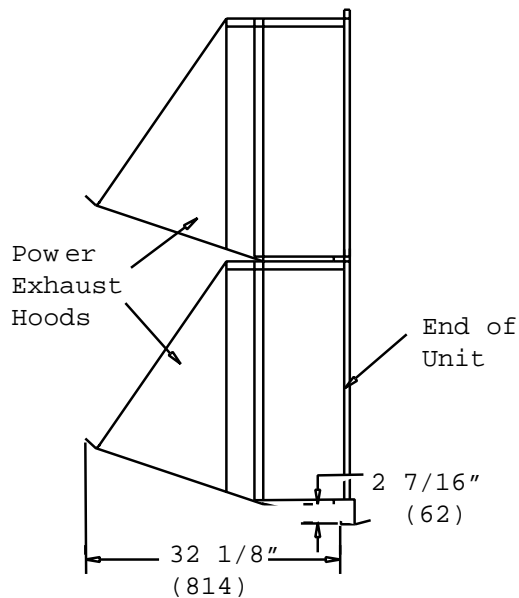

Figure 12. Side view showing power exhaust hoods for horizontal return



**Note:** The two horizontal power exhaust hoods and the three horizontal fresh air hoods are located side by side. The fresh air hoods (not shown) extend only 23 15/16" from the end of the unit.

Figure 13. 60 Hz 27.5-35, 50 Hz 23-29 Tons (TCD, TED, YCD low heat)

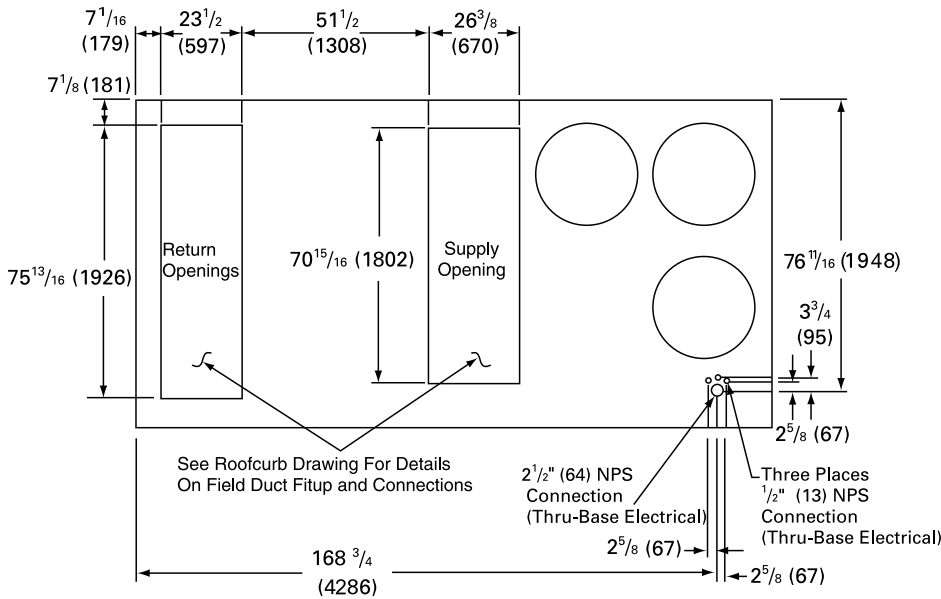
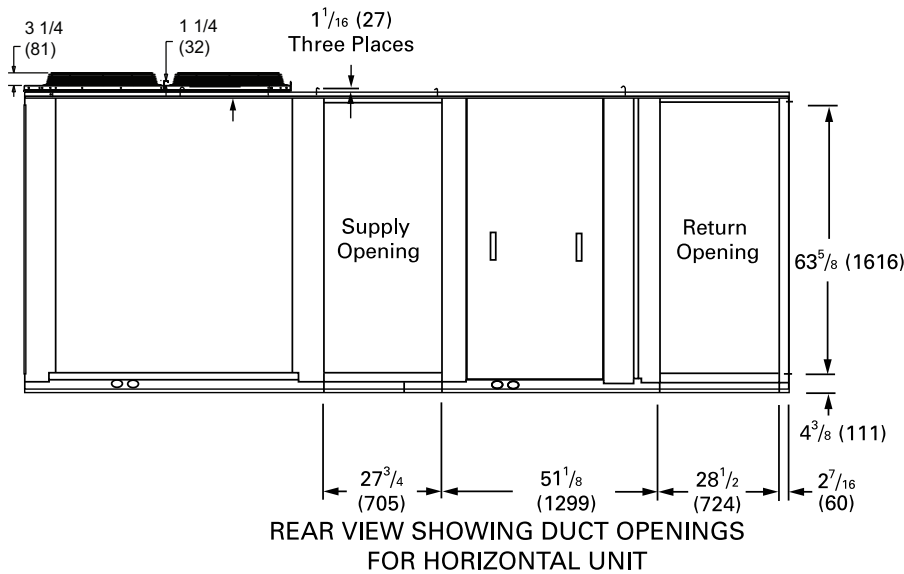

Figure 14. Rear view showing duct openings for horizontal supply and return, 60 Hz 27.5-35, 50Hz 23-29 Tons (TCH, TEH, YCH low heat)



REAR VIEW SHOWING DUCT OPENINGS FOR HORIZONTAL UNIT

**Notes:**

- On horizontal units, the VFD is located between the supply and return ductwork, which makes access limited.
- For combination of horizontal and downflow openings (digit 3 = F or R) see [Figure 13, p. 91](#) for appropriate downflow dimensions and [Figure 14, p. 91](#) for appropriate horizontal dimensions.



Figure 17. 60 Hz 27.5-35 tons (YCD high heat)

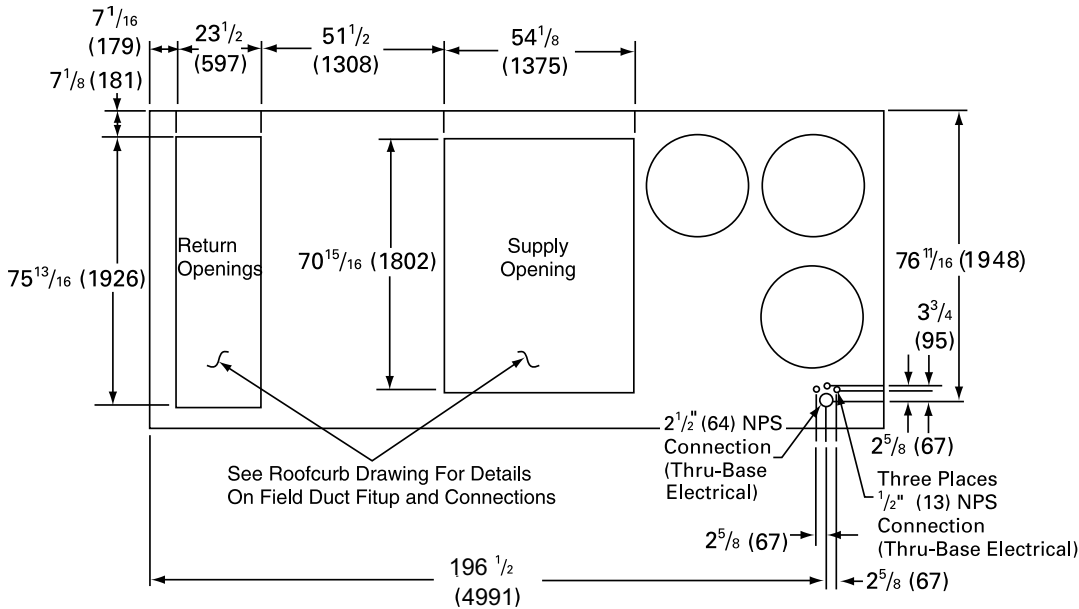
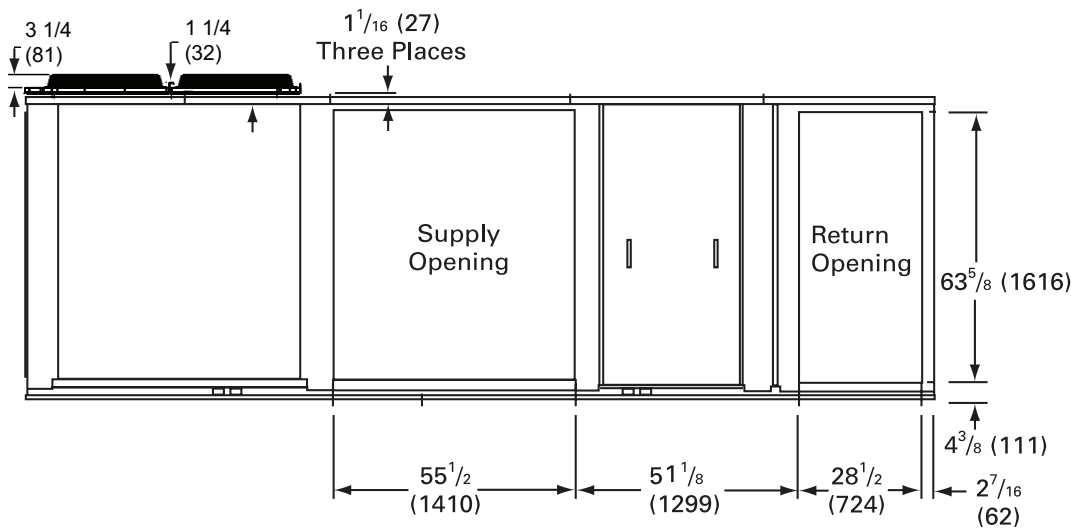

Figure 18. Rear view showing duct openings for horizontal supply and return, 60 Hz 27.5-35 Tons (YCH high heat)



**Notes:**

- On horizontal units, the VFD is located between the supply and return ductwork, which makes access limited.
- For combination of horizontal and downflow openings (digit 3 = F or R) see Figure 17, p. 93 for appropriate downflow dimensions and Figure 18, p. 93 for appropriate horizontal dimensions.

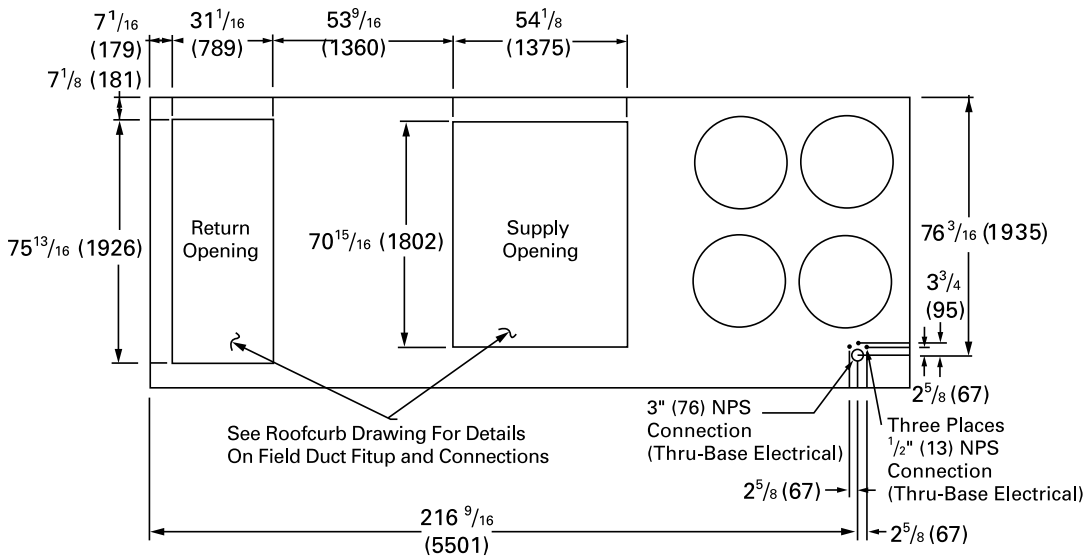
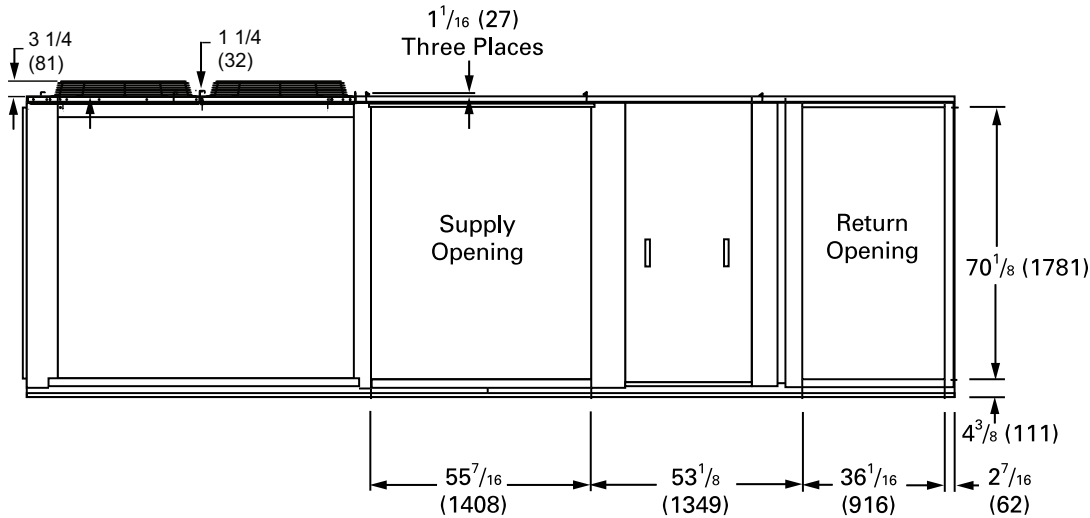

**Figure 21. 60 Hz 40-50, 50 Hz 33-42 tons (TCD, TED, YCD low and high heat)**

**Figure 22. Rear view showing duct openings for horizontal supply and return, 60 Hz 40-50, 50Hz 33-42 Tons (TCH, TEH, YCH low and high heat)**

**Notes:**

- On horizontal units, the VFD is located between the supply and return ductwork, which makes access limited.
- For combination of horizontal and downflow openings (digit 3 = F or R) see [Figure 21, p. 95](#) for appropriate downflow dimensions and [Figure 22, p. 95](#) for appropriate horizontal dimensions.





# Weights

**Table 57. Approximate units operating weight**

Average Unit Weight (lb)				
Unit (60Hz)	TC	TE	YC Low	YC High
27.5 Tons	4183	4303	4468	4651
30 Tons	4195	4315	4480	4663
35 Tons	4226	4346	4511	4694
40 Tons	4821	5044	5130	5409
50 Tons	4878	5101	5187	5466

**Notes:**

- Weights shown are for standard efficiency units and include the following features: 10HP supply fan motor, supply fan VFD, 100% economizer, 2" MERV 8 filters, SZVAV system control, GFCI, no exhaust, and hail guards.
- Weights shown are subject to change based on the specific unit configuration.
- Weights shown represent approximate operating weights and have a  $\pm 10\%$  accuracy. To calculate weight for a specific unit configuration, utilize Trane Select Assist™ or contact your local Trane® sales representative.

**Table 58. Average unit load weight (lb)**

Average Unit Point Load Weight (lb)						
Unit (60Hz)	1	2	3	4	5	6
27.5 Tons	880	696	867	683	854	670
30 Tons	878	697	868	687	857	676
35 Tons	874	699	870	695	866	691
40 Tons	1009	818	997	806	985	794
50 Tons	1032	823	1015	807	999	790

**Notes:**

- Point Loads shown are for standard efficiency units and include the following features: 10HP supply fan motor, supply fan VFD, 100% economizer, 2" MERV 8 filters, SZVAV system control, GFCI, no exhaust, and hail guards.
- Point Loads shown are subject to change based on the specific unit configuration
- Point Loads shown are based on the weights of YC high gas heat units.
- Point Loads shown are approximate and have a  $\pm 10\%$  accuracy. To calculate point loads for a specific unit configuration, utilize Trane Select Assist™ or contact your local Trane® sales representative.

**Figure 25. Point loading**

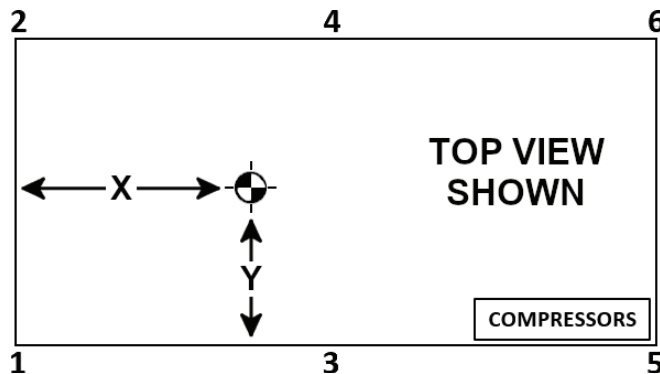



# Weights

**Table 59. Center of gravity**

Center of Gravity (inches)								
Unit (60Hz)	TC		TE		YC Low		YC High	
	X	Y	X	Y	X	Y	X	Y
27.5 Tons	91.0	40.8	91.1	41.0	91.3	40.2	102.9	40.1
30 Tons	91.2	40.9	91.4	41.0	91.5	40.3	103.1	40.1
35 Tons	91.9	41.1	92.0	41.3	92.2	40.5	103.7	40.4
40 Tons	114.6	41.2	114.7	41.3	114.3	41.9	115.4	40.6
50 Tons	114.1	40.8	114.3	40.9	114.0	41.5	115.0	40.2

**Notes:**

1. CGs shown are for standard efficiency units and include the following features: 10HP supply fan motor, supply fan VFD, 100% conomizer, 2" MERV 8 filters, SZVAV system control, GFCI, no exhaust, and hail guards.
2. CGs shown are subject to change based on the specific unit configuration.
3. CGs shown are approximate and have a ±10% accuracy. To calculate CG for a specific unit configuration, utilize Trane Select Assist™ or contact your local Trane® sales representative.

**Table 60. Approximate operating weights— optional components — lbs./kg**

Unit Model (60Hz/50Hz)	Baro. Relief	Power Exhaust	0-25% Man Damper	Econ.	Var. Freq. Drives (VFD's)		Serv. Valves	Thru-the base Elec.	Non- Fused Discon. Switch	Factory GFI with Discon. Switch	Roof Curb		HGRH Coil
					W/O	With					Lo	Hi	
					Bypass								
** (D,F) 330/275	110/50	167/76	50/23	260/117	108/49	114/52	18/8	6/3	30/14	85/38	310/141	330/150	107/49
** (H,R) 330/275	145/65	191/87	50/23	285/128	108/49	114/52	18/8	6/3	30/14	85/38	310/141	330/150	107/49
** (D,F) 360/305	110/50	167/76	50/23	260/117	108/49	114/52	18/8	6/3	30/14	85/38	310/141	330/150	107/49
** (H,R) 360/305	145/65	191/87	50/23	285/128	108/49	114/52	18/8	6/3	30/14	85/38	310/141	330/150	107/49
** (D,F) 420/350	110/50	167/76	50/23	260/117	108/49	114/52	18/8	6/3	30/14	85/38	310/141	330/150	107/49
** (H,R) 420/350	145/65	191/87	50/23	285/128	108/49	114/52	18/8	6/3	30/14	85/38	310/141	330/150	107/49
** (D,F) 480/400	110/50	167/76	50/23	290/131	150/68	158/72	18/8	6/3	30/14	85/38	365/169	365/169	112/51
** (H,R) 480/400	145/65	191/87	50/23	300/135	150/68	158/72	18/8	6/3	30/14	85/38	365/169	365/169	112/51
** (D,F) 600/500	110/50	167/76	50/23	290/131	150/68	158/72	18/8	6/3	30/14	85/38	365/169	365/169	112/51
** (H,R) 600/500	145/65	191/87	50/23	300/135	150/68	158/72	18/8	6/3	30/14	85/38	365/169	365/169	112/51
Con- denser Hail Guards	Ultra Low Leak Econ	Ultra Low Leak 50% Exhaust	Ultra Low Leak 100% Exhaust	eStage, High Efficien- cy									
105/48	112/51	34 / 15	74 / 34	251/114									
105/48	78/35	34 / 15	77 / 35	251/114									
105/48	112/51	34 / 15	74 / 34	251/114									
105/48	78 /35	34 / 15	77 / 35	251/114									
105/48	112/51	34 / 15	74 / 34	175/79									
105/48	78/35	34 / 15	77 / 35	175/79									
130/59	114/52	34 / 15	74 / 34	- / -									
130/59	100/45	34 / 15	84 / 38	- / -									
130/59	114/52	34 / 15	74 / 34	- / -									
130/59	100/45	34 / 15	84 / 38	- / -									

**Notes:**

1. Basic unit weight includes minimum horsepower supply fan motor.
2. Weights shown represent approximate operating weights and have a ±10% accuracy. To calculate weight for a specific unit configuration, utilize Trane Select Assist (TSA) or contact the local Trane sales representative. ACTUAL WEIGHTS ARE STAMPED ON THE UNIT NAMEPLATE.

**Table 61. Minimum operating clearances for unit installation**

	Econ/Exhaust End	Condenser Coil <sup>(a)</sup> End/Side	Service Side Access
Single Unit <sup>(b)</sup>	6 Feet (1.82 m)	8 Feet/8 Feet (2.43/2.43 m)	4 Feet (1.21 m)
Multiple Unit <sup>(c)</sup>	12 Feet (3.65 m)	16 Feet/16 Feet (4.87/4.87 m)	8 Feet (2.43 m)

<sup>(a)</sup> Condenser coil is located at the end and side of the unit.

<sup>(b)</sup> Horizontal, downflow, and mixed airflow configuration units, all sizes.

<sup>(c)</sup> Clearances on multiple unit installations are distances between units.



# Mechanical Specifications

## General

The units shall be dedicated downflow, horizontal, or mixed airflow configuration. The operating range shall be between 115°F and 0°F in cooling as standard from the factory for all units. Cooling performance shall be rated in accordance with AHRI testing procedures. All units shall be factory assembled, internally wired, fully charged with R-454B refrigerant and 100% run tested to check cooling operation, fan and blower rotation and control sequence before leaving the factory. Wiring internal to the unit shall be numbered for simplified identification. Units shall be UL listed to U.S. and Canadian safety standards.

## Certified AHRI Performance

Packaged Rooftop units cooling, heating capacities and efficiencies shall be rated within the scope of the Air-Conditioning, Heating and Refrigeration Institute (AHRI) Certification Program and display the AHRI Certified® mark as a visual confirmation of conformance to the certification sections of AHRI Standard 340-360 (I-P) and ANSI Z83.8/CSA 2.6 and 10 CFR Part 431 pertaining to Commercial Warm Air Furnaces. The applications in this catalog specifically excluded from the AHRI certification program are:

- Ventilation modes
- Heat Recovery

## Casing

Unit casing shall be constructed of zinc coated, heavy gauge, galvanized steel phosphatized, and finished with a pre-applied baked polyurethane enamel. All components shall be mounted in a weather resistant steel cabinet with a painted exterior. Cabinet surface shall be tested 672 hours in salt spray in compliance with ASTM B117. Fully gasketed removable access panels. Structural members shall be heavy gauge with access doors and removable panels of heavy gauge. Provide 1/2 inch thick foil faced fiberglass insulation on all exterior panels and roof in contact with the return and conditioned air stream. Where top cover seams exist, they shall be double hemmed and gasket sealed to prevent water leakage. Cabinet construction shall allow for all maintenance on one side of the unit. Service panels shall have handles and shall be removable while providing a water and air tight seal. Control box access shall be hinged. The indoor air section shall be completely insulated with fire resistant, permanent, odorless, foil faced glass fiber material. The base of the unit shall have provisions for crane lifting.

## Filters

Two inch, MERV 4, throwaway filters shall be standard on all size units. MERV 8 two inch "high efficiency", MERV 8 four inch "high efficiency" and MERV 14 four inch "high efficiency" filters shall be optional.

## Compressors

The 3-D Scroll shall include a direct-drive, 3600 rpm, suction gas cooled hermetic motor. Dependent on the compressor model, motor protection shall be provided by either a patented motor cap and integral line break motor protector or an external 24 Vac module which provides protection against incorrect phase sequence, excess motor temperatures, over current protection, and phase loss. Trane 3-D compressor shall include centrifugal oil pump, scroll tips seals, internal heat shield that lowers the heat transfer from discharge and suction gas, oil level sight glass and oil charge valve. Some compressor models shall also provide a dip tube that allows for oil draining, in addition to a low leakage internal discharge check valve to help prevent refrigerant migration. Each compressor shall have a crankcase heater installed, properly sized to minimize the amount of liquid refrigerant present in the oil sump during off cycles.

## eStage

eStage shall provide five stages of mechanical cooling with the ability to be at or below 25% compressor displacement at stage one.

## Refrigerant Circuits

Each refrigerant circuit shall have independent thermostatic expansion devices, service pressure ports and refrigerant line filter driers factory-installed as standard. An area shall be provided for replacement suction line driers.

## Leak Detection Sensors

Unit shall be furnished with a leak detection system from the factory when a circuit refrigerant charge exceeds 4 lbs. The leak detection system shall consist of one or more refrigerant detection sensors. When the system detects a leak, the unit controller shall initiate mitigation actions.

## Evaporator and Condenser Coils

Condenser coils shall have all Aluminum Microchannel coils. Evaporator coils shall be internally finned Copper tubes mechanically bonded to high performance Aluminum plate fins. All coils shall be leak tested at the factory to ensure pressure integrity. The evaporator coil is pressure tested to 450 psig and the condenser coil at 650 psig. All dual circuit evaporator coils shall be of intermingled configuration. Sloped condensate drain pans are standard.

## Outdoor Fans

The outdoor fan shall be direct-drive, statically and dynamically balanced, draw through in the vertical discharge position. The fan motor(s) shall be permanently lubricated and have built-in thermal overload protection in a weather tight casing.

## Indoor Fan

Units shall have belt driven, FC, centrifugal fans with fixed motor sheaves. Complete fan assemblies shall be statically and dynamically balanced. Fan shaft shall be mounted on grease lubricated ball bearings. All motors shall be circuit breaker protected. All 50 Hz indoor fan motors meet the U.S. Energy Policy Act of 1992 (EPACT). All 60 Hz indoor fan motors meet the Energy Independence & Security Act of 2007 (EISA).

## Variable Frequency Drives (VFDs)

VFDs shall be factory installed and tested to provide supply fan motor speed modulation. If the unit is configured for traditional VAV control, the VFD shall receive a signal from the unit controls via Modbus communication based upon supply static pressure and shall cause the drive to accelerate or decelerate as required to maintain the supply static pressure setpoint. The VFD shall receive a feedback signal from the unit controls via Modbus communication based on zone demand if configured for Single Zone VAV control and shall cause the drive to accelerate or decelerate as required to maintain the load of the zone. When subjected to high ambient return conditions the VFD shall reduce its output frequency to maintain operation. Bypass control to provide full nominal air flow in the event of drive failure shall be optional.

## Electric Heaters

Electric heat shall be available for factory installation within basic unit. Electric heater elements shall be constructed of heavy-duty nickel chromium elements internally delta connected for 240 volt and wye connected for 480 and 600 volt. Staging shall be achieved through the Symbio indoor options module (IOM). Each heater package shall have multiple automatic reset and single operation high temperature limit controls operating to break line power to the heater element. All heaters shall be individually fused from factory, where required, and meet all NEC and CEC requirements. Power assemblies shall provide single-point connection. Electric heat shall be cULus listed.

## Gas Heating Section

The heating section shall have a tubular heat exchanger(s) design with primary and secondary surfaces of corrosion resistant aluminized steel or optional stainless steel (all modulating gas heat units shall have stainless steel).

Heat exchangers shall have a tubular design with in-shot burners. Direct spark ignition shall be provided. All tubes shall be dimpled for proper heat transfer. Heating system shall incorporate induced draft fans and include a chimney that exhausts away from the air intake.



## Mechanical Specifications

---

Two stage and modulating gas heat units will be suitable for use with natural gas or propane (field installed kit).

Modulating gas turn down ratio on high fire units shall be accomplished by allowing the furnaces to act independently of one another. The modulating bank shall be activated first and is allowed to modulate itself to meet the heating needs. If the modulating bank is unable to meet the need at high fire, the second bank shall be turned on and then the first bank again modulates to the appropriate level. This system shall create a range of capacity from low fire on the modulating bank to high fire of both furnaces together.

## Outside Air

### Manual Outside Air

A manually controllable outside air damper shall be adjustable for up to 25 percent outside air. Manual damper is set at desired position at unit start up.

### Economizer

Economizer shall be factory installed. The assembly includes: fully modulating 0-100 percent motor and dampers, minimum position setting(s), preset linkage, wiring harness, and fixed dry bulb control. Solid state enthalpy and differential enthalpy control shall be a factory or field installed option.

### Ultra Low Leak Economizer with Fault Detection and Diagnostic (FDD)

The return air and fresh air dampers shall be provided with airfoil blades and independent direct drive actuators. Dampers shall have a leakage rate of 3 CFM/sq-ft at 1.0 in WC pressure differential (AMCA Class 1A). Dampers shall have a functional life of 60,000 opening & closing cycles.

*Note: Based on testing completed in accordance with AMCA Standard 500D.*

Fault Detection and Diagnostic (FDD) control shall also be provided with Ultra Low Leak Economizers. FDD control shall monitor the commanded position of the economizer compared to the feedback position of the damper. If the damper position is outside +/- 10% of the commanded position, a diagnostic shall be generated.

### Ventilation Override

Ventilation Override shall allow a binary input from the fire/life safety panel to cause the unit to override standard operation and assume one of three factory preset ventilation sequences, exhaust, pressurization or purge. The three sequences shall be selectable based upon a binary select input.

### Outside Air Measurement (Traq™)

A factory mounted airflow measurement station (Traq) shall be provided in the outside air opening to measure airflow. The airflow measurement station shall measure from 40 cfm/ton maximum airflow. The airflow measurement station shall adjust for temperature variations. Measurement accuracy shall meet requirements of LEED IE Q Credit 1 as defined by ASHRAE 62.1-2007.

## Exhaust Air

### 100% Power Exhaust Fan

Power exhaust shall be available on all units and shall be factory installed. It shall assist the barometric relief damper in maintaining building pressurization.

### 50% Power Exhaust Fan

Power exhaust shall be available on all units and shall be factory installed. It shall assist the barometric relief damper in maintaining building pressurization.

### 100% Modulating Exhaust Fan with Statitrac™ Control Option

A differential pressure control system (Statitrac™), shall use a differential pressure transducer to compare indoor building pressure to outdoor ambient atmospheric pressure and shall turn the exhaust

fans on and off and modulate the barometric exhaust dampers to control the building pressure to within the adjustable, specified dead band that shall be adjustable at the Symbio 700 onboard interface or through the Trane Mobile App.

### **100% Fresh Air Tracking Power Exhaust**

Modulating power exhaust shall be available on all units and shall be factory installed. It shall assist with maintaining building pressurization by exhausting a proportional amount of the entering fresh air.

### **50% Fresh Air Tracking Power Exhaust**

Modulating power exhaust shall be available on the on all units and shall be factory installed. It shall assist with maintaining building pressurization by exhausting a proportional amount of the entering fresh air.

### **Barometric Relief**

The barometric relief damper shall be optional with the economizer. Option shall provide a pressure operated damper for the purpose of space pressure equalization and be gravity closing to prohibit entrance of outside air during the equipment “off” cycle.

### **Ultra Low Leak Exhaust**

The exhaust damper shall be provided with airfoil blades and independent direct drive actuator. Damper shall have a leakage rate of 3 CFM/sq-ft at 1.0 in WC pressure differential (AMCA Class 1A). Damper shall have a functional life of 60,000 opening & closing cycles.

*Note: Based on testing completed in accordance with AMCA Standard 500D.*

## **Miscellaneous Unit Options**

### **Clogged Filter Indication**

This optional factory installed differential pressure switch allows dirty filter indication at the zone sensor with service LED. When closed, the dirty filter switch will light the service LED on the zone sensor and allow the unit to continue normal operation.

### **Comparative Enthalpy Kit**

Field installed enthalpy kit shall provide inputs for economizer control based upon comparison of the enthalpies of the return and outdoor air streams. Also available factory installed.

### **Condenser Coil Guards**

Factory installed condenser vinyl coated wire mesh coil guards shall be available to provide full area protection against debris and vandalism.

### **Condenser Hail Guards**

Hail-protection-quality louvered coil guards shall be available for condenser coil protection from the factory or as a field installed option..

### **Corrosion Protected Condenser Coil**

All Aluminum Microchannel condenser coil protection shall consist of a corrosion resistant coating that shall withstand ASTM B117 Salt Spray test for 6000 hours and ASTM G85 A2 Cyclic Acidified Salt Fog test for 2400 hours. This coating shall be added after coil construction covering all tubes, headers and fin edges, therefore providing optimal protection in more corrosive environments.

### **Discharge Air Sensing**

This option shall provide true discharge air sensing in heating and cooling models. This sensor shall be a status indicator readable through Tracer, Tracker, or LCI. Discharge air sensing shall be standard with Variable Air Volume (VAV) units, Single Zone Variable Air Volume units, and is optional with multi-speed units.



## Mechanical Specifications

---

### **GFI Convenience Outlet (Factory Powered)**

A 15A, 115V Ground Fault Interrupter convenience outlet shall be factory installed. It shall be wired and powered from a factory mounted transformer. Unit mounted non-fused disconnect with external handle shall be furnished with factory powered outlet.

### **GFI Convenience Outlet (Field Powered)**

A 15A, 115V Ground Fault Interrupter convenience outlet shall be factory installed and shall be powered by customer provided 115V circuit.

### **Unit Interrupt Rating (Short Circuit Current Rating-SCCR)**

An optional 65,000 Amp rating (480V) and 25,000 Amp rating (600V) shall be applied to the unit enclosure using a non-fused circuit breaker for disconnect switch purposes. Fan motors, compressors, and electric heat circuits shall be included with protective devices that will provide the elevated level of fault protection. The unit shall be marked with approved cULus markings and will adhere to cULus regulations.

### **High Temperature Thermostats**

Field installed, manually resettable high temperature thermostats shall provide input to the unit controls to shut down the system if the temperature sensed at the return is 135°F or if the discharge temperature is 240°F.

### **Hinged Service Access**

Filter access panel and supply fan access panel shall be hinged for ease of unit service.

### **Modulating Hot Gas Reheat**

A reheat condenser coil shall be factory installed downstream of the unit evaporator coil. Modulating valves shall control the flow of refrigerant between the indoor reheat and outdoor condensers in response to the unit discharge air temperature in order to dehumidify the space.

### **LP Conversion Kit**

Provided for field conversion of gas/electric units from natural gas to propane.

### **Modulating Gas**

Modulating Gas Heaters shall be made from grades of stainless steel suitable for condensing situations. The natural gas heater shall have a turn down ratio of 10:1.

### **Motor Shaft Grounding Ring (Optional)**

Motors with internal Shaft grounding rings shall be used with VFDs to provide a conductive discharge path away from the motor bearings to ground.

### **Non-Fused Disconnect Switch**

A factory installed non-fused disconnect switch with external handle shall be provided and shall satisfy NEC requirements for a service disconnect. The non-fused disconnect shall be mounted inside the unit control box.

### **Phase Monitor**

Standard on all Voyager 3 units. Protects 3-phase equipment from phase loss, phase reversal, and phase unbalance. Any fault condition shall send the unit into an emergency stop condition that shall not require field adjustments for resets. cULus approved.

### **Reference Enthalpy Kit**

Field installed enthalpy kit shall provide inputs for economizer control based upon comparison of the outside air stream to a definable enthalpy reference point. May also be factory installed.



### **Remote Potentiometer**

A remote potentiometer shall be available to remotely adjust the unit economizer minimum position.

### **Roof Curb**

The roof curb shall be designed to mate with the unit and provide support and a water tight installation when installed properly. The roof curb design shall allow field-fabricated rectangular supply/return ductwork to be connected directly to the curb when used with downflow units. Curb design shall comply with NRCA requirements. Curb shall ship knocked down for field assembly and include wood nailer strips.

### **Service Valves**

Discharge service valve standard with all units. Suction service valve optional.

### **Single Zone Variable Air Volume**

Single Zone VAV option shall be provided with all necessary controls to operate a rooftop unit based on maintaining two temperature setpoints: discharge air and zone. Option shall include factory-installed variable frequency drive (VFD) to provide supply fan motor speed modulation. During One Zone VAV cooling, the unit shall maintain zone cooling setpoint by modulating the supply fan speed more or less to meet zone load demand; and the unit will maintain discharge temperature to the discharge cooling setpoint by modulating economizer if available and staging dx cooling.

### **Stainless Steel Drain Pans**

Sloped stainless steel evaporator coil drain pans shall be durable, long-lasting and highly corrosion resistant.

### **Condensate Overflow Switch**

This option shall shut the unit down in the event that a clogged condensate drain line prevents proper condensate removal from the unit.

### **Stainless Steel Heat Exchanger**

Stainless steel heat exchangers shall be durable, long-lasting and highly corrosion resistant.

### **Through-The-Base Electrical Provision**

An electrical service entrance shall be provided which allows access to route all high and low voltage electrical wiring inside the curb, through the bottom of the outdoor section of the unit and into the control box area.



**Notes**

---



Trane - by Trane Technologies (NYSE: TT), a global innovator - creates comfortable, energy efficient indoor environments for commercial and residential applications. For more information, please visit [trane.com](https://trane.com) or [tranetechnologies.com](https://tranetechnologies.com).

Trane has a policy of continuous product and product data improvements and reserves the right to change design and specifications without notice. We are committed to using environmentally conscious print practices.

RT-PRC123B-EN 09 Mar 2025  
Supersedes RT-PRC123A-EN (March 2024)

©2025 Trane