



Product Catalog

Packaged Rooftop Air Conditioners

IntelliPak™ 2

90 to 150 Tons – Air-Cooled Condensers





Introduction

IntelliPak™ 2 Rooftops Designed For Today, Tomorrow and Beyond

Built on the legacy of Trane's industry leading IntelliPak, the IntelliPak 2 90 to 150 ton platform is designed for the future. Expanded features and benefits, controls enhancements and world class energy efficiencies make the IntelliPak 2 the right choice for demanding applications today, and tomorrow.

The addition of the Symbio 800 controller and TD7 touch screen user interface provides a high degree of control, superior monitoring capability, and unmatched diagnostic information.

The Symbio 800 controller integrates with all common standard building communication protocols, including BACnet® MS/TP, BACnet®/IP, LonTalk® (optional), and Modbus®.

The Trane IntelliPak 2 has the technology and flexibility to bring total comfort to every building space.

Note: AHRI certifies up to 63 Ton units, all air-cooled units over 63 tons are tested in accordance with the code.

Copyright

This document and the information in it are the property of Trane, and may not be used or reproduced in whole or in part without written permission. Trane reserves the right to revise this publication at any time, and to make changes to its content without obligation to notify any person of such revision or change.

Trademarks

All trademarks referenced in this document are the trademarks of their respective owners.



Table of Contents

Features and Benefits	6
Cabinet	6
Refrigeration	7
Airflow	8
Electrical	9
Gas Heat - Option	10
Electric Heat - Option	10
Symbio™ 800 Controls	11
Features and Benefits	11
Options	12
Specifications	12
Variable Air Volume (VAV) Operation	13
Single Zone Variable Air Volume (SZVAV) Operation	15
SZVAV and VAV Operation	17
Application Considerations	24
High Capacity Evaporator	24
eFlex™ Variable Speed	24
Relief/Return Fan Options	24
100% Modulating relief with Statitrac™ Control, and Variable Air Volume (VAV) Units	24
100% Modulating Relief with Statitrac Control, SZVAV Units	25
100% Modulating Return Fan Systems with Statitrac Control and Variable Air Volume (VAV) Units	25
Other Cooling Options	26
A2L Application Considerations	31
Leak Detection System(Refrigerant charge greater than 3.91 lb per circuit)	33
Selection Procedure	34
Cooling Capacity Selection	34
Heating Capacity Selection	36
Total Energy Recovery Wheel	39
Hot Gas Reheat Selection	40
Model Number Description	41
General Data	44
Performance Adjustment Factors	48



Table of Contents

Performance Data	50
Gross Cooling Capacities	50
Supply Fan	86
Relief Fan	90
Return Fan	93
Heating Capacities	96
Component Static Pressure Drops	99
Fan Drive Selections	106
Electrical Data	108
Electrical Service Sizing	108
Dimensional Data	112
Electrical Entry Details	117
Minimum Required Clearance	117
Optional Roof Curb	118
Weights	121

Mechanical Specifications	124
General	124
Casing	124
Access Doors	124
Blank Sections	124
Two-Piece Construction	124
Airflow Path	124
Burglar Bars	125
Belt Guard	125
Refrigeration System	125
Air-Cooled Condensing	126
Electrical	126
Control Options	127
System Control Options	127
Electrical System	128
Filters	129
Relief Air	131
Return Air	132
Outside Air	132
Heating System	134
Energy Saving Options	135
Accessories	135
Trane Start-Up	136
Certified AHRI Performance	137



Features and Benefits

Cabinet



Features		Benefits
Standard	Salt spray testing IAC w ASTM B117 standard	Durable enough to withstand a minimum of 672 hours consecutive salt spray to handle corrosive environments
	Double Wall Construction	Foam injected R8 insulation throughout the air handler section, enabling industry leading efficiency and reliability
	Pitched roof over air handler section	Prevents water leakage in cabinet, pooling water on top of cabinet
	Single point latching / hinged access doors on control panel, filter, supply, and relief/ return fan section as well as gas heat section	Provide easy and fast access to critical sections of the unit
	Double sloped stainless-steel drain pans	Prevents standing water under the evaporator coil
Optional	Single or two piece construction	Installation flexibility to facilitate lifting and rigging of the unit
	Extended casing	Versatility for heating and cooling applications
	Flexible downflow and horizontal discharge/ return paths	Ability to mix and match airflow paths allows usage on varying installations
	Blank Sections <ul style="list-style-type: none"> • 4ft blank section • 8ft blank section 	Versatility for heating and cooling applications
	Burglar bars on select configured units	Prevents building entry via the HVAC duct

Refrigeration

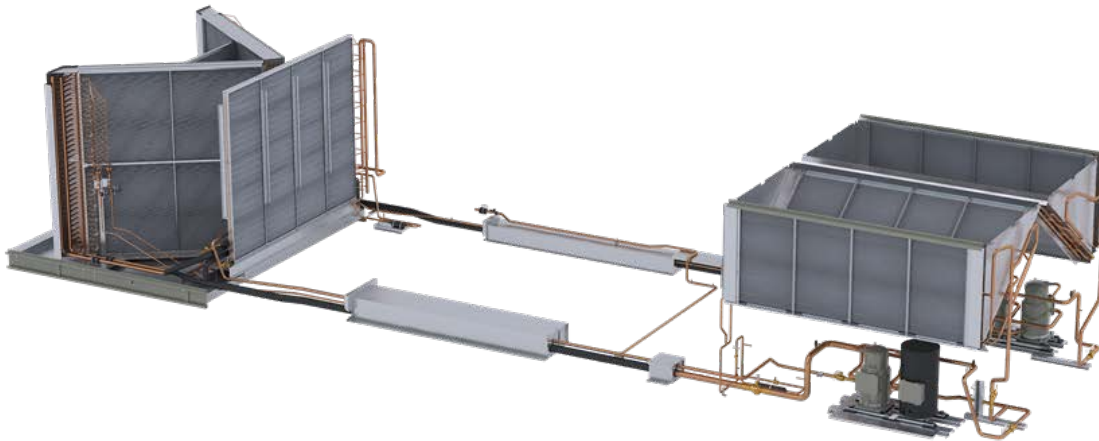

Features		Benefits
Standard	R-454B Refrigerant	Low GWP HFC Refrigerant
	Microchannel condenser coil	Reduced refrigerant quantity enabling LEED EA Credit 4, decreased weight, and minimized galvanic corrosion
	Electronic expansion valve	More accurate superheat reading and control. Provides consistent superheat setting that improves efficiency and compressor reliability.
	Refrigeration pressures constantly monitored by transducers	Provides faster, more accurate readings that maximize efficiency of the refrigeration system Monitors compressors in real time to ensure performance within reliable limits Allows service technician to read system pressures at either the user interface or remotely through optional building automation system (BAS) Provides loss of charge protection
	Coil frost protection limit	Prevents coil icing by using temperature and pressure sensors on each refrigeration circuit used to determine if the coil is approaching a freezing condition
	Drain pans	Stainless steel positively sloping evaporator coil drain pan
	Leak detection system	Trane's Leak Detection System (LDS) consists of one or more refrigerant detection sensors and is required in ducted HVAC systems that have more than 3.91 lbs of A2L refrigerant charge, per safety standard UL 60335-2-40. For any units with more than 3.91 lbs of charge in a circuit, Trane will factory-install an LDS. Having the leak detector installed in the factory by the manufacturer on applicable units reduces the risk of improper installation in the field as well as bypassing the added cost in the field for installation, leading to peace of mind that the right solution has been applied to your unit.
	Optional	eFlex™ variable speed compressors
High capacity evaporator coils		Allows flexibility to match building load capacities
Low ambient control		Provides refrigeration cooling in lower ambient temperatures to 0°F, improving the unit's operating range
Suction Service Valve		Reduces service time if repairs are needed
Replaceable core filter driers		Helps serviceability and allows for quicker replacement
Modulating hot gas reheat		Effective humidity control w/o using additional energy to reheat cooled air
Corrosion protected condenser coil		Coil tested to withstand ASTM B117 salt spray test for 6,000 hours and ASTM G85 A2 Cyclic Acidified Salt Fog test for 2,400 hours optimizing coil protection in more corrosive environments
Variable speed condenser fans		Minimizes fan cycling and maximizes part load efficiency



Features and Benefits

Airflow

Features		Benefits
Standard	Variable speed supply fan with backward curved, airfoil-shaped blades	Variable speed technology enables precision adjustments to output and/or capacity according to the building space requirements Standard and low airflow options to achieve specific cfm requirements for the application
	Spring fan isolation	Reduces undesirable vibration and noise
	MERV 8 high efficiency throwaway filter	These filters have 90% efficiency in trapping particles at 3 to 10 micrometers in size
Optional	Trane Air Quality (TraQ™) outside air measurement system	Traq controls the amount of outdoor air intake to accurately meet minimum fresh air requirements and energy-efficiency goals
	Statitrac™ direct space building pressurization control	Highly accurate and efficient method of maintaining building pressure control
	Ventilation override mode	Flexibility to temporarily override airflow management during non-standard situations
	Economizer operations	Enables use of outside air as an initial stage of cooling, reducing compressor runtime, resulting in lower energy consumption and longer unit lifespan
	Supply/Relief/Return Fan Piezometers	Measures airflow within 5% total accuracy when operating within the stable operating region of the fan curve
	Relief Fans	The Trane 100% modulating relief fan is an excellent choice for controlling building pressure
	Return Fans	Trane's 100% modulating return fan is an excellent choice for systems with high return static pressure losses
	Energy Recovery Wheel	Recycles energy from the normally relief building air to pre-condition incoming ventilation air
	Pre-evaporator and final filter rating up to MERV 17	Variety of options available to meet indoor air/filtration requirements
	Ultra-low leak damper leakage rate down to 3 CFM/ sq. ft. with fault detection and diagnostics	Energy efficiency and code compliance (ASHRAE 90.1, California Title 24)
Demand Control Ventilation	Minimizes energy consumption while meeting the ventilation requirements of ASHRAE Std 62.1.	

Electrical

Figure 1. Control panel

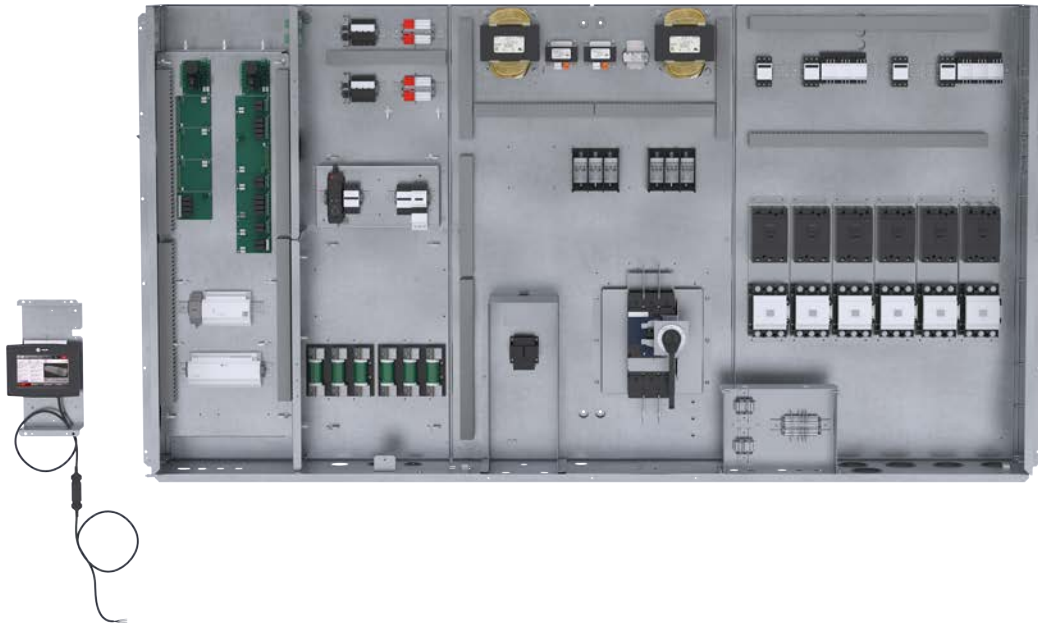

Features		Benefits
Standard	Separation of H/L voltage in control box	Safer to service the control panel
	Compressor protection module	Protect compressors against reverse rotation
Optional	High Fault SCCR with unit interrupt rating of 65,000 amp (480V) and 25,000 amp (600V)	Meets needs of building systems with high available fault current requirements
	Voltage Options	460/60/3 XL 575/60/3 XL 380/50/3 XL
	Through the door non-fused disconnect with external handle	Safe and Convenient way to quickly shut off power to the unit
	Convenience Outlet	Allows technicians to plug tools or equipment directly into the unit / no need for extension cords
	LED Marine Lights in service compartments	Convenient way to maintain and service the unit



Features and Benefits

Gas Heat - Option

Features		Benefits
Standard	Drum and tube heat exchangers with forced draft burners tested under UL 795	Meets product safety regulations
	Flue to exhaust above the unit	Removes hot air away from the unit and prevents recirculation with the combustion intake
	81% steady state efficiency	All gas heaters meet the 2023 Department of Energy efficiency code
	Air rise capability up to 60° F	Range of capacity to meet discharge air temperature
Optional	Staged and modulating offerings for each MBH	Assortment of option combinations provides the best solution for a variety of applications, along with the ability to achieve turndown up to 20:1 10:1 modulating gas heat 850 MBh 20:1 modulating gas heat 1100, 1800, and 2500 MBh
	Low Medium High heat offerings	

Electric Heat - Option

Features		Benefits
Standard	Full-faced element coil	Creates a more consistent heat profile
	<ul style="list-style-type: none"> • High grade element wire • Low watt density heater coils 	Allows for increased reliability
	90 to 300 kW range	Provides best solution for the application
	Air rise capability up to 50°F	Range of capacity meets discharge air temperature requirements



Symbio™ 800 Controls

The Symbio™ 800 controller is a factory-installed, application specific and programmable controller designed to control chillers and large packaged HVAC equipment. A 7-inch user interface features a touch-sensitive color screen that provides facility managers at-a-glance operating status, performance monitoring, scheduling changes, and operating adjustments. Other advanced features include automated controller back-up, and optional features such as secure remote connectivity, wireless building communications, mobile device connectivity, and custom programming with expandable I/O.

Features and Benefits

Symbio™ 800 Feature	Benefits
Multiple, open standard protocol support <ul style="list-style-type: none"> Air-Fi® Wireless (BACnet®/AirFi, optional) BACnet MS/TP BACnet/IP LonTalk® (Optional) Modbus RTU Modbus TCP 	Simplified, lower cost, and more flexible integration with all common open standard protocols using Trane or competitive BAS systems and controllers
Remote connection to building or equipment	Trane Connect™ provides an easy, secure option to connect remotely to a Tracer SC+ or directly to your Trane equipment
Common integration strategies and equipment specific points lists	Simplified, lower cost, and uncompromised integration
Application specific and configurable	Reduced project costs with superior reliability, comfort, performance - applications specific and configurable system ensures machine continues to run within operating envelope. Ability to upgrade firmware with a simple file transfer.
Smart Analytics	Smart analytics provide superior reliability through the life of the equipment with minimum downtime
Data logging	Standard, local or remote Intuitive review and analysis of equipment, zone, and building performance
Local scheduling	Capable of operating in stand-alone operation without a building automation system as a temporary back-up schedule for ongoing comfort and energy savings
Rugged, 7-inch color touch screen user interface	Easy, touch navigation for viewing data and making operational changes
Display preferences	Choose how to view dates, times, units (SI, IP), screen brightness, data format, and backlight timeout. 3 built-in languages are supported and selectable for all TD7 screens.
Intuitive navigation	Helps operators access data and alarms for quick and accurate response and resolution
At-a-glance status	Easily readable color display showing key operating parameters of major equipment components
Reports	Quickly summarizes data for clear understanding and interpretation to enable local monitoring of expected performance and operating efficiency
Graphs	Easily visualize trend data for local troubleshooting and fine-tuning
Multiple language support	Suitable for operation in multiple geographies
Adaptive Control™ Algorithms	Pre-empts potential equipment disruptions during rapidly changing conditions – providing consistent equipment performance and building comfort
SD card backup/restore	Faster, lower cost repairs with reduced downtime
Modbus device support	Capable of integrating optional Modbus devices for local or remote diagnostics — provides faster, lower cost troubleshooting and increased equipment performance



Symbio™ 800 Controls

Options

Symbio™ 800 Feature	Benefits
Remote connection to building or equipment	Trane Connect™ provides an easy, secure option to connect remotely to a Tracer SC+ or directly to your Trane equipment
Programmable	Equipment application flexibility and cost-reduced control of nearby equipment
Expandable I/O	Field or factory installed I/O for programmable feature - Reduced installation costs and increased installation flexibility
User security with audit trail support	Flexible and secure access for multiple users allows monitoring, overriding/releasing points, release of all overrides, custom report editing, and tracking changes by user
Wi-Fi Adapter	Enables the operation of wireless service tools for increased technician productivity and flexibility
LonTalk®	The LonTalk module provides an interface to a Tracer SC+ building automation system or other control system that supports LonTalk.
Air-Fi® Wireless (BACnet®, optional)	Air-Fi provides wireless communication to Air-Fi™ wireless sensors, service tools, equipment controls, and building controller.

Specifications

Controller Specifications	
Input power	24 Vdc +/- 10%, 400mA max.
Storage temperature	-67°F to 185°F (-55°C to 85°C), Humidity: Between 5% to 100% (Condensing).
Operating temperature	-40°F to 158°F (-40°C to 70°C).
Environmental rating (enclosure)	IP3x.
Time clock	On-board real time clock with 10 year battery backup.
Mounting weight	Mounting surface must support 1.3 lb. (0.6 kg).
Overall dimensions	5.65 in. (143.5 mm) wide x 4.00 in. (101.6 mm) high x 2.38 in. (60.6 mm) deep.
Agency Compliance	
<ul style="list-style-type: none"> • UL PAZX, Energy Management Equipment, UL 60730-1, 5th Ed. • UL94-5V Flammability. • CE. • FCC CFR Title 47, Part 15.109: Class B Limit, (30 MHz—10 GHz). • BTL Listed—Advanced Application Profile (B-AAC). 	
User Interface Specifications	
Input power	24 Vdc +/- 10%, 400 mA max
Storage temperature	-67°F to 203°F (-55°C to 95°C), Humidity: Between 5% to 100% (Condensing).
Operating temperature	-40°F to 158°F (-40°C to 70°C), Humidity: Between 5% to 100% (Condensing).
Environmental rating (enclosure)	IP56 (dust and strong water jet protected) with optional sealed Ethernet cable (PN: X19070632020).
Mounting weight	Mounting surface must support 1.6 lb. (0.74 kg).
Overall dimensions	8.3 in. (211.6 mm) wide x 6.3 in. (158.8 mm) high x 2.1 in. (53.2 mm) deep [bezel depth 0.4 in. (11.3 mm)].

Variable Air Volume (VAV) Operation

Supply Air Pressure Control

Variable Frequency Drive (VFD) Control

A pressure transducer measures duct static pressure, and the VFD is modulated to maintain the supply air static pressure within an adjustable user-defined range. The range is determined by the supply air pressure setpoint and supply air pressure deadband, which are set through the user interface. or BAS/Network.

The variable frequency drives provide supply fan motor speed modulation. The drive will accelerate or decelerate as required to maintain the supply static pressure setpoint.

Supply Air Static Pressure Limit

The opening of VAV terminals, and the amount of supply air provided by the variable frequency drive are coordinated during startup and transition to/from Occupied/Unoccupied modes to prevent over pressurization of the supply air ductwork. However, if for any reason the supply air pressure exceeds the user-defined supply air static pressure limit that was set at the user interface, the supply fan and VFD are shut down. The unit is then allowed to restart three times. If the over pressurization condition occurs on the third restart, the unit is shut down and a manual reset diagnostic is set and displayed at the user interface and BAS/Network.

Space Pressure Control - Statitrac

A pressure transducer is used to measure and report direct space (building) static pressure. The user-defined control parameters used in this control scheme are space static pressure setpoint, space pressure deadband and relief enable point. As the economizer opens, the building pressure rises and once above the relief enable point, enables the relief fan and dampers or relief VFD. The relief dampers or VFD then modulate to maintain space pressure within the deadband.

Supply Air Temperature Controls

Cooling/Economizer

During Occupied cooling mode of operation, the economizer (if available) and mechanical cooling are used to control the supply air temperature. The supply air temperature setpoint and deadband are user-defined at the user interface. The supply air temperature setpoint may be user-defined from the BAS/Network. If the conditions of the outside air are appropriate to use "free cooling," the economizer will be used first in an attempt to satisfy the supply air setpoint; then, if required, the mechanical cooling will be staged on to maintain supply air temperature setpoint. Minimum On/Off timing of the mechanical cooling prevents rapid cycling.

On units with economizer, a call for cooling will modulate the outside air dampers open. The rate of economizer modulation is based on deviation of the supply air temperature from setpoint, i.e., the further away from setpoint, the faster the outside air damper will open. First stage of cooling will be allowed to start after the economizer reaches full open.

The economizer is only allowed to function freely if one of the following conditions is met:

- For dry bulb economizer control the ambient temperature must be below the dry bulb temperature control setting.
- For reference enthalpy economizer control, outdoor air enthalpy must be below the enthalpy control setting. At outdoor air conditions above the enthalpy control setting, mechanical cooling only is used and the outside air dampers remain at minimum position.
- For comparative enthalpy economizer control, outdoor air enthalpy must be below the enthalpy of the return air.
- For differential dry bulb economizer control, the ambient dry bulb temperature must be below the dry bulb temperature of the return air.

If the unit does not include an economizer, mechanical cooling only is used to satisfy cooling requirements. The outdoor air dampers may be set for a maximum of 25% outdoor air, through the unit mounted user interface or a signal from the BAS/network, if the rooftop is equipped with 0 to 25% motorized outside air dampers.

Heating

Gas Heating: Staged Heat

Up to two stages of gas heat will be sequenced based on zone demand. Status messages and diagnostics are communicated to the user interface. To prevent cycling, a three-minute delay shall be provided between first- and second- stage, gas valve operation on two-stage heaters.

Modulating Gas

Upon a call for heating, the Symbio controller closes the heating contacts, beginning the firing sequence. First, the heat exchanger combustion blower begins operation. Upon positive proving of combustion airflow, a 30 second pre-purge cycle is executed. Then the ignition sequence takes place.

If ignition is not proven, the safety control locks out and must be manually reset. As long as there is a call for heat, the safety control can be reset, which starts another purge cycle and try for ignition. Once ignited, as additional heat is required, the combustion air increases the firing rate.

During heating operation, an electronic flame safety control provides continuous flame supervision. If combustion should become unstable for any reason, heating will automatically shut down and be locked out until reset at the unit mounted user interface panel. As the heating requirement is satisfied, the gas heat controller will modulate the combustion air and the firing rate will lower to maintain the desired outlet temperature. When the requirement is fully satisfied, the heating contacts are opened, de-energizing the heat. The specific sequence of operation of the gas heat will depend on the size of the heat exchanger.

Electric Heating

The individual stages of electric heat will be sequenced on the zone demand. The number of available stages will depend on the unit size and heat capacity selected.

Supply Air Setpoint Temperature Reset

Figure 2. Supply air temperature reset

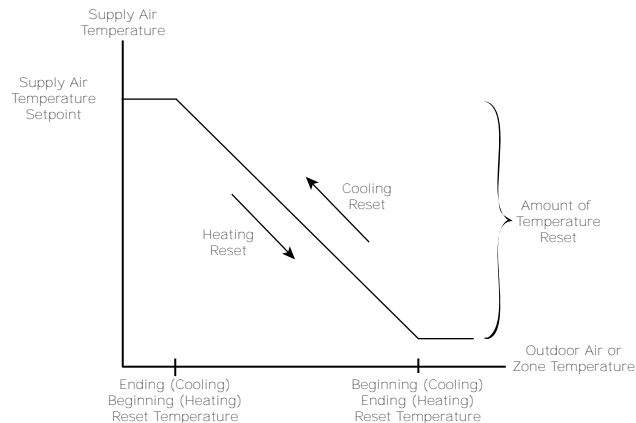

Supply air setpoint reset can be used to adjust the supply air temperature setpoint on the basis of a zone temperature or on outdoor air temperature. Supply air setpoint reset adjustment is available from the user interface for supply air heating and supply air cooling control.

Outdoor Air Cooling Reset

Outdoor air cooling reset is sometimes used in applications where the outdoor temperature has a large effect on building load. When the outside air temperature is low and the building cooling load is low, the supply air setpoint can be raised, thereby preventing sub-cooling of critical zones. This reset can lower usage of mechanical cooling, thus savings in compressor kW, but an increase in supply fan kW may occur.

Outdoor Air Heating Reset

Outdoor air heating reset is the inverse of cooling, with the same principles applied. For both outdoor air cooling reset and heating reset, there are three user-defined parameters that are adjustable through the user interface:

- Beginning reset temperature
- Ending reset temperature
- Amount of temperature reset

Zone Reset

Zone reset is applied to the zone(s) in a building that tend to be overly cool or overly hot. The supply air temperature setpoint is adjusted based on the temperature of the critical zone(s). This can have the effect of improving comfort and/or lowering energy usage. The user-defined parameters are the same as for outdoor air reset.

Supply Air Tempering

A feature that is used with modulating heat options, modulating gas, or hot water. Supply air tempering is enabled when the supply air temperature falls below the supply air temperature deadband low end. The heat valve is then modulated open to maintain the set minimum supply air temperature.

Zone Temperature Control

Unoccupied Zone Heating and Cooling

During Unoccupied mode, the unit is operated as a constant volume unit. VFDs operate at 100% and VAV boxes are driven full open. The unit controls zone temperature to the Unoccupied zone cooling and heating (heating units only) setpoints.

Morning Warmup Options (Not applicable to SZVAV)

This feature may be enabled on all types of factory installed heat units as well as cooling only units configured as “External Heat” (for example, VAV boxes with reheat). At the conclusion of Unoccupied mode, while the economizer (if supplied) is kept closed, the selected zone is heated to the user-defined Morning Warmup setpoint (see descriptions below). The unit is then released to Occupied mode.

Cycling Capacity Morning Warmup (MWU)

Cycling capacity Morning Warmup provides a more gradual heating of the zone. Normal zone temperature control with varying capacity is used to raise the zone temperature to the MWU zone temperature setpoint. This method of warmup is used to overcome the “building sink” effect. Cycling capacity MWU will operate until the MWU setpoint is reached or for 60 minutes, then the unit switches to Occupied mode. A control algorithm is used to increase or decrease the amount of heat in order to achieve the MWU zone temperature setpoint.

Note: *When using the Morning Warmup option in a VAV heating/cooling rooftop, airflow must be maintained through the rooftop unit. This can be accomplished by electrically tying the VAV boxes to the VAV box output relay contacts on the Symbio™ 800 Controls or by using changeover thermostats. Either of these methods will assure adequate airflow through the unit and satisfactory heating of the building.*

Daytime Warmup

This feature is available on all types of heating units. During Occupied mode, if the zone temperature falls to a preset, user-defined zone low limit temperature setpoint, the unit is put into Unoccupied mode and Daytime Warmup is initiated. The system changes over to constant volume heating (full unit airflow), the VAV boxes are fully opened and full heating capacity is provided until the Daytime Warmup setpoint is reached. The unit is then returned to normal Occupied mode.

Single Zone Variable Air Volume (SZVAV) Operation

The IntelliPak® controls platform will support Single Zone VAV as an optional unit control type in order to meet ASHRAE 90.1. The basic control will be a hybrid variable air volume/constant volume configured unit that provides discharge temperature control to a varying discharge air temperature target setpoint based on the space temperature and/or humidity conditions. Concurrently, the unit will control and optimize the supply fan speed to maintain the zone temperature to a zone temperature setpoint.

VFD Control

The VFD will modulate the supply fan motor speed, accelerating or decelerating as required to maintain the zone temperature to the zone temperature setpoint.



When subjected to high ambient return conditions the VFD will reduce its output frequency to maintain operation.

Supply Fan Output Control

Units configured for Single Zone VAV control will utilize the same supply fan output control scheme as on traditional VAV units except the VFD signal will be based on zone heating and cooling demand instead of the supply air pressure.

Space Pressure Control – Statitrac™

For units configured with Space Pressure Control with or without Statitrac, the new schemes implemented for economizer minimum position handling require changes to the existing Space Pressure Control scheme in order to prevent over/under pressurization. The overall scheme will remain very similar to VAV units with Space Pressure Control with the exception of the dynamic Relief Enable Setpoint.

For SZVAV, a Relief Enable Setpoint must be selected during the 100% Fan Speed Command. Once selected, the difference between the Relief Enable Setpoint and Design OA Damper Minimum Position at 100% Fan Speed Command will be calculated. The difference calculated will be used as an offset and added to the Active Building Design OA Minimum Position Target in order to calculate the dynamic Relief Enable Target, which will be used throughout the Supply Fan Speed/OA Damper Position range.

The Relief Enable Target could be above or below the Active Building Design OA Minimum Position Target Setpoint, based on the Active Relief Enable Setpoint being set above or below the Building Design Minimum Position at 100% Fan Speed Command. Note that a Relief Enable Setpoint of 0% will result in the same effect on Relief Fan control as on VAV applications with and without Statitrac.

Occupied Cooling Operation

For normal cooling operation, cooling capacity will be staged or modulated in order to meet the calculated discharge air target setpoint. If the current active cooling capacity is controlling the discharge air within the deadband, no additional cooling capacity change will be requested. As the Discharge Air Temperature rises above the deadband, the algorithm will request additional capacity as required (additional compressors or economizer). As the Discharge Air Temperature falls below the deadband, the algorithm will request a reduction in active capacity.

Default Economizer Operation

By default, the unit will be set up to optimize the minimum supply fan speed capability during Economizer Only operation. If the economizer is able to meet the demand alone, due to desirable ambient conditions, the supply fan speed will be allowed to increase above the minimum prior to utilizing mechanical cooling if discharge air setpoint falls below the discharge air Lower Limit (Cooling) setpoint.

Occupied Heating Operation

Occupied heating operation will utilize two separate control methodologies based on heating configurations. For all “Staged” Heating types, the unit will utilize full airflow during all active heating periods exactly like traditional Constant Volume units. For “Modulating” Heating types the unit will have the ability to utilize SZVAV Heating, much like Active Cooling, in order to maintain the Zone Temperature to the Zone Heating setpoint. Also, on units configured with a Modulating Heat type, the customer will have the ability to select between SZVAV Heating control, or to utilize traditional Constant Volume, full airflow heating based on the associated unit setup.

Unoccupied Mode

In Unoccupied periods the unit will utilize setback setpoints, 0% Minimum OA Damper position, and Auto Fan Mode operation as on normal Constant Volume units. The Supply Fan speed will be forced to 100% to operate in a constant volume mode for all active heating and cooling requests.

Cooling Sequence

If the controller determines that there is a need for compressor stages in order to meet the calculated discharge air target setpoint, once supply fan proving has been made, the unit will begin to stage compressors accordingly.

Note: The compressor staging order will be based on unit configuration and compressor lead/lag status. Once the discharge air target setpoint calculation has reached the user defined Minimum Setpoint and compressors are being utilized to meet the demand, if the cooling demand increases, the discharge air target setpoint value will continue to lower past the minimum setpoint and begin to ramp the supply fan speed upward toward 100%.

Once the discharge air target setpoint calculation has reached the Minimum Setpoint and compressors are being utilized to meet the demand, as the discharge air target setpoint value continues to calculate lower the algorithm will begin to ramp the supply fan speed up toward 100%. Note that the supply fan speed will remain at the compressor stage's associated minimum value (as described below) until the discharge air target setpoint value is calculated below the discharge air temperature Minimum Setpoint (limited discharge air target setpoint).

As the cooling load in the zone decreases the zone cooling algorithm will reduce the speed of the fan down to minimum per compressor stage and control the compressors accordingly. As the compressors begin to de-energize, the supply fan speed will fall back to the Cooling Stage's associated minimum fan speed, but not below. As the load in the zone continues to drop, cooling capacity will be reduced in order to maintain the discharge air within the $\pm\frac{1}{2}$ discharge air target deadband.

Heating

Gas Heating: Staged Heat

Up to two stages of gas heat will be sequenced based on zone demand. Status messages and diagnostics are communicated to the user interface.

Modulating Gas

Modulating gas heat will consist of one modulating valve for precise heating control. The output will be modulated as the demand in the zone changes. Status messages and diagnostics are communicated to the user interface.

Electric Heating

The individual stages of electric heat will be sequenced on the zone demand. The number of available stages will depend on the unit size and heat capacity selected.

SZVAV and VAV Operation

Note: SZVAV exceptions are noted in parenthesis.

Outside Air Control

Outside Air Measurement

Trane air quality (Traq™) outside air measurement system utilizes velocity pressure sensing rings. Based on unit design CFM, the Symbio™ 800 monitors and controls the quantity of outside air entering the unit. The outside airflow can be calibrated to compensate for altitude.

An optional CO₂ sensor may be connected to control outside air based on CO₂ Demand Control Ventilation (DCV).

Outside Airflow Compensation

As the supply fan modulates, this function proportionally adjusts the economizer minimum position to compensate for the change in total airflow, in order to maintain a constant percent of outside air. The modified economizer minimum position is computed as a linear function – based on VFD position – given the two endpoints:

- Minimum Position with VFD @ 0%
- Minimum Position with VFD @ 100%

Both are user adjustable at the user interface.

Unit Feedback – Supply and Relief Fan Speed Setpoints

Controls VAV Unit Feedback Setpoints BACnet® network points are available to allow for communication of the Supply and Relief Fan Speed Setpoints to the BAS. These points are only



Symbio™ 800 Controls

available for multi-zone VAV units. These setpoints will be overridden by equipment protection functionality, when applicable.

Emergency Override

When a LonTalk® communication protocol or BACnet® control network is installed, the user can initiate from the Tracer® Ensemble™ building automation system (BAS), Tracer® SC+ or third party BAS one of five predefined, not available to configure, Emergency Override sequences. All compressors, condenser fans and the Humidification output are de-energized for any Emergency Override sequence. Each Emergency Override sequence commands the unit operation as follows:

<p>PRESSURIZE_EMERG:</p> <ul style="list-style-type: none"> • Supply Fan - On • Supply Fan VFD - Max • Relief Fan - Off; Relief Dampers - Closed (if so equipped) • OA Dampers - Open; Return Damper - Closed • Heat - All heat stages off; Mod Heat output at 0 VDC • Occupied/Unoccupied/VAV box output - Energized • VOM Relay - Energized (if so equipped) • Preheat Output - Off • Return Fan - Off; Relief Dampers - Closed (if so equipped) • Return VFD - Min (if so equipped) 	<p>EMERG_DEPRESSURIZE:</p> <ul style="list-style-type: none"> • Supply Fan - Off • Supply Fan VFD - Min • Relief Fan - On; Relief Dampers - Open/Max (if so equipped) • OA Dampers - Closed; Return Damper - Open • Heat - All heat stages off; Mod Heat output at 0 VDC • Occupied/Unoccupied/VAV box output - Energized • VOM Relay - Energized (if so equipped) • Preheat Output - Off • Return Fan - On; Relief Dampers - Open (if so equipped) • Return VFD - Max (if so equipped)
<p>EMERG_PURGE:</p> <ul style="list-style-type: none"> • Supply Fan - On • Supply Fan VFD - Max • Relief Fan - On; Relief Dampers Open (if so equipped) • OA Dampers - Open; Return Damper - Closed • Heat - All heat stages off; Mod Heat output at 0 VDC • Occupied/Unoccupied/VAV box output - Energized • VOM Relay - Energized (if so equipped) • Preheat Output - Off • Return Fan - On; Relief Dampers - Open (if so equipped) • Return VFD - Max (if so equipped) 	<p>EMERG_SHUTDOWN:</p> <ul style="list-style-type: none"> • Supply Fan - Off • Supply Fan VFD - Min • Relief Fan - Off; Relief Dampers - Closed (if so equipped) • OA Dampers - Closed; Return Damper - Open • Heat - All heat stages off; Mod Heat output at 0 VDC • Occupied/Unoccupied/VAV box output - Energized • VOM Relay - Energized (if so equipped) • Preheat Output - Off • Return Fan - Off; Relief Dampers - Closed (if so equipped) • Return VFD - Min (if so equipped)
<p>EMERG_FIRE - Input from fire pull box/system:</p> <ul style="list-style-type: none"> • Supply Fan - Off • Supply Fan VFD - Min • Relief Fan - Off; Relief Dampers - Closed (if so equipped) • OA Dampers - Closed; Return Damper - Open • Heat - All heat stages off; Mod Heat output at 0 VDC • Occupied/Unoccupied/VAV box output - Energized • VOM Relay - Energized (if so equipped) • Preheat Output - Off • Return Fan - Off; Relief Dampers - Closed (if so equipped) • Return VFD - Min (if so equipped) 	

Ventilation Override Module (VOM)

The user can customize up to five different override sequences for purposes of ventilation override control. If more than one VOM sequence is being requested, the sequence with the highest priority is initiated first. Sequence hierarchy is the sequence “A” (UNIT OFF) is first, with sequence “E” (PURGE with Duct Pressure Control) last. A ventilation override mode can be initiated by closing any of the five corresponding binary inputs on the VOM module. A binary output is provided on the VOM module to provide remote indication of an active VOM mode. All compressors, condenser fans and the Humidification output are de-energized for any VOM sequence. The factory default definitions for each mode are as follows:

<p>UNIT OFF sequence “A” When complete system shutdown is required the following sequence can be used.</p> <ul style="list-style-type: none"> • Supply Fan - Off • Supply Fan VFD - Min • Relief Fan - Off; Relief Dampers - Closed (if so equipped) • OA Dampers - Closed; Return Damper - Open • Heat - All heat stages off; Mod Heat output at 0 VDC • Occupied/Unoccupied/VAV box output - Deenergized • VOM Relay - Energized • Preheat Output - Off • Return Fan - Off; Relief Dampers - Closed (if so equipped) • Return VFD - Min (if so equipped) • OA Bypass Dampers - Open (if so equipped) • Relief Bypass Dampers - Open (if so equipped) 	<p>PRESSURIZE sequence “B” Perhaps a positively pressurized space is desired instead of a negatively pressurized space. In this case, the supply fan should be turned on with VFD at 100% speed and exhaust fan should be turned off.</p> <ul style="list-style-type: none"> • Supply Fan - On • Supply Fan VFD - Max • Relief Fan - Off; Relief Dampers - Closed (if so equipped) • OA Dampers - Open; Return Damper - Closed • Heat - All heat stages off; Mod Heat output at 0 VDC • Occupied/Unoccupied/VAV box output - Energized • VOM Relay - Energized • Preheat Output - Off • Return Fan - Off; Relief Dampers - Closed (if so equipped) • Return VFD - Min (if so equipped) • OA Bypass Dampers - Open (if so equipped) • Relief Bypass Dampers - Open (if so equipped)
<p>EXHAUST sequence “C” With only the exhaust fans running (supply fan off), the space that is conditioned by the rooftop would become negatively pressurized. This is desirable for clearing the area of smoke from the now-extinguished fire, possibly keeping smoke out of areas that were not damaged.</p> <ul style="list-style-type: none"> • Supply Fan - Off • Supply Fan VFD - Min • Relief Fan - On; Relief Dampers Open (if so equipped) • OA Dampers - Closed; Return Damper - Open • Heat - All heat stages off; Mod Heat output at 0 VDC • Occupied/Unoccupied/VAV box output - Deenergized • VOM Relay - Energized • Preheat Output - Off • Return Fan - On; Relief Dampers - Open (if so equipped) • Return VFD - Max (if so equipped) • OA Bypass Dampers - Open (if so equipped) • Relief Bypass Dampers - Open (if so equipped) 	<p>PURGE sequence “D” Possibly this sequence could be used for purging the air out of a building before coming out of Unoccupied mode of operation on VAV units or for the purging of smoke or stale air if required after a fire.</p> <ul style="list-style-type: none"> • Supply Fan - On • Supply Fan VFD - Max • Relief Fan - On; Relief Dampers Open (if so equipped) • OA Dampers - Open; Return Damper - Closed • Heat - All heat stages off; Mod Heat output at 0 VDC • Occupied/Unoccupied/VAV box output - Energized • VOM Relay - Energized • Preheat Output - Off • Return Fan - On; Relief Dampers - Open (if so equipped) • Return VFD - Max (if so equipped) • OA Bypass Dampers - Open (if so equipped) • Relief Bypass Dampers - Open (if so equipped)
<p>PURGE with duct pressure control sequence “E” This sequence can be used when supply air control is required for smoke control.</p> <ul style="list-style-type: none"> • Supply Fan - On • Supply Fan VFD - Controlled by Supply Air Pressure Control function; Supply Air Pressure High Limit disabled • Relief Fan - On; Relief Dampers Open (if so equipped) • OA Dampers - Open; Return Damper - Closed • Heat - All heat stages off; Mod Heat output at 0 VDC • Occupied/Unoccupied/VAV box output - Energized • VOM Relay - Energized • Preheat Output - Off • Return Fan - On; Relief Dampers - Open (if so equipped) • Return VFD - Max (if so equipped) • OA Bypass Dampers - Open (if so equipped) • Relief Bypass Dampers - Open (if so equipped) 	

User Interface (UI)

A 7 inch user interface features a touch-sensitive color screen that provides operating status, performance monitoring, and scheduling changes and operating adjustments.

Frost/Freeze Avoidance

Evaporator Coil Frost Protection Limit

Temperature and pressure readings on each evaporator circuit are used to determine if the coil is approaching a freezing condition. The coil frost protection limit reduces the need for hot gas bypass and sheds cooling when coil frosting conditions occur. The supply fans are not shut off and will de-ice the coil. Timers prevent the compressors from rapid cycling.



Steam and Hot Water Coil - Freeze Avoidance

Freeze Avoidance is a feature which helps prevent freezing of steam or hot water heat coils during periods of unit inactivity and low ambient temperatures. Whenever the unit supply fan is off, the outdoor air temperature is monitored. If the temperature falls below a predetermined value, the heating valve is opened to a position selected on the user interface to allow a minimum amount of steam or hot water to flow through the coil and avoid freezing conditions.

Occupied/Unoccupied Switching

There are two ways to switch between Occupied or Unoccupied:

- Field-supplied contact closure (hard wired binary input to Symbio™ 800 Controls) (SZVAV and VAV). This input accepts a field supplied switch or contacts closure, such as a time-of-day clock
- Tracer (or third party BAS)

Economizer Controls

Comparative Enthalpy Control of Economizer

An optional comparative enthalpy system is used to control the operation of the economizer, and measures the temperature and humidity of both return air and outside air to determine which source has lower enthalpy. This system allows true comparison of outdoor air and return air enthalpy by measurement of outdoor air and return air temperatures and humidities.

Reference Enthalpy Control of Economizer

The optional reference enthalpy compares outdoor air temperature and humidity to the economizer enthalpy control setpoint. If outdoor air temperature and humidity are below the economizer enthalpy control setpoint, the economizer will operate freely. This system provides more sophisticated control where outdoor air humidity levels may not be acceptable for building comfort and indoor air quality.

Dry Bulb Temperature Control of Economizer

The optional dry bulb system measures outdoor temperature comparing it to the economizer control temperature setpoint. If the outdoor temperature is below the economizer dry bulb temperature control setpoint, the economizer will operate freely. This system is best suited for arid regions where the humidity levels of outside air would not be detrimental to building comfort and indoor air quality.

Differential Dry Bulb Temperature Control of Economizer

The optional differential dry bulb system measures outdoor temperature comparing it to the return air temperature. If the outdoor temperature is below the return air dry bulb temperature minus the economizer dry bulb enable offset the economizer will operate freely. This system is best suited for arid regions where the humidity levels of outside air would not be detrimental to building comfort and indoor air quality.

Balanced Starts

Balanced starts is a user-selectable feature through the User Interface available on all units without the eFlex™ variable speed option. After each request for compressor operation, the lead refrigeration circuit switches, thereby causing a more equitable or balanced run time among compressors.

Emergency Stop Input

A binary input is provided for installation of field provided switch or contacts for immediate shutdown of all unit functions.

Anti-Short Cycle Protection

A standard feature provided to prevent excessive cycling and premature wear of the compressors, contactors and related components.

High Duct Temperature Sensor

Two temperature sensors, Discharge Air and Return Air (if installed) are used to determine if duct temperatures are excessively high. If the discharge air temperature exceeds 200°F or if the return air temperature exceeds 135°F, the unit will be placed into Emergency Stop Mode.

CO₂ Control - Demand Control Ventilation (DCV)

A ventilation reset function that provides the necessary ventilation for occupants and reduces energy consumption by minimizing the outdoor air damper position (or the OA flow setpoint with Traq) below the Building Design Minimum, while still meeting the ASHRAE Std 62.1 ventilation requirements.

- If the space CO₂ level is greater than or equal to the CO₂ Design Setpoint, the outdoor air damper will open to the Design Min Outdoor Air Damper (or OA Flow) Setpoint. If there is a call for economizer cooling, the outdoor air damper may be opened further to satisfy the cooling request.
- If the space CO₂ level is less than or equal to the CO₂ Minimum Setpoint, the outdoor air damper will close to the DCV Minimum Outdoor Air Damper (or OA Flow) Setpoint. If there is a call for economizer cooling, the outdoor air damper may be opened further to satisfy the cooling request.
- If the space CO₂ level is greater than the CO₂ Minimum Setpoint and less than the CO₂ Design Setpoint, the outdoor air damper position is (or OA flow) modulated proportionally to the Space CO₂ level relative to a point between the CO₂ Min Setpoint and the CO₂ Design Setpoint. If there is a call for economizer cooling, the outdoor air damper may be opened further to satisfy the cooling request.

Note: CO₂ sensor used with Demand Control Ventilation must be powered from an external power source or separate 24 VAC transformer.

Figure 3. CO₂ control

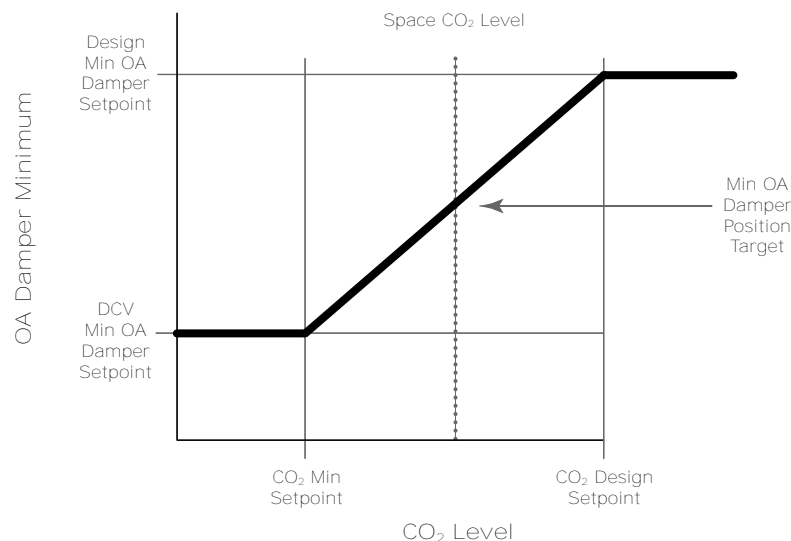

Low Charge Protection

A refrigerant charge estimate is calculated using a combination of measured temperatures, calculated saturated temperatures, refrigerant mass flow and the expansion valve opening. At the touch screen interface, a warning diagnostic is displayed when a low charge has been detected on the circuit, but is not critical enough to force a circuit shutdown. When a critical low charge has been detected on the circuit, a circuit shut down is triggered, and a shutdown diagnostic is displayed at the touch screen interface. Other diagnostic messages include the following:

- A diagnostic message displayed at the user interface, warning of a low charge situation when the unit is just slightly undercharged. The unit will be allowed to run.
- A diagnostic message displayed at the user interface, warning of a low charge situation when the unit is undercharged. The undercharged circuit will be locked out to protect the compressors.



Condenser Fan Control

The Symbio™ 800 controller cycles or modulates condenser fans based on ambient temperature and saturated condensing temperature to ensure the optimum operating conditions for the unit.

LonTalk® Building Automation System

The LonTalk® communication protocol for the Symbio™ 800 controller expands communications from the unit UCM network to a Tracer® Ensemble™ building automation system or third party building automation system. Utilizing LonTalk®, the BAS allows external setpoint and configuration adjustment and monitoring of status and diagnostics. The Symbio™ 800 utilizes an FTT-10A free topology transceiver, which supports non-polarity sensitive, free topology wiring—which in turn allows the system installer to utilize star, bus, and loop architectures. This controller works in standalone mode, peer-to-peer with one or more other units, or when connected to a Tracer® Ensemble™ or a third party building automation system that supports LonTalk®. The LON controller is available as a factory or field-installed kit.

BACnet® Building Automation Control Network

The BACnet® control network for Symbio™ 800 expands communications from the unit controller network to the Tracer® Ensemble™ building automation system or third party building automation system. Utilizing BACnet, the BAS allows external setpoint and configuration adjustment and monitoring of status and diagnostics. The Symbio™ 800 utilizes the BACnet defined MS/TP protocol as defined in ASHRAE standard 135-2004. This controller works in standalone mode, with Tracer® Ensemble™ or when connected to a third party building automation system that supports BACnet.

AirFi® Wireless Communication Interface

Trane AirFi® Wireless Comm replaces the BACnet communication link and sensor wire on Tracer® building automation systems for faster, easier, lower-risk installation and life-cycle savings.

The Air-Fi Wireless Communications Interface (WCI) enables wireless communications between system controls, unit controls, and wireless sensors for Trane® control products that use the BACnet® protocol. The WCI replaces the need for communications wire in all system applications.

The Air-Fi Wireless Communications Sensor (WCS) is compatible with any Trane controller that uses a WCI. The WCS provides the same functions as many currently available Trane wired sensors. No further software or hardware is necessary for site evaluation, installation, or maintenance.

Adherence to ANSI/ASHRAE® Standards 125-2016 (BACnet Zigbee®), enables secure and reliable wireless monitoring and control over commercial building systems. It also conforms to the IEEE® 802.15.4 standard, which ensures that your wireless BAS Communication system will reliably coexist with other wireless systems, including Bluetooth and Wi-Fi.

Modulating Hot Gas Reheat for Dehumidification

Modulating hot gas reheat involves adding a refrigerant-to-air heat exchanger downstream of the evaporator (cooling) coil. A valve diverts the hot refrigerant vapor leaving the compressor through this heat exchanger to reheat the dehumidified air leaving the evaporator coil. This allows the use of heat that is recovered from the refrigeration circuit of the rooftop unit to reduce system operating costs by avoiding the use of “new” energy for reheat.

The main function of the IntelliPak® rooftop unit is to provide zone temperature control. While modulating hot gas reheat will improve dehumidification performance at part-load conditions, it does not function as a standalone dehumidifier. In general, hot gas reheat requires a call for cooling to initiate. If there is a need for dehumidification when there is no need for sensible cooling, another solution may need to be investigated. IntelliPak packaged rooftop systems include non-standard solutions that might be considered for these applications.

Applications which should be investigated before using the standard modulating hot gas reheat option include:

- Process humidity control applications
- Makeup air or 100% outdoor air
- Zones with dramatically varying load conditions (sanctuaries, locker rooms, gymnasiums, etc.)

Low Ambient Compressor Start Lockout

This function will lock out the compressor if the outdoor air temperature is below the low ambient compressor lock out temperature setpoint. The factory setpoint is 50°F on standard units and 0°F on low ambient units. This setpoint is adjustable at the user interface. Compressors will be locked out when outdoor air temperatures fall below the selected temperature and will be allowed to start again when temperatures rise 5°F above the setpoint.

Isolation Damper Control

The Symbio™ 800 supports field installed discharge and/or return isolation dampers including damper parameter setup, damper command, position status and associated alarms.

Refrigerant Detection and Mitigation

Equipment with R-454B refrigerant will require a refrigerant detection system. When the refrigerant detection system is in a normal state, the equipment provides normal heating, cooling, and ventilation.

The refrigerant sensor creates an alarm signal when the sensed refrigerant concentration has exceeded the refrigerant concentration alarm threshold. The alarm threshold is a non-adjustable preset value. Refrigerant concentration is read and reported from the leak detector.

While the refrigerant detection system is in an alarm state, the equipment is required to mitigate the alarm condition for a minimum of 5 minutes after the refrigerant detection system has reset to a normal state.

In the event the control system detects the refrigerant sensor has failed, become disconnected or unpowered; controls will respond with a diagnostic and mitigation becomes active. The unit shall operate to provide mitigation actions for the duration of the sensor failure mode. The supply fan will operate continuously, and all compressor operation is disabled. In heating modes of operation, non-compressor heating and ventilation are allowed to maintain space comfort. Economizer cooling operation is also allowed.



Application Considerations

High Capacity Evaporator

Rooftops are popular because of their “packaged” nature. Everything needed is contained in one box; mix-matching is neither necessary nor available. With this convenience comes some disadvantages, among them correctly matching cooling capacity to building load. For example, a 105 ton rooftop would need to be used on an application that is 91 tons, simply because the ton rooftop does not meet capacity. Matching the rooftop’s capacity to the building load is critical, which is why the IntelliPak line offers a high capacity coil option on its rooftops.

Capacity tables for both standard and high capacity units are available in the cooling data section of this catalog. Use the pressure drops associated with the high capacity coil option by adding them to the total static pressure used to size the supply fan motor. eFlex™, variable speed compressors also help units match the load needed by varying the compressor capacity down to 15% of full load.

eFlex™ Variable Speed

A state of the art Trane eFlex™ variable speed compressor is combined with fixed capacity compressors to provide a superior part load efficiency (IEER) option. Compressor designs are optimized and selected to maximize part load performance. Continuous capacity from 15-100% means that discharge air temperature is controlled within +/-1°F. This eliminates discharge air temperature swings caused by cycling fixed capacity compressors, improves humidity control, and leads to increased comfort in the space.

Relief/Return Fan Options

The Trane 100% modulating relief system with Statitrac is an excellent choice for controlling building pressure. With a relief fan system, the supply fan motor and drives must be sized to overcome the total system static pressure, including return losses, and pull return air back to the unit during non-economizer operation.

For systems with high return static pressure losses, Trane’s 100% modulating return fan system is recommended. In a return fan system, the return fan works in series with the supply fan, and operates continuously whenever the supply fan is operating to maintain return air volume. The return fan motor and drives are sized to pull the return CFM back to the unit based on return duct static. Therefore, with a return fan system, the supply fan ordinarily requires less horsepower than a system with a relief fan.

Either return or relief fan systems with Statitrac may be used on any rooftop application that has an outdoor air economizer.

Relief/Return Fan Systems

Reasons for selecting either return or relief fan systems include economy, building pressure control, code requirements, and generally accepted engineering practices.

- 100% modulating relief with Statitrac direct space sensing building pressurization control
- 100% modulating plenum return airfoil fan with Statitrac direct space sensing building pressurization control with variable frequency drive

100% Modulating relief with Statitrac™ Control, and Variable Air Volume (VAV) Units

For VAV rooftops, the 100% modulating relief discharge dampers (or VFD) are modulated in response to building pressure. A differential pressure control system, Statitrac, uses a differential pressure transducer to compare indoor building pressure to atmospheric pressure. The FC relief fan is turned on when required to lower building static pressure to setpoint. The Statitrac control system then modulates the discharge dampers (or VFD) to control the building pressure to within the adjustable, specified deadband that is set at the user interface. Economizer and return air dampers are modulated independent of the relief dampers (or VFD) based on ventilation control and economizer cooling requests.

Advantages

- The relief fan runs only when needed to lower building static pressure.
- Statitrac compensates for pressure variations within the building from remote relief fans and makeup air units.
- The relief fan discharges in a single direction resulting in more efficient fan operation compared to return fan systems.
- When discharge dampers are utilized to modulate the relief airflow, the relief fan may be running unloaded whenever the economizer dampers are less than 100% open.

The Trane 100% modulating relief system with Statitrac provides efficient control of building pressure in most applications simply because 100 percent modulating relief discharge dampers and VFD are controlled directly from building pressure, rather than from an indirect indicator of building pressure, such as outdoor air damper position.

100% Modulating Relief with Statitrac Control, SZVAV Units

The overall scheme will remain very similar to non-Single Zone VAV units with Space Pressure Control with the exception of the dynamic Relief Enable Setpoint.

For SZVAV the user will select an Relief Enable Setpoint during the 100% Fan Speed Command. Once selected, the difference between the Relief Enable Setpoint and Design OA Damper Minimum Position at 100% Fan Speed Command will be calculated. The difference calculated will be used as an offset to be added to the Active Building Design OA Minimum Position Target to calculate the dynamic Relief Enable Target to be used throughout the Supply Fan Speed/OA Damper Position range.

Advantages

- The relief fan runs only when the economizer reaches the desired relief enable point.
- Relief dampers are modulated based on the economizer position.
- The relief fan discharges in a single direction resulting in more efficient fan operation compared to return fan systems.
- When discharge dampers are utilized to modulate the relief airflow, the relief fan may be running unloaded whenever the economizer dampers are less than 100% open.

The Trane 100% modulating relief system provides excellent linear control of building relief in most applications where maintaining building pressure is not important.

100% Modulating Return Fan Systems with Statitrac Control and Variable Air Volume (VAV) Units

The IntelliPak rooftop offers 100% modulating return fan systems. A differential pressure control system, Statitrac, uses a differential pressure transducer to compare indoor building pressure to atmospheric pressure.

The return fan relief dampers are modulated, based on space pressure, to control the building pressure to within the adjustable, specified deadband that is set at the user interface. A VFD modulates the return fan speed based on return duct static pressure.

Economizer and return air dampers are modulated independent of the relief dampers based on ventilation control and economizer cooling requests.

Advantages

- The return fan operates independently of the supply fan to provide proper balance throughout the airflow envelope.
- Statitrac compensates for pressure variations within the building from remote relief fans and makeup air units.
- The return fan acts as both relief and return fan based on operation requirements.

The Trane 100% modulating return system with Statitrac provides efficient control of building pressure in applications with higher return duct static pressure and applications requiring duct returns. Relief

discharge dampers are controlled directly from building pressure, return fan VFD is controlled from return static pressure, and return/economizer dampers are controlled based on ventilation control and economizer cooling requests.

Other Cooling Options

Cooling, Rapid Restart Units Only

This is for applications where the space has a high heat load with critical temperature control requirements. A typical application is a computer room that has a large number of routers and servers. If the cooling capacity is lost due to a power interruption, the temperature in the room can rise as much as 3-4°F per minute. Once power is restored (e.g., backup generator has started), the cooling capacity needs to be maximized as soon as possible to help get the space under control. Once cooling capacity has been maximized, the unit can then manage the load using its normal capacity control algorithms.

Supply and Return Airflow Configurations

The typical rooftop installation has both the supply and return air paths routed through the roof curb and building roof. However, many rooftop installations require horizontal supply and/or return from the rooftop because of a building's unique design or for acoustic considerations.

There are several ways to accomplish horizontal supply, see and/or .

Figure 4. Left/right unit orientation and horizontal airflow

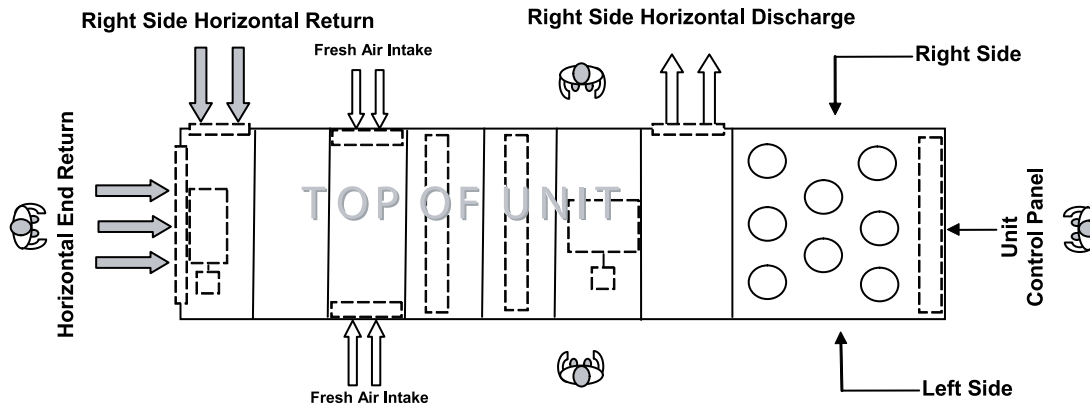

Table 1. Supply airflow configuration

Cabinet Configuration	Supply Airflow Discharge Direction	Type	Acceptable Application	With Bag Final Filters	With Cartridge Final Filters	With HEPA Final Filters
Standard Length	Downflow - Standard Option	Cooling Only	Yes	No	No	No
Standard Length	Horizontal - Right Side - Standard Option	Cooling Only	Yes	No	No	No
Standard Length	Horizontal - Left Side - Field Convertible	Cooling Only	Field Convert	No	No	No
Standard Length	Downflow - Standard Option	Gas, Electric, Steam, Hot Water Heat	Yes	No	No	No
Standard Length	Horizontal - Right Side - Standard Option	Gas, Electric, Steam, Hot Water Heat	Yes	No	No	No
Standard Length	Horizontal - Left Side - Field Convertible	Gas, Electric, Steam, Hot Water Heat	No	No	No	No
4 ft. Blank Section	Downflow - Standard Option	Cooling Only	Yes	Yes	Yes	Yes

Table 1. Supply airflow configuration (continued)

Cabinet Configuration	Supply Airflow Discharge Direction	Type	Acceptable Application	With Bag Final Filters	With Cartridge Final Filters	With HEPA Final Filters
4 ft. Blank Section	Horizontal - Right Side - Standard Option	Cooling Only	Yes	Yes	Yes	Yes
4 ft. Blank Section	Horizontal - Left Side - Field Convertible	Cooling Only	Field Convert	Yes	Yes	Yes
4 ft. Blank Section	Downflow - Standard Option	Gas, Electric, Steam, Hot Water Heat	No	No	No	No
4 ft. Blank Section	Horizontal - Right Side - Standard Option	Gas, Electric, Steam, Hot Water Heat	No	No	No	No
4 ft. Blank Section	Horizontal - Left Side - Field Convertible	Gas, Electric, Steam, Hot Water Heat	No	No	No	No
8 ft. Blank Section	Downflow - Standard Option	Cooling Only, Steam Heat, Hot Water Heat	Yes	Yes	Yes	Yes
8 ft. Blank Section	Horizontal - Right Side - Standard Option	Cooling Only, Steam Heat, Hot Water Heat	Yes	Yes	Yes	Yes
8 ft. Blank Section	Horizontal - Left Side - Field Convertible	Cooling Only, Steam Heat, Hot Water Heat	Field Convert	Yes	Yes	Yes
8 ft. Blank Section	Downflow - Standard Option	Gas ^(a) or Electric ^(b)	Yes	No	High Temp	High Temp
8 ft. Blank Section	Horizontal - Right Side - Standard Option	Gas ^(a) or Electric ^(b)	Yes	No	High Temp	High Temp
8 ft. Blank Section	Horizontal - Left Side - Field Convertible	Gas ^(a) or Electric ^(b)	Field Convert	No	High Temp	High Temp

^(a) Not available with 2.5M MBh heater.

^(b) Multi-piece units with electric heat and eight foot blank section are not field convertible from right side horizontal to left side horizontal configuration.

Note: For left/right unit orientation, see [Figure 4, p. 26](#).

Table 2. Return airflow configuration

Airflow Config	Relief Fan VFD	Return Fan VFD
Vertical	Yes	Yes
Horizontal - Right	Yes	Yes
Horizontal - Left	No	No
Horizontal - End	Yes	No

Note: For left/right unit orientation, see [Figure 4, p. 26](#).

When using an IntelliPak 2 Rooftop for horizontal supply and/or return, an additional pressure drop must be added to the supply external static to account for the 90 degree turn the air is making. This additional pressure drop depends on airflow and rooftop size, but a range of 0.10 inches to 0.30 inches can be expected. The openings on the rooftop all have a one inch lip around the perimeter to facilitate ductwork attachment

Corrosive Atmospheres

Trane's IntelliPak™ Rooftops are designed and built to industrial standards and will perform to those standards for an extended period depending on the hours of use, the quality of maintenance performed, and the regularity of that maintenance.

One factor that can have an adverse effect on unit life is operation in a corrosive environment. Since the Microchannel condenser coil is an all-aluminum design, it provides a high level of corrosion protection on its own. Uncoated, it withstands a salt spray test in accordance with ASTM B117 for 1,000 hours. When rooftops are operated in highly corrosive environments, Trane recommends the corrosion protected condenser coil option.

This corrosion protection option meets the most stringent testing in the industry, including ASTM B117 Salt Spray test for 6,000 hours and ASTM G85 A2 Cyclic Acidified Salt Fog test for 2,400 hours. The acid fog test is the most stringent available today. This coating is added after coil construction covering all tubes, headers, fins and edges. The design provides superior protection from any corrosive agent. For evaporator coils, epoxy coating can be utilized as a design special.

IntelliPak paint innately handles harsh weather, including most coastal and salt environments and direct sun. The unit paint was salt spray tested in accordance with ASTM B117 and UV weathering resistance



Application Considerations

tested in accordance with ASTM G155 Test cycle 1 for 2000 hours. For further detail on the paint testing, refer to PROD-SLB034*-EN.

Note: *Field coating is not allowed on Microchannel coils.*

Ventilation Override Sequences

One of the benefits of using a relief fan rather than a return fan, in addition to the benefits of lower energy usage is that the rooftop can be used as part of a ventilation override system. Several types of sequences can be easily done when relief fans are a part of the rooftop system. One of the benefits of using a relief fan rather than a return fan, in addition to the benefits of lower energy usage is that the rooftop can be used as part of a ventilation override system. Several types of sequences can be easily done when relief fans are a part of the rooftop system.

Typically, a manual switch is used and located near the fire protection control panel. This enables the fire department access to the control for use during or after a fire. It is also possible to initiate the sequence from a field-installed automatic smoke detector. In either case, a contact closure begins the ventilation override control sequence.

The user can customize up to five (5) different override sequences for purposes such as smoke control. The following parameters within the unit can be defined for each of the five sequences:

- Supply Fan - on/off
- Variable Frequency Drives - on (60 Hz)/off (0 Hz)/controlling
- Relief/Return Fan - on/off
- Relief Dampers - open/closed
- Economizer Dampers - open/closed
- Heat - off/controlling (output for) VAV Boxes - open/controlling

Compressors and condenser fans are shut down for any Ventilation Override sequence. Factory preset sequences include unit Off, Relief, Purge, Purge with duct pressure control, and Pressurization. Any of the user-defined Ventilation Override sequences can be initiated by closing a field supplied switch or contacts connected to an input on the Ventilation Override Module. If more than one ventilation override sequence is being requested, the sequence with the highest priority is initiated. Refer to the Ventilation Override Mode (VOM) information in the Control section of this catalog for more details on each override sequence.

Natural Gas Heating Considerations

Trane uses 304L stainless steel throughout the construction of its IntelliPak™ natural gas drum and tube heat exchangers.

These heat exchangers can be applied with confidence, particularly with full modulation control, when mixed air temperatures are below 50°F, and low ambient temperatures can cause condensation to form on the heat exchanger. The natural gas heat exchangers are not recommended for applications with mixed air conditions entering the heat exchanger below 30°F to ensure adequate leaving air heating temperature. For airflow limitations and temperature rise across the heat exchanger information, see Natural Gas Heating Capacities table in Performance Data.

Acoustic Considerations

The best time to make provisions to reduce sound transmission to the occupied space is during the project design phase. Proper placement of rooftop equipment is critical to reducing sound transmitted into the building. The most economical means of avoiding an acoustical problem is to locate rooftop equipment away from acoustically-sensitive areas. If possible, locate rooftop equipment above corridors, utility rooms, restrooms, or other areas where higher sound levels are acceptable.

It is not possible to totally quantify the effect of the building structure on sound transmission, since this depends on the response of the roof and building members to the sound and vibration of the unit components. However, the following guidelines have been proven through experience to help reduce sound transmission through the building structure:

- Never cantilever the condensing section of the rooftop unit; a structural cross member must support this end of the unit.
- Locate the unit's center of gravity close to (or over) a column or main support beam to minimize roof deflection and vibration-related noise.

- If the roof structure is very light, roof joists should be replaced by a structural shape in the critical areas described above.
- If several units are to be placed on one span, they should be staggered to reduce deflection over that span.

For more information:

- ASHRAE. 2015. *ASHRAE Handbook – HVAC Applications* (Chapter 48: Noise and Vibration Control). Atlanta, GA: ASHRAE.
- ASHRAE. 2011. *Practical Guide to Noise and Vibration Control for HVAC Systems*. Atlanta, GA: ASHRAE.
- Guckelberger, D. 2000. "Controlling Noise From Large Rooftop Units," *ASHRAE Journal* (May): pp. 55-62.
- Trane. Guckelberger, D. and Bradley, B. 2006. *Acoustics in Air Conditioning*, ISS-APM001-EN. La Crosse, WI: Inland Printing Company.
- Trane. Murphy, J. and Harshaw, J. 2012. *Rooftop VAV Systems*, SYS-APM007-EN. La Crosse, WI: Inland Printing Company.

In addition, the Trane Acoustics Program™ (TAP) allows for modeling of various sound paths to predict sound levels in the occupied space. The software models airborne sound from supply- and return-air paths, as well as duct breakout and roof transmission sound, so that the designer can identify potential sound problems and make design alterations before equipment installation. TAP is also capable of modeling the effect of outdoor sound on adjacent properties. This program is available at www.trane.com. Ask your local Trane representative for additional information.

High Entering Return Temperature Applications

Some applications may have high entering return temperatures. It is recommended that the dry bulb temperatures in any application not exceed 95°F for extended periods of time. If this is a requirement, please work with the Applications or Product Support group in developing a specific assessment. Other factors, such as wet bulb and ambient temperatures, will also affect the system's reaction.

Clearance Requirements

The recommended clearances identified in [Figure 21, p. 117](#) and should be maintained to assure adequate service capability, maximum capacity and peak operating efficiency. A reduction in unit clearance could result in condenser coil starvation or warm condenser air recirculation. If the clearances shown are not possible on a particular job, consider the following:

- Do the clearances available allow for major service work such as changing compressors or coils?
- Do the clearances available allow for proper outside air intake, relief air removal, and condenser airflow?
- If screening around the unit is being used, is there a possibility of air recirculation from the relief to the outside air intake, or from condenser exhaust to condenser intake?
- Do clearances meet all applicable codes?

Actual clearances which appear inadequate should be reviewed with a local Trane sales engineer.

When two or more units are to be placed side by side, the distance between the units should be increased to 150 percent of the recommended single unit clearance. The units should also be staggered for the following reasons:

- To reduce span deflection if more than one unit is placed on a single span. Reducing deflection discourages sound transmission.
- To assure proper diffusion of relief air before contact with the outside air intake of adjacent unit.

Figure 5. Unit placement

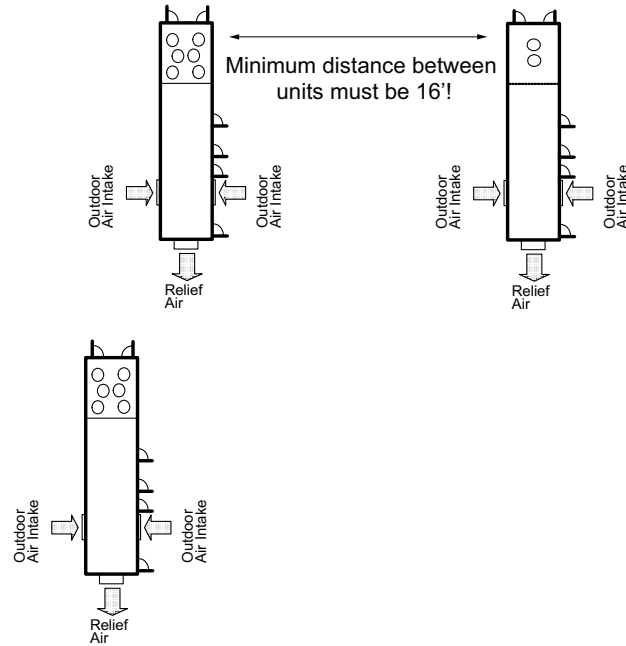

Duct Design

It is important to note that the rated capacities of the rooftop can be met only if the rooftop is properly installed in the field. A well-designed duct system is essential in meeting these capacities.

The satisfactory distribution of air throughout the system requires that there be an unrestricted and uniform airflow from the rooftop discharge duct. This discharge section should be straight for at least several duct diameters to allow the conversion of fan energy from velocity pressure to static pressure.

However, when job conditions dictate elbows be installed near the rooftop outlet, the loss of capacity and static pressure may be reduced through the use of guide vanes and proper direction of the bend in the elbow. The high velocity side of the rooftop outlet should be directed at the outside radius of the elbow rather than the inside as illustrated in [Figure 6, p. 30](#).

Figure 6. Duct design

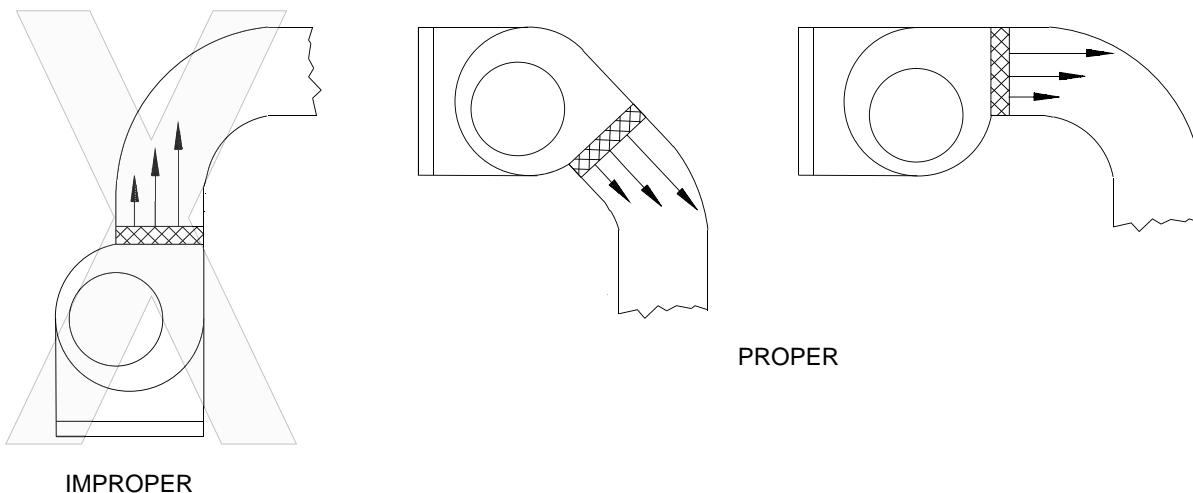

Energy Recovery Wheel

For applications where the air streams within the rooftop must be isolated, consider using alternative technologies that guarantee separation of the air streams.

Important: *Do not use energy wheels in applications where the relief air is contaminated with harmful toxins or biohazards or where even a minor mixing of the air streams presents a health risk. See IntelliPak™ 2 Commercial Rooftop Air Conditioners Installation, Operation, and Maintenance (RT-SVX073*-EN) for more information.*

The energy recovery option was designed as a partial flow outside air system, where the required outside air is less than 100 percent. IntelliPak 2 monitors outside air, return air, and zone conditions. It compares them with setpoints (set in the rooftop user interface) and checks for suitable energy recovery system operation. Energy recovery can be activated when both supply and relief fans are in operation. Heat can be recovered when the return air dry bulb temperature is greater than the outside air dry bulb temperature.

Energy recovery is disabled when economizer cooling operation is requested. Economizer cooling in energy recovery wheel equipped units requires the relief air and outside air bypass dampers to be open and the recovery wheel motor to be off. The energy recovery wheel can provide free cooling when outside air enthalpy is greater than return air enthalpy. In general, energy recovery works well in applications where a high outside airflow minimum is required, often because of high occupancy.

Modulating Hot Gas Reheat

Often supply fan VAV modulation, staged compressor control, or the addition of an eFlex™ variable speed compressor are sufficient in handling building humidity in a wide range of indoor load conditions. Applications where non-peak load conditions can be dominated by latent loads are candidates for the Hot Gas Reheat option. This includes many applications subject to ASHRAE Standard 62 requirements.

When a Hot Gas Reheat coil is energized, it increases the air temperature after exiting the evaporator coil. While this provides dehumidification, this is not a dehumidifier. The main function of the Packaged RTU is to provide zone temperature control. For times when dehumidification is needed, the hot gas reheat will be energized.

Applications which should be investigated before using the standard modulating hot gas reheat option, and will require additional investigation include the following:

- Process applications
- Units utilized as a make-up air or 100% outside air units
- Zones with dramatically varying load conditions (sanctuaries, locker rooms, gymnasiums, etc.)

A2L Application Considerations

This product is listed to UL standard 60335-2-40, Household and Similar Electrical Appliances – Safety – Part 2-40: Particular Requirements for Electrical Heat Pumps, Air-Conditioners and Dehumidifiers, which defines safe design and use strategies for equipment using A2L refrigerants. This standard limits the refrigerant concentration in a space in the event of a refrigerant leak. To meet the requirements, the UL standard defines minimum room area, refrigerant charge limit, minimum circulation airflow and/or ventilation airflow requirements, and limits the use of ignition sources in ductwork and spaces. The standard may require a unit refrigerant leak detection system.

For equipment with R-454B and charge amounts less than or equal to 3.91 lbs per circuit, this UL standard does not prescribe a room area limit and does not require a refrigerant leak detection system or any circulation airflow or ventilation airflow mitigation strategies. However, ignition sources in ductwork must be evaluated.

Depending on the application, a specific requirement of ANSI/ASHRAE Standard 15, Safety Standard for Refrigeration Systems, could be more stringent than UL 60335-2-40 requirements. See *Refrigeration Systems and Machinery Rooms Application Considerations for Compliance with ASHRAE® Standard 15-2022 Application Engineering Manual (APP-APM001*-EN)* for more information.



Application Considerations

Minimum Room Area Limits (Refrigerant charge greater than 3.91 lb per circuit)

Equipment with R-454B charge amounts greater than 3.91 lb per circuit may require additional circulation or ventilation airflow mitigation strategies. In this case, two minimum room area (A_{min}) thresholds:

- The first threshold defines when equipment serving a single room is required to provide circulation airflow, either continuous or activated by a leak detection system. A ducted system requires circulation airflow unless the smallest room it serves is larger than the adjusted A_{min} threshold. This product contains a leak detection system if a circuit charge is greater than 3.91 lbs. As a result, no further leak detection system evaluation is required.
- The second threshold defines when additional ventilation airflow is required. If the room area, A or TA, is below the adjusted A_{min} or TA_{min} threshold, additional ventilation is required to remove refrigerant in the event of a leak. Refer to UL 60335-2-40 Clause GG.8 and ANSI/ASHRAE Standard 15 Section 7 for natural and mechanical ventilation requirements. See equipment nameplate for minimum room area.

Minimum Room Area (A_{min}) Adjustments

- **Altitude:** The A_{min} threshold changes with altitude. Multiple the altitude adjustment factor in the following table by A_{min} shown on the unit nameplate.

Table 3. Altitude adjustment factor

Altitude (ft)	Sea Level to 2000	2001 to 4000	4001 to 6000	6001 to 8000	8001 to 10000	10001 to 12000	12001 to 14000	14001 to 15000	Over 15000
A_{min} Adjustment	1	1.05	1.11	1.17	1.24	1.32	1.41	1.51	1.57

- **Height :** A_{min} can be adjusted if the unit is installed in a room at a height higher than the minimum height shown on the unit. Multiply A_{min} by the ratio of the unit minimum installation height (in meters) / actual installation height (in meters).
- **Institutional Occupancies:** For institutional occupancies, ASHRAE Standard 15 applies an additional adjustment factor, FOCC, to the amount of charge allowed in a space. To calculate the adjusted A_{min} for institutional occupancies, divide the A_{min} on the nameplate by 0.5.

Determining Room Area (A or TA)

The room area (A) is the room area enclosed by the projection to the floor of the walls, partitions, and doors of the space that the equipment serves. For ducted systems, total room area (TA) of all rooms connected by ducts, may be used instead of A.

Rooms connected by drop ceilings only are not considered a single room.

Rooms on the same floor of the building, and connected by an open passageway, can be considered part of the same room if the passageway is a permanent opening, extends to the floor and is intended for people to walk through.

Adjacent rooms on the same floor of the building and connected by permanent openings in the walls and/or doors between rooms (including gaps between the wall and the floor), can be considered part of the same room if the openings meet the following criteria.

- The opening is permanent and cannot be closed.
- Openings extending to the floor, such as door gaps, need to be at least 20mm above the floor covering surface.
- Natural ventilations opening areas must meet the requirements of ANSI/ASHRAE Standard 15-2022, Section 7.2.3.2.

Rooms that are connected by a mechanical ventilation system can be considered a single room area if the mechanical ventilation system meets the requirements of ANSI/ASHRAE Standard 15-2022, Section 7.6.4.

Leak Detection System (Refrigerant charge greater than 3.91 lb per circuit)

The leak detection system consists of one or more refrigerant detection sensors. When the system detects a leak, the following mitigation actions will be initiated until refrigerant has not been detected for at least 5 minutes:

- Energize the supply fan(s) to deliver a required minimum amount of circulation airflow.
- Disable compressor operation.
- Provide an output signal to fully open all zoning dampers, such as VAV boxes.
- Provide an output to energize additional mechanical ventilation (if needed).
- Units without airflow proving will disable electric heat sources.

Building fire and smoke systems may override this function.

If the refrigerant sensor has a fault, is at the end of its life, or is disconnected, the unit will initiate the mitigation actions. Mitigation actions may be verified by disconnecting the sensor.

The refrigerant sensors do not need service. Use only Trane-approved sensors when replacement is required.



Selection Procedure

This section outlines a step-by-step procedure that may be used to select a Trane air-cooled single-zone air conditioner. Air-cooled models should be selected based on dry bulb (DB) conditions. For specific model selection, utilize TSA or contact the local Trane Sales Office. This sample selection is based on the following conditions:

Note: When calculating capacities for evaporative condensers, use ambient wet bulb (WB).

Summer Design	
Summer outdoor design conditions	95 DB/76 WB ambient temperature
Summer room design conditions	78 DB/65 WB
Total cooling load	980 MBh (81.6 tons)
Sensible cooling load	735 MBh (61.25 tons)
Outdoor air ventilation load	154.0 MBh (12.8 tons)
Return air temperature	78 DB/65 WB
Winter design:	
Winter outdoor design conditions	0°F
Return air temperature	70°F
Total heating load	720 MBh
Winter outdoor air ventilation load	288.6 MBh
Total winter heating load	1008.6 MBh
Air delivery data:	
Supply fan CFM	36,000 CFM
External duct static pressure	1.86 in wg
Minimum outdoor air ventilation fan CFM	3,600 CFM
Return air duct negative static pressure	0.3 in wg
Electrical characteristics:	
Voltage/cycle/phase	460/60/3
Unit Accessories	<ul style="list-style-type: none"> • Gas fired heat exchanger - high heat • Downflow supply and upflow return • High efficiency throwaway filters • Economizer • Modulating 100% relief

Cooling Capacity Selection

1. Nominal Unit Size Selection

A summation of the peak cooling load and the outside air ventilation load shows: 980 MBh + 154.0 MBh = 1134.0 MBh required unit capacity. From [Table 13, p. 52](#), a 105 ton unit with standard capacity evaporator coil at 80 DB / 65 WB, 95°F outdoor air temperature and 36,000 total supply CFM is 1,217 MBh total and 1,022 MBh sensible. Thus, a nominal 105 ton unit with standard capacity evaporator coil is selected.

2. Evaporator Coil Entering Conditions

Mixed air dry bulb temperature determination:

Using the minimum percent of OA (3,600 CFM ÷ 36,000 CFM = 10%), determine the mixture dry bulb to the evaporator.

$$RADB + \% OA (OADB - RADB) = 78 + (0.10) (95 - 78) = 78 + 1.5 = 79.5^{\circ}\text{F}$$

Approximate wet bulb mixture temperature:

$$RAWB + \% OA (OAWB - RAWB) = 65 + (0.10) (76 - 65) = 65 + 1.1 = 66.1^{\circ}\text{F}$$

3. Determine Supply Fan Motor Heat Gain

Having selected a nominal 105 ton unit, the supply fan bhp can be calculated. The supply fan motor heat gain must be considered in final determination of unit capacity.

Table 4. Determine unit total static pressure at design supply CFM

Supply Duct Static Pressure	2.2 inches
Evaporator Coil (Table 54, p. 99)	0.64 inches
Return Duct Negative Static Pressure	0.30
Heat Exchanger (Table 54, p. 99)	0.03
Throwaway Filter (Table 54, p. 99)	0.26
Economizer Damper ^(a) (Table 54, p. 99)	0.57
Unit Total Static Pressure	4.0

^(a) Add either the economizer damper value or return damper value, depending on which static pressure is greater. (Do not use both.)

Using total of 36,000 CFM and total static pressure of 4.0 inches, enter 40.4 bhp with 1,097 rpm required for the 36-inch supply fan. Supply fan motor heat gain = 109.0 MBh, or 109.0 MBh ÷ 36000 CFM x 1.085 = 2.8°F supply fan motor heat. See supply fan graph in [Figure 12, p. 89](#).

4. Determine Total Required Cooling Capacity

Required capacity = Total peak load + OA load + supply air fan motor heat

$$\text{Required capacity} = 980.0 + 154.0 + 109.0 = 1243.0 \text{ MBh (103.6 tons)}$$

5. Determine Unit Capacity

From [Table 13, p. 52](#), unit total capacity at 79.5 DB/66.1 WB entering the evaporator, 36,000 supply air CFM, 95°F outdoor ambient is 1,232 MBh (102.7 tons) with 965 MBh (80.4 tons) sensible capacity.

6. Determine Leaving Air Temperature

Unit sensible heat capacity corrected for supply air fan motor heat = 965 MBh sensible - 109.0 MBh motor heat = 856 MBh.

Supply air dry bulb temperature difference =

$$\frac{\text{Sensible Btu}}{1.085 \times \text{Supply CFM}} =$$

$$\text{Sensible Btu} = 856 \text{ MBh} / (1.085 \times 36,000 \text{ CFM}) = 21.9$$

$$\text{Supply air dry bulb} = 79.5 \text{ DB} - 21.9 = 57.6 \text{ leaving evaporator coil}$$

$$\frac{\text{Total Btu}}{4.5 \times \text{Supply CFM}} =$$

$$\text{Unit enthalpy difference} = 1,232 \text{ MBh} \div (4.5 \times 36,000 \text{ CFM}) = 7.60 \text{ Btu/lb.}$$

$$\text{Leaving enthalpy} = h (\text{ent WB}) - h (\text{diff}). \text{ From } \text{Table 8, p. 48}, h (\text{ent WB}) = 30.9 \text{ Btu/lb.}$$

$$\text{Leaving enthalpy} = 30.9 \text{ Btu/lb.} - 7.60 \text{ Btu/lb.} = 23.30 \text{ Btu/lb.}$$

$$\text{Supply air wet bulb} = 55.1 \text{ leaving evaporator coil.}$$

$$\text{Leaving air temperature} = 57.6 \text{ DB/55.1 WB}$$

Heating Capacity Selection

1. **Determine air temperature entering heating module**

Mixed air temperature = $RADB + \% OA (OADB - RADB) = 70 + (0.10) (0 - 70) = 63^{\circ}F$

Supply air fan motor heat temperature rise = $109000 \text{ Btu} \div (1.085 \times 36000 \text{ CFM}) = 2.8^{\circ}F$

Air temperature entering heating module = $63.0 + 2.8 = 65.8^{\circ}F$

2. **Determine total winter heating load**

Total winter heating load = peak heating load + ventilation load - supply fan motor heat = $720 + 288.6 - 109.0 = 899.6 \text{ MBh}$

a. **Electric heating system**

Unit operating on 460/60/3 power supply.

From [Table 48, p. 96](#), kW may be selected for a nominal 105 ton unit operating 460-volt power. The 265 kW heat module (904.4 MBh) will satisfy the winter heating load of 899.6 MBh.

[Table 48, p. 96](#) shows an air temperature rise of $23.2^{\circ}F$ for 36,000 CFM through the 265 kW heat module.

Unit supply temperature at design heating conditions = mixed air temperature + air temperature rise = $65.8^{\circ}F + 23.2^{\circ}F = 89.0^{\circ}F$.

b. **Gas heating system (natural gas)**

From [Table 47, p. 96](#) select the high heat module (1,458 MBh output) to satisfy winter heating load of 899.6 MBh at unit CFM.

[Table 47, p. 96](#) also shows an air temperature rise of $37.3^{\circ}F$ for **36,000 CFM** through the heating module.

Unit supply temperature at design heating conditions = mixed air temperature + air temperature rise = $65.8^{\circ}F + 37.3^{\circ}F = 103.1^{\circ}F$.

c. **Hot water heating system**

Assume a hot water supply temperature of $190^{\circ}F$ and an entering coil temperature of $65.8^{\circ}F$.

Subtract the mixed air temperature from the hot water temperature to determine the ITD (initial temperature difference).

$ITD = 190^{\circ}F - 65.0^{\circ}F = 125^{\circ}F$. Divide the winter heating load by ITD = $1008.6 \text{ MBh} \div 125^{\circ}F = 8.0 \text{ Q/ITD}$.

From [Table 51, p. 97](#), select the low heat module. By interpolation, a Q/ITD of 8.0 can be obtained at a gpm of 40.0. Water pressure drop at 40.0 gpm is 0.33 ft. of water.

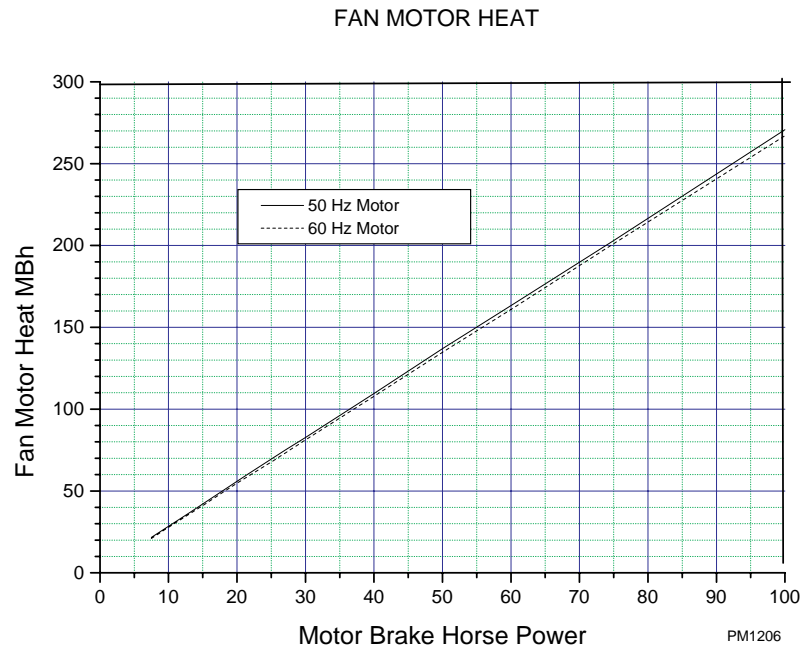
Figure 7. Fan motor heat

Heat module temperature rise is determined by:

$$\frac{\text{Total Btu}}{1.085 \times \text{Supply CFM}} = \Delta T$$

$$\frac{1008600}{1.085 \times 36000} = 25.8$$

Unit supply air temperature = mixed air temperature + air temperature rise = 65.4 + 25.8 = 91.2° F.

d. **Steam heating system**

Assume a 15 psig steam supply.

From [Table 53, p. 98](#), the saturated temperature steam is 250°F. Subtract mixed air temperature from the steam temperature to determine ITD.

$$\text{ITD} = 250^\circ\text{F} - 65.0^\circ\text{F} = 185^\circ\text{F}.$$

Divide winter heating load by ITD = 1008.6 MBh ÷ 185°F = 5.45 Q/ITD.

From [Table 52, p. 98](#), select the low heat module. The low heat module at 36,000 CFM has a Q/ITD = 7.45.

$$\text{Heat module capacity, Q} = \text{ITD} \times \text{Q/ITD} = 185^\circ\text{F} \times 7.45 \text{ Q/ITD} = 1378 \text{ MBh}$$

Heat module air temperature rise is determined by:

$$\frac{\text{Total Btu}}{1.085 \times \text{Supply CFM}} = \Delta T$$

$$\frac{1378000}{1.085 \times 36000} = 35.3$$

Unit supply temperature at design conditions = mixed air temperature + air temperature rise = $65.4^{\circ}\text{F} + 35.3^{\circ}\text{F} = 100.7^{\circ}\text{F}$.

e. Air delivery procedure

Supply fan performance tables include internal resistance of rooftop. For total static pressure determination, system external static must be added to appropriate component static pressure drop (evaporator coil, filters, optional economizer, optional relief fan, optional heating system, optional cooling only extended casing).

f. Supply fan motor sizing

The supply fan motor selected in the cooling capacity determination was 40.4 bhp and 1,097 rpm. Thus, a 40 hp supply fan motor is selected.

Enter [Table 61, p. 106](#) to select the proper drive. For a 105 ton rooftop with 40 hp motor, a drive letter A - 1,100 rpm is selected.

g. Relief fan motor sizing

The relief/return fan is selected based on total return system negative static pressure and relief fan CFM. Return system negative static includes return duct static, and any other job site applicable static pressure drop.

Return duct static pressure = 0.30 inches.

Total return system negative static pressure = 0.30 inches.

Exhaust fan CFM = 36,000 CFM

From the relief fan curve ([Figure 15, p. 92](#)), the required bhp is estimated at 21 bhp at 400 rpm. Thus, the relief fan motor selected is 25 hp.

To select a drive, enter [Table 62, p. 106](#) for a 25 hp motor for a 105 ton unit. Drive selection number 4 - 400 rpm.

h. Return fan motor sizing

Return fan drive selection is shown on [Table 63, p. 107](#). The same static pressure and CFM considerations must be taken for return fan size, horsepower, and drive selection as are required for relief fan sizing. However, since the return fan runs continuously the sensible heat generated by the return fan motor must be included in the entering evaporator coil mixed air temperature equation.

In this selection, if the return motor bhp is equal to the relief motor bhp, $21.44 \text{ bhp} = 58.1 \text{ MBh} \div (1.085 \times 36,000 \text{ Return CFM}) = 1.5^{\circ}\text{F}$ added to the return air temperature.

Where altitudes are significantly above sea level, use [Table 9, p. 49](#) and [Figure 8, p. 48](#) for applicable correction factors.

i. Unit Electrical Requirements

Selection procedures for electrical requirements for wire sizing amps, maximum fuse sizing, and dual element fuses are given in the electrical service section of this catalog.

j. Altitude Corrections

The rooftop performance tables and curves of this catalog are based on standard air (.075 lbs/ft). If the rooftop airflow requirements are at other than standard conditions (sea level), an air density correction is needed to project accurate unit performance.

[Figure 8, p. 48](#) shows the air density ratio at various temperatures and elevations. Trane rooftops are designed to operate between 40° and 90°F leaving air temperature. The procedure to use when selecting a supply or relief/return fan on a rooftop for elevations and temperatures other than standard is as follows:

- Determine the air density ratio using [Figure 8, p. 48](#).
- Divide the static pressure at the nonstandard condition by the air density ratio to obtain the corrected static pressure.
- Use the actual CFM and the corrected static pressure to determine the fan rpm and bhp from the rooftop performance tables or curves.
- The fan rpm is correct as selected.
- Bhp must be multiplied by the air density ratio to obtain the actual operating bhp.

In order to better illustrate this procedure, the following example is used: Consider a 90 ton rooftop unit that is to deliver 32,000 actual CFM at 3-inches total static pressure (tsp), 55°F leaving air temperature, at an elevation of 5,000 ft.

- From [Figure 8, p. 48](#), the air density ratio is 0.86.
- $Tsp = 3.0\text{-inches} / 0.86 = 3.49\text{ inches tsp}$.
- From the supply fan curve [Figure 10, p. 87](#) a 90 ton rooftop will deliver 32,000 CFM at 3.49 inches TSP at 997 rpm and an estimated 30 bhp.
- $Bhp = 30 \times 0.86 = 25.8\text{ bhp actual}$.
- The rpm is correct as selected - 997 rpm.

Compressor MBh, SHR, and kW should be calculated at standard and then converted to actual using the correction factors in [Table 9, p. 49](#). Apply these factors to the capacities selected at standard CFM so as to correct for the reduced mass flow rate across the condenser. Heat selections other than gas heat will not be affected by altitude. Nominal gas capacity (output) should be multiplied by the factors given in [Table 10, p. 49](#) before calculating the heating supply air temperature.

Total Energy Recovery Wheel

Utilize Trane Select Assist (TSA) or contact the local Trane sales office to calculate required return air preheat temperature for the given minimum outdoor air temperature and return air relative humidity.

To calculate the supply and relief air conditions leaving the wheel, you must know the wheel effectiveness. Refer to for total effectiveness measurements.

Note: *The effectiveness numbers shown assume equal supply and relief airflows. If the airflows are unbalanced, the effectiveness changes. Use TSA to determine effectiveness values for these conditions.*

Calculate Wheel Performance

Use the following equations to calculate supply air conditions. Use TSA to calculate relief air conditions and to obtain actual dry bulb temperature and enthalpy values for coil and equipment sizing.

1. Dry bulb temperature:

$$\text{Cooling: } Tsa = Toa - (E \times (Toa - Tra))$$

$$\text{Heating: } Tsa = Toa + (E \times (Tra - Toa))$$

where:

Tsa = Dry bulb temperature of supply air (°F)

Toa = Dry bulb temperature of outside air (°F)

Tra = Dry bulb temperature of return air (°F)

E = Sensible Effectiveness

2. Enthalpy:

$$\text{Cooling: } Hsa = Hoa - (E \times (Hoa - Hra))$$

$$\text{Heating: } Hsa = Hoa + (E \times (Hra - Hoa))$$

where:

Hsa = Enthalpy of supply air (Btu/ lb)

Hoa = Enthalpy of outside air (Btu/ lb)

Hra = Enthalpy of return air (Btu/lb)

E = Total Effectiveness

After calculating these two points, use a psychrometric chart to obtain the supply air wet bulb temperature and/or grains moisture.

3. Energy wheel application example

In this example, a wheel sized for nominal 10,500 CFM will be used for the initial evaluation. The air pressure drop is 1.07 in. wg and the total effectiveness is 73% (see). The total and latent



Selection Procedure

effectiveness values are close to equal for Trane energy wheels. For this example, total effectiveness is assumed to be 73% in cooling mode and 75% in heating mode. TSA could be used to obtain the exact values.

- a. Supply air conditions, cooling mode:

$$T_{sa} = T_{oa} - (E \times (T_{oa} - T_{ra})) = 95^{\circ}\text{F} - (.73 \times (95^{\circ}\text{F} - 75^{\circ}\text{F})) = 81^{\circ}\text{F}$$

$$H_{sa} = H_{oa} - (E \times (H_{oa} - H_{ra})) = 38.4 \text{ Btu/lb} - (.73 \times (38.4 \text{ Btu/lb} - 26.0 \text{ Btu/lb})) = 29.3 \text{ Btu/lb}$$

According to a psychrometric chart, the supply air wet bulb temperature is 64.4°F, 64 grains/lbm.

$$T_{sa} = T_{oa} + (E \times (T_{ra} - T_{oa})) = 10^{\circ}\text{F} + (.75 \times (70^{\circ}\text{F} - 10^{\circ}\text{F})) = 55^{\circ}\text{F}$$

$$H_{sa} = H_{oa} + (E \times (H_{ra} - H_{oa})) = 3.2 \text{ Btu/lb} + (.75 \times (22.7 \text{ Btu/lb} - 3.2 \text{ Btu/lb})) = 17.8 \text{ Btu/lb}$$

According to a psychrometric chart, the supply air wet bulb temperature is 45.5°F, 30 grains/lbm.

When designing the remainder of the air-handling system, remember to account for the air pressure drop imposed by the energy wheel.

Hot Gas Reheat Selection

The hot gas reheat coil is designed to deliver maximum reheat temperatures. Contact the local Trane Sales Office or refer to the IntelliPak™ Trane Select Assist (TSA) program to determine leaving air temperature, latent capacity, reheat sensible capacity, leaving unit dew point, and moisture removal when the unit is in reheat operation. If the reheat setpoint is not obtainable at the provided conditions the customer will be required to make adjustments to the conditions or change the reheat setpoint value. Please note that reheat operation will not be allowed when there is a call for heating.



Model Number Description

Digit 1 — Unit Type

S = Self-Contained (Packaged Rooftop)

Digit 2 — Unit Function

E = DX Cooling, Electric Heat
F = DX Cooling, Natural Gas Heat
L = DX Cooling, Hot Water Heat
S = DX Cooling, Steam Heat
X = DX Cooling, No Heat

Digit 3 — System Type

H = Single Zone

Digit 4 — Development Sequence

T = R-454B

Digit 5, 6, 7 — Nominal Capacity

090 = 90 Ton Air-Cooled
105 = 105 Ton Air-Cooled
120 = 120 Ton Air-Cooled
130 = 130 Ton Air-Cooled
150 = 150 Ton Air-Cooled

Digit 8 — Voltage Selection

4 = 460/60/3
5 = 575/60/3
C = 380/50/3

Digit 9 — Heating Capacity Selection

0 = No Heat
1 = Electric Heat 90/56 kW 60/50 Hz
2 = Electric Heat 140/88 kW 60/50 Hz
3 = Electric Heat 265/166 kW 60/50 Hz
4 = Electric Heat 300/188 kW 60/50 Hz
A = Low Gas Heat – 2-stage
B = Medium Gas Heat – 2-stage
C = High Gas Heat – 2-stage
D = Low Gas Heat – Modulating
E = Medium Gas Heat – Modulating
F = High Gas Heat – Modulating
G = Low Heat - 1.0" (25mm) Valve
H = Low Heat - 1.25" (32mm) Valve
J = Low Heat - 1.5" (38mm) Valve
K = Low Heat - 2.0" (50mm) Valve
L = Low Heat - 2.50" (64mm) Valve
M = Low Heat - 3.0" (76mm) Valve
N = High Heat - 1.0" (25mm) Valve
P = High Heat - 1.25" (32mm) Valve
Q = High Heat - 1.5" (38mm) Valve
R = High Heat - 2.0" (50mm) Valve
T = High Heat - 2.50" (64mm) Valve
U = High Heat - 3.0" (76mm) Valve

Digit 10, 11 — Design Sequence

Digit 12 — Unit Configuration Selection

1 = One-Piece Unit w/o Blank Section
2 = One-Piece Unit w/4' Blank Section
3 = One-Piece Unit w/8' Blank Section
4 = Two-Piece Unit w/o Blank Section
5 = Two-Piece Unit w/4' Blank Section
6 = Two-Piece Unit w/8' Blank Section

Digit 13 — Supply/Return Airflow Direction

1 = Downflow Supply/Upflow Return
2 = Downflow Supply/Horiz End Return
3 = Downflow Supply/Horiz Right Return
4 = Right Side Horiz Supply/Upflow Return
5 = Right Side Horiz Supply/Horizontal End Return
6 = Right Side Horiz Supply/Horizontal Right Return

Digit 14 — Supply Fan Options

1 = Standard CFM Supply Fan Motor(s)
3 = Standard CFM Supply Fan - TEFC High EFF Motor(s)
4 = Low CFM Supply Fan Motor(s)
6 = Low CFM Supply Fan - TEFC High EFF Motor (s)
7 = Standard CFM Supply Fan - with Internal Shaft Grounding
9 = Standard CFM Supply Fan - TEFC Motor and internal SGR
A = Low CFM Supply Fan - with Internal Shaft Grounding
C = Low CFM Supply Fan - TEFC Motor and internal SGR
D = Standard CFM Fan Motor(s) and Piezometer
E = Standard CFM Fan - TEFC Motor(s) and Piezometer
F = Standard CFM Fan - ODP with SGR Motor(s) and Piezometer
G = Standard CFM Fan - TEFC with SGR Motor(s) and Piezometer
H = Low CFM Fan Motor(s) and Piezometer
J = Low CFM Fan - TEFC Motor(s) and Piezometer
L = Low CFM Fan - ODP with SGR Motor(s) and Piezometer
M = Low CFM Fan - TEFC with SGR Motor(s) and Piezometer

Digit 15 — Supply Fan Motor Selection

F = 15 Hp
G = 20 Hp
H = 25 Hp
J = 30 Hp
K = 40 Hp
L = 50 Hp
M = 60 Hp
N = 75 Hp
P = 100 Hp

Digit 16 — Supply Fan RPM Selection

7 = 700
8 = 800
9 = 900
A = 1000
B = 1100
C = 1200
D = 1300
E = 1400
F = 1500
G = 1600
H = 1700
J = 1800
K = 1900
L = 2000

Digit 17 — Relief/Return Fan Options

0 = None
5 = Std CFM Exhaust with VFD with Bypass
6 = Low CFM Exhaust with VFD with Bypass
7 = Std CFM Exhaust with VFD without Bypass
8 = Low CFM Exhaust with VFD without Bypass
C = Std CFM Return with VFD with Bypass
D = Low CFM Return with VFD with Bypass
E = Std CFM Return with VFD without Bypass
F = Low CFM Return with VFD without Bypass
G = Std CFM Exhaust with VFD with Bypass and Piezometer
H = Low CFM Exhaust with VFD with Bypass and Piezometer
J = Std CFM Exhaust with VFD without Bypass and Piezometer
K = Low CFM Exhaust with VFD without Bypass and Piezometer
L = Std CFM Return with VFD with Bypass and Piezometer
M = Low CFM Return with VFD with Bypass and Piezometer
N = Std CFM Return with VFD without Bypass and Piezometer
P = Low CFM Return with VFD without Bypass and Piezometer



Model Number Description

Digit 18 — Relief/Return Fan Motor Selection

0 = None
 D = 7.5 Hp
 E = 10 Hp
 F = 15 Hp
 G = 20 Hp
 H = 25 Hp
 J = 30 Hp
 K = 40 Hp
 L = 50 Hp
 M = 60 Hp

Digit 19 — Relief/Return RPM Selection

0 = None
 3 = 300
 4 = 400
 5 = 500
 6 = 600
 7 = 700
 8 = 800
 9 = 900
 A = 1000
 B = 1100
 C = 1200
 D = 1300
 E = 1400

Digit 20 — System Control Selection

4 = VAV (Discharge Temp Control) with VFD Supply
 5 = VAV(Discharge Temp Control) with VFD Supply with Bypass
 6 = VAV (Single Zone) with VFD Supply
 7 = VAV(Single Zone) with VFD with Bypass

Digit 21 — Fresh Air Options/Controls

A = 0-25% Motorized Damper
 B = Economizer with Dry Bulb
 C = Economizer with Reference Enthalpy
 D = Economizer with Comparative Enthalpy
 E = Econ with Fresh Air Measure/Dry Bulb
 F = Econ with Fresh Air Measure/Ref Enthalpy
 G = Econ with Fresh Air Measure/Comp Enthalpy
 H = Econ with DCV/Dry Bulb^(a)
 J = Econ with DCV/Ref Enthalpy^(a)
 K = Econ with DCV/Comp Enthalpy^(a)
 L = Econ with Differential Dry Bulb
 M = Econ with DVC/Differential Dry Bulb^(a)
 N = Econ with Fresh Air Measure/DVC/Differential Dry Bulb^(a)

Digit 22 — Damper Option

0 = Standard
 1 = Low Leak Damper(s)-AMCA Class 2, 10cfm/ft²
 2 = Ultra Low Leak Damper(s)-AMCA Class 1, 4cfm/ft²
 3 = Ultra Low Leak, AMCA 1A, Title 24

Digit 23— Pre-Evaporator Coil Filter Selection

0 = Pre-Evap Filters-MERV 8, High Eff Filters
 1 = Pre-Evap Filters-2" Rack/Less Filters
 2 = Pre-Evap Filters-MERV 15 Bag Filters w/ Prefilters
 3 = Pre-Evap Filters - Bag Filter Rack/Less Filters
 4 = Pre-Evap Filters - MERV 14 Cartridge Filters w/ Prefilters
 5 = Pre-Evap Filters - Cartridge Rack/Less Filters
 6 = Pre-Evap Filters - MERV 14 Low PD Cartridge w/Prefilters
 7 = Pre-Evap Filters - Low PD Cartridge Rack/Less Filters

Digit 24 — Blank Section Application Options

0 = None
 A = Final MERV 15 Bag Filters with Prefilters
 B = Final MERV 14 Low PD Cartridge Filters with Prefilters
 C = Final MERV 14 , Cartridge Filters with Prefilters
 D = Final MERV 14 High Temp Cartridge Filters with Prefilters
 E = Final MERV 17 HEPA Filters with Prefilters
 F = Final MERV 17 High Temp HEPA Filters with Prefilters

Digit 25 — Energy Recovery Wheel

0 = None
 1 = Low CFM ERW with Bypass Defrost
 2 = Standard CFM ERW with Bypass Defrost

Digit 26 — Unit Mounted Power Connection Selection

A = Terminal Block
 B = Non-Fused Disconnect
 C = Non-Fused Disconnect with Powered Convenience Outlet
 D = Unit Disconnect Switch with High Fault SCCR
 E = Unit Disconnect Switch with High Fault SCCR/ Powered Convenience Outlet

Digit 27 — Condenser Coil Selection

0 = All Aluminum Air-Cooled Condenser Coil
 J = Corrosion Protected Condenser Coil

Digit 28 — Efficiency, Capacity, and Drain Pan Option

A = Standard Evap Coil with Stainless Steel Drain Pan
 C = High Cap Evap Coil with Stainless Steel Drain Pan
 W = eFlex™ with Std Evap Coil with SS Drain Pan
 Z = eFlex™ with Hi Cap Evap Coil with SS Drain Pan

Digit 29 — Refrigeration System A

0 = Standard
 A = Suction Service Valves
 B = Replaceable Core Liquid Filter Driers
 C = Suction Service Valves and Replaceable Core Liquid Filter Driers

Digit 30 — Refrigeration System B

0 = Standard
 1 = Modulating Hot Gas Reheat
 2 = Hot Gas Bypass
 3 = Modulating Hot Gas Reheat/Hot Gas By-Pass

Digit 31 — Ambient Control Option

0 = Standard Ambient
 1 = Low Ambient

Digit 32 — Controls

0 = None
 1 = Expansion Module
 2 = Power Meter
 3 = Expansion Module with Power Meter

Digit 33 — Controls (continued)

0 = None
 3 = Rapid Restart
 4 = Filter Monitoring
 5 = Rapid Restart with Filter Monitoring

^(a) Requires CO₂ Sensor(s).

Digit 34 — Module Options

0 = None
1 = Modbus®
2 = Modbus and Ventilation Override
3 = Air-Fi®
4 = AirFi and Ventilation Override
D = Ventilation Override
F = LonTalk®
L = LonTalk and Ventilation Override
M = BACnet®
N = BACnet and Ventilation Override
W = BACnet with AirFi
Z = BACnet Interface and Ventilation Override

Digit 35 — Zone Sensor Option

0 = No Accessory Panel
A = BAYSENS108 - Dual Setpoint with Man/Auto
Changover
C = BAYSENS073 - Room Sensor with Timed
Override and Cancel
D = BAYSENS074 - Room Snsr with TO and
Cancel and Local Stpt Adj
M = BAYSENS800 - Programmable Zone Sensor

Digit 36 — Agency Approval Option

0 = None
1 = cULus

Digit 37 — Service Enhancements

0 = Single Side Access Door
A = Dual Side Access Door
B = Single Side Access Doors/ Marine Lights
C = Dual Side Access Doors/ Marine Lights

Digit 38 — Miscellaneous Options

0 = None
1 = Belt Guards
2 = Burglar Bars
3 = Belt Guards/Burglar Bars
4 = Isolation Damper Control
5 = Belt Guards/Isolation Damper Control
6 = Burglar Bars/Isolation Damper Control
7 = Belt Guards/Burglar Bars/Isolation Damper
Control



General Data

Table 5. General data (all dimensions in inches)

	90 Tons	105 Tons	120 Tons	130 Tons	150 Tons
Compressor Data - Fixed Speed					
Number/Size (Nominal)	4/20.5T	6/15T	4/15T, 2/20.5T	6/19.5T	6/20.5T
Type	Scroll	Scroll	Scroll	Scroll	Scroll
Unit Capacity Steps	100/75/50/25	100/83/67/50/33/17	100/80/65/50/35/15	100/83/67/50/33/17	100/83/67/50/33/17
RPM	3500	3500	3500	3500	3500
No. of Circuits	2	2	2	2	2
Compressor Data - eFlex™ Variable Speed (Air-Cooled Only)					
Number/Size (Nominal)	1/6-25T, 4/15.6T	1/6-25T, 1/21.1T, 3/15.6T	1/6-25T, 1/26.2T, 2/15.6T, 1/21.1T	1/6-25T, 1/30.7T, 3/20.1T	1/6-25T, 2/30.7T, 1/21.1T, 1/15.6T
Type	Scroll	Scroll	Scroll	Scroll	Scroll
Unit Capacity Steps	15-100	15-100	15-100	15-100	15-100
No. of Circuits	2	2	2	2	2
Evaporator Coil - Standard					
Dimensions	118x90	118x90	170x90	170x90	170x90
Size (ft ²)	73.75	73.75	106.25	106.25	106.25
Rows/Fin Series	3/168	4/168	4/168	4/168	6/168
Tube Diameter	1/2	1/2	1/2	1/2	1/2
Surface	Enhanced	Enhanced	Enhanced	Enhanced	Enhanced
Evaporator Coil - High Capacity					
Dimensions	118x90	118x90	170x90	170x90	N/A
Size (ft ²)	73.75	73.75	106.25	106.25	N/A
Rows/Fin Series	5/168	6/168	6/168	6/168	N/A
Tube Diameter	1/2	1/2	1/2	1/2	N/A
Surface	Enhanced	Enhanced	Enhanced	Enhanced	N/A
Air-Cooled - Condenser Fans					
Number/Size/Type	6/30/Prop	6/30/Prop	8/30/Prop	8/30/Prop	8/30/Prop
HP (each)	1.5	1.5	1.5	1.5	1.5
Air-Cooled - Condenser Coil					
Size (ft ²)	134	161	161	161	161
Rows/Fin Series	2/252	2/252	2/252	2/252	2/252
Type	Microchannel	Microchannel	Microchannel	Microchannel	Microchannel
Supply Fans Standard CFM					
Number/Size/Type	1/36/DW AF	1/36/DW AF	1/40/DW AF	1/40/DW AF	1/40/DW AF
Number of Motors	1	1	1	1	1
HP Range	15-60	20-75	20-75	20-100	20-100
CFM Range	20000-40000	23000-45000	27000-54000	29000-58000	29000-58000
Total SP Range-(In. WG)	7.5	7.5	7.5	7.5	7.5
Supply Fans Low CFM					
Number/Size/Type	1/25/DW AF ^(a)	1/32/DW AF	1/32/DW AF	1/32/DW AF	1/32/DW AF
Number of Motors	1	1	1	1	1
HP Range	15-50	15-60	15-60	20-60	20-60
CFM Range	16000-31000	19000-36000	21000-42000	23000-45000	23000-45000
ESP Range-(In. WG)	7.5	7.5	7.5	7.5	7.5
Exhaust Fans Standard CFM					
Number/Size/Type	1/28/DW AF	1/32/DW AF	1/32/DW AF	1/32/DW AF	1/32/DW AF
Number of Motors	1	1	1	1	1
HP Range	10-50	15-50	15-60	15-60	15-60
CFM Range	20000-36000	23000-40000	27000-48000	29000-52000	29000-52000
ESP Range-(In. WG)	2.5	2.5	2.5	2.5	2.5

Table 5. General data (all dimensions in inches) (continued)

	90 Tons	105 Tons	120 Tons	130 Tons	150 Tons
Exhaust Fans Low CFM					
Number/Size/Type	1/25/DW FC	1/28/DW FC	1/28/DW FC	1/28/DW FC	1/28/DW FC
Number of Motors	1	1	1	1	1
HP Range	7.5-25	7.5-25	7.5-30	7.5-50	7.5-50
CFM Range	10000-28000	12000-33000	14000-37000	15000-41000	15000-41000
ESP Range-(In. WG)	2.5	2.5	2.5	2.5	2.5
Return Fans Standard CFM					
Number/Size/Type	1/40/Plenum AF	1/40/Plenum AF	1/44/Plenum AF	1/44/Plenum AF	1/44/Plenum AF
Number of Motors	1	1	1	1	1
HP Range	10-30	15-40	15-40	20-50	20-50
CFM Range	20000-40000	24000-44000	27000-51000	29000-54000	29000-54000
ESP Range-(In. WG)	2.5	2.5	2.5	2.5	2.5
Return Fans Low CFM					
Number/Size/Type	1/36.5/Plenum	1/36.5/Plenum	1/36.5/Plenum	1/36.5/Plenum	1/36.5/Plenum
Number of Motors	1	1	1	1	1
HP Range	7.5-20	10-25	10-40	15-40	15-40
CFM Range	16000-28000	19000-33000	21000-36000	23000-36000	23000-36000
ESP Range-(In. WG)	2.5	2.5	2.5	2.5	2.5
Energy Recovery Standard CFM					
Cassette Dimensions (LxWxH)	104x104x10	108x108x14	115x115x14	115x115x14	115x115x14
Wheel Segments	16	16	16	16	16
Motor (V/ph/Hz)	460/3/60 575/5/60	460/3/60 575/5/60	460/3/60 575/5/60	460/3/60 575/5/60	460/3/60 575/5/60
HP	0.33	0.33	0.33	0.33	0.33
Galv. Steel RA Filters - Number/Size	10/24x24x1	10/24x24x1	10/24x24x1	10/24x24x1	10/24x24x1
Galv. Steel FA Filters - Number/Size	8/24x24x1	8/24x24x1	8/24x24x1	8/24x24x1	8/24x24x1
CFM Range	8500-18000	9000-21000	10000-24000	13000-29000	13000-29000
Energy Recovery Low CFM					
Cassette Dimensions (LxWxH)	85x85x7.07	85x85x7.07	91x91x10	96x96x10	96x96x10
Wheel Segments	8	8	8	16	16
Motor (V/ph/Hz)	460/3/60 575/5/60	460/3/60 575/5/60	460/3/60 575/5/60	460/3/60 575/5/60	460/3/60 575/5/60
HP	0.25	0.25	0.25	0.25	0.25
Galv. Steel RA Filters - Number/Size	10/24x24x1	10/24x24x1	10/24x24x1	10/24x24x1	10/24x24x1
Galv. Steel FA Filters - Number/Size	8/24x24x1	8/24x24x1	6/24x24x1 2/12x24x1	6/24x24x1 2/12x24x1	6/24x24x1 2/12x24x1
CFM Range	8500-14000	9000-14000	9000-15000	9000-16000	9000-16000
Electric Heat (60 Hz)					
kW	90-265	90-265	140-300	140-300	140-300
Circuit Capacity Steps	30-37.5 kW	30-37.5 kW	35-37.5 kW	35-37.5 kW	35-37.5 kW
Electric Heat (50 Hz)					
kW	56-166	56-166	88-188	88-188	88-188
Circuit Capacity Steps	18-23.5 kW	18-23.5 kW	21.9-23.5 kW	21.9-23.5 kW	21.9-23.5 kW
Natural Gas Heat					
Low Heat Input (mbh)	850	850	1100	1100	1100
Medium Heat Input (mbh)	1100	1100	1800	1800	1800
High Heat Input (mbh)	1800	1800	2500	2500	2500
Low/Medium/High Heat - No. of Stages	2	2	2	2	2
Low Heat Modulating Turndown	10:1	10:1	20:1	20:1	20:1
Medium Heat Modulating Turndown	20:1	20:1	20:1	20:1	20:1
High Heat Modulating Turndown	20:1	20:1	20:1	20:1	20:1
Heat Exchanger Material	Stainless Steel	Stainless Steel	Stainless Steel	Stainless Steel	Stainless Steel
Gas Heat Steady State Efficiency% ^(b)	81	81	81	81	81



General Data

Table 5. General data (all dimensions in inches) (continued)

	90 Tons	105 Tons	120 Tons	130 Tons	150 Tons
Hot Water Coil					
Size	33 x 88 x 2 rows	33 x 88 x 2 rows	33 x110 x 2 rows	33 x110 x 2 rows	33 x110 x 2 rows
Quantity	2	2	2	2	2
Type	5W, PrimaFlo	5W, PrimaFlo	5W, PrimaFlo	5W, PrimaFlo	5W, PrimaFlo
High Heat (fins/ft)	122	122	122	122	122
Low Heat (fins/ft)	80	80	80	80	80
Steam Coil					
Size	33 x 88 x 1 rows	33 x 88 x 1 rows	33 x110 x 1 rows	33 x110 x 1 rows	33 x110 x 1 rows
Quantity	2	2	2	2	2
Type	NS, SigmaFlo	NS, SigmaFlo	NS, SigmaFlo	NS, SigmaFlo	NS, SigmaFlo
High Heat (fins/ft)	112	112	112	112	112
Low Heat (fins/ft)	62	62	62	62	62
Pre-Evap Filters					
Standard 2-inch High Efficiency Throwaway Filters					
Number/Size	21-20 x 24 x 2 5-12 x 24 x 2	21-20 x 24 x 2 5-12 x 24 x 2	21-20 x 24 x 2 5-12 x 24 x 2	21-20 x 24 x 2 5-12 x 24 x 2	21-20 x 24 x 2 5-12 x 24 x 2
Face area (ft ²)	80	80	93	93	93
90-95% Bag Filters w/Prefilters					
Number/Size	21-20 x 24 x 19 5-12 x 24 x 19	21-20 x 24 x 19 5-12 x 24 x 19	21-20 x 24 x 19 5-12 x 24 x 19	21-20 x 24 x 19 5-12 x 24 x 19	21-20 x 24 x 19 5-12 x 24 x 19
Face area (ft ²)	80	80	80	80	80
Number/Size (Prefilters)	21-20 x 24 x 2 5-12 x 24 x 2	21-20 x 24 x 2 5-12 x 24 x 2	21-20 x 24 x 2 5-12 x 24 x 2	21-20 x 24 x 2 5-12 x 24 x 2	21-20 x 24 x 2 5-12 x 24 x 2
90-95% Cartridge Filters w/Prefilters					
Number/Size	21-20 x 24 x 12 5-12 x 24 x 12	21-20 x 24 x 12 5-12 x 24 x 12	21-20 x 24 x 12 5-12 x 24 x 12	21-20 x 24 x 12 5-12 x 24 x 12	21-20 x 24 x 12 5-12 x 24 x 12
Face area (ft ²)	80	80	80	80	80
Number/Size (Prefilters)	21-20 x 24 x 2 5-12 x 24 x 2	21-20 x 24 x 2 5-12 x 24 x 2	21-20 x 24 x 2 5-12 x 24 x 2	21-20 x 24 x 2 5-12 x 24 x 2	21-20 x 24 x 2 5-12 x 24 x 2
90-95% Low Pressure Cartridge Filters w/Prefilters					
Number/Size	21-20 x 24 x 12 5-12 x 24 x 12	21-20 x 24 x 12 5-12 x 24 x 12	21-20 x 24 x 12 5-12 x 24 x 12	21-20 x 24 x 12 5-12 x 24 x 12	21-20 x 24 x 12 5-12 x 24 x 12
Face area (ft ²)	80	80	80	80	80
Number/Size (Prefilters)	21-20 x 24 x 2 5-12 x 24 x 2	21-20 x 24 x 2 5-12 x 24 x 2	21-20 x 24 x 2 5-12 x 24 x 2	21-20 x 24 x 2 5-12 x 24 x 2	21-20 x 24 x 2 5-12 x 24 x 2
Post-Evap Filters					
90-95% Low Pressure Cartridge Filters w/Prefilters (c)					
Number/Size	15-24 x 24 x 12 7-12 x 24 x 12	15-24 x 24 x 12 7-12 x 24 x 12	15-24 x 24 x 12 7-12 x 24 x 12	15-24 x 24 x 12 7-12 x 24 x 12	15-24 x 24 x 12 7-12 x 24 x 12
Face area (ft ²)	74	74	74	74	74
Number/Size (Prefilters)	15-24 x 24 x 4 7-12 x 24 x 4	15-24 x 24 x 4 7-12 x 24 x 4	15-24 x 24 x 4 7-12 x 24 x 4	15-24 x 24 x 4 7-12 x 24 x 4	15-24 x 24 x 4 7-12 x 24 x 4
90-95% Bag Filters w/Prefilter (d)					
Number/Size	15-24 x 24 x 19 7-12 x 24 x 19	15-24 x 24 x 19 7-12 x 24 x 19	15-24 x 24 x 19 7-12 x 24 x 19	15-24 x 24 x 19 7-12 x 24 x 19	15-24 x 24 x 19 7-12 x 24 x 19
Face area (ft ²)	74	74	74	74	74
Number/Size (Prefilters)	15-24 x 24 x 2 7-12 x 24 x 2	15-24 x 24 x 2 7-12 x 24 x 2	15-24 x 24 x 2 7-12 x 24 x 2	15-24 x 24 x 2 7-12 x 24 x 2	15-24 x 24 x 2 7-12 x 24 x 2
90-95% Cartridge Filters (d)					
Number/Size	15-24 x 24 x 12 7-12 x 24 x 12	15-24 x 24 x 12 7-12 x 24 x 12	15-24 x 24 x 12 7-12 x 24 x 12	15-24 x 24 x 12 7-12 x 24 x 12	15-24 x 24 x 12 7-12 x 24 x 12
Face area (ft ²)	74	74	74	74	74
Number/Size (Prefilters)	15-24 x 24 x 2 7-12 x 24 x 2	15-24 x 24 x 2 7-12 x 24 x 2	15-24 x 24 x 2 7-12 x 24 x 2	15-24 x 24 x 2 7-12 x 24 x 2	15-24 x 24 x 2 7-12 x 24 x 2
90-95% High Temp Cartridge Filters (e)					
Number/Size	15-24 x 24 x 12 7-12 x 24 x 12	15-24 x 24 x 12 7-12 x 24 x 12	15-24 x 24 x 12 7-12 x 24 x 12	15-24 x 24 x 12 7-12 x 24 x 12	15-24 x 24 x 12 7-12 x 24 x 12
Face area (ft ²)	74	74	74	74	74

Table 5. General data (all dimensions in inches) (continued)

	90 Tons	105 Tons	120 Tons	130 Tons	150 Tons
Number/Size (Prefilters)	15-24 x 24 x 2 7-12 x 24 x 2	15-24 x 24 x 2 7-12 x 24 x 2	15-24 x 24 x 2 7-12 x 24 x 2	15-24 x 24 x 2 7-12 x 24 x 2	15-24 x 24 x 2 7-12 x 24 x 2
HEPA Filters w/Prefilter^(d)					
Number/Size	15-24 x 24 x 12 7-12 x 24 x 12	15-24 x 24 x 12 7-12 x 24 x 12	15-24 x 24 x 12 7-12 x 24 x 12	15-24 x 24 x 12 7-12 x 24 x 12	15-24 x 24 x 12 7-12 x 24 x 12
Face area (ft ²)	74	74	74	74	74
Number/Size (Prefilters)	15-24 x 24 x 2 7-12 x 24 x 2	15-24 x 24 x 2 7-12 x 24 x 2	15-24 x 24 x 2 7-12 x 24 x 2	15-24 x 24 x 2 7-12 x 24 x 2	15-24 x 24 x 2 7-12 x 24 x 2
High Temp HEPA Cartridge Filters w/Prefilter^(e)					
Number/Size	15-24 x 24 x 12 7-12 x 24 x 12	15-24 x 24 x 12 7-12 x 24 x 12	15-24 x 24 x 12 7-12 x 24 x 12	15-24 x 24 x 12 7-12 x 24 x 12	15-24 x 24 x 12 7-12 x 24 x 12
Face area (ft ²)	74	74	74	74	74
Number/Size (Prefilters)	15-24 x 24 x 2 7-12 x 24 x 2	15-24 x 24 x 2 7-12 x 24 x 2	15-24 x 24 x 2 7-12 x 24 x 2	15-24 x 24 x 2 7-12 x 24 x 2	15-24 x 24 x 2 7-12 x 24 x 2

(a) 90T unit with Gas Heat requires 32-inch supply fan for low CFM option.

(b) Heating Performance is AHRI and DOE certified.

(c) Standard airflow application of cooling only units require High Efficiency Throwaway Prefilters with the 90-95% Low PD Cartridge Filter Options.

(d) Standard airflow application of cooling only units include 2-inch High Efficiency Throwaway Prefilters with the 90-95% Bag and HEPA Filter Options.

(e) Gas/Electric units require 2-inch High Efficiency High Temperature Rated Throwaway Prefilters with High Temperature Rated 90-95% Cartridge and HEPA filter options.

Table 6. Gas heat inputs/input ranges/inlet sizes

Two-Stage Gas Heat				
Standard Gas Heat Input (MBh)	Low Gas Heat Inputs (MBh)	High Fire Heat Input (MBh)	Modulating Gas Heat Range (MBh)	Gas Heat Inlet Sizes (in.)
850	425	850	85-850	1 1/4
1100	550	1100	55-1100	1 1/4
1800	900	1800	90-1800	2
2500	1250	2500	125-2500	2

Table 7. Economizer outdoor air damper leakage (at rated airflow)¹

Damper	Leakage Rate/CFM/ft ²
Standard	20
Optional "Low Leak"	10 (Class 2 AMCA 511-99)
Optional "Ultra Low Leak"	4 (Class 1 AMCA 511-99)
Title 24 Ultra Low Leak	3 (Class 1A AMCA 511-99)

¹ Leakage/ft² at 1.0 in WC pressure difference



Performance Adjustment Factors

Figure 8. Air density ratios

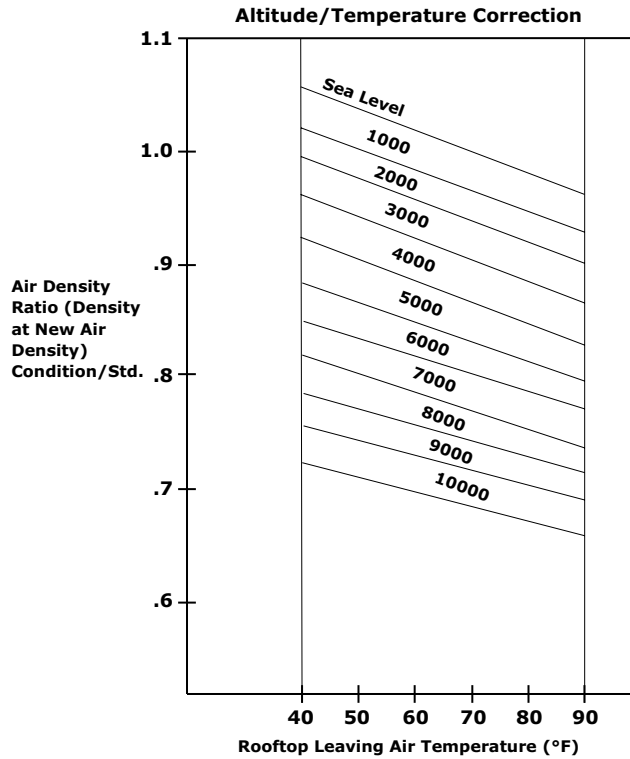

Table 8. Enthalpy of saturated air

Wet Bulb Temperature	Btu per Pound
41	15.70
43	16.66
42	16.17
43	16.66
44	17.15
45	17.65
46	18.16
47	18.68
48	19.21
49	19.75
50	20.30
51	20.86
52	21.44
53	22.02
54	22.62
55	23.22
56	23.84

Table 8. Enthalpy of saturated air (continued)

Wet Bulb Temperature	Btu per Pound
57	24.48
58	25.12
59	25.78
60	26.46
61	27.15
62	27.85
63	28.57
64	29.31
65	30.06
66	30.83
67	31.62
68	32.42
69	33.25
70	34.09
71	34.95
72	35.83
73	36.74
74	37.66

Table 9. Cooling capacity altitude correction factors

	Altitude (ft.)							
	Sea Level	1000	2000	3000	4000	5000	6000	7000
Cooling Capacity Multiplier	1.00	0.99	0.99	0.98	0.97	0.96	0.95	0.94
KW Correction Multiplier (Compressors)	1.00	1.01	1.02	1.03	1.04	1.05	1.06	1.07
Sensible Heat Ratio Correction Multiplier	1.00	.98	.95	.93	.91	.89	.87	.85
Maximum Condenser Ambient	115°F	114°F	113°F	112°F	111°F	110°F	109°F	108°F

Table 10. Gas heating capacity altitude correction factors

	Sea Level to 2000	2001 to 2500	2501 to 3500	3501 to 4500	4501 to 5500	5501 to 6500	6501 to 7500
Capacity Multiplier	1.00	.92	.88	.84	.80	.76	.72

Note: Correction factors are per ANSI Z223.1/NFPA 54. Local codes may supersede.



Performance Data

Gross Cooling Capacities

Air-Cooled, 60Hz, Standard and High Capacity Evaporator Coils

Table 11. Gross cooling capacities – 90 tons – standard evaporator coil, 60Hz

CFM	Ent DB (°F)	Ambient Temperature (°F)																														
		85						95						105						115												
		Entering Wet Bulb (°F)			73			61			67			73			61			67			73			61			67			73
	75	896	637	1001	528	1115	414	860	617	961	508	1069	393	821	595	917	486	1018	370	778	572	868	462	962	345							
16000	80	897	728	1002	620	1115	506	861	708	962	599	1069	485	823	686	918	577	1019	462	780	663	870	553	963	438							
	85	900	819	1003	711	1116	597	865	796	964	690	1070	577	827	774	920	668	1020	554	785	750	872	645	964	529							
	90	908	908	1004	801	1117	689	875	875	965	781	1072	668	840	840	921	759	1022	646	804	804	873	736	966	621							
	75	956	714	1064	575	1177	430	915	691	1018	553	1125	407	871	668	968	529	1066	382	822	643	913	503	1002	356							
20000	80	959	827	1066	690	1178	545	918	805	1020	667	1125	522	874	777	970	643	1067	498	826	751	915	618	1003	471							
	85	967	937	1068	803	1180	659	928	915	1023	781	1127	637	885	885	972	757	1069	612	840	840	917	732	1005	586							
	90	966	996	1071	917	1181	774	962	962	1026	895	1129	751	925	925	976	866	1071	727	883	883	922	840	1007	700							
	75	1009	802	1118	628	1227	444	963	779	1066	604	1168	420	913	753	1009	578	1103	394	858	723	947	551	1031	366							
25000	80	1016	938	1121	771	1229	588	970	914	1069	747	1169	564	922	888	1012	721	1104	538	869	860	950	694	1033	510							
	85	1035	1035	1123	913	1231	732	996	996	1072	889	1172	708	954	954	1015	864	1107	682	906	906	954	828	1036	654							
	90	1090	1090	1131	1048	1233	875	1049	1049	1080	1023	1174	851	1004	1004	1025	997	1109	825	954	954	965	965	1038	796							
	75	1046	880	1154	677	1260	457	996	854	1097	652	1195	432	942	826	1036	625	1125	404	884	797	969	596	1048	375							
30000	80	1059	1049	1157	848	1262	630	1010	1010	1100	823	1197	604	959	959	1039	796	1127	577	905	905	972	767	1051	548							
	85	1103	1103	1162	1010	1264	802	1058	1058	1106	984	1200	777	1010	1010	1046	956	1130	749	955	955	980	925	1053	720							
	90	1160	1160	1175	1175	1267	973	1113	1113	1121	1121	1203	948	1061	1061	1063	1063	1133	921	1003	1003	1004	1004	1056	879							
	75	1064	928	1170	706	1274	464	1012	901	1111	680	1207	438	956	872	1047	652	1134	410	896	842	978	623	1055	381							
33000	80	1081	1081	1173	894	1276	654	1032	1032	1114	868	1210	628	981	981	1051	841	1137	600	927	927	982	800	1058	571							
	85	1135	1135	1180	1070	1279	844	1088	1088	1123	1043	1212	817	1036	1036	1060	1014	1140	790	978	978	992	983	1060	760							
	90	1194	1194	1199	1199	1282	1032	1143	1143	1144	1144	1216	994	1088	1088	1089	1089	1143	964	1025	1025	1026	1026	1064	932							
	75	1079	975	1183	734	1286	471	1026	947	1122	707	1216	445	968	918	1057	679	1142	416	906	887	985	649	1061	386							
36000	80	1103	1103	1187	939	1289	679	1055	1055	1126	902	1219	652	1003	1003	1061	872	1145	623	945	945	990	840	1063	593							
	85	1164	1164	1196	1130	1291	885	1113	1113	1137	1102	1222	858	1058	1058	1072	1072	1147	830	996	996	1002	1002	1065	799							
	90	1223	1223	1224	1224	1295	1077	1169	1169	1170	1170	1226	1049	1110	1110	1111	1111	1152	1018	1043	1043	1043	1043	1070	985							
	75	1097	1037	1198	771	1298	480	1042	1009	1135	744	1227	453	982	978	1066	715	1150	424	918	918	992	684	1066	393							
40000	80	1134	1134	1202	987	1302	711	1083	1083	1139	958	1230	683	1027	1027	1072	927	1153	654	966	966	998	893	1069	623							
	85	1196	1196	1215	1210	1305	940	1142	1142	1153	1153	1233	912	1082	1082	1087	1087	1155	883	1016	1016	1017	1016	1071	835							
	90	1255	1255	1256	1256	1310	1151	1197	1197	1198	1198	1238	1121	1133	1133	1134	1134	1161	1090	1061	1061	1061	1061	1076	1055							

Table 12. Gross cooling capacities – 90 tons eFlex™ variable speed – standard evaporator coil, 60Hz

CFM	Ent DB (°F)	Ambient Temperature (°F)																											
		85						95						105						115									
		Entering Wet Bulb (°F)			73			Entering Wet Bulb (°F)			73			Entering Wet Bulb (°F)			67			Entering Wet Bulb (°F)			67			73			
		CAP	SHC	SHC	CAP	SHC	SHC	CAP	SHC	SHC	CAP	SHC	SHC	CAP	SHC	SHC	CAP	SHC	SHC	CAP	SHC	SHC	CAP	SHC	SHC				
16000	75	889	633	994	525	1109	411	859	617	960	508	1069	393	827	600	924	491	827	600	924	491	1026	375	792	582	884	472	978	355
	80	890	724	995	616	1109	503	861	708	962	600	1070	486	829	691	925	582	829	691	925	582	1027	487	794	671	885	563	978	447
	85	893	814	997	707	1110	595	864	798	963	691	1071	577	833	780	927	673	833	780	927	673	1028	559	799	762	887	655	980	539
20000	90	906	884	998	798	1111	686	880	865	965	782	1072	669	852	844	929	765	852	844	929	765	1029	651	821	821	889	744	982	630
	75	948	709	1056	571	1169	425	914	691	1018	553	1123	407	878	673	976	534	878	673	976	534	1073	387	838	654	930	514	1017	365
	80	951	820	1059	685	1170	541	918	803	1020	668	1124	522	882	785	978	649	882	785	978	649	1074	502	843	765	932	629	1018	480
25000	85	960	921	1061	799	1172	656	930	896	1022	782	1126	637	897	872	981	763	897	872	981	763	1076	617	862	846	935	743	1021	595
	90	993	993	1065	911	1174	770	965	965	1027	893	1128	751	935	935	986	874	935	935	986	874	1078	731	901	901	941	853	1022	709
	75	999	794	1108	623	1215	439	962	776	1065	604	1163	419	921	756	1018	584	921	756	1018	584	1106	398	878	735	966	562	1043	375
30000	80	1008	934	1111	766	1217	583	971	915	1068	747	1165	563	932	885	1021	727	932	885	1021	727	1109	542	890	851	969	705	1046	519
	85	1035	1031	1115	905	1219	726	1001	1001	1072	886	1168	707	965	965	1025	865	965	965	1025	865	1111	685	927	927	974	843	1048	662
	90	1087	1087	1124	1044	1222	869	1053	1053	1082	1021	1170	849	1016	1016	1037	987	1016	1016	1037	987	1113	828	975	975	989	950	1050	801
33000	75	1036	877	1142	671	1243	449	996	857	1095	651	1187	429	952	833	1044	631	952	833	1044	631	1126	407	906	811	988	608	1060	384
	80	1053	1013	1146	842	1246	622	1015	986	1099	819	1190	602	975	958	1048	797	975	958	1048	797	1128	580	930	928	992	774	1063	557
	85	1098	1098	1153	1008	1248	794	1062	1062	1106	984	1192	774	1022	1022	1056	962	1022	1022	1056	962	1131	752	978	978	1001	938	1065	729
36000	90	1156	1156	1172	1132	1251	961	1117	1117	1128	1104	1195	940	1074	1074	1080	1072	1074	1074	1080	1072	1135	917	1024	1024	1026	1026	1069	893
	75	1053	921	1157	699	1255	455	1012	901	1109	679	1197	435	967	860	1056	658	967	860	1056	658	1135	413	919	857	998	635	1067	390
	80	1078	1059	1161	883	1258	645	1039	1032	1113	862	1200	625	996	996	1060	840	996	996	1060	840	1138	603	950	950	1002	817	1071	580
40000	85	1131	1131	1171	1065	1260	834	1092	1092	1123	1044	1203	814	1049	1049	1071	1012	1049	1049	1071	1012	1141	792	1001	1001	1014	970	1073	769
	90	1189	1189	1197	1186	1264	1017	1147	1147	1151	1151	1207	996	1099	1099	1100	1100	1099	1099	1100	1100	1146	973	1044	1044	1045	1045	1078	942
	75	1069	968	1169	726	1264	461	1026	948	1119	706	1206	441	980	922	1065	685	980	922	1065	685	1142	419	931	885	1005	662	1073	396
36000	80	1100	1100	1174	926	1268	669	1059	1059	1124	905	1209	648	1017	1017	1070	883	1017	1017	1070	883	1146	626	970	970	1011	859	1077	603
	85	1158	1158	1186	1117	1271	875	1117	1117	1137	1082	1213	849	1071	1071	1084	1042	1071	1071	1084	1042	1149	826	1019	1019	1027	1003	1079	801
	90	1216	1216	1219	1219	1277	1073	1170	1170	1172	1172	1218	1046	1119	1119	1120	1120	1119	1119	1120	1120	1155	1022	1060	1060	1061	1061	1085	995
40000	75	1086	1023	1182	763	1276	470	1042	991	1131	742	1216	449	995	955	1074	721	995	955	1074	721	1150	427	946	918	1013	691	1080	404
	80	1126	1126	1188	983	1280	700	1086	1086	1137	957	1220	680	1041	1041	1081	933	1041	1041	1081	933	1154	657	991	991	1019	907	1083	634
	85	1188	1188	1204	1160	1284	923	1144	1144	1155	1124	1223	901	1094	1094	1101	1090	1094	1094	1101	1090	1157	878	1038	1038	1041	1041	1086	852
90	1245	1245	1246	1246	1291	1141	1195	1195	1196	1196	1196	1196	1118	1140	1140	1141	1141	1140	1140	1141	1164	1092	1079	1079	1079	1079	1094	1043	



Performance Data

Table 13. Gross cooling capacities – 105 tons – standard evaporator coil, 60Hz

CFM	Ent DB (°F)	Ambient Temperature (°F)																																																																																																				
		85						95						105						115																																																																																		
		Entering Wet Bulb (°F)			73			61			67			73			61			67			73			61			67			73																																																																						
		CAP	SHC	CHC	CAP	SHC	CHC	CAP	SHC	CHC	CAP	SHC	CHC	CAP	SHC	CHC	CAP	SHC	CHC	CAP	SHC	CHC	CAP	SHC	CHC	CAP	SHC	CHC	CAP	SHC	CHC																																																																							
19000	75	1028	738	1149	609	1279	472	984	714	1099	584	1221	447	936	688	1045	557	1159	419	885	661	988	530	1092	391	80	1031	846	1151	718	1279	582	986	822	1101	692	1222	556	939	796	1047	666	1160	529	889	769	990	638	1093	500	85	1036	952	1153	826	1281	691	993	927	1103	801	1224	665	947	901	1049	774	1162	638	888	874	992	747	1095	609	90	1050	1050	1155	934	1282	799	1013	1013	1106	909	1225	774	974	974	1053	883	1164	747	932	932	996	855	1097	718		
	23000	75	1085	813	1208	654	1336	487	1035	787	1152	628	1271	460	982	759	1092	599	1202	431	925	730	1028	570	1126	400	80	1090	945	1211	786	1337	619	1040	914	1155	759	1272	592	988	886	1095	731	1203	563	933	856	1030	702	1128	533	85	1101	1072	1213	917	1339	751	1054	1046	1157	890	1275	724	1004	1004	1098	862	1206	695	955	955	1034	833	1131	665	90	1143	1143	1218	1049	1341	883	1101	1101	1163	1017	1277	856	1056	1056	1105	988	1208	827	1007	1007	1041	958	1133	796	
		28000	75	1136	902	1260	706	1383	501	1081	873	1197	678	1311	472	1023	841	1131	648	1235	442	961	807	1060	617	1152	410	80	1146	1056	1263	867	1385	662	1092	1027	1201	838	1314	634	1035	997	1135	808	1238	603	975	965	1064	777	1155	571	85	1174	1174	1267	1026	1388	823	1127	1127	1206	995	1317	794	1077	1077	1140	961	1240	764	1022	1022	1070	929	1157	731	90	1236	1236	1277	1179	1390	983	1187	1187	1217	1150	1319	954	1134	1134	1153	1119	1243	924	1076	1076	1084	1084	1160	891
			33000	75	1175	980	1296	756	1414	513	1116	949	1229	726	1338	483	1053	917	1158	695	1256	452	988	884	1082	662	1169	419	80	1191	1167	1299	944	1417	703	1133	1133	1232	914	1341	673	1074	1074	1161	883	1259	642	1014	1014	1086	842	1171	608	85	1243	1243	1307	1124	1420	893	1190	1190	1241	1093	1344	862	1134	1134	1171	1060	1262	831	1071	1071	1096	1026	1173	797	90	1308	1308	1323	1311	1423	1081	1253	1253	1259	1259	1347	1051	1192	1192	1194	1194	1265	1009	1124	1124	1126	1126	1177
38000				75	1205	1059	1322	803	1437	525	1142	1027	1251	772	1356	494	1077	994	1176	740	1271	462	1007	959	1096	706	1179	428	80	1230	1230	1326	1020	1440	744	1174	1174	1256	980	1359	712	1115	1115	1181	946	1274	680	1051	1051	1102	909	1181	645	85	1298	1298	1338	1224	1443	961	1240	1240	1268	1192	1362	930	1177	1177	1194	1158	1276	897	1107	1107	1115	1115	1182	857	90	1364	1364	1366	1366	1448	1167	1302	1302	1304	1304	1367	1133	1234	1234	1235	1235	1281	1098	1158	1158	1159	1159	1187
	43000			75	1229	1137	1342	850	1454	536	1164	1104	1268	818	1370	504	1096	1069	1189	785	1281	471	1024	1024	1106	750	1186	437	80	1271	1271	1348	1083	1457	783	1212	1212	1274	1049	1373	751	1148	1148	1196	1014	1283	718	1078	1078	1113	976	1187	683	85	1342	1342	1363	1324	1460	1030	1278	1278	1291	1289	1375	997	1210	1210	1214	1214	1285	949	1134	1134	1135	1135	1189	910	90	1408	1408	1410	1410	1466	1258	1340	1340	1341	1341	1382	1223	1264	1264	1266	1266	1292	1187	1180	1180	1181	1181	1197
		45000		75	1238	1168	1349	868	1459	541	1172	1135	1273	836	1374	509	1102	1100	1194	803	1284	475	1029	1029	1109	768	1188	440	80	1286	1286	1355	1111	1463	799	1225	1225	1281	1077	1377	767	1159	1159	1201	1041	1286	733	1088	1088	1117	1003	1189	698	85	1357	1357	1372	1363	1465	1057	1291	1291	1299	1299	1380	1010	1220	1220	1222	1222	1289	973	1142	1142	1143	1143	1191	934	90	1423	1423	1425	1425	1473	1294	1352	1352	1353	1353	1387	1259	1274	1274	1275	1275	1296	1222	1188	1188	1189	1189	1201

Table 14. Gross cooling capacities – 105 tons eFlex™ variable speed – standard evaporator coil, 60Hz

CFM	Ent DB (°F)	Ambient Temperature (°F)																							
		85						95						105						115					
		Entering Wet Bulb (°F)						Entering Wet Bulb (°F)						Entering Wet Bulb (°F)						Entering Wet Bulb (°F)					
		61	67	73	79	85	91	61	67	73	79	85	91	61	67	73	79	85	91	61	67	73	79	85	91
19000	75	1013	730	1132	601	1259	465	974	708	1088	579	1208	442	932	686	1040	555	1153	418	887	661	989	531	1092	392
	80	1016	838	1134	710	1259	574	977	812	1090	687	1209	551	935	794	1042	664	1154	527	891	768	991	639	1094	501
	85	1022	944	1135	818	1261	683	984	922	1092	795	1211	660	943	899	1045	772	1156	636	900	875	994	747	1096	610
23000	75	1041	1037	1138	926	1263	791	1007	1007	1095	904	1213	769	972	972	1049	881	1158	744	935	935	998	854	1098	718
	80	1067	804	1188	646	1313	479	1023	781	1139	622	1255	454	977	756	1086	597	1194	428	927	731	1029	571	1126	401
	85	1073	934	1191	777	1314	611	1030	911	1142	754	1257	586	984	884	1089	729	1196	561	935	857	1032	702	1128	533
28000	75	1086	1060	1194	908	1316	743	1046	1026	1145	885	1260	718	1003	995	1093	860	1198	692	958	958	1036	831	1131	665
	80	1131	1131	1200	1038	1318	874	1094	1094	1152	1014	1262	849	1054	1054	1100	986	1200	824	1010	1010	1044	959	1133	796
	85	1117	890	1238	697	1356	492	1069	865	1183	672	1293	466	1018	838	1124	645	1225	439	963	807	1061	617	1150	410
33000	75	1129	1046	1241	857	1359	653	1081	1021	1186	832	1296	627	1031	994	1128	805	1228	600	978	952	1065	777	1153	570
	80	1161	1161	1247	1014	1361	813	1119	1119	1193	989	1298	787	1075	1075	1135	962	1230	760	1025	1025	1072	929	1155	730
	85	1223	1223	1258	1170	1364	973	1179	1179	1205	1144	1301	947	1132	1132	1148	1113	1233	920	1079	1079	1088	1066	1158	886
38000	75	1155	970	1272	746	1385	503	1103	943	1213	719	1317	477	1048	914	1150	691	1244	448	989	884	1082	662	1165	418
	80	1173	1146	1276	934	1388	693	1124	1106	1217	904	1320	666	1073	1070	1155	876	1247	637	1018	1018	1087	845	1168	607
	85	1229	1229	1285	1114	1391	882	1182	1182	1227	1086	1323	855	1131	1131	1165	1057	1250	826	1075	1075	1097	1026	1170	795
43000	75	1293	1293	1305	1276	1395	1066	1243	1243	1250	1239	1327	1038	1188	1188	1191	1191	1254	1004	1127	1127	1128	1128	1175	972
	80	1184	1049	1297	793	1406	514	1130	1021	1234	765	1334	487	1071	991	1167	736	1258	457	1009	959	1095	706	1175	426
	85	1215	1215	1302	1005	1409	732	1165	1165	1240	972	1337	704	1112	1112	1174	942	1260	675	1054	1054	1102	909	1178	644
45000	75	1282	1282	1315	1214	1413	950	1230	1230	1254	1185	1340	922	1173	1173	1188	1151	1264	887	1110	1110	1118	1095	1181	855
	80	1347	1347	1348	1348	1420	1155	1290	1290	1292	1292	1347	1125	1228	1228	1230	1230	1271	1094	1158	1158	1159	1159	1188	1060
	85	1208	1127	1315	839	1422	526	1151	1097	1250	811	1346	497	1090	1060	1180	781	1267	467	1026	1007	1104	743	1182	435
45000	75	1255	1255	1323	1072	1427	773	1202	1202	1258	1041	1351	744	1144	1144	1188	1009	1271	713	1081	1081	1113	975	1185	682
	80	1324	1324	1340	1304	1430	1013	1267	1267	1276	1251	1355	982	1205	1205	1209	1206	1275	944	1135	1135	1136	1136	1189	909
	85	1387	1387	1389	1389	1440	1247	1325	1325	1326	1326	1364	1216	1257	1257	1258	1258	1284	1183	1182	1182	1183	1183	1196	1147
45000	75	1217	1158	1321	858	1427	530	1158	1124	1255	829	1351	501	1097	1076	1184	793	1270	471	1033	1027	1107	760	1184	439
	80	1269	1269	1330	1099	1432	789	1214	1214	1263	1069	1355	759	1155	1155	1193	1036	1274	729	1090	1090	1117	1002	1188	697
	85	1338	1338	1349	1325	1437	1039	1279	1279	1285	1277	1360	1002	1215	1215	1217	1217	1278	969	1143	1143	1144	1144	1191	933
90	1401	1401	1402	1402	1447	1284	1337	1337	1338	1338	1369	1252	1267	1267	1269	1269	1288	1218	1190	1190	1191	1191	1200	1172	



Performance Data

Table 15. Gross cooling capacities – 120 tons – standard evaporator coil, 60Hz

CFM	Ent DB (°F)	Ambient Temperature (°F)																							
		85						95						105						115					
		Entering Wet Bulb (°F)			Entering Wet Bulb (°F)			Entering Wet Bulb (°F)			Entering Wet Bulb (°F)			Entering Wet Bulb (°F)			Entering Wet Bulb (°F)			Entering Wet Bulb (°F)			Entering Wet Bulb (°F)		
		61	67	73	61	67	73	61	67	73	61	67	73	61	67	73	61	67	73	61	67	73	61	67	73
21000	75	1190	828	1338	688	1500	540	1134	793	1276	663	1429	505	1074	758	1210	617	1355	468	1011	721	1139	579	1275	430
	80	1192	947	1340	808	1500	661	1136	913	1277	773	1430	626	1077	877	1212	737	1356	589	1014	840	1141	700	1276	551
	85	1195	1066	1341	927	1502	782	1139	1032	1279	892	1432	746	1080	997	1213	857	1358	710	1018	959	1143	819	1278	672
26000	75	1201	1184	1343	1047	1503	902	1148	1148	1281	1012	1433	867	1100	1100	1216	976	1359	830	1048	1048	1146	939	1280	792
	80	1273	925	1426	749	1585	561	1209	888	1355	711	1505	524	1142	850	1280	673	1421	485	1071	811	1200	632	1331	444
	85	1277	1074	1428	898	1587	711	1213	1037	1357	860	1507	674	1146	999	1283	822	1423	635	1075	959	1203	781	1333	594
31000	75	1283	1220	1431	1046	1589	861	1221	1183	1361	1009	1510	823	1156	1145	1286	970	1426	784	1093	1093	1207	930	1336	744
	80	1326	1326	1435	1194	1590	1009	1273	1273	1365	1157	1512	972	1216	1216	1291	1119	1428	933	1156	1156	1212	1079	1339	892
	85	1334	1017	1488	804	1641	577	1263	977	1410	764	1554	538	1190	937	1328	723	1462	497	1113	896	1241	681	1365	455
36000	75	1340	1194	1491	981	1643	756	1270	1152	1414	942	1557	716	1198	1111	1332	901	1466	676	1122	1068	1246	859	1369	633
	80	1360	1360	1496	1158	1646	933	1301	1301	1419	1119	1560	894	1239	1239	1337	1079	1468	853	1173	1173	1251	1037	1371	811
	85	1435	1435	1502	1335	1649	1111	1374	1374	1426	1293	1563	1072	1310	1310	1346	1251	1472	1031	1241	1241	1261	1208	1375	989
41000	75	1380	1104	1532	854	1679	590	1304	1063	1449	814	1587	550	1225	1018	1362	771	1490	508	1143	973	1270	728	1387	465
	80	1391	1306	1537	1060	1683	797	1317	1264	1454	1020	1590	757	1240	1222	1367	978	1493	715	1164	1164	1275	934	1391	671
	85	1444	1444	1543	1266	1685	1003	1379	1379	1461	1226	1593	963	1310	1310	1374	1179	1496	921	1236	1236	1283	1134	1393	877
46000	75	1523	1523	1554	1467	1689	1209	1456	1456	1474	1426	1597	1169	1384	1384	1390	1383	1500	1127	1306	1306	1309	1309	1397	1083
	80	1416	1185	1565	903	1707	603	1336	1141	1478	861	1611	561	1254	1097	1386	818	1509	518	1167	1050	1289	773	1402	474
	85	1434	1418	1571	1138	1711	838	1361	1361	1484	1096	1614	796	1289	1289	1392	1053	1512	753	1212	1212	1295	1008	1405	708
51000	75	1513	1513	1580	1367	1714	1072	1442	1442	1494	1324	1617	1030	1367	1367	1403	1279	1515	987	1286	1286	1308	1232	1407	943
	80	1595	1595	1599	1599	1719	1307	1520	1520	1523	1523	1622	1265	1440	1440	1443	1443	1520	1222	1354	1354	1357	1357	1412	1169
	85	1446	1266	1590	951	1729	615	1363	1221	1499	907	1628	572	1277	1174	1403	863	1523	528	1187	1127	1303	817	1413	483
54000	75	1484	1484	1597	1214	1732	878	1411	1411	1506	1171	1631	835	1334	1334	1411	1119	1525	791	1251	1251	1312	1071	1414	745
	80	1570	1570	1610	1469	1735	1141	1494	1494	1520	1424	1634	1098	1412	1412	1426	1378	1528	1054	1325	1325	1329	1329	1416	1008
	85	1651	1651	1654	1654	1742	1404	1570	1570	1573	1573	1640	1353	1483	1483	1486	1486	1534	1306	1389	1389	1391	1391	1422	1257
	75	1471	1345	1610	998	1746	626	1385	1299	1516	953	1642	583	1297	1252	1417	908	1534	538	1205	1203	1313	861	1420	492
	80	1530	1530	1618	1282	1749	918	1452	1452	1525	1236	1644	874	1370	1370	1427	1188	1535	829	1282	1282	1324	1139	1420	782
	85	1617	1617	1635	1569	1754	1210	1535	1535	1543	1524	1647	1166	1448	1448	1450	1450	1538	1120	1354	1354	1356	1356	1423	1061
	75	1697	1697	1700	1700	1765	1493	1610	1610	1612	1612	1655	1444	1516	1516	1517	1517	1545	1396	1414	1414	1415	1415	1428	1345
	80	1484	1393	1620	1026	1755	634	1397	1346	1524	981	1649	590	1308	1298	1423	935	1539	544	1218	1218	1317	887	1421	498
	85	1554	1554	1629	1325	1758	942	1474	1474	1534	1278	1650	897	1389	1389	1434	1230	1539	852	1298	1298	1329	1180	1423	805
	75	1641	1641	1649	1630	1764	1252	1556	1556	1558	1558	1654	1206	1466	1466	1467	1467	1543	1149	1368	1368	1370	1370	1425	1098
	80	1720	1720	1723	1723	1777	1549	1629	1629	1631	1631	1663	1499	1531	1531	1532	1532	1550	1450	1424	1424	1424	1425	1432	1398

Table 16. Gross cooling capacities – 120 tons eFlex™ variable speed – standard evaporator coil, 60Hz

CFM	Ent DB (°F)	Ambient Temperature (°F)																							
		85						95						105						115					
		Entering Wet Bulb (°F)			Entering Wet Bulb (°F)			Entering Wet Bulb (°F)			Entering Wet Bulb (°F)			Entering Wet Bulb (°F)			Entering Wet Bulb (°F)			Entering Wet Bulb (°F)					
		61	67	73	61	67	73	61	67	73	61	67	73	61	67	73	61	67	73						
21000	75	1166	810	1314	671	1476	525	1113	778	1255	638	1410	491	1058	744	1194	604	1340	456	1000	709	1129	568	1266	419
	80	1168	930	1315	791	1477	646	1115	897	1257	758	1411	612	1060	863	1196	724	1341	577	1002	828	1131	688	1268	540
	85	1170	1049	1317	911	1478	767	1117	1016	1259	878	1413	733	1063	982	1198	843	1343	697	1005	947	1133	808	1270	661
26000	75	1174	1154	1319	1030	1479	887	1132	1122	1261	997	1414	853	1083	1083	1200	963	1345	818	1036	1036	1136	927	1272	781
	80	1248	908	1401	733	1563	548	1189	873	1334	697	1488	512	1126	837	1265	660	1408	474	1061	799	1191	622	1324	435
	85	1252	1056	1404	882	1565	698	1192	1021	1337	845	1491	661	1130	984	1268	808	1412	624	1065	946	1195	770	1328	584
31000	75	1257	1202	1407	1030	1567	847	1200	1164	1341	994	1493	810	1143	1120	1271	957	1414	773	1081	1081	1198	919	1331	733
	80	1303	1303	1411	1178	1570	996	1253	1253	1345	1142	1496	959	1201	1201	1275	1104	1418	921	1145	1145	1203	1066	1334	882
	85	1309	1000	1463	788	1620	565	1243	962	1390	750	1538	527	1175	924	1314	711	1452	487	1103	884	1233	671	1361	446
36000	75	1314	1175	1468	966	1624	743	1250	1136	1395	928	1542	705	1182	1097	1319	889	1456	665	1111	1057	1238	848	1365	624
	80	1337	1337	1472	1143	1627	921	1282	1282	1400	1105	1546	882	1224	1224	1324	1066	1460	843	1163	1163	1243	1024	1369	802
	85	1412	1412	1479	1318	1631	1098	1355	1355	1407	1278	1550	1060	1295	1295	1331	1239	1464	1020	1231	1231	1252	1198	1373	979
41000	75	1354	1086	1509	840	1660	579	1284	1047	1431	800	1573	539	1211	1006	1349	760	1481	498	1135	963	1263	718	1384	456
	80	1365	1289	1514	1046	1665	785	1296	1248	1436	1006	1577	746	1228	1197	1355	966	1486	705	1157	1146	1269	924	1389	662
	85	1422	1422	1521	1250	1668	992	1361	1361	1443	1210	1581	952	1296	1296	1362	1167	1490	911	1228	1228	1277	1124	1392	868
46000	75	1503	1503	1532	1452	1673	1197	1439	1439	1458	1407	1586	1157	1372	1372	1375	1375	1494	1116	1299	1299	1302	1302	1397	1072
	80	1391	1169	1543	889	1689	592	1316	1127	1460	848	1598	551	1239	1084	1374	806	1502	509	1159	1040	1284	763	1401	466
	85	1414	1386	1549	1124	1694	826	1344	1336	1467	1083	1602	785	1275	1275	1381	1039	1506	743	1204	1204	1291	994	1404	699
51000	75	1493	1493	1559	1353	1698	1061	1426	1426	1477	1311	1606	1020	1355	1355	1392	1268	1510	977	1280	1280	1293	1233	1408	934
	80	1577	1577	1585	1562	1704	1295	1506	1506	1509	1509	1612	1252	1431	1431	1434	1434	1515	1208	1351	1351	1353	1353	1413	1160
	85	1421	1249	1569	937	1712	604	1343	1206	1483	895	1616	562	1263	1162	1392	852	1517	519	1179	1116	1298	807	1412	475
54000	75	1464	1464	1577	1198	1716	867	1394	1394	1491	1153	1620	824	1322	1322	1402	1108	1520	781	1245	1245	1308	1061	1414	736
	80	1552	1552	1590	1455	1720	1130	1480	1480	1505	1412	1624	1087	1403	1403	1418	1363	1524	1042	1321	1321	1329	1301	1418	995
	85	1636	1636	1639	1639	1727	1386	1559	1559	1562	1562	1631	1342	1477	1477	1480	1480	1530	1297	1389	1389	1390	1390	1424	1249
51000	75	1447	1329	1589	984	1729	616	1366	1285	1500	941	1630	573	1284	1235	1406	894	1528	530	1200	1175	1309	847	1420	485
	80	1511	1511	1599	1269	1733	907	1438	1438	1511	1224	1634	864	1360	1360	1418	1178	1530	820	1278	1278	1321	1130	1422	774
	85	1601	1601	1617	1556	1739	1199	1523	1523	1533	1495	1639	1151	1441	1441	1445	1436	1535	1102	1353	1353	1355	1355	1425	1053
54000	75	1684	1684	1687	1687	1749	1480	1601	1601	1603	1603	1646	1434	1512	1512	1514	1514	1542	1387	1415	1415	1417	1417	1431	1337
	80	1461	1377	1599	1013	1738	624	1379	1329	1508	966	1638	580	1298	1269	1413	919	1533	536	1212	1210	1314	868	1423	491
	85	1537	1537	1611	1312	1742	932	1460	1460	1520	1266	1640	888	1380	1380	1426	1219	1535	843	1294	1294	1327	1171	1425	797
54000	85	1626	1626	1636	1599	1749	1237	1546	1546	1550	1540	1646	1187	1460	1460	1462	1462	1540	1139	1368	1368	1370	1370	1428	1089
	90	1708	1708	1711	1711	1761	1537	1621	1621	1623	1623	1655	1489	1528	1528	1530	1530	1547	1441	1427	1427	1428	1428	1436	1385



Performance Data

Table 17. Gross cooling capacities – 130 tons – standard evaporator coil, 60Hz

CFM	Ent DB (°F)	Ambient Temperature (°F)																							
		85				95				105				115											
		Entering Wet Bulb (°F)			73	Entering Wet Bulb (°F)			61	67	73	Entering Wet Bulb (°F)			61	67	73								
23000	75	1344	929	1509	775	1685	611	1282	892	1440	737	1606	571	1216	852	1366	696	1523	530	1145	811	1287	655	1433	488
	80	1346	1060	1510	907	1685	743	1284	1023	1441	868	1607	704	1218	983	1368	828	1524	663	1148	943	1289	786	1435	620
	85	1348	1191	1512	1038	1687	876	1287	1154	1443	1000	1609	836	1221	1114	1370	960	1526	796	1152	1074	1291	918	1437	753
	90	1354	1321	1514	1169	1688	1007	1290	1278	1445	1113	1610	968	1237	1237	1372	1091	1528	927	1180	1180	1294	1049	1439	885
26000	75	1399	990	1567	813	1741	624	1332	950	1492	773	1656	583	1261	909	1413	731	1567	540	1186	866	1328	687	1470	496
	80	1402	1138	1569	962	1742	774	1335	1098	1494	922	1658	733	1265	1058	1415	880	1568	690	1190	1015	1331	836	1472	646
	85	1406	1286	1571	1110	1744	923	1340	1247	1497	1070	1660	882	1271	1204	1418	1028	1570	840	1197	1161	1334	985	1474	796
	90	1425	1425	1575	1258	1745	1072	1370	1370	1501	1218	1661	1031	1312	1312	1422	1177	1572	989	1249	1249	1338	1133	1477	944
30000	75	1459	1066	1628	859	1797	637	1386	1024	1547	817	1705	595	1309	981	1461	773	1608	551	1228	936	1370	728	1505	505
	80	1464	1237	1631	1031	1799	810	1391	1196	1550	988	1707	768	1314	1153	1464	945	1611	724	1234	1108	1373	900	1507	678
	85	1472	1406	1634	1202	1801	983	1401	1364	1553	1160	1710	940	1327	1321	1468	1117	1613	896	1258	1258	1378	1071	1510	850
	90	1525	1525	1639	1373	1803	1154	1464	1464	1559	1331	1712	1112	1399	1399	1474	1288	1616	1068	1328	1328	1383	1243	1512	1022
35000	75	1518	1156	1685	912	1847	651	1439	1113	1597	868	1748	607	1355	1067	1505	822	1644	561	1267	1020	1407	775	1533	514
	80	1525	1357	1688	1112	1850	853	1447	1310	1601	1068	1751	808	1364	1263	1509	1023	1647	763	1278	1216	1411	975	1536	715
	85	1547	1547	1694	1312	1852	1054	1481	1481	1606	1268	1754	1009	1410	1410	1515	1223	1650	964	1334	1334	1417	1176	1538	916
	90	1630	1630	1701	1513	1856	1254	1561	1561	1615	1465	1757	1210	1487	1487	1524	1418	1653	1164	1408	1408	1428	1370	1542	1116
40000	75	1563	1243	1727	961	1884	664	1479	1198	1634	916	1779	618	1390	1151	1536	869	1669	571	1297	1097	1432	820	1553	523
	80	1575	1468	1732	1190	1887	894	1492	1422	1639	1145	1782	848	1406	1374	1541	1098	1672	801	1318	1318	1438	1049	1555	752
	85	1630	1630	1739	1419	1890	1123	1556	1556	1646	1374	1784	1077	1479	1479	1549	1327	1674	1030	1395	1395	1446	1272	1557	981
	90	1715	1715	1751	1643	1894	1352	1639	1639	1660	1596	1788	1306	1557	1557	1585	1548	1679	1259	1468	1468	1471	1471	1561	1209
45000	75	1599	1328	1759	1009	1911	675	1510	1276	1661	963	1801	628	1418	1226	1559	915	1687	581	1321	1174	1451	864	1566	531
	80	1618	1580	1765	1267	1915	934	1533	1533	1667	1220	1804	886	1451	1451	1565	1172	1689	838	1365	1365	1457	1122	1567	788
	85	1698	1698	1774	1520	1920	1193	1618	1618	1677	1471	1807	1144	1534	1534	1576	1421	1692	1096	1443	1443	1468	1369	1569	1045
	90	1785	1785	1794	1775	1927	1451	1701	1701	1704	1704	1812	1402	1611	1611	1614	1614	1697	1353	1513	1513	1513	1515	1574	1295
50000	75	1628	1405	1784	1057	1934	688	1537	1355	1682	1009	1819	639	1441	1304	1576	959	1701	590	1341	1250	1464	908	1576	540
	80	1662	1662	1791	1343	1940	976	1581	1581	1689	1295	1821	925	1495	1495	1583	1246	1702	876	1403	1403	1471	1185	1577	825
	85	1754	1754	1803	1621	1946	1263	1669	1669	1703	1571	1824	1212	1578	1578	1598	1520	1704	1162	1480	1480	1487	1466	1578	1108
	90	1841	1841	1844	1844	1955	1551	1750	1750	1752	1752	1833	1491	1653	1653	1655	1655	1711	1438	1546	1546	1548	1548	1583	1383
55000	75	1654	1484	1804	1103	1954	700	1559	1433	1699	1054	1832	650	1461	1380	1589	1004	1711	600	1357	1326	1473	952	1576	540
	80	1709	1709	1812	1418	1961	1017	1623	1623	1707	1369	1835	965	1532	1532	1598	1308	1711	914	1434	1434	1483	1253	1577	825
	85	1801	1801	1829	1721	1967	1333	1710	1710	1725	1670	1841	1281	1613	1613	1618	1617	1714	1229	1508	1508	1510	1510	1578	1108
	90	1888	1888	1891	1891	1979	1640	1789	1789	1792	1792	1852	1585	1685	1685	1687	1687	1725	1530	1570	1570	1571	1571	1583	1383
58000	75	1667	1532	1814	1131	1964	708	1571	1480	1707	1082	1839	656	1471	1427	1595	1031	1716	606	1367	1367	1478	978	1576	540
	80	1733	1733	1823	1484	1971	1042	1644	1644	1716	1403	1843	989	1550	1550	1605	1350	1718	937	1449	1449	1488	1294	1577	825
	85	1826	1826	1843	1781	1978	1375	1731	1731	1737	1729	1850	1322	1631	1631	1633	1633	1721	1270	1522	1522	1524	1524	1578	1108
	90	1915	1915	1918	1918	1985	1709	1809	1809	1812	1812	1863	1641	1701	1701	1702	1702	1733	1585	1583	1583	1583	1585	1585	1586

Table 18. Gross cooling capacities – 130 tons eFlex™ variable speed – standard evaporator coil, 60Hz

CFM	Ent DB (°F)	Ambient Temperature (°F)																							
		85				95				105				115											
		Entering Wet Bulb (°F)				Entering Wet Bulb (°F)				Entering Wet Bulb (°F)				Entering Wet Bulb (°F)											
		61	67	73	79	61	67	73	79	61	67	73	79	61	67	73	79								
23000	75	1286	894	1446	741	1619	579	1228	858	1381	704	1546	541	1167	821	1314	667	1469	502	1103	783	1242	628	1385	462
	80	1288	1025	1447	872	1620	711	1230	989	1383	835	1547	673	1170	952	1316	798	1470	635	1106	914	1244	759	1387	594
	85	1290	1155	1449	1003	1622	843	1233	1119	1385	966	1549	805	1172	1082	1318	929	1472	766	1109	1043	1247	890	1390	726
	90	1292	1283	1452	1133	1623	974	1250	1231	1388	1097	1551	937	1194	1194	1321	1059	1474	898	1142	1142	1249	1020	1392	857
26000	75	1339	954	1502	778	1674	592	1276	916	1432	740	1594	553	1211	878	1358	700	1511	512	1142	838	1281	660	1421	470
	80	1342	1101	1504	927	1675	742	1280	1064	1434	888	1597	703	1214	1026	1361	849	1513	662	1146	985	1284	808	1424	620
	85	1345	1248	1507	1075	1677	890	1284	1210	1438	1036	1599	851	1220	1169	1365	997	1516	811	1158	1120	1287	956	1426	769
	90	1374	1374	1510	1222	1680	1039	1322	1322	1441	1184	1601	1000	1268	1268	1368	1145	1518	959	1210	1210	1291	1104	1429	917
30000	75	1395	1029	1561	824	1728	606	1328	990	1485	784	1642	565	1258	949	1405	743	1552	523	1183	908	1321	700	1455	479
	80	1400	1199	1564	995	1731	779	1333	1159	1488	955	1645	738	1263	1119	1409	914	1555	696	1189	1077	1325	871	1458	651
	85	1411	1360	1568	1166	1733	950	1350	1313	1493	1126	1648	909	1285	1264	1414	1085	1558	867	1218	1218	1330	1042	1461	823
	90	1470	1470	1573	1337	1736	1122	1412	1412	1498	1296	1652	1081	1352	1352	1419	1254	1561	1038	1287	1287	1336	1211	1465	994
35000	75	1451	1119	1616	877	1776	620	1377	1077	1534	835	1684	578	1301	1034	1448	792	1587	534	1221	989	1357	747	1483	489
	80	1458	1316	1620	1077	1780	821	1385	1273	1539	1035	1688	779	1310	1230	1453	992	1591	735	1234	1178	1362	947	1487	689
	85	1491	1482	1626	1277	1783	1021	1428	1428	1544	1235	1691	979	1362	1362	1459	1190	1594	935	1292	1292	1369	1144	1490	889
	90	1573	1573	1633	1474	1787	1221	1508	1508	1550	1481	1695	1179	1439	1439	1468	1387	1598	1134	1365	1365	1385	1326	1493	1088
40000	75	1494	1204	1656	927	1811	633	1416	1160	1570	884	1714	589	1335	1115	1479	839	1611	544	1250	1068	1383	792	1502	498
	80	1506	1430	1662	1156	1815	862	1433	1375	1576	1112	1717	818	1358	1318	1485	1067	1615	773	1278	1261	1388	1019	1505	725
	85	1571	1571	1670	1382	1819	1091	1503	1503	1583	1338	1721	1047	1430	1430	1493	1292	1618	1001	1352	1352	1397	1243	1508	954
	90	1657	1657	1685	1602	1824	1319	1585	1585	1604	1544	1726	1275	1509	1509	1520	1484	1623	1227	1425	1425	1428	1428	1512	1179
45000	75	1529	1287	1688	975	1838	645	1447	1240	1596	931	1735	600	1362	1193	1501	885	1628	554	1273	1144	1400	837	1515	506
	80	1557	1516	1694	1232	1842	903	1480	1460	1603	1186	1739	857	1402	1402	1508	1139	1631	810	1322	1322	1408	1090	1517	762
	85	1639	1639	1705	1484	1846	1160	1564	1564	1614	1438	1743	1114	1485	1485	1520	1390	1635	1067	1400	1400	1421	1338	1520	1018
	90	1726	1726	1736	1701	1853	1414	1647	1647	1651	1644	1749	1367	1562	1562	1565	1565	1640	1319	1470	1470	1472	1472	1525	1266
50000	75	1558	1366	1712	1023	1859	657	1473	1319	1617	977	1752	611	1385	1270	1518	930	1642	564	1292	1220	1413	881	1525	515
	80	1603	1603	1720	1305	1864	943	1526	1526	1625	1258	1755	896	1446	1446	1527	1210	1643	848	1360	1360	1422	1156	1525	799
	85	1695	1695	1734	1585	1870	1229	1615	1615	1640	1537	1759	1181	1529	1529	1546	1475	1647	1130	1437	1437	1446	1405	1528	1079
	90	1782	1782	1785	1785	1879	1511	1696	1696	1698	1698	1768	1459	1603	1603	1606	1606	1654	1408	1502	1502	1504	1504	1534	1355
55000	75	1583	1445	1731	1070	1877	670	1495	1397	1633	1023	1765	622	1406	1338	1530	971	1652	574	1314	1271	1422	919	1531	525
	80	1649	1649	1741	1379	1883	985	1568	1568	1643	1327	1768	935	1482	1482	1541	1277	1652	887	1390	1390	1433	1224	1533	836
	85	1742	1742	1762	1676	1889	1296	1656	1656	1669	1610	1775	1245	1564	1564	1570	1543	1657	1194	1465	1465	1467	1467	1534	1137
	90	1827	1827	1830	1830	1900	1603	1734	1734	1737	1737	1785	1551	1635	1635	1636	1636	1667	1499	1525	1525	1526	1526	1542	1443
58000	75	1597	1493	1741	1098	1886	678	1509	1436	1641	1047	1772	629	1420	1370	1537	996	1657	581	1325	1303	1427	944	1535	531
	80	1673	1673	1752	1419	1892	1009	1589	1589	1653	1369	1776	960	1501	1501	1549	1318	1657	910	1406	1406	1439	1264	1536	859
	85	1766	1766	1779	1718	1899	1336	1677	1677	1684	1652	1762	1285	1582	1582	1583	1583	1663	1583	1478	1478	1480	1480	1538	1174
	90	1851	1851	1854	1854	1912	1660	1754	1754	1754	1754	1793	1606	1650	1650	1651	1651	1651	1651	1521	1521	1521	1521	1549	1479



Performance Data

Table 19. Gross cooling capacities – 150 tons – standard evaporator coil, 60Hz

CFM	Ent DB (°F)	Ambient Temperature (°F)																							
		85						95						105						115					
		Entering Wet Bulb (°F)			Entering Wet Bulb (°F)			Entering Wet Bulb (°F)			Entering Wet Bulb (°F)			Entering Wet Bulb (°F)			Entering Wet Bulb (°F)			Entering Wet Bulb (°F)					
		61	67	73	61	67	73	61	67	73	61	67	73	61	67	73	61	67	73						
23000	75	1406	963	1577	808	1754	640	1342	924	1507	769	1676	600	1274	883	1431	727	1591	558	1200	839	1350	683	1499	513
	80	1407	1094	1578	940	1755	773	1344	1055	1508	900	1677	733	1276	1014	1432	859	1592	691	1202	970	1351	815	1500	646
	85	1409	1225	1579	1071	1756	905	1347	1186	1509	1031	1678	865	1279	1144	1434	990	1594	823	1205	1101	1353	946	1501	779
	90	1413	1354	1581	1202	1756	1036	1350	1315	1511	1162	1679	997	1285	1271	1436	1121	1595	955	1220	1220	1356	1077	1503	710
26000	75	1467	1025	1641	847	1811	652	1399	984	1565	806	1727	610	1325	941	1483	762	1636	567	1246	896	1394	716	1537	521
	80	1470	1173	1643	996	1812	802	1402	1133	1567	955	1728	760	1329	1090	1485	911	1638	717	1249	1044	1397	865	1539	671
	85	1473	1321	1644	1144	1813	951	1405	1281	1569	1103	1729	910	1332	1236	1488	1060	1639	866	1254	1191	1400	1014	1540	820
	90	1480	1467	1647	1292	1815	1099	1419	1419	1572	1251	1731	1058	1359	1359	1491	1208	1641	1015	1294	1294	1403	1162	1542	969
30000	75	1534	1103	1707	894	1867	663	1460	1060	1625	850	1775	620	1380	1015	1536	805	1678	576	1295	968	1441	757	1572	529
	80	1538	1274	1709	1065	1868	836	1464	1231	1627	1022	1777	793	1384	1187	1539	977	1679	748	1299	1139	1444	929	1573	701
	85	1544	1444	1712	1236	1870	1008	1470	1400	1630	1193	1778	965	1392	1355	1542	1148	1681	920	1309	1307	1448	1101	1575	873
	90	1579	1579	1716	1407	1871	1179	1517	1517	1634	1364	1780	1136	1450	1450	1547	1319	1683	1092	1378	1378	1452	1272	1577	1044
35000	75	1600	1195	1767	946	1919	676	1518	1150	1678	901	1817	630	1431	1103	1584	854	1712	585	1340	1053	1481	805	1600	536
	80	1605	1395	1770	1146	1921	878	1525	1348	1681	1101	1818	831	1438	1300	1587	1054	1713	785	1347	1249	1485	1005	1600	737
	85	1615	1591	1774	1346	1924	1079	1539	1539	1686	1301	1819	1031	1467	1467	1592	1254	1714	985	1388	1388	1490	1205	1601	936
	90	1688	1688	1779	1545	1927	1279	1619	1619	1691	1498	1821	1231	1544	1544	1598	1450	1716	1185	1462	1462	1496	1399	1603	1136
40000	75	1650	1283	1810	994	1961	690	1563	1236	1716	948	1847	640	1471	1187	1616	900	1735	593	1373	1132	1509	850	1617	544
	80	1658	1508	1813	1223	1963	920	1573	1460	1720	1177	1849	870	1482	1410	1620	1129	1735	821	1385	1358	1513	1078	1617	771
	85	1693	1693	1818	1451	1966	1149	1619	1619	1725	1405	1852	1099	1540	1540	1626	1354	1736	1049	1453	1453	1519	1302	1617	999
	90	1775	1775	1826	1674	1969	1379	1698	1698	1733	1627	1856	1328	1615	1615	1634	1578	1739	1278	1524	1524	1528	1515	1618	1227
45000	75	1688	1367	1842	1041	1992	703	1598	1316	1743	994	1873	652	1502	1264	1640	945	1753	602	1399	1209	1528	893	1626	552
	80	1701	1619	1846	1298	1995	961	1612	1570	1748	1251	1875	909	1516	1516	1644	1202	1754	858	1427	1427	1532	1151	1627	806
	85	1763	1763	1852	1550	1999	1220	1683	1683	1754	1502	1878	1167	1597	1597	1651	1451	1755	1116	1503	1503	1539	1397	1628	1063
	90	1843	1843	1862	1802	2005	1478	1758	1758	1766	1744	1882	1425	1667	1667	1670	1670	1760	1368	1567	1567	1569	1569	1632	1313
50000	75	1720	1446	1866	1087	2018	716	1626	1395	1764	1039	1893	663	1526	1342	1657	969	1768	611	1420	1286	1541	936	1634	560
	80	1738	1721	1871	1373	2022	1003	1651	1651	1769	1324	1894	949	1563	1563	1662	1269	1768	896	1467	1467	1546	1214	1637	843
	85	1818	1818	1879	1649	2026	1290	1732	1732	1777	1599	1898	1235	1640	1640	1669	1547	1770	1182	1539	1539	1554	1492	1639	1122
	90	1899	1899	1903	1903	2033	1571	1804	1804	1807	1807	1904	1515	1705	1705	1707	1707	1775	1458	1596	1596	1596	1598	1641	1401
55000	75	1746	1524	1886	1133	2039	729	1649	1472	1780	1084	1910	675	1546	1418	1670	1033	1780	622	1437	1361	1551	980	1644	569
	80	1780	1780	1892	1441	2043	1044	1693	1693	1786	1389	1910	989	1600	1600	1675	1336	1781	932	1499	1499	1556	1280	1644	881
	85	1864	1864	1904	1749	2047	1360	1772	1772	1795	1696	1915	1304	1673	1673	1682	1645	1782	1242	1566	1566	1566	1567	1645	1183
	90	1951	1951	2003	2003	2055	1665	1846	1846	1849	1849	1922	1607	1737	1737	1739	1739	1788	1549	1632	1632	1641	1641	1650	1491
58000	75	1759	1571	1896	1161	2050	736	1659	1565	1788	1110	1917	681	1557	1463	1676	1059	1780	628	1445	1405	1556	999	1648	575
	80	1804	1804	1904	1484	2053	1069	1715	1715	1794	1430	1919	1013	1619	1619	1681	1376	1784	958	1514	1514	1560	1320	1649	904
	85	1889	1889	1919	1810	2058	1402	1791	1791	1804	1754	1924	1338	1689	1689	1691	1691	1788	1279	1578	1578	1578	1579	1649	1220
	90	1979	1979	1982	1982	2066	1721	1868	1868	1871	1871	1931	1663	1754	1754	1756	1756	1794	1604	1632	1632	1634	1634	1654	1545

Table 20. Gross cooling capacities – 150 tons eFlex™ variable speed – standard evaporator coil, 60Hz

CFM	Ent DB (°F)	Ambient Temperature (°F)																							
		85						95						105						115					
		Entering Wet Bulb (°F)			Entering Wet Bulb (°F)			Entering Wet Bulb (°F)			Entering Wet Bulb (°F)			Entering Wet Bulb (°F)			Entering Wet Bulb (°F)			Entering Wet Bulb (°F)			Entering Wet Bulb (°F)		
		61	67	73	61	67	73	61	67	73	61	67	73	61	67	73	61	67	73	61	67	73	61	67	73
23000	75	1392	953	1570	802	1760	641	1332	915	1503	764	1685	601	1268	876	1433	724	1606	561	1201	835	1358	682	1522	519
	80	1393	1083	1570	934	1761	773	1333	1045	1504	895	1686	734	1269	1006	1434	855	1607	693	1202	965	1359	814	1523	651
	85	1395	1213	1571	1064	1761	905	1335	1175	1505	1026	1686	866	1271	1136	1435	986	1608	825	1204	1095	1361	945	1524	783
26000	75	1396	1341	1572	1194	1762	1036	1339	1297	1507	1156	1687	997	1282	1251	1437	1116	1609	956	1213	1213	1362	1075	1525	915
	80	1456	1017	1637	843	1828	657	1391	977	1566	803	1747	616	1322	935	1490	761	1661	574	1249	893	1409	718	1569	529
	85	1458	1164	1638	991	1829	807	1393	1124	1567	951	1748	766	1324	1083	1491	910	1662	723	1251	1040	1411	867	1570	679
30000	75	1460	1311	1640	1139	1830	956	1395	1271	1569	1099	1749	915	1327	1229	1493	1058	1664	872	1272	1187	1413	1015	1572	828
	80	1462	1454	1642	1286	1832	1104	1400	1400	1571	1247	1751	1063	1352	1352	1495	1205	1666	1021	1293	1293	1415	1162	1574	977
	85	1527	1096	1709	892	1897	674	1455	1054	1630	850	1809	631	1380	1011	1548	806	1716	587	1301	966	1461	761	1617	541
35000	75	1530	1267	1712	1063	1898	846	1459	1225	1633	1021	1811	804	1384	1181	1551	978	1718	760	1305	1136	1464	933	1619	713
	80	1533	1436	1714	1234	1900	1018	1460	1392	1636	1192	1813	976	1392	1340	1554	1149	1720	932	1310	1276	1467	1104	1621	885
	85	1569	1569	1717	1404	1902	1189	1511	1511	1639	1362	1815	1147	1449	1449	1557	1319	1723	1103	1383	1383	1470	1273	1623	1057
40000	75	1595	1190	1779	949	1958	689	1518	1146	1693	904	1864	645	1437	1101	1602	858	1764	600	1351	1053	1508	811	1657	552
	80	1600	1388	1783	1148	1960	890	1524	1344	1696	1104	1866	846	1443	1298	1606	1058	1766	801	1374	1259	1512	1011	1660	753
	85	1616	1567	1786	1348	1962	1091	1545	1513	1701	1303	1868	1047	1468	1468	1610	1257	1769	1001	1397	1397	1516	1210	1662	954
45000	75	1684	1684	1791	1546	1965	1290	1619	1619	1705	1501	1871	1247	1550	1550	1615	1455	1772	1201	1476	1476	1521	1407	1665	1153
	80	1649	1279	1831	1001	2003	702	1567	1234	1740	955	1902	657	1481	1186	1643	907	1797	610	1390	1136	1541	857	1685	561
	85	1656	1505	1836	1229	2005	932	1575	1459	1744	1183	1904	886	1488	1408	1648	1135	1799	840	1430	1384	1546	1086	1687	791
50000	75	1691	1690	1841	1457	2007	1161	1621	1621	1750	1410	1907	1115	1548	1548	1654	1362	1802	1069	1469	1469	1552	1312	1690	1020
	80	1782	1782	1846	1742	2011	1389	1709	1709	1757	1636	1911	1343	1632	1632	1664	1577	1806	1297	1549	1549	1553	1553	1693	1248
	85	1692	1365	1871	1051	2036	715	1605	1317	1775	1003	1930	668	1515	1268	1674	954	1821	620	1419	1217	1567	903	1704	570
55000	75	1702	1615	1876	1308	2038	972	1621	1554	1781	1260	1932	926	1537	1492	1680	1211	1822	878	1443	1443	1573	1159	1705	828
	80	1770	1770	1883	1562	2041	1230	1694	1694	1794	1572	1935	1183	1613	1613	1688	1465	1825	1135	1528	1528	1593	1437	1708	1085
	85	1863	1863	1896	1802	2046	1487	1784	1784	1807	1739	1939	1440	1700	1700	1704	1704	1829	1390	1609	1609	1612	1612	1712	1339
58000	75	1725	1506	1902	1099	2064	727	1636	1398	1802	1050	1952	679	1542	1348	1698	1000	1838	630	1443	1295	1586	948	1717	579
	80	1753	1701	1908	1384	2066	1014	1660	1660	1809	1335	1953	965	1577	1577	1705	1284	1839	916	1490	1490	1594	1231	1718	865
	85	1837	1837	1917	1665	2071	1300	1756	1756	1818	1616	1957	1250	1669	1669	1708	1579	1842	1201	1576	1576	1604	1506	1721	1150
58000	75	1930	1930	1945	1897	2078	1584	1845	1845	1848	1848	1961	1533	1754	1754	1757	1757	1847	1483	1656	1656	1658	1658	1725	1430
	80	1759	1530	1927	1146	2087	741	1663	1479	1824	1097	1969	690	1564	1426	1716	1046	1852	640	1461	1371	1601	993	1727	589
	85	1795	1795	1934	1458	2091	1056	1711	1711	1831	1408	1970	1004	1623	1623	1724	1357	1852	954	1529	1529	1610	1301	1727	902
58000	75	1893	1893	1944	1767	2097	1371	1807	1807	1843	1717	1975	1318	1715	1715	1761	1707	1855	1266	1616	1616	1631	1573	1730	1213
	80	1985	1985	1988	1988	2105	1682	1893	1893	1896	1896	1979	1710	1796	1796	1799	1799	1859	1574	1691	1691	1693	1693	1730	1564
	85	1775	1579	1939	1174	2100	749	1677	1527	1834	1125	1978	697	1576	1473	1725	1073	1858	646	1475	1403	1608	1018	1732	594
58000	75	1824	1824	1947	1502	2104	1081	1738	1738	1843	1452	1980	1028	1647	1647	1733	1398	1858	977	1550	1550	1617	1343	1733	925
	80	1922	1922	1959	1828	2110	1413	1833	1833	1882	1824	1984	1357	1738	1738	1754	1688	1861	1304	1636	1636	1638	1638	1734	1251
	85	2013	2013	2016	2016	2120	1739	1918	1918	1921	1921	1991	1683	1817	1817	1819	1819	1866	1629	1707	1707	1709	1709	1738	1574



Performance Data

Table 21. Gross cooling capacities – 90 tons – high capacity evaporator coil, 60Hz

CFM	Ent DB (°F)	Ambient Temperature (°F)																											
		85				95				105				115															
		61			67			73			61			67			73			61			67			73			
		CAP	SHC	SHC	CAP	SHC	SHC	CAP	SHC	SHC	CAP	SHC	SHC	CAP	SHC	SHC	CAP	SHC	SHC	CAP	SHC	SHC	CAP	SHC	SHC	CAP	SHC	SHC	
16000	75	949	665	1174	438	910	643	1017	533	1126	415	868	619	969	509	1072	391	822	593	917	483	1013	365	824	684	919	574	1013	457
	80	950	755	1174	530	912	733	1017	624	1126	509	870	710	970	600	1072	483	824	684	919	574	1013	457	824	684	919	574	1013	457
	85	953	847	1175	621	915	825	1018	715	1127	599	873	801	971	691	1073	574	828	774	920	665	1014	548	828	774	920	665	1014	548
	90	959	937	1175	713	918	909	1020	806	1127	699	883	883	973	782	1074	666	846	846	922	756	1015	640	846	846	922	756	1015	640
20000	75	1015	742	1126	602	971	718	1077	578	1180	427	922	692	1023	552	1119	401	870	665	964	524	1053	374	870	665	964	524	1053	374
	80	1018	856	1127	716	974	832	1078	692	1181	542	926	806	1025	666	1120	516	874	778	966	638	1054	489	874	778	966	638	1054	489
	85	1024	968	1129	829	981	944	1080	805	1182	657	933	917	1027	780	1121	631	885	885	968	752	1055	603	885	885	968	752	1055	603
	90	1052	1052	1132	943	1015	1015	1084	920	1183	771	974	974	1030	894	1123	745	930	930	972	865	1056	717	930	930	972	865	1056	717
25000	75	1071	831	1180	653	1022	805	1125	627	1220	438	968	778	1065	600	1153	411	910	749	1000	571	1081	383	910	749	1000	571	1081	383
	80	1078	971	1181	795	1029	945	1127	770	1221	582	976	917	1067	742	1155	555	919	887	1002	713	1082	526	919	887	1002	713	1082	526
	85	1096	1096	1184	937	1054	1054	1130	912	1222	725	1008	1008	1071	885	1156	698	957	957	1006	854	1082	669	957	957	1006	854	1082	669
	90	1150	1150	1190	1077	1106	1106	1137	1051	1224	867	1058	1058	1078	1023	1157	840	1005	1005	1015	993	1084	811	1005	1005	1015	993	1084	811
30000	75	1110	916	1214	700	1057	887	1155	674	1245	448	999	855	1091	645	1174	420	937	824	1021	615	1097	391	937	824	1021	615	1097	391
	80	1122	1082	1216	871	1118	1055	1158	845	1246	620	1014	1014	1094	816	1174	592	958	958	1024	786	1097	562	958	958	1024	786	1097	562
	85	1166	1166	1222	1038	1118	1118	1163	1011	1247	791	1066	1066	1100	981	1175	763	1008	1008	1031	950	1097	734	1008	1008	1031	950	1097	734
	90	1221	1221	1232	1207	1171	1171	1176	1167	1249	962	1115	1115	1117	1117	1177	934	1054	1054	1055	1055	1100	898	1054	1054	1055	1055	1100	898
33000	75	1129	960	1229	728	1073	932	1168	701	1256	454	1014	902	1102	672	1182	426	949	870	1030	641	1103	396	949	870	1030	641	1103	396
	80	1144	1144	1232	916	1093	1093	1171	889	1256	643	1040	1040	1105	860	1182	614	982	982	1034	824	1103	584	982	982	1034	824	1103	584
	85	1199	1199	1239	1098	1148	1148	1179	1070	1256	831	1093	1093	1113	1040	1183	802	1031	1031	1042	1008	1103	772	1031	1031	1042	1008	1103	772
	90	1253	1253	1256	1256	1200	1200	1202	1202	1260	1019	1141	1141	1141	1142	1185	983	1075	1075	1076	1076	1105	951	1075	1075	1076	1076	1105	951
36000	75	1144	1007	1242	755	1087	979	1179	728	1264	480	1026	948	1111	698	1188	431	960	915	1037	667	1107	401	960	915	1037	667	1107	401
	80	1169	1169	1245	960	1118	1118	1182	930	1264	665	1062	1062	1115	897	1189	637	1001	1001	1041	864	1107	606	1001	1001	1041	864	1107	606
	85	1227	1227	1253	1157	1173	1173	1192	1129	1265	871	1114	1114	1124	1098	1189	842	1049	1049	1052	1048	1107	812	1049	1049	1052	1048	1107	812
	90	1281	1281	1282	1282	1224	1224	1225	1225	1270	1068	1161	1161	1161	1162	1193	1037	1090	1090	1091	1091	1112	1004	1090	1090	1091	1091	1112	1004
40000	75	1162	1070	1255	792	1103	1040	1190	763	1274	468	1040	1008	1120	734	1193	439	971	964	1043	702	1110	408	971	964	1043	702	1110	408
	80	1200	1200	1259	1012	1146	1146	1195	983	1274	696	1087	1087	1125	951	1195	667	1021	1021	1049	918	1111	636	1021	1021	1049	918	1111	636
	85	1258	1258	1270	1236	1201	1201	1207	1203	1275	925	1138	1138	1139	1139	1196	895	1068	1068	1069	1069	1112	853	1068	1068	1069	1069	1112	853
	90	1310	1310	1311	1311	1249	1249	1250	1250	1281	1141	1181	1181	1181	1182	1182	1202	1109	1107	1107	1108	1108	1118	1076	1107	1107	1108	1118	1076

Table 22. Gross cooling capacities – 90 tons eFlex™ variable speed – high capacity evaporator coil, 60Hz

CFM	Ent DB (°F)	Ambient Temperature (°F)																							
		85						95						105						115					
		Entering Wet Bulb (°F)			Entering Wet Bulb (°F)			Entering Wet Bulb (°F)			Entering Wet Bulb (°F)			Entering Wet Bulb (°F)			Entering Wet Bulb (°F)			Entering Wet Bulb (°F)					
		61	67	73	CAP	SHC	SHC	61	67	73	CAP	SHC	SHC	61	67	73	CAP	SHC	SHC	61	67	73	CAP	SHC	SHC
16000	75	933	657	1043	549	1155	431	897	637	1003	528	1110	410	860	615	960	506	1060	387	819	593	914	482	1006	363
	80	934	748	1044	640	1156	523	899	728	1004	619	1111	502	861	706	961	597	1061	479	821	684	915	574	1007	455
	85	937	838	1045	731	1156	614	902	818	1005	710	1111	593	865	797	963	688	1062	571	824	774	916	665	1008	547
20000	75	947	917	1046	822	1157	706	915	893	1007	801	1112	685	867	867	964	779	1063	662	844	844	918	756	1009	638
	80	998	734	1108	595	1211	443	957	712	1063	572	1160	420	913	689	1013	548	1103	396	866	664	960	523	1040	370
	85	1001	847	1109	709	1212	558	960	825	1064	686	1160	535	917	801	1015	663	1104	511	871	777	962	637	1041	485
25000	75	1007	955	1111	822	1213	672	970	928	1066	800	1162	650	930	897	1017	777	1105	625	888	866	964	751	1042	599
	80	1039	1039	1114	935	1214	786	1005	1005	1070	913	1163	764	968	968	1021	889	1106	739	928	928	968	864	1043	713
	85	1053	823	1159	645	1252	453	1008	799	1108	621	1193	429	959	773	1053	596	1130	404	907	746	993	569	1062	376
30000	75	1060	964	1161	787	1253	597	1015	940	1110	764	1195	572	967	908	1055	738	1131	547	918	872	995	711	1063	520
	80	1085	1070	1164	928	1254	740	1043	1041	1114	904	1196	715	1001	1001	1059	879	1132	690	954	954	1000	851	1063	662
	85	1135	1135	1171	1070	1256	882	1094	1094	1121	1046	1197	858	1049	1049	1068	1005	1134	832	1000	1000	1012	966	1065	803
33000	75	1092	905	1191	691	1281	464	1043	880	1136	666	1217	439	990	853	1076	640	1149	412	933	825	1012	612	1075	384
	80	1107	1055	1193	862	1282	636	1060	1021	1138	838	1217	610	1011	986	1079	808	1149	584	957	949	1015	780	1075	555
	85	1150	1150	1199	1030	1284	808	1105	1105	1144	1005	1218	782	1057	1057	1085	976	1150	755	1003	1003	1021	947	1076	726
36000	75	1202	1202	1215	1165	1287	977	1154	1154	1163	1129	1222	950	1102	1102	1105	1091	1153	922	1042	1042	1043	1043	1079	893
	80	1110	954	1204	718	1293	470	1059	928	1147	693	1227	444	1004	898	1085	666	1157	417	946	868	1019	637	1079	389
	85	1132	1101	1207	904	1295	660	1083	1067	1150	878	1227	633	1031	1031	1089	850	1156	606	978	978	1022	821	1080	577
40000	75	1181	1181	1214	1088	1297	849	1133	1133	1158	1062	1229	822	1081	1081	1097	1022	1158	794	1022	1022	1033	979	1082	761
	80	1231	1231	1236	1217	1302	1033	1180	1180	1181	1181	1234	1006	1122	1122	1123	1123	1163	978	1058	1058	1059	1059	1086	945
	85	1125	999	1215	745	1304	477	1072	972	1156	719	1235	450	1016	944	1092	692	1163	423	956	899	1024	663	1082	394
40000	75	1153	1148	1219	947	1306	683	1104	1104	1160	920	1236	656	1052	1052	1097	892	1163	628	995	995	1028	862	1084	599
	80	1207	1207	1227	1144	1309	890	1156	1156	1170	1100	1239	859	1100	1100	1109	1058	1165	830	1037	1037	1042	1014	1086	799
	85	1257	1257	1259	1259	1316	1091	1201	1201	1201	1202	1202	1246	1062	1140	1140	1141	1171	1030	1073	1073	1073	1073	1092	998
40000	75	1142	1061	1226	781	1316	486	1088	1020	1165	754	1244	458	1031	980	1100	726	1170	430	971	937	1029	691	1087	401
	80	1181	1181	1231	1003	1319	715	1130	1130	1170	973	1246	687	1074	1074	1104	944	1170	659	1013	1013	1033	912	1089	629
	85	1234	1234	1245	1188	1323	940	1179	1179	1186	1149	1250	911	1118	1118	1121	1107	1173	881	1051	1051	1052	1052	1091	849
90	1289	1289	1291	1291	1332	1163	1228	1228	1229	1229	1229	1259	1133	1163	1163	1164	1164	1182	1098	1091	1091	1092	1092	1101	1041



Performance Data

Table 23. Gross cooling capacities – 105 tons – high capacity evaporator coil, 60Hz

CFM	Ent DB (°F)	Ambient Temperature (°F)																							
		85						95						105						115					
		61		67		73		61		67		73		61		67		73		61		67		73	
		CAP	SHC	CAP	SHC	CAP	SHC	CAP	SHC	CAP	SHC	CAP	SHC	CAP	SHC	CAP	SHC	CAP	SHC	CAP	SHC	CAP	SHC	CAP	SHC
19000	75	1060	754	1185	625	1316	487	1014	728	1133	599	1257	461	964	701	1077	571	1194	433	912	673	1018	542	1127	404
	80	1062	862	1186	733	1316	596	1017	837	1134	707	1258	570	968	810	1079	680	1196	542	916	782	1020	651	1128	513
	85	1067	971	1188	842	1317	705	1021	944	1136	815	1260	679	973	916	1081	788	1197	651	922	888	1022	760	1130	622
	90	1077	1077	1190	950	1319	814	1038	1038	1139	924	1261	788	999	999	1084	897	1199	760	956	956	1026	868	1132	731
23000	75	1120	830	1247	671	1373	501	1068	802	1189	643	1308	473	1013	774	1127	614	1239	444	956	744	1061	583	1164	414
	80	1125	962	1249	802	1374	633	1073	934	1191	774	1310	605	1019	902	1129	745	1241	577	962	872	1064	715	1166	546
	85	1134	1091	1251	933	1376	765	1084	1063	1194	906	1311	737	1031	1031	1133	877	1243	708	982	982	1068	847	1168	678
	90	1174	1174	1256	1065	1377	896	1131	1131	1199	1037	1313	869	1085	1085	1138	1005	1244	840	1035	1035	1074	974	1170	809
28000	75	1175	919	1300	723	1419	514	1118	890	1236	693	1349	485	1057	859	1169	663	1273	455	993	823	1097	631	1193	424
	80	1184	1075	1302	882	1421	675	1127	1045	1239	853	1351	646	1068	1014	1172	823	1276	616	1005	982	1100	791	1195	584
	85	1209	1209	1307	1043	1423	835	1161	1161	1244	1014	1353	806	1109	1109	1177	979	1277	776	1054	1054	1106	946	1196	744
	90	1272	1272	1315	1198	1425	995	1222	1222	1253	1168	1355	966	1168	1168	1188	1136	1280	936	1109	1109	1118	1104	1199	904
33000	75	1215	1000	1336	771	1451	526	1154	968	1268	741	1375	496	1089	935	1196	709	1296	465	1021	901	1120	676	1211	433
	80	1230	1187	1340	960	1453	715	1170	1156	1272	929	1377	685	1108	1108	1200	898	1298	654	1048	1048	1124	859	1212	622
	85	1282	1282	1347	1142	1454	904	1228	1228	1280	1111	1379	874	1170	1170	1209	1078	1299	843	1107	1107	1133	1044	1213	810
	90	1347	1347	1360	1329	1457	1092	1290	1290	1295	1289	1382	1063	1229	1229	1231	1231	1303	1025	1161	1161	1163	1163	1217	990
38000	75	1247	1080	1362	818	1473	537	1182	1047	1291	787	1394	507	1114	1013	1215	754	1312	475	1043	977	1135	721	1223	442
	80	1270	1270	1367	1035	1475	755	1214	1214	1296	997	1396	724	1153	1153	1221	963	1312	692	1088	1088	1141	927	1223	659
	85	1339	1339	1377	1242	1476	972	1279	1279	1307	1210	1397	941	1216	1216	1233	1176	1313	909	1146	1146	1154	1140	1224	867
	90	1403	1403	1405	1405	1482	1181	1340	1340	1342	1342	1401	1148	1272	1272	1274	1274	1317	1113	1197	1197	1199	1199	1227	1077
43000	75	1272	1158	1382	864	1490	548	1205	1124	1307	832	1409	517	1134	1089	1229	799	1321	485	1060	1052	1145	765	1230	452
	80	1315	1315	1388	1100	1491	794	1254	1254	1314	1067	1409	763	1188	1188	1236	1031	1322	730	1118	1118	1154	994	1230	696
	85	1383	1383	1401	1341	1495	1041	1319	1319	1329	1308	1410	999	1250	1250	1253	1253	1323	964	1175	1175	1176	1176	1231	926
	90	1446	1446	1448	1448	1504	1273	1377	1377	1379	1379	1418	1239	1303	1303	1304	1304	1329	1203	1221	1221	1222	1222	1236	1165
45000	75	1280	1189	1388	883	1496	553	1212	1155	1313	851	1413	522	1141	1119	1233	817	1325	489	1067	1067	1149	772	1232	456
	80	1330	1330	1395	1128	1497	810	1267	1267	1320	1094	1413	778	1200	1200	1241	1059	1326	746	1128	1128	1157	1021	1232	711
	85	1398	1398	1410	1381	1502	1064	1332	1332	1337	1337	1415	1024	1261	1261	1262	1262	1326	988	1184	1184	1185	1185	1232	950
	90	1460	1460	1462	1462	1511	1310	1390	1390	1391	1391	1424	1275	1313	1313	1314	1314	1334	1239	1228	1228	1229	1229	1240	1200

Table 24. Gross cooling capacities – 105 tons eFlex™ variable speed – high capacity evaporator coil, 60Hz

CFM	Ent DB (°F)	Ambient Temperature (°F)																							
		85						95						105						115					
		Entering Wet Bulb (°F)						Entering Wet Bulb (°F)						Entering Wet Bulb (°F)						Entering Wet Bulb (°F)					
		61	67	73	79	85	91	61	67	73	79	85	91	61	67	73	79	85	91	61	67	73	79	85	91
19000	75	1054	752	1178	623	1308	484	1014	729	1133	589	1256	461	970	705	1084	575	1201	436	924	680	1031	549	1140	410
	80	1057	860	1180	731	1308	594	1017	838	1134	708	1257	570	974	814	1086	683	1202	546	927	788	1033	658	1142	519
	85	1061	968	1181	839	1310	703	1021	945	1136	816	1259	679	979	920	1088	792	1204	655	933	895	1035	766	1143	629
23000	75	1075	1065	1184	948	1311	811	1039	1039	1139	925	1260	788	1004	1004	1091	900	1205	763	966	966	1039	875	1145	737
	80	1114	828	1239	668	1363	498	1068	803	1188	643	1306	473	1020	777	1134	617	1244	447	969	751	1075	590	1177	419
	85	1119	959	1241	800	1364	630	1073	934	1191	775	1308	605	1025	908	1136	749	1246	579	975	879	1078	722	1180	552
28000	75	1128	1088	1245	931	1366	762	1084	1058	1194	906	1309	737	1040	1026	1140	881	1248	711	993	993	1082	853	1181	684
	80	1170	1170	1249	1063	1367	893	1132	1132	1199	1037	1311	869	1091	1091	1145	1011	1250	843	1046	1046	1088	981	1184	815
	85	1168	917	1291	720	1407	510	1118	891	1235	694	1345	485	1064	861	1175	666	1278	458	1007	832	1111	637	1206	429
33000	75	1177	1073	1294	880	1409	671	1127	1046	1239	854	1347	645	1075	1018	1179	826	1280	618	1018	989	1115	798	1208	589
	80	1205	1205	1299	1040	1411	831	1162	1162	1244	1012	1349	806	1116	1116	1185	984	1282	778	1066	1066	1121	953	1209	750
	85	1267	1267	1308	1195	1413	991	1223	1223	1253	1169	1351	966	1175	1175	1195	1141	1285	939	1122	1122	1133	1101	1212	910
38000	75	1208	1000	1326	768	1436	521	1154	969	1267	741	1370	495	1097	939	1203	712	1300	467	1036	908	1134	682	1223	438
	80	1223	1185	1330	956	1439	711	1171	1145	1271	930	1372	684	1118	1108	1207	901	1301	656	1061	1061	1139	868	1224	626
	85	1277	1277	1338	1139	1441	900	1229	1229	1279	1111	1373	872	1177	1177	1216	1082	1302	844	1121	1121	1148	1050	1225	815
43000	75	1340	1340	1352	1315	1446	1089	1290	1290	1297	1278	1378	1058	1235	1235	1237	1237	1306	1029	1174	1174	1176	1176	1228	995
	80	1239	1077	1351	814	1460	533	1182	1048	1288	787	1388	505	1122	1017	1221	757	1315	477	1058	984	1149	726	1232	447
	85	1266	1266	1357	1028	1463	751	1215	1215	1294	1000	1390	723	1161	1161	1228	966	1315	694	1102	1102	1156	934	1234	663
45000	75	1332	1332	1367	1239	1465	968	1279	1279	1305	1210	1393	940	1223	1223	1239	1179	1318	908	1160	1160	1169	1136	1237	876
	80	1394	1394	1396	1396	1472	1178	1338	1338	1340	1340	1399	1147	1277	1277	1279	1279	1323	1116	1209	1209	1211	1211	1241	1083
	85	1264	1155	1370	860	1477	545	1205	1125	1304	832	1402	516	1142	1093	1235	802	1325	486	1075	1048	1160	770	1240	456
45000	75	1308	1308	1377	1096	1480	791	1254	1254	1312	1066	1405	762	1196	1196	1243	1034	1326	732	1132	1132	1168	1000	1242	701
	80	1375	1375	1390	1337	1484	1037	1318	1318	1327	1293	1408	1003	1256	1256	1261	1249	1329	966	1188	1188	1189	1189	1245	932
	85	1437	1437	1439	1439	1493	1270	1375	1375	1376	1376	1415	1238	1308	1308	1309	1309	1335	1206	1235	1235	1236	1236	1250	1171
45000	75	1273	1186	1376	879	1483	549	1213	1155	1310	850	1407	520	1149	1119	1239	820	1329	490	1083	1068	1163	782	1243	459
	80	1323	1323	1384	1124	1486	807	1267	1267	1318	1093	1409	777	1208	1208	1247	1061	1330	747	1142	1142	1172	1027	1245	716
	85	1389	1389	1399	1362	1491	1059	1331	1331	1336	1320	1413	1023	1267	1267	1268	1268	1333	990	1197	1197	1198	1198	1247	956
45000	75	1452	1452	1454	1454	1501	1307	1388	1388	1389	1389	1421	1275	1319	1319	1320	1320	1339	1241	1243	1243	1244	1244	1253	1206



Performance Data

Table 25. Gross cooling capacities – 120 tons – high capacity evaporator coil, 60Hz

CFM	Ent DB (°F)	Ambient Temperature (°F)																							
		85				95				105				115											
		61	67	73	79	61	67	73	79	61	67	73	79	61	67	73	79								
21000	75	1205	835	1355	694	1511	543	1148	800	1292	659	1442	508	1087	764	1225	622	1368	472	1023	726	1154	585	1289	434
	80	1206	954	1356	815	1512	664	1150	920	1293	779	1443	629	1089	884	1226	743	1369	593	1025	846	1155	705	1290	555
	85	1208	1073	1357	934	1512	785	1152	1039	1294	899	1444	750	1091	1003	1228	863	1370	714	1027	965	1157	825	1292	676
	90	1211	1191	1359	1054	1513	905	1156	1156	1296	1019	1445	870	1108	1108	1230	982	1372	834	1056	1056	1159	945	1293	796
26000	75	1291	934	1444	755	1590	561	1226	896	1373	718	1514	525	1158	858	1297	679	1432	487	1086	817	1217	639	1344	448
	80	1294	1082	1446	904	1592	711	1229	1044	1375	867	1515	674	1161	1006	1300	828	1434	637	1089	966	1220	788	1347	597
	85	1297	1228	1448	1053	1593	860	1233	1190	1378	1015	1517	824	1167	1150	1303	977	1436	786	1102	1102	1223	936	1349	747
	90	1336	1336	1451	1200	1595	1008	1283	1283	1380	1163	1518	972	1226	1226	1306	1125	1438	935	1165	1165	1226	1084	1351	895
31000	75	1355	1026	1504	809	1642	574	1283	986	1427	770	1559	537	1208	945	1346	730	1472	498	1130	903	1260	688	1378	458
	80	1359	1203	1507	986	1643	752	1288	1162	1431	947	1560	715	1213	1120	1350	907	1473	676	1136	1077	1264	865	1380	635
	85	1372	1372	1510	1163	1645	930	1313	1313	1434	1124	1561	892	1250	1250	1354	1084	1474	853	1184	1184	1267	1042	1381	813
	90	1445	1445	1514	1339	1647	1107	1384	1384	1438	1299	1563	1069	1320	1320	1358	1258	1476	1030	1251	1251	1273	1216	1383	990
36000	75	1402	1114	1546	858	1680	588	1325	1072	1465	818	1590	548	1245	1030	1380	777	1498	509	1161	982	1288	734	1399	468
	80	1409	1316	1550	1064	1683	795	1333	1274	1469	1024	1590	753	1255	1231	1384	983	1498	714	1177	1177	1292	940	1400	672
	85	1455	1455	1554	1269	1686	1001	1391	1391	1473	1230	1591	959	1322	1322	1388	1186	1499	919	1248	1248	1298	1141	1400	878
	90	1529	1529	1560	1470	1689	1207	1463	1463	1480	1430	1593	1164	1392	1392	1397	1388	1501	1125	1315	1315	1318	1318	1402	1083
41000	75	1437	1199	1577	906	1710	601	1357	1152	1492	865	1609	559	1274	1107	1403	823	1514	519	1186	1060	1308	779	1409	477
	80	1449	1427	1581	1140	1714	836	1375	1375	1496	1099	1612	792	1303	1303	1408	1057	1515	751	1226	1226	1313	1013	1411	709
	85	1522	1522	1586	1370	1717	1072	1452	1452	1502	1328	1615	1027	1378	1378	1414	1285	1515	985	1298	1298	1320	1239	1412	942
	90	1595	1595	1598	1598	1722	1307	1522	1522	1524	1524	1617	1261	1445	1445	1447	1447	1517	1215	1360	1360	1362	1362	1414	1170
46000	75	1466	1276	1600	952	1735	615	1383	1231	1512	911	1631	571	1297	1185	1420	868	1526	529	1205	1137	1322	823	1421	487
	80	1497	1497	1604	1215	1738	878	1424	1424	1517	1173	1631	832	1347	1347	1425	1125	1526	788	1265	1265	1327	1078	1421	745
	85	1575	1575	1611	1470	1742	1142	1500	1500	1524	1427	1633	1096	1420	1420	1433	1383	1527	1051	1335	1335	1337	1337	1421	1008
	90	1648	1648	1651	1651	1748	1401	1566	1566	1569	1569	1639	1353	1483	1483	1485	1485	1531	1305	1392	1392	1393	1393	1421	1258
51000	75	1489	1355	1618	998	1753	627	1404	1309	1528	956	1640	582	1315	1262	1433	913	1532	540	1222	1209	1332	867	1422	497
	80	1540	1540	1623	1283	1758	920	1464	1464	1533	1239	1645	872	1383	1383	1438	1193	1536	827	1296	1296	1338	1145	1424	783
	85	1617	1617	1632	1569	1762	1212	1537	1537	1543	1525	1649	1165	1453	1453	1455	1455	1540	1112	1362	1362	1363	1363	1426	1062
	90	1697	1696	1699	1699	1769	1496	1605	1605	1606	1606	1657	1446	1511	1511	1513	1513	1544	1397	1413	1413	1414	1414	1428	1347
54000	75	1501	1402	1628	1026	1763	635	1415	1356	1535	983	1648	589	1325	1308	1439	940	1540	547	1235	1235	1337	884	1423	505
	80	1563	1563	1633	1326	1767	945	1484	1484	1541	1281	1653	896	1401	1401	1445	1234	1542	851	1311	1311	1343	1186	1423	807
	85	1640	1640	1646	1630	1772	1255	1556	1556	1558	1558	1658	1198	1468	1468	1470	1470	1543	1148	1374	1374	1376	1376	1428	1098
	90	1723	1723	1726	1726	1780	1553	1627	1627	1629	1629	1665	1502	1528	1528	1530	1530	1551	1452	1424	1424	1426	1426	1433	1402

Table 26. Gross cooling capacities – 120 tons eFlex™ variable speed – high capacity evaporator coil, 60Hz

CFM	Ent DB (°F)	Ambient Temperature (°F)																							
		85				95				105				115											
		67		73		61		67		73		61		67		73									
		CAP	SHC	CAP	SHC	CAP	SHC	CAP	SHC	CAP	SHC	CAP	SHC	CAP	SHC	CAP	SHC								
21000	75	1186	821	1337	682	1501	535	1133	787	1279	648	1436	501	1076	753	1217	613	1366	465	1017	718	1151	577	1293	429
	80	1187	940	1338	802	1502	656	1134	907	1280	768	1437	622	1078	872	1218	733	1368	587	1019	837	1153	698	1294	550
	85	1189	1059	1340	921	1503	776	1135	1025	1282	888	1438	742	1079	991	1220	853	1369	707	1021	955	1155	817	1296	671
	90	1190	1176	1341	1040	1505	896	1145	1133	1283	1007	1440	862	1095	1095	1222	972	1371	827	1047	1047	1157	937	1298	791
26000	75	1274	921	1430	745	1590	557	1213	885	1362	708	1517	521	1149	847	1293	671	1440	484	1083	809	1219	633	1357	445
	80	1276	1068	1432	893	1592	707	1215	1032	1365	857	1520	671	1152	995	1296	820	1442	634	1085	957	1223	782	1360	595
	85	1278	1216	1435	1042	1594	856	1217	1179	1368	1005	1522	820	1159	1134	1298	968	1445	783	1096	1096	1225	930	1363	745
	90	1319	1319	1437	1189	1596	1004	1269	1269	1370	1153	1524	969	1216	1216	1301	1116	1447	932	1161	1161	1228	1078	1366	893
31000	75	1338	1013	1496	801	1648	573	1271	975	1422	763	1570	536	1202	936	1346	723	1486	498	1129	896	1265	683	1398	458
	80	1341	1189	1499	978	1650	751	1275	1151	1426	940	1573	714	1206	1110	1350	901	1490	676	1134	1069	1269	860	1402	636
	85	1355	1355	1503	1155	1653	928	1300	1300	1430	1117	1575	891	1242	1242	1353	1077	1492	853	1181	1181	1273	1037	1404	813
	90	1431	1431	1506	1330	1655	1105	1373	1373	1434	1292	1578	1068	1313	1313	1358	1252	1495	1030	1250	1250	1278	1210	1407	990
36000	75	1386	1102	1543	852	1689	586	1315	1062	1466	813	1606	549	1240	1020	1384	772	1518	510	1163	977	1298	730	1425	469
	80	1393	1304	1547	1058	1691	792	1322	1263	1470	1019	1608	754	1251	1216	1389	978	1520	715	1179	1163	1303	936	1428	674
	85	1442	1442	1551	1263	1693	998	1381	1381	1474	1223	1610	960	1317	1317	1393	1182	1523	920	1249	1249	1308	1139	1430	880
	90	1522	1522	1557	1465	1695	1203	1459	1459	1481	1425	1613	1165	1393	1393	1407	1371	1525	1126	1322	1322	1325	1325	1433	1085
41000	75	1424	1186	1578	901	1719	600	1348	1143	1497	861	1632	561	1271	1100	1411	819	1540	521	1189	1055	1321	776	1444	479
	80	1434	1407	1583	1136	1720	833	1366	1366	1502	1095	1633	793	1298	1298	1416	1054	1541	753	1228	1228	1326	1009	1445	711
	85	1515	1515	1588	1366	1723	1067	1449	1449	1508	1325	1635	1027	1379	1379	1423	1282	1543	987	1304	1304	1334	1238	1447	945
	90	1595	1595	1605	1577	1727	1301	1527	1527	1530	1530	1637	1261	1454	1454	1457	1457	1546	1219	1377	1377	1379	1379	1450	1175
46000	75	1456	1267	1605	949	1742	612	1376	1223	1521	908	1649	572	1294	1178	1431	865	1555	531	1210	1132	1337	821	1455	489
	80	1488	1488	1610	1210	1745	874	1419	1419	1526	1169	1651	832	1347	1347	1438	1123	1556	791	1270	1270	1345	1078	1457	749
	85	1574	1574	1617	1467	1748	1137	1503	1503	1534	1425	1653	1095	1428	1428	1447	1382	1558	1064	1348	1348	1359	1323	1459	1009
	90	1652	1652	1655	1655	1753	1397	1579	1579	1582	1582	1656	1351	1501	1501	1503	1503	1561	1308	1417	1417	1419	1419	1461	1264
51000	75	1481	1347	1625	996	1763	625	1400	1302	1538	954	1663	584	1315	1256	1446	909	1567	543	1230	1198	1349	862	1465	500
	80	1537	1537	1631	1282	1764	915	1464	1464	1545	1238	1665	872	1387	1387	1454	1193	1568	830	1306	1306	1359	1146	1467	788
	85	1622	1622	1641	1568	1769	1207	1547	1547	1553	1537	1668	1160	1467	1467	1473	1456	1570	1114	1383	1383	1385	1385	1467	1068
	90	1698	1698	1701	1701	1777	1491	1620	1620	1622	1622	1673	1444	1536	1536	1538	1538	1571	1399	1446	1446	1448	1448	1468	1353
54000	75	1495	1394	1636	1025	1773	634	1412	1349	1547	980	1670	592	1328	1293	1454	934	1569	550	1240	1240	1356	883	1467	507
	80	1562	1562	1642	1324	1775	940	1487	1487	1555	1280	1673	896	1408	1408	1462	1235	1572	854	1324	1324	1365	1187	1468	808
	85	1646	1646	1657	1615	1780	1246	1569	1569	1574	1559	1677	1197	1487	1487	1489	1489	1574	1151	1399	1399	1401	1401	1470	1104
	90	1724	1724	1727	1727	1789	1548	1640	1640	1642	1642	1681	1500	1553	1553	1554	1554	1577	1453	1459	1459	1461	1461	1471	1410



Performance Data

Table 27. Gross cooling capacities – 130 tons – high capacity evaporator coil, 60Hz

CFM	Ent DB (°F)	Ambient Temperature (°F)																							
		85				95				105				115											
		67		73		61		67		73		61		67		73									
		CAP	SHC	CAP	SHC	CAP	SHC	CAP	SHC	CAP	SHC	CAP	SHC	CAP	SHC	CAP	SHC								
23000	75	1360	938	1527	784	1703	617	1296	899	1457	745	1626	578	1229	859	1383	704	1543	538	1158	817	1305	662	1455	496
	80	1362	1069	1529	915	1704	750	1299	1030	1459	876	1627	711	1232	990	1385	836	1545	671	1161	949	1307	794	1456	628
	85	1364	1199	1530	1046	1705	882	1301	1161	1461	1007	1628	843	1235	1121	1387	967	1546	803	1164	1078	1309	925	1458	761
	90	1368	1328	1533	1177	1706	1014	1306	1290	1463	1139	1630	975	1245	1245	1389	1098	1548	935	1187	1187	1312	1056	1460	893
26000	75	1418	999	1588	822	1760	630	1350	959	1513	782	1677	590	1278	917	1433	739	1589	548	1202	874	1348	695	1494	505
	80	1421	1147	1590	971	1761	780	1353	1107	1515	930	1678	740	1282	1065	1435	888	1591	698	1205	1022	1350	844	1496	655
	85	1424	1295	1593	1119	1762	929	1357	1254	1518	1079	1680	889	1286	1211	1439	1037	1593	848	1211	1167	1354	993	1499	804
	90	1436	1436	1596	1267	1764	1078	1381	1381	1521	1227	1682	1038	1322	1322	1442	1185	1595	997	1260	1260	1357	1141	1501	953
30000	75	1482	1076	1652	869	1816	643	1407	1034	1571	826	1727	602	1330	990	1485	783	1633	559	1248	945	1393	737	1532	515
	80	1486	1248	1654	1040	1818	816	1412	1205	1574	998	1729	774	1334	1162	1488	954	1635	732	1253	1114	1397	909	1535	687
	85	1493	1416	1658	1212	1820	988	1420	1373	1577	1169	1731	946	1344	1329	1492	1126	1637	904	1270	1270	1401	1080	1537	859
	90	1538	1538	1662	1383	1822	1160	1476	1476	1582	1341	1733	1118	1411	1411	1496	1297	1640	1075	1341	1341	1406	1249	1539	1030
35000	75	1544	1168	1711	921	1868	657	1463	1124	1624	878	1771	614	1378	1077	1531	832	1672	571	1290	1030	1433	785	1565	525
	80	1550	1365	1714	1122	1870	858	1471	1320	1627	1078	1773	815	1387	1273	1536	1033	1674	771	1299	1225	1438	986	1566	725
	85	1562	1562	1719	1322	1872	1059	1496	1496	1632	1278	1775	1015	1425	1425	1541	1233	1675	971	1349	1349	1443	1186	1568	925
	90	1644	1644	1725	1518	1876	1259	1575	1575	1639	1474	1778	1215	1502	1502	1548	1427	1678	1171	1424	1424	1451	1379	1570	1125
40000	75	1592	1256	1754	971	1908	671	1506	1210	1662	926	1804	626	1417	1158	1565	880	1699	581	1323	1107	1462	831	1588	535
	80	1602	1479	1758	1200	1912	901	1518	1432	1666	1155	1805	854	1429	1384	1570	1109	1700	809	1337	1334	1467	1060	1587	762
	85	1646	1646	1764	1428	1916	1131	1574	1574	1673	1379	1806	1083	1496	1496	1577	1332	1701	1037	1413	1413	1474	1282	1588	990
	90	1729	1729	1773	1649	1921	1360	1654	1654	1682	1604	1810	1311	1574	1574	1587	1556	1704	1266	1487	1487	1490	1490	1591	1214
45000	75	1630	1336	1787	1019	1941	685	1541	1288	1690	973	1829	637	1447	1237	1590	926	1718	592	1349	1184	1483	876	1601	544
	80	1644	1590	1792	1276	1946	944	1557	1542	1696	1230	1829	894	1471	1471	1595	1183	1718	847	1385	1385	1489	1127	1602	799
	85	1715	1715	1799	1526	1950	1202	1637	1637	1703	1479	1833	1152	1553	1553	1604	1430	1719	1104	1464	1464	1497	1379	1602	1055
	90	1798	1798	1812	1779	1955	1459	1716	1716	1719	1719	1839	1404	1629	1629	1632	1632	1722	1353	1534	1534	1537	1537	1604	1302
50000	75	1661	1416	1812	1066	1967	699	1569	1366	1712	1019	1848	649	1472	1314	1608	971	1731	602	1370	1260	1498	921	1612	554
	80	1683	1683	1818	1350	1972	986	1602	1602	1719	1298	1851	934	1517	1517	1615	1248	1732	885	1426	1426	1505	1195	1612	836
	85	1771	1771	1827	1626	1976	1272	1687	1687	1728	1577	1855	1221	1599	1599	1625	1527	1734	1171	1503	1503	1515	1475	1613	1112
	90	1854	1854	1857	1857	1984	1551	1765	1765	1767	1767	1861	1496	1671	1671	1673	1673	1740	1444	1569	1569	1571	1571	1614	1390
55000	75	1687	1495	1833	1113	1989	713	1591	1444	1730	1065	1865	661	1492	1391	1623	1016	1740	613	1387	1336	1509	957	1612	565
	80	1730	1730	1840	1418	1993	1027	1645	1645	1737	1367	1868	975	1555	1555	1630	1316	1744	924	1459	1459	1517	1262	1614	874
	85	1818	1818	1851	1725	1999	1343	1729	1729	1748	1675	1874	1282	1635	1635	1643	1624	1748	1227	1533	1533	1535	1535	1619	1171
	90	1907	1907	1911	1911	2009	1646	1806	1806	1809	1809	1881	1589	1703	1703	1705	1705	1753	1534	1594	1594	1596	1596	1624	1479
58000	75	1700	1542	1844	1141	2001	721	1604	1490	1739	1093	1874	668	1503	1436	1630	1036	1747	620	1397	1381	1515	980	1614	572
	80	1755	1755	1851	1460	2004	1052	1667	1667	1746	1409	1877	999	1574	1574	1638	1357	1750	948	1475	1475	1522	1302	1619	898
	85	1843	1843	1865	1785	2011	1377	1750	1750	1759	1734	1881	1320	1653	1653	1655	1655	1754	1264	1548	1548	1549	1549	1624	1208
	90	1934	1934	1938	1938	2022	1702	1830	1830	1833	1833	1891	1645	1722	1722	1724	1724	1761	1589	1608	1608	1610	1610	1628	1532

Table 28. Gross cooling capacities – 130 tons eFlex™ variable speed – high capacity evaporator coil, 60Hz

CFM	Ent DB (°F)	Ambient Temperature (°F)																							
		85				95				105				115											
		67		73		61		67		73		61		67		73									
		CAP	SHC	CAP	SHC	CAP	SHC	CAP	SHC	CAP	SHC	CAP	SHC	CAP	SHC	CAP	SHC								
23000	75	1328	916	1494	763	1672	600	1269	879	1429	726	1599	562	1207	841	1361	688	1522	523	1142	802	1288	648	1439	482
	80	1330	1047	1495	894	1673	732	1271	1010	1431	857	1600	694	1209	972	1363	819	1524	655	1144	933	1291	779	1441	615
	85	1332	1177	1497	1025	1674	864	1273	1140	1433	988	1602	826	1211	1102	1365	950	1525	787	1146	1062	1293	910	1443	746
	90	1335	1301	1499	1156	1676	995	1275	1264	1435	1119	1604	958	1223	1223	1367	1081	1527	919	1170	1170	1295	1041	1445	878
26000	75	1386	977	1555	802	1730	613	1322	939	1484	763	1652	574	1255	899	1410	723	1569	534	1185	858	1333	681	1480	492
	80	1388	1125	1557	950	1732	763	1325	1087	1487	911	1654	724	1258	1047	1413	871	1571	684	1188	1006	1336	830	1483	642
	85	1391	1272	1560	1098	1733	912	1328	1233	1489	1059	1656	873	1262	1193	1416	1019	1574	833	1191	1150	1339	978	1485	790
	90	1406	1406	1563	1246	1736	1060	1354	1354	1492	1207	1658	1021	1300	1300	1419	1167	1576	981	1242	1242	1341	1126	1488	939
30000	75	1448	1055	1619	849	1788	628	1380	1014	1543	808	1704	587	1307	973	1462	766	1615	546	1231	930	1377	723	1520	502
	80	1452	1225	1623	1021	1790	800	1383	1184	1546	980	1707	760	1311	1142	1466	938	1618	718	1236	1098	1381	894	1523	674
	85	1457	1392	1626	1191	1792	971	1390	1347	1550	1151	1709	931	1324	1297	1470	1109	1621	890	1253	1252	1385	1065	1526	846
	90	1507	1507	1630	1362	1795	1143	1449	1449	1554	1366	1712	1102	1389	1389	1474	1278	1624	1061	1324	1324	1388	1256	1529	1017
35000	75	1510	1146	1680	903	1840	642	1435	1104	1597	860	1750	601	1357	1060	1511	817	1656	558	1275	1014	1419	771	1555	513
	80	1516	1343	1684	1103	1843	842	1441	1300	1602	1060	1753	801	1364	1255	1516	1017	1658	758	1304	1216	1424	971	1557	713
	85	1531	1531	1689	1302	1845	1042	1468	1468	1606	1260	1755	1000	1402	1402	1520	1215	1661	958	1333	1333	1429	1169	1560	912
	90	1614	1614	1694	1498	1848	1242	1549	1549	1613	1455	1758	1200	1481	1481	1527	1411	1664	1157	1407	1407	1436	1364	1562	1112
40000	75	1558	1233	1724	953	1879	656	1477	1188	1637	910	1784	613	1395	1141	1546	865	1684	569	1308	1093	1449	818	1578	523
	80	1567	1457	1729	1182	1881	883	1488	1412	1643	1138	1785	840	1407	1358	1551	1093	1686	796	1319	1319	1454	1045	1579	750
	85	1616	1616	1735	1408	1885	1112	1547	1547	1649	1362	1788	1068	1475	1475	1558	1316	1688	1024	1397	1397	1466	1301	1581	978
	90	1701	1701	1743	1630	1889	1340	1630	1630	1657	1586	1791	1296	1555	1555	1559	1559	1691	1251	1474	1474	1477	1477	1584	1203
45000	75	1597	1315	1758	1002	1909	689	1512	1268	1667	957	1809	625	1425	1220	1572	911	1706	580	1334	1171	1470	863	1596	533
	80	1612	1560	1764	1259	1913	925	1524	1524	1673	1212	1809	879	1449	1449	1578	1165	1706	834	1369	1369	1477	1114	1596	787
	85	1687	1687	1771	1509	1918	1182	1612	1612	1681	1463	1812	1136	1534	1534	1587	1415	1707	1090	1450	1450	1486	1365	1597	1042
	90	1772	1772	1788	1740	1924	1438	1695	1695	1703	1680	1816	1387	1613	1613	1616	1616	1710	1340	1524	1524	1526	1526	1598	1290
50000	75	1629	1396	1785	1050	1935	682	1541	1347	1690	1004	1830	636	1450	1298	1591	957	1719	591	1354	1246	1486	906	1607	543
	80	1654	1653	1791	1330	1939	967	1577	1577	1697	1283	1831	919	1497	1497	1599	1233	1721	873	1411	1411	1495	1182	1607	825
	85	1745	1745	1800	1609	1945	1253	1666	1666	1707	1561	1853	1202	1582	1582	1609	1513	1722	1154	1492	1492	1494	1494	1607	1100
	90	1829	1829	1832	1832	1953	1532	1745	1745	1748	1748	1837	1479	1657	1657	1659	1659	1725	1429	1561	1561	1563	1563	1608	1377
55000	75	1655	1475	1806	1097	1957	696	1565	1425	1709	1048	1846	649	1471	1374	1607	999	1733	602	1372	1316	1499	944	1611	555
	80	1703	1703	1814	1401	1961	1009	1622	1622	1716	1352	1848	960	1537	1537	1615	1302	1733	912	1446	1446	1508	1249	1612	861
	85	1793	1793	1824	1708	1968	1320	1709	1709	1728	1655	1849	1265	1620	1620	1622	1622	1734	1213	1524	1524	1526	1526	1614	1160
	90	1876	1876	1880	1880	1978	1626	1786	1786	1788	1788	1857	1572	1691	1691	1693	1693	1738	1519	1588	1588	1589	1589	1616	1466
58000	75	1669	1522	1817	1123	1968	704	1589	1518	1718	1074	1856	657	1482	1420	1615	1021	1739	610	1377	1377	1506	967	1612	562
	80	1728	1728	1825	1443	1973	1035	1645	1645	1726	1394	1857	985	1557	1557	1623	1343	1741	933	1464	1464	1514	1289	1615	881
	85	1818	1818	1837	1762	1981	1358	1731	1731	1733	1733	1858	1302	1639	1639	1641	1641	1742	1250	1540	1540	1542	1542	1617	1195
	90	1906	1906	1909	1909	1991	1683	1807	1807	1809	1809	1867	1628	1708	1708	1709	1709	1744	1573	1600	1600	1602	1602	1620	1518



Air-Cooled, 50Hz, Standard and High Capacity Evaporator Coils

Table 29. Gross cooling capacities – 90 tons – standard evaporator coil, 50Hz

CFM	Ent DB (°F)	Ambient Temperature (°F)																							
		85						95						105						115					
		Entering Wet Bulb (°F)			Entering Wet Bulb (°F)			Entering Wet Bulb (°F)			Entering Wet Bulb (°F)			Entering Wet Bulb (°F)			Entering Wet Bulb (°F)			Entering Wet Bulb (°F)					
61	67	73	61	67	73	61	67	73	61	67	73	61	67	73	61	67	73	61	67	73					
CAP	SHC	SHC	CAP	SHC	SHC	CAP	SHC	SHC	CAP	SHC	SHC	CAP	SHC	SHC	CAP	SHC	SHC	CAP	SHC	SHC	CAP	SHC			
16000	75	796	586	887	475	983	359	762	567	849	456	939	340	725	547	806	436	890	319	684	525	760	414	835	296
	80	798	676	889	567	984	451	764	658	850	548	939	432	727	638	808	527	890	411	687	613	762	505	836	388
	85	803	764	890	658	985	543	770	745	852	639	941	524	734	725	810	619	892	503	695	695	764	597	838	480
	90	821	821	892	749	986	635	793	793	854	730	942	615	762	762	812	710	894	594	727	727	767	686	840	571
20000	75	843	658	935	518	1028	372	804	638	891	498	978	351	762	616	843	476	922	328	716	593	791	452	861	304
	80	848	767	937	633	1029	487	809	746	893	612	979	486	768	724	846	590	924	444	723	701	793	567	863	419
	85	860	860	939	747	1031	602	825	825	896	726	981	581	790	790	848	704	926	558	750	750	796	675	865	534
	90	902	902	944	855	1033	716	869	869	901	834	983	695	831	831	855	811	928	673	789	789	804	787	866	648
25000	75	883	744	974	568	1063	385	840	715	925	546	1007	362	793	691	872	523	946	339	743	666	814	498	879	313
	80	893	879	977	711	1065	529	851	851	928	689	1009	506	807	807	875	666	948	483	760	760	817	641	881	457
	85	929	929	981	846	1067	672	891	891	933	823	1011	650	849	849	880	799	950	626	802	802	823	772	883	600
	90	978	978	991	987	1069	815	937	937	945	945	1013	792	892	892	894	894	952	760	842	842	843	843	885	733
30000	75	912	817	1000	616	1085	396	866	793	947	593	1025	373	816	768	890	568	960	348	762	740	828	542	889	322
	80	931	931	1003	787	1087	569	890	890	950	755	1027	545	845	845	893	729	962	521	795	795	832	701	891	494
	85	982	982	1010	946	1089	741	939	939	959	922	1029	717	891	891	903	896	964	692	837	837	842	842	892	666
	90	1032	1032	1033	1033	1092	901	985	985	986	986	1033	876	933	933	934	934	967	849	874	874	875	875	896	820
33000	75	926	864	1011	644	1094	403	878	839	956	620	1032	379	826	813	897	595	966	354	771	771	833	568	893	327
	80	955	955	1015	822	1097	593	911	911	960	796	1035	569	864	864	902	770	968	543	811	811	838	741	895	516
	85	1007	1007	1025	1006	1099	782	961	961	971	971	1037	758	909	909	914	914	970	720	852	852	852	852	896	690
	90	1057	1057	1058	1058	1103	956	1007	1007	1008	1008	1041	930	951	951	952	952	974	902	888	888	888	888	900	872
36000	75	938	910	1021	671	1102	410	889	885	964	647	1039	385	836	836	903	621	970	360	779	779	837	594	896	333
	80	976	976	1025	864	1105	616	930	930	969	838	1041	592	879	879	909	810	972	566	823	823	843	780	897	539
	85	1029	1029	1038	1038	1107	822	979	979	983	983	1043	785	925	925	925	925	974	757	864	864	865	865	898	726
	90	1078	1078	1079	1079	1112	1010	1025	1025	1026	1026	1048	984	965	965	966	966	979	955	897	897	897	898	898	904
40000	75	952	952	1031	708	1111	418	901	901	972	683	1045	394	847	847	909	644	975	367	792	792	842	613	899	340
	80	1000	1000	1036	919	1114	648	950	950	978	892	1048	623	896	896	916	864	976	597	837	837	848	833	899	569
	85	1052	1052	1054	1054	1116	861	1000	1000	1000	1000	1050	834	941	941	942	942	978	805	876	876	876	876	900	773
	90	1101	1101	1102	1102	1122	1083	1043	1043	1044	1044	1056	1055	979	979	980	980	984	984	984	910	910	910	910	911

Table 30. Gross cooling capacities – 90 tons eFlex™ variable speed – standard evaporator coil, 50Hz

CFM	Ent DB (°F)	Ambient Temperature (°F)																									
		85						95						105						115							
		Entering Wet Bulb (°F)			Entering Wet Bulb (°F)			Entering Wet Bulb (°F)			Entering Wet Bulb (°F)			Entering Wet Bulb (°F)			Entering Wet Bulb (°F)			Entering Wet Bulb (°F)							
		61	67	73	61	67	73	61	67	73	61	67	73	61	67	73	61	67	73								
16000	75	793	583	886	475	987	360	360	360	765	569	855	460	950	345	735	554	821	444	909	328	703	537	784	427	864	310
	80	795	673	888	566	987	452	452	452	767	658	857	551	951	437	738	643	823	536	910	420	706	626	786	519	865	402
	85	800	762	890	657	989	544	544	544	773	739	859	643	952	529	746	717	825	627	912	512	718	696	788	610	867	494
	90	823	823	892	747	991	636	636	636	799	799	861	732	954	620	775	775	828	716	914	604	748	748	791	699	868	586
20000	75	840	656	935	518	1032	372	372	372	808	638	900	502	989	356	775	622	861	486	943	338	739	604	819	468	891	319
	80	845	767	938	632	1033	488	488	488	815	750	902	617	991	471	782	733	864	600	945	453	747	708	822	582	893	434
	85	864	849	940	744	1035	603	603	603	836	829	905	728	993	586	806	806	867	711	947	568	774	774	825	693	895	548
	90	905	905	947	858	1037	717	717	717	878	878	912	842	995	700	849	849	875	821	948	682	816	816	834	789	896	663
25000	75	880	738	975	567	1064	384	384	384	846	721	935	551	1017	367	810	704	893	533	965	348	771	682	846	514	910	328
	80	893	854	978	710	1067	528	528	528	862	832	938	691	1020	511	828	809	896	673	968	492	792	783	849	653	913	472
	85	932	932	984	849	1069	671	671	671	902	902	945	829	1022	654	869	869	903	811	970	635	833	833	856	790	915	615
	90	983	983	999	957	1072	811	811	811	951	951	962	933	1025	793	915	915	922	907	973	773	874	874	874	878	918	753
30000	75	910	815	1000	614	1084	394	394	394	874	798	958	597	1035	377	836	779	912	579	981	358	794	749	862	559	922	338
	80	936	933	1004	781	1088	567	567	567	902	902	962	763	1038	550	866	866	916	745	984	531	828	828	866	720	926	511
	85	987	987	1014	946	1091	739	739	739	952	952	973	917	1041	717	915	915	928	883	987	703	871	871	880	850	929	676
	90	1038	1038	1042	1042	1095	905	905	905	1000	1000	1002	1002	1046	882	957	957	958	958	992	861	908	908	909	909	933	839
33000	75	924	862	1011	642	1094	401	401	401	888	836	968	625	1043	383	848	806	920	606	988	364	807	774	868	581	928	344
	80	958	958	1016	824	1098	591	591	591	924	924	973	802	1047	573	887	887	926	782	991	554	846	846	874	760	932	534
	85	1012	1012	1029	980	1101	775	775	775	976	976	988	948	1050	756	934	934	942	919	994	736	888	888	892	887	935	715
	90	1062	1062	1064	1064	1107	955	955	955	1021	1021	1022	1022	1056	936	975	975	976	976	1001	915	924	924	924	924	940	884
36000	75	937	890	1020	669	1102	407	407	407	900	860	975	647	1050	389	861	832	927	627	993	370	818	803	873	606	933	350
	80	979	979	1026	862	1106	614	614	614	943	943	982	843	1054	596	904	904	933	823	997	577	860	860	880	800	937	557
	85	1033	1033	1044	1014	1110	814	814	814	994	994	1001	986	1057	795	950	950	954	954	1001	775	900	900	900	900	939	753
	90	1082	1082	1083	1083	1116	1010	1010	1010	1039	1039	1040	1040	1064	990	991	991	991	991	1008	952	937	937	937	937	946	906
40000	75	953	924	1029	699	1111	416	416	416	916	898	983	681	1057	398	875	871	933	661	999	379	831	831	879	639	938	358
	80	1003	1003	1037	917	1115	646	646	646	965	965	991	898	1061	628	923	923	941	877	1004	609	875	875	887	840	941	588
	85	1056	1056	1061	1061	1118	866	866	866	1014	1014	1016	1016	1065	847	966	966	967	967	1007	819	914	914	914	915	944	795
	90	1105	1105	1106	1106	1128	1064	1064	1064	1059	1059	1060	1060	1074	1026	1008	1008	1009	1009	1018	986	952	952	952	952	957	949



Performance Data

Table 31. Gross cooling capacities – 105 tons – standard evaporator coil, 50Hz

CFM	Ent DB (°F)	Ambient Temperature (°F)																							
		85						95						105						115					
		Entering Wet Bulb (°F)			Wet Bulb (°F)			Entering Wet Bulb (°F)			Wet Bulb (°F)			Entering Wet Bulb (°F)			Wet Bulb (°F)			Entering Wet Bulb (°F)			Wet Bulb (°F)		
		61	67	73	CAP	SHC	SHC	61	67	73	CAP	SHC	SHC	61	67	73	CAP	SHC	SHC	61	67	73	CAP	SHC	SHC
19000	75	911	678	1014	547	1121	408	868	655	966	524	1065	384	823	631	915	499	1005	359	774	606	860	474	940	333
	80	914	787	1016	656	1122	517	872	762	968	632	1067	494	827	736	917	608	1007	469	780	711	862	583	942	442
	85	923	892	1018	764	1123	626	882	869	970	741	1068	603	839	839	919	716	1009	578	796	796	865	691	944	551
	90	955	955	1022	872	1125	735	919	919	975	846	1070	711	881	881	925	821	1011	686	839	839	870	795	946	660
23000	75	954	749	1057	589	1159	419	907	725	1004	564	1098	394	857	700	948	539	1033	368	804	669	887	512	961	340
	80	961	876	1060	720	1161	552	915	851	1007	696	1100	527	866	825	950	670	1035	500	815	798	889	643	964	473
	85	981	981	1063	852	1163	684	941	941	1011	827	1102	659	898	898	955	796	1037	632	852	852	894	768	965	604
	90	1032	1032	1071	977	1165	815	991	991	1019	952	1104	790	946	946	964	926	1038	764	896	896	904	897	967	735
28000	75	993	829	1094	638	1191	431	942	802	1036	612	1124	405	888	774	974	585	1053	378	831	745	908	556	977	349
	80	1007	987	1097	798	1193	592	957	957	1039	772	1127	566	906	906	977	745	1056	539	854	854	911	709	978	509
	85	1052	1052	1104	950	1195	753	1006	1006	1046	923	1129	726	956	956	985	895	1057	699	901	901	919	865	979	669
	90	1106	1106	1117	1109	1198	913	1057	1057	1061	1061	1131	886	1003	1003	1005	1005	1060	850	944	944	945	945	982	818
33000	75	1023	908	1119	685	1212	442	968	880	1057	658	1141	415	911	851	991	630	1066	387	850	820	921	600	986	357
	80	1047	1047	1123	866	1214	632	998	998	1061	837	1144	605	946	946	996	807	1068	576	889	889	926	776	987	546
	85	1105	1105	1133	1050	1216	821	1053	1053	1072	1022	1145	793	997	997	1007	992	1069	765	934	934	938	938	987	723
	90	1160	1160	1161	1161	1220	998	1104	1104	1105	1105	1149	969	1042	1042	1043	1043	1073	938	973	973	974	974	990	904
38000	75	1046	986	1137	731	1226	453	989	956	1072	703	1153	426	929	926	1003	674	1075	397	865	865	929	633	990	366
	80	1087	1087	1143	936	1229	671	1034	1034	1078	906	1155	643	976	976	1009	875	1076	614	913	913	935	842	991	583
	85	1145	1145	1157	1149	1230	888	1088	1088	1093	1093	1156	848	1026	1026	1027	1027	1077	816	957	957	957	957	992	781
	90	1199	1199	1200	1200	1236	1089	1137	1137	1138	1138	1162	1058	1067	1067	1068	1068	1082	1026	991	991	992	992	999	992
43000	75	1065	1062	1150	777	1238	464	1006	1006	1082	748	1162	436	945	945	1011	705	1080	406	882	882	934	670	990	375
	80	1119	1119	1158	1005	1239	711	1061	1061	1090	975	1163	682	999	999	1019	942	1081	652	931	931	942	907	993	620
	85	1176	1176	1178	1178	1241	941	1114	1114	1115	1115	1164	909	1046	1046	1047	1047	1082	875	971	971	972	972	996	841
	90	1228	1228	1229	1229	1249	1179	1160	1160	1160	1160	1173	1148	1086	1086	1087	1087	1092	1092	1009	1009	1009	1009	1010	1010
45000	75	1072	1072	1155	795	1241	469	1012	1012	1086	754	1164	440	952	952	1013	721	1080	410	888	888	936	685	992	379
	80	1129	1129	1163	1033	1243	727	1070	1070	1095	1002	1165	698	1006	1006	1022	969	1082	667	936	936	944	933	995	618
	85	1187	1187	1216	1188	1245	965	1123	1123	1124	1124	1167	934	1053	1053	1053	1053	1084	900	975	975	976	976	998	865
	90	1237	1237	1238	1238	1255	1216	1168	1168	1169	1169	1178	1178	1093	1093	1094	1094	1097	1097	1014	1014	1015	1015	1016	1016

Table 32. Gross cooling capacities – 105 tons eFlex™ variable speed – standard evaporator coil, 50Hz

CFM	Ent DB (°F)	Ambient Temperature (°F)																							
		85						95						105						115					
		Entering Wet Bulb (°F)			Entering Wet Bulb (°F)			Entering Wet Bulb (°F)			Entering Wet Bulb (°F)			Entering Wet Bulb (°F)			Entering Wet Bulb (°F)			Entering Wet Bulb (°F)					
		61	67	73	61	67	73	61	67	73	61	67	73	61	67	73	61	67	73						
19000	75	900	673	1005	543	1114	406	863	653	964	523	1067	386	824	632	920	502	1016	364	782	610	872	480	960	341
	80	904	780	1007	652	1116	516	868	760	966	632	1069	495	829	737	922	610	1018	474	788	715	875	588	962	450
	85	913	887	1009	760	1117	625	879	858	968	740	1071	604	844	832	925	719	1020	582	806	805	878	697	964	559
23000	75	949	949	1014	867	1119	733	918	918	974	847	1072	713	885	885	930	825	1022	691	849	849	884	801	966	668
	80	943	744	1048	585	1154	418	902	721	1003	564	1101	396	860	699	954	542	1045	373	814	675	902	518	983	349
	85	951	871	1051	717	1156	550	912	850	1006	695	1104	529	870	827	957	673	1048	506	825	800	905	649	986	481
28000	75	975	975	1056	846	1158	682	940	940	1011	824	1106	660	903	903	963	802	1050	637	864	864	911	775	988	612
	80	1028	1028	1064	974	1161	813	992	992	1020	952	1109	792	953	953	973	929	1052	769	911	911	922	893	990	744
	85	983	824	1086	635	1186	430	939	801	1036	612	1129	407	892	776	983	588	1067	383	843	751	925	563	1001	358
33000	75	998	973	1089	795	1189	591	957	941	1040	769	1132	568	913	910	987	745	1070	544	867	867	930	719	1003	518
	80	1047	1047	1097	947	1191	751	1007	1007	1048	924	1134	728	965	965	996	899	1072	704	918	918	939	873	1004	678
	85	1103	1103	1114	1087	1195	908	1061	1061	1068	1056	1138	884	1016	1016	1017	1017	1076	856	964	964	966	966	1009	828
38000	75	1013	903	1111	682	1207	441	966	879	1058	658	1146	418	917	853	1001	634	1081	393	864	826	940	607	1011	366
	80	1042	1042	1117	863	1210	631	1000	1000	1064	838	1149	607	954	954	1007	812	1084	582	905	905	946	784	1013	555
	85	1102	1102	1128	1048	1213	820	1057	1057	1076	1023	1152	795	1009	1009	1020	991	1087	765	955	955	961	944	1016	733
43000	75	1158	1158	1160	1160	1220	998	1110	1110	1112	1112	1158	972	1057	1057	1059	1059	1093	945	997	997	998	998	1021	916
	80	1037	981	1130	728	1223	453	988	955	1073	704	1158	428	936	911	1013	673	1090	402	882	873	949	645	1018	375
	85	1083	1083	1137	933	1227	671	1037	1037	1081	907	1163	646	987	987	1022	880	1094	620	933	933	958	850	1020	592
45000	75	1144	1144	1153	1128	1231	882	1094	1094	1100	1088	1166	851	1040	1040	1043	1043	1098	823	980	980	981	981	1023	792
	80	1199	1199	1200	1200	1239	1090	1145	1145	1146	1146	1174	1062	1086	1086	1087	1087	1105	1034	1021	1021	1022	1022	1032	1000
	85	1058	1038	1143	769	1235	464	1008	999	1084	743	1168	438	955	955	1022	709	1098	412	899	899	956	679	1023	384
45000	75	1115	1115	1153	1003	1240	711	1065	1065	1095	976	1173	685	1012	1012	1033	947	1101	658	953	953	966	916	1025	630
	80	1176	1175	1178	1178	1245	941	1122	1122	1123	1123	1177	913	1063	1063	1063	1063	1105	884	997	997	998	998	1029	852
	85	1232	1232	1233	1233	1256	1181	1173	1173	1174	1174	1188	1150	1109	1109	1110	1110	1117	1097	1039	1039	1040	1040	1043	1043
45000	75	1066	1055	1148	786	1240	469	1015	1015	1088	754	1172	443	962	962	1025	725	1100	416	906	906	957	694	1024	388
	80	1126	1126	1158	1031	1244	727	1075	1075	1099	1003	1176	701	1020	1020	1036	974	1104	667	959	959	968	939	1026	636
	85	1186	1186	1187	1187	1249	967	1130	1130	1131	1131	1180	938	1069	1069	1070	1070	1108	908	1003	1003	1004	1004	1031	876
90	1243	1243	1244	1244	1263	1218	1182	1182	1183	1183	1194	1168	1117	1117	1118	1118	1123	1116	1046	1046	1047	1047	1048	1048	



Performance Data

Table 33. Gross cooling capacities – 120 tons – standard evaporator coil, 50Hz

CFM	Ent DB (°F)	Ambient Temperature (°F)																							
		85				95				105				115											
		Entering Wet Bulb (°F)			73	Entering Wet Bulb (°F)			61	Entering Wet Bulb (°F)			67	Entering Wet Bulb (°F)			73								
21000	75	1053	756	1181	614	1315	463	1000	725	1122	582	1248	431	944	693	1059	549	1177	398	884	659	992	515	1102	363
	80	1056	876	1183	735	1316	584	1003	845	1124	703	1250	552	947	812	1061	670	1179	519	888	779	995	635	1104	484
	85	1060	994	1185	854	1317	705	1008	963	1126	822	1251	673	953	930	1064	790	1181	639	895	895	998	755	1106	604
	90	1087	1087	1188	974	1319	825	1043	1043	1129	942	1253	793	996	996	1067	909	1183	759	946	946	1001	875	1108	725
26000	75	1116	849	1246	670	1372	479	1056	815	1179	636	1299	445	994	780	1110	601	1220	410	928	744	1036	564	1137	374
	80	1121	997	1249	819	1375	629	1062	961	1182	785	1301	595	1000	926	1113	750	1223	560	935	889	1039	713	1140	523
	85	1136	1136	1252	967	1377	778	1086	1086	1186	933	1303	744	1033	1033	1117	898	1225	709	976	976	1043	862	1142	672
	90	1199	1199	1257	1116	1379	926	1147	1147	1192	1079	1306	892	1092	1092	1123	1043	1228	857	1033	1033	1051	1006	1145	820
31000	75	1162	936	1290	721	1409	492	1097	901	1218	685	1330	457	1029	861	1143	648	1247	420	958	822	1063	610	1158	383
	80	1172	1109	1293	898	1412	669	1108	1073	1222	862	1333	634	1042	1036	1147	826	1249	598	978	978	1067	788	1160	560
	85	1219	1219	1299	1075	1413	847	1163	1163	1227	1040	1335	812	1103	1103	1153	999	1251	775	1039	1039	1074	960	1162	737
	90	1286	1286	1308	1247	1416	1024	1227	1227	1238	1211	1338	989	1164	1164	1166	1166	1254	952	1096	1096	1098	1098	1165	914
36000	75	1197	1016	1321	769	1435	503	1128	978	1245	732	1352	467	1056	939	1165	694	1264	430	981	898	1080	655	1172	392
	80	1214	1214	1325	975	1436	709	1154	1154	1250	938	1353	673	1091	1091	1170	900	1265	635	1023	1023	1086	855	1172	596
	85	1285	1285	1333	1175	1438	914	1222	1222	1258	1137	1355	878	1156	1156	1179	1098	1267	841	1084	1084	1096	1057	1173	801
	90	1352	1352	1354	1354	1442	1120	1286	1286	1288	1288	1359	1084	1215	1215	1217	1217	1270	1039	1139	1139	1140	1140	1176	998
41000	75	1224	1096	1343	816	1453	515	1152	1057	1263	778	1367	478	1077	1016	1180	739	1274	440	999	974	1092	698	1178	401
	80	1265	1265	1349	1050	1454	748	1200	1200	1270	1006	1367	711	1131	1131	1187	965	1276	672	1058	1058	1100	922	1179	633
	85	1336	1336	1359	1275	1456	982	1269	1269	1282	1236	1369	945	1196	1196	1200	1196	1277	906	1118	1118	1119	1119	1180	857
	90	1402	1402	1404	1404	1461	1208	1329	1329	1331	1331	1373	1169	1251	1251	1253	1253	1281	1128	1166	1166	1167	1167	1182	1085
46000	75	1247	1175	1360	862	1465	526	1173	1134	1277	823	1376	489	1096	1093	1191	783	1282	450	1019	1019	1100	732	1182	410
	80	1306	1306	1367	1116	1467	787	1237	1237	1286	1075	1377	749	1163	1163	1200	1033	1283	710	1084	1084	1109	989	1183	670
	85	1377	1377	1382	1375	1469	1050	1304	1304	1305	1305	1379	1003	1225	1225	1227	1227	1284	961	1141	1141	1142	1142	1184	916
	90	1439	1439	1441	1441	1475	1300	1360	1360	1362	1362	1383	1259	1275	1275	1276	1276	1288	1217	1182	1182	1183	1183	1185	1172
51000	75	1267	1253	1373	908	1475	538	1192	1192	1288	868	1384	500	1118	1118	1199	816	1289	461	1040	1040	1106	770	1192	421
	80	1340	1340	1382	1186	1478	827	1266	1266	1298	1144	1385	788	1188	1188	1209	1101	1288	749	1104	1104	1116	1056	1193	694
	85	1409	1409	1410	1410	1480	1106	1331	1331	1332	1332	1386	1065	1247	1247	1248	1248	1288	1021	1157	1157	1157	1157	1194	975
	90	1468	1468	1469	1469	1490	1393	1383	1383	1392	1392	1402	1349	1291	1291	1292	1292	1294	1292	1192	1192	1193	1193	1194	1194
54000	75	1280	1280	1380	936	1479	546	1207	1207	1294	884	1388	507	1131	1131	1203	839	1296	468	1050	1050	1109	793	1196	427
	80	1356	1356	1389	1228	1483	851	1281	1281	1304	1186	1389	812	1200	1200	1214	1142	1299	772	1114	1114	1120	1096	1198	712
	85	1424	1424	1426	1426	1486	1145	1343	1343	1345	1345	1390	1102	1257	1257	1258	1258	1301	1058	1163	1163	1164	1164	1200	1011
	90	1485	1485	1487	1487	1500	1449	1395	1395	1396	1396	1400	1400	1301	1301	1302	1302	1304	1304	1201	1201	1202	1202	1203	1203

Table 34. Gross cooling capacities – 120 tons eFlex™ variable speed – standard evaporator coil, 50Hz

CFM	Ent DB (°F)	Ambient Temperature (°F)																							
		85				95				105				115											
		Entering Wet Bulb (°F)		73		61		67		73		61		67		73		61		67		73			
21000	75	1034	743	1164	603	1305	457	984	713	1109	572	1244	425	933	682	1051	541	1178	393	878	650	991	508	1110	360
	80	1037	863	1166	723	1307	577	987	832	1111	692	1246	546	935	802	1054	661	1181	514	881	769	994	629	1113	481
	85	1039	987	1168	843	1309	698	991	950	1114	812	1248	667	942	915	1057	781	1183	635	892	876	996	748	1115	601
	90	1070	1070	1171	962	1311	818	1029	1029	1117	931	1250	787	986	986	1059	900	1186	755	940	940	999	868	1118	722
26000	75	1098	836	1232	660	1370	475	1043	804	1170	627	1301	442	985	771	1106	594	1228	408	924	736	1038	559	1152	373
	80	1103	983	1235	809	1374	625	1048	950	1174	776	1305	592	990	916	1110	743	1232	558	931	882	1042	708	1156	522
	85	1119	1119	1239	957	1376	774	1072	1072	1178	924	1308	741	1024	1024	1114	891	1236	707	972	972	1046	856	1159	671
	90	1184	1184	1244	1104	1380	923	1135	1135	1183	1071	1311	890	1085	1085	1120	1037	1239	855	1031	1031	1052	1003	1162	820
31000	75	1144	923	1279	712	1413	490	1084	888	1212	678	1338	456	1022	852	1143	643	1260	420	957	815	1070	606	1178	384
	80	1154	1097	1284	890	1417	668	1095	1058	1217	856	1342	633	1037	1015	1148	820	1284	598	975	975	1075	784	1182	561
	85	1205	1205	1290	1066	1420	845	1152	1152	1223	1031	1346	811	1097	1097	1154	994	1268	775	1039	1039	1082	957	1185	738
	90	1276	1276	1299	1240	1424	1022	1221	1221	1237	1197	1350	988	1164	1164	1172	1151	1271	952	1102	1102	1105	1105	1188	913
36000	75	1181	1005	1313	762	1442	503	1116	968	1242	726	1363	468	1050	931	1168	690	1280	431	981	893	1090	652	1194	393
	80	1203	1190	1319	968	1446	709	1144	1144	1248	931	1367	673	1086	1086	1174	894	1284	636	1024	1024	1097	853	1197	598
	85	1276	1276	1328	1169	1450	915	1218	1218	1258	1132	1371	879	1156	1156	1184	1095	1288	842	1092	1092	1107	1056	1200	804
	90	1349	1349	1352	1352	1455	1118	1288	1288	1291	1291	1376	1082	1224	1224	1226	1226	1293	1042	1154	1154	1156	1156	1205	1002
41000	75	1210	1086	1339	810	1464	516	1142	1048	1264	773	1381	479	1073	1009	1185	735	1295	441	1001	963	1104	693	1205	403
	80	1255	1255	1346	1040	1467	749	1194	1194	1272	1002	1384	712	1131	1131	1195	963	1298	674	1064	1064	1114	922	1207	635
	85	1333	1333	1359	1271	1471	983	1270	1270	1285	1233	1388	944	1203	1203	1212	1180	1302	905	1132	1132	1135	1128	1210	862
	90	1407	1407	1409	1409	1477	1211	1339	1339	1342	1342	1394	1172	1267	1267	1269	1269	1307	1132	1190	1190	1191	1191	1214	1090
46000	75	1235	1165	1358	857	1480	528	1165	1122	1279	816	1395	490	1096	1071	1199	776	1305	452	1022	1022	1115	731	1212	413
	80	1300	1300	1368	1112	1483	789	1235	1235	1291	1073	1397	752	1167	1167	1210	1032	1308	713	1095	1095	1126	990	1214	674
	85	1379	1379	1389	1355	1489	1049	1311	1311	1313	1313	1401	1006	1238	1238	1240	1240	1311	965	1161	1161	1162	1162	1216	921
	90	1451	1451	1453	1453	1497	1304	1377	1377	1379	1379	1408	1263	1299	1299	1300	1300	1315	1301	1213	1213	1214	1214	1222	1174
51000	75	1259	1230	1373	900	1493	541	1189	1179	1292	856	1405	502	1119	1119	1209	813	1313	464	1046	1046	1123	770	1218	424
	80	1338	1338	1385	1183	1497	830	1269	1269	1306	1143	1407	792	1196	1196	1222	1101	1316	746	1120	1120	1136	1057	1218	702
	85	1417	1417	1419	1419	1504	1111	1343	1343	1345	1345	1411	1068	1265	1265	1267	1267	1318	1026	1182	1182	1183	1183	1219	981
	90	1486	1486	1497	1497	1515	1398	1415	1415	1419	1407	1422	1355	1321	1321	1322	1322	1328	1295	1229	1229	1230	1230	1231	1231
54000	75	1274	1265	1381	923	1500	549	1204	1204	1299	881	1410	510	1133	1133	1214	837	1317	471	1058	1058	1126	792	1220	430
	80	1357	1357	1394	1226	1504	855	1286	1286	1313	1185	1413	810	1211	1211	1229	1142	1320	762	1131	1131	1141	1094	1222	716
	85	1435	1435	1437	1437	1511	1150	1359	1359	1361	1361	1417	1106	1278	1278	1280	1280	1321	1062	1192	1192	1193	1193	1224	1017
	90	1507	1507	1509	1509	1525	1454	1423	1423	1424	1424	1432	1394	1334	1334	1335	1335	1337	1337	1239	1239	1240	1240	1241	1241



Performance Data

Table 35. Gross cooling capacities – 130 tons – standard evaporator coil, 50Hz

CFM	Ent DB (°F)	Ambient Temperature (°F)																							
		85				95				105				115											
		Entering Wet Bulb (°F)				Entering Wet Bulb (°F)				Entering Wet Bulb (°F)				Entering Wet Bulb (°F)											
		61	67	73	79	61	67	73	79	61	67	73	79	61	67	73	79								
23000	75	1177	836	1317	679	1453	506	1113	797	1244	638	1369	464	1043	756	1165	596	1279	420	970	713	1083	552	1184	375
	80	1179	968	1319	811	1454	640	1116	929	1246	771	1370	598	1046	887	1168	728	1280	554	973	845	1086	684	1186	508
	85	1184	1100	1322	943	1455	772	1121	1059	1249	902	1372	730	1053	1015	1170	860	1282	686	982	972	1088	816	1187	641
	90	1202	1202	1324	1074	1457	904	1150	1150	1251	1034	1374	862	1091	1091	1173	991	1284	818	1028	1028	1092	947	1189	773
26000	75	1220	894	1359	713	1487	514	1150	852	1280	670	1397	471	1076	809	1196	626	1301	425	998	765	1109	581	1201	379
	80	1223	1042	1361	862	1488	665	1154	1001	1283	820	1398	621	1080	958	1199	775	1303	576	1003	914	1112	730	1203	529
	85	1232	1187	1364	1011	1490	814	1165	1146	1286	968	1400	771	1093	1093	1202	924	1305	726	1024	1024	1115	879	1204	679
	90	1275	1275	1367	1159	1491	963	1215	1215	1290	1117	1402	920	1150	1150	1207	1073	1306	874	1081	1081	1120	1028	1205	827
30000	75	1265	966	1400	754	1518	522	1190	923	1316	710	1422	477	1109	877	1226	664	1321	431	1026	831	1133	617	1215	384
	80	1271	1138	1403	926	1520	696	1196	1090	1319	882	1424	651	1117	1044	1229	836	1323	604	1036	996	1136	789	1216	556
	85	1289	1289	1406	1097	1522	868	1220	1220	1322	1054	1426	823	1153	1153	1233	1008	1324	776	1080	1080	1140	961	1216	728
	90	1354	1354	1412	1269	1523	1040	1287	1287	1329	1219	1427	995	1213	1213	1241	1172	1325	948	1135	1135	1149	1123	1217	899
35000	75	1307	1053	1437	802	1545	531	1227	1008	1347	756	1443	485	1141	961	1251	709	1337	438	1052	913	1152	660	1226	390
	80	1318	1247	1440	1003	1547	733	1239	1201	1350	957	1444	687	1156	1153	1254	909	1337	639	1071	1071	1155	861	1225	590
	85	1362	1362	1444	1203	1548	934	1290	1290	1355	1157	1445	887	1213	1213	1259	1110	1337	839	1130	1130	1161	1051	1224	790
	90	1429	1429	1455	1394	1550	1134	1353	1353	1367	1347	1447	1087	1270	1270	1273	1273	1338	1039	1180	1180	1181	1181	1224	989
40000	75	1339	1137	1463	849	1564	541	1254	1090	1368	801	1457	494	1165	1032	1268	753	1347	446	1073	981	1164	703	1232	396
	80	1358	1357	1466	1077	1565	771	1275	1275	1371	1030	1458	723	1194	1194	1271	982	1345	674	1110	1110	1167	932	1228	624
	85	1420	1420	1473	1306	1566	1000	1341	1341	1379	1249	1458	952	1255	1255	1279	1198	1344	903	1164	1164	1175	1145	1226	852
	90	1485	1485	1489	1489	1568	1229	1399	1399	1401	1401	1459	1180	1306	1306	1308	1308	1345	1131	1205	1205	1206	1206	1226	1080
45000	75	1365	1210	1482	894	1579	551	1277	1160	1383	846	1468	503	1183	1108	1279	796	1353	454	1088	1055	1171	745	1235	404
	80	1393	1393	1485	1151	1579	809	1314	1314	1386	1103	1466	760	1228	1228	1282	1053	1349	710	1136	1136	1175	989	1229	659
	85	1465	1465	1495	1395	1584	1066	1379	1379	1396	1345	1466	1017	1285	1285	1293	1292	1348	967	1186	1186	1186	1186	1227	916
	90	1525	1525	1527	1527	1585	1325	1431	1431	1432	1432	1469	1274	1329	1329	1330	1330	1352	1208	1218	1218	1218	1218	1231	1153
50000	75	1386	1287	1496	939	1590	561	1295	1236	1394	890	1475	512	1199	1183	1286	839	1357	462	1101	1101	1175	787	1237	411
	80	1432	1432	1500	1225	1591	848	1346	1346	1398	1176	1472	797	1253	1253	1291	1110	1343	768	1156	1156	1180	1054	1229	695
	85	1499	1499	1513	1493	1594	1136	1406	1406	1411	1411	1473	1084	1306	1306	1305	1305	1352	1033	1199	1199	1200	1200	1228	982
	90	1556	1556	1557	1557	1603	1424	1454	1454	1454	1454	1483	1353	1343	1343	1344	1344	1360	1297	1230	1230	1230	1230	1236	1236
55000	75	1404	1365	1507	984	1600	572	1310	1310	1401	934	1481	522	1212	1212	1291	883	1361	471	1112	1112	1178	830	1237	420
	80	1462	1462	1512	1299	1602	889	1370	1370	1407	1231	1479	836	1273	1273	1297	1176	1354	784	1169	1169	1183	1119	1229	732
	85	1526	1526	1528	1528	1607	1206	1427	1427	1424	1424	1483	1153	1320	1320	1321	1321	1357	1100	1206	1206	1207	1207	1232	1026
	90	1582	1582	1583	1583	1619	1502	1474	1474	1475	1475	1495	1445	1361	1361	1349	1349	1368	1368	1241	1241	1237	1237	1239	1239
58000	75	1414	1411	1513	1012	1606	580	1318	1318	1405	961	1484	528	1219	1219	1293	909	1362	477	1123	1123	1178	855	1238	425
	80	1477	1477	1519	1326	1609	914	1382	1382	1411	1272	1483	860	1282	1282	1300	1216	1356	807	1175	1175	1184	1158	1229	755
	85	1539	1539	1538	1538	1614	1248	1436	1436	1437	1437	1487	1194	1326	1326	1327	1327	1360	1141	1211	1211	1211	1211	1232	1062
	90	1600	1600	1601	1601	1627	1558	1488	1488	1479	1479	1501	1500	1370	1370	1371	1371	1372	1372	1245	1245	1245	1245	1246	1246

Table 36. Gross cooling capacities – 130 tons eFlex™ variable speed – standard evaporator coil, 50Hz

CFM	Ent DB (°F)	Ambient Temperature (°F)																							
		85				95				105				115											
		Entering Wet Bulb (°F)			73	Entering Wet Bulb (°F)			61	Entering Wet Bulb (°F)			67	Entering Wet Bulb (°F)			61	Entering Wet Bulb (°F)			67	Entering Wet Bulb (°F)			73
23000	75	1190	843	1337	689	1493	526	1127	804	1267	650	1415	486	1061	764	1195	609	1332	445	995	724	1120	568	1245	402
	80	1192	973	1339	821	1494	659	1129	934	1269	781	1416	619	1064	895	1198	741	1334	577	998	855	1123	700	1247	534
	85	1197	1105	1341	952	1496	791	1135	1064	1272	912	1418	715	1070	1024	1200	872	1336	709	1006	981	1125	832	1249	666
	90	1217	1211	1343	1082	1497	922	1161	1161	1274	1043	1420	882	1106	1106	1203	1003	1338	841	1050	1050	1129	963	1251	798
26000	75	1235	900	1384	725	1536	537	1167	860	1309	684	1452	496	1097	819	1232	642	1364	453	1026	777	1152	600	1270	408
	80	1238	1048	1387	874	1537	687	1171	1008	1312	833	1454	646	1102	967	1235	791	1365	603	1031	923	1155	748	1272	558
	85	1247	1195	1389	1022	1539	836	1181	1152	1315	981	1456	795	1115	1096	1238	939	1368	752	1051	1047	1158	897	1274	707
	90	1287	1287	1393	1170	1542	985	1230	1230	1319	1129	1458	943	1171	1171	1243	1088	1370	900	1110	1110	1164	1043	1276	855
30000	75	1283	974	1432	769	1578	549	1210	931	1352	726	1488	506	1135	889	1289	683	1392	461	1059	845	1183	638	1291	414
	80	1289	1145	1436	941	1580	722	1217	1100	1356	898	1490	679	1143	1057	1273	855	1395	634	1069	1011	1187	810	1293	587
	85	1309	1289	1439	1111	1582	894	1242	1240	1360	1069	1492	850	1175	1175	1277	1026	1397	805	1110	1110	1192	981	1295	758
	90	1373	1373	1446	1283	1585	1065	1310	1310	1367	1237	1494	1021	1244	1244	1286	1194	1399	977	1175	1175	1201	1149	1297	929
35000	75	1329	1062	1478	820	1614	561	1251	1018	1392	776	1517	516	1172	973	1303	731	1415	470	1090	924	1210	684	1308	421
	80	1340	1259	1481	1020	1617	762	1264	1211	1396	976	1520	717	1186	1158	1307	931	1418	671	1109	1094	1214	884	1309	622
	85	1382	1382	1487	1220	1619	963	1316	1316	1402	1176	1522	917	1246	1246	1313	1131	1419	871	1172	1172	1221	1080	1310	822
	90	1460	1460	1499	1416	1621	1162	1390	1390	1415	1367	1524	1117	1316	1316	1330	1298	1422	1070	1236	1236	1243	1238	1312	1021
40000	75	1365	1147	1510	869	1640	572	1283	1098	1420	823	1538	526	1200	1051	1326	777	1431	478	1114	999	1228	728	1318	429
	80	1385	1354	1514	1097	1643	802	1306	1291	1424	1052	1540	755	1229	1229	1330	1005	1432	707	1149	1149	1232	957	1318	657
	85	1452	1452	1523	1322	1646	1031	1378	1378	1433	1275	1542	984	1301	1301	1340	1223	1433	935	1219	1219	1243	1172	1319	885
	90	1529	1529	1543	1517	1650	1259	1451	1451	1459	1453	1545	1211	1368	1368	1370	1370	1436	1163	1277	1277	1278	1278	1322	1113
45000	75	1395	1226	1535	917	1662	584	1310	1179	1440	870	1552	536	1223	1124	1342	821	1441	487	1134	1074	1239	772	1324	437
	80	1428	1428	1540	1173	1665	843	1349	1349	1445	1126	1555	793	1269	1269	1347	1078	1442	744	1187	1187	1245	1023	1325	694
	85	1506	1506	1551	1424	1667	1100	1427	1427	1458	1370	1557	1051	1342	1342	1361	1320	1444	1001	1252	1252	1260	1245	1327	951
	90	1582	1582	1584	1584	1673	1357	1496	1496	1498	1498	1563	1308	1404	1404	1406	1406	1451	1251	1302	1302	1303	1303	1332	1199
50000	75	1420	1302	1554	963	1679	597	1332	1252	1456	915	1566	547	1242	1201	1353	866	1449	496	1150	1132	1247	815	1330	445
	80	1467	1467	1559	1248	1682	883	1388	1388	1462	1201	1568	833	1303	1303	1360	1144	1451	782	1214	1214	1254	1092	1330	731
	85	1550	1550	1575	1518	1685	1169	1465	1465	1479	1451	1571	1119	1374	1374	1379	1375	1454	1068	1275	1275	1276	1276	1332	1017
	90	1623	1623	1625	1625	1693	1455	1530	1530	1531	1531	1579	1396	1429	1429	1431	1431	1462	1335	1322	1322	1323	1323	1339	1279
55000	75	1442	1381	1569	1009	1693	609	1352	1319	1467	960	1576	558	1259	1247	1362	910	1457	506	1167	1167	1252	858	1334	455
	80	1505	1505	1576	1323	1696	924	1420	1420	1475	1266	1579	873	1330	1330	1370	1214	1459	821	1235	1235	1261	1150	1334	769
	85	1585	1585	1597	1572	1700	1239	1494	1494	1500	1500	1582	1187	1396	1396	1398	1398	1461	1136	1290	1290	1291	1291	1335	1083
	90	1658	1658	1660	1660	1712	1544	1558	1558	1559	1559	1592	1481	1453	1453	1454	1454	1471	1425	1338	1338	1338	1338	1343	1340
58000	75	1454	1417	1576	1037	1700	616	1362	1346	1473	987	1581	565	1269	1269	1366	936	1461	513	1176	1176	1254	884	1336	460
	80	1524	1524	1584	1359	1703	949	1436	1436	1482	1308	1584	897	1344	1344	1375	1247	1462	844	1245	1245	1264	1190	1335	791
	85	1603	1603	1611	1611	1708	1281	1508	1508	1511	1511	1587	1228	1407	1407	1408	1408	1465	1176	1297	1297	1298	1298	1337	1111
	90	1677	1677	1679	1679	1722	1593	1574	1574	1575	1575	1599	1535	1464	1464	1465	1465	1476	1457	1344	1344	1344	1345	1345	1346



Performance Data

Table 37. Gross cooling capacities – 150 tons – standard evaporator coil, 50Hz

CFM	Ent DB (°F)	Ambient Temperature (°F)																							
		85					95					105					115								
		Entering Wet Bulb (°F)					Entering Wet Bulb (°F)					Entering Wet Bulb (°F)					Entering Wet Bulb (°F)								
		61	67	73	79	85	61	67	73	79	85	61	67	73	79	85	61	67	73	79	85				
23000	75	1248	873	1399	716	1540	541	1179	831	1322	673	1454	497	1105	786	1240	629	1362	453	1029	742	1158	584	1270	408
	80	1250	1004	1400	848	1540	674	1182	962	1323	805	1455	631	1108	918	1242	761	1363	586	1033	874	1160	716	1271	541
	85	1254	1136	1401	980	1541	806	1186	1092	1325	937	1456	763	1113	1048	1244	892	1365	719	1039	1003	1162	848	1273	674
	90	1265	1264	1404	1111	1542	938	1208	1208	1328	1068	1457	895	1147	1147	1247	1024	1366	850	1084	1084	1165	980	1274	806
	75	1296	932	1445	751	1574	546	1223	888	1363	706	1483	502	1143	842	1276	660	1387	457	1063	796	1188	614	1289	411
26000	80	1300	1080	1447	900	1575	697	1226	1037	1365	855	1484	653	1148	991	1278	809	1388	607	1068	945	1190	764	1290	562
	85	1306	1227	1449	1048	1576	847	1234	1183	1367	1004	1485	802	1157	1137	1280	958	1389	757	1083	1083	1193	912	1291	711
	90	1342	1342	1452	1197	1577	995	1279	1279	1370	1153	1486	951	1213	1213	1284	1107	1390	906	1144	1144	1197	1061	1292	860
	75	1347	1005	1491	792	1604	552	1267	960	1403	746	1507	507	1183	912	1310	698	1406	461	1098	865	1217	651	1304	415
	80	1352	1177	1493	964	1606	726	1273	1129	1405	918	1509	680	1190	1081	1312	871	1407	634	1106	1033	1219	823	1304	588
30000	85	1364	1346	1496	1135	1606	898	1291	1291	1408	1089	1509	852	1219	1219	1316	1042	1408	806	1147	1147	1223	995	1304	759
	90	1428	1428	1500	1307	1607	1069	1358	1358	1413	1258	1510	1024	1284	1284	1321	1209	1408	977	1207	1207	1229	1161	1305	931
	75	1395	1093	1530	839	1630	559	1309	1045	1436	792	1527	513	1219	996	1339	744	1421	466	1130	947	1240	695	1314	419
	80	1404	1289	1532	1040	1631	761	1319	1241	1439	992	1527	714	1231	1191	1341	944	1420	667	1144	1139	1243	896	1312	619
	85	1442	1442	1536	1239	1632	962	1367	1367	1443	1193	1526	914	1287	1287	1346	1144	1419	867	1206	1206	1248	1090	1310	819
35000	90	1510	1510	1543	1433	1633	1162	1431	1431	1451	1385	1527	1114	1347	1347	1354	1330	1419	1066	1260	1260	1262	1262	1309	1019
	75	1431	1178	1556	885	1651	569	1340	1124	1459	836	1538	520	1246	1072	1357	787	1429	472	1152	1020	1254	738	1319	424
	80	1445	1401	1558	1113	1651	799	1357	1351	1461	1065	1538	749	1271	1271	1359	1016	1423	700	1187	1187	1257	967	1313	652
	85	1505	1505	1563	1336	1652	1028	1423	1423	1466	1287	1539	978	1336	1336	1365	1236	1424	929	1246	1246	1263	1185	1311	880
	90	1567	1567	1573	1559	1654	1257	1480	1480	1481	1481	1541	1207	1386	1386	1388	1388	1426	1157	1289	1289	1290	1290	1314	1107
45000	75	1459	1254	1575	929	1667	579	1365	1202	1474	880	1550	528	1267	1149	1368	830	1434	479	1170	1096	1263	780	1321	431
	80	1482	1482	1577	1186	1667	838	1399	1399	1476	1137	1549	786	1310	1310	1371	1087	1431	736	1219	1219	1266	1029	1314	686
	85	1551	1551	1583	1433	1668	1096	1462	1462	1482	1382	1549	1044	1368	1368	1378	1331	1430	993	1271	1271	1273	1261	1312	944
	90	1606	1606	1607	1607	1673	1354	1510	1510	1511	1511	1555	1300	1407	1407	1408	1408	1431	1239	1300	1300	1300	1300	1311	1187
	75	1481	1333	1588	973	1680	590	1384	1280	1484	923	1559	538	1283	1225	1376	872	1439	487	1184	1171	1268	822	1322	438
50000	80	1522	1522	1591	1258	1680	878	1433	1433	1487	1200	1556	824	1338	1338	1379	1148	1434	773	1243	1243	1271	1094	1314	723
	85	1584	1584	1598	1529	1683	1165	1489	1489	1494	1477	1556	1111	1389	1389	1389	1389	1432	1059	1284	1284	1285	1285	1312	998
	90	1638	1638	1640	1640	1688	1441	1533	1533	1534	1534	1562	1384	1422	1422	1423	1423	1434	1328	1307	1307	1307	1307	1309	1273
	75	1499	1410	1598	1017	1691	602	1400	1356	1491	967	1566	548	1298	1295	1381	915	1443	497	1200	1200	1270	864	1323	447
	80	1552	1552	1601	1320	1692	918	1458	1458	1494	1268	1562	863	1359	1359	1384	1214	1436	810	1258	1258	1273	1160	1313	759
55000	85	1609	1609	1612	1607	1694	1235	1508	1508	1508	1508	1564	1179	1401	1401	1401	1401	1435	1112	1284	1284	1290	1290	1312	1035
	90	1668	1668	1665	1665	1700	1535	1553	1553	1555	1555	1570	1476	1434	1434	1434	1434	1438	1418	1311	1311	1311	1311	1311	1311
	75	1508	1456	1603	1044	1697	609	1409	1401	1495	993	1569	555	1308	1308	1383	941	1445	503	1210	1210	1271	890	1324	452
	80	1567	1567	1606	1361	1697	943	1470	1470	1498	1308	1566	887	1368	1368	1386	1254	1441	826	1264	1264	1273	1199	1320	746
	85	1623	1623	1624	1623	1699	1276	1516	1516	1517	1517	1568	1208	1405	1405	1406	1406	1436	1150	1292	1292	1292	1293	1316	1040
90	1685	1685	1686	1686	1706	1591	1565	1565	1566	1566	1574	1531	1440	1440	1441	1441	1441	1441	1440	1311	1311	1311	1311	1312	1333

Table 38. Gross cooling capacities – 150 tons eFlex™ variable speed – standard evaporator coil, 50Hz

CFM	Ent DB (°F)	Ambient Temperature (°F)																							
		85				95				105				115											
		Entering Wet Bulb (°F)				Entering Wet Bulb (°F)				Entering Wet Bulb (°F)				Entering Wet Bulb (°F)											
		61	67	73	79	61	67	73	79	61	67	73	79	61	67	73	79								
23000	75	1308	904	1474	753	1649	591	1241	862	1401	711	1569	549	1173	819	1326	668	1486	506	1083	767	1227	616	1374	452
	80	1310	1034	1475	884	1650	723	1243	992	1403	842	1570	681	1175	950	1328	800	1487	638	1086	898	1229	747	1375	585
	85	1313	1165	1476	1014	1651	855	1247	1123	1404	973	1571	813	1179	1080	1330	930	1488	770	1091	1028	1231	878	1377	717
	90	1320	1294	1478	1145	1652	986	1250	1250	1406	1103	1572	944	1198	1198	1332	1061	1490	902	1125	1125	1234	1009	1378	848
26000	75	1363	964	1532	791	1703	603	1291	921	1453	747	1618	560	1218	877	1374	704	1530	516	1122	823	1268	649	1410	461
	80	1366	1112	1533	939	1704	753	1294	1069	1455	896	1619	710	1221	1025	1376	852	1531	666	1126	971	1270	798	1412	611
	85	1371	1259	1535	1087	1705	901	1300	1214	1457	1044	1620	859	1228	1170	1378	1000	1533	815	1138	1109	1273	946	1413	760
	90	1393	1392	1538	1235	1706	1050	1334	1334	1461	1191	1622	1007	1274	1274	1382	1148	1534	963	1195	1195	1277	1094	1415	908
30000	75	1422	1041	1592	838	1755	615	1345	996	1508	792	1665	571	1266	950	1422	747	1570	526	1164	893	1309	690	1443	470
	80	1427	1212	1594	1009	1756	788	1351	1167	1510	963	1666	744	1272	1120	1425	918	1572	699	1171	1063	1312	861	1444	642
	85	1437	1380	1597	1179	1757	959	1362	1335	1513	1134	1668	916	1291	1277	1428	1089	1574	871	1202	1202	1316	1033	1446	814
	90	1492	1492	1602	1350	1759	1130	1427	1427	1519	1305	1669	1087	1361	1361	1434	1258	1575	1042	1273	1273	1322	1201	1448	985
35000	75	1480	1132	1648	891	1799	627	1398	1085	1559	844	1703	582	1314	1037	1466	797	1571	525	1204	979	1345	738	1467	478
	80	1488	1330	1651	1090	1801	828	1407	1281	1562	1044	1705	783	1324	1232	1470	996	1573	726	1216	1173	1348	938	1470	679
	85	1515	1508	1655	1289	1802	1028	1443	1443	1567	1243	1706	983	1372	1372	1475	1196	1574	925	1278	1278	1354	1135	1471	878
	90	1595	1595	1663	1486	1804	1227	1523	1523	1575	1438	1708	1182	1449	1449	1485	1390	1576	1125	1351	1351	1368	1319	1472	1078
40000	75	1525	1219	1689	940	1830	638	1438	1171	1595	893	1729	592	1349	1119	1498	844	1592	533	1234	1058	1370	784	1476	483
	80	1538	1442	1692	1168	1832	867	1452	1393	1599	1121	1730	821	1366	1340	1502	1072	1592	762	1261	1253	1374	1012	1479	713
	85	1594	1594	1698	1396	1833	1095	1518	1518	1606	1346	1731	1049	1440	1440	1510	1297	1593	990	1337	1337	1383	1233	1481	941
	90	1678	1678	1710	1617	1836	1323	1600	1600	1619	1569	1733	1276	1519	1519	1528	1501	1595	1217	1409	1409	1411	1411	1485	1166
45000	75	1561	1302	1719	988	1856	649	1470	1251	1622	939	1748	601	1378	1197	1521	890	1606	542	1258	1134	1388	828	1481	489
	80	1581	1548	1723	1244	1859	908	1496	1482	1626	1196	1748	858	1412	1412	1526	1147	1605	799	1306	1306	1393	1082	1484	747
	85	1660	1660	1731	1494	1862	1165	1580	1580	1635	1445	1748	1114	1496	1496	1535	1394	1605	1055	1384	1384	1405	1331	1487	1004
	90	1742	1742	1752	1721	1867	1422	1658	1658	1661	1661	1751	1370	1570	1570	1572	1572	1607	1305	1449	1449	1451	1451	1490	1254
50000	75	1591	1381	1742	1034	1879	663	1496	1328	1642	985	1762	611	1401	1275	1538	935	1616	551	1278	1210	1400	872	1485	496
	80	1626	1626	1746	1319	1882	949	1542	1542	1647	1270	1761	896	1456	1456	1543	1216	1614	835	1343	1343	1407	1152	1487	782
	85	1713	1713	1757	1593	1885	1235	1628	1628	1658	1543	1763	1181	1538	1538	1556	1492	1613	1119	1418	1418	1425	1394	1488	1062
	90	1791	1791	1794	1794	1898	1521	1701	1701	1703	1703	1769	1461	1576	1576	1578	1578	1616	1391	1473	1473	1474	1474	1492	1337
55000	75	1616	1461	1760	1080	1898	675	1519	1407	1657	1031	1774	621	1420	1353	1550	980	1624	560	1297	1264	1409	916	1486	504
	80	1670	1670	1765	1389	1903	990	1583	1583	1663	1339	1774	935	1493	1493	1557	1283	1620	872	1373	1373	1416	1216	1488	818
	85	1756	1756	1778	1693	1908	1305	1665	1665	1678	1637	1777	1249	1571	1571	1547	1530	1619	1180	1443	1443	1444	1444	1490	1124
	90	1833	1833	1835	1835	1913	1609	1733	1733	1735	1735	1785	1550	1600	1600	1601	1601	1626	1482	1485	1485	1486	1486	1495	1424
58000	75	1629	1508	1769	1108	1907	683	1531	1454	1664	1058	1781	628	1431	1399	1556	1006	1627	566	1309	1295	1413	942	1488	509
	80	1693	1693	1775	1429	1909	1015	1604	1604	1671	1377	1782	959	1511	1511	1564	1324	1622	895	1388	1388	1421	1257	1487	839
	85	1777	1777	1790	1745	1913	1347	1684	1684	1691	1668	1786	1291	1557	1557	1558	1558	1623	1218	1454	1454	1455	1455	1490	1162
	90	1858	1858	1860	1860	1924	1666	1750	1750	1752	1752	1794	1606	1612	1612	1613	1613	1631	1536	1492	1492	1493	1493	1497	1476



Performance Data

Table 39. Gross cooling capacities – 90 tons – high capacity evaporator coil, 50Hz

CFM	Ent DB (°F)	Ambient Temperature (°F)																							
		85						95						105						115					
		Entering Wet Bulb (°F)			Entering Wet Bulb (°F)			Entering Wet Bulb (°F)			Entering Wet Bulb (°F)			Entering Wet Bulb (°F)			Entering Wet Bulb (°F)			Entering Wet Bulb (°F)					
		61	67	73	61	67	73	61	67	73	61	67	73	61	67	73	61	67	73						
16000	75	838	606	932	494	1023	374	586	891	474	977	354	762	564	846	452	927	332	718	541	797	429	871	308	
	80	840	697	933	586	1024	466	804	677	892	565	978	446	764	655	847	544	927	424	721	633	798	520	872	400
	85	844	787	934	677	1024	558	808	767	893	656	979	537	769	745	848	635	928	516	728	722	800	611	873	492
	90	861	861	936	768	1025	649	831	831	895	747	980	629	798	798	851	726	929	607	761	761	803	703	874	583
20000	75	888	678	979	536	1064	384	846	657	933	515	1013	334	801	634	883	491	957	340	753	609	829	467	896	316
	80	892	791	980	650	1065	499	851	769	935	629	1014	478	807	745	885	605	958	455	759	720	830	581	896	430
	85	898	894	982	764	1065	613	866	866	937	742	1015	592	828	828	887	720	959	569	786	786	833	695	897	545
	90	945	945	986	876	1066	727	909	909	942	854	1016	706	870	870	892	830	960	683	826	826	839	805	898	659
25000	75	929	764	1015	584	1094	395	883	738	965	561	1039	373	834	712	910	537	978	349	781	686	851	511	912	324
	80	938	902	1017	726	1094	538	894	879	967	704	1039	516	846	846	913	679	978	492	798	798	853	654	912	466
	85	974	974	1021	865	1095	680	933	933	972	842	1040	658	889	889	917	817	978	634	840	840	859	790	912	609
	90	1019	1019	1029	1006	1097	823	977	977	981	973	1041	801	930	930	931	931	980	777	877	877	878	878	914	746
30000	75	958	840	1038	629	1113	405	909	816	985	606	1054	382	857	789	927	581	990	358	800	761	864	554	920	332
	80	977	977	1041	800	1113	576	934	934	988	773	1054	553	886	886	930	746	990	529	834	834	867	718	920	503
	85	1025	1025	1047	964	1114	747	980	980	995	940	1054	724	929	929	937	914	989	700	874	874	876	872	920	674
	90	1069	1069	1071	1071	1118	913	1021	1021	1022	1022	1058	888	967	967	968	968	993	862	906	906	907	907	923	834
33000	75	971	887	1048	657	1122	411	921	862	993	633	1059	388	867	835	933	607	993	363	810	806	869	580	922	337
	80	1001	1001	1052	839	1122	599	955	955	997	814	1060	576	905	905	937	787	994	551	850	850	873	758	923	524
	85	1049	1049	1060	1023	1123	788	1000	1000	1006	999	1061	764	947	947	948	948	995	736	887	887	888	888	924	704
	90	1091	1091	1092	1092	1128	968	1040	1040	1041	1041	1066	943	982	982	982	982	999	916	919	919	919	919	928	888
36000	75	983	933	1056	684	1129	417	932	908	1000	659	1064	394	877	876	939	633	996	369	819	819	873	606	924	343
	80	1021	1021	1060	881	1130	623	973	973	1004	855	1066	599	920	920	943	828	998	573	862	862	877	798	925	547
	85	1068	1068	1071	1067	1131	829	1017	1017	1018	1018	1068	797	960	960	961	961	999	769	898	898	898	898	927	740
	90	1111	1111	1112	1112	1139	1024	1056	1056	1057	1057	1074	998	996	996	996	996	1005	970	929	929	930	930	933	931
40000	75	996	994	1065	719	1137	426	944	944	1007	695	1070	402	891	891	944	668	1000	377	833	833	876	630	927	350
	80	1043	1043	1070	936	1138	655	992	992	1012	910	1072	630	936	936	949	882	1002	604	875	875	882	851	928	577
	85	1088	1088	1089	1089	1141	874	1034	1034	1035	1035	1074	847	974	974	975	975	1004	818	908	908	909	909	929	788
	90	1135	1135	1136	1136	1152	1098	1076	1076	1077	1076	1085	1071	1012	1012	1013	1013	1015	1015	1015	942	942	943	943	944

Table 40. Gross cooling capacities – 90 tons eFlex™ variable speed – high capacity evaporator coil, 50Hz

CFM	Ent DB (°F)	Ambient Temperature (°F)																							
		85						95						105						115					
		Entering Wet Bulb (°F)			Entering Wet Bulb (°F)			Entering Wet Bulb (°F)			Entering Wet Bulb (°F)			Entering Wet Bulb (°F)			Entering Wet Bulb (°F)			Entering Wet Bulb (°F)					
		61	67	73	61	67	73	61	67	73	61	67	73	61	67	73	61	67	73						
16000	75	831	603	927	494	1021	374	798	585	890	475	979	356	762	565	850	455	933	335	724	545	807	434	883	314
	80	833	694	929	585	1022	466	800	676	892	566	980	448	765	666	852	547	934	428	727	635	808	526	883	406
	85	837	785	930	676	1023	558	804	761	893	657	981	539	772	737	853	638	935	519	737	711	810	617	884	497
	90	857	851	932	767	1023	649	829	829	895	749	982	631	800	800	856	728	936	610	768	768	813	707	885	589
20000	75	882	677	976	536	1060	384	844	657	935	516	1013	364	804	636	890	495	961	342	761	612	841	473	904	319
	80	887	789	978	650	1061	498	849	769	936	630	1014	479	810	748	891	609	962	457	767	720	842	587	905	434
	85	903	880	980	764	1062	613	869	855	939	744	1014	593	832	829	894	722	962	571	795	795	846	699	906	548
	90	943	943	985	877	1063	727	910	910	944	857	1015	707	875	875	900	835	963	685	836	836	853	801	907	662
25000	75	925	761	1013	584	1092	395	884	739	967	563	1039	373	839	716	918	541	982	351	792	693	863	517	921	327
	80	936	888	1015	726	1093	538	898	860	969	706	1040	516	856	830	920	681	982	494	812	799	866	657	921	470
	85	973	973	1020	866	1095	681	936	936	974	845	1040	659	896	896	925	823	983	637	851	851	871	797	921	613
	90	1018	1018	1032	983	1098	822	980	980	989	953	1044	800	936	936	941	921	986	777	888	888	889	889	924	752
30000	75	955	840	1036	629	1115	406	911	817	986	607	1057	383	864	793	933	584	996	360	813	758	875	559	928	335
	80	979	967	1039	797	1117	578	937	937	990	775	1058	555	894	894	937	751	996	531	846	846	879	726	930	506
	85	1024	1024	1045	965	1120	750	982	982	997	929	1061	727	936	936	946	895	998	700	884	884	890	857	932	674
	90	1067	1067	1069	1069	1126	918	1021	1021	1023	1023	1066	894	971	971	972	972	1004	867	915	915	916	916	937	840
33000	75	969	887	1045	656	1125	413	923	857	994	634	1065	389	876	824	939	610	1002	366	825	788	880	581	932	341
	80	1001	1001	1048	840	1128	602	958	958	998	817	1067	579	913	913	943	790	1002	554	862	862	884	763	934	529
	85	1047	1047	1059	1000	1132	788	1002	1002	1010	966	1070	764	952	952	956	931	1005	738	896	896	897	894	936	711
	90	1094	1094	1096	1096	1139	973	1044	1044	1045	1045	1077	948	991	991	992	992	1012	922	931	931	931	932	944	878
36000	75	982	920	1052	683	1134	420	936	888	1000	656	1072	396	888	854	944	631	1007	371	835	817	883	605	934	346
	80	1020	1020	1057	882	1137	626	976	976	1005	856	1074	602	927	927	948	830	1007	577	874	874	887	803	937	551
	85	1066	1066	1074	1039	1141	828	1017	1017	1021	1004	1078	803	964	964	965	965	1011	777	906	906	907	907	940	745
	90	1118	1118	1119	1119	1149	1029	1065	1065	1066	1066	1086	1003	1007	1007	1008	1008	1020	954	943	943	944	944	950	910
40000	75	998	961	1062	714	1143	429	951	928	1006	690	1079	404	900	893	948	664	1013	379	846	846	885	636	936	353
	80	1041	1041	1068	936	1147	658	994	994	1013	911	1081	633	942	942	954	884	1012	602	884	884	892	837	940	574
	85	1091	1091	1093	1093	1152	881	1037	1037	1039	1039	1086	855	981	981	982	982	1017	823	920	920	921	921	943	794
	90	1145	1145	1146	1146	1163	1083	1087	1087	1088	1088	1099	1042	1024	1024	1025	1025	1031	999	954	954	954	955	955	956



Performance Data

Table 41. Gross cooling capacities – 105 tons – high capacity evaporator coil, 50Hz

CFM	Ent DB (°F)	Ambient Temperature (°F)																							
		85				95				105				115											
		67		73		61		67		73		61		67		73									
		CAP	SHC	CAP	SHC	CAP	SHC	CAP	SHC	CAP	SHC	CAP	SHC	CAP	SHC	CAP	SHC								
19000	75	937	690	1043	559	1148	418	893	667	994	535	1093	394	846	642	941	510	1034	370	797	617	886	484	970	343
	80	940	799	1045	668	1149	527	896	776	996	644	1094	504	850	749	944	619	1036	479	802	723	888	593	972	453
	85	947	905	1047	776	1150	636	904	882	998	752	1096	613	859	856	946	727	1037	588	816	816	891	702	973	562
23000	75	978	978	1050	884	1151	745	942	942	1002	861	1097	721	902	902	950	834	1038	696	860	860	895	807	975	670
	80	983	762	1087	601	1186	429	934	737	1033	576	1126	404	883	711	976	550	1062	378	828	684	915	522	993	351
	85	989	891	1089	732	1188	561	941	865	1036	707	1128	536	891	839	979	681	1064	510	837	811	918	654	995	483
28000	75	1006	1006	1093	863	1189	692	966	966	1040	839	1129	668	922	922	983	813	1065	642	875	875	922	781	996	615
	80	1059	1059	1099	991	1190	824	1016	1016	1046	966	1131	799	971	971	990	939	1067	773	921	921	930	911	998	746
	85	1024	844	1124	649	1217	440	971	817	1066	623	1153	415	916	788	1004	596	1085	388	857	759	938	567	1011	360
33000	75	1035	1003	1127	809	1218	600	984	976	1069	783	1154	575	931	931	1007	756	1085	548	880	880	941	728	1011	520
	80	1080	1080	1133	964	1219	760	1033	1033	1075	937	1155	735	983	983	1014	909	1086	708	929	929	949	879	1012	680
	85	1133	1133	1143	1122	1221	920	1084	1084	1087	1087	1157	895	1031	1031	1033	1033	1089	862	973	973	974	974	1014	832
38000	75	1054	924	1149	696	1238	451	998	895	1087	669	1170	425	939	865	1021	641	1098	398	877	834	952	611	1021	369
	80	1078	1078	1153	879	1238	639	1028	1028	1091	851	1170	613	975	975	1026	821	1098	586	918	918	957	790	1021	557
	85	1134	1134	1161	1063	1238	828	1082	1082	1100	1035	1171	801	1026	1026	1036	1006	1098	774	965	965	967	967	1021	736
43000	75	1186	1186	1188	1188	1242	1008	1131	1131	1133	1133	1174	980	1071	1071	1072	1072	1101	950	1004	1004	1005	1005	1023	919
	80	1077	1001	1166	742	1251	462	1019	972	1101	714	1181	436	958	941	1033	685	1107	408	894	894	961	646	1030	379
	85	1119	1119	1172	949	1252	678	1065	1065	1107	919	1181	651	1007	1007	1040	889	1107	623	945	945	967	856	1030	594
45000	75	1174	1174	1183	1162	1253	887	1118	1118	1120	1120	1182	858	1056	1056	1057	1057	1106	827	989	989	990	990	1030	795
	80	1224	1224	1225	1225	1260	1099	1163	1163	1164	1164	1187	1069	1096	1096	1097	1097	1110	1038	1022	1022	1023	1023	1029	1006
	85	1097	1078	1179	787	1258	474	1037	1037	1112	759	1189	446	976	976	1042	717	1117	418	914	914	967	683	1036	389
45000	75	1150	1150	1186	1018	1262	718	1093	1093	1120	988	1190	690	1031	1031	1049	956	1118	662	964	964	975	922	1038	618
	80	1205	1205	1206	1206	1266	950	1143	1143	1144	1144	1190	919	1077	1077	1078	1078	1119	887	1005	1005	1005	1005	1039	853
	85	1254	1254	1256	1256	1275	1191	1188	1188	1189	1189	1200	1160	1116	1116	1117	1117	1120	1120	1039	1039	1040	1040	1041	1041
45000	75	1104	1104	1183	805	1262	478	1044	1044	1116	765	1191	451	984	984	1045	733	1120	422	920	920	969	698	1038	393
	80	1161	1161	1191	1045	1266	734	1102	1102	1124	1015	1192	706	1038	1038	1053	983	1122	664	970	970	977	948	1041	630
	85	1215	1215	1216	1216	1271	976	1152	1152	1153	1153	1194	944	1084	1084	1084	1084	1124	911	1009	1009	1010	1010	1044	877
90	1266	1266	1267	1267	1282	1228	1197	1197	1198	1198	1205	1196	1124	1124	1125	1125	1125	1126	1126	1045	1045	1046	1046	1046	1046

Table 42. Gross cooling capacities – 105 tons eFlex™ variable speed – high capacity evaporator coil, 50Hz

CFM	Ent DB (°F)	Ambient Temperature (°F)																							
		85				95				105				115											
		67		73		67		73		61		67		73		61		67		73					
		CAP	SHC	CAP	SHC	CAP	SHC	CAP	SHC	CAP	SHC	CAP	SHC	CAP	SHC	CAP	SHC	CAP	SHC	CAP	SHC				
19000	75	936	691	1045	561	1155	422	898	670	1003	540	1107	401	858	649	957	518	1057	379	815	626	908	495	1001	356
	80	940	800	1047	669	1156	531	902	778	1005	649	1109	510	862	756	959	627	1058	489	819	732	911	604	1003	465
	85	946	906	1049	778	1157	640	909	885	1007	757	1111	619	872	856	962	735	1060	598	831	831	914	712	1005	574
	90	979	979	1053	887	1159	749	947	947	1011	866	1112	728	914	914	967	843	1062	706	877	877	918	820	1007	683
23000	75	983	763	1091	603	1195	433	941	741	1045	581	1143	411	896	718	995	558	1088	389	849	693	941	534	1028	364
	80	990	892	1094	735	1196	565	948	870	1047	713	1145	543	904	846	998	690	1090	521	857	821	945	666	1030	496
	85	1008	1008	1098	867	1198	697	973	973	1052	845	1146	675	935	935	1002	820	1091	652	895	895	949	796	1031	628
	90	1062	1062	1104	995	1200	828	1026	1026	1059	972	1149	806	987	987	1010	949	1094	784	944	944	958	924	1033	760
28000	75	1026	848	1130	652	1226	444	980	822	1079	629	1171	422	931	797	1026	605	1112	399	880	770	967	580	1047	374
	80	1038	1005	1133	813	1228	605	994	972	1083	790	1172	582	949	940	1030	764	1113	559	901	901	972	738	1048	533
	85	1085	1085	1140	968	1230	765	1044	1044	1090	944	1173	742	1001	1001	1037	919	1114	719	954	954	980	893	1049	693
	90	1140	1140	1151	1118	1234	926	1098	1098	1105	1087	1177	900	1053	1053	1054	1054	1117	874	1002	1002	1004	1004	1052	847
33000	75	1057	926	1156	699	1250	456	1009	901	1102	675	1190	432	957	874	1045	651	1127	408	902	846	984	624	1057	383
	80	1083	1083	1161	885	1252	645	1039	1039	1107	858	1191	621	993	993	1051	832	1127	596	944	944	990	804	1059	570
	85	1142	1142	1169	1068	1254	834	1097	1097	1117	1043	1193	810	1048	1048	1060	1017	1129	785	995	995	1002	977	1061	751
	90	1195	1195	1197	1197	1260	1015	1148	1148	1149	1149	1198	990	1096	1096	1098	1098	1134	963	1038	1038	1040	1040	1065	935
38000	75	1082	1004	1174	745	1267	468	1031	978	1118	721	1204	443	978	950	1058	695	1138	418	922	906	994	663	1065	392
	80	1126	1126	1180	953	1269	685	1079	1079	1125	927	1205	660	1029	1029	1066	900	1138	635	974	974	1002	871	1067	608
	85	1184	1184	1193	1157	1273	898	1134	1134	1140	1122	1207	868	1081	1081	1083	1083	1141	840	1023	1023	1024	1024	1068	811
	90	1237	1237	1239	1239	1282	1108	1184	1184	1185	1185	1215	1081	1126	1126	1128	1128	1146	1053	1063	1063	1064	1064	1074	1023
43000	75	1103	1075	1188	787	1280	479	1051	1036	1130	757	1215	454	997	997	1068	728	1145	428	941	941	1002	698	1072	401
	80	1159	1159	1195	1022	1287	720	1109	1109	1138	996	1215	699	1055	1055	1077	967	1146	668	996	996	1011	937	1073	633
	85	1215	1215	1217	1217	1289	959	1162	1162	1163	1163	1219	930	1104	1104	1105	1105	1148	901	1041	1041	1041	1041	1074	870
	90	1274	1274	1276	1276	1300	1201	1214	1214	1216	1216	1231	1172	1151	1151	1152	1152	1159	1128	1082	1082	1083	1083	1084	1084
45000	75	1111	1094	1192	804	1285	484	1059	1058	1134	773	1218	458	1005	1005	1071	744	1146	432	949	949	1004	713	1074	406
	80	1170	1170	1200	1050	1287	741	1118	1118	1142	1023	1218	715	1063	1063	1080	994	1149	689	1003	1003	1014	964	1074	646
	85	1227	1227	1228	1228	1294	985	1171	1171	1172	1172	1223	956	1112	1112	1113	1113	1151	925	1047	1047	1048	1048	1075	894
	90	1287	1287	1289	1289	1307	1238	1226	1226	1227	1227	1227	1203	1160	1160	1161	1161	1166	1153	1089	1089	1090	1090	1091	1091



Performance Data

Table 43. Gross cooling capacities – 120 tons – high capacity evaporator coil, 50Hz

CFM	Ent DB (°F)	Ambient Temperature (°F)																							
		85				95				105				115											
		61	67	73	79	61	67	73	79	61	67	73	79	61	67	73	79								
21000	75	1065	762	1193	619	1315	461	1011	730	1133	587	1251	430	955	697	1071	554	1183	398	895	663	1004	519	1110	364
	80	1067	882	1194	739	1316	582	1013	850	1135	707	1252	551	957	817	1073	674	1185	519	897	783	1006	640	1112	485
	85	1069	1001	1196	858	1317	702	1016	968	1137	827	1254	672	960	935	1075	794	1186	640	901	901	1008	760	1113	606
	90	1094	1094	1198	978	1318	822	1050	1050	1139	946	1255	792	1003	1003	1077	913	1188	760	953	953	1011	879	1115	726
26000	75	1131	855	1255	672	1366	474	1070	821	1190	639	1297	442	1006	785	1121	604	1224	409	940	749	1048	568	1145	375
	80	1134	1003	1257	821	1367	623	1073	968	1192	788	1298	591	1010	932	1124	753	1225	558	944	895	1051	717	1145	523
	85	1144	1144	1259	969	1368	771	1094	1094	1195	936	1298	739	1041	1041	1127	902	1225	706	984	984	1054	866	1146	672
	90	1205	1205	1262	1117	1369	920	1153	1153	1198	1084	1300	888	1099	1099	1131	1048	1227	855	1040	1040	1058	1011	1147	820
31000	75	1177	942	1295	721	1399	485	1111	907	1226	687	1325	453	1042	870	1153	651	1247	419	970	828	1075	614	1164	382
	80	1182	1116	1298	898	1399	662	1118	1080	1229	864	1325	629	1051	1043	1156	828	1247	595	987	987	1078	791	1163	559
	85	1225	1225	1301	1074	1399	838	1169	1169	1232	1041	1325	805	1110	1110	1160	1002	1247	771	1046	1046	1082	964	1163	735
	90	1286	1286	1306	1247	1401	1015	1228	1228	1238	1211	1326	982	1167	1167	1169	1169	1248	948	1100	1100	1102	1102	1164	912
36000	75	1210	1023	1323	767	1420	497	1141	985	1250	732	1337	464	1069	947	1174	696	1258	429	993	906	1092	658	1173	390
	80	1222	1222	1325	973	1424	701	1162	1162	1254	938	1339	666	1100	1100	1177	902	1259	631	1033	1033	1096	859	1173	595
	85	1286	1286	1330	1173	1427	908	1225	1225	1258	1138	1341	871	1160	1160	1183	1100	1260	836	1090	1090	1102	1061	1173	800
	90	1344	1344	1346	1346	1431	1114	1281	1281	1283	1283	1344	1076	1213	1213	1215	1215	1262	1036	1139	1139	1141	1141	1173	998
41000	75	1235	1102	1342	813	1443	509	1164	1064	1268	777	1347	474	1089	1023	1188	740	1279	439	1011	982	1104	702	1184	408
	80	1269	1269	1346	1043	1445	743	1206	1206	1271	1006	1352	711	1139	1139	1192	967	1283	669	1067	1067	1108	927	1188	632
	85	1332	1332	1351	1272	1449	978	1266	1266	1277	1235	1357	939	1197	1197	1198	1198	1289	902	1121	1121	1122	1122	1203	856
	90	1387	1387	1389	1389	1454	1207	1317	1317	1319	1319	1362	1166	1244	1244	1245	1245	1336	1125	1163	1163	1164	1164	1244	1085
46000	75	1256	1180	1358	859	1460	522	1182	1141	1281	823	1362	487	1106	1100	1199	779	1292	451	1030	1030	1112	735	1201	415
	80	1306	1306	1361	1113	1462	784	1239	1239	1284	1074	1367	744	1168	1168	1202	1035	1295	708	1092	1092	1116	993	1204	662
	85	1367	1367	1368	1368	1466	1048	1296	1296	1298	1298	1371	999	1222	1222	1223	1223	1316	957	1141	1141	1142	1142	1231	915
	90	1429	1429	1431	1431	1472	1301	1348	1348	1350	1350	1376	1259	1265	1265	1267	1267	1359	1216	1178	1178	1178	1178	1267	1173
51000	75	1273	1257	1371	899	1471	544	1201	1201	1291	858	1374	501	1128	1128	1207	817	1303	465	1051	1051	1118	772	1209	425
	80	1336	1336	1373	1182	1475	825	1265	1265	1293	1143	1378	784	1190	1190	1210	1102	1306	735	1110	1110	1121	1059	1212	692
	85	1394	1394	1396	1396	1479	1107	1319	1319	1320	1320	1381	1063	1241	1241	1241	1241	1337	1019	1155	1155	1156	1156	1247	974
	90	1465	1465	1466	1466	1486	1395	1378	1378	1380	1380	1388	1351	1289	1289	1290	1290	1386	1292	1194	1194	1195	1195	1286	1196
54000	75	1285	1285	1377	923	1478	556	1215	1215	1296	882	1381	509	1140	1140	1211	840	1309	473	1061	1061	1120	795	1210	431
	80	1351	1351	1379	1224	1482	850	1278	1278	1298	1184	1383	809	1201	1201	1213	1143	1312	753	1118	1118	1123	1099	1213	709
	85	1413	1413	1415	1415	1486	1145	1330	1330	1331	1331	1386	1101	1249	1249	1250	1250	1348	1056	1161	1161	1161	1161	1251	1011
	90	1483	1483	1484	1484	1494	1451	1393	1393	1394	1394	1396	1396	1300	1300	1301	1301	1400	1303	1202	1202	1203	1203	1293	1204

Table 44. Gross cooling capacities – 120 tons eFlex™ variable speed – high capacity evaporator coil, 50Hz

CFM	Ent DB (°F)	Ambient Temperature (°F)																							
		85				95				105				115											
		67		73		61		67		73		61		67		73									
CAP	SHC	CAP	SHC	CAP	SHC	CAP	SHC	CAP	SHC	CAP	SHC	CAP	SHC	CAP	SHC	CAP	SHC								
21000	75	1053	752	1186	612	1327	463	1002	722	1130	581	1266	433	950	690	1072	549	1202	401	895	658	1011	516	1134	368
	80	1055	871	1188	732	1328	585	1004	841	1132	701	1268	554	952	809	1075	670	1204	522	897	777	1014	637	1136	489
	85	1068	995	1189	852	1330	705	1023	968	1134	821	1270	674	954	926	1077	789	1206	643	904	887	1016	757	1138	610
	90	1082	1082	1191	971	1331	825	1041	1041	1136	940	1272	795	997	997	1079	909	1208	763	951	951	1018	876	1141	730
26000	75	1121	846	1257	670	1391	481	1064	813	1195	637	1325	449	1005	780	1130	603	1254	416	944	745	1062	568	1180	382
	80	1123	994	1260	819	1393	630	1067	961	1198	786	1328	599	1008	926	1133	752	1257	566	947	891	1066	717	1184	531
	85	1133	1133	1263	967	1395	779	1087	1087	1201	934	1330	747	1038	1038	1136	900	1260	714	986	986	1069	865	1186	680
	90	1198	1198	1265	1114	1397	928	1150	1150	1204	1081	1332	896	1099	1099	1140	1047	1262	863	1046	1046	1072	1011	1188	829
31000	75	1170	935	1306	722	1433	495	1108	900	1240	688	1362	462	1044	864	1170	653	1287	429	978	826	1097	616	1208	393
	80	1195	1117	1310	899	1434	672	1113	1073	1244	865	1364	639	1055	1029	1174	830	1290	605	991	991	1101	794	1211	570
	85	1221	1221	1314	1076	1436	849	1169	1169	1247	1041	1366	816	1114	1114	1178	1006	1292	782	1055	1055	1105	968	1213	747
	90	1291	1291	1317	1263	1438	1025	1237	1237	1253	1215	1368	993	1180	1180	1191	1165	1294	959	1120	1120	1122	1122	1216	924
36000	75	1207	1018	1341	772	1463	508	1141	981	1271	736	1389	475	1074	944	1197	700	1310	440	1004	905	1120	662	1228	403
	80	1223	1206	1345	977	1464	712	1163	1163	1275	942	1389	678	1104	1104	1202	905	1311	643	1042	1042	1125	865	1228	607
	85	1293	1293	1350	1179	1465	918	1235	1235	1281	1143	1390	883	1175	1175	1208	1106	1312	849	1111	1111	1129	1073	1230	813
	90	1363	1363	1365	1365	1468	1123	1304	1304	1306	1306	1392	1087	1241	1241	1243	1243	1315	1051	1174	1174	1174	1176	1176	1232
41000	75	1223	1132	1366	819	1485	521	1151	1084	1293	783	1408	486	1097	1022	1216	746	1327	450	1023	981	1134	705	1239	414
	80	1274	1274	1371	1051	1486	753	1214	1214	1299	1013	1409	717	1151	1151	1222	975	1326	682	1084	1084	1142	935	1240	645
	85	1349	1349	1378	1280	1489	988	1288	1288	1306	1244	1409	948	1222	1222	1234	1196	1326	913	1153	1153	1155	1155	1241	873
	90	1416	1416	1419	1419	1494	1217	1353	1353	1355	1355	1410	1178	1285	1285	1287	1287	1327	1141	1212	1212	1212	1214	1214	1242
46000	75	1261	1179	1385	866	1504	534	1189	1141	1309	827	1418	499	1119	1089	1230	786	1340	463	1043	1043	1146	743	1251	425
	80	1320	1320	1391	1122	1505	795	1256	1256	1316	1084	1420	757	1189	1189	1237	1044	1348	721	1118	1118	1155	1003	1252	685
	85	1393	1393	1403	1368	1509	1055	1328	1328	1330	1330	1422	1012	1258	1258	1260	1260	1370	973	1184	1184	1186	1186	1253	933
	90	1459	1459	1461	1461	1515	1312	1389	1389	1390	1390	1426	1271	1312	1312	1317	1317	1427	1230	1237	1237	1237	1238	1238	1253
51000	75	1284	1250	1401	907	1520	548	1214	1199	1323	867	1432	512	1142	1142	1241	825	1351	476	1069	1069	1155	782	1259	437
	80	1357	1357	1407	1192	1521	837	1290	1290	1330	1153	1433	794	1219	1219	1249	1113	1359	752	1144	1144	1164	1071	1260	710
	85	1428	1428	1430	1430	1525	1119	1359	1359	1360	1360	1433	1076	1285	1285	1287	1287	1396	1034	1207	1207	1208	1208	1260	993
	90	1499	1499	1502	1502	1534	1407	1420	1420	1422	1422	1439	1364	1339	1339	1340	1340	1450	1309	1254	1254	1255	1255	1261	1256
54000	75	1298	1285	1409	932	1529	557	1228	1228	1330	891	1434	521	1157	1157	1246	849	1356	484	1083	1083	1160	804	1262	445
	80	1376	1376	1415	1235	1529	858	1307	1307	1337	1195	1439	812	1234	1234	1250	1174	1360	771	1157	1157	1169	1112	1263	728
	85	1445	1445	1447	1447	1534	1158	1374	1374	1375	1375	1445	1114	1298	1298	1299	1299	1409	1071	1217	1217	1218	1218	1264	997
	90	1515	1515	1524	1524	1544	1464	1438	1438	1440	1440	1440	1408	1352	1352	1354	1354	1464	1355	1263	1263	1264	1264	1266	1266

Table 45. Gross cooling capacities – 130 tons – high capacity evaporator coil, 50Hz

CFM	Ent DB (°F)	Ambient Temperature (°F)																															
		85								95								105								115							
		67				73				61				67				73				61				67				73			
		CAP	SHC	SFC	SHC	CAP	SHC	SFC	SHC	CAP	SHC	SFC	SHC	CAP	SHC	SFC	SHC	CAP	SHC	SFC	SHC	CAP	SHC	SFC	SHC	CAP	SHC	SFC	SHC				
23000	75	1212	853	1355	695	1486	517	1145	812	1280	653	1404	476	1073	769	1200	609	1316	433	998	725	1117	565	1226	390								
	80	1215	984	1357	827	1487	650	1148	944	1282	785	1405	609	1076	901	1202	741	1317	566	1002	857	1120	697	1227	523								
	85	1219	1113	1359	958	1488	782	1154	1072	1284	917	1406	741	1082	1029	1205	873	1319	698	1009	985	1122	829	1228	655								
	90	1235	1235	1361	1089	1489	914	1180	1180	1287	1048	1407	873	1120	1120	1208	1005	1320	830	1057	1057	1126	961	1229	786								
	75	1257	910	1397	728	1519	523	1185	868	1318	685	1432	482	1108	823	1233	640	1340	439	1029	778	1146	595	1246	395								
	80	1261	1059	1400	877	1520	674	1189	1017	1320	834	1433	632	1113	973	1236	789	1341	588	1035	923	1149	744	1246	544								
	85	1268	1204	1402	1025	1521	823	1198	1161	1323	983	1433	780	1124	1116	1238	938	1341	737	1054	1054	1152	893	1246	693								
	90	1309	1309	1405	1174	1521	971	1248	1248	1327	1131	1434	929	1181	1181	1243	1083	1342	885	1112	1112	1157	1037	1247	841								
	75	1304	983	1439	768	1550	531	1227	939	1354	724	1458	488	1144	892	1265	678	1362	445	1061	846	1173	632	1263	401								
	80	1310	1151	1441	939	1550	703	1233	1105	1356	895	1458	660	1152	1058	1267	850	1361	616	1069	1010	1176	804	1262	571								
	85	1324	1322	1444	1111	1551	875	1257	1257	1360	1067	1458	831	1186	1186	1271	1022	1361	787	1112	1112	1180	971	1260	742								
	90	1389	1389	1449	1277	1551	1046	1321	1321	1365	1232	1458	1002	1248	1248	1277	1185	1361	958	1171	1171	1187	1138	1260	913								
	75	1348	1070	1475	815	1578	541	1265	1024	1385	770	1480	497	1178	969	1291	723	1380	453	1089	919	1195	676	1278	408								
	80	1358	1263	1477	1014	1576	740	1277	1216	1387	970	1478	696	1191	1166	1293	923	1376	651	1106	1106	1198	876	1272	605								
	85	1399	1399	1480	1214	1575	939	1327	1327	1392	1163	1477	895	1249	1249	1298	1115	1374	850	1168	1168	1202	1065	1269	804								
	90	1463	1463	1487	1403	1588	1139	1387	1387	1400	1357	1477	1094	1305	1305	1309	1300	1374	1049	1219	1219	1220	1220	1269	995								
	75	1382	1146	1500	860	1598	551	1295	1097	1407	814	1497	506	1203	1046	1309	767	1393	461	1110	994	1209	719	1288	416								
	80	1396	1371	1501	1088	1596	778	1313	1313	1408	1042	1491	732	1231	1231	1311	995	1385	686	1148	1148	1212	938	1278	640								
	85	1457	1457	1506	1306	1598	1007	1377	1377	1414	1258	1488	959	1293	1293	1317	1209	1382	913	1204	1204	1217	1158	1273	866								
	90	1515	1515	1519	1515	1602	1237	1431	1431	1433	1433	1490	1177	1341	1341	1343	1343	1380	1127	1246	1246	1247	1247	1270	1077								
	75	1407	1224	1518	905	1615	561	1317	1174	1421	858	1509	516	1223	1121	1320	810	1403	470	1127	1068	1218	762	1295	425								
	80	1435	1435	1520	1161	1615	819	1353	1353	1424	1104	1501	769	1267	1267	1323	1054	1391	722	1178	1178	1220	1002	1281	675								
	85	1499	1499	1525	1401	1617	1077	1413	1413	1429	1352	1500	1026	1323	1323	1330	1302	1389	976	1228	1228	1229	1229	1275	916								
	90	1553	1553	1554	1554	1623	1323	1461	1461	1462	1462	1505	1268	1363	1363	1364	1364	1387	1214	1259	1259	1260	1260	1271	1162								
	75	1427	1300	1532	950	1630	574	1334	1248	1432	902	1519	526	1238	1195	1329	854	1410	480	1141	1141	1224	805	1301	434								
	80	1470	1470	1534	1220	1630	860	1384	1384	1434	1170	1510	807	1293	1293	1331	1119	1395	759	1199	1199	1225	1066	1283	712								
	85	1531	1531	1541	1496	1633	1147	1440	1440	1442	1442	1512	1094	1343	1343	1344	1344	1392	1026	1242	1242	1243	1243	1274	972								
	90	1588	1588	1590	1590	1639	1415	1485	1485	1487	1487	1518	1359	1378	1378	1379	1379	1395	1303	1270	1270	1270	1270	1275	1248								
	75	1444	1375	1543	995	1642	586	1350	1323	1441	947	1528	537	1252	1252	1335	898	1417	491	1158	1158	1229	830	1306	444								
	80	1498	1498	1545	1288	1643	901	1408	1408	1442	1236	1519	847	1313	1313	1442	1184	1392	781	1214	1214	1228	1130	1284	749								
	85	1556	1556	1556	1556	1646	1201	1459	1459	1460	1460	1521	1143	1357	1357	1357	1357	1397	1086	1250	1250	1251	1251	1275	1031								
	90	1622	1622	1623	1623	1652	1507	1511	1511	1513	1513	1527	1449	1397	1397	1398	1398	1402	1391	1281	1281	1281	1281	1281	1281								
	75	1453	1420	1548	1022	1649	593	1358	1358	1445	974	1533	544	1263	1263	1339	907	1421	497	1167	1167	1230	852	1309	451								
	80	1512	1512	1550	1328	1649	926	1419	1419	1446	1276	1523	872	1322	1322	1339	1223	1400	820	1221	1221	1230	1168	1285	772								
	85	1569	1569	1570	1570	1652	1239	1468	1468	1469	1469	1525	1180	1362	1362	1363	1363	1399	1123	1253	1253	1253	1253	1276	1066								
	90	1638	1638	1640	1640	1659	1562	1524	1524	1525	1525	1532	1503	1405	1405	1406	1406	1406	1406	1406	1406	1406	1406	1406	1406								

Table 46. Gross cooling capacities – 130 tons eFlex™ variable speed – high capacity evaporator coil, 50Hz

CFM	Ent DB (°F)	Ambient Temperature (°F)																							
		85						95						105						115					
		61		67		73		61		67		73		61		67		73		61		67		73	
		CAP	SHC	CAP	SHC	CAP	SHC	CAP	SHC	CAP	SHC	CAP	SHC	CAP	SHC	CAP	SHC	CAP	SHC	CAP	SHC	CAP	SHC	CAP	SHC
23000	75	1230	862	1383	709	1541	543	1164	821	1311	668	1462	503	1096	780	1237	627	1380	462	1028	739	1161	585	1294	419
	80	1233	993	1385	840	1542	676	1167	952	1313	800	1463	636	1100	911	1239	758	1381	594	1031	870	1164	717	1296	552
	85	1237	1122	1387	971	1543	808	1172	1082	1316	931	1465	767	1105	1039	1242	889	1383	726	1038	997	1167	848	1298	684
	90	1254	1239	1390	1102	1545	939	1195	1195	1319	1061	1467	899	1139	1139	1245	1020	1385	858	1082	1082	1170	979	1300	815
26000	75	1278	921	1433	745	1583	553	1208	879	1356	703	1500	512	1136	836	1277	660	1413	470	1062	793	1196	617	1322	426
	80	1282	1069	1436	894	1585	703	1212	1027	1359	852	1502	662	1140	982	1280	809	1415	619	1068	939	1199	766	1324	576
	85	1290	1213	1439	1042	1586	852	1221	1171	1362	1000	1504	811	1152	1121	1283	957	1417	768	1085	1071	1203	914	1326	725
	90	1327	1327	1443	1190	1588	1000	1268	1268	1367	1148	1506	959	1208	1208	1288	1103	1419	916	1145	1145	1208	1060	1328	873
30000	75	1330	995	1484	789	1625	564	1255	951	1402	748	1536	522	1177	907	1318	701	1444	479	1099	862	1231	656	1348	434
	80	1336	1164	1488	961	1626	736	1262	1120	1406	917	1538	694	1185	1073	1321	873	1446	650	1108	1027	1234	828	1350	606
	85	1353	1321	1491	1132	1628	907	1284	1269	1410	1088	1540	865	1215	1215	1326	1044	1447	821	1149	1149	1239	999	1351	777
	90	1417	1417	1497	1300	1629	1078	1352	1352	1417	1256	1541	1035	1285	1285	1333	1209	1449	992	1216	1216	1248	1163	1352	947
35000	75	1380	1084	1530	840	1661	575	1299	1036	1444	795	1568	532	1217	989	1354	750	1471	488	1134	939	1261	703	1369	443
	80	1391	1277	1534	1039	1663	776	1311	1230	1448	995	1568	732	1230	1183	1358	949	1471	687	1152	1124	1266	903	1368	641
	85	1431	1431	1539	1236	1665	975	1362	1362	1453	1191	1568	930	1290	1290	1364	1145	1471	886	1216	1216	1273	1094	1368	840
	90	1508	1508	1548	1430	1667	1175	1436	1436	1464	1384	1570	1129	1362	1362	1378	1330	1472	1085	1283	1283	1292	1270	1369	1038
40000	75	1419	1166	1563	888	1691	588	1334	1115	1473	842	1590	542	1248	1065	1379	796	1489	498	1160	1016	1282	748	1383	451
	80	1436	1389	1567	1116	1692	816	1356	1324	1477	1070	1589	769	1275	1265	1383	1024	1487	724	1195	1195	1287	972	1380	677
	85	1502	1502	1574	1335	1694	1044	1427	1427	1485	1288	1590	997	1349	1349	1392	1240	1485	950	1267	1267	1295	1190	1378	903
	90	1575	1575	1590	1542	1698	1272	1498	1498	1506	1483	1593	1225	1416	1416	1418	1418	1487	1172	1328	1328	1330	1330	1379	1118
45000	75	1451	1243	1588	934	1714	601	1362	1193	1494	888	1607	553	1272	1142	1396	841	1502	507	1181	1091	1295	792	1394	460
	80	1481	1466	1592	1186	1715	857	1399	1399	1498	1139	1607	808	1319	1319	1402	1087	1497	760	1236	1236	1301	1035	1400	811
	85	1556	1556	1600	1433	1719	1114	1477	1477	1508	1385	1608	1065	1393	1393	1412	1335	1498	1016	1304	1304	1314	1278	1385	968
	90	1626	1626	1628	1628	1725	1366	1542	1542	1544	1544	1612	1308	1452	1452	1454	1454	1502	1257	1356	1356	1357	1357	1388	1205
50000	75	1476	1322	1606	980	1733	613	1385	1271	1509	933	1620	563	1293	1218	1409	885	1513	517	1199	1163	1305	835	1401	469
	80	1522	1522	1611	1258	1735	899	1441	1441	1515	1204	1621	848	1356	1356	1415	1153	1508	799	1267	1267	1312	1101	1392	749
	85	1599	1599	1622	1529	1739	1185	1514	1514	1527	1479	1622	1133	1425	1425	1432	1405	1508	1076	1330	1330	1331	1331	1392	1017
	90	1668	1668	1671	1671	1746	1454	1575	1575	1577	1577	1628	1399	1478	1478	1479	1479	1512	1345	1375	1375	1376	1376	1393	1291
55000	75	1498	1399	1621	1026	1749	626	1405	1347	1521	978	1634	576	1311	1278	1418	929	1521	527	1218	1209	1312	871	1407	479
	80	1559	1559	1626	1322	1751	940	1473	1473	1527	1271	1632	888	1384	1384	1425	1220	1516	838	1290	1290	1319	1166	1397	787
	85	1633	1633	1643	1600	1754	1247	1542	1542	1547	1535	1633	1192	1448	1448	1449	1449	1516	1131	1347	1347	1348	1348	1396	1076
	90	1706	1706	1713	1713	1765	1548	1607	1607	1609	1609	1642	1490	1502	1502	1504	1504	1520	1434	1392	1392	1393	1393	1398	1369
56000	75	1510	1445	1628	1054	1757	634	1417	1379	1527	1005	1641	583	1324	1308	1423	948	1526	534	1228	1228	1316	888	1410	485
	80	1578	1578	1634	1363	1759	965	1490	1490	1533	1312	1638	912	1398	1398	1430	1259	1520	861	1301	1301	1322	1205	1400	811
	85	1651	1651	1657	1640	1763	1287	1556	1556	1557	1557	1640	1223	1459	1459	1460	1460	1519	1167	1354	1354	1355	1355	1397	1111
	90	1732	1732	1734	1734	1775	1603	1625	1625	1627	1627	1650	1545	1515	1515	1516	1516	1526	1485	1397	1405	1405	1400	1400	1403



Supply Fan

Figure 9. Supply fan performance - 90 ton – Low CFM

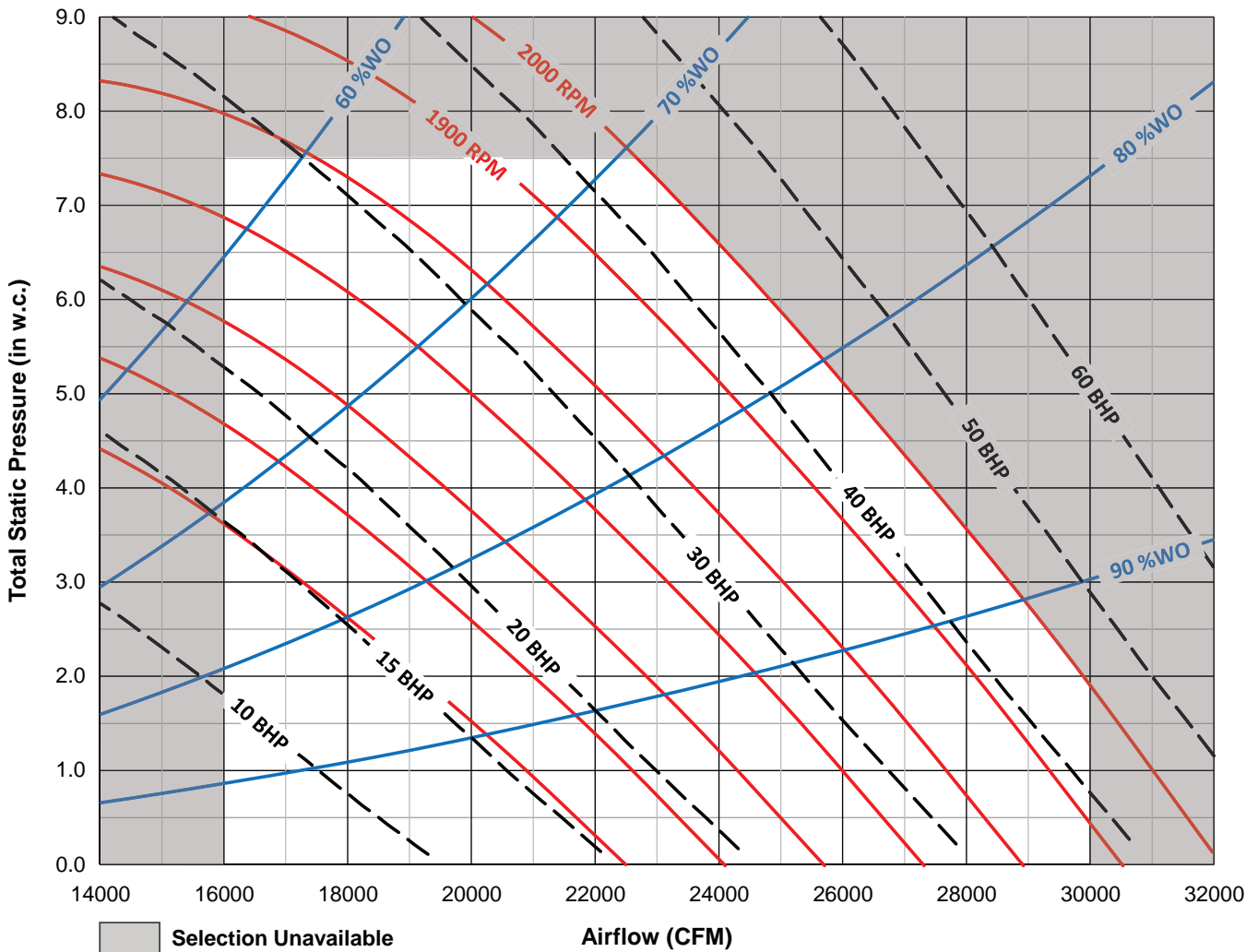

Notes:

- Supply fan performance curve includes internal resistance of rooftop. For total static pressure determination, system external static must be added to appropriate component (evaporator coil, filters, etc.) static pressure drops.
- Static pressure drops from the supply fan to the space (optional heat + curb + supply ESP) cannot exceed 5.5 in w.c.
- Curve can show combined operating min/max for multiple tonnages. Refer to general data for appropriate operating parameters such as motor horsepower and airflow ranges.
- Shaded areas represent unavailable selections. Contact your local Trane® representative for more information on selections in these shaded regions.
- Max RPM is indicated on curve and RPM values are in increments of 100 RPM unless otherwise shown.
- Catalog curves represent fan data corrected to the following standard conditions: 70°F dry bulb temperature, barometric pressure of 14.696 psia, and an air density of 0.075 lb/ft³. Utilize Trane Select Assist™ to generate fan curves for unit-specific operating temperatures and elevations.

Figure 10. Supply fan performance - 90 ton gas heat, 105, 120, 130, and 150 ton – Low CFM

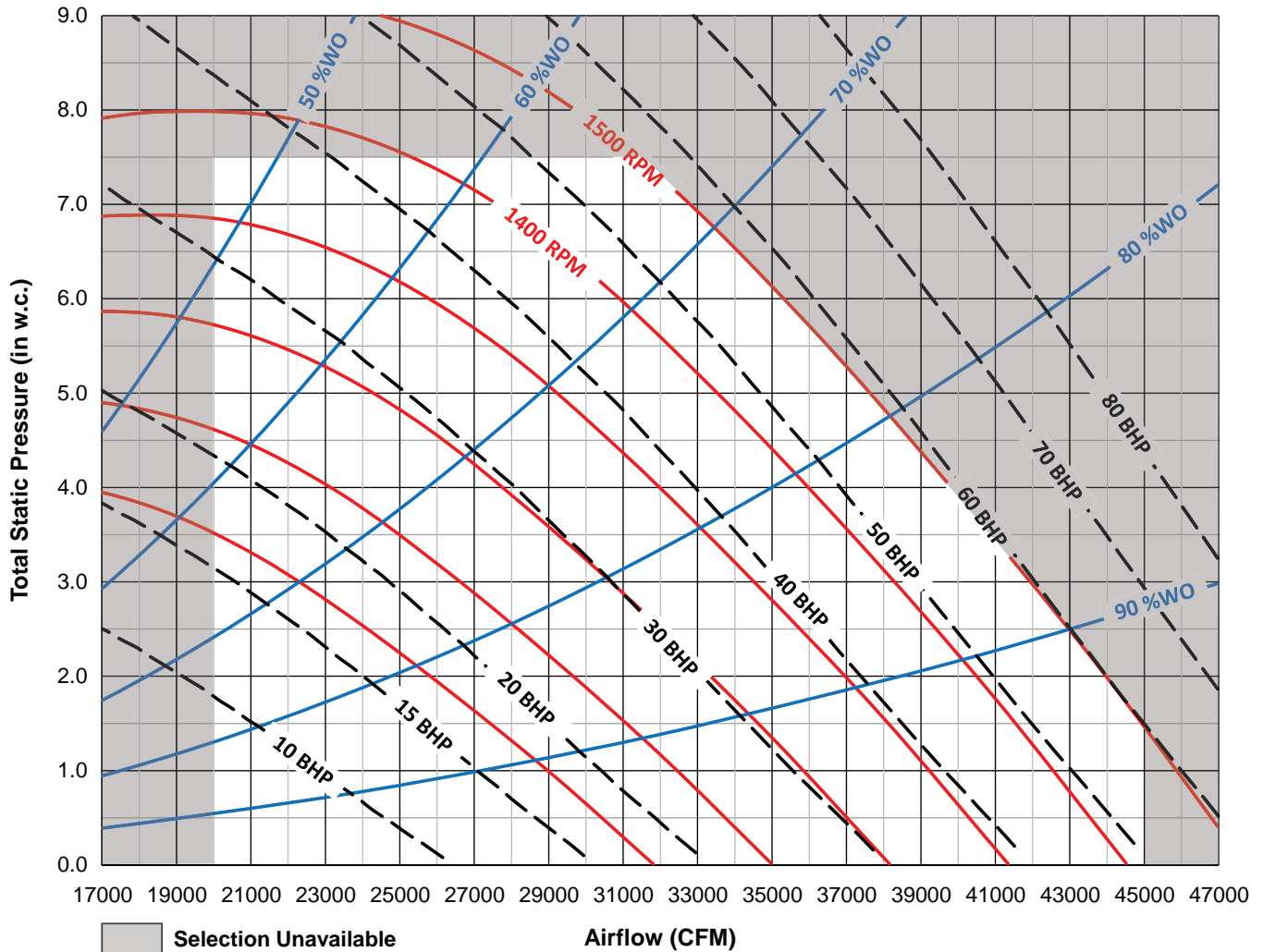

Notes:

- Supply fan performance curve includes internal resistance of rooftop. For total static pressure determination, system external static must be added to appropriate component (evaporator coil, filters, etc.) static pressure drops.
- Static pressure drops from the supply fan to the space (optional heat + curb + supply ESP) cannot exceed 5.5 in w.c.
- Curve can show combined operating min/max for multiple tonnages. Refer to general data for appropriate operating parameters such as motor horsepower and airflow ranges.
- Shaded areas represent unavailable selections. Contact your local Trane® representative for more information on selections in these shaded regions.
- Max RPM is indicated on curve and RPM values are in increments of 100 RPM unless otherwise shown.
- Catalog curves represent fan data corrected to the following standard conditions: 70°F dry bulb temperature, barometric pressure of 14.696 psia, and an air density of 0.075 lb/ft³. Utilize Trane Select Assist™ to generate fan curves for unit-specific operating temperatures and elevations.



Performance Data

Figure 11. Supply fan performance - 90 and 105 ton – Standard CFM

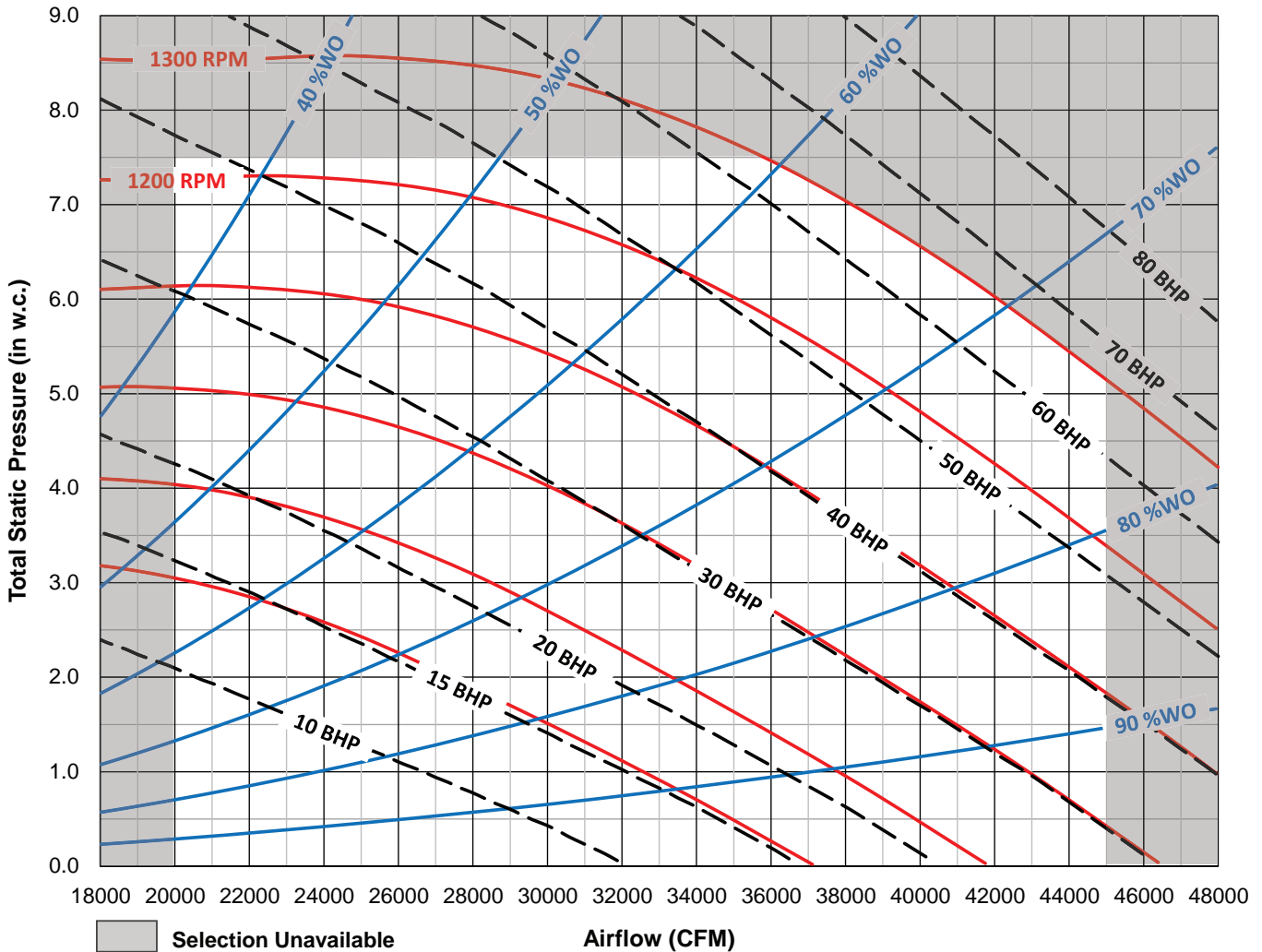

Notes:

- Supply fan performance curve includes internal resistance of rooftop. For total static pressure determination, system external static must be added to appropriate component (evaporator coil, filters, etc.) static pressure drops.
- Static pressure drops from the supply fan to the space (optional heat + curb + supply ESP) cannot exceed 5.5 in w.c.
- Curve can show combined operating min/max for multiple tonnages. Refer to general data for appropriate operating parameters such as motor horsepower and airflow ranges.
- Shaded areas represent unavailable selections. Contact your local Trane® representative for more information on selections in these shaded regions.
- Max RPM is indicated on curve and RPM values are in increments of 100 RPM unless otherwise shown.
- Catalog curves represent fan data corrected to the following standard conditions: 70°F dry bulb temperature, barometric pressure of 14.696 psia, and an air density of 0.075 lb/ft³. Utilize Trane Select Assist™ to generate fan curves for unit-specific operating temperatures and elevations.

Figure 12. Supply fan performance - 120, 130, and 150 ton – Standard CFM

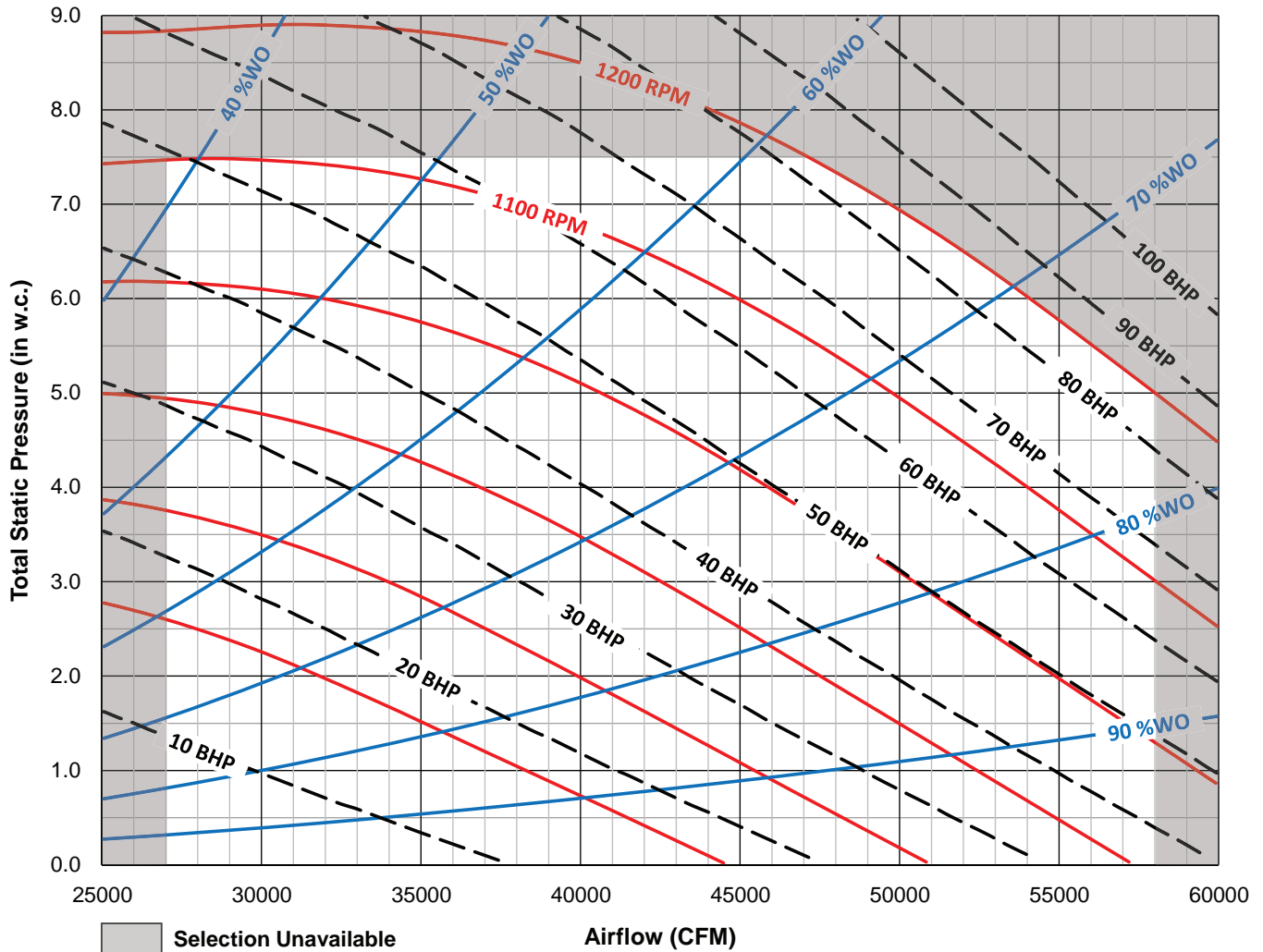

Notes:

- Supply fan performance curve includes internal resistance of rooftop. For total static pressure determination, system external static must be added to appropriate component (evaporator coil, filters, etc.) static pressure drops.
- Static pressure drops from the supply fan to the space (optional heat + curb + supply ESP) cannot exceed 5.5 in w.c.
- Curve can show combined operating min/max for multiple tonnages. Refer to general data for appropriate operating parameters such as motor horsepower and airflow ranges.
- Shaded areas represent unavailable selections. Contact your local Trane® representative for more information on selections in these shaded regions.
- Max RPM is indicated on curve and RPM values are in increments of 100 RPM unless otherwise shown.
- Catalog curves represent fan data corrected to the following standard conditions: 70°F dry bulb temperature, barometric pressure of 14.696 psia, and an air density of 0.075 lb/ft³. Utilize Trane Select Assist™ to generate fan curves for unit-specific operating temperatures and elevations.

Relief Fan

Figure 13. Relief fan performance - 90 ton – Low CFM

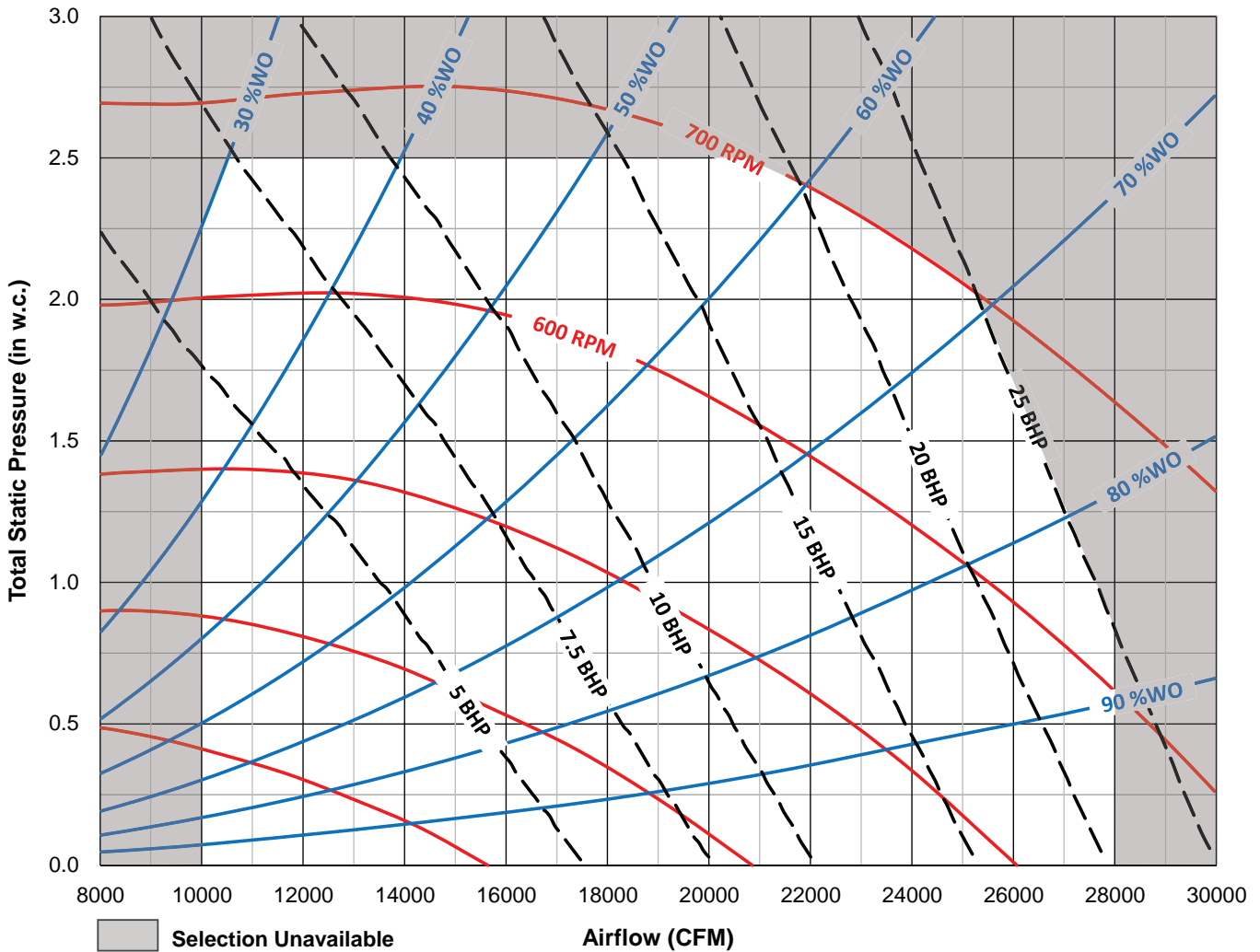

Notes:

- Supply fan performance curve includes internal resistance of rooftop. For total static pressure determination, system external static must be added to appropriate component (evaporator coil, filters, etc.) static pressure drops.
- Static pressure drops from the supply fan to the space (optional heat + curb + supply ESP) cannot exceed 5.5 in w.c.
- Curve can show combined operating min/max for multiple tonnages. Refer to general data for appropriate operating parameters such as motor horsepower and airflow ranges.
- Shaded areas represent unavailable selections. Contact your local Trane® representative for more information on selections in these shaded regions.
- Max RPM is indicated on curve and RPM values are in increments of 100 RPM unless otherwise shown.
- Catalog curves represent fan data corrected to the following standard conditions: 70°F dry bulb temperature, barometric pressure of 14.696 psia, and an air density of 0.075 lb/ft³. Utilize Trane Select Assist™ to generate fan curves for unit-specific operating temperatures and elevations.

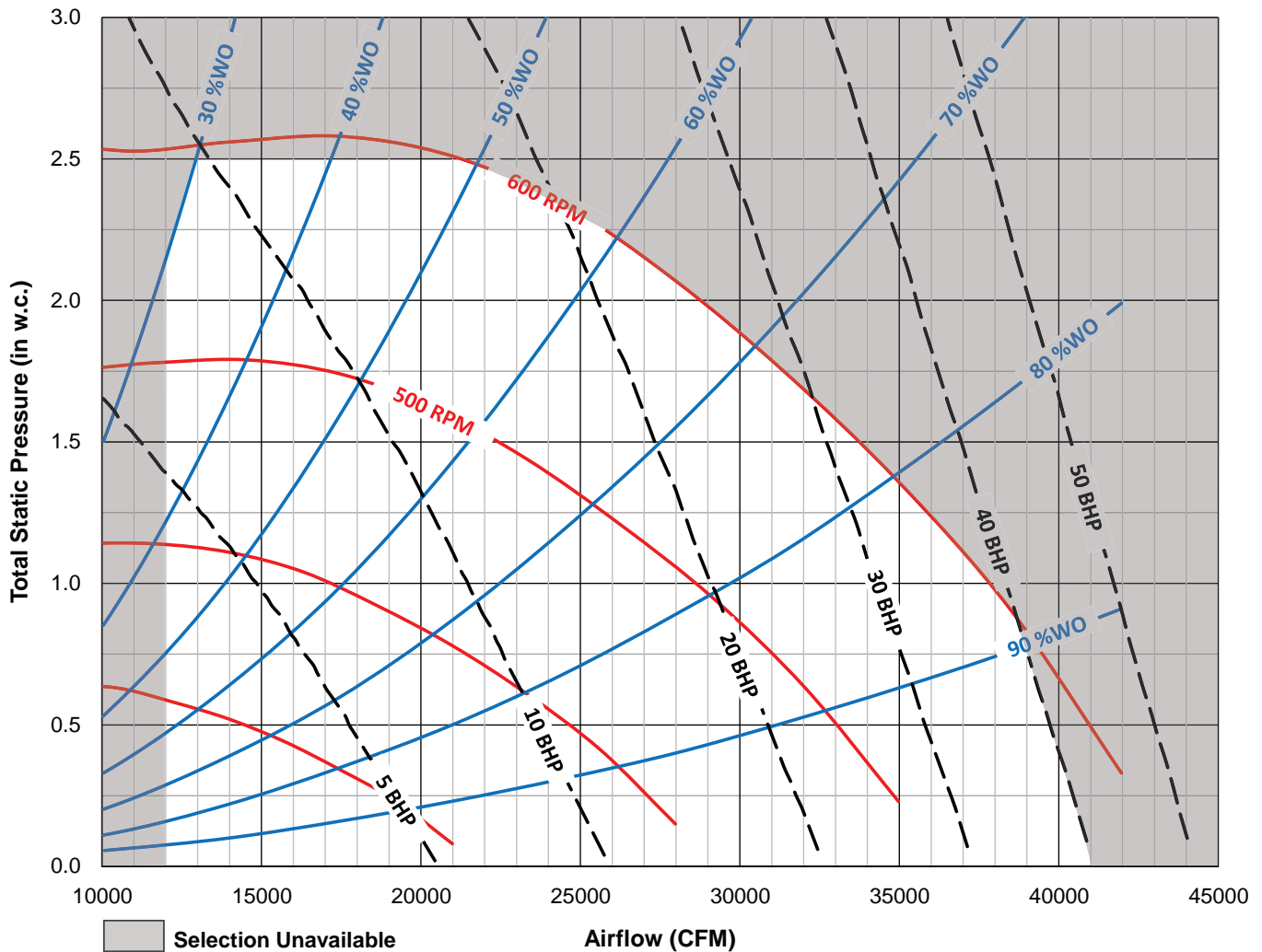
Figure 14. Relief fan performance - 90 ton – Standard CFM, 105, 120, 130, and 150 ton – Low CFM

Notes:

- Supply fan performance curve includes internal resistance of rooftop. For total static pressure determination, system external static must be added to appropriate component (evaporator coil, filters, etc.) static pressure drops.
- Static pressure drops from the supply fan to the space (optional heat + curb + supply ESP) cannot exceed 5.5 in w.c.
- Curve can show combined operating min/max for multiple tonnages. Refer to general data for appropriate operating parameters such as motor horsepower and airflow ranges.
- Shaded areas represent unavailable selections. Contact your local Trane® representative for more information on selections in these shaded regions.
- Max RPM is indicated on curve and RPM values are in increments of 100 RPM unless otherwise shown.
- Catalog curves represent fan data corrected to the following standard conditions: 70°F dry bulb temperature, barometric pressure of 14.696 psia, and an air density of 0.075 lb/ft³. Utilize Trane Select Assist™ to generate fan curves for unit-specific operating temperatures and elevations.

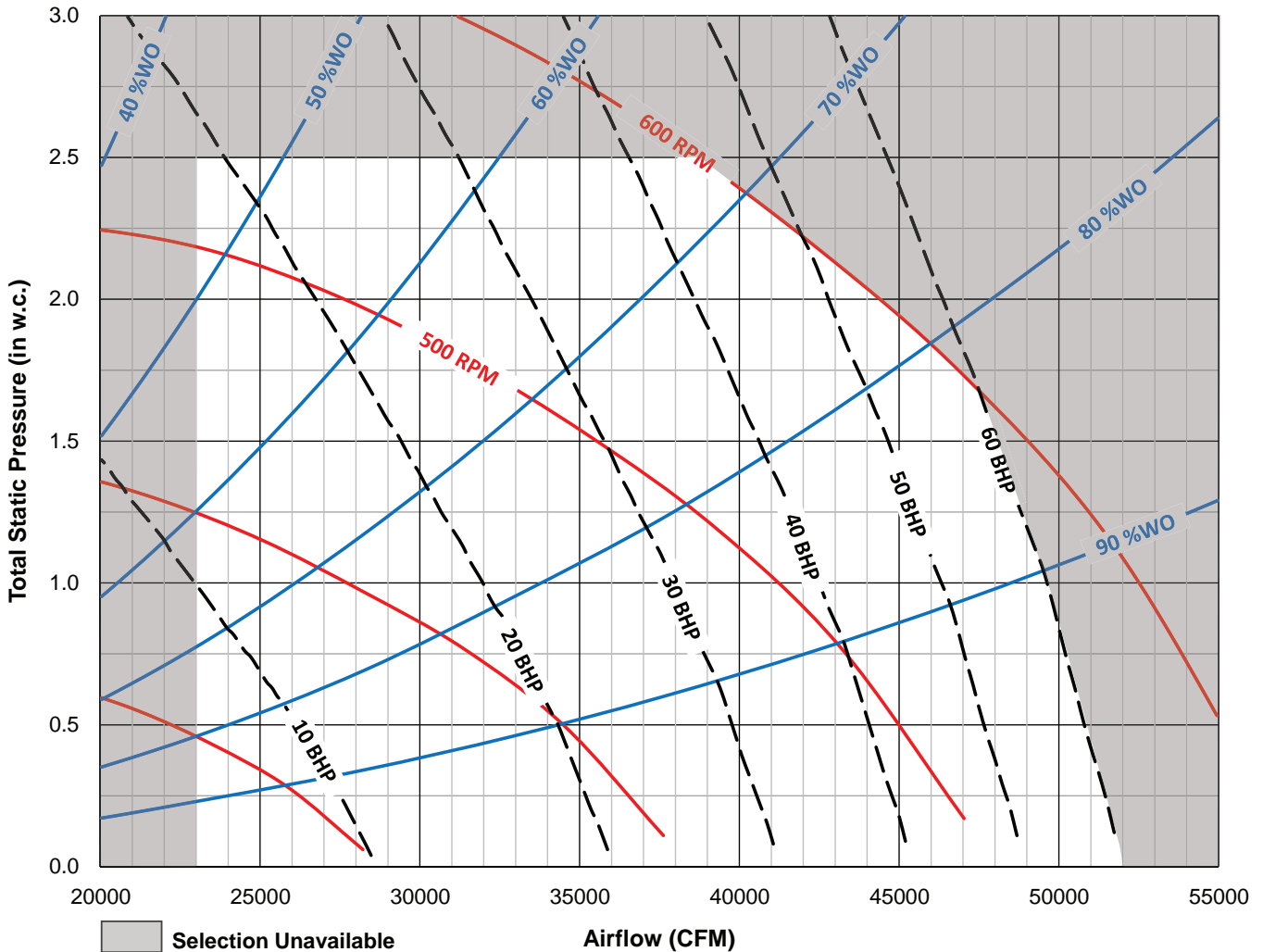

Performance Data

Figure 15. Relief fan performance - 105, 120, 130, and 150 ton – Standard CFM



Notes:

- Supply fan performance curve includes internal resistance of rooftop. For total static pressure determination, system external static must be added to appropriate component (evaporator coil, filters, etc.) static pressure drops.
- Static pressure drops from the supply fan to the space (optional heat + curb + supply ESP) cannot exceed 5.5 in w.c.
- Curve can show combined operating min/max for multiple tonnages. Refer to general data for appropriate operating parameters such as motor horsepower and airflow ranges.
- Shaded areas represent unavailable selections. Contact your local Trane® representative for more information on selections in these shaded regions.
- Max RPM is indicated on curve and RPM values are in increments of 100 RPM unless otherwise shown.
- Catalog curves represent fan data corrected to the following standard conditions: 70°F dry bulb temperature, barometric pressure of 14.696 psia, and an air density of 0.075 lb/ft³. Utilize Trane Select Assist™ to generate fan curves for unit-specific operating temperatures and elevations.

Return Fan

Figure 16. Return fan performance - 90, 105, 120, 130, and 150 ton – Low CFM

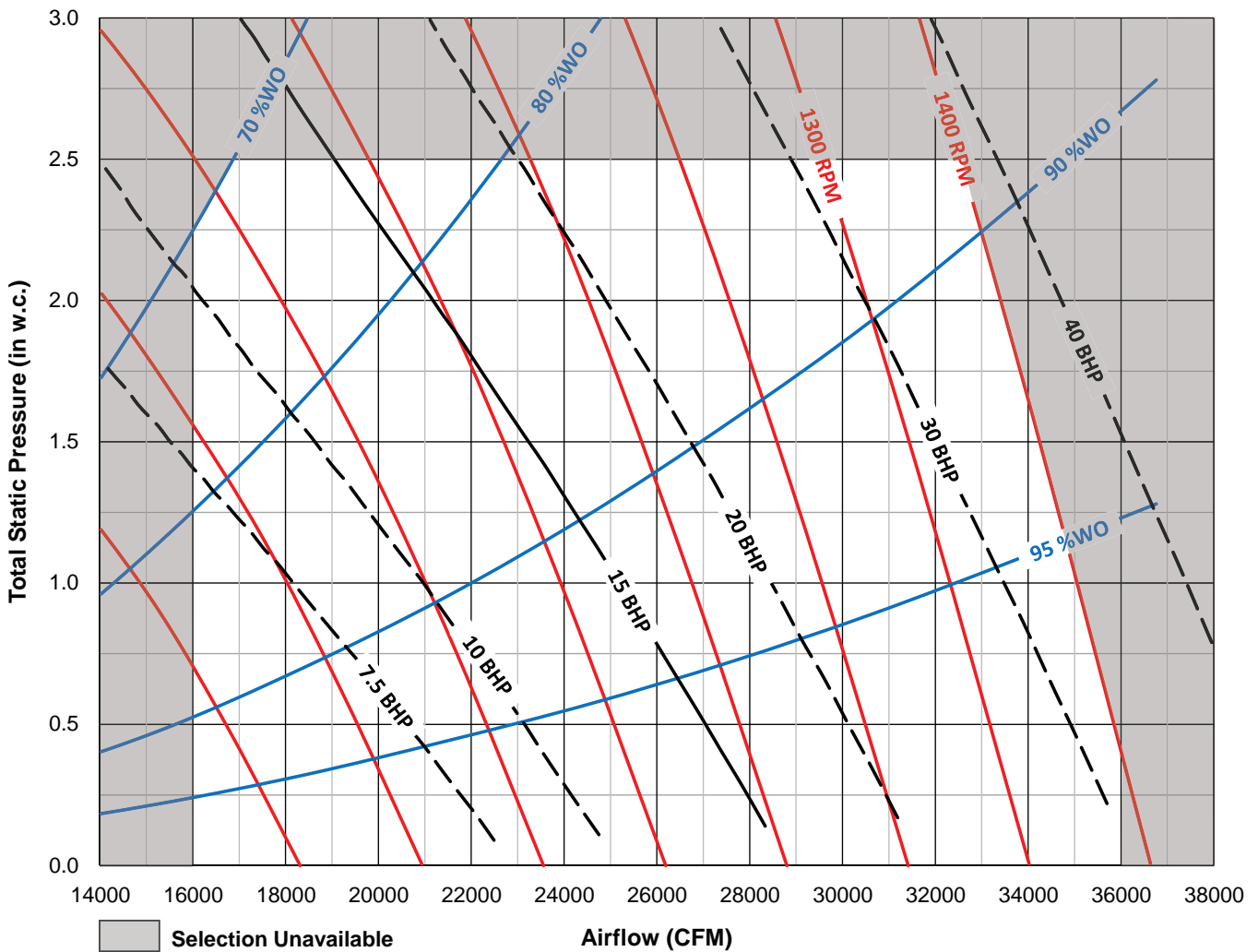

Notes:

- Supply fan performance curve includes internal resistance of rooftop. For total static pressure determination, system external static must be added to appropriate component (evaporator coil, filters, etc.) static pressure drops.
- Static pressure drops from the supply fan to the space (optional heat + curb + supply ESP) cannot exceed 5.5 in w.c.
- Curve can show combined operating min/max for multiple tonnages. Refer to general data for appropriate operating parameters such as motor horsepower and airflow ranges.
- Shaded areas represent unavailable selections. Contact your local Trane® representative for more information on selections in these shaded regions.
- Max RPM is indicated on curve and RPM values are in increments of 100 RPM unless otherwise shown.
- Catalog curves represent fan data corrected to the following standard conditions: 70°F dry bulb temperature, barometric pressure of 14.696 psia, and an air density of 0.075 lb/ft³. Utilize Trane Select Assist™ to generate fan curves for unit-specific operating temperatures and elevations.



Performance Data

Figure 17. Return fan performance - 90 and 105 ton – Standard CFM

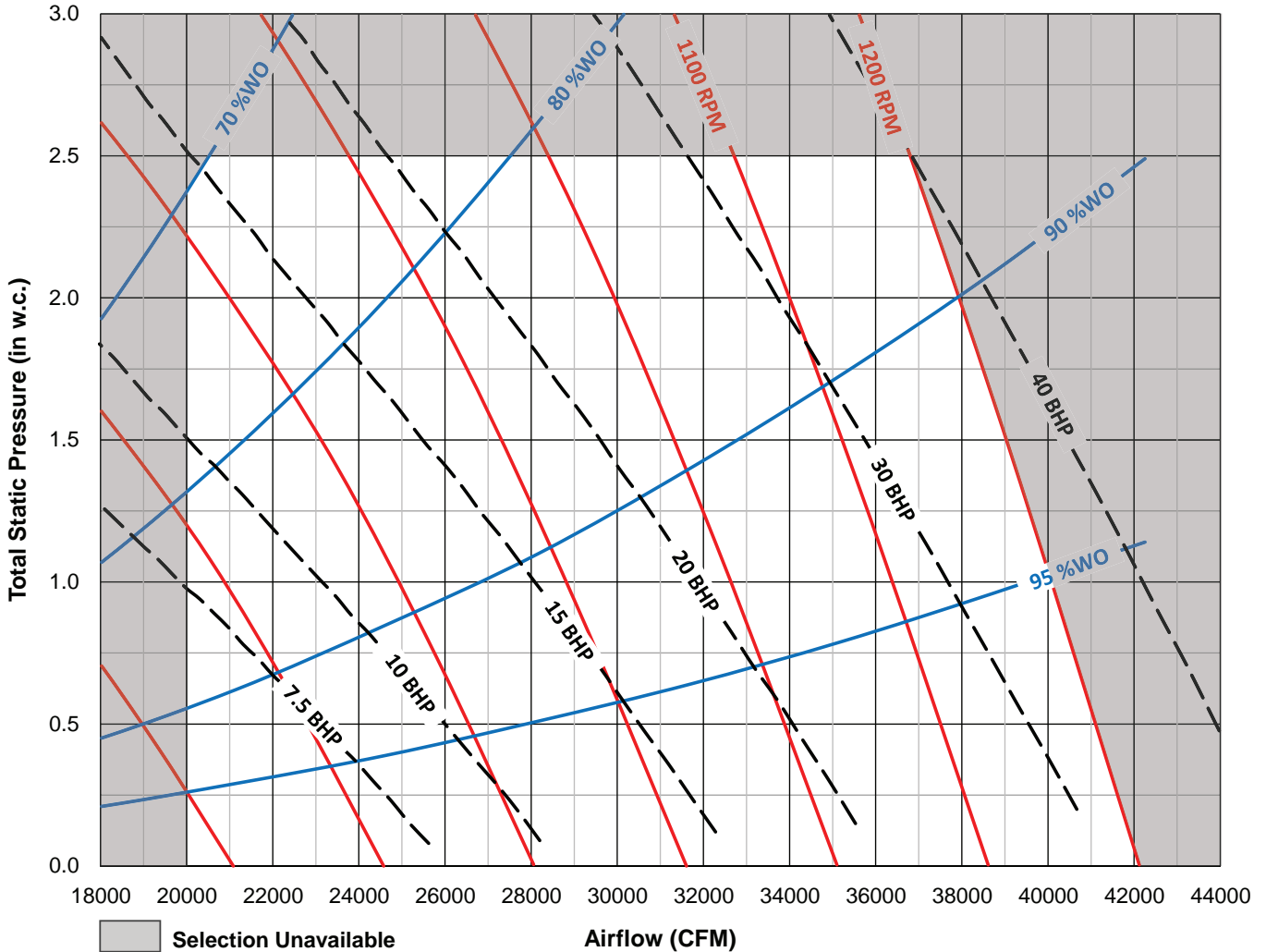

Notes:

- Supply fan performance curve includes internal resistance of rooftop. For total static pressure determination, system external static must be added to appropriate component (evaporator coil, filters, etc.) static pressure drops.
- Static pressure drops from the supply fan to the space (optional heat + curb + supply ESP) cannot exceed 5.5 in w.c.
- Curve can show combined operating min/max for multiple tonnages. Refer to general data for appropriate operating parameters such as motor horsepower and airflow ranges.
- Shaded areas represent unavailable selections. Contact your local Trane® representative for more information on selections in these shaded regions.
- Max RPM is indicated on curve and RPM values are in increments of 100 RPM unless otherwise shown.
- Catalog curves represent fan data corrected to the following standard conditions: 70°F dry bulb temperature, barometric pressure of 14.696 psia, and an air density of 0.075 lb/ft³. Utilize Trane Select Assist™ to generate fan curves for unit-specific operating temperatures and elevations.

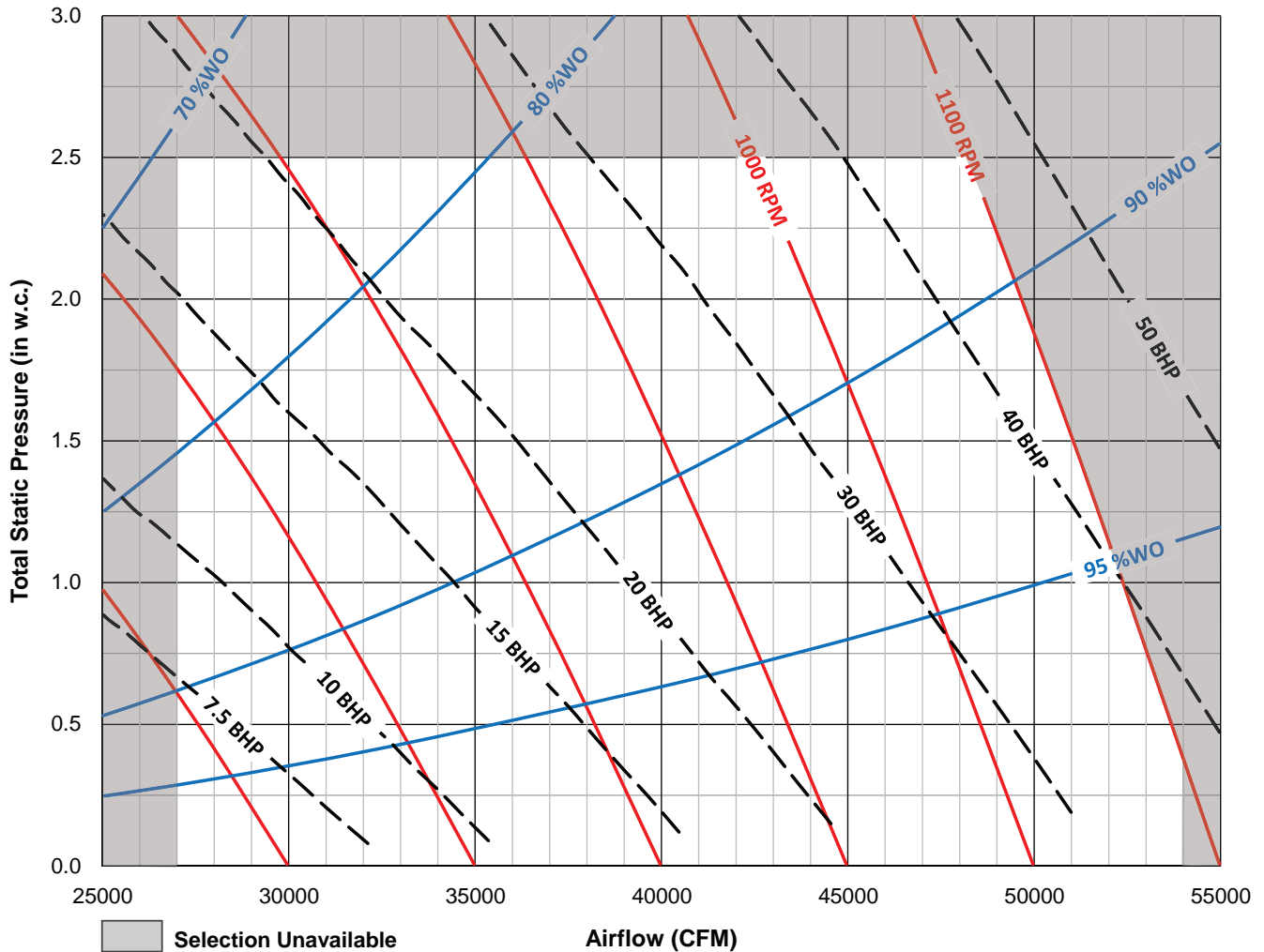
Figure 18. Return fan performance - 120, 130, and 150 ton – Standard CFM

Notes:

- Supply fan performance curve includes internal resistance of rooftop. For total static pressure determination, system external static must be added to appropriate component (evaporator coil, filters, etc.) static pressure drops.
- Static pressure drops from the supply fan to the space (optional heat + curb + supply ESP) cannot exceed 5.5 in w.c.
- Curve can show combined operating min/max for multiple tonnages. Refer to general data for appropriate operating parameters such as motor horsepower and airflow ranges.
- Shaded areas represent unavailable selections. Contact your local Trane® representative for more information on selections in these shaded regions.
- Max RPM is indicated on curve and RPM values are in increments of 100 RPM unless otherwise shown.
- Catalog curves represent fan data corrected to the following standard conditions: 70°F dry bulb temperature, barometric pressure of 14.696 psia, and an air density of 0.075 lb/ft³. Utilize Trane Select Assist™ to generate fan curves for unit-specific operating temperatures and elevations.



Performance Data

Heating Capacities

Table 47. Natural gas heating capacities

Nominal Tons	Heat Module	MBh (Input)	MBh (Output)	Air Temperature Rise ^(a) vs. Unit CFM											
				18500	20000	23500	25000	27000	31500	34000	38000	42000	46000	54000	58000
90-105	LOW	850	688.5	34.3	31.7	27.0	25.4	23.5	20.1	18.7	16.7	15.1	13.8	11.8	10.9
	MEDIUM	1100	891	44.4	41.1	34.9	32.8	30.4	26.1	24.2	21.6	19.6	17.9	15.2	14.2
	HIGH	1800	1458	-	-	-	53.8	49.8	42.7	39.5	35.4	32.0	29.2	24.9	23.2
120-150	LOW	1100	891	-	-	34.9	32.8	30.4	26.1	24.2	21.6	19.6	17.9	15.2	14.2
	MEDIUM	1800	1458	-	-	-	-	49.8	42.7	39.5	35.4	32.0	29.2	24.9	23.2
	HIGH	2500	2025	-	-	-	-	-	59.2	54.9	49.1	44.4	40.6	34.6	32.2

Notes:

1. Actual limits may be + or - the values shown; to accurately calculate capacities, contact the local Trane Sales Office or utilize TSA.
2. Follow the supply CFM ranges posted in the General Data for each case size.
3. All heaters are 81% efficient.
4. CFM values below the minimum and above the maximum shown in this table are not cULus approved.

^(a) Air temperature rise (at sea level) = heat output (Btu) ÷ (CFM x 1.085).

Table 48. Electric heat air temperature rise (60 Hz)

Nominal Tons	KW Input (60 Hz)	Total (MBh)	CFM									
			20000	22000	26000	30000	34000	38000	42000	46000	54000	58000
90	90	307.2	14.2	12.9	10.9	9.4	8.3	7.5	6.7	—	—	—
	265	904.4	—	37.9	32.1	27.8	24.5	21.9	19.8	—	—	—
105	90	307.2	14.2	12.9	10.9	9.4	8.3	7.5	6.7	—	—	—
	265	904.4	41.6	37.9	32.1	27.8	24.5	21.9	19.8	—	—	—
120	140	477.8	—	20	16.9	14.7	13	11.6	10.5	9.6	8.2	7.6
	300	1023.9	—	42.9	36.3	31.5	27.8	24.8	22.5	20.5	17.5	16.3

Notes:

1. Actual limits may be + or - the values shown; to accurately calculate capacities, contact the local Trane Sales Office or utilize TSA.
2. Follow the supply CFM ranges posted in the General Data for each case size.

Table 49. Electric heat air temperature rise (50 Hz)

Nominal Tons	KW Input (50 Hz)	Total (MBh)	CFM									
			20000	22000	26000	30000	34000	38000	42000	46000	54000	58000
90	56	191.1	8.8	8	6.8	5.9	5.2	4.6	4.2	—	—	—
	166	566.6	—	23.7	20.1	17.4	15.4	13.7	12.4	—	—	—
105	56	191.1	8.8	8	6.8	5.9	5.2	4.6	4.2	—	—	—
	166	566.6	26.1	23.7	20.1	17.4	15.4	13.7	12.4	—	—	—
120	88	300.3	—	12.6	10.6	9.2	8.1	7.3	6.6	6	5.3	4.8
	188	641.6	—	26.9	22.7	19.7	17.4	15.6	14.1	12.9	11.4	10.2

Notes:

1. Actual limits may be + or - the values shown; to accurately calculate capacities, contact the local Trane Sales Office or utilize TSA.
2. Follow the supply CFM ranges posted in the General Data for each case size.

Table 50. Electric heat kW ranges

Nominal Tons	Nominal Voltage		
	460	575	380
90	90-265	90-265	56-166
105	90-265	90-265	56-166
120	140-300	140-300	88-188

Table 50. Electric heat kW ranges (continued)

130-150	140-300	140-300	88-188
---------	---------	---------	--------

Notes:

- Actual limits may be + or - the values shown; to accurately calculate capacities, contact the local Trane Sales Office or utilize TSA.
- Follow the supply CFM ranges posted in the General Data for each case size.

Table 51. Hot water coil heating capacities (Q/ITD)

Nom Tons	Airflow (CFM)	High Capacity					Low Capacity				
		40	80	120	160	200	30	60	100	140	175
		0.3	1	2.1	3.7	5.6	0.2	0.6	1.5	2.8	4.3
90	16000	7.57	9.02	9.59	9.9	10.1	5.5	6.54	7.05	7.29	7.42
	20000	8.26	10.08	10.84	11.25	11.52	6.02	7.34	8.01	8.33	8.5
	25000	8.9	11.15	12.12	12.66	13.01	6.52	8.15	9	9.42	9.65
	30000	9.4	12.02	13.18	13.84	14.27	6.91	8.81	9.84	10.35	10.62
	33000	9.65	12.46	13.74	14.47	14.94	7.11	9.15	10.28	10.84	11.14
	36000	9.86	12.86	14.25	15.04	15.56	7.28	9.46	10.68	11.29	11.63
	40000	10.12	13.35	14.86	15.73	16.31	7.48	9.83	11.16	11.84	12.21
105	19000	8.1	9.83	10.55	10.94	11.18	5.9	7.15	7.78	8.09	8.25
	23000	8.67	10.75	11.64	12.13	12.44	6.34	7.85	8.63	9.01	9.21
	28000	9.21	11.69	12.78	13.39	13.79	6.77	8.56	9.52	9.99	10.25
	33000	9.65	12.46	13.74	14.47	14.94	7.11	9.15	10.28	10.84	11.14
	38000	10	13.11	14.56	15.4	15.94	7.38	9.65	10.93	11.58	11.93
	43000	10.29	13.67	15.28	16.21	16.83	7.61	10.08	11.5	12.22	12.62
	45000	10.39	13.87	15.54	16.51	17.15	7.69	10.23	11.71	12.46	12.88
120	21000	9.19	11.27	12.12	12.58	12.88	6.67	8.17	8.93	9.29	9.48
	26000	9.89	12.46	13.55	14.16	14.55	7.21	9.07	10.04	10.51	10.76
	31000	0	13.43	14.75	15.5	15.98	7.64	9.81	10.98	11.55	11.86
	36000	0	14.24	15.78	16.66	17.22	0	10.43	11.78	12.46	12.83
	41000	0	14.94	16.67	17.67	18.32	0	10.96	12.49	13.27	13.69
	46000	0	15.54	17.45	18.57	19.3	0	11.42	13.12	13.99	14.46
	51000	0	16.06	18.15	19.37	20.18	0	11.83	13.68	14.63	15.15
	54000	0	16.35	18.53	19.82	20.67	0	12.05	13.98	14.99	15.54
130	23000	9.49	11.77	12.73	13.25	13.58	6.91	8.55	9.39	9.8	10.01
	26000	9.89	12.46	13.55	14.16	14.55	7.21	9.07	10.04	10.51	10.76
	30000	10.33	13.25	14.53	15.25	15.71	7.56	9.67	10.8	11.35	11.65
	35000	0	14.09	15.59	16.44	16.99	0	10.31	11.63	12.29	12.64
	40000	0	14.81	16.5	17.48	18.11	0	10.86	12.36	13.11	13.52
	45000	0	15.42	17.3	18.4	19.11	0	11.34	13	13.85	14.31
	50000	0	15.96	18.02	19.22	20.01	0	11.75	13.57	14.51	15.02
	55000	0	16.44	18.65	19.96	20.82	0	12.12	14.08	15.1	15.67
58000	0	16.7	19	20.37	21.28	0	12.32	14.37	15.44	16.03	
150	23000	9.49	11.77	12.73	13.25	13.58	6.91	8.55	9.39	9.8	10.01
	26000	9.89	12.46	13.55	14.16	14.55	7.21	9.07	10.04	10.51	10.76
	30000	10.33	13.25	14.53	15.25	15.71	7.56	9.67	10.8	11.35	11.65
	35000	0	14.09	15.59	16.44	16.99	0	10.31	11.63	12.29	12.64
	40000	0	14.81	16.5	17.48	18.11	0	10.86	12.36	13.11	13.52
	45000	0	15.42	17.3	18.4	19.11	0	11.34	13	13.85	14.31
	50000	0	15.96	18.02	19.22	20.01	0	11.75	13.57	14.51	15.02
	55000	0	16.44	18.65	19.96	20.82	0	12.12	14.08	15.1	15.67
58000	0	16.7	19	20.37	21.28	0	12.32	14.37	15.44	16.03	

Notes:

- Nominal capacity is in tons
- WPD is waterside pressure drop in feet of water
- Hot water capacity is at 180°F entering water temperature and 65°F entering air temperature
- Maximum entering water temperature is 200°F.



Performance Data

Table 52. Steam coil heating capacities (Q/ITD)

Nominal Tons	Airflow	High Cap	Low Cap
90	16000	7.33	4.99
	20000	8.17	5.67
	25000	9.06	6.35
	30000	9.84	6.91
	33000	10.26	7.19
	36000	10.66	7.44
	40000	11.16	7.74
105	19000	7.97	5.51
	23000	8.73	6.1
	28000	9.55	6.71
	33000	10.27	7.2
	38000	10.92	7.61
	43000	11.52	7.95
	45000	11.74	8.07
120	21000	9.4	6.43
	26000	10.41	7.24
	31000	11.29	7.92
	36000	12.08	8.49
	41000	12.8	8.97
	46000	13.45	9.39
	51000	14.06	9.75
	54000	14.4	9.95
130	23000	9.82	6.78
	26000	10.41	7.24
	30000	11.12	7.79
	35000	11.93	8.38
	40000	12.66	8.88
	45000	13.32	9.31
	50000	13.94	9.68
	55000	14.52	10.01
150	23000	9.82	6.78
	26000	10.41	7.24
	30000	11.12	7.79
	35000	11.93	8.38
	40000	12.66	8.88
	45000	13.32	9.31
	50000	13.94	9.68
	55000	14.52	10.01

Notes:

1. Nominal capacity is in tons.
2. Steam coil capacity is at 15 psig and 65°F entering air temperature.
3. Capacities are expressed as mbh (Q) per degree (°F) of initial temperature difference (ITD) between the entering steam temperature (°F) and the entering (return) air temperature (°F) to the coil.
4. The maximum recommended steam pressure is 35 psig.

Table 53. Properties of steam

Steam Pressure (psig)	2	5	10	15	20	25	30	40	50
Temperature of Steam (°F)	219	227	239	250	259	267	274	287	298

Component Static Pressure Drops

Table 54. Component static pressure drops (in. H₂O)

Nom Tons	CFM	Evaporator Coil					(Dampers wide open)			
		Standard		High Capacity		Reheat Coil	Return Damper	Outside Air ^(a)		
		Dry	Wet	Dry	Wet	Dry		Econo Damper	Traq Damper	
90	16000	0.1	0.13	0.17	0.22	0.04	0.06	0.11	0.19	
	20000	0.15	0.19	0.24	0.31	0.06	0.1	0.17	0.29	
	25000	0.21	0.27	0.35	0.45	0.08	0.16	0.27	0.45	
	30000	0.28	0.36	0.47	0.6	0.11	0.23	0.39	0.65	
	33000	0.33	0.42	0.55	0.7	0.13	0.28	0.47	0.79	
	36000	0.38	0.48	0.63	0.8	0.15	0.34	0.57	0.94	
	40000	0.45	0.57	0.75	0.95	0.18	0.42	0.7	1.16	
105	19000	0.18	0.23	0.27	0.32	0.05	0.09	0.15	0.26	
	23000	0.2	0.31	0.37	0.47	0.07	0.13	0.23	0.38	
	28000	0.34	0.43	0.51	0.64	0.1	0.2	0.34	0.57	
	33000	0.44	0.56	0.66	0.84	0.13	0.28	0.47	0.79	
	38000	0.55	0.7	0.83	1.05	0.16	0.38	0.63	1.05	
	43000	0.67	0.85	1.01	1.28	0.2	0.49	0.81	1.34	
	45000	0.73	0.92	1.09	1.38	0.21	0.53	0.89	1.47	
120	21000	0.11	0.14	0.18	0.23	0.04	0.05	0.1	0.17	
	26000	0.17	0.22	0.25	0.32	0.06	0.09	0.15	0.26	
	31000	0.23	0.29	0.34	0.43	0.08	0.12	0.22	0.36	
	36000	0.29	0.38	0.43	0.55	0.1	0.17	0.3	0.49	
	41000	0.36	0.45	0.53	0.67	0.12	0.22	0.39	0.64	
	46000	0.44	0.55	0.64	0.81	0.15	0.28	0.49	0.8	
	51000	0.51	0.64	0.75	0.95	0.18	0.35	0.61	0.99	
54000	0.55	0.69	0.83	1.05	0.2	0.39	0.68	1.11		
130	23000	0.14	0.18	0.21	0.27	0.05	0.07	0.12	0.2	
	26000	0.17	0.22	0.25	0.32	0.06	0.09	0.15	0.26	
	30000	0.21	0.27	0.32	0.41	0.07	0.12	0.21	0.34	
	35000	0.27	0.35	0.41	0.52	0.1	0.16	0.28	0.46	
	40000	0.34	0.43	0.51	0.65	0.12	0.21	0.37	0.61	
	45000	0.41	0.52	0.61	0.78	0.15	0.27	0.47	0.77	
	50000	0.49	0.62	0.73	0.93	0.17	0.33	0.59	0.95	
	55000	0.57	0.72	0.85	1.08	0.2	0.4	0.71	1.15	
58000	0.62	0.78	0.93	1.18	0.22	0.45	0.79	1.28		
150	23000	0.21	0.27	-	-	0.05	0.07	0.12	0.2	
	26000	0.25	0.32	-	-	0.06	0.09	0.15	0.26	
	30000	0.32	0.41	-	-	0.07	0.12	0.21	0.34	
	35000	0.41	0.52	-	-	0.1	0.16	0.28	0.46	
	40000	0.51	0.65	-	-	0.12	0.21	0.37	0.61	
	45000	0.61	0.78	-	-	0.15	0.27	0.47	0.77	
	50000	0.73	0.93	-	-	0.17	0.33	0.59	0.95	
	55000	0.85	1.08	-	-	0.2	0.4	0.71	1.15	
58000	0.93	1.18	-	-	0.22	0.45	0.79	1.28		

Note: Actual Supply Fan CFM Range: 90 Ton 16000-40000; 105 Ton 19000-45000; 120 Ton 21000-54000; 130-150 Ton 23000-58000

^(a) Use only 1 value. Select Traq value if option is selected.



Performance Data

Table 55. Component static pressure drops (in. H₂O)

Nom Tons	CFM	Electric Heating (Hz) All kW's	Gas Heating						Hydronic Heating Coil Data			
			Low Heat		Medium Heat		High Heat		Hot Water Coil		Steam Coil	
			DF	Hz	DF	Hz	DF	Hz	High	Low	High	Low
90	16000	0.01	0.01	0.02	0.01	0.04	0.03	0.07	0.13	0.08	0.12	0.08
	20000	0.02	0.01	0.04	0.01	0.07	0.04	0.12	0.19	0.12	0.17	0.12
	25000	0.03	0.02	0.05	0.02	0.11	0.07	0.18	0.27	0.17	0.26	0.18
	30000	0.05	0.03	0.06	0.03	0.15	0.10	0.26	0.36	0.24	0.35	0.25
	33000	0.06	0.04	0.07	0.04	0.18	0.12	0.32	0.42	0.28	0.41	0.3
	36000	0.07	0.04	0.10	0.04	0.22	0.14	0.38	0.49	0.33	0.48	0.35
	40000	0.08	0.06	0.12	0.06	0.27	0.18	0.47	0.58	0.39	0.57	0.43
105	19000	0.02	0.01	0.03	0.01	0.06	0.04	0.11	0.17	0.11	0.16	0.11
	23000	0.03	0.02	0.04	0.02	0.09	0.06	0.15	0.23	0.15	0.22	0.16
	28000	0.04	0.03	0.06	0.03	0.13	0.09	0.23	0.32	0.21	0.31	0.22
	33000	0.06	0.04	0.07	0.04	0.18	0.12	0.32	0.42	0.28	0.41	0.3
	38000	0.07	0.05	0.10	0.05	0.24	0.16	0.42	0.53	0.36	0.52	0.39
	43000	0.1	0.06	0.14	0.06	0.31	0.20	0.54	0.65	0.45	0.65	0.49
	45000	0.1	0.07	0.15	0.07	0.34	0.22	0.59	0.71	0.49	0.7	0.53
120	21000	0.02	0.02	0.07	0.05	0.13	0.08	0.18	0.14	0.09	0.13	0.09
	26000	0.03	0.02	0.11	0.07	0.20	0.13	0.28	0.2	0.13	0.19	0.13
	31000	0.05	0.03	0.16	0.11	0.28	0.18	0.40	0.26	0.17	0.25	0.18
	36000	0.07	0.04	0.22	0.14	0.38	0.24	0.54	0.33	0.22	0.33	0.24
	41000	0.09	0.06	0.28	0.19	0.49	0.31	0.70	0.42	0.28	0.41	0.3
	46000	0.11	0.07	0.36	0.23	0.62	0.39	0.88	0.5	0.34	0.5	0.37
	51000	0.13	0.09	0.44	0.29	0.76	0.48	1.08	0.6	0.41	0.59	0.44
	54000	0.15	0.10	0.49	0.32	0.85	0.54	1.21	0.66	0.45	0.65	0.49
130	23000	0.03	0.02	0.09	0.06	0.15	0.10	0.22	0.16	0.1	0.15	0.1
	26000	0.03	0.02	0.11	0.07	0.20	0.13	0.28	0.2	0.13	0.19	0.13
	30000	0.05	0.03	0.15	0.10	0.26	0.17	0.37	0.25	0.16	0.24	0.17
	35000	0.06	0.04	0.21	0.14	0.36	0.23	0.51	0.32	0.21	0.31	0.22
	40000	0.08	0.06	0.27	0.18	0.47	0.30	0.66	0.4	0.27	0.39	0.28
	45000	0.1	0.07	0.34	0.22	0.59	0.38	0.84	0.49	0.33	0.48	0.35
	50000	0.13	0.09	0.42	0.28	0.73	0.46	1.03	0.58	0.39	0.57	0.43
	55000	0.16	0.10	0.51	0.33	0.88	0.56	1.25	0.68	0.47	0.67	0.51
	58000	0.17	0.12	0.57	0.37	0.98	0.63	1.39	0.75	0.51	0.74	0.56
150	23000	0.03	0.02	0.09	0.06	0.15	0.10	0.22	0.16	0.1	0.15	0.1
	26000	0.03	0.02	0.11	0.07	0.20	0.13	0.28	0.2	0.13	0.19	0.13
	30000	0.05	0.03	0.15	0.10	0.26	0.17	0.37	0.25	0.16	0.24	0.17
	35000	0.06	0.04	0.21	0.14	0.36	0.23	0.51	0.32	0.21	0.31	0.22
	40000	0.08	0.06	0.27	0.18	0.47	0.30	0.66	0.4	0.27	0.39	0.28
	45000	0.1	0.07	0.34	0.22	0.59	0.38	0.84	0.49	0.33	0.48	0.35
	50000	0.13	0.09	0.42	0.28	0.73	0.46	1.03	0.58	0.39	0.57	0.43
	55000	0.16	0.10	0.51	0.33	0.88	0.56	1.25	0.68	0.47	0.67	0.51
	58000	0.17	0.12	0.57	0.37	0.98	0.63	1.39	0.75	0.51	0.74	0.56

Note: There is no pressure drop with electric heat DF configuration

Table 56. Component static pressure drops (in. H₂O) — filters

Nom Tons	CFM	Standard Filter Section (Pre Evap)					Final Filter Section (Post Evap)					
		Std 2" High Eff Throw Away Filters	90-95% Low PD Cartridge Filters w/ 2" Prefilter	90-95% Low PD Cartridge Filters w/ 4" Prefilter	90-95% Cartridge Filters w/ 2" Prefilter (a)	90-95% Bag Filters w/ 2" Prefilter (a)	90-95% Std Temp Low PD Cartridge Filters w/4" Prefilter (b)	90-95% Std Temp Bag Filters w/ 2" Prefilter (c)	90-95% Std Temp Cartridge Filters w/ 2" Prefilter (c)	90-95% Hi Temp Cartridge Filters w/ 2" Hi Temp Prefilter (c)	90-95% Hi Temp HEPA w/ 2" Hi Temp Prefilter (d)	90-95% Std Temp HEPA Filters w/ 2" Hi Temp Prefilter (d)
90	16000	0.08	0.24	—	0.27	0.34	0.23	0.36	0.29	0.35	0.54	0.48
	20000	0.11	0.31	—	0.33	0.41	0.31	0.43	0.36	0.44	0.69	0.61
	25000	0.15	0.42	—	0.42	0.5	0.43	0.54	0.47	0.58	0.89	0.78
	30000	0.2	0.53	—	0.54	0.6	0.56	0.65	0.6	0.74	1.1	0.95
	33000	0.23	0.61	—	0.61	0.67	0.65	0.73	0.69	0.86	1.22	1.06
	36000	0.26	0.69	—	0.7	0.73	0.74	0.8	0.79	0.98	1.36	1.16
	40000	0.3	0.8	—	0.82	0.83	0.88	0.91	0.93	1.15	—	—
105	19000	0.1	0.27	—	0.3	0.37	0.27	0.4	0.32	0.4	0.62	0.55
	23000	0.11	0.29	—	0.32	0.39	0.29	0.42	0.34	0.42	0.66	0.58
	28000	0.18	0.49	—	0.49	0.56	0.51	0.61	0.54	0.68	1.01	0.88
	33000	0.23	0.61	—	0.61	0.67	0.65	0.73	0.69	0.86	1.22	1.06
	38000	0.28	0.74	—	0.76	0.78	0.81	0.86	0.86	1.06	—	—
	43000	0.33	0.89	—	0.92	0.91	0.98	1	1.05	1.3	—	—
	45000	0.36	0.95	—	0.99	0.96	1.05	1.06	1.13	1.4	—	—
120	21000	0.1	—	0.3	0.35	0.42	0.34	0.45	0.38	0.47	0.73	0.64
	26000	0.13	—	0.41	0.44	0.52	0.46	0.56	0.49	0.61	0.93	0.81
	31000	0.17	—	0.53	0.56	0.62	0.59	0.68	0.63	0.78	1.14	0.99
	36000	0.2	—	0.66	0.7	0.73	0.74	0.8	0.79	0.98	1.36	1.16
	41000	0.25	—	0.81	0.85	0.86	0.91	0.94	0.97	1.2	—	—
	46000	0.29	—	0.96	1.03	0.99	1.09	1.09	1.17	1.45	—	—
	51000	0.34	—	1.14	—	—	1.29	—	—	—	—	—
	54000	0.37	—	1.25	—	—	1.42	—	—	—	—	—
130	23000	0.1	—	0.32	0.37	0.44	0.36	0.47	0.4	0.49	0.77	0.68
	26000	0.14	—	0.43	0.47	0.54	0.48	0.58	0.52	0.64	0.97	0.85
	30000	0.17	—	0.55	0.59	0.64	0.62	0.7	0.66	0.82	1.18	1.02
	35000	0.21	—	0.69	0.73	0.76	0.78	0.83	0.82	1.02	1.4	1.2
	40000	0.26	—	0.84	0.89	0.88	0.94	0.97	1.01	1.25	—	—
	45000	0.3	—	1	1.07	1.02	1.13	1.12	1.22	1.51	—	—
	50000	0.35	—	1.17	1.27	1.16	1.33	—	—	—	—	—
	55000	0.41	—	1.36	—	—	1.55	—	—	—	—	—
58000	0.44	—	1.48	—	—	—	—	—	—	—	—	
150	23000	0.1	—	0.32	0.37	0.44	0.36	0.47	0.4	0.49	0.77	0.68
	26000	0.14	—	0.43	0.47	0.54	0.48	0.58	0.52	0.64	0.97	0.85
	30000	0.17	—	0.55	0.59	0.64	0.62	0.7	0.66	0.82	1.18	1.02
	35000	0.21	—	0.69	0.73	0.76	0.78	0.83	0.82	1.02	1.4	1.2
	40000	0.26	—	0.84	0.89	0.88	0.94	0.97	1.01	1.25	—	—
	45000	0.3	—	1	1.07	1.02	1.13	1.12	1.22	1.51	—	—
	50000	0.35	—	1.17	1.27	1.16	1.33	—	—	—	—	—
	55000	0.41	—	1.36	—	—	1.55	—	—	—	—	—
58000	0.44	—	1.48	—	—	—	—	—	—	—	—	

(a) 120-150 Ton Max CFM 50000

(b) 130-150 Ton Max CFM 55500

(c) 120-150 Ton Max CFM 46250

(d) 90-150 Ton Max CFM 37000



Performance Data

Table 57. Energy recovery wheel component static pressure drops — low CFM

Nom Tons	CFM	Outside Air Bypass Damper Open	Outside Air Bypass Damper Closed	Relief Air Bypass Damper Open	Relief Air Bypass Damper Closed
Low CFM Energy Recovery Wheel					
90	8000	0.07	0.78	0.09	0.66
	9000	0.09	0.88	0.11	0.79
	10000	0.12	0.99	0.14	0.92
	12000	0.16	1.20	0.19	1.16
	14000	0.21	1.42	0.24	1.41
	16000	0.27	—	0.29	—
	20000	0.40	—	0.42	—
	25000	0.59	—	0.60	—
	30000	0.80	—	0.80	—
	33000	0.94	—	0.94	—
	36000	1.08	—	1.07	—
	40000	1.30	—	1.27	—
105	9000	0.09	0.88	0.11	0.79
	12000	0.16	1.20	0.19	1.16
	14000	0.21	1.42	0.24	1.41
	16000	0.27	—	0.29	—
	19000	0.36	—	0.39	—
	23000	0.51	—	0.52	—
	28000	0.71	—	0.72	—
	33000	0.94	—	0.94	—
	38000	1.19	—	1.18	—
	43000	1.46	—	1.41	—
		45000	1.58	—	1.52
120	9000	0.09	0.78	0.11	0.69
	12000	0.16	1.06	0.18	1.02
	15000	0.23	1.36	0.26	1.36
	18000	0.31	—	0.34	—
	21000	0.41	—	0.44	—
	26000	0.59	—	0.62	—
	31000	0.79	—	0.82	—
	36000	1.01	—	1.04	—
	41000	1.25	—	1.28	—
	46000	1.51	—	1.52	—
		51000	1.79	—	1.79
	54000	1.96	—	1.95	—
130	9000	0.09	0.71	0.10	0.62
	12000	0.15	0.97	0.18	0.92
	16000	0.25	1.34	0.28	1.33
	20000	0.36	—	0.40	—
	23000	0.46	—	0.49	—
	26000	0.57	—	0.60	—
	30000	0.72	—	0.75	—
	35000	0.93	—	0.97	—
	40000	1.16	—	1.20	—
	45000	1.40	—	1.43	—
	50000	1.67	—	1.69	—
	55000	1.95	—	1.96	—
		58000	2.12	—	2.12

Table 57. Energy recovery wheel component static pressure drops — low CFM (continued)

Nom Tons	CFM	Outside Air Bypass Damper Open	Outside Air Bypass Damper Closed	Relief Air Bypass Damper Open	Relief Air Bypass Damper Closed
Low CFM Energy Recovery Wheel					
150	9000	0.09	0.71	0.10	0.62
	12000	0.15	0.97	0.18	0.92
	16000	0.25	1.34	0.28	1.33
	20000	0.36	—	0.40	—
	23000	0.46	—	0.49	—
	26000	0.57	—	0.60	—
	30000	0.72	—	0.75	—
	35000	0.93	—	0.97	—
	40000	1.16	—	1.20	—
	45000	1.40	—	1.43	—
	50000	1.67	—	1.69	—
	55000	1.95	—	1.96	—
	58000	2.12	—	2.12	—

Table 58. Energy recovery wheel component static pressure drops — standard CFM

Nom Tons	CFM	Outside Air Bypass Damper Open	Outside Air Bypass Damper Closed	Relief Air Bypass Damper Open	Relief Air Bypass Damper Closed
Standard CFM Energy Recovery Wheel					
90	8000	0.06	0.54	0.07	0.44
	9000	0.08	0.61	0.10	0.53
	10000	0.10	0.68	0.12	0.62
	12000	0.15	0.83	0.17	0.77
	14000	0.19	0.99	0.22	0.94
	16000	0.24	1.16	0.26	1.12
	18000	0.30	1.32	0.31	1.29
	20000	0.35	-	0.37	-
	25000	0.52	-	0.54	-
	30000	0.70	-	0.73	-
	33000	0.82	-	0.84	-
	36000	0.95	-	0.97	-
	40000	1.12	-	1.14	-
105	9000	0.08	0.57	0.09	0.47
	12000	0.14	0.77	0.16	0.65
	14000	0.19	0.93	0.21	0.78
	16000	0.24	1.08	0.26	0.91
	19000	0.32	1.33	0.34	1.11
	21000	0.37	1.49	0.40	1.25
	23000	0.44	-	0.46	-
	28000	0.61	-	0.64	-
	33000	0.80	-	0.82	-
	38000	1.00	-	1.03	-
	43000	1.23	-	1.25	-
45000	1.33	-	1.34	-	



Performance Data

Table 58. Energy recovery wheel component static pressure drops — standard CFM (continued)

Nom Tons	CFM	Outside Air Bypass Damper Open	Outside Air Bypass Damper Closed	Relief Air Bypass Damper Open	Relief Air Bypass Damper Closed
Standard CFM Energy Recovery Wheel					
120	10000	0.10	0.56	0.11	0.50
	12000	0.14	0.69	0.16	0.63
	15000	0.20	0.89	0.23	0.85
	18000	0.27	1.10	0.29	1.05
	21000	0.35	1.33	0.38	1.28
	24000	0.43	1.57	0.47	1.51
	26000	0.50	-	0.54	-
	31000	0.66	-	0.72	-
	36000	0.84	-	0.91	-
	41000	1.04	-	1.11	-
	46000	1.26	-	1.34	-
	51000	1.49	-	1.56	-
54000	1.63	-	1.71	-	
130-150	13000	0.16	0.59	0.17	0.53
	15000	0.20	0.69	0.22	0.63
	18000	0.26	0.86	0.28	0.79
	21000	0.33	1.04	0.36	0.96
	23000	0.38	1.16	0.42	1.06
	26000	0.45	1.36	0.50	1.24
	29000	0.54	1.57	0.60	1.42
	30000	0.57	-	0.63	-
	35000	0.72	-	0.80	-
	40000	0.89	-	0.98	-
	45000	1.08	-	1.17	-
	50000	1.28	-	1.38	-
	55000	1.50	-	1.60	-
	58000	1.63	-	1.74	-

Table 59. Energy recovery wheel component static pressure drops — dampers

Tons	CFM	Return Damper, ERW only	Econo Damper, ERW only
90	16000	0.14	0.15
	20000	0.2	0.24
	25000	0.29	0.39
	30000	0.42	0.56
	33000	0.51	0.69
	36000	0.61	0.82
	40000	0.75	1.01
105	19000	0.19	0.22
	23000	0.25	0.33
	28000	0.37	0.49
	33000	0.51	0.69
	38000	0.68	0.91
	43000	0.87	1.17
120	45000	0.96	1.29
	21000	0.22	0.18
	26000	0.32	0.27
	31000	0.45	0.39
	36000	0.61	0.53
	41000	0.79	0.69
	46000	1	0.87
	51000	1.24	1.07
54000	1.4	1.2	

Table 59. Energy recovery wheel component static pressure drops — dampers (continued)

Tons	CFM	Return Damper, ERW only	Econo Damper, ERW only
130-150	23000	0.25	0.21
	26000	0.32	0.27
	30000	0.42	0.36
	35000	0.57	0.5
	40000	0.75	0.65
	45000	0.96	0.83
	50000	1.19	1.02
	55000	1.45	1.24
	58000	1.63	1.38

Table 60. Energy recovery wheel pressure loss ΔP (in. wg) and total effectiveness

Actual Airflow CFM	90-105 Tons Low		120 Tons Low		130-150 Tons Low		90 Tons Standard		105 Tons Standard		120 Tons Standard		130-150 Tons Standard	
	ΔP	Eff	ΔP	Eff	ΔP	Eff	ΔP	Eff	ΔP	Eff	ΔP	Eff	ΔP	Eff
8000	0.73	77.50	0.64	79.00	0.58	80.00	0.49	81.60	—	—	—	—	—	—
9000	0.82	75.90	0.72	77.60	0.65	78.70	0.55	80.60	0.51	81.30	—	—	—	—
10000	0.91	74.30	0.80	76.20	0.73	77.50	0.61	79.50	0.56	80.30	0.49	81.60	—	—
11000	1.00	72.70	0.88	74.80	0.80	76.20	0.67	78.50	0.62	79.40	0.54	80.70	—	—
12000	1.09	71.10	0.96	73.40	0.87	75.00	0.73	77.40	0.67	78.40	0.59	79.80	—	—
13000	1.18	69.50	1.04	72.00	0.94	73.70	0.79	76.40	0.73	77.40	0.64	79.00	0.48	74.70
14000	—	—	1.12	70.60	1.02	72.40	0.85	75.30	0.79	76.50	0.69	78.10	0.51	72.90
15000	—	—	1.20	69.20	1.09	71.10	0.91	74.30	0.84	75.50	0.74	77.30	0.55	71.90
16000	—	—	—	—	1.16	69.80	0.97	73.20	0.90	74.50	0.79	76.40	0.58	71.00
17000	—	—	—	—	1.24	68.50	1.03	72.10	0.95	73.50	0.83	75.60	0.61	70.00
18000	—	—	—	—	—	—	1.09	71.10	1.01	72.50	0.88	74.70	0.64	69.00
19000	—	—	—	—	—	—	1.15	70.00	1.07	71.50	0.93	73.90	0.67	68.10
20000	—	—	—	—	—	—	1.22	68.90	1.12	70.50	0.98	73.00	0.71	67.10
21000	—	—	—	—	—	—	—	—	1.18	69.50	1.03	72.10	0.74	66.10
22000	—	—	—	—	—	—	—	—	1.23	68.50	1.08	71.30	0.77	65.10
23000	—	—	—	—	—	—	—	—	—	—	1.13	70.40	0.80	64.20
24000	—	—	—	—	—	—	—	—	—	—	1.18	69.50	0.84	63.20
25000	—	—	—	—	—	—	—	—	—	—	1.23	68.70	0.87	62.20
26000	—	—	—	—	—	—	—	—	—	—	—	—	0.90	61.20
27000	—	—	—	—	—	—	—	—	—	—	—	—	0.93	60.30
28000	—	—	—	—	—	—	—	—	—	—	—	—	0.97	59.30
29000	—	—	—	—	—	—	—	—	—	—	—	—	1.00	58.30



Performance Data

Fan Drive Selections

Table 61. Supply air fan drive selections

		Horse Power (hp)									
Nom Tons	Low/Std	RPM	15 hp	20 hp	25 hp	30 hp	40 hp	50 hp	60 hp	75 hp	100 hp
			Drive/No.								
90	Low	2000						L			
	Low	1900					K				
	Low	1800					J				
	Low	1700				H					
	Low	1600			G						
	Low	1500		F							
	Low	1400	E	E							
90-105	Std	1300							D	D	
	Std	1200						C	C		
	Std	1100					B	B			
	Std	1000				A	A				
	Std	900		9	9	9					
	Std	800	8	8	8						
105-150	Low	1500							F		
	Low	1400						E	E		
	Low	1300					D	D			
	Low	1200				C	C				
	Low	1100			B	B					
	Low	1000		A	A						
	Low	900	9	9							
120-150	Std	1200									C
	Std	1100							B	B	B
	Std	1000						A	A	A	A
	Std	900					9	9	9	9	
	Std	800			8	8	8	8	8		
	Std	700		7	7	7	7				

Table 62. Relief air fan drive selections

		Horse Power (hp)									
Nom Tons	Low/Std	RPM	15 hp	20 hp	25 hp	30 hp	40 hp	50 hp	60 hp	75 hp	100 hp
			Drive/No.								
90	Low	700				7	7				
	Low	600	6	6	6	6	6				
	Low	500	5	5	5	5					
	Low	400	4	4	4						
	Std	600				6	6				
	Std	500			5	5	5				
	Std	400		4	4	4	4				
	Std	300		3	3						
105-150	Low	600				6	6	6	6	6	
	Low	500			5	5	5	5	5	5	
	Low	400	4	4	4	4	4	4	4		
	Low	300	3	3	3						
	Std	600								6	6
	Std	500			5	5	5	5	5		
	Std	400			4	4	4				

Table 63. Return air fan drive selections

Nom Tons	Low/Std	RPM	Horse Power (hp)							
			7.5 hp	10 hp	15 hp	20 hp	25 hp	30 hp	40 hp	50 hp
			Drive/No.							
All	Low	1400							E	
	Low	1300						D		
	Low	1200					C	C		
	Low	1100				B				
	Low	1000			A	A				
	Low	900			9					
	Low	800	8	8						
	Low	700	7							
90-105	Std	1200							C	
	Std	1100						B	B	
	Std	1000					A	A		
	Std	900				9				
	Std	800			8					
	Std	700		7						
120-150	Std	1100								B
	Std	1000							A	A
	Std	900						9	9	
	Std	800				8	8			
	Std	700			7					
	Std	600			6					



Electrical Data

Electrical Service Sizing

To correctly size electrical service wiring for a unit, find the appropriate calculations listed below. Each type of unit has its own set of calculations for MCA (Minimum Circuit Ampacity) and MOP (Maximum Overcurrent Protection). Read the load definitions that follow and then find the appropriate set of calculations based on unit type.

Note: Set 1 is for cooling only and cooling with gas heat units, and set 2 is for cooling with electric heat units.

Load Definitions: (To determine load values, see the Electrical Service Sizing Data Tables on the following page.)

LOAD1 = Current of the largest motor (compressor or fan motor)

LOAD2 = Sum of the currents of all remaining motors

LOAD3 = Current of electric heaters

LOAD4 = Any other load rated at 1 AMP or more

Set 1: Cooling Only Rooftop Units and Cooling with Gas Heat Rooftop Units

$$\text{MCA} = (1.25 \times \text{LOAD1}) + \text{LOAD2} + \text{LOAD4}$$

$$\text{MOP} = (2.25 \times \text{LOAD1}) + \text{LOAD2} + \text{LOAD4}$$

Select a fuse rating equal to the MOP value. If the MOP value does not equal a standard fuse size as listed in NEC 240-6, select the next lower standard fuse rating.

Note: If selected MOP is less than the MCA, then select the lowest standard maximum fuse size which is equal to or larger than the MCA, provided the selected fuse size does not exceed 800 amps.

Set 2: Rooftop units with Electric Heat

To arrive at the correct MCA and MOP values for these units, two sets of calculations must be performed. First calculate the MCA and MOP values as if the unit was in cooling mode (use the equations given in Set 1). Then calculate the MCA and MOP values as if the unit were in heating mode as follows. (Keep in mind when determining LOADS that the compressors do not run while the unit is in heating mode).

$$\text{MCA} = 1.25 \times (\text{LOAD1} + \text{LOAD2} + \text{LOAD4}) + \text{LOAD3}$$

The nameplate MCA value will be the larger of the cooling mode MCA value or the heating mode MCA value calculated above.

$$\text{MOP} = (2.25 \times \text{LOAD1}) + \text{LOAD2} + \text{LOAD3} + \text{LOAD4}$$

The selection MOP value will be the larger of the cooling mode MOP value or the heating mode MOP value calculated above.

Select a fuse rating equal to the MOP value. If the MOP value does not equal a standard fuse size as listed in NEC 240-6, select the next lower standard fuse rating.

Notes:

- If selected MOP is less than the MCA, then select the lowest standard maximum fuse size which is equal to or larger than the MCA, provided the selected fuse size does not exceed 800 amps.
- On 90 to 150 ton rooftops, the selected MOP value is stamped in the MOP field on the unit nameplate.

Service Sizing Data

Table 64. Electrical service sizing data

Fixed Capacity Compressors								
Nom Tons	Compressor		Nominal Voltage					
	Size	No per Unit	460 V		575 V		380 V	
			RLA (ea.)	LRA (ea.)	RLA (ea.)	LRA (ea.)	RLA (ea.)	LRA (ea.)
90	237	4	37.2	215	29.8	175	39.1	215
105	178	6	25.9	160	20.72	135	27.3	160
120	178	4	25.9	160	20.72	135	27.3	160
	237	2	37.2	215	29.8	175	39.1	215
130	227	6	35.7	215	28.6	175	37.6	215
150	237	6	37.2	215	29.8	175	39.1	215

Table 65. Electrical service sizing data

eFlex™ Variable Speed Compressor								
Nom Tons	Compressor		Nominal Voltage					
	Size	No per Unit	460 V		575 V		380 V	
			RLA (ea.)	LRA (ea.)	RLA (ea.)	LRA (ea.)	RLA (ea.)	LRA (ea.)
90	170 ^(a)	1	39.8	N/A	31.8	N/A	45.8	N/A
	178	4	25.3	160	20.2	135	25.3	160
105	170 ^(a)	1	39.8	N/A	31.8	N/A	45.8	N/A
	178	3	25.3	160	20.2	135	25.3	160
	237	1	35.1	215	28.1	175	35.1	215
120	170 ^(a)	1	39.8	N/A	31.8	N/A	45.8	N/A
	178	2	25.3	160	20.2	135	25.3	160
	237	1	35.1	215	28.1	175	35.1	215
	297	1	47.5	260	35	210	47.5	260
130	170 ^(a)	1	39.8	N/A	31.8	N/A	45.8	N/A
	227	3	33.7	215	27.1	175	33.7	215
	346	1	53.9	235	43.1	187	53.9	235
150	170 ^(a)	1	39.8	N/A	31.8	N/A	45.8	N/A
	178	1	25.3	160	20.2	135	25.3	160
	237	1	35.1	215	28.1	175	35.1	215
	346	2	53.9	235	43.1	187	53.9	235

^(a) Variable Speed Compressor



Electrical Data

Table 66. Electrical service sizing data—motors — air-cooled and evaporative condensing

Nominal Tonnage	No of Fans	Fixed Speed						Variable Speed		
		Standard Ambient			Low Ambient			Standard or Low Ambient		
		Voltage								
		460	575	380	460	575	380	460	575	380
90, 105	6	16.2	13.2	15	15	12.4	14.8	12.5	10.8	14.3
120, 130, 150	8	21.6	17.6	20	20.4	16.8	19.8	16.6	14.4	19.1

Table 67. Electrical service sizing data—supply, relief/return fan motors — air-cooled and evaporative condensing

Motor HP	460 V	575 V	380 V
	FLA	FLA	FLA
Supply Fan Motors			
15	18.5	15.0	22.0
20	24.7	19.6	28.0
25	31.0	25.0	36.0
30	36.6	29.0	43.5
40	49.0	39.0	54.0
50	59.0	47.2	68.0
60	71.5	57.2	81.0
75	90.0	72.0	103.0
100	115.0	91.3	N/A
Relief/Return Fan Motors			
7.5	9.8	7.8	12.1
10	12.6	10.1	15.2
15	18.5	15.0	22.0
20	24.7	19.6	28.0
25	31.0	25.0	36.0
30	36.6	29.0	43.5
40	49.0	39.0	54.0
50	59.0	47.2	68.0
60	71.5	57.2	81.0

Table 68. Electrical service sizing data—electric heat module (electric heat units only)

Module kW	Voltage		
	460	575	380
	FLA	FLA	FLA
90 / 56	108.3	86.6	85.1
140 / 88	168.4	134.7	133.3
265 / 166	318.8	255.0	252.3
300 / 188	360.8	288.7	285.7

Note: Electric heat FLA are determined at 480, 600, 380 volts.

Table 69. Transformer 1 and 2 primary amps

Nom Tons	Voltage		
	460	575	380
90-150	9	7	11

Table 70. Voltage utilization range

Unit Voltage	Range
460/60/3	414-506
575/60/3	517-633
380/50/3	342-418

Table 71. Electrical service sizing data—energy recovery wheel motor

Nom Tons	Unit Function	Voltage	
		460	575
		FLA	FLA
90-120	1 (Low CFM ERW)	1.1	0.90
130-150	1 (Low CFM ERW)	1.8	1.4
All	2 (High. CFM ERW)	2.6	2.5



Dimensional Data

Figure 19. Unit top/left view

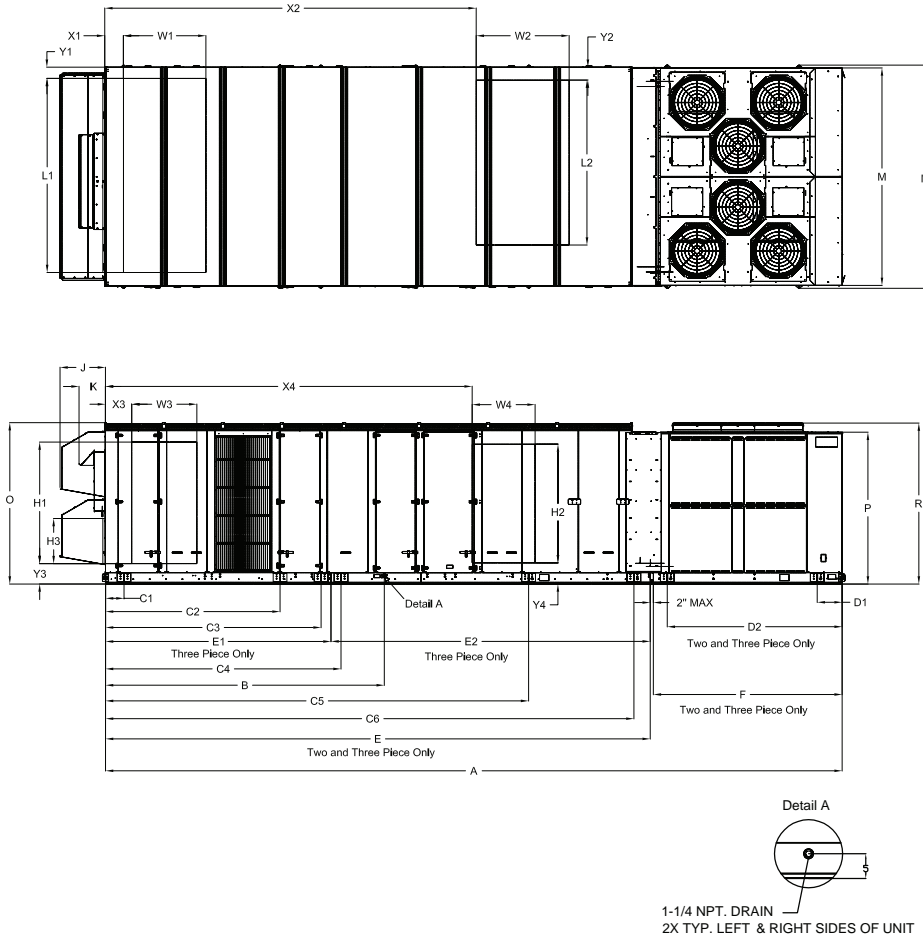

Table 72. Unit dimensions (in.)—ONE-PIECE unit —WITHOUT energy recovery wheel

Tons	Blank Section	Lifting Lug Locations						Unit Width		Unit Height			Return Fan	Exhaust Fan
		Unit Dimensions		Air Handler Side		Condenser Side	M	N	O	P	R	J	K	
		A	B	C1	C2	C3								D1
90	None	437 3/16	159 15/16	66	252 14/16	N/A	27 11/16	139 13/16	143 8/16	103 12/16	97 9/16	103 7/16	29 3/16	17
	4 ft	485 6/16	159 15/16	66	252 14/16	N/A	54 2/16	139 13/16	143 8/16					
	8 ft	533 9/16	159 15/16	66	252 14/16	N/A	54 2/16	139 13/16	143 8/16					
105	None	455 3/16	159 15/16	66	252 14/16	N/A	27 11/16	139 13/16	143 8/16	103 12/16	97 9/16	103 7/16	29 3/16	17
	4 ft	503 6/16	159 15/16	66	252 14/16	N/A	54 2/16	139 13/16	143 8/16					
	8 ft	551 9/16	159 15/16	66	252 14/16	N/A	54 2/16	139 13/16	143 8/16					
120-150 (a)	None	528 15/16	197 1/16	66	269 6/16	N/A	63 2/16	139 13/16	143 8/16	—	—	—	—	—

Table 72. Unit dimensions (in.)—ONE-PIECE unit —WITHOUT energy recovery wheel (continued)

Tons	Blank Section	Unit Dimensions		Lifting Lug Locations				Unit Width		Unit Height			Return Fan	Exhaust Fan
				Air Handler Side			Condenser Side	M	N	O	P	R	J	K
		A	B	C1	C2	C3	D1							
120-150 (a)	4 ft	577 2/16	197 1/16	66	269 6/16	N/A	63 2/16	139 13/16	143 8/16	—	—	—	—	—
120-150 (b)	None	540 15/16	197 1/16	66	269 6/16	N/A	63 2/16	139 13/16	143 8/16	—	—	—	—	—

(a) All units except high heat gas models

(b) High heat gas models only

Table 73. Unit dimensions (in.)—ONE-PIECE unit —WITH energy recovery wheel

Tons	Blank Section	Unit Dimensions		Lifting Lug Locations				Unit Width		Unit Height		
		A	B	Air Handler Side			Condenser Side	M	N	O	P	R
				C1	C2	C3	D1					
90	None	533 9/16	256 5/16	66	201 1/16	349 4/16	27 11/16	139 13/16	143 8/16	103 12/16	97 9/16	103 7/16
90	4 ft	581 13/16	256 5/16	66	201 1/16	349 4/16	54 2/16	139 13/16	143 8/16	103 12/16	97 9/16	103 7/16
105	None	551 9/16	256 5/16	66	201 1/16	349 4/16	27 11/16	139 13/16	143 8/16	103 12/16	97 9/16	103 7/16
105	4 ft	599 13/16	256 5/16	66	201 1/16	349 4/16	54 2/16	139 13/16	143 8/16	103 12/16	97 9/16	103 7/16
Tons	Blank Section	Return Fan	Exhaust Fan									
		J	K									
90	None	N/A	17									
90	4 ft	N/A	17									
105	None	N/A	17									
105	4 ft	N/A	17									

Table 74. Unit dimensions (in.)—TWO-PIECE unit —WITHOUT energy recovery wheel

Tons	Blank Section	Unit Dimensions				Lifting Lug Locations				Lug Locations	
		A	B	E	F	Air Handler Side				Condenser Side	
						C1	C2	C3	C4	D1	D2
90	None	454 4/16	159 15/16	330 14/16	121 6/16	66	252 14/16	N/A	N/A	16	112 7/16
	4 ft	502 7/16	159 15/16	379 1/16	121 6/16	66	252 14/16	368 6/16	N/A	16	112 7/16
	8 ft	550 11/16	159 15/16	427 4/16	121 6/16	66	252 14/16	416 10/16	N/A	16	112 7/16
105	None	472 4/16	159 15/16	330 14/16	139 6/16	66	252 14/16	N/A	N/A	16	130 7/16
	4 ft	520 7/16	159 15/16	379 1/16	139 6/16	66	252 14/16	368 6/16	N/A	16	130 7/16
	8 ft	568 11/16	159 15/16	427 4/16	139 6/16	66	252 14/16	416 10/16	N/A	16	130 7/16
120-150 (a)	None	546	197 1/16	395 10/16	148 6/16	66	269 6/16	384 15/16	N/A	16	139 7/16
120-150 (a)	4 ft	594 4/16	197 1/16	443 13/16	148 6/16	66	269 6/16	433 2/16	N/A	16	139 7/16
120-150 (a)	8 ft	642 7/16	197 1/16	492 1/16	148 6/16	66	269 6/16	481 6/16	N/A	16	139 7/16
120-150 (a)	None	558	197 1/16	407 10/16	148 6/16	66	269 6/16	396 15/16	N/A	16	139 7/16



Dimensional Data

Table 74. Unit dimensions (in.)—TWO-PIECE unit —WITHOUT energy recovery wheel (continued)

Tons	Blank Section	Unit Width		Unit Height			Return Fan	Exhaust Fan
		M	N	O	P	R	J	K
90	None	139 13/16	143 8/16	103 12/16	97 9/16	103 7/16	29 3/16	17
	4 ft	139 13/16	143 8/16	103 12/16	97 9/16	103 7/16	29 3/16	17
	8 ft	139 13/16	143 8/16	103 12/16	97 9/16	103 7/16	29 3/16	17
105	None	139 13/16	143 8/16	103 12/16	97 9/16	103 7/16	29 3/16	17
	4 ft	139 13/16	143 8/16	103 12/16	97 9/16	103 7/16	29 3/16	17
	8 ft	139 13/16	143 8/16	103 12/16	97 9/16	103 7/16	29 3/16	17
120-150 (a)	None	139 13/16	143 8/16	103 12/16	97 9/16	103 7/16	29 3/16	17
120-150 (a)	4 ft	139 13/16	143 8/16	103 12/16	97 9/16	103 7/16	29 3/16	17
120-150 (a)	8 ft	139 13/16	143 8/16	103 12/16	97 9/16	103 7/16	29 3/16	17
120-150 (b)	None	139 13/16	143 8/16	103 12/16	97 9/16	103 7/16	29 3/16	17

(a) High Heat Gas Models Only

(b) High Heat Gas Models Only

Table 75. Unit dimensions (in.)—TWO-PIECE unit —WITH energy recovery wheel

Tons	Blank Section	Unit Dimensions				Lifting Lug Locations				Lug Locations	
		A	B	E	F	Air Handler Side				Condenser Side	
						C1	C2	C3	C4	D1	D2
90	None	550 11/16	256 5/16	427 5/16	121 6/16	66	201 1/16	349 4/16	N/A	16	112 7/16
	4 ft	598 14/16	256 5/16	475 8/16	121 6/16	66	201 1/16	349 4/16	464 13/16	16	112 7/16
	8 ft	647 2/16	256 5/16	523 12/16	121 6/16	66	201 1/16	349 4/16	513	16	112 7/16
105	None	568 11/16	256 5/16	427 5/16	139 6/16	66	201 1/16	349 4/16	N/A	16	130 7/16
	4 ft	616 14/16	256 5/16	475 8/16	139 6/16	66	201 1/16	349 4/16	464 13/16	16	130 7/16
	8 ft	665 2/16	256 5/16	523 12/16	139 6/16	66	201 1/16	349 4/16	513	16	130 7/16
120-150(a)	None	642 7/16	293 8/16	492 1/16	148 6/16	66	238 5/16	365 5/16	480 14/16	16	139 7/16
120-150(a)	4 ft	690 10/16	293 8/16	540 4/16	148 6/16	66	238 5/16	365 5/16	529 2/16	16	139 7/16
120-150(a)	8 ft	738 14/16	293 8/16	588 8/16	148 6/16	66	238 5/16	365 5/16	577 5/16	16	139 7/16
120-150(a)	None	654 7/16	293 8/16	504 1/16	148 6/16	66	238 5/16	365 5/16	492 14/16	16	139 7/16

Tons	Blank Section	Unit Width		Unit Height			Return Fan	Exhaust Fan
		M	N	O	P	R	J	K
90	None	139 13/16	143 8/16	103 12/16	97 9/16	103 7/16	N/A	17
	4 ft	139 13/16	143 8/16	103 12/16	97 9/16	103 7/16	N/A	17
	8 ft	139 13/16	143 8/16	103 12/16	97 9/16	103 7/16	N/A	17
105	None	139 13/16	143 8/16	103 12/16	97 9/16	103 7/16	N/A	17
	4 ft	139 13/16	143 8/16	103 12/16	97 9/16	103 7/16	N/A	17
	8 ft	139 13/16	143 8/16	103 12/16	97 9/16	103 7/16	N/A	17
120-150(a)	None	139 13/16	143 8/16	103 12/16	97 9/16	103 7/16	N/A	17
120-150(a)	4 ft	139 13/16	143 8/16	103 12/16	97 9/16	103 7/16	N/A	17
120-150(a)	8 ft	139 13/16	143 8/16	103 12/16	97 9/16	103 7/16	N/A	17
120-150(b)	None	139 13/16	143 8/16	103 12/16	97 9/16	103 7/16	N/A	17

(a) High Heat Gas Models Only

(b) High Heat Gas Models Only

Table 76. Downflow/horizontal airflow configuration dimensions (in.) without energy recovery wheel (ERW)

Tonnage	Blank Section	Gas Heat	DOWNFLOW Opening Dimensions							
			Return Opening-with or without Relief Fan				Return Opening-with Return Fan			
			X1	Y1	W1	L1	X1	Y1	W1	L1
90-105	None	None	14 13/16	8 14/16	48 3/16	121 15/16	14 13/16	42 14/16	48 3/16	53 14/16
	4 ft	None	14 13/16	8 14/16	48 3/16	121 15/16	14 13/16	42 14/16	48 3/16	53 14/16
	8 ft	None	14 13/16	8 14/16	48 3/16	121 15/16	14 13/16	42 14/16	48 3/16	53 14/16
120-150	None	None	14 13/16	8 14/16	48 3/16	121 15/16	14 13/16	42 14/16	48 3/16	53 14/16
	4 ft	None	14 13/16	8 14/16	48 3/16	121 15/16	14 13/16	42 14/16	48 3/16	53 14/16
	8 ft	None	14 13/16	8 14/16	48 3/16	121 15/16	14 13/16	42 14/16	48 3/16	53 14/16
90-105	None	Low/Med/High	14 13/16	8 14/16	48 3/16	121 15/16	14 13/16	42 14/16	48 3/16	53 14/16
	8 ft	Low/Med/High	14 13/16	8 14/16	48 3/16	121 15/16	14 13/16	42 14/16	48 3/16	53 14/16
120-150	None	Low/Med	14 13/16	8 14/16	48 3/16	121 15/16	14 13/16	42 14/16	48 3/16	53 14/16
	8 ft	Low/Med	14 13/16	8 14/16	48 3/16	121 15/16	14 13/16	42 14/16	48 3/16	53 14/16
	None	High	14 13/16	8 14/16	48 3/16	121 15/16	14 13/16	42 14/16	48 3/16	53 14/16
Tonnage	Blank Section	Gas Heat	DOWNFLOW Opening Dimensions				HORIZONTAL Opening Dimensions			
			Supply Opening				Return Side Opening			
			X2	Y2	W2	L2	X3	Y3	W3	H1
90-105	None	None	256 1/16	13	47 14/16	102 8/16	9 5/16	10 10/16	54 12/16	84 15/16
	4 ft	None	304 4/16	13	47 14/16	102 8/16	9 5/16	10 10/16	54 12/16	84 15/16
	8 ft	None	352 8/16	13	47 14/16	102 8/16	9 5/16	10 10/16	54 12/16	84 15/16
120-150	None	None	320 13/16	13	47 14/16	102 8/16	—	—	—	—
	4 ft	None	369	13	47 14/16	102 8/16	—	—	—	—
	8 ft	None	417 3/16	13	47 14/16	102 8/16	9 5/16	10 10/16	54 12/16	84 15/16
90-105	None	Low/Med/High	256 1/16	13	47 14/16	102 8/16	9 5/16	10 10/16	54 12/16	84 15/16
	8 ft	Low/Med/High	352 8/16	13	47 14/16	102 8/16	9 5/16	10 10/16	54 12/16	84 15/16
120-150	None	Low/Med	320 13/16	13	47 14/16	102 8/16	9 5/16	10 10/16	54 12/16	84 15/16
	8 ft	Low/Med	417 3/16	13	47 14/16	102 8/16	9 5/16	10 10/16	54 12/16	84 15/16
	None	High	320 13/16	13	59 14/16	102 8/16	9 5/16	10 10/16	54 12/16	84 15/16
Tonnage	Blank Section	Gas Heat	HORIZONTAL Opening Dimensions							
			Return End Opening				Supply Opening			
			Y1	Y3	H3	L1	X4	Y4	W4	H2
90-105	None	None	6 5/16	8 3/16	35 3/16	127 2/16	254 12/16	10 10/16	54 12/16	84 15/16
	4 ft	None	6 5/16	8 3/16	35 3/16	127 2/16	302 15/16	10 10/16	54 12/16	84 15/16
	8 ft	None	6 5/16	8 3/16	35 3/16	127 2/16	351 2/16	10 10/16	54 12/16	84 15/16
120-150	None	None	—	—	—	—	319 8/16	10 10/16	54 12/16	84 15/16
	4 ft	None	—	—	—	—	367 11/16	10 10/16	54 12/16	84 15/16
	8 ft	None	6 5/16	8 3/16	35 3/16	127 2/16	415 15/16	10 10/16	54 12/16	84 15/16
90-105	None	Low/Med/High	6 5/16	8 3/16	35 3/16	127 2/16	254 12/16	10 10/16	54 12/16	66 11/16
	8 ft	Low/Med/High	6 5/16	8 3/16	35 3/16	127 2/16	351 2/16	10 10/16	54 12/16	84 15/16
120-150	None	Low/Med	6 5/16	8 3/16	35 3/16	127 2/16	319 8/16	10 10/16	54 12/16	66 11/16
	8 ft	Low/Med	6 5/16	8 3/16	35 3/16	127 2/16	415 15/16	10 10/16	54 12/16	84 15/16
	None	High	6 5/16	8 3/16	35 3/16	127 2/16	319 8/16	10 10/16	66 12/16	66 11/16



Dimensional Data

Table 77. Downflow/horizontal airflow configuration dimensions (in.) with energy recovery wheel

Tonnage	Blank Section	Gas Heat	DOWNFLOW Opening Dimensions											
			Return Opening-with or without Relief Fan				Return Opening-with Return Fan				Supply Opening			
			X1	Y1	W1	L1	X1	Y1	W1	L1	X2	Y2	W2	L2
90-105	None	None	82 3/16	8 14/16	49 10/16	121 15/16	N/A	N/A	N/A	N/A	352 8/16	13	47 14/16	102 8/16
	4 ft	None	82 3/16	8 14/16	49 10/16	121 15/16	N/A	N/A	N/A	N/A	400 11/16	13	47 14/16	102 8/16
	8 ft	None	82 3/16	8 14/16	49 10/16	121 15/16	N/A	N/A	N/A	N/A	448 15/16	13	47 14/16	102 8/16
120-150	None	None	82 3/16	8 14/16	49 10/16	121 15/16	N/A	N/A	N/A	N/A	417 4/16	13	47 14/16	102 8/16
	4 ft	None	82 3/16	8 14/16	49 10/16	121 15/16	N/A	N/A	N/A	N/A	465 7/16	13	47 14/16	102 8/16
	8 ft	None	82 3/16	8 14/16	49 10/16	121 15/16	N/A	N/A	N/A	N/A	513 10/16	13	47 14/16	102 8/16
90-105	None	Low/Med/High	82 3/16	8 14/16	49 10/16	121 15/16	N/A	N/A	N/A	N/A	352 8/16	13	47 14/16	102 8/16
	8 ft	Low/Med/High	82 3/16	8 14/16	49 10/16	121 15/16	N/A	N/A	N/A	N/A	448 15/16	13	47 14/16	102 8/16
120-150	None	Low/Med	82 3/16	8 14/16	49 10/16	121 15/16	N/A	N/A	N/A	N/A	417 4/16	13	47 14/16	102 8/16
	8 ft	Low/Med	82 3/16	8 14/16	49 10/16	121 15/16	N/A	N/A	N/A	N/A	513 10/16	13	47 14/16	102 8/16
	None	High	82 3/16	8 14/16	49 10/16	121 15/16	N/A	N/A	N/A	N/A	417 4/16	13	59 14/16	102 8/16
Tonnage	Blank Section	Gas Heat	HORIZONTAL Opening Dimensions											
			Return Side Opening				Supply Opening							
			X3	Y3	W3	H1	X4	Y4	W4	H2				
90-105	None	None	71 8/16	10 10/16	54 12/16	43 6/16	351 3/16	10 10/16	54 12/16	84 15/16				
	4 ft	None	71 8/16	10 10/16	54 12/16	43 6/16	399 6/16	10 10/16	54 12/16	84 15/16				
	8 ft	None	71 8/16	10 10/16	54 12/16	43 6/16	447 10/16	10 10/16	54 12/16	84 15/16				
120-150	None	None	71 8/16	10 10/16	54 12/16	43 6/16	415 15/16	10 10/16	54 12/16	84 15/16				
	4 ft	None	71 8/16	10 10/16	54 12/16	43 6/16	464 2/16	10 10/16	54 12/16	84 15/16				
	8 ft	None	71 8/16	10 10/16	54 12/16	43 6/16	512 6/16	10 10/16	54 12/16	84 15/16				
90-105	None	Low/Med/High	71 8/16	10 10/16	54 12/16	43 6/16	351 3/16	10 10/16	54 12/16	66 11/16				
	8 ft	Low/Med/High	71 8/16	10 10/16	54 12/16	43 6/16	447 10/16	10 10/16	54 12/16	84 15/16				
120-150	None	Low/Med	71 8/16	10 10/16	54 12/16	43 6/16	415 15/16	10 10/16	54 12/16	66 11/16				
	8 ft	Low/Med	71 8/16	10 10/16	54 12/16	43 6/16	512 6/16	10 10/16	54 12/16	84 15/16				
	None	High	71 8/16	10 10/16	54 12/16	43 6/16	415 15/16	10 10/16	66 12/16	66 11/16				

Notes:

1. On horizontal return with ERW units, the return end opening can be on the front, rear, or both sides of the unit and must be specified.
2. ERW is not allowed w/ end return

Electrical Entry Details

Figure 20. Electrical entry details/bottom view

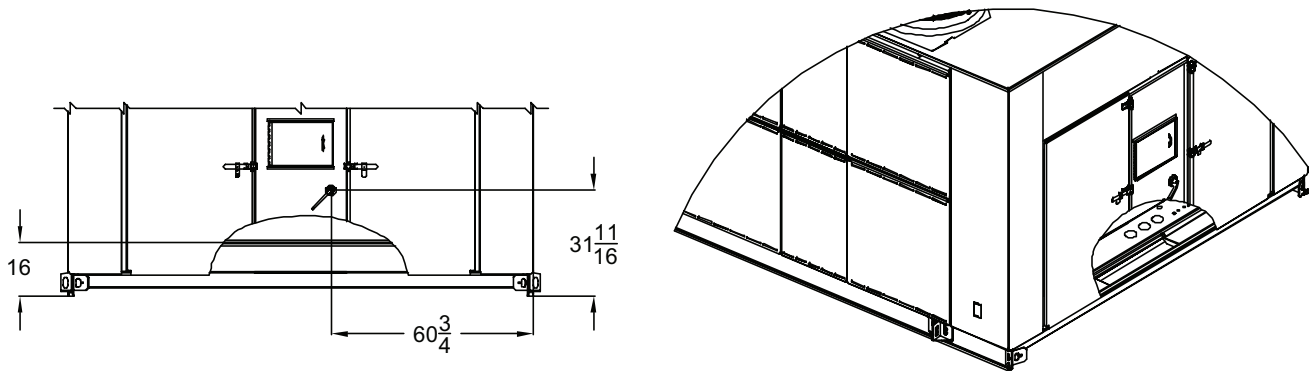

Bottom View

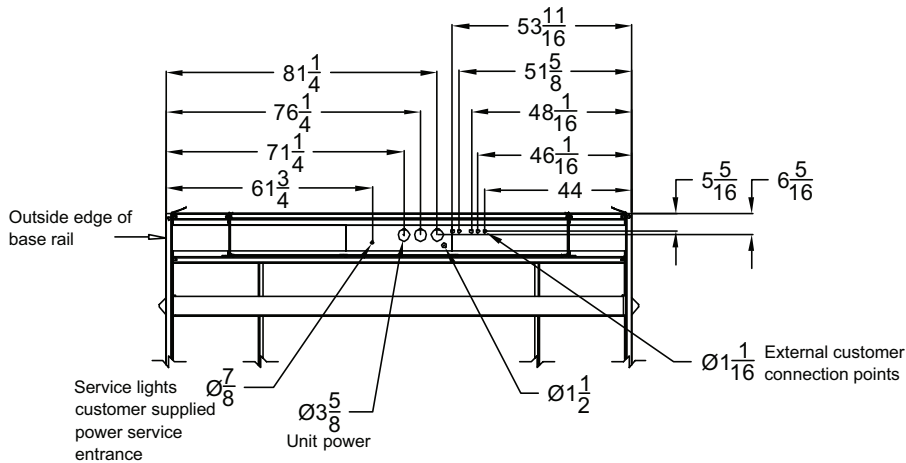

Minimum Required Clearance

Figure 21. Minimum required clearance

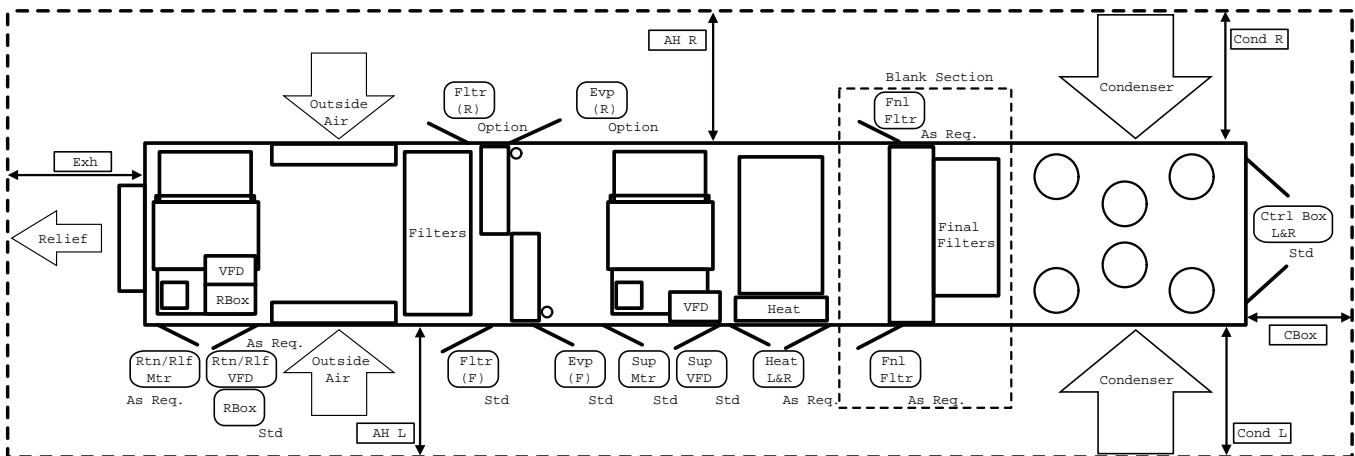

Note: Unit drawing is representative only and may not accurately depict all models.



Dimensional Data

Table 78. Minimum required clearance

Door Location	Availability	Unit Option Selection (Door Swing Ft. and In.)									
		Standard		VFD		Heat	Reheat	Two-side Access		Final Filter	Energy Recovery
		90-105	120-150	Return/Relief	Supply			Electric/Hot Water/Steam	90-105		
Relief/Ret Motor	Std	2' 2"	2' 2"	*	*	*	*	*	*	*	
Relief/Ret VFD and Return Control Panel	As Req.	*	*	2' 2"	*	*	*	*	*	*	
ERW Filtr (L & R) (F)	Option	*	*	*	*	*	*	*	*	*	2' 2"
ERW Filtr(a) (L & R) (R)	Option	*	*	*	*	*	*	*	*	*	2' 2"
Filter (Front)	Std	2' 8"	2' 8"	*	*	*	*	*	*	*	
Filter (Rear)	Option	*	*	*	*	*	*	2' 2"	2' 8"	*	
Evap (Front)	Std	2' 2"	2' 2"	*	*	*	*	*	*	*	
Evap (Rear)	Std	2' 8"	*	*	*	*	*	*	*	*	
or Evap (Rear)	Option	*	*	*	*	*	2' 2"	*	2' 2"	*	
Supply Motor	Std	2' 8"	2' 8"	*	*	*	*	*	*	*	
Supply VFD	As Req.	*	*	*	2' 2"	*	*	*	*	*	
Heat (Left & Right)	As Req.	*	*	*	*	2' 2"	*	*	*	*	
Final Filter (Front)	As Req.	*	*	*	*	*	*	*	*	2' 2"	
Final Filter (Rear)	As Req.	*	*	*	*	*	*	*	*	2' 2"	
Control Box (L & R)	Std	3' 2"	3' 2"	*	*	*	*	*	*	*	

Minimum Required Clearance (Ft.)	AH_L	AH_R	Exh	Cond_L	Cond_R	Control Box
	8'	8'	8'	8'	8'	6'

Note: See Unit Dimensions for Energy Recovery Wheel location.

Optional Roof Curb

Figure 22. Optional roof curb (downflow)

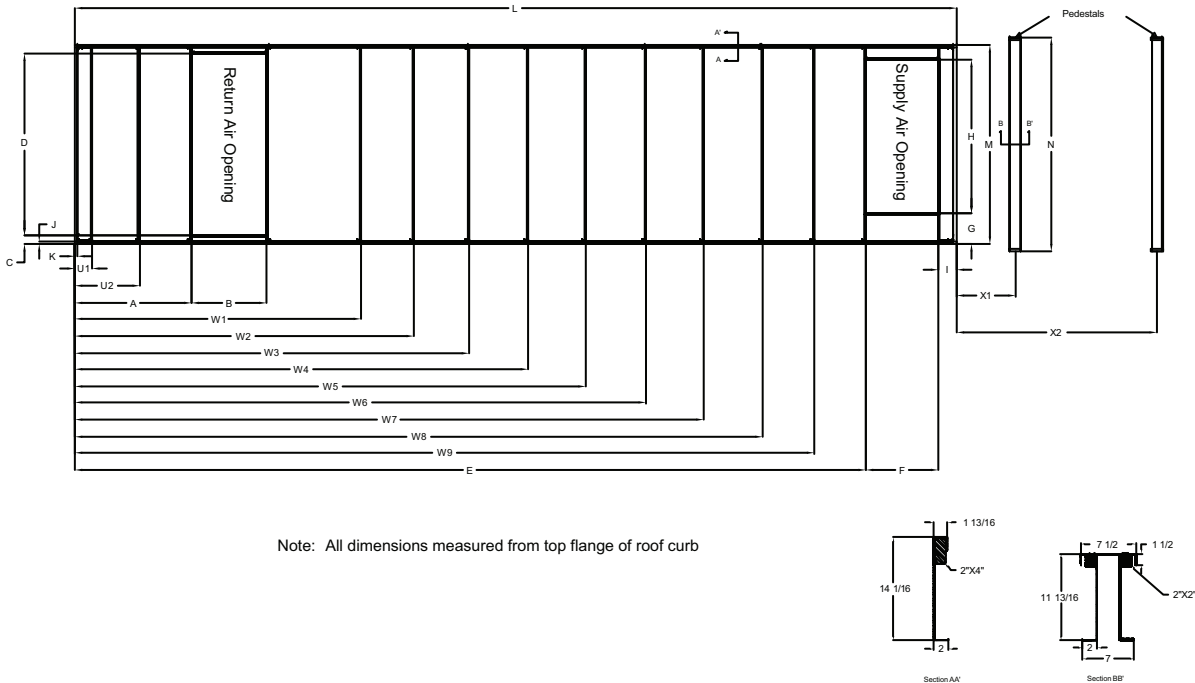

Note: All dimensions measured from top flange of roof curb

Table 79. Roof curb dimensions, ONE or TWO-piece unit without energy recovery wheel (in.)

Tons	Blank Section	Dimensions									
		A	B	C	D	E	F	G	H	I	J
90-105	None	11 15/16	49 8/16	5 15/16	123	253 2/16	49 8/16	20 15/16	104	11 15/16	1 13/16
90-105	4 ft	11 15/16	49 8/16	5 15/16	123	301 5/16	49 8/16	20 15/16	104	11 15/16	1 13/16
90-105	8 ft	11 15/16	49 8/16	5 15/16	123	349 9/16	49 8/16	20 15/16	104	11 15/16	1 13/16
120-150 ^(a)	None	11 15/16	49 8/16	5 15/16	123	317 14/16	49 8/16	20 15/16	104	11 15/16	1 13/16
120-150	4 ft	11 15/16	49 8/16	5 15/16	123	366 2/16	49 8/16	20 15/16	104	11 15/16	1 13/16
120-150	8 ft	11 15/16	49 8/16	5 15/16	123	414 5/16	49 8/16	20 15/16	104	11 15/16	1 13/16
120-150 ^(b)	None	11 15/16	49 8/16	5 15/16	123	317 14/16	49 8/16	20 15/16	104	11 15/16	1 13/16

Tons	Blank Section	Dimensions		
		K	L	M
90-105	None	1 13/16	314 9/16	134 14/16
90-105	4 ft	1 13/16	362 12/16	134 14/16
90-105	8 ft	1 13/16	411	134 14/16
120-150 ^(c)	None	1 13/16	379 5/16	134 14/16
120-150	4 ft	1 13/16	427 8/16	134 14/16
120-150	8 ft	1 13/16	475 12/16	134 14/16
120-150 ^(d)	None	1 13/16	391 5/16	134 14/16

- (a) Except High Heat Gas Models
- (b) High Heat Gas Models Only
- (c) Except High Heat Gas Models
- (d) High Heat Gas Models Only

Table 80. Roof curb cross member dimensions, ONE or TWO-piece unit without energy recovery wheel (in.)

Tons	Blank Section	Cross Member Locations							
		W1	W2	W3	W4	W5	W6	W7	W8
90-105	None	103 6/16	145 11/16	183 6/16	218 4/16	N/A	N/A	N/A	N/A
90-105	4 ft	103 6/16	145 11/16	187 15/16	231 10/16	266 8/16	N/A	N/A	N/A
90-105	8 ft	103 6/16	145 11/16	189 15/16	234 3/16	279 13/16	314 11/16	N/A	N/A
120-150 ^(a)	None	103 6/16	145 11/16	179 6/16	213 1/16	248 2/16	289	N/A	N/A
120-150	4 ft	103 6/16	145 11/16	181 11/16	217 12/16	255 3/16	296 6/16	331 4/16	N/A
120-150	8 ft	103 6/16	145 11/16	185 4/16	224 13/16	265 12/16	304 7/16	344 9/16	379 7/16
120-150 ^(b)	None	103 6/16	145 11/16	179 5/16	213 1/16	248 2/16	289	N/A	N/A

- (a) Except High Heat Gas Models
- (b) High Heat Gas Models Only

Table 81. Roof curb dimensions, ONE or TWO-piece unit with energy recovery wheel (in.)

Tons	Blank Section	Dimensions									
		A	B	C	D	E	F	G	H	I	J
90-105	None	79 5/16	50 12/16	5 15/16	123	349 9/16	49 8/16	20 15/16	104	11 15/16	1 13/16
90-105	4 ft	79 5/16	50 12/16	5 15/16	123	397 12/16	49 8/16	20 15/16	104	11 15/16	1 13/16
90-105	8 ft	79 5/16	50 12/16	5 15/16	123	446	49 8/16	20 15/16	104	11 15/16	1 13/16
120-150 ^(a)	None	79 5/16	50 12/16	5 15/16	123	414 5/16	49 8/16	20 15/16	104	11 15/16	1 13/16
120-150	4 ft	79 5/16	50 12/16	5 15/16	123	462 8/16	49 8/16	20 15/16	104	11 15/16	1 13/16
120-150	8 ft	79 5/16	50 12/16	5 15/16	123	510 12/16	49 8/16	20 15/16	104	11 15/16	1 13/16
120-150 ^(b)	None	79 5/16	50 12/16	5 15/16	123	414 5/16	49 8/16	20 15/16	104	11 15/16	1 13/16

Tons	Blank Section	Dimensions		
		K	L	M
90-105	None	1 13/16	411	134 14/16
90-105	4 ft	1 13/16	459 3/16	134 14/16
90-105	8 ft	1 13/16	507 6/16	134 14/16
120-150 ^(c)	None	1 13/16	476 1/16	134 14/16
120-150	4 ft	1 13/16	524 4/16	134 14/16



Dimensional Data

Table 81. Roof curb dimensions, ONE or TWO-piece unit with energy recovery wheel (in.) (continued)

Tons	Blank Section	Dimensions		
		K	L	M
120-150	8 ft	1 13/16	572 8/16	134 14/16
120-150 ^(d)	None	1 13/16	488 1/16	134 14/16

(a) Except High Heat Gas Models

(b) High Heat Gas Models Only

(c) Except High Heat Gas Models

(d) High Heat Gas Models Only

Table 82. Roof curb cross member dimensions, ONE or TWO-piece unit with energy recovery wheel (in.)

Tons	Blank Section	Cross Member Locations										
		U1	U2	W1	W2	W3	W4	W5	W6	W7	W8	W9
90-105	None	11 15/16	43 15/16	168 10/16	204 11/16	242 1/16	279 13/16	314 11/16	N/A	N/A	N/A	N/A
90-105	4 ft	11 15/16	43 15/16	168 10/16	204 11/16	242 1/16	284 6/16	328	362 14/16	N/A	N/A	N/A
90-105	8 ft	11 15/16	43 15/16	168 10/16	204 11/16	242 1/16	286 5/16	330 9/16	376 4/16	411 2/16	N/A	N/A
120-150 ^(a)	None	11 15/16	43 15/16	168 10/16	204 11/16	242 1/16	275 12/16	309 8/16	344 9/16	385 7/16	N/A	N/A
120-150	4 ft	11 15/16	43 15/16	168 10/16	204 11/16	242 1/16	278 2/16	314 3/16	351 9/16	392 12/16	427 10/16	N/A
120-150	8 ft	11 15/16	43 15/16	168 10/16	204 11/16	242 1/16	281 10/16	321 3/16	362 3/16	400 14/16	441	475 14/16
120-150 ^(b)	None	11 15/16	43 15/16	168 10/16	204 11/16	242 1/16	275 12/16	309 8/16	344 9/16	385 7/16	N/A	N/A

(a) Except High Heat Gas Models

(b) High Heat Gas Models Only

Table 83. Pedestal dimensions

Tons	One-, Two-Piece Unit	Pedestal Dimensions		
		N	X1	X2
90	1	145.25	N/A	93 1/16
90	2	145.25	36 3/16	111 3/16
105	1	145.25	N/A	111 1/16
105	2	145.25	36 3/16	129 3/16
120-150	1	145.25	N/A	117 1/16
120-150	2	145.25	40 3/16	136 3/16



Weights

Table 84. Approximate operating weights (lbs.)

Air-Cooled Units		
Nominal Tons	Unit (Minimum)	Roof Curb (Minimum)
90	14973	907
105	16411	907
120	18447	1040
130	18467	1040
150	19176	1040

Notes:

- Weights shown include the following features: No heat, standard evap capacity coils, fixed speed compressors, 0-25% outside air, 2-inch throwaway filters, low CFM supply fan, minimum supply motor sizes, no return or exhaust fan.
- Weights shown represent approximate minimum operating weights. To calculate weight for a specific unit configuration, utilize TOPSS or contact the local Trane sales representative. Weight outputs have a + 10% accuracy. ACTUAL WEIGHTS ARE STAMPED ON THE UNIT NAMEPLATE.

Table 85. Component weights

	90		105		120		130		150	
	Size	Weight	Size	Weight	Size	Weight	Size	Weight	Size	Weight
Refrigeration										
Compressor Assy. - Fixed capacity compressors	-	1126	-	1630	-	1642	-	1666	-	1666
Compressor Assy. - eFlex™ Variable speed	-	1479	-	1503	-	1626	-	1524	-	1786
Air-Cooled Condensing Coil (AI)	-	1173	-	1421	-	1485	-	1485	-	1485
Evap Coil - Std. Cap	-	1034	-	1300	-	1892	-	1892	-	2564
Evap Coil - Hi. Cap.	-	1382	-	1462	-	2564	-	2564	-	
Reheat Coil & Tubing	-	292	-	294	-	367	-	367	-	367
Replaceable Core Filter Driers	-	26	-	25	-	35	-	35	-	35
HGBP	-	46	-	49	-	53	-	53	-	53
Supply Fan Assembly										
Supply Fan & Fan Board Assy. - Low CFM	25"	1159	32"	1361	32"	1361	32"	1361	32"	1361
Supply Fan & Fan Board Assy. - Std. CFM	36"	1490	36"	1490	40"	1653	40"	1653	40"	1653
Belt Guard	-	116	-	116	-	116	-	116	-	116
Supply VFD (50 hp and below)	-	233	-	233	-	233	-	233	-	233
Supply VFD (60-100 hp)	-	284	-	284	-	284	-	284	-	284
Supply Fan Motor - 15 hp	-	181	-	181	-	181	-	181	-	181
Supply Fan Motor - 20 hp	-	206	-	206	-	206	-	206	-	206
Supply Fan Motor - 25 hp	-	358	-	358	-	358	-	358	-	358
Supply Fan Motor - 30 hp	-	413	-	413	-	413	-	413	-	413
Supply Fan Motor - 40 hp	-	495	-	495	-	495	-	495	-	495
Supply Fan Motor - 50 hp	-	604	-	604	-	604	-	604	-	604
Supply Fan Motor - 60 hp	-	776	-	776	-	776	-	776	-	776
Supply Fan Motor - 75 hp	-	879	-	879	-	879	-	879	-	879
Supply Fan Motor - 100 hp	-	1102	-	1102	-	1102	-	1102	-	1102
Return/Relief Fan Assembly										
Return Fan & Dampers - Low CFM	36"	2294	36"	2294	36"	2294	36"	2294	36"	2294
Return Fan & Dampers - Std. CFM	40"	2343	40"	2343	44"	2445	44"	2445	44"	2445
Exhaust Fan & Dampers - Low CFM	25"	889	28"	979	28"	979	28"	979	28"	979
Exhaust Fan & Dampers - Std. CFM	28"	979	32"	1429	32"	1429	32"	1429	32"	1429
Belt Guard	-	119	-	119	-	119	-	119	-	119
Exhaust / Return VFD (50 hp and below)	-	244	-	244	-	244	-	244	-	244
Exhaust / Return VFD (60-100 hp)	-	295	-	295	-	295	-	295	-	295
Exh / Rtn Fan Motor - 7.5 hp	-	160	-	160	-	160	-	160	-	160
Exh / Rtn Fan Motor - 10 hp	-	181	-	181	-	181	-	181	-	181
Exh / Rtn Fan Motor - 15 hp	-	206	-	206	-	206	-	206	-	206
Exh / Rtn Fan Motor - 20 hp	-	206	-	206	-	206	-	206	-	206



Weights

Table 85. Component weights (continued)

	90		105		120		130		150	
	Size	Weight	Size	Weight	Size	Weight	Size	Weight	Size	Weight
Exh / Rtn Fan Motor - 25 hp	-	358	-	358	-	358	-	358	-	358
Exh / Rtn Fan Motor - 30 hp	-	413	-	413	-	413	-	413	-	413
Exh / Rtn Fan Motor - 40 hp	-	495	-	495	-	495	-	495	-	495
Exh / Rtn Fan Motor - 50 hp	-	604	-	604	-	604	-	604	-	604
Exh Fan Motor - 60 hp	-	776	-	776	-	776	-	776	-	776
Heat										
Gas Heat Low	0.85M	690	0.85M	690	1.1M	840	1.1M	840	1.1M	840
Gas Heat Med	1.1M	840	1.1M	840	1.8M	1150	1.8M	1150	1.8M	1150
Gas Heat High	1.8M	1150	1.8M	1150	2.5M	1398 ^(a)	2.5M	1398	2.5M	1398
Electric Heat	-	485	-	485	-	485	-	485	-	485
Steam Heat Low	-	753	-	753	-	802	-	802	-	802
Steam Heat High	-	821	-	821	-	886	-	886	-	886
Hot Water Heat Low	-	773	-	773	-	841	-	841	-	841
Hot Water Heat High	-	818	-	818	-	897	-	897	-	897
Filters										
Filter Rack - Throwaway Filters	-	181	-	181	-	191	-	191	-	191
Filter Rack - Bag Filters	-	395	-	395	-	395	-	395	-	395
Filter Rack - Cartridge Filters	-	662	-	662	-	662	-	662	-	662
Final Filters - Bag Filters	-	392	-	392	-	392	-	392	-	392
Final Filters - Cartridge Filters w/ 2" pre-filter	-	607	-	607	-	607	-	607	-	607
Final Filters - Cartridge Filters w/ 4" pre-filter	-	638	-	638	-	638	-	638	-	638
Final Filters - High Temp. Cartridge	-	669	-	669	-	669	-	669	-	669
Final Filters - HEPA	-	1777	-	1777	-	1777	-	1777	-	1777
Final Filters - HEPA High Temp.	-	1839	-	1839	-	1839	-	1839	-	1839
Outside Air										
0-25% Damper	-	637	-	637	-	699	-	699	-	699
Econ	-	760	-	760	-	865	-	865	-	865
Econ w/ Air Measure	-	724	-	724	-	807	-	807	-	807
ERW, Low CFM w/ Econ ^(b)	-	3307	-	3307	-	3518	-	3681	-	3681
ERW, High CFM w/ Econ ^(b)	-	3545	-	3514	-	3756	-	3756	-	3756
ERW, Low CFM w/ Econ & Air Measure ^(b)	-	3487	-	3487	-	3727	-	3890	-	3890
ERW, High CFM w/ Econ & Air Measure ^(b)	-	3725	-	3694	-	3965	-	3965	-	3965
Cabinet										
Cabinet	-	8097	-	8315	-	9473	-	9473	-	9473
Cabinet - 4' Blank Section	-	935	-	935	-	901	-	901	-	901
Cabinet - 8' Blank Section	-	1709	-	1709	-	1682	-	1682	-	1682
Electrical Panels										
Control Box - Main	-	519	-	519	-	519	-	519	-	519
Convenience Outlet	-	36	-	36	-	36	-	36	-	36
Return Box	-	80	-	80	-	80	-	80	-	80
Junction Box	-	60	-	60	-	60	-	60	-	60
2-Piece Unit Adder										
2-Piece Adder	-	406	-	406	-	406	-	406	-	406

^(a) 2.5M includes weight associated with 12" of cabinet length

^(b) Energy Recovery includes weight associated w/ 96" of cabinet length.

Table 86. Roof curb weights

Tonnage	Energy Recovery Wheel	Blank Section	One-Piece Unit	Two-Piece Unit
90-105	No	None	907	1055
90-105	No	4 ft	988	1136
90-105	No	8 ft	1069	1217
90-105	Yes	None	1093	1240

Table 86. Roof curb weights (continued)

Tonnage	Energy Recovery Wheel	Blank Section	One-Piece Unit	Two-Piece Unit
90-105	Yes	4 ft	1174	1321
90-105	Yes	8 ft	N/A	1401
120-150 (All Units Except High Heat Gas models)	No	None	1040	1194
120-150 (All Units Except High Heat Gas models)	No	4 ft	1122	1275
120-150 (All Units Except High Heat Gas models)	No	8 ft	N/A	1357
120-150 (High Heat Gas Models Only)	No	None	1055	1209
120-150 (All Units Except High Heat Gas models)	Yes	None	N/A	1378
120-150 (All Units Except High Heat Gas models)	Yes	4 ft	N/A	1459
120-150 (All Units Except High Heat Gas models)	Yes	8 ft	N/A	1540
120-150 (High Heat Gas Models Only)	Yes	None	N/A	1393

Table 87. Pre-engineered options

Component	Options
Cabinet	4' or 8' blank in Pre DX or Return Position
Electrical	Dual Power
Energy Recovery	Energy recovery with Horizontal Return
Fans	Beltless Direct Drive Plenum Supply Fan
	Propeller Relief Fan
Heat	LP Gas Heat Field Kit



Mechanical Specifications

General

Units shall be specifically designed for outdoor rooftop installation on a roof curb and be completely factory assembled and tested, piped, internally wired, fully charged with compressor oil and shipped in one, two or three-pieces for field reassembly into a single unit. Single piece units shall be fully charged.

Units shall be available for direct expansion cooling only, or direct expansion cooling with natural gas, electric, hot water or steam heating. Filters, outside air system, relief air system, optional non-fused disconnect switches and all operating and safety controls shall be furnished factory installed.

In select configurations, cooling capacity shall be tested in accordance with AHRI Standard 360. All units shall have decals and tags to aid in service and indicate caution areas. Electrical diagrams shall be printed on long life water resistant material and shall ship attached to control panel doors.

Casing

Exterior panels shall be zinc coated galvanized steel, phosphatized and painted with a slate grey air-dry finish durable enough to withstand a minimum of 672 hours consecutive salt spray application in accordance with standard ASTM B117. Screws shall be magnigard coated.

Refrigeration components and compressor shall be accessible through removable louvered panels as standard. Unit air handling section shall be laminated double-wall construction with polyurethane foam core injected between sheet metal panels and liners. Insulation value shall be R8. All interior surfaces shall be suitable for cleaning per ASHRAE 62. All access doors and panels shall have neoprene gaskets. Unit base shall be watertight with heavy gauge formed load bearing members and curb overhang. Unit lifting lugs shall accept chains or cables for rigging. Lifting lugs shall also serve as unit tie down points.

Access Doors

Access doors shall be hinged with a single, exterior mounted, height and tension adjustable, handle to provide positive latching at three points. Access doors shall provide a door stop mechanism to latch the door in the open position to prevent unsafe door closure by wind.

Doors of laminated double wall construction with a polyurethane foam core between the exterior sheet metal pane and the interior liner, with an insulating value of R8 shall be provided on the air handlers serviceable compartments such as return/relief fan, filters, evaporator coil, and blank sections. Two single wall doors shall be provided for access to the control panel.

Blank Sections

Blank section shall be [four][eight] foot length of laminated double wall construction with a polyurethane foam core between the exterior sheet metal panel and the interior liner, with an insulating value of R8. Hinged access doors of similar construction shall be provided on on either side.

Two-Piece Construction

Two-piece construction shall facilitate lifting and rigging of the unit. The condenser section shall contain the associated valving and electrical box for recoupling of refrigeration, power and control systems. Transition panels shall be provided for the integrity on the recoupled unit.

Note: Multi-piece units are shipped with nitrogen and must be field charged with R-454B.

Airflow Path

Unit shall have [downflow][horizontal] discharge conditioned air path. Return airflow path shall be either upflow or horizontal through the side or the end.

Burglar Bars

A grate system shall be installed in supply and return air duct connection areas on non-horizontal airflow path units to minimize unwanted intrusion into duct systems.

Belt Guard

Supply and relief fans shall have a universal size belt guard to accommodate any applicable drive configuration. The guard shall completely enclose the drive system and is provided with a two-piece removable front panel for servicing. Return fan guards shall be individually sized with a single piece removable panel for servicing.

Refrigeration System

Compressors

Compressors shall be direct-drive, hermetic, scroll-type compressors with centrifugal-type oil pumps. Each compressor has a crankcase heater to minimize the amount of liquid refrigerant present in the oil sump during off cycles. Discharge line service valves shall be standard on each refrigerant circuit, as well as liquid moisture indicator/sight glass.

eFlex™ Variable Speed Compressors

The Trane eFlex™ variable speed compressor shall be capable of speed modulation from 25 Hz to a maximum of 100 Hz. The minimum unit capacity shall be 15% of full load or less. The compressor motor shall be a permanent magnet type. Each compressor shall have a crankcase heater installed, properly sized to minimize the amount of liquid refrigerant present in the oil sump during off cycles. Compressors shall be equipped with a bearing oil injection system that optimizes scroll set lubrication, sealing, and controls the oil circulation rate.

Optimal bearing lubrication shall be provided by a gerotor oil pump. Each variable speed compressor shall be matched with a specially designed variable frequency drive which modulates the speed of the compressor motor and provides several compressor protection functions. Control of the variable speed compressor and inverter control shall be integrated with the IntelliPak unit controller to ensure optimal equipment reliability and efficiency.

Supply Fan

[Standard][Low] airflow supply fan shall have a single fan assembly with double width, double inlet, airfoil fan, motor and fixed pitch sheave drive. All fans shall be statically and dynamically balanced for the operating envelop. It shall be tested in the factory. Supply fans shall be test run in unit as part of the unit test. Fan operating envelop rpm shall be below first critical speed. Fan shafts shall be mounted on two grease lubricated ball bearings designed for 200,000 hours average life.

Extended grease lines shall allow greasing of bearings from section base rail. Fan motor and fan assembly shall be mounted on common base to allow consistent belt tension with no relative motion between fan and motor shafts. Entire assemblies shall be completely isolated from unit by two-inch deflection spring isolators.

Evaporator Coil

Internally enhanced copper tubing of ½-inch O.D. shall be mechanically bonded to heavy-duty aluminum fins of configured design. All coils shall be equipped with electronic expansion valves, and are factory pressure and leak tested. A double sloped stainless steel drain pan shall be provided to drain condensate to both sides of the unit.

Stainless Steel Drain Pans

Drain pan shall be stainless steel, double sloped, and located under the evaporator coil in order to promote runoff of standing water from condensation inside the unit as well as provide protection in corrosive environments. Two drain pipes shall be installed through the base channel on each side of the unit.



Mechanical Specifications

Hot Gas Bypass

The hot gas bypass option shall consist of valves, piping and controls that are all included on circuit 1 to allow operation at low airflow, avoiding coil frosting and damage to the compressor. When saturated suction temperature falls below controls adjustable setpoint, the valve shall modulate hot gas to the inlet of the evaporator.

Filter Drier

Removable core filter driers shall be optionally available and installed on each refrigeration circuit. For easy access, the filter driers are conveniently located in the condenser section close to the periphery of the unit.

Suction Service Valves

Each compressor shall be optionally equipped with a suction service valve in order to facilitate compressor servicing.

Leak Detection Sensors

Unit shall be furnished with a leak detection system from the factory when a circuit refrigerant charge exceeds 3.91 lbs. The leak detection system shall consist of one or more refrigerant detection sensors. When the system detects a leak, the unit controller shall initiate mitigation actions.

Air-Cooled Condensing

Air-Cooled Condenser Coil

Condenser coils shall have all-aluminum, Microchannel coils. All coils shall be leak tested at the factory to ensure pressure integrity. The condenser coil shall be pressure tested to 650 psig. Subcooling circuit (s) shall be provided as standard.

Air-Cooled Condenser Fans and Motors

All condenser fans shall be vertical discharge, direct drive fans, statically balanced, with steel blades and zinc plated steel hubs. Condenser fan motors shall be totally enclosed three-phase motors with permanently lubricated ball bearings, built-in current and thermal overload protection and weather tight slingers over motor bearings.

Corrosion Protected Condenser Coil

All aluminum Microchannel condenser coil protection shall consist of a corrosion resistant coating that shall withstand ASTM B117 Salt Spray test for 6,000 hours and ASTM G85 A2 Cyclic Acidified Salt Fog test for 2,400 hours. This coating shall be added after coil construction covering all tubes, headers and fin edges, therefore providing optimum protection in more corrosive environments.

Electrical

Unit shall be completely factory wired with necessary control and contactor pressure lugs or terminal block for power wiring. Units shall provide an internal location for a non-fused disconnect with external handle for safety.

Symbio™ 800 Controller

The Symbio 800 controller is an application-specific, programmable controller that is factory installed and designed to control packaged HVAC equipment. A 7-inch user interface features a touch-sensitive color screen that provides facility managers with at-a-glance operating status, performance monitoring, scheduling changes, and operating adjustments. Other advanced features include automated controller backup and optional features such as secure remote connectivity, wireless building communications, mobile device connectivity, and custom programming with expandable I/O.

Control Options

Modbus Communication Protocol

All documented status and control points shall be available as Modbus RTU or Modbus TCP registers as defined in the Modbus protocol specification through an RS485, two wire communication link.

Trane LonTalk® Communication Interface Module

The rooftop controller shall support LonTalk® allowing for control and monitoring of the unit through a RS485, two wire communication link.

BACnet® Communication

Rooftop controller communication interface shall utilize the BACnet protocol with an Ethernet (IEEE 802.3) or RS485 (EIA-485) physical interface and an appropriate data link technology as defined in ANSI®/ASHRAE® Standard 135-2012. (e.g. BACnet/IP, BACnet/MSTP). The rooftop controller shall be BTL listed as a BACnet Advanced Application Controller (B-AAC) as defined in ANSI/ASHRAE Standard 135-2012.

AirFi® Wireless Communication Interface Module (WCI) (Field Installed)

Rooftop controller communication interface shall utilize the BACnet protocol with a ZigBee (IEEE 802.15.4) physical interface and an appropriate data link technology as defined in ANSI®/ASHRAE® Standard 135-2012. Wireless communication shall utilize open standard protocols, of which BACnet and ZigBee shall be considered appropriate.

Each rooftop controller wireless communication interface shall self-heal to maintain operation in the event of network communication failure.

Each zone sensor wireless communication interface shall be capable of many-to-one sensors per controller to support averaging, monitoring, and multiple zone applications. Sensing options shall include temperature, relative humidity, CO₂, and occupancy.

Power Monitor

Factory installed power meter shall measure unit energy usage to 0.2 percent accuracy (ANSI C12.20) and communicate through the Symbio™ 800 controller enabling viewing through user interface or building automation system.

Ambient Control

Variable speed condenser motors shall be provided to allow the unit to operate down to 0°F.

Controls Expansion Hardware

The rooftop controller shall have field applied controls capability. Factory installed expansion hardware (XM70) shall have 19 inputs/outputs. Additional expansions may be added in the field.

Rapid Restart

Option provides immediate start-up upon power failure. A backup generator shall be required on site before unit start-up. Rapid Restart shall begin immediately after recovery from a power loss and work by restarting the compressors and supply fan quickly to provide full cooling within 3 to 4 minutes.

System Control Options

Variable Air Volume Supply Air Temperature control

Option provides all the necessary controls to operate a VAV rooftop from the discharge air temperature, including discharge air microprocessor controller and discharge air sensor. The microprocessor controller coordinates the economizer control and the stages of cooling with zone or outdoor air reset capabilities and an adjustable control band to fine-tune the control to specific applications.



Mechanical Specifications

Multi Zone Variable Air Volume (Discharge Air Temperature)

Option provides all necessary controls to operate a VAV rooftop from the discharge air temperature, including discharge air microprocessor controller and discharge air sensor.

Variable Frequency Drive (VFD) Bypass

Supply fan bypass control provides airflow at 60Hz in the event of drive failure.

Single Zone Variable Air Volume

Single zone VAV option provides all necessary controls to operate a rooftop unit based on maintaining two temperature setpoints; the discharge air and zone. Option includes factory-installed variable frequency drive (VFD) to provide supply fan motor speed modulation. During Single Zone VAV cooling, the unit maintains zone cooling setpoint by modulating the supply fan speed more or less to meet zone load demand, and the unit maintains discharge temperature to the discharge cooling setpoint by modulating economizer if available and staging DX cooling.

Electrical System

Power Supply

Air-cooled rooftops shall be available with 460 or 575 voltage, 3 phase 60 hertz power supply and 380 voltage, 3 phase 50 hertz power supply.

Convenience Outlet

A 15A, 115V Ground Fault Interrupter convenience outlet shall be factory installed and wired and powered from a factory mounted transformer. A unit mounted, non-fused disconnect with internal handle is furnished with the factory powered convenience outlet.

Non-Fused Disconnect Switch

An external handle mounted on the control box door shall be provided to disconnect unit power with the control box door closed for safety.

Compressor Protection

Compressor Protection Modules shall be included in the junction box to protect compressors against reverse rotation.

Unit Interrupt Rating (Short Circuit Current Rating-SCCR)

An optional 65,000 Amp rating (480V) and 25,000 Amp rating (600V) shall be applied to the unit enclosure using a non-fused circuit breaker for disconnect switch purposes. . The unit shall be marked with approved cULus markings and will adhere to cULus regulations.

Marine Lights (Customer Powered)

A customer-provided 120V service will supply power to a fused disconnect switch which feeds a transformer providing class 2, 24V power to the LED Marine Lights. The LED Marine Lights shall be placed in the Supply Section (2), Outside Air Section (1), Return Section (1), and Extended Casing Section (1) for units without heat.

Supply/Relief/Return Motors

Supply, relief/return motors shall be either open drip-proof or totally enclosed fan cooled (TEFC). All 60 Hz motors meet the Energy Independence and Security Act of 2007 (EISA). All 50 Hz supply, relief/return motors shall meet the U.S. Energy Policy Act of 1992 (EPACT). Motors with internal Shaft grounding rings can be selected for use with VFD applications and shall provide a conductive discharge path away from the motor bearings to ground.

Filters

General

Filter options shall mount integral within the unit and be accessible by a hinged access door with a single point latching device.



Pre-evaporator Coil Filter Options

No Filters (Two-inch Nominal Thickness Throwaway Filter Rack Only)

Shall provide a galvanized steel filter rack (less filter media) with filter channels to handle a complete set of two-inch nominal thickness throwaway filters to accommodate applications which require field supplied filters.

No Filters (Bag or Cartridge Filter Rack with Throwaway Prefilter Rack Only)

Shall provide a galvanized steel filter rack (less filter media) to handle a complete set of two-inch (depending on airflow) nominal thickness throwaway prefilters and 7/8-inch actual header thickness bag or cartridge filters to accommodate applications which require field supplied filters.

MERV 8 Throwaway Filters (Standard)

Shall be provided as standard-U.L. Class 2, two-inch nominal thickness, high efficiency pleated media filters rated MERV 8 per ASHRAE 52.2. Filters shall be provided mounted in a galvanized steel filter rack.

MERV 15, 90-95 Percent Bag Filters Option

Nineteen-inch deep bag filters shall be U.L. Class 2 and have synthetic media mounted to a 7/8-inch nominal thickness header frame. These bag filters shall have an efficiency rating of MERV 15 per ASHRAE 52.2. To ensure maximum bag filter life two-inch prefilters shall be included with the bag filters. Filters shall be mounted in a galvanized steel filter rack.

MERV 14, 90-95 Percent Cartridge Filters Option

Twelve-inch deep cartridge filters shall be U.L. Class 1 and be mounted with a 7/8-inch nominal thickness header frame. These cartridge filters shall have an efficiency rating of MERV 14 per ASHRAE 52.2. To ensure maximum cartridge filter life, two-inch (or four-inch, depending on the application) prefilters shall be included with the cartridge filters. Filters shall be mounted in a galvanized steel filter rack.

MERV 14, 90-95 Percent, Low Pressure Drop, Totally Incinerable, Cartridge

Twelve-inch deep cartridge filter shall be U.L. Class 2 and mounted with a rigid 7/8-inch nominal thickness header frame. These low pressure drop cartridge filters shall have an efficiency rating of MERV 14 per ASHRAE 52.2. To ensure maximum cartridge filter life two-inch or four-inch prefilters (depending on airflow) shall be included with the high-flow, cartridge filters. Filters shall be mounted in a galvanized steel filter rack.

Final Filters Options (Available Only on Units with Blank Section)

Final filter section filter options shall mount integral within the blank section unit casing and be accessible by hinged access doors.

MERV 15, 90-95 Percent, Bag, Final Filter Option

Note: Available on cooling only units with four or eight-foot blank section, as well as steam and hot water units with eight-foot blank section, unit casing only.

Nineteen-inch deep bag filters shall be U.L. Class 2 and have synthetic media mounted to a 7/8-inch nominal thickness header frame. These bag filters shall have an efficiency rating of MERV 15 per ASHRAE 52.2. To ensure maximum bag final filter life two-inch, MERV 8 prefilters shall be included with the bag filters. Filters shall be mounted in a galvanized steel filter frame bank.

MERV 14, 90-95 Percent, Cartridge, Final Filter Option

Note: Available on cooling only units with four or eight-foot blank section, as well as steam and hot water units with eight-foot blank section, unit casing only.

Twelve-inch deep cartridge filters shall be U.L. Class 1 and be mounted with a 7/8-inch nominal thickness header frame. These cartridge filters shall have an efficiency rating of MERV 14 per ASHRAE 52.2. To ensure maximum cartridge filter life, two-inch, MERV 8 prefilters shall be included with the cartridge filters. Filters shall be mounted in a galvanized steel filter frame bank.

MERV 14, 90-95 Percent, Low Pressure Drop, Totally Incinerable, Cartridge

Note: Available on cooling only units with four or eight-foot blank section, as well as steam and hot water units with eight-foot blank section, unit casing only.

Twelve-inch deep cartridge filter shall be U.L. Class 2 and mounted with a rigid 7/8-inch nominal thickness header frame. These cartridge filters shall have an efficiency rating of MERV 14 per ASHRAE 52.2. To ensure maximum cartridge final filter life four-inch, MERV 8 prefilters shall be included with these cartridge filters. Filters shall be mounted in a galvanized steel filter frame bank.

MERV 14, 90-95 Percent, High Temperature Rated, Cartridge, Final Filter Option

Note: Available on gas and electric heat units with eight-foot blank section casing only.

Twelve-inch deep cartridge filters shall be U.L. Class 1 and be mounted in a galvanized steel casing with a 7/8-inch nominal thickness header frame. These cartridge filters shall have an efficiency rating of MERV 14 per ASHRAE 52.2. To ensure maximum cartridge final filter life high temperature rated two-inch, MERV 8 prefilters shall be included with the cartridge filters. Filters shall be mounted in a galvanized steel filter frame bank.

MERV 17, 99.97 Percent, Standard Temperature Rated, HEPA, Final Filter Option

Note: Available on cooling only units with four or eight-foot blank section, as well as steam and hot water units with eight-foot blank section, unit casing only.

Twelve-inch deep HEPA filters shall be U.L. Class 1 and be mounted in a galvanized steel casing. These filters have an efficiency rating of MERV 17 per ASHRAE 52.2 and an efficiency of 99.97% on a 0.3 micron DOP particle size. To ensure maximum HEPA final filter life two-inch, MERV 8 prefilters shall be included with the HEPA final filters. Filters shall be mounted in a galvanized steel filter frame bank.

MERV 17, 99.97 Percent, High Temperature Rated, HEPA, Final Filter Option

Note: Available on gas and electric heat units with eight-foot blank section casing only.

Twelve-inch deep HEPA filters shall be U.L. Class 1 and be mounted in a galvanized steel casing. These filters have an efficiency rating of MERV 17 per ASHRAE 52.2 and an efficiency of 99.97% on a 0.3 micron DOP particle size. To ensure maximum HEPA final filter life high temperature rated two-inch, MERV 8 prefilters shall be included with the HEPA final filters. Filters shall be mounted in a galvanized steel filter frame bank.

Relief Air

General

Relief air options include no relief, 100 percent modulating relief fan and 100 percent modulating relief fan with direct space building pressurization control. Relief fans are either standard or low airflow.

No Relief (Standard)

Relief air opening is sealed with panel and made watertight.

100 Percent Modulating Relief Fan Option

Fan design is double width, double inlet forward-curved type. Fan is mounted on a shaft with fixed sheave drive. All fans are dynamically balanced and tested in factory before being installed in unit. It is test run in unit as part of unit test.

Fan operating envelop rpm is below first critical speed. Fan shaft is mounted on two grease lubricated ball or roller bearings as applicable designed for 200,000-hour average life. Extended grease lines are provided to allow greasing of bearings from section base rail. Fan motor and assembly is mounted on common base to allow consistent belt tension with no relative motion between fan and motor shafts. The entire assembly is completely isolated from unit with 2-inch spring isolation. Discharge dampers at unit outlet modulate relief airflow in response to OA damper position.

The fan operates when economizer damper is open greater than minimum position. Discharge dampers at fan outlet modulate in response to economizer damper position on Constant Volume (CV) rooftops.

100 Percent Modulating Relief Fan with Statitrac Control Option

Fan design is double width, double inlet forward-curved type. Fan is mounted on a shaft with fixed sheave drive. All fans are dynamically balanced and tested in factory before being installed in unit. Relief fan is test run as part of unit final run test.



Mechanical Specifications

Fan operating envelop rpm is be below first critical speed. Fan shaft is be mounted on two grease lubricated ball or roller bearings designed for 200,000-hour average life. Extended grease lines are provided to allow greasing of bearings from section base rail.

Fan motor and assembly is mounted on common base to allow consistent belt tension with no relative motion between fan and motor shafts. The entire assembly is completely isolated from unit with 2-inch spring isolators. For VAV rooftops, the 100 percent modulating relief discharge damper (or VFD) is modulated in response to building pressure. A differential pressure control system, (Statitrac), uses a differential pressure transducer to compare indoor building pressure to outdoor ambient atmospheric pressure. The FC relief fan is turned on when required to lower building static pressure setpoint.

The (Statitrac) control system then modulates the discharge dampers (or VFD) to control the building pressure to within the adjustable, specified deadband that shall be adjustable at the user interface. Optional bypass can be factory installed to provide full nominal airflow in the event of a drive failure.

Return Air

General

Return air options shall include 100 percent modulating return fan and 100 percent modulating return with direct space building pressurization control. Return fans shall be either standard or low airflow.

100 Percent Modulating Return Fan

A single width plenum fan with airfoil blade shall be mounted on a shaft with fixed sheave drive. The fan shall be dynamically balanced for the operating envelop and tested in factory before being installed in unit. The plenum fan shall be test run in unit as part of unit test. Fan operating envelop rpm shall be below first critical speed. Fan shaft shall be mounted on two grease lubricated ball or roller bearings designed for 200,000-hour average life. Extended grease lines shall be provided to allow greasing of bearings from section base rail.

Fan motor and assembly shall be mounted on common base to allow consistent belt tension with no relative motion between fan and motor shafts. The entire assembly shall be completely isolated from unit with 2-inch spring isolators. Discharge dampers at unit outlet shall modulate relief airflow in response to OA / return air damper position. The return fan VFD shall operate in conjunction with the supply fan.

100 Percent Modulating Return Fan with Statitrac Control Option

A single width plenum fan with airfoil blade shall be mounted on a shaft with fixed sheave drive. The fan shall be dynamically balanced for the operating envelop and tested in factory before being installed in unit. The plenum fan shall be test run as part of unit final run test. Fan operating envelop rpm shall be below first critical speed. Fan shaft shall be mounted on two grease lubricated ball or roller bearings designed for 200,000-hour average life. Extended grease lines shall be provided to allow greasing of bearings from section base rail.

Fan motor and assembly shall be mounted on common base to allow consistent belt tension with no relative motion between fan and motor shafts. The entire assembly shall be completely isolated from unit with 2-inch spring isolators. The 100 percent modulating relief damper shall be modulated in response to building pressure. A differential pressure control system, (Statitrac), shall use a differential pressure transducer to compare indoor building pressure to outdoor ambient atmospheric pressure.

The Statitrac control system shall modulate the discharge dampers to control the building pressure to within the adjustable, specified deadband that shall be adjustable at the user interface. The return fan VFD shall modulate in response to return duct static pressure. Optional bypass can be factory installed to provide full nominal airflow in the event of a drive failure.

Outside Air

General

Three outside air options: 0 to 25 percent motorized controlled outside air, 0-100 percent fully modulating economizer, and 0-100 percent fully modulating economizer with outside air measurement.

0-25 Percent Motorized Outside Air Damper Option

0-25 percent motorized outside air damper option includes an outside air opening with moisture eliminator and motorized position damper for drawing up to 25 percent outside air. The damper position will be adjustable at the user interface.

0-100 Percent Modulating Economizer Option

Economizer is operated through the primary temperature controls to automatically utilize OA for "free" cooling. Automatically modulated return and OA dampers maintains proper temperature in the conditioned space. Economizer is equipped with an automatic lockout when the outdoor high ambient temperature is too high for proper cooling. Minimum position control is standard and adjustable at the user interface or with a remote potentiometer or through the building management system. A spring return motor ensures closure of OA dampers during unit shutdown or power interruption. Mechanical cooling is available to aid the economizer mode at any ambient. Standard economizer dampers have a leakage rate of 20 CFM/ft² at 1.0 in W.C. pressure difference.

Low Leak Dampers

Low leak dampers are provided with chlorinated polyvinyl chloride gasketing added to the damper blades and rolled stainless steel jamb seals to the sides of the damper assembly. The low leak dampers have a leakage rate of 10 CFM/ft² (AMCA Class 2) at 1.0 in W.C. pressure difference.

Ultra Low Leak Dampers AMCA Class 1

Standard ultra low leak damper will have added sealing under the jam seals and in the frame. The ultra low leak dampers have a leakage rate of 4 CFM/ft² (AMCA Class 1) at 1.0 in W.C. pressure difference.

Note: Based on testing completed in accordance with AMCA Standard 500D.

Ultra Low Leak, AMCA 1A Economizer

The AMCA 1A rated Ultra Low Leak Economizer option is provided with parallel operating, horizontal airfoil blades and spring-return actuators (to the fresh air closed, return air open position). The economizer, including linkages and actuators, have a 5 year limited warranty and functional life of 60,000 opening and closed cycles. Dampers are AMCA 511 Class 1A certified with a maximum leakage rate of 3 CFM/sq-ft at 1.0 in WC pressure differential.

Economizer frame and 6-inch wide blades are galvanized steel. Blade edge seals are Ruskiprene (-72° F to + 275°F) and jamb seals are be compressible, flexible metal.

The economizer fresh air damper includes an adjustable linkage to allow for field damper balance of pressure drop between 100% fresh and 100% return airflow paths. The adjustable linkage is used to limit the fresh air damper maximum wide open stroke.

Fault Detection and Diagnostic

Fault Detection and Diagnostic (FDD) control are also be provided with Ultra Low Leak Economizers. FDD control monitors the commanded position of the economizer compared to the feedback position of the damper. If the damper position is outside +/- 10 percent of the commanded position, a diagnostic is generated.

Intellipak units ordered with Ultra Low Leak Economizers are listed on the California Energy Commission Registry for factory compliance with Title 24 Economizer and FDD requirements. A label is applied to the unit identifying construction with the Ultra Low Leak Economizer and FDD controls.

Economizer Control with Comparative Enthalpy

Option includes two enthalpy sensors to compare total heat content of the indoor air and outdoor air to determine the most efficient air source when economizing.

Economizer Control with Reference Enthalpy

Option includes an outdoor enthalpy sensor to compare the total heat content of outdoor air to a locally adjustable setpoint. The setpoint is programmed at the user interface, or remote user interface, to determine if the outdoor enthalpy condition is suitable for economizer operation.



Mechanical Specifications

Economizer Control with Dry Bulb

Option includes an outdoor temperature sensor for comparing the outdoor dry bulb temperature to a locally adjustable temperature setpoint. The setpoint is programmed at the user interface, or remote user interface, to determine if outdoor air temperature is suitable for economizer operation.

Outside Air Measurement (Traq)

A factory mounted airflow measurement station (Traq) is provided in the outside air opening to measure airflow. The airflow measurement station is AMCA certified (+/- 5.0%) from 300fpm to 2500fpm. The airflow measurement station adjusts for temperature variations

Demand Control Ventilation

When equipped with a CO₂ sensor and the (VCM) module, the outside air damper position modulates in response to a CO₂ sensor in the conditioned space, in order to minimize the unit energy consumption, yet simultaneously meet the ventilation requirements of ASHRAE Std 62.1. The Traq airflow monitoring solution augments the system, allowing for measurement and control of outside airflow.

Note: CO₂ sensor used with Demand Control Ventilation must be powered from an external power source or separate 24 VAC transformer.

Ventilation Override Mode

With the optional Ventilation Override Mode (VOM) installed, the unit is programmed to transition to up to 5 different programmed sequences for Smoke Purge, Evacuation, Pressurization, Purge, Purge with duct control sequence and Unit off. The transition occurs when a binary input on the VOM is closed (shorted); typically a hard-wired relay output from a smoke detector or fire control panel.

Heating System

Electric Heating Option

All electric heat models shall be completely assembled and have wired electric heating system integral within the rooftop unit. Heavy duty nickel chromium elements internally wired with a maximum density of 40 watts per square inch shall be provided. Heater circuits shall be 48 amps or less, each individually fused. Automatic reset high limit control shall operate through heater backup contactors. The 460 and 575 volt electric units shall have optional factory mounted non-fused disconnect switch located in the main control panel to serve the entire unit.

Gas Fired Heating Option

All gas-fired units shall be completely assembled, have a wired, gas-fired heating system integral within unit, and fire tested prior to shipment. Units shall be cULus approved specifically for outdoor applications downstream from refrigerant cooling coils.

All gas heaters shall have 81% steady state efficiency, meeting the 2023 Department of Energy efficiency code. Gas-fired heating system control shall be fully integrated with the unit controls. Gas safety controls shall include electronic flame sensing capability, which proves combustion air prior to ignition sequence and during operation. The ignition sequence shall include a pre-purge cycle. Direct spark ignition shall be provided to the pilot line on all heat exchangers.

A three minute delay shall be provided between first and second stage gas valve operation on two-stage heaters.

Heat exchangers shall be drum and tube design with pre-mix burners. Free-floating design shall eliminate expansion and contraction stresses and noises. Heating system shall incorporate forced draft fans and include a chimney that exhausts away from the air intake. All gas heaters shall be made from 304L stainless steel suitable for condensing situations. Gasketed cleanout plate shall be provided for maintenance and inspection of tubes/turbulators.

All gas piping shall be threaded connection with a pipe cap provided. Gas supply connection shall be provided through the side or bottom of unit. Heat exchanger shall be factory pressure and leak tested.

Steam Heating Option

Steam coils shall be Type NS with non-freeze steam distribution circuits. Distributor tubes shall be located concentrically within condensing tubes to assure even steam distribution. Coils shall be pitched to provide complete drainage. Steam modulating valve with actuator shall be provided.

Hot Water Heating Option

Hot water coils shall be Type 5W and factory mounted in the rooftop unit to provide complete drainage of coil. Hot water modulating valve with actuator shall be provided.

Energy Saving Options

Energy Recovery Wheel

The energy recovery option shall incorporate a rotary wheel in an insulated cassette frame complete with seals, drive motor, and drive belt. Two wheel size options shall be available for each unit. The standard size option shall be capable of treating 50% of maximum unit outside airflow, while the low CFM shall be able to treat only 30%. A relief fan shall be required in conjunction with the energy recovery option. A return fan option is incompatible with the energy recovery wheel option.

A total energy recovery wheel shall be required to recover both sensible and latent energy. The factory installed wheel shall be coated with a silica gel desiccant. The desiccant shall be permanently bonded without the use of binders or adhesives or other means which may degrade desiccant performance. The substrate shall be lightweight polymer and shall not degrade nor require additional coatings for application in marine or coastal environments.

Desiccant shall not dissolve or deliquesce in the presence of water or high humidity. The coated wheel segments shall be washable with non-acid coil cleaner or alkaline detergent and warm water. Wheel segments shall be removable without specialized tools or compartment modifications to facilitate maintenance and cleaning.

Hot Gas Reheat Option

Hot Gas Reheat option shall consist of hot gas reheat coil, located on the leaving air side of the evaporator coil, and pre-piped to circuit 1 along with a set of modulating reheat valves.

Accessories

Roof Mounting Curb

Roof mounting curb shall be heavy gauge zinc coated steel with nominal two-inch by four-inch nailer setup. Supply/return air opening gasketing shall be provided. Curb shall ship knocked down for easy assembly. Channel shall be provided to allow for adjustment of return air opening location. Curb shall be manufactured to National Roofing Contractors Association guidelines.

Electronic Zone Sensors

- Zone Sensor provide two temperature setpoint levers, Heat, Auto, Off, or Cool system switch, Fan Auto or Fan On switch. This sensor is used with SZVAV units.
- VAV Zone Sensor is provided with supply air single temperature setpoint and AUTO/OFF system switch. Sensor is provided for zone temperature control with VAV units. VAV units are not compatible with SZVAV units.
- Fast Warmup Sensor is used as morning warmup sensor with VAV units.
- Integrated Comfort System sensors is available with sensor only, sensor with timed override, and sensor with local temperature setpoint adjustment with timed override.
- AirFi™ Wireless Zone Sensor is available with a RF wireless zone temperature, setpoint and timed override transmitter and a RF receiver that connects directly to the IntelliPak 2 controller and uses spread spectrum technology. Option includes sensor, receiver wiring harness and (2) AA lithium batteries. Sensor battery life provides at least 5 years life under normal operating conditions and provides a readily visual indication of battery condition.



Mechanical Specifications

CO₂ (Carbon Dioxide) Sensing

The CO₂ sensor shall have the ability to monitor space occupancy levels within the building by measuring the parts per million of CO₂ in the air. As the CO₂ levels increase, the outside air damper modulates to meet the CO₂ space ventilation requirements.

Humidity Sensor

A wall or duct-mounted humidity sensor shall be used to control activation of the hot gas reheat dehumidification option. The humidity sensor shall be set for humidity levels between 40 percent and 60 percent relative humidity.

High Duct Temperature Thermostats

Two temperature sensors, Discharge Air and Return Air (if installed) are used to determine if duct temperatures are excessively high. If the discharge air temperature exceeds 200°F or if the return air temperature exceeds 135°F, the unit will be placed into Emergency Stop Mode.

Trane Start-Up

A Trane technician shall provide unit startup after the unit is properly installed. The installation shall include:

- Unit and all ship-with items installed
- All utilities and drain pipes connected
- All refrigerant piping reconnected and all refrigerant charge adequately distributed throughout the system
- All ductwork attached to the unit

Prior to Trane Unit Start-Up

Prior to Trane start-up, the following work should be inspected and verified:

Unit inspection - Cabinet

Review the overall unit for exterior damage (dents, bends, missing panels, doors working properly, etc). Verify the unit interior is free from debris/obstructions, the panels and doors are secured properly, the unit clearances are adequate to avoid air recirculation, and that the unit drain lines and traps are properly installed.

Wiring

Review the unit main power to ensure that the unit is properly grounded, the main power feed wire gauge is adequately sized, the correct voltage is supplied to the unit and electric heaters (if applicable), and the incoming voltage is phase balanced. Verify that all wiring connections are tight, all field installed control wiring is landed on correct terminals, and that all automation and remote controls, along with control wiring for CV and VAV controls, are correctly installed/wired.

Refrigeration system

Review the refrigeration system to ensure the coil fins are straightened, shipping hardware and plastic covers for compressors have been removed, compressors contain the correct oil level, service valves are in the correct position, and the crankcase heaters have been operational for at least 12 hours prior to Trane start-up.

Fans

Check the unit fans to ensure the condenser fan blade set-screws to the motor shaft are tight, hold down bolts and channels from fan sections have been removed, proper adjustment of fan section spring isolators, proper fan belts tension, adequate fan bearings greased, alignment of fan sheaves, adequate tightness of supply and relief fan pulley bolts, proper fan rotation, and proper fan motor amperage.

Multi-piece units

Check to ensure both piping to the condenser and air handler side of the system have been completed and interconnecting refrigerant tubing has been evacuated. Verify base rail connection points. Inspect and verify wiring connection points related to multi-piece units.

Economizer

Check all damper linkages for proper adjustment. Verify proper damper operation and outside air pressure sensors.

Electric Heat

On units equipped with electric heaters, check to ensure the heating system matches the unit nameplate and verify that the correct voltage is supplied to the heaters.

Hot Water/Steam

On units equipped with hot water heat, check and verify the following: hot water pipes are properly routed, sized and leak free; the presence of swing joints or flexible connectors next to the hot water coil; proper gate valve installation in the supply and return branch line; proper three way modulating valve installation, and proper coil venting. On units equipped with steam heat, check and verify the following: hot water pipes are properly routed, sized and leak free; proper swing check vacuum breaker installation; proper 2-way modulating valve installation; and proper steam trap installation.

Gas Heat

On units equipped with gas heaters, check to ensure that the flue assembly is secure and properly installed, sufficient gas pressure exists at the unit, no leaks exist in gas supply line, the gas heat piping includes a drip leg, and condensate line is run if required.

Trane Unit Start-Up

After the unit installation has been fully completed, a Trane technician shall do the following:

- Verify and log supply fan operation, proper compressor operation, and condenser fan operation, as well as correct levels of superheat and subcooling.
- Verify operation of all VAV modes per job requirements, which include: Supply Air Cooling and Heating, Daytime Warmup, Morning Warmup, and Supply Air Tempering.

Return Fan — Establish the return fan maximum setpoint based on the required building pressure setpoint.

Space pressure control — Verify that unit is sensing field installed building pressure input.

Ventilation override — Verify that sequences are set up and functional per customer requirement.

Economizer — Adjust outside air travel and verify all sensor inputs.

Dehumidification — Verify that dehumidification mode operates correctly and is set up per job requirements.

Outside Air Measurement — Verify that there is correct Traq damper linkage and actuator operation, as well as matched left and right air flow. Verify that Demand Flow Ventilation function is correct.

Gas Heat — Startup gas heat per the unit Installation, Operation, Maintenance Manual (IOM) and record CO₂ and O₂ levels.

Energy Recovery — Check to ensure proper rotation and operation of the wheel. Use the service test guide in the unit Installation, Operation, Maintenance Manual (IOM) to operate unit components.

All units — Verify user interface programming, including setpoints and sensor sources per customer requirements. Leave the unit in a running state or off per customer requirement. Once the IntelliPak® unit startup is complete, provide a startup activities communication and the associated operating log.

Certified AHRI Performance

Packaged Rooftop units cooling, heating capacities and efficiencies shall be rated within the scope of the Air-Conditioning, Heating and Refrigeration Institute (AHRI) Certification Program and display the AHRI Certified® mark as a visual confirmation of conformance to the certification sections of AHRI Standard 340-360 (I-P) and ANSI Z21.47 and 10 CFR Part 431 pertaining to Commercial Warm Air Furnaces. The applications in this catalog specifically excluded from the AHRI certification program are:

- Ventilation modes
- Heat Recovery



Notes



The AHRI Certified mark indicates Trane U.S. Inc. participation in the AHRI Certification program. For verification of individual certified products, go to ahridirectory.org.

Trane - by Trane Technologies (NYSE: TT), a global innovator - creates comfortable, energy efficient indoor environments for commercial and residential applications. For more information, please visit trane.com or tranetechnologies.com.

Trane has a policy of continuous product and product data improvements and reserves the right to change design and specifications without notice. We are committed to using environmentally conscious print practices.