



Product Catalog

Precedent™ Packaged Rooftop Units

Cooling and Gas/Electric

Ultra High Efficiency

3 to 25 Tons — 60 Hz





Introduction

Packaged Rooftop Precedent Units

Precedent™ rooftop units have been redesigned to deliver the most complete offering of 3 to 25 ton gas, hybrid, and all-electric light commercial packaged rooftop solutions. The wide range of capacities, efficiencies, heating types, and available options allow Precedent rooftop systems to serve a variety of commercial applications. Plus, new features including the intuitive Symbio™ unit controller, hinged control panel access, color-coded wiring, and direct drive motors simplify installation, start-up, and maintenance.

Copyright

This document and the information in it are the property of Trane, and may not be used or reproduced in whole or in part without written permission. Trane reserves the right to revise this publication at any time, and to make changes to its content without obligation to notify any person of such revision or change.

Trademarks

All trademarks referenced in this document are the trademarks of their respective owners.

Revision History

- Added fan curve plot 12.5 to 25 tons downflow and horizontal for model TZK in Evaporator Fan Performance – Cooling chapter.
- Updated AHRI net capacity for TZK060, cool – ultra high efficiency and YZK060, gas – ultra high efficiency in General data chapter.
- Added TZK – unit wiring, TZK – electric heat and YZK – unit wiring tables in Electrical data chapter.
- Updated Model weights, corner weights and center of gravity dimensions tables for cooling and gas/electric in Weights chapter.



Table of Contents

Features and Benefits	5
Features	5
Control Options	7
Accessories	7
Key Benefits	10
Application Considerations	18
A2L Application Considerations	18
Leak Detection System(Refrigerant charge greater than 3.91 lb per circuit)	19
Model Number Description	20
General Data	22
Gross Cooling Capacities	29
Reheat Temperature Rise	53
Evaporator Fan Performance — Cooling	77
Downflow	77
Horizontal	88
Evaporator Fan Performance — Gas Heat	99
Downflow	99
Horizontal	107
Fan Performance	115
Heating Performance	119
Controls	122
Enhanced BAS Integration and Connectivity	122
Secure Remote Connectivity with Trane Connect	122
Serviceability	122
Flexibility	124
Economizer Controls	125
Zone Sensors	125
Air-Fi Wireless Communicating Zone Sensors	126
Thermostats	127
Humidity Control (HGRH)	127
Electrical Data	129
Dimensional Data	143
Weights	156



Mechanical Specifications	158
General	158
Casing	158
Microchannel Coils	158
Coil Guards	158
Compressors	158
Filters	159
Frostat™	159
Gas Heating Section	159
Indoor Fan	159
Powered or Unpowered Convenience Outlet	159
Stainless Steel Drain Pan	159
Stainless Steel Heat Exchanger	159
Through-the-Base Electrical with Circuit Breaker	160
Through-the-Base Electrical with Disconnect Switch	160
Through-the-Base Gas Piping	160
Standard Economizer	160
Electric Heaters	160
Manual Outside Air Damper	160
Motorized Outside Air Damper	160
Power Exhaust	161
Roof Curb	161
Ventilation Override Operation	161
Leak Detection Sensors	161



Features and Benefits

Features

Table 1. Cabinet size — cooling and gas/electric ultra high efficiency

Unit Size (Tons)	Model Number Digits 4, 5, 6	TZK, YZK
3	036	B.0
4	048	
5	060	
6	072	
7.5	090	
8.5	102	
10	120	C.0
12.5	150	D.1
15	180	
17.5	210	
20	240	
25	300	

Note: Equipment feature availability is dependent on unit configuration. For more information, see Trane® Select Assist™ or contact product support.

Table 2. Features – standard and optional

	Standard Features	Options		
		Factory Installed	Factory or Field Installed	Field Installed
3-year Limited Parts Warranty	X			
5-year Limited Compressor Warranty	X			
10-year Limited Heat Exchanger Warranty	X			
15-year Limited Warranty Stainless Steel Heat Exchanger		X		
2 inch Filter	X			
2 inch MERV 8 Filters		X		
2 inch MERV 13 Filters		X		
Access Doors — Hinged	X			
Access Door — Hinged (Control Box)	X			
Anti-Short Cycle Timer	X			
Barometric Relief			X	
CO ₂ Sensor				X
Clogged Filter Switch			X	
Coil guards	X			
CompleteCoat™ Condenser Coil		X		
Condensate Overflow Switch			X	
Convertible Airflow	X			
Colored and Numbered Wiring	X			
Crankcase Heaters	X			
Direct Drive Plenum/Supply Fan	X			
Discharge Air Temperature Sensing Kit	X			
Economizer: Low Leak — Downflow			X	
Economizer: Low Leak — Horizontal				X



Features and Benefits

Table 2. Features – standard and optional (continued)

	Standard Features	Options		
		Factory Installed	Factory or Field Installed	Field Installed
Economizer: Standard — Convertible			X	
Economizer: Standard — Downflow			X	
Economizer: Standard — Horizontal				X
Electric Heater			X	
Expansion Modules			X	
Fault Detection and Diagnostics (FDD)	X			
Filter Removal Tool	X			
Foil-Faced and Edge Protected Insulation	X			
Frostat™	X			
Tubular Gas Heat Exchanger	X			
High Pressure Control	X			
High Altitude Kit				X
High Static/Oversized Motor		X		
High Temperature Sensor				X
Humidity Control- Modulating Hot Gas Reheat (HGRH)		X		
IAQ Dual Sloped Composite Drain Pan	X			
Liquid Line Refrigerant Drier	X			
Low Ambient Cooling to 0°F				X
Low Pressure Control	X			
LP Conversion Kit				X
Microchannel Coils	X			
Modulating Gas Heat		X		
Motorized Outdoor Air Damper			X	
Operating Charge of R-454B	X			
Phase Balance/Loss/Reversal Protection	X			
Phase Monitor	X			
Power Exhaust				X
Powered or Unpowered Convenience Outlet		X		
Quick Adapt Curbs				X
Reference or Comparative Enthalpy			X	
Remote Potentiometer				X
Roof Curb				X
Single Point Power	X			
Single Side Service	X			
Smoke Detector - Return		X		
Smoke Detector - Supply		X		
Stainless Steel Drain Pan		X		
Symbio Controls	X			
Through-the-Base Condensate	X			
Thermal Expansion Valve	X			
Through-the-Base Electrical Access		X		
Through-the-Base Electrical with Circuit Breaker		X		
Through-the-Base Electrical with Disconnect Switch		X		
Through-the-Base Gas Piping		X		
Variable Air Flow (MZVAV)		X		
Variable Air Flow (SZVAV)	X			

Table 2. Features – standard and optional (continued)

	Standard Features	Options		
		Factory Installed	Factory or Field Installed	Field Installed
Variable Speed Scroll Compressor	X			
Ventilation Override				X

Control Options

Note: Control option availability is dependent on unit configuration. For more information, see Trane® Select Assist™ or contact product support.

Table 3. Control options — standard and optional

	Standard Features	Options		
		Factory Installed	Factory or Field Installed	Field Installed
Dual Thermistor Remote Zone Sensor				X
Symbio Service and Installation App	X			
Symbio™ 700 Advanced Module			X	
Humidity Sensor/Humidistat				X
Thermostat				X
Wireless Zone Sensor				X
Zone Sensor				X
LonTalk® Communication Interface (LCI)			X	
Trane® Air-Fi® Wireless Communication Interface (WCI)		X		

Note: For more information, reference the Controls chapter.

Accessories

Note: Accessory availability is dependent on unit configuration. Some accessories may require additional accessories/options for full functionality. For more information, contact product support.

Table 4. Accessories

FIA KIT	DESCRIPTION
FIABARM001*	Barometric Relief
FIABARM002*	Barometric Relief
FIABARM003*	Barometric Relief
FIAC02K001*	CO ₂ (DCV) Wall Mounted Sensor
FIAC02K002*	CO ₂ (DCV) Duct Mounted Sensor
FIACLFS001*	Clogged Filter Switch
FIACLFS002*	Clogged Filter Switch (MERV13)
FIACLFS003*	Clogged Filter Switch
FIACLFS004*	Clogged Filter Switch (MERV13)
FIACLFS005*	Clogged Filter Switch Standard and MERV 8 filter
FIACLFS006*	Clogged Filter Switch MERV 13 filter
FIACURB401*	14-Inch Full Perimeter Knockdown Curb
FIACURB402*	14-inch Full Perimeter Knockdown Curb
FIACURB403*	14-inch Full Perimeter Knockdown Curb
FIACURB404*	14-inch Full Perimeter Knockdown Curb



Features and Benefits

Table 4. Accessories (continued)

FIA KIT	DESCRIPTION
FIACURB801*	18-inch Full Perimeter Knockdown Curb
FIACURB802*	18-inch Full Perimeter Knockdown Curb
FIACURB803*	18-inch Full Perimeter Knockdown Curb
FIACURB804*	18-inch Full Perimeter Knockdown Curb
FIADAST001*	Discharge Air Sensing Tube Kit T/W
FIADAST002*	Discharge Air Sensing Tube Kit Y/D
FIADAST003*	Discharge Air Sensing Tube Kit
FIADAST004*	Discharge Air Sensing Tube Kit
FIADAST005*	Discharge Air Sensing Tube Kit
FIADAST006*	Discharge Air Sensing Tube Kit
FIADAST007*	Discharge Air Sensing Tube Kit
FIADAST008*	Discharge Air Sensing Tube Kit
FIADAST009*	Discharge Air Sensing Tube Kit
FIADFDB001*	Differential Dry Bulb Economizer Control
FIADMPR001*	Manual Damper
FIADMPR002*	Manual Damper
FIADMPR003*	Manual Damper
FIADMPR101*	Motorized Damper
FIADMPR102*	Motorized Damper
FIADMPR103*	Motorized Damper
FIAECON001*	Dry Bulb Economizer
FIAECON002*	Dry Bulb Economizer
FIAECON003*	Dry Bulb Economizer
FIAECON101*	Dry Bulb Downflow Low Leak
FIAECON102*	Dry Bulb Downflow Low Leak
FIAECON103*	Dry Bulb Downflow Low Leak
FIAECON201*	Dry Bulb Horizontal Low Leak
FIAECON202*	Dry Bulb Horizontal Low Leak
FIAECON203*	Dry Bulb Horizontal Low Leak
FIAECON303*	Dry Bulb Horizontal Economizer
FIAEHTB306*	6kW, 208-230V Electric Heater
FIAEHTB312*	12kW, 208-230V Electric Heater
FIAEHTB406*	6kW, 460V Electric Heater
FIAEHTB412*	12kW, 460V Electric Heater
FIAEHTW406*	6kW, 575V Electric Heater
FIAEHTBW12*	12kW, 575V Electric Heater
FIAEHTB309*	9kW, 208-230V Electric Heater
FIAEHTB318*	18kW, 208-230V Electric Heater
FIAEHTB327*	27kW, 208-230V Electric Heater
FIAEHTB336*	36kW, 208-230V Electric Heater
FIAEHTB354*	54kW, 208-230V Electric Heater
FIAEHTB409*	9kW, 460V Electric Heater
FIAEHTB418*	18kW, 460V Electric Heater
FIAEHTB427*	27kW, 460V Electric Heater
FIAEHTB436*	36kW, 460V Electric Heater
FIAEHTB454*	54kW, 460V Electric Heater
FIAEHTBW09*	9kW, 575V Electric Heater

Table 4. Accessories (continued)

FIA KIT	DESCRIPTION
FIAEHTBW18*	18kW, 575V Electric Heater
FIAEHTBW27*	27kW, 575V Electric Heater
FIAEHTBW36*	36kW, 575V Electric Heater
FIAEHTBW54*	54kW, 575V Electric Heater
FIAEHTC318*	18kW, 208-230V Electric Heater
FIAEHTC327*	27kW, 208-230V Electric Heater
FIAEHTC336*	36kW, 208-230V Electric Heater
FIAEHTC354*	54kW, 208-230V Electric Heater
FIAEHTC418*	18kW, 460V Electric Heater
FIAEHTC427*	27kW, 460V Electric Heater
FIAEHTC436*	36kW, 460V Electric Heater
FIAEHTC454*	54kW, 460V Electric Heater
FIAEHTCW18*	18kW, 575V Electric Heater
FIAEHTCW27*	27kW, 575V Electric Heater
FIAEHTCW36*	36kW, 575V Electric Heater
FIAEHTCW54*	54kW, 575V Electric Heater
FIAEHTD318*	18kW, 208-230V Electric Heater
FIAEHTD336*	36kW, 208-230V Electric Heater
FIAEHTD354*	54kW, 208-230V Electric Heater
FIAEHTD372*	72kW, 208-230V Electric Heater
FIAEHTD418*	18kW, 460V Electric Heater
FIAEHTD436*	36kW, 460V Electric Heater
FIAEHTD454*	54kW, 460V Electric Heater
FIAEHTD472*	72kW, 460V Electric Heater
FIAEHTDW18*	18kW, 575V Electric Heater
FIAEHTDW36*	36kW, 575V Electric Heater
FIAEHTDW54*	54kW, 575V Electric Heater
FIAEHTDW72*	72kW, 575V Electric Heater
FIAENTH001*	Reference Enthalpy Economizer Control
FIAENTH002*	Comparative Enthalpy Economizer Control
FIAHALT001*	High Altitude Gas Adjustment Kit - 2-Stage gas
FIAHALT002*	High Altitude Gas Adjustment Kit - 2-Stage gas
FIAHALT003*	High Altitude Gas Adjustment Kit - 2-Stage gas
FIAHTST001*	High Temperature (Fire) Duct Mounted Stat
FIAHZDC001*	Horizontal Conversion Panel
FIALPKT001*	LP Gas Conversion Kit - 2-Stage gas
FIALPKT002*	LP Gas Conversion Kit - 2-Stage gas
FIALPKT003*	LP Gas Conversion Kit - 2-Stage gas
FIALPKTM01*	LP Gas Conversion Kit - Modulating gas
FIALPKTM02*	LP Gas Conversion Kit - Modulating gas
FIALPKTM03*	LP Gas Conversion Kit - Modulating gas
FIALPKTM04*	LP Gas Conversion Kit - Modulating gas
FIALPKTM05*	LP Gas Conversion Kit - Modulating gas
FIALPKTM06*	LP Gas Conversion Kit - Modulating gas
FIALPKTM07*	LP Gas Conversion Kit - Modulating gas
FIALPKTM08*	LP Gas Conversion Kit - Modulating gas
FIALPKTM09*	LP Gas Conversion Kit - Modulating gas

Table 4. Accessories (continued)

FIA KIT	DESCRIPTION
FIALPKTM10*	LP Gas Conversion Kit - Modulating gas
FIALOAM001*	Low Ambient
FIALTCI001*	LonTalk® Communication Interface
FIAOPTN001*	Indoor Options Module
FIAOPTN002*	Fresh Air Options Module
FIAOVFL001*	Condensate Overflow Switch
FIAPWRX301*	Power Exhaust 230V
FIAPWRX302*	Power Exhaust 230V
FIAPWRX303*	Power Exhaust 230V
FIAPWRX401*	Power Exhaust 460V
FIAPWRX402*	Power Exhaust 460V
FIAPWRX403*	Power Exhaust 460V
FIAPWRXW01*	Power Exhaust 575V
FIAPWRXW02*	Power Exhaust 575V
FIAPWRXW03*	Power Exhaust 575V
FIQACB026*	Adapter Curb, BAYCURB026 to FIACURB403/803
FIQACB027*	Adapter Curb, BAYCURB027 to FIACURB403/803
FIQACB042*	Adapter Curb, BAYCURB042 to FIACURB402/802
FIQACB043*	Adapter Curb, BAYCURB043 to FIACURB403/803
FIQACB044*	Adapter Curb, BAYCURB044 to FIACURB402/802
FIQACB045*	Adapter Curb, BAYCURB045 to FIACURB401/801
FIAS7ADV01*	Symbio™ 700 Advanced Controls and BACnet BAS Upgrade Kit
FIASCCM001*	Symbio Customer Connection Module
FIAXMOD030*	Symbio 700 XM30 Expansion Module
FIAXMOD032*	Symbio 700 XM32 Expansion Module

Key Benefits

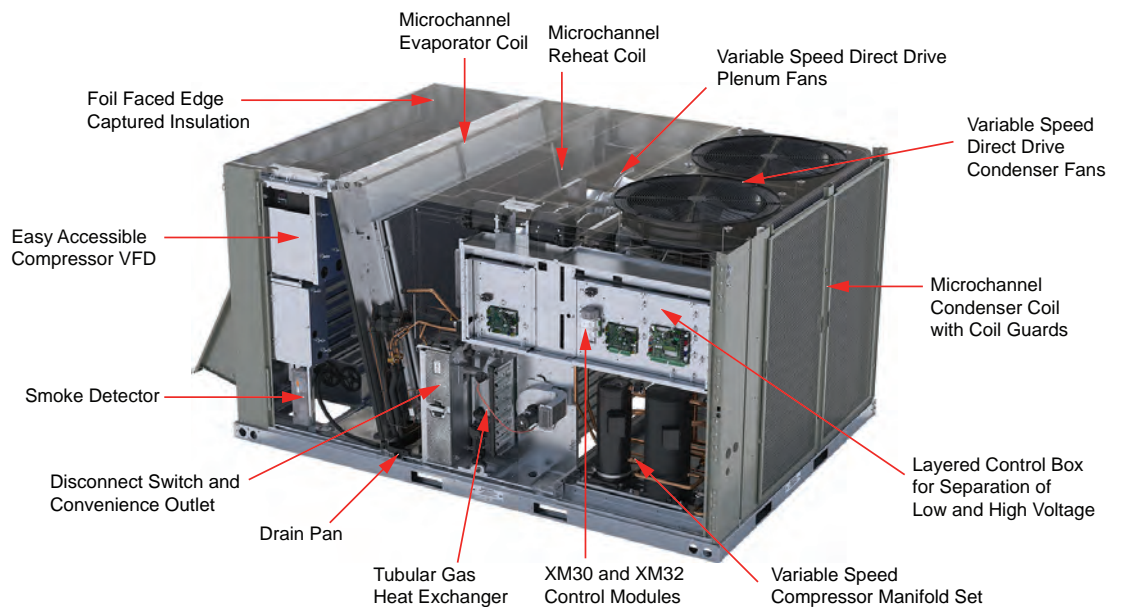

Airflow Distribution

When replacing an older unit and ductwork, the Precedent™ unit airflow provides better air distribution, leading to increased comfort in many cases.

Cabinet Integrity

For added water integrity, a raised 1–inch lip around the supply and return of the downflow units is provided to prevent water from entering the ductwork.

Coil Guards

Coil guards protect condenser coil during shipping and from hail, vandals, wind, and other damage. Toolless design lends itself to ease of maintenance in cleaning coils.

CO₂ Sensor — Demand Control Ventilation (DCV)

Demand-controlled ventilation (DCV) is a control strategy that responds to the actual demand (need) for ventilation by regulating the rate the HVAC system brings outdoor air into the building. A carbon dioxide (CO₂) sensor measures the concentration (parts per million, ppm) of CO₂ in the air. As CO₂ concentration changes, the outside air damper modulates to meet the current ventilation needs of the zone. The CO₂ sensor kit is available as a field installed accessory and wires directly to the Symbio™ 700 controller.

CompleteCoat™ Condenser Coil

This optional coated coil provides excellent corrosion resistance, and uniformity of coverage and coating thickness.

Controls — Symbio™

Enhanced BAS Integration and Connectivity

- Open standard communications
 - BACnet® over Zigbee¹ (Air-Fi Wireless)
 - BACnet MS/TP
 - BACnet IP
 - Modbus™ RTU
 - Modbus TCP/IP
 - LonTalk®
- Securely access, troubleshoot, and monitor equipment from anywhere via Trane Connect™

Serviceability

- Wireless mobile app interface (iOS and Android) to simplify startup/service
- On-board user interface
- Data trending
- Real-time, clear language diagnostics
- Historical alarm logs
- Backup and Restore functionality to reduce commissioning and service time

Flexibility

- Future-ready upgradable software, supporting changing codes and new sequences of operation
- Standard, consistent pre-engineered applications that meet industry standards
- Built-in Schedules (requires Tracer® TU)
- Expandable inputs and outputs (requires Tracer TU)

¹ ZigBee® is a registered trademark of the ZigBee Alliance.



Features and Benefits

- Ability to add custom programmed sequences (requires Tracer TU)

Accessibility

Control box consists of a multilevel design with Symbio™ Controls located on hinged panels which provide protection from high voltage components for ease of servicing.

Convenience Outlet

Two convenience outlet options are available:

- GFCI, 120V/15A, 2 plug, powered
- GFCI, 120V/20A, 2 plug, unpowered

This option is available when through-the-base-electrical (with either disconnect switch or circuit breaker) is selected.



Convertible Units

Units ship in a downflow configuration and can be converted to horizontal by removing two panels. Optional field accessory kits required for D.0 or D.1 cabinet units.

Note: Ultra-low NOx units are not compatible with horizontal discharge units.



Direct Drive Supply Fans

All B.0, C.0, D.0 and D.1 cabinet units are equipped with a direct drive supply fan design featuring.

- External rotor direct drive variable speed indoor motor.
- Variable speed adjustment available in Symbio™ controller.
- Designed to slide out for ease of maintenance.



Drain Pan

Every Precedent unit has an easy-to-clean, composite, removable, dual-sloped drain pan (IAQ). On units with B.0 or C.0 size cabinets, the drain pan is reversible, allowing installation of the drain trap on either side of the unit. See [Table 1, p. 5](#).



eFlex™ Variable Speed Scroll Compressor

Variable speed scroll compressors are matched with a specially designed variable frequency drive that modulates capacity. This allows for precise control of leaving air temperatures to meet space loads.

The eFlex™ compressors also include brushless permanent magnet motors designed to operate at higher efficiency resulting in significant part load energy savings. This makes units with eFlex™ compressors the most efficient products in their class at part load.

Fault Detection and Diagnostics (FDD)

The FDD system meets the mandatory requirement of CA Title 24 of fully configurable diagnostics allowing fault history and reading fault codes at the unit via Symbio™ 700 board or app. The following faults are detected:

- Air temperature sensor failure/fault
- Notification of acceptable economizer mode

The FDD system is certified by the Energy Commission as meeting the requirements.

Flexibility

For flexibility, units are built to order in our standard ship cycle time.

High Altitude Kit

High Altitude Kits contain gas orifices that derate the gas input rate (BTUH) by 10 percent for use on units applied above 2,000 feet. Domestic contractors should consult with local authority on best practice.

Note: *The High Altitude Kit is not available with the Ultra Low NOx gas furnace option.*



Features and Benefits

High Efficiency Filtration

There are a variety of high efficiency filtration options. MERV 8 and MERV 13 filters provide additional filtration beyond the capabilities of 2-inch standard filters.

High Static Motor

Available on select 17.5 and 20 ton models and all 25 ton models, this high static motor option extends beyond the capability of the standard motor.

Hinged Access Doors

Hinged access doors permit easy access to the filter, compressor and control sections. Reduces risk of roof damage from screws or sharp access panel corners.



Humidity Sensor/Humidistat

The humidity sensor/humidistat, when used in conjunction with our dehumidification (hot gas reheat) units provides outstanding humidity control and comfort. Humidity sensors can be wall or duct mounted. The humidity deadband can be set between 40% and 60% relative humidity.

Humidity Control – Modulating Hot Gas Reheat (HGRH)

The factory-installed modulating hot gas reheat (HGRH) humidity control system allows for full independent control of latent capacity (via staged or modulating refrigeration system) and independent control of discharge air temperature (via a modulating hot gas reheat valve). This provides tightly controlled humidity levels without overcooling the space to deliver year-round comfort by improving indoor air quality.

- Modulating reheat, no more on/off
- Maintains stable neutral leaving air temperature, resulting in less cycling
- Includes both relative humidity and dew point control
- Available on downflow or horizontal

Leak Detection System

The Leak Detection System (LDS) consists of one or more refrigerant detection sensors and is required in ducted HVAC systems that have more than 3.91 lbs of A2L refrigerant charge, per safety standard UL 60335-2-40. For any units with more than 3.91 lbs of charge in a circuit, an LDS will be factory-installed. Having the leak detector installed in the factory by the manufacturer on applicable units reduces the risk of improper installation in the field as well as bypassing the added cost in the field for installation, leading to peace of mind that the right solution has been applied to your unit.

Low Ambient Cooling

All Precedent™ ultra high efficiency units (except 575 V) have cooling capabilities down to 0°F as standard from the factory. 575 V models have cooling capabilities down to 40°F, a low ambient field installed kit is required for operation down to 0°F.

Low Leak Economizer

This accessory meets low leak requirements for ASHRAE 90.1, IECC, and CA Title 24 standards (4 cfm/ft²@1" wg exterior air/return air). This option allows 0 to 100% outdoor air supply from modulating

dampers and is standard with barometric relief. It can be paired with power exhaust for additional building pressure relief. This option can be paired with or without fault detection and diagnostics (FDD) to meet current mandatory CA Title 24 requirements.

The economizers come with four control options: dry bulb, reference enthalpy, comparative enthalpy, or differential dry bulb.



Note: Downflow low leak economizer is available as a factory installed option. Horizontal low leak economizer option is only available as a field installed option.

LP Conversion Kit

This kit allows for field conversion of gas/electric units from natural gas to propane.

Note: The Ultra Low NOx gas furnace option is for natural gas operation only.

Microchannel Coils

Microchannel coils are all-aluminum coils with fully-brazed construction. This design reduces risk of leaks and provides increased coil rigidity — making them more rugged on the jobsite. Their flat streamlined tubes with small ports and metallurgical tube-to-fin bond allow for exceptional heat transfer. Microchannel all-aluminum construction provides several additional benefits:

- Light weight (simplifies coil handling)
- Easy to recycle
- Minimize galvanic corrosion

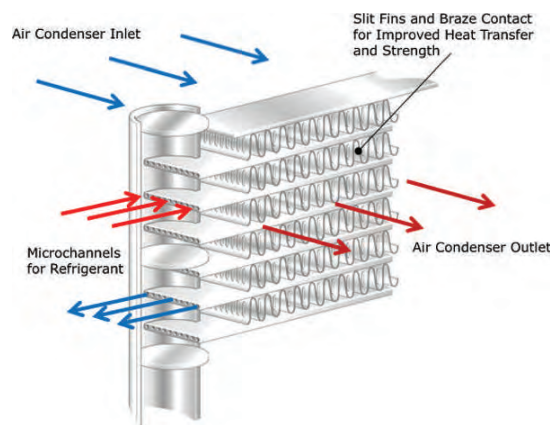

Modulating Gas Heat

Note: Not available with 3 to 5 ton units.

Modulating natural gas heat option, with a high modulation range of 10:1, automatically modulates the gas valve and combustion blower motor, providing improved comfort with stable temperature control.

- Less on/off cycling



Features and Benefits

- Continuous heating output
- Wide operation range (low and high heat)
- Coupled with variable speed fan control enables independent control of supply airflow and discharge air temperature
- With Zoned Rooftop Systems, modulating gas heat enables effective supply air tempering as well as warm-up sequences

Multiple-Zone VAV (MZVAV)

MZVAV is a system that consists of a packaged rooftop unit that serves several individually controlled zones. Each zone is equipped with a VAV terminal unit that varies the quantity of air delivered to maintain the desired temperature in that zone. The rooftop unit controller varies the speed of the indoor fan to maintain the static pressure in the supply ductwork at a setpoint, verifying that all zones receive required air. Cooling capacity is cycled to maintain the supply air temperature at the desired setpoint.

Quick Adapt Curbs

Enables easy upgrade of existing Precedent™ and Voyager™ 3 to 25 tons units on replacement jobs.

Rigorous Testing

Precedent quality is validated through rigorous factory testing:

- Rain testing for water integrity.
- Transportation vibration and forklift testing.
- Rigging lift and drop tests for lifting lug and rail integrity.
- Leak testing, including 100 percent coil leak test, and assembled unit leak test to 465 psig.
- Final assembly inspection.
- Run test (100 percent) to confirm performance requirements.

Single Zone VAV (SZVAV)

SZVAV is fully integrated into the control system. It provides the simplest and fastest commissioning in the industry through proven factory-installed, wired, and tested system controllers. All control modules, logic boards and sensors are factory installed and tested to confirm the highest quality and most reliable system available. This means no special programming of algorithms, or hunting at the jobsite for field installed sensors, boards, etc. SZVAV is a quick and simple solution for many applications and is available from your most trusted rooftop VAV system solution provider -Trane.

Building system modeling in energy simulation software such as TRACE is recommended to evaluate performance improvements for your application.

Supply/Return Air Smoke Detector

With this option installed, if smoke is detected, all unit operation will be shut down. Reset will be manual at the unit. In order for the supply air smoke detector or return air smoke detector to properly sense smoke in the supply air stream or the return air stream, the air velocity entering the smoke detector unit must be between 500 to 4000 feet per minute. Equipment covered in this manual will develop an airflow velocity that falls within these limits over the entire airflow range specified in the evaporator fan performance table.

Through-the-Base Condensate

Through-the-base condensate drain connections, available on B.0, and C.0 cabinet units, allow the drain to be connected through the roof curb, and avoid the need for roof modification.

Through-the-Base Electrical Access

An electrical service entrance is provided to allow electrical access for both control and main power connections inside the curb and through-the-base of the unit. Option will allow for field installation of liquid-tight conduit and an external field installed disconnect switch.

Through-the-Base Gas Piping

Factory-provided through-the-base openings simplify gas piping connections. Because these utility openings frequently minimize the number of roof penetrations, the integrity of roofing materials is enhanced.

This option includes all necessary piping, including black steel, manual gas shut-off valve, elbows, and union. This assembly requires field installation.

Note: *Through-the-base gas is not available with the Ultra Low NOx gas furnace option.*

Ventilation Override

Ventilation override allows the unit to transition to up to three different pre-programmed sequences for smoke purge, pressurization, and exhaust. The transition occurs when a binary input on the Customer Connection Module is closed (shorted). This would typically be a hard wired relay output from a smoke detector or fire control panel. The Customer Connection module that allows ventilation override is available as a field installed accessory (FIASCCM001*). For more information on functionality, refer to *Symbio™ 700 Controller with Precedent™ Packaged Rooftop Air-Conditioners Application Guide (ACC-APG002*-EN)*.



Application Considerations

A2L Application Considerations

This product is listed to UL standard 60335-2-40, Household and Similar Electrical Appliances – Safety – Part 2-40: Particular Requirements for Electrical Heat Pumps, Air-Conditioners and Dehumidifiers, which defines safe design and use strategies for equipment using A2L refrigerants. This standard limits the refrigerant concentration in a space in the event of a refrigerant leak. To meet the requirements, the UL standard defines minimum room area, refrigerant charge limit, minimum circulation airflow and/or ventilation airflow requirements, and limits the use of ignition sources in spaces. The standard may require a unit refrigerant leak detection system.

For equipment with R-454B and charge amounts less than or equal to 3.91 lbs per circuit, this UL standard does not prescribe a room area limit and does not require a refrigerant leak detection system or any circulation airflow or ventilation airflow mitigation strategies. However, ignition sources in ductwork must be evaluated.

Depending on the application, a specific requirement of ANSI/ASHRAE Standard 15, Safety Standard for Refrigeration Systems, could be more stringent than UL 60335-2-40 requirements. See *Refrigeration Systems and Machinery Rooms Application Considerations for Compliance with ASHRAE® Standard 15-2022 Application Engineering Manual (APP-APM001*-EN)* for more information.

Minimum Room Area Limits (Refrigerant charge greater than 3.91 lb per circuit)

Equipment with R-454B charge amounts greater than 3.91 lb per circuit may require additional circulation or ventilation airflow mitigation strategies. In this case, two minimum room area (A_{min}) thresholds:

- The first threshold defines when equipment serving a single room is required to provide circulation airflow, either continuous or activated by a leak detection system. A ducted system requires circulation airflow unless the smallest room it serves is larger than the adjusted A_{min} threshold. This product contains a leak detection system if a circuit charge is greater than 3.91 lbs. As a result, no further leak detection system evaluation is required.
- The second threshold defines when additional ventilation airflow is required. If the room area, A or TA , is below the adjusted A_{min} or TA_{min} threshold, additional ventilation is required to remove refrigerant in the event of a leak. Refer to UL 60335-2-40 Clause GG.8 and ANSI/ASHRAE Standard 15 Section 7 for natural and mechanical ventilation requirements. For minimum room area, see equipment nameplate or unit Installation, Operation, and Maintenance (IOM) manual.

Minimum Room Area (A_{min}) Adjustments

- **Altitude:** The A_{min} threshold changes with altitude. Multiple the altitude adjustment factor in the following table by A_{min} shown on the unit nameplate or in the Installation, Operation, and Maintenance (IOM) manual.

Table 5. Altitude adjustment factor

Altitude (ft)	Sea Level to 2000	2001 to 4000	4001 to 6000	6001 to 8000	8001 to 10000	10001 to 12000	12001 to 14000	14001 to 15000	Over 15000
A_{min} Adjustment	1	1.05	1.11	1.17	1.24	1.32	1.41	1.51	1.57

- **Height :** A_{min} can be adjusted if the unit is installed in a room at a height higher than the minimum height shown on the unit. Multiply A_{min} by the ratio of the unit minimum release height (in meters) / actual release height (in meters).
- **Institutional Occupancies:** For institutional occupancies, ASHRAE Standard 15 applies an additional adjustment factor, FOCC, to the amount of charge allowed in a space. To calculate the adjusted A_{min} for institutional occupancies, divide the A_{min} on the nameplate by 0.5.

Determining Room Area (A or TA)

The room area (A) is the room area enclosed by the projection to the floor of the walls, partitions, and doors of the space that the equipment serves. For ducted systems, total room area (TA) of all rooms connected by ducts, may be used instead of A.

Rooms connected by drop ceilings only are not considered a single room.

Rooms on the same floor of the building, and connected by an open passageway, can be considered part of the same room if the passageway is a permanent opening, extends to the floor and is intended for people to walk through.

Adjacent rooms on the same floor of the building and connected by permanent openings in the walls and/or doors between rooms (including gaps between the wall and the floor), can be considered part of the same room if the openings meet the following criteria.

- The opening is permanent and cannot be closed.
- Openings extending to the floor, such as door gaps, need to be at least 20 mm above the floor covering surface.
- Natural ventilations opening areas must meet the requirements of ANSI/ASHRAE Standard 15-2022, Section 7.2.3.2.

Rooms that are connected by a mechanical ventilation system can be considered a single room area if the mechanical ventilation system meets the requirements of ANSI/ASHRAE Standard 15-2022, Section 7.6.4.

Leak Detection System (Refrigerant charge greater than 3.91 lb per circuit)

The leak detection system consists of one or more refrigerant detection sensors. When the system detects a leak, the following mitigation actions will be initiated until refrigerant has not been detected for at least 5 minutes:

- Energize the supply fan(s) to deliver a required minimum amount of circulation airflow.
- Disable compressor operation.
- Provide an output signal to fully open all zoning dampers, such as VAV boxes.
- Provide an output to energize additional mechanical ventilation (if needed).
- Units without airflow proving will disable electric heat sources.

Building fire and smoke systems may override this function.

If the refrigerant sensor has a fault, is at the end of its life, or is disconnected, the unit will initiate the mitigation actions. Mitigation actions may be verified by disconnecting the sensor.

The refrigerant sensors do not need service. Use only manufacturer-approved sensors when replacement is required.



Model Number Description

Digit 1 — Unit Function

T = DX Cooling
Y = DX Cooling, Gas Heat

Digit 2 — Cooling Efficiency

Z = Ultra High Efficiency

Digit 3 — Refrigerant

K = R-454B

Digit 4,5,6 — Nominal Gross Cooling Capacity (MBh)

036 = 3 Ton
048 = 4 Ton
060 = 5 Ton
072 = 6 Ton
090 = 7.5 Ton
102 = 8.5 Ton
120 = 10 Ton
150 = 12.5 Ton
180 = 15 Ton
210 = 17.5 Ton
240 = 20 Ton
300 = 25 Ton

Digit 7 — Design Sequence

Digit 8 — Voltage Selection

3 = 208–230/60/3
4 = 460/60/3
W = 575/60/3

Digit 9 — Unit Controls

S = Symbio™ 700

Digit 10 — Heat Type

0 = Base Model
A = Stainless Steel Gas Heat
B = Modulating Gas Heat

Digit 11 — Heating Capacity

0 = No Heat
B = 6 kW Electric Heat
C = 9 kW Electric Heat
E = 12 kW Electric Heat
G = 18 kW Electric Heat
J = 23 kW Electric Heat
K = 27 kW Electric Heat
N = 36 kW Electric Heat
P = 54 kW Electric Heat
R = 72 kW Electric Heat
L = Low Gas Heat
M = Medium Gas Heat
H = High Gas Heat

Digit 12, 13 — Service Sequence

** = Factory Assigned

Digit 14 — Fresh Air Selection

0 = No Fresh Air
A = Manual Outside Air Damper 0–50%
B = Motorized Outside Air Damper 0–50%
C = Economizer, Dry Bulb 0–100% without Barometric Relief
D = Economizer, Dry Bulb 0–100% with Barometric Relief
E = Economizer, Reference Enthalpy 0–100% without Barometric Relief
F = Economizer, Reference Enthalpy 0–100% with Barometric Relief
G = Economizer, Comparative Enthalpy 0–100% without Barometric Relief
H = Economizer, Comparative Enthalpy 0–100% with Barometric Relief
K = Downflow Low Leak Economizer, Dry Bulb with Barometric Relief
M = Downflow Low Leak Economizer, Reference Enthalpy with Barometric Relief
P = Downflow Low Leak Economizer, Comparative Enthalpy with Barometric Relief
R = Downflow Low Leak Economizer, Differential Dry Bulb with Barometric Relief

Digit 15 — Supply Fan/Drive Type/Motor

2 = Single Zone Variable Air Volume with Standard Motor
3 = Single Zone Variable Air Volume with Oversized/High Static Motor
4 = Multiple Zone Variable Air Volume with Standard Motor
5 = Multiple Zone Variable Air Volume with Oversized/High Static Motor

Digit 16 — Hinged Access/Filters

A = Hinged Access Panels/Standard Filters
C = Hinged Access Panels/2 inch MERV 8 Filters
E = Hinged Access Panels/2 inch MERV 13 Filters

Digit 17 — Condenser Coil Protection

0 = Standard Coil
1 = Condenser with CompleteCoat™

Digit 18 — Through-the-Base Provisions

0 = No Through-the-Base Provisions
A = Through-the-Base Electric
B = Through-the-Base Gas Piping
C = Through-the-Base Electric and Gas Piping

Digit 19 — Disconnect/Circuit Breaker (three-phase only)

0 = No Disconnect/No Circuit Breaker
1 = Unit Mounted/Non-Fused Disconnect
2 = Unit Mounted Circuit Breaker

Digit 20 — Convenience Outlet

0 = No Convenience Outlet
A = Unpowered 20A Convenience Outlet
B = Powered 15A Convenience Outlet

Digit 21 — Communications Options

0 = No Communications Interface
1 = Advanced Controller with BACnet® Communications Interface
2 = Advanced Controller with LonTalk® Communications Interface
3 = Advanced Controller with Air-Fi® Communications Interface

Digit 22 — Refrigeration System Option

0 = Standard Refrigeration System
A = Humidity Control Option

Digit 23 — Controls Expansion Module

0 = None
1 = XM-30 Expansion Module
2 = XM-32 Expansion Module
3 = XM-30 and XM-32 Expansion Module
4 = XM-30 Expansion Module (Qty 2)
5 = XM-32 Expansion Module (Qty 2)

Digit 24 — Smoke Detector

0 = No Smoke Detector
A = Return Air Smoke Detector
B = Supply Air Smoke Detector
C = Supply and Return Air Smoke Detectors

Digit 25 — System Monitoring Controls

- 0 = No Monitoring Control
- 1 = Clogged Filter Switch
- 2 = Condensate Overflow Switch
- 3 = Discharge Air Sensing Tube
- 4 = Clogged Filter Switch and Condensate Overflow Switch

Digit 26 — Not Used**Digit 27 — Unit Hardware Enhancements**

- 0 = No Enhancements
- 1 = Stainless Steel Drain Pan

Digit 28 — Short Circuit Current Rating

- 0 = Standard (5k) SCCR Marking
- A = Tier 2 (65K) SCCR Marking

Digit 29 — Low Ambient

- 0 = None
- A = Low Ambient Cooling to 0°F



General Data

Table 6. General data – cool - ultra high efficiency

	3 Tons	4 Tons	5 Tons	6 Tons	7.5 Tons	8.5 Tons	10 Tons	12.5 Tons	15 Tons	17.5 Tons	20 Tons	25 Tons
	TZK036	TZK048	TZK060	TZK072	TZK090	TZK102	TZK120	TZK150	TZK180	TZK210	TZK240	TZK300
Cooling Performance^(a)												
Gross Cooling Capacity	36600	49000	60500	72000	88000	100000	112000	152000	183000	218000	245000	282000
EER ^(b) / EER2 ^(c) (208/230/460 Volt)	14.3/13.5	14.3/13.5	14.3/13.5	13.5	12.9	12.3	12.5	14.0	12.7	12.7	11.8	11.2
EER ^(b) / EER2 ^(c) (575 Volt)	14.3/13.5	14.3/13.5	14.3/13.5	13.5	12.9	12.3	12.5	14.0	12.7	12.7	11.8	11.2
Nominal cfm/AHRI Rated cfm	1200/1200	1600/1600	2000/2000	2400/2100	3000/2625	3400/2975	4000/3500	5000/5000	6000/6000	7000/6650	8000/8000	10000/9500
AHRI Net Cooling Capacity	36000	48000	59500	71000	87000	99000	109000	150000	180000	214000	240000	274000
IEER ^(d) / SEER ^(e) / SEER2 ^(c) (208-230/460V)	19.6 / 18.8	19.8 / 19.0	20.2 / 19.4	25.6	22.0	20.5	20.6	25.4	23.9	21.9	21.3	20.3
IEER ^(d) / SEER ^(e) / SEER2 ^(c) (575V)	19.1 / 18.4	18.5 / 17.8	19.1 / 18.4	23.8	20.2	18.7	18.8	23.3	22.2	18.8	18.8	18.5
System Power (kW)	2.67	3.56	4.41	5.26	6.74	8.05	8.72	10.71	14.17	16.85	20.34	24.46
Compressor												
Number/Type	1/Scroll	1/Scroll	1/Scroll	1/Scroll	1/Scroll	1/Scroll	1/Scroll	1/Scroll	1/Scroll	2/Manifold Scroll	2/Manifold Scroll	2/Manifold Scroll
Minimum Percent Capacity	36%	31%	31%	28%	32%	28%	25%	29%	23%	12%	9%	12%
Sound												
Outdoor Sound Rating (dBA)	81	81	85	86	86	86	89	88	90	91	94	94
Outdoor Coil												
Type	Microchannel	Microchannel	Microchannel	Microchannel	Microchannel	Microchannel	Microchannel	Microchannel	Microchannel	Microchannel	Microchannel	Microchannel
Configuration	Full Face	Full Face	Full Face	Full Face	Full Face	Full Face	Full Face	Full Face	Full Face	Full Face	Full Face	Full Face
Tube Size (in.)	0.7	0.7	0.7	0.7	0.7	1.0	1.0	0.7	0.7	1.0	1.0	1.0
Face Area (sq. ft.)	21.64	21.64	21.64	21.64	21.64	21.64	28.32	38.85	38.85	38.85	38.85	38.85
Rows/FPI (Fins per inch)	1/23	1/23	1/23	1/23	1/23	1/23	1/23	1/23	1/23	1/23	1/23	1/23
Indoor Coil												
Type	Microchannel	Microchannel	Microchannel	Microchannel	Microchannel	Microchannel	Microchannel	Microchannel	Microchannel	Microchannel	Microchannel	Microchannel
Configuration	Full Face	Full Face	Full Face	Full Face	Full Face	Full Face	Full Face	Full Face	Full Face	Full Face	Full Face	Full Face
Tube Size (in.)	0.6	0.6	0.6	1.0	1.0	1.0	1.0	1.0	1.0	1.0	1.0	1.0
Face Area (sq. ft.)	11.8	11.8	11.8	11.8	11.8	11.8	14.3	28.1	28.1	28.1	28.1	28.1
Rows/FPI (Fins per inch)	2/18	2/18	2/18	2/18	2/18	2/18	2/18	2/18	2/18	2/18	2/18	2/18
Refrigerant Control	TXV	TXV	TXV	TXV	TXV	TXV	TXV	TXV	TXV	TXV	TXV	TXV
Drain Connection No./Size (in.) NPT	1/0.75	1/0.75	1/0.75	1/0.75	1/0.75	1/0.75	1/0.75	1/1.0	1/1.0	1/1.0	1/1.0	1/1.0

Table 6. General data – cool - ultra high efficiency (continued)

	3 Tons	4 Tons	5 Tons	6 Tons	7.5 Tons	8.5 Tons	10 Tons	12.5 Tons	15 Tons	17.5 Tons	20 Tons	25 Tons
Reheat Coil												
	TZK036	TZK048	TZK060	TZK072	TZK090	TZK102	TZK120	TZK150	TZK180	TZK210	TZK240	TZK300
Type	Microchannel	Microchannel	Microchannel	Microchannel	Microchannel	Microchannel	Microchannel	Microchannel	Microchannel	Microchannel	Microchannel	Microchannel
Configuration	Full Face	Full Face	Full Face	Full Face	Full Face	Full Face	Full Face	Full Face	Full Face	Full Face	Full Face	Full Face
Tube Size (in.)	0.6	0.6	0.6	0.6	0.6	0.6	0.6	0.6	0.6	0.6	0.6	0.6
Face Area (sq. ft.)	9.04	9.04	9.04	9.04	9.04	9.04	11.82	21.83	21.83	21.83	21.83	21.83
Rows/FPI (Fins per inch)	1/23	1/23	1/23	1/23	1/23	1/23	1/23	1/23	1/23	1/23	1/23	1/23
Outdoor Fan												
Type	Propeller	Propeller	Propeller	Propeller	Propeller	Propeller	Propeller	Propeller	Propeller	Propeller	Propeller	Propeller
No. Used/Diameter (in.)	1/26	1/26	1/26	1/26	1/26	1/26	1/30	2/26	2/26	2/28	2/28	2/28
Drive Type/No. Speeds (208-230/460V)	Direct/Variable	Direct/Variable	Direct/Variable	Direct/Variable	Direct/Variable	Direct/Variable	Direct/Variable	Direct/Variable	Direct/Variable	Direct/Variable	Direct/Variable	Direct/Variable
Drive Type/No. Speeds (575V)	Direct/1	Direct/1	Direct/1	Direct/1	Direct/1	Direct/1	Direct/1	Direct/1	Direct/1	Direct/1	Direct/1	Direct/1
CFM (208-230/460V)	4020	4130	4870	7200	7200	7200	8200	11340	11340	17030	17030	17030
CFM (575V)	4020	4550	4550	7200	7200	7200	8200	11340	11340	16100	16100	16100
Motor HP (208-230/460V)	0.33	0.50	0.50	0.75	0.75	0.75	0.75	0.50	0.50	1.00	1.00	1.00
Motor HP (575V)	0.25	0.40	0.40	0.75	0.75	0.75	1.00	0.50	0.50	1.00	1.00	1.00
Motor RPM (208-230/460V)	1100	1000	1180	1100	1100	1100	1100	1125	1125	1190	1190	1190
Motor RPM (575V)	1100	1100	1100	1100	1100	1100	1100	1125	1125	1125	1125	1125
Indoor Fan												
Type	BC Plenum	BC Plenum	BC Plenum	BC Plenum	BC Plenum	BC Plenum	BC Plenum	BC Plenum	BC Plenum	BC Plenum	BC Plenum	BC Plenum
No. Used/Diameter (in.)/Width (in.)	1/23x6	1/23x6	1/23x6	1/23x6	1/23x6	1/23x6	1/23x6	2/23x6	2/23x6	2/23x6	2/23x6	2/23x6
Drive Type/No. Speeds	Direct/Variable	Direct/Variable	Direct/Variable	Direct/Variable	Direct/Variable	Direct/Variable	Direct/Variable	Direct/Variable	Direct/Variable	Direct/Variable	Direct/Variable	Direct/Variable
Motor HP (Standard/Oversized)	3.0 / -	3.0 / -	3.0 / -	3.0 / -	3.0 / -	3.0 / -	4.6 / -	3.0 / -	3.0 / -	3.0 / -	3.0 / -	3.0 / 4.6
Max Motor RPM	1850	1850	1850	1850	1850	1850	1940	1850	1850	1850	1850	1850/1940
Filters^(e)												
Type Furnished	Throwaway	Throwaway	Throwaway	Throwaway	Throwaway	Throwaway	Throwaway	Throwaway	Throwaway	Throwaway	Throwaway	Throwaway
Number Size Recommended	(2) 18x24x2 (3) 24x16x2	(2) 18x24x2 (3) 24x16x2	(2) 18x24x2 (3) 24x16x2	(2) 18x24x2 (3) 24x16x2	(2) 18x24x2 (3) 24x16x2	(2) 18x24x2 (3) 24x16x2	(3) 18x18x2 (3) 24x18x2	(4) 20x24x2 (4) 20x30x2	(4) 20x24x2 (4) 20x30x2	(4) 20x24x2 (4) 20x30x2	(4) 20x24x2 (4) 20x30x2	(4) 20x24x2 (4) 20x30x2
Refrigerant Charge												
lbs of R-454B	7.0	7.0	7.0	7.6	8.6	8.2	10.0	13.2	12.8	15.4	15.4	16.0



General Data

Table 6. General data – cool - ultra high efficiency (continued)

	3 Tons	4 Tons	5 Tons	6 Tons	7.5 Tons	8.5 Tons	10 Tons	12.5 Tons	15 Tons	17.5 Tons	20 Tons	25 Tons
lbs of R-454B, Hot Gas Reheat	TZK036 7.4	TZK048 7.4	TZK060 7.4	TZK072 8.0	TZK090 9.2	TZK102 8.3	TZK120 10.2	TZK150 13.9	TZK180 13.5	TZK210 16.0	TZK240 16.0	TZK300 16.6
Cabinet												
Cabinet Size	B.0	B.0	B.0	B.0	B.0	B.0	C.0	D.1	D.1	D.1	D.1	D.1

- (a) 3 to 5T cooling performance is rated at 96°F ambient, 80°F entering dry bulb, 67°F entering wet bulb. Gross capacity does not include the effect of fan motor heat. AHRI capacity is net and includes the effect of fan motor heat. Units are suitable for operation to ±20% of nominal cfm. Units are certified in accordance with the Unitary Air-Conditioner Equipment certification program, which is based on AHRI Standard 210/240.
- (b) SEER shown for 3 to 5T units only, 3-5T EER and SEER are rated at AHRI conditions and calculated in accordance with AHRI Standard 210/240-2017. Airflow and net cooling capacity not shown.
- (c) EER2 and SEER2 shown for 3 to 5T units only. EER2 and SEER2 are rated at AHRI conditions and certified in accordance with AHRI Standard 210/240-2023.
- (d) IEER shown for 6 to 25T units only.
- (e) Outdoor sound rating shown is tested in accordance with AHRI 370-2015. For additional information reference the outdoor sound power level data in the performance section.

Table 7. General data – gas - ultra high efficiency

	3 Tons	4 Tons	5 Tons	6 Tons	7.5 Tons	8.5 Tons	10 Tons	12.5 Tons	15 Tons	17.5 Tons	20 Tons	25 Tons
	YZK036	YZK048	YZK060	YZK072	YZK090	YZK102	YZK120	YZK150	YZK180	YZK210	YZK240	YZK300
Cooling Performance^(a)												
Gross Cooling Capacity	36800	49000	61000	72000	88000	100000	112000	153000	184000	219000	246000	283000
EER ^(b) / EER2 ^(c) (208/230/460 Volt)	14.3/13.5	14.3/13.5	14.3/13.5	13.4	12.9	12.3	12.5	13.8	12.5	12.5	11.6	11.0
EER ^(b) / EER2 ^(c) (575 Volt)	14.3/13.5	14.3/13.5	14.3/13.5	13.4	12.9	12.3	12.5	13.8	12.5	12.5	11.6	11.0
Nominal cfm/AHRI Rated cfm	1200/1200	1600/1600	2000/2000	2400/2100	3000/2625	3400/2975	4000/3500	5000/5000	6000/6000	7000/6650	8000/8000	10000/9500
AHRI Net Cooling Capacity	36000	48000	59500	71000	87000	99000	110000	150000	180000	212000	240000	272000
IEER ^(b) / SEER ^(b) / SEER2 ^(c) (208/230/460 Volt)	19.6 / 18.8	19.8 / 19.0	20.2 / 19.4	24.2	21.6	20.2	20.3	25.0	23.5	21.5	20.8	20.0
IEER ^(b) / SEER ^(b) / SEER2 ^(c) (575 Volt)	19.1 / 18.4	18.5 / 17.8	19.1 / 18.4	22.4	19.8	18.4	18.5	23.0	21.9	18.4	18.4	18.1
System Power (kW)	2.67	3.56	4.41	5.30	6.74	8.05	8.80	10.87	14.40	17.12	20.69	24.91
Cooling Performance with Modulating Gas												
Gross Cooling Capacity	-	-	-	72000	88000	100000	112000	153000	184000	217000	248000	282000
EER ^(b) (208/230/460 Volt)	-	-	-	12.5	12.2	11.3	12.3	13.6	12.4	12.3	11.2	10.5
EER ^(b) (575 Volt)	-	-	-	12.5	12.2	11.3	12.3	13.6	12.4	12.3	11.2	10.5
Nominal cfm/AHRI Rated cfm	-	-	-	2400/2100	3000/2625	3400/2975	4000/3500	5000/5000	6000/6000	7000/6650	8000/8000	10000/9500
AHRI Net Cooling Capacity	-	-	-	70000	86000	96000	109000	150000	180000	212000	240000	270000
IEER (SZVAV/MZVAV) (208/230/460 Volt)	-	-	-	23.3	21.2	19.8	20.4	25.0	23.4	21.4	20.5	19.3
IEER (SZVAV/MZVAV) (575 Volt)	-	-	-	21.5	19.4	18.0	18.6	23.0	21.8	18.4	18.2	17.6
System Power (kW)	-	-	-	5.60	7.05	8.50	8.86	11.03	14.52	17.24	21.43	25.71
Compressor												
Number/Type	1/Scroll	1/Scroll	1/Scroll	1/Scroll	1/Scroll	1/Scroll	1/Scroll	1/Scroll	1/Scroll	2/Manifold Scroll	2/Manifold Scroll	2/Manifold Scroll
Minimum Percent Capacity	36%	31%	31%	28%	32%	28%	25%	29%	23%	12%	9%	12%
Sound												
Outdoor Sound Rating (dBA)	81	81	85	86	86	86	89	88	90	91	94	94
Outdoor Coil												
Type	Microchannel	Microchannel	Microchannel	Microchannel	Microchannel	Microchannel	Microchannel	Microchannel	Microchannel	Microchannel	Microchannel	Microchannel
Configuration	Full Face	Full Face	Full Face	Full Face	Full Face	Full Face	Full Face	Full Face	Full Face	Full Face	Full Face	Full Face

Table 7. General data – gas - ultra high efficiency (continued)

	3 Tons	4 Tons	5 Tons	6 Tons	7.5 Tons	8.5 Tons	10 Tons	12.5 Tons	15 Tons	17.5 Tons	20 Tons	25 Tons
	YZK036	YZK048	YZK060	YZK072	YZK090	YZK102	YZK120	YZK150	YZK180	YZK210	YZK240	YZK300
Tube Size (in.)	0.7	0.7	0.7	0.7	0.7	1.0	1.0	0.7	0.7	1.0	1.0	1.0
Face Area (sq. ft.)	21.64	21.64	21.64	21.64	21.64	21.64	28.32	38.85	38.85	38.85	38.85	38.85
Rows/FPI (Fins per inch)	1/23	1/23	1/23	1/23	1/23	1/23	1/23	1/23	1/23	1/23	1/23	1/23
Indoor Coil												
Type	Microchannel	Microchannel	Microchannel	Microchannel	Microchannel	Microchannel	Microchannel	Microchannel	Microchannel	Microchannel	Microchannel	Microchannel
Configuration	Full Face	Full Face	Full Face	Full Face	Full Face	Full Face	Full Face	Full Face	Full Face	Full Face	Full Face	Full Face
Tube Size (in.)	0.6	0.6	0.6	1.0	1.0	1.0	1.0	1.0	1.0	1.0	1.0	1.0
Face Area (sq. ft.)	11.8	11.8	11.8	11.8	11.8	11.8	14.3	28.1	28.1	28.1	28.1	28.1
Rows/FPI (Fins per inch)	2/18	2/18	2/18	2/18	2/18	2/18	2/18	2/18	2/18	2/18	2/18	2/18
Refrigerant Control	TXV	TXV	TXV	TXV	TXV	TXV	TXV	TXV	TXV	TXV	TXV	TXV
Drain Connection No./Size (in.) NPT	1/0.75	1/0.75	1/0.75	1/0.75	1/0.75	1/0.75	1/0.75	1/1.0	1/1.0	1/1.0	1/1.0	1/1.0
Reheat Coil												
Type	Microchannel	Microchannel	Microchannel	Microchannel	Microchannel	Microchannel	Microchannel	Microchannel	Microchannel	Microchannel	Microchannel	Microchannel
Configuration	Full Face	Full Face	Full Face	Full Face	Full Face	Full Face	Full Face	Full Face	Full Face	Full Face	Full Face	Full Face
Tube Size (in.)	0.6	0.6	0.6	0.6	0.6	0.6	0.6	0.6	0.6	0.6	0.6	0.6
Face Area (sq. ft.)	9.04	9.04	9.04	9.04	9.04	9.04	11.82	21.83	21.83	21.83	21.83	21.83
Rows/FPI (Fins per inch)	1/23	1/23	1/23	1/23	1/23	1/23	1/23	1/23	1/23	1/23	1/23	1/23
Outdoor Fan												
Type	Propeller	Propeller	Propeller	Propeller	Propeller	Propeller	Propeller	Propeller	Propeller	Propeller	Propeller	Propeller
No. Used/Diameter (in.)	1/26	1/26	1/26	1/26	1/26	1/26	1/30	2/26	2/26	2/28	2/28	2/28
Drive Type/No. Speeds (208-230/460V)	Direct/Variable	Direct/Variable	Direct/Variable	Direct/Variable	Direct/Variable	Direct/Variable	Direct/Variable	Direct/Variable	Direct/Variable	Direct/Variable	Direct/Variable	Direct/Variable
Drive Type/No. Speeds (575V)	Direct/1	Direct/1	Direct/1	Direct/1	Direct/1	Direct/1	Direct/1	Direct/1	Direct/1	Direct/1	Direct/1	Direct/1
CFM (208-230/460V)	4020	4130	4870	7200	7200	7200	8200	11340	11340	17030	17030	17030
CFM (575V)	4020	4550	4550	7200	7200	7200	8200	11340	11340	16100	16100	16100
Motor HP (208-230/460V)	0.33	0.50	0.50	0.75	0.75	0.75	0.75	0.50	0.50	1.00	1.00	1.00
Motor HP (575V)	0.25	0.40	0.40	0.75	0.75	0.75	1.00	0.50	0.50	1.00	1.00	1.00
Motor RPM (208-230/460V)	1100	1000	1180	1100	1100	1100	1100	1125	1125	1190	1190	1190

Table 7. General data – gas - ultra high efficiency (continued)

	3 Tons	4 Tons	5 Tons	6 Tons	7.5 Tons	8.5 Tons	10 Tons	12.5 Tons	15 Tons	17.5 Tons	20 Tons	25 Tons
YZK036	1100	1100	1100	1100	1100	1100	1100	1125	1125	1125	1125	1125
YZK048	1100	1100	1100	1100	1100	1100	1100	1125	1125	1125	1125	1125
YZK060	1100	1100	1100	1100	1100	1100	1100	1125	1125	1125	1125	1125
YZK072	1100	1100	1100	1100	1100	1100	1100	1125	1125	1125	1125	1125
YZK090	1100	1100	1100	1100	1100	1100	1100	1125	1125	1125	1125	1125
YZK102	1100	1100	1100	1100	1100	1100	1100	1125	1125	1125	1125	1125
YZK120	1100	1100	1100	1100	1100	1100	1100	1125	1125	1125	1125	1125
YZK150	1125	1125	1125	1125	1125	1125	1125	1125	1125	1125	1125	1125
YZK180	1125	1125	1125	1125	1125	1125	1125	1125	1125	1125	1125	1125
YZK210	1125	1125	1125	1125	1125	1125	1125	1125	1125	1125	1125	1125
YZK240	1125	1125	1125	1125	1125	1125	1125	1125	1125	1125	1125	1125
YZK300	1125	1125	1125	1125	1125	1125	1125	1125	1125	1125	1125	1125
Indoor Fan												
Type	BC Plenum	BC Plenum	BC Plenum	BC Plenum	BC Plenum	BC Plenum	BC Plenum	BC Plenum	BC Plenum	BC Plenum	BC Plenum	BC Plenum
No. Used/Diameter (in.)/Width (in.)	1/23x6	1/23x6	1/23x6	1/23x6	1/23x6	1/23x6	1/23x6	2/23x6	2/23x6	2/23x6	2/23x6	2/23x6
Drive Type/No. Speeds	Direct/Variable	Direct/Variable	Direct/Variable	Direct/Variable	Direct/Variable	Direct/Variable	Direct/Variable	Direct/Variable	Direct/Variable	Direct/Variable	Direct/Variable	Direct/Variable
Motor HP (Standard/Oversized)	3.0 / -	3.0 / -	3.0 / -	3.0 / -	3.0 / -	3.0 / -	4.6 / -	3.0 / -	3.0 / -	3.0 / 4.6(e)	3.0 / 4.6(e)	3.0 / 4.6
Max Motor RPM	1850	1850	1850	1850	1850	1850	1940	1850	1850	1850/1940	1850/1940	1850 /1940
Filters^(f)												
Type Furnished	Throwaway	Throwaway	Throwaway	Throwaway	Throwaway	Throwaway	Throwaway	Throwaway	Throwaway	Throwaway	Throwaway	Throwaway
Number Size Recommended	(2) 18x24x2 (3) 24x16x2	(2) 18x24x2 (3) 24x16x2	(2) 18x24x2 (3) 24x16x2	(2) 18x24x2 (3) 24x16x2	(2) 18x24x2 (3) 24x16x2	(2) 18x24x2 (3) 24x16x2	(3) 18x18x2 (3) 24x18x2	(4) 20x24x2 (4) 20x30x2	(4) 20x24x2 (4) 20x30x2	(4) 20x24x2 (4) 20x30x2	(4) 20x24x2 (4) 20x30x2	(4) 20x24x2 (4) 20x30x2
Refrigerant Charge												
lbs of R-454B	7.0	7.0	7.0	7.6	8.6	8.2	10.0	13.2	12.8	15.4	15.4	16.0
lbs of R-454B, Hot Gas Reheat	7.4	7.4	7.4	8.0	9.2	8.3	10.2	13.9	13.5	16.0	16.0	16.6
Heating Performance (Gas/Electric Only)												
Heating Input: Staged												
Low Heat Input (Btu) (High/Low Stage)	80,000/56,000	80,000/56,000	80,000/56,000	80,000/56,000	120,000/84,000	120,000/84,000	150,000/105,000	150,000/105,000	250,000/175,000	250,000/175,000	250,000/175,000	250,000/175,000
Mid Heat Input (Btu) (High/Low Stage)	100,000/70,000	100,000/70,000	100,000/70,000	120,000/84,000	150,000/105,000	150,000/105,000	200,000/140,000	200,000/140,000	320,000/224,000	320,000/224,000	320,000/224,000	320,000/224,000
High Heat Input (Btu) (High/Low Stage)	120,000/84,000	130,000/91,000	150,000/105,000	150,000/105,000	200,000/140,000	200,000/140,000	250,000/175,000	250,000/175,000	400,000/280,000	400,000/280,000	400,000/280,000	400,000/280,000
Heating Output: Staged												
Low Heat Output (Btu) (High/Low Stage)	64,800/45,300	64,800/45,300	64,800/45,300	64,800/45,300	97,200/68,000	97,200/68,000	121,500/85,000	121,500/85,000	202,500/141,750	202,500/141,750	202,500/141,750	202,500/141,750
Mid Heat Output (Btu) (High/Low Stage)	81,000/56,700	81,000/56,700	81,000/56,700	81,000/56,700	121,500/85,000	121,500/85,000	162,000/113,400	162,000/113,400	259,200/181,440	259,200/181,440	259,200/181,440	259,200/181,440
High Heat Output (Btu) (High/Low Stage)	97,200/68,000	105,300/73,710	121,500/85,000	121,500/85,000	162,000/113,400	162,000/113,400	202,500/141,750	202,500/141,750	324,000/226,800	324,000/226,800	324,000/226,800	324,000/226,800
Heating Input: Modulating												
Low Heat Input (Btu) (Maximum/Minimum)	-	-	-	80,000/8,000	120,000/12,000	120,000/12,000	150,000/15,000	150,000/15,000	-	250,000/25,000	250,000/25,000	250,000/25,000
High Heat Input (Btu) (Maximum/Minimum)	-	-	-	150,000/15,000	200,000/20,000	200,000/20,000	250,000/25,000	250,000/25,000	400,000/40,000	400,000/40,000	400,000/40,000	400,000/40,000
Heating Output: Modulating												
Low Heat Output (Btu) (Maximum/Minimum)	-	-	-	64,800/6,480	97,200/9,720	97,200/9,720	121,500/12,150	121,500/12,150	202,500/20,250	202,500/20,250	202,500/20,250	202,500/20,250

Table 7. General data – gas - ultra high efficiency (continued)

	3 Tons	4 Tons	5 Tons	6 Tons	7.5 Tons	8.5 Tons	10 Tons	12.5 Tons	15 Tons	17.5 Tons	20 Tons	25 Tons
High Heat Output (Btu) (Maximum/Minimum)	YZK036	YZK048	YZK060	YZK072	YZK090	YZK102	YZK120	YZK150	YZK180	YZK210	YZK240	YZK300
	-	-	-	121,500/ 12,150	162,000/ 16,200	162,000/ 16,200	202,500/ 20,250	202,500/ 20,250	324,000/ 32,400	324,000/ 32,400	324,000/ 32,400	324,000/ 32,400
Steady State Efficiency %												
Low Heat Input	81	81	81	81	81	81	81	81	81	81	81	81
Mid Heat Input	81	81	81	81	81	81	81	81	81	81	81	81
High Heat Input	81	81	81	81	81	81	81	81	81	81	81	81
No. Burners: Staged												
Low Heat Input	3	3	3	3	3	3	4	5	5	5	5	5
Mid Heat Input	4	4	4	3	4	4	4	5	7	7	7	7
High Heat Input	5	5	5	4	6	6	6	7	8	8	8	8
No. Burners: Modulating												
Low Heat Input	-	-	-	2	4	4	4	-	6	6	6	6
High Heat Input	-	-	-	4	6	6	6	6	8	8	8	8
No. Stages												
Low Heat Input	2	2	2	2	2	2	2	2	2	2	2	2
Mid Heat Input	2	2	2	2	2	2	2	2	2	2	2	2
High Heat Input	2	2	2	2	2	2	2	2	2	2	2	2
Gas Supply Line Pressure (inWC)												
Natural (minimum/ maximum) Low Heat	4.5/14.0	4.5/14.0	4.5/14.0	4.5/14.0	4.5/14.0	4.5/14.0	4.5/14.0	4.5/14.0	4.5/14.0	4.5/14.0	4.5/14.0	4.5/14.0
Natural (minimum/ maximum) Mid Heat	4.5/14.0	4.5/14.0	4.5/14.0	4.5/14.0	4.5/14.0	4.5/14.0	4.5/14.0	4.5/14.0	4.5/14.0	4.5/14.0	4.5/14.0	4.5/14.0
Natural (minimum/ maximum) High Heat	4.5/14.0	4.5/14.0	4.5/14.0	4.5/14.0	4.5/14.0	4.5/14.0	4.5/14.0	4.5/14.0	6.0/14.0	6.0/14.0	6.0/14.0	6.0/14.0
LP (minimum/ maximum)	11.5/14.0	11.5/14.0	11.5/14.0	11.5/14.0	11.5/14.0	11.5/14.0	11.5/14.0	11.5/14.0	11.5/14.0	11.5/14.0	11.5/14.0	11.5/14.0
Gas Connection Pipe Size (in.)												
Low Heat	3/4	3/4	3/4	1/2	3/4	3/4	3/4	3/4	3/4	3/4	3/4	3/4
Mid Heat	3/4	3/4	3/4	3/4	3/4	3/4	3/4	3/4	3/4	3/4	3/4	3/4
High Heat	3/4	3/4	3/4	3/4	3/4	3/4	3/4	3/4	3/4	3/4	3/4	3/4
Cabinet												
Cabinet Size	B.0	B.0	B.0	B.0	B.0	B.0	C.0	D.1	D.1	D.1	D.1	D.1

(a) 3 to 5T cooling performance is rated at 95°F ambient, 80°F entering dry bulb, 67°F entering wet bulb. Gross capacity does not include the effect of fan motor heat. AHR1 capacity is net and includes the effect of fan motor heat. Units are suitable for operation to ±20% of nominal cfm. Units are certified in accordance with the Unitary Air-Conditioner Equipment certification program, which is based on AHRI Standard 210/240.

(b) SEER shown for 3 to 5T units only. 3 to 5T EER and SEER are rated at AHRI conditions and calculated in accordance with AHRI Standard 210/240-2017. Airflow and net cooling capacity not shown.

(c) EER2 and SEER2 shown for 3-5T units only. EER2 and SEER2 are rated at AHRI conditions and certified in accordance with AHRI Standard 210/240-2023.

(d) IEER shown for 6 to 25T units only.

(e) Oversized Indoor Motor only available with Modulating Gas Heat Option.

(f) Outdoor sound rating shown is tested in accordance with AHRI 370-2015. For additional information reference the outdoor sound power level data in the performance section.



Gross Cooling Capacities

Table 8. Gross cooling capacities — 3 tons, ultra high efficiency

CFM	Ent DB (°F)	Entering Wet Bulb Temp (°F)						Entering Wet Bulb Temp (°F)						Entering Wet Bulb Temp (°F)					
		61		67		73		61		67		73		61		67		73	
		MBh	SHC	MBh	SHC	MBh	SHC	MBh	SHC	MBh	SHC	MBh	SHC	MBh	SHC	MBh	SHC	MBh	SHC
		Ambient Temperature 85°F						Ambient Temperature 95°F						Ambient Temperature 105°F					
900	75	32.4	25.5	36.7	19.5	41.7	13.3	30.5	24.4	34.6	18.4	39.5	12.3	28.5	23.3	32.4	17.3	37.1	11.2
	80	32.4	30.5	36.8	24.6	41.5	18.4	30.5	29.4	34.7	23.5	39.2	17.4	28.6	28.3	32.6	22.4	36.9	16.3
	85	33.6	33.6	36.8	29.6	41.6	23.5	32.0	32.0	34.8	28.6	39.4	22.5	30.4	30.4	32.6	27.5	37.0	21.4
	90	35.7	35.7	36.9	34.6	41.7	28.6	34.1	34.1	34.8	33.5	39.5	27.6	32.4	32.4	32.7	32.5	37.1	26.5
1080	75	33.7	28.5	38.1	21.3	42.4	13.6	31.7	26.8	35.9	20.2	39.9	12.6	29.5	26.3	33.6	19.1	37.3	11.4
	80	33.9	33.9	38.3	27.4	43.1	19.9	32.2	32.2	36.1	26.3	40.7	18.9	30.5	30.5	33.8	25.2	38.2	17.8
	85	36.2	36.2	38.3	32.1	43.2	26.1	34.5	34.5	36.1	32.3	40.9	25.1	32.7	32.7	33.8	31.2	38.4	24.0
	90	38.5	38.5	38.6	38.6	43.3	32.2	36.8	36.8	36.8	36.8	40.9	31.2	34.9	34.9	35.0	35.0	38.5	30.1
1200	75	34.3	30.4	38.9	22.4	42.9	13.9	32.3	29.3	36.6	21.3	40.4	12.8	30.1	28.2	34.2	20.2	37.9	11.7
	80	35.2	35.2	39.0	29.2	43.9	20.9	33.5	33.5	36.8	28.1	41.4	19.9	31.6	31.6	34.4	27.0	38.8	18.8
	85	37.6	37.6	39.0	35.8	44.0	27.8	35.8	35.8	36.8	34.8	41.6	26.7	33.9	33.9	34.4	33.7	39.1	25.7
	90	40.1	40.1	40.1	40.1	44.1	34.6	38.2	38.2	38.3	38.3	41.7	33.3	36.3	36.3	36.4	36.4	39.1	31.2
1320	75	34.9	32.3	39.5	23.5	43.6	14.1	32.8	31.2	37.2	22.4	40.9	13.0	30.6	30.1	34.7	21.3	38.1	12.0
	80	36.4	36.4	39.7	31.0	44.5	21.9	34.5	34.5	37.3	29.9	42.0	20.8	32.6	32.6	34.9	28.1	39.4	19.7
	85	38.9	38.9	39.6	38.3	44.7	29.4	37.0	37.0	37.3	37.2	42.2	28.4	35.1	35.1	35.1	35.1	39.6	27.3
	90	41.4	41.4	41.5	41.5	44.7	36.7	39.6	39.6	39.6	39.6	42.2	35.7	37.5	37.5	37.6	37.6	39.6	34.6
1440	75	35.4	34.2	40.0	24.6	43.6	14.6	33.2	33.1	37.6	23.5	40.9	13.4	31.0	31.0	35.1	22.3	37.9	12.2
	80	37.4	37.4	40.2	32.0	45.1	22.8	35.5	35.5	37.7	31.5	42.5	21.7	33.5	33.5	35.2	30.5	39.8	20.6
	85	40.0	40.0	40.1	40.1	45.3	31.1	38.1	38.1	38.1	38.1	42.8	30.0	36.0	36.0	36.1	36.1	40.1	28.9
	90	42.7	42.7	42.7	42.7	45.2	39.0	40.7	40.7	40.8	40.8	42.7	38.0	38.6	38.6	38.7	38.7	40.0	36.9
		Ambient Temperature 115°F						Ambient Temperature 125°F											
900	75	26.4	22.2	30.2	16.2	33.8	9.9	24.1	20.6	27.7	15.0	31.1	8.7						
	80	26.7	26.7	30.3	21.3	34.4	15.2	24.8	24.8	27.9	20.2	31.7	14.0						
	85	28.6	28.6	30.4	25.9	34.6	20.3	26.8	26.8	27.9	25.2	31.9	19.2						
	90	30.6	30.6	30.7	30.7	34.6	25.4	28.7	28.7	28.8	28.8	32.0	24.3						
1080	75	27.3	25.1	31.2	17.9	34.8	10.3	24.9	23.9	28.6	16.7	31.8	9.3						
	80	28.6	28.6	31.4	24.1	35.5	16.7	26.6	26.6	28.8	22.9	32.8	15.5						
	85	30.8	30.8	31.4	30.1	35.7	22.9	28.7	28.7	28.9	28.9	33.0	21.7						
	90	33.0	33.0	33.0	33.0	35.8	29.0	30.9	30.9	30.9	30.9	33.0	27.0						
1200	75	27.8	27.0	31.8	19.0	35.1	10.5	25.4	25.4	29.1	17.8	31.8	9.5						
	80	29.7	29.7	31.9	25.9	36.1	17.6	27.6	27.6	29.3	23.8	33.3	16.5						
	85	31.9	31.9	32.0	32.0	36.4	24.5	29.8	29.8	29.9	29.9	33.5	23.4						
	90	34.3	34.3	34.3	34.3	36.4	31.2	32.1	32.1	32.1	32.1	33.5	30.1						
1320	75	28.3	28.3	32.2	20.1	35.2	10.9	26.1	26.1	29.5	18.9	31.7	9.9						
	80	30.6	30.6	32.3	27.6	36.6	18.6	28.4	28.4	29.6	26.4	33.7	17.4						
	85	33.0	33.0	33.0	33.0	36.8	26.2	30.8	30.8	30.8	30.8	33.9	25.0						
	90	35.4	35.4	35.5	35.5	36.8	33.5	33.1	33.1	33.2	33.2	33.9	32.3						
1440	75	29.0	29.0	32.5	21.2	35.4	10.5	26.8	26.8	29.7	19.9	32.2	8.6						
	80	31.4	31.4	32.6	29.3	37.0	19.5	29.2	29.2	29.9	28.1	34.0	18.3						
	85	33.9	33.9	33.9	33.9	37.2	27.8	31.6	31.6	31.6	31.6	34.2	26.3						
	90	36.4	36.4	36.5	36.5	37.2	35.8	34.0	34.0	34.1	34.1	34.2	34.2						

Notes:

1. All capacities shown are gross and have not considered indoor fan heat. To obtain NET cooling capacity subtract indoor fan heat. For indoor fan heat formula, refer to appropriate airflow table notes.
2. MBh = Total gross capacity
3. SHC = Sensible heat capacity



Gross Cooling Capacities

Table 9. Gross cooling capacities — 4 tons, ultra high efficiency

CFM	Ent DB (°F)	Entering Wet Bulb Temp (°F)						Entering Wet Bulb Temp (°F)						Entering Wet Bulb Temp (°F)					
		61		67		73		61		67		73		61		67		73	
		MBh	SHC	MBh	SHC	MBh	SHC	MBh	SHC	MBh	SHC	MBh	SHC	MBh	SHC	MBh	SHC	MBh	SHC
		Ambient Temperature 85°F						Ambient Temperature 95°F						Ambient Temperature 105°F					
1200	75	43.3	34.0	49.0	26.0	55.2	17.6	40.8	32.6	46.3	24.6	52.3	16.4	38.1	31.1	43.4	23.1	49.4	14.9
	80	43.3	40.6	49.1	32.7	55.2	24.5	40.8	39.2	46.4	31.3	52.2	23.1	38.2	37.7	43.5	29.9	49.2	21.6
	85	44.8	44.8	49.1	39.4	55.2	31.2	42.7	42.7	46.4	38.0	52.4	29.9	40.5	40.5	43.6	36.6	49.3	28.4
	90	47.5	47.5	49.1	46.0	55.2	38.0	45.4	45.4	46.4	44.6	52.4	36.6	43.2	43.2	43.6	43.1	49.4	35.2
1440	75	45.1	38.0	50.9	28.3	57.1	18.3	42.4	35.7	48.1	26.9	54.3	17.0	39.6	35.0	45.0	25.4	51.1	15.5
	80	45.2	45.2	51.0	36.5	57.1	26.5	43.0	43.0	48.1	35.0	54.1	25.1	40.6	40.6	45.1	33.5	50.9	23.6
	85	48.2	48.2	51.0	44.4	57.1	34.6	45.9	45.9	48.1	43.0	54.2	33.3	43.5	43.5	45.1	41.5	51.1	31.8
	90	51.1	51.1	51.2	51.2	57.2	42.7	48.9	48.9	49.0	49.0	54.2	41.4	46.4	46.4	46.5	46.5	51.1	39.9
1600	75	45.9	40.5	51.9	29.9	58.1	18.7	43.2	39.0	49.0	28.4	55.2	17.4	40.3	37.5	45.9	26.9	52.0	15.9
	80	46.9	46.9	52.0	38.9	58.1	27.8	44.6	44.6	49.0	37.4	55.1	26.4	42.2	42.2	45.9	35.9	51.8	24.9
	85	50.0	50.0	51.9	47.6	58.1	36.8	47.7	47.7	49.0	46.2	55.2	35.5	45.2	45.2	45.9	44.7	51.9	34.0
	90	53.1	53.1	53.2	53.2	58.1	45.8	50.8	50.8	50.9	50.9	55.2	43.6	48.2	48.2	48.3	48.3	51.9	42.9
1760	75	46.7	43.0	52.7	31.3	58.9	19.1	43.9	41.5	49.7	29.9	55.0	17.4	40.9	40.0	46.6	28.3	52.7	16.3
	80	48.4	48.4	52.8	41.3	58.9	29.0	46.0	46.0	49.8	39.5	55.8	27.6	43.5	43.5	46.6	36.8	52.5	26.2
	85	51.7	51.7	52.7	50.8	59.0	39.0	49.2	49.2	49.7	49.3	55.9	37.6	46.7	46.7	46.7	46.7	52.7	36.2
	90	54.9	54.9	54.9	54.9	58.9	48.7	52.5	52.5	52.5	52.5	55.9	47.3	49.8	49.8	49.9	49.9	52.6	45.9
1920	75	47.3	45.5	53.4	32.8	59.7	19.4	44.4	44.0	50.3	31.3	55.4	17.7	41.5	41.5	47.1	29.8	51.9	16.1
	80	49.7	49.7	53.4	41.9	59.6	30.2	47.3	47.3	50.3	42.0	56.5	28.8	44.7	44.7	47.1	40.4	53.2	27.4
	85	53.1	53.1	53.3	53.3	59.7	41.1	50.6	50.6	50.7	50.7	56.6	39.8	47.9	47.9	48.0	48.0	53.3	38.4
	90	56.4	56.4	56.4	56.4	59.5	51.6	53.9	53.9	54.0	54.0	56.4	50.3	51.3	51.3	51.3	51.3	53.1	48.9
		Ambient Temperature 115°F						Ambient Temperature 125°F											
1200	75	35.3	29.6	40.4	21.6	46.2	13.4	32.4	27.5	37.4	20.0	42.9	11.9						
	80	35.6	35.6	40.5	28.4	46.0	20.2	33.2	33.2	37.5	26.8	42.7	18.6						
	85	38.2	38.2	40.6	34.3	46.2	27.0	35.8	35.8	37.5	33.5	42.8	25.5						
	90	40.8	40.8	40.9	40.9	46.2	33.8	38.3	38.3	38.4	38.4	42.9	32.3						
1440	75	36.6	33.4	41.9	23.9	47.8	14.0	33.6	31.8	38.7	22.3	43.4	12.2						
	80	38.2	38.2	42.0	32.0	47.6	22.2	35.6	35.6	38.8	30.5	44.1	20.6						
	85	41.0	41.0	42.0	39.9	47.7	30.4	38.4	38.4	38.8	38.4	44.2	28.8						
	90	43.9	43.9	44.0	44.0	47.8	38.2	41.2	41.2	41.3	41.3	44.3	36.8						
1600	75	37.3	35.9	42.7	25.3	48.5	14.4	34.2	34.2	39.4	23.8	43.9	12.5						
	80	39.6	39.6	42.7	34.1	48.4	23.4	37.0	37.0	39.5	31.3	44.8	21.9						
	85	42.6	42.6	42.7	42.7	48.5	32.5	39.9	39.9	39.9	39.9	45.0	31.0						
	90	45.6	45.6	45.7	45.7	48.5	41.4	42.8	42.8	42.9	42.9	44.9	39.9						
1760	75	37.9	37.9	43.3	26.8	48.0	14.4	35.1	35.1	39.9	25.2	44.3	12.7						
	80	40.8	40.8	43.3	36.6	49.1	24.7	38.1	38.1	39.9	35.0	45.4	23.1						
	85	44.0	44.0	44.0	44.0	49.2	34.7	41.1	41.1	41.2	41.2	45.5	33.2						
	90	47.1	47.1	47.2	47.2	49.1	44.4	44.2	44.2	44.3	44.3	45.5	42.9						
1920	75	38.8	38.8	43.8	28.2	48.3	14.6	36.0	36.0	40.4	26.6	44.2	13.2						
	80	41.9	41.9	43.8	38.9	49.6	25.9	39.1	39.1	40.3	37.3	45.9	24.3						
	85	45.2	45.2	45.2	45.2	49.7	36.9	42.3	42.3	42.3	42.3	46.0	34.0						
	90	48.4	48.4	48.5	48.5	49.6	47.4	45.5	45.5	45.5	45.5	45.9	45.8						

Notes:

1. All capacities shown are gross and have not considered indoor fan heat. To obtain NET cooling capacity subtract indoor fan heat. For indoor fan heat formula, refer to appropriate airflow table notes.
2. MBh = Total gross capacity
3. SHC = Sensible heat capacity

Table 10. Gross cooling capacities — 5 tons, ultra high efficiency

CFM	Ent DB (°F)	Entering Wet Bulb Temp (°F)						Entering Wet Bulb Temp (°F)						Entering Wet Bulb Temp (°F)					
		61		67		73		61		67		73		61		67		73	
		MBh	SHC	MBh	SHC	MBh	SHC	MBh	SHC	MBh	SHC	MBh	SHC	MBh	SHC	MBh	SHC	MBh	SHC
		Ambient Temperature 85°F						Ambient Temperature 95°F						Ambient Temperature 105°F					
1500	75	53.8	43.0	60.8	33.1	68.4	22.7	50.8	41.4	57.6	31.4	65.2	21.2	47.7	39.7	54.3	29.7	61.7	19.6
	80	53.8	51.2	60.8	41.5	68.4	31.3	50.9	49.5	57.7	39.9	65.1	29.7	47.8	47.8	54.4	38.2	61.4	28.0
	85	55.9	55.9	60.8	49.8	68.4	39.7	53.4	53.4	57.7	48.2	65.1	38.2	50.9	50.9	54.4	46.0	61.6	36.5
	90	59.3	59.3	60.8	57.9	68.4	48.1	56.8	56.8	57.7	56.3	65.1	46.6	54.2	54.2	54.4	54.4	61.6	44.9
1800	75	55.9	47.0	63.1	36.0	70.8	23.5	52.7	46.2	59.8	34.3	67.5	22.0	49.5	44.5	56.3	32.6	63.8	20.4
	80	56.3	56.3	63.1	46.1	70.8	33.7	53.7	53.7	59.8	44.5	67.3	32.2	50.9	50.9	56.3	42.8	63.5	30.5
	85	59.9	59.9	63.0	55.9	70.8	43.9	57.3	57.3	59.7	54.3	67.4	42.4	54.5	54.5	56.3	52.6	63.6	40.7
	90	63.6	63.6	63.7	63.7	70.8	54.0	61.0	61.0	61.1	61.1	67.4	52.5	58.2	58.2	58.3	58.3	63.6	50.8
2000	75	56.9	51.1	64.3	37.9	72.0	24.0	53.7	49.3	60.9	36.2	68.6	22.5	50.3	47.6	57.3	34.5	64.8	20.8
	80	58.3	58.3	64.3	49.1	72.0	35.3	55.6	55.6	60.9	47.5	68.5	33.8	52.8	52.8	57.3	45.8	64.6	32.1
	85	62.2	62.2	64.1	59.9	72.0	46.7	59.4	59.4	60.8	58.3	68.5	45.1	56.6	56.6	57.2	56.5	64.7	43.4
	90	66.0	66.0	66.1	66.1	72.0	56.8	63.3	63.3	63.4	63.4	68.5	53.7	60.4	60.4	60.5	60.5	64.6	54.4
2200	75	57.7	54.2	65.3	39.7	73.1	24.5	54.4	52.4	61.8	38.0	69.6	22.9	51.0	50.7	58.1	36.3	65.7	21.2
	80	60.1	60.1	65.2	51.7	73.0	36.9	57.3	57.3	61.8	48.7	69.4	35.3	54.4	54.4	58.0	48.5	65.5	33.6
	85	64.1	64.1	65.0	63.8	73.0	49.4	61.3	61.3	61.6	61.6	69.5	47.8	58.4	58.4	58.4	58.4	65.6	46.1
	90	68.1	68.1	68.2	68.2	72.9	61.4	65.3	65.3	65.4	65.4	69.3	59.8	62.3	62.3	62.4	62.4	65.4	58.1
2400	75	58.4	57.2	66.1	41.5	73.9	24.9	55.0	55.0	62.5	39.8	70.4	23.3	51.9	51.9	58.8	38.0	66.2	21.6
	80	61.7	61.7	65.9	54.7	73.9	38.4	58.9	58.9	62.4	53.0	70.2	36.8	55.9	55.9	58.6	51.3	66.2	35.1
	85	65.9	65.9	65.9	65.9	73.9	52.0	63.0	63.0	63.1	63.1	70.3	50.5	59.9	59.9	60.0	60.0	66.3	48.8
	90	70.0	70.0	70.1	70.1	73.6	65.0	67.1	67.1	67.2	67.2	70.0	63.5	64.0	64.0	64.1	64.1	66.0	61.8
		Ambient Temperature 115°F						Ambient Temperature 125°F											
1500	75	44.5	37.9	50.9	28.0	57.9	17.9	41.2	35.0	47.2	26.2	53.9	16.1						
	80	45.0	45.0	50.9	36.5	57.7	26.3	42.3	42.3	47.3	34.7	53.7	24.5						
	85	48.2	48.2	51.0	42.9	57.8	34.8	45.4	45.4	47.4	43.0	53.8	33.0						
	90	51.5	51.5	51.6	51.6	57.8	43.3	48.6	48.6	48.7	48.7	53.9	41.5						
1800	75	46.1	42.7	52.6	30.9	59.8	18.6	42.6	40.8	48.8	29.0	55.6	16.8						
	80	48.2	48.2	52.7	41.0	59.6	28.8	45.2	45.2	48.9	39.2	55.4	26.9						
	85	51.6	51.6	52.6	50.8	59.7	39.0	48.6	48.6	48.9	48.9	55.5	37.2						
	90	55.2	55.2	55.3	55.3	59.7	47.5	52.0	52.0	52.1	52.1	55.5	47.1						
2000	75	46.9	45.8	53.5	32.7	60.7	19.1	43.3	43.3	49.6	30.9	56.4	17.2						
	80	49.9	49.9	53.6	42.6	60.5	30.3	46.8	46.8	49.6	42.0	56.2	28.5						
	85	53.5	53.5	53.6	53.6	60.6	41.7	50.4	50.4	50.4	50.4	56.4	39.9						
	90	57.3	57.3	57.4	57.4	60.6	52.7	53.9	53.9	54.0	54.0	56.3	50.9						
2200	75	47.6	47.6	54.3	34.5	60.0	19.0	44.5	44.5	50.3	32.6	55.4	19.3						
	80	51.4	51.4	54.2	46.7	61.3	31.8	48.2	48.2	50.2	44.8	56.9	30.0						
	85	55.2	55.2	55.3	55.3	61.4	44.4	51.9	51.9	51.9	51.9	57.0	42.6						
	90	59.1	59.1	59.2	59.2	61.2	56.4	55.6	55.6	55.7	55.7	56.9	54.6						
2400	75	48.8	48.8	54.9	36.2	60.3	19.1	45.6	45.6	50.9	34.4	55.5	17.5						
	80	52.7	52.7	54.7	49.5	62.0	33.3	49.4	49.4	50.7	47.6	57.5	31.5						
	85	56.7	56.7	56.7	56.7	62.0	46.0	53.2	53.2	53.3	53.3	57.5	45.0						
	90	60.7	60.7	60.7	60.7	61.8	60.0	57.1	57.1	57.2	57.2	57.4	57.4						

Notes:

1. All capacities shown are gross and have not considered indoor fan heat. To obtain NET cooling capacity subtract indoor fan heat. For indoor fan heat formula, refer to appropriate airflow table notes.
2. MBh = Total gross capacity
3. SHC = Sensible heat capacity



Gross Cooling Capacities

Table 11. Gross cooling capacities — 6 tons, ultra high efficiency

CFM	Ent DB (°F)	Entering Wet Bulb Temp (°F)						Entering Wet Bulb Temp (°F)						Entering Wet Bulb Temp (°F)					
		61		67		73		61		67		73		61		67		73	
		MBh	SHC	MBh	SHC	MBh	SHC	MBh	SHC	MBh	SHC	MBh	SHC	MBh	SHC	MBh	SHC	MBh	SHC
		Ambient Temperature 85°F						Ambient Temperature 95°F						Ambient Temperature 105°F					
1800	75	64.6	52.6	73.1	41.3	81.9	29.4	61.6	51.2	69.7	39.9	78.3	28.0	58.5	49.7	66.2	38.4	74.4	26.5
	80	64.6	62.1	73.1	51.1	82.0	39.3	61.6	60.7	69.8	49.6	78.4	37.9	58.6	58.6	66.3	48.1	74.5	36.4
	85	67.3	67.3	73.1	60.8	82.1	49.2	65.0	65.0	69.8	59.4	78.5	47.8	62.4	62.4	66.3	57.8	74.6	46.3
	90	71.4	71.4	73.0	70.3	82.1	59.0	68.9	68.9	69.7	68.8	78.5	57.6	66.3	66.3	66.4	66.4	74.6	56.1
2160	75	67.2	58.6	75.9	45.0	84.8	30.6	64.0	56.0	72.4	43.5	81.0	29.2	60.6	55.4	68.6	41.9	76.9	27.6
	80	67.8	67.8	75.9	56.7	85.1	42.6	65.3	65.3	72.4	55.2	81.2	41.1	62.6	62.6	68.7	53.6	77.1	39.6
	85	72.3	72.3	75.9	68.1	85.1	54.4	69.6	69.6	72.3	66.6	81.2	52.9	66.7	66.7	68.6	65.0	77.1	51.3
	90	76.7	76.7	76.8	76.8	85.1	66.1	73.9	73.9	74.1	74.1	81.3	64.6	71.0	71.0	71.1	71.1	77.1	63.1
2400	75	68.5	62.3	77.4	47.3	86.3	31.3	65.2	60.7	73.7	45.8	82.4	29.9	61.7	59.1	69.9	44.2	78.2	28.4
	80	70.4	70.4	77.4	60.3	86.7	44.6	67.7	67.7	73.7	58.8	82.7	43.1	64.8	64.8	69.9	57.2	78.4	41.6
	85	75.0	75.0	77.2	72.8	86.7	57.7	72.2	72.2	73.5	71.3	82.7	56.2	69.2	69.2	69.7	69.6	78.4	54.6
	90	79.6	79.6	79.8	79.8	86.7	70.7	76.7	76.7	76.8	76.8	82.7	68.7	73.6	73.6	73.7	73.7	78.5	65.0
2640	75	69.5	66.0	78.6	49.6	87.6	32.1	66.1	64.4	74.9	48.0	83.6	30.6	62.5	62.5	70.9	46.4	79.3	29.0
	80	72.6	72.6	78.7	63.9	88.0	46.6	69.8	69.8	74.9	62.3	83.9	45.1	66.7	66.7	70.9	58.9	79.5	43.5
	85	77.4	77.4	78.3	77.5	88.0	61.0	74.5	74.5	74.6	74.6	83.9	59.5	71.3	71.3	71.4	71.4	79.5	57.9
	90	82.2	82.2	82.3	82.3	88.0	75.0	79.1	79.1	79.3	79.3	83.8	73.5	75.8	75.8	76.0	76.0	79.3	71.8
2880	75	70.3	69.5	79.7	51.8	88.7	32.7	66.9	66.9	75.8	50.2	84.6	31.3	63.8	63.8	71.8	48.6	80.2	29.7
	80	74.6	74.6	79.7	65.1	89.1	48.6	71.6	71.6	75.8	65.5	84.9	47.0	68.5	68.5	71.6	63.8	80.4	45.4
	85	79.5	79.5	79.7	79.7	89.1	64.2	76.5	76.5	76.6	76.6	84.9	62.7	73.2	73.2	73.3	73.3	80.4	61.1
	90	84.4	84.4	84.6	84.6	88.8	79.3	81.3	81.3	81.4	81.4	84.5	77.7	77.8	77.8	77.9	77.9	79.9	76.1
		Ambient Temperature 115°F						Ambient Temperature 125°F											
1800	75	55.2	48.1	62.5	36.8	70.3	24.9	51.7	46.1	58.6	35.1	65.8	23.3						
	80	55.9	55.9	62.6	46.5	70.4	34.9	53.1	53.1	58.6	44.9	66.0	33.2						
	85	59.7	59.7	62.6	55.4	70.4	44.7	56.7	56.7	58.6	54.5	66.0	43.0						
	90	63.4	63.4	63.6	63.6	70.5	54.5	60.3	60.3	60.5	60.5	66.0	52.8						
2160	75	57.1	53.8	64.7	40.3	72.5	26.0	53.3	52.0	60.5	38.5	67.8	24.4						
	80	59.6	59.6	64.7	52.0	72.7	37.9	56.5	56.5	60.5	50.3	67.9	36.2						
	85	63.7	63.7	64.6	63.3	72.7	49.7	60.4	60.4	60.5	60.5	68.0	48.0						
	90	67.8	67.8	67.9	67.9	72.7	61.5	64.3	64.3	64.4	64.4	68.0	57.3						
2400	75	58.0	57.4	65.8	42.5	73.6	26.7	54.4	54.4	61.4	40.8	68.8	25.0						
	80	61.7	61.7	65.8	55.5	73.8	39.9	58.4	58.4	61.5	51.8	69.0	38.2						
	85	65.9	65.9	66.1	66.1	73.9	53.0	62.5	62.5	62.5	62.5	69.0	51.3						
	90	70.2	70.2	70.3	70.3	73.8	65.7	66.5	66.5	66.6	66.6	68.8	63.9						
2640	75	59.2	59.2	66.7	44.7	74.6	27.4	55.8	55.8	62.2	43.0	69.6	25.7						
	80	63.5	63.5	66.6	58.8	74.8	41.8	60.0	60.0	62.1	56.9	69.8	40.1						
	85	67.9	67.9	68.0	68.0	74.8	56.2	64.2	64.2	64.3	64.3	69.9	54.5						
	90	72.3	72.3	72.4	72.4	74.5	70.0	68.4	68.4	68.5	68.5	69.4	68.2						
2880	75	60.6	60.6	67.5	46.9	75.5	28.4	57.1	57.1	62.9	45.1	68.9	25.7						
	80	65.1	65.1	67.3	62.1	75.6	43.7	61.5	61.5	62.7	60.2	70.5	42.0						
	85	69.6	69.6	69.7	69.7	75.7	59.5	65.8	65.8	65.9	65.9	70.6	56.1						
	90	74.1	74.1	74.2	74.2	75.0	74.3	70.0	70.0	70.1	70.1	70.2	70.2						

Notes:

1. All capacities shown are gross and have not considered indoor fan heat. To obtain NET cooling capacity subtract indoor fan heat. For indoor fan heat formula, refer to appropriate airflow table notes.
2. MBh = Total gross capacity
3. SHC = Sensible heat capacity

Table 12. Gross cooling capacities – 7.5 tons, ultra high efficiency

CFM	Ent DB (°F)	Entering Wet Bulb Temp (°F)						Entering Wet Bulb Temp (°F)						Entering Wet Bulb Temp (°F)					
		61		67		73		61		67		73		61		67		73	
		MBh	SHC	MBh	SHC	MBh	SHC	MBh	SHC	MBh	SHC	MBh	SHC	MBh	SHC	MBh	SHC	MBh	SHC
		Ambient Temperature 85°F						Ambient Temperature 95°F						Ambient Temperature 105°F					
2250	75	79.7	65.2	90.1	51.2	101.5	36.6	75.8	63.1	85.8	49.1	96.7	34.5	71.8	60.7	81.3	46.9	91.6	32.3
	80	79.5	76.3	90.1	63.2	101.3	48.8	75.7	74.1	85.8	61.1	96.5	46.7	71.7	71.7	81.2	58.9	91.3	44.5
	85	82.3	82.3	89.8	75.1	101.1	60.9	79.2	79.2	85.6	71.4	96.4	58.8	75.8	75.8	81.1	70.4	91.3	56.5
	90	87.2	87.2	89.6	86.1	100.9	72.9	84.0	84.0	85.4	84.0	96.2	70.8	80.5	80.5	80.9	80.9	91.2	68.6
2700	75	82.4	71.6	93.4	55.4	104.8	38.0	78.3	69.4	88.8	53.3	99.8	35.8	74.0	67.1	84.0	51.0	94.3	33.6
	80	82.5	82.5	93.2	69.8	104.4	52.4	79.2	79.2	88.6	67.6	99.3	50.2	75.6	75.6	83.8	65.3	94.0	47.9
	85	87.8	87.8	92.7	83.1	104.4	66.9	84.3	84.3	88.2	80.9	99.4	64.7	80.6	80.6	83.4	78.5	94.0	62.4
	90	93.1	93.1	93.2	93.2	104.1	81.3	89.5	89.5	89.7	89.7	99.1	78.1	85.7	85.7	85.8	85.8	93.7	73.5
3000	75	83.7	75.8	95.0	58.1	106.5	38.8	79.5	73.5	90.3	55.9	101.3	36.7	75.0	71.2	85.3	53.6	95.7	34.4
	80	85.2	85.2	94.7	74.0	106.2	54.7	81.8	81.8	90.0	71.6	101.0	52.5	78.0	78.0	85.0	67.4	95.4	50.2
	85	90.8	90.8	94.1	88.3	106.0	70.7	87.2	87.2	89.4	86.1	100.8	68.5	83.3	83.3	84.4	83.7	95.3	66.2
	90	96.3	96.3	96.5	96.5	105.6	85.9	92.6	92.6	92.7	92.7	100.4	83.6	88.5	88.5	88.6	88.6	94.8	81.2
3300	75	84.7	79.8	96.4	60.7	107.9	39.6	80.4	77.5	91.5	58.4	102.6	37.5	75.8	75.1	86.4	56.1	96.9	35.2
	80	87.7	87.7	95.9	75.2	107.6	57.0	84.0	84.0	91.0	75.1	102.3	54.7	80.2	80.2	85.8	72.7	96.6	52.4
	85	93.4	93.4	95.1	93.4	107.3	74.5	89.6	89.6	90.3	90.3	102.0	72.3	85.6	85.6	85.7	85.7	96.4	70.0
	90	99.2	99.2	99.3	99.3	106.7	90.7	95.2	95.2	95.3	95.3	101.3	88.4	91.0	91.0	91.1	91.1	95.6	86.0
3600	75	85.5	83.7	97.5	63.2	109.1	40.4	81.0	81.0	92.5	60.9	103.7	38.3	76.5	76.5	87.3	58.5	97.8	35.9
	80	89.8	89.8	96.7	81.1	108.8	59.1	86.0	86.0	91.8	78.7	103.3	56.9	82.0	82.0	86.5	76.3	97.5	54.5
	85	95.7	95.7	95.8	95.8	108.4	78.2	91.8	91.8	91.9	91.9	103.0	76.0	87.6	87.6	87.7	87.7	97.2	71.9
	90	101.6	101.6	101.7	101.7	107.4	95.4	97.6	97.6	97.6	97.6	102.0	93.1	93.1	93.2	93.2	96.1	90.7	
		Ambient Temperature 115°F						Ambient Temperature 125°F											
2250	75	67.5	57.0	76.4	44.6	86.1	30.0	62.8	55.9	71.3	42.1	80.3	27.5						
	80	67.7	67.7	76.4	56.6	85.7	42.1	64.0	64.0	71.3	54.2	79.9	39.6						
	85	72.2	72.2	76.2	68.0	85.9	54.2	68.3	68.3	71.1	65.5	80.1	51.8						
	90	76.8	76.8	76.9	76.9	85.8	66.3	72.7	72.7	72.8	72.8	80.0	63.9						
2700	75	69.4	64.7	78.8	48.6	88.5	31.2	64.5	62.1	73.3	46.1	82.4	28.8						
	80	71.8	71.8	78.7	63.0	88.2	45.5	67.7	67.7	73.2	58.6	82.1	43.0						
	85	76.7	76.7	78.3	76.1	88.2	60.0	72.4	72.4	72.8	72.8	82.1	57.5						
	90	81.5	81.5	81.6	81.6	87.9	73.7	77.0	77.0	77.1	77.1	81.8	71.1						
3000	75	70.3	68.7	80.0	51.1	89.8	32.0	65.3	65.3	74.4	48.6	83.4	29.5						
	80	74.1	74.1	79.7	66.4	89.5	47.8	69.8	69.8	74.0	63.8	83.2	45.2						
	85	79.1	79.1	79.2	79.2	89.4	63.8	74.6	74.6	74.7	74.7	83.1	61.3						
	90	84.2	84.2	84.2	84.2	88.9	78.6	79.4	79.4	79.5	79.5	82.5	76.0						
3300	75	71.0	71.0	81.0	53.6	90.8	32.8	66.6	66.6	75.2	51.0	84.3	30.3						
	80	76.0	76.0	80.4	70.1	90.5	49.9	71.5	71.5	74.7	67.5	84.1	47.3						
	85	81.2	81.2	81.3	81.3	90.3	67.5	76.5	76.5	76.6	76.6	83.9	62.6						
	90	86.4	86.4	86.5	86.5	89.5	83.4	81.4	81.4	81.5	81.5	83.0	80.7						
3600	75	72.4	72.4	81.8	56.1	91.5	33.5	68.0	68.0	75.9	53.4	84.7	30.9						
	80	77.7	77.7	81.0	73.7	91.4	52.0	73.1	73.1	75.1	71.0	84.8	49.3						
	85	83.1	83.1	83.1	83.1	90.9	70.4	78.1	78.1	78.2	78.2	84.3	67.7						
	90	88.3	88.3	88.4	88.4	90.0	88.1	83.1	83.1	83.2	83.2	83.4	83.4						

Notes:

1. All capacities shown are gross and have not considered indoor fan heat. To obtain NET cooling capacity subtract indoor fan heat. For indoor fan heat formula, refer to appropriate airflow table notes.
2. MBh = Total gross capacity
3. SHC = Sensible heat capacity



Gross Cooling Capacities

Table 13. Gross cooling capacities — 8.5 tons, ultra high efficiency

CFM	Ent DB (°F)	Entering Wet Bulb Temp (°F)						Entering Wet Bulb Temp (°F)						Entering Wet Bulb Temp (°F)					
		61		67		73		61		67		73		61		67		73	
		MBh	SHC	MBh	SHC	MBh	SHC	MBh	SHC	MBh	SHC	MBh	SHC	MBh	SHC	MBh	SHC	MBh	SHC
		Ambient Temperature 85°F						Ambient Temperature 95°F						Ambient Temperature 105°F					
2550	75	90.4	73.1	102.4	57.7	115.6	41.4	86.4	71.1	97.9	55.5	110.4	39.3	82.2	68.9	93.8	41.1	104.9	37.0
	80	90.0	85.2	102.4	71.1	115.4	55.1	86.1	83.1	97.9	68.9	110.2	53.0	81.9	80.8	93.1	66.7	104.6	50.7
	85	92.4	92.4	102.0	84.3	115.2	68.5	89.3	89.3	97.6	81.3	110.0	66.3	85.9	85.9	92.8	77.2	104.5	64.0
	90	98.0	98.0	101.7	96.2	114.8	81.9	94.7	94.7	97.2	94.0	109.7	79.7	91.1	91.1	92.5	91.7	104.2	77.5
3060	75	93.6	78.0	106.3	62.4	119.5	43.0	89.3	77.9	101.5	60.2	114.0	40.8	84.8	75.5	96.4	57.9	108.0	38.5
	80	92.9	92.9	106.0	78.2	118.9	59.5	89.2	89.2	101.1	76.0	113.4	56.8	85.6	85.6	96.0	73.7	107.5	54.4
	85	98.5	98.5	105.4	92.8	118.9	75.0	95.0	95.0	100.5	90.5	113.4	72.8	91.2	91.2	95.4	88.0	107.6	70.4
	90	104.5	104.5	104.7	104.7	118.5	91.0	100.9	100.9	101.0	101.0	113.0	88.8	96.9	96.9	97.0	97.0	107.2	84.2
3400	75	95.0	84.6	108.3	65.3	121.5	44.0	90.6	82.2	103.3	63.1	115.8	41.8	85.9	79.8	97.9	60.7	109.7	39.4
	80	95.7	95.7	107.8	82.8	120.9	61.6	92.1	92.1	102.7	80.6	115.3	59.3	88.4	88.4	97.5	77.5	109.2	56.8
	85	101.9	101.9	106.8	98.4	120.8	79.2	98.2	98.2	101.8	96.0	115.1	77.0	94.2	94.2	96.5	93.5	109.1	74.6
	90	108.2	108.2	108.3	108.3	120.2	93.0	104.3	104.3	104.4	104.4	114.5	93.5	100.1	100.1	100.2	100.2	108.4	90.9
3740	75	96.1	88.8	109.9	68.1	123.2	44.9	91.6	86.4	104.7	65.8	117.3	42.7	86.8	84.0	99.2	63.4	111.0	40.3
	80	98.4	98.4	109.2	85.8	122.7	64.0	94.7	94.7	104.0	81.5	116.8	61.7	90.7	90.7	98.4	81.6	110.6	59.2
	85	104.8	104.8	107.9	103.7	122.3	83.3	100.9	100.9	102.7	101.4	116.5	81.0	96.8	96.8	97.3	97.3	110.3	78.6
	90	111.3	111.3	111.4	111.4	121.4	101.0	107.2	107.2	107.3	107.3	115.5	98.6	102.8	102.8	102.9	102.9	109.2	96.0
4080	75	96.9	92.9	111.2	70.8	124.6	45.8	92.3	90.5	105.9	68.5	118.5	43.5	87.4	87.4	100.2	66.1	112.1	41.1
	80	100.8	100.8	110.1	90.4	124.2	66.3	96.9	96.9	104.8	87.9	118.1	64.0	92.8	92.8	99.1	85.4	111.7	61.5
	85	107.4	107.4	108.6	108.6	123.6	87.4	103.4	103.4	103.5	103.5	117.6	85.0	99.0	99.0	99.1	99.1	111.2	82.6
	90	114.1	114.1	114.2	114.2	122.2	106.1	109.8	109.8	109.9	109.9	116.2	103.6	105.2	105.2	105.3	105.3	109.8	101.0
		Ambient Temperature 115°F						Ambient Temperature 125°F											
2550	75	77.8	65.8	88.1	51.0	98.9	34.6	73.0	61.8	82.6	48.5	92.5	32.1						
	80	77.5	77.5	88.0	64.4	98.7	48.3	73.4	73.4	82.6	61.9	92.3	45.8						
	85	82.2	82.2	87.7	76.9	98.6	61.6	78.2	78.2	82.2	74.3	92.3	59.1						
	90	87.3	87.3	87.4	87.4	98.4	75.1	83.0	83.0	83.1	83.1	92.1	72.5						
3060	75	80.0	73.0	90.9	55.4	101.7	36.0	74.9	70.4	85.1	52.8	94.9	33.4						
	80	81.8	81.8	90.6	71.3	101.3	51.9	77.6	77.6	84.8	68.1	94.6	49.2						
	85	87.2	87.2	89.9	85.5	101.3	68.0	82.7	82.7	84.1	82.8	94.6	65.3						
	90	92.6	92.6	92.7	92.7	100.9	83.0	87.8	87.8	87.9	87.9	94.1	80.2						
3400	75	81.0	77.3	92.3	58.2	103.1	36.9	75.7	74.7	86.3	55.6	96.1	34.3						
	80	84.3	84.3	91.9	72.8	102.8	54.3	79.9	79.9	85.7	72.2	95.9	51.6						
	85	89.9	89.9	90.9	90.9	102.6	72.0	85.2	85.2	85.3	85.3	95.7	69.4						
	90	95.5	95.5	95.6	95.6	101.9	88.2	90.4	90.4	90.5	90.5	94.9	85.4						
3740	75	81.7	81.5	93.4	60.9	104.3	37.8	76.4	76.4	87.2	58.2	97.1	35.1						
	80	86.5	86.5	92.6	78.9	104.0	56.6	81.9	81.9	86.4	76.1	96.9	53.8						
	85	92.2	92.2	92.3	92.3	103.7	76.0	87.3	87.3	87.4	87.4	96.6	72.6						
	90	98.0	98.0	98.0	98.0	102.5	93.3	92.6	92.6	92.7	92.7	95.4	90.4						
4080	75	82.5	82.5	94.3	63.5	105.2	38.6	78.0	78.0	88.0	60.8	97.9	35.9						
	80	88.4	88.4	93.2	82.7	105.0	58.8	83.6	83.6	86.9	79.9	97.7	56.0						
	85	94.3	94.3	94.4	94.4	104.5	77.3	89.1	89.1	89.2	89.2	97.0	76.2						
	90	100.1	100.1	100.2	100.2	103.0	98.2	94.5	94.5	94.6	94.6	95.7	95.4						

Notes:

1. All capacities shown are gross and have not considered indoor fan heat. To obtain NET cooling capacity subtract indoor fan heat. For indoor fan heat formula, refer to appropriate airflow table notes.
2. MBh = Total gross capacity
3. SHC = Sensible heat capacity

Table 14. Gross cooling capacities — 10 tons, ultra high efficiency

CFM	Ent DB (°F)	Entering Wet Bulb Temp (°F)						Entering Wet Bulb Temp (°F)						Entering Wet Bulb Temp (°F)					
		61		67		73		61		67		73		61		67		73	
		MBh	SHC	MBh	SHC	MBh	SHC	MBh	SHC	MBh	SHC	MBh	SHC	MBh	SHC	MBh	SHC	MBh	SHC
		Ambient Temperature 85°F						Ambient Temperature 95°F						Ambient Temperature 105°F					
3000	75	100.4	83.2	113.2	64.3	126.4	44.4	95.8	80.7	108.0	61.8	120.3	41.9	90.9	77.9	102.4	59.2	113.8	39.2
	80	100.0	98.0	113.4	80.5	126.6	61.1	95.4	95.4	108.1	78.0	120.6	58.5	90.6	90.6	102.5	75.4	114.1	55.6
	85	104.6	104.6	113.4	95.6	126.7	77.1	100.7	100.7	108.1	91.2	120.6	74.6	96.5	96.5	102.4	90.8	114.2	71.8
	90	110.9	110.9	112.8	111.1	126.7	93.3	106.8	106.8	107.5	107.5	120.6	90.8	102.4	102.4	102.5	102.5	114.2	88.1
3600	75	103.9	91.8	117.3	69.9	130.3	46.3	98.8	89.2	111.6	67.3	123.8	43.7	93.5	86.4	105.6	64.5	116.9	40.9
	80	104.6	104.6	117.3	89.2	130.5	65.7	100.5	100.5	111.7	86.6	124.2	63.0	96.2	96.2	105.8	83.9	117.3	60.2
	85	111.4	111.4	116.7	107.1	130.6	85.1	107.1	107.1	111.0	104.3	124.2	82.4	102.4	102.4	104.9	101.5	117.4	79.6
	90	118.1	118.1	118.3	118.3	130.6	104.5	113.5	113.5	113.7	113.7	124.3	99.3	108.6	108.6	108.7	108.7	117.2	98.2
4000	75	105.4	97.3	119.3	73.4	132.3	47.4	100.2	94.6	113.4	70.7	125.6	44.8	94.7	91.8	107.3	67.9	118.5	42.0
	80	108.1	108.1	119.4	94.9	132.6	68.7	103.8	103.8	113.5	91.6	126.0	66.0	99.2	99.2	107.4	86.7	119.0	63.1
	85	115.1	115.1	118.1	114.0	132.7	90.2	110.5	110.5	112.2	111.2	126.1	87.5	105.6	105.6	105.9	105.9	119.0	84.7
	90	122.0	122.0	122.2	122.2	132.3	110.6	117.2	117.2	117.3	117.3	125.5	107.7	111.9	111.9	112.0	112.0	118.2	104.7
4400	75	106.5	102.6	121.0	76.8	134.0	48.5	101.2	99.9	115.0	74.1	127.2	45.9	95.6	95.6	108.6	71.2	120.0	43.1
	80	111.1	111.1	121.0	96.1	134.3	71.6	106.6	106.6	114.6	96.6	127.6	68.8	101.7	101.7	108.1	93.7	120.4	65.8
	85	118.3	118.3	119.1	119.1	134.4	95.3	113.5	113.5	113.6	113.6	127.6	92.5	108.3	108.3	108.4	108.4	120.4	89.6
	90	125.4	125.4	125.5	125.5	133.3	117.0	120.3	120.3	120.4	120.4	126.3	114.1	114.7	114.7	114.8	114.8	118.8	111.0
4800	75	107.3	107.3	122.4	80.1	126.3	45.9	101.9	101.9	116.3	77.3	119.3	43.2	97.1	97.1	109.8	74.4	121.4	44.3
	80	113.7	113.7	121.7	104.3	135.8	74.3	109.0	109.0	115.4	101.5	128.9	71.4	104.0	104.0	108.8	98.5	121.5	68.4
	85	121.1	121.1	121.2	121.2	135.9	100.2	116.1	116.1	116.2	116.2	129.0	97.4	110.7	110.7	110.8	110.8	121.6	92.4
	90	128.3	128.3	128.5	128.5	134.0	123.3	123.0	123.0	123.1	123.1	126.9	120.3	117.1	117.1	117.2	117.2	119.2	117.3
		Ambient Temperature 115°F						Ambient Temperature 125°F											
3000	75	85.8	73.6	96.4	56.4	106.7	36.4	80.1	72.2	90.1	53.5	99.1	33.4						
	80	86.4	86.4	96.6	72.6	107.3	52.8	81.8	81.8	90.2	69.7	99.9	49.7						
	85	92.0	92.0	96.4	87.9	107.3	69.0	87.1	87.1	89.8	84.8	99.8	65.9						
	90	97.6	97.6	97.7	97.7	107.3	85.2	92.2	92.2	92.4	92.4	99.8	81.9						
3600	75	88.0	83.5	99.3	61.6	109.5	38.0	82.0	80.5	92.5	58.6	95.5	32.6						
	80	91.5	91.5	99.5	81.0	110.1	57.2	86.4	86.4	92.7	75.8	102.3	54.1						
	85	97.4	97.4	98.5	98.5	110.1	76.7	91.9	91.9	92.0	92.0	102.2	73.5						
	90	103.1	103.1	103.3	103.3	109.6	95.0	97.1	97.1	97.2	97.2	101.4	91.7						
4000	75	89.0	88.9	100.7	65.0	110.9	39.1	83.0	83.0	93.8	61.8	103.0	36.1						
	80	94.2	94.2	100.5	85.7	111.5	60.0	88.8	88.8	93.4	82.4	103.5	56.7						
	85	100.3	100.3	100.4	100.4	111.5	81.6	94.4	94.4	94.5	94.5	103.4	78.4						
	90	106.1	106.1	106.2	106.2	110.4	101.5	99.6	99.6	99.7	99.7	102.0	98.1						
4400	75	90.2	90.2	101.9	68.2	104.0	36.8	85.0	85.0	94.8	64.9	104.4	37.3						
	80	96.6	96.6	101.3	90.6	112.7	62.7	90.9	90.9	94.0	87.3	104.5	59.3						
	85	102.7	102.7	102.8	102.8	112.7	86.6	96.5	96.5	96.6	96.6	104.3	80.9						
	90	108.6	108.6	108.7	108.7	110.9	107.8	101.7	101.7	101.8	101.8	102.3	102.3						
4800	75	92.1	92.1	102.9	71.2	113.3	41.2	86.6	86.6	95.4	67.9	95.8	28.9						
	80	98.6	98.6	101.8	95.3	113.7	65.2	92.6	92.6	94.4	92.0	105.2	61.7						
	85	104.8	104.8	104.9	104.9	113.2	90.4	98.3	98.3	98.4	98.4	104.5	87.0						
	90	110.7	110.7	110.8	110.8	111.1	111.1	103.5	103.5	103.6	103.6	103.7	103.7						

Notes:

1. All capacities shown are gross and have not considered indoor fan heat. To obtain NET cooling capacity subtract indoor fan heat. For indoor fan heat formula, refer to appropriate airflow table notes.
2. MBh = Total gross capacity
3. SHC = Sensible heat capacity



Gross Cooling Capacities

Table 15. Gross cooling capacities — 12.5 tons, ultra high efficiency

CFM	Ent DB (°F)	Entering Wet Bulb Temp (°F)						Entering Wet Bulb Temp (°F)						Entering Wet Bulb Temp (°F)					
		61		67		73		61		67		73		61		67		73	
		MBh	SHC	MBh	SHC	MBh	SHC	MBh	SHC	MBh	SHC	MBh	SHC	MBh	SHC	MBh	SHC	MBh	SHC
		Ambient Temperature 85°F						Ambient Temperature 95°F						Ambient Temperature 105°F					
3750	75	136.5	110.4	152.5	86.1	166.8	58.9	129.4	106.5	145.4	82.4	159.1	55.5	122.0	102.5	137.5	78.5	151.4	52.0
	80	136.6	129.9	152.6	106.5	167.1	80.5	129.6	125.9	145.5	102.9	159.7	77.0	122.2	121.8	137.7	99.0	152.0	73.6
	85	141.0	141.0	152.6	126.8	167.1	101.0	135.4	135.4	145.6	123.3	160.3	97.8	129.3	129.3	137.9	118.5	152.5	94.2
	90	148.5	148.5	152.1	145.8	167.2	121.5	143.0	143.0	145.3	142.2	160.4	118.3	136.9	136.9	137.7	137.7	152.6	114.8
4500	75	141.6	120.9	157.6	93.2	172.2	61.0	134.2	115.9	150.2	89.5	163.4	58.2	126.2	113.7	142.1	85.6	155.3	54.6
	80	141.8	141.8	157.7	117.6	172.2	86.7	135.8	135.8	150.4	114.0	165.0	83.4	129.3	129.3	142.2	110.1	156.8	79.7
	85	149.9	149.9	157.5	141.0	172.3	111.2	144.1	144.1	150.1	137.2	164.8	107.9	137.6	137.6	141.9	133.1	156.7	104.3
	90	157.5	157.5	157.7	157.7	172.3	135.7	151.7	151.7	152.0	152.0	165.0	132.5	145.3	145.3	145.5	145.5	157.0	126.6
5000	75	144.1	129.5	160.2	97.7	174.9	63.4	136.4	125.3	152.7	94.1	165.7	59.5	128.3	121.0	144.4	90.1	157.5	56.0
	80	146.4	146.4	160.3	124.9	174.9	90.6	140.3	140.3	152.8	121.2	167.4	87.2	133.6	133.6	144.5	117.1	159.1	83.6
	85	154.6	154.6	159.4	150.0	175.0	117.9	148.6	148.6	151.9	146.2	167.2	114.5	142.0	142.0	143.6	142.2	158.9	110.8
	90	162.2	162.2	162.4	162.4	175.0	141.4	156.3	156.3	156.5	156.5	167.4	140.7	149.7	149.7	149.9	149.9	158.7	136.9
5500	75	145.9	136.6	162.4	102.2	177.3	64.8	138.1	132.4	154.8	98.5	167.8	59.8	129.9	128.0	146.3	94.5	159.4	57.3
	80	150.4	150.4	162.6	130.8	177.2	94.4	144.1	144.1	154.9	124.4	169.3	91.0	137.2	137.2	146.2	123.4	160.8	87.3
	85	158.6	158.6	160.6	158.8	177.3	124.5	152.5	152.5	153.2	153.2	169.2	121.0	145.7	145.7	145.9	145.9	160.7	117.3
	90	166.4	166.4	166.6	166.6	176.9	152.8	160.1	160.1	160.3	160.3	168.2	149.0	153.3	153.3	153.5	153.5	159.5	145.2
6000	75	147.3	143.5	164.3	106.5	179.4	66.2	139.5	139.3	156.6	102.8	169.5	62.2	131.3	131.3	147.9	98.8	161.7	58.9
	80	153.8	153.8	164.2	137.9	179.2	98.2	147.4	147.4	156.2	134.0	171.1	94.7	140.4	140.4	147.4	129.8	162.4	91.0
	85	162.1	162.1	162.2	162.2	179.2	131.0	155.8	155.8	156.0	156.0	171.0	127.5	148.8	148.8	149.0	149.0	162.4	123.8
	90	170.5	170.5	170.7	170.7	178.2	161.2	163.4	163.4	163.6	163.6	168.8	157.2	156.4	156.4	156.6	156.6	160.0	153.3
		Ambient Temperature 115°F						Ambient Temperature 125°F											
3750	75	114.1	97.8	129.1	74.4	142.9	48.3	105.7	91.6	120.0	70.0	133.5	44.8						
	80	115.0	115.0	129.3	94.9	143.5	69.8	108.1	108.1	120.3	90.5	134.1	65.8						
	85	122.7	122.7	129.5	114.7	143.8	90.4	115.7	115.7	120.4	110.3	134.3	86.2						
	90	130.3	130.3	130.5	130.5	144.0	110.9	123.1	123.1	123.3	123.3	134.5	106.8						
4500	75	117.9	109.2	133.2	81.4	146.8	51.0	109.1	104.6	123.7	76.9	136.9	46.9						
	80	122.4	122.4	133.4	105.9	147.8	75.8	114.9	114.9	123.9	101.1	137.7	71.6						
	85	130.5	130.5	133.1	128.8	147.7	100.4	122.9	122.9	123.6	123.5	137.7	96.2						
	90	138.2	138.2	138.4	138.4	147.9	124.2	130.4	130.4	130.6	130.6	137.6	119.8						
5000	75	119.7	116.5	135.3	85.8	148.5	52.2	110.7	110.7	125.5	81.3	138.8	48.2						
	80	126.4	126.4	135.4	109.5	149.7	79.6	118.6	118.6	125.6	107.7	139.5	75.3						
	85	134.7	134.7	134.8	134.8	149.7	106.9	126.7	126.7	126.9	126.9	139.5	102.7						
	90	142.3	142.3	142.5	142.5	149.1	132.7	134.1	134.1	134.3	134.3	138.7	128.3						
5500	75	121.2	121.2	137.0	90.2	150.3	53.6	113.2	113.2	127.1	85.6	140.2	49.5						
	80	129.8	129.8	136.8	118.9	151.3	83.3	121.8	121.8	126.8	114.2	140.9	79.0						
	85	138.2	138.2	138.3	138.3	151.3	113.4	129.9	129.9	130.1	130.1	141.0	108.5						
	90	145.7	145.7	145.9	145.9	149.9	141.0	137.3	137.3	137.4	137.4	139.3	136.6						
6000	75	123.8	123.8	138.5	94.4	152.1	55.0	115.8	115.8	128.3	89.8	138.3	48.7						
	80	132.8	132.8	137.9	125.3	152.8	87.0	124.5	124.5	127.7	120.6	142.3	82.6						
	85	141.1	141.1	141.3	141.3	152.8	116.0	132.6	132.6	132.8	132.8	141.9	114.4						
	90	148.6	148.6	148.7	148.7	150.3	149.2	-	-	-	-	-	-						

Notes:

1. All capacities shown are gross and have not considered indoor fan heat. To obtain NET cooling capacity subtract indoor fan heat. For indoor fan heat formula, refer to appropriate airflow table notes.
2. MBh = Total gross capacity
3. SHC = Sensible heat capacity

Table 16. Gross cooling capacities — 15 tons, ultra high efficiency

CFM	Ent DB (°F)	Entering Wet Bulb Temp (°F)						Entering Wet Bulb Temp (°F)						Entering Wet Bulb Temp (°F)					
		61		67		73		61		67		73		61		67		73	
		MBh	SHC	MBh	SHC	MBh	SHC	MBh	SHC	MBh	SHC	MBh	SHC	MBh	SHC	MBh	SHC	MBh	SHC
		Ambient Temperature 85°F						Ambient Temperature 95°F						Ambient Temperature 105°F					
4500	75	164.0	132.0	183.4	103.4	200.5	70.9	155.9	127.5	175.0	99.1	192.2	67.4	147.3	122.9	165.6	94.4	183.0	63.4
	80	164.0	154.4	183.4	127.3	201.0	96.7	155.9	149.9	175.1	123.1	192.7	92.9	147.4	145.1	166.0	118.6	183.5	88.8
	85	168.2	168.2	183.3	151.3	201.4	120.9	161.7	161.7	175.1	147.2	193.1	117.1	154.7	154.7	166.0	141.2	183.7	112.9
	90	177.3	177.3	182.9	173.3	201.3	145.1	170.8	170.8	174.7	169.0	193.2	141.3	163.7	163.7	165.7	164.4	183.8	137.2
5400	75	170.0	143.9	189.4	111.4	206.3	73.3	161.5	138.4	180.7	107.1	197.4	70.6	152.3	135.5	171.1	102.4	187.8	66.4
	80	169.4	169.4	189.5	140.1	207.4	104.2	161.9	161.9	180.8	135.9	198.7	100.5	154.5	154.5	171.3	131.3	188.8	95.5
	85	178.6	178.6	189.2	167.2	207.2	132.5	171.8	171.8	180.4	162.7	198.6	128.7	164.3	164.3	170.7	157.9	188.8	124.4
	90	187.9	187.9	188.1	188.1	207.4	161.5	181.1	181.1	181.4	181.4	198.7	157.7	173.6	173.6	173.8	173.8	188.9	151.1
6000	75	172.9	153.5	192.6	116.5	209.6	76.1	164.0	148.6	183.7	112.2	200.1	72.1	154.6	143.6	173.8	107.5	190.3	68.0
	80	174.3	174.3	192.6	148.4	210.8	108.2	167.1	167.1	183.7	144.1	201.6	104.2	159.4	159.4	173.9	139.5	191.4	99.8
	85	184.2	184.2	191.4	177.3	210.3	140.0	177.2	177.2	182.5	172.9	201.4	136.2	169.4	169.4	172.7	168.1	191.4	131.8
	90	193.6	193.6	193.8	193.8	210.5	167.6	186.6	186.6	186.8	186.8	201.4	166.7	178.8	178.8	179.0	179.0	191.0	162.1
6600	75	175.0	161.4	195.2	121.5	212.4	77.7	165.9	156.5	186.1	117.1	202.5	73.7	156.3	151.4	176.1	112.4	192.9	69.7
	80	178.9	178.9	195.2	156.2	213.4	112.4	171.6	171.6	186.1	148.6	204.0	108.3	163.7	163.7	175.9	146.1	193.7	103.8
	85	189.0	189.0	193.0	187.2	212.9	147.5	181.8	181.8	184.0	182.8	203.8	143.5	173.7	173.7	174.1	174.1	193.6	139.2
	90	198.4	198.4	198.6	198.6	212.2	180.2	191.2	191.2	191.4	191.4	202.7	176.0	183.1	183.1	183.3	183.3	192.2	171.4
7200	75	176.6	169.0	197.5	126.3	214.7	79.3	167.4	164.1	188.2	121.9	204.6	74.0	157.7	157.7	178.0	117.1	189.5	68.3
	80	182.9	182.9	197.1	162.8	215.6	116.4	175.5	175.5	187.6	158.2	206.1	112.2	167.3	167.3	177.2	153.2	195.6	107.7
	85	193.1	193.1	194.1	194.1	215.2	154.8	185.7	185.7	185.9	185.9	205.9	150.8	177.5	177.5	177.6	177.6	195.4	146.4
	90	202.5	202.5	202.7	202.7	213.1	189.3	195.2	195.2	195.3	195.3	203.5	185.1	186.9	186.9	187.0	187.0	192.9	180.6
		Ambient Temperature 115°F						Ambient Temperature 125°F											
4500	75	138.3	117.8	155.8	89.6	172.8	59.0	128.6	110.5	145.2	84.6	161.5	54.9						
	80	138.5	138.5	156.2	113.9	173.3	84.4	130.2	130.2	145.6	108.9	162.0	79.7						
	85	147.1	147.1	156.3	134.1	173.4	108.4	139.0	139.0	145.7	131.8	162.1	103.5						
	90	156.0	156.0	156.3	156.3	173.6	132.7	147.7	147.7	147.9	147.9	162.3	127.8						
5400	75	142.6	130.3	160.7	97.5	177.2	62.0	132.4	124.8	149.6	92.4	165.5	57.3						
	80	146.6	146.6	161.0	126.5	177.9	90.8	138.0	138.0	149.9	121.3	166.1	85.8						
	85	156.1	156.1	160.4	152.9	178.0	119.8	147.3	147.3	149.3	147.5	166.2	114.9						
	90	165.3	165.3	165.5	165.5	178.2	142.2	156.2	156.2	156.3	156.3	166.0	142.3						
6000	75	144.7	138.3	163.2	102.5	179.5	63.5	134.2	132.8	151.8	97.2	167.6	58.7						
	80	151.2	151.2	163.4	131.7	180.3	95.0	142.2	142.2	151.8	128.1	168.1	89.8						
	85	160.9	160.9	162.2	162.2	180.4	127.2	151.7	151.7	151.8	151.8	168.3	122.2						
	90	170.1	170.1	170.3	170.3	179.6	157.2	160.6	160.6	160.8	160.8	167.3	151.8						
6600	75	146.2	146.1	165.2	107.3	176.5	62.5	135.9	135.9	153.5	101.9	169.5	60.3						
	80	155.1	155.1	164.9	140.9	182.3	98.9	145.8	145.8	153.1	135.4	169.9	93.6						
	85	165.0	165.0	165.1	165.1	182.3	134.5	155.4	155.4	155.6	155.5	170.0	129.5						
	90	174.2	174.2	174.4	174.4	180.7	166.5	164.3	164.3	164.4	164.4	168.2	161.2						
7200	75	148.0	148.0	166.9	111.9	175.9	61.7	138.8	138.8	155.0	106.4	161.3	48.2						
	80	158.5	158.5	166.1	148.0	184.0	102.7	148.9	148.9	154.1	142.4	171.3	97.2						
	85	168.5	168.5	168.6	168.6	184.0	139.7	158.6	158.6	158.7	158.7	171.2	134.5						
	90	177.6	177.6	177.8	177.8	181.3	175.6	—	—	—	—	—	—						

Notes:

1. All capacities shown are gross and have not considered indoor fan heat. To obtain NET cooling capacity subtract indoor fan heat. For indoor fan heat formula, refer to appropriate airflow table notes.
2. MBh = Total gross capacity
3. SHC = Sensible heat capacity



Gross Cooling Capacities

Table 17. Gross cooling capacities — 17.5 tons, ultra high efficiency

CFM	Ent DB (°F)	Entering Wet Bulb Temp (°F)						Entering Wet Bulb Temp (°F)						Entering Wet Bulb Temp (°F)					
		61		67		73		61		67		73		61		67		73	
		MBh	SHC	MBh	SHC	MBh	SHC	MBh	SHC	MBh	SHC	MBh	SHC	MBh	SHC	MBh	SHC	MBh	SHC
		Ambient Temperature 85°F						Ambient Temperature 95°F						Ambient Temperature 105°F					
5250	75	193.7	153.7	218.4	122.0	239.7	85.3	184.2	148.5	208.1	117.0	228.6	80.6	174.0	143.0	196.8	111.6	216.3	75.4
	80	193.3	178.6	218.1	149.0	239.9	114.3	183.8	173.1	207.8	143.9	228.9	109.5	173.7	167.4	196.6	138.4	216.6	104.2
	85	195.9	195.9	217.6	176.1	240.1	141.9	188.4	188.4	207.4	171.0	229.2	137.0	180.2	180.2	196.3	165.6	216.9	131.6
	90	207.1	207.1	217.2	200.5	240.1	169.3	199.4	199.4	206.9	195.1	229.2	164.4	191.0	191.0	195.8	189.3	217.0	159.1
6300	75	201.1	169.4	225.9	131.3	247.2	89.2	191.0	161.7	214.9	125.8	234.5	84.0	180.1	152.1	203.0	120.2	221.3	78.5
	80	200.0	197.0	225.7	163.4	247.0	122.5	190.0	190.0	214.8	158.1	235.0	117.5	180.1	180.1	202.9	152.5	222.0	112.1
	85	208.7	208.7	225.0	190.3	246.8	154.6	200.5	200.5	214.2	188.0	235.3	149.6	191.5	191.5	202.1	181.9	222.3	144.1
	90	220.3	220.3	223.3	222.1	246.9	187.3	211.9	211.9	212.6	212.6	235.4	182.3	202.6	202.6	202.8	202.8	222.4	176.9
7000	75	204.8	172.6	229.8	136.9	251.1	91.1	194.3	171.7	218.6	131.6	238.1	85.8	182.9	165.5	206.4	125.9	224.0	80.2
	80	203.3	203.3	229.4	172.5	250.8	127.8	195.0	195.0	218.2	167.3	238.2	122.6	185.9	185.9	206.0	161.6	225.0	116.3
	85	215.6	215.6	228.2	204.5	250.5	162.9	207.1	207.1	216.9	198.9	238.3	157.8	197.6	197.6	204.5	192.8	225.0	152.2
	90	227.3	227.3	227.6	227.6	250.4	199.0	218.5	218.5	218.7	218.7	238.5	189.4	208.6	208.6	208.8	208.8	225.1	186.0
7700	75	207.5	186.0	233.2	142.5	254.4	92.9	196.6	180.1	221.7	137.1	241.0	87.5	185.0	173.9	209.1	131.3	226.6	81.8
	80	209.1	209.1	232.5	181.5	253.8	131.9	200.4	200.4	221.0	176.1	240.9	126.5	190.9	190.9	208.5	167.1	227.2	120.8
	85	221.5	221.5	230.3	215.1	253.7	171.1	212.6	212.6	218.7	209.4	240.9	165.8	202.8	202.8	206.1	203.3	227.2	160.2
	90	233.2	233.2	233.4	233.4	253.1	207.6	224.0	224.0	224.2	224.2	240.4	202.0	213.6	213.6	213.8	213.8	226.2	195.8
8400	75	209.5	194.2	235.8	147.9	257.1	94.6	198.4	188.2	224.1	142.5	243.4	89.2	186.5	182.0	211.3	136.6	228.7	83.4
	80	214.1	214.1	235.1	187.1	256.6	136.5	205.1	205.1	223.3	182.6	243.0	130.9	195.3	195.3	210.2	176.3	229.0	125.1
	85	226.6	226.6	231.7	225.3	256.3	179.1	217.4	217.4	220.0	220.0	243.1	173.7	207.2	207.2	207.3	207.3	229.1	168.1
	90	238.2	238.2	238.4	238.4	254.5	217.4	228.6	228.6	228.8	228.8	241.2	211.6	217.7	217.7	217.9	217.9	226.8	205.4
		Ambient Temperature 115°F						Ambient Temperature 125°F											
5250	75	163.2	137.3	184.6	105.8	202.5	70.4	151.5	128.8	171.2	99.7	187.4	64.2						
	80	162.9	161.3	184.5	132.6	203.0	98.5	151.5	151.5	171.3	126.5	188.0	92.4						
	85	171.3	171.3	184.2	155.8	203.3	125.8	161.6	161.6	171.2	152.0	188.3	119.5						
	90	181.7	181.7	183.7	183.2	203.4	153.3	171.4	171.4	171.6	171.6	188.5	147.1						
6300	75	168.5	150.5	190.2	114.2	206.8	72.7	156.0	143.8	176.3	107.8	190.9	66.5						
	80	170.7	170.7	190.0	146.6	207.8	105.8	160.5	160.5	176.1	140.2	192.1	99.2						
	85	181.8	181.8	189.1	175.5	207.9	138.2	171.0	171.0	175.1	168.8	192.1	131.7						
	90	192.2	192.2	192.4	192.4	208.1	166.9	180.6	180.6	180.8	180.8	192.1	162.3						
7000	75	170.9	159.1	193.1	119.8	209.0	74.2	158.0	152.3	178.7	113.3	192.6	67.9						
	80	176.1	176.1	192.7	155.5	210.2	110.2	165.3	165.3	178.4	144.1	193.9	103.6						
	85	187.3	187.3	191.1	186.3	210.2	146.2	175.8	175.8	176.6	176.6	193.9	139.7						
	90	197.6	197.6	197.8	197.8	209.8	179.4	185.1	185.1	185.2	185.2	193.0	172.3						
7700	75	172.7	167.4	195.4	125.1	211.2	75.8	159.5	159.5	180.7	118.5	194.5	69.5						
	80	180.7	180.7	194.8	162.2	212.1	114.6	169.4	169.4	179.8	155.1	195.4	107.9						
	85	191.9	191.9	192.4	192.4	212.1	154.1	179.8	179.8	180.0	180.0	195.5	147.5						
	90	201.9	201.9	202.1	202.1	210.5	189.2	188.6	188.6	188.8	188.8	193.4	182.0						
8400	75	174.0	173.9	197.3	130.3	213.0	77.4	161.6	161.6	182.3	123.6	196.0	71.0						
	80	184.6	184.6	196.0	169.6	213.6	118.8	172.9	172.9	180.8	162.5	196.7	112.0						
	85	195.8	195.8	196.0	196.0	213.8	161.9	183.1	183.1	183.3	183.3	196.9	149.1						
	90	205.4	205.4	205.6	205.6	210.9	198.8	191.4	191.4	191.5	191.5	193.5	191.6						

Notes:

1. All capacities shown are gross and have not considered indoor fan heat. To obtain NET cooling capacity subtract indoor fan heat. For indoor fan heat formula, refer to appropriate airflow table notes.
2. MBh = Total gross capacity
3. SHC = Sensible heat capacity

Table 18. Gross cooling capacities — 20 tons, ultra high efficiency

CFM	Ent DB (°F)	Entering Wet Bulb Temp (°F)						Entering Wet Bulb Temp (°F)						Entering Wet Bulb Temp (°F)					
		61		67		73		61		67		73		61		67		73	
		MBh	SHC	MBh	SHC	MBh	SHC	MBh	SHC	MBh	SHC	MBh	SHC	MBh	SHC	MBh	SHC	MBh	SHC
		Ambient Temperature 85°F						Ambient Temperature 95°F						Ambient Temperature 105°F					
6000	75	218.1	172.5	246.5	137.9	272.5	97.2	207.7	166.9	235.0	132.3	260.3	92.0	196.7	160.9	222.6	126.3	246.7	86.4
	80	217.3	199.7	246.0	167.6	272.5	129.8	206.9	193.7	234.6	161.9	260.3	124.5	195.9	187.4	222.3	155.9	246.7	118.7
	85	218.9	218.9	245.1	197.6	272.2	161.0	210.8	210.8	233.9	192.0	260.0	154.6	202.0	202.0	221.7	186.1	246.5	148.7
	90	231.5	231.5	244.3	224.1	272.1	190.6	223.1	223.1	233.0	218.1	259.9	185.2	214.1	214.1	220.8	211.8	246.5	179.3
7200	75	226.2	189.5	254.7	148.2	280.5	101.6	215.1	181.4	242.4	141.4	267.5	96.1	203.4	171.2	229.4	135.2	253.1	90.2
	80	224.3	219.2	254.6	183.1	280.6	138.9	213.3	213.0	242.5	177.3	267.5	133.4	201.6	201.6	229.4	171.1	253.1	127.5
	85	232.8	232.8	253.3	211.1	280.5	174.0	224.0	224.0	241.3	209.9	267.6	168.4	214.4	214.4	228.1	203.2	253.2	162.3
	90	246.1	246.1	251.0	247.2	280.0	210.1	237.0	237.0	239.0	239.0	267.2	204.6	227.0	227.0	227.2	227.2	252.9	198.6
8000	75	230.2	193.1	259.2	153.5	284.5	103.5	218.6	191.5	246.8	147.6	271.1	98.0	206.3	184.7	233.4	141.2	256.3	92.0
	80	227.4	227.4	258.8	192.9	284.6	144.7	217.5	217.5	246.4	187.0	271.1	139.1	207.8	207.8	232.9	180.8	256.2	131.2
	85	240.5	240.5	256.8	227.8	284.6	182.8	231.2	231.2	244.2	221.4	271.3	177.1	221.1	221.1	230.7	214.7	256.5	170.9
	90	254.0	254.0	254.2	254.2	284.0	222.8	244.5	244.5	244.7	244.7	270.8	213.1	233.9	233.9	234.1	234.1	256.1	208.1
8800	75	233.0	206.9	263.2	159.5	287.9	105.4	221.0	200.3	250.5	153.4	274.1	99.8	208.3	193.5	236.6	146.9	259.0	93.8
	80	232.8	232.8	262.3	202.5	287.8	148.1	223.4	223.4	249.5	196.5	274.1	142.2	213.3	213.3	235.7	189.1	259.0	135.8
	85	247.0	247.0	259.1	238.9	287.9	191.4	237.4	237.4	246.2	232.6	274.3	185.6	226.9	226.9	232.3	225.8	259.2	179.4
	90	260.8	260.8	261.0	261.0	287.2	231.6	250.8	250.8	251.0	251.0	273.1	225.4	239.8	239.8	240.0	240.0	257.5	218.6
9600	75	235.0	215.4	266.5	165.2	291.0	107.2	222.8	208.8	253.4	159.0	276.7	101.5	209.8	201.9	239.1	152.4	261.2	95.5
	80	238.3	238.3	265.1	209.4	290.8	152.8	228.6	228.6	252.1	199.9	276.8	146.8	218.1	218.1	237.4	196.2	261.5	140.2
	85	252.8	252.8	260.6	249.8	290.8	199.8	242.8	242.8	247.5	243.4	276.8	194.0	231.9	231.9	233.2	233.2	261.5	187.7
	90	266.6	266.6	266.7	266.7	288.5	241.9	256.3	256.3	256.4	256.4	274.2	235.6	244.8	244.8	244.9	244.9	258.4	228.8
		Ambient Temperature 115°F						Ambient Temperature 125°F											
6000	75	184.9	154.7	209.1	120.4	231.8	81.1	172.4	146.8	194.4	112.4	215.4	74.5	161.5	146.0	195.0	106.0	215.5	74.5
	80	184.2	180.8	209.2	149.6	231.8	112.6	171.8	171.8	195.0	142.9	215.5	106.0	161.5	146.0	195.0	106.0	215.5	74.5
	85	192.5	192.5	208.6	175.4	231.9	142.4	182.2	182.2	194.6	170.9	215.7	135.5	161.5	146.0	195.0	106.0	215.5	74.5
	90	204.2	204.2	207.7	205.1	231.8	173.0	193.3	193.3	193.6	193.6	215.6	166.2	161.5	146.0	195.0	106.0	215.5	74.5
7200	75	190.7	168.6	215.4	128.6	237.3	83.9	177.2	161.3	200.4	121.6	220.0	77.1	161.5	146.0	195.0	106.0	215.5	74.5
	80	191.5	191.5	215.4	164.5	237.4	121.2	180.7	180.7	200.4	157.6	220.0	112.5	161.5	146.0	195.0	106.0	215.5	74.5
	85	204.0	204.0	214.0	196.2	237.6	155.7	192.5	192.5	198.8	188.8	220.5	148.6	161.5	146.0	195.0	106.0	215.5	74.5
	90	216.1	216.1	216.3	216.3	237.4	189.1	203.9	203.9	204.1	204.1	220.2	182.5	161.5	146.0	195.0	106.0	215.5	74.5
8000	75	193.2	177.6	219.0	134.5	240.1	85.7	179.2	170.2	203.4	127.2	222.3	78.8	161.5	146.0	195.0	106.0	215.5	74.5
	80	197.4	197.4	218.5	174.1	240.1	124.4	186.0	186.0	203.0	163.4	222.6	117.1	161.5	146.0	195.0	106.0	215.5	74.5
	85	210.1	210.1	216.1	207.6	240.5	164.3	198.1	198.1	200.5	200.2	222.9	157.1	161.5	146.0	195.0	106.0	215.5	74.5
	90	222.3	222.3	222.5	222.5	239.5	200.9	209.4	209.4	209.5	209.5	221.5	193.1	161.5	146.0	195.0	106.0	215.5	74.5
8800	75	194.9	186.3	221.7	140.0	242.4	87.4	180.7	178.8	205.7	132.6	224.3	80.5	161.5	146.0	195.0	106.0	215.5	74.5
	80	202.4	202.4	220.6	181.0	242.6	128.9	190.5	190.5	204.4	173.2	224.7	121.4	161.5	146.0	195.0	106.0	215.5	74.5
	85	215.4	215.4	217.5	217.5	242.8	172.6	202.7	202.7	202.9	202.9	224.8	165.4	161.5	146.0	195.0	106.0	215.5	74.5
	90	227.6	227.6	227.7	227.7	240.6	211.3	213.9	213.9	214.0	214.0	222.2	203.5	161.5	146.0	195.0	106.0	215.5	74.5
9600	75	196.1	194.7	223.9	145.4	245.6	89.5	181.6	181.6	207.6	137.8	226.0	82.2	161.5	146.0	195.0	106.0	215.5	74.5
	80	206.8	206.8	222.0	188.8	244.7	133.1	194.5	194.5	205.4	181.1	226.4	125.4	161.5	146.0	195.0	106.0	215.5	74.5
	85	219.9	219.9	220.0	220.0	244.7	180.9	206.7	206.7	206.8	206.8	226.5	170.2	161.5	146.0	195.0	106.0	215.5	74.5
	90	232.0	232.0	232.1	232.1	241.2	221.5	217.6	217.6	217.7	217.7	222.6	213.8	161.5	146.0	195.0	106.0	215.5	74.5

Notes:

1. All capacities shown are gross and have not considered indoor fan heat. To obtain NET cooling capacity subtract indoor fan heat. For indoor fan heat formula, refer to appropriate airflow table notes.
2. MBh = Total gross capacity
3. SHC = Sensible heat capacity



Gross Cooling Capacities

Table 19. Gross cooling capacities — 25 tons, ultra high efficiency

CFM	Ent DB (°F)	Entering Wet Bulb Temp (°F)						Entering Wet Bulb Temp (°F)						Entering Wet Bulb Temp (°F)					
		61		67		73		61		67		73		61		67		73	
		MBh	SHC	MBh	SHC	MBh	SHC	MBh	SHC	MBh	SHC	MBh	SHC	MBh	SHC	MBh	SHC	MBh	SHC
		Ambient Temperature 85°F						Ambient Temperature 95°F						Ambient Temperature 105°F					
7500	75	250.2	201.1	284.0	160.4	315.6	112.3	238.6	194.6	271.1	154.0	301.8	106.4	226.3	187.8	257.1	147.2	286.5	100.9
	80	248.0	231.7	283.3	195.5	315.2	151.2	236.5	224.8	270.5	189.0	301.4	145.1	224.2	217.6	256.7	182.0	286.2	138.5
	85	251.0	251.0	281.3	231.1	314.4	187.0	242.0	242.0	268.6	224.7	300.7	180.7	232.2	232.2	255.0	212.8	285.7	173.8
	90	265.7	265.7	279.1	260.7	313.9	223.3	256.4	256.4	266.4	253.9	300.2	217.0	246.3	246.3	252.8	246.6	285.1	210.2
9000	75	258.5	216.7	292.8	170.9	324.7	117.4	246.2	206.8	279.4	164.2	310.1	111.1	233.0	203.5	264.9	157.0	294.0	104.4
	80	254.4	253.3	292.4	213.3	324.1	161.8	242.2	242.2	278.8	206.6	309.4	155.6	230.8	230.8	264.2	199.5	293.2	149.7
	85	266.2	266.2	289.6	250.9	323.9	202.9	256.4	256.4	275.8	243.6	309.3	196.4	245.8	245.8	261.1	235.9	293.3	189.4
	90	281.9	281.9	285.0	285.0	322.5	245.9	271.8	271.8	272.0	272.0	308.1	239.5	260.7	260.7	260.9	260.9	292.1	230.0
10000	75	262.3	228.7	298.3	178.1	329.3	119.7	249.3	221.3	284.4	171.2	314.3	113.4	235.5	213.6	269.4	163.9	297.8	106.6
	80	258.4	258.4	296.9	224.6	328.4	167.7	248.5	248.5	282.9	217.8	312.9	159.5	237.8	237.8	267.9	210.5	296.4	152.2
	85	274.6	274.6	292.4	263.8	328.3	213.1	264.4	264.4	278.3	256.5	313.4	206.5	253.3	253.3	263.3	248.8	296.9	199.3
	90	290.7	290.7	290.9	290.9	326.7	254.2	280.1	280.1	280.3	280.3	311.7	250.0	268.5	268.5	268.7	268.7	294.8	242.2
11000	75	264.6	238.6	302.9	184.9	333.1	121.8	251.3	231.1	288.6	177.9	317.8	115.5	237.2	223.3	273.0	170.4	300.8	108.6
	80	265.3	265.3	300.3	235.5	331.9	171.8	255.0	255.0	286.0	225.8	316.6	164.9	243.9	243.9	270.3	218.2	299.8	157.5
	85	281.9	281.9	294.2	276.3	332.0	222.9	271.3	271.3	279.9	269.0	316.7	216.3	259.7	259.7	264.5	261.3	299.9	209.0
	90	298.2	298.2	298.4	298.4	329.0	269.1	287.3	287.3	287.4	287.4	313.3	261.8	275.2	275.2	275.3	275.3	296.0	254.0
12000	75	266.1	248.0	306.3	191.3	336.3	123.9	252.6	240.5	291.6	184.2	320.7	117.5	238.3	232.7	275.7	176.5	303.4	110.6
	80	271.3	271.3	302.8	242.7	335.4	177.0	260.7	260.7	287.7	235.0	319.8	170.0	249.2	249.2	271.6	227.0	302.6	162.4
	85	288.3	288.3	295.2	288.4	335.0	232.6	277.3	277.3	280.7	280.7	319.4	225.9	265.3	265.3	265.5	265.5	302.3	218.6
	90	304.8	304.8	305.0	305.0	330.0	280.6	293.5	293.5	293.6	293.6	314.1	273.4	280.9	280.9	281.0	281.0	296.6	265.6
		Ambient Temperature 115°F						Ambient Temperature 125°F											
7500	75	213.2	180.7	241.9	140.0	269.9	93.7	199.1	168.2	225.5	130.7	251.6	86.1						
	80	211.1	210.0	241.9	174.7	269.5	132.7	197.1	197.1	226.0	167.0	251.2	123.7						
	85	221.7	221.7	240.5	207.7	269.3	166.4	210.1	210.1	224.5	199.3	251.2	158.5						
	90	235.4	235.4	238.1	238.1	268.7	202.9	223.3	223.3	223.4	223.4	250.7	195.1						
9000	75	218.8	195.5	249.3	149.4	276.4	97.1	203.6	187.1	232.5	141.2	257.1	89.3						
	80	219.8	219.8	248.6	191.9	275.4	141.4	207.8	207.8	231.8	183.9	256.0	130.7						
	85	234.3	234.3	245.4	227.9	275.8	181.8	221.7	221.7	228.5	219.4	256.8	173.6						
	90	248.7	248.7	248.8	248.8	274.7	221.8	235.3	235.3	235.5	235.5	255.3	212.9						
10000	75	221.0	205.5	253.4	156.1	279.7	99.2	205.4	197.0	235.9	147.7	260.0	91.4						
	80	226.2	226.2	251.8	201.1	278.5	144.4	213.7	213.7	234.0	191.9	259.0	135.8						
	85	241.2	241.2	247.1	240.7	279.0	191.6	227.9	227.9	229.8	229.8	259.5	183.3						
	90	255.8	255.8	255.9	255.9	276.4	233.9	241.7	241.7	241.8	241.8	256.5	225.0						
11000	75	222.3	215.2	256.3	162.4	282.3	101.2	206.5	206.5	238.4	153.8	262.1	93.3						
	80	231.9	231.9	253.4	209.8	281.4	149.4	218.8	218.8	235.4	200.9	261.5	140.6						
	85	247.1	247.1	247.9	247.9	281.5	201.2	233.3	233.3	233.4	233.4	261.6	192.8						
	90	261.8	261.8	262.0	262.0	277.4	245.7	247.0	247.0	247.1	247.1	257.1	236.8						
12000	75	223.1	223.1	258.7	168.4	284.6	103.1	208.2	208.2	240.5	159.7	264.0	95.2						
	80	236.8	236.8	254.4	218.5	283.8	154.2	223.2	223.2	236.2	209.7	263.5	145.2						
	85	252.2	252.2	252.4	252.4	283.6	210.7	237.8	237.8	237.9	237.9	262.8	197.9						
	90	267.0	267.0	267.1	267.1	277.7	257.3	-	-	-	-	-	-						

Notes:

1. All capacities shown are gross and have not considered indoor fan heat. To obtain NET cooling capacity subtract indoor fan heat. For indoor fan heat formula, refer to appropriate airflow table notes.
2. MBh = Total gross capacity
3. SHC = Sensible heat capacity

Table 20. Gross cooling capacities — 3 tons, ultra high efficiency, gas/electric

CFM	Ent DB (°F)	Entering Wet Bulb Temp (°F)						Entering Wet Bulb Temp (°F)						Entering Wet Bulb Temp (°F)					
		61		67		73		61		67		73		61		67		73	
		MBh	SHC	MBh	SHC	MBh	SHC	MBh	SHC	MBh	SHC	MBh	SHC	MBh	SHC	MBh	SHC	MBh	SHC
		Ambient Temperature 85°F						Ambient Temperature 95°F						Ambient Temperature 105°F					
900	75	32.4	25.5	36.7	19.5	41.7	13.3	30.5	24.4	34.6	18.4	39.5	12.3	28.5	23.3	32.4	17.3	37.1	11.2
	80	32.4	30.5	36.8	24.6	41.5	18.4	30.5	29.4	34.7	23.5	39.2	17.4	28.6	28.3	32.6	22.4	36.9	16.3
	85	33.6	33.6	36.8	29.6	41.6	23.5	32.0	32.0	34.8	28.6	39.4	22.5	30.4	30.4	32.6	27.5	37.0	21.4
	90	35.7	35.7	36.9	34.6	41.7	28.6	34.1	34.1	34.8	33.5	39.5	27.6	32.4	32.4	32.7	32.5	37.1	26.5
1080	75	33.7	28.5	38.1	21.3	42.4	13.6	31.7	26.8	35.9	20.2	39.9	12.6	29.5	26.3	33.6	19.1	37.3	11.4
	80	33.9	33.9	38.3	27.4	43.1	19.9	32.2	32.2	36.1	26.3	40.7	18.9	30.5	30.5	33.8	25.2	38.2	17.8
	85	36.2	36.2	38.3	32.1	43.2	26.1	34.5	34.5	36.1	32.3	40.9	25.1	32.7	32.7	33.8	31.2	38.4	24.0
	90	38.5	38.5	38.6	38.6	43.3	32.2	36.8	36.8	36.8	36.8	40.9	31.2	34.9	34.9	35.0	35.0	38.5	30.1
1200	75	34.3	30.4	38.9	22.4	42.9	13.9	32.3	29.3	36.6	21.3	40.4	12.8	30.1	28.2	34.2	20.2	37.9	11.7
	80	35.2	35.2	39.0	29.2	43.9	20.9	33.5	33.5	36.8	28.1	41.4	19.9	31.6	31.6	34.4	27.0	38.8	18.8
	85	37.6	37.6	39.0	35.8	44.0	27.8	35.8	35.8	36.8	34.8	41.6	26.7	33.9	33.9	34.4	33.7	39.1	25.7
	90	40.1	40.1	40.1	40.1	44.1	34.6	38.2	38.2	38.3	38.3	41.7	33.3	36.3	36.3	36.4	36.4	39.1	31.2
1320	75	34.9	32.3	39.5	23.5	43.6	14.1	32.8	31.2	37.2	22.4	40.9	13.0	30.6	30.1	34.7	21.3	38.1	12.0
	80	36.4	36.4	39.7	31.0	44.5	21.9	34.5	34.5	37.3	29.9	42.0	20.8	32.6	32.6	34.9	28.1	39.4	19.7
	85	38.9	38.9	39.6	38.3	44.7	29.4	37.0	37.0	37.3	37.2	42.2	28.4	35.1	35.1	35.1	35.1	39.6	27.3
	90	41.4	41.4	41.5	41.5	44.7	36.7	39.6	39.6	39.6	39.6	42.2	35.7	37.5	37.5	37.6	37.6	39.6	34.6
1440	75	35.4	34.2	40.0	24.6	43.6	14.6	33.2	33.1	37.6	23.5	40.9	13.4	31.0	31.0	35.1	22.3	37.9	12.2
	80	37.4	37.4	40.2	32.0	45.1	22.8	35.5	35.5	37.7	31.5	42.5	21.7	33.5	33.5	35.2	30.5	39.8	20.6
	85	40.0	40.0	40.1	40.1	45.3	31.1	38.1	38.1	38.1	38.1	42.8	30.0	36.0	36.0	36.1	36.1	40.1	28.9
	90	42.7	42.7	42.7	42.7	45.2	39.0	40.7	40.7	40.8	40.8	42.7	38.0	38.6	38.6	38.7	38.7	40.0	36.9
		Ambient Temperature 115°F						Ambient Temperature 125°F											
900	75	26.4	22.2	30.2	16.2	33.8	9.9	24.1	20.6	27.7	15.0	31.1	8.7						
	80	26.7	26.7	30.3	21.3	34.4	15.2	24.8	24.8	27.9	20.2	31.7	14.0						
	85	28.6	28.6	30.4	25.9	34.6	20.3	26.8	26.8	27.9	25.2	31.9	19.2						
	90	30.6	30.6	30.7	30.7	34.6	25.4	28.7	28.7	28.8	28.8	32.0	24.3						
1080	75	27.3	25.1	31.2	17.9	34.8	10.3	24.9	23.9	28.6	16.7	31.8	9.3						
	80	28.6	28.6	31.4	24.1	35.5	16.7	26.6	26.6	28.8	22.9	32.8	15.5						
	85	30.8	30.8	31.4	30.1	35.7	22.9	28.7	28.7	28.9	28.9	33.0	21.7						
	90	33.0	33.0	33.0	33.0	35.8	29.0	30.9	30.9	30.9	30.9	33.0	27.0						
1200	75	27.8	27.0	31.8	19.0	35.1	10.5	25.4	25.4	29.1	17.8	31.8	9.5						
	80	29.7	29.7	31.9	25.9	36.1	17.6	27.6	27.6	29.3	23.8	33.3	16.5						
	85	31.9	31.9	32.0	32.0	36.4	24.5	29.8	29.8	29.9	29.9	33.5	23.4						
	90	34.3	34.3	34.3	34.3	36.4	31.2	32.1	32.1	32.1	32.1	33.5	30.1						
1320	75	28.3	28.3	32.2	20.1	35.2	10.9	26.1	26.1	29.5	18.9	31.7	9.9						
	80	30.6	30.6	32.3	27.6	36.6	18.6	28.4	28.4	29.6	26.4	33.7	17.4						
	85	33.0	33.0	33.0	33.0	36.8	26.2	30.8	30.8	30.8	30.8	33.9	25.0						
	90	35.4	35.4	35.5	35.5	36.8	33.5	33.1	33.1	33.2	33.2	33.9	32.3						
1440	75	29.0	29.0	32.5	21.2	35.4	10.5	26.8	26.8	29.7	19.9	32.2	8.6						
	80	31.4	31.4	32.6	29.3	37.0	19.5	29.2	29.2	29.9	28.1	34.0	18.3						
	85	33.9	33.9	33.9	33.9	37.2	27.8	31.6	31.6	31.6	31.6	34.2	26.3						
	90	36.4	36.4	36.5	36.5	37.2	35.8	34.0	34.0	34.1	34.1	34.2	34.2						

Notes:

1. All capacities shown are gross and have not considered indoor fan heat. To obtain NET cooling capacity subtract indoor fan heat. For indoor fan heat formula, refer to appropriate airflow table notes.
2. MBh = Total gross capacity
3. SHC = Sensible heat capacity



Gross Cooling Capacities

Table 21. Gross cooling capacities — 4 tons, ultra high efficiency, gas/electric

CFM	Ent DB (°F)	Entering Wet Bulb Temp (°F)						Entering Wet Bulb Temp (°F)						Entering Wet Bulb Temp (°F)					
		61		67		73		61		67		73		61		67		73	
		MBh	SHC	MBh	SHC	MBh	SHC	MBh	SHC	MBh	SHC	MBh	SHC	MBh	SHC	MBh	SHC	MBh	SHC
		Ambient Temperature 85°F						Ambient Temperature 95°F						Ambient Temperature 105°F					
1200	75	43.3	34.0	49.0	26.0	55.2	17.6	40.8	32.6	46.3	24.6	52.3	16.4	38.1	31.1	43.4	23.1	49.4	14.9
	80	43.3	40.6	49.1	32.7	55.2	24.5	40.8	39.2	46.4	31.3	52.2	23.1	38.2	37.7	43.5	29.9	49.2	21.6
	85	44.8	44.8	49.1	39.4	55.2	31.2	42.7	42.7	46.4	38.0	52.4	29.9	40.5	40.5	43.6	36.6	49.3	28.4
	90	47.5	47.5	49.1	46.0	55.2	38.0	45.4	45.4	46.4	44.6	52.4	36.6	43.2	43.2	43.6	43.1	49.4	35.2
1440	75	45.1	38.0	50.9	28.3	57.1	18.3	42.4	35.7	48.1	26.9	54.3	17.0	39.6	35.0	45.0	25.4	51.1	15.5
	80	45.2	45.2	51.0	36.5	57.1	26.5	43.0	43.0	48.1	35.0	54.1	25.1	40.6	40.6	45.1	33.5	50.9	23.6
	85	48.2	48.2	51.0	44.4	57.1	34.6	45.9	45.9	48.1	43.0	54.2	33.3	43.5	43.5	45.1	41.5	51.1	31.8
	90	51.1	51.1	51.2	51.2	57.2	42.7	48.9	48.9	49.0	49.0	54.2	41.4	46.4	46.4	46.5	46.5	51.1	39.9
1600	75	45.9	40.5	51.9	29.9	58.1	18.7	43.2	39.0	49.0	28.4	55.2	17.4	40.3	37.5	45.9	26.9	52.0	15.9
	80	46.9	46.9	52.0	38.9	58.1	27.8	44.6	44.6	49.0	37.4	55.1	26.4	42.2	42.2	45.9	35.9	51.8	24.9
	85	50.0	50.0	51.9	47.6	58.1	36.8	47.7	47.7	49.0	46.2	55.2	35.5	45.2	45.2	45.9	44.7	51.9	34.0
	90	53.1	53.1	53.2	53.2	58.1	45.8	50.8	50.8	50.9	50.9	55.2	43.6	48.2	48.2	48.3	48.3	51.9	42.9
1760	75	46.7	43.0	52.7	31.3	58.9	19.1	43.9	41.5	49.7	29.9	55.0	17.4	40.9	40.0	46.6	28.3	52.7	16.3
	80	48.4	48.4	52.8	41.3	58.9	29.0	46.0	46.0	49.8	39.5	55.8	27.6	43.5	43.5	46.6	36.8	52.5	26.2
	85	51.7	51.7	52.7	50.8	59.0	39.0	49.2	49.2	49.7	49.3	55.9	37.6	46.7	46.7	46.7	46.7	52.7	36.2
	90	54.9	54.9	54.9	54.9	58.9	48.7	52.5	52.5	52.5	52.5	55.9	47.3	49.8	49.8	49.9	49.9	52.6	45.9
1920	75	47.3	45.5	53.4	32.8	59.7	19.4	44.4	44.0	50.3	31.3	55.4	17.7	41.5	41.5	47.1	29.8	51.9	16.1
	80	49.7	49.7	53.4	41.9	59.6	30.2	47.3	47.3	50.3	42.0	56.5	28.8	44.7	44.7	47.1	40.4	53.2	27.4
	85	53.1	53.1	53.3	53.3	59.7	41.1	50.6	50.6	50.7	50.7	56.6	39.8	47.9	47.9	48.0	48.0	53.3	38.4
	90	56.4	56.4	56.4	56.4	59.5	51.6	53.9	53.9	54.0	54.0	56.4	50.3	51.3	51.3	51.3	51.3	53.1	48.9
		Ambient Temperature 115°F						Ambient Temperature 125°F											
1200	75	35.3	29.6	40.4	21.6	46.2	13.4	32.4	27.5	37.4	20.0	42.9	11.9						
	80	35.6	35.6	40.5	28.4	46.0	20.2	33.2	33.2	37.5	26.8	42.7	18.6						
	85	38.2	38.2	40.6	34.3	46.2	27.0	35.8	35.8	37.5	33.5	42.8	25.5						
	90	40.8	40.8	40.9	40.9	46.2	33.8	38.3	38.3	38.4	38.4	42.9	32.3						
1440	75	36.6	33.4	41.9	23.9	47.8	14.0	33.6	31.8	38.7	22.3	43.4	12.2						
	80	38.2	38.2	42.0	32.0	47.6	22.2	35.6	35.6	38.8	30.5	44.1	20.6						
	85	41.0	41.0	42.0	39.9	47.7	30.4	38.4	38.4	38.8	38.4	44.2	28.8						
	90	43.9	43.9	44.0	44.0	47.8	38.2	41.2	41.2	41.3	41.3	44.3	36.8						
1600	75	37.3	35.9	42.7	25.3	48.5	14.4	34.2	34.2	39.4	23.8	43.9	12.5						
	80	39.6	39.6	42.7	34.1	48.4	23.4	37.0	37.0	39.5	31.3	44.8	21.9						
	85	42.6	42.6	42.7	42.7	48.5	32.5	39.9	39.9	39.9	39.9	45.0	31.0						
	90	45.6	45.6	45.7	45.7	48.5	41.4	42.8	42.8	42.9	42.9	44.9	39.9						
1760	75	37.9	37.9	43.3	26.8	48.0	14.4	35.1	35.1	39.9	25.2	44.3	12.7						
	80	40.8	40.8	43.3	36.6	49.1	24.7	38.1	38.1	39.9	35.0	45.4	23.1						
	85	44.0	44.0	44.0	44.0	49.2	34.7	41.1	41.1	41.2	41.2	45.5	33.2						
	90	47.1	47.1	47.2	47.2	49.1	44.4	44.2	44.2	44.3	44.3	45.5	42.9						
1920	75	38.8	38.8	43.8	28.2	48.3	14.6	36.0	36.0	40.4	26.6	44.2	13.2						
	80	41.9	41.9	43.8	38.9	49.6	25.9	39.1	39.1	40.3	37.3	45.9	24.3						
	85	45.2	45.2	45.2	45.2	49.7	36.9	42.3	42.3	42.3	42.3	46.0	34.0						
	90	48.4	48.4	48.5	48.5	49.6	47.4	45.5	45.5	45.5	45.5	45.9	45.8						

Notes:

1. All capacities shown are gross and have not considered indoor fan heat. To obtain NET cooling capacity subtract indoor fan heat. For indoor fan heat formula, refer to appropriate airflow table notes.
2. MBh = Total gross capacity
3. SHC = Sensible heat capacity

Table 22. Gross cooling capacities — 5 tons, ultra high efficiency, gas/electric

CFM	Ent DB (°F)	Entering Wet Bulb Temp (°F)						Entering Wet Bulb Temp (°F)						Entering Wet Bulb Temp (°F)					
		61		67		73		61		67		73		61		67		73	
		MBh	SHC	MBh	SHC	MBh	SHC	MBh	SHC	MBh	SHC	MBh	SHC	MBh	SHC	MBh	SHC	MBh	SHC
		Ambient Temperature 85°F						Ambient Temperature 95°F						Ambient Temperature 105°F					
1500	75	53.8	43.0	60.8	33.1	68.4	22.7	50.8	41.4	57.6	31.4	65.2	21.2	47.7	39.7	54.3	29.7	61.7	19.6
	80	53.8	51.2	60.8	41.5	68.4	31.3	50.9	49.5	57.7	39.9	65.1	29.7	47.8	47.8	54.4	38.2	61.4	28.0
	85	55.9	55.9	60.8	49.8	68.4	39.7	53.4	53.4	57.7	48.2	65.1	38.2	50.9	50.9	54.4	46.0	61.6	36.5
	90	59.3	59.3	60.8	57.9	68.4	48.1	56.8	56.8	57.7	56.3	65.1	46.6	54.2	54.2	54.4	54.4	61.6	44.9
1800	75	55.9	47.0	63.1	36.0	70.8	23.5	52.7	46.2	59.8	34.3	67.5	22.0	49.5	44.5	56.3	32.6	63.8	20.4
	80	56.3	56.3	63.1	46.1	70.8	33.7	53.7	53.7	59.8	44.5	67.3	32.2	50.9	50.9	56.3	42.8	63.5	30.5
	85	59.9	59.9	63.0	55.9	70.8	43.9	57.3	57.3	59.7	54.3	67.4	42.4	54.5	54.5	56.3	52.6	63.6	40.7
	90	63.6	63.6	63.7	63.7	70.8	54.0	61.0	61.0	61.1	61.1	67.4	52.5	58.2	58.2	58.3	58.3	63.6	50.8
2000	75	56.9	51.1	64.3	37.9	72.0	24.0	53.7	49.3	60.9	36.2	68.6	22.5	50.3	47.6	57.3	34.5	64.8	20.8
	80	58.3	58.3	64.3	49.1	72.0	35.3	55.6	55.6	60.9	47.5	68.5	33.8	52.8	52.8	57.3	45.8	64.6	32.1
	85	62.2	62.2	64.1	59.9	72.0	46.7	59.4	59.4	60.8	58.3	68.5	45.1	56.6	56.6	57.2	56.5	64.7	43.4
	90	66.0	66.0	66.1	66.1	72.0	56.8	63.3	63.3	63.4	63.4	68.5	53.7	60.4	60.4	60.5	60.5	64.6	54.4
2200	75	57.7	54.2	65.3	39.7	73.1	24.5	54.4	52.4	61.8	38.0	69.6	22.9	51.0	50.7	58.1	36.3	65.7	21.2
	80	60.1	60.1	65.2	51.7	73.0	36.9	57.3	57.3	61.8	48.7	69.4	35.3	54.4	54.4	58.0	48.5	65.5	33.6
	85	64.1	64.1	65.0	63.8	73.0	49.4	61.3	61.3	61.6	61.6	69.5	47.8	58.4	58.4	58.4	58.4	65.6	46.1
	90	68.1	68.1	68.2	68.2	72.9	61.4	65.3	65.3	65.4	65.4	69.3	59.8	62.3	62.3	62.4	62.4	65.4	58.1
2400	75	58.4	57.2	66.1	41.5	73.9	24.9	55.0	55.0	62.5	39.8	70.4	23.3	51.9	51.9	58.8	38.0	66.2	21.6
	80	61.7	61.7	65.9	54.7	73.9	38.4	58.9	58.9	62.4	53.0	70.2	36.8	55.9	55.9	58.6	51.3	66.2	35.1
	85	65.9	65.9	65.9	65.9	73.9	52.0	63.0	63.0	63.1	63.1	70.3	50.5	59.9	59.9	60.0	60.0	66.3	48.8
	90	70.0	70.0	70.1	70.1	73.6	65.0	67.1	67.1	67.2	67.2	70.0	63.5	64.0	64.0	64.1	64.1	66.0	61.8
		Ambient Temperature 115°F						Ambient Temperature 125°F											
1500	75	44.5	37.9	50.9	28.0	57.9	17.9	41.2	35.0	47.2	26.2	53.9	16.1						
	80	45.0	45.0	50.9	36.5	57.7	26.3	42.3	42.3	47.3	34.7	53.7	24.5						
	85	48.2	48.2	51.0	42.9	57.8	34.8	45.4	45.4	47.4	43.0	53.8	33.0						
	90	51.5	51.5	51.6	51.6	57.8	43.3	48.6	48.6	48.7	48.7	53.9	41.5						
1800	75	46.1	42.7	52.6	30.9	59.8	18.6	42.6	40.8	48.8	29.0	55.6	16.8						
	80	48.2	48.2	52.7	41.0	59.6	28.8	45.2	45.2	48.9	39.2	55.4	26.9						
	85	51.6	51.6	52.6	50.8	59.7	39.0	48.6	48.6	48.9	48.9	55.5	37.2						
	90	55.2	55.2	55.3	55.3	59.7	47.5	52.0	52.0	52.1	52.1	55.5	47.1						
2000	75	46.9	45.8	53.5	32.7	60.7	19.1	43.3	43.3	49.6	30.9	56.4	17.2						
	80	49.9	49.9	53.6	42.6	60.5	30.3	46.8	46.8	49.6	42.0	56.2	28.5						
	85	53.5	53.5	53.6	53.6	60.6	41.7	50.4	50.4	50.4	50.4	56.4	39.9						
	90	57.3	57.3	57.4	57.4	60.6	52.7	53.9	53.9	54.0	54.0	56.3	50.9						
2200	75	47.6	47.6	54.3	34.5	60.0	19.0	44.5	44.5	50.3	32.6	55.4	19.3						
	80	51.4	51.4	54.2	46.7	61.3	31.8	48.2	48.2	50.2	44.8	56.9	30.0						
	85	55.2	55.2	55.3	55.3	61.4	44.4	51.9	51.9	51.9	51.9	57.0	42.6						
	90	59.1	59.1	59.2	59.2	61.2	56.4	55.6	55.6	55.7	55.7	56.9	54.6						
2400	75	48.8	48.8	54.9	36.2	60.3	19.1	45.6	45.6	50.9	34.4	55.5	17.5						
	80	52.7	52.7	54.7	49.5	62.0	33.3	49.4	49.4	50.7	47.6	57.5	31.5						
	85	56.7	56.7	56.7	56.7	62.0	46.0	53.2	53.2	53.3	53.3	57.5	45.0						
	90	60.7	60.7	60.7	60.7	61.8	60.0	57.1	57.1	57.2	57.2	57.4	57.4						

Notes:

1. All capacities shown are gross and have not considered indoor fan heat. To obtain NET cooling capacity subtract indoor fan heat. For indoor fan heat formula, refer to appropriate airflow table notes.
2. MBh = Total gross capacity
3. SHC = Sensible heat capacity



Gross Cooling Capacities

Table 23. Gross cooling capacities — 6 tons, ultra high efficiency, gas/electric

CFM	Ent DB (°F)	Entering Wet Bulb Temp (°F)						Entering Wet Bulb Temp (°F)						Entering Wet Bulb Temp (°F)					
		61		67		73		61		67		73		61		67		73	
		MBh	SHC	MBh	SHC	MBh	SHC	MBh	SHC	MBh	SHC	MBh	SHC	MBh	SHC	MBh	SHC	MBh	SHC
		Ambient Temperature 85°F						Ambient Temperature 95°F						Ambient Temperature 105°F					
1800	75	64.7	52.7	73.2	41.4	82.1	29.4	61.7	51.3	69.9	40.0	78.5	28.0	58.6	49.8	66.4	38.4	74.6	26.5
	80	64.7	62.3	73.2	51.2	82.2	39.4	61.7	60.8	69.9	49.7	78.6	38.0	58.7	58.7	66.4	48.2	74.7	36.5
	85	67.5	67.5	73.2	60.9	82.3	49.3	65.1	65.1	69.9	59.5	78.6	47.9	62.5	62.5	66.4	58.0	74.7	46.4
	90	71.6	71.6	73.2	70.4	82.3	59.1	69.1	69.1	69.9	68.9	78.6	57.7	66.4	66.4	66.6	66.6	74.8	56.2
2160	75	67.3	58.8	76.1	45.1	85.0	30.7	64.1	56.1	72.5	43.6	81.2	29.2	60.8	55.5	68.8	42.0	77.0	27.7
	80	68.0	68.0	76.1	56.8	85.2	42.7	65.4	65.4	72.5	55.3	81.4	41.2	62.7	62.7	68.8	53.7	77.2	39.6
	85	72.4	72.4	76.1	68.3	85.3	54.5	69.7	69.7	72.5	66.7	81.4	53.0	66.9	66.9	68.7	65.1	77.2	51.4
	90	76.8	76.8	77.0	77.0	85.3	66.2	74.1	74.1	74.2	74.2	81.4	64.8	71.1	71.1	71.2	71.2	77.3	63.2
2400	75	68.6	62.4	77.6	47.4	86.5	31.4	65.3	60.9	73.9	45.9	82.6	30.0	61.8	59.2	70.0	44.3	78.3	28.4
	80	70.5	70.5	77.6	60.4	86.8	44.7	67.8	67.8	73.9	58.9	82.8	43.2	64.9	64.9	70.0	57.3	78.5	41.6
	85	75.1	75.1	77.4	73.0	86.8	57.8	72.3	72.3	73.7	71.4	82.8	56.3	69.3	69.3	69.8	69.8	78.6	54.8
	90	79.8	79.8	79.9	79.9	86.9	70.9	76.9	76.9	77.0	77.0	82.9	68.9	73.7	73.7	73.8	73.8	78.6	65.1
2640	75	69.6	66.1	78.8	49.7	87.8	32.1	66.2	64.5	75.0	48.1	83.8	30.6	62.6	62.6	71.0	46.5	79.4	29.1
	80	72.7	72.7	78.8	64.0	88.1	46.7	69.9	69.9	75.0	62.4	84.0	45.2	66.9	66.9	71.1	59.0	79.6	43.6
	85	77.6	77.6	78.4	77.6	88.2	61.1	74.6	74.6	74.7	74.7	84.1	59.6	71.4	71.4	71.5	71.5	79.7	58.0
	90	82.3	82.3	82.5	82.5	88.2	75.2	79.3	79.3	79.4	79.4	83.9	73.6	76.0	76.0	76.1	76.1	79.4	71.9
2880	75	70.5	69.7	79.9	51.9	88.9	32.8	67.0	67.0	76.0	50.3	84.8	31.3	63.9	63.9	71.9	48.7	80.4	29.8
	80	74.7	74.7	79.9	65.2	89.3	48.7	71.7	71.7	75.9	65.6	85.1	47.1	68.6	68.6	71.8	63.9	80.6	45.5
	85	79.7	79.7	79.8	79.8	89.3	64.4	76.6	76.6	76.7	76.7	85.1	62.9	73.3	73.3	73.4	73.4	80.6	61.3
	90	84.6	84.6	84.7	84.7	89.0	79.5	81.4	81.4	81.6	81.6	84.7	77.9	78.0	78.0	78.1	78.1	80.1	76.2
		Ambient Temperature 115°F						Ambient Temperature 125°F											
1800	75	55.3	48.2	62.6	36.8	70.4	25.0	51.8	46.2	58.7	35.2	66.0	23.3						
	80	56.0	56.0	62.7	46.6	70.5	34.9	53.2	53.2	58.7	45.0	66.1	33.3						
	85	59.8	59.8	62.7	55.5	70.6	44.8	56.8	56.8	58.8	54.6	66.1	43.1						
	90	63.6	63.6	63.7	63.7	70.6	54.6	60.5	60.5	60.6	60.6	66.2	52.9						
2160	75	57.2	53.9	64.8	40.3	72.6	26.1	53.4	52.1	60.6	38.6	67.9	24.4						
	80	59.8	59.8	64.8	52.1	72.8	38.0	56.6	56.6	60.6	50.4	68.1	36.3						
	85	63.8	63.8	64.7	63.4	72.8	49.8	60.5	60.5	60.6	60.6	68.1	48.1						
	90	67.9	67.9	68.0	68.0	72.9	61.6	64.5	64.5	64.6	64.6	68.2	57.5						
2400	75	58.1	57.5	65.9	42.6	73.8	26.8	54.5	54.5	61.6	40.9	68.9	25.1						
	80	61.8	61.8	66.0	55.6	74.0	40.0	58.5	58.5	61.6	51.9	69.1	38.2						
	85	66.1	66.1	66.2	66.2	74.0	53.1	62.6	62.6	62.7	62.7	69.1	51.4						
	90	70.3	70.3	70.5	70.5	73.9	65.9	66.6	66.6	66.8	66.8	68.9	64.0						
2640	75	59.3	59.3	66.8	44.8	74.8	27.5	56.0	56.0	62.4	43.0	69.8	25.7						
	80	63.6	63.6	66.8	58.9	74.9	41.9	60.1	60.1	62.3	57.0	70.0	40.2						
	85	68.0	68.0	68.1	68.1	75.0	56.4	64.4	64.4	64.5	64.5	70.0	54.6						
	90	72.4	72.4	72.5	72.5	74.6	70.2	68.5	68.5	68.6	68.6	69.5	68.3						
2880	75	60.7	60.7	67.6	47.0	75.6	28.4	57.3	57.3	63.1	45.2	69.1	25.8						
	80	65.2	65.2	67.4	62.2	75.8	43.8	61.6	61.6	62.8	60.3	70.7	42.0						
	85	69.8	69.8	69.9	69.9	75.8	59.6	65.9	65.9	66.0	66.0	70.7	56.2						
	90	74.2	74.2	74.4	74.4	75.2	74.4	70.2	70.2	70.3	70.3	70.4	70.4						

Notes:

1. All capacities shown are gross and have not considered indoor fan heat. To obtain NET cooling capacity subtract indoor fan heat. For indoor fan heat formula, refer to appropriate airflow table notes.
2. MBh = Total gross capacity
3. SHC = Sensible heat capacity

Table 24. Gross cooling capacities — 7.5 tons, ultra high efficiency, gas/electric

CFM	Ent DB (°F)	Entering Wet Bulb Temp (°F)						Entering Wet Bulb Temp (°F)						Entering Wet Bulb Temp (°F)					
		61		67		73		61		67		73		61		67		73	
		MBh	SHC	MBh	SHC	MBh	SHC	MBh	SHC	MBh	SHC	MBh	SHC	MBh	SHC	MBh	SHC	MBh	SHC
		Ambient Temperature 85°F						Ambient Temperature 95°F						Ambient Temperature 105°F					
2250	75	79.3	64.8	89.7	50.8	101.2	36.2	75.8	63.0	85.8	49.0	96.7	34.4	72.2	61.1	81.6	47.0	92.0	32.4
	80	79.0	75.9	89.8	62.9	101.1	48.5	75.6	74.0	85.8	61.0	96.7	46.7	71.9	71.9	81.7	59.1	91.9	44.7
	85	81.9	81.9	89.7	74.9	101.0	60.6	79.0	79.0	85.7	72.9	96.5	58.7	76.0	76.0	81.6	69.4	91.8	56.8
	90	86.8	86.8	89.3	85.9	100.9	72.7	83.9	83.9	85.4	83.9	96.4	70.8	80.7	80.7	81.3	81.3	91.7	68.9
2700	75	82.3	69.8	93.2	55.2	104.6	37.7	78.6	66.7	89.0	53.2	99.9	35.8	74.5	67.4	84.5	51.2	94.9	33.8
	80	82.1	82.1	93.1	69.5	104.4	52.2	79.1	79.1	88.9	67.6	99.6	50.3	75.9	75.9	84.4	65.6	94.6	48.2
	85	87.4	87.4	92.7	83.0	104.4	66.7	84.3	84.3	88.4	80.9	99.7	64.7	80.9	80.9	83.9	78.8	94.7	62.7
	90	92.8	92.8	92.9	92.9	104.3	81.1	89.5	89.5	89.6	89.6	99.6	79.2	86.0	86.0	86.1	86.1	94.6	76.4
3000	75	83.6	75.6	95.0	57.9	106.4	38.6	79.7	73.6	90.6	55.9	101.5	36.7	75.6	71.5	85.9	53.9	96.3	34.6
	80	84.9	84.9	94.8	73.8	106.2	54.5	81.7	81.7	90.4	71.8	101.3	52.6	78.4	78.4	85.8	69.8	96.1	50.5
	85	90.5	90.5	94.0	88.2	106.2	70.6	87.2	87.2	89.6	86.2	101.3	68.6	83.6	83.6	85.0	84.0	96.1	66.6
	90	96.1	96.1	96.2	96.2	106.0	84.0	92.7	92.7	92.8	92.8	101.1	83.8	88.9	88.9	89.0	89.0	95.8	81.7
3300	75	84.6	79.6	96.4	60.5	107.9	39.4	80.6	77.6	91.9	58.5	102.9	37.5	76.3	75.5	87.1	56.4	97.5	35.4
	80	87.4	87.4	96.2	77.3	107.7	56.8	84.1	84.1	91.7	73.6	102.7	54.8	80.5	80.5	86.8	73.2	97.4	52.7
	85	93.2	93.2	95.0	93.3	107.6	74.4	89.7	89.7	90.5	90.5	102.7	72.4	86.0	86.0	86.1	86.1	97.3	70.4
	90	99.0	99.0	99.1	99.1	107.1	90.8	95.4	95.4	95.5	95.5	102.0	88.7	91.5	91.5	91.6	91.6	96.6	86.5
3600	75	85.3	83.5	97.6	63.1	109.1	40.2	81.2	81.2	93.0	61.1	104.0	38.3	76.9	76.9	88.1	58.9	98.6	36.2
	80	89.6	89.6	97.1	81.2	109.0	59.0	86.1	86.1	92.4	79.0	103.9	57.0	82.5	82.5	87.5	76.8	98.4	54.9
	85	95.6	95.6	95.8	95.8	108.9	78.2	91.9	91.9	92.0	92.0	103.8	76.2	88.1	88.1	88.2	88.2	98.4	74.1
	90	101.6	101.6	101.7	101.7	107.8	95.5	97.8	97.8	97.9	97.9	102.7	93.4	93.7	93.7	93.8	93.8	97.1	91.2
		Ambient Temperature 115°F						Ambient Temperature 125°F											
2250	75	68.3	58.9	77.2	45.0	86.9	30.4	64.1	55.3	72.5	42.9	81.5	28.2						
	80	68.3	68.3	77.3	57.1	86.8	42.7	64.9	64.9	72.5	54.9	81.3	40.5						
	85	72.8	72.8	77.2	68.6	86.8	54.7	69.2	69.2	72.4	66.4	81.4	52.5						
	90	77.3	77.3	77.4	77.4	86.7	66.8	73.6	73.6	73.7	73.7	81.4	64.6						
2700	75	70.3	65.3	79.8	49.1	89.5	31.7	65.8	63.0	74.7	46.9	83.7	29.5						
	80	72.5	72.5	79.7	63.5	89.2	46.1	68.8	68.8	74.7	61.3	83.5	43.8						
	85	77.3	77.3	79.2	76.7	89.3	60.6	73.4	73.4	74.2	74.2	83.6	58.3						
	90	82.2	82.2	82.3	82.3	89.3	71.8	78.1	78.1	78.2	78.2	83.4	72.1						
3000	75	71.2	69.3	81.0	51.7	90.8	32.5	66.6	66.6	75.8	49.4	84.9	30.3						
	80	74.8	74.8	81.0	65.8	90.6	48.3	70.9	70.9	75.6	64.8	84.7	46.0						
	85	79.8	79.8	80.1	80.1	90.6	64.4	75.7	75.7	75.8	75.8	84.8	62.1						
	90	84.9	84.9	85.0	85.0	90.1	79.4	80.6	80.6	80.6	80.6	84.2	76.9						
3300	75	71.9	71.9	82.1	54.2	91.9	33.3	67.8	67.8	76.8	51.9	85.8	31.0						
	80	76.8	76.8	81.7	70.9	91.7	50.5	72.7	72.7	76.3	68.5	85.6	48.1						
	85	82.0	82.0	82.1	82.1	91.7	68.2	77.7	77.7	77.8	77.8	85.7	65.9						
	90	87.3	87.3	87.3	87.3	90.8	84.2	82.6	82.6	82.7	82.7	84.7	81.7						
3600	75	73.2	73.2	83.0	56.7	92.9	34.1	69.2	69.2	77.5	54.4	86.5	31.8						
	80	78.5	78.5	82.3	74.5	92.6	52.6	74.3	74.3	76.8	72.1	86.4	50.2						
	85	83.9	83.9	84.0	84.0	92.6	70.7	79.4	79.4	79.5	79.5	86.2	68.8						
	90	89.3	89.3	89.3	89.3	91.3	88.9	84.4	84.4	84.5	84.5	85.0	85.0						

Notes:

1. All capacities shown are gross and have not considered indoor fan heat. To obtain NET cooling capacity subtract indoor fan heat. For indoor fan heat formula, refer to appropriate airflow table notes.
2. MBh = Total gross capacity
3. SHC = Sensible heat capacity



Gross Cooling Capacities

Table 25. Gross cooling capacities — 8.5 tons, ultra high efficiency, gas/electric

CFM	Ent DB (°F)	Entering Wet Bulb Temp (°F)						Entering Wet Bulb Temp (°F)						Entering Wet Bulb Temp (°F)					
		61		67		73		61		67		73		61		67		73	
		MBh	SHC	MBh	SHC	MBh	SHC	MBh	SHC	MBh	SHC	MBh	SHC	MBh	SHC	MBh	SHC	MBh	SHC
		Ambient Temperature 85°F						Ambient Temperature 95°F						Ambient Temperature 105°F					
2550	75	90.6	73.3	102.7	57.8	116.0	41.5	86.6	71.2	98.2	55.6	110.8	39.3	82.4	69.0	93.4	53.4	105.2	37.0
	80	90.3	85.5	102.8	71.3	115.8	55.3	86.3	83.3	98.2	69.1	110.6	53.1	82.1	81.0	93.4	66.9	105.0	50.8
	85	92.8	92.8	102.4	84.6	115.6	68.7	89.6	89.6	97.9	81.5	110.4	66.5	86.1	86.1	93.1	77.4	104.9	64.2
	90	98.3	98.3	102.1	96.5	115.3	82.2	95.0	95.0	97.5	94.3	110.1	80.0	91.4	91.4	92.7	92.0	104.6	77.7
3060	75	93.9	78.2	106.7	62.5	120.0	43.1	89.5	78.1	101.8	60.3	114.4	40.9	85.0	75.7	96.7	57.9	108.4	38.5
	80	93.2	93.2	106.4	78.5	119.3	59.2	89.5	89.5	101.5	76.2	113.8	56.9	85.9	85.9	96.3	73.9	107.9	54.5
	85	98.9	98.9	105.8	93.1	119.4	75.3	95.3	95.3	100.9	90.8	113.9	73.0	91.5	91.5	95.7	88.3	107.9	70.6
	90	104.9	104.9	105.1	105.1	119.0	91.4	101.2	101.2	101.3	101.3	113.4	89.1	97.2	97.2	97.3	97.3	107.6	84.4
3400	75	95.3	84.8	108.7	65.5	122.0	44.1	90.8	82.5	103.6	63.2	116.2	41.8	86.1	80.0	98.2	60.8	110.0	39.4
	80	96.0	96.0	108.2	83.1	121.4	61.7	92.4	92.4	103.1	80.8	115.7	59.4	88.6	88.6	97.8	77.6	109.6	57.0
	85	102.3	102.3	107.2	98.7	121.3	79.5	98.5	98.5	102.2	96.3	115.6	77.2	94.5	94.5	96.8	93.8	109.5	74.8
	90	108.6	108.6	108.7	108.7	120.7	93.3	104.7	104.7	104.8	104.8	114.9	93.8	100.4	100.4	100.5	100.5	108.8	91.2
3740	75	96.4	89.1	110.3	68.3	123.7	45.0	91.8	86.7	105.1	66.0	117.7	42.7	87.0	84.2	99.5	63.5	111.4	40.3
	80	98.7	98.7	109.6	86.1	123.2	64.2	95.0	95.0	104.4	81.7	117.3	61.8	91.0	91.0	98.7	81.8	111.0	59.3
	85	105.2	105.2	108.3	104.2	122.9	83.7	101.3	101.3	103.1	101.7	117.0	81.3	97.1	97.1	97.6	97.6	110.7	78.9
	90	111.8	111.8	111.9	111.9	121.9	101.5	107.7	107.7	107.8	107.8	116.0	99.0	103.2	103.2	103.3	103.3	109.6	96.3
4080	75	97.3	93.2	111.6	71.1	125.1	45.9	92.5	90.8	106.2	68.7	119.0	43.6	87.6	87.6	100.6	66.2	112.5	41.1
	80	101.2	101.2	110.5	90.7	124.7	66.6	97.3	97.3	105.1	88.2	118.6	64.1	93.1	93.1	99.5	85.6	112.2	61.6
	85	107.9	107.9	109.1	109.1	124.1	87.7	103.8	103.8	103.9	103.9	118.1	85.3	99.4	99.4	99.4	99.4	111.7	82.8
	90	114.6	114.6	114.7	114.7	122.8	106.5	110.3	110.3	110.4	110.4	116.7	104.0	105.6	105.6	105.7	105.7	110.2	101.4
		Ambient Temperature 115°F						Ambient Temperature 125°F											
2550	75	77.9	65.9	88.3	51.0	99.2	34.6	73.1	61.8	82.8	48.5	92.8	32.0						
	80	77.7	77.7	88.2	64.5	99.0	48.4	73.5	73.5	82.7	62.0	92.5	45.8						
	85	82.4	82.4	88.0	77.1	98.9	61.7	78.4	78.4	82.4	74.5	92.6	59.1						
	90	87.5	87.5	87.7	87.7	98.7	75.3	83.2	83.2	83.3	83.3	92.4	72.7						
3060	75	80.1	73.2	91.1	55.5	102.0	36.0	75.0	70.5	85.2	52.8	95.2	33.4						
	80	82.0	82.0	90.9	71.5	101.6	52.0	77.7	77.7	85.0	68.2	94.9	49.3						
	85	87.4	87.4	90.2	85.7	101.6	68.1	82.9	82.9	84.3	83.0	94.9	65.4						
	90	92.9	92.9	93.0	93.0	101.2	83.3	88.1	88.1	88.2	88.2	94.4	80.4						
3400	75	81.1	77.5	92.5	58.3	103.4	36.9	75.8	74.8	86.4	55.6	96.4	34.2						
	80	84.5	84.5	92.1	72.9	103.1	54.4	80.0	80.0	85.9	72.4	96.2	51.6						
	85	90.2	90.2	91.2	91.2	103.0	72.2	85.4	85.4	85.5	85.5	96.0	69.5						
	90	95.8	95.8	95.9	95.9	102.2	88.5	90.7	90.7	90.8	90.8	95.2	85.6						
3740	75	81.9	81.7	93.7	61.0	104.6	37.7	76.5	76.5	87.4	58.2	97.4	35.0						
	80	86.7	86.7	92.8	79.1	104.4	56.7	82.0	82.0	86.6	76.3	97.2	53.9						
	85	92.5	92.5	92.6	92.6	104.0	76.3	87.5	87.5	87.6	87.6	96.9	72.8						
	90	98.3	98.3	98.4	98.4	102.9	93.6	92.9	92.9	93.0	93.0	95.7	90.7						
4080	75	82.7	82.7	94.6	63.6	105.6	38.6	78.1	78.1	88.2	60.8	98.2	35.9						
	80	88.6	88.6	93.5	82.9	105.3	58.9	83.8	83.8	87.1	80.1	98.0	56.1						
	85	94.6	94.6	94.7	94.7	104.9	77.5	89.4	89.4	89.5	89.5	97.3	76.4						
	90	100.5	100.5	100.5	100.5	103.3	98.6	94.8	94.8	94.9	94.9	96.0	95.7						

Notes:

1. All capacities shown are gross and have not considered indoor fan heat. To obtain NET cooling capacity subtract indoor fan heat. For indoor fan heat formula, refer to appropriate airflow table notes.
2. MBh = Total gross capacity
3. SHC = Sensible heat capacity

Table 26. Gross cooling capacities — 10 tons, ultra high efficiency, gas/electric

CFM	Ent DB (°F)	Entering Wet Bulb Temp (°F)						Entering Wet Bulb Temp (°F)						Entering Wet Bulb Temp (°F)					
		61		67		73		61		67		73		61		67		73	
		MBh	SHC	MBh	SHC	MBh	SHC	MBh	SHC	MBh	SHC	MBh	SHC	MBh	SHC	MBh	SHC	MBh	SHC
		Ambient Temperature 85°F						Ambient Temperature 95°F						Ambient Temperature 105°F					
3000	75	103.0	84.7	116.1	65.6	129.6	45.6	98.1	82.1	110.6	63.0	123.3	43.0	93.1	78.2	104.8	60.3	116.5	40.2
	80	102.7	99.6	116.2	81.9	129.7	62.3	97.9	97.0	110.7	79.3	123.4	59.7	92.9	92.9	104.9	76.6	116.6	56.6
	85	107.0	107.0	116.1	96.1	129.7	78.5	103.0	103.0	110.6	91.5	123.4	75.8	98.7	98.7	104.7	92.1	116.7	73.0
	90	113.4	113.4	115.7	112.8	129.6	94.8	109.2	109.2	110.2	110.1	123.4	92.1	104.6	104.6	104.7	104.7	116.7	89.3
3600	75	106.4	93.3	120.1	71.2	133.5	47.4	101.2	90.5	114.2	68.5	126.8	44.7	95.7	87.7	108.0	65.6	119.6	41.9
	80	107.1	107.1	120.0	90.6	133.5	66.9	102.8	102.8	114.2	87.9	126.9	64.1	98.3	98.3	108.0	85.1	119.9	61.2
	85	113.9	113.9	119.5	108.6	133.6	86.4	109.4	109.4	113.6	105.8	127.0	83.7	104.6	104.6	107.3	102.9	119.9	80.8
	90	120.7	120.7	120.9	120.9	133.4	104.2	116.0	116.0	116.1	116.1	126.8	98.7	110.8	110.8	111.0	111.0	119.5	99.3
4000	75	108.0	98.8	122.1	74.7	135.6	48.6	102.6	96.0	116.0	71.9	128.7	45.8	97.0	93.1	109.6	69.0	114.2	40.2
	80	110.6	110.6	122.0	96.2	135.6	69.8	106.1	106.1	115.9	91.4	128.8	67.0	101.3	101.3	109.4	89.8	121.6	64.1
	85	117.7	117.7	121.0	115.6	135.6	91.5	112.9	112.9	114.9	112.8	128.7	88.8	107.8	107.8	108.4	108.4	121.4	85.8
	90	124.7	124.7	124.8	124.8	135.0	111.9	119.6	119.6	119.8	119.8	128.0	109.0	114.1	114.1	114.3	114.3	120.5	105.9
4400	75	109.1	104.2	123.7	78.1	137.3	49.7	103.6	101.3	117.5	75.2	130.3	46.9	97.8	97.8	111.0	72.2	114.4	40.7
	80	113.6	113.6	123.2	100.8	137.3	72.7	108.9	108.9	116.9	97.9	130.4	69.8	103.9	103.9	110.3	94.8	123.0	66.8
	85	120.9	120.9	122.1	122.1	137.2	96.6	116.0	116.0	116.1	116.1	130.2	93.8	110.6	110.6	110.7	110.7	122.7	90.8
	90	128.1	128.1	128.2	128.2	136.1	118.4	122.8	122.8	122.9	122.9	128.9	115.4	117.0	117.0	117.1	117.1	121.2	112.3
4800	75	110.0	109.4	125.1	81.3	129.3	46.9	104.4	104.4	118.8	78.4	122.1	44.1	99.2	99.2	112.1	75.4	124.1	45.3
	80	116.3	116.3	124.2	105.7	138.7	75.4	111.4	111.4	117.8	102.7	131.6	72.5	106.2	106.2	111.0	99.6	124.1	69.3
	85	123.7	123.7	123.9	123.9	138.5	101.5	118.6	118.6	118.7	118.7	131.4	96.8	112.9	112.9	113.0	113.0	123.3	94.7
	90	131.0	131.0	131.1	131.1	136.8	124.7	125.5	125.5	125.6	125.6	129.5	121.8	119.4	119.4	119.5	119.5	121.7	118.6
		Ambient Temperature 115°F						Ambient Temperature 125°F											
3000	75	87.7	73.8	98.6	57.4	109.2	37.2	81.8	73.2	91.9	54.3	101.2	34.1						
	80	88.3	88.3	98.7	73.7	109.5	53.7	83.5	83.5	92.0	70.7	101.9	50.5						
	85	94.0	94.0	98.4	89.1	109.5	70.0	88.8	88.8	91.7	85.9	101.7	66.8						
	90	99.6	99.6	99.7	99.7	109.4	86.3	94.0	94.0	94.1	94.1	101.6	81.3						
3600	75	89.9	84.7	101.4	62.6	106.0	36.6	83.8	81.5	94.4	59.4	97.7	33.4						
	80	93.4	93.4	101.4	81.0	112.4	58.1	88.1	88.1	94.2	78.2	104.3	54.9						
	85	99.4	99.4	100.6	99.8	112.2	77.7	93.6	93.6	93.7	93.7	104.0	74.4						
	90	105.2	105.2	105.3	105.3	111.6	96.1	98.8	98.8	98.9	98.9	103.2	92.7						
4000	75	91.0	90.1	102.9	65.9	113.4	40.0	84.6	84.6	95.6	62.7	97.8	30.2						
	80	96.2	96.2	102.4	86.7	113.9	60.9	90.5	90.5	95.0	83.4	105.6	57.5						
	85	102.3	102.3	102.4	102.4	113.6	82.7	96.1	96.1	96.2	96.2	105.2	79.4						
	90	108.1	108.1	108.2	108.2	112.5	102.6	101.4	101.4	101.5	101.5	103.7	99.1						
4400	75	92.1	92.1	104.0	69.1	106.3	34.2	86.6	86.6	96.6	65.8	97.8	27.8						
	80	98.5	98.5	103.2	91.6	115.1	63.5	92.5	92.5	95.7	88.2	106.7	60.1						
	85	104.7	104.7	104.8	104.8	114.7	85.8	98.2	98.2	98.3	98.3	105.7	83.4						
	90	110.6	110.6	110.7	110.7	113.0	109.0	103.5	103.5	103.5	103.5	104.1	104.1						
4800	75	94.0	94.0	104.9	72.2	106.3	32.1	88.3	88.3	97.2	68.8	97.9	27.4						
	80	100.5	100.5	103.8	96.4	116.1	66.0	94.3	94.3	96.1	93.0	107.4	62.4						
	85	106.8	106.8	106.9	106.9	115.0	91.4	100.0	100.0	100.1	100.1	106.1	87.9						
	90	112.7	112.7	112.8	112.8	113.3	113.3	105.2	105.2	105.3	105.3	105.4	105.4						

Notes:

1. All capacities shown are gross and have not considered indoor fan heat. To obtain NET cooling capacity subtract indoor fan heat. For indoor fan heat formula, refer to appropriate airflow table notes.
2. MBh = Total gross capacity
3. SHC = Sensible heat capacity



Gross Cooling Capacities

Table 27. Gross cooling capacities — 12.5 tons, ultra high efficiency, gas/electric

CFM	Ent DB (°F)	Entering Wet Bulb Temp (°F)						Entering Wet Bulb Temp (°F)						Entering Wet Bulb Temp (°F)					
		61		67		73		61		67		73		61		67		73	
		MBh	SHC	MBh	SHC	MBh	SHC	MBh	SHC	MBh	SHC	MBh	SHC	MBh	SHC	MBh	SHC	MBh	SHC
		Ambient Temperature 85°F						Ambient Temperature 95°F						Ambient Temperature 105°F					
3750	75	136.5	110.4	152.5	86.1	166.8	58.9	129.4	106.5	145.4	82.4	159.1	55.5	122.0	102.5	137.5	78.5	151.4	52.0
	80	136.6	129.9	152.6	106.5	167.1	80.5	129.6	125.9	145.5	102.9	159.7	77.0	122.2	121.8	137.7	99.0	152.0	73.6
	85	141.0	141.0	152.6	126.8	167.1	101.0	135.4	135.4	145.6	123.3	160.3	97.8	129.3	129.3	137.9	118.5	152.5	94.2
	90	148.5	148.5	152.1	145.8	167.2	121.5	143.0	143.0	145.3	142.2	160.4	118.3	136.9	136.9	137.7	137.7	152.6	114.8
4500	75	141.6	120.9	157.6	93.2	172.2	61.0	134.2	115.9	150.2	89.5	163.4	58.2	126.2	113.7	142.1	85.6	155.3	54.6
	80	141.8	141.8	157.7	117.6	172.2	86.7	135.8	135.8	150.4	114.0	165.0	83.4	129.3	129.3	142.2	110.1	156.8	79.7
	85	149.9	149.9	157.5	141.0	172.3	111.2	144.1	144.1	150.1	137.2	164.8	107.9	137.6	137.6	141.9	133.1	156.7	104.3
	90	157.5	157.5	157.7	157.7	172.3	135.7	151.7	151.7	152.0	152.0	165.0	132.5	145.3	145.3	145.5	145.5	157.0	126.6
5000	75	144.1	129.5	160.2	97.7	174.9	63.4	136.4	125.3	152.7	94.1	165.7	59.5	128.3	121.0	144.4	90.1	157.5	56.0
	80	146.4	146.4	160.3	124.9	174.9	90.6	140.3	140.3	152.8	121.2	167.4	87.2	133.6	133.6	144.5	117.1	159.1	83.6
	85	154.6	154.6	159.4	150.0	175.0	117.9	148.6	148.6	151.9	146.2	167.2	114.5	142.0	142.0	143.6	142.2	158.9	110.8
	90	162.2	162.2	162.4	162.4	175.0	141.4	156.3	156.3	156.5	156.5	167.4	140.7	149.7	149.7	149.9	149.9	158.7	136.9
5500	75	145.9	136.6	162.4	102.2	177.3	64.8	138.1	132.4	154.8	98.5	167.8	59.8	129.9	128.0	146.3	94.5	159.4	57.3
	80	150.4	150.4	162.6	130.8	177.2	94.4	144.1	144.1	154.9	124.4	169.3	91.0	137.2	137.2	146.2	123.4	160.8	87.3
	85	158.6	158.6	160.6	158.8	177.3	124.5	152.5	152.5	153.2	153.2	169.2	121.0	145.7	145.7	145.9	145.9	160.7	117.3
	90	166.4	166.4	166.6	166.6	176.9	152.8	160.1	160.1	160.3	160.3	168.2	149.0	153.3	153.3	153.5	153.5	159.5	145.2
6000	75	147.3	143.5	164.3	106.5	179.4	66.2	139.5	139.3	156.6	102.8	169.5	62.2	131.3	131.3	147.9	98.8	161.7	58.9
	80	153.8	153.8	164.2	137.9	179.2	98.2	147.4	147.4	156.2	134.0	171.1	94.7	140.4	140.4	147.4	129.8	162.4	91.0
	85	162.1	162.1	162.2	162.2	179.2	131.0	155.8	155.8	156.0	156.0	171.0	127.5	148.8	148.8	149.0	149.0	162.4	123.8
	90	170.5	170.5	170.7	170.7	178.2	161.2	163.4	163.4	163.6	163.6	168.8	157.2	156.4	156.4	156.6	156.6	160.0	153.3
		Ambient Temperature 115°F						Ambient Temperature 125°F											
3750	75	114.1	97.8	129.1	74.4	142.9	48.3	105.7	91.6	120.0	70.0	133.5	44.8						
	80	115.0	115.0	129.3	94.9	143.5	69.8	108.1	108.1	120.3	90.5	134.1	65.8						
	85	122.7	122.7	129.5	114.7	143.8	90.4	115.7	115.7	120.4	110.3	134.3	86.2						
	90	130.3	130.3	130.5	130.5	144.0	110.9	123.1	123.1	123.3	123.3	134.5	106.8						
4500	75	117.9	109.2	133.2	81.4	146.8	51.0	109.1	104.6	123.7	76.9	136.9	46.9						
	80	122.4	122.4	133.4	105.9	147.8	75.8	114.9	114.9	123.9	101.1	137.7	71.6						
	85	130.5	130.5	133.1	128.8	147.7	100.4	122.9	122.9	123.6	123.5	137.7	96.2						
	90	138.2	138.2	138.4	138.4	147.9	124.2	130.4	130.4	130.6	130.6	137.6	119.8						
5000	75	119.7	116.5	135.3	85.8	148.5	52.2	110.7	110.7	125.5	81.3	138.8	48.2						
	80	126.4	126.4	135.4	109.5	149.7	79.6	118.6	118.6	125.6	107.7	139.5	75.3						
	85	134.7	134.7	134.8	134.8	149.7	106.9	126.7	126.7	126.9	126.9	139.5	102.7						
	90	142.3	142.3	142.5	142.5	149.1	132.7	134.1	134.1	134.3	134.3	138.7	128.3						
5500	75	121.2	121.2	137.0	90.2	150.3	53.6	113.2	113.2	127.1	85.6	140.2	49.5						
	80	129.8	129.8	136.8	118.9	151.3	83.3	121.8	121.8	126.8	114.2	140.9	79.0						
	85	138.2	138.2	138.3	138.3	151.3	113.4	129.9	129.9	130.1	130.1	141.0	108.5						
	90	145.7	145.7	145.9	145.9	149.9	141.0	137.3	137.3	137.4	137.4	139.3	136.6						
6000	75	123.8	123.8	138.5	94.4	152.1	55.0	115.8	115.8	128.3	89.8	138.3	48.7						
	80	132.8	132.8	137.9	125.3	152.8	87.0	124.5	124.5	127.7	120.6	142.3	82.6						
	85	141.1	141.1	141.3	141.3	152.8	116.0	132.6	132.6	132.8	132.8	141.9	114.4						
	90	148.6	148.6	148.7	148.7	150.3	149.2	-	-	-	-	-	-						

Notes:

1. All capacities shown are gross and have not considered indoor fan heat. To obtain NET cooling capacity subtract indoor fan heat. For indoor fan heat formula, refer to appropriate airflow table notes.
2. MBh = Total gross capacity
3. SHC = Sensible heat capacity

Table 28. Gross cooling capacities — 15 tons, ultra high efficiency, gas/electric

CFM	Ent DB (°F)	Entering Wet Bulb Temp (°F)						Entering Wet Bulb Temp (°F)						Entering Wet Bulb Temp (°F)					
		61		67		73		61		67		73		61		67		73	
		MBh	SHC	MBh	SHC	MBh	SHC	MBh	SHC	MBh	SHC	MBh	SHC	MBh	SHC	MBh	SHC	MBh	SHC
		Ambient Temperature 85°F						Ambient Temperature 95°F						Ambient Temperature 105°F					
4500	75	164.0	132.0	183.4	103.4	200.5	70.9	155.9	127.5	175.0	99.1	192.2	67.4	147.3	122.9	165.6	94.4	183.0	63.4
	80	164.0	154.4	183.4	127.3	201.0	96.7	155.9	149.9	175.1	123.1	192.7	92.9	147.4	145.1	166.0	118.6	183.5	88.8
	85	168.2	168.2	183.3	151.3	201.4	120.9	161.7	161.7	175.1	147.2	193.1	117.1	154.7	154.7	166.0	141.2	183.7	112.9
	90	177.3	177.3	182.9	173.3	201.3	145.1	170.8	170.8	174.7	169.0	193.2	141.3	163.7	163.7	165.7	164.4	183.8	137.2
5400	75	170.0	143.9	189.4	111.4	206.3	73.3	161.5	138.4	180.7	107.1	197.4	70.6	152.3	135.5	171.1	102.4	187.8	66.4
	80	169.4	169.4	189.5	140.1	207.4	104.2	161.9	161.9	180.8	135.9	198.7	100.5	154.5	154.5	171.3	131.3	188.8	95.5
	85	178.6	178.6	189.2	167.2	207.2	132.5	171.8	171.8	180.4	162.7	198.6	128.7	164.3	164.3	170.7	157.9	188.8	124.4
	90	187.9	187.9	188.1	188.1	207.4	161.5	181.1	181.1	181.4	181.4	198.7	157.7	173.6	173.6	173.8	173.8	188.9	151.1
6000	75	172.9	153.5	192.6	116.5	209.6	76.1	164.0	148.6	183.7	112.2	200.1	72.1	154.6	143.6	173.8	107.5	190.3	68.0
	80	174.3	174.3	192.6	148.4	210.8	108.2	167.1	167.1	183.7	144.1	201.6	104.2	159.4	159.4	173.9	139.5	191.4	99.8
	85	184.2	184.2	191.4	177.3	210.3	140.0	177.2	177.2	182.5	172.9	201.4	136.2	169.4	169.4	172.7	168.1	191.4	131.8
	90	193.6	193.6	193.8	193.8	210.5	167.6	186.6	186.6	186.8	186.8	201.4	166.7	178.8	178.8	179.0	179.0	191.0	162.1
6600	75	175.0	161.4	195.2	121.5	212.4	77.7	165.9	156.5	186.1	117.1	202.5	73.7	156.3	151.4	176.1	112.4	192.9	69.7
	80	178.9	178.9	195.2	156.2	213.4	112.4	171.6	171.6	186.1	148.6	204.0	108.3	163.7	163.7	175.9	146.1	193.7	103.8
	85	189.0	189.0	193.0	187.2	212.9	147.5	181.8	181.8	184.0	182.8	203.8	143.5	173.7	173.7	174.1	174.1	193.6	139.2
	90	198.4	198.4	198.6	198.6	212.2	180.2	191.2	191.2	191.4	191.4	202.7	176.0	183.1	183.1	183.3	183.3	192.2	171.4
7200	75	176.6	169.0	197.5	126.3	214.7	79.3	167.4	164.1	188.2	121.9	204.6	74.0	157.7	157.7	178.0	117.1	189.5	68.3
	80	182.9	182.9	197.1	162.8	215.6	116.4	175.5	175.5	187.6	158.2	206.1	112.2	167.3	167.3	177.2	153.2	195.6	107.7
	85	193.1	193.1	194.1	194.1	215.2	154.8	185.7	185.7	185.9	185.9	205.9	150.8	177.5	177.5	177.6	177.6	195.4	146.4
	90	202.5	202.5	202.7	202.7	213.1	189.3	195.2	195.2	195.3	195.3	203.5	185.1	186.9	186.9	187.0	187.0	192.9	180.6
		Ambient Temperature 115°F						Ambient Temperature 125°F											
4500	75	138.3	117.8	155.8	89.6	172.8	59.0	128.6	110.5	145.2	84.6	161.5	54.9						
	80	138.5	138.5	156.2	113.9	173.3	84.4	130.2	130.2	145.6	108.9	162.0	79.7						
	85	147.1	147.1	156.3	134.1	173.4	108.4	139.0	139.0	145.7	131.8	162.1	103.5						
	90	156.0	156.0	156.3	156.3	173.6	132.7	147.7	147.7	147.9	147.9	162.3	127.8						
5400	75	142.6	130.3	160.7	97.5	177.2	62.0	132.4	124.8	149.6	92.4	165.5	57.3						
	80	146.6	146.6	161.0	126.5	177.9	90.8	138.0	138.0	149.9	121.3	166.1	85.8						
	85	156.1	156.1	160.4	152.9	178.0	119.8	147.3	147.3	149.3	147.5	166.2	114.9						
	90	165.3	165.3	165.5	165.5	178.2	142.2	156.2	156.2	156.3	156.3	166.0	142.3						
6000	75	144.7	138.3	163.2	102.5	179.5	63.5	134.2	132.8	151.8	97.2	167.6	58.7						
	80	151.2	151.2	163.4	131.7	180.3	95.0	142.2	142.2	151.8	128.1	168.1	89.8						
	85	160.9	160.9	162.2	162.2	180.4	127.2	151.7	151.7	151.8	151.8	168.3	122.2						
	90	170.1	170.1	170.3	170.3	179.6	157.2	160.6	160.6	160.8	160.8	167.3	151.8						
6600	75	146.2	146.1	165.2	107.3	176.5	62.5	135.9	135.9	153.5	101.9	169.5	60.3						
	80	155.1	155.1	164.9	140.9	182.3	98.9	145.8	145.8	153.1	135.4	169.9	93.6						
	85	165.0	165.0	165.1	165.1	182.3	134.5	155.4	155.4	155.6	155.5	170.0	129.5						
	90	174.2	174.2	174.4	174.4	180.7	166.5	164.3	164.3	164.4	164.4	168.2	161.2						
7200	75	148.0	148.0	166.9	111.9	175.9	61.7	138.8	138.8	155.0	106.4	161.3	48.2						
	80	158.5	158.5	166.1	148.0	184.0	102.7	148.9	148.9	154.1	142.4	171.3	97.2						
	85	168.5	168.5	168.6	168.6	184.0	139.7	158.6	158.6	158.7	158.7	171.2	134.5						
	90	177.6	177.6	177.8	177.8	181.3	175.6	—	—	—	—	—	—						

Notes:

1. All capacities shown are gross and have not considered indoor fan heat. To obtain NET cooling capacity subtract indoor fan heat. For indoor fan heat formula, refer to appropriate airflow table notes.
2. MBh = Total gross capacity
3. SHC = Sensible heat capacity



Gross Cooling Capacities

Table 29. Gross cooling capacities — 17.5 tons, ultra high efficiency, gas/electric

CFM	Ent DB (°F)	Entering Wet Bulb Temp (°F)						Entering Wet Bulb Temp (°F)						Entering Wet Bulb Temp (°F)					
		61		67		73		61		67		73		61		67		73	
		MBh	SHC	MBh	SHC	MBh	SHC	MBh	SHC	MBh	SHC	MBh	SHC	MBh	SHC	MBh	SHC	MBh	SHC
		Ambient Temperature 85°F						Ambient Temperature 95°F						Ambient Temperature 105°F					
5250	75	193.7	153.7	218.4	122.0	239.7	85.3	184.2	148.5	208.1	117.0	228.6	80.6	174.0	143.0	196.8	111.6	216.3	75.4
	80	193.3	178.6	218.1	149.0	239.9	114.3	183.8	173.1	207.8	143.9	228.9	109.5	173.7	167.4	196.6	138.4	216.6	104.2
	85	195.9	195.9	217.6	176.1	240.1	141.9	188.4	188.4	207.4	171.0	229.2	137.0	180.2	180.2	196.3	165.6	216.9	131.6
	90	207.1	207.1	217.2	200.5	240.1	169.3	199.4	199.4	206.9	195.1	229.2	164.4	191.0	191.0	195.8	189.3	217.0	159.1
6300	75	201.1	169.4	225.9	131.3	247.2	89.2	191.0	161.7	214.9	125.8	234.5	84.0	180.1	152.1	203.0	120.2	221.3	78.5
	80	200.0	197.0	225.7	163.4	247.0	122.5	190.0	190.0	214.8	158.1	235.0	117.5	180.1	180.1	202.9	152.5	222.0	112.1
	85	208.7	208.7	225.0	190.3	246.8	154.6	200.5	200.5	214.2	188.0	235.3	149.6	191.5	191.5	202.1	181.9	222.3	144.1
	90	220.3	220.3	223.3	222.1	246.9	187.3	211.9	211.9	212.6	212.6	235.4	182.3	202.6	202.6	202.8	202.8	222.4	176.9
7000	75	204.8	172.6	229.8	136.9	251.1	91.1	194.3	171.7	218.6	131.6	238.1	85.8	182.9	165.5	206.4	125.9	224.0	80.2
	80	203.3	203.3	229.4	172.5	250.8	127.8	195.0	195.0	218.2	167.3	238.2	122.6	185.9	185.9	206.0	161.6	225.0	116.3
	85	215.6	215.6	228.2	204.5	250.5	162.9	207.1	207.1	216.9	198.9	238.3	157.8	197.6	197.6	204.5	192.8	225.0	152.2
	90	227.3	227.3	227.6	227.6	250.4	199.0	218.5	218.5	218.7	218.7	238.5	189.4	208.6	208.6	208.8	208.8	225.1	186.0
7700	75	207.5	186.0	233.2	142.5	254.4	92.9	196.6	180.1	221.7	137.1	241.0	87.5	185.0	173.9	209.1	131.3	226.6	81.8
	80	209.1	209.1	232.5	181.5	253.8	131.9	200.4	200.4	221.0	176.1	240.9	126.5	190.9	190.9	208.5	167.1	227.2	120.8
	85	221.5	221.5	230.3	215.1	253.7	171.1	212.6	212.6	218.7	209.4	240.9	165.8	202.8	202.8	206.1	203.3	227.2	160.2
	90	233.2	233.2	233.4	233.4	253.1	207.6	224.0	224.0	224.2	224.2	240.4	202.0	213.6	213.6	213.8	213.8	226.2	195.8
8400	75	209.5	194.2	235.8	147.9	257.1	94.6	198.4	188.2	224.1	142.5	243.4	89.2	186.5	182.0	211.3	136.6	228.7	83.4
	80	214.1	214.1	235.1	187.1	256.6	136.5	205.1	205.1	223.3	182.6	243.0	130.9	195.3	195.3	210.2	176.3	229.0	125.1
	85	226.6	226.6	231.7	225.3	256.3	179.1	217.4	217.4	220.0	220.0	243.1	173.7	207.2	207.2	207.3	207.3	229.1	168.1
	90	238.2	238.2	238.4	238.4	254.5	217.4	228.6	228.6	228.8	228.8	241.2	211.6	217.7	217.7	217.9	217.9	226.8	205.4
		Ambient Temperature 115°F						Ambient Temperature 125°F											
5250	75	163.2	137.3	184.6	105.8	202.5	70.4	151.5	128.8	171.2	99.7	187.4	64.2						
	80	162.9	161.3	184.5	132.6	203.0	98.5	151.5	151.5	171.3	126.5	188.0	92.4						
	85	171.3	171.3	184.2	155.8	203.3	125.8	161.6	161.6	171.2	152.0	188.3	119.5						
	90	181.7	181.7	183.7	183.2	203.4	153.3	171.4	171.4	171.6	171.6	188.5	147.1						
6300	75	168.5	150.5	190.2	114.2	206.8	72.7	156.0	143.8	176.3	107.8	190.9	66.5						
	80	170.7	170.7	190.0	146.6	207.8	105.8	160.5	160.5	176.1	140.2	192.1	99.2						
	85	181.8	181.8	189.1	175.5	207.9	138.2	171.0	171.0	175.1	168.8	192.1	131.7						
	90	192.2	192.2	192.4	192.4	208.1	166.9	180.6	180.6	180.8	180.8	192.1	162.3						
7000	75	170.9	159.1	193.1	119.8	209.0	74.2	158.0	152.3	178.7	113.3	192.6	67.9						
	80	176.1	176.1	192.7	155.5	210.2	110.2	165.3	165.3	178.4	144.1	193.9	103.6						
	85	187.3	187.3	191.1	186.3	210.2	146.2	175.8	175.8	176.6	176.6	193.9	139.7						
	90	197.6	197.6	197.8	197.8	209.8	179.4	185.1	185.1	185.2	185.2	193.0	172.3						
7700	75	172.7	167.4	195.4	125.1	211.2	75.8	159.5	159.5	180.7	118.5	194.5	69.5						
	80	180.7	180.7	194.8	162.2	212.1	114.6	169.4	169.4	179.8	155.1	195.4	107.9						
	85	191.9	191.9	192.4	192.4	212.1	154.1	179.8	179.8	180.0	180.0	195.5	147.5						
	90	201.9	201.9	202.1	202.1	210.5	189.2	188.6	188.6	188.8	188.8	193.4	182.0						
8400	75	174.0	173.9	197.3	130.3	213.0	77.4	161.6	161.6	182.3	123.6	196.0	71.0						
	80	184.6	184.6	196.0	169.6	213.6	118.8	172.9	172.9	180.8	162.5	196.7	112.0						
	85	195.8	195.8	196.0	196.0	213.8	161.9	183.1	183.1	183.3	183.3	196.9	149.1						
	90	205.4	205.4	205.6	205.6	210.9	198.8	191.4	191.4	191.5	191.5	193.5	191.6						

Notes:

1. All capacities shown are gross and have not considered indoor fan heat. To obtain NET cooling capacity subtract indoor fan heat. For indoor fan heat formula, refer to appropriate airflow table notes.
2. MBh = Total gross capacity
3. SHC = Sensible heat capacity

Table 30. Gross cooling capacities — 20 tons, ultra high efficiency, gas/electric

CFM	Ent DB (°F)	Entering Wet Bulb Temp (°F)						Entering Wet Bulb Temp (°F)						Entering Wet Bulb Temp (°F)					
		61		67		73		61		67		73		61		67		73	
		MBh	SHC	MBh	SHC	MBh	SHC	MBh	SHC	MBh	SHC	MBh	SHC	MBh	SHC	MBh	SHC	MBh	SHC
		Ambient Temperature 85°F						Ambient Temperature 95°F						Ambient Temperature 105°F					
6000	75	218.1	172.5	246.5	137.9	272.5	97.2	207.7	166.9	235.0	132.3	260.3	92.0	196.7	160.9	222.6	126.3	246.7	86.4
	80	217.3	199.7	246.0	167.6	272.5	129.8	206.9	193.7	234.6	161.9	260.3	124.5	195.9	187.4	222.3	155.9	246.7	118.7
	85	218.9	218.9	245.1	197.6	272.2	161.0	210.8	210.8	233.9	192.0	260.0	154.6	202.0	202.0	221.7	186.1	246.5	148.7
	90	231.5	231.5	244.3	224.1	272.1	190.6	223.1	223.1	233.0	218.1	259.9	185.2	214.1	214.1	220.8	211.8	246.5	179.3
7200	75	226.2	189.5	254.7	148.2	280.5	101.6	215.1	181.4	242.4	141.4	267.5	96.1	203.4	171.2	229.4	135.2	253.1	90.2
	80	224.3	219.2	254.6	183.1	280.6	138.9	213.3	213.0	242.5	177.3	267.5	133.4	201.6	201.6	229.4	171.1	253.1	127.5
	85	232.8	232.8	253.3	211.1	280.5	174.0	224.0	224.0	241.3	209.9	267.6	168.4	214.4	214.4	228.1	203.2	253.2	162.3
	90	246.1	246.1	251.0	247.2	280.0	210.1	237.0	237.0	239.0	239.0	267.2	204.6	227.0	227.0	227.2	227.2	252.9	198.6
8000	75	230.2	193.1	259.2	153.5	284.5	103.5	218.6	191.5	246.8	147.6	271.1	98.0	206.3	184.7	233.4	141.2	256.3	92.0
	80	227.4	227.4	258.8	192.9	284.6	144.7	217.5	217.5	246.4	187.0	271.1	139.1	207.8	207.8	232.9	180.8	256.2	131.2
	85	240.5	240.5	256.8	227.8	284.6	182.8	231.2	231.2	244.2	221.4	271.3	177.1	221.1	221.1	230.7	214.7	256.5	170.9
	90	254.0	254.0	254.2	254.2	284.0	222.8	244.5	244.5	244.7	244.7	270.8	213.1	233.9	233.9	234.1	234.1	256.1	208.1
8800	75	233.0	206.9	263.2	159.5	287.9	105.4	221.0	200.3	250.5	153.4	274.1	99.8	208.3	193.5	236.6	146.9	259.0	93.8
	80	232.8	232.8	262.3	202.5	287.8	148.1	223.4	223.4	249.5	196.5	274.1	142.2	213.3	213.3	235.7	189.1	259.0	135.8
	85	247.0	247.0	259.1	238.9	287.9	191.4	237.4	237.4	246.2	232.6	274.3	185.6	226.9	226.9	232.3	225.8	259.2	179.4
	90	260.8	260.8	261.0	261.0	287.2	231.6	250.8	250.8	251.0	251.0	273.1	225.4	239.8	239.8	240.0	240.0	257.5	218.6
9600	75	235.0	215.4	266.5	165.2	291.0	107.2	222.8	208.8	253.4	159.0	276.7	101.5	209.8	201.9	239.1	152.4	261.2	95.5
	80	238.3	238.3	265.1	209.4	290.8	152.8	228.6	228.6	252.1	199.9	276.8	146.8	218.1	218.1	237.4	196.2	261.5	140.2
	85	252.8	252.8	260.6	249.8	290.8	199.8	242.8	242.8	247.5	243.4	276.8	194.0	231.9	231.9	233.2	233.2	261.5	187.7
	90	266.6	266.6	266.7	266.7	288.5	241.9	256.3	256.3	256.4	256.4	274.2	235.6	244.8	244.8	244.9	244.9	258.4	228.8
		Ambient Temperature 115°F						Ambient Temperature 125°F											
6000	75	184.9	154.7	209.1	120.4	231.8	81.1	172.4	146.8	194.4	112.4	215.4	74.5						
	80	184.2	180.8	209.2	149.6	231.8	112.6	171.8	171.8	195.0	142.9	215.5	106.0						
	85	192.5	192.5	208.6	175.4	231.9	142.4	182.2	182.2	194.6	170.9	215.7	135.5						
	90	204.2	204.2	207.7	205.1	231.8	173.0	193.3	193.3	193.6	193.6	215.6	166.2						
7200	75	190.7	168.6	215.4	128.6	237.3	83.9	177.2	161.3	200.4	121.6	220.0	77.1						
	80	191.5	191.5	215.4	164.5	237.4	121.2	180.7	180.7	200.4	157.6	220.0	112.5						
	85	204.0	204.0	214.0	196.2	237.6	155.7	192.5	192.5	198.8	188.8	220.5	148.6						
	90	216.1	216.1	216.3	216.3	237.4	189.1	203.9	203.9	204.1	204.1	220.2	182.5						
8000	75	193.2	177.6	219.0	134.5	240.1	85.7	179.2	170.2	203.4	127.2	222.3	78.8						
	80	197.4	197.4	218.5	174.1	240.1	124.4	186.0	186.0	203.0	163.4	222.6	117.1						
	85	210.1	210.1	216.1	207.6	240.5	164.3	198.1	198.1	200.5	200.2	222.9	157.1						
	90	222.3	222.3	222.5	222.5	239.5	200.9	209.4	209.4	209.5	209.5	221.5	193.1						
8800	75	194.9	186.3	221.7	140.0	242.4	87.4	180.7	178.8	205.7	132.6	224.3	80.5						
	80	202.4	202.4	220.6	181.0	242.6	128.9	190.5	190.5	204.4	173.2	224.7	121.4						
	85	215.4	215.4	217.5	217.5	242.8	172.6	202.7	202.7	202.9	202.9	224.8	165.4						
	90	227.6	227.6	227.7	227.7	240.6	211.3	213.9	213.9	214.0	214.0	222.2	203.5						
9600	75	196.1	194.7	223.9	145.4	245.6	89.5	181.6	181.6	207.6	137.8	226.0	82.2						
	80	206.8	206.8	222.0	188.8	244.7	133.1	194.5	194.5	205.4	181.1	226.4	125.4						
	85	219.9	219.9	220.0	220.0	244.7	180.9	206.7	206.7	206.8	206.8	226.5	170.2						
	90	232.0	232.0	232.1	232.1	241.2	221.5	217.6	217.6	217.7	217.7	222.6	213.8						

Notes:

1. All capacities shown are gross and have not considered indoor fan heat. To obtain NET cooling capacity subtract indoor fan heat. For indoor fan heat formula, refer to appropriate airflow table notes.
2. MBh = Total gross capacity
3. SHC = Sensible heat capacity



Gross Cooling Capacities

Table 31. Gross cooling capacities — 25 tons, ultra high efficiency, gas/electric

CFM	Ent DB (°F)	Entering Wet Bulb Temp (°F)						Entering Wet Bulb Temp (°F)						Entering Wet Bulb Temp (°F)					
		61		67		73		61		67		73		61		67		73	
		MBh	SHC	MBh	SHC	MBh	SHC	MBh	SHC	MBh	SHC	MBh	SHC	MBh	SHC	MBh	SHC	MBh	SHC
		Ambient Temperature 85°F						Ambient Temperature 95°F						Ambient Temperature 105°F					
7500	75	250.2	201.1	284.0	160.4	315.6	112.3	238.6	194.6	271.1	154.0	301.8	106.4	226.3	187.8	257.1	147.2	286.5	100.9
	80	248.0	231.7	283.3	195.5	315.2	151.2	236.5	224.8	270.5	189.0	301.4	145.1	224.2	217.6	256.7	182.0	286.2	138.5
	85	251.0	251.0	281.3	231.1	314.4	187.0	242.0	242.0	268.6	224.7	300.7	180.7	232.2	232.2	255.0	212.8	285.7	173.8
	90	265.7	265.7	279.1	260.7	313.9	223.3	256.4	256.4	266.4	253.9	300.2	217.0	246.3	246.3	252.8	246.6	285.1	210.2
9000	75	258.5	216.7	292.8	170.9	324.7	117.4	246.2	206.8	279.4	164.2	310.1	111.1	233.0	203.5	264.9	157.0	294.0	104.4
	80	254.4	253.3	292.4	213.3	324.1	161.8	242.2	242.2	278.8	206.6	309.4	155.6	230.8	230.8	264.2	199.5	293.2	149.7
	85	266.2	266.2	289.6	250.9	323.9	202.9	256.4	256.4	275.8	243.6	309.3	196.4	245.8	245.8	261.1	235.9	293.3	189.4
	90	281.9	281.9	285.0	285.0	322.5	245.9	271.8	271.8	272.0	272.0	308.1	239.5	260.7	260.7	260.9	260.9	292.1	230.0
10000	75	262.3	228.7	298.3	178.1	329.3	119.7	249.3	221.3	284.4	171.2	314.3	113.4	235.5	213.6	269.4	163.9	297.8	106.6
	80	258.4	258.4	296.9	224.6	328.4	167.7	248.5	248.5	282.9	217.8	312.9	159.5	237.8	237.8	267.9	210.5	296.4	152.2
	85	274.6	274.6	292.4	263.8	328.3	213.1	264.4	264.4	278.3	256.5	313.4	206.5	253.3	253.3	263.3	248.8	296.9	199.3
	90	290.7	290.7	290.9	290.9	326.7	254.2	280.1	280.1	280.3	280.3	311.7	250.0	268.5	268.5	268.7	268.7	294.8	242.2
11000	75	264.6	238.6	302.9	184.9	333.1	121.8	251.3	231.1	288.6	177.9	317.8	115.5	237.2	223.3	273.0	170.4	300.8	108.6
	80	265.3	265.3	300.3	235.5	331.9	171.8	255.0	255.0	286.0	225.8	316.6	164.9	243.9	243.9	270.3	218.2	299.8	157.5
	85	281.9	281.9	294.2	276.3	332.0	222.9	271.3	271.3	279.9	269.0	316.7	216.3	259.7	259.7	264.5	261.3	299.9	209.0
	90	298.2	298.2	298.4	298.4	329.0	269.1	287.3	287.3	287.4	287.4	313.3	261.8	275.2	275.2	275.3	275.3	296.0	254.0
12000	75	266.1	248.0	306.3	191.3	336.3	123.9	252.6	240.5	291.6	184.2	320.7	117.5	238.3	232.7	275.7	176.5	303.4	110.6
	80	271.3	271.3	302.8	242.7	335.4	177.0	260.7	260.7	287.7	235.0	319.8	170.0	249.2	249.2	271.6	227.0	302.6	162.4
	85	288.3	288.3	295.2	288.4	335.0	232.6	277.3	277.3	280.7	280.7	319.4	225.9	265.3	265.3	265.5	265.5	302.3	218.6
	90	304.8	304.8	305.0	305.0	330.0	280.6	293.5	293.5	293.6	293.6	314.1	273.4	280.9	280.9	281.0	281.0	296.6	265.6
		Ambient Temperature 115°F						Ambient Temperature 125°F											
7500	75	213.2	180.7	241.9	140.0	269.9	93.7	199.1	168.2	225.5	130.7	251.6	86.1						
	80	211.1	210.0	241.9	174.7	269.5	132.7	197.1	197.1	226.0	167.0	251.2	123.7						
	85	221.7	221.7	240.5	207.7	269.3	166.4	210.1	210.1	224.5	199.3	251.2	158.5						
	90	235.4	235.4	238.1	238.1	268.7	202.9	223.3	223.3	223.4	223.4	250.7	195.1						
9000	75	218.8	195.5	249.3	149.4	276.4	97.1	203.6	187.1	232.5	141.2	257.1	89.3						
	80	219.8	219.8	248.6	191.9	275.4	141.4	207.8	207.8	231.8	183.9	256.0	130.7						
	85	234.3	234.3	245.4	227.9	275.8	181.8	221.7	221.7	228.5	219.4	256.8	173.6						
	90	248.7	248.7	248.8	248.8	274.7	221.8	235.3	235.3	235.5	235.5	255.3	212.9						
10000	75	221.0	205.5	253.4	156.1	279.7	99.2	205.4	197.0	235.9	147.7	260.0	91.4						
	80	226.2	226.2	251.8	201.1	278.5	144.4	213.7	213.7	234.0	191.9	259.0	135.8						
	85	241.2	241.2	247.1	240.7	279.0	191.6	227.9	227.9	229.8	229.8	259.5	183.3						
	90	255.8	255.8	255.9	255.9	276.4	233.9	241.7	241.7	241.8	241.8	256.5	225.0						
11000	75	222.3	215.2	256.3	162.4	282.3	101.2	206.5	206.5	238.4	153.8	262.1	93.3						
	80	231.9	231.9	253.4	209.8	281.4	149.4	218.8	218.8	235.4	200.9	261.5	140.6						
	85	247.1	247.1	247.9	247.9	281.5	201.2	233.3	233.3	233.4	233.4	261.6	192.8						
	90	261.8	261.8	262.0	262.0	277.4	245.7	247.0	247.0	247.1	247.1	257.1	236.8						
12000	75	223.1	223.1	258.7	168.4	284.6	103.1	208.2	208.2	240.5	159.7	264.0	95.2						
	80	236.8	236.8	254.4	218.5	283.8	154.2	223.2	223.2	236.2	209.7	263.5	145.2						
	85	252.2	252.2	252.4	252.4	283.6	210.7	237.8	237.8	237.9	237.9	262.8	197.9						
	90	267.0	267.0	267.1	267.1	277.7	257.3	-	-	-	-	-	-						

Notes:

1. All capacities shown are gross and have not considered indoor fan heat. To obtain NET cooling capacity subtract indoor fan heat. For indoor fan heat formula, refer to appropriate airflow table notes.
2. MBh = Total gross capacity
3. SHC = Sensible heat capacity



Reheat Temperature Rise

Table 32. Reheat temperature rise - 3 tons, ultra high efficiency

Airflow (cfm)	Ent DB (°F)	Entering Wet Bulb (°F)											
		51				55				59			
		Lvg Evap DB (°F)		Lvg Reheat DB (°F)		Lvg Evap DB (°F)		Lvg Reheat DB (°F)		Lvg Evap DB (°F)		Lvg Reheat DB (°F)	
		MIN	MAX	MIN	MAX	MIN	MAX	MIN	MAX	MIN	MAX	MIN	MAX
Ambient DB 60°F													
900	60	36.4	34.8	44.6	56.2	40.5	39.0	49.2	61.7	44.4	43.0	53.7	67.2
	65	36.6	34.7	44.7	56.0	40.4	38.8	49.1	61.5	44.6	43.1	53.8	67.4
	70	39.0	36.4	47.3	58.0	40.5	38.7	49.2	61.4	44.5	43.0	53.8	67.2
	75	42.2	39.4	50.9	62.2	42.3	39.5	51.0	62.3	44.5	42.9	53.7	67.1
1080	60	38.8	37.3	45.8	55.4	42.9	41.4	50.3	60.8	46.7	45.4	54.7	66.0
	65	39.1	37.3	46.0	55.3	42.8	41.3	50.3	60.6	47.0	45.5	54.9	66.1
	70	42.9	40.3	50.1	59.1	43.1	41.3	50.5	60.4	47.0	45.4	54.9	65.9
	75	46.2	43.6	53.8	63.3	46.3	43.7	53.9	63.4	47.2	45.4	55.0	65.8
1200	60	40.0	38.6	46.4	55.1	44.1	42.7	50.8	60.3	47.8	47.2	55.1	65.7
	65	41.5	39.1	47.8	55.5	44.1	42.6	50.9	60.1	48.2	46.8	55.4	65.5
	70	45.0	42.5	51.6	59.8	44.4	42.6	51.1	60.0	48.2	46.7	55.4	65.3
	75	48.4	45.9	55.4	64.0	48.5	46.0	55.5	64.1	48.5	46.8	55.7	65.2
1320	60	41.1	39.6	46.9	54.8	45.2	43.8	51.3	59.9	48.8	48.4	55.5	65.2
	65	43.2	40.9	49.0	56.1	45.2	43.7	51.4	59.8	49.3	47.9	55.8	65.0
	70	46.8	44.4	52.9	60.4	46.8	44.5	53.0	60.5	49.3	47.8	55.9	64.9
	75	50.3	47.9	56.8	64.7	50.4	47.9	56.9	64.8	49.7	47.9	56.2	64.8
1440	60	42.0	40.6	47.4	54.5	46.0	44.8	51.7	59.6	49.7	49.3	55.8	64.6
	65	44.6	42.5	50.1	56.6	46.1	44.6	51.8	59.4	50.2	48.8	56.2	64.6
	70	48.3	46.0	54.0	60.9	48.4	46.1	54.1	61.0	50.2	48.7	56.3	64.5
	75	52.0	49.6	58.0	65.3	52.0	49.7	58.1	65.4	52.1	49.8	58.2	65.5
Ambient DB 65°F													
900	60	36.7	35.0	45.0	56.4	40.8	39.2	49.6	61.9	44.6	43.2	54.1	67.3
	65	36.8	34.9	45.1	56.2	40.7	39.0	49.5	61.7	44.9	43.3	54.2	67.4
	70	39.4	36.7	47.9	58.4	40.8	38.9	49.6	61.6	44.8	43.1	54.2	67.2
	75	42.6	39.8	51.5	62.5	42.7	39.9	51.6	62.6	44.8	43.1	54.2	67.1
1080	60	39.1	37.5	46.1	55.6	43.1	41.6	50.6	61.0	46.9	45.7	55.0	66.2
	65	39.3	37.5	46.3	55.5	43.1	41.5	50.6	60.8	47.2	45.7	55.2	66.2
	70	43.3	40.7	50.6	59.5	43.3	41.5	50.8	60.7	47.2	45.6	55.2	66.1
	75	46.6	44.0	54.4	63.7	46.7	44.1	54.5	63.8	47.4	45.6	55.4	66.0
1200	60	40.3	38.7	46.7	55.2	44.3	42.9	51.2	60.5	48.1	47.4	55.5	65.9
	65	41.8	39.4	48.2	55.8	44.3	42.8	51.2	60.3	48.5	47.0	55.7	65.7
	70	45.3	42.8	52.1	60.1	44.7	42.8	51.5	60.2	48.4	46.9	55.8	65.5
	75	48.8	46.2	56.0	64.4	48.9	46.3	56.1	64.5	48.8	46.9	56.0	65.5
1320	60	41.3	39.8	47.2	54.9	45.4	44.0	51.6	60.1	49.0	48.5	55.8	65.3
	65	43.5	41.2	49.4	56.4	45.4	43.9	51.7	59.9	49.5	48.1	56.2	65.2
	70	47.1	44.7	53.4	60.7	47.2	44.8	53.4	60.8	49.5	48.0	56.2	65.1
	75	50.7	48.2	57.3	65.1	50.8	48.3	57.4	65.2	50.9	48.1	57.5	65.0



Reheat Temperature Rise

Table 32. Reheat temperature rise - 3 tons, ultra high efficiency (continued)

Airflow (cfm)	Ent DB (°F)	Entering Wet Bulb (°F)											
		51				55				59			
		Lvg Evap DB (°F)		Lvg Reheat DB (°F)		Lvg Evap DB (°F)		Lvg Reheat DB (°F)		Lvg Evap DB (°F)		Lvg Reheat DB (°F)	
		MIN	MAX	MIN	MAX	MIN	MAX	MIN	MAX	MIN	MAX	MIN	MAX
1440	60	42.2	40.7	47.6	54.7	46.2	44.9	52.0	59.8	49.9	49.5	56.1	64.8
	65	45.0	42.7	50.5	56.9	46.3	44.8	52.1	59.6	50.4	49.0	56.5	64.8
	70	48.6	46.3	54.5	61.3	48.7	46.4	54.6	61.3	50.4	48.9	56.6	64.7
	75	52.3	49.9	58.5	65.7	52.4	50.0	58.6	65.7	52.5	50.1	58.7	65.8
Ambient DB 70°F													
900	60	37.0	35.2	45.4	56.6	41.1	39.4	50.0	62.2	44.9	43.5	54.5	67.5
	65	37.1	35.2	45.5	56.5	41.0	39.2	49.9	61.9	45.1	43.4	54.7	67.6
	70	39.9	37.1	48.5	58.8	41.1	39.2	50.0	61.8	45.1	43.4	54.6	67.4
	75	43.1	40.2	52.1	62.9	43.2	40.3	52.2	63.1	45.1	43.3	54.6	67.3
1080	60	39.3	37.7	46.5	55.8	43.4	41.8	51.0	61.2	47.1	45.9	55.4	66.4
	65	39.6	37.6	46.7	55.7	43.3	41.7	51.0	61.0	47.5	45.9	55.6	66.5
	70	43.6	41.0	51.1	59.8	43.6	41.7	51.2	60.9	47.4	45.8	55.6	66.3
	75	47.1	44.3	55.0	64.1	47.2	44.4	55.0	64.2	47.7	45.8	55.8	66.2
1200	60	40.5	38.9	47.0	55.4	44.6	43.1	51.5	60.7	48.3	47.6	55.8	66.1
	65	42.2	39.7	48.7	56.1	44.5	42.9	51.5	60.5	48.7	47.1	56.1	65.9
	70	45.7	43.1	52.6	60.5	45.8	43.0	52.7	60.4	48.7	47.1	56.1	65.7
	75	49.2	46.6	56.5	64.8	49.3	46.6	56.6	64.9	49.0	47.1	56.4	65.7
1320	60	41.5	40.0	47.5	55.1	45.6	44.2	51.9	60.3	49.3	48.7	56.1	65.4
	65	43.8	41.4	49.9	56.7	45.6	44.0	52.0	60.1	49.7	48.2	56.5	65.4
	70	47.4	45.0	53.8	61.0	47.5	45.1	53.9	61.1	49.7	48.1	56.5	65.2
	75	51.1	48.5	57.8	65.5	51.2	48.6	57.9	65.5	51.2	48.2	58.0	65.2
1440	60	42.4	40.9	47.9	54.9	46.4	45.1	52.3	60.0	50.4	49.6	56.5	64.9
	65	45.3	43.0	50.9	57.2	46.5	44.9	52.3	59.8	50.6	49.1	56.8	64.9
	70	49.0	46.6	54.9	61.6	49.0	46.7	55.0	61.7	50.6	49.0	56.9	64.8
	75	52.7	50.2	59.0	66.0	52.8	50.3	59.0	66.1	52.8	50.4	59.1	66.2

Note: MIN, MAX: The leaving evaporator temperature is affected by the modulating valve position. The MIN and MAX numbers represent modulating valve position impact on both the leaving evaporator temperature and the leaving reheat coil temperature. MAX represents wide open, MIN represents closed to minimum position.

Table 33. Reheat temperature rise - 4 tons, ultra high efficiency

Airflow (cfm)	Ent DB (°F)	Entering Wet Bulb (°F)											
		51				55				59			
		Lvg Evap DB (°F)		Lvg Reheat DB (°F)		Lvg Evap DB (°F)		Lvg Reheat DB (°F)		Lvg Evap DB (°F)		Lvg Reheat DB (°F)	
		MIN	MAX	MIN	MAX	MIN	MAX	MIN	MAX	MIN	MAX	MIN	MAX
Ambient DB 60°F													
1200	60	37.8	35.0	46.3	56.1	41.9	39.2	50.9	61.6	45.6	43.3	56.4	66.9
	65	38.1	35.0	46.6	56.0	41.9	39.1	51.2	61.4	46.0	43.3	56.0	67.0
	70	41.2	36.8	50.3	58.2	42.1	39.0	51.5	61.3	46.0	43.2	56.3	66.8
	75	44.4	40.0	54.3	62.3	44.5	40.1	54.4	62.4	46.0	43.2	56.4	66.7
1440	60	40.1	37.5	47.4	55.5	44.2	41.7	51.9	60.8	47.9	45.7	57.3	66.0
	65	41.4	37.5	48.8	55.4	44.2	41.6	52.2	60.6	48.3	45.8	56.9	66.0
	70	44.9	40.8	53.0	59.4	44.5	41.6	52.7	60.6	48.3	45.7	57.2	65.9
	75	48.3	44.1	57.2	63.7	48.4	44.2	57.3	63.8	48.6	45.7	57.7	65.9
1600	60	41.3	38.8	48.0	55.2	45.4	43.0	52.4	60.3	49.3	47.4	56.5	65.5
	65	43.3	39.5	50.1	55.8	45.4	42.8	52.8	60.2	49.4	47.1	57.3	65.5
	70	46.9	42.9	54.4	60.1	47.0	42.9	54.5	60.2	49.5	47.0	57.7	65.4
	75	50.4	46.4	58.7	64.4	50.5	46.5	58.8	64.5	49.9	47.1	58.2	65.4
1760	60	42.3	39.9	48.4	54.9	46.3	44.1	52.8	60.0	50.2	48.0	56.8	65.1
	65	44.9	41.3	51.3	56.4	46.4	43.9	53.2	59.9	50.4	48.1	57.6	65.1
	70	48.6	44.8	55.6	60.7	48.6	44.9	55.7	60.8	50.5	48.1	58.0	65.0
	75	52.2	48.4	60.0	65.1	52.3	48.4	60.0	65.2	52.4	48.2	60.1	65.1
1920	60	43.2	40.8	48.8	54.7	47.2	45.0	53.1	59.7	51.0	49.3	57.1	64.6
	65	46.3	42.8	52.3	56.9	47.3	44.9	53.5	59.6	51.2	49.1	57.9	64.7
	70	50.0	46.4	56.6	61.3	50.1	46.5	56.7	61.4	51.3	49.0	58.3	64.7
	75	53.8	50.1	61.0	65.7	53.8	50.2	61.1	65.8	53.9	50.2	61.2	65.9
Ambient DB 65°F													
1200	60	38.2	35.2	46.8	56.3	42.3	39.4	51.4	61.8	45.9	43.5	57.0	67.2
	65	38.4	35.2	47.1	56.2	42.2	39.3	51.8	61.6	46.4	43.5	56.5	67.2
	70	41.7	37.1	51.0	58.6	42.4	39.2	52.1	61.5	46.3	43.4	56.9	67.1
	75	45.0	40.3	55.2	62.7	45.1	40.4	55.3	62.9	46.4	43.4	57.2	67.0
1440	60	40.4	37.7	47.8	55.7	44.5	41.9	52.3	60.9	48.1	45.9	57.7	66.2
	65	41.8	37.7	49.4	55.6	44.5	41.7	52.7	60.8	48.5	45.9	57.3	66.2
	70	45.3	41.1	53.6	59.7	44.8	41.8	53.2	60.8	48.5	45.9	57.7	66.1
	75	48.8	44.4	57.9	64.0	48.9	44.5	58.0	64.1	48.9	45.9	58.2	66.1
1600	60	41.6	39.0	48.4	55.3	45.6	43.1	52.8	60.5	49.5	47.6	56.9	65.7
	65	43.7	39.7	50.7	56.1	45.7	43.0	53.2	60.4	49.7	47.2	57.7	65.7
	70	47.3	43.2	55.0	60.4	47.4	43.1	55.1	60.4	49.7	47.1	58.1	65.6
	75	50.9	46.7	59.4	64.8	51.0	46.8	59.5	64.9	51.0	47.2	59.6	65.6
1760	60	42.5	40.0	48.8	55.1	46.6	44.2	53.1	60.1	50.4	48.6	57.2	65.0
	65	45.3	41.5	51.8	56.6	46.6	44.1	53.6	60.0	50.6	48.3	58.0	65.2
	70	49.0	45.1	56.2	61.0	49.0	45.1	56.3	61.1	50.7	48.2	58.5	65.2
	75	52.6	48.6	60.6	65.5	52.7	48.7	60.7	65.5	52.8	48.4	60.8	65.2
1920	60	43.4	41.0	49.1	54.8	47.4	45.1	53.4	59.8	51.2	49.0	57.4	64.8
	65	46.6	43.1	52.8	57.1	47.5	45.0	53.9	59.7	51.4	49.2	58.3	64.8
	70	50.4	46.7	57.2	61.6	50.5	46.8	57.3	61.7	51.5	49.1	58.7	64.8
	75	54.2	50.3	61.7	66.0	54.2	50.4	61.7	66.1	54.3	50.5	61.8	66.2
Ambient DB 70°F													



Reheat Temperature Rise

Table 33. Reheat temperature rise - 4 tons, ultra high efficiency (continued)

Airflow (cfm)	Ent DB (°F)	Entering Wet Bulb (°F)											
		51				55				59			
		Lvg Evap DB (°F)		Lvg Reheat DB (°F)		Lvg Evap DB (°F)		Lvg Reheat DB (°F)		Lvg Evap DB (°F)		Lvg Reheat DB (°F)	
		MIN	MAX	MIN	MAX	MIN	MAX	MIN	MAX	MIN	MAX	MIN	MAX
1200	60	38.5	35.5	47.3	56.5	42.6	39.6	52.0	62.0	46.3	43.7	57.6	67.5
	65	38.7	35.4	47.7	56.4	42.5	39.5	52.3	61.9	46.7	43.7	57.1	67.5
	70	42.2	37.4	51.8	58.9	42.8	39.4	52.7	61.8	46.6	43.6	57.5	67.3
	75	45.5	40.6	56.0	63.1	45.6	40.7	56.1	63.3	46.8	43.6	57.8	67.3
1440	60	40.7	37.9	48.3	55.9	44.7	42.1	52.8	61.1	48.3	46.4	58.0	66.5
	65	42.2	37.9	50.0	55.8	44.7	41.9	53.2	61.0	48.8	46.1	57.8	66.4
	70	45.8	41.4	54.3	60.1	45.1	41.9	53.7	61.0	48.8	46.0	58.2	66.3
	75	49.3	44.7	58.7	64.4	49.4	44.8	58.8	64.5	49.2	46.1	58.7	66.3
1600	60	41.8	39.1	48.8	55.5	45.9	43.3	53.2	60.7	49.8	47.7	57.4	65.9
	65	44.1	40.0	51.3	56.4	45.9	43.2	53.6	60.6	49.9	47.4	58.2	65.8
	70	47.7	43.5	55.7	60.7	47.8	43.3	55.7	60.6	50.0	47.3	58.6	65.8
	75	51.3	47.0	60.1	65.1	51.4	47.0	60.2	65.2	51.5	47.4	60.3	65.8
1760	60	42.8	40.2	49.2	55.2	46.8	44.4	53.5	60.3	50.7	48.8	57.6	65.3
	65	45.7	41.8	52.4	56.9	46.9	44.2	53.9	60.2	50.9	48.4	58.4	65.4
	70	49.4	45.3	56.8	61.3	49.4	45.4	56.9	61.4	50.9	48.4	58.9	65.3
	75	53.1	48.9	61.3	65.8	53.2	49.0	61.4	65.9	53.2	49.1	61.5	66.0
1920	60	43.6	41.1	49.5	55.0	47.6	45.3	53.8	60.0	51.5	49.1	57.9	64.9
	65	47.0	43.3	53.3	57.4	47.7	45.1	54.2	59.9	51.7	49.3	58.7	65.0
	70	50.8	46.9	57.8	61.8	50.9	47.0	57.8	61.9	51.8	49.3	59.1	64.9
	75	54.6	50.6	62.3	66.3	54.7	50.7	62.4	66.4	54.7	50.7	62.5	66.5

Note: MIN, MAX: The leaving evaporator temperature is affected by the modulating valve position. The MIN and MAX numbers represent modulating valve position impact on both the leaving evaporator temperature and the leaving reheat coil temperature. MAX represents wide open, MIN represents closed to minimum position.

Table 34. Reheat temperature rise - 5 tons, ultra high efficiency

Airflow (cfm)	Ent DB (°F)	Entering Wet Bulb (°F)											
		51				55				59			
		Lvg Evap DB (°F)		Lvg Reheat DB (°F)		Lvg Evap DB (°F)		Lvg Reheat DB (°F)		Lvg Evap DB (°F)		Lvg Reheat DB (°F)	
		MIN	MAX	MIN	MAX	MIN	MAX	MIN	MAX	MIN	MAX	MIN	MAX
Ambient DB 60°F													
1500	60	37.9	35.9	45.6	56.1	41.8	40.0	50.1	61.5	45.5	44.1	54.6	67.1
	65	38.2	35.9	45.9	56.1	41.8	39.9	50.2	61.5	45.9	44.1	54.8	67.0
	70	41.2	38.1	49.2	58.9	42.1	39.9	50.4	61.4	45.9	44.1	54.9	67.0
	75	44.4	41.4	52.9	63.2	44.5	41.5	53.0	63.3	46.2	44.0	55.1	66.9
1800	60	40.1	38.2	46.7	55.6	44.0	42.4	51.1	60.8	47.7	46.4	55.5	66.2
	65	40.6	38.3	47.2	55.6	44.1	42.3	51.2	60.8	48.1	46.5	55.7	66.1
	70	44.8	42.0	51.8	60.2	44.6	42.4	51.7	60.8	48.2	46.4	55.9	66.1
	75	48.3	45.4	55.7	64.6	48.4	45.5	55.8	64.7	48.7	46.5	56.3	66.1
2000	60	41.3	39.5	47.3	55.3	45.2	43.6	51.6	60.4	48.8	48.0	55.9	65.5
	65	43.2	40.6	49.3	56.5	45.3	43.5	51.8	60.4	49.3	47.7	56.2	65.6
	70	46.8	44.1	53.2	60.9	46.9	44.2	53.3	61.0	49.4	47.7	56.4	65.6
	75	50.4	47.6	57.2	65.3	50.5	47.7	57.3	65.4	50.0	47.8	56.9	65.7
2200	60	42.3	40.5	47.8	55.0	46.1	44.6	52.1	60.0	50.0	49.1	56.2	64.9
	65	44.8	42.3	50.4	57.0	46.3	44.6	52.3	60.0	50.2	48.7	56.6	65.2
	70	48.5	45.9	54.5	61.5	48.6	46.0	54.5	61.6	50.4	48.7	56.8	65.2
	75	52.2	49.5	58.5	66.0	52.2	49.6	58.6	66.0	52.3	49.7	58.7	66.1
2400	60	43.1	41.4	48.2	54.8	47.0	45.5	52.4	59.7	50.8	49.8	56.5	65.2
	65	46.2	43.8	51.4	57.5	47.2	45.5	52.7	59.8	51.1	49.6	57.0	64.8
	70	49.9	47.5	55.5	62.0	50.0	47.6	55.6	62.1	51.4	49.9	57.3	65.2
	75	53.7	51.2	59.6	66.5	53.8	51.3	59.7	66.6	53.9	51.4	59.8	66.7
Ambient DB 65°F													
1500	60	38.1	36.1	46.0	56.4	42.1	40.2	50.5	61.8	45.8	44.3	55.0	67.4
	65	38.4	36.1	46.3	56.3	42.1	40.1	50.6	61.7	46.1	44.3	55.2	67.3
	70	41.6	38.4	49.8	59.3	42.4	40.0	50.8	61.7	46.2	44.2	55.3	67.2
	75	44.9	41.7	53.5	63.6	45.0	41.8	53.6	63.7	46.5	44.2	55.5	67.2
1800	60	40.3	38.4	47.1	55.8	44.2	42.5	51.4	61.0	47.9	46.6	55.8	66.4
	65	41.7	38.5	48.4	55.8	44.3	42.4	51.6	61.0	48.3	46.6	56.1	66.3
	70	45.2	42.3	52.3	60.5	44.8	42.6	52.0	61.0	48.4	46.6	56.2	66.3
	75	48.7	45.7	56.2	64.9	48.8	45.8	56.3	65.0	48.9	46.7	56.6	66.3
2000	60	41.5	39.6	47.6	55.4	45.4	43.8	51.9	60.6	49.0	48.2	56.2	65.6
	65	43.6	40.8	49.7	56.8	45.5	43.7	52.1	60.6	49.5	47.9	56.5	65.8
	70	47.1	44.4	53.7	61.2	47.2	44.5	53.8	61.3	49.6	47.8	56.7	65.8
	75	50.7	47.9	57.7	65.7	50.8	48.0	57.8	65.8	50.2	48.0	57.2	65.9
2200	60	42.5	40.6	48.1	55.2	46.3	44.8	52.3	60.2	50.3	49.3	56.5	65.1
	65	45.1	42.6	50.8	57.3	46.5	44.7	52.5	60.2	50.4	48.9	56.9	65.3
	70	48.8	46.2	54.9	61.8	48.9	46.3	55.0	61.9	50.6	48.8	57.1	65.3
	75	52.5	49.8	59.0	66.3	52.6	49.9	59.1	66.4	52.7	50.0	59.1	66.5
2400	60	43.3	41.6	48.5	55.0	47.1	45.7	52.7	59.9	51.0	49.8	56.7	64.3
	65	46.5	44.0	51.8	57.8	47.5	45.6	53.0	59.9	51.3	49.8	57.2	65.0
	70	50.2	47.7	55.9	62.3	50.3	47.8	56.0	62.4	51.6	49.8	57.6	65.0
	75	54.0	51.4	60.1	66.8	54.1	51.5	60.1	66.9	54.2	51.6	60.2	67.0
Ambient DB 70°F													



Reheat Temperature Rise

Table 34. Reheat temperature rise - 5 tons, ultra high efficiency (continued)

Airflow (cfm)	Ent DB (°F)	Entering Wet Bulb (°F)											
		51				55				59			
		Lvg Evap DB (°F)		Lvg Reheat DB (°F)		Lvg Evap DB (°F)		Lvg Reheat DB (°F)		Lvg Evap DB (°F)		Lvg Reheat DB (°F)	
		MIN	MAX	MIN	MAX	MIN	MAX	MIN	MAX	MIN	MAX	MIN	MAX
1500	60	38.4	36.3	46.4	56.6	42.4	40.4	50.9	62.0	46.0	44.5	55.4	67.7
	65	38.7	36.3	46.7	56.6	42.4	40.3	51.0	62.0	46.4	44.5	55.6	67.6
	70	42.0	38.7	50.3	59.7	42.7	40.3	51.2	61.9	46.4	44.4	55.7	67.5
	75	45.3	42.0	54.1	64.0	45.4	42.1	54.2	64.2	46.7	44.4	55.9	67.5
1800	60	40.6	38.6	47.4	56.0	44.5	42.7	51.8	61.2	48.1	46.8	56.1	66.6
	65	42.1	39.1	48.9	56.5	44.5	42.6	51.9	61.2	48.6	46.8	56.4	66.5
	70	45.6	42.6	52.8	60.9	45.0	42.7	52.3	61.2	48.7	46.8	56.6	66.5
	75	49.1	46.0	56.8	65.3	49.2	46.1	56.9	65.4	49.2	46.9	57.0	66.6
2000	60	41.7	39.8	47.9	55.6	45.6	43.9	52.2	60.8	49.2	48.4	56.5	65.8
	65	43.9	41.1	50.2	57.1	45.7	43.8	52.4	60.7	49.7	48.0	56.8	66.0
	70	47.5	44.6	54.2	61.5	47.6	44.7	54.2	61.6	49.8	48.0	57.0	66.0
	75	51.1	48.2	58.2	66.0	51.2	48.3	58.3	66.1	51.3	48.1	58.4	66.1
2200	60	42.7	40.8	48.4	55.3	46.5	44.9	52.6	60.4	50.0	49.4	56.7	65.2
	65	45.4	42.8	51.2	57.6	46.7	44.8	52.8	60.4	50.6	49.0	57.2	65.5
	70	49.1	46.4	55.3	62.1	49.2	46.5	55.4	62.2	50.8	49.0	57.4	65.5
	75	52.9	50.1	59.4	66.6	52.9	50.1	59.5	66.7	53.0	50.2	59.6	66.8
2400	60	43.5	41.7	48.7	55.1	47.3	45.8	53.0	60.1	51.1	50.0	57.0	64.4
	65	46.8	44.3	52.2	58.1	47.7	45.8	53.3	60.1	51.4	49.9	57.5	65.1
	70	50.6	48.0	56.3	62.6	50.6	48.0	56.4	62.7	51.8	49.9	57.8	65.2
	75	54.4	51.7	60.5	67.2	54.4	51.8	60.6	67.3	54.5	51.9	60.7	67.3

Note: MIN, MAX: The leaving evaporator temperature is affected by the modulating valve position. The MIN and MAX numbers represent modulating valve position impact on both the leaving evaporator temperature and the leaving reheat coil temperature. MAX represents wide open, MIN represents closed to minimum position.

Table 35. Reheat temperature rise - 6 tons, ultra high efficiency

Airflow (cfm)	Ent DB (°F)	Entering Wet Bulb (°F)											
		51				55				59			
		Lvg Evap DB (°F)		Lvg Reheat DB (°F)		Lvg Evap DB (°F)		Lvg Reheat DB (°F)		Lvg Evap DB (°F)		Lvg Reheat DB (°F)	
		MIN	MAX	MIN	MAX	MIN	MAX	MIN	MAX	MIN	MAX	MIN	MAX
Ambient DB 60°F													
1800	60	37.8	36.8	42.5	56.7	42.8	42.5	47.5	60.9	44.6	48.4	50.5	64.0
	65	37.2	36.2	42.1	56.6	41.5	41.5	46.6	61.2	46.6	48.3	51.8	64.6
	70	39.8	38.8	44.9	59.4	41.0	41.0	46.4	61.0	45.4	47.5	50.9	64.4
	75	42.8	44.0	48.2	62.8	42.9	44.1	48.3	62.9	45.0	46.6	50.7	64.2
2160	60	40.9	39.7	44.9	56.5	45.5	44.7	49.3	60.9	49.5	49.6	53.2	64.2
	65	39.7	38.7	43.9	56.3	44.6	43.9	49.0	61.0	49.4	50.0	53.7	65.1
	70	43.6	42.4	48.0	60.5	43.6	43.0	48.1	61.1	48.0	49.3	52.7	64.9
	75	48.5	47.4	51.8	64.2	46.8	47.6	51.6	64.3	47.5	48.2	52.4	64.7
2400	60	42.4	41.2	46.0	56.3	46.8	46.0	50.3	60.8	46.0	50.3	47.0	64.1
	65	42.5	40.1	46.3	56.1	46.2	45.2	50.1	61.1	50.9	51.1	54.7	65.3
	70	45.7	44.5	49.8	61.2	44.9	44.2	49.0	61.0	50.0	50.4	54.3	65.1
	75	48.9	47.7	53.3	64.7	49.0	49.6	53.3	65.1	48.8	49.1	53.3	64.9
2640	60	43.6	42.5	46.9	56.3	48.0	47.1	51.1	60.6	50.7	51.0	52.2	63.9
	65	44.3	42.9	47.8	57.6	47.4	46.4	50.9	61.0	52.1	52.0	55.5	65.4
	70	47.5	46.4	51.3	61.8	47.6	46.5	51.4	61.8	51.3	51.3	55.1	65.2
	75	50.8	51.3	54.8	65.7	50.9	51.4	54.9	65.8	50.0	51.5	54.0	65.9
2880	60	44.7	43.7	47.6	56.2	48.9	48.1	51.8	60.5	52.2	51.6	55.0	63.6
	65	45.9	44.6	49.1	58.1	48.2	47.4	52.2	60.9	53.1	52.8	56.2	65.4
	70	49.2	48.0	52.6	62.3	49.3	48.1	52.7	62.4	52.4	52.1	56.1	65.3
	75	52.5	52.9	56.2	66.4	52.5	53.1	56.3	66.5	52.6	53.2	56.4	66.5
Ambient DB 65°F													
1800	60	38.5	36.8	43.3	56.9	42.9	41.9	47.5	61.6	47.7	45.0	52.2	65.8
	65	37.5	36.3	42.5	56.9	41.9	40.9	47.0	62.1	47.0	46.9	52.2	66.1
	70	40.3	38.5	45.4	59.6	41.4	40.4	46.7	62.0	45.7	45.9	51.3	66.3
	75	43.3	42.3	48.8	63.6	43.4	42.4	48.9	63.7	45.3	45.5	51.1	66.1
2160	60	41.3	39.9	45.3	56.8	45.8	44.6	49.7	61.2	49.8	46.6	53.5	65.7
	65	40.0	39.0	44.2	56.6	45.0	43.4	49.4	61.5	49.8	49.0	54.0	66.1
	70	44.0	42.3	48.5	60.8	43.9	42.8	48.4	61.6	48.8	47.8	53.6	66.3
	75	47.2	46.0	52.0	64.8	47.3	46.1	52.1	64.9	47.7	47.3	52.7	66.1
2400	60	42.8	41.4	46.3	56.6	47.1	46.1	50.6	61.0	50.7	50.0	54.1	64.6
	65	42.9	41.4	46.7	57.4	46.5	45.2	50.4	61.5	51.2	50.3	55.0	66.0
	70	46.1	44.5	50.2	61.5	46.2	44.2	50.3	61.3	50.3	49.5	54.6	66.1
	75	49.3	48.1	53.8	65.5	49.4	48.2	53.8	65.6	45.5	48.4	54.6	66.0
2640	60	44.0	42.8	47.2	56.4	48.2	47.4	51.4	60.9	51.5	50.9	54.6	64.1
	65	44.7	43.3	48.2	58.0	47.8	46.5	51.3	61.3	52.4	51.4	55.8	65.9
	70	48.0	46.4	51.7	62.1	48.1	46.5	51.8	62.2	53.3	50.6	56.0	66.0
	75	51.2	49.9	55.3	66.2	51.3	50.0	55.4	66.3	51.4	49.4	55.5	65.9
2880	60	45.0	43.9	47.9	56.4	49.2	48.4	52.1	60.7	52.2	55.8	55.0	65.9
	65	46.3	45.0	49.5	58.5	50.3	47.7	51.5	61.3	53.4	52.5	56.5	65.8
	70	49.6	48.1	53.1	62.6	49.7	48.2	53.2	62.7	52.7	51.6	56.2	66.0
	75	52.9	51.6	56.7	66.7	53.0	51.7	56.8	66.8	52.9	51.8	57.2	66.9
Ambient DB 70°F													



Reheat Temperature Rise

Table 35. Reheat temperature rise - 6 tons, ultra high efficiency (continued)

Airflow (cfm)	Ent DB (°F)	Entering Wet Bulb (°F)											
		51				55				59			
		Lvg Evap DB (°F)		Lvg Reheat DB (°F)		Lvg Evap DB (°F)		Lvg Reheat DB (°F)		Lvg Evap DB (°F)		Lvg Reheat DB (°F)	
		MIN	MAX	MIN	MAX	MIN	MAX	MIN	MAX	MIN	MAX	MIN	MAX
1800	60	38.9	37.1	43.7	57.1	43.5	42.0	48.2	62.0	45.2	45.7	51.2	66.8
	65	37.9	36.5	42.8	57.2	42.2	40.8	47.4	62.3	47.4	46.2	52.6	67.0
	70	40.7	38.8	46.0	60.1	41.7	40.4	47.1	62.4	46.1	45.1	51.7	67.4
	75	43.8	41.8	49.4	64.0	43.9	41.9	49.5	64.1	45.6	44.8	51.5	67.3
2160	60	41.7	40.1	45.6	56.9	46.1	44.9	50.0	61.5	47.3	49.1	52.5	65.3
	65	41.4	39.1	45.5	56.7	45.4	43.9	49.8	62.1	50.1	48.8	54.4	66.6
	70	44.5	42.7	49.0	61.3	44.2	43.0	48.7	61.9	49.2	47.5	54.0	66.9
	75	47.7	45.8	52.5	65.3	47.8	45.9	52.6	65.4	48.1	46.9	53.0	66.8
2400	60	43.1	41.7	46.7	56.7	47.4	46.3	50.9	61.2	50.9	47.4	54.3	66.2
	65	43.4	41.7	47.2	57.6	46.9	45.4	50.8	61.8	51.5	50.3	55.3	66.4
	70	46.6	44.8	50.7	61.9	46.7	44.4	50.8	61.6	50.7	49.2	55.0	66.7
	75	49.8	48.0	54.3	66.0	49.9	48.1	54.4	66.1	49.4	48.3	53.9	66.5
2640	60	44.3	43.0	47.5	56.6	48.5	47.5	51.7	61.0	51.7	51.1	54.8	64.2
	65	45.2	43.5	48.6	58.2	48.1	46.7	51.7	61.6	52.7	51.6	56.1	66.2
	70	48.4	46.8	52.2	62.5	48.5	46.8	52.3	62.6	52.0	50.5	55.9	66.5
	75	51.7	50.0	55.8	66.6	51.8	50.1	55.9	66.7	51.9	49.5	56.0	66.2
2880	60	45.4	44.1	48.3	56.5	49.5	48.5	52.3	60.8	52.4	51.8	55.2	63.8
	65	46.7	45.2	49.9	58.6	49.2	47.8	52.4	61.4	53.7	52.7	56.8	66.0
	70	50.1	48.5	53.5	63.0	50.1	48.5	53.6	63.1	53.1	51.7	56.6	66.3
	75	53.4	51.7	57.2	67.1	53.4	51.8	57.8	67.2	53.3	51.9	57.6	67.3

MIN, MAX: The leaving evaporator temperature is affected by the modulating valve position. The MIN and MAX numbers represent modulating valve position impact on both the leaving evaporator temperature and the leaving reheat coil temperature. MAX represents wide open, MIN represents closed to minimum position.

Table 36. Reheat temperature rise - 7.5 tons, ultra high efficiency

Airflow (cfm)	Ent DB (°F)	Entering Wet Bulb (°F)											
		51				55				59			
		Lvg Evap DB (°F)		Lvg Reheat DB (°F)		Lvg Evap DB (°F)		Lvg Reheat DB (°F)		Lvg Evap DB (°F)		Lvg Reheat DB (°F)	
		MIN	MAX	MIN	MAX	MIN	MAX	MIN	MAX	MIN	MAX	MIN	MAX
Ambient DB 60°F													
2250	60	36.8	39.0	44.7	58.9	40.7	44.6	49.1	62.0	44.4	49.5	53.6	64.7
	65	37.2	39.5	45.0	59.1	40.8	44.6	49.2	62.1	44.7	50.2	53.7	65.1
	70	39.7	46.2	47.8	62.9	40.9	46.3	49.3	62.9	44.8	50.2	53.8	65.0
	75	42.8	52.6	51.3	66.2	42.9	52.7	51.4	66.3	44.9	52.8	53.9	66.3
2700	60	39.1	40.0	45.9	59.1	43.0	45.6	50.2	62.2	46.6	50.4	54.5	64.9
	65	39.7	42.1	46.4	60.1	43.1	45.6	50.4	62.3	47.0	51.2	54.8	65.3
	70	43.4	48.5	50.4	63.8	43.6	48.6	50.8	63.9	47.1	51.2	54.9	65.3
	75	46.7	55.4	54.1	67.3	46.8	55.5	54.2	67.3	47.6	55.6	55.3	67.4
3000	60	40.3	40.6	46.5	59.1	44.2	46.1	50.8	62.3	47.8	50.9	55.0	64.9
	65	42.0	43.3	48.1	60.5	44.3	46.2	51.0	62.4	48.2	51.8	55.3	65.3
	70	45.4	49.9	51.9	64.3	45.0	50.0	51.6	64.4	48.4	52.0	55.5	65.4
	75	48.8	56.9	55.6	67.8	48.8	57.0	55.7	67.9	49.0	57.1	56.0	68.0
3300	60	41.4	41.3	47.1	58.9	45.2	46.6	51.3	62.3	48.7	52.1	55.4	64.9
	65	43.6	44.5	49.2	60.8	45.4	46.7	51.5	62.4	49.3	52.3	55.8	65.4
	70	47.1	50.6	53.1	64.1	47.2	51.2	53.2	64.8	49.4	52.5	56.0	65.4
	75	50.5	58.3	56.9	68.3	50.6	58.4	57.0	68.4	50.2	58.5	56.6	68.4
3600	60	42.3	42.0	47.5	58.7	46.1	47.0	51.7	62.2	49.5	51.7	55.7	64.8
	65	45.0	45.5	50.2	61.1	46.3	47.4	51.9	62.4	50.2	52.8	56.2	65.4
	70	48.6	52.2	54.2	65.0	48.6	52.3	54.2	65.1	50.3	53.0	56.4	65.5
	75	52.1	59.5	58.1	68.8	52.2	59.6	58.1	68.8	52.3	59.7	58.2	68.9
Ambient DB 65°F													
2250	60	37.1	37.7	45.0	60.6	41.0	43.3	49.4	63.8	44.7	48.4	53.9	66.8
	65	37.5	38.1	45.3	60.8	41.0	43.4	49.5	63.9	45.0	48.9	54.0	67.0
	70	40.1	43.6	48.2	63.9	41.3	43.8	49.8	64.1	45.1	49.0	54.1	67.1
	75	43.3	43.9	51.8	67.5	43.4	49.9	51.9	67.5	45.2	49.4	54.2	67.2
2700	60	39.4	39.0	46.1	60.3	43.2	44.2	50.5	64.0	46.9	49.3	54.8	66.9
	65	40.0	39.6	46.7	60.6	43.3	44.4	50.6	64.1	47.3	49.9	55.0	67.2
	70	43.8	45.8	50.8	64.7	43.9	45.0	51.1	64.3	47.4	50.0	55.2	67.2
	75	47.1	52.4	54.5	68.3	47.2	52.5	54.6	68.4	47.9	52.6	55.6	68.5
3000	60	40.6	40.0	46.7	59.8	44.4	44.8	51.0	63.9	48.0	49.8	55.3	66.9
	65	42.3	41.6	48.4	61.0	44.5	45.0	51.2	64.1	48.5	50.4	55.5	67.2
	70	45.7	47.1	52.2	65.1	45.2	47.2	51.8	65.2	48.6	50.5	55.7	67.3
	75	49.1	53.8	56.0	68.8	49.2	53.9	56.1	68.9	49.2	54.1	56.3	69.0
3300	60	41.6	40.9	47.3	59.4	45.4	45.4	51.5	63.8	48.9	50.2	55.6	66.9
	65	43.9	43.1	49.6	61.2	45.6	45.6	51.7	63.9	49.5	50.9	56.0	67.2
	70	47.4	48.3	53.5	65.5	47.5	48.4	53.5	65.6	49.6	51.1	56.2	67.3
	75	50.9	55.1	57.3	69.3	51.0	55.2	57.4	69.3	50.4	55.4	56.9	69.4
3600	60	42.4	41.8	47.7	58.9	46.3	46.0	51.9	63.5	49.7	50.6	55.9	66.8
	65	45.2	44.4	50.6	61.4	46.4	46.2	52.1	63.7	50.4	51.4	56.4	67.2
	70	48.9	49.4	54.5	65.8	48.9	49.5	54.6	65.8	50.5	51.7	56.6	67.4
	75	52.5	56.3	58.4	69.6	52.5	56.4	58.5	69.7	52.6	56.5	58.6	69.7
Ambient DB 70°F													



Reheat Temperature Rise

Table 36. Reheat temperature rise - 7.5 tons, ultra high efficiency (continued)

Airflow (cfm)	Ent DB (°F)	Entering Wet Bulb (°F)											
		51				55				59			
		Lvg Evap DB (°F)		Lvg Reheat DB (°F)		Lvg Evap DB (°F)		Lvg Reheat DB (°F)		Lvg Evap DB (°F)		Lvg Reheat DB (°F)	
		MIN	MAX	MIN	MAX	MIN	MAX	MIN	MAX	MIN	MAX	MIN	MAX
2250	60	37.4	36.8	45.3	61.6	41.2	42.1	49.7	65.6	45.0	47.4	54.2	68.7
	65	37.7	37.2	45.6	61.8	41.3	42.2	49.8	65.6	45.2	47.8	54.3	68.9
	70	40.5	41.1	48.6	64.8	41.6	42.6	50.1	65.8	45.3	47.9	54.4	68.9
	75	43.7	47.2	52.3	68.4	43.8	47.4	52.4	68.5	45.4	48.3	54.5	69.1
2700	60	39.6	38.8	46.4	60.7	43.5	43.2	50.7	65.4	47.1	48.2	55.1	68.8
	65	40.2	39.4	46.9	61.0	43.6	43.3	50.9	65.5	47.5	48.7	55.3	69.0
	70	44.1	43.6	51.2	65.4	44.1	43.9	51.4	65.8	47.6	48.8	55.4	69.1
	75	47.5	49.5	55.0	69.3	47.6	49.6	55.1	69.4	48.1	49.4	55.9	69.4
3000	60	40.8	39.9	47.0	60.1	44.6	44.1	51.2	64.9	48.2	48.7	55.5	68.8
	65	42.6	40.6	48.8	60.5	44.8	44.2	51.4	65.1	48.7	49.2	55.8	69.0
	70	46.1	45.3	52.6	65.6	45.5	45.0	52.0	65.5	48.8	49.4	56.0	69.1
	75	49.5	50.8	56.5	69.7	49.6	51.0	56.5	69.8	49.5	50.1	56.5	69.4
3300	60	41.8	40.9	47.5	59.5	45.6	44.9	51.7	64.4	49.2	49.2	55.9	68.6
	65	44.2	43.0	49.9	61.4	45.8	45.1	51.9	64.6	49.7	49.7	56.2	68.9
	70	47.7	46.9	53.8	65.9	47.8	46.9	53.9	66.0	49.8	49.9	56.4	69.0
	75	51.3	52.1	57.7	70.1	51.4	52.2	57.8	70.2	51.4	52.3	57.9	70.3
3600	60	42.7	41.9	48.0	59.1	46.5	45.8	52.1	63.9	49.9	49.7	56.2	68.2
	65	45.5	44.4	50.9	61.5	46.8	45.9	52.4	64.1	50.6	50.3	56.6	68.6
	70	49.2	48.2	54.9	66.1	49.3	48.3	54.9	66.2	51.3	50.5	57.2	68.7
	75	52.8	53.3	58.8	70.4	52.9	53.4	58.9	70.5	53.0	53.5	59.0	70.6

MIN, MAX: The leaving evaporator temperature is affected by the modulating valve position. The MIN and MAX numbers represent modulating valve position impact on both the leaving evaporator temperature and the leaving reheat coil temperature. MAX represents wide open, MIN represents closed to minimum position.

Table 37. Reheat temperature rise - 8.5 tons, ultra high efficiency

Airflow (cfm)	Ent DB (°F)	Entering Wet Bulb (°F)											
		51				55				59			
		Lvg Evap DB (°F)		Lvg Reheat DB (°F)		Lvg Evap DB (°F)		Lvg Reheat DB (°F)		Lvg Evap DB (°F)		Lvg Reheat DB (°F)	
		MIN	MAX	MIN	MAX	MIN	MAX	MIN	MAX	MIN	MAX	MIN	MAX
Ambient DB 60°F													
2550	60	37.3	36.7	45.1	57.1	41.1	41.8	49.5	60.6	45.0	47.1	54.2	63.2
	65	37.7	37.2	45.5	57.3	41.3	42.0	49.7	60.6	45.2	47.4	54.2	63.5
	70	40.5	40.9	48.6	59.9	41.6	42.5	50.0	60.8	45.3	47.6	54.4	63.5
	75	43.7	54.9	52.2	66.3	43.8	46.8	52.3	63.0	45.5	48.0	54.5	63.7
3060	60	39.6	38.7	46.3	57.1	43.4	43.4	50.6	60.7	47.2	48.4	55.2	63.5
	65	40.2	39.4	46.9	57.5	43.6	43.6	50.9	60.8	47.5	48.9	55.2	63.8
	70	44.2	44.2	51.2	61.0	44.2	44.3	51.4	61.1	47.7	49.1	55.5	63.9
	75	47.6	50.1	55.0	64.3	47.6	50.2	55.1	64.3	48.2	49.8	55.9	64.1
3400	60	40.8	39.8	46.9	56.9	44.6	44.3	51.2	60.7	48.3	49.1	55.6	63.5
	65	42.6	40.6	48.7	57.4	44.8	44.5	51.4	60.8	48.7	49.7	55.8	63.9
	70	46.1	46.1	52.7	61.6	45.6	45.4	52.1	61.2	48.9	49.9	56.0	64.0
	75	49.6	52.0	56.5	65.0	49.7	52.1	56.6	65.0	49.6	52.3	56.6	65.1
3740	60	41.8	40.8	47.4	56.7	45.6	45.1	51.6	60.6	49.3	49.8	56.0	63.5
	65	44.2	42.9	49.9	58.4	45.8	45.4	51.9	60.8	49.7	50.4	56.2	64.0
	70	47.8	47.7	53.9	62.1	47.9	47.8	54.0	62.2	49.9	50.6	56.5	64.1
	75	51.4	53.7	57.8	65.6	51.5	53.8	57.9	65.7	51.6	53.9	58.0	65.7
4080	60	42.8	41.7	48.0	56.4	46.5	45.9	52.1	60.5	50.1	50.3	56.3	63.5
	65	45.6	44.3	50.9	58.8	46.9	46.1	52.5	60.7	50.6	51.1	56.6	64.0
	70	49.3	49.1	55.0	62.6	49.4	49.2	55.0	62.6	50.9	51.5	56.9	64.2
	75	52.9	55.2	59.0	66.1	53.0	55.3	59.0	66.2	53.1	55.4	59.1	66.3
Ambient DB 65°F													
2550	60	37.7	36.4	45.6	58.0	41.5	40.9	50.0	62.0	45.4	46.1	54.8	65.1
	65	38.1	36.8	46.0	58.3	41.7	41.1	50.2	62.2	45.6	46.4	54.7	65.4
	70	41.1	39.8	49.3	60.9	42.0	41.3	50.5	62.3	45.8	46.6	54.9	65.4
	75	44.3	44.6	53.0	64.2	44.4	44.7	53.1	64.2	45.9	47.0	55.0	65.6
3060	60	39.9	38.6	46.7	57.6	43.8	42.8	51.0	62.1	47.6	47.5	55.6	65.3
	65	41.2	39.3	48.0	58.0	43.9	43.0	51.3	62.2	47.9	47.9	55.7	65.6
	70	44.7	43.1	51.9	62.0	44.6	43.6	51.8	62.6	48.1	48.1	55.9	65.6
	75	48.2	48.0	55.8	65.4	48.3	48.1	55.9	65.4	48.6	48.8	56.4	65.9
3400	60	41.1	39.9	47.3	57.3	44.9	43.8	51.6	61.8	48.7	48.3	56.1	65.3
	65	43.1	40.7	49.3	57.8	45.1	44.0	51.8	62.0	49.0	48.8	56.2	65.6
	70	46.7	45.0	53.3	62.5	46.8	44.8	53.4	62.5	49.3	49.0	56.5	65.7
	75	50.2	49.9	57.3	66.0	50.3	50.0	57.4	66.1	50.0	49.8	57.1	66.0
3740	60	42.0	41.0	47.8	57.1	45.9	44.8	52.0	61.5	49.6	49.0	56.4	65.2
	65	44.7	42.9	50.4	58.8	46.1	45.0	52.3	61.8	50.0	49.5	56.6	65.5
	70	48.3	46.6	54.5	63.0	48.4	46.7	54.6	63.1	50.2	49.8	56.9	65.7
	75	52.0	51.6	58.6	66.6	52.1	51.7	58.6	66.7	52.2	51.8	58.7	66.7
4080	60	43.1	41.9	48.3	56.8	46.8	45.6	52.4	61.3	50.4	49.6	56.7	65.2
	65	46.0	44.4	51.4	59.2	47.2	45.9	52.8	61.5	50.9	50.3	57.0	65.5
	70	49.8	48.1	55.6	63.4	49.9	48.2	55.6	63.5	51.3	50.5	57.4	65.6
	75	53.5	53.1	59.7	67.1	53.6	53.2	59.7	67.1	53.7	53.3	59.8	67.2
Ambient DB 70°F													



Reheat Temperature Rise

Table 37. Reheat temperature rise - 8.5 tons, ultra high efficiency (continued)

Airflow (cfm)	Ent DB (°F)	Entering Wet Bulb (°F)											
		51				55				59			
		Lvg Evap DB (°F)		Lvg Reheat DB (°F)		Lvg Evap DB (°F)		Lvg Reheat DB (°F)		Lvg Evap DB (°F)		Lvg Reheat DB (°F)	
		MIN	MAX	MIN	MAX	MIN	MAX	MIN	MAX	MIN	MAX	MIN	MAX
2550	60	38.0	36.5	46.0	58.5	41.9	40.4	50.5	63.3	45.9	45.3	55.3	66.9
	65	38.5	36.8	46.4	58.8	42.1	40.7	50.7	63.4	46.0	45.5	55.2	67.1
	70	41.7	39.4	50.0	61.5	42.5	40.8	51.0	63.5	46.2	45.7	55.5	67.2
	75	45.0	43.3	53.8	65.4	45.1	43.4	53.9	65.5	46.3	45.9	55.6	67.2
3060	60	40.2	38.9	47.1	58.0	44.1	42.7	51.4	62.7	48.0	46.8	56.2	67.1
	65	41.7	39.5	48.6	58.5	44.3	42.8	51.7	62.9	48.2	47.2	56.2	67.2
	70	45.3	43.0	52.6	62.4	45.0	43.4	52.3	63.3	48.4	47.4	56.4	67.4
	75	48.8	46.7	56.6	66.5	48.9	46.8	56.7	66.6	49.1	48.0	57.0	67.6
3400	60	41.4	40.1	47.7	57.6	45.3	43.9	52.0	62.3	49.1	47.7	56.6	66.9
	65	43.6	41.6	49.9	58.9	45.5	44.1	52.2	62.5	49.4	48.2	56.6	67.1
	70	47.2	45.0	54.0	63.0	47.3	44.8	54.1	63.0	49.6	48.4	56.9	67.3
	75	50.9	48.7	58.1	67.1	51.0	48.8	58.1	67.2	50.4	49.1	57.6	67.7
3740	60	42.3	41.1	48.1	57.3	46.2	44.9	52.4	62.0	50.0	48.5	56.9	66.6
	65	45.1	43.3	51.0	59.3	46.4	45.1	52.7	62.2	50.4	49.1	57.0	66.8
	70	48.9	46.7	55.2	63.4	49.0	46.8	55.2	63.5	50.6	49.3	57.3	67.0
	75	52.6	50.4	59.3	67.6	52.7	50.5	59.4	67.7	52.8	50.2	59.5	67.5
4080	60	43.3	42.0	48.7	57.0	47.1	45.9	52.7	61.7	50.7	49.3	57.1	66.2
	65	46.5	44.7	52.0	59.6	47.5	46.1	53.2	62.0	51.2	49.9	57.3	66.5
	70	50.3	48.2	56.2	63.8	50.4	48.3	56.3	63.9	51.6	50.1	57.8	66.7
	75	54.1	51.9	60.4	68.0	54.2	52.0	60.5	68.1	54.3	52.1	60.5	68.2

Note: MIN, MAX: The leaving evaporator temperature is affected by the modulating valve position. The MIN and MAX numbers represent modulating valve position impact on both the leaving evaporator temperature and the leaving reheat coil temperature. MAX represents wide open, MIN represents closed to minimum position.

Table 38. Reheat temperature rise - 10 tons, ultra high efficiency

Airflow (cfm)	Ent DB (°F)	Entering Wet Bulb (°F)											
		51				55				59			
		Lvg Evap DB (°F)		Lvg Reheat DB (°F)		Lvg Evap DB (°F)		Lvg Reheat DB (°F)		Lvg Evap DB (°F)		Lvg Reheat DB (°F)	
		MIN	MAX	MIN	MAX	MIN	MAX	MIN	MAX	MIN	MAX	MIN	MAX
Ambient DB 60°F													
3000	60	39.1	38.4	45.7	54.0	42.8	42.2	49.7	58.2	46.1	46.1	53.8	61.5
	65	40.0	39.2	46.5	54.7	43.1	42.5	50.1	58.6	46.8	46.9	54.2	61.9
	70	43.2	42.3	49.9	57.8	43.8	43.3	50.8	59.1	47.1	47.3	54.6	62.2
	75	46.4	46.2	53.5	61.1	46.5	46.3	53.6	61.2	47.5	48.1	55.0	62.6
3600	60	41.3	40.6	46.9	54.1	44.9	44.3	50.8	58.2	48.1	47.8	54.8	61.6
	65	42.4	41.7	47.9	54.9	45.3	44.7	51.3	58.7	48.9	48.8	55.3	62.2
	70	46.6	45.7	52.4	59.1	46.3	45.8	52.3	59.4	49.3	49.3	55.8	62.5
	75	50.0	50.0	56.1	62.5	50.1	50.1	56.2	62.6	50.3	50.4	56.7	63.0
4000	60	42.4	41.8	47.6	54.2	46.0	45.4	51.4	58.2	49.2	48.8	55.2	61.7
	65	44.8	43.9	49.8	55.9	46.5	45.8	52.0	58.7	50.1	49.8	55.9	62.3
	70	48.4	47.6	53.7	59.9	47.7	47.1	53.0	59.6	50.5	50.4	56.4	62.6
	75	51.9	52.0	57.5	63.3	51.9	52.1	57.6	63.4	51.7	51.7	57.4	63.3
4400	60	43.4	42.9	48.1	54.2	46.9	46.3	51.9	58.2	50.0	49.6	55.6	61.7
	65	46.3	45.4	50.9	56.5	47.5	46.8	52.5	58.7	51.0	50.7	56.4	62.3
	70	49.9	49.2	54.8	60.5	50.0	49.3	54.9	60.6	51.5	51.3	56.9	62.7
	75	53.5	53.7	58.7	64.0	53.6	53.8	58.8	64.1	53.6	53.9	58.9	64.1
4800	60	44.3	43.7	48.6	54.2	47.8	47.2	52.4	58.1	50.7	50.3	55.9	61.7
	65	47.5	46.7	51.9	57.0	48.3	47.7	52.9	58.7	51.9	51.5	56.8	62.4
	70	51.2	50.6	55.8	61.1	51.3	50.6	55.9	61.1	52.4	52.1	57.4	62.8
	75	54.9	55.3	59.8	64.6	55.0	55.4	59.8	64.7	55.0	55.5	59.9	64.8
Ambient DB 65°F													
3000	60	39.5	38.6	46.1	54.5	43.1	42.2	50.1	58.8	46.5	45.7	54.3	63.1
	65	40.3	39.5	46.9	55.1	43.5	42.5	50.6	59.2	47.2	46.4	54.7	63.4
	70	43.7	42.5	50.5	58.3	44.2	43.3	51.3	59.8	47.5	46.8	55.1	63.8
	75	47.0	45.8	54.1	62.1	47.1	45.9	54.2	62.2	48.2	47.2	55.7	64.0
3600	60	41.6	40.9	47.3	54.5	45.2	44.4	51.2	58.7	48.5	47.6	55.2	62.9
	65	43.5	42.0	49.1	55.3	45.6	44.8	51.7	59.2	49.3	48.5	55.7	63.4
	70	47.1	45.9	52.9	59.6	46.7	45.8	52.7	59.9	49.7	48.9	56.2	63.8
	75	50.5	49.4	56.7	63.5	50.6	49.5	56.8	63.6	50.7	50.0	57.1	64.5
4000	60	42.7	42.0	47.9	54.4	46.3	45.6	51.8	58.7	49.5	48.6	55.6	62.7
	65	45.2	44.3	50.3	56.4	46.8	46.0	52.3	59.2	50.4	49.6	56.3	63.3
	70	48.8	47.7	54.2	60.4	48.9	47.2	54.3	60.0	50.9	50.1	56.8	63.8
	75	52.4	51.3	58.1	64.3	52.5	51.4	58.2	64.4	52.0	51.3	57.8	64.6
4400	60	43.7	43.0	48.4	54.4	47.2	46.6	52.2	58.6	50.3	49.5	56.0	62.5
	65	46.7	45.8	51.4	57.0	47.8	47.1	52.8	59.2	51.4	50.6	56.7	63.2
	70	50.4	49.3	55.4	61.0	50.4	49.3	55.4	61.1	51.9	51.1	57.3	63.7
	75	54.0	53.0	59.3	65.0	54.1	53.0	59.4	65.1	54.2	52.4	59.5	64.6
4800	60	44.5	43.9	48.9	54.4	48.0	47.4	52.7	58.5	51.0	50.2	56.3	62.4
	65	47.9	47.0	52.3	57.5	48.8	48.0	53.4	59.1	52.2	51.4	57.1	63.1
	70	51.7	50.6	56.3	61.5	51.7	50.7	56.4	61.6	52.9	52.0	57.9	63.6
	75	55.4	54.4	60.3	65.6	55.5	54.5	60.4	65.7	55.5	54.6	60.5	65.7
Ambient DB 70°F													



Reheat Temperature Rise

Table 38. Reheat temperature rise - 10 tons, ultra high efficiency (continued)

Airflow (cfm)	Ent DB (°F)	Entering Wet Bulb (°F)											
		51				55				59			
		Lvg Evap DB (°F)		Lvg Reheat DB (°F)		Lvg Evap DB (°F)		Lvg Reheat DB (°F)		Lvg Evap DB (°F)		Lvg Reheat DB (°F)	
		MIN	MAX	MIN	MAX	MIN	MAX	MIN	MAX	MIN	MAX	MIN	MAX
3000	60	39.8	38.9	46.5	54.8	43.5	42.5	50.6	59.3	46.9	45.7	54.8	63.8
	65	40.7	39.7	47.3	55.5	43.8	42.9	51.0	59.8	47.6	46.5	55.2	64.1
	70	44.2	42.9	51.1	59.0	44.6	43.6	51.7	60.4	47.9	46.8	55.6	64.5
	75	47.6	46.0	54.9	62.7	47.7	46.1	54.9	62.8	48.6	47.2	56.2	64.8
3600	60	41.9	41.1	47.6	54.7	45.6	44.7	51.6	59.1	48.9	47.8	55.7	63.4
	65	44.0	42.2	49.6	55.6	46.0	45.1	52.1	59.6	49.7	48.7	56.1	63.8
	70	47.6	46.3	53.5	60.3	47.0	46.1	53.1	60.4	50.1	49.0	56.7	64.3
	75	51.1	49.6	57.4	64.1	51.2	49.7	57.5	64.2	51.1	50.0	57.6	65.0
4000	60	43.1	42.2	48.2	54.7	46.6	45.8	52.1	58.9	49.8	48.9	56.1	63.3
	65	45.7	44.6	50.8	56.8	47.1	46.3	52.7	59.5	50.8	49.9	56.7	63.8
	70	49.3	48.1	54.8	61.0	49.4	47.5	54.9	60.4	51.2	50.3	57.2	64.2
	75	53.0	51.5	58.8	64.9	53.1	51.6	58.9	65.0	52.4	51.4	58.2	65.1
4400	60	44.0	43.2	48.7	54.6	47.5	46.8	52.6	58.8	50.6	49.8	56.4	63.1
	65	47.1	46.0	51.9	57.3	48.1	47.3	53.2	59.4	51.7	50.9	57.1	63.7
	70	50.9	49.7	55.9	61.6	50.9	49.8	56.0	61.6	52.2	51.3	57.7	64.2
	75	54.6	53.2	60.0	65.5	54.6	53.2	60.0	65.6	54.7	52.6	60.1	65.1
4800	60	44.9	44.1	49.3	54.6	48.3	47.6	53.0	58.7	51.3	50.5	56.6	62.9
	65	48.3	47.3	52.8	57.8	49.1	48.1	53.7	59.3	52.5	51.7	57.5	63.6
	70	52.2	51.0	56.9	62.1	52.2	51.1	56.9	62.2	53.2	52.2	58.2	64.1
	75	55.9	54.6	61.0	66.1	56.0	54.7	61.0	66.2	56.1	54.7	61.1	66.2

Note: MIN, MAX: The leaving evaporator temperature is affected by the modulating valve position. The MIN and MAX numbers represent modulating valve position impact on both the leaving evaporator temperature and the leaving reheat coil temperature. MAX represents wide open, MIN represents closed to minimum position.

Table 39. Reheat temperature rise - 12.5 tons, ultra high efficiency

Airflow (cfm)	Ent DB (°F)	Entering Wet Bulb (°F)											
		51				55				59			
		Lvg Evap DB (°F)		Lvg Reheat DB (°F)		Lvg Evap DB (°F)		Lvg Reheat DB (°F)		Lvg Evap DB (°F)		Lvg Reheat DB (°F)	
		MIN	MAX	MIN	MAX	MIN	MAX	MIN	MAX	MIN	MAX	MIN	MAX
Ambient DB 60°F													
3750	60	35.4	35.0	47.1	57.2	39.3	39.0	52.0	62.6	43.3	43.4	57.0	68.1
	65	35.4	35.0	47.1	57.2	39.3	39.1	52.0	62.6	43.3	43.4	56.9	68.1
	70	37.3	36.8	49.4	59.4	39.3	39.1	52.0	62.6	43.3	43.4	56.9	68.1
	75	40.4	40.1	53.1	63.6	40.5	40.2	53.2	63.8	43.4	43.4	56.9	68.1
4500	60	37.8	37.4	47.9	56.3	41.7	41.3	52.6	61.5	45.7	45.6	57.4	66.9
	65	38.0	37.6	48.1	56.5	41.8	41.4	52.7	61.5	45.8	45.6	57.5	66.9
	70	41.2	40.6	51.8	60.2	42.0	41.6	52.9	61.7	45.8	45.7	57.5	66.9
	75	44.4	44.0	55.6	64.5	44.5	44.1	55.7	64.6	46.0	45.8	57.6	67.0
5000	60	39.0	38.6	48.3	55.9	42.9	42.6	53.0	60.9	47.0	46.7	57.7	66.2
	65	39.9	39.0	49.2	56.2	43.0	42.7	53.0	61.0	47.0	46.8	57.7	66.3
	70	43.3	42.7	53.1	60.7	43.3	43.0	53.3	61.2	47.1	46.8	57.7	66.3
	75	46.6	46.1	56.9	65.0	46.7	46.2	57.0	65.1	47.4	47.1	58.0	66.5
5500	60	40.1	39.7	48.6	55.5	44.0	43.6	53.2	60.5	48.0	47.7	57.8	65.7
	65	41.6	41.0	50.2	56.9	44.1	43.7	53.3	60.5	48.1	47.8	57.9	65.7
	70	45.1	44.5	54.2	61.2	45.1	44.2	54.3	60.9	48.2	47.9	58.0	65.7
	75	48.5	48.0	58.1	65.5	48.6	48.1	58.2	65.6	48.6	48.3	58.3	66.1
6000	60	41.0	40.6	48.9	55.2	44.9	44.5	53.4	60.1	48.9	48.5	58.0	65.2
	65	43.1	42.5	51.2	57.3	45.0	44.7	53.5	60.1	49.0	48.7	58.0	65.2
	70	46.6	46.1	55.2	61.6	46.7	46.2	55.2	61.7	49.1	48.8	58.1	65.3
	75	50.2	49.6	59.1	66.0	50.2	49.7	59.2	66.1	50.3	49.8	59.3	66.2
Ambient DB 65°F													
3750	60	35.4	35.0	47.1	57.2	39.3	39.0	52.0	62.6	43.3	43.4	57.0	68.1
	65	35.4	35.0	47.1	57.2	39.3	39.1	52.0	62.6	43.3	43.4	56.9	68.1
	70	37.3	36.8	49.4	59.4	39.3	39.1	52.0	62.6	43.3	43.4	56.9	68.1
	75	40.4	40.1	53.1	63.6	40.5	40.2	53.2	63.8	43.4	43.4	56.9	68.1
4500	60	38.0	37.5	48.2	56.2	41.9	41.4	52.9	61.4	45.9	45.6	57.7	66.8
	65	38.2	37.7	48.4	56.4	41.9	41.5	53.0	61.4	45.9	45.6	57.7	66.8
	70	41.5	40.8	52.2	60.2	42.2	41.7	53.1	61.5	46.0	45.7	57.8	66.8
	75	44.7	44.1	56.0	64.4	44.8	44.2	56.1	64.5	46.2	45.9	57.9	66.9
5000	60	39.2	38.8	48.6	55.8	43.1	42.7	53.2	60.8	47.1	46.8	57.9	66.1
	65	40.2	39.1	49.5	56.1	43.2	42.8	53.3	60.8	47.2	46.8	57.9	66.1
	70	43.6	42.9	53.5	60.7	43.5	43.1	53.5	61.1	47.3	46.9	58.0	66.1
	75	46.9	46.3	57.3	64.9	47.0	46.4	57.4	65.0	47.6	47.2	58.2	66.3
5500	60	40.2	39.8	48.9	55.4	44.1	43.8	53.4	60.3	48.1	47.8	58.0	65.5
	65	41.9	41.2	50.6	56.9	44.2	43.9	53.5	60.3	48.2	47.9	58.1	65.5
	70	45.3	44.7	54.6	61.1	45.4	44.8	54.6	61.2	48.3	48.0	58.2	65.5
	75	48.8	48.2	58.5	65.5	48.9	48.3	58.6	65.6	48.7	48.4	58.5	65.9
6000	60	41.1	40.8	49.1	55.1	45.0	44.7	53.6	59.9	49.0	48.6	58.1	65.0
	65	43.3	42.8	51.5	57.2	45.1	44.8	53.7	59.9	49.1	48.8	58.2	65.0
	70	46.9	46.3	55.5	61.5	47.0	46.4	55.6	61.6	49.2	48.9	58.3	65.1
	75	50.4	49.8	59.5	65.9	50.5	49.9	59.6	66.0	50.6	50.0	59.6	66.1
Ambient DB 70°F													



Reheat Temperature Rise

Table 39. Reheat temperature rise - 12.5 tons, ultra high efficiency (continued)

Airflow (cfm)	Ent DB (°F)	Entering Wet Bulb (°F)											
		51				55				59			
		Lvg Evap DB (°F)		Lvg Reheat DB (°F)		Lvg Evap DB (°F)		Lvg Reheat DB (°F)		Lvg Evap DB (°F)		Lvg Reheat DB (°F)	
		MIN	MAX	MIN	MAX	MIN	MAX	MIN	MAX	MIN	MAX	MIN	MAX
3750	60	35.4	35.0	47.1	57.2	39.3	39.0	52.0	62.6	43.3	43.4	57.0	68.1
	65	35.4	35.0	47.1	57.2	39.3	39.1	52.0	62.6	43.3	43.4	56.9	68.1
	70	37.3	36.8	49.4	59.4	39.3	39.1	52.0	62.6	43.3	43.4	56.9	68.1
	75	40.4	40.1	53.1	63.6	40.5	40.2	53.2	63.8	43.4	43.4	56.9	68.1
4500	60	38.2	37.7	48.5	56.1	42.1	41.6	53.2	61.2	46.1	45.7	58.0	66.6
	65	38.4	37.9	48.7	56.3	42.1	41.7	53.3	61.2	46.1	45.7	58.0	66.5
	70	41.8	41.0	52.6	60.1	42.4	41.9	53.4	61.4	46.2	45.8	58.0	66.5
	75	45.1	44.3	56.5	64.3	45.2	44.4	56.6	64.4	46.4	46.0	58.2	66.7
5000	60	39.4	38.9	48.9	55.7	43.3	42.9	53.5	60.6	47.3	46.9	58.1	65.8
	65	40.5	39.7	49.9	56.4	43.4	42.9	53.5	60.6	47.4	47.0	58.2	65.8
	70	43.9	43.1	53.9	60.6	43.7	43.3	53.8	60.9	47.4	47.0	58.2	65.9
	75	47.2	46.5	57.7	64.8	47.3	46.6	57.8	64.9	47.8	47.3	58.5	66.1
5500	60	40.4	40.0	49.1	55.3	44.3	43.9	53.7	60.1	48.3	47.9	58.2	65.3
	65	42.1	41.5	50.9	56.8	44.4	44.0	53.8	60.2	48.4	48.0	58.3	65.3
	70	45.6	45.0	54.9	61.1	45.7	45.0	55.0	61.1	48.5	48.1	58.4	65.3
	75	49.1	48.4	58.8	65.4	49.2	48.5	58.9	65.5	48.9	48.5	58.7	65.7
6000	60	41.4	40.9	49.5	55.0	45.2	44.8	53.9	59.7	49.1	48.8	58.3	64.8
	65	43.6	43.0	51.8	57.2	45.3	44.9	53.9	59.8	49.3	48.9	58.4	64.8
	70	47.2	46.5	55.8	61.5	47.2	46.6	55.9	61.5	49.4	49.0	58.5	64.8
	75	50.7	50.1	59.8	65.9	50.8	50.2	59.9	65.9	50.9	50.2	60.0	66.0

Note: MIN, MAX: The leaving evaporator temperature is affected by the modulating valve position. The MIN and MAX numbers represent modulating valve position impact on both the leaving evaporator temperature and the leaving reheat coil temperature. MAX represents wide open, MIN represents closed to minimum position.

Table 40. Reheat temperature rise - 15 tons, ultra high efficiency

Airflow (cfm)	Ent DB (°F)	Entering Wet Bulb (°F)											
		51				55				59			
		Lvg Evap DB (°F)		Lvg Reheat DB (°F)		Lvg Evap DB (°F)		Lvg Reheat DB (°F)		Lvg Evap DB (°F)		Lvg Reheat DB (°F)	
		MIN	MAX	MIN	MAX	MIN	MAX	MIN	MAX	MIN	MAX	MIN	MAX
Ambient DB 60°F													
4500	60	35.7	35.3	48.2	57.5	39.5	39.2	52.8	62.8	43.5	43.4	57.6	68.3
	65	36.0	35.4	48.4	57.6	39.7	39.4	52.9	62.9	43.6	43.5	57.6	68.3
	70	38.0	37.4	50.6	59.9	39.8	39.5	53.0	62.9	43.8	43.7	57.8	68.4
	75	41.1	40.6	54.3	64.1	41.2	40.7	54.4	64.2	43.9	43.8	57.8	68.4
5400	60	38.2	37.8	48.8	56.6	42.1	41.8	53.4	61.7	45.9	45.5	57.9	67.1
	65	38.6	38.2	49.2	57.0	42.2	41.8	53.5	61.9	46.2	45.9	58.2	67.2
	70	41.8	41.3	52.8	60.7	42.6	42.2	53.9	62.2	46.3	46.0	58.3	67.3
	75	45.1	44.6	56.6	65.0	45.2	44.7	56.7	65.1	46.7	46.3	58.6	67.6
6000	60	39.5	39.1	49.2	56.2	43.4	43.0	53.7	61.2	47.1	46.7	58.1	66.4
	65	40.0	39.7	49.7	56.7	43.5	43.1	53.8	61.4	47.5	47.2	58.4	66.5
	70	43.9	43.4	54.0	61.2	44.0	43.7	54.3	61.8	47.6	47.3	58.5	66.7
	75	47.3	46.8	57.9	65.5	47.4	46.9	58.0	65.6	48.1	47.8	58.9	67.1
6600	60	40.5	40.2	49.5	55.8	44.5	44.1	53.9	60.7	48.1	47.8	58.2	65.9
	65	42.2	41.7	51.1	57.2	44.6	44.2	54.1	60.9	48.6	48.2	58.6	66.0
	70	45.7	45.2	55.0	61.6	45.3	44.9	54.6	61.5	48.7	48.4	58.7	66.2
	75	49.2	48.7	59.0	66.1	49.3	48.8	59.1	66.2	49.4	49.0	59.2	66.7
7200	60	41.5	41.2	49.8	55.6	45.4	45.1	54.2	60.4	49.0	48.6	58.3	65.4
	65	43.7	43.2	51.9	57.6	45.5	45.2	54.3	60.6	49.5	49.2	58.8	65.6
	70	47.3	46.8	56.0	62.1	47.4	46.8	56.0	62.1	49.6	49.3	58.9	65.8
	75	50.9	50.3	60.0	66.5	51.0	50.4	60.1	66.6	50.4	50.1	59.5	66.4
Ambient DB 65°F													
4500	60	35.9	35.5	48.5	57.4	39.7	39.3	53.1	62.6	43.7	43.3	57.9	68.3
	65	36.2	35.7	48.7	57.7	39.9	39.5	53.3	62.8	43.8	43.4	57.9	68.3
	70	38.3	37.6	51.0	59.9	40.0	39.6	53.3	62.8	44.0	43.7	58.1	68.4
	75	41.4	40.8	54.7	64.1	41.5	40.9	54.8	64.2	44.1	43.7	58.2	68.5
5400	60	38.4	37.9	49.1	56.5	42.3	41.9	53.7	61.6	46.1	45.6	58.2	67.0
	65	38.8	38.4	49.5	56.9	42.4	42.0	53.8	61.7	46.4	46.0	58.4	67.0
	70	42.1	41.5	53.2	60.6	42.8	42.4	54.1	62.1	46.5	46.1	58.5	67.2
	75	45.4	44.8	57.0	64.9	45.5	44.9	57.1	65.1	46.9	46.5	58.9	67.5
6000	60	39.6	39.2	49.5	56.1	43.6	43.2	53.9	61.0	47.3	46.9	58.3	66.3
	65	40.2	39.8	49.9	56.6	43.7	43.3	54.1	61.2	47.7	47.3	58.6	66.4
	70	44.2	43.6	54.3	61.1	44.2	43.8	54.5	61.7	47.8	47.4	58.7	66.6
	75	47.6	47.0	58.2	65.5	47.7	47.1	58.3	65.6	48.3	47.9	59.2	67.0
6600	60	40.7	40.3	49.7	55.7	44.6	44.3	54.2	60.6	48.3	47.9	58.4	65.7
	65	42.4	41.9	51.4	57.2	44.7	44.4	54.3	60.8	48.7	48.4	58.8	65.9
	70	46.0	45.4	55.4	61.6	45.4	45.0	54.8	61.4	48.9	48.5	58.9	66.1
	75	49.5	48.9	59.3	66.0	49.6	49.0	59.4	66.1	49.5	49.1	59.5	66.6
7200	60	41.6	41.3	50.0	55.5	45.6	45.2	54.4	60.3	49.2	48.8	58.5	65.3
	65	43.9	43.4	52.2	57.6	45.7	45.3	54.5	60.5	49.7	49.3	59.0	65.5
	70	47.5	47.0	56.3	62.0	47.6	47.1	56.4	62.1	49.8	49.4	59.1	65.7
	75	51.2	50.5	60.3	66.5	51.3	50.6	60.4	66.6	51.3	50.2	60.5	66.3
Ambient DB 70°F													



Reheat Temperature Rise

Table 40. Reheat temperature rise - 15 tons, ultra high efficiency (continued)

Airflow (cfm)	Ent DB (°F)	Entering Wet Bulb (°F)											
		51				55				59			
		Lvg Evap DB (°F)		Lvg Reheat DB (°F)		Lvg Evap DB (°F)		Lvg Reheat DB (°F)		Lvg Evap DB (°F)		Lvg Reheat DB (°F)	
		MIN	MAX	MIN	MAX	MIN	MAX	MIN	MAX	MIN	MAX	MIN	MAX
4500	60	36.2	35.6	48.9	57.4	39.9	39.4	53.4	62.5	43.9	43.4	58.2	68.2
	65	36.4	35.9	49.1	57.6	40.1	39.6	53.6	62.6	44.0	43.5	58.3	68.1
	70	38.6	37.9	51.5	59.9	40.2	39.7	53.7	62.7	44.2	43.8	58.4	68.3
	75	41.7	41.0	55.2	64.0	41.8	41.1	55.3	64.1	44.3	43.8	58.5	68.3
5400	60	38.6	38.1	49.4	56.5	42.5	42.1	54.0	61.5	46.3	45.8	58.4	66.9
	65	39.0	38.6	49.8	56.8	42.6	42.1	54.1	61.6	46.6	46.1	58.7	66.9
	70	42.4	41.7	53.6	60.6	43.0	42.5	54.4	62.0	46.7	46.2	58.8	67.1
	75	45.7	45.0	57.4	64.9	45.8	45.1	57.5	65.0	47.1	46.6	59.1	67.4
6000	60	39.8	39.4	49.7	56.0	43.7	43.3	54.2	60.9	47.5	47.0	58.5	66.2
	65	41.0	40.0	50.8	56.5	43.8	43.4	54.3	61.1	47.8	47.4	58.9	66.3
	70	44.5	43.8	54.7	61.1	44.4	44.0	54.8	61.6	48.0	47.5	59.0	66.5
	75	47.9	47.2	58.6	65.5	48.0	47.3	58.7	65.6	48.5	48.0	59.4	66.9
6600	60	40.9	40.5	50.0	55.7	44.8	44.4	54.4	60.5	48.5	48.0	58.6	65.6
	65	42.7	42.1	51.7	57.2	44.9	44.5	54.5	60.7	48.9	48.5	59.0	65.8
	70	46.2	45.6	55.7	61.6	46.3	45.2	55.8	61.3	49.0	48.6	59.1	66.0
	75	49.8	49.1	59.7	66.0	49.9	49.2	59.8	66.1	49.7	49.3	59.7	66.5
7200	60	41.8	41.4	50.2	55.4	45.7	45.4	54.6	60.2	49.3	48.9	58.7	65.1
	65	44.1	43.6	52.6	57.6	45.8	45.5	54.7	60.4	49.8	49.5	59.2	65.4
	70	47.8	47.2	56.6	62.1	47.9	47.3	56.7	62.2	49.9	49.6	59.3	65.5
	75	51.5	50.8	60.6	66.5	51.5	50.8	60.7	66.6	51.6	50.3	60.8	66.2

Note: MIN, MAX: The leaving evaporator temperature is affected by the modulating valve position. The MIN and MAX numbers represent modulating valve position impact on both the leaving evaporator temperature and the leaving reheat coil temperature. MAX represents wide open, MIN represents closed to minimum position.

Table 41. Reheat temperature rise - 17.5 tons, ultra high efficiency

Airflow (cfm)	Ent DB (°F)	Entering Wet Bulb (°F)											
		51				55				59			
		Lvg Evap DB (°F)		Lvg Reheat DB (°F)		Lvg Evap DB (°F)		Lvg Reheat DB (°F)		Lvg Evap DB (°F)		Lvg Reheat DB (°F)	
		MIN	MAX	MIN	MAX	MIN	MAX	MIN	MAX	MIN	MAX	MIN	MAX
Ambient DB 60°F													
5250	60	36.0	35.5	45.9	56.3	39.6	39.2	50.3	61.5	43.6	43.6	55.1	67.0
	65	36.5	36.0	46.3	56.6	39.9	39.5	50.6	61.7	43.6	43.5	55.0	66.9
	70	38.5	37.9	48.5	58.8	40.2	39.8	50.8	61.9	43.9	43.8	55.2	67.1
	75	41.5	41.1	52.1	63.0	41.6	40.9	52.1	62.9	44.2	43.8	55.5	67.1
6300	60	38.4	38.0	47.0	55.7	42.0	41.6	51.2	60.6	46.0	45.7	55.8	66.1
	65	39.2	38.8	47.7	56.3	42.4	42.0	51.5	60.9	46.1	45.7	55.8	66.0
	70	42.2	41.7	51.0	59.7	43.1	42.7	52.1	61.5	46.4	46.1	56.1	66.3
	75	45.5	45.0	54.6	64.0	45.6	45.1	54.7	64.1	47.0	46.8	56.7	66.8
7000	60	39.7	39.3	47.5	55.4	43.2	42.9	51.6	60.2	47.2	46.8	56.1	65.5
	65	40.6	40.2	48.3	56.1	43.7	43.3	52.0	60.5	47.4	47.0	56.3	65.6
	70	44.2	43.7	52.3	60.3	44.6	44.2	52.8	61.3	47.7	47.4	56.6	65.9
	75	47.6	47.1	56.0	64.6	47.7	47.2	56.1	64.7	48.6	48.2	57.3	66.5
7700	60	40.7	40.4	48.0	55.1	44.3	44.0	52.1	59.9	48.2	47.8	56.4	65.0
	65	42.5	41.9	49.6	56.4	44.8	44.4	52.4	60.2	48.5	48.1	56.6	65.2
	70	46.0	45.5	53.4	60.8	45.8	45.5	53.4	61.1	48.9	48.5	57.0	65.5
	75	49.4	48.9	57.3	65.2	49.5	49.0	57.3	65.3	49.9	49.5	57.9	66.3
8400	60	41.6	41.4	48.3	54.9	45.2	44.9	52.4	59.6	49.0	48.7	56.7	64.6
	65	43.9	43.5	50.6	56.9	45.7	45.4	52.8	59.9	49.4	49.0	56.9	64.8
	70	47.5	47.0	54.4	61.3	47.6	46.9	54.5	61.2	49.8	49.5	57.3	65.1
	75	51.0	50.5	58.3	65.7	51.1	50.6	58.4	65.8	51.0	50.6	58.3	66.1
Ambient DB 65°F													
5250	60	36.5	35.7	40.8	56.2	40.1	39.3	44.8	61.4	44.2	43.5	49.3	67.1
	65	37.0	36.0	41.3	56.4	40.4	39.6	45.1	61.6	44.2	43.4	49.2	67.0
	70	39.2	38.1	43.6	58.8	40.8	40.0	45.5	61.8	44.5	43.7	49.5	67.2
	75	42.3	41.2	47.0	63.0	42.4	41.2	47.1	63.0	44.8	44.0	49.7	67.4
6300	60	38.9	38.1	42.6	55.6	42.5	41.7	46.5	60.5	46.5	45.7	50.8	66.0
	65	39.7	38.9	43.4	56.2	42.8	42.1	46.9	60.8	46.6	45.8	50.9	66.0
	70	42.9	41.9	46.8	59.7	43.6	42.8	47.6	61.4	47.0	46.2	51.2	66.3
	75	46.2	45.1	50.3	64.0	46.3	45.2	50.4	64.1	47.6	46.8	51.9	66.8
7000	60	40.1	39.4	43.5	55.3	43.8	43.0	47.4	60.1	47.7	46.9	51.6	65.4
	65	41.1	40.4	44.5	56.1	44.1	43.4	47.8	60.4	47.9	47.1	51.8	65.5
	70	44.9	43.9	48.5	60.3	45.0	44.3	48.6	61.2	48.2	47.5	52.1	65.8
	75	48.3	47.3	52.1	64.6	48.4	47.4	52.2	64.7	49.1	48.3	52.9	66.4
7700	60	41.1	40.5	44.3	55.0	44.8	44.1	48.2	59.8	48.7	47.9	52.3	64.9
	65	43.1	42.2	46.2	56.5	45.2	44.6	48.6	60.1	48.9	48.2	52.5	65.0
	70	46.6	45.7	49.9	60.8	46.4	45.6	49.7	61.0	49.3	48.6	52.9	65.3
	75	50.2	49.1	53.6	65.2	50.3	49.2	53.7	65.3	50.3	49.6	53.9	66.2
8400	60	42.0	41.5	45.0	54.8	45.6	45.0	48.8	59.5	49.5	48.8	52.9	64.5
	65	44.5	43.7	47.4	57.0	46.1	45.5	49.2	59.8	49.8	49.1	53.2	64.7
	70	48.1	47.2	51.2	61.3	48.2	46.7	51.3	60.8	50.3	49.6	53.6	65.0
	75	51.8	50.7	55.0	65.7	51.9	50.8	55.1	65.8	51.5	50.8	54.7	65.9
Ambient DB 70°F													



Reheat Temperature Rise

Table 41. Reheat temperature rise - 17.5 tons, ultra high efficiency (continued)

Airflow (cfm)	Ent DB (°F)	Entering Wet Bulb (°F)											
		51				55				59			
		Lvg Evap DB (°F)		Lvg Reheat DB (°F)		Lvg Evap DB (°F)		Lvg Reheat DB (°F)		Lvg Evap DB (°F)		Lvg Reheat DB (°F)	
		MIN	MAX	MIN	MAX	MIN	MAX	MIN	MAX	MIN	MAX	MIN	MAX
5250	60	36.8	35.8	41.2	56.1	40.4	39.5	45.2	61.3	44.5	43.6	49.6	67.0
	65	37.3	36.3	41.7	56.5	40.7	39.8	45.4	61.5	44.5	43.5	49.5	66.9
	70	39.6	38.4	44.1	58.8	41.1	40.1	45.8	61.7	44.8	43.8	49.8	67.1
	75	42.7	41.4	47.4	62.9	42.8	41.1	47.6	62.6	45.0	44.1	50.0	67.3
6300	60	39.1	38.3	42.9	55.5	42.7	41.9	46.8	60.4	46.7	45.9	51.1	65.9
	65	39.9	39.1	43.7	56.1	43.1	42.3	47.2	60.7	46.9	45.9	51.2	65.8
	70	43.3	42.1	47.2	59.7	43.8	43.0	47.9	61.3	47.2	46.3	51.5	66.1
	75	46.6	45.4	50.7	64.0	46.7	45.5	50.8	64.1	47.9	47.0	52.1	66.6
7000	60	40.3	39.6	43.8	55.2	44.0	43.2	47.7	60.0	47.9	47.1	51.9	65.3
	65	41.4	40.5	44.8	56.0	44.3	43.6	48.0	60.3	48.1	47.3	52.1	65.3
	70	45.2	44.1	48.8	60.3	45.3	44.5	48.9	61.1	48.5	47.7	52.4	65.6
	75	48.7	47.5	52.5	64.6	48.8	47.6	52.6	64.7	49.3	48.5	53.2	66.3
7700	60	41.3	40.7	44.6	55.0	45.0	44.3	48.4	59.7	48.9	48.1	52.5	64.8
	65	43.4	42.4	46.6	56.5	45.4	44.7	48.8	60.0	49.1	48.4	52.8	64.9
	70	46.9	45.9	50.3	60.8	46.7	45.8	50.0	60.9	49.5	48.8	53.1	65.2
	75	50.5	49.3	54.0	65.2	50.6	49.4	54.1	65.3	50.6	49.8	54.1	66.0
8400	60	42.4	41.6	45.3	54.8	45.8	45.2	49.0	59.4	49.7	48.9	53.1	64.4
	65	44.8	43.9	47.7	57.0	46.4	45.7	49.6	59.8	50.0	49.3	53.4	64.6
	70	48.4	47.4	51.5	61.3	48.5	47.5	51.6	61.4	50.5	49.7	53.8	64.9
	75	52.1	51.0	55.4	65.7	52.2	51.0	55.5	65.8	52.3	50.9	55.5	65.8

MIN, MAX: The leaving evaporator temperature is affected by the modulating valve position. The MIN and MAX numbers represent modulating valve position impact on both the leaving evaporator temperature and the leaving reheat coil temperature. MAX represents wide open, MIN represents closed to minimum position.

Table 42. Reheat temperature rise - 20 tons, ultra high efficiency

Airflow (cfm)	Ent DB (°F)	Entering Wet Bulb (°F)											
		51				55				59			
		Lvg Evap DB (°F)		Lvg Reheat DB (°F)		Lvg Evap DB (°F)		Lvg Reheat DB (°F)		Lvg Evap DB (°F)		Lvg Reheat DB (°F)	
		MIN	MAX	MIN	MAX	MIN	MAX	MIN	MAX	MIN	MAX	MIN	MAX
Ambient DB 60°F													
6000	60	36.4	36.0	46.9	60.6	39.9	39.7	50.9	65.7	43.8	43.8	55.4	71.5
	65	37.2	36.7	47.6	61.0	40.3	40.1	51.4	66.1	43.8	43.9	55.4	71.4
	70	39.4	38.9	49.7	63.3	40.8	40.6	51.8	66.4	44.3	44.3	55.9	71.8
	75	42.4	42.1	53.1	67.6	42.0	41.9	52.8	67.6	44.8	44.8	56.3	72.1
7200	60	38.9	38.5	47.8	59.4	42.2	41.9	51.6	64.3	45.9	45.8	55.8	69.6
	65	39.9	39.5	48.7	60.2	42.8	42.6	52.2	64.8	46.2	46.1	56.2	69.8
	70	42.9	42.5	51.9	63.6	43.8	43.5	53.1	65.5	46.8	46.7	56.7	70.3
	75	46.2	45.9	55.5	68.0	46.3	46.0	55.6	68.2	47.7	47.6	57.5	71.0
8000	60	40.1	39.8	48.3	58.8	43.5	43.2	52.1	63.6	47.2	47.1	56.3	68.9
	65	41.4	41.0	49.4	59.8	44.1	43.9	52.7	64.1	47.6	47.5	56.7	69.1
	70	44.9	44.5	53.1	63.9	45.3	45.0	53.7	65.0	48.1	48.0	57.2	69.5
	75	48.2	48.0	56.8	68.3	48.3	48.1	56.8	68.4	49.2	49.1	58.1	70.4
8800	60	41.2	40.9	48.7	58.3	44.6	44.3	52.5	63.0	48.1	48.0	56.5	68.1
	65	42.7	42.4	49.9	59.6	45.2	45.0	53.1	63.6	48.7	48.5	57.0	68.4
	70	46.6	46.2	54.1	64.2	46.5	46.3	54.2	64.6	49.3	49.1	57.6	68.9
	75	50.0	49.8	57.9	68.6	50.1	49.9	58.0	68.7	50.5	50.4	58.7	69.9
9600	60	42.1	41.9	49.1	57.9	45.5	45.2	52.8	62.6	49.0	48.8	56.7	67.5
	65	44.5	44.1	51.2	59.9	46.2	45.9	53.5	63.1	49.6	49.4	57.3	67.8
	70	48.0	47.7	55.1	64.4	47.5	47.4	54.6	64.2	50.2	50.1	57.9	68.4
	75	51.5	51.3	58.9	68.9	51.6	51.4	59.0	69.0	51.6	51.5	59.1	69.5
Ambient DB 65°F													
6000	60	36.9	36.1	41.6	60.5	40.3	39.7	45.1	65.8	44.2	43.8	49.2	71.5
	65	37.7	36.8	42.3	61.0	40.8	40.2	45.6	66.1	44.3	43.9	49.3	71.5
	70	40.0	39.0	44.6	63.3	41.3	40.6	46.1	66.4	44.7	44.4	49.7	71.8
	75	43.0	42.2	47.7	67.6	43.1	42.0	47.8	67.6	45.2	44.8	50.2	72.1
7200	60	39.3	38.6	43.2	59.4	42.6	42.0	46.7	64.3	46.4	45.8	50.7	69.6
	65	40.3	39.6	44.2	60.2	43.2	42.6	47.3	64.8	46.6	46.2	50.9	69.8
	70	43.5	42.7	47.4	63.7	44.2	43.6	48.2	65.5	47.2	46.8	51.5	70.3
	75	46.7	46.0	50.8	68.0	46.8	46.1	50.9	68.2	48.1	47.6	52.3	71.0
8000	60	40.5	39.9	44.1	58.8	43.9	43.3	47.7	63.5	47.5	47.1	51.4	68.8
	65	41.8	41.1	45.3	59.7	44.5	43.9	48.2	64.1	48.0	47.5	51.9	69.0
	70	45.4	44.7	49.0	63.9	45.6	45.1	49.3	65.0	48.5	48.1	52.4	69.5
	75	48.7	48.1	52.4	68.3	48.8	48.2	52.5	68.4	49.6	49.1	53.4	70.4
8800	60	41.6	41.0	44.9	58.3	44.9	44.4	48.4	63.0	48.5	48.1	52.1	68.1
	65	43.6	42.6	46.8	59.6	45.5	45.0	49.0	63.5	49.0	48.6	52.6	68.4
	70	47.1	46.4	50.4	64.2	46.9	46.4	50.2	64.5	49.6	49.2	53.2	68.9
	75	50.5	49.9	53.9	68.6	50.6	49.9	54.0	68.7	50.9	50.4	54.4	69.8
9600	60	42.5	42.0	45.6	57.9	45.8	45.3	49.0	62.5	49.3	48.9	52.6	67.4
	65	44.9	44.3	47.9	59.9	46.5	46.0	49.6	63.0	49.9	49.5	53.2	67.8
	70	48.5	47.8	51.5	64.4	48.6	47.5	51.6	64.2	50.6	50.1	53.8	68.3
	75	52.0	51.4	55.2	68.9	52.1	51.5	55.3	69.0	52.0	51.6	55.2	69.4
Ambient DB 70°F													



Reheat Temperature Rise

Table 42. Reheat temperature rise - 20 tons, ultra high efficiency (continued)

Airflow (cfm)	Ent DB (°F)	Entering Wet Bulb (°F)											
		51				55				59			
		Lvg Evap DB (°F)		Lvg Reheat DB (°F)		Lvg Evap DB (°F)		Lvg Reheat DB (°F)		Lvg Evap DB (°F)		Lvg Reheat DB (°F)	
		MIN	MAX	MIN	MAX	MIN	MAX	MIN	MAX	MIN	MAX	MIN	MAX
6000	60	37.2	36.3	42.0	60.5	40.6	39.8	45.6	65.7	44.5	43.8	49.6	71.5
	65	38.0	36.9	42.8	61.0	41.1	40.3	46.1	66.1	44.5	43.9	49.7	71.5
	70	40.4	39.2	45.1	63.4	41.7	40.8	46.6	66.4	45.0	44.4	50.2	71.8
	75	43.4	42.3	48.3	67.7	43.5	42.2	48.4	67.7	45.5	44.8	50.6	72.1
7200	60	39.5	38.7	43.6	59.4	42.9	42.1	47.1	64.3	46.6	45.9	51.0	69.6
	65	40.6	39.8	44.6	60.2	43.4	42.7	47.7	64.7	46.8	46.2	51.2	69.8
	70	43.9	42.8	47.9	63.7	44.4	43.7	48.6	65.5	47.4	46.8	51.8	70.3
	75	47.1	46.1	51.3	68.1	47.2	46.2	51.4	68.2	48.4	47.7	52.7	70.9
8000	60	40.7	40.0	44.5	58.8	44.2	43.4	48.0	63.5	47.7	47.1	51.7	68.8
	65	42.2	41.3	45.8	59.7	44.7	44.0	48.6	64.0	48.2	47.6	52.2	69.0
	70	45.7	44.8	49.5	63.9	45.9	45.2	49.7	64.9	48.7	48.1	52.7	69.5
	75	49.1	48.2	52.9	68.3	49.2	48.3	53.0	68.4	49.8	49.2	53.8	70.3
8800	60	41.8	41.1	45.2	58.3	45.1	44.5	48.7	62.9	48.7	48.1	52.3	68.0
	65	43.9	42.6	47.2	59.4	45.8	45.1	49.3	63.5	49.2	48.6	52.9	68.3
	70	47.4	46.5	50.8	64.2	47.2	46.5	50.6	64.5	49.8	49.2	53.5	68.8
	75	50.8	50.0	54.3	68.6	50.9	50.1	54.4	68.7	51.1	50.5	54.7	69.8
9600	60	42.7	42.1	45.9	57.9	46.0	45.4	49.3	62.4	49.5	48.9	52.9	67.4
	65	45.2	44.4	48.3	60.0	46.7	46.1	50.0	63.0	50.1	49.5	53.5	67.7
	70	48.8	48.0	51.9	64.4	48.9	47.7	52.0	64.2	50.7	50.2	54.1	68.2
	75	52.3	51.5	55.6	68.9	52.4	51.6	55.6	69.0	52.2	51.6	55.5	69.3

MIN, MAX: The leaving evaporator temperature is affected by the modulating valve position. The MIN and MAX numbers represent modulating valve position impact on both the leaving evaporator temperature and the leaving reheat coil temperature. MAX represents wide open, MIN represents closed to minimum position.

Table 43. Reheat temperature rise - 25 tons, ultra high efficiency

Airflow (cfm)	Ent DB (°F)	Entering Wet Bulb (°F)											
		51				55				59			
		Lvg Evap DB (°F)		Lvg Reheat DB (°F)		Lvg Evap DB (°F)		Lvg Reheat DB (°F)		Lvg Evap DB (°F)		Lvg Reheat DB (°F)	
		MIN	MAX	MIN	MAX	MIN	MAX	MIN	MAX	MIN	MAX	MIN	MAX
Ambient DB 60°F													
7500	60	38.5	37.9	42.6	59.7	41.6	41.2	45.9	64.5	45.3	45.1	49.8	69.8
	65	39.6	39.0	43.7	60.6	42.5	42.1	46.8	65.2	45.7	45.4	50.2	70.0
	70	42.4	41.8	46.4	63.4	43.2	42.8	47.5	65.7	46.5	46.3	51.0	70.7
	75	45.6	45.1	49.8	67.7	45.7	45.2	49.9	67.8	47.2	47.0	51.7	71.3
9000	60	40.8	40.3	44.3	58.8	43.9	43.4	47.6	63.3	47.3	47.0	51.2	68.3
	65	42.2	41.7	45.6	59.9	44.8	44.4	48.5	64.1	48.1	47.7	52.0	68.7
	70	45.7	45.2	49.2	63.8	46.1	45.7	49.7	65.2	48.9	48.6	52.7	69.5
	75	49.1	48.7	52.7	68.2	49.2	48.8	52.8	68.3	50.1	49.8	53.9	70.5
10000	60	42.0	41.5	45.2	58.4	45.3	44.9	48.6	62.8	48.5	48.2	52.1	67.7
	65	43.8	43.2	46.9	59.6	46.0	45.6	49.4	63.6	49.4	49.1	52.9	68.1
	70	47.5	47.0	50.7	64.1	47.6	47.2	50.8	64.8	50.2	49.8	53.6	68.9
	75	51.0	50.6	54.3	68.6	51.1	50.7	54.4	68.7	51.6	51.3	55.0	70.0
11000	60	43.0	42.6	45.9	58.0	46.3	45.9	49.3	62.3	49.4	49.0	52.7	67.0
	65	45.5	45.0	48.3	59.9	47.1	46.7	50.1	63.2	50.4	50.1	53.6	67.6
	70	49.1	48.6	52.0	64.4	48.8	48.4	51.7	64.4	51.2	50.9	54.4	68.4
	75	52.7	52.3	55.7	68.9	52.8	52.4	55.8	69.0	52.8	52.5	55.9	69.6
12000	60	44.0	43.5	46.6	57.7	47.1	46.7	50.0	61.9	50.1	49.8	53.2	66.5
	65	46.7	46.3	49.3	60.2	48.0	47.6	50.8	62.8	51.3	51.0	54.3	67.2
	70	50.4	50.0	53.1	64.7	50.5	50.1	53.2	64.7	52.1	51.8	55.1	68.0
	75	54.1	53.7	56.9	69.2	54.2	53.8	57.0	69.3	53.9	53.6	56.7	69.3
Ambient DB 65°F													
7500	60	38.7	38.0	43.0	59.7	41.9	41.2	46.3	64.5	45.7	45.1	50.3	69.8
	65	39.9	39.2	44.1	60.6	42.7	42.1	47.1	65.1	45.9	45.5	50.5	70.0
	70	42.7	41.9	46.9	63.4	43.7	43.0	48.1	65.8	46.8	46.3	51.4	70.7
	75	45.9	45.2	50.2	67.7	46.0	45.3	50.3	67.8	47.5	47.0	52.1	71.2
9000	60	41.0	40.4	44.6	58.8	44.2	43.5	48.0	63.2	47.5	47.0	51.5	68.3
	65	42.4	41.8	46.0	59.9	45.0	44.5	48.8	64.1	48.4	47.7	52.4	68.6
	70	46.0	45.3	49.6	63.8	46.4	45.8	50.1	65.1	49.1	48.6	53.0	69.5
	75	49.4	48.8	53.1	68.2	49.5	48.9	53.2	68.3	50.4	49.9	54.2	70.5
10000	60	42.2	41.6	45.5	58.3	45.5	45.0	48.9	62.7	48.7	48.2	52.3	67.6
	65	44.1	43.3	47.3	59.6	46.2	45.7	49.7	63.5	49.6	49.1	53.2	68.1
	70	47.8	47.2	51.1	64.1	47.8	47.3	51.1	64.7	50.4	49.9	53.9	68.9
	75	51.3	50.7	54.7	68.6	51.4	50.8	54.8	68.7	51.8	51.3	55.3	70.0
11000	60	43.2	42.7	46.2	58.0	46.5	46.0	49.6	62.3	49.6	49.1	52.9	67.0
	65	45.7	45.1	48.6	59.9	47.3	46.8	50.4	63.1	50.6	50.1	53.9	67.6
	70	49.3	48.7	52.4	64.4	48.9	48.5	52.0	64.4	51.4	51.0	54.7	68.4
	75	53.0	52.4	56.1	68.9	53.0	52.5	56.2	69.0	53.0	52.6	56.2	69.6
12000	60	44.1	43.6	46.9	57.7	47.3	46.8	50.2	61.9	50.3	49.8	53.4	66.4
	65	47.0	46.4	49.7	60.2	48.2	47.7	51.1	62.7	51.5	51.0	54.5	67.1
	70	50.7	50.1	53.5	64.7	50.7	50.2	53.5	64.7	52.4	51.9	55.4	67.9
	75	54.4	53.8	57.3	69.2	54.5	53.9	57.3	69.3	54.2	53.7	57.1	69.2
Ambient DB 70°F													



Reheat Temperature Rise

Table 43. Reheat temperature rise - 25 tons, ultra high efficiency (continued)

Airflow (cfm)	Ent DB (°F)	Entering Wet Bulb (°F)											
		51				55				59			
		Lvg Evap DB (°F)		Lvg Reheat DB (°F)		Lvg Evap DB (°F)		Lvg Reheat DB (°F)		Lvg Evap DB (°F)		Lvg Reheat DB (°F)	
		MIN	MAX	MIN	MAX	MIN	MAX	MIN	MAX	MIN	MAX	MIN	MAX
7500	60	39.0	38.2	43.4	59.7	42.1	41.3	46.7	64.4	45.7	45.1	50.5	69.8
	65	40.1	39.3	44.5	60.6	43.0	42.2	47.5	65.1	46.2	45.5	50.9	70.0
	70	43.0	42.0	47.4	63.4	44.0	43.0	48.5	65.6	47.0	46.4	51.8	70.7
	75	46.3	45.3	50.7	67.7	46.4	45.4	50.8	67.8	47.8	47.1	52.5	71.2
9000	60	41.2	40.5	44.9	58.8	44.5	43.6	48.3	63.2	47.8	47.1	51.9	68.2
	65	42.7	42.0	46.3	59.9	45.2	44.6	49.1	64.0	48.7	47.8	52.7	68.6
	70	46.3	45.5	50.0	63.8	46.6	45.9	50.4	65.1	49.3	48.7	53.4	69.4
	75	49.7	48.9	53.6	68.2	49.8	49.0	53.7	68.3	50.6	50.0	54.6	70.4
10000	60	42.4	41.7	45.8	58.3	45.7	45.1	49.2	62.7	48.9	48.3	52.6	67.6
	65	44.5	43.4	47.8	59.6	46.4	45.8	50.0	63.5	49.8	49.2	53.5	68.0
	70	48.1	47.3	51.5	64.1	48.0	47.4	51.4	64.6	50.6	50.0	54.2	68.8
	75	51.6	50.8	55.1	68.6	51.7	50.9	55.2	68.7	52.0	51.4	55.6	69.9
11000	60	43.4	42.8	46.5	57.9	46.7	46.1	49.9	62.2	49.7	49.2	53.1	66.9
	65	46.0	45.2	49.0	60.0	47.4	46.9	50.7	63.0	50.8	50.2	54.2	67.5
	70	49.6	48.9	52.7	64.4	49.1	48.6	52.2	64.3	51.6	51.0	55.0	68.3
	75	53.2	52.5	56.5	68.9	53.3	52.6	56.5	69.0	53.2	52.7	56.5	69.5
12000	60	44.4	43.6	47.2	57.6	47.5	46.9	50.5	61.8	50.4	49.9	53.6	66.4
	65	47.2	46.5	50.0	60.2	48.4	47.8	51.4	62.7	51.7	51.1	54.8	67.1
	70	50.9	50.3	53.8	64.7	51.0	50.3	53.9	64.7	52.6	52.0	55.7	67.9
	75	54.6	53.9	57.6	69.2	54.7	54.0	57.7	69.2	54.6	53.8	57.6	69.2

MIN, MAX: The leaving evaporator temperature is affected by the modulating valve position. The MIN and MAX numbers represent modulating valve position impact on both the leaving evaporator temperature and the leaving reheat coil temperature. MAX represents wide open, MIN represents closed to minimum position.



Evaporator Fan Performance — Cooling

Table 44. Fan curve limits

Unit Size (tons)	Efficiency	Motor	Maximum			
			hp	rpm	CFM (cfm/ton)	ESP
3 to 5	Ultra High	Std	3.0	1850	480	2.0 in H ₂ O @ 400 cfm/ton
5 to 10	Ultra High	Std	3.0	1850	480	2.0 in H ₂ O @ 400 cfm/ton
12.5	Ultra High	Std	4.55	1940	480	2.0 in H ₂ O @ 400 cfm/ton
12.5 to 25	Ultra High	Std	6	1850	480	2.0 in H ₂ O @ 400 cfm/ton
25	Ultra High	High Static	9.1	1940	480	2.0 in H ₂ O @ 400 cfm/ton

The fan curve graphs include standard filter and a wet indoor coil. ESP capability is reduced with options based on the accessory table component pressure drop. To determine ESP at rpm/cfm and other options/accessories, select intersection point of the RPM vs CFM and then reduce ESP shown in graph by the sum of additional option static pressure drop listed in the fan performance accessory table section.

Downflow

Figure 1. Fan curves – 3 to 5 tons (model TZK), downflow

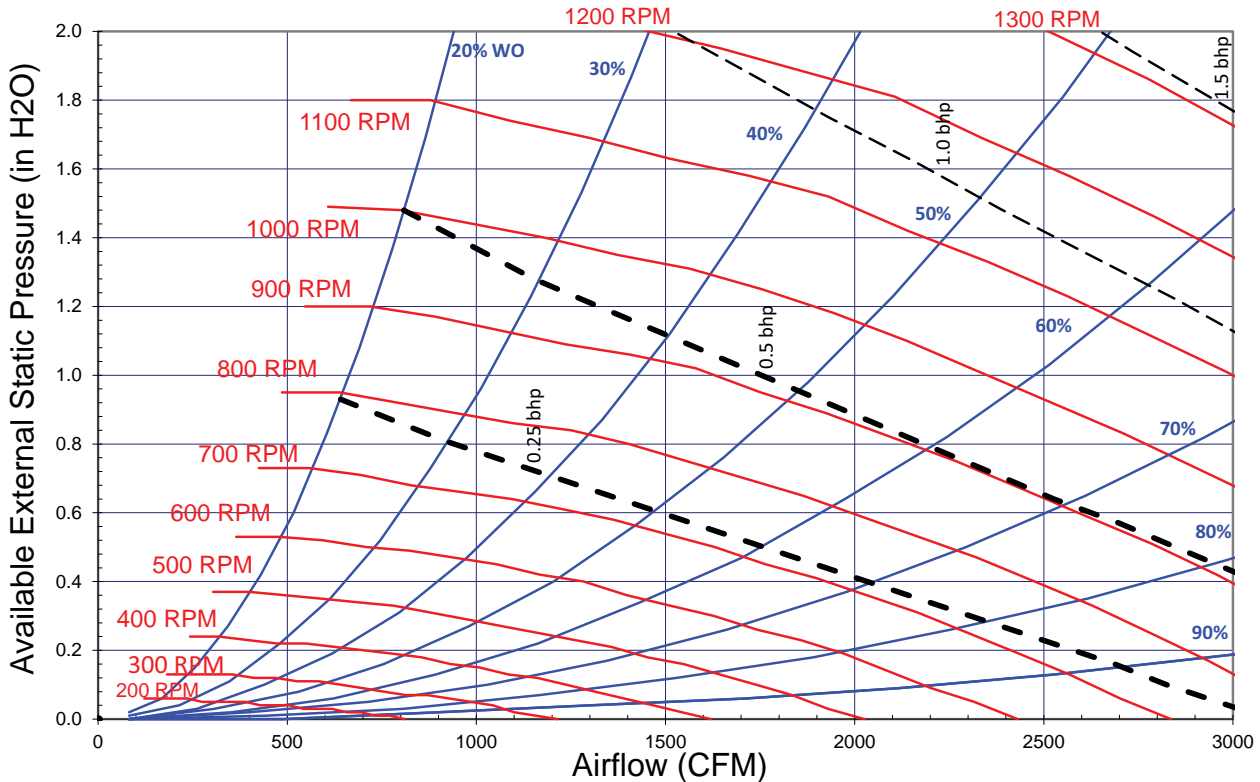



Evaporator Fan Performance — Cooling

Table 45. Evaporator fan performance – 3 ton (model TZK), downflow

Available External Static Pressure (Inches of Water Gauge)																				
CFM	0.10		0.20		0.30		0.40		0.50		0.60		0.70		0.80		0.90		1.00	
	RPM	BHP	RPM	BHP	RPM	BHP	RPM	BHP	RPM	BHP	RPM	BHP	RPM	BHP	RPM	BHP	RPM	BHP	RPM	BHP
900	340	0.03	425	0.05	494	0.08	556	0.11	613	0.14	665	0.17	713	0.21	757	0.24	799	0.28	839	0.32
960	350	0.03	433	0.05	502	0.08	561	0.11	618	0.14	670	0.18	718	0.21	762	0.25	804	0.29	843	0.33
1080	371	0.03	451	0.06	518	0.09	576	0.12	628	0.16	679	0.19	727	0.23	771	0.27	813	0.31	853	0.35
1200	392	0.04	469	0.07	534	0.10	592	0.14	643	0.17	690	0.21	736	0.25	781	0.29	822	0.33	862	0.38
1320	415	0.05	489	0.08	552	0.11	608	0.15	659	0.19	705	0.23	748	0.27	790	0.31	832	0.35	871	0.40
1440	439	0.06	509	0.09	570	0.13	625	0.16	675	0.20	721	0.24	763	0.29	803	0.33	841	0.38	881	0.43
Available External Static Pressure (Inches of Water Gauge)																				
CFM	1.10		1.20		1.30		1.40		1.50		1.60		1.70		1.80		1.90		2.00	
	RPM	BHP	RPM	BHP	RPM	BHP	RPM	BHP	RPM	BHP	RPM	BHP	RPM	BHP	RPM	BHP	RPM	BHP	RPM	BHP
900	876	0.36	912	0.4	947	0.45	980	0.49	1012	0.53	1043	0.58	1073	0.63	1102	0.68	1132	0.73	1161	0.78
960	881	0.37	917	0.41	951	0.46	984	0.5	1016	0.55	1047	0.6	1077	0.65	1107	0.69	1135	0.74	1163	0.80
1080	890	0.4	926	0.44	960	0.49	994	0.53	1026	0.58	1056	0.63	1086	0.68	1116	0.73	1144	0.78	1172	0.84
1200	899	0.42	935	0.47	970	0.52	1003	0.56	1035	0.61	1066	0.67	1096	0.72	1125	0.77	1153	0.82	1181	0.88
1320	909	0.45	944	0.5	979	0.55	1012	0.60	1044	0.65	1075	0.70	1105	0.75	1134	0.81	1162	0.87	1190	0.92
1440	918	0.47	954	0.53	988	0.58	1021	0.63	1053	0.68	1084	0.74	1114	0.79	1143	0.85	1171	0.91	1199	0.97

Notes:

1. Available External Static Pressure is the static pressure difference between the return duct and the supply duct plus the static pressure drop caused by accessories and options.
2. Data includes pressure drop due to standard filters and wet coils. No accessories or options are included in pressure drop data.
3. To determine static pressure drop due to other options/accessories, refer to the applicable table in the fan performance section.
4. Direct drive fan motor heat is negligible.
5. Factory supplied motors, in commercial equipment, are definite purpose motors, specifically designed and tested to operate reliably and continuously at all cataloged conditions. Using the full horsepower range of our fan motors as shown in our tabular data will not result in nuisance tripping or premature motor failure. Our product's warranty will not be affected.

Table 46. Evaporator fan performance – 4 ton (model TZK), downflow

Available External Static Pressure (Inches of Water Gauge)																				
CFM	0.10		0.20		0.30		0.40		0.50		0.60		0.70		0.80		0.90		1.00	
	RPM	BHP	RPM	BHP	RPM	BHP	RPM	BHP	RPM	BHP	RPM	BHP	RPM	BHP	RPM	BHP	RPM	BHP	RPM	BHP
1200	392	0.04	469	0.07	534	0.10	592	0.14	643	0.17	690	0.21	736	0.25	781	0.29	822	0.33	862	0.38
1280	408	0.05	482	0.08	546	0.11	602	0.14	653	0.18	700	0.22	743	0.26	787	0.30	829	0.35	868	0.39
1440	439	0.06	509	0.09	570	0.13	625	0.16	675	0.20	721	0.24	763	0.29	803	0.33	841	0.38	881	0.43
1600	472	0.07	537	0.10	596	0.14	649	0.18	697	0.23	742	0.27	784	0.32	824	0.36	861	0.41	897	0.46
1760	506	0.08	567	0.12	623	0.16	673	0.21	721	0.25	765	0.30	806	0.35	845	0.40	882	0.45	917	0.50
1920	541	0.10	598	0.14	651	0.19	700	0.23	745	0.28	789	0.33	829	0.38	867	0.43	903	0.49	938	0.54
Available External Static Pressure (Inches of Water Gauge)																				
CFM	1.10		1.20		1.30		1.40		1.50		1.60		1.70		1.80		1.90		2.00	
	RPM	BHP	RPM	BHP	RPM	BHP	RPM	BHP	RPM	BHP	RPM	BHP	RPM	BHP	RPM	BHP	RPM	BHP	RPM	BHP
1200	899	0.42	935	0.47	970	0.52	1003	0.56	1035	0.61	1066	0.67	1096	0.72	1125	0.77	1153	0.82	1181	0.88
1280	906	0.44	941	0.49	976	0.54	1009	0.59	1041	0.64	1072	0.69	1102	0.74	1131	0.8	1159	0.85	1187	0.91
1440	918	0.47	954	0.53	988	0.58	1021	0.63	1053	0.68	1084	0.74	1114	0.79	1143	0.85	1171	0.91	1199	0.97
1600	931	0.51	967	0.57	1001	0.62	1034	0.67	1066	0.73	1097	0.79	1126	0.85	1155	0.91	1184	0.97	1211	1.03
1760	951	0.55	983	0.61	1014	0.66	1047	0.72	1078	0.78	1109	0.84	1139	0.9	1168	0.96	1196	1.03	1224	1.09
1920	972	0.6	1004	0.65	1035	0.71	1065	0.77	1093	0.83	1122	0.9	1152	0.96	1181	1.02	1209	1.09	1236	1.16

Notes:

1. Available External Static Pressure is the static pressure difference between the return duct and the supply duct plus the static pressure drop caused by accessories and options.
2. Data includes pressure drop due to standard filters and wet coils. No accessories or options are included in pressure drop data.
3. To determine static pressure drop due to other options/accessories, refer to the applicable table in the fan performance section.
4. Direct drive fan motor heat is negligible.
5. Factory supplied motors, in commercial equipment, are definite purpose motors, specifically designed and tested to operate reliably and continuously at all cataloged conditions. Using the full horsepower range of our fan motors as shown in our tabular data will not result in nuisance tripping or premature motor failure. Our product's warranty will not be affected.

Table 47. Evaporator fan performance – 5 ton (model TZK), downflow

Available External Static Pressure (Inches of Water Gauge)																				
CFM	0.10		0.20		0.30		0.40		0.50		0.60		0.70		0.80		0.90		1.00	
	RPM	BHP	RPM	BHP	RPM	BHP	RPM	BHP	RPM	BHP	RPM	BHP	RPM	BHP	RPM	BHP	RPM	BHP	RPM	BHP
1500	451	0.06	519	0.09	579	0.13	634	0.17	683	0.21	729	0.25	771	0.30	811	0.34	849	0.39	885	0.44
1600	472	0.07	537	0.10	596	0.14	649	0.18	697	0.23	742	0.27	784	0.32	824	0.36	861	0.41	897	0.46
1800	515	0.09	575	0.13	630	0.17	680	0.21	727	0.26	771	0.31	811	0.36	850	0.41	887	0.46	923	0.51
2000	559	0.11	614	0.15	665	0.20	713	0.25	758	0.30	801	0.35	841	0.40	878	0.45	914	0.51	949	0.56
2200	603	0.14	655	0.18	703	0.23	749	0.28	792	0.34	832	0.39	871	0.45	908	0.50	943	0.56	977	0.62
2400	648	0.17	697	0.22	742	0.27	785	0.32	826	0.38	865	0.44	902	0.50	939	0.56	973	0.62	1006	0.68

Available External Static Pressure (Inches of Water Gauge)																				
CFM	1.10		1.20		1.30		1.40		1.50		1.60		1.70		1.80		1.90		2.00	
	RPM	BHP	RPM	BHP	RPM	BHP	RPM	BHP	RPM	BHP	RPM	BHP	RPM	BHP	RPM	BHP	RPM	BHP	RPM	BHP
1500	923	0.49	959	0.54	993	0.59	1026	0.65	1058	0.7	1089	0.76	1119	0.81	1148	0.87	1176	0.93	1204	0.99
1600	931	0.51	967	0.57	1001	0.62	1034	0.67	1066	0.73	1097	0.79	1126	0.85	1155	0.91	1184	0.97	1211	1.03
1800	956	0.56	988	0.62	1019	0.68	1050	0.73	1082	0.79	1112	0.85	1142	0.92	1171	0.98	1199	1.04	1227	1.11
2000	982	0.62	1014	0.68	1045	0.74	1075	0.8	1104	0.86	1131	0.92	1158	0.99	1187	1.05	1215	1.12	1243	1.19
2200	1009	0.68	1041	0.74	1071	0.81	1101	0.87	1129	0.94	1157	1.00	1184	1.07	1210	1.14	1236	1.21	1260	1.28
2400	1038	0.75	1069	0.81	1098	0.88	1127	0.95	1156	1.01	1183	1.08	1210	1.15	1236	1.23	1261	1.30	1286	1.37

Notes:

1. Available External Static Pressure is the static pressure difference between the return duct and the supply duct plus the static pressure drop caused by accessories and options.
2. For direct drive evaporator fan speed (rpm), refer to the applicable table in the fan performance section.
3. Data includes pressure drop due to standard filters and wet coils. No accessories or options are included in pressure drop data.
4. To determine static pressure drop due to other options/accessories, refer to the applicable table in the fan performance section.
5. Direct drive fan motor heat is negligible.
6. Factory supplied motors, in commercial equipment, are definite purpose motors, specifically designed and tested to operate reliably and continuously at all cataloged conditions. Using the full horsepower range of our fan motors as shown in our tabular data will not result in nuisance tripping or premature motor failure. Our product's warranty will not be affected.

Figure 2. Fan curves — 6 to 10 tons (model T*K), downflow

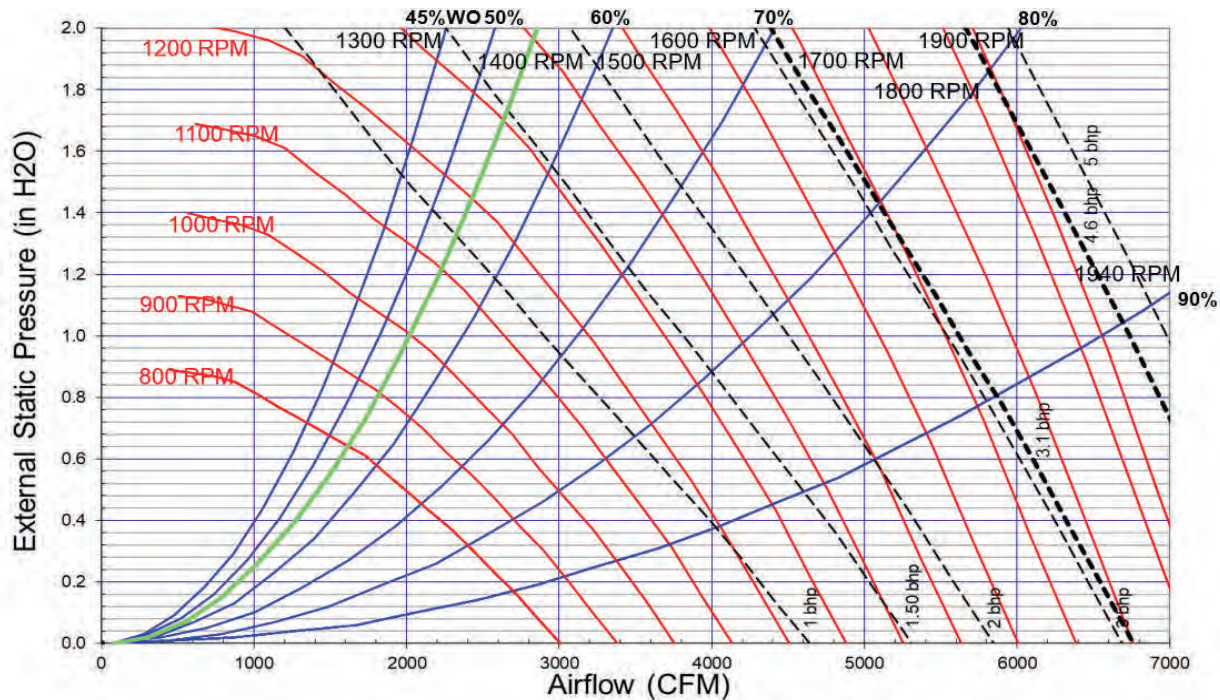



Evaporator Fan Performance — Cooling

Table 48. Evaporator fan performance – 6 ton (model TZK), downflow

Available External Static Pressure (Inches of Water Gauge)																				
CFM	0.10		0.20		0.30		0.40		0.50		0.60		0.70		0.80		0.90		1.00	
	RPM	BHP	RPM	BHP	RPM	BHP	RPM	BHP	RPM	BHP	RPM	BHP	RPM	BHP	RPM	BHP	RPM	BHP	RPM	BHP
1800	549	0.10	612	0.15	667	0.20	719	0.25	766	0.30	809	0.35	849	0.41	891	0.47	931	0.53	969	0.59
1920	577	0.12	638	0.16	691	0.22	741	0.27	787	0.32	830	0.38	870	0.44	907	0.50	946	0.56	984	0.62
2040	606	0.13	663	0.18	716	0.24	763	0.29	809	0.35	851	0.41	891	0.47	928	0.53	963	0.60	999	0.66
2160	634	0.15	689	0.20	741	0.26	787	0.32	831	0.38	873	0.44	912	0.50	948	0.57	983	0.63	1017	0.70
2280	663	0.17	716	0.23	766	0.29	811	0.35	853	0.41	894	0.47	933	0.54	969	0.61	1004	0.67	1037	0.74
2400	693	0.19	743	0.25	791	0.31	836	0.38	877	0.44	916	0.51	955	0.58	991	0.65	1025	0.72	1058	0.79
2520	723	0.22	771	0.28	817	0.34	861	0.41	901	0.48	939	0.55	977	0.62	1012	0.69	1046	0.76	1079	0.83
2640	753	0.24	799	0.31	843	0.37	886	0.44	925	0.51	963	0.59	999	0.66	1034	0.73	1068	0.81	1100	0.88
2760	783	0.27	827	0.34	869	0.41	911	0.48	950	0.55	987	0.63	1022	0.70	1056	0.78	1089	0.86	1121	0.94
2880	813	0.30	855	0.37	897	0.44	937	0.52	975	0.59	1011	0.67	1046	0.75	1078	0.83	1111	0.91	1143	0.99
Available External Static Pressure (Inches of Water Gauge)																				
CFM	1.10		1.20		1.30		1.40		1.50		1.60		1.70		1.80		1.90		2.00	
	RPM	BHP	RPM	BHP	RPM	BHP	RPM	BHP	RPM	BHP	RPM	BHP	RPM	BHP	RPM	BHP	RPM	BHP	RPM	BHP
1800	1005	0.65	1040	0.71	1074	0.78	1106	0.84	1137	0.91	1167	0.98	1197	1.04	1225	1.11	1253	1.19	1280	1.26
1920	1020	0.69	1055	0.75	1088	0.82	1121	0.89	1152	0.96	1182	1.03	1211	1.1	1240	1.17	1267	1.24	1294	1.32
2040	1035	0.73	1070	0.8	1103	0.86	1135	0.93	1166	1.01	1196	1.08	1226	1.15	1254	1.23	1282	1.3	1309	1.38
2160	1050	0.77	1085	0.84	1118	0.91	1150	0.98	1181	1.06	1211	1.13	1240	1.21	1269	1.28	1296	1.36	1323	1.44
2280	1069	0.81	1100	0.89	1133	0.96	1165	1.04	1196	1.11	1226	1.19	1255	1.27	1283	1.35	1311	1.43	1338	1.51
2400	1089	0.86	1119	0.94	1149	1.01	1180	1.09	1211	1.17	1241	1.25	1270	1.33	1298	1.41	1326	1.49	1352	1.57
2520	1110	0.91	1140	0.99	1169	1.07	1197	1.15	1226	1.23	1256	1.31	1285	1.39	1313	1.47	1340	1.56	1367	1.64
2640	1131	0.96	1161	1.04	1189	1.12	1217	1.2	1244	1.29	1271	1.37	1300	1.46	1328	1.54	1355	1.63	1382	1.72
2760	1152	1.02	1182	1.1	1210	1.18	1238	1.26	1265	1.35	1291	1.44	1316	1.52	1343	1.61	1371	1.7	1397	1.79
2880	1173	1.07	1203	1.16	1231	1.24	1259	1.33	1285	1.41	1311	1.5	1336	1.59	1361	1.68	1386	1.77	1412	1.87

Notes:

1. Available External Static Pressure is the static pressure difference between the return duct and the supply duct plus the static pressure drop caused by accessories and options.
2. For direct drive evaporator fan speed (rpm), refer to the applicable table in the fan performance section.
3. Data includes pressure drop due to standard filters and wet coils. No accessories or options are included in pressure drop data.
4. To determine static pressure drop due to other options/accessories, refer to the applicable table in the fan performance section.
5. Direct drive fan motor heat is negligible.
6. Factory supplied motors, in commercial equipment, are definite purpose motors, specifically designed and tested to operate reliably and continuously at all cataloged conditions. Using the full horsepower range of our fan motors as shown in our tabular data will not result in nuisance tripping or premature motor failure. Our product's warranty will not be affected.

Table 49. Evaporator fan performance – 7.5 ton (model TZK), downflow

Available External Static Pressure (Inches of Water Gauge)																				
CFM	0.10		0.20		0.30		0.40		0.50		0.60		0.70		0.80		0.90		1.00	
	RPM	BHP	RPM	BHP	RPM	BHP	RPM	BHP	RPM	BHP	RPM	BHP	RPM	BHP	RPM	BHP	RPM	BHP	RPM	BHP
2250	656	0.17	709	0.22	759	0.28	805	0.34	848	0.40	889	0.47	928	0.53	964	0.60	999	0.66	1032	0.73
2400	693	0.19	743	0.25	791	0.31	836	0.38	877	0.44	916	0.51	955	0.58	991	0.65	1025	0.72	1058	0.79
2550	730	0.22	778	0.29	823	0.35	867	0.42	907	0.49	945	0.56	982	0.63	1018	0.70	1052	0.77	1084	0.85
2700	768	0.26	813	0.32	856	0.39	898	0.46	938	0.53	975	0.61	1010	0.68	1045	0.76	1079	0.83	1111	0.91
2850	806	0.30	848	0.36	890	0.43	930	0.51	969	0.58	1005	0.66	1040	0.74	1073	0.82	1106	0.90	1138	0.98
3000	844	0.34	884	0.41	924	0.48	963	0.56	1000	0.64	1036	0.72	1070	0.80	1102	0.88	1134	0.96	1165	1.05
3150	882	0.38	920	0.46	959	0.53	996	0.61	1032	0.69	1067	0.78	1100	0.86	1132	0.95	1162	1.03	1193	1.12
3300	920	0.43	957	0.51	994	0.59	1030	0.67	1065	0.76	1099	0.84	1131	0.93	1163	1.02	1192	1.11	1221	1.20
3600	997	0.55	1031	0.63	1065	0.71	1099	0.80	1131	0.90	1163	0.99	1194	1.08	1225	1.18	1254	1.27	1282	1.37

Table 49. Evaporator fan performance – 7.5 ton (model TZK), downflow (continued)

Available External Static Pressure (Inches of Water Gauge)																				
CFM	1.10		1.20		1.30		1.40		1.50		1.60		1.70		1.80		1.90		2.00	
	RPM	BHP	RPM	BHP	RPM	BHP	RPM	BHP	RPM	BHP	RPM	BHP	RPM	BHP	RPM	BHP	RPM	BHP	RPM	BHP
2250	1064	0.8	1096	0.88	1130	0.95	1161	1.02	1192	1.1	1222	1.17	1251	1.25	1280	1.33	1307	1.41	1334	1.49
2400	1089	0.86	1119	0.94	1149	1.01	1180	1.09	1211	1.17	1241	1.25	1270	1.33	1298	1.41	1326	1.49	1352	1.57
2550	1115	0.92	1145	1	1174	1.08	1202	1.16	1230	1.24	1260	1.32	1289	1.41	1317	1.49	1344	1.58	1371	1.66
2700	1141	0.99	1171	1.07	1200	1.15	1227	1.23	1254	1.32	1280	1.4	1308	1.49	1336	1.58	1363	1.66	1390	1.75
2850	1168	1.06	1197	1.14	1226	1.23	1253	1.31	1280	1.4	1306	1.49	1331	1.57	1356	1.66	1382	1.76	1409	1.85
3000	1195	1.13	1224	1.22	1252	1.3	1280	1.39	1306	1.48	1332	1.57	1357	1.67	1381	1.76	1405	1.85	1428	1.95
3150	1223	1.21	1251	1.3	1279	1.39	1306	1.48	1332	1.57	1358	1.67	1383	1.76	1407	1.86	1431	1.95	1454	2.05
3300	1250	1.29	1279	1.38	1306	1.48	1333	1.57	1359	1.67	1384	1.76	1409	1.86	1433	1.96	1457	2.06	1480	2.16
3600	1309	1.47	1335	1.57	1361	1.67	1388	1.77	1413	1.87	1438	1.97	1462	2.08	1486	2.18	1509	2.28	1532	2.39

Notes:

1. Available External Static Pressure is the static pressure difference between the return duct and the supply duct plus the static pressure drop caused by accessories and options.
2. For direct drive evaporator fan speed (rpm), refer to the applicable table in the fan performance section.
3. Data includes pressure drop due to standard filters and wet coils. No accessories or options are included in pressure drop data.
4. To determine static pressure drop due to other options/accessories, refer to the applicable table in the fan performance section.
5. Direct drive fan motor heat is negligible.
6. Factory supplied motors, in commercial equipment, are definite purpose motors, specifically designed and tested to operate reliably and continuously at all cataloged conditions. Using the full horsepower range of our fan motors as shown in our tabular data will not result in nuisance tripping or premature motor failure. Our product's warranty will not be affected.

Table 50. Evaporator fan performance – 8.5 ton (model TZK), downflow

Available External Static Pressure (Inches of Water Gauge)																				
CFM	0.10		0.20		0.30		0.40		0.50		0.60		0.70		0.80		0.90		1.00	
	RPM	BHP	RPM	BHP	RPM	BHP	RPM	BHP	RPM	BHP	RPM	BHP	RPM	BHP	RPM	BHP	RPM	BHP	RPM	BHP
2550	730	0.22	778	0.29	823	0.35	867	0.42	907	0.49	945	0.56	982	0.63	1018	0.70	1052	0.77	1084	0.85
2720	773	0.26	817	0.33	860	0.40	903	0.47	942	0.54	979	0.61	1014	0.69	1049	0.76	1082	0.84	1114	0.92
2890	816	0.31	858	0.37	899	0.45	939	0.52	977	0.60	1013	0.67	1048	0.75	1080	0.83	1113	0.91	1145	0.99
3060	859	0.36	898	0.43	938	0.50	976	0.58	1013	0.66	1048	0.74	1082	0.82	1114	0.91	1145	0.99	1176	1.08
3230	902	0.41	940	0.48	977	0.56	1014	0.64	1050	0.73	1084	0.81	1117	0.90	1148	0.98	1178	1.07	1208	1.16
3400	946	0.47	982	0.55	1017	0.63	1052	0.71	1086	0.80	1120	0.89	1152	0.98	1183	1.07	1213	1.16	1241	1.25
3570	989	0.54	1024	0.62	1057	0.70	1092	0.79	1124	0.88	1157	0.97	1188	1.06	1218	1.16	1247	1.25	1275	1.35
3740	1033	0.61	1066	0.69	1098	0.78	1131	0.87	1163	0.97	1193	1.06	1224	1.16	1254	1.26	1283	1.35	1310	1.46
4080	1121	0.77	1152	0.86	1181	0.96	1211	1.06	1241	1.16	1270	1.26	1298	1.36	1326	1.47	1354	1.57	1381	1.68

Available External Static Pressure (Inches of Water Gauge)																				
CFM	1.10		1.20		1.30		1.40		1.50		1.60		1.70		1.80		1.90		2.00	
	RPM	BHP	RPM	BHP	RPM	BHP	RPM	BHP	RPM	BHP	RPM	BHP	RPM	BHP	RPM	BHP	RPM	BHP	RPM	BHP
2550	1115	0.92	1145	1	1174	1.08	1202	1.16	1230	1.24	1260	1.32	1289	1.41	1317	1.49	1344	1.58	1371	1.66
2720	1145	1	1175	1.08	1203	1.16	1231	1.24	1258	1.33	1284	1.41	1310	1.5	1338	1.59	1366	1.68	1392	1.77
2890	1175	1.08	1205	1.16	1233	1.25	1260	1.33	1287	1.42	1313	1.51	1338	1.6	1362	1.69	1387	1.78	1414	1.87
3060	1206	1.16	1235	1.25	1263	1.34	1290	1.43	1317	1.52	1342	1.61	1367	1.7	1391	1.8	1415	1.89	1439	1.99
3230	1237	1.25	1266	1.34	1294	1.44	1320	1.53	1347	1.62	1372	1.72	1397	1.81	1421	1.91	1444	2.01	1468	2.11
3400	1269	1.35	1297	1.44	1325	1.54	1351	1.63	1377	1.73	1402	1.83	1427	1.93	1451	2.03	1474	2.13	1497	2.23
3570	1303	1.45	1329	1.55	1356	1.65	1382	1.75	1408	1.85	1433	1.95	1457	2.05	1481	2.16	1504	2.26	1527	2.37
3740	1337	1.56	1363	1.66	1388	1.76	1414	1.87	1439	1.97	1464	2.08	1488	2.18	1511	2.29	1534	2.4	1557	2.51



Evaporator Fan Performance — Cooling

Table 50. Evaporator fan performance – 8.5 ton (model TZK), downflow (continued)

Available External Static Pressure (Inches of Water Gauge)																				
CFM	1.10		1.20		1.30		1.40		1.50		1.60		1.70		1.80		1.90		2.00	
	RPM	BHP	RPM	BHP	RPM	BHP	RPM	BHP	RPM	BHP	RPM	BHP	RPM	BHP	RPM	BHP	RPM	BHP	RPM	BHP
4080	1407	1.79	1432	1.9	1456	2.01	1480	2.12	1503	2.24	1526	2.35	1550	2.46	1573	2.58	1596	2.69	1618	2.81

Notes:

1. Available External Static Pressure is the static pressure difference between the return duct and the supply duct plus the static pressure drop caused by accessories and options.
2. For direct drive evaporator fan speed (rpm), refer to the applicable table in the fan performance section.
3. Data includes pressure drop due to standard filters and wet coils. No accessories or options are included in pressure drop data.
4. To determine static pressure drop due to other options/accessories, refer to the applicable table in the fan performance section.
5. Direct drive fan motor heat is negligible.
6. Factory supplied motors, in commercial equipment, are definite purpose motors, specifically designed and tested to operate reliably and continuously at all cataloged conditions. Using the full horsepower range of our fan motors as shown in our tabular data will not result in nuisance tripping or premature motor failure. Our product's warranty will not be affected.

Table 51. Evaporator fan performance – 10 ton (model TZK), downflow

Available External Static Pressure (Inches of Water Gauge)																				
CFM	0.10		0.20		0.30		0.40		0.50		0.60		0.70		0.80		0.90		1.00	
	RPM	BHP	RPM	BHP	RPM	BHP	RPM	BHP	RPM	BHP	RPM	BHP	RPM	BHP	RPM	BHP	RPM	BHP	RPM	BHP
3000	795	0.29	834	0.35	871	0.41	909	0.48	945	0.55	979	0.62	1012	0.69	1045	0.77	1077	0.84	1108	0.92
3200	843	0.34	880	0.40	914	0.47	950	0.54	985	0.61	1018	0.69	1050	0.76	1081	0.84	1111	0.92	1142	1.01
3400	891	0.40	926	0.47	959	0.54	992	0.61	1026	0.69	1058	0.76	1088	0.84	1118	0.92	1147	1.01	1176	1.09
3600	939	0.47	973	0.54	1004	0.61	1035	0.68	1067	0.77	1098	0.85	1128	0.93	1156	1.01	1185	1.10	1212	1.19
3800	988	0.54	1020	0.62	1050	0.69	1079	0.77	1109	0.85	1139	0.94	1168	1.02	1196	1.11	1223	1.20	1250	1.29
4000	1036	0.62	1067	0.70	1096	0.78	1124	0.86	1152	0.94	1181	1.03	1209	1.13	1236	1.22	1262	1.31	1288	1.40
4200	1085	0.71	1114	0.79	1142	0.88	1169	0.96	1195	1.05	1223	1.14	1250	1.23	1277	1.33	1302	1.43	1327	1.52
4400	1133	0.81	1162	0.90	1189	0.98	1215	1.07	1240	1.16	1265	1.25	1292	1.35	1318	1.45	1343	1.55	1367	1.65
4600	1181	0.92	1210	1.01	1236	1.10	1261	1.19	1285	1.28	1309	1.37	1334	1.48	1359	1.58	1384	1.69	1408	1.79
4800	1230	1.03	1258	1.13	1283	1.22	1308	1.32	1331	1.41	1354	1.51	1377	1.61	1402	1.72	1425	1.83	1449	1.94

Available External Static Pressure (Inches of Water Gauge)																				
CFM	1.10		1.20		1.30		1.40		1.50		1.60		1.70		1.80		1.90		2.00	
	RPM	BHP	RPM	BHP	RPM	BHP	RPM	BHP	RPM	BHP	RPM	BHP	RPM	BHP	RPM	BHP	RPM	BHP	RPM	BHP
3000	1139	1.01	1169	1.1	1198	1.18	1229	1.27	1258	1.36	1286	1.46	1314	1.55	1341	1.64	1367	1.74	1392	1.84
3200	1171	1.09	1200	1.18	1229	1.27	1256	1.36	1284	1.46	1313	1.55	1340	1.65	1367	1.75	1393	1.85	1418	1.95
3400	1205	1.18	1233	1.27	1260	1.36	1287	1.46	1314	1.55	1340	1.65	1366	1.75	1393	1.86	1419	1.96	1444	2.06
3600	1239	1.28	1267	1.37	1294	1.46	1319	1.56	1345	1.66	1371	1.76	1396	1.86	1420	1.97	1445	2.08	1470	2.18
3800	1276	1.38	1302	1.48	1328	1.57	1353	1.67	1378	1.77	1402	1.87	1427	1.98	1451	2.09	1475	2.2	1498	2.31
4000	1314	1.5	1339	1.59	1363	1.69	1388	1.79	1412	1.9	1436	2	1459	2.11	1483	2.22	1506	2.33	1529	2.44
4200	1352	1.62	1376	1.72	1400	1.82	1423	1.93	1447	2.03	1470	2.14	1493	2.25	1516	2.36	1538	2.47	1560	2.58
4400	1391	1.75	1415	1.86	1438	1.96	1461	2.07	1483	2.17	1505	2.28	1528	2.4	1550	2.51	1572	2.62	1593	2.74
4600	1431	1.9	1454	2	1476	2.11	1499	2.22	1521	2.33	1542	2.44	1563	2.55	1585	2.67	1606	2.79	1627	2.91
4800	1472	2.05	1494	2.16	1516	2.27	1537	2.38	1559	2.49	1580	2.61	1601	2.72	1621	2.84	1641	2.96	1662	3.08

Notes:

1. Available External Static Pressure is the static pressure difference between the return duct and the supply duct plus the static pressure drop caused by accessories and options.
2. For direct drive evaporator fan speed (rpm), refer to the applicable table in the fan performance section.
3. Data includes pressure drop due to standard filters and wet coils. No accessories or options are included in pressure drop data.
4. To determine static pressure drop due to other options/accessories, refer to the applicable table in the fan performance section.
5. Direct drive fan motor heat is negligible.
6. Factory supplied motors, in commercial equipment, are definite purpose motors, specifically designed and tested to operate reliably and continuously at all cataloged conditions. Using the full horsepower range of our fan motors as shown in our tabular data will not result in nuisance tripping or premature motor failure. Our product's warranty will not be affected.

Figure 3. Fan curves – 12.5 to 25 tons (model TZK), downflow

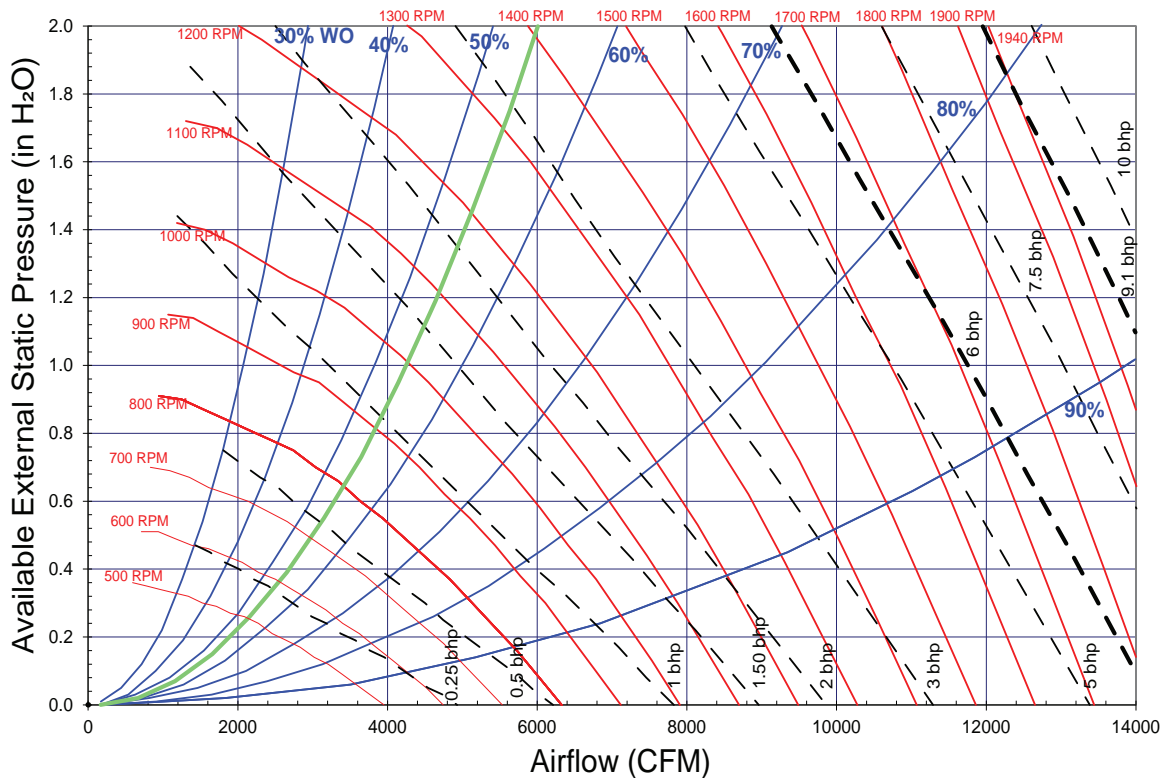

Table 52. Evaporator fan performance – 12.5 ton (model TZK), downflow

Available External Static Pressure (Inches of Water Gauge)																				
CFM	0.10		0.20		0.30		0.40		0.50		0.60		0.70		0.80		0.90		1.00	
	RPM	BHP	RPM	BHP	RPM	BHP	RPM	BHP	RPM	BHP	RPM	BHP	RPM	BHP	RPM	BHP	RPM	BHP	RPM	BHP
3750	545	0.19	608	0.28	663	0.38	715	0.48	763	0.58	807	0.68	848	0.79	888	0.90	926	1.01	963	1.13
4000	573	0.22	634	0.32	687	0.42	736	0.52	783	0.63	827	0.74	867	0.85	906	0.96	943	1.08	979	1.20
4500	629	0.29	685	0.39	736	0.51	782	0.62	826	0.74	868	0.86	907	0.98	945	1.10	981	1.22	1015	1.35
5000	687	0.37	738	0.48	786	0.61	830	0.73	871	0.86	911	0.99	949	1.12	986	1.25	1021	1.39	1054	1.52
5500	746	0.47	792	0.59	838	0.72	880	0.86	919	0.99	956	1.13	993	1.28	1028	1.42	1062	1.57	1095	1.71
6000	805	0.58	849	0.72	890	0.85	931	1.00	969	1.15	1004	1.30	1039	1.45	1072	1.60	1105	1.76	1136	1.92
Available External Static Pressure (Inches of Water Gauge)																				
CFM	1.10		1.20		1.30		1.40		1.50		1.60		1.70		1.80		1.90		2.00	
	RPM	BHP	RPM	BHP	RPM	BHP	RPM	BHP	RPM	BHP	RPM	BHP	RPM	BHP	RPM	BHP	RPM	BHP	RPM	BHP
3750	998	1.25	1032	1.37	1064	1.5	1095	1.63	1127	1.76	1159	1.9	1189	2.04	1218	2.18	1247	2.32	1275	2.47
4000	1014	1.33	1048	1.45	1080	1.58	1111	1.71	1141	1.85	1170	1.99	1201	2.13	1230	2.27	1259	2.42	1286	2.57
4500	1048	1.48	1081	1.62	1113	1.76	1144	1.9	1173	2.04	1202	2.19	1230	2.33	1257	2.48	1284	2.63	1310	2.79
5000	1086	1.66	1117	1.81	1147	1.95	1177	2.1	1206	2.25	1235	2.4	1263	2.56	1290	2.72	1316	2.88	1342	3.04
5500	1126	1.86	1157	2.01	1186	2.17	1214	2.32	1242	2.48	1269	2.64	1296	2.8	1323	2.97	1349	3.14	1375	3.31
6000	1167	2.08	1197	2.24	1226	2.4	1254	2.57	1281	2.73	1308	2.9	1333	3.07	1358	3.25	1383	3.42	1408	3.6

Notes:

1. Available External Static Pressure is the static pressure difference between the return duct and the supply duct plus the static pressure drop caused by accessories and options.
2. For direct drive evaporator fan speed (rpm), refer to the applicable table in the fan performance section.
3. Data includes pressure drop due to standard filters and wet coils. No accessories or options are included in pressure drop data.
4. To determine static pressure drop due to other options/accessories, refer to the applicable table in the fan performance section.
5. Direct drive fan motor heat is negligible.
6. Factory supplied motors, in commercial equipment, are definite purpose motors, specifically designed and tested to operate reliably and continuously at all cataloged conditions. Using the full horsepower range of our fan motors as shown in our tabular data will not result in nuisance tripping or premature motor failure. Our product's warranty will not be affected.



Evaporator Fan Performance — Cooling

Table 53. Evaporator fan performance – 15 ton (model TZK), downflow

Available External Static Pressure (Inches of Water Gauge)																				
CFM	0.10		0.20		0.30		0.40		0.50		0.60		0.70		0.80		0.90		1.00	
	RPM	BHP	RPM	BHP	RPM	BHP	RPM	BHP	RPM	BHP	RPM	BHP	RPM	BHP	RPM	BHP	RPM	BHP	RPM	BHP
4500	629	0.29	685	0.39	736	0.51	782	0.62	826	0.74	868	0.86	907	0.98	945	1.10	981	1.22	1015	1.35
4800	664	0.34	716	0.45	766	0.56	810	0.68	852	0.81	893	0.93	932	1.06	969	1.19	1005	1.32	1038	1.45
5400	734	0.45	781	0.57	828	0.70	870	0.83	909	0.96	947	1.10	984	1.24	1019	1.39	1053	1.53	1086	1.67
6000	805	0.58	849	0.72	890	0.85	931	1.00	969	1.15	1004	1.30	1039	1.45	1072	1.60	1105	1.76	1136	1.92
6600	877	0.74	917	0.89	955	1.04	994	1.20	1030	1.36	1064	1.52	1096	1.68	1128	1.85	1158	2.02	1189	2.19
7200	950	0.94	987	1.10	1023	1.26	1057	1.42	1092	1.60	1125	1.77	1156	1.95	1186	2.13	1216	2.31	1244	2.49
Available External Static Pressure (Inches of Water Gauge)																				
CFM	1.10		1.20		1.30		1.40		1.50		1.60		1.70		1.80		1.90		2.00	
	RPM	BHP	RPM	BHP	RPM	BHP	RPM	BHP	RPM	BHP	RPM	BHP	RPM	BHP	RPM	BHP	RPM	BHP	RPM	BHP
4500	1048	1.48	1081	1.62	1113	1.76	1144	1.9	1173	2.04	1202	2.19	1230	2.33	1257	2.48	1284	2.63	1310	2.79
4800	1071	1.59	1101	1.73	1133	1.87	1163	2.02	1193	2.16	1222	2.31	1250	2.47	1277	2.62	1303	2.78	1329	2.94
5400	1118	1.82	1149	1.97	1178	2.12	1207	2.28	1234	2.43	1262	2.59	1289	2.75	1316	2.92	1343	3.08	1368	3.25
6000	1167	2.08	1197	2.24	1226	2.4	1254	2.57	1281	2.73	1308	2.9	1333	3.07	1358	3.25	1383	3.42	1408	3.6
6600	1218	2.36	1247	2.54	1275	2.71	1303	2.89	1329	3.07	1355	3.25	1381	3.43	1406	3.61	1430	3.8	1453	3.98
7200	1272	2.68	1299	2.86	1327	3.05	1353	3.24	1379	3.43	1404	3.62	1429	3.82	1454	4.01	1478	4.21	1501	4.4

Notes:

1. Available External Static Pressure is the static pressure difference between the return duct and the supply duct plus the static pressure drop caused by accessories and options.
2. For direct drive evaporator fan speed (rpm), refer to the applicable table in the fan performance section.
3. Data includes pressure drop due to standard filters and wet coils. No accessories or options are included in pressure drop data.
4. To determine static pressure drop due to other options/accessories, refer to the applicable table in the fan performance section.
5. Direct drive fan motor heat is negligible.
6. Factory supplied motors, in commercial equipment, are definite purpose motors, specifically designed and tested to operate reliably and continuously at all cataloged conditions. Using the full horsepower range of our fan motors as shown in our tabular data will not result in nuisance tripping or premature motor failure. Our product's warranty will not be affected.

Table 54. Evaporator fan performance – 17.5 ton (model TZK), downflow

Available External Static Pressure (Inches of Water Gauge)																				
CFM	0.10		0.20		0.30		0.40		0.50		0.60		0.70		0.80		0.90		1.00	
	RPM	BHP	RPM	BHP	RPM	BHP	RPM	BHP	RPM	BHP	RPM	BHP	RPM	BHP	RPM	BHP	RPM	BHP	RPM	BHP
5250	716	0.42	765	0.54	812	0.66	855	0.79	895	0.92	933	1.06	971	1.19	1006	1.33	1041	1.47	1074	1.62
5600	758	0.49	804	0.61	848	0.75	890	0.88	929	1.02	966	1.16	1001	1.31	1037	1.46	1070	1.60	1103	1.75
6300	841	0.66	883	0.80	922	0.94	962	1.10	999	1.25	1034	1.40	1067	1.56	1099	1.72	1131	1.89	1162	2.05
7000	926	0.87	963	1.02	1000	1.18	1036	1.34	1071	1.51	1105	1.68	1136	1.86	1167	2.03	1196	2.21	1225	2.39
7700	1011	1.12	1046	1.29	1079	1.46	1112	1.64	1144	1.82	1177	2.00	1208	2.19	1237	2.38	1264	2.57	1292	2.76
8400	1097	1.42	1129	1.60	1160	1.79	1190	1.98	1220	2.17	1250	2.37	1280	2.57	1308	2.78	1335	2.98	1361	3.19
Available External Static Pressure (Inches of Water Gauge)																				
CFM	1.10		1.20		1.30		1.40		1.50		1.60		1.70		1.80		1.90		2.00	
	RPM	BHP	RPM	BHP	RPM	BHP	RPM	BHP	RPM	BHP	RPM	BHP	RPM	BHP	RPM	BHP	RPM	BHP	RPM	BHP
5250	1106	1.76	1137	1.91	1166	2.06	1195	2.21	1223	2.36	1252	2.52	1279	2.68	1306	2.84	1333	3.01	1358	3.17
5600	1134	1.9	1165	2.06	1194	2.21	1222	2.37	1250	2.53	1276	2.69	1303	2.85	1330	3.02	1356	3.19	1381	3.37
6300	1192	2.22	1222	2.39	1250	2.55	1278	2.72	1305	2.9	1331	3.07	1357	3.25	1382	3.42	1406	3.6	1430	3.78
7000	1254	2.57	1282	2.75	1309	2.94	1336	3.12	1362	3.31	1388	3.49	1413	3.68	1438	3.87	1462	4.07	1485	4.26
7700	1319	2.96	1345	3.16	1371	3.36	1397	3.56	1422	3.76	1447	3.96	1471	4.17	1495	4.37	1518	4.58	1541	4.78

Table 54. Evaporator fan performance – 17.5 ton (model TZK), downflow (continued)

Available External Static Pressure (Inches of Water Gauge)																				
CFM	1.10		1.20		1.30		1.40		1.50		1.60		1.70		1.80		1.90		2.00	
	RPM	BHP	RPM	BHP	RPM	BHP	RPM	BHP	RPM	BHP	RPM	BHP	RPM	BHP	RPM	BHP	RPM	BHP	RPM	BHP
8400	1387	3.4	1412	3.61	1437	3.82	1461	4.04	1484	4.26	1508	4.47	1532	4.69	1555	4.91	1577	5.13	1599	5.36

Notes:

1. Available External Static Pressure is the static pressure difference between the return duct and the supply duct plus the static pressure drop caused by accessories and options.
2. For direct drive evaporator fan speed (rpm), refer to the applicable table in the fan performance section.
3. Data includes pressure drop due to standard filters and wet coils. No accessories or options are included in pressure drop data.
4. To determine static pressure drop due to other options/accessories, refer to the applicable table in the fan performance section.
5. Direct drive fan motor heat is negligible.
6. Factory supplied motors, in commercial equipment, are definite purpose motors, specifically designed and tested to operate reliably and continuously at all cataloged conditions. Using the full horsepower range of our fan motors as shown in our tabular data will not result in nuisance tripping or premature motor failure. Our product's warranty will not be affected.

Table 55. Evaporator fan performance – 17.5 ton (model TZK), downflow, high static motor

Available External Static Pressure (Inches of Water Gauge)																				
CFM	0.10		0.20		0.30		0.40		0.50		0.60		0.70		0.80		0.90		1.00	
	RPM	BHP	RPM	BHP	RPM	BHP	RPM	BHP	RPM	BHP	RPM	BHP	RPM	BHP	RPM	BHP	RPM	BHP	RPM	BHP
5250	716	0.42	765	0.54	812	0.66	855	0.79	895	0.92	933	1.06	971	1.19	1006	1.33	1041	1.47	1074	1.62
5600	758	0.49	804	0.61	848	0.75	890	0.88	929	1.02	966	1.16	1001	1.31	1037	1.46	1070	1.60	1103	1.75
6300	841	0.66	883	0.80	922	0.94	962	1.10	999	1.25	1034	1.40	1067	1.56	1099	1.72	1131	1.89	1162	2.05
7000	926	0.87	963	1.02	1000	1.18	1036	1.34	1071	1.51	1105	1.68	1136	1.86	1167	2.03	1196	2.21	1225	2.39
7700	1011	1.12	1046	1.29	1079	1.46	1112	1.64	1144	1.82	1177	2.00	1208	2.19	1237	2.38	1264	2.57	1292	2.76
8400	1097	1.42	1129	1.60	1160	1.79	1190	1.98	1220	2.17	1250	2.37	1280	2.57	1308	2.78	1335	2.98	1361	3.19

Available External Static Pressure (Inches of Water Gauge)

CFM	1.10		1.20		1.30		1.40		1.50		1.60		1.70		1.80		1.90		2.00	
	RPM	BHP	RPM	BHP	RPM	BHP	RPM	BHP	RPM	BHP	RPM	BHP	RPM	BHP	RPM	BHP	RPM	BHP	RPM	BHP
5250	1106	1.76	1137	1.91	1166	2.06	1195	2.21	1223	2.36	1252	2.52	1279	2.68	1306	2.84	1333	3.01	1358	3.17
5600	1134	1.9	1165	2.06	1194	2.21	1222	2.37	1250	2.53	1276	2.69	1303	2.85	1330	3.02	1356	3.19	1381	3.37
6300	1192	2.22	1222	2.39	1250	2.55	1278	2.72	1305	2.9	1331	3.07	1357	3.25	1382	3.42	1406	3.6	1430	3.78
7000	1254	2.57	1282	2.75	1309	2.94	1336	3.12	1362	3.31	1388	3.49	1413	3.68	1438	3.87	1462	4.07	1485	4.26
7700	1319	2.96	1345	3.16	1371	3.36	1397	3.56	1422	3.76	1447	3.96	1471	4.17	1495	4.37	1518	4.58	1541	4.78
8400	1387	3.4	1412	3.61	1437	3.82	1461	4.04	1484	4.26	1508	4.47	1532	4.69	1555	4.91	1577	5.13	1599	5.36

Notes:

1. Available External Static Pressure is the static pressure difference between the return duct and the supply duct plus the static pressure drop caused by accessories and options.
2. For direct drive evaporator fan speed (rpm), refer to the applicable table in the fan performance section.
3. Data includes pressure drop due to standard filters and wet coils. No accessories or options are included in pressure drop data.
4. To determine static pressure drop due to other options/accessories, refer to the applicable table in the fan performance section.
5. Direct drive fan motor heat is negligible.
6. Factory supplied motors, in commercial equipment, are definite purpose motors, specifically designed and tested to operate reliably and continuously at all cataloged conditions. Using the full horsepower range of our fan motors as shown in our tabular data will not result in nuisance tripping or premature motor failure. Our product's warranty will not be affected.

Table 56. Evaporator fan performance – 20 ton (model TZK), downflow

Available External Static Pressure (Inches of Water Gauge)																				
CFM	0.10		0.20		0.30		0.40		0.50		0.60		0.70		0.80		0.90		1.00	
	RPM	BHP	RPM	BHP	RPM	BHP	RPM	BHP	RPM	BHP	RPM	BHP	RPM	BHP	RPM	BHP	RPM	BHP	RPM	BHP
6000	805	0.58	849	0.72	890	0.85	931	1.00	969	1.15	1004	1.30	1039	1.45	1072	1.60	1105	1.76	1136	1.92
6400	853	0.69	894	0.83	933	0.97	973	1.13	1010	1.28	1044	1.44	1077	1.60	1109	1.77	1140	1.93	1171	2.10
7200	950	0.94	987	1.10	1023	1.26	1057	1.42	1092	1.60	1125	1.77	1156	1.95	1186	2.13	1216	2.31	1244	2.49
8000	1048	1.24	1081	1.42	1114	1.60	1145	1.78	1176	1.96	1208	2.16	1239	2.35	1267	2.55	1295	2.74	1321	2.94
8800	1146	1.61	1177	1.81	1207	2.00	1236	2.20	1264	2.40	1292	2.60	1322	2.81	1350	3.03	1376	3.24	1402	3.46
9600	1244	2.05	1273	2.27	1301	2.48	1328	2.69	1355	2.91	1381	3.12	1406	3.34	1433	3.57	1459	3.81	1485	4.04



Evaporator Fan Performance — Cooling

Table 56. Evaporator fan performance – 20 ton (model TZK), downflow (continued)

Available External Static Pressure (Inches of Water Gauge)																				
CFM	1.10		1.20		1.30		1.40		1.50		1.60		1.70		1.80		1.90		2.00	
	RPM	BHP	RPM	BHP	RPM	BHP	RPM	BHP	RPM	BHP	RPM	BHP	RPM	BHP	RPM	BHP	RPM	BHP	RPM	BHP
6000	1167	2.08	1197	2.24	1226	2.4	1254	2.57	1281	2.73	1308	2.9	1333	3.07	1358	3.25	1383	3.42	1408	3.6
6400	1201	2.27	1230	2.44	1258	2.61	1286	2.78	1313	2.95	1339	3.13	1365	3.31	1390	3.49	1414	3.67	1438	3.85
7200	1272	2.68	1299	2.86	1327	3.05	1353	3.24	1379	3.43	1404	3.62	1429	3.82	1454	4.01	1478	4.21	1501	4.4
8000	1348	3.14	1374	3.35	1399	3.55	1423	3.76	1448	3.97	1473	4.17	1497	4.39	1520	4.6	1543	4.81	1566	5.02
8800	1427	3.67	1451	3.89	1475	4.11	1499	4.34	1522	4.56	1544	4.79	1567	5.02	1590	5.24	1612	5.47	1634	5.7
9600	1508	4.28	1532	4.51	1555	4.75	1577	4.99	1599	5.23	1621	5.47	1642	5.71	1663	5.96	-	-	-	-

Notes:

1. Available External Static Pressure is the static pressure difference between the return duct and the supply duct plus the static pressure drop caused by accessories and options.
2. For direct drive evaporator fan speed (rpm), refer to the applicable table in the fan performance section.
3. Data includes pressure drop due to standard filters and wet coils. No accessories or options are included in pressure drop data.
4. To determine static pressure drop due to other options/accessories, refer to the applicable table in the fan performance section.
5. Direct drive fan motor heat is negligible.
6. Factory supplied motors, in commercial equipment, are definite purpose motors, specifically designed and tested to operate reliably and continuously at all cataloged conditions. Using the full horsepower range of our fan motors as shown in our tabular data will not result in nuisance tripping or premature motor failure. Our product's warranty will not be affected.

Table 57. Evaporator fan performance – 20 ton (model TZK), downflow, high static motor

Available External Static Pressure (Inches of Water Gauge)																				
CFM	0.10		0.20		0.30		0.40		0.50		0.60		0.70		0.80		0.90		1.00	
	RPM	BHP	RPM	BHP	RPM	BHP	RPM	BHP	RPM	BHP	RPM	BHP	RPM	BHP	RPM	BHP	RPM	BHP	RPM	BHP
6000	805	0.58	849	0.72	890	0.85	931	1.00	969	1.15	1004	1.30	1039	1.45	1072	1.60	1105	1.76	1136	1.92
6400	853	0.69	894	0.83	933	0.97	973	1.13	1010	1.28	1044	1.44	1077	1.60	1109	1.77	1140	1.93	1171	2.10
7200	950	0.94	987	1.10	1023	1.26	1057	1.42	1092	1.60	1125	1.77	1156	1.95	1186	2.13	1216	2.31	1244	2.49
8000	1048	1.24	1081	1.42	1114	1.60	1145	1.78	1176	1.96	1208	2.16	1239	2.35	1267	2.55	1295	2.74	1321	2.94
8800	1146	1.61	1177	1.81	1207	2.00	1236	2.20	1264	2.40	1292	2.60	1322	2.81	1350	3.03	1376	3.24	1402	3.46
9600	1244	2.05	1273	2.27	1301	2.48	1328	2.69	1355	2.91	1381	3.12	1406	3.34	1433	3.57	1459	3.81	1485	4.04

Available External Static Pressure (Inches of Water Gauge)

CFM	1.10		1.20		1.30		1.40		1.50		1.60		1.70		1.80		1.90		2.00	
	RPM	BHP	RPM	BHP	RPM	BHP	RPM	BHP	RPM	BHP	RPM	BHP	RPM	BHP	RPM	BHP	RPM	BHP	RPM	BHP
6000	1167	2.08	1197	2.24	1226	2.4	1254	2.57	1281	2.73	1308	2.9	1333	3.07	1358	3.25	1383	3.42	1408	3.6
6400	1201	2.27	1230	2.44	1258	2.61	1286	2.78	1313	2.95	1339	3.13	1365	3.31	1390	3.49	1414	3.67	1438	3.85
7200	1272	2.68	1299	2.86	1327	3.05	1353	3.24	1379	3.43	1404	3.62	1429	3.82	1454	4.01	1478	4.21	1501	4.4
8000	1348	3.14	1374	3.35	1399	3.55	1423	3.76	1448	3.97	1473	4.17	1497	4.39	1520	4.6	1543	4.81	1566	5.02
8800	1427	3.67	1451	3.89	1475	4.11	1499	4.34	1522	4.56	1544	4.79	1567	5.02	1590	5.24	1612	5.47	1634	5.7
9600	1508	4.28	1532	4.51	1555	4.75	1577	4.99	1599	5.23	1621	5.47	1642	5.71	1663	5.96	1681	6.13	1702	6.38

Notes:

1. Available External Static Pressure is the static pressure difference between the return duct and the supply duct plus the static pressure drop caused by accessories and options.
2. For direct drive evaporator fan speed (rpm), refer to the applicable table in the fan performance section.
3. Data includes pressure drop due to standard filters and wet coils. No accessories or options are included in pressure drop data.
4. To determine static pressure drop due to other options/accessories, refer to the applicable table in the fan performance section.
5. Direct drive fan motor heat is negligible.
6. Factory supplied motors, in commercial equipment, are definite purpose motors, specifically designed and tested to operate reliably and continuously at all cataloged conditions. Using the full horsepower range of our fan motors as shown in our tabular data will not result in nuisance tripping or premature motor failure. Our product's warranty will not be affected.

Table 58. Evaporator fan performance – 25 ton (model TZK), downflow

Available External Static Pressure (Inches of Water Gauge)																				
CFM	0.10		0.20		0.30		0.40		0.50		0.60		0.70		0.80		0.90		1.00	
	RPM	BHP	RPM	BHP	RPM	BHP	RPM	BHP	RPM	BHP	RPM	BHP	RPM	BHP	RPM	BHP	RPM	BHP	RPM	BHP
7500	987	1.04	1022	1.21	1056	1.38	1090	1.55	1123	1.73	1156	1.91	1187	2.09	1216	2.28	1245	2.46	1273	2.65
8000	1048	1.24	1081	1.42	1114	1.60	1145	1.78	1176	1.96	1208	2.16	1239	2.35	1267	2.55	1295	2.74	1321	2.94
9000	1170	1.72	1201	1.92	1230	2.12	1259	2.32	1287	2.52	1314	2.72	1343	2.94	1370	3.16	1397	3.38	1423	3.60

Table 58. Evaporator fan performance – 25 ton (model TZK), downflow (continued)

Available External Static Pressure (Inches of Water Gauge)																				
CFM	0.10		0.20		0.30		0.40		0.50		0.60		0.70		0.80		0.90		1.00	
	RPM	BHP	RPM	BHP	RPM	BHP	RPM	BHP	RPM	BHP	RPM	BHP	RPM	BHP	RPM	BHP	RPM	BHP	RPM	BHP
10000	1294	2.30	1321	2.52	1348	2.74	1374	2.97	1400	3.19	1425	3.42	1450	3.64	1475	3.88	1501	4.12	1526	4.36
11000	1418	3.01	1443	3.26	1468	3.50	1492	3.74	1515	3.99	1539	4.24	1562	4.48	1585	4.73	1607	4.98	1630	5.24
12000	1542	3.86	1565	4.13	1588	4.39	1611	4.66	1633	4.92	1654	5.19	1676	5.46	1697	5.73	1718	6.00	-	-
Available External Static Pressure (Inches of Water Gauge)																				
CFM	1.10		1.20		1.30		1.40		1.50		1.60		1.70		1.80		1.90		2.00	
	RPM	BHP	RPM	BHP	RPM	BHP	RPM	BHP	RPM	BHP	RPM	BHP	RPM	BHP	RPM	BHP	RPM	BHP	RPM	BHP
7500	1300	2.84	1326	3.04	1353	3.23	1379	3.43	1405	3.63	1429	3.83	1454	4.03	1478	4.22	1502	4.43	1525	4.63
8000	1348	3.14	1374	3.35	1399	3.55	1423	3.76	1448	3.97	1473	4.17	1497	4.39	1520	4.6	1543	4.81	1566	5.02
9000	1447	3.82	1471	4.04	1495	4.26	1518	4.49	1541	4.72	1563	4.95	1585	5.18	1608	5.42	1630	5.65	1652	5.88
10000	1550	4.61	1573	4.85	1595	5.09	1617	5.34	1638	5.59	1660	5.84	-	-	-	-	-	-	-	-
11000	1653	5.51	1676	5.78	1698	6.05	-	-	-	-	-	-	-	-	-	-	-	-	-	-
12000	-	-	-	-	-	-	-	-	-	-	-	-	-	-	-	-	-	-	-	-

Notes:

1. Available External Static Pressure is the static pressure difference between the return duct and the supply duct plus the static pressure drop caused by accessories and options.
2. For direct drive evaporator fan speed (rpm), refer to the applicable table in the fan performance section.
3. Data includes pressure drop due to standard filters and wet coils. No accessories or options are included in pressure drop data.
4. To determine static pressure drop due to other options/accessories, refer to the applicable table in the fan performance section.
5. Direct drive fan motor heat is negligible.
6. Factory supplied motors, in commercial equipment, are definite purpose motors, specifically designed and tested to operate reliably and continuously at all cataloged conditions. Using the full horsepower range of our fan motors as shown in our tabular data will not result in nuisance tripping or premature motor failure. Our product's warranty will not be affected.

Table 59. Evaporator fan performance – 25 ton (model TZK), downflow, high static motor

Available External Static Pressure (Inches of Water Gauge)																				
CFM	0.10		0.20		0.30		0.40		0.50		0.60		0.70		0.80		0.90		1.00	
	RPM	BHP	RPM	BHP	RPM	BHP	RPM	BHP	RPM	BHP	RPM	BHP	RPM	BHP	RPM	BHP	RPM	BHP	RPM	BHP
7500	987	1.04	1022	1.21	1056	1.38	1090	1.55	1123	1.73	1156	1.91	1187	2.09	1216	2.28	1245	2.46	1273	2.65
8000	1048	1.24	1081	1.42	1114	1.60	1145	1.78	1176	1.96	1208	2.16	1239	2.35	1267	2.55	1295	2.74	1321	2.94
9000	1170	1.72	1201	1.92	1230	2.12	1259	2.32	1287	2.52	1314	2.72	1343	2.94	1370	3.16	1397	3.38	1423	3.60
10000	1294	2.30	1321	2.52	1348	2.74	1374	2.97	1400	3.19	1425	3.42	1450	3.64	1475	3.88	1501	4.12	1526	4.36
11000	1418	3.01	1443	3.26	1468	3.50	1492	3.74	1515	3.99	1539	4.24	1562	4.48	1585	4.73	1607	4.98	1630	5.24
12000	1542	3.86	1565	4.13	1588	4.39	1611	4.66	1633	4.92	1654	5.19	1676	5.46	1697	5.73	1718	6.00	1734	6.12
Available External Static Pressure (Inches of Water Gauge)																				
CFM	1.10		1.20		1.30		1.40		1.50		1.60		1.70		1.80		1.90		2.00	
	RPM	BHP	RPM	BHP	RPM	BHP	RPM	BHP	RPM	BHP	RPM	BHP	RPM	BHP	RPM	BHP	RPM	BHP	RPM	BHP
7500	1300	2.84	1326	3.04	1353	3.23	1379	3.43	1405	3.63	1429	3.83	1454	4.03	1478	4.22	1502	4.43	1525	4.63
8000	1348	3.14	1374	3.35	1399	3.55	1423	3.76	1448	3.97	1473	4.17	1497	4.39	1520	4.6	1543	4.81	1566	5.02
9000	1447	3.82	1471	4.04	1495	4.26	1518	4.49	1541	4.72	1563	4.95	1585	5.18	1608	5.42	1630	5.65	1652	5.88
10000	1550	4.61	1573	4.85	1595	5.09	1617	5.34	1638	5.59	1660	5.84	1673	5.97	1696	6.24	1717	6.49	1738	6.74
11000	1653	5.51	1676	5.78	1698	6.05	1716	6.19	1735	6.46	1757	6.73	1761	6.76	1784	7.06	1804	7.33	1824	7.6
12000	1756	6.41	1779	6.71	1801	7.01	1815	7.04	1832	7.33	1854	7.62	1849	7.55	1872	7.88	1891	8.17	1910	8.46

Notes:

1. Available External Static Pressure is the static pressure difference between the return duct and the supply duct plus the static pressure drop caused by accessories and options.
2. For direct drive evaporator fan speed (rpm), refer to the applicable table in the fan performance section.
3. Data includes pressure drop due to standard filters and wet coils. No accessories or options are included in pressure drop data.
4. To determine static pressure drop due to other options/accessories, refer to the applicable table in the fan performance section.
5. Direct drive fan motor heat is negligible.
6. Factory supplied motors, in commercial equipment, are definite purpose motors, specifically designed and tested to operate reliably and continuously at all cataloged conditions. Using the full horsepower range of our fan motors as shown in our tabular data will not result in nuisance tripping or premature motor failure. Our product's warranty will not be affected.



Evaporator Fan Performance — Cooling

Horizontal

Figure 4. Fan curves – 3 to 5 tons (model TZK), horizontal

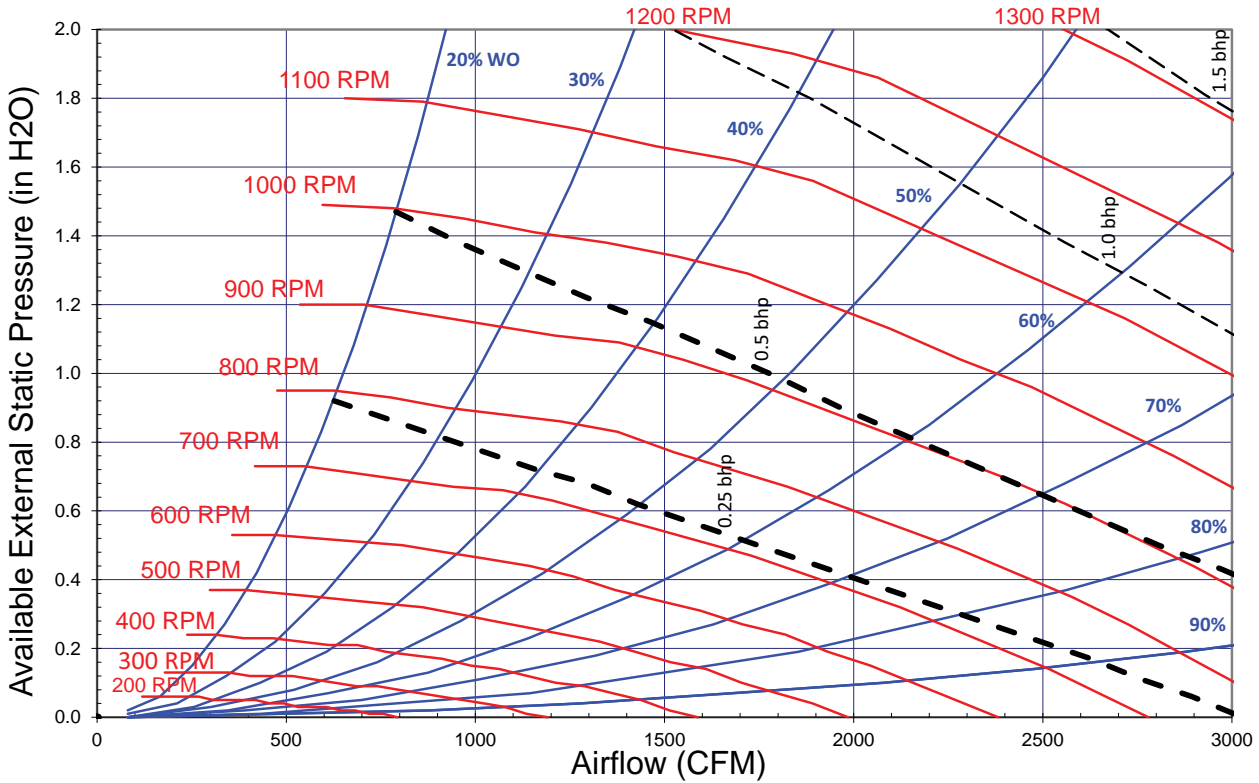

Table 60. Evaporator fan performance – 3 ton (model TZK), horizontal

Available External Static Pressure (Inches of Water Gauge)																				
CFM	0.10		0.20		0.30		0.40		0.50		0.60		0.70		0.80		0.90		1.00	
	RPM	BHP	RPM	BHP	RPM	BHP	RPM	BHP	RPM	BHP	RPM	BHP	RPM	BHP	RPM	BHP	RPM	BHP	RPM	BHP
900	340	0.03	424	0.05	492	0.08	550	0.11	609	0.14	661	0.17	709	0.21	754	0.24	797	0.28	837	0.32
960	350	0.03	432	0.05	499	0.08	557	0.11	612	0.14	665	0.18	713	0.21	758	0.25	801	0.29	841	0.33
1080	371	0.03	450	0.06	516	0.09	573	0.12	624	0.16	673	0.19	721	0.23	766	0.27	808	0.31	848	0.35
1200	394	0.04	468	0.07	533	0.10	589	0.14	640	0.17	686	0.21	729	0.24	774	0.29	816	0.33	856	0.37
1320	417	0.05	488	0.08	551	0.11	606	0.15	656	0.19	701	0.22	744	0.26	783	0.31	824	0.35	864	0.40
1440	441	0.06	509	0.09	569	0.13	624	0.16	672	0.20	717	0.24	759	0.29	799	0.33	836	0.37	872	0.42
Available External Static Pressure (Inches of Water Gauge)																				
CFM	1.10		1.20		1.30		1.40		1.50		1.60		1.70		1.80		1.90		2.00	
	RPM	BHP	RPM	BHP	RPM	BHP	RPM	BHP	RPM	BHP	RPM	BHP	RPM	BHP	RPM	BHP	RPM	BHP	RPM	BHP
900	875	0.36	911	0.41	946	0.45	980	0.49	1012	0.54	1044	0.59	1074	0.64	1103	0.69	1132	0.74	1162	0.79
960	879	0.37	915	0.42	950	0.46	984	0.51	1016	0.56	1047	0.6	1078	0.65	1107	0.7	1136	0.76	1164	0.81
1080	886	0.4	923	0.44	958	0.49	991	0.54	1023	0.59	1055	0.64	1085	0.69	1115	0.74	1143	0.79	1171	0.85
1200	894	0.42	930	0.47	965	0.52	999	0.57	1031	0.62	1062	0.67	1093	0.72	1122	0.77	1151	0.83	1179	0.89
1320	902	0.44	938	0.49	973	0.54	1006	0.59	1039	0.65	1070	0.7	1100	0.76	1130	0.81	1158	0.87	1186	0.93
1440	909	0.47	946	0.52	981	0.57	1014	0.63	1046	0.68	1078	0.74	1108	0.79	1137	0.85	1166	0.91	1194	0.97

Notes:

1. Available External Static Pressure is the static pressure difference between the return duct and the supply duct plus the static pressure drop caused by accessories and options.
2. Data includes pressure drop due to standard filters and wet coils. No accessories or options are included in pressure drop data.
3. To determine static pressure drop due to other options/accessories, refer to the applicable table in the fan performance section.
4. Direct drive fan motor heat is negligible.
5. Factory supplied motors, in commercial equipment, are definite purpose motors, specifically designed and tested to operate reliably and continuously at all cataloged conditions. Using the full horsepower range of our fan motors as shown in our tabular data will not result in nuisance tripping or premature motor failure. Our product's warranty will not be affected.

Table 61. Evaporator fan performance – 4 ton (model TZK), horizontal

Available External Static Pressure (Inches of Water Gauge)																				
CFM	0.10		0.20		0.30		0.40		0.50		0.60		0.70		0.80		0.90		1.00	
	RPM	BHP	RPM	BHP	RPM	BHP	RPM	BHP	RPM	BHP	RPM	BHP	RPM	BHP	RPM	BHP	RPM	BHP	RPM	BHP
1200	394	0.04	468	0.07	533	0.10	589	0.14	640	0.17	686	0.21	729	0.24	774	0.29	816	0.33	856	0.37
1280	409	0.05	482	0.08	545	0.11	600	0.14	650	0.18	696	0.22	738	0.26	779	0.30	821	0.34	861	0.39
1440	441	0.06	509	0.09	569	0.13	624	0.16	672	0.20	717	0.24	759	0.29	799	0.33	836	0.37	872	0.42
1600	475	0.07	538	0.11	595	0.14	647	0.18	696	0.23	740	0.27	781	0.31	820	0.36	857	0.41	892	0.46
1760	510	0.08	569	0.12	623	0.17	673	0.21	719	0.25	763	0.30	804	0.35	842	0.40	878	0.45	913	0.50
1920	545	0.10	600	0.14	652	0.19	699	0.23	744	0.28	787	0.33	827	0.38	865	0.43	900	0.49	934	0.54
Available External Static Pressure (Inches of Water Gauge)																				
CFM	1.10		1.20		1.30		1.40		1.50		1.60		1.70		1.80		1.90		2.00	
	RPM	BHP	RPM	BHP	RPM	BHP	RPM	BHP	RPM	BHP	RPM	BHP	RPM	BHP	RPM	BHP	RPM	BHP	RPM	BHP
1200	894	0.42	930	0.47	965	0.52	999	0.57	1031	0.62	1062	0.67	1093	0.72	1122	0.77	1151	0.83	1179	0.89
1280	899	0.44	935	0.48	970	0.53	1004	0.58	1036	0.64	1067	0.69	1098	0.74	1127	0.8	1156	0.86	1184	0.91
1440	909	0.47	946	0.52	981	0.57	1014	0.63	1046	0.68	1078	0.74	1108	0.79	1137	0.85	1166	0.91	1194	0.97
1600	925	0.51	957	0.56	991	0.61	1024	0.67	1057	0.72	1088	0.78	1118	0.84	1148	0.9	1176	0.96	1204	1.02
1760	946	0.55	978	0.6	1008	0.66	1038	0.71	1067	0.77	1098	0.83	1129	0.89	1158	0.95	1187	1.02	1215	1.08
1920	967	0.59	999	0.65	1029	0.71	1059	0.77	1087	0.82	1114	0.88	1141	0.95	1168	1.01	1197	1.07	1225	1.14

Notes:

1. Available External Static Pressure is the static pressure difference between the return duct and the supply duct plus the static pressure drop caused by accessories and options.
2. Data includes pressure drop due to standard filters and wet coils. No accessories or options are included in pressure drop data.
3. To determine static pressure drop due to other options/accessories, refer to the applicable table in the fan performance section.
4. Direct drive fan motor heat is negligible.
5. Factory supplied motors, in commercial equipment, are definite purpose motors, specifically designed and tested to operate reliably and continuously at all cataloged conditions. Using the full horsepower range of our fan motors as shown in our tabular data will not result in nuisance tripping or premature motor failure. Our product's warranty will not be affected.

Table 62. Evaporator fan performance – 5 ton (model TZK), horizontal

Available External Static Pressure (Inches of Water Gauge)																				
CFM	0.10		0.20		0.30		0.40		0.50		0.60		0.70		0.80		0.90		1.00	
	RPM	BHP	RPM	BHP	RPM	BHP	RPM	BHP	RPM	BHP	RPM	BHP	RPM	BHP	RPM	BHP	RPM	BHP	RPM	BHP
1500	454	0.06	520	0.10	579	0.13	632	0.17	681	0.21	726	0.25	767	0.30	807	0.34	844	0.39	879	0.43
1600	475	0.07	538	0.11	595	0.14	647	0.18	696	0.23	740	0.27	781	0.31	820	0.36	857	0.41	892	0.46
1800	519	0.09	577	0.13	630	0.17	679	0.21	725	0.26	769	0.31	809	0.36	847	0.40	884	0.46	918	0.51
2000	563	0.11	617	0.16	667	0.20	713	0.25	757	0.30	799	0.35	839	0.40	876	0.45	912	0.51	946	0.56
2200	609	0.14	659	0.19	705	0.24	750	0.29	791	0.34	831	0.39	869	0.45	906	0.50	941	0.56	975	0.62
2400	655	0.17	702	0.22	745	0.28	787	0.33	827	0.39	865	0.44	902	0.50	937	0.56	971	0.62	1004	0.69
Available External Static Pressure (Inches of Water Gauge)																				
CFM	1.10		1.20		1.30		1.40		1.50		1.60		1.70		1.80		1.90		2.00	
	RPM	BHP	RPM	BHP	RPM	BHP	RPM	BHP	RPM	BHP	RPM	BHP	RPM	BHP	RPM	BHP	RPM	BHP	RPM	BHP
1500	913	0.48	950	0.53	984	0.59	1018	0.64	1050	0.7	1082	0.75	1112	0.81	1141	0.87	1170	0.93	1198	0.99
1600	925	0.51	957	0.56	991	0.61	1024	0.67	1057	0.72	1088	0.78	1118	0.84	1148	0.9	1176	0.96	1204	1.02
1800	951	0.56	983	0.61	1014	0.67	1043	0.73	1071	0.78	1101	0.84	1131	0.9	1161	0.97	1189	1.03	1217	1.1
2000	978	0.62	1010	0.68	1040	0.73	1069	0.79	1097	0.85	1125	0.91	1151	0.98	1177	1.04	1202	1.1	1230	1.17
2200	1007	0.68	1037	0.74	1067	0.8	1096	0.87	1124	0.93	1151	0.99	1178	1.06	1203	1.13	1228	1.19	1253	1.26
2400	1036	0.75	1066	0.81	1095	0.88	1124	0.94	1151	1.01	1178	1.08	1204	1.15	1230	1.22	1255	1.29	1279	1.36

Notes:

1. Available External Static Pressure is the static pressure difference between the return duct and the supply duct plus the static pressure drop caused by accessories and options.
2. Data includes pressure drop due to standard filters and wet coils. No accessories or options are included in pressure drop data.
3. To determine static pressure drop due to other options/accessories, refer to the applicable table in the fan performance section.
4. Direct drive fan motor heat is negligible.
5. Factory supplied motors, in commercial equipment, are definite purpose motors, specifically designed and tested to operate reliably and continuously at all cataloged conditions. Using the full horsepower range of our fan motors as shown in our tabular data will not result in nuisance tripping or premature motor failure. Our product's warranty will not be affected.



Evaporator Fan Performance — Cooling

Figure 5. Fan curves — 6 to 10 tons (model T*K), horizontal

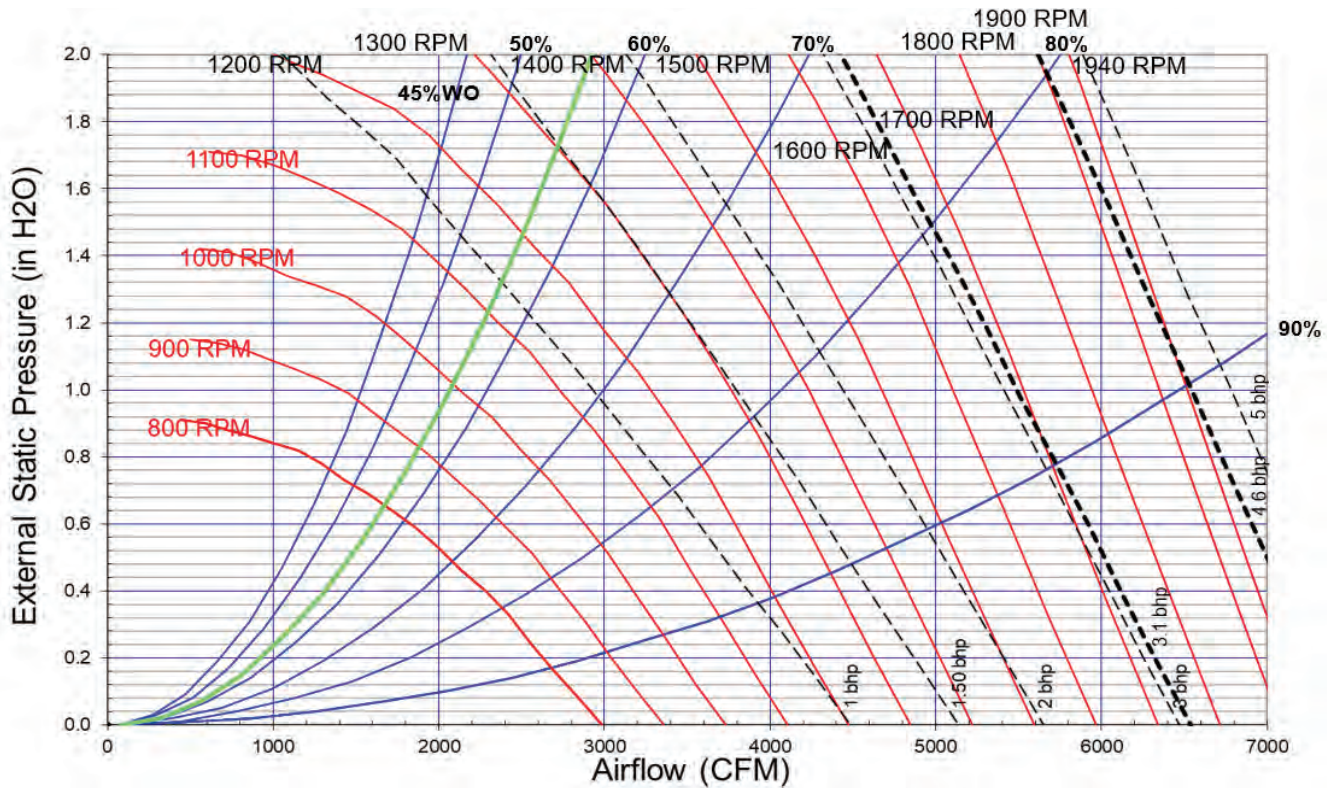

Table 63. Evaporator fan performance – 6 ton (model TZK), horizontal

Available External Static Pressure (Inches of Water Gauge)																				
CFM	0.10		0.20		0.30		0.40		0.50		0.60		0.70		0.80		0.90		1.00	
	RPM	BHP	RPM	BHP	RPM	BHP	RPM	BHP	RPM	BHP	RPM	BHP	RPM	BHP	RPM	BHP	RPM	BHP	RPM	BHP
1800	550	0.11	606	0.15	658	0.19	708	0.24	754	0.29	797	0.35	839	0.40	878	0.46	915	0.52	951	0.58
1920	579	0.12	632	0.17	682	0.22	730	0.27	775	0.32	817	0.37	858	0.43	896	0.49	933	0.55	968	0.61
2040	608	0.14	659	0.19	707	0.24	753	0.29	797	0.35	838	0.40	876	0.46	915	0.52	951	0.59	986	0.65
2160	638	0.16	687	0.21	732	0.26	776	0.32	819	0.37	859	0.43	897	0.49	933	0.56	970	0.62	1004	0.69
2280	667	0.18	715	0.24	758	0.29	801	0.35	842	0.41	881	0.47	919	0.53	954	0.59	988	0.66	1023	0.73
2400	697	0.21	744	0.26	785	0.32	825	0.38	865	0.44	904	0.50	940	0.57	975	0.63	1009	0.70	1041	0.77
2520	727	0.24	772	0.29	812	0.35	851	0.41	889	0.48	926	0.54	963	0.61	997	0.68	1030	0.75	1061	0.82
2640	758	0.26	801	0.33	840	0.39	877	0.45	914	0.52	950	0.58	985	0.65	1019	0.72	1052	0.79	1083	0.87
2760	788	0.30	830	0.36	868	0.42	904	0.49	939	0.56	974	0.63	1008	0.70	1041	0.77	1073	0.84	1104	0.92
2880	818	0.33	859	0.40	896	0.46	930	0.53	965	0.60	998	0.67	1032	0.75	1064	0.82	1096	0.90	1126	0.97
Available External Static Pressure (Inches of Water Gauge)																				
CFM	1.10		1.20		1.30		1.40		1.50		1.60		1.70		1.80		1.90		2.00	
	RPM	BHP	RPM	BHP	RPM	BHP	RPM	BHP	RPM	BHP	RPM	BHP	RPM	BHP	RPM	BHP	RPM	BHP	RPM	BHP
1800	985	0.64	1018	0.7	1050	0.76	1080	0.83	1109	0.89	1138	0.96	1165	1.03	1193	1.1	1223	1.17	1251	1.25
1920	1002	0.68	1034	0.74	1066	0.81	1096	0.87	1126	0.94	1154	1.01	1181	1.08	1208	1.15	1234	1.22	1260	1.29
2040	1019	0.72	1051	0.78	1083	0.85	1113	0.92	1142	0.99	1170	1.06	1198	1.13	1224	1.21	1250	1.28	1276	1.35
2160	1037	0.76	1069	0.83	1099	0.9	1129	0.97	1158	1.04	1187	1.11	1214	1.19	1241	1.26	1267	1.34	1292	1.42
2280	1056	0.8	1087	0.87	1117	0.94	1147	1.02	1175	1.09	1203	1.17	1231	1.25	1257	1.32	1283	1.4	1308	1.48
2400	1074	0.84	1105	0.92	1135	0.99	1165	1.07	1193	1.15	1220	1.23	1247	1.31	1274	1.39	1300	1.47	1325	1.55
2520	1093	0.89	1124	0.97	1154	1.05	1183	1.12	1211	1.2	1238	1.29	1265	1.37	1291	1.45	1316	1.53	1341	1.62
2640	1113	0.94	1142	1.02	1172	1.1	1201	1.18	1229	1.26	1256	1.35	1283	1.43	1308	1.52	1333	1.6	1358	1.69
2760	1134	1	1163	1.08	1191	1.16	1220	1.24	1248	1.32	1275	1.41	1301	1.49	1326	1.58	1351	1.67	1376	1.76

Table 63. Evaporator fan performance – 6 ton (model TZK), horizontal (continued)

Available External Static Pressure (Inches of Water Gauge)																				
CFM	1.10		1.20		1.30		1.40		1.50		1.60		1.70		1.80		1.90		2.00	
	RPM	BHP	RPM	BHP	RPM	BHP	RPM	BHP	RPM	BHP	RPM	BHP	RPM	BHP	RPM	BHP	RPM	BHP	RPM	BHP
2880	1156	1.05	1184	1.13	1211	1.22	1238	1.3	1266	1.39	1293	1.47	1319	1.56	1345	1.65	1369	1.74	1394	1.83

Notes:

1. Available External Static Pressure is the static pressure difference between the return duct and the supply duct plus the static pressure drop caused by accessories and options.
2. For direct drive evaporator fan speed (rpm), refer to the applicable table in the fan performance section.
3. Data includes pressure drop due to standard filters and wet coils. No accessories or options are included in pressure drop data.
4. To determine static pressure drop due to other options/accessories, refer to the applicable table in the fan performance section.
5. Direct drive fan motor heat is negligible.
6. Factory supplied motors, in commercial equipment, are definite purpose motors, specifically designed and tested to operate reliably and continuously at all cataloged conditions. Using the full horsepower range of our fan motors as shown in our tabular data will not result in nuisance tripping or premature motor failure. Our product's warranty will not be affected.

Table 64. Evaporator fan performance – 7.5 ton (model TZK), horizontal

Available External Static Pressure (Inches of Water Gauge)																				
CFM	0.10		0.20		0.30		0.40		0.50		0.60		0.70		0.80		0.90		1.00	
	RPM	BHP	RPM	BHP	RPM	BHP	RPM	BHP	RPM	BHP	RPM	BHP	RPM	BHP	RPM	BHP	RPM	BHP	RPM	BHP
2250	660	0.18	708	0.23	752	0.28	795	0.34	836	0.40	876	0.46	913	0.52	949	0.58	984	0.65	1018	0.72
2400	697	0.21	744	0.26	785	0.32	825	0.38	865	0.44	904	0.50	940	0.57	975	0.63	1009	0.70	1041	0.77
2550	735	0.24	779	0.30	819	0.36	857	0.42	895	0.49	932	0.55	968	0.62	1003	0.69	1035	0.76	1067	0.83
2700	773	0.28	816	0.34	854	0.40	890	0.47	926	0.54	962	0.60	996	0.67	1030	0.74	1062	0.82	1094	0.89
2850	811	0.32	852	0.39	889	0.45	924	0.52	958	0.59	992	0.66	1026	0.73	1058	0.81	1090	0.88	1121	0.96
3000	849	0.37	889	0.44	925	0.51	958	0.58	991	0.65	1023	0.72	1056	0.80	1087	0.87	1118	0.95	1148	1.03
3150	887	0.42	926	0.49	961	0.56	994	0.64	1025	0.71	1056	0.79	1087	0.87	1117	0.95	1147	1.03	1176	1.11
3300	926	0.47	963	0.55	997	0.63	1029	0.70	1059	0.78	1089	0.86	1118	0.94	1148	1.02	1177	1.11	1205	1.19
3600	1003	0.60	1038	0.68	1070	0.77	1101	0.85	1129	0.93	1156	1.01	1184	1.10	1211	1.19	1238	1.28	1265	1.37

Available External Static Pressure (Inches of Water Gauge)																				
CFM	1.10		1.20		1.30		1.40		1.50		1.60		1.70		1.80		1.90		2.00	
	RPM	BHP	RPM	BHP	RPM	BHP	RPM	BHP	RPM	BHP	RPM	BHP	RPM	BHP	RPM	BHP	RPM	BHP	RPM	BHP
2250	1051	0.79	1083	0.86	1113	0.93	1142	1.01	1171	1.08	1199	1.16	1226	1.23	1253	1.31	1279	1.39	1304	1.46
2400	1074	0.84	1105	0.92	1135	0.99	1165	1.07	1193	1.15	1220	1.23	1247	1.31	1274	1.39	1300	1.47	1325	1.55
2550	1097	0.9	1128	0.98	1158	1.06	1187	1.14	1215	1.22	1243	1.3	1269	1.38	1295	1.47	1320	1.55	1345	1.63
2700	1123	0.97	1152	1.05	1182	1.13	1210	1.21	1238	1.29	1265	1.38	1292	1.46	1317	1.55	1342	1.64	1367	1.72
2850	1150	1.04	1179	1.12	1206	1.2	1234	1.28	1261	1.37	1288	1.46	1315	1.55	1340	1.63	1365	1.72	1389	1.82
3000	1177	1.11	1206	1.2	1233	1.28	1259	1.37	1285	1.45	1312	1.54	1338	1.63	1363	1.72	1388	1.82	1412	1.91
3150	1205	1.19	1233	1.28	1260	1.36	1286	1.45	1311	1.54	1336	1.63	1361	1.72	1386	1.82	1411	1.92	1435	2.01
3300	1233	1.28	1260	1.36	1287	1.45	1313	1.54	1338	1.64	1363	1.73	1386	1.82	1410	1.92	1434	2.02	1458	2.12
3600	1291	1.46	1317	1.55	1343	1.65	1368	1.74	1393	1.84	1417	1.94	1440	2.04	1463	2.14	1486	2.24	1507	2.34

Notes:

1. Available External Static Pressure is the static pressure difference between the return duct and the supply duct plus the static pressure drop caused by accessories and options.
2. For direct drive evaporator fan speed (rpm), refer to the applicable table in the fan performance section.
3. Data includes pressure drop due to standard filters and wet coils. No accessories or options are included in pressure drop data.
4. To determine static pressure drop due to other options/accessories, refer to the applicable table in the fan performance section.
5. Direct drive fan motor heat is negligible.
6. Factory supplied motors, in commercial equipment, are definite purpose motors, specifically designed and tested to operate reliably and continuously at all cataloged conditions. Using the full horsepower range of our fan motors as shown in our tabular data will not result in nuisance tripping or premature motor failure. Our product's warranty will not be affected.

Table 65. Evaporator fan performance – 8.5 ton (model TZK), horizontal

Available External Static Pressure (Inches of Water Gauge)																				
CFM	0.10		0.20		0.30		0.40		0.50		0.60		0.70		0.80		0.90		1.00	
	RPM	BHP	RPM	BHP	RPM	BHP	RPM	BHP	RPM	BHP	RPM	BHP	RPM	BHP	RPM	BHP	RPM	BHP	RPM	BHP
2550	735	0.24	779	0.30	819	0.36	857	0.42	895	0.49	932	0.55	968	0.62	1003	0.69	1035	0.76	1067	0.83
2720	778	0.29	820	0.35	859	0.41	895	0.48	930	0.54	966	0.61	1000	0.68	1034	0.75	1066	0.83	1097	0.90



Evaporator Fan Performance — Cooling

Table 65. Evaporator fan performance – 8.5 ton (model TZK), horizontal (continued)

Available External Static Pressure (Inches of Water Gauge)																				
CFM	0.10		0.20		0.30		0.40		0.50		0.60		0.70		0.80		0.90		1.00	
	RPM	BHP	RPM	BHP	RPM	BHP	RPM	BHP	RPM	BHP	RPM	BHP	RPM	BHP	RPM	BHP	RPM	BHP	RPM	BHP
2890	821	0.33	862	0.40	899	0.47	933	0.53	967	0.61	1001	0.68	1034	0.75	1066	0.82	1097	0.90	1128	0.98
3060	864	0.39	903	0.46	940	0.53	972	0.60	1004	0.67	1036	0.75	1068	0.82	1099	0.90	1129	0.98	1159	1.06
3230	908	0.45	945	0.52	980	0.60	1012	0.67	1043	0.75	1073	0.83	1103	0.91	1133	0.99	1163	1.07	1191	1.15
3400	952	0.51	988	0.59	1021	0.67	1053	0.75	1082	0.83	1111	0.91	1140	0.99	1168	1.08	1197	1.16	1225	1.25
3570	996	0.59	1030	0.67	1063	0.75	1094	0.83	1122	0.92	1150	1.00	1177	1.08	1205	1.17	1232	1.26	1259	1.35
3740	1040	0.67	1073	0.75	1104	0.84	1134	0.92	1163	1.01	1189	1.10	1215	1.18	1242	1.28	1267	1.37	1293	1.46
4080	1128	0.85	1159	0.94	1189	1.03	1217	1.13	1244	1.22	1269	1.32	1294	1.41	1318	1.50	1342	1.60	1366	1.71
Available External Static Pressure (Inches of Water Gauge)																				
CFM	1.10		1.20		1.30		1.40		1.50		1.60		1.70		1.80		1.90		2.00	
	RPM	BHP	RPM	BHP	RPM	BHP	RPM	BHP	RPM	BHP	RPM	BHP	RPM	BHP	RPM	BHP	RPM	BHP	RPM	BHP
2550	1097	0.9	1128	0.98	1158	1.06	1187	1.14	1215	1.22	1243	1.3	1269	1.38	1295	1.47	1320	1.55	1345	1.63
2720	1127	0.98	1156	1.06	1185	1.14	1214	1.22	1241	1.3	1268	1.39	1295	1.47	1320	1.56	1345	1.65	1370	1.74
2890	1157	1.06	1186	1.14	1213	1.22	1240	1.31	1268	1.39	1295	1.48	1321	1.57	1346	1.66	1371	1.75	1395	1.84
3060	1188	1.14	1216	1.23	1243	1.31	1270	1.4	1295	1.49	1321	1.58	1347	1.67	1372	1.76	1397	1.86	1421	1.95
3230	1220	1.24	1247	1.32	1274	1.41	1300	1.5	1326	1.59	1350	1.68	1374	1.78	1399	1.87	1423	1.97	1447	2.07
3400	1252	1.33	1279	1.42	1305	1.52	1331	1.61	1356	1.7	1380	1.8	1404	1.89	1427	1.99	1450	2.09	1474	2.19
3570	1285	1.44	1311	1.53	1337	1.63	1362	1.72	1387	1.82	1411	1.92	1435	2.02	1458	2.12	1480	2.22	1502	2.32
3740	1319	1.56	1345	1.65	1369	1.75	1394	1.84	1418	1.94	1442	2.04	1466	2.15	1488	2.25	1511	2.35	1532	2.46
4080	1389	1.81	1413	1.91	1437	2.01	1460	2.11	1483	2.22	1506	2.32	1528	2.43	1551	2.54	1573	2.65	1594	2.76

Notes:

1. Available External Static Pressure is the static pressure difference between the return duct and the supply duct plus the static pressure drop caused by accessories and options.
2. For direct drive evaporator fan speed (rpm), refer to the applicable table in the fan performance section.
3. Data includes pressure drop due to standard filters and wet coils. No accessories or options are included in pressure drop data.
4. To determine static pressure drop due to other options/accessories, refer to the applicable table in the fan performance section.
5. Direct drive fan motor heat is negligible.
6. Factory supplied motors, in commercial equipment, are definite purpose motors, specifically designed and tested to operate reliably and continuously at all cataloged conditions. Using the full horsepower range of our fan motors as shown in our tabular data will not result in nuisance tripping or premature motor failure. Our product's warranty will not be affected.

Table 66. Evaporator fan performance – 10 ton (model TZK), horizontal

Available External Static Pressure (Inches of Water Gauge)																				
CFM	0.10		0.20		0.30		0.40		0.50		0.60		0.70		0.80		0.90		1.00	
	RPM	BHP	RPM	BHP	RPM	BHP	RPM	BHP	RPM	BHP	RPM	BHP	RPM	BHP	RPM	BHP	RPM	BHP	RPM	BHP
3000	834	0.34	869	0.40	901	0.46	935	0.52	967	0.59	999	0.66	1030	0.73	1063	0.81	1094	0.89	1124	0.96
3200	885	0.41	918	0.47	949	0.53	980	0.59	1011	0.66	1041	0.74	1070	0.81	1100	0.89	1131	0.97	1160	1.06
3400	936	0.48	968	0.54	997	0.61	1026	0.67	1056	0.75	1084	0.82	1112	0.90	1140	0.98	1167	1.06	1197	1.15
3600	987	0.56	1018	0.63	1046	0.70	1073	0.77	1101	0.84	1128	0.92	1155	1.00	1182	1.08	1208	1.16	1234	1.25
3800	1039	0.65	1068	0.72	1095	0.80	1121	0.87	1147	0.94	1173	1.02	1199	1.11	1224	1.19	1250	1.28	1274	1.37
4000	1091	0.75	1118	0.83	1144	0.90	1170	0.98	1194	1.06	1219	1.14	1244	1.23	1268	1.31	1292	1.40	1316	1.49
4200	1142	0.86	1169	0.94	1194	1.02	1218	1.10	1242	1.18	1265	1.26	1289	1.35	1312	1.44	1335	1.54	1359	1.63
4400	1194	0.98	1220	1.07	1244	1.15	1267	1.23	1290	1.32	1312	1.40	1335	1.49	1358	1.59	1380	1.68	1402	1.78
4600	1246	1.12	1271	1.20	1294	1.29	1317	1.38	1339	1.46	1360	1.55	1381	1.64	1403	1.74	1425	1.84	1446	1.94
4800	1297	1.26	1322	1.35	1344	1.44	1366	1.53	1388	1.62	1408	1.71	1429	1.81	1449	1.90	1470	2.01	1491	2.11
Available External Static Pressure (Inches of Water Gauge)																				
CFM	1.10		1.20		1.30		1.40		1.50		1.60		1.70		1.80		1.90		2.00	
	RPM	BHP	RPM	BHP	RPM	BHP	RPM	BHP	RPM	BHP	RPM	BHP	RPM	BHP	RPM	BHP	RPM	BHP	RPM	BHP
3000	1152	1.04	1179	1.12	1208	1.2	1236	1.29	1263	1.37	1290	1.46	1316	1.54	1342	1.63	1367	1.72	1391	1.82
3200	1188	1.14	1215	1.22	1241	1.3	1268	1.39	1294	1.48	1320	1.57	1345	1.66	1370	1.75	1395	1.84	1420	1.94
3400	1225	1.24	1252	1.33	1277	1.42	1302	1.5	1326	1.59	1352	1.69	1377	1.78	1401	1.87	1425	1.97	1448	2.06
3600	1261	1.34	1288	1.44	1314	1.54	1339	1.63	1363	1.72	1386	1.81	1409	1.91	1433	2.01	1456	2.11	1480	2.2

Table 66. Evaporator fan performance – 10 ton (model TZK), horizontal (continued)

CFM	Available External Static Pressure (Inches of Water Gauge)																			
	1.10		1.20		1.30		1.40		1.50		1.60		1.70		1.80		1.90		2.00	
	RPM	BHP	RPM	BHP	RPM	BHP	RPM	BHP	RPM	BHP	RPM	BHP	RPM	BHP	RPM	BHP	RPM	BHP	RPM	BHP
3800	1298	1.46	1325	1.56	1350	1.66	1375	1.76	1399	1.86	1422	1.95	1445	2.05	1466	2.15	1488	2.25	1511	2.35
4000	1339	1.59	1362	1.68	1387	1.78	1412	1.89	1436	1.99	1459	2.1	1481	2.2	1503	2.31	1524	2.41	1545	2.52
4200	1381	1.73	1403	1.82	1425	1.92	1448	2.03	1472	2.14	1495	2.25	1518	2.36	1540	2.47	1561	2.58	1581	2.69
4400	1424	1.88	1445	1.98	1467	2.08	1487	2.18	1509	2.29	1532	2.4	1554	2.52	1576	2.64	1597	2.76	1618	2.87
4600	1467	2.04	1488	2.14	1509	2.25	1529	2.35	1549	2.46	1569	2.57	1591	2.69	1613	2.81	1634	2.93	1654	3.05
4800	1511	2.21	1531	2.32	1551	2.43	1571	2.54	1591	2.65	1610	2.76	1629	2.87	1649	2.99	1670	3.12	1691	3.24

Notes:

1. Available External Static Pressure is the static pressure difference between the return duct and the supply duct plus the static pressure drop caused by accessories and options.
2. For direct drive evaporator fan speed (rpm), refer to the applicable table in the fan performance section.
3. Data includes pressure drop due to standard filters and wet coils. No accessories or options are included in pressure drop data.
4. To determine static pressure drop due to other options/accessories, refer to the applicable table in the fan performance section.
5. Direct drive fan motor heat is negligible.
6. Factory supplied motors, in commercial equipment, are definite purpose motors, specifically designed and tested to operate reliably and continuously at all cataloged conditions. Using the full horsepower range of our fan motors as shown in our tabular data will not result in nuisance tripping or premature motor failure. Our product's warranty will not be affected.

Figure 6. Fan curves – 12.5 to 25 ton, (model TZK) horizontal

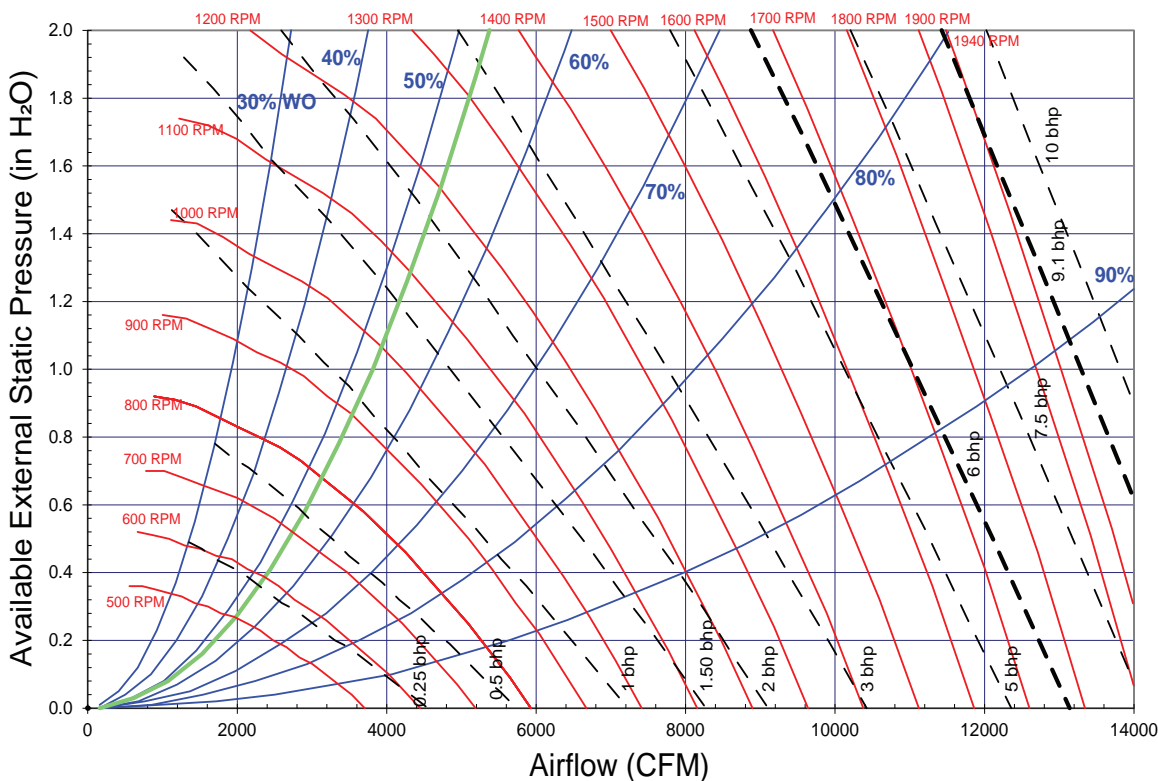

Table 67. Evaporator fan performance – 12.5 ton (model TZK), horizontal

CFM	Available External Static Pressure (Inches of Water Gauge)																			
	0.10		0.20		0.30		0.40		0.50		0.60		0.70		0.80		0.90		1.00	
	RPM	BHP	RPM	BHP	RPM	BHP	RPM	BHP	RPM	BHP	RPM	BHP	RPM	BHP	RPM	BHP	RPM	BHP	RPM	BHP
3750	569	0.22	626	0.31	678	0.40	726	0.49	772	0.59	815	0.70	855	0.80	894	0.91	930	1.02	965	1.13
4000	599	0.26	654	0.35	704	0.44	750	0.54	794	0.65	836	0.75	876	0.86	914	0.97	950	1.09	984	1.20
4500	660	0.34	710	0.44	757	0.55	800	0.66	842	0.77	880	0.88	919	1.00	955	1.12	990	1.25	1024	1.37
5000	722	0.44	769	0.55	812	0.67	852	0.78	892	0.91	929	1.03	964	1.16	999	1.29	1033	1.42	1065	1.56



Evaporator Fan Performance — Cooling

Table 67. Evaporator fan performance – 12.5 ton (model TZK), horizontal (continued)

Available External Static Pressure (Inches of Water Gauge)																				
CFM	0.10		0.20		0.30		0.40		0.50		0.60		0.70		0.80		0.90		1.00	
	RPM	BHP	RPM	BHP	RPM	BHP	RPM	BHP	RPM	BHP	RPM	BHP	RPM	BHP	RPM	BHP	RPM	BHP	RPM	BHP
5500	785	0.56	828	0.68	869	0.81	907	0.93	944	1.06	979	1.20	1013	1.34	1046	1.48	1077	1.62	1109	1.76
6000	849	0.70	889	0.83	927	0.97	963	1.11	998	1.25	1031	1.39	1064	1.54	1095	1.69	1125	1.84	1155	1.99
Available External Static Pressure (Inches of Water Gauge)																				
CFM	1.10		1.20		1.30		1.40		1.50		1.60		1.70		1.80		1.90		2.00	
	RPM	BHP	RPM	BHP	RPM	BHP	RPM	BHP	RPM	BHP	RPM	BHP	RPM	BHP	RPM	BHP	RPM	BHP	RPM	BHP
3750	999	1.25	1033	1.37	1064	1.49	1095	1.62	1125	1.75	1154	1.88	1182	2.01	1210	2.15	1239	2.29	1267	2.43
4000	1016	1.32	1049	1.45	1081	1.58	1112	1.71	1142	1.84	1170	1.97	1198	2.11	1225	2.25	1252	2.39	1278	2.54
4500	1056	1.5	1087	1.63	1117	1.76	1146	1.89	1175	2.03	1204	2.18	1231	2.32	1258	2.47	1285	2.62	1310	2.77
5000	1097	1.69	1127	1.83	1157	1.97	1185	2.12	1213	2.26	1240	2.41	1266	2.56	1292	2.71	1318	2.87	1344	3.03
5500	1139	1.91	1168	2.06	1197	2.21	1226	2.36	1253	2.51	1279	2.67	1305	2.83	1330	2.98	1355	3.15	1379	3.31
6000	1184	2.15	1212	2.3	1240	2.46	1267	2.63	1294	2.79	1320	2.95	1346	3.12	1370	3.29	1395	3.46	1418	3.63

Notes:

1. Available External Static Pressure is the static pressure difference between the return duct and the supply duct plus the static pressure drop caused by accessories and options.
2. For direct drive evaporator fan speed (rpm), refer to the applicable table in the fan performance section.
3. Data includes pressure drop due to standard filters and wet coils. No accessories or options are included in pressure drop data.
4. To determine static pressure drop due to other options/accessories, refer to the applicable table in the fan performance section.
5. Direct drive fan motor heat is negligible.
6. Factory supplied motors, in commercial equipment, are definite purpose motors, specifically designed and tested to operate reliably and continuously at all cataloged conditions. Using the full horsepower range of our fan motors as shown in our tabular data will not result in nuisance tripping or premature motor failure. Our product's warranty will not be affected.

Table 68. Evaporator fan performance – 15 ton (model TZK), horizontal

Available External Static Pressure (Inches of Water Gauge)																				
CFM	0.10		0.20		0.30		0.40		0.50		0.60		0.70		0.80		0.90		1.00	
	RPM	BHP	RPM	BHP	RPM	BHP	RPM	BHP	RPM	BHP	RPM	BHP	RPM	BHP	RPM	BHP	RPM	BHP	RPM	BHP
4500	660	0.34	710	0.44	757	0.55	800	0.66	842	0.77	880	0.88	919	1.00	955	1.12	990	1.25	1024	1.37
4800	697	0.40	745	0.51	790	0.62	831	0.73	871	0.85	909	0.97	946	1.09	981	1.22	1015	1.35	1048	1.48
5400	772	0.53	816	0.65	857	0.78	896	0.90	933	1.03	969	1.16	1003	1.30	1036	1.44	1068	1.58	1100	1.72
6000	849	0.70	889	0.83	927	0.97	963	1.11	998	1.25	1031	1.39	1064	1.54	1095	1.69	1125	1.84	1155	1.99
6600	926	0.90	962	1.05	998	1.20	1032	1.35	1064	1.50	1096	1.65	1126	1.81	1156	1.97	1185	2.13	1213	2.30
7200	1004	1.14	1037	1.30	1071	1.46	1103	1.62	1133	1.79	1162	1.95	1191	2.12	1219	2.29	1247	2.46	1274	2.64
Available External Static Pressure (Inches of Water Gauge)																				
CFM	1.10		1.20		1.30		1.40		1.50		1.60		1.70		1.80		1.90		2.00	
	RPM	BHP	RPM	BHP	RPM	BHP	RPM	BHP	RPM	BHP	RPM	BHP	RPM	BHP	RPM	BHP	RPM	BHP	RPM	BHP
4500	1056	1.5	1087	1.63	1117	1.76	1146	1.89	1175	2.03	1204	2.18	1231	2.32	1258	2.47	1285	2.62	1310	2.77
4800	1080	1.61	1111	1.75	1141	1.89	1169	2.02	1197	2.17	1224	2.31	1252	2.46	1278	2.61	1305	2.77	1330	2.92
5400	1130	1.86	1160	2.01	1189	2.16	1217	2.31	1245	2.46	1271	2.61	1297	2.77	1323	2.93	1347	3.09	1371	3.25
6000	1184	2.15	1212	2.3	1240	2.46	1267	2.63	1294	2.79	1320	2.95	1346	3.12	1370	3.29	1395	3.46	1418	3.63
6600	1241	2.46	1268	2.63	1294	2.8	1320	2.98	1346	3.15	1371	3.33	1395	3.51	1419	3.69	1443	3.87	1467	4.05
7200	1300	2.82	1326	3	1352	3.18	1376	3.37	1400	3.55	1424	3.74	1448	3.93	1472	4.12	1494	4.31	1517	4.51

Notes:

1. Available External Static Pressure is the static pressure difference between the return duct and the supply duct plus the static pressure drop caused by accessories and options.
2. For direct drive evaporator fan speed (rpm), refer to the applicable table in the fan performance section.
3. Data includes pressure drop due to standard filters and wet coils. No accessories or options are included in pressure drop data.
4. To determine static pressure drop due to other options/accessories, refer to the applicable table in the fan performance section.
5. Direct drive fan motor heat is negligible.
6. Factory supplied motors, in commercial equipment, are definite purpose motors, specifically designed and tested to operate reliably and continuously at all cataloged conditions. Using the full horsepower range of our fan motors as shown in our tabular data will not result in nuisance tripping or premature motor failure. Our product's warranty will not be affected.

Table 69. Evaporator fan performance – 17.5 ton (model TZK), horizontal

Available External Static Pressure (Inches of Water Gauge)																				
CFM	0.10		0.20		0.30		0.40		0.50		0.60		0.70		0.80		0.90		1.00	
	RPM	BHP	RPM	BHP	RPM	BHP	RPM	BHP	RPM	BHP	RPM	BHP	RPM	BHP	RPM	BHP	RPM	BHP	RPM	BHP
5250	753	0.50	798	0.61	840	0.73	880	0.86	917	0.98	954	1.11	988	1.25	1022	1.38	1055	1.52	1087	1.66
5600	798	0.59	840	0.71	880	0.84	918	0.97	954	1.10	989	1.24	1023	1.37	1056	1.52	1087	1.66	1118	1.81
6300	887	0.80	925	0.94	962	1.08	997	1.22	1031	1.37	1063	1.52	1095	1.67	1125	1.82	1155	1.98	1184	2.14
7000	978	1.06	1012	1.21	1046	1.37	1079	1.53	1110	1.69	1140	1.85	1169	2.01	1198	2.18	1226	2.35	1254	2.52
7700	1069	1.38	1100	1.54	1131	1.71	1162	1.88	1191	2.06	1219	2.24	1247	2.41	1274	2.59	1300	2.77	1326	2.96

Available External Static Pressure (Inches of Water Gauge)																				
CFM	1.10		1.20		1.30		1.40		1.50		1.60		1.70		1.80		1.90		2.00	
	RPM	BHP	RPM	BHP	RPM	BHP	RPM	BHP	RPM	BHP	RPM	BHP	RPM	BHP	RPM	BHP	RPM	BHP	RPM	BHP
5250	1117	1.8	1148	1.94	1177	2.09	1205	2.24	1233	2.38	1259	2.53	1285	2.69	1311	2.84	1335	3	1360	3.16
5600	1148	1.95	1177	2.11	1206	2.26	1234	2.41	1261	2.57	1287	2.72	1313	2.88	1338	3.04	1363	3.21	1387	3.37
6300	1212	2.3	1239	2.46	1267	2.63	1293	2.8	1319	2.97	1345	3.14	1370	3.31	1395	3.48	1419	3.66	1443	3.83
7000	1280	2.7	1307	2.87	1332	3.05	1357	3.23	1382	3.41	1406	3.6	1430	3.78	1454	3.97	1477	4.16	1500	4.35
7700	1352	3.15	1377	3.34	1401	3.53	1425	3.72	1448	3.92	1471	4.11	1494	4.31	1516	4.51	1539	4.71	1561	4.92

Notes:

1. Available External Static Pressure is the static pressure difference between the return duct and the supply duct plus the static pressure drop caused by accessories and options.
2. For direct drive evaporator fan speed (rpm), refer to the applicable table in the fan performance section.
3. Data includes pressure drop due to standard filters and wet coils. No accessories or options are included in pressure drop data.
4. To determine static pressure drop due to other options/accessories, refer to the applicable table in the fan performance section.
5. Direct drive fan motor heat is negligible.
6. Factory supplied motors, in commercial equipment, are definite purpose motors, specifically designed and tested to operate reliably and continuously at all cataloged conditions. Using the full horsepower range of our fan motors as shown in our tabular data will not result in nuisance tripping or premature motor failure. Our product's warranty will not be affected.

Table 70. Evaporator fan performance – 17.5 ton (model TZK), horizontal, high static motor

Available External Static Pressure (Inches of Water Gauge)																				
CFM	0.10		0.20		0.30		0.40		0.50		0.60		0.70		0.80		0.90		1.00	
	RPM	BHP	RPM	BHP	RPM	BHP	RPM	BHP	RPM	BHP	RPM	BHP	RPM	BHP	RPM	BHP	RPM	BHP	RPM	BHP
5250	753	0.50	798	0.61	840	0.73	880	0.86	917	0.98	954	1.11	988	1.25	1022	1.38	1055	1.52	1087	1.66
5600	798	0.59	840	0.71	880	0.84	918	0.97	954	1.10	989	1.24	1023	1.37	1056	1.52	1087	1.66	1118	1.81
6300	887	0.80	925	0.94	962	1.08	997	1.22	1031	1.37	1063	1.52	1095	1.67	1125	1.82	1155	1.98	1184	2.14
7000	978	1.06	1012	1.21	1046	1.37	1079	1.53	1110	1.69	1140	1.85	1169	2.01	1198	2.18	1226	2.35	1254	2.52
7700	1069	1.38	1100	1.54	1131	1.71	1162	1.88	1191	2.06	1219	2.24	1247	2.41	1274	2.59	1300	2.77	1326	2.96
8400	1160	1.75	1189	1.93	1218	2.12	1247	2.30	1274	2.49	1301	2.68	1327	2.88	1352	3.07	1377	3.26	1401	3.46

Available External Static Pressure (Inches of Water Gauge)																				
CFM	1.10		1.20		1.30		1.40		1.50		1.60		1.70		1.80		1.90		2.00	
	RPM	BHP	RPM	BHP	RPM	BHP	RPM	BHP	RPM	BHP	RPM	BHP	RPM	BHP	RPM	BHP	RPM	BHP	RPM	BHP
5250	1117	1.8	1148	1.94	1177	2.09	1205	2.24	1233	2.38	1259	2.53	1285	2.69	1311	2.84	1335	3	1360	3.16
5600	1148	1.95	1177	2.11	1206	2.26	1234	2.41	1261	2.57	1287	2.72	1313	2.88	1338	3.04	1363	3.21	1387	3.37
6300	1212	2.3	1239	2.46	1267	2.63	1293	2.8	1319	2.97	1345	3.14	1370	3.31	1395	3.48	1419	3.66	1443	3.83
7000	1280	2.7	1307	2.87	1332	3.05	1357	3.23	1382	3.41	1406	3.6	1430	3.78	1454	3.97	1477	4.16	1500	4.35
7700	1352	3.15	1377	3.34	1401	3.53	1425	3.72	1448	3.92	1471	4.11	1494	4.31	1516	4.51	1539	4.71	1561	4.92
8400	1425	3.66	1449	3.86	1473	4.07	1495	4.27	1518	4.48	1540	4.69	1562	4.9	1583	5.12	1604	5.33	1625	5.55

Notes:

1. Available External Static Pressure is the static pressure difference between the return duct and the supply duct plus the static pressure drop caused by accessories and options.
2. For direct drive evaporator fan speed (rpm), refer to the applicable table in the fan performance section.
3. Data includes pressure drop due to standard filters and wet coils. No accessories or options are included in pressure drop data.
4. To determine static pressure drop due to other options/accessories, refer to the applicable table in the fan performance section.
5. Direct drive fan motor heat is negligible.
6. Factory supplied motors, in commercial equipment, are definite purpose motors, specifically designed and tested to operate reliably and continuously at all cataloged conditions. Using the full horsepower range of our fan motors as shown in our tabular data will not result in nuisance tripping or premature motor failure. Our product's warranty will not be affected.



Evaporator Fan Performance — Cooling

Table 71. Evaporator fan performance – 20 ton (model TZK), horizontal

Available External Static Pressure (Inches of Water Gauge)																				
CFM	0.10		0.20		0.30		0.40		0.50		0.60		0.70		0.80		0.90		1.00	
	RPM	BHP	RPM	BHP	RPM	BHP	RPM	BHP	RPM	BHP	RPM	BHP	RPM	BHP	RPM	BHP	RPM	BHP	RPM	BHP
6000	849	0.70	889	0.83	927	0.97	963	1.11	998	1.25	1031	1.39	1064	1.54	1095	1.69	1125	1.84	1155	1.99
6400	900	0.83	938	0.97	974	1.12	1009	1.26	1042	1.41	1074	1.56	1105	1.71	1136	1.87	1165	2.03	1194	2.19
7200	1004	1.14	1037	1.30	1071	1.46	1103	1.62	1133	1.79	1162	1.95	1191	2.12	1219	2.29	1247	2.46	1274	2.64
8000	1108	1.53	1138	1.70	1168	1.88	1198	2.06	1227	2.24	1254	2.42	1281	2.60	1307	2.79	1333	2.98	1358	3.16
8800	1213	2.00	1241	2.19	1267	2.38	1295	2.57	1322	2.77	1348	2.97	1373	3.17	1398	3.37	1422	3.57	1445	3.78
9600	1319	2.55	1344	2.76	1369	2.97	1394	3.18	1419	3.39	1444	3.61	1467	3.82	1491	4.04	1513	4.26	1535	4.48
Available External Static Pressure (Inches of Water Gauge)																				
CFM	1.10		1.20		1.30		1.40		1.50		1.60		1.70		1.80		1.90		2.00	
	RPM	BHP	RPM	BHP	RPM	BHP	RPM	BHP	RPM	BHP	RPM	BHP	RPM	BHP	RPM	BHP	RPM	BHP	RPM	BHP
6000	1184	2.15	1212	2.3	1240	2.46	1267	2.63	1294	2.79	1320	2.95	1346	3.12	1370	3.29	1395	3.46	1418	3.63
6400	1222	2.35	1248	2.52	1276	2.69	1302	2.86	1328	3.03	1353	3.2	1378	3.37	1403	3.55	1427	3.73	1451	3.9
7200	1300	2.82	1326	3	1352	3.18	1376	3.37	1400	3.55	1424	3.74	1448	3.93	1472	4.12	1494	4.31	1517	4.51
8000	1383	3.36	1408	3.55	1431	3.75	1455	3.95	1478	4.15	1501	4.35	1523	4.56	1545	4.76	1566	4.97	1588	5.18
8800	1469	3.98	1491	4.19	1514	4.4	1537	4.62	1559	4.83	1580	5.05	1601	5.27	1623	5.49	1643	5.71	1664	5.94
9600	1557	4.7	1579	4.93	1600	5.15	1621	5.38	1642	5.61	1663	5.84	-	-	-	-	-	-	-	-

Notes:

1. Available External Static Pressure is the static pressure difference between the return duct and the supply duct plus the static pressure drop caused by accessories and options.
2. For direct drive evaporator fan speed (rpm), refer to the applicable table in the fan performance section.
3. Data includes pressure drop due to standard filters and wet coils. No accessories or options are included in pressure drop data.
4. To determine static pressure drop due to other options/accessories, refer to the applicable table in the fan performance section.
5. Direct drive fan motor heat is negligible.
6. Factory supplied motors, in commercial equipment, are definite purpose motors, specifically designed and tested to operate reliably and continuously at all cataloged conditions. Using the full horsepower range of our fan motors as shown in our tabular data will not result in nuisance tripping or premature motor failure. Our product's warranty will not be affected.

Table 72. Evaporator fan performance – 20 ton (model TZK), horizontal, high static motor

Available External Static Pressure (Inches of Water Gauge)																				
CFM	0.10		0.20		0.30		0.40		0.50		0.60		0.70		0.80		0.90		1.00	
	RPM	BHP	RPM	BHP	RPM	BHP	RPM	BHP	RPM	BHP	RPM	BHP	RPM	BHP	RPM	BHP	RPM	BHP	RPM	BHP
6000	849	0.70	889	0.83	927	0.97	963	1.11	998	1.25	1031	1.39	1064	1.54	1095	1.69	1125	1.84	1155	1.99
6400	900	0.83	938	0.97	974	1.12	1009	1.26	1042	1.41	1074	1.56	1105	1.71	1136	1.87	1165	2.03	1194	2.19
7200	1004	1.14	1037	1.30	1071	1.46	1103	1.62	1133	1.79	1162	1.95	1191	2.12	1219	2.29	1247	2.46	1274	2.64
8000	1108	1.53	1138	1.70	1168	1.88	1198	2.06	1227	2.24	1254	2.42	1281	2.60	1307	2.79	1333	2.98	1358	3.16
8800	1213	2.00	1241	2.19	1267	2.38	1295	2.57	1322	2.77	1348	2.97	1373	3.17	1398	3.37	1422	3.57	1445	3.78
9600	1319	2.55	1344	2.76	1369	2.97	1394	3.18	1419	3.39	1444	3.61	1467	3.82	1491	4.04	1513	4.26	1535	4.48
Available External Static Pressure (Inches of Water Gauge)																				
CFM	1.10		1.20		1.30		1.40		1.50		1.60		1.70		1.80		1.90		2.00	
	RPM	BHP	RPM	BHP	RPM	BHP	RPM	BHP	RPM	BHP	RPM	BHP	RPM	BHP	RPM	BHP	RPM	BHP	RPM	BHP
6000	1184	2.15	1212	2.3	1240	2.46	1267	2.63	1294	2.79	1320	2.95	1346	3.12	1370	3.29	1395	3.46	1418	3.63
6400	1222	2.35	1248	2.52	1276	2.69	1302	2.86	1328	3.03	1353	3.2	1378	3.37	1403	3.55	1427	3.73	1451	3.9
7200	1300	2.82	1326	3	1352	3.18	1376	3.37	1400	3.55	1424	3.74	1448	3.93	1472	4.12	1494	4.31	1517	4.51
8000	1383	3.36	1408	3.55	1431	3.75	1455	3.95	1478	4.15	1501	4.35	1523	4.56	1545	4.76	1566	4.97	1588	5.18
8800	1469	3.98	1491	4.19	1514	4.4	1537	4.62	1559	4.83	1580	5.05	1601	5.27	1623	5.49	1643	5.71	1664	5.94

Table 72. Evaporator fan performance – 20 ton (model TZK), horizontal, high static motor (continued)

Available External Static Pressure (Inches of Water Gauge)																				
CFM	1.10		1.20		1.30		1.40		1.50		1.60		1.70		1.80		1.90		2.00	
	RPM	BHP	RPM	BHP	RPM	BHP	RPM	BHP	RPM	BHP	RPM	BHP	RPM	BHP	RPM	BHP	RPM	BHP	RPM	BHP
9600	1557	4.7	1579	4.93	1600	5.15	1621	5.38	1642	5.61	1663	5.84	1679	5.98	1701	6.22	1720	6.45	1740	6.7

Notes:

1. Available External Static Pressure is the static pressure difference between the return duct and the supply duct plus the static pressure drop caused by accessories and options.
2. For direct drive evaporator fan speed (rpm), refer to the applicable table in the fan performance section.
3. Data includes pressure drop due to standard filters and wet coils. No accessories or options are included in pressure drop data.
4. To determine static pressure drop due to other options/accessories, refer to the applicable table in the fan performance section.
5. Direct drive fan motor heat is negligible.
6. Factory supplied motors, in commercial equipment, are definite purpose motors, specifically designed and tested to operate reliably and continuously at all cataloged conditions. Using the full horsepower range of our fan motors as shown in our tabular data will not result in nuisance tripping or premature motor failure. Our product's warranty will not be affected.

Table 73. Evaporator fan performance – 25 ton (model TZK), horizontal

Available External Static Pressure (Inches of Water Gauge)																				
CFM	0.10		0.20		0.30		0.40		0.50		0.60		0.70		0.80		0.90		1.00	
	RPM	BHP	RPM	BHP	RPM	BHP	RPM	BHP	RPM	BHP	RPM	BHP	RPM	BHP	RPM	BHP	RPM	BHP	RPM	BHP
7500	1043	1.28	1075	1.44	1107	1.61	1138	1.78	1168	1.95	1196	2.12	1225	2.29	1252	2.47	1279	2.65	1305	2.83
8000	1108	1.53	1138	1.70	1168	1.88	1198	2.06	1227	2.24	1254	2.42	1281	2.60	1307	2.79	1333	2.98	1358	3.16
9000	1239	2.13	1266	2.32	1293	2.52	1320	2.72	1346	2.92	1372	3.12	1397	3.32	1421	3.53	1444	3.74	1468	3.94
10000	1372	2.87	1396	3.08	1420	3.30	1443	3.52	1468	3.74	1492	3.96	1515	4.19	1538	4.41	1560	4.64	1581	4.87
11000	1505	3.76	1526	4.00	1548	4.24	1570	4.48	1591	4.72	1614	4.96	1635	5.21	1657	5.46	1677	5.70	1698	5.95
12000	1638	4.84	1657	5.10	1677	5.36	1697	5.62	1717	5.88	-	-	-	-	-	-	-	-	-	-

Available External Static Pressure (Inches of Water Gauge)

CFM	1.10		1.20		1.30		1.40		1.50		1.60		1.70		1.80		1.90		2.00	
	RPM	BHP	RPM	BHP	RPM	BHP	RPM	BHP	RPM	BHP	RPM	BHP	RPM	BHP	RPM	BHP	RPM	BHP	RPM	BHP
7500	1331	3.01	1356	3.2	1381	3.39	1405	3.58	1429	3.77	1452	3.96	1475	4.15	1498	4.35	1521	4.55	1543	4.75
8000	1383	3.36	1408	3.55	1431	3.75	1455	3.95	1478	4.15	1501	4.35	1523	4.56	1545	4.76	1566	4.97	1588	5.18
9000	1491	4.15	1513	4.37	1535	4.58	1558	4.8	1579	5.02	1601	5.24	1622	5.46	1642	5.69	1663	5.91	-	-
10000	1602	5.1	1623	5.33	1644	5.56	1665	5.8	1685	6.03	-	-	-	-	-	-	-	-	-	-
11000	-	-	-	-	-	-	-	-	-	-	-	-	-	-	-	-	-	-	-	-
12000	-	-	-	-	-	-	-	-	-	-	-	-	-	-	-	-	-	-	-	-

Notes:

1. Available External Static Pressure is the static pressure difference between the return duct and the supply duct plus the static pressure drop caused by accessories and options.
2. For direct drive evaporator fan speed (rpm), refer to the applicable table in the fan performance section.
3. Data includes pressure drop due to standard filters and wet coils. No accessories or options are included in pressure drop data.
4. To determine static pressure drop due to other options/accessories, refer to the applicable table in the fan performance section.
5. Direct drive fan motor heat is negligible.
6. Factory supplied motors, in commercial equipment, are definite purpose motors, specifically designed and tested to operate reliably and continuously at all cataloged conditions. Using the full horsepower range of our fan motors as shown in our tabular data will not result in nuisance tripping or premature motor failure. Our product's warranty will not be affected.

Table 74. Evaporator fan performance – 25 ton (model TZK), horizontal, high static motor

Available External Static Pressure (Inches of Water Gauge)																				
CFM	0.10		0.20		0.30		0.40		0.50		0.60		0.70		0.80		0.90		1.00	
	RPM	BHP	RPM	BHP	RPM	BHP	RPM	BHP	RPM	BHP	RPM	BHP	RPM	BHP	RPM	BHP	RPM	BHP	RPM	BHP
7500	1043	1.28	1075	1.44	1107	1.61	1138	1.78	1168	1.95	1196	2.12	1225	2.29	1252	2.47	1279	2.65	1305	2.83
8000	1108	1.53	1138	1.70	1168	1.88	1198	2.06	1227	2.24	1254	2.42	1281	2.60	1307	2.79	1333	2.98	1358	3.16
9000	1239	2.13	1266	2.32	1293	2.52	1320	2.72	1346	2.92	1372	3.12	1397	3.32	1421	3.53	1444	3.74	1468	3.94
10000	1372	2.87	1396	3.08	1420	3.30	1443	3.52	1468	3.74	1492	3.96	1515	4.19	1538	4.41	1560	4.64	1581	4.87
11000	1505	3.76	1526	4.00	1548	4.24	1570	4.48	1591	4.72	1614	4.96	1635	5.21	1657	5.46	1677	5.70	1698	5.95
12000	1638	4.84	1657	5.10	1677	5.36	1697	5.62	1717	5.88	1736	5.96	1755	6.23	1776	6.51	1794	6.76	1815	7.03



Evaporator Fan Performance — Cooling

Table 74. Evaporator fan performance – 25 ton (model TZK), horizontal, high static motor (continued)

	Available External Static Pressure (Inches of Water Gauge)																			
CFM	1.10		1.20		1.30		1.40		1.50		1.60		1.70		1.80		1.90		2.00	
	RPM	BHP	RPM	BHP	RPM	BHP	RPM	BHP	RPM	BHP	RPM	BHP	RPM	BHP	RPM	BHP	RPM	BHP	RPM	BHP
7500	1331	3.01	1356	3.2	1381	3.39	1405	3.58	1429	3.77	1452	3.96	1475	4.15	1498	4.35	1521	4.55	1543	4.75
8000	1383	3.36	1408	3.55	1431	3.75	1455	3.95	1478	4.15	1501	4.35	1523	4.56	1545	4.76	1566	4.97	1588	5.18
9000	1491	4.15	1513	4.37	1535	4.58	1558	4.8	1579	5.02	1601	5.24	1622	5.46	1642	5.69	1663	5.91	1684	6.13
10000	1602	5.1	1623	5.33	1644	5.56	1665	5.8	1685	6.03	1701	6.13	1721	6.36	1739	6.62	1760	6.85	1781	7.08
11000	1713	6.05	1733	6.29	1753	6.54	1772	6.8	1791	7.04	1801	7.02	1820	7.26	1836	7.55	1857	7.79	1878	8.03
12000	1824	7	1843	7.25	1862	7.52	1879	7.8	1897	8.05	1901	7.91	1919	8.16	1933	8.48	-	-	-	-

Notes:

1. Available External Static Pressure is the static pressure difference between the return duct and the supply duct plus the static pressure drop caused by accessories and options.
2. For direct drive evaporator fan speed (rpm), refer to the applicable table in the fan performance section.
3. Data includes pressure drop due to standard filters and wet coils. No accessories or options are included in pressure drop data.
4. To determine static pressure drop due to other options/accessories, refer to the applicable table in the fan performance section.
5. Direct drive fan motor heat is negligible.
6. Factory supplied motors, in commercial equipment, are definite purpose motors, specifically designed and tested to operate reliably and continuously at all cataloged conditions. Using the full horsepower range of our fan motors as shown in our tabular data will not result in nuisance tripping or premature motor failure. Our product's warranty will not be affected.



Evaporator Fan Performance — Gas Heat

Downflow

Table 75. Evaporator fan performance - 3 ton (model YZK), downflow, high heat

Available External Static Pressure (Inches of Water Gauge)																				
CFM	0.10		0.20		0.30		0.40		0.50		0.60		0.70		0.80		0.90		1.00	
	RPM	BHP	RPM	BHP	RPM	BHP	RPM	BHP	RPM	BHP	RPM	BHP	RPM	BHP	RPM	BHP	RPM	BHP	RPM	BHP
900 ^(a)	346	0.03	431	0.05	500	0.08	559	0.11	616	0.14	668	0.17	716	0.21	760	0.25	802	0.28	842	0.32
960	356	0.03	441	0.06	508	0.08	566	0.11	621	0.15	673	0.18	721	0.22	765	0.26	807	0.29	847	0.34
1080	376	0.04	459	0.06	525	0.09	583	0.13	634	0.16	683	0.20	731	0.23	775	0.27	817	0.32	856	0.36
1200	399	0.04	478	0.07	543	0.10	599	0.14	651	0.18	697	0.21	741	0.25	785	0.29	826	0.34	866	0.38
1320	422	0.05	497	0.08	562	0.12	617	0.15	667	0.19	713	0.23	756	0.27	796	0.32	836	0.36	876	0.41
1440	446	0.06	517	0.09	581	0.13	636	0.17	685	0.21	730	0.25	773	0.29	812	0.34	850	0.38	886	0.43
Available External Static Pressure (Inches of Water Gauge)																				
CFM	1.10		1.20		1.30		1.40		1.50		1.60		1.70		1.80		1.90		2.00	
	RPM	BHP	RPM	BHP	RPM	BHP	RPM	BHP	RPM	BHP	RPM	BHP	RPM	BHP	RPM	BHP	RPM	BHP	RPM	BHP
900 ^(b)	879	0.36	915	0.41	950	0.45	983	0.5	1015	0.54	1046	0.59	1076	0.64	1105	0.68	1134	0.73	1163	0.79
960	884	0.38	920	0.42	955	0.46	988	0.51	1020	0.56	1051	0.6	1081	0.65	1110	0.7	1138	0.75	1166	0.81
1080	894	0.4	930	0.45	964	0.49	997	0.54	1029	0.59	1060	0.64	1090	0.69	1119	0.74	1148	0.79	1175	0.85
1200	903	0.43	939	0.47	974	0.52	1007	0.57	1039	0.62	1070	0.67	1100	0.73	1129	0.78	1157	0.83	1185	0.89
1320	913	0.45	949	0.5	983	0.55	1016	0.6	1048	0.66	1079	0.71	1109	0.76	1138	0.82	1167	0.88	1194	0.93
1440	923	0.48	959	0.53	993	0.59	1026	0.64	1058	0.69	1089	0.75	1119	0.8	1148	0.86	1176	0.92	1204	0.98

Notes:

1. Available External Static Pressure is the static pressure difference between the return duct and the supply duct plus the static pressure drop caused by accessories and options.
2. For direct drive evaporator fan speed (rpm), refer to the applicable table in the fan performance section.
3. Data includes pressure drop due to standard filters and wet coils. No accessories or options are included in pressure drop data.
4. To determine static pressure drop due to other options/accessories, refer to the applicable table in the fan performance section.
5. Direct drive fan motor heat is negligible.
6. Factory supplied motors, in commercial equipment, are definite purpose motors, specifically designed and tested to operate reliably and continuously at all cataloged conditions. Using the full horsepower range of our fan motors as shown in our tabular data will not result in nuisance tripping or premature motor failure. Our product's warranty will not be affected.

^(a) Model digit 11 selection of high heat is limited to minimum 320 cfm/ton full load airflow.

^(b) Model digit 11 selection of high heat is limited to minimum 320 cfm/ton full load airflow.

Table 76. Evaporator fan performance - 4 ton (model YZK), downflow, high heat

Available External Static Pressure (Inches of Water Gauge)																				
CFM	0.10		0.20		0.30		0.40		0.50		0.60		0.70		0.80		0.90		1.00	
	RPM	BHP	RPM	BHP	RPM	BHP	RPM	BHP	RPM	BHP	RPM	BHP	RPM	BHP	RPM	BHP	RPM	BHP	RPM	BHP
1200 ^(a)	399	0.04	478	0.07	543	0.10	599	0.14	651	0.18	697	0.21	741	0.25	785	0.29	826	0.34	866	0.38
1280	414	0.05	490	0.08	556	0.11	611	0.15	662	0.19	708	0.22	751	0.27	791	0.31	833	0.35	872	0.40
1440	446	0.06	517	0.09	581	0.13	636	0.17	685	0.21	730	0.25	773	0.29	812	0.34	850	0.38	886	0.43
1600	481	0.07	545	0.11	605	0.15	661	0.19	709	0.23	754	0.28	795	0.32	834	0.37	871	0.42	907	0.47
1760	516	0.09	576	0.13	632	0.17	685	0.21	734	0.26	778	0.31	819	0.36	857	0.41	894	0.46	929	0.51
1920	552	0.11	608	0.15	661	0.19	711	0.24	759	0.29	803	0.34	843	0.39	881	0.45	917	0.50	951	0.56
Available External Static Pressure (Inches of Water Gauge)																				
CFM	1.10		1.20		1.30		1.40		1.50		1.60		1.70		1.80		1.90		2.00	
	RPM	BHP	RPM	BHP	RPM	BHP	RPM	BHP	RPM	BHP	RPM	BHP	RPM	BHP	RPM	BHP	RPM	BHP	RPM	BHP
1200 ^(b)	903	0.43	939	0.47	974	0.52	1007	0.57	1039	0.62	1070	0.67	1100	0.73	1129	0.78	1157	0.83	1185	0.89
1280	910	0.45	946	0.49	980	0.54	1013	0.59	1045	0.65	1076	0.7	1106	0.75	1135	0.81	1163	0.86	1191	0.92
1440	923	0.48	959	0.53	993	0.59	1026	0.64	1058	0.69	1089	0.75	1119	0.80	1148	0.86	1176	0.92	1204	0.98
1600	940	0.52	973	0.57	1006	0.63	1039	0.68	1071	0.74	1102	0.8	1132	0.86	1161	0.92	1189	0.98	1217	1.04
1760	962	0.57	994	0.62	1025	0.68	1055	0.73	1084	0.79	1115	0.85	1145	0.92	1174	0.98	1202	1.04	1230	1.11



Evaporator Fan Performance — Gas Heat

Table 76. Evaporator fan performance - 4 ton (model YZK), downflow, high heat (continued)

Available External Static Pressure (Inches of Water Gauge)																				
CFM	1.10		1.20		1.30		1.40		1.50		2.00									
	RPM	BHP	RPM	BHP	RPM	BHP	RPM	BHP	RPM	BHP	RPM	BHP								
1920	984	0.61	1016	0.67	1047	0.73	1077	0.79	1105	0.85	1133	0.91	1160	0.98	1187	1.04	1215	1.11	1243	1.17

Notes:

1. Available External Static Pressure is the static pressure difference between the return duct and the supply duct plus the static pressure drop caused by accessories and options.
2. For direct drive evaporator fan speed (rpm), refer to the applicable table in the fan performance section.
3. Data includes pressure drop due to standard filters and wet coils. No accessories or options are included in pressure drop data.
4. To determine static pressure drop due to other options/accessories, refer to the applicable table in the fan performance section.
5. Direct drive fan motor heat is negligible.
6. Factory supplied motors, in commercial equipment, are definite purpose motors, specifically designed and tested to operate reliably and continuously at all cataloged conditions. Using the full horsepower range of our fan motors as shown in our tabular data will not result in nuisance tripping or premature motor failure. Our product's warranty will not be affected.

(a) Model digit 11 selection of High Gas Heat is limited to minimum 320 cfm/ton full load airflow.

(b) Model digit 11 selection of High Gas Heat is limited to minimum 320 cfm/ton full load airflow.

Table 77. Evaporator fan performance - 5 ton (model YZK), downflow, high heat

Available External Static Pressure (Inches of Water Gauge)																				
CFM	0.10		0.20		0.30		0.40		0.50		0.60		0.70		0.80		0.90		1.00	
	RPM	BHP	RPM	BHP	RPM	BHP	RPM	BHP	RPM	BHP	RPM	BHP	RPM	BHP	RPM	BHP	RPM	BHP	RPM	BHP
1500 ^(a)	459	0.06	527	0.10	590	0.14	645	0.18	694	0.22	738	0.26	781	0.31	820	0.35	858	0.40	893	0.45
1600	481	0.07	545	0.11	605	0.15	661	0.19	709	0.23	754	0.28	795	0.32	834	0.37	871	0.42	907	0.47
1800	525	0.09	584	0.13	639	0.18	692	0.22	741	0.27	784	0.32	825	0.37	863	0.42	899	0.47	934	0.52
2000	570	0.12	624	0.16	676	0.21	724	0.26	771	0.31	816	0.36	856	0.41	893	0.47	929	0.52	963	0.58
2200	617	0.15	666	0.19	714	0.24	760	0.29	804	0.35	846	0.41	887	0.46	925	0.52	960	0.58	993	0.64
2400	664	0.18	710	0.23	754	0.28	797	0.34	838	0.40	879	0.46	918	0.52	956	0.58	991	0.64	1024	0.71

Available External Static Pressure (Inches of Water Gauge)																				
CFM	1.10		1.20		1.30		1.40		1.50		1.60		1.70		1.80		1.90		2.00	
	RPM	BHP	RPM	BHP	RPM	BHP	RPM	BHP	RPM	BHP	RPM	BHP	RPM	BHP	RPM	BHP	RPM	BHP	RPM	BHP
1500 ^(b)	928	0.5	964	0.55	998	0.6	1031	0.66	1063	0.71	1094	0.77	1124	0.82	1153	0.88	1181	0.94	1209	1.00
1600	940	0.52	973	0.57	1006	0.63	1039	0.68	1071	0.74	1102	0.80	1132	0.86	1161	0.92	1189	0.98	1217	1.04
1800	968	0.58	1000	0.63	1031	0.69	1060	0.75	1089	0.81	1118	0.87	1148	0.93	1177	0.99	1205	1.06	1233	1.12
2000	995	0.64	1027	0.7	1058	0.76	1087	0.82	1116	0.88	1144	0.94	1171	1.01	1197	1.07	1222	1.14	1249	1.21
2200	1025	0.7	1056	0.77	1086	0.83	1115	0.89	1144	0.96	1171	1.03	1198	1.09	1224	1.16	1249	1.23	1274	1.30
2400	1056	0.77	1087	0.84	1116	0.91	1144	0.97	1172	1.04	1199	1.11	1225	1.18	1251	1.26	1277	1.33	1301	1.40

Notes:

1. Available External Static Pressure is the static pressure difference between the return duct and the supply duct plus the static pressure drop caused by accessories and options.
2. For direct drive evaporator fan speed (rpm), refer to the applicable table in the fan performance section.
3. Data includes pressure drop due to standard filters and wet coils. No accessories or options are included in pressure drop data.
4. To determine static pressure drop due to other options/accessories, refer to the applicable table in the fan performance section.
5. Direct drive fan motor heat is negligible.
6. Factory supplied motors, in commercial equipment, are definite purpose motors, specifically designed and tested to operate reliably and continuously at all cataloged conditions. Using the full horsepower range of our fan motors as shown in our tabular data will not result in nuisance tripping or premature motor failure. Our product's warranty will not be affected.

(a) Model digit 11 selection of High Gas Heat is limited to minimum 320 cfm/ton full load airflow.

(b) Model digit 11 selection of High Gas Heat is limited to minimum 320 cfm/ton full load airflow.

Table 78. Evaporator fan performance - 6 ton (model YZK), downflow, high heat

Available External Static Pressure (Inches of Water Gauge)																				
CFM	0.10		0.20		0.30		0.40		0.50		0.60		0.70		0.80		0.90		1.00	
	RPM	BHP	RPM	BHP	RPM	BHP	RPM	BHP	RPM	BHP	RPM	BHP	RPM	BHP	RPM	BHP	RPM	BHP	RPM	BHP
1800	560	0.11	621	0.16	676	0.21	727	0.26	775	0.32	820	0.37	861	0.43	900	0.49	937	0.56	973	0.62
1920	590	0.13	647	0.18	701	0.23	750	0.29	796	0.34	840	0.40	881	0.47	920	0.53	957	0.59	992	0.66
2040	619	0.15	674	0.20	726	0.26	773	0.32	818	0.37	861	0.44	901	0.50	940	0.57	976	0.63	1011	0.70
2160	649	0.17	702	0.23	751	0.29	797	0.34	841	0.41	882	0.47	922	0.54	960	0.60	996	0.67	1031	0.74
2280	679	0.20	730	0.25	777	0.31	822	0.38	864	0.44	905	0.51	943	0.57	981	0.64	1017	0.72	1051	0.79

Table 78. Evaporator fan performance - 6 ton (model YZK), downflow, high heat (continued)

Available External Static Pressure (Inches of Water Gauge)																				
CFM	0.10		0.20		0.30		0.40		0.50		0.60		0.70		0.80		0.90		1.00	
	RPM	BHP	RPM	BHP	RPM	BHP	RPM	BHP	RPM	BHP	RPM	BHP	RPM	BHP	RPM	BHP	RPM	BHP	RPM	BHP
2400	709	0.22	758	0.28	804	0.35	847	0.41	888	0.48	928	0.54	965	0.61	1002	0.69	1037	0.76	1071	0.84
2520	739	0.25	787	0.31	831	0.38	873	0.45	913	0.52	951	0.59	988	0.66	1023	0.73	1058	0.81	1091	0.89
2640	770	0.28	816	0.35	858	0.42	899	0.49	938	0.56	975	0.63	1012	0.71	1046	0.78	1080	0.86	1113	0.94
2760	800	0.31	845	0.38	886	0.46	925	0.53	963	0.60	1000	0.68	1035	0.76	1069	0.83	1102	0.91	1134	1.00
2880	831	0.35	874	0.42	914	0.50	952	0.57	989	0.65	1025	0.73	1059	0.81	1093	0.89	1125	0.97	1156	1.05
Available External Static Pressure (Inches of Water Gauge)																				
CFM	1.10		1.20		1.30		1.40		1.50		1.60		1.70		1.80		1.90		2.00	
	RPM	BHP	RPM	BHP	RPM	BHP	RPM	BHP	RPM	BHP	RPM	BHP	RPM	BHP	RPM	BHP	RPM	BHP	RPM	BHP
1800	1008	0.69	1041	0.75	1073	0.82	1103	0.89	1133	0.97	1162	1.04	1190	1.11	1219	1.19	1248	1.27	1276	1.35
1920	1026	0.73	1059	0.8	1090	0.87	1121	0.94	1150	1.02	1179	1.09	1207	1.17	1234	1.24	1260	1.32	1287	1.41
2040	1044	0.77	1077	0.84	1108	0.92	1138	0.99	1168	1.07	1196	1.14	1224	1.22	1251	1.3	1277	1.38	1303	1.47
2160	1064	0.82	1096	0.89	1126	0.97	1156	1.04	1186	1.12	1214	1.2	1241	1.28	1268	1.36	1294	1.45	1320	1.53
2280	1084	0.86	1115	0.94	1145	1.02	1175	1.1	1204	1.18	1232	1.26	1259	1.34	1286	1.43	1312	1.51	1337	1.6
2400	1104	0.91	1135	0.99	1165	1.07	1194	1.15	1222	1.24	1250	1.32	1277	1.41	1304	1.49	1330	1.58	1355	1.67
2520	1124	0.97	1155	1.05	1185	1.13	1214	1.21	1242	1.3	1269	1.38	1296	1.47	1322	1.56	1348	1.65	1373	1.74
2640	1144	1.02	1175	1.11	1205	1.19	1234	1.28	1262	1.36	1289	1.45	1315	1.54	1341	1.63	1366	1.72	1391	1.82
2760	1165	1.08	1196	1.17	1225	1.25	1254	1.34	1282	1.43	1309	1.52	1335	1.61	1360	1.71	1385	1.8	1410	1.9
2880	1187	1.14	1217	1.23	1246	1.32	1274	1.41	1302	1.5	1328	1.6	1355	1.69	1380	1.78	1405	1.88	1429	1.98

Notes:

1. Available External Static Pressure is the static pressure difference between the return duct and the supply duct plus the static pressure drop caused by accessories and options.
2. For direct drive evaporator fan speed (rpm), refer to the applicable table in the fan performance section.
3. Data includes pressure drop due to standard filters and wet coils. No accessories or options are included in pressure drop data.
4. To determine static pressure drop due to other options/accessories, refer to the applicable table in the fan performance section.
5. Direct drive fan motor heat is negligible.
6. Factory supplied motors, in commercial equipment, are definite purpose motors, specifically designed and tested to operate reliably and continuously at all cataloged conditions. Using the full horsepower range of our fan motors as shown in our tabular data will not result in nuisance tripping or premature motor failure. Our product's warranty will not be affected.

Table 79. Evaporator fan performance - 7.5 ton (model YZK), downflow, high heat

Available External Static Pressure (Inches of Water Gauge)																				
CFM	0.10		0.20		0.30		0.40		0.50		0.60		0.70		0.80		0.90		1.00	
	RPM	BHP	RPM	BHP	RPM	BHP	RPM	BHP	RPM	BHP	RPM	BHP	RPM	BHP	RPM	BHP	RPM	BHP	RPM	BHP
2250	676	0.19	728	0.25	775	0.31	820	0.37	863	0.44	903	0.50	943	0.57	980	0.64	1016	0.71	1050	0.79
2400	713	0.22	764	0.29	809	0.35	852	0.42	893	0.48	933	0.55	970	0.62	1007	0.70	1042	0.77	1075	0.85
2550	752	0.26	800	0.33	843	0.40	884	0.47	924	0.54	962	0.61	999	0.68	1034	0.76	1069	0.83	1102	0.91
2700	790	0.30	836	0.37	878	0.44	918	0.52	956	0.59	993	0.66	1029	0.74	1063	0.82	1096	0.90	1129	0.98
2850	828	0.35	873	0.42	914	0.50	952	0.57	988	0.65	1024	0.73	1059	0.81	1092	0.89	1125	0.97	1156	1.06
3000	867	0.40	910	0.47	950	0.55	987	0.63	1022	0.71	1056	0.80	1090	0.88	1122	0.96	1154	1.05	1185	1.14
3150	906	0.45	948	0.53	986	0.62	1022	0.70	1056	0.78	1089	0.87	1122	0.96	1153	1.04	1184	1.13	1214	1.22
3300	945	0.51	985	0.59	1023	0.68	1057	0.77	1091	0.86	1123	0.95	1154	1.04	1185	1.13	1215	1.22	1244	1.31
3600	1024	0.64	1061	0.74	1096	0.83	1130	0.93	1161	1.02	1191	1.12	1221	1.22	1249	1.32	1278	1.41	1306	1.51
Available External Static Pressure (Inches of Water Gauge)																				
CFM	1.10		1.20		1.30		1.40		1.50		1.60		1.70		1.80		1.90		2.00	
	RPM	BHP	RPM	BHP	RPM	BHP	RPM	BHP	RPM	BHP	RPM	BHP	RPM	BHP	RPM	BHP	RPM	BHP	RPM	BHP
2250	1082	0.86	1114	0.94	1144	1.01	1174	1.09	1203	1.17	1231	1.25	1259	1.34	1286	1.42	1312	1.51	1337	1.59
2400	1108	0.93	1139	1	1169	1.08	1198	1.17	1226	1.25	1254	1.33	1281	1.42	1308	1.5	1334	1.59	1359	1.68
2550	1134	0.99	1165	1.08	1194	1.16	1223	1.24	1251	1.33	1278	1.42	1305	1.5	1331	1.59	1356	1.68	1382	1.78
2700	1160	1.07	1190	1.15	1220	1.24	1249	1.33	1276	1.41	1303	1.5	1329	1.59	1355	1.69	1380	1.78	1404	1.87
2850	1187	1.14	1217	1.23	1246	1.32	1274	1.41	1302	1.5	1329	1.6	1355	1.69	1380	1.79	1405	1.88	1429	1.98
3000	1215	1.23	1244	1.32	1273	1.41	1300	1.5	1328	1.6	1354	1.69	1380	1.79	1405	1.89	1430	1.99	1454	2.09



Evaporator Fan Performance — Gas Heat

Table 79. Evaporator fan performance - 7.5 ton (model YZK), downflow, high heat (continued)

Available External Static Pressure (Inches of Water Gauge)																				
CFM	1.10		1.20		1.30		1.40		1.50		1.60		1.70		1.80		1.90		2.00	
	RPM	BHP	RPM	BHP	RPM	BHP	RPM	BHP	RPM	BHP	RPM	BHP	RPM	BHP	RPM	BHP	RPM	BHP	RPM	BHP
3150	1243	1.31	1272	1.41	1300	1.5	1327	1.6	1354	1.7	1380	1.8	1406	1.9	1431	2	1455	2.1	1479	2.2
3300	1273	1.41	1301	1.5	1328	1.6	1355	1.7	1381	1.8	1407	1.9	1432	2.01	1457	2.11	1481	2.22	1505	2.32
3600	1333	1.61	1360	1.71	1386	1.81	1412	1.92	1437	2.03	1462	2.13	1486	2.24	1510	2.35	1534	2.47	1557	2.58

Notes:

1. Available External Static Pressure is the static pressure difference between the return duct and the supply duct plus the static pressure drop caused by accessories and options.
2. For direct drive evaporator fan speed (rpm), refer to the applicable table in the fan performance section.
3. Data includes pressure drop due to standard filters and wet coils. No accessories or options are included in pressure drop data.
4. To determine static pressure drop due to other options/accessories, refer to the applicable table in the fan performance section.
5. Direct drive fan motor heat is negligible.
6. Factory supplied motors, in commercial equipment, are definite purpose motors, specifically designed and tested to operate reliably and continuously at all cataloged conditions. Using the full horsepower range of our fan motors as shown in our tabular data will not result in nuisance tripping or premature motor failure. Our product's warranty will not be affected.

Table 80. Evaporator fan performance - 8.5 ton (model YZK), downflow, high heat

Available External Static Pressure (Inches of Water Gauge)																				
CFM	0.10		0.20		0.30		0.40		0.50		0.60		0.70		0.80		0.90		1.00	
	RPM	BHP	RPM	BHP	RPM	BHP	RPM	BHP	RPM	BHP	RPM	BHP	RPM	BHP	RPM	BHP	RPM	BHP	RPM	BHP
2550	752	0.26	800	0.33	843	0.40	884	0.47	924	0.54	962	0.61	999	0.68	1034	0.76	1069	0.83	1102	0.91
2720	795	0.31	841	0.38	883	0.45	923	0.52	960	0.60	997	0.67	1033	0.75	1067	0.83	1100	0.91	1132	0.99
2890	839	0.36	883	0.43	923	0.51	961	0.59	997	0.67	1033	0.75	1067	0.82	1100	0.91	1133	0.99	1164	1.08
3060	883	0.42	925	0.50	964	0.58	1001	0.66	1036	0.74	1069	0.83	1103	0.91	1134	0.99	1166	1.08	1197	1.17
3230	927	0.48	968	0.56	1006	0.65	1041	0.74	1075	0.82	1107	0.91	1139	1.00	1170	1.09	1200	1.17	1230	1.27
3400	971	0.55	1011	0.64	1047	0.73	1081	0.82	1114	0.91	1146	1.00	1176	1.10	1206	1.19	1236	1.28	1264	1.37
3570	1016	0.63	1054	0.72	1089	0.81	1122	0.91	1154	1.00	1184	1.10	1214	1.20	1243	1.30	1271	1.39	1299	1.49
3740	1061	0.71	1097	0.81	1131	0.91	1164	1.01	1194	1.11	1224	1.21	1253	1.31	1281	1.41	1308	1.51	1335	1.61
4080	1151	0.91	1184	1.01	1216	1.12	1247	1.22	1276	1.33	1304	1.44	1331	1.55	1358	1.66	1384	1.77	1409	1.88

Available External Static Pressure (Inches of Water Gauge)																				
CFM	1.10		1.20		1.30		1.40		1.50		1.60		1.70		1.80		1.90		2.00	
	RPM	BHP	RPM	BHP	RPM	BHP	RPM	BHP	RPM	BHP	RPM	BHP	RPM	BHP	RPM	BHP	RPM	BHP	RPM	BHP
2550	1134	0.99	1165	1.08	1194	1.16	1223	1.24	1251	1.33	1278	1.42	1305	1.5	1331	1.59	1356	1.68	1382	1.78
2720	1163	1.08	1194	1.16	1223	1.25	1252	1.34	1280	1.43	1307	1.52	1333	1.61	1358	1.7	1383	1.79	1408	1.89
2890	1194	1.16	1224	1.25	1253	1.34	1281	1.44	1309	1.53	1335	1.62	1361	1.72	1387	1.81	1411	1.91	1436	2.01
3060	1226	1.26	1255	1.35	1284	1.45	1311	1.54	1338	1.64	1364	1.73	1390	1.83	1415	1.93	1440	2.03	1464	2.13
3230	1259	1.36	1287	1.46	1315	1.55	1342	1.65	1368	1.75	1394	1.85	1420	1.95	1445	2.06	1469	2.16	1493	2.27
3400	1292	1.47	1320	1.57	1347	1.67	1373	1.77	1399	1.87	1425	1.98	1450	2.08	1474	2.19	1498	2.3	1522	2.4
3570	1326	1.59	1354	1.69	1380	1.79	1406	1.9	1431	2	1456	2.11	1481	2.22	1505	2.33	1528	2.44	1551	2.55
3740	1362	1.71	1388	1.82	1414	1.92	1439	2.03	1464	2.14	1488	2.25	1512	2.36	1536	2.48	1559	2.59	1582	2.71
4080	1434	1.99	1459	2.1	1484	2.21	1507	2.33	1531	2.44	1555	2.56	1578	2.68	1600	2.8	1622	2.92	1644	3.04

Notes:

1. Available External Static Pressure is the static pressure difference between the return duct and the supply duct plus the static pressure drop caused by accessories and options.
2. For direct drive evaporator fan speed (rpm), refer to the applicable table in the fan performance section.
3. Data includes pressure drop due to standard filters and wet coils. No accessories or options are included in pressure drop data.
4. To determine static pressure drop due to other options/accessories, refer to the applicable table in the fan performance section.
5. Direct drive fan motor heat is negligible.
6. Factory supplied motors, in commercial equipment, are definite purpose motors, specifically designed and tested to operate reliably and continuously at all cataloged conditions. Using the full horsepower range of our fan motors as shown in our tabular data will not result in nuisance tripping or premature motor failure. Our product's warranty will not be affected.

Table 81. Evaporator fan performance - 10 ton (model YZK), downflow, high heat

Available External Static Pressure (Inches of Water Gauge)																				
CFM	0.10		0.20		0.30		0.40		0.50		0.60		0.70		0.80		0.90		1.00	
	RPM	BHP	RPM	BHP	RPM	BHP	RPM	BHP	RPM	BHP	RPM	BHP	RPM	BHP	RPM	BHP	RPM	BHP	RPM	BHP
3000	817	0.32	859	0.39	897	0.46	932	0.52	966	0.59	999	0.66	1033	0.74	1065	0.82	1098	0.90	1130	0.98
3200	866	0.38	906	0.45	943	0.52	977	0.60	1009	0.67	1040	0.74	1071	0.82	1103	0.90	1133	0.98	1164	1.07
3400	915	0.45	953	0.52	988	0.60	1021	0.68	1052	0.75	1083	0.83	1112	0.91	1141	0.99	1171	1.08	1200	1.17
3600	964	0.52	1000	0.60	1035	0.68	1067	0.76	1097	0.84	1125	0.92	1154	1.01	1182	1.09	1209	1.18	1237	1.27
3800	1014	0.60	1048	0.69	1081	0.77	1112	0.86	1142	0.94	1169	1.03	1196	1.11	1223	1.20	1250	1.29	1275	1.38
4000	1065	0.70	1097	0.78	1128	0.87	1158	0.96	1187	1.05	1214	1.14	1240	1.23	1266	1.32	1291	1.41	1316	1.51
4200	1115	0.80	1145	0.89	1176	0.98	1205	1.07	1233	1.17	1259	1.26	1284	1.36	1309	1.45	1334	1.55	1358	1.65
4400	1166	0.91	1194	1.00	1223	1.10	1251	1.20	1278	1.30	1305	1.40	1329	1.49	1353	1.59	1376	1.69	1400	1.79
4600	1217	1.03	1243	1.12	1271	1.23	1298	1.33	1325	1.43	1350	1.54	1374	1.64	1398	1.74	1420	1.84	1443	1.95
4800	1268	1.17	1292	1.26	1319	1.36	1346	1.47	1371	1.58	1396	1.69	1420	1.80	1443	1.90	1465	2.01	1486	2.12
Available External Static Pressure (Inches of Water Gauge)																				
CFM	1.10		1.20		1.30		1.40		1.50		1.60		1.70		1.80		1.90		2.00	
	RPM	BHP	RPM	BHP	RPM	BHP	RPM	BHP	RPM	BHP	RPM	BHP	RPM	BHP	RPM	BHP	RPM	BHP	RPM	BHP
3000	1162	1.07	1193	1.16	1223	1.25	1252	1.34	1282	1.44	1310	1.53	1337	1.63	1364	1.72	1390	1.82	1415	1.92
3200	1194	1.16	1224	1.25	1253	1.35	1282	1.44	1310	1.54	1338	1.64	1365	1.74	1392	1.84	1418	1.94	1443	2.04
3400	1229	1.26	1257	1.35	1285	1.45	1313	1.55	1341	1.65	1368	1.75	1394	1.85	1420	1.96	1446	2.06	1471	2.17
3600	1265	1.36	1292	1.46	1319	1.56	1346	1.66	1372	1.76	1398	1.87	1424	1.97	1450	2.08	1475	2.19	1499	2.3
3800	1302	1.48	1328	1.58	1354	1.68	1380	1.78	1405	1.89	1430	2	1455	2.1	1480	2.22	1505	2.33	1529	2.44
4000	1340	1.61	1366	1.71	1391	1.81	1415	1.92	1440	2.02	1464	2.13	1489	2.25	1512	2.36	1535	2.47	1559	2.59
4200	1381	1.74	1404	1.84	1429	1.95	1453	2.06	1476	2.17	1499	2.28	1523	2.4	1546	2.51	1569	2.63	1591	2.75
4400	1423	1.89	1445	2	1467	2.1	1491	2.21	1514	2.33	1536	2.44	1558	2.56	1580	2.68	1603	2.8	1625	2.92
4600	1465	2.05	1487	2.16	1509	2.27	1530	2.38	1552	2.49	1574	2.61	1596	2.73	1617	2.85	1638	2.97	1659	3.1
4800	1508	2.23	1529	2.34	1550	2.45	1571	2.56	1591	2.68	1612	2.79	1633	2.92	1654	3.04	1675	3.16	1695	3.29

Notes:

1. Available External Static Pressure is the static pressure difference between the return duct and the supply duct plus the static pressure drop caused by accessories and options.
2. For direct drive evaporator fan speed (rpm), refer to the applicable table in the fan performance section.
3. Data includes pressure drop due to standard filters and wet coils. No accessories or options are included in pressure drop data.
4. To determine static pressure drop due to other options/accessories, refer to the applicable table in the fan performance section.
5. Direct drive fan motor heat is negligible.
6. Factory supplied motors, in commercial equipment, are definite purpose motors, specifically designed and tested to operate reliably and continuously at all cataloged conditions. Using the full horsepower range of our fan motors as shown in our tabular data will not result in nuisance tripping or premature motor failure. Our product's warranty will not be affected.

Table 82. Evaporator fan performance - 12.5 ton (model YZK), downflow, high heat

Available External Static Pressure (Inches of Water Gauge)																				
CFM	0.10		0.20		0.30		0.40		0.50		0.60		0.70		0.80		0.90		1.00	
	RPM	BHP	RPM	BHP	RPM	BHP	RPM	BHP	RPM	BHP	RPM	BHP	RPM	BHP	RPM	BHP	RPM	BHP	RPM	BHP
3750	562	0.21	623	0.30	677	0.40	726	0.50	772	0.60	816	0.70	857	0.81	895	0.92	932	1.03	968	1.15
4000	591	0.25	650	0.34	701	0.44	749	0.55	794	0.65	836	0.76	877	0.87	915	0.98	951	1.10	986	1.22
4500	650	0.32	704	0.43	753	0.54	798	0.65	841	0.77	881	0.89	919	1.01	956	1.13	991	1.26	1025	1.38
5000	710	0.42	760	0.53	807	0.65	849	0.78	889	0.90	928	1.03	964	1.16	999	1.30	1033	1.43	1066	1.57
5500	771	0.53	817	0.65	862	0.79	902	0.92	940	1.06	976	1.19	1011	1.34	1045	1.48	1078	1.63	1109	1.77
6000	833	0.66	876	0.80	917	0.94	956	1.08	993	1.23	1027	1.38	1060	1.53	1093	1.68	1124	1.84	1154	2.00
Available External Static Pressure (Inches of Water Gauge)																				
CFM	1.10		1.20		1.30		1.40		1.50		1.60		1.70		1.80		1.90		2.00	
	RPM	BHP	RPM	BHP	RPM	BHP	RPM	BHP	RPM	BHP	RPM	BHP	RPM	BHP	RPM	BHP	RPM	BHP	RPM	BHP
3750	1003	1.27	1036	1.39	1069	1.51	1099	1.64	1129	1.77	1158	1.9	1188	2.04	1217	2.18	1246	2.33	1274	2.47
4000	1020	1.34	1053	1.47	1085	1.6	1116	1.73	1146	1.87	1175	2	1203	2.14	1230	2.28	1257	2.43	1285	2.58
4500	1058	1.51	1089	1.65	1119	1.78	1150	1.92	1180	2.07	1208	2.21	1236	2.36	1263	2.51	1290	2.66	1315	2.81
5000	1098	1.71	1129	1.85	1159	1.99	1187	2.14	1215	2.29	1242	2.44	1270	2.59	1297	2.75	1323	2.91	1349	3.07



Evaporator Fan Performance — Gas Heat

Table 82. Evaporator fan performance - 12.5 ton (model YZK), downflow, high heat (continued)

Available External Static Pressure (Inches of Water Gauge)																				
CFM	1.10		1.20		1.30		1.40		1.50		1.60		1.70		1.80		1.90		2.00	
	RPM	BHP	RPM	BHP	RPM	BHP	RPM	BHP	RPM	BHP	RPM	BHP	RPM	BHP	RPM	BHP	RPM	BHP	RPM	BHP
5500	1139	1.92	1170	2.07	1199	2.23	1227	2.38	1255	2.54	1282	2.7	1308	2.86	1333	3.02	1358	3.18	1383	3.35
6000	1184	2.16	1213	2.32	1240	2.48	1268	2.65	1296	2.81	1322	2.98	1348	3.15	1373	3.32	1397	3.49	1421	3.67

Notes:

1. Available External Static Pressure is the static pressure difference between the return duct and the supply duct plus the static pressure drop caused by accessories and options.
2. For direct drive evaporator fan speed (rpm), refer to the applicable table in the fan performance section.
3. Data includes pressure drop due to standard filters and wet coils. No accessories or options are included in pressure drop data.
4. To determine static pressure drop due to other options/accessories, refer to the applicable table in the fan performance section.
5. Direct drive fan motor heat is negligible.
6. Factory supplied motors, in commercial equipment, are definite purpose motors, specifically designed and tested to operate reliably and continuously at all cataloged conditions. Using the full horsepower range of our fan motors as shown in our tabular data will not result in nuisance tripping or premature motor failure. Our product's warranty will not be affected.

Table 83. Evaporator fan performance - 15 ton (model YZK), downflow, high heat

Available External Static Pressure (Inches of Water Gauge)																				
CFM	0.10		0.20		0.30		0.40		0.50		0.60		0.70		0.80		0.90		1.00	
	RPM	BHP	RPM	BHP	RPM	BHP	RPM	BHP	RPM	BHP	RPM	BHP	RPM	BHP	RPM	BHP	RPM	BHP	RPM	BHP
4500	650	0.32	704	0.43	753	0.54	798	0.65	841	0.77	881	0.89	919	1.01	956	1.13	991	1.26	1025	1.38
4800	686	0.38	738	0.49	785	0.61	828	0.73	869	0.85	908	0.97	946	1.10	981	1.23	1016	1.36	1050	1.49
5400	759	0.50	806	0.63	850	0.76	891	0.89	930	1.02	966	1.16	1002	1.30	1036	1.44	1069	1.59	1100	1.73
6000	833	0.66	876	0.80	917	0.94	956	1.08	993	1.23	1027	1.38	1060	1.53	1093	1.68	1124	1.84	1154	2.00
6600	909	0.84	948	0.99	985	1.15	1022	1.31	1057	1.47	1090	1.63	1122	1.79	1152	1.96	1182	2.12	1211	2.30
7200	984	1.06	1020	1.23	1055	1.40	1090	1.57	1123	1.74	1155	1.91	1185	2.09	1214	2.27	1243	2.45	1270	2.63

Available External Static Pressure (Inches of Water Gauge)																				
CFM	1.10		1.20		1.30		1.40		1.50		1.60		1.70		1.80		1.90		2.00	
	RPM	BHP	RPM	BHP	RPM	BHP	RPM	BHP	RPM	BHP	RPM	BHP	RPM	BHP	RPM	BHP	RPM	BHP	RPM	BHP
4500	1058	1.51	1089	1.65	1119	1.78	1150	1.92	1180	2.07	1208	2.21	1236	2.36	1263	2.51	1290	2.66	1315	2.81
4800	1082	1.63	1113	1.77	1143	1.91	1172	2.05	1200	2.19	1229	2.34	1256	2.5	1283	2.65	1310	2.81	1335	2.97
5400	1131	1.88	1162	2.03	1191	2.18	1219	2.33	1247	2.49	1274	2.64	1300	2.8	1325	2.96	1351	3.13	1376	3.3
6000	1184	2.16	1213	2.32	1240	2.48	1268	2.65	1296	2.81	1322	2.98	1348	3.15	1373	3.32	1397	3.49	1421	3.67
6600	1240	2.47	1267	2.64	1294	2.82	1321	2.99	1346	3.17	1371	3.35	1397	3.53	1421	3.72	1446	3.9	1469	4.09
7200	1297	2.81	1324	3	1350	3.19	1375	3.38	1400	3.57	1425	3.76	1449	3.95	1472	4.15	1495	4.34	1518	4.54

Notes:

1. Available External Static Pressure is the static pressure difference between the return duct and the supply duct plus the static pressure drop caused by accessories and options.
2. For direct drive evaporator fan speed (rpm), refer to the applicable table in the fan performance section.
3. Data includes pressure drop due to standard filters and wet coils. No accessories or options are included in pressure drop data.
4. To determine static pressure drop due to other options/accessories, refer to the applicable table in the fan performance section.
5. Direct drive fan motor heat is negligible.
6. Factory supplied motors, in commercial equipment, are definite purpose motors, specifically designed and tested to operate reliably and continuously at all cataloged conditions. Using the full horsepower range of our fan motors as shown in our tabular data will not result in nuisance tripping or premature motor failure. Our product's warranty will not be affected.

Table 84. Evaporator fan performance - 17.5 ton (model YZK), downflow, high heat

Available External Static Pressure (Inches of Water Gauge)																				
CFM	0.10		0.20		0.30		0.40		0.50		0.60		0.70		0.80		0.90		1.00	
	RPM	BHP	RPM	BHP	RPM	BHP	RPM	BHP	RPM	BHP	RPM	BHP	RPM	BHP	RPM	BHP	RPM	BHP	RPM	BHP
5250	741	0.47	789	0.59	834	0.72	875	0.85	914	0.98	952	1.11	987	1.25	1022	1.39	1055	1.53	1087	1.67
5600	784	0.55	829	0.68	873	0.82	913	0.95	950	1.09	986	1.23	1021	1.37	1054	1.52	1087	1.67	1118	1.82
6300	871	0.75	912	0.89	951	1.04	989	1.19	1025	1.34	1059	1.50	1091	1.66	1122	1.82	1153	1.98	1183	2.14
7000	959	0.99	996	1.15	1032	1.31	1067	1.48	1101	1.64	1133	1.81	1164	1.99	1194	2.16	1222	2.34	1250	2.51
7700	1047	1.28	1081	1.45	1115	1.63	1147	1.81	1179	1.99	1210	2.18	1239	2.37	1267	2.56	1295	2.75	1321	2.94
8400	1136	1.62	1168	1.81	1199	2.00	1229	2.20	1258	2.40	1288	2.60	1316	2.80	1343	3.00	1369	3.21	1395	3.42

Table 84. Evaporator fan performance - 17.5 ton (model YZK), downflow, high heat (continued)

Available External Static Pressure (Inches of Water Gauge)																				
CFM	1.10		1.20		1.30		1.40		1.50		1.60		1.70		1.80		1.90		2.00	
	RPM	BHP	RPM	BHP	RPM	BHP	RPM	BHP	RPM	BHP	RPM	BHP	RPM	BHP	RPM	BHP	RPM	BHP	RPM	BHP
5250	1119	1.81	1149	1.96	1179	2.11	1207	2.26	1235	2.41	1262	2.56	1288	2.72	1314	2.88	1340	3.04	1366	3.21
5600	1148	1.97	1178	2.12	1207	2.28	1236	2.43	1263	2.59	1290	2.75	1316	2.91	1341	3.08	1365	3.24	1390	3.41
6300	1211	2.31	1240	2.48	1267	2.65	1294	2.82	1320	2.99	1347	3.16	1372	3.34	1397	3.51	1421	3.69	1445	3.87
7000	1278	2.69	1305	2.88	1331	3.06	1357	3.24	1382	3.43	1407	3.62	1431	3.81	1455	4	1479	4.19	1502	4.38
7700	1347	3.13	1373	3.33	1398	3.52	1423	3.72	1447	3.92	1470	4.13	1494	4.33	1517	4.54	1539	4.74	1562	4.95
8400	1420	3.62	1444	3.83	1467	4.04	1491	4.26	1514	4.47	1537	4.69	1560	4.91	1582	5.13	1603	5.35	1625	5.57

Notes:

1. Available External Static Pressure is the static pressure difference between the return duct and the supply duct plus the static pressure drop caused by accessories and options.
2. For direct drive evaporator fan speed (rpm), refer to the applicable table in the fan performance section.
3. Data includes pressure drop due to standard filters and wet coils. No accessories or options are included in pressure drop data.
4. To determine static pressure drop due to other options/accessories, refer to the applicable table in the fan performance section.
5. Direct drive fan motor heat is negligible.
6. Factory supplied motors, in commercial equipment, are definite purpose motors, specifically designed and tested to operate reliably and continuously at all cataloged conditions. Using the full horsepower range of our fan motors as shown in our tabular data will not result in nuisance tripping or premature motor failure. Our product's warranty will not be affected.

Table 85. Evaporator fan performance - 20 ton (model YZK), downflow, high heat

Available External Static Pressure (Inches of Water Gauge)																				
CFM	0.10		0.20		0.30		0.40		0.50		0.60		0.70		0.80		0.90		1.00	
	RPM	BHP	RPM	BHP	RPM	BHP	RPM	BHP	RPM	BHP	RPM	BHP	RPM	BHP	RPM	BHP	RPM	BHP	RPM	BHP
6000	833	0.66	876	0.80	917	0.94	956	1.08	993	1.23	1027	1.38	1060	1.53	1093	1.68	1124	1.84	1154	2.00
6400	883	0.78	924	0.92	963	1.08	1000	1.23	1036	1.38	1069	1.54	1101	1.70	1132	1.86	1163	2.03	1192	2.19
7200	984	1.06	1020	1.23	1055	1.40	1090	1.57	1123	1.74	1155	1.91	1185	2.09	1214	2.27	1243	2.45	1270	2.63
8000	1086	1.42	1118	1.60	1150	1.78	1182	1.97	1213	2.16	1243	2.35	1272	2.55	1300	2.74	1326	2.94	1353	3.14
8800	1188	1.84	1218	2.04	1247	2.24	1276	2.45	1304	2.66	1333	2.87	1360	3.08	1387	3.29	1412	3.50	1437	3.72
9600	1290	2.35	1318	2.57	1345	2.79	1372	3.01	1398	3.23	1424	3.46	1450	3.69	1476	3.92	1500	4.15	1524	4.38

Available External Static Pressure (Inches of Water Gauge)																				
CFM	1.10		1.20		1.30		1.40		1.50		1.60		1.70		1.80		1.90		2.00	
	RPM	BHP	RPM	BHP	RPM	BHP	RPM	BHP	RPM	BHP	RPM	BHP	RPM	BHP	RPM	BHP	RPM	BHP	RPM	BHP
6000	1184	2.16	1213	2.32	1240	2.48	1268	2.65	1296	2.81	1322	2.98	1348	3.15	1373	3.32	1397	3.49	1421	3.67
6400	1221	2.36	1249	2.53	1276	2.7	1303	2.87	1329	3.05	1355	3.22	1380	3.4	1405	3.58	1429	3.76	1453	3.94
7200	1297	2.81	1324	3	1350	3.19	1375	3.38	1400	3.57	1425	3.76	1449	3.95	1472	4.15	1495	4.34	1518	4.54
8000	1378	3.33	1403	3.54	1427	3.74	1452	3.94	1476	4.15	1499	4.36	1522	4.57	1544	4.78	1567	4.99	1588	5.21
8800	1462	3.94	1485	4.15	1509	4.37	1531	4.59	1554	4.81	1576	5.04	1598	5.26	1620	5.49	1641	5.72	1662	5.95
9600	1548	4.61	1570	4.85	1593	5.09	1614	5.32	1636	5.56	1657	5.8	1678	6.04	-	-	-	-	-	-

Notes:

1. Available External Static Pressure is the static pressure difference between the return duct and the supply duct plus the static pressure drop caused by accessories and options.
2. For direct drive evaporator fan speed (rpm), refer to the applicable table in the fan performance section.
3. Data includes pressure drop due to standard filters and wet coils. No accessories or options are included in pressure drop data.
4. To determine static pressure drop due to other options/accessories, refer to the applicable table in the fan performance section.
5. Direct drive fan motor heat is negligible.
6. Factory supplied motors, in commercial equipment, are definite purpose motors, specifically designed and tested to operate reliably and continuously at all cataloged conditions. Using the full horsepower range of our fan motors as shown in our tabular data will not result in nuisance tripping or premature motor failure. Our product's warranty will not be affected.

Table 86. Evaporator fan performance - 25 ton (model YZK), downflow, high heat

Available External Static Pressure (Inches of Water Gauge)																				
CFM	0.10		0.20		0.30		0.40		0.50		0.60		0.70		0.80		0.90		1.00	
	RPM	BHP	RPM	BHP	RPM	BHP	RPM	BHP	RPM	BHP	RPM	BHP	RPM	BHP	RPM	BHP	RPM	BHP	RPM	BHP
7500	1022	1.19	1057	1.36	1091	1.53	1124	1.71	1157	1.89	1188	2.07	1217	2.25	1246	2.44	1274	2.62	1301	2.81
8000	1086	1.42	1118	1.60	1150	1.78	1182	1.97	1213	2.16	1243	2.35	1272	2.55	1300	2.74	1326	2.94	1353	3.14
9000	1213	1.96	1243	2.17	1271	2.37	1300	2.58	1328	2.79	1356	3.01	1383	3.22	1409	3.44	1434	3.66	1459	3.87



Evaporator Fan Performance — Gas Heat

Table 86. Evaporator fan performance - 25 ton (model YZK), downflow, high heat (continued)

Available External Static Pressure (Inches of Water Gauge)																				
CFM	0.10		0.20		0.30		0.40		0.50		0.60		0.70		0.80		0.90		1.00	
	RPM	BHP	RPM	BHP	RPM	BHP	RPM	BHP	RPM	BHP	RPM	BHP	RPM	BHP	RPM	BHP	RPM	BHP	RPM	BHP
10000	1342	2.64	1369	2.87	1395	3.09	1420	3.32	1446	3.55	1471	3.79	1496	4.03	1521	4.26	1545	4.50	1568	4.75
11000	1471	3.47	1495	3.71	1519	3.96	1543	4.21	1566	4.46	1589	4.72	1612	4.98	1635	5.24	1658	5.50	1680	5.76
12000	1601	4.45	1623	4.71	1645	4.98	1667	5.26	1688	5.53	1710	5.81	-	-	-	-	-	-	-	-
Available External Static Pressure (Inches of Water Gauge)																				
CFM	1.10		1.20		1.30		1.40		1.50		1.60		1.70		1.80		1.90		2.00	
	RPM	BHP	RPM	BHP	RPM	BHP	RPM	BHP	RPM	BHP	RPM	BHP	RPM	BHP	RPM	BHP	RPM	BHP	RPM	BHP
7500	1327	3	1353	3.19	1379	3.38	1404	3.58	1428	3.78	1452	3.98	1476	4.18	1499	4.38	1522	4.58	1544	4.78
8000	1378	3.33	1403	3.54	1427	3.74	1452	3.94	1476	4.15	1499	4.36	1522	4.57	1544	4.78	1567	4.99	1588	5.21
9000	1483	4.1	1506	4.32	1529	4.54	1552	4.77	1574	4.99	1596	5.22	1618	5.45	1639	5.68	1660	5.91	-	-
10000	1591	4.99	1613	5.23	1635	5.48	1657	5.72	1678	5.97	-	-	-	-	-	-	-	-	-	-
11000	1702	6.02	-	-	-	-	-	-	-	-	-	-	-	-	-	-	-	-	-	-
12000	-	-	-	-	-	-	-	-	-	-	-	-	-	-	-	-	-	-	-	-

Notes:

1. Available External Static Pressure is the static pressure difference between the return duct and the supply duct plus the static pressure drop caused by accessories and options.
2. For direct drive evaporator fan speed (rpm), refer to the applicable table in the fan performance section.
3. Data includes pressure drop due to standard filters and wet coils. No accessories or options are included in pressure drop data.
4. To determine static pressure drop due to other options/accessories, refer to the applicable table in the fan performance section.
5. Direct drive fan motor heat is negligible.
6. Factory supplied motors, in commercial equipment, are definite purpose motors, specifically designed and tested to operate reliably and continuously at all cataloged conditions. Using the full horsepower range of our fan motors as shown in our tabular data will not result in nuisance tripping or premature motor failure. Our product's warranty will not be affected.

Table 87. Evaporator fan performance - 25 ton (model YZK), downflow, high heat, high static motor

Available External Static Pressure (Inches of Water Gauge)																				
CFM	0.10		0.20		0.30		0.40		0.50		0.60		0.70		0.80		0.90		1.00	
	RPM	BHP	RPM	BHP	RPM	BHP	RPM	BHP	RPM	BHP	RPM	BHP	RPM	BHP	RPM	BHP	RPM	BHP	RPM	BHP
7500	1022	1.19	1057	1.36	1091	1.53	1124	1.71	1157	1.89	1188	2.07	1217	2.25	1246	2.44	1274	2.62	1301	2.81
8000	1086	1.42	1118	1.60	1150	1.78	1182	1.97	1213	2.16	1243	2.35	1272	2.55	1300	2.74	1326	2.94	1353	3.14
9000	1213	1.96	1243	2.17	1271	2.37	1300	2.58	1328	2.79	1356	3.01	1383	3.22	1409	3.44	1434	3.66	1459	3.87
10000	1342	2.64	1369	2.87	1395	3.09	1420	3.32	1446	3.55	1471	3.79	1496	4.03	1521	4.26	1545	4.50	1568	4.75
11000	1471	3.47	1495	3.71	1519	3.96	1543	4.21	1566	4.46	1589	4.72	1612	4.98	1635	5.24	1658	5.50	1680	5.76
12000	1601	4.45	1623	4.71	1645	4.98	1667	5.26	1688	5.53	1710	5.81	1728	5.93	1749	6.22	1771	6.50	1792	6.77
Available External Static Pressure (Inches of Water Gauge)																				
CFM	1.10		1.20		1.30		1.40		1.50		1.60		1.70		1.80		1.90		2.00	
	RPM	BHP	RPM	BHP	RPM	BHP	RPM	BHP	RPM	BHP	RPM	BHP	RPM	BHP	RPM	BHP	RPM	BHP	RPM	BHP
7500	1327	3	1353	3.19	1379	3.38	1404	3.58	1428	3.78	1452	3.98	1476	4.18	1499	4.38	1522	4.58	1544	4.78
8000	1378	3.33	1403	3.54	1427	3.74	1452	3.94	1476	4.15	1499	4.36	1522	4.57	1544	4.78	1567	4.99	1588	5.21
9000	1483	4.1	1506	4.32	1529	4.54	1552	4.77	1574	4.99	1596	5.22	1618	5.45	1639	5.68	1660	5.91	1681	6.14
10000	1591	4.99	1613	5.23	1635	5.48	1657	5.72	1678	5.97	1693	6.08	1714	6.33	1734	6.58	1753	6.83	1772	7.08
11000	1702	6.02	1720	6.14	1741	6.42	1762	6.67	1782	6.95	1790	6.94	1810	7.21	1829	7.48	1846	7.75	1863	8.02
12000	1813	7.05	1827	7.05	1847	7.36	1867	7.62	1886	7.93	1887	7.8	1906	8.09	1924	8.38	-	-	-	-

Notes:

1. Available External Static Pressure is the static pressure difference between the return duct and the supply duct plus the static pressure drop caused by accessories and options.
2. For direct drive evaporator fan speed (rpm), refer to the applicable table in the fan performance section.
3. Data includes pressure drop due to standard filters and wet coils. No accessories or options are included in pressure drop data.
4. To determine static pressure drop due to other options/accessories, refer to the applicable table in the fan performance section.
5. Direct drive fan motor heat is negligible.
6. Factory supplied motors, in commercial equipment, are definite purpose motors, specifically designed and tested to operate reliably and continuously at all cataloged conditions. Using the full horsepower range of our fan motors as shown in our tabular data will not result in nuisance tripping or premature motor failure. Our product's warranty will not be affected.

Horizontal

Table 88. Evaporator fan performance - 3 ton (model YZK), horizontal, high heat

Available External Static Pressure (Inches of Water Gauge)																				
CFM	0.10		0.20		0.30		0.40		0.50		0.60		0.70		0.80		0.90		1.00	
	RPM	BHP	RPM	BHP	RPM	BHP	RPM	BHP	RPM	BHP	RPM	BHP	RPM	BHP	RPM	BHP	RPM	BHP	RPM	BHP
900 ^(a)	364	0.03	443	0.06	508	0.08	568	0.11	621	0.15	671	0.18	720	0.21	765	0.25	807	0.29	847	0.33
960	377	0.04	454	0.06	518	0.09	576	0.12	629	0.15	677	0.19	724	0.22	769	0.26	811	0.30	851	0.34
1080	404	0.04	477	0.07	539	0.10	594	0.13	645	0.17	693	0.21	737	0.24	779	0.28	821	0.32	861	0.37
1200	433	0.05	500	0.08	560	0.12	614	0.15	663	0.19	708	0.22	753	0.27	794	0.31	833	0.35	870	0.39
1320	463	0.07	525	0.10	583	0.13	635	0.17	683	0.21	727	0.25	768	0.29	809	0.33	848	0.38	885	0.42
1440	493	0.08	551	0.11	607	0.15	657	0.19	703	0.23	747	0.27	788	0.31	825	0.36	864	0.41	900	0.45
Available External Static Pressure (Inches of Water Gauge)																				
CFM	1.10		1.20		1.30		1.40		1.50		1.60		1.70		1.80		1.90		2.00	
	RPM	BHP	RPM	BHP	RPM	BHP	RPM	BHP	RPM	BHP	RPM	BHP	RPM	BHP	RPM	BHP	RPM	BHP	RPM	BHP
900 ^(b)	885	0.37	921	0.41	956	0.45	990	0.5	1022	0.54	1054	0.59	1084	0.64	1114	0.68	1142	0.73	1170	0.78
960	890	0.38	926	0.43	961	0.47	994	0.52	1027	0.56	1058	0.61	1089	0.66	1118	0.71	1147	0.76	1175	0.81
1080	899	0.41	935	0.46	970	0.5	1003	0.55	1036	0.6	1067	0.65	1097	0.70	1127	0.75	1156	0.8	1184	0.85
1200	908	0.44	944	0.49	979	0.54	1012	0.58	1045	0.63	1076	0.69	1106	0.74	1136	0.79	1165	0.85	1192	0.9
1320	920	0.47	953	0.52	988	0.57	1021	0.62	1054	0.67	1085	0.73	1115	0.78	1145	0.84	1173	0.89	1201	0.95
1440	935	0.5	968	0.55	1000	0.61	1031	0.66	1063	0.71	1094	0.77	1124	0.83	1154	0.88	1182	0.94	1210	1.00

Notes:

1. Available External Static Pressure is the static pressure difference between the return duct and the supply duct plus the static pressure drop caused by accessories and options.
2. For direct drive evaporator fan speed (rpm), refer to the applicable table in the fan performance section.
3. Data includes pressure drop due to standard filters and wet coils. No accessories or options are included in pressure drop data.
4. To determine static pressure drop due to other options/accessories, refer to the applicable table in the fan performance section.
5. Direct drive fan motor heat is negligible.
6. Factory supplied motors, in commercial equipment, are definite purpose motors, specifically designed and tested to operate reliably and continuously at all cataloged conditions. Using the full horsepower range of our fan motors as shown in our tabular data will not result in nuisance tripping or premature motor failure. Our product's warranty will not be affected.

^(a) Model digit 11 selection of high heat is limited to minimum 320 cfm/ton full load airflow.

^(b) Model digit 11 selection of high heat is limited to minimum 320 cfm/ton full load airflow.

Table 89. Evaporator fan performance - 4 ton (model YZK), horizontal, high heat

Available External Static Pressure (Inches of Water Gauge)																				
CFM	0.10		0.20		0.30		0.40		0.50		0.60		0.70		0.80		0.90		1.00	
	RPM	BHP	RPM	BHP	RPM	BHP	RPM	BHP	RPM	BHP	RPM	BHP	RPM	BHP	RPM	BHP	RPM	BHP	RPM	BHP
1200 ^(a)	433	0.05	500	0.08	560	0.12	614	0.15	663	0.19	708	0.22	753	0.27	794	0.31	833	0.35	870	0.39
1280	453	0.06	517	0.09	576	0.13	628	0.16	676	0.20	720	0.24	763	0.28	804	0.32	843	0.37	880	0.41
1440	493	0.08	551	0.11	607	0.15	657	0.19	703	0.23	747	0.27	788	0.31	825	0.36	864	0.41	900	0.45
1600	534	0.10	589	0.14	640	0.18	689	0.22	733	0.26	774	0.31	814	0.35	852	0.40	887	0.45	921	0.50
1760	576	0.13	628	0.17	675	0.21	720	0.25	764	0.30	804	0.35	842	0.39	879	0.44	914	0.50	948	0.55
1920	619	0.16	668	0.20	712	0.24	754	0.29	796	0.34	836	0.39	872	0.44	907	0.49	942	0.55	975	0.60
Available External Static Pressure (Inches of Water Gauge)																				
CFM	1.10		1.20		1.30		1.40		1.50		1.60		1.70		1.80		1.90		2.00	
	RPM	BHP	RPM	BHP	RPM	BHP	RPM	BHP	RPM	BHP	RPM	BHP	RPM	BHP	RPM	BHP	RPM	BHP	RPM	BHP
1200 ^(b)	908	0.44	944	0.49	979	0.54	1012	0.58	1045	0.63	1076	0.69	1106	0.74	1136	0.79	1165	0.85	1192	0.9
1280	915	0.46	950	0.51	985	0.56	1018	0.61	1051	0.66	1082	0.71	1112	0.77	1142	0.82	1170	0.88	1198	0.93
1440	935	0.5	968	0.55	1000	0.61	1031	0.66	1063	0.71	1094	0.77	1124	0.83	1154	0.88	1182	0.94	1210	1.00
1600	956	0.55	989	0.6	1021	0.66	1052	0.71	1081	0.77	1110	0.83	1138	0.89	1166	0.95	1195	1.01	1222	1.07
1760	980	0.6	1010	0.66	1042	0.72	1072	0.77	1102	0.83	1131	0.89	1159	0.95	1186	1.02	1212	1.08	1238	1.14



Evaporator Fan Performance — Gas Heat

Table 89. Evaporator fan performance - 4 ton (model YZK), horizontal, high heat (continued)

Available External Static Pressure (Inches of Water Gauge)																				
CFM	1.10		1.20		1.30		1.40		1.50		1.60		1.70		1.80		1.90		2.00	
	RPM	BHP	RPM	BHP	RPM	BHP	RPM	BHP	RPM	BHP	RPM	BHP	RPM	BHP	RPM	BHP	RPM	BHP	RPM	BHP
1920	1006	0.66	1037	0.72	1066	0.78	1094	0.84	1123	0.9	1151	0.96	1179	1.03	1206	1.09	1232	1.16	1258	1.22

Notes:

1. Available External Static Pressure is the static pressure difference between the return duct and the supply duct plus the static pressure drop caused by accessories and options.
2. Data includes pressure drop due to standard filters and wet coils. No accessories or options are included in pressure drop data.
3. To determine static pressure drop due to other options/accessories, refer to the applicable table in the fan performance section.
4. Direct drive fan motor heat is negligible.
5. Factory supplied motors, in commercial equipment, are definite purpose motors, specifically designed and tested to operate reliably and continuously at all cataloged conditions. Using the full horsepower range of our fan motors as shown in our tabular data will not result in nuisance tripping or premature motor failure. Our product's warranty will not be affected.

(a) Model digit 11 selection of High Gas Heat is limited to minimum 320 cfm/ton full load airflow.

(b) Model digit 11 selection of High Gas Heat is limited to minimum 320 cfm/ton full load airflow.

Table 90. Evaporator fan performance - 5 ton (model YZK), horizontal, high heat

Available External Static Pressure (Inches of Water Gauge)																				
CFM	0.10		0.20		0.30		0.40		0.50		0.60		0.70		0.80		0.90		1.00	
	RPM	BHP	RPM	BHP	RPM	BHP	RPM	BHP	RPM	BHP	RPM	BHP	RPM	BHP	RPM	BHP	RPM	BHP	RPM	BHP
1500 ^(a)	508	0.09	565	0.12	619	0.16	669	0.20	714	0.24	757	0.28	798	0.33	835	0.37	871	0.42	908	0.47
1600	534	0.10	589	0.14	640	0.18	689	0.22	733	0.26	774	0.31	814	0.35	852	0.40	887	0.45	921	0.50
1800	587	0.13	638	0.17	684	0.21	729	0.26	772	0.31	812	0.36	849	0.41	886	0.46	921	0.51	954	0.56
2000	640	0.17	688	0.22	731	0.26	772	0.31	812	0.36	851	0.41	888	0.47	922	0.52	956	0.58	988	0.63
2200	695	0.22	739	0.27	780	0.32	818	0.37	855	0.42	892	0.48	927	0.53	961	0.59	994	0.65	1024	0.71
2400	750	0.27	791	0.33	830	0.38	866	0.43	900	0.49	935	0.55	968	0.61	1001	0.67	1033	0.74	1063	0.80

Available External Static Pressure (Inches of Water Gauge)

CFM	1.10		1.20		1.30		1.40		1.50		1.60		1.70		1.80		1.90		2.00	
	RPM	BHP	RPM	BHP	RPM	BHP	RPM	BHP	RPM	BHP	RPM	BHP	RPM	BHP	RPM	BHP	RPM	BHP	RPM	BHP
1500 ^(b)	943	0.52	976	0.57	1008	0.63	1039	0.68	1069	0.73	1099	0.79	1129	0.85	1158	0.91	1187	0.97	1215	1.03
1600	956	0.55	989	0.6	1021	0.66	1052	0.71	1081	0.77	1110	0.83	1138	0.89	1166	0.95	1195	1.01	1222	1.07
1800	986	0.62	1017	0.67	1047	0.73	1078	0.79	1107	0.85	1136	0.91	1164	0.97	1191	1.04	1217	1.10	1243	1.16
2000	1020	0.69	1050	0.75	1079	0.81	1108	0.87	1135	0.93	1162	1.00	1190	1.06	1217	1.13	1243	1.20	1268	1.27
2200	1054	0.77	1084	0.84	1113	0.90	1141	0.97	1168	1.03	1194	1.1	1220	1.17	1245	1.23	1269	1.30	1294	1.37
2400	1092	0.87	1120	0.93	1148	1.00	1175	1.07	1202	1.14	1228	1.21	1253	1.28	1278	1.35	1302	1.42	1325	1.5

Notes:

1. Available External Static Pressure is the static pressure difference between the return duct and the supply duct plus the static pressure drop caused by accessories and options.
2. Data includes pressure drop due to standard filters and wet coils. No accessories or options are included in pressure drop data.
3. To determine static pressure drop due to other options/accessories, refer to the applicable table in the fan performance section.
4. Direct drive fan motor heat is negligible.
5. Factory supplied motors, in commercial equipment, are definite purpose motors, specifically designed and tested to operate reliably and continuously at all cataloged conditions. Using the full horsepower range of our fan motors as shown in our tabular data will not result in nuisance tripping or premature motor failure. Our product's warranty will not be affected.

(a) Model digit 11 selection of High Gas Heat is limited to minimum 320 cfm/ton full load airflow.

(b) Model digit 11 selection of High Gas Heat is limited to minimum 320 cfm/ton full load airflow.

Table 91. Evaporator fan performance - 6 ton (model YZK), horizontal, high heat

Available External Static Pressure (Inches of Water Gauge)																				
CFM	0.10		0.20		0.30		0.40		0.50		0.60		0.70		0.80		0.90		1.00	
	RPM	BHP	RPM	BHP	RPM	BHP	RPM	BHP	RPM	BHP	RPM	BHP	RPM	BHP	RPM	BHP	RPM	BHP	RPM	BHP
1800	631	0.17	684	0.22	732	0.27	777	0.32	819	0.37	859	0.43	896	0.48	932	0.54	968	0.60	1002	0.67
1920	665	0.20	716	0.25	763	0.30	806	0.36	847	0.41	886	0.47	923	0.53	957	0.59	991	0.65	1024	0.72
2040	700	0.23	749	0.28	794	0.34	836	0.40	875	0.46	913	0.52	949	0.58	983	0.64	1016	0.71	1047	0.77
2160	736	0.27	782	0.32	825	0.38	866	0.44	904	0.50	941	0.57	976	0.63	1010	0.70	1042	0.77	1073	0.83
2280	771	0.31	816	0.37	858	0.43	897	0.49	934	0.55	970	0.62	1004	0.69	1037	0.76	1069	0.83	1099	0.90
2400	807	0.35	850	0.41	890	0.48	928	0.54	964	0.61	999	0.68	1033	0.75	1065	0.82	1096	0.89	1126	0.97

Table 91. Evaporator fan performance - 6 ton (model YZK), horizontal, high heat (continued)

Available External Static Pressure (Inches of Water Gauge)																				
CFM	0.10		0.20		0.30		0.40		0.50		0.60		0.70		0.80		0.90		1.00	
	RPM	BHP	RPM	BHP	RPM	BHP	RPM	BHP	RPM	BHP	RPM	BHP	RPM	BHP	RPM	BHP	RPM	BHP	RPM	BHP
2520	843	0.40	885	0.46	923	0.53	960	0.60	995	0.67	1029	0.74	1061	0.81	1093	0.89	1123	0.96	1153	1.04
2640	879	0.45	919	0.52	957	0.59	992	0.66	1026	0.73	1059	0.81	1091	0.88	1122	0.96	1152	1.04	1180	1.12
2760	915	0.51	954	0.58	990	0.65	1025	0.73	1058	0.80	1090	0.88	1121	0.96	1150	1.04	1180	1.12	1208	1.20
2880	951	0.57	989	0.65	1024	0.72	1058	0.80	1090	0.88	1121	0.96	1151	1.04	1180	1.12	1209	1.20	1237	1.29
Available External Static Pressure (Inches of Water Gauge)																				
CFM	1.10		1.20		1.30		1.40		1.50		1.60		1.70		1.80		1.90		2.00	
	RPM	BHP	RPM	BHP	RPM	BHP	RPM	BHP	RPM	BHP	RPM	BHP	RPM	BHP	RPM	BHP	RPM	BHP	RPM	BHP
1800	1034	0.73	1066	0.79	1096	0.86	1126	0.93	1156	1	1185	1.07	1213	1.15	1241	1.22	1267	1.3	1293	1.38
1920	1057	0.78	1088	0.85	1118	0.92	1147	0.99	1175	1.06	1203	1.13	1231	1.21	1258	1.29	1285	1.36	1311	1.44
2040	1079	0.84	1110	0.91	1140	0.98	1169	1.05	1197	1.13	1224	1.2	1250	1.27	1276	1.35	1303	1.43	1329	1.52
2160	1103	0.9	1133	0.97	1162	1.05	1191	1.12	1219	1.2	1246	1.27	1272	1.35	1297	1.43	1322	1.51	1347	1.59
2280	1129	0.97	1157	1.04	1185	1.11	1214	1.19	1241	1.27	1268	1.35	1294	1.43	1319	1.51	1344	1.59	1368	1.68
2400	1155	1.04	1183	1.12	1210	1.19	1236	1.27	1264	1.35	1290	1.43	1316	1.51	1341	1.6	1366	1.68	1390	1.77
2520	1182	1.12	1209	1.2	1236	1.27	1262	1.35	1287	1.43	1313	1.52	1339	1.6	1364	1.69	1388	1.77	1412	1.86
2640	1209	1.2	1236	1.28	1262	1.36	1288	1.44	1313	1.52	1337	1.61	1362	1.69	1386	1.78	1411	1.87	1434	1.96
2760	1236	1.28	1263	1.37	1289	1.45	1315	1.54	1339	1.62	1363	1.71	1387	1.79	1410	1.88	1434	1.97	1457	2.07
2880	1264	1.37	1290	1.46	1316	1.55	1341	1.64	1366	1.73	1390	1.81	1413	1.9	1436	1.99	1458	2.08	1480	2.17

Notes:

1. Available External Static Pressure is the static pressure difference between the return duct and the supply duct plus the static pressure drop caused by accessories and options.
2. For direct drive evaporator fan speed (rpm), refer to the applicable table in the fan performance section.
3. Data includes pressure drop due to standard filters and wet coils. No accessories or options are included in pressure drop data.
4. To determine static pressure drop due to other options/accessories, refer to the applicable table in the fan performance section.
5. Direct drive fan motor heat is negligible.
6. Factory supplied motors, in commercial equipment, are definite purpose motors, specifically designed and tested to operate reliably and continuously at all cataloged conditions. Using the full horsepower range of our fan motors as shown in our tabular data will not result in nuisance tripping or premature motor failure. Our product's warranty will not be affected.

Table 92. Evaporator fan performance - 7.5 ton (model YZK), horizontal, high heat

Available External Static Pressure (Inches of Water Gauge)																				
CFM	0.10		0.20		0.30		0.40		0.50		0.60		0.70		0.80		0.90		1.00	
	RPM	BHP	RPM	BHP	RPM	BHP	RPM	BHP	RPM	BHP	RPM	BHP	RPM	BHP	RPM	BHP	RPM	BHP	RPM	BHP
2250	707	0.23	748	0.28	790	0.34	831	0.39	870	0.45	906	0.51	941	0.57	973	0.63	1007	0.70	1039	0.76
2400	748	0.27	788	0.33	826	0.38	865	0.44	903	0.51	939	0.57	973	0.63	1005	0.70	1035	0.76	1066	0.83
2550	790	0.32	828	0.38	863	0.44	900	0.50	937	0.56	972	0.63	1005	0.70	1036	0.77	1066	0.83	1095	0.90
2700	832	0.37	868	0.43	901	0.49	936	0.56	971	0.63	1005	0.70	1038	0.77	1069	0.84	1098	0.91	1127	0.98
2850	874	0.43	909	0.49	941	0.56	973	0.63	1006	0.70	1039	0.77	1071	0.84	1102	0.92	1131	0.99	1158	1.07
3000	916	0.49	950	0.56	981	0.63	1010	0.70	1042	0.77	1073	0.85	1105	0.92	1135	1.00	1163	1.08	1191	1.16
3150	959	0.56	991	0.63	1021	0.71	1049	0.78	1079	0.85	1109	0.93	1139	1.01	1168	1.09	1197	1.18	1224	1.26
3300	1001	0.64	1032	0.72	1061	0.79	1089	0.87	1116	0.94	1145	1.02	1173	1.11	1202	1.19	1230	1.28	1257	1.36
3600	1086	0.81	1116	0.90	1143	0.98	1169	1.06	1194	1.14	1219	1.23	1246	1.32	1271	1.41	1297	1.50	1324	1.59
Available External Static Pressure (Inches of Water Gauge)																				
CFM	1.10		1.20		1.30		1.40		1.50		1.60		1.70		1.80		1.90		2.00	
	RPM	BHP	RPM	BHP	RPM	BHP	RPM	BHP	RPM	BHP	RPM	BHP	RPM	BHP	RPM	BHP	RPM	BHP	RPM	BHP
2250	1069	0.83	1100	0.9	1130	0.97	1159	1.04	1187	1.12	1214	1.19	1241	1.26	1267	1.34	1292	1.42	1318	1.5
2400	1097	0.9	1126	0.97	1155	1.04	1184	1.12	1211	1.2	1238	1.27	1265	1.35	1290	1.43	1315	1.51	1339	1.59
2550	1124	0.97	1153	1.05	1181	1.12	1208	1.2	1236	1.28	1263	1.36	1289	1.44	1314	1.52	1339	1.6	1363	1.69
2700	1154	1.06	1181	1.13	1209	1.21	1236	1.29	1262	1.37	1287	1.45	1313	1.53	1339	1.62	1363	1.7	1387	1.79
2850	1186	1.15	1212	1.22	1237	1.3	1264	1.38	1289	1.47	1314	1.55	1339	1.63	1363	1.72	1388	1.81	1412	1.9
3000	1217	1.24	1243	1.32	1268	1.4	1292	1.48	1317	1.57	1342	1.66	1366	1.74	1390	1.83	1413	1.92	1436	2.01
3150	1250	1.34	1275	1.43	1300	1.51	1324	1.59	1347	1.68	1370	1.77	1394	1.86	1418	1.95	1440	2.04	1463	2.13



Evaporator Fan Performance — Gas Heat

Table 92. Evaporator fan performance - 7.5 ton (model YZK), horizontal, high heat (continued)

Available External Static Pressure (Inches of Water Gauge)																				
CFM	1.10		1.20		1.30		1.40		1.50		1.60		1.70		1.80		1.90		2.00	
	RPM	BHP	RPM	BHP	RPM	BHP	RPM	BHP	RPM	BHP	RPM	BHP	RPM	BHP	RPM	BHP	RPM	BHP	RPM	BHP
3300	1283	1.45	1307	1.54	1332	1.63	1355	1.71	1378	1.8	1401	1.89	1423	1.98	1446	2.07	1468	2.17	1490	2.26
3600	1349	1.69	1373	1.78	1397	1.87	1420	1.97	1442	2.06	1464	2.16	1486	2.26	1507	2.35	1528	2.45	1548	2.55

Notes:

1. Available External Static Pressure is the static pressure difference between the return duct and the supply duct plus the static pressure drop caused by accessories and options.
2. For direct drive evaporator fan speed (rpm), refer to the applicable table in the fan performance section.
3. Data includes pressure drop due to standard filters and wet coils. No accessories or options are included in pressure drop data.
4. To determine static pressure drop due to other options/accessories, refer to the applicable table in the fan performance section.
5. Direct drive fan motor heat is negligible.
6. Factory supplied motors, in commercial equipment, are definite purpose motors, specifically designed and tested to operate reliably and continuously at all cataloged conditions. Using the full horsepower range of our fan motors as shown in our tabular data will not result in nuisance tripping or premature motor failure. Our product's warranty will not be affected.

Table 93. Evaporator fan performance - 8.5 ton (model YZK), horizontal, high heat

Available External Static Pressure (Inches of Water Gauge)																				
CFM	0.10		0.20		0.30		0.40		0.50		0.60		0.70		0.80		0.90		1.00	
	RPM	BHP	RPM	BHP	RPM	BHP	RPM	BHP	RPM	BHP	RPM	BHP	RPM	BHP	RPM	BHP	RPM	BHP	RPM	BHP
2550	790	0.32	828	0.38	863	0.44	900	0.50	937	0.56	972	0.63	1005	0.70	1036	0.77	1066	0.83	1095	0.90
2720	838	0.38	873	0.44	907	0.50	941	0.57	975	0.64	1010	0.71	1042	0.78	1073	0.85	1103	0.92	1131	0.99
2890	885	0.45	920	0.51	951	0.58	983	0.65	1016	0.72	1048	0.79	1080	0.87	1110	0.94	1139	1.02	1167	1.09
3060	933	0.52	966	0.59	997	0.66	1026	0.73	1057	0.80	1087	0.88	1118	0.96	1148	1.04	1177	1.12	1204	1.20
3230	982	0.60	1013	0.68	1042	0.75	1070	0.82	1099	0.90	1128	0.98	1157	1.06	1186	1.14	1214	1.23	1241	1.31
3400	1029	0.70	1060	0.77	1088	0.85	1115	0.93	1141	1.01	1170	1.09	1197	1.17	1225	1.26	1252	1.35	1279	1.44
3570	1077	0.80	1107	0.88	1134	0.96	1161	1.04	1186	1.12	1211	1.21	1238	1.29	1264	1.38	1291	1.47	1317	1.57
3740	1126	0.91	1155	0.99	1181	1.08	1206	1.16	1231	1.25	1254	1.34	1280	1.43	1305	1.52	1330	1.61	1355	1.71
4080	1222	1.16	1250	1.25	1275	1.35	1298	1.44	1321	1.53	1344	1.63	1365	1.72	1388	1.82	1412	1.92	1435	2.02

Available External Static Pressure (Inches of Water Gauge)																				
CFM	1.10		1.20		1.30		1.40		1.50		1.60		1.70		1.80		1.90		2.00	
	RPM	BHP	RPM	BHP	RPM	BHP	RPM	BHP	RPM	BHP	RPM	BHP	RPM	BHP	RPM	BHP	RPM	BHP	RPM	BHP
2550	1124	0.97	1153	1.05	1181	1.12	1208	1.20	1236	1.28	1263	1.36	1289	1.44	1314	1.52	1339	1.60	1363	1.69
2720	1158	1.07	1185	1.14	1213	1.22	1239	1.30	1265	1.38	1291	1.46	1317	1.55	1342	1.63	1366	1.72	1391	1.80
2890	1194	1.17	1220	1.25	1245	1.33	1271	1.41	1297	1.49	1322	1.58	1346	1.66	1370	1.75	1394	1.84	1418	1.93
3060	1230	1.28	1256	1.36	1281	1.44	1305	1.53	1329	1.61	1353	1.70	1377	1.79	1401	1.88	1424	1.97	1446	2.06
3230	1267	1.40	1292	1.48	1317	1.57	1341	1.66	1364	1.74	1386	1.83	1409	1.92	1432	2.01	1455	2.11	1478	2.20
3400	1305	1.53	1329	1.62	1353	1.70	1377	1.80	1400	1.89	1422	1.98	1444	2.07	1465	2.16	1487	2.26	1509	2.35
3570	1342	1.66	1367	1.75	1390	1.85	1413	1.94	1436	2.04	1458	2.13	1479	2.23	1501	2.32	1521	2.42	1542	2.52
3740	1380	1.80	1404	1.90	1428	2.00	1451	2.10	1473	2.20	1494	2.30	1516	2.40	1536	2.50	1557	2.60	1577	2.70
4080	1457	2.12	1481	2.23	1504	2.33	1526	2.44	1548	2.55	1569	2.65	1589	2.76	1610	2.87	1629	2.98	-	-

Notes:

1. Available External Static Pressure is the static pressure difference between the return duct and the supply duct plus the static pressure drop caused by accessories and options.
2. For direct drive evaporator fan speed (rpm), refer to the applicable table in the fan performance section.
3. Data includes pressure drop due to standard filters and wet coils. No accessories or options are included in pressure drop data.
4. To determine static pressure drop due to other options/accessories, refer to the applicable table in the fan performance section.
5. Direct drive fan motor heat is negligible.
6. Factory supplied motors, in commercial equipment, are definite purpose motors, specifically designed and tested to operate reliably and continuously at all cataloged conditions. Using the full horsepower range of our fan motors as shown in our tabular data will not result in nuisance tripping or premature motor failure. Our product's warranty will not be affected.

Table 94. Evaporator fan performance - 10 ton (model YZK), horizontal, high heat

Available External Static Pressure (Inches of Water Gauge)																				
CFM	0.10		0.20		0.30		0.40		0.50		0.60		0.70		0.80		0.90		1.00	
	RPM	BHP	RPM	BHP	RPM	BHP	RPM	BHP	RPM	BHP	RPM	BHP	RPM	BHP	RPM	BHP	RPM	BHP	RPM	BHP
3000	889	0.42	931	0.50	969	0.57	1004	0.65	1038	0.72	1070	0.79	1103	0.88	1134	0.96	1165	1.04	1196	1.12
3200	942	0.50	982	0.58	1019	0.66	1053	0.74	1086	0.82	1117	0.90	1146	0.98	1177	1.07	1207	1.15	1236	1.24
3400	996	0.59	1034	0.67	1070	0.76	1103	0.84	1134	0.93	1164	1.01	1193	1.10	1221	1.18	1250	1.27	1278	1.37
3600	1050	0.69	1086	0.78	1121	0.87	1153	0.96	1183	1.05	1212	1.14	1240	1.23	1267	1.32	1294	1.41	1321	1.50
3800	1104	0.80	1139	0.90	1172	0.99	1203	1.08	1233	1.18	1261	1.27	1288	1.37	1314	1.46	1340	1.56	1365	1.65
4000	1159	0.93	1192	1.02	1224	1.12	1254	1.22	1283	1.32	1310	1.42	1336	1.52	1362	1.62	1387	1.72	1411	1.82
4200	1213	1.06	1245	1.16	1276	1.27	1305	1.37	1333	1.48	1360	1.58	1385	1.68	1410	1.79	1434	1.89	1458	2.00
4400	1268	1.21	1299	1.32	1328	1.43	1357	1.53	1384	1.64	1410	1.75	1435	1.86	1459	1.97	1482	2.08	1505	2.19
4600	1322	1.37	1353	1.49	1381	1.60	1408	1.71	1435	1.82	1460	1.94	1485	2.05	1508	2.17	1531	2.28	1553	2.40
4800	1377	1.55	1406	1.67	1434	1.78	1460	1.90	1486	2.02	1511	2.14	1535	2.26	1558	2.38	1580	2.50	1602	2.62
Available External Static Pressure (Inches of Water Gauge)																				
CFM	1.10		1.20		1.30		1.40		1.50		1.60		1.70		1.80		1.90		2.00	
	RPM	BHP	RPM	BHP	RPM	BHP	RPM	BHP	RPM	BHP	RPM	BHP	RPM	BHP	RPM	BHP	RPM	BHP	RPM	BHP
3000	1225	1.21	1253	1.3	1279	1.38	1305	1.47	1330	1.56	1355	1.65	1381	1.75	1406	1.85	1431	1.95	1455	2.05
3200	1265	1.33	1293	1.42	1320	1.51	1345	1.61	1370	1.7	1394	1.79	1417	1.89	1440	1.98	1465	2.09	1489	2.19
3400	1305	1.46	1333	1.56	1359	1.65	1385	1.75	1410	1.85	1434	1.94	1457	2.04	1479	2.14	1501	2.24	1523	2.34
3600	1348	1.6	1373	1.7	1400	1.8	1425	1.9	1450	2.01	1474	2.11	1497	2.21	1520	2.31	1541	2.42	1563	2.52
3800	1391	1.75	1416	1.86	1441	1.96	1465	2.07	1490	2.17	1514	2.28	1537	2.39	1560	2.5	1582	2.61	1603	2.72
4000	1435	1.92	1459	2.03	1484	2.13	1507	2.24	1530	2.35	1554	2.47	1577	2.58	1599	2.69	1622	2.81	1643	2.92
4200	1481	2.1	1503	2.21	1527	2.32	1550	2.43	1573	2.55	1595	2.66	1617	2.78	1640	2.9	1661	3.02	1683	3.13
4400	1528	2.3	1550	2.41	1571	2.52	1594	2.64	1616	2.75	1638	2.87	1659	2.99	1680	3.12	1702	3.24	1723	3.36
4600	1575	2.51	1597	2.62	1618	2.74	1638	2.85	1660	2.97	1681	3.1	1702	3.22	1723	3.35	1743	3.47	1763	3.6
4800	1623	2.74	1644	2.85	1665	2.97	1685	3.09	1705	3.21	1725	3.34	1746	3.47	1766	3.59	1786	3.73	1805	3.86

Notes:

1. Available External Static Pressure is the static pressure difference between the return duct and the supply duct plus the static pressure drop caused by accessories and options.
2. For direct drive evaporator fan speed (rpm), refer to the applicable table in the fan performance section.
3. Data includes pressure drop due to standard filters and wet coils. No accessories or options are included in pressure drop data.
4. To determine static pressure drop due to other options/accessories, refer to the applicable table in the fan performance section.
5. Direct drive fan motor heat is negligible.
6. Factory supplied motors, in commercial equipment, are definite purpose motors, specifically designed and tested to operate reliably and continuously at all cataloged conditions. Using the full horsepower range of our fan motors as shown in our tabular data will not result in nuisance tripping or premature motor failure. Our product's warranty will not be affected.

Table 95. Evaporator fan performance - 12.5 ton (model YZK), horizontal, high heat

Available External Static Pressure (Inches of Water Gauge)																				
CFM	0.10		0.20		0.30		0.40		0.50		0.60		0.70		0.80		0.90		1.00	
	RPM	BHP	RPM	BHP	RPM	BHP	RPM	BHP	RPM	BHP	RPM	BHP	RPM	BHP	RPM	BHP	RPM	BHP	RPM	BHP
3750	596	0.26	651	0.35	700	0.44	746	0.54	788	0.64	831	0.74	872	0.85	910	0.96	947	1.07	982	1.19
4000	628	0.31	680	0.40	728	0.50	772	0.60	814	0.70	854	0.81	893	0.92	931	1.04	967	1.15	1002	1.28
4500	693	0.41	742	0.51	786	0.62	827	0.73	867	0.85	904	0.96	939	1.08	975	1.20	1009	1.33	1043	1.46
5000	759	0.53	805	0.65	846	0.76	884	0.88	921	1.01	957	1.14	991	1.27	1023	1.40	1055	1.53	1087	1.67
5500	825	0.68	868	0.81	907	0.94	943	1.07	978	1.20	1012	1.34	1044	1.48	1076	1.62	1106	1.76	1134	1.91
6000	893	0.85	933	1.00	970	1.14	1004	1.28	1037	1.42	1069	1.56	1099	1.71	1130	1.87	1159	2.03	1187	2.18
Available External Static Pressure (Inches of Water Gauge)																				
CFM	1.10		1.20		1.30		1.40		1.50		1.60		1.70		1.80		1.90		2.00	
	RPM	BHP	RPM	BHP	RPM	BHP	RPM	BHP	RPM	BHP	RPM	BHP	RPM	BHP	RPM	BHP	RPM	BHP	RPM	BHP
3750	1015	1.31	1048	1.43	1079	1.56	1110	1.69	1140	1.82	1169	1.95	1197	2.09	1224	2.23	1250	2.37	1276	2.51
4000	1035	1.4	1067	1.52	1097	1.65	1128	1.78	1158	1.92	1186	2.06	1214	2.2	1241	2.34	1268	2.49	1293	2.63
4500	1076	1.59	1107	1.73	1137	1.86	1167	2	1195	2.14	1222	2.28	1249	2.43	1276	2.58	1303	2.74	1328	2.89
5000	1118	1.81	1149	1.95	1179	2.1	1207	2.25	1235	2.4	1262	2.55	1289	2.7	1314	2.86	1339	3.01	1364	3.17



Evaporator Fan Performance — Gas Heat

Table 95. Evaporator fan performance - 12.5 ton (model YZK), horizontal, high heat (continued)

Available External Static Pressure (Inches of Water Gauge)																				
CFM	1.10		1.20		1.30		1.40		1.50		1.60		1.70		1.80		1.90		2.00	
	RPM	BHP	RPM	BHP	RPM	BHP	RPM	BHP	RPM	BHP	RPM	BHP	RPM	BHP	RPM	BHP	RPM	BHP	RPM	BHP
5500	1164	2.05	1193	2.2	1221	2.36	1249	2.51	1277	2.67	1304	2.84	1330	3	1355	3.16	1380	3.33	1404	3.5
6000	1214	2.33	1240	2.49	1267	2.65	1294	2.82	1320	2.98	1346	3.15	1371	3.32	1396	3.5	1421	3.67	1445	3.85

Notes:

1. Available External Static Pressure is the static pressure difference between the return duct and the supply duct plus the static pressure drop caused by accessories and options.
2. For direct drive evaporator fan speed (rpm), refer to the applicable table in the fan performance section.
3. Data includes pressure drop due to standard filters and wet coils. No accessories or options are included in pressure drop data.
4. To determine static pressure drop due to other options/accessories, refer to the applicable table in the fan performance section.
5. Direct drive fan motor heat is negligible.
6. Factory supplied motors, in commercial equipment, are definite purpose motors, specifically designed and tested to operate reliably and continuously at all cataloged conditions. Using the full horsepower range of our fan motors as shown in our tabular data will not result in nuisance tripping or premature motor failure. Our product's warranty will not be affected.

Table 96. Evaporator fan performance - 15 ton (model YZK), horizontal, high heat

Available External Static Pressure (Inches of Water Gauge)																				
CFM	0.10		0.20		0.30		0.40		0.50		0.60		0.70		0.80		0.90		1.00	
	RPM	BHP	RPM	BHP	RPM	BHP	RPM	BHP	RPM	BHP	RPM	BHP	RPM	BHP	RPM	BHP	RPM	BHP	RPM	BHP
4500	693	0.41	742	0.51	786	0.62	827	0.73	867	0.85	904	0.96	939	1.08	975	1.20	1009	1.33	1043	1.46
4800	732	0.48	779	0.59	821	0.70	861	0.82	899	0.94	935	1.07	970	1.19	1002	1.31	1036	1.45	1069	1.58
5400	812	0.65	855	0.78	895	0.90	932	1.03	966	1.16	1001	1.30	1034	1.44	1065	1.58	1095	1.71	1124	1.85
6000	893	0.85	933	1.00	970	1.14	1004	1.28	1037	1.42	1069	1.56	1099	1.71	1130	1.87	1159	2.03	1187	2.18
6600	974	1.10	1011	1.26	1046	1.42	1079	1.57	1109	1.72	1139	1.88	1168	2.04	1196	2.20	1224	2.37	1251	2.54
7200	1056	1.40	1090	1.57	1123	1.74	1154	1.91	1184	2.08	1212	2.25	1239	2.42	1266	2.59	1291	2.77	1317	2.95

Available External Static Pressure (Inches of Water Gauge)

CFM	1.10		1.20		1.30		1.40		1.50		1.60		1.70		1.80		1.90		2.00	
	RPM	BHP	RPM	BHP	RPM	BHP	RPM	BHP	RPM	BHP	RPM	BHP	RPM	BHP	RPM	BHP	RPM	BHP	RPM	BHP
4500	1076	1.59	1107	1.73	1137	1.86	1167	2	1195	2.14	1222	2.28	1249	2.43	1276	2.58	1303	2.74	1328	2.89
4800	1101	1.72	1132	1.86	1162	2	1191	2.15	1219	2.29	1246	2.44	1273	2.59	1298	2.74	1324	2.9	1349	3.06
5400	1154	2	1184	2.15	1212	2.3	1241	2.46	1268	2.62	1295	2.78	1321	2.94	1347	3.1	1372	3.27	1396	3.43
6000	1214	2.33	1240	2.49	1267	2.65	1294	2.82	1320	2.98	1346	3.15	1371	3.32	1396	3.5	1421	3.67	1445	3.85
6600	1277	2.72	1303	2.89	1328	3.05	1352	3.22	1375	3.4	1400	3.58	1425	3.76	1449	3.94	1472	4.13	1495	4.31
7200	1343	3.13	1367	3.32	1391	3.51	1415	3.69	1438	3.88	1460	4.06	1482	4.25	1504	4.44	1527	4.63	1549	4.83

Notes:

1. Available External Static Pressure is the static pressure difference between the return duct and the supply duct plus the static pressure drop caused by accessories and options.
2. For direct drive evaporator fan speed (rpm), refer to the applicable table in the fan performance section.
3. Data includes pressure drop due to standard filters and wet coils. No accessories or options are included in pressure drop data.
4. To determine static pressure drop due to other options/accessories, refer to the applicable table in the fan performance section.
5. Direct drive fan motor heat is negligible.
6. Factory supplied motors, in commercial equipment, are definite purpose motors, specifically designed and tested to operate reliably and continuously at all cataloged conditions. Using the full horsepower range of our fan motors as shown in our tabular data will not result in nuisance tripping or premature motor failure. Our product's warranty will not be affected.

Table 97. Evaporator fan performance - 17.5 ton (model YZK), horizontal, high heat

Available External Static Pressure (Inches of Water Gauge)																				
CFM	0.10		0.20		0.30		0.40		0.50		0.60		0.70		0.80		0.90		1.00	
	RPM	BHP	RPM	BHP	RPM	BHP	RPM	BHP	RPM	BHP	RPM	BHP	RPM	BHP	RPM	BHP	RPM	BHP	RPM	BHP
5250	792	0.60	836	0.73	876	0.85	914	0.97	949	1.10	984	1.24	1017	1.37	1049	1.51	1079	1.64	1110	1.78
5600	839	0.71	881	0.84	920	0.98	955	1.11	990	1.24	1023	1.38	1055	1.53	1086	1.67	1116	1.81	1145	1.96
6300	933	0.97	972	1.12	1008	1.27	1041	1.42	1073	1.56	1104	1.72	1133	1.87	1163	2.03	1191	2.19	1219	2.36
7000	1028	1.30	1064	1.46	1097	1.63	1129	1.79	1159	1.96	1187	2.12	1215	2.29	1242	2.46	1268	2.63	1295	2.81
7700	1124	1.69	1157	1.87	1188	2.05	1218	2.24	1246	2.42	1273	2.59	1299	2.77	1325	2.96	1350	3.14	1374	3.33
8400	1220	2.15	1251	2.35	1280	2.55	1308	2.75	1335	2.95	1361	3.15	1386	3.34	1410	3.53	1433	3.73	1456	3.93

Evaporator Fan Performance — Gas Heat

Table 97. Evaporator fan performance - 17.5 ton (model YZK), horizontal, high heat (continued)

Available External Static Pressure (Inches of Water Gauge)																				
CFM	1.10		1.20		1.30		1.40		1.50		1.60		1.70		1.80		1.90		2.00	
	RPM	BHP	RPM	BHP	RPM	BHP	RPM	BHP	RPM	BHP	RPM	BHP	RPM	BHP	RPM	BHP	RPM	BHP	RPM	BHP
5250	1141	1.93	1170	2.07	1199	2.22	1228	2.38	1256	2.53	1283	2.69	1309	2.85	1335	3.01	1360	3.17	1384	3.33
5600	1173	2.11	1202	2.26	1230	2.41	1258	2.57	1285	2.73	1312	2.9	1338	3.06	1363	3.23	1388	3.4	1412	3.57
6300	1245	2.52	1271	2.68	1296	2.84	1321	3.01	1347	3.18	1373	3.36	1398	3.53	1422	3.71	1446	3.89	1470	4.08
7000	1321	2.99	1346	3.17	1370	3.35	1394	3.53	1417	3.71	1439	3.89	1461	4.08	1485	4.27	1508	4.46	1531	4.65
7700	1398	3.52	1422	3.72	1446	3.92	1468	4.12	1491	4.32	1513	4.52	1534	4.71	1555	4.91	1576	5.11	1596	5.31
8400	1479	4.14	1501	4.34	1523	4.55	1545	4.77	1567	4.98	1588	5.2	1609	5.42	1629	5.64	1649	5.85	-	-

Notes:

1. Available External Static Pressure is the static pressure difference between the return duct and the supply duct plus the static pressure drop caused by accessories and options.
2. For direct drive evaporator fan speed (rpm), refer to the applicable table in the fan performance section.
3. Data includes pressure drop due to standard filters and wet coils. No accessories or options are included in pressure drop data.
4. To determine static pressure drop due to other options/accessories, refer to the applicable table in the fan performance section.
5. Direct drive fan motor heat is negligible.
6. Factory supplied motors, in commercial equipment, are definite purpose motors, specifically designed and tested to operate reliably and continuously at all cataloged conditions. Using the full horsepower range of our fan motors as shown in our tabular data will not result in nuisance tripping or premature motor failure. Our product's warranty will not be affected.

Table 98. Evaporator fan performance - 20 ton (model YZK), horizontal, high heat

Available External Static Pressure (Inches of Water Gauge)																				
CFM	0.10		0.20		0.30		0.40		0.50		0.60		0.70		0.80		0.90		1.00	
	RPM	BHP	RPM	BHP	RPM	BHP	RPM	BHP	RPM	BHP	RPM	BHP	RPM	BHP	RPM	BHP	RPM	BHP	RPM	BHP
6000	893	0.85	933	1.00	970	1.14	1004	1.28	1037	1.42	1069	1.56	1099	1.71	1130	1.87	1159	2.03	1187	2.18
6400	947	1.02	985	1.17	1021	1.32	1054	1.47	1085	1.62	1116	1.77	1145	1.93	1174	2.09	1202	2.25	1229	2.42
7200	1056	1.40	1090	1.57	1123	1.74	1154	1.91	1184	2.08	1212	2.25	1239	2.42	1266	2.59	1291	2.77	1317	2.95
8000	1165	1.88	1197	2.07	1227	2.26	1256	2.45	1284	2.64	1311	2.82	1336	3.01	1361	3.19	1385	3.38	1409	3.58
8800	1276	2.46	1305	2.66	1333	2.87	1360	3.08	1386	3.29	1411	3.50	1436	3.70	1459	3.91	1482	4.11	1504	4.32
9600	1387	3.15	1413	3.37	1439	3.60	1465	3.83	1489	4.06	1513	4.28	1537	4.51	1559	4.73	1581	4.95	1602	5.18

Available External Static Pressure (Inches of Water Gauge)																				
CFM	1.10		1.20		1.30		1.40		1.50		1.60		1.70		1.80		1.90		2.00	
	RPM	BHP	RPM	BHP	RPM	BHP	RPM	BHP	RPM	BHP	RPM	BHP	RPM	BHP	RPM	BHP	RPM	BHP	RPM	BHP
6000	1214	2.33	1240	2.49	1267	2.65	1294	2.82	1320	2.98	1346	3.15	1371	3.32	1396	3.5	1421	3.67	1445	3.85
6400	1256	2.58	1282	2.75	1307	2.91	1331	3.08	1357	3.25	1382	3.43	1407	3.61	1431	3.79	1455	3.97	1478	4.16
7200	1343	3.13	1367	3.32	1391	3.51	1415	3.69	1438	3.88	1460	4.06	1482	4.25	1504	4.44	1527	4.63	1549	4.83
8000	1432	3.77	1455	3.97	1479	4.18	1501	4.39	1523	4.6	1545	4.81	1566	5.01	1587	5.21	1607	5.42	1627	5.62
8800	1526	4.53	1548	4.74	1569	4.96	1590	5.17	1611	5.4	1632	5.62	1653	5.85	-	-	-	-	-	-
9600	1622	5.4	1643	5.63	1663	5.86	-	-	-	-	-	-	-	-	-	-	-	-	-	-

Notes:

1. Available External Static Pressure is the static pressure difference between the return duct and the supply duct plus the static pressure drop caused by accessories and options.
2. For direct drive evaporator fan speed (rpm), refer to the applicable table in the fan performance section.
3. Data includes pressure drop due to standard filters and wet coils. No accessories or options are included in pressure drop data.
4. To determine static pressure drop due to other options/accessories, refer to the applicable table in the fan performance section.
5. Direct drive fan motor heat is negligible.
6. Factory supplied motors, in commercial equipment, are definite purpose motors, specifically designed and tested to operate reliably and continuously at all cataloged conditions. Using the full horsepower range of our fan motors as shown in our tabular data will not result in nuisance tripping or premature motor failure. Our product's warranty will not be affected.

Table 99. Evaporator fan performance - 25 ton (model YZK), horizontal, high heat

Available External Static Pressure (Inches of Water Gauge)																				
CFM	0.10		0.20		0.30		0.40		0.50		0.60		0.70		0.80		0.90		1.00	
	RPM	BHP	RPM	BHP	RPM	BHP	RPM	BHP	RPM	BHP	RPM	BHP	RPM	BHP	RPM	BHP	RPM	BHP	RPM	BHP
7500	1097	1.57	1130	1.75	1162	1.92	1192	2.10	1221	2.28	1249	2.45	1275	2.62	1301	2.80	1326	2.99	1351	3.17
8000	1165	1.88	1197	2.07	1227	2.26	1256	2.45	1284	2.64	1311	2.82	1336	3.01	1361	3.19	1385	3.38	1409	3.58
9000	1304	2.62	1332	2.83	1359	3.05	1386	3.26	1412	3.47	1437	3.68	1461	3.89	1484	4.10	1506	4.31	1528	4.52



Evaporator Fan Performance — Gas Heat

Table 99. Evaporator fan performance - 25 ton (model YZK), horizontal, high heat (continued)

Available External Static Pressure (Inches of Water Gauge)																				
CFM	0.10		0.20		0.30		0.40		0.50		0.60		0.70		0.80		0.90		1.00	
	RPM	BHP	RPM	BHP	RPM	BHP	RPM	BHP	RPM	BHP	RPM	BHP	RPM	BHP	RPM	BHP	RPM	BHP	RPM	BHP
10000	1443	3.55	1468	3.77	1493	4.01	1518	4.25	1542	4.48	1565	4.72	1587	4.96	1609	5.20	1631	5.42	1651	5.65
11000	1583	4.67	1605	4.91	1628	5.17	1651	5.43	1673	5.70	1695	5.95	-	-	-	-	-	-	-	-
12000	1724	6.02	-	-	-	-	-	-	-	-	-	-	-	-	-	-	-	-	-	-

Available External Static Pressure (Inches of Water Gauge)																				
CFM	1.10		1.20		1.30		1.40		1.50		1.60		1.70		1.80		1.90		2.00	
	RPM	BHP	RPM	BHP	RPM	BHP	RPM	BHP	RPM	BHP	RPM	BHP	RPM	BHP	RPM	BHP	RPM	BHP	RPM	BHP
7500	1376	3.36	1400	3.55	1424	3.75	1447	3.95	1469	4.14	1492	4.33	1513	4.52	1534	4.72	1555	4.91	1577	5.11
8000	1432	3.77	1455	3.97	1479	4.18	1501	4.39	1523	4.6	1545	4.81	1566	5.01	1587	5.21	1607	5.42	1627	5.62
9000	1550	4.73	1572	4.95	1592	5.17	1613	5.39	1633	5.61	1654	5.84	-	-	-	-	-	-	-	-
10000	1671	5.89	-	-	-	-	-	-	-	-	-	-	-	-	-	-	-	-	-	-
11000	-	-	-	-	-	-	-	-	-	-	-	-	-	-	-	-	-	-	-	-
12000	-	-	-	-	-	-	-	-	-	-	-	-	-	-	-	-	-	-	-	-

Notes:

1. Available External Static Pressure is the static pressure difference between the return duct and the supply duct plus the static pressure drop caused by accessories and options.
2. For direct drive evaporator fan speed (rpm), refer to the applicable table in the fan performance section.
3. Data includes pressure drop due to standard filters and wet coils. No accessories or options are included in pressure drop data.
4. To determine static pressure drop due to other options/accessories, refer to the applicable table in the fan performance section.
5. Direct drive fan motor heat is negligible.
6. Factory supplied motors, in commercial equipment, are definite purpose motors, specifically designed and tested to operate reliably and continuously at all cataloged conditions. Using the full horsepower range of our fan motors as shown in our tabular data will not result in nuisance tripping or premature motor failure. Our product's warranty will not be affected.

Table 100. Evaporator fan performance - 25 ton (model YZK), horizontal, high heat, high static motor

Available External Static Pressure (Inches of Water Gauge)																				
CFM	0.10		0.20		0.30		0.40		0.50		0.60		0.70		0.80		0.90		1.00	
	RPM	BHP	RPM	BHP	RPM	BHP	RPM	BHP	RPM	BHP	RPM	BHP	RPM	BHP	RPM	BHP	RPM	BHP	RPM	BHP
7500	1097	1.57	1130	1.75	1162	1.92	1192	2.10	1221	2.28	1249	2.45	1275	2.62	1301	2.80	1326	2.99	1351	3.17
8000	1165	1.88	1197	2.07	1227	2.26	1256	2.45	1284	2.64	1311	2.82	1336	3.01	1361	3.19	1385	3.38	1409	3.58
9000	1304	2.62	1332	2.83	1359	3.05	1386	3.26	1412	3.47	1437	3.68	1461	3.89	1484	4.10	1506	4.31	1528	4.52
10000	1443	3.55	1468	3.77	1493	4.01	1518	4.25	1542	4.48	1565	4.72	1587	4.96	1609	5.20	1631	5.42	1651	5.65
11000	1583	4.67	1605	4.91	1628	5.17	1651	5.43	1673	5.70	1695	5.95	1713	6.03	1734	6.30	1756	6.53	1774	6.78
12000	1724	6.02	1742	6.05	1763	6.33	1784	6.61	1804	6.92	1825	7.18	1839	7.10	1859	7.40	1881	7.64	1897	7.91

Available External Static Pressure (Inches of Water Gauge)																				
CFM	1.10		1.20		1.30		1.40		1.50		1.60		1.70		1.80		1.90		2.00	
	RPM	BHP	RPM	BHP	RPM	BHP	RPM	BHP	RPM	BHP	RPM	BHP	RPM	BHP	RPM	BHP	RPM	BHP	RPM	BHP
7500	1376	3.36	1400	3.55	1424	3.75	1447	3.95	1469	4.14	1492	4.33	1513	4.52	1534	4.72	1555	4.91	1577	5.11
8000	1432	3.77	1455	3.97	1479	4.18	1501	4.39	1523	4.6	1545	4.81	1566	5.01	1587	5.21	1607	5.42	1627	5.62
9000	1550	4.73	1572	4.95	1592	5.17	1613	5.39	1633	5.61	1654	5.84	1672	5.99	1693	6.19	1711	6.44	1727	6.64
10000	1671	5.89	1689	5.93	1705	6.16	1725	6.39	1743	6.62	1763	6.87	1778	6.97	1799	7.17	1815	7.46	1827	7.66
11000	1792	7.05	1806	6.91	1818	7.15	1837	7.39	1853	7.63	1872	7.9	1884	7.95	1905	8.15	1919	8.48	1927	8.68
12000	1913	8.21	1923	7.89	1931	8.14	-	-	-	-	-	-	-	-	-	-	-	-	-	-

Notes:

1. Available External Static Pressure is the static pressure difference between the return duct and the supply duct plus the static pressure drop caused by accessories and options.
2. For direct drive evaporator fan speed (rpm), refer to the applicable table in the fan performance section.
3. Data includes pressure drop due to standard filters and wet coils. No accessories or options are included in pressure drop data.
4. To determine static pressure drop due to other options/accessories, refer to the applicable table in the fan performance section.
5. Direct drive fan motor heat is negligible.
6. Factory supplied motors, in commercial equipment, are definite purpose motors, specifically designed and tested to operate reliably and continuously at all cataloged conditions. Using the full horsepower range of our fan motors as shown in our tabular data will not result in nuisance tripping or premature motor failure. Our product's warranty will not be affected.



Fan Performance

Table 101. Outdoor sound power level

Tons	Unit Model Number	Octave Center Frequency								Overall dBA
		63	125	250	500	1000	2000	4000	8000	
3	T/YZK036	89	78	80	79	77	72	69	63	81
4	T/YZK048	81	83	81	80	76	72	68	63	81
5	T/YZK060	85	84	84	84	81	77	73	69	85
6	T/YZK072	84	85	84	85	82	76	73	67	86
7.5	T/YZK090	84	86	84	85	82	76	73	67	86
8.5	T/YZK102	85	85	84	85	82	76	73	67	86
10	T/YZK120	88	89	90	87	84	79	75	67	89
12.5	T/YZK150	95	87	88	85	84	79	77	72	88
15	T/YZK180	96	89	88	86	86	80	77	72	90
17.5	T/YZK210	90	90	91	89	86	83	79	75	91
20	T/YZK240	95	91	93	92	89	84	81	77	94
25	T/YZK300	95	91	93	92	89	84	81	76	94

Notes:

1. Outdoor sound rating shown is tested in accordance with AHRI 270/370-2015. For additional information reference the outdoor sound power level data in the performance section.
2. Taken in accordance with AHRI 270/370-2015.
3. Indoor sound in accordance with AHRI 260 is available through Trane's selection software.

Table 102. Static pressure drop through accessories (inches water column)

Tons	Unit Model Number	cfm	Stand-ard Filters (a)	2" MERV 8 Filter(b)	2" MERV 13 Filter(b)	Re-heat Coil	Economizer with OA/RA Dampers(c)								Electric Heater				
							Downflow		Horizontal		Low Leak Downflow		Low Leak Horizontal		Accessory (kW)				
							100% OA	100% RA	100% OA	100% RA	100% OA	100% RA	100% OA	100% RA	5-6	9-18	23-36	54	72
3	T/YZK036A	900	0.02	0.02	0.03	0.01	0.01	0.00	0.02	0.01	0.02	-0.00	0.04	0.02	0.00	0.00	0.01	-	-
		1200	0.02	0.03	0.04	0.02	0.02	0.00	0.02	0.01	0.04	-0.00	0.06	0.03	0.00	0.00	0.02	-	-
		1440	0.03	0.03	0.05	0.03	0.03	0.01	0.03	0.01	0.05	0.00	0.08	0.05	0.01	0.01	0.02	-	-
4	T/YZK048A	1200	0.02	0.03	0.04	0.02	0.02	0.00	0.02	0.01	0.04	-0.00	0.06	0.03	0.00	0.00	0.02	-	-
		1600	0.03	0.04	0.06	0.03	0.04	0.01	0.03	0.02	0.07	0.00	0.10	0.06	0.01	0.01	0.02	-	-
		1920	0.03	0.04	0.08	0.04	0.06	0.01	0.04	0.02	0.10	0.00	0.14	0.09	0.01	0.01	0.02	-	-
5	T/YZK060A	1500	0.03	0.03	0.06	0.03	0.03	0.01	0.03	0.02	0.06	0.00	0.09	0.05	0.01	0.01	0.02	-	-
		2000	0.03	0.05	0.08	0.04	0.07	0.01	0.05	0.02	0.11	0.00	0.15	0.09	0.01	0.01	0.02	-	-
		2400	0.04	0.06	0.10	0.05	0.10	0.01	0.06	0.03	0.16	0.01	0.20	0.13	0.02	0.02	0.03	-	-
6	T/YZK072A	1800	0.03	0.04	0.07	0.04	0.05	0.01	0.04	0.02	0.09	0.00	0.12	0.08	-	0.01	0.02	-	-
		2400	0.04	0.06	0.10	0.06	0.10	0.01	0.06	0.03	0.16	0.01	0.2	0.13	-	0.02	0.03	-	-
		2880	0.04	0.07	0.13	0.07	0.14	0.02	0.08	0.04	0.24	0.01	0.28	0.19	-	0.03	0.03	-	-
7.5	T/YZK090A	2250	0.03	0.05	0.09	0.05	0.09	0.01	0.05	0.02	0.14	0.01	0.18	0.12	-	0.02	0.02	-	-
		3000	0.05	0.08	0.13	0.07	0.15	0.02	0.09	0.04	0.26	0.01	0.3	0.21	-	0.03	0.03	-	-
		3600	0.05	0.10	0.17	0.09	0.22	0.02	0.12	0.06	0.39	0.02	0.42	0.29	-	0.04	0.05	-	-
8.5	T/YZK102A	2550	0.04	0.06	0.11	0.06	0.11	0.01	0.06	0.03	0.19	0.01	0.23	0.15	-	0.02	0.03	-	-
		3400	0.05	0.09	0.16	0.09	0.20	0.02	0.11	0.05	0.34	0.02	0.38	0.26	-	0.03	0.04	-	-
		4080	0.06	0.12	0.20	0.1	0.28	0.03	0.15	0.07	0.50	0.03	0.53	0.37	-	0.05	0.06	-	-
10	T/YZK120A	3000	0.04	0.06	0.12	0.07	0.15	0.02	0.09	0.04	0.26	0.01	0.3	0.21	-	0.01	0.02	-	-
		4000	0.05	0.09	0.17	0.08	0.27	0.03	0.15	0.07	0.48	0.03	0.51	0.35	-	0.02	0.03	-	-
		4800	0.07	0.12	0.21	0.1	0.39	0.03	0.20	0.09	0.71	0.05	0.71	0.49	-	0.02	0.03	-	-
12.5	T/YZK150A	3750	0.02	0.04	0.07	0.02	0.10	0.02	0.10	0.02	0.11	0.09	0.05	0.09	-	0	0.01	0.01	-
		5000	0.03	0.06	0.1	0.02	0.15	0.03	0.15	0.03	0.17	0.13	0.09	0.14	-	0.01	0.03	0.03	-
		6000	0.04	0.08	0.13	0.03	0.20	0.04	0.20	0.04	0.23	0.17	0.12	0.18	-	0.01	0.04	0.04	-



Fan Performance

Table 102. Static pressure drop through accessories (inches water column) (continued)

Tons	Unit Model Number	cfm	Stand-ard Filters (a)	2" MERV 8 Filter(b)	2" MERV 13 Filter(b)	Re-heat Coil	Economizer with OA/RA Dampers(c)								Electric Heater				
							Downflow		Horizontal		Low Leak Downflow		Low Leak Horizontal		Accessory (kW)				
							100% OA	100% RA	100% OA	100% RA	100% OA	100% RA	100% OA	100% RA	5-6	9-18	23-36	54	72
15	T/YZK180A	4500	0.03	0.05	0.09	0.02	0.13	0.02	0.13	0.02	0.14	0.11	0.07	0.12	-	0.01	0.02	0.02	-
		6000	0.04	0.08	0.13	0.03	0.20	0.04	0.20	0.04	0.23	0.17	0.12	0.18	-	0.01	0.04	0.04	-
		7200	0.06	0.10	0.17	0.04	0.27	0.05	0.27	0.05	0.32	0.23	0.16	0.25	-	0.02	0.06	0.06	-
17.5	T/YZK210A	5250	0.04	0.06	0.11	0.03	0.16	0.03	0.16	0.03	0.19	0.14	0.09	0.15	-	-	0.03	0.03	0.03
		7000	0.05	0.10	0.17	0.04	0.26	0.05	0.26	0.05	0.30	0.22	0.15	0.24	-	-	0.06	0.06	0.06
		8400	0.07	0.13	0.22	0.05	0.35	0.06	0.35	0.06	0.42	0.29	0.21	0.33	-	-	0.09	0.09	0.09
20	T/YZK240A	6000	0.04	0.08	0.13	0.03	0.20	0.04	0.20	0.04	0.23	0.17	0.12	0.18	-	-	0.04	0.04	0.04
		8000	0.07	0.12	0.21	0.05	0.32	0.06	0.32	0.06	0.39	0.27	0.19	0.3	-	-	0.08	0.08	0.08
		9600	0.09	0.16	0.27	0.06	0.44	0.07	0.44	0.07	0.54	0.37	0.27	0.41	-	-	0.12	0.12	0.12
25	T/YZK300A	7500	0.06	0.11	0.19	0.04	0.29	0.05	0.29	0.05	0.34	0.24	0.17	0.27	-	-	0.07	0.07	0.07
		10000	0.09	0.17	0.29	0.06	0.48	0.08	0.48	0.08	0.58	0.40	0.29	0.45	-	-	0.13	0.13	0.13
		12000	0.12	0.23	0.39	0.08	0.66	0.11	0.66	0.11	0.82	0.55	0.39	0.62	-	-	0.20	0.20	0.20

(a) Tested with: 2-in. filters 6 to 25 Tons.

(b) Difference in pressure drop should be considered when utilizing optional 2-in. pleated filters.

(c) OA = Outside Air and RA = Return Air.

Table 103. Static pressure drop through accessories (inches water column) - gas heater option

Tons	Unit Model Number	cfm	2-Stage Gas Heater(a)					
			Downflow			Horizontal		
			L(b)	M(c)	H(d)	L (b)	M (c)	H (d)
3	YZK036A	900*	0.04	0.04	0.07	0.04	0.02	0.07
		1200	0.04	0.04	0.08	0.07	0.02	0.11
		1440	0.05	0.05	0.09	0.10	0.04	0.15
4	YZK048A	1200*	0.04	0.04	0.08	0.07	0.02	0.11
		1600	0.06	0.06	0.10	0.11	0.05	0.17
		1920	0.08	0.08	0.11	0.16	0.08	0.23
5	YZK060A	1500*	0.05	0.05	0.09	0.10	0.04	0.16
		2000	0.08	0.08	0.11	0.17	0.09	0.24
		2400	0.11	0.11	0.13	0.22	0.16	0.32
6	YZK072A	1800	0.04	0.04	0.03	0.13	0.13	0.13
		2400	0.05	0.05	0.05	0.24	0.24	0.21
		2880	0.07	0.07	0.08	0.35	0.35	0.3
7.5	YZK090A	2250	0.11	0.11	0.05	0.19	0.19	0.11
		3000	0.17	0.17	0.08	0.33	0.33	0.16
		3600	0.24	0.24	0.11	0.46	0.46	0.23
8.5	YZK102A	2550	0.13	0.13	0.06	0.24	0.24	0.13
		3400	0.22	0.22	0.1	0.41	0.41	0.2
		4080	0.31	0.31	0.14	0.59	0.59	0.3
10	YZK120A	3000	0.16	0.16	0.08	0.07	0.07	0.15
		4000	0.32	0.32	0.12	0.26	0.26	0.24
		4800	0.48	0.48	0.16	0.47	0.47	0.32
12.5	YZK150A	3750	-0.07	-0.07	-0.05	0.08	0.08	0.07
		5000	-0.06	-0.06	-0.04	0.1	0.1	0.1
		6000	-0.03	-0.03	-0.02	0.12	0.12	0.13

Table 103. Static pressure drop through accessories (inches water column) - gas heater option (continued)

Tons	Unit Model Number	cfm	2-Stage Gas Heater ^(a)					
			Downflow			Horizontal		
			L ^(b)	M ^(c)	H ^(d)	L ^(b)	M ^(c)	H ^(d)
15	YZK180A	4500	-0.07	-0.05	-0.06	0.08	0.08	0.1
		6000	-0.03	-0.02	-0.02	0.12	0.13	0.16
		7200	-0.01	0	0.01	0.11	0.13	0.19
17.5	YZK210A	5250	-0.05	-0.03	-0.04	0.11	0.11	0.13
		7000	-0.01	-0.01	0	0.11	0.13	0.18
		8400	0.02	0.02	0.04	0.1	0.13	0.2
20	YZK240A	6000	-0.03	-0.02	-0.02	0.12	0.13	0.16
		8000	0.01	0.01	0.03	0.1	0.13	0.19
		9600	0.04	0.05	0.07	0.1	0.14	0.21
25	YZK300A	7500	0	0	0.01	0.11	0.13	0.19
		10000	0.06	0.07	0.08	0.11	0.15	0.21
		12000	0.14	0.15	0.14	0.16	0.21	0.31

^(a) For 12.5 ton units: Model digit 11 selection of Low/Medium Gas Heat is 5x5 and High Gas Heat is 7x7.

For 15 to 25 ton units: Model digit 11 selection of Low Gas Heat is 5x5, Medium Gas Heat is 7x7, and High Gas Heat is 8x8.

^(b) Model digit 11 selection of Low Gas Heat is limited to minimum 360 cfm/ton full load airflow for downflow (DF) and horizontal (HZ) 3 ton units, and DF 4 ton units. Low heat is limited to min 320 cfm/ton full load airflow on DF 5 ton units.

^(c) Model digit 11 selection of Medium Gas Heat is limited to minimum 360 cfm/ton full load airflow for 3 to 5 ton units.

^(d) Model digit 11 selection of High Gas Heat is limited to minimum 320 cfm/ton full load airflow for 3 to 5 ton units.

Table 104. Static pressure drop through accessories (inches water column) - modulating gas heat option

Tons	Unit Model Number	cfm	Modulating Gas Heater ^(a)			
			Downflow		Horizontal	
			L	H	L	H
3	YZK036A					
4	YZK048A					
5	YZK060A					
6	YZK072A	1800	0.03	0.02	0.22	0.47
		2400	0.05	0.05	0.34	0.81
		2880	0.07	0.08	0.47	1.16
7.5	YZK090A	2250	0.04	0.09	0.32	0.28
		3000	0.09	0.13	0.61	0.43
		3600	0.14	0.19	0.91	0.59
8.5	YZK102A	2550	0.06	0.09	0.42	0.33
		3400	0.12	0.17	0.81	0.53
		4080	0.18	0.25	1.19	0.73
10	YZK120A	3000	0.11	0.11	0.28	0.15
		4000	0.14	0.16	0.39	0.27
		4800	0.16	0.21	0.51	0.39
12.5	YZK150A	3750	–	0.04	–	0.08
		5000	–	0.08	–	0.14
		6000	–	0.11	–	0.2



Fan Performance

Table 104. Static pressure drop through accessories (inches water column) - modulating gas heat option (continued)

Tons	Unit Model Number	cfm	Modulating Gas Heater ^(a)			
			Downflow		Horizontal	
			L	H	L	H
15	YZK180A	4500	0.06	0.09	0.11	0.15
		6000	0.11	0.19	0.2	0.28
		7200	0.16	0.28	0.29	0.42
17.5	YZK210A	5250	0.09	0.14	0.15	0.21
		7000	0.16	0.26	0.27	0.39
		8400	0.23	0.4	0.4	0.57
20	YZK240A	6000	0.11	0.19	0.2	0.28
		8000	0.2	0.36	0.36	0.52
		9600	0.3	0.53	0.52	0.75
25	YZK300A	7500	0.18	0.31	0.31	0.45
		10000	0.33	0.58	0.56	0.82
		12000	0.49	0.87	0.81	1.17

^(a) Model digit 10 selection B is Mod Gas of which Low Gas Heat is 2x2 for 6 tons, 4x4 for 7.5 to 10 tons, High Gas Heat is 4x4 for 6 tons, 6x6 for 7.5 to 10 tons. 12.5 tons is High only with 6-Tube. 15 to 25 ton units are Low with 6-Tube and High with 8-Tube.



Heating Performance

Table 105. Auxiliary electric heat capacity - cooling ultra high efficiency

Tons	Unit Model Number	Total ^(a)		No. of Stages	Stage 1		Stage 2	
		kw Input ^(b)	MBh Output		kw Input	MBh Output	kw Input	MBh Output
3	TZ*036*3,4,W	6.0	20.48	1	6.0	20.48	–	–
		12.0	40.97	2	6.0	20.48	6.0	20.48
		18.0	59.40	2	9.0	29.70	9.0	29.70
4	TZ*048*3,4,W	6.0	20.48	1	6.0	20.48	–	–
		12.0	40.97	2	6.0	20.48	6.0	20.48
		18.0	59.40	2	9.0	29.70	9.0	29.70
5	TZ*060*3,4,W	6.0	20.48	1	6.0	20.48	–	–
		12.0	40.97	2	6.0	20.48	6.0	20.48
		18.0	59.40	2	9.0	30.73	9.0	30.73
		27.0	92.21	2	18.0	61.47	9.0	30.73
6 to 8.5	TZ*072*3,4,W TZ*090*3,4,W TZ*102*3,4,W	9.0	30.73	1	9.0	30.73	–	–
		18.0	61.47	2	9.0	30.73	9.0	30.73
		27.0	92.20	2	18.0	61.47	9.0	30.73
		36.0	122.94	2	18.0	61.47	18.0	61.47
10	TZ*120*3,4,W	18.0	61.47	1	18.0	61.47	–	–
		27.0	92.20	2	18.0	61.47	9.0	30.73
		36.0	122.94	2	18.0	61.47	18.0	61.47
		54.0	184.41	2	36.0	122.94	18.0	61.47
12.5 to 15	TZ*150*3,4,W TZ*180*3,4,W	18.0	61.47	1	18.0	61.47	–	–
		36.0	122.94	2	18.0	61.47	18.0	61.47
		54.0	184.41	2	36.0	122.94	18.0	61.47
17.5 to 25	TZ*210*3,4,W TZ*240*3,4,W TZ*300*3,4,W	36.0	122.94	2	18.0	61.47	18.0	61.47
		54.0	184.41	2	36.0	122.94	18.0	61.47
		72.0	245.88	2	36.0	122.94	36.0	122.94

^(a) Heaters are rated at 240V, 480V, and 600V. For other than rated voltage, CAP = (voltage/rated voltage)² x rated cap.

^(b) For all input/output categories, does not include fan power or heat.

Table 106. Air temperature rise - cooling ultra high efficiency

kW	Stages	3 Tons 900 cfm	4 Tons 1200 cfm	5 Tons 1500 cfm	6 Tons 1800 cfm
		Three Phase TZ*036*3,4,W	Three Phase TZ*048*3,4,W	Three Phase TZ*060*3,4,W	Three Phase TZ*072*3,4,W
6.00	1	21.07	15.81	12.64	–
9.00	1	–	–	–	15.81
12.00	2	42.15	31.61	25.29	–
18.00	1 OR 2	63.22	47.42	37.93	31.61
23.00	2	–	–	–	–
27.00	2	–	–	56.9	47.42
36.00	2	–	–	–	63.22
54.00	2	–	–	–	–
72.00	2	–	–	–	–
kW	Stages	7.5 Tons 2250 cfm	8.5 Tons 2550 cfm	10 Tons 3000 cfm	12.5 Tons 3750 cfm
		Three Phase TZ*090*3,4,W	Three Phase TZ*102*3,4,W	Three Phase TZ*120*3,4,W	Three Phase TZ*150*3,4,W
6.00	1	–	–	–	–
9.00	1	12.64	11.16	–	–
12.00	2	–	–	–	–
18.00	1 OR 2	25.29	22.31	18.97	15.17
23.00	2	–	–	–	–
27.00	2	37.93	33.47	28.45	–



Heating Performance

Table 106. Air temperature rise - cooling ultra high efficiency (continued)

kW	Stages	7.5 Tons 2250 cfm	8.5 Tons 2550 cfm	10 Tons 3000 cfm	12.5 Tons 3750 cfm
		Three Phase TZ*090*3,4,W	Three Phase TZ*102*3,4,W	Three Phase TZ*120*3,4,W	Three Phase TZ*150*3,4,W
36.00	2	50.58	44.63	37.93	30.35
54.00	2	-	-	56.90	45.52
72.00	2	-	-	-	-
kW	Stages	15 Tons 4500 cfm	17.5 Tons 5250 cfm	20 Tons 6000 cfm	25 Tons 7500 cfm
		Three Phase TZ*180*3,4,W	Three Phase TZ*210*3,4,W	Three Phase TZ*240*3,4,W	Three Phase TZ*300*3,4,W
6.00	1	-	-	-	-
9.00	1	-	-	-	-
12.00	2	-	-	-	-
18.00	1 OR 2	12.64	-	-	-
23.00	2	-	-	-	-
27.00	2	-	-	-	-
36.00	2	25.28	21.67	18.96	15.17
54.00	2	37.93	32.51	28.45	22.76
72.00	2	-	43.35	37.93	30.34

Note: For minimum design airflow, see airflow performance table for each unit. To calculate temp. rise at different airflow, use the following formula:
Temp. rise across Electric Heater = (kW x 3414)/(1.08 x cfm).

Table 107. Gas-fired heating capacities - staged gas - ultra high efficiency

Tons	Unit Model Number	Heating Input BTU (High / Low Stage)	Heating Output BTU (High / Low Stage)	Air Temperature Rise°F
3	YZK036A**(0,A)L	80,000/56,000	64,800/45,300	35-65
	YZK036A**(0,A)M	100,000/70,000	81,000/56,700	50-80
	YZK036A**(0,A)H	120,000/84,000	97,200/68,000	60-90
4	YZK048A**(0,A)L	80,000/56,000	64,800/45,300	25-55
	YZK048A**(0,A)M	100,000/70,000	81,000/56,700	30-60
	YZK048A**(0,A)H	130,000/91,000	105,300/73,700	45-75
5	YZK060A**(0,A)L	80,000/56,000	64,800/45,300	15-45
	YZK060A**(0,A)M	100,000/70,000	81,000/56,700	25-55
	YZK060A**(0,A)H	150,000/105,000	121,500/85,100	30-60
6	YZK072A**(0,A)L	80,000/56,000	64,800/45,300	10 - 40
	YZK072A**(0,A)M	120,000/84,000	97,200/68,000	20 - 50
	YZK072A**(0,A)H	150,000/105,000	121,500/85,000	30 - 60
7.5	YZK090A**(0,A)L	120,000/84,000	97,200/68,000	15 - 45
	YZK090A**(0,A)M	150,000/105,000	121,500/85,000	20 - 50
	YZK090A**(0,A)H	200,000/140,000	162,000/113,400	30 - 60
8.5	YZK102A**(0,A)L	120,000/84,000	97,200/68,000	15 - 45
	YZK102A**(0,A)M	150,000/105,000	121,500/85,100	20 - 50
	YZK102A**(0,A)H	200,000/140,000	162,000/113,400	30 - 60
10	YZK120A**(0,A)L	150,000/105,000	121,500/85,000	15 - 45
	YZK120A**(0,A)M	200,000/140,000	162,000/113,400	25 - 55
	YZK120A**(0,A)H	250,000/175,000	202,500/141,750	30 - 60
12.5	YZK150A**(0,A)L	150,000 / 105,000	121,500 / 85,000	10 - 40
	YZK150A**(0,A)M	200,000 / 140,000	162,000 / 113,400	15 - 45
	YZK150A**(0,A)H	250,000 / 175,000	202,500 / 141,750	25 - 55

Table 107. Gas-fired heating capacities - staged gas - ultra high efficiency (continued)

Tons	Unit Model Number	Heating Input BTU (High / Low Stage)	Heating Output BTU (High / Low Stage)	Air Temperature Rise°F
15	YZK180A**(0,A)L	250,000 / 175,000	202,500 / 141,750	15 - 45
	YZK180A**(0,A)M	320,000 / 224,000	259,200 / 181,440	20 - 50
	YZK180A**(0,A)H	400,000 / 280,000	324,000 / 226,800	25 - 55
17.5	YZK210A**(0,A)L	250,000 / 175,000	202,500 / 141,750	15 - 45
	YZK210A**(0,A)M	320,000 / 224,000	259,200 / 181,440	20 - 50
	YZK210A**(0,A)H	400,000 / 280,000	324,000 / 226,800	25 - 55
20	YZK240A**(0,A)L	250,000 / 175,000	202,500 / 141,750	10 - 40
	YZK240A**(0,A)M	320,000 / 224,000	259,200 / 181,440	15 - 45
	YZK240A**(0,A)H	400,000 / 280,000	324,000 / 226,800	20 - 50
25	YZK300A**(0,A)L	250,000 / 175,000	202,500 / 141,750	10 - 40
	YZK300A**(0,A)M	320,000 / 224,000	259,200 / 181,440	15 - 45
	YZK300A**(0,A)H	400,000 / 280,000	324,000 / 226,800	20 - 50

Table 108. Gas-fired heating capacities - modulating gas - ultra high efficiency

Tons	Unit Model Number	Heating Input BTU (Maximum / Minimum)	Heating Output BTU (Maximum / Minimum)	Air Temperature Rise°F
6	YZK072A**BL	80,000/8,000	64,800/6,480	5 - 40
	YZK072A**BH	150,000/15,000	121,500/12,150	5 - 60
7.5	YZK090A**BL	120,000/12,000	97,200/9,720	5 - 45
	YZK090A**BH	200,000/20,000	162,000/16,200	5 - 60
8.5	YZK102A**BL	120,000/12,000	97,200/9,720	5 - 45
	YZK102A**BH	200,000/20,000	162,000/16,200	5 - 60
10	YZK120A**BL	150,000/15,000	121,500/12,150	5 - 40
	YZK120A**BH	250,000/25,000	202,500/20,250	5 - 55
12.5	YZK150A**BH	250,000 / 25,000	202,500 / 20,250	5 - 55
15	YZK180A**BL	250,000 / 25,000	202,500 / 20,250	5 - 45
	YZK180A**BH	400,000 / 40,000	324,000 / 32,400	5 - 55
17.5	YZK210A**BL	250,000 / 25,000	202,500 / 20,250	5 - 45
	YZK210A**BH	400,000 / 40,000	324,000 / 32,400	5 - 55
20	YZK240A**BL	250,000 / 25,000	202,500 / 20,250	5 - 40
	YZK240A**BH	400,000 / 40,000	324,000 / 32,400	5 - 50
25	YZK300A**BL	250,000 / 25,000	202,500 / 20,250	5 - 40
	YZK300A**BH	400,000 / 40,000	324,000 / 32,400	5 - 50



Controls

Enhanced BAS Integration and Connectivity

- Symbio™ 700 integrates seamlessly with Tracer® Synchrony and Tracer Ensemble® to deliver optimized building automation and building management features and functions.
- Easily integrate with open standard protocols to connect seamlessly to a Building Automation System (BAS).
- Digit 21 must equal 1, 2, or 3 for communication support.

BACnet Communications

Symbio™ 700 includes native BACnet® communications which allows the unit to communicate directly with a Tracer® or other BAS via open protocol BACnet MS/TP or IP.

Modbus Communications

Symbio™ 700 includes native Modbus communications which allows the unit to communicate directly with a Tracer® or other BAS via open protocol Modbus™ RTU or TCP/IP.

LonTalk Communications

The optional LonTalk® communications module allows the unit to communicate directly with a Tracer® or other BAS via open protocol LonTalk.

Air-Fi Wireless Communications

The optional Air-Fi® communications module allows the unit to communicate directly with a Tracer® or other BAS via open protocol BACnet over Zigbee wireless.

Secure Remote Connectivity with Trane Connect

The Symbio™ controller enables secure remote connectivity via Trane Connect® to Trane Intelligent Services and remote monitoring. Trane Connect provides anywhere/anytime access to monitor and manage with secure remote access and connectivity options through a multitude of platforms.

Serviceability

Symbio Service and Installation Mobile App

The Symbio™ Service and Installation mobile app is accessible through mobile devices (phones and tablets) via Bluetooth connectivity or via Trane Connect. The intuitive mobile app feels natural to technicians and operators. They will quickly be able to view equipment status and alarms, perform start-up tasks, change configurations, test the equipment's performance in specific modes—and much more. Free for download from App Store (Apple iOS) and Google Play (Android devices).

To download the Symbio Service and Installation Mobile App use the links below or scan the code with your mobile phone camera.

[Apple download link \(https://apps.apple.com/us/app/symbio-service-installation/id1309310176\)](https://apps.apple.com/us/app/symbio-service-installation/id1309310176)

[Google Play \(Android\) download link \(https://play.google.com/store/apps/details?id=com.trane.mobileservicetool\)](https://play.google.com/store/apps/details?id=com.trane.mobileservicetool)

Figure 7. Scan code



Figure 8. Symbio service and installation mobile app

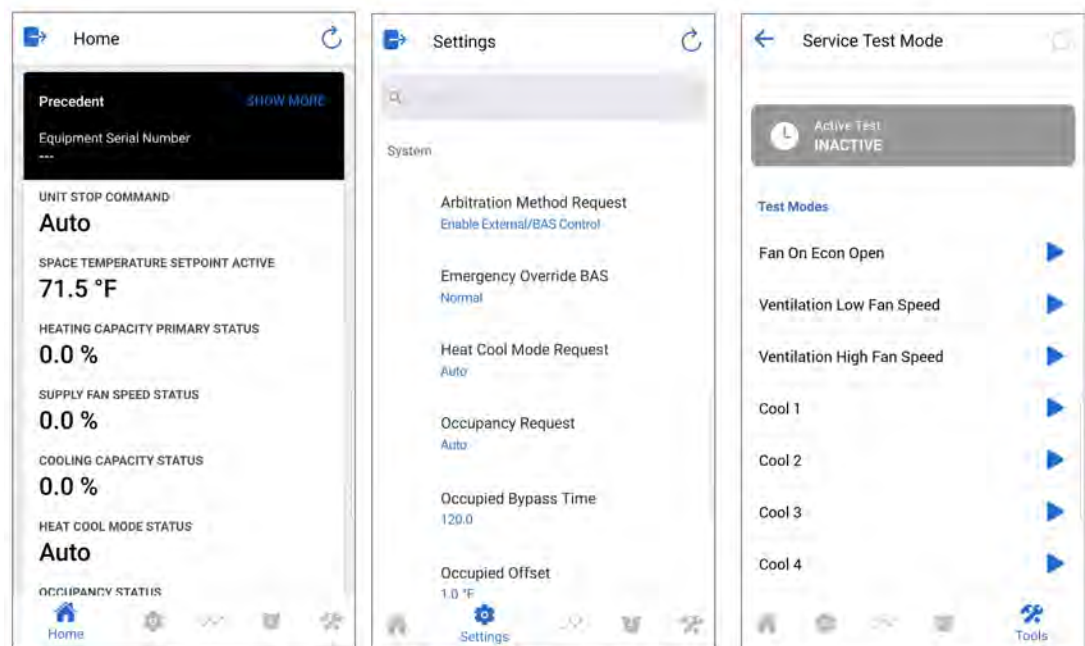

Onboard User Interface

An integrated onboard user interface that makes setup and continued operation easy. It provides real time operational performance, status, data, and alarms. It also allows the user to interact with, service, troubleshoot, and control their equipment without additional service software tools or when a mobile interface is not available.

Figure 9. Onboard user interface

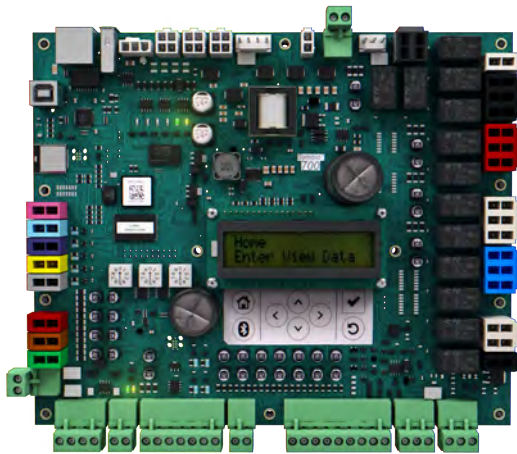

Service Test Mode

Symbio™ 700 requires no special tools to run the unit through its paces. Simply navigate to the ‘Service’ section of the on-board user interface or the ‘Tools’ section of the Symbio Service and Installation Mobile App and enter the ‘Service Test Mode’ section. Here the unit can be placed in the desired operating condition for a pre-determined amount of time supporting troubleshooting efforts in the field. The Symbio 700 will return to normal control when the user exits test mode or when the pre-determined, user-selected Service Test time has expired.

Symbio 700 Controls with Upgradeable Software

Equipment and systems feature engineered, tested, and proven applications that meet industry energy standards and provide the flexibility to customize and update over the life of the equipment. Professional operational algorithms are embedded within the Symbio™ 700 controller at the factory. Symbio 700 standardizes each equipment unit to maintain standards for comfort, efficiency, and air quality, without additional field programming. Symbio 700 provides the flexibility over the life of the equipment to meet changing customer needs and/or industry standards.

Flexibility

Expansion Modules

- XM30 – Provides 4 universal inputs or analog outputs
- XM32 – Provides 4 binary outputs

Field Programming via TGP2

- Control ancillary equipment
- Custom sequences

TGP2 and XM Limitations

- Programs will only have access to available BACnet® points. (Ensures system reliability.)
- TGP2 programs will not have direct I/O control access for factory components. (Compressors will not be able to be directly controlled On/Off without going through factory provided protection sequences.)
- Onboard I/O will not be available to custom applied TGP2 programs. If additional I/O is required for a new control loop, a separate expansion module will be required.
- I/O will be limited to a maximum combination of 2 XM modules. Only XM30 or XM32 modules are supported by the Symbio™ 700.

Economizer Controls

Four options for economizer control are available: Dry Bulb Temperature, Comparative Enthalpy, Reference Enthalpy and Differential Dry Bulb Temperature.

Dry Bulb Temperature Control

The dry bulb system measures outdoor temperature comparing it to the economizer enable setpoint. If the outdoor temperature is below the economizer enable setpoint, the economizer will operate freely. This system is best suited for arid regions where the humidity levels of outside air would not be detrimental to building comfort and indoor air quality.

Comparative Enthalpy Control

The comparative enthalpy system measures the temperature and humidity of both return air and outside air to determine which source has lower enthalpy. This system allows true comparison of outdoor air and return air enthalpy by measurement of outdoor air and return air temperature and humidity.

Reference Enthalpy Control

The reference enthalpy system compares outdoor air temperature and humidity to the economizer enthalpy enable setpoint. If outdoor air temperature and humidity are below the economizer enthalpy enable setpoint, the economizer will operate freely. This system provides more sophisticated control where outdoor air humidity levels may not be acceptable for building comfort and indoor air quality.

Differential Dry Bulb Temperature Control

The differential dry bulb system measures the temperature of both return air and outside air to determine when to economize. If outdoor air temperature is below the return air temperature minus a differential, the economizer will operate freely. This system is best suited for arid regions where the humidity levels of outside air would not be detrimental to building comfort and indoor air quality.

Zone Sensors

Zone Temperature Only

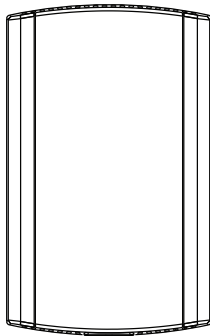

BAYSENS077

Provides temperature input only. Can be used as a secondary remote temperature input for thermostats.

Manual Changeover

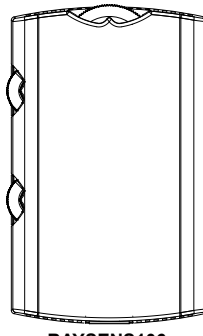

BAYSENS106

Heat, Cool or Off System Switch. Fan Auto or Off Switch. Single temperature setpoint thumbwheel.

Manual/Automatic Changeover

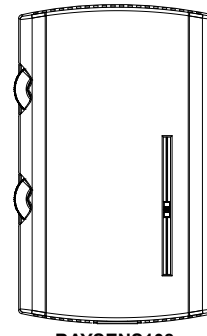

BAYSENS108

Auto, Heat, Cool or Off System Switch. Fan Auto or Off Switch. Dual temperature setpoint sliders

Integrated Comfort™ System

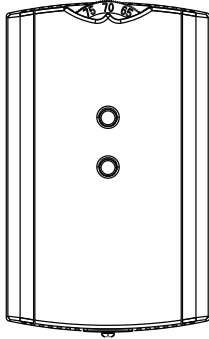

BAYSENS073 / BAYSENS074 / BAYSENS075

Sensor(s) available with optional temperature adjustment and override buttons to provide central control.

Wired Display Sensor

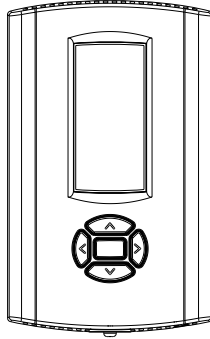

BAYSENS135

LCD display that provides heat, cool, auto, or off. Includes two temperature setpoints and a lockable setting with °F or °C indicators.

Touchscreen Digital Display Communicating Sensor



BAYSENS800

Uses BACnet® MS/TP link to communicate zone temperature and setpoints. Auto, Heat, Cool or Off System Switch. Fan Auto or On Switch. 7-day programmable thermostat with night setback.

Note: Not compatible with VAV units. Requires BACnet communications.

Air-Fi Wireless Communicating Zone Sensors

Wireless Zone Temperature Only

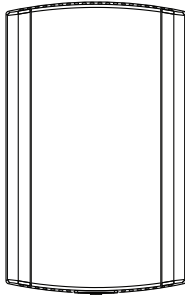

BAYSENS077

Measures temperature and optional humidity (with WCS-SH) for use in public spaces where no local user interface is preferred.

Note: Requires BACnet communications.

Wireless Display Sensor

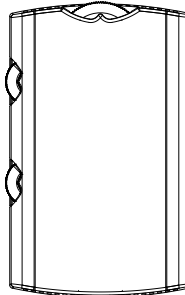

BAYSENS106

Easy-to-use interface for clear and simple monitoring and control. Can be configured for any system.

Note: Requires BACnet communications.

Wired CO₂ Sensor

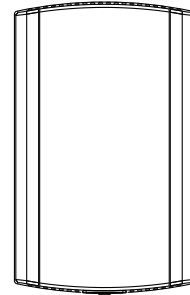

X13790422010

The maintenance-free carbon dioxide (CO₂) sensor is primarily used for demand control ventilation applications.

Wired Zone Temperature and Humidity Sensor

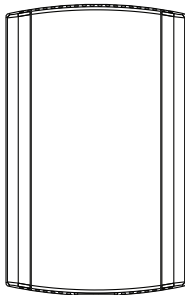

BAYSENS036

Measures temperature and relative humidity. Relative humidity input is used to control activation of dehumidification.

Thermostats

Digital Display Thermostat (3H/2C)

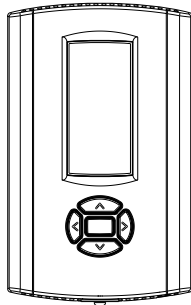

BAYSTAT155

Three Heat/Two Cool Auto changeover display thermostat.

Note: Not compatible with VAV units.

Pivot® Web Enabled Smart Thermostat (3H/2C)

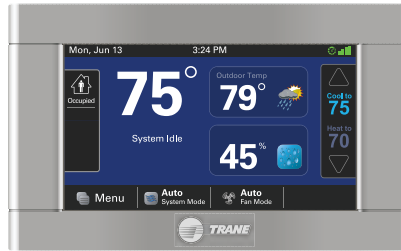

BAYSTAT814

Our Pivot Smart Thermostat system is great for commercial buildings. With its intuitive touchscreen and customizable display, it is easy for occupants to use. The Pivot mobile app enables users to control multiple buildings remotely, making changes in seconds to all systems.

Note: Not compatible with VAV units.

Touchscreen Programmable Thermostat with Relative Humidity Sensor (3H/2C)



BAYSTAT152

Three Heat, Two Cool digital display thermostat with built-in humidity control. This thermostat combines both humidity and temperature into one.

Note: Not compatible with VAV units.

Humidity Control (HGRH)

Sequence of Operations

Humidity Control system capable of operating in normal cooling, dual mode to satisfy cooling and humidity requirements, and hot gas reheat mode when only humidity demand is required. Function between requirements and unit transition seamlessly providing an all-around comfort solution.

Note: Supports Humidistat control. When the Humidistat input becomes active, compressors will stage to full capacity and modulate the 3-way valve.

Initiation of Humidity Control

- Conforms to ASHRAE standard (62.1-2022)
- Dehumidification is initiated when too much moisture is in the space (>60°F Dew point)
 - Two measurement options are available for dehumidification status. Humidity control is started when:
 - Dew point is too high (60°F is default),
 - Relative Humidity is too high (60 percent is default)
 - Choice between these values above is user-configurable, and the actual values are adjustable by customer if desired
- Reheat circuit is initiated when space temperature drops below setpoint during humidity control.

Humidity Control Routine

There are two independent control loops: One to control latent load, the other to control sensible load.

Latent load is controlled by compressor staging:

- Compressors initially move up one stage from the last cooling mode stage.
- Compressors are staged up as needed by the controller to achieve a target leaving ID air dew point based on space conditions.

Sensible load is controlled with the Modulating 3 way valve:

- Modulating valve opens when space temperature is below setpoint.
- The reheat valve adjusts the amount of flow to reheat coil to achieve the targeted leaving ID air temperature, based on space conditions.

Purge Cycle

During dehumidification, every 120 minutes (default) a 3 minute cooling “purge cycle” will be executed. This purge cycle is executed for system reliability, specifically it helps manage oil return to compressors.

- Modulating valve moves to a fixed position based on OD air and compressor stage.
- Compressors move to full load.

Leaving Humidity Control and Returning to Cooling Only

- When space humidity drops to below the threshold humidity value (60°F dew point or 60% relative humidity), system reverts back to cooling mode. Dead band of ~5°F yields approximately 55°F dew point for switch to cooling.
- Unit can stay in humidity control mode indefinitely, with purge cycles happening regularly.
 - Relative humidity setpoint is 65 percent for unoccupied mode.
 - Dew point for unoccupied mode is the same as occupied (default 60°F DP).



Electrical Data

Table 109. Electrical characteristics – unit wiring – cooling

Tons	Unit Model Number	Voltage Range	Standard Indoor Fan Motor		Oversized/High Static Indoor Fan Motor		Optional Power Exhaust Standard Indoor Fan Motor		Optional Power Exhaust Oversized/High Static Indoor Fan Motor	
			MCA	Max Fuse Size or Max Circuit Breaker	MCA	Max Fuse Size or Max Circuit Breaker	MCA	Max Fuse Size or Max Circuit Breaker	MCA	Max Fuse Size or Max Circuit Breaker
3	TZK036A3	187-253	23	30	—	—	29	35	—	—
	TZK036A4	414-506	13	15	—	—	16	20	—	—
	TZK036AW	517-632	10	15	—	—	12	15	—	—
4	TZK048A3	187-253	35	50	—	—	40	50	—	—
	TZK048A4	414-506	17	20	—	—	21	25	—	—
	TZK048AW	517-632	12	15	—	—	14	15	—	—
5	TZK060A3	187-253	35	50	—	—	40	50	—	—
	TZK060A4	414-506	17	20	—	—	21	25	—	—
	TZK060AW	517-632	12	15	—	—	14	15	—	—
6	TZK072A3	187-253	42	60	—	—	47	60	—	—
	TZK072A4	414-506	23	35	—	—	27	35	—	—
	TZK072AW	517-632	18	25	—	—	20	30	—	—
7.5	TZK090A3	187-253	42	60	—	—	48	60	—	—
	TZK090A4	414-506	24	35	—	—	28	40	—	—
	TZK090AW	517-632	19	25	—	—	21	30	—	—
8.5	TZK102A3	187-253	48	70	—	—	53	70	—	—
	TZK102A4	414-506	28	40	—	—	31	45	—	—
	TZK102AW	517-632	22	35	—	—	24	35	—	—
10	TZK120A3	187-253	57	80	—	—	63	90	—	—
	TZK120A4	414-506	32	50	—	—	36	50	—	—
	TZK120AW	517-632	27	40	—	—	29	45	—	—
12.5	TZK150A3	187-253	76	110	—	—	81	110	—	—
	TZK150A4	414-506	41	60	—	—	44	60	—	—
	TZK150AW	517-632	30	45	—	—	33	45	—	—
15	TZK180A3	187-253	89	125	—	—	95	125	—	—
	TZK180A4	414-506	48	70	—	—	51	70	—	—
	TZK180AW	517-632	37	50	—	—	40	60	—	—
17.5	TZK210A3	187-253	94	125	98	125	99	125	104	125
	TZK210A4	414-506	50	60	52	60	54	70	55	70
	TZK210AW	517-632	41	50	42	50	43	50	44	50
20	TZK240A3	187-253	108	125	113	150	114	150	118	150
	TZK240A4	414-506	60	80	62	80	64	80	65	90
	TZK240AW	517-632	48	60	49	60	50	60	52	70
25	TZK300A3	187-253	110	150	114	150	115	150	120	150
	TZK300A4	414-506	58	80	60	80	61	80	63	80
	TZK300AW	517-632	50	70	51	70	52	70	54	70



Electrical Data

Table 110. Electrical characteristics – unit wiring with electric heat – cooling

Tons	Unit Model Number	Heater Model Number	Heater kW Rating	Control Stages	Standard Indoor Fan Motor ^(a)		Oversized/High Static Indoor Fan Motor		Optional Power Exhaust Standard Indoor Fan Motor		Optional Power Exhaust Oversized/High Static Indoor Fan Motor	
					MCA	Max Fuse Size or Max Circuit Breaker	MCA	Max Fuse Size or Max Circuit Breaker	MCA	Max Fuse Size or Max Circuit Breaker	MCA	Max Fuse Size or Max Circuit Breaker
208/230 Volts Three Phase												
3	TZK036A3	FIAEHTB306*	6	1	28/31	30/35	—	—	36/38	40/40	—	—
		FIAEHTB312*	12	2	44/49	45/50	—	—	51/56	60/60	—	—
		FIAEHTB318*	18	2	60/67	60/70	—	—	67/74	70/80	—	—
4	TZK048A3	FIAEHTB306*	6	1	35/35	50/50	—	—	40/40	50/50	—	—
		FIAEHTB312*	12	2	44/49	50/50	—	—	51/56	60/60	—	—
		FIAEHTB318*	18	2	60/67	60/70	—	—	67/74	70/80	—	—
5	TZK060A3	FIAEHTB306*	6	1	35/35	50/50	—	—	40/40	50/50	—	—
		FIAEHTB312*	12	2	44/49	50/50	—	—	51/56	60/60	—	—
		FIAEHTB318*	18	2	60/67	60/70	—	—	67/74	70/80	—	—
		FIAEHTB327*	27	2	83/94	90/100	—	—	90/101	90/110	—	—
6	TZK072A3	FIAEHTB309*	9	1	42/42	60/60	—	—	47/47	60/60	—	—
		FIAEHTB318*	18	2	60/67	60/70	—	—	67/74	70/80	—	—
		FIAEHTB327*	27	2	83/94	90/100	—	—	90/101	90/110	—	—
		FIAEHTB336*	36	2	107/121	110/125	—	—	114/128	125/150	—	—
7.5	TZK090A3	FIAEHTB309*	9	1	42/42	60/60	—	—	48/48	60/60	—	—
		FIAEHTB318*	18	2	60/67	60/70	—	—	67/74	70/80	—	—
		FIAEHTB327*	27	2	83/94	90/100	—	—	90/101	90/110	—	—
		FIAEHTB336*	36	2	107/121	110/125	—	—	114/128	125/150	—	—
8.5	TZK102A3	FIAEHTB309*	9	1	48/48	70/70	—	—	53/53	70/70	—	—
		FIAEHTB318*	18	2	60/67	70/70	—	—	67/74	70/80	—	—
		FIAEHTB327*	27	2	83/94	90/100	—	—	90/101	90/110	—	—
		FIAEHTB336*	36	2	107/121	110/125	—	—	114/128	125/150	—	—
10	TZK120A3	FIAEHTC318*	18	1	62/70	80/80	—	—	70/77	90/90	—	—
		FIAEHTC327*	27	2	86/97	90/100	—	—	93/104	100/110	—	—
		FIAEHTC336*	36	2	109/124	110/125	—	—	116/131	125/150	—	—
		FIAEHTC354*	54	2	156/145	175/175	—	—	163/153	175/175	—	—
12.5	TZK150A3	FIAEHTD318*	18	1	76/78	110/110	—	—	81/85	110/110	—	—
		FIAEHTD336*	36	2	118/132	125/150	—	—	125/139	125/150	—	—
		FIAEHTD354*	54	2	164/154	175/175	—	—	172/161	175/175	—	—

Table 110. Electrical characteristics – unit wiring with electric heat – cooling (continued)

Tons	Unit Model Number	Heater Model Number	Heater kW Rating	Control Stages	Standard Indoor Fan Motor ^(a)		Oversized/High Static Indoor Fan Motor		Optional Power Exhaust Standard Indoor Fan Motor		Optional Power Exhaust Oversized/High Static Indoor Fan Motor	
					MCA	Max Fuse Size or Max Circuit Breaker	MCA	Max Fuse Size or Max Circuit Breaker	MCA	Max Fuse Size or Max Circuit Breaker	MCA	Max Fuse Size or Max Circuit Breaker
15	TZK180A3	FIAEHTD318*	18	1	89/89	125/125	—	—	95/95	125/125	—	—
		FIAEHTD336*	36	2	118/132	125/150	—	—	125/139	125/150	—	—
		FIAEHTD354*	54	2	164/154	175/175	—	—	172/161	175/175	—	—
17.5	TZK210A3	FIAEHTD336*	36	2	118/132	125/150	123/138	125/150	125/139	125/150	130/145	150/150
		FIAEHTD354*	54	2	164/154	175/175	170/159	175/175	172/161	175/175	177/166	200/175
		FIAEHTD372*	72	2	174/197	200/225	179/202	200/225	181/204	200/225	186/210	200/225
20	TZK240A3	FIAEHTD336*	36	2	118/132	125/150	123/138	150/150	125/139	150/150	130/145	150/150
		FIAEHTD354*	54	2	164/154	175/175	170/159	175/175	172/161	175/175	177/166	200/175
		FIAEHTD372*	72	2	174/197	200/225	179/202	200/225	181/204	200/225	186/210	200/225
25	TZK300A3	FIAEHTD336*	36	2	118/132	150/150	123/138	150/150	125/139	150/150	130/145	150/150
		FIAEHTD354*	54	2	164/154	175/175	170/159	175/175	172/161	175/175	177/166	200/175
		FIAEHTD372*	72	2	174/197	200/225	179/202	200/225	181/204	200/225	186/210	200/225
460 Volts Three Phase												
3	TZK036A4	FIAEHTB406*	6	1	17	20	—	—	21	25	—	—
		FIAEHTB412*	12	2	26	30	—	—	30	30	—	—
		FIAEHTB418*	18	2	35	35	—	—	39	40	—	—
4	TZK048A4	FIAEHTB406*	6	1	17	20	—	—	21	25	—	—
		FIAEHTB412*	12	2	26	30	—	—	30	30	—	—
		FIAEHTB418*	18	2	35	35	—	—	39	40	—	—
5	TZK060A4	FIAEHTB406*	6	1	17	20	—	—	21	25	—	—
		FIAEHTB412*	12	2	26	30	—	—	30	30	—	—
		FIAEHTB418*	18	2	35	35	—	—	39	40	—	—
		FIAEHTA427*	23	2	48	50	—	—	52	60	—	—
6	TZK072A4	FIAEHTB409*	9	1	23	35	—	—	27	35	—	—
		FIAEHTB418*	18	2	35	35	—	—	39	40	—	—
		FIAEHTB427*	27	2	48	50	—	—	52	60	—	—
		FIAEHTB436*	36	2	62	70	—	—	66	70	—	—
7.5	TZK090A4	FIAEHTB409*	9	1	24	35	—	—	28	40	—	—
		FIAEHTB418*	18	2	35	35	—	—	39	40	—	—
		FIAEHTB427*	27	2	48	50	—	—	52	60	—	—
		FIAEHTB436*	36	2	62	70	—	—	66	70	—	—



Electrical Data

Table 110. Electrical characteristics – unit wiring with electric heat – cooling (continued)

Tons	Unit Model Number	Heater Model Number	Heater kW Rating	Control Stages	Standard Indoor Fan Motor ^(a)		Oversized/High Static Indoor Fan Motor		Optional Power Exhaust Standard Indoor Fan Motor		Optional Power Exhaust Oversized/High Static Indoor Fan Motor	
					MCA	Max Fuse Size or Max Circuit Breaker	MCA	Max Fuse Size or Max Circuit Breaker	MCA	Max Fuse Size or Max Circuit Breaker	MCA	Max Fuse Size or Max Circuit Breaker
8.5	TZK102A4	FIAEHTB409*	9	1	28	40	—	—	31	45	—	—
		FIAEHTB418*	18	2	35	40	—	—	39	45	—	—
		FIAEHTB427*	27	2	48	50	—	—	52	60	—	—
		FIAEHTB436*	36	2	62	70	—	—	66	70	—	—
10	TZK120A4	FIAEHTC418*	18	1	36	50	—	—	40	50	—	—
		FIAEHTC427*	27	2	49	50	—	—	53	60	—	—
		FIAEHTC436*	36	2	63	70	—	—	67	70	—	—
		FIAEHTC454*	54	2	74	90	—	—	78	90	—	—
12.5	TZK150A4	FIAEHTD418*	18	1	41	60	—	—	44	60	—	—
		FIAEHTD436*	36	2	67	70	—	—	72	80	—	—
		FIAEHTD454*	54	2	78	90	—	—	82	90	—	—
15	TZK180A4	FIAEHTD418*	18	1	48	70	—	—	51	70	—	—
		FIAEHTD436*	36	2	67	70	—	—	72	80	—	—
		FIAEHTD454*	54	2	78	90	—	—	82	90	—	—
17.5	TZK210A4	FIAEHTD436*	36	2	67	70	70	70	72	80	74	80
		FIAEHTD454*	54	2	78	90	80	90	82	90	85	90
		FIAEHTD472*	72	2	100	110	102	110	104	110	106	110
20	TZK240A4	FIAEHTD436*	36	2	67	80	70	80	72	80	74	90
		FIAEHTD454*	54	2	78	90	80	90	82	90	85	90
		FIAEHTD472*	72	2	100	110	102	110	104	110	106	110
25	TZK300A4	FIAEHTD436*	36	2	67	80	70	80	72	80	74	80
		FIAEHTD454*	54	2	78	90	80	90	82	90	85	90
		FIAEHTD472*	72	2	100	110	102	110	104	110	106	110
575 Volts Three Phase												
3	TZK036AW	FIAEHTBW06*	6	1	13	15	—	—	16	20	—	—
		FIAEHTBW12*	12	2	20	20	—	—	23	25	—	—
		FIAEHTBW18*	18	2	27	30	—	—	30	30	—	—
4	TZK048AW	FIAEHTBW06*	6	1	13	15	—	—	16	20	—	—
		FIAEHTBW12*	12	2	20	20	—	—	23	25	—	—
		FIAEHTBW18*	18	2	27	30	—	—	30	30	—	—

Table 110. Electrical characteristics – unit wiring with electric heat – cooling (continued)

Tons	Unit Model Number	Heater Model Number	Heater kW Rating	Control Stages	Standard Indoor Fan Motor ^(a)		Oversized/High Static Indoor Fan Motor		Optional Power Exhaust Standard Indoor Fan Motor		Optional Power Exhaust Oversized/High Static Indoor Fan Motor	
					MCA	Max Fuse Size or Max Circuit Breaker	MCA	Max Fuse Size or Max Circuit Breaker	MCA	Max Fuse Size or Max Circuit Breaker	MCA	Max Fuse Size or Max Circuit Breaker
5	TZK060AW	FIAEHTBW06*	6	1	13	15	—	—	16	20	—	—
		FIAEHTBW12*	12	2	20	20	—	—	23	25	—	—
		FIAEHTBW18*	18	2	27	30	—	—	30	30	—	—
		FIAEHTAW23*	23	2	38	40	—	—	41	45	—	—
6	TZK072AW	FIAEHTBW09*	9	1	18	25	—	—	20	30	—	—
		FIAEHTBW18*	18	2	27	30	—	—	30	30	—	—
		FIAEHTBW27*	27	2	38	40	—	—	41	45	—	—
		FIAEHTBW36*	36	2	49	50	—	—	52	60	—	—
7.5	TZK090AW	FIAEHTBW09*	9	1	19	25	—	—	21	30	—	—
		FIAEHTBW18*	18	2	27	30	—	—	30	30	—	—
		FIAEHTBW27*	27	2	38	40	—	—	41	45	—	—
		FIAEHTBW36*	36	2	49	50	—	—	52	60	—	—
8.5	TZK102AW	FIAEHTBW09*	9	1	22	35	—	—	24	35	—	—
		FIAEHTBW18*	18	2	27	35	—	—	30	35	—	—
		FIAEHTBW27*	27	2	38	40	—	—	41	45	—	—
		FIAEHTBW36*	36	2	49	50	—	—	52	60	—	—
10	TZK120AW	FIAEHTCW18*	18	1	28	40	—	—	31	45	—	—
		FIAEHTCW27*	27	2	39	40	—	—	42	45	—	—
		FIAEHTCW36*	36	2	50	50	—	—	53	60	—	—
		FIAEHTCW54*	54	2	59	70	—	—	61	70	—	—
12.5	TZK150AW	FIAEHTDW18*	18	1	31	45	—	—	34	45	—	—
		FIAEHTDW36*	36	2	53	60	—	—	56	60	—	—
		FIAEHTDW54*	54	2	62	70	—	—	65	70	—	—
15	TZK180AW	FIAEHTDW18*	18	1	37	50	—	—	40	60	—	—
		FIAEHTDW36*	36	2	53	60	—	—	56	60	—	—
		FIAEHTDW54*	54	2	62	70	—	—	65	70	—	—
17.5	TZK210AW	FIAEHTDW36*	36	2	53	60	55	60	56	60	58	60
		FIAEHTDW54*	54	2	62	70	63	70	65	70	66	70
		FIAEHTDW72*	72	2	79	90	81	90	82	90	84	90
20	TZK240AW	FIAEHTDW36*	36	2	53	60	55	60	56	60	58	70
		FIAEHTDW54*	54	2	62	70	63	70	65	70	66	70
		FIAEHTDW72*	72	2	79	90	81	90	82	90	84	90



Electrical Data

Table 110. Electrical characteristics – unit wiring with electric heat – cooling (continued)

Tons	Unit Model Number	Heater Model Number	Heater kW Rating	Control Stages	Standard Indoor Fan Motor ^(a)		Oversized/High Static Indoor Fan Motor		Optional Power Exhaust Standard Indoor Fan Motor		Optional Power Exhaust Oversized/High Static Indoor Fan Motor	
					MCA	Max Fuse Size or Max Circuit Breaker	MCA	Max Fuse Size or Max Circuit Breaker	MCA	Max Fuse Size or Max Circuit Breaker	MCA	Max Fuse Size or Max Circuit Breaker
25	TZK300AW	FIAEHTDW36*	36	2	53	70	55	70	56	70	58	70
		FIAEHTDW54*	54	2	62	70	63	70	65	70	66	70
		FIAEHTDW72*	72	2	79	90	81	90	82	90	84	90

^(a) The standard motor is a multispeed, direct drive motor.

Table 111. Electrical characteristics – compressor motor and condenser motor – cooling

Tons	Unit Model Number	No.	Compressor Motors						No.	Condenser Fan Motor				
			Volts	Phase	hp ^(a)	rpm	Amps ^(b)			Volts	Phase	hp	Amps	
							RLA	LRA					FLA	LRA
3	TZK036A3	1	208/230	3	—	—	8.8	—	1	208/230	1	0.33	2.8	—
	TZK036A4	1	460	3	—	—	5.1	—	1	460	1	0.33	1.6	—
	TZK036AW	1	575	3	—	—	4.5	—	1	575	3	0.4	0.6	2.1
4	TZK048A3	1	208/230	3	—	—	16	—	1	208/230	1	0.50	5.3	—
	TZK048A4	1	460	3	—	—	7.6	—	1	460	1	0.50	2.3	—
	TZK048AW	1	575	3	—	—	6.1	—	1	575	3	0.4	0.6	2.1
5	TZK060A3	1	208/230	3	—	—	16	—	1	208/230	1	0.50	5.3	—
	TZK060A4	1	460	3	—	—	7.6	—	1	460	1	0.50	2.3	—
	TZK060AW	1	575	3	—	—	6.1	—	1	575	3	0.4	0.6	2.1
6	TZK072A3	1	208/230	3	—	—	20.8	—	1	208/230	1	0.75	6.3	—
	TZK072A4	1	460	3	—	—	12.2	—	1	460	1	0.75	3	—
	TZK072AW	1	575	3	—	—	10.5	—	1	575	3	0.75	1.14	4.53
7.5	TZK090A3	1	208/230	3	—	—	21.5	—	1	208/230	1	0.75	6.3	—
	TZK090A4	1	460	3	—	—	13.1	—	1	460	1	0.75	3	—
	TZK090AW	1	575	3	—	—	11.4	—	1	575	3	0.75	1.14	4.53
8.5	TZK102A3	1	208/230	3	—	—	25.7	—	1	208/230	1	0.75	6.3	—
	TZK102A4	1	460	3	—	—	15.7	—	1	460	1	0.75	3	—
	TZK102AW	1	575	3	—	—	13.8	—	1	575	3	0.75	1.14	4.53
10	TZK120A3	1	208/230	3	—	—	31.3	—	1	208/230	1	0.75	6.3	—
	TZK120A4	1	460	3	—	—	18.8	—	1	460	1	0.75	3	—
	TZK120AW	1	575	3	—	—	16.5	—	1	575	3	1	1.8	8.1
12.5	TZK150A3	1	208/230	3	—	—	35.6	—	2	208/230	1	.5	4.7	—
	TZK150A4	1	460	3	—	—	21.3	—	2	460	1	.5	2.3	—
	TZK150AW	1	575	3	—	—	15.8	—	2	575	3	.5	1.1	3.6
15	TZK180A3	1	208/230	3	—	—	49.3	—	2	208/230	1	.5	4.7	—
	TZK180A4	1	460	3	—	—	26.9	—	2	460	1	.5	2.3	—
	TZK180AW	1	575	3	—	—	22.7	—	2	575	3	.5	1.1	3.6

Table 111. Electrical characteristics – compressor motor and condenser motor – cooling (continued)

Tons	Unit Model Number	No.	Compressor Motors						No.	Condenser Fan Motor				
			Volts	Phase	hp ^(a)	rpm	Amps ^(b)			Volts	Phase	hp	Amps	
							RLA	LRA					FLA	LRA
17.5	TZK210A3	2	208/230	3	-/8.7	-/3500	30/32.3	-/255	2	208/230	3	1	2.6	—
	TZK210A4	2	460	3	-/8.7	-/3500	18/15.5	-/140	2	460	3	1	1.3	—
	TZK210AW	2	575	3	-/8.7	-/3500	14/12.4	-/107.6	2	575	3	1	1.9	8
20	TZK240A3	2	208/230	3	-/8.7	-/3500	42.1/32.3	-/255	2	208/230	3	1	2.6	—
	TZK240A4	2	460	3	-/8.7	-/3500	26/15.5	-/140	2	460	3	1	1.3	—
	TZK240AW	2	575	3	-/8.7	-/3500	20/12.4	-/107.6	2	575	3	1	1.9	8
25	TZK300A3	2	208/230	3	-/8.7	-/3500	43.3/32.3	-/255	2	208/230	3	1	2.6	—
	TZK300A4	2	460	3	-/8.7	-/3500	24/15.5	-/140	2	460	3	1	1.3	—
	TZK300AW	2	575	3	-/8.7	-/3500	21.5/12.4	-/107.6	2	575	3	1	1.9	8

^(a) Hp for each compressor.

^(b) Amp draw for each motor (compressor and condenser fan motor); multiply value by number of motors to determine total amps.

Table 112. Electrical characteristics – indoor fan motor – cooling

Tons	Unit Model Number	No.	Volts	Phase	hp	Amps ^(a)	
						FLA	LRA
3	TZK036A3	1	208/230	3	3	8.8	—
	TZK036A4	1	460	3	3	4.6	—
	TZK036AW	1	575	3	3	3.2	—
4	TZK048A3	1	208/230	3	3	8.8	—
	TZK048A4	1	460	3	3	4.6	—
	TZK048AW	1	575	3	3	3.2	—
5	TZK060A3	1	208/230	3	3	8.8	—
	TZK060A4	1	460	3	3	4.6	—
	TZK060AW	1	575	3	3	3.2	—
6	TZK072A3	1	208/230	3	3	8.8	—
	TZK072A4	1	460	3	3	4.6	—
	TZK072AW	1	575	3	3	3.2	—
7.5	TZK090A3	1	208/230	3	3	8.8	—
	TZK090A4	1	460	3	3	4.6	—
	TZK090AW	1	575	3	3	3.2	—
8.5	TZK102A3	1	208/230	3	3	8.8	—
	TZK102A4	1	460	3	3	4.6	—
	TZK102AW	1	575	3	3	3.2	—
10	TZK120A3	1	208/230	3	5	11	—
	TZK120A4	1	460	3	5	5.5	—
	TZK120AW	1	575	3	5	3.9	—
12.5	TZK150A3	2	208/230	3	3	8.8	—
	TZK150A4	2	460	3	3	4.6	—
	TZK150AW	2	575	3	3	3.2	—
15	TZK180A3	2	208/230	3	3	8.8	—
	TZK180A4	2	460	3	3	4.6	—
	TZK180AW	2	575	3	3	3.2	—



Electrical Data

Table 112. Electrical characteristics – indoor fan motor – cooling (continued)

Tons	Unit Model Number	No.	Volts	Phase	hp	Amps ^(a)	
						FLA	LRA
17.5	TZK210A3	2	208/230	3	3	8.8	—
	TZK210A4	2	460	3	3	4.6	—
	TZK210AW	2	575	3	3	3.2	—
20	TZK240A3	2	208/230	3	3	8.8	—
	TZK240A4	2	460	3	3	4.6	—
	TZK240AW	2	575	3	3	3.2	—
25	TZK300A3	2	208/230	3	3	8.8	—
	TZK300A4	2	460	3	3	4.6	—
	TZK300AW	2	575	3	3	3.2	—

^(a) Amp draw for each motor (compressor and condenser fan motor); multiply value by number of motors to determine total amps.

Table 113. Electrical characteristics – oversized indoor fan motor – cooling

Tons	Unit Model Number	No.	Volts	Phase	hp	Amps ^(a)	
						FLA	LRA
3	TZK036A3	N/A	208/230	N/A	N/A	N/A	N/A
	TZK036A4	N/A	460	N/A	N/A	N/A	N/A
	TZK036AW	N/A	575	N/A	N/A	N/A	N/A
4	TZK048A3	N/A	208/230	N/A	N/A	N/A	N/A
	TZK048A4	N/A	460	N/A	N/A	N/A	N/A
	TZK048AW	N/A	575	N/A	N/A	N/A	N/A
5	TZK060A3	N/A	208/230	N/A	N/A	N/A	N/A
	TZK060A4	N/A	460	N/A	N/A	N/A	N/A
	TZK060AW	N/A	575	N/A	N/A	N/A	N/A
6	TZK072A3	—	208/230	—	—	—	—
	TZK072A4	—	460	—	—	—	—
	TZK072AW	—	575	—	—	—	—
7.5	TZK090A3	—	208/230	—	—	—	—
	TZK090A4	—	460	—	—	—	—
	TZK090AW	—	575	—	—	—	—
8.5	TZK102A3	—	208/230	—	—	—	—
	TZK102A4	—	460	—	—	—	—
	TZK102AW	—	575	—	—	—	—
10	TZK120A3	—	208/230	—	—	—	—
	TZK120A4	—	460	—	—	—	—
	TZK120AW	—	575	—	—	—	—
25	TZK300A3	2	208/230	3	5	11	—
	TZK300A4	2	460	3	5	5.5	—
	TZK300AW	2	575	3	5	3.9	—

^(a) Amp draw for each motor (compressor and condenser fan motor); multiply value by number of motors to determine total amps.

Table 114. Electrical characteristics – power exhaust – cooling

Tons	Volts	Phase	hp	rpm	FLA	LRA
3 to 5	208/230	1	0.87	1075	5.7	13.6
3 to 5	460	1	0.87	1075	3.3	7.2

Table 114. Electrical characteristics – power exhaust – cooling (continued)

Tons	Volts	Phase	hp	rpm	FLA	LRA
3 to 5	575	1	0.87	1075	2.3	5.8
6 to 10	208/230	1	0.87	1075	5.7	13.6
6 to 10	460	1	0.87	1075	3.3	7.2
6 to 10	575	1	0.8	1075	2.3	5.8
12.5 to 25	208/230	1	0.87	1075	5.7	13.6
12.5 to 25	460	1	0.87	1075	3.3	7.2
12.5 to 25	575	1	0.8	1075	2.3	5.8

Note: For 6 to 10 ton models, rpm = two speed.

Table 115. Electrical characteristics – unit wiring – gas

Tons	Unit Model Number	Voltage Range	Standard Indoor Fan Motor		Oversized/High Static Indoor Fan Motor		Optional Power Exhaust Standard Indoor Fan Motor		Optional Power Exhaust Oversized/High Static Indoor Fan Motor	
			MCA	Max Fuse Size or Max Circuit Breaker	MCA	Max Fuse Size or Max Circuit Breaker	MCA	Max Fuse Size or Max Circuit Breaker	MCA	Max Fuse Size or Max Circuit Breaker
3	YZK036A3	187-253	23	30	—	—	29	35	—	—
	YZK036A4	414-506	13	15	—	—	16	20	—	—
	YZK036AW	517-632	10	15	—	—	12	15	—	—
4	YZK048A3	187-253	35	50	—	—	40	50	—	—
	YZK048A4	414-506	17	20	—	—	21	25	—	—
	YZK048AW	517-632	12	15	—	—	14	15	—	—
5	YZK060A3	187-253	35	50	—	—	40	50	—	—
	YZK060A4	414-506	17	20	—	—	21	25	—	—
	YZK060AW	517-632	12	15	—	—	14	15	—	—
6	YZK072A3	187-253	42	60	—	—	47	60	—	—
	YZK072A4	414-506	23	35	—	—	27	35	—	—
	YZK072AW	517-632	18	25	—	—	20	30	—	—
7.5	YZK090A3	187-253	42	60	—	—	48	60	—	—
	YZK090A4	414-506	24	35	—	—	28	40	—	—
	YZK090AW	517-632	19	25	—	—	21	30	—	—
8.5	YZK102A3	187-253	48	70	—	—	53	70	—	—
	YZK102A4	414-506	28	40	—	—	31	45	—	—
	YZK102AW	517-632	22	35	—	—	24	35	—	—
10	YZK120A3	187-253	57	80	—	—	63	90	—	—
	YZK120A4	414-506	32	50	—	—	36	50	—	—
	YZK120AW	517-632	27	40	—	—	29	45	—	—
12.5	YZK150A3	187-253	76	110	—	—	81	110	—	—
	YZK150A4	414-506	41	60	—	—	44	60	—	—
	YZK150AW	517-632	30	45	—	—	33	45	—	—
15	YZK180A3	187-253	89	125	—	—	95	125	—	—
	YZK180A4	414-506	48	70	—	—	51	70	—	—
	YZK180AW	517-632	37	50	—	—	40	60	—	—



Electrical Data

Table 115. Electrical characteristics – unit wiring – gas (continued)

Tons	Unit Model Number	Voltage Range	Standard Indoor Fan Motor		Oversized/High Static Indoor Fan Motor		Optional Power Exhaust Standard Indoor Fan Motor		Optional Power Exhaust Oversized/High Static Indoor Fan Motor	
			MCA	Max Fuse Size or Max Circuit Breaker	MCA	Max Fuse Size or Max Circuit Breaker	MCA	Max Fuse Size or Max Circuit Breaker	MCA	Max Fuse Size or Max Circuit Breaker
17.5	YZK210A3	187-253	94	125	98	125	99	125	104	125
	YZK210A4	414-506	50	60	52	60	54	70	55	70
	YZK210AW	517-632	41	50	42	50	43	50	44	50
20	YZK240A3	187-253	108	125	113	150	114	150	118	150
	YZK240A4	414-506	60	80	62	80	64	80	65	90
	YZK240AW	517-632	48	60	49	60	50	60	52	70
25	YZK300A3	187-253	110	150	114	150	115	150	120	150
	YZK300A4	414-506	58	80	60	80	61	80	63	80
	YZK300AW	517-632	50	70	51	70	52	70	54	70

Table 116. Electrical characteristics – compressor motor and condenser motor – gas

Tons	Unit Model Number	No.	Compressor Motors						No.	Condenser Fan Motor				
			Volts	Phase	hp ^(a)	rpm	Amps ^(b)			Volts	Phase	hp	Amps	
							RLA	LRA					FLA	LRA
3	YZK036A3	1	208/230	3	—	—	8.8	—	1	208/230	1	0.33	2.8	—
	YZK036A4	1	460	3	—	—	5.1	—	1	460	1	0.33	1.6	—
	YZK036AW	1	575	3	—	—	4.5	—	1	575	3	0.4	0.6	2.1
4	YZK048A3	1	208/230	3	—	—	16	—	1	208/230	1	0.50	5.3	—
	YZK048A4	1	460	3	—	—	7.6	—	1	460	1	0.50	2.3	—
	YZK048AW	1	575	3	—	—	6.1	—	1	575	3	0.4	0.6	2.1
5	YZK060A3	1	208/230	3	—	—	16	—	1	208/230	1	0.50	5.3	—
	YZK060A4	1	460	3	—	—	7.6	—	1	460	1	0.50	2.3	—
	YZK060AW	1	575	3	—	—	6.1	—	1	575	3	0.4	0.6	2.1
6	YZK072A3	1	208/230	3	—	—	20.8	—	1	208/230	1	0.75	6.3	—
	YZK072A4	1	460	3	—	—	12.2	—	1	460	1	0.75	3	—
	YZK072AW	1	575	3	—	—	10.5	—	1	575	3	0.75	1.14	4.53
7.5	YZK090A3	1	208/230	3	—	—	21.5	—	1	208/230	1	0.75	6.3	—
	YZK090A4	1	460	3	—	—	13.1	—	1	460	1	0.75	3	—
	YZK090AW	1	575	3	—	—	11.4	—	1	575	3	0.75	1.14	4.53
8.5	YZK102A3	1	208/230	3	—	—	25.7	—	1	208/230	1	0.75	6.3	—
	YZK102A4	1	460	3	—	—	15.7	—	1	460	1	0.75	3	—
	YZK102AW	1	575	3	—	—	13.8	—	1	575	3	0.75	1.14	4.53
10	YZK120A3	1	208/230	3	—	—	31.3	—	1	208/230	1	0.75	6.3	—
	YZK120A4	1	460	3	—	—	18.8	—	1	460	1	0.75	3	—
	YZK120AW	1	575	3	—	—	16.5	—	1	575	3	1	1.8	8.1
12.5	YZK150A3	1	208/230	3	—	—	35.6	—	2	208/230	1	0.5	4.7	—
	YZK150A4	1	460	3	—	—	21.3	—	2	460	1	0.5	2.3	—
	YZK150AW	1	575	3	—	—	15.8	—	2	575	3	0.5	1.1	3.6

Table 116. Electrical characteristics – compressor motor and condenser motor – gas (continued)

Tons	Unit Model Number	No.	Compressor Motors						No.	Condenser Fan Motor				
			Volts	Phase	hp ^(a)	rpm	Amps ^(b)			Volts	Phase	hp	Amps	
							RLA	LRA					FLA	LRA
15	YZK180A3	1	208/230	3	—	—	49.3	—	2	208/230	1	0.5	4.7	—
	YZK180A4	1	460	3	—	—	26.9	—	2	460	1	0.5	2.3	—
	YZK180AW	1	575	3	—	—	22.7	—	2	575	3	0.5	1.1	3.6
17.5	YZK210A3	2	208/230	3	-/8.7	-/3500	30/32.3	-/255	2	208/230	3	1	2.6	—
	YZK210A4	2	460	3	-/8.7	-/3500	18/15.5	-/140	2	460	3	1	1.3	—
	YZK210AW	2	575	3	-/8.7	-/3500	14/12.4	-/107.6	2	575	3	1	1.9	8
20	YZK240A3	2	208/230	3	-/8.7	-/3500	42.1/32.3	-/255	2	208/230	3	1	2.6	—
	YZK240A4	2	460	3	-/8.7	-/3500	26/15.5	-/140	2	460	3	1	1.3	—
	YZK240AW	2	575	3	-/8.7	-/3500	20/12.4	-/107.6	2	575	3	1	1.9	8
25	YZK300A3	2	208/230	3	-/8.7	-/3500	43.3/32.3	-/255	2	208/230	3	1	2.6	—
	YZK300A4	2	460	3	-/8.7	-/3500	24/15.5	-/140	2	460	3	1	1.3	—
	YZK300AW	2	575	3	-/8.7	-/3500	21.5/12.4	-/107.6	2	575	3	1	1.9	8

^(a) Hp for each compressor.

^(b) Amp draw for each motor (compressor and condenser fan motor); multiply value by number of motors to determine total amps.

Table 117. Electrical characteristics – indoor fan motor – gas

Tons	Unit Model Number	No.	Volts	Phase	hp	Amps ^(a)	
						FLA	LRA
3	YZK036A3	1	208/230	3	3	8.8	—
	YZK036A4	1	460	3	3	4.6	—
	YZK036AW	1	575	3	3	3.2	—
4	YZK048A3	1	208/230	3	3	8.8	—
	YZK048A4	1	460	3	3	4.6	—
	YZK048AW	1	575	3	3	3.2	—
5	YZK060A3	1	208/230	3	3	8.8	—
	YZK060A4	1	460	3	3	4.6	—
	YZK060AW	1	575	3	3	3.2	—
6	YZK072A3	1	208/230	3	3	8.8	—
	YZK072A4	1	460	3	3	4.6	—
	YZK072AW	1	575	3	3	3.2	—
7.5	YZK090A3	1	208/230	3	3	8.8	—
	YZK090A4	1	460	3	3	4.6	—
	YZK090AW	1	575	3	3	3.2	—
8.5	YZK102A3	1	208/230	3	3	8.8	—
	YZK102A4	1	460	3	3	4.6	—
	YZK102AW	1	575	3	3	3.2	—
10	YZK120A3	1	208/230	3	5	11	—
	YZK120A4	1	460	3	5	5.5	—
	YZK120AW	1	575	3	5	3.9	—
12.5	YZK150A3	2	208/230	3	3	8.8	—
	YZK150A4	2	460	3	3	4.6	—
	YZK150AW	2	575	3	3	3.2	—



Electrical Data

Table 117. Electrical characteristics – indoor fan motor – gas (continued)

Tons	Unit Model Number	No.	Volts	Phase	hp	Amps ^(a)	
						FLA	LRA
15	YZK180A3	2	208/230	3	3	8.8	—
	YZK180A4	2	460	3	3	4.6	—
	YZK180AW	2	575	3	3	3.2	—
17.5	YZK210A3	2	208/230	3	3	8.8	—
	YZK210A4	2	460	3	3	4.6	—
	YZK210AW	2	575	3	3	3.2	—
20	YZK240A3	2	208/230	3	3	8.8	—
	YZK240A4	2	460	3	3	4.6	—
	YZK240AW	2	575	3	3	3.2	—
25	YZK300A3	2	208/230	3	3	8.8	—
	YZK300A4	2	460	3	3	4.6	—
	YZK300AW	2	575	3	3	3.2	—

^(a) Amp draw for each motor (compressor and condenser fan motor); multiply value by number of motors to determine total amps.

Table 118. Electrical characteristics – oversized indoor fan motor – gas

Tons	Unit Model Number	No.	Volts	Phase	hp	Amps ^(a)	
						FLA	LRA
3	YZK036A3	N/A	208/230	N/A	N/A	N/A	N/A
	YZK036A4	N/A	460	N/A	N/A	N/A	N/A
	YZK036AW	N/A	575	N/A	N/A	N/A	N/A
4	YZK048A3	N/A	208/230	N/A	N/A	N/A	N/A
	YZK048A4	N/A	460	N/A	N/A	N/A	N/A
	YZK048AW	N/A	575	N/A	N/A	N/A	N/A
5	YZK060A3	N/A	208/230	N/A	N/A	N/A	N/A
	YZK060A4	N/A	460	N/A	N/A	N/A	N/A
	YZK060AW	N/A	575	N/A	N/A	N/A	N/A
6	YZK072A3	—	208/230	—	—	—	—
	YZK072A4	—	460	—	—	—	—
	YZK072AW	—	575	—	—	—	—
7.5	YZK090A3	—	208/230	—	—	—	—
	YZK090A4	—	460	—	—	—	—
	YZK090AW	—	575	—	—	—	—
8.5	YZK102A3	—	208/230	—	—	—	—
	YZK102A4	—	460	—	—	—	—
	YZK102AW	—	575	—	—	—	—
10	YZK120A3	—	208/230	—	—	—	—
	YZK120A4	—	460	—	—	—	—
	YZK120AW	—	575	—	—	—	—
17.5	YZK210A3	2	208/230	3	5	11	—
	YZK210A4	2	460	3	5	5.5	—
	YZK210AW	2	575	3	5	3.9	—
20	YZK240A3	2	208/230	3	5	11	—
	YZK240A4	2	460	3	5	5.5	—
	YZK240AW	2	575	3	5	3.9	—

Table 118. Electrical characteristics – oversized indoor fan motor – gas (continued)

Tons	Unit Model Number	No.	Volts	Phase	hp	Amps ^(a)	
						FLA	LRA
25	YZK300A3	2	208/230	3	5	11	—
	YZK300A4	2	460	3	5	5.5	—
	YZK300AW	2	575	3	5	3.9	—

^(a) Amp draw for each motor (compressor and condenser fan motor); multiply value by number of motors to determine total amps.

Table 119. Electrical characteristics – power exhaust – gas

Tons	Volts	Phase	hp	rpm	FLA	LRA
3 to 5	208/230	1	0.87	1075	5.7	13.6
3 to 5	460	1	0.87	1075	3.3	7.2
3 to 5	575	1	0.87	1075	2.3	5.8
6 to 10	208/230	1	0.87	1075	5.7	13.6
6 to 10	460	1	0.87	1075	3.3	7.2
6 to 10	575	1	0.8	1075	2.3	5.8
12.5 to 25	208/230	1	0.87	1075	5.7	13.6
12.5 to 25	460	1	0.87	1075	3.3	7.2
12.5 to 25	575	1	0.8	1075	2.3	5.8

Note: For 6 to 10 ton models, rpm = two speed.

Table 120. Electrical characteristics – inducer motor – gas

Tons	Unit Model Number	Stages	hp	rpm	Volts	Phase	FLA	LRA
2-Stage Gas Heat								
3	YZK036A**(0,A)(L,M,H)	2	1/35	3500/2800	208-230	1	0.24/0.18	0.67
4	YZK048A**(0,A)(L,M,H)	2	1/35	3500/2800	208-230	1	0.24/0.18	0.67
5	YZK060A**(0,A)(L,M,H)	2	1/35	3500/2800	208-230	1	0.24/0.18	0.67
6	YZK072A**(0,A)(L,M)	2	1/35	3500/2800	208-230	1	0.24/0.18	0.67
	YZK072A**(0,A)H	2	1/15	3350/2800	208-230	1	0.42/0.50	0.73
7.5	YZK090A**(0,A)L	2	1/35	3500/2800	208-230	1	0.24/0.18	0.67
	YZK090A**(0,A)(M,H)	2	1/15	3350/2800	208-230	1	0.42/0.50	0.73
8.5	YZK102A**(0,A)L	2	1/35	3500/2800	208-230	1	0.24/0.18	0.67
	YZK102A**(0,A)(M,H)	2	1/15	3350/2800	208-230	1	0.42/0.50	0.73
10	YZK120A**(0,A)M	2	1/35	3500/2800	208-230	1	0.24/0.18	0.67
	YZK120A**(0,A)(L,H)	2	1/15	3350/2800	208-230	1	0.42/0.50	0.73
12.5	YZK150A**(0,A)(L,M,H)	2	1/15	3300/2800	208-230	1	0.36/0.3	0.73
15	YZK180A**(0,A)(L,M)	2	1/15	3300/2800	208-230	1	0.36/0.3	0.73
	YZK180A**(0,A)H	2	1/6	3300/2300	208-230	1	0.95/0.49	1.53
17.5	YZK210A**(0,A)(L,M)	2	1/15	3300/2800	208-230	1	0.36/0.3	0.73
	YZK210A**(0,A)H	2	1/6	3300/2300	208-230	1	0.95/0.49	1.53
20	YZK240A**(0,A)(L,M)	2	1/15	3300/2800	208-230	1	0.36/0.3	0.73
	YZK240A**(0,A)H	2	1/6	3300/2300	208-230	1	0.95/0.49	1.53
25	YZK300A**(0,A)(L,M)	2	1/15	3300/2800	208-230	1	0.36/0.3	0.73
	YZK300A**(0,A)H	2	1/6	3300/2300	208-230	1	0.95/0.49	1.53
Modulating 10:1 Gas Heat								



Electrical Data

Table 120. Electrical characteristics – inducer motor – gas (continued)

Tons	Unit Model Number	Stages	hp	rpm	Volts	Phase	FLA	LRA
6 to 10	YZK(072,090,102,120)A**B	Variable	1/8	3400	120	1	1.3	3.3
12.5 to 25	YZK(150,180,210,240,300)A**B	Variable	1/5	3300	115	1	3.4	7.3

Dimensional Data

Note: See Table 1, p. 5 for cabinet sizes.

Figure 10. B.0 cabinet

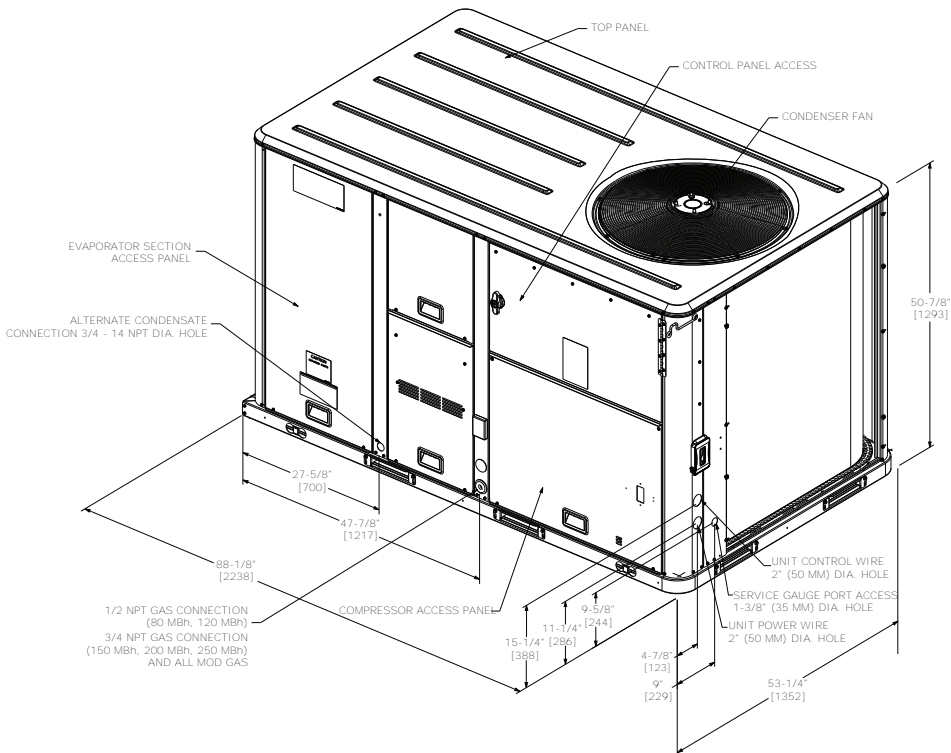

Figure 11. B.0 cabinet – downflow airflow supply/return, through-the-base utilities

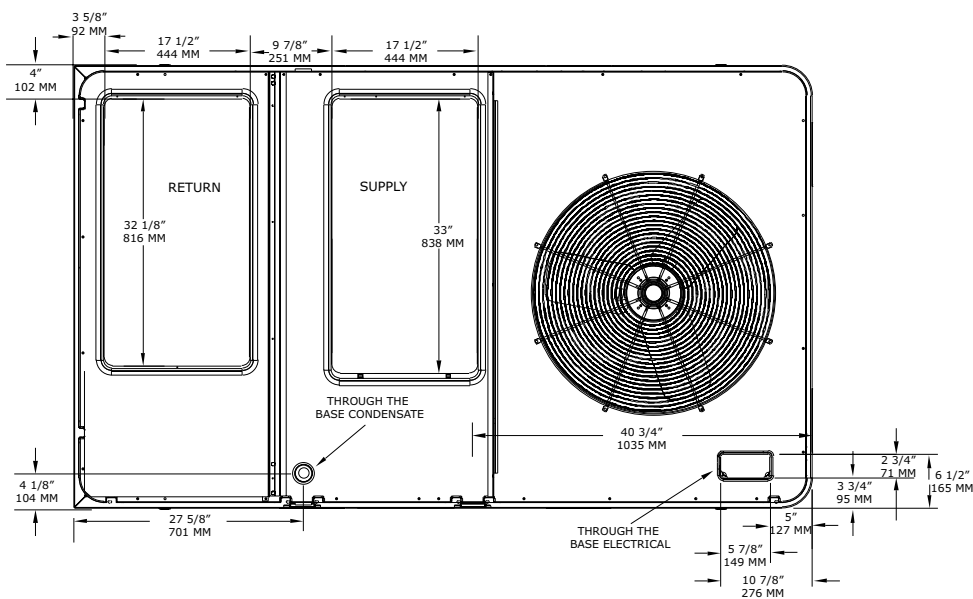

Figure 12. B.0 cabinet – horizontal airflow supply/return

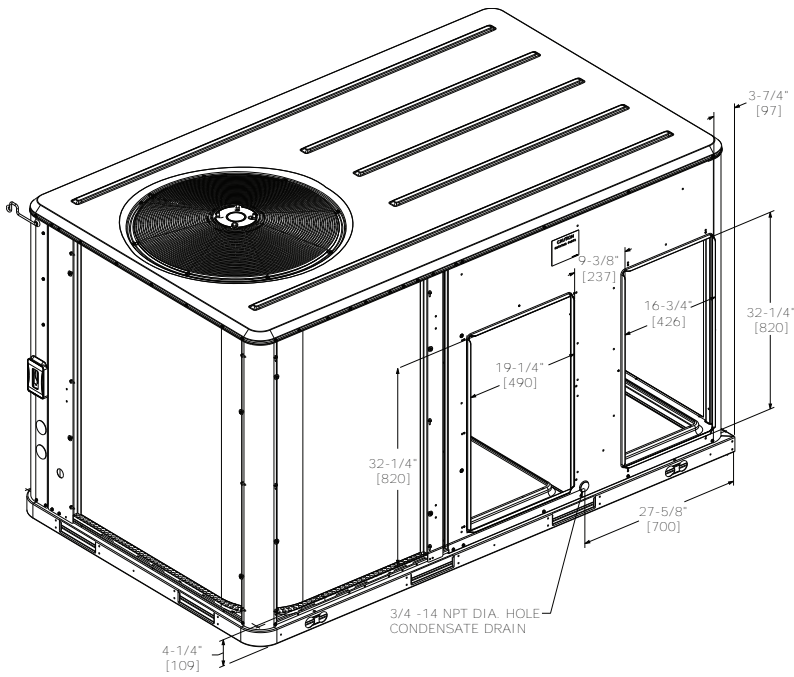

Figure 13. B.0 cabinet – unit clearance and roof opening

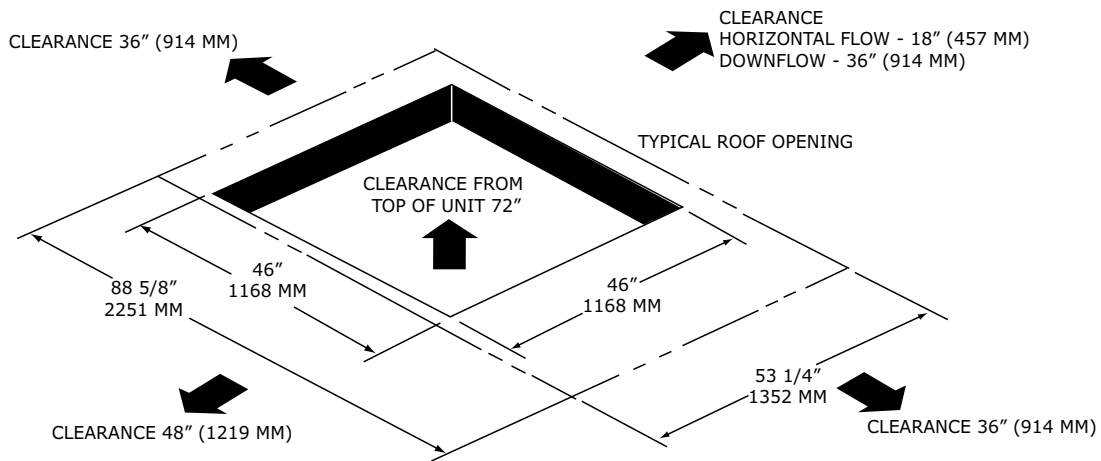

Figure 14. B.0 cabinet – roof curb

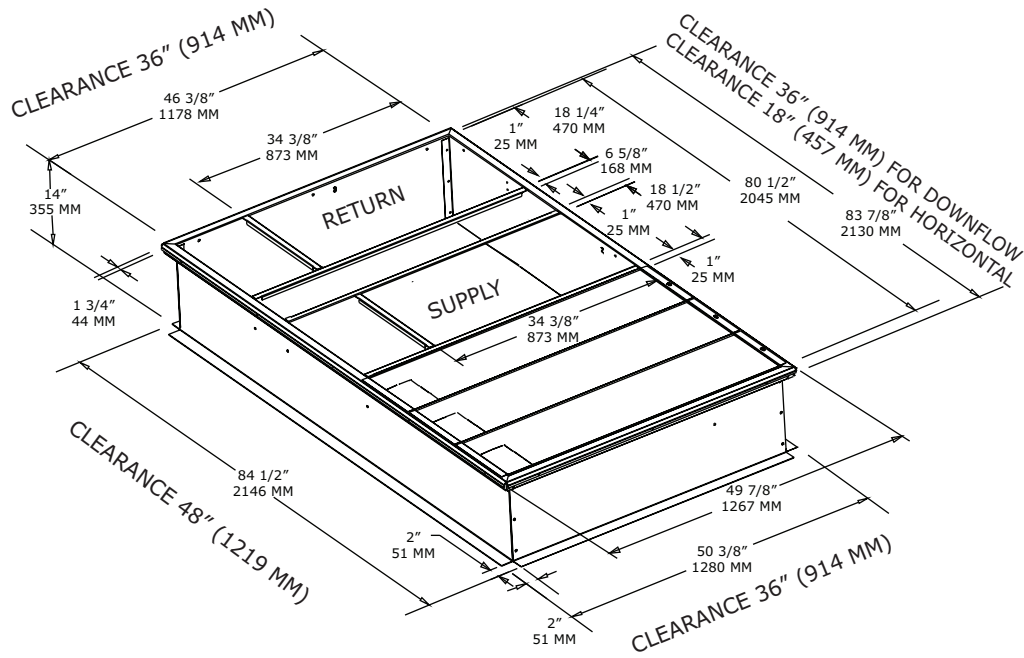
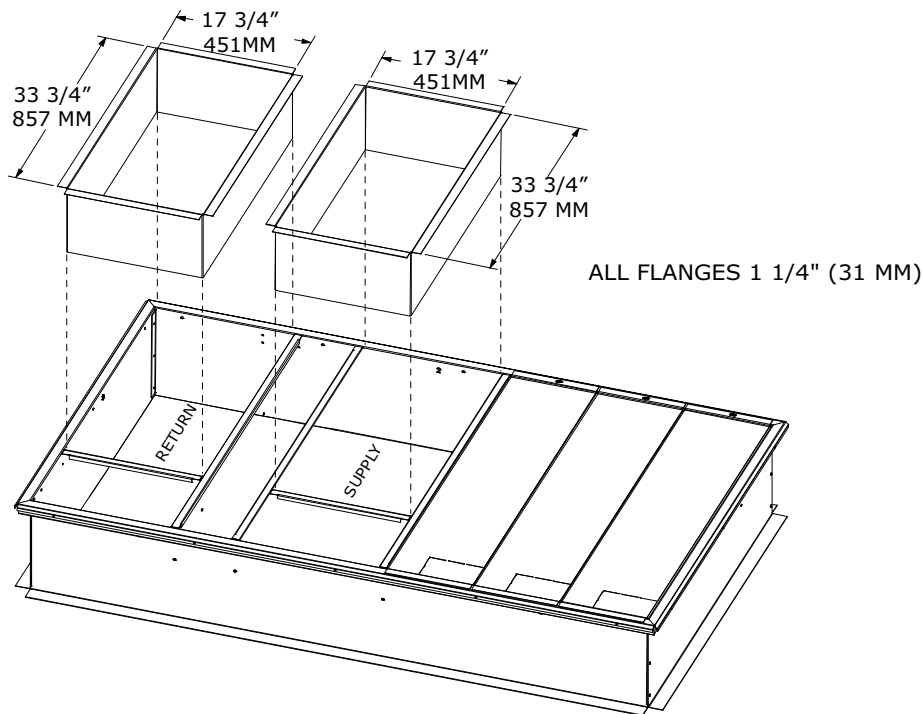

Figure 15. B.0 cabinet – downflow duct connections, field fabricated





Dimensional Data

Figure 16. B.0 cabinet – swing diameter for hinged door(s) option

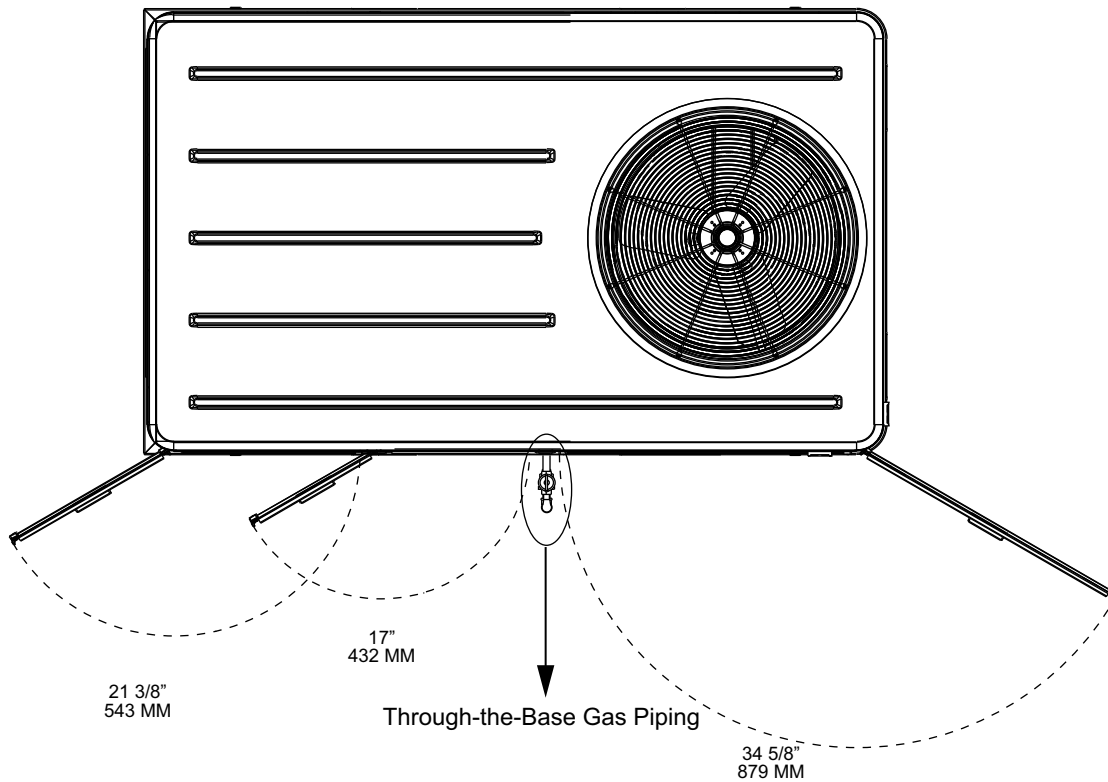

Figure 17. C.0 cabinet

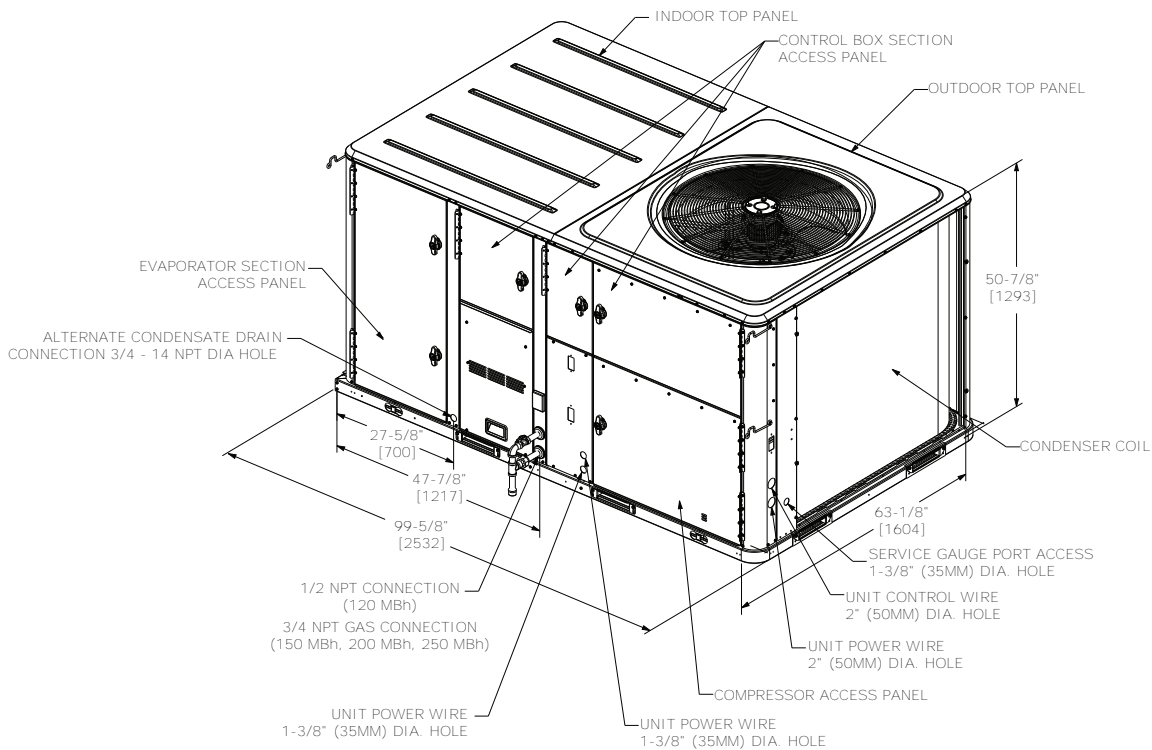

Figure 18. C.0 cabinet – downflow airflow supply/return, through-the-base utilities

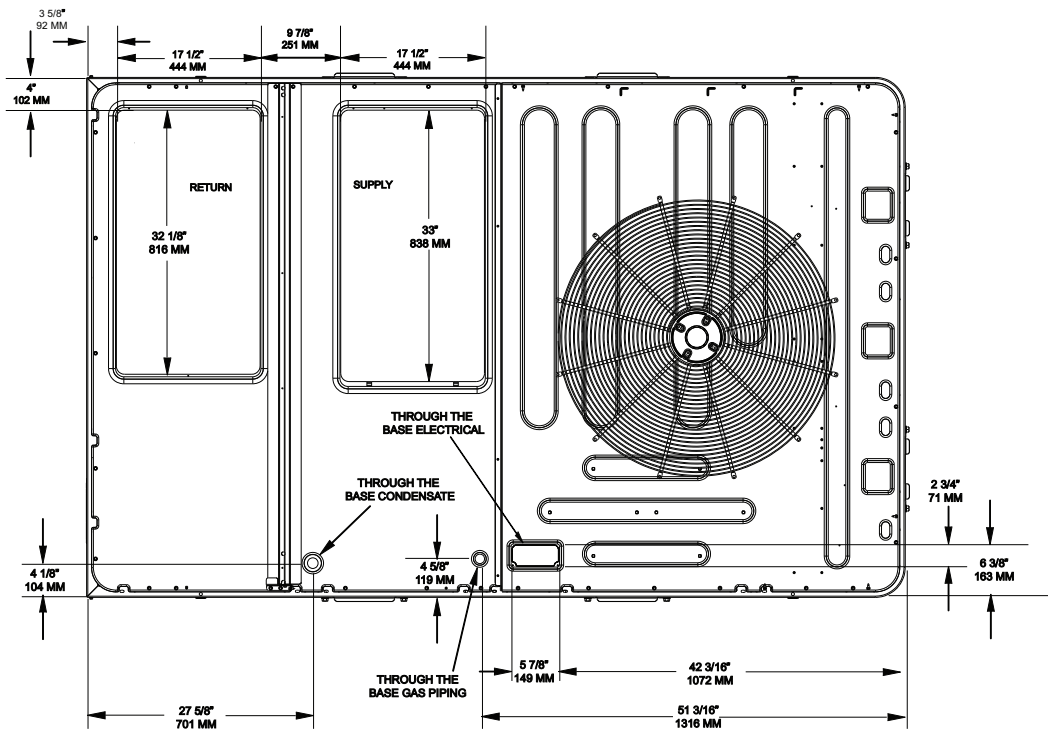

Figure 19. C.0 cabinet – horizontal airflow, supply and return

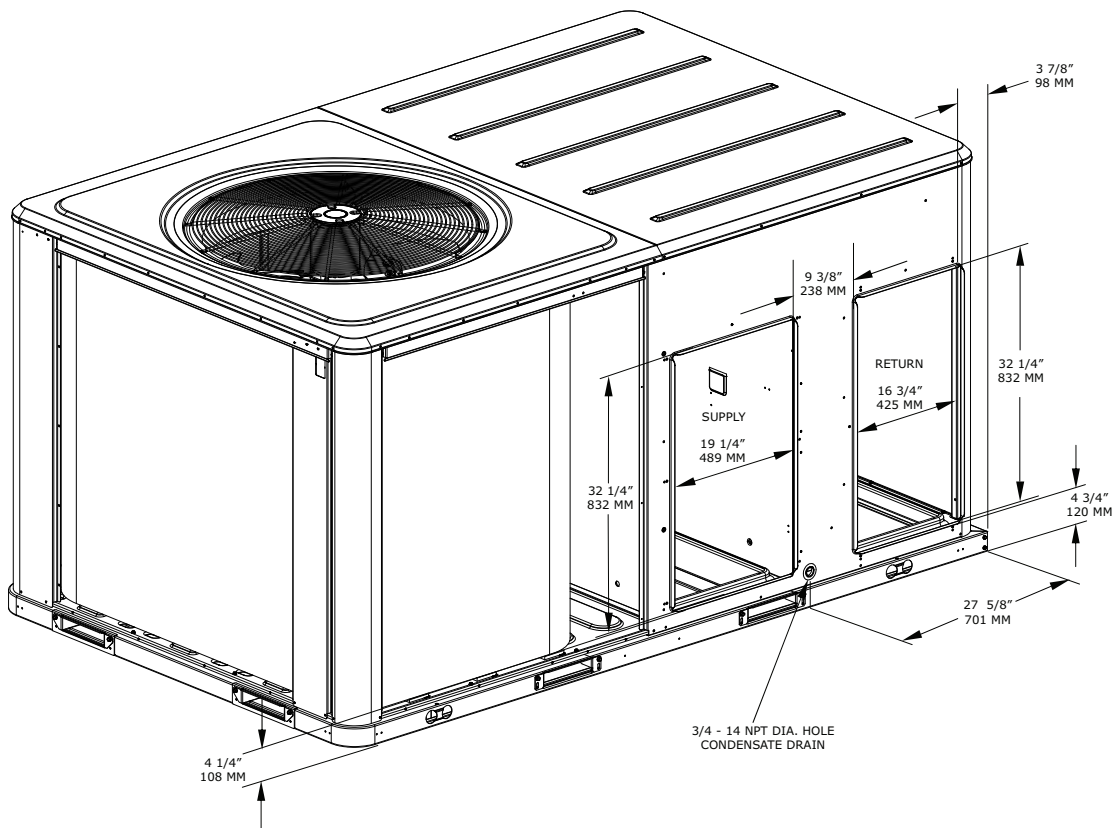

Figure 20. C.0 cabinet – unit clearance and roof opening

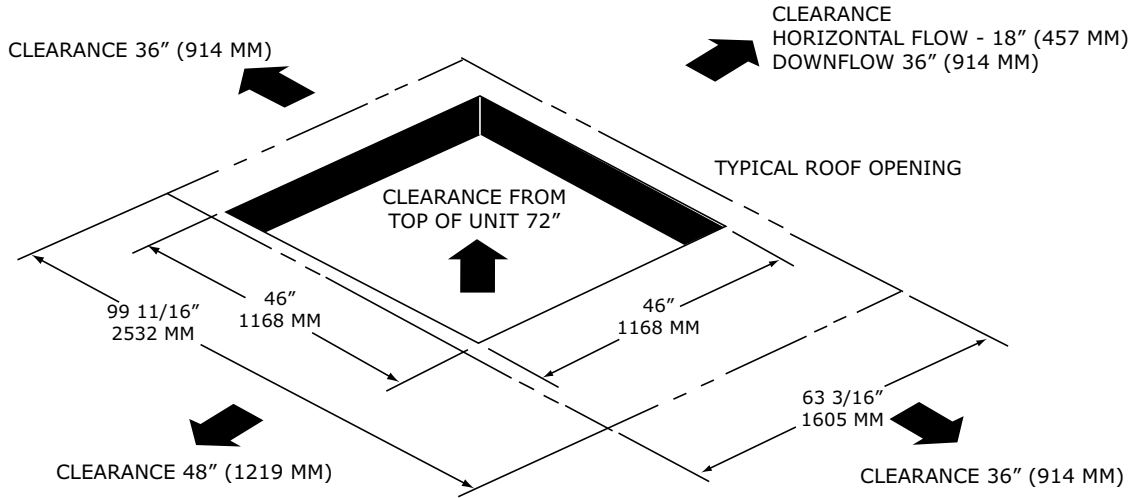

Figure 21. C.0 cabinet – roof curb

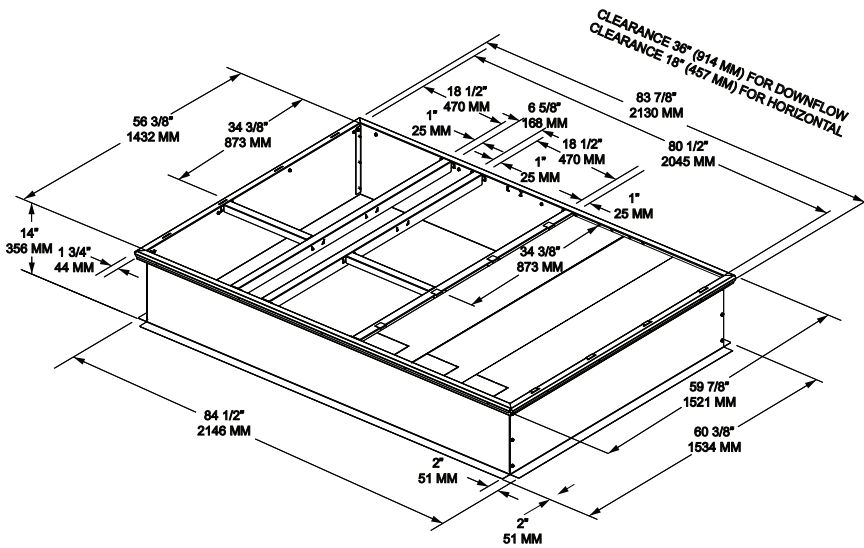

Figure 22. C.0 cabinet – swing diameter for hinged door(s) option

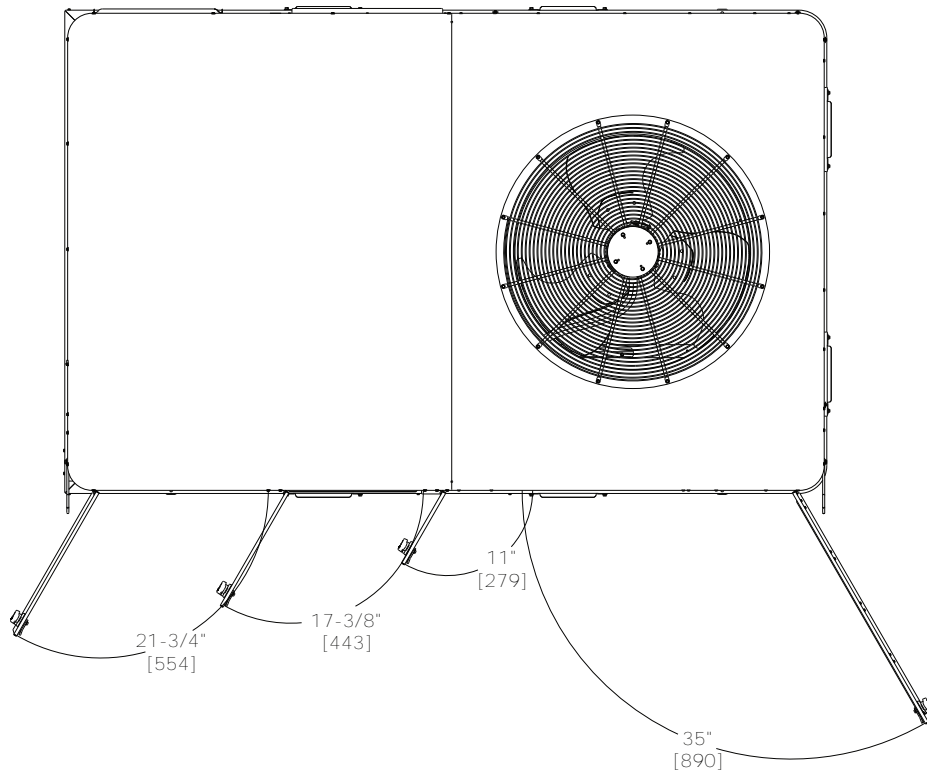
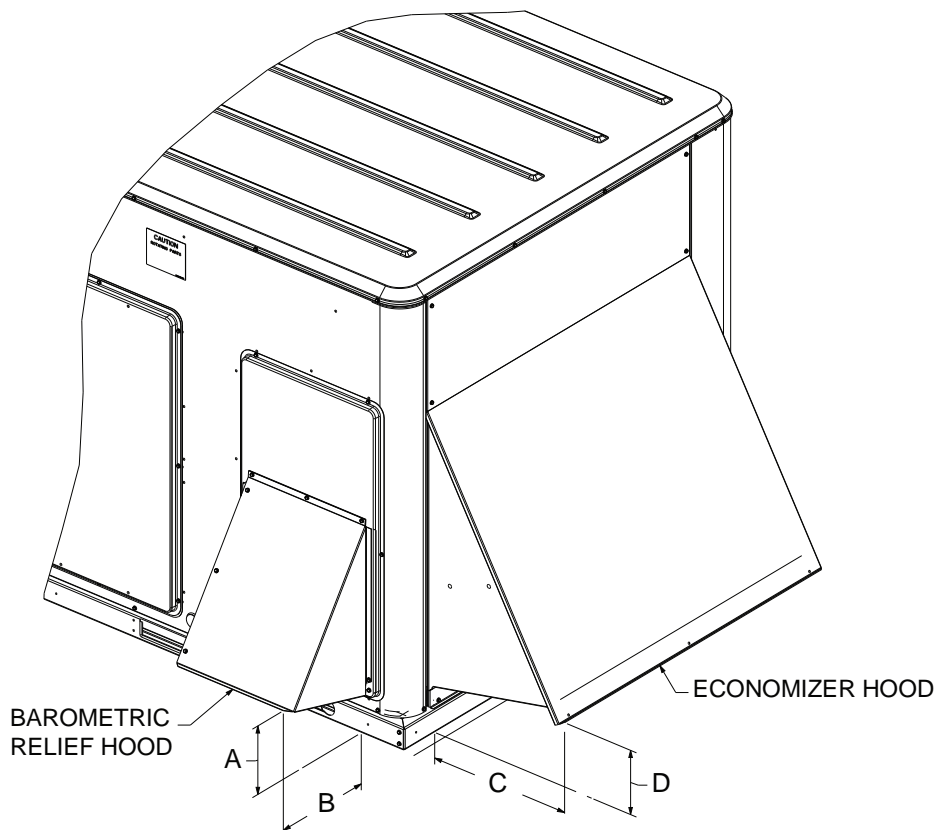

Figure 23. B.0 and C.0 cabinets – standard economizer, manual or motorized fresh air damper





Dimensional Data

Cabinet	Dimension							
	A		B		C		D	
	inch	mm	inch	mm	inch	mm	inch	mm
B.0 and C.0	7 3/4	197	12	305	16 3/4	425	7 1/4	184

Figure 24. B.0 and C.0 cabinet – power exhaust with standard economizer

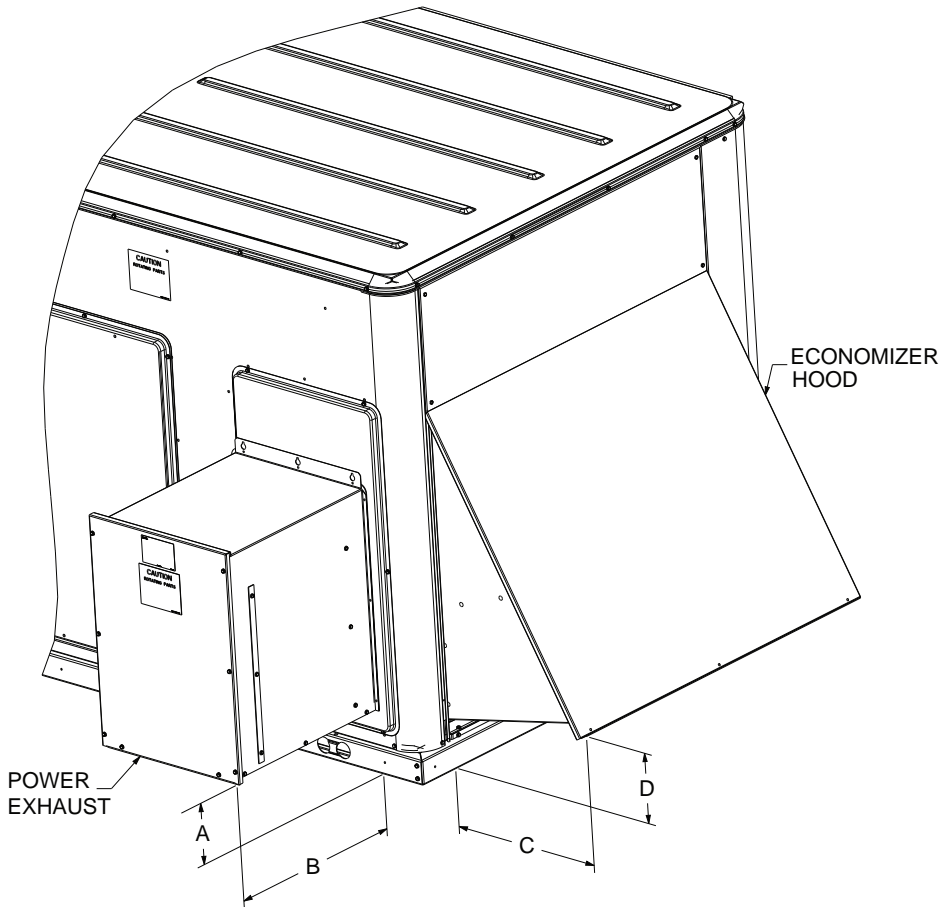

Cabinet	Dimension							
	A		B		C		D	
	inch	mm	inch	mm	inch	mm	inch	mm
B.0 and C.0	6 3/8	162	20 1/2	521	16 3/4	425	7 1/4	184

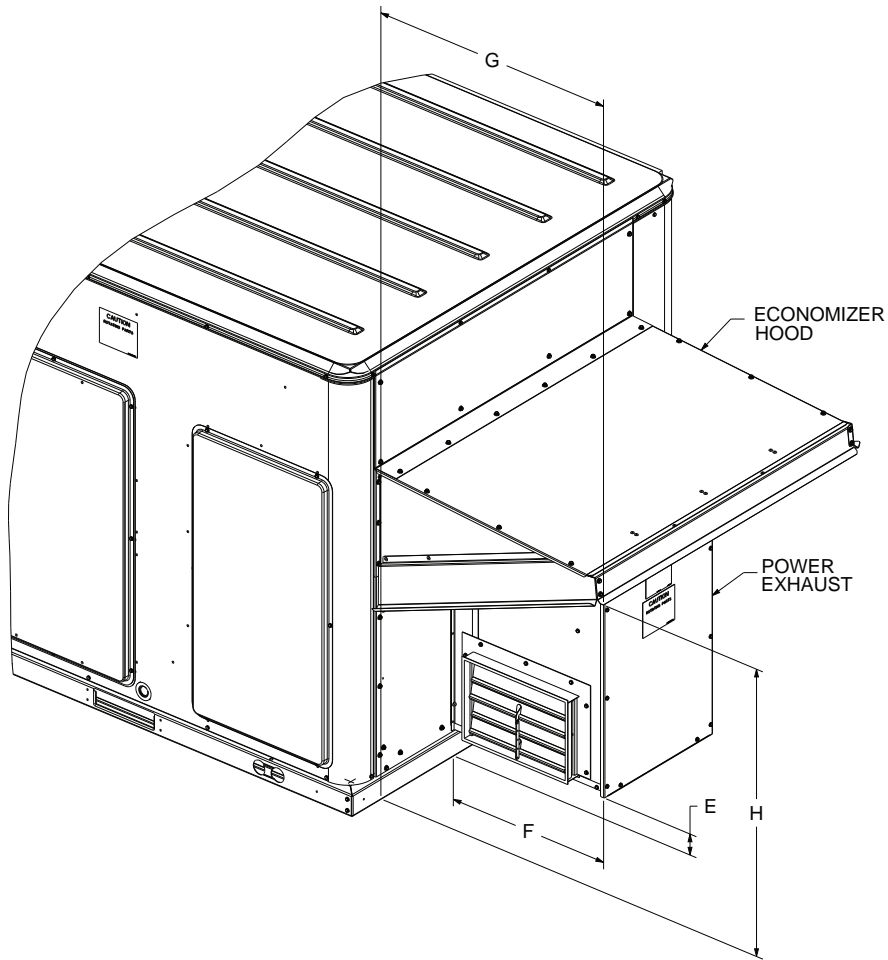
Figure 25. B.0 and C.0 cabinet – power exhaust with low leak economizer

Cabinet	Dimension							
	E		F		G		H	
	inch	mm	inch	mm	inch	mm	inch	mm
B.0 and C.0	2 1/2	64	19 3/4	502	29 1/4	743	33 1/2	852

Figure 26. D.0 and D.1 cabinets

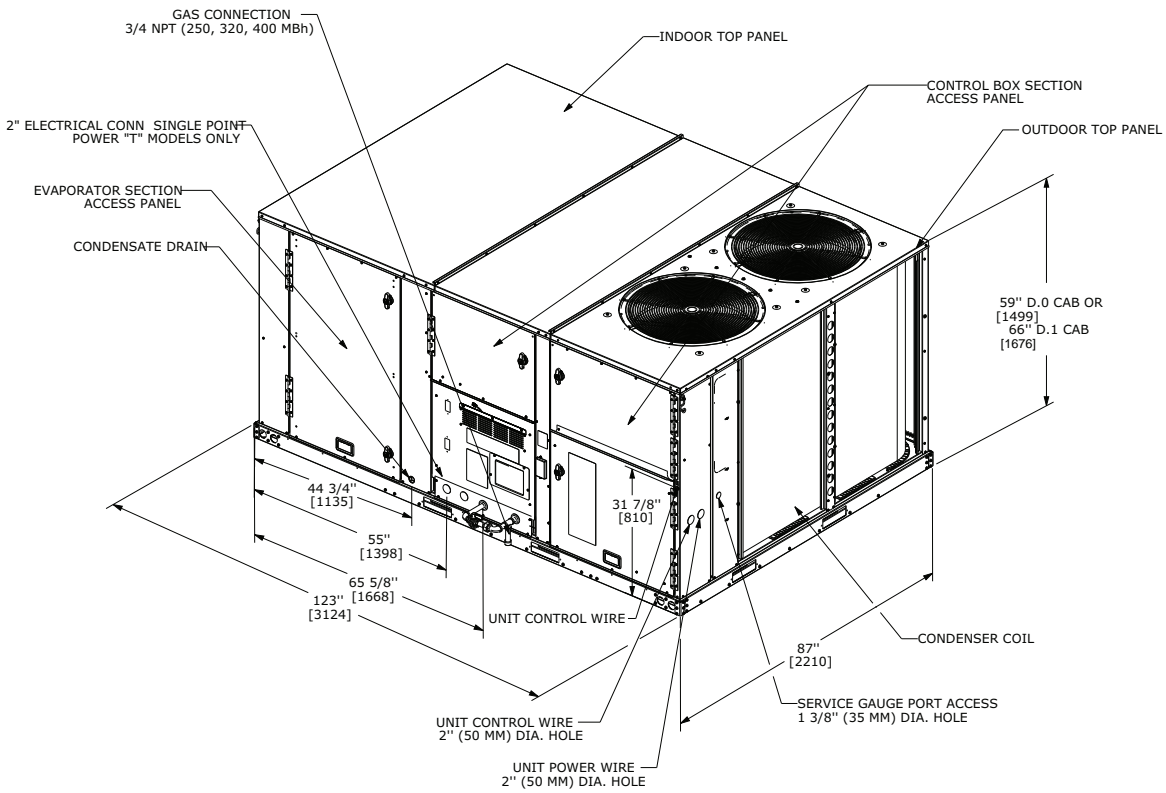

Figure 27. D.0 and D.1 cabinets – downflow airflow supply/return, through-the-base utilities

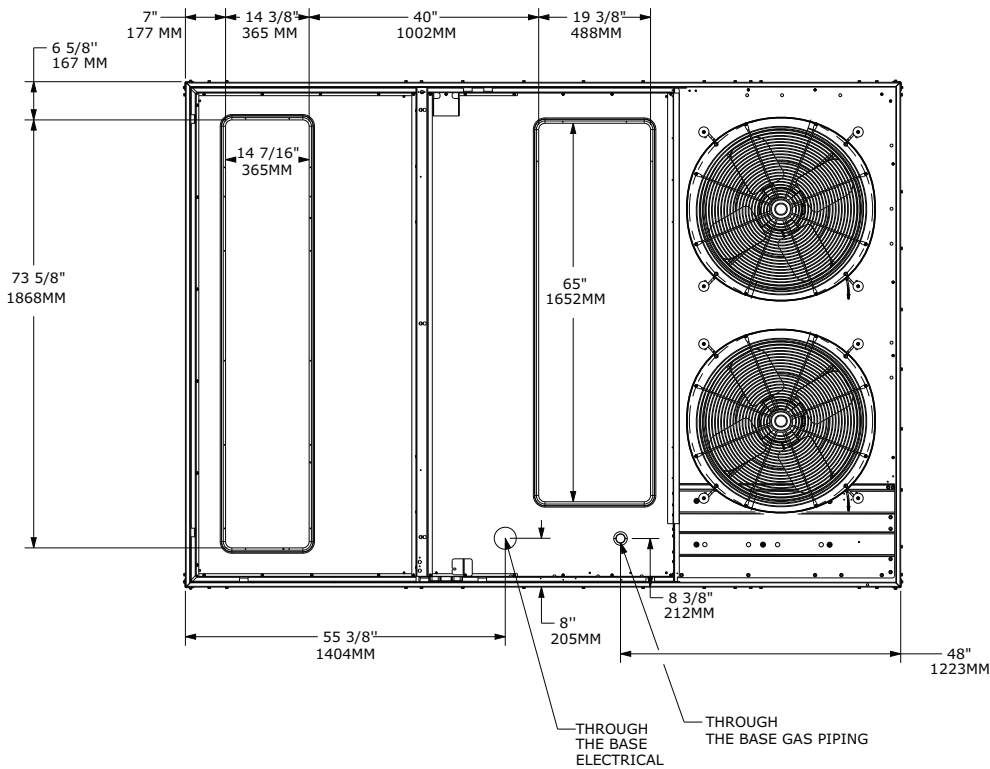

Figure 28. D.0 and D.1 cabinets – horizontal airflow supply/return

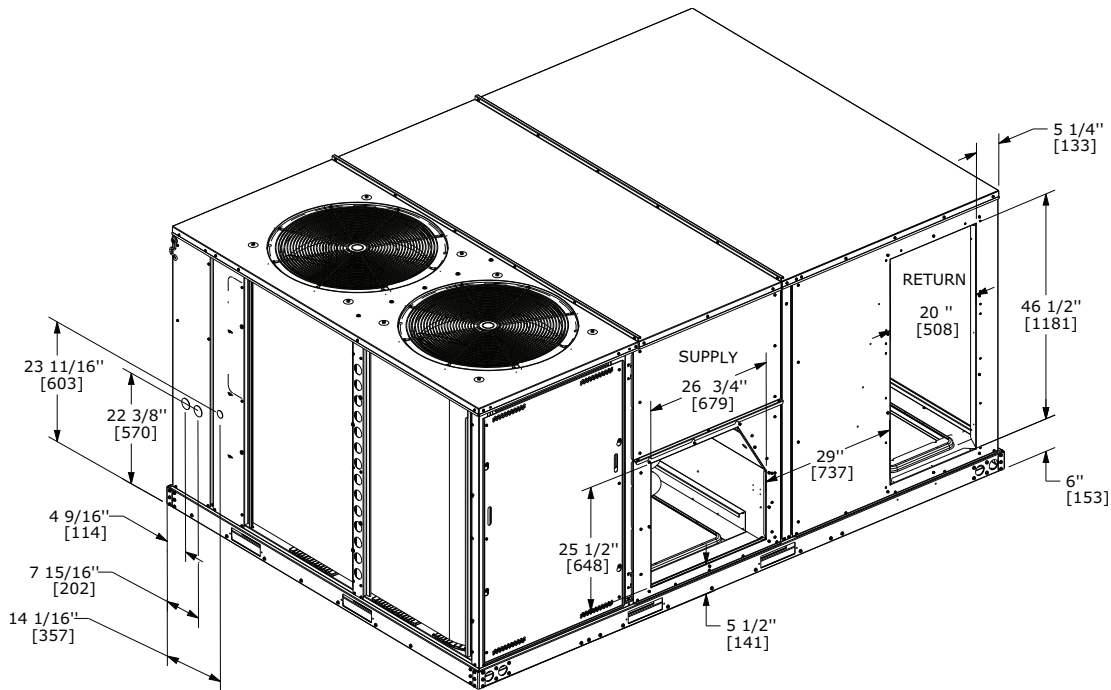

Figure 29. D.0 and D.1 cabinets – unit clearance and roof opening

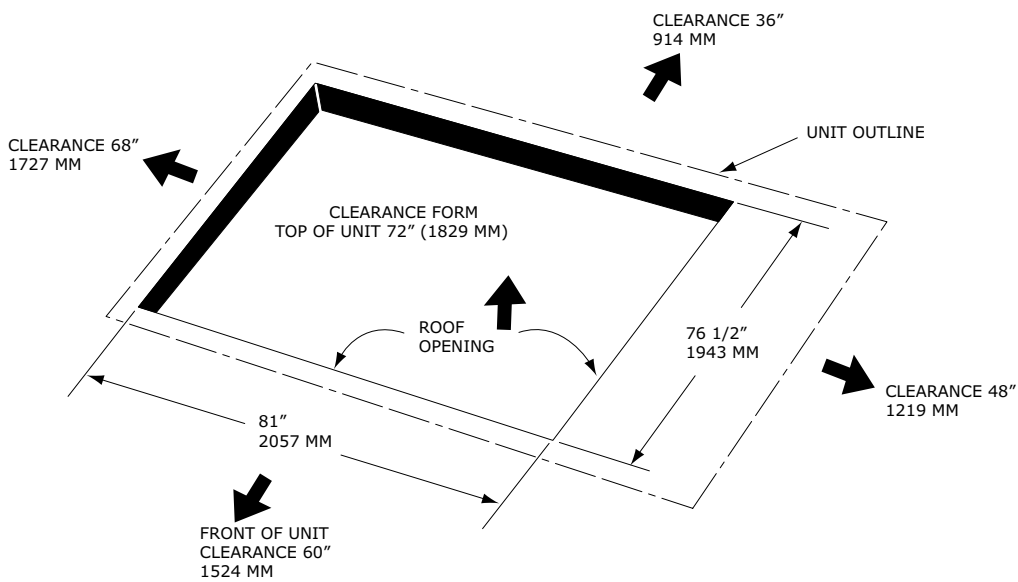

Figure 30. D.0 and D.1 cabinets – roof curb

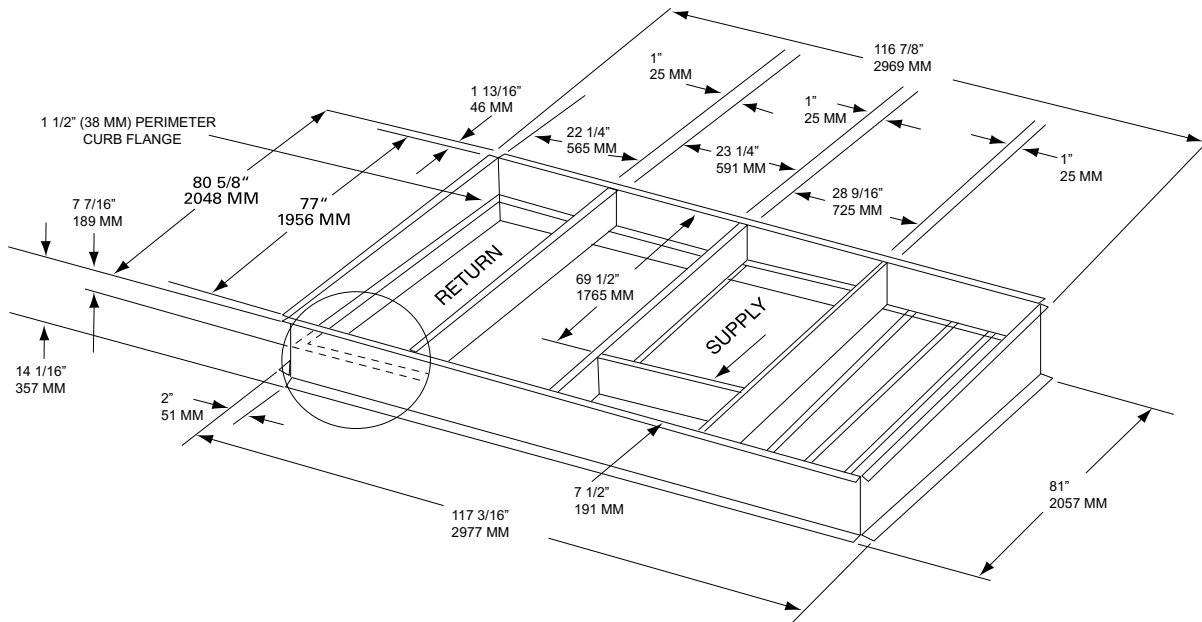

Figure 31. D.0 and D.1 cabinets – swing diameter for hinged door(s) option

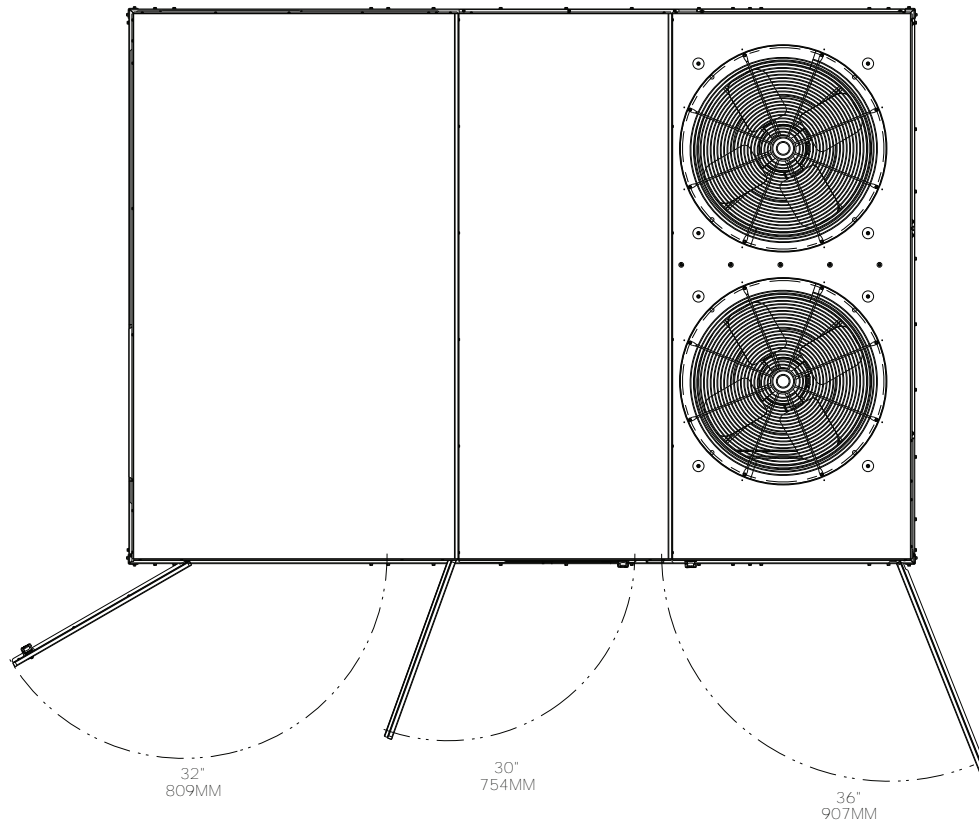
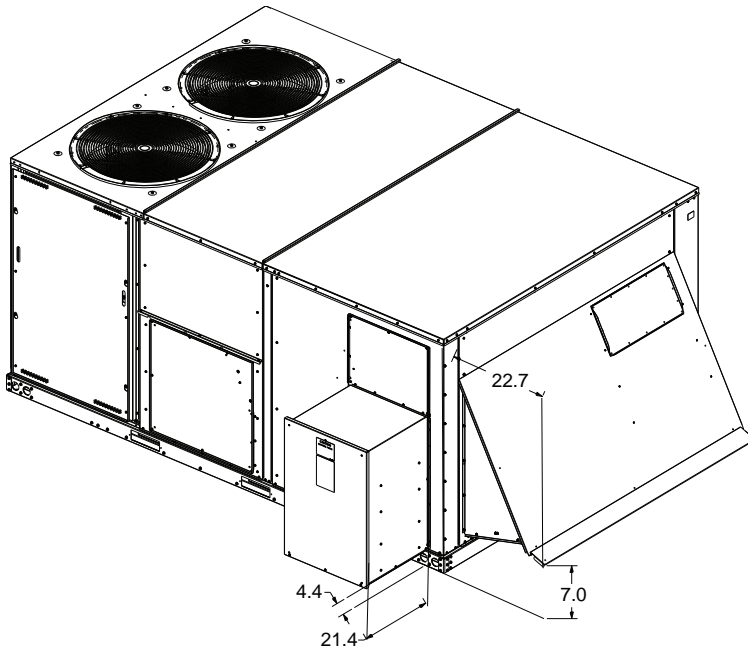
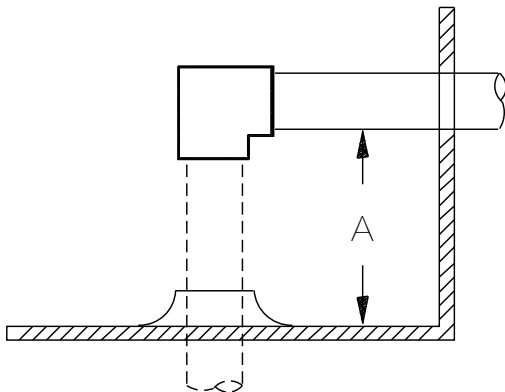

Figure 32. D.0 and D.1 cabinets – power exhaust

Figure 33. Gas pipe height

Note: Height of gas pipe required from inside unit base to gas shut off assembly (factory provided).

Cabinet	Dimension A	
	inch	mm
B.0, and C.0	4 5/8	117
D.0 and D.1	1 3/6	30



Weights

Table 121. Model weights, corner weights (lbs) and center of gravity dimensions (in.)

Tons	Unit Model No.	Model Weights ^(a)		Corner Weights ^(b)				Center of Gravity (in.)	
		Shipping	Net	A	B	C	D	Length	Width
3	TZK036	888	790	225	194	171	200	41	25
4	TZK048	895	797	227	195	174	201	41	25
5	TZK060	903	805	230	197	175	203	41	25
6	TZK072	908	810	231	198	176	205	41	25
7.5	TZK090	957	859	213	208	216	222	44	27
8.5	TZK102	964	876	217	212	221	226	44	27
10	TZK120	1372	1178	345	347	244	242	50	26
12.5	TZK150	2161	1941	595	498	386	462	56	38
15	TZK180	2166	1946	597	499	387	462	56	38
17.5	TZK210	2266	2046	660	516	382	488	54	37
20	TZK240	2271	2051	661	517	383	489	54	37
25	TZK300	2274	2054	662	518	384	490	54	37

^(a) Weights are approximate. Weights do not include additional factory or field installed options/accessories. For option/accessory additional weights to be added to unit weight, reference the following table.

^(b) Corner weights are given for information only.

Table 122. Model weights, corner weights (lbs) and center of gravity dimensions (in.) - gas/electric

Tons	Unit Model No.	Model Weights ^(a)		Corner Weights ^(b)				Center of Gravity (in.)	
		Shipping	Net	A	B	C	D	Length	Width
3	YZK036	939	841	227	217	194	203	43	25
4	YZK048	944	846	226	221	197	202	44	25
5	YZK060	948	850	230	225	195	200	44	25
6	YZK072	953	855	236	231	191	197	44	24
7.5	YZK090	1009	911	234	231	221	225	44	26
8.5	YZK102	1016	918	236	231	223	228	44	26
10	YZK120	1439	1245	377	371	246	251	50	25
12.5	YZK150	2341	2121	651	544	422	505	56	38
15	YZK180	2346	2126	652	545	423	506	56	38
17.5	YZK210	2446	2226	718	562	416	531	54	37
20	YZK240	2451	2231	719	563	417	532	54	37
25	YZK300	2454	2234	720	564	417	533	54	37

^(a) Weights are approximate. Weights do not include additional factory or field installed options/accessories. For option/accessory additional weights to be added to unit weight, reference the following table.

^(b) Corner weights are given for information only.

Figure 34. Corner weights

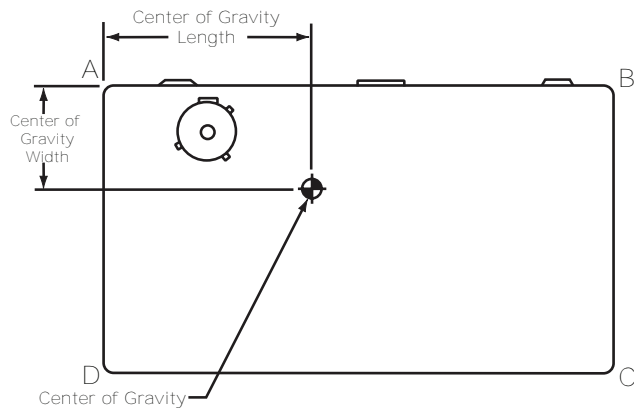

Table 123. Factory installed options (FIOPS)/accessory net weights (lb)

Accessory	T/YZK036-102	T/YZK120	T/YZK150-300
Barometric Relief	10	10	40
Economizer	36	36	91
Electric Heaters ^(a)	44	50	75
Low Leak Economizer - Downflow	91	91	150
Low Leak Economizer - Horizontal	186	186	180
Manual Outside Air Damper	26	26	15
Motorized Outside Air Damper	30	30	82
Oversized Motor ^(b)	14	14	30
Powered Convenience Outlet	38	50	50
Power Exhaust	80	80	110
Reheat Coil	16	20	33
Roof Curb	105	111	235
Smoke Detector, Supply ^(b)	5	5	5
Smoke Detector, Return	7	7	5
Stainless Steel Heat Exchanger ^(c)	6	6	5
Through-the-Base Electrical	13	13	10
Through-the-Base Gas ^(c)	5	5	10
Unit Mounted Circuit Breaker	10	10	10
Unit Mounted Disconnect	5	5	10

Notes:

1. Weights for options not listed are less than 5 pounds.
2. Net weight should be added to unit weight when ordering factory-installed accessories.
3. Weights are approximate.

- ^(a) Only applies to T*K models.
^(b) Not available on all models.
^(c) Only applies to Y*K models.



Mechanical Specifications

General

- Precedent unit cooling capacities, heating capacities, and efficiencies are certified to the following standards:
 - 3 to 5 ton units: AHRI Standard 210/240.
 - 6 to 25 ton units: AHRI Standard 340/360.
- Gas Heating Units: ANSI Z21.47 and 10 CFR Part 431 for Commercial Warm Air.
- Symbio controls operating range between 0°F and 125°F in cooling mode standard from the factory.
- Factory assembled, internally wired, fully charged, and 100 percent run tested to verify cooling operation, fan and blower rotation, and control sequence.
- Colored and numbered wiring internal to the unit for simplified identification.
- cULus listed and classified in accordance for Central Cooling Air Conditioners.

Casing

- Zinc coated, heavy gauge, galvanized steel.
- Weather resistant pre-painted metal with galvanized substrate.
- Meets ASTM B117, 672 hour salt spray test.
- Single side maintenance through hinged access panels.
- Exposed vertical panels and top covers in the indoor air section insulated with a cleanable foil-faced, fire-retardant permanent, odorless glass fiber material.
- Base pan with no penetrations within the perimeter of the curb other than the raised 1-inch downflow supply/return openings to provide an added water integrity precaution, if the condensate drain backs up.
- Base of the unit insulated with 1/8-inch, foil-faced, closed-cell insulation.
- Unit base provisions for forklift and/or crane lifting on three sides of unit.

Microchannel Coils

- Optimal heat transfer performance due to flat, streamlined tubes with small ports, and metallurgical tube-to-fin bond.
- Reduce system refrigerant charge by up to 50 percent leading for better compressor reliability.
- Compact all-aluminum microchannel coils reduce the unit weight.
- Recyclable all-aluminum coils. All-aluminium construction minimizes galvanic corrosion.
- Strong aluminum brazed structure provides better fin protection.
- Flat streamlined tubes more dust resistant and easy to clean.
- Coils leak tested at the factory to verify the pressure integrity.

Coil Guards

Provides condenser coil protection.

Compressors

- All units have a variable speed compressor matched with a variable frequency drive that modulates the speed of the compressor motor and provides added compressor protection functions.
- Permanent magnet motor with voltage utilization range of plus or minus 10 percent of unit nameplate voltage.
- Crankcase heaters sized to minimize the amount liquid refrigerant present in the oil sump during off cycles are standard on all compressors.
- Single variable speed compressors in 3 to 15 ton units. Manifolded variable and fixed speed compressors in 17.5 to 25 ton units.
- Variable speed modulation to 15 Hz equating to 27% or less of full capacity
- Control of the eFlex system is integrated with the Symbio™ 700 unit controller to ensure optimal equipment reliability and performance.

Filters

- Standard 2-inch filters.
- Optional 2-inch MERV 8 and MERV 13 filters.

Frostat™

- Used as a safety device.
- Opens to prevent freezing temperatures on evaporator coil.
- Closes when temperature rises to 50°F.
- Utilized in low airflow or high outside air applications (cooling only).

Gas Heating Section

- Compact cabinet features a tubular heat exchanger in low, medium and high heat capacities.
- Corrosion-resistant aluminized steel tubes and burners are standard on all models.
- Induced draft combustion blower is used to pull the combustion products through the firing tubes.
- Heater uses a direct spark ignition (DSI) system and a flame sensor as a safety device to validate the flame.
- Units are suitable for use with natural gas or propane (field-installed kit).
- Stainless steel heat exchanger with 409 stainless steel tubes and 439 stainless steel burners (optional).

Indoor Fan

- Direct drive plenum fan design.
- Plenum fan design — backward-curved fan wheel along with an external rotor direct drive variable speed indoor motor.
- Supply fan speed adjustments can be made using the Symbio™ 700 or Mobile App.
- Motors are electronically protected.
- Variable speed direct drive motors are high efficiency.

Powered or Unpowered Convenience Outlet

- Powered GFCI, 120V/15A, 2 plug, convenience outlet or unpowered GFCI, 120V/20A, 2 plug, convenience outlet.
- When convenience outlet is powered, a service receptacle disconnect is available.
- Convenience outlet is powered from the line side of the disconnect or circuit breaker, and will not be affected by the position of the disconnect or circuit breaker.
- Available to order when through-the-base electrical with disconnect switch or circuit breaker option is selected.

Stainless Steel Drain Pan

- Corrosion and oxidation resistance.
- Constructed of 304 stainless steel.

Stainless Steel Heat Exchanger

- Constructed of 409 stainless steel tubes and 439 stainless steel burners.
- Resistant to corrosion and oxidation and easy to clean.
- High temperature material for more reliability at lower temperatures and higher ventilation rates.
- 15-year stainless steel heat exchanger warranty is standard.

Note: The stainless steel heat exchanger is standard with the Ultra-Low NOx gas furnace option.



Through-the-Base Electrical with Circuit Breaker

- Thermal magnetic, molded case, HACR circuit breaker with provisions for through-the-base electrical connections.
- Circuit breaker installed within unit in water tight enclosure.
- Wiring provided from the switch to the unit high voltage terminal block.
- Circuit breaker will provide overcurrent protection, sized per NEC and cULus guidelines, and agency recognized by cULus.

Through-the-Base Electrical with Disconnect Switch

- 3-pole, molded case, disconnect switch with provisions for through-the-base electrical connections.
- Disconnect switch installed within unit in a water tight enclosure.
- Wiring provided from the switch to the unit high voltage terminal block.
- Switch cULus agency recognized.

Note: Disconnect switch sized per NEC and cULus guidelines but does not replace unit overcurrent protection

Through-the-Base Gas Piping

- Standard through-the-base gas provisions.
- All required piping, including black steel manual gas shut-off valve, elbows, and union.
- Manual shutoff valve with 1/8-inch NPT pressure tap.
- Requires minor field assembly.

Note: Through-the-Base gas is not available with Ultra-Low NOx gas furnace option.

Standard Economizer

- Available with or without barometric relief.
- Fully modulating 0 to 100 percent motor and dampers, minimum position setting, preset linkage, wiring harness with plug, spring return actuator and fixed dry bulb control.
- Barometric relief provides a pressure-operated, gravity-closing damper.
- Barometric relief prevents entrance of outside air during the equipment **off** cycle.
- Optional solid state or differential enthalpy control.
- Arrives in shipping position and must be switched to operating position by the installing contractor.

Electric Heaters

- Constructed of heavy-duty nickel chromium elements internally delta connected for 240V, wye connected for 480V and 600V.
- Staging achieved through Symbio™ controller.
- Multiple automatic reset and single operation high temperature limit controls operating to break line power to the heater element.
- Heaters individually fused from the factory.
- Meets all NEC and CEC requirements when properly installed.
- Power assemblies provide single-point connection.
- Modules are cULus listed.

Manual Outside Air Damper

Rain hood and screen provide up to 50 percent outside air.

Motorized Outside Air Damper

- Once set, when indoor fan starts, outdoor air dampers open to set position.

- When indoor fan shuts down, damper fully closes.

Power Exhaust

- Provides exhaust of return air, when using an economizer.
- Maintain better building pressurization.

Roof Curb

- Designed to connect with the unit's downflow supply and return.
- Provides support and a water tight installation when installed properly.
- Allows field-fabricated rectangular supply/return ductwork to be connected directly to the curb.
- Curb shipped knocked down for field assembly.
- Includes wood nailer strips.

Ventilation Override Operation

- Unit can be set to transition up to 3 different pre-programmed sequences for smoke purge, pressurization, and exhaust.
- Transition occurs when binary input on the Symbio™ controller is closed (shorted) (typically hard wired relay output from a smoke detector/ fire control panel).

Note: Requires Symbio™ Customer Connection Module, FIASCCM001*.

Leak Detection Sensors

Unit shall be furnished with a leak detection system from the factory when a circuit refrigerant charge exceeds 3.91 lbs. The leak detection system shall consist of one or more refrigerant detection sensors. When the system detects a leak, the unit controller shall initiate mitigation actions.



Notes



The AHRI Certified mark indicates Trane U.S. Inc. participation in the AHRI Certification program. For verification of individual certified products, go to ahridirectory.org.

Trane - by Trane Technologies (NYSE: TT), a global innovator - creates comfortable, energy efficient indoor environments for commercial and residential applications. For more information, please visit trane.com or tranetechnologies.com.

Trane has a policy of continuous product and product data improvements and reserves the right to change design and specifications without notice. We are committed to using environmentally conscious print practices.