



Product Catalog

# Precedent™ Packaged Rooftop Units

Cooling and Gas/Electric  
Standard and High Efficiency  
3 to 25 Tons — 60 Hz





# Introduction

## Packaged Rooftop Precedent Units

Precedent™ rooftop units have been redesigned to deliver the most complete offering of 3 to 25 ton gas, hybrid, and all-electric light commercial packaged rooftop solutions. The wide range of capacities, efficiencies, heating types, and available options allow Precedent rooftop systems to serve a variety of commercial applications. Plus, new features including the intuitive Symbio™ unit controller, hinged control panel access, color-coded wiring, and direct drive motors simplify installation, start-up, and maintenance.

## Copyright

This document and the information in it are the property of Trane, and may not be used or reproduced in whole or in part without written permission. Trane reserves the right to revise this publication at any time, and to make changes to its content without obligation to notify any person of such revision or change.

## Trademarks

All trademarks referenced in this document are the trademarks of their respective owners.

## Revision History

- Removed LonTalk® information throughout the document.
- Added Heating Operation and Optional Stainless Steel Heat Exchanger topics in Application Considerations chapter.



# Table of Contents

Features and Benefits .....	6
Features .....	6
Control Options .....	8
Accessories .....	8
Key Benefits .....	12
Application Considerations .....	20
A2L Application Considerations .....	20
Leak Detection System (Refrigerant charge greater than 3.91 lb per circuit) .....	21
Heating Operation .....	21
Optional Stainless Steel Heat Exchanger .....	21
Model Number Description .....	22
General Data .....	24
Gross Cooling Capacities .....	38
Reheat Temperature Rise .....	83
Evaporator Fan Performance — Cooling .....	108
Fan Curve Limits .....	108
3 to 5 Tons .....	109
6 to 25 Tons — Downflow .....	120
6 to 25 Tons — Horizontal .....	130
Evaporator Fan Performance — Gas Heat .....	141
3 to 5 Tons .....	141
6 to 25 Tons — Downflow .....	149
6 to 25 Tons — Horizontal .....	157
Fan Performance .....	165
Heating Performance .....	169



## Table of Contents

---

Controls .....	175
Enhanced BAS Integration and Connectivity .....	175
Secure Remote Connectivity with Trane Connect .....	175
Serviceability .....	175
Flexibility .....	177
Economizer Controls .....	177
Zone Sensors .....	178
Air-Fi Wireless Communicating Zone Sensors .....	179
Thermostats .....	180
Humidity Control (HGRH) .....	180
Electrical Data .....	182
Dimensional Data .....	200
Weights .....	217

Mechanical Specifications .....	220
General .....	220
Casing .....	220
Microchannel Coils .....	220
Coil Guards .....	220
Compressors .....	220
Filters .....	221
Frostat .....	221
Gas Heating Section .....	221
Indoor Fan .....	221
Powered or Unpowered Convenience Outlet .....	221
Stainless Steel Drain Pan .....	221
Stainless Steel Heat Exchanger .....	221
Through-the-Base Electrical with Circuit Breaker .....	221
Through-the-Base Electrical with Disconnect Switch .....	222
Through-the-Base Gas Piping .....	222
Standard Economizer .....	222
Electric Heaters .....	222
Manual Outside Air Damper .....	222
Motorized Outside Air Damper .....	222
Power Exhaust .....	222
Roof Curb .....	223
Ventilation Override Operation .....	223
Leak Detection Sensors .....	223



# Features and Benefits

## Features

**Table 1. Cabinet size — cooling and gas heat**

Unit Size (Tons)	Model Number Digits 4, 5, 6	Model	
		TSK, YSK	THK, YHK
3	036	A.0	A.0
4	048		B.0
5	060		
6	072		
7.5	090		
8.5	102	C.0	D.0
10	120		
12.5	150		
15	180	D.0	D.0
17.5	210		
20	240		
25	300		

**Note:** Equipment feature availability is dependent on unit configuration. For more information, see Trane® Select Assist™ or contact product support.

**Table 2. Precedent features — standard and optional**

	Standard Features	Options		
		Factory Installed	Factory or Field Installed	Field Installed
3-year Limited Parts Warranty	X			
5-year Limited Compressor Warranty	X			
10-year Limited Heat Exchanger Warranty	X			
15-year Limited Warranty Stainless Steel Heat Exchanger	X			
2-inch Filter	X			
2-inch MERV 8 Filters		X		
2-inch MERV 13 Filters		X		
Access Doors - Hinged		X		
Access Door - Hinged (Control Box)	X			
Access Panels	X			
Anti-Short Cycle Timer	X			
Barometric Relief			X	
CO <sub>2</sub> Sensor				X
Clogged Filter Switch			X	
Coil Guards	X			
CompleteCoat™ Condenser Coil		X		
Condensate Overflow Switch			X	
Convertible Airflow	X			
Colored and Numbered Wiring	X			
Crankcase Heaters	X			
Humidity Control - Modulating Hot Gas Reheat (HGRH)		X		

**Table 2. Precedent features — standard and optional (continued)**

	Standard Features	Options		
		Factory Installed	Factory or Field Installed	Field Installed
Direct Drive Forward Curve Fan	X			
Direct Drive Fans	X			
Discharge Air Temperature Sensing Kit — MZVAV, SZVAV, Economizer HGRH, Modulating Gas Heat	X			
Discharge Air Temperature Sensing Kit — Standard (Multispeed)			X	
Economizer: Low Leak — Downflow			X	
Economizer: Low Leak — Horizontal				X
Economizer: Standard — Convertible			X	
Economizer: Standard — Downflow			X	
Economizer: Standard — Horizontal				X
Electric Heater			X	
Expansion Modules			X	
Fault Detection and Diagnostics (FDD)	X			
Foil-Faced and Edge Protected Insulation	X			
Frostat™	X			
High Altitude Kit				X
High Pressure Control	X			
High Static/Oversized Motor		X		
High Temperature Sensor				X
IAQ Dual Sloped Composite Drain Pan	X			
Liquid Line Refrigerant Drier	X			
Low Ambient Cooling to 0°F				X
Low Ambient Cooling to 40°F	X			
Low Pressure Control	X			
LP Conversion Kit				X
Manual Outside Air Damper			X	
Microchannel Coils	X			
Modulating Gas Heat		X		
Motorized Outside Air Damper			X	
Operating Charge of R-454B	X			
Phase Balance/Loss/Reversal Protection	X			
Phase Monitor	X			
Power Exhaust				X
Powered or Unpowered Convenience Outlet		X		
Quick Adapt Curbs				X
Reference or Comparative Enthalpy			X	
Roof Curb				X
Single Point Power	X			
Smoke Detector - Return		X		
Smoke Detector - Supply		X		
Stainless Steel Drain Pan		X		
Symbio Controls	X			
Thermal Expansion Valve	X			
Through-the-Base Condensate	X			
Through-the-Base Electrical Access		X		
Through-the-Base Electrical with Circuit Breaker		X		



## Features and Benefits

**Table 2. Precedent features — standard and optional (continued)**

	Standard Features	Options		
		Factory Installed	Factory or Field Installed	Field Installed
Through-the-Base Electrical with Disconnect Switch		X		
Through-the-Base Gas Piping		X		
Tubular Gas Heat Exchanger		X		
Variable Airflow (SZVAV)/Variable Airflow (MZVAV)		X		
Ventilation Override				X

## Control Options

**Note:** Control option availability is dependent on unit configuration. For more information, see Trane® Select Assist™ or contact product support.

**Table 3. Control options — standard and optional**

	Standard Features	Options		
		Factory Installed	Factory or Field Installed	Field Installed
Dual Thermistor Remote Zone Sensor				X
Symbio Service and Installation App	X			
Symbio™ 700 Advanced Module			X	
Humidity Sensor/Humidistat				X
Thermostat				X
Wireless Zone Sensor				X
Zone Sensor				X
Trane® Air-Fi® Wireless Communication Interface (WCI)		X		

**Note:** For more information, reference the Controls chapter.

## Accessories

**Note:** Accessory availability is dependent on unit configuration. Some accessories may require additional accessories/options for full functionality. For more information, contact product support.

**Table 4. Accessories**

FIA Kit	Description
FIABARM001*	Barometric Relief
FIABARM002*	Barometric Relief
FIABARM003*	Barometric Relief
FIAC02K001*	CO <sub>2</sub> (DCV) Wall Mounted Sensor
FIAC02K002*	CO <sub>2</sub> (DCV) Duct Mounted Sensor
FIACLFS001*	Clogged Filter Switch
FIACLFS002*	Clogged Filter Switch (MERV13)
FIACLFS003*	Clogged Filter Switch
FIACLFS004*	Clogged Filter Switch (MERV13)
FIACLFS005*	Clogged Filter Switch Standard and MERV 8 filter
FIACLFS006*	Clogged Filter Switch MERV 13 filter
FIACURB401*	Roof Curb
FIACURB402*	14-inch Full Perimeter Knockdown Curb

**Table 4. Accessories (continued)**

<b>FIA Kit</b>	<b>Description</b>
FIACURB403*	14-inch Full Perimeter Knockdown Curb
FIACURB404*	14-inch Full Perimeter Knockdown Curb
FIACURB801*	18-inch Full Perimeter Knockdown Curb
FIACURB802*	18-inch Full Perimeter Knockdown Curb
FIACURB803*	18-inch Full Perimeter Knockdown Curb
FIADAST001*	Discharge Air Sensing Tube Kit T/W
FIADAST002*	Discharge Air Sensing Tube Kit Y/D
FIADAST003*	Discharge Air Sensing Tube Kit
FIADAST004*	Discharge Air Sensing Tube Kit
FIADAST005*	Discharge Air Sensing Tube Kit
FIADAST006*	Discharge Air Sensing Tube Kit
FIADAST007*	Discharge Air Sensing Tube Kit
FIADAST008*	Discharge Air Sensing Tube Kit
FIADFDB001*	Differential Dry Bulb Economizer Control
FIADMPR001*	Manual Damper
FIADMPR002*	Manual Damper
FIADMPR003*	Manual Damper
FIADMPR101*	Motorized Damper
FIADMPR102*	Motorized Damper
FIADMPR103*	Motorized Damper
FIAECON001*	Dry Bulb Economizer
FIAECON002*	Dry Bulb Economizer
FIAECON003*	Dry Bulb Economizer
FIAECON101*	Dry Bulb Downflow Low Leak
FIAECON102*	Dry Bulb Downflow Low Leak
FIAECON103*	Dry Bulb Downflow Low Leak
FIAECON201*	Dry Bulb Horizontal Low Leak
FIAECON202*	Dry Bulb Horizontal Low Leak
FIAECON203*	Dry Bulb Horizontal Low Leak
FIAECON303*	Dry Bulb Horizontal Economizer
FIAEHTA306*	6kW Electric Heater 3 ph
FIAEHTA312*	12kW Electric Heater 3 ph
FIAEHTA318*	18kW Electric Heater 3 ph
FIAEHTA323*	23kW Electric Heater 3 ph
FIAEHTA406*	6kW Electric Heater 3 ph
FIAEHTA412*	12kW Electric Heater 3 ph
FIAEHTA418*	18kW Electric Heater 3 ph
FIAEHTA423*	23kW Electric Heater 3 ph
FIAEHTAW06*	6kW Electric Heater 3 ph
FIAEHTAW12*	12kW Electric Heater 3 ph
FIAEHTAW18*	18kW Electric Heater 3 ph
FIAEHTAW23*	23kW Electric Heater 3 ph
FIAEHTB309*	9kW, 208-230V Electric Heater
FIAEHTB318*	18kW, 208-230V Electric Heater
FIAEHTB327*	27kW, 208-230V Electric Heater
FIAEHTB336*	36kW, 208-230V Electric Heater
FIAEHTB354*	54kW, 208-230V Electric Heater



## Features and Benefits

**Table 4. Accessories (continued)**

FIA Kit	Description
FIAEHTB409*	9kW, 460V Electric Heater
FIAEHTB418*	18kW, 460V Electric Heater
FIAEHTB427*	27kW, 460V Electric Heater
FIAEHTB436*	36kW, 460V Electric Heater
FIAEHTB454*	54kW, 460V Electric Heater
FIAEHTBW09*	9kW, 575V Electric Heater
FIAEHTBW18*	18kW, 575V Electric Heater
FIAEHTBW27*	27kW, 575V Electric Heater
FIAEHTBW36*	36kW, 575V Electric Heater
FIAEHTBW54*	54kW, 575V Electric Heater
FIAEHTC318*	18kW, 208-230V Electric Heater
FIAEHTC327*	27kW, 208-230V Electric Heater
FIAEHTC336*	36kW, 208-230V Electric Heater
FIAEHTC354*	54kW, 208-230V Electric Heater
FIAEHTC418*	18kW, 460V Electric Heater
FIAEHTC427*	27kW, 460V Electric Heater
FIAEHTC436*	36kW, 460V Electric Heater
FIAEHTC454*	54kW, 460V Electric Heater
FIAEHTCW18*	18kW, 575V Electric Heater
FIAEHTCW27*	27kW, 575V Electric Heater
FIAEHTCW36*	36kW, 575V Electric Heater
FIAEHTCW54*	54kW, 575V Electric Heater
FIAEHTD318*	18kW, 208-230V Electric Heater
FIAEHTD336*	36kW, 208-230V Electric Heater
FIAEHTD354*	54kW, 208-230V Electric Heater
FIAEHTD372*	72kW, 208-230V Electric Heater
FIAEHTD418*	18kW, 460V Electric Heater
FIAEHTD436*	36kW, 460V Electric Heater
FIAEHTD454*	54kW, 460V Electric Heater
FIAEHTD472*	72kW, 460V Electric Heater
FIAEHTDW18*	18kW, 575V Electric Heater
FIAEHTDW36*	36kW, 575V Electric Heater
FIAEHTDW54*	54kW, 575V Electric Heater
FIAEHTDW72*	72kW, 575V Electric Heater
FIAENTH001*	Reference Enthalpy Economizer Control
FIAENTH002*	Comparative Enthalpy Economizer Control
FIAHALT001*	High Altitude Kit - 2-Stage gas
FIAHALT002*	High Altitude Gas Adjustment Kit - 2-Stage gas
FIAHALT003*	High Altitude Gas Adjustment Kit - 2-Stage gas
FIAHTST001*	High Temperature (Fire) Duct Mounted Stat
FIAHZDC001*	Horizontal Conversion Panel
FIALPKT001*	LP Conversion Kit - 2-Stage gas
FIALPKT002*	LP Gas Conversion Kit - 2-Stage gas
FIALPKT003*	LP Gas Conversion Kit - 2-Stage gas
FIALPKTM01*	LP Gas Conversion Kit - Modulating gas
FIALPKTM02*	LP Gas Conversion Kit - Modulating gas
FIALPKTM03*	LP Gas Conversion Kit - Modulating gas

**Table 4. Accessories (continued)**

FIA Kit	Description
FIALPKTM04*	LP Gas Conversion Kit - Modulating gas
FIALPKTM05*	LP Gas Conversion Kit - Modulating gas
FIALPKTM06*	LP Gas Conversion Kit - Modulating gas
FIALPKTM07*	LP Gas Conversion Kit - Modulating gas
FIALPKTM08*	LP Gas Conversion Kit - Modulating gas
FIALPKTM09*	LP Gas Conversion Kit - Modulating gas
FIALPKTM10*	LP Gas Conversion Kit - Modulating gas
FIALOAM001*	Low Ambient
FIAOPTN001*	Indoor Options Module
FIAOPTN002*	Fresh Air Options Module
FIAOVFL001*	Condensate Overflow Switch
FIAPWRX301*	Power Exhaust 230V
FIAPWRX302*	Power Exhaust 230V
FIAPWRX303*	Power Exhaust 230V
FIAPWRX401*	Power Exhaust 460V
FIAPWRX402*	Power Exhaust 460V
FIAPWRX403*	Power Exhaust 460V
FIAPWRXW01*	Power Exhaust 575V
FIAPWRXW02*	Power Exhaust 575V
FIAPWRXW03*	Power Exhaust 575V
FIAQACB026*	Adapter Curb, BAYCURB026 to FIACURB403/803
FIAQACB027*	Adapter Curb, BAYCURB027 to FIACURB403/803
FIAQACB042*	Adapter Curb, BAYCURB042 to FIACURB402/802
FIAQACB043*	Adapter Curb, BAYCURB043 to FIACURB403/803
FIAQACB044*	Adapter Curb, BAYCURB044 to FIACURB402/802
FIAQACB045*	Adapter Curb, BAYCURB045 to FIACURB401/801
FIAS7ADV01*	Symbio™ 700 Advanced Controls and BACnet BAS Upgrade Kit
FIASCCM001*	Symbio Customer Connection Module
FIAXMOD030*	Symbio 700 XM30 Expansion Module
FIAXMOD032*	Symbio 700 XM32 Expansion Module



## Features and Benefits

### Key Benefits

Figure 1. Unit overview

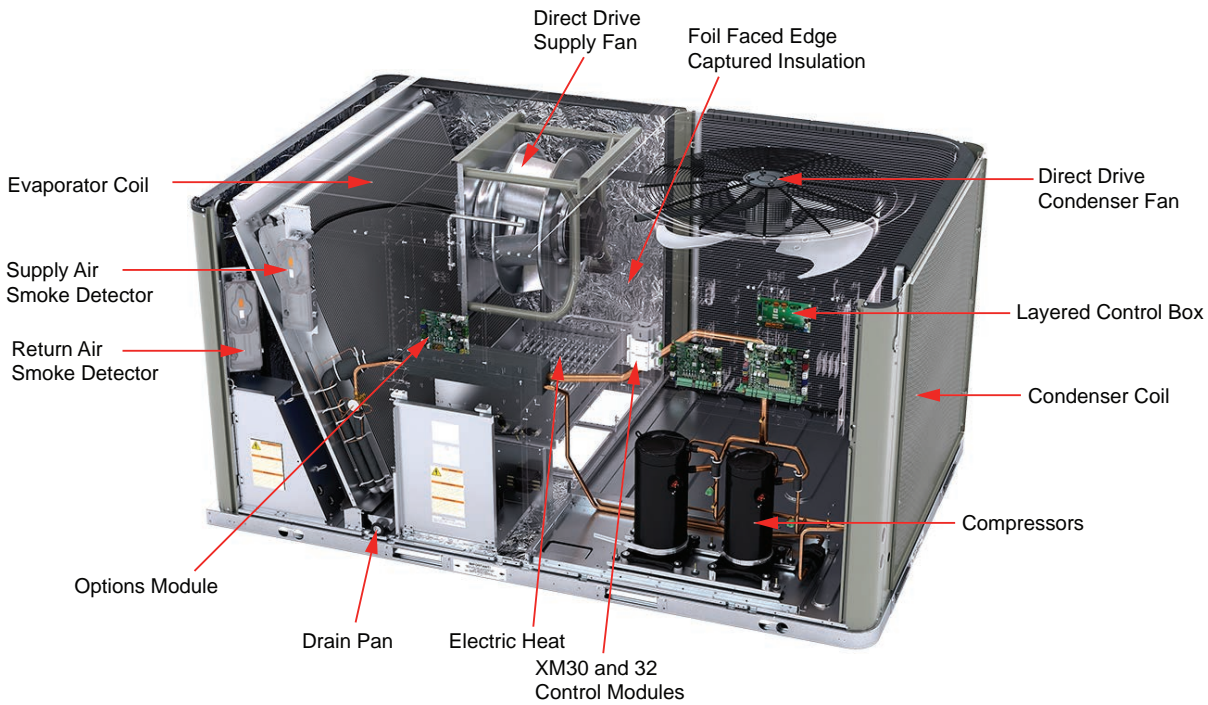

**Note:** This graphic is representative. Component availability and location will vary depending on unit configuration.

### Airflow Distribution

When replacing an older unit and ductwork, the Precedent™ unit airflow provides better air distribution, leading to increased comfort in many cases.

### Cabinet Integrity

For added water integrity, a raised 1-inch lip around the supply and return of the downflow units is provided to prevent water from entering the ductwork.

### Coil Guards

Coil guards protect condenser coil during shipping and from hail, vandals, wind, and other damage. Toolless design lends itself to ease of maintenance in cleaning coils.

Figure 2. Coil guards



## CO<sub>2</sub> Sensor — Demand Control Ventilation (DCV)

Demand-controlled ventilation (DCV) is a control strategy that responds to the actual demand (need) for ventilation by regulating the rate the HVAC system brings outdoor air into the building. A carbon dioxide (CO<sub>2</sub>) sensor measures the concentration (parts per million, ppm) of CO<sub>2</sub> in the air. As CO<sub>2</sub> concentration changes, the outside air damper modulates to meet the current ventilation needs of the zone. The CO<sub>2</sub> sensor kit is available as a field installed accessory and wires directly to the Symbio™ 700 controller.

## CompleteCoat Condenser Coil

This optional coated coil provides excellent corrosion resistance, and uniformity of coverage and coating thickness.

## Controls — Symbio

### Enhanced BAS Integration and Connectivity

- Open standard communications
  - BACnet® over Zigbee<sup>1</sup> (Air-Fi Wireless)
  - BACnet MS/TP
  - BACnet IP
  - Modbus™ RTU
  - Modbus TCP/IP
- Securely access, troubleshoot, and monitor equipment from anywhere via Trane Connect™

### Serviceability

- Wireless mobile app interface (iOS and Android) to simplify start-up/service
- On-board user interface
- Data trending
- Real-time, clear language diagnostics
- Historical alarm logs
- Backup and Restore functionality to reduce commissioning and service time

### Flexibility

- Future-ready upgradable software, supporting changing codes and new sequences of operation
- Standard, consistent pre-engineered applications that meet industry standards
- Built-in Schedules (requires Tracer® TU)
- Expandable inputs and outputs (requires Tracer TU)
- Ability to add custom programmed sequences (requires Tracer TU)

### Accessibility

Control box consists of a multilevel design with Symbio™ Controls located on hinged panels which provide protection from high voltage components for ease of servicing.

## Convenience Outlet

Two convenience outlet options are available:

- GFCI, 120V/15A, 2 plug, powered
- GFCI, 120V/20A, 2 plug, unpowered

This option is available when through-the-base-electrical (with either disconnect switch or circuit breaker) is selected.

<sup>1</sup>. ZigBee® is a registered trademark of the ZigBee Alliance.



## Features and Benefits

---

Figure 3. Convenience outlet



### Convertible Units

Units ship in a downflow configuration and can be converted to horizontal by removing two panels. Optional field accessory kits required for D.0 or D.1 cabinet units (model number digit 39 to 40 = D.0 or D.1).

**Note:** Ultra-low NOx units are not compatible with horizontal discharge units.

Figure 4. Convertible units



### Direct Drive Supply Fans

All A.0 cabinet units are equipped with direct drive fan design featuring:

- Direct drive indoor motor with 5-speed taps for 3 to 5 ton standard efficiency units
- Variable speed adjustment available in the Symbio™ controller for 3 ton high efficiency

All B.0, C.0, D.0 and D.1 cabinet units are equipped with a direct drive supply fan design featuring:

- External rotor direct drive variable speed indoor motor
- Variable speed adjustment available in Symbio™ controller
- Designed to slide out for ease of maintenance

Figure 5. Direct drive supply fans



## Drain Pan

Every unit includes an easy-to-clean, composite, removable, dual-sloped drain pan (IAQ). On units with A.0, B.0 or C.0 size cabinets, the drain pan configuration is modifiable, allowing installation of the drain trap on either side of the unit or through the base.

**Figure 6. Drain pan**

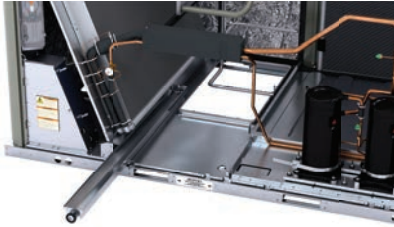

## Fault Detection and Diagnostics (FDD)

The FDD system meets the mandatory requirement of CA Title 24 of fully configurable diagnostics allowing fault history and reading fault codes at the unit via Symbio™ 700 board or app. The following faults are detected:

- Air temperature sensor failure/fault
- Notification of acceptable economizer mode

The FDD system is certified by the Energy Commission as meeting the requirements.

## Flexibility

For flexibility, units are built to order in our standard ship cycle time.

## High Altitude Kit

High Altitude Kits contain gas orifices that derate the gas input rate (BTUH) by 10 percent for use on units applied above 2,000 feet. Domestic contractors should consult with local authority on best practice.

**Note:** *The High Altitude Kit is not available with the Ultra Low NOx gas furnace option.*

## High Efficiency Filtration

There are a variety of high efficiency filtration options. MERV 8 and MERV 13 filters provide additional filtration beyond the capabilities of 2-inch standard filters.

## High Static Motor

The high static motor option provides additional capabilities beyond the standard motor. Available on select models, as shown in general data tables.

## Hinged Access Doors

Hinged access doors permit easy access to the filter, fan, and compressor/control sections. Risk of roof damage from screws or sharp access panel corners is reduced.



## Features and Benefits

---

Figure 7. Hinged access doors



### Humidity Sensor/Humidistat

The humidity sensor/humidistat, when used in conjunction with our dehumidification (hot gas reheat) units provides outstanding humidity control and comfort. Humidity sensors can be wall or duct mounted. The humidity deadband can be set between 40% and 60% relative humidity.

### Leak Detection System

The Leak Detection System (LDS) consists of one or more refrigerant detection sensors and is required in ducted HVAC systems that have more than 3.91 lbs of A2L refrigerant charge, per safety standard UL 60335-2-40. For any units with more than 3.91 lbs of charge in a circuit, an LDS will be factory-installed. Having the leak detector installed in the factory by the manufacturer on applicable units reduces the risk of improper installation in the field as well as bypassing the added cost in the field for installation, leading to peace of mind that the right solution has been applied to your unit.

### Low Ambient Cooling

All units have cooling capabilities down to 40°F. Field installed accessory extends operation down to 0°F.

### Low Leak Economizer

This accessory meets low leak requirements for ASHRAE 90.1, IECC, and CA Title 24 standards (4 cfm/ft<sup>2</sup>@1inch wg exterior air/return air). This option allows 0 to 100 percent outdoor air supply from modulating dampers and is standard with barometric relief. It can be paired with power exhaust for additional building pressure relief. This option can be paired with or without fault detection and diagnostics (FDD) to meet current mandatory CA Title 24 requirements.

The economizers come with four control options: dry bulb, reference enthalpy, comparative enthalpy, or differential dry bulb.

Figure 8. Low leak economizer

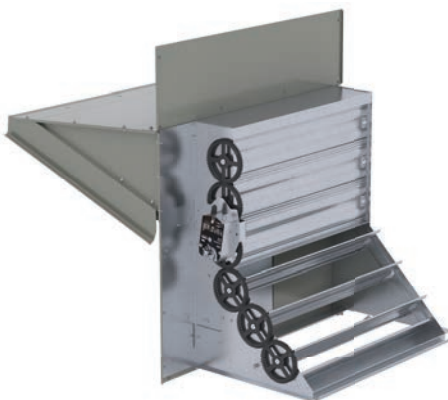

**Note:** Downflow low leak economizer is available as a factory installed option. Horizontal low leak economizer is only available as a field installed option.

## LP Conversion Kit

This kit allows for field conversion of gas/electric units from natural gas to propane.

**Note:** *The Ultra Low NOx gas furnace option is for natural gas operation only.*

## Microchannel Coils

Microchannel coils are all-aluminum coils with fully-brazed construction. This design reduces risk of leaks and provides increased coil rigidity — making them more rugged on the jobsite. Their flat streamlined tubes with small ports and metallurgical tube-to-fin bond allow for exceptional heat transfer. Microchannel all-aluminum construction provides several additional benefits:

- Light weight (simplifies coil handling)
- Easy to recycle
- Minimize galvanic corrosion

**Figure 9. Microchannel condenser coil**

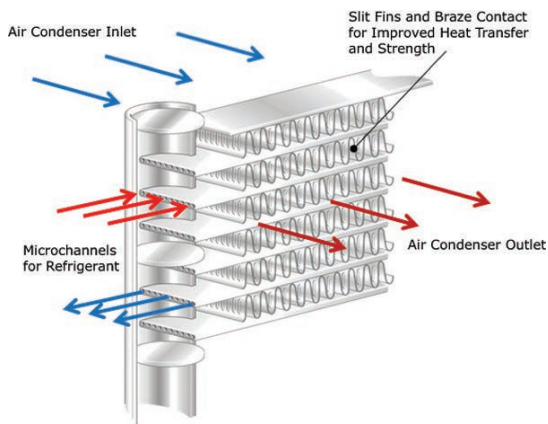

## Modulating Gas Heat

**Note:** *Not available with 3 to 5 ton units.*

Modulating natural gas heat option, with a high modulation range of 10:1, automatically modulates the gas value and combustion blower motor, providing improved comfort with stable temperature control. Modulating gas heat option includes stainless steel heat exchanger.

- Less on/off cycling
- Continuous heating output
- Wide operation range (low and high heat)
- Coupled with variable speed fan control enables independent control of supply airflow and discharge air temperature
- With Zoned Rooftop Systems, modulating gas heat enables effective supply air tempering as well as warm-up sequences

## Humidity Control – Modulating Hot Gas Reheat (HGRH)

The factory-installed modulating hot gas reheat (HGRH) humidity control system allows for full independent control of latent capacity (via staged or modulating refrigeration system) and independent control of discharge air temperature (via a modulating hot gas reheat valve). This provides tightly controlled humidity levels without overcooling the space to deliver year-round comfort by improving indoor air quality.

- Modulating reheat, no more on/off
- Maintains stable neutral leaving air temperature, resulting in less cycling
- Includes both relative humidity and dew point control
- Available on downflow or horizontal

## Multi-Speed Indoor Fan System

**Note:** *Not available with 3 to 5 ton standard efficiency units.*



## Features and Benefits

---

This system incorporates multi-speed fan control to change the speed of the fan to 66 percent of full airflow depending on compressor stages.

### Multiple-Zone VAV (MZVAV)

**Note:** Not available with 3 to 5 ton standard efficiency units.

MZVAV is a system that consists of a packaged rooftop unit that serves several individually controlled zones. Each zone is equipped with a VAV terminal unit that varies the quantity of air delivered to maintain the desired temperature in that zone. The rooftop unit controller varies the speed of the indoor fan to maintain the static pressure in the supply ductwork at a setpoint, verifying that all zones receive required air. Cooling capacity is cycled to maintain the supply air temperature at the desired setpoint.

### Quick Adapt Curbs

Enables easy upgrade of existing Precedent™ and Voyager™ 3 to 25 tons units on replacement jobs.

### Rigorous Testing

Precedent quality is validated through rigorous factory testing:

- Rain testing for water integrity.
- Transportation vibration and forklift testing.
- Rigging lift and drop tests for lifting lug and rail integrity.
- Leak testing, including 100 percent coil leak test, and assembled unit leak test to 465 psig.
- Final assembly inspection.
- Run test (100 percent) to confirm performance requirements.

### Single Zone VAV (SZVAV)

**Note:** Not available with 3 to 5 ton standard efficiency units.

SZVAV is fully integrated into the control system. It provides the simplest and fastest commissioning in the industry through proven factory-installed, wired, and tested system controllers. All control modules, logic boards and sensors are factory installed and tested to confirm the highest quality and most reliable system available. This means no special programming of algorithms, or hunting at the jobsite for field installed sensors, boards, etc. SZVAV is a quick and simple solution for many applications and is available from your most trusted rooftop system solution provider -Trane.

Building system modeling in energy simulation software such as TRACE is recommended to evaluate performance improvements for your application.

### Supply/Return Air Smoke Detector

**Note:** Supply side smoke detector is not available with A.0 cabinet units.

With this option installed, if smoke is detected, all unit operation will be shut down. Reset will be manual at the unit. In order for the supply air smoke detector or return air smoke detector to properly sense smoke in the supply air stream or the return air stream, the air velocity entering the smoke detector unit must be between 500 to 4000 feet per minute. Equipment covered in this manual will develop an airflow velocity that falls within these limits over the entire airflow range specified in the evaporator fan performance table.

### Through-the-Base Condensate

Through-the-base condensate drain connections, available on A.0, B.0, and C.0 cabinet units, allow the drain to be connected through the roof curb, and avoid the need for roof modification.

### Through-the-Base Electrical Access

An electrical service entrance is provided to allow electrical access for both control and main power connections inside the curb and through-the-base of the unit. Option will allow for field installation of liquid-tight conduit and an external field installed disconnect switch.

### Through-the-Base Gas Piping

Factory-provided through-the-base openings simplify piping. Because these utility openings frequently minimize the number of roof penetrations, the integrity of roofing materials is enhanced.

This option includes all necessary piping, including black steel, manual gas shut-off valve, elbows, and union. This assembly requires field installation.

**Note:** *Through-the-base gas is not available with the Ultra Low NOx gas furnace option.*

## **Ventilation Override**

Ventilation override allows the unit to transition to up to three different pre-programmed sequences for smoke purge, pressurization, and exhaust. The transition occurs when a binary input on the Customer Connection Module is closed (shorted). This would typically be a hard wired relay output from a smoke detector or fire control panel. The Customer Connection module that allows ventilation override is available as a field installed accessory (FIASCCM001\*). For more information on functionality, see *Symbio™ 700 Controller with Precedent™ Packaged Rooftop Air-Conditioners Application Guide (ACC-APG002\*-EN)*.



# Application Considerations

## A2L Application Considerations

This product is listed to UL standard 60335-2-40, Household and Similar Electrical Appliances – Safety – Part 2-40: Particular Requirements for Electrical Heat Pumps, Air-Conditioners and Dehumidifiers, which defines safe design and use strategies for equipment using A2L refrigerants. This standard limits the refrigerant concentration in a space in the event of a refrigerant leak. To meet the requirements, the UL standard defines minimum room area, refrigerant charge limit, minimum circulation airflow and/or ventilation airflow requirements, and limits the use of ignition sources in spaces. The standard may require a unit refrigerant leak detection system.

For equipment with R-454B and charge amounts less than or equal to 3.91 lbs per circuit, this UL standard does not prescribe a room area limit and does not require a refrigerant leak detection system or any circulation airflow or ventilation airflow mitigation strategies. However, ignition sources in ductwork must be evaluated.

Depending on the application, a specific requirement of ANSI/ASHRAE Standard 15, Safety Standard for Refrigeration Systems, could be more stringent than UL 60335-2-40 requirements. See *Refrigeration Systems and Machinery Rooms Application Considerations for Compliance with ASHRAE® Standard 15-2022 Application Engineering Manual (APP-APM001\*-EN)* for more information.

### Minimum Room Area Limits (Refrigerant charge greater than 3.91 lb per circuit)

Equipment with R-454B charge amounts greater than 3.91 lb per circuit may require additional circulation or ventilation airflow mitigation strategies. In this case, two minimum room area ( $A_{min}$ ) thresholds:

- The first threshold defines when equipment serving a single room is required to provide circulation airflow, either continuous or activated by a leak detection system. A ducted system requires circulation airflow unless the smallest room it serves is larger than the adjusted  $A_{min}$  threshold. This product contains a leak detection system if a circuit charge is greater than 3.91 lbs. As a result, no further leak detection system evaluation is required.
- The second threshold defines when additional ventilation airflow is required. If the room area, A or TA, is below the adjusted  $A_{min}$  or  $TA_{min}$  threshold, additional ventilation is required to remove refrigerant in the event of a leak. Refer to UL 60335-2-40 Clause GG.8 and ANSI/ASHRAE Standard 15 Section 7 for natural and mechanical ventilation requirements. For minimum room area, see equipment nameplate or unit Installation, Operation, and Maintenance (IOM) manual.

### Minimum Room Area ( $A_{min}$ ) Adjustments

- **Altitude:** The  $A_{min}$  threshold changes with altitude. Multiple the altitude adjustment factor in the following table by  $A_{min}$  shown on the unit nameplate or in the Installation, Operation, and Maintenance (IOM) manual.

**Table 5. Altitude adjustment factor**

Altitude (ft)	Sea Level to 2000	2001 to 4000	4001 to 6000	6001 to 8000	8001 to 10000	10001 to 12000	12001 to 14000	14001 to 15000	Over 15000
$A_{min}$ Adjustment	1	1.05	1.11	1.17	1.24	1.32	1.41	1.51	1.57

- **Height :**  $A_{min}$  can be adjusted if the unit is installed in a room at a height higher than the minimum height shown on the unit. Multiply  $A_{min}$  by the ratio of the unit minimum release height (in meters) / actual release height (in meters).
- **Institutional Occupancies:** For institutional occupancies, ASHRAE Standard 15 applies an additional adjustment factor, FOCC, to the amount of charge allowed in a space. To calculate the adjusted  $A_{min}$  for institutional occupancies, divide the  $A_{min}$  on the nameplate by 0.5.

### Determining Room Area (A or TA)

The room area (A) is the room area enclosed by the projection to the floor of the walls, partitions, and doors of the space that the equipment serves. For ducted systems, total room area (TA) of all rooms connected by ducts, may be used instead of A.

Rooms connected by drop ceilings only are not considered a single room.

Rooms on the same floor of the building, and connected by an open passageway, can be considered part of the same room if the passageway is a permanent opening, extends to the floor and is intended for people to walk through.

Adjacent rooms on the same floor of the building and connected by permanent openings in the walls and/or doors between rooms (including gaps between the wall and the floor), can be considered part of the same room if the openings meet the following criteria.

- The opening is permanent and cannot be closed.
- Openings extending to the floor, such as door gaps, need to be at least 20 mm above the floor covering surface.
- Natural ventilations opening areas must meet the requirements of ANSI/ASHRAE Standard 15-2022, Section 7.2.3.2.

Rooms that are connected by a mechanical ventilation system can be considered a single room area if the mechanical ventilation system meets the requirements of ANSI/ASHRAE Standard 15-2022, Section 7.6.4.

## **Leak Detection System (Refrigerant charge greater than 3.91 lb per circuit)**

The leak detection system consists of one or more refrigerant detection sensors. When the system detects a leak, the following mitigation actions will be initiated until refrigerant has not been detected for at least 5 minutes:

- Energize the supply fan(s) to deliver a required minimum amount of circulation airflow.
- Disable compressor operation.
- Provide an output signal that can be used to fully open zone dampers and/or VAV boxes and disable electric heat in VAV boxes.
- Provide an output signal that can be used to energize additional mechanical ventilation (if needed).
- Units without airflow proving will disable electric heat sources.

Building fire and smoke systems may override this function.

If the refrigerant sensor has a fault, is at the end of its life, or is disconnected, the unit will initiate the mitigation actions. Mitigation actions may be verified by disconnecting the sensor.

The refrigerant sensors do not need service. Use only manufacturer-approved sensors when replacement is required.

## **Heating Operation**

The heat exchanger is manufactured with aluminized steel. To prevent condensation within the heat exchanger, do not exceed 50% outside air or a minimum mixed air temperature of 40°F.

## **Optional Stainless Steel Heat Exchanger**

The optional stainless steel heat exchanger is manufactured with 409 stainless steel tubes and 439 stainless steel burners. To prevent corrosion and prolong heat exchanger reliability, the minimum mixed air temperature allowed across the heat exchanger is 20°F.

The stainless steel heat exchanger option is an excellent option that compliments the dehumidification package. Whenever high outside air or outside applications exist, these options should be utilized.



# Model Number Description

## Digit 1 — Unit Function

T = DX Cooling  
Y = DX Cooling, Gas Heat

## Digit 2 — Cooling Efficiency

S = Standard Efficiency  
H = High Efficiency

## Digit 3 — Refrigerant

K = R-454B

## Digit 4,5,6 — Nominal Gross Cooling Capacity (MBh)

036 = 3 Ton  
048 = 4 Ton  
060 = 5 Ton  
072 = 6 Ton  
090 = 7.5 Ton  
102 = 8.5 Ton  
120 = 10 Ton  
150 = 12.5 Ton  
180 = 15 Ton  
210 = 17.5 Ton  
240 = 20 Ton  
300 = 25 Ton

## Digit 7 — Design Sequence

## Digit 8 — Voltage Selection

3 = 208–230/60/3  
4 = 460/60/3  
W = 575/60/3

## Digit 9 — Unit Controls

S = Symbio™ 700

## Digit 10 — Heat Type

0 = Base Model  
A = Stainless Steel Gas Heat  
B = Modulating Gas Heat

## Digit 11 — Heating Capacity

0 = No Heat  
B = 6 kW Electric Heat  
C = 9 kW Electric Heat  
E = 12 kW Electric Heat  
G = 18 kW Electric Heat  
J = 23 kW Electric Heat  
K = 27 kW Electric Heat  
N = 36 kW Electric Heat  
P = 54 kW Electric Heat  
R = 72 kW Electric Heat  
L = Low Gas Heat  
M = Medium Gas Heat  
H = High Gas Heat

## Digit 12, 13 — Service Sequence

\*\* = Factory Assigned

## Digit 14 — Fresh Air Selection

0 = No Fresh Air  
A = Manual Outside Air Damper 0–50%  
B = Motorized Outside Air Damper 0–50%  
C = Economizer, Dry Bulb 0–100% without Barometric Relief  
D = Economizer, Dry Bulb 0–100% with Barometric Relief  
E = Economizer, Reference Enthalpy 0–100% without Barometric Relief  
F = Economizer, Reference Enthalpy 0–100% with Barometric Relief  
G = Economizer, Comparative Enthalpy 0–100% without Barometric Relief  
H = Economizer, Comparative Enthalpy 0–100% with Barometric Relief  
K = Downflow Low Leak Economizer, Dry Bulb with Barometric Relief  
M = Downflow Low Leak Economizer, Reference Enthalpy with Barometric Relief  
P = Downflow Low Leak Economizer, Comparative Enthalpy with Barometric Relief  
R = Downflow Low Leak Economizer, Differential Dry Bulb with Barometric Relief

## Digit 15 — Supply Fan/Drive Type/Motor

0 = Multi-Speed Motor  
1 = Optional High Static Motor  
2 = Single Zone Variable Air Volume with Standard Motor  
3 = Single Zone Variable Air Volume with Oversized/High Static Motor  
4 = Multiple Zone Variable Air Volume with Standard Motor  
5 = Multiple Zone Variable Air Volume with Oversized/High Static Motor

## Digit 16 — Hinged Access/Filters

0 = Standard Panels/Standard Filters  
A = Hinged Access Panels/Standard Filters  
B = Standard Panels/2 inch MERV 8 Filters  
C = Hinged Access Panels/2 inch MERV 8 Filters  
D = Standard Panels/2 inch MERV 13 Filters  
E = Hinged Access Panels/2 inch MERV 13 Filters

## Digit 17 — Condenser Coil Protection

0 = Standard Coil  
1 = Condenser with CompleteCoat™

## Digit 18 — Through-the-Base Provisions

0 = No Through-the-Base Provisions  
A = Through-the-Base Electric  
B = Through-the-Base Gas Piping  
C = Through-the-Base Electric and Gas Piping

## Digit 19 — Disconnect/Circuit Breaker (three-phase only)

0 = No Disconnect/No Circuit Breaker  
1 = Unit Mounted/Non-Fused Disconnect  
2 = Unit Mounted Circuit Breaker

## Digit 20 — Convenience Outlet

0 = No Convenience Outlet  
A = Unpowered 20A Convenience Outlet  
B = Powered 15A Convenience Outlet

## Digit 21 — Communications Options

0 = No Communications Interface  
1 = Advanced Controller with BACnet® Communications Interface  
3 = Advanced Controller with Air-Fi® Communications Interface

## Digit 22 — Refrigeration System Option

0 = Standard Refrigeration System  
A = Humidity Control Option

## Digit 23 — Controls Expansion Module

0 = None  
1 = XM-30 Expansion Module  
2 = XM-32 Expansion Module  
3 = XM-30 and XM-32 Expansion Module  
4 = XM-30 Expansion Module (Qty 2)  
5 = XM-32 Expansion Module (Qty 2)

## Digit 24 — Smoke Detector

0 = No Smoke Detector  
A = Return Air Smoke Detector  
B = Supply Air Smoke Detector  
C = Supply and Return Air Smoke Detectors

**Digit 25 — System Monitoring Controls**

- 0 = No Monitoring Control
- 1 = Clogged Filter Switch
- 2 = Condensate Overflow Switch
- 3 = Discharge Air Sensing Tube
- 4 = Clogged Filter Switch and Condensate Overflow Switch
- 5 = Clogged Filter Switch and Discharge Air Sensing Tube
- 6 = Condensate Overflow Switch and Discharge Air Sensing Tube
- 7 = Clogged Filter Switch, Condensate Overflow Switch and Discharge Air Sensing Tube

**Digit 26 — Not Used****Digit 27 — Unit Hardware Enhancements**

- 0 = No Enhancements
- 1 = Stainless Steel Drain Pan

**Digit 28 — Short Circuit Current Rating**

- 0 = Standard (5k) SCCR Marking
- A = Tier 2 (65K) SCCR Marking

**Digit 29 — Low Ambient**

- 0 = None
- A = Low Ambient Cooling to 0°F



# General Data

**Table 6. General data — cooling - standard efficiency**

	3 Tons	4 Tons	5 Tons	6 Tons	7.5 Tons	8.5 Tons	10 Tons	12.5 Tons	15 Tons	17.5 Tons	20 Tons	25 Tons
	TSK036	TSK048	TSK060	TSK072	TSK090	TSK102	TSK120	TSK150	TSK180	TSK210	TSK240	TSK300
<b>Cooling Performance<sup>(e)</sup></b>												
Gross Cooling Capacity	37800	50000	61500	79000	92000	108000	122000	144000	183000	214000	248000	283000
EER <sup>(b)</sup> / EER2 <sup>(c)</sup>	12.0/11.0	12.0/11.0	12.0/11.0	11.2	11.2	11.2	11.2	11.0	11.0	11.0	10.0	10.0
Nominal cfm/AHRI Rated cfm	1200/1200	1600/1600	2000/2000	2400/1860	3000/2625	3400/2635	4000/3100	5000/3875	6000/5250	7000/6650	8000/8000	10000/10000
AHRI Net Cooling Capacity	37000	48500	59500	78000	91000	106000	120000	141000 (140000) <sup>(d)</sup>	180000	210000	242000	274000
IEER <sup>(e)</sup> (2-Speed) / SEER <sup>(b)</sup> / SEER2 <sup>(c)</sup>	14.0/13.4	14.0/13.4	14.0/13.4	14.8	14.8	14.8	14.8	14.2	14.2	14.2	13.2	13.2
IEER (SZVAV/ MZVAV)	N/A	N/A	N/A	15.3/15.3	15.3/15.3	15.3/15.3	15.3/15.3	14.7/14.7	14.7/14.7	14.7/14.7	13.7/13.7	13.7/13.7
System Power (kW)	3.36	4.41	5.41	6.96	8.13	9.46	10.71	12.82 (12.73) <sup>(d)</sup>	16.36	19.09	24.20	27.40
<b>Compressor</b>												
Number/Type	1/Scroll	1/Scroll	1/Scroll	2/Manifold Scroll	2/Manifold Scroll	2/Manifold Scroll	2/Manifold Scroll	2/Manifold Scroll	2/Manifold Scroll	2/Manifold Scroll	2/Manifold Scroll	2/Manifold Scroll
Percent Capacity (Stage 1 - Stage 4)	100	100	100	34/66/100	33/67/100	32/68/100	28/72/100	32/68/100	33/67/100	33/67/100	24/36/64/100	25/37/63/100
<b>Sound<sup>(f)</sup></b>												
Outdoor Sound Rating (dBA)	79	82	82	86	86	86	86	89	87	91	91	93
<b>Outdoor Coil</b>												
Type	Microchannel	Microchannel	Microchannel	Microchannel	Microchannel	Microchannel	Microchannel	Microchannel	Microchannel	Microchannel	Microchannel	Microchannel
Configuration	Full Face	Full Face	Full Face	Full Face	Full Face	Full Face	Full Face	Full Face	Full Face	Full Face	Full Face	Full Face
Tube Size (in.)	0.6	0.6	1.0	0.7	0.7	1.0	1.0	1.0	0.7	0.7	1.0	1.0
Face Area (sq. ft.)	10.50	10.50	11.91	21.64	21.64	21.64	21.64	28.32	33.89	33.89	33.89	33.89
Rows/FPI (Fins per inch)	1/23	1/23	1/23	1/23	1/23	1/23	1/23	1/23	1/23	1/23	1/21	1/21
<b>Indoor Coil</b>												
Type	Microchannel	Microchannel	Microchannel	Microchannel	Microchannel	Microchannel	Microchannel	Microchannel	Microchannel	Microchannel	Microchannel	Microchannel
Configuration	Full Face	Full Face	Full Face	Full Face	Full Face	Full Face	Full Face	Full Face	Full Face	Full Face	Full Face	Full Face
Tube Size (in.)	0.6	0.6	0.8	1.0	1.0	1.0	1.0	1.0	1.0	1.0	1.0	1.0
Face Area (sq. ft.)	6.81	6.81	7.99	11.84	11.84	11.84	11.84	14.27	23.93	23.93	23.93	23.93
Rows/FPI (Fins per inch)	2/16	2/16	2/16	2/18	2/18	2/18	2/18	2/18	2/18	2/18	2/18	2/18

**Table 6. General data — cooling - standard efficiency (continued)**

	3 Tons	4 Tons	5Tons	6 Tons	7.5 Tons	8.5 Tons	10 Tons	12.5 Tons	15 Tons	17.5 Tons	20 Tons	25 Tons
Refrigerant Control	TSK036 TXV	TSK048 TXV	TSK060 TXV	TSK072 TXV	TSK090 TXV	TSK102 TXV	TSK120 TXV	TSK150 TXV	TSK180 TXV	TSK210 TXV	TSK240 TXV	TSK300 TXV
Drain Connection No./Size (in.) NPT	1/0.75	1/0.75	1/0.75	1/0.75	1/0.75	1/0.75	1/0.75	1/0.75	1/1.0	1/1.0	1/1.0	1/1.0
<b>Reheat Coil</b>												
Type	Microchannel	Microchannel	Microchannel	Microchannel	Microchannel	Microchannel	Microchannel	Microchannel	Microchannel	Microchannel	Microchannel	Microchannel
Configuration	Full Face	Full Face	Full Face	Full Face	Full Face	Full Face	Full Face	Full Face	Full Face	Full Face	Full Face	Full Face
Tube Size (in.)	0.6	0.6	0.6	0.6	0.6	0.6	0.6	0.6	0.6	0.6	0.6	0.6
Face Area (sq. ft.)	5.51	5.51	5.51	9.04	9.04	9.04	9.04	11.82	21.83	21.83	21.83	21.83
Rows/FPI (Fins per inch)	1/23	1/23	1/23	1/23	1/23	1/23	1/23	1/23	1/23	1/23	1/23	1/23
<b>Outdoor Fan</b>												
Type	Propeller	Propeller	Propeller	Propeller	Propeller	Propeller	Propeller	Propeller	Propeller	Propeller	Propeller	Propeller
No. Used/Diameter (in.)	1/22	1/22	1/22	1/26	1/26	1/26	1/26	1/30	2/26	2/26	2/26	2/28
Drive Type/No. Speeds	Direct/1	Direct/1	Direct/1	Direct/1	Direct/1	Direct/1	Direct/1	Direct/1	Direct/1	Direct/1	Direct/1	Direct/1
CFM/ CFM-Modulating HGRH	3600/3100	4000/3875	3800/3650	5900	5900	7200	7200	8200	11520	14660	14220	16600
Motor HP/ Motor HP Modulating HGRH	0.25/0.33	0.33/0.5	0.4/0.5	0.70	0.70	0.75	0.75	1.00	0.50	1.00	1.00	1.00
Motor RPM/Motor RPM Modulating HGRH	1100/1000	1100	1100	1100	1100	1100	1100	1100	1125	1125	1125	1125
<b>Indoor Fan</b>												
Type	FC Centrifugal	FC Centrifugal	FC Centrifugal	BC Plenum	BC Plenum	BC Plenum	BC Plenum	BC Plenum	BC Plenum	BC Plenum	BC Plenum	BC Plenum
No. Used/Diameter (in.)/Width (in.)	1/11x11	1/11x11	1/11x11	1/23x6	1/23x6	1/23x6	1/23x6	1/23x6	2/23x6	2/23x6	2/23x6	2/23x6
Drive Type/No. Speeds/RPM	Direct/5	Direct/5	Direct/5	Direct/Variable	Direct/Variable	Direct/Variable	Direct/Variable	Direct/Variable	Direct/Variable	Direct/Variable	Direct/Variable	Direct/Variable
Motor HP (Standard/ Oversized)	0.75 (1.0)/1.5	1.0/1.5	1/1.5	3.0 / -	3.0 / -	3.0 / -	3.0 / 4.6	4.6 / -	3.0 / -	3.0 / -	3.0 / -	3.0 / 4.6
Max Motor RPM	1200/1400	1200/1400	1200/1400	1850	1850	1850	1850/1940	1940	1850	1850	1850	1850/1940
<b>Filters</b>												
Type Furnished	Throwaway	Throwaway	Throwaway	Throwaway	Throwaway	Throwaway	Throwaway	Throwaway	Throwaway	Throwaway	Throwaway	Throwaway
Number Size Recommended	(4) 20x20x2	(4) 20x20x2	(4) 20x20x2	(2) 18x24x2 (3) 24x16x2	(2) 18x24x2 (3) 24x16x2	(2) 18x24x2 (3) 24x16x2	(2) 18x24x2 (3) 24x16x2	(3) 18x18x2 (3) 24x18x2	(8) 20x24x2	(8) 20x24x2	(8) 20x24x2	(8) 20x24x2
<b>Refrigerant Charge</b>												
lbs of R-454B	3.1	3.3	3.9	8.0	7.6	8.3	8.0	9.8	11.8	12.0	14.0	14.6
lbs of R-454B, Hot Gas Reheat	3.6	3.7	4.7	8.4	8.2	9.1	9.0	10.0	12.9	12.9	14.6	15.4



General Data

Table 6. General data — cooling - standard efficiency (continued)

	3 Tons	4 Tons	5Tons	6 Tons	7.5 Tons	8.5 Tons	10 Tons	12.5 Tons	15 Tons	17.5 Tons	20 Tons	25 Tons
	TSK036	TSK048	TSK060	TSK072	TSK090	TSK102	TSK120	TSK150	TSK180	TSK210	TSK240	TSK300
<b>Cabinet</b>												
Cabinet Size	A.0	A.0	A.0	B.0	B.0	B.0	B.0	C.0	D.0	D.0	D.0	D.0

(a) The 3 to 5 ton cooling performance is rated at 95°F ambient, 80°F entering dry bulb, 67°F entering wet bulb. Gross capacity does not include the effect of fan motor heat. AHRI capacity is net and includes the effect of fan motor heat. Units are suitable for operation to ±20% of nominal cfm. Units are certified in accordance with the Unitary Air-Conditioner Equipment certification program, which is based on AHRI Standard 210/240.

(b) SEER shown for 3 to 5 ton units only. The 3 to 5 ton EER and SEER are rated at AHRI conditions and calculated in accordance with AHRI Standard 210/240-2017. Airflow and net cooling capacity not shown. EER2 and SEER2 shown for 3 to 5 ton units only. EER2 and SEER2 are rated at AHRI conditions and certified in accordance with AHRI Standard 210/240-2023.

(c) Values for 575V unit.

(d) IEEER shown for 6 to 25 ton units only.

(e) Outdoor sound rating shown is tested in accordance with AHRI 370-2015. For additional information reference the outdoor sound power level data in the performance section.

(f) TSK036 uses 1HP as standard motor for 575V application.

Table 7. General data — cooling - high efficiency

	3 Tons	4 Tons	5 Tons	6 Tons	7.5 Tons	8.5 Tons	10 Tons	12.5 Tons	15 Tons	17.5 Tons	20 Tons	25 Tons
	THK036	THK048	THK060	THK072	THK090	THK102	THK120	THK150	THK180	THK210	THK240	THK300
<b>Cooling Performance<sup>(a)</sup></b>												
Gross Cooling Capacity	38900	50000	62400	79000	92000	108000	122000	152000	183000	213000	248000	280000
EER <sup>(b)</sup> / EER2 <sup>(c)</sup>	12.9/12.2	12.9/12.2	12.9/12.2	12.4	12.3	12.3	11.7	12.7	12.5	12.1	11.2	11.0
Nominal cfm/AHRI Rated cfm	1200/1200	1600/1600	2000/2000	2400/1860	3000/2625	3400/2635	4000/3100	5000/3875	6000/5250	7000/5950	8000/8000	10000/9000
AHRI Net Cooling Capacity	38000	49000	61000	78000	91000	106000	120000	150000	180000	210000	242000	272000
IEER <sup>(d)</sup> (2-Speed) / SEER <sup>(e)</sup> / SEER2 <sup>(c)</sup>	17.1/16.4	17.1/16.4	17.1/16.4	17.3	17.3	16.3	15.7	18.1	18.2	16.7	16.0	15.8
IEER (SZ/AV/MZ/AV)	—	—	—	17.8/17.8	17.8/17.8	16.8/16.8	16.2/16.2	18.6/18.6	18.7/18.7	17.2/17.2	16.5/16.5	16.3/16.3
System Power (kW)	3.11	4.02	5.00	6.29	7.40	8.62	10.26	12.40	14.88	17.36	22.00	24.73
<b>Compressor</b>												
Number/Type	1/Scroll	1/Scroll	1/Scroll	2/Manifold Scroll	2/Manifold Scroll	2/Manifold Scroll	2/Manifold Scroll	2/Manifold Scroll	2/Manifold Scroll	2/Manifold Scroll	2/Manifold Scroll	2/Manifold Scroll
Percent Capacity (Stage 1 - Stage 4)	67/100	67/100	67/100	34/66/100	33/67/100	32/68/100	28/72/100	32/68/100	33/67/100	33/67/100	24/36/64/100	25/37/63/100
<b>Sound</b>												
Outdoor Sound Rating (dBA)	79	88	88	86	86	86	86	87	87	91	91	93
<b>Outdoor Coil</b>												
Type	Microchannel	Microchannel	Microchannel	Microchannel	Microchannel	Microchannel	Microchannel	Microchannel	Microchannel	Microchannel	Microchannel	Microchannel
Configuration	Full Face	Full Face	Full Face	Full Face	Full Face	Full Face	Full Face	Full Face	Full Face	Full Face	Full Face	Full Face
Tube Size (in.)	0.6	0.7	0.7	0.7	0.7	1.0	1.0	0.7	0.7	1.0	1.0	1.0
Face Area (sq. ft.)	13.8	21.64	21.64	21.64	21.64	21.64	21.64	33.89	33.89	33.89	33.89	33.89
Rows/FPI (Fins per inch)	1/23	1/23	1/23	1/23	1/23	1/23	1/23	1/23	1/23	1/21	1/21	1/21
<b>Indoor Coil</b>												
Type	Microchannel	Microchannel	Microchannel	Microchannel	Microchannel	Microchannel	Microchannel	Microchannel	Microchannel	Microchannel	Microchannel	Microchannel
Configuration	Full Face	Full Face	Full Face	Full Face	Full Face	Full Face	Full Face	Full Face	Full Face	Full Face	Full Face	Full Face
Tube Size (in.)	1.0	0.6	0.6	1.0	1.0	1.0	1.0	1.0	1.0	1.0	1.0	1.0
Face Area (sq. ft.)	8.83	11.84	11.84	11.84	11.84	11.84	11.84	23.93	23.93	23.93	23.93	23.93
Rows/FPI (Fins per inch)	2/18	2/18	2/18	2/18	2/18	2/18	2/18	2/18	2/18	2/18	2/18	2/18
Refrigerant Control	TXV	TXV	TXV	TXV	TXV	TXV	TXV	TXV	TXV	TXV	TXV	TXV
Drain Connection No./Size (in.) NPT	1/0.75	1/0.75	1/0.75	1/0.75	1/0.75	1/0.75	1/0.75	1/1.0	1/1.0	1/1.0	1/1.0	1/1.0
<b>Reheat Coil</b>												
Type	Microchannel	Microchannel	Microchannel	Microchannel	Microchannel	Microchannel	Microchannel	Microchannel	Microchannel	Microchannel	Microchannel	Microchannel
Configuration	Full Face	Full Face	Full Face	Full Face	Full Face	Full Face	Full Face	Full Face	Full Face	Full Face	Full Face	Full Face

Table 7. General data — cooling - high efficiency (continued)

	3 Tons	4 Tons	5 Tons	6 Tons	7.5 Tons	8.5 Tons	10 Tons	12.5 Tons	15 Tons	17.5 Tons	20 Tons	25 Tons
THK036	THK048	THK060	THK072	THK090	THK102	THK120	THK150	THK180	THK210	THK240	THK300	
Tube Size (in.)	0.6	0.6	0.6	0.6	0.6	0.6	0.6	0.6	0.6	0.6	0.6	0.6
Face Area (sq. ft.)	5.49	9.04	9.04	9.04	9.04	9.04	9.04	21.83	21.83	21.83	21.83	21.83
Rows/FPI (Fins per inch)	1/23	1/23	1/23	1/23	1/23	1/23	1/23	1/23	1/23	1/23	1/23	1/23
<b>Outdoor Fan</b>												
Type	Propeller	Propeller	Propeller	Propeller	Propeller	Propeller	Propeller	Propeller	Propeller	Propeller	Propeller	Propeller
No. Used/Diameter (in.)	1/22	1/26	1/26	1/26	1/26	1/26	1/26	2/26	2/26	2/26	2/26	2/28
Drive Type/No. Speeds	Direct/1	Direct/1	Direct/1	Direct/1	Direct/1	Direct/1	Direct/1	Direct/1	Direct/1	Direct/1	Direct/1	Direct/1
CFM/CFM-Modulating HGRH	3650/3370	4590/4130	4590/4870	5900	7200	7200	11520	11520	11520	14220	14220	16600
Motor HP / Motor HP Modulating HGRH	0.25/0.33	0.4/0.5	0.4/0.5	0.70	0.75	0.75	0.50	0.50	1.00	1.00	1.00	1.00
Motor RPM/Motor RPM Modulating HGRH	1100/1014	1110/1000	1110/1180	1100	1100	1100	1125	1125	1125	1125	1125	1125
<b>Indoor Fan</b>												
Type	FC Centrifugal	BC Plenum	BC Plenum	BC Plenum	BC Plenum	BC Plenum	BC Plenum	BC Plenum	BC Plenum	BC Plenum	BC Plenum	BC Plenum
No. Used/Diameter (in.)/Width (in.)	1/11X11	1/23x6	1/23x6	1/23x6	1/23x6	1/23x6	1/23x6	2/23x6	2/23x6	2/23x6	2/23x6	2/23x6
Drive Type/No. Speeds/RPM	Direct/Variable	Direct/Variable	Direct/Variable	Direct/Variable	Direct/Variable	Direct/Variable	Direct/Variable	Direct/Variable	Direct/Variable	Direct/Variable	Direct/Variable	Direct/Variable
Motor HP (Standard/Oversized)	0.75/1.0	3.0/-	3.0/-	3.0/-	3.0/-	3.0/4.6	3.0/-	3.0/-	3.0/-	3.0/-	3.0/4.6	3.0/4.6
Max Motor RPM	1310	1850	1850	1850	1850	1850/1940	1850	1850	1850	1850	1850	1850/1940
<b>Filters<sup>(e)</sup></b>												
Type Furnished	Throwaway	Throwaway	Throwaway	Throwaway	Throwaway	Throwaway	Throwaway	Throwaway	Throwaway	Throwaway	Throwaway	Throwaway
Number Size Recommended	(4) 20x20x2	(2) 18x24x2 (3) 24x16x2	(2) 18x24x2 (3) 24x16x2	(2) 18x24x2 (3) 24x16x2	(2) 18x24x2 (3) 24x16x2	(2) 18x24x2 (3) 24x16x2	(2) 18x24x2 (3) 24x16x2	(8) 20x24x2	(8) 20x24x2	(8) 20x24x2	(8) 20x24x2	(8) 20x24x2
<b>Refrigerant Charge</b>												
lbs of R-454B	5.3	7.5	7.5	8.0	7.6	8.4	8.3	11.9	11.8	13.2	14.0	14.6
lbs of R-454B, Hot Gas Reheat	5.6	7.9	7.9	8.4	8.2	9.4	9.1	12.9	12.9	13.9	14.6	15.4
<b>Cabinet</b>												
Cabinet Size	A.0	B.0	B.0	B.0	B.0	B.0	B.0	D.0	D.0	D.0	D.0	D.0

(a) The 3 to 5 ton cooling performance is rated at 95°F ambient, 80°F entering dry bulb, 67°F entering wet bulb. Gross capacity does not include the effect of fan motor heat. AHRI capacity is net and includes the effect of fan motor heat. Units are suitable for operation to ±20% of nominal cfm. Units are certified in accordance with the Unitary Air-Conditioner Equipment certification program, which is based on AHRI Standard 210/240.

(b) SEER shown for 3 to 5 ton units only. The 3 to 5 ton EER and SEER are rated at AHRI conditions and calculated in accordance with AHRI Standard 210/240-2017. Airflow and net cooling capacity not shown.

(c) EER2 and SEER2 shown for 3 to 5 ton units only. EER2 and SEER2 are rated at AHRI conditions and certified in accordance with AHRI Standard 210/240-2023.

**Table 7. General data — cooling - high efficiency (continued)**

(d) IEER shown for 6 to 25T units only.

(e) Outdoor sound rating shown is tested in accordance with AHRI 370-2015. For additional information reference the outdoor sound power level data in the performance section.



General Data

Table 8. General data — gas - standard efficiency

	3 Tons	4 Tons	5Tons	6 Tons	7.5 Tons	8.5 Tons	10 Tons	12.5 Tons	15 Tons	17.5 Tons	20 Tons	25 Tons
	YSK036	YSK048	YSK060	YSK072	YSK090	YSK102	YSK120	YSK150	YSK180	YSK210	YSK240	YSK300
<b>Cooling Performance<sup>(a)</sup></b>												
Gross Cooling Capacity	37800	50000	61500	79000	92000	108000	122000	144000	183000	215000	249000	285000
EER <sup>(b)</sup> / EER2 <sup>(c)</sup>	12.0/11.0	12.0/11.0	12.0/11.0	11.0	11.0	11.0	11.0	10.8	10.8	10.8	9.8	9.8
Nominal cfm/AHRI Rated cfm	1200/1200	1600/1600	2000/2000	2400/1860	3000/2625	3400/2635	4000/3100	5000/3875	6000/5250	7000/6650	8000/8000	10000/10000
AHRI Net Cooling Capacity	37000	48500	59500	78000	90000	106000	119000	140000	180000	210000	242000	274000
IEER <sup>(d)</sup> (2-Speed) / SEER <sup>(b)</sup> / SEER2 <sup>(c)</sup>	14.0/13.4	14.0/13.4	14.0/13.4	14.6	14.6	14.6	14.6	14.0	14.0	14.0	13.0	13.0
IEER (SZ/AV/MZ/AV)	—	—	—	15.1/15.1	15.1/15.1	15.1/15.1	15.1/15.1	14.5/14.5	14.5/14.5	14.5/14.5	13.5/13.5	13.5/13.5
System Power (kW) <sup>(e)</sup>	3.36	4.41	5.41	7.09	8.18	9.64	10.82	12.96	16.67	19.44	24.70	27.96
<b>Cooling Performance with Modulating Gas</b>												
Gross Cooling Capacity	—	—	—	79000	92000	107000	121000	144000	184000	216000	249000	286000
EER	—	—	—	11.0	11.0	11.0	11.0	10.8	10.8	10.8	9.8	9.8
Nominal cfm/AHRI Rated cfm	—	—	—	2400/1860	3000/2625	3400/2635	4000/3100	5000/3875	6000/5250	7000/6650	8000/8000	10000/10000
AHRI Net Cooling Capacity	—	—	—	78000	90000	105000	119000	140000	180000	210000	240000	272000
IEER <sup>(d)</sup> (2-Speed)	—	—	—	14.6	14.6	14.6	14.6	14.0	14.0	14.0	13.0	13.0
IEER (SZ/AV/MZ/AV)	—	—	—	15.1/15.1	15.1/15.1	15.1/15.1	15.1/15.1	14.5/14.5	14.5/14.5	14.5/14.5	13.5/13.5	13.5/13.5
System Power (kW)	—	—	—	7.09	8.18	9.55	10.82	12.96	16.67	19.44	24.49	27.76
<b>Compressor</b>												
Number/Type	1/Scroll	1/Scroll	1/Scroll	2/Manifold Scroll	2/Manifold Scroll	2/Manifold Scroll	2/Manifold Scroll	2/Manifold Scroll	2/Manifold Scroll	2/Manifold Scroll	2/Manifold Scroll	2/Manifold Scroll
Percent Capacity (Stage 1 - Stage 4)	100	100	100	34/66/100	33/67/100	32/68/100	28/72/100	32/68/100	33/67/100	33/67/100	24/36/64/100	25/37/63/100
<b>Sound<sup>(f)</sup></b>												
Outdoor Sound Rating (dBA)	79	82	82	86	86	86	86	89	87	91	91	93
<b>Outdoor Coil</b>												
Type	Microchannel	Microchannel	Microchannel	Microchannel	Microchannel	Microchannel	Microchannel	Microchannel	Microchannel	Microchannel	Microchannel	Microchannel
Configuration	Full Face	Full Face	Full Face	Full Face	Full Face	Full Face	Full Face	Full Face	Full Face	Full Face	Full Face	Full Face
Tube Size (in.)	0.6	0.6	1.0	0.7	0.7	1.0	1.0	1.0	0.7	0.7	1.0	1.0
Face Area (sq. ft.)	10.50	10.50	11.91	21.64	21.64	21.64	21.64	28.32	33.89	33.89	33.89	33.89
Rows/FPI (Fins per inch)	1/23	1/23	1/23	1/23	1/23	1/23	1/23	1/23	1/23	1/23	1/21	1/21
<b>Indoor Coil</b>												
Type	Microchannel	Microchannel	Microchannel	Microchannel	Microchannel	Microchannel	Microchannel	Microchannel	Microchannel	Microchannel	Microchannel	Microchannel
Configuration	Full Face	Full Face	Full Face	Full Face	Full Face	Full Face	Full Face	Full Face	Full Face	Full Face	Full Face	Full Face

**Table 8. General data — gas - standard efficiency (continued)**

	3 Tons	4 Tons	5Tons	6 Tons	7.5 Tons	8.5 Tons	10 Tons	12.5 Tons	15 Tons	17.5 Tons	20 Tons	25 Tons
	YSK036	YSK048	YSK060	YSK072	YSK090	YSK102	YSK120	YSK150	YSK180	YSK210	YSK240	YSK300
Tube Size (in.)	0.6	0.6	0.8	0.6	1.0	1.0	1.0	1.0	1.0	1.0	1.0	1.0
Face Area (sq. ft.)	6.81	6.81	7.99	11.84	11.84	11.84	11.84	14.27	23.93	23.93	23.93	23.93
Rows/FPI (F'ins per inch)	2/16	2/16	2/16	2/18	2/18	2/18	2/18	2/18	2/18	2/18	2/18	2/18
Refrigerant Control	TXV	TXV	TXV	TXV	TXV	TXV	TXV	TXV	TXV	TXV	TXV	TXV
Drain Connection No./Size (in.) NPT	1/0.75	1/0.75	1/0.75	1/0.75	1/0.75	1/0.75	1/0.75	1/0.75	1/1.0	1/1.0	1/1.0	1/1.0
<b>Reheat Coil</b>												
Type	Microchannel	Microchannel	Microchannel	Microchannel	Microchannel	Microchannel	Microchannel	Microchannel	Microchannel	Microchannel	Microchannel	Microchannel
Configuration	Full Face	Full Face	Full Face	Full Face	Full Face	Full Face	Full Face	Full Face	Full Face	Full Face	Full Face	Full Face
Tube Size (in.)	0.6	0.6	0.6	0.6	0.6	0.6	0.6	0.6	0.6	0.6	0.6	0.6
Face Area (sq. ft.)	5.51	5.51	5.51	9.04	9.04	9.04	9.04	11.82	21.83	21.83	21.83	21.83
Rows/FPI (F'ins per inch)	1/23	1/23	1/23	1/23	1/23	1/23	1/23	1/23	1/23	1/23	1/23	1/23
<b>Outdoor Fan</b>												
Type	Propeller	Propeller	Propeller	Propeller	Propeller	Propeller	Propeller	Propeller	Propeller	Propeller	Propeller	Propeller
No. Used/Diameter (in.)	1/22	1/22	1/22	1/26	1/26	1/26	1/26	1/30	2/26	2/26	2/26	2/28
Drive Type/No. Speeds	Direct/1	Direct/1	Direct/1	Direct/1	Direct/1	Direct/1	Direct/1	Direct/1	Direct/1	Direct/1	Direct/1	Direct/1
CFM/CFM-Modulating HGRH	3600/3100	4000/3875	3800/3650	5900	5900	7200	7200	8200	11520	14660	14220	16600
Motor HP/ Motor HP Modulating HGRH	0.25/0.33	0.33/0.5	0.4/0.5	0.70	0.70	0.75	0.75	1.00	0.50	1.00	1.00	1.00
Motor RPM/Motor RPM Modulating HGRH	1100/1000	1100	1100	1100	1100	1100	1100	1100	1125	1125	1125	1125
<b>Indoor Fan</b>												
Type	FC Centrifugal	FC Centrifugal	FC Centrifugal	BC Plenum	BC Plenum	BC Plenum	BC Plenum	BC Plenum	BC Plenum	BC Plenum	BC Plenum	BC Plenum
No. Used/Diameter (in.)/Width (in.)	1/11x11	1/11x11	1/11x11	1/23x6	1/23x6	1/23x6	1/23x6	1/23x6	2/23x6	2/23x6	2/23x6	2/23x6
Drive Type/No. Speeds/RPM	Direct/5	Direct/5	Direct/5	Direct/Variable	Direct/Variable	Direct/Variable	Direct/Variable	Direct/Variable	Direct/Variable	Direct/Variable	Direct/Variable	Direct/Variable
Motor HP (Standard/Oversized)	0.75 (1.0) <sup>(6)</sup> /1.5	1.0/1.5	1/1.5	3.1/-	3.1/-	3.1/-	3.1 / 4.6	4.6 / -	3.0 / -	3.0 / 4.6 <sup>(h)</sup>	3.0 / 4.6 <sup>(h)</sup>	3.0 / 4.6
Max Motor RPM	1200/1400	1200/1400	1200/1400	1850	1850	1850	1850/1940	1940	1850	1850/1940 <sup>(h)</sup>	1850/1940 <sup>(h)</sup>	1850/1940
<b>Filters<sup>(f)</sup></b>												
Type Furnished	Throwaway	Throwaway	Throwaway	Throwaway	Throwaway	Throwaway	Throwaway	Throwaway	Throwaway	Throwaway	Throwaway	Throwaway

**Table 8. General data — gas - standard efficiency (continued)**

	3 Tons	4 Tons	5Tons	6 Tons	7.5 Tons	8.5 Tons	10 Tons	12.5 Tons	15 Tons	17.5 Tons	20 Tons	25 Tons
Number Size Recommended	YSK036 (4) 20x20x2	YSK048 (4) 20x20x2	YSK060 (4) 20x20x2	YSK072 (2) 18x24x2 (3) 24x16x2	YSK090 (2) 18x24x2 (3) 24x16x2	YSK102 (2) 18x24x2 (3) 24x16x2	YSK120 (2) 18x24x2 (3) 24x16x2	YSK150 (2) 18x24x2 (3) 24x16x2	YSK180 (8) 20x24x2	YSK210 (8) 20x24x2	YSK240 (8) 20x24x2	YSK300 (8) 20x24x2
<b>Refrigerant Charge</b>												
lbs of R-454B	3.1	3.3	3.9	8.0	7.6	8.3	8.0	9.8	11.8	12.0	14.0	14.6
lbs of R-454B: Hot Gas Reheat	3.6	3.7	4.7	8.4	8.2	9.1	9.0	10.0	12.9	12.9	14.6	15.4
<b>Heating Performance (Gas/Electric Only)</b>												
<b>Heating Input: Staged</b>												
Low Heat Input (Btu) (High/Low Stage)	80,000/ 56,000	80,000/ 56,000	80,000/ 56,000	80,000/ 56,000	120,000/ 84,000	120,000/ 84,000	150,000/ 105,000	150,000/ 105,000	250,000/ 175,000	250,000/ 175,000	250,000/ 175,000	250,000/ 175,000
Mid Heat Input (Btu) (High/Low Stage)	100,000/ 70,000	100,000/ 70,000	100,000/ 70,000	120,000/ 84,000	150,000/ 105,000	150,000/ 105,000	200,000/ 140,000	200,000/ 140,000	320,000/ 224,000	320,000/ 224,000	320,000/ 224,000	320,000/ 224,000
High Heat Input (Btu) (High/Low Stage)	120,000/ 84,000	130,000/ 91,000	150,000/ 105,000	150,000/ 105,000	200,000/ 140,000	200,000/ 140,000	240,000/ 168,000	250,000/ 175,000	400,000/ 280,000	400,000/ 280,000	400,000/ 280,000	400,000/ 280,000
<b>Heating Output: Staged</b>												
Low Heat Output (Btu) (High/Low Stage)	64,800/ 45,300	64,800/ 45,300	64,800/ 45,300	64,800/ 45,300	97,200/ 68,000	97,200/ 68,000	121,500/ 85,000	121,500/ 85,000	202,500/ 141,750	202,500/ 141,750	202,500/ 141,750	202,500/ 141,750
Mid Heat Output (Btu) (High/Low Stage)	81,000/ 56,700	81,000/ 56,700	81,000/ 56,700	97,200/ 68,000	121,500/ 85,000	121,500/ 85,100	162,000/ 113,400	162,000/ 113,400	259,200/ 181,440	259,200/ 181,440	259,200/ 181,440	259,200/ 181,440
High Heat Output (Btu) (High/Low Stage)	97,200/ 68,000	105,300/ 73,700	121,500/ 85,100	121,500/ 85,000	162,000/ 113,400	162,000/ 113,400	194,400/ 136,000	202,500/ 141,750	324,000/ 226,800	324,000/ 226,800	324,000/ 226,800	324,000/ 226,800
<b>Heating Input: Modulating</b>												
Low Heat Input (Btu) (Maximum/Minimum)	—	—	—	80,000/8,000	120,000/ 12,000	120,000/ 12,000	—	150,000/ 15,000	250,000/ 25,000	250,000/ 25,000	250,000/ 25,000	250,000/ 25,000
High Heat Input (Btu) (Maximum/Minimum)	—	—	—	150,000/ 15,000	200,000/ 20,000	200,000/ 20,000	240,000/ 24,000	250,000/ 25,000	400,000/ 40,000	400,000/ 40,000	400,000/ 40,000	400,000/ 40,000
<b>Heating Output: Modulating</b>												
Low Heat Output (Btu) (Maximum/Minimum)	—	—	—	64,800/6,480	97,200/9,720	97,200/9,720	—	121,500/ 12,150	202,500/ 20,250	202,500/ 20,250	202,500/ 20,250	202,500/ 20,250
High Heat Output (Btu) (Maximum/Minimum)	—	—	—	121,500/ 12,150	162,000/ 16,200	162,000/ 16,200	194,000/ 19,440	202,500/ 20,250	324,000/ 32,400	324,000/ 32,400	324,000/ 32,400	324,000/ 32,400
<b>Steady State Efficiency %</b>												
Low Heat Input	81	81	81	81	81	81	81	81	81	81	81	81
Mid Heat Input	81	81	81	81	81	81	81	81	81	81	81	81
High Heat Input	81	81	81	81	81	81	81	81	81	81	81	81
<b>No. Burners: Staged</b>												
Low Heat Input	2	2	2	3	3	3	4	4	5	5	5	5
Mid Heat Input	3	3	3	3	4	4	6	4	7	7	7	7
High Heat Input	4	4	4	4	6	6	6	6	8	8	8	8

**Table 8. General data — gas - standard efficiency (continued)**

	3 Tons	4 Tons	5Tons	6 Tons	7.5 Tons	8.5 Tons	10 Tons	12.5 Tons	15 Tons	17.5 Tons	20 Tons	25 Tons
	YSK036	YSK048	YSK060	YSK072	YSK090	YSK102	YSK120	YSK150	YSK180	YSK210	YSK240	YSK300
<b>No. Burners : Modulating</b>												
Low Heat Input	—	—	—	2	4	4	4	4	6	6	6	6
High Heat Input	—	—	—	4	6	6	6	6	8	8	8	8
<b>No. Stages</b>												
Low Heat Input	2	2	2	2	2	2	2	2	2	2	2	2
Mid Heat Input	2	2	2	2	2	2	2	2	2	2	2	2
High Heat Input	2	2	2	2	2	2	2	2	2	2	2	2
<b>Gas Supply Line Pressure (inWC)</b>												
Natural (minimum/ maximum) Low Heat	4.5/14.0	4.5/14.0	4.5/14.0	4.5/14.0	4.5/14.0	4.5/14.0	4.5/14.0	4.5/14.0	4.5/14.0	4.5/14.0	4.5/14.0	4.5/14.0
Natural (minimum/ maximum) Mid Heat Heat	4.5/14.0	4.5/14.0	4.5/14.0	4.5/14.0	4.5/14.0	4.5/14.0	4.5/14.0	4.5/14.0	4.5/14.0	4.5/14.0	4.5/14.0	4.5/14.0
Natural (minimum/ maximum) High Heat	4.5/14.0	4.5/14.0	4.5/14.0	4.5/14.0	4.5/14.0	4.5/14.0	4.5/14.0	4.5/14.0	6.0/14.0	6.0/14.0	6.0/14.0	6.0/14.0
LP (minimum/ maximum)	11.5/14.0	11.5/14.0	11.5/14.0	11.5/14.0	11.5/14.0	11.5/14.0	11.5/14.0	11.5/14.0	11.5/14.0	11.5/14.0	11.5/14.0	11.5/14.0
<b>Gas Connection Pipe Size (in.)</b>												
Low Heat	1/2	1/2	1/2	1/2	3/4	3/4	3/4	3/4	3/4	3/4	3/4	3/4
Mid Heat	1/2	1/2	1/2	3/4	3/4	3/4	3/4	3/4	3/4	3/4	3/4	3/4
High Heat	3/4	3/4	3/4	3/4	3/4	3/4	3/4	3/4	3/4	3/4	3/4	3/4
<b>Cabinet</b>												
Cabinet Size	A.0	A.0	A.0	B.0	B.0	B.0	B.0	C.0	D.0	D.0	D.0	D.0

(a) The 3 to 5 ton cooling performance is rated at 95°F ambient, 80°F entering dry bulb, 67°F entering wet bulb. Gross capacity does not include the effect of fan motor heat. AHRI capacity is net and includes the effect of fan motor heat. Units are suitable for operation to ±20% of nominal cfm. Units are certified in accordance with the Unitary Air-Conditioner Equipment certification program, which is based on AHRI Standard 210/240. SEER shown for 3 to 5 ton units only. Then 3 to 5 ton EER and SEER are rated at AHRI conditions and calculated in accordance with AHRI Standard 210/240-2017. Airflow and net cooling capacity not shown.

(b) EER2 and SEER2 shown for 3 to 5 ton units only. EER2 and SEER2 are rated at AHRI conditions and certified in accordance with AHRI Standard 210/240-2023.

(c) IEER shown for 6 to 25 ton units only.

(d) Values for 575V unit.

(e) Outdoor sound rating shown is tested in accordance with AHRI 370-2015. For additional information reference the outdoor sound power level data in the performance section.

(f) YSK036 uses 1HP as standard motor for 575V application.

(g) For 17.5 to 20 ton, the oversized motor is only offered on units with optional modulating gas heat.

**Table 9. General data — gas - high efficiency**

	3 Tons	4 Tons	5 Tons	6 Tons	7.5 Tons	8.5 Tons	10 Tons	12.5 Tons	15 Tons	17.5 Tons	20 Tons	25 Tons
	YHK036	YHK048	YHK060	YHK072	YHK090	YHK102	YHK120	YHK150	YHK180	YHK210	YHK240	YHK300
<b>Cooling Performance<sup>(a)</sup></b>												
Gross Cooling Capacity	38900	50000	62400	79000	92000	108000	122000	152000	183000	214000	249000	281000
EER <sup>(b)</sup> / EER2 <sup>(c)</sup>	12.9 / 12.2	12.9 / 12.2	12.9 / 12.2	12.2	12.1	12.1	11.6	12.6	12.3	11.9	11.0	10.8
Nominal cfm/AHRI Rated cfm	1200 / 1200	1600 / 1600	2000 / 2000	2400 / 1860	3000 / 2625	3400 / 2635	4000 / 3100	5000/3875	6000/5250	7000/5950	8000/8000	10000/9000
AHRI Net Cooling Capacity	38000	49000	61000	78000	90000	106000	120000	150000	180000	210000	242000	272000
IEER <sup>(d)</sup> (2-Speed) / SEER <sup>(b)</sup> / SEER2 <sup>(c)</sup>	17.1 / 16.4	17.1 / 16.4	17.1 / 16.4	17.2	17.2	16.3	15.8	17.9	18.0	16.5	15.8	15.5
IEER (SZVAV/ MZVAV)	—	—	—	17.7/17.7	17.7/17.7	16.8/16.8	16.3/16.3	18.4/18.4	18.5/18.5	17.0/17.0	16.3/16.3	16.0/16.0
System Power (kW)	3.11	4.02	5.00	6.40	7.44	8.76	10.34	11.90	14.63	17.65	22.00	25.19
<b>Cooling Performance with Modulating Gas</b>												
Gross Cooling Capacity	—	—	—	79000	92000	107000	121000	152000	184000	214000	249000	281000
EER	—	—	—	12.2	12.1	11.8	11.3	12.6	12.2	11.9	10.8	10.3
Nominal cfm/AHRI Rated cfm	—	—	—	2400 / 1860	3000 / 2625	3400 / 2635	4000 / 3100	5000/3875	6000/5250	7000/5950	8000/8000	10000/9000
AHRI Net Cooling Capacity	—	—	—	78000	90000	105000	119000	150000	180000	210000	240000	270000
IEER <sup>(d)</sup> (2-Speed)	—	—	—	17.2	17.2	16.3	15.8	17.9	18.0	16.5	15.8	15.5
IEER (SZVAV/ MZVAV)	—	—	—	17.7/17.7	17.7/17.7	16.8/16.8	16.3/16.3	18.4/18.4	18.5/18.5	17.0/17.0	16.3/16.3	16.0/16.0
System Power (kW)	—	—	—	6.40	7.44	8.90	10.53	11.90	14.75	17.65	22.22	26.21
<b>Compressor</b>												
Number/Type	1/Scroll	1/Scroll	1/Scroll	2/Manifold Scroll	2/Manifold Scroll	2/Manifold Scroll	2/Manifold Scroll	2/Manifold Scroll	2/Manifold Scroll	2/Manifold Scroll	2/Manifold Scroll	2/Manifold Scroll
Percent Capacity (Stage 1 - Stage 4)	67/100	67/100	67/100	34/66/100	33/67/100	32/68/100	28/72/100	32/68/100	33/67/100	33/67/100	24/36/64/100	25/37/63/100
<b>Sound</b>												
Outdoor Sound Rating (dBA)	79	88	88	86	86	86	86	87	87	91	91	93
<b>Outdoor Coil</b>												
Type	Microchannel	Microchannel	Microchannel	Microchannel	Microchannel	Microchannel	Microchannel	Microchannel	Microchannel	Microchannel	Microchannel	Microchannel
Configuration	Full Face	Full Face	Full Face	Full Face	Full Face	Full Face	Full Face	Full Face	Full Face	Full Face	Full Face	Full Face
Tube Size (in.)	0.6	0.7	0.7	0.7	0.7	1.0	1.0	0.7	0.7	1.0	1.0	1.0
Face Area (sq. ft.)	13.8	21.64	21.64	21.64	21.64	21.64	21.64	33.89	33.89	33.89	33.89	33.89
Rows/FPI (Fins per inch)	1/23	1/23	1/23	1/23	1/23	1/23	1/23	1/23	1/23	1/21	1/21	1/21
<b>Indoor Coil</b>												
Type	Microchannel	Microchannel	Microchannel	Microchannel	Microchannel	Microchannel	Microchannel	Microchannel	Microchannel	Microchannel	Microchannel	Microchannel

**Table 9. General data — gas - high efficiency (continued)**

	3 Tons	4 Tons	5Tons	6 Tons	7.5 Tons	8.5 Tons	10 Tons	12.5 Tons	15 Tons	17.5 Tons	20 Tons	25 Tons
Configuration	YHK036 Full Face	YHK048 Full Face	YHK060 Full Face	YHK072 Full Face	YHK090 Full Face	YHK102 Full Face	YHK120 Full Face	YHK150 Full Face	YHK180 Full Face	YHK210 Full Face	YHK240 Full Face	YHK300 Full Face
Tube Size (in.)	1.0	0.6	0.6	1.0	1.0	1.0	1.0	1.0	1.0	1.0	1.0	1.0
Face Area (sq. ft.)	8.83	11.84	11.84	11.84	11.84	11.84	11.84	23.93	23.93	23.93	23.93	23.93
Rows/FPI (Fins per inch)	2/18	2/18	2/18	2/18	2/18	2/18	2/18	2/18	2/18	2/18	2/18	2/18
Refrigerant Control	TXV	TXV	TXV	TXV	TXV	TXV	TXV	TXV	TXV	TXV	TXV	TXV
Drain Connection No./Size (in.) NPT	1/0.75	1/0.75	1/0.75	1/0.75	1/0.75	1/0.75	1/0.75	1/1.0	1/1.0	1/1.0	1/1.0	1/1.0
<b>Reheat Coil</b>												
Type	Microchannel	Microchannel	Microchannel	Microchannel	Microchannel	Microchannel	Microchannel	Microchannel	Microchannel	Microchannel	Microchannel	Microchannel
Configuration	Full Face	Full Face	Full Face	Full Face	Full Face	Full Face	Full Face	Full Face	Full Face	Full Face	Full Face	Full Face
Tube Size (in.)	0.6	0.6	0.6	0.6	0.6	0.6	0.6	0.6	0.6	0.6	0.6	0.6
Face Area (sq. ft.)	5.49	9.04	9.04	9.04	9.04	9.04	9.04	21.83	21.83	21.83	21.83	21.83
Rows/FPI (Fins per inch)	1/23	1/23	1/23	1/23	1/23	1/23	1/23	1/23	1/23	1/23	1/23	1/23
<b>Outdoor Fan</b>												
Type	Propeller	Propeller	Propeller	Propeller	Propeller	Propeller	Propeller	Propeller	Propeller	Propeller	Propeller	Propeller
No. Used/Diameter (in.)	1/22	1/26	1/26	1/26	1/26	1/26	1/26	2/26	2/26	2/26	2/26	2/28
Drive Type/No. Speeds	Direct/1	Direct/1	Direct/1	Direct/1	Direct/1	Direct/1	Direct/1	Direct/1	Direct/1	Direct/1	Direct/1	Direct/1
CFM/ CFM-Modulating HGRH	3650/3370	4590/4130	4590/4870	5900	5900	7200	7200	11520	11520	14220	14220	16600
Motor HP/ Motor HP Modulating HGRH	0.25/0.33	0.4/0.5	0.4/0.5	0.70	0.70	0.75	0.75	0.50	0.50	1.00	1.00	1.00
Motor RPM/Motor RPM Modulating HGRH	1100/1014	1110/1000	1110/1180	1100	1100	1100	1100	1125	1125	1125	1125	1125
<b>Indoor Fan</b>												
Type	FC Centrifugal	BC Plenum	BC Plenum	BC Plenum	BC Plenum	BC Plenum	BC Plenum	BC Plenum	BC Plenum	BC Plenum	BC Plenum	BC Plenum
No. Used/Diameter (in.)/Width (in.)	1/11X11	1/23x6	1/23x6	1/23x6	1/23x6	1/23x6	1/23x6	2/23x6	2/23x6	2/23x6	2/23x6	2/23x6
Drive Type/No. Speeds/RPM	Direct/Variable	Direct/Variable	Direct/Variable	Direct/Variable	Direct/Variable	Direct/Variable	Direct/Variable	Direct/Variable	Direct/Variable	Direct/Variable	Direct/Variable	Direct/Variable
Motor HP (Standard/Oversized)	0.75/1.0	3.0/-	3.0/-	3.0/-	3.0/-	3.0/-	3.0/4.6	3.0/-	3.0/-	3.0/4.6(e)	3.0/4.6(e)	3.0/4.6
Max Motor RPM	1310	1850	1850	1850	1850	1850	1850/1940	1850	1850	1850 / 1940(e)	1850 / 1940(e)	1850 / 1940
<b>Filters<sup>(6)</sup></b>												
Type Furnished	Throwaway	Throwaway	Throwaway	Throwaway	Throwaway	Throwaway	Throwaway	Throwaway	Throwaway	Throwaway	Throwaway	Throwaway

**Table 9. General data — gas - high efficiency (continued)**

	3 Tons	4 Tons	5Tons	6 Tons	7.5 Tons	8.5 Tons	10 Tons	12.5 Tons	15 Tons	17.5 Tons	20 Tons	25 Tons
Number Size Recommended	YHK036 (4) 20x20x2	YHK048 (2) 18x24x2 (3) 24x16x2	YHK060 (2) 18x24x2 (3) 24x16x2	YHK072 (2) 18x24x2 (3) 24x16x2	YHK090 (2) 18x24x2 (3) 24x16x2	YHK102 (2) 18x24x2 (3) 24x16x2	YHK120 (2) 18x24x2 (3) 24x16x2	YHK150 (8) 20x24x2	YHK180 (8) 20x24x2	YHK210 (8) 20x24x2	YHK240 (8) 20x24x2	YHK300 (8) 20x24x2
<b>Refrigerant Charge</b>												
lbs of R-454B	5.3	7.5	7.5	8.0	7.6	8.3	8.4	11.9	11.8	13.2	14.0	14.6
lbs of R-454B, Hot Gas Reheat	5.6	7.9	7.9	8.4	8.2	9.1	9.4	12.9	12.9	13.9	14.6	15.4
<b>Heating Performance (Gas/Electric Only)</b>												
<b>Heating Input: Staged</b>												
Low Heat Input (Btu) (High/Low Stage)	80,000/ 56,000	80,000/ 56,000	80,000/ 56,000	80,000/ 56,000	120,000/ 84,000	120,000/ 84,000	150,000/ 105,000	150,000/ 105,000	250,000/ 175,000	250,000/ 175,000	250,000/ 175,000	250,000/ 175,000
Mid Heat Input (Btu) (High/Low Stage)	100,000/ 70,000	100,000/ 70,000	100,000/ 70,000	120,000/ 84,000	150,000/ 105,000	150,000/ 105,000	200,000/ 140,000	200,000/ 140,000	320,000/ 224,000	320,000/ 224,000	320,000/ 224,000	320,000/ 224,000
High Heat Input (Btu) (High/Low Stage)	120,000/ 84,000	130,000/ 91,000	150,000/ 105,000	150,000/ 105,000	200,000/ 140,000	200,000/ 140,000	240,000/ 168,000	250,000/ 175,000	400,000/ 280,000	400,000/ 280,000	400,000/ 280,000	400,000/ 280,000
<b>Heating Output: Staged</b>												
Low Heat Output (Btu) (High/Low Stage)	64,800/ 45,300	64,800/ 45,300	64,800/ 45,300	64,800/ 45,300	97,200/ 68,000	97,200/ 68,000	121,500/ 85,000	121,500/ 85,000	202,500/ 141,750	202,500/ 141,750	202,500/ 141,750	202,500/ 141,750
Mid Heat Output (Btu) (High/Low Stage)	81,000/ 56,700	81,000/ 56,700	81,000/ 56,700	97,200/ 68,000	121,500/ 85,000	121,500/ 85,100	162,000/ 113,400	162,000/ 113,400	259,200/ 181,440	259,200/ 181,440	259,200/ 181,440	259,200/ 181,440
High Heat Output (Btu) (High/Low Stage)	97,200/ 68,000	105,300/ 73,710	121,500/ 85,000	121,500/ 85,000	162,000/ 113,400	162,000/ 113,400	194,400/ 136,000	202,500/ 141,750	324,000/ 226,800	324,000/ 226,800	324,000/ 226,800	324,000/ 226,800
<b>Heating Input: Modulating</b>												
Low Heat Input (Btu) (Maximum/Minimum)	—	—	—	80,000/8,000	120,000/ 12,000	120,000/ 12,000	—	—	250,000/ 25,000	250,000/ 25,000	250,000/ 25,000	250,000/ 25,000
High Heat Input (Btu) (Maximum/Minimum)	—	—	—	150,000/ 15,000	200,000/ 20,000	200,000/ 20,000	240,000/24,000	250,000/ 25,000	400,000/ 40,000	400,000/ 40,000	400,000/ 40,000	400,000/ 40,000
<b>Heating Output: Modulating</b>												
Low Heat Output (Btu) (Maximum/Minimum)	—	—	—	64,800/6,480	97,200/9,720	97,200/9,720	—	—	202,500/ 20,250	202,500/ 20,250	202,500/ 20,250	202,500/ 20,250
High Heat Output (Btu) (Maximum/Minimum)	—	—	—	121,500/ 12,150	162,000/ 16,200	162,000/ 16,200	194,000/19,440	202,500/ 20,250	324,000/ 32,400	324,000/ 32,400	324,000/ 32,400	324,000/ 32,400
<b>Steady State Efficiency %</b>												
Low Heat Input	81	81	81	81	81	81	81	81	81	81	81	81
Mid Heat Input	81	81	81	81	81	81	81	81	81	81	81	81
High Heat Input	81	81	81	81	81	81	81	81	81	81	81	81
<b>No. Burners: Staged</b>												

**Table 9. General data — gas - high efficiency (continued)**

	3 Tons	4 Tons	5Tons	6 Tons	7.5 Tons	8.5 Tons	10 Tons	12.5 Tons	15 Tons	17.5 Tons	20 Tons	25 Tons
	YHK036	YHK048	YHK060	YHK072	YHK090	YHK102	YHK120	YHK150	YHK180	YHK210	YHK240	YHK300
Low Heat Input	2	3	3	3	3	3	4	5	5	5	5	5
Mid Heat Input	3	4	4	3	4	4	6	5	7	7	7	7
High Heat Input	4	5	5	4	6	6	6	7	8	8	8	8
<b>No. Burners: Modulating</b>												
Low Heat Input	—	—	—	2	4	4	4	—	6	6	6	6
High Heat Input	—	—	—	4	6	6	6	6	8	8	8	8
<b>No. Stages</b>												
Low Heat Input	2	2	2	2	2	2	2	2	2	2	2	2
Mid Heat Input	2	2	2	2	2	2	2	2	2	2	2	2
High Heat Input	2	2	2	2	2	2	2	2	2	2	2	2
<b>Gas Supply Line Pressure (inWC)</b>												
Natural (minimum/ maximum) Low Heat	4.5/14.0	4.5/14.0	4.5/14.0	4.5/14.0	4.5/14.0	4.5/14.0	4.5/14.0	4.5/14.0	4.5/14.0	4.5/14.0	4.5/14.0	4.5/14.0
Natural (minimum/ maximum) Mid Heat	4.5/14.0	4.5/14.0	4.5/14.0	4.5/14.0	4.5/14.0	4.5/14.0	4.5/14.0	4.5/14.0	4.5/14.0	4.5/14.0	4.5/14.0	4.5/14.0
Natural (minimum/ maximum) High Heat	4.5/14.0	4.5/14.0	4.5/14.0	4.5/14.0	4.5/14.0	4.5/14.0	4.5/14.0	4.5/14.0	6.0/14.0	6.0/14.0	6.0/14.0	6.0/14.0
LP (minimum/ maximum)	11.5/14.0	11.5/14.0	11.5/14.0	11.5/14.0	11.5/14.0	11.5/14.0	11.5/14.0	11.5/14.0	11.5/14.0	11.5/14.0	11.5/14.0	11.5/14.0
<b>Gas Connection Pipe Size (in.)</b>												
Low Heat	1/2	3/4	3/4	1/2	3/4	3/4	3/4	3/4	3/4	3/4	3/4	3/4
Mid Heat	1/2	3/4	3/4	3/4	3/4	3/4	3/4	3/4	3/4	3/4	3/4	3/4
High Heat	3/4	3/4	3/4	3/4	3/4	3/4	3/4	3/4	3/4	3/4	3/4	3/4
<b>Cabinet</b>												
Cabinet Size	A.0	B.0	B.0	B.0	B.0	B.0	B.0	D.0	D.0	D.0	D.0	D.0

(e) The 3 to 5 ton cooling performance is rated at 95°F ambient, 80°F entering dry bulb, 67°F entering wet bulb. Gross capacity does not include the effect of fan motor heat. AHRI capacity is net and includes the effect of fan motor heat. Units are suitable for operation to ±20% of nominal cfm. Units are certified in accordance with the Unitary Air-Conditioner Equipment certification program, which is based on AHRI Standard 210/240.  
 (b) SEER shown for 3 to 5 ton units only. The 3 to 5 ton EER and SEER are rated at AHRI conditions and calculated in accordance with AHRI Standard 210/240-2017. Airflow and net cooling capacity not shown.  
 (c) EER2 and SEER2 shown for 3 to 5 ton units only. EER2 and SEER2 are rated at AHRI conditions and certified in accordance with AHRI Standard 210/240-2023.  
 (d) IEER shown for 6 to 25 ton units only.  
 (e) For 17.5 to 20 ton, the oversized motor is only offered on units with optional modulating gas heat.  
 (f) Outdoor sound rating shown is tested in accordance with AHRI 370-2015. For additional information reference the outdoor sound power level data in the performance section.



# Gross Cooling Capacities

Table 10. Gross cooling capacities — 3 tons, standard efficiency

CFM	Ent DB (°F)	Entering Wet Bulb Temp (°F)						Entering Wet Bulb Temp (°F)						Entering Wet Bulb Temp (°F)					
		61		67		73		61		67		73		61		67		73	
		MBh	SHC	MBh	SHC	MBh	SHC	MBh	SHC	MBh	SHC	MBh	SHC	MBh	SHC	MBh	SHC	MBh	SHC
		Ambient Temperature 85°F						Ambient Temperature 95°F						Ambient Temperature 105°F					
1800	75	79.0	54.0	82.5	45.3	90.5	32.5	69.8	54.9	78.4	43.3	86.0	30.6	65.7	52.8	73.9	41.2	81.0	28.5
	80	73.5	65.3	82.4	55.1	90.7	42.6	69.8	64.4	78.4	53.1	86.3	40.7	65.7	62.3	73.9	51.0	81.4	38.6
	85	74.3	74.3	82.4	64.8	91.2	52.6	71.3	71.3	78.4	62.8	86.8	50.7	68.0	68.0	73.9	60.7	81.7	48.6
	90	78.3	78.3	82.4	72.5	91.1	62.4	75.3	75.3	78.4	72.3	86.6	60.4	71.9	71.9	73.8	70.1	81.6	58.3
2160	75	76.6	63.0	85.8	49.0	93.4	33.6	72.7	60.9	81.4	46.9	88.7	31.7	68.3	58.7	76.6	44.7	83.3	29.5
	80	76.6	74.2	85.7	60.7	94.3	45.8	72.6	72.1	81.4	58.6	89.9	44.0	68.6	68.6	76.6	56.4	84.6	41.8
	85	79.7	79.7	85.7	72.3	94.3	57.6	76.4	76.4	81.4	69.2	89.6	55.6	72.7	72.7	76.5	67.9	84.2	53.5
	90	84.0	84.0	85.3	83.3	94.2	69.3	80.6	80.6	80.9	80.9	89.4	67.3	76.7	76.7	76.8	76.8	84.0	65.1
2400	75	78.3	66.8	87.5	51.3	95.2	34.4	74.2	63.2	83.0	49.2	90.1	32.3	69.6	62.3	78.0	47.0	81.7	29.2
	80	78.1	78.1	87.4	64.3	96.4	48.0	74.8	74.8	82.9	62.2	91.5	46.0	71.0	71.0	77.9	60.0	86.0	43.7
	85	82.7	82.7	87.3	76.9	95.9	60.9	79.2	79.2	82.7	74.8	91.0	58.9	75.3	75.3	77.6	72.4	85.4	56.7
	90	87.0	87.0	87.2	87.2	95.8	73.9	83.4	83.4	83.5	83.5	90.8	71.9	79.2	79.2	79.4	79.4	85.3	69.5
2640	75	79.6	70.4	88.9	53.5	96.3	35.0	75.3	68.2	84.3	51.4	91.2	33.0	70.6	65.9	79.1	49.1	81.8	26.7
	80	80.6	80.6	88.9	67.8	97.9	49.9	77.1	77.1	84.2	65.7	92.8	47.9	73.1	73.1	79.1	63.4	87.2	45.6
	85	85.2	85.2	88.5	81.4	97.3	64.1	81.6	81.6	83.7	79.3	92.2	62.1	77.4	77.4	78.5	76.9	86.5	59.8
	90	89.6	89.6	89.7	89.7	97.1	78.1	85.8	85.8	85.9	85.9	92.1	73.7	81.3	81.3	81.5	81.5	86.1	73.7
2880	75	80.6	74.0	90.1	55.7	92.9	33.5	76.2	71.8	85.4	53.6	87.6	28.0	71.4	69.4	80.1	51.3	86.7	31.5
	80	82.7	82.7	90.0	71.3	99.1	51.8	79.1	79.1	85.3	69.0	93.8	49.7	75.0	75.0	80.0	64.5	88.2	47.4
	85	87.5	87.5	89.3	85.9	98.4	67.2	83.6	83.6	84.5	83.7	93.2	65.2	79.3	79.3	79.4	79.4	87.4	62.9
	90	91.8	91.8	91.9	91.9	98.1	82.4	87.8	87.8	87.9	87.9	92.6	80.2	83.1	83.1	83.2	83.2	86.5	77.8
		Ambient Temperature 115°F						Ambient Temperature 125°F											
1800	75	61.2	50.4	68.9	38.9	75.3	26.2	56.2	47.9	63.3	36.4	69.1	23.7						
	80	61.2	59.9	68.9	48.7	75.9	36.3	56.5	56.5	63.3	46.1	70.2	34.0						
	85	64.3	64.3	68.9	58.4	76.1	46.2	60.1	60.1	63.3	54.8	69.8	43.7						
	90	68.0	68.0	68.7	67.7	75.9	56.0	63.5	63.5	63.6	63.6	69.6	53.5						
2160	75	63.5	54.6	71.2	42.3	77.3	27.2	58.1	53.5	65.3	39.8	70.8	24.7						
	80	64.6	64.6	71.2	54.0	78.7	39.5	60.1	60.1	65.3	51.5	72.2	36.9						
	85	68.6	68.6	71.1	65.4	78.2	51.1	63.8	63.8	65.0	62.7	71.5	48.5						
	90	72.3	72.3	72.4	72.4	78.0	62.8	67.2	67.2	67.3	67.3	71.3	58.8						
2400	75	64.6	59.8	72.5	44.5	78.4	27.8	59.0	57.1	66.4	41.9	71.8	25.3						
	80	66.8	66.8	72.4	57.5	79.9	41.4	62.1	62.1	66.3	54.7	73.2	38.8						
	85	70.8	70.8	72.0	69.9	79.2	54.2	65.8	65.8	65.9	65.9	72.4	51.6						
	90	74.5	74.5	74.6	74.6	79.0	66.9	69.1	69.1	69.1	69.1	71.9	64.2						
2640	75	65.5	63.4	73.5	46.7	77.5	27.8	59.8	59.8	67.3	44.0	72.9	26.1						
	80	68.7	68.7	73.4	59.9	80.9	43.2	63.8	63.8	67.0	58.0	74.2	40.6						
	85	72.7	72.7	72.8	72.8	80.1	57.4	67.4	67.4	67.5	67.5	73.2	54.8						
	90	76.3	76.3	76.4	76.4	79.4	71.1	70.5	70.5	70.6	70.6	72.1	68.3						
2880	75	66.1	66.1	74.3	48.8	80.7	29.2	61.1	61.1	68.0	46.1	74.9	27.0						
	80	70.4	70.4	74.0	64.0	81.9	45.0	65.2	65.2	67.5	61.2	75.0	42.3						
	85	74.4	74.4	74.5	74.5	80.9	60.5	68.8	68.8	68.9	68.9	73.8	57.5						
	90	77.8	77.8	77.9	77.9	79.7	75.2	71.9	71.9	72.0	72.0	72.4	72.4						

**Notes:**

1. All capacities shown are gross and have not considered indoor fan heat. To obtain NET cooling capacity subtract indoor fan heat. For indoor fan heat formula, refer to appropriate airflow table notes.
2. MBh = Total gross capacity.
3. SHC = Sensible heat capacity.

**Table 11. Gross cooling capacities — 4 tons, standard efficiency**

CFM	Ent DB (°F)	Entering Wet Bulb Temp (°F)						Entering Wet Bulb Temp (°F)						Entering Wet Bulb Temp (°F)					
		61		67		73		61		67		73		61		67		73	
		MBh	SHC	MBh	SHC	MBh	SHC	MBh	SHC	MBh	SHC	MBh	SHC	MBh	SHC	MBh	SHC	MBh	SHC
		Ambient Temperature 85°F						Ambient Temperature 95°F						Ambient Temperature 105°F					
1200	75	43.8	34.2	49.9	27.4	55.9	19.5	41.3	32.7	47.2	25.9	52.8	18.1	38.5	31.1	44.1	24.3	49.3	16.5
	80	44.1	39.7	50.0	33.6	55.9	26.0	41.6	37.6	47.2	32.1	52.8	24.6	38.8	36.2	44.1	30.5	49.4	23.0
	85	45.0	45.0	50.0	39.6	55.9	32.3	43.0	43.0	47.2	38.1	52.9	30.8	40.6	40.6	44.2	36.5	49.4	29.2
	90	47.8	47.8	50.2	45.1	55.9	38.5	45.6	45.6	47.4	42.8	52.9	37.0	43.3	43.3	44.5	42.1	49.5	35.3
1440	75	45.7	37.7	51.8	29.5	57.7	20.2	43.0	36.2	48.8	28.0	54.4	18.9	40.0	34.5	45.6	26.4	50.7	17.3
	80	46.1	44.3	51.8	36.8	57.7	27.9	43.5	42.7	48.8	35.2	54.4	26.4	40.7	40.7	45.5	33.4	50.8	24.7
	85	48.2	48.2	51.9	43.8	57.7	35.2	46.0	46.0	48.9	42.3	54.5	33.7	43.4	43.4	45.7	40.2	50.8	32.0
	90	51.1	51.1	52.2	50.3	57.7	42.3	48.8	48.8	49.4	48.7	54.5	40.8	46.1	46.1	46.3	46.3	50.9	39.1
1600	75	46.7	39.9	52.7	30.8	58.7	20.9	43.9	38.3	49.6	29.3	55.2	19.3	40.9	36.2	46.3	27.7	51.4	17.7
	80	47.3	46.9	52.8	38.7	58.7	29.0	44.7	44.7	49.7	37.0	55.3	27.5	42.0	42.0	46.3	35.4	51.5	25.8
	85	50.0	50.0	53.0	46.5	58.7	37.1	47.6	47.6	49.8	44.1	55.3	35.5	44.9	44.9	46.7	41.7	51.5	33.8
	90	53.1	53.1	53.4	53.3	58.7	44.9	50.5	50.5	50.6	50.6	55.3	43.3	47.7	47.7	47.7	47.7	51.6	41.6
1760	75	47.5	42.0	53.5	32.1	59.4	21.2	44.7	39.7	50.3	30.5	55.9	19.7	41.6	37.3	47.1	28.9	52.0	18.0
	80	48.4	48.4	53.7	40.6	59.4	30.1	45.9	45.9	50.6	39.0	55.9	28.6	43.2	43.2	47.0	37.2	52.1	26.9
	85	51.5	51.5	53.6	47.9	59.4	38.8	49.0	49.0	50.6	45.6	55.9	37.2	46.2	46.2	47.3	45.0	52.1	35.3
	90	54.8	54.8	54.5	54.5	59.5	47.3	51.9	51.9	51.9	51.9	56.0	45.7	48.9	48.9	49.0	49.0	52.2	44.0
1920	75	48.3	43.2	54.1	33.3	60.1	21.6	45.4	41.5	50.9	31.7	56.5	20.0	42.2	39.4	47.4	30.0	52.5	18.4
	80	49.6	49.6	54.2	42.3	60.1	31.2	47.1	47.1	51.1	40.8	56.5	29.6	44.3	44.3	47.7	39.1	52.5	27.9
	85	52.8	52.8	54.4	49.2	60.0	40.4	50.3	50.3	51.4	49.1	56.5	38.7	47.3	47.3	47.9	47.2	52.6	36.9
	90	55.8	55.8	55.8	55.8	60.1	49.7	53.1	53.1	53.1	53.1	56.6	48.1	50.0	50.0	50.1	50.1	52.7	45.3
		Ambient Temperature 115°F						Ambient Temperature 125°F											
1200	75	35.4	29.4	40.6	22.6	45.5	15.0	32.1	27.6	36.8	20.8	41.3	13.1						
	80	35.9	35.1	40.7	28.8	45.6	21.3	32.7	32.7	36.9	26.8	41.3	19.4						
	85	38.0	38.0	40.8	34.8	45.6	27.5	35.2	35.2	37.1	32.6	41.4	25.7						
	90	40.6	40.6	41.2	40.3	45.7	33.5	37.6	37.6	37.7	37.7	41.5	31.7						
1440	75	36.9	32.6	41.9	24.6	46.7	15.6	33.4	30.0	38.0	22.7	42.2	13.7						
	80	37.8	37.8	42.0	31.7	46.7	23.0	34.8	34.8	38.0	29.7	42.3	21.1						
	85	40.5	40.5	42.2	37.6	46.8	30.3	37.4	37.4	38.4	36.4	42.3	28.1						
	90	43.3	43.3	43.2	43.2	46.9	37.4	39.8	39.8	39.8	39.8	42.5	35.4						
1600	75	37.6	33.9	42.5	25.8	47.3	15.9	33.9	32.3	38.4	23.9	42.7	14.0						
	80	39.1	39.1	42.8	33.6	47.3	24.1	35.9	35.9	38.7	31.6	42.7	22.2						
	85	42.0	42.0	42.9	40.8	47.3	31.8	38.6	38.6	39.0	38.7	42.8	29.8						
	90	44.5	44.5	44.5	44.5	47.5	39.8	40.9	40.9	41.0	41.0	43.0	36.8						
1760	75	38.2	36.2	43.1	27.0	47.8	16.2	34.6	34.1	38.8	25.0	43.1	14.3						
	80	40.2	40.2	43.3	35.4	47.8	25.1	37.0	37.0	39.1	33.4	43.1	23.1						
	85	43.2	43.2	43.5	43.0	47.9	33.5	39.5	39.5	39.6	39.6	43.2	31.5						
	90	45.6	45.6	45.6	45.6	48.0	41.3	41.9	41.9	42.0	42.0	43.4	39.4						
1920	75	38.8	37.9	43.4	27.9	48.2	16.6	35.1	35.1	39.2	25.8	43.4	14.6						
	80	41.2	41.2	43.6	37.2	48.2	26.1	37.8	37.8	39.7	34.7	43.4	24.1						
	85	44.0	44.0	44.1	44.1	48.3	35.1	40.3	40.3	40.4	40.4	43.6	33.0						
	90	46.6	46.6	46.6	46.6	48.4	43.6	42.8	42.8	42.8	42.8	43.8	41.4						

**Notes:**

1. All capacities shown are gross and have not considered indoor fan heat. To obtain NET cooling capacity subtract indoor fan heat. For indoor fan heat formula, refer to appropriate airflow table notes.
2. MBh = Total gross capacity.
3. SHC = Sensible heat capacity.



# Gross Cooling Capacities

**Table 12. Gross cooling capacities — 5 tons, standard efficiency**

CFM	Ent DB (°F)	Entering Wet Bulb Temp (°F)						Entering Wet Bulb Temp (°F)						Entering Wet Bulb Temp (°F)					
		61		67		73		61		67		73		61		67		73	
		MBh	SHC	MBh	SHC	MBh	SHC	MBh	SHC	MBh	SHC	MBh	SHC	MBh	SHC	MBh	SHC	MBh	SHC
		<b>Ambient Temperature 85°F</b>						<b>Ambient Temperature 95°F</b>						<b>Ambient Temperature 105°F</b>					
1500	75	56.0	44.4	62.3	34.7	68.3	24.0	52.8	42.6	58.7	32.9	64.3	22.3	49.3	40.8	54.7	31.0	59.9	20.7
	80	56.1	50.1	62.4	42.8	68.4	32.5	52.9	50.2	58.7	41.0	64.3	30.7	49.4	48.2	54.7	39.0	59.9	28.8
	85	57.4	57.4	62.4	50.7	68.4	40.6	54.7	54.7	58.8	48.9	64.4	38.8	51.6	51.6	54.8	47.0	60.0	37.0
	90	60.4	60.4	62.4	58.2	68.4	48.5	57.6	57.6	58.8	56.3	64.3	46.8	54.3	54.3	54.8	54.3	60.0	44.9
1800	75	58.2	49.1	64.4	37.5	70.4	25.2	54.7	47.3	60.5	35.7	66.1	23.4	51.0	44.8	56.2	33.7	61.4	21.5
	80	58.3	57.8	64.4	47.0	70.5	34.9	55.0	55.0	60.5	45.1	66.1	33.1	51.7	51.7	56.2	43.1	61.5	31.2
	85	61.1	61.1	64.4	56.0	70.5	44.6	58.0	58.0	60.6	52.3	66.2	42.8	54.6	54.6	56.3	52.1	61.5	40.7
	90	64.1	64.1	64.4	64.4	70.4	54.0	60.9	60.9	61.0	61.0	66.2	52.2	57.3	57.3	57.4	57.4	61.6	50.3
2000	75	59.2	51.8	65.4	39.3	71.5	25.7	55.7	48.8	61.4	37.4	67.0	23.9	51.8	47.8	56.9	35.4	62.2	21.9
	80	59.7	59.7	65.4	49.7	71.5	36.5	56.7	56.7	61.4	47.8	67.0	34.6	53.3	53.3	57.0	45.8	62.2	32.7
	85	63.0	63.0	65.4	59.6	71.5	47.0	59.8	59.8	61.4	57.6	67.1	45.1	56.1	56.1	56.9	55.4	62.3	43.2
	90	66.1	66.1	66.2	66.2	71.5	57.5	62.7	62.7	62.8	62.8	67.1	55.7	59.1	59.1	59.1	59.1	62.4	52.7
2200	75	60.1	51.8	66.2	40.9	72.3	26.2	56.5	52.5	62.1	38.9	67.7	24.4	52.4	50.3	57.6	36.9	62.8	22.4
	80	61.4	61.4	66.2	52.4	72.3	38.0	58.1	58.1	62.1	50.5	67.8	36.1	54.6	54.6	57.6	48.4	62.9	34.2
	85	64.6	64.6	66.2	62.9	72.3	49.4	61.2	61.2	62.0	60.9	67.8	47.6	57.4	57.4	57.5	57.5	62.9	45.6
	90	67.8	67.8	67.9	67.9	72.3	60.4	64.4	64.4	64.4	64.4	67.8	56.3	60.5	60.5	60.6	60.6	63.0	56.4
2400	75	60.9	57.1	66.9	42.4	73.7	26.9	57.1	55.0	62.7	40.5	68.8	25.1	53.0	52.8	58.1	38.4	63.3	22.9
	80	62.7	62.7	66.9	55.0	73.0	39.5	59.4	59.4	62.7	53.0	68.4	37.6	55.7	55.7	58.1	49.1	63.4	35.6
	85	66.0	66.0	66.7	66.1	73.1	51.8	62.5	62.5	62.5	62.5	68.4	49.9	58.7	58.7	58.7	58.7	63.5	48.0
	90	69.4	69.4	69.5	69.5	73.1	63.6	65.8	65.8	65.8	65.8	68.4	61.6	61.8	61.8	61.8	61.8	63.4	59.5
		<b>Ambient Temperature 115°F</b>						<b>Ambient Temperature 125°F</b>											
1500	75	45.4	38.7	50.2	29.0	55.1	18.7	41.1	36.3	45.5	26.8	49.7	16.6						
	80	45.6	45.6	50.3	36.9	55.1	26.9	41.9	41.9	45.5	34.7	49.8	24.7						
	85	48.2	48.2	50.4	44.3	55.2	34.9	44.3	44.3	45.6	42.4	49.9	32.7						
	90	50.7	50.7	50.7	50.7	55.3	42.9	46.8	46.8	46.8	46.8	50.0	40.8						
1800	75	46.8	42.9	51.5	31.6	56.3	19.4	42.3	40.5	46.6	29.2	50.7	17.3						
	80	48.1	48.1	51.6	41.0	56.4	29.2	44.0	44.0	46.7	38.8	50.8	27.0						
	85	50.7	50.7	51.6	49.8	56.5	38.6	46.6	46.6	46.7	46.7	50.9	36.4						
	90	53.5	53.5	53.6	53.6	56.5	48.0	49.1	49.1	49.2	49.2	51.0	45.6						
2000	75	47.5	45.5	52.1	33.1	56.9	19.9	42.8	42.8	47.1	30.9	51.2	17.7						
	80	49.5	49.5	52.2	43.7	57.0	30.6	45.2	45.2	47.2	40.2	51.3	28.5						
	85	52.2	52.2	52.3	52.3	58.6	41.6	47.9	47.9	47.9	47.9	51.4	38.9						
	90	55.0	55.0	55.0	55.0	57.2	51.1	50.3	50.3	50.4	50.4	51.4	48.7						
2200	75	48.0	48.0	52.7	34.7	57.4	20.4	43.6	43.6	47.6	32.4	51.6	18.2						
	80	50.5	50.5	52.8	44.4	57.5	32.1	46.2	46.2	47.7	43.5	51.7	29.5						
	85	53.4	53.4	53.5	53.5	59.3	44.1	48.9	48.9	48.9	48.9	54.6	42.1						
	90	56.2	56.2	56.3	56.3	57.5	54.2	51.3	51.3	51.4	51.4	51.6	51.6						
2400	75	48.7	48.7	53.2	36.2	57.9	20.8	44.3	44.3	48.0	34.0	51.9	18.6						
	80	51.5	51.5	53.3	48.2	58.0	33.1	47.1	47.1	48.0	45.8	52.1	30.8						
	85	54.5	54.5	54.5	54.5	59.9	46.5	49.7	49.7	51.2	51.2	52.2	42.5						
	90	57.2	57.2	57.3	57.3	57.8	57.2	52.1	52.1	52.2	52.2	52.2	52.2						

**Notes:**

1. All capacities shown are gross and have not considered indoor fan heat. To obtain NET cooling capacity subtract indoor fan heat. For indoor fan heat formula, refer to appropriate airflow table notes.
2. MBh = Total gross capacity.
3. SHC = Sensible heat capacity.

**Table 13. Gross cooling capacities — 6 tons, standard efficiency**

CFM	Ent DB (°F)	Entering Wet Bulb Temp (°F)						Entering Wet Bulb Temp (°F)						Entering Wet Bulb Temp (°F)					
		61		67		73		61		67		73		61		67		73	
		MBh	SHC	MBh	SHC	MBh	SHC	MBh	SHC	MBh	SHC	MBh	SHC	MBh	SHC	MBh	SHC	MBh	SHC
		<b>Ambient Temperature 85°F</b>						<b>Ambient Temperature 95°F</b>						<b>Ambient Temperature 105°F</b>					
1800	75	78.8	53.9	82.3	45.2	90.3	32.5	69.6	54.8	78.2	43.3	85.9	30.5	65.6	52.7	73.7	41.1	80.8	28.4
	80	73.3	65.2	82.3	55.0	90.5	42.5	69.7	64.3	78.2	53.0	86.1	40.6	65.6	62.1	73.7	50.9	81.2	38.5
	85	74.1	74.1	82.2	64.7	91.0	52.5	71.2	71.2	78.2	62.7	86.6	50.6	67.9	67.9	73.7	60.6	81.5	48.5
	90	78.2	78.2	82.2	72.3	90.9	62.2	75.1	75.1	78.2	72.2	86.4	60.3	71.7	71.7	73.6	70.0	81.4	58.2
2160	75	76.5	62.8	85.6	48.9	93.2	33.5	72.5	60.8	81.2	46.8	88.5	31.6	68.2	58.6	76.4	44.6	83.1	29.5
	80	76.4	74.0	85.6	60.5	94.1	45.7	72.5	72.0	81.2	58.5	89.7	43.9	68.4	68.4	76.4	56.3	84.5	41.7
	85	79.5	79.5	85.5	72.2	94.1	57.5	76.3	76.3	81.2	69.1	89.4	55.5	72.6	72.6	76.4	67.7	84.0	53.3
	90	83.8	83.8	85.1	83.2	94.0	69.2	80.4	80.4	80.8	80.8	89.2	67.2	76.5	76.5	76.7	76.7	83.8	65.0
2400	75	78.1	66.6	87.3	51.2	95.0	34.3	74.0	63.1	82.8	49.1	89.9	32.3	69.5	62.2	77.8	46.9	81.5	29.1
	80	78.0	78.0	87.3	64.1	96.2	47.9	74.6	74.6	82.8	62.1	91.3	45.9	70.9	70.9	77.8	59.8	85.8	43.7
	85	82.5	82.5	87.1	76.7	95.7	60.7	79.0	79.0	82.6	74.6	90.8	58.7	75.1	75.1	77.5	72.3	85.3	56.5
	90	86.8	86.8	87.0	87.0	95.6	73.7	83.2	83.2	83.4	83.4	90.7	71.7	79.1	79.1	79.2	79.2	85.1	69.3
2640	75	79.4	70.3	88.7	53.4	96.1	34.9	75.2	68.1	84.1	51.3	91.1	32.9	70.5	65.7	79.0	49.0	81.7	26.6
	80	80.4	80.4	88.7	67.6	97.7	49.8	76.9	76.9	84.0	65.6	92.6	47.8	73.0	73.0	78.9	63.3	87.0	45.5
	85	85.1	85.1	88.3	81.3	97.1	63.9	81.4	81.4	83.6	79.1	92.0	61.9	77.3	77.3	78.3	76.8	86.3	59.7
	90	89.4	89.4	89.6	89.6	96.9	78.0	85.6	85.6	85.7	85.7	91.9	73.6	81.2	81.2	81.3	81.3	85.9	73.5
2880	75	80.4	73.8	90.0	55.6	92.7	33.4	76.1	71.6	85.2	53.5	87.5	28.0	71.3	69.3	79.9	51.2	86.5	31.4
	80	82.6	82.6	89.9	71.1	98.9	51.6	78.9	78.9	85.1	68.8	93.7	49.6	74.8	74.8	79.8	64.4	88.0	47.3
	85	87.3	87.3	89.1	85.7	98.2	67.1	83.5	83.5	84.3	83.5	93.0	65.1	79.1	79.1	79.2	79.2	87.2	62.8
	90	91.6	91.6	91.7	91.7	97.9	82.2	87.6	87.6	87.7	87.7	92.4	80.0	82.9	82.9	83.0	83.0	86.3	77.6
		<b>Ambient Temperature 115°F</b>						<b>Ambient Temperature 125°F</b>											
1800	75	61.1	50.3	68.7	38.8	75.2	26.1	56.1	47.8	63.2	36.3	68.9	23.7						
	80	61.1	59.8	68.7	48.6	75.7	36.3	56.3	56.3	63.2	46.0	70.1	34.0						
	85	64.2	64.2	68.7	58.3	75.9	46.1	59.9	59.9	63.2	54.7	69.7	43.6						
	90	67.8	67.8	68.6	67.6	75.8	55.9	63.4	63.4	63.5	63.5	69.5	53.3						
2160	75	63.4	54.5	71.1	42.2	77.2	27.1	58.0	53.4	65.2	39.7	70.6	24.6						
	80	64.5	64.5	71.1	53.9	78.5	39.4	60.0	60.0	65.2	51.3	72.0	36.8						
	85	68.4	68.4	70.9	65.2	78.0	51.0	63.7	63.7	64.9	62.5	71.4	48.4						
	90	72.1	72.1	72.2	72.2	77.8	62.6	67.1	67.1	67.2	67.2	71.2	58.6						
2400	75	64.4	59.7	72.3	44.4	78.3	27.8	58.9	57.0	66.2	41.8	71.6	25.3						
	80	66.7	66.7	72.2	57.4	79.7	41.3	62.0	62.0	66.2	54.6	73.1	38.7						
	85	70.7	70.7	71.8	69.8	79.1	54.1	65.7	65.7	65.7	65.7	72.3	51.5						
	90	74.3	74.3	74.4	74.4	78.8	66.8	68.9	68.9	69.0	69.0	71.7	64.0						
2640	75	65.3	63.2	73.3	46.6	77.3	27.3	59.6	59.6	67.1	43.9	72.8	26.0						
	80	68.6	68.6	73.2	59.7	80.8	43.1	63.6	63.6	66.8	57.9	74.0	40.5						
	85	72.6	72.6	72.7	72.7	80.0	57.3	67.3	67.3	67.4	67.4	73.0	54.6						
	90	76.1	76.1	76.2	76.2	79.3	70.9	70.4	70.4	70.5	70.5	71.9	68.1						
2880	75	66.0	66.0	74.2	48.7	80.5	29.2	61.0	61.0	67.8	46.0	74.6	26.9						
	80	70.2	70.2	73.8	63.9	81.7	44.9	65.0	65.0	67.3	61.1	74.8	42.2						
	85	74.2	74.2	74.3	74.3	80.7	60.4	68.7	68.7	68.7	68.7	73.6	57.4						
	90	77.6	77.6	77.7	77.7	79.5	75.0	71.7	71.7	71.8	71.8	72.3	72.3						

**Notes:**

1. All capacities shown are gross and have not considered indoor fan heat. To obtain NET cooling capacity subtract indoor fan heat. For indoor fan heat formula, refer to appropriate airflow table notes.
2. MBh = Total gross capacity.
3. SHC = Sensible heat capacity.



# Gross Cooling Capacities

**Table 14. Gross cooling capacities — 7.5 tons, standard efficiency**

CFM	Ent DB (°F)	Entering Wet Bulb Temp (°F)						Entering Wet Bulb Temp (°F)						Entering Wet Bulb Temp (°F)					
		61		67		73		61		67		73		61		67		73	
		MBh	SHC	MBh	SHC	MBh	SHC	MBh	SHC	MBh	SHC	MBh	SHC	MBh	SHC	MBh	SHC	MBh	SHC
		<b>Ambient Temperature 85°F</b>						<b>Ambient Temperature 95°F</b>						<b>Ambient Temperature 105°F</b>					
2250	75	92.3	68.1	94.9	53.2	105.0	37.9	79.3	64.7	89.8	50.8	99.4	35.5	74.4	62.1	84.4	48.2	93.3	33.0
	80	83.6	78.2	94.8	65.1	105.1	50.1	79.1	75.7	89.7	62.7	99.5	47.8	74.2	73.0	84.3	60.2	93.4	45.2
	85	85.4	85.4	94.5	77.0	105.1	62.3	81.8	81.8	89.5	74.6	99.6	59.9	77.9	77.9	84.1	71.9	93.5	57.4
	90	90.4	90.4	94.2	87.9	105.0	74.3	86.7	86.7	89.2	85.4	99.5	71.9	82.5	82.5	83.8	82.7	93.4	69.4
2700	75	87.1	74.2	98.4	57.5	108.1	39.1	82.2	70.3	93.0	55.0	102.2	36.7	77.0	68.5	87.3	52.4	95.7	34.1
	80	86.6	86.6	98.2	71.7	108.3	53.8	82.0	82.0	92.8	69.2	102.4	51.3	77.9	77.9	87.0	66.6	96.0	48.8
	85	91.2	91.2	97.8	82.4	108.3	68.2	87.2	87.2	92.4	82.5	102.4	65.7	82.9	82.9	86.5	79.7	96.0	63.1
	90	96.5	96.5	97.1	97.1	108.2	82.5	92.3	92.3	92.4	92.4	102.3	80.1	87.7	87.7	87.8	87.8	95.9	77.5
3000	75	89.7	75.8	100.3	60.2	109.7	39.9	83.6	75.3	94.7	57.7	103.6	37.4	78.1	72.5	88.7	55.0	96.9	34.8
	80	88.9	88.9	99.9	75.9	110.0	56.1	84.8	84.8	94.3	73.4	103.9	53.6	80.4	80.4	88.3	70.7	97.2	51.0
	85	94.4	94.4	99.2	90.2	109.9	72.0	90.2	90.2	93.6	87.5	103.9	69.5	85.6	85.6	87.6	84.7	97.2	66.9
	90	99.8	99.8	99.9	99.9	109.9	87.9	95.3	95.3	95.5	95.5	103.8	83.5	90.5	90.5	90.6	90.6	97.1	81.9
3300	75	89.9	82.0	101.7	62.8	111.0	40.6	84.6	79.2	96.0	60.3	104.7	38.1	79.1	76.4	89.8	57.6	97.9	35.5
	80	91.5	91.5	101.2	80.0	111.3	58.3	87.3	87.3	95.5	77.4	105.1	55.8	82.7	82.7	89.4	72.1	98.2	53.2
	85	97.1	97.1	100.2	95.2	111.3	75.7	92.7	92.7	94.5	92.4	105.0	73.3	87.9	87.9	88.3	88.3	98.3	70.6
	90	102.5	102.5	102.7	102.7	111.1	92.1	97.9	97.9	98.0	98.0	104.7	89.4	92.8	92.8	92.9	92.9	97.7	86.5
3600	75	90.8	85.8	102.9	65.3	112.1	41.3	85.4	83.0	97.0	62.8	105.6	38.8	79.7	79.7	90.7	60.1	98.7	36.2
	80	93.8	93.8	102.3	82.3	112.4	60.4	89.4	89.4	96.4	80.5	106.0	58.0	84.6	84.6	90.0	77.6	99.1	55.3
	85	99.5	99.5	101.0	100.0	112.4	79.4	94.9	94.9	95.1	95.1	106.0	77.0	89.9	89.9	89.9	89.9	99.1	74.3
	90	104.9	104.9	105.0	105.0	111.7	96.7	100.1	100.1	100.2	100.2	105.1	93.9	94.7	94.7	94.8	94.8	98.0	91.0
		<b>Ambient Temperature 115°F</b>						<b>Ambient Temperature 125°F</b>											
2250	75	69.1	59.5	78.5	45.5	86.7	30.3	63.4	54.5	72.2	42.7	79.5	27.5						
	80	69.0	69.0	78.4	57.5	86.8	42.6	64.4	64.4	72.1	54.6	79.7	39.8						
	85	73.5	73.5	78.2	66.6	86.9	54.7	68.8	68.8	71.8	65.9	79.8	51.8						
	90	78.0	78.0	78.1	78.1	86.9	66.7	73.0	73.0	73.1	73.1	79.8	63.9						
2700	75	71.3	65.5	81.0	49.6	88.7	31.4	65.2	62.4	74.3	46.7	81.2	28.5						
	80	73.3	73.3	80.7	63.8	89.0	46.0	68.3	68.3	74.0	60.9	81.5	43.1						
	85	78.1	78.1	80.2	76.7	89.0	60.4	72.8	72.8	73.5	73.5	81.5	57.5						
	90	82.7	82.7	82.8	82.8	89.0	72.0	77.0	77.0	77.1	77.1	81.3	71.0						
3000	75	72.3	69.5	82.2	52.2	89.7	32.1	66.1	66.1	75.3	49.2	82.0	29.2						
	80	75.6	75.6	81.9	66.8	90.1	48.2	70.4	70.4	74.9	64.2	82.4	45.3						
	85	80.5	80.5	81.1	81.1	90.1	64.2	75.0	75.0	75.0	75.0	82.4	61.2						
	90	85.1	85.1	85.2	85.2	89.7	78.9	79.1	79.1	79.2	79.2	81.8	75.6						
3300	75	73.1	73.1	83.2	54.7	90.6	32.8	67.3	67.3	76.1	51.7	82.7	29.9						
	80	77.6	77.6	82.7	71.0	90.9	50.4	72.2	72.2	75.5	67.8	83.1	47.4						
	85	82.6	82.6	82.6	82.6	91.0	67.9	76.7	76.7	76.8	76.8	83.2	64.4						
	90	87.1	87.1	87.2	87.2	90.1	83.4	80.7	80.7	80.8	80.8	82.0	80.2						
3600	75	74.2	74.2	84.0	57.2	91.3	33.4	68.8	68.8	76.8	54.2	83.4	30.5						
	80	79.4	79.4	83.2	74.5	91.7	52.5	73.7	73.7	75.9	71.3	83.7	49.6						
	85	84.3	84.3	84.4	84.4	91.7	70.3	78.2	78.2	78.3	78.3	83.6	67.7						
	90	88.7	88.7	88.8	88.8	90.3	87.9	82.1	82.1	82.1	82.1	82.2	82.2						

**Notes:**

1. All capacities shown are gross and have not considered indoor fan heat. To obtain NET cooling capacity subtract indoor fan heat. For indoor fan heat formula, refer to appropriate airflow table notes.
2. MBh = Total gross capacity.
3. SHC = Sensible heat capacity.

**Table 15. Gross cooling capacities — 8.5 tons, standard efficiency**

CFM	Ent DB (° F)	Entering Wet Bulb Temp (°F)						Entering Wet Bulb Temp (°F)						Entering Wet Bulb Temp (°F)					
		61		67		73		61		67		73		61		67		73	
		MBh	SHC	MBh	SHC	MBh	SHC	MBh	SHC	MBh	SHC	MBh	SHC	MBh	SHC	MBh	SHC	MBh	SHC
		<b>Ambient Temperature 85°F</b>						<b>Ambient Temperature 95°F</b>						<b>Ambient Temperature 105°F</b>					
2550	75	107.4	74.2	112.3	62.2	126.6	45.9	93.7	74.8	106.8	59.6	120.4	43.2	88.5	72.1	101.0	56.9	113.8	40.4
	80	98.3	89.9	112.1	75.6	126.5	59.6	93.4	87.2	106.6	72.9	120.3	56.9	88.2	84.3	100.7	70.2	113.7	54.2
	85	99.2	99.2	111.6	88.8	126.3	73.2	95.4	95.4	106.1	86.2	120.1	70.4	91.3	91.3	100.4	83.4	113.6	67.7
	90	105.1	105.1	111.2	101.1	126.0	86.5	101.1	101.1	105.8	98.3	119.9	83.9	96.9	96.9	100.0	95.4	113.3	81.1
3060	75	102.7	85.5	117.0	67.3	131.6	47.7	97.4	82.8	111.0	64.5	124.9	44.9	91.8	78.0	104.8	61.6	117.8	42.1
	80	102.0	99.4	116.6	83.1	131.5	64.0	96.8	96.6	110.7	80.3	124.8	61.3	91.4	91.4	104.4	77.5	117.7	58.4
	85	106.2	106.2	115.9	97.3	131.2	80.0	102.0	102.0	110.1	92.1	124.6	77.3	97.5	97.5	103.8	92.2	117.5	74.4
	90	112.7	112.7	115.2	112.5	130.7	95.9	108.3	108.3	109.4	109.4	124.0	93.2	103.6	103.6	103.8	103.8	117.0	90.3
3400	75	104.7	88.4	119.5	70.4	134.2	48.8	99.2	87.0	113.4	67.6	127.2	46.0	93.4	83.9	106.9	64.7	119.8	43.1
	80	103.8	103.8	118.9	87.8	134.0	66.8	99.2	99.2	112.7	85.0	127.0	64.0	94.6	94.6	106.2	82.1	119.6	60.9
	85	110.2	110.2	118.0	103.9	133.7	84.4	105.8	105.8	111.9	101.0	126.7	81.6	101.0	101.0	105.4	97.9	119.4	78.7
	90	117.0	117.0	117.1	117.1	133.0	102.0	112.3	112.3	112.5	112.5	126.1	99.2	107.4	107.4	107.5	107.5	118.8	94.9
3740	75	106.3	94.3	121.7	73.4	136.3	49.8	100.5	91.3	115.3	70.6	129.1	46.9	94.5	88.2	108.5	67.6	121.5	44.0
	80	106.8	106.8	120.7	92.5	136.0	69.3	102.3	102.3	114.4	89.6	128.9	66.5	97.5	97.5	107.7	86.7	121.4	63.5
	85	113.7	113.7	119.6	109.5	135.6	88.7	109.0	109.0	113.2	106.5	128.5	85.8	104.0	104.0	106.5	103.3	120.9	82.8
	90	120.7	120.7	120.9	120.9	134.8	106.7	115.9	115.9	116.0	116.0	127.7	104.0	110.6	110.6	110.7	110.7	120.1	100.8
4080	75	107.5	98.6	123.4	76.3	138.1	50.7	101.6	95.6	116.7	73.4	130.8	47.8	95.4	92.4	109.8	70.4	123.0	44.9
	80	109.6	109.6	122.2	97.0	137.9	71.9	104.9	104.9	115.7	92.3	130.6	69.0	100.0	100.0	108.7	90.1	122.9	66.0
	85	116.8	116.8	120.7	114.9	137.3	92.8	111.9	111.9	114.2	111.9	129.9	89.9	106.7	106.7	107.4	107.4	122.2	87.0
	90	124.1	124.1	124.2	124.2	136.2	112.2	119.0	119.0	119.1	119.1	128.8	109.1	113.5	113.5	113.6	113.6	121.1	105.9
		<b>Ambient Temperature 115°F</b>						<b>Ambient Temperature 125°F</b>											
2550	75	82.9	69.2	94.7	54.0	106.7	37.5	77.0	66.1	88.0	50.8	99.1	34.5						
	80	82.7	81.3	94.5	67.3	106.7	51.3	76.7	76.7	87.8	64.2	99.1	48.2						
	85	86.8	86.8	94.2	80.1	106.6	64.8	82.0	82.0	87.6	74.2	99.0	61.7						
	90	92.3	92.3	93.9	92.4	106.3	78.2	87.3	87.3	87.4	87.4	98.8	75.1						
3060	75	85.8	76.2	98.2	58.6	110.2	39.1	79.4	72.9	91.1	55.5	102.1	35.9						
	80	86.7	86.7	97.7	74.5	110.1	55.4	81.6	81.6	90.6	71.3	102.0	52.1						
	85	92.6	92.6	97.2	89.0	109.9	71.3	87.3	87.3	90.0	85.7	101.9	68.2						
	90	98.5	98.5	98.7	98.7	109.5	87.3	93.0	93.0	93.1	93.1	101.5	81.7						
3400	75	87.2	80.7	100.0	61.6	112.0	40.0	80.6	77.3	92.6	58.4	103.6	36.8						
	80	89.7	89.7	99.3	79.1	111.9	57.9	84.4	84.4	92.0	74.5	103.6	54.7						
	85	95.8	95.8	98.5	94.6	111.6	75.6	90.2	90.2	91.2	91.2	103.3	72.4						
	90	102.0	102.0	102.1	102.1	111.1	92.2	96.1	96.1	96.2	96.2	102.7	88.7						
3740	75	88.2	84.9	101.4	64.5	113.5	40.9	81.4	81.4	93.8	61.2	104.9	37.7						
	80	92.3	92.3	100.6	80.6	113.4	60.4	86.7	86.7	92.9	79.3	104.9	57.1						
	85	98.6	98.6	99.5	99.5	112.9	79.7	92.8	92.8	92.9	92.9	104.4	76.5						
	90	105.0	105.0	105.1	105.1	112.1	97.4	98.8	98.8	98.9	98.9	103.5	93.9						
4080	75	88.9	88.9	102.5	67.3	114.7	41.7	82.6	82.6	94.7	64.0	106.0	38.5						
	80	94.6	94.6	101.4	86.7	114.6	62.8	88.8	88.8	93.7	83.2	105.9	59.5						
	85	101.1	101.1	101.2	101.2	114.0	83.8	95.0	95.0	95.1	95.1	105.3	80.3						
	90	107.6	107.6	107.7	107.7	112.8	102.5	101.1	101.1	101.2	101.2	104.1	99.0						

**Notes:**

1. All capacities shown are gross and have not considered indoor fan heat. To obtain NET cooling capacity subtract indoor fan heat. For indoor fan heat formula, refer to appropriate airflow table notes.
2. MBh = Total gross capacity.
3. SHC = Sensible heat capacity.

**Table 16. Gross cooling capacities — 10 tons, standard efficiency**

CFM	Ent DB (° F)	Entering Wet Bulb Temp (°F)						Entering Wet Bulb Temp (°F)						Entering Wet Bulb Temp (°F)					
		61		67		73		61		67		73		61		67		73	
		MBh	SHC	MBh	SHC	MBh	SHC	MBh	SHC	MBh	SHC	MBh	SHC	MBh	SHC	MBh	SHC	MBh	SHC
		<b>Ambient Temperature 85°F</b>						<b>Ambient Temperature 95°F</b>						<b>Ambient Temperature 105°F</b>					
3000	75	121.9	85.7	128.3	71.7	140.9	51.0	108.5	87.5	121.3	68.5	132.7	47.7	101.9	84.2	113.7	65.0	123.8	44.1
	80	114.0	105.3	128.2	87.6	141.0	67.2	107.9	101.9	121.2	84.3	132.8	63.9	101.4	98.4	113.6	80.8	123.9	60.3
	85	115.3	115.3	127.8	103.3	141.0	83.3	110.5	110.5	120.9	100.0	132.9	79.9	105.1	105.1	113.4	96.6	124.1	76.3
	90	121.6	121.6	127.3	117.6	140.9	99.2	116.5	116.5	120.3	114.1	132.8	95.8	110.8	110.8	112.7	110.4	124.1	92.3



# Gross Cooling Capacities

**Table 16. Gross cooling capacities — 10 tons, standard efficiency (continued)**

CFM	Ent DB (° F)	Entering Wet Bulb Temp (°F)						Entering Wet Bulb Temp (°F)						Entering Wet Bulb Temp (°F)									
		61		67		73		61		67		73		61		67		73					
		MBh	SHC	MBh	SHC	MBh	SHC	MBh	SHC	MBh	SHC	MBh	SHC	MBh	SHC	MBh	SHC	MBh	SHC				
3600	75	118.8	99.9	132.9	77.3	144.9	52.6	112.2	96.6	125.3	73.9	136.1	49.1	105.2	90.2	117.1	70.3	127.0	45.6				
	80	117.7	116.1	132.6	96.0	145.1	71.9	111.1	111.1	125.0	92.7	136.3	68.4	105.2	105.2	116.9	89.1	127.0	64.9				
	85	122.7	122.7	132.1	112.0	145.1	90.9	117.3	117.3	124.4	110.2	136.4	87.4	111.2	111.2	116.2	106.3	127.0	83.8				
	90	129.3	129.3	130.7	130.4	145.0	109.8	123.5	123.5	123.6	123.6	136.4	106.4	117.0	117.0	117.1	117.1	127.0	102.8				
4000	75	120.9	103.1	135.2	80.8	147.0	53.6	113.9	101.3	127.3	77.3	138.1	50.2	106.5	97.5	118.9	73.7	128.8	46.6				
	80	119.9	119.9	134.8	101.5	147.2	74.9	114.4	114.4	126.9	98.0	138.1	71.4	108.4	108.4	118.5	94.4	128.8	67.8				
	85	126.8	126.8	133.8	120.3	147.2	95.8	120.9	120.9	125.8	116.6	138.2	92.3	114.5	114.5	117.3	112.6	128.5	88.7				
	90	133.5	133.5	133.6	133.6	147.1	116.8	127.2	127.2	127.3	127.3	138.1	111.8	120.2	120.2	120.3	120.3	128.3	108.4				
4400	75	122.3	110.0	137.1	84.2	149.0	54.6	115.2	106.3	129.0	80.6	139.9	51.2	107.5	102.4	120.2	76.9	130.3	47.6				
	80	123.2	123.2	136.5	106.8	149.0	77.8	117.4	117.4	128.4	103.3	139.8	74.3	111.1	111.1	119.8	97.4	130.3	70.7				
	85	130.3	130.3	135.0	126.6	148.9	100.7	124.1	124.1	126.8	122.8	139.6	97.2	117.2	117.2	118.0	118.0	129.8	93.5				
	90	137.0	137.0	137.2	137.2	149.0	118.6	130.4	130.4	130.5	130.5	139.1	118.4	122.9	122.9	123.0	123.0	128.8	114.2				
4800	75	123.4	114.9	138.7	87.5	150.7	55.6	116.1	111.1	130.3	83.9	141.4	52.2	108.3	107.2	121.4	80.1	131.6	48.5				
	80	126.2	126.2	138.0	111.8	150.6	80.6	120.1	120.1	129.9	104.4	141.3	77.1	113.5	113.5	120.5	103.3	131.6	73.5				
	85	133.3	133.3	135.8	132.7	150.4	105.5	126.8	126.8	127.3	127.3	140.9	101.9	119.6	119.6	119.7	119.7	130.9	98.3				
	90	140.1	140.1	140.2	140.2	149.4	128.2	133.0	133.0	133.1	133.1	139.6	124.2	125.2	125.2	125.3	125.3	129.4	120.1				
<b>Ambient Temperature 115°F</b>																		<b>Ambient Temperature 125°F</b>					
3000	75	94.9	80.7	105.6	61.4	114.5	40.4	87.4	75.8	96.8	57.5	104.8	36.7										
	80	94.3	94.3	105.5	77.2	114.6	56.6	87.6	87.6	96.7	73.3	104.9	52.9										
	85	99.2	99.2	105.3	90.4	114.6	72.6	92.6	92.6	96.4	88.1	104.9	68.8										
	90	104.4	104.4	104.5	104.5	114.6	88.5	97.2	97.2	97.3	97.3	104.7	84.7										
3600	75	97.6	88.5	108.4	66.5	117.4	42.0	89.4	84.3	99.0	62.5	107.1	38.2										
	80	99.0	99.0	108.2	85.3	117.5	61.2	92.2	92.2	98.9	81.4	107.3	57.3										
	85	104.6	104.6	107.4	102.2	117.3	80.1	97.1	97.1	97.8	97.8	107.1	76.3										
	90	109.7	109.7	109.8	109.8	117.0	95.3	101.5	101.5	101.6	101.6	106.7	93.9										
4000	75	98.7	93.5	109.8	69.8	118.9	42.9	90.2	89.2	100.1	65.8	108.3	39.1										
	80	101.8	101.8	109.6	90.1	119.0	64.1	94.5	94.5	99.8	85.6	108.5	60.2										
	85	107.3	107.3	108.1	108.1	118.7	85.0	99.4	99.4	99.4	99.4	108.2	81.1										
	90	112.4	112.4	112.5	112.5	118.0	104.1	104.0	104.0	104.1	104.1	107.4	99.9										
4400	75	99.4	98.3	110.9	73.0	120.1	43.9	91.2	91.2	101.0	69.0	109.3	40.0										
	80	104.2	104.2	110.4	94.6	120.2	66.9	96.5	96.5	100.3	90.1	109.4	63.0										
	85	109.7	109.7	109.7	109.7	119.8	89.8	101.2	101.2	101.3	101.3	109.1	85.1										
	90	114.6	114.6	114.7	114.7	118.6	110.1	106.3	106.3	106.3	106.3	107.8	105.9										
4800	75	100.2	100.2	111.9	76.2	121.2	44.8	92.9	92.9	101.8	72.1	110.1	40.9										
	80	106.2	106.2	110.9	99.0	121.2	69.7	98.1	98.1	100.6	94.5	110.2	65.8										
	85	111.6	111.6	111.7	111.7	120.7	93.0	102.7	102.7	102.8	102.8	109.6	89.3										
	90	117.0	117.0	117.0	117.0	119.1	116.0	108.2	108.2	108.3	108.3	108.4	108.4										

**Notes:**

1. All capacities shown are gross and have not considered indoor fan heat. To obtain NET cooling capacity subtract indoor fan heat. For indoor fan heat formula, refer to appropriate airflow table notes.
2. MBh = Total gross capacity.
3. SHC = Sensible heat capacity.

**Table 17. Gross cooling capacities — 12.5 tons, standard efficiency**

CFM	Ent DB (° F)	Entering Wet Bulb Temp (°F)						Entering Wet Bulb Temp (°F)						Entering Wet Bulb Temp (°F)															
		61		67		73		61		67		73		61		67		73											
		MBh	SHC	MBh	SHC	MBh	SHC	MBh	SHC	MBh	SHC	MBh	SHC	MBh	SHC	MBh	SHC	MBh	SHC										
<b>Ambient Temperature 85°F</b>																		<b>Ambient Temperature 95°F</b>						<b>Ambient Temperature 105°F</b>					
3750	75	143.7	100.0	151.0	84.0	167.4	60.2	127.2	101.7	143.1	80.2	158.3	56.3	119.7	97.8	134.5	76.1	148.2	52.1										
	80	133.4	122.2	150.7	102.2	167.4	79.2	126.6	118.3	142.8	98.3	158.3	75.3	119.1	114.1	134.3	94.2	148.3	71.1										
	85	134.3	134.3	150.1	120.4	167.2	97.7	128.9	128.9	142.3	116.6	158.2	93.8	122.8	122.8	133.8	112.2	148.3	89.5										
	90	141.9	141.9	149.5	136.9	166.9	116.1	136.1	136.1	141.7	132.8	157.9	112.2	129.8	129.8	133.1	128.4	148.0	108.0										
4500	75	139.0	116.1	156.4	90.2	172.7	62.3	131.6	110.5	147.9	86.2	162.9	58.2	123.6	107.0	138.8	82.0	152.2	53.9										
	80	137.8	134.7	156.0	111.9	172.7	84.9	130.4	130.4	147.5	108.0	163.0	80.9	122.9	122.9	138.4	103.7	152.4	76.3										
	85	143.1	143.1	155.2	132.3	172.5	106.5	137.0	137.0	146.7	128.0	162.8	102.5	130.3	130.3	137.4	123.5	152.2	98.1										
	90	151.1	151.1	153.7	151.6	172.0	128.5	144.7	144.7	145.3	145.3	162.3	124.4	137.5	137.5	137.6	137.6	151.8	120.1										

**Table 17. Gross cooling capacities — 12.5 tons, standard efficiency (continued)**

CFM	Ent DB (°F)	Entering Wet Bulb Temp (°F)						Entering Wet Bulb Temp (°F)						Entering Wet Bulb Temp (°F)					
		61		67		73		61		67		73		61		67		73	
		MBh	SHC	MBh	SHC	MBh	SHC	MBh	SHC	MBh	SHC	MBh	SHC	MBh	SHC	MBh	SHC	MBh	SHC
5000	75	141.4	121.6	159.4	94.2	175.5	63.5	133.7	117.4	150.6	90.2	165.3	59.4	125.3	112.9	141.0	85.8	154.2	55.1
	80	139.7	139.7	158.6	118.2	175.4	88.1	133.4	133.4	149.9	114.1	165.4	83.9	126.7	126.7	140.4	109.8	154.5	79.5
	85	147.9	147.9	157.3	139.8	175.1	112.2	141.5	141.5	148.5	135.5	165.1	108.1	134.3	134.3	138.9	130.8	154.2	103.6
	90	156.2	156.2	156.3	156.3	174.5	136.5	149.3	149.3	149.5	149.5	164.5	128.3	141.6	141.6	141.8	141.8	153.5	126.3
5500	75	143.1	127.4	161.7	98.1	177.7	64.7	135.1	123.1	152.6	93.9	167.2	60.6	126.5	118.5	142.8	89.5	155.9	56.2
	80	143.5	143.5	160.7	124.3	177.7	91.3	137.1	137.1	151.7	120.2	167.4	87.1	130.0	130.0	142.0	111.8	156.3	82.6
	85	152.1	152.1	158.8	147.0	177.3	117.8	145.3	145.3	149.7	142.6	167.0	113.6	137.7	137.7	139.9	138.0	155.8	109.1
	90	160.5	160.5	160.7	160.7	176.3	142.4	153.3	153.3	153.4	153.4	165.8	137.9	145.1	145.1	145.3	145.3	154.4	133.0
6000	75	144.4	132.9	163.6	101.8	179.6	65.8	136.2	128.6	154.3	97.6	168.9	61.7	127.3	123.9	144.2	93.1	157.4	57.3
	80	147.0	147.0	162.4	127.0	179.7	94.5	140.3	140.3	153.0	124.5	169.2	90.2	132.9	132.9	142.8	119.7	157.8	85.6
	85	155.7	155.7	159.8	154.1	179.0	123.2	148.6	148.6	150.5	149.7	168.5	119.0	140.7	140.7	140.8	140.8	157.1	114.4
	90	164.3	164.3	164.5	164.5	177.4	149.1	156.7	156.7	156.8	156.8	166.6	144.6	148.2	148.2	148.3	148.3	155.0	139.7
		Ambient Temperature 115°F						Ambient Temperature 125°F											
3750	75	111.6	93.5	125.0	71.5	137.4	47.7	102.7	87.0	114.9	66.8	125.6	43.0						
	80	110.9	109.6	124.9	89.8	137.5	66.7	102.2	102.2	114.8	85.2	125.9	62.1						
	85	116.1	116.1	124.6	104.1	137.5	85.0	108.5	108.5	114.3	102.2	125.9	80.3						
	90	122.6	122.6	123.8	123.8	137.3	103.5	114.5	114.5	114.6	114.6	125.6	98.7						
4500	75	114.8	102.3	128.9	77.4	140.6	49.4	105.2	97.3	118.0	72.6	128.3	44.7						
	80	115.8	115.8	128.4	99.2	141.1	71.6	107.9	107.9	117.6	94.4	128.9	66.7						
	85	122.7	122.7	127.4	118.6	140.8	93.5	114.3	114.3	116.5	113.4	128.5	88.6						
	90	129.4	129.4	129.6	129.6	140.5	110.6	120.3	120.3	120.4	120.4	127.8	109.0						
5000	75	116.2	108.1	130.7	81.2	142.4	50.5	106.3	103.0	119.6	76.2	129.7	45.8						
	80	119.2	119.2	130.1	103.7	142.8	74.8	110.8	110.8	118.8	99.1	130.3	69.8						
	85	126.3	126.3	128.5	125.9	142.4	99.0	117.3	117.3	117.4	117.4	129.8	94.0						
	90	133.0	133.0	133.1	133.1	141.4	121.2	123.3	123.3	123.4	123.4	128.5	115.8						
5500	75	117.1	113.7	132.2	84.8	143.8	51.6	107.0	107.0	120.8	79.8	130.9	46.8						
	80	122.1	122.1	131.1	109.6	144.3	77.8	113.4	113.4	119.6	104.2	131.5	72.7						
	85	129.3	129.3	129.4	129.4	143.7	104.3	119.9	119.9	119.9	119.9	130.9	98.6						
	90	136.0	136.0	136.1	136.1	142.1	127.9	125.8	125.8	125.9	125.9	128.9	122.5						
6000	75	117.8	117.8	133.4	88.3	145.1	52.7	108.6	108.6	121.8	83.2	132.1	48.0						
	80	124.7	124.7	131.9	114.6	145.5	80.8	115.5	115.5	120.1	109.3	132.5	75.6						
	85	131.9	131.9	132.0	132.0	144.8	107.7	122.0	122.0	122.1	122.1	131.3	103.2						
	90	138.6	138.6	138.7	138.7	142.4	134.5	127.9	127.9	128.0	128.0	129.1	129.1						

**Notes:**

- All capacities shown are gross and have not considered indoor fan heat. To obtain NET cooling capacity subtract indoor fan heat. For indoor fan heat formula, refer to appropriate airflow table notes.
- MBh = Total gross capacity.
- SHC = Sensible heat capacity.

**Table 18. Gross cooling capacities — 15 tons, standard efficiency**

CFM	Ent DB (°F)	Entering Wet Bulb Temp (°F)						Entering Wet Bulb Temp (°F)						Entering Wet Bulb Temp (°F)					
		61		67		73		61		67		73		61		67		73	
		MBh	SHC	MBh	SHC	MBh	SHC	MBh	SHC	MBh	SHC	MBh	SHC	MBh	SHC	MBh	SHC	MBh	SHC
		Ambient Temperature 85°F						Ambient Temperature 95°F						Ambient Temperature 105°F					
4500	75	169.0	134.0	187.5	105.2	205.0	72.9	160.6	129.5	178.6	100.9	194.2	68.4	151.4	124.6	168.7	96.3	182.7	63.7
	80	168.7	155.9	187.5	128.7	204.9	98.2	160.3	151.1	178.6	124.4	194.1	93.5	151.1	146.0	168.8	119.6	183.3	89.0
	85	170.7	170.7	187.3	152.4	204.6	121.8	164.0	164.0	178.6	148.1	194.2	117.3	156.5	156.5	168.8	141.8	183.7	112.7
	90	179.4	179.4	186.8	173.7	204.5	145.7	172.5	172.5	177.9	169.1	194.3	141.2	164.9	164.9	168.0	164.1	183.8	136.7
5400	75	175.1	147.6	193.3	112.7	211.3	75.5	166.2	140.3	184.0	108.3	199.8	71.6	156.4	136.7	173.7	103.4	187.6	66.7
	80	173.9	171.9	193.3	141.0	211.0	105.4	165.0	165.0	184.0	136.5	199.4	100.6	156.4	156.4	173.7	131.7	188.2	95.2
	85	180.7	180.7	193.0	167.4	210.9	133.2	173.5	173.5	183.5	162.6	199.6	128.4	165.3	165.3	172.9	157.5	187.9	123.5
	90	189.5	189.5	190.8	190.8	210.6	161.6	182.0	182.0	182.2	182.2	199.3	156.8	173.6	173.6	173.8	173.8	188.1	150.4
6000	75	178.0	154.6	196.3	117.6	214.5	78.0	168.6	149.6	186.8	113.1	202.6	73.2	158.5	144.1	176.2	108.1	190.1	68.2
	80	176.7	176.7	196.3	148.9	213.8	109.0	169.2	169.2	186.7	144.4	202.0	104.0	161.0	161.0	176.1	139.5	190.4	99.2
	85	186.0	186.0	195.0	176.9	214.1	140.4	178.4	178.4	185.2	172.1	202.4	135.6	170.0	170.0	174.4	166.9	190.0	130.5
	90	194.7	194.7	194.9	194.9	213.7	170.5	186.9	186.9	187.1	187.1	202.0	165.2	178.1	178.1	178.2	178.2	189.7	159.9



# Gross Cooling Capacities

**Table 18. Gross cooling capacities — 15 tons, standard efficiency (continued)**

CFM	Ent DB (°F)	Entering Wet Bulb Temp (°F)						Entering Wet Bulb Temp (°F)						Entering Wet Bulb Temp (°F)									
		61		67		73		61		67		73		61		67		73					
		MBh	SHC	MBh	SHC	MBh	SHC	MBh	SHC	MBh	SHC	MBh	SHC	MBh	SHC	MBh	SHC	MBh	SHC				
6600	75	179.9	162.0	198.9	122.3	217.2	79.5	170.4	156.9	189.1	117.7	205.0	74.7	160.0	151.4	178.2	112.7	192.2	69.7				
	80	181.1	181.1	198.7	156.6	216.6	113.1	173.4	173.4	188.9	150.9	204.5	108.0	164.9	164.9	178.1	142.1	192.2	102.9				
	85	190.5	190.5	196.3	186.1	216.7	147.5	182.6	182.6	186.4	181.3	204.7	142.6	173.8	173.8	175.4	175.4	192.0	137.5				
	90	199.2	199.2	199.4	199.4	215.8	179.4	191.0	191.0	191.1	191.1	203.6	174.1	181.7	181.7	181.9	181.9	190.6	168.7				
7200	75	181.4	169.1	201.0	126.9	219.5	81.0	171.7	164.0	191.0	122.3	207.0	76.1	161.1	158.5	180.0	117.2	193.9	71.1				
	80	184.9	184.9	200.8	159.0	218.9	117.0	177.0	177.0	190.4	157.6	206.6	111.9	168.2	168.2	179.0	152.2	193.7	106.6				
	85	194.3	194.3	197.1	195.1	218.9	154.5	186.2	186.2	187.0	187.0	206.6	149.5	177.0	177.0	177.1	177.1	193.6	144.3				
	90	203.8	203.8	203.9	203.9	217.1	188.1	194.5	194.5	194.7	194.7	204.7	182.9	184.7	184.7	184.9	184.9	191.5	177.4				
Ambient Temperature 115°F												Ambient Temperature 125°F											
4500	75	141.5	119.4	157.9	90.7	170.9	59.5	130.8	110.8	146.2	85.3	158.3	54.4										
	80	141.2	140.5	158.1	114.5	171.8	84.2	131.0	131.0	146.5	109.1	159.3	79.1										
	85	148.3	148.3	158.1	132.9	172.1	107.8	139.2	139.2	146.3	131.4	159.4	102.5										
	90	156.3	156.3	157.2	157.2	172.2	131.8	146.9	146.9	147.0	147.0	159.5	126.5										
5400	75	145.7	130.9	162.4	98.2	174.6	61.6	134.3	124.9	150.2	92.6	161.2	56.4										
	80	147.7	147.7	162.4	126.5	176.0	90.1	138.3	138.3	150.2	121.0	162.8	84.7										
	85	156.4	156.4	161.4	151.9	175.7	118.5	146.5	146.5	148.9	146.0	162.5	113.1										
	90	164.2	164.2	164.4	164.4	175.9	145.6	153.8	153.8	153.9	153.9	162.0	139.7										
6000	75	147.5	138.4	164.6	102.8	176.8	63.1	135.8	132.3	152.1	97.2	162.8	57.8										
	80	152.0	152.0	164.6	132.4	177.9	94.0	142.1	142.1	151.8	127.2	164.4	88.5										
	85	160.6	160.6	162.6	161.3	177.6	125.4	150.2	150.2	150.3	150.3	164.1	120.0										
	90	168.2	168.2	168.3	168.3	176.6	154.4	157.2	157.2	157.3	157.3	162.6	148.5										
6600	75	148.8	145.6	166.4	107.4	178.6	64.5	136.9	136.9	153.6	101.6	164.4	59.2										
	80	155.5	155.5	165.8	139.9	179.5	97.7	145.3	145.3	152.7	133.9	165.8	92.1										
	85	164.0	164.0	164.1	164.1	179.2	132.3	153.2	153.2	153.3	153.3	165.4	126.6										
	90	171.4	171.4	171.5	171.5	177.1	163.0	159.9	159.9	160.0	160.0	162.8	157.2										
7200	75	149.8	149.8	168.0	111.8	180.1	65.9	139.1	139.1	155.0	105.9	166.0	60.7										
	80	158.5	158.5	166.6	146.5	180.9	101.2	147.9	147.9	153.3	140.4	167.0	95.5										
	85	166.9	166.9	167.0	167.0	180.6	136.7	155.7	155.7	155.8	155.8	166.0	131.9										
	90	174.0	174.0	174.1	174.1	177.5	171.6	162.1	162.1	162.1	162.1	162.9	162.9										

**Notes:**

1. All capacities shown are gross and have not considered indoor fan heat. To obtain NET cooling capacity subtract indoor fan heat. For indoor fan heat formula, refer to appropriate airflow table notes.
2. MBh = Total gross capacity.
3. SHC = Sensible heat capacity.

**Table 19. Gross cooling capacities — 17.5 tons, standard efficiency**

CFM	Ent DB (°F)	Entering Wet Bulb Temp (°F)						Entering Wet Bulb Temp (°F)						Entering Wet Bulb Temp (°F)									
		61		67		73		61		67		73		61		67		73					
		MBh	SHC	MBh	SHC	MBh	SHC	MBh	SHC	MBh	SHC	MBh	SHC	MBh	SHC	MBh	SHC	MBh	SHC				
Ambient Temperature 85°F												Ambient Temperature 95°F											
5250	75	194.3	153.9	217.2	121.9	238.8	85.4	184.7	148.8	206.9	116.9	226.0	80.2	174.6	143.4	195.7	111.7	212.7	75.4				
	80	193.6	178.3	217.1	148.6	238.6	114.2	184.0	172.8	206.8	143.5	225.8	108.8	173.9	167.1	195.7	138.2	212.5	103.3				
	85	195.2	195.2	216.6	175.5	238.0	141.1	187.6	187.6	206.4	170.5	225.4	135.6	179.5	179.5	195.4	164.3	213.0	130.3				
	90	205.8	205.8	215.8	199.2	237.8	168.2	198.0	198.0	205.5	193.8	225.4	162.8	189.6	189.6	194.3	188.2	213.1	157.6				
6300	75	201.4	169.2	224.1	130.4	246.5	89.5	191.2	160.8	213.2	125.2	232.7	83.9	180.4	152.4	201.5	119.7	218.4	78.2				
	80	199.6	196.0	224.0	162.4	246.1	122.5	189.4	189.4	213.1	157.2	232.3	116.9	179.2	179.2	201.4	151.8	217.9	111.0				
	85	207.1	207.1	223.5	192.1	245.8	153.9	198.9	198.9	212.2	186.4	232.2	148.3	190.0	190.0	200.2	180.5	218.2	142.5				
	90	217.8	217.8	220.7	219.8	245.1	186.1	209.3	209.3	209.8	209.8	231.7	180.5	200.0	200.0	200.2	200.2	217.8	173.9				
7000	75	204.8	176.9	227.8	135.9	250.4	91.3	194.1	171.0	216.5	130.6	236.1	85.7	182.8	164.9	204.5	125.1	221.4	79.9				
	80	202.2	202.2	227.5	171.2	249.6	127.1	193.6	193.6	216.2	166.0	235.3	120.8	184.7	184.7	204.1	160.5	220.8	114.8				
	85	213.5	213.5	225.8	202.5	249.6	162.1	204.8	204.8	214.3	196.8	235.5	156.3	195.5	195.5	202.0	190.8	221.0	150.4				
	90	224.1	224.1	224.3	224.3	248.7	196.4	215.1	215.1	215.3	215.3	234.8	188.1	205.2	205.2	205.4	205.4	220.0	183.2				
7700	75	207.1	184.9	230.8	141.2	253.7	93.1	196.1	179.0	219.2	135.9	238.9	87.3	184.5	172.9	206.8	130.2	223.8	81.5				
	80	207.3	207.3	230.3	179.9	252.7	131.3	198.6	198.6	218.8	174.5	238.2	125.3	189.3	189.3	206.4	164.5	223.4	119.2				
	85	218.8	218.8	227.4	212.5	252.7	170.1	209.8	209.8	215.6	206.8	238.2	164.2	200.0	200.0	203.0	200.8	223.3	158.2				
	90	229.4	229.4	229.6	229.6	251.3	205.7	219.9	219.9	220.1	220.1	236.6	199.4	209.4	209.4	209.6	209.6	221.5	193.0				

Table 19. Gross cooling capacities — 17.5 tons, standard efficiency (continued)

CFM	Ent DB (° F)	Entering Wet Bulb Temp (°F)						Entering Wet Bulb Temp (°F)						Entering Wet Bulb Temp (°F)						
		61		67		73		61		67		73		61		67		73		
		MBh	SHC	MBh	SHC	MBh	SHC	MBh	SHC	MBh	SHC	MBh	SHC	MBh	SHC	MBh	SHC	MBh	SHC	
8400	75	208.7	192.7	233.3	146.4	256.4	94.8	197.5	186.8	221.4	140.9	241.3	89.0	185.7	180.6	208.8	135.2	225.8	83.1	
	80	211.9	211.9	232.7	183.7	255.6	135.7	202.9	202.9	220.5	180.5	240.8	129.7	193.3	193.3	207.5	174.3	225.5	123.4	
	85	223.4	223.4	228.3	222.3	255.3	177.8	214.0	214.0	216.4	216.4	240.5	171.9	203.8	203.8	204.0	204.0	225.3	165.9	
	90	234.3	234.3	234.4	234.4	252.8	215.3	223.9	223.9	224.0	224.0	237.8	208.9	212.8	212.8	213.0	213.0	222.4	202.4	
		Ambient Temperature 115°F						Ambient Temperature 125°F												
5250	75	164.0	137.8	183.9	105.6	198.6	69.7	152.7	130.2	171.0	99.6	183.9	63.9							
	80	163.3	161.2	183.9	132.6	199.3	97.9	152.1	152.1	171.2	126.7	185.0	92.1							
	85	170.9	170.9	183.6	154.5	199.7	124.7	161.4	161.4	170.9	151.8	185.3	118.7							
	90	180.5	180.5	182.5	182.2	199.9	152.0	170.4	170.4	170.6	170.6	185.5	146.1							
6300	75	168.9	150.4	189.0	113.9	203.6	72.3	156.7	143.9	175.6	107.8	187.9	66.3							
	80	170.1	170.1	188.8	146.0	203.7	104.4	160.3	160.3	175.5	140.0	188.6	98.3							
	85	180.4	180.4	187.5	174.3	203.5	136.5	169.9	169.9	173.9	167.8	188.4	130.4							
	90	189.7	189.7	189.9	189.9	203.8	162.6	178.4	178.4	178.5	178.5	188.1	160.4							
7000	75	170.9	158.6	191.6	119.2	206.0	73.9	158.4	152.1	177.8	112.9	189.9	67.8							
	80	175.1	175.1	191.3	153.6	205.7	108.6	164.7	164.7	177.4	146.9	190.1	102.3							
	85	185.3	185.3	188.9	184.6	206.0	144.4	174.2	174.2	175.0	175.0	190.0	138.1							
	90	194.3	194.3	194.4	194.4	204.7	176.7	182.1	182.1	182.2	182.2	188.5	170.0							
7700	75	172.4	166.5	193.6	124.2	208.0	75.5	159.6	159.6	179.5	117.9	191.5	69.3							
	80	179.3	179.3	192.8	160.7	207.9	112.9	168.4	168.4	178.4	154.0	191.5	106.3							
	85	189.4	189.4	189.8	189.8	207.9	152.1	177.7	177.7	177.8	177.8	191.5	145.7							
	90	197.8	197.8	198.0	198.0	205.7	186.3	184.9	184.9	185.0	185.0	189.3	179.6							
8400	75	173.4	173.3	195.3	129.1	209.7	77.0	161.2	161.2	181.0	122.7	192.9	70.9							
	80	182.9	182.9	193.7	167.8	209.7	117.0	171.6	171.6	179.0	161.1	193.1	110.3							
	85	192.7	192.7	192.8	192.8	209.5	158.3	180.5	180.5	180.6	180.6	192.2	151.1							
	90	200.6	200.6	200.7	200.7	206.3	195.8	187.5	187.5	187.6	187.6	189.6	189.0							

Notes:

1. All capacities shown are gross and have not considered indoor fan heat. To obtain NET cooling capacity subtract indoor fan heat. For indoor fan heat formula, refer to appropriate airflow table notes.
2. MBh = Total gross capacity.
3. SHC = Sensible heat capacity.

Table 20. Gross cooling capacities — 20 tons, standard efficiency

CFM	Ent DB (° F)	Entering Wet Bulb Temp (°F)						Entering Wet Bulb Temp (°F)						Entering Wet Bulb Temp (°F)					
		61		67		73		61		67		73		61		67		73	
		MBh	SHC	MBh	SHC	MBh	SHC	MBh	SHC	MBh	SHC	MBh	SHC	MBh	SHC	MBh	SHC	MBh	SHC
		Ambient Temperature 85°F						Ambient Temperature 95°F						Ambient Temperature 105°F					
6000	75	219.3	172.1	249.3	138.6	276.4	98.7	208.5	166.2	237.3	132.8	263.1	93.0	196.6	159.9	223.9	126.4	247.9	86.9
	80	217.6	198.2	248.9	167.9	276.3	130.8	206.8	191.9	236.9	162.0	263.0	125.0	194.9	185.1	223.5	155.5	247.9	118.6
	85	217.2	217.2	247.3	197.2	275.9	161.4	208.9	208.9	235.5	191.3	262.6	154.8	199.8	199.8	222.2	184.9	247.7	148.3
	90	230.1	230.1	245.9	222.8	275.6	190.5	221.6	221.6	233.9	216.4	262.4	184.7	212.1	212.1	220.6	209.5	247.5	178.2
7200	75	227.7	188.8	258.3	149.1	284.8	103.0	216.1	182.6	245.3	142.1	270.4	97.1	203.3	171.6	231.2	135.4	254.2	90.5
	80	224.6	217.0	257.9	183.1	284.7	139.6	213.0	210.4	245.0	177.0	270.4	133.6	200.3	200.3	230.7	170.3	254.3	127.1
	85	231.4	231.4	255.8	211.8	284.6	174.2	222.4	222.4	243.1	208.6	270.4	168.1	212.3	212.3	228.6	201.3	254.3	161.4
	90	245.1	245.1	252.5	244.8	283.8	209.5	235.8	235.8	239.8	238.3	269.7	203.5	225.2	225.2	225.6	225.6	253.7	196.9
8000	75	231.8	194.9	263.2	154.5	289.0	104.9	219.6	190.2	250.0	148.2	274.0	98.8	206.1	182.8	235.4	141.4	257.3	92.2
	80	227.6	227.6	262.2	192.8	288.9	145.1	215.9	215.9	248.9	186.5	274.1	138.7	205.7	205.7	234.2	179.7	257.4	131.1
	85	239.3	239.3	259.4	226.5	288.8	182.8	229.8	229.8	245.9	219.6	274.1	176.6	219.2	219.2	231.0	212.2	257.4	169.8
	90	253.3	253.3	255.0	255.0	287.8	221.8	243.4	243.4	243.6	243.6	273.2	215.7	232.2	232.2	232.4	232.4	256.8	201.8
8800	75	234.6	205.6	267.5	160.4	292.5	106.7	221.9	198.6	253.9	154.1	277.0	100.5	208.1	191.1	238.8	147.1	259.8	93.8
	80	231.5	231.5	265.8	202.0	292.3	149.1	222.0	222.0	252.1	195.7	277.1	142.7	211.4	211.4	236.9	188.8	260.1	135.7
	85	246.2	246.2	261.6	237.1	292.2	191.2	236.3	236.3	247.7	230.2	277.0	184.9	225.1	225.1	232.4	222.7	260.0	178.0
	90	260.3	260.3	260.5	260.5	291.1	226.6	250.0	250.0	250.2	250.2	275.6	223.7	238.2	238.2	238.3	238.3	258.1	216.0
9600	75	236.6	213.7	271.1	166.1	296.1	108.6	223.6	206.7	256.9	159.6	279.5	102.1	209.4	199.2	241.3	152.5	261.9	95.4
	80	237.3	237.3	268.6	211.1	295.4	153.8	227.3	227.3	254.6	201.1	279.8	147.3	216.3	216.3	238.6	194.7	262.4	140.1
	85	252.1	252.1	262.9	247.3	295.0	199.4	241.8	241.8	248.8	240.4	279.5	193.0	230.2	230.2	233.2	232.9	262.1	186.0
	90	266.4	266.4	266.6	266.6	292.6	240.4	255.6	255.6	255.8	255.8	276.6	233.4	243.2	243.2	243.4	243.4	258.8	225.7
		Ambient Temperature 115°F						Ambient Temperature 125°F											

**Gross Cooling Capacities**
**Table 20. Gross cooling capacities — 20 tons, standard efficiency (continued)**

CFM	Ent DB (°F)	Entering Wet Bulb Temp (°F)						Entering Wet Bulb Temp (°F)						Entering Wet Bulb Temp (°F)					
		61		67		73		61		67		73		61		67		73	
		MBh	SHC	MBh	SHC	MBh	SHC	MBh	SHC	MBh	SHC	MBh	SHC	MBh	SHC	MBh	SHC	MBh	SHC
6000	75	183.7	153.1	209.1	119.5	231.0	80.8	169.7	144.3	192.8	111.3	212.4	73.3						
	80	182.1	177.9	208.9	148.5	231.1	111.7	168.2	168.2	192.9	141.1	212.6	104.4						
	85	189.7	189.7	207.8	174.7	231.1	141.2	178.4	178.4	191.9	168.1	212.8	133.6						
	90	201.5	201.5	206.1	202.0	230.8	171.2	189.6	189.6	190.3	190.3	212.5	163.6						
7200	75	189.3	166.4	215.7	128.2	236.2	83.4	174.2	158.2	198.8	120.4	216.5	75.8						
	80	188.6	188.6	215.1	163.1	236.4	120.0	176.8	176.8	198.1	155.4	216.9	111.0						
	85	201.2	201.2	212.8	193.4	236.5	154.1	188.7	188.7	195.7	185.1	217.0	146.2						
	90	213.4	213.4	213.5	213.5	236.1	187.8	199.9	199.9	200.1	200.1	216.5	179.0						
8000	75	191.7	175.0	219.3	134.0	238.7	85.0	176.0	166.7	201.7	126.0	218.5	77.3						
	80	194.5	194.5	218.0	172.4	239.1	123.6	182.1	182.1	200.5	160.3	219.1	115.5						
	85	207.4	207.4	214.7	204.3	239.1	162.3	194.1	194.1	197.0	195.8	219.1	154.4						
	90	219.6	219.6	219.7	219.7	238.0	197.8	205.2	205.2	205.4	205.4	217.4	189.1						
8800	75	193.2	183.2	222.0	139.5	240.8	86.5	177.2	174.8	203.9	131.4	220.1	78.8						
	80	199.6	199.6	220.2	178.6	241.3	128.1	186.6	186.6	201.7	170.2	220.9	119.7						
	85	212.7	212.7	215.8	214.7	241.2	170.5	198.7	198.7	198.8	198.8	220.8	162.4						
	90	224.8	224.8	224.9	224.9	238.8	207.7	209.5	209.5	209.7	209.7	217.9	198.9						
9600	75	194.2	191.2	224.2	144.8	242.5	88.1	177.9	177.9	205.7	136.6	221.5	80.4						
	80	204.1	204.1	221.2	186.3	243.2	132.3	190.6	190.6	202.5	177.5	222.3	123.9						
	85	217.2	217.2	217.3	217.3	243.0	178.4	202.6	202.6	202.7	202.7	222.2	166.4						
	90	229.1	229.1	229.2	229.2	239.2	217.4	213.0	213.0	213.2	213.2	218.0	208.6						

**Notes:**

1. All capacities shown are gross and have not considered indoor fan heat. To obtain NET cooling capacity subtract indoor fan heat. For indoor fan heat formula, refer to appropriate airflow table notes.
2. MBh = Total gross capacity.
3. SHC = Sensible heat capacity.

**Table 21. Gross cooling capacities — 25 tons, standard efficiency**

CFM	Ent DB (°F)	Entering Wet Bulb Temp (°F)						Entering Wet Bulb Temp (°F)						Entering Wet Bulb Temp (°F)					
		61		67		73		61		67		73		61		67		73	
		MBh	SHC	MBh	SHC	MBh	SHC	MBh	SHC	MBh	SHC	MBh	SHC	MBh	SHC	MBh	SHC	MBh	SHC
		<b>Ambient Temperature 85°F</b>						<b>Ambient Temperature 95°F</b>						<b>Ambient Temperature 105°F</b>					
7500	75	254.1	203.6	289.1	162.7	319.0	113.4	240.8	196.3	273.8	155.3	302.3	107.5	228.7	189.7	259.1	148.3	285.5	100.3
	80	251.1	234.1	288.4	198.2	318.8	152.6	237.8	226.3	273.2	190.7	302.1	145.4	225.8	219.3	258.8	183.6	285.3	138.8
	85	253.8	253.8	286.0	234.0	318.2	188.8	243.5	243.5	271.0	225.2	301.8	181.5	233.9	233.9	256.9	211.8	285.3	174.1
	90	269.1	269.1	283.3	263.7	317.5	225.4	258.3	258.3	268.3	255.7	301.0	218.1	248.0	248.0	254.1	248.2	284.5	210.8
9000	75	262.7	220.0	298.3	173.6	327.2	118.1	248.3	213.0	282.4	165.9	309.5	110.7	235.0	205.4	267.0	158.4	291.5	103.4
	80	257.7	256.1	297.2	216.1	326.8	163.4	243.4	243.4	281.1	208.4	309.2	155.0	232.6	232.6	265.7	201.0	291.2	146.5
	85	269.8	269.8	293.7	253.8	326.6	204.7	258.4	258.4	277.6	245.5	309.0	197.1	247.6	247.6	262.1	237.5	291.4	189.5
	90	285.6	285.6	289.0	289.0	325.3	248.0	273.6	273.6	273.8	273.8	307.9	240.6	262.0	262.0	262.1	262.1	290.4	226.0
10000	75	266.3	231.7	303.6	180.9	331.2	120.1	251.2	223.3	287.2	173.0	313.0	112.7	237.5	215.6	271.2	165.3	294.5	105.3
	80	261.8	261.8	301.3	227.5	330.7	167.6	250.4	250.4	284.8	219.7	312.7	159.9	239.7	239.7	268.9	212.2	294.5	152.1
	85	278.4	278.4	296.5	266.9	330.6	214.8	266.4	266.4	279.8	258.5	312.6	207.2	254.9	254.9	263.9	250.4	294.4	199.5
	90	294.4	294.4	294.6	294.6	329.1	259.1	281.8	281.8	282.0	282.0	310.6	250.7	269.3	269.3	269.5	269.5	292.0	242.3
11000	75	268.6	241.7	307.8	187.7	334.5	122.1	253.1	233.2	290.7	179.7	315.9	114.7	239.0	225.4	274.1	171.8	296.9	107.2
	80	268.9	268.9	304.5	238.5	334.3	173.2	257.0	257.0	287.6	225.1	315.9	165.3	245.7	245.7	270.8	219.6	297.2	157.3
	85	285.8	285.8	298.1	279.5	333.9	224.8	273.2	273.2	281.0	271.0	315.5	217.1	261.0	261.0	264.8	263.0	296.9	209.3
	90	301.9	301.9	302.0	302.0	330.6	271.0	288.6	288.6	288.8	288.8	311.7	262.6	275.4	275.4	275.6	275.6	292.8	254.2
12000	75	270.0	251.3	310.8	194.2	337.3	124.1	254.2	242.7	293.4	186.1	318.3	116.6	239.8	234.9	276.5	178.2	299.0	109.0
	80	275.2	275.2	306.5	245.6	337.3	178.5	262.8	262.8	288.8	236.9	318.5	170.5	251.0	251.0	271.9	228.5	299.4	162.3
	85	292.2	292.2	298.8	291.7	336.5	234.6	279.1	279.1	281.6	281.6	317.8	226.9	266.4	266.4	266.5	266.5	298.9	219.1
	90	308.2	308.2	308.4	308.4	331.3	282.6	294.4	294.4	294.6	294.6	312.2	274.2	280.6	280.6	280.7	280.7	293.0	265.9
		<b>Ambient Temperature 115°F</b>						<b>Ambient Temperature 125°F</b>											
7500	75	218.9	184.1	245.5	140.6	268.8	93.2	212.2	179.7	233.6	134.4	252.4	86.2						
	80	216.1	213.5	245.5	176.9	268.8	131.3	209.7	209.4	233.6	170.8	252.8	124.4						
	85	225.3	225.3	243.9	210.0	268.9	166.8	218.4	218.4	232.2	203.7	253.0	159.7						
	90	238.4	238.4	241.2	241.2	268.4	203.7	229.5	229.5	229.9	229.9	252.7	196.7						

**Table 21. Gross cooling capacities — 25 tons, standard efficiency (continued)**

9000	75	224.0	199.0	252.7	151.4	273.7	96.0	216.2	194.2	239.5	144.7	256.1	88.8
	80	223.8	223.8	251.5	194.1	273.9	139.0	217.0	217.0	238.5	187.7	256.8	131.5
	85	237.6	237.6	248.0	230.2	274.0	182.0	228.5	228.5	235.3	223.6	256.9	174.7
	90	250.8	250.8	250.9	250.9	272.9	222.0	240.0	240.0	240.2	240.2	255.8	214.2
10000	75	225.8	209.0	256.1	158.0	276.1	97.9	217.5	204.0	242.1	151.2	257.9	90.6
	80	230.1	230.1	254.2	200.5	276.6	144.3	222.0	222.0	240.4	195.7	258.9	136.6
	85	244.1	244.1	249.3	243.1	276.5	191.9	234.0	234.0	236.3	236.3	258.9	184.4
	90	257.2	257.2	257.3	257.3	273.9	234.1	245.3	245.3	245.4	245.4	256.4	226.3
11000	75	226.9	218.7	258.6	164.4	278.0	99.7	218.2	213.6	244.2	157.4	259.4	92.3
	80	235.5	235.5	255.4	211.8	278.7	149.3	226.3	226.3	241.4	204.8	260.5	141.4
	85	249.5	249.5	250.0	250.0	278.5	201.6	238.6	238.6	238.7	238.7	260.5	193.4
	90	262.4	262.4	262.5	262.5	274.4	246.0	249.4	249.4	249.5	249.5	256.5	238.1
12000	75	227.4	227.4	260.6	170.6	279.8	101.5	218.5	218.5	245.9	163.5	260.8	94.2
	80	240.1	240.1	256.2	220.7	280.5	154.2	230.3	230.3	241.9	213.6	261.8	146.1
	85	254.1	254.1	254.3	254.3	279.7	209.2	242.4	242.4	242.5	242.5	260.7	200.4
	90	266.7	266.7	266.9	266.9	274.4	257.7	252.8	252.8	252.8	252.8	256.3	249.9

**Notes:**

1. All capacities shown are gross and have not considered indoor fan heat. To obtain NET cooling capacity subtract indoor fan heat. For indoor fan heat formula, refer to appropriate airflow table notes.
2. MBh = Total gross capacity.
3. SHC = Sensible heat capacity.

**Table 22. Gross cooling capacities — 3 tons, high efficiency**

CFM	Ent DB (°F)	Entering Wet Bulb Temp (°F)						Entering Wet Bulb Temp (°F)						Entering Wet Bulb Temp (°F)					
		61		67		73		61		67		73		61		67		73	
		MBh	SHC	MBh	SHC	MBh	SHC	MBh	SHC	MBh	SHC	MBh	SHC	MBh	SHC	MBh	SHC	MBh	SHC
		Ambient Temperature 85°F						Ambient Temperature 95°F						Ambient Temperature 105°F					
900	75	34.0	26.0	38.6	20.6	42.9	14.5	31.9	24.7	36.3	19.3	40.9	13.5	29.6	23.3	33.8	17.9	41.9	11.6
	80	34.1	30.2	38.7	25.4	43.4	19.7	31.9	29.4	36.5	24.1	41.2	18.5	29.7	28.0	34.0	22.8	38.6	17.2
	85	34.6	34.6	38.7	30.2	43.4	24.5	32.9	32.9	36.6	28.9	41.1	23.3	31.0	31.0	34.2	27.6	38.7	22.0
	90	36.7	36.7	38.7	34.0	43.3	29.2	35.0	35.0	36.6	33.6	41.1	28.1	33.1	33.1	34.2	32.2	38.7	26.8
1080	75	35.6	29.1	40.3	22.5	44.7	15.2	33.3	27.7	37.8	21.1	41.9	14.1	30.9	26.3	35.2	19.7	38.8	12.6
	80	35.6	34.7	40.4	28.2	45.1	21.3	33.4	33.3	38.1	26.9	42.8	20.1	31.2	31.2	35.5	25.5	40.1	18.8
	85	37.4	37.4	40.4	33.9	45.0	27.0	35.6	35.6	38.1	32.3	42.7	25.8	33.5	33.5	35.5	31.3	40.2	24.5
	90	39.6	39.6	40.2	39.4	45.0	32.7	37.8	37.8	38.0	38.0	42.7	31.6	35.8	35.8	35.9	35.9	40.2	30.3
1200	75	36.4	31.0	41.1	23.6	45.0	15.7	34.0	29.0	38.6	22.3	43.3	14.5	31.5	28.1	35.9	20.8	38.7	13.2
	80	36.5	36.5	41.2	30.0	46.0	22.3	34.6	34.6	38.9	28.7	43.6	21.1	32.5	32.5	36.2	27.3	40.8	19.7
	85	38.9	38.9	41.2	36.3	45.9	28.7	37.0	37.0	38.8	35.0	43.6	27.5	35.0	35.0	36.3	33.5	41.0	26.2
	90	41.2	41.2	41.3	41.3	45.9	35.0	39.3	39.3	39.4	39.4	43.6	33.8	37.3	37.3	37.4	37.4	41.0	32.6
1320	75	37.0	32.8	41.8	24.8	46.3	16.0	34.6	31.4	39.3	23.4	42.0	15.0	32.0	29.9	36.5	21.9	38.8	12.3
	80	37.8	37.8	42.0	31.8	46.8	23.3	35.8	35.8	39.6	30.5	44.3	22.1	33.6	33.6	36.8	29.0	41.4	20.7
	85	40.2	40.2	41.8	38.5	46.7	30.3	38.3	38.3	39.4	37.3	44.3	29.1	36.2	36.2	36.8	35.8	41.6	27.8
	90	42.6	42.6	42.6	42.6	46.6	37.3	40.7	40.7	40.7	40.7	44.3	35.4	38.6	38.6	38.6	38.6	41.5	34.6
1440	75	37.5	34.6	42.4	25.8	45.1	16.6	35.1	33.2	39.8	24.4	41.9	11.6	32.5	31.7	37.0	22.9	39.8	12.2
	80	38.9	38.9	42.6	33.5	47.4	24.2	36.9	36.9	40.1	32.2	44.8	23.0	34.6	34.6	37.3	30.3	41.9	21.6
	85	41.4	41.4	42.3	40.8	47.3	31.9	39.4	39.4	39.9	39.5	44.9	30.7	37.2	37.2	37.3	37.3	42.1	29.4
	90	43.7	43.7	43.8	43.8	47.1	39.3	41.8	41.8	41.9	41.9	44.7	38.1	39.6	39.6	39.7	39.7	41.9	36.7
		Ambient Temperature 115°F						Ambient Temperature 125°F											
900	75	27.2	21.9	31.2	16.5	35.1	10.7	24.6	20.3	28.4	15.0	31.8	9.2						
	80	27.3	26.6	31.5	21.3	35.8	15.8	24.8	24.8	28.7	19.8	32.8	14.3						
	85	29.0	29.0	31.6	26.1	36.0	20.7	26.8	26.8	28.8	24.6	33.1	19.2						
	90	31.1	31.1	31.6	30.8	36.1	25.5	28.9	28.9	29.0	29.0	33.2	24.0						
1080	75	28.3	24.2	32.5	18.2	37.3	11.6	25.5	23.1	29.5	16.7	31.8	10.0						
	80	29.1	29.1	32.8	24.1	37.1	17.3	26.8	26.8	29.8	22.5	33.9	15.8						
	85	31.4	31.4	32.8	29.7	37.4	23.2	29.0	29.0	29.9	28.2	34.3	21.7						
	90	33.7	33.7	33.7	33.7	37.4	28.9	31.3	31.3	31.3	31.3	34.4	27.4						
1200	75	28.9	26.5	33.1	19.3	35.5	11.3	26.0	24.9	30.0	17.7	31.9	9.5						
	80	30.3	30.3	33.4	25.8	37.8	18.3	27.9	27.9	30.4	24.3	34.5	16.7						
	85	32.7	32.7	33.5	32.0	38.1	24.8	30.3	30.3	30.5	30.5	34.9	23.3						
	90	35.1	35.1	35.1	35.1	38.1	30.7	32.6	32.6	32.6	32.6	34.9	29.6						



# Gross Cooling Capacities

**Table 22. Gross cooling capacities — 3 tons, high efficiency (continued)**

CFM	Ent DB (°F)	Entering Wet Bulb Temp (°F)						Entering Wet Bulb Temp (°F)						Entering Wet Bulb Temp (°F)						
		61		67		73		61		67		73		61		67		73		
		MBh	SHC	MBh	SHC	MBh	SHC	MBh	SHC	MBh	SHC	MBh	SHC	MBh	SHC	MBh	SHC	MBh	SHC	
1320	75	29.3	28.3	33.6	20.4	35.4	11.8	26.5	26.5	30.4	18.7	32.3	10.4							
	80	31.3	31.3	33.9	27.5	38.3	19.2	28.9	28.9	30.8	25.2	34.9	17.6							
	85	33.8	33.8	34.0	34.0	38.6	26.4	31.3	31.3	31.4	31.4	35.4	24.8							
	90	36.3	36.3	36.3	36.3	38.6	33.2	33.7	33.7	33.8	33.8	35.3	31.7							
1440	75	29.7	29.7	33.9	21.4	35.1	7.8	27.1	27.1	30.7	19.7	31.5	5.9							
	80	32.2	32.2	34.2	29.2	38.6	20.1	29.7	29.7	31.1	27.5	35.1	18.4							
	85	34.8	34.8	34.9	34.9	39.1	27.9	32.2	32.2	32.3	32.3	35.7	26.4							
	90	37.3	37.3	37.3	37.3	38.9	35.3	34.7	34.7	34.7	34.7	35.6	33.8							

**Notes:**

- 1. All capacities shown are gross and have not considered indoor fan heat. To obtain NET cooling capacity subtract indoor fan heat. For indoor fan heat formula, refer to appropriate airflow table notes.
- 2. MBh = Total gross capacity.
- 3. SHC = Sensible heat capacity.

**Table 23. Gross cooling capacities — 4 tons, high efficiency**

CFM	Ent DB (°F)	Entering Wet Bulb Temp (°F)						Entering Wet Bulb Temp (°F)						Entering Wet Bulb Temp (°F)					
		61		67		73		61		67		73		61		67		73	
		MBh	SHC	MBh	SHC	MBh	SHC	MBh	SHC	MBh	SHC	MBh	SHC	MBh	SHC	MBh	SHC	MBh	SHC
		<b>Ambient Temperature 85°F</b>						<b>Ambient Temperature 95°F</b>						<b>Ambient Temperature 105°F</b>					
1200	75	44.0	32.9	49.6	24.5	55.3	15.5	41.6	31.6	47.1	23.2	52.8	14.4	39.1	30.3	44.3	22.0	50.0	13.2
	80	44.0	38.6	49.7	31.2	55.4	22.4	41.6	38.3	47.1	30.0	52.9	21.3	39.1	37.0	44.4	28.7	50.1	20.1
	85	44.8	44.8	49.7	37.9	55.5	29.2	42.8	42.8	47.2	36.7	52.9	28.1	40.8	40.8	44.4	35.5	50.1	26.9
	90	47.4	47.4	49.7	43.1	55.5	35.9	45.4	45.4	47.2	43.3	53.0	34.8	43.3	43.3	44.5	42.0	50.1	33.7
1440	75	45.9	36.9	51.7	26.8	57.3	16.0	43.4	35.6	49.0	25.5	54.7	15.0	40.7	34.2	46.1	24.2	51.8	13.8
	80	46.0	44.7	51.8	34.9	57.6	24.3	43.4	43.4	49.1	33.6	54.9	23.2	41.1	41.1	46.1	32.3	51.9	22.0
	85	48.2	48.2	51.8	42.9	57.6	32.5	46.1	46.1	49.1	40.9	54.9	31.4	43.8	43.8	46.2	40.3	51.9	30.2
	90	51.0	51.0	51.7	50.7	57.6	40.6	48.9	48.9	49.1	49.1	55.0	39.5	46.6	46.6	46.7	46.7	52.0	38.3
1600	75	46.9	39.1	52.8	28.2	58.4	16.4	44.3	36.8	50.0	27.0	55.7	15.3	41.5	36.7	47.0	25.7	52.7	14.1
	80	47.1	47.1	52.9	37.2	58.7	25.6	45.0	45.0	50.0	36.0	55.9	24.5	42.6	42.6	47.1	34.7	52.8	23.2
	85	50.1	50.1	52.8	46.0	58.7	34.6	47.9	47.9	50.0	44.8	55.9	33.5	45.5	45.5	47.0	43.5	52.9	32.3
	90	53.0	53.0	53.1	53.1	58.7	43.6	50.8	50.8	50.9	50.9	56.0	42.5	48.5	48.5	48.6	48.6	52.9	41.4
1760	75	47.7	41.9	53.7	29.7	59.3	16.7	45.0	40.6	50.8	28.4	56.6	15.6	42.1	39.2	47.7	27.1	53.5	14.4
	80	48.7	48.7	53.7	39.6	59.7	26.8	46.4	46.4	50.9	38.3	56.8	25.7	44.0	44.0	47.8	37.1	53.6	24.4
	85	51.8	51.8	53.6	49.2	59.6	36.7	49.5	49.5	50.8	47.9	56.8	35.6	47.1	47.1	47.7	46.6	53.7	34.4
	90	54.7	54.7	54.8	54.8	59.6	46.7	52.5	52.5	52.6	52.6	56.8	44.2	50.1	50.1	50.2	50.2	53.7	44.2
1920	75	48.4	44.3	54.5	31.1	60.1	17.0	45.6	43.0	51.5	29.8	57.3	15.9	42.7	41.6	48.4	28.5	54.2	14.7
	80	50.1	50.1	54.5	41.9	60.4	28.0	47.7	47.7	51.5	40.4	57.5	26.8	45.2	45.2	48.5	37.7	54.3	25.6
	85	53.2	53.2	54.2	52.3	60.4	38.8	50.9	50.9	51.4	51.0	57.5	37.8	48.4	48.4	48.5	48.5	54.3	36.6
	90	56.2	56.2	56.3	56.3	60.3	49.4	54.0	54.0	54.1	54.1	57.4	48.3	51.5	51.5	51.5	51.5	54.2	47.1
		<b>Ambient Temperature 115°F</b>						<b>Ambient Temperature 125°F</b>											
1200	75	36.4	29.0	41.4	20.6	46.9	12.0	33.6	27.6	38.4	19.3	43.6	10.7						
	80	36.5	35.6	41.5	27.4	46.9	18.8	33.7	33.7	38.5	26.1	43.6	17.5						
	85	38.5	38.5	41.6	34.2	47.0	25.6	36.2	36.2	38.5	32.6	43.7	24.3						
	90	41.1	41.1	41.6	40.7	47.1	32.4	38.7	38.7	38.8	38.8	43.7	31.1						
1440	75	37.8	31.7	43.0	22.9	48.5	12.5	34.8	31.4	39.8	21.5	44.5	11.1						
	80	38.7	38.7	43.1	31.0	48.6	20.7	36.2	36.2	39.9	29.7	45.1	19.4						
	85	41.4	41.4	43.1	39.0	48.7	28.9	38.9	38.9	39.9	37.6	45.2	27.6						
	90	44.2	44.2	44.3	44.3	48.7	37.0	41.6	41.6	41.7	41.7	45.2	35.7						
1600	75	38.5	35.3	43.9	24.3	49.4	12.9	35.5	33.9	40.5	22.9	45.8	11.5						
	80	40.2	40.2	43.9	33.4	49.4	22.0	37.6	37.6	40.6	32.0	45.8	20.6						
	85	43.1	43.1	43.9	42.1	49.5	31.1	40.4	40.4	40.6	40.6	45.9	29.7						
	90	45.9	45.9	46.0	46.0	49.6	39.0	43.2	43.2	43.3	43.3	45.9	38.6						
1760	75	39.1	37.8	44.5	25.7	50.1	13.2	36.0	36.0	41.1	24.3	45.6	11.6						
	80	41.5	41.5	44.6	35.2	50.2	23.2	38.8	38.8	41.2	34.2	46.4	21.8						
	85	44.5	44.5	44.6	44.6	50.2	33.2	41.7	41.7	41.8	41.8	46.5	31.9						
	90	47.4	47.4	47.5	47.5	50.2	42.9	44.6	44.6	44.6	44.6	46.4	41.6						



**Table 23. Gross cooling capacities — 4 tons, high efficiency (continued)**

CFM	Ent DB (°F)	Entering Wet Bulb Temp (°F)						Entering Wet Bulb Temp (°F)						Entering Wet Bulb Temp (°F)					
		61		67		73		61		67		73		61		67		73	
		MBh	SHC	MBh	SHC	MBh	SHC	MBh	SHC	MBh	SHC	MBh	SHC	MBh	SHC	MBh	SHC	MBh	SHC
1920	75	39.6	39.6	45.1	27.1	49.8	13.2	36.9	36.9	41.6	25.7	45.9	11.8						
	80	42.6	42.6	45.1	37.9	50.8	24.3	39.9	39.9	41.6	36.5	47.0	23.0						
	85	45.7	45.7	45.8	45.8	50.8	35.5	42.8	42.8	42.9	42.9	47.1	34.0						
	90	48.7	48.7	48.8	48.8	50.6	45.8	45.7	45.7	45.8	45.8	46.8	44.5						

Notes:

1. All capacities shown are gross and have not considered indoor fan heat. To obtain NET cooling capacity subtract indoor fan heat. For indoor fan heat formula, refer to appropriate airflow table notes.
2. MBh = Total gross capacity.
3. SHC = Sensible heat capacity.

**Table 24. Gross cooling capacities — 5 tons, high efficiency**

CFM	Ent DB (°F)	Entering Wet Bulb Temp (°F)						Entering Wet Bulb Temp (°F)						Entering Wet Bulb Temp (°F)							
		61		67		73		61		67		73		61		67		73			
		MBh	SHC	MBh	SHC	MBh	SHC	MBh	SHC	MBh	SHC	MBh	SHC	MBh	SHC	MBh	SHC	MBh	SHC		
		<b>Ambient Temperature 85°F</b>						<b>Ambient Temperature 95°F</b>						<b>Ambient Temperature 105°F</b>							
1500	75	55.1	41.1	62.1	30.5	68.6	19.0	52.0	39.6	58.8	29.0	65.5	17.8	48.8	38.0	55.3	27.5	61.9	16.4		
	80	55.1	48.1	62.0	38.9	68.8	27.6	52.0	47.8	58.8	37.4	65.6	26.3	48.8	46.2	55.3	35.9	62.0	24.9		
	85	55.9	55.9	62.0	47.3	68.9	36.1	53.4	53.4	58.8	45.8	65.7	34.8	50.8	50.8	55.4	44.3	62.1	33.4		
	90	59.1	59.1	62.0	53.5	68.9	44.6	56.6	56.6	58.8	54.0	65.7	43.3	54.0	54.0	55.4	52.4	62.1	41.9		
1800	75	57.4	46.1	64.6	33.3	71.0	19.6	54.2	44.5	61.1	31.8	67.7	18.3	50.8	42.5	57.4	30.2	64.0	16.9		
	80	57.4	55.8	64.6	43.4	71.3	30.0	54.2	54.2	61.2	41.9	68.1	28.7	51.2	51.2	57.5	40.4	64.2	27.3		
	85	60.1	60.1	64.6	53.4	71.4	40.1	57.4	57.4	61.2	50.7	68.0	38.8	54.6	54.6	57.5	50.3	64.2	37.4		
	90	63.5	63.5	64.4	63.0	71.4	50.2	60.8	60.8	61.0	61.0	68.1	49.0	57.9	57.9	58.0	58.0	64.3	47.6		
2000	75	58.7	48.7	65.9	35.1	72.2	19.9	55.3	45.8	62.4	33.6	68.9	18.7	51.8	45.9	58.5	32.0	65.1	17.3		
	80	58.8	58.8	65.9	46.3	72.8	31.5	56.0	56.0	62.4	44.8	69.3	30.2	53.1	53.1	58.6	43.3	65.3	28.7		
	85	62.4	62.4	65.8	57.2	72.7	42.7	59.6	59.6	62.3	55.7	69.2	41.5	56.7	56.7	58.5	54.2	65.3	40.1		
	90	65.8	65.8	66.0	66.0	72.7	54.0	63.1	63.1	63.2	63.2	69.3	52.7	60.1	60.1	60.2	60.2	65.4	51.3		
2200	75	59.7	52.2	67.0	36.8	73.3	20.3	56.2	50.6	63.4	35.3	69.9	19.0	52.6	48.9	59.5	33.7	66.0	17.6		
	80	60.7	60.7	67.0	49.2	73.8	32.9	57.9	57.9	63.4	47.7	70.3	31.6	54.8	54.8	59.5	46.2	66.3	30.2		
	85	64.4	64.4	66.8	61.1	73.7	45.3	61.6	61.6	63.2	59.6	70.3	44.1	58.5	58.5	59.3	58.0	66.3	42.7		
	90	67.9	67.9	68.0	68.0	73.8	57.4	65.1	65.1	65.2	65.2	70.3	54.3	62.0	62.0	62.1	62.1	66.2	54.8		
2400	75	60.5	55.2	67.9	38.5	74.2	20.6	56.9	53.6	64.2	37.0	70.7	19.4	53.2	51.9	60.2	35.5	66.8	17.9		
	80	62.4	62.4	67.9	52.1	74.7	34.3	59.4	59.4	64.2	50.0	71.1	33.0	56.3	56.3	60.3	46.6	67.0	31.6		
	85	66.1	66.1	67.5	64.8	74.7	47.9	63.2	63.2	63.8	63.4	71.1	46.7	60.0	60.0	60.1	60.1	67.0	45.3		
	90	69.6	69.6	69.8	69.8	74.6	61.1	66.8	66.8	66.9	66.9	70.9	59.8	63.6	63.6	63.7	63.7	66.8	58.4		
		<b>Ambient Temperature 115°F</b>						<b>Ambient Temperature 125°F</b>													
1500	75	45.5	36.4	51.7	25.9	58.0	14.9	42.2	34.9	48.0	24.3	53.9	13.3								
	80	45.6	44.6	51.7	34.4	58.1	23.5	42.4	42.4	48.0	32.8	54.0	21.9								
	85	48.1	48.1	51.8	42.8	58.2	32.0	45.3	45.3	48.1	40.6	54.1	30.4								
	90	51.2	51.2	51.8	50.9	58.2	40.4	48.3	48.3	48.4	48.4	54.1	38.9								
1800	75	47.3	39.5	53.6	28.6	59.9	15.5	43.8	39.5	49.6	27.0	55.6	13.9								
	80	48.3	48.3	53.7	38.8	60.1	25.8	45.4	45.4	49.7	37.2	55.7	24.2								
	85	51.6	51.6	53.6	48.7	60.1	35.9	48.5	48.5	49.7	47.0	55.7	34.4								
	90	54.9	54.9	55.0	55.0	60.1	46.1	51.6	51.6	51.7	51.7	55.8	44.4								
2000	75	48.2	44.2	54.6	30.4	60.9	15.8	44.5	42.6	50.5	28.8	56.4	14.3								
	80	50.1	50.1	54.6	41.7	61.1	27.2	47.0	47.0	50.6	40.1	56.6	25.7								
	85	53.5	53.5	54.5	52.5	61.1	38.6	50.3	50.3	50.5	50.5	56.6	37.0								
	90	56.9	56.9	57.0	57.0	61.1	47.8	53.5	53.5	53.6	53.6	56.6	48.1								
2200	75	48.9	47.3	55.4	32.1	61.7	16.1	45.1	45.1	51.2	30.5	57.2	14.6								
	80	51.7	51.7	55.4	43.4	61.9	28.7	48.4	48.4	51.2	42.8	57.3	27.1								
	85	55.2	55.2	55.3	55.3	61.9	41.2	51.8	51.8	51.9	51.9	57.3	39.7								
	90	58.6	58.6	58.7	58.7	61.8	53.3	55.0	55.0	55.1	55.1	57.1	51.7								
2400	75	49.5	49.5	56.1	33.8	62.5	16.5	46.1	46.1	51.8	32.2	57.9	14.9								
	80	53.0	53.0	56.0	47.2	62.6	30.1	49.6	49.6	51.7	45.5	57.9	28.5								
	85	56.7	56.7	56.7	56.7	62.6	44.1	53.1	53.1	53.2	53.2	58.0	42.3								
	90	60.1	60.1	60.2	60.2	62.2	56.8	56.4	56.4	56.4	56.4	57.5	55.3								



## Gross Cooling Capacities

**Table 24. Gross cooling capacities — 5 tons, high efficiency (continued)**

CFM	Ent DB (° F)	Entering Wet Bulb Temp (°F)						Entering Wet Bulb Temp (°F)					
		61		67		73		61		67		73	
		MBh	SHC	MBh	SHC	MBh	SHC	MBh	SHC	MBh	SHC	MBh	SHC

**Notes:**

- All capacities shown are gross and have not considered indoor fan heat. To obtain NET cooling capacity subtract indoor fan heat. For indoor fan heat formula, refer to appropriate airflow table notes.
- MBh = Total gross capacity.
- SHC = Sensible heat capacity.

**Table 25. Gross cooling capacities — 6 tons, high efficiency**

CFM	Ent DB (° F)	Entering Wet Bulb Temp (°F)						Entering Wet Bulb Temp (°F)						Entering Wet Bulb Temp (°F)					
		61		67		73		61		67		73		61		67		73	
		MBh	SHC	MBh	SHC	MBh	SHC	MBh	SHC	MBh	SHC	MBh	SHC	MBh	SHC	MBh	SHC	MBh	SHC
		Ambient Temperature 85°F						Ambient Temperature 95°F						Ambient Temperature 105°F					
1800	75	78.8	53.9	82.3	45.2	90.3	32.5	69.6	54.8	78.2	43.3	85.9	30.5	65.6	52.7	73.7	41.1	80.8	28.4
	80	73.3	65.2	82.3	55.0	90.5	42.5	69.7	64.3	78.2	53.0	86.1	40.6	65.6	62.1	73.7	50.9	81.2	38.5
	85	74.1	74.1	82.2	64.7	91.0	52.5	71.2	71.2	78.2	62.7	86.6	50.6	67.9	67.9	73.7	60.6	81.5	48.5
	90	78.2	78.2	82.2	72.3	90.9	62.2	75.1	75.1	78.2	72.2	86.4	60.3	71.7	71.7	73.6	70.0	81.4	58.2
2160	75	76.5	62.8	85.6	48.9	93.2	33.5	72.5	60.8	81.2	46.8	88.5	31.6	68.2	58.6	76.4	44.6	83.1	29.5
	80	76.4	74.0	85.6	60.5	94.1	45.7	72.5	72.0	81.2	58.5	89.7	43.9	68.4	68.4	76.4	56.3	84.5	41.7
	85	79.5	79.5	85.5	72.2	94.1	57.5	76.3	76.3	81.2	69.1	89.4	55.5	72.6	72.6	76.4	67.7	84.0	53.3
	90	83.8	83.8	85.1	83.2	94.0	69.2	80.4	80.4	80.8	80.8	89.2	67.2	76.5	76.5	76.7	76.7	83.8	65.0
2400	75	78.1	66.6	87.3	51.2	95.0	34.3	74.0	63.1	82.8	49.1	89.9	32.3	69.5	62.2	77.8	46.9	81.5	29.1
	80	78.0	78.0	87.3	64.1	96.2	47.9	74.6	74.6	82.8	62.1	91.3	45.9	70.9	70.9	77.8	59.8	85.8	43.7
	85	82.5	82.5	87.1	76.7	95.7	60.7	79.0	79.0	82.6	74.6	90.8	58.7	75.1	75.1	77.5	72.3	85.3	56.5
	90	86.8	86.8	87.0	87.0	95.6	73.7	83.2	83.2	83.4	83.4	90.7	71.7	79.1	79.1	79.2	79.2	85.1	69.3
2640	75	79.4	70.3	88.7	53.4	96.1	34.9	75.2	68.1	84.1	51.3	91.1	32.9	70.5	65.7	79.0	49.0	81.7	26.6
	80	80.4	80.4	88.7	67.6	97.7	49.8	76.9	76.9	84.0	65.6	92.6	47.8	73.0	73.0	78.9	63.3	87.0	45.5
	85	85.1	85.1	88.3	81.3	97.1	63.9	81.4	81.4	83.6	79.1	92.0	61.9	77.3	77.3	78.3	76.8	86.3	59.7
	90	89.4	89.4	89.6	89.6	96.9	78.0	85.6	85.6	85.7	85.7	91.9	73.6	81.2	81.2	81.3	81.3	85.9	73.5
2880	75	80.4	73.8	90.0	55.6	92.7	33.4	76.1	71.6	85.2	53.5	87.5	28.0	71.3	69.3	79.9	51.2	86.5	31.4
	80	82.6	82.6	89.9	71.1	98.9	51.6	78.9	78.9	85.1	68.8	93.7	49.6	74.8	74.8	79.8	64.4	88.0	47.3
	85	87.3	87.3	89.1	85.7	98.2	67.1	83.5	83.5	84.3	83.5	93.0	65.1	79.1	79.1	79.2	79.2	87.2	62.8
	90	91.6	91.6	91.7	91.7	97.9	82.2	87.6	87.6	87.7	87.7	92.4	80.0	82.9	82.9	83.0	83.0	86.3	77.6
		Ambient Temperature 115°F						Ambient Temperature 125°F											
1800	75	61.1	50.3	68.7	38.8	75.2	26.1	56.1	47.8	63.2	36.3	68.9	23.7						
	80	61.1	59.8	68.7	48.6	75.7	36.3	56.3	56.3	63.2	46.0	70.1	34.0						
	85	64.2	64.2	68.7	58.3	75.9	46.1	59.9	59.9	63.2	54.7	69.7	43.6						
	90	67.8	67.8	68.6	67.6	75.8	55.9	63.4	63.4	63.5	63.5	69.5	53.3						
2160	75	63.4	54.5	71.1	42.2	77.2	27.1	58.0	53.4	65.2	39.7	70.6	24.6						
	80	64.5	64.5	71.1	53.9	78.5	39.4	60.0	60.0	65.2	51.3	72.0	36.8						
	85	68.4	68.4	70.9	65.2	78.0	51.0	63.7	63.7	64.9	62.5	71.4	48.4						
	90	72.1	72.1	72.2	72.2	77.8	62.6	67.1	67.1	67.2	67.2	71.2	58.6						
2400	75	64.4	59.7	72.3	44.4	78.3	27.8	58.9	57.0	66.2	41.8	71.6	25.3						
	80	66.7	66.7	72.2	57.4	79.7	41.3	62.0	62.0	66.2	54.6	73.1	38.7						
	85	70.7	70.7	71.8	69.8	79.1	54.1	65.7	65.7	65.7	65.7	72.3	51.5						
	90	74.3	74.3	74.4	74.4	78.8	66.8	68.9	68.9	69.0	69.0	71.7	64.0						
2640	75	65.3	63.2	73.3	46.6	77.3	27.3	59.6	59.6	67.1	43.9	72.8	26.0						
	80	68.6	68.6	73.2	59.7	80.8	43.1	63.6	63.6	66.8	57.9	74.0	40.5						
	85	72.6	72.6	72.7	72.7	80.0	57.3	67.3	67.3	67.4	67.4	73.0	54.6						
	90	76.1	76.1	76.2	76.2	79.3	70.9	70.4	70.4	70.5	70.5	71.9	68.1						
2880	75	66.0	66.0	74.2	48.7	80.5	29.2	61.0	61.0	67.8	46.0	74.6	26.9						
	80	70.2	70.2	73.8	63.9	81.7	44.9	65.0	65.0	67.3	61.1	74.8	42.2						
	85	74.2	74.2	74.3	74.3	80.7	60.4	68.7	68.7	68.7	68.7	73.6	57.4						
	90	77.6	77.6	77.7	77.7	79.5	75.0	71.7	71.7	71.8	71.8	72.3	72.3						

**Notes:**

- All capacities shown are gross and have not considered indoor fan heat. To obtain NET cooling capacity subtract indoor fan heat. For indoor fan heat formula, refer to appropriate airflow table notes.
- MBh = Total gross capacity.
- SHC = Sensible heat capacity.



## Gross Cooling Capacities

Table 26. Gross cooling capacities — 7.5 tons, high efficiency

CFM	Ent DB (° F)	Entering Wet Bulb Temp (°F)						Entering Wet Bulb Temp (°F)						Entering Wet Bulb Temp (°F)					
		61		67		73		61		67		73		61		67		73	
		MBh	SHC	MBh	SHC	MBh	SHC	MBh	SHC	MBh	SHC	MBh	SHC	MBh	SHC	MBh	SHC	MBh	SHC
		Ambient Temperature 85°F						Ambient Temperature 95°F						Ambient Temperature 105°F					
2250	75	92.3	68.1	94.9	53.2	105.0	37.9	79.3	64.7	89.8	50.8	99.4	35.5	74.4	62.1	84.4	48.2	93.3	33.0
	80	83.6	78.2	94.8	65.1	105.1	50.1	79.1	75.7	89.7	62.7	99.5	47.8	74.2	73.0	84.3	60.2	93.4	45.2
	85	85.4	85.4	94.5	77.0	105.1	62.3	81.8	81.8	89.5	74.6	99.6	59.9	77.9	77.9	84.1	71.9	93.5	57.4
	90	90.4	90.4	94.2	87.9	105.0	74.3	86.7	86.7	89.2	85.4	99.5	71.9	82.5	82.5	83.8	82.7	93.4	69.4
2700	75	87.1	74.2	98.4	57.5	108.1	39.1	82.2	70.3	93.0	55.0	102.2	36.7	77.0	68.5	87.3	52.4	95.7	34.1
	80	86.6	86.6	98.2	71.7	108.3	53.8	82.0	82.0	92.8	69.2	102.4	51.3	77.9	77.9	87.0	66.6	96.0	48.8
	85	91.2	91.2	97.8	82.4	108.3	68.2	87.2	87.2	92.4	82.5	102.4	65.7	82.9	82.9	86.5	79.7	96.0	63.1
	90	96.5	96.5	97.1	97.1	108.2	82.5	92.3	92.3	92.4	92.4	102.3	80.1	87.7	87.7	87.8	87.8	95.9	77.5
3000	75	89.7	75.8	100.3	60.2	109.7	39.9	83.6	75.3	94.7	57.7	103.6	37.4	78.1	72.5	88.7	55.0	96.9	34.8
	80	88.9	88.9	99.9	75.9	110.0	56.1	84.8	84.8	94.3	73.4	103.9	53.6	80.4	80.4	88.3	70.7	97.2	51.0
	85	94.4	94.4	99.2	90.2	109.9	72.0	90.2	90.2	93.6	87.5	103.9	69.5	85.6	85.6	87.6	84.7	97.2	66.9
	90	99.8	99.8	99.9	99.9	109.9	87.9	95.3	95.3	95.5	95.5	103.8	83.5	90.5	90.5	90.6	90.6	97.1	81.9
3300	75	89.9	82.0	101.7	62.8	111.0	40.6	84.6	79.2	96.0	60.3	104.7	38.1	79.1	76.4	89.8	57.6	97.9	35.5
	80	91.5	91.5	101.2	80.0	111.3	58.3	87.3	87.3	95.5	77.4	105.1	55.8	82.7	82.7	89.4	72.1	98.2	53.2
	85	97.1	97.1	100.2	95.2	111.3	75.7	92.7	92.7	94.5	92.4	105.0	73.3	87.9	87.9	88.3	88.3	98.3	70.6
	90	102.5	102.5	102.7	102.7	111.1	92.1	97.9	97.9	98.0	98.0	104.7	89.4	92.8	92.8	92.9	92.9	97.7	86.5
3600	75	90.8	85.8	102.9	65.3	112.1	41.3	85.4	83.0	97.0	62.8	105.6	38.8	79.7	79.7	90.7	60.1	98.7	36.2
	80	93.8	93.8	102.3	82.3	112.4	60.4	89.4	89.4	96.4	80.5	106.0	58.0	84.6	84.6	90.0	77.6	99.1	55.3
	85	99.5	99.5	101.0	100.0	112.4	79.4	94.9	94.9	95.1	95.1	106.0	77.0	89.9	89.9	89.9	89.9	99.1	74.3
	90	104.9	104.9	105.0	105.0	111.7	96.7	100.1	100.1	100.2	100.2	105.1	93.9	94.7	94.7	94.8	94.8	98.0	91.0
		Ambient Temperature 115°F						Ambient Temperature 125°F											
2250	75	69.1	59.5	78.5	45.5	86.7	30.3	63.4	54.5	72.2	42.7	79.5	27.5						
	80	69.0	69.0	78.4	57.5	86.8	42.6	64.4	64.4	72.1	54.6	79.7	39.8						
	85	73.5	73.5	78.2	66.6	86.9	54.7	68.8	68.8	71.8	65.9	79.8	51.8						
	90	78.0	78.0	78.1	78.1	86.9	66.7	73.0	73.0	73.1	73.1	79.8	63.9						
2700	75	71.3	65.5	81.0	49.6	88.7	31.4	65.2	62.4	74.3	46.7	81.2	28.5						
	80	73.3	73.3	80.7	63.8	89.0	46.0	68.3	68.3	74.0	60.9	81.5	43.1						
	85	78.1	78.1	80.2	76.7	89.0	60.4	72.8	72.8	73.5	73.5	81.5	57.5						
	90	82.7	82.7	82.8	82.8	89.0	72.0	77.0	77.0	77.1	77.1	81.3	71.0						
3000	75	72.3	69.5	82.2	52.2	89.7	32.1	66.1	66.1	75.3	49.2	82.0	29.2						
	80	75.6	75.6	81.9	66.8	90.1	48.2	70.4	70.4	74.9	64.2	82.4	45.3						
	85	80.5	80.5	81.1	81.1	90.1	64.2	75.0	75.0	75.0	75.0	82.4	61.2						
	90	85.1	85.1	85.2	85.2	89.7	78.9	79.1	79.1	79.2	79.2	81.8	75.6						
3300	75	73.1	73.1	83.2	54.7	90.6	32.8	67.3	67.3	76.1	51.7	82.7	29.9						
	80	77.6	77.6	82.7	71.0	90.9	50.4	72.2	72.2	75.5	67.8	83.1	47.4						
	85	82.6	82.6	82.6	82.6	91.0	67.9	76.7	76.7	76.8	76.8	83.2	64.4						
	90	87.1	87.1	87.2	87.2	90.1	83.4	80.7	80.7	80.8	80.8	82.0	80.2						
3600	75	74.2	74.2	84.0	57.2	91.3	33.4	68.8	68.8	76.8	54.2	83.4	30.5						
	80	79.4	79.4	83.2	74.5	91.7	52.5	73.7	73.7	75.9	71.3	83.7	49.6						
	85	84.3	84.3	84.4	84.4	91.7	70.3	78.2	78.2	78.3	78.3	83.6	67.7						
	90	88.7	88.7	88.8	88.8	90.3	87.9	82.1	82.1	82.1	82.1	82.2	82.2						

**Notes:**

- All capacities shown are gross and have not considered indoor fan heat. To obtain NET cooling capacity subtract indoor fan heat. For indoor fan heat formula, refer to appropriate airflow table notes.
- MBh = Total gross capacity.
- SHC = Sensible heat capacity.

Table 27. Gross cooling capacities — 8.5 tons, high efficiency

CFM	Ent DB (° F)	Entering Wet Bulb Temp (°F)						Entering Wet Bulb Temp (°F)						Entering Wet Bulb Temp (°F)					
		61		67		73		61		67		73		61		67		73	
		MBh	SHC	MBh	SHC	MBh	SHC	MBh	SHC	MBh	SHC	MBh	SHC	MBh	SHC	MBh	SHC	MBh	SHC
		Ambient Temperature 85°F						Ambient Temperature 95°F						Ambient Temperature 105°F					
2550	75	107.4	74.2	112.3	62.2	126.6	45.9	93.7	74.8	106.8	59.6	120.4	43.2	88.5	72.1	101.0	56.9	113.8	40.4
	80	98.3	89.9	112.1	75.6	126.5	59.6	93.4	87.2	106.6	72.9	120.3	56.9	88.2	84.3	100.7	70.2	113.7	54.2
	85	99.2	99.2	111.6	88.8	126.3	73.2	95.4	95.4	106.2	86.2	120.1	70.4	91.3	91.3	100.4	83.4	113.6	67.7
	90	105.1	105.1	111.2	101.1	126.0	86.5	101.1	101.1	105.8	98.3	119.9	83.9	96.9	96.9	100.0	95.4	113.3	81.1



## Gross Cooling Capacities

**Table 27. Gross cooling capacities — 8.5 tons, high efficiency (continued)**

CFM	Ent DB (°F)	Entering Wet Bulb Temp (°F)						Entering Wet Bulb Temp (°F)						Entering Wet Bulb Temp (°F)					
		61		67		73		61		67		73		61		67		73	
		MBh	SHC	MBh	SHC	MBh	SHC	MBh	SHC	MBh	SHC	MBh	SHC	MBh	SHC	MBh	SHC	MBh	SHC
3060	75	102.7	85.5	117.0	67.3	131.6	47.7	97.4	82.8	111.0	64.5	124.9	44.9	91.8	78.0	104.8	61.6	117.8	42.1
	80	102.0	99.4	116.6	83.1	131.5	64.0	96.8	96.6	110.7	80.3	124.8	61.3	91.4	91.4	104.4	77.5	117.7	58.4
	85	106.2	106.2	115.9	97.3	131.3	80.0	102.0	102.0	110.1	92.1	124.6	77.3	97.5	97.5	103.8	92.2	117.5	74.4
	90	112.7	112.7	115.2	112.5	130.7	95.9	108.3	108.3	109.4	109.4	124.0	93.2	103.6	103.6	103.8	103.8	117.0	90.3
3400	75	104.7	88.4	119.5	70.4	134.2	48.8	99.2	87.0	113.4	67.6	127.2	46.0	93.4	83.9	106.9	64.7	119.8	43.1
	80	103.8	103.8	118.9	87.8	134.0	66.8	99.2	99.2	112.7	85.0	127.0	64.0	94.7	94.7	106.2	82.1	119.7	60.9
	85	110.2	110.2	118.0	103.9	133.7	84.4	105.8	105.8	111.9	101.0	126.7	81.6	101.0	101.0	105.4	97.9	119.4	78.7
	90	117.0	117.0	117.1	117.1	133.0	102.0	112.3	112.3	112.5	112.5	126.1	99.2	107.4	107.4	107.5	107.5	118.8	94.9
3740	75	106.3	94.3	121.7	73.4	136.3	49.8	100.5	91.3	115.3	70.6	129.1	46.9	94.5	88.2	108.5	67.6	121.6	44.0
	80	106.8	106.8	120.7	92.5	136.0	69.3	102.3	102.3	114.4	89.6	128.9	66.5	97.5	97.5	107.7	86.7	121.4	63.5
	85	113.7	113.7	119.6	109.5	135.6	88.7	109.0	109.0	113.2	106.5	128.5	85.8	104.0	104.0	106.5	103.3	120.9	82.8
	90	120.7	120.7	120.9	120.9	134.8	106.7	115.9	115.9	116.0	116.0	127.7	100.3	110.6	110.6	110.8	110.8	120.2	100.8
4080	75	107.5	98.6	123.4	76.3	138.1	50.7	101.6	95.6	116.7	73.4	130.8	47.8	95.5	92.4	109.8	70.4	123.0	44.9
	80	109.6	109.6	122.2	97.0	137.9	71.9	104.9	104.9	115.7	92.3	130.6	69.0	100.0	100.0	108.7	90.1	122.9	66.0
	85	116.8	116.8	120.7	114.9	137.3	92.8	111.9	111.9	114.2	111.9	129.9	90.0	106.7	106.7	107.4	107.4	122.2	87.0
	90	124.1	124.1	124.2	124.2	136.2	112.2	119.0	119.0	119.1	119.1	128.9	109.1	113.5	113.5	113.6	113.6	121.1	105.9
Ambient Temperature 115°F						Ambient Temperature 125°F													
2550	75	83.0	69.2	94.7	54.0	106.7	37.5	77.0	66.1	88.0	50.9	99.2	34.5						
	80	82.7	81.3	94.5	67.3	106.7	51.3	76.7	76.7	87.8	64.2	99.1	48.2						
	85	86.8	86.8	94.2	80.1	106.6	64.8	82.0	82.0	87.6	74.2	99.0	61.7						
	90	92.3	92.3	93.9	92.4	106.3	78.2	87.3	87.3	87.4	87.4	98.8	75.1						
3060	75	85.8	76.2	98.2	58.6	110.2	39.1	79.4	72.9	91.1	55.5	102.1	35.9						
	80	86.7	86.7	97.8	74.5	110.1	55.4	81.6	81.6	90.6	71.3	102.1	52.1						
	85	92.6	92.6	97.2	89.0	110.0	71.4	87.3	87.3	90.1	85.7	101.9	68.2						
	90	98.5	98.5	98.7	98.7	109.6	87.3	93.0	93.0	93.1	93.1	101.6	81.7						
3400	75	87.2	80.7	100.0	61.6	112.0	40.0	80.6	77.3	92.6	58.4	103.7	36.8						
	80	89.7	89.7	99.3	79.1	111.9	57.9	84.4	84.4	92.0	74.5	103.6	54.7						
	85	95.8	95.8	98.5	94.6	111.6	75.6	90.2	90.2	91.2	91.2	103.3	72.4						
	90	102.0	102.0	102.1	102.1	111.1	92.2	96.1	96.1	96.2	96.2	102.7	88.7						
3740	75	88.2	84.9	101.4	64.5	113.5	40.9	81.4	81.4	93.8	61.2	104.9	37.7						
	80	92.3	92.3	100.6	80.6	113.4	60.4	86.7	86.7	93.0	79.3	104.9	57.1						
	85	98.7	98.7	99.5	99.5	113.0	79.8	92.8	92.8	92.9	92.9	104.4	76.5						
	90	105.0	105.0	105.1	105.1	112.1	97.4	98.8	98.8	98.9	98.9	103.5	93.9						
4080	75	88.9	88.9	102.5	67.3	114.8	41.8	82.6	82.6	94.7	64.0	106.0	38.5						
	80	94.6	94.6	101.4	86.7	114.7	62.8	88.8	88.8	93.7	83.2	105.9	59.5						
	85	101.1	101.1	101.2	101.2	114.1	83.8	95.0	95.0	95.1	95.1	105.4	80.3						
	90	107.6	107.6	107.7	107.7	112.9	102.5	101.1	101.1	101.2	101.2	104.1	99.0						

**Notes:**

- All capacities shown are gross and have not considered indoor fan heat. To obtain NET cooling capacity subtract indoor fan heat. For indoor fan heat formula, refer to appropriate airflow table notes.
- MBh = Total gross capacity.
- SHC = Sensible heat capacity.

**Table 28. Gross cooling capacities — 10 tons, high efficiency**

CFM	Ent DB (°F)	Entering Wet Bulb Temp (°F)						Entering Wet Bulb Temp (°F)						Entering Wet Bulb Temp (°F)					
		61		67		73		61		67		73		61		67		73	
		MBh	SHC	MBh	SHC	MBh	SHC	MBh	SHC	MBh	SHC	MBh	SHC	MBh	SHC	MBh	SHC	MBh	SHC
Ambient Temperature 85°F						Ambient Temperature 95°F						Ambient Temperature 105°F							
3000	75	121.8	84.6	127.3	71.0	142.3	52.1	106.8	85.6	121.2	68.2	135.2	49.2	101.0	82.7	114.6	65.3	127.6	46.1
	80	111.1	101.8	127.1	86.1	142.2	67.5	105.7	98.8	121.0	83.3	135.2	64.7	100.0	95.7	114.4	80.3	127.6	61.6
	85	111.4	111.4	126.2	100.9	142.0	82.8	107.3	107.3	120.0	98.1	135.0	79.9	102.9	102.9	113.5	95.1	127.4	76.9
	90	117.8	117.8	125.1	114.1	141.7	97.9	113.6	113.6	119.0	111.1	134.6	95.0	108.9	108.9	112.5	107.8	127.0	92.0
3600	75	116.4	97.0	132.3	76.5	147.4	53.9	110.5	94.1	125.7	73.5	139.7	50.9	104.3	89.6	118.7	70.4	131.5	47.7
	80	114.7	111.6	131.8	94.1	147.3	72.2	108.9	108.5	125.1	91.2	139.6	69.2	102.8	102.8	118.0	88.0	131.4	66.1
	85	118.7	118.7	130.5	110.6	147.2	90.2	114.2	114.2	123.9	104.6	139.5	87.2	109.3	109.3	116.6	103.9	131.2	84.0
	90	125.7	125.7	128.8	125.8	146.2	108.0	120.9	120.9	122.2	122.2	138.6	105.0	115.7	115.7	115.8	115.8	130.4	101.8

**Table 28. Gross cooling capacities — 10 tons, high efficiency (continued)**

CFM	Ent DB (°F)	Entering Wet Bulb Temp (°F)						Entering Wet Bulb Temp (°F)						Entering Wet Bulb Temp (°F)					
		61		67		73		61		67		73		61		67		73	
		MBh	SHC	MBh	SHC	MBh	SHC	MBh	SHC	MBh	SHC	MBh	SHC	MBh	SHC	MBh	SHC	MBh	SHC
4000	75	118.4	101.1	135.1	79.8	150.0	55.0	112.6	95.8	128.2	76.8	142.0	51.9	105.6	94.9	120.9	73.6	133.4	48.7
	80	116.3	116.3	134.1	99.2	149.9	75.2	111.1	111.1	127.2	96.2	141.9	72.1	106.1	106.1	119.7	93.0	133.3	68.7
	85	122.8	122.8	132.2	116.5	149.6	94.8	118.0	118.0	125.3	113.2	141.6	91.8	112.8	112.8	118.0	109.7	133.0	88.5
	90	130.1	130.1	130.3	130.3	148.4	114.4	125.0	125.0	125.1	125.1	140.5	111.4	119.5	119.5	119.6	119.6	132.1	106.3
4400	75	119.7	106.0	137.4	83.1	152.1	56.0	113.3	102.7	130.3	80.0	143.8	52.8	106.7	99.3	122.6	76.7	135.0	49.6
	80	119.0	119.0	135.9	104.1	151.9	77.8	114.2	114.2	128.7	101.0	143.8	74.7	109.0	109.0	121.1	97.8	135.0	71.4
	85	126.4	126.4	133.6	122.2	151.4	99.3	121.4	121.4	126.4	118.8	143.2	96.2	115.9	115.9	118.8	115.3	134.4	92.9
	90	133.9	133.9	134.0	134.0	150.1	119.8	128.5	128.5	128.6	128.6	141.8	116.0	122.7	122.7	122.8	122.8	132.9	112.3
4800	75	120.7	110.3	139.3	86.2	153.9	56.9	114.2	107.0	131.8	83.0	145.4	53.7	107.4	103.5	123.9	79.7	136.3	50.4
	80	122.0	122.0	137.3	108.9	153.8	80.5	117.0	117.0	130.0	104.9	145.4	77.3	111.6	111.6	121.9	101.1	136.3	74.0
	85	129.6	129.6	134.5	127.7	153.0	103.7	124.4	124.4	127.1	124.3	144.5	100.6	118.6	118.6	119.4	119.4	135.5	97.2
	90	137.3	137.3	137.4	137.4	151.1	124.7	131.7	131.7	131.8	131.8	142.6	121.2	125.5	125.5	125.6	125.6	133.5	117.5
<b>Ambient Temperature 115°F</b>						<b>Ambient Temperature 125°F</b>													
3000	75	94.8	79.7	107.6	62.1	119.4	42.9	88.2	76.4	99.9	58.7	110.4	39.4						
	80	93.9	92.4	107.3	77.1	119.3	58.4	87.3	87.3	99.6	73.8	110.4	55.0						
	85	98.0	98.0	106.5	91.4	119.3	73.6	92.7	92.7	98.9	87.6	110.4	70.2						
	90	103.8	103.8	105.6	104.4	118.8	88.7	98.2	98.2	98.3	98.3	110.0	85.3						
3600	75	97.5	86.8	111.1	67.1	122.6	44.3	90.4	83.1	103.0	63.7	113.0	40.8						
	80	97.7	97.7	110.4	84.8	122.6	62.7	92.1	92.1	102.2	81.3	113.1	59.1						
	85	103.9	103.9	109.1	100.3	122.3	80.6	98.0	98.0	100.9	96.6	112.8	77.0						
	90	110.0	110.0	110.1	110.1	121.7	98.5	103.7	103.7	103.7	103.7	112.5	91.1						
4000	75	98.7	91.3	113.0	70.3	124.1	45.2	91.4	87.6	104.5	66.7	114.2	41.6						
	80	100.8	100.8	111.9	89.7	124.2	65.3	94.9	94.9	103.5	84.7	114.4	61.7						
	85	107.1	107.1	110.1	106.1	123.8	85.1	100.8	100.8	101.7	101.7	114.0	81.4						
	90	113.4	113.4	113.5	113.5	122.8	103.2	106.5	106.5	106.6	106.6	112.9	99.1						
4400	75	99.6	95.7	114.4	73.3	125.4	46.1	92.0	91.9	105.6	69.7	115.3	42.4						
	80	103.4	103.4	113.0	91.6	125.6	67.9	97.2	97.2	104.1	89.4	115.5	64.2						
	85	109.9	109.9	110.8	110.8	125.0	89.5	103.2	103.2	103.3	103.3	115.0	85.8						
	90	116.2	116.2	116.3	116.3	123.5	108.4	109.0	109.0	109.0	109.0	113.3	104.4						
4800	75	100.1	99.9	115.4	76.2	126.5	46.9	92.9	92.9	106.5	72.6	116.1	43.2						
	80	105.7	105.7	113.5	97.3	126.7	70.4	99.2	99.2	104.6	93.3	116.3	66.7						
	85	112.3	112.3	112.4	112.4	125.9	93.8	105.3	105.3	105.4	105.4	115.7	88.9						
	90	118.7	118.7	118.7	118.7	123.8	113.6	111.0	111.0	111.1	111.1	113.5	109.5						

**Notes:**

1. All capacities shown are gross and have not considered indoor fan heat. To obtain NET cooling capacity subtract indoor fan heat. For indoor fan heat formula, refer to appropriate airflow table notes.
2. MBh = Total gross capacity.
3. SHC = Sensible heat capacity.

**Table 29. Gross cooling capacities — 12.5 tons, high efficiency**

CFM	Ent DB (°F)	Entering Wet Bulb Temp (°F)						Entering Wet Bulb Temp (°F)						Entering Wet Bulb Temp (°F)					
		61		67		73		61		67		73		61		67		73	
		MBh	SHC	MBh	SHC	MBh	SHC	MBh	SHC	MBh	SHC	MBh	SHC	MBh	SHC	MBh	SHC	MBh	SHC
<b>Ambient Temperature 85°F</b>						<b>Ambient Temperature 95°F</b>						<b>Ambient Temperature 105°F</b>							
3750	75	142.5	112.4	158.7	88.7	174.9	62.1	135.3	108.4	151.1	84.9	165.6	58.2	127.4	104.2	142.5	80.5	155.6	54.0
	80	142.3	130.8	158.7	108.3	174.8	83.2	135.1	126.7	151.2	104.5	165.5	79.2	127.3	122.2	142.8	100.4	155.6	75.0
	85	143.8	143.8	158.6	128.1	174.5	103.0	138.1	138.1	151.2	124.4	165.4	99.0	131.7	131.7	142.8	120.1	156.0	94.8
	90	151.4	151.4	158.3	146.1	174.4	123.0	145.6	145.6	150.8	142.1	165.4	118.9	139.0	139.0	142.3	137.8	156.1	114.9
4500	75	147.8	123.8	163.9	95.0	180.6	64.4	140.2	118.5	155.9	91.2	170.7	61.0	131.9	111.6	147.0	86.9	160.1	56.7
	80	147.0	144.4	163.9	118.7	180.3	89.3	139.5	139.5	156.0	114.8	170.3	85.0	131.6	131.6	147.1	110.6	160.0	80.3
	85	152.6	152.6	163.8	137.8	180.3	112.7	146.5	146.5	155.7	136.8	170.5	108.5	139.5	139.5	146.6	132.3	160.1	104.1
	90	160.3	160.3	162.1	161.9	180.0	136.4	154.0	154.0	154.3	154.3	170.4	132.3	146.8	146.8	147.0	147.0	160.0	127.9
5000	75	150.5	128.9	166.6	99.2	183.5	66.6	142.5	125.5	158.5	95.3	173.3	62.4	133.7	120.8	149.3	91.0	162.3	58.0
	80	149.2	149.2	166.6	125.3	182.8	92.5	142.8	142.8	158.4	121.4	172.7	88.2	135.7	135.7	149.3	117.2	162.0	83.7
	85	157.3	157.3	165.7	149.0	183.2	118.8	150.9	150.9	157.4	144.8	173.1	114.6	143.6	143.6	148.1	140.3	162.3	110.1
	90	165.0	165.0	165.1	165.1	182.9	145.1	158.4	158.4	158.5	158.5	172.9	137.0	150.8	150.8	150.9	150.9	162.0	134.8







# Gross Cooling Capacities

**Table 31. Gross cooling capacities — 17.5 tons, high efficiency (continued)**

CFM	Ent DB (°F)	Entering Wet Bulb Temp (°F)						Entering Wet Bulb Temp (°F)						Entering Wet Bulb Temp (°F)					
		61		67		73		61		67		73		61		67		73	
		MBh	SHC	MBh	SHC	MBh	SHC	MBh	SHC	MBh	SHC	MBh	SHC	MBh	SHC	MBh	SHC	MBh	SHC
5250	75	164.3	137.6	185.8	106.8	205.8	72.3	153.1	130.4	173.0	100.3	191.3	66.4						
	80	163.6	161.0	185.9	133.1	205.9	100.1	152.5	152.5	173.2	127.2	191.6	94.3						
	85	171.3	171.3	185.5	156.2	206.0	126.8	162.1	162.1	172.8	152.2	191.7	120.8						
	90	181.7	181.7	184.6	182.6	205.9	153.9	172.0	172.0	172.1	172.1	191.7	148.0						
6300	75	169.4	150.3	191.8	114.9	210.8	74.8	157.4	143.9	178.4	108.7	195.6	68.9						
	80	170.5	170.5	191.5	146.7	211.0	107.0	160.9	160.9	178.1	140.6	195.9	100.7						
	85	181.6	181.6	190.2	175.0	211.2	138.9	171.4	171.4	176.7	168.5	196.0	132.8						
	90	192.3	192.3	192.5	192.5	211.0	168.0	181.5	181.5	181.7	181.7	195.7	162.9						
7000	75	171.7	158.5	194.9	120.3	213.3	76.4	159.3	152.0	180.9	114.0	197.7	70.4						
	80	175.8	175.8	194.3	155.4	213.7	111.3	165.7	165.7	180.5	146.2	198.2	105.0						
	85	187.2	187.2	192.1	185.4	213.7	146.8	176.4	176.4	178.2	178.2	198.2	140.6						
	90	198.0	198.0	198.1	198.1	212.9	179.3	186.5	186.5	186.6	186.6	196.9	172.6						
7700	75	173.3	166.5	197.2	125.4	215.4	77.9	160.6	159.9	183.0	119.0	199.5	71.9						
	80	180.4	180.4	196.1	161.7	215.9	115.6	169.8	169.8	181.7	154.9	200.0	109.1						
	85	191.9	191.9	193.3	193.3	215.8	154.5	180.6	180.6	180.7	180.7	200.0	148.2						
	90	202.7	202.7	202.8	202.8	213.9	188.9	190.5	190.5	190.7	190.7	197.6	182.1						
8400	75	174.4	174.2	199.2	130.4	217.2	79.4	161.9	161.9	184.7	123.9	201.0	73.4						
	80	184.4	184.4	197.3	168.9	217.7	119.6	173.3	173.3	182.6	162.1	201.6	113.1						
	85	196.0	196.0	196.1	196.1	217.6	162.9	184.2	184.2	184.3	184.3	201.5	151.3						
	90	206.7	206.7	206.8	206.8	214.4	198.2	193.9	193.9	194.0	194.0	198.0	191.4						

**Notes:**

- 1. All capacities shown are gross and have not considered indoor fan heat. To obtain NET cooling capacity subtract indoor fan heat. For indoor fan heat formula, refer to appropriate airflow table notes.
- 2. MBh = Total gross capacity.
- 3. SHC = Sensible heat capacity.

**Table 32. Gross cooling capacities — 20 tons, high efficiency**

CFM	Ent DB (°F)	Entering Wet Bulb Temp (°F)						Entering Wet Bulb Temp (°F)						Entering Wet Bulb Temp (°F)					
		61		67		73		61		67		73		61		67		73	
		MBh	SHC	MBh	SHC	MBh	SHC	MBh	SHC	MBh	SHC	MBh	SHC	MBh	SHC	MBh	SHC	MBh	SHC
		<b>Ambient Temperature 85°F</b>						<b>Ambient Temperature 95°F</b>						<b>Ambient Temperature 105°F</b>					
6000	75	219.3	172.1	249.3	138.6	276.4	98.7	208.5	166.2	237.3	132.8	263.1	93.0	196.6	159.9	223.9	126.4	247.9	86.9
	80	217.6	198.2	248.9	167.9	276.3	130.8	206.8	191.9	236.9	162.0	263.0	125.0	194.9	185.1	223.5	155.5	247.9	118.6
	85	217.2	217.2	247.3	197.2	275.9	161.4	208.9	208.9	235.5	191.3	262.6	154.8	199.8	199.8	222.2	184.9	247.7	148.3
	90	230.1	230.1	245.9	222.8	275.6	190.5	221.6	221.6	233.9	216.4	262.4	184.7	212.1	212.1	220.6	209.5	247.5	178.2
7200	75	227.7	188.8	258.3	149.1	284.8	103.0	216.1	182.6	245.3	142.1	270.4	97.1	203.3	171.6	231.2	135.4	254.2	90.5
	80	224.6	217.0	257.9	183.1	284.7	139.6	213.0	210.4	245.0	177.0	270.4	133.6	200.3	200.3	230.7	170.3	254.3	127.1
	85	231.4	231.4	255.8	211.8	284.6	174.2	222.4	222.4	243.1	208.6	270.4	168.1	212.3	212.3	228.6	201.3	254.3	161.4
	90	245.1	245.1	252.5	244.8	283.8	209.5	235.8	235.8	239.8	238.3	269.7	203.5	225.2	225.2	225.6	225.6	253.7	196.9
8000	75	231.8	194.9	263.2	154.5	289.0	104.9	219.6	190.2	250.0	148.2	274.0	98.8	206.1	182.8	235.4	141.4	257.3	92.2
	80	227.6	227.6	262.2	192.8	288.9	145.1	215.9	215.9	248.9	186.5	274.1	138.7	205.7	205.7	234.2	179.7	257.4	131.1
	85	239.3	239.3	259.4	226.5	288.8	182.8	229.8	229.8	245.9	219.6	274.1	176.6	219.2	219.2	231.0	212.2	257.4	169.8
	90	253.3	253.3	255.0	255.0	287.8	221.8	243.4	243.4	243.6	243.6	273.2	215.7	232.2	232.2	232.4	232.4	256.8	201.8
8800	75	234.6	205.6	267.5	160.4	292.5	106.7	221.9	198.6	253.9	154.1	277.0	100.5	208.1	191.1	238.8	147.1	259.8	93.8
	80	231.5	231.5	265.8	202.0	292.3	149.1	222.0	222.0	252.1	195.7	277.1	142.7	211.4	211.4	236.9	188.8	260.1	135.7
	85	246.2	246.2	261.6	237.1	292.2	191.2	236.3	236.3	247.7	230.2	277.0	184.9	225.1	225.1	232.4	222.7	260.0	178.0
	90	260.3	260.3	260.5	260.5	291.1	226.6	250.0	250.0	250.2	250.2	275.6	223.7	238.2	238.2	238.3	238.3	258.1	216.0
9600	75	236.6	213.7	271.1	166.1	296.1	108.6	223.6	206.7	256.9	159.6	279.5	102.1	209.4	199.2	241.3	152.5	261.9	95.4
	80	237.3	237.3	268.6	211.1	295.4	153.8	227.3	227.3	254.6	201.1	279.8	147.3	216.3	216.3	238.6	194.7	262.4	140.1
	85	252.1	252.1	262.9	247.3	295.0	199.4	241.8	241.8	248.8	240.4	279.5	193.0	230.2	230.2	233.2	232.9	262.1	186.0
	90	266.4	266.4	266.6	266.6	292.6	240.4	255.6	255.6	255.8	255.8	276.6	233.4	243.2	243.2	243.4	243.4	258.8	225.7
		<b>Ambient Temperature 115°F</b>						<b>Ambient Temperature 125°F</b>											
6000	75	183.7	153.1	209.1	119.5	231.0	80.8	169.7	144.3	192.8	111.3	212.4	73.3						
	80	182.1	177.9	208.9	148.5	231.1	111.7	168.2	168.2	192.9	141.1	212.6	104.4						
	85	189.7	189.7	207.8	174.7	231.1	141.2	178.4	178.4	191.9	168.1	212.8	133.6						
	90	201.5	201.5	206.1	202.0	230.8	171.2	189.6	189.6	190.3	190.3	212.5	163.6						

Table 32. Gross cooling capacities — 20 tons, high efficiency (continued)

CFM	Ent DB (° F)	Entering Wet Bulb Temp (°F)						Entering Wet Bulb Temp (°F)						Entering Wet Bulb Temp (°F)					
		61		67		73		61		67		73		61		67		73	
		MBh	SHC	MBh	SHC	MBh	SHC	MBh	SHC	MBh	SHC	MBh	SHC	MBh	SHC	MBh	SHC	MBh	SHC
7200	75	189.3	166.4	215.7	128.2	236.2	83.4	174.2	158.2	198.8	120.4	216.5	75.8						
	80	188.6	188.6	215.1	163.1	236.4	120.0	176.8	176.8	198.1	155.4	216.9	111.0						
	85	201.2	201.2	212.8	193.4	236.5	154.1	188.7	188.7	195.7	185.1	217.0	146.2						
	90	213.4	213.4	213.5	213.5	236.1	187.8	199.9	199.9	200.1	200.1	216.5	179.0						
8000	75	191.7	175.0	219.3	134.0	238.7	85.0	176.0	166.7	201.7	126.0	218.5	77.3						
	80	194.5	194.5	218.0	172.4	239.1	123.6	182.1	182.1	200.5	160.3	219.1	115.5						
	85	207.4	207.4	214.7	204.3	239.1	162.3	194.1	194.1	197.0	195.8	219.1	154.4						
	90	219.6	219.6	219.7	219.7	238.0	197.8	205.2	205.2	205.4	205.4	217.4	189.1						
8800	75	193.2	183.2	222.0	139.5	240.8	86.5	177.2	174.8	203.9	131.4	220.1	78.8						
	80	199.6	199.6	220.2	178.6	241.3	128.1	186.6	186.6	201.7	170.2	220.9	119.7						
	85	212.7	212.7	215.8	214.7	241.2	170.5	198.7	198.7	198.8	198.8	220.8	162.4						
	90	224.8	224.8	224.9	224.9	238.8	207.7	209.5	209.5	209.7	209.7	217.9	198.9						
9600	75	194.2	191.2	224.2	144.8	242.5	88.1	177.9	177.9	205.7	136.6	221.5	80.4						
	80	204.1	204.1	221.2	186.3	243.2	132.3	190.6	190.6	202.5	177.5	222.3	123.9						
	85	217.2	217.2	217.3	217.3	243.0	178.4	202.6	202.6	202.7	202.7	222.2	166.4						
	90	229.1	229.1	229.2	229.2	239.2	217.4	213.0	213.0	213.2	213.2	218.0	208.6						

- Notes:
1. All capacities shown are gross and have not considered indoor fan heat. To obtain NET cooling capacity subtract indoor fan heat. For indoor fan heat formula, refer to appropriate airflow table notes.
  2. MBh = Total gross capacity
  3. SHC = Sensible heat capacity

Table 33. Gross cooling capacities — 25 tons, high efficiency

CFM	Ent DB (° F)	Entering Wet Bulb Temp (°F)						Entering Wet Bulb Temp (°F)						Entering Wet Bulb Temp (°F)					
		61		67		73		61		67		73		61		67		73	
		MBh	SHC	MBh	SHC	MBh	SHC	MBh	SHC	MBh	SHC	MBh	SHC	MBh	SHC	MBh	SHC	MBh	SHC
		<b>Ambient Temperature 85°F</b>						<b>Ambient Temperature 95°F</b>						<b>Ambient Temperature 105°F</b>					
7500	75	254.2	203.6	288.8	162.5	317.7	112.8	240.9	196.3	273.5	155.2	301.0	106.9	228.7	189.6	258.7	148.1	284.0	99.7
	80	251.2	234.1	288.1	198.1	317.6	152.1	237.9	226.3	273.0	190.6	300.9	144.9	225.8	219.2	258.5	183.4	284.0	138.2
	85	253.8	253.8	285.8	233.9	317.1	188.3	243.6	243.6	270.9	225.1	300.7	180.9	233.9	233.9	256.6	211.6	284.0	173.5
	90	269.0	269.0	283.1	263.6	316.5	224.9	258.3	258.3	268.1	255.6	300.0	217.6	247.9	247.9	253.8	248.0	283.3	210.3
9000	75	262.8	220.1	297.8	173.4	325.6	117.4	248.4	213.0	281.9	165.7	307.8	110.1	235.1	205.4	266.5	158.2	289.7	102.6
	80	257.8	256.1	296.8	215.9	325.4	162.3	243.5	243.5	280.7	208.2	307.7	154.1	232.6	232.6	265.3	200.8	289.7	145.9
	85	269.7	269.7	293.5	253.6	325.3	204.1	258.3	258.3	277.3	245.3	307.7	196.5	247.4	247.4	261.8	237.3	289.9	188.9
	90	285.4	285.4	288.7	288.7	324.1	247.5	273.4	273.4	273.6	273.6	306.7	240.0	261.6	261.6	261.8	261.8	289.1	225.0
10000	75	266.3	231.7	303.0	180.6	329.5	119.4	251.3	223.3	286.6	172.7	311.2	112.0	237.5	215.6	270.6	165.0	292.5	104.5
	80	261.8	261.8	300.9	227.3	329.2	167.0	250.4	250.4	284.4	219.5	311.2	159.2	239.6	239.6	268.5	211.9	292.9	151.4
	85	278.3	278.3	296.1	266.7	329.1	214.2	266.3	266.3	279.4	258.2	311.1	206.6	254.6	254.6	263.5	250.2	292.8	198.8
	90	294.1	294.1	294.3	294.3	327.9	258.5	281.4	281.4	281.6	281.6	309.2	250.1	268.8	268.8	269.0	269.0	290.5	241.6
11000	75	268.6	241.7	307.1	187.4	332.7	121.4	253.2	233.2	290.0	179.4	313.9	113.9	239.0	225.4	273.4	171.5	294.8	106.4
	80	268.9	268.9	304.1	238.3	332.7	172.5	257.0	257.0	287.2	225.0	314.2	164.6	245.6	245.6	270.3	219.3	295.4	156.5
	85	285.6	285.6	297.6	279.2	332.3	224.1	273.0	273.0	280.7	270.8	313.9	216.4	260.7	260.7	264.4	262.7	295.1	208.6
	90	301.4	301.4	301.6	301.6	329.2	270.4	288.1	288.1	288.2	288.2	310.2	261.9	274.7	274.7	274.9	274.9	291.2	253.5
12000	75	270.1	251.3	310.1	193.9	335.4	123.3	254.3	242.7	292.7	185.8	316.2	115.8	239.8	234.8	275.8	177.8	296.8	108.2
	80	275.1	275.1	306.0	245.3	335.6	177.7	262.7	262.7	288.3	236.6	316.7	169.7	250.8	250.8	271.3	228.2	297.5	161.5
	85	291.9	291.9	298.4	291.5	334.9	233.9	278.8	278.8	281.0	281.0	316.2	226.2	265.9	265.9	266.1	266.1	297.1	218.0
	90	307.6	307.6	307.7	307.7	329.8	282.0	293.7	293.7	293.9	293.9	310.6	273.5	279.7	279.7	279.8	279.8	291.4	265.1
		<b>Ambient Temperature 115°F</b>						<b>Ambient Temperature 125°F</b>											
7500	75	218.4	183.8	245.1	140.3	267.1	92.5	211.1	178.6	232.9	134.1	250.4	85.4						
	80	215.7	213.2	245.1	176.7	267.3	130.6	208.6	208.6	232.9	170.5	251.0	123.7						
	85	225.2	225.2	243.6	209.8	267.4	166.2	217.5	217.5	231.6	203.4	251.2	159.0						
	90	238.1	238.1	240.9	240.9	267.0	203.1	229.1	229.1	229.3	229.3	251.1	196.1						
9000	75	223.5	198.7	252.1	151.0	271.6	95.3	215.1	193.6	238.6	144.4	253.7	88.0						
	80	223.6	223.6	250.9	193.8	272.2	138.3	216.1	216.1	237.8	187.3	254.9	130.7						
	85	237.3	237.3	247.5	229.9	272.3	181.3	228.1	228.1	234.6	223.2	254.9	173.8						
	90	250.3	250.3	250.4	250.4	271.3	221.3	239.2	239.2	239.4	239.4	253.9	213.4						



# Gross Cooling Capacities

**Table 33. Gross cooling capacities — 25 tons, high efficiency (continued)**

CFM	Ent DB (°F)	Entering Wet Bulb Temp (°F)						Entering Wet Bulb Temp (°F)						Entering Wet Bulb Temp (°F)					
		61		67		73		61		67		73		61		67		73	
		MBh	SHC	MBh	SHC	MBh	SHC	MBh	SHC	MBh	SHC	MBh	SHC	MBh	SHC	MBh	SHC	MBh	SHC
10000	75	225.5	208.8	255.3	157.7	273.9	97.0	216.4	203.4	241.2	150.8	255.7	89.8						
	80	229.9	229.9	253.6	200.0	274.7	143.5	221.3	221.3	239.6	195.3	256.7	135.7						
	85	243.7	243.7	248.8	242.8	274.6	191.2	233.4	233.4	235.5	235.5	256.7	183.5						
	90	256.4	256.4	256.6	256.6	272.2	233.4	244.2	244.2	244.3	244.3	254.3	225.4						
11000	75	226.7	218.5	257.8	164.0	275.7	98.8	217.1	213.0	243.2	156.9	256.8	91.4						
	80	235.3	235.3	254.7	211.5	276.7	148.5	225.9	225.9	240.5	204.3	258.2	140.5						
	85	249.0	249.0	249.3	249.3	276.6	200.9	237.9	237.9	238.0	238.0	258.3	191.3						
	90	261.5	261.5	261.6	261.6	272.5	245.2	248.1	248.1	248.2	248.2	254.4	237.2						
12000	75	227.3	227.3	259.7	170.2	277.3	100.6	217.4	217.4	244.8	163.0	258.1	93.2						
	80	239.9	239.9	255.5	220.4	278.3	153.3	229.8	229.8	241.0	213.2	259.4	145.1						
	85	253.5	253.5	253.6	253.6	277.7	207.0	241.5	241.5	241.6	241.6	258.4	199.4						
	90	265.6	265.6	265.7	265.7	272.5	256.9	251.1	251.1	251.2	251.2	254.1	249.0						

**Notes:**

- 1. All capacities shown are gross and have not considered indoor fan heat. To obtain NET cooling capacity subtract indoor fan heat. For indoor fan heat formula, refer to appropriate airflow table notes.
- 2. MBh = Total gross capacity.
- 3. SHC = Sensible heat capacity.

**Table 34. Gross cooling capacities — 3 tons, standard efficiency, gas/electric**

CFM	Ent DB (°F)	Entering Wet Bulb Temp (°F)						Entering Wet Bulb Temp (°F)						Entering Wet Bulb Temp (°F)					
		61		67		73		61		67		73		61		67		73	
		MBh	SHC	MBh	SHC	MBh	SHC	MBh	SHC	MBh	SHC	MBh	SHC	MBh	SHC	MBh	SHC	MBh	SHC
		<b>Ambient Temperature 85°F</b>						<b>Ambient Temperature 95°F</b>						<b>Ambient Temperature 105°F</b>					
900	75	33.1	25.7	37.9	20.6	42.9	14.9	31.1	24.5	35.8	19.4	40.6	13.8	29.0	23.2	33.4	18.1	38.0	12.5
	80	33.2	29.7	37.9	25.3	42.9	19.7	31.3	28.1	35.7	24.1	40.6	18.6	29.2	27.6	33.4	22.7	38.0	17.3
	85	33.9	33.9	37.9	29.9	42.9	24.5	32.2	32.2	35.8	28.7	40.6	23.4	30.4	30.4	33.5	27.4	38.1	22.1
	90	36.0	36.0	38.0	33.7	42.9	29.2	34.4	34.4	35.9	32.0	40.6	28.0	32.6	32.6	33.7	31.8	38.1	26.7
1080	75	34.5	28.4	39.4	22.3	44.4	15.5	32.4	27.2	37.1	21.0	41.9	14.3	30.1	25.9	34.6	19.7	39.2	13.0
	80	34.8	33.5	39.3	27.7	44.4	21.2	32.7	32.2	37.1	26.5	41.9	20.0	30.6	30.6	34.7	25.2	39.2	18.7
	85	36.4	36.4	39.4	33.3	44.4	26.9	34.7	34.7	37.2	32.1	41.9	25.7	32.7	32.7	34.8	30.2	39.2	24.4
	90	38.8	38.8	39.7	38.3	44.4	32.3	37.0	37.0	37.5	37.0	42.0	31.1	35.0	35.0	35.2	35.2	39.3	29.9
1200	75	35.2	30.2	40.1	23.3	45.2	15.9	33.1	28.9	37.7	22.1	42.6	14.6	30.8	26.9	35.2	20.8	39.8	13.3
	80	35.7	35.6	40.1	29.3	45.2	22.2	33.6	33.6	37.8	28.1	42.6	20.9	31.6	31.6	35.3	26.7	39.8	19.6
	85	37.8	37.8	40.2	34.9	45.1	28.4	36.0	36.0	37.9	33.1	42.6	27.0	34.0	34.0	35.4	31.1	39.8	25.6
	90	40.3	40.3	40.6	40.6	45.2	34.4	38.4	38.4	38.4	38.4	42.7	33.1	36.3	36.3	36.4	36.4	40.0	31.8
1320	75	35.9	31.4	40.7	24.3	45.8	16.2	33.7	29.6	38.3	23.0	43.2	15.0	31.3	27.7	35.6	21.8	40.3	13.6
	80	36.5	36.5	40.8	30.8	45.8	23.0	34.7	34.7	38.4	29.6	43.2	21.8	32.6	32.6	35.8	28.2	40.3	20.5
	85	39.1	39.1	40.9	35.8	45.7	29.6	37.2	37.2	38.6	35.7	43.2	28.3	35.1	35.1	36.1	34.3	40.4	27.0
	90	41.6	41.6	41.6	41.6	45.8	36.3	39.6	39.6	39.7	39.7	43.3	35.1	37.5	37.5	37.5	37.5	40.5	33.8
1440	75	36.4	32.2	41.2	25.3	46.4	16.5	34.2	30.4	38.7	24.0	43.7	15.3	31.8	30.2	36.0	22.4	40.8	13.9
	80	37.5	37.5	41.3	32.3	46.3	23.9	35.6	35.6	38.9	31.1	43.6	22.7	33.5	33.5	36.3	29.7	40.7	21.4
	85	40.1	40.1	41.5	38.9	46.3	30.9	38.2	38.2	39.2	37.5	43.7	29.7	36.0	36.0	36.6	36.1	40.8	28.3
	90	42.7	42.7	42.7	42.7	46.4	38.2	40.7	40.7	40.8	40.8	43.8	36.8	38.5	38.5	38.5	38.5	40.9	34.6
		<b>Ambient Temperature 115°F</b>						<b>Ambient Temperature 125°F</b>											
900	75	26.6	21.8	30.9	16.8	35.2	11.2	24.1	20.4	28.0	15.3	32.2	9.8						
	80	26.9	26.2	30.9	21.4	35.3	16.0	24.4	24.4	28.1	19.9	32.2	14.6						
	85	28.5	28.5	31.0	26.1	35.3	20.8	26.4	26.4	28.2	24.3	32.2	19.4						
	90	30.6	30.6	31.2	30.3	35.3	25.4	28.4	28.4	28.5	28.5	32.3	24.0						
1080	75	27.7	24.1	31.9	18.4	36.3	11.7	25.0	21.9	28.9	16.9	33.1	10.2						
	80	28.4	28.4	32.0	23.8	36.3	17.4	26.1	26.1	29.1	22.3	33.1	15.9						
	85	30.6	30.6	32.1	28.0	36.3	22.8	28.3	28.3	29.3	27.5	33.1	21.4						
	90	32.9	32.9	32.9	32.9	36.4	28.5	30.5	30.5	30.5	30.5	33.3	27.0						
1200	75	28.3	24.9	32.4	19.3	36.8	12.0	25.6	24.2	29.3	17.6	33.5	10.5						
	80	29.5	29.5	32.6	25.3	36.8	18.3	27.1	27.1	29.6	23.8	33.5	16.8						
	85	31.8	31.8	32.8	31.0	36.9	24.2	29.4	29.4	29.9	29.4	33.6	22.8						
	90	34.1	34.1	34.1	34.1	37.0	30.4	31.6	31.6	31.6	31.6	33.7	28.3						

**Table 34. Gross cooling capacities — 3 tons, standard efficiency, gas/electric (continued)**

CFM	Ent DB (° F)	Entering Wet Bulb Temp (°F)						Entering Wet Bulb Temp (°F)						Entering Wet Bulb Temp (°F)					
		61		67		73		61		67		73		61		67		73	
		MBh	SHC	MBh	SHC	MBh	SHC	MBh	SHC	MBh	SHC	MBh	SHC	MBh	SHC	MBh	SHC	MBh	SHC
1320	75	28.8	27.3	32.8	20.0	37.3	12.3	26.0	25.6	29.8	18.5	33.9	10.8						
	80	30.4	30.4	33.0	26.8	37.2	19.1	28.0	28.0	30.0	25.3	33.8	17.6						
	85	32.8	32.8	33.3	32.8	37.3	25.6	30.3	30.3	30.4	30.4	34.0	24.1						
	90	35.1	35.1	35.2	35.2	37.4	31.5	32.5	32.5	32.5	32.5	34.1	29.0						
1440	75	29.2	28.7	33.2	20.9	37.6	12.5	26.4	26.4	30.1	19.4	34.2	11.1						
	80	31.2	31.2	33.5	28.3	37.6	19.9	28.7	28.7	30.4	25.9	34.1	18.4						
	85	33.7	33.7	33.8	33.8	37.7	26.9	31.1	31.1	31.1	31.1	34.3	25.4						
	90	36.0	36.0	36.1	36.1	37.8	32.2	33.3	33.3	33.3	33.3	34.5	32.0						

**Notes:**

1. All capacities shown are gross and have not considered indoor fan heat. To obtain NET cooling capacity subtract indoor fan heat. For indoor fan heat formula, refer to appropriate airflow table notes.
2. MBh = Total gross capacity.
3. SHC = Sensible heat capacity.

**Table 35. Gross cooling capacities — 4 tons, standard efficiency, gas/electric**

CFM	Ent DB (° F)	Entering Wet Bulb Temp (°F)						Entering Wet Bulb Temp (°F)						Entering Wet Bulb Temp (°F)					
		61		67		73		61		67		73		61		67		73	
		MBh	SHC	MBh	SHC	MBh	SHC	MBh	SHC	MBh	SHC	MBh	SHC	MBh	SHC	MBh	SHC	MBh	SHC
		<b>Ambient Temperature 85°F</b>						<b>Ambient Temperature 95°F</b>						<b>Ambient Temperature 105°F</b>					
1200	75	43.8	34.2	49.9	27.4	55.9	19.5	41.3	32.7	47.2	25.9	52.8	18.1	38.5	31.1	44.1	24.3	49.3	16.5
	80	44.1	39.7	50.0	33.6	55.9	26.0	41.6	37.6	47.2	32.1	52.8	24.6	38.8	36.2	44.1	30.5	49.4	23.0
	85	45.0	45.0	50.0	39.6	55.9	32.3	43.0	43.0	47.2	38.1	52.9	30.8	40.6	40.6	44.2	36.5	49.4	29.2
	90	47.8	47.8	50.2	45.1	55.9	38.5	45.6	45.6	47.4	42.8	52.9	37.0	43.3	43.3	44.5	42.1	49.5	35.3
1440	75	45.7	37.7	51.8	29.5	57.7	20.2	43.0	36.2	48.8	28.0	54.4	18.9	40.0	34.5	45.6	26.4	50.7	17.3
	80	46.1	44.3	51.8	36.8	57.7	27.9	43.5	42.7	48.8	35.2	54.4	26.4	40.7	40.7	45.5	33.4	50.8	24.7
	85	48.2	48.2	51.9	43.8	57.7	35.2	46.0	46.0	48.9	42.3	54.5	33.7	43.4	43.4	45.7	40.2	50.8	32.0
	90	51.1	51.1	52.2	50.3	57.7	42.3	48.8	48.8	49.4	48.7	54.5	40.8	46.1	46.1	46.3	46.3	50.9	39.1
1600	75	46.7	39.9	52.7	30.8	58.7	20.9	43.9	38.3	49.6	29.3	55.2	19.3	40.9	36.2	46.3	27.7	51.4	17.7
	80	47.3	46.9	52.8	38.7	58.7	29.0	44.7	44.7	49.7	37.0	55.3	27.5	42.0	42.0	46.3	35.4	51.5	25.8
	85	50.0	50.0	53.0	46.5	58.7	37.1	47.6	47.6	49.8	44.1	55.3	35.5	44.9	44.9	46.7	41.7	51.5	33.8
	90	53.1	53.1	53.4	53.3	58.7	44.9	50.5	50.5	50.6	50.6	55.3	43.3	47.7	47.7	47.7	47.7	51.6	41.6
1760	75	47.5	42.0	53.5	32.1	59.4	21.2	44.7	39.7	50.3	30.5	55.9	19.7	41.6	37.3	47.1	28.9	52.0	18.0
	80	48.4	48.4	53.7	40.6	59.4	30.1	45.9	45.9	50.6	39.0	55.9	28.6	43.2	43.2	47.0	37.2	52.1	26.9
	85	51.5	51.5	53.6	47.9	59.4	38.8	49.0	49.0	50.6	45.6	55.9	37.2	46.2	46.2	47.3	45.0	52.1	35.3
	90	54.8	54.8	54.5	54.5	59.5	47.3	51.9	51.9	51.9	51.9	56.0	45.7	48.9	48.9	49.0	49.0	52.2	44.0
1920	75	48.3	43.2	54.1	33.3	60.1	21.6	45.4	41.5	50.9	31.7	56.5	20.0	42.2	39.4	47.4	30.0	52.5	18.4
	80	49.6	49.6	54.2	42.3	60.1	31.2	47.1	47.1	51.1	40.8	56.5	29.6	44.3	44.3	47.7	39.1	52.5	27.9
	85	52.8	52.8	54.4	49.2	60.0	40.4	50.3	50.3	51.4	49.1	56.5	38.7	47.3	47.3	47.9	47.2	52.6	36.9
	90	55.8	55.8	55.8	55.8	60.1	49.7	53.1	53.1	53.1	53.1	56.6	48.1	50.0	50.0	50.1	50.1	52.7	45.3
		<b>Ambient Temperature 115°F</b>						<b>Ambient Temperature 125°F</b>											
1200	75	35.4	29.4	40.6	22.6	45.5	15.0	32.1	27.6	36.8	20.8	41.3	13.1						
	80	35.9	35.1	40.7	28.8	45.6	21.3	32.7	32.7	36.9	26.8	41.3	19.4						
	85	38.0	38.0	40.8	34.8	45.6	27.5	35.2	35.2	37.1	32.6	41.4	25.7						
	90	40.6	40.6	41.2	40.3	45.7	33.5	37.6	37.6	37.7	37.7	41.5	31.7						
1440	75	36.9	32.6	41.9	24.6	46.7	15.6	33.4	30.0	38.0	22.7	42.2	13.7						
	80	37.8	37.8	42.0	31.7	46.7	23.0	34.8	34.8	38.0	29.7	42.3	21.1						
	85	40.5	40.5	42.2	37.6	46.8	30.3	37.4	37.4	38.4	36.4	42.3	28.1						
	90	43.3	43.3	43.2	43.2	46.9	37.4	39.8	39.8	39.8	39.8	42.5	35.4						
1600	75	37.6	33.9	42.5	25.8	47.3	15.9	33.9	32.3	38.4	23.9	42.7	14.0						
	80	39.1	39.1	42.8	33.6	47.3	24.1	35.9	35.9	38.7	31.6	42.7	22.2						
	85	42.0	42.0	42.9	40.8	47.3	31.8	38.6	38.6	39.0	38.7	42.8	29.8						
	90	44.5	44.5	44.5	44.5	47.5	39.8	40.9	40.9	41.0	41.0	43.0	36.8						
1760	75	38.2	36.2	43.1	27.0	47.8	16.2	34.6	34.1	38.8	25.0	43.1	14.3						
	80	40.2	40.2	43.3	35.4	47.8	25.1	37.0	37.0	39.1	33.4	43.1	23.1						
	85	43.2	43.2	43.5	43.0	47.9	33.5	39.5	39.5	39.6	39.6	43.2	31.5						
	90	45.6	45.6	45.6	45.6	48.0	41.3	41.9	41.9	42.0	42.0	43.4	39.4						

### Gross Cooling Capacities

Table 35. Gross cooling capacities — 4 tons, standard efficiency, gas/electric (continued)

CFM	Ent DB (° F)	Entering Wet Bulb Temp (°F)						Entering Wet Bulb Temp (°F)						Entering Wet Bulb Temp (°F)					
		61		67		73		61		67		73		61		67		73	
		MBh	SHC	MBh	SHC	MBh	SHC	MBh	SHC	MBh	SHC	MBh	SHC	MBh	SHC	MBh	SHC	MBh	SHC
1920	75	38.8	37.9	43.4	27.9	48.2	16.6	35.1	35.1	39.2	25.8	43.4	14.6						
	80	41.2	41.2	43.6	37.2	48.2	26.1	37.8	37.8	39.7	34.7	43.4	24.1						
	85	44.0	44.0	44.1	44.1	48.3	35.1	40.3	40.3	40.4	40.4	43.6	33.0						
	90	46.6	46.6	46.6	46.6	48.4	43.6	42.8	42.8	42.8	42.8	43.8	41.4						

Notes:

- All capacities shown are gross and have not considered indoor fan heat. To obtain NET cooling capacity subtract indoor fan heat. For indoor fan heat formula, refer to appropriate airflow table notes.
- MBh = Total gross capacity.
- SHC = Sensible heat capacity.

Table 36. Gross cooling capacities — 5 tons, standard efficiency, gas/electric

CFM	Ent DB (° F)	Entering Wet Bulb Temp (°F)						Entering Wet Bulb Temp (°F)						Entering Wet Bulb Temp (°F)					
		61		67		73		61		67		73		61		67		73	
		MBh	SHC	MBh	SHC	MBh	SHC	MBh	SHC	MBh	SHC	MBh	SHC	MBh	SHC	MBh	SHC	MBh	SHC
		<b>Ambient Temperature 85°F</b>						<b>Ambient Temperature 95°F</b>						<b>Ambient Temperature 105°F</b>					
1500	75	56.0	44.4	62.3	34.7	68.3	24.0	52.8	42.6	58.7	32.9	64.3	22.3	49.3	40.8	54.7	31.0	59.9	20.7
	80	56.1	50.1	62.4	42.8	68.4	32.5	52.9	50.2	58.7	41.0	64.3	30.7	49.4	48.2	54.7	39.0	59.9	28.8
	85	57.4	57.4	62.4	50.7	68.4	40.6	54.7	54.7	58.8	48.9	64.4	38.8	51.6	51.6	54.8	47.0	60.0	37.0
	90	60.4	60.4	62.4	58.2	68.4	48.5	57.6	57.6	58.8	56.3	64.3	46.8	54.3	54.3	54.8	54.3	60.0	44.9
1800	75	58.2	49.1	64.4	37.5	70.4	25.2	54.7	47.3	60.5	35.7	66.1	23.4	51.0	44.8	56.2	33.7	61.4	21.5
	80	58.3	57.8	64.4	47.0	70.5	34.9	55.0	55.0	60.5	45.1	66.1	33.1	51.7	51.7	56.2	43.1	61.5	31.2
	85	61.1	61.1	64.4	56.0	70.5	44.6	58.0	58.0	60.6	52.3	66.2	42.8	54.6	54.6	56.3	52.1	61.5	40.7
	90	64.1	64.1	64.4	64.4	70.4	54.0	60.9	60.9	61.0	61.0	66.2	52.2	57.3	57.3	57.4	57.4	61.6	50.3
2000	75	59.2	51.8	65.4	39.3	71.5	25.7	55.7	48.8	61.4	37.4	67.0	23.9	51.8	47.8	56.9	35.4	62.2	21.9
	80	59.7	59.7	65.4	49.7	71.5	36.5	56.7	56.7	61.4	47.8	67.0	34.6	53.3	53.3	57.0	45.8	62.2	32.7
	85	63.0	63.0	65.4	59.6	71.5	47.0	59.8	59.8	61.4	57.6	67.1	45.1	56.1	56.1	56.9	55.4	62.3	43.2
	90	66.1	66.1	66.2	66.2	71.5	57.5	62.7	62.7	62.8	62.8	67.1	55.7	59.1	59.1	59.1	59.1	62.4	52.7
2200	75	60.1	51.8	66.2	40.9	72.3	26.2	56.5	52.5	62.1	38.9	67.7	24.4	52.4	50.3	57.6	36.9	62.8	22.4
	80	61.4	61.4	66.2	52.4	72.3	38.0	58.1	58.1	62.1	50.5	67.8	36.1	54.6	54.6	57.6	48.4	62.9	34.2
	85	64.6	64.6	66.2	62.9	72.3	49.4	61.2	61.2	62.0	60.9	67.8	47.6	57.4	57.4	57.5	57.5	62.9	45.6
	90	67.8	67.8	67.9	67.9	72.3	60.4	64.4	64.4	64.4	64.4	67.8	56.3	60.5	60.5	60.6	60.6	63.0	56.4
2400	75	60.9	57.1	66.9	42.4	73.7	26.9	57.1	55.0	62.7	40.5	68.8	25.1	53.0	52.8	58.1	38.4	63.3	22.9
	80	62.7	62.7	66.9	55.0	73.0	39.5	59.4	59.4	62.7	53.0	68.4	37.6	55.7	55.7	58.1	49.1	63.4	35.6
	85	66.0	66.0	66.7	66.1	73.1	51.8	62.5	62.5	62.5	62.5	68.4	49.9	58.7	58.7	58.7	58.7	63.5	48.0
	90	69.4	69.4	69.5	69.5	73.1	63.6	65.8	65.8	65.8	65.8	68.4	61.6	61.8	61.8	61.8	61.8	63.4	59.5
		<b>Ambient Temperature 115°F</b>						<b>Ambient Temperature 125°F</b>											
1500	75	45.4	38.7	50.2	29.0	55.1	18.7	41.1	36.3	45.5	26.8	49.7	16.6						
	80	45.6	45.6	50.3	36.9	55.1	26.9	41.9	41.9	45.5	34.7	49.8	24.7						
	85	48.2	48.2	50.4	44.3	55.2	34.9	44.3	44.3	45.6	42.4	49.9	32.7						
	90	50.7	50.7	50.7	50.7	55.3	42.9	46.8	46.8	46.8	46.8	50.0	40.8						
1800	75	46.8	42.9	51.5	31.6	56.3	19.4	42.3	40.5	46.6	29.2	50.7	17.3						
	80	48.1	48.1	51.6	41.0	56.4	29.2	44.0	44.0	46.7	38.8	50.8	27.0						
	85	50.7	50.7	51.6	49.8	56.5	38.6	46.6	46.6	46.7	46.7	50.9	36.4						
	90	53.5	53.5	53.6	53.6	56.5	48.0	49.1	49.1	49.2	49.2	51.0	45.6						
2000	75	47.5	45.5	52.1	33.1	56.9	19.9	42.8	42.8	47.1	30.9	51.2	17.7						
	80	49.5	49.5	52.2	43.7	57.0	30.6	45.2	45.2	47.2	40.2	51.3	28.5						
	85	52.2	52.2	52.3	52.3	58.6	41.6	47.9	47.9	47.9	47.9	51.4	38.9						
	90	55.0	55.0	55.0	55.0	57.2	51.1	50.3	50.3	50.4	50.4	51.4	48.7						
2200	75	48.0	48.0	52.7	34.7	57.4	20.4	43.6	43.6	47.6	32.4	51.6	18.2						
	80	50.5	50.5	52.8	44.4	57.5	32.1	46.2	46.2	47.7	43.5	51.7	29.5						
	85	53.4	53.4	53.5	53.5	59.3	44.1	48.9	48.9	48.9	48.9	54.6	42.1						
	90	56.2	56.2	56.3	56.3	57.5	54.2	51.3	51.3	51.4	51.4	51.6	51.6						
2400	75	48.7	48.7	53.2	36.2	57.9	20.8	44.3	44.3	48.0	34.0	51.9	18.6						
	80	51.5	51.5	53.3	48.2	58.0	33.1	47.1	47.1	48.0	45.8	52.1	30.8						
	85	54.5	54.5	54.5	54.5	59.9	46.5	49.7	49.7	51.2	51.2	52.2	42.5						
	90	57.2	57.2	57.3	57.3	57.8	57.2	52.1	52.1	52.2	52.2	52.2	52.2						

**Table 36. Gross cooling capacities — 5 tons, standard efficiency, gas/electric (continued)**

CFM	Ent DB (°F)	Entering Wet Bulb Temp (°F)						Entering Wet Bulb Temp (°F)					
		61		67		73		61		67		73	
		MBh	SHC	MBh	SHC	MBh	SHC	MBh	SHC	MBh	SHC	MBh	SHC

**Notes:**

1. All capacities shown are gross and have not considered indoor fan heat. To obtain NET cooling capacity subtract indoor fan heat. For indoor fan heat formula, refer to appropriate airflow table notes.
2. MBh = Total gross capacity.
3. SHC = Sensible heat capacity.

**Table 37. Gross cooling capacities — 6 tons, standard efficiency, gas/electric**

CFM	Ent DB (°F)	Entering Wet Bulb Temp (°F)						Entering Wet Bulb Temp (°F)						Entering Wet Bulb Temp (°F)					
		61		67		73		61		67		73		61		67		73	
		MBh	SHC	MBh	SHC	MBh	SHC	MBh	SHC	MBh	SHC	MBh	SHC	MBh	SHC	MBh	SHC	MBh	SHC
		<b>Ambient Temperature 85°F</b>						<b>Ambient Temperature 95°F</b>						<b>Ambient Temperature 105°F</b>					
1800	75	79.0	54.0	82.5	45.3	90.5	32.5	69.8	54.9	78.4	43.3	86.0	30.6	65.7	52.8	73.9	41.2	81.0	28.5
	80	73.5	65.3	82.4	55.1	90.7	42.6	69.8	64.4	78.4	53.1	86.3	40.7	65.7	62.3	73.9	51.0	81.4	38.6
	85	74.3	74.3	82.4	64.8	91.2	52.6	71.3	71.3	78.4	62.8	86.8	50.7	68.0	68.0	73.9	60.7	81.7	48.6
	90	78.3	78.3	82.4	72.5	91.1	62.4	75.3	75.3	78.4	72.3	86.6	60.4	71.9	71.9	73.8	70.1	81.6	58.3
2160	75	76.6	63.0	85.8	49.0	93.4	33.6	72.7	60.9	81.4	46.9	88.7	31.7	68.3	58.7	76.6	44.7	83.3	29.5
	80	76.6	74.2	85.7	60.7	94.3	45.8	72.6	72.1	81.4	58.6	89.9	44.0	68.6	68.6	76.6	56.4	84.6	41.8
	85	79.7	79.7	85.7	72.3	94.3	57.6	76.4	76.4	81.4	69.2	89.6	55.6	72.7	72.7	76.5	67.9	84.2	53.5
	90	84.0	84.0	85.3	83.3	94.2	69.3	80.6	80.6	80.9	80.9	89.4	67.3	76.7	76.7	76.8	76.8	84.0	65.1
2400	75	78.3	66.8	87.5	51.3	95.2	34.4	74.2	63.2	83.0	49.2	90.1	32.3	69.6	62.3	78.0	47.0	81.7	29.2
	80	78.1	78.1	87.4	64.3	96.4	48.0	74.8	74.8	82.9	62.2	91.5	46.0	71.0	71.0	77.9	60.0	86.0	43.7
	85	82.7	82.7	87.3	76.9	95.9	60.9	79.2	79.2	82.7	74.8	91.0	58.9	75.3	75.3	77.6	72.4	85.4	56.7
	90	87.0	87.0	87.2	87.2	95.8	73.9	83.4	83.4	83.5	83.5	90.8	71.9	79.2	79.2	79.4	79.4	85.3	69.5
2640	75	79.6	70.4	88.9	53.5	96.3	35.0	75.3	68.2	84.3	51.4	91.2	33.0	70.6	65.9	79.1	49.1	81.8	26.7
	80	80.6	80.6	88.9	67.8	97.9	49.9	77.1	77.1	84.2	65.7	92.8	47.9	73.1	73.1	79.1	63.4	87.2	45.6
	85	85.2	85.2	88.5	81.4	97.3	64.1	81.6	81.6	83.7	79.3	92.2	62.1	77.4	77.4	78.5	76.9	86.5	59.8
	90	89.6	89.6	89.7	89.7	97.1	78.1	85.8	85.8	85.9	85.9	92.1	73.7	81.3	81.3	81.5	81.5	86.1	73.7
2880	75	80.6	74.0	90.1	55.7	92.9	33.5	76.2	71.8	85.4	53.6	87.6	28.0	71.4	69.4	80.1	51.3	86.7	31.5
	80	82.7	82.7	90.0	71.3	99.1	51.8	79.1	79.1	85.3	69.0	93.8	49.7	75.0	75.0	80.0	64.5	88.2	47.4
	85	87.5	87.5	89.3	85.9	98.4	67.2	83.6	83.6	84.5	83.7	93.2	65.2	79.3	79.3	79.4	79.4	87.4	62.9
	90	91.8	91.8	91.9	91.9	98.1	82.4	87.8	87.8	87.9	87.9	92.6	80.2	83.1	83.1	83.2	83.2	86.5	77.8
		<b>Ambient Temperature 115°F</b>						<b>Ambient Temperature 125°F</b>											
1800	75	61.2	50.4	68.9	38.9	75.3	26.2	56.2	47.9	63.3	36.4	69.1	23.7						
	80	61.2	59.9	68.9	48.7	75.9	36.3	56.5	56.5	63.3	46.1	70.2	34.0						
	85	64.3	64.3	68.9	58.4	76.1	46.2	60.1	60.1	63.3	54.8	69.8	43.7						
	90	68.0	68.0	68.7	67.7	75.9	56.0	63.5	63.5	63.6	63.6	69.6	53.5						
2160	75	63.5	54.6	71.2	42.3	77.3	27.2	58.1	53.5	65.3	39.8	70.8	24.7						
	80	64.6	64.6	71.2	54.0	78.7	39.5	60.1	60.1	65.3	51.5	72.2	36.9						
	85	68.6	68.6	71.1	65.4	78.2	51.1	63.8	63.8	65.0	62.7	71.5	48.5						
	90	72.3	72.3	72.4	72.4	78.0	62.8	67.2	67.2	67.3	67.3	71.3	58.8						
2400	75	64.6	59.8	72.5	44.5	78.4	27.8	59.0	57.1	66.4	41.9	71.8	25.3						
	80	66.8	66.8	72.4	57.5	79.9	41.4	62.1	62.1	66.3	54.7	73.2	38.8						
	85	70.8	70.8	72.0	69.9	79.2	54.2	65.8	65.8	65.9	65.9	72.4	51.6						
	90	74.5	74.5	74.6	74.6	79.0	66.9	69.1	69.1	69.1	69.1	71.9	64.2						
2640	75	65.5	63.4	73.5	46.7	77.5	27.8	59.8	59.8	67.3	44.0	72.9	26.1						
	80	68.7	68.7	73.4	59.9	80.9	43.2	63.8	63.8	67.0	58.0	74.2	40.6						
	85	72.7	72.7	72.8	72.8	80.1	57.4	67.4	67.4	67.5	67.5	73.2	54.8						
	90	76.3	76.3	76.4	76.4	79.4	71.1	70.5	70.5	70.6	70.6	72.1	68.3						
2880	75	66.1	66.1	74.3	48.8	80.7	29.2	61.1	61.1	68.0	46.1	74.9	27.0						
	80	70.4	70.4	74.0	64.0	81.9	45.0	65.2	65.2	67.5	61.2	75.0	42.3						
	85	74.4	74.4	74.5	74.5	80.9	60.5	68.8	68.8	68.9	68.9	73.8	57.5						
	90	77.8	77.8	77.9	77.9	79.7	75.2	71.9	71.9	72.0	72.0	72.4	72.4						

**Notes:**

1. All capacities shown are gross and have not considered indoor fan heat. To obtain NET cooling capacity subtract indoor fan heat. For indoor fan heat formula, refer to appropriate airflow table notes.
2. MBh = Total gross capacity.
3. SHC = Sensible heat capacity.



# Gross Cooling Capacities

**Table 38. Gross cooling capacities — 7.5 tons, standard efficiency, gas/electric**

CFM	Ent DB (° F)	Entering Wet Bulb Temp (°F)						Entering Wet Bulb Temp (°F)						Entering Wet Bulb Temp (°F)					
		61		67		73		61		67		73		61		67		73	
		MBh	SHC	MBh	SHC	MBh	SHC	MBh	SHC	MBh	SHC	MBh	SHC	MBh	SHC	MBh	SHC	MBh	SHC
		Ambient Temperature 85°F						Ambient Temperature 95°F						Ambient Temperature 105°F					
2250	75	91.6	67.6	94.1	52.7	104.2	37.6	78.7	64.1	89.1	50.4	98.6	35.2	73.8	61.6	83.7	47.8	92.5	32.7
	80	82.9	77.5	94.0	64.6	104.2	49.7	78.4	75.0	89.0	62.2	98.7	47.4	73.6	72.4	83.6	59.7	92.6	44.9
	85	84.7	84.7	93.7	76.4	104.3	61.8	81.1	81.1	88.7	74.0	98.8	59.4	77.2	77.2	83.4	71.3	92.7	56.9
	90	89.7	89.7	93.4	87.2	104.2	73.7	86.0	86.0	88.4	84.7	98.7	71.3	81.9	81.9	83.1	82.0	92.7	68.8
2700	75	86.4	73.6	97.6	57.0	107.3	38.8	81.6	69.7	92.3	54.5	101.3	36.4	76.3	67.9	86.5	51.9	94.9	33.8
	80	85.9	85.9	97.4	71.1	107.4	53.3	81.4	81.4	92.0	68.6	101.5	50.9	77.2	77.2	86.2	66.0	95.2	48.4
	85	90.5	90.5	97.0	81.7	107.5	67.6	86.5	86.5	91.6	81.8	101.6	65.2	82.2	82.2	85.8	79.0	95.2	62.6
	90	95.7	95.7	96.3	96.3	107.4	81.8	91.6	91.6	91.7	91.7	101.5	79.4	87.0	87.0	87.1	87.1	95.1	76.9
3000	75	88.0	77.4	99.4	59.7	108.8	39.6	82.9	74.7	93.9	57.2	102.7	37.1	77.5	71.9	87.9	54.6	96.1	34.6
	80	88.2	88.2	99.0	75.3	109.1	55.7	84.1	84.1	93.5	72.8	103.0	53.2	79.8	79.8	87.6	70.1	96.4	50.6
	85	93.6	93.6	98.4	89.5	109.1	71.4	89.5	89.5	92.8	86.8	103.0	69.0	84.9	84.9	86.8	84.0	96.4	66.4
	90	98.9	98.9	99.1	99.1	109.0	87.1	94.6	94.6	94.7	94.7	102.9	82.8	89.7	89.7	89.8	89.8	96.3	81.2
3300	75	89.1	81.3	100.9	62.3	110.1	40.3	83.9	78.6	95.2	59.8	103.8	37.8	78.4	75.7	89.1	57.1	97.1	35.2
	80	90.8	90.8	100.4	79.3	110.4	57.8	86.5	86.5	94.7	76.8	104.2	55.3	82.0	82.0	88.6	71.5	97.4	52.7
	85	96.3	96.3	99.4	94.4	110.4	75.1	92.0	92.0	93.7	91.7	104.2	72.7	87.2	87.2	87.5	87.5	97.5	70.1
	90	101.7	101.7	101.8	101.8	110.2	91.4	97.1	97.1	97.2	97.2	103.8	88.7	92.0	92.0	92.1	92.1	96.9	85.8
3600	75	90.0	85.1	102.1	64.8	111.1	41.0	84.7	82.3	96.3	62.3	104.8	38.5	79.1	79.1	90.0	59.6	97.9	35.9
	80	93.0	93.0	101.5	81.7	111.5	60.0	88.7	88.7	95.6	79.9	105.2	57.5	83.9	83.9	89.3	77.0	98.3	54.9
	85	98.7	98.7	100.1	99.1	111.5	78.8	94.1	94.1	94.3	94.3	105.2	76.3	89.1	89.1	89.2	89.2	98.3	73.7
	90	104.1	104.1	104.2	104.2	110.8	95.9	99.3	99.3	99.4	99.4	104.3	93.2	93.9	93.9	94.0	94.0	97.2	90.3
		Ambient Temperature 115°F						Ambient Temperature 125°F											
2250	75	68.5	59.0	77.8	45.1	85.9	30.0	62.9	54.0	71.6	42.3	78.8	27.2						
	80	68.4	68.4	77.7	57.0	86.1	42.2	63.8	63.8	71.4	54.2	79.0	39.4						
	85	72.9	72.9	77.6	66.1	86.2	54.2	68.2	68.2	71.2	65.3	79.1	51.4						
	90	77.4	77.4	77.5	77.5	86.1	66.2	72.4	72.4	72.5	72.5	79.1	63.4						
2700	75	70.7	65.0	80.3	49.2	88.0	31.1	64.7	61.9	73.6	46.3	80.5	28.3						
	80	72.7	72.7	80.1	63.3	88.3	45.6	67.7	67.7	73.4	60.4	80.8	42.8						
	85	77.4	77.4	79.6	76.1	88.3	59.9	72.2	72.2	72.8	72.8	80.9	57.0						
	90	82.0	82.0	82.1	82.1	88.3	71.4	76.4	76.4	76.5	76.5	80.7	70.4						
3000	75	71.7	68.9	81.5	51.8	89.0	31.8	65.5	65.5	74.7	48.8	81.3	29.0						
	80	75.0	75.0	81.2	66.2	89.3	47.8	69.8	69.8	74.3	63.7	81.7	44.9						
	85	79.9	79.9	80.4	80.4	89.3	63.6	74.3	74.3	74.4	74.4	81.7	60.7						
	90	84.4	84.4	84.5	84.5	89.0	78.2	78.4	78.4	78.5	78.5	81.1	75.0						
3300	75	72.5	72.5	82.5	54.3	89.8	32.5	66.7	66.7	75.5	51.3	82.0	29.6						
	80	77.0	77.0	82.0	70.4	90.2	50.0	71.6	71.6	74.9	67.2	82.4	47.0						
	85	81.9	81.9	82.0	82.0	90.2	67.3	76.1	76.1	76.1	76.1	82.5	63.8						
	90	86.3	86.3	86.4	86.4	89.4	82.7	80.1	80.1	80.1	80.1	81.4	79.5						
3600	75	73.5	73.5	83.3	56.7	90.5	33.2	68.2	68.2	76.2	53.7	82.7	30.3						
	80	78.7	78.7	82.5	73.9	90.9	52.1	73.1	73.1	75.3	70.7	83.0	49.1						
	85	83.6	83.6	83.7	83.7	91.0	69.7	77.5	77.5	77.6	77.6	82.9	67.1						
	90	88.0	88.0	88.1	88.1	89.6	87.2	81.4	81.4	81.4	81.4	81.5	81.5						

**Notes:**

- All capacities shown are gross and have not considered indoor fan heat. To obtain NET cooling capacity subtract indoor fan heat. For indoor fan heat formula, refer to appropriate airflow table notes.
- MBh = Total gross capacity.
- SHC = Sensible heat capacity.

**Table 39. Gross cooling capacities — 8.5 tons, standard efficiency, gas/electric**

CFM	Ent DB (° F)	Entering Wet Bulb Temp (°F)						Entering Wet Bulb Temp (°F)						Entering Wet Bulb Temp (°F)					
		61		67		73		61		67		73		61		67		73	
		MBh	SHC	MBh	SHC	MBh	SHC	MBh	SHC	MBh	SHC	MBh	SHC	MBh	SHC	MBh	SHC	MBh	SHC
		Ambient Temperature 85°F						Ambient Temperature 95°F						Ambient Temperature 105°F					
2550	75	107.7	74.4	112.7	62.4	127.0	46.0	94.0	75.1	107.1	59.8	120.7	43.3	88.8	72.3	101.3	57.0	114.1	40.6
	80	98.6	90.2	112.4	75.8	126.9	59.8	93.7	87.4	106.9	73.2	120.7	57.1	88.5	84.6	101.1	70.4	114.1	54.3
	85	99.5	99.5	112.0	89.1	126.7	73.4	95.7	95.7	106.5	86.5	120.5	70.7	91.5	91.5	100.7	83.7	113.9	67.9
	90	105.4	105.4	111.6	101.4	126.4	86.8	101.4	101.4	106.1	98.7	120.2	84.1	97.2	97.2	100.3	95.7	113.7	81.3



## Gross Cooling Capacities

**Table 39. Gross cooling capacities — 8.5 tons, standard efficiency, gas/electric (continued)**

CFM	Ent DB (°F)	Entering Wet Bulb Temp (°F)						Entering Wet Bulb Temp (°F)						Entering Wet Bulb Temp (°F)						
		61		67		73		61		67		73		61		67		73		
		MBh	SHC	MBh	SHC	MBh	SHC	MBh	SHC	MBh	SHC	MBh	SHC	MBh	SHC	MBh	SHC	MBh	SHC	
3060	75	103.0	85.8	117.4	67.6	132.0	47.8	97.7	83.0	111.4	64.7	125.3	45.1	92.1	78.2	105.1	61.8	118.1	42.2	
	80	102.3	99.7	117.0	83.3	131.9	64.2	97.1	96.9	111.0	80.6	125.1	61.5	91.7	91.7	104.7	77.7	118.0	58.6	
	85	106.6	106.6	116.3	97.6	131.6	80.3	102.3	102.3	110.4	92.3	124.9	77.5	97.8	97.8	104.1	92.5	117.8	74.6	
	90	113.0	113.0	115.6	112.8	131.1	96.2	108.7	108.7	109.7	109.7	124.4	93.5	103.9	103.9	104.1	104.1	117.4	90.6	
3400	75	105.0	88.7	119.9	70.6	134.6	48.9	99.5	87.2	113.7	67.8	127.6	46.1	93.6	84.1	107.2	64.9	120.2	43.2	
	80	104.1	104.1	119.3	88.1	134.4	67.0	99.6	99.6	113.1	85.3	127.4	64.2	94.9	94.9	106.5	82.4	120.0	61.1	
	85	110.5	110.5	118.4	104.3	134.1	84.7	106.1	106.1	112.2	101.3	127.1	81.8	101.3	101.3	105.7	98.2	119.8	78.9	
	90	117.3	117.3	117.5	117.5	133.4	102.3	112.7	112.7	112.8	112.8	126.5	99.5	107.7	107.7	107.8	107.8	119.2	95.2	
3740	75	106.6	94.6	122.1	73.7	136.7	49.9	100.9	91.6	115.6	70.8	129.5	47.1	94.8	88.5	108.8	67.8	121.9	44.1	
	80	107.1	107.1	121.1	92.7	136.4	69.5	102.6	102.6	114.7	89.9	129.3	66.7	97.8	97.8	108.0	86.9	121.7	63.7	
	85	114.1	114.1	119.9	109.9	136.1	88.9	109.4	109.4	113.6	106.8	128.9	86.1	104.4	104.4	106.9	103.7	121.3	83.1	
	90	121.1	121.1	121.2	121.2	135.2	107.0	116.2	116.2	116.4	116.4	128.1	104.3	111.0	111.0	111.1	111.1	120.5	101.1	
4080	75	107.8	98.9	123.7	76.6	138.6	50.8	101.9	95.9	117.1	73.6	131.2	48.0	95.8	92.7	110.2	70.6	123.4	45.0	
	80	110.0	110.0	122.6	97.3	138.3	72.1	105.3	105.3	116.0	92.6	131.0	69.2	100.3	100.3	109.1	90.3	123.2	66.2	
	85	117.2	117.2	121.1	115.3	137.7	93.1	112.3	112.3	114.6	112.2	130.3	90.2	107.1	107.1	107.7	107.7	122.6	87.2	
	90	124.5	124.5	124.6	124.6	136.6	112.6	119.4	119.4	119.5	119.5	129.2	109.4	113.9	113.9	114.0	114.0	121.4	106.2	
		Ambient Temperature 115°F						Ambient Temperature 125°F												
2550	75	83.2	69.5	95.0	54.1	107.1	37.7	77.2	66.3	88.3	51.0	99.5	34.6							
	80	82.9	81.5	94.8	67.5	107.0	51.4	77.0	77.0	88.1	64.4	99.4	48.4							
	85	87.1	87.1	94.5	80.4	106.9	65.0	82.2	82.2	87.8	74.5	99.3	61.9							
	90	92.6	92.6	94.2	92.7	106.6	78.4	87.6	87.6	87.7	87.7	99.1	75.3							
3060	75	86.1	76.4	98.5	58.8	110.6	39.2	79.7	73.1	91.4	55.7	102.5	36.1							
	80	87.0	87.0	98.1	74.7	110.5	55.6	81.9	81.9	90.9	71.6	102.4	52.3							
	85	92.9	92.9	97.5	89.3	110.3	71.6	87.6	87.6	90.3	85.9	102.2	68.4							
	90	98.9	98.9	99.0	99.0	109.9	87.6	93.3	93.3	93.4	93.4	101.9	82.0							
3400	75	87.5	80.9	100.3	61.8	112.4	40.2	80.8	77.5	92.9	58.6	104.0	36.9							
	80	90.0	90.0	99.7	79.3	112.2	58.1	84.6	84.6	92.3	74.8	103.9	54.8							
	85	96.1	96.1	98.8	94.9	112.0	75.8	90.5	90.5	91.4	91.4	103.6	72.6							
	90	102.3	102.3	102.4	102.4	111.4	92.5	96.4	96.4	96.5	96.5	103.0	89.0							
3740	75	88.5	85.2	101.7	64.7	113.8	41.0	81.7	81.7	94.1	61.4	105.2	37.8							
	80	92.6	92.6	100.9	80.8	113.8	60.6	87.0	87.0	93.2	79.6	105.2	57.3							
	85	99.0	99.0	99.8	99.8	113.3	80.0	93.1	93.1	93.2	93.2	104.8	76.7							
	90	105.3	105.3	105.4	105.4	112.5	97.7	99.1	99.1	99.2	99.2	103.8	94.2							
4080	75	89.2	89.2	102.8	67.5	115.1	41.9	82.9	82.9	95.0	64.2	106.3	38.6							
	80	94.9	94.9	101.8	87.0	115.0	63.0	89.1	89.1	94.0	83.5	106.2	59.7							
	85	101.4	101.4	101.5	101.5	114.4	84.1	95.3	95.3	95.4	95.4	105.7	80.5							
	90	107.9	107.9	108.0	108.0	113.2	102.8	101.4	101.4	101.5	101.5	104.4	99.3							

**Notes:**

1. All capacities shown are gross and have not considered indoor fan heat. To obtain NET cooling capacity subtract indoor fan heat. For indoor fan heat formula, refer to appropriate airflow table notes.
2. MBh = Total gross capacity.
3. SHC = Sensible heat capacity.

**Table 40. Gross cooling capacities — 10 tons, standard efficiency, gas/electric**

CFM	Ent DB (°F)	Entering Wet Bulb Temp (°F)						Entering Wet Bulb Temp (°F)						Entering Wet Bulb Temp (°F)					
		61		67		73		61		67		73		61		67		73	
		MBh	SHC	MBh	SHC	MBh	SHC	MBh	SHC	MBh	SHC	MBh	SHC	MBh	SHC	MBh	SHC	MBh	SHC
		Ambient Temperature 85°F						Ambient Temperature 95°F						Ambient Temperature 105°F					
3000	75	121.3	85.3	127.7	71.4	140.2	50.8	107.9	87.1	120.7	68.1	132.0	47.4	101.4	83.8	113.1	64.7	123.2	43.9
	80	113.4	104.7	127.6	87.1	140.3	66.9	107.4	101.4	120.6	83.9	132.1	63.5	100.8	97.8	113.0	80.4	123.3	60.0
	85	114.7	114.7	127.2	102.7	140.3	82.9	109.9	109.9	120.2	99.5	132.2	79.5	104.6	104.6	112.8	96.1	123.4	76.0
	90	121.0	121.0	126.6	117.0	140.2	98.7	115.9	115.9	119.7	113.6	132.2	95.4	110.2	110.2	112.1	109.9	123.4	91.8
3600	75	118.2	99.4	132.2	76.9	144.2	52.3	111.7	96.1	124.7	73.5	135.4	48.9	104.7	89.8	116.6	69.9	126.4	45.4
	80	117.1	115.5	131.9	95.6	144.4	71.5	110.6	110.6	124.4	92.2	135.6	68.1	104.7	104.7	116.3	88.6	126.4	64.6
	85	122.1	122.1	131.4	111.4	144.4	90.4	116.7	116.7	123.8	109.6	135.7	87.0	110.7	110.7	115.6	105.7	126.3	83.4
	90	128.7	128.7	130.0	129.7	144.3	109.3	122.9	122.9	123.0	123.0	135.7	105.9	116.4	116.4	116.5	116.5	126.4	102.3



**Gross Cooling Capacities**

**Table 40. Gross cooling capacities — 10 tons, standard efficiency, gas/electric (continued)**

CFM	Ent DB (°F)	Entering Wet Bulb Temp (°F)						Entering Wet Bulb Temp (°F)						Entering Wet Bulb Temp (°F)					
		61		67		73		61		67		73		61		67		73	
		MBh	SHC	MBh	SHC	MBh	SHC	MBh	SHC	MBh	SHC	MBh	SHC	MBh	SHC	MBh	SHC	MBh	SHC
4000	75	120.3	102.6	134.5	80.4	146.2	53.3	113.3	100.8	126.7	76.9	137.4	49.9	106.0	97.0	118.3	73.3	128.2	46.4
	80	119.3	119.3	134.1	101.0	146.5	74.5	113.8	113.8	126.3	97.5	137.4	71.0	107.8	107.8	117.9	93.9	128.2	67.4
	85	126.1	126.1	133.1	119.7	146.5	95.4	120.3	120.3	125.2	116.0	137.5	91.9	113.9	113.9	116.7	112.0	127.9	88.2
	90	132.8	132.8	133.0	133.0	146.4	116.2	126.6	126.6	126.7	126.7	137.4	111.3	119.6	119.6	119.7	119.7	127.7	107.8
4400	75	121.7	109.4	136.5	83.8	148.2	54.4	114.6	105.8	128.3	80.2	139.2	50.9	107.0	101.9	119.6	76.5	129.7	47.4
	80	122.6	122.6	135.8	106.3	148.2	77.4	116.8	116.8	127.8	102.8	139.1	73.9	110.6	110.6	119.2	96.9	129.7	70.3
	85	129.6	129.6	134.3	126.0	148.2	100.2	123.4	123.4	126.1	122.2	138.9	96.7	116.6	116.6	117.4	117.4	129.2	93.0
	90	136.4	136.4	136.5	136.5	148.3	118.0	129.7	129.7	129.8	129.8	138.4	117.8	122.3	122.3	122.4	122.4	128.2	113.6
4800	75	122.8	114.3	138.0	87.0	150.0	55.4	115.5	110.6	129.6	83.5	140.7	51.9	107.7	106.6	120.7	79.7	130.9	48.3
	80	125.5	125.5	137.3	111.3	149.8	80.2	119.5	119.5	129.3	103.9	140.6	76.8	112.9	112.9	119.9	102.7	130.9	73.1
	85	132.6	132.6	135.1	132.1	149.6	105.0	126.1	126.1	126.7	126.7	140.2	101.4	119.0	119.0	119.1	119.1	130.3	97.8
	90	139.4	139.4	139.5	139.5	148.7	127.5	132.4	132.4	132.5	132.5	138.9	123.6	124.5	124.5	124.6	124.6	128.8	119.5
		Ambient Temperature 115°F						Ambient Temperature 125°F											
3000	75	94.4	80.3	105.0	61.1	113.9	40.2	86.9	75.4	96.3	57.2	104.3	36.5						
	80	93.9	93.9	104.9	76.8	114.0	56.3	87.2	87.2	96.2	73.0	104.3	52.6						
	85	98.7	98.7	104.7	90.0	114.0	72.2	92.1	92.1	95.9	87.7	104.3	68.5						
	90	103.9	103.9	104.0	104.0	114.0	88.1	96.7	96.7	96.8	96.8	104.2	84.3						
3600	75	97.0	88.0	107.9	66.2	116.8	41.8	88.9	83.9	98.5	62.2	106.6	38.0						
	80	98.5	98.5	107.6	84.9	116.9	60.9	91.7	91.7	98.4	81.0	106.7	57.0						
	85	104.0	104.0	106.8	101.6	116.7	79.7	96.6	96.6	97.3	97.3	106.6	75.9						
	90	109.1	109.1	109.3	109.3	116.4	94.9	101.0	101.0	101.1	101.1	106.1	93.4						
4000	75	98.2	93.0	109.2	69.5	118.3	42.7	89.8	88.8	99.6	65.4	107.8	38.9						
	80	101.3	101.3	109.0	89.6	118.4	63.8	94.0	94.0	99.3	85.2	107.9	59.9						
	85	106.8	106.8	107.6	107.6	118.1	84.5	98.8	98.8	98.9	98.9	107.7	80.7						
	90	111.8	111.8	111.9	111.9	117.4	103.6	103.5	103.5	103.6	103.6	106.8	99.4						
4400	75	98.9	97.8	110.4	72.7	119.5	43.7	90.7	90.7	100.5	68.6	108.7	39.8						
	80	103.6	103.6	109.8	94.1	119.6	66.6	96.0	96.0	99.8	89.6	108.9	62.7						
	85	109.1	109.1	109.2	109.2	119.2	89.3	100.7	100.7	100.8	100.8	108.6	84.7						
	90	114.1	114.1	114.2	114.2	118.0	109.6	105.7	105.7	105.8	105.8	107.2	105.3						
4800	75	99.7	99.7	111.3	75.8	120.6	44.6	92.4	92.4	101.3	71.8	109.6	40.7						
	80	105.6	105.6	110.3	98.5	120.6	69.4	97.6	97.6	100.1	94.0	109.7	65.4						
	85	111.0	111.0	111.1	111.1	120.1	92.6	102.2	102.2	102.3	102.3	109.1	88.9						
	90	116.4	116.4	116.5	116.5	118.5	115.4	107.6	107.6	107.7	107.7	107.8	107.8						

- Notes:**
1. All capacities shown are gross and have not considered indoor fan heat. To obtain NET cooling capacity subtract indoor fan heat. For indoor fan heat formula, refer to appropriate airflow table notes.
  2. MBh = Total gross capacity.
  3. SHC = Sensible heat capacity.

**Table 41. Gross cooling capacities — 12.5 tons, standard efficiency, gas/electric**

CFM	Ent DB (°F)	Entering Wet Bulb Temp (°F)						Entering Wet Bulb Temp (°F)						Entering Wet Bulb Temp (°F)					
		61		67		73		61		67		73		61		67		73	
		MBh	SHC	MBh	SHC	MBh	SHC	MBh	SHC	MBh	SHC	MBh	SHC	MBh	SHC	MBh	SHC	MBh	SHC
		Ambient Temperature 85°F						Ambient Temperature 95°F						Ambient Temperature 105°F					
3750	75	143.4	99.8	150.7	83.8	167.1	60.1	126.9	101.5	142.8	80.0	157.9	56.2	119.4	97.6	134.2	76.0	147.9	52.0
	80	133.1	122.0	150.4	101.9	167.0	79.0	126.3	118.0	142.5	98.1	157.9	75.1	118.8	113.9	134.0	94.0	148.0	71.0
	85	134.0	134.0	149.8	120.1	166.8	97.5	128.6	128.6	142.0	116.3	157.8	93.6	122.5	122.5	133.5	112.0	148.0	89.4
	90	141.6	141.6	149.2	136.6	166.5	115.9	135.8	135.8	141.4	132.5	157.5	112.0	129.5	129.5	132.8	128.2	147.7	107.8
4500	75	138.7	115.8	156.0	90.0	172.4	62.1	131.4	110.2	147.6	86.0	162.5	58.1	123.3	106.8	138.5	81.8	151.9	53.8
	80	137.5	134.4	155.7	111.7	172.4	84.7	130.1	130.1	147.2	107.7	162.6	80.7	122.6	122.6	138.1	103.5	152.1	76.1
	85	142.8	142.8	154.8	132.0	172.1	106.3	136.7	136.7	146.4	127.8	162.5	102.3	130.0	130.0	137.1	123.2	151.9	97.9
	90	150.8	150.8	153.4	151.3	171.6	128.2	144.4	144.4	145.0	145.0	162.0	124.2	137.2	137.2	137.3	137.3	151.5	119.8
5000	75	141.1	121.4	159.0	94.0	175.1	63.4	133.4	117.1	150.3	90.0	164.9	59.3	125.0	112.6	140.7	85.6	153.9	55.0
	80	139.4	139.4	158.3	117.9	175.1	88.3	133.2	133.2	149.5	113.9	165.0	83.7	126.4	126.4	140.1	109.6	154.2	79.3
	85	147.6	147.6	157.0	139.5	174.8	112.0	141.1	141.1	148.2	135.2	164.7	107.8	134.0	134.0	138.6	130.5	153.8	103.4
	90	155.8	155.8	156.0	156.0	174.1	136.2	149.0	149.0	149.1	149.1	164.2	128.1	141.3	141.3	141.5	141.5	153.1	126.0



# Gross Cooling Capacities

**Table 41. Gross cooling capacities — 12.5 tons, standard efficiency, gas/electric (continued)**

CFM	Ent DB (° F)	Entering Wet Bulb Temp (°F)						Entering Wet Bulb Temp (°F)						Entering Wet Bulb Temp (°F)					
		61		67		73		61		67		73		61		67		73	
		MBh	SHC	MBh	SHC	MBh	SHC	MBh	SHC	MBh	SHC	MBh	SHC	MBh	SHC	MBh	SHC	MBh	SHC
5500	75	142.8	127.1	161.4	97.9	177.3	64.5	134.8	122.8	152.3	93.7	166.9	60.4	126.2	118.2	142.5	89.3	155.6	56.1
	80	143.2	143.2	160.4	124.0	177.4	91.1	136.8	136.8	151.4	119.9	167.1	86.9	129.7	129.7	141.7	111.5	156.0	82.4
	85	151.8	151.8	158.5	146.7	176.9	117.5	145.0	145.0	149.4	142.3	166.6	113.3	137.4	137.4	139.6	137.7	155.4	108.9
	90	160.2	160.2	160.3	160.3	176.0	142.1	152.9	152.9	153.1	153.1	165.5	137.6	144.8	144.8	145.0	145.0	154.1	132.8
6000	75	144.1	132.6	163.3	101.6	179.3	65.7	135.9	128.3	154.0	97.4	168.6	61.6	127.0	123.7	143.9	92.9	157.0	57.2
	80	146.6	146.6	162.1	126.8	179.4	94.3	140.0	140.0	152.7	124.3	168.8	90.0	132.6	132.6	142.5	119.5	157.4	85.4
	85	155.4	155.4	159.5	153.8	178.7	122.9	148.3	148.3	150.2	149.3	168.1	118.7	140.4	140.4	140.5	140.5	156.7	114.2
	90	164.0	164.0	164.1	164.1	177.0	148.8	156.4	156.4	156.5	156.5	166.3	144.3	147.8	147.8	147.9	147.9	154.6	139.4
<b>Ambient Temperature 115°F</b>						<b>Ambient Temperature 125°F</b>													
3750	75	111.3	93.3	124.7	71.3	137.0	47.6	102.4	86.8	114.6	66.7	125.3	42.9						
	80	110.7	109.4	124.7	89.6	137.2	66.6	102.0	102.0	114.5	85.0	125.6	62.0						
	85	115.8	115.8	124.3	103.9	137.2	84.9	108.2	108.2	114.1	101.9	125.6	80.1						
	90	122.3	122.3	123.5	123.5	137.0	103.3	114.2	114.2	114.4	114.4	125.4	98.5						
4500	75	114.5	102.1	128.6	77.3	140.3	49.3	105.0	97.1	117.8	72.4	128.0	44.6						
	80	115.5	115.5	128.1	99.0	140.8	71.5	107.6	107.6	117.4	94.2	128.6	66.6						
	85	122.4	122.4	127.1	118.4	140.5	93.3	114.0	114.0	116.2	113.2	128.2	88.4						
	90	129.1	129.1	129.3	129.3	140.2	110.4	120.1	120.1	120.2	120.2	127.6	108.7						
5000	75	115.9	107.9	130.4	81.0	142.0	50.4	106.0	102.7	119.3	76.1	129.4	45.7						
	80	118.9	118.9	129.8	103.5	142.5	74.6	110.6	110.6	118.5	98.9	130.0	69.6						
	85	126.0	126.0	128.2	125.6	142.1	98.7	117.1	117.1	117.1	117.1	129.5	93.8						
	90	132.7	132.7	132.8	132.8	141.1	120.9	123.1	123.1	123.2	123.2	128.2	115.6						
5500	75	116.9	113.4	131.9	84.6	143.5	51.5	106.8	106.8	120.5	79.6	130.6	46.8						
	80	121.9	121.9	130.8	109.3	144.0	77.6	113.1	113.1	119.3	104.0	131.2	72.6						
	85	129.0	129.0	129.1	129.1	143.4	104.1	119.6	119.6	119.7	119.7	130.6	98.4						
	90	135.7	135.7	135.9	135.9	141.8	127.6	125.6	125.6	125.7	125.7	128.6	122.3						
6000	75	117.5	117.5	133.1	88.1	144.8	52.6	108.4	108.4	121.5	83.1	131.8	47.9						
	80	124.4	124.4	131.6	114.4	145.2	80.6	115.3	115.3	119.8	109.0	132.2	75.5						
	85	131.6	131.6	131.7	131.7	144.5	107.5	121.8	121.8	121.8	121.8	131.0	103.0						
	90	138.3	138.3	138.4	138.4	142.1	134.2	127.7	127.7	127.7	127.7	128.8	128.8						

**Notes:**

- All capacities shown are gross and have not considered indoor fan heat. To obtain NET cooling capacity subtract indoor fan heat. For indoor fan heat formula, refer to appropriate airflow table notes.
- MBh = Total gross capacity.
- SHC = Sensible heat capacity.

**Table 42. Gross cooling capacities — 15 tons, standard efficiency, gas/electric**

CFM	Ent DB (° F)	Entering Wet Bulb Temp (°F)						Entering Wet Bulb Temp (°F)						Entering Wet Bulb Temp (°F)					
		61		67		73		61		67		73		61		67		73	
		MBh	SHC	MBh	SHC	MBh	SHC	MBh	SHC	MBh	SHC	MBh	SHC	MBh	SHC	MBh	SHC	MBh	SHC
<b>Ambient Temperature 85°F</b>						<b>Ambient Temperature 95°F</b>						<b>Ambient Temperature 105°F</b>							
4500	75	169.0	134.0	187.5	105.2	205.0	72.9	160.6	129.5	178.6	100.9	194.2	68.4	151.4	124.6	168.7	96.3	182.7	63.7
	80	168.7	155.9	187.5	128.7	204.9	98.2	160.3	151.1	178.6	124.4	194.1	93.5	151.1	146.0	168.8	119.6	183.3	89.0
	85	170.7	170.7	187.3	152.4	204.6	121.8	164.0	164.0	178.6	148.1	194.2	117.3	156.5	156.5	168.8	141.8	183.7	112.7
	90	179.4	179.4	186.8	173.7	204.5	145.7	172.5	172.5	177.9	169.1	194.3	141.2	164.9	164.9	168.0	164.1	183.8	136.7
5400	75	175.1	147.6	193.3	112.7	211.3	75.5	166.2	140.3	184.0	108.3	199.8	71.6	156.4	136.7	173.7	103.4	187.6	66.7
	80	173.9	171.9	193.3	141.0	211.0	105.4	165.0	165.0	184.0	136.5	199.4	100.6	156.4	156.4	173.7	131.7	188.2	95.2
	85	180.7	180.7	193.0	167.4	210.9	133.2	173.5	173.5	183.5	162.6	199.6	128.4	165.3	165.3	172.9	157.5	187.9	123.5
	90	189.5	189.5	190.8	190.8	210.6	161.6	182.0	182.0	182.2	182.2	199.3	156.8	173.6	173.6	173.8	173.8	188.1	150.4
6000	75	178.0	154.6	196.3	117.6	214.5	78.0	168.6	149.6	186.8	113.1	202.6	73.2	158.5	144.1	176.2	108.1	190.1	68.2
	80	176.7	176.7	196.3	148.9	213.8	109.0	169.2	169.2	186.7	144.4	202.0	104.0	161.0	161.0	176.1	139.5	190.4	99.2
	85	186.0	186.0	195.0	176.9	214.1	140.4	178.4	178.4	185.2	172.1	202.4	135.6	170.0	170.0	174.4	166.9	190.0	130.5
	90	194.7	194.7	194.9	194.9	213.7	170.5	186.9	186.9	187.1	187.1	202.0	165.2	178.1	178.1	178.2	178.2	189.7	159.9
6600	75	179.9	162.0	198.9	122.3	217.2	79.5	170.4	156.9	189.1	117.7	205.0	74.7	160.0	151.4	178.2	112.7	192.2	69.7
	80	181.1	181.1	198.7	156.6	216.6	113.1	173.4	173.4	188.9	150.9	204.5	108.0	164.9	164.9	178.1	142.1	192.2	102.9
	85	190.5	190.5	196.3	186.1	216.7	147.5	182.6	182.6	186.4	181.3	204.7	142.6	173.8	173.8	175.4	175.4	192.0	137.5
	90	199.2	199.2	199.4	199.4	215.8	179.4	191.0	191.0	191.1	191.1	203.6	174.1	181.7	181.7	181.9	181.9	190.6	168.7

### Gross Cooling Capacities

**Table 42. Gross cooling capacities — 15 tons, standard efficiency, gas/electric (continued)**

CFM	Ent DB (°F)	Entering Wet Bulb Temp (°F)						Entering Wet Bulb Temp (°F)						Entering Wet Bulb Temp (°F)					
		61		67		73		61		67		73		61		67		73	
		MBh	SHC	MBh	SHC	MBh	SHC	MBh	SHC	MBh	SHC	MBh	SHC	MBh	SHC	MBh	SHC	MBh	SHC
7200	75	181.4	169.1	201.0	126.9	219.5	81.0	171.7	164.0	191.0	122.3	207.0	76.1	161.1	158.5	180.0	117.2	193.9	71.1
	80	184.9	184.9	200.8	159.0	218.9	117.0	177.0	177.0	190.4	157.6	206.6	111.9	168.2	168.2	179.0	152.2	193.7	106.6
	85	194.3	194.3	197.1	195.1	218.9	154.5	186.2	186.2	187.0	187.0	206.6	149.5	177.0	177.0	177.1	177.1	193.6	144.3
	90	203.8	203.8	203.9	203.9	217.1	188.1	194.5	194.5	194.7	194.7	204.7	182.9	184.7	184.7	184.9	184.9	191.5	177.4
		Ambient Temperature 115°F						Ambient Temperature 125°F											
4500	75	141.5	119.4	157.9	90.7	170.9	59.5	130.8	110.8	146.2	85.3	158.3	54.4						
	80	141.2	140.5	158.1	114.5	171.8	84.2	131.0	131.0	146.5	109.1	159.3	79.1						
	85	148.3	148.3	158.1	132.9	172.1	107.8	139.2	139.2	146.3	131.4	159.4	102.5						
	90	156.3	156.3	157.2	157.2	172.2	131.8	146.9	146.9	147.0	147.0	159.5	126.5						
5400	75	145.7	130.9	162.4	98.2	174.6	61.6	134.3	124.9	150.2	92.6	161.2	56.4						
	80	147.7	147.7	162.4	126.5	176.0	90.1	138.3	138.3	150.2	121.0	162.8	84.7						
	85	156.4	156.4	161.4	151.9	175.7	118.5	146.5	146.5	148.9	146.0	162.5	113.1						
	90	164.2	164.2	164.4	164.4	175.9	145.6	153.8	153.8	153.9	153.9	162.0	139.7						
6000	75	147.5	138.4	164.6	102.8	176.8	63.1	135.8	132.3	152.1	97.2	162.8	57.8						
	80	152.0	152.0	164.6	132.4	177.9	94.0	142.1	142.1	151.8	127.2	164.4	88.5						
	85	160.6	160.6	162.6	161.3	177.6	125.4	150.2	150.2	150.3	150.3	164.1	120.0						
	90	168.2	168.2	168.3	168.3	176.6	154.4	157.2	157.2	157.3	157.3	162.6	148.5						
6600	75	148.8	145.6	166.4	107.4	178.6	64.5	136.9	136.9	153.6	101.6	164.4	59.2						
	80	155.5	155.5	165.8	139.9	179.5	97.7	145.3	145.3	152.7	133.9	165.8	92.1						
	85	164.0	164.0	164.1	164.1	179.2	132.3	153.2	153.2	153.3	153.3	165.4	126.6						
	90	171.4	171.4	171.5	171.5	177.1	163.0	159.9	159.9	160.0	160.0	162.8	157.2						
7200	75	149.8	149.8	168.0	111.8	180.1	65.9	139.1	139.1	155.0	105.9	166.0	60.7						
	80	158.5	158.5	166.6	146.5	180.9	101.2	147.9	147.9	153.3	140.4	167.0	95.5						
	85	166.9	166.9	167.0	167.0	180.6	136.7	155.7	155.7	155.8	155.8	166.0	131.9						
	90	174.0	174.0	174.1	174.1	177.5	171.6	162.1	162.1	162.1	162.1	162.9	162.9						

**Notes:**

1. All capacities shown are gross and have not considered indoor fan heat. To obtain NET cooling capacity subtract indoor fan heat. For indoor fan heat formula, refer to appropriate airflow table notes.
2. MBh = Total gross capacity.
3. SHC = Sensible heat capacity.

**Table 43. Gross cooling capacities — 17.5 tons, standard efficiency, gas/electric**

CFM	Ent DB (°F)	Entering Wet Bulb Temp (°F)						Entering Wet Bulb Temp (°F)						Entering Wet Bulb Temp (°F)					
		61		67		73		61		67		73		61		67		73	
		MBh	SHC	MBh	SHC	MBh	SHC	MBh	SHC	MBh	SHC	MBh	SHC	MBh	SHC	MBh	SHC	MBh	SHC
		Ambient Temperature 85°F						Ambient Temperature 95°F						Ambient Temperature 105°F					
5250	75	194.3	153.9	217.2	121.9	238.8	85.4	184.7	148.8	206.9	116.9	226.0	80.2	174.6	143.4	195.7	111.7	212.7	75.4
	80	193.6	178.3	217.1	148.6	238.6	114.2	184.0	172.8	206.8	143.5	225.8	108.8	173.9	167.1	195.7	138.2	212.5	103.3
	85	195.2	195.2	216.6	175.5	238.0	141.1	187.6	187.6	206.4	170.5	225.4	135.6	179.5	179.5	195.4	164.3	213.0	130.3
	90	205.8	205.8	215.8	199.2	237.8	168.2	198.0	198.0	205.5	193.8	225.4	162.8	189.6	189.6	194.3	188.2	213.1	157.6
6300	75	201.4	169.2	224.1	130.4	246.5	89.5	191.2	160.8	213.2	125.2	232.7	83.9	180.4	152.4	201.5	119.7	218.4	78.2
	80	199.6	196.0	224.0	162.4	246.1	122.5	189.4	189.4	213.1	157.2	232.3	116.9	179.2	179.2	201.4	151.8	217.9	111.0
	85	207.1	207.1	223.5	192.1	245.8	153.9	198.9	198.9	212.2	186.4	232.2	148.3	190.0	190.0	200.2	180.5	218.2	142.5
	90	217.8	217.8	220.7	219.8	245.1	186.1	209.3	209.3	209.8	209.8	231.7	180.5	200.0	200.0	200.2	200.2	217.8	173.9
7000	75	204.8	176.9	227.8	135.9	250.4	91.3	194.1	171.0	216.5	130.6	236.1	85.7	182.8	164.9	204.5	125.1	221.4	79.9
	80	202.2	202.2	227.5	171.2	249.6	127.1	193.6	193.6	216.2	166.0	235.3	120.8	184.7	184.7	204.1	160.5	220.8	114.8
	85	213.5	213.5	225.8	202.5	249.6	162.1	204.8	204.8	214.3	196.8	235.5	156.3	195.5	195.5	202.0	190.8	221.0	150.4
	90	224.1	224.1	224.3	224.3	248.7	196.4	215.1	215.1	215.3	215.3	234.8	188.1	205.2	205.2	205.4	205.4	220.0	183.2
7700	75	207.1	184.9	230.8	141.2	253.7	93.1	196.1	179.0	219.2	135.9	238.9	87.3	184.5	172.9	206.8	130.2	223.8	81.5
	80	207.3	207.3	230.3	179.9	252.7	131.3	198.6	198.6	218.8	174.5	238.2	125.3	189.3	189.3	206.4	164.5	223.4	119.2
	85	218.8	218.8	227.4	212.5	252.7	170.1	209.8	209.8	215.6	206.8	238.2	164.2	200.0	200.0	203.0	200.8	223.3	158.2
	90	229.4	229.4	229.6	229.6	251.3	205.7	219.9	219.9	220.1	220.1	236.6	199.4	209.4	209.4	209.6	209.6	221.5	193.0
8400	75	208.7	192.7	233.3	146.4	256.4	94.8	197.5	186.8	221.4	140.9	241.3	89.0	185.7	180.6	208.8	135.2	225.8	83.1
	80	211.9	211.9	232.7	183.7	255.6	135.7	202.9	202.9	220.5	180.5	240.8	129.7	193.3	193.3	207.5	174.3	225.5	123.4
	85	223.4	223.4	228.3	222.3	255.3	177.8	214.0	214.0	216.4	216.4	240.5	171.9	203.8	203.8	204.0	204.0	225.3	165.9
	90	234.3	234.3	234.4	234.4	252.8	215.3	223.9	223.9	224.0	224.0	237.8	208.9	212.8	212.8	213.0	213.0	222.4	202.4
		Ambient Temperature 115°F						Ambient Temperature 125°F											

**Table 43. Gross cooling capacities — 17.5 tons, standard efficiency, gas/electric (continued)**

CFM	Ent DB (° F)	Entering Wet Bulb Temp (°F)						Entering Wet Bulb Temp (°F)						Entering Wet Bulb Temp (°F)					
		61		67		73		61		67		73		61		67		73	
		MBh	SHC	MBh	SHC	MBh	SHC	MBh	SHC	MBh	SHC	MBh	SHC	MBh	SHC	MBh	SHC	MBh	SHC
5250	75	164.0	137.8	183.9	105.6	198.6	69.7	152.7	130.2	171.0	99.6	183.9	63.9						
	80	163.3	161.2	183.9	132.6	199.3	97.9	152.1	152.1	171.2	126.7	185.0	92.1						
	85	170.9	170.9	183.6	154.5	199.7	124.7	161.4	161.4	170.9	151.8	185.3	118.7						
	90	180.5	180.5	182.5	182.2	199.9	152.0	170.4	170.4	170.6	170.6	185.5	146.1						
6300	75	168.9	150.4	189.0	113.9	203.6	72.3	156.7	143.9	175.6	107.8	187.9	66.3						
	80	170.1	170.1	188.8	146.0	203.7	104.4	160.3	160.3	175.5	140.0	188.6	98.3						
	85	180.4	180.4	187.5	174.3	203.5	136.5	169.9	169.9	173.9	167.8	188.4	130.4						
	90	189.7	189.7	189.9	189.9	203.8	162.6	178.4	178.4	178.5	178.5	188.1	160.4						
7000	75	170.9	158.6	191.6	119.2	206.0	73.9	158.4	152.1	177.8	112.9	189.9	67.8						
	80	175.1	175.1	191.3	153.6	205.7	108.6	164.7	164.7	177.4	146.9	190.1	102.3						
	85	185.3	185.3	188.9	184.6	206.0	144.4	174.2	174.2	175.0	175.0	190.0	138.1						
	90	194.3	194.3	194.4	194.4	204.7	176.7	182.1	182.1	182.2	182.2	188.5	170.0						
7700	75	172.4	166.5	193.6	124.2	208.0	75.5	159.6	159.6	179.5	117.9	191.5	69.3						
	80	179.3	179.3	192.8	160.7	207.9	112.9	168.4	168.4	178.4	154.0	191.5	106.3						
	85	189.4	189.4	189.8	189.8	207.9	152.1	177.7	177.7	177.8	177.8	191.5	145.7						
	90	197.8	197.8	198.0	198.0	205.7	186.3	184.9	184.9	185.0	185.0	189.3	179.6						
8400	75	173.4	173.3	195.3	129.1	209.7	77.0	161.2	161.2	181.0	122.7	192.9	70.9						
	80	182.9	182.9	193.7	167.8	209.7	117.0	171.6	171.6	179.0	161.1	193.1	110.3						
	85	192.7	192.7	192.8	192.8	209.5	158.3	180.5	180.5	180.6	180.6	192.2	151.1						
	90	200.6	200.6	200.7	200.7	206.3	195.8	187.5	187.5	187.6	187.6	189.6	189.0						

**Notes:**

1. All capacities shown are gross and have not considered indoor fan heat. To obtain NET cooling capacity subtract indoor fan heat. For indoor fan heat formula, refer to appropriate airflow table notes.
2. MBh = Total gross capacity.
3. SHC = Sensible heat capacity.

**Table 44. Gross cooling capacities — 20 tons, standard efficiency, gas/electric**

CFM	Ent DB (° F)	Entering Wet Bulb Temp (°F)						Entering Wet Bulb Temp (°F)						Entering Wet Bulb Temp (°F)					
		61		67		73		61		67		73		61		67		73	
		MBh	SHC	MBh	SHC	MBh	SHC	MBh	SHC	MBh	SHC	MBh	SHC	MBh	SHC	MBh	SHC	MBh	SHC
		<b>Ambient Temperature 85°F</b>						<b>Ambient Temperature 95°F</b>						<b>Ambient Temperature 105°F</b>					
6000	75	219.3	172.1	249.3	138.6	276.4	98.7	208.5	166.2	237.3	132.8	263.1	93.0	196.6	159.9	223.9	126.4	247.9	86.9
	80	217.6	198.2	248.9	167.9	276.3	130.8	206.8	191.9	236.9	162.0	263.0	125.0	194.9	185.1	223.5	155.5	247.9	118.6
	85	217.2	217.2	247.3	197.2	275.9	161.4	208.9	208.9	235.5	191.3	262.6	154.8	199.8	199.8	222.2	184.9	247.7	148.3
	90	230.1	230.1	245.9	222.8	275.6	190.5	221.6	221.6	233.9	216.4	262.4	184.7	212.1	212.1	220.6	209.5	247.5	178.2
7200	75	227.7	188.8	258.3	149.1	284.8	103.0	216.1	182.6	245.3	142.1	270.4	97.1	203.3	171.6	231.2	135.4	254.2	90.5
	80	224.6	217.0	257.9	183.1	284.7	139.6	213.0	210.4	245.0	177.0	270.4	133.6	200.3	200.3	230.7	170.3	254.3	127.1
	85	231.4	231.4	255.8	211.8	284.6	174.2	222.4	222.4	243.1	208.6	270.4	168.1	212.3	212.3	228.6	201.3	254.3	161.4
	90	245.1	245.1	252.5	244.8	283.8	209.5	235.8	235.8	239.8	238.3	269.7	203.5	225.2	225.2	225.6	225.6	253.7	196.9
8000	75	231.8	194.9	263.2	154.5	289.0	104.9	219.6	190.2	250.0	148.2	274.0	98.8	206.1	182.8	235.4	141.4	257.3	92.2
	80	227.6	227.6	262.2	192.8	288.9	145.1	215.9	215.9	248.9	186.5	274.1	138.7	205.7	205.7	234.2	179.7	257.4	131.1
	85	239.3	239.3	259.4	226.5	288.8	182.8	229.8	229.8	245.9	219.6	274.1	176.6	219.2	219.2	231.0	212.2	257.4	169.8
	90	253.3	253.3	255.0	255.0	287.8	221.8	243.4	243.4	243.6	243.6	273.2	215.7	232.2	232.2	232.4	232.4	258.8	201.8
8800	75	234.6	205.6	267.5	160.4	292.5	106.7	221.9	198.6	253.9	154.1	277.0	100.5	208.1	191.1	238.8	147.1	259.8	93.8
	80	231.5	231.5	265.8	202.0	292.3	149.1	222.0	222.0	252.1	195.7	277.1	142.7	211.4	211.4	236.9	188.8	260.1	135.7
	85	246.2	246.2	261.6	237.1	292.2	191.2	236.3	236.3	247.7	230.2	277.0	184.9	225.1	225.1	232.4	222.7	260.0	178.0
	90	260.3	260.3	260.5	260.5	291.1	226.6	250.0	250.0	250.2	250.2	275.6	223.7	238.2	238.2	238.3	238.3	258.1	216.0
9600	75	236.6	213.7	271.1	166.1	296.1	108.6	223.6	206.7	256.9	159.6	279.5	102.1	209.4	199.2	241.3	152.5	261.9	95.4
	80	237.3	237.3	268.6	211.1	295.4	153.8	227.3	227.3	254.6	201.1	279.8	147.3	216.3	216.3	238.6	194.7	262.4	140.1
	85	252.1	252.1	262.9	247.3	295.0	199.4	241.8	241.8	248.8	240.4	279.5	193.0	230.2	230.2	233.2	232.9	262.1	186.0
	90	266.4	266.4	266.6	266.6	292.6	240.4	255.6	255.6	255.8	255.8	276.6	233.4	243.2	243.2	243.4	243.4	258.8	225.7
		<b>Ambient Temperature 115°F</b>						<b>Ambient Temperature 125°F</b>											
6000	75	183.7	153.1	209.1	119.5	231.0	80.8	169.7	144.3	192.8	111.3	212.4	73.3						
	80	182.1	177.9	208.9	148.5	231.1	111.7	168.2	168.2	192.9	141.1	212.6	104.4						
	85	189.7	189.7	207.8	174.7	231.1	141.2	178.4	178.4	191.9	168.1	212.8	133.6						
	90	201.5	201.5	206.1	202.0	230.8	171.2	189.6	189.6	190.3	190.3	212.5	163.6						



### Gross Cooling Capacities

**Table 44. Gross cooling capacities — 20 tons, standard efficiency, gas/electric (continued)**

CFM	Ent DB (°F)	Entering Wet Bulb Temp (°F)						Entering Wet Bulb Temp (°F)						Entering Wet Bulb Temp (°F)						
		61		67		73		61		67		73		61		67		73		
		MBh	SHC	MBh	SHC	MBh	SHC	MBh	SHC	MBh	SHC	MBh	SHC	MBh	SHC	MBh	SHC	MBh	SHC	
7200	75	189.3	166.4	215.7	128.2	236.2	83.4	174.2	158.2	198.8	120.4	216.5	75.8							
	80	188.6	188.6	215.1	163.1	236.4	120.0	176.8	176.8	198.1	155.4	216.9	111.0							
	85	201.2	201.2	212.8	193.4	236.5	154.1	188.7	188.7	195.7	185.1	217.0	146.2							
	90	213.4	213.4	213.5	213.5	236.1	187.8	199.9	199.9	200.1	200.1	216.5	179.0							
8000	75	191.7	175.0	219.3	134.0	238.7	85.0	176.0	166.7	201.7	126.0	218.5	77.3							
	80	194.5	194.5	218.0	172.4	239.1	123.6	182.1	182.1	200.5	160.3	219.1	115.5							
	85	207.4	207.4	214.7	204.3	239.1	162.3	194.1	194.1	197.0	195.8	219.1	154.4							
	90	219.6	219.6	219.7	219.7	238.0	197.8	205.2	205.2	205.4	205.4	217.4	189.1							
8800	75	193.2	183.2	222.0	139.5	240.8	86.5	177.2	174.8	203.9	131.4	220.1	78.8							
	80	199.6	199.6	220.2	178.6	241.3	128.1	186.6	186.6	201.7	170.2	220.9	119.7							
	85	212.7	212.7	215.8	214.7	241.2	170.5	198.7	198.7	198.8	198.8	220.8	162.4							
	90	224.8	224.8	224.9	224.9	238.8	207.7	209.5	209.5	209.7	209.7	217.9	198.9							
9600	75	194.2	191.2	224.2	144.8	242.5	88.1	177.9	177.9	205.7	136.6	221.5	80.4							
	80	204.1	204.1	221.2	186.3	243.2	132.3	190.6	190.6	202.5	177.5	222.3	123.9							
	85	217.2	217.2	217.3	217.3	243.0	178.4	202.6	202.6	202.7	202.7	222.2	166.4							
	90	229.1	229.1	229.2	229.2	239.2	217.4	213.0	213.0	213.2	213.2	218.0	208.6							

**Notes:**

1. All capacities shown are gross and have not considered indoor fan heat. To obtain NET cooling capacity subtract indoor fan heat. For indoor fan heat formula, refer to appropriate airflow table notes.
2. MBh = Total gross capacity.
3. SHC = Sensible heat capacity.

**Table 45. Gross cooling capacities — 25 tons, standard efficiency, gas/electric**

CFM	Ent DB (°F)	Entering Wet Bulb Temp (°F)						Entering Wet Bulb Temp (°F)						Entering Wet Bulb Temp (°F)					
		61		67		73		61		67		73		61		67		73	
		MBh	SHC	MBh	SHC	MBh	SHC	MBh	SHC	MBh	SHC	MBh	SHC	MBh	SHC	MBh	SHC	MBh	SHC
		<b>Ambient Temperature 85°F</b>						<b>Ambient Temperature 95°F</b>						<b>Ambient Temperature 105°F</b>					
7500	75	254.1	203.6	289.1	162.7	319.0	113.4	240.8	196.3	273.8	155.3	302.3	107.5	228.7	189.7	259.1	148.3	285.5	100.3
	80	251.1	234.1	288.4	198.2	318.8	152.6	237.8	226.3	273.2	190.7	302.1	145.4	225.8	219.3	258.8	183.6	285.3	138.8
	85	253.8	253.8	286.0	234.0	318.2	188.8	243.5	243.5	271.0	225.2	301.8	181.5	233.9	233.9	256.9	211.8	285.3	174.1
	90	269.1	269.1	283.3	263.7	317.5	225.4	258.3	258.3	268.3	255.7	301.0	218.1	248.0	248.0	254.1	248.2	284.5	210.8
9000	75	262.7	220.0	298.3	173.6	327.2	118.1	248.3	213.0	282.4	165.9	309.5	110.7	235.0	205.4	267.0	158.4	291.5	103.4
	80	257.7	256.1	297.2	216.1	326.8	163.4	243.4	243.4	281.1	208.4	309.2	155.0	232.6	232.6	265.7	201.0	291.2	146.5
	85	269.8	269.8	293.7	253.8	326.6	204.7	258.4	258.4	277.6	245.5	309.0	197.1	247.6	247.6	262.1	237.5	291.4	189.5
	90	285.6	285.6	289.0	289.0	325.3	248.0	273.6	273.6	273.8	273.8	307.9	240.6	262.0	262.0	262.1	262.1	290.4	226.0
10000	75	266.3	231.7	303.6	180.9	331.2	120.1	251.2	223.3	287.2	173.0	313.0	112.7	237.5	215.6	271.2	165.3	294.5	105.3
	80	261.8	261.8	301.3	227.5	330.7	167.6	250.4	250.4	284.8	219.7	312.7	159.9	239.7	239.7	268.9	212.2	294.5	152.1
	85	278.4	278.4	296.5	266.9	330.6	214.8	266.4	266.4	279.8	258.5	312.6	207.2	254.9	254.9	263.9	250.4	294.4	199.5
	90	294.4	294.4	294.6	294.6	329.1	259.1	281.8	281.8	282.0	282.0	310.6	250.7	269.3	269.3	269.5	269.5	292.0	242.3
11000	75	268.6	241.7	307.8	187.7	334.5	122.1	253.1	233.2	290.7	179.7	315.9	114.7	239.0	225.4	274.1	171.8	296.9	107.2
	80	268.9	268.9	304.5	238.5	334.3	173.2	257.0	257.0	287.6	225.1	315.9	165.3	245.7	245.7	270.8	219.6	297.2	157.3
	85	285.8	285.8	298.1	279.5	333.9	224.8	273.2	273.2	281.0	271.0	315.5	217.1	261.0	261.0	264.8	263.0	296.9	209.3
	90	301.9	301.9	302.0	302.0	330.6	271.0	288.6	288.6	288.8	288.8	311.7	262.6	275.4	275.4	275.6	275.6	292.8	254.2
12000	75	270.0	251.3	310.8	194.2	337.3	124.1	254.2	242.7	293.4	186.1	318.3	116.6	239.8	234.9	276.5	178.2	299.0	109.0
	80	275.2	275.2	306.5	245.6	337.3	178.5	262.8	262.8	288.8	236.9	318.5	170.5	251.0	251.0	271.9	228.5	299.4	162.3
	85	292.2	292.2	298.8	291.7	336.5	234.6	279.1	279.1	281.6	281.6	317.8	226.9	266.4	266.4	266.5	266.5	298.9	219.1
	90	308.2	308.2	308.4	308.4	331.3	282.6	294.4	294.4	294.6	294.6	312.2	274.2	280.6	280.6	280.7	280.7	293.0	265.9
		<b>Ambient Temperature 115°F</b>						<b>Ambient Temperature 125°F</b>											
7500	75	218.9	184.1	245.5	140.6	268.8	93.2	212.2	179.7	233.6	134.4	252.4	86.2						
	80	216.1	213.5	245.5	176.9	268.8	131.3	209.7	209.4	233.6	170.8	252.8	124.4						
	85	225.3	225.3	243.9	210.0	268.9	166.8	218.4	218.4	232.2	203.7	253.0	159.7						
	90	238.4	238.4	241.2	241.2	268.4	203.7	229.5	229.5	229.9	229.9	252.7	196.7						
9000	75	224.0	199.0	252.7	151.4	273.7	96.0	216.2	194.2	239.5	144.7	256.1	88.8						
	80	223.8	223.8	251.5	194.1	273.9	139.0	217.0	217.0	238.5	187.7	256.8	131.5						
	85	237.6	237.6	248.0	230.2	274.0	182.0	228.5	228.5	235.3	223.6	256.9	174.7						
	90	250.8	250.8	250.9	250.9	272.9	222.0	240.0	240.0	240.2	240.2	255.8	214.2						



Gross Cooling Capacities

**Table 45. Gross cooling capacities — 25 tons, standard efficiency, gas/electric (continued)**

CFM	Ent DB (° F)	Entering Wet Bulb Temp (°F)						Entering Wet Bulb Temp (°F)						Entering Wet Bulb Temp (°F)					
		61		67		73		61		67		73		61		67		73	
		MBh	SHC	MBh	SHC	MBh	SHC	MBh	SHC	MBh	SHC	MBh	SHC	MBh	SHC	MBh	SHC	MBh	SHC
10000	75	225.8	209.0	256.1	158.0	276.1	97.9	217.5	204.0	242.1	151.2	257.9	90.6						
	80	230.1	230.1	254.2	200.5	276.6	144.3	222.0	222.0	240.4	195.7	258.9	136.6						
	85	244.1	244.1	249.3	243.1	276.5	191.9	234.0	234.0	236.3	236.3	258.9	184.4						
	90	257.2	257.2	257.3	257.3	273.9	234.1	245.3	245.3	245.4	245.4	256.4	226.3						
11000	75	226.9	218.7	258.6	164.4	278.0	99.7	218.2	213.6	244.2	157.4	259.4	92.3						
	80	235.5	235.5	255.4	211.8	278.7	149.3	226.3	226.3	241.4	204.8	260.5	141.4						
	85	249.5	249.5	250.0	250.0	278.5	201.6	238.6	238.6	238.7	238.7	260.5	193.4						
	90	262.4	262.4	262.5	262.5	274.4	246.0	249.4	249.4	249.5	249.5	256.5	238.1						
12000	75	227.4	227.4	260.6	170.6	279.8	101.5	218.5	218.5	245.9	163.5	260.8	94.2						
	80	240.1	240.1	256.2	220.7	280.5	154.2	230.3	230.3	241.9	213.6	261.8	146.1						
	85	254.1	254.1	254.3	254.3	279.7	209.2	242.4	242.4	242.5	242.5	260.7	200.4						
	90	266.7	266.7	266.9	266.9	274.4	257.7	252.8	252.8	252.8	252.8	256.3	249.9						

Notes:

- All capacities shown are gross and have not considered indoor fan heat. To obtain NET cooling capacity subtract indoor fan heat. For indoor fan heat formula, refer to appropriate airflow table notes.
- MBh = Total gross capacity.
- SHC = Sensible heat capacity.

**Table 46. Gross cooling capacities — 3 tons, high efficiency, gas/electric**

CFM	Ent DB (° F)	Entering Wet Bulb Temp (°F)						Entering Wet Bulb Temp (°F)						Entering Wet Bulb Temp (°F)						
		61		67		73		61		67		73		61		67		73		
		MBh	SHC	MBh	SHC	MBh	SHC	MBh	SHC	MBh	SHC	MBh	SHC	MBh	SHC	MBh	SHC	MBh	SHC	
		<b>Ambient Temperature 85°F</b>						<b>Ambient Temperature 95°F</b>						<b>Ambient Temperature 105°F</b>						
900	75	34.0	26.0	38.6	20.6	42.9	14.5	31.9	24.7	36.3	19.3	40.9	13.5	29.6	23.3	33.8	17.9	41.9	11.6	
	80	34.1	30.2	38.7	25.4	43.4	19.7	31.9	29.4	36.5	24.1	41.2	18.5	29.7	28.0	34.0	22.8	38.6	17.2	
	85	34.6	34.6	38.7	30.2	43.4	24.5	32.9	32.9	36.6	28.9	41.1	23.3	31.0	31.0	34.2	27.6	38.7	22.0	
	90	36.7	36.7	38.7	34.0	43.3	29.2	35.0	35.0	36.6	33.6	41.1	28.1	33.1	33.1	34.2	32.2	38.7	26.8	
1080	75	35.6	29.1	40.3	22.5	44.7	15.2	33.3	27.7	37.8	21.1	41.9	14.1	30.9	26.3	35.2	19.7	38.8	12.6	
	80	35.6	34.7	40.4	28.2	45.1	21.3	33.4	33.3	38.1	26.9	42.8	20.1	31.2	31.2	35.5	25.5	40.1	18.8	
	85	37.4	37.4	40.4	33.9	45.0	27.0	35.6	35.6	38.1	32.3	42.7	25.8	33.5	33.5	35.5	31.3	40.2	24.5	
	90	39.6	39.6	40.2	39.4	45.0	32.7	37.8	37.8	38.0	38.0	42.7	31.6	35.8	35.8	35.9	35.9	40.2	30.3	
1200	75	36.4	31.0	41.1	23.6	45.0	15.7	34.0	29.0	38.6	22.3	43.3	14.5	31.5	28.1	35.9	20.8	38.7	13.2	
	80	36.5	36.5	41.2	30.0	46.0	22.3	34.6	34.6	38.9	28.7	43.6	21.1	32.5	32.5	36.2	27.3	40.8	19.7	
	85	38.9	38.9	41.2	36.3	45.9	28.7	37.0	37.0	38.8	35.0	43.6	27.5	35.0	35.0	36.3	33.5	41.0	26.2	
	90	41.2	41.2	41.3	41.3	45.9	35.0	39.3	39.3	39.4	39.4	43.6	33.8	37.3	37.3	37.4	37.4	41.0	32.6	
1320	75	37.0	32.8	41.8	24.8	46.3	16.0	34.6	31.4	39.3	23.4	42.0	15.0	32.0	29.9	36.5	21.9	38.8	12.3	
	80	37.8	37.8	42.0	31.8	46.8	23.3	35.8	35.8	39.6	30.5	44.3	22.1	33.6	33.6	36.8	29.0	41.4	20.7	
	85	40.2	40.2	41.8	38.5	46.7	30.3	38.3	38.3	39.4	37.3	44.3	29.1	36.2	36.2	36.8	35.8	41.6	27.8	
	90	42.6	42.6	42.6	42.6	46.6	37.3	40.7	40.7	40.7	40.7	44.3	35.4	38.6	38.6	38.6	38.6	41.5	34.6	
1440	75	37.5	34.6	42.4	25.8	45.1	16.6	35.1	33.2	39.8	24.4	41.9	11.6	32.5	31.7	37.0	22.9	39.8	12.2	
	80	38.9	38.9	42.6	33.5	47.4	24.2	36.9	36.9	40.1	32.2	44.8	23.0	34.6	34.6	37.3	30.3	41.9	21.6	
	85	41.4	41.4	42.3	40.8	47.3	31.9	39.4	39.4	39.9	39.5	44.9	30.7	37.2	37.2	37.3	37.3	42.1	29.4	
	90	43.7	43.7	43.8	43.8	47.1	39.3	41.8	41.8	41.9	41.9	44.7	38.1	39.6	39.6	39.7	39.7	41.9	36.7	
		<b>Ambient Temperature 115°F</b>						<b>Ambient Temperature 125°F</b>												
900	75	27.2	21.9	31.2	16.5	35.1	10.7	24.6	20.3	28.4	15.0	31.8	9.2							
	80	27.3	26.6	31.5	21.3	35.8	15.8	24.8	24.8	28.7	19.8	32.8	14.3							
	85	29.0	29.0	31.6	26.1	36.0	20.7	26.8	26.8	28.8	24.6	33.1	19.2							
	90	31.1	31.1	31.6	30.8	36.1	25.5	28.9	28.9	29.0	29.0	33.2	24.0							
1080	75	28.3	24.2	32.5	18.2	37.3	11.6	25.5	23.1	29.5	16.7	31.8	10.0							
	80	29.1	29.1	32.8	24.1	37.1	17.3	26.8	26.8	29.8	22.5	33.9	15.8							
	85	31.4	31.4	32.8	29.7	37.4	23.2	29.0	29.0	29.9	28.2	34.3	21.7							
	90	33.7	33.7	33.7	33.7	37.4	28.9	31.3	31.3	31.3	31.3	34.4	27.4							
1200	75	28.9	26.5	33.1	19.3	35.5	11.3	26.0	24.9	30.0	17.7	31.9	9.5							
	80	30.3	30.3	33.4	25.8	37.8	18.3	27.9	27.9	30.4	24.3	34.5	16.7							
	85	32.7	32.7	33.5	32.0	38.1	24.8	30.3	30.3	30.5	30.5	34.9	23.3							
	90	35.1	35.1	35.1	35.1	38.1	30.7	32.6	32.6	32.6	32.6	34.9	29.6							



# Gross Cooling Capacities

**Table 46. Gross cooling capacities — 3 tons, high efficiency, gas/electric (continued)**

CFM	Ent DB (°F)	Entering Wet Bulb Temp (°F)						Entering Wet Bulb Temp (°F)						Entering Wet Bulb Temp (°F)					
		61		67		73		61		67		73		61		67		73	
		MBh	SHC	MBh	SHC	MBh	SHC	MBh	SHC	MBh	SHC	MBh	SHC	MBh	SHC	MBh	SHC	MBh	SHC
1320	75	29.3	28.3	33.6	20.4	35.4	11.8	26.5	26.5	30.4	18.7	32.3	10.4						
	80	31.3	31.3	33.9	27.5	38.3	19.2	28.9	28.9	30.8	25.2	34.9	17.6						
	85	33.8	33.8	34.0	34.0	38.6	26.4	31.3	31.3	31.4	31.4	35.4	24.8						
	90	36.3	36.3	36.3	36.3	38.6	33.2	33.7	33.7	33.8	33.8	35.3	31.7						
1440	75	29.7	29.7	33.9	21.4	35.1	7.8	27.1	27.1	30.7	19.7	31.5	5.9						
	80	32.2	32.2	34.2	29.2	38.6	20.1	29.7	29.7	31.1	27.5	35.1	18.4						
	85	34.8	34.8	34.9	34.9	39.1	27.9	32.2	32.2	32.3	32.3	35.7	26.4						
	90	37.3	37.3	37.3	37.3	38.9	35.3	34.7	34.7	34.7	34.7	35.6	33.8						

**Notes:**

- All capacities shown are gross and have not considered indoor fan heat. To obtain NET cooling capacity subtract indoor fan heat. For indoor fan heat formula, refer to appropriate airflow table notes.
- MBh = Total gross capacity.
- SHC = Sensible heat capacity.

**Table 47. Gross cooling capacities — 4 tons, high efficiency, gas/electric**

CFM	Ent DB (°F)	Entering Wet Bulb Temp (°F)						Entering Wet Bulb Temp (°F)						Entering Wet Bulb Temp (°F)					
		61		67		73		61		67		73		61		67		73	
		MBh	SHC	MBh	SHC	MBh	SHC	MBh	SHC	MBh	SHC	MBh	SHC	MBh	SHC	MBh	SHC	MBh	SHC
		<b>Ambient Temperature 85°F</b>						<b>Ambient Temperature 95°F</b>						<b>Ambient Temperature 105°F</b>					
1200	75	44.0	32.9	49.6	24.5	55.3	15.5	41.6	31.6	47.1	23.2	52.8	14.4	39.1	30.3	44.3	22.0	50.0	13.2
	80	44.0	38.6	49.7	31.2	55.4	22.4	41.6	38.3	47.1	30.0	52.9	21.3	39.1	37.0	44.4	28.7	50.1	20.1
	85	44.8	44.8	49.7	37.9	55.5	29.2	42.8	42.8	47.2	36.7	52.9	28.1	40.8	40.8	44.4	35.5	50.1	26.9
	90	47.4	47.4	49.7	43.1	55.5	35.9	45.4	45.4	47.2	43.3	53.0	34.8	43.3	43.3	44.5	42.0	50.1	33.7
1440	75	45.9	36.9	51.7	26.8	57.3	16.0	43.4	35.6	49.0	25.5	54.7	15.0	40.7	34.2	46.1	24.2	51.8	13.8
	80	46.0	44.7	51.8	34.9	57.6	24.3	43.4	43.4	49.1	33.6	54.9	23.2	41.1	41.1	46.1	32.3	51.9	22.0
	85	48.2	48.2	51.8	42.9	57.6	32.5	46.1	46.1	49.1	40.9	54.9	31.4	43.8	43.8	46.2	40.3	51.9	30.2
	90	51.0	51.0	51.7	50.7	57.6	40.6	48.9	48.9	49.1	49.1	55.0	39.5	46.6	46.6	46.7	46.7	52.0	38.3
1600	75	46.9	39.1	52.8	28.2	58.4	16.4	44.3	36.8	50.0	27.0	55.7	15.3	41.5	36.7	47.0	25.7	52.7	14.1
	80	47.1	47.1	52.9	37.2	58.7	25.6	45.0	45.0	50.0	36.0	55.9	24.5	42.6	42.6	47.1	34.7	52.8	23.2
	85	50.1	50.1	52.8	46.0	58.7	34.6	47.9	47.9	50.0	44.8	55.9	33.5	45.5	45.5	47.0	43.5	52.9	32.3
	90	53.0	53.0	53.1	53.1	58.7	43.6	50.8	50.8	50.9	50.9	56.0	42.5	48.5	48.5	48.6	48.6	52.9	41.4
1760	75	47.7	41.9	53.7	29.7	59.3	16.7	45.0	40.6	50.8	28.4	56.6	15.6	42.1	39.2	47.7	27.1	53.5	14.4
	80	48.7	48.7	53.7	39.6	59.7	26.8	46.4	46.4	50.9	38.3	56.8	25.7	44.0	44.0	47.8	37.1	53.6	24.4
	85	51.8	51.8	53.6	49.2	59.6	36.7	49.5	49.5	50.8	47.9	56.8	35.6	47.1	47.1	47.7	46.6	53.7	34.4
	90	54.7	54.7	54.8	54.8	59.6	46.7	52.5	52.5	52.6	52.6	56.8	44.2	50.1	50.1	50.2	50.2	53.7	44.2
1920	75	48.4	44.3	54.5	31.1	60.1	17.0	45.6	43.0	51.5	29.8	57.3	15.9	42.7	41.6	48.4	28.5	54.2	14.7
	80	50.1	50.1	54.5	41.9	60.4	28.0	47.7	47.7	51.5	40.4	57.5	26.8	45.2	45.2	48.5	37.7	54.3	25.6
	85	53.2	53.2	54.2	52.3	60.4	38.8	50.9	50.9	51.4	51.0	57.5	37.8	48.4	48.4	48.5	48.5	54.3	36.6
	90	56.2	56.2	56.3	56.3	60.3	49.4	54.0	54.0	54.1	54.1	57.4	48.3	51.5	51.5	51.5	51.5	54.2	47.1
		<b>Ambient Temperature 115°F</b>						<b>Ambient Temperature 125°F</b>											
1200	75	36.4	29.0	41.4	20.6	46.9	12.0	33.6	27.6	38.4	19.3	43.6	10.7						
	80	36.5	35.6	41.5	27.4	46.9	18.8	33.7	33.7	38.5	26.1	43.6	17.5						
	85	38.5	38.5	41.6	34.2	47.0	25.6	36.2	36.2	38.5	32.6	43.7	24.3						
	90	41.1	41.1	41.6	40.7	47.1	32.4	38.7	38.7	38.8	38.8	43.7	31.1						
1440	75	37.8	31.7	43.0	22.9	48.5	12.5	34.8	31.4	39.8	21.5	44.5	11.1						
	80	38.7	38.7	43.1	31.0	48.6	20.7	36.2	36.2	39.9	29.7	45.1	19.4						
	85	41.4	41.4	43.1	39.0	48.7	28.9	38.9	38.9	39.9	37.6	45.2	27.6						
	90	44.2	44.2	44.3	44.3	48.7	37.0	41.6	41.6	41.7	41.7	45.2	35.7						
1600	75	38.5	35.3	43.9	24.3	49.4	12.9	35.5	33.9	40.5	22.9	45.8	11.5						
	80	40.2	40.2	43.9	33.4	49.4	22.0	37.6	37.6	40.6	32.0	45.8	20.6						
	85	43.1	43.1	43.9	42.1	49.5	31.1	40.4	40.4	40.6	40.6	45.9	29.7						
	90	45.9	45.9	46.0	46.0	49.6	39.0	43.2	43.2	43.3	43.3	45.9	38.6						
1760	75	39.1	37.8	44.5	25.7	50.1	13.2	36.0	36.0	41.1	24.3	45.6	11.6						
	80	41.5	41.5	44.6	35.2	50.2	23.2	38.8	38.8	41.2	34.2	46.4	21.8						
	85	44.5	44.5	44.6	44.6	50.2	33.2	41.7	41.7	41.8	41.8	46.5	31.9						
	90	47.4	47.4	47.5	47.5	50.2	42.9	44.6	44.6	44.6	44.6	46.4	41.6						

**Table 47. Gross cooling capacities — 4 tons, high efficiency, gas/electric (continued)**

CFM	Ent DB (°F)	Entering Wet Bulb Temp (°F)						Entering Wet Bulb Temp (°F)						Entering Wet Bulb Temp (°F)					
		61		67		73		61		67		73		61		67		73	
		MBh	SHC	MBh	SHC	MBh	SHC	MBh	SHC	MBh	SHC	MBh	SHC	MBh	SHC	MBh	SHC	MBh	SHC
1920	75	39.6	39.6	45.1	27.1	49.8	13.2	36.9	36.9	41.6	25.7	45.9	11.8						
	80	42.6	42.6	45.1	37.9	50.8	24.3	39.9	39.9	41.6	36.5	47.0	23.0						
	85	45.7	45.7	45.8	45.8	50.8	35.5	42.8	42.8	42.9	42.9	47.1	34.0						
	90	48.7	48.7	48.8	48.8	50.6	45.8	45.7	45.7	45.8	45.8	46.8	44.5						

**Notes:**

- All capacities shown are gross and have not considered indoor fan heat. To obtain NET cooling capacity subtract indoor fan heat. For indoor fan heat formula, refer to appropriate airflow table notes.
- MBh = Total gross capacity.
- SHC = Sensible heat capacity.

**Table 48. Gross cooling capacities — 5 tons, high efficiency, gas/electric**

CFM	Ent DB (°F)	Entering Wet Bulb Temp (°F)						Entering Wet Bulb Temp (°F)						Entering Wet Bulb Temp (°F)						
		61		67		73		61		67		73		61		67		73		
		MBh	SHC	MBh	SHC	MBh	SHC	MBh	SHC	MBh	SHC	MBh	SHC	MBh	SHC	MBh	SHC	MBh	SHC	
		<b>Ambient Temperature 85°F</b>						<b>Ambient Temperature 95°F</b>						<b>Ambient Temperature 105°F</b>						
1500	75	55.1	41.1	62.1	30.5	68.6	19.0	52.0	39.6	58.8	29.0	65.5	17.8	48.8	38.0	55.3	27.5	61.9	16.4	
	80	55.1	48.1	62.0	38.9	68.8	27.6	52.0	47.8	58.8	37.4	65.6	26.3	48.8	46.2	55.3	35.9	62.0	24.9	
	85	55.9	55.9	62.0	47.3	68.9	36.1	53.4	53.4	58.8	45.8	65.7	34.8	50.8	50.8	55.4	44.3	62.1	33.4	
	90	59.1	59.1	62.0	53.5	68.9	44.6	56.6	56.6	58.8	54.0	65.7	43.3	54.0	54.0	55.4	52.4	62.1	41.9	
1800	75	57.4	46.1	64.6	33.3	71.0	19.6	54.2	44.5	61.1	31.8	67.7	18.3	50.8	42.5	57.4	30.2	64.0	16.9	
	80	57.4	55.8	64.6	43.4	71.3	30.0	54.2	54.2	61.2	41.9	68.1	28.7	51.2	51.2	57.5	40.4	64.2	27.3	
	85	60.1	60.1	64.6	53.4	71.4	40.1	57.4	57.4	61.2	50.7	68.0	38.8	54.6	54.6	57.5	50.3	64.2	37.4	
	90	63.5	63.5	64.4	63.0	71.4	50.2	60.8	60.8	61.0	61.0	68.1	49.0	57.9	57.9	58.0	58.0	64.3	47.6	
2000	75	58.7	48.7	65.9	35.1	72.2	19.9	55.3	45.8	62.4	33.6	68.9	18.7	51.8	45.9	58.5	32.0	65.1	17.3	
	80	58.8	58.8	65.9	46.3	72.8	31.5	56.0	56.0	62.4	44.8	69.3	30.2	53.1	53.1	58.6	43.3	65.3	28.7	
	85	62.4	62.4	65.8	57.2	72.7	42.7	59.6	59.6	62.3	55.7	69.2	41.5	56.7	56.7	58.5	54.2	65.3	40.1	
	90	65.8	65.8	66.0	66.0	72.7	54.0	63.1	63.1	63.2	63.2	69.3	52.7	60.1	60.1	60.2	60.2	65.4	51.3	
2200	75	59.7	52.2	67.0	36.8	73.3	20.3	56.2	50.6	63.4	35.3	69.9	19.0	52.6	48.9	59.5	33.7	66.0	17.6	
	80	60.7	60.7	67.0	49.2	73.8	32.9	57.9	57.9	63.4	47.7	70.3	31.6	54.8	54.8	59.5	46.2	66.3	30.2	
	85	64.4	64.4	66.8	61.1	73.7	45.3	61.6	61.6	63.2	59.6	70.3	44.1	58.5	58.5	59.3	58.0	66.3	42.7	
	90	67.9	67.9	68.0	68.0	73.8	57.4	65.1	65.1	65.2	65.2	70.3	54.3	62.0	62.0	62.1	62.1	66.2	54.8	
2400	75	60.5	55.2	67.9	38.5	74.2	20.6	56.9	53.6	64.2	37.0	70.7	19.4	53.2	51.9	60.2	35.5	66.8	17.9	
	80	62.4	62.4	67.9	52.1	74.7	34.3	59.4	59.4	64.2	50.0	71.1	33.0	56.3	56.3	60.3	46.6	67.0	31.6	
	85	66.1	66.1	67.5	64.8	74.7	47.9	63.2	63.2	63.8	63.4	71.1	46.7	60.0	60.0	60.1	60.1	67.0	45.3	
	90	69.6	69.6	69.8	69.8	74.6	61.1	66.8	66.8	66.9	66.9	70.9	59.8	63.6	63.6	63.7	63.7	66.8	58.4	
		<b>Ambient Temperature 115°F</b>						<b>Ambient Temperature 125°F</b>												
1500	75	45.5	36.4	51.7	25.9	58.0	14.9	42.2	34.9	48.0	24.3	53.9	13.3							
	80	45.6	44.6	51.7	34.4	58.1	23.5	42.4	42.4	48.0	32.8	54.0	21.9							
	85	48.1	48.1	51.8	42.8	58.2	32.0	45.3	45.3	48.1	40.6	54.1	30.4							
	90	51.2	51.2	51.8	50.9	58.2	40.4	48.3	48.3	48.4	48.4	54.1	38.9							
1800	75	47.3	39.5	53.6	28.6	59.9	15.5	43.8	39.5	49.6	27.0	55.6	13.9							
	80	48.3	48.3	53.7	38.8	60.1	25.8	45.4	45.4	49.7	37.2	55.7	24.2							
	85	51.6	51.6	53.6	48.7	60.1	35.9	48.5	48.5	49.7	47.0	55.7	34.4							
	90	54.9	54.9	55.0	55.0	60.1	46.1	51.6	51.6	51.7	51.7	55.8	44.4							
2000	75	48.2	44.2	54.6	30.4	60.9	15.8	44.5	42.6	50.5	28.8	56.4	14.3							
	80	50.1	50.1	54.6	41.7	61.1	27.2	47.0	47.0	50.6	40.1	56.6	25.7							
	85	53.5	53.5	54.5	52.5	61.1	38.6	50.3	50.3	50.5	50.5	56.6	37.0							
	90	56.9	56.9	57.0	57.0	61.1	47.8	53.5	53.5	53.6	53.6	56.6	48.1							
2200	75	48.9	47.3	55.4	32.1	61.7	16.1	45.1	45.1	51.2	30.5	57.2	14.6							
	80	51.7	51.7	55.4	43.4	61.9	28.7	48.4	48.4	51.2	42.8	57.3	27.1							
	85	55.2	55.2	55.3	55.3	61.9	41.2	51.8	51.8	51.9	51.9	57.3	39.7							
	90	58.6	58.6	58.7	58.7	61.8	53.3	55.0	55.0	55.1	55.1	57.1	51.7							
2400	75	49.5	49.5	56.1	33.8	62.5	16.5	46.1	46.1	51.8	32.2	57.9	14.9							
	80	53.0	53.0	56.0	47.2	62.6	30.1	49.6	49.6	51.7	45.5	57.9	28.5							
	85	56.7	56.7	56.7	56.7	62.6	44.1	53.1	53.1	53.2	53.2	58.0	42.3							
	90	60.1	60.1	60.2	60.2	62.2	56.8	56.4	56.4	56.4	56.4	57.5	55.3							

# Gross Cooling Capacities

**Table 48. Gross cooling capacities — 5 tons, high efficiency, gas/electric (continued)**

CFM	Ent DB (° F)	Entering Wet Bulb Temp (°F)						Entering Wet Bulb Temp (°F)					
		61		67		73		61		67		73	
		MBh	SHC	MBh	SHC	MBh	SHC	MBh	SHC	MBh	SHC	MBh	SHC

- Notes:
1. All capacities shown are gross and have not considered indoor fan heat. To obtain NET cooling capacity subtract indoor fan heat. For indoor fan heat formula, refer to appropriate airflow table notes.
  2. MBh = Total gross capacity.
  3. SHC = Sensible heat capacity.

**Table 49. Gross cooling capacities — 6 tons, high efficiency, gas/electric**

CFM	Ent DB (° F)	Entering Wet Bulb Temp (°F)						Entering Wet Bulb Temp (°F)											
		61		67		73		61		67		73							
		MBh	SHC	MBh	SHC	MBh	SHC	MBh	SHC	MBh	SHC	MBh	SHC						
		<b>Ambient Temperature 85°F</b>						<b>Ambient Temperature 95°F</b>						<b>Ambient Temperature 105°F</b>					
1800	75	79.0	54.0	82.5	45.3	90.5	32.5	69.8	54.9	78.4	43.3	86.0	30.6	65.7	52.8	73.9	41.2	81.0	28.5
	80	73.5	65.3	82.4	55.1	90.7	42.6	69.8	64.4	78.4	53.1	86.3	40.7	65.7	62.3	73.9	51.0	81.4	38.6
	85	74.3	74.3	82.4	64.8	91.2	52.6	71.3	71.3	78.4	62.8	86.8	50.7	68.0	68.0	73.9	60.7	81.7	48.6
	90	78.3	78.3	82.4	72.5	91.1	62.4	75.3	75.3	78.4	72.3	86.6	60.4	71.9	71.9	73.8	70.1	81.6	58.3
2160	75	76.6	63.0	85.8	49.0	93.4	33.6	72.7	60.9	81.4	46.9	88.7	31.7	68.3	58.7	76.6	44.7	83.3	29.5
	80	76.6	74.2	85.7	60.7	94.3	45.8	72.6	72.1	81.4	58.6	89.9	44.0	68.6	68.6	76.6	56.4	84.6	41.8
	85	79.7	79.7	85.7	72.3	94.3	57.6	76.4	76.4	81.4	69.2	89.6	55.6	72.7	72.7	76.5	67.9	84.2	53.5
	90	84.0	84.0	85.3	83.3	94.2	69.3	80.6	80.6	80.9	80.9	89.4	67.3	76.7	76.7	76.8	76.8	84.0	65.1
2400	75	78.3	66.8	87.5	51.3	95.2	34.4	74.2	63.2	83.0	49.2	90.1	32.3	69.6	62.3	78.0	47.0	81.7	29.2
	80	78.1	78.1	87.4	64.3	96.4	48.0	74.8	74.8	82.9	62.2	91.5	46.0	71.0	71.0	77.9	60.0	86.0	43.7
	85	82.7	82.7	87.3	76.9	95.9	60.9	79.2	79.2	82.7	74.8	91.0	58.9	75.3	75.3	77.6	72.4	85.4	56.7
	90	87.0	87.0	87.2	87.2	95.8	73.9	83.4	83.4	83.5	83.5	90.8	71.9	79.2	79.2	79.4	79.4	85.3	69.5
1640	75	79.6	70.4	88.9	53.5	96.3	35.0	75.3	68.2	84.3	51.4	91.2	33.0	70.6	65.9	79.1	49.1	81.8	26.7
	80	80.6	80.6	88.9	67.8	97.9	49.9	77.1	77.1	84.2	65.7	92.8	47.9	73.1	73.1	79.1	63.4	87.2	45.6
	85	85.2	85.2	88.5	81.4	97.3	64.1	81.6	81.6	83.7	79.3	92.2	62.1	77.4	77.4	78.5	76.9	86.5	59.8
	90	89.6	89.6	89.7	89.7	97.1	78.1	85.8	85.8	85.9	85.9	92.1	73.7	81.3	81.3	81.5	81.5	86.1	73.7
2880	75	80.6	74.0	90.1	55.7	92.9	33.5	76.2	71.8	85.4	53.6	87.6	28.0	71.4	69.4	80.1	51.3	86.7	31.5
	80	82.7	82.7	90.0	71.3	99.1	51.8	79.1	79.1	85.3	69.0	93.8	49.7	75.0	75.0	80.0	64.5	88.2	47.4
	85	87.5	87.5	89.3	85.9	98.4	67.2	83.6	83.6	84.5	83.7	93.2	65.2	79.3	79.3	79.4	79.4	87.4	62.9
	90	91.8	91.8	91.9	91.9	98.1	82.4	87.8	87.8	87.9	87.9	92.6	80.2	83.1	83.1	83.2	83.2	86.5	77.8
		<b>Ambient Temperature 115°F</b>						<b>Ambient Temperature 125°F</b>											
1800	75	61.2	50.4	68.9	38.9	75.3	26.2	56.2	47.9	63.3	36.4	69.1	23.7						
	80	61.2	59.9	68.9	48.7	75.9	36.3	56.5	56.5	63.3	46.1	70.2	34.0						
	85	64.3	64.3	68.9	58.4	76.1	46.2	60.1	60.1	63.3	54.8	69.8	43.7						
	90	68.0	68.0	68.7	67.7	75.9	56.0	63.5	63.5	63.6	63.6	69.6	53.5						
2160	75	63.5	54.6	71.2	42.3	77.3	27.2	58.1	53.5	65.3	39.8	70.8	24.7						
	80	64.6	64.6	71.2	54.0	78.7	39.5	60.1	60.1	65.3	51.5	72.2	36.9						
	85	68.6	68.6	71.1	65.4	78.2	51.1	63.8	63.8	65.0	62.7	71.5	48.5						
	90	72.3	72.3	72.4	72.4	78.0	62.8	67.2	67.2	67.3	67.3	71.3	58.8						
2400	75	64.6	59.8	72.5	44.5	78.4	27.8	59.0	57.1	66.4	41.9	71.8	25.3						
	80	66.8	66.8	72.4	57.5	79.9	41.4	62.1	62.1	66.3	54.7	73.2	38.8						
	85	70.8	70.8	72.0	69.9	79.2	54.2	65.8	65.8	65.9	65.9	72.4	51.6						
	90	74.5	74.5	74.6	74.6	79.0	66.9	69.1	69.1	69.1	69.1	71.9	64.2						
1640	75	65.5	63.4	73.5	46.7	77.5	27.8	59.8	59.8	67.3	44.0	72.9	26.1						
	80	68.7	68.7	73.4	59.9	80.9	43.2	63.8	63.8	67.0	58.0	74.2	40.6						
	85	72.7	72.7	72.8	72.8	80.1	57.4	67.4	67.4	67.5	67.5	73.2	54.8						
	90	76.3	76.3	76.4	76.4	79.4	71.1	70.5	70.5	70.6	70.6	72.1	68.3						
2880	75	66.1	66.1	74.3	48.8	80.7	29.2	61.1	61.1	68.0	46.1	74.9	27.0						
	80	70.4	70.4	74.0	64.0	81.9	45.0	65.2	65.2	67.5	61.2	75.0	42.3						
	85	74.4	74.4	74.5	74.5	80.9	60.5	68.8	68.8	68.9	68.9	73.8	57.5						
	90	77.8	77.8	77.9	77.9	79.7	75.2	71.9	71.9	72.0	72.0	72.4	72.4						

- Notes:
1. All capacities shown are gross and have not considered indoor fan heat. To obtain NET cooling capacity subtract indoor fan heat. For indoor fan heat formula, refer to appropriate airflow table notes.
  2. MBh = Total gross capacity.
  3. SHC = Sensible heat capacity.



# Gross Cooling Capacities

**Table 50. Gross cooling capacities — 7.5 tons, high efficiency, gas/electric**

CFM	Ent DB (° F)	Entering Wet Bulb Temp (°F)						Entering Wet Bulb Temp (°F)						Entering Wet Bulb Temp (°F)					
		61		67		73		61		67		73		61		67		73	
		MBh	SHC	MBh	SHC	MBh	SHC	MBh	SHC	MBh	SHC	MBh	SHC	MBh	SHC	MBh	SHC	MBh	SHC
		Ambient Temperature 85°F						Ambient Temperature 95°F						Ambient Temperature 105°F					
2250	75	91.6	67.6	94.1	52.7	104.2	37.6	78.7	64.1	89.1	50.4	98.6	35.2	73.8	61.6	83.7	47.8	92.5	32.7
	80	82.9	77.5	94.0	64.6	104.2	49.7	78.4	75.0	89.0	62.2	98.7	47.4	73.6	72.4	83.6	59.7	92.6	44.9
	85	84.7	84.7	93.7	76.4	104.3	61.8	81.1	81.1	88.7	74.0	98.8	59.4	77.2	77.2	83.4	71.3	92.7	56.9
	90	89.7	89.7	93.4	87.2	104.2	73.7	86.0	86.0	88.4	84.7	98.7	71.3	81.9	81.9	83.1	82.0	92.7	68.8
2700	75	86.4	73.6	97.6	57.0	107.3	38.8	81.6	69.7	92.3	54.5	101.3	36.4	76.3	67.9	86.5	51.9	94.9	33.8
	80	85.9	85.9	97.4	71.1	107.4	53.3	81.4	81.4	92.0	68.6	101.5	50.9	77.2	77.2	86.2	66.0	95.2	48.4
	85	90.5	90.5	97.0	81.7	107.5	67.6	86.5	86.5	91.6	81.8	101.6	65.2	82.2	82.2	85.8	79.0	95.2	62.6
	90	95.7	95.7	96.3	96.3	107.4	81.8	91.6	91.6	91.7	91.7	101.5	79.4	87.0	87.0	87.1	87.1	95.1	76.9
3000	75	88.0	77.4	99.4	59.7	108.8	39.6	82.9	74.7	93.9	57.2	102.7	37.1	77.5	71.9	87.9	54.6	96.1	34.6
	80	88.2	88.2	99.0	75.3	109.1	55.7	84.1	84.1	93.5	72.8	103.0	53.2	79.8	79.8	87.6	70.1	96.4	50.6
	85	93.6	93.6	98.4	89.5	109.1	71.4	89.5	89.5	92.8	86.8	103.0	69.0	84.9	84.9	86.8	84.0	96.4	66.4
	90	98.9	98.9	99.1	99.1	109.0	87.1	94.6	94.6	94.7	94.7	102.9	82.8	89.7	89.7	89.8	89.8	96.3	81.2
3300	75	89.1	81.3	100.9	62.3	110.1	40.3	83.9	78.6	95.2	59.8	103.8	37.8	78.4	75.7	89.1	57.1	97.1	35.2
	80	90.8	90.8	100.4	79.3	110.4	57.8	86.5	86.5	94.7	76.8	104.2	55.3	82.0	82.0	88.6	71.5	97.4	52.7
	85	96.3	96.3	99.4	94.4	110.4	75.1	92.0	92.0	93.7	91.7	104.2	72.7	87.2	87.2	87.5	87.5	97.5	70.1
	90	101.7	101.7	101.8	101.8	110.2	91.4	97.1	97.1	97.2	97.2	103.8	88.7	92.0	92.0	92.1	92.1	96.9	85.8
3600	75	90.0	85.1	102.1	64.8	111.1	41.0	84.7	82.3	96.3	62.3	104.8	38.5	79.1	79.1	90.0	59.6	97.9	35.9
	80	93.0	93.0	101.5	81.7	111.5	60.0	88.7	88.7	95.6	79.9	105.2	57.5	83.9	83.9	89.3	77.0	98.3	54.9
	85	98.7	98.7	100.1	99.1	111.5	78.8	94.1	94.1	94.3	94.3	105.2	76.3	89.1	89.1	89.2	89.2	98.3	73.7
	90	104.1	104.1	104.2	104.2	110.8	95.9	99.3	99.3	99.4	99.4	104.3	93.2	93.9	93.9	94.0	94.0	97.2	90.3
		Ambient Temperature 115°F						Ambient Temperature 125°F											
2250	75	68.5	59.0	77.8	45.1	85.9	30.0	62.9	54.0	71.6	42.3	78.8	27.2						
	80	68.4	68.4	77.7	57.0	86.1	42.2	63.8	63.8	71.4	54.2	79.0	39.4						
	85	72.9	72.9	77.6	66.1	86.2	54.2	68.2	68.2	71.2	65.3	79.1	51.4						
	90	77.4	77.4	77.5	77.5	86.1	66.2	72.4	72.4	72.5	72.5	79.1	63.4						
2700	75	70.7	65.0	80.3	49.2	88.0	31.1	64.7	61.9	73.6	46.3	80.5	28.3						
	80	72.7	72.7	80.1	63.3	88.3	45.6	67.7	67.7	73.4	60.4	80.8	42.8						
	85	77.4	77.4	79.6	76.1	88.3	59.9	72.2	72.2	72.8	72.8	80.9	57.0						
	90	82.0	82.0	82.1	82.1	88.3	71.4	76.4	76.4	76.5	76.5	80.7	70.4						
3000	75	71.7	68.9	81.5	51.8	89.0	31.8	65.5	65.5	74.7	48.8	81.3	29.0						
	80	75.0	75.0	81.2	66.2	89.3	47.8	69.8	69.8	74.3	63.7	81.7	44.9						
	85	79.9	79.9	80.4	80.4	89.3	63.6	74.3	74.3	74.4	74.4	81.7	60.7						
	90	84.4	84.4	84.5	84.5	89.0	78.2	78.4	78.4	78.5	78.5	81.1	75.0						
3300	75	72.5	72.5	82.5	54.3	89.8	32.5	66.7	66.7	75.5	51.3	82.0	29.6						
	80	77.0	77.0	82.0	70.4	90.2	50.0	71.6	71.6	74.9	67.2	82.4	47.0						
	85	81.9	81.9	82.0	82.0	90.2	67.3	76.1	76.1	76.1	76.1	82.5	63.8						
	90	86.3	86.3	86.4	86.4	89.4	82.7	80.1	80.1	80.1	80.1	81.4	79.5						
3600	75	73.5	73.5	83.3	56.7	90.5	33.2	68.2	68.2	76.2	53.7	82.7	30.3						
	80	78.7	78.7	82.5	73.9	90.9	52.1	73.1	73.1	75.3	70.7	83.0	49.1						
	85	83.6	83.6	83.7	83.7	91.0	69.7	77.5	77.5	77.6	77.6	82.9	67.1						
	90	88.0	88.0	88.1	88.1	89.6	87.2	81.4	81.4	81.4	81.4	81.5	81.5						

**Notes:**

- All capacities shown are gross and have not considered indoor fan heat. To obtain NET cooling capacity subtract indoor fan heat. For indoor fan heat formula, refer to appropriate airflow table notes.
- MBh = Total gross capacity.
- SHC = Sensible heat capacity.

**Table 51. Gross cooling capacities — 8.5 tons, high efficiency, gas/electric**

CFM	Ent DB (° F)	Entering Wet Bulb Temp (°F)						Entering Wet Bulb Temp (°F)						Entering Wet Bulb Temp (°F)					
		61		67		73		61		67		73		61		67		73	
		MBh	SHC	MBh	SHC	MBh	SHC	MBh	SHC	MBh	SHC	MBh	SHC	MBh	SHC	MBh	SHC	MBh	SHC
		Ambient Temperature 85°F						Ambient Temperature 95°F						Ambient Temperature 105°F					
2550	75	107.6	74.4	112.6	62.4	126.8	46.0	93.9	75.0	107.0	59.7	120.6	43.3	88.7	72.3	101.2	57.0	114.0	40.5
	80	98.5	90.1	112.3	75.8	126.8	59.7	93.6	87.3	106.8	73.1	120.5	57.0	88.4	84.5	101.0	70.3	114.0	54.3
	85	99.4	99.4	111.8	89.0	126.6	73.3	95.6	95.6	106.4	86.4	120.3	70.6	91.4	91.4	100.6	83.6	113.8	67.8
	90	105.3	105.3	111.5	101.3	126.3	86.7	101.3	101.3	106.0	98.6	120.1	84.0	97.1	97.1	100.2	95.6	113.5	81.2



# Gross Cooling Capacities

Table 51. Gross cooling capacities — 8.5 tons, high efficiency, gas/electric (continued)

CFM	Ent DB (°F)	Entering Wet Bulb Temp (°F)						Entering Wet Bulb Temp (°F)						Entering Wet Bulb Temp (°F)					
		61		67		73		61		67		73		61		67		73	
		MBh	SHC	MBh	SHC	MBh	SHC	MBh	SHC	MBh	SHC	MBh	SHC	MBh	SHC	MBh	SHC	MBh	SHC
3060	75	102.9	85.7	117.2	67.5	131.9	47.8	97.6	82.9	111.3	64.6	125.1	45.0	92.0	78.2	105.0	61.7	118.0	42.2
	80	102.2	99.6	116.9	83.3	131.7	64.1	97.0	96.8	110.9	80.5	125.0	61.4	91.6	91.6	104.6	77.6	117.9	58.5
	85	106.5	106.5	116.2	97.5	131.5	80.2	102.2	102.2	110.3	92.3	124.8	77.4	97.7	97.7	104.0	92.4	117.7	74.5
	90	112.9	112.9	115.5	112.7	130.9	96.1	108.5	108.5	109.6	109.6	124.3	93.4	103.8	103.8	104.0	104.0	117.3	90.5
3400	75	104.9	88.6	119.8	70.5	134.4	48.9	99.4	87.1	113.6	67.7	127.5	46.1	93.5	84.0	107.1	64.8	120.1	43.2
	80	104.0	104.0	119.1	88.0	134.3	66.9	99.4	99.4	112.9	85.2	127.3	64.1	94.8	94.8	106.4	82.3	119.9	61.1
	85	110.4	110.4	118.3	104.2	133.9	84.6	106.0	106.0	112.1	101.2	127.0	81.8	101.2	101.2	105.6	98.1	119.6	78.8
	90	117.2	117.2	117.3	117.3	133.3	102.2	112.6	112.6	112.7	112.7	126.4	99.4	107.6	107.6	107.7	107.7	119.9	95.1
3740	75	106.5	94.5	122.0	73.6	136.6	49.9	100.8	91.5	115.5	70.7	129.4	47.0	94.7	88.4	108.7	67.7	121.8	44.1
	80	107.0	107.0	121.0	92.7	136.3	69.5	102.5	102.5	114.6	89.8	129.2	66.6	97.7	97.7	107.9	86.8	121.6	63.6
	85	113.9	113.9	119.8	109.7	135.9	88.8	109.3	109.3	113.5	106.7	128.8	86.0	104.3	104.3	106.8	103.6	121.2	83.0
	90	121.0	121.0	121.1	121.1	135.1	106.9	116.1	116.1	116.2	116.2	128.0	104.2	110.9	110.9	111.0	111.0	120.4	101.0
4080	75	107.7	98.8	123.6	76.5	138.4	50.8	101.8	95.8	117.0	73.6	131.0	47.9	95.7	92.6	110.0	70.5	123.2	45.0
	80	109.8	109.8	122.5	97.2	138.2	72.0	105.2	105.2	115.9	92.5	130.8	69.1	100.2	100.2	109.0	90.2	123.1	66.1
	85	117.1	117.1	121.0	115.2	137.5	93.0	112.2	112.2	114.5	112.1	130.2	90.1	107.0	107.0	107.6	107.6	122.5	87.1
	90	124.3	124.3	124.5	124.5	136.5	112.4	119.2	119.2	119.4	119.4	129.1	109.3	113.7	113.7	113.9	113.9	121.3	106.1
		<b>Ambient Temperature 115°F</b>						<b>Ambient Temperature 125°F</b>											
2550	75	83.1	69.4	94.9	54.1	107.0	37.6	77.1	66.3	88.2	51.0	99.4	34.6						
	80	82.8	81.5	94.7	67.4	106.9	51.4	76.9	76.9	88.0	64.4	99.3	48.3						
	85	87.0	87.0	94.4	80.3	106.8	64.9	82.2	82.2	87.7	74.4	99.2	61.8						
	90	92.5	92.5	94.1	92.6	106.5	78.3	87.5	87.5	87.6	87.6	99.0	75.3						
3060	75	86.0	76.4	98.4	58.8	110.5	39.2	79.6	73.0	91.3	55.6	102.3	36.0						
	80	86.9	86.9	98.0	74.6	110.4	55.5	81.8	81.8	90.8	71.5	102.3	52.2						
	85	92.8	92.8	97.4	89.2	110.2	71.5	87.5	87.5	90.2	85.8	102.1	68.3						
	90	98.8	98.8	98.9	98.9	109.8	87.5	93.2	93.2	93.3	93.3	101.8	81.9						
3400	75	87.4	80.8	100.2	61.7	112.3	40.1	80.7	77.4	92.8	58.5	103.9	36.9						
	80	89.9	89.9	99.5	79.3	112.1	58.0	84.5	84.5	92.2	74.7	103.8	54.8						
	85	96.0	96.0	98.7	94.8	111.8	75.8	90.4	90.4	91.4	91.4	103.5	72.5						
	90	102.2	102.2	102.3	102.3	111.3	92.4	96.3	96.3	96.4	96.4	102.9	88.9						
3740	75	88.4	85.1	101.6	64.6	113.7	41.0	81.6	81.6	94.0	61.3	105.1	37.8						
	80	92.5	92.5	100.8	80.7	113.6	60.5	86.9	86.9	93.1	79.5	105.1	57.3						
	85	98.9	98.9	99.7	99.7	113.2	79.9	93.0	93.0	93.1	93.1	104.7	76.7						
	90	105.2	105.2	105.3	105.3	112.3	97.6	99.0	99.0	99.1	99.1	103.7	94.1						
4080	75	89.1	89.1	102.7	67.4	115.0	41.8	82.8	82.8	94.9	64.1	106.2	38.6						
	80	94.8	94.8	101.7	86.9	114.9	63.0	89.0	89.0	93.9	83.4	106.1	59.6						
	85	101.3	101.3	101.4	101.4	114.3	84.0	95.2	95.2	95.3	95.3	105.6	80.4						
	90	107.8	107.8	107.9	107.9	113.1	102.7	101.3	101.3	101.4	101.4	104.3	99.2						

**Notes:**

- All capacities shown are gross and have not considered indoor fan heat. To obtain NET cooling capacity subtract indoor fan heat. For indoor fan heat formula, refer to appropriate airflow table notes.
- MBh = Total gross capacity.
- SHC = Sensible heat capacity.

Table 52. Gross cooling capacities — 10 tons, high efficiency, gas/electric

CFM	Ent DB (°F)	Entering Wet Bulb Temp (°F)						Entering Wet Bulb Temp (°F)						Entering Wet Bulb Temp (°F)					
		61		67		73		61		67		73		61		67		73	
		MBh	SHC	MBh	SHC	MBh	SHC	MBh	SHC	MBh	SHC	MBh	SHC	MBh	SHC	MBh	SHC	MBh	SHC
		<b>Ambient Temperature 85°F</b>						<b>Ambient Temperature 95°F</b>						<b>Ambient Temperature 105°F</b>					
3000	75	122.2	84.9	127.7	71.2	142.7	52.2	107.1	85.9	121.5	68.4	135.7	49.3	101.3	83.0	115.0	65.5	128.0	46.3
	80	111.4	102.1	127.5	86.4	142.7	67.8	106.0	99.2	121.4	83.6	135.6	64.9	100.3	96.0	114.7	80.5	127.9	61.8
	85	111.7	111.7	126.5	101.2	142.4	83.1	107.6	107.6	120.4	98.4	135.4	80.2	103.2	103.2	113.9	95.4	127.8	77.1
	90	118.2	118.2	125.5	114.5	142.1	98.2	113.9	113.9	119.4	111.4	135.0	95.3	109.3	109.3	112.9	108.2	127.4	92.3
3600	75	116.7	97.3	132.8	76.7	147.9	54.1	110.9	94.4	126.1	73.7	140.2	51.1	104.6	89.9	119.1	70.6	131.9	47.9
	80	115.0	112.0	132.2	94.4	147.7	72.4	109.2	108.9	125.5	91.5	140.1	69.4	103.1	103.1	118.4	88.3	131.8	66.3
	85	119.1	119.1	130.9	110.9	147.6	90.5	114.6	114.6	124.3	104.9	139.9	87.5	109.6	109.6	117.0	104.3	131.6	84.2
	90	126.1	126.1	129.2	126.2	146.7	108.3	121.3	121.3	122.6	122.6	139.0	105.3	116.1	116.1	116.2	116.2	130.9	102.1

**Table 52. Gross cooling capacities — 10 tons, high efficiency, gas/electric (continued)**

CFM	Ent DB (° F)	Entering Wet Bulb Temp (°F)						Entering Wet Bulb Temp (°F)						Entering Wet Bulb Temp (°F)					
		61		67		73		61		67		73		61		67		73	
		MBh	SHC	MBh	SHC	MBh	SHC	MBh	SHC	MBh	SHC	MBh	SHC	MBh	SHC	MBh	SHC	MBh	SHC
4000	75	118.8	101.4	135.5	80.1	150.4	55.1	112.9	96.1	128.6	77.0	142.4	52.1	105.9	95.2	121.3	73.9	133.8	48.8
	80	116.6	116.6	134.5	99.5	150.3	75.4	111.4	111.4	127.5	96.5	142.3	72.3	106.5	106.5	120.1	93.3	133.8	69.0
	85	123.2	123.2	132.7	116.9	150.0	95.1	118.4	118.4	125.7	113.6	142.0	92.0	113.2	113.2	118.3	110.1	133.4	88.8
	90	130.5	130.5	130.7	130.7	148.9	114.8	125.4	125.4	125.5	125.5	141.0	111.7	119.8	119.8	119.9	119.9	132.5	106.6
4400	75	120.0	106.3	137.9	83.3	152.6	56.1	113.7	103.0	130.7	80.3	144.3	53.0	107.0	99.6	123.0	77.0	135.4	49.7
	80	119.4	119.4	136.3	104.4	152.4	78.1	114.6	114.6	129.1	101.3	144.2	74.9	109.4	109.4	121.5	98.1	135.4	71.6
	85	126.8	126.8	134.0	122.6	151.9	99.6	121.8	121.8	126.8	119.2	143.6	96.5	116.3	116.3	119.2	115.7	134.8	93.2
	90	134.3	134.3	134.4	134.4	150.6	120.2	128.9	128.9	129.1	129.1	142.3	116.4	123.1	123.1	123.2	123.2	133.3	112.7
4800	75	121.1	110.7	139.8	86.5	154.4	57.1	114.6	107.3	132.2	83.3	145.8	53.9	107.7	103.8	124.3	80.0	136.7	50.6
	80	122.4	122.4	137.7	109.2	154.3	80.8	117.4	117.4	130.4	105.3	145.8	77.6	111.9	111.9	122.3	101.4	136.8	74.2
	85	130.0	130.0	134.9	128.1	153.4	104.0	124.7	124.7	127.5	124.7	145.0	100.9	119.0	119.0	119.7	119.7	135.9	97.6
	90	137.7	137.7	137.8	137.8	151.5	125.1	132.1	132.1	132.2	132.2	143.0	121.6	125.9	125.9	126.0	126.0	133.9	117.9
		Ambient Temperature 115°F						Ambient Temperature 125°F											
3000	75	95.1	79.9	107.9	62.3	119.7	43.0	88.5	76.7	100.2	58.9	110.7	39.6						
	80	94.2	92.7	107.6	77.4	119.7	58.6	87.6	87.6	99.9	74.0	110.7	55.1						
	85	98.3	98.3	106.8	91.6	119.6	73.9	93.0	93.0	99.2	87.9	110.7	70.4						
	90	104.2	104.2	105.9	104.7	119.2	89.0	98.5	98.5	98.6	98.6	110.3	85.6						
3600	75	97.8	87.0	111.5	67.3	122.9	44.5	90.7	83.3	103.3	63.9	113.3	40.9						
	80	98.0	98.0	110.7	85.0	122.9	62.9	92.4	92.4	102.6	81.6	113.4	59.2						
	85	104.2	104.2	109.4	100.7	122.7	80.8	98.3	98.3	101.2	96.9	113.2	77.3						
	90	110.4	110.4	110.5	110.5	122.1	98.8	104.0	104.0	104.1	104.1	112.8	91.4						
4000	75	99.0	91.6	113.4	70.5	124.5	45.4	91.7	87.8	104.8	66.9	114.6	41.8						
	80	101.1	101.1	112.2	90.0	124.6	65.5	95.2	95.2	103.8	85.0	114.8	61.9						
	85	107.5	107.5	110.5	106.4	124.2	85.3	101.1	101.1	102.0	102.0	114.4	81.7						
	90	113.7	113.7	113.8	113.8	123.2	103.5	106.9	106.9	107.0	107.0	113.3	99.4						
4400	75	99.9	96.0	114.7	73.5	125.8	46.2	92.3	92.2	105.9	69.9	115.6	42.6						
	80	103.7	103.7	113.4	91.9	126.0	68.1	97.5	97.5	104.4	89.6	115.8	64.4						
	85	110.2	110.2	111.1	111.1	125.4	89.7	103.6	103.6	103.6	103.6	115.3	86.1						
	90	116.6	116.6	116.7	116.7	123.8	108.8	109.3	109.3	109.4	109.4	113.7	104.7						
4800	75	100.4	100.2	115.8	76.5	126.9	47.1	93.2	93.2	106.8	72.8	116.5	43.4						
	80	106.0	106.0	113.9	97.6	127.1	70.7	99.5	99.5	104.9	93.6	116.7	66.9						
	85	112.7	112.7	112.7	112.7	126.3	94.1	105.7	105.7	105.7	105.7	116.1	89.1						
	90	119.0	119.0	119.1	119.1	124.2	114.0	111.4	111.4	111.4	111.4	113.9	109.9						

**Notes:**

- All capacities shown are gross and have not considered indoor fan heat. To obtain NET cooling capacity subtract indoor fan heat. For indoor fan heat formula, refer to appropriate airflow table notes.
- MBh = Total gross capacity.
- SHC = Sensible heat capacity.

**Table 53. Gross cooling capacities — 12.5 tons, high efficiency, gas/electric**

CFM	Ent DB (° F)	Entering Wet Bulb Temp (°F)						Entering Wet Bulb Temp (°F)						Entering Wet Bulb Temp (°F)					
		61		67		73		61		67		73		61		67		73	
		MBh	SHC	MBh	SHC	MBh	SHC	MBh	SHC	MBh	SHC	MBh	SHC	MBh	SHC	MBh	SHC	MBh	SHC
		Ambient Temperature 85°F						Ambient Temperature 95°F						Ambient Temperature 105°F					
3750	75	142.5	112.4	158.7	88.7	174.9	62.1	135.3	108.4	151.1	84.9	165.6	58.2	127.4	104.2	142.5	80.5	155.6	54.0
	80	142.3	130.8	158.7	108.3	174.8	83.2	135.1	126.7	151.2	104.5	165.5	79.2	127.3	122.2	142.8	100.4	155.6	75.0
	85	143.8	143.8	158.6	128.1	174.5	103.0	138.1	138.1	151.2	124.4	165.4	99.0	131.7	131.7	142.8	120.1	156.0	94.8
	90	151.4	151.4	158.3	146.1	174.4	123.0	145.6	145.6	150.8	142.1	165.4	118.9	139.0	139.0	142.3	137.8	156.1	114.9
4500	75	147.8	123.8	163.9	95.0	180.6	64.4	140.2	118.5	155.9	91.2	170.7	61.0	131.9	111.6	147.0	86.9	160.1	56.7
	80	147.0	144.4	163.9	118.7	180.3	89.3	139.5	139.5	156.0	114.8	170.3	85.0	131.6	131.6	147.1	110.6	160.0	80.3
	85	152.6	152.6	163.8	137.8	180.3	112.7	146.5	146.5	155.7	136.8	170.5	108.5	139.5	139.5	146.6	132.3	160.1	104.1
	90	160.3	160.3	162.1	161.9	180.0	136.4	154.0	154.0	154.3	154.3	170.4	132.3	146.8	146.8	147.0	147.0	160.0	127.9
5000	75	150.5	128.9	166.6	99.2	183.5	66.6	142.5	125.5	158.5	95.3	173.3	62.4	133.7	120.8	149.3	91.0	162.3	58.0
	80	149.2	149.2	166.6	125.3	182.8	92.5	142.8	142.8	158.4	121.4	172.7	88.2	135.7	135.7	149.3	117.2	162.0	83.7
	85	157.3	157.3	165.7	149.0	183.2	118.8	150.9	150.9	157.4	144.8	173.1	114.6	143.6	143.6	148.1	140.3	162.3	110.1
	90	165.0	165.0	165.1	165.1	182.9	145.1	158.4	158.4	158.5	158.5	172.9	137.0	150.8	150.8	150.9	150.9	162.0	134.8



# Gross Cooling Capacities

**Table 53. Gross cooling capacities — 12.5 tons, high efficiency, gas/electric (continued)**

CFM	Ent DB (° F)	Entering Wet Bulb Temp (°F)						Entering Wet Bulb Temp (°F)						Entering Wet Bulb Temp (°F)					
		61		67		73		61		67		73		61		67		73	
		MBh	SHC	MBh	SHC	MBh	SHC	MBh	SHC	MBh	SHC	MBh	SHC	MBh	SHC	MBh	SHC	MBh	SHC
5500	75	152.3	136.2	168.9	103.2	186.0	67.9	144.1	131.8	160.5	99.2	175.5	63.7	135.2	127.0	151.1	94.9	164.2	59.2
	80	153.0	153.0	168.8	131.9	185.4	96.0	146.5	146.5	160.4	127.9	175.0	91.7	139.1	139.1	151.1	121.0	163.9	87.1
	85	161.2	161.2	167.0	156.7	185.6	124.8	154.6	154.6	158.6	152.6	175.2	120.5	147.0	147.0	149.0	148.0	164.1	116.0
	90	169.3	169.3	169.5	169.5	185.0	151.7	162.0	162.0	162.1	162.1	174.5	147.1	154.0	154.0	154.2	154.2	163.2	142.3
6000	75	153.6	142.2	170.8	107.1	188.1	69.2	145.4	137.8	162.2	103.1	177.3	64.9	136.3	133.0	152.7	98.6	165.8	60.5
	80	156.4	156.4	170.7	135.9	187.5	99.4	149.7	149.7	162.1	128.8	176.9	95.0	142.1	142.1	152.0	128.0	165.6	90.2
	85	164.6	164.6	167.9	164.3	187.6	130.7	157.8	157.8	159.3	159.3	177.0	126.4	149.9	149.9	150.0	150.0	165.7	121.8
	90	173.4	173.4	173.5	173.5	186.3	159.1	165.6	165.6	165.7	165.7	175.6	154.5	157.0	157.0	157.2	157.2	164.1	149.6
Ambient Temperature 115°F																			
3750	75	118.8	99.6	133.1	76.0	144.8	50.1	109.3	92.4	122.8	71.1	133.4	45.5						
	80	118.7	117.5	133.4	95.9	145.5	70.8	109.5	109.5	123.0	91.1	134.4	66.3						
	85	124.6	124.6	133.4	112.2	145.8	90.5	116.6	116.6	123.0	109.8	134.4	85.7						
	90	131.6	131.6	132.9	132.9	145.9	110.5	123.3	123.3	123.4	123.4	134.6	105.8						
4500	75	122.5	109.4	137.1	82.3	148.7	52.1	112.4	104.0	126.3	77.3	136.4	47.3						
	80	124.1	124.1	137.2	106.0	149.2	75.8	115.8	115.8	126.3	101.0	137.4	70.9						
	85	131.7	131.7	136.5	127.4	149.0	99.5	123.0	123.0	125.5	122.1	137.2	94.7						
	90	138.6	138.6	138.8	138.8	149.2	122.2	129.4	129.4	129.5	129.5	137.0	117.0						
5000	75	124.2	115.7	139.1	86.3	150.6	53.4	113.8	110.3	128.0	81.2	138.0	48.5						
	80	127.8	127.8	139.1	112.1	150.9	79.1	119.1	119.1	128.0	103.1	138.8	74.1						
	85	135.4	135.4	137.7	135.3	150.7	105.4	126.2	126.2	126.5	126.5	138.6	100.5						
	90	142.2	142.2	142.3	142.3	150.1	129.7	132.4	132.4	132.5	132.5	137.5	124.4						
5500	75	125.4	121.9	140.7	90.1	152.2	54.6	114.8	114.8	129.3	84.9	139.3	49.7						
	80	131.0	131.0	140.4	117.4	152.3	82.3	121.9	121.9	128.7	112.0	140.0	77.2						
	85	138.5	138.5	138.6	138.6	152.2	111.2	128.9	128.9	129.0	129.0	139.8	106.2						
	90	145.0	145.0	145.1	145.1	151.1	137.2	134.8	134.8	134.9	134.9	138.1	131.8						
6000	75	126.3	126.3	142.1	93.8	153.6	55.8	116.4	116.4	130.5	88.6	140.4	50.9						
	80	133.7	133.7	141.2	122.9	153.5	85.3	124.3	124.3	129.3	117.4	141.1	80.2						
	85	141.0	141.0	141.1	141.1	153.5	117.1	131.1	131.1	131.2	131.2	140.5	110.4						
	90	147.6	147.6	147.7	147.7	151.7	144.5	137.1	137.1	137.2	137.2	138.5	138.5						

**Notes:**

1. All capacities shown are gross and have not considered indoor fan heat. To obtain NET cooling capacity subtract indoor fan heat. For indoor fan heat formula, refer to appropriate airflow table notes.
2. MBh = Total gross capacity.
3. SHC = Sensible heat capacity.

**Table 54. Gross cooling capacities — 15 tons, high efficiency, gas/electric**

CFM	Ent DB (° F)	Entering Wet Bulb Temp (°F)						Entering Wet Bulb Temp (°F)						Entering Wet Bulb Temp (°F)					
		61		67		73		61		67		73		61		67		73	
		MBh	SHC	MBh	SHC	MBh	SHC	MBh	SHC	MBh	SHC	MBh	SHC	MBh	SHC	MBh	SHC	MBh	SHC
Ambient Temperature 85°F																			
4500	75	169.0	134.0	187.5	105.2	205.0	72.9	160.6	129.5	178.6	100.9	194.2	68.4	151.4	124.6	168.7	96.3	182.7	63.7
	80	168.7	155.9	187.5	128.7	204.9	98.2	160.3	151.1	178.6	124.4	194.1	93.5	151.1	146.0	168.8	119.6	183.3	89.0
	85	170.7	170.7	187.3	152.4	204.6	121.8	164.0	164.0	178.6	148.1	194.2	117.3	156.5	156.5	168.8	141.8	183.7	112.7
	90	179.4	179.4	186.8	173.7	204.5	145.7	172.5	172.5	177.9	169.1	194.3	141.2	164.9	164.9	168.0	164.1	183.8	136.7
5400	75	175.1	147.6	193.3	112.7	211.3	75.5	166.2	140.3	184.0	108.3	199.8	71.6	156.4	136.7	173.7	103.4	187.6	66.7
	80	173.9	171.9	193.3	141.0	211.0	105.4	165.0	165.0	184.0	136.5	199.4	100.6	156.4	156.4	173.7	131.7	188.2	95.2
	85	180.7	180.7	193.0	167.4	210.9	133.2	173.5	173.5	183.5	162.6	199.6	128.4	165.3	165.3	172.9	157.5	187.9	123.5
	90	189.5	189.5	190.8	190.8	210.6	161.6	182.0	182.0	182.2	182.2	199.3	156.8	173.6	173.6	173.8	173.8	188.1	150.4
6000	75	178.0	154.6	196.3	117.6	214.5	78.0	168.6	149.6	186.8	113.1	202.6	73.2	158.5	144.1	176.2	108.1	190.1	68.2
	80	176.7	176.7	196.3	148.9	213.8	109.0	169.2	169.2	186.7	144.4	202.0	104.0	161.0	161.0	176.1	139.5	190.4	99.2
	85	186.0	186.0	195.0	176.9	214.1	140.4	178.4	178.4	185.2	172.1	202.4	135.6	170.0	170.0	174.4	166.9	190.0	130.5
	90	194.7	194.7	194.9	194.9	213.7	170.5	186.9	186.9	187.1	187.1	202.0	165.2	178.1	178.1	178.2	178.2	189.7	159.9
6600	75	179.9	162.0	198.9	122.3	217.2	79.5	170.4	156.9	189.1	117.7	205.0	74.7	160.0	151.4	178.2	112.7	192.2	69.7
	80	181.1	181.1	198.7	156.6	216.6	113.1	173.4	173.4	188.9	150.9	204.5	108.0	164.9	164.9	178.1	142.1	192.2	102.9
	85	190.5	190.5	196.3	186.1	216.7	147.5	182.6	182.6	186.4	181.3	204.7	142.6	173.8	173.8	175.4	175.4	192.0	137.5
	90	199.2	199.2	199.4	199.4	215.8	179.4	191.0	191.0	191.1	191.1	203.6	174.1	181.7	181.7	181.9	181.9	190.6	168.7

## Gross Cooling Capacities

**Table 54. Gross cooling capacities — 15 tons, high efficiency, gas/electric (continued)**

CFM	Ent DB (° F)	Entering Wet Bulb Temp (°F)						Entering Wet Bulb Temp (°F)						Entering Wet Bulb Temp (°F)					
		61		67		73		61		67		73		61		67		73	
		MBh	SHC	MBh	SHC	MBh	SHC	MBh	SHC	MBh	SHC	MBh	SHC	MBh	SHC	MBh	SHC	MBh	SHC
7200	75	181.4	169.1	201.0	126.9	219.5	81.0	171.7	164.0	191.0	122.3	207.0	76.1	161.1	158.5	180.0	117.2	193.9	71.1
	80	184.9	184.9	200.8	159.0	218.9	117.0	177.0	177.0	190.4	157.6	206.6	111.9	168.2	168.2	179.0	152.2	193.7	106.6
	85	194.3	194.3	197.1	195.1	218.9	154.5	186.2	186.2	187.0	187.0	206.6	149.5	177.0	177.0	177.1	177.1	193.6	144.3
	90	203.8	203.8	203.9	203.9	217.1	188.1	194.5	194.5	194.7	194.7	204.7	182.9	184.7	184.7	184.9	184.9	191.5	177.4
		<b>Ambient Temperature 115°F</b>						<b>Ambient Temperature 125°F</b>											
4500	75	141.5	119.4	157.9	90.7	170.9	59.5	130.8	110.8	146.2	85.3	158.3	54.4						
	80	141.2	140.5	158.1	114.5	171.8	84.2	131.0	131.0	146.5	109.1	159.3	79.1						
	85	148.3	148.3	158.1	132.9	172.1	107.8	139.2	139.2	146.3	131.4	159.4	102.5						
	90	156.3	156.3	157.2	157.2	172.2	131.8	146.9	146.9	147.0	147.0	159.5	126.5						
5400	75	145.7	130.9	162.4	98.2	174.6	61.6	134.3	124.9	150.2	92.6	161.2	56.4						
	80	147.7	147.7	162.4	126.5	176.0	90.1	138.3	138.3	150.2	121.0	162.8	84.7						
	85	156.4	156.4	161.4	151.9	175.7	118.5	146.5	146.5	148.9	146.0	162.5	113.1						
	90	164.2	164.2	164.4	164.4	175.9	145.6	153.8	153.8	153.9	153.9	162.0	139.7						
6000	75	147.5	138.4	164.6	102.8	176.8	63.1	135.8	132.3	152.1	97.2	162.8	57.8						
	80	152.0	152.0	164.6	132.4	177.9	94.0	142.1	142.1	151.8	127.2	164.4	88.5						
	85	160.6	160.6	162.6	161.3	177.6	125.4	150.2	150.2	150.3	150.3	164.1	120.0						
	90	168.2	168.2	168.3	168.3	176.6	154.4	157.2	157.2	157.3	157.3	162.6	148.5						
6600	75	148.8	145.6	166.4	107.4	178.6	64.5	136.9	136.9	153.6	101.6	164.4	59.2						
	80	155.5	155.5	165.8	139.9	179.5	97.7	145.3	145.3	152.7	133.9	165.8	92.1						
	85	164.0	164.0	164.1	164.1	179.2	132.3	153.2	153.2	153.3	153.3	165.4	126.6						
	90	171.4	171.4	171.5	171.5	177.1	163.0	159.9	159.9	160.0	160.0	162.8	157.2						
7200	75	149.8	149.8	168.0	111.8	180.1	65.9	139.1	139.1	155.0	105.9	166.0	60.7						
	80	158.5	158.5	166.6	146.5	180.9	101.2	147.9	147.9	153.3	140.4	167.0	95.5						
	85	166.9	166.9	167.0	167.0	180.6	136.7	155.7	155.7	155.8	155.8	166.0	131.9						
	90	174.0	174.0	174.1	174.1	177.5	171.6	162.1	162.1	162.1	162.1	162.9	162.9						

**Notes:**

1. All capacities shown are gross and have not considered indoor fan heat. To obtain NET cooling capacity subtract indoor fan heat. For indoor fan heat formula, refer to appropriate airflow table notes.
2. MBh = Total gross capacity.
3. SHC = Sensible heat capacity.

**Table 55. Gross cooling capacities — 17.5 tons, high efficiency, gas/electric**

CFM	Ent DB (° F)	Entering Wet Bulb Temp (°F)						Entering Wet Bulb Temp (°F)						Entering Wet Bulb Temp (°F)					
		61		67		73		61		67		73		61		67		73	
		MBh	SHC	MBh	SHC	MBh	SHC	MBh	SHC	MBh	SHC	MBh	SHC	MBh	SHC	MBh	SHC	MBh	SHC
		<b>Ambient Temperature 85°F</b>						<b>Ambient Temperature 95°F</b>						<b>Ambient Temperature 105°F</b>					
5250	75	194.6	153.8	219.8	122.9	242.9	86.9	185.0	148.6	209.2	117.8	231.5	82.1	174.9	143.2	197.9	112.4	219.1	77.0
	80	193.8	178.0	219.5	149.3	242.9	115.7	184.2	172.5	208.9	144.2	231.6	110.8	174.2	166.8	197.7	138.8	219.2	105.6
	85	195.3	195.3	218.7	176.0	242.7	142.7	187.8	187.8	208.3	170.9	231.5	137.7	179.8	179.8	197.2	165.5	219.2	132.4
	90	206.5	206.5	217.9	199.7	242.6	169.7	198.8	198.8	207.5	194.3	231.4	164.8	190.5	190.5	196.3	188.6	219.1	159.5
6300	75	201.9	169.1	227.3	131.6	250.1	90.7	191.7	161.7	216.2	126.3	238.0	85.7	180.9	152.7	204.3	120.7	224.9	80.4
	80	200.3	195.8	227.2	163.4	250.3	123.8	190.0	190.0	216.0	158.1	238.2	118.8	179.5	179.5	204.1	152.5	225.1	113.5
	85	207.9	207.9	226.1	187.0	250.3	155.3	199.8	199.8	215.0	187.2	238.2	150.2	191.0	191.0	202.9	181.2	225.2	144.7
	90	219.8	219.8	224.0	220.7	249.9	187.4	211.3	211.3	212.9	212.9	238.0	182.4	202.2	202.2	202.4	202.4	225.0	177.0
7000	75	205.6	172.2	231.6	137.3	253.8	92.5	194.7	170.9	220.1	131.9	241.3	87.4	183.5	164.8	207.9	126.2	227.8	82.1
	80	203.1	203.1	231.0	172.3	254.1	129.0	194.1	194.1	219.5	167.0	241.5	122.9	185.2	185.2	207.2	161.3	228.1	117.3
	85	214.9	214.9	229.3	203.5	254.0	163.3	206.3	206.3	217.6	197.7	241.6	158.2	197.1	197.1	205.2	191.7	228.2	152.6
	90	226.9	226.9	227.1	227.1	253.6	198.9	218.1	218.1	218.3	218.3	241.3	189.7	208.4	208.4	208.6	208.6	227.8	185.7
7700	75	208.1	185.0	235.2	142.8	256.8	94.1	196.9	179.0	223.3	137.3	244.0	89.0	185.4	172.8	210.6	131.5	230.2	83.6
	80	208.2	208.2	234.2	181.0	257.2	132.7	199.5	199.5	222.3	175.6	244.4	127.3	190.2	190.2	209.7	167.1	230.6	121.6
	85	220.8	220.8	231.3	213.7	257.1	171.2	211.9	211.9	219.4	207.9	244.4	166.0	202.3	202.3	206.7	201.8	230.6	160.4
	90	233.0	233.0	233.2	233.2	256.5	207.2	223.8	223.8	224.0	224.0	243.3	201.4	213.7	213.7	213.9	213.9	229.1	195.3
8400	75	209.9	192.8	238.0	148.0	259.6	95.8	198.6	186.8	225.8	142.4	246.4	90.6	186.7	180.6	212.9	136.6	232.8	85.2
	80	213.2	213.2	236.7	187.2	259.9	137.0	204.2	204.2	224.5	181.7	246.9	131.6	194.6	194.6	211.2	175.4	232.8	125.8
	85	226.0	226.0	232.7	223.6	259.7	179.0	216.8	216.8	220.6	217.8	246.7	173.7	206.8	206.8	207.6	207.6	232.7	168.0
	90	238.3	238.3	238.5	238.5	257.7	216.6	228.7	228.7	228.9	228.9	244.3	210.8	218.2	218.2	218.3	218.3	229.9	204.6
		<b>Ambient Temperature 115°F</b>						<b>Ambient Temperature 125°F</b>											



**Gross Cooling Capacities**

**Table 55. Gross cooling capacities — 17.5 tons, high efficiency, gas/electric (continued)**

CFM	Ent DB (°F)	Entering Wet Bulb Temp (°F)						Entering Wet Bulb Temp (°F)						Entering Wet Bulb Temp (°F)					
		61		67		73		61		67		73		61		67		73	
		MBh	SHC	MBh	SHC	MBh	SHC	MBh	SHC	MBh	SHC	MBh	SHC	MBh	SHC	MBh	SHC	MBh	SHC
5250	75	164.3	137.6	185.8	106.8	205.8	72.3	153.1	130.4	173.0	100.3	191.3	66.4						
	80	163.6	161.0	185.9	133.1	205.9	100.1	152.5	152.5	173.2	127.2	191.6	94.3						
	85	171.3	171.3	185.5	156.2	206.0	126.8	162.1	162.1	172.8	152.2	191.7	120.8						
	90	181.7	181.7	184.6	182.6	205.9	153.9	172.0	172.0	172.1	172.1	191.7	148.0						
6300	75	169.4	150.3	191.8	114.9	210.8	74.8	157.4	143.9	178.4	108.7	195.6	68.9						
	80	170.5	170.5	191.5	146.7	211.0	107.0	160.9	160.9	178.1	140.6	195.9	100.7						
	85	181.6	181.6	190.2	175.0	211.2	138.9	171.4	171.4	176.7	168.5	196.0	132.8						
	90	192.3	192.3	192.5	192.5	211.0	168.0	181.5	181.5	181.7	181.7	195.7	162.9						
7000	75	171.7	158.5	194.9	120.3	213.3	76.4	159.3	152.0	180.9	114.0	197.7	70.4						
	80	175.8	175.8	194.3	155.4	213.7	111.3	165.7	165.7	180.5	146.2	198.2	105.0						
	85	187.2	187.2	192.1	185.4	213.7	146.8	176.4	176.4	178.2	178.2	198.2	140.6						
	90	198.0	198.0	198.1	198.1	212.9	179.3	186.5	186.5	186.6	186.6	196.9	172.6						
7700	75	173.3	166.5	197.2	125.4	215.4	77.9	160.6	159.9	183.0	119.0	199.5	71.9						
	80	180.4	180.4	196.1	161.7	215.9	115.6	169.8	169.8	181.7	154.9	200.0	109.1						
	85	191.9	191.9	193.3	193.3	215.8	154.5	180.6	180.6	180.7	180.7	200.0	148.2						
	90	202.7	202.7	202.8	202.8	213.9	188.9	190.5	190.5	190.7	190.7	197.6	182.1						
8400	75	174.4	174.2	199.2	130.4	217.2	79.4	161.9	161.9	184.7	123.9	201.0	73.4						
	80	184.4	184.4	197.3	168.9	217.7	119.6	173.3	173.3	182.6	162.1	201.6	113.1						
	85	196.0	196.0	196.1	196.1	217.6	162.9	184.2	184.2	184.3	184.3	201.5	151.3						
	90	206.7	206.7	206.8	206.8	214.4	198.2	193.9	193.9	194.0	194.0	198.0	191.4						

- Notes:**
- All capacities shown are gross and have not considered indoor fan heat. To obtain NET cooling capacity subtract indoor fan heat. For indoor fan heat formula, refer to appropriate airflow table notes.
  - MBh = Total gross capacity.
  - SHC = Sensible heat capacity.

**Table 56. Gross cooling capacities — 20 tons, high efficiency, gas/electric**

CFM	Ent DB (°F)	Entering Wet Bulb Temp (°F)						Entering Wet Bulb Temp (°F)						Entering Wet Bulb Temp (°F)					
		61		67		73		61		67		73		61		67		73	
		MBh	SHC	MBh	SHC	MBh	SHC	MBh	SHC	MBh	SHC	MBh	SHC	MBh	SHC	MBh	SHC	MBh	SHC
		<b>Ambient Temperature 85°F</b>						<b>Ambient Temperature 95°F</b>						<b>Ambient Temperature 105°F</b>					
6000	75	219.3	172.1	249.3	138.6	276.4	98.7	208.5	166.2	237.3	132.8	263.1	93.0	196.6	159.9	223.9	126.4	247.9	86.9
	80	217.6	198.2	248.9	167.9	276.3	130.8	206.8	191.9	236.9	162.0	263.0	125.0	194.9	185.1	223.5	155.5	247.9	118.6
	85	217.2	217.2	247.3	197.2	275.9	161.4	208.9	208.9	235.5	191.3	262.6	154.8	199.8	199.8	222.2	184.9	247.7	148.3
	90	230.1	230.1	245.9	222.8	275.6	190.5	221.6	221.6	233.9	216.4	262.4	184.7	212.1	212.1	220.6	209.5	247.5	178.2
7200	75	227.7	188.8	258.3	149.1	284.8	103.0	216.1	182.6	245.3	142.1	270.4	97.1	203.3	171.6	231.2	135.4	254.2	90.5
	80	224.6	217.0	257.9	183.1	284.7	139.6	213.0	210.4	245.0	177.0	270.4	133.6	200.3	200.3	230.7	170.3	254.3	127.1
	85	231.4	231.4	255.8	211.8	284.6	174.2	222.4	222.4	243.1	208.6	270.4	168.1	212.3	212.3	228.6	201.3	254.3	161.4
	90	245.1	245.1	252.5	244.8	283.8	209.5	235.8	235.8	239.8	238.3	269.7	203.5	225.2	225.2	225.6	225.6	253.7	196.9
8000	75	231.8	194.9	263.2	154.5	289.0	104.9	219.6	190.2	250.0	148.2	274.0	98.8	206.1	182.8	235.4	141.4	257.3	92.2
	80	227.6	227.6	262.2	192.8	288.9	145.1	215.9	215.9	248.9	186.5	274.1	138.7	205.7	205.7	234.2	179.7	257.4	131.1
	85	239.3	239.3	259.4	226.5	288.8	182.8	229.8	229.8	245.9	219.6	274.1	176.6	219.2	219.2	231.0	212.2	257.4	169.8
	90	253.3	253.3	255.0	255.0	287.8	221.8	243.4	243.4	243.6	243.6	273.2	215.7	232.2	232.2	232.4	232.4	256.8	201.8
8800	75	234.6	205.6	267.5	160.4	292.5	106.7	221.9	198.6	253.9	154.1	277.0	100.5	208.1	191.1	238.8	147.1	259.8	93.8
	80	231.5	231.5	265.8	202.0	292.3	149.1	222.0	222.0	252.1	195.7	277.1	142.7	211.4	211.4	236.9	188.8	260.1	135.7
	85	246.2	246.2	261.6	237.1	292.2	191.2	236.3	236.3	247.7	230.2	277.0	184.9	225.1	225.1	232.4	222.7	260.0	178.0
	90	260.3	260.3	260.5	260.5	291.1	226.6	250.0	250.0	250.2	250.2	275.6	223.7	238.2	238.2	238.3	238.3	258.1	216.0
9600	75	236.6	213.7	271.1	166.1	296.1	108.6	223.6	206.7	256.9	159.6	279.5	102.1	209.4	199.2	241.3	152.5	261.9	95.4
	80	237.3	237.3	268.6	211.1	295.4	153.8	227.3	227.3	254.6	201.1	279.8	147.3	216.3	216.3	238.6	194.7	262.4	140.1
	85	252.1	252.1	262.9	247.3	295.0	199.4	241.8	241.8	248.8	240.4	279.5	193.0	230.2	230.2	233.2	232.9	262.1	186.0
	90	266.4	266.4	266.6	266.6	292.6	240.4	255.6	255.6	255.8	255.8	276.6	233.4	243.2	243.2	243.4	243.4	258.8	225.7
		<b>Ambient Temperature 115°F</b>						<b>Ambient Temperature 125°F</b>											
6000	75	183.7	153.1	209.1	119.5	231.0	80.8	169.7	144.3	192.8	111.3	212.4	73.3						
	80	182.1	177.9	208.9	148.5	231.1	111.7	168.2	168.2	192.9	141.1	212.6	104.4						
	85	189.7	189.7	207.8	174.7	231.1	141.2	178.4	178.4	191.9	168.1	212.8	133.6						
	90	201.5	201.5	206.1	202.0	230.8	171.2	189.6	189.6	190.3	190.3	212.5	163.6						

**Table 56. Gross cooling capacities — 20 tons, high efficiency, gas/electric (continued)**

CFM	Ent DB (° F)	Entering Wet Bulb Temp (°F)						Entering Wet Bulb Temp (°F)						Entering Wet Bulb Temp (°F)					
		61		67		73		61		67		73		61		67		73	
		MBh	SHC	MBh	SHC	MBh	SHC	MBh	SHC	MBh	SHC	MBh	SHC	MBh	SHC	MBh	SHC	MBh	SHC
7200	75	189.3	166.4	215.7	128.2	236.2	83.4	174.2	158.2	198.8	120.4	216.5	75.8						
	80	188.6	188.6	215.1	163.1	236.4	120.0	176.8	176.8	198.1	155.4	216.9	111.0						
	85	201.2	201.2	212.8	193.4	236.5	154.1	188.7	188.7	195.7	185.1	217.0	146.2						
	90	213.4	213.4	213.5	213.5	236.1	187.8	199.9	199.9	200.1	200.1	216.5	179.0						
8000	75	191.7	175.0	219.3	134.0	238.7	85.0	176.0	166.7	201.7	126.0	218.5	77.3						
	80	194.5	194.5	218.0	172.4	239.1	123.6	182.1	182.1	200.5	160.3	219.1	115.5						
	85	207.4	207.4	214.7	204.3	239.1	162.3	194.1	194.1	197.0	195.8	219.1	154.4						
	90	219.6	219.6	219.7	219.7	238.0	197.8	205.2	205.2	205.4	205.4	217.4	189.1						
8800	75	193.2	183.2	222.0	139.5	240.8	86.5	177.2	174.8	203.9	131.4	220.1	78.8						
	80	199.6	199.6	220.2	178.6	241.3	128.1	186.6	186.6	201.7	170.2	220.9	119.7						
	85	212.7	212.7	215.8	214.7	241.2	170.5	198.7	198.7	198.8	198.8	220.8	162.4						
	90	224.8	224.8	224.9	224.9	238.8	207.7	209.5	209.5	209.7	209.7	217.9	198.9						
9600	75	194.2	191.2	224.2	144.8	242.5	88.1	177.9	177.9	205.7	136.6	221.5	80.4						
	80	204.1	204.1	221.2	186.3	243.2	132.3	190.6	190.6	202.5	177.5	222.3	123.9						
	85	217.2	217.2	217.3	217.3	243.0	178.4	202.6	202.6	202.7	202.7	222.2	166.4						
	90	229.1	229.1	229.2	229.2	239.2	217.4	213.0	213.0	213.2	213.2	218.0	208.6						

**Notes:**

1. All capacities shown are gross and have not considered indoor fan heat. To obtain NET cooling capacity subtract indoor fan heat. For indoor fan heat formula, refer to appropriate airflow table notes.
2. MBh = Total gross capacity.
3. SHC = Sensible heat capacity.

**Table 57. Gross cooling capacities — 25 tons, high efficiency, gas/electric**

CFM	Ent DB (° F)	Entering Wet Bulb Temp (°F)						Entering Wet Bulb Temp (°F)						Entering Wet Bulb Temp (°F)					
		61		67		73		61		67		73		61		67		73	
		MBh	SHC	MBh	SHC	MBh	SHC	MBh	SHC	MBh	SHC	MBh	SHC	MBh	SHC	MBh	SHC	MBh	SHC
		<b>Ambient Temperature 85°F</b>						<b>Ambient Temperature 95°F</b>						<b>Ambient Temperature 105°F</b>					
7500	75	254.2	203.6	288.8	162.5	317.7	112.8	240.9	196.3	273.5	155.2	301.0	106.9	228.7	189.6	258.7	148.1	284.0	99.7
	80	251.2	234.1	288.1	198.1	317.6	152.1	237.9	226.3	273.0	190.6	300.9	144.9	225.8	219.2	258.5	183.4	284.0	138.2
	85	253.8	253.8	285.8	233.9	317.1	188.3	243.6	243.6	270.9	225.1	300.7	180.9	233.9	233.9	256.6	211.6	284.0	173.5
	90	269.0	269.0	283.1	263.6	316.5	224.9	258.3	258.3	268.1	255.6	300.0	217.6	247.9	247.9	253.8	248.0	283.3	210.3
9000	75	262.8	220.1	297.8	173.4	325.6	117.4	248.4	213.0	281.9	165.7	307.8	110.1	235.1	205.4	266.5	158.2	289.7	102.6
	80	257.8	256.1	296.8	215.9	325.4	162.3	243.5	243.5	280.7	208.2	307.7	154.1	232.6	232.6	265.3	200.8	289.7	145.9
	85	269.7	269.7	293.5	253.6	325.3	204.1	258.3	258.3	277.3	245.3	307.7	196.5	247.4	247.4	261.8	237.3	289.9	188.9
	90	285.4	285.4	288.7	288.7	324.1	247.5	273.4	273.4	273.6	273.6	306.7	240.0	261.6	261.6	261.8	261.8	289.1	225.0
10000	75	266.3	231.7	303.0	180.6	329.5	119.4	251.3	223.3	286.6	172.7	311.2	112.0	237.5	215.6	270.6	165.0	292.5	104.5
	80	261.8	261.8	300.9	227.3	329.2	167.0	250.4	250.4	284.4	219.5	311.2	159.2	239.6	239.6	268.5	211.9	292.9	151.4
	85	278.3	278.3	296.1	266.7	329.1	214.2	266.3	266.3	279.4	258.2	311.1	206.6	254.6	254.6	263.5	250.2	292.8	198.8
	90	294.1	294.1	294.3	294.3	327.9	258.5	281.4	281.4	281.6	281.6	309.2	250.1	268.8	268.8	269.0	269.0	290.5	241.6
11000	75	268.6	241.7	307.1	187.4	332.7	121.4	253.2	233.2	290.0	179.4	313.9	113.9	239.0	225.4	273.4	171.5	294.8	106.4
	80	268.9	268.9	304.1	238.3	332.7	172.5	257.0	257.0	287.2	225.0	314.2	164.6	245.6	245.6	270.3	219.3	295.4	156.5
	85	285.6	285.6	297.6	279.2	332.3	224.1	273.0	273.0	280.7	270.8	313.9	216.4	260.7	260.7	264.4	262.7	295.1	208.6
	90	301.4	301.4	301.6	301.6	329.2	270.4	288.1	288.1	288.2	288.2	310.2	261.9	274.7	274.7	274.9	274.9	291.2	253.5
12000	75	270.1	251.3	310.1	193.9	335.4	123.3	254.3	242.7	292.7	185.8	316.2	115.8	239.8	234.8	275.8	177.8	296.8	108.2
	80	275.1	275.1	306.0	245.3	335.6	177.7	262.7	262.7	288.3	236.6	316.7	169.7	250.8	250.8	271.3	228.2	297.5	161.5
	85	291.9	291.9	298.4	291.5	334.9	233.9	278.8	278.8	281.0	281.0	316.2	226.2	265.9	265.9	266.1	266.1	297.1	218.0
	90	307.6	307.6	307.7	307.7	329.8	282.0	293.7	293.7	293.9	293.9	310.6	273.5	279.7	279.7	279.8	279.8	291.4	265.1
		<b>Ambient Temperature 115°F</b>						<b>Ambient Temperature 125°F</b>											
7500	75	218.4	183.8	245.1	140.3	267.1	92.5	211.1	178.6	232.9	134.1	250.4	85.4						
	80	215.7	213.2	245.1	176.7	267.3	130.6	208.6	208.6	232.9	170.5	251.0	123.7						
	85	225.2	225.2	243.6	209.8	267.4	166.2	217.5	217.5	231.6	203.4	251.2	159.0						
	90	238.1	238.1	240.9	240.9	267.0	203.1	229.1	229.1	229.3	229.3	251.1	196.1						
9000	75	223.5	198.7	252.1	151.0	271.6	95.3	215.1	193.6	238.6	144.4	253.7	88.0						
	80	223.6	223.6	250.9	193.8	272.2	138.3	216.1	216.1	237.8	187.3	254.9	130.7						
	85	237.3	237.3	247.5	229.9	272.3	181.3	228.1	228.1	234.6	223.2	254.9	173.8						
	90	250.3	250.3	250.4	250.4	271.3	221.3	239.2	239.2	239.4	239.4	253.9	213.4						



## Gross Cooling Capacities

**Table 57. Gross cooling capacities — 25 tons, high efficiency, gas/electric (continued)**

CFM	Ent DB (°F)	Entering Wet Bulb Temp (°F)						Entering Wet Bulb Temp (°F)						Entering Wet Bulb Temp (°F)					
		61		67		73		61		67		73		61		67		73	
		MBh	SHC	MBh	SHC	MBh	SHC	MBh	SHC	MBh	SHC	MBh	SHC	MBh	SHC	MBh	SHC	MBh	SHC
10000	75	225.5	208.8	255.3	157.7	273.9	97.0	216.4	203.4	241.2	150.8	255.7	89.8						
	80	229.9	229.9	253.6	200.0	274.7	143.5	221.3	221.3	239.6	195.3	256.7	135.7						
	85	243.7	243.7	248.8	242.8	274.6	191.2	233.4	233.4	235.5	235.5	256.7	183.5						
	90	256.4	256.4	256.6	256.6	272.2	233.4	244.2	244.2	244.3	244.3	254.3	225.4						
11000	75	226.7	218.5	257.8	164.0	275.7	98.8	217.1	213.0	243.2	156.9	256.8	91.4						
	80	235.3	235.3	254.7	211.5	276.7	148.5	225.9	225.9	240.5	204.3	258.2	140.5						
	85	249.0	249.0	249.3	249.3	276.6	200.9	237.9	237.9	238.0	238.0	258.3	191.3						
	90	261.5	261.5	261.6	261.6	272.5	245.2	248.1	248.1	248.2	248.2	254.4	237.2						
12000	75	227.3	227.3	259.7	170.2	277.3	100.6	217.4	217.4	244.8	163.0	258.1	93.2						
	80	239.9	239.9	255.5	220.4	278.3	153.3	229.8	229.8	241.0	213.2	259.4	145.1						
	85	253.5	253.5	253.6	253.6	277.7	207.0	241.5	241.5	241.6	241.6	258.4	199.4						
	90	265.6	265.6	265.7	265.7	272.5	256.9	251.1	251.1	251.2	251.2	254.1	249.0						

**Notes:**

1. All capacities shown are gross and have not considered indoor fan heat. To obtain NET cooling capacity subtract indoor fan heat. For indoor fan heat formula, refer to appropriate airflow table notes.
2. MBh = Total gross capacity.
3. SHC = Sensible heat capacity.



# Reheat Temperature Rise

Table 58. Reheat temperature rise - 3 tons, standard efficiency

Airflow (cfm)	Ent DB (°F)	Entering Wet Bulb (°F)											
		51				55				59			
		Lvg Evap DB (°F)		Lvg Reheat DB (°F)		Lvg Evap DB (°F)		Lvg Reheat DB (°F)		Lvg Evap DB (°F)		Lvg Reheat DB (°F)	
		MIN	MAX	MIN	MAX	MIN	MAX	MIN	MAX	MIN	MAX	MIN	MAX
Ambient DB 60°F													
900	60	37.4	35.9	57.1	64.4	41.3	39.7	62.6	70.2	45.6	44.0	68.6	76.2
	65	37.7	36.1	57.4	64.6	41.6	40.0	62.8	70.4	45.5	44.0	68.5	76.1
	70	40.3	37.9	60.8	67.0	41.8	40.2	63.1	70.6	45.9	44.3	68.7	76.3
	75	43.7	41.1	65.5	71.7	43.8	41.1	65.6	71.7	46.1	44.0	68.9	76.1
1050	60	39.4	38.0	56.7	63.1	43.2	41.7	62.0	68.7	47.4	45.9	67.7	74.4
	65	40.0	38.3	57.4	63.5	43.6	42.1	62.3	68.9	47.5	46.0	67.7	74.4
	70	43.4	41.1	61.9	67.2	44.2	42.4	62.9	69.2	47.9	46.4	68.0	74.6
	75	47.0	44.5	66.6	71.8	47.1	44.6	66.7	71.9	48.3	46.6	68.4	74.9
1200	60	41.0	39.7	56.4	62.1	44.7	43.3	61.4	67.4	48.8	47.4	66.9	72.9
	65	42.0	40.3	57.6	62.9	45.2	43.8	61.9	67.7	49.0	47.6	67.0	73.0
	70	46.0	43.7	62.7	67.4	45.9	44.4	62.7	68.4	49.4	48.0	67.4	73.3
	75	49.7	47.2	67.5	72.0	49.8	47.3	67.6	72.1	50.1	48.4	68.2	73.7
1320	60	42.0	40.8	56.3	61.4	45.7	44.4	61.1	66.5	49.7	48.4	66.4	71.9
	65	43.9	41.8	58.5	62.6	46.2	44.9	61.6	66.9	50.0	48.6	66.5	72.0
	70	47.7	45.5	63.3	67.4	47.8	45.7	63.4	67.8	50.5	49.1	67.0	72.4
	75	51.5	49.1	68.1	72.1	51.6	49.2	68.2	72.2	51.6	49.9	68.2	73.2
1440	60	42.9	41.7	56.1	60.9	46.6	45.3	60.8	65.8	50.5	49.2	65.9	71.1
	65	45.3	43.3	59.0	62.8	47.1	45.8	61.3	66.3	50.8	49.5	66.1	71.2
	70	49.2	47.0	63.8	67.5	49.3	47.0	63.9	67.5	51.3	50.1	66.6	71.7
	75	53.1	50.7	68.6	72.2	53.2	50.8	68.7	72.3	53.3	51.0	68.8	72.6
Ambient DB 65°F													
900	60	37.7	36.1	57.4	64.5	41.5	39.9	62.9	70.4	45.8	44.1	68.9	76.5
	65	37.9	36.3	57.7	64.7	41.9	40.2	63.1	70.5	45.8	44.1	68.9	76.4
	70	40.7	38.1	61.3	67.2	42.1	40.4	63.5	70.7	46.1	44.4	69.1	76.5
	75	44.1	41.4	66.0	72.0	44.2	41.4	66.2	72.1	46.3	44.6	69.3	76.7
1050	60	39.7	38.2	57.0	63.2	43.4	41.9	62.2	68.8	47.6	46.1	68.0	74.6
	65	40.2	38.6	57.7	63.7	43.8	42.3	62.6	69.0	47.7	46.1	67.9	74.5
	70	43.8	41.3	62.4	67.4	44.4	42.6	63.2	69.4	48.1	46.5	68.3	74.8
	75	47.4	44.7	67.1	72.1	47.5	44.8	67.2	72.2	48.4	46.8	68.6	75.1
1200	60	41.2	39.8	56.7	62.1	44.9	43.5	61.7	67.5	49.0	47.6	67.2	73.0
	65	42.6	40.5	58.4	63.0	45.4	43.9	62.1	67.8	49.2	47.7	67.2	73.1
	70	46.4	43.9	63.2	67.6	46.3	44.6	63.1	68.5	49.6	48.2	67.6	73.4
	75	50.1	47.5	68.0	72.2	50.2	47.6	68.1	72.3	50.4	48.5	68.5	73.8
1320	60	42.2	40.9	56.5	61.5	45.9	44.5	61.3	66.6	49.9	48.5	66.6	72.0
	65	44.2	41.8	58.9	62.6	46.4	45.0	61.8	67.0	50.1	48.7	66.7	72.1
	70	48.1	45.7	63.7	67.7	48.1	45.8	63.8	67.9	50.6	49.3	67.2	72.5
	75	51.9	49.4	68.5	72.3	52.0	49.4	68.6	72.4	51.7	50.0	68.4	73.3



# Reheat Temperature Rise

**Table 58. Reheat temperature rise - 3 tons, standard efficiency (continued)**

Airflow (cfm)	Ent DB (°F)	Entering Wet Bulb (°F)											
		51				55				59			
		Lvg Evap DB (°F)		Lvg Reheat DB (°F)		Lvg Evap DB (°F)		Lvg Reheat DB (°F)		Lvg Evap DB (°F)		Lvg Reheat DB (°F)	
		MIN	MAX	MIN	MAX	MIN	MAX	MIN	MAX	MIN	MAX	MIN	MAX
1440	60	43.0	41.8	56.3	60.9	46.7	45.4	60.9	65.8	50.6	49.4	66.1	71.1
	65	45.6	43.6	59.3	63.0	47.2	46.0	61.5	66.3	51.1	49.7	66.3	71.3
	70	49.5	47.3	64.2	67.7	49.6	47.2	64.3	67.7	51.5	50.2	66.9	71.8
	75	53.4	51.0	69.0	72.4	53.5	51.1	69.1	72.5	53.6	51.1	69.2	72.8
<b>Ambient DB 70°F</b>													
900	60	38.0	36.3	57.7	64.6	41.8	40.1	63.3	70.5	46.1	44.3	69.3	76.6
	65	38.4	36.5	58.2	64.8	42.1	40.4	63.5	70.7	46.0	44.3	69.2	76.5
	70	41.1	38.4	61.9	67.5	42.3	40.6	63.7	70.9	46.4	44.6	69.4	76.7
	75	44.6	41.7	66.6	72.3	44.7	41.6	66.7	72.2	46.6	44.8	69.6	76.9
1050	60	39.9	38.4	57.3	63.3	43.6	42.1	62.5	68.9	47.8	46.2	68.2	74.7
	65	40.5	38.9	58.0	63.9	44.1	42.5	62.8	69.2	47.9	46.3	68.2	74.7
	70	44.2	41.6	62.8	67.7	44.6	42.8	63.5	69.5	48.3	46.7	68.5	74.9
	75	47.8	45.0	67.6	72.4	47.9	45.1	67.7	72.5	48.9	47.0	69.2	75.2
1200	60	41.4	40.0	56.9	62.2	45.1	43.6	61.9	67.5	49.2	47.7	67.4	73.1
	65	43.0	40.7	58.8	63.1	45.6	44.1	62.3	67.9	49.4	47.8	67.4	73.2
	70	46.7	44.2	63.6	67.8	46.7	44.8	63.7	68.7	49.8	48.3	67.9	73.5
	75	50.4	47.8	68.4	72.5	50.5	47.9	68.5	72.6	50.6	48.7	68.7	73.9
1320	60	42.4	41.1	56.7	61.6	46.1	44.7	61.5	66.7	50.1	48.7	66.8	72.1
	65	44.5	42.2	59.3	63.0	46.6	45.2	62.0	67.1	50.3	48.9	66.9	72.2
	70	48.4	46.0	64.1	67.9	48.4	46.0	64.2	68.0	50.8	49.4	67.4	72.6
	75	52.2	49.6	69.0	72.6	52.3	49.7	69.1	72.7	51.8	50.2	68.6	73.5
1440	60	43.2	42.0	56.5	61.0	47.0	45.6	61.2	65.9	50.8	49.5	66.3	71.2
	65	45.9	43.8	59.7	63.2	47.4	46.1	61.7	66.4	51.3	49.8	66.5	71.3
	70	49.8	47.5	64.5	67.9	49.9	47.3	64.6	67.8	51.7	50.3	67.1	71.8
	75	53.8	51.2	69.5	72.7	53.8	51.3	69.5	72.8	53.9	51.3	69.6	72.9

**Note:** MIN, MAX: The leaving evaporator temperature is affected by the modulating valve position. The MIN and MAX numbers represent modulating valve position impact on both the leaving evaporator temperature and the leaving reheat coil temperature. MAX represents wide open, MIN represents closed to minimum position.

**Table 59. Reheat temperature rise - 4 tons, standard efficiency**

Airflow (cfm)	Ent DB (°F)	Entering Wet Bulb (°F)											
		51				55				59			
		Lvg Evap DB (°F)		Lvg Reheat DB (°F)		Lvg Evap DB (°F)		Lvg Reheat DB (°F)		Lvg Evap DB (°F)		Lvg Reheat DB (°F)	
		MIN	MAX	MIN	MAX	MIN	MAX	MIN	MAX	MIN	MAX	MIN	MAX
<b>Ambient DB 60°F</b>													
1200	60	38.1	36.3	58.2	64.8	42.0	40.1	63.6	70.4	46.2	44.3	69.5	76.6
	65	38.5	36.7	58.6	65.2	42.3	40.5	63.9	70.7	46.3	44.4	69.5	76.6
	70	41.2	38.4	62.3	67.5	42.6	40.8	64.3	71.0	46.6	44.7	69.7	76.8
	75	44.7	41.6	67.0	72.2	44.8	41.6	67.2	72.2	47.0	45.1	70.1	77.1
1400	60	40.1	38.5	57.7	63.5	43.8	42.1	62.9	68.9	48.0	46.1	68.4	74.6
	65	40.8	38.8	58.6	63.9	44.3	42.5	63.3	69.2	48.1	46.3	68.5	74.8
	70	44.3	41.5	63.2	67.6	45.0	43.0	64.1	69.7	48.7	46.8	68.9	75.1
	75	48.1	45.0	68.0	72.4	48.1	45.1	68.1	72.5	49.0	47.2	69.4	75.5

# Reheat Temperature Rise

**Table 59. Reheat temperature rise - 4 tons, standard efficiency (continued)**

Airflow (cfm)	Ent DB (°F)	Entering Wet Bulb (°F)											
		51				55				59			
		Lvg Evap DB (°F)		Lvg Reheat DB (°F)		Lvg Evap DB (°F)		Lvg Reheat DB (°F)		Lvg Evap DB (°F)		Lvg Reheat DB (°F)	
		MIN	MAX	MIN	MAX	MIN	MAX	MIN	MAX	MIN	MAX	MIN	MAX
1600	60	41.6	40.1	57.4	62.5	45.2	43.7	62.3	67.6	49.3	47.7	67.6	73.2
	65	42.5	40.9	58.6	63.4	45.9	44.3	62.8	68.1	49.6	47.9	67.8	73.4
	70	46.9	44.1	64.0	67.8	46.8	44.7	63.9	68.7	50.2	48.5	68.3	73.8
	75	50.7	47.7	68.8	72.5	50.8	47.8	68.9	72.6	51.1	49.0	69.3	74.4
1760	60	42.6	41.2	57.1	61.8	46.2	44.7	61.9	66.8	50.2	48.6	67.0	72.2
	65	44.7	42.2	59.6	63.0	46.9	45.4	62.5	67.3	50.5	48.9	67.2	72.4
	70	48.6	45.9	64.5	67.9	48.7	46.3	64.5	68.4	51.2	49.6	67.9	73.0
	75	52.5	49.6	69.3	72.6	52.6	49.6	69.4	72.7	52.5	50.2	69.3	73.6
1920	60	43.5	42.1	57.0	61.2	47.0	45.6	61.5	66.1	50.8	49.5	66.3	71.3
	65	46.0	43.4	60.0	62.8	47.7	46.3	62.2	66.7	51.3	49.8	66.8	71.6
	70	50.1	47.5	64.9	68.0	50.1	47.4	65.0	67.9	52.1	50.5	67.5	72.2
	75	54.1	51.2	69.8	72.7	54.2	51.3	69.9	72.8	54.3	51.6	69.9	73.4
<b>Ambient DB 65°F</b>													
1200	60	38.4	36.5	58.5	65.0	42.2	40.3	64.0	70.6	46.5	44.5	69.8	76.8
	65	38.6	36.9	58.9	65.4	42.6	40.6	64.3	70.9	46.5	44.5	69.8	76.8
	70	41.6	38.6	62.8	67.8	43.0	41.0	64.7	71.2	46.8	44.8	70.0	77.0
	75	45.2	41.9	67.6	72.6	45.3	41.9	67.8	72.6	47.3	45.2	70.5	77.3
1400	60	40.3	38.6	58.0	63.6	44.0	42.3	63.2	69.0	48.2	46.2	68.7	74.7
	65	41.0	39.1	58.9	64.2	44.6	42.8	63.6	69.4	48.4	46.5	68.8	75.0
	70	44.7	41.8	63.7	67.9	45.2	43.1	64.4	69.8	48.9	47.0	69.2	75.3
	75	48.5	45.2	68.5	72.7	48.6	45.4	68.6	72.8	49.2	47.4	69.6	75.7
1600	60	41.8	40.3	57.6	62.6	45.4	43.8	62.5	67.7	49.5	47.8	67.8	73.3
	65	43.4	41.1	59.6	63.5	46.1	44.4	63.1	68.2	49.8	48.1	68.0	73.5
	70	47.2	44.4	64.4	68.0	47.2	44.9	64.4	68.8	50.4	48.6	68.5	74.0
	75	51.1	48.0	69.3	72.8	51.2	48.0	69.4	72.9	51.3	48.6	69.6	73.9
1760	60	42.8	41.3	57.4	61.9	46.4	44.9	62.1	66.9	50.4	48.8	67.2	72.3
	65	45.0	42.4	60.0	63.2	47.0	45.5	62.7	67.4	50.7	49.1	67.5	72.5
	70	48.9	46.2	64.9	68.1	49.0	46.4	64.9	68.5	51.4	49.7	68.1	73.1
	75	52.9	49.8	69.8	72.9	53.0	49.9	69.9	73.0	53.0	50.1	69.8	73.6
1920	60	43.6	42.3	57.2	61.3	47.1	45.7	61.7	66.2	50.9	49.6	66.5	71.4
	65	46.3	43.6	60.4	63.0	47.9	46.4	62.4	66.8	51.5	50.0	67.0	71.7
	70	50.4	47.7	65.3	68.2	50.4	47.7	65.3	68.2	52.2	50.7	67.7	72.3
	75	54.4	51.4	70.2	73.0	54.5	51.5	70.3	73.1	54.6	51.7	70.4	73.5
<b>Ambient DB 70°F</b>													
1200	60	38.7	36.7	58.9	65.1	42.5	40.5	64.3	70.8	46.7	44.7	70.1	77.0
	65	38.8	37.1	59.2	65.5	42.9	40.8	64.6	71.0	46.8	44.7	70.2	77.0
	70	42.0	39.0	63.4	68.2	43.1	41.2	64.9	71.4	47.1	45.0	70.4	77.2
	75	45.6	42.3	68.2	72.9	45.7	42.3	68.3	73.0	47.6	45.4	70.9	77.6
1400	60	40.5	38.8	58.3	63.7	44.2	42.5	63.5	69.2	48.4	46.6	69.0	75.1
	65	41.3	39.2	59.3	64.2	44.8	43.0	63.9	69.5	48.6	46.7	69.1	75.1
	70	45.1	42.1	64.2	68.2	45.5	43.3	64.8	70.0	49.1	47.2	69.5	75.5
	75	48.9	45.6	69.1	73.0	49.0	45.7	69.2	73.1	49.6	47.6	70.1	75.9



## Reheat Temperature Rise

**Table 59. Reheat temperature rise - 4 tons, standard efficiency (continued)**

Airflow (cfm)	Ent DB (°F)	Entering Wet Bulb (°F)											
		51				55				59			
		Lvg Evap DB (°F)		Lvg Reheat DB (°F)		Lvg Evap DB (°F)		Lvg Reheat DB (°F)		Lvg Evap DB (°F)		Lvg Reheat DB (°F)	
		MIN	MAX	MIN	MAX	MIN	MAX	MIN	MAX	MIN	MAX	MIN	MAX
1600	60	42.0	40.4	57.9	62.7	45.6	44.0	62.8	67.9	49.7	48.0	68.0	73.5
	65	43.7	41.2	60.0	63.7	46.2	44.6	63.3	68.3	50.0	48.2	68.2	73.6
	70	47.6	44.7	64.8	68.3	47.3	45.2	64.6	69.0	50.6	48.8	68.8	74.1
	75	51.5	48.3	69.8	73.1	51.6	48.4	69.8	73.2	51.5	49.2	69.9	74.6
1760	60	43.0	41.5	57.6	62.0	46.5	45.0	62.3	67.0	50.5	48.9	67.4	72.4
	65	45.3	42.7	60.4	63.5	47.2	45.7	62.9	67.5	50.9	49.2	67.7	72.6
	70	49.2	46.4	65.3	68.4	49.3	46.6	65.4	68.6	51.6	49.9	68.3	73.2
	75	53.3	50.1	70.2	73.2	53.3	50.2	70.3	73.3	53.4	50.8	70.4	74.2
1920	60	43.8	42.4	57.4	61.4	47.3	45.9	61.9	66.3	51.1	49.7	66.7	71.5
	65	46.6	44.2	60.7	63.6	48.1	46.6	62.6	66.9	51.7	50.1	67.2	71.8
	70	50.7	48.0	65.7	68.4	50.8	47.9	65.7	68.3	52.4	50.8	67.9	72.4
	75	54.8	51.7	70.6	73.3	54.8	51.8	70.7	73.4	54.9	51.9	70.8	73.6

**Note:** MIN, MAX: The leaving evaporator temperature is affected by the modulating valve position. The MIN and MAX numbers represent modulating valve position impact on both the leaving evaporator temperature and the leaving reheat coil temperature. MAX represents wide open, MIN represents closed to minimum position.

**Table 60. Reheat temperature rise - 5 tons, standard efficiency**

Airflow (cfm)	Ent DB (°F)	Entering Wet Bulb (°F)											
		51				55				59			
		Lvg Evap DB (°F)		Lvg Reheat DB (°F)		Lvg Evap DB (°F)		Lvg Reheat DB (°F)		Lvg Evap DB (°F)		Lvg Reheat DB (°F)	
		MIN	MAX	MIN	MAX	MIN	MAX	MIN	MAX	MIN	MAX	MIN	MAX
<b>Ambient DB 60°F</b>													
1500	60	39.3	36.6	57.9	62.7	43.3	40.5	63.4	68.5	47.6	45.0	69.3	74.5
	65	39.9	36.7	58.5	62.8	43.5	40.7	63.5	68.5	47.6	44.9	69.2	74.4
	70	43.6	39.1	63.6	66.1	43.8	40.8	63.9	68.6	47.8	45.0	69.3	74.4
	75	47.3	42.5	68.5	70.8	47.4	42.6	68.6	70.9	48.1	45.1	69.6	74.5
1750	60	41.0	38.5	57.5	61.8	45.0	42.4	62.7	67.4	49.2	46.7	68.4	73.2
	65	42.8	38.9	59.6	62.2	45.2	42.6	62.9	67.5	49.2	46.7	68.3	73.2
	70	46.6	42.2	64.6	66.7	46.7	43.0	64.6	67.9	49.4	46.9	68.5	73.3
	75	50.3	45.7	69.5	71.4	50.4	45.8	69.6	71.5	50.5	47.2	69.7	73.6
2000	60	42.3	40.0	57.1	61.0	46.4	43.9	62.1	66.4	50.4	48.1	67.7	72.1
	65	45.0	41.2	60.3	62.3	46.6	44.2	62.4	66.6	50.6	48.1	67.6	72.1
	70	48.9	44.8	65.3	67.1	49.0	44.7	65.4	67.1	50.8	48.4	67.9	72.2
	75	52.7	48.4	70.3	71.9	52.8	48.5	70.4	72.0	52.9	48.9	70.5	72.7
2200	60	43.3	41.0	56.9	60.4	47.3	44.9	61.7	65.7	51.0	49.0	67.0	71.4
	65	46.5	42.8	60.8	62.5	47.5	45.2	62.2	65.9	51.5	49.1	67.1	71.3
	70	50.5	46.5	65.8	67.4	50.5	46.6	65.8	67.5	51.7	49.4	67.5	71.5
	75	54.4	50.2	70.8	72.2	54.5	50.3	70.8	72.3	54.5	50.2	70.9	72.4
2400	60	44.1	41.9	56.7	60.0	48.0	45.9	61.4	65.0	51.7	49.8	66.5	70.6
	65	47.8	44.2	61.2	62.7	48.3	46.1	61.9	65.4	52.2	50.1	66.7	70.6
	70	51.8	48.0	66.2	67.6	51.9	48.1	66.2	67.7	52.5	50.3	67.2	70.9
	75	55.8	51.8	71.2	72.5	55.9	51.9	71.2	72.6	56.0	51.9	71.3	72.7
<b>Ambient DB 65°F</b>													

**Table 60. Reheat temperature rise - 5 tons, standard efficiency (continued)**

Airflow (cfm)	Ent DB (°F)	Entering Wet Bulb (°F)											
		51				55				59			
		Lvg Evap DB (°F)		Lvg Reheat DB (°F)		Lvg Evap DB (°F)		Lvg Reheat DB (°F)		Lvg Evap DB (°F)		Lvg Reheat DB (°F)	
		MIN	MAX	MIN	MAX	MIN	MAX	MIN	MAX	MIN	MAX	MIN	MAX
1500	60	39.6	36.8	58.4	63.1	43.6	40.8	63.9	69.0	47.9	45.2	69.8	75.0
	65	40.4	37.0	59.5	63.3	43.8	40.9	64.0	69.0	47.8	45.1	69.7	74.9
	70	44.1	39.5	64.4	66.8	44.4	41.0	64.5	69.1	48.0	45.2	69.8	74.9
	75	47.7	42.9	69.3	71.5	47.8	43.0	69.4	71.6	48.3	45.3	70.2	75.0
1750	60	41.3	38.7	57.9	62.1	45.2	42.6	63.1	67.8	49.4	46.9	68.9	73.7
	65	43.2	39.1	60.3	62.6	45.4	42.8	63.3	67.9	49.4	46.9	68.7	73.6
	70	47.0	42.6	65.3	67.2	47.1	43.2	65.3	68.3	49.7	47.1	69.0	73.7
	75	50.7	46.1	70.2	72.1	50.8	46.2	70.3	72.2	50.9	47.4	70.4	74.0
2000	60	42.6	40.2	57.5	61.3	46.6	44.1	62.5	66.7	50.6	48.3	68.0	72.5
	65	45.4	41.5	60.9	62.8	46.8	44.4	62.8	66.9	50.8	48.3	68.0	72.4
	70	49.3	45.1	65.9	67.6	49.4	45.0	66.0	67.6	51.0	48.6	68.3	72.6
	75	53.1	48.7	70.9	72.5	53.2	48.8	71.0	72.6	53.3	49.1	71.1	73.1
2200	60	43.5	41.2	57.3	60.7	47.5	45.1	62.0	66.0	51.2	49.2	67.3	71.7
	65	46.9	43.1	61.3	63.0	47.7	45.4	62.5	66.2	51.7	49.3	67.5	71.6
	70	50.8	46.8	66.3	67.9	50.9	46.9	66.4	67.9	51.9	49.6	67.9	71.8
	75	54.8	50.5	71.4	72.8	54.8	50.6	71.4	72.8	54.9	50.6	71.5	72.9
2400	60	44.3	42.1	57.1	60.2	48.2	46.0	61.7	65.3	51.8	49.9	66.8	70.9
	65	48.1	44.5	61.7	63.1	48.5	46.3	62.2	65.6	52.4	50.2	67.0	70.9
	70	52.1	48.3	66.7	68.1	52.2	48.4	66.8	68.2	52.7	50.4	67.5	71.2
	75	56.2	52.0	71.7	73.0	56.2	52.1	71.8	73.1	56.3	52.2	71.9	73.2
<b>Ambient DB 70°F</b>													
1500	60	39.9	37.1	58.9	63.5	43.9	41.0	64.4	69.4	48.1	45.4	70.4	75.6
	65	40.9	37.3	60.2	63.8	44.1	41.2	64.5	69.4	48.1	45.3	70.2	75.4
	70	44.6	39.9	65.2	67.4	44.6	41.3	65.1	69.6	48.3	45.4	70.3	75.5
	75	48.2	43.3	70.1	72.2	48.3	43.4	70.2	72.3	48.6	45.6	70.7	75.6
1750	60	41.5	38.9	58.3	62.5	45.5	42.8	63.5	68.1	49.6	47.1	69.3	74.1
	65	43.6	39.3	61.0	63.0	45.7	43.1	63.8	68.2	49.7	47.0	69.2	74.0
	70	47.4	42.9	65.9	67.8	47.5	43.4	66.0	68.7	49.9	47.3	69.4	74.1
	75	51.2	46.4	70.9	72.7	51.2	46.5	71.0	72.8	51.3	47.6	71.1	74.5
2000	60	42.8	40.4	57.8	61.6	46.9	44.3	62.8	67.0	50.8	48.4	68.4	72.9
	65	45.8	41.8	61.5	63.2	47.0	44.6	63.2	67.2	51.0	48.5	68.3	72.8
	70	49.7	45.4	66.5	68.1	49.7	45.4	66.6	68.0	51.2	48.7	68.7	72.9
	75	53.5	49.0	71.6	73.0	53.6	49.1	71.6	73.1	53.7	49.3	71.7	73.5
2200	60	43.8	41.4	57.6	61.0	47.7	45.2	62.4	66.2	51.4	49.3	67.7	72.0
	65	47.2	43.4	61.9	63.4	47.9	45.5	62.9	66.5	51.9	49.4	67.8	71.9
	70	51.2	47.1	66.9	68.3	51.2	47.2	67.0	68.4	52.1	49.7	68.2	72.1
	75	55.1	50.8	71.9	73.3	55.2	50.9	72.0	73.4	55.3	50.9	72.1	73.4
2400	60	44.5	42.3	57.4	60.5	48.4	46.2	62.0	65.6	52.0	50.1	67.1	71.2
	65	48.5	44.8	62.2	63.6	48.7	46.4	62.6	65.9	52.6	50.4	67.3	71.2
	70	52.5	48.6	67.2	68.5	52.5	48.6	67.3	68.6	52.9	50.6	67.8	71.5
	75	56.5	52.3	72.2	73.5	56.6	52.4	72.3	73.5	56.6	52.5	72.4	73.6

**Note:** MIN, MAX: The leaving evaporator temperature is affected by the modulating valve position. The MIN and MAX numbers represent modulating valve position impact on both the leaving evaporator temperature and the leaving reheat coil temperature. MAX represents wide open, MIN represents closed to minimum position.



## Reheat Temperature Rise

**Table 61. Reheat temperature rise - 6 tons, standard/high efficiency**

Air-flow (cfm)	Ent DB (°F)	Entering Wet Bulb (°F)											
		51				55				59			
		Lvg Evap DB (°F)		Lvg Reheat DB (°F)		Lvg Evap DB (°F)		Lvg Reheat DB (°F)		Lvg Evap DB (°F)		Lvg Reheat DB (°F)	
		MIN	MAX	MIN	MAX	MIN	MAX	MIN	MAX	MIN	MAX	MIN	MAX
<b>Ambient DB 60°F</b>													
1800	60	35.8	38.8	45.5	57.4	39.6	44.3	50.1	60.4	43.6	49.5	54.9	63.1
	65	36.0	39.2	45.7	57.5	39.7	44.4	50.1	60.4	43.6	49.8	54.8	63.4
	70	38.1	46.0	48.1	61.2	39.8	46.1	50.2	61.3	43.7	49.8	54.9	63.3
	75	41.1	52.4	51.7	64.5	41.2	52.5	51.8	64.6	43.8	52.6	54.9	64.7
2160	60	38.3	39.8	46.7	57.7	42.1	45.3	51.1	60.8	46.1	50.5	55.9	63.4
	65	38.7	41.9	47.1	58.7	42.3	45.5	51.3	60.8	46.2	50.8	55.8	63.7
	70	42.1	48.0	50.9	62.1	42.7	48.6	51.7	62.4	46.3	51.1	56.0	63.7
	75	45.3	55.4	54.6	65.7	45.4	55.5	54.7	65.8	46.6	55.6	56.3	65.9
2400	60	39.6	40.4	47.3	57.8	43.4	45.9	51.7	60.9	47.4	51.0	56.4	63.5
	65	40.8	43.1	48.5	59.2	43.6	46.0	51.9	60.9	47.5	51.4	56.3	63.8
	70	44.2	49.9	52.4	62.9	44.1	50.0	52.4	63.0	47.6	51.7	56.5	63.9
	75	47.5	57.0	56.2	66.4	47.6	57.1	56.2	66.4	48.1	57.1	56.9	66.5
2640	60	40.7	40.9	47.8	57.9	44.5	46.3	52.1	61.0	48.4	51.4	56.8	63.5
	65	42.5	44.3	49.7	59.6	44.7	46.7	52.4	61.1	48.6	51.9	56.7	63.9
	70	46.0	51.2	53.7	63.4	46.1	51.3	53.7	63.4	48.7	52.3	56.9	64.0
	75	49.4	58.5	57.5	67.0	49.5	58.6	57.6	67.0	49.4	58.7	57.5	67.1
2880	60	41.6	41.5	48.2	57.9	45.4	46.8	52.5	61.0	49.3	52.3	57.1	63.6
	65	44.0	45.4	50.8	60.0	45.6	47.2	52.7	61.2	49.5	52.4	57.1	63.9
	70	47.6	52.4	54.8	63.8	47.7	52.5	54.8	63.9	49.7	52.8	57.3	64.0
	75	51.1	59.8	58.7	67.5	51.2	59.9	58.7	67.5	51.3	60.0	58.8	67.6
<b>Ambient DB 65°F</b>													
1800	60	36.3	37.5	46.2	59.0	40.2	43.2	50.8	62.2	44.2	48.5	55.8	65.1
	65	36.6	37.9	46.4	59.2	40.3	43.3	50.9	62.2	44.2	48.7	55.6	65.2
	70	39.0	43.5	49.2	62.2	40.4	43.6	51.0	62.3	44.3	48.8	55.7	65.2
	75	42.1	49.8	52.9	65.7	42.2	49.9	53.0	65.7	44.4	50.1	55.8	65.8
2160	60	38.8	38.6	47.3	59.3	42.7	44.1	51.8	62.5	46.7	49.4	56.7	65.3
	65	39.3	39.1	47.8	59.5	42.8	44.3	52.0	62.5	46.7	49.7	56.5	65.6
	70	43.0	45.8	52.0	63.3	43.3	45.9	52.4	63.3	46.9	49.9	56.8	65.6
	75	46.3	52.5	55.8	66.8	46.4	52.6	55.9	66.9	47.3	52.8	57.1	66.9
2400	60	40.1	39.2	47.9	59.3	43.9	44.7	52.3	62.6	47.9	49.9	57.2	65.4
	65	41.6	39.9	49.4	59.6	44.1	44.9	52.6	62.7	48.0	50.3	57.0	65.7
	70	45.1	47.1	53.5	63.8	44.7	47.3	53.1	63.9	48.2	50.4	57.2	65.7
	75	48.5	54.1	57.4	67.4	48.6	54.2	57.5	67.5	48.7	54.3	57.8	67.5
2640	60	41.1	39.8	48.4	59.4	45.0	45.2	52.7	62.7	49.0	50.4	57.5	65.5
	65	43.3	41.9	50.6	60.5	45.2	45.4	53.0	62.7	49.1	50.7	57.4	65.8
	70	46.9	48.3	54.7	64.2	47.0	48.5	54.8	64.3	49.3	51.1	57.6	65.9
	75	50.4	55.5	58.7	67.9	50.5	55.6	58.8	68.0	50.6	55.7	58.9	68.0
2880	60	42.2	40.4	48.8	59.4	45.9	45.6	53.1	62.7	49.8	50.8	57.8	65.5
	65	44.8	42.9	51.7	60.8	46.2	45.9	53.4	62.7	50.0	51.2	57.7	65.8
	70	48.5	49.4	55.8	64.6	48.6	49.6	55.9	64.7	50.2	51.6	57.9	65.9
	75	52.1	56.7	59.9	68.4	52.2	56.8	59.9	68.4	52.2	56.9	60.0	68.5
<b>Ambient DB 70°F</b>													

**Table 61. Reheat temperature rise - 6 tons, standard/high efficiency (continued)**

Air-flow (cfm)	Ent DB (°F)	Entering Wet Bulb (°F)											
		51				55				59			
		Lvg Evap DB (°F)		Lvg Reheat DB (°F)		Lvg Evap DB (°F)		Lvg Reheat DB (°F)		Lvg Evap DB (°F)		Lvg Reheat DB (°F)	
		MIN	MAX	MIN	MAX	MIN	MAX	MIN	MAX	MIN	MAX	MIN	MAX
1800	60	36.9	36.3	47.0	60.6	40.8	42.1	51.5	63.9	44.9	47.6	56.7	66.9
	65	37.2	36.6	47.2	60.7	40.9	42.1	51.7	64.0	44.9	47.7	56.4	67.1
	70	39.9	41.0	50.4	63.2	41.2	42.5	52.0	64.1	45.0	47.8	56.6	67.1
	75	43.2	47.4	54.2	66.7	43.3	47.5	54.3	66.8	45.1	48.1	56.7	67.2
2160	60	39.3	37.5	48.0	60.9	43.2	43.0	52.5	64.2	47.3	48.4	57.6	67.2
	65	40.4	37.9	49.1	61.2	43.4	43.1	52.8	64.3	47.3	48.7	57.3	67.4
	70	43.9	43.2	53.2	64.2	43.9	43.6	53.3	64.5	47.5	48.8	57.6	67.4
	75	47.3	49.8	57.2	67.8	47.4	49.9	57.3	67.9	48.0	49.3	58.0	67.6
2400	60	40.6	38.4	48.5	60.7	44.5	43.6	53.0	64.3	48.5	48.9	58.0	67.3
	65	42.4	38.9	50.5	61.1	44.7	43.8	53.3	64.4	48.6	49.2	57.8	67.5
	70	46.0	44.6	54.6	64.7	46.1	44.4	54.7	64.6	48.8	49.4	58.0	67.6
	75	49.6	51.2	58.7	68.4	49.7	51.3	58.8	68.5	49.4	51.4	58.6	68.5
2640	60	41.6	39.3	49.0	60.3	45.5	44.1	53.3	64.4	49.5	49.4	58.3	67.4
	65	44.1	40.0	51.6	60.8	45.7	44.3	53.6	64.5	49.6	49.7	58.1	67.6
	70	47.8	45.7	55.9	65.1	47.9	45.0	55.9	64.8	49.9	49.9	58.4	67.6
	75	51.5	52.4	60.0	68.9	51.6	52.6	60.1	69.0	51.6	52.7	60.2	69.0
2880	60	42.6	40.2	49.4	59.9	46.3	44.6	53.6	64.4	50.4	49.7	58.5	67.4
	65	45.6	41.9	52.6	61.4	46.8	44.8	54.1	64.5	50.5	50.1	58.4	67.6
	70	49.4	46.8	56.9	65.5	49.5	46.9	57.0	65.6	50.9	50.5	58.8	67.7
	75	53.1	53.7	61.2	69.3	53.2	53.8	61.2	69.4	53.3	53.9	61.3	69.4

**Note:** MIN, MAX: The leaving evaporator temperature is affected by the modulating valve position. The MIN and MAX numbers represent modulating valve position impact on both the leaving evaporator temperature and the leaving reheat coil temperature. MAX represents wide open, MIN represents closed to minimum position.

**Table 62. Reheat temperature rise - 7.5 tons, standard/high efficiency**

Air-flow (cfm)	Ent DB (°F)	Entering Wet Bulb (°F)											
		51				55				59			
		Lvg Evap DB (°F)		Lvg Reheat DB (°F)		Lvg Evap DB (°F)		Lvg Reheat DB (°F)		Lvg Evap DB (°F)		Lvg Reheat DB (°F)	
		MIN	MAX	MIN	MAX	MIN	MAX	MIN	MAX	MIN	MAX	MIN	MAX
<b>Ambient DB 60°F</b>													
2250	60	36.8	38.8	46.4	57.9	40.7	44.5	51.1	60.7	44.7	49.9	55.9	63.3
	65	37.0	39.2	46.6	58.1	40.7	44.6	51.1	60.7	44.7	50.0	55.9	63.4
	70	39.7	46.8	49.6	61.7	40.8	46.9	51.1	61.8	44.8	50.1	55.9	63.4
	75	42.8	55.2	53.3	65.7	42.9	53.7	53.4	65.1	44.9	53.8	55.9	65.2
2700	60	39.1	39.8	47.5	58.1	43.0	45.4	52.1	60.9	47.1	50.8	56.8	63.5
	65	40.1	42.2	48.4	59.2	43.2	45.6	52.1	61.0	47.1	51.0	56.8	63.6
	70	43.5	49.3	52.3	62.7	43.6	49.5	52.5	62.8	47.2	51.4	56.8	63.8
	75	46.9	56.5	56.2	66.2	46.9	56.6	56.2	66.3	47.6	45.5	57.2	72.5
3000	60	40.3	40.4	48.0	58.1	44.3	46.0	52.6	60.9	48.3	51.3	57.2	63.6
	65	42.1	43.5	49.7	59.7	44.4	46.2	52.6	61.0	48.4	51.5	57.3	63.7
	70	45.6	50.8	53.8	63.3	45.7	50.9	53.8	63.3	48.5	52.0	57.3	63.9
	75	49.0	58.2	57.7	66.9	49.1	58.3	57.8	66.9	49.1	58.4	57.8	67.0



# Reheat Temperature Rise

**Table 62. Reheat temperature rise - 7.5 tons, standard/high efficiency (continued)**

Air-flow (cfm)	Ent DB (°F)	Entering Wet Bulb (°F)											
		51				55				59			
		Lvg Evap DB (°F)		Lvg Reheat DB (°F)		Lvg Evap DB (°F)		Lvg Reheat DB (°F)		Lvg Evap DB (°F)		Lvg Reheat DB (°F)	
		MIN	MAX	MIN	MAX	MIN	MAX	MIN	MAX	MIN	MAX	MIN	MAX
3300	60	41.3	41.0	48.4	58.1	45.3	46.5	53.0	60.9	49.3	51.8	57.6	63.6
	65	43.7	44.8	50.9	60.0	45.4	46.9	53.0	61.2	49.4	52.0	57.6	63.7
	70	47.4	52.1	55.0	63.7	47.4	52.2	55.1	63.8	49.5	52.6	57.6	64.0
	75	50.9	59.6	59.0	67.4	51.0	59.6	59.1	67.4	51.1	59.7	59.1	67.5
3600	60	42.4	41.6	48.9	58.0	46.1	46.9	53.3	60.9	50.1	52.1	57.8	63.6
	65	45.2	45.9	51.9	60.3	46.5	47.4	53.5	61.2	50.2	52.4	57.9	63.7
	70	48.9	53.3	56.1	64.1	49.0	53.4	56.1	64.1	50.6	53.1	58.0	64.0
	75	52.5	60.8	60.1	67.9	52.6	60.9	60.2	67.9	52.7	61.0	60.2	68.0
<b>Ambient DB 65°F</b>													
2250	60	37.3	37.5	47.1	59.6	41.3	43.3	51.9	62.6	45.3	48.9	56.7	65.3
	65	37.6	37.9	47.4	59.8	41.3	43.4	51.9	62.7	45.4	49.0	56.7	65.4
	70	40.6	43.9	50.7	62.9	41.6	43.8	52.0	62.9	45.4	49.1	56.7	65.4
	75	43.8	50.8	54.6	66.2	43.9	50.9	54.7	66.3	45.5	51.1	56.7	66.4
2700	60	39.6	38.7	48.1	59.7	43.6	44.2	52.8	62.8	47.6	49.8	57.6	65.5
	65	40.9	39.3	49.4	60.0	43.7	44.4	52.8	62.9	47.7	49.9	57.6	65.6
	70	44.4	46.3	53.4	63.8	44.2	46.5	53.3	63.8	47.8	50.1	57.6	65.7
	75	47.8	53.5	57.4	67.3	47.9	53.6	57.5	67.4	48.3	53.8	58.0	67.4
3000	60	40.8	39.3	48.6	59.8	44.8	44.8	53.2	62.8	48.8	50.3	58.0	65.6
	65	42.8	41.0	50.7	60.6	44.9	45.0	53.2	62.9	48.9	50.4	58.0	65.7
	70	46.5	47.8	54.9	64.2	46.5	47.9	54.9	64.3	49.0	50.8	58.0	65.9
	75	50.0	55.0	58.9	67.9	50.1	55.2	59.0	67.9	50.2	55.2	59.1	68.0
3300	60	41.8	40.0	48.9	59.7	45.7	45.3	53.6	62.8	49.8	50.7	58.2	65.6
	65	44.5	42.1	51.9	60.9	45.9	45.5	53.6	62.9	49.9	50.9	58.3	65.7
	70	48.2	49.0	56.1	64.6	48.3	49.2	56.1	64.7	50.0	51.4	58.3	65.9
	75	51.9	56.5	60.2	68.4	52.0	56.6	60.3	68.4	52.0	56.7	60.4	68.5
3600	60	42.8	40.7	49.4	59.4	46.6	45.8	53.8	62.7	50.6	51.1	58.5	65.5
	65	46.0	43.3	52.8	61.3	46.9	46.2	54.1	62.9	50.7	51.3	58.5	65.7
	70	49.8	50.2	57.1	65.0	49.8	50.3	57.2	65.0	51.1	51.9	58.7	65.9
	75	53.5	57.6	61.3	68.8	53.6	57.7	61.4	68.9	53.7	57.9	61.5	68.9
<b>Ambient DB 70°F</b>													
2250	60	37.9	36.4	47.8	61.3	41.9	42.1	52.7	64.5	46.0	47.9	57.7	67.4
	65	38.2	36.8	48.2	61.4	42.0	42.2	52.7	64.6	46.0	47.9	57.7	67.4
	70	41.5	41.2	52.0	64.0	42.2	42.6	52.9	64.7	46.1	48.0	57.7	67.5
	75	44.9	48.0	56.0	67.4	45.0	48.2	56.1	67.5	46.2	48.5	57.6	67.7
2700	60	40.1	37.7	48.8	61.2	44.2	43.1	53.5	64.6	48.3	48.7	58.4	67.5
	65	41.7	38.2	50.4	61.5	44.3	43.3	53.5	64.7	48.3	48.9	58.4	67.6
	70	45.4	43.6	54.6	64.8	45.4	43.9	54.7	65.0	48.4	49.0	58.4	67.7
	75	48.9	50.6	58.8	68.4	49.0	50.7	58.9	68.4	49.0	50.8	58.9	68.5
3000	60	41.3	38.8	49.2	60.8	45.3	43.6	53.9	64.7	49.4	49.2	58.7	67.6
	65	43.7	39.4	51.8	61.2	45.4	43.8	53.9	64.8	49.5	49.4	58.8	67.7
	70	47.4	44.9	56.1	65.3	47.5	44.5	56.1	65.1	49.6	49.6	58.7	67.7
	75	51.1	52.1	60.3	68.9	51.2	52.2	60.4	69.0	51.3	52.3	60.5	69.1

**Table 62. Reheat temperature rise - 7.5 tons, standard/high efficiency (continued)**

Air-flow (cfm)	Ent DB (°F)	Entering Wet Bulb (°F)											
		51				55				59			
		Lvg Evap DB (°F)		Lvg Reheat DB (°F)		Lvg Evap DB (°F)		Lvg Reheat DB (°F)		Lvg Evap DB (°F)		Lvg Reheat DB (°F)	
		MIN	MAX	MIN	MAX	MIN	MAX	MIN	MAX	MIN	MAX	MIN	MAX
3300	60	42.4	39.8	49.7	60.3	46.3	44.2	54.2	64.7	50.4	49.6	59.0	67.6
	65	45.3	41.3	52.9	61.6	46.5	44.4	54.4	64.8	50.5	49.8	59.0	67.7
	70	49.2	46.1	57.3	65.6	49.3	46.3	57.3	65.7	50.7	50.1	59.1	67.8
	75	53.0	53.3	61.6	69.3	53.1	53.4	61.6	69.4	53.1	53.6	61.7	69.5
3600	60	43.3	40.7	50.0	59.9	47.1	44.7	54.5	64.5	51.1	50.0	59.2	67.6
	65	46.8	42.7	53.9	61.8	47.5	45.0	54.7	64.6	51.3	50.2	59.2	67.7
	70	50.7	47.3	58.3	66.0	50.8	47.4	58.4	66.0	51.7	50.7	59.5	67.9
	75	54.6	54.4	62.7	69.7	54.7	54.5	62.7	69.8	54.7	54.6	62.8	69.9

Note: MIN, MAX: The leaving evaporator temperature is affected by the modulating valve position. The MIN and MAX numbers represent modulating valve position impact on both the leaving evaporator temperature and the leaving reheat coil temperature. MAX represents wide open, MIN represents closed to minimum position.

**Table 63. Reheat temperature rise - 8.5 tons, standard/high efficiency**

Air-flow (cfm)	Ent DB (°F)	Entering Wet Bulb (°F)											
		51				55				59			
		Lvg Evap DB (°F)		Lvg Reheat DB (°F)		Lvg Evap DB (°F)		Lvg Reheat DB (°F)		Lvg Evap DB (°F)		Lvg Reheat DB (°F)	
		MIN	MAX	MIN	MAX	MIN	MAX	MIN	MAX	MIN	MAX	MIN	MAX
Ambient DB 60°F													
2550	60	34.1	34.7	42.7	57.2	37.9	40.4	47.1	60.1	41.8	45.9	51.7	63.0
	65	34.3	34.9	42.8	57.2	38.1	40.6	47.2	60.2	41.9	46.0	51.7	63.1
	70	35.9	38.0	44.4	58.8	38.2	40.7	47.3	60.2	42.0	46.1	51.8	63.1
	75	38.8	43.8	47.8	61.9	38.8	43.8	47.8	61.9	42.2	46.5	52.0	63.3
3060	60	36.7	36.6	44.1	57.2	40.5	41.8	48.4	60.6	44.3	47.2	52.9	63.5
	65	37.2	37.1	44.6	57.5	40.7	42.1	48.6	60.7	44.5	47.4	53.0	63.6
	70	39.8	41.1	47.3	60.1	41.1	42.7	49.0	60.9	44.7	47.7	53.1	63.7
	75	42.1	47.2	49.2	63.3	42.3	47.3	49.3	63.4	44.9	48.3	53.3	63.9
3400	60	38.1	37.8	44.9	57.0	41.8	42.6	49.1	60.8	45.6	48.0	53.5	63.7
	65	38.7	38.4	45.4	57.4	42.0	42.9	49.3	60.9	45.8	48.2	53.6	63.8
	70	41.2	42.9	47.2	60.7	41.9	43.7	47.6	61.2	46.1	48.5	53.8	63.9
	75	44.0	49.1	50.0	64.1	44.2	49.2	50.1	64.1	46.6	49.3	54.3	64.2
3740	60	39.2	38.9	45.5	56.8	42.9	43.3	49.7	60.9	46.7	48.6	54.0	63.8
	65	39.6	39.7	44.2	57.3	43.2	43.7	49.9	61.0	47.0	48.9	54.2	63.9
	70	39.0	40.7	46.0	59.6	39.0	40.7	46.0	59.6	47.2	49.2	54.4	64.0
	75	41.6	46.7	49.1	63.1	41.6	46.7	49.1	63.1	47.9	51.0	55.0	64.9
4080	60	39.9	39.8	43.8	56.5	43.9	44.0	50.1	61.0	47.0	49.2	53.9	63.9
	65	41.3	41.4	44.6	57.8	44.2	44.3	50.4	61.1	47.4	49.5	54.1	64.0
	70	39.0	40.7	46.0	59.6	39.0	40.7	46.0	59.6	47.5	49.8	54.3	64.2
	75	41.6	46.7	49.1	63.1	41.6	46.7	49.1	63.1	45.4	48.2	53.6	63.5
Ambient DB 65°F													
2550	60	34.4	34.1	43.0	58.2	38.2	39.2	47.4	62.2	42.1	44.8	52.0	65.2
	65	34.6	34.3	43.1	58.3	38.4	39.3	47.5	62.3	42.2	44.9	52.1	65.2
	70	36.3	36.0	44.9	59.9	38.5	39.3	47.7	61.3	42.3	45.1	52.2	65.3
	75	39.2	41.4	48.3	63.2	39.1	41.5	48.2	63.3	42.5	45.2	52.3	65.3



## Reheat Temperature Rise

**Table 63. Reheat temperature rise - 8.5 tons, standard/high efficiency (continued)**

Air-flow (cfm)	Ent DB (°F)	Entering Wet Bulb (°F)											
		51				55				59			
		Lvg Evap DB (°F)		Lvg Reheat DB (°F)		Lvg Evap DB (°F)		Lvg Reheat DB (°F)		Lvg Evap DB (°F)		Lvg Reheat DB (°F)	
		MIN	MAX	MIN	MAX	MIN	MAX	MIN	MAX	MIN	MAX	MIN	MAX
3060	60	37.0	36.4	44.4	57.7	40.7	40.7	48.7	62.5	44.6	46.1	53.2	65.6
	65	37.5	37.0	44.8	58.0	40.9	40.9	48.9	62.6	44.7	46.3	53.3	65.7
	70	40.1	39.6	47.7	60.9	41.4	42.2	49.2	62.8	44.9	46.5	53.4	65.8
	75	45.4	48.2	53.6	63.5	38.6	41.1	47.9	63.1	45.2	47.1	53.6	66.0
3400	60	38.3	37.8	45.1	57.3	42.0	41.7	49.3	62.2	45.9	46.9	53.7	65.8
	65	39.0	38.4	45.7	57.8	42.3	42.0	49.5	62.4	47.1	47.1	53.0	65.9
	70	45.0	47.3	53.3	63.2	41.8	42.6	49.1	62.7	46.3	47.3	54.1	66.0
	75	45.4	48.2	53.6	63.5	38.6	41.1	47.9	63.1	46.8	49.3	54.5	69.7
3740	60	39.4	38.9	45.7	57.0	43.1	42.7	49.9	61.9	47.0	47.5	54.2	65.9
	65	37.6	39.7	47.6	57.6	43.4	43.0	50.1	62.1	47.2	47.7	54.4	66.0
	70	41.1	43.4	52.0	61.9	43.0	43.8	49.0	62.6	47.5	48.1	54.6	66.1
	75	45.4	48.2	53.6	63.5	38.6	41.1	47.9	63.1	48.1	50.6	55.2	70.4
4080	60	40.4	39.9	46.2	56.7	44.1	43.6	50.3	61.6	48.1	48.0	53.0	65.9
	65	39.4	41.4	48.1	58.0	44.4	44.0	50.6	61.8	48.1	48.3	54.8	66.0
	70	42.7	45.0	52.4	62.3	44.1	44.9	48.8	62.4	47.9	48.7	52.6	66.2
	75	45.4	48.2	53.6	63.5	38.6	41.1	47.9	63.1	47.2	49.7	51.4	66.6
<b>Ambient DB 70°F</b>													
2550	60	34.7	34.0	43.3	58.7	38.5	38.3	47.8	63.7	42.4	43.7	52.3	67.3
	65	34.9	34.2	43.5	58.7	38.6	38.4	47.9	63.8	42.5	43.8	52.4	67.4
	70	36.7	35.8	45.3	60.3	38.8	38.6	48.0	63.8	42.6	43.9	52.5	67.4
	75	39.7	39.4	48.7	64.3	39.4	39.2	48.5	64.2	42.8	44.1	52.6	67.5
3060	60	37.2	36.5	44.7	58.0	41.0	40.4	49.0	63.1	44.8	45.0	53.4	67.7
	65	37.8	37.0	45.1	58.3	41.2	40.6	49.1	63.2	45.0	45.1	53.5	67.8
	70	40.5	39.6	48.1	61.2	41.6	41.1	49.5	63.5	45.2	45.4	53.7	67.9
	75	43.6	43.1	51.6	65.4	43.8	43.1	51.8	64.5	45.4	45.6	53.9	67.9
3400	60	38.6	37.9	45.3	57.6	42.2	41.6	49.6	62.6	46.1	45.9	54.0	67.5
	65	39.2	38.5	45.9	58.0	42.5	41.9	49.8	62.8	46.3	46.1	54.1	67.6
	70	42.6	41.7	49.6	61.7	43.1	42.5	50.3	63.2	46.5	46.3	54.3	67.7
	75	45.8	45.2	53.2	66.0	45.9	45.3	53.3	66.1	47.1	46.9	54.8	68.1
3740	60	39.7	39.0	45.9	57.2	43.4	42.7	50.1	62.2	47.2	46.8	54.5	67.2
	65	41.0	39.8	47.2	57.7	43.6	43.0	50.4	62.3	47.4	47.0	54.6	67.3
	70	44.4	43.5	50.9	62.2	44.4	43.8	51.0	62.9	47.7	47.3	54.9	67.4
	75	47.7	47.0	53.7	66.5	47.8	47.1	53.8	66.6	48.4	48.0	55.5	67.9
4080	60	40.6	40.0	46.4	56.9	44.3	43.7	50.6	61.8	48.1	47.6	54.9	66.8
	65	42.5	41.6	48.3	58.2	44.6	44.0	50.8	62.0	48.3	47.9	55.1	66.9
	70	40.6	39.7	48.8	60.5	45.8	44.9	50.9	62.6	48.7	48.2	55.3	67.1
	75	49.3	48.6	54.2	66.9	49.4	48.7	54.3	67.0	49.5	49.1	56.1	67.6

**Note:** MIN, MAX: The leaving evaporator temperature is affected by the modulating valve position. The MIN and MAX numbers represent modulating valve position impact on both the leaving evaporator temperature and the leaving reheat coil temperature. MAX represents wide open, MIN represents closed to minimum position.

### Reheat Temperature Rise

**Table 64. Reheat temperature rise - 10 tons, standard/high efficiency**

Air-flow (cfm)	Ent DB (°F)	Entering Wet Bulb (°F)											
		51				55				59			
		Lvg Evap DB (°F)		Lvg Reheat DB (°F)		Lvg Evap DB (°F)		Lvg Reheat DB (°F)		Lvg Evap DB (°F)		Lvg Reheat DB (°F)	
		MIN	MAX	MIN	MAX	MIN	MAX	MIN	MAX	MIN	MAX	MIN	MAX
<b>Ambient DB 60°F</b>													
3000	60	36.7	35.5	46.3	56.7	40.7	41.0	51.1	59.7	44.7	46.4	55.9	62.7
	65	37.1	35.8	46.5	56.8	40.8	41.1	51.1	59.8	44.8	46.6	55.9	62.8
	70	39.7	39.3	49.5	58.7	40.9	41.3	51.1	59.9	44.9	46.8	56.0	62.8
	75	43.0	46.1	53.3	62.1	43.1	46.2	53.4	62.2	45.1	47.2	56.0	63.0
3600	60	39.2	37.3	47.5	57.1	43.1	42.5	52.1	60.2	47.2	47.8	56.9	63.1
	65	39.8	38.0	48.0	57.4	43.3	42.8	52.2	60.3	47.3	47.9	56.9	63.2
	70	43.6	42.7	52.3	60.0	43.8	43.0	52.7	60.6	47.4	48.3	57.0	63.3
	75	47.1	50.2	56.2	65.0	47.1	48.7	56.3	63.4	47.9	49.0	57.3	63.6
4000	60	40.4	38.4	48.0	57.0	44.3	43.3	52.6	60.3	48.4	48.6	57.3	63.3
	65	42.1	39.2	49.7	57.5	44.5	43.7	52.7	60.4	48.5	49.2	57.4	63.7
	70	45.7	44.5	53.8	60.7	45.8	44.9	53.9	61.8	48.7	49.1	57.5	63.5
	75	49.3	52.4	57.8	66.6	49.3	52.4	57.9	66.7	49.4	50.8	58.0	64.3
4400	60	41.4	39.4	48.4	56.9	45.4	44.1	53.1	60.4	49.4	49.2	57.7	63.4
	65	43.8	40.3	50.9	57.4	45.6	44.4	53.1	60.5	49.6	50.2	57.8	64.1
	70	47.5	46.7	55.1	63.0	47.6	46.7	55.1	63.1	49.7	49.8	57.8	63.6
	75	51.2	54.3	59.1	67.9	51.2	52.3	59.2	64.9	51.3	52.6	59.3	65.4
4800	60	42.5	40.4	49.0	56.7	46.2	44.7	53.4	60.4	50.2	49.7	58.0	63.5
	65	45.3	42.3	51.9	58.2	46.6	44.1	53.6	61.6	50.4	51.1	58.1	64.4
	70	49.1	48.2	56.2	64.1	49.1	48.3	56.2	64.2	50.8	50.5	58.2	63.7
	75	52.8	55.9	60.3	69.1	52.9	53.8	60.4	65.5	52.9	53.9	60.5	65.5
<b>Ambient DB 65°F</b>													
3000	60	37.4	34.8	47.1	58.3	41.4	39.9	52.0	61.8	45.5	45.4	56.9	64.8
	65	37.7	35.0	47.4	58.4	41.5	40.1	52.0	61.8	45.6	45.6	57.0	64.9
	70	40.7	37.5	50.8	60.2	41.8	40.3	52.2	61.9	45.7	45.7	57.0	64.9
	75	44.1	41.4	54.8	60.0	44.2	43.1	54.9	63.3	45.8	45.9	57.0	65.0
3600	60	39.7	37.1	48.2	58.0	43.7	41.5	53.0	62.1	47.8	46.8	57.8	65.2
	65	41.0	37.6	49.4	58.3	43.9	41.8	53.0	62.2	47.9	47.0	57.8	65.3
	70	44.6	40.9	53.6	61.3	44.5	42.3	53.6	62.5	48.1	47.2	57.9	65.4
	75	48.2	45.5	57.7	62.9	48.3	45.6	57.8	63.0	48.6	47.9	58.3	65.6
4000	60	40.9	38.4	48.7	57.7	44.9	42.5	53.4	62.2	49.0	47.5	58.2	65.3
	65	43.0	39.1	50.8	58.2	45.1	42.8	53.5	62.3	49.1	47.9	58.3	65.5
	70	46.7	42.8	55.1	62.0	46.8	43.2	55.2	62.7	49.3	48.1	58.3	65.5
	75	50.4	47.7	59.3	64.5	50.5	48.2	59.3	65.4	50.5	48.9	59.4	65.9
4400	60	41.9	39.5	49.1	57.5	45.9	43.4	53.8	62.0	50.0	48.2	58.5	65.4
	65	44.7	40.4	52.0	58.0	46.1	43.7	53.8	62.2	50.1	48.8	58.6	65.9
	70	48.5	45.0	56.3	63.8	48.6	45.0	56.4	63.9	50.3	48.8	58.6	65.6
	75	52.3	49.8	60.6	65.9	52.3	49.9	60.6	66.0	52.4	49.8	60.7	66.0
4800	60	43.0	40.5	49.6	57.3	46.8	44.3	54.1	61.8	50.8	48.8	58.7	65.4
	65	46.1	42.6	53.0	61.9	47.2	44.6	54.3	61.9	51.0	49.1	58.8	65.5
	70	50.1	46.1	57.4	62.9	50.1	46.6	57.5	65.0	51.4	49.5	59.0	65.7
	75	53.9	51.2	61.7	66.9	53.9	51.3	61.7	67.0	54.0	51.5	61.8	66.6
<b>Ambient DB 70°F</b>													

## Reheat Temperature Rise

**Table 64. Reheat temperature rise - 10 tons, standard/high efficiency (continued)**

Air-flow (cfm)	Ent DB (°F)	Entering Wet Bulb (°F)											
		51				55				59			
		Lvg Evap DB (°F)		Lvg Reheat DB (°F)		Lvg Evap DB (°F)		Lvg Reheat DB (°F)		Lvg Evap DB (°F)		Lvg Reheat DB (°F)	
		MIN	MAX	MIN	MAX	MIN	MAX	MIN	MAX	MIN	MAX	MIN	MAX
3000	60	38.0	34.7	48.0	59.1	42.1	39.2	53.0	63.7	46.3	44.4	58.0	66.9
	65	38.4	35.0	48.3	59.2	42.2	39.3	53.0	63.8	46.3	44.6	58.0	67.0
	70	41.8	36.9	52.2	61.1	42.5	39.5	53.2	63.8	46.4	44.7	58.1	67.0
	75	45.3	41.1	56.4	64.7	45.4	41.2	56.5	64.8	49.4	44.9	0.0	67.1
3600	60	40.3	37.4	49.0	58.7	44.4	41.2	53.8	63.4	48.5	45.9	58.8	67.2
	65	42.0	37.9	50.7	59.0	44.5	41.4	53.9	63.5	48.6	46.6	58.8	67.7
	70	45.7	40.7	55.0	62.1	45.8	41.9	55.1	63.8	48.8	46.3	58.8	67.4
	75	49.4	44.4	59.3	64.4	49.5	44.7	59.4	66.1	49.4	45.0	59.4	65.3
4000	60	41.5	38.8	49.4	58.6	45.5	42.4	54.2	63.1	49.7	46.8	59.1	67.3
	65	43.9	39.5	52.0	59.0	45.7	42.7	54.3	63.2	49.8	47.8	59.2	68.0
	70	47.8	42.8	56.5	62.7	47.9	43.3	56.6	63.6	50.0	47.3	59.2	67.5
	75	51.6	46.6	60.9	66.7	51.7	46.8	60.9	66.8	51.8	47.4	61.0	66.9
4400	60	42.6	40.0	49.9	58.3	46.5	43.5	54.6	62.8	50.6	47.7	59.3	67.2
	65	45.6	41.5	53.2	59.6	46.8	43.8	54.7	62.9	50.8	47.9	59.4	67.3
	70	49.6	44.6	57.7	63.2	49.7	44.6	57.8	63.4	51.1	48.2	59.6	67.4
	75	53.5	48.4	62.1	67.2	53.6	48.5	62.2	67.3	53.6	49.0	62.3	67.9
4800	60	43.5	40.9	50.3	57.9	47.3	44.4	54.8	62.5	51.4	48.4	59.5	67.0
	65	47.1	43.1	54.2	60.0	47.8	44.8	55.1	62.6	51.6	49.5	59.6	68.5
	70	51.1	46.1	58.8	65.2	51.2	46.3	58.8	63.7	52.1	49.0	59.9	67.3
	75	55.1	50.0	63.2	67.7	55.2	50.1	63.3	67.8	55.2	50.8	63.4	69.2

Note: MIN, MAX: The leaving evaporator temperature is affected by the modulating valve position. The MIN and MAX numbers represent modulating valve position impact on both the leaving evaporator temperature and the leaving reheat coil temperature. MAX represents wide open, MIN represents closed to minimum position.

**Table 65. Reheat temperature rise - 12.5 tons, standard efficiency**

Air-flow (cfm)	Ent DB (°F)	Entering Wet Bulb (°F)											
		51				55				59			
		Lvg Evap DB (°F)		Lvg Reheat DB (°F)		Lvg Evap DB (°F)		Lvg Reheat DB (°F)		Lvg Evap DB (°F)		Lvg Reheat DB (°F)	
		MIN	MAX	MIN	MAX	MIN	MAX	MIN	MAX	MIN	MAX	MIN	MAX
<b>Ambient DB 60°F</b>													
3750	60	37.7	38.0	45.7	58.5	40.8	42.5	49.5	61.3	44.2	47.2	53.6	64.0
	65	38.5	39.5	46.4	59.2	41.6	43.6	50.2	61.8	44.8	48.0	54.1	64.3
	70	41.4	43.6	49.3	61.3	42.5	45.0	51.0	62.4	45.6	49.1	54.9	64.8
	75	44.6	49.1	52.8	64.4	44.2	44.5	52.5	64.0	46.4	50.5	55.6	65.4
4500	60	40.0	39.9	47.0	58.3	43.1	44.3	50.6	61.3	46.4	48.6	54.5	64.0
	65	41.6	41.7	48.3	59.3	44.0	45.4	51.5	61.9	47.2	49.8	55.2	64.5
	70	44.9	46.8	51.7	62.2	45.5	47.2	52.7	62.6	48.1	50.8	56.1	65.0
	75	48.2	52.5	55.4	65.7	48.3	48.1	55.5	67.7	49.4	52.6	57.2	65.7
5000	60	41.3	41.0	47.6	58.1	44.4	45.2	51.3	61.3	47.5	49.3	55.0	63.9
	65	43.0	43.0	49.2	59.2	45.3	46.3	52.1	61.8	48.5	50.6	55.9	64.5
	70	46.7	48.5	53.0	62.7	47.0	48.4	53.5	62.7	49.4	51.8	56.7	65.0
	75	50.1	54.2	56.8	66.0	50.2	50.5	56.9	68.4	50.9	53.8	58.0	65.9

**Table 65. Reheat temperature rise - 12.5 tons, standard efficiency (continued)**

Air-flow (cfm)	Ent DB (° F)	Entering Wet Bulb (°F)											
		51				55				59			
		Lvg Evap DB (°F)		Lvg Reheat DB (°F)		Lvg Evap DB (°F)		Lvg Reheat DB (°F)		Lvg Evap DB (°F)		Lvg Reheat DB (°F)	
		MIN	MAX	MIN	MAX	MIN	MAX	MIN	MAX	MIN	MAX	MIN	MAX
5500	60	42.4	42.0	48.2	57.9	45.4	45.9	51.7	61.2	48.4	50.0	55.4	63.9
	65	44.3	44.2	49.9	59.2	46.4	47.2	52.7	61.8	49.5	51.6	56.3	64.9
	70	48.3	50.0	54.1	63.1	48.2	49.4	54.3	62.8	50.5	52.6	57.2	65.1
	75	51.8	56.1	58.0	68.3	51.9	52.2	58.1	69.6	52.2	56.0	58.7	66.7
6000	60	43.3	42.9	48.7	57.7	46.3	46.6	52.2	61.1	49.2	50.5	55.7	63.8
	65	46.0	45.9	51.2	59.7	47.4	47.9	53.1	61.8	50.4	52.4	56.7	65.3
	70	49.7	51.4	55.1	63.5	49.4	51.5	54.9	63.5	51.5	53.6	57.7	65.2
	75	53.2	57.6	59.0	69.3	53.3	53.6	59.1	70.6	53.4	56.6	59.3	67.4
<b>Ambient DB 65°F</b>													
3750	60	37.9	37.4	46.0	59.4	41.1	41.4	49.8	63.2	44.5	46.1	54.0	66.1
	65	39.1	38.3	47.1	60.0	41.9	42.4	50.6	63.7	45.1	46.9	54.5	66.4
	70	41.8	41.7	49.7	62.5	42.7	43.4	51.3	64.1	45.9	48.0	55.3	66.9
	75	45.0	46.9	53.3	65.9	44.5	47.1	52.9	65.9	46.7	48.6	55.9	66.3
4500	60	40.3	39.7	47.3	58.8	43.4	43.2	50.9	62.8	46.6	47.5	54.9	66.0
	65	41.8	41.3	48.6	59.9	44.3	44.3	51.8	63.5	47.6	48.7	55.6	66.5
	70	45.2	45.0	52.1	63.3	45.7	46.0	53.0	64.4	48.4	49.7	56.4	67.0
	75	48.6	50.2	55.8	66.3	48.7	50.6	55.9	66.3	49.7	51.4	57.5	67.7
5000	60	41.5	40.9	47.9	58.5	44.7	44.3	51.5	62.6	47.7	48.3	55.3	65.9
	65	43.3	42.7	49.4	59.7	45.6	45.4	52.4	63.3	48.8	49.6	56.2	66.4
	70	47.0	46.8	53.4	63.7	47.2	47.2	53.8	64.3	49.7	50.7	57.0	67.0
	75	50.5	52.1	57.2	67.3	50.6	52.5	57.3	67.6	51.2	52.6	58.3	67.8
5500	60	42.6	42.0	48.4	58.2	45.6	45.2	52.0	62.3	48.7	49.0	55.7	65.7
	65	44.5	44.0	50.1	59.5	46.6	46.3	52.9	63.1	49.8	50.3	56.6	66.3
	70	48.6	48.3	54.5	64.0	48.5	48.4	54.5	64.3	50.8	51.5	57.5	66.9
	75	52.1	53.8	58.4	68.9	52.2	53.8	58.5	67.8	52.5	53.6	59.0	67.8
6000	60	43.5	42.9	48.9	57.9	46.5	46.0	52.4	62.0	49.5	49.6	56.0	65.5
	65	46.3	45.6	51.5	60.0	47.6	47.2	53.4	62.9	50.6	51.0	57.0	66.2
	70	50.0	49.7	55.5	64.3	49.6	49.4	55.1	64.2	51.7	52.2	58.0	66.8
	75	53.6	55.1	59.4	68.1	53.7	55.2	59.5	68.2	53.6	55.3	59.6	68.2
<b>Ambient DB 70°F</b>													
3750	60	38.2	37.4	46.4	59.7	41.4	40.7	50.2	64.3	44.8	45.1	54.4	68.1
	65	39.4	38.3	47.4	60.3	42.2	41.6	51.0	65.0	45.4	45.9	54.9	68.5
	70	42.2	41.3	50.1	63.0	43.0	42.6	51.7	65.5	46.2	46.9	55.6	69.0
	75	45.4	45.2	53.8	67.0	44.8	44.5	53.2	66.7	47.0	47.8	56.3	69.4
4500	60	40.5	39.8	47.6	59.1	43.7	42.9	51.2	63.5	46.9	46.7	55.2	67.7
	65	42.1	41.3	48.9	60.1	44.6	43.9	52.1	64.3	47.8	47.7	55.9	68.2
	70	45.6	44.7	52.5	63.6	46.0	45.4	53.4	65.3	48.6	48.7	56.7	68.8
	75	48.9	48.5	56.3	67.8	49.0	48.7	56.4	67.9	50.0	50.3	57.9	69.6
5000	60	41.8	41.0	48.2	58.7	44.9	44.2	51.8	63.0	48.0	47.6	55.7	67.3
	65	43.5	42.8	49.7	59.9	45.8	45.1	52.7	63.8	49.0	48.7	56.5	67.9
	70	47.4	46.5	53.8	64.0	47.5	46.8	54.1	65.0	49.9	49.7	57.3	68.6
	75	50.9	50.4	57.6	68.2	50.9	50.5	57.7	68.3	51.5	51.5	58.7	69.5



## Reheat Temperature Rise

**Table 65. Reheat temperature rise - 12.5 tons, standard efficiency (continued)**

Air-flow (cfm)	Ent DB (°F)	Entering Wet Bulb (°F)											
		51				55				59			
		Lvg Evap DB (°F)		Lvg Reheat DB (°F)		Lvg Evap DB (°F)		Lvg Reheat DB (°F)		Lvg Evap DB (°F)		Lvg Reheat DB (°F)	
		MIN	MAX	MIN	MAX	MIN	MAX	MIN	MAX	MIN	MAX	MIN	MAX
5500	60	42.8	42.1	48.7	58.4	45.9	45.2	52.3	62.6	48.9	48.4	56.0	66.9
	65	45.3	44.1	50.9	59.7	46.9	46.2	53.2	63.5	50.0	49.6	56.9	67.6
	70	48.9	48.1	54.9	64.3	48.7	48.1	54.8	64.8	51.0	50.7	57.8	68.4
	75	52.5	52.1	58.8	69.3	52.6	52.1	58.9	69.4	52.8	52.6	59.3	69.4
6000	60	43.7	43.0	49.1	58.1	46.7	46.0	52.7	62.3	49.7	49.1	56.3	66.5
	65	46.6	45.8	51.8	60.2	47.8	47.1	53.6	63.2	50.9	50.3	57.3	67.3
	70	50.3	49.4	55.8	64.6	49.8	49.2	55.4	64.5	51.9	51.5	58.2	68.1
	75	53.9	53.5	59.8	68.9	54.0	53.6	59.9	69.0	53.9	53.6	59.9	69.3

Note: MIN, MAX: The leaving evaporator temperature is affected by the modulating valve position. The MIN and MAX numbers represent modulating valve position impact on both the leaving evaporator temperature and the leaving reheat coil temperature. MAX represents wide open, MIN represents closed to minimum position.

**Table 66. Reheat temperature rise - 12.5 tons, high efficiency**

Air-flow (cfm)	Ent DB (°F)	Entering Wet Bulb (°F)											
		51				55				59			
		Lvg Evap DB (°F)		Lvg Reheat DB (°F)		Lvg Evap DB (°F)		Lvg Reheat DB (°F)		Lvg Evap DB (°F)		Lvg Reheat DB (°F)	
		MIN	MAX	MIN	MAX	MIN	MAX	MIN	MAX	MIN	MAX	MIN	MAX
Ambient DB 60°F													
3750	60	36.1	35.8	52.2	56.2	39.9	39.6	57.0	61.3	43.9	43.6	62.3	66.7
	65	36.5	36.2	52.5	56.5	40.1	39.8	57.2	61.5	43.9	43.6	62.1	66.5
	70	38.7	38.3	54.9	58.8	40.4	40.0	57.4	61.6	44.1	43.8	62.3	66.7
	75	41.8	41.4	58.8	62.9	41.9	41.5	58.9	63.0	44.3	44.0	62.4	66.8
4500	60	38.6	38.3	52.3	55.8	42.3	42.1	57.0	60.6	46.2	45.9	62.0	66.0
	65	39.2	39.0	52.9	56.3	42.6	42.3	57.2	60.9	46.4	46.1	62.0	65.9
	70	42.5	42.1	56.6	60.0	43.2	42.9	57.7	61.3	46.6	46.3	62.2	66.1
	75	45.8	45.3	60.6	64.1	45.9	45.4	60.7	64.2	47.2	46.9	62.7	66.5
5000	60	39.8	39.6	52.4	55.5	43.6	43.3	57.0	60.3	47.4	47.2	61.9	65.5
	65	40.6	40.5	53.1	56.2	43.8	43.6	57.2	60.5	47.7	47.4	61.9	65.5
	70	44.5	44.1	57.5	60.6	44.6	44.4	57.9	61.2	47.9	47.7	62.1	65.7
	75	47.9	47.5	61.6	64.8	48.0	47.6	61.7	64.9	48.7	48.4	62.7	66.3
5500	60	40.9	40.7	52.4	55.3	44.6	44.4	56.9	60.0	48.4	48.2	61.8	65.1
	65	42.8	42.4	54.2	56.9	44.9	44.7	57.2	60.3	48.7	48.5	61.8	65.1
	70	46.3	45.9	58.3	61.2	45.9	45.6	58.1	61.0	49.0	48.8	62.1	65.4
	75	49.8	49.4	62.5	65.4	49.9	49.5	62.5	65.5	49.9	49.7	62.8	66.1
6000	60	41.8	41.6	52.4	55.1	45.5	45.3	56.9	59.7	49.3	49.0	61.6	64.7
	65	44.2	43.9	54.9	57.4	45.8	45.6	57.2	60.0	49.6	49.4	61.8	64.8
	70	47.8	47.5	59.0	61.7	47.9	47.5	59.1	61.8	49.9	49.7	62.0	65.0
	75	51.4	51.0	63.2	66.0	51.5	51.1	63.3	66.1	51.3	50.9	63.2	66.0
Ambient DB 65°F													
3750	60	36.4	36.0	52.4	56.3	40.1	39.7	57.2	61.3	44.2	43.8	62.5	67.0
	65	36.8	36.4	52.7	56.6	40.3	40.0	57.4	61.5	44.2	43.8	62.3	66.8
	70	39.0	38.5	55.2	59.0	40.6	40.3	57.6	61.7	44.4	44.0	62.5	66.9
	75	42.1	41.6	59.1	63.1	42.2	41.7	59.3	63.2	44.6	44.2	62.6	67.0

**Table 66. Reheat temperature rise - 12.5 tons, high efficiency (continued)**

Air-flow (cfm)	Ent DB (°F)	Entering Wet Bulb (°F)											
		51				55				59			
		Lvg Evap DB (°F)		Lvg Reheat DB (°F)		Lvg Evap DB (°F)		Lvg Reheat DB (°F)		Lvg Evap DB (°F)		Lvg Reheat DB (°F)	
		MIN	MAX	MIN	MAX	MIN	MAX	MIN	MAX	MIN	MAX	MIN	MAX
4500	60	38.8	38.5	52.5	55.8	42.6	42.2	57.1	60.7	46.5	46.1	62.2	66.0
	65	39.4	39.1	53.1	56.3	42.8	42.5	57.4	60.9	46.6	46.3	62.1	65.9
	70	42.8	42.3	56.9	60.1	43.4	43.1	57.9	61.4	46.8	46.5	62.4	66.2
	75	46.1	45.6	60.9	64.3	46.2	45.7	61.0	64.4	47.4	47.1	62.8	66.6
5000	60	40.0	39.8	52.5	55.5	43.8	43.5	57.1	60.3	47.7	47.4	62.0	65.5
	65	40.9	40.6	53.3	56.2	44.0	43.8	57.3	60.6	47.9	47.6	62.0	65.5
	70	44.8	44.4	57.8	60.7	44.8	44.5	58.0	61.2	48.1	47.8	62.3	65.7
	75	48.3	47.8	61.9	65.0	48.4	47.9	62.0	65.1	48.9	48.6	62.9	66.3
5500	60	41.1	40.8	52.6	55.3	44.8	44.5	57.1	60.0	48.6	48.4	61.9	65.1
	65	43.1	42.7	54.5	57.0	45.1	44.9	57.3	60.3	48.9	48.6	62.0	65.1
	70	46.6	46.2	58.6	61.3	46.3	45.9	58.3	61.1	49.2	48.9	62.2	65.3
	75	50.1	49.7	62.8	65.6	50.2	49.7	62.8	65.7	50.1	49.8	63.0	66.1
6000	60	42.0	41.7	52.6	55.1	45.7	45.4	57.0	59.7	49.5	49.2	61.7	64.7
	65	44.5	44.1	55.1	57.5	46.0	45.8	57.3	60.0	49.8	49.6	61.9	64.8
	70	48.1	47.7	59.3	61.8	48.2	47.8	59.4	61.9	50.1	49.9	62.1	65.0
	75	51.7	51.3	63.5	66.1	51.8	51.4	63.6	66.2	51.6	51.3	63.5	66.2
<b>Ambient DB 70°F</b>													
3750	60	36.6	36.2	52.6	56.3	40.4	40.0	57.4	61.4	44.4	44.0	62.7	67.0
	65	37.0	36.6	52.9	56.7	40.6	40.2	57.6	61.6	44.4	44.0	62.5	66.8
	70	39.4	38.8	55.6	59.2	40.8	40.5	57.7	61.7	44.6	44.2	62.7	67.0
	75	42.5	42.0	59.5	63.3	42.6	42.1	59.6	63.4	44.8	44.4	62.8	67.1
4500	60	39.0	38.7	52.6	55.8	42.8	42.4	57.3	60.7	46.7	46.4	62.4	66.0
	65	39.7	39.3	53.2	56.4	43.0	42.7	57.5	60.9	46.9	46.5	62.3	65.9
	70	43.1	42.6	57.2	60.3	43.6	43.3	58.1	61.4	47.1	46.7	62.5	66.1
	75	46.5	45.9	61.3	64.5	46.6	46.0	61.4	64.6	47.7	47.3	63.0	66.6
5000	60	40.2	39.9	52.7	55.6	44.0	43.7	57.2	60.3	47.9	47.6	62.2	65.5
	65	41.3	40.9	53.6	56.4	44.3	44.0	57.5	60.6	48.1	47.8	62.2	65.5
	70	45.2	44.7	58.1	60.9	45.1	44.7	58.2	61.2	48.4	48.0	62.4	65.7
	75	48.6	48.1	62.2	65.1	48.7	48.2	62.3	65.2	49.1	48.8	63.1	66.3
5500	60	41.3	41.0	52.7	55.3	45.0	44.7	57.2	60.0	48.8	48.6	62.0	65.0
	65	43.3	42.9	54.7	57.2	45.3	45.0	57.5	60.3	49.1	48.8	62.1	65.1
	70	46.9	46.5	58.9	61.4	47.0	46.2	59.0	61.3	49.4	49.1	62.3	65.3
	75	50.5	50.0	63.1	65.7	50.5	50.1	63.2	65.8	50.4	50.0	63.1	66.1
6000	60	42.1	41.9	52.7	55.1	45.9	45.6	57.1	59.7	49.7	49.4	61.8	64.6
	65	44.8	44.4	55.4	57.6	46.2	45.9	57.4	60.0	50.0	49.7	62.0	64.7
	70	48.4	48.0	59.6	61.9	48.5	48.1	59.7	62.0	50.3	50.1	62.2	65.0
	75	52.1	51.6	63.8	66.3	52.1	51.7	63.9	66.4	52.2	51.6	64.0	66.3

**Note:** MIN, MAX: The leaving evaporator temperature is affected by the modulating valve position. The MIN and MAX numbers represent modulating valve position impact on both the leaving evaporator temperature and the leaving reheat coil temperature. MAX represents wide open, MIN represents closed to minimum position.



# Reheat Temperature Rise

**Table 67. Reheat temperature rise - 15 tons, standard/high efficiency**

Air-flow (cfm)	Ent DB (°F)	Entering Wet Bulb (°F)											
		51				55				59			
		Lvg Evap DB (°F)		Lvg Reheat DB (°F)		Lvg Evap DB (°F)		Lvg Reheat DB (°F)		Lvg Evap DB (°F)		Lvg Reheat DB (°F)	
		MIN	MAX	MIN	MAX	MIN	MAX	MIN	MAX	MIN	MAX	MIN	MAX
<b>Ambient DB 60°F</b>													
4500	60	35.7	35.3	52.7	57.3	39.4	39.0	57.6	62.5	43.5	43.1	63.0	68.1
	65	36.0	35.6	53.0	57.5	39.7	39.3	57.8	62.7	43.5	43.1	62.9	68.0
	70	38.1	37.5	55.2	59.6	39.9	39.5	57.9	62.8	43.7	43.3	63.0	68.1
	75	41.2	40.6	59.2	63.7	41.2	40.5	59.2	63.7	43.9	43.5	63.2	68.2
5400	60	38.2	37.8	52.8	56.6	42.0	41.5	57.5	61.7	45.9	45.5	62.7	67.2
	65	38.9	38.5	53.3	57.1	42.2	41.8	57.8	61.9	46.1	45.6	62.6	67.1
	70	41.9	41.4	56.9	60.6	42.8	42.4	58.2	62.4	46.3	45.9	62.9	67.3
	75	45.2	44.7	60.9	64.9	45.3	44.8	61.0	65.0	46.9	46.4	63.3	67.7
6000	60	39.5	39.2	52.8	56.3	43.2	42.9	57.4	61.3	47.2	46.8	62.5	66.7
	65	40.3	40.0	53.5	56.9	43.5	43.2	57.7	61.5	47.4	47.0	62.5	66.7
	70	44.0	43.5	57.8	61.2	44.3	43.9	58.4	62.1	47.6	47.3	62.7	66.9
	75	47.4	46.9	61.9	65.6	47.5	47.0	62.0	65.7	48.4	48.0	63.3	67.4
6600	60	40.6	40.3	52.8	56.0	44.3	44.0	57.4	60.9	48.2	47.8	62.3	66.2
	65	42.3	41.5	54.4	57.0	44.7	44.3	57.7	61.2	48.5	48.1	62.4	66.2
	70	45.8	45.3	58.6	61.7	45.6	45.2	58.5	61.9	48.8	48.4	62.6	66.5
	75	49.3	48.8	62.8	66.1	49.4	48.9	62.8	66.2	49.7	49.3	63.4	67.2
7200	60	41.5	41.2	52.8	55.8	45.2	44.9	57.3	60.6	49.1	48.7	62.2	65.8
	65	43.8	43.3	55.0	57.8	45.6	45.3	57.6	60.9	49.4	49.0	62.3	65.9
	70	47.4	46.9	59.3	62.2	47.5	46.7	59.4	62.0	49.7	49.4	62.5	66.1
	75	51.0	50.4	63.5	66.7	51.1	50.5	63.6	66.8	50.8	50.4	63.4	66.9
<b>Ambient DB 65°F</b>													
4500	60	35.9	35.5	52.9	57.3	39.6	39.2	57.8	62.6	43.8	43.3	63.3	68.5
	65	36.3	35.8	53.3	57.6	39.9	39.5	58.0	62.7	43.7	43.2	63.1	68.3
	70	38.4	37.8	55.6	59.7	40.2	39.7	58.2	62.8	44.0	43.5	63.3	68.4
	75	41.6	40.9	59.5	63.9	41.7	40.8	59.7	63.9	44.2	43.7	63.4	68.5
5400	60	38.4	38.0	53.0	56.6	42.2	41.7	57.7	61.7	46.2	45.7	62.9	67.4
	65	39.1	38.7	53.5	57.2	42.4	42.0	57.9	61.9	46.3	45.9	62.8	67.2
	70	42.3	41.7	57.2	60.7	43.1	42.6	58.4	62.4	46.5	46.1	63.0	67.5
	75	45.6	44.9	61.3	65.1	45.7	45.0	61.4	65.2	47.1	46.6	63.5	67.9
6000	60	39.7	39.3	53.0	56.3	43.5	43.1	57.6	61.3	47.4	47.0	62.7	66.8
	65	40.5	40.2	53.7	57.0	43.7	43.4	57.9	61.5	47.6	47.2	62.6	66.7
	70	44.4	43.8	58.1	61.3	44.5	44.1	58.5	62.1	47.9	47.4	62.9	66.9
	75	47.8	47.1	62.2	65.7	47.9	47.2	62.3	65.8	48.6	48.2	63.5	67.5
6600	60	40.8	40.5	53.0	56.0	44.5	44.2	57.5	60.9	48.4	48.0	62.5	66.3
	65	42.6	42.1	54.7	57.5	44.9	44.5	57.8	61.2	48.7	48.3	62.5	66.2
	70	46.2	45.6	58.9	61.9	45.8	45.4	58.6	61.9	49.0	48.6	62.8	66.5
	75	49.7	49.1	63.1	66.3	49.8	49.1	63.2	66.4	49.9	49.5	63.5	67.2
7200	60	41.7	41.4	52.9	55.8	45.4	45.1	57.5	60.6	49.3	48.9	62.3	65.8
	65	44.1	43.6	55.3	57.9	45.8	45.4	57.7	60.9	49.6	49.2	62.4	65.9
	70	47.7	47.2	59.6	62.4	47.8	47.2	59.6	62.4	49.9	49.6	62.6	66.1
	75	51.4	50.7	63.8	66.8	51.4	50.8	63.9	66.9	51.3	50.6	63.8	66.9
<b>Ambient DB 70°F</b>													

**Table 67. Reheat temperature rise - 15 tons, standard/high efficiency (continued)**

Air-flow (cfm)	Ent DB (°F)	Entering Wet Bulb (°F)											
		51				55				59			
		Lvg Evap DB (°F)		Lvg Reheat DB (°F)		Lvg Evap DB (°F)		Lvg Reheat DB (°F)		Lvg Evap DB (°F)		Lvg Reheat DB (°F)	
		MIN	MAX	MIN	MAX	MIN	MAX	MIN	MAX	MIN	MAX	MIN	MAX
4500	60	36.2	35.7	53.1	57.3	39.9	39.4	58.1	62.6	44.1	43.5	63.5	68.5
	65	36.6	36.0	53.5	57.6	40.2	39.7	58.2	62.8	44.0	43.5	63.3	68.3
	70	38.8	38.1	55.9	59.9	40.5	39.9	58.4	62.9	44.3	43.7	63.5	68.5
	75	42.0	41.2	59.9	64.1	42.1	41.3	60.1	64.2	44.5	43.9	63.6	68.6
5400	60	38.6	38.2	53.1	56.7	42.4	42.0	57.9	61.7	46.4	45.9	63.1	67.4
	65	39.3	38.9	53.7	57.2	42.7	42.2	58.1	62.0	46.6	46.1	63.0	67.3
	70	42.6	42.0	57.5	60.9	43.3	42.8	58.6	62.4	46.8	46.3	63.2	67.5
	75	46.0	45.3	61.7	65.3	46.1	45.4	61.8	65.4	47.4	46.9	63.7	67.9
6000	60	39.9	39.5	53.1	56.3	43.7	43.3	57.8	61.3	47.6	47.2	62.8	66.8
	65	40.8	40.4	53.9	57.0	44.0	43.6	58.0	61.5	47.8	47.4	62.8	66.7
	70	44.7	44.1	58.4	61.5	44.8	44.3	58.7	62.2	48.1	47.7	63.0	66.9
	75	48.2	47.5	62.6	65.9	48.3	47.6	62.7	66.0	48.9	48.4	63.7	67.5
6600	60	41.0	40.6	53.1	56.0	44.7	44.3	57.7	60.9	48.6	48.2	62.6	66.3
	65	42.9	42.4	54.9	57.6	45.1	44.7	58.0	61.2	48.9	48.5	62.7	66.2
	70	46.5	45.9	59.2	62.0	46.2	45.6	58.9	61.9	49.2	48.8	62.9	66.5
	75	50.1	49.4	63.4	66.5	50.2	49.5	63.5	66.6	50.1	49.7	63.7	67.2
7200	60	41.8	41.5	53.1	55.8	45.6	45.3	57.6	60.6	49.5	49.1	62.4	65.8
	65	44.3	43.8	55.6	58.0	45.9	45.6	57.9	60.9	49.8	49.4	62.5	65.8
	70	48.0	47.4	59.9	62.5	48.1	47.5	59.9	62.6	50.1	49.8	62.8	66.1
	75	51.7	51.0	64.2	67.0	51.8	51.1	64.2	67.1	51.9	51.0	64.3	67.1

**Note:** MIN, MAX: The leaving evaporator temperature is affected by the modulating valve position. The MIN and MAX numbers represent modulating valve position impact on both the leaving evaporator temperature and the leaving reheat coil temperature. MAX represents wide open, MIN represents closed to minimum position.

**Table 68. Reheat temperature rise - 17.5 tons, standard efficiency**

Air-flow (cfm)	Ent DB (°F)	Entering Wet Bulb (°F)											
		51				55				59			
		Lvg Evap DB (°F)		Lvg Reheat DB (°F)		Lvg Evap DB (°F)		Lvg Reheat DB (°F)		Lvg Evap DB (°F)		Lvg Reheat DB (°F)	
		MIN	MAX	MIN	MAX	MIN	MAX	MIN	MAX	MIN	MAX	MIN	MAX
<b>Ambient DB 60°F</b>													
5250	60	36.0	35.6	52.8	57.5	39.6	39.2	57.7	62.7	43.7	43.3	63.0	68.4
	65	36.4	36.1	53.2	57.8	40.0	39.6	57.9	63.0	43.7	43.2	62.9	68.3
	70	38.7	38.1	55.5	59.9	40.4	39.9	58.2	63.2	44.0	43.6	63.2	68.5
	75	41.8	41.2	59.5	64.2	41.7	41.0	59.4	64.2	44.4	44.0	63.4	68.8
6300	60	38.5	38.1	52.9	56.9	42.1	41.7	57.5	61.9	46.0	45.6	62.7	67.4
	65	39.4	39.0	53.7	57.5	42.5	42.1	57.9	62.3	46.2	45.8	62.7	67.4
	70	42.5	42.0	57.1	61.0	43.4	42.9	58.5	62.8	46.6	46.2	63.0	67.7
	75	45.8	45.2	61.1	65.3	45.9	45.3	61.2	65.4	47.4	46.9	63.6	68.2
7000	60	39.8	39.5	53.0	56.6	43.4	43.0	57.5	61.5	47.2	46.9	62.5	66.8
	65	40.9	40.5	53.8	57.4	43.9	43.5	57.8	61.8	47.5	47.1	62.6	66.9
	70	44.5	44.0	58.0	61.6	44.9	44.5	58.7	62.6	48.0	47.6	62.9	67.3
	75	47.9	47.4	62.1	65.9	48.0	47.5	62.2	66.0	48.9	48.5	63.7	67.9



## Reheat Temperature Rise

Table 68. Reheat temperature rise - 17.5 tons, standard efficiency (continued)

Air-flow (cfm)	Ent DB (°F)	Entering Wet Bulb (°F)											
		51				55				59			
		Lvg Evap DB (°F)		Lvg Reheat DB (°F)		Lvg Evap DB (°F)		Lvg Reheat DB (°F)		Lvg Evap DB (°F)		Lvg Reheat DB (°F)	
		MIN	MAX	MIN	MAX	MIN	MAX	MIN	MAX	MIN	MAX	MIN	MAX
7700	60	40.9	40.6	53.0	56.3	44.5	44.1	57.4	61.1	48.2	47.9	62.3	66.3
	65	42.8	41.8	54.6	57.3	45.0	44.6	57.8	61.5	48.6	48.2	62.5	66.5
	70	46.3	45.8	58.7	62.1	46.2	45.8	58.8	62.4	49.1	48.7	62.8	66.8
	75	49.8	49.3	62.9	66.5	49.9	49.4	63.0	66.6	50.2	49.9	63.7	67.7
8400	60	41.8	41.6	53.0	56.1	45.4	45.0	57.4	60.8	49.1	48.7	62.1	65.9
	65	44.2	43.8	55.2	58.1	45.9	45.6	57.8	61.2	49.5	49.2	62.4	66.1
	70	47.8	47.3	59.4	62.5	47.9	47.0	59.5	62.3	50.1	49.7	62.8	66.4
	75	51.4	50.9	63.7	66.9	51.5	51.0	63.7	67.0	51.3	51.0	63.8	67.4
<b>Ambient DB 65°F</b>													
5250	60	36.2	35.8	53.0	57.5	39.9	39.4	57.8	62.8	44.0	43.5	63.1	68.6
	65	36.8	36.2	53.5	57.7	40.3	39.8	58.1	63.0	44.0	43.5	63.0	68.5
	70	39.1	38.4	55.8	60.1	40.6	40.2	58.3	63.2	44.3	43.9	63.3	68.7
	75	42.2	41.6	59.8	64.3	42.3	41.3	59.9	64.3	44.7	44.2	63.5	68.9
6300	60	38.7	38.3	53.1	56.9	42.3	41.9	57.6	61.9	46.3	45.8	62.8	67.4
	65	39.7	39.2	53.8	57.6	42.8	42.3	58.0	62.2	46.4	46.0	62.8	67.4
	70	42.8	42.3	57.4	61.1	43.6	43.2	58.7	62.8	46.9	46.4	63.1	67.7
	75	46.2	45.6	61.4	65.4	46.3	45.7	61.5	65.5	47.6	47.2	63.7	68.3
7000	60	40.0	39.7	53.1	56.6	43.6	43.2	57.6	61.4	47.4	47.0	62.6	66.8
	65	41.1	40.8	54.0	57.4	44.1	43.7	57.9	61.8	47.7	47.3	62.7	66.9
	70	44.9	44.3	58.2	61.7	45.1	44.7	58.8	62.6	48.2	47.8	63.0	67.2
	75	48.3	47.7	62.4	66.0	48.4	47.8	62.5	66.1	49.2	48.7	63.8	67.9
7700	60	41.1	40.8	53.1	56.3	44.7	44.3	57.5	61.1	48.4	48.1	62.4	66.3
	65	43.0	42.1	54.8	57.3	45.2	44.8	57.9	61.4	48.8	48.4	62.6	66.4
	70	46.6	46.1	59.0	62.2	46.4	46.0	58.9	62.4	49.3	48.9	62.9	66.8
	75	50.1	49.6	63.2	66.6	50.2	49.6	63.3	66.7	50.5	50.1	63.9	67.6
8400	60	42.0	41.7	53.1	56.0	45.6	45.2	57.5	60.7	49.3	48.9	62.2	65.8
	65	44.5	44.0	55.4	58.2	46.1	45.8	57.8	61.1	49.7	49.4	62.5	66.0
	70	48.1	47.6	59.7	62.6	48.2	47.3	59.7	62.3	50.2	49.9	62.8	66.4
	75	51.7	51.2	63.9	67.1	51.8	51.3	64.0	67.1	51.6	51.2	63.9	67.4
<b>Ambient DB 70°F</b>													
5250	60	36.5	36.0	53.2	57.5	40.2	39.7	58.0	62.7	44.2	43.7	63.3	68.6
	65	37.1	36.4	53.7	57.7	40.5	40.0	58.2	63.0	44.2	43.7	63.2	68.5
	70	39.5	38.8	56.2	60.2	41.0	40.4	58.5	63.2	44.6	44.1	63.5	68.7
	75	42.6	41.9	60.1	64.5	42.7	41.8	60.2	64.4	45.0	44.4	63.7	68.9
6300	60	39.0	38.6	53.2	56.9	42.6	42.1	57.8	61.8	46.5	46.0	62.9	67.4
	65	39.9	39.5	54.0	57.6	43.0	42.6	58.1	62.2	46.7	46.2	62.9	67.4
	70	43.2	42.6	57.7	61.2	43.9	43.4	58.8	62.8	47.1	46.6	63.3	67.7
	75	46.6	45.9	61.7	65.6	46.7	46.0	61.8	65.7	47.9	47.4	63.9	68.3
7000	60	40.2	39.9	53.2	56.5	43.9	43.4	57.7	61.4	47.7	47.2	62.7	66.8
	65	41.4	41.0	54.1	57.4	44.3	43.9	58.1	61.8	48.0	47.5	62.8	66.8
	70	45.2	44.6	58.5	61.8	45.4	44.9	58.9	62.6	48.4	48.0	63.1	67.2
	75	48.7	48.0	62.7	66.2	48.8	48.1	62.8	66.3	49.4	49.0	63.9	67.9

**Table 68. Reheat temperature rise - 17.5 tons, standard efficiency (continued)**

Air-flow (cfm)	Ent DB (°F)	Entering Wet Bulb (°F)											
		51				55				59			
		Lvg Evap DB (°F)		Lvg Reheat DB (°F)		Lvg Evap DB (°F)		Lvg Reheat DB (°F)		Lvg Evap DB (°F)		Lvg Reheat DB (°F)	
		MIN	MAX	MIN	MAX	MIN	MAX	MIN	MAX	MIN	MAX	MIN	MAX
7700	60	41.3	41.0	53.2	56.3	44.9	44.5	57.6	61.0	48.6	48.2	62.5	66.2
	65	43.3	42.8	55.1	57.9	45.4	45.0	58.0	61.4	49.0	48.6	62.7	66.3
	70	46.9	46.4	59.2	62.3	46.6	46.2	59.0	62.3	49.5	49.1	63.0	66.7
	75	50.5	49.9	63.5	66.7	50.6	50.0	63.6	66.8	50.7	50.3	64.0	67.6
8400	60	42.2	41.9	53.1	56.0	45.8	45.4	57.6	60.7	49.5	49.1	62.3	65.7
	65	44.8	44.3	55.7	58.3	46.3	46.0	57.9	61.1	49.9	49.5	62.6	66.0
	70	48.4	47.9	59.9	62.7	48.5	48.0	60.0	62.8	50.4	50.1	62.9	66.3
	75	52.1	51.5	64.2	67.2	52.2	51.6	64.3	67.3	51.8	51.4	64.0	67.3

**Note:** MIN, MAX: The leaving evaporator temperature is affected by the modulating valve position. The MIN and MAX numbers represent modulating valve position impact on both the leaving evaporator temperature and the leaving reheat coil temperature. MAX represents wide open, MIN represents closed to minimum position.

**Table 69. Reheat temperature rise - 17.5 tons, high efficiency**

Air-flow (cfm)	Ent DB (°F)	Entering Wet Bulb (°F)											
		51				55				59			
		Lvg Evap DB (°F)		Lvg Reheat DB (°F)		Lvg Evap DB (°F)		Lvg Reheat DB (°F)		Lvg Evap DB (°F)		Lvg Reheat DB (°F)	
		MIN	MAX	MIN	MAX	MIN	MAX	MIN	MAX	MIN	MAX	MIN	MAX
<b>Ambient DB 60°F</b>													
5250	60	36.3	35.7	51.2	57.3	39.9	39.3	55.9	62.5	44.0	43.4	61.1	67.9
	65	36.9	36.1	51.7	57.6	40.3	39.7	56.2	62.7	44.0	43.4	61.0	67.8
	70	39.1	38.3	54.0	59.8	40.7	40.0	56.4	62.9	44.4	43.8	61.3	68.1
	75	42.3	41.4	57.9	63.9	42.2	41.1	57.9	63.8	44.7	44.1	61.5	68.2
6300	60	38.8	38.2	51.5	56.8	42.4	41.7	56.1	61.7	46.3	45.7	61.1	67.1
	65	39.7	39.1	52.3	57.5	42.8	42.2	56.4	62.1	46.5	45.8	61.1	67.0
	70	42.9	42.1	55.9	60.9	43.7	43.0	57.1	62.7	46.9	46.3	61.4	67.4
	75	46.2	45.3	59.9	65.1	46.3	45.4	60.0	65.2	47.7	47.0	62.0	67.9
7000	60	40.1	39.5	51.7	56.5	43.7	43.1	56.2	61.3	47.5	46.9	61.0	66.6
	65	41.2	40.6	52.6	57.3	44.1	43.6	56.5	61.7	47.8	47.2	61.1	66.6
	70	44.9	44.1	56.9	61.5	45.2	44.6	57.4	62.5	48.3	47.6	61.5	67.0
	75	48.4	47.5	61.0	65.7	48.5	47.6	61.1	65.8	49.2	48.6	62.3	67.6
7700	60	41.1	40.7	51.9	56.2	44.7	44.2	56.2	61.0	48.5	48.0	61.0	66.2
	65	43.1	41.8	53.6	57.1	45.2	44.7	56.6	61.4	48.9	48.3	61.1	66.3
	70	46.7	45.9	57.8	62.0	46.4	45.9	57.6	62.3	49.4	48.8	61.5	66.6
	75	50.2	49.4	61.9	66.3	50.3	49.4	62.0	66.4	50.5	49.9	62.5	67.4
8400	60	42.0	41.6	51.9	56.0	45.6	45.1	56.3	60.7	49.4	48.8	60.9	65.7
	65	44.5	43.8	54.3	58.0	46.2	45.7	56.7	61.1	49.8	49.3	61.2	65.9
	70	48.2	47.4	58.5	62.4	48.3	47.1	58.6	62.2	50.3	49.8	61.5	66.3
	75	51.8	51.0	62.7	66.8	51.9	51.1	62.8	66.9	51.6	51.1	62.6	67.2
<b>Ambient DB 65°F</b>													
5250	60	36.6	35.9	51.5	57.4	40.2	39.5	56.2	62.6	44.3	43.6	61.4	68.3
	65	37.2	36.4	52.0	57.7	40.6	39.9	56.4	62.9	44.3	43.6	61.3	68.2
	70	39.5	38.6	54.4	60.0	41.0	40.3	56.7	63.1	44.7	44.0	61.6	68.5
	75	42.7	41.7	58.4	64.3	42.8	41.5	58.5	64.2	45.0	44.3	61.8	68.7



# Reheat Temperature Rise

**Table 69. Reheat temperature rise - 17.5 tons, high efficiency (continued)**

Air-flow (cfm)	Ent DB (°F)	Entering Wet Bulb (°F)											
		51				55				59			
		Lvg Evap DB (°F)		Lvg Reheat DB (°F)		Lvg Evap DB (°F)		Lvg Reheat DB (°F)		Lvg Evap DB (°F)		Lvg Reheat DB (°F)	
		MIN	MAX	MIN	MAX	MIN	MAX	MIN	MAX	MIN	MAX	MIN	MAX
6300	60	39.0	38.4	51.8	56.8	42.6	42.0	56.3	61.8	46.6	45.9	61.3	67.3
	65	39.9	39.3	52.5	57.5	43.1	42.4	56.6	62.1	46.8	46.1	61.3	67.3
	70	43.3	42.4	56.2	61.1	43.9	43.3	57.3	62.8	47.2	46.5	61.7	67.6
	75	46.7	45.7	60.3	65.4	46.8	45.8	60.4	65.5	48.0	47.3	62.3	68.1
7000	60	40.3	39.7	51.9	56.5	43.9	43.3	56.4	61.4	47.8	47.1	61.2	66.7
	65	41.4	40.8	52.8	57.4	44.4	43.8	56.7	61.8	48.1	47.4	61.3	66.8
	70	45.3	44.4	57.2	61.7	45.4	44.8	57.6	62.5	48.5	47.9	61.7	67.1
	75	48.8	47.8	61.4	66.0	48.9	47.9	61.5	66.1	49.5	48.8	62.5	67.8
7700	60	41.4	40.8	52.0	56.3	45.0	44.4	56.4	61.0	48.8	48.2	61.1	66.2
	65	43.4	42.2	53.9	57.3	45.5	44.9	56.8	61.4	49.1	48.5	61.3	66.3
	70	47.0	46.2	58.1	62.2	46.6	46.1	57.8	62.3	49.6	49.0	61.7	66.7
	75	50.6	49.7	62.3	66.6	50.7	49.8	62.4	66.7	50.8	50.1	62.7	67.5
8400	60	42.2	41.8	52.1	56.0	45.8	45.3	56.4	60.7	49.6	49.0	61.1	65.8
	65	44.8	44.1	54.6	58.2	46.3	45.9	56.8	61.1	50.0	49.4	61.3	66.0
	70	48.5	47.7	58.9	62.6	48.6	47.4	58.9	62.4	50.5	50.0	61.7	66.3
	75	52.2	51.3	63.1	67.1	52.3	51.4	63.2	67.2	52.0	51.3	62.9	67.3
<b>Ambient DB 70°F</b>													
5250	60	36.8	36.1	51.7	57.5	40.5	39.7	56.4	62.7	44.6	43.8	61.6	68.5
	65	37.5	36.6	52.2	57.8	40.9	40.1	56.7	63.0	44.6	43.8	61.6	68.4
	70	39.9	38.9	54.9	60.3	41.4	40.5	57.0	63.1	45.0	44.2	61.9	68.6
	75	43.2	42.0	58.8	64.5	43.3	41.9	58.9	64.4	45.4	44.6	62.1	68.8
6300	60	39.3	38.6	52.0	56.9	42.9	42.2	56.5	61.9	46.9	46.1	61.5	67.4
	65	40.2	39.5	52.8	57.6	43.3	42.7	56.9	62.2	47.1	46.3	61.5	67.4
	70	43.7	42.7	56.6	61.3	44.2	43.5	57.6	62.8	47.5	46.7	61.9	67.7
	75	47.1	46.0	60.7	65.6	47.2	46.1	60.8	65.7	48.3	47.5	62.5	68.2
7000	60	40.5	39.9	52.1	56.6	44.2	43.5	56.6	61.4	48.0	47.4	61.4	66.8
	65	41.6	41.0	53.0	57.4	44.6	44.0	56.9	61.8	48.4	47.6	61.5	66.8
	70	45.7	44.7	57.6	61.9	45.7	45.0	57.8	62.6	48.8	48.1	61.9	67.2
	75	49.2	48.2	61.8	66.2	49.3	48.3	61.9	66.3	49.8	49.1	62.7	67.9
7700	60	41.6	41.0	52.2	56.3	45.2	44.6	56.6	61.1	49.0	48.4	61.3	66.3
	65	43.7	42.9	54.2	57.9	45.7	45.1	57.0	61.5	49.4	48.7	61.5	66.4
	70	47.4	46.5	58.5	62.4	47.0	46.3	58.1	62.4	49.9	49.2	61.9	66.7
	75	51.0	50.0	62.7	66.8	51.1	50.1	62.8	66.9	51.1	50.4	62.9	67.6
8400	60	42.4	42.0	52.2	56.1	46.1	45.5	56.6	60.8	49.8	49.2	61.2	65.8
	65	45.1	44.4	54.9	58.4	46.5	46.0	57.0	61.2	50.3	49.6	61.5	66.0
	70	48.9	48.0	59.2	62.8	49.0	48.1	59.3	62.9	50.7	50.2	61.8	66.3
	75	52.6	51.6	63.5	67.3	52.7	51.7	63.6	67.4	52.8	51.5	63.7	67.4

**Note:** MIN, MAX: The leaving evaporator temperature is affected by the modulating valve position. The MIN and MAX numbers represent modulating valve position impact on both the leaving evaporator temperature and the leaving reheat coil temperature. MAX represents wide open, MIN represents closed to minimum position.

Table 70. Reheat temperature rise - 20 tons, standard/high efficiency

Air-flow (cfm)	Ent DB (°F)	Entering Wet Bulb (°F)											
		51				55				59			
		Lvg Evap DB (°F)		Lvg Reheat DB (°F)		Lvg Evap DB (°F)		Lvg Reheat DB (°F)		Lvg Evap DB (°F)		Lvg Reheat DB (°F)	
		MIN	MAX	MIN	MAX	MIN	MAX	MIN	MAX	MIN	MAX	MIN	MAX
<b>Ambient DB 60°F</b>													
6000	60	38.8	37.9	48.8	58.2	41.8	40.8	52.5	62.8	45.3	44.3	57.2	68.5
	65	39.4	38.4	49.4	58.8	42.9	41.9	53.5	63.7	46.2	44.8	57.5	68.4
	70	42.0	40.9	51.9	61.1	43.3	42.3	54.0	64.2	47.0	45.9	58.4	69.3
	75	45.3	44.0	55.7	65.3	45.1	43.7	55.6	65.3	47.5	46.4	58.9	69.9
7200	60	41.3	40.4	49.8	57.7	44.9	44.0	53.7	62.1	47.4	46.5	57.6	67.4
	65	42.2	41.4	50.6	58.6	45.4	44.4	54.5	63.0	49.1	48.1	58.5	67.6
	70	45.6	44.5	54.2	61.9	46.3	45.3	55.3	63.9	49.5	48.5	59.3	68.6
	75	49.0	47.8	58.1	66.3	49.1	47.9	58.2	66.4	50.3	48.9	60.0	69.0
8000	60	42.6	41.8	50.3	57.5	46.2	45.4	54.1	61.7	48.6	47.6	58.0	66.8
	65	43.6	42.9	51.3	58.4	46.7	45.8	55.0	62.7	50.4	49.5	58.9	67.1
	70	47.5	46.4	55.4	62.4	47.7	46.8	55.9	63.6	50.9	49.9	59.8	68.2
	75	51.0	49.8	59.4	66.8	51.1	49.9	59.5	66.9	51.8	50.9	60.6	69.0
8800	60	43.7	42.9	50.8	57.3	47.3	46.5	54.5	61.3	49.5	48.7	58.1	66.3
	65	45.1	44.1	52.0	58.3	47.9	47.0	55.4	62.5	51.5	50.6	59.3	66.7
	70	49.1	48.0	56.4	62.9	48.9	48.1	56.4	63.4	52.0	51.1	60.2	67.9
	75	52.7	51.5	60.5	67.3	52.8	51.6	60.5	67.4	53.0	52.2	61.0	68.7
9600	60	44.7	43.9	51.2	57.2	48.2	47.5	54.8	61.1	50.2	49.5	58.3	65.9
	65	46.8	45.9	53.2	58.9	48.9	48.0	55.8	62.3	52.5	51.6	59.6	66.4
	70	50.5	49.5	57.3	63.3	50.0	49.2	56.9	63.3	53.0	52.1	60.5	67.6
	75	54.2	53.1	61.4	67.8	54.2	53.1	61.5	67.9	54.1	53.3	61.4	68.5
<b>Ambient DB 65°F</b>													
6000	60	39.1	38.1	49.1	58.2	42.2	41.0	52.8	62.7	45.6	44.5	57.5	68.5
	65	39.7	38.6	49.7	58.8	43.1	42.1	53.8	63.6	46.5	45.1	57.8	68.4
	70	42.4	41.1	52.4	61.1	43.6	42.5	54.3	64.1	47.3	46.1	58.7	69.3
	75	45.7	44.3	56.2	65.3	45.5	43.9	56.1	65.2	47.7	46.6	59.2	69.8
7200	60	41.5	40.6	50.0	57.7	45.2	44.2	53.9	62.0	47.6	46.7	57.9	67.3
	65	42.5	41.6	50.9	58.5	45.6	44.6	54.7	63.0	49.4	48.3	58.7	67.5
	70	45.9	44.7	54.6	62.0	46.5	45.5	55.6	63.8	49.8	48.7	59.5	68.5
	75	49.4	48.0	58.5	66.3	49.5	48.1	58.6	66.4	50.6	49.1	60.3	69.0
8000	60	42.8	42.0	50.6	57.5	46.4	45.6	54.4	61.6	48.8	47.8	58.2	66.7
	65	43.9	43.1	51.5	58.4	47.0	46.0	55.3	62.7	50.7	49.7	59.1	67.0
	70	47.8	46.6	55.8	62.5	47.9	47.0	56.1	63.5	51.1	50.1	60.0	68.1
	75	51.3	50.0	59.7	66.9	51.4	50.1	59.8	67.0	52.0	51.0	60.8	68.9
8800	60	43.9	43.1	51.0	57.3	47.5	46.7	54.7	61.3	49.6	48.8	58.3	66.3
	65	45.7	44.3	52.7	58.2	48.1	47.2	55.7	62.5	51.8	50.8	59.5	66.6
	70	49.4	48.3	56.8	62.9	49.1	48.3	56.6	63.4	52.3	51.3	60.4	67.8
	75	53.0	51.8	60.8	67.4	53.1	51.9	60.9	67.5	53.2	52.3	61.2	68.7
9600	60	44.9	44.1	51.4	57.1	48.3	47.7	55.0	61.0	50.4	49.6	58.5	65.8
	65	47.0	46.1	53.5	58.9	49.1	48.2	56.0	62.2	52.7	51.8	59.8	66.3
	70	50.8	49.7	57.6	63.4	50.9	49.4	57.7	63.2	53.3	52.3	60.7	67.5
	75	54.5	53.3	61.7	67.8	54.5	53.4	61.8	67.9	54.3	53.5	61.6	68.4
<b>Ambient DB 70°F</b>													



## Reheat Temperature Rise

**Table 70. Reheat temperature rise - 20 tons, standard/high efficiency (continued)**

Air-flow (cfm)	Ent DB (°F)	Entering Wet Bulb (°F)											
		51				55				59			
		Lvg Evap DB (°F)		Lvg Reheat DB (°F)		Lvg Evap DB (°F)		Lvg Reheat DB (°F)		Lvg Evap DB (°F)		Lvg Reheat DB (°F)	
		MIN	MAX	MIN	MAX	MIN	MAX	MIN	MAX	MIN	MAX	MIN	MAX
6000	60	39.4	38.3	49.4	58.1	42.5	41.2	53.1	62.6	45.8	44.7	57.8	68.4
	65	39.8	38.9	49.9	58.8	43.5	42.3	54.1	63.5	46.8	45.4	58.1	68.4
	70	42.7	41.4	52.8	61.1	44.0	42.8	54.7	64.1	47.6	46.3	59.0	69.2
	75	46.1	44.5	56.7	65.4	46.2	44.0	56.8	65.1	48.0	46.8	59.5	69.8
7200	60	41.8	40.8	50.3	57.6	45.5	44.4	54.2	61.9	47.8	46.8	58.1	67.2
	65	42.7	41.8	51.2	58.5	45.9	44.8	55.0	62.9	49.7	48.5	59.0	67.4
	70	46.3	45.0	55.0	62.0	46.8	45.7	55.8	63.7	50.1	48.9	59.8	68.5
	75	49.7	48.3	58.9	66.4	49.8	48.4	59.0	66.5	50.8	49.3	60.6	68.9
8000	60	43.1	42.1	50.8	57.4	46.7	45.8	54.6	61.5	49.0	47.9	58.4	66.6
	65	44.1	43.2	51.7	58.3	47.3	46.2	55.5	62.7	51.0	49.9	59.4	66.9
	70	48.2	46.9	56.1	62.5	48.2	47.2	56.4	63.5	51.4	50.3	60.3	68.1
	75	51.7	50.3	60.1	67.0	51.8	50.4	60.2	67.0	52.3	51.2	61.1	68.9
8800	60	44.2	43.3	51.3	57.3	47.7	46.9	55.0	61.2	49.8	49.0	58.6	66.2
	65	46.0	44.4	53.0	58.1	48.4	47.4	55.9	62.4	52.0	51.0	59.7	66.6
	70	49.7	48.5	57.1	63.0	49.3	48.5	56.8	63.3	52.5	51.5	60.6	67.8
	75	53.3	52.1	61.2	67.5	53.4	52.1	61.3	67.5	53.4	52.5	61.5	68.6
9600	60	45.1	44.3	51.6	57.1	48.5	47.8	55.1	61.0	50.6	49.8	58.7	65.7
	65	47.3	46.3	53.8	59.0	49.3	48.4	56.2	62.2	52.9	52.0	60.0	66.2
	70	51.1	49.9	58.0	63.4	51.2	49.6	58.0	63.2	53.5	52.5	60.9	67.5
	75	54.8	53.6	62.1	67.9	54.9	53.6	62.2	68.0	54.5	53.6	61.8	68.3

**Note:** MIN, MAX: The leaving evaporator temperature is affected by the modulating valve position. The MIN and MAX numbers represent modulating valve position impact on both the leaving evaporator temperature and the leaving reheat coil temperature. MAX represents wide open, MIN represents closed to minimum position.

**Table 71. Reheat temperature rise - 25 tons, standard efficiency**

Air-flow (cfm)	Ent DB (°F)	Entering Wet Bulb (°F)											
		51				55				59			
		Lvg Evap DB (°F)		Lvg Reheat DB (°F)		Lvg Evap DB (°F)		Lvg Reheat DB (°F)		Lvg Evap DB (°F)		Lvg Reheat DB (°F)	
		MIN	MAX	MIN	MAX	MIN	MAX	MIN	MAX	MIN	MAX	MIN	MAX
<b>Ambient DB 60°F</b>													
7500	60	37.9	37.5	51.6	57.5	40.9	40.5	55.9	62.5	44.5	44.2	60.8	67.9
	65	39.1	38.7	52.5	58.3	41.6	41.2	56.5	63.0	44.8	44.5	61.0	68.1
	70	41.8	41.3	55.3	61.0	42.4	42.0	57.1	63.4	45.5	45.2	61.6	68.7
	75	44.7	44.2	59.1	65.2	44.8	43.9	59.2	64.9	46.2	46.0	62.2	69.1
9000	60	40.1	39.7	51.9	57.0	43.1	42.7	56.1	61.7	46.6	46.3	60.6	66.9
	65	41.7	41.3	53.1	58.1	43.9	43.6	56.8	62.4	47.1	46.8	61.0	67.2
	70	44.9	44.5	56.8	61.8	45.3	45.0	57.9	63.3	47.9	47.6	61.7	67.9
	75	48.1	47.7	60.8	66.1	48.2	47.8	60.9	66.2	49.2	48.9	62.8	68.7
10000	60	41.3	40.9	52.1	56.8	44.3	43.9	56.2	61.3	47.8	47.5	60.6	66.4
	65	43.0	42.7	53.5	58.0	45.2	44.9	56.9	62.0	48.4	48.1	61.1	66.7
	70	46.7	46.3	57.7	62.3	46.8	46.5	58.2	63.2	49.2	48.9	61.8	67.4
	75	50.0	49.6	61.7	66.7	50.1	49.7	61.8	66.8	50.7	50.4	63.0	68.5

**Table 71. Reheat temperature rise - 25 tons, standard efficiency (continued)**

Air-flow (cfm)	Ent DB (°F)	Entering Wet Bulb (°F)											
		51				55				59			
		Lvg Evap DB (°F)		Lvg Reheat DB (°F)		Lvg Evap DB (°F)		Lvg Reheat DB (°F)		Lvg Evap DB (°F)		Lvg Reheat DB (°F)	
		MIN	MAX	MIN	MAX	MIN	MAX	MIN	MAX	MIN	MAX	MIN	MAX
11000	60	42.3	42.0	52.3	56.5	45.3	45.0	56.3	61.0	48.7	48.4	60.6	65.9
	65	44.8	44.4	54.4	58.4	46.2	45.9	57.0	61.7	49.4	49.1	61.1	66.3
	70	48.2	47.8	58.5	62.8	48.0	47.7	58.4	63.0	50.3	50.1	61.9	67.0
	75	51.7	51.3	62.5	67.2	51.8	51.4	62.6	67.2	52.0	51.7	63.2	68.2
12000	60	43.2	42.9	52.4	56.4	46.1	45.9	56.3	60.7	49.5	49.2	60.5	65.4
	65	46.0	45.7	55.0	58.7	47.2	46.9	57.2	61.5	50.3	50.0	61.1	66.0
	70	49.6	49.2	59.1	63.1	49.6	48.8	59.2	62.8	51.3	51.0	61.9	66.7
	75	53.1	52.8	63.3	67.6	53.2	52.8	63.3	67.7	53.1	52.9	63.4	68.0
<b>Ambient DB 65°F</b>													
7500	60	38.2	37.7	51.8	57.5	41.2	40.7	56.2	62.5	44.7	44.4	61.0	68.0
	65	39.4	39.0	52.8	58.4	41.9	41.4	56.8	63.1	45.1	44.7	61.2	68.2
	70	42.2	41.7	55.7	61.2	42.7	42.3	57.3	63.6	45.8	45.4	61.8	68.7
	75	45.1	44.6	59.5	65.4	45.2	44.4	59.6	65.3	46.5	46.1	62.4	69.2
9000	60	40.3	39.9	52.1	57.0	43.3	42.9	56.3	61.7	46.8	46.4	60.8	66.9
	65	41.9	41.5	53.3	58.1	44.2	43.8	57.0	62.4	47.4	47.0	61.2	67.2
	70	45.3	44.8	57.2	62.0	45.6	45.2	58.1	63.4	48.2	47.8	61.9	67.9
	75	48.5	48.0	61.1	66.3	48.6	48.1	61.2	66.4	49.5	49.1	63.0	68.8
10000	60	41.5	41.1	52.3	56.8	44.5	44.2	56.4	61.4	48.0	47.7	60.8	66.4
	65	43.4	42.9	53.7	58.0	45.4	45.1	57.1	62.0	48.6	48.3	61.3	66.7
	70	47.0	46.6	58.0	62.5	47.0	46.7	58.4	63.2	49.5	49.1	62.0	67.4
	75	50.4	49.9	62.0	66.8	50.5	50.0	62.1	66.9	51.0	50.6	63.2	68.5
11000	60	42.5	42.2	52.4	56.6	45.5	45.2	56.4	61.0	48.9	48.6	60.7	65.8
	65	45.1	44.7	54.7	58.5	46.4	46.1	57.2	61.7	49.6	49.3	61.3	66.3
	70	48.5	48.1	58.8	62.9	48.2	47.9	58.6	63.0	50.5	50.2	62.0	67.0
	75	52.0	51.6	62.8	67.3	52.1	51.6	62.9	67.4	52.2	51.9	63.4	68.2
12000	60	43.5	43.1	52.7	56.4	46.3	46.0	56.5	60.7	49.7	49.4	60.6	65.4
	65	46.3	45.9	55.3	58.9	47.4	47.1	57.3	61.5	50.5	50.2	61.3	66.0
	70	49.9	49.4	59.4	63.3	49.9	49.5	59.5	63.3	51.5	51.2	62.1	66.6
	75	53.4	53.0	63.5	67.7	53.5	53.1	63.6	67.8	53.3	53.0	63.5	68.0
<b>Ambient DB 70°F</b>													
7500	60	38.4	38.0	52.1	57.6	41.4	41.0	56.4	62.6	45.0	44.6	61.2	68.0
	65	39.7	39.3	53.1	58.4	42.2	41.7	57.0	63.1	45.3	44.9	61.5	68.2
	70	42.5	42.0	56.1	61.4	43.2	42.5	57.9	63.6	46.0	45.6	62.1	68.8
	75	45.5	44.9	59.9	65.6	45.6	45.0	60.0	65.7	46.8	46.4	62.6	69.2
9000	60	40.6	40.2	52.4	57.1	43.6	43.2	56.5	61.8	47.0	46.6	60.9	66.8
	65	42.2	41.8	53.6	58.2	44.4	44.0	57.2	62.4	47.6	47.2	61.4	67.2
	70	45.6	45.1	57.5	62.2	45.9	45.5	58.3	63.4	48.4	48.0	62.1	67.9
	75	48.8	48.3	61.5	66.5	48.9	48.4	61.6	66.6	49.7	49.3	63.2	68.8
10000	60	41.7	41.4	52.5	56.8	44.8	44.4	56.6	61.4	48.2	47.8	60.9	66.3
	65	44.0	43.1	54.3	58.0	45.6	45.3	57.3	62.0	48.9	48.5	61.4	66.7
	70	47.3	46.9	58.4	62.6	47.3	46.9	58.6	63.2	49.7	49.3	62.1	67.4
	75	50.7	50.2	62.4	67.0	50.8	50.3	62.5	67.1	51.2	50.8	63.4	68.5



# Reheat Temperature Rise

**Table 71. Reheat temperature rise - 25 tons, standard efficiency (continued)**

Air-flow (cfm)	Ent DB (°F)	Entering Wet Bulb (°F)											
		51				55				59			
		Lvg Evap DB (°F)		Lvg Reheat DB (°F)		Lvg Evap DB (°F)		Lvg Reheat DB (°F)		Lvg Evap DB (°F)		Lvg Reheat DB (°F)	
		MIN	MAX	MIN	MAX	MIN	MAX	MIN	MAX	MIN	MAX	MIN	MAX
11000	60	42.7	42.4	52.6	56.6	45.7	45.4	56.6	61.0	49.1	48.8	60.8	65.8
	65	45.4	45.0	55.0	58.7	46.7	46.3	57.4	61.7	49.8	49.5	61.4	66.3
	70	48.8	48.4	59.1	63.0	48.4	48.2	58.7	63.0	50.7	50.4	62.2	67.0
	75	52.3	51.8	63.1	67.4	52.4	51.9	63.2	67.5	52.5	52.1	63.5	68.2
12000	60	43.8	43.4	52.9	56.5	46.5	46.2	56.6	60.7	49.9	49.6	60.7	65.3
	65	46.6	46.2	55.6	59.0	47.7	47.3	57.6	61.5	50.7	50.4	61.4	65.9
	70	50.1	49.7	59.7	63.4	50.2	49.8	59.8	63.5	51.7	51.4	62.2	66.6
	75	53.7	53.3	63.8	67.8	53.8	53.4	63.9	67.9	53.5	53.2	63.7	68.0

**Note:** MIN, MAX: The leaving evaporator temperature is affected by the modulating valve position. The MIN and MAX numbers represent modulating valve position impact on both the leaving evaporator temperature and the leaving reheat coil temperature. MAX represents wide open, MIN represents closed to minimum position.

**Table 72. Reheat temperature rise - 25 tons, high efficiency**

Air-flow (cfm)	Ent DB (°F)	Entering Wet Bulb (°F)											
		51				55				59			
		Lvg Evap DB (°F)		Lvg Reheat DB (°F)		Lvg Evap DB (°F)		Lvg Reheat DB (°F)		Lvg Evap DB (°F)		Lvg Reheat DB (°F)	
		MIN	MAX	MIN	MAX	MIN	MAX	MIN	MAX	MIN	MAX	MIN	MAX
<b>Ambient DB 60°F</b>													
7500	60	37.8	37.4	51.5	57.4	40.9	40.5	55.8	62.4	44.5	44.2	60.7	67.8
	65	39.1	38.6	52.4	58.2	41.6	41.2	56.4	62.9	44.8	44.5	60.9	68.0
	70	41.8	41.3	55.2	60.9	42.4	42.1	57.0	63.5	45.5	45.2	61.5	68.5
	75	44.7	44.2	59.0	65.1	44.8	44.2	59.1	65.1	46.2	46.0	62.1	69.0
9000	60	40.1	39.7	51.9	56.9	43.0	42.7	56.0	61.6	46.6	46.3	60.5	66.7
	65	41.6	41.3	53.1	58.0	43.9	43.6	56.7	62.3	47.1	46.8	60.9	67.1
	70	44.9	44.5	56.7	61.7	45.3	45.0	57.8	63.3	47.9	47.6	61.7	67.7
	75	48.1	47.7	60.7	66.0	48.2	47.8	60.8	66.1	49.2	48.9	62.7	68.6
10000	60	41.2	40.9	52.0	56.7	44.3	43.9	56.1	61.2	47.8	47.5	60.6	66.3
	65	43.0	42.7	53.4	57.9	45.2	44.8	56.8	62.0	48.4	48.1	61.0	66.6
	70	46.7	46.3	57.6	62.2	46.8	46.4	58.1	63.1	49.2	48.9	61.7	67.3
	75	50.0	49.6	61.6	66.6	50.1	49.7	61.7	66.7	50.7	50.4	62.9	68.4
11000	60	42.3	42.0	52.2	56.5	45.3	45.0	56.2	61.0	48.8	48.5	60.5	65.8
	65	44.8	44.4	54.3	58.3	46.2	45.9	57.0	61.7	49.4	49.1	61.1	66.2
	70	48.2	47.8	58.4	62.7	48.0	47.7	58.4	62.9	50.3	50.1	61.8	66.9
	75	51.7	51.3	62.5	67.1	51.8	51.4	62.5	67.2	52.0	51.7	63.1	68.1
12000	60	43.1	42.8	52.3	56.3	46.1	45.9	56.3	60.7	49.6	49.3	60.4	65.3
	65	46.0	45.6	54.9	58.7	47.1	46.9	57.0	61.4	50.3	50.0	61.1	65.9
	70	49.5	49.2	59.1	63.1	49.6	48.9	59.1	62.9	51.3	51.0	61.8	66.6
	75	53.1	52.8	63.2	67.5	53.2	52.8	63.3	67.6	53.1	52.8	63.3	67.9
<b>Ambient DB 65°F</b>													
7500	60	38.1	37.7	51.7	57.4	41.1	40.7	56.1	62.4	44.7	44.3	60.8	67.8
	65	39.4	38.9	52.7	58.2	41.9	41.4	56.7	63.0	45.1	44.7	61.1	68.1
	70	42.1	41.6	55.6	61.0	42.7	42.3	57.2	63.4	45.8	45.4	61.7	68.6
	75	45.1	44.5	59.4	65.3	45.2	44.2	59.5	65.0	46.5	46.1	62.2	69.1

**Table 72. Reheat temperature rise - 25 tons, high efficiency (continued)**

Air-flow (cfm)	Ent DB (°F)	Entering Wet Bulb (°F)											
		51				55				59			
		Lvg Evap DB (°F)		Lvg Reheat DB (°F)		Lvg Evap DB (°F)		Lvg Reheat DB (°F)		Lvg Evap DB (°F)		Lvg Reheat DB (°F)	
		MIN	MAX	MIN	MAX	MIN	MAX	MIN	MAX	MIN	MAX	MIN	MAX
9000	60	40.3	39.9	52.1	57.0	43.3	42.9	56.2	61.6	46.8	46.4	60.7	66.7
	65	41.9	41.5	53.3	58.0	44.2	43.8	56.9	62.3	47.3	47.0	61.1	67.1
	70	45.3	44.8	57.1	61.9	45.6	45.2	58.0	63.3	48.2	47.8	61.8	67.8
	75	48.5	48.0	61.0	66.2	48.6	48.1	61.1	66.3	49.5	49.1	62.9	68.7
10000	60	41.5	41.1	52.2	56.7	44.5	44.2	56.3	61.3	48.0	47.7	60.7	66.3
	65	43.2	42.9	53.5	57.9	45.4	45.0	57.0	61.9	48.6	48.3	61.2	66.6
	70	47.0	46.5	57.9	62.4	47.0	46.7	58.3	63.1	49.5	49.1	61.9	67.3
	75	50.3	49.9	61.9	66.7	50.4	50.0	62.0	66.8	51.0	50.6	63.1	68.4
11000	60	42.5	42.2	52.4	56.5	45.5	45.2	56.3	60.9	49.0	48.6	60.6	65.7
	65	45.1	44.7	54.6	58.4	46.4	46.1	57.1	61.6	49.7	49.3	61.2	66.2
	70	48.5	48.1	58.7	62.8	48.2	47.9	58.5	62.9	50.5	50.2	61.9	66.9
	75	52.0	51.5	62.7	67.2	52.1	51.6	62.8	67.3	52.2	51.9	63.3	68.1
12000	60	43.5	43.0	52.7	56.3	46.3	46.0	56.4	60.7	49.7	49.4	60.6	65.3
	65	46.3	45.9	55.2	58.8	47.3	47.0	57.2	61.4	50.5	50.2	61.2	65.9
	70	49.8	49.4	59.3	63.2	49.9	49.5	59.4	63.3	51.4	51.2	61.9	66.6
	75	53.4	53.0	63.5	67.6	53.5	53.1	63.5	67.7	53.3	53.0	63.5	67.9
<b>Ambient DB 70°F</b>													
7500	60	38.4	38.0	52.0	57.5	41.4	41.0	56.3	62.4	45.0	44.6	61.0	67.9
	65	39.7	39.2	53.0	58.3	42.1	41.7	56.9	63.0	45.3	44.9	61.3	68.1
	70	42.5	42.0	56.0	61.2	43.2	42.5	57.8	63.4	46.0	45.6	61.9	68.6
	75	45.4	44.9	59.8	65.5	45.5	45.0	59.9	65.6	46.8	46.4	62.5	69.1
9000	60	40.6	40.2	52.3	57.0	43.6	43.2	56.4	61.6	47.0	46.6	60.8	66.7
	65	42.2	41.8	53.5	58.1	44.4	44.0	57.1	62.3	47.6	47.2	61.3	67.1
	70	45.6	45.1	57.4	62.1	45.9	45.4	58.2	63.3	48.4	48.0	62.0	67.7
	75	48.8	48.3	61.4	66.3	48.9	48.4	61.5	66.4	49.7	49.3	63.1	68.7
10000	60	41.7	41.4	52.4	56.7	44.8	44.4	56.5	61.3	48.3	47.9	60.8	66.2
	65	43.4	43.1	53.6	57.9	45.6	45.3	57.2	61.9	48.9	48.5	61.3	66.6
	70	47.3	46.9	58.3	62.5	47.3	46.9	58.5	63.1	49.7	49.3	62.0	67.3
	75	50.7	50.2	62.3	66.9	50.8	50.3	62.3	66.9	51.2	50.8	63.3	68.4
11000	60	42.7	42.4	52.5	56.5	45.7	45.4	56.5	60.9	49.2	48.8	60.7	65.7
	65	45.4	45.0	54.9	58.6	46.7	46.3	57.3	61.6	49.9	49.5	61.3	66.2
	70	48.8	48.4	59.0	62.9	48.4	48.1	58.6	62.9	50.8	50.4	62.1	66.9
	75	52.3	51.8	63.0	67.3	52.4	51.9	63.1	67.4	52.5	52.1	63.4	68.1
12000	60	43.8	43.4	52.8	56.5	46.5	46.2	56.5	60.7	49.9	49.6	60.7	65.3
	65	46.6	46.2	55.5	58.9	47.7	47.2	57.5	61.3	50.7	50.4	61.3	65.8
	70	50.1	49.7	59.6	63.3	50.2	49.8	59.7	63.4	51.7	51.3	62.1	66.5
	75	53.8	53.3	63.7	67.7	53.8	53.4	63.8	67.8	53.5	53.2	63.6	67.9

**Note:** MIN, MAX: The leaving evaporator temperature is affected by the modulating valve position. The MIN and MAX numbers represent modulating valve position impact on both the leaving evaporator temperature and the leaving reheat coil temperature. MAX represents wide open, MIN represents closed to minimum position.



# Evaporator Fan Performance — Cooling

## Fan Curve Limits

Table 73. Fan curve limits

Unit Size (tons)	Efficiency	Motor	Maximum			
			hp	rpm	CFM (cfm/ton)	ESP
3	Std	Standard	0.75 1.0 (575 V)	1200	480	2.0 in H <sub>2</sub> O @ 400 cfm/ton
3	Std	High Static	1.5	1400	480	2.0 in H <sub>2</sub> O @ 400 cfm/ton
3	High	Standard	0.75	1300	480	2.0 in H <sub>2</sub> O @ 400 cfm/ton
3	High	High Static	1.0	1300	480	2.0 in H <sub>2</sub> O @ 400 cfm/ton
4 to 5	Std	Standard	1.0	1200	480	2.0 in H <sub>2</sub> O @ 400 cfm/ton
4 to 5	Std	High Static	1.5	1400	480	2.0 in H <sub>2</sub> O @ 400 cfm/ton
4 to 5	High	Standard	3.0	1850	480	2.0 in H <sub>2</sub> O @ 400 cfm/ton
6 to 10	Std, High	Standard	3.0	1850	480	2.0 in H <sub>2</sub> O @ 400 cfm/ton
10	Std, High	High Static	4.55	1940	480	2.0 in H <sub>2</sub> O @ 400 cfm/ton
12.5	Std	Standard	4.55	1940	480	2.0 in H <sub>2</sub> O @ 400 cfm/ton
12.5	High	Standard	3.0	1850	480	2.0 in H <sub>2</sub> O @ 400 cfm/ton
15 to 25	Std, High	Standard	6.0	1850	480	2.0 in H <sub>2</sub> O @ 400 cfm/ton
25	Std, High	High Static	9.1	1940	480	2.0 in H <sub>2</sub> O @ 400 cfm/ton

The fan curve graphs include standard filter and a wet indoor coil. ESP capability is reduced with options based on the accessory table component pressure drop. To determine ESP at rpm/cfm with other options/accessories, select intersection point of the RPM vs CFM and then reduce ESP shown in graph by the sum of additional option static pressure drop listed in the fan performance accessory table section.

### 3 to 5 Tons

Figure 10. Fan curves – 3 to 5 tons (model TSK), downflow

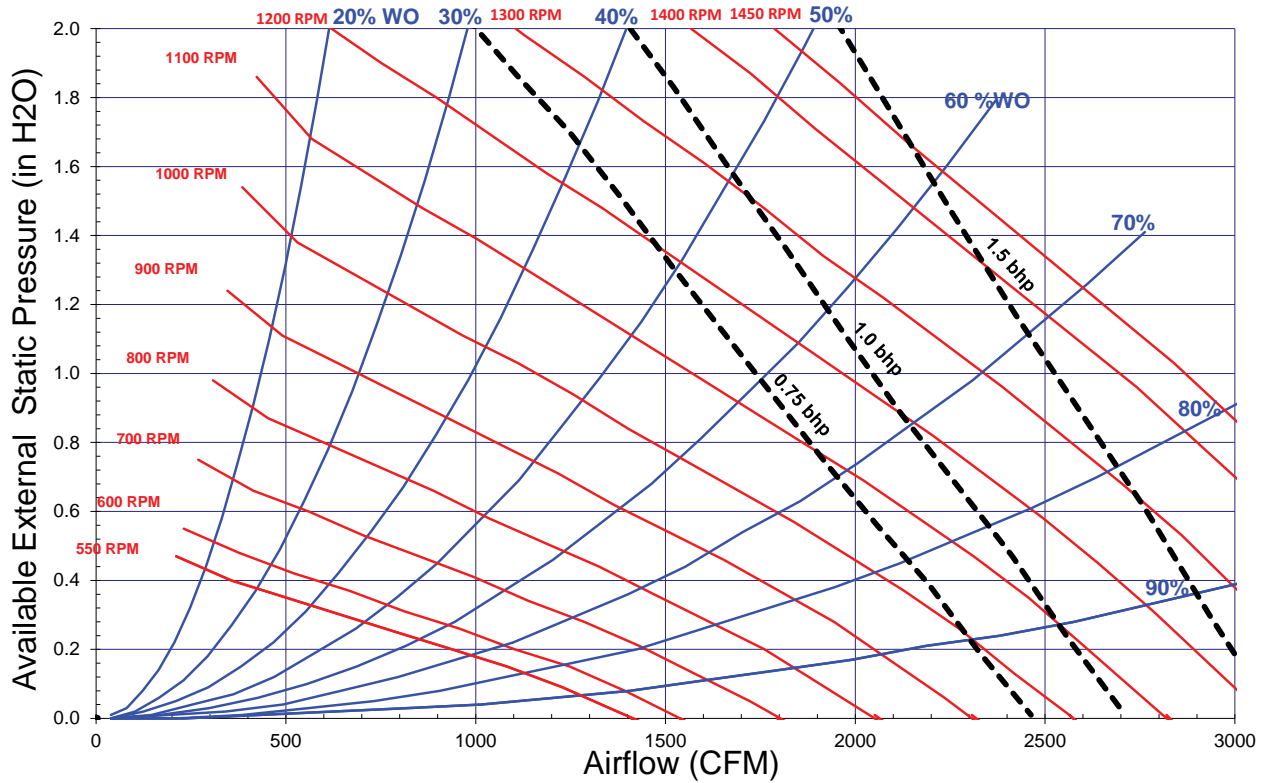
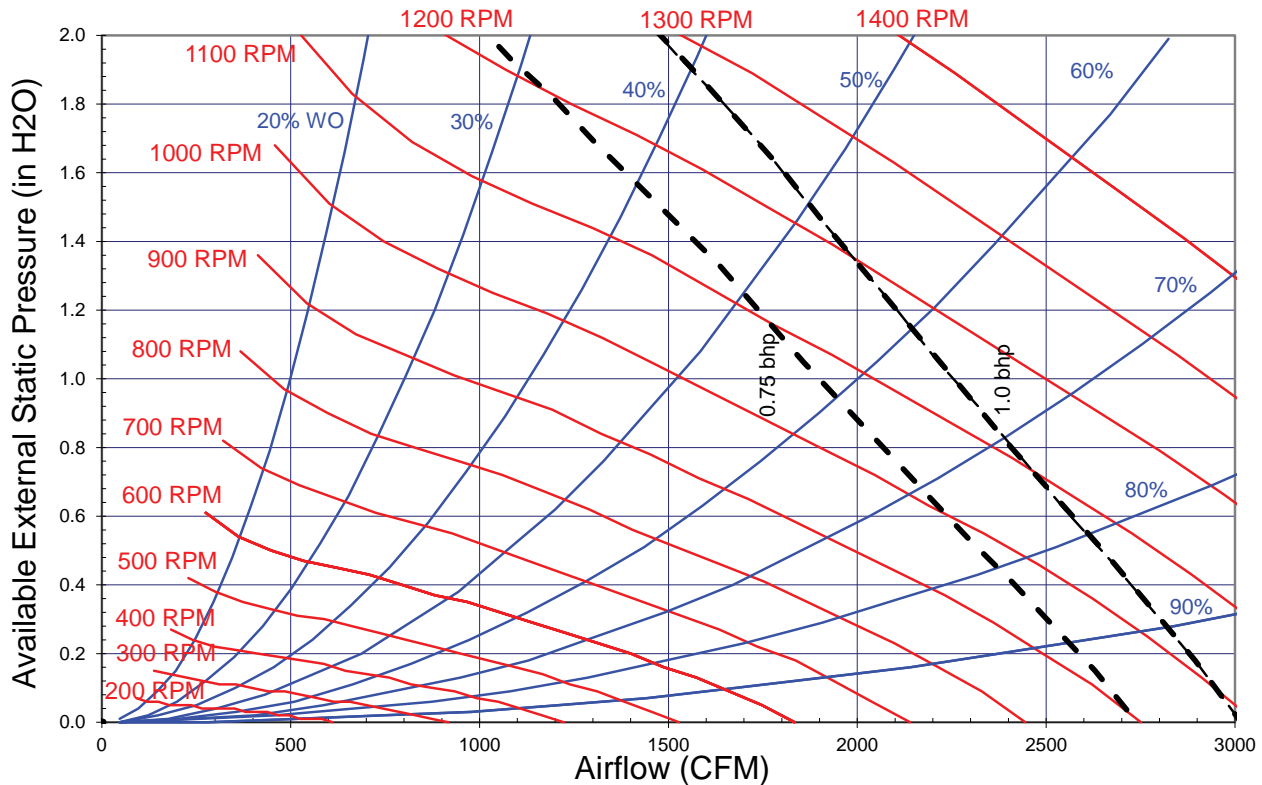

Figure 11. Fan curves – 3 tons (model THK), downflow





# Evaporator Fan Performance — Cooling

Figure 12. Fan curves – 4 and 5 tons (model THK), downflow

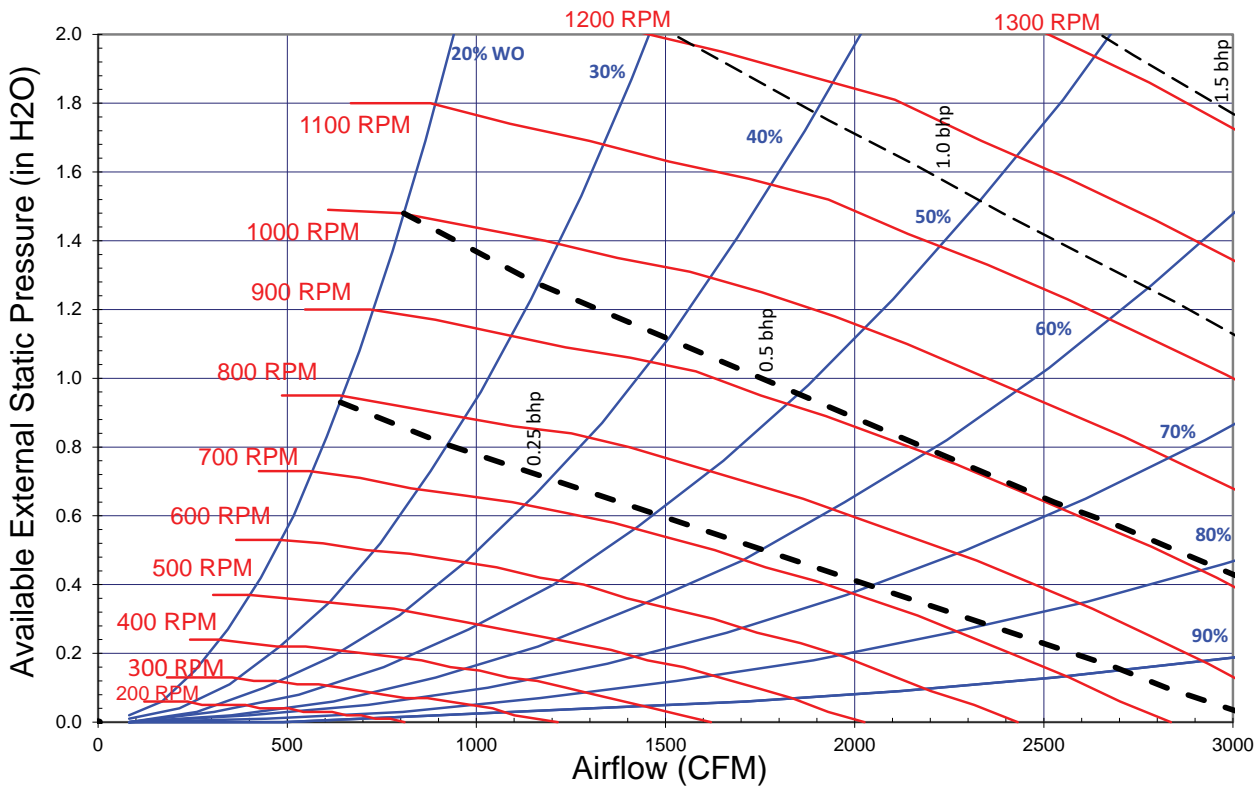

Figure 13. Fan curves – 3 to 5 tons (model TSK), horizontal

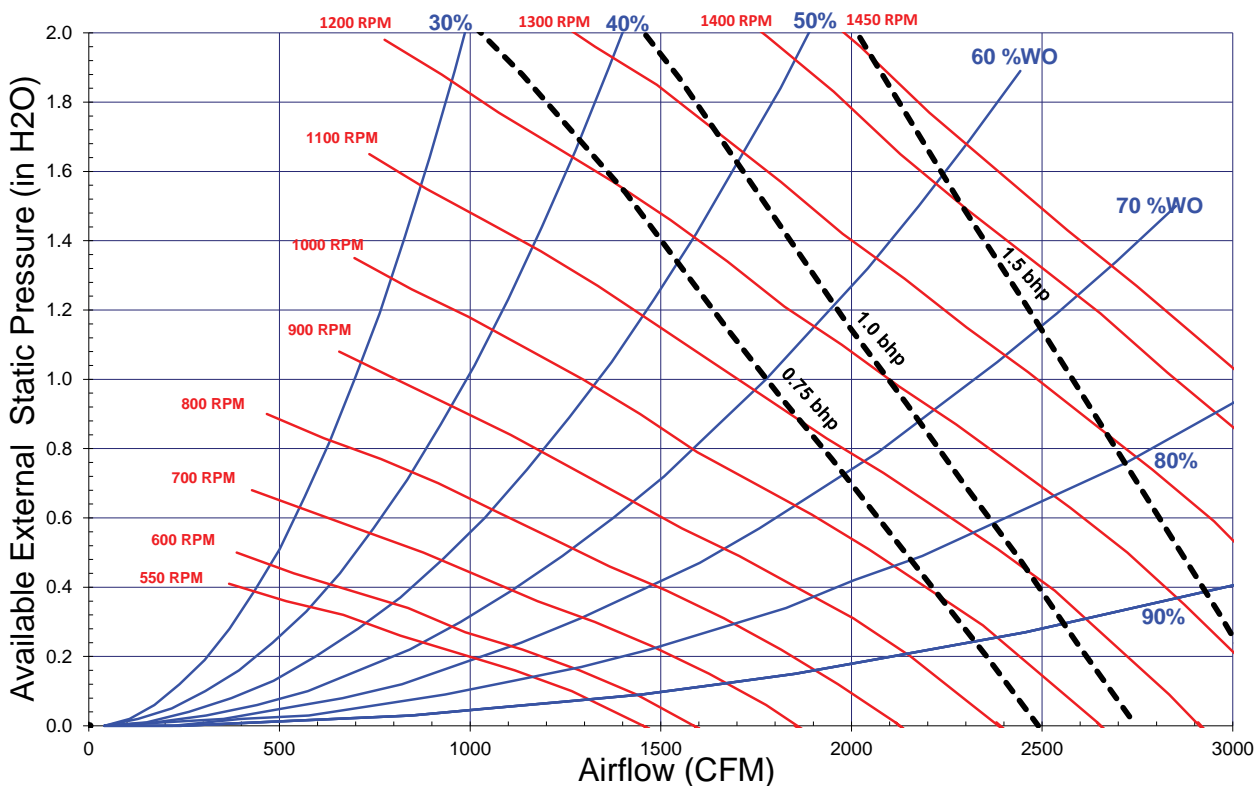

Figure 14. Fan curves – 3 (model THK), horizontal

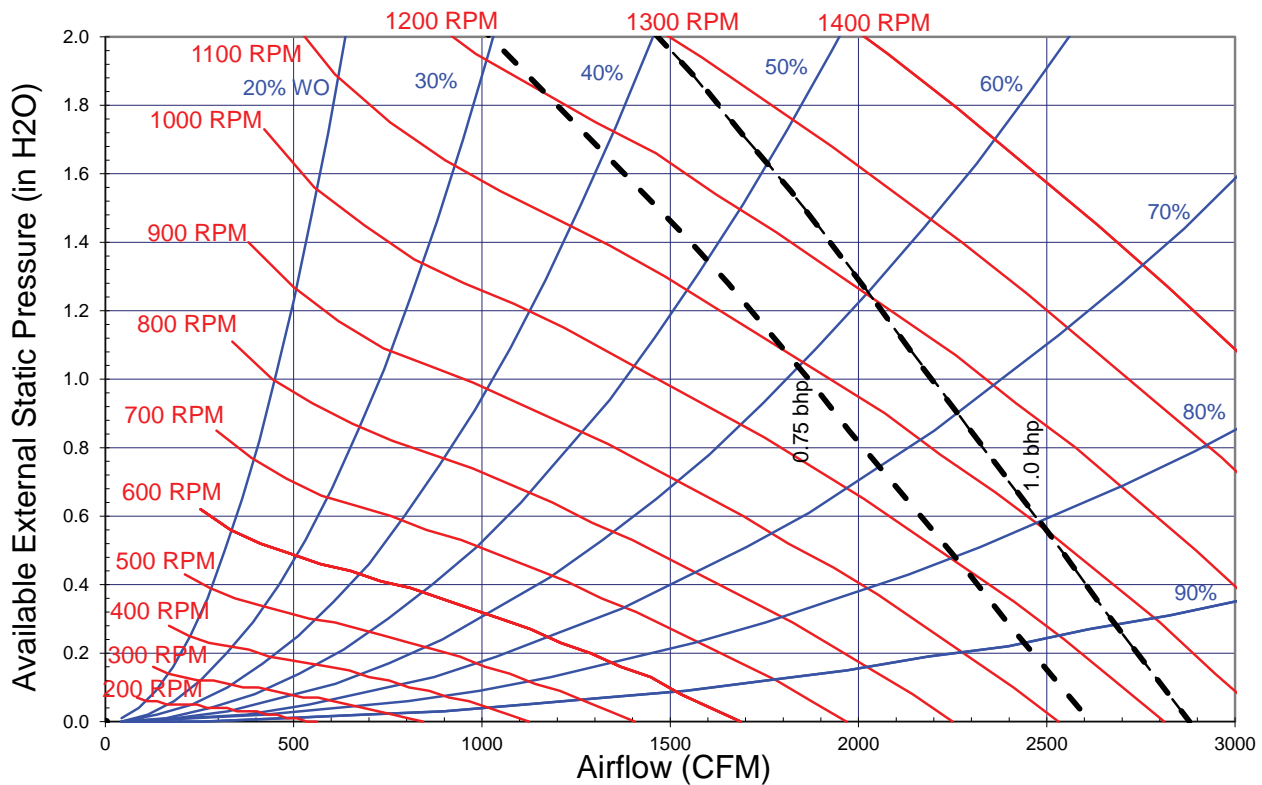
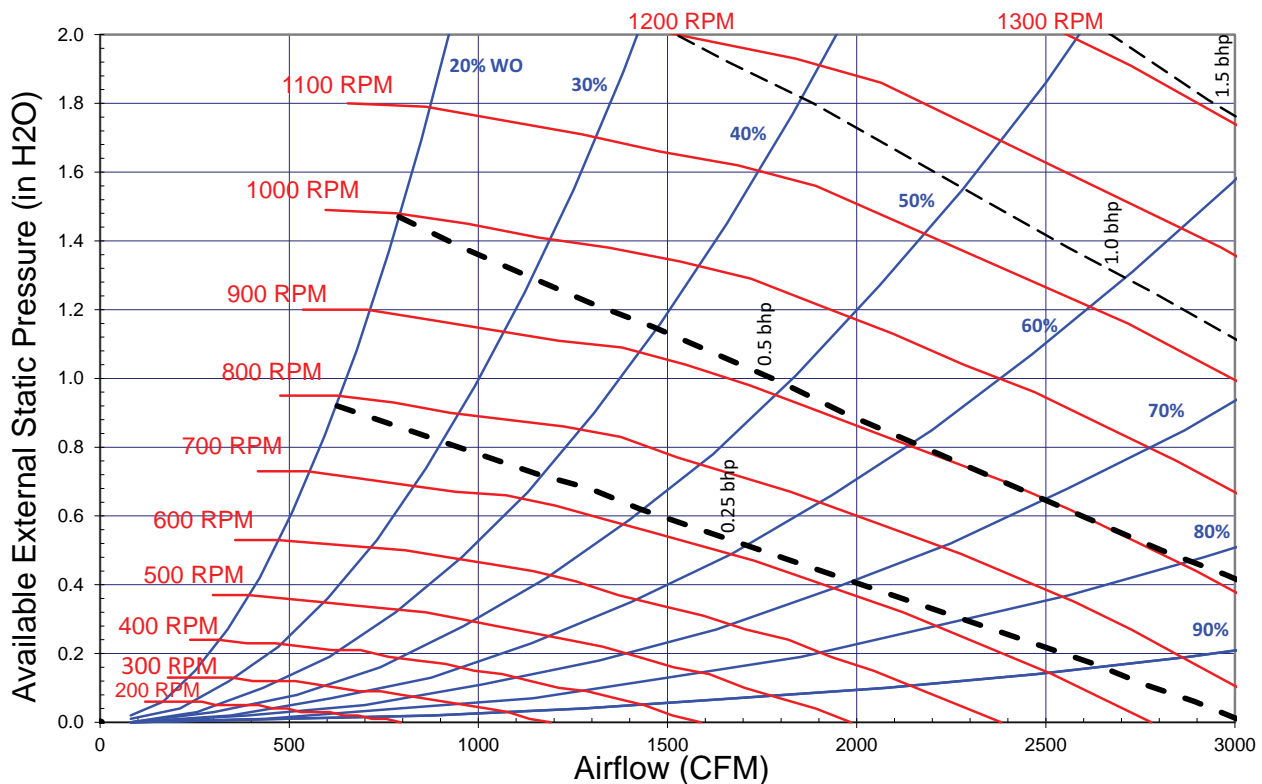

Figure 15. Fan curves – 4 and 5 tons (model THK), horizontal





## Evaporator Fan Performance — Cooling

Table 74. Evaporator fan performance – 3 to 5 tons (model TSK)

Unit Size (tons)	Model Number	CFM	External Static Pressure (in. water) and Motor Power (Bhp)														
			Speed Set 1			Speed Set 2			Speed Set 3			Speed Set 4			Speed Set 5		
			ESP	RPM	BHP	ESP	RPM	BHP	ESP	RPM	BHP	ESP	RPM	BHP	ESP	RPM	BHP
3	TSK036*3, 4, W Downflow	900	0.62	742	0.18	1.00	889	0.30	1.31	999	0.40	1.57	1080	0.50	1.83	1153	0.60
		960	0.55	724	0.18	0.92	874	0.29	1.23	984	0.40	1.49	1067	0.50	1.75	1142	0.60
		1020	0.49	705	0.17	0.85	857	0.29	1.16	969	0.39	1.41	1053	0.49	1.66	1129	0.59
		1080	0.42	685	0.17	0.78	839	0.28	1.08	953	0.39	1.33	1039	0.48	1.58	1116	0.58
		1140	0.35	665	0.16	0.71	820	0.27	1.00	936	0.38	1.25	1023	0.47	1.49	1101	0.58
		1200	0.28	643	0.16	0.63	801	0.27	0.92	918	0.37	1.16	1006	0.47	1.41	1086	0.57
		1260	0.21	621	0.15	0.56	780	0.26	0.84	899	0.36	1.08	989	0.46	1.32	1070	0.56
		1320	0.14	597	0.15	0.48	759	0.25	0.76	879	0.36	1.00	970	0.45	1.23	1052	0.55
		1380	0.07	573	0.14	0.40	736	0.25	0.68	859	0.35	0.91	951	0.44	1.14	1034	0.54
		1440	—	—	—	0.33	713	0.24	0.60	837	0.34	0.83	931	0.43	1.05	1015	0.53
3	TSK036*3, 4, W Horizontal	900	0.51	722	0.18	0.86	876	0.29	1.15	991	0.40	1.39	1077	0.50	1.63	1154	0.60
		960	0.44	702	0.17	0.78	858	0.29	1.07	973	0.39	1.30	1060	0.49	1.54	1138	0.60
		1020	0.37	681	0.17	0.71	838	0.28	0.99	955	0.39	1.22	1043	0.48	1.46	1122	0.59
		1080	0.31	659	0.16	0.64	818	0.27	0.91	937	0.38	1.14	1026	0.48	1.37	1106	0.58
		1140	0.24	637	0.16	0.56	798	0.27	0.83	917	0.37	1.06	1007	0.47	1.28	1089	0.57
		1200	0.17	614	0.15	0.49	776	0.26	0.75	897	0.36	0.98	989	0.46	1.20	1071	0.56
		1260	0.10	591	0.15	0.41	754	0.25	0.67	877	0.35	0.89	969	0.45	1.11	1053	0.55
		1320	0.03	566	0.14	0.34	732	0.24	0.59	856	0.35	0.81	949	0.44	1.02	1034	0.54
		1380	—	—	—	0.26	709	0.24	0.51	834	0.34	0.72	928	0.43	0.93	1014	0.53
		1440	—	—	—	0.19	685	0.23	0.43	811	0.33	0.64	907	0.42	0.85	994	0.52
4	TSK048*3, 4, W Downflow	1200	0.64	847	0.31	1.08	1024	0.50	1.27	1091	0.58	1.49	1164	0.69	—	—	—
		1280	0.55	820	0.30	0.98	1001	0.49	1.16	1069	0.57	1.38	1143	0.68	—	—	—
		1360	0.46	792	0.29	0.87	976	0.47	1.05	1045	0.56	1.27	1121	0.67	—	—	—
		1440	0.36	762	0.28	0.77	949	0.46	0.95	1020	0.55	1.15	1098	0.65	1.49	1200	0.83
		1520	0.27	730	0.27	0.67	921	0.45	0.84	994	0.53	1.04	1073	0.64	1.37	1184	0.82
		1600	0.17	697	0.26	0.56	891	0.43	0.73	965	0.52	0.93	1047	0.62	1.25	1161	0.80
		1680	0.07	662	0.24	0.46	860	0.42	0.62	936	0.50	0.81	1019	0.61	1.13	1136	0.78
		1760	—	—	—	0.35	828	0.40	0.51	905	0.48	0.70	989	0.59	1.01	1109	0.77
		1840	—	—	—	0.24	793	0.39	0.40	872	0.47	0.59	959	0.57	0.88	1081	0.75
		1920	—	—	—	0.14	758	0.37	0.29	838	0.45	0.47	926	0.55	0.76	1052	0.73
4	TSK048*3, 4, W Horizontal	1200	0.61	839	0.31	1.05	1011	0.49	1.24	1076	0.58	1.47	1148	0.68	—	—	—
		1280	0.51	813	0.30	0.94	988	0.48	1.13	1055	0.56	1.35	1128	0.67	—	—	—
		1360	0.40	785	0.29	0.82	964	0.47	1.01	1032	0.55	1.23	1106	0.66	1.58	1200	0.84
		1440	0.30	757	0.28	0.71	938	0.46	0.89	1007	0.54	1.10	1084	0.64	1.45	1191	0.82
		1520	0.19	727	0.27	0.59	911	0.44	0.76	982	0.53	0.98	1059	0.63	1.32	1169	0.81
		1600	0.07	695	0.26	0.47	883	0.43	0.64	955	0.51	0.85	1034	0.62	1.18	1147	0.79
		1680	—	—	—	0.35	853	0.41	0.51	926	0.50	0.72	1007	0.60	1.05	1122	0.77
		1760	—	—	—	0.22	822	0.40	0.39	897	0.48	0.59	979	0.58	0.91	1097	0.76
		1840	—	—	—	0.10	789	0.38	0.26	865	0.46	0.45	950	0.57	0.77	1070	0.74
		1920	—	—	—	—	—	—	0.13	833	0.45	0.32	919	0.55	0.62	1041	0.72

Table 74. Evaporator fan performance – 3 to 5 tons (model TSK) (continued)

Unit Size (tons)	Model Number	CFM	External Static Pressure (in. water) and Motor Power (Bhp)														
			Speed Set 1			Speed Set 2			Speed Set 3			Speed Set 4			Speed Set 5		
			ESP	RPM	BHP	ESP	RPM	BHP	ESP	RPM	BHP	ESP	RPM	BHP	ESP	RPM	BHP
5	TSK060*3, 4, W Downflow	1500	1.01	1049	0.60	1.22	1123	0.71	1.46	1200	0.84	—	—	—	—	—	—
		1600	0.87	1015	0.58	1.07	1092	0.69	1.31	1174	0.82	—	—	—	—	—	—
		1700	0.74	979	0.56	0.93	1058	0.67	1.16	1142	0.80	1.32	1193	0.89	—	—	—
		1800	0.60	941	0.54	0.79	1022	0.64	1.01	1109	0.78	1.17	1161	0.87	—	—	—
		1900	0.46	900	0.51	0.64	984	0.62	0.86	1073	0.75	1.01	1127	0.84	1.23	1198	0.98
		2000	0.32	857	0.49	0.50	943	0.59	0.71	1035	0.73	0.86	1091	0.82	1.07	1165	0.96
		2100	0.18	812	0.46	0.36	900	0.57	0.56	995	0.70	0.70	1052	0.79	0.91	1128	0.93
		2200	0.04	764	0.44	0.21	854	0.54	0.41	952	0.67	0.54	1011	0.76	0.74	1090	0.90
		2300	—	—	—	0.06	806	0.51	0.26	907	0.64	0.39	967	0.73	0.58	1049	0.86
		2400	—	—	—	—	—	—	0.11	859	0.60	0.23	922	0.69	0.42	1006	0.83
5	TSK060*3, 4, W Horizontal	1500	0.95	1036	0.59	1.16	1109	0.70	1.42	1187	0.83	—	—	—	—	—	—
		1600	0.79	1003	0.57	1.00	1078	0.68	1.25	1159	0.81	1.42	1200	0.91	—	—	—
		1700	0.63	969	0.55	0.83	1046	0.66	1.08	1129	0.79	1.25	1179	0.88	—	—	—
		1800	0.47	932	0.53	0.67	1011	0.64	0.91	1097	0.77	1.07	1149	0.86	—	—	—
		1900	0.31	893	0.51	0.50	974	0.61	0.73	1063	0.75	0.89	1116	0.84	1.13	1187	0.97
		2000	0.14	853	0.49	0.33	936	0.59	0.55	1026	0.72	0.71	1081	0.81	0.94	1155	0.95
		2100	—	—	—	0.16	895	0.56	0.38	988	0.69	0.52	1044	0.78	0.75	1120	0.92
		2200	—	—	—	—	—	—	0.19	947	0.66	0.34	1005	0.75	0.55	1083	0.89
		2300	—	—	—	—	—	—	0.01	904	0.63	0.15	964	0.72	0.36	1045	0.86
		2400	—	—	—	—	—	—	—	—	—	—	—	—	0.16	1004	0.82

Notes:

1. Available External Static Pressure is the static pressure difference between the return duct and the supply duct plus the static pressure drop caused by accessories and options.
2. For direct drive evaporator fan speed (rpm), refer to the applicable table in the fan performance section.
3. Data includes pressure drop due to standard filters and wet coils. No accessories or options are included in pressure drop data.
4. To determine static pressure drop due to other options/accessories, refer to the applicable table in the fan performance section.
5. For 036 models, fan motor heat (MBh) = 2.72 x Fan Bhp + 0.16. For 048 and 060 models, fan motorheat (MBh) = 2.87 x Fan Bhp + 0.15
6. Factory supplied motors, in commercial equipment, are definite purpose motors, specifically designed and tested to operate reliably and continuously at all cataloged conditions. Using the full horsepower range of our fan motors as shown in our tabular data will not result in nuisance tripping or premature motor failure. Our product's warranty will not be affected.



## Evaporator Fan Performance — Cooling

Table 75. Evaporator fan performance - 3 to 5 tons (model TSK), high static motor

Unit Size (tons)	Model Number	CFM	External Static Pressure (in. water) and Motor Power (Bhp)														
			Speed Set 1			Speed Set 2			Speed Set 3			Speed Set 4			Speed Set 5		
			ESP	RPM	BHP	ESP	RPM	BHP	ESP	RPM	BHP	ESP	RPM	BHP	ESP	RPM	BHP
3	TSK036*3, 4, W Downflow Airflow	900	1.28	1031	0.47	1.78	1194	0.68	—	—	—	—	—	—	—	—	—
		960	1.21	1016	0.46	1.70	1181	0.67	1.98	1263	0.81	—	—	—	—	—	—
		1020	1.13	999	0.45	1.62	1167	0.67	1.90	1250	0.80	—	—	—	—	—	—
		1080	1.05	982	0.44	1.54	1152	0.66	1.81	1237	0.79	2.00	1297	0.91	—	—	—
		1140	0.98	964	0.44	1.45	1137	0.65	1.73	1223	0.79	1.95	1285	0.90	—	—	—
		1200	0.90	945	0.43	1.37	1120	0.64	1.64	1208	0.78	1.86	1271	0.89	—	—	—
		1260	0.83	926	0.42	1.29	1103	0.63	1.56	1192	0.77	1.77	1256	0.88	—	—	—
		1320	0.75	905	0.41	1.21	1085	0.62	1.47	1176	0.76	1.68	1241	0.87	—	—	—
		1380	0.67	884	0.40	1.12	1066	0.61	1.38	1158	0.74	1.59	1225	0.86	1.99	1331	1.09
		1440	0.59	862	0.39	1.04	1047	0.60	1.29	1140	0.73	1.50	1208	0.85	1.90	1317	1.08
3	TSK036*3, 4, W Horizontal Airflow	900	1.31	1025	0.46	1.79	1183	0.68	—	—	—	—	—	—	—	—	—
		960	1.23	1008	0.46	1.71	1169	0.67	1.99	1254	0.81	—	—	—	—	—	—
		1020	1.15	991	0.45	1.63	1153	0.66	1.91	1240	0.80	—	—	—	—	—	—
		1080	1.06	973	0.44	1.55	1137	0.65	1.83	1225	0.79	2.00	1292	0.91	—	—	—
		1140	0.98	953	0.43	1.46	1121	0.64	1.74	1210	0.78	1.96	1278	0.90	—	—	—
		1200	0.89	934	0.42	1.37	1103	0.63	1.65	1194	0.77	1.88	1263	0.89	—	—	—
		1260	0.80	913	0.41	1.28	1085	0.62	1.56	1177	0.76	1.78	1247	0.88	—	—	—
		1320	0.70	892	0.40	1.19	1066	0.61	1.47	1160	0.75	1.69	1231	0.86	—	—	—
		1380	0.61	870	0.39	1.09	1046	0.60	1.37	1141	0.73	1.60	1214	0.85	2.00	1342	1.10
		1440	0.51	847	0.38	0.99	1026	0.59	1.27	1122	0.72	1.50	1196	0.84	1.93	1326	1.09
4	TSK048*3, 4, W Downflow Airflow	1200	1.37	1120	0.64	1.90	1282	0.92	—	—	—	—	—	—	—	—	—
		1280	1.26	1097	0.63	1.78	1263	0.90	—	—	—	—	—	—	—	—	—
		1360	1.15	1073	0.61	1.66	1243	0.89	1.99	1327	1.07	—	—	—	—	—	—
		1440	1.04	1047	0.60	1.54	1220	0.87	1.86	1307	1.06	—	—	—	—	—	—
		1520	0.92	1019	0.58	1.42	1197	0.85	1.73	1286	1.04	—	—	—	—	—	—
		1600	0.81	990	0.57	1.30	1172	0.84	1.60	1264	1.02	1.98	1350	1.26	—	—	—
		1680	0.70	960	0.55	1.17	1145	0.82	1.47	1240	1.00	1.84	1330	1.24	—	—	—
		1760	0.58	928	0.53	1.05	1118	0.80	1.34	1215	0.98	1.70	1308	1.22	2.00	1357	1.42
		1840	0.47	895	0.51	0.92	1088	0.78	1.21	1188	0.96	1.56	1284	1.20	1.86	1337	1.40
		1920	0.35	860	0.49	0.80	1057	0.76	1.08	1160	0.94	1.42	1260	1.18	1.71	1315	1.38
4	TSK048*3, 4, W Horizontal Airflow	1200	1.37	1103	0.63	1.92	1276	0.91	—	—	—	—	—	—	—	—	—
		1280	1.25	1079	0.62	1.80	1256	0.90	—	—	—	—	—	—	—	—	—
		1360	1.12	1053	0.60	1.67	1234	0.88	2.00	1335	1.08	—	—	—	—	—	—
		1440	0.99	1026	0.59	1.54	1210	0.86	1.89	1314	1.06	—	—	—	—	—	—
		1520	0.86	997	0.57	1.41	1186	0.85	1.75	1292	1.05	—	—	—	—	—	—
		1600	0.72	968	0.55	1.27	1160	0.83	1.62	1269	1.03	2.00	1390	1.30	—	—	—
		1680	0.58	936	0.53	1.13	1132	0.81	1.47	1244	1.01	1.90	1368	1.28	—	—	—
		1760	0.43	904	0.52	0.98	1104	0.79	1.33	1218	0.99	1.76	1345	1.26	—	—	—
		1840	0.28	870	0.50	0.83	1074	0.77	1.18	1190	0.96	1.61	1321	1.23	1.98	1417	1.48
		1920	0.13	835	0.48	0.67	1042	0.74	1.02	1162	0.94	1.45	1296	1.21	1.82	1395	1.46

**Table 75. Evaporator fan performance - 3 to 5 tons (model TSK), high static motor (continued)**

Unit Size (tons)	Model Number	CFM	External Static Pressure (in. water) and Motor Power (Bhp)														
			Speed Set 1			Speed Set 2			Speed Set 3			Speed Set 4			Speed Set 5		
			ESP	RPM	BHP	ESP	RPM	BHP	ESP	RPM	BHP	ESP	RPM	BHP	ESP	RPM	BHP
5	TSK060*3, 4, W Downflow Airflow	1500	1.51	1215	0.88	1.82	1301	1.07	—	—	—	—	—	—	—	—	—
		1600	1.36	1185	0.86	1.66	1274	1.05	1.95	1340	1.23	—	—	—	—	—	—
		1700	1.21	1152	0.84	1.50	1244	1.02	1.78	1314	1.20	1.92	1340	1.29	—	—	—
		1800	1.05	1117	0.81	1.34	1212	1.00	1.61	1285	1.18	1.74	1313	1.27	1.98	1349	1.42
		1900	0.90	1079	0.78	1.18	1178	0.97	1.44	1254	1.15	1.57	1284	1.24	1.80	1323	1.39
		2000	0.74	1040	0.75	1.01	1142	0.94	1.27	1221	1.12	1.39	1252	1.21	1.61	1294	1.36
		2100	0.59	998	0.72	0.85	1103	0.91	1.10	1186	1.09	1.22	1218	1.17	1.43	1264	1.33
		2200	0.43	954	0.69	0.69	1062	0.87	0.93	1148	1.05	1.04	1182	1.14	1.24	1230	1.30
		2300	0.27	907	0.66	0.52	1019	0.84	0.75	1108	1.02	0.86	1144	1.10	1.06	1195	1.26
		2400	0.12	858	0.62	0.35	974	0.80	0.58	1066	0.98	0.68	1103	1.06	0.87	1158	1.22
5	TSK060*3, 4, W Horizontal Airflow	1500	1.51	1206	0.88	1.85	1310	1.08	—	—	—	—	—	—	—	—	
		1600	1.34	1174	0.85	1.68	1282	1.05	2.01	1374	1.26	—	—	—	—	—	—
		1700	1.16	1140	0.83	1.51	1251	1.03	1.84	1346	1.23	2.00	1389	1.34	—	—	—
		1800	0.98	1104	0.80	1.33	1218	1.00	1.65	1317	1.21	1.81	1361	1.31	—	—	—
		1900	0.79	1066	0.77	1.14	1183	0.97	1.47	1285	1.18	1.63	1330	1.28	1.91	1405	1.48
		2000	0.60	1026	0.74	0.94	1146	0.94	1.27	1251	1.15	1.43	1298	1.25	1.72	1376	1.45
		2100	0.40	983	0.71	0.74	1106	0.91	1.07	1215	1.11	1.23	1264	1.22	1.52	1345	1.42
		2200	0.19	939	0.68	0.54	1065	0.87	0.87	1177	1.08	1.03	1227	1.18	1.31	1311	1.38
		2300	—	—	—	0.33	1022	0.84	0.66	1137	1.04	0.81	1188	1.15	1.10	1275	1.34
		2400	—	—	—	0.11	976	0.80	0.44	1094	1.00	0.60	1148	1.11	0.88	1238	1.30

**Notes:**

1. Available External Static Pressure is the static pressure difference between the return duct and the supply duct plus the static pressure drop caused by accessories and options.
2. For direct drive evaporator fan speed (rpm), refer to the applicable table in the fan performance section.
3. Data includes pressure drop due to standard filters and wet coils. No accessories or options are included in pressure drop data.
4. To determine static pressure drop due to other options/accessories, refer to the applicable table in the fan performance section.
5. For 036 models, fan motor heat (MBh) = 2.72 x Fan Bhp + 0.16. For 048 and 060 models, fan motorheat (MBh) = 2.87 x Fan Bhp + 0.15
6. Factory supplied motors, in commercial equipment, are definite purpose motors, specifically designed and tested to operate reliably and continuously at all cataloged conditions. Using the full horsepower range of our fan motors as shown in our tabular data will not result in nuisance tripping or premature motor failure. Our product's warranty will not be affected.

**Table 76. Evaporator fan performance – 3 tons (model THK), downflow**

Available External Static Pressure (Inches of Water Gauge)																				
CFM	0.10		0.20		0.30		0.40		0.50		0.60		0.70		0.80		0.90		1.00	
	RPM	BHP	RPM	BHP	RPM	BHP	RPM	BHP	RPM	BHP	RPM	BHP	RPM	BHP	RPM	BHP	RPM	BHP	RPM	BHP
900	404	0.05	489	0.07	558	0.10	618	0.12	671	0.15	720	0.18	767	0.21	811	0.24	852	0.28	891	0.31
960	418	0.06	502	0.08	570	0.11	629	0.14	682	0.16	730	0.19	776	0.23	820	0.26	861	0.29	900	0.33
1080	448	0.07	528	0.10	595	0.13	653	0.16	705	0.19	752	0.22	797	0.26	838	0.29	879	0.33	918	0.36
1200	478	0.09	555	0.12	620	0.16	677	0.19	728	0.22	775	0.26	819	0.29	860	0.33	899	0.37	936	0.40
1320	510	0.12	583	0.15	646	0.19	702	0.22	753	0.26	799	0.29	842	0.33	883	0.37	921	0.41	958	0.45
1440	544	0.14	612	0.18	673	0.22	727	0.26	777	0.30	823	0.34	866	0.38	906	0.42	944	0.46	980	0.50
Available External Static Pressure (Inches of Water Gauge)																				
CFM	1.10		1.20		1.30		1.40		1.50		1.60		1.70		1.80		1.90		2.00	
	RPM	BHP	RPM	BHP	RPM	BHP	RPM	BHP	RPM	BHP	RPM	BHP	RPM	BHP	RPM	BHP	RPM	BHP	RPM	BHP
900	927	0.35	962	0.38	996	0.42	1028	0.45	1059	0.49	1089	0.53	1119	0.57	1146	0.61	1172	0.65	1197	0.69
960	937	0.36	972	0.4	1005	0.44	1037	0.48	1069	0.51	1099	0.55	1128	0.59	1156	0.63	1184	0.68	1211	0.72
1080	955	0.4	990	0.44	1024	0.48	1056	0.52	1087	0.56	1118	0.6	1147	0.65	1175	0.69	1203	0.73	-	-
1200	973	0.44	1008	0.49	1042	0.53	1074	0.57	1106	0.61	1136	0.66	1166	0.7	1194	0.75	-	-	-	-
1320	992	0.49	1026	0.53	1060	0.58	1092	0.62	1123	0.67	1154	0.71	-	-	-	-	-	-	-	-



## Evaporator Fan Performance — Cooling

**Table 76. Evaporator fan performance – 3 tons (model THK), downflow (continued)**

Available External Static Pressure (Inches of Water Gauge)																				
CFM	1.10		1.20		1.30		1.40		1.50		1.60		1.70		1.80		1.90		2.00	
	RPM	BHP	RPM	BHP	RPM	BHP	RPM	BHP	RPM	BHP	RPM	BHP	RPM	BHP	RPM	BHP	RPM	BHP	RPM	BHP
1440	1015	0.54	1048	0.59	1080	0.63	1111	0.68	1142	0.73	-	-	-	-	-	-	-	-	-	-

**Notes:**

1. Available External Static Pressure is the static pressure difference between the return duct and the supply duct plus the static pressure drop caused by accessories and options.
2. Data includes pressure drop due to standard filters and wet coils. No accessories or options are included in pressure drop data.
3. To determine static pressure drop due to other options/accessories, refer to the applicable table in the fan performance section.
4. Direct Drive Fan Motor Heat (MBH) = 2.9245xFan BHP + 0.055.
5. Factory supplied motors, in commercial equipment, are definite purpose motors, specifically designed and tested to operate reliably and continuously at all cataloged conditions. Using the full horsepower range of our fan motors as shown in our tabular data will not result in nuisance tripping or premature motor failure. Our product's warranty will not be affected.

**Table 77. Evaporator fan performance – 3 tons (model THK), downflow, high static motor**

Available External Static Pressure (Inches of Water Gauge)																				
CFM	0.10		0.20		0.30		0.40		0.50		0.60		0.70		0.80		0.90		1.00	
	RPM	BHP	RPM	BHP	RPM	BHP	RPM	BHP	RPM	BHP	RPM	BHP	RPM	BHP	RPM	BHP	RPM	BHP	RPM	BHP
900	403	0.05	486	0.07	554	0.10	616	0.12	670	0.15	719	0.18	765	0.21	808	0.24	849	0.27	887	0.31
960	417	0.06	499	0.08	566	0.11	626	0.13	681	0.16	729	0.19	775	0.22	818	0.26	858	0.29	896	0.32
1080	447	0.07	526	0.10	590	0.13	648	0.16	702	0.19	751	0.22	796	0.25	837	0.29	877	0.32	915	0.36
1200	477	0.09	553	0.12	616	0.16	672	0.19	723	0.22	771	0.25	817	0.29	859	0.32	898	0.36	934	0.40
1320	509	0.12	581	0.15	643	0.18	697	0.22	747	0.25	793	0.29	837	0.33	880	0.37	920	0.40	956	0.44
1440	542	0.14	610	0.18	670	0.22	724	0.26	772	0.29	817	0.33	859	0.37	900	0.41	940	0.45	977	0.49

**Available External Static Pressure (Inches of Water Gauge)**

CFM	1.10		1.20		1.30		1.40		1.50		1.60		1.70		1.80		1.90		2.00	
	RPM	BHP	RPM	BHP	RPM	BHP	RPM	BHP	RPM	BHP	RPM	BHP	RPM	BHP	RPM	BHP	RPM	BHP	RPM	BHP
900	923	0.34	957	0.38	990	0.41	1022	0.45	1053	0.49	1083	0.53	1112	0.56	1140	0.60	1165	0.64	1190	0.69
960	933	0.36	967	0.4	1000	0.43	1032	0.47	1063	0.51	1093	0.55	1121	0.59	1149	0.63	1177	0.67	1203	0.71
1080	952	0.40	986	0.44	1020	0.48	1052	0.52	1083	0.56	1112	0.60	1141	0.64	1169	0.68	1196	0.73	1223	0.77
1200	971	0.44	1005	0.48	1039	0.52	1071	0.56	1102	0.61	1132	0.65	1161	0.69	1189	0.74	1216	0.79	1242	0.83
1320	991	0.48	1025	0.53	1058	0.57	1090	0.62	1121	0.66	1150	0.71	1179	0.75	1208	0.80	1235	0.85	1262	0.90
1440	1013	0.53	1046	0.58	1078	0.62	1109	0.67	1140	0.72	1169	0.77	1198	0.82	1227	0.87	1254	0.92	1281	0.97

**Notes:**

1. Available External Static Pressure is the static pressure difference between the return duct and the supply duct plus the static pressure drop caused by accessories and options.
2. Data includes pressure drop due to standard filters and wet coils. No accessories or options are included in pressure drop data.
3. To determine static pressure drop due to other options/accessories, refer to the applicable table in the fan performance section.
4. Direct Drive Fan Motor Heat (MBH) = 2.9245xFan BHP + 0.055.
5. Factory supplied motors, in commercial equipment, are definite purpose motors, specifically designed and tested to operate reliably and continuously at all cataloged conditions. Using the full horsepower range of our fan motors as shown in our tabular data will not result in nuisance tripping or premature motor failure. Our product's warranty will not be affected.

**Table 78. Evaporator fan performance – 4 tons (model THK), downflow**

Available External Static Pressure (Inches of Water Gauge)																				
CFM	0.10		0.20		0.30		0.40		0.50		0.60		0.70		0.80		0.90		1.00	
	RPM	BHP	RPM	BHP	RPM	BHP	RPM	BHP	RPM	BHP	RPM	BHP	RPM	BHP	RPM	BHP	RPM	BHP	RPM	BHP
1200	392	0.04	469	0.07	534	0.10	592	0.14	643	0.17	690	0.21	736	0.25	781	0.29	822	0.33	862	0.38
1280	408	0.05	482	0.08	546	0.11	602	0.14	653	0.18	700	0.22	743	0.26	787	0.30	829	0.35	868	0.39
1440	439	0.06	509	0.09	570	0.13	625	0.16	675	0.20	721	0.24	763	0.29	803	0.33	841	0.38	881	0.43
1600	472	0.07	537	0.10	596	0.14	649	0.18	697	0.23	742	0.27	784	0.32	824	0.36	861	0.41	897	0.46
1760	506	0.08	567	0.12	623	0.16	673	0.21	721	0.25	765	0.30	806	0.35	845	0.40	882	0.45	917	0.50
1920	541	0.10	598	0.14	651	0.19	700	0.23	745	0.28	789	0.33	829	0.38	867	0.43	903	0.49	938	0.54

**Table 78. Evaporator fan performance – 4 tons (model THK), downflow (continued)**

Available External Static Pressure (Inches of Water Gauge)																				
CFM	1.10		1.20		1.30		1.40		1.50		1.60		1.70		1.80		1.90		2.00	
	RPM	BHP	RPM	BHP	RPM	BHP	RPM	BHP	RPM	BHP	RPM	BHP	RPM	BHP	RPM	BHP	RPM	BHP	RPM	BHP
1200	899	0.42	935	0.47	970	0.52	1003	0.56	1035	0.61	1066	0.67	1096	0.72	1125	0.77	1153	0.82	1181	0.88
1280	906	0.44	941	0.49	976	0.54	1009	0.59	1041	0.64	1072	0.69	1102	0.74	1131	0.8	1159	0.85	1187	0.91
1440	918	0.47	954	0.53	988	0.58	1021	0.63	1053	0.68	1084	0.74	1114	0.79	1143	0.85	1171	0.91	1199	0.97
1600	931	0.51	967	0.57	1001	0.62	1034	0.67	1066	0.73	1097	0.79	1126	0.85	1155	0.91	1184	0.97	1211	1.03
1760	951	0.55	983	0.61	1014	0.66	1047	0.72	1078	0.78	1109	0.84	1139	0.9	1168	0.96	1196	1.03	1224	1.09
1920	972	0.6	1004	0.65	1035	0.71	1065	0.77	1093	0.83	1122	0.9	1152	0.96	1181	1.02	1209	1.09	1236	1.16

**Notes:**

1. Available External Static Pressure is the static pressure difference between the return duct and the supply duct plus the static pressure drop caused by accessories and options.
2. Data includes pressure drop due to standard filters and wet coils. No accessories or options are included in pressure drop data.
3. To determine static pressure drop due to other options/accessories, refer to the applicable table in the fan performance section.
4. Direct drive fan motor heat is negligible.
5. Factory supplied motors, in commercial equipment, are definite purpose motors, specifically designed and tested to operate reliably and continuously at all cataloged conditions. Using the full horsepower range of our fan motors as shown in our tabular data will not result in nuisance tripping or premature motor failure. Our product's warranty will not be affected.

**Table 79. Evaporator fan performance – 5 tons (model THK), downflow**

Available External Static Pressure (Inches of Water Gauge)																				
CFM	0.10		0.20		0.30		0.40		0.50		0.60		0.70		0.80		0.90		1.00	
	RPM	BHP	RPM	BHP	RPM	BHP	RPM	BHP	RPM	BHP	RPM	BHP	RPM	BHP	RPM	BHP	RPM	BHP	RPM	BHP
1500	451	0.06	519	0.09	579	0.13	634	0.17	683	0.21	729	0.25	771	0.30	811	0.34	849	0.39	885	0.44
1600	472	0.07	537	0.10	596	0.14	649	0.18	697	0.23	742	0.27	784	0.32	824	0.36	861	0.41	897	0.46
1800	515	0.09	575	0.13	630	0.17	680	0.21	727	0.26	771	0.31	811	0.36	850	0.41	887	0.46	923	0.51
2000	559	0.11	614	0.15	665	0.20	713	0.25	758	0.30	801	0.35	841	0.40	878	0.45	914	0.51	949	0.56
2200	603	0.14	655	0.18	703	0.23	749	0.28	792	0.34	832	0.39	871	0.45	908	0.50	943	0.56	977	0.62
2400	648	0.17	697	0.22	742	0.27	785	0.32	826	0.38	865	0.44	902	0.50	939	0.56	973	0.62	1006	0.68

Available External Static Pressure (Inches of Water Gauge)																				
CFM	1.10		1.20		1.30		1.40		1.50		1.60		1.70		1.80		1.90		2.00	
	RPM	BHP	RPM	BHP	RPM	BHP	RPM	BHP	RPM	BHP	RPM	BHP	RPM	BHP	RPM	BHP	RPM	BHP	RPM	BHP
1500	923	0.49	959	0.54	993	0.59	1026	0.65	1058	0.7	1089	0.76	1119	0.81	1148	0.87	1176	0.93	1204	0.99
1600	931	0.51	967	0.57	1001	0.62	1034	0.67	1066	0.73	1097	0.79	1126	0.85	1155	0.91	1184	0.97	1211	1.03
1800	956	0.56	988	0.62	1019	0.68	1050	0.73	1082	0.79	1112	0.85	1142	0.92	1171	0.98	1199	1.04	1227	1.11
2000	982	0.62	1014	0.68	1045	0.74	1075	0.8	1104	0.86	1131	0.92	1158	0.99	1187	1.05	1215	1.12	1243	1.19
2200	1009	0.68	1041	0.74	1071	0.81	1101	0.87	1129	0.94	1157	1.00	1184	1.07	1210	1.14	1236	1.21	1260	1.28
2400	1038	0.75	1069	0.81	1098	0.88	1127	0.95	1156	1.01	1183	1.08	1210	1.15	1236	1.23	1261	1.30	1286	1.37

**Notes:**

1. Available External Static Pressure is the static pressure difference between the return duct and the supply duct plus the static pressure drop caused by accessories and options.
2. For direct drive evaporator fan speed (rpm), refer to the applicable table in the fan performance section.
3. Data includes pressure drop due to standard filters and wet coils. No accessories or options are included in pressure drop data.
4. To determine static pressure drop due to other options/accessories, refer to the applicable table in the fan performance section.
5. Direct drive fan motor heat is negligible.
6. Factory supplied motors, in commercial equipment, are definite purpose motors, specifically designed and tested to operate reliably and continuously at all cataloged conditions. Using the full horsepower range of our fan motors as shown in our tabular data will not result in nuisance tripping or premature motor failure. Our product's warranty will not be affected.

**Table 80. Evaporator fan performance – 3 tons (model THK), horizontal**

Available External Static Pressure (Inches of Water Gauge)																				
CFM	0.10		0.20		0.30		0.40		0.50		0.60		0.70		0.80		0.90		1.00	
	RPM	BHP	RPM	BHP	RPM	BHP	RPM	BHP	RPM	BHP	RPM	BHP	RPM	BHP	RPM	BHP	RPM	BHP	RPM	BHP
900	422	0.05	501	0.08	567	0.10	626	0.13	678	0.15	726	0.18	772	0.21	814	0.25	854	0.28	892	0.31
960	438	0.06	515	0.09	581	0.11	638	0.14	690	0.17	738	0.20	782	0.23	824	0.26	865	0.29	903	0.33
1080	472	0.08	545	0.11	608	0.14	664	0.16	715	0.19	762	0.23	806	0.26	846	0.29	885	0.33	923	0.37



## Evaporator Fan Performance — Cooling

**Table 80. Evaporator fan performance – 3 tons (model THK), horizontal (continued)**

Available External Static Pressure (Inches of Water Gauge)																				
CFM	0.10		0.20		0.30		0.40		0.50		0.60		0.70		0.80		0.90		1.00	
	RPM	BHP	RPM	BHP	RPM	BHP	RPM	BHP	RPM	BHP	RPM	BHP	RPM	BHP	RPM	BHP	RPM	BHP	RPM	BHP
1200	507	0.10	577	0.13	637	0.16	692	0.19	741	0.23	786	0.26	830	0.30	870	0.33	908	0.37	945	0.41
1320	544	0.13	609	0.16	667	0.20	720	0.23	768	0.26	813	0.30	855	0.34	895	0.38	933	0.42	969	0.46
1440	581	0.16	643	0.20	699	0.23	749	0.27	796	0.31	840	0.35	881	0.38	920	0.42	957	0.47	993	0.51
Available External Static Pressure (Inches of Water Gauge)																				
CFM	1.10		1.20		1.30		1.40		1.50		1.60		1.70		1.80		1.90		2.00	
	RPM	BHP	RPM	BHP	RPM	BHP	RPM	BHP	RPM	BHP	RPM	BHP	RPM	BHP	RPM	BHP	RPM	BHP	RPM	BHP
900	929	0.35	963	0.38	996	0.42	1028	0.46	1059	0.49	1089	0.53	1118	0.57	1146	0.61	1174	0.65	1199	0.69
960	939	0.36	973	0.4	1007	0.44	1038	0.48	1069	0.52	1099	0.56	1128	0.6	1156	0.64	1184	0.68	1210	0.72
1080	959	0.4	993	0.44	1027	0.48	1059	0.52	1089	0.56	1119	0.6	1148	0.65	1176	0.69	1203	0.73	-	-
1200	979	0.45	1014	0.49	1047	0.53	1079	0.57	1109	0.62	1139	0.66	1168	0.7	1196	0.75	-	-	-	-
1320	1003	0.5	1036	0.54	1068	0.58	1099	0.63	1130	0.67	1159	0.72	-	-	-	-	-	-	-	-
1440	1027	0.55	1060	0.6	1091	0.64	1122	0.69	1151	0.73	-	-	-	-	-	-	-	-	-	-

**Notes:**

1. Available External Static Pressure is the static pressure difference between the return duct and the supply duct plus the static pressure drop caused by accessories and options.
2. Data includes pressure drop due to standard filters and wet coils. No accessories or options are included in pressure drop data.
3. To determine static pressure drop due to other options/accessories, refer to the applicable table in the fan performance section.
4. Direct Drive Fan Motor Heat (MBH) = 2.9245xFan BHP + 0.055.
5. Factory supplied motors, in commercial equipment, are definite purpose motors, specifically designed and tested to operate reliably and continuously at all cataloged conditions. Using the full horsepower range of our fan motors as shown in our tabular data will not result in nuisance tripping or premature motor failure. Our product's warranty will not be affected.

**Table 81. Evaporator fan performance – 3 tons (model THK), horizontal, high static motor**

Available External Static Pressure (Inches of Water Gauge)																				
CFM	0.10		0.20		0.30		0.40		0.50		0.60		0.70		0.80		0.90		1.00	
	RPM	BHP	RPM	BHP	RPM	BHP	RPM	BHP	RPM	BHP	RPM	BHP	RPM	BHP	RPM	BHP	RPM	BHP	RPM	BHP
900	424	0.05	502	0.08	568	0.10	627	0.13	679	0.16	727	0.18	772	0.21	814	0.25	854	0.28	892	0.31
960	440	0.06	517	0.09	581	0.11	639	0.14	691	0.17	739	0.20	783	0.23	825	0.26	865	0.29	902	0.33
1080	473	0.08	548	0.11	610	0.14	665	0.16	716	0.20	763	0.23	807	0.26	848	0.30	887	0.33	924	0.37
1200	508	0.10	580	0.13	639	0.16	692	0.20	742	0.23	787	0.26	831	0.30	872	0.33	910	0.37	946	0.41
1320	545	0.13	612	0.16	670	0.20	722	0.23	769	0.27	814	0.30	856	0.34	896	0.38	934	0.42	970	0.46
1440	583	0.16	645	0.20	702	0.23	752	0.27	798	0.31	841	0.35	882	0.39	921	0.43	958	0.47	994	0.51
Available External Static Pressure (Inches of Water Gauge)																				
CFM	1.10		1.20		1.30		1.40		1.50		1.60		1.70		1.80		1.90		2.00	
	RPM	BHP	RPM	BHP	RPM	BHP	RPM	BHP	RPM	BHP	RPM	BHP	RPM	BHP	RPM	BHP	RPM	BHP	RPM	BHP
900	927	0.34	962	0.38	995	0.42	1027	0.45	1057	0.49	1087	0.53	1116	0.57	1144	0.61	1171	0.65	1198	0.69
960	938	0.36	972	0.4	1005	0.44	1037	0.47	1067	0.51	1097	0.55	1126	0.59	1154	0.63	1181	0.68	1208	0.72
1080	959	0.4	993	0.44	1026	0.48	1058	0.52	1088	0.56	1117	0.6	1146	0.64	1174	0.69	1201	0.73	1228	0.78
1200	981	0.45	1015	0.49	1048	0.53	1079	0.57	1109	0.62	1139	0.66	1167	0.7	1195	0.75	1222	0.79	1248	0.84
1320	1005	0.5	1038	0.54	1070	0.58	1101	0.63	1131	0.67	1160	0.72	1189	0.77	1216	0.81	1243	0.86	1269	0.91
1440	1029	0.55	1062	0.6	1093	0.64	1124	0.69	1153	0.74	1182	0.78	1210	0.83	1238	0.88	1265	0.93	1291	0.98

**Notes:**

1. Available External Static Pressure is the static pressure difference between the return duct and the supply duct plus the static pressure drop caused by accessories and options.
2. Data includes pressure drop due to standard filters and wet coils. No accessories or options are included in pressure drop data.
3. To determine static pressure drop due to other options/accessories, refer to the applicable table in the fan performance section.
4. Direct Drive Fan Motor Heat (MBH) = 2.9245xFan BHP + 0.055.
5. Factory supplied motors, in commercial equipment, are definite purpose motors, specifically designed and tested to operate reliably and continuously at all cataloged conditions. Using the full horsepower range of our fan motors as shown in our tabular data will not result in nuisance tripping or premature motor failure. Our product's warranty will not be affected.

**Table 82. Evaporator fan performance – 4 tons (model THK), horizontal**

Available External Static Pressure (Inches of Water Gauge)																				
CFM	0.10		0.20		0.30		0.40		0.50		0.60		0.70		0.80		0.90		1.00	
	RPM	BHP	RPM	BHP	RPM	BHP	RPM	BHP	RPM	BHP	RPM	BHP	RPM	BHP	RPM	BHP	RPM	BHP	RPM	BHP
1200	394	0.04	468	0.07	533	0.10	589	0.14	640	0.17	686	0.21	729	0.24	774	0.29	816	0.33	856	0.37
1280	409	0.05	482	0.08	545	0.11	600	0.14	650	0.18	696	0.22	738	0.26	779	0.30	821	0.34	861	0.39
1440	441	0.06	509	0.09	569	0.13	624	0.16	672	0.20	717	0.24	759	0.29	799	0.33	836	0.37	872	0.42
1600	475	0.07	538	0.11	595	0.14	647	0.18	696	0.23	740	0.27	781	0.31	820	0.36	857	0.41	892	0.46
1760	510	0.08	569	0.12	623	0.17	673	0.21	719	0.25	763	0.30	804	0.35	842	0.40	878	0.45	913	0.50
1920	545	0.10	600	0.14	652	0.19	699	0.23	744	0.28	787	0.33	827	0.38	865	0.43	900	0.49	934	0.54
Available External Static Pressure (Inches of Water Gauge)																				
CFM	1.10		1.20		1.30		1.40		1.50		1.60		1.70		1.80		1.90		2.00	
	RPM	BHP	RPM	BHP	RPM	BHP	RPM	BHP	RPM	BHP	RPM	BHP	RPM	BHP	RPM	BHP	RPM	BHP	RPM	BHP
1200	894	0.42	930	0.47	965	0.52	999	0.57	1031	0.62	1062	0.67	1093	0.72	1122	0.77	1151	0.83	1179	0.89
1280	899	0.44	935	0.48	970	0.53	1004	0.58	1036	0.64	1067	0.69	1098	0.74	1127	0.8	1156	0.86	1184	0.91
1440	909	0.47	946	0.52	981	0.57	1014	0.63	1046	0.68	1078	0.74	1108	0.79	1137	0.85	1166	0.91	1194	0.97
1600	925	0.51	957	0.56	991	0.61	1024	0.67	1057	0.72	1088	0.78	1118	0.84	1148	0.9	1176	0.96	1204	1.02
1760	946	0.55	978	0.6	1008	0.66	1038	0.71	1067	0.77	1098	0.83	1129	0.89	1158	0.95	1187	1.02	1215	1.08
1920	967	0.59	999	0.65	1029	0.71	1059	0.77	1087	0.82	1114	0.88	1141	0.95	1168	1.01	1197	1.07	1225	1.14

**Notes:**

1. Available External Static Pressure is the static pressure difference between the return duct and the supply duct plus the static pressure drop caused by accessories and options.
2. Data includes pressure drop due to standard filters and wet coils. No accessories or options are included in pressure drop data.
3. To determine static pressure drop due to other options/accessories, refer to the applicable table in the fan performance section.
4. Direct drive fan motor heat is negligible.
5. Factory supplied motors, in commercial equipment, are definite purpose motors, specifically designed and tested to operate reliably and continuously at all cataloged conditions. Using the full horsepower range of our fan motors as shown in our tabular data will not result in nuisance tripping or premature motor failure. Our product's warranty will not be affected.

**Table 83. Evaporator fan performance – 5 tons (model THK), horizontal**

Available External Static Pressure (Inches of Water Gauge)																				
CFM	0.10		0.20		0.30		0.40		0.50		0.60		0.70		0.80		0.90		1.00	
	RPM	BHP	RPM	BHP	RPM	BHP	RPM	BHP	RPM	BHP	RPM	BHP	RPM	BHP	RPM	BHP	RPM	BHP	RPM	BHP
1500	454	0.06	520	0.10	579	0.13	632	0.17	681	0.21	726	0.25	767	0.30	807	0.34	844	0.39	879	0.43
1600	475	0.07	538	0.11	595	0.14	647	0.18	696	0.23	740	0.27	781	0.31	820	0.36	857	0.41	892	0.46
1800	519	0.09	577	0.13	630	0.17	679	0.21	725	0.26	769	0.31	809	0.36	847	0.40	884	0.46	918	0.51
2000	563	0.11	617	0.16	667	0.20	713	0.25	757	0.30	799	0.35	839	0.40	876	0.45	912	0.51	946	0.56
2200	609	0.14	659	0.19	705	0.24	750	0.29	791	0.34	831	0.39	869	0.45	906	0.50	941	0.56	975	0.62
2400	655	0.17	702	0.22	745	0.28	787	0.33	827	0.39	865	0.44	902	0.50	937	0.56	971	0.62	1004	0.69
Available External Static Pressure (Inches of Water Gauge)																				
CFM	1.10		1.20		1.30		1.40		1.50		1.60		1.70		1.80		1.90		2.00	
	RPM	BHP	RPM	BHP	RPM	BHP	RPM	BHP	RPM	BHP	RPM	BHP	RPM	BHP	RPM	BHP	RPM	BHP	RPM	BHP
1500	913	0.48	950	0.53	984	0.59	1018	0.64	1050	0.7	1082	0.75	1112	0.81	1141	0.87	1170	0.93	1198	0.99
1600	925	0.51	957	0.56	991	0.61	1024	0.67	1057	0.72	1088	0.78	1118	0.84	1148	0.9	1176	0.96	1204	1.02
1800	951	0.56	983	0.61	1014	0.67	1043	0.73	1071	0.78	1101	0.84	1131	0.9	1161	0.97	1189	1.03	1217	1.1
2000	978	0.62	1010	0.68	1040	0.73	1069	0.79	1097	0.85	1125	0.91	1151	0.98	1177	1.04	1202	1.1	1230	1.17
2200	1007	0.68	1037	0.74	1067	0.8	1096	0.87	1124	0.93	1151	0.99	1178	1.06	1203	1.13	1228	1.19	1253	1.26
2400	1036	0.75	1066	0.81	1095	0.88	1124	0.94	1151	1.01	1178	1.08	1204	1.15	1230	1.22	1255	1.29	1279	1.36

**Notes:**

1. Available External Static Pressure is the static pressure difference between the return duct and the supply duct plus the static pressure drop caused by accessories and options.
2. Data includes pressure drop due to standard filters and wet coils. No accessories or options are included in pressure drop data.
3. To determine static pressure drop due to other options/accessories, refer to the applicable table in the fan performance section.
4. Direct drive fan motor heat is negligible.
5. Factory supplied motors, in commercial equipment, are definite purpose motors, specifically designed and tested to operate reliably and continuously at all cataloged conditions. Using the full horsepower range of our fan motors as shown in our tabular data will not result in nuisance tripping or premature motor failure. Our product's warranty will not be affected.



Evaporator Fan Performance — Cooling

6 to 25 Tons — Downflow

Figure 16. Fan curves — 6 to 10 tons (model T\*K), downflow

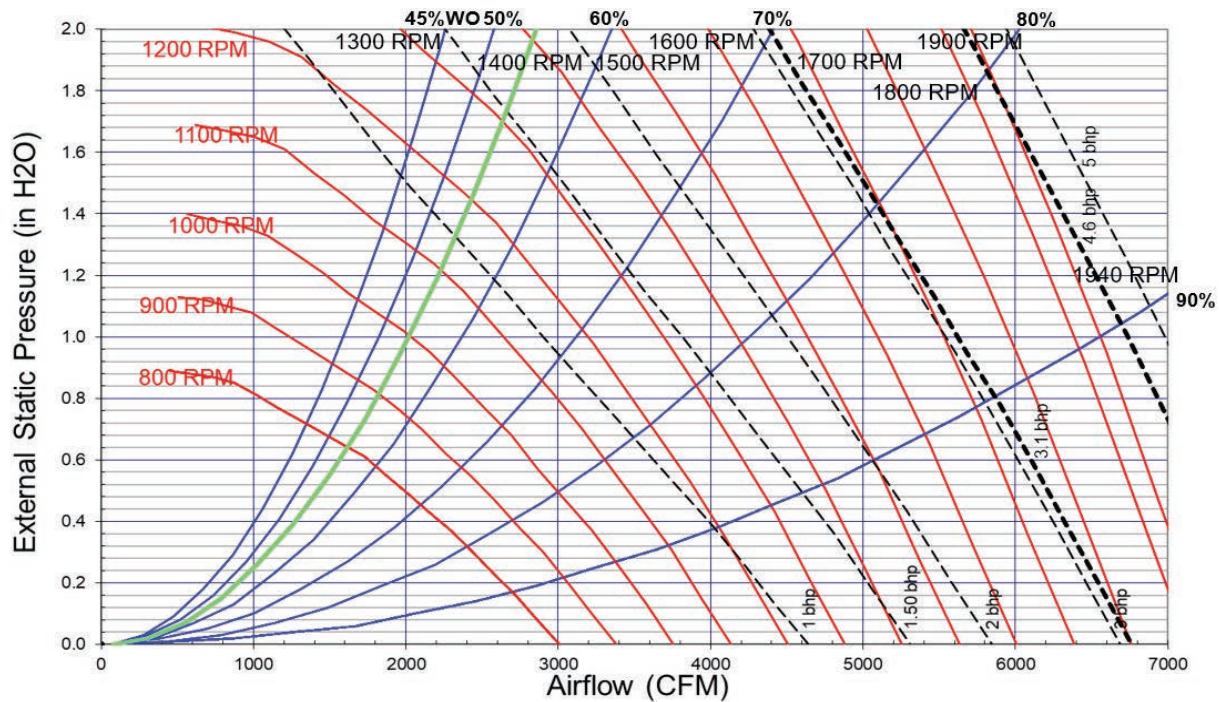

Table 84. Evaporator fan performance – 6 ton (model TSK, THK), downflow

Available External Static Pressure (Inches of Water Gauge)																				
CFM	0.10		0.20		0.30		0.40		0.50		0.60		0.70		0.80		0.90		1.00	
	RPM	BHP	RPM	BHP	RPM	BHP	RPM	BHP	RPM	BHP	RPM	BHP	RPM	BHP	RPM	BHP	RPM	BHP	RPM	BHP
1800	549	0.10	612	0.15	667	0.20	719	0.25	766	0.30	809	0.35	849	0.41	891	0.47	931	0.53	969	0.59
1920	577	0.12	638	0.16	691	0.22	741	0.27	787	0.32	830	0.38	870	0.44	907	0.50	946	0.56	984	0.62
2040	606	0.13	663	0.18	716	0.24	763	0.29	809	0.35	851	0.41	891	0.47	928	0.53	963	0.60	999	0.66
2160	634	0.15	689	0.20	741	0.26	787	0.32	831	0.38	873	0.44	912	0.50	948	0.57	983	0.63	1017	0.70
2280	663	0.17	716	0.23	766	0.29	811	0.35	853	0.41	894	0.47	933	0.54	969	0.61	1004	0.67	1037	0.74
2400	693	0.19	743	0.25	791	0.31	836	0.38	877	0.44	916	0.51	955	0.58	991	0.65	1025	0.72	1058	0.79
2520	723	0.22	771	0.28	817	0.34	861	0.41	901	0.48	939	0.55	977	0.62	1012	0.69	1046	0.76	1079	0.83
2640	753	0.24	799	0.31	843	0.37	886	0.44	925	0.51	963	0.59	999	0.66	1034	0.73	1068	0.81	1100	0.88
2760	783	0.27	827	0.34	869	0.41	911	0.48	950	0.55	987	0.63	1022	0.70	1056	0.78	1089	0.86	1121	0.94
2880	813	0.30	855	0.37	897	0.44	937	0.52	975	0.59	1011	0.67	1046	0.75	1078	0.83	1111	0.91	1143	0.99
Available External Static Pressure (Inches of Water Gauge)																				
CFM	1.10		1.20		1.30		1.40		1.50		1.60		1.70		1.80		1.90		2.00	
	RPM	BHP	RPM	BHP	RPM	BHP	RPM	BHP	RPM	BHP	RPM	BHP	RPM	BHP	RPM	BHP	RPM	BHP	RPM	BHP
1800	1005	0.65	1040	0.71	1074	0.78	1106	0.84	1137	0.91	1167	0.98	1197	1.04	1225	1.11	1253	1.19	1280	1.26
1920	1020	0.69	1055	0.75	1088	0.82	1121	0.89	1152	0.96	1182	1.03	1211	1.1	1240	1.17	1267	1.24	1294	1.32
2040	1035	0.73	1070	0.8	1103	0.86	1135	0.93	1166	1.01	1196	1.08	1226	1.15	1254	1.23	1282	1.3	1309	1.38
2160	1050	0.77	1085	0.84	1118	0.91	1150	0.98	1181	1.06	1211	1.13	1240	1.21	1269	1.28	1296	1.36	1323	1.44
2280	1069	0.81	1100	0.89	1133	0.96	1165	1.04	1196	1.11	1226	1.19	1255	1.27	1283	1.35	1311	1.43	1338	1.51
2400	1089	0.86	1119	0.94	1149	1.01	1180	1.09	1211	1.17	1241	1.25	1270	1.33	1298	1.41	1326	1.49	1352	1.57
2520	1110	0.91	1140	0.99	1169	1.07	1197	1.15	1226	1.23	1256	1.31	1285	1.39	1313	1.47	1340	1.56	1367	1.64
2640	1131	0.96	1161	1.04	1189	1.12	1217	1.2	1244	1.29	1271	1.37	1300	1.46	1328	1.54	1355	1.63	1382	1.72
2760	1152	1.02	1182	1.1	1210	1.18	1238	1.26	1265	1.35	1291	1.44	1316	1.52	1343	1.61	1371	1.7	1397	1.79

**Table 84. Evaporator fan performance – 6 ton (model TSK, THK), downflow (continued)**

Available External Static Pressure (Inches of Water Gauge)																				
CFM	1.10		1.20		1.30		1.40		1.50		2.00									
	RPM	BHP	RPM	BHP	RPM	BHP	RPM	BHP	RPM	BHP	RPM	BHP								
2880	1173	1.07	1203	1.16	1231	1.24	1259	1.33	1285	1.41	1311	1.5	1336	1.59	1361	1.68	1386	1.77	1412	1.87

**Notes:**

1. Available External Static Pressure is the static pressure difference between the return duct and the supply duct plus the static pressure drop caused by accessories and options.
2. For direct drive evaporator fan speed (rpm), refer to the applicable table in the fan performance section.
3. Data includes pressure drop due to standard filters and wet coils. No accessories or options are included in pressure drop data.
4. To determine static pressure drop due to other options/accessories, refer to the applicable table in the fan performance section.
5. Direct drive fan motor heat is negligible.
6. Factory supplied motors, in commercial equipment, are definite purpose motors, specifically designed and tested to operate reliably and continuously at all cataloged conditions. Using the full horsepower range of our fan motors as shown in our tabular data will not result in nuisance tripping or premature motor failure. Our product's warranty will not be affected.

**Table 85. Evaporator fan performance – 7.5 ton (model TSK, THK), downflow**

Available External Static Pressure (Inches of Water Gauge)																				
CFM	0.10		0.20		0.30		0.40		0.50		0.60		0.70		0.80		0.90		1.00	
	RPM	BHP	RPM	BHP	RPM	BHP	RPM	BHP	RPM	BHP	RPM	BHP	RPM	BHP	RPM	BHP	RPM	BHP	RPM	BHP
2250	656	0.17	709	0.22	759	0.28	805	0.34	848	0.40	889	0.47	928	0.53	964	0.60	999	0.66	1032	0.73
2400	693	0.19	743	0.25	791	0.31	836	0.38	877	0.44	916	0.51	955	0.58	991	0.65	1025	0.72	1058	0.79
2550	730	0.22	778	0.29	823	0.35	867	0.42	907	0.49	945	0.56	982	0.63	1018	0.70	1052	0.77	1084	0.85
2700	768	0.26	813	0.32	856	0.39	898	0.46	938	0.53	975	0.61	1010	0.68	1045	0.76	1079	0.83	1111	0.91
2850	806	0.30	848	0.36	890	0.43	930	0.51	969	0.58	1005	0.66	1040	0.74	1073	0.82	1106	0.90	1138	0.98
3000	844	0.34	884	0.41	924	0.48	963	0.56	1000	0.64	1036	0.72	1070	0.80	1102	0.88	1134	0.96	1165	1.05
3150	882	0.38	920	0.46	959	0.53	996	0.61	1032	0.69	1067	0.78	1100	0.86	1132	0.95	1162	1.03	1193	1.12
3300	920	0.43	957	0.51	994	0.59	1030	0.67	1065	0.76	1099	0.84	1131	0.93	1163	1.02	1192	1.11	1221	1.20
3600	997	0.55	1031	0.63	1065	0.71	1099	0.80	1131	0.90	1163	0.99	1194	1.08	1225	1.18	1254	1.27	1282	1.37

**Available External Static Pressure (Inches of Water Gauge)**

CFM	1.10		1.20		1.30		1.40		1.50		1.60		1.70		1.80		1.90		2.00	
	RPM	BHP	RPM	BHP	RPM	BHP	RPM	BHP	RPM	BHP	RPM	BHP	RPM	BHP	RPM	BHP	RPM	BHP	RPM	BHP
2250	1064	0.8	1096	0.88	1130	0.95	1161	1.02	1192	1.1	1222	1.17	1251	1.25	1280	1.33	1307	1.41	1334	1.49
2400	1089	0.86	1119	0.94	1149	1.01	1180	1.09	1211	1.17	1241	1.25	1270	1.33	1298	1.41	1326	1.49	1352	1.57
2550	1115	0.92	1145	1	1174	1.08	1202	1.16	1230	1.24	1260	1.32	1289	1.41	1317	1.49	1344	1.58	1371	1.66
2700	1141	0.99	1171	1.07	1200	1.15	1227	1.23	1254	1.32	1280	1.4	1308	1.49	1336	1.58	1363	1.66	1390	1.75
2850	1168	1.06	1197	1.14	1226	1.23	1253	1.31	1280	1.4	1306	1.49	1331	1.57	1356	1.66	1382	1.76	1409	1.85
3000	1195	1.13	1224	1.22	1252	1.3	1280	1.39	1306	1.48	1332	1.57	1357	1.67	1381	1.76	1405	1.85	1428	1.95
3150	1223	1.21	1251	1.3	1279	1.39	1306	1.48	1332	1.57	1358	1.67	1383	1.76	1407	1.86	1431	1.95	1454	2.05
3300	1250	1.29	1279	1.38	1306	1.48	1333	1.57	1359	1.67	1384	1.76	1409	1.86	1433	1.96	1457	2.06	1480	2.16
3600	1309	1.47	1335	1.57	1361	1.67	1388	1.77	1413	1.87	1438	1.97	1462	2.08	1486	2.18	1509	2.28	1532	2.39

**Notes:**

1. Available External Static Pressure is the static pressure difference between the return duct and the supply duct plus the static pressure drop caused by accessories and options.
2. For direct drive evaporator fan speed (rpm), refer to the applicable table in the fan performance section.
3. Data includes pressure drop due to standard filters and wet coils. No accessories or options are included in pressure drop data.
4. To determine static pressure drop due to other options/accessories, refer to the applicable table in the fan performance section.
5. Direct drive fan motor heat is negligible.
6. Factory supplied motors, in commercial equipment, are definite purpose motors, specifically designed and tested to operate reliably and continuously at all cataloged conditions. Using the full horsepower range of our fan motors as shown in our tabular data will not result in nuisance tripping or premature motor failure. Our product's warranty will not be affected.

**Table 86. Evaporator fan performance – 8.5 ton (model TSK, THK), downflow**

Available External Static Pressure (Inches of Water Gauge)																				
CFM	0.10		0.20		0.30		0.40		0.50		0.60		0.70		0.80		0.90		1.00	
	RPM	BHP	RPM	BHP	RPM	BHP	RPM	BHP	RPM	BHP	RPM	BHP	RPM	BHP	RPM	BHP	RPM	BHP	RPM	BHP
2550	730	0.22	778	0.29	823	0.35	867	0.42	907	0.49	945	0.56	982	0.63	1018	0.70	1052	0.77	1084	0.85
2720	773	0.26	817	0.33	860	0.40	903	0.47	942	0.54	979	0.61	1014	0.69	1049	0.76	1082	0.84	1114	0.92



## Evaporator Fan Performance — Cooling

**Table 86. Evaporator fan performance – 8.5 ton (model TSK, THK), downflow (continued)**

Available External Static Pressure (Inches of Water Gauge)																				
CFM	0.10		0.20		0.30		0.40		0.50		0.60		0.70		0.80		0.90		1.00	
	RPM	BHP	RPM	BHP	RPM	BHP	RPM	BHP	RPM	BHP	RPM	BHP	RPM	BHP	RPM	BHP	RPM	BHP	RPM	BHP
2890	816	0.31	858	0.37	899	0.45	939	0.52	977	0.60	1013	0.67	1048	0.75	1080	0.83	1113	0.91	1145	0.99
3060	859	0.36	898	0.43	938	0.50	976	0.58	1013	0.66	1048	0.74	1082	0.82	1114	0.91	1145	0.99	1176	1.08
3230	902	0.41	940	0.48	977	0.56	1014	0.64	1050	0.73	1084	0.81	1117	0.90	1148	0.98	1178	1.07	1208	1.16
3400	946	0.47	982	0.55	1017	0.63	1052	0.71	1086	0.80	1120	0.89	1152	0.98	1183	1.07	1213	1.16	1241	1.25
3570	989	0.54	1024	0.62	1057	0.70	1092	0.79	1124	0.88	1157	0.97	1188	1.06	1218	1.16	1247	1.25	1275	1.35
3740	1033	0.61	1066	0.69	1098	0.78	1131	0.87	1163	0.97	1193	1.06	1224	1.16	1254	1.26	1283	1.35	1310	1.46
4080	1121	0.77	1152	0.86	1181	0.96	1211	1.06	1241	1.16	1270	1.26	1298	1.36	1326	1.47	1354	1.57	1381	1.68
Available External Static Pressure (Inches of Water Gauge)																				
CFM	1.10		1.20		1.30		1.40		1.50		1.60		1.70		1.80		1.90		2.00	
	RPM	BHP	RPM	BHP	RPM	BHP	RPM	BHP	RPM	BHP	RPM	BHP	RPM	BHP	RPM	BHP	RPM	BHP	RPM	BHP
2550	1115	0.92	1145	1	1174	1.08	1202	1.16	1230	1.24	1260	1.32	1289	1.41	1317	1.49	1344	1.58	1371	1.66
2720	1145	1	1175	1.08	1203	1.16	1231	1.24	1258	1.33	1284	1.41	1310	1.5	1338	1.59	1366	1.68	1392	1.77
2890	1175	1.08	1205	1.16	1233	1.25	1260	1.33	1287	1.42	1313	1.51	1338	1.6	1362	1.69	1387	1.78	1414	1.87
3060	1206	1.16	1235	1.25	1263	1.34	1290	1.43	1317	1.52	1342	1.61	1367	1.7	1391	1.8	1415	1.89	1439	1.99
3230	1237	1.25	1266	1.34	1294	1.44	1320	1.53	1347	1.62	1372	1.72	1397	1.81	1421	1.91	1444	2.01	1468	2.11
3400	1269	1.35	1297	1.44	1325	1.54	1351	1.63	1377	1.73	1402	1.83	1427	1.93	1451	2.03	1474	2.13	1497	2.23
3570	1303	1.45	1329	1.55	1356	1.65	1382	1.75	1408	1.85	1433	1.95	1457	2.05	1481	2.16	1504	2.26	1527	2.37
3740	1337	1.56	1363	1.66	1388	1.76	1414	1.87	1439	1.97	1464	2.08	1488	2.18	1511	2.29	1534	2.4	1557	2.51
4080	1407	1.79	1432	1.9	1456	2.01	1480	2.12	1503	2.24	1526	2.35	1550	2.46	1573	2.58	1596	2.69	1618	2.81

**Notes:**

1. Available External Static Pressure is the static pressure difference between the return duct and the supply duct plus the static pressure drop caused by accessories and options.
2. For direct drive evaporator fan speed (rpm), refer to the applicable table in the fan performance section.
3. Data includes pressure drop due to standard filters and wet coils. No accessories or options are included in pressure drop data.
4. To determine static pressure drop due to other options/accessories, refer to the applicable table in the fan performance section.
5. Direct drive fan motor heat is negligible.
6. Factory supplied motors, in commercial equipment, are definite purpose motors, specifically designed and tested to operate reliably and continuously at all cataloged conditions. Using the full horsepower range of our fan motors as shown in our tabular data will not result in nuisance tripping or premature motor failure. Our product's warranty will not be affected.

**Table 87. Evaporator fan performance – 10 ton (model TSK, THK), downflow**

Available External Static Pressure (Inches of Water Gauge)																				
CFM	0.10		0.20		0.30		0.40		0.50		0.60		0.70		0.80		0.90		1.00	
	RPM	BHP	RPM	BHP	RPM	BHP	RPM	BHP	RPM	BHP	RPM	BHP	RPM	BHP	RPM	BHP	RPM	BHP	RPM	BHP
3000	844	0.34	884	0.41	924	0.48	963	0.56	1000	0.64	1036	0.72	1070	0.80	1102	0.88	1134	0.96	1165	1.05
3200	894	0.40	932	0.47	970	0.55	1007	0.63	1043	0.71	1078	0.80	1111	0.88	1142	0.97	1172	1.06	1202	1.15
3400	946	0.47	982	0.55	1017	0.63	1052	0.71	1086	0.80	1120	0.89	1152	0.98	1183	1.07	1213	1.16	1241	1.25
3600	997	0.55	1031	0.63	1065	0.71	1099	0.80	1131	0.90	1163	0.99	1194	1.08	1225	1.18	1254	1.27	1282	1.37
3800	1048	0.64	1081	0.72	1113	0.81	1145	0.90	1176	1.00	1206	1.09	1237	1.19	1267	1.29	1295	1.39	1322	1.49
4000	1100	0.73	1132	0.82	1162	0.91	1192	1.01	1222	1.11	1251	1.21	1280	1.31	1309	1.42	1337	1.52	1364	1.63
4200	1152	0.84	1182	0.93	1211	1.03	1240	1.13	1269	1.23	1297	1.34	1324	1.44	1352	1.55	1379	1.66	1406	1.77
4400	1204	0.95	1233	1.05	1261	1.15	1288	1.25	1316	1.36	1343	1.47	1370	1.58	1396	1.69	1422	1.81	1448	1.92
4800	1308	1.22	1335	1.33	1361	1.43	1386	1.54	1411	1.66	1437	1.77	1462	1.89	1486	2.01	1510	2.14	1534	2.26
Available External Static Pressure (Inches of Water Gauge)																				
CFM	1.10		1.20		1.30		1.40		1.50		1.60		1.70		1.80		1.90		2.00	
	RPM	BHP	RPM	BHP	RPM	BHP	RPM	BHP	RPM	BHP	RPM	BHP	RPM	BHP	RPM	BHP	RPM	BHP	RPM	BHP
3000	1195	1.13	1224	1.22	1252	1.3	1280	1.39	1306	1.48	1332	1.57	1357	1.67	1381	1.76	1405	1.85	1428	1.95
3200	1232	1.24	1260	1.33	1288	1.42	1315	1.51	1341	1.60	1367	1.70	1391	1.79	1416	1.89	1439	1.99	1462	2.09
3400	1269	1.35	1297	1.44	1325	1.54	1351	1.63	1377	1.73	1402	1.83	1427	1.93	1451	2.03	1474	2.13	1497	2.23
3600	1309	1.47	1335	1.57	1361	1.67	1388	1.77	1413	1.87	1438	1.97	1462	2.08	1486	2.18	1509	2.28	1532	2.39
3800	1349	1.60	1375	1.07	1400	1.81	1425	1.91	1450	2.02	1475	2.12	1499	2.23	1522	2.34	1545	2.45	1567	2.56

**Table 87. Evaporator fan performance – 10 ton (model TSK, THK), downflow (continued)**

Available External Static Pressure (Inches of Water Gauge)																				
CFM	1.10		1.20		1.30		1.40		1.50		1.60		1.70		1.80		1.90		2.00	
	RPM	BHP	RPM	BHP	RPM	BHP	RPM	BHP	RPM	BHP	RPM	BHP	RPM	BHP	RPM	BHP	RPM	BHP	RPM	BHP
4000	1390	1.73	1415	1.84	1440	1.95	1464	2.06	1487	2.17	1512	2.28	1535	2.39	1558	2.51	1581	2.62	1603	2.73
4200	1431	1.88	1456	1.99	1481	2.11	1504	2.22	1527	2.34	1550	2.45	1572	2.57	1595	2.69	1618	2.80	1640	2.92
4400	1473	2.04	1498	2.15	1522	2.27	1545	2.39	1568	2.51	1590	2.63	1612	2.75	1633	2.87	1655	3.00	-	-
4800	1559	2.38	1582	2.51	1605	2.63	1628	2.76	1650	2.89	1671	3.02	-	-	-	-	-	-	-	-

**Notes:**

1. Available External Static Pressure is the static pressure difference between the return duct and the supply duct plus the static pressure drop caused by accessories and options.
2. For direct drive evaporator fan speed (rpm), refer to the applicable table in the fan performance section.
3. Data includes pressure drop due to standard filters and wet coils. No accessories or options are included in pressure drop data.
4. To determine static pressure drop due to other options/accessories, refer to the applicable table in the fan performance section.
5. Direct drive fan motor heat is negligible.
6. Factory supplied motors, in commercial equipment, are definite purpose motors, specifically designed and tested to operate reliably and continuously at all cataloged conditions. Using the full horsepower range of our fan motors as shown in our tabular data will not result in nuisance tripping or premature motor failure. Our product's warranty will not be affected.

**Table 88. Evaporator fan performance - 10 ton (model TSK, THK), downflow, high static motor**

Available External Static Pressure (Inches of Water Gauge)																				
CFM	0.10		0.20		0.30		0.40		0.50		0.60		0.70		0.80		0.90		1.00	
	RPM	BHP	RPM	BHP	RPM	BHP	RPM	BHP	RPM	BHP	RPM	BHP	RPM	BHP	RPM	BHP	RPM	BHP	RPM	BHP
3000	816	0.31	859	0.38	900	0.46	941	0.53	980	0.62	1018	0.70	1054	0.78	1089	0.87	1123	0.96	1158	1.05
3200	865	0.37	905	0.44	944	0.52	982	0.60	1020	0.69	1057	0.77	1092	0.86	1126	0.95	1159	1.04	1191	1.14
3400	913	0.43	952	0.51	989	0.59	1026	0.68	1061	0.76	1097	0.86	1130	0.95	1163	1.04	1195	1.14	1226	1.24
3600	962	0.50	1000	0.58	1034	0.67	1069	0.76	1103	0.85	1137	0.95	1170	1.04	1202	1.14	1232	1.24	1263	1.34
3800	1012	0.58	1047	0.67	1081	0.75	1114	0.85	1146	0.94	1178	1.04	1210	1.14	1241	1.25	1271	1.35	1300	1.46
4000	1061	0.66	1095	0.76	1128	0.85	1158	0.95	1190	1.05	1220	1.15	1251	1.25	1281	1.36	1310	1.47	1339	1.58
4200	1111	0.76	1144	0.85	1175	0.95	1204	1.05	1234	1.16	1264	1.26	1293	1.37	1322	1.48	1350	1.60	1378	1.71
4400	1160	0.86	1192	0.96	1222	1.07	1251	1.17	1279	1.28	1308	1.39	1335	1.50	1363	1.61	1391	1.73	1418	1.85
4600	1210	0.97	1241	1.08	1270	1.19	1298	1.30	1325	1.41	1352	1.52	1379	1.63	1405	1.75	1432	1.87	1458	2.00
4800	1260	1.10	1290	1.21	1318	1.32	1345	1.43	1371	1.55	1397	1.66	1423	1.78	1448	1.90	1474	2.03	1499	2.15

**Available External Static Pressure (Inches of Water Gauge)**

CFM	1.10		1.20		1.30		1.40		1.50		1.60		1.70		1.80		1.90		2.00	
	RPM	BHP	RPM	BHP	RPM	BHP	RPM	BHP	RPM	BHP	RPM	BHP	RPM	BHP	RPM	BHP	RPM	BHP	RPM	BHP
3000	1192	1.15	1224	1.24	1253	1.33	1281	1.43	1308	1.52	1334	1.62	1360	1.71	1384	1.81	1409	1.91	1432	2.01
3200	1223	1.24	1255	1.34	1287	1.44	1315	1.54	1342	1.64	1368	1.74	1393	1.84	1418	1.94	1442	2.05	1466	2.15
3400	1257	1.34	1286	1.44	1317	1.55	1347	1.65	1376	1.76	1402	1.87	1428	1.97	1452	2.08	1476	2.19	1499	2.29
3600	1292	1.45	1321	1.55	1349	1.66	1378	1.77	1407	1.88	1435	2	1462	2.11	1486	2.22	1510	2.34	1533	2.45
3800	1329	1.56	1357	1.67	1384	1.78	1411	1.89	1438	2.01	1466	2.13	1493	2.25	1519	2.37	1545	2.49	1568	2.61
4000	1366	1.69	1393	1.8	1420	1.92	1447	2.03	1473	2.15	1498	2.27	1524	2.39	1550	2.52	1576	2.64	1600	2.77
4200	1405	1.83	1431	1.94	1457	2.06	1483	2.18	1508	2.3	1533	2.42	1557	2.55	1581	2.67	1607	2.8	1631	2.93
4400	1444	1.97	1470	2.09	1495	2.21	1520	2.34	1545	2.46	1569	2.59	1593	2.71	1616	2.84	1639	2.97	1663	3.1
4600	1484	2.12	1509	2.25	1534	2.38	1558	2.5	1582	2.63	1605	2.76	1629	2.89	1652	3.02	1675	3.16	1697	3.29
4800	1525	2.28	1549	2.42	1573	2.55	1597	2.68	1620	2.81	1643	2.94	1666	3.08	1688	3.21	1711	3.35	1733	3.49

**Notes:**

1. Available External Static Pressure is the static pressure difference between the return duct and the supply duct plus the static pressure drop caused by accessories and options.
2. For direct drive evaporator fan speed (rpm), refer to the applicable table in the fan performance section.
3. Data includes pressure drop due to standard filters and wet coils. No accessories or options are included in pressure drop data.
4. To determine static pressure drop due to other options/accessories, refer to the applicable table in the fan performance section.
5. Direct drive fan motor heat is negligible.
6. Factory supplied motors, in commercial equipment, are definite purpose motors, specifically designed and tested to operate reliably and continuously at all cataloged conditions. Using the full horsepower range of our fan motors as shown in our tabular data will not result in nuisance tripping or premature motor failure. Our product's warranty will not be affected.



# Evaporator Fan Performance — Cooling

Figure 17. Fan curves - 12.5 ton (standard efficiency), downflow

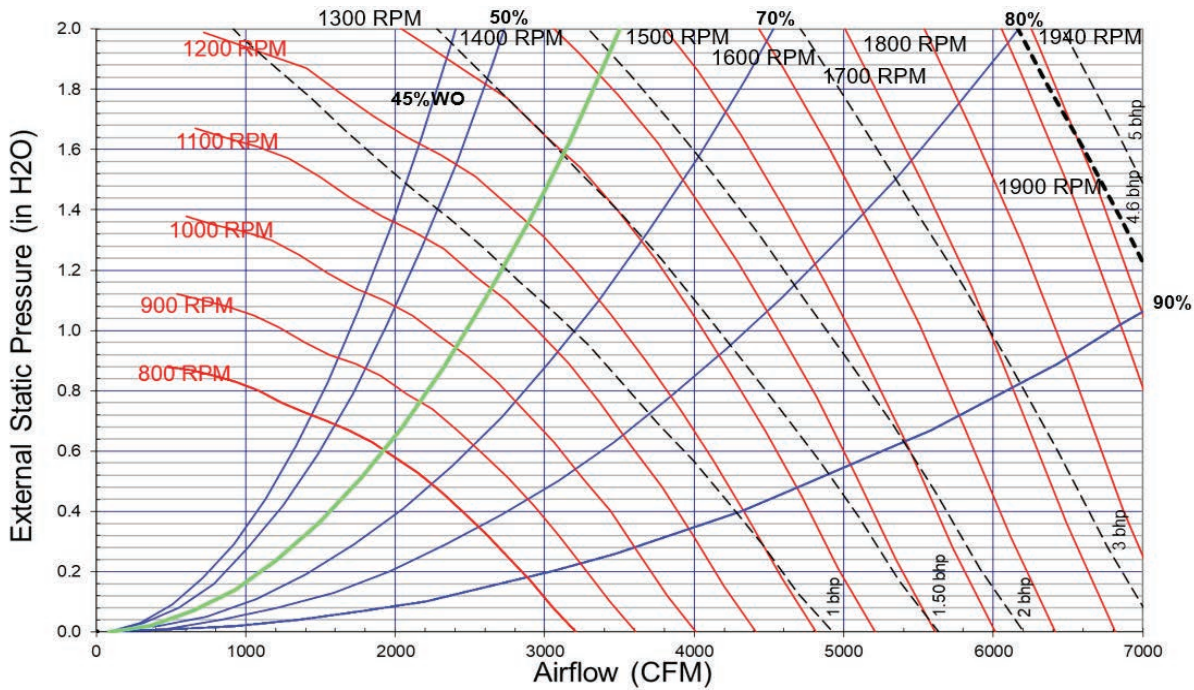

Table 89. Evaporator fan performance – 12.5 ton (model TSK), downflow

Available External Static Pressure (Inches of Water Gauge)																				
CFM	0.10		0.20		0.30		0.40		0.50		0.60		0.70		0.80		0.90		1.00	
	RPM	BHP	RPM	BHP	RPM	BHP	RPM	BHP	RPM	BHP	RPM	BHP	RPM	BHP	RPM	BHP	RPM	BHP	RPM	BHP
3750	975	0.52	1008	0.60	1038	0.67	1067	0.75	1099	0.83	1129	0.91	1158	1.00	1186	1.09	1213	1.17	1240	1.26
4000	1036	0.62	1067	0.70	1096	0.78	1124	0.86	1152	0.94	1181	1.03	1209	1.13	1236	1.22	1262	1.31	1288	1.40
4250	1097	0.74	1126	0.82	1154	0.90	1181	0.99	1206	1.07	1233	1.17	1261	1.26	1287	1.36	1313	1.46	1337	1.55
4500	1157	0.86	1186	0.95	1213	1.04	1238	1.13	1263	1.22	1287	1.31	1313	1.41	1339	1.51	1363	1.62	1388	1.72
4750	1218	1.00	1246	1.10	1271	1.19	1296	1.28	1320	1.38	1343	1.47	1366	1.58	1391	1.68	1415	1.79	1438	1.90
5000	1279	1.16	1306	1.26	1331	1.36	1354	1.45	1377	1.55	1399	1.65	1421	1.76	1444	1.86	1467	1.98	1490	2.09
5250	1340	1.33	1367	1.44	1390	1.54	1413	1.64	1435	1.75	1456	1.85	1477	1.96	1498	2.06	1520	2.18	1542	2.30
5500	1401	1.51	1427	1.63	1450	1.74	1472	1.84	1493	1.95	1514	2.06	1534	2.17	1554	2.28	1574	2.40	1595	2.52
5750	1462	1.72	1488	1.84	1510	1.95	1531	2.07	1551	2.18	1572	2.29	1591	2.41	1610	2.52	1629	2.64	1648	2.76
6000	1523	1.94	1548	2.07	1570	2.19	1590	2.31	1610	2.42	1630	2.54	1649	2.66	1667	2.78	1686	2.90	1704	3.02
Available External Static Pressure (Inches of Water Gauge)																				
CFM	1.10		1.20		1.30		1.40		1.50		1.60		1.70		1.80		1.90		2.00	
	RPM	BHP	RPM	BHP	RPM	BHP	RPM	BHP	RPM	BHP	RPM	BHP	RPM	BHP	RPM	BHP	RPM	BHP	RPM	BHP
3750	1267	1.36	1293	1.45	1319	1.55	1345	1.64	1370	1.74	1394	1.85	1419	1.95	1443	2.06	1467	2.17	1490	2.28
4000	1314	1.5	1339	1.59	1363	1.69	1388	1.79	1412	1.9	1436	2	1459	2.11	1483	2.22	1506	2.33	1529	2.44
4250	1362	1.65	1386	1.75	1410	1.86	1433	1.96	1455	2.06	1479	2.17	1502	2.28	1524	2.39	1546	2.51	1568	2.62
4500	1411	1.82	1434	1.93	1457	2.03	1480	2.14	1502	2.25	1523	2.36	1545	2.47	1567	2.59	1589	2.7	1610	2.82
4750	1461	2.01	1484	2.12	1506	2.23	1527	2.34	1549	2.45	1570	2.56	1591	2.68	1612	2.8	1632	2.91	1653	3.04
5000	1512	2.21	1534	2.32	1556	2.43	1577	2.55	1597	2.67	1618	2.78	1638	2.9	1658	3.02	1678	3.15	1697	3.27
5250	1564	2.42	1585	2.54	1606	2.66	1627	2.78	1647	2.9	1667	3.02	1686	3.14	1706	3.27	1725	3.39	1744	3.52
5500	1616	2.65	1637	2.77	1657	2.9	1677	3.02	1697	3.15	1717	3.27	1736	3.4	1754	3.53	1773	3.66	1792	3.79
5750	1669	2.89	1689	3.02	1709	3.15	1729	3.28	1748	3.42	1767	3.55	1786	3.68	1804	3.81	1822	3.94	1840	4.08

**Table 89. Evaporator fan performance – 12.5 ton (model TSK), downflow (continued)**

Available External Static Pressure (Inches of Water Gauge)																				
CFM	1.10		1.20		1.30		1.40		1.50		1.60		1.70		1.80		1.90		2.00	
	RPM	BHP	RPM	BHP	RPM	BHP	RPM	BHP	RPM	BHP	RPM	BHP	RPM	BHP	RPM	BHP	RPM	BHP	RPM	BHP
6000	1722	3.15	1742	3.29	1762	3.42	1781	3.56	1799	3.7	1818	3.84	1836	3.97	1854	4.11	1872	4.25	1889	4.38

**Notes:**

1. Available External Static Pressure is the static pressure difference between the return duct and the supply duct plus the static pressure drop caused by accessories and options.
2. For direct drive evaporator fan speed (rpm), refer to the applicable table in the fan performance section.
3. Data includes pressure drop due to standard filters and wet coils. No accessories or options are included in pressure drop data.
4. To determine static pressure drop due to other options/accessories, refer to the applicable table in the fan performance section.
5. Direct drive fan motor heat is negligible.
6. Factory supplied motors, in commercial equipment, are definite purpose motors, specifically designed and tested to operate reliably and continuously at all cataloged conditions. Using the full horsepower range of our fan motors as shown in our tabular data will not result in nuisance tripping or premature motor failure. Our product's warranty will not be affected.

**Figure 18. Fan curves - 12.5 ton (high efficiency) to 25 ton, downflow**

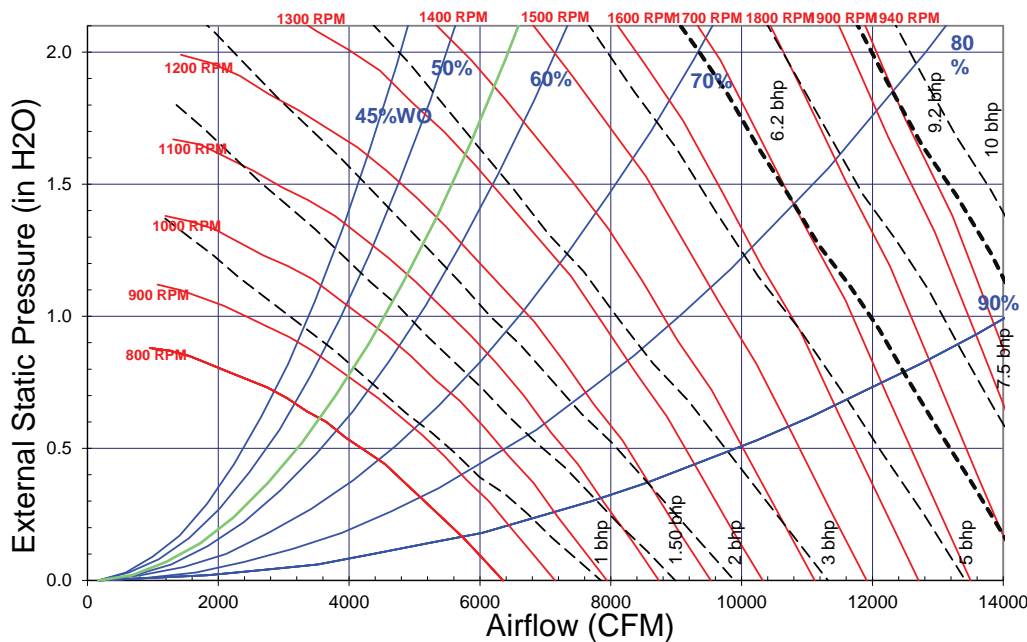

**Table 90. Evaporator fan performance – 12.5 ton (model THK), downflow**

Available External Static Pressure (Inches of Water Gauge)																				
CFM	0.10		0.20		0.30		0.40		0.50		0.60		0.70		0.80		0.90		1.00	
	RPM	BHP	RPM	BHP	RPM	BHP	RPM	BHP	RPM	BHP	RPM	BHP	RPM	BHP	RPM	BHP	RPM	BHP	RPM	BHP
3750	544	0.19	606	0.28	663	0.38	715	0.48	764	0.58	809	0.69	852	0.80	893	0.91	932	1.03	969	1.16
4000	572	0.22	631	0.32	686	0.42	736	0.52	784	0.63	828	0.74	870	0.86	911	0.97	949	1.10	986	1.22
4500	628	0.29	683	0.39	734	0.51	781	0.62	826	0.74	868	0.86	909	0.98	947	1.11	984	1.24	1020	1.37
5000	686	0.37	736	0.49	783	0.61	828	0.73	870	0.86	911	0.99	949	1.12	986	1.26	1022	1.39	1057	1.54
5500	745	0.47	791	0.59	835	0.72	877	0.86	917	0.99	955	1.13	992	1.28	1028	1.42	1062	1.57	1096	1.72
6000	804	0.58	847	0.71	889	0.86	928	1.00	966	1.15	1002	1.30	1037	1.45	1072	1.61	1105	1.76	1137	1.92

Available External Static Pressure (Inches of Water Gauge)																				
CFM	1.10		1.20		1.30		1.40		1.50		1.60		1.70		1.80		1.90		2.00	
	RPM	BHP	RPM	BHP	RPM	BHP	RPM	BHP	RPM	BHP	RPM	BHP	RPM	BHP	RPM	BHP	RPM	BHP	RPM	BHP
3750	1005	1.28	1040	1.41	1073	1.55	1106	1.68	1137	1.82	1168	1.97	1198	2.11	1227	2.26	1255	2.42	1283	2.57
4000	1021	1.35	1055	1.49	1088	1.62	1120	1.76	1151	1.91	1182	2.05	1211	2.2	1240	2.36	1268	2.51	1295	2.67
4500	1054	1.51	1088	1.65	1120	1.79	1151	1.94	1182	2.09	1211	2.24	1240	2.4	1268	2.55	1296	2.72	1323	2.88
5000	1090	1.68	1122	1.83	1154	1.98	1184	2.13	1214	2.29	1243	2.45	1271	2.61	1299	2.78	1326	2.94	1352	3.12



## Evaporator Fan Performance — Cooling

**Table 90. Evaporator fan performance – 12.5 ton (model THK), downflow (continued)**

Available External Static Pressure (Inches of Water Gauge)																				
CFM	1.10		1.20		1.30		1.40		1.50		1.60		1.70		1.80		1.90		2.00	
	RPM	BHP	RPM	BHP	RPM	BHP	RPM	BHP	RPM	BHP	RPM	BHP	RPM	BHP	RPM	BHP	RPM	BHP	RPM	BHP
5500	1128	1.87	1159	2.03	1190	2.19	1219	2.35	1248	2.51	1277	2.68	1304	2.85	1331	3.02	1358	3.2	1384	3.37
6000	1168	2.09	1198	2.25	1228	2.42	1257	2.59	1285	2.76	1312	2.93	1339	3.11	1366	3.29	1392	3.47	1417	3.66

**Notes:**

1. Available External Static Pressure is the static pressure difference between the return duct and the supply duct plus the static pressure drop caused by accessories and options.
2. For direct drive evaporator fan speed (rpm), refer to the applicable table in the fan performance section.
3. Data includes pressure drop due to standard filters and wet coils. No accessories or options are included in pressure drop data.
4. To determine static pressure drop due to other options/accessories, refer to the applicable table in the fan performance section.
5. Direct drive fan motor heat is negligible.
6. Factory supplied motors, in commercial equipment, are definite purpose motors, specifically designed and tested to operate reliably and continuously at all cataloged conditions. Using the full horsepower range of our fan motors as shown in our tabular data will not result in nuisance tripping or premature motor failure. Our product's warranty will not be affected.

**Table 91. Evaporator fan performance – 15 ton (model TSK, THK), downflow**

Available External Static Pressure (Inches of Water Gauge)																				
CFM	0.10		0.20		0.30		0.40		0.50		0.60		0.70		0.80		0.90		1.00	
	RPM	BHP	RPM	BHP	RPM	BHP	RPM	BHP	RPM	BHP	RPM	BHP	RPM	BHP	RPM	BHP	RPM	BHP	RPM	BHP
4500	628	0.29	684	0.40	734	0.51	779	0.62	825	0.74	869	0.86	910	0.98	948	1.11	984	1.24	1019	1.37
4800	663	0.34	715	0.45	764	0.57	808	0.68	851	0.80	893	0.93	934	1.07	971	1.20	1007	1.33	1042	1.47
5400	734	0.45	778	0.56	827	0.70	868	0.83	907	0.96	944	1.10	983	1.24	1020	1.39	1055	1.54	1089	1.69
6000	804	0.58	847	0.71	888	0.85	930	1.01	967	1.15	1002	1.30	1036	1.44	1070	1.60	1104	1.76	1137	1.93
6600	876	0.74	916	0.89	951	1.03	992	1.20	1028	1.37	1062	1.52	1094	1.68	1125	1.84	1155	2.01	1187	2.18
7200	948	0.93	986	1.09	1020	1.25	1053	1.41	1090	1.61	1123	1.78	1154	1.96	1184	2.13	1213	2.30	1241	2.48

Available External Static Pressure (Inches of Water Gauge)																				
CFM	1.10		1.20		1.30		1.40		1.50		1.60		1.70		1.80		1.90		2.00	
	RPM	BHP	RPM	BHP	RPM	BHP	RPM	BHP	RPM	BHP	RPM	BHP	RPM	BHP	RPM	BHP	RPM	BHP	RPM	BHP
4500	1054	1.51	1088	1.65	1120	1.79	1151	1.94	1182	2.09	1211	2.24	1239	2.39	1267	2.55	1294	2.71	1322	2.87
4800	1075	1.61	1107	1.75	1140	1.9	1171	2.05	1201	2.21	1230	2.36	1258	2.52	1286	2.68	1313	2.85	1339	3.01
5400	1121	1.84	1152	1.99	1182	2.14	1211	2.3	1240	2.46	1269	2.63	1297	2.8	1325	2.97	1351	3.15	1377	3.32
6000	1169	2.09	1199	2.25	1229	2.42	1258	2.59	1285	2.76	1312	2.93	1338	3.11	1364	3.28	1391	3.47	1417	3.66
6600	1218	2.37	1248	2.55	1277	2.73	1305	2.91	1332	3.09	1359	3.27	1385	3.46	1410	3.64	1435	3.83	1459	4.02
7200	1269	2.66	1298	2.86	1326	3.05	1354	3.25	1381	3.45	1407	3.64	1432	3.84	1457	4.04	1482	4.24	1505	4.44

**Notes:**

1. Available External Static Pressure is the static pressure difference between the return duct and the supply duct plus the static pressure drop caused by accessories and options.
2. For direct drive evaporator fan speed (rpm), refer to the applicable table in the fan performance section.
3. Data includes pressure drop due to standard filters and wet coils. No accessories or options are included in pressure drop data.
4. To determine static pressure drop due to other options/accessories, refer to the applicable table in the fan performance section.
5. Direct drive fan motor heat is negligible.
6. Factory supplied motors, in commercial equipment, are definite purpose motors, specifically designed and tested to operate reliably and continuously at all cataloged conditions. Using the full horsepower range of our fan motors as shown in our tabular data will not result in nuisance tripping or premature motor failure. Our product's warranty will not be affected.

**Table 92. Evaporator fan performance – 17.5 ton (model TSK, THK), downflow**

Available External Static Pressure (Inches of Water Gauge)																				
CFM	0.10		0.20		0.30		0.40		0.50		0.60		0.70		0.80		0.90		1.00	
	RPM	BHP	RPM	BHP	RPM	BHP	RPM	BHP	RPM	BHP	RPM	BHP	RPM	BHP	RPM	BHP	RPM	BHP	RPM	BHP
5250	716	0.42	761	0.53	811	0.67	853	0.79	893	0.92	931	1.05	970	1.20	1008	1.34	1043	1.48	1077	1.63
5600	757	0.49	801	0.61	847	0.75	888	0.89	927	1.02	963	1.16	1000	1.30	1036	1.46	1071	1.61	1105	1.76
6300	840	0.66	881	0.80	919	0.94	961	1.11	997	1.26	1032	1.41	1065	1.56	1096	1.71	1129	1.88	1162	2.05
7000	924	0.86	963	1.02	997	1.17	1033	1.34	1070	1.53	1103	1.69	1134	1.86	1164	2.03	1193	2.20	1221	2.37
7700	1009	1.11	1045	1.29	1077	1.46	1107	1.62	1141	1.82	1176	2.02	1205	2.21	1234	2.39	1262	2.58	1289	2.76
8400	1094	1.41	1127	1.60	1159	1.79	1187	1.97	1214	2.15	1247	2.37	1278	2.60	1306	2.80	1333	3.00	1358	3.20

**Table 92. Evaporator fan performance – 17.5 ton (model TSK, THK), downflow (continued)**

Available External Static Pressure (Inches of Water Gauge)																				
CFM	1.10		1.20		1.30		1.40		1.50		1.60		1.70		1.80		1.90		2.00	
	RPM	BHP	RPM	BHP	RPM	BHP	RPM	BHP	RPM	BHP	RPM	BHP	RPM	BHP	RPM	BHP	RPM	BHP	RPM	BHP
5250	1109	1.78	1141	1.93	1171	2.08	1201	2.24	1230	2.4	1259	2.56	1288	2.73	1315	2.9	1342	3.07	1368	3.24
5600	1137	1.92	1168	2.07	1198	2.23	1227	2.39	1255	2.56	1283	2.73	1311	2.9	1338	3.07	1364	3.25	1390	3.43
6300	1193	2.23	1223	2.4	1253	2.57	1281	2.74	1309	2.92	1336	3.1	1362	3.28	1387	3.46	1412	3.64	1437	3.83
7000	1252	2.56	1281	2.75	1310	2.94	1337	3.14	1364	3.33	1391	3.52	1416	3.71	1441	3.9	1466	4.1	1490	4.3
7700	1315	2.95	1341	3.14	1368	3.34	1395	3.55	1422	3.76	1447	3.98	1473	4.19	1497	4.4	1521	4.6	1545	4.82
8400	1384	3.4	1409	3.6	1433	3.81	1456	4.01	1481	4.23	1506	4.46	1531	4.69	1555	4.92	1578	5.15	1601	5.38

**Notes:**

1. Available External Static Pressure is the static pressure difference between the return duct and the supply duct plus the static pressure drop caused by accessories and options.
2. For direct drive evaporator fan speed (rpm), refer to the applicable table in the fan performance section.
3. Data includes pressure drop due to standard filters and wet coils. No accessories or options are included in pressure drop data.
4. To determine static pressure drop due to other options/accessories, refer to the applicable table in the fan performance section.
5. Direct drive fan motor heat is negligible.
6. Factory supplied motors, in commercial equipment, are definite purpose motors, specifically designed and tested to operate reliably and continuously at all cataloged conditions. Using the full horsepower range of our fan motors as shown in our tabular data will not result in nuisance tripping or premature motor failure. Our product's warranty will not be affected.

**Table 93. Evaporator fan performance – 17.5 ton (model TSK, THK), downflow, high static motor**

Available External Static Pressure (Inches of Water Gauge)																				
CFM	0.10		0.20		0.30		0.40		0.50		0.60		0.70		0.80		0.90		1.00	
	RPM	BHP	RPM	BHP	RPM	BHP	RPM	BHP	RPM	BHP	RPM	BHP	RPM	BHP	RPM	BHP	RPM	BHP	RPM	BHP
5250	716	0.42	761	0.53	811	0.67	853	0.79	893	0.92	931	1.05	970	1.20	1008	1.34	1043	1.48	1077	1.63
5600	757	0.49	801	0.61	847	0.75	888	0.89	927	1.02	963	1.16	1000	1.30	1036	1.46	1071	1.61	1105	1.76
6300	840	0.66	881	0.80	919	0.94	961	1.11	997	1.26	1032	1.41	1065	1.56	1096	1.71	1129	1.88	1162	2.05
7000	924	0.86	963	1.02	997	1.17	1033	1.34	1070	1.53	1103	1.69	1134	1.86	1164	2.03	1193	2.20	1221	2.37
7700	1009	1.11	1045	1.29	1077	1.46	1107	1.62	1141	1.82	1176	2.02	1205	2.21	1234	2.39	1262	2.58	1289	2.76
8400	1094	1.41	1127	1.60	1159	1.79	1187	1.97	1214	2.15	1247	2.37	1278	2.60	1306	2.80	1333	3.00	1358	3.20

**Available External Static Pressure (Inches of Water Gauge)**

CFM	1.10		1.20		1.30		1.40		1.50		1.60		1.70		1.80		1.90		2.00	
	RPM	BHP	RPM	BHP	RPM	BHP	RPM	BHP	RPM	BHP	RPM	BHP	RPM	BHP	RPM	BHP	RPM	BHP	RPM	BHP
5250	1109	1.78	1141	1.93	1171	2.08	1201	2.24	1230	2.4	1259	2.56	1288	2.73	1315	2.9	1342	3.07	1368	3.24
5600	1137	1.92	1168	2.07	1198	2.23	1227	2.39	1255	2.56	1283	2.73	1311	2.9	1338	3.07	1364	3.25	1390	3.43
6300	1193	2.23	1223	2.4	1253	2.57	1281	2.74	1309	2.92	1336	3.1	1362	3.28	1387	3.46	1412	3.64	1437	3.83
7000	1252	2.56	1281	2.75	1310	2.94	1337	3.14	1364	3.33	1391	3.52	1416	3.71	1441	3.9	1466	4.1	1490	4.3
7700	1315	2.95	1341	3.14	1368	3.34	1395	3.55	1422	3.76	1447	3.98	1473	4.19	1497	4.4	1521	4.6	1545	4.82
8400	1384	3.4	1409	3.6	1433	3.81	1456	4.01	1481	4.23	1506	4.46	1531	4.69	1555	4.92	1578	5.15	1601	5.38

**Notes:**

1. Available External Static Pressure is the static pressure difference between the return duct and the supply duct plus the static pressure drop caused by accessories and options.
2. For direct drive evaporator fan speed (rpm), refer to the applicable table in the fan performance section.
3. Data includes pressure drop due to standard filters and wet coils. No accessories or options are included in pressure drop data.
4. To determine static pressure drop due to other options/accessories, refer to the applicable table in the fan performance section.
5. Direct drive fan motor heat is negligible.
6. Factory supplied motors, in commercial equipment, are definite purpose motors, specifically designed and tested to operate reliably and continuously at all cataloged conditions. Using the full horsepower range of our fan motors as shown in our tabular data will not result in nuisance tripping or premature motor failure. Our product's warranty will not be affected.

**Table 94. Evaporator fan performance – 20 ton (model TSK, THK), downflow**

Available External Static Pressure (Inches of Water Gauge)																				
CFM	0.10		0.20		0.30		0.40		0.50		0.60		0.70		0.80		0.90		1.00	
	RPM	BHP	RPM	BHP	RPM	BHP	RPM	BHP	RPM	BHP	RPM	BHP	RPM	BHP	RPM	BHP	RPM	BHP	RPM	BHP
6000	804	0.58	847	0.71	888	0.85	930	1.01	967	1.15	1002	1.30	1036	1.44	1070	1.60	1104	1.76	1137	1.93
6400	852	0.68	893	0.83	929	0.97	971	1.14	1008	1.29	1042	1.45	1074	1.60	1106	1.76	1138	1.92	1170	2.10
7200	948	0.93	986	1.09	1020	1.25	1053	1.41	1090	1.61	1123	1.78	1154	1.96	1184	2.13	1213	2.30	1241	2.48



## Evaporator Fan Performance — Cooling

**Table 94. Evaporator fan performance – 20 ton (model TSK, THK), downflow (continued)**

Available External Static Pressure (Inches of Water Gauge)																				
CFM	0.10		0.20		0.30		0.40		0.50		0.60		0.70		0.80		0.90		1.00	
	RPM	BHP	RPM	BHP	RPM	BHP	RPM	BHP	RPM	BHP	RPM	BHP	RPM	BHP	RPM	BHP	RPM	BHP	RPM	BHP
8000	1045	1.23	1080	1.41	1112	1.59	1141	1.76	1172	1.95	1206	2.17	1237	2.37	1265	2.56	1292	2.75	1319	2.94
8800	1143	1.60	1175	1.80	1206	2.00	1233	2.19	1260	2.38	1288	2.59	1319	2.82	1348	3.06	1374	3.26	1399	3.47
9600	1241	2.04	1271	2.25	1300	2.47	1327	2.69	1351	2.89	1375	3.10	1401	3.32	1429	3.58	1457	3.84	1482	4.08
Available External Static Pressure (Inches of Water Gauge)																				
CFM	1.10		1.20		1.30		1.40		1.50		1.60		1.70		1.80		1.90		2.00	
	RPM	BHP	RPM	BHP	RPM	BHP	RPM	BHP	RPM	BHP	RPM	BHP	RPM	BHP	RPM	BHP	RPM	BHP	RPM	BHP
6000	1169	2.09	1199	2.25	1229	2.42	1258	2.59	1285	2.76	1312	2.93	1338	3.11	1364	3.28	1391	3.47	1417	3.66
6400	1201	2.27	1232	2.45	1261	2.62	1289	2.8	1317	2.98	1343	3.15	1369	3.34	1395	3.52	1419	3.71	1444	3.89
7200	1269	2.66	1298	2.86	1326	3.05	1354	3.25	1381	3.45	1407	3.64	1432	3.84	1457	4.04	1482	4.24	1505	4.44
8000	1345	3.14	1370	3.33	1394	3.53	1421	3.74	1447	3.96	1472	4.18	1497	4.4	1521	4.62	1545	4.84	1569	5.05
8800	1424	3.69	1448	3.9	1472	4.11	1495	4.32	1518	4.54	1540	4.75	1564	4.99	1588	5.23	1611	5.47	1634	5.72
9600	1506	4.3	1529	4.53	1551	4.76	1573	4.99	1595	5.22	1617	5.46	1638	5.69	1659	5.92	-	-	-	-

**Notes:**

1. Available External Static Pressure is the static pressure difference between the return duct and the supply duct plus the static pressure drop caused by accessories and options.
2. For direct drive evaporator fan speed (rpm), refer to the applicable table in the fan performance section.
3. Data includes pressure drop due to standard filters and wet coils. No accessories or options are included in pressure drop data.
4. To determine static pressure drop due to other options/accessories, refer to the applicable table in the fan performance section.
5. Direct drive fan motor heat is negligible.
6. Factory supplied motors, in commercial equipment, are definite purpose motors, specifically designed and tested to operate reliably and continuously at all cataloged conditions. Using the full horsepower range of our fan motors as shown in our tabular data will not result in nuisance tripping or premature motor failure. Our product's warranty will not be affected.

**Table 95. Evaporator fan performance – 20 ton (model TSK, THK), downflow, high static motor**

Available External Static Pressure (Inches of Water Gauge)																				
CFM	0.10		0.20		0.30		0.40		0.50		0.60		0.70		0.80		0.90		1.00	
	RPM	BHP	RPM	BHP	RPM	BHP	RPM	BHP	RPM	BHP	RPM	BHP	RPM	BHP	RPM	BHP	RPM	BHP	RPM	BHP
6000	804	0.58	847	0.71	888	0.85	930	1.01	967	1.15	1002	1.30	1036	1.44	1070	1.60	1104	1.76	1137	1.93
6400	852	0.68	893	0.83	929	0.97	971	1.14	1008	1.29	1042	1.45	1074	1.60	1106	1.76	1138	1.92	1170	2.10
7200	948	0.93	986	1.09	1020	1.25	1053	1.41	1090	1.61	1123	1.78	1154	1.96	1184	2.13	1213	2.30	1241	2.48
8000	1045	1.23	1080	1.41	1112	1.59	1141	1.76	1172	1.95	1206	2.17	1237	2.37	1265	2.56	1292	2.75	1319	2.94
8800	1143	1.60	1175	1.80	1206	2.00	1233	2.19	1260	2.38	1288	2.59	1319	2.82	1348	3.06	1374	3.26	1399	3.47
9600	1241	2.04	1271	2.25	1300	2.47	1327	2.69	1351	2.89	1375	3.10	1401	3.32	1429	3.58	1457	3.84	1482	4.08
Available External Static Pressure (Inches of Water Gauge)																				
CFM	1.10		1.20		1.30		1.40		1.50		1.60		1.70		1.80		1.90		2.00	
	RPM	BHP	RPM	BHP	RPM	BHP	RPM	BHP	RPM	BHP	RPM	BHP	RPM	BHP	RPM	BHP	RPM	BHP	RPM	BHP
6000	1169	2.09	1199	2.25	1229	2.42	1258	2.59	1285	2.76	1312	2.93	1338	3.11	1364	3.28	1391	3.47	1417	3.66
6400	1201	2.27	1232	2.45	1261	2.62	1289	2.8	1317	2.98	1343	3.15	1369	3.34	1395	3.52	1419	3.71	1444	3.89
7200	1269	2.66	1298	2.86	1326	3.05	1354	3.25	1381	3.45	1407	3.64	1432	3.84	1457	4.04	1482	4.24	1505	4.44
8000	1345	3.14	1370	3.33	1394	3.53	1421	3.74	1447	3.96	1472	4.18	1497	4.4	1521	4.62	1545	4.84	1569	5.05
8800	1424	3.69	1448	3.9	1472	4.11	1495	4.32	1518	4.54	1540	4.75	1564	4.99	1588	5.23	1611	5.47	1634	5.72
9600	1506	4.3	1529	4.53	1551	4.76	1573	4.99	1595	5.22	1617	5.46	1638	5.69	1659	5.92	1677	6.1	1699	6.39

**Notes:**

1. Available External Static Pressure is the static pressure difference between the return duct and the supply duct plus the static pressure drop caused by accessories and options.
2. For direct drive evaporator fan speed (rpm), refer to the applicable table in the fan performance section.
3. Data includes pressure drop due to standard filters and wet coils. No accessories or options are included in pressure drop data.
4. To determine static pressure drop due to other options/accessories, refer to the applicable table in the fan performance section.
5. Direct drive fan motor heat is negligible.
6. Factory supplied motors, in commercial equipment, are definite purpose motors, specifically designed and tested to operate reliably and continuously at all cataloged conditions. Using the full horsepower range of our fan motors as shown in our tabular data will not result in nuisance tripping or premature motor failure. Our product's warranty will not be affected.

**Table 96. Evaporator fan performance – 25 ton (model TSK, THK), downflow**

Available External Static Pressure (Inches of Water Gauge)																				
CFM	0.10		0.20		0.30		0.40		0.50		0.60		0.70		0.80		0.90		1.00	
	RPM	BHP	RPM	BHP	RPM	BHP	RPM	BHP	RPM	BHP	RPM	BHP	RPM	BHP	RPM	BHP	RPM	BHP	RPM	BHP
7500	984	1.03	1021	1.21	1054	1.37	1085	1.53	1121	1.73	1155	1.92	1185	2.10	1214	2.28	1242	2.46	1270	2.64
8000	1045	1.23	1080	1.41	1112	1.59	1141	1.76	1172	1.95	1206	2.17	1237	2.37	1265	2.56	1292	2.75	1319	2.94
9000	1167	1.70	1199	1.90	1229	2.11	1257	2.31	1283	2.50	1309	2.70	1339	2.94	1368	3.19	1395	3.40	1420	3.62
10000	1290	2.28	1319	2.50	1347	2.73	1374	2.96	1398	3.18	1421	3.39	1444	3.61	1471	3.86	1498	4.13	1524	4.40
11000	1413	2.99	1440	3.23	1466	3.47	1491	3.73	1515	3.98	1536	4.22	1558	4.45	1579	4.69	1601	4.94	1626	5.24
12000	1537	3.83	1561	4.09	1585	4.36	1609	4.63	1631	4.91	1653	5.18	1673	5.44	1693	5.69	1712	5.95	-	-
Available External Static Pressure (Inches of Water Gauge)																				
CFM	1.10		1.20		1.30		1.40		1.50		1.60		1.70		1.80		1.90		2.00	
	RPM	BHP	RPM	BHP	RPM	BHP	RPM	BHP	RPM	BHP	RPM	BHP	RPM	BHP	RPM	BHP	RPM	BHP	RPM	BHP
7500	1296	2.83	1323	3.02	1351	3.22	1379	3.43	1405	3.64	1431	3.84	1456	4.05	1481	4.25	1505	4.46	1529	4.66
8000	1345	3.14	1370	3.33	1394	3.53	1421	3.74	1447	3.96	1472	4.18	1497	4.4	1521	4.62	1545	4.84	1569	5.05
9000	1444	3.83	1468	4.05	1491	4.26	1514	4.48	1537	4.7	1559	4.92	1581	5.15	1605	5.39	1628	5.64	1651	5.89
10000	1547	4.64	1570	4.88	1592	5.12	1614	5.36	1635	5.6	1656	5.84	-	-	-	-	-	-	-	-
11000	1650	5.53	1674	5.83	-	-	-	-	-	-	-	-	-	-	-	-	-	-	-	-
12000	-	-	-	-	-	-	-	-	-	-	-	-	-	-	-	-	-	-	-	-

**Notes:**

1. Available External Static Pressure is the static pressure difference between the return duct and the supply duct plus the static pressure drop caused by accessories and options.
2. For direct drive evaporator fan speed (rpm), refer to the applicable table in the fan performance section.
3. Data includes pressure drop due to standard filters and wet coils. No accessories or options are included in pressure drop data.
4. To determine static pressure drop due to other options/accessories, refer to the applicable table in the fan performance section.
5. Direct drive fan motor heat is negligible.
6. Factory supplied motors, in commercial equipment, are definite purpose motors, specifically designed and tested to operate reliably and continuously at all cataloged conditions. Using the full horsepower range of our fan motors as shown in our tabular data will not result in nuisance tripping or premature motor failure. Our product's warranty will not be affected.

**Table 97. Evaporator fan performance – 25 ton (model TSK, THK), downflow, high static motor**

Available External Static Pressure (Inches of Water Gauge)																				
CFM	0.10		0.20		0.30		0.40		0.50		0.60		0.70		0.80		0.90		1.00	
	RPM	BHP	RPM	BHP	RPM	BHP	RPM	BHP	RPM	BHP	RPM	BHP	RPM	BHP	RPM	BHP	RPM	BHP	RPM	BHP
7500	984	1.03	1021	1.21	1054	1.37	1085	1.53	1121	1.73	1155	1.92	1185	2.10	1214	2.28	1242	2.46	1270	2.64
8000	1045	1.23	1080	1.41	1112	1.59	1141	1.76	1172	1.95	1206	2.17	1237	2.37	1265	2.56	1292	2.75	1319	2.94
9000	1167	1.70	1199	1.90	1229	2.11	1257	2.31	1283	2.50	1309	2.70	1339	2.94	1368	3.19	1395	3.40	1420	3.62
10000	1290	2.28	1319	2.50	1347	2.73	1374	2.96	1398	3.18	1421	3.39	1444	3.61	1471	3.86	1498	4.13	1524	4.40
11000	1413	2.99	1440	3.23	1466	3.47	1491	3.73	1515	3.98	1536	4.22	1558	4.45	1579	4.69	1601	4.94	1626	5.24
12000	1537	3.83	1561	4.09	1585	4.36	1609	4.63	1631	4.91	1653	5.18	1673	5.44	1693	5.69	1712	5.95	1728	6.08
Available External Static Pressure (Inches of Water Gauge)																				
CFM	1.10		1.20		1.30		1.40		1.50		1.60		1.70		1.80		1.90		2.00	
	RPM	BHP	RPM	BHP	RPM	BHP	RPM	BHP	RPM	BHP	RPM	BHP	RPM	BHP	RPM	BHP	RPM	BHP	RPM	BHP
7500	1296	2.83	1323	3.02	1351	3.22	1379	3.43	1405	3.64	1431	3.84	1456	4.05	1481	4.25	1505	4.46	1529	4.66
8000	1345	3.14	1370	3.33	1394	3.53	1421	3.74	1447	3.96	1472	4.18	1497	4.4	1521	4.62	1545	4.84	1569	5.05
9000	1444	3.83	1468	4.05	1491	4.26	1514	4.48	1537	4.7	1559	4.92	1581	5.15	1605	5.39	1628	5.64	1651	5.89
10000	1547	4.64	1570	4.88	1592	5.12	1614	5.36	1635	5.6	1656	5.84	1665	5.9	1689	6.16	1711	6.44	1733	6.73
11000	1650	5.53	1674	5.83	1693	5.98	1714	6.24	1733	6.5	1753	6.76	1749	6.65	1773	6.93	1794	7.24	1815	7.57



## Evaporator Fan Performance — Cooling

**Table 97. Evaporator fan performance – 25 ton (model TSK, THK), downflow, high static motor (continued)**

CFM	Available External Static Pressure (Inches of Water Gauge)																			
	1.10		1.20		1.30		1.40		1.50		1.60		1.70		1.80		1.90		2.00	
	RPM	BHP	RPM	BHP	RPM	BHP	RPM	BHP	RPM	BHP	RPM	BHP	RPM	BHP	RPM	BHP	RPM	BHP	RPM	BHP
12000	1753	6.42	1778	6.78	1794	6.84	1814	7.12	1831	7.4	1850	7.68	1833	7.4	1857	7.7	1877	8.04	1897	8.41

**Notes:**

1. Available External Static Pressure is the static pressure difference between the return duct and the supply duct plus the static pressure drop caused by accessories and options.
2. For direct drive evaporator fan speed (rpm), refer to the applicable table in the fan performance section.
3. Data includes pressure drop due to standard filters and wet coils. No accessories or options are included in pressure drop data.
4. To determine static pressure drop due to other options/accessories, refer to the applicable table in the fan performance section.
5. Direct drive fan motor heat is negligible.
6. Factory supplied motors, in commercial equipment, are definite purpose motors, specifically designed and tested to operate reliably and continuously at all cataloged conditions. Using the full horsepower range of our fan motors as shown in our tabular data will not result in nuisance tripping or premature motor failure. Our product's warranty will not be affected.

## 6 to 25 Tons — Horizontal

**Figure 19. Fan curves — 6 to 10 tons (model T\*K), horizontal**

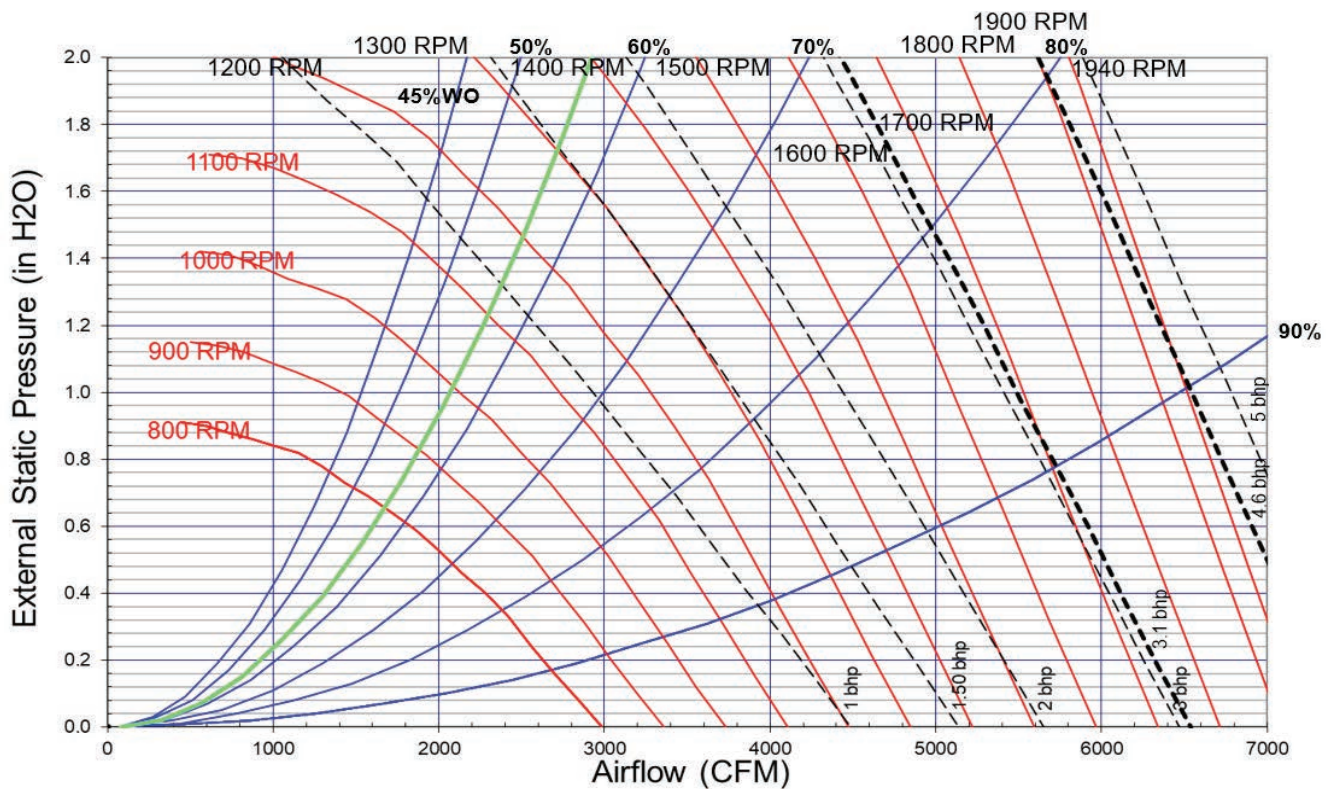

**Table 98. Evaporator fan performance – 6 ton (model TSK, THK), horizontal**

CFM	Available External Static Pressure (Inches of Water Gauge)																			
	0.10		0.20		0.30		0.40		0.50		0.60		0.70		0.80		0.90		1.00	
	RPM	BHP	RPM	BHP	RPM	BHP	RPM	BHP	RPM	BHP	RPM	BHP	RPM	BHP	RPM	BHP	RPM	BHP	RPM	BHP
1800	550	0.11	606	0.15	658	0.19	708	0.24	754	0.29	797	0.35	839	0.40	878	0.46	915	0.52	951	0.58
1920	579	0.12	632	0.17	682	0.22	730	0.27	775	0.32	817	0.37	858	0.43	896	0.49	933	0.55	968	0.61
2040	608	0.14	659	0.19	707	0.24	753	0.29	797	0.35	838	0.40	876	0.46	915	0.52	951	0.59	986	0.65
2160	638	0.16	687	0.21	732	0.26	776	0.32	819	0.37	859	0.43	897	0.49	933	0.56	970	0.62	1004	0.69
2280	667	0.18	715	0.24	758	0.29	801	0.35	842	0.41	881	0.47	919	0.53	954	0.59	988	0.66	1023	0.73
2400	697	0.21	744	0.26	785	0.32	825	0.38	865	0.44	904	0.50	940	0.57	975	0.63	1009	0.70	1041	0.77
2520	727	0.24	772	0.29	812	0.35	851	0.41	889	0.48	926	0.54	963	0.61	997	0.68	1030	0.75	1061	0.82

**Table 98. Evaporator fan performance – 6 ton (model TSK, THK), horizontal (continued)**

Available External Static Pressure (Inches of Water Gauge)																				
CFM	0.10		0.20		0.30		0.40		0.50		0.60		0.70		0.80		0.90		1.00	
	RPM	BHP	RPM	BHP	RPM	BHP	RPM	BHP	RPM	BHP	RPM	BHP	RPM	BHP	RPM	BHP	RPM	BHP	RPM	BHP
2640	758	0.26	801	0.33	840	0.39	877	0.45	914	0.52	950	0.58	985	0.65	1019	0.72	1052	0.79	1083	0.87
2760	788	0.30	830	0.36	868	0.42	904	0.49	939	0.56	974	0.63	1008	0.70	1041	0.77	1073	0.84	1104	0.92
2880	818	0.33	859	0.40	896	0.46	930	0.53	965	0.60	998	0.67	1032	0.75	1064	0.82	1096	0.90	1126	0.97
Available External Static Pressure (Inches of Water Gauge)																				
CFM	1.10		1.20		1.30		1.40		1.50		1.60		1.70		1.80		1.90		2.00	
	RPM	BHP	RPM	BHP	RPM	BHP	RPM	BHP	RPM	BHP	RPM	BHP	RPM	BHP	RPM	BHP	RPM	BHP	RPM	BHP
1800	985	0.64	1018	0.7	1050	0.76	1080	0.83	1109	0.89	1138	0.96	1165	1.03	1193	1.1	1223	1.17	1251	1.25
1920	1002	0.68	1034	0.74	1066	0.81	1096	0.87	1126	0.94	1154	1.01	1181	1.08	1208	1.15	1234	1.22	1260	1.29
2040	1019	0.72	1051	0.78	1083	0.85	1113	0.92	1142	0.99	1170	1.06	1198	1.13	1224	1.21	1250	1.28	1276	1.35
2160	1037	0.76	1069	0.83	1099	0.9	1129	0.97	1158	1.04	1187	1.11	1214	1.19	1241	1.26	1267	1.34	1292	1.42
2280	1056	0.8	1087	0.87	1117	0.94	1147	1.02	1175	1.09	1203	1.17	1231	1.25	1257	1.32	1283	1.4	1308	1.48
2400	1074	0.84	1105	0.92	1135	0.99	1165	1.07	1193	1.15	1220	1.23	1247	1.31	1274	1.39	1300	1.47	1325	1.55
2520	1093	0.89	1124	0.97	1154	1.05	1183	1.12	1211	1.2	1238	1.29	1265	1.37	1291	1.45	1316	1.53	1341	1.62
2640	1113	0.94	1142	1.02	1172	1.1	1201	1.18	1229	1.26	1256	1.35	1283	1.43	1308	1.52	1333	1.6	1358	1.69
2760	1134	1	1163	1.08	1191	1.16	1220	1.24	1248	1.32	1275	1.41	1301	1.49	1326	1.58	1351	1.67	1376	1.76
2880	1156	1.05	1184	1.13	1211	1.22	1238	1.3	1266	1.39	1293	1.47	1319	1.56	1345	1.65	1369	1.74	1394	1.83

**Notes:**

1. Available External Static Pressure is the static pressure difference between the return duct and the supply duct plus the static pressure drop caused by accessories and options.
2. For direct drive evaporator fan speed (rpm), refer to the applicable table in the fan performance section.
3. Data includes pressure drop due to standard filters and wet coils. No accessories or options are included in pressure drop data.
4. To determine static pressure drop due to other options/accessories, refer to the applicable table in the fan performance section.
5. Direct drive fan motor heat is negligible.
6. Factory supplied motors, in commercial equipment, are definite purpose motors, specifically designed and tested to operate reliably and continuously at all cataloged conditions. Using the full horsepower range of our fan motors as shown in our tabular data will not result in nuisance tripping or premature motor failure. Our product's warranty will not be affected.

**Table 99. Evaporator fan performance – 7.5 ton (model TSK, THK), horizontal**

Available External Static Pressure (Inches of Water Gauge)																				
CFM	0.10		0.20		0.30		0.40		0.50		0.60		0.70		0.80		0.90		1.00	
	RPM	BHP	RPM	BHP	RPM	BHP	RPM	BHP	RPM	BHP	RPM	BHP	RPM	BHP	RPM	BHP	RPM	BHP	RPM	BHP
2250	660	0.18	708	0.23	752	0.28	795	0.34	836	0.40	876	0.46	913	0.52	949	0.58	984	0.65	1018	0.72
2400	697	0.21	744	0.26	785	0.32	825	0.38	865	0.44	904	0.50	940	0.57	975	0.63	1009	0.70	1041	0.77
2550	735	0.24	779	0.30	819	0.36	857	0.42	895	0.49	932	0.55	968	0.62	1003	0.69	1035	0.76	1067	0.83
2700	773	0.28	816	0.34	854	0.40	890	0.47	926	0.54	962	0.60	996	0.67	1030	0.74	1062	0.82	1094	0.89
2850	811	0.32	852	0.39	889	0.45	924	0.52	958	0.59	992	0.66	1026	0.73	1058	0.81	1090	0.88	1121	0.96
3000	849	0.37	889	0.44	925	0.51	958	0.58	991	0.65	1023	0.72	1056	0.80	1087	0.87	1118	0.95	1148	1.03
3150	887	0.42	926	0.49	961	0.56	994	0.64	1025	0.71	1056	0.79	1087	0.87	1117	0.95	1147	1.03	1176	1.11
3300	926	0.47	963	0.55	997	0.63	1029	0.70	1059	0.78	1089	0.86	1118	0.94	1148	1.02	1177	1.11	1205	1.19
3600	1003	0.60	1038	0.68	1070	0.77	1101	0.85	1129	0.93	1156	1.01	1184	1.10	1211	1.19	1238	1.28	1265	1.37
Available External Static Pressure (Inches of Water Gauge)																				
CFM	1.10		1.20		1.30		1.40		1.50		1.60		1.70		1.80		1.90		2.00	
	RPM	BHP	RPM	BHP	RPM	BHP	RPM	BHP	RPM	BHP	RPM	BHP	RPM	BHP	RPM	BHP	RPM	BHP	RPM	BHP
2250	1051	0.79	1083	0.86	1113	0.93	1142	1.01	1171	1.08	1199	1.16	1226	1.23	1253	1.31	1279	1.39	1304	1.46
2400	1074	0.84	1105	0.92	1135	0.99	1165	1.07	1193	1.15	1220	1.23	1247	1.31	1274	1.39	1300	1.47	1325	1.55
2550	1097	0.9	1128	0.98	1158	1.06	1187	1.14	1215	1.22	1243	1.3	1269	1.38	1295	1.47	1320	1.55	1345	1.63
2700	1123	0.97	1152	1.05	1182	1.13	1210	1.21	1238	1.29	1265	1.38	1292	1.46	1317	1.55	1342	1.64	1367	1.72
2850	1150	1.04	1179	1.12	1206	1.2	1234	1.28	1261	1.37	1288	1.46	1315	1.55	1340	1.63	1365	1.72	1389	1.82
3000	1177	1.11	1206	1.2	1233	1.28	1259	1.37	1285	1.45	1312	1.54	1338	1.63	1363	1.72	1388	1.82	1412	1.91
3150	1205	1.19	1233	1.28	1260	1.36	1286	1.45	1311	1.54	1336	1.63	1361	1.72	1386	1.82	1411	1.92	1435	2.01
3300	1233	1.28	1260	1.36	1287	1.45	1313	1.54	1338	1.64	1363	1.73	1386	1.82	1410	1.92	1434	2.02	1458	2.12



## Evaporator Fan Performance — Cooling

**Table 99. Evaporator fan performance – 7.5 ton (model TSK, THK), horizontal (continued)**

Available External Static Pressure (Inches of Water Gauge)																				
CFM	1.10		1.20		1.30		1.40		1.50		1.60		1.70		1.80		1.90		2.00	
	RPM	BHP	RPM	BHP	RPM	BHP	RPM	BHP	RPM	BHP	RPM	BHP	RPM	BHP	RPM	BHP	RPM	BHP	RPM	BHP
3600	1291	1.46	1317	1.55	1343	1.65	1368	1.74	1393	1.84	1417	1.94	1440	2.04	1463	2.14	1486	2.24	1507	2.34

**Notes:**

1. Available External Static Pressure is the static pressure difference between the return duct and the supply duct plus the static pressure drop caused by accessories and options.
2. For direct drive evaporator fan speed (rpm), refer to the applicable table in the fan performance section.
3. Data includes pressure drop due to standard filters and wet coils. No accessories or options are included in pressure drop data.
4. To determine static pressure drop due to other options/accessories, refer to the applicable table in the fan performance section.
5. Direct drive fan motor heat is negligible.
6. Factory supplied motors, in commercial equipment, are definite purpose motors, specifically designed and tested to operate reliably and continuously at all cataloged conditions. Using the full horsepower range of our fan motors as shown in our tabular data will not result in nuisance tripping or premature motor failure. Our product's warranty will not be affected.

**Table 100. Evaporator fan performance – 8.5 ton (model TSK, THK), horizontal**

Available External Static Pressure (Inches of Water Gauge)																				
CFM	0.10		0.20		0.30		0.40		0.50		0.60		0.70		0.80		0.90		1.00	
	RPM	BHP	RPM	BHP	RPM	BHP	RPM	BHP	RPM	BHP	RPM	BHP	RPM	BHP	RPM	BHP	RPM	BHP	RPM	BHP
2550	735	0.24	779	0.30	819	0.36	857	0.42	895	0.49	932	0.55	968	0.62	1003	0.69	1035	0.76	1067	0.83
2720	778	0.29	820	0.35	859	0.41	895	0.48	930	0.54	966	0.61	1000	0.68	1034	0.75	1066	0.83	1097	0.90
2890	821	0.33	862	0.40	899	0.47	933	0.53	967	0.61	1001	0.68	1034	0.75	1066	0.82	1097	0.90	1128	0.98
3060	864	0.39	903	0.46	940	0.53	972	0.60	1004	0.67	1036	0.75	1068	0.82	1099	0.90	1129	0.98	1159	1.06
3230	908	0.45	945	0.52	980	0.60	1012	0.67	1043	0.75	1073	0.83	1103	0.91	1133	0.99	1163	1.07	1191	1.15
3400	952	0.51	988	0.59	1021	0.67	1053	0.75	1082	0.83	1111	0.91	1140	0.99	1168	1.08	1197	1.16	1225	1.25
3570	996	0.59	1030	0.67	1063	0.75	1094	0.83	1122	0.92	1150	1.00	1177	1.08	1205	1.17	1232	1.26	1259	1.35
3740	1040	0.67	1073	0.75	1104	0.84	1134	0.92	1163	1.01	1189	1.10	1215	1.18	1242	1.28	1267	1.37	1293	1.46
4080	1128	0.85	1159	0.94	1189	1.03	1217	1.13	1244	1.22	1269	1.32	1294	1.41	1318	1.50	1342	1.60	1366	1.71

Available External Static Pressure (Inches of Water Gauge)																				
CFM	1.10		1.20		1.30		1.40		1.50		1.60		1.70		1.80		1.90		2.00	
	RPM	BHP	RPM	BHP	RPM	BHP	RPM	BHP	RPM	BHP	RPM	BHP	RPM	BHP	RPM	BHP	RPM	BHP	RPM	BHP
2550	1097	0.9	1128	0.98	1158	1.06	1187	1.14	1215	1.22	1243	1.3	1269	1.38	1295	1.47	1320	1.55	1345	1.63
2720	1127	0.98	1156	1.06	1185	1.14	1214	1.22	1241	1.3	1268	1.39	1295	1.47	1320	1.56	1345	1.65	1370	1.74
2890	1157	1.06	1186	1.14	1213	1.22	1240	1.31	1268	1.39	1295	1.48	1321	1.57	1346	1.66	1371	1.75	1395	1.84
3060	1188	1.14	1216	1.23	1243	1.31	1270	1.4	1295	1.49	1321	1.58	1347	1.67	1372	1.76	1397	1.86	1421	1.95
3230	1220	1.24	1247	1.32	1274	1.41	1300	1.5	1326	1.59	1350	1.68	1374	1.78	1399	1.87	1423	1.97	1447	2.07
3400	1252	1.33	1279	1.42	1305	1.52	1331	1.61	1356	1.7	1380	1.8	1404	1.89	1427	1.99	1450	2.09	1474	2.19
3570	1285	1.44	1311	1.53	1337	1.63	1362	1.72	1387	1.82	1411	1.92	1435	2.02	1458	2.12	1480	2.22	1502	2.32
3740	1319	1.56	1345	1.65	1369	1.75	1394	1.84	1418	1.94	1442	2.04	1466	2.15	1488	2.25	1511	2.35	1532	2.46
4080	1389	1.81	1413	1.91	1437	2.01	1460	2.11	1483	2.22	1506	2.32	1528	2.43	1551	2.54	1573	2.65	1594	2.76

**Notes:**

1. Available External Static Pressure is the static pressure difference between the return duct and the supply duct plus the static pressure drop caused by accessories and options.
2. For direct drive evaporator fan speed (rpm), refer to the applicable table in the fan performance section.
3. Data includes pressure drop due to standard filters and wet coils. No accessories or options are included in pressure drop data.
4. To determine static pressure drop due to other options/accessories, refer to the applicable table in the fan performance section.
5. Direct drive fan motor heat is negligible.
6. Factory supplied motors, in commercial equipment, are definite purpose motors, specifically designed and tested to operate reliably and continuously at all cataloged conditions. Using the full horsepower range of our fan motors as shown in our tabular data will not result in nuisance tripping or premature motor failure. Our product's warranty will not be affected.

**Table 101. Evaporator fan performance – 10 ton (model TSK, THK), horizontal**

Available External Static Pressure (Inches of Water Gauge)																				
CFM	0.10		0.20		0.30		0.40		0.50		0.60		0.70		0.80		0.90		1.00	
	RPM	BHP	RPM	BHP	RPM	BHP	RPM	BHP	RPM	BHP	RPM	BHP	RPM	BHP	RPM	BHP	RPM	BHP	RPM	BHP
3000	849	0.37	889	0.44	925	0.51	958	0.58	991	0.65	1023	0.72	1056	0.80	1087	0.87	1118	0.95	1148	1.03
3200	900	0.44	938	0.51	973	0.58	1005	0.66	1036	0.73	1067	0.81	1097	0.89	1127	0.97	1157	1.05	1186	1.13

**Table 101. Evaporator fan performance – 10 ton (model TSK, THK), horizontal (continued)**

Available External Static Pressure (Inches of Water Gauge)																				
CFM	0.10		0.20		0.30		0.40		0.50		0.60		0.70		0.80		0.90		1.00	
	RPM	BHP	RPM	BHP	RPM	BHP	RPM	BHP	RPM	BHP	RPM	BHP	RPM	BHP	RPM	BHP	RPM	BHP	RPM	BHP
3400	952	0.51	988	0.59	1021	0.67	1053	0.75	1082	0.83	1111	0.91	1140	0.99	1168	1.08	1197	1.16	1225	1.25
3600	1003	0.60	1038	0.68	1070	0.77	1101	0.85	1129	0.93	1156	1.01	1184	1.10	1211	1.19	1238	1.28	1265	1.37
3800	1055	0.70	1088	0.78	1119	0.87	1149	0.96	1177	1.05	1203	1.13	1229	1.22	1255	1.31	1281	1.41	1306	1.50
4000	1107	0.80	1139	0.89	1169	0.98	1197	1.08	1225	1.17	1250	1.26	1275	1.35	1299	1.45	1324	1.55	1349	1.65
4200	1159	0.92	1190	1.01	1219	1.11	1246	1.21	1273	1.31	1298	1.40	1322	1.50	1345	1.60	1369	1.69	1392	1.80
4400	1211	1.05	1241	1.15	1269	1.25	1295	1.35	1321	1.45	1346	1.55	1370	1.65	1392	1.75	1414	1.86	1437	1.96
4800	1316	1.34	1344	1.45	1370	1.56	1395	1.67	1419	1.78	1442	1.89	1465	2.00	1487	2.11	1508	2.22	1529	2.33
Available External Static Pressure (Inches of Water Gauge)																				
CFM	1.10		1.20		1.30		1.40		1.50		1.60		1.70		1.80		1.90		2.00	
	RPM	BHP	RPM	BHP	RPM	BHP	RPM	BHP	RPM	BHP	RPM	BHP	RPM	BHP	RPM	BHP	RPM	BHP	RPM	BHP
3000	1177	1.11	1206	1.2	1233	1.28	1259	1.37	1285	1.45	1312	1.54	1338	1.63	1363	1.72	1388	1.82	1412	1.91
3200	1214	1.22	1242	1.31	1269	1.39	1295	1.48	1320	1.57	1345	1.66	1369	1.76	1394	1.85	1419	1.95	1443	2.05
3400	1252	1.33	1279	1.42	1305	1.52	1331	1.61	1356	1.70	1380	1.80	1404	1.89	1427	1.99	1450	2.09	1474	2.19
3600	1291	1.46	1317	1.55	1343	1.65	1368	1.74	1393	1.84	1417	1.94	1440	2.04	1463	2.14	1486	2.24	1507	2.34
3800	1332	1.60	1357	1.69	1381	1.79	1405	1.89	1430	1.99	1453	2.09	1477	2.19	1499	2.30	1521	2.40	1543	2.51
4000	1373	1.75	1397	1.85	1421	1.95	1444	2.05	1467	2.15	1491	2.25	1514	2.36	1536	2.47	1558	2.58	1579	2.69
4200	1415	1.90	1438	2.01	1462	2.11	1485	2.22	1507	2.32	1529	2.43	1551	2.54	1573	2.65	1595	2.76	1616	2.88
4400	1459	2.07	1481	2.18	1503	2.29	1525	2.40	1547	2.51	1569	2.62	1590	2.73	1611	2.84	1632	2.96	-	-
4800	1549	2.44	1569	2.56	1590	2.68	1610	2.80	1630	2.92	1650	3.04	-	-	-	-	-	-	-	-

**Notes:**

1. Available External Static Pressure is the static pressure difference between the return duct and the supply duct plus the static pressure drop caused by accessories and options.
2. For direct drive evaporator fan speed (rpm), refer to the applicable table in the fan performance section.
3. Data includes pressure drop due to standard filters and wet coils. No accessories or options are included in pressure drop data.
4. To determine static pressure drop due to other options/accessories, refer to the applicable table in the fan performance section.
5. Direct drive fan motor heat is negligible.
6. Factory supplied motors, in commercial equipment, are definite purpose motors, specifically designed and tested to operate reliably and continuously at all cataloged conditions. Using the full horsepower range of our fan motors as shown in our tabular data will not result in nuisance tripping or premature motor failure. Our product's warranty will not be affected.

**Table 102. Evaporator fan performance - 10 ton (model TSK, THK), horizontal, high static motor**

Available External Static Pressure (Inches of Water Gauge)																				
CFM	0.10		0.20		0.30		0.40		0.50		0.60		0.70		0.80		0.90		1.00	
	RPM	BHP	RPM	BHP	RPM	BHP	RPM	BHP	RPM	BHP	RPM	BHP	RPM	BHP	RPM	BHP	RPM	BHP	RPM	BHP
3000	856	0.38	894	0.45	929	0.52	962	0.58	995	0.65	1028	0.73	1060	0.80	1092	0.88	1122	0.95	1152	1.03
3200	908	0.45	944	0.52	978	0.60	1010	0.67	1040	0.74	1071	0.82	1102	0.90	1132	0.98	1162	1.06	1190	1.14
3400	960	0.53	994	0.61	1027	0.69	1058	0.76	1087	0.84	1114	0.92	1145	1.00	1174	1.08	1202	1.17	1230	1.25
3600	1012	0.62	1045	0.70	1076	0.78	1106	0.87	1134	0.95	1161	1.03	1188	1.11	1216	1.20	1244	1.29	1270	1.38
3800	1065	0.72	1096	0.81	1126	0.89	1155	0.98	1182	1.07	1208	1.15	1233	1.24	1259	1.33	1286	1.42	1312	1.51
4000	1117	0.84	1148	0.92	1176	1.01	1204	1.10	1231	1.19	1256	1.28	1280	1.37	1304	1.47	1329	1.56	1355	1.66
4200	1170	0.96	1199	1.05	1227	1.14	1254	1.24	1279	1.33	1304	1.43	1328	1.52	1351	1.62	1373	1.72	1398	1.82
4400	1223	1.09	1251	1.19	1278	1.29	1304	1.38	1328	1.48	1352	1.58	1376	1.68	1398	1.78	1420	1.88	1441	1.98
4600	1276	1.24	1303	1.34	1329	1.44	1354	1.54	1378	1.65	1401	1.75	1424	1.86	1446	1.96	1467	2.06	1488	2.17
4800	1329	1.40	1355	1.50	1380	1.61	1404	1.72	1428	1.82	1450	1.93	1472	2.04	1494	2.15	1514	2.26	1535	2.37
Available External Static Pressure (Inches of Water Gauge)																				
CFM	1.10		1.20		1.30		1.40		1.50		1.60		1.70		1.80		1.90		2.00	
	RPM	BHP	RPM	BHP	RPM	BHP	RPM	BHP	RPM	BHP	RPM	BHP	RPM	BHP	RPM	BHP	RPM	BHP	RPM	BHP
3000	1180	1.11	1208	1.2	1235	1.28	1261	1.37	1286	1.45	1311	1.54	1337	1.63	1362	1.72	1387	1.81	1411	1.91
3200	1218	1.22	1245	1.31	1271	1.39	1297	1.48	1322	1.57	1346	1.66	1370	1.75	1394	1.85	1418	1.94	1442	2.04
3400	1257	1.34	1283	1.43	1309	1.52	1334	1.61	1359	1.7	1383	1.8	1406	1.89	1429	1.99	1451	2.09	1473	2.18
3600	1297	1.47	1322	1.56	1347	1.65	1372	1.75	1396	1.84	1420	1.94	1443	2.04	1465	2.14	1488	2.24	1509	2.34



## Evaporator Fan Performance — Cooling

**Table 102. Evaporator fan performance - 10 ton (model TSK, THK), horizontal, high static motor (continued)**

CFM	Available External Static Pressure (Inches of Water Gauge)																			
	1.10		1.20		1.30		1.40		1.50		1.60		1.70		1.80		1.90		2.00	
	RPM	BHP	RPM	BHP	RPM	BHP	RPM	BHP	RPM	BHP	RPM	BHP	RPM	BHP	RPM	BHP	RPM	BHP	RPM	BHP
3800	1337	1.61	1362	1.7	1387	1.8	1411	1.89	1434	1.99	1458	2.1	1480	2.2	1503	2.3	1524	2.41	1546	2.51
4000	1379	1.76	1403	1.86	1427	1.96	1450	2.06	1473	2.16	1496	2.26	1518	2.37	1540	2.47	1562	2.58	1583	2.69
4200	1422	1.92	1445	2.02	1468	2.12	1491	2.23	1513	2.33	1535	2.44	1557	2.55	1578	2.66	1600	2.77	1620	2.88
4400	1465	2.09	1488	2.2	1510	2.31	1532	2.41	1554	2.52	1576	2.63	1597	2.74	1618	2.86	1638	2.97	1659	3.08
4600	1508	2.28	1531	2.39	1553	2.5	1574	2.61	1595	2.72	1616	2.84	1637	2.95	1658	3.07	1678	3.18	1698	3.3
4800	1555	2.48	1574	2.59	1596	2.7	1617	2.82	1638	2.94	1658	3.06	1678	3.17	1698	3.29	1718	3.41	1737	3.53

**Notes:**

1. Available External Static Pressure is the static pressure difference between the return duct and the supply duct plus the static pressure drop caused by accessories and options.
2. For direct drive evaporator fan speed (rpm), refer to the applicable table in the fan performance section.
3. Data includes pressure drop due to standard filters and wet coils. No accessories or options are included in pressure drop data.
4. To determine static pressure drop due to other options/accessories, refer to the applicable table in the fan performance section.
5. Direct drive fan motor heat is negligible.
6. Factory supplied motors, in commercial equipment, are definite purpose motors, specifically designed and tested to operate reliably and continuously at all cataloged conditions. Using the full horsepower range of our fan motors as shown in our tabular data will not result in nuisance tripping or premature motor failure. Our product's warranty will not be affected.

**Figure 20. Fan curves - 12.5 ton (standard efficiency), horizontal**

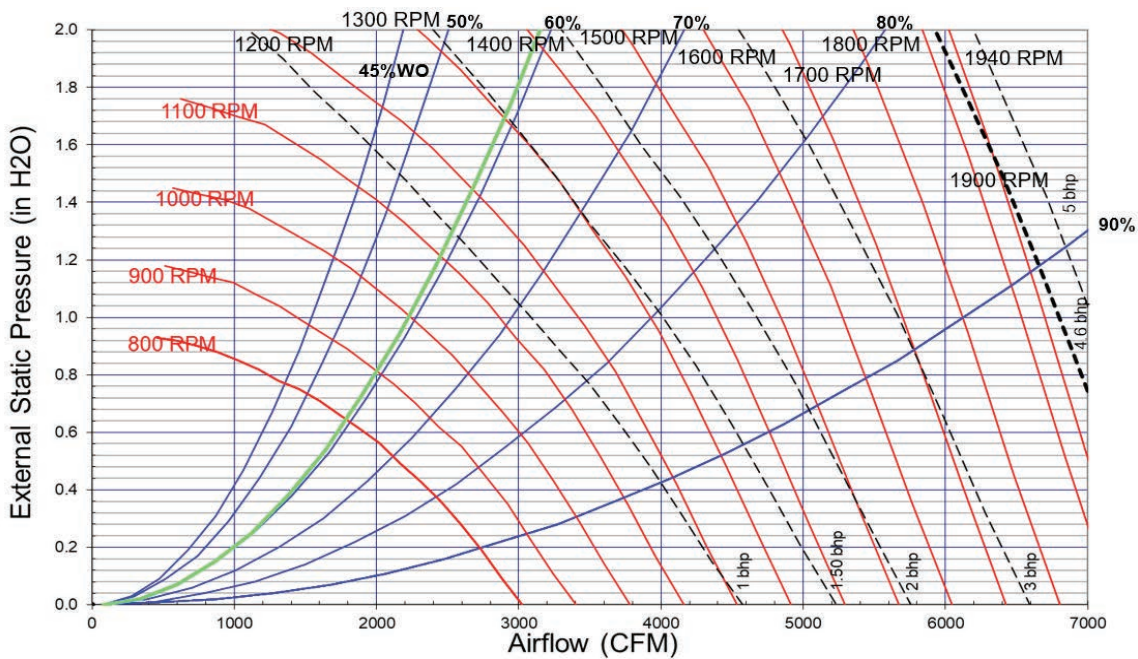

**Table 103. Evaporator fan performance – 12.5 ton (model TSK), horizontal**

CFM	Available External Static Pressure (Inches of Water Gauge)																			
	0.10		0.20		0.30		0.40		0.50		0.60		0.70		0.80		0.90		1.00	
	RPM	BHP	RPM	BHP	RPM	BHP	RPM	BHP	RPM	BHP	RPM	BHP	RPM	BHP	RPM	BHP	RPM	BHP	RPM	BHP
3750	1026	0.63	1055	0.70	1083	0.77	1109	0.84	1135	0.92	1162	1.00	1188	1.08	1214	1.16	1239	1.25	1263	1.34
4000	1091	0.75	1118	0.83	1144	0.90	1170	0.98	1194	1.06	1219	1.14	1244	1.23	1268	1.31	1292	1.40	1316	1.49
4250	1155	0.89	1181	0.97	1206	1.05	1231	1.13	1254	1.21	1276	1.30	1300	1.39	1324	1.48	1346	1.57	1369	1.67
4500	1220	1.05	1245	1.13	1269	1.22	1292	1.30	1314	1.39	1336	1.48	1358	1.56	1380	1.66	1402	1.76	1424	1.86
4750	1284	1.22	1309	1.31	1332	1.40	1354	1.49	1375	1.58	1396	1.67	1417	1.76	1437	1.86	1459	1.96	1480	2.07
5000	1349	1.41	1373	1.51	1395	1.60	1416	1.70	1437	1.79	1457	1.89	1477	1.98	1496	2.08	1516	2.18	1536	2.29
5250	1414	1.62	1437	1.73	1458	1.83	1479	1.93	1499	2.02	1518	2.12	1537	2.23	1556	2.33	1574	2.43	1593	2.54
5500	1479	1.86	1502	1.97	1522	2.07	1542	2.17	1561	2.28	1580	2.38	1598	2.49	1616	2.59	1634	2.70	1651	2.81

**Table 103. Evaporator fan performance – 12.5 ton (model TSK), horizontal (continued)**

Available External Static Pressure (Inches of Water Gauge)																				
CFM	0.10		0.20		0.30		0.40		0.50		0.60		0.70		0.80		0.90		1.00	
	RPM	BHP	RPM	BHP	RPM	BHP	RPM	BHP	RPM	BHP	RPM	BHP	RPM	BHP	RPM	BHP	RPM	BHP	RPM	BHP
5750	1544	2.11	1566	2.23	1586	2.34	1605	2.44	1623	2.55	1641	2.66	1659	2.77	1677	2.88	1694	2.99	1711	3.10
6000	1609	2.39	1631	2.51	1650	2.62	1668	2.74	1686	2.85	1704	2.96	1721	3.08	1738	3.19	1754	3.31	1771	3.42

  

Available External Static Pressure (Inches of Water Gauge)																				
CFM	1.10		1.20		1.30		1.40		1.50		1.60		1.70		1.80		1.90		2.00	
	RPM	BHP	RPM	BHP	RPM	BHP	RPM	BHP	RPM	BHP	RPM	BHP	RPM	BHP	RPM	BHP	RPM	BHP	RPM	BHP
3750	1289	1.43	1316	1.53	1341	1.63	1366	1.73	1390	1.82	1413	1.92	1436	2.02	1457	2.11	1480	2.21	1503	2.32
4000	1339	1.59	1362	1.68	1387	1.78	1412	1.89	1436	1.99	1459	2.1	1481	2.2	1503	2.31	1524	2.41	1545	2.52
4250	1392	1.76	1414	1.86	1435	1.96	1458	2.06	1481	2.17	1504	2.29	1527	2.4	1549	2.51	1570	2.62	1590	2.73
4500	1445	1.96	1467	2.06	1488	2.16	1508	2.27	1528	2.37	1550	2.49	1573	2.6	1594	2.72	1615	2.84	1636	2.96
4750	1500	2.17	1520	2.28	1541	2.38	1561	2.49	1580	2.6	1600	2.71	1619	2.82	1640	2.94	1661	3.07	1682	3.19
5000	1556	2.4	1575	2.51	1594	2.62	1614	2.73	1633	2.85	1652	2.96	1671	3.08	1689	3.19	1707	3.31	1728	3.44
5250	1612	2.65	1631	2.76	1650	2.88	1668	2.99	1687	3.11	1705	3.23	1723	3.35	1741	3.47	1759	3.59	1776	3.71
5500	1669	2.92	1688	3.04	1706	3.16	1724	3.28	1741	3.4	1759	3.52	1776	3.65	1794	3.77	1811	3.9	1828	4.02
5750	1727	3.21	1745	3.33	1763	3.46	1780	3.58	1797	3.71	1814	3.83	1830	3.96	1847	4.09	1864	4.22	1881	4.35
6000	1787	3.54	1803	3.65	1820	3.78	1837	3.91	1853	4.04	1870	4.17	1886	4.3	1902	4.43	1918	4.57	-	-

**Notes:**

1. Available External Static Pressure is the static pressure difference between the return duct and the supply duct plus the static pressure drop caused by accessories and options.
2. For direct drive evaporator fan speed (rpm), refer to the applicable table in the fan performance section.
3. Data includes pressure drop due to standard filters and wet coils. No accessories or options are included in pressure drop data.
4. To determine static pressure drop due to other options/accessories, refer to the applicable table in the fan performance section.
5. Direct drive fan motor heat is negligible.
6. Factory supplied motors, in commercial equipment, are definite purpose motors, specifically designed and tested to operate reliably and continuously at all cataloged conditions. Using the full horsepower range of our fan motors as shown in our tabular data will not result in nuisance tripping or premature motor failure. Our product's warranty will not be affected.

**Figure 21. Fan curves - 12.5 ton (high efficiency) to 25 ton, horizontal**

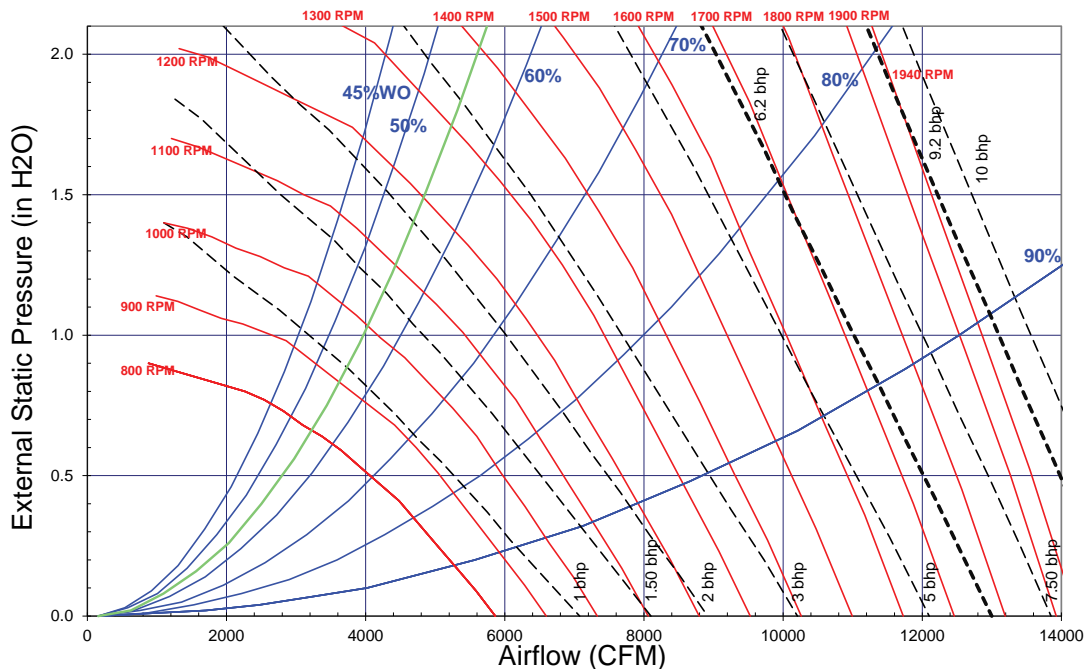



## Evaporator Fan Performance — Cooling

**Table 104. Evaporator fan performance – 12.5 ton (model THK), horizontal**

Available External Static Pressure (Inches of Water Gauge)																				
CFM	0.10		0.20		0.30		0.40		0.50		0.60		0.70		0.80		0.90		1.00	
	RPM	BHP	RPM	BHP	RPM	BHP	RPM	BHP	RPM	BHP	RPM	BHP	RPM	BHP	RPM	BHP	RPM	BHP	RPM	BHP
3750	575	0.23	629	0.31	678	0.40	726	0.50	771	0.59	814	0.70	855	0.80	894	0.91	932	1.03	968	1.14
4000	606	0.27	657	0.36	705	0.45	750	0.55	793	0.65	835	0.75	875	0.86	913	0.98	950	1.09	985	1.21
4500	668	0.36	716	0.45	759	0.56	801	0.66	841	0.77	880	0.88	917	1.00	954	1.12	989	1.25	1023	1.37
5000	732	0.46	776	0.57	816	0.68	855	0.80	892	0.92	928	1.04	964	1.16	998	1.29	1031	1.42	1064	1.56
5500	795	0.59	837	0.71	875	0.83	911	0.96	946	1.08	980	1.21	1013	1.34	1045	1.48	1077	1.62	1108	1.76
6000	860	0.74	899	0.87	935	1.00	969	1.14	1002	1.27	1034	1.41	1065	1.55	1095	1.70	1125	1.84	1154	1.99
Available External Static Pressure (Inches of Water Gauge)																				
CFM	1.10		1.20		1.30		1.40		1.50		1.60		1.70		1.80		1.90		2.00	
	RPM	BHP	RPM	BHP	RPM	BHP	RPM	BHP	RPM	BHP	RPM	BHP	RPM	BHP	RPM	BHP	RPM	BHP	RPM	BHP
3750	1003	1.26	1036	1.39	1069	1.52	1100	1.65	1131	1.78	1161	1.92	1190	2.06	1218	2.2	1246	2.35	1273	2.5
4000	1020	1.34	1053	1.47	1085	1.6	1116	1.73	1146	1.87	1176	2.01	1204	2.15	1232	2.3	1260	2.45	1287	2.6
4500	1056	1.51	1088	1.64	1119	1.78	1150	1.92	1179	2.06	1208	2.21	1236	2.36	1263	2.51	1290	2.66	1316	2.82
5000	1095	1.69	1126	1.84	1156	1.98	1186	2.13	1214	2.28	1242	2.43	1270	2.59	1296	2.74	1323	2.91	1348	3.07
5500	1138	1.91	1167	2.06	1196	2.21	1224	2.36	1252	2.52	1279	2.68	1306	2.84	1332	3.01	1357	3.17	1382	3.34
6000	1183	2.15	1211	2.3	1239	2.46	1266	2.62	1292	2.79	1319	2.96	1344	3.12	1370	3.3	1394	3.47	1419	3.65

**Notes:**

1. Available External Static Pressure is the static pressure difference between the return duct and the supply duct plus the static pressure drop caused by accessories and options.
2. For direct drive evaporator fan speed (rpm), refer to the applicable table in the fan performance section.
3. Data includes pressure drop due to standard filters and wet coils. No accessories or options are included in pressure drop data.
4. To determine static pressure drop due to other options/accessories, refer to the applicable table in the fan performance section.
5. Direct drive fan motor heat is negligible.
6. Factory supplied motors, in commercial equipment, are definite purpose motors, specifically designed and tested to operate reliably and continuously at all cataloged conditions. Using the full horsepower range of our fan motors as shown in our tabular data will not result in nuisance tripping or premature motor failure. Our product's warranty will not be affected.

**Table 105. Evaporator fan performance – 15 ton (model TSK, THK), horizontal**

Available External Static Pressure (Inches of Water Gauge)																				
CFM	0.10		0.20		0.30		0.40		0.50		0.60		0.70		0.80		0.90		1.00	
	RPM	BHP	RPM	BHP	RPM	BHP	RPM	BHP	RPM	BHP	RPM	BHP	RPM	BHP	RPM	BHP	RPM	BHP	RPM	BHP
4500	667	0.36	716	0.46	760	0.56	800	0.66	841	0.77	880	0.88	917	1.00	954	1.12	990	1.25	1024	1.38
4800	705	0.42	752	0.52	795	0.63	833	0.74	870	0.85	908	0.97	944	1.09	979	1.22	1014	1.35	1048	1.48
5400	781	0.56	825	0.68	864	0.80	901	0.92	935	1.05	968	1.17	1002	1.31	1035	1.44	1067	1.58	1098	1.72
6000	858	0.74	899	0.87	936	1.01	971	1.14	1003	1.28	1034	1.41	1063	1.55	1094	1.69	1124	1.84	1153	1.99
6600	936	0.95	973	1.10	1008	1.25	1041	1.39	1073	1.54	1102	1.69	1130	1.84	1157	1.99	1184	2.15	1212	2.31
7200	1015	1.21	1049	1.36	1082	1.53	1113	1.69	1143	1.85	1171	2.01	1199	2.17	1225	2.34	1250	2.50	1274	2.66
Available External Static Pressure (Inches of Water Gauge)																				
CFM	1.10		1.20		1.30		1.40		1.50		1.60		1.70		1.80		1.90		2.00	
	RPM	BHP	RPM	BHP	RPM	BHP	RPM	BHP	RPM	BHP	RPM	BHP	RPM	BHP	RPM	BHP	RPM	BHP	RPM	BHP
4500	1057	1.51	1089	1.64	1120	1.78	1150	1.92	1180	2.06	1208	2.21	1236	2.36	1263	2.51	1289	2.66	1315	2.82
4800	1081	1.62	1112	1.76	1143	1.9	1172	2.04	1200	2.19	1229	2.34	1256	2.5	1283	2.65	1310	2.81	1335	2.97
5400	1128	1.86	1159	2.01	1189	2.16	1218	2.32	1246	2.47	1273	2.63	1300	2.79	1325	2.95	1351	3.12	1376	3.29
6000	1182	2.15	1210	2.3	1237	2.46	1265	2.62	1293	2.79	1320	2.96	1346	3.13	1372	3.3	1396	3.48	1421	3.65
6600	1240	2.47	1266	2.64	1293	2.81	1318	2.97	1343	3.15	1368	3.32	1393	3.5	1419	3.69	1443	3.87	1467	4.06

**Table 105. Evaporator fan performance – 15 ton (model TSK, THK), horizontal (continued)**

Available External Static Pressure (Inches of Water Gauge)																				
CFM	1.10		1.20		1.30		1.40		1.50		1.60		1.70		1.80		1.90		2.00	
	RPM	BHP	RPM	BHP	RPM	BHP	RPM	BHP	RPM	BHP	RPM	BHP	RPM	BHP	RPM	BHP	RPM	BHP	RPM	BHP
7200	1299	2.84	1325	3.01	1350	3.19	1374	3.37	1399	3.56	1423	3.74	1446	3.93	1469	4.11	1491	4.3	1515	4.5

**Notes:**

1. Available External Static Pressure is the static pressure difference between the return duct and the supply duct plus the static pressure drop caused by accessories and options.
2. For direct drive evaporator fan speed (rpm), refer to the applicable table in the fan performance section.
3. Data includes pressure drop due to standard filters and wet coils. No accessories or options are included in pressure drop data.
4. To determine static pressure drop due to other options/accessories, refer to the applicable table in the fan performance section.
5. Direct drive fan motor heat is negligible.
6. Factory supplied motors, in commercial equipment, are definite purpose motors, specifically designed and tested to operate reliably and continuously at all cataloged conditions. Using the full horsepower range of our fan motors as shown in our tabular data will not result in nuisance tripping or premature motor failure. Our product's warranty will not be affected.

**Table 106. Evaporator fan performance – 17.5 ton (model TSK, THK), horizontal**

Available External Static Pressure (Inches of Water Gauge)																				
CFM	0.10		0.20		0.30		0.40		0.50		0.60		0.70		0.80		0.90		1.00	
	RPM	BHP	RPM	BHP	RPM	BHP	RPM	BHP	RPM	BHP	RPM	BHP	RPM	BHP	RPM	BHP	RPM	BHP	RPM	BHP
5250	762	0.52	806	0.64	847	0.76	884	0.88	918	0.99	953	1.12	987	1.25	1021	1.38	1053	1.52	1084	1.65
5600	807	0.62	849	0.74	888	0.87	924	0.99	958	1.12	989	1.25	1022	1.38	1054	1.52	1086	1.66	1116	1.81
6300	897	0.84	936	0.98	972	1.12	1006	1.26	1038	1.40	1068	1.55	1097	1.69	1124	1.84	1154	1.99	1183	2.15
7000	989	1.12	1024	1.27	1057	1.43	1089	1.58	1119	1.74	1148	1.90	1176	2.06	1202	2.22	1227	2.38	1252	2.54
7700	1081	1.45	1113	1.62	1144	1.79	1174	1.96	1202	2.14	1230	2.31	1256	2.48	1282	2.66	1306	2.83	1330	3.01
8400	1175	1.85	1203	2.03	1232	2.22	1260	2.41	1287	2.59	1313	2.78	1338	2.97	1363	3.16	1386	3.35	1409	3.54

**Available External Static Pressure (Inches of Water Gauge)**

CFM	1.10		1.20		1.30		1.40		1.50		1.60		1.70		1.80		1.90		2.00	
	RPM	BHP	RPM	BHP	RPM	BHP	RPM	BHP	RPM	BHP	RPM	BHP	RPM	BHP	RPM	BHP	RPM	BHP	RPM	BHP
5250	1116	1.8	1147	1.95	1177	2.09	1206	2.25	1234	2.4	1262	2.56	1288	2.71	1314	2.87	1340	3.04	1366	3.21
5600	1145	1.95	1175	2.1	1205	2.26	1234	2.42	1262	2.58	1289	2.74	1315	2.9	1341	3.07	1366	3.23	1390	3.4
6300	1210	2.31	1238	2.47	1265	2.63	1291	2.79	1317	2.96	1344	3.13	1370	3.31	1395	3.49	1420	3.67	1444	3.85
7000	1279	2.71	1305	2.88	1331	3.06	1355	3.24	1380	3.41	1404	3.59	1427	3.78	1451	3.96	1475	4.15	1499	4.35
7700	1353	3.18	1375	3.36	1400	3.55	1424	3.74	1447	3.93	1470	4.12	1492	4.32	1515	4.52	1537	4.71	1558	4.91
8400	1431	3.73	1453	3.92	1474	4.11	1494	4.31	1516	4.51	1539	4.72	1560	4.93	1582	5.13	1602	5.35	1623	5.56

**Notes:**

1. Available External Static Pressure is the static pressure difference between the return duct and the supply duct plus the static pressure drop caused by accessories and options.
2. For direct drive evaporator fan speed (rpm), refer to the applicable table in the fan performance section.
3. Data includes pressure drop due to standard filters and wet coils. No accessories or options are included in pressure drop data.
4. To determine static pressure drop due to other options/accessories, refer to the applicable table in the fan performance section.
5. Direct drive fan motor heat is negligible.
6. Factory supplied motors, in commercial equipment, are definite purpose motors, specifically designed and tested to operate reliably and continuously at all cataloged conditions. Using the full horsepower range of our fan motors as shown in our tabular data will not result in nuisance tripping or premature motor failure. Our product's warranty will not be affected.

**Table 107. Evaporator fan performance – 17.5 ton (model TSK, THK), horizontal, high static motor**

Available External Static Pressure (Inches of Water Gauge)																				
CFM	0.10"		0.20"		0.30"		0.40"		0.50"		0.60"		0.70"		0.80"		0.90"		1.00"	
	RPM	BHP	RPM	BHP	RPM	BHP	RPM	BHP	RPM	BHP	RPM	BHP	RPM	BHP	RPM	BHP	RPM	BHP	RPM	BHP
5250	762	0.52	806	0.64	847	0.76	884	0.88	918	0.99	953	1.12	987	1.25	1021	1.38	1053	1.52	1084	1.65
5600	807	0.62	849	0.74	888	0.87	924	0.99	958	1.12	989	1.25	1022	1.38	1054	1.52	1086	1.66	1116	1.81
6300	897	0.84	936	0.98	972	1.12	1006	1.26	1038	1.40	1068	1.55	1097	1.69	1124	1.84	1154	1.99	1183	2.15
7000	989	1.12	1024	1.27	1057	1.43	1089	1.58	1119	1.74	1148	1.90	1176	2.06	1202	2.22	1227	2.38	1252	2.54
7700	1081	1.45	1113	1.62	1144	1.79	1174	1.96	1202	2.14	1230	2.31	1256	2.48	1282	2.66	1306	2.83	1330	3.01
8400	1175	1.85	1203	2.03	1232	2.22	1260	2.41	1287	2.59	1313	2.78	1338	2.97	1363	3.16	1386	3.35	1409	3.54



## Evaporator Fan Performance — Cooling

**Table 107. Evaporator fan performance – 17.5 ton (model TSK, THK), horizontal, high static motor (continued)**

Available External Static Pressure (Inches of Water Gauge)																				
CFM	1.10"		1.20"		1.30"		1.40"		1.50"		1.60"		1.70"		1.80"		1.90"		2.00"	
	RPM	BHP	RPM	BHP	RPM	BHP	RPM	BHP	RPM	BHP	RPM	BHP	RPM	BHP	RPM	BHP	RPM	BHP	RPM	BHP
5250	1116	1.8	1147	1.95	1177	2.09	1206	2.25	1234	2.4	1262	2.56	1288	2.71	1314	2.87	1340	3.04	1366	3.21
5600	1145	1.95	1175	2.1	1205	2.26	1234	2.42	1262	2.58	1289	2.74	1315	2.9	1341	3.07	1366	3.23	1390	3.4
6300	1210	2.31	1238	2.47	1265	2.63	1291	2.79	1317	2.96	1344	3.13	1370	3.31	1395	3.49	1420	3.67	1444	3.85
7000	1279	2.71	1305	2.88	1331	3.06	1355	3.24	1380	3.41	1404	3.59	1427	3.78	1451	3.96	1475	4.15	1499	4.35
7700	1353	3.18	1375	3.36	1400	3.55	1424	3.74	1447	3.93	1470	4.12	1492	4.32	1515	4.52	1537	4.71	1558	4.91
8400	1431	3.73	1453	3.92	1474	4.11	1494	4.31	1516	4.51	1539	4.72	1560	4.93	1582	5.13	1602	5.35	1623	5.56

**Notes:**

1. Available External Static Pressure is the static pressure difference between the return duct and the supply duct plus the static pressure drop caused by accessories and options.
2. For direct drive evaporator fan speed (rpm), refer to the applicable table in the fan performance section.
3. Data includes pressure drop due to standard filters and wet coils. No accessories or options are included in pressure drop data.
4. To determine static pressure drop due to other options/accessories, refer to the applicable table in the fan performance section.
5. Direct drive fan motor heat is negligible.
6. Factory supplied motors, in commercial equipment, are definite purpose motors, specifically designed and tested to operate reliably and continuously at all cataloged conditions. Using the full horsepower range of our fan motors as shown in our tabular data will not result in nuisance tripping or premature motor failure. Our product's warranty will not be affected.

**Table 108. Evaporator fan performance – 20 ton (model TSK, THK), horizontal**

Available External Static Pressure (Inches of Water Gauge)																				
CFM	0.10		0.20		0.30		0.40		0.50		0.60		0.70		0.80		0.90		1.00	
	RPM	BHP	RPM	BHP	RPM	BHP	RPM	BHP	RPM	BHP	RPM	BHP	RPM	BHP	RPM	BHP	RPM	BHP	RPM	BHP
6000	858	0.74	899	0.87	936	1.01	971	1.14	1003	1.28	1034	1.41	1063	1.55	1094	1.69	1124	1.84	1153	1.99
6400	910	0.88	948	1.02	984	1.16	1018	1.30	1049	1.45	1079	1.59	1108	1.74	1135	1.89	1164	2.04	1192	2.20
7200	1015	1.21	1049	1.36	1082	1.53	1113	1.69	1143	1.85	1171	2.01	1199	2.17	1225	2.34	1250	2.50	1274	2.66
8000	1121	1.61	1151	1.79	1182	1.97	1211	2.14	1239	2.32	1265	2.50	1291	2.68	1316	2.86	1341	3.05	1364	3.23
8800	1228	2.11	1254	2.30	1283	2.49	1310	2.69	1336	2.89	1361	3.08	1386	3.28	1409	3.48	1433	3.68	1455	3.88
9600	1335	2.70	1359	2.90	1385	3.12	1410	3.33	1435	3.54	1459	3.76	1482	3.97	1504	4.19	1526	4.40	1548	4.62

**Available External Static Pressure (Inches of Water Gauge)**

CFM	1.10		1.20		1.30		1.40		1.50		1.60		1.70		1.80		1.90		2.00	
	RPM	BHP	RPM	BHP	RPM	BHP	RPM	BHP	RPM	BHP	RPM	BHP	RPM	BHP	RPM	BHP	RPM	BHP	RPM	BHP
6000	1182	2.15	1210	2.3	1237	2.46	1265	2.62	1293	2.79	1320	2.96	1346	3.13	1372	3.3	1396	3.48	1421	3.65
6400	1220	2.36	1247	2.52	1274	2.69	1300	2.85	1325	3.02	1352	3.2	1378	3.37	1403	3.55	1427	3.74	1452	3.92
7200	1299	2.84	1325	3.01	1350	3.19	1374	3.37	1399	3.56	1423	3.74	1446	3.93	1469	4.11	1491	4.3	1515	4.5
8000	1386	3.41	1408	3.59	1430	3.78	1453	3.97	1476	4.17	1499	4.37	1521	4.57	1543	4.77	1565	4.98	1586	5.18
8800	1477	4.08	1498	4.27	1518	4.47	1539	4.67	1558	4.88	1579	5.09	1600	5.3	1621	5.52	1642	5.74	1662	5.96
9600	1569	4.84	1589	5.05	1609	5.27	1629	5.49	1648	5.71	1666	5.92	-	-	-	-	-	-	-	-

**Notes:**

1. Available External Static Pressure is the static pressure difference between the return duct and the supply duct plus the static pressure drop caused by accessories and options.
2. For direct drive evaporator fan speed (rpm), refer to the applicable table in the fan performance section.
3. Data includes pressure drop due to standard filters and wet coils. No accessories or options are included in pressure drop data.
4. To determine static pressure drop due to other options/accessories, refer to the applicable table in the fan performance section.
5. Direct drive fan motor heat is negligible.
6. Factory supplied motors, in commercial equipment, are definite purpose motors, specifically designed and tested to operate reliably and continuously at all cataloged conditions. Using the full horsepower range of our fan motors as shown in our tabular data will not result in nuisance tripping or premature motor failure. Our product's warranty will not be affected.

**Table 109. Evaporator fan performance – 20 ton (model TSK, THK), horizontal, high static motor**

Available External Static Pressure (Inches of Water Gauge)																				
CFM	0.10"		0.20"		0.30"		0.40"		0.50"		0.60"		0.70"		0.80"		0.90"		1.00"	
	RPM	BHP	RPM	BHP	RPM	BHP	RPM	BHP	RPM	BHP	RPM	BHP	RPM	BHP	RPM	BHP	RPM	BHP	RPM	BHP
6000	858	0.74	899	0.87	936	1.01	971	1.14	1003	1.28	1034	1.41	1063	1.55	1094	1.69	1124	1.84	1153	1.99
6400	910	0.88	948	1.02	984	1.16	1018	1.30	1049	1.45	1079	1.59	1108	1.74	1135	1.89	1164	2.04	1192	2.20
7200	1015	1.21	1049	1.36	1082	1.53	1113	1.69	1143	1.85	1171	2.01	1199	2.17	1225	2.34	1250	2.50	1274	2.66

**Table 109. Evaporator fan performance – 20 ton (model TSK, THK), horizontal, high static motor (continued)**

Available External Static Pressure (Inches of Water Gauge)																				
CFM	0.10"		0.20"		0.30"		0.40"		0.50"		0.60"		0.70"		0.80"		0.90"		1.00"	
	RPM	BHP	RPM	BHP	RPM	BHP	RPM	BHP	RPM	BHP	RPM	BHP	RPM	BHP	RPM	BHP	RPM	BHP	RPM	BHP
8000	1121	1.61	1151	1.79	1182	1.97	1211	2.14	1239	2.32	1265	2.50	1291	2.68	1316	2.86	1341	3.05	1364	3.23
8800	1228	2.11	1254	2.30	1283	2.49	1310	2.69	1336	2.89	1361	3.08	1386	3.28	1409	3.48	1433	3.68	1455	3.88
9600	1335	2.70	1359	2.90	1385	3.12	1410	3.33	1435	3.54	1459	3.76	1482	3.97	1504	4.19	1526	4.40	1548	4.62

Available External Static Pressure (Inches of Water Gauge)																				
CFM	1.10"		1.20"		1.30"		1.40"		1.50"		1.60"		1.70"		1.80"		1.90"		2.00"	
	RPM	BHP	RPM	BHP	RPM	BHP	RPM	BHP	RPM	BHP	RPM	BHP	RPM	BHP	RPM	BHP	RPM	BHP	RPM	BHP
6000	1182	2.15	1210	2.3	1237	2.46	1265	2.62	1293	2.79	1320	2.96	1346	3.13	1372	3.3	1396	3.48	1421	3.65
6400	1220	2.36	1247	2.52	1274	2.69	1300	2.85	1325	3.02	1352	3.2	1378	3.37	1403	3.55	1427	3.74	1452	3.92
7200	1299	2.84	1325	3.01	1350	3.19	1374	3.37	1399	3.56	1423	3.74	1446	3.93	1469	4.11	1491	4.3	1515	4.5
8000	1386	3.41	1408	3.59	1430	3.78	1453	3.97	1476	4.17	1499	4.37	1521	4.57	1543	4.77	1565	4.98	1586	5.18
8800	1477	4.08	1498	4.27	1518	4.47	1539	4.67	1558	4.88	1579	5.09	1600	5.3	1621	5.52	1642	5.74	1662	5.96
9600	1569	4.84	1589	5.05	1609	5.27	1629	5.49	1648	5.71	1666	5.92	1679	6.03	1699	6.27	1719	6.5	1738	6.74

**Notes:**

1. Available External Static Pressure is the static pressure difference between the return duct and the supply duct plus the static pressure drop caused by accessories and options.
2. For direct drive evaporator fan speed (rpm), refer to the applicable table in the fan performance section.
3. Data includes pressure drop due to standard filters and wet coils. No accessories or options are included in pressure drop data.
4. To determine static pressure drop due to other options/accessories, refer to the applicable table in the fan performance section.
5. Direct drive fan motor heat is negligible.
6. Factory supplied motors, in commercial equipment, are definite purpose motors, specifically designed and tested to operate reliably and continuously at all cataloged conditions. Using the full horsepower range of our fan motors as shown in our tabular data will not result in nuisance tripping or premature motor failure. Our product's warranty will not be affected.

**Table 110. Evaporator fan performance – 25 ton (model TSK, THK), horizontal**

Available External Static Pressure (Inches of Water Gauge)																				
CFM	0.10		0.20		0.30		0.40		0.50		0.60		0.70		0.80		0.90		1.00	
	RPM	BHP	RPM	BHP	RPM	BHP	RPM	BHP	RPM	BHP	RPM	BHP	RPM	BHP	RPM	BHP	RPM	BHP	RPM	BHP
7500	1055	1.35	1087	1.51	1119	1.68	1150	1.85	1178	2.02	1206	2.18	1233	2.35	1259	2.52	1284	2.69	1307	2.86
8000	1121	1.61	1151	1.79	1182	1.97	1211	2.14	1239	2.32	1265	2.50	1291	2.68	1316	2.86	1341	3.05	1364	3.23
9000	1255	2.25	1280	2.44	1308	2.64	1335	2.84	1361	3.04	1385	3.24	1409	3.45	1433	3.65	1456	3.85	1478	4.05
10000	1388	3.03	1412	3.25	1436	3.46	1461	3.69	1485	3.91	1508	4.13	1530	4.36	1552	4.58	1574	4.81	1595	5.03
11000	1523	3.99	1544	4.22	1565	4.46	1588	4.70	1610	4.95	1632	5.19	1653	5.44	1674	5.68	1694	5.93	-	-
12000	1657	5.13	1677	5.38	1696	5.64	1716	5.90	-	-	-	-	-	-	-	-	-	-	-	-

Available External Static Pressure (Inches of Water Gauge)																				
CFM	1.10		1.20		1.30		1.40		1.50		1.60		1.70		1.80		1.90		2.00	
	RPM	BHP	RPM	BHP	RPM	BHP	RPM	BHP	RPM	BHP	RPM	BHP	RPM	BHP	RPM	BHP	RPM	BHP	RPM	BHP
7500	1330	3.04	1355	3.22	1380	3.4	1404	3.59	1427	3.78	1451	3.97	1474	4.16	1496	4.35	1518	4.54	1540	4.74
8000	1386	3.41	1408	3.59	1430	3.78	1453	3.97	1476	4.17	1499	4.37	1521	4.57	1543	4.77	1565	4.98	1586	5.18
9000	1500	4.26	1521	4.46	1541	4.66	1561	4.87	1580	5.07	1599	5.28	1620	5.5	1641	5.72	1661	5.94	-	-
10000	1615	5.25	1635	5.48	1655	5.71	1675	5.94	-	-	-	-	-	-	-	-	-	-	-	-
11000	-	-	-	-	-	-	-	-	-	-	-	-	-	-	-	-	-	-	-	-
12000	-	-	-	-	-	-	-	-	-	-	-	-	-	-	-	-	-	-	-	-

**Notes:**

1. Available External Static Pressure is the static pressure difference between the return duct and the supply duct plus the static pressure drop caused by accessories and options.
2. For direct drive evaporator fan speed (rpm), refer to the applicable table in the fan performance section.
3. Data includes pressure drop due to standard filters and wet coils. No accessories or options are included in pressure drop data.
4. To determine static pressure drop due to other options/accessories, refer to the applicable table in the fan performance section.
5. Direct drive fan motor heat is negligible.
6. Factory supplied motors, in commercial equipment, are definite purpose motors, specifically designed and tested to operate reliably and continuously at all cataloged conditions. Using the full horsepower range of our fan motors as shown in our tabular data will not result in nuisance tripping or premature motor failure. Our product's warranty will not be affected.



## Evaporator Fan Performance — Cooling

**Table 111. Evaporator fan performance – 25 ton (model TSK, THK), horizontal, high static motor**

Available External Static Pressure (Inches of Water Gauge)																				
CFM	0.10		0.20		0.30		0.40		0.50		0.60		0.70		0.80		0.90		1.00	
	RPM	BHP	RPM	BHP	RPM	BHP	RPM	BHP	RPM	BHP	RPM	BHP	RPM	BHP	RPM	BHP	RPM	BHP	RPM	BHP
7500	1055	1.35	1087	1.51	1119	1.68	1150	1.85	1178	2.02	1206	2.18	1233	2.35	1259	2.52	1284	2.69	1307	2.86
8000	1121	1.61	1151	1.79	1182	1.97	1211	2.14	1239	2.32	1265	2.50	1291	2.68	1316	2.86	1341	3.05	1364	3.23
9000	1255	2.25	1280	2.44	1308	2.64	1335	2.84	1361	3.04	1385	3.24	1409	3.45	1433	3.65	1456	3.85	1478	4.05
10000	1388	3.03	1412	3.25	1436	3.46	1461	3.69	1485	3.91	1508	4.13	1530	4.36	1552	4.58	1574	4.81	1595	5.03
11000	1523	3.99	1544	4.22	1565	4.46	1588	4.70	1610	4.95	1632	5.19	1653	5.44	1674	5.68	1694	5.93	1712	6.01
12000	1657	5.13	1677	5.38	1696	5.64	1716	5.90	1735	5.99	1756	6.25	1776	6.52	1796	6.78	1814	7.05	1829	6.99
Available External Static Pressure (Inches of Water Gauge)																				
CFM	1.10		1.20		1.30		1.40		1.50		1.60		1.70		1.80		1.90		2.00	
	RPM	BHP	RPM	BHP	RPM	BHP	RPM	BHP	RPM	BHP	RPM	BHP	RPM	BHP	RPM	BHP	RPM	BHP	RPM	BHP
7500	1330	3.04	1355	3.22	1380	3.4	1404	3.59	1427	3.78	1451	3.97	1474	4.16	1496	4.35	1518	4.54	1540	4.74
8000	1386	3.41	1408	3.59	1430	3.78	1453	3.97	1476	4.17	1499	4.37	1521	4.57	1543	4.77	1565	4.98	1586	5.18
9000	1500	4.26	1521	4.46	1541	4.66	1561	4.87	1580	5.07	1599	5.28	1620	5.5	1641	5.72	1661	5.94	1681	6.16
10000	1615	5.25	1635	5.48	1655	5.71	1675	5.94	1684	5.97	1699	6.19	1719	6.43	1739	6.67	1757	6.9	1775	7.13
11000	1730	6.24	1749	6.5	1769	6.76	1789	7.01	1788	6.87	1799	7.1	1818	7.36	1837	7.62	1853	7.86	1869	8.1
12000	1845	7.23	1863	7.52	1883	7.81	1903	8.08	1892	7.77	1899	8.01	1917	8.29	1935	8.57	-	-	-	-

**Notes:**

1. Available External Static Pressure is the static pressure difference between the return duct and the supply duct plus the static pressure drop caused by accessories and options.
2. For direct drive evaporator fan speed (rpm), refer to the applicable table in the fan performance section.
3. Data includes pressure drop due to standard filters and wet coils. No accessories or options are included in pressure drop data.
4. To determine static pressure drop due to other options/accessories, refer to the applicable table in the fan performance section.
5. Direct drive fan motor heat is negligible.
6. Factory supplied motors, in commercial equipment, are definite purpose motors, specifically designed and tested to operate reliably and continuously at all cataloged conditions. Using the full horsepower range of our fan motors as shown in our tabular data will not result in nuisance tripping or premature motor failure. Our product's warranty will not be affected.



# Evaporator Fan Performance — Gas Heat

## 3 to 5 Tons

Table 112. Evaporator fan performance – 3 to 5 tons (model YSK), high heat

Unit Size (tons)	Model Number	CFM	External Static Pressure (in. water) and Motor Power (Bhp)														
			Speed Set 1			Speed Set 2			Speed Set 3			Speed Set 4			Speed Set 5		
			ESP	RPM	BHP	ESP	RPM	BHP	ESP	RPM	BHP	ESP	RPM	BHP	ESP	RPM	BHP
3	YSK036*3, 4, W Downflow Airflow	900	0.61	742	0.18	0.98	889	0.30	1.30	999	0.40	1.56	1080	0.50	1.82	1153	0.60
		960	0.54	724	0.18	0.91	874	0.29	1.22	984	0.40	1.47	1067	0.50	1.73	1142	0.60
		1020	0.47	705	0.17	0.83	857	0.29	1.14	969	0.39	1.39	1053	0.49	1.64	1129	0.59
		1080	0.40	685	0.17	0.76	839	0.28	1.06	953	0.39	1.31	1039	0.48	1.56	1116	0.58
		1140	0.33	665	0.16	0.68	820	0.27	0.98	936	0.38	1.22	1023	0.47	1.47	1101	0.58
		1200	0.26	643	0.16	0.61	801	0.27	0.90	918	0.37	1.14	1006	0.47	1.38	1086	0.57
		1260	0.19	621	0.15	0.53	780	0.26	0.81	899	0.36	1.05	989	0.46	1.29	1070	0.56
		1320	0.11	597	0.15	0.45	759	0.25	0.73	879	0.36	0.97	970	0.45	1.20	1052	0.55
		1380	0.04	573	0.14	0.37	736	0.25	0.65	859	0.35	0.88	951	0.44	1.11	1034	0.54
		1440	—	—	—	0.29	713	0.24	0.56	837	0.34	0.79	931	0.43	1.02	1015	0.53
3	YSK036*3, 4, W Horizontal Airflow	900	0.46	722	0.18	0.81	876	0.29	1.10	991	0.40	1.34	1077	0.50	1.58	1154	0.60
		960	0.39	702	0.17	0.73	858	0.29	1.01	973	0.39	1.25	1060	0.49	1.49	1138	0.60
		1020	0.32	681	0.17	0.65	838	0.28	0.93	955	0.39	1.17	1043	0.48	1.40	1122	0.59
		1080	0.24	659	0.16	0.57	818	0.27	0.85	937	0.38	1.08	1026	0.48	1.31	1106	0.58
		1140	0.17	637	0.16	0.49	798	0.27	0.76	917	0.37	0.99	1007	0.47	1.21	1089	0.57
		1200	0.10	614	0.15	0.41	776	0.26	0.68	897	0.36	0.90	989	0.46	1.12	1071	0.56
		1260	0.02	591	0.15	0.33	754	0.25	0.59	877	0.35	0.81	969	0.45	1.03	1053	0.55
		1320	—	—	—	0.25	732	0.24	0.51	856	0.35	0.72	949	0.44	0.94	1034	0.54
		1380	—	—	—	0.17	709	0.24	0.42	834	0.34	0.63	928	0.43	0.84	1014	0.53
		1440	—	—	—	0.09	685	0.23	0.33	811	0.33	0.54	907	0.42	0.75	994	0.52
4	YSK048*3, 4, W Downflow Airflow	1200	0.62	847	0.31	1.05	1024	0.50	1.24	1091	0.58	1.46	1164	0.69	—	—	—
		1280	0.52	820	0.30	0.95	1001	0.49	1.13	1069	0.57	1.35	1143	0.68	—	—	—
		1360	0.43	792	0.29	0.84	976	0.47	1.02	1045	0.56	1.23	1121	0.67	—	—	—
		1440	0.33	762	0.28	0.74	949	0.46	0.91	1020	0.55	1.12	1098	0.65	1.45	1206	0.83
		1520	0.23	730	0.27	0.63	921	0.45	0.80	994	0.53	1.00	1073	0.64	1.33	1184	0.82
		1600	0.13	697	0.26	0.52	891	0.43	0.69	965	0.52	0.89	1047	0.62	1.21	1161	0.80
		1680	0.03	662	0.24	0.41	860	0.42	0.57	936	0.50	0.77	1019	0.61	1.08	1136	0.78
		1760	—	—	—	0.30	828	0.40	0.46	905	0.48	0.65	989	0.59	0.96	1109	0.77
		1840	—	—	—	0.19	793	0.39	0.35	872	0.47	0.53	959	0.57	0.83	1081	0.75
		1920	—	—	—	0.08	758	0.37	0.23	838	0.45	0.41	926	0.55	0.70	1052	0.73
4	YSK048*3, 4, W Horizontal Airflow	1200	0.54	839	0.31	0.98	1011	0.49	1.17	1076	0.58	1.40	1148	0.68	—	—	—
		1280	0.43	813	0.30	0.86	988	0.48	1.04	1055	0.56	1.27	1128	0.67	—	—	—
		1360	0.31	785	0.29	0.73	964	0.47	0.92	1032	0.55	1.14	1106	0.66	—	—	—
		1440	0.20	757	0.28	0.61	938	0.46	0.79	1007	0.54	1.00	1084	0.64	1.35	1191	0.82
		1520	0.08	727	0.27	0.48	911	0.44	0.66	982	0.53	0.87	1059	0.63	1.21	1169	0.81
		1600	—	—	—	0.35	883	0.43	0.52	955	0.51	0.73	1034	0.62	1.07	1147	0.79
		1680	—	—	—	0.22	853	0.41	0.39	926	0.50	0.59	1007	0.60	0.92	1122	0.77
		1760	—	—	—	0.09	822	0.40	0.25	897	0.48	0.45	979	0.58	0.77	1097	0.76
		1840	—	—	—	—	—	—	0.11	865	0.46	0.30	950	0.57	0.62	1070	0.74
		1920	—	—	—	—	—	—	—	—	—	0.16	919	0.55	0.47	1041	0.72



## Evaporator Fan Performance — Gas Heat

Table 112. Evaporator fan performance – 3 to 5 tons (model YSK), high heat (continued)

Unit Size (tons)	Model Number	CFM	External Static Pressure (in. water) and Motor Power (Bhp)														
			Speed Set 1			Speed Set 2			Speed Set 3			Speed Set 4			Speed Set 5		
			ESP	RPM	BHP	ESP	RPM	BHP	ESP	RPM	BHP	ESP	RPM	BHP	ESP	RPM	BHP
5	YSK060*3, 4, W Downflow Airflow	1500	0.97	1049	0.60	1.18	1123	0.71	1.42	1200	0.84	—	—	—	—	—	—
		1600	0.83	1015	0.58	1.03	1092	0.69	1.27	1174	0.82	—	—	—	—	—	—
		1700	0.69	979	0.56	0.88	1058	0.67	1.12	1142	0.80	1.27	1193	0.89	—	—	—
		1800	0.55	941	0.54	0.74	1022	0.64	0.96	1109	0.78	1.11	1161	0.87	—	—	—
		1900	0.40	900	0.51	0.59	984	0.62	0.81	1073	0.75	0.95	1127	0.84	1.17	1198	0.98
		2000	0.26	857	0.49	0.44	943	0.59	0.65	1035	0.73	0.79	1091	0.82	1.01	1165	0.96
		2100	0.12	812	0.46	0.29	900	0.57	0.50	995	0.70	0.63	1052	0.79	0.84	1128	0.93
		2200	—	—	—	0.14	854	0.54	0.34	952	0.67	0.47	1011	0.76	0.67	1090	0.90
		2300	—	—	—	—	—	—	0.18	907	0.64	0.31	967	0.73	0.50	1049	0.86
2400	—	—	—	—	—	—	0.02	859	0.60	0.15	922	0.69	0.33	1006	0.83		
5	YSK060*3, 4, W Horizontal Airflow	1500	0.84	1036	0.59	1.05	1109	0.70	1.31	1187	0.83	—	—	—	—	—	
		1600	0.67	1003	0.57	0.88	1078	0.68	1.13	1159	0.81	1.30	1200	0.91	—	—	
		1700	0.50	969	0.55	0.71	1046	0.66	0.95	1129	0.79	1.12	1179	0.88	—	—	
		1800	0.33	932	0.53	0.53	1011	0.64	0.77	1097	0.77	0.93	1149	0.86	—	—	
		1900	0.15	893	0.51	0.35	974	0.61	0.58	1063	0.75	0.73	1116	0.84	0.97	1187	0.97
		2000	—	—	—	0.16	936	0.59	0.39	1026	0.72	0.54	1081	0.81	0.77	1155	0.95
		2100	—	—	—	—	—	—	0.19	988	0.69	0.34	1044	0.78	0.56	1120	0.92
		2200	—	—	—	—	—	—	—	—	—	0.14	1005	0.75	0.36	1083	0.89
		2300	—	—	—	—	—	—	—	—	—	—	—	—	0.15	1045	0.86
2400	—	—	—	—	—	—	—	—	—	—	—	—	—	—	—		

Notes:

1. Available External Static Pressure is the static pressure difference between the return duct and the supply duct plus the static pressure drop caused by accessories and options.
2. For direct drive evaporator fan speed (rpm), refer to the applicable table in the fan performance section.
3. Data includes pressure drop due to standard filters and wet coils. No accessories or options are included in pressure drop data.
4. To determine static pressure drop due to other options/accessories, refer to the applicable table in the fan performance section.
5. For 036 models, fan motor heat (MBh) = 2.72 x Fan Bhp + 0.16. For 048 and 060 models, fan motorheat (MBh) = 2.87 x Fan Bhp + 0.15
6. Factory supplied motors, in commercial equipment, are definite purpose motors, specifically designed and tested to operate reliably and continuously at all cataloged conditions. Using the full horsepower range of our fan motors as shown in our tabular data will not result in nuisance tripping or premature motor failure. Our product's warranty will not be affected.

**Table 113. Evaporator fan performance – 3 to 5 tons (model YSK), high static motor, high heat**

Unit Size (tons)	Model Number	CFM	External Static Pressure (in. water) and Motor Power (Bhp)														
			Speed Set 1			Speed Set 2			Speed Set 3			Speed Set 4			Speed Set 5		
			ESP	RPM	BHP	ESP	RPM	BHP	ESP	RPM	BHP	ESP	RPM	BHP	ESP	RPM	BHP
3	YSK036*3, 4, W Downflow Airflow	900	1.27	1031	0.47	1.77	1194	0.68	—	—	—	—	—	—	—	—	—
		960	1.19	1016	0.46	1.68	1181	0.67	1.97	1263	0.81	—	—	—	—	—	—
		1020	1.11	999	0.45	1.60	1167	0.67	1.88	1250	0.80	—	—	—	—	—	—
		1080	1.04	982	0.44	1.52	1152	0.66	1.79	1237	0.79	—	—	—	—	—	—
		1140	0.96	964	0.44	1.43	1137	0.65	1.71	1223	0.79	—	—	—	—	—	—
		1200	0.88	945	0.43	1.35	1120	0.64	1.62	1208	0.78	1.92	1294	0.94	—	—	—
		1260	0.80	926	0.42	1.26	1103	0.63	1.53	1192	0.77	1.83	1280	0.93	—	—	—
		1320	0.72	905	0.41	1.18	1085	0.62	1.44	1176	0.76	1.74	1265	0.92	—	—	—
		1380	0.64	884	0.40	1.09	1066	0.61	1.35	1158	0.74	1.64	1249	0.91	2.00	1348	1.14
		1440	0.56	862	0.39	1.00	1047	0.60	1.26	1140	0.73	1.55	1233	0.89	1.94	1334	1.13
3	YSK036*3, 4, W Horizontal Airflow	900	1.26	1025	0.46	1.74	1183	0.68	2.00	1267	0.81	—	—	—	—	—	—
		960	1.18	1008	0.46	1.66	1169	0.67	1.94	1254	0.81	—	—	—	—	—	—
		1020	1.09	991	0.45	1.57	1153	0.66	1.85	1240	0.80	—	—	—	—	—	—
		1080	1.00	973	0.44	1.48	1137	0.65	1.76	1225	0.79	—	—	—	—	—	—
		1140	0.91	953	0.43	1.39	1121	0.64	1.67	1210	0.78	1.98	1303	0.95	—	—	—
		1200	0.81	934	0.42	1.30	1103	0.63	1.58	1194	0.77	1.89	1289	0.94	—	—	—
		1260	0.72	913	0.41	1.20	1085	0.62	1.48	1177	0.76	1.79	1274	0.92	—	—	—
		1320	0.62	892	0.40	1.10	1066	0.61	1.38	1160	0.75	1.69	1258	0.91	—	—	—
		1380	0.51	870	0.39	1.00	1046	0.60	1.28	1141	0.73	1.59	1242	0.90	2.00	1365	1.15
		1440	0.41	847	0.38	0.89	1026	0.59	1.17	1122	0.72	1.49	1224	0.89	1.92	1350	1.14
4	YSK048*3, 4, W Downflow Airflow	1200	1.35	1120	0.64	1.88	1282	0.92	—	—	—	—	—	—	—	—	—
		1280	1.23	1097	0.63	1.76	1263	0.90	2.00	1345	1.09	—	—	—	—	—	—
		1360	1.12	1073	0.61	1.63	1243	0.89	1.96	1327	1.07	—	—	—	—	—	—
		1440	1.00	1047	0.60	1.51	1220	0.87	1.82	1307	1.06	—	—	—	—	—	—
		1520	0.89	1019	0.58	1.38	1197	0.85	1.69	1286	1.04	2.00	1369	1.28	—	—	—
		1600	0.77	990	0.57	1.25	1172	0.84	1.56	1264	1.02	1.94	1350	1.26	—	—	—
		1680	0.65	960	0.55	1.13	1145	0.82	1.42	1240	1.00	1.79	1330	1.24	—	—	—
		1760	0.53	928	0.53	1.00	1118	0.80	1.29	1215	0.98	1.65	1308	1.22	1.95	1357	1.42
		1840	0.41	895	0.51	0.87	1088	0.78	1.15	1188	0.96	1.51	1284	1.20	1.80	1337	1.40
		1920	0.29	860	0.49	0.74	1057	0.76	1.02	1160	0.94	1.36	1260	1.18	1.65	1315	1.38
4	YSK048*3, 4, W Horizontal Airflow	1200	1.35	1103	0.63	1.90	1276	0.91	—	—	—	—	—	—	—	—	—
		1280	1.22	1079	0.62	1.77	1256	0.90	—	—	—	—	—	—	—	—	—
		1360	1.09	1053	0.60	1.64	1234	0.88	1.99	1335	1.08	—	—	—	—	—	—
		1440	0.96	1026	0.59	1.51	1210	0.86	1.85	1314	1.06	—	—	—	—	—	—
		1520	0.82	997	0.57	1.37	1186	0.85	1.72	1292	1.05	—	—	—	—	—	—
		1600	0.68	968	0.55	1.23	1160	0.83	1.57	1269	1.03	2.00	1390	1.30	—	—	—
		1680	0.53	936	0.53	1.08	1132	0.81	1.43	1244	1.01	1.86	1368	1.28	—	—	—
		1760	0.38	904	0.52	0.93	1104	0.79	1.28	1218	0.99	1.71	1345	1.26	—	—	—
		1840	0.23	870	0.50	0.78	1074	0.77	1.12	1190	0.96	1.55	1321	1.23	1.92	1417	1.48
		1920	0.07	835	0.48	0.62	1042	0.74	0.96	1162	0.94	1.40	1296	1.21	1.76	1395	1.46



## Evaporator Fan Performance — Gas Heat

**Table 113. Evaporator fan performance – 3 to 5 tons (model YSK), high static motor, high heat (continued)**

Unit Size (tons)	Model Number	CFM	External Static Pressure (in. water) and Motor Power (Bhp)														
			Speed Set 1			Speed Set 2			Speed Set 3			Speed Set 4			Speed Set 5		
			ESP	RPM	BHP	ESP	RPM	BHP	ESP	RPM	BHP	ESP	RPM	BHP	ESP	RPM	BHP
5	YSK060*3, 4, W Downflow Airflow	1500	1.47	1215	0.88	1.79	1301	1.07	—	—	—	—	—	—	—	—	—
		1600	1.32	1185	0.86	1.62	1274	1.05	1.91	1340	1.23	—	—	—	—	—	—
		1700	1.16	1152	0.84	1.46	1244	1.02	1.74	1314	1.20	1.87	1340	1.29	—	—	—
		1800	1.00	1117	0.81	1.29	1212	1.00	1.56	1285	1.18	1.69	1313	1.27	1.93	1349	1.42
		1900	0.84	1079	0.78	1.12	1178	0.97	1.38	1254	1.15	1.51	1284	1.24	1.74	1323	1.39
		2000	0.68	1040	0.75	0.95	1142	0.94	1.21	1221	1.12	1.33	1252	1.21	1.55	1294	1.36
		2100	0.52	998	0.72	0.78	1103	0.91	1.03	1186	1.09	1.15	1218	1.17	1.36	1264	1.33
		2200	0.36	954	0.69	0.61	1062	0.87	0.85	1148	1.05	0.97	1182	1.14	1.17	1230	1.30
		2300	0.20	907	0.66	0.44	1019	0.84	0.67	1108	1.02	0.79	1144	1.10	0.98	1195	1.26
		2400	0.03	858	0.62	0.27	974	0.80	0.50	1066	0.98	0.60	1103	1.06	0.79	1158	1.22
5	YSK060*3, 4, W Horizontal Airflow	1500	1.40	1206	0.88	1.75	1310	1.08	—	—	—	—	—	—	—	—	—
		1600	1.22	1174	0.85	1.57	1282	1.05	1.90	1374	1.26	2.00	1415	1.36	—	—	—
		1700	1.03	1140	0.83	1.38	1251	1.03	1.71	1346	1.23	1.87	1389	1.34	—	—	—
		1800	0.84	1104	0.80	1.18	1218	1.00	1.51	1317	1.21	1.67	1361	1.31	—	—	—
		1900	0.64	1066	0.77	0.98	1183	0.97	1.31	1285	1.18	1.47	1330	1.28	1.76	1405	1.48
		2000	0.43	1026	0.74	0.77	1146	0.94	1.10	1251	1.15	1.26	1298	1.25	1.55	1376	1.45
		2100	0.22	983	0.71	0.56	1106	0.91	0.89	1215	1.11	1.05	1264	1.22	1.34	1345	1.42
		2200	-0.00	939	0.68	0.34	1065	0.87	0.67	1177	1.08	0.83	1227	1.18	1.12	1311	1.38
		2300	-0.23	892	0.65	0.11	1022	0.84	0.44	1137	1.04	0.60	1188	1.15	0.89	1275	1.34
		2400	-0.46	843	0.61	-0.12	976	0.80	0.21	1094	1.00	0.37	1148	1.11	0.66	1238	1.30

**Notes:**

1. Available External Static Pressure is the static pressure difference between the return duct and the supply duct plus the static pressure drop caused by accessories and options.
2. For direct drive evaporator fan speed (rpm), refer to the applicable table in the fan performance section.
3. Data includes pressure drop due to standard filters and wet coils. No accessories or options are included in pressure drop data.
4. To determine static pressure drop due to other options/accessories, refer to the applicable table in the fan performance section.
5. For 036 models, fan motor heat (MBh) = 2.72 x Fan Bhp + 0.16. For 048 and 060 models, fan motorheat (MBh) = 2.87 x Fan Bhp + 0.15
6. Factory supplied motors, in commercial equipment, are definite purpose motors, specifically designed and tested to operate reliably and continuously at all cataloged conditions. Using the full horsepower range of our fan motors as shown in our tabular data will not result in nuisance tripping or premature motor failure. Our product's warranty will not be affected.

**Table 114. Evaporator fan performance – 3 tons (model YHK), downflow, high heat**

Available External Static Pressure (Inches of Water Gauge)																				
CFM	0.10		0.20		0.30		0.40		0.50		0.60		0.70		0.80		0.90		1.00	
	RPM	BHP	RPM	BHP	RPM	BHP	RPM	BHP	RPM	BHP	RPM	BHP	RPM	BHP	RPM	BHP	RPM	BHP	RPM	BHP
900	426	0.05	506	0.08	576	0.10	637	0.13	692	0.16	742	0.19	788	0.22	831	0.26	871	0.29	910	0.32
960	443	0.06	520	0.09	589	0.11	649	0.14	703	0.17	753	0.21	799	0.24	842	0.27	882	0.31	921	0.34
1080	478	0.08	550	0.11	615	0.14	674	0.17	727	0.20	776	0.24	821	0.27	864	0.31	904	0.35	942	0.38
1200	514	0.11	582	0.14	642	0.17	700	0.20	752	0.23	799	0.27	844	0.31	887	0.35	927	0.39	965	0.43
1320	552	0.13	615	0.17	673	0.20	726	0.24	778	0.27	825	0.31	869	0.35	910	0.39	950	0.43	987	0.47
1440	589	0.17	650	0.20	705	0.24	755	0.28	804	0.31	850	0.35	894	0.39	935	0.44	973	0.48	1010	0.53
Available External Static Pressure (Inches of Water Gauge)																				
RPM	1.10		1.20		1.30		1.40		1.50		1.60		1.70		1.80		1.90		2.00	
	BHP	RPM	BHP	RPM	BHP	RPM	BHP	RPM	BHP	RPM	BHP	RPM	BHP	RPM	BHP	RPM	BHP	RPM	BHP	
947	0.36	982	0.4	1016	0.43	1049	0.47	1080	0.51	1111	0.55	1140	0.59	1169	0.63	1197	0.67	1223	0.71	
957	0.38	992	0.42	1026	0.46	1059	0.49	1090	0.53	1121	0.57	1150	0.61	1179	0.66	1207	0.7	1234	0.74	
979	0.42	1014	0.46	1047	0.5	1079	0.54	1110	0.59	1141	0.63	1170	0.67	1199	0.72	-	-	-	-	
1001	0.47	1036	0.51	1069	0.56	1101	0.60	1132	0.64	1162	0.69	1191	0.73	-	-	-	-	-	-	
1023	0.52	1058	0.57	1091	0.61	1123	0.66	1154	0.71	1184	0.75	-	-	-	-	-	-	-	-	

**Table 114. Evaporator fan performance – 3 tons (model YHK), downflow, high heat (continued)**

Available External Static Pressure (Inches of Water Gauge)																			
1.10		1.20		1.30		1.40		1.50		1.60		1.70		1.80		1.90		2.00	
RPM	BHP	RPM	BHP	RPM	BHP	RPM	BHP	RPM	BHP	RPM	BHP	RPM	BHP	RPM	BHP	RPM	BHP	RPM	BHP
1046	0.57	1080	0.62	1113	0.67	1145	0.72	-	-	-	-	-	-	-	-	-	-	-	-

**Notes:**

1. Available External Static Pressure is the static pressure difference between the return duct and the supply duct plus the static pressure drop caused by accessories and options.
2. For direct drive evaporator fan speed (rpm), refer to the applicable table in the fan performance section.
3. Data includes pressure drop due to standard filters and wet coils. No accessories or options are included in pressure drop data.
4. To determine static pressure drop due to other options/accessories, refer to the applicable table in the fan performance section.
5. Direct Drive Fan Motor Heat (MBH) = 2.9245xFan BHP + 0.055.
6. Factory supplied motors, in commercial equipment, are definite purpose motors, specifically designed and tested to operate reliably and continuously at all cataloged conditions. Using the full horsepower range of our fan motors as shown in our tabular data will not result in nuisance tripping or premature motor failure. Our product's warranty will not be affected.

**Table 115. Evaporator fan performance – 3 tons (model YHK), downflow, high static motor, high heat**

Available External Static Pressure (Inches of Water Gauge)																				
CFM	0.10		0.20		0.30		0.40		0.50		0.60		0.70		0.80		0.90		1.00	
	RPM	BHP	RPM	BHP	RPM	BHP	RPM	BHP	RPM	BHP	RPM	BHP	RPM	BHP	RPM	BHP	RPM	BHP	RPM	BHP
900	422	0.05	504	0.08	574	0.10	634	0.13	687	0.16	736	0.18	782	0.22	825	0.25	866	0.28	904	0.31
960	439	0.06	517	0.09	587	0.11	647	0.14	699	0.17	748	0.20	792	0.23	835	0.26	876	0.30	915	0.33
1080	473	0.08	546	0.11	612	0.14	672	0.17	724	0.20	772	0.23	816	0.26	858	0.30	897	0.33	935	0.37
1200	509	0.10	577	0.13	638	0.16	697	0.20	749	0.23	797	0.26	841	0.30	882	0.34	920	0.37	957	0.41
1320	545	0.13	610	0.16	668	0.20	722	0.23	775	0.27	822	0.30	866	0.34	907	0.38	945	0.42	981	0.46
1440	583	0.16	644	0.20	699	0.23	751	0.27	800	0.31	847	0.35	891	0.39	932	0.43	970	0.47	1006	0.51

**Available External Static Pressure (Inches of Water Gauge)**

CFM	1.10		1.20		1.30		1.40		1.50		1.60		1.70		1.80		1.90		2.00	
	RPM	BHP	RPM	BHP	RPM	BHP	RPM	BHP	RPM	BHP	RPM	BHP	RPM	BHP	RPM	BHP	RPM	BHP	RPM	BHP
900	941	0.34	976	0.38	1010	0.41	1042	0.45	1074	0.49	1104	0.52	1133	0.56	1162	0.6	1190	0.64	1217	0.68
960	951	0.36	986	0.4	1020	0.43	1052	0.47	1084	0.51	1114	0.55	1143	0.59	1172	0.63	1200	0.67	1227	0.71
1080	972	0.41	1007	0.44	1040	0.48	1073	0.52	1104	0.56	1134	0.6	1163	0.64	1192	0.68	1219	0.73	1246	0.77
1200	993	0.45	1027	0.49	1061	0.53	1093	0.57	1124	0.62	1154	0.66	1184	0.7	1212	0.75	1240	0.79	1267	0.83
1320	1016	0.5	1050	0.54	1082	0.59	1114	0.63	1145	0.68	1175	0.72	1204	0.77	1232	0.81	1260	0.86	1287	0.91
1440	1041	0.56	1074	0.6	1106	0.65	1137	0.69	1167	0.74	1196	0.79	1225	0.84	1253	0.89	1281	0.93	1307	0.98

**Notes:**

1. Available External Static Pressure is the static pressure difference between the return duct and the supply duct plus the static pressure drop caused by accessories and options.
2. Data includes pressure drop due to standard filters and wet coils. No accessories or options are included in pressure drop data.
3. To determine static pressure drop due to other options/accessories, refer to the applicable table in the fan performance section.
4. Direct Drive Fan Motor Heat (MBH) = 2.9245xFan BHP + 0.055.
5. Factory supplied motors, in commercial equipment, are definite purpose motors, specifically designed and tested to operate reliably and continuously at all cataloged conditions. Using the full horsepower range of our fan motors as shown in our tabular data will not result in nuisance tripping or premature motor failure. Our product's warranty will not be affected.

**Table 116. Evaporator fan performance – 4 tons (model YHK), downflow, high heat**

Available External Static Pressure (Inches of Water Gauge)																				
CFM	0.10		0.20		0.30		0.40		0.50		0.60		0.70		0.80		0.90		1.00	
	RPM	BHP	RPM	BHP	RPM	BHP	RPM	BHP	RPM	BHP	RPM	BHP	RPM	BHP	RPM	BHP	RPM	BHP	RPM	BHP
1200 <sup>(a)</sup>	399	0.04	478	0.07	543	0.10	599	0.14	651	0.18	697	0.21	741	0.25	785	0.29	826	0.34	866	0.38
1280	414	0.05	490	0.08	556	0.11	611	0.15	662	0.19	708	0.22	751	0.27	791	0.31	833	0.35	872	0.40
1440	446	0.06	517	0.09	581	0.13	636	0.17	685	0.21	730	0.25	773	0.29	812	0.34	850	0.38	886	0.43
1600	481	0.07	545	0.11	605	0.15	661	0.19	709	0.23	754	0.28	795	0.32	834	0.37	871	0.42	907	0.47
1760	516	0.09	576	0.13	632	0.17	685	0.21	734	0.26	778	0.31	819	0.36	857	0.41	894	0.46	929	0.51
1920	552	0.11	608	0.15	661	0.19	711	0.24	759	0.29	803	0.34	843	0.39	881	0.45	917	0.50	951	0.56



## Evaporator Fan Performance — Gas Heat

**Table 116. Evaporator fan performance – 4 tons (model YHK), downflow, high heat (continued)**

Available External Static Pressure (Inches of Water Gauge)																				
CFM	1.10		1.20		1.30		1.40		1.50		1.60		1.70		1.80		1.90		2.00	
	RPM	BHP	RPM	BHP	RPM	BHP	RPM	BHP	RPM	BHP	RPM	BHP	RPM	BHP	RPM	BHP	RPM	BHP	RPM	BHP
1200 <sup>(b)</sup>	903	0.43	939	0.47	974	0.52	1007	0.57	1039	0.62	1070	0.67	1100	0.73	1129	0.78	1157	0.83	1185	0.89
1280	910	0.45	946	0.49	980	0.54	1013	0.59	1045	0.65	1076	0.7	1106	0.75	1135	0.81	1163	0.86	1191	0.92
1440	923	0.48	959	0.53	993	0.59	1026	0.64	1058	0.69	1089	0.75	1119	0.80	1148	0.86	1176	0.92	1204	0.98
1600	940	0.52	973	0.57	1006	0.63	1039	0.68	1071	0.74	1102	0.8	1132	0.86	1161	0.92	1189	0.98	1217	1.04
1760	962	0.57	994	0.62	1025	0.68	1055	0.73	1084	0.79	1115	0.85	1145	0.92	1174	0.98	1202	1.04	1230	1.11
1920	984	0.61	1016	0.67	1047	0.73	1077	0.79	1105	0.85	1133	0.91	1160	0.98	1187	1.04	1215	1.11	1243	1.17

**Notes:**

1. Available External Static Pressure is the static pressure difference between the return duct and the supply duct plus the static pressure drop caused by accessories and options.
2. For direct drive evaporator fan speed (rpm), refer to the applicable table in the fan performance section.
3. Data includes pressure drop due to standard filters and wet coils. No accessories or options are included in pressure drop data.
4. To determine static pressure drop due to other options/accessories, refer to the applicable table in the fan performance section.
5. Direct drive fan motor heat is negligible.
6. Factory supplied motors, in commercial equipment, are definite purpose motors, specifically designed and tested to operate reliably and continuously at all cataloged conditions. Using the full horsepower range of our fan motors as shown in our tabular data will not result in nuisance tripping or premature motor failure. Our product's warranty will not be affected.

<sup>(a)</sup> Model digit 11 selection of High Gas Heat is limited to minimum 320 cfm/ton full load airflow.

<sup>(b)</sup> Model digit 11 selection of High Gas Heat is limited to minimum 320 cfm/ton full load airflow.

**Table 117. Evaporator fan performance – 5 tons (model YHK), downflow, high heat**

Available External Static Pressure (Inches of Water Gauge)																				
CFM	0.10		0.20		0.30		0.40		0.50		0.60		0.70		0.80		0.90		1.00	
	RPM	BHP	RPM	BHP	RPM	BHP	RPM	BHP	RPM	BHP	RPM	BHP	RPM	BHP	RPM	BHP	RPM	BHP	RPM	BHP
1500 <sup>(a)</sup>	459	0.06	527	0.10	590	0.14	645	0.18	694	0.22	738	0.26	781	0.31	820	0.35	858	0.40	893	0.45
1600	481	0.07	545	0.11	605	0.15	661	0.19	709	0.23	754	0.28	795	0.32	834	0.37	871	0.42	907	0.47
1800	525	0.09	584	0.13	639	0.18	692	0.22	741	0.27	784	0.32	825	0.37	863	0.42	899	0.47	934	0.52
2000	570	0.12	624	0.16	676	0.21	724	0.26	771	0.31	816	0.36	856	0.41	893	0.47	929	0.52	963	0.58
2200	617	0.15	666	0.19	714	0.24	760	0.29	804	0.35	846	0.41	887	0.46	925	0.52	960	0.58	993	0.64
2400	664	0.18	710	0.23	754	0.28	797	0.34	838	0.40	879	0.46	918	0.52	956	0.58	991	0.64	1024	0.71

**Available External Static Pressure (Inches of Water Gauge)**

CFM	1.10		1.20		1.30		1.40		1.50		1.60		1.70		1.80		1.90		2.00	
	RPM	BHP	RPM	BHP	RPM	BHP	RPM	BHP	RPM	BHP	RPM	BHP	RPM	BHP	RPM	BHP	RPM	BHP	RPM	BHP
1500 <sup>(b)</sup>	928	0.5	964	0.55	998	0.6	1031	0.66	1063	0.71	1094	0.77	1124	0.82	1153	0.88	1181	0.94	1209	1.00
1600	940	0.52	973	0.57	1006	0.63	1039	0.68	1071	0.74	1102	0.80	1132	0.86	1161	0.92	1189	0.98	1217	1.04
1800	968	0.58	1000	0.63	1031	0.69	1060	0.75	1089	0.81	1118	0.87	1148	0.93	1177	0.99	1205	1.06	1233	1.12
2000	995	0.64	1027	0.7	1058	0.76	1087	0.82	1116	0.88	1144	0.94	1171	1.01	1197	1.07	1222	1.14	1249	1.21
2200	1025	0.7	1056	0.77	1086	0.83	1115	0.89	1144	0.96	1171	1.03	1198	1.09	1224	1.16	1249	1.23	1274	1.30
2400	1056	0.77	1087	0.84	1116	0.91	1144	0.97	1172	1.04	1199	1.11	1225	1.18	1251	1.26	1277	1.33	1301	1.40

**Notes:**

1. Available External Static Pressure is the static pressure difference between the return duct and the supply duct plus the static pressure drop caused by accessories and options.
2. For direct drive evaporator fan speed (rpm), refer to the applicable table in the fan performance section.
3. Data includes pressure drop due to standard filters and wet coils. No accessories or options are included in pressure drop data.
4. To determine static pressure drop due to other options/accessories, refer to the applicable table in the fan performance section.
5. Direct drive fan motor heat is negligible.
6. Factory supplied motors, in commercial equipment, are definite purpose motors, specifically designed and tested to operate reliably and continuously at all cataloged conditions. Using the full horsepower range of our fan motors as shown in our tabular data will not result in nuisance tripping or premature motor failure. Our product's warranty will not be affected.

<sup>(a)</sup> Model digit 11 selection of High Gas Heat is limited to minimum 320 cfm/ton full load airflow.

<sup>(b)</sup> Model digit 11 selection of High Gas Heat is limited to minimum 320 cfm/ton full load airflow.

**Table 118. Evaporator fan performance – 3 tons (model YHK), horizontal, high heat**

Available External Static Pressure (Inches of Water Gauge)																				
CFM	0.10		0.20		0.30		0.40		0.50		0.60		0.70		0.80		0.90		1.00	
	RPM	BHP	RPM	BHP	RPM	BHP	RPM	BHP	RPM	BHP	RPM	BHP	RPM	BHP	RPM	BHP	RPM	BHP	RPM	BHP
900	438	0.06	517	0.08	586	0.11	646	0.13	700	0.16	748	0.19	794	0.23	836	0.26	876	0.29	914	0.32
960	456	0.07	532	0.09	599	0.12	659	0.15	712	0.18	761	0.21	806	0.24	848	0.27	888	0.31	926	0.34
1080	494	0.09	564	0.11	628	0.14	685	0.17	738	0.21	786	0.24	831	0.28	873	0.31	912	0.35	949	0.39
1200	532	0.11	598	0.14	658	0.17	713	0.21	765	0.24	812	0.28	857	0.31	898	0.35	937	0.39	974	0.43
1320	572	0.14	634	0.17	690	0.21	742	0.24	792	0.28	839	0.32	883	0.36	924	0.40	963	0.44	999	0.48
1440	612	0.18	671	0.21	723	0.25	774	0.29	821	0.33	867	0.37	909	0.41	950	0.45	989	0.50	1025	0.54
Available External Static Pressure (Inches of Water Gauge)																				
CFM	1.10		1.20		1.30		1.40		1.50		1.60		1.70		1.80		1.90		2.00	
	RPM	BHP	RPM	BHP	RPM	BHP	RPM	BHP	RPM	BHP	RPM	BHP	RPM	BHP	RPM	BHP	RPM	BHP	RPM	BHP
900	950	0.36	984	0.4	1017	0.43	1049	0.47	1080	0.51	1110	0.54	1139	0.58	1167	0.62	1194	0.66	1221	0.7
960	962	0.38	996	0.42	1029	0.45	1061	0.49	1092	0.53	1121	0.57	1150	0.61	1178	0.65	1206	0.69	1232	0.73
1080	985	0.43	1019	0.46	1052	0.5	1084	0.55	1115	0.59	1145	0.63	1173	0.67	1201	0.71	1228	0.76	1255	0.8
1200	1009	0.47	1043	0.52	1076	0.56	1108	0.6	1138	0.65	1168	0.69	1197	0.73	1225	0.78	1252	0.83	1278	0.87
1320	1035	0.53	1068	0.57	1100	0.62	1132	0.66	1162	0.71	1192	0.76	1220	0.8	1248	0.85	1275	0.9	1302	0.95
1440	1060	0.59	1094	0.63	1126	0.68	1157	0.73	1187	0.78	1216	0.83	1244	0.88	1272	0.93	1299	0.98	-	-

**Notes:**

1. Available External Static Pressure is the static pressure difference between the return duct and the supply duct plus the static pressure drop caused by accessories and options.
2. Data includes pressure drop due to standard filters and wet coils. No accessories or options are included in pressure drop data.
3. To determine static pressure drop due to other options/accessories, refer to the applicable table in the fan performance section.
4. Direct Drive Fan Motor Heat (MBH) = 2.9245xFan BHP +0.055.
5. Factory supplied motors, in commercial equipment, are definite purpose motors, specifically designed and tested to operate reliably and continuously at all cataloged conditions. Using the full horsepower range of our fan motors as shown in our tabular data will not result in nuisance tripping or premature motor failure. Our product's warranty will not be affected.

**Table 119. Evaporator fan performance – 3 tons (model YHK), horizontal, high static motor, high heat**

Available External Static Pressure (Inches of Water Gauge)																				
CFM	0.10		0.20		0.30		0.40		0.50		0.60		0.70		0.80		0.90		1.00	
	RPM	BHP	RPM	BHP	RPM	BHP	RPM	BHP	RPM	BHP	RPM	BHP	RPM	BHP	RPM	BHP	RPM	BHP	RPM	BHP
900	438	0.06	517	0.08	586	0.11	646	0.13	700	0.16	748	0.19	794	0.23	836	0.26	876	0.29	914	0.32
960	456	0.07	532	0.09	599	0.12	659	0.15	712	0.18	761	0.21	806	0.24	848	0.27	888	0.31	926	0.34
1080	494	0.09	564	0.11	628	0.14	685	0.17	738	0.21	786	0.24	831	0.28	873	0.31	912	0.35	949	0.39
1200	532	0.11	598	0.14	658	0.17	713	0.21	765	0.24	812	0.28	857	0.31	898	0.35	937	0.39	974	0.43
1320	572	0.14	634	0.17	690	0.21	742	0.24	792	0.28	839	0.32	883	0.36	924	0.40	963	0.44	999	0.48
1440	612	0.18	671	0.21	723	0.25	774	0.29	821	0.33	867	0.37	909	0.41	950	0.45	989	0.50	1025	0.54
Available External Static Pressure (Inches of Water Gauge)																				
CFM	1.10		1.20		1.30		1.40		1.50		1.60		1.70		1.80		1.90		2.00	
	RPM	BHP	RPM	BHP	RPM	BHP	RPM	BHP	RPM	BHP	RPM	BHP	RPM	BHP	RPM	BHP	RPM	BHP	RPM	BHP
900	950	0.36	984	0.4	1017	0.43	1049	0.47	1080	0.51	1110	0.54	1139	0.58	1167	0.62	1194	0.66	1221	0.7
960	962	0.38	996	0.42	1029	0.45	1061	0.49	1092	0.53	1121	0.57	1150	0.61	1178	0.65	1206	0.69	1232	0.73
1080	985	0.43	1019	0.46	1052	0.5	1084	0.55	1115	0.59	1145	0.63	1173	0.67	1201	0.71	1228	0.76	1255	0.8
1200	1009	0.47	1043	0.52	1076	0.56	1108	0.6	1138	0.65	1168	0.69	1197	0.73	1225	0.78	1252	0.83	1278	0.87
1320	1035	0.53	1068	0.57	1100	0.62	1132	0.66	1162	0.71	1192	0.76	1220	0.8	1248	0.85	1275	0.9	1302	0.95
1440	1060	0.59	1094	0.63	1126	0.68	1157	0.73	1187	0.78	1216	0.83	1244	0.88	1272	0.93	1299	0.98	-	-

**Notes:**

1. Available External Static Pressure is the static pressure difference between the return duct and the supply duct plus the static pressure drop caused by accessories and options.
2. Data includes pressure drop due to standard filters and wet coils. No accessories or options are included in pressure drop data.
3. To determine static pressure drop due to other options/accessories, refer to the applicable table in the fan performance section.
4. Direct Drive Fan Motor Heat (MBH) = 2.9245xFan BHP +0.055.
5. Factory supplied motors, in commercial equipment, are definite purpose motors, specifically designed and tested to operate reliably and continuously at all cataloged conditions. Using the full horsepower range of our fan motors as shown in our tabular data will not result in nuisance tripping or premature motor failure. Our product's warranty will not be affected.



## Evaporator Fan Performance — Gas Heat

**Table 120. Evaporator fan performance – 4 tons (model YHK), horizontal, high heat**

Available External Static Pressure (Inches of Water Gauge)																				
CFM	0.10		0.20		0.30		0.40		0.50		0.60		0.70		0.80		0.90		1.00	
	RPM	BHP	RPM	BHP	RPM	BHP	RPM	BHP	RPM	BHP	RPM	BHP	RPM	BHP	RPM	BHP	RPM	BHP	RPM	BHP
1200 <sup>(a)</sup>	433	0.05	500	0.08	560	0.12	614	0.15	663	0.19	708	0.22	753	0.27	794	0.31	833	0.35	870	0.39
1280	453	0.06	517	0.09	576	0.13	628	0.16	676	0.20	720	0.24	763	0.28	804	0.32	843	0.37	880	0.41
1440	493	0.08	551	0.11	607	0.15	657	0.19	703	0.23	747	0.27	788	0.31	825	0.36	864	0.41	900	0.45
1600	534	0.10	589	0.14	640	0.18	689	0.22	733	0.26	774	0.31	814	0.35	852	0.40	887	0.45	921	0.50
1760	576	0.13	628	0.17	675	0.21	720	0.25	764	0.30	804	0.35	842	0.39	879	0.44	914	0.50	948	0.55
1920	619	0.16	668	0.20	712	0.24	754	0.29	796	0.34	836	0.39	872	0.44	907	0.49	942	0.55	975	0.60
Available External Static Pressure (Inches of Water Gauge)																				
CFM	1.10		1.20		1.30		1.40		1.50		1.60		1.70		1.80		1.90		2.00	
	RPM	BHP	RPM	BHP	RPM	BHP	RPM	BHP	RPM	BHP	RPM	BHP	RPM	BHP	RPM	BHP	RPM	BHP	RPM	BHP
1200 <sup>(b)</sup>	908	0.44	944	0.49	979	0.54	1012	0.58	1045	0.63	1076	0.69	1106	0.74	1136	0.79	1165	0.85	1192	0.9
1280	915	0.46	950	0.51	985	0.56	1018	0.61	1051	0.66	1082	0.71	1112	0.77	1142	0.82	1170	0.88	1198	0.93
1440	935	0.5	968	0.55	1000	0.61	1031	0.66	1063	0.71	1094	0.77	1124	0.83	1154	0.88	1182	0.94	1210	1.00
1600	956	0.55	989	0.6	1021	0.66	1052	0.71	1081	0.77	1110	0.83	1138	0.89	1166	0.95	1195	1.01	1222	1.07
1760	980	0.6	1010	0.66	1042	0.72	1072	0.77	1102	0.83	1131	0.89	1159	0.95	1186	1.02	1212	1.08	1238	1.14
1920	1006	0.66	1037	0.72	1066	0.78	1094	0.84	1123	0.9	1151	0.96	1179	1.03	1206	1.09	1232	1.16	1258	1.22

**Notes:**

1. Available External Static Pressure is the static pressure difference between the return duct and the supply duct plus the static pressure drop caused by accessories and options.
2. Data includes pressure drop due to standard filters and wet coils. No accessories or options are included in pressure drop data.
3. To determine static pressure drop due to other options/accessories, refer to the applicable table in the fan performance section.
4. Direct drive fan motor heat is negligible.
5. Factory supplied motors, in commercial equipment, are definite purpose motors, specifically designed and tested to operate reliably and continuously at all cataloged conditions. Using the full horsepower range of our fan motors as shown in our tabular data will not result in nuisance tripping or premature motor failure. Our product's warranty will not be affected.

<sup>(a)</sup> Model digit 11 selection of High Gas Heat is limited to minimum 320 cfm/ton full load airflow.

<sup>(b)</sup> Model digit 11 selection of High Gas Heat is limited to minimum 320 cfm/ton full load airflow.

**Table 121. Evaporator fan performance – 5 tons (model YHK), horizontal, high heat**

Available External Static Pressure (Inches of Water Gauge)																				
CFM	0.10		0.20		0.30		0.40		0.50		0.60		0.70		0.80		0.90		1.00	
	RPM	BHP	RPM	BHP	RPM	BHP	RPM	BHP	RPM	BHP	RPM	BHP	RPM	BHP	RPM	BHP	RPM	BHP	RPM	BHP
1500 <sup>(a)</sup>	508	0.09	565	0.12	619	0.16	669	0.20	714	0.24	757	0.28	798	0.33	835	0.37	871	0.42	908	0.47
1600	534	0.10	589	0.14	640	0.18	689	0.22	733	0.26	774	0.31	814	0.35	852	0.40	887	0.45	921	0.50
1800	587	0.13	638	0.17	684	0.21	729	0.26	772	0.31	812	0.36	849	0.41	886	0.46	921	0.51	954	0.56
2000	640	0.17	688	0.22	731	0.26	772	0.31	812	0.36	851	0.41	888	0.47	922	0.52	956	0.58	988	0.63
2200	695	0.22	739	0.27	780	0.32	818	0.37	855	0.42	892	0.48	927	0.53	961	0.59	994	0.65	1024	0.71
2400	750	0.27	791	0.33	830	0.38	866	0.43	900	0.49	935	0.55	968	0.61	1001	0.67	1033	0.74	1063	0.80
Available External Static Pressure (Inches of Water Gauge)																				
CFM	1.10		1.20		1.30		1.40		1.50		1.60		1.70		1.80		1.90		2.00	
	RPM	BHP	RPM	BHP	RPM	BHP	RPM	BHP	RPM	BHP	RPM	BHP	RPM	BHP	RPM	BHP	RPM	BHP	RPM	BHP
1500 <sup>(b)</sup>	943	0.52	976	0.57	1008	0.63	1039	0.68	1069	0.73	1099	0.79	1129	0.85	1158	0.91	1187	0.97	1215	1.03
1600	956	0.55	989	0.6	1021	0.66	1052	0.71	1081	0.77	1110	0.83	1138	0.89	1166	0.95	1195	1.01	1222	1.07
1800	986	0.62	1017	0.67	1047	0.73	1078	0.79	1107	0.85	1136	0.91	1164	0.97	1191	1.04	1217	1.10	1243	1.16
2000	1020	0.69	1050	0.75	1079	0.81	1108	0.87	1135	0.93	1162	1.00	1190	1.06	1217	1.13	1243	1.20	1268	1.27
2200	1054	0.77	1084	0.84	1113	0.90	1141	0.97	1168	1.03	1194	1.1	1220	1.17	1245	1.23	1269	1.30	1294	1.37

**Table 121. Evaporator fan performance – 5 tons (model YHK), horizontal, high heat (continued)**

Available External Static Pressure (Inches of Water Gauge)																				
CFM	1.10		1.20		1.30		1.40		1.50		1.60		1.70		1.80		1.90		2.00	
	RPM	BHP	RPM	BHP	RPM	BHP	RPM	BHP	RPM	BHP	RPM	BHP	RPM	BHP	RPM	BHP	RPM	BHP	RPM	BHP
2400	1092	0.87	1120	0.93	1148	1.00	1175	1.07	1202	1.14	1228	1.21	1253	1.28	1278	1.35	1302	1.42	1325	1.5

**Notes:**

1. Available External Static Pressure is the static pressure difference between the return duct and the supply duct plus the static pressure drop caused by accessories and options.
2. Data includes pressure drop due to standard filters and wet coils. No accessories or options are included in pressure drop data.
3. To determine static pressure drop due to other options/accessories, refer to the applicable table in the fan performance section.
4. Direct drive fan motor heat is negligible.
5. Factory supplied motors, in commercial equipment, are definite purpose motors, specifically designed and tested to operate reliably and continuously at all cataloged conditions. Using the full horsepower range of our fan motors as shown in our tabular data will not result in nuisance tripping or premature motor failure. Our product's warranty will not be affected.

(a) Model digit 11 selection of High Gas Heat is limited to minimum 320 cfm/ton full load airflow.  
 (b) Model digit 11 selection of High Gas Heat is limited to minimum 320 cfm/ton full load airflow.

## 6 to 25 Tons — Downflow

**Table 122. Evaporator fan performance – 6 ton (model YSK, YHK), downflow, high heat**

Available External Static Pressure (Inches of Water Gauge)																				
CFM	0.10		0.20		0.30		0.40		0.50		0.60		0.70		0.80		0.90		1.00	
	RPM	BHP	RPM	BHP	RPM	BHP	RPM	BHP	RPM	BHP	RPM	BHP	RPM	BHP	RPM	BHP	RPM	BHP	RPM	BHP
1800	560	0.11	621	0.16	676	0.21	727	0.26	775	0.32	820	0.37	861	0.43	900	0.49	937	0.56	973	0.62
1920	590	0.13	647	0.18	701	0.23	750	0.29	796	0.34	840	0.40	881	0.47	920	0.53	957	0.59	992	0.66
2040	619	0.15	674	0.20	726	0.26	773	0.32	818	0.37	861	0.44	901	0.50	940	0.57	976	0.63	1011	0.70
2160	649	0.17	702	0.23	751	0.29	797	0.34	841	0.41	882	0.47	922	0.54	960	0.60	996	0.67	1031	0.74
2280	679	0.20	730	0.25	777	0.31	822	0.38	864	0.44	905	0.51	943	0.57	981	0.64	1017	0.72	1051	0.79
2400	709	0.22	758	0.28	804	0.35	847	0.41	888	0.48	928	0.54	965	0.61	1002	0.69	1037	0.76	1071	0.84
2520	739	0.25	787	0.31	831	0.38	873	0.45	913	0.52	951	0.59	988	0.66	1023	0.73	1058	0.81	1091	0.89
2640	770	0.28	816	0.35	858	0.42	899	0.49	938	0.56	975	0.63	1012	0.71	1046	0.78	1080	0.86	1113	0.94
2760	800	0.31	845	0.38	886	0.46	925	0.53	963	0.60	1000	0.68	1035	0.76	1069	0.83	1102	0.91	1134	1.00
2880	831	0.35	874	0.42	914	0.50	952	0.57	989	0.65	1025	0.73	1059	0.81	1093	0.89	1125	0.97	1156	1.05

Available External Static Pressure (Inches of Water Gauge)																				
CFM	1.10		1.20		1.30		1.40		1.50		1.60		1.70		1.80		1.90		2.00	
	RPM	BHP	RPM	BHP	RPM	BHP	RPM	BHP	RPM	BHP	RPM	BHP	RPM	BHP	RPM	BHP	RPM	BHP	RPM	BHP
1800	1008	0.69	1041	0.75	1073	0.82	1103	0.89	1133	0.97	1162	1.04	1190	1.11	1219	1.19	1248	1.27	1276	1.35
1920	1026	0.73	1059	0.8	1090	0.87	1121	0.94	1150	1.02	1179	1.09	1207	1.17	1234	1.24	1260	1.32	1287	1.41
2040	1044	0.77	1077	0.84	1108	0.92	1138	0.99	1168	1.07	1196	1.14	1224	1.22	1251	1.3	1277	1.38	1303	1.47
2160	1064	0.82	1096	0.89	1126	0.97	1156	1.04	1186	1.12	1214	1.2	1241	1.28	1268	1.36	1294	1.45	1320	1.53
2280	1084	0.86	1115	0.94	1145	1.02	1175	1.1	1204	1.18	1232	1.26	1259	1.34	1286	1.43	1312	1.51	1337	1.6
2400	1104	0.91	1135	0.99	1165	1.07	1194	1.15	1222	1.24	1250	1.32	1277	1.41	1304	1.49	1330	1.58	1355	1.67
2520	1124	0.97	1155	1.05	1185	1.13	1214	1.21	1242	1.3	1269	1.38	1296	1.47	1322	1.56	1348	1.65	1373	1.74
2640	1144	1.02	1175	1.11	1205	1.19	1234	1.28	1262	1.36	1289	1.45	1315	1.54	1341	1.63	1366	1.72	1391	1.82
2760	1165	1.08	1196	1.17	1225	1.25	1254	1.34	1282	1.43	1309	1.52	1335	1.61	1360	1.71	1385	1.8	1410	1.9
2880	1187	1.14	1217	1.23	1246	1.32	1274	1.41	1302	1.5	1328	1.6	1355	1.69	1380	1.78	1405	1.88	1429	1.98

**Notes:**

1. Available External Static Pressure is the static pressure difference between the return duct and the supply duct plus the static pressure drop caused by accessories and options.
2. For direct drive evaporator fan speed (rpm), refer to the applicable table in the fan performance section.
3. Data includes pressure drop due to standard filters and wet coils. No accessories or options are included in pressure drop data.
4. To determine static pressure drop due to other options/accessories, refer to the applicable table in the fan performance section.
5. Direct drive fan motor heat is negligible.
6. Factory supplied motors, in commercial equipment, are definite purpose motors, specifically designed and tested to operate reliably and continuously at all cataloged conditions. Using the full horsepower range of our fan motors as shown in our tabular data will not result in nuisance tripping or premature motor failure. Our product's warranty will not be affected.



## Evaporator Fan Performance — Gas Heat

**Table 123. Evaporator fan performance –7.5 ton (model YSK, YHK), downflow, high heat**

Available External Static Pressure (Inches of Water Gauge)																				
CFM	0.10		0.20		0.30		0.40		0.50		0.60		0.70		0.80		0.90		1.00	
	RPM	BHP	RPM	BHP	RPM	BHP	RPM	BHP	RPM	BHP	RPM	BHP	RPM	BHP	RPM	BHP	RPM	BHP	RPM	BHP
2250	676	0.19	728	0.25	775	0.31	820	0.37	863	0.44	903	0.50	943	0.57	980	0.64	1016	0.71	1050	0.79
2400	713	0.22	764	0.29	809	0.35	852	0.42	893	0.48	933	0.55	970	0.62	1007	0.70	1042	0.77	1075	0.85
2550	752	0.26	800	0.33	843	0.40	884	0.47	924	0.54	962	0.61	999	0.68	1034	0.76	1069	0.83	1102	0.91
2700	790	0.30	836	0.37	878	0.44	918	0.52	956	0.59	993	0.66	1029	0.74	1063	0.82	1096	0.90	1129	0.98
2850	828	0.35	873	0.42	914	0.50	952	0.57	988	0.65	1024	0.73	1059	0.81	1092	0.89	1125	0.97	1156	1.06
3000	867	0.40	910	0.47	950	0.55	987	0.63	1022	0.71	1056	0.80	1090	0.88	1122	0.96	1154	1.05	1185	1.14
3150	906	0.45	948	0.53	986	0.62	1022	0.70	1056	0.78	1089	0.87	1122	0.96	1153	1.04	1184	1.13	1214	1.22
3300	945	0.51	985	0.59	1023	0.68	1057	0.77	1091	0.86	1123	0.95	1154	1.04	1185	1.13	1215	1.22	1244	1.31
3600	1024	0.64	1061	0.74	1096	0.83	1130	0.93	1161	1.02	1191	1.12	1221	1.22	1249	1.32	1278	1.41	1306	1.51
Available External Static Pressure (Inches of Water Gauge)																				
CFM	1.10		1.20		1.30		1.40		1.50		1.60		1.70		1.80		1.90		2.00	
	RPM	BHP	RPM	BHP	RPM	BHP	RPM	BHP	RPM	BHP	RPM	BHP	RPM	BHP	RPM	BHP	RPM	BHP	RPM	BHP
2250	1082	0.86	1114	0.94	1144	1.01	1174	1.09	1203	1.17	1231	1.25	1259	1.34	1286	1.42	1312	1.51	1337	1.59
2400	1108	0.93	1139	1	1169	1.08	1198	1.17	1226	1.25	1254	1.33	1281	1.42	1308	1.5	1334	1.59	1359	1.68
2550	1134	0.99	1165	1.08	1194	1.16	1223	1.24	1251	1.33	1278	1.42	1305	1.5	1331	1.59	1356	1.68	1382	1.78
2700	1160	1.07	1190	1.15	1220	1.24	1249	1.33	1276	1.41	1303	1.5	1329	1.59	1355	1.69	1380	1.78	1404	1.87
2850	1187	1.14	1217	1.23	1246	1.32	1274	1.41	1302	1.5	1329	1.6	1355	1.69	1380	1.79	1405	1.88	1429	1.98
3000	1215	1.23	1244	1.32	1273	1.41	1300	1.5	1328	1.6	1354	1.69	1380	1.79	1405	1.89	1430	1.99	1454	2.09
3150	1243	1.31	1272	1.41	1300	1.5	1327	1.6	1354	1.7	1380	1.8	1406	1.9	1431	2	1455	2.1	1479	2.2
3300	1273	1.41	1301	1.5	1328	1.6	1355	1.7	1381	1.8	1407	1.9	1432	2.01	1457	2.11	1481	2.22	1505	2.32
3600	1333	1.61	1360	1.71	1386	1.81	1412	1.92	1437	2.03	1462	2.13	1486	2.24	1510	2.35	1534	2.47	1557	2.58

**Notes:**

1. Available External Static Pressure is the static pressure difference between the return duct and the supply duct plus the static pressure drop caused by accessories and options.
2. For direct drive evaporator fan speed (rpm), refer to the applicable table in the fan performance section.
3. Data includes pressure drop due to standard filters and wet coils. No accessories or options are included in pressure drop data.
4. To determine static pressure drop due to other options/accessories, refer to the applicable table in the fan performance section.
5. Direct drive fan motor heat is negligible.
6. Factory supplied motors, in commercial equipment, are definite purpose motors, specifically designed and tested to operate reliably and continuously at all cataloged conditions. Using the full horsepower range of our fan motors as shown in our tabular data will not result in nuisance tripping or premature motor failure. Our product's warranty will not be affected.

**Table 124. Evaporator fan performance –8.5 ton (model YSK, YHK), downflow, high heat**

Available External Static Pressure (Inches of Water Gauge)																				
CFM	0.10		0.20		0.30		0.40		0.50		0.60		0.70		0.80		0.90		1.00	
	RPM	BHP	RPM	BHP	RPM	BHP	RPM	BHP	RPM	BHP	RPM	BHP	RPM	BHP	RPM	BHP	RPM	BHP	RPM	BHP
2550	752	0.26	800	0.33	843	0.40	884	0.47	924	0.54	962	0.61	999	0.68	1034	0.76	1069	0.83	1102	0.91
2720	795	0.31	841	0.38	883	0.45	923	0.52	960	0.60	997	0.67	1033	0.75	1067	0.83	1100	0.91	1132	0.99
2890	839	0.36	883	0.43	923	0.51	961	0.59	997	0.67	1033	0.75	1067	0.82	1100	0.91	1133	0.99	1164	1.08
3060	883	0.42	925	0.50	964	0.58	1001	0.66	1036	0.74	1069	0.83	1103	0.91	1134	0.99	1166	1.08	1197	1.17
3230	927	0.48	968	0.56	1006	0.65	1041	0.74	1075	0.82	1107	0.91	1139	1.00	1170	1.09	1200	1.17	1230	1.27
3400	971	0.55	1011	0.64	1047	0.73	1081	0.82	1114	0.91	1146	1.00	1176	1.10	1206	1.19	1236	1.28	1264	1.37
3570	1016	0.63	1054	0.72	1089	0.81	1122	0.91	1154	1.00	1184	1.10	1214	1.20	1243	1.30	1271	1.39	1299	1.49
3740	1061	0.71	1097	0.81	1131	0.91	1164	1.01	1194	1.11	1224	1.21	1253	1.31	1281	1.41	1308	1.51	1335	1.61
4080	1151	0.91	1184	1.01	1216	1.12	1247	1.22	1276	1.33	1304	1.44	1331	1.55	1358	1.66	1384	1.77	1409	1.88
Available External Static Pressure (Inches of Water Gauge)																				
CFM	1.10		1.20		1.30		1.40		1.50		1.60		1.70		1.80		1.90		2.00	
	RPM	BHP	RPM	BHP	RPM	BHP	RPM	BHP	RPM	BHP	RPM	BHP	RPM	BHP	RPM	BHP	RPM	BHP	RPM	BHP
2550	1134	0.99	1165	1.08	1194	1.16	1223	1.24	1251	1.33	1278	1.42	1305	1.5	1331	1.59	1356	1.68	1382	1.78
2720	1163	1.08	1194	1.16	1223	1.25	1252	1.34	1280	1.43	1307	1.52	1333	1.61	1358	1.7	1383	1.79	1408	1.89
2890	1194	1.16	1224	1.25	1253	1.34	1281	1.44	1309	1.53	1335	1.62	1361	1.72	1387	1.81	1411	1.91	1436	2.01

**Table 124. Evaporator fan performance –8.5 ton (model YSK, YHK), downflow, high heat (continued)**

Available External Static Pressure (Inches of Water Gauge)																				
CFM	1.10		1.20		1.30		1.40		1.50		1.60		1.70		1.80		1.90		2.00	
	RPM	BHP	RPM	BHP	RPM	BHP	RPM	BHP	RPM	BHP	RPM	BHP	RPM	BHP	RPM	BHP	RPM	BHP	RPM	BHP
3060	1226	1.26	1255	1.35	1284	1.45	1311	1.54	1338	1.64	1364	1.73	1390	1.83	1415	1.93	1440	2.03	1464	2.13
3230	1259	1.36	1287	1.46	1315	1.55	1342	1.65	1368	1.75	1394	1.85	1420	1.95	1445	2.06	1469	2.16	1493	2.27
3400	1292	1.47	1320	1.57	1347	1.67	1373	1.77	1399	1.87	1425	1.98	1450	2.08	1474	2.19	1498	2.3	1522	2.4
3570	1326	1.59	1354	1.69	1380	1.79	1406	1.9	1431	2	1456	2.11	1481	2.22	1505	2.33	1528	2.44	1551	2.55
3740	1362	1.71	1388	1.82	1414	1.92	1439	2.03	1464	2.14	1488	2.25	1512	2.36	1536	2.48	1559	2.59	1582	2.71
4080	1434	1.99	1459	2.1	1484	2.21	1507	2.33	1531	2.44	1555	2.56	1578	2.68	1600	2.8	1622	2.92	1644	3.04

**Notes:**

1. Available External Static Pressure is the static pressure difference between the return duct and the supply duct plus the static pressure drop caused by accessories and options.
2. For direct drive evaporator fan speed (rpm), refer to the applicable table in the fan performance section.
3. Data includes pressure drop due to standard filters and wet coils. No accessories or options are included in pressure drop data.
4. To determine static pressure drop due to other options/accessories, refer to the applicable table in the fan performance section.
5. Direct drive fan motor heat is negligible.
6. Factory supplied motors, in commercial equipment, are definite purpose motors, specifically designed and tested to operate reliably and continuously at all cataloged conditions. Using the full horsepower range of our fan motors as shown in our tabular data will not result in nuisance tripping or premature motor failure. Our product's warranty will not be affected.

**Table 125. Evaporator fan performance – 10 ton (model YSK, YHK), downflow, high heat**

Available External Static Pressure (Inches of Water Gauge)																				
CFM	0.10		0.20		0.30		0.40		0.50		0.60		0.70		0.80		0.90		1.00	
	RPM	BHP	RPM	BHP	RPM	BHP	RPM	BHP	RPM	BHP	RPM	BHP	RPM	BHP	RPM	BHP	RPM	BHP	RPM	BHP
3000	867	0.40	910	0.47	950	0.55	987	0.63	1022	0.71	1056	0.80	1090	0.88	1122	0.96	1154	1.05	1185	1.14
3200	919	0.47	960	0.55	998	0.64	1034	0.72	1068	0.81	1100	0.90	1132	0.98	1164	1.07	1194	1.16	1224	1.25
3400	971	0.55	1011	0.64	1047	0.73	1081	0.82	1114	0.91	1146	1.00	1176	1.10	1206	1.19	1236	1.28	1264	1.37
3600	1024	0.64	1061	0.74	1096	0.83	1130	0.93	1161	1.02	1191	1.12	1221	1.22	1249	1.32	1278	1.41	1306	1.51
3800	1077	0.74	1112	0.84	1146	0.94	1178	1.04	1209	1.14	1238	1.24	1266	1.35	1294	1.45	1321	1.56	1348	1.66
4000	1129	0.86	1164	0.96	1196	1.06	1227	1.17	1257	1.28	1285	1.38	1313	1.49	1340	1.60	1366	1.71	1391	1.82
4200	1183	0.98	1215	1.09	1247	1.20	1277	1.31	1305	1.42	1333	1.53	1360	1.64	1386	1.76	1411	1.87	1436	1.99
4400	1236	1.12	1267	1.23	1297	1.34	1326	1.46	1354	1.58	1381	1.69	1407	1.81	1432	1.93	1457	2.04	1481	2.16
4600	1289	1.27	1319	1.38	1349	1.50	1377	1.62	1404	1.74	1430	1.87	1455	1.99	1480	2.11	1503	2.23	1527	2.36
4800	1343	1.43	1372	1.55	1400	1.67	1427	1.80	1453	1.92	1479	2.05	1503	2.18	1527	2.31	1550	2.43	1573	2.56

Available External Static Pressure (Inches of Water Gauge)																				
CFM	1.10		1.20		1.30		1.40		1.50		1.60		1.70		1.80		1.90		2.00	
	RPM	BHP	RPM	BHP	RPM	BHP	RPM	BHP	RPM	BHP	RPM	BHP	RPM	BHP	RPM	BHP	RPM	BHP	RPM	BHP
3000	1215	1.23	1244	1.32	1273	1.41	1300	1.50	1328	1.60	1354	1.69	1380	1.79	1405	1.89	1430	1.99	1454	2.09
3200	1253	1.34	1281	1.44	1309	1.53	1336	1.63	1363	1.73	1389	1.83	1414	1.93	1439	2.03	1464	2.14	1488	2.24
3400	1292	1.47	1320	1.57	1347	1.67	1373	1.77	1399	1.87	1425	1.98	1450	2.08	1474	2.19	1498	2.30	1522	2.40
3600	1333	1.61	1360	1.71	1386	1.81	1412	1.92	1437	2.03	1462	2.13	1486	2.24	1510	2.35	1534	2.47	1557	2.58
3800	1375	1.76	1400	1.86	1426	1.97	1451	2.08	1476	2.19	1500	2.30	1523	2.42	1547	2.53	1570	2.65	1593	2.76
4000	1417	1.93	1442	2.03	1467	2.14	1491	2.25	1515	2.37	1539	2.48	1562	2.60	1585	2.72	1607	2.84	1630	2.96
4200	1460	2.10	1485	2.21	1509	2.33	1532	2.44	1555	2.56	1579	2.68	1601	2.80	1624	2.92	1646	3.04	-	-
4400	1505	2.29	1528	2.41	1551	2.53	1575	2.64	1597	2.76	1619	2.88	1641	3.01	-	-	-	-	-	-
4600	1550	2.48	1573	2.61	1595	2.74	1617	2.86	1640	2.98	-	-	-	-	-	-	-	-	-	-
4800	1596	2.69	1618	2.82	1640	2.95	-	-	-	-	-	-	-	-	-	-	-	-	-	-

**Notes:**

1. Available External Static Pressure is the static pressure difference between the return duct and the supply duct plus the static pressure drop caused by accessories and options.
2. For direct drive evaporator fan speed (rpm), refer to the applicable table in the fan performance section.
3. Data includes pressure drop due to standard filters and wet coils. No accessories or options are included in pressure drop data.
4. To determine static pressure drop due to other options/accessories, refer to the applicable table in the fan performance section.
5. Direct drive fan motor heat is negligible.
6. Factory supplied motors, in commercial equipment, are definite purpose motors, specifically designed and tested to operate reliably and continuously at all cataloged conditions. Using the full horsepower range of our fan motors as shown in our tabular data will not result in nuisance tripping or premature motor failure. Our product's warranty will not be affected.



## Evaporator Fan Performance — Gas Heat

**Table 126. Evaporator fan performance – 10 ton (model YSK, YHK), downflow, high heat, high static motor**

Available External Static Pressure (Inches of Water Gauge)																				
CFM	0.10		0.20		0.30		0.40		0.50		0.60		0.70		0.80		0.90		1.00	
	RPM	BHP	RPM	BHP	RPM	BHP	RPM	BHP	RPM	BHP	RPM	BHP	RPM	BHP	RPM	BHP	RPM	BHP	RPM	BHP
3000	879	0.42	921	0.49	961	0.57	998	0.65	1035	0.74	1070	0.82	1104	0.90	1137	0.99	1169	1.08	1199	1.17
3200	932	0.49	972	0.57	1010	0.66	1046	0.74	1080	0.83	1114	0.92	1147	1.01	1179	1.10	1210	1.19	1240	1.29
3400	985	0.58	1023	0.67	1059	0.75	1094	0.85	1127	0.94	1159	1.03	1191	1.12	1221	1.22	1252	1.32	1281	1.41
3600	1038	0.68	1075	0.77	1110	0.86	1142	0.96	1174	1.05	1205	1.15	1236	1.25	1265	1.35	1294	1.45	1323	1.55
3800	1092	0.79	1127	0.88	1160	0.98	1192	1.08	1222	1.18	1252	1.28	1281	1.39	1310	1.49	1338	1.60	1365	1.70
4000	1145	0.91	1179	1.01	1211	1.11	1242	1.21	1271	1.32	1300	1.43	1328	1.54	1355	1.65	1383	1.75	1409	1.86
4200	1199	1.04	1232	1.14	1263	1.25	1292	1.36	1320	1.47	1348	1.58	1375	1.70	1402	1.81	1428	1.93	1454	2.04
4400	1253	1.18	1284	1.29	1314	1.41	1343	1.52	1370	1.63	1397	1.75	1423	1.87	1449	1.99	1474	2.11	1499	2.23
4600	1307	1.34	1337	1.46	1366	1.57	1394	1.69	1420	1.81	1446	1.93	1472	2.05	1497	2.18	1521	2.30	1545	2.43
4800	1361	1.51	1391	1.63	1418	1.76	1445	1.88	1471	2.00	1496	2.13	1520	2.25	1545	2.38	1568	2.51	1592	2.64

Available External Static Pressure (Inches of Water Gauge)																				
CFM	1.10		1.20		1.30		1.40		1.50		1.60		1.70		1.80		1.90		2.00	
	RPM	BHP	RPM	BHP	RPM	BHP	RPM	BHP	RPM	BHP	RPM	BHP	RPM	BHP	RPM	BHP	RPM	BHP	RPM	BHP
3000	1229	1.26	1258	1.36	1287	1.45	1314	1.55	1342	1.65	1369	1.75	1395	1.86	1421	1.96	1446	2.07	1470	2.18
3200	1269	1.38	1297	1.48	1324	1.58	1351	1.68	1378	1.79	1404	1.89	1430	2	1455	2.11	1480	2.22	1504	2.33
3400	1309	1.51	1337	1.62	1363	1.72	1390	1.82	1415	1.93	1441	2.04	1466	2.15	1490	2.26	1514	2.37	1538	2.49
3600	1350	1.66	1377	1.76	1404	1.87	1429	1.98	1454	2.09	1479	2.2	1503	2.31	1527	2.43	1551	2.54	1574	2.66
3800	1392	1.81	1419	1.92	1444	2.03	1470	2.14	1494	2.26	1518	2.37	1542	2.49	1565	2.61	1588	2.73	1611	2.85
4000	1435	1.97	1461	2.09	1486	2.2	1511	2.32	1535	2.44	1558	2.56	1582	2.68	1604	2.8	1626	2.92	1648	3.05
4200	1479	2.16	1504	2.27	1528	2.39	1552	2.51	1576	2.63	1599	2.76	1622	2.88	1644	3.01	1666	3.13	1688	3.26
4400	1524	2.35	1548	2.47	1571	2.59	1595	2.72	1618	2.84	1641	2.97	1663	3.1	1685	3.23	1706	3.36	1728	3.49
4600	1569	2.56	1592	2.68	1615	2.81	1638	2.93	1660	3.06	1683	3.19	1705	3.33	1726	3.46	1747	3.6	1768	3.73
4800	1614	2.78	1637	2.91	1660	3.04	1682	3.17	1704	3.3	1725	3.43	1747	3.57	1768	3.71	1789	3.85	1810	3.99

**Notes:**

1. Available External Static Pressure is the static pressure difference between the return duct and the supply duct plus the static pressure drop caused by accessories and options.
2. For direct drive evaporator fan speed (rpm), refer to the applicable table in the fan performance section.
3. Data includes pressure drop due to standard filters and wet coils. No accessories or options are included in pressure drop data.
4. To determine static pressure drop due to other options/accessories, refer to the applicable table in the fan performance section.
5. Direct drive fan motor heat is negligible.
6. Factory supplied motors, in commercial equipment, are definite purpose motors, specifically designed and tested to operate reliably and continuously at all cataloged conditions. Using the full horsepower range of our fan motors as shown in our tabular data will not result in nuisance tripping or premature motor failure. Our product's warranty will not be affected.

**Table 127. Evaporator fan performance – 12.5 ton (model YSK), downflow, high heat**

Available External Static Pressure (Inches of Water Gauge)																				
CFM	0.10		0.20		0.30		0.40		0.50		0.60		0.70		0.80		0.90		1.00	
	RPM	BHP	RPM	BHP	RPM	BHP	RPM	BHP	RPM	BHP	RPM	BHP	RPM	BHP	RPM	BHP	RPM	BHP	RPM	BHP
3750	1002	0.58	1036	0.66	1070	0.75	1101	0.83	1130	0.92	1158	1.00	1186	1.09	1213	1.17	1239	1.26	1266	1.35
4000	1065	0.70	1097	0.78	1128	0.87	1158	0.96	1187	1.05	1214	1.14	1240	1.23	1266	1.32	1291	1.41	1316	1.51
4250	1128	0.83	1157	0.91	1187	1.01	1216	1.10	1244	1.20	1271	1.30	1296	1.39	1320	1.48	1344	1.58	1368	1.68
4500	1191	0.97	1218	1.06	1247	1.16	1275	1.26	1301	1.36	1327	1.47	1352	1.57	1375	1.67	1398	1.77	1421	1.87
4750	1255	1.13	1279	1.22	1307	1.33	1334	1.43	1359	1.54	1384	1.65	1408	1.76	1431	1.86	1454	1.97	1475	2.07
5000	1319	1.31	1341	1.40	1367	1.51	1393	1.62	1418	1.74	1442	1.85	1465	1.96	1488	2.08	1510	2.19	1531	2.30
5250	1383	1.51	1403	1.60	1428	1.72	1453	1.83	1477	1.95	1500	2.07	1523	2.19	1545	2.31	1566	2.43	1587	2.54
5500	1446	1.72	1466	1.82	1489	1.94	1513	2.06	1536	2.18	1559	2.31	1581	2.43	1602	2.55	1623	2.68	1643	2.80
5750	1510	1.96	1529	2.06	1550	2.18	1573	2.31	1596	2.43	1618	2.56	1639	2.69	1660	2.82	1680	2.95	1700	3.08
6000	1574	2.21	1593	2.32	1612	2.44	1634	2.57	1656	2.71	1677	2.84	1697	2.97	1718	3.11	1737	3.24	1757	3.38

**Table 127. Evaporator fan performance – 12.5 ton (model YSK), downflow, high heat (continued)**

Available External Static Pressure (Inches of Water Gauge)																			
1.10		1.20		1.30		1.40		1.50		1.60		1.70		1.80		1.90		2.00	
RPM	BHP	RPM	BHP	RPM	BHP	RPM	BHP	RPM	BHP	RPM	BHP	RPM	BHP	RPM	BHP	RPM	BHP	RPM	BHP
1293	1.45	1319	1.55	1345	1.65	1371	1.75	1397	1.86	1422	1.96	1447	2.07	1473	2.18	1497	2.29	1521	2.41
1340	1.61	1366	1.71	1391	1.81	1415	1.92	1440	2.02	1464	2.13	1489	2.25	1512	2.36	1535	2.47	1559	2.59
1392	1.78	1414	1.88	1438	1.99	1462	2.1	1485	2.21	1508	2.32	1531	2.43	1555	2.55	1577	2.67	1599	2.79
1444	1.97	1466	2.08	1488	2.19	1510	2.29	1533	2.41	1555	2.53	1577	2.64	1598	2.76	1620	2.88	1642	3.01
1497	2.18	1519	2.29	1540	2.4	1561	2.52	1581	2.63	1602	2.75	1624	2.87	1645	2.99	1666	3.12	1686	3.24
1551	2.41	1572	2.52	1593	2.64	1613	2.76	1633	2.87	1652	2.99	1671	3.11	1692	3.24	1713	3.37	1733	3.5
1607	2.66	1626	2.77	1646	2.89	1666	3.01	1685	3.14	1704	3.26	1723	3.38	1741	3.51	1760	3.64	1780	3.77
1663	2.93	1682	3.05	1701	3.17	1719	3.29	1738	3.42	1757	3.55	1775	3.68	1793	3.8	1811	3.93	1829	4.07
1719	3.21	1738	3.34	1756	3.47	1774	3.59	1792	3.72	1810	3.85	1828	3.99	1846	4.12	1863	4.26	1880	4.39
1776	3.52	1794	3.65	1812	3.79	1830	3.92	1847	4.05	1864	4.18	1881	4.32	1899	4.46	1916	4.6	-	-

**Notes:**

1. Available External Static Pressure is the static pressure difference between the return duct and the supply duct plus the static pressure drop caused by accessories and options.
2. For direct drive evaporator fan speed (rpm), refer to the applicable table in the fan performance section.
3. Data includes pressure drop due to standard filters and wet coils. No accessories or options are included in pressure drop data.
4. To determine static pressure drop due to other options/accessories, refer to the applicable table in the fan performance section.
5. Direct drive fan motor heat is negligible.
6. Factory supplied motors, in commercial equipment, are definite purpose motors, specifically designed and tested to operate reliably and continuously at all cataloged conditions. Using the full horsepower range of our fan motors as shown in our tabular data will not result in nuisance tripping or premature motor failure. Our product's warranty will not be affected.

**Table 128. Evaporator fan performance – 12.5 ton (model YHK), downflow, high heat**

Available External Static Pressure (Inches of Water Gauge)																				
CFM	0.10		0.20		0.30		0.40		0.50		0.60		0.70		0.80		0.90		1.00	
	RPM	BHP	RPM	BHP	RPM	BHP	RPM	BHP	RPM	BHP	RPM	BHP	RPM	BHP	RPM	BHP	RPM	BHP	RPM	BHP
3750	552	0.20	608	0.28	659	0.37	708	0.46	754	0.56	797	0.66	839	0.76	879	0.87	917	0.98	954	1.10
4000	584	0.23	638	0.32	687	0.41	733	0.51	777	0.61	819	0.71	860	0.82	898	0.93	936	1.05	972	1.17
4500	647	0.32	697	0.41	742	0.51	784	0.62	825	0.73	864	0.84	902	0.95	939	1.07	975	1.20	1009	1.32
5000	713	0.42	760	0.53	802	0.64	841	0.75	879	0.87	915	0.99	951	1.12	985	1.24	1019	1.37	1052	1.51
5500	781	0.55	824	0.67	863	0.79	900	0.92	935	1.04	969	1.17	1003	1.30	1035	1.44	1067	1.58	1098	1.72
6000	849	0.71	890	0.84	926	0.97	961	1.10	994	1.24	1026	1.38	1057	1.52	1087	1.66	1117	1.81	1147	1.96

Available External Static Pressure (Inches of Water Gauge)																				
CFM	1.10		1.20		1.30		1.40		1.50		1.60		1.70		1.80		1.90		2.00	
	RPM	BHP	RPM	BHP	RPM	BHP	RPM	BHP	RPM	BHP	RPM	BHP	RPM	BHP	RPM	BHP	RPM	BHP	RPM	BHP
3750	989	1.21	1023	1.33	1056	1.46	1088	1.58	1119	1.71	1149	1.84	1179	1.97	1207	2.11	1235	2.24	1262	2.38
4000	1007	1.29	1040	1.41	1073	1.54	1104	1.67	1135	1.8	1165	1.94	1193	2.07	1222	2.21	1249	2.35	1276	2.49
4500	1043	1.45	1075	1.59	1107	1.72	1137	1.86	1167	2	1196	2.14	1224	2.28	1252	2.43	1279	2.58	1306	2.73
5000	1084	1.65	1115	1.79	1145	1.93	1175	2.07	1204	2.22	1232	2.37	1260	2.53	1287	2.68	1313	2.84	1339	3
5500	1128	1.86	1158	2.01	1187	2.16	1215	2.32	1243	2.47	1271	2.63	1297	2.79	1324	2.95	1349	3.12	1375	3.29
6000	1176	2.11	1204	2.27	1232	2.42	1259	2.59	1286	2.75	1312	2.92	1338	3.09	1363	3.26	1388	3.43	1413	3.61

**Notes:**

1. Available External Static Pressure is the static pressure difference between the return duct and the supply duct plus the static pressure drop caused by accessories and options.
2. For direct drive evaporator fan speed (rpm), refer to the applicable table in the fan performance section.
3. Data includes pressure drop due to standard filters and wet coils. No accessories or options are included in pressure drop data.
4. To determine static pressure drop due to other options/accessories, refer to the applicable table in the fan performance section.
5. Direct drive fan motor heat is negligible.
6. Factory supplied motors, in commercial equipment, are definite purpose motors, specifically designed and tested to operate reliably and continuously at all cataloged conditions. Using the full horsepower range of our fan motors as shown in our tabular data will not result in nuisance tripping or premature motor failure. Our product's warranty will not be affected.



## Evaporator Fan Performance — Gas Heat

**Table 129. Evaporator fan performance – 15 ton (model YSK, YHK), downflow, high heat**

Available External Static Pressure (Inches of Water Gauge)										
	0.10	0.20	0.30	0.40	0.50	0.60	0.70	0.80	0.90	1.00
CFM	RPM BHP	RPM BHP	RPM BHP	RPM BHP	RPM BHP	RPM BHP	RPM BHP	RPM BHP	RPM BHP	RPM BHP
4500	642 0.31	697 0.42	749 0.54	795 0.65	838 0.77	877 0.89	916 1.01	954 1.13	990 1.26	1025 1.40
4800	678 0.37	728 0.48	780 0.61	825 0.73	867 0.85	905 0.97	942 1.10	978 1.23	1014 1.36	1048 1.50
5400	751 0.49	796 0.61	842 0.75	886 0.89	926 1.03	963 1.16	998 1.30	1032 1.44	1064 1.58	1096 1.73
6000	825 0.64	865 0.78	905 0.91	948 1.07	987 1.23	1023 1.38	1057 1.53	1089 1.69	1120 1.84	1150 2.00
6600	900 0.83	936 0.97	973 1.12	1009 1.28	1049 1.46	1084 1.63	1117 1.80	1148 1.96	1178 2.13	1207 2.30
7200	975 1.04	1009 1.20	1042 1.36	1076 1.53	1110 1.71	1146 1.90	1178 2.09	1209 2.27	1238 2.45	1266 2.64
Available External Static Pressure (Inches of Water Gauge)										
	1.10	1.20	1.30	1.40	1.50	1.60	1.70	1.80	1.90	2.00
CFM	RPM BHP	RPM BHP	RPM BHP	RPM BHP	RPM BHP	RPM BHP	RPM BHP	RPM BHP	RPM BHP	RPM BHP
4500	1058 1.53	1090 1.67	1122 1.81	1153 1.96	1184 2.1	1213 2.26	1241 2.41	1269 2.56	1295 2.72	1322 2.88
4800	1081 1.64	1113 1.78	1143 1.93	1173 2.08	1203 2.23	1232 2.39	1261 2.54	1288 2.7	1315 2.87	1341 3.03
5400	1129 1.88	1160 2.03	1190 2.19	1219 2.35	1247 2.51	1274 2.67	1300 2.83	1328 3	1354 3.18	1380 3.35
6000	1179 2.15	1208 2.32	1237 2.48	1266 2.65	1294 2.82	1321 3	1347 3.17	1372 3.35	1397 3.53	1421 3.71
6600	1235 2.47	1262 2.64	1289 2.81	1315 2.99	1342 3.17	1368 3.36	1394 3.54	1419 3.73	1444 3.92	1468 4.11
7200	1293 2.82	1320 3.01	1345 3.19	1370 3.38	1394 3.56	1418 3.75	1443 3.95	1467 4.15	1492 4.35	1515 4.55

**Notes:**

1. Available External Static Pressure is the static pressure difference between the return duct and the supply duct plus the static pressure drop caused by accessories and options.
2. For direct drive evaporator fan speed (rpm), refer to the applicable table in the fan performance section.
3. Data includes pressure drop due to standard filters and wet coils. No accessories or options are included in pressure drop data.
4. To determine static pressure drop due to other options/accessories, refer to the applicable table in the fan performance section.
5. Direct drive fan motor heat is negligible.
6. Factory supplied motors, in commercial equipment, are definite purpose motors, specifically designed and tested to operate reliably and continuously at all cataloged conditions. Using the full horsepower range of our fan motors as shown in our tabular data will not result in nuisance tripping or premature motor failure. Our product's warranty will not be affected.

**Table 130. Evaporator fan performance – 17.5 ton (model YSK, YHK), downflow, high heat**

Available External Static Pressure (Inches of Water Gauge)											
	0.10	0.20	0.30	0.40	0.50	0.60	0.70	0.80	0.90	1.00	
CFM	RPM BHP	RPM BHP	RPM BHP	RPM BHP	RPM BHP	RPM BHP	RPM BHP	RPM BHP	RPM BHP	RPM BHP	RPM BHP
5250	733 0.46	779 0.58	826 0.71	871 0.85	911 0.98	949 1.11	984 1.25	1018 1.39	1051 1.52	1084 1.67	
5600	776 0.54	819 0.66	862 0.80	907 0.95	946 1.09	983 1.23	1018 1.38	1051 1.52	1082 1.67	1113 1.81	
6300	862 0.73	900 0.87	939 1.01	979 1.17	1018 1.34	1053 1.50	1087 1.66	1119 1.82	1149 1.98	1179 2.15	
7000	950 0.97	985 1.12	1019 1.28	1053 1.44	1090 1.62	1126 1.81	1158 1.99	1188 2.16	1218 2.34	1246 2.52	
7700	1038 1.25	1070 1.42	1101 1.59	1132 1.76	1163 1.94	1197 2.15	1230 2.36	1260 2.56	1289 2.75	1316 2.94	
8400	1127 1.59	1156 1.77	1185 1.96	1213 2.14	1242 2.34	1270 2.53	1301 2.76	1332 2.99	1361 3.21	1387 3.42	
Available External Static Pressure (Inches of Water Gauge)											
	1.10	1.20	1.30	1.40	1.50	1.60	1.70	1.80	1.90	2.00	
CFM	RPM BHP	RPM BHP	RPM BHP	RPM BHP	RPM BHP	RPM BHP	RPM BHP	RPM BHP	RPM BHP	RPM BHP	RPM BHP
5250	1117 1.82	1148 1.97	1178 2.12	1207 2.28	1235 2.43	1262 2.59	1290 2.76	1318 2.93	1344 3.1	1370 3.27	
5600	1145 1.97	1176 2.13	1205 2.28	1234 2.45	1262 2.61	1289 2.77	1316 2.94	1341 3.11	1367 3.29	1393 3.47	
6300	1207 2.31	1234 2.47	1262 2.64	1290 2.82	1318 2.99	1344 3.17	1370 3.35	1396 3.53	1420 3.72	1444 3.9	
7000	1274 2.7	1300 2.88	1326 3.06	1351 3.24	1376 3.43	1401 3.61	1426 3.81	1451 4	1476 4.2	1499 4.4	
7700	1343 3.14	1368 3.34	1394 3.53	1418 3.73	1442 3.93	1465 4.13	1488 4.33	1510 4.53	1532 4.73	1556 4.95	

**Table 130. Evaporator fan performance – 17.5 ton (model YSK, YHK), downflow, high heat (continued)**

Available External Static Pressure (Inches of Water Gauge)																				
CFM	1.10		1.20		1.30		1.40		1.50		1.60		1.70		1.80		1.90		2.00	
	RPM	BHP	RPM	BHP	RPM	BHP	RPM	BHP	RPM	BHP	RPM	BHP	RPM	BHP	RPM	BHP	RPM	BHP	RPM	BHP
8400	1413	3.63	1438	3.84	1462	4.05	1486	4.27	1510	4.49	1532	4.7	1554	4.92	1576	5.14	1597	5.35	1618	5.57

**Notes:**

1. Available External Static Pressure is the static pressure difference between the return duct and the supply duct plus the static pressure drop caused by accessories and options.
2. For direct drive evaporator fan speed (rpm), refer to the applicable table in the fan performance section.
3. Data includes pressure drop due to standard filters and wet coils. No accessories or options are included in pressure drop data.
4. To determine static pressure drop due to other options/accessories, refer to the applicable table in the fan performance section.
5. Direct drive fan motor heat is negligible.
6. Factory supplied motors, in commercial equipment, are definite purpose motors, specifically designed and tested to operate reliably and continuously at all cataloged conditions. Using the full horsepower range of our fan motors as shown in our tabular data will not result in nuisance tripping or premature motor failure. Our product's warranty will not be affected.

**Table 131. Evaporator fan performance – 20 ton (model YSK, YHK), downflow, high heat**

Available External Static Pressure (Inches of Water Gauge)																				
CFM	0.10		0.20		0.30		0.40		0.50		0.60		0.70		0.80		0.90		1.00	
	RPM	BHP	RPM	BHP	RPM	BHP	RPM	BHP	RPM	BHP	RPM	BHP	RPM	BHP	RPM	BHP	RPM	BHP	RPM	BHP
6000	825	0.64	865	0.78	905	0.91	948	1.07	987	1.23	1023	1.38	1057	1.53	1089	1.69	1120	1.84	1150	2.00
6400	875	0.76	912	0.90	950	1.05	989	1.21	1029	1.38	1064	1.54	1097	1.70	1128	1.87	1159	2.03	1188	2.20
7200	975	1.04	1009	1.20	1042	1.36	1076	1.53	1110	1.71	1146	1.90	1178	2.09	1209	2.27	1238	2.45	1266	2.64
8000	1076	1.39	1107	1.56	1137	1.74	1167	1.92	1197	2.11	1228	2.31	1260	2.52	1291	2.74	1319	2.94	1346	3.14
8800	1177	1.81	1206	2.00	1234	2.19	1260	2.39	1288	2.59	1315	2.79	1342	3.01	1373	3.25	1402	3.49	1429	3.72
9600	1279	2.31	1306	2.52	1331	2.72	1356	2.94	1381	3.15	1406	3.37	1431	3.59	1455	3.82	1483	4.08	1510	4.34

**Available External Static Pressure (Inches of Water Gauge)**

CFM	1.10		1.20		1.30		1.40		1.50		1.60		1.70		1.80		1.90		2.00	
	RPM	BHP	RPM	BHP	RPM	BHP	RPM	BHP	RPM	BHP	RPM	BHP	RPM	BHP	RPM	BHP	RPM	BHP	RPM	BHP
6000	1179	2.15	1208	2.32	1237	2.48	1266	2.65	1294	2.82	1321	3	1347	3.17	1372	3.35	1397	3.53	1421	3.71
6400	1216	2.36	1244	2.53	1270	2.7	1298	2.87	1326	3.05	1352	3.23	1378	3.41	1403	3.6	1428	3.78	1452	3.97
7200	1293	2.82	1320	3.01	1345	3.19	1370	3.38	1394	3.56	1418	3.75	1443	3.95	1467	4.15	1492	4.35	1515	4.55
8000	1372	3.34	1398	3.55	1423	3.75	1447	3.96	1471	4.17	1494	4.37	1516	4.57	1538	4.78	1560	4.99	1581	5.2
8800	1454	3.94	1479	4.16	1502	4.38	1526	4.6	1549	4.83	1571	5.05	1593	5.28	1615	5.51	1636	5.73	1656	5.96
9600	1537	4.6	1561	4.85	1584	5.09	1607	5.33	1629	5.57	1650	5.81	-	-	-	-	-	-	-	-

**Notes:**

1. Available External Static Pressure is the static pressure difference between the return duct and the supply duct plus the static pressure drop caused by accessories and options.
2. For direct drive evaporator fan speed (rpm), refer to the applicable table in the fan performance section.
3. Data includes pressure drop due to standard filters and wet coils. No accessories or options are included in pressure drop data.
4. To determine static pressure drop due to other options/accessories, refer to the applicable table in the fan performance section.
5. Direct drive fan motor heat is negligible.
6. Factory supplied motors, in commercial equipment, are definite purpose motors, specifically designed and tested to operate reliably and continuously at all cataloged conditions. Using the full horsepower range of our fan motors as shown in our tabular data will not result in nuisance tripping or premature motor failure. Our product's warranty will not be affected.

**Table 132. Evaporator fan performance – 25 ton (model YSK, YHK), downflow, high heat**

Available External Static Pressure (Inches of Water Gauge)																				
CFM	0.10		0.20		0.30		0.40		0.50		0.60		0.70		0.80		0.90		1.00	
	RPM	BHP	RPM	BHP	RPM	BHP	RPM	BHP	RPM	BHP	RPM	BHP	RPM	BHP	RPM	BHP	RPM	BHP	RPM	BHP
7500	1013	1.16	1046	1.33	1077	1.49	1110	1.67	1141	1.84	1176	2.05	1210	2.25	1239	2.44	1268	2.63	1296	2.82
8000	1076	1.39	1107	1.56	1137	1.74	1167	1.92	1197	2.11	1228	2.31	1260	2.52	1291	2.74	1319	2.94	1346	3.14
9000	1203	1.93	1231	2.12	1258	2.32	1284	2.52	1311	2.72	1338	2.93	1364	3.14	1393	3.38	1422	3.63	1450	3.87
10000	1330	2.60	1356	2.81	1381	3.02	1405	3.24	1428	3.47	1453	3.69	1477	3.92	1500	4.16	1524	4.40	1551	4.67
11000	1458	3.41	1482	3.64	1505	3.87	1527	4.11	1549	4.36	1570	4.60	1592	4.85	1614	5.10	1636	5.36	1657	5.62
12000	1587	4.37	1608	4.63	1630	4.88	1650	5.14	1671	5.40	1691	5.67	1710	5.94	-	-	-	-	-	-



## Evaporator Fan Performance — Gas Heat

**Table 132. Evaporator fan performance – 25 ton (model YSK, YHK), downflow, high heat (continued)**

Available External Static Pressure (Inches of Water Gauge)																				
CFM	1.10		1.20		1.30		1.40		1.50		1.60		1.70		1.80		1.90		2.00	
	RPM	BHP	RPM	BHP	RPM	BHP	RPM	BHP	RPM	BHP	RPM	BHP	RPM	BHP	RPM	BHP	RPM	BHP	RPM	BHP
7500	1323	3.01	1349	3.2	1374	3.4	1399	3.59	1423	3.78	1446	3.97	1469	4.17	1492	4.37	1516	4.58	1540	4.78
8000	1372	3.34	1398	3.55	1423	3.75	1447	3.96	1471	4.17	1494	4.37	1516	4.57	1538	4.78	1560	4.99	1581	5.2
9000	1475	4.1	1499	4.32	1523	4.55	1546	4.78	1569	5	1591	5.23	1613	5.47	1634	5.7	1655	5.93	-	-
10000	1577	4.95	1602	5.22	1626	5.48	1648	5.72	1670	5.97	-	-	-	-	-	-	-	-	-	-
11000	1680	5.89	-	-	-	-	-	-	-	-	-	-	-	-	-	-	-	-	-	-
12000	-	-	-	-	-	-	-	-	-	-	-	-	-	-	-	-	-	-	-	-

**Notes:**

1. Available External Static Pressure is the static pressure difference between the return duct and the supply duct plus the static pressure drop caused by accessories and options.
2. For direct drive evaporator fan speed (rpm), refer to the applicable table in the fan performance section.
3. Data includes pressure drop due to standard filters and wet coils. No accessories or options are included in pressure drop data.
4. To determine static pressure drop due to other options/accessories, refer to the applicable table in the fan performance section.
5. Direct drive fan motor heat is negligible.
6. Factory supplied motors, in commercial equipment, are definite purpose motors, specifically designed and tested to operate reliably and continuously at all cataloged conditions. Using the full horsepower range of our fan motors as shown in our tabular data will not result in nuisance tripping or premature motor failure. Our product's warranty will not be affected.

**Table 133. Evaporator fan performance – 25 ton (model YSK, YHK), downflow, high heat, high static motor**

Available External Static Pressure (Inches of Water Gauge)																				
CFM	0.10		0.20		0.30		0.40		0.50		0.60		0.70		0.80		0.90		1.00	
	RPM	BHP	RPM	BHP	RPM	BHP	RPM	BHP	RPM	BHP	RPM	BHP	RPM	BHP	RPM	BHP	RPM	BHP	RPM	BHP
7500	1013	1.16	1046	1.33	1077	1.49	1110	1.67	1141	1.84	1176	2.05	1210	2.25	1239	2.44	1268	2.63	1296	2.82
8000	1076	1.39	1107	1.56	1137	1.74	1167	1.92	1197	2.11	1228	2.31	1260	2.52	1291	2.74	1319	2.94	1346	3.14
9000	1203	1.93	1231	2.12	1258	2.32	1284	2.52	1311	2.72	1338	2.93	1364	3.14	1393	3.38	1422	3.63	1450	3.87
10000	1330	2.60	1356	2.81	1381	3.02	1405	3.24	1428	3.47	1453	3.69	1477	3.92	1500	4.16	1524	4.40	1551	4.67
11000	1458	3.41	1482	3.64	1505	3.87	1527	4.11	1549	4.36	1570	4.60	1592	4.85	1614	5.10	1636	5.36	1657	5.62
12000	1587	4.37	1608	4.63	1630	4.88	1650	5.14	1671	5.40	1691	5.67	1710	5.94	1728	6.04	1748	6.32	1763	6.57

Available External Static Pressure (Inches of Water Gauge)																				
CFM	1.10		1.20		1.30		1.40		1.50		1.60		1.70		1.80		1.90		2.00	
	RPM	BHP	RPM	BHP	RPM	BHP	RPM	BHP	RPM	BHP	RPM	BHP	RPM	BHP	RPM	BHP	RPM	BHP	RPM	BHP
7500	1323	3.01	1349	3.2	1374	3.4	1399	3.59	1423	3.78	1446	3.97	1469	4.17	1492	4.37	1516	4.58	1540	4.78
8000	1372	3.34	1398	3.55	1423	3.75	1447	3.96	1471	4.17	1494	4.37	1516	4.57	1538	4.78	1560	4.99	1581	5.2
9000	1475	4.1	1499	4.32	1523	4.55	1546	4.78	1569	5	1591	5.23	1613	5.47	1634	5.7	1655	5.93	1676	6.16
10000	1577	4.95	1602	5.22	1626	5.48	1648	5.72	1670	5.97	1688	6.09	1710	6.37	1730	6.62	1750	6.87	1770	7.12
11000	1680	5.89	1705	6.12	1729	6.41	1750	6.66	1771	6.94	1785	6.95	1807	7.27	1826	7.54	1845	7.81	1864	8.08
12000	1783	6.83	1808	7.02	1832	7.34	1852	7.6	1872	7.91	1882	7.81	1904	8.17	1922	8.46	-	-	-	-

**Notes:**

1. Available External Static Pressure is the static pressure difference between the return duct and the supply duct plus the static pressure drop caused by accessories and options.
2. For direct drive evaporator fan speed (rpm), refer to the applicable table in the fan performance section.
3. Data includes pressure drop due to standard filters and wet coils. No accessories or options are included in pressure drop data.
4. To determine static pressure drop due to other options/accessories, refer to the applicable table in the fan performance section.
5. Direct drive fan motor heat is negligible.
6. Factory supplied motors, in commercial equipment, are definite purpose motors, specifically designed and tested to operate reliably and continuously at all cataloged conditions. Using the full horsepower range of our fan motors as shown in our tabular data will not result in nuisance tripping or premature motor failure. Our product's warranty will not be affected.

## 6 to 25 Tons — Horizontal

**Table 134. Evaporator fan performance – 6 ton (model YSK, YHK), horizontal, high heat**

Available External Static Pressure (Inches of Water Gauge)																				
CFM	0.10		0.20		0.30		0.40		0.50		0.60		0.70		0.80		0.90		1.00	
	RPM	BHP	RPM	BHP	RPM	BHP	RPM	BHP	RPM	BHP	RPM	BHP	RPM	BHP	RPM	BHP	RPM	BHP	RPM	BHP
1800	631	0.17	684	0.22	732	0.27	777	0.32	819	0.37	859	0.43	896	0.48	932	0.54	968	0.60	1002	0.67
1920	665	0.20	716	0.25	763	0.30	806	0.36	847	0.41	886	0.47	923	0.53	957	0.59	991	0.65	1024	0.72
2040	700	0.23	749	0.28	794	0.34	836	0.40	875	0.46	913	0.52	949	0.58	983	0.64	1016	0.71	1047	0.77
2160	736	0.27	782	0.32	825	0.38	866	0.44	904	0.50	941	0.57	976	0.63	1010	0.70	1042	0.77	1073	0.83
2280	771	0.31	816	0.37	858	0.43	897	0.49	934	0.55	970	0.62	1004	0.69	1037	0.76	1069	0.83	1099	0.90
2400	807	0.35	850	0.41	890	0.48	928	0.54	964	0.61	999	0.68	1033	0.75	1065	0.82	1096	0.89	1126	0.97
2520	843	0.40	885	0.46	923	0.53	960	0.60	995	0.67	1029	0.74	1061	0.81	1093	0.89	1123	0.96	1153	1.04
2640	879	0.45	919	0.52	957	0.59	992	0.66	1026	0.73	1059	0.81	1091	0.88	1122	0.96	1152	1.04	1180	1.12
2760	915	0.51	954	0.58	990	0.65	1025	0.73	1058	0.80	1090	0.88	1121	0.96	1150	1.04	1180	1.12	1208	1.20
2880	951	0.57	989	0.65	1024	0.72	1058	0.80	1090	0.88	1121	0.96	1151	1.04	1180	1.12	1209	1.20	1237	1.29
Available External Static Pressure (Inches of Water Gauge)																				
CFM	1.10		1.20		1.30		1.40		1.50		1.60		1.70		1.80		1.90		2.00	
	RPM	BHP	RPM	BHP	RPM	BHP	RPM	BHP	RPM	BHP	RPM	BHP	RPM	BHP	RPM	BHP	RPM	BHP	RPM	BHP
1800	1034	0.73	1066	0.79	1096	0.86	1126	0.93	1156	1	1185	1.07	1213	1.15	1241	1.22	1267	1.3	1293	1.38
1920	1057	0.78	1088	0.85	1118	0.92	1147	0.99	1175	1.06	1203	1.13	1231	1.21	1258	1.29	1285	1.36	1311	1.44
2040	1079	0.84	1110	0.91	1140	0.98	1169	1.05	1197	1.13	1224	1.2	1250	1.27	1276	1.35	1303	1.43	1329	1.52
2160	1103	0.9	1133	0.97	1162	1.05	1191	1.12	1219	1.2	1246	1.27	1272	1.35	1297	1.43	1322	1.51	1347	1.59
2280	1129	0.97	1157	1.04	1185	1.11	1214	1.19	1241	1.27	1268	1.35	1294	1.43	1319	1.51	1344	1.59	1368	1.68
2400	1155	1.04	1183	1.12	1210	1.19	1236	1.27	1264	1.35	1290	1.43	1316	1.51	1341	1.6	1366	1.68	1390	1.77
2520	1182	1.12	1209	1.2	1236	1.27	1262	1.35	1287	1.43	1313	1.52	1339	1.6	1364	1.69	1388	1.77	1412	1.86
2640	1209	1.2	1236	1.28	1262	1.36	1288	1.44	1313	1.52	1337	1.61	1362	1.69	1386	1.78	1411	1.87	1434	1.96
2760	1236	1.28	1263	1.37	1289	1.45	1315	1.54	1339	1.62	1363	1.71	1387	1.79	1410	1.88	1434	1.97	1457	2.07
2880	1264	1.37	1290	1.46	1316	1.55	1341	1.64	1366	1.73	1390	1.81	1413	1.9	1436	1.99	1458	2.08	1480	2.17

**Notes:**

1. Available External Static Pressure is the static pressure difference between the return duct and the supply duct plus the static pressure drop caused by accessories and options.
2. For direct drive evaporator fan speed (rpm), refer to the applicable table in the fan performance section.
3. Data includes pressure drop due to standard filters and wet coils. No accessories or options are included in pressure drop data.
4. To determine static pressure drop due to other options/accessories, refer to the applicable table in the fan performance section.
5. Direct drive fan motor heat is negligible.
6. Factory supplied motors, in commercial equipment, are definite purpose motors, specifically designed and tested to operate reliably and continuously at all cataloged conditions. Using the full horsepower range of our fan motors as shown in our tabular data will not result in nuisance tripping or premature motor failure. Our product's warranty will not be affected.

**Table 135. Evaporator fan performance – 7.5 ton (model YSK, YHK), horizontal, high heat**

Available External Static Pressure (Inches of Water Gauge)																				
CFM	0.10		0.20		0.30		0.40		0.50		0.60		0.70		0.80		0.90		1.00	
	RPM	BHP	RPM	BHP	RPM	BHP	RPM	BHP	RPM	BHP	RPM	BHP	RPM	BHP	RPM	BHP	RPM	BHP	RPM	BHP
2250	707	0.23	748	0.28	790	0.34	831	0.39	870	0.45	906	0.51	941	0.57	973	0.63	1007	0.70	1039	0.76
2400	748	0.27	788	0.33	826	0.38	865	0.44	903	0.51	939	0.57	973	0.63	1005	0.70	1035	0.76	1066	0.83
2550	790	0.32	828	0.38	863	0.44	900	0.50	937	0.56	972	0.63	1005	0.70	1036	0.77	1066	0.83	1095	0.90
2700	832	0.37	868	0.43	901	0.49	936	0.56	971	0.63	1005	0.70	1038	0.77	1069	0.84	1098	0.91	1127	0.98
2850	874	0.43	909	0.49	941	0.56	973	0.63	1006	0.70	1039	0.77	1071	0.84	1102	0.92	1131	0.99	1158	1.07
3000	916	0.49	950	0.56	981	0.63	1010	0.70	1042	0.77	1073	0.85	1105	0.92	1135	1.00	1163	1.08	1191	1.16
3150	959	0.56	991	0.63	1021	0.71	1049	0.78	1079	0.85	1109	0.93	1139	1.01	1168	1.09	1197	1.18	1224	1.26
3300	1001	0.64	1032	0.72	1061	0.79	1089	0.87	1116	0.94	1145	1.02	1173	1.11	1202	1.19	1230	1.28	1257	1.36
3600	1086	0.81	1116	0.90	1143	0.98	1169	1.06	1194	1.14	1219	1.23	1246	1.32	1271	1.41	1297	1.50	1324	1.59



## Evaporator Fan Performance — Gas Heat

**Table 135. Evaporator fan performance – 7.5 ton (model YSK, YHK), horizontal, high heat (continued)**

Available External Static Pressure (Inches of Water Gauge)																				
CFM	1.10		1.20		1.30		1.40		1.50		1.60		1.70		1.80		1.90		2.00	
	RPM	BHP	RPM	BHP	RPM	BHP	RPM	BHP	RPM	BHP	RPM	BHP	RPM	BHP	RPM	BHP	RPM	BHP	RPM	BHP
2250	1069	0.83	1100	0.9	1130	0.97	1159	1.04	1187	1.12	1214	1.19	1241	1.26	1267	1.34	1292	1.42	1318	1.5
2400	1097	0.9	1126	0.97	1155	1.04	1184	1.12	1211	1.2	1238	1.27	1265	1.35	1290	1.43	1315	1.51	1339	1.59
2550	1124	0.97	1153	1.05	1181	1.12	1208	1.2	1236	1.28	1263	1.36	1289	1.44	1314	1.52	1339	1.6	1363	1.69
2700	1154	1.06	1181	1.13	1209	1.21	1236	1.29	1262	1.37	1287	1.45	1313	1.53	1339	1.62	1363	1.7	1387	1.79
2850	1186	1.15	1212	1.22	1237	1.3	1264	1.38	1289	1.47	1314	1.55	1339	1.63	1363	1.72	1388	1.81	1412	1.9
3000	1217	1.24	1243	1.32	1268	1.4	1292	1.48	1317	1.57	1342	1.66	1366	1.74	1390	1.83	1413	1.92	1436	2.01
3150	1250	1.34	1275	1.43	1300	1.51	1324	1.59	1347	1.68	1370	1.77	1394	1.86	1418	1.95	1440	2.04	1463	2.13
3300	1283	1.45	1307	1.54	1332	1.63	1355	1.71	1378	1.8	1401	1.89	1423	1.98	1446	2.07	1468	2.17	1490	2.26
3600	1349	1.69	1373	1.78	1397	1.87	1420	1.97	1442	2.06	1464	2.16	1486	2.26	1507	2.35	1528	2.45	1548	2.55

**Notes:**

1. Available External Static Pressure is the static pressure difference between the return duct and the supply duct plus the static pressure drop caused by accessories and options.
2. For direct drive evaporator fan speed (rpm), refer to the applicable table in the fan performance section.
3. Data includes pressure drop due to standard filters and wet coils. No accessories or options are included in pressure drop data.
4. To determine static pressure drop due to other options/accessories, refer to the applicable table in the fan performance section.
5. Direct drive fan motor heat is negligible.
6. Factory supplied motors, in commercial equipment, are definite purpose motors, specifically designed and tested to operate reliably and continuously at all cataloged conditions. Using the full horsepower range of our fan motors as shown in our tabular data will not result in nuisance tripping or premature motor failure. Our product's warranty will not be affected.

**Table 136. Evaporator fan performance – 8.5 ton (model YSK, YHK), horizontal, high heat**

Available External Static Pressure (Inches of Water Gauge)																				
CFM	0.10		0.20		0.30		0.40		0.50		0.60		0.70		0.80		0.90		1.00	
	RPM	BHP	RPM	BHP	RPM	BHP	RPM	BHP	RPM	BHP	RPM	BHP	RPM	BHP	RPM	BHP	RPM	BHP	RPM	BHP
2550	790	0.32	828	0.38	863	0.44	900	0.50	937	0.56	972	0.63	1005	0.70	1036	0.77	1066	0.83	1095	0.90
2720	838	0.38	873	0.44	907	0.50	941	0.57	975	0.64	1010	0.71	1042	0.78	1073	0.85	1103	0.92	1131	0.99
2890	885	0.45	920	0.51	951	0.58	983	0.65	1016	0.72	1048	0.79	1080	0.87	1110	0.94	1139	1.02	1167	1.09
3060	933	0.52	966	0.59	997	0.66	1026	0.73	1057	0.80	1087	0.88	1118	0.96	1148	1.04	1177	1.12	1204	1.20
3230	982	0.60	1013	0.68	1042	0.75	1070	0.82	1099	0.90	1128	0.98	1157	1.06	1186	1.14	1214	1.23	1241	1.31
3400	1029	0.70	1060	0.77	1088	0.85	1115	0.93	1141	1.01	1170	1.09	1197	1.17	1225	1.26	1252	1.35	1279	1.44
3570	1077	0.80	1107	0.88	1134	0.96	1161	1.04	1186	1.12	1211	1.21	1238	1.29	1264	1.38	1291	1.47	1317	1.57
3740	1126	0.91	1155	0.99	1181	1.08	1206	1.16	1231	1.25	1254	1.34	1280	1.43	1305	1.52	1330	1.61	1355	1.71
4080	1222	1.16	1250	1.25	1275	1.35	1298	1.44	1321	1.53	1344	1.63	1365	1.72	1388	1.82	1412	1.92	1435	2.02
Available External Static Pressure (Inches of Water Gauge)																				
CFM	1.10		1.20		1.30		1.40		1.50		1.60		1.70		1.80		1.90		2.00	
	RPM	BHP	RPM	BHP	RPM	BHP	RPM	BHP	RPM	BHP	RPM	BHP	RPM	BHP	RPM	BHP	RPM	BHP	RPM	BHP
2550	1124	0.97	1153	1.05	1181	1.12	1208	1.20	1236	1.28	1263	1.36	1289	1.44	1314	1.52	1339	1.60	1363	1.69
2720	1158	1.07	1185	1.14	1213	1.22	1239	1.30	1265	1.38	1291	1.46	1317	1.55	1342	1.63	1366	1.72	1391	1.80
2890	1194	1.17	1220	1.25	1245	1.33	1271	1.41	1297	1.49	1322	1.58	1346	1.66	1370	1.75	1394	1.84	1418	1.93
3060	1230	1.28	1256	1.36	1281	1.44	1305	1.53	1329	1.61	1353	1.70	1377	1.79	1401	1.88	1424	1.97	1446	2.06
3230	1267	1.40	1292	1.48	1317	1.57	1341	1.66	1364	1.74	1386	1.83	1409	1.92	1432	2.01	1455	2.11	1478	2.20
3400	1305	1.53	1329	1.62	1353	1.70	1377	1.80	1400	1.89	1422	1.98	1444	2.07	1465	2.16	1487	2.26	1509	2.35
3570	1342	1.66	1367	1.75	1390	1.85	1413	1.94	1436	2.04	1458	2.13	1479	2.23	1501	2.32	1521	2.42	1542	2.52
3740	1380	1.80	1404	1.90	1428	2.00	1451	2.10	1473	2.20	1494	2.30	1516	2.40	1536	2.50	1557	2.60	1577	2.70

**Table 136. Evaporator fan performance – 8.5 ton (model YSK, YHK), horizontal, high heat (continued)**

Available External Static Pressure (Inches of Water Gauge)																				
CFM	1.10		1.20		1.30		1.40		1.50		1.60		1.70		1.80		1.90		2.00	
	RPM	BHP	RPM	BHP	RPM	BHP	RPM	BHP	RPM	BHP	RPM	BHP	RPM	BHP	RPM	BHP	RPM	BHP	RPM	BHP
4080	1457	2.12	1481	2.23	1504	2.33	1526	2.44	1548	2.55	1569	2.65	1589	2.76	1610	2.87	1629	2.98	-	-

**Notes:**

1. Available External Static Pressure is the static pressure difference between the return duct and the supply duct plus the static pressure drop caused by accessories and options.
2. For direct drive evaporator fan speed (rpm), refer to the applicable table in the fan performance section.
3. Data includes pressure drop due to standard filters and wet coils. No accessories or options are included in pressure drop data.
4. To determine static pressure drop due to other options/accessories, refer to the applicable table in the fan performance section.
5. Direct drive fan motor heat is negligible.
6. Factory supplied motors, in commercial equipment, are definite purpose motors, specifically designed and tested to operate reliably and continuously at all cataloged conditions. Using the full horsepower range of our fan motors as shown in our tabular data will not result in nuisance tripping or premature motor failure. Our product's warranty will not be affected.

**Table 137. Evaporator fan performance – 10 ton (model YSK, YHK), horizontal, high heat**

Available External Static Pressure (Inches of Water Gauge)																				
CFM	0.10		0.20		0.30		0.40		0.50		0.60		0.70		0.80		0.90		1.00	
	RPM	BHP	RPM	BHP	RPM	BHP	RPM	BHP	RPM	BHP	RPM	BHP	RPM	BHP	RPM	BHP	RPM	BHP	RPM	BHP
3000	916	0.49	950	0.56	981	0.63	1010	0.70	1042	0.77	1073	0.85	1105	0.92	1135	1.00	1163	1.08	1191	1.16
3200	973	0.59	1005	0.66	1034	0.73	1062	0.81	1091	0.88	1121	0.96	1150	1.04	1179	1.13	1208	1.21	1235	1.29
3400	1029	0.70	1060	0.77	1088	0.85	1115	0.93	1141	1.01	1170	1.09	1197	1.17	1225	1.26	1252	1.35	1279	1.44
3600	1086	0.81	1116	0.90	1143	0.98	1169	1.06	1194	1.14	1219	1.23	1246	1.32	1271	1.41	1297	1.50	1324	1.59
3800	1143	0.95	1171	1.04	1197	1.12	1222	1.21	1247	1.30	1270	1.38	1295	1.47	1320	1.57	1344	1.66	1369	1.76
4000	1199	1.09	1228	1.19	1253	1.28	1277	1.37	1300	1.46	1322	1.55	1344	1.65	1369	1.74	1392	1.84	1415	1.94
4200	1256	1.25	1284	1.36	1308	1.45	1331	1.55	1354	1.64	1375	1.74	1397	1.84	1418	1.93	1441	2.04	1464	2.14
4400	1314	1.43	1341	1.54	1364	1.64	1386	1.74	1408	1.84	1429	1.94	1449	2.04	1469	2.14	1490	2.25	1512	2.35
4600	1371	1.63	1397	1.74	1420	1.84	1441	1.95	1462	2.05	1483	2.16	1503	2.26	1522	2.37	1541	2.48	1562	2.59
4800	1428	1.84	1454	1.96	1476	2.07	1497	2.18	1517	2.28	1537	2.39	1556	2.50	1575	2.61	1594	2.72	1612	2.84

Available External Static Pressure (Inches of Water Gauge)																				
CFM	1.10		1.20		1.30		1.40		1.50		1.60		1.70		1.80		1.90		2.00	
	RPM	BHP	RPM	BHP	RPM	BHP	RPM	BHP	RPM	BHP	RPM	BHP	RPM	BHP	RPM	BHP	RPM	BHP	RPM	BHP
3000	1217	1.24	1243	1.32	1268	1.40	1292	1.48	1317	1.57	1342	1.66	1366	1.74	1390	1.83	1413	1.92	1436	2.01
3200	1261	1.38	1286	1.46	1310	1.55	1334	1.63	1358	1.72	1380	1.81	1404	1.90	1427	1.99	1450	2.08	1472	2.18
3400	1305	1.53	1329	1.62	1353	1.70	1377	1.80	1400	1.89	1422	1.98	1444	2.07	1465	2.16	1487	2.26	1509	2.35
3600	1349	1.69	1373	1.78	1397	1.87	1420	1.97	1442	2.06	1464	2.16	1486	2.26	1507	2.35	1528	2.45	1548	2.55
3800	1394	1.86	1418	1.96	1441	2.06	1464	2.16	1486	2.26	1507	2.36	1529	2.46	1549	2.56	1570	2.66	1590	2.76
4000	1439	2.04	1463	2.15	1486	2.25	1508	2.36	1530	2.46	1551	2.57	1572	2.67	1592	2.78	1612	2.88	1632	2.99
4200	1486	2.24	1508	2.35	1531	2.46	1553	2.57	1574	2.68	1596	2.79	1616	2.90	1636	3.01	-	-	-	-
4400	1534	2.46	1555	2.57	1576	2.68	1598	2.80	1619	2.91	1640	3.03	-	-	-	-	-	-	-	-
4600	1583	2.70	1603	2.81	1623	2.92	1643	3.04	-	-	-	-	-	-	-	-	-	-	-	-
4800	1632	2.95	-	-	-	-	-	-	-	-	-	-	-	-	-	-	-	-	-	-

**Notes:**

1. Available External Static Pressure is the static pressure difference between the return duct and the supply duct plus the static pressure drop caused by accessories and options.
2. For direct drive evaporator fan speed (rpm), refer to the applicable table in the fan performance section.
3. Data includes pressure drop due to standard filters and wet coils. No accessories or options are included in pressure drop data.
4. To determine static pressure drop due to other options/accessories, refer to the applicable table in the fan performance section.
5. Direct drive fan motor heat is negligible.
6. Factory supplied motors, in commercial equipment, are definite purpose motors, specifically designed and tested to operate reliably and continuously at all cataloged conditions. Using the full horsepower range of our fan motors as shown in our tabular data will not result in nuisance tripping or premature motor failure. Our product's warranty will not be affected.



## Evaporator Fan Performance — Gas Heat

**Table 138. Evaporator fan performance – 10 ton (model YSK, YHK), horizontal, high heat, high static motor**

Available External Static Pressure (Inches of Water Gauge)																				
CFM	0.10		0.20		0.30		0.40		0.50		0.60		0.70		0.80		0.90		1.00	
	RPM	BHP	RPM	BHP	RPM	BHP	RPM	BHP	RPM	BHP	RPM	BHP	RPM	BHP	RPM	BHP	RPM	BHP	RPM	BHP
3000	920	0.49	958	0.57	993	0.64	1028	0.72	1061	0.80	1093	0.87	1123	0.95	1152	1.03	1181	1.12	1208	1.20
3200	976	0.59	1012	0.66	1046	0.74	1078	0.83	1110	0.91	1141	0.99	1171	1.08	1199	1.16	1227	1.25	1253	1.34
3400	1032	0.69	1067	0.78	1099	0.86	1130	0.94	1160	1.03	1190	1.12	1219	1.21	1247	1.30	1273	1.39	1299	1.48
3600	1089	0.81	1122	0.90	1153	0.99	1182	1.08	1211	1.17	1240	1.26	1268	1.36	1295	1.45	1321	1.55	1346	1.64
3800	1146	0.94	1177	1.04	1207	1.13	1235	1.22	1263	1.32	1290	1.42	1317	1.52	1344	1.62	1369	1.72	1393	1.82
4000	1202	1.09	1233	1.19	1261	1.28	1289	1.38	1315	1.48	1341	1.59	1367	1.69	1393	1.79	1418	1.90	1442	2.00
4200	1259	1.25	1289	1.35	1316	1.46	1343	1.56	1368	1.66	1393	1.77	1417	1.88	1442	1.99	1467	2.10	1490	2.21
4400	1316	1.42	1345	1.53	1371	1.64	1397	1.75	1422	1.86	1446	1.97	1469	2.08	1493	2.19	1516	2.31	1539	2.43
4600	1373	1.61	1401	1.73	1427	1.84	1451	1.96	1475	2.07	1499	2.19	1521	2.30	1543	2.42	1566	2.54	1589	2.66
4800	1431	1.82	1458	1.95	1482	2.06	1506	2.18	1529	2.30	1552	2.42	1574	2.54	1595	2.66	1617	2.78	1639	2.91
Available External Static Pressure (Inches of Water Gauge)																				
CFM	1.10		1.20		1.30		1.40		1.50		1.60		1.70		1.80		1.90		2.00	
	RPM	BHP	RPM	BHP	RPM	BHP	RPM	BHP	RPM	BHP	RPM	BHP	RPM	BHP	RPM	BHP	RPM	BHP	RPM	BHP
3000	1237	1.29	1265	1.38	1292	1.47	1319	1.56	1345	1.66	1371	1.75	1396	1.85	1421	1.95	1445	2.05	1468	2.14
3200	1279	1.42	1305	1.52	1332	1.61	1358	1.71	1383	1.81	1408	1.9	1433	2	1457	2.11	1481	2.21	1504	2.31
3400	1325	1.57	1349	1.67	1373	1.76	1398	1.86	1423	1.97	1448	2.07	1472	2.17	1495	2.28	1518	2.38	1541	2.49
3600	1370	1.74	1395	1.84	1418	1.94	1441	2.04	1464	2.14	1488	2.24	1511	2.35	1534	2.46	1557	2.57	1579	2.68
3800	1417	1.92	1440	2.02	1464	2.12	1486	2.22	1508	2.33	1530	2.44	1552	2.55	1574	2.66	1597	2.77	1618	2.89
4000	1465	2.11	1488	2.21	1510	2.32	1532	2.43	1553	2.54	1575	2.65	1595	2.76	1616	2.87	1637	2.99	1658	3.11
4200	1513	2.32	1535	2.43	1557	2.54	1578	2.65	1599	2.76	1620	2.88	1641	2.99	1661	3.11	1680	3.23	1700	3.34
4400	1562	2.54	1584	2.66	1605	2.77	1626	2.89	1646	3	1666	3.12	1686	3.24	1706	3.36	1725	3.48	1744	3.6
4600	1611	2.78	1632	2.9	1653	3.02	1674	3.14	1694	3.26	1713	3.38	1733	3.5	1752	3.63	1771	3.75	1790	3.88
4800	1660	3.04	1681	3.16	1702	3.29	1722	3.41	1742	3.54	1761	3.66	1780	3.79	1799	3.92	1817	4.04	1835	4.17

**Notes:**

1. Available External Static Pressure is the static pressure difference between the return duct and the supply duct plus the static pressure drop caused by accessories and options.
2. For direct drive evaporator fan speed (rpm), refer to the applicable table in the fan performance section.
3. Data includes pressure drop due to standard filters and wet coils. No accessories or options are included in pressure drop data.
4. To determine static pressure drop due to other options/accessories, refer to the applicable table in the fan performance section.
5. Direct drive fan motor heat is negligible.
6. Factory supplied motors, in commercial equipment, are definite purpose motors, specifically designed and tested to operate reliably and continuously at all cataloged conditions. Using the full horsepower range of our fan motors as shown in our tabular data will not result in nuisance tripping or premature motor failure. Our product's warranty will not be affected.

**Table 139. Evaporator fan performance – 12.5 ton (model YSK), horizontal, high heat, high heat**

Available External Static Pressure (Inches of Water Gauge)																				
CFM	0.10		0.20		0.30		0.40		0.50		0.60		0.70		0.80		0.90		1.00	
	RPM	BHP	RPM	BHP	RPM	BHP	RPM	BHP	RPM	BHP	RPM	BHP	RPM	BHP	RPM	BHP	RPM	BHP	RPM	BHP
3750	1091	0.77	1126	0.87	1159	0.96	1191	1.05	1220	1.14	1249	1.24	1276	1.33	1302	1.42	1328	1.52	1354	1.61
4000	1159	0.93	1192	1.02	1224	1.12	1254	1.22	1283	1.32	1310	1.42	1336	1.52	1362	1.62	1387	1.72	1411	1.82
4250	1227	1.10	1259	1.20	1289	1.31	1318	1.41	1346	1.52	1372	1.62	1398	1.73	1422	1.83	1446	1.94	1470	2.04
4500	1295	1.29	1326	1.40	1355	1.51	1382	1.62	1409	1.73	1435	1.84	1460	1.95	1483	2.07	1507	2.18	1529	2.29
4750	1363	1.50	1393	1.62	1421	1.74	1447	1.85	1473	1.97	1498	2.09	1522	2.21	1545	2.32	1568	2.44	1590	2.56
5000	1431	1.74	1460	1.86	1487	1.98	1513	2.11	1537	2.23	1562	2.35	1585	2.48	1608	2.60	1630	2.73	1651	2.85
5250	1500	1.99	1528	2.13	1554	2.26	1578	2.39	1602	2.51	1626	2.64	1648	2.77	1671	2.91	1692	3.04	1713	3.17
5500	1568	2.28	1596	2.42	1621	2.56	1644	2.69	1668	2.83	1690	2.96	1712	3.10	1734	3.23	1755	3.37	1775	3.51
5750	1637	2.59	1664	2.74	1688	2.88	1711	3.02	1733	3.16	1755	3.30	1776	3.45	1797	3.59	1818	3.73	1838	3.88
6000	1706	2.93	1732	3.09	1755	3.24	1777	3.38	1799	3.53	1820	3.68	1841	3.82	1861	3.97	1881	4.12	1901	4.27

**Table 139. Evaporator fan performance – 12.5 ton (model YSK), horizontal, high heat, high heat (continued)**

Available External Static Pressure (Inches of Water Gauge)																				
CFM	1.10		1.20		1.30		1.40		1.50		1.60		1.70		1.80		1.90		2.00	
	RPM	BHP	RPM	BHP	RPM	BHP	RPM	BHP	RPM	BHP	RPM	BHP	RPM	BHP	RPM	BHP	RPM	BHP	RPM	BHP
3750	1380	1.72	1405	1.82	1430	1.92	1455	2.03	1480	2.13	1504	2.24	1527	2.34	1550	2.45	1572	2.56	1593	2.67
4000	1435	1.92	1459	2.03	1484	2.13	1507	2.24	1530	2.35	1554	2.47	1577	2.58	1599	2.69	1622	2.81	1643	2.92
4250	1492	2.15	1515	2.26	1538	2.37	1561	2.48	1584	2.6	1606	2.71	1627	2.83	1650	2.95	1671	3.07	1693	3.19
4500	1551	2.4	1573	2.51	1594	2.63	1616	2.74	1638	2.86	1659	2.98	1681	3.11	1701	3.23	1722	3.35	1743	3.48
4750	1611	2.68	1632	2.79	1653	2.91	1673	3.03	1693	3.15	1714	3.28	1735	3.4	1755	3.53	1775	3.66	1795	3.79
5000	1672	2.98	1692	3.1	1712	3.22	1732	3.35	1751	3.47	1770	3.6	1789	3.72	1809	3.86	1829	3.99	1848	4.13
5250	1733	3.3	1753	3.43	1772	3.56	1792	3.69	1811	3.82	1829	3.95	1847	4.08	1865	4.21	1884	4.35	1903	4.49
5500	1795	3.64	1814	3.78	1833	3.92	1852	4.06	1870	4.19	1888	4.33	1906	4.46	1924	4.6	-	-	-	-
5750	1857	4.02	1876	4.16	1894	4.3	1913	4.45	1930	4.59	-	-	-	-	-	-	-	-	-	-
6000	1920	4.42	1938	4.57	-	-	-	-	-	-	-	-	-	-	-	-	-	-	-	-

**Notes:**

1. Available External Static Pressure is the static pressure difference between the return duct and the supply duct plus the static pressure drop caused by accessories and options.
2. For direct drive evaporator fan speed (rpm), refer to the applicable table in the fan performance section.
3. Data includes pressure drop due to standard filters and wet coils. No accessories or options are included in pressure drop data.
4. To determine static pressure drop due to other options/accessories, refer to the applicable table in the fan performance section.
5. Direct drive fan motor heat is negligible.
6. Factory supplied motors, in commercial equipment, are definite purpose motors, specifically designed and tested to operate reliably and continuously at all cataloged conditions. Using the full horsepower range of our fan motors as shown in our tabular data will not result in nuisance tripping or premature motor failure. Our product's warranty will not be affected.

**Table 140. Evaporator fan performance – 12.5 ton (model YHK), horizontal, high heat**

Available External Static Pressure (Inches of Water Gauge)																				
CFM	0.10		0.20		0.30		0.40		0.50		0.60		0.70		0.80		0.90		1.00	
	RPM	BHP	RPM	BHP	RPM	BHP	RPM	BHP	RPM	BHP	RPM	BHP	RPM	BHP	RPM	BHP	RPM	BHP	RPM	BHP
3750	552	0.20	608	0.28	659	0.37	708	0.46	754	0.56	797	0.66	839	0.76	879	0.87	917	0.98	954	1.10
4000	584	0.23	638	0.32	687	0.41	733	0.51	777	0.61	819	0.71	860	0.82	898	0.93	936	1.05	972	1.17
4500	647	0.32	697	0.41	742	0.51	784	0.62	825	0.73	864	0.84	902	0.95	939	1.07	975	1.20	1009	1.32
5000	713	0.42	760	0.53	802	0.64	841	0.75	879	0.87	915	0.99	951	1.12	985	1.24	1019	1.37	1052	1.51
5500	781	0.55	824	0.67	863	0.79	900	0.92	935	1.04	969	1.17	1003	1.30	1035	1.44	1067	1.58	1098	1.72
6000	849	0.71	890	0.84	926	0.97	961	1.10	994	1.24	1026	1.38	1057	1.52	1087	1.66	1117	1.81	1147	1.96

Available External Static Pressure (Inches of Water Gauge)																				
CFM	1.10		1.20		1.30		1.40		1.50		1.60		1.70		1.80		1.90		2.00	
	RPM	BHP	RPM	BHP	RPM	BHP	RPM	BHP	RPM	BHP	RPM	BHP	RPM	BHP	RPM	BHP	RPM	BHP	RPM	BHP
3750	989	1.21	1023	1.33	1056	1.46	1088	1.58	1119	1.71	1149	1.84	1179	1.97	1207	2.11	1235	2.24	1262	2.38
4000	1007	1.29	1040	1.41	1073	1.54	1104	1.67	1135	1.8	1165	1.94	1193	2.07	1222	2.21	1249	2.35	1276	2.49
4500	1043	1.45	1075	1.59	1107	1.72	1137	1.86	1167	2	1196	2.14	1224	2.28	1252	2.43	1279	2.58	1306	2.73
5000	1084	1.65	1115	1.79	1145	1.93	1175	2.07	1204	2.22	1232	2.37	1260	2.53	1287	2.68	1313	2.84	1339	3
5500	1128	1.86	1158	2.01	1187	2.16	1215	2.32	1243	2.47	1271	2.63	1297	2.79	1324	2.95	1349	3.12	1375	3.29
6000	1176	2.11	1204	2.27	1232	2.42	1259	2.59	1286	2.75	1312	2.92	1338	3.09	1363	3.26	1388	3.43	1413	3.61

**Notes:**

1. Available External Static Pressure is the static pressure difference between the return duct and the supply duct plus the static pressure drop caused by accessories and options.
2. For direct drive evaporator fan speed (rpm), refer to the applicable table in the fan performance section.
3. Data includes pressure drop due to standard filters and wet coils. No accessories or options are included in pressure drop data.
4. To determine static pressure drop due to other options/accessories, refer to the applicable table in the fan performance section.
5. Direct drive fan motor heat is negligible.
6. Factory supplied motors, in commercial equipment, are definite purpose motors, specifically designed and tested to operate reliably and continuously at all cataloged conditions. Using the full horsepower range of our fan motors as shown in our tabular data will not result in nuisance tripping or premature motor failure. Our product's warranty will not be affected.



## Evaporator Fan Performance — Gas Heat

**Table 141. Evaporator fan performance – 15 ton (model YSK, YHK), horizontal, high heat**

Available External Static Pressure (Inches of Water Gauge)																				
CFM	0.10		0.20		0.30		0.40		0.50		0.60		0.70		0.80		0.90		1.00	
	RPM	BHP	RPM	BHP	RPM	BHP	RPM	BHP	RPM	BHP	RPM	BHP	RPM	BHP	RPM	BHP	RPM	BHP	RPM	BHP
4500	688	0.39	737	0.50	782	0.61	823	0.72	864	0.84	903	0.96	941	1.08	978	1.21	1013	1.34	1047	1.47
4800	727	0.46	774	0.58	817	0.69	857	0.81	895	0.93	933	1.06	970	1.19	1005	1.32	1039	1.46	1073	1.59
5400	805	0.62	849	0.76	890	0.89	927	1.02	962	1.15	995	1.28	1030	1.43	1063	1.57	1096	1.71	1127	1.86
6000	885	0.82	926	0.97	963	1.11	999	1.26	1032	1.40	1064	1.55	1094	1.70	1125	1.85	1155	2.01	1185	2.17
6600	965	1.06	1003	1.22	1039	1.38	1072	1.54	1103	1.70	1134	1.86	1163	2.02	1190	2.18	1217	2.35	1246	2.52
7200	1047	1.35	1082	1.52	1115	1.69	1146	1.87	1176	2.04	1205	2.21	1233	2.39	1260	2.56	1286	2.74	1311	2.92
Available External Static Pressure (Inches of Water Gauge)																				
CFM	1.10		1.20		1.30		1.40		1.50		1.60		1.70		1.80		1.90		2.00	
	RPM	BHP	RPM	BHP	RPM	BHP	RPM	BHP	RPM	BHP	RPM	BHP	RPM	BHP	RPM	BHP	RPM	BHP	RPM	BHP
4500	1080	1.61	1111	1.74	1142	1.88	1171	2.02	1200	2.17	1228	2.31	1255	2.46	1282	2.62	1307	2.77	1333	2.93
4800	1105	1.73	1136	1.87	1166	2.02	1195	2.16	1224	2.31	1251	2.46	1278	2.62	1304	2.78	1330	2.94	1355	3.1
5400	1158	2.01	1188	2.17	1217	2.32	1246	2.48	1273	2.64	1300	2.8	1326	2.96	1352	3.13	1377	3.29	1401	3.46
6000	1214	2.33	1243	2.5	1271	2.66	1297	2.83	1325	3	1351	3.18	1377	3.35	1402	3.53	1427	3.71	1451	3.89
6600	1274	2.7	1301	2.87	1327	3.05	1354	3.23	1379	3.41	1404	3.6	1429	3.78	1453	3.97	1478	4.16	1501	4.35
7200	1336	3.11	1362	3.29	1388	3.48	1412	3.68	1437	3.87	1461	4.06	1485	4.26	1508	4.46	1531	4.66	1553	4.86

**Notes:**

1. Available External Static Pressure is the static pressure difference between the return duct and the supply duct plus the static pressure drop caused by accessories and options.
2. For direct drive evaporator fan speed (rpm), refer to the applicable table in the fan performance section.
3. Data includes pressure drop due to standard filters and wet coils. No accessories or options are included in pressure drop data.
4. To determine static pressure drop due to other options/accessories, refer to the applicable table in the fan performance section.
5. Direct drive fan motor heat is negligible.
6. Factory supplied motors, in commercial equipment, are definite purpose motors, specifically designed and tested to operate reliably and continuously at all cataloged conditions. Using the full horsepower range of our fan motors as shown in our tabular data will not result in nuisance tripping or premature motor failure. Our product's warranty will not be affected.

**Table 142. Evaporator fan performance – 17.5 ton (model YSK, YHK), horizontal, high heat**

Available External Static Pressure (Inches of Water Gauge)																				
CFM	0.10		0.20		0.30		0.40		0.50		0.60		0.70		0.80		0.90		1.00	
	RPM	BHP	RPM	BHP	RPM	BHP	RPM	BHP	RPM	BHP	RPM	BHP	RPM	BHP	RPM	BHP	RPM	BHP	RPM	BHP
5250	786	0.58	830	0.71	871	0.83	909	0.96	945	1.09	980	1.22	1015	1.36	1048	1.50	1081	1.65	1113	1.79
5600	832	0.69	875	0.82	914	0.96	951	1.09	985	1.23	1018	1.37	1051	1.51	1084	1.66	1115	1.81	1146	1.96
6300	925	0.94	964	1.09	1001	1.24	1035	1.39	1068	1.54	1098	1.70	1128	1.85	1156	2.01	1186	2.18	1215	2.34
7000	1019	1.25	1055	1.41	1089	1.58	1121	1.75	1152	1.92	1181	2.09	1209	2.26	1236	2.43	1263	2.61	1288	2.78
7700	1114	1.62	1147	1.80	1179	1.99	1209	2.18	1238	2.36	1266	2.55	1293	2.73	1318	2.92	1343	3.11	1368	3.30
8400	1210	2.07	1240	2.27	1270	2.47	1298	2.67	1326	2.87	1352	3.08	1377	3.28	1402	3.48	1426	3.68	1449	3.89
Available External Static Pressure (Inches of Water Gauge)																				
CFM	1.10		1.20		1.30		1.40		1.50		1.60		1.70		1.80		1.90		2.00	
	RPM	BHP	RPM	BHP	RPM	BHP	RPM	BHP	RPM	BHP	RPM	BHP	RPM	BHP	RPM	BHP	RPM	BHP	RPM	BHP
5250	1144	1.94	1175	2.09	1204	2.24	1233	2.4	1261	2.55	1288	2.71	1314	2.87	1340	3.03	1365	3.2	1390	3.37
5600	1176	2.12	1205	2.27	1234	2.43	1263	2.59	1290	2.76	1317	2.92	1343	3.09	1369	3.26	1393	3.43	1418	3.6
6300	1244	2.51	1271	2.68	1299	2.85	1325	3.03	1351	3.2	1377	3.38	1403	3.56	1428	3.74	1452	3.93	1476	4.11
7000	1315	2.96	1342	3.15	1367	3.33	1392	3.52	1417	3.71	1442	3.9	1466	4.1	1489	4.29	1512	4.49	1536	4.69
7700	1391	3.49	1414	3.68	1439	3.88	1463	4.08	1487	4.29	1510	4.49	1533	4.7	1555	4.91	1578	5.12	1600	5.33

## Evaporator Fan Performance — Gas Heat

**Table 142. Evaporator fan performance – 17.5 ton (model YSK, YHK), horizontal, high heat (continued)**

Available External Static Pressure (Inches of Water Gauge)																				
CFM	1.10		1.20		1.30		1.40		1.50		1.60		1.70		1.80		1.90		2.00	
	RPM	BHP	RPM	BHP	RPM	BHP	RPM	BHP	RPM	BHP	RPM	BHP	RPM	BHP	RPM	BHP	RPM	BHP	RPM	BHP
8400	1472	4.09	1494	4.3	1516	4.51	1537	4.72	1559	4.94	1582	5.16	1604	5.38	1625	5.6	1647	5.82	1667	6.05

**Notes:**

1. Available External Static Pressure is the static pressure difference between the return duct and the supply duct plus the static pressure drop caused by accessories and options.
2. For direct drive evaporator fan speed (rpm), refer to the applicable table in the fan performance section.
3. Data includes pressure drop due to standard filters and wet coils. No accessories or options are included in pressure drop data.
4. To determine static pressure drop due to other options/accessories, refer to the applicable table in the fan performance section.
5. Direct drive fan motor heat is negligible.
6. Factory supplied motors, in commercial equipment, are definite purpose motors, specifically designed and tested to operate reliably and continuously at all cataloged conditions. Using the full horsepower range of our fan motors as shown in our tabular data will not result in nuisance tripping or premature motor failure. Our product's warranty will not be affected.

**Table 143. Evaporator fan performance – 20 ton (model YSK, YHK), horizontal, high heat**

Available External Static Pressure (Inches of Water Gauge)																				
CFM	0.10		0.20		0.30		0.40		0.50		0.60		0.70		0.80		0.90		1.00	
	RPM	BHP	RPM	BHP	RPM	BHP	RPM	BHP	RPM	BHP	RPM	BHP	RPM	BHP	RPM	BHP	RPM	BHP	RPM	BHP
6000	885	0.82	926	0.97	963	1.11	999	1.26	1032	1.40	1064	1.55	1094	1.70	1125	1.85	1155	2.01	1185	2.17
6400	938	0.98	977	1.13	1013	1.29	1047	1.44	1079	1.59	1110	1.75	1139	1.91	1168	2.07	1197	2.23	1226	2.40
7200	1047	1.35	1082	1.52	1115	1.69	1146	1.87	1176	2.04	1205	2.21	1233	2.39	1260	2.56	1286	2.74	1311	2.92
8000	1155	1.80	1187	1.99	1218	2.19	1247	2.38	1275	2.57	1302	2.77	1329	2.96	1354	3.15	1379	3.34	1403	3.54
8800	1265	2.36	1294	2.56	1322	2.78	1350	2.99	1376	3.20	1402	3.41	1426	3.63	1450	3.84	1474	4.05	1497	4.26
9600	1375	3.02	1401	3.24	1428	3.47	1453	3.70	1478	3.94	1502	4.17	1526	4.40	1549	4.63	1571	4.86	1593	5.09

**Available External Static Pressure (Inches of Water Gauge)**

CFM	1.10		1.20		1.30		1.40		1.50		1.60		1.70		1.80		1.90		2.00	
	RPM	BHP	RPM	BHP	RPM	BHP	RPM	BHP	RPM	BHP	RPM	BHP	RPM	BHP	RPM	BHP	RPM	BHP	RPM	BHP
6000	1214	2.33	1243	2.5	1271	2.66	1297	2.83	1325	3	1351	3.18	1377	3.35	1402	3.53	1427	3.71	1451	3.89
6400	1254	2.57	1281	2.74	1308	2.92	1335	3.09	1361	3.27	1386	3.45	1411	3.63	1436	3.82	1460	4	1484	4.19
7200	1336	3.11	1362	3.29	1388	3.48	1412	3.68	1437	3.87	1461	4.06	1485	4.26	1508	4.46	1531	4.66	1553	4.86
8000	1426	3.74	1448	3.94	1470	4.14	1494	4.35	1518	4.56	1541	4.77	1563	4.98	1585	5.19	1607	5.41	1628	5.63
8800	1519	4.48	1541	4.69	1562	4.91	1583	5.13	1603	5.35	1623	5.57	1645	5.8	1666	6.03	-	-	-	-
9600	1614	5.32	1635	5.56	1655	5.79	1675	6.02	-	-	-	-	-	-	-	-	-	-	-	-

**Notes:**

1. Available External Static Pressure is the static pressure difference between the return duct and the supply duct plus the static pressure drop caused by accessories and options.
2. For direct drive evaporator fan speed (rpm), refer to the applicable table in the fan performance section.
3. Data includes pressure drop due to standard filters and wet coils. No accessories or options are included in pressure drop data.
4. To determine static pressure drop due to other options/accessories, refer to the applicable table in the fan performance section.
5. Direct drive fan motor heat is negligible.
6. Factory supplied motors, in commercial equipment, are definite purpose motors, specifically designed and tested to operate reliably and continuously at all cataloged conditions. Using the full horsepower range of our fan motors as shown in our tabular data will not result in nuisance tripping or premature motor failure. Our product's warranty will not be affected.

**Table 144. Evaporator fan performance – 25 ton (model YSK, YHK), horizontal, high heat**

Available External Static Pressure (Inches of Water Gauge)																				
CFM	0.10		0.20		0.30		0.40		0.50		0.60		0.70		0.80		0.90		1.00	
	RPM	BHP	RPM	BHP	RPM	BHP	RPM	BHP	RPM	BHP	RPM	BHP	RPM	BHP	RPM	BHP	RPM	BHP	RPM	BHP
7500	1087	1.51	1121	1.69	1153	1.87	1184	2.05	1213	2.23	1241	2.41	1269	2.59	1295	2.77	1320	2.96	1345	3.14
8000	1155	1.80	1187	1.99	1218	2.19	1247	2.38	1275	2.57	1302	2.77	1329	2.96	1354	3.15	1379	3.34	1403	3.54
9000	1292	2.51	1320	2.72	1348	2.94	1376	3.16	1402	3.38	1427	3.59	1451	3.81	1475	4.03	1498	4.24	1521	4.46
10000	1430	3.40	1455	3.63	1481	3.86	1506	4.10	1530	4.35	1553	4.59	1576	4.83	1598	5.07	1620	5.31	1641	5.55
11000	1568	4.47	1591	4.72	1614	4.97	1637	5.24	1660	5.51	1682	5.77	1703	6.04	-	-	-	-	-	-
12000	1706	5.75	1728	6.02	-	-	-	-	-	-	-	-	-	-	-	-	-	-	-	-



## Evaporator Fan Performance — Gas Heat

**Table 144. Evaporator fan performance – 25 ton (model YSK, YHK), horizontal, high heat (continued)**

Available External Static Pressure (Inches of Water Gauge)																				
CFM	1.10		1.20		1.30		1.40		1.50		1.60		1.70		1.80		1.90		2.00	
	RPM	BHP	RPM	BHP	RPM	BHP	RPM	BHP	RPM	BHP	RPM	BHP	RPM	BHP	RPM	BHP	RPM	BHP	RPM	BHP
7500	1369	3.33	1393	3.52	1418	3.72	1443	3.92	1467	4.12	1490	4.32	1513	4.52	1536	4.72	1559	4.93	1581	5.14
8000	1426	3.74	1448	3.94	1470	4.14	1494	4.35	1518	4.56	1541	4.77	1563	4.98	1585	5.19	1607	5.41	1628	5.63
9000	1543	4.68	1564	4.9	1585	5.12	1606	5.34	1626	5.57	1645	5.79	1666	6.02	-	-	-	-	-	-
10000	1662	5.79	1683	6.03	-	-	-	-	-	-	-	-	-	-	-	-	-	-	-	-
11000	-	-	-	-	-	-	-	-	-	-	-	-	-	-	-	-	-	-	-	-
12000	-	-	-	-	-	-	-	-	-	-	-	-	-	-	-	-	-	-	-	-

**Notes:**

1. Available External Static Pressure is the static pressure difference between the return duct and the supply duct plus the static pressure drop caused by accessories and options.
2. For direct drive evaporator fan speed (rpm), refer to the applicable table in the fan performance section.
3. Data includes pressure drop due to standard filters and wet coils. No accessories or options are included in pressure drop data.
4. To determine static pressure drop due to other options/accessories, refer to the applicable table in the fan performance section.
5. Direct drive fan motor heat is negligible.
6. Factory supplied motors, in commercial equipment, are definite purpose motors, specifically designed and tested to operate reliably and continuously at all cataloged conditions. Using the full horsepower range of our fan motors as shown in our tabular data will not result in nuisance tripping or premature motor failure. Our product's warranty will not be affected.

**Table 145. Evaporator fan performance – 25 ton (model YSK, YHK), horizontal, high heat, high static motor**

Available External Static Pressure (Inches of Water Gauge)																				
CFM	0.10		0.20		0.30		0.40		0.50		0.60		0.70		0.80		0.90		1.00	
	RPM	BHP	RPM	BHP	RPM	BHP	RPM	BHP	RPM	BHP	RPM	BHP	RPM	BHP	RPM	BHP	RPM	BHP	RPM	BHP
7500	1087	1.51	1121	1.69	1153	1.87	1184	2.05	1213	2.23	1241	2.41	1269	2.59	1295	2.77	1320	2.96	1345	3.14
8000	1155	1.80	1187	1.99	1218	2.19	1247	2.38	1275	2.57	1302	2.77	1329	2.96	1354	3.15	1379	3.34	1403	3.54
9000	1292	2.51	1320	2.72	1348	2.94	1376	3.16	1402	3.38	1427	3.59	1451	3.81	1475	4.03	1498	4.24	1521	4.46
10000	1430	3.40	1455	3.63	1481	3.86	1506	4.10	1530	4.35	1553	4.59	1576	4.83	1598	5.07	1620	5.31	1641	5.55
11000	1568	4.47	1591	4.72	1614	4.97	1637	5.24	1660	5.51	1682	5.77	1703	6.04	1721	6.11	1742	6.38	1761	6.64
12000	1706	5.75	1728	6.02	1747	6.08	1768	6.38	1790	6.67	1811	6.95	1830	7.25	1844	7.15	1864	7.45	1881	7.73

Available External Static Pressure (Inches of Water Gauge)																				
CFM	1.10		1.20		1.30		1.40		1.50		1.60		1.70		1.80		1.90		2.00	
	RPM	BHP	RPM	BHP	RPM	BHP	RPM	BHP	RPM	BHP	RPM	BHP	RPM	BHP	RPM	BHP	RPM	BHP	RPM	BHP
7500	1369	3.33	1393	3.52	1418	3.72	1443	3.92	1467	4.12	1490	4.32	1513	4.52	1536	4.72	1559	4.93	1581	5.14
8000	1426	3.74	1448	3.94	1470	4.14	1494	4.35	1518	4.56	1541	4.77	1563	4.98	1585	5.19	1607	5.41	1628	5.63
9000	1543	4.68	1564	4.9	1585	5.12	1606	5.34	1626	5.57	1645	5.79	1666	6.02	1683	6.13	1703	6.37	1722	6.61
10000	1662	5.79	1683	6.03	1700	6.1	1718	6.33	1734	6.58	1749	6.81	1769	7.06	1781	7.07	1799	7.33	1816	7.59
11000	1781	6.9	1802	7.16	1815	7.08	1830	7.32	1842	7.59	1853	7.83	1872	8.1	1879	8.01	1895	8.29	1910	8.57
12000	1900	8.01	1921	8.29	1930	8.06	-	-	-	-	-	-	-	-	-	-	-	-	-	-

**Notes:**

1. Available External Static Pressure is the static pressure difference between the return duct and the supply duct plus the static pressure drop caused by accessories and options.
2. For direct drive evaporator fan speed (rpm), refer to the applicable table in the fan performance section.
3. Data includes pressure drop due to standard filters and wet coils. No accessories or options are included in pressure drop data.
4. To determine static pressure drop due to other options/accessories, refer to the applicable table in the fan performance section.
5. Direct drive fan motor heat is negligible.
6. Factory supplied motors, in commercial equipment, are definite purpose motors, specifically designed and tested to operate reliably and continuously at all cataloged conditions. Using the full horsepower range of our fan motors as shown in our tabular data will not result in nuisance tripping or premature motor failure. Our product's warranty will not be affected.



# Fan Performance

Table 146. Outdoor sound power level

Tons	Unit Model Number	Octave Center Frequency								Overall dBA
		63	125	250	500	1000	2000	4000	8000	
<b>Standard Efficiency</b>										
3	T/YSK036	82	81	80	77	73	69	65	61	79
4	T/YSK048	83	84	82	80	76	72	68	63	82
5	T/YSK060	84	84	82	80	77	73	69	67	82
6	T/YSK072	84	85	84	85	82	76	73	67	86
7.5	T/YSK090	84	86	84	85	82	76	73	67	86
8.5	T/YSK102	87	87	86	83	81	77	73	67	86
10	T/YSK120	86	87	87	83	81	77	73	67	86
12.5	T/YSK150	88	91	90	87	84	80	75	67	89
15	T/YSK180	83	87	87	85	82	77	74	69	87
17.5	T/YSK210	89	89	91	89	86	82	79	73	91
20	T/YSK240	89	89	91	89	86	82	79	73	91
25	T/YSK300	94	90	92	91	88	84	81	75	93
<b>High Efficiency</b>										
3	T/YHK036	82	81	80	77	73	69	65	61	79
4	T/YHK048	85	87	86	85	83	78	73	68	88
5	T/YHK060	85	87	86	85	83	79	74	70	88
6	T/YHK072	87	87	86	83	81	77	73	67	86
7.5	T/YHK090	87	87	86	83	81	77	73	67	86
8.5	T/YHK102	87	87	86	83	81	77	73	67	86
10	T/YHK120	86	87	87	83	81	77	73	67	86
12.5	T/YHK150	83	87	87	85	82	77	74	69	87
15	T/YHK180	83	87	87	85	82	77	74	69	87
17.5	T/YHK210	89	89	91	89	86	82	79	73	91
20	T/YHK240	89	89	91	89	86	82	79	73	91
25	T/YHK300	94	90	92	91	88	84	81	75	93

**Notes:**

1. Outdoor sound rating shown is tested in accordance with AHRI 270/370-2015.
2. Indoor sound in accordance with AHRI 260 is available through Trane's selection software.



## Fan Performance

**Table 147. Static pressure drop through accessories (inches water column)**

Tons	Unit Model Number	cfm	Standard Filters (a)	2" MERV 8 Filter(b)	2" MERV 13 Filter(b)	Reheat Coil	Economizer with OA/RA Dampers(c)								Electric Heater				
							Downflow		Horizontal		Low Leak Downflow(e)		Low Leak Horizontal		Accessory (kW)				
							100% OA	100% RA	100% OA	100% RA	100% OA	100% RA	100% OA	100% RA	5-6	9-18	23-36	54	72
3	T/YSK036A	900	0.01	0.01	0.03	0.03	0.12	0.01	0.12	0.01	0.07	0.04	0.15	0.01	0.01	0.01	0.01	—	—
		1200	0.01	0.02	0.04	0.04	0.20	0.02	0.20	0.01	0.12	0.08	0.25	0.01	0.02	0.02	0.02	—	—
		1440	0.02	0.03	0.06	0.05	0.27	0.03	0.27	0.02	0.17	0.11	0.35	0.02	0.02	0.03	0.03	—	—
	T/YHK036A	900	0.01	0.01	0.03	0.03	0.12	0.01	0.12	0.01	0.07	0.04	0.15	0.01	0.01	0.01	0.01	—	—
		1200	0.01	0.02	0.04	0.04	0.20	0.02	0.20	0.01	0.12	0.08	0.25	0.01	0.02	0.02	0.02	—	—
		1440	0.02	0.03	0.06	0.05	0.27	0.03	0.27	0.02	0.17	0.11	0.35	0.02	0.02	0.03	0.03	—	—
4	T/YSK048A	1200	0.01	0.02	0.04	0.04	0.20	0.02	0.20	0.01	0.12	0.08	0.25	0.01	0.02	0.03	0.03	—	—
		1600	0.02	0.03	0.06	0.06	0.33	0.03	0.33	0.02	0.21	0.14	0.42	0.02	0.04	0.05	0.05	—	—
		1920	0.03	0.04	0.09	0.08	0.45	0.04	0.45	0.03	0.30	0.20	0.60	0.03	0.05	0.06	0.08	—	—
	T/YHK048A	1200	0.02	0.03	0.04	0.02	0.02	0.00	0.02	0.01	0.04	-0.00	0.06	0.03	0.00	0.00	0.02	—	—
		1600	0.03	0.04	0.06	0.03	0.04	0.01	0.03	0.02	0.07	0.00	0.10	0.06	0.01	0.01	0.02	—	—
		1920	0.03	0.04	0.08	0.04	0.06	0.01	0.04	0.02	0.10	0.00	0.14	0.09	0.01	0.01	0.02	—	—
5	T/YSK060A	1500	0.02	0.03	0.06	0.05	0.29	0.03	0.29	0.02	0.18	0.12	0.38	0.02	0.04	0.05	0.05	—	—
		2000	0.03	0.04	0.09	0.08	0.48	0.05	0.48	0.03	0.32	0.22	0.65	0.04	0.06	0.07	0.08	—	—
		2400	0.04	0.06	0.12	0.11	0.66	0.07	0.66	0.04	0.46	0.31	0.92	0.05	0.08	0.10	0.12	—	—
	T/YHK060A	1500	0.03	0.03	0.06	0.03	0.03	0.01	0.03	0.02	0.06	0.00	0.09	0.05	0.01	0.01	0.02	—	—
		2000	0.03	0.05	0.08	0.04	0.07	0.01	0.05	0.02	0.11	0.00	0.15	0.09	0.01	0.01	0.02	—	—
		2400	0.04	0.06	0.10	0.05	0.10	0.01	0.06	0.03	0.16	0.01	0.20	0.13	0.02	0.02	0.03	—	—
6	T/YSK072A T/YHK072A	1800	0.03	0.04	0.07	0.04	0.05	0.01	0.04	0.02	0.09	0.00	0.12	0.08	—	0.01	0.02	—	—
		2400	0.04	0.06	0.10	0.06	0.10	0.01	0.06	0.03	0.16	0.01	0.2	0.13	—	0.02	0.03	—	—
		2880	0.04	0.07	0.13	0.07	0.14	0.02	0.08	0.04	0.24	0.01	0.28	0.19	—	0.03	0.03	—	—
7.5	T/YSK090A T/YHK090A	2250	0.03	0.05	0.09	0.05	0.09	0.01	0.05	0.02	0.14	0.01	0.18	0.12	—	0.02	0.02	—	—
		3000	0.05	0.08	0.13	0.07	0.15	0.02	0.09	0.04	0.26	0.01	0.3	0.21	—	0.03	0.03	—	—
		3600	0.05	0.10	0.17	0.09	0.22	0.02	0.12	0.06	0.39	0.02	0.42	0.29	—	0.04	0.05	—	—
8.5	T/YSK102A T/YHK102A	2550	0.04	0.06	0.11	0.06	0.11	0.01	0.06	0.03	0.19	0.01	0.23	0.15	—	0.02	0.03	—	—
		3400	0.05	0.09	0.16	0.09	0.20	0.02	0.11	0.05	0.34	0.02	0.38	0.26	—	0.03	0.04	—	—
		4080	0.06	0.12	0.20	0.10	0.28	0.03	0.15	0.07	0.50	0.03	0.53	0.37	—	0.05	0.06	—	—
10	T/YSK120A T/YHK120A	3000	0.05	0.08	0.13	0.07	0.15	0.02	0.09	0.04	0.26	0.01	0.3	0.21	—	0.02	0.03	0.05	—
		4000	0.06	0.12	0.20	0.10	0.27	0.03	0.15	0.07	0.48	0.03	0.51	0.35	—	0.02	0.03	0.05	—
		4800	0.07	0.16	0.25	0.12	0.39	0.03	0.20	0.09	0.71	0.05	0.71	0.49	—	0.03	0.04	0.06	—
12.5	T/YSK150A	3750	0.05	0.09	0.16	0.08	0.24	0.02	0.13	0.06	0.18	0.1	0.46	0.31	—	0.02	0.03	0.05	—
		5000	0.07	0.13	0.22	0.10	0.42	0.04	0.22	0.10	0.3	0.19	0.77	0.53	—	0.02	0.03	0.05	—
		6000	0.09	0.16	0.27	0.12	0.60	0.05	0.31	0.13	0.41	0.27	1.07	0.74	—	0.03	0.04	0.06	—
	T/YHK150A	3750	0.02	0.04	0.07	0.03	0.10	0.02	0.10	0.02	0.11	0.09	0.05	0.09	—	0	0.01	0.01	—
		5000	0.03	0.06	0.10	0.04	0.15	0.03	0.15	0.03	0.17	0.13	0.09	0.14	—	0.01	0.03	0.03	—
		6000	0.04	0.08	0.13	0.05	0.20	0.04	0.20	0.04	0.23	0.17	0.12	0.18	—	0.01	0.04	0.04	—
15	T/YSK180A T/YHK180A	4500	0.03	0.05	0.09	0.04	0.13	0.02	0.13	0.02	0.14	0.11	0.07	0.12	—	0.01	0.02	0.02	—
		6000	0.04	0.08	0.13	0.05	0.20	0.04	0.20	0.04	0.23	0.17	0.12	0.18	—	0.01	0.04	0.04	—
		7200	0.06	0.10	0.17	0.07	0.27	0.05	0.27	0.05	0.32	0.23	0.16	0.25	—	0.02	0.06	0.06	—
17.5	T/YSK210A T/YHK210A	5250	0.04	0.06	0.11	0.05	0.16	0.03	0.16	0.03	0.19	0.14	0.09	0.15	—	—	0.03	0.03	0.03
		7000	0.05	0.10	0.17	0.06	0.26	0.05	0.26	0.05	0.30	0.22	0.15	0.24	—	—	0.06	0.06	0.06
		8400	0.07	0.13	0.22	0.08	0.35	0.06	0.35	0.06	0.42	0.29	0.21	0.33	—	—	0.09	0.09	0.09
20	T/YSK240A T/YHK240A	6000	0.04	0.08	0.13	0.05	0.20	0.04	0.20	0.04	0.23	0.17	0.12	0.18	—	—	0.04	0.04	0.04
		8000	0.07	0.12	0.21	0.08	0.32	0.06	0.32	0.06	0.39	0.27	0.19	0.3	—	—	0.08	0.08	0.08
		9600	0.09	0.16	0.27	0.10	0.44	0.07	0.44	0.07	0.54	0.37	0.27	0.41	—	—	0.12	0.12	0.12

**Table 147. Static pressure drop through accessories (inches water column) (continued)**

Tons	Unit Model Number	cfm	Standard Filters (a)	2" MERV 8 Filter(b)	2" MERV 13 Filter(b)	Reheat Coil	Economizer with OA/RA Dampers(c)								Electric Heater					
							Downflow		Horizontal		Low Leak Downflow(e)		Low Leak Horizontal		Accessory (kW)					
							100% OA	100% RA	100% OA	100% RA	100% OA	100% RA	100% OA	100% RA	5-6	9-18	23-36	54	72	
25	T/YSK300A T/YHK300A	7500	0.06	0.11	0.19	0.07	0.29	0.05	0.29	0.05	0.34	0.24	0.17	0.27	—	—	0.07	0.07	0.07	
		10000	0.09	0.17	0.29	0.11	0.11	0.48	0.08	0.48	0.08	0.58	0.40	0.29	0.45	—	—	0.13	0.13	0.13
		12000	0.12	0.23	0.39	0.14	0.14	0.66	0.11	0.66	0.11	0.82	0.55	0.39	0.62	—	—	0.20	0.20	0.20

(a) Tested with: 2-in filters 3 to 25 Tons.

(b) Difference in pressure drop should be considered when utilizing optional 2-in pleated filters.

(c) OA = Outside Air and RA = Return Air.

**Table 148. Static pressure drop through accessories (inches water column) - with gas heater and modulating gas heat option**

Tons	Unit Model Number	cfm	2-Stage Gas Heater(a)						Modulating Gas Heater(b)			
			Downflow			Horizontal			Downflow		Horizontal	
			L (c)	M (d)	H (e)	L (c)	M (d)	H (e)	L	H	L	H
3	YSK036A	900	0.01	0.01	0.01	0.02	0.02	0.04	—	—	—	—
		1200	0.01	0.01	0.02	0.04	0.04	0.08	—	—	—	—
		1440	0.02	0.02	0.03	0.06	0.06	0.11	—	—	—	—
	YHK036A	900	0.01	0.01	0.01	0.02	0.02	0.04	—	—	—	—
		1200	0.01	0.01	0.02	0.04	0.04	0.08	—	—	—	—
		1440	0.02	0.02	0.03	0.06	0.06	0.11	—	—	—	—
4	YSK048A	1200	0.01	0.01	0.02	0.04	0.04	0.08	—	—	—	—
		1600	0.03	0.03	0.04	0.06	0.06	0.12	—	—	—	—
		1920	0.05	0.05	0.06	0.06	0.06	0.16	—	—	—	—
	YHK048A	1200*	0.04	0.04	0.08	0.07	0.02	0.11	—	—	—	—
		1600	0.06	0.06	0.10	0.11	0.05	0.17	—	—	—	—
		1920	0.08	0.08	0.11	0.16	0.08	0.23	—	—	—	—
5	YSK060A	1500	0.02	0.02	0.04	0.06	0.06	0.11	—	—	—	—
		2000	0.05	0.05	0.06	0.07	0.07	0.17	—	—	—	—
		2400	0.08	0.08	0.08	0.08	0.08	0.23	—	—	—	—
	YHK060A	1500*	0.05	0.05	0.09	0.10	0.04	0.16	—	—	—	—
		2000	0.08	0.08	0.11	0.17	0.09	0.24	—	—	—	—
		2400	0.11	0.11	0.13	0.22	0.16	0.32	—	—	—	—
6	YSK072A YHK072A	1800	0.04	0.04	0.03	0.13	0.13	0.13	0.03	0.02	0.22	0.47
		2400	0.05	0.05	0.05	0.24	0.24	0.21	0.05	0.05	0.34	0.81
		2880	0.07	0.07	0.08	0.35	0.35	0.30	0.07	0.08	0.47	1.16
7.5	YSK090A YHK090A	2250	0.11	0.11	0.05	0.19	0.19	0.11	0.04	0.09	0.32	0.28
		3000	0.17	0.17	0.08	0.33	0.33	0.16	0.09	0.13	0.61	0.43
		3600	0.24	0.24	0.11	0.46	0.46	0.23	0.14	0.19	0.91	0.59
8.5	YSK102A YHK102A	2550	0.13	0.13	0.06	0.24	0.24	0.13	0.06	0.09	0.42	0.33
		3400	0.22	0.22	0.10	0.41	0.41	0.20	0.12	0.17	0.81	0.53
		4080	0.31	0.31	0.14	0.59	0.59	0.30	0.18	0.25	1.19	0.73
10	YSK120A YHK120A	3000	0.16	0.16	0.08	0.16	0.16	0.16	0.09	0.13	0.61	0.43
		4000	0.28	0.28	0.13	0.28	0.28	0.28	0.18	0.24	1.14	0.70
		4800	0.44	0.44	0.20	0.44	0.44	0.44	0.27	0.36	1.65	0.97



## Fan Performance

**Table 148. Static pressure drop through accessories (inches water column) - with gas heater and modulating gas heat option (continued)**

Tons	Unit Model Number	cfm	2-Stage Gas Heater <sup>(a)</sup>						Modulating Gas Heater <sup>(b)</sup>			
			Downflow			Horizontal			Downflow		Horizontal	
			L <sup>(c)</sup>	M <sup>(d)</sup>	H <sup>(e)</sup>	L <sup>(c)</sup>	M <sup>(d)</sup>	H <sup>(e)</sup>	L	H	L	H
12.5	YSK150A	3750	0.23	0.23	0.11	0.11	0.11	0.22	0.13	0.15	0.23	0.24
		5000	0.42	0.42	0.18	0.27	0.27	0.34	0.17	0.22	0.35	0.42
		6000	0.64	0.64	0.24	0.46	0.46	0.42	0.20	0.29	0.48	0.61
	YHK150A	3750	-0.07	-0.07	-0.05	0.08	0.08	0.07	—	0.04	—	0.08
		5000	-0.06	-0.06	-0.04	0.10	0.10	0.10	—	0.08	—	0.14
		6000	-0.03	-0.03	-0.02	0.12	0.12	0.13	—	0.11	—	0.20
15	YSK180A YHK180A	4500	-0.07	-0.05	-0.06	0.08	0.08	0.10	0.06	0.09	0.11	0.15
		6000	-0.03	-0.02	-0.02	0.12	0.13	0.16	0.11	0.19	0.20	0.28
		7200	-0.01	0.00	0.01	0.11	0.13	0.19	0.16	0.28	0.29	0.42
17.5	YSK210A YHK210A	5250	-0.05	-0.03	-0.04	0.11	0.11	0.13	0.09	0.14	0.15	0.21
		7000	-0.01	-0.01	0.00	0.11	0.13	0.18	0.16	0.26	0.27	0.39
		8400	0.02	0.02	0.04	0.10	0.13	0.20	0.23	0.40	0.40	0.57
20	YSK240A YHK240A	6000	-0.03	-0.02	-0.02	0.12	0.13	0.16	0.11	0.19	0.20	0.28
		8000	0.01	0.01	0.03	0.10	0.13	0.19	0.20	0.36	0.36	0.52
		9600	0.04	0.05	0.07	0.10	0.14	0.21	0.30	0.53	0.52	0.75
25	YSK300A YHK300A	7500	0.00	0.00	0.01	0.11	0.13	0.19	0.18	0.31	0.31	0.45
		10000	0.06	0.07	0.08	0.11	0.15	0.21	0.33	0.58	0.56	0.82
		12000	0.14	0.15	0.14	0.16	0.21	0.31	0.49	0.87	0.81	1.17

- <sup>(a)</sup> Model digit 11 selection of Low/Medium Gas Heat is 5x5 and High Gas Heat is 7x7 for 12.5T (YHK) units.
- <sup>(b)</sup> Model digit 10 selection B is Mod Gas of which Low Gas Heat is 2x2 for 6T, 4x4 for 7.5 to 12.5T (YSK), High Gas Heat is 4x4 for 6T, 6x6 for 7.5 to 12.5T (YSK), 12.5T (YHK) is High only with 6-Tube. 15 to 25T units are Low with 6-Tube and High with 8-Tube.
- <sup>(c)</sup> Model digit 11 selection of Medium Gas Heat is limited to minimum 360 cfm/ton full load airflow for 4 to 5T YHK units.
- <sup>(d)</sup> Model digit 11 selection of High Gas Heat is limited to minimum 320 cfm/ton full load airflow for 4 to 5T YHK units.
- <sup>(e)</sup> Model digit 11 selection of Low Gas Heat is 5x5, Medium Gas Heat is 7x7, and High Gas Heat is 8x8 for 15 to 25T units.



# Heating Performance

**Table 149. Auxiliary electric heat capacity — cooling standard efficiency**

Tons	Unit Model Number	Total <sup>(a)</sup>		No. of Stages	Stage 1		Stage 2	
		kw Input <sup>(b)</sup>	MBh Output		kw Input	MBh Output	kw Input	MBh Output
3	TS*036*3,4,W	6.0	20.48	1	6.0	20.48	—	—
		12.0	40.97	2	6.0	20.48	6.0	20.48
		17.4	59.4	2	8.7	29.70	8.7	29.70
4	TS*048*3,4,W	6.0	20.48	1	6.0	20.48	—	—
		12.0	40.97	2	6.0	20.48	6.0	20.48
		17.4	59.4	2	8.7	29.70	8.7	29.70
5	TS*060*3,4,W	6.0	20.48	1	6.0	20.48	—	—
		12.0	40.97	2	6.0	20.48	6.0	20.48
		17.4	59.4	2	8.7	29.70	8.7	29.70
		23.0	78.52	2	8.7	29.70	14.3	48.82
6	TS*072*3,4,W	9.0	30.735	1	9.0	30.73	—	—
		18.0	61.47	2	9.0	30.73	9.0	30.73
		27.0	92.205	2	18.0	61.47	9.0	30.73
		36.0	122.94	2	18.0	61.47	18.0	61.47
7.5	TS*090*3,4,W	9.0	30.735	1	9.0	30.73	—	—
		18.0	61.47	2	9.0	30.73	9.0	30.73
		27.0	92.205	2	18.0	61.47	9.0	30.73
		36.0	122.94	2	18.0	61.47	18.0	61.47
8.5	TS*102*3,4,W	9.0	30.735	1	9.0	30.73	—	—
		18.0	61.47	2	9.0	30.73	9.0	30.73
		27.0	92.205	2	18.0	61.47	9.0	30.73
		36.0	122.94	2	18.0	61.47	18.0	61.47
10	TS*120*3,4,W	18.0	61.47	1	18.0	61.47	—	—
		27.0	92.205	2	18.0	61.47	9.0	30.73
		36.0	122.94	2	18.0	61.47	18.0	61.47
		54.0	184.41	2	36.0	122.94	18.0	61.47
12.5	TS*150*3,4,W	18.0	61.47	1	18.0	61.47	—	—
		27.0	92.205	2	18.0	61.47	9.0	30.73
		36.0	122.94	2	18.0	61.47	18.0	61.47
		54.0	184.41	2	36.0	122.94	18.0	61.47
15	TS*180*3,4,W	18.0	61.47	1	18.0	61.47	—	—
		36.0	122.94	2	18.0	61.47	18.0	61.47
		54.0	184.41	2	36.0	122.94	18.0	61.47
17.5 to 25	TS*210*3,4,W TS*240*3,4,W TS*300*3,4,W	36.0	122.94	2	18.0	61.47	18.0	61.47
		54.0	184.41	2	36.0	122.94	18.0	61.47
		72.0	245.88	2	36.0	122.94	36.0	122.94

<sup>(a)</sup> Heaters are rated at 240V, 480V and 600V. For other than rated voltage, CAP= (voltage/rated voltage)<sup>2</sup> x rated cap.

<sup>(b)</sup> For all input/output categories, does not include fan power or heat.

**Table 150. Auxiliary electric heat capacity — cooling high efficiency**

Tons	Unit Model Number	Total <sup>(a)</sup>		No. of Stages	Stage 1		Stage 2	
		kw Input <sup>(b)</sup>	MBh Output		kw Input	MBh Output	kw Input	MBh Output
3	TH*036*3,4,W	6.0	20.48	1	6.0	20.48	—	—
		12.0	40.97	2	6.0	20.48	6.0	20.48
		18.0	59.4	2	8.7	29.70	8.7	29.70
4	TH*048*3,4,W	6.0	20.48	1	6.0	20.48	—	—
		12.0	40.97	2	6.0	20.48	6.0	20.48
		18.0	59.4	2	9.0	30.73	9.0	30.73
5	TH*060*3,4,W	6.0	20.48	1	6.0	20.48	—	—
		12.0	40.97	2	6.0	20.48	6.0	20.48
		18.0	59.4	2	9.0	30.73	9.0	30.73
		27.0	92.21	2	18.0	61.47	9.0	30.73



## Heating Performance

**Table 150. Auxiliary electric heat capacity — cooling high efficiency (continued)**

Tons	Unit Model Number	Total <sup>(a)</sup>		No. of Stages	Stage 1		Stage 2	
		kw Input <sup>(b)</sup>	MBh Output		kw Input	MBh Output	kw Input	MBh Output
6 to 8.5	TH*072*3,4,W TH*090*3,4,W TH*102*3,4,W	9.0	30.735	1	9.0	30.73	—	—
		18.0	61.47	2	9.0	30.73	9.0	30.73
		27.0	92.205	2	18.0	61.47	9.0	30.73
		36.0	122.94	2	18.0	61.47	18.0	61.47
10	TH*120*3,4,W	18.0	61.47	1	18.0	61.47	—	—
		27.0	92.205	2	18.0	61.47	9.0	30.73
		36.0	122.94	2	18.0	61.47	18.0	61.47
		54.0	184.41	2	36.0	122.94	18.0	61.47
12.5 to 15	TH*150*3,4,W TH*180*3,4,W	18.0	61.47	1	18.0	61.47	—	—
		36.0	122.94	2	18.0	61.47	18.0	61.47
		54.0	184.41	2	36.0	122.94	18.0	61.47
17.5 to 25	TH*210*3,4,W TH*240*3,4,W TH*300*3,4,W	36.0	122.94	2	18.0	61.47	18.0	61.47
		54.0	184.41	2	36.0	122.94	18.0	61.47
		72.0	245.88	2	36.0	122.94	36.0	122.94

<sup>(a)</sup> Heaters are rated at 240V, 480V and 600V. For other than rated voltage, CAP= (voltage/rated voltage)<sup>2</sup> x rated cap.

<sup>(b)</sup> For all input/output categories, does not include fan power or heat.

**Table 151. Air temperature rise — cooling standard efficiency**

kW	Stages	3 Tons 900 cfm	4 Tons 1200 cfm	5 Tons 1500 cfm	6 Tons 1800 cfm
		Three Phase TS*036*3,4,W	Three Phase TS*048*3,4,W	Three Phase TS*060*3,4,2	Three Phase TS*072*3,4,W
6.00	1	21.07	15.81	12.64	—
9.00	1	—	—	—	15.81
12.00	2	42.15	31.61	25.29	—
18.00	1 OR 2	63.22	47.42	37.93	31.61
23.00	2	—	—	48.47	—
27.00	2	—	—	—	47.42
36.00	2	—	—	—	63.22
54.00	2	—	—	—	—
72.00	2	—	—	—	—
kW	Stages	7.5 Tons 2250 cfm	8.5 Tons 2550 cfm	10 Tons 3000 cfm	12.5 Tons 3750 cfm
		Three Phase TS*090*3,4,W	Three Phase TS*102*3,4,2	Three Phase TS*120*3,4,W	Three Phase TS*150*3,4,W
6.00	1	—	—	—	—
9.00	1	12.64	11.16	—	—
12.00	2	—	—	—	—
18.00	1 OR 2	25.29	22.31	18.97	15.17
23.00	2	—	—	—	—
27.00	2	37.93	33.47	28.45	22.76
36.00	2	50.58	44.63	37.93	30.35
54.00	2	—	—	56.90	45.52
72.00	2	—	—	—	—
kW	Stages	15 Tons 4500 cfm	17.5 Tons 5250 cfm	20 Tons 6000 cfm	25 Tons 7500 cfm
		Three Phase TS*180*3,4,W	Three Phase TS*210*3,4,W	Three Phase TS*240*3,4,W	Three Phase TS*300*3,4,W
6.00	1	—	—	—	—
9.00	1	—	—	—	—
12.00	2	—	—	—	—
18.00	1 OR 2	12.64	—	—	—

**Table 151. Air temperature rise — cooling standard efficiency (continued)**

kW	Stages	15 Tons 4500 cfm	17.5 Tons 5250 cfm	20 Tons 6000 cfm	25 Tons 7500 cfm
		Three Phase TS*180*3,4,W	Three Phase TS*210*3,4,W	Three Phase TS*240*3,4,W	Three Phase TS*300*3,4,W
23.00	2	—	—	—	—
27.00	2	—	—	—	—
36.00	2	25.28	21.67	18.96	15.17
54.00	2	37.93	32.51	28.45	22.76
72.00	2	—	43.35	37.93	30.34

**Note:** For minimum design airflow, see airflow performance table for each unit. To calculate temp. rise at different airflow, use the following formula:  
Temp. rise across Electric Heater = (kW x 3414)/(1.08 x cfm).

**Table 152. Air temperature rise — cooling high efficiency**

kW	Stages	3 Tons 900 cfm	4 Tons 1200 cfm	5 Tons 1500 cfm	6 Tons 1800 cfm
		Three Phase TH*036*3,4,W	Three Phase TH*048*3,4,W	Three Phase TH*060*3,4,2	Three Phase TH*072*3,4,W
6.00	1	21.07	15.81	12.64	—
9.00	1	—	—	—	15.81
12.00	2	42.15	31.61	25.29	—
18.00	1 OR 2	63.22	47.42	37.93	31.61
23.00	2	—	—	—	—
27.00	2	—	—	56.9	47.42
36.00	2	—	—	—	63.22
54.00	2	—	—	—	—
72.00	2	—	—	—	—
kW	Stages	7.5 Tons 2250 cfm	8.5 Tons 2550 cfm	10 Tons 3000 cfm	12.5 Tons 3750 cfm
		Three Phase TH*090*3,4,W	Three Phase TH*102*3,4,2	Three Phase TH*120*3,4,W	Three Phase TH*150*3,4,W
6.00	1	—	—	—	—
9.00	1	12.64	11.16	—	—
12.00	2	—	—	—	—
18.00	1 OR 2	25.29	22.31	18.97	15.17
23.00	2	—	—	—	—
27.00	2	37.93	33.47	28.45	—
36.00	2	50.58	44.63	37.93	30.35
54.00	2	—	—	56.90	45.52
72.00	2	—	—	—	—
kW	Stages	15 Tons 4500 cfm	17.5 Tons 5250 cfm	20 Tons 6000 cfm	25 Tons 7500 cfm
		Three Phase TH*180*3,4,W	Three Phase TH*210*3,4,W	Three Phase TH*240*3,4,W	Three Phase TH*300*3,4,W
6.00	1	—	—	—	—
9.00	1	—	—	—	—
12.00	2	—	—	—	—
18.00	1 OR 2	12.64	—	—	—
23.00	2	—	—	—	—
27.00	2	—	—	—	—
36.00	2	25.28	21.67	18.96	15.17
54.00	2	37.93	32.51	28.45	22.76
72.00	2	—	43.35	37.93	30.34

**Note:** For minimum design airflow, see airflow performance table for each unit. To calculate temp. rise at different airflow, use the following formula:  
Temp. rise across Electric Heater = (kW x 3414)/(1.08 x cfm).



## Heating Performance

**Table 153. Gas-fired heating capacities— staged gas - standard efficiency**

Tons	Unit Model Number	Heating Input BTU (High / Low Stage)	Heating Output BTU (High / Low Stage)	Air Temperature Rise°F
3	YSK036A**(0,A)L	80,000/56,000	64,800/45,300	35-65
	YSK036A**(0,A)M	100,000/70,000	81,000/56,700	50-80
	YSK036A**(0,A)H	120,000/84,000	97,200/68,000	55-85
4	YSK048A**(0,A)L	80,000/56,000	64,800/45,300	20-50
	YSK048A**(0,A)M	100,000/70,000	81,000/56,700	30-60
	YSK048A**(0,A)H	130,000/91,000	105,300/73,700	45-75
5	YSK060A**(0,A)L	80,000/56,000	64,800/45,300	15-45
	YSK060A**(0,A)M	100,000/70,000	81,000/56,700	25-55
	YSK060A**(0,A)H	150,000/105,000	121,500/85,100	40-70
6	YSK072A**(0,A)L	80,000/56,000	64,800/45,300	10 - 40
	YSK072A**(0,A)M	120,000/84,000	97,200/68,000	20 - 50
	YSK072A**(0,A)H	150,000/105,000	121,500/85,000	30 - 60
7.5	YSK090A**(0,A)L	120,000/84,000	97,200/68,000	15 - 45
	YSK090A**(0,A)M	150,000/105,000	121,500/85,000	20 - 50
	YSK090A**(0,A)H	200,000/140,000	162,000/113,400	30 - 60
8.5	YSK102A**(0,A)L	120,000/84,000	97,200/68,000	15 - 45
	YSK102A**(0,A)M	150,000/105,000	121,500/85,100	20 - 50
	YSK102A**(0,A)H	200,000/140,000	162,000/113,400	30 - 60
10	YSK120A**(0,A)L	150,000/105,000	121,500/85,000	15 - 45
	YSK120A**(0,A)M	200,000/140,000	162,000/113,400	25 - 55
	YSK120A**(0,A)H	240,000 / 168,000	194,400/136,000	30 - 60
12.5	YSK150A**(0,A)L	150,000 / 105,000	121,500 / 85,000	10 - 40
	YSK150A**(0,A)M	200,000 / 140,000	162,000 / 113,400	15 - 45
	YSK150A**(0,A)H	250,000 / 175,000	202,500 / 141,750	25 - 55
15	YSK180A**(0,A)L	250,000 / 175,000	202,500 / 141,750	15 - 45
	YSK180A**(0,A)M	320,000 / 224,000	259,200 / 181,440	20 - 50
	YSK180A**(0,A)H	400,000 / 280,000	324,000 / 226,800	25 - 55
17.5	YSK210A**(0,A)L	250,000 / 175,000	202,500 / 141,750	15 - 45
	YSK210A**(0,A)M	320,000 / 224,000	259,200 / 181,440	20 - 50
	YSK210A**(0,A)H	400,000 / 280,000	324,000 / 226,800	25 - 55
20	YSK240A**(0,A)L	250,000 / 175,000	202,500 / 141,750	10 - 40
	YSK240A**(0,A)M	320,000 / 224,000	259,200 / 181,440	15 - 45
	YSK240A**(0,A)H	400,000 / 280,000	324,000 / 226,800	20 - 50
25	YSK300A**(0,A)L	250,000 / 175,000	202,500 / 141,750	10 - 40
	YSK300A**(0,A)M	320,000 / 224,000	259,200 / 181,440	15 - 45
	YSK300A**(0,A)H	400,000 / 280,000	324,000 / 226,800	20 - 50

**Table 154. Gas-fired heating capacities - staged gas - high efficiency**

Tons	Unit Model Number	Heating Input BTU (High / Low Stage)	Heating Output BTU (High / Low Stage)	Air Temperature Rise°F
3	YHK036A**(0,A)L	80,000/56,000	64,800/45,300	35-65
	YHK036A**(0,A)M	100,000/70,000	81,000/56,700	50-80
	YHK036A**(0,A)H	120,000/84,000	97,200/68,000	55-85
4	YHK048A**(0,A)L	80,000/56,000	64,800/45,300	25-55
	YHK048A**(0,A)M	100,000/70,000	81,000/56,700	30-60
	YHK048A**(0,A)H	130,000/91,000	105,300/73,700	45-75
5	YHK060A**(0,A)L	80,000/56,000	64,800/45,300	15-45
	YHK060A**(0,A)M	100,000/70,000	81,000/56,700	25-55
	YHK060A**(0,A)H	150,000/105,000	121,500/85,100	30-60

**Table 154. Gas-fired heating capacities - staged gas - high efficiency (continued)**

Tons	Unit Model Number	Heating Input BTU (High / Low Stage)	Heating Output BTU (High / Low Stage)	Air Temperature Rise°F
6	YHK072A**(0,A)L	80,000/56,000	64,800/45,300	10 - 40
	YHK072A**(0,A)M	120,000/84,000	97,200/68,000	20 - 50
	YHK072A**(0,A)H	150,000/105,000	121,500/85,000	30 - 60
7.5	YHK090A**(0,A)L	120,000/84,000	97,200/68,000	15 - 45
	YHK090A**(0,A)M	150,000/105,000	121,500/85,000	20 - 50
	YHK090A**(0,A)H	200,000/140,000	162,000/113,400	30 - 60
8.5	YHK102A**(0,A)L	120,000/84,000	97,200/68,000	15 - 45
	YHK102A**(0,A)M	150,000/105,000	121,500/85,100	20 - 50
	YHK102A**(0,A)H	200,000/140,000	162,000/113,400	30 - 60
10	YHK120A**(0,A)L	150,000/105,000	121,500/85,000	15 - 45
	YHK120A**(0,A)M	200,000/140,000	162,000/113,400	25 - 55
	YHK120A**(0,A)H	240,000 / 168,000	194,400/136,000	30 - 60
12.5	YHK150A**(0,A)L	150,000 / 105,000	121,500 / 85,000	10 - 40
	YHK150A**(0,A)M	200,000 / 140,000	162,000 / 113,400	15 - 45
	YHK150A**(0,A)H	250,000 / 175,000	202,500 / 141,750	25 - 55
15	YHK180A**(0,A)L	250,000 / 175,000	202,500 / 141,750	15 - 45
	YHK180A**(0,A)M	320,000 / 224,000	259,200 / 181,440	20 - 50
	YHK180A**(0,A)H	400,000 / 280,000	324,000 / 226,800	25 - 55
17.5	YHK210A**(0,A)L	250,000 / 175,000	202,500 / 141,750	15 - 45
	YHK210A**(0,A)M	320,000 / 224,000	259,200 / 181,440	20 - 50
	YHK210A**(0,A)H	400,000 / 280,000	324,000 / 226,800	25 - 55
20	YHK240A**(0,A)L	250,000 / 175,000	202,500 / 141,750	10 - 40
	YHK240A**(0,A)M	320,000 / 224,000	259,200 / 181,440	15 - 45
	YHK240A**(0,A)H	400,000 / 280,000	324,000 / 226,800	20 - 50
25	YHK300A**(0,A)L	250,000 / 175,000	202,500 / 141,750	10 - 40
	YHK300A**(0,A)M	320,000 / 224,000	259,200 / 181,440	15 - 45
	YHK300A**(0,A)H	400,000 / 280,000	324,000 / 226,800	20 - 50

**Table 155. Gas-fired heating capacities - modulating gas - standard efficiency**

Tons	Unit Model Number	Heating Input BTU (Maximum / Minimum)	Heating Output BTU (Maximum / Minimum)	Air Temperature Rise°F
6	YSK072A**BL	80,000/8,000	64,800/6,480	5 - 40
	YSK072A**BH	150,000/15,000	121,500/12,150	5 - 60
7.5	YSK090A**BL	120,000/12,000	97,200/9,720	5 - 45
	YSK090A**BH	200,000/20,000	162,000/16,200	5 - 60
8.5	YSK102A**BL	120,000/12,000	97,200/9,720	5 - 45
	YSK102A**BH	200,000/20,000	162,000/16,200	5 - 60
10	YSK120A**BH	240,000 / 24,000	194,400 / 136,000	5 - 60
12.5	YSK150A**BL	150,000/15,000	121,500/12,150	5 - 60
	YSK150A**BH	250,000 / 25,000	202,500 / 20,250	5 - 55
15	YSK180A**BL	250,000 / 25,000	202,500 / 20,250	5 - 45
	YSK180A**BH	400,000 / 40,000	324,000 / 32,400	5 - 55
17.5	YSK210A**BL	250,000 / 25,000	202,500 / 20,250	5 - 45
	YSK210A**BH	400,000 / 40,000	324,000 / 32,400	5 - 55
20	YSK240A**BL	250,000 / 25,000	202,500 / 20,250	5 - 40
	YSK240A**BH	400,000 / 40,000	324,000 / 32,400	5 - 50



## Heating Performance

**Table 155. Gas-fired heating capacities - modulating gas - standard efficiency (continued)**

Tons	Unit Model Number	Heating Input BTU (Maximum / Minimum)	Heating Output BTU (Maximum / Minimum)	Air Temperature Rise°F
25	YSK300A**BL	250,000 / 25,000	202,500 / 20,250	5 - 40
	YSK300A**BH	400,000 / 40,000	324,000 / 32,400	5 - 50

**Table 156. Gas-fired heating capacities - modulating gas - high efficiency**

Tons	Unit Model Number	Heating Input BTU (Maximum / Minimum)	Heating Output BTU (Maximum / Minimum)	Air Temperature Rise°F
6	YHK072A**BL	80,000/8,000	64,800/6,480	5 - 40
	YHK072A**BH	150,000/15,000	121,500/12,150	5 - 60
7.5	YHK090A**BL	120,000/12,000	97,200/9,720	5 - 45
	YHK090A**BH	200,000/20,000	162,000/16,200	5 - 60
8.5	YHK102A**BL	120,000/12,000	97,200/9,720	5 - 45
	YHK102A**BH	200,000/20,000	162,000/16,200	5 - 60
10	YHK120A**BH	240,000 / 24,000	194,400 / 136,000	5 - 60
12.5	YHK150B**BH	250,000 / 25,000	202,500 / 20,250	5 - 55
15	YHK180A**BL	250,000 / 25,000	202,500 / 20,250	5 - 45
	YHK180A**BH	400,000 / 40,000	324,000 / 32,400	5 - 55
17.5	YHK210A**BL	250,000 / 25,000	202,500 / 20,250	5 - 45
	YHK210A**BH	400,000 / 40,000	324,000 / 32,400	5 - 55
20	YHK240A**BL	250,000 / 25,000	202,500 / 20,250	5 - 40
	YHK240A**BH	400,000 / 40,000	324,000 / 32,400	5 - 50
25	YHK300A**BL	250,000 / 25,000	202,500 / 20,250	5 - 40
	YHK300A**BH	400,000 / 40,000	324,000 / 32,400	5 - 50



## Controls

### Enhanced BAS Integration and Connectivity

- Symbio™ 700 integrates seamlessly with Tracer® Synchrony and Tracer Ensemble® to deliver optimized building automation and building management features and functions.
- Easily integrate with open standard protocols to connect seamlessly to a Building Automation System (BAS).
- Digit 21 must equal 1, 2, or 3 for communication support.

### BACnet Communications

Symbio™ 700 includes native BACnet® communications which allows the unit to communicate directly with a Tracer® or other BAS via open protocol BACnet MS/TP or IP.

### Modbus Communications

Symbio™ 700 includes native Modbus communications which allows the unit to communicate directly with a Tracer® or other BAS via open protocol Modbus™ RTU or TCP/IP.

### Air-Fi Wireless Communications

The optional Air-Fi® communications module allows the unit to communicate directly with a Tracer® or other BAS via open protocol BACnet over Zigbee wireless.

### Secure Remote Connectivity with Trane Connect

The Symbio™ controller enables secure remote connectivity via Trane Connect® to Trane Intelligent Services and remote monitoring. Trane Connect provides anywhere/anytime access to monitor and manage with secure remote access and connectivity options through a multitude of platforms.

## Serviceability

### Symbio Service and Installation Mobile App

The Symbio™ Service and Installation mobile app is accessible through mobile devices (phones and tablets) via Bluetooth connectivity or via Trane Connect. The intuitive mobile app feels natural to technicians and operators. They will quickly be able to view equipment status and alarms, perform start-up tasks, change configurations, test the equipment's performance in specific modes—and much more. Free for download from App Store (Apple iOS) and Google Play (Android devices).

To download the Symbio Service and Installation Mobile App use the links below or scan the code with your mobile phone camera.

Apple download link (<https://apps.apple.com/us/app/symbio-service-installation/id1309310176>)

Google Play (Android) download link (<https://play.google.com/store/apps/details?id=com.trane.mobileservicetool>)

Figure 22. Scan code

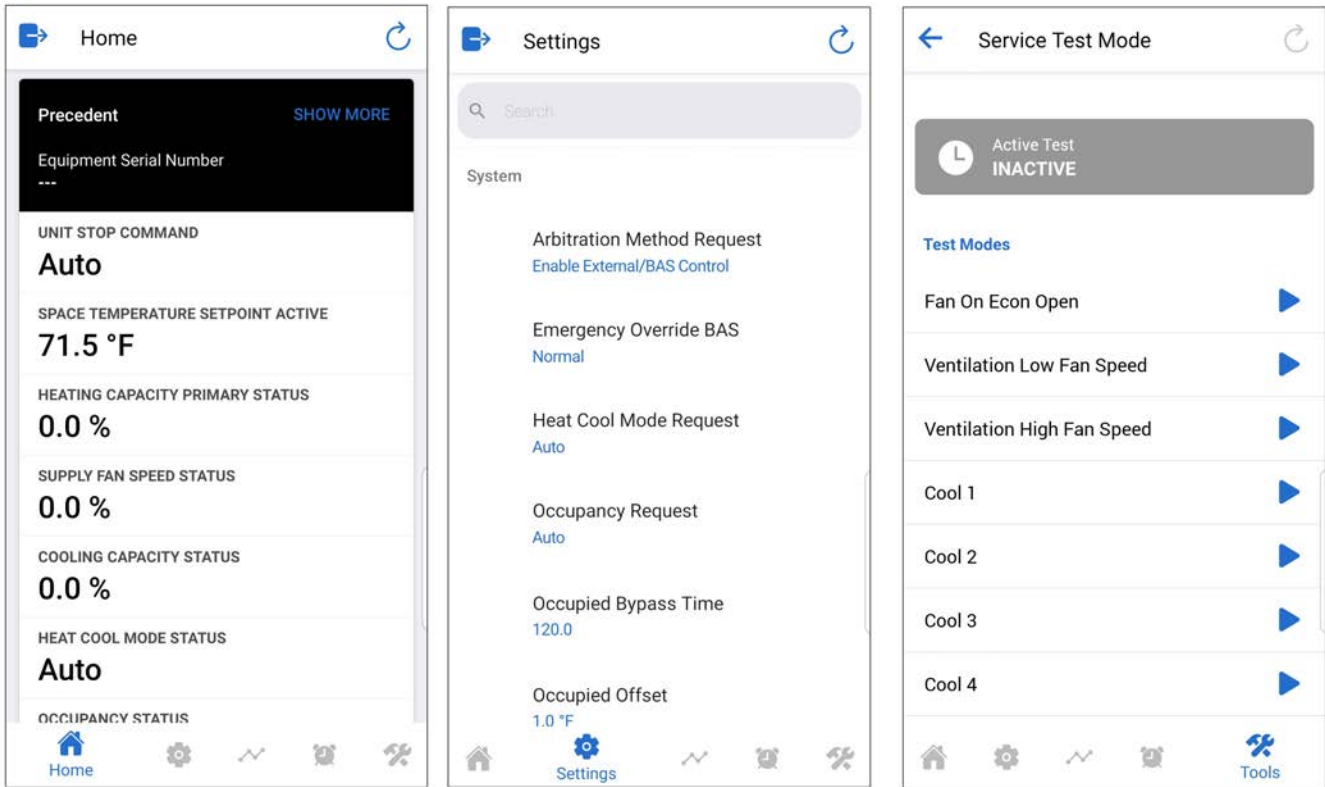

**Figure 23. Symbio service and installation mobile app**

## Onboard User Interface

An integrated onboard user interface that makes setup and continued operation easy. It provides real time operational performance, status, data, and alarms. It also allows the user to interact with, service, troubleshoot, and control their equipment without additional service software tools or when a mobile interface is not available.

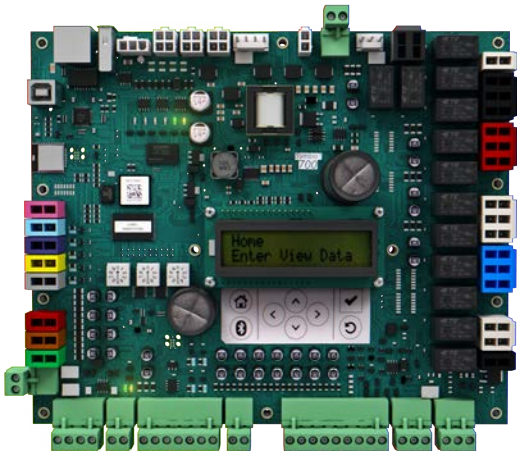
**Figure 24. Onboard user interface**

## Service Test Mode

Symbio™ 700 requires no special tools to run the unit through its paces. Simply navigate to the ‘Service’ section of the on-board user interface or the ‘Tools’ section of the Symbio Service and Installation Mobile App and enter the ‘Service Test Mode’ section.

Here the unit can be placed in the desired operating condition for a pre-determined amount of time supporting troubleshooting efforts in the field. The Symbio 700 will return to normal control when the user exits test mode or when the pre-determined, user-selected Service Test time has expired.

## Symbio 700 Controls with Upgradeable Software

Equipment and systems feature engineered, tested, and proven applications that meet industry energy standards and provide the flexibility to customize and update over the life of the equipment. Professional operational algorithms are embedded within the Symbio™ 700 controller at the J factory. Symbio 700 standardizes each equipment unit to maintain standards for comfort, efficiency, and air quality, without additional field programming. Symbio 700 provides the flexibility over the life of the equipment to meet changing customer needs and/or industry standards.

## Flexibility

### Expansion Modules

- XM30 – Provides 4 universal inputs or analog outputs
- XM32 – Provides 4 binary outputs

### Field Programming via TGP2

- Control ancillary equipment
- Custom sequences

### TGP2 and XM Limitations

- Programs will only have access to available BACnet® points. (Ensures system reliability.)
- TGP2 programs will not have direct I/O control access for factory components. (Compressors will not be able to be directly controlled On/Off without going through factory provided protection sequences.)
- Onboard I/O will not be available to custom applied TGP2 programs. If additional I/O is required for a new control loop, a separate expansion module will be required.
- I/O will be limited to a maximum combination of 2 XM modules. Only XM30 or XM32 modules are supported by the Symbio™ 700.

## Economizer Controls

Four options for economizer control are available: Dry Bulb Temperature, Comparative Enthalpy, Reference Enthalpy, and Differential Dry Bulb Temperature.

### Dry Bulb Temperature Control

The dry bulb system measures outdoor temperature comparing it to the economizer enable setpoint. If the outdoor temperature is below the economizer enable setpoint, the economizer will operate freely. This system is best suited for arid regions where the humidity levels of outside air would not be detrimental to building comfort and indoor air quality.

### Comparative Enthalpy Control

The comparative enthalpy system measures the temperature and humidity of both return air and outside air to determine which source has lower enthalpy. This system allows true comparison of outdoor air and return air enthalpy by measurement of outdoor air and return air temperature and humidity.

### Reference Enthalpy Control

The reference enthalpy system compares outdoor air temperature and humidity to the economizer enthalpy enable setpoint. If outdoor air temperature and humidity are below the economizer enthalpy enable setpoint, the economizer will operate freely. This system provides more sophisticated control where outdoor air humidity levels may not be acceptable for building comfort and indoor air quality.

### Differential Dry Bulb Temperature Control

The differential dry bulb system measures the temperature of both return air and outside air to determine when to economize. If outdoor air temperature is below the return air temperature minus a differential, the economizer will operate freely. This system is best suited for arid regions where the humidity levels of outside air would not be detrimental to building comfort and indoor air quality.



# Zone Sensors

Zone Temperature Only

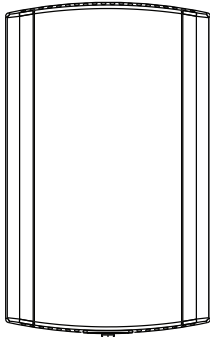

**BAYSENS077**

Provides temperature input only. Can be used as a secondary remote temperature input for thermostats.

Manual Changeover

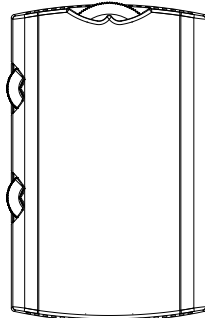

**BAYSENS106**

Heat, Cool or Off System Switch. Fan Auto or Off Switch. Single temperature setpoint thumbwheel.

Manual/Automatic Changeover

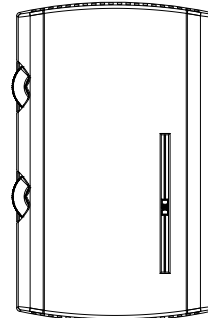

**BAYSENS108**

Auto, Heat, Cool or Off System Switch. Fan Auto or Off Switch. Dual temperature setpoint sliders

Integrated Comfort™ System

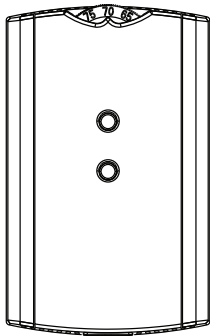

**BAYSENS073 / BAYSENS074 / BAYSENS075**

Sensor(s) available with optional temperature adjustment and override buttons to provide central control.

Wired Display Sensor

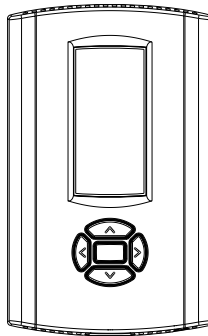

**BAYSENS135**

LCD display that provides heat, cool, auto, or off. Includes two temperature setpoints and a lockable setting with °F or °C indicators.

Touchscreen Digital Display Communicating Sensor



**BAYSENS800**

Uses BACnet® MS/TP link to communicate zone temperature and setpoints. Auto, Heat, Cool or Off System Switch. Fan Auto or On Switch. 7-day programmable thermostat with night setback.

**Note:** Not compatible with VAV units. Requires BACnet communications.

# Air-Fi Wireless Communicating Zone Sensors

Wireless Zone Temperature Only

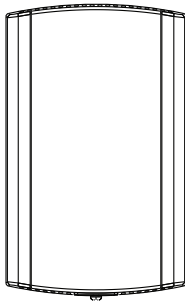

**BAYSENS077**

Measures temperature and optional humidity (with WCS-SH) for use in public spaces where no local user interface is preferred.

**Note:** Requires BACnet communications.

Wireless Display Sensor

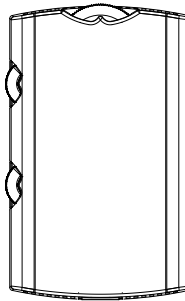

**BAYSENS106**

Easy-to-use interface for clear and simple monitoring and control. Can be configured for any system.

**Note:** Requires BACnet communications.

Wired CO<sub>2</sub> Sensor

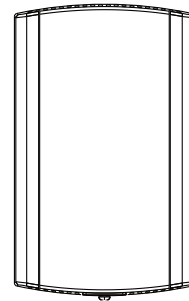

**X13790422010**

The maintenance-free carbon dioxide (CO<sub>2</sub>) sensor is primarily used for demand control ventilation applications.

Wired Zone Temperature and Humidity Sensor

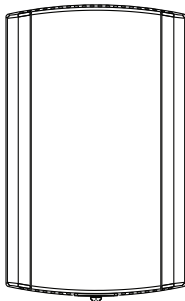

**BAYSENS036**

Measures temperature and relative humidity. Relative humidity input is used to control activation of dehumidification.

## Thermostats

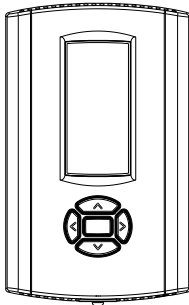
**Digital Display Thermostat (3H/2C)**

**BAYSTAT155**

Three Heat/Two Cool Auto changeover display thermostat.

**Note:** Not compatible with VAV units.

**Pivot® Web Enabled Smart Thermostat (3H/2C)**

**BAYSTAT814**

Our Pivot Smart Thermostat system is great for commercial buildings. With its intuitive touchscreen and customizable display, it is easy for occupants to use. The Pivot mobile app enables users to control multiple buildings remotely, making changes in seconds to all systems.

**Note:** Not compatible with VAV units.

**Touchscreen Programmable Thermostat with Relative Humidity Sensor (3H/2C)**

**BAYSTAT152**

Three Heat, Two Cool digital display thermostat with built-in humidity control. This thermostat combines both humidity and temperature into one.

**Note:** Not compatible with VAV units.

## Humidity Control (HGRH)

### Sequence of Operations

Humidity Control system capable of operating in normal cooling, dual mode to satisfy cooling and humidity requirements, and hot gas reheat mode when only humidity demand is required. Function between requirements and unit transition seamlessly providing an all-around comfort solution.

**Note:** Supports Humidistat control. When the Humidistat input becomes active, compressors will stage to full capacity and modulate the 3-way valve.

### Initiation of Humidity Control

- Conforms to ASHRAE standard (62.1-2022)
- Dehumidification is initiated when too much moisture is in the space (>60°F Dew point)
  - Two measurement options are available for dehumidification status. Humidity control is started when:
    - Dew point is too high (60°F is default),
    - Relative Humidity is too high (60 percent is default)
    - Choice between these values above is user-configurable, and the actual values are adjustable by customer if desired
- Reheat circuit is initiated when space temperature drops below setpoint during humidity control.

### Humidity Control Routine

There are two independent control loops: One to control latent load, the other to control sensible load.

Latent load is controlled by compressor staging:

- Compressors initially move up one stage from the last cooling mode stage.
- Compressors are staged up as needed by the controller to achieve a target leaving ID air dew point based on space conditions.

Sensible load is controlled with the Modulating 3 way valve:

- Modulating valve opens when space temperature is below setpoint.
- The reheat valve adjusts the amount of flow to reheat coil to achieve the targeted leaving ID air temperature, based on space conditions.

---

## Purge Cycle

During dehumidification, every 120 minutes (default) a 3 minute cooling “purge cycle” will be executed. This purge cycle is executed for system reliability, specifically it helps manage oil return to compressors.

- Modulating valve moves to a fixed position based on OD air and compressor stage.
- Compressors move to full load.

## Leaving Humidity Control and Returning to Cooling Only

- When space humidity drops to below the threshold humidity value (60°F dew point or 60% relative humidity), system reverts back to cooling mode. Dead band of ~5°F yields approximately 55°F dew point for switch to cooling.
- Unit can stay in humidity control mode indefinitely, with purge cycles happening regularly.
  - Relative humidity setpoint is 65 percent for unoccupied mode.
  - Dew point for unoccupied mode is the same as occupied (default 60°F DP).



# Electrical Data

Table 157. Unit wiring – cooling

Tons	Unit Model Number	Voltage Range	Standard Indoor Fan Motor		Oversized/High Static Indoor Fan Motor		Optional Power Exhaust Standard Indoor Fan Motor		Optional Power Exhaust Oversized/High Static Indoor Fan Motor	
			MCA	Max Fuse Size or Max Circuit Breaker	MCA	Max Fuse Size or Max Circuit Breaker	MCA	Max Fuse Size or Max Circuit Breaker	MCA	Max Fuse Size or Max Circuit Breaker
3	TSK036A3	187-253	23	30	25	35	25	35	28	35
	TSK036A4	414-506	10	15	13	15	11	15	14	15
	TSK036AW	517-632	10	15	11	15	11	15	12	15
3 HGRH	TSK036A3	187-253	25	35	27	35	27	35	29	40
	TSK036A4	414-506	11	15	14	15	12	15	15	20
3	THK036A3	187-253	22	30	24	30	24	30	26	35
	THK036A4	414-506	11	15	12	15	12	15	13	15
3 HGRH	THK036A3	187-253	23	30	25	35	26	35	28	35
	THK036A4	414-506	12	15	13	15	13	15	14	15
4	TSK048A3	187-253	27	40	29	40	29	40	31	45
	TSK048A4	414-506	12	15	14	20	13	15	15	20
	TSK048AW	517-632	12	15	13	15	13	15	14	20
4 HGRH	TSK048A3	187-253	31	45	32	45	33	45	35	45
	TSK048A4	414-506	14	20	16	20	15	20	17	20
4	THK048A3	187-253	28	40	—	—	34	45	—	—
	THK048A4	414-506	16	20	—	—	19	25	—	—
	THK048AW	517-632	11	15	—	—	14	15	—	—
4 HGRH	THK048A3	187-253	32	45	—	—	38	50	—	—
	THK048A4	414-506	17	20	—	—	20	25	—	—
5	TSK060A3	187-253	29	45	31	45	32	45	33	45
	TSK060A4	414-506	14	20	16	20	15	20	17	20
	TSK060AW	517-632	13	20	14	20	14	20	15	20
5 HGRH	TSK060A3	187-253	33	45	35	50	36	50	37	50
	TSK060A4	414-506	15	20	17	20	16	20	18	25
5	THK060A3	187-253	31	45	—	—	36	50	—	—
	THK060A4	414-506	16	20	—	—	19	25	—	—
	THK060AW	517-632	13	15	—	—	15	20	—	—
5 HGRH	THK060A3	187-253	34	45	—	—	40	50	—	—
	THK060A4	414-506	17	20	—	—	21	25	—	—
6	TS/HK072A3	187-253	38	50	—	—	44	50	—	—
	TS/HK072A4	414-506	20	25	—	—	23	25	—	—
	TS/HK072AW	517-632	17	20	—	—	20	25	—	—
7.5	TS/HK090A3	187-253	43	50	—	—	49	60	—	—
	TS/HK090A4	414-506	22	25	—	—	25	30	—	—
	TS/HK090AW	517-632	19	25	—	—	21	25	—	—

**Table 157. Unit wiring – cooling (continued)**

Tons	Unit Model Number	Voltage Range	Standard Indoor Fan Motor		Oversized/High Static Indoor Fan Motor		Optional Power Exhaust Standard Indoor Fan Motor		Optional Power Exhaust Oversized/High Static Indoor Fan Motor	
			MCA	Max Fuse Size or Max Circuit Breaker	MCA	Max Fuse Size or Max Circuit Breaker	MCA	Max Fuse Size or Max Circuit Breaker	MCA	Max Fuse Size or Max Circuit Breaker
8.5	TS/HK102A3	187-253	53	70	—	—	58	70	—	—
	TS/HK102A4	414-506	26	35	—	—	29	35	—	—
	TS/HK102AW	517-632	21	25	—	—	23	30	—	—
10	TSK120A3	187-253	57	80	59	80	62	80	65	80
	TSK120A4	414-506	30	40	30	40	33	45	34	45
	TSK120AW	517-632	24	30	24	30	26	35	27	35
10	THK120A3	187-253	60	80	62	80	66	90	68	90
	THK120A4	414-506	31	40	32	45	34	45	35	45
	THK120AW	517-632	24	30	24	30	26	35	27	35
12.5	TSK150A3	187-253	67	90	—	—	73	100	—	—
	TSK150A4	414-506	33	45	—	—	36	50	—	—
	TSK150AW	517-632	26	35	—	—	28	35	—	—
12.5	THK150A3	187-253	74	100	—	—	80	100	—	—
	THK150A4	414-506	37	50	—	—	41	50	—	—
	THK150AW	517-632	29	35	—	—	31	40	—	—
15	TS/HK180A3	187-253	79	110	—	—	85	110	—	—
	TS/HK180A4	414-506	40	50	—	—	43	50	—	—
	TS/HK180AW	517-632	32	40	—	—	34	45	—	—
17.5	TS/HK210A3	187-253	95	125	—	—	101	125	—	—
	TS/HK210A4	414-506	47	60	—	—	51	60	—	—
	TS/HK210AW	517-632	38	50	—	—	41	50	—	—
20	TS/HK240A3	187-253	108	150	—	—	114	150	—	—
	TS/HK240A4	414-506	55	70	—	—	58	80	—	—
	TS/HK240AW	517-632	40	50	—	—	43	50	—	—
25	TS/HK300A3	187-253	118	150	123	150	124	150	128	175
	TS/HK300A4	414-506	59	80	61	80	62	80	64	80
	TS/HK300AW	517-632	42	50	44	60	45	60	46	60



**Electrical Data**

**Table 158. Unit wiring with electric heat – cooling**

Tons	Unit Model Number	Heater Model Number	Heater kW Rating	Control Stages	Standard Indoor Fan Motor <sup>(a)</sup>		Oversized/High Static Indoor Fan Motor		Optional Power Exhaust Standard Indoor Fan Motor		Optional Power Exhaust Oversized/High Static Indoor Fan Motor	
					MCA	Max Fuse Size or Max Circuit Breaker	MCA	Max Fuse Size or Max Circuit Breaker	MCA	Max Fuse Size or Max Circuit Breaker	MCA	Max Fuse Size or Max Circuit Breaker
3	TSK036A3	FIAEHTA306*	6	1	25/27	30/30	28/30	35/35	27/30	35/35	30/33	35/35
		FIAEHTA312*	12	2	40/45	40/45	43/48	45/50	43/48	45/50	46/51	50/60
		FIAEHTA318*	18	2	54/61	60/70	57/64	60/70	57/64	60/70	60/67	60/70
3 HGRH	TSK036A3	FIAEHTA306*	6	1	25/27	35/35	28/30	35/35	27/30	35/35	30/33	40/40
		FIAEHTA312*	12	2	40/45	40/45	43/48	45/50	43/48	45/50	46/51	50/60
		FIAEHTA318*	18	2	54/61	60/70	57/64	60/70	57/64	60/70	60/67	60/70
3	THK036A3	FIAEHTA306*	6	1	27/29	30/30	29/32	30/35	29/32	30/35	32/34	35/35
		FIAEHTA312*	12	2	42/47	45/50	45/50	45/50	45/50	45/50	48/52	50/60
		FIAEHTA318*	18	2	56/63	60/70	59/66	60/70	59/66	60/70	62/69	70/70
3 HGRH	THK036A3	FIAEHTA306*	6	1	27/29	30/30	29/32	35/35	29/32	35/35	32/34	35/35
		FIAEHTA312*	12	2	42/47	45/50	45/50	45/50	45/50	45/50	48/52	50/60
		FIAEHTA318*	18	2	56/63	60/70	59/66	60/70	59/66	60/70	62/69	70/70
4	TSK048A3	FIAEHTA306*	6	1	27/28	40/40	29/30	40/40	29/31	40/40	31/33	45/45
		FIAEHTA312*	12	2	42/46	45/50	43/48	45/50	44/49	45/50	46/51	50/60
		FIAEHTA318*	18	2	56/63	60/70	57/64	60/70	58/65	60/70	60/67	60/70
4 HGRH	TSK048A3	FIAEHTA306*	6	1	31/31	45/45	32/32	45/45	33/33	45/45	35/35	45/45
		FIAEHTA312*	12	2	42/46	45/50	43/48	45/50	44/49	45/50	46/51	50/60
		FIAEHTA318*	18	2	56/63	60/70	57/64	60/70	58/65	60/70	60/67	60/70
4	THK048A3	FIAEHTB306*	6	1	28/31	40/40	—	—	36/38	45/45	—	—
		FIAEHTB312*	12	2	44/49	45/50	—	—	51/56	60/60	—	—
		FIAEHTB318*	18	2	60/67	60/70	—	—	67/74	70/80	—	—
4 HGRH	THK048A3	FIAEHTB306*	6	1	32/32	45/45	—	—	38/38	50/50	—	—
		FIAEHTB312*	12	2	44/49	45/50	—	—	51/56	60/60	—	—
		FIAEHTB318*	18	2	60/67	60/70	—	—	67/74	70/80	—	—
5	TSK060A3	FIAEHTA306*	6	1	31/31	45/45	32/32	45/45	33/33	45/45	35/35	45/45
		FIAEHTA312*	12	2	42/46	45/50	43/48	45/50	44/49	45/50	46/51	50/60
		FIAEHTA318*	18	2	56/63	60/70	57/64	60/70	58/65	60/70	60/67	60/70
		FIAEHTA323*	23	2	70/80	70/80	72/81	80/90	73/82	80/90	75/84	80/90
5 HGRH	TSK060A3	FIAEHTA306*	6	1	31/31	45/45	32/32	45/45	33/33	45/45	35/35	45/45
		FIAEHTA312*	12	2	42/46	45/50	43/48	50/50	44/49	50/50	46/51	50/60
		FIAEHTA318*	18	2	56/63	60/70	57/64	60/70	58/65	60/70	60/67	60/70
		FIAEHTA323*	23	2	70/80	70/80	72/81	80/90	73/82	80/90	75/84	80/90

**Table 158. Unit wiring with electric heat – cooling (continued)**

Tons	Unit Model Number	Heater Model Number	Heater kW Rating	Control Stages	Standard Indoor Fan Motor <sup>(a)</sup>		Oversized/High Static Indoor Fan Motor		Optional Power Exhaust Standard Indoor Fan Motor		Optional Power Exhaust Oversized/High Static Indoor Fan Motor	
					MCA	Max Fuse Size or Max Circuit Breaker	MCA	Max Fuse Size or Max Circuit Breaker	MCA	Max Fuse Size or Max Circuit Breaker	MCA	Max Fuse Size or Max Circuit Breaker
5	THK060A3	FIAEHTB306*	6	1	31/31	45/45	—	—	36/38	50/50	—	—
		FIAEHTB312*	12	2	44/49	45/50	—	—	51/56	60/60	—	—
		FIAEHTB318*	18	2	60/67	60/70	—	—	67/74	70/80	—	—
		FIAEHTB327*	27	2	83/94	90/100	—	—	90/101	90/110	—	—
5 HGRH	THK060A3	FIAEHTB306*	6	1	34/34	45/45	—	—	40/40	50/50	—	—
		FIAEHTB312*	12	2	44/49	45/50	—	—	51/56	60/60	—	—
		FIAEHTB318*	18	2	60/67	60/70	—	—	67/74	70/80	—	—
		FIAEHTB327*	27	2	83/94	90/100	—	—	90/101	90/110	—	—
6	TS/ HK072A3	FIAEHTB309*	9	1	38/40	50/50	—	—	44/47	50/50	—	—
		FIAEHTB318*	18	2	60/67	60/70	—	—	67/74	70/80	—	—
		FIAEHTB327*	27	2	83/94	90/100	—	—	90/101	90/110	—	—
		FIAEHTB336*	36	2	107/121	110/125	—	—	114/128	125/150	—	—
7.5	TS/ HK090A3	FIAEHTB309*	9	1	43/43	50/50	—	—	49/49	60/60	—	—
		FIAEHTB318*	18	2	60/67	60/70	—	—	67/74	70/80	—	—
		FIAEHTB327*	27	2	83/94	90/100	—	—	90/101	90/110	—	—
		FIAEHTB336*	36	2	107/121	110/125	—	—	114/128	125/150	—	—
8.5	TS/ HK102A3	FIAEHTB309*	9	1	53/53	70/70	—	—	58/58	70/70	—	—
		FIAEHTB318*	18	2	60/67	70/70	—	—	67/74	70/80	—	—
		FIAEHTB327*	27	2	83/94	90/100	—	—	90/101	90/110	—	—
		FIAEHTB336*	36	2	107/121	110/125	—	—	114/128	125/150	—	—
10	TS/ HK120A3	FIAEHTB318*	18	2	60/67	80/80	62/70	80/80	67/74	80/80	70/77	80/80
		FIAEHTB327*	27	2	83/94	90/100	86/97	90/100	90/101	90/110	93/104	100/110
		FIAEHTB336*	36	2	107/121	110/125	109/124	110/125	114/128	125/150	116/131	125/150
		FIAEHTB354*	54	2	153/143	175/175	156/145	175/175	161/150	175/175	163/153	175/175
12.5	TSK150A3	FIAEHTC318*	18	1	67/70	90/90	—	—	73/77	100/100	—	—
		FIAEHTC327*	27	2	86/97	90/100	—	—	93/104	100/110	—	—
		FIAEHTC336*	36	2	109/124	110/125	—	—	116/131	125/150	—	—
		FIAEHTC354*	54	2	156/145	175/175	—	—	163/153	175/175	—	—
12.5	THK150A3	FIAEHTD318*	18	1	74/78	100/100	—	—	80/85	100/100	—	—
		FIAEHTD336*	36	2	118/132	125/150	—	—	125/139	125/150	—	—
		FIAEHTD354*	54	2	164/154	175/175	—	—	172/161	175/175	—	—



**Electrical Data**

**Table 158. Unit wiring with electric heat – cooling (continued)**

Tons	Unit Model Number	Heater Model Number	Heater kW Rating	Control Stages	Standard Indoor Fan Motor <sup>(a)</sup>		Oversized/High Static Indoor Fan Motor		Optional Power Exhaust Standard Indoor Fan Motor		Optional Power Exhaust Oversized/High Static Indoor Fan Motor	
					MCA	Max Fuse Size or Max Circuit Breaker	MCA	Max Fuse Size or Max Circuit Breaker	MCA	Max Fuse Size or Max Circuit Breaker	MCA	Max Fuse Size or Max Circuit Breaker
15	TS/ HK180A3	FIAEHTD318*	18	1	79/79	110/110	—	—	85/85	110/110	—	—
		FIAEHTD336*	36	2	118/132	125/150	—	—	125/139	125/150	—	—
		FIAEHTD354*	54	2	164/154	175/175	—	—	172/161	175/175	—	—
17.5	TS/ HK210A3	FIAEHTD336*	36	2	118/132	125/150	—	—	125/139	125/150	—	—
		FIAEHTD354*	54	2	164/154	175/175	—	—	172/161	175/175	—	—
		FIAEHTD372*	72	2	174/197	200/225	—	—	181/204	200/225	—	—
20	TS/ HK240A3	FIAEHTD336*	36	2	118/132	150/150	—	—	125/139	150/150	—	—
		FIAEHTD354*	54	2	164/154	175/175	—	—	172/161	175/175	—	—
		FIAEHTD372*	72	2	174/197	200/225	—	—	181/204	200/225	—	—
25	TS/ HK300A3	FIAEHTD336*	36	2	118/132	150/150	123/138	150/150	125/139	150/150	130/145	175/175
		FIAEHTD354*	54	2	164/154	175/175	170/159	175/175	172/161	175/175	177/166	200/175
		FIAEHTD372*	72	2	174/197	200/225	179/202	200/225	181/204	200/225	186/210	200/225
<b>460 Volts Three Phase</b>												
3	TSK036A4	FIAEHTA406*	6	1	13	15	16	20	14	15	17	20
		FIAEHTA412*	12	2	22	25	25	25	23	25	26	30
		FIAEHTA418*	18	2	30	30	33	35	31	35	35	35
3 HGRH	TSK036A3	FIAEHTA406*	6	1	13	15	16	20	14	15	17	20
		FIAEHTA412*	12	2	22	25	25	25	23	25	26	30
		FIAEHTA418*	18	2	30	30	33	35	31	35	35	35
3	THK036A4	FIAEHTA406*	6	1	14	15	15	15	16	20	17	20
		FIAEHTA412*	12	2	23	25	24	25	25	25	26	30
		FIAEHTA418*	18	2	31	35	32	35	33	35	34	35
3 HGRH	THK036A4	FIAEHTA406*	6	1	14	15	15	15	16	20	17	20
		FIAEHTA412*	12	2	23	25	24	25	25	25	26	30
		FIAEHTA418*	18	2	31	35	32	35	33	35	34	35
4	TSK048A4	FIAEHTA406*	6	1	14	15	16	20	15	15	17	20
		FIAEHTA412*	12	2	23	25	25	25	24	25	26	30
		FIAEHTA418*	18	2	31	35	33	35	32	35	35	35
4 HGRH	TSK048A4	FIAEHTA406*	6	1	14	20	16	20	15	20	17	20
		FIAEHTA412*	12	2	23	25	25	25	24	25	26	30
		FIAEHTA418*	18	2	31	35	33	35	32	35	35	35

**Table 158. Unit wiring with electric heat – cooling (continued)**

Tons	Unit Model Number	Heater Model Number	Heater kW Rating	Control Stages	Standard Indoor Fan Motor <sup>(a)</sup>		Oversized/High Static Indoor Fan Motor		Optional Power Exhaust Standard Indoor Fan Motor		Optional Power Exhaust Oversized/High Static Indoor Fan Motor	
					MCA	Max Fuse Size or Max Circuit Breaker	MCA	Max Fuse Size or Max Circuit Breaker	MCA	Max Fuse Size or Max Circuit Breaker	MCA	Max Fuse Size or Max Circuit Breaker
4	THK048A4	FIAEHTB406*	6	1	17	20	—	—	21	25	—	—
		FIAEHTB412*	12	2	26	30	—	—	30	30	—	—
		FIAEHTB418*	18	2	35	35	—	—	39	40	—	—
4 HGRH	THK048A4	FIAEHTB406*	6	1	17	20	—	—	21	25	—	—
		FIAEHTB412*	12	2	26	30	—	—	30	30	—	—
		FIAEHTB418*	18	2	35	35	—	—	39	40	—	—
5	TSK060A4	FIAEHTA406*	6	1	14	20	16	20	15	20	17	20
		FIAEHTA412*	12	2	23	25	25	25	24	25	26	30
		FIAEHTA418*	18	2	31	35	33	35	32	35	35	35
		FIAEHTA423*	23	2	39	40	42	45	41	45	43	45
5 HGRH	TSK060A4	FIAEHTA406*	6	1	14	20	16	20	15	20	17	20
		FIAEHTA412*	12	2	23	25	25	25	24	25	26	30
		FIAEHTA418*	18	2	31	35	33	35	32	35	35	35
		FIAEHTA423*	23	2	39	40	42	45	41	45	43	45
5	THK060A4	FIAEHTB406*	6	1	17	20	—	—	21	25	—	—
		FIAEHTB412*	12	2	26	30	—	—	30	30	—	—
		FIAEHTB418*	18	2	35	35	—	—	39	40	—	—
		FIAEHTB427*	27	2	48	50	—	—	52	60	—	—
5 HGRH	THK060A4	FIAEHTB406*	6	1	17	20	—	—	21	25	—	—
		FIAEHTB412*	12	2	26	30	—	—	30	30	—	—
		FIAEHTB418*	18	2	35	35	—	—	39	40	—	—
		FIAEHTB427*	27	2	48	50	—	—	52	60	—	—
6	TS/ HK072A4	FIAEHTB409*	9	1	21	25	—	—	25	25	—	—
		FIAEHTB418*	18	2	35	35	—	—	39	40	—	—
		FIAEHTB427*	27	2	48	50	—	—	52	60	—	—
		FIAEHTB436*	36	2	62	70	—	—	66	70	—	—
7.5	TS/ HK090A4	FIAEHTB409*	9	1	22	25	—	—	25	30	—	—
		FIAEHTB418*	18	2	35	35	—	—	39	40	—	—
		FIAEHTB427*	27	2	48	50	—	—	52	60	—	—
		FIAEHTB436*	36	2	62	70	—	—	66	70	—	—



**Electrical Data**

**Table 158. Unit wiring with electric heat – cooling (continued)**

Tons	Unit Model Number	Heater Model Number	Heater kW Rating	Control Stages	Standard Indoor Fan Motor <sup>(a)</sup>		Oversized/High Static Indoor Fan Motor		Optional Power Exhaust Standard Indoor Fan Motor		Optional Power Exhaust Oversized/High Static Indoor Fan Motor	
					MCA	Max Fuse Size or Max Circuit Breaker	MCA	Max Fuse Size or Max Circuit Breaker	MCA	Max Fuse Size or Max Circuit Breaker	MCA	Max Fuse Size or Max Circuit Breaker
8.5	TS/ HK102A4	FIAEHTB409*	9	1	26	35	—	—	29	35	—	—
		FIAEHTB418*	18	2	35	35	—	—	39	40	—	—
		FIAEHTB427*	27	2	48	50	—	—	52	60	—	—
		FIAEHTB436*	36	2	62	70	—	—	66	70	—	—
10	TS/ HK120A4	FIAEHTB418*	18	2	35	40	36	40	39	45	40	45
		FIAEHTB427*	27	2	48	50	49	50	52	60	53	60
		FIAEHTB436*	36	2	62	70	63	70	66	70	67	70
		FIAEHTB454*	54	2	72	90	74	90	77	90	78	90
12.5	TSK150A4	FIAEHTC418*	18	1	36	45	—	—	40	50	—	—
		FIAEHTC427*	27	2	49	50	—	—	53	60	—	—
		FIAEHTC436*	36	2	63	70	—	—	67	70	—	—
		FIAEHTC454*	54	2	74	90	—	—	78	90	—	—
12.5	THK150A4	FIAEHTD418*	18	1	40	50	—	—	44	50	—	—
		FIAEHTD436*	36	2	67	70	—	—	72	80	—	—
		FIAEHTD454*	54	2	78	90	—	—	82	90	—	—
15	TS/ HK180A4	FIAEHTD418*	18	1	40	50	—	—	44	50	—	—
		FIAEHTD436*	36	2	67	70	—	—	72	80	—	—
		FIAEHTD454*	54	2	78	90	—	—	82	90	—	—
17.5	TS/ HK210A4	FIAEHTD436*	36	2	67	70	—	—	72	80	—	—
		FIAEHTD454*	54	2	78	90	—	—	82	90	—	—
		FIAEHTD472*	72	2	100	110	—	—	104	110	—	—
20	TS/ HK240A4	FIAEHTD436*	36	2	67	70	—	—	72	80	—	—
		FIAEHTD454*	54	2	78	90	—	—	82	90	—	—
		FIAEHTD472*	72	2	100	110	—	—	104	110	—	—
25	TS/ HK300A4	FIAEHTD436*	36	2	67	80	70	80	72	80	74	80
		FIAEHTD454*	54	2	78	90	80	90	82	90	85	90
		FIAEHTD472*	72	2	100	110	102	110	104	110	106	110
<b>575 Volts Three Phase</b>												
3	TSK036AW	FIAEHTAW06*	6	1	13	15	14	15	14	15	15	15
		FIAEHTAW12*	12	2	20	20	21	25	21	25	22	25
		FIAEHTAW18*	18	2	26	30	28	30	28	30	29	30

**Table 158. Unit wiring with electric heat – cooling (continued)**

Tons	Unit Model Number	Heater Model Number	Heater kW Rating	Control Stages	Standard Indoor Fan Motor <sup>(a)</sup>		Oversized/High Static Indoor Fan Motor		Optional Power Exhaust Standard Indoor Fan Motor		Optional Power Exhaust Oversized/High Static Indoor Fan Motor	
					MCA	Max Fuse Size or Max Circuit Breaker	MCA	Max Fuse Size or Max Circuit Breaker	MCA	Max Fuse Size or Max Circuit Breaker	MCA	Max Fuse Size or Max Circuit Breaker
4	TSK048AW	FIAEHTAW06*	6	1	13	15	14	15	14	15	15	20
		FIAEHTAW12*	12	2	20	20	21	25	21	25	22	25
		FIAEHTAW18*	18	2	26	30	28	30	28	30	29	30
4	THK048AW	FIAEHTBW06*	6	1	13	15	—	—	16	20	—	—
		FIAEHTBW12*	12	2	20	20	—	—	23	25	—	—
		FIAEHTBW18*	18	2	27	30	—	—	30	30	—	—
5	TSK060AW	FIAEHTAW06*	6	1	13	15	14	15	14	15	15	20
		FIAEHTAW12*	12	2	20	20	21	25	21	25	22	25
		FIAEHTAW18*	18	2	26	30	28	30	28	30	29	30
		FIAEHTAW23*	23	2	33	35	34	35	34	35	35	40
5	THK060AW	FIAEHTBW06*	6	1	13	15	—	—	16	20	—	—
		FIAEHTBW12*	12	2	20	20	—	—	23	25	—	—
		FIAEHTBW18*	18	2	27	30	—	—	30	30	—	—
		FIAEHTBW23*	27	2	38	40	—	—	41	45	—	—
6	TS/ HK072AW	FIAEHTBW09*	9	1	17	20	—	—	20	25	—	—
		FIAEHTBW18*	18	2	27	30	—	—	30	30	—	—
		FIAEHTBW27*	27	2	38	40	—	—	41	45	—	—
		FIAEHTBW36*	36	2	49	50	—	—	52	60	—	—
7.5	TS/ HK090AW	FIAEHTBW09*	9	1	19	25	—	—	21	25	—	—
		FIAEHTBW18*	18	2	27	30	—	—	30	30	—	—
		FIAEHTBW27*	27	2	38	40	—	—	41	45	—	—
		FIAEHTBW36*	36	2	49	50	—	—	52	60	—	—
8.5	TS/ HK102AW	FIAEHTBW09*	9	1	21	25	—	—	23	30	—	—
		FIAEHTBW18*	18	2	27	30	—	—	30	30	—	—
		FIAEHTBW27*	27	2	38	40	—	—	41	45	—	—
		FIAEHTBW36*	36	2	49	50	—	—	52	60	—	—
10	TS/ HK120AW	FIAEHTBW18*	18	2	27	30	28	30	30	35	31	35
		FIAEHTBW27*	27	2	38	40	39	40	41	45	42	45
		FIAEHTBW36*	36	2	49	50	50	50	52	60	53	60
		FIAEHTBW54*	54	2	58	70	59	70	61	70	61	70
12.5	TSK150AW	FIAEHTCW18*	18	1	28	35	—	—	31	35	—	—
		FIAEHTCW27*	27	2	39	40	—	—	42	45	—	—
		FIAEHTCW36*	36	2	50	50	—	—	53	60	—	—
		FIAEHTCW54*	54	2	59	70	—	—	61	70	—	—



**Electrical Data**

**Table 158. Unit wiring with electric heat – cooling (continued)**

Tons	Unit Model Number	Heater Model Number	Heater kW Rating	Control Stages	Standard Indoor Fan Motor <sup>(a)</sup>		Oversized/High Static Indoor Fan Motor		Optional Power Exhaust Standard Indoor Fan Motor		Optional Power Exhaust Oversized/High Static Indoor Fan Motor	
					MCA	Max Fuse Size or Max Circuit Breaker	MCA	Max Fuse Size or Max Circuit Breaker	MCA	Max Fuse Size or Max Circuit Breaker	MCA	Max Fuse Size or Max Circuit Breaker
12.5	THK150AW	FIAEHTDW18*	18	1	31	35	—	—	34	40	—	—
		FIAEHTDW36*	36	2	53	60	—	—	56	60	—	—
		FIAEHTDW54*	54	2	62	70	—	—	65	70	—	—
15	TS/ HK180AW	FIAEHTDW18*	18	1	32	40	—	—	34	45	—	—
		FIAEHTDW36*	36	2	53	60	—	—	56	60	—	—
		FIAEHTDW54*	54	2	62	70	—	—	65	70	—	—
17.5	TS/ HK210AW	FIAEHTDW36*	36	2	53	60	—	—	56	60	—	—
		FIAEHTDW54*	54	2	62	70	—	—	65	70	—	—
		FIAEHTDW72*	72	2	79	90	—	—	82	90	—	—
20	TS/ HK240AW	FIAEHTDW36*	36	2	53	60	—	—	56	60	—	—
		FIAEHTDW54*	54	2	62	70	—	—	65	70	—	—
		FIAEHTDW72*	72	2	79	90	—	—	82	90	—	—
25	TS/ HK300AW	FIAEHTDW36*	36	2	53	60	55	60	56	60	58	60
		FIAEHTDW54*	54	2	62	70	63	70	65	70	66	70
		FIAEHTDW72*	72	2	79	90	81	90	82	90	84	90

**Note:** Kit used with Title 24/SZVAV models.

<sup>(a)</sup> The standard motor is a multispeed, direct drive motor.

**Table 159. Electrical characteristics – compressor motor and condenser motor – cooling**

Tons	Unit Model Number	No.	Compressor Motors					No.	Condenser Fan Motor				
			Volts	Phase	rpm	Amps <sup>(a)</sup>			Volts	Phase	hp	Amps	
						RLA	LRA					FLA	LRA
3	TSK036A3	1	208/230	3	3500	12.5	97.5	1	208/230	3	0.25	1.1	3.6
	TSK036A4	1	460	3	3500	5.9	44.3	1	460	3	0.25	0.55	1.8
	TSK036AW	1	575	3	3500	4.6	27.1	1	575	3	0.25	0.45	1.4
3 HGRH	TSK036A3	1	208/230	3	3500	12.5	97.5	1	208/230	1	0.33	2.8	—
	TSK036A4	1	460	3	3500	5.9	44.3	1	460	1	0.33	1.6	—
3	THK036A3	1	208/230	3	3500	10.2	82.0	1	208/230	3	0.25	1.1	3.6
	THK036A4	1	460	3	3500	5.6	44.3	1	460	3	0.25	0.55	1.8
3 HGRH	THK036A3	1	208/230	3	3500	10.2	82.0	1	208/230	1	0.33	2.8	—
	THK036A4	1	460	3	3500	5.6	44.3	1	460	1	0.33	1.6	—
4	TSK048A3	1	208/230	3	3500	14.8	120.4	1	208/230	3	0.33	1.4	4.6
	TSK048A4	1	460	3	3500	7.0	49.4	1	460	3	0.33	0.7	2.3
	TSK048AW	1	575	3	3500	6.7	41.0	1	575	3	0.33	0.55	1.8
4 HGRH	TSK048A3	1	208/230	3	3500	14.8	120.4	1	208/230	1	0.50	5.3	—
	TSK048A4	1	460	3	3500	7.0	49.4	1	460	1	0.50	2.3	—

**Table 159. Electrical characteristics – compressor motor and condenser motor – cooling (continued)**

Tons	Unit Model Number	No.	Compressor Motors					No.	Condenser Fan Motor				
			Volts	Phase	rpm	Amps <sup>(a)</sup>			Volts	Phase	hp	Amps	
						RLA	LRA					FLA	LRA
4	THK048A3	1	208/230	3	3500	13.8	112.0	1	208/230	3	0.4	1.4	5.2
	THK048A4	1	460	3	3500	7.8	61.8	1	460	3	0.4	0.7	2.6
	THK048AW	1	575	3	3500	5.6	39.0	1	575	3	0.4	0.6	2.1
4 HGRH	THK048A3	1	208/230	3	3500	13.8	112.0	1	208/230	1	0.5	5.3	—
	THK048A4	1	460	3	3500	7.8	61.8	1	460	1	0.5	2.3	—
5	TSK060A3	1	208/230	3	3500	16.5	156.4	1	208/230	3	0.4	1.4	5.2
	TSK060A4	1	460	3	3500	8.1	69.0	1	460	3	0.4	0.7	2.6
	TSK060AW	1	575	3	3500	7.4	47.8	1	575	3	0.4	0.6	2.1
5 HGRH	TSK060A3	1	208/230	3	3500	16.5	156.4	1	208/230	1	0.50	5.3	—
	TSK060A4	1	460	3	3500	8.1	69.0	1	460	1	0.50	2.3	—
5	THK060A3	1	208/230	3	3500	15.9	161	1	208/230	3	0.4	1.4	5.2
	THK060A4	1	460	3	3500	7.9	58.0	1	460	3	0.4	0.7	2.6
	THK060AW	1	575	3	3500	6.7	47.8	1	575	3	0.4	0.6	2.1
5 HGRH	THK060A3	1	208/230	3	3500	15.9	161.0	1	208/230	1	0.50	5.3	—
	THK060A4	1	460	3	3500	7.9	58.0	1	460	1	0.50	2.3	—
6	TS/HK072A3	2	208/230	3	3500	14.8/7.4	120.4/58.7	1	208/230	3	0.70	3.3	12.3
	TS/HK072A4	2	460	3	3500	7.0/4.2	49.4/26.3	1	460	3	0.70	1.5	6.1
	TS/HK072AW	2	575	3	3500	6.7/3.8	41.0/24	1	575	3	0.70	1.4	5.1
7.5	TS/HK090A3	2	208/230	3	3500	16.5/9.9	156.4/67.7	1	208/230	3	0.70	3.3	12.3
	TS/HK090A4	2	460	3	3500	8.1/5.2	69.0/38.1	1	460	3	0.70	1.5	6.1
	TS/HK090AW	2	575	3	3500	7.4/4.4	47.8/27.7	1	575	3	0.70	1.4	5.1
8.5	TS/HK102A3	2	208/230	3	3500	21.8/13.2	156.5/97.5	1	208/230	3	0.75	2.8	10.4
	TS/HK102A4	2	460	3	3500	10.5/5.9	74.8/44.3	1	460	3	0.75	1.4	5.2
	TS/HK102AW	2	575	3	3500	8.9/5.2	47.8/27.1	1	575	3	0.75	1.14	4.5
10	TSK120A3	2	208/230	3	3500	25.2/13.2	210.0/97.5	1	208/230	3	0.75	2.8	10.4
	TSK120A4	2	460	3	3500	13.7/5.9	103.0/44.3	1	460	3	0.75	1.4	5.2
	TSK120AW	2	575	3	3500	10.8/5.2	78.0/27.1	1	575	3	0.75	1.14	4.5
10	THK120A3	2	208/230	3	3500	25.2/13.2	210.0/97.5	1	208/230	1	0.75	6.3	—
	THK120A4	2	460	3	3500	13.7/5.9	103.0/44.3	1	460	1	0.75	3.0	—
	THK120AW	2	575	3	3500	10.8/5.2	78.0/27.1	1	575	3	0.75	1.14	4.5
12.5	TSK150A3	2	208/230	3	3500	29.5/14.8	207.5/120.4	1	208/230	3	1	4.3	18.9
	TSK150A4	2	460	3	3500	14.4/7.0	100.2/49.4	1	460	3	1	2.2	9.5
	TSK150AW	2	575	3	3500	10.4/6.7	78.0/41.0	1	575	3	1	1.8	8.1
12.5	THK150A3	2	208/230	3	3500	29.5/14.8	207.5/120.4	2	208/230	3	0.5	2.2	8.4
	THK150A4	2	460	3	3500	14.4/7	100.2/49.4	2	460	3	0.5	1.3	4.2
	THK150AW	2	575	3	3500	10.4/6.7	78.0/41.0	2	575	3	0.5	1.1	3.6
15	TS/HK180A3	2	208/230	3	3500	32.3/16.5	255/156.4	2	208/230	3	0.5	2.2	8.4
	TS/HK180A4	2	460	3	3500	15.5/8.1	123.0/69.0	2	460	3	0.5	1.3	4.2
	TS/HK180AW	2	575	3	3500	12.4/7.4	93.7/47.8	2	575	3	0.5	1.1	3.6
17.5	TS/HK210A3	2	208/230	3	3500	37.1/21.8	255/156.5	2	208/230	3	1	4.3	20
	TS/HK210A4	2	460	3	3500	17.8/10.5	140.0/74.8	2	460	3	1	2.5	10.1
	TS/HK210AW	2	575	3	3500	14.9/8.9	107.6/47.8	2	575	3	1	1.9	8



**Electrical Data**

**Table 159. Electrical characteristics – compressor motor and condenser motor – cooling (continued)**

Tons	Unit Model Number	No.	Compressor Motors					No.	Condenser Fan Motor				
			Volts	Phase	rpm	Amps <sup>(a)</sup>			Volts	Phase	hp	Amps	
						RLA	LRA					FLA	LRA
20	TS/HK240A3	2	208/230	3	3500	44.5/25.9	270.0/ 178.5	2	208/230	3	1	4.3	20
	TS/HK240A4	2	460	3	3500	22.4/12.2	147.0/79.1	2	460	3	1	2.5	10.1
	TS/HK240AW	2	575	3	3500	15.8/9.9	109.0/65.0	2	575	3	1	1.9	8.0
25	TS/HK300A3	2	208/230	3	3500	49.2/30	335.5/ 190.7	2	208/230	3	1	4.3	20
	TS/HK300A4	2	460	3	3500	23.8/14.4	141.0/ 100.2	2	460	3	1	2.5	10.1
	TS/HK300AW	2	575	3	3500	16.7/10.9	109.0/65.0	2	575	3	1	1.9	8.0

<sup>(a)</sup> Amp draw for each motor (compressor and condenser fan motor); multiply value by number of motors to determine total amps.

**Table 160. Electrical characteristics – indoor fan motor – cooling**

Tons	Unit Model Number	No.	Volts	Phase	hp	Amps <sup>(a)</sup>	
						FLA	LRA
3	TSK036A3	1	208/230	1	0.75	5.7	—
	TSK036A4	1	460	1	0.75	1.7	—
	TSK036AW	1	575	1	1	2.9	—
	THK036A3	1	208/230	1	0.75	7.3	—
	THK036A4	1	460	1	0.75	2.7	—
4	TSK048A3	1	208/230	1	1	6.9	—
	TSK048A4	1	460	1	1	2.4	—
	TSK048AW	1	575	1	1	2.9	—
	THK048A3	1	208/230	1	3	8.8	—
	THK048A4	1	460	1	3	4.6	—
	THK048AW	1	575	1	3	3.2	—
5	TSK060A3	1	208/230	1	1	6.9	—
	TSK060A4	1	460	1	1	2.4	—
	TSK060AW	1	575	1	1	2.9	—
	THK060A3	1	208/230	1	3	8.8	—
	THK060A4	1	460	1	3	4.6	—
	THK060AW	1	575	1	3	3.2	—
6	TS/HK072A3	1	208/230	3	3	8.8	—
	TS/HK072A4	1	460	3	3	4.6	—
	TS/HK072AW	1	575	3	3	3.2	—
7.5	TS/HK090A3	1	208/230	3	3	8.8	—
	TS/HK090A4	1	460	3	3	4.6	—
	TS/HK090AW	1	575	3	3	3.2	—
8.5	TS/HK102A3	1	208/230	3	3	8.8	—
	TS/HK102A4	1	460	3	3	4.6	—
	TS/HK102AW	1	575	3	3	3.2	—
10	TS/HK120A3	1	208/230	3	3	8.8	—
	TS/HK120A4	1	460	3	3	4.6	—
	TS/HK120AW	1	575	3	3	3.2	—
12.5	TSK150A3	1	208/230	3	5	11	—
	TSK150A4	1	460	3	5	5.5	—
	TSK150AW	1	575	3	5	3.9	—

**Table 160. Electrical characteristics – indoor fan motor – cooling (continued)**

Tons	Unit Model Number	No.	Volts	Phase	hp	Amps <sup>(a)</sup>	
						FLA	LRA
12.5	THK150A3	2	208/230	3	3	8.8	—
	THK150A4	2	460	3	3	4.6	—
	THK150AW	2	575	3	3	3.2	—
15	TS/HK180A3	2	208/230	3	3	8.8	—
	TS/HK180A4	2	460	3	3	4.6	—
	TS/HK180AW	2	575	3	3	3.2	—
17.5	TS/HK210A3	2	208/230	3	3	8.8	—
	TS/HK210A4	2	460	3	3	4.6	—
	TS/HK210AW	2	575	3	3	3.2	—
20	TS/HK240A3	2	208/230	3	3	8.8	—
	TS/HK240A4	2	460	3	3	4.6	—
	TS/HK240AW	2	575	3	3	3.2	—
25	TS/HK300A3	2	208/230	3	3	8.8	—
	TS/HK300A4	2	460	3	3	4.6	—
	TS/HK300AW	2	575	3	3	3.2	—

<sup>(a)</sup> Amp draw for each motor (compressor and condenser fan motor); multiply value by number of motors to determine total amps.

**Table 161. Electrical characteristics – oversized indoor fan motor – cooling**

Tons	Unit Model Number	No.	Volts	Phase	hp	Amps <sup>(a)</sup>	
						FLA	LRA
3	TSK036A3	1	208/230	1	1.5	8.2	—
	TSK036A4	1	460	1	1.5	4.2	—
	TSK036AW	1	575	1	1.5	3.9	—
	THK036A3	1	208/230	1	1	9.4	—
	THK036A4	1	460	1	1	3.5	—
4	TSK048A3	1	208/230	1	1.5	8.2	—
	TSK048A4	1	460	1	1.5	4.2	—
	TSK048AW	1	575	1	1.5	3.9	—
5	TSK060A3	1	208/230	1	1.5	8.2	—
	TSK060A4	1	460	1	1.5	4.2	—
	TSK060AW	1	575	1	1.5	3.9	—
10	TS/HK120A3	1	208/230	3	5	11	—
	TS/HK120A4	1	460	3	5	5.5	—
	TS/HK120AW	1	575	3	5	3.9	—
25	TS/HK300A3	2	208/230	3	5	11	—
	TS/HK300A4	2	460	3	5	5.5	—
	TS/HK300AW	2	575	3	5	3.9	—

<sup>(a)</sup> Amp draw for each motor (compressor and condenser fan motor); multiply value by number of motors to determine total amps.

**Table 162. Electrical characteristics – power exhaust – cooling**

Tons	Volts	Phase	hp	rpm	FLA	LRA
3 to 5T, Std Eff	208/230	1	0.33	1075	2.2	3.9
3 to 5T, Std Eff	460	1	0.33	1075	1.1	2.0
3 to 5T, Std Eff	575	1	0.33	1075	1	1.8



## Electrical Data

**Table 162. Electrical characteristics – power exhaust – cooling (continued)**

Tons	Volts	Phase	hp	rpm	FLA	LRA
3 to 5T, High Eff	208/230	1	0.87	1075	5.7	13.6
3 to 5T, High Eff	460	1	0.87	1075	3.3	7.2
3 to 5T, High Eff	575	1	0.80	1075	2.3	5.8
6 to 10T 12.5T, Std Eff	208/230	1	0.87	1075	5.7	13.6
6 to 10T 12.5T, Std Eff	460	1	0.87	1075	3.3	7.2
6 to 10T 12.5T, Std Eff	575	1	0.80	1075	2.3	5.8
12.5T, High Eff 15 to 25T	208/230	1	0.87	1075	5.7	13.6
12.5T, High Eff 15 to 25T	460	1	0.87	1075	3.3	7.2
12.5T, High Eff 15 to 25T	575	1	0.80	1075	2.3	5.8

**Note:** For 6 to 10 ton models, rpm = two speed.

**Table 163. Unit wiring – gas**

Tons	Unit Model Number	Voltage Range	Standard Indoor Fan Motor		Oversized/High Static Indoor Fan Motor		Optional Power Exhaust Standard Indoor Fan Motor		Optional Power Exhaust Oversized/High Static Indoor Fan Motor	
			MCA	Max Fuse Size or Max Circuit Breaker	MCA	Max Fuse Size or Max Circuit Breaker	MCA	Max Fuse Size or Max Circuit Breaker	MCA	Max Fuse Size or Max Circuit Breaker
3	YSK036A3	187-253	23	30	25	35	25	35	28	35
	YSK036A4	414-506	10	15	13	15	11	15	14	15
	YSK036AW	517-632	10	15	11	15	11	15	12	15
3 HGRH	YSK036A3	187-253	25	35	27	35	27	35	29	40
	YSK036A4	414-506	11	15	14	15	12	15	15	20
3	YHK036A3	187-253	22	30	24	30	24	30	26	35
	YHK036A4	414-506	11	15	12	15	12	15	13	15
3 HGRH	YHK036A3	187-253	23	30	25	35	26	35	28	35
	YHK036A4	414-506	12	15	13	15	13	15	14	15
4	YSK048A3	187-253	27	40	29	40	29	40	31	45
	YSK048A4	414-506	12	15	14	20	13	15	15	20
	YSK048AW	517-632	12	15	13	15	13	15	14	20
4 HGRH	YSK048A3	187-253	31	45	32	45	33	45	35	45
	YSK048A4	414-506	14	20	16	20	15	20	17	20
4	YHK048A3	187-253	28	40	—	—	34	45	—	—
	YHK048A4	414-506	16	20	—	—	19	25	—	—
	YHK048AW	517-632	11	15	—	—	14	15	—	—
4 HGRH	YHK048A3	187-253	32	45	—	—	38	50	—	—
	YHK048A4	414-506	17	20	—	—	20	25	—	—
5	YSK060A3	187-253	29	45	31	45	32	45	33	45
	YSK060A4	414-506	14	20	16	20	15	20	17	20
	YSK060AW	517-632	13	20	14	20	14	20	15	20
5 HGRH	YSK060A3	187-253	33	45	35	50	36	50	37	50
	YSK060A4	414-506	15	20	17	20	16	20	18	25

**Table 163. Unit wiring – gas (continued)**

Tons	Unit Model Number	Voltage Range	Standard Indoor Fan Motor		Oversized/High Static Indoor Fan Motor		Optional Power Exhaust Standard Indoor Fan Motor		Optional Power Exhaust Oversized/High Static Indoor Fan Motor	
			MCA	Max Fuse Size or Max Circuit Breaker	MCA	Max Fuse Size or Max Circuit Breaker	MCA	Max Fuse Size or Max Circuit Breaker	MCA	Max Fuse Size or Max Circuit Breaker
5	YHK060A3	187-253	31	45	—	—	36	50	—	—
	YHK060A4	414-506	16	20	—	—	19	25	—	—
	YHK060AW	517-632	13	15	—	—	15	20	—	—
5 HGRH	YHK060A3	187-253	34	45	—	—	40	50	—	—
	YHK060A4	414-506	17	20	—	—	21	25	—	—
6	YS/HK072A3	187-253	38	50	—	—	44	50	—	—
	YS/HK072A4	414-506	20	25	—	—	23	25	—	—
	YS/HK072AW	517-632	17	20	—	—	20	25	—	—
7.5	YS/HK090A3	187-253	43	50	—	—	49	60	—	—
	YS/HK090A4	414-506	22	25	—	—	25	30	—	—
	YS/HK090AW	517-632	19	25	—	—	21	25	—	—
8.5	YS/HK102A3	187-253	53	70	—	—	58	70	—	—
	YS/HK102A4	414-506	26	35	—	—	29	35	—	—
	YS/HK102AW	517-632	21	25	—	—	23	30	—	—
10	YSK120A3	187-253	57	80	59	80	62	80	65	80
	YSK120A4	414-506	30	40	30	40	33	45	34	45
	YSK120AW	517-632	24	30	24	30	26	35	27	35
10	YHK120A3	187-253	60	80	62	80	66	90	68	90
	YHK120A4	414-506	31	40	32	45	34	45	35	45
	YHK120AW	517-632	24	30	24	30	26	35	27	35
12.5	YSK150A3	187-253	67	90	—	—	73	100	—	—
	YSK150A4	414-506	33	45	—	—	36	50	—	—
	YSK150AW	517-632	26	35	—	—	28	35	—	—
12.5	YHK150A3	187-253	74	100	—	—	80	100	—	—
	YHK150A4	414-506	37	50	—	—	41	50	—	—
	YHK150AW	517-632	29	35	—	—	31	40	—	—
15	YS/HK180A3	187-253	79	110	—	—	85	110	—	—
	YS/HK180A4	414-506	40	50	—	—	43	50	—	—
	YS/HK180AW	517-632	32	40	—	—	34	45	—	—
17.5	YS/HK210A3	187-253	95	125	99	125	101	125	105	125
	YS/HK210A4	414-506	47	60	49	60	51	60	53	60
	YS/HK210AW	517-632	38	50	40	50	41	50	42	50
20	YS/HK240A3	187-253	108	150	113	150	114	150	118	150
	YS/HK240A4	414-506	55	70	57	70	58	80	60	80
	YS/HK240AW	517-632	40	50	42	50	43	50	44	50
25	YS/HK300A3	187-253	118	150	123	150	124	150	128	175
	YS/HK300A4	414-506	59	80	61	80	62	80	64	80
	YS/HK300AW	517-632	42	50	44	60	45	60	46	60



**Electrical Data**

**Table 164. Electrical characteristics – compressor motor and condenser motor – gas**

Tons	Unit Model Number	No.	Compressor Motors					No.	Condenser Fan Motor				
			Volts	Phase	rpm	Amps <sup>(a)</sup>			Volts	Phase	hp	Amps	
						RLA	LRA					FLA	LRA
3	YSK036A3	1	208/230	3	3500	12.5	97.5	1	208/230	3	0.25	1.1	3.6
	YSK036A4	1	460	3	3500	5.9	44.3	1	460	3	0.25	0.55	1.8
	YSK036AW	1	575	3	3500	4.6	27.1	1	575	3	0.25	0.45	1.4
3 HGRH	YSK036A3	1	208/230	3	3500	12.5	97.5	1	208/230	1	0.33	2.8	—
	YSK036A4	1	460	3	3500	5.9	44.3	1	460	1	0.33	1.6	—
3	YHK036A3	1	208/230	3	3500	10.2	82	1	208/230	3	0.25	1.1	3.6
	YHK036A4	1	460	3	3500	5.6	44.3	1	460	3	0.25	0.55	1.8
3 HGRH	YHK036A3	1	208/230	3	3500	10.2	82	1	208/230	1	0.33	2.8	—
	YHK036A4	1	460	3	3500	5.6	44.3	1	460	1	0.33	1.6	—
4	YSK048A3	1	208/230	3	3500	14.8	120.4	1	208/230	3	0.33	1.4	4.6
	YSK048A4	1	460	3	3500	7	49.4	1	460	3	0.33	0.7	2.3
	YSK048AW	1	575	3	3500	6.7	41	1	575	3	0.33	0.55	1.8
4 HGRH	YSK048A3	1	208/230	3	3500	14.8	120.4	1	208/230	1	0.50	5.3	—
	YSK048A4	1	460	3	3500	7	49.4	1	460	1	0.50	2.3	—
4	YHK048A3	1	208/230	3	3500	13.8	112	1	208/230	3	0.4	1.4	5.2
	YHK048A4	1	460	3	3500	7.8	61.8	1	460	3	0.4	0.7	2.6
	YHK048AW	1	575	3	3500	5.6	39	1	575	3	0.4	0.6	2.1
4 HGRH	YHK048A3	1	208/230	3	3500	13.8	112	1	208/230	1	0.5	5.3	—
	YHK048A4	1	460	3	3500	7.8	61.8	1	460	1	0.5	2.3	—
5	YSK060A3	1	208/230	3	3500	16.5	156.4	1	208/230	3	0.4	1.4	5.2
	YSK060A4	1	460	3	3500	8.1	69	1	460	3	0.4	0.7	2.6
	YSK060AW	1	575	3	3500	7.4	47.8	1	575	3	0.4	0.6	2.1
5 HGRH	YSK060A3	1	208/230	3	3500	16.5	156.4	1	208/230	1	0.50	5.3	—
	YSK060A4	1	460	3	3500	8.1	69	1	460	1	0.50	2.3	—
5	YHK060A3	1	208/230	3	3500	15.9	161	1	208/230	3	0.4	1.4	
	YHK060A4	1	460	3	3500	7.9	58	1	460	3	0.4	0.7	
	YHK060AW	1	575	3	3500	6.7	47.8	1	575	3	0.4	0.6	
5 HGRH	YHK060A3	1	208/230	3	3500	15.9	161	1	208/230	1	0.50	5.3	—
	YHK060A4	1	460	3	3500	7.9	58	1	460	1	0.50	2.3	—
6	YS/HK072A3	2	208/230	3	3500	14.8/7.4	120.4/58.7	1	208/230	3	0.70	3.3	12.3
	YS/HK072A4	2	460	3	3500	7.0/4.2	49.4/26.3	1	460	3	0.70	1.5	6.1
	YS/HK072AW	2	575	3	3500	6.7/3.8	41.0/24	1	575	3	0.70	1.4	5.1
7.5	YS/HK090A3	2	208/230	3	3500	16.5/9.9	156.4/67.7	1	208/230	3	0.70	3.3	12.3
	YS/HK090A4	2	460	3	3500	8.1/5.2	69.0/38.1	1	460	3	0.70	1.5	6.1
	YS/HK090AW	2	575	3	3500	7.4/4.4	47.8/27.7	1	575	3	0.70	1.4	5.1
8.5	YS/HK102A3	2	208/230	3	3500	21.8/13.2	156.5/97.5	1	208/230	3	0.75	2.8	10.4
	YS/HK102A4	2	460	3	3500	10.5/5.9	74.8/44.3	1	460	3	0.75	1.4	5.2
	YS/HK102AW	2	575	3	3500	8.9/5.2	47.8/27.1	1	575	3	0.75	1.14	4.5
10	YSK120A3	2	208/230	3	3500	25.2/13.2	210.0/97.5	1	208/230	3	0.75	2.8	10.4
	YSK120A4	2	460	3	3500	13.7/5.9	103.0/44.3	1	460	3	0.75	1.4	5.2
	YSK120AW	2	575	3	3500	10.8/5.2	78.0/27.1	1	575	3	0.75	1.14	4.5

**Table 164. Electrical characteristics – compressor motor and condenser motor – gas (continued)**

Tons	Unit Model Number	No.	Compressor Motors					No.	Condenser Fan Motor				
			Volts	Phase	rpm	Amps <sup>(a)</sup>			Volts	Phase	hp	Amps	
						RLA	LRA					FLA	LRA
10	YHK120A3	2	208/230	3	3500	25.2/13.2	210.0/97.5	1	208/230	1	0.75	6.3	—
	YHK120A4	2	460	3	3500	13.7/5.9	103.0/44.3	1	460	1	0.75	3.0	—
	YHK120AW	2	575	3	3500	10.8/5.2	78.0/27.1	1	575	3	0.75	1.14	4.5
12.5	YSK150A3	2	208/230	3	3500	29.5/14.8	207.5/120.4	1	208/230	3	1	4.3	18.9
	YSK150A4	2	460	3	3500	14.4/7.0	100.2/49.4	1	460	3	1	2.2	9.5
	YSK150AW	2	575	3	3500	10.4/6.7	78.0/41.0	1	575	3	1	1.8	8.1
12.5	YHK150A3	2	208/230	3	3500	29.5/14.8	207.5/120.4	2	208/230	3	0.5	2.2	8.4
	YHK150A4	2	460	3	3500	14.4/7	100.2/49.4	2	460	3	0.5	1.3	4.2
	YHK150AW	2	575	3	3500	10.4/6.7	78/41	2	575	3	0.5	1.1	3.6
15	YS/HK180A3	2	208/230	3	3500	32.3/16.5	255/156.4	2	208/230	3	0.5	2.2	8.4
	YS/HK180A4	2	460	3	3500	15.5/8.1	123/69	2	460	3	0.5	1.3	4.2
	YS/HK180AW	2	575	3	3500	12.4/7.4	93.7/47.8	2	575	3	0.5	1.1	3.6
17.5	YS/HK210A3	2	208/230	3	3500	37.1/21.8	255/156.5	2	208/230	3	1	4.3	20
	YS/HK210A4	2	460	3	3500	17.8/10.5	140/74.8	2	460	3	1	2.5	10.1
	YS/HK210AW	2	575	3	3500	14.9/8.9	107.6/47.8	2	575	3	1	1.9	8
20	YS/HK240A3	2	208/230	3	3500	44.5/25.9	270/178.5	2	208/230	3	1	4.3	20
	YS/HK240A4	2	460	3	3500	22.4/12.2	147/79.1	2	460	3	1	2.5	10.1
	YS/HK240AW	2	575	3	3500	15.8/9.9	109/65	2	575	3	1	1.9	8
25	YS/HK300A3	2	208/230	3	3500	49.2/30	335.5/190.7	2	208/230	3	1	4.3	20
	YS/HK300A4	2	460	3	3500	23.8/14.4	141/100.2	2	460	3	1	2.5	10.1
	YS/HK300AW	2	575	3	3500	16.7/10.9	109/65	2	575	3	1	1.9	8

<sup>(a)</sup> Amp draw for each motor (compressor and condenser fan motor); multiply value by number of motors to determine total amps.

**Table 165. Electrical characteristics – indoor fan motor – gas**

Tons	Unit Model Number	No.	Volts	Phase	hp	Amps <sup>(a)</sup>	
						FLA	LRA
3	YSK036A3	1	208/230	1	0.75	5.7	—
	YSK036A4	1	460	1	0.75	1.7	—
	YSK036AW	1	575	1	1	2.9	—
	YHK036A3	1	208/230	1	0.75	7.3	—
	YHK036A4	1	460	1	0.75	2.7	—
4	YSK048A3	1	208/230	1	1	6.9	—
	YSK048A4	1	460	1	1	2.4	—
	YSK048AW	1	575	1	1	2.9	—
	YHK048A3	1	208/230	1	3	8.8	—
	YHK048A4	1	460	1	3	4.6	—
5	YSK060A3	1	208/230	1	1	6.9	—
	YSK060A4	1	460	1	1	2.4	—
	YSK060AW	1	575	1	1	2.9	—
	YHK060A3	1	208/230	1	3	8.8	—
	YHK060A4	1	460	1	3	4.6	—
	YHK060AW	1	575	1	3	3.2	—



**Electrical Data**

**Table 165. Electrical characteristics – indoor fan motor – gas (continued)**

Tons	Unit Model Number	No.	Volts	Phase	hp	Amps <sup>(a)</sup>	
						FLA	LRA
6	YS/HK072A3	1	208/230	3	3	8.8	—
	YS/HK072A4	1	460	3	3	4.6	—
	YS/HK072AW	1	575	3	3	3.2	—
7.5	YS/HK090A3	1	208/230	3	3	8.8	—
	YS/HK090A4	1	460	3	3	4.6	—
	YS/HK090AW	1	575	3	3	3.2	—
8.5	YS/HK102A3	1	208/230	3	3	8.8	—
	YS/HK102A4	1	460	3	3	4.6	—
	YS/HK102AW	1	575	3	3	3.2	—
10	YS/HK120A3	1	208/230	3	3	8.8	—
	YS/HK120A4	1	460	3	3	4.6	—
	YS/HK120AW	1	575	3	3	3.2	—
12.5	YSK150A3	1	208/230	3	5	11	—
	YSK150A4	1	460	3	5	5.5	—
	YSK150AW	1	575	3	5	3.9	—
	YHK150A3	2	208/230	3	3	8.8	—
	YHK150A4	2	460	3	3	4.6	—
	YHK150AW	2	575	3	3	3.2	—
15	YS/HK180A3	2	208/230	3	3	8.8	—
	YS/HK180A4	2	460	3	3	4.6	—
	YS/HK180AW	2	575	3	3	3.2	—
17.5	YS/HK210A3	2	208/230	3	3	8.8	—
	YS/HK210A4	2	460	3	3	4.6	—
	YS/HK210AW	2	575	3	3	3.2	—
20	YS/HK240A3	2	208/230	3	3	8.8	—
	YS/HK240A4	2	460	3	3	4.6	—
	YS/HK240AW	2	575	3	3	3.2	—
25	YS/HK300A3	2	208/230	3	3	8.8	—
	YS/HK300A4	2	460	3	3	4.6	—
	YS/HK300AW	2	575	3	3	3.2	—

<sup>(a)</sup> Amp draw for each motor (compressor and condenser fan motor); multiply value by number of motors to determine total amps.

**Table 166. Electrical characteristics – oversized indoor fan motor – gas**

Tons	Unit Model Number	No.	Volts	Phase	hp	Amps <sup>(a)</sup>	
						FLA	LRA
3	YSK036A3	1	208/230	1	1.5	8.2	—
	YSK036A4	1	460	1	1.5	4.2	—
	YSK036AW	1	575	1	1.5	3.9	—
	YHK036A3	1	208/230	1	1	9.4	—
	YHK036A4	1	460	1	1	3.5	—
4	YSK048A3	1	208/230	1	1.5	8.2	—
	YSK048A4	1	460	1	1.5	4.2	—
	YSK048AW	1	575	1	1.5	3.9	—

**Table 166. Electrical characteristics – oversized indoor fan motor – gas (continued)**

Tons	Unit Model Number	No.	Volts	Phase	hp	Amps <sup>(a)</sup>	
						FLA	LRA
5	YSK060A3	1	208/230	1	1.5	8.2	—
	YSK060A4	1	460	1	1.5	4.2	—
	YSK060AW	1	575	1	1.5	3.9	—
10	YS/HK120A3	1	208/230	3	5	11	—
	YS/HK120A4	1	460	3	5	5.5	—
	YS/HK120AW	1	575	3	5	3.9	—
17.5	YS/HK210A3	2	208/230	3	5	11	—
	YS/HK210A4	2	460	3	5	5.5	—
	YS/HK210AW	2	575	3	5	3.9	—
20	YS/HK240A3	2	208/230	3	5	11	—
	YS/HK240A4	2	460	3	5	5.5	—
	YS/HK240AW	2	575	3	5	3.9	—
25	YS/HK300A3	2	208/230	3	5	11	—
	YS/HK300A4	2	460	3	5	5.5	—
	YS/HK300AW	2	575	3	5	3.9	—

<sup>(a)</sup> Amp draw for each motor (compressor and condenser fan motor); multiply value by number of motors to determine total amps.

**Table 167. Electrical characteristics – inducer motor – gas**

Tons	Unit Model Number	Stages	hp	rpm	Volts	Phase	FLA	LRA
<b>2-Stage Gas Heat</b>								
3	Y(S,H)K036A**(0,A)(L,M,H)	2	1/35	3500/2800	208-230	1	0.24/0.18	0.67
4	Y(S,H)K048A**(0,A)(L,M,H)	2	1/35	3500/2800	208-230	1	0.24/0.18	0.67
5	Y(S,H)K060A**(0,A)(L,M,H)	2	1/35	3500/2800	208-230	1	0.24/0.18	0.67
6	Y(S,H)K072A**(0,A)(L,M)	2	1/35	3500/2800	208-230	1	0.24/0.18	0.67
	Y(S,H)K072A**(0,A)H	2	1/15	3350/2800	208-230	1	0.42/0.50	0.73
7.5	Y(S,H)K090A**(0,A)L	2	1/35	3500/2800	208-230	1	0.24/0.18	0.67
	Y(S,H)K090A**(0,A)(M,H)	2	1/15	3350/2800	208-230	1	0.42/0.50	0.73
8.5	Y(S,H)K102A**(0,A)L	2	1/35	3500/2800	208-230	1	0.24/0.18	0.67
	Y(S,H)K102A**(0,A)(M,H)	2	1/15	3350/2800	208-230	1	0.42/0.50	0.73
10	Y(S,H)K120A**(0,A)(L,M,H)	2	1/15	3350/2800	208-230	1	0.42/0.50	0.73
12.5	YSK150A**(0,A)M	2	1/35	3500/2800	208-230	1	0.24/0.18	0.67
	YSK150A**(0,A)(L,H)	2	1/15	3350/2800	208-230	1	0.42/0.50	0.73
	YHK150A**(0,A)(L,M,H)	2	1/15	3300/2800	208-230	1	0.36/0.3	0.73
15	Y(S,H)K180A**(0,A)(L,M)	2	1/15	3300/2800	208-230	1	0.36/0.3	0.73
	Y(S,H)K180A**(0,A)H	2	1/6	3300/2300	208-230	1	0.95/0.49	1.53
17.5	Y(S,H)K210A**(0,A)(L,M)	2	1/15	3300/2800	208-230	1	0.36/0.3	0.73
	Y(S,H)K210A**(0,A)H	2	1/6	3300/2300	208-230	1	0.95/0.49	1.53
20	Y(S,H)K240A**(0,A)(L,M)	2	1/15	3300/2800	208-230	1	0.36/0.3	0.73
	Y(S,H)K240A**(0,A)H	2	1/6	3300/2300	208-230	1	0.95/0.49	1.53
25	Y(S,H)K300A**(0,A)(L,M)	2	1/15	3300/2800	208-230	1	0.36/0.3	0.73
	Y(S,H)K300A**(0,A)H	2	1/6	3300/2300	208-230	1	0.95/0.49	1.53
<b>Modulating 10:1 Gas Heat</b>								
6 to 10	Y(S,H)K(072,090,102,120)A**B	Variable	1/8	3400	120	1	1.3	3.3
12.5 to 25	Y(S,H)K(150,180,210,240,300)A**B	Variable	1/5	3300	115	1	3.4	7.3

# Dimensional Data

Note: See Table 1, p. 6 for cabinet sizes.

Figure 25. A.0 cabinet

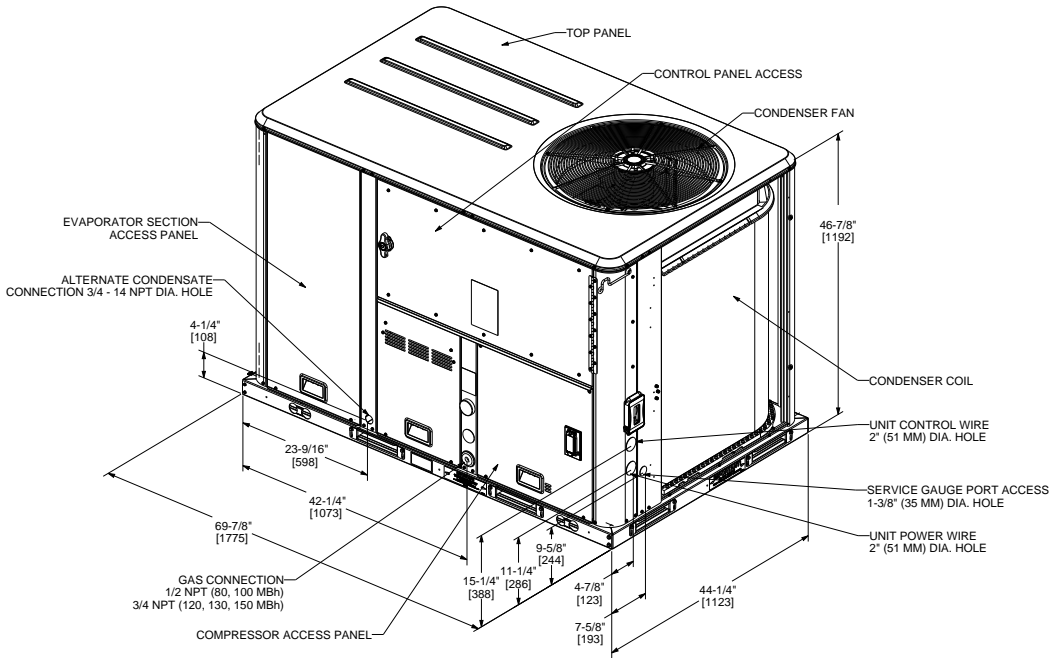

Figure 26. A.0 cabinet – downflow airflow supply/return, through-the-base utilities

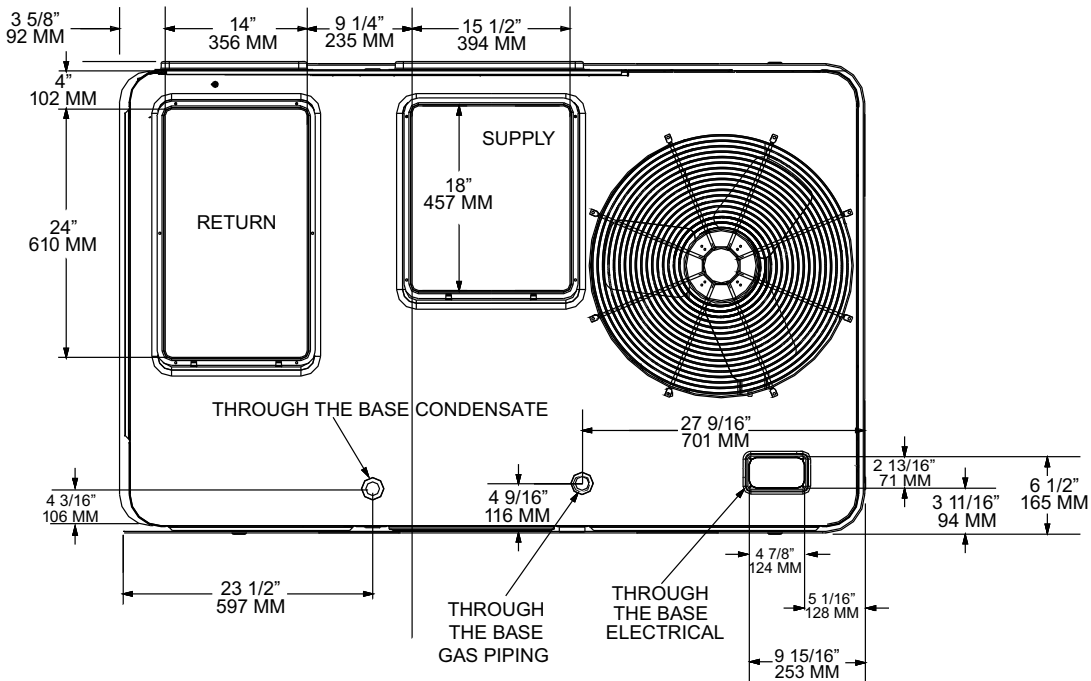

Figure 27. A.0 cabinet – horizontal airflow supply/return

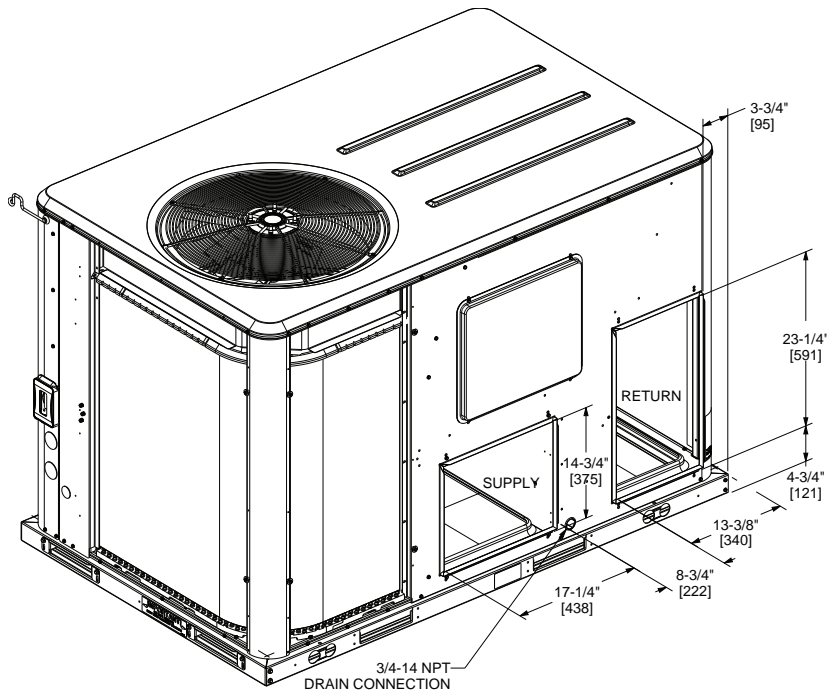
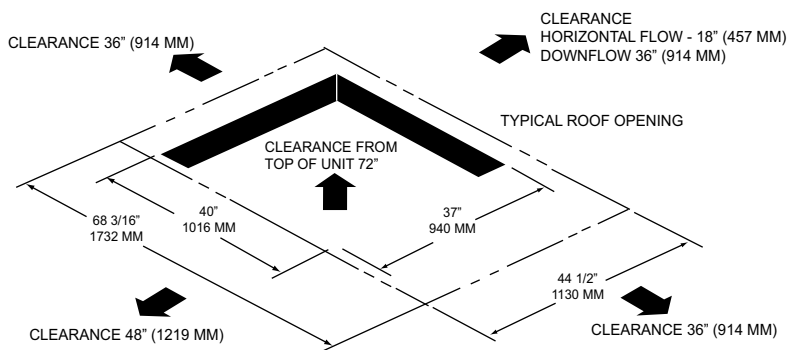
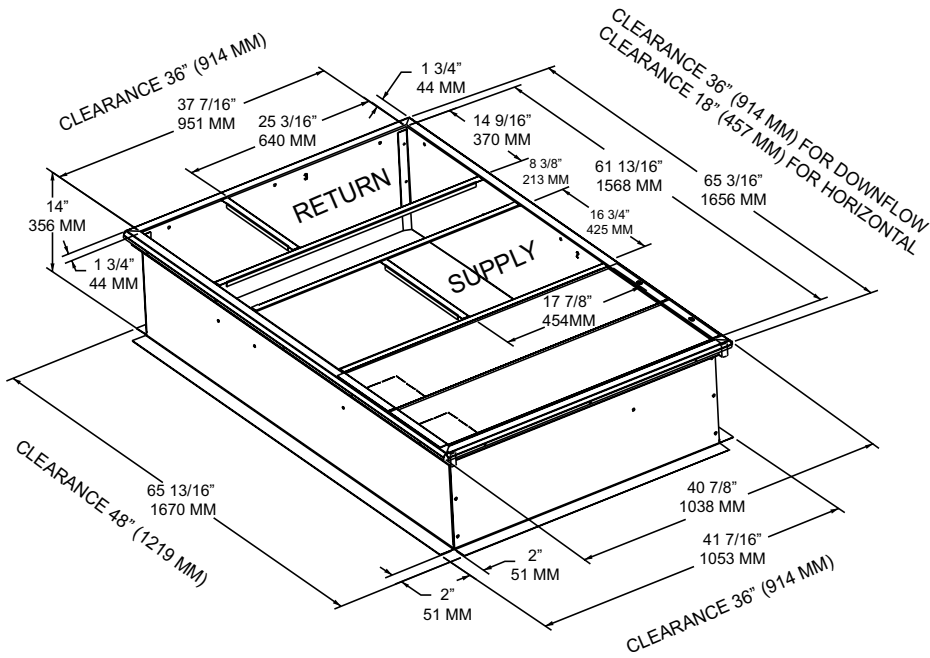

Figure 28. A.0 cabinet – unit clearance and roof opening



**Figure 29. A.0 cabinet – roof curb**



**Figure 30. A.0 cabinet – downflow duct connections, field fabricated**

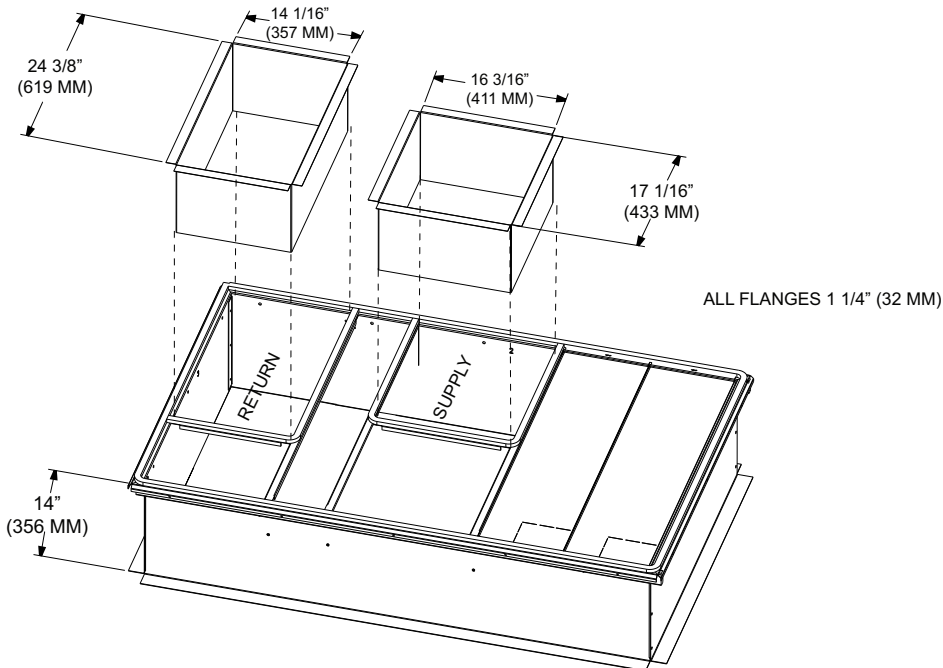

Figure 31. A.0 cabinet – swing diameter for hinged door(s) option

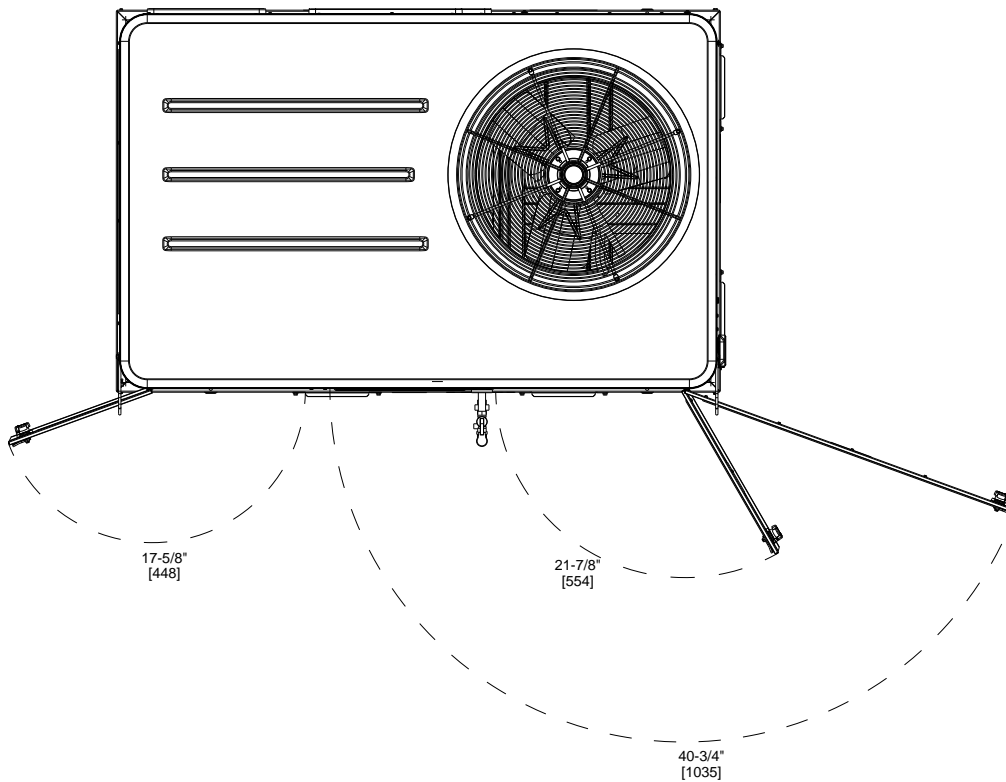
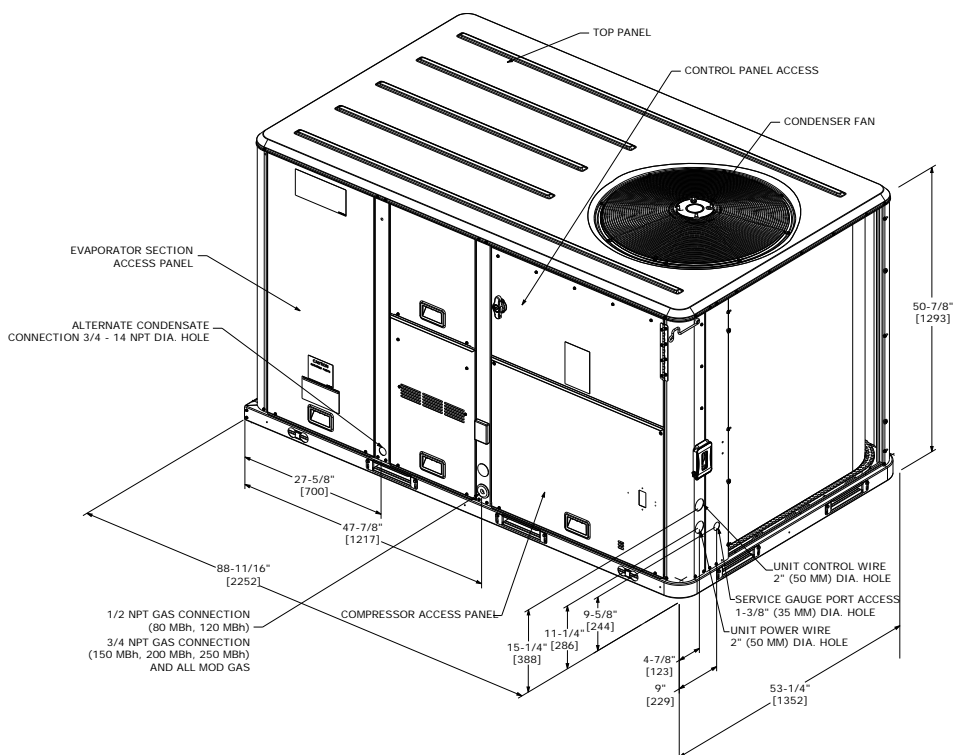
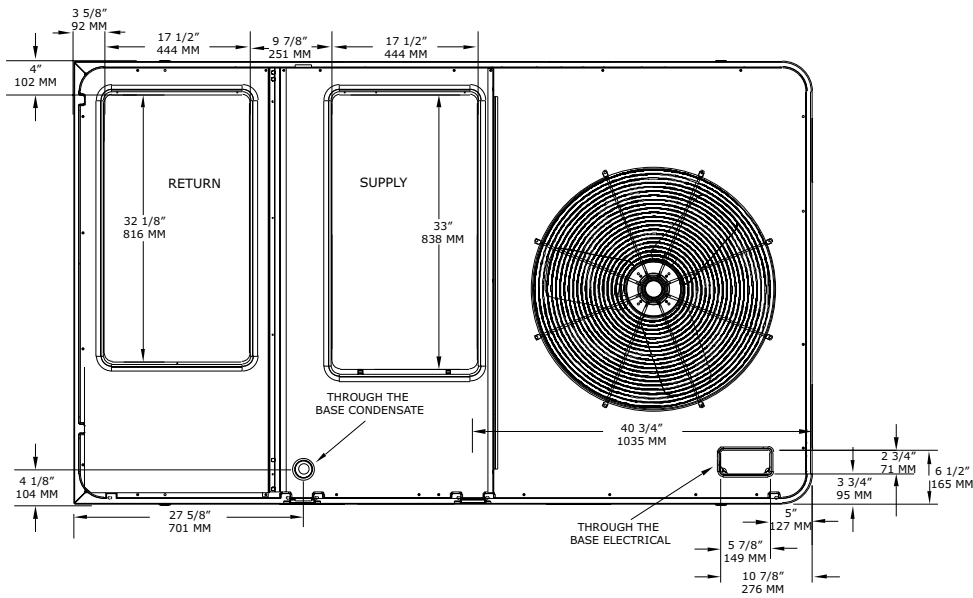

Figure 32. B.0 cabinet



**Figure 33. B.0 cabinet – downflow airflow supply/return, through-the-base utilities**



**Figure 34. B.0 cabinet – horizontal airflow supply/return**

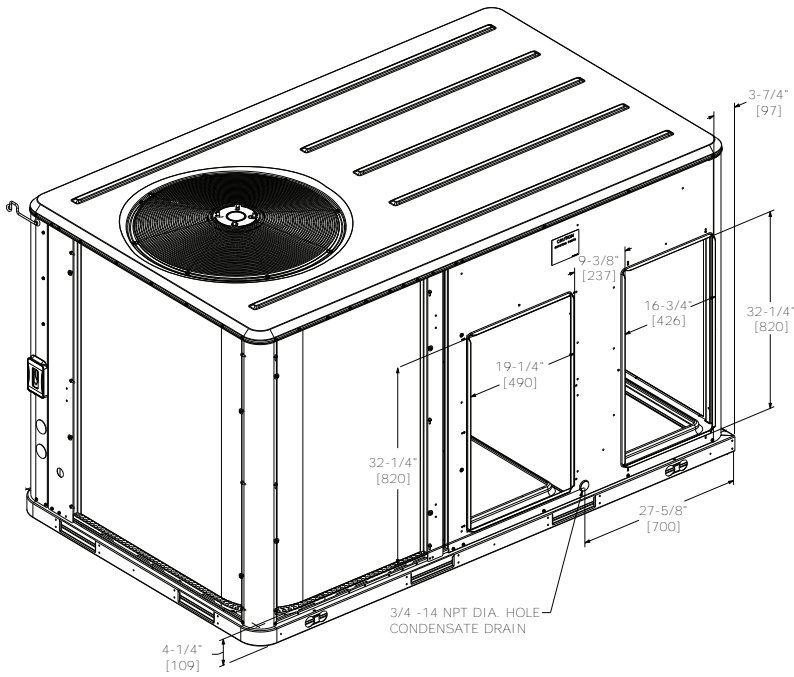

Figure 35. B.0 cabinet – unit clearance and roof opening

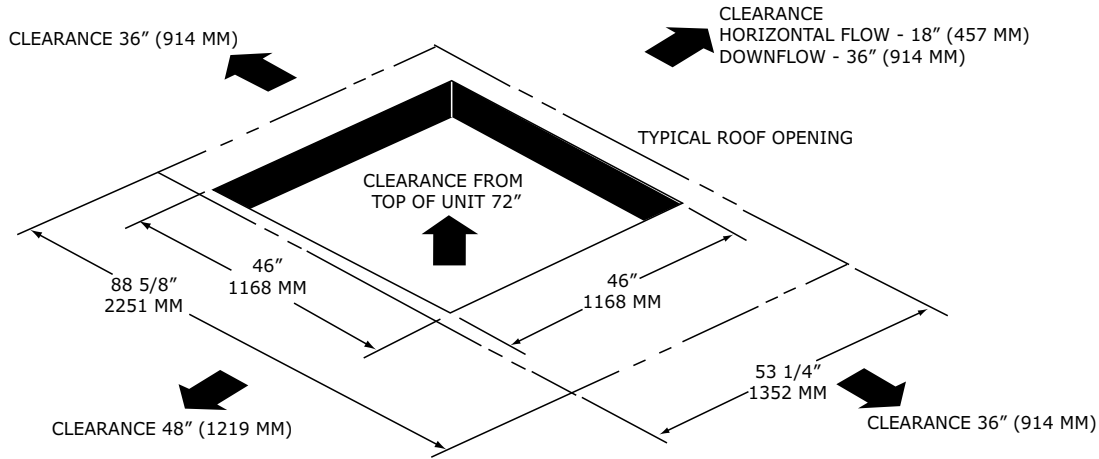
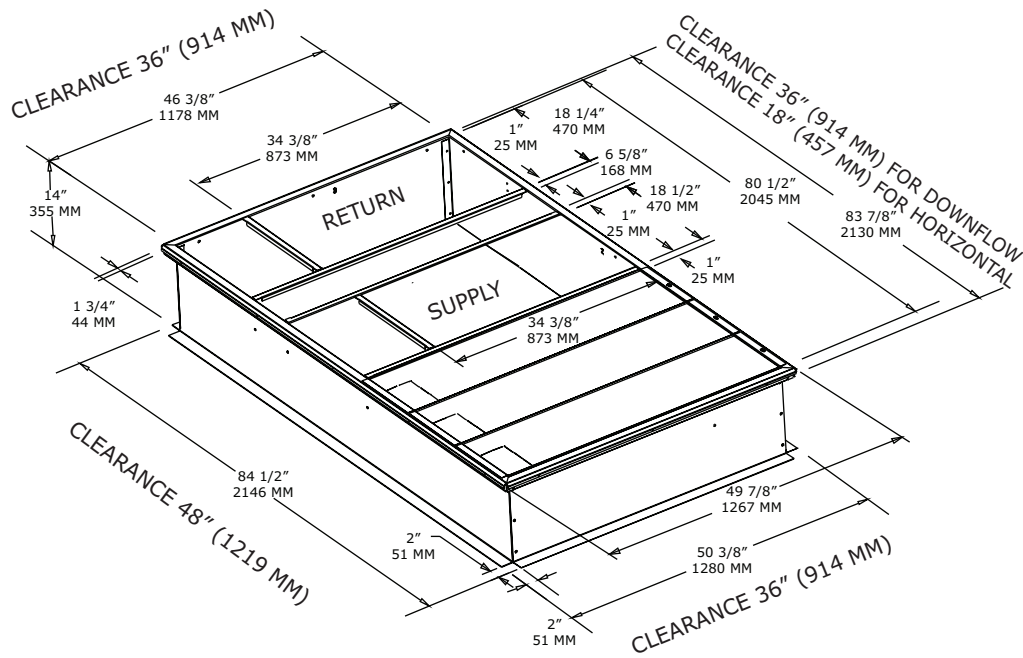

Figure 36. B.0 cabinet – roof curb



## Dimensional Data

Figure 37. B.0 cabinet – downflow duct connections, field fabricated

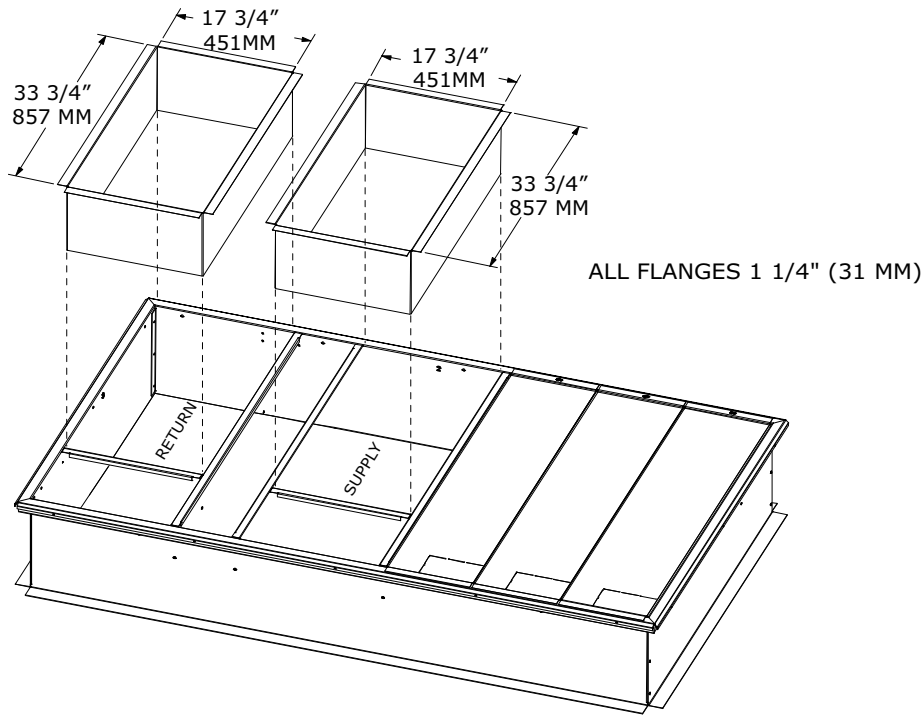

Figure 38. B.0 cabinet – swing diameter for hinged door(s) option

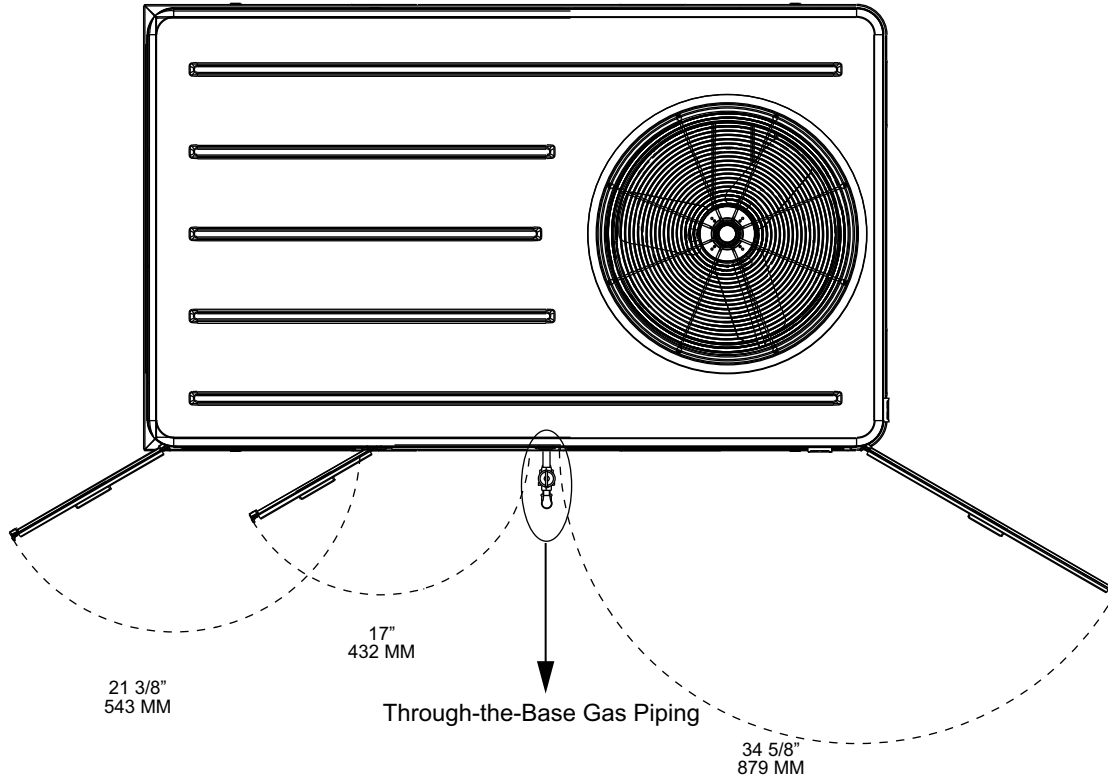

Figure 39. C.0 cabinet

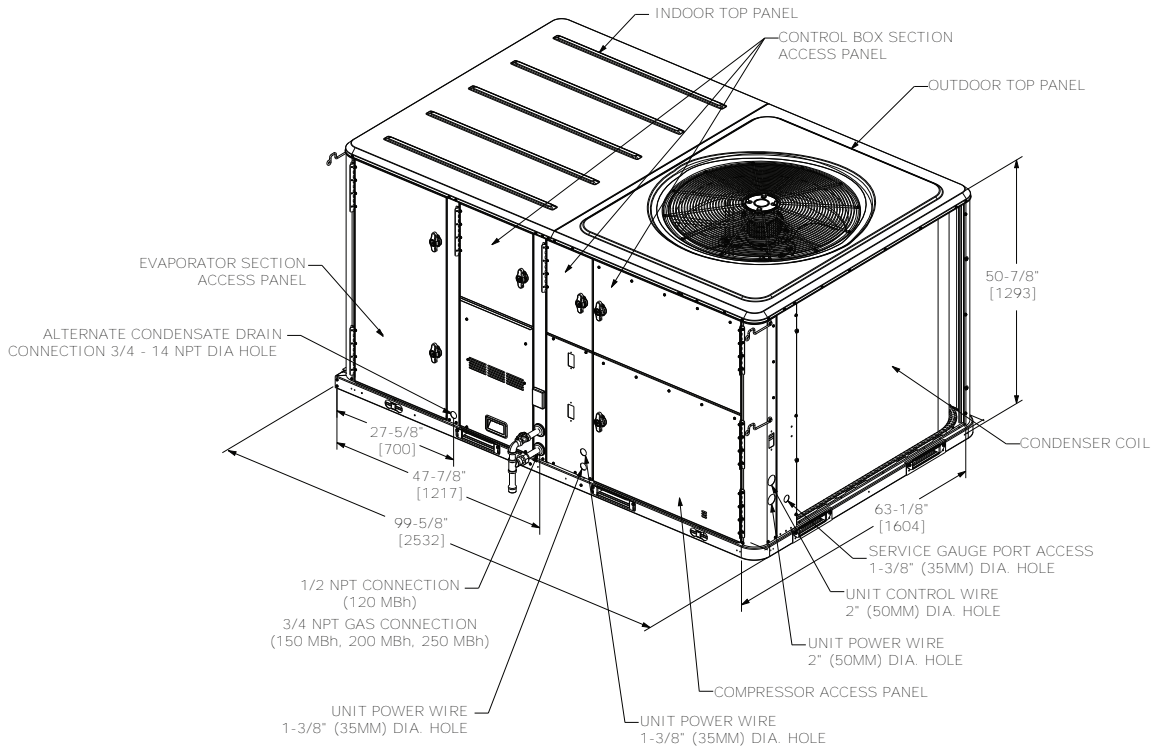
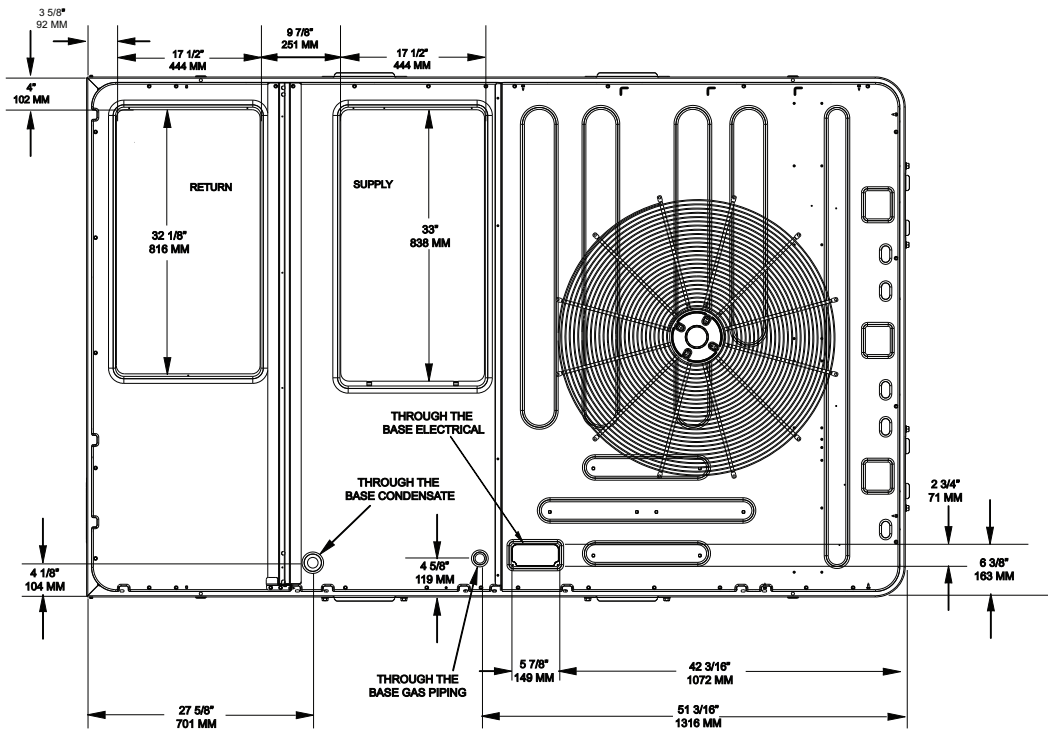

Figure 40. C.0 cabinet – downflow airflow supply/return, through-the-base utilities





## Dimensional Data

Figure 41. C.0 cabinet – horizontal airflow, supply and return

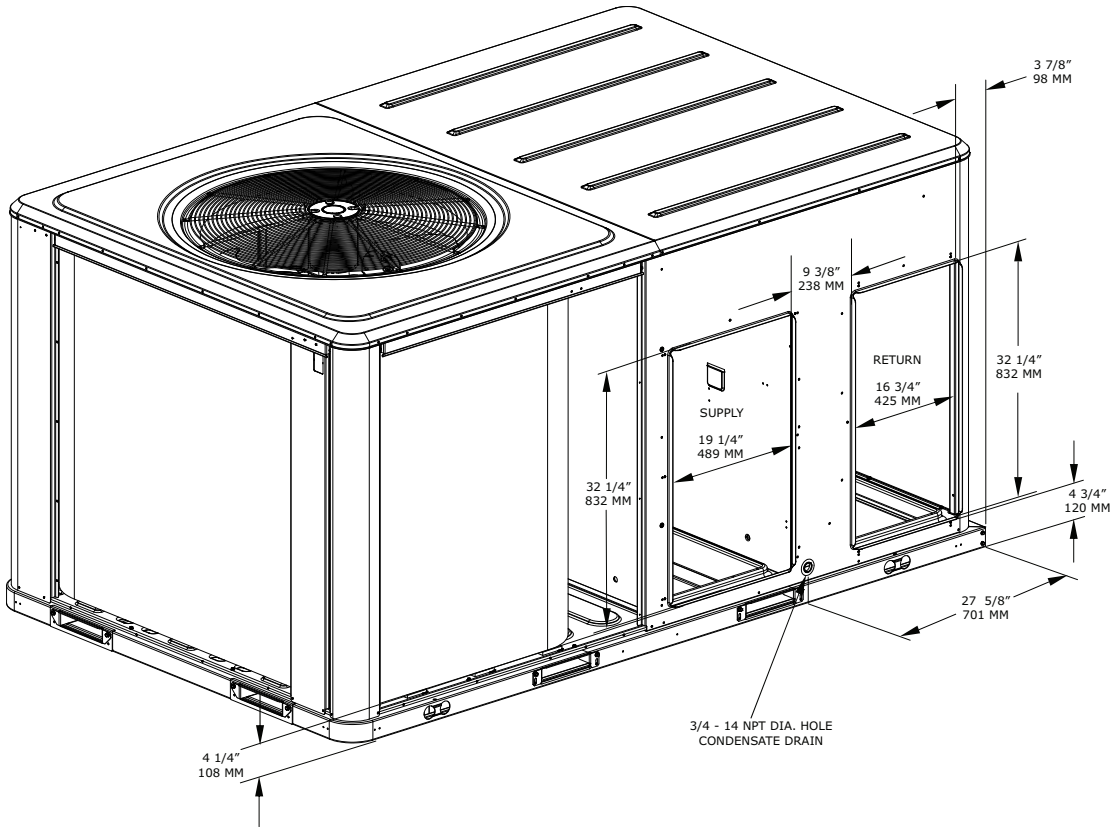
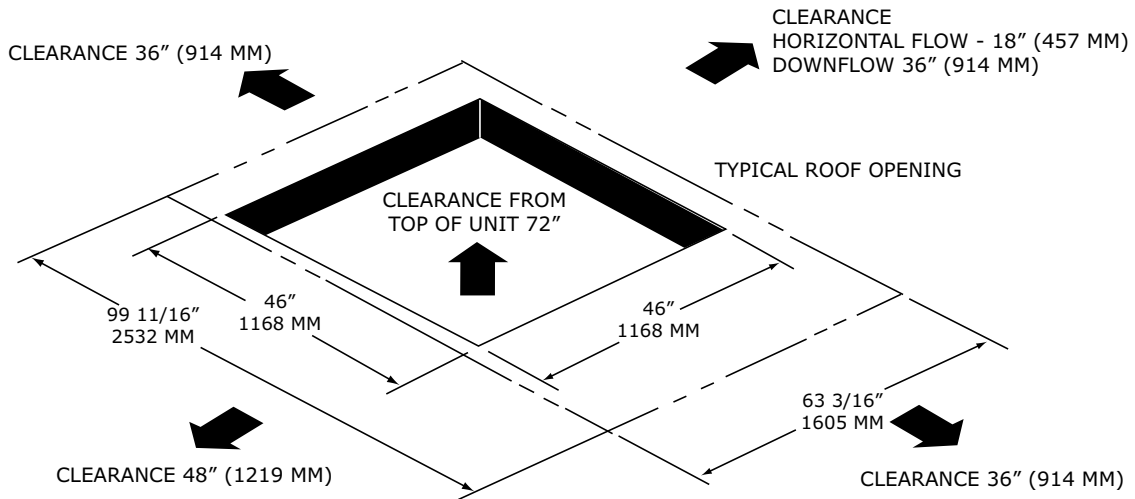

Figure 42. C.0 cabinet – unit clearance and roof opening







## Dimensional Data

Figure 45. A.0, B.0 and C.0 cabinets – standard economizer, manual or motorized fresh air damper

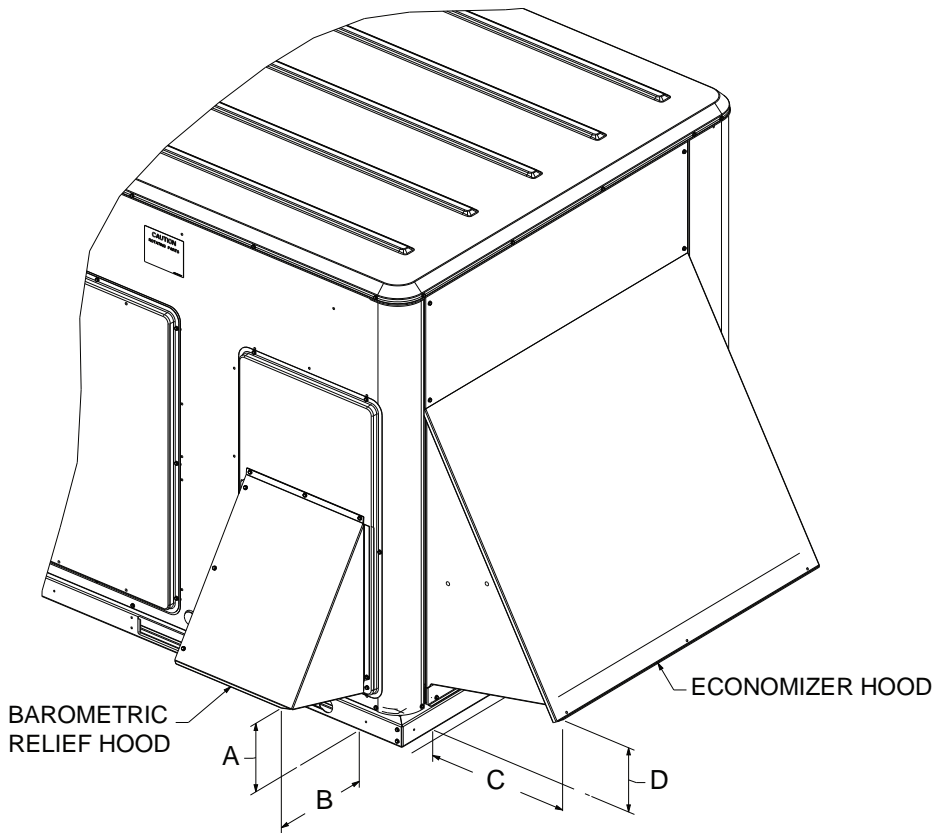
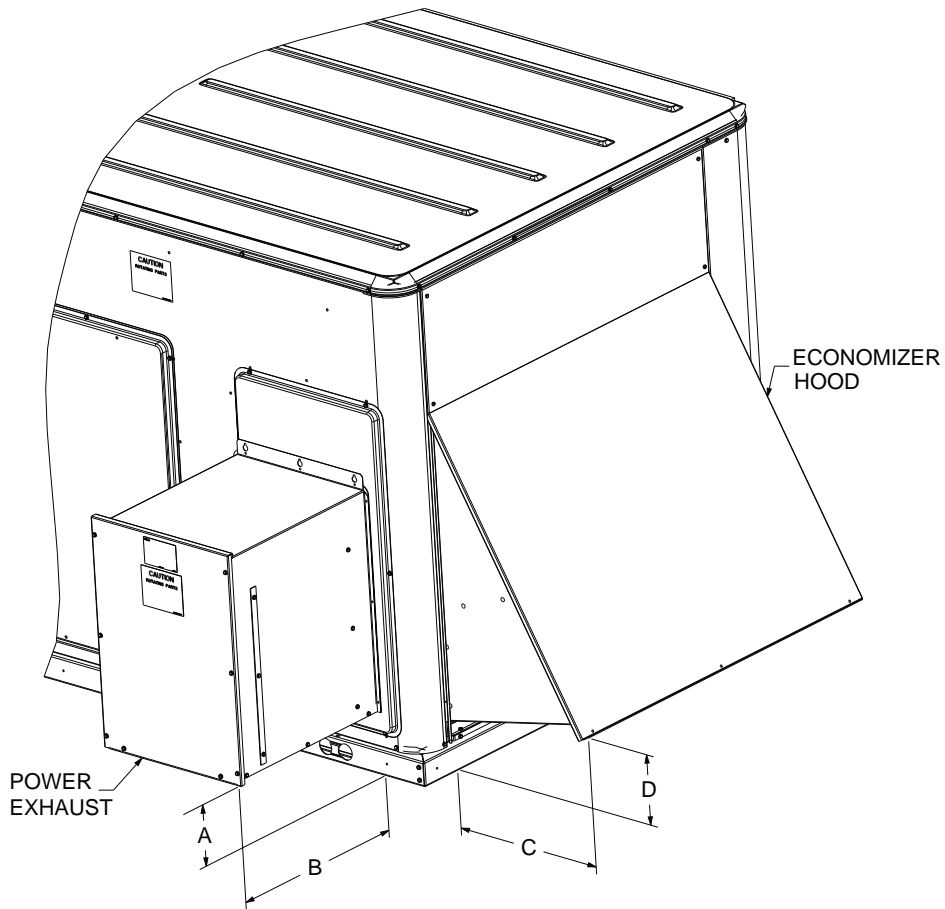

Table 168. A.0, B.0, and C.0 cabinet – standard economizer, manual or motorized fresh air damper dimensions

Cabinet	A		B		C		D	
	inch	mm	inch	mm	inch	mm	inch	mm
A.0	6 7/8	175	9 1/8	232	12 1/2	318	6 1/4	159
B.0 and C.0	7 3/4	197	12	305	16 3/4	425	7 1/4	184

**Figure 46. A.0, B.0 and C.0 cabinets – power exhaust with standard economizer**

**Table 169. A.0, B.0, and C.0 cabinet – power exhaust with standard economizer dimensions**

Cabinet	A		B		C		D	
	inch	mm	inch	mm	inch	mm	inch	mm
A.0	6 1/4	159	16 3/4	425	12 1/2	318	6 1/4	159
B.0 and C.0	6 3/8	162	20 1/2	521	16 3/4	425	7 1/4	184



## Dimensional Data

Figure 47. A.0, B.0 and C.0 cabinets – power exhaust with low leak economizer

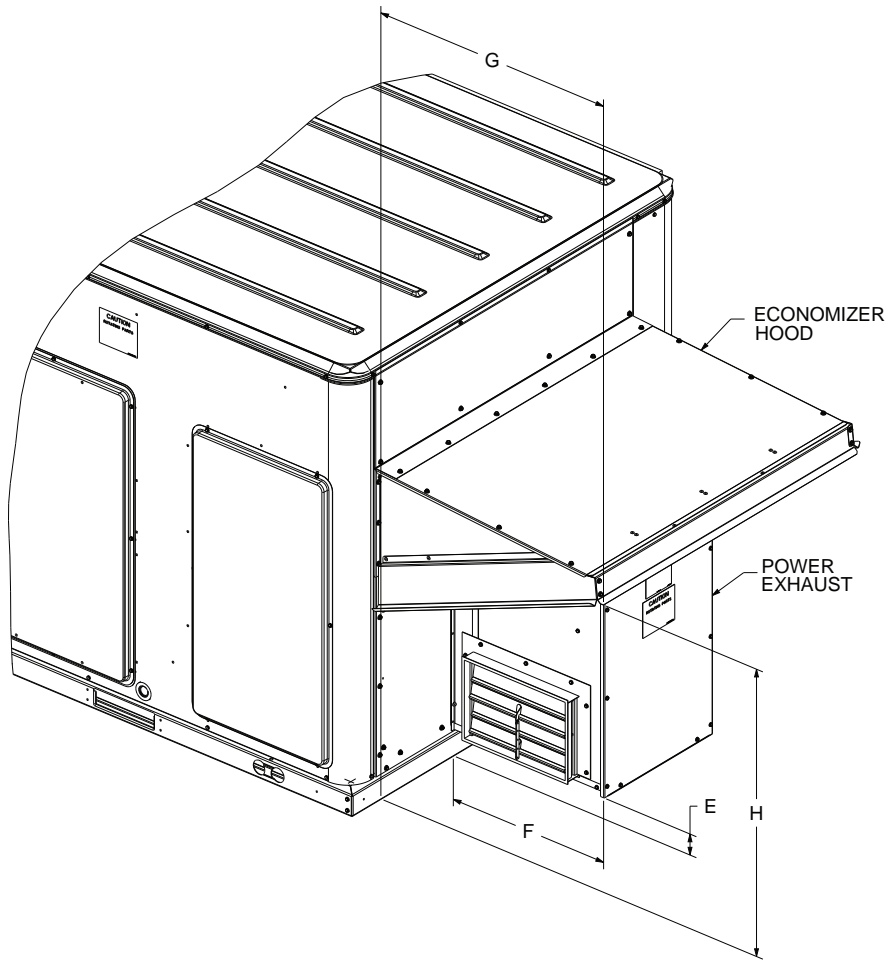

Table 170. A.0, B.0, and C.0 cabinets – power exhaust with low leak economizer dimensions

Cabinet	E		F		G		H	
	inch	mm	inch	mm	inch	mm	inch	mm
A.0	2 1/2	64	16	406	19 3/4	502	27	686
B.0 and C.0	2 1/2	64	19 3/4	502	29 1/4	743	33 1/2	852

Figure 48. D.0 and D.1 cabinets

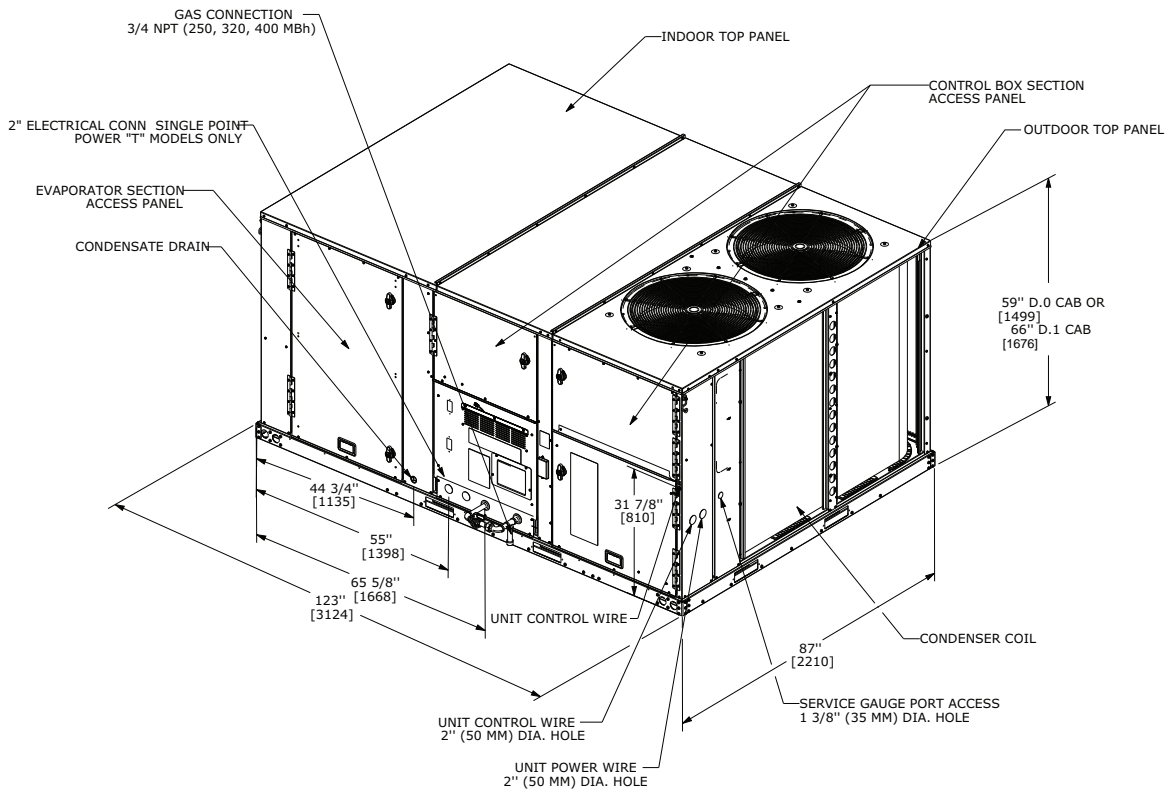
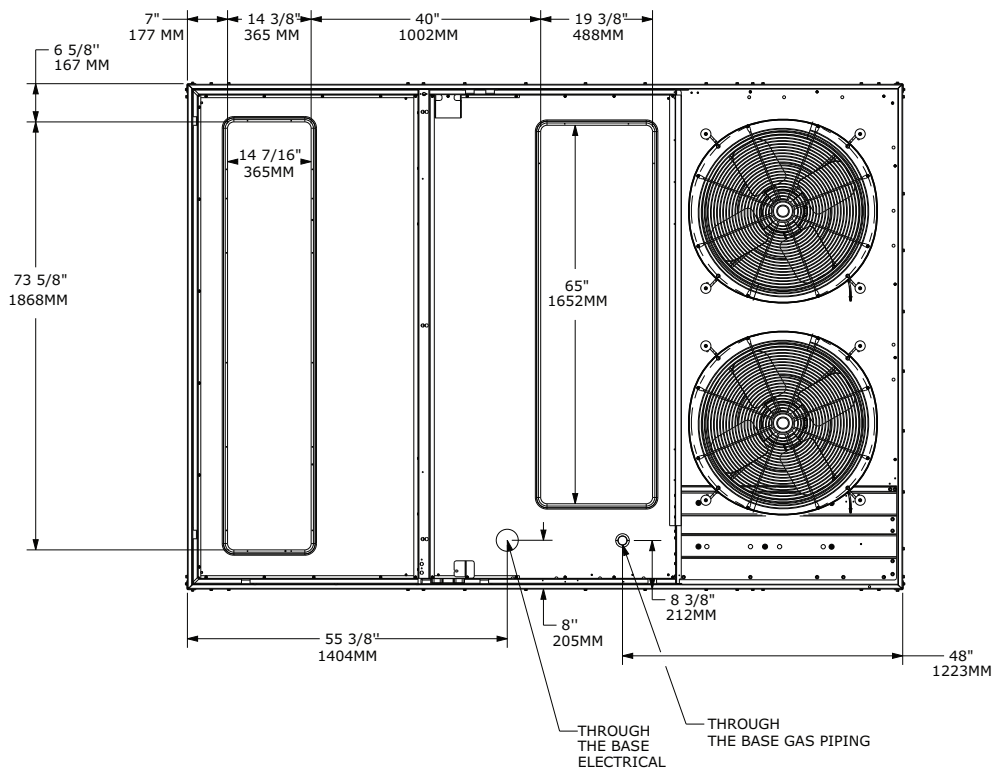

Figure 49. D.0 and D.1 cabinets – downflow airflow supply/return, through-the-base utilities





## Dimensional Data

Figure 50. D.0 and D.1 cabinets – horizontal airflow supply/return

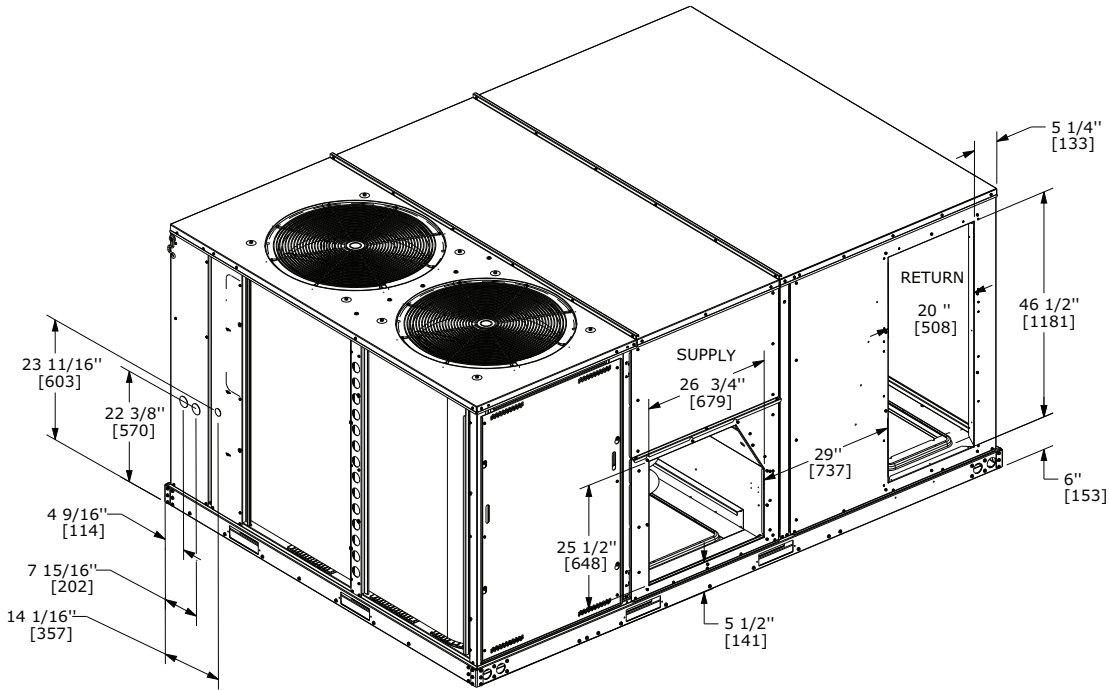

Figure 51. D.0 and D.1 cabinets – unit clearance and roof opening

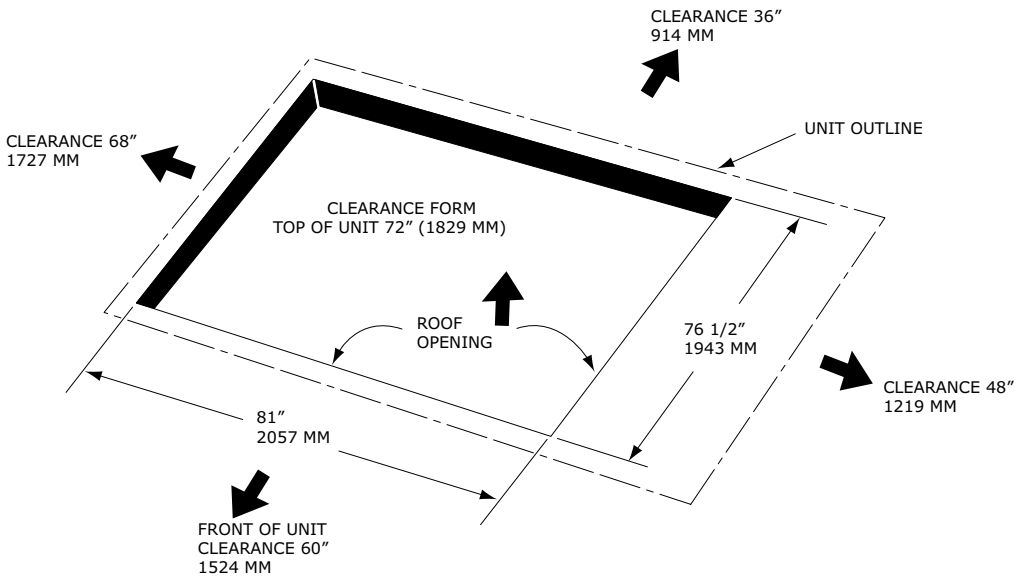

Figure 52. D.0 and D.1 cabinets – roof curb

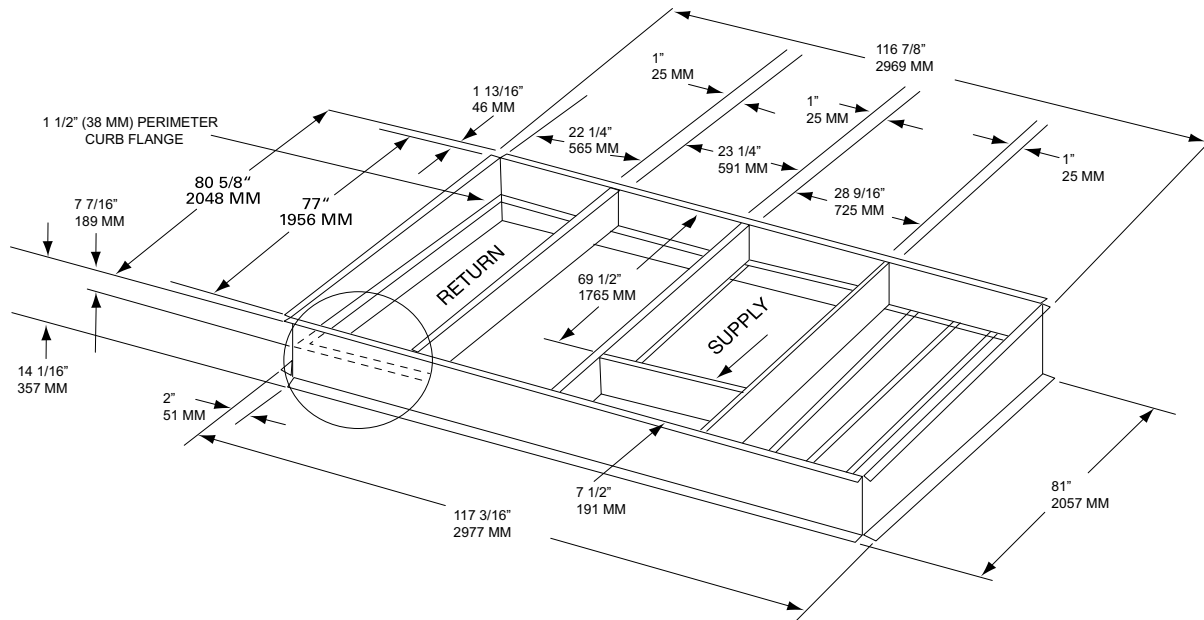
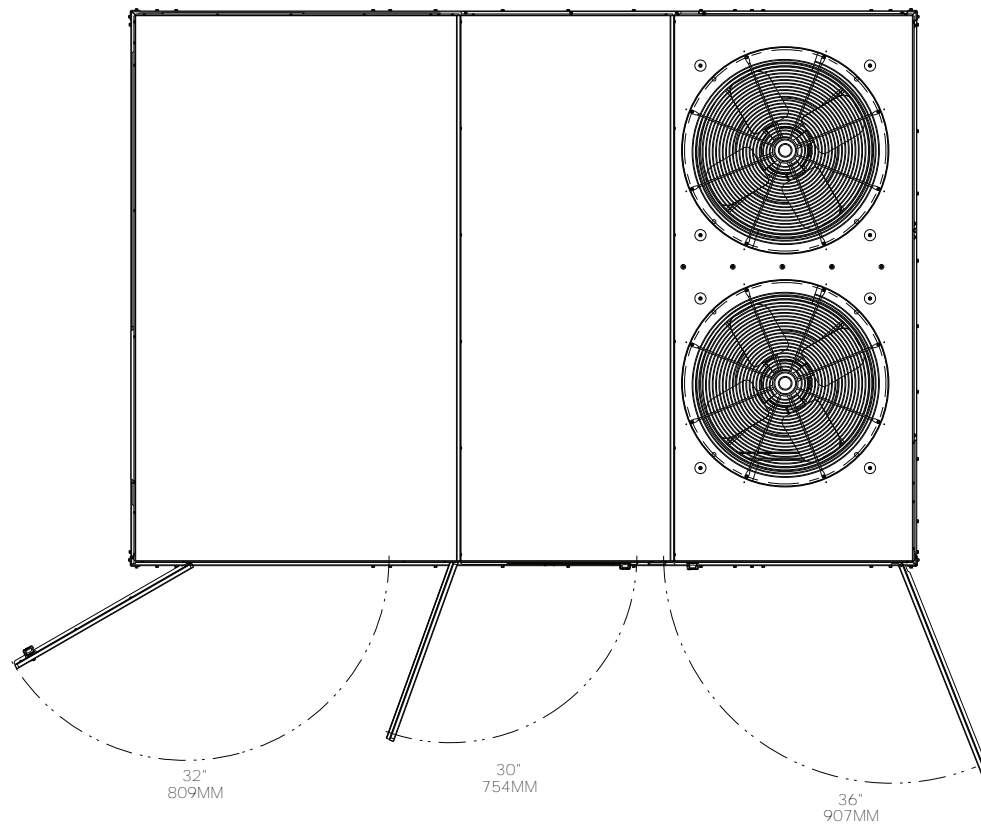

Figure 53. D.0 and D.1 cabinets – swing diameter for hinged door(s) option





## Dimensional Data

Figure 54. D.0 and D.1 cabinets – power exhaust

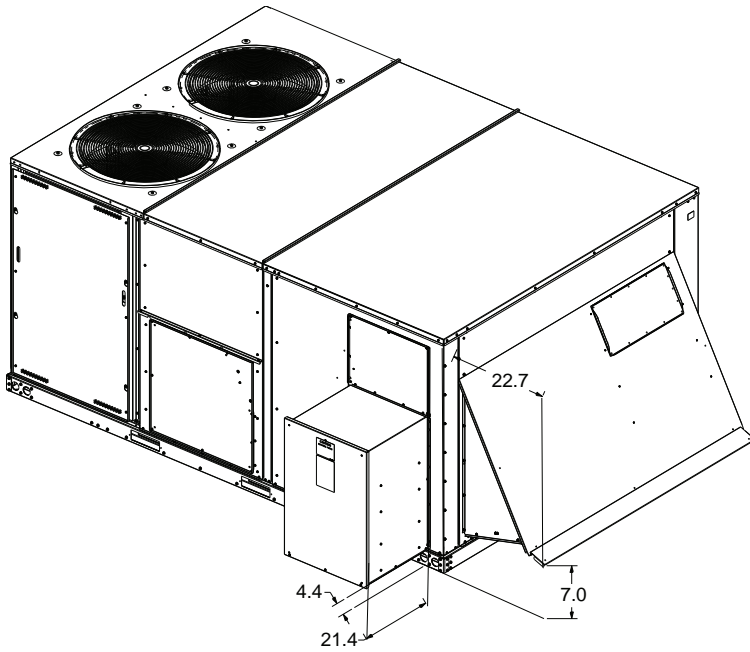
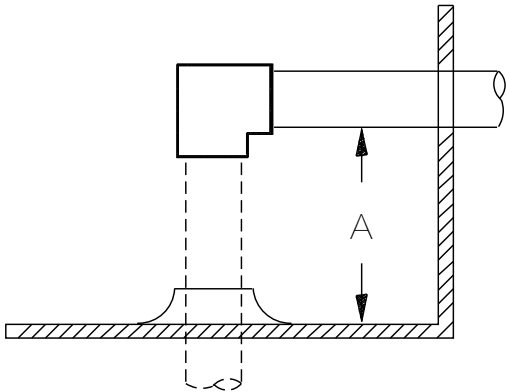

Figure 55. Gas pipe height



**Note:** Height of gas pipe required from inside unit base to gas shut off assembly (factory provided).

Table 171. Gas pipe height dimensions

Cabinet	Dimension A	
	inch	mm
A.0, B.0, and C.0	4-5/8	117
D.0 and D.1	1-3/6	30



# Weights

**Table 172. Model weights, corner weights (lbs), and center of gravity dimensions (in.)**

Tons	Unit Model No.	Model Weights <sup>(a)</sup>		Corner Weights <sup>(b)</sup>				Center of Gravity (in.)	
		Shipping	Net	A	B	C	D	Length	Width
<b>Standard Efficiency</b>									
3	TSK036	667	589	184	147	111	147	31	19
4	TSK048	686	609	194	153	111	152	30	19
5	TSK060	705	629	202	154	112	160	30	19
6	TSK072	986	892	319	267	139	167	41	18
7.5	TSK090	1008	914	327	273	143	171	41	18
8.5	TSK102	1029	935	335	279	146	175	41	18
10	TSK120	1044	950	340	284	148	178	41	18
12.5	TSK150	1412	1218	464	343	175	236	43	21
15	TSK180	2040	1820	611	447	322	440	52	36
17.5	TSK210	2070	1850	612	463	334	441	53	36
20	TSK240	2140	1920	689	472	309	450	50	34
25	TSK300	2190	1970	684	485	332	469	51	35
<b>High Efficiency</b>									
3	THK036	684	607	192	153	116	146	31	19
4	THK048	875	777	293	231	112	141	39	17
5	THK060	895	797	293	239	119	146	40	18
6	THK072	986	892	319	267	139	167	41	18
7.5	THK090	1008	914	327	273	143	171	41	18
8.5	THK102	1029	935	335	279	146	175	41	18
10	THK120	1044	950	340	284	148	178	41	18
12.5	THK150	2040	1820	611	447	322	440	52	36
15	THK180	2040	1820	611	447	322	440	52	36
17.5	THK210	2070	1850	612	463	334	441	53	36
20	THK240	2140	1920	689	472	309	450	50	34
25	THK300	2190	1970	684	485	332	469	51	35

<sup>(a)</sup> Weights are approximate. Weights do not include additional factory or field installed options/accessories. For option/accessory additional weights to be added to unit weight, reference the following table.

<sup>(b)</sup> Corner weights are given for information only.

**Table 173. Model weights, corner weights (lbs), and center of gravity dimensions (in.) - gas/electric**

Tons	Unit Model No.	Model Weights <sup>(a)</sup>		Corner Weights <sup>(b)</sup>				Center of Gravity (in.)	
		Shipping	Net	A	B	C	D	Length	Width
<b>Standard Efficiency</b>									
3	YSK036	728	651	201	165	125	160	31	19
4	YSK048	748	671	210	170	127	164	31	19
5	YSK060	768	691	220	172	126	173	30	19
6	YSK072	1031	937	329	279	152	177	41	18
7.5	YSK090	1060	966	338	287	158	183	41	18
8.5	YSK102	1096	998	345	295	165	193	41	19
10	YSK120	1115	1017	354	302	168	193	41	18
12.5	YSK150	1412	1218	464	343	175	236	43	21

# Weights

**Table 173. Model weights, corner weights (lbs), and center of gravity dimensions (in.) - gas/electric (continued)**

Tons	Unit Model No.	Model Weights <sup>(a)</sup>		Corner Weights <sup>(b)</sup>				Center of Gravity (in.)	
		Shipping	Net	A	B	C	D	Length	Width
15	YSK180	2220	2000	671	492	354	483	52	36
17.5	YSK210	2250	2030	672	508	366	484	53	36
20	YSK240	2320	2100	754	516	337	493	50	34
25	YSK300	2370	2150	746	529	363	512	51	35
<b>High Efficiency</b>									
3	YHK036	728	651	201	165	125	160	31	19
4	YHK048	923	825	295	250	129	151	41	18
5	YHK060	951	853	304	259	134	156	41	18
6	YHK072	1035	937	329	279	152	177	41	18
7.5	YHK090	1064	966	338	287	158	183	41	18
8.5	YHK102	1096	998	345	295	165	193	41	19
10	YHK120	1115	1017	354	302	168	193	41	18
12.5	YHK150	2220	2000	671	492	354	483	52	36
15	YHK180	2220	2000	671	492	354	483	52	36
17.5	YHK210	2250	2030	672	508	366	484	53	36
20	YHK240	2320	2100	754	516	337	493	50	34
25	YHK300	2370	2150	746	529	363	512	51	35

<sup>(a)</sup> Weights are approximate. Weights do not include additional factory or field installed options/accessories. For option/accessory additional weights to be added to unit weight, reference the following table.

<sup>(b)</sup> Corner weights are given for information only.

**Figure 56. Corner weights**

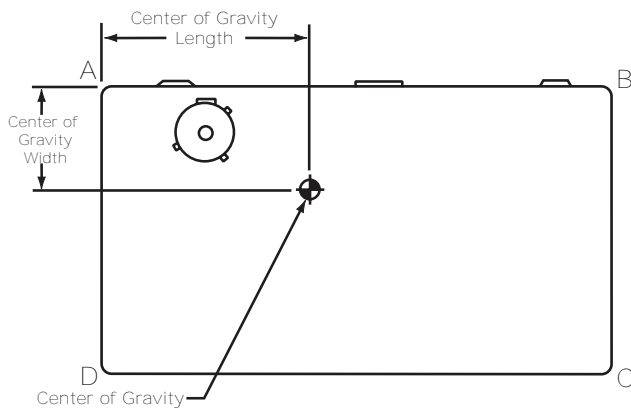

**Table 174. Factory installed options (FIOPS)/accessory net weights (lb)**

Accessory	Standard Efficiency				High Efficiency		
	T/YSK036-060	T/YSK072-120	T/YSK150	T/YSK180-300	T/YHK036	T/YHK048-120	T/YHK150-300
Barometric Relief	7	10	10	40	7	10	40
Economizer	26	36	36	91	26	36	91
Electric Heaters <sup>(a)</sup>	15	44	50	75	15	44	75
Hinged Doors	10	12	12	20	10	12	20
Low Leak Economizer - Downflow	79	91	91	150	79	91	150
Low Leak Economizer - Horizontal	130	186	186	180	130	186	180
Manual Outside Air Damper	16	26	26	15	16	26	15
Motorized Outside Air Damper	20	30	30	82	20	30	82

**Table 174. Factory installed options (FIOPS)/accessory net weights (lb) (continued)**

Accessory	Standard Efficiency				High Efficiency		
	T/YSK036-060	T/YSK072-120	T/YSK150	T/YSK180-300	T/YHK036	T/YHK048-120	T/YHK150-300
Oversized Motor <sup>(b)</sup>	5	14	14	30	5	14	30
Powered Convenience Outlet	38	38	50	50	38	38	50
Power Exhaust	40	80	80	110	40	80	110
Reheat Coil	13	16	20	33	13	16	33
Roof Curb	61	105	111	235	61	105	235
Smoke Detector, Supply <sup>(b)</sup>	-	5	5	5	-	5	5
Smoke Detector, Return	7	7	7	5	7	7	5
Stainless Steel Heat Exchanger <sup>(c)</sup>	4	6	6	5	4	6	5
Through-the-Base Electrical	8	13	13	10	8	13	10
Through-the-Base Gas <sup>(c)</sup>	5	5	5	10	5	5	10
Unit Mounted Circuit Breaker	5	10	10	10	5	10	10
Unit Mounted Disconnect	5	5	5	10	5	5	10

**Notes:**

1. Weights for options not listed are less than 5 pounds.
2. Net weight should be added to unit weight when ordering factory-installed accessories.
3. Weights are approximate.

- <sup>(a)</sup> Only applies to T\*K models.  
<sup>(b)</sup> Not available on all models.  
<sup>(c)</sup> Only applies to Y\*K models.



# Mechanical Specifications

## General

- Precedent unit cooling capacities, heating capacities, and efficiencies are certified to the following standards:
  - 3 to 5 ton units: AHRI Standard 210/240.
  - 6 to 25 ton units: AHRI Standard 340/360.
- Gas Heating Units: ANSI Z21.47 and 10 CFR Part 431 for Commercial Warm Air.
- Convertible airflow.
- Symbio™ controls operating range between 40°F and 125°F in cooling mode standard from the factory. Field-installed low ambient kit extends operating range down to 0°F.
- Factory assembled, internally wired, fully charged, and 100 percent run tested to verify cooling operation, fan and blower rotation, and control sequence.
- Colored and numbered wiring internal to the unit for simplified identification.
- cULus listed and classified in accordance for Central Cooling Air Conditioners.

## Casing

- Zinc coated, heavy gauge, galvanized steel.
- Weather resistant pre-painted metal with galvanized substrate.
- Meets ASTM B117, 672 hour salt spray test.
- Removable single side maintenance access panels.
- Lifting handles in maintenance access panels (can be removed and reinstalled by removing fasteners while providing a water and air tight seal).
- Exposed vertical panels and top covers in the indoor air section insulated with a cleanable foil-faced, fire-retardant permanent, odorless glass fiber material.
- Base pan with no penetrations within the perimeter of the curb other than the raised 1-inch downflow supply/return openings to provide an added water integrity precaution, if the condensate drain backs up.
- Base of the unit insulated with 1/8-inch, foil-faced, closed-cell insulation.
- Unit base provisions for forklift and/or crane lifting on three sides of unit.

## Microchannel Coils

- Optimal heat transfer performance due to flat, streamlined tubes with small ports, and metallurgical tube-to-fin bond.
- Reduce system refrigerant charge by up to 50 percent leading for better compressor reliability.
- Compact all-aluminum microchannel coils reduce the unit weight.
- Recyclable all-aluminum coils. All-aluminium construction minimizes galvanic corrosion.
- Strong aluminum brazed structure provides better fin protection.
- Flat streamlined tubes more dust resistant and easy to clean.
- Coils leak tested at the factory to verify the pressure integrity.

## Coil Guards

Provides condenser coil protection.

## Compressors

- All units have direct-drive, hermetic, scroll type compressors with centrifugal type oil pumps.
- Suction gas-cooled motor with voltage utilization range of plus or minus 10 percent of unit nameplate voltage.
- Internal overloads standard with scroll compressors.
- Crankcase heaters are standard on all compressors.
- Dual compressors (6 to 25 ton units only).
- Cooling stages available:
  - 6 to 17.5 ton units – three.
  - 20 and 25 ton units – four.

## Filters

- Standard 2-inch filters.
- Optional 2-inch MERV 8 and MERV 13 filters.

## Frostat

- Used as a safety device.
- Opens to prevent freezing temperatures on evaporator coil.
- Closes when temperature rises to 50°F.
- Utilized in low airflow or high outside air applications (cooling only).

## Gas Heating Section

- Compact cabinet features a tubular heat exchanger in low, medium and high heat capacities.
- Corrosion-resistant aluminized steel tubes and burners are standard on all models.
- Induced draft combustion blower is used to pull the combustion products through the firing tubes.
- Heater uses a direct spark ignition (DSI) system and a flame sensor as a safety device to validate the flame.
- Units are suitable for use with natural gas or propane (field-installed kit).
- Stainless steel heat exchanger with 409 stainless steel tubes and 439 stainless steel burners (optional).

## Indoor Fan

- Direct drive forward curve fan design – A.0 cabinet.
- Direct drive plenum fan design – B.0, C.0, D.0, and D.1 cabinets.
- Plenum fan design – backward-curved fan wheel along with an external rotor direct drive variable speed indoor motor.
- Supply fan speed adjustments can be made using the Symbio™ 700 or Mobile App.
- Motors are electronically protected.
- Variable speed direct drive motors are high efficiency.

## Powered or Unpowered Convenience Outlet

- Powered GFCI, 120V/15A, 2 plug, convenience outlet or unpowered GFCI, 120V/20A, 2 plug, convenience outlet.
- When convenience outlet is powered, a service receptacle disconnect is available.
- Convenience outlet is powered from the line side of the disconnect or circuit breaker, and will not be affected by the position of the disconnect or circuit breaker.
- Available to order when through-the-base electrical with disconnect switch or circuit breaker option is selected.

## Stainless Steel Drain Pan

- Corrosion and oxidation resistance.
- Constructed of 304 stainless steel.

## Stainless Steel Heat Exchanger

- Constructed of 409 stainless steel tubes and 439 stainless steel burners.
- Resistant to corrosion and oxidation and easy to clean.
- High temperature material for more reliability at lower temperatures and higher ventilation rates.
- 15-year stainless steel heat exchanger warranty is standard.

**Note:** *The stainless steel heat exchanger is standard with the Ultra-Low NOx gas furnace option.*

## Through-the-Base Electrical with Circuit Breaker

- Thermal magnetic, molded case, HACR circuit breaker with provisions for through-the-base electrical connections.
- Circuit breaker installed within unit in water tight enclosure.
- Wiring provided from the switch to the unit high voltage terminal block.
- Circuit breaker will provide overcurrent protection, sized per NEC and cULus guidelines, and agency recognized by cULus.



## Mechanical Specifications

---

### Through-the-Base Electrical with Disconnect Switch

- 3-pole, molded case, disconnect switch with provisions for through-the-base electrical connections.
- Disconnect switch installed within unit in a water tight enclosure.
- Wiring provided from the switch to the unit high voltage terminal block.
- Switch cULus agency recognized.

**Note:** Disconnect switch sized per NEC and cULus guidelines but does not replace unit overcurrent protection

### Through-the-Base Gas Piping

- Standard through-the-base gas provisions.
- All required piping, including black steel manual gas shut-off valve, elbows, and union.
- Manual shutoff valve with 1/8-inch NPT pressure tap.
- Requires minor field assembly.

**Note:** Through-the-Base gas is not available with Ultra-Low NOx gas furnace option.

### Standard Economizer

- Available with or without barometric relief.
- Fully modulating 0 to 100 percent motor and dampers, minimum position setting, preset linkage, wiring harness with plug, spring return actuator and fixed dry bulb control.
- Barometric relief provides a pressure-operated, gravity-closing damper.
- Barometric relief prevents entrance of outside air during the equipment **off** cycle.
- Optional solid state or differential enthalpy control.
- Arrives in shipping position and must be switched to operating position by the installing contractor.

### Electric Heaters

- Constructed of heavy-duty nickel chromium elements internally delta connected for 240V, wye connected for 480V and 600V.
- Staging achieved through Symbio™ controller.
- Multiple automatic reset and single operation high temperature limit controls operating to break line power to the heater element.
- Heaters individually fused from the factory.
- Meets all NEC and CEC requirements when properly installed.
- Power assemblies provide single-point connection.
- Modules are cULus listed.

### Manual Outside Air Damper

Rain hood and screen provide up to 50 percent outside air.

### Motorized Outside Air Damper

- Once set, when indoor fan starts, outdoor air dampers open to set position.
- When indoor fan shuts down, damper fully closes.

### Power Exhaust

- Provides exhaust of return air, when using an economizer.
- Maintain better building pressurization.

## Roof Curb

- Designed to connect with the unit's downflow supply and return.
- Provides support and a water tight installation when installed properly.
- Allows field-fabricated rectangular supply/return ductwork to be connected directly to the curb.
- Curb shipped knocked down for field assembly.
- Includes wood nailer strips.

## Ventilation Override Operation

- Unit can be set to transition up to 3 different pre-programmed sequences for smoke purge, pressurization, and exhaust.
- Transition occurs when binary input on the Symbio™ controller is closed (shorted) (typically hard wired relay output from a smoke detector/ fire control panel).

**Note:** Requires Symbio™ Customer Connection Module, FIASCCM001\*.

## Leak Detection Sensors

Unit shall be furnished with a leak detection system from the factory when a circuit refrigerant charge exceeds 3.91 lbs. The leak detection system shall consist of one or more refrigerant detection sensors. When the system detects a leak, the unit controller shall initiate mitigation actions.



The AHRI Certified mark indicates Trane U.S. Inc. participation in the AHRI Certification program. For verification of individual certified products, go to [ahrirectory.org](http://ahrirectory.org).

Trane - by Trane Technologies (NYSE: TT), a global innovator - creates comfortable, energy efficient indoor environments for commercial and residential applications. For more information, please visit [trane.com](http://trane.com) or [tranetechnologies.com](http://tranetechnologies.com).

Trane has a policy of continuous product and product data improvements and reserves the right to change design and specifications without notice. We are committed to using environmentally conscious print practices.