



Product Catalog

# Packaged Rooftop Air Conditioners Precedent™ Cooling and Gas/Electric

Standard Efficiency

6 to 25 Tons — 60 Hz





# Introduction

## Packaged Rooftop Air Conditioners

Trane's customers demand products that provide exceptional reliability, meet stringent performance requirements, and are competitively priced. Trane delivers with Precedent™.

Precedent™ features cutting edge technologies: reliable compressors, Trane engineered Symbio controls, computer-aided run testing, and Integrated Comfort™ Systems. So, whether you're the contractor, the engineer, or the owner you can be certain Precedent™ products are built to meet your needs.

The Precedent product is designed for comfort cooling, mixed air applications. If the product is being considered for other types of applications, such as process cooling, dedicated outdoor air, indoor agriculture, etc. Consult with your local Trane Sales Representative. Applying the units in an unintended application could result in inadequate performance and/or premature component failures.

Through the years, Trane has designed and developed the most complete line of Packaged Rooftop products available in the market today. Trane was the first to introduce the Micro—microelectronic unit controls—and has continued to improve and revolutionize this design concept.

Symbio control platform offers the same great features and functionality as the original Micro, with additional benefits for greater application flexibility.

With its sleek, compact cabinet, Precedent™ continues to provide the highest standards in quality and reliability, comfort, ease of service, and the performance of Trane light commercial products.

## Copyright

This document and the information in it are the property of Trane, and may not be used or reproduced in whole or in part without written permission. Trane reserves the right to revise this publication at any time, and to make changes to its content without obligation to notify any person of such revision or change.

## Trademarks

All trademarks referenced in this document are the trademarks of their respective owners.

## Revision History

Updated the following 12.5 ton unit data in the following tables:

- General data table cooling performance
- Gross cooling capacities
- Fan performance
- Heating performance
- Electrical data



# Table of Contents

Features and Benefits .....	5
Features .....	5
Control Options .....	6
Accessories .....	7
Key Benefits .....	9
Model Number Description .....	16
General Data .....	18
Gross Cooling Capacities .....	24
Reheat Temperature Rise .....	33
Evaporator Fan Performance .....	56
Tables .....	56
Fan Performance .....	70
Heating Performance .....	73
Controls .....	75
Enhanced BAS Integration and Connectivity .....	75
Secure Remote Connectivity with Trane Connect .....	75
Serviceability .....	75
Flexibility .....	77
Economizer Controls .....	78
Zone Sensors .....	78
Air-Fi Wireless Communicating Zone Sensors .....	79
Thermostats .....	80
Humidity Control (HGRH) .....	80
Electrical Data .....	82
Dimensional Data .....	86
Weights .....	98



## Table of Contents

---

Mechanical Specifications .....	100
General .....	100
Casing .....	100
Coils .....	100
Coil Guards .....	100
Compressors .....	100
Filters .....	101
Frostat™ .....	101
Gas Heating Section .....	101
Tubular Gas Heat Exchanger .....	101
Indoor Fan .....	101
Powered or Unpowered Convenience Outlet .....	101
Stainless Steel Drain Pan .....	102
Stainless Steel Heat Exchanger .....	102
Through-the-Base Electrical with Circuit Breaker .....	102
Through-the-Base Electrical with Disconnect Switch .....	102
Economizer (Standard) .....	102
Manual Outside Air Damper .....	102
Motorized Outside Air Damper .....	102
Powered Exhaust .....	102
Roof Curb .....	103
Ventilation Override Operation .....	103





# Features and Benefits

## Features

*Note: Equipment feature availability is dependent on unit configuration. For more information, see Packaged Rooftop Air Conditioners Precedent™ Quick Reference Support Guide (PREC-PRC001\*-EN), the ordering system, or contact product support.*

**Table 1. Features – standard and optional**

	Standard Features	Options		
		Factory Installed	Factory or Field Installed	Field Installed
3-year Limited Parts Warranty	X			
5-year Limited Compressor Warranty	X			
10-year Limited Heat Exchanger Warranty	X			
15-year Limited Warranty Stainless Steel Heat Exchanger		X		
2 inch Filter	X			
2 inch MERV 8 Filters		X		
2 inch MERV 13 Filters		X		
Access Doors		X		
Access Door (Control Box)	X			
Access Panels	X			
Anti-Short Cycle Timer	X			
Barometric Relief			X	
CO <sub>2</sub> Sensor				X
Clogged Filter Switch			X	
Coil guards	X			
CompleteCoat™ Condenser Coil		X		
Condensate Overflow Switch			X	
Convertible Airflow	X			
Colored and Numbered Wiring	X			
Crankcase Heaters	X			
Direct Drive Plenum Fan	X			
Discharge Air Temperature Sensing Kit — MZVAV, SZVAV, Economizer, HGRH, mod gas	X			
Discharge Air Temperature Sensing Kit — Standard (Multispeed)			X	
Economizer: Low Leak — Downflow (6 to 25 Tons)			X	
Economizer: Low Leak — Horizontal (6 to 25 Tons)				X
Economizer: Standard — Convertible (6 to 12.5 Tons)			X	
Economizer: Standard — Downflow (15 to 25 Tons)			X	
Economizer: Standard — Horizontal (15 to 25 Tons)				X
Expansion Modules			X	
Fault Detection and Diagnostics (FDD)	X			
Filter Removal Tool	X			
Foil-Faced and Edge Protected Insulation	X			
Frostat™	X			
High Pressure Control	X			
High Altitude Kit				X
High Static/Oversized Motor		X		
High Temperature Sensor				X
IAQ Dual Sloped Composite Drain Pan	X			
Liquid Line Refrigerant Drier	X			



## Features and Benefits

**Table 1. Features – standard and optional (continued)**

	Standard Features	Options		
		Factory Installed	Factory or Field Installed	Field Installed
Low Ambient Cooling to 0°F				X
Low Ambient Cooling to 40°F	X			
Low Pressure Control	X			
LP Conversion Kit				X
Manual Outside Air Damper			X	
Microchannel Coils	X			
Modulating Gas Heat (10:1)		X		
Modulating Hot Gas Reheat (HGRH)		X		
Motorized Outside Air Damper			X	
Multispeed Direct Drive Motors	X			
Multiple Zone VAV (Variable Air Volume)		X		
Operating Charge of R-410A	X			
Phase Balance/Loss/Reversal Protection	X			
Phase Monitor	X			
Powered Exhaust				X
Powered or Unpowered Convenience Outlet		X		
Provisions for Through-the-Base Gas and Condensate Drain Connections	X			
Quick Adapt Curbs				X
Reference or Comparative Enthalpy			X	
Roof Curb				X
Single Point Power	X			
Single Side Service	X			
Smoke Detector - Return		X		
Smoke Detector - Supply		X		
Stainless Steel Drain Pan		X		
Standardized Components	X			
Symbio Controls	X			
Thermal Expansion Valve	X			
Through-the-Base Condensate	X			
Through-the-Base Electrical Access		X		
Through-the-Base Electrical with Circuit Breaker		X		
Through-the-Base Electrical with Disconnect Switch		X		
Through-the-Base Gas Piping		X		
Tubular Gas Heat Exchanger	X			
Variable Air Flow (SZVAV)/Variable Air Flow (MZVAV)		X		
Ventilation Override				X

## Control Options

**Note:** Control option availability is dependent on unit configuration. For more information, see *Packaged Rooftop Air Conditioners Precedent™ Quick Reference Support Guide (PREC-PRC001\*-EN)*, the ordering system, or contact product support.

**Table 2. Control options — standard and optional**

	Standard Features	Options		
		Factory Installed	Factory or Field Installed	Field Installed
Dual Thermistor Remote Zone Sensor				X
Symbio Service and Installation App	X			
Symbio 700 Advanced Module			X	
Humidity Sensor/Humidistat				X
Thermostat				X
Wireless Zone Sensor				X
Zone Sensor				X
LonTalk® Communication Interface (LCI)			X	
Trane® Air-Fi® Wireless Communication Interface (WCI)			X	

**Note:** For more information, reference the Controls chapter.

## Accessories

**Note:** Accessory availability is dependent on unit configuration. Some accessories may require additional accessories/options for full functionality. For more information, see *Packaged Rooftop Air Conditioners Precedent™ Quick Reference Support Guide (PREC-PRC001\*-EN)*, the ordering system, or contact product support.

FIA KIT	DESCRIPTION
FIABARM002*	Barometric Relief
FIABARM003*	Barometric Relief
FIAC02K001*	CO <sub>2</sub> (DCV) Wall Mounted Sensor
FIAC02K002*	CO <sub>2</sub> (DCV) Duct Mounted Sensor
FIACURB402*	14-inch Full Perimeter Knockdown Curb
FIACURB403*	14-inch Full Perimeter Knockdown Curb
FIACURB404*	14-inch Full Perimeter Knockdown Curb
FIACLFS001*	Clogged Filter Switch
FIACLFS002*	Clogged Filter Switch (MERV13)
FIACLFS003*	Clogged Filter Switch
FIACLFS004*	Clogged Filter Switch (MERV13)
FIADAST003*	Discharge Air Sensing Tube Kit
FIADAST004*	Discharge Air Sensing Tube Kit
FIADAST005*	Discharge Air Sensing Tube Kit
FIADAST006*	Discharge Air Sensing Tube Kit
FIADAST007*	Discharge Air Sensing Tube Kit
FIADAST008*	Discharge Air Sensing Tube Kit
FIADFDB001*	Differential Dry Bulb Economizer Control
FIADMPR002*	Manual Damper
FIADMPR003*	Manual Damper
FIADMPR102*	Motorized Damper
FIADMPR103*	Motorized Damper
FIAECON002*	Dry Bulb Economizer
FIAECON102*	Dry Bulb Downflow Low Leak
FIAECON003*	Dry Bulb Downflow Economizer



## Features and Benefits

FIA KIT	DESCRIPTION
FIAECON303*	Dry Bulb Horizontal Economizer
FIAECON103*	Dry Bulb Downflow Low Leak
FIAECON203*	Dry Bulb Horizontal Low Leak
FIAENTH001*	Reference Enthalpy Economizer Control
FIAENTH002*	Comparative Enthalpy Economizer Control
FIAHTST001*	High Temperature (Fire) Duct Mounted Stat
FIAHZDC001*	Horizontal Conversion Panel
FIALOAM001*	Low Ambient
FIALTCI001*	LonTalk Communication Interface
FIAOPTN001*	Indoor Options Module
FIAOPTN002*	Fresh Air Options Module
FIAOVFL001*	Condensate Overflow Switch
FIAPWRX302*	Power Exhaust 230V
FIAPWRX402*	Power Exhaust 460V
FIAPWRXW02*	Power Exhaust 575V
FIAHALT002*	High Altitude Gas Adjustment Kit - 2-Stage gas
FIAHALT003*	High Altitude Gas Adjustment Kit - 2-Stage gas
FIALPKT002*	LP Gas Conversion Kit - 2-Stage gas
FIALPKTM01*	LP Gas Conversion Kit - Modulating gas
FIALPKTM02*	LP Gas Conversion Kit - Modulating gas
FIALPKTM03*	LP Gas Conversion Kit - Modulating gas
FIALPKTM04*	LP Gas Conversion Kit - Modulating gas
FIALPKTM05*	LP Gas Conversion Kit - Modulating gas
FIALPKTM06*	LP Gas Conversion Kit - Modulating gas
FIALPKTM07*	LP Gas Conversion Kit - Modulating gas
FIALPKT003*	LP Gas Conversion Kit - 2-Stage gas
FIALPKTM09*	LP Gas Conversion Kit - Modulating gas
FIALPKTM10*	LP Gas Conversion Kit - Modulating gas
FIAPWRX303*	Power Exhaust 230V
FIAPWRX403*	Power Exhaust 460V
FIAPWRXW03*	Power Exhaust 575V
FIAQACB026*	Adapter Curb, BAYCURB026 to FIACURB403A
FIAQACB027*	Adapter Curb, BAYCURB027 to BAYCURB403A
FIAQACB044*	Adapter Curb, BAYCURB044 to BAYCURB402A
FIAS7ADV01*	Symbio 700 Advanced Controls and BACnet BAS Upgrade Kit
FIASCCM001*	Symbio Customer Connection Module
FIAXMOD030*	Symbio 700 XM30 Expansion Module
FIAXMOD032*	Symbio 700 XM32 Expansion Module

## Key Benefits

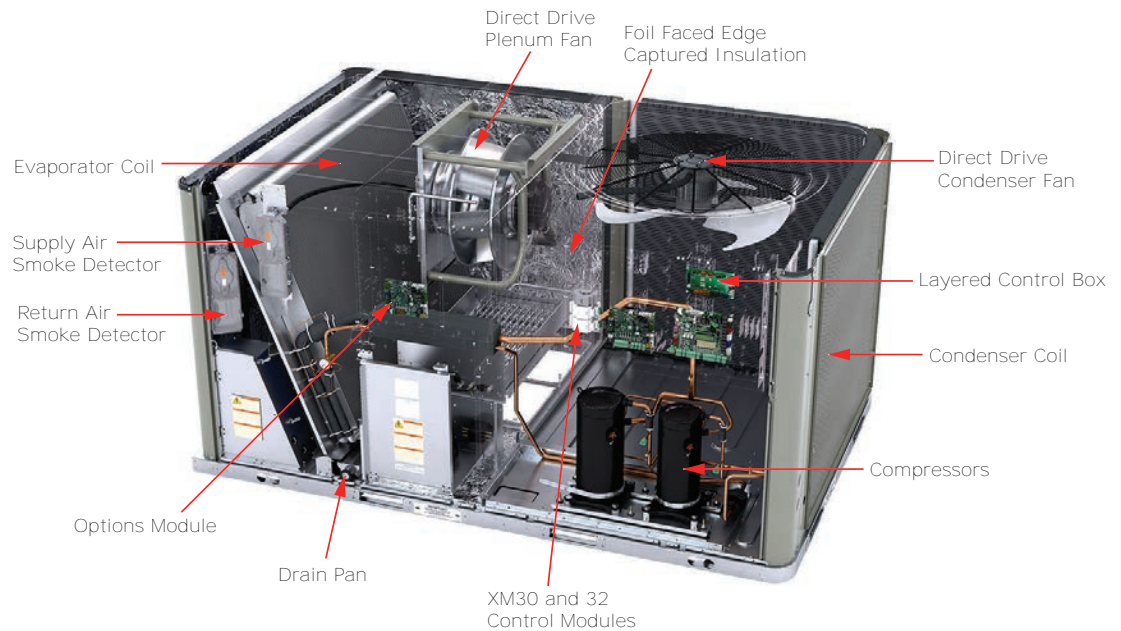

### Airflow Distribution

Airflow is outstanding. Precedent™ can replace an older machine with old ductwork and, in many cases, improve the comfort through better air distribution.

### Cabinet Integrity

For added water integrity, Precedent™ has a raised 1 inch lip around the supply and return of the downflow units to prevent water from blowing into the ductwork.

### Coil Guards

Coil guards protect condenser coil during shipping as well as hail, vandals, wind, etc. Toolless design lends itself to ease of maintenance in cleaning coils.



### CO<sub>2</sub> Sensor — Demand Control Ventilation (DCV)

Demand-controlled ventilation (DCV) is a control strategy that responds to the actual demand (need) for ventilation by regulating the rate at which the HVAC system brings outdoor air into the building. A CO<sub>2</sub> sensor measures the concentration (parts per million, ppm) of CO<sub>2</sub> (carbon dioxide) in the air. As the CO<sub>2</sub> concentration changes, the outside air damper modulates to meet the current ventilation needs of the zone. The CO<sub>2</sub> sensor kit is available as a field installed accessory and wires directly to the Symbio 700 controller.



## Features and Benefits

---

### CompleteCoat™ Condenser Coil

This optional coated coil provides excellent corrosion resistance as well as uniformity of coverage and coating thickness.

### Controls — Symbio™

#### Enhanced BAS Integration and Connectivity

- Open standard communications
  - BACnet® over Zigbee (Air-Fi Wireless)
  - BACnet MS/TP
  - BACnet IP
  - Modbus™ RTU
  - Modbus TCP/IP
  - LonTalk®
- Securely access, troubleshoot, and monitor equipment from anywhere via Trane Connect™

#### Serviceability

- Wireless mobile app interface (iPhone and Android) to simplify startup/service
- On-board user interface
- Data Trending
- Real-time, clear language diagnostics
- Historical alarm logs
- Backup and Restore functionality to reduce commissioning and service time

#### Flexibility

- Future-ready upgradable software, supporting changing codes and new sequences of operation
- Standard, consistent pre-engineered applications that meet industry standards
- Built-in Schedules (requires Tracer® TU)
- Expandable inputs and outputs (requires Tracer TU)
- Ability to add custom programmed sequences (requires Tracer TU)

#### Accessibility

Control box consists of a multilevel design with Symbio Controls located on hinged panels which provide protection from high voltage components for ease of servicing.

### Convenience Outlet

This option is GFCI, 120V/15A, 2 plug, convenience outlet powered or GFCI, 120V/20A, 2 plug convenience outlet unpowered. This option can be ordered when through the base electrical with either the disconnect switch or circuit breaker option is ordered.



## Convertible Units

Units ship in a downflow configuration and can be easily converted to horizontal by simply removing two panels. Optional field accessory kits required for 15 to 25 ton units.

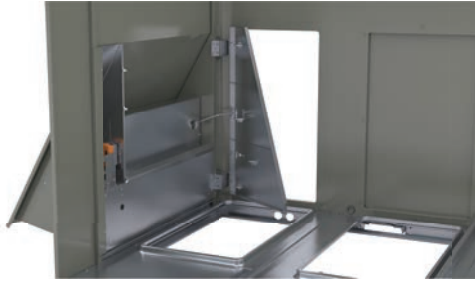

## Direct Drive Plenum Fans

All 6 to 25 tons units are equipped with a direct drive plenum fan design with the following features.

- Backward-curved fan wheel
- External rotor direct drive variable speed indoor motor
- Variable speed adjustment available in Symbio controller
- Designed to slide out for ease of maintenance



## Drain Pan

Every Precedent™ unit has an easy-to-clean, composite removable dual-sloped drain pan (IAQ). On units with B or C (6 to 12.5T) size cabinets, the drain pan is reversible, allowing installation of the draining trap on either side of the unit.





## Features and Benefits

---

### Fault Detection and Diagnostics (FDD)

This offering meets the mandatory requirement of CA Title 24 of fully configurable diagnostics allowing fault history and reading fault codes at the unit via Symbio™ 700 board or app. This feature provides detection of the following faults: Air temperature sensor failure/fault and notification of acceptable economizer mode. The FDD system shall be certified by the Energy Commission as meeting the requirements.

### Flexibility

Precedent™ offers ultimate flexibility. Units are built to order in our standard ship cycle time.

### High Altitude Kit

While recommended for units applied above 2,000 feet, domestic contractors should consult with local authority on best practice. High altitude kits contain gas orifices that derate the gas input rate (Btuh/r) by 10%.

### High Efficiency Filtration

Precedent™ units offer a variety of high efficiency filtration options. MERV 8 and MERV 13 filters provide additional filtration beyond the capabilities of typical 2 inches throwaway filters.

### High Static Motor

Available on 10 and 25 ton models, this high static motor option extends beyond the capability of the standard motor.

### Hinged Access Doors

These doors permit easy access to the filter, fan and compressor/control sections. They reduce the potential roof damage from screws or sharp access door corners.



### Humidity Sensor/Humidistat

The humidity sensor/humidistat, when used in conjunction with our dehumidification (hot gas reheat) units will provide outstanding humidity control and comfort. Humidity sensors can be wall or duct mounted. The humidity deadband can be set between 40% and 60% relative humidity.

### Low Ambient Cooling

All Precedent™ units have cooling capabilities down to 40°F. Field installed accessory extends operation down to 0°F.

### Low Leak Economizer

This accessory meets low leak requirements for ASHRAE 90.1, IECC, and CA Title 24 standards (4 cfm/ft<sup>2</sup>@1" wg exterior air/return air). This option allows 100% outdoor air supply from 0 to 100% modulating dampers and is standard with barometric relief. It can be paired with powered exhaust for additional building pressure relief. This option can be paired with or without fault detection and diagnostics (FDD) to meet current mandatory CA Title 24 requirements.



The economizers come with four control options, dry bulb, reference enthalpy, comparative enthalpy, or differential dry bulb.



**Note:** Downflow low leak economizer is available as a factory installed option. Horizontal low leak economizer option is only available as a field installed option.

### LP Conversion Kit

Provided for field conversion of gas/electric units from natural gas to propane.

### Microchannel Coils

Microchannel coils are all-aluminum coils with fully-brazed construction. This design reduces risk of leaks and provides increased coil rigidity — making them more rugged on the jobsite. Their flat streamlined tubes with small ports and metallurgical tube-to-fin bond allow for exceptional heat transfer. Microchannel all-aluminum construction provides several additional benefits:

- Light weight (simplifies coil handling)
- Easy to recycle
- Minimize galvanic corrosion

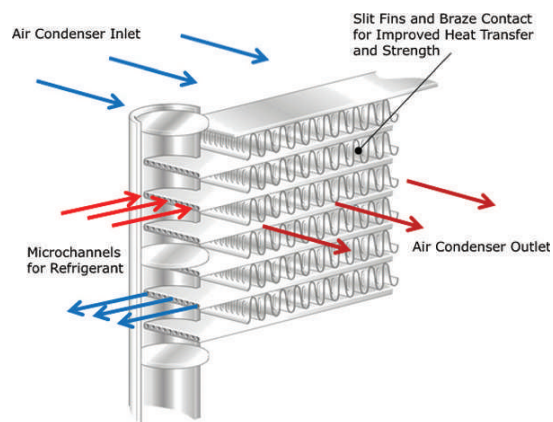

### Modulating Gas Heat (10:1)

Modulating natural gas heat option, with a high modulation range of 10:1, automatically modulates the gas value and combustion blower motor providing improved comfort with stable temperature control.

- Less on/off cycling
- Continuous heating output
- Wide operation range (low and high heat)



## Features and Benefits

---

- Coupled with variable speed fan control enables independent control of supply airflow and discharge air temperature
- With Zoned Rooftop Systems, modulating gas heat enables effective supply air tempering as well as warm-up sequences

### Modulating Hot Gas Reheat (HGRH)

All 12.5 to 25 tons units can be ordered with a factory installed modulating hot gas reheat (HGRH) humidity control system designed to provide year around comfort by improving indoor air quality while controlling humidity levels.

- Modulating gas reheat, no more on/off
- Maintains stable neutral leaving air temperature, resulting in less cycling
- Includes both relative humidity and dew point control
- Available on downflow or horizontal

### Multi-Speed Indoor Fan System

This system incorporates a multi-speed fan control to change the speed of the fan to 66% of full airflow based off of compressor stages.

### Multiple-Zone VAV Control

A multiple-zone VAV (MZVAV) system consists of a packaged rooftop unit that serves several individually controlled zones. Each zone is equipped with a VAV terminal unit that varies the quantity of air delivered to maintain the desired temperature in that zone. The rooftop unit controller varies the speed of the indoor fan to maintain the static pressure in the supply ductwork at a setpoint, ensuring that all zones receive the necessary quantity of air. In addition, cooling capacity is cycled to maintain the supply air temperature at the desired setpoint.

For decades, Trane has been an industry leader in rooftop VAV systems. Now, multiple-zone VAV control is available in the light commercial rooftop platform (6 to 25 tons).

### Other Benefits

- Cabinet design ensures water integrity
- Ease of Service, Installation and Maintenance
- Mixed model build enables “fastest in the industry” ship cycle times
- Outstanding Airflow Distribution
- Symbio Controls

### Quick Adapt Curbs

Enables easy upgrade of existing Voyager™ 6 to 25 tons units to Precedent™ units on replacement jobs.

### Rigorous Testing

All of the Precedent™ designs were rigorously rain tested at the factory to ensure water integrity.

Actual shipping tests were performed to determine packaging requirements. Units were test shipped around the country to determine the best packaging design. Factory shake and drop tests were used as part of the package design process to help assure that the unit arrives at the job site in top condition.

Rigging tests include lifting a unit into the air and letting it drop one foot, assuring that the lifting lugs and rails hold up under stress.

We perform a 100% coil leak test at the factory. The assembled unit is leak tested to 465 psig.

All parts are inspected at the point of final assembly. Sub-standard parts are identified and rejected immediately.

Every unit receives a 100% unit run test before leaving the production line to make sure it meets rigorous requirements.

## Single Zone VAV (SZVAV)

SZVAV is fully integrated into the control system. It provides the simplest and fastest commissioning in the industry through proven factory-installed, wired, and tested system controllers. All control modules, logic boards and sensors are factory installed and tested to ensure the highest quality and most reliable system available. This means no special programming of algorithms, or hunting at the jobsite for field installed sensors, boards, etc. SZVAV is a quick and simple solution for many applications and is available from your most trusted rooftop VAV system solution provider -Trane.

Building system modeling in energy simulation software such as TRACE is recommended to evaluate performance improvements for your application.

## Supply/Return Air Smoke Detector

With this option installed, if smoke is detected, all unit operation will be shut down. Reset will be manual at the unit. In order for the supply air smoke detector or return air smoke detector to properly sense smoke in the supply air stream or the return air stream, the air velocity entering the smoke detector unit must be between 500 to 4000 feet per minute. Equipment covered in this manual will develop an airflow velocity that falls within these limits over the entire airflow range specified in the evaporator fan performance table. Supply and/or return smoke detectors may not be used with the plenum smoke detector.



## Through-the-Base Condensate

6 to 12.5 tons unit includes provisions for through-the-base condensate drain connections. This allows the drain to be connected through the roof curb instead of a roof penetration.

## Through-the-Base Electrical Access

An electrical service entrance shall be provided allowing electrical access for both control and main power connections inside the curb and through-the-base of the unit. Option will allow for field installation of liquid-tight conduit and an external field installed disconnect switch.

## Through-the-Base Gas Piping

Factory provided through-the-base openings simplify piping. Because these utility openings frequently minimize the number of roof penetrations, the integrity of roofing materials is enhanced.

This option shall have all piping necessary including, black steel, manual gas shut-off valve, elbows, and union. This assembly will require minor field labor to install.

## Ventilation Override

Ventilation override allows the unit to be set to transition to up to three different pre-programmed sequences for smoke purge, pressurization, and exhaust. The transition occurs when a binary input on the Customer Connection Module is closed (shorted). This would typically be a hard wired relay output from a smoke detector or fire control panel. The Customer Connection module that allows ventilation override is available as a field installed accessory (FIASCCM001). For more information on functionality, refer to *Symbio™ 700 Controller with Precedent™ Packaged Rooftop Air-Conditioners Application Guide* (ACC-APG002\*-EN).



# Model Number Description

## Digit 1 — Unit Function

Y = DX Cooling, Gas Heat

## Digit 2 — Cooling Efficiency

S = Standard Efficiency

## Digit 3 — Refrigerant

J = R-410A

## Digit 4,5,6 — Nominal Gross Cooling Capacity (MBh)

072 = 6 Ton

090 = 7.5 Ton

102 = 8.5 Ton

120 = 10 Ton

150 = 12.5 Ton

180 = 15 Ton

210 = 17.5 Ton

240 = 20 Ton

300 = 25 Ton

## Digit 7 — Major Design Sequence

## Digit 8 — Voltage Selection

3 = 208–230/60/3

4 = 460/60/3

W = 575/60/3

## Digit 9 — Unit Controls

S = Symbio™ 700

## Digit 10 — Heat Type

0 = Base Model

A = Stainless Steel Gas Heat

B = Modulating Gas Heat

## Digit 11 — Heating Capacity

L = Low Gas Heat

M = Medium Gas Heat

H = High Gas Heat

## Digit 12, 13 — Service Sequence

\*\* = Factory Assigned

## Digit 14 — Fresh Air Selection

0 = No Fresh Air

A = Manual Outside Air Damper 0–50%

B = Motorized Outside Air Damper 0–50%

C = Economizer, Dry Bulb 0–100% without Barometric Relief

D = Economizer, Dry Bulb 0–100% with Barometric Relief

E = Economizer, Reference Enthalpy 0–100% without Barometric Relief

F = Economizer, Reference Enthalpy 0–100% with Barometric Relief

G = Economizer, Comparative Enthalpy 0–100% without Barometric Relief

H = Economizer, Comparative Enthalpy 0–100% with Barometric Relief

K = Downflow Low Leak Economizer, Dry Bulb with Barometric Relief

M = Downflow Low Leak Economizer, Reference Enthalpy with Barometric Relief

P = Downflow Low Leak Economizer, Comparative Enthalpy with Barometric Relief

R = Downflow Low Leak Economizer, Differential Dry Bulb with Barometric Relief

## Digit 15 — Supply Fan/Drive Type/Motor

0 = Multi-Speed Motor

1 = Optional Oversized/High Static Motor

2 = Single Zone Variable Air Volume with Standard Motor

3 = Single Zone Variable Air Volume with Oversized/High Static Motor

4 = Multiple Zone Variable Air Volume with Standard Motor

5 = Multiple Zone Variable Air Volume with Oversized/High Static Motor

## Digit 16 — Hinged Service Access/Filters

0 = Standard Panels/Standard Filters

A = Hinged Access Panels/Standard Filters

B = Standard Panels/2 inch MERV 8 Filters

C = Hinged Access Panels/2 inch MERV 8 Filters

D = Standard Panels/2 inch MERV 13 Filters

E = Hinged Access Panels/2 inch MERV 13 Filters

## Digit 17 — Condenser Coil Protection

0 = Standard Coil

1 = Condenser with CompleteCoat™

## Digit 18 — Through-the-Base Provisions

0 = No Through-the-Base Provisions

A = Through-the-Base Electric

B = Through-the-Base Gas Piping

C = Through-the-Base Electric and Gas Piping

## Digit 19 — Disconnect/Circuit Breaker (three-phase only)

0 = No Disconnect/No Circuit Breaker

1 = Unit Mounted/Non-Fused Disconnect

2 = Unit Mounted Circuit Breaker

## Digit 20— Convenience Outlet

0 = No Convenience Outlet

A = Unpowered 20A Convenience Outlet

B = Powered 15A Convenience Outlet (three-phase only)

## Digit 21— Communications Options

0 = No Communications Interface

1 = Advanced Controller with BACnet® Communications Interface

2 = Advanced Controller with LonTalk® Communications Interface

3 = Advanced Controller with Air-Fi® Communications Interface

## Digit 22— Refrigeration System Option

0 = Standard Refrigeration System

A = Dehumidification Option

## Digit 23— Controls Expansion Module

0 = None

1 = XM-30 Expansion Module

2 = XM-32 Expansion Module

3 = XM-30 and XM-32 Expansion Module

4 = XM-30 Expansion Module (Qty 2)

5 = XM-32 Expansion Module (Qty 2)

## Digit 24— Smoke Detector

0 = No Smoke Detector

A = Return Air Smoke Detector

B = Supply Air Smoke Detector

C = Supply and Return Air Smoke Detectors

**Digit 25— System Monitoring Controls**

- 0 = No Monitoring Control
- 1 = Clogged Filter Switch
- 2 = Condensate Overflow Switch
- 3 = Discharge Air Sensing Tube
- 4 = Clogged Filter Switch and Condensate Overflow Switch
- 5 = Clogged Filter Switch and Discharge Air Sensing Tube
- 6 = Condensate Overflow Switch and Discharge Air Sensing Tube
- 7 = Clogged Filter Switch, Condensate Overflow Switch and Discharge Air Sensing Tube

**Digit 26— Not Used****Digit 27— Unit Hardware Enhancements**

- 0 = No Enhancements
- 1 = Stainless Steel Drain Pan

**Digit 28— Short Circuit Current Rating**

- 0 = Standard (5k) SCCR Marking
- A = Tier 2 (=65K) SCCR Marking

**Digit 29— Low Ambient**

- 0 = None
- A = Low Ambient Cooling to 0°F



# General Data

**Table 3. General data— 6 to 12.5 tons— standard efficiency**

	6 Tons	7.5 Tons	8.5 Tons	10 Tons	12.5 Tons
	YSJ072	YSJ090	YSJ102	YSJ120	YSJ150
<b>Cooling Performance</b>					
Gross Cooling Capacity	73000	91000	104000	123000	145000
EER	11.0	11.0	11.0	11.0	10.8
Nominal cfm/AHRI Rated cfm	1860	2475	2975	3700	4875
AHRI Net Cooling Capacity	72000	90000	102000	120000	142000
IEER (2-Speed)	14.6	14.6	14.6	14.6	14.0
IEER (SZVAV/MZVAV)	15.1/15.1	15.1/15.1	15.1/15.1	15.1/15.1	14.5/14.5
System Power (kW)	6.55	8.18	9.27	10.91	13.15
<b>Compressor</b>					
Number/Type	2/Manifold Scroll	2/Manifold Scroll	2/Manifold Scroll	2/Manifold Scroll	2/Manifold Scroll
Percent Capacity (Stage 1 - Stage 3)	32/68/100	33/67/100	32/68/100	28/72/100	32/68/100
<b>Sound</b>					
Outdoor Sound Rating (dBA)	86	86	86	86	89
<b>Outdoor Coil</b>					
Type	Microchannel	Microchannel	Microchannel	Microchannel	Microchannel
Configuration	Full Face	Full Face	Full Face	Full Face	Full Face
Tube Size (in.)	0.7	0.7	1.0	1.0	1.0
Face Area (sq. ft.)	21.64	21.64	21.64	21.64	28.32
Rows/FPI (Fins per inch)	1/23	1/23	1/23	1/23	1/23
<b>Indoor Coil</b>					
Type	Microchannel	Microchannel	Microchannel	Microchannel	Microchannel
Configuration	Full Face	Full Face	Full Face	Full Face	Full Face
Tube Size (in.)	1.0	1.0	1.0	1.0	1.0
Face Area (sq. ft.)	11.84	11.84	11.84	11.84	14.27
Rows/FPI (Fins per inch)	2/18	2/18	2/18	2/18	2/18
Refrigerant Control	TXV	TXV	TXV	TXV	TXV
Drain Connection No./Size (in.) NPT	1/0.75	1/0.75	1/0.75	1/0.75	1/0.75
<b>Reheat Coil</b>					
Type	Microchannel	Microchannel	Microchannel	Microchannel	Microchannel
Configuration	Full Face	Full Face	Full Face	Full Face	Full Face
Tube Size (in.)	0.6	0.6	0.6	0.6	0.6
Face Area (sq. ft.)	9.04	9.04	9.04	9.04	11.82
Rows/FPI (Fins per inch)	1/23	1/23	1/23	1/23	1/23
<b>Outdoor Fan</b>					
Type	Propeller	Propeller	Propeller	Propeller	Propeller
No. Used/Diameter (in.)	1/26	1/26	1/26	1/26	1/30
Drive Type/No. Speeds	Direct/1	Direct/1	Direct/1	Direct/1	Direct/1
CFM	5900	5900	5900	6700	8200
Motor HP	0.70	0.70	0.70	0.75	1.00
Motor RPM	1100	1100	1100	1100	1100
<b>Indoor Fan</b>					

**Table 3. General data— 6 to 12.5 tons— standard efficiency (continued)**

	<b>6 Tons</b>	<b>7.5 Tons</b>	<b>8.5 Tons</b>	<b>10 Tons</b>	<b>12.5 Tons</b>
	<b>YSJ072</b>	<b>YSJ090</b>	<b>YSJ102</b>	<b>YSJ120</b>	<b>YSJ150</b>
Type	BC Plenum	BC Plenum	BC Plenum	BC Plenum	BC Plenum
No. Used/Diameter (in.)/Width (in.)	1/23x6	1/23x6	1/23x6	1/23x6	1/23x6
Drive Type/No. Speeds/RPM	Direct / Variable	Direct / Variable	Direct / Variable	Direct / Variable	Direct / Variable
Motor HP (Standard/Oversized)	3.1 / –	3.1 / –	3.1 / –	3.1 / 4.6	4.6 / –
Max Motor RPM	1850	1850	1850	1850 / 1940	1940
<b>Filters<sup>(a)</sup></b>					
Type Furnished	Throwaway	Throwaway	Throwaway	Throwaway	Throwaway
Number Size Recommended	(2) 18 x 24 x 2 (3) 24 x 16 x 2	(2) 18 x 24 x 2 (3) 24 x 16 x 2	(2) 18 x 24 x 2 (3) 24 x 16 x 2	(2) 18 x 24 x 2 (3) 24 x 16 x 2	(3) 18 x 18 x 2 (3) 24 x 18 x 2
<b>Refrigerant Charge</b>					
lbs of R-410A	9.0	9.0	9.5	10.1	11.4
lbs of R-410A, Hot Gas Reheat	10.3	9.6	10.1	10.7	11.6
<b>Heating Performance (Gas/Electric Only)</b>					
<b>Heating Input: Staged</b>					
Low Heat Input (Btu) (High/Low Stage)	80,000/56,000	120,000/84,000	120,000/84,000	150,000/105,000	150,000/105,000
Mid Heat Input (Btu) (High/Low Stage)	120,000/84,000	150,000/105,000	150,000/105,000	200,000/140,000	200,000/140,000
High Heat Input (Btu) (High/Low Stage)	150,000/105,000	200,000/140,000	200,000/140,000	240,000/168,000	250,000/175,000
<b>Heating Output: Staged</b>					
Low Heat Output (Btu) (High/Low Stage)	64,800/45,300	97,200/68,000	97,200/68,000	121,500/85,000	121,500/85,000
Mid Heat Output (Btu) (High/Low Stage)	97,200/68,000	121,500/85,000	121,500/85,000	162,000/113,400	162,000/113,400
High Heat Output (Btu) (High/Low Stage)	121,500/85,000	162,000/113,400	162,000/113,400	194,400/136,000	202,500/141,750
<b>Heating Input: Modulating</b>					
Low Heat Input (Btu) (Maximum/Minimum)	80,000/8,000	120,000/12,000	120,000/12,000	n/a	150,000/15,000
High Heat Input (Btu) (Maximum/Minimum)	150,000/15,000	200,000/20,000	200,000/20,000	240,000/24,000	250,000/25,000
<b>Heating Output: Modulating</b>					
Low Heat Output (Btu) (Maximum/Minimum)	64,800/6,480	97,200/9,720	97,200/9,720	n/a	121,500/12,150
High Heat Output (Btu) (Maximum/Minimum)	121,500/12,150	162,000/16,200	162,000/16,200	194,400/19,440	202,500/20,250
<b>Steady State Efficiency %</b>					
Low Heat Input	81	81	81	81	81
Mid Heat Input	81	81	81	81	81
High Heat Input	81	81	81	81	81
<b>No. Burners: Staged</b>					
Low Heat Output	3	3	3	n/a	4
Mid Heat Output	3	4	4	6	4
High Heat Output	4	6	6	6	6
<b>No. Burners: Modulating</b>					
Low Heat Output	2	4	4	4	4
High Heat Output	4	6	6	6	6
<b>No. Stages</b>					
Low Heat Input	2	2	2	2	2
Mid Heat Input	2	2	2	2	2
High Heat Input	2	2	2	2	2
<b>Gas Supply Line Pressure (inWC)</b>					
Natural (minimum/maximum)	4.5/14.0	4.5/14.0	4.5/14.0	4.5/14.0	4.5/14.0



## General Data

**Table 3. General data— 6 to 12.5 tons— standard efficiency (continued)**

	<b>6 Tons</b>	<b>7.5 Tons</b>	<b>8.5 Tons</b>	<b>10 Tons</b>	<b>12.5 Tons</b>
	<b>YSJ072</b>	<b>YSJ090</b>	<b>YSJ102</b>	<b>YSJ120</b>	<b>YSJ150</b>
LP (minimum/maximum)	11.5/14.0	11.5/14.0	11.5/14.0	11.5/14.0	11.5/14.0
<b>Gas Connection Pipe Size (in.)</b>					
Low Heat	Staged: 1/2 Modulating: 3/4	3/4	3/4	3/4	3/4
Mid Heat	3/4	3/4	3/4	3/4	3/4
High Heat	3/4	3/4	3/4	3/4	3/4
<b>Cabinet</b>					
Cabinet Size	B0	B0	B0	B0	C0

<sup>(a)</sup> Outdoor sound rating shown is tested in accordance with AHRI 370-2015. For additional information reference the outdoor sound power level data in the performance section.



**Table 4. General data— 15 to 25 tons— standard efficiency**

	15 Tons	17.5 Tons	20 Tons	25 Tons
	YSJ180	YSJ210	YSJ240	YSJ300
<b>Cooling Performance</b>				
Gross Cooling Capacity	185000	215000	24700	282000
EER	10.8	10.8	9.8	9.8
Nominal cfm/AHRI Rated cfm	5250	6650	8000	10000
AHRI Net Cooling Capacity	182000	210000	240000	271000
IEER (2-Speed)	14	14.0	13.0	13.0
IEER (SZVAV/MZVAV)	14.5 / 14.5	14.5 / 14.5	13.5 / 13.5	13.5 / 13.5
System Power (kW)	16.85	19.44	24.49	27.65
<b>Compressor</b>				
Number/Type	2/Manifold Scroll	2/Manifold Scroll	2/Manifold Scroll	2/Manifold Scroll
Percent Capacity (Stage 1 - Stage 4)	33/67/100/NA	33/67/100/NA	24/36/64/100	25/37/63/100
<b>Sound</b>				
Outdoor Sound Rating (dBA)	87	91	91	93
<b>Outdoor Coil</b>				
Type	Microchannel	Microchannel	Microchannel	Microchannel
Configuration	Full Face	Full Face	Full Face	Full Face
Tube Size (in.)	0.71	0.71	1.0	1.0
Face Area (sq. ft.)	33.90	33.90	33.89	33.89
Rows/FPI (Fins per inch)	1/23	1/23	1/21	1/21
<b>Indoor Coil</b>				
Type	Microchannel	Microchannel	Microchannel	Microchannel
Configuration	Full Face	Full Face	Full Face	Full Face
Tube Size (in.)	1.0	1.0	1.0	1.0
Face Area (sq. ft.)	23.93	23.93	23.93	23.93
Rows/FPI (Fins per inch)	2/18	2/18	2/18	2/18
Refrigerant Control	TXV	TXV	TXV	TXV
STD. Drain Connection No./Size (in.)	1/1.00 PVC Socket	1/1.00 PVC Socket	1/1.00 PVC Socket	1/1.00 PVC Socket
Stainless Drain Connection No./Size (in.)	1/1.00 NPT	1/1.00 NPT	1/1.00 NPT	1/1.00 NPT
<b>Reheat Coil</b>				
Type	Microchannel	Microchannel	Microchannel	Microchannel
Configuration	Full Face	Full Face	Full Face	Full Face
Tube Size (in.)	0.6	0.6	0.6	0.6
Face Area (sq. ft.)	21.83	21.83	21.83	21.83
Rows/FPI (Fins per inch)	1/23	1/23	1/23	1/23
<b>Outdoor Fan</b>				
Type	Propeller	Propeller	Propeller	Propeller
No. Used/Diameter (in.)	2/26x3	2/26x4	2/26x4	2/28x4
Drive Type/No. Speeds	Direct/1	Direct/1	Direct/1	Direct/1
CFM	11520	14660	14220	16600
Motor HP	2/0.50	2/1.0	2/1.0	2/1.0
Motor RPM	1125	1125	1125	1125
<b>Indoor Fan</b>				
Type	BC Plenum	BC Plenum	BC Plenum	BC Plenum
No. Used/Diameter (in.)/Width (in.)	2/23x6	2/23x6	2/23x6	2/23x6



## General Data

**Table 4. General data— 15 to 25 tons— standard efficiency (continued)**

	15 Tons	17.5 Tons	20 Tons	25 Tons
	YSJ180	YSJ210	YSJ240	YSJ300
Drive Type/No. Speeds/RPM	Direct / Variable	Direct / Variable	Direct / Variable	Direct / Variable
Motor HP (Standard/Oversized)	3.1 / –	Staged: 3.1 / – Modulating: 3.1 / 4.6	Staged: 3.1 / – Modulating: 3.1 / 4.6	Staged: 3.1 / 4.6 Modulating: 3.1 / 4.6
Max Motor RPM	1850	1850 / 1940	1850 / 1940	1850 / 1940
<b>Filters<sup>(a)</sup></b>				
Motor Frame Size (Standard/Oversized)	– / –	– / –	– / –	– / –
Type Furnished	Throwaway	Throwaway	Throwaway	Throwaway
Number Size Recommended	(8) 20 x 24 x 2	(8) 20 x 24 x 2	(8) 20 x 24 x 2	(8) 20 x 24 x 2
<b>Refrigerant Charge</b>				
lbs of R-410A	14.5	14.2	16.6	16.9
lbs of R-410A, Hot Gas Reheat	15.8	15.0	17.2	17.7
<b>Heating Performance (Gas/Electric Only)</b>				
<b>Heating Input: Staged</b>				
Low Heat Input (Btu) (High/Low Stage)	250,000/175,000	250,000/175,000	250,000/175,000	250,000/175,000
Mid Heat Input (Btu) (High/Low Stage)	320,000/224,000	320,000/224,000	320,000/224,000	320,000/224,000
High Heat Input (Btu) (High/Low Stage)	400,000/280,000	400,000/280,000	400,000/280,000	400,000/280,000
<b>Heating Output: Staged</b>				
Low Heat Input (Btu) (High/Low Stage)	202,500/141,750	202,500/141,750	202,500/141,750	202,500/141,750
Mid Heat Input (Btu) (High/Low Stage)	259,200/181,440	259,200/181,440	259,200/181,440	259,200/181,440
High Heat Input (Btu) (High/Low Stage)	324,000/226,800	324,000/226,800	324,000/226,800	324,000/226,800
<b>Heating Input: Modulating</b>				
Low Heat Input (Btu) (Maximum/Minimum)	250,000/25,000	250,000/25,000	250,000/25,000	250,000/25,000
High Heat Input (Btu) (Maximum/Minimum)	400,000/40,000	400,000/40,000	400,000/40,000	400,000/40,000
<b>Heating Output: Modulating</b>				
Low Heat Output (Btu) (Maximum/Minimum)	202,500/20,250	202,500/20,250	202,500/20,250	202,500/20,250
High Heat Output (Btu) (Maximum/Minimum)	324,000/32,400	324,000/32,400	324,000/32,400	324,000/32,400
<b>Steady State Efficiency %</b>				
Low Heat Input	81	81	81	81
Mid Heat Input	81	81	81	81
High Heat Input	81	81	81	81
<b>No. Burners: Modulating</b>				
Low Heat Output	6	6	6	6
High Heat Output	8	8	8	8
<b>No. Burners: Staged</b>				
Low Heat Output	5	5	5	5
Mid Heat Output	7	7	7	7
High Heat Output	8	8	8	8
<b>No. Stages</b>				
Low Heat Input	2	2	2	2
Mid Heat Input	2	2	2	2
High Heat Input	2	2	2	2
<b>Gas Supply Line Pressure (InWC)</b>				
Natural (minimum/maximum) Low Heat	4.5/14.0	4.5/14.0	4.5/14.0	4.5/14.0
Natural (minimum/maximum) Mid Heat	4.5/14.0	4.5/14.0	4.5/14.0	4.5/14.0
Natural (minimum/maximum) High Heat	6.0/14.0	6.0/14.0	6.0/14.0	6.0/14.0
LP (minimum/maximum)	11.5/14.0	11.5/14.0	11.5/14.0	11.5/14.0

**Table 4. General data— 15 to 25 tons— standard efficiency (continued)**

	15 Tons	17.5 Tons	20 Tons	25 Tons
	YSJ180	YSJ210	YSJ240	YSJ300
<b>Gas Connection Pipe Size (in.)</b>				
Low Heat	3/4	3/4	3/4	3/4
Mid Heat	3/4	3/4	3/4	3/4
High Heat	3/4	3/4	3/4	3/4
<b>Cabinet</b>				
Cabinet Size	D0	D0	D0	D0

<sup>(a)</sup> Outdoor sound rating shown is tested in accordance with AHRI 370-2015. For additional information reference the outdoor sound power level data in the performance section.



# Gross Cooling Capacities

Table 5. Gross cooling capacities — 6 tons

CFM	Ent DB (°F)	Entering Wet Bulb Temp (°F)						Entering Wet Bulb Temp (°F)						Entering Wet Bulb Temp (°F)					
		61		67		73		61		67		73		61		67		73	
		MBh	SHC	MBh	SHC	MBh	SHC	MBh	SHC	MBh	SHC	MBh	SHC	MBh	SHC	MBh	SHC	MBh	SHC
		Ambient Temperature 85°F						Ambient Temperature 95°F						Ambient Temperature 105°F					
1860	75	67.9	54.2	77.6	43.2	85.6	29.1	63.8	51.9	73.0	40.9	80.2	28.6	59.4	49.6	68.1	38.5	74.1	26.5
	80	67.7	63.3	77.5	53.0	85.9	40.7	63.7	60.9	73.0	50.7	80.6	38.3	59.3	58.5	68.1	48.3	74.8	35.8
	85	69.3	69.3	77.3	62.5	86.1	50.9	66.1	66.1	72.9	60.5	81.0	48.4	62.5	62.5	68.0	57.9	75.2	45.9
	90	77.1	71.7	77.1	71.7	86.2	60.6	70.3	70.3	72.7	69.4	81.0	58.3	66.7	66.7	67.9	66.9	75.3	55.8
2160	75	70.3	59.0	80.0	46.2	87.3	30.8	65.9	56.4	75.2	43.7	81.5	28.7	61.3	52.4	70.0	41.2	75.1	27.2
	80	69.9	69.0	79.9	57.4	87.7	42.9	65.7	65.7	75.2	55.0	82.1	40.6	61.6	61.6	70.0	52.6	76.0	38.1
	85	73.4	73.4	79.7	68.0	88.0	54.5	69.9	69.9	75.0	63.6	82.5	52.1	66.1	66.1	69.8	63.1	76.3	49.5
	90	77.9	77.9	79.3	78.4	88.1	66.0	74.3	74.3	74.6	74.6	82.6	63.6	70.3	70.3	70.4	70.4	76.5	61.0
2400	75	71.7	61.4	81.6	48.2	88.3	31.6	67.2	57.2	76.6	45.8	82.6	29.3	62.3	57.0	71.3	43.3	76.1	27.9
	80	71.3	71.3	81.5	60.7	88.8	44.8	67.7	67.7	76.5	59.3	83.1	42.4	63.9	63.9	71.2	55.9	76.9	39.9
	85	76.1	76.1	81.0	72.3	89.1	57.4	72.4	72.4	76.1	69.8	83.4	55.0	68.4	68.4	70.7	67.1	76.9	52.3
	90	80.8	80.8	80.9	80.9	89.2	70.1	76.9	76.9	77.0	77.0	83.5	67.7	72.5	72.5	72.6	72.6	77.2	63.1
2640	75	72.7	65.3	82.9	50.3	89.5	32.3	68.0	62.8	77.8	47.9	83.4	30.5	63.1	60.1	72.3	45.3	77.0	26.1
	80	73.5	73.5	82.7	64.0	89.9	46.5	69.8	69.8	77.6	61.6	84.1	44.0	65.8	65.8	72.1	59.0	77.6	41.3
	85	78.5	78.5	82.0	76.2	89.9	60.3	74.6	74.6	76.9	73.7	84.0	57.8	70.4	70.4	71.4	71.4	77.5	55.1
	90	83.2	83.2	83.3	83.3	90.1	73.3	79.0	79.0	79.1	79.1	84.2	67.9	74.2	74.2	74.3	74.3	77.3	67.9
2880	75	73.5	68.4	84.0	52.3	90.5	32.9	68.8	65.8	78.7	49.9	84.3	30.8	63.7	63.1	73.0	47.3	77.7	28.9
	80	75.5	75.5	83.7	67.2	90.7	48.1	71.7	71.7	78.5	64.2	84.6	45.5	67.5	67.5	72.8	59.5	78.3	43.0
	85	80.6	80.6	82.7	80.1	90.6	63.1	76.5	76.5	77.5	77.5	84.5	60.6	72.0	72.0	72.1	72.1	78.2	58.0
	90	85.1	85.1	85.2	85.2	90.6	77.1	80.7	80.7	80.7	80.7	84.3	74.4	75.4	75.4	75.5	75.5	77.6	71.5
		Ambient Temperature 115°F						Ambient Temperature 125°F											
1860	75	54.7	46.9	62.7	36.0	67.7	23.3	49.6	42.5	56.9	33.2	60.9	18.6						
	80	54.7	54.7	62.8	45.8	68.3	33.1	50.6	50.6	57.0	43.0	61.3	30.3						
	85	58.7	58.7	62.8	53.6	68.7	43.1	54.4	54.4	56.9	52.3	61.5	40.1						
	90	62.6	62.6	62.7	62.7	68.9	53.1	57.9	57.9	58.0	58.0	61.6	50.1						
2160	75	56.2	51.0	64.4	38.6	68.9	24.1	50.8	48.1	58.3	35.8	61.8	21.0						
	80	57.7	57.7	64.4	50.0	69.4	35.3	53.3	53.3	58.3	47.1	62.4	32.4						
	85	61.9	61.9	64.2	60.3	69.5	46.6	57.1	57.1	58.0	57.3	62.4	43.8						
	90	65.7	65.7	65.8	65.8	69.6	57.3	60.1	60.1	60.2	60.2	62.4	54.6						
2400	75	57.1	54.2	65.5	40.6	69.8	24.4	51.6	51.3	59.1	37.7	62.2	22.4						
	80	59.7	59.7	65.4	53.2	70.2	36.9	55.0	55.0	59.1	48.8	63.0	34.0						
	85	63.9	63.9	64.9	64.3	70.2	49.6	58.7	58.7	58.8	58.8	63.0	47.2						
	90	67.4	67.4	67.4	67.4	70.1	61.3	61.0	61.0	61.0	61.0	62.7	58.2						
2640	75	57.8	57.3	66.3	42.6	70.4	26.1	52.3	52.3	59.7	39.7	65.2	24.0						
	80	61.4	61.4	66.2	54.3	70.9	38.6	56.5	56.5	59.4	52.6	63.5	35.6						
	85	65.6	65.6	65.6	65.6	70.9	52.4	59.9	59.9	60.0	60.0	63.4	48.8						
	90	68.5	68.5	68.5	68.5	70.5	65.0	62.1	62.1	62.1	62.1	62.9	61.8						
2880	75	58.4	58.4	66.9	44.5	71.1	24.9	53.5	53.5	60.2	41.5	66.4	23.5						
	80	62.9	62.9	66.5	58.5	71.5	40.2	57.7	57.7	59.7	55.3	63.9	37.2						
	85	66.8	66.8	66.9	66.9	71.4	55.3	60.7	60.7	60.8	60.8	63.8	50.4						
	90	69.3	69.3	69.4	69.4	70.7	68.6	63.0	63.0	63.0	63.0	63.1	63.1						

Notes:

1. All capacities shown are gross and have not considered indoor fan heat. To obtain NET cooling capacity subtract indoor fan heat. For indoor fan heat formula, refer to appropriate airflow table notes.
2. MBh = Total gross capacity
3. SHC = Sensible heat capacity

Table 6. Gross cooling capacities — 7.5 tons

CFM	Ent DB (°F)	Entering Wet Bulb Temp (°F)						Entering Wet Bulb Temp (°F)						Entering Wet Bulb Temp (°F)					
		61		67		73		61		67		73		61		67		73	
		MBh	SHC	MBh	SHC	MBh	SHC	MBh	SHC	MBh	SHC	MBh	SHC	MBh	SHC	MBh	SHC	MBh	SHC
		Ambient Temperature 85°F						Ambient Temperature 95°F						Ambient Temperature 105°F					
2400	75	84.8	69.0	96.5	54.8	107.4	34.9	79.9	66.5	91.0	52.3	100.5	34.2	74.7	63.8	85.0	49.5	93.2	33.7
	80	84.4	80.3	96.3	67.2	107.0	51.6	79.5	77.6	90.8	64.6	100.7	49.0	74.3	74.3	84.9	61.9	93.8	46.2
	85	86.8	86.8	96.0	79.7	107.1	64.4	83.0	83.0	90.6	77.0	100.9	61.8	78.7	78.7	84.7	72.1	94.1	58.9
	90	95.5	90.7	95.5	90.7	107.0	77.0	88.1	88.1	90.1	88.0	100.8	74.4	83.7	83.7	84.3	84.3	94.0	71.6
2700	75	86.9	73.6	98.8	57.7	108.4	40.0	81.8	69.9	92.9	54.7	101.7	37.3	76.3	65.2	86.7	51.9	94.6	34.0
	80	86.2	86.2	98.5	71.4	108.9	53.9	81.2	81.2	92.8	68.8	102.4	51.3	76.7	76.7	86.6	66.0	95.2	48.6
	85	90.5	90.5	98.1	83.3	109.1	68.1	86.4	86.4	92.3	81.8	102.6	65.4	81.9	81.9	86.1	78.8	95.4	62.6
	90	96.0	96.0	97.4	97.2	108.9	82.3	91.8	91.8	91.9	91.9	102.5	79.6	87.0	87.0	87.1	87.1	95.4	76.8
3000	75	88.5	75.2	100.6	60.0	110.5	35.1	83.0	74.4	94.6	57.3	102.9	38.0	77.3	71.4	88.2	54.5	95.4	35.2
	80	88.0	88.0	100.3	75.5	110.5	56.2	83.8	83.8	94.3	72.8	103.8	53.5	79.3	79.3	88.0	70.0	96.5	50.8
	85	93.7	93.7	99.5	89.5	110.6	71.7	89.4	89.4	93.6	86.7	103.9	69.0	84.7	84.7	87.2	83.6	96.5	66.1
	90	99.4	99.4	99.5	99.5	110.5	87.4	94.8	94.8	94.9	94.9	103.8	84.2	89.7	89.7	89.8	89.8	96.5	78.3
3300	75	89.5	81.0	102.2	62.6	110.8	41.9	84.0	78.1	96.0	59.8	104.0	35.9	78.2	75.1	89.4	56.9	96.2	35.9
	80	90.6	90.6	101.7	79.5	111.9	58.5	86.3	86.3	95.6	76.8	105.1	55.5	81.5	81.5	89.0	73.0	97.5	51.7
	85	96.5	96.5	100.6	94.3	111.8	75.3	92.0	92.0	94.4	94.4	104.9	72.6	87.0	87.0	87.9	87.9	97.3	69.6
	90	102.3	102.3	102.4	102.4	111.7	89.6	97.4	97.4	97.5	97.5	104.6	88.5	92.0	92.0	92.0	92.0	96.8	85.2
3600	75	90.5	84.7	103.5	65.0	112.3	39.6	84.8	84.8	97.1	62.3	104.8	36.0	78.8	78.8	90.3	59.3	96.9	36.1
	80	92.9	92.9	102.9	83.4	113.1	60.3	88.4	88.4	96.6	78.5	105.9	57.5	83.5	83.5	89.6	76.5	98.2	54.5
	85	99.0	99.0	101.3	101.3	112.8	78.8	94.2	94.2	95.1	95.1	105.8	76.0	88.9	88.9	89.0	89.0	98.0	73.1
	90	104.7	104.7	104.8	104.8	112.2	95.8	99.6	99.6	99.7	99.7	105.0	92.8	93.7	93.7	93.8	93.8	97.0	89.5
		Ambient Temperature 115°F						Ambient Temperature 125°F											
2400	75	69.0	59.6	78.5	46.4	86.1	28.2	62.8	57.2	71.6	43.3	77.5	26.3						
	80	69.3	69.3	78.5	59.0	86.3	43.4	64.4	64.4	71.6	55.9	78.1	40.3						
	85	74.1	74.1	78.2	70.7	86.6	55.9	69.0	69.0	71.3	67.4	78.3	52.7						
	90	78.8	78.8	78.9	78.9	86.6	68.6	73.2	73.2	73.3	73.3	78.4	64.8						
2700	75	70.2	64.4	80.1	49.0	86.9	28.5	63.8	61.1	72.9	45.8	78.1	26.8						
	80	72.0	72.0	80.0	63.0	87.6	45.5	66.8	66.8	72.8	59.9	79.3	42.1						
	85	77.0	77.0	79.5	75.7	87.6	59.5	71.4	71.4	72.2	72.2	79.1	56.2						
	90	81.7	81.7	81.8	81.8	87.7	71.9	75.5	75.5	75.6	75.6	78.9	69.4						
3000	75	71.2	68.2	81.3	51.5	87.5	28.9	64.6	64.6	73.8	48.2	78.5	27.4						
	80	74.4	74.4	81.1	66.8	88.6	47.4	68.9	68.9	73.5	63.0	79.9	44.1						
	85	79.4	79.4	80.3	80.3	88.4	63.0	73.4	73.4	73.5	73.5	79.6	60.2						
	90	83.9	83.9	84.0	84.0	88.1	77.4	77.1	77.1	77.2	77.2	79.0	73.8						
3300	75	71.9	71.9	82.3	53.8	87.9	29.3	65.6	65.6	74.6	50.6	79.0	27.5						
	80	76.3	76.3	81.7	69.9	89.3	49.3	70.6	70.6	74.0	66.4	80.3	45.9						
	85	81.4	81.4	81.4	81.4	89.1	66.5	75.0	75.0	75.1	75.1	80.1	63.0						
	90	85.7	85.7	85.8	85.8	88.3	81.8	78.3	78.3	78.3	78.3	79.0	78.1						
3600	75	72.6	72.6	83.1	56.2	88.5	30.9	67.0	67.0	75.3	52.8	79.4	28.0						
	80	78.1	78.1	82.3	73.2	89.8	51.2	72.0	72.0	74.4	69.7	80.7	47.8						
	85	83.0	83.0	83.1	83.1	89.6	69.9	76.3	76.3	76.3	76.3	80.3	65.8						
	90	87.0	87.0	87.1	87.1	88.4	86.0	79.0	79.0	79.0	79.0	79.0	79.0						

Notes:

1. All capacities shown are gross and have not considered indoor fan heat. To obtain NET cooling capacity subtract indoor fan heat. For indoor fan heat formula, refer to appropriate airflow table notes.
2. MBh = Total gross capacity
3. SHC = Sensible heat capacity



# Gross Cooling Capacities

**Table 7. Gross cooling capacities — 8.5 tons**

CFM	Ent DB (°F)	Entering Wet Bulb Temp (°F)						Entering Wet Bulb Temp (°F)						Entering Wet Bulb Temp (°F)					
		61		67		73		61		67		73		61		67		73	
		MBh	SHC	MBh	SHC	MBh	SHC	MBh	SHC	MBh	SHC	MBh	SHC	MBh	SHC	MBh	SHC	MBh	SHC
		<b>Ambient Temperature 85°F</b>						<b>Ambient Temperature 95°F</b>						<b>Ambient Temperature 105°F</b>					
2720	75	96.9	78.0	109.0	61.5	118.8	42.5	91.3	75.0	102.5	58.5	110.7	39.2	85.4	71.9	95.4	55.0	102.3	34.9
	80	96.3	90.6	108.8	75.4	119.0	57.1	90.8	87.5	102.4	72.3	111.1	53.9	84.8	84.2	95.3	69.0	102.4	50.3
	85	98.2	98.2	108.5	87.7	119.3	71.9	93.8	93.8	102.1	82.8	111.5	68.2	88.8	88.8	95.2	81.1	102.9	64.6
	90	107.9	101.8	107.9	101.8	119.2	85.7	99.1	99.1	101.5	98.5	111.4	82.4	93.7	93.7	94.5	94.5	102.9	78.8
3060	75	99.2	83.1	111.4	64.7	120.5	43.3	93.4	79.8	104.5	61.5	112.1	39.9	87.1	75.5	97.1	57.7	103.8	36.5
	80	98.3	96.5	111.1	80.1	120.9	59.7	92.5	92.5	104.3	76.9	112.6	56.3	86.9	86.9	97.0	73.5	104.0	53.0
	85	102.3	102.3	110.7	93.5	121.2	75.6	97.4	97.4	103.9	91.4	113.0	72.2	92.1	92.1	96.4	87.8	104.1	68.5
	90	108.0	108.0	109.7	108.8	121.1	91.5	102.8	102.8	103.0	103.0	113.0	88.1	96.8	96.8	96.9	96.9	104.1	84.4
3400	75	101.0	86.0	113.3	67.2	121.8	43.9	94.8	83.8	106.2	63.9	113.7	40.7	88.2	80.3	98.5	60.4	105.1	35.1
	80	99.8	99.8	113.0	84.5	122.5	62.4	94.9	94.9	105.9	81.3	114.0	59.0	89.5	89.5	98.3	77.8	105.3	55.7
	85	105.7	105.7	112.1	100.2	122.7	79.5	100.5	100.5	105.0	96.8	114.2	76.1	94.7	94.7	97.3	93.0	105.2	72.5
	90	111.5	111.5	111.6	111.6	122.6	97.1	105.8	105.8	105.9	105.9	114.2	93.1	99.3	99.3	99.3	99.3	104.8	88.8
3740	75	102.1	91.3	114.9	70.0	123.3	44.8	95.8	87.9	107.5	66.6	114.9	41.5	89.1	84.4	99.6	63.1	106.1	38.1
	80	102.5	102.5	114.4	88.9	123.9	64.8	97.4	97.4	107.1	85.6	115.5	60.9	91.8	91.8	99.3	81.3	106.4	57.2
	85	108.6	108.6	113.2	105.4	123.9	83.4	103.1	103.1	105.8	101.9	115.1	79.9	96.9	96.9	97.8	97.8	106.2	76.4
	90	114.4	114.4	114.5	114.5	123.8	99.2	108.2	108.2	108.3	108.3	114.8	97.6	101.1	101.1	101.2	101.2	105.3	93.7
4080	75	103.1	95.4	116.2	72.7	124.6	45.6	96.6	91.9	108.6	69.2	116.0	42.3	89.7	88.3	100.5	65.6	106.8	39.3
	80	105.0	105.0	115.6	93.2	125.2	66.6	99.6	99.6	108.2	87.9	116.2	63.0	93.7	93.7	99.8	85.0	107.3	59.4
	85	111.2	111.2	113.9	110.5	124.9	87.3	105.3	105.3	106.3	106.3	115.9	83.7	98.7	98.7	98.7	98.7	107.0	80.2
	90	116.8	116.8	116.9	116.9	124.2	106.2	110.2	110.2	110.3	110.3	115.0	102.3	102.6	102.6	102.7	102.7	105.7	98.5
		<b>Ambient Temperature 115°F</b>						<b>Ambient Temperature 125°F</b>											
2720	75	79.0	67.9	87.7	51.7	93.3	31.2	71.9	61.9	79.2	47.5	83.8	28.5						
	80	78.5	78.5	87.7	65.4	93.8	47.0	72.7	72.7	79.1	61.6	84.2	43.3						
	85	83.2	83.2	87.4	78.5	93.9	60.9	76.7	76.7	78.7	74.4	84.3	57.1						
	90	87.5	87.5	87.5	87.5	93.8	75.1	79.9	79.9	80.0	80.0	84.2	69.8						
3060	75	80.2	72.4	89.1	54.1	94.5	33.7	72.8	68.5	80.2	50.1	88.7	30.6						
	80	81.3	81.3	89.0	69.8	95.1	49.6	74.9	74.9	80.1	65.9	85.4	45.3						
	85	85.9	85.9	88.3	83.9	95.1	64.9	78.7	78.7	79.3	79.3	85.1	61.0						
	90	89.9	89.9	89.9	89.9	95.0	77.7	81.5	81.5	81.6	81.6	84.8	75.7						
3400	75	81.2	76.6	90.2	56.7	95.5	34.6	73.5	72.6	81.0	52.6	90.1	31.4						
	80	83.6	83.6	90.0	74.0	96.2	51.4	76.7	76.7	80.6	69.2	86.1	47.4						
	85	88.1	88.1	88.9	88.9	96.0	68.8	80.2	80.2	80.2	80.2	85.8	64.6						
	90	91.6	91.6	91.6	91.6	95.4	84.8	83.2	83.2	83.3	83.3	85.1	80.6						
3740	75	81.9	80.6	91.0	59.2	96.5	34.5	74.0	74.0	81.6	55.1	91.0	32.7						
	80	85.5	85.5	90.5	77.2	97.1	53.6	78.2	78.2	80.9	72.8	86.7	49.6						
	85	89.7	89.7	89.8	89.8	96.8	72.2	81.2	81.2	81.3	81.3	86.3	68.0						
	90	93.1	93.1	93.2	93.2	95.8	89.7	84.6	84.6	84.6	84.6	85.2	85.2						
4080	75	82.3	82.3	91.7	61.7	97.1	35.7	75.3	75.3	82.1	57.6	91.7	32.8						
	80	87.1	87.1	90.9	80.8	97.7	55.7	79.3	79.3	81.1	76.4	87.2	51.6						
	85	91.0	91.0	91.1	91.1	97.4	76.3	82.3	82.3	82.3	82.3	86.5	71.4						
	90	94.7	94.7	94.7	94.7	96.0	94.5	85.6	85.6	85.7	85.7	85.7	85.7						

**Notes:**

1. All capacities shown are gross and have not considered indoor fan heat. To obtain NET cooling capacity subtract indoor fan heat. For indoor fan heat formula, refer to appropriate airflow table notes.
2. MBh = Total gross capacity
3. SHC = Sensible heat capacity

**Table 8. Gross cooling capacities — 10 tons**

CFM	Ent DB (°F)	Entering Wet Bulb Temp (°F)						Entering Wet Bulb Temp (°F)						Entering Wet Bulb Temp (°F)					
		61		67		73		61		67		73		61		67		73	
		MBh	SHC	MBh	SHC	MBh	SHC	MBh	SHC	MBh	SHC	MBh	SHC	MBh	SHC	MBh	SHC	MBh	SHC
		<b>Ambient Temperature 85°F</b>						<b>Ambient Temperature 95°F</b>						<b>Ambient Temperature 105°F</b>					
3200	75	113.8	92.0	128.1	72.4	139.1	47.3	107.3	88.6	120.5	69.0	129.8	46.0	100.3	84.9	112.3	65.2	119.8	42.0
	80	113.0	106.7	127.9	89.0	139.4	67.1	106.5	103.0	120.4	85.4	130.2	63.4	99.5	99.5	112.2	81.6	120.1	59.3
	85	115.4	115.4	127.4	105.5	139.7	84.6	110.2	110.2	120.0	102.0	130.7	80.4	104.4	104.4	111.9	95.5	120.7	76.2
	90	126.5	119.9	126.5	119.9	139.6	101.0	116.4	116.4	119.1	116.1	130.7	97.2	110.2	110.2	111.0	111.0	120.8	93.1
3600	75	116.5	95.1	130.8	76.2	140.9	50.7	109.7	94.0	122.9	72.6	131.2	46.7	102.4	87.5	114.2	68.2	121.5	42.9
	80	115.2	115.2	130.5	94.4	141.4	70.1	108.4	108.4	122.6	90.7	131.9	66.2	102.1	102.1	114.0	88.0	121.7	62.5
	85	120.0	120.0	129.9	109.7	141.8	88.9	114.5	114.5	121.9	107.8	132.4	85.0	108.2	108.2	113.3	103.5	121.9	80.8
	90	126.7	126.7	128.5	128.0	141.7	107.2	120.7	120.7	120.9	120.9	132.4	103.8	113.8	113.8	113.9	113.9	122.1	99.7
4000	75	118.5	101.0	132.9	79.2	142.3	51.4	111.2	98.7	124.7	75.4	132.9	47.7	103.5	94.6	115.8	71.4	122.9	43.8
	80	116.9	116.9	132.5	101.5	143.1	71.0	111.4	111.4	124.4	96.9	133.3	69.4	105.2	105.2	115.5	92.5	123.2	65.5
	85	124.0	124.0	131.4	118.0	143.4	93.5	118.1	118.1	123.2	114.0	133.6	89.6	111.3	111.3	114.1	114.1	123.1	85.4
	90	130.7	130.7	130.8	130.8	143.3	114.3	124.2	124.2	124.3	124.3	133.7	108.1	116.6	116.6	116.7	116.7	122.7	104.6
4400	75	119.7	107.5	134.8	82.4	143.8	52.3	112.3	103.5	126.2	78.6	134.3	48.6	104.5	99.4	117.0	74.4	124.0	44.7
	80	120.2	120.2	134.2	104.8	144.6	75.7	114.4	114.4	125.8	101.0	134.8	71.6	107.8	107.8	116.6	95.6	124.4	67.5
	85	127.4	127.4	132.4	124.0	144.6	98.1	121.0	121.0	123.9	123.9	134.6	94.1	113.8	113.8	114.7	114.7	124.2	89.9
	90	134.0	134.0	134.1	134.1	144.5	118.6	127.0	127.0	127.1	127.1	134.2	114.8	118.8	118.8	118.8	118.8	123.1	110.2
4800	75	120.7	112.1	136.2	85.5	145.2	53.2	113.1	113.1	127.4	81.6	135.4	49.5	105.1	105.1	118.0	77.4	124.9	45.5
	80	123.1	123.1	135.5	109.6	145.9	78.1	116.9	116.9	126.9	102.4	135.7	74.0	110.1	110.1	117.1	100.1	125.4	70.0
	85	130.3	130.3	133.1	133.1	145.7	102.6	123.6	123.6	124.4	124.4	135.5	97.9	115.9	115.9	116.0	116.0	125.0	94.5
	90	136.8	136.8	136.9	136.9	144.8	124.7	129.2	129.2	129.3	129.3	134.3	120.3	120.3	120.4	120.4	123.4	115.8	
		<b>Ambient Temperature 115°F</b>						<b>Ambient Temperature 125°F</b>											
3200	75	92.9	80.1	103.3	61.2	109.6	37.9	84.6	76.1	93.4	56.3	102.0	34.9						
	80	92.4	92.4	103.2	77.5	109.9	55.4	85.8	85.8	93.3	72.2	98.8	50.9						
	85	98.0	98.0	102.9	92.8	110.1	71.9	90.5	90.5	92.8	88.0	98.9	67.5						
	90	103.0	103.0	103.1	103.1	110.0	88.7	94.3	94.3	94.4	94.4	98.9	81.7						
3600	75	94.3	85.5	104.9	64.0	110.9	38.8	85.8	81.0	94.5	59.4	104.1	36.1						
	80	95.7	95.7	104.7	82.7	111.4	58.5	88.4	88.4	94.4	78.1	100.0	53.5						
	85	101.2	101.2	103.9	99.0	111.4	76.6	92.8	92.8	93.4	93.4	99.8	72.1						
	90	105.8	105.8	105.9	105.9	111.2	93.9	95.9	95.9	95.9	95.9	99.4	89.3						
4000	75	95.3	90.3	106.0	67.0	111.9	39.7	86.5	86.5	95.3	62.4	99.8	35.2						
	80	98.4	98.4	105.9	87.1	112.6	60.6	90.5	90.5	95.0	81.8	100.8	56.0						
	85	103.7	103.7	104.4	104.4	112.4	82.7	94.5	94.5	94.6	94.6	104.3	77.8						
	90	107.7	107.7	107.7	107.7	111.7	99.9	97.7	97.7	97.8	97.8	99.6	95.0						
4400	75	96.0	96.0	107.0	70.0	112.8	40.5	87.2	87.2	96.0	65.3	100.4	36.0						
	80	100.6	100.6	106.4	91.2	113.5	63.1	92.2	92.2	95.2	86.1	105.7	60.0						
	85	105.6	105.6	105.6	105.6	113.2	83.4	95.7	95.7	95.7	95.7	101.1	81.0						
	90	109.2	109.2	109.3	109.3	112.0	112.0	99.2	99.2	99.3	99.3	99.7	99.7						
4800	75	96.6	96.6	107.7	73.0	113.5	41.3	88.8	88.8	96.5	68.2	101.0	36.9						
	80	102.4	102.4	106.7	95.3	114.2	65.6	93.5	93.5	95.3	95.3	106.7	62.3						
	85	107.0	107.0	107.1	107.1	113.9	88.5	96.7	96.7	96.7	96.7	101.2	84.2						
	90	110.9	110.9	111.0	111.0	112.2	111.2	100.3	100.3	100.3	100.3	100.4	100.4						

**Notes:**

1. All capacities shown are gross and have not considered indoor fan heat. To obtain NET cooling capacity subtract indoor fan heat. For indoor fan heat formula, refer to appropriate airflow table notes.
2. MBh = Total gross capacity
3. SHC = Sensible heat capacity



# Gross Cooling Capacities

**Table 9. Gross cooling capacities — 12.5 tons**

CFM	Ent DB (°F)	Entering Wet Bulb Temp (°F)						Entering Wet Bulb Temp (°F)						Entering Wet Bulb Temp (°F)					
		61		67		73		61		67		73		61		67		73	
		MBh	SHC	MBh	SHC	MBh	SHC	MBh	SHC	MBh	SHC	MBh	SHC	MBh	SHC	MBh	SHC	MBh	SHC
		<b>Ambient Temperature 85°F</b>						<b>Ambient Temperature 95°F</b>						<b>Ambient Temperature 105°F</b>					
4000	75	131.2	107.1	150.1	84.7	169.4	59.5	123.3	102.8	141.4	80.3	159.7	55.9	115.0	98.3	132.1	75.8	149.5	51.4
	80	129.4	123.7	149.5	104.4	169.2	80.8	121.7	119.1	140.8	100.0	159.5	76.4	113.5	112.9	131.5	95.5	149.3	72.0
	85	132.8	132.8	148.1	123.9	168.7	100.8	126.7	126.7	139.5	118.6	159.0	96.5	120.1	120.1	130.4	111.2	149.0	92.0
	90	146.3	140.1	146.3	140.1	167.8	120.7	134.7	134.7	137.8	135.5	158.1	116.3	127.9	127.9	128.8	128.8	147.9	111.8
4500	75	134.0	114.0	153.7	89.1	173.5	61.8	125.9	107.6	144.5	84.6	163.3	57.4	118.9	103.3	137.5	80.8	152.7	52.9
	80	131.6	131.4	152.7	110.8	173.1	84.7	123.7	123.7	143.6	106.4	163.0	80.3	116.8	116.8	136.6	102.8	152.3	75.7
	85	138.2	138.2	151.0	128.6	172.6	106.9	131.8	131.8	141.6	125.8	162.4	102.4	124.8	124.8	134.5	122.0	151.7	97.8
	90	146.8	146.8	148.6	148.6	171.0	128.9	140.1	140.1	140.3	140.3	160.9	124.4	133.0	133.0	133.1	133.1	150.4	119.9
5000	75	136.2	117.4	156.6	93.0	176.8	63.3	127.2	113.9	147.3	88.4	166.3	58.8	118.3	108.9	137.5	83.8	155.4	54.2
	80	134.1	134.1	155.3	117.0	176.3	88.4	127.5	127.5	145.8	112.5	165.7	83.9	120.5	120.5	135.9	107.8	154.6	79.3
	85	142.9	142.9	152.5	137.7	175.4	112.6	136.2	136.2	143.2	132.9	164.9	108.1	128.9	128.9	133.4	127.9	153.9	103.4
	90	151.9	151.9	152.0	152.0	173.5	136.8	144.9	144.9	145.1	145.1	163.1	131.2	137.4	137.4	137.6	137.6	156.4	125.9
5500	75	137.1	124.2	159.3	97.0	179.7	64.7	128.4	119.3	149.7	92.3	168.8	60.1	119.2	114.2	139.4	87.5	157.5	55.5
	80	137.9	137.9	157.2	123.0	178.8	92.0	131.1	131.1	147.5	118.4	167.8	87.1	123.8	123.8	137.4	111.0	156.5	82.2
	85	147.1	147.1	153.8	144.6	177.6	118.1	140.1	140.1	144.2	139.7	166.8	113.5	134.5	134.5	134.2	134.2	155.5	108.8
	90	156.4	156.4	156.5	156.5	175.3	140.3	149.1	149.1	149.2	149.2	164.0	137.3	141.3	141.3	141.4	141.4	152.8	132.1
6000	75	138.0	129.4	161.4	100.7	182.0	66.0	129.2	124.4	151.3	96.0	170.9	61.4	119.8	119.3	140.8	91.1	159.4	56.7
	80	141.3	141.3	158.7	128.4	180.8	94.9	134.3	134.3	148.8	119.6	169.8	90.3	128.5	128.5	137.8	117.0	158.5	85.5
	85	150.8	150.8	154.5	151.3	179.4	123.5	143.5	143.5	144.7	144.7	168.3	118.9	135.7	135.7	135.8	135.8	156.8	114.1
	90	160.4	160.4	160.5	160.5	175.8	148.7	152.8	152.8	153.0	153.0	164.9	143.7	144.8	144.8	144.9	144.9	153.5	138.6
		<b>Ambient Temperature 115°F</b>						<b>Ambient Temperature 125°F</b>											
4000	75	106.2	90.8	122.3	71.2	138.9	46.8	96.4	87.0	112.0	66.0	127.5	42.0						
	80	105.5	105.5	121.8	90.7	138.6	67.4	98.0	98.0	111.5	85.8	127.2	62.6						
	85	113.0	113.0	120.4	108.4	138.2	87.3	105.3	105.3	110.1	103.1	126.8	82.4						
	90	120.6	120.6	120.7	120.7	137.3	107.2	112.7	112.7	112.8	112.8	126.0	98.3						
4500	75	107.7	98.1	125.0	75.0	141.7	48.2	97.8	92.7	114.4	70.0	130.0	43.4						
	80	109.6	109.6	124.0	97.0	141.2	71.1	101.7	101.7	113.3	92.0	129.4	66.8						
	85	117.4	117.4	122.0	115.7	140.6	93.0	109.4	109.4	111.4	110.3	128.9	88.1						
	90	125.3	125.3	125.5	125.5	139.4	113.0	117.1	117.1	117.2	117.2	127.3	108.2						
5000	75	108.8	103.6	127.2	78.9	144.0	49.5	98.8	98.1	116.1	73.7	132.0	44.6						
	80	113.0	113.0	125.6	102.6	143.1	74.1	104.9	104.9	114.3	96.2	131.2	69.1						
	85	121.2	121.2	123.1	122.7	142.5	98.6	112.8	112.8	112.9	112.9	130.4	93.3						
	90	129.4	129.4	129.5	129.5	140.4	120.3	120.8	120.8	120.9	120.9	128.4	114.9						
5500	75	109.6	108.9	128.7	82.5	145.9	50.7	99.7	99.7	117.4	77.4	133.6	45.8						
	80	116.1	116.1	126.2	106.8	145.0	77.4	107.7	107.7	115.0	101.2	132.9	72.3						
	85	124.5	124.5	124.6	124.6	143.9	104.0	115.8	115.8	115.9	115.9	131.7	98.9						
	90	133.0	133.0	133.1	133.1	141.2	126.9	124.1	124.1	124.2	124.2	129.1	121.5						
6000	75	110.3	110.3	129.9	86.1	147.5	51.9	101.9	101.9	118.5	80.9	135.0	46.9						
	80	118.8	118.8	126.9	111.6	146.7	80.6	110.1	110.1	115.5	106.0	134.2	75.4						
	85	127.4	127.4	127.5	127.5	145.0	109.2	118.5	118.5	118.6	118.6	132.6	101.2						
	90	136.2	136.2	136.3	136.3	141.6	141.6	126.9	126.9	127.0	127.0	129.4	129.4						

**Notes:**

1. All capacities shown are gross and have not considered indoor fan heat. To obtain NET cooling capacity subtract indoor fan heat. For indoor fan heat formula, refer to appropriate airflow table notes.
2. MBh = Total gross capacity
3. SHC = Sensible heat capacity



Table 10. Gross cooling capacities — 15 tons

CFM	Ent DB (°F)	Entering Wet Bulb Temp (°F)						Entering Wet Bulb Temp (°F)						Entering Wet Bulb Temp (°F)					
		61		67		73		61		67		73		61		67		73	
		MBh	SHC	MBh	SHC	MBh	SHC	MBh	SHC	MBh	SHC	MBh	SHC	MBh	SHC	MBh	SHC	MBh	SHC
		Ambient Temperature 85°F						Ambient Temperature 95°F						Ambient Temperature 105°F					
4800	75	171.4	138.6	192.9	109.4	211.2	72.4	162.1	133.8	182.5	104.9	199.1	71.7	152.3	128.8	171.4	99.9	186.2	66.6
	80	170.4	160.6	192.6	134.2	211.4	102.3	161.3	155.6	182.2	129.3	199.5	97.5	151.5	151.5	171.2	124.3	186.8	92.4
	85	173.9	173.9	191.9	158.8	211.7	128.2	166.7	166.7	181.7	154.0	200.0	123.5	158.7	158.7	170.7	147.5	187.5	117.7
	90	190.9	180.4	190.9	180.4	211.6	152.6	176.1	176.1	180.6	175.2	199.9	147.8	167.8	167.8	169.6	169.6	187.3	142.6
5400	75	175.4	147.5	197.2	115.2	214.7	78.1	165.8	142.6	186.3	110.3	202.1	73.1	155.5	134.3	174.7	104.9	188.7	67.9
	80	173.9	173.9	196.7	142.3	215.1	106.9	164.4	164.4	185.9	137.4	202.7	101.9	155.1	155.1	174.4	132.2	189.6	96.8
	85	180.9	180.9	195.9	167.0	215.7	135.0	173.2	173.2	185.3	158.3	203.3	130.0	164.7	164.7	173.4	157.3	190.2	124.8
	90	191.0	191.0	194.1	192.6	215.3	162.9	182.9	182.9	183.5	183.5	203.1	157.9	173.8	173.8	174.0	174.0	190.0	152.7
6000	75	178.6	154.8	200.6	120.5	218.0	79.7	168.7	144.8	189.4	114.7	204.6	74.5	157.6	143.6	177.5	109.5	190.7	69.2
	80	176.6	176.6	200.0	150.2	218.3	111.3	168.5	168.5	188.8	146.8	205.5	106.8	160.0	160.0	176.9	139.9	192.1	101.7
	85	186.9	186.9	198.6	177.7	218.7	142.1	178.7	178.7	187.3	172.3	205.9	137.0	169.7	169.7	175.2	166.6	192.4	131.7
	90	197.2	197.2	197.4	197.4	218.3	172.9	188.4	188.4	188.6	188.6	205.7	167.9	178.8	178.8	178.9	178.9	192.2	157.6
6600	75	180.7	161.9	203.5	124.7	221.0	81.2	170.3	156.4	192.0	119.6	207.0	75.9	159.3	150.7	179.7	114.2	192.6	70.6
	80	181.3	181.3	202.7	157.9	221.1	116.2	173.1	173.1	191.2	153.3	208.0	111.3	164.2	164.2	179.0	147.5	194.4	106.3
	85	192.1	192.1	200.4	186.7	221.2	149.0	183.4	183.4	188.8	181.2	208.1	143.9	174.0	174.0	176.4	176.4	194.2	138.6
	90	202.4	202.4	202.6	202.6	220.8	179.3	193.1	193.1	193.3	193.3	207.6	174.4	182.8	182.8	183.0	183.0	193.1	169.1
7200	75	182.4	168.8	206.0	129.4	223.8	82.8	171.8	163.3	194.1	124.2	209.2	77.4	160.5	160.5	181.6	118.8	194.5	71.9
	80	185.6	185.6	204.9	165.4	223.6	120.8	177.1	177.1	193.1	158.8	210.4	114.4	167.8	167.8	180.7	148.6	196.3	108.9
	85	196.6	196.6	201.6	201.6	223.3	155.9	187.5	187.5	189.8	189.8	209.9	154.9	177.5	177.5	177.7	177.7	195.7	145.3
	90	206.8	206.8	207.0	207.0	222.0	189.1	197.0	197.0	197.2	197.2	208.2	183.3	186.2	186.2	186.3	186.3	193.5	177.3
		Ambient Temperature 115°F						Ambient Temperature 125°F											
4800	75	141.8	122.9	159.5	94.4	172.5	61.3	130.5	113.5	146.6	89.1	157.7	55.6						
	80	141.2	141.2	159.3	118.9	173.3	87.1	132.0	132.0	146.4	113.2	158.6	81.8						
	85	150.1	150.1	159.0	137.0	174.0	112.3	140.4	140.4	145.7	135.8	159.2	106.5						
	90	158.6	158.6	158.8	158.8	173.8	137.3	148.1	148.1	148.3	148.3	159.1	131.5						
5400	75	144.3	130.3	162.4	99.1	174.6	62.5	132.4	124.2	149.1	93.3	159.3	56.8						
	80	146.3	146.3	162.1	126.8	175.7	91.9	136.7	136.7	148.7	120.5	160.8	86.4						
	85	155.4	155.4	160.9	151.4	176.2	119.3	145.0	145.0	147.4	147.4	161.0	113.4						
	90	163.9	163.9	164.0	164.0	176.1	146.7	152.5	152.5	152.6	152.6	160.6	139.4						
6000	75	146.2	137.7	164.8	103.9	176.2	63.8	133.9	133.9	151.0	98.0	160.6	58.0						
	80	150.7	150.7	164.2	131.8	178.0	96.5	140.5	140.5	150.5	125.8	163.1	89.6						
	85	159.9	159.9	162.4	162.4	178.0	126.2	148.8	148.8	148.9	148.9	162.4	122.6						
	90	168.1	168.1	168.2	168.2	177.3	154.5	155.9	155.9	156.0	156.0	161.1	147.8						
6600	75	147.6	147.6	166.7	108.5	177.7	65.0	135.1	135.1	152.5	102.5	161.8	59.3						
	80	154.5	154.5	166.0	137.6	180.1	99.4	143.7	143.7	151.3	133.6	164.3	93.4						
	85	163.5	163.5	163.7	163.7	179.4	132.9	151.9	151.9	152.0	152.0	163.5	126.7						
	90	171.4	171.4	171.6	171.6	177.8	162.8	158.5	158.5	158.6	158.6	161.2	156.2						
7200	75	148.6	148.6	168.2	113.1	179.2	66.4	137.5	137.5	153.8	107.0	163.0	60.6						
	80	157.7	157.7	166.6	146.5	181.3	103.2	146.5	146.5	152.0	139.9	165.3	97.1						
	85	166.6	166.6	166.7	166.7	180.7	139.6	154.4	154.4	154.5	154.5	164.5	130.7						
	90	174.2	174.2	174.3	174.3	177.9	171.0	160.5	160.5	160.6	160.6	161.2	161.2						

Notes:

1. All capacities shown are gross and have not considered indoor fan heat. To obtain NET cooling capacity subtract indoor fan heat. For indoor fan heat formula, refer to appropriate airflow table notes.
2. MBh = Total gross capacity
3. SHC = Sensible heat capacity



# Gross Cooling Capacities

**Table 11. Gross cooling capacities — 17.5 tons**

CFM	Ent DB (°F)	Entering Wet Bulb Temp (°F)						Entering Wet Bulb Temp (°F)						Entering Wet Bulb Temp (°F)					
		61		67		73		61		67		73		61		67		73	
		MBh	SHC	MBh	SHC	MBh	SHC	MBh	SHC	MBh	SHC	MBh	SHC	MBh	SHC	MBh	SHC	MBh	SHC
		<b>Ambient Temperature 85°F</b>						<b>Ambient Temperature 95°F</b>						<b>Ambient Temperature 105°F</b>					
5600	75	195.0	155.8	221.2	123.2	241.9	80.7	184.3	149.7	209.0	117.3	226.7	78.3	172.8	143.3	195.9	110.8	210.5	71.2
	80	193.3	180.4	220.7	151.4	241.8	114.4	182.8	174.0	208.6	145.1	226.5	107.5	171.3	171.3	195.5	138.4	210.7	100.5
	85	196.1	196.1	219.5	179.3	241.7	144.0	187.7	187.7	207.6	173.1	226.7	137.3	178.4	178.4	194.7	166.0	210.6	128.9
	90	207.8	207.8	218.0	203.4	241.7	171.7	199.0	199.0	206.1	196.8	226.9	164.9	189.3	189.3	193.2	189.8	210.7	157.6
6300	75	199.7	165.9	226.3	129.9	247.2	87.4	188.6	159.6	213.4	123.5	230.9	80.1	176.6	151.3	199.6	116.8	213.7	72.8
	80	197.3	197.3	225.6	160.5	247.2	119.9	186.3	186.3	212.8	154.1	230.9	112.8	174.5	174.5	199.1	151.6	214.0	106.0
	85	204.4	204.4	224.1	185.8	246.5	151.4	195.4	195.4	211.7	179.8	231.2	143.7	185.6	185.6	197.7	175.7	214.1	137.0
	90	216.5	216.5	221.8	217.0	245.4	182.9	207.0	207.0	209.3	209.3	229.7	175.9	196.4	196.4	196.6	196.6	213.3	168.6
7000	75	203.4	174.4	230.3	135.9	251.4	89.3	191.9	164.0	216.9	129.5	234.2	81.8	179.1	159.8	202.6	121.2	216.2	74.3
	80	200.3	200.3	229.3	169.3	251.3	125.1	189.8	189.8	214.1	162.8	234.3	117.8	179.9	179.9	201.9	155.8	216.7	110.6
	85	211.5	211.5	227.2	200.3	250.7	159.7	202.0	202.0	216.0	193.3	234.0	152.3	191.5	191.5	199.8	185.9	216.6	144.7
	90	223.8	223.8	224.3	224.3	249.0	194.2	213.5	213.5	213.7	213.7	233.3	185.0	201.9	201.9	202.1	202.1	215.9	177.2
7700	75	205.8	181.8	233.5	140.3	254.9	91.1	193.8	174.9	219.7	133.5	237.0	83.5	181.0	167.6	205.0	126.3	218.3	75.8
	80	204.7	204.7	232.7	175.5	254.7	130.9	195.2	195.2	218.6	164.2	237.0	123.6	184.9	184.9	204.0	159.1	218.9	116.3
	85	217.7	217.7	229.3	210.3	253.8	167.5	207.6	207.6	215.4	215.4	236.5	160.0	196.5	196.5	200.9	200.9	218.5	152.3
	90	229.8	229.8	230.0	230.0	252.2	202.9	218.7	218.7	218.9	218.9	235.0	194.6	206.0	206.0	206.2	206.2	216.9	186.7
8400	75	207.7	189.5	236.3	145.5	257.8	92.8	195.9	181.9	222.0	138.5	239.2	85.1	182.2	182.2	206.8	131.3	220.0	77.2
	80	209.9	209.9	234.6	178.2	257.5	135.3	200.0	200.0	220.6	165.6	239.3	126.5	189.3	189.3	205.8	166.9	220.8	118.6
	85	222.9	222.9	230.5	230.5	256.4	175.2	212.4	212.4	216.5	216.5	238.5	173.3	200.6	200.6	201.7	201.7	220.0	158.7
	90	234.8	234.8	235.0	235.0	253.6	212.3	222.8	222.8	223.0	223.0	236.0	204.2	208.9	208.9	209.0	209.0	217.6	195.9
		<b>Ambient Temperature 115°F</b>						<b>Ambient Temperature 125°F</b>											
5600	75	160.6	136.5	181.7	103.9	193.3	63.7	147.4	126.8	166.3	96.5	174.2	55.8						
	80	159.2	159.2	181.4	131.4	193.7	93.1	147.2	147.2	166.1	123.9	175.1	85.3						
	85	168.4	168.4	180.8	154.0	194.1	121.6	157.1	157.1	165.3	149.5	175.6	113.7						
	90	178.5	178.5	179.3	179.3	193.6	150.0	166.0	166.0	166.2	166.2	175.5	142.2						
6300	75	163.9	140.2	184.9	109.8	195.5	65.1	149.7	136.3	168.8	100.9	175.6	57.0						
	80	163.9	163.9	184.4	140.1	196.2	98.2	152.7	152.7	168.4	133.3	176.9	89.9						
	85	174.8	174.8	183.1	168.0	196.4	129.3	162.6	162.6	166.8	166.8	177.1	121.2						
	90	184.5	184.5	184.6	184.6	196.1	160.2	170.3	170.3	170.4	170.4	176.8	150.7						
7000	75	165.8	152.3	187.3	113.8	197.3	66.5	151.3	151.3	170.7	105.9	176.7	58.3						
	80	169.2	169.2	186.7	146.9	198.2	103.7	157.4	157.4	170.2	139.8	178.6	93.9						
	85	180.0	180.0	184.4	184.4	198.2	136.9	166.8	166.8	167.9	167.9	178.1	130.0						
	90	188.6	188.6	188.7	188.7	197.4	169.0	172.3	172.3	172.4	172.4	177.3	160.0						
7700	75	167.2	167.2	189.2	118.8	198.7	67.9	152.6	152.6	172.0	110.7	177.5	59.6						
	80	173.7	173.7	188.5	154.0	200.0	106.4	161.2	161.2	171.1	146.2	179.6	97.8						
	85	184.1	184.1	185.3	185.3	199.5	145.0	169.8	169.8	169.9	169.9	179.1	136.7						
	90	191.1	191.1	191.2	191.2	198.0	178.2	174.4	174.4	174.5	174.5	177.5	169.2						
8400	75	168.4	168.4	190.6	123.6	199.8	69.2	153.8	153.8	173.1	115.5	178.2	60.8						
	80	177.5	177.5	189.1	161.7	201.3	110.5	164.4	164.4	171.5	153.1	180.3	101.9						
	85	187.4	187.4	187.5	187.5	200.7	152.6	171.8	171.8	171.9	171.9	179.8	141.7						
	90	193.4	193.4	193.5	193.5	198.3	187.3	176.4	176.4	176.5	176.5	177.5	177.5						

**Notes:**

1. All capacities shown are gross and have not considered indoor fan heat. To obtain NET cooling capacity subtract indoor fan heat. For indoor fan heat formula, refer to appropriate airflow table notes.
2. MBh = Total gross capacity
3. SHC = Sensible heat capacity

Table 12. Gross cooling capacities — 20 tons

CFM	Ent DB (°F)	Entering Wet Bulb Temp (°F)						Entering Wet Bulb Temp (°F)						Entering Wet Bulb Temp (°F)					
		61		67		73		61		67		73		61		67		73	
		MBh	SHC	MBh	SHC	MBh	SHC	MBh	SHC	MBh	SHC	MBh	SHC	MBh	SHC	MBh	SHC	MBh	SHC
		Ambient Temperature 85°F						Ambient Temperature 95°F						Ambient Temperature 105°F					
6400	75	226.5	180.4	254.8	142.6	275.1	92.9	213.2	173.3	239.2	135.3	256.8	91.0	198.7	165.7	222.0	127.3	237.1	83.1
	80	224.0	207.9	254.6	174.6	275.4	131.6	210.8	200.4	239.1	167.1	256.9	123.9	196.3	196.3	221.9	159.1	237.3	116.0
	85	225.9	225.9	253.2	206.0	275.9	165.2	215.6	215.6	237.9	198.7	256.9	157.4	204.0	204.0	221.1	181.1	237.5	148.3
	90	238.8	238.8	251.1	233.1	276.0	196.5	227.9	227.9	235.8	225.2	257.0	188.5	215.3	215.3	218.8	216.5	237.0	180.2
7200	75	231.9	190.5	260.3	149.9	280.2	100.7	217.9	184.3	243.8	142.4	261.1	93.0	202.8	175.3	225.7	134.3	240.2	84.8
	80	228.4	228.4	259.8	184.7	280.2	137.3	214.6	214.6	243.4	177.0	261.3	129.6	199.6	199.6	225.3	174.1	240.7	122.2
	85	235.1	235.1	258.2	219.7	280.0	173.1	224.0	224.0	242.2	207.2	261.3	165.4	211.5	211.5	223.9	200.6	240.9	157.1
	90	248.3	248.3	254.9	247.9	279.8	208.9	236.3	236.3	238.8	238.8	260.2	200.8	222.3	222.3	222.5	222.5	240.2	192.7
8000	75	236.1	202.3	264.6	156.5	284.6	102.7	221.6	191.6	247.4	148.0	264.5	94.8	205.2	183.9	228.6	139.2	242.7	86.3
	80	231.6	231.6	263.8	194.4	284.6	143.0	218.0	218.0	246.7	186.5	264.8	135.8	205.6	205.6	228.0	176.6	243.4	127.8
	85	243.0	243.0	261.3	229.4	284.2	182.0	231.1	231.1	244.3	220.8	264.6	174.1	217.6	217.6	225.5	211.6	243.4	165.7
	90	256.1	256.1	257.3	257.3	282.7	221.0	243.0	243.0	243.2	243.2	263.4	213.2	227.6	227.6	227.7	227.7	242.6	198.6
8800	75	239.4	204.6	268.1	161.5	288.1	104.5	223.5	201.2	250.3	153.4	267.2	96.4	207.0	192.4	230.8	144.7	244.5	87.9
	80	235.7	235.7	267.0	203.8	288.2	149.2	224.0	224.0	249.3	193.6	267.7	141.4	210.9	210.9	230.1	178.5	245.7	133.3
	85	249.7	249.7	263.4	240.2	287.5	190.7	237.0	237.0	245.7	231.5	267.2	182.7	222.5	222.5	226.3	226.3	245.3	174.1
	90	262.6	262.6	262.8	262.8	285.5	232.3	248.3	248.3	248.5	248.5	265.4	221.6	231.3	231.3	231.5	231.5	243.3	212.4
9600	75	240.7	217.9	271.0	167.2	291.0	106.2	225.1	209.5	252.6	159.0	269.4	98.0	208.2	208.2	232.4	150.2	246.0	89.3
	80	241.4	241.4	269.5	211.1	291.1	154.4	229.1	229.1	251.5	199.4	270.1	146.5	215.3	215.3	231.8	189.8	247.6	136.3
	85	255.4	255.4	264.5	264.5	290.1	199.2	241.9	241.9	246.4	246.4	269.3	196.8	226.3	226.3	226.7	226.7	246.9	178.7
	90	268.0	268.0	268.1	268.1	286.8	240.8	252.5	252.5	252.6	252.6	266.2	231.9	234.2	234.2	234.4	234.4	243.9	222.5
		Ambient Temperature 115°F						Ambient Temperature 125°F											
6400	75	182.9	157.7	203.0	119.3	215.1	74.5	165.7	144.0	181.8	110.1	190.1	65.0						
	80	180.7	180.7	203.0	150.4	215.6	107.5	166.1	166.1	181.9	141.0	191.2	98.9						
	85	191.0	191.0	202.5	174.6	216.1	139.7	175.5	175.5	180.9	169.3	191.8	130.2						
	90	200.6	200.6	200.8	200.8	215.8	171.7	182.2	182.2	182.3	182.3	191.8	160.4						
7200	75	186.0	165.7	205.9	124.8	217.1	75.9	167.6	156.1	183.7	114.7	191.0	66.3						
	80	186.4	186.4	205.6	159.9	218.0	113.6	171.4	171.4	183.6	146.0	192.9	104.5						
	85	197.1	197.1	203.9	190.9	218.4	148.3	179.8	179.8	181.6	181.6	193.1	138.6						
	90	205.6	205.6	205.7	205.7	218.1	180.4	185.7	185.7	185.8	185.8	192.5	171.1						
8000	75	187.9	174.6	207.9	130.0	218.5	77.3	168.9	168.9	184.9	120.1	191.6	67.5						
	80	191.7	191.7	207.6	161.0	220.1	119.2	175.5	175.5	185.0	153.7	194.4	107.7						
	85	201.8	201.8	204.7	204.7	220.1	156.7	182.6	182.6	182.7	182.7	194.0	141.9						
	90	208.7	208.7	208.8	208.8	218.9	192.2	189.0	189.0	189.1	189.1	192.6	181.4						
8800	75	189.2	189.2	209.4	135.4	219.6	78.7	169.9	169.9	185.9	125.4	192.1	68.8						
	80	196.1	196.1	209.2	172.5	221.8	122.3	178.6	178.6	185.0	164.7	195.0	112.2						
	85	205.3	205.3	205.4	205.4	221.4	165.0	184.6	184.6	184.7	184.7	194.8	153.0						
	90	212.6	212.6	212.7	212.7	219.3	202.4	191.2	191.2	191.3	191.3	192.5	191.5						
9600	75	190.1	190.1	210.6	140.7	220.5	80.0	172.2	172.2	186.8	130.7	192.6	70.2						
	80	199.6	199.6	209.3	183.2	222.9	126.8	181.0	181.0	185.0	172.1	195.4	116.6						
	85	207.8	207.8	207.9	207.9	222.5	174.2	187.1	187.1	187.2	187.2	195.1	160.6						
	90	215.8	215.8	215.9	215.9	219.4	212.4	192.5	192.5	192.6	192.6	192.6	192.6						

Notes:

1. All capacities shown are gross and have not considered indoor fan heat. To obtain NET cooling capacity subtract indoor fan heat. For indoor fan heat formula, refer to appropriate airflow table notes.
2. MBh = Total gross capacity
3. SHC = Sensible heat capacity



# Gross Cooling Capacities

**Table 13. Gross cooling capacities — 25 tons**

CFM	Ent DB (°F)	Entering Wet Bulb Temp (°F)						Entering Wet Bulb Temp (°F)						Entering Wet Bulb Temp (°F)					
		61		67		73		61		67		73		61		67		73	
		MBh	SHC	MBh	SHC	MBh	SHC	MBh	SHC	MBh	SHC	MBh	SHC	MBh	SHC	MBh	SHC	MBh	SHC
		<b>Ambient Temperature 85°F</b>						<b>Ambient Temperature 95°F</b>						<b>Ambient Temperature 105°F</b>					
8000	75	255.1	208.2	290.7	166.0	319.2	115.1	241.0	200.7	274.2	158.4	298.9	106.7	225.7	192.8	256.3	149.9	276.4	97.6
	80	250.0	250.0	289.6	202.5	319.4	154.4	236.1	236.1	273.1	194.7	299.4	146.1	221.1	221.1	255.2	186.3	277.3	137.2
	85	255.1	255.1	286.4	239.3	319.5	194.9	244.4	244.4	270.3	213.6	299.9	184.5	232.5	232.5	252.9	215.2	278.1	175.4
	90	270.3	270.3	281.6	268.6	318.4	230.7	259.0	259.0	265.6	260.3	298.9	222.4	246.3	246.3	248.2	248.2	277.5	213.5
9000	75	260.3	220.8	297.1	174.5	324.1	117.2	245.6	211.2	279.7	166.7	302.6	108.4	228.8	201.7	260.8	156.0	279.2	99.2
	80	253.7	253.7	295.2	225.3	324.6	160.9	239.2	239.2	278.0	206.1	303.6	152.4	226.4	226.4	259.3	200.1	280.6	143.9
	85	265.0	265.0	291.0	250.7	324.9	203.2	253.6	253.6	273.5	242.3	304.0	194.5	240.9	240.9	254.9	232.9	281.2	185.2
	90	280.8	280.8	284.8	284.8	323.2	245.2	268.6	268.6	268.8	268.8	302.9	236.8	254.8	254.8	255.0	255.0	280.6	227.7
10000	75	263.5	228.8	302.0	180.1	327.9	119.0	247.7	220.7	284.1	171.8	305.4	110.1	231.0	211.5	264.8	162.9	282.6	101.2
	80	257.3	257.3	299.5	226.2	328.8	168.5	245.9	245.9	281.6	218.6	307.1	158.7	233.2	233.2	262.3	202.3	283.6	149.5
	85	273.6	273.6	293.3	263.7	328.7	213.1	261.5	261.5	275.6	254.8	307.1	204.3	248.0	248.0	256.3	256.3	283.4	205.7
	90	289.7	289.7	289.9	289.9	326.9	259.5	276.7	276.7	276.9	276.9	305.9	245.6	261.7	261.7	261.9	261.9	281.7	237.0
11000	75	265.4	238.9	306.5	187.1	330.9	120.7	249.4	230.1	288.0	178.6	308.6	112.1	232.2	232.2	267.7	169.5	285.3	103.2
	80	264.4	264.4	302.8	229.2	332.4	175.1	252.4	252.4	284.5	226.8	310.3	164.6	239.2	239.2	264.7	214.8	286.1	154.1
	85	281.1	281.1	294.7	294.7	331.8	222.8	268.3	268.3	276.6	276.6	309.5	226.3	254.0	254.0	257.0	257.0	285.4	205.8
	90	297.4	297.4	297.6	297.6	328.5	268.8	283.4	283.4	283.6	283.6	306.3	258.9	267.4	267.4	267.5	267.5	282.0	248.4
12000	75	266.5	266.5	310.1	193.7	334.3	122.8	250.3	250.3	290.8	185.1	311.8	114.2	232.9	232.9	269.9	175.8	287.6	105.1
	80	270.6	270.6	305.4	229.9	335.6	178.4	258.1	258.1	285.7	235.0	312.6	169.1	244.3	244.3	264.8	224.7	288.0	159.3
	85	287.7	287.7	295.4	295.4	334.3	232.4	274.2	274.2	277.0	277.0	311.6	226.8	259.0	259.0	259.2	259.2	287.0	206.0
	90	304.0	304.0	304.2	304.2	329.2	279.9	289.1	289.1	289.3	289.3	306.5	270.1	271.9	271.9	272.1	272.1	282.2	258.5
		<b>Ambient Temperature 115°F</b>						<b>Ambient Temperature 125°F</b>											
8000	75	209.3	181.4	236.7	141.3	252.1	88.0	190.7	172.0	215.1	130.1	226.8	78.3						
	80	206.0	206.0	235.7	183.0	253.1	128.5	192.1	192.1	214.2	164.6	227.9	118.0						
	85	219.3	219.3	232.8	210.2	254.0	165.5	204.1	204.1	211.3	211.3	227.6	155.0						
	90	231.9	231.9	232.1	232.1	253.8	203.8	214.7	214.7	214.8	214.8	227.5	186.5						
9000	75	211.5	192.2	240.6	146.8	255.4	90.0	192.6	192.6	218.1	136.7	228.9	80.2						
	80	213.2	213.2	239.0	186.0	256.0	133.7	198.2	198.2	216.8	172.2	230.6	123.0						
	85	226.6	226.6	234.6	234.6	256.1	175.2	210.0	210.0	212.5	212.5	229.6	164.8						
	90	238.9	238.9	239.1	239.1	255.5	214.3	219.6	219.6	219.7	219.7	227.7	201.5						
10000	75	213.1	213.1	243.6	153.4	257.9	91.9	193.8	193.8	220.2	143.1	230.7	81.9						
	80	219.3	219.3	241.5	189.1	258.7	138.8	203.3	203.3	217.7	185.7	232.4	128.5						
	85	232.7	232.7	235.6	235.6	257.8	184.7	214.7	214.7	214.8	214.8	231.3	166.7						
	90	244.3	244.3	244.5	244.5	255.7	225.8	223.0	223.0	223.1	223.1	227.8	213.1						
11000	75	214.0	214.0	245.8	159.8	260.0	93.8	194.8	194.8	221.8	149.3	232.1	83.7						
	80	224.4	224.4	242.1	205.6	261.6	142.1	207.6	207.6	218.1	194.3	233.9	133.7						
	85	237.6	237.6	237.7	237.7	259.5	185.1	218.3	218.3	218.4	218.4	232.5	181.7						
	90	248.5	248.5	248.6	248.6	255.8	236.2	225.1	225.1	225.2	225.2	228.0	224.7						
12000	75	214.4	214.4	247.5	166.0	261.7	95.6	198.5	198.5	223.0	163.2	233.5	85.5						
	80	228.8	228.8	242.5	214.1	262.9	149.5	211.1	211.1	218.1	218.1	235.1	138.8						
	85	241.7	241.7	241.8	241.8	260.6	201.7	221.0	221.0	221.1	221.1	232.7	188.8						
	90	251.6	251.6	251.6	251.6	255.8	245.3	228.0	228.0	228.0	228.0	228.1	228.1						

**Notes:**

1. All capacities shown are gross and have not considered indoor fan heat. To obtain NET cooling capacity subtract indoor fan heat. For indoor fan heat formula, refer to appropriate airflow table notes.
2. MBh = Total gross capacity
3. SHC = Sensible heat capacity



# Reheat Temperature Rise

Table 14. Reheat temperature rise — 6 tons

Airflow (cfm)	Ent DB (°F)	Entering Wet Bulb (°F)											
		51				55				59			
		Lvg Evap DB (°F)		Lvg Reheat DB (°F)		Lvg Evap DB (°F)		Lvg Reheat DB (°F)		Lvg Evap DB (°F)		Lvg Reheat DB (°F)	
		MIN	MAX	MIN	MAX	MIN	MAX	MIN	MAX	MIN	MAX	MIN	MAX
<b>Ambient DB 60°F</b>													
1200	60	28.5 <sup>(a)</sup>	32.0 <sup>(a)</sup>	45.9	54.1	32.2 <sup>(a)</sup>	36.9	50.7	56.7	36.3	41.8	55.2	59.0
	65	28.5 <sup>(a)</sup>	32.0 <sup>(a)</sup>	45.9	54.2	32.2 <sup>(a)</sup>	36.9	50.7	56.7	36.4	41.8	55.2	59.0
	70	28.5 <sup>(a)</sup>	32.2 <sup>(a)</sup>	45.8	54.2	32.2 <sup>(a)</sup>	36.9	50.6	56.7	36.3	41.8	55.1	59.0
	75	30.1 <sup>(a)</sup>	36.4	47.7	56.3	32.2 <sup>(a)</sup>	37.1	50.6	56.7	36.3	41.8	55.1	59.1
1440	60	31.5 <sup>(a)</sup>	33.9 <sup>(a)</sup>	46.6	54.8	35.2	38.9	51.3	57.4	39.2	44.0	56.0	60.0
	65	31.6 <sup>(a)</sup>	34.0 <sup>(a)</sup>	46.7	54.9	35.3	39.0	51.3	57.4	39.3	43.9	56.0	59.9
	70	31.9 <sup>(a)</sup>	35.8	47.0	55.7	35.4	39.0	51.4	57.5	39.3	43.9	56.1	60.0
	75	34.6 <sup>(a)</sup>	40.1	50.1	57.9	35.4	40.2	51.4	58.0	39.4	44.0	56.1	60.0
1680	60	33.9 <sup>(a)</sup>	35.5	47.2	55.2	37.7	40.5	51.9	57.9	41.5	45.6	56.6	60.7
	65	34.0 <sup>(a)</sup>	35.7	47.3	55.3	37.8	40.6	52.0	58.0	41.6	45.5	56.6	60.6
	70	35.4	38.7	48.7	56.9	37.9	40.6	52.1	58.0	41.7	45.6	56.7	60.7
	75	38.3	43.2	52.2	59.3	38.4	43.3	52.4	59.3	41.8	45.7	56.8	60.7
1920	60	35.8	36.8	47.8	55.7	39.6	41.7	52.5	58.4	43.6	46.8	57.1	61.1
	65	36.0	37.0	48.0	55.7	39.8	41.9	52.6	58.5	43.5	46.7	57.0	61.1
	70	38.3	41.1	50.4	57.9	39.9	42.1	52.7	58.5	43.6	46.9	57.1	61.2
	75	41.3	45.8	53.9	60.4	41.4	45.9	54.0	60.5	43.8	47.1	57.3	61.3
2160	60	37.4	37.0	48.3	56.1	41.2	42.8	52.9	58.7	45.1	47.8	57.4	61.5
	65	38.0	38.6	48.7	56.2	41.4	43.0	53.0	58.8	45.0	47.8	57.4	61.5
	70	40.8	43.2	51.9	58.7	41.7	43.7	53.2	59.1	45.2	48.0	57.5	61.6
	75	43.8	48.0	55.4	61.4	43.9	48.2	55.5	61.5	45.4	48.7	57.7	61.8
2400	60	38.8	38.9	48.7	56.0	42.5	43.6	53.2	58.9	46.3	48.6	57.7	61.7
	65	39.5	40.0	49.3	56.6	42.7	43.9	53.4	59.0	46.3	48.6	57.7	61.7
	70	42.9	45.0	53.2	59.4	43.4	44.8	53.9	59.4	46.5	48.9	57.8	61.8
	75	45.9	50.0	56.6	62.2	46.0	50.1	56.7	62.3	46.9	49.8	58.1	62.2
2640	60	39.9	39.8	49.1	55.9	43.5	44.4	53.5	59.0	47.4	49.3	57.9	61.9
	65	41.3	41.5	50.4	57.0	43.8	44.7	53.7	59.2	47.4	49.4	57.9	61.9
	70	44.7	46.6	54.2	60.1	44.6	46.7	54.3	60.1	47.7	49.7	58.1	62.0
	75	47.8	51.7	57.7	62.9	47.8	51.8	57.8	63.0	48.4	51.9	58.6	63.1
2880	60	40.8	40.6	49.3	55.7	44.4	45.1	53.7	59.1	48.3	49.8	58.1	61.9
	65	42.8	42.9	51.2	57.4	44.8	45.5	53.9	59.3	48.4	50.1	58.1	62.0
	70	46.2	48.1	55.2	60.6	45.7	48.2	54.7	60.6	48.7	50.4	58.3	62.2
	75	49.4	53.2	58.7	63.6	49.5	53.3	58.8	63.6	49.5	53.5	59.0	63.7
<b>Ambient DB 65°F</b>													
1200	60	29.0 <sup>(a)</sup>	31.4 <sup>(a)</sup>	46.4	56.4	32.6 <sup>(a)</sup>	36.4	51.1	59.0	36.5	41.4	56.1	61.5
	65	29.0 <sup>(a)</sup>	31.5 <sup>(a)</sup>	46.4	56.4	32.6 <sup>(a)</sup>	36.4	51.0	59.0	36.6	41.4	56.2	61.5
	70	29.0 <sup>(a)</sup>	31.7 <sup>(a)</sup>	46.3	56.4	32.6 <sup>(a)</sup>	36.5	51.0	59.0	36.5	41.4	56.0	61.5
	75	30.8 <sup>(a)</sup>	35.6	48.5	58.5	32.6 <sup>(a)</sup>	36.4	51.0	59.0	36.5	41.4	56.0	61.5



# Reheat Temperature Rise

**Table 14. Reheat temperature rise — 6 tons (continued)**

Airflow (cfm)	Ent DB (°F)	Entering Wet Bulb (°F)											
		51				55				59			
		Lvg Evap DB (°F)		Lvg Reheat DB (°F)		Lvg Evap DB (°F)		Lvg Reheat DB (°F)		Lvg Evap DB (°F)		Lvg Reheat DB (°F)	
		MIN	MAX	MIN	MAX	MIN	MAX	MIN	MAX	MIN	MAX	MIN	MAX
1440	60	32.0 <sup>(a)</sup>	33.2 <sup>(a)</sup>	47.0	56.9	35.7	38.3	51.8	59.7	39.5	43.5	56.6	62.4
	65	32.1 <sup>(a)</sup>	33.3 <sup>(a)</sup>	47.1	56.9	35.8	38.4	51.8	59.7	39.6	43.4	56.6	62.4
	70	32.4 <sup>(a)</sup>	34.8 <sup>(a)</sup>	47.4	57.6	35.9	38.5	51.8	59.8	39.6	43.4	56.6	62.4
	75	35.3	39.1	50.9	60.0	35.9	38.9	51.9	59.9	39.7	43.5	56.7	62.4
1680	60	34.3 <sup>(a)</sup>	34.7 <sup>(a)</sup>	47.7	57.4	38.2	39.8	52.4	60.3	42.0	45.0	57.2	63.1
	65	34.5 <sup>(a)</sup>	34.9 <sup>(a)</sup>	47.7	57.4	38.3	39.9	52.5	60.3	42.0	44.9	57.2	63.0
	70	36.1	37.5	49.4	58.8	38.4	40.1	52.6	60.4	42.1	45.0	57.3	63.1
	75	39.0	42.1	53.0	61.3	38.9	42.2	53.0	61.4	42.2	45.1	57.3	63.1
1920	60	36.3	36.1	48.3	57.2	40.1	41.0	52.9	60.7	44.1	46.2	57.8	63.5
	65	36.5	36.3	48.4	57.3	40.2	41.2	53.0	60.7	44.0	46.1	57.7	63.5
	70	39.0	39.8	51.1	59.8	40.4	41.4	53.1	60.8	44.2	46.3	57.8	63.5
	75	42.0	44.5	54.8	62.4	42.1	44.7	54.9	62.5	44.4	46.5	57.9	63.6
2160	60	37.8	37.5	48.7	56.8	41.6	42.0	53.3	60.9	45.6	47.1	58.1	63.8
	65	38.4	38.1	49.1	57.2	41.7	42.2	53.4	61.0	45.5	47.1	58.0	63.8
	70	41.4	41.8	52.5	60.5	42.2	42.8	53.7	61.2	45.7	47.3	58.2	63.9
	75	44.5	46.7	56.2	63.3	44.6	46.8	56.3	63.4	46.0	47.9	58.3	64.1
2400	60	39.1	38.7	49.0	56.5	42.8	42.9	53.5	60.9	46.8	47.9	58.3	64.0
	65	39.9	39.5	49.7	57.0	43.0	43.2	53.7	61.0	46.8	48.0	58.3	64.0
	70	43.4	43.6	53.7	61.1	43.7	44.0	54.2	61.4	47.0	48.2	58.4	64.1
	75	46.7	48.6	57.5	64.1	46.8	48.7	57.6	64.1	47.3	49.0	58.6	64.4
2640	60	40.2	39.8	49.3	56.1	43.8	43.7	53.7	60.7	47.8	48.6	58.4	64.0
	65	41.8	41.2	50.8	57.3	44.1	44.0	54.0	60.9	47.9	48.7	58.5	64.1
	70	45.2	45.2	54.7	61.5	45.0	45.0	54.7	61.5	48.1	49.0	58.7	64.2
	75	48.5	50.2	58.6	64.7	48.6	50.4	58.7	64.7	48.9	50.0	59.2	64.6
2880	60	41.1	40.7	49.6	55.8	44.7	44.5	53.9	60.5	48.7	49.2	58.6	64.1
	65	43.3	42.7	51.7	57.7	45.1	44.9	54.2	60.7	48.8	49.4	58.6	64.1
	70	46.7	46.6	55.6	62.0	46.8	46.7	55.7	62.0	49.1	49.7	58.8	64.3
	75	50.1	51.7	59.6	65.2	50.2	51.8	59.6	65.3	50.0	52.0	59.6	65.4
<b>Ambient DB 70°F</b>													
1200	60	29.5 <sup>(a)</sup>	30.9 <sup>(a)</sup>	46.9	58.4	33.2 <sup>(a)</sup>	36.0	51.7	61.3	37.0	41.0	56.6	63.9
	65	29.5 <sup>(a)</sup>	30.9 <sup>(a)</sup>	46.8	58.4	33.1 <sup>(a)</sup>	35.9	51.6	61.3	37.1	41.0	56.7	63.9
	70	29.5 <sup>(a)</sup>	31.1 <sup>(a)</sup>	46.8	58.5	33.1 <sup>(a)</sup>	36.0	51.5	61.3	37.0	41.0	56.6	63.9
	75	31.5 <sup>(a)</sup>	34.8 <sup>(a)</sup>	49.2	60.6	33.1 <sup>(a)</sup>	36.0	51.5	61.3	37.0	41.0	56.5	63.9
1440	60	32.5 <sup>(a)</sup>	32.6 <sup>(a)</sup>	47.5	58.7	36.3	37.7	52.3	62.0	40.2	43.0	57.4	64.9
	65	32.5 <sup>(a)</sup>	32.7 <sup>(a)</sup>	47.5	58.7	36.3	37.8	52.3	62.1	40.2	42.8	57.4	64.8
	70	33.0 <sup>(a)</sup>	33.1 <sup>(a)</sup>	48.0	59.0	36.4	37.9	52.4	62.1	40.3	42.9	57.4	64.8
	75	36.0	38.1	51.6	62.1	36.4	38.3	52.4	62.3	40.3	43.0	57.4	64.9
1680	60	34.8 <sup>(a)</sup>	34.5 <sup>(a)</sup>	48.1	58.1	38.6	39.1	52.9	62.5	42.5	44.4	57.8	65.5
	65	34.9 <sup>(a)</sup>	34.6 <sup>(a)</sup>	48.2	58.2	38.7	39.2	53.0	62.6	42.6	44.3	57.8	65.4
	70	36.8	36.5	50.1	60.0	38.9	39.4	53.0	62.6	42.6	44.4	57.9	65.5
	75	39.7	40.9	53.8	63.4	39.6	41.0	53.7	63.5	42.8	44.5	58.0	65.5

Table 14. Reheat temperature rise — 6 tons (continued)

Airflow (cfm)	Ent DB (°F)	Entering Wet Bulb (°F)											
		51				55				59			
		Lvg Evap DB (°F)		Lvg Reheat DB (°F)		Lvg Evap DB (°F)		Lvg Reheat DB (°F)		Lvg Evap DB (°F)		Lvg Reheat DB (°F)	
		MIN	MAX	MIN	MAX	MIN	MAX	MIN	MAX	MIN	MAX	MIN	MAX
1920	60	36.7	36.2	48.7	57.4	40.4	40.3	53.3	62.4	44.5	45.5	58.2	65.8
	65	36.9	36.5	48.8	57.7	40.6	40.5	53.4	62.5	44.4	45.4	58.2	65.8
	70	39.6	39.1	51.7	60.5	40.8	40.7	53.5	62.6	44.5	45.6	58.3	65.9
	75	42.6	43.2	55.4	64.3	42.7	43.4	55.5	64.4	44.7	45.8	58.4	65.9
2160	60	38.2	37.7	49.0	56.8	41.9	41.6	53.6	61.9	45.9	46.5	58.5	66.0
	65	38.8	38.3	49.5	57.2	42.1	41.8	53.7	62.1	45.9	46.4	58.4	66.0
	70	41.9	41.4	53.1	61.0	42.5	42.0	54.1	62.2	46.1	46.6	58.6	66.1
	75	45.1	45.3	56.9	65.0	45.2	45.5	57.0	65.1	46.3	47.1	58.7	66.3
2400	60	39.4	38.9	49.4	56.4	43.1	42.7	53.8	61.5	47.1	47.3	58.6	66.0
	65	40.4	39.7	50.2	56.9	43.4	42.9	54.0	61.6	47.1	47.3	58.6	66.0
	70	43.9	43.3	54.2	61.4	44.1	43.7	54.6	62.1	47.4	47.6	58.8	66.1
	75	47.2	47.2	58.1	65.5	47.3	47.3	58.2	65.6	48.0	48.3	59.2	66.5
2640	60	40.5	40.0	49.6	56.2	44.1	43.7	54.0	61.0	48.1	48.0	58.7	65.8
	65	42.3	41.6	51.3	57.5	44.4	44.0	54.2	61.2	48.2	48.0	58.8	65.8
	70	45.7	45.0	55.2	61.8	45.5	44.8	55.1	61.8	48.5	48.4	59.0	66.0
	75	49.0	48.9	59.2	66.0	49.1	49.0	59.2	66.1	49.2	49.3	59.6	66.5
2880	60	41.4	41.0	49.8	55.9	45.0	44.6	54.2	60.6	49.0	48.7	58.8	65.4
	65	43.7	43.1	52.1	57.9	45.3	44.9	54.4	60.8	49.1	48.8	58.9	65.5
	70	47.2	46.5	56.1	62.2	47.2	46.6	56.2	62.3	49.4	49.2	59.1	65.7
	75	50.6	50.4	60.1	66.4	50.7	50.5	60.2	66.5	50.6	50.2	60.2	66.4

Note: MIN, MAX: The leaving evaporator temperature is affected by the modulating valve position. The MIN and MAX numbers represent modulating valve position impact on both the leaving evaporator temperature and the leaving reheat coil temperature. MAX represents wide open, MIN represents closed to minimum position.

(a) The unit might be tripped by Froststat at these conditions due to low leaving evaporator air temperature.

Table 15. Reheat temperature rise — 7.5 tons

Airflow (cfm)	Ent DB (°F)	Entering Wet Bulb (°F)											
		51				55				59			
		Lvg Evap DB (°F)		Lvg Reheat DB (°F)		Lvg Evap DB (°F)		Lvg Reheat DB (°F)		Lvg Evap DB (°F)		Lvg Reheat DB (°F)	
		MIN	MAX	MIN	MAX	MIN	MAX	MIN	MAX	MIN	MAX	MIN	MAX
<b>Ambient DB 60°F</b>													
1500	60	29.5 <sup>(a)</sup>	32.9 <sup>(a)</sup>	46.1	55.0	33.1 <sup>(a)</sup>	38.0	50.7	57.8	36.7	43.2	55.0	60.6
	65	29.7 <sup>(a)</sup>	33.0 <sup>(a)</sup>	46.2	55.1	33.0 <sup>(a)</sup>	38.1	50.6	57.8	36.9	43.1	55.2	60.5
	70	29.7 <sup>(a)</sup>	34.1 <sup>(a)</sup>	46.2	55.5	33.2 <sup>(a)</sup>	38.3	50.7	57.9	36.8	43.2	55.1	60.6
	75	31.9 <sup>(a)</sup>	38.7	48.7	58.0	33.3 <sup>(a)</sup>	38.7	50.7	58.1	36.9	43.4	55.1	60.6
1800	60	32.5 <sup>(a)</sup>	34.8 <sup>(a)</sup>	47.0	55.7	36.1	39.8	51.6	58.5	39.8	45.1	56.0	61.3
	65	32.7 <sup>(a)</sup>	35.0	47.1	55.8	36.3	40.1	51.7	58.6	39.9	45.0	56.0	61.2
	70	33.3 <sup>(a)</sup>	37.6	47.7	57.1	36.5	40.3	51.8	58.7	40.0	45.2	56.1	61.3
	75	36.4	42.3	51.2	59.7	37.0	42.5	52.2	59.7	40.2	45.4	56.2	61.4
2100	60	34.8 <sup>(a)</sup>	36.3	47.7	56.2	38.5	41.3	52.3	58.9	42.2	46.5	56.7	61.7
	65	35.1	36.8	47.9	56.4	38.7	41.6	52.4	59.1	42.3	46.5	56.8	61.7
	70	37.0	40.4	49.8	58.2	39.0	42.0	52.6	59.2	42.5	46.8	56.9	61.9
	75	40.0	45.4	53.3	60.9	39.8	45.5	53.3	61.0	42.8	47.1	57.1	62.0



## Reheat Temperature Rise

Table 15. Reheat temperature rise — 7.5 tons (continued)

Airflow (cfm)	Ent DB (°F)	Entering Wet Bulb (°F)											
		51				55				59			
		Lvg Evap DB (°F)		Lvg Reheat DB (°F)		Lvg Evap DB (°F)		Lvg Reheat DB (°F)		Lvg Evap DB (°F)		Lvg Reheat DB (°F)	
		MIN	MAX	MIN	MAX	MIN	MAX	MIN	MAX	MIN	MAX	MIN	MAX
2400	60	36.7	37.5	48.3	56.4	40.3	42.4	52.8	59.2	44.2	47.6	57.4	62.0
	65	37.4	38.3	48.8	56.8	40.6	42.8	53.0	59.4	44.2	47.6	57.3	62.0
	70	39.8	42.8	51.4	59.2	41.0	43.6	53.2	59.7	44.5	48.0	57.5	62.2
	75	42.9	48.0	55.0	62.0	43.0	48.1	55.1	62.0	44.8	48.8	57.7	62.5
2700	60	38.3	38.6	48.7	56.5	41.8	43.4	53.1	59.4	45.7	48.5	57.7	62.2
	65	39.1	39.6	49.4	57.0	42.2	43.9	53.4	59.6	45.7	48.6	57.7	62.2
	70	42.2	44.9	52.8	59.9	42.9	44.9	54.0	60.0	46.1	49.1	57.9	62.4
	75	45.3	50.2	56.4	62.8	45.4	50.3	56.5	62.9	46.6	50.1	58.3	62.9
3000	60	39.5	39.6	49.1	56.4	43.1	44.3	53.4	59.5	46.9	49.3	57.9	62.3
	65	40.6	40.8	50.0	57.1	43.5	44.8	53.8	59.7	47.0	49.5	58.0	62.4
	70	44.2	46.7	54.0	60.5	44.4	46.0	54.5	60.2	47.4	50.0	58.3	62.6
	75	47.4	52.1	57.6	63.6	47.4	52.3	57.7	63.6	48.2	52.4	58.9	63.7
3300	60	40.6	40.5	49.4	56.3	44.1	45.1	53.7	59.6	47.9	49.9	58.1	62.4
	65	42.5	42.8	51.1	57.8	44.6	45.6	54.0	59.8	48.1	50.3	58.2	62.5
	70	45.9	48.3	55.0	61.1	45.7	48.4	54.9	61.1	48.5	50.8	58.5	62.7
	75	49.1	53.8	58.7	64.2	49.2	53.9	58.8	64.3	49.5	54.0	59.3	64.3
3600	60	41.5	41.3	49.7	56.1	45.0	45.7	53.9	59.6	48.8	50.3	58.3	62.3
	65	43.9	44.2	52.0	58.1	45.5	46.3	54.3	59.8	49.0	50.9	58.4	62.6
	70	47.4	49.7	55.9	61.6	47.5	49.8	56.0	61.6	49.5	51.8	58.8	63.0
	75	50.7	55.3	59.6	64.8	50.8	55.4	59.7	64.8	50.7	55.5	59.7	64.9
<b>Ambient DB 65°F</b>													
1500	60	29.9 <sup>(a)</sup>	32.0 <sup>(a)</sup>	46.6	57.3	33.6 <sup>(a)</sup>	37.2	51.4	60.1	37.2	42.5	56.0	62.9
	65	30.1 <sup>(a)</sup>	32.1 <sup>(a)</sup>	46.7	57.3	33.5 <sup>(a)</sup>	37.3	51.3	60.1	37.4	42.4	56.2	62.9
	70	30.4 <sup>(a)</sup>	32.6 <sup>(a)</sup>	47.0	57.6	33.7 <sup>(a)</sup>	37.4	51.4	60.2	37.3	42.5	56.1	62.9
	75	32.4 <sup>(a)</sup>	37.3	49.4	60.0	33.8 <sup>(a)</sup>	37.9	51.5	60.4	37.5	42.7	56.1	63.0
1800	60	32.9 <sup>(a)</sup>	33.7 <sup>(a)</sup>	47.4	57.8	36.5	38.9	52.1	60.7	40.3	44.3	56.9	63.6
	65	33.1 <sup>(a)</sup>	33.9 <sup>(a)</sup>	47.6	57.9	36.7	39.1	52.2	60.8	40.4	44.2	57.0	63.6
	70	33.7 <sup>(a)</sup>	35.9	48.2	58.9	36.9	39.4	52.4	60.9	40.5	44.4	57.1	63.7
	75	36.9	40.7	51.9	61.5	37.4	40.8	52.8	61.6	40.7	44.6	57.2	63.7
2100	60	35.2	35.2	48.1	57.9	38.8	40.3	52.7	61.1	42.9	45.7	57.7	64.0
	65	35.5	35.6	48.3	58.1	39.1	40.6	52.9	61.2	42.8	45.6	57.6	64.0
	70	37.5	38.6	50.4	59.9	39.3	40.9	53.1	61.4	43.0	45.9	57.8	64.1
	75	40.4	43.6	54.0	62.7	40.2	43.8	53.8	62.8	43.3	46.2	57.9	64.2
2400	60	37.0	36.7	48.6	57.6	40.6	41.5	53.2	61.3	44.5	46.7	57.9	64.2
	65	37.7	37.4	49.2	58.1	41.0	41.8	53.4	61.5	44.6	46.8	58.0	64.3
	70	40.3	41.0	52.0	60.7	41.3	42.6	53.6	61.8	44.9	47.1	58.2	64.4
	75	43.4	46.1	55.7	63.6	43.5	46.3	55.8	63.7	45.2	47.9	58.4	64.7
2700	60	38.5	38.1	49.1	57.3	42.1	42.5	53.5	61.3	46.1	47.7	58.3	64.4
	65	39.4	39.0	49.8	57.9	42.5	42.9	53.8	61.6	46.1	47.7	58.3	64.4
	70	42.6	43.0	53.3	61.3	43.3	43.8	54.4	62.0	46.5	48.2	58.6	64.6
	75	45.8	48.3	57.1	64.4	45.9	48.4	57.2	64.5	46.9	49.1	58.8	65.0



Table 15. Reheat temperature rise — 7.5 tons (continued)

Airflow (cfm)	Ent DB (°F)	Entering Wet Bulb (°F)											
		51				55				59			
		Lvg Evap DB (°F)		Lvg Reheat DB (°F)		Lvg Evap DB (°F)		Lvg Reheat DB (°F)		Lvg Evap DB (°F)		Lvg Reheat DB (°F)	
		MIN	MAX	MIN	MAX	MIN	MAX	MIN	MAX	MIN	MAX	MIN	MAX
3000	60	39.8	39.3	49.4	56.9	43.4	43.4	53.8	61.2	47.3	48.4	58.5	64.4
	65	40.9	40.4	50.3	57.7	43.8	43.9	54.1	61.5	47.4	48.6	58.5	64.5
	70	44.6	44.8	54.5	61.8	44.7	45.0	54.9	62.1	47.8	49.1	58.8	64.7
	75	47.9	50.2	58.4	65.1	48.0	50.3	58.5	65.1	48.7	50.2	59.5	65.2
3300	60	40.9	40.4	49.7	56.7	44.4	44.2	54.0	61.1	48.3	49.1	58.6	64.4
	65	42.9	42.2	51.6	58.1	44.9	44.7	54.4	61.3	48.5	49.4	58.7	64.5
	70	46.3	46.4	55.5	62.3	46.1	46.3	55.4	62.2	48.9	49.9	59.1	64.8
	75	49.7	51.8	59.4	65.6	49.8	51.9	59.5	65.7	50.0	52.1	59.9	65.8
3600	60	41.8	41.3	50.0	56.4	45.3	45.0	54.2	60.8	49.1	49.7	58.8	64.3
	65	44.3	43.7	52.4	58.4	45.8	45.5	54.6	61.2	49.4	50.0	58.9	64.5
	70	47.8	47.9	56.4	62.7	47.9	48.0	56.5	62.7	49.9	50.5	59.3	64.8
	75	51.3	53.3	60.4	66.1	51.4	53.4	60.5	66.2	51.1	53.5	60.2	66.2
Ambient DB 70°F													
1500	60	30.3 <sup>(a)</sup>	31.1 <sup>(a)</sup>	47.1	59.4	34.0 <sup>(a)</sup>	36.3	52.0	62.3	37.7	41.8	56.9	65.3
	65	30.4 <sup>(a)</sup>	31.2 <sup>(a)</sup>	47.2	59.4	33.9 <sup>(a)</sup>	36.4	51.9	62.4	37.9	41.6	57.0	65.2
	70	30.8 <sup>(a)</sup>	31.7 <sup>(a)</sup>	47.5	59.7	34.1 <sup>(a)</sup>	36.6	52.0	62.4	37.9	41.7	57.0	65.2
	75	33.0 <sup>(a)</sup>	35.8	50.1	61.9	34.2 <sup>(a)</sup>	37.0	52.0	62.6	38.0	41.9	57.0	65.3
1800	60	33.2 <sup>(a)</sup>	33.0 <sup>(a)</sup>	47.9	59.2	36.9	38.0	52.6	62.9	40.7	43.5	57.6	65.9
	65	33.4 <sup>(a)</sup>	33.2 <sup>(a)</sup>	48.0	59.3	37.1	38.2	52.7	63.0	40.8	43.4	57.6	65.8
	70	34.3 <sup>(a)</sup>	33.8 <sup>(a)</sup>	48.8	59.8	37.3	38.4	52.8	63.1	41.0	43.6	57.7	65.9
	75	37.4	39.1	52.6	63.3	37.8	39.1	53.3	63.4	41.2	43.8	57.8	66.0
2100	60	35.5	34.9 <sup>(a)</sup>	48.5	58.5	39.2	39.4	53.2	63.0	43.2	44.8	58.2	66.2
	65	35.8	35.2	48.7	58.7	39.4	39.7	53.3	63.2	43.2	44.7	58.1	66.2
	70	38.0	37.4	50.9	60.7	39.7	40.0	53.5	63.3	43.4	45.0	58.3	66.3
	75	41.0	41.9	54.6	64.3	40.7	42.0	54.4	64.4	43.6	45.3	58.4	66.5
2400	60	37.3	36.7	49.0	58.0	41.0	40.6	53.6	62.7	45.0	45.9	58.5	66.4
	65	38.0	37.4	49.5	58.4	41.3	41.0	53.8	62.9	45.0	45.9	58.5	66.4
	70	40.8	40.0	52.5	61.2	41.8	41.6	54.2	63.3	45.3	46.2	58.7	66.6
	75	43.9	44.3	56.3	65.1	44.0	44.5	56.4	65.2	45.6	46.8	58.9	66.8
2700	60	38.8	38.3	49.4	57.7	42.4	41.9	53.9	62.3	46.4	46.8	58.7	66.4
	65	39.7	39.1	50.1	58.2	42.8	42.3	54.1	62.5	46.5	46.8	58.7	66.4
	70	43.1	42.3	53.9	61.7	43.6	43.1	54.8	63.1	46.8	47.3	59.0	66.6
	75	46.3	46.5	57.7	65.7	46.4	46.6	57.8	65.8	47.5	48.2	59.5	67.0
3000	60	40.1	39.5	49.7	57.3	43.6	43.1	54.1	61.9	47.6	47.6	58.9	66.2
	65	41.3	40.6	50.8	58.0	44.1	43.5	54.4	62.2	47.7	47.8	58.9	66.3
	70	45.1	44.3	55.0	62.2	45.0	44.5	55.2	62.8	48.1	48.2	59.2	66.5
	75	48.4	48.4	59.0	66.3	48.5	48.5	59.0	66.4	49.0	49.3	59.9	67.1
3300	60	41.1	40.6	50.0	57.0	44.7	44.1	54.3	61.6	48.6	48.4	59.0	66.0
	65	43.3	42.5	52.0	58.5	45.1	44.6	54.7	61.9	48.8	48.6	59.1	66.1
	70	46.8	46.0	56.0	62.7	46.7	45.7	56.0	62.7	49.2	49.1	59.4	66.4
	75	50.2	50.1	60.0	66.7	50.3	50.2	60.1	66.8	50.3	50.3	60.3	67.0



## Reheat Temperature Rise

**Table 15. Reheat temperature rise — 7.5 tons (continued)**

Airflow (cfm)	Ent DB (°F)	Entering Wet Bulb (°F)											
		51				55				59			
		Lvg Evap DB (°F)		Lvg Reheat DB (°F)		Lvg Evap DB (°F)		Lvg Reheat DB (°F)		Lvg Evap DB (°F)		Lvg Reheat DB (°F)	
		MIN	MAX	MIN	MAX	MIN	MAX	MIN	MAX	MIN	MAX	MIN	MAX
3600	60	42.0	41.5	50.2	56.7	45.6	45.0	54.5	61.3	49.4	49.1	59.1	65.9
	65	44.7	43.9	52.8	58.9	46.0	45.5	54.9	61.6	49.7	49.3	59.2	66.0
	70	48.2	47.5	56.9	63.1	48.3	47.5	57.0	63.2	50.1	49.8	59.6	66.3
	75	51.8	51.6	61.0	67.2	51.9	51.7	61.0	67.3	51.8	51.2	61.0	67.0

Note: MIN, MAX: The leaving evaporator temperature is affected by the modulating valve position. The MIN and MAX numbers represent modulating valve position impact on both the leaving evaporator temperature and the leaving reheat coil temperature. MAX represents wide open, MIN represents closed to minimum position.

(a) The unit might be tripped by Froststat at these conditions due to low leaving evaporator air temperature.

**Table 16. Reheat temperature rise — 8.5 tons**

Airflow (cfm)	Ent DB (°F)	Entering Wet Bulb (°F)											
		51				55				59			
		Lvg Evap DB (°F)		Lvg Reheat DB (°F)		Lvg Evap DB (°F)		Lvg Reheat DB (°F)		Lvg Evap DB (°F)		Lvg Reheat DB (°F)	
		MIN	MAX	MIN	MAX	MIN	MAX	MIN	MAX	MIN	MAX	MIN	MAX
<b>Ambient DB 60°F</b>													
1700	60	29.0 <sup>(a)</sup>	32.9 <sup>(a)</sup>	45.5	51.9	32.7 <sup>(a)</sup>	37.7	49.7	54.6	37.2	42.5	52.8	57.2
	65	29.2 <sup>(a)</sup>	33.2 <sup>(a)</sup>	45.7	52.0	32.8 <sup>(a)</sup>	37.8	49.7	54.6	37.4	42.6	52.9	57.3
	70	29.4 <sup>(a)</sup>	33.9 <sup>(a)</sup>	45.8	52.4	33.0 <sup>(a)</sup>	38.1	49.9	54.8	37.4	42.8	52.9	57.4
	75	31.4 <sup>(a)</sup>	38.4	47.9	54.8	33.2 <sup>(a)</sup>	38.7	50.0	55.0	37.6	43.1	53.0	57.5
2040	60	32.0 <sup>(a)</sup>	35.2	46.4	52.6	35.7	39.9	50.7	55.3	40.1	44.9	53.9	58.1
	65	32.3 <sup>(a)</sup>	35.5	46.6	52.8	35.8	40.3	50.8	55.4	40.2	44.9	54.0	58.0
	70	33.0 <sup>(a)</sup>	38.2	47.3	54.1	36.2	40.6	51.0	55.6	40.4	45.2	54.1	58.2
	75	35.9	42.6	50.4	56.6	36.8	42.7	51.4	56.7	40.8	45.3	54.3	58.3
2380	60	34.3 <sup>(a)</sup>	37.1	47.1	53.1	37.9	41.7	51.3	55.7	42.3	46.6	54.7	58.5
	65	34.7 <sup>(a)</sup>	37.8	47.4	53.4	38.3	42.1	51.6	55.9	42.5	46.6	54.8	58.5
	70	36.3	41.4	48.9	55.4	38.6	42.8	51.8	56.3	42.9	47.0	55.0	58.8
	75	39.5	46.0	52.3	58.0	39.6	46.1	52.5	58.1	43.2	47.4	55.2	58.9
2720	60	36.2	38.5	47.7	53.4	39.8	43.0	51.9	56.0	44.3	47.9	55.4	58.8
	65	36.8	39.5	48.2	53.8	40.2	43.6	52.2	56.3	44.3	48.0	55.4	58.9
	70	39.3	44.1	50.7	56.4	40.6	44.5	52.5	56.7	44.8	48.5	55.7	59.2
	75	42.6	48.8	53.9	59.2	41.8	48.9	53.4	59.2	45.2	49.4	55.9	59.6
3060	60	37.8	39.8	48.2	53.6	41.3	44.2	52.3	56.3	45.7	48.9	55.8	59.1
	65	38.7	41.1	49.0	54.2	41.8	44.8	52.7	56.6	45.8	49.3	55.9	59.2
	70	41.7	46.3	52.0	57.3	42.6	45.9	53.3	57.1	46.3	49.7	56.2	59.5
	75	45.3	51.2	55.2	60.2	45.4	51.3	55.3	60.2	46.9	50.8	56.5	60.0
3400	60	39.1	40.8	48.7	53.7	42.5	45.3	52.7	56.5	46.9	49.8	56.2	59.2
	65	40.2	43.2	49.6	55.0	43.1	45.8	53.1	56.7	47.1	50.2	56.3	59.4
	70	43.7	48.2	53.2	58.1	44.2	48.3	53.9	58.1	47.7	50.7	56.6	59.7
	75	47.6	53.2	56.3	61.0	47.7	53.3	56.4	61.1	48.8	53.4	57.2	61.1
3740	60	40.2	41.7	49.0	53.8	43.6	46.1	53.0	56.6	47.9	50.4	56.4	59.2
	65	41.6	44.8	50.2	55.6	44.2	46.7	53.5	56.9	48.2	51.0	56.7	59.6
	70	45.4	49.9	54.2	58.7	45.5	50.0	54.4	58.8	48.8	51.7	57.0	60.0
	75	49.6	54.9	57.3	61.8	49.7	55.0	57.4	61.8	50.1	55.1	57.7	61.9

**Table 16. Reheat temperature rise — 8.5 tons (continued)**

Airflow (cfm)	Ent DB (°F)	Entering Wet Bulb (°F)											
		51				55				59			
		Lvg Evap DB (°F)		Lvg Reheat DB (°F)		Lvg Evap DB (°F)		Lvg Reheat DB (°F)		Lvg Evap DB (°F)		Lvg Reheat DB (°F)	
		MIN	MAX	MIN	MAX	MIN	MAX	MIN	MAX	MIN	MAX	MIN	MAX
4080	60	41.2	42.5	49.4	53.9	44.6	46.8	53.3	56.7	48.7	51.0	56.7	59.3
	65	43.4	46.2	51.3	56.1	45.2	47.7	53.8	57.2	49.1	51.7	56.9	59.7
	70	47.0	51.4	55.0	59.3	46.6	51.4	54.8	59.3	49.8	52.7	57.3	60.2
	75	51.4	56.5	58.2	62.5	51.5	56.5	58.3	62.5	51.2	56.6	58.1	62.6
<b>Ambient DB 65°F</b>													
1700	60	29.3 <sup>(a)</sup>	32.2 <sup>(a)</sup>	45.8	54.1	32.9 <sup>(a)</sup>	37.1	50.5	56.8	36.8	41.9	54.7	59.5
	65	29.5 <sup>(a)</sup>	32.4 <sup>(a)</sup>	46.0	54.2	32.9 <sup>(a)</sup>	37.2	50.5	56.9	37.0	42.1	54.9	59.6
	70	29.7 <sup>(a)</sup>	33.0 <sup>(a)</sup>	46.1	54.5	33.2 <sup>(a)</sup>	37.1	50.6	56.8	37.0	42.2	54.8	59.6
	75	31.7 <sup>(a)</sup>	37.3	48.4	56.8	33.3 <sup>(a)</sup>	38.0	50.8	57.3	37.2	42.5	55.0	59.8
2040	60	32.3 <sup>(a)</sup>	34.4 <sup>(a)</sup>	46.8	54.7	35.8	39.2	51.2	57.4	39.7	44.3	55.6	60.3
	65	32.6 <sup>(a)</sup>	34.4 <sup>(a)</sup>	47.0	54.7	36.0	39.6	51.3	57.6	39.9	44.3	55.7	60.2
	70	33.3 <sup>(a)</sup>	36.9	47.6	56.0	36.3	39.5	51.6	57.6	40.0	44.6	55.8	60.4
	75	36.2	41.4	50.9	58.5	36.9	41.5	52.1	58.6	40.4	44.9	56.0	60.5
2380	60	34.7 <sup>(a)</sup>	36.2	47.5	55.1	38.1	40.9	51.8	57.8	42.0	45.9	56.2	60.7
	65	35.0	36.6	47.8	55.3	38.4	41.3	52.1	58.0	42.2	46.0	56.4	60.7
	70	36.9	40.1	49.5	57.1	38.8	41.7	52.3	58.2	42.5	46.4	56.6	60.9
	75	39.7	44.7	52.9	59.8	39.7	44.9	53.1	59.9	42.8	46.8	56.8	61.0
2720	60	36.6	37.7	48.1	55.3	40.0	42.3	52.3	58.1	44.0	47.2	56.9	60.9
	65	37.0	38.6	48.4	55.8	40.4	42.8	52.6	58.3	44.0	47.3	56.9	60.9
	70	39.7	42.7	51.2	58.1	40.8	43.7	53.0	58.7	44.4	47.9	57.2	61.2
	75	42.7	47.5	54.6	60.8	42.8	47.6	54.7	60.9	44.8	48.7	57.4	61.6
3060	60	38.1	38.9	48.6	55.5	41.5	43.4	52.8	58.2	45.4	48.3	57.2	61.1
	65	39.1	40.0	49.4	56.0	42.0	44.0	53.1	58.5	45.5	48.5	57.2	61.1
	70	42.1	44.9	52.6	58.8	42.8	45.1	53.8	59.0	46.0	49.1	57.6	61.4
	75	45.1	49.8	56.1	61.7	45.2	50.0	56.2	61.8	46.5	50.1	57.9	62.0
3400	60	39.4	40.0	49.0	55.5	42.8	44.4	53.1	58.3	46.6	49.1	57.5	61.2
	65	40.5	41.2	50.0	56.1	43.3	45.0	53.5	58.6	46.8	49.5	57.5	61.3
	70	44.0	46.8	53.7	59.5	44.3	46.8	54.3	59.5	47.3	50.1	58.0	61.6
	75	47.2	51.9	57.3	62.5	47.3	52.0	57.4	62.6	48.3	51.3	58.7	62.2
3740	60	40.5	40.9	49.4	55.5	43.9	45.3	53.5	58.4	47.6	49.9	57.7	61.2
	65	42.1	43.4	50.7	56.9	44.5	45.9	53.9	58.7	47.8	50.4	57.8	61.4
	70	45.6	48.5	54.6	60.1	45.6	48.6	54.8	60.1	48.5	50.9	58.3	61.7
	75	49.0	53.6	58.3	63.2	49.1	53.7	58.4	63.2	49.6	53.8	59.1	63.3
4080	60	41.5	41.7	49.7	55.5	44.9	46.1	53.7	58.4	48.5	50.4	57.8	61.1
	65	43.8	44.8	51.8	57.3	45.4	46.7	54.2	58.7	48.8	51.1	58.1	61.5
	70	47.1	50.0	55.5	60.6	47.0	50.1	55.5	60.7	49.4	52.0	58.5	62.0
	75	50.6	55.1	59.3	63.8	50.7	55.2	59.3	63.8	50.8	55.3	59.5	63.9
<b>Ambient DB 70°F</b>													
1700	60	29.6 <sup>(a)</sup>	31.4 <sup>(a)</sup>	46.3	56.3	33.3 <sup>(a)</sup>	36.4	51.0	59.0	36.9	41.4	55.6	61.8
	65	29.9 <sup>(a)</sup>	31.7 <sup>(a)</sup>	46.4	56.4	33.3 <sup>(a)</sup>	36.5	51.0	59.1	37.1	41.5	55.8	61.8
	70	30.0 <sup>(a)</sup>	32.3 <sup>(a)</sup>	46.6	56.7	33.5 <sup>(a)</sup>	36.8	51.1	59.2	37.1	41.6	55.7	61.9
	75	32.2 <sup>(a)</sup>	36.2	49.0	58.8	33.7 <sup>(a)</sup>	37.3	51.2	59.5	37.3	41.9	55.9	62.0



## Reheat Temperature Rise

**Table 16. Reheat temperature rise — 8.5 tons (continued)**

Airflow (cfm)	Ent DB (°F)	Entering Wet Bulb (°F)											
		51				55				59			
		Lvg Evap DB (°F)		Lvg Reheat DB (°F)		Lvg Evap DB (°F)		Lvg Reheat DB (°F)		Lvg Evap DB (°F)		Lvg Reheat DB (°F)	
		MIN	MAX	MIN	MAX	MIN	MAX	MIN	MAX	MIN	MAX	MIN	MAX
2040	60	32.7 <sup>(a)</sup>	33.6 <sup>(a)</sup>	47.2	56.8	36.2	38.5	51.8	59.6	39.9	43.7	56.3	62.5
	65	32.9 <sup>(a)</sup>	33.9 <sup>(a)</sup>	47.4	56.9	36.4	38.8	51.9	59.8	40.0	43.6	56.4	62.5
	70	33.7 <sup>(a)</sup>	34.9 <sup>(a)</sup>	48.1	57.5	36.7	39.1	52.1	59.9	40.2	44.0	56.5	62.6
	75	36.7	40.2	51.6	60.4	37.3	40.0	52.7	60.3	40.5	43.9	56.8	62.6
2380	60	34.9 <sup>(a)</sup>	35.3	47.9	57.0	38.5	40.2	52.4	59.9	42.2	45.3	56.8	62.8
	65	35.3	35.8	48.1	57.2	38.9	40.6	52.6	60.1	42.4	45.3	57.0	62.8
	70	37.3	38.7	50.1	58.8	39.2	40.8	52.9	60.2	42.7	45.7	57.2	63.0
	75	40.3	43.4	53.7	61.5	40.1	43.5	53.7	61.6	43.0	45.8	57.5	63.0
2720	60	36.8	36.9	48.5	56.9	40.4	41.5	52.9	60.1	44.3	46.6	57.5	63.0
	65	37.6	37.7	49.1	57.4	40.8	42.0	53.2	60.3	44.3	46.6	57.5	63.0
	70	40.1	41.3	51.7	59.7	41.3	42.8	53.6	60.7	44.6	47.2	57.7	63.3
	75	43.2	46.1	55.4	62.5	43.3	46.3	55.5	62.6	45.0	48.0	58.0	63.7
3060	60	38.4	38.3	49.0	56.7	41.8	42.7	53.2	60.1	45.7	47.6	57.8	63.1
	65	39.3	39.3	49.7	57.4	42.3	43.2	53.6	60.4	45.8	47.8	57.8	63.1
	70	42.4	43.5	53.1	60.3	43.2	44.3	54.3	60.9	46.3	48.3	58.2	63.4
	75	45.6	48.5	56.8	63.3	45.7	48.6	56.9	63.4	46.9	49.4	58.7	63.9
3400	60	39.7	39.5	49.3	56.5	43.1	43.6	53.5	60.1	46.9	48.5	58.1	63.1
	65	40.8	40.7	50.3	57.3	43.6	44.3	54.0	60.5	47.1	48.8	58.1	63.3
	70	44.4	45.4	54.2	60.9	44.7	45.5	54.8	61.1	47.6	49.4	58.5	63.5
	75	47.7	50.5	58.0	64.0	47.8	50.6	58.1	64.1	48.5	50.6	59.2	64.1
3740	60	40.7	40.6	49.7	56.3	44.1	44.6	53.8	60.1	47.9	49.2	58.3	63.1
	65	42.2	41.9	50.9	57.2	44.7	45.2	54.3	60.4	48.2	49.7	58.4	63.3
	70	46.1	47.1	55.2	61.4	46.0	47.0	55.3	61.4	48.7	50.2	58.8	63.6
	75	49.5	52.2	59.0	64.6	49.5	52.3	59.1	64.6	49.8	52.4	59.7	64.7
4080	60	41.7	41.5	49.9	56.1	45.1	45.3	54.0	60.1	48.8	49.9	58.4	63.0
	65	44.1	43.9	52.2	58.1	45.7	46.0	54.5	60.4	49.1	50.4	58.6	63.3
	70	47.6	48.6	56.1	61.9	47.4	48.7	55.9	61.9	49.7	51.0	59.1	63.6
	75	51.0	53.7	59.9	65.1	51.1	53.8	60.0	65.2	51.0	53.9	60.1	65.2

Note: MIN, MAX: The leaving evaporator temperature is affected by the modulating valve position. The MIN and MAX numbers represent modulating valve position impact on both the leaving evaporator temperature and the leaving reheat coil temperature. MAX represents wide open, MIN represents closed to minimum position.

<sup>(a)</sup> The unit might be tripped by Froststat at these conditions due to low leaving evaporator air temperature.

**Table 17. Reheat temperature rise — 10 tons**

Airflow (cfm)	Ent DB (°F)	Entering Wet Bulb (°F)											
		51				55				59			
		Lvg Evap DB (°F)		Lvg Reheat DB (°F)		Lvg Evap DB (°F)		Lvg Reheat DB (°F)		Lvg Evap DB (°F)		Lvg Reheat DB (°F)	
		MIN	MAX	MIN	MAX	MIN	MAX	MIN	MAX	MIN	MAX	MIN	MAX
<b>Ambient DB 60°F</b>													
2000	60	29.8 <sup>(a)</sup>	33.5 <sup>(a)</sup>	45.8	52.6	33.6 <sup>(a)</sup>	38.3	50.2	55.4	37.9	43.4	53.4	58.3
	65	30.1 <sup>(a)</sup>	33.8 <sup>(a)</sup>	46.1	52.8	33.6 <sup>(a)</sup>	38.5	50.2	55.5	38.1	43.3	53.5	58.2
	70	30.7 <sup>(a)</sup>	35.0	46.5	53.4	33.9 <sup>(a)</sup>	38.5	50.4	55.5	38.2	43.5	53.6	58.3
	75	32.7 <sup>(a)</sup>	39.6	48.7	56.0	34.1 <sup>(a)</sup>	39.6	50.5	56.0	38.5	43.8	53.7	58.5

Table 17. Reheat temperature rise — 10 tons (continued)

Airflow (cfm)	Ent DB (°F)	Entering Wet Bulb (°F)											
		51				55				59			
		Lvg Evap DB (°F)		Lvg Reheat DB (°F)		Lvg Evap DB (°F)		Lvg Reheat DB (°F)		Lvg Evap DB (°F)		Lvg Reheat DB (°F)	
		MIN	MAX	MIN	MAX	MIN	MAX	MIN	MAX	MIN	MAX	MIN	MAX
2400	60	32.8 <sup>(a)</sup>	35.8	46.8	53.2	36.4	40.5	51.0	55.9	40.7	45.5	54.4	58.8
	65	33.1 <sup>(a)</sup>	36.3	47.0	53.4	36.6	40.9	51.2	56.1	40.9	45.5	54.5	58.8
	70	34.0 <sup>(a)</sup>	39.3	47.8	55.0	37.0	41.2	51.4	56.3	41.2	45.9	54.6	59.0
	75	37.2	43.8	51.2	57.7	37.8	43.9	52.0	57.7	41.6	46.2	54.9	59.1
2800	60	35.1	37.7	47.5	53.6	38.7	42.2	51.7	56.3	42.9	47.1	55.1	59.2
	65	35.5	38.5	47.8	54.0	39.0	42.7	52.0	56.5	43.2	47.2	55.2	59.2
	70	37.6	42.5	49.8	56.2	39.5	43.5	52.3	56.9	43.6	47.7	55.5	59.5
	75	40.8	47.2	53.1	59.0	40.6	47.3	53.1	59.1	44.1	48.5	55.7	59.9
3200	60	36.9	39.1	48.1	53.8	40.5	43.6	52.2	56.5	44.9	48.4	55.7	59.4
	65	37.8	40.2	48.8	54.3	40.9	44.2	52.6	56.8	45.0	48.6	55.8	59.5
	70	40.4	45.2	51.4	57.2	41.5	45.3	52.9	57.4	45.5	49.2	56.1	59.8
	75	43.9	50.0	54.7	60.1	44.0	50.1	54.8	60.2	46.0	50.2	56.4	60.3
3600	60	38.5	40.4	48.6	53.9	41.9	44.7	52.6	56.7	46.3	49.4	56.1	59.5
	65	39.6	42.3	49.5	54.9	42.5	45.4	53.1	57.0	46.5	49.8	56.2	59.8
	70	42.7	47.4	52.7	58.1	43.5	47.5	53.8	58.1	47.1	50.4	56.6	60.0
	75	46.5	52.3	55.9	61.1	46.6	52.4	56.0	61.1	48.1	52.6	57.2	61.2
4000	60	39.8	41.4	49.1	54.0	43.2	45.8	53.0	56.8	47.5	50.1	56.4	59.5
	65	41.0	44.2	50.1	55.6	43.8	46.4	53.5	57.2	47.7	50.8	56.6	59.9
	70	44.7	49.3	53.9	58.8	45.0	49.4	54.3	58.8	48.4	51.4	57.0	60.3
	75	48.8	54.3	57.0	61.9	48.9	54.4	57.1	62.0	49.6	54.5	57.7	62.0
4400	60	40.9	42.3	49.4	54.1	44.2	46.6	53.2	56.9	48.4	50.8	56.6	59.6
	65	42.8	45.7	51.0	56.1	44.9	47.3	53.8	57.3	48.8	51.6	56.9	60.0
	70	46.5	50.9	54.8	59.4	46.3	51.0	54.8	59.5	49.5	52.5	57.3	60.5
	75	50.8	56.0	58.0	62.7	50.9	56.1	58.1	62.7	50.9	56.2	58.2	62.8
4800	60	41.8	43.3	49.7	54.3	45.2	47.3	53.5	57.0	49.2	51.4	56.8	59.7
	65	44.3	47.1	51.9	56.6	45.9	48.3	54.1	57.5	49.7	52.2	57.2	60.1
	70	48.0	52.3	55.6	60.0	47.4	52.4	55.2	60.0	50.4	53.3	57.6	60.7
	75	52.5	57.5	58.9	63.3	52.6	57.6	58.9	63.4	52.1	57.7	58.6	63.4
<b>Ambient DB 65°F</b>													
2000	60	30.1 <sup>(a)</sup>	32.6 <sup>(a)</sup>	46.3	54.7	33.6 <sup>(a)</sup>	37.5	50.8	57.5	37.4	42.4	55.1	60.3
	65	30.4 <sup>(a)</sup>	33.0 <sup>(a)</sup>	46.5	54.8	33.6 <sup>(a)</sup>	37.7	50.8	57.6	37.7	42.6	55.3	60.3
	70	30.9 <sup>(a)</sup>	33.7 <sup>(a)</sup>	47.0	55.2	33.9 <sup>(a)</sup>	38.1	51.0	57.7	37.7	42.8	55.3	60.4
	75	32.9 <sup>(a)</sup>	38.3	49.2	57.8	34.2 <sup>(a)</sup>	38.7	51.2	58.1	38.0	43.1	55.4	60.6
2400	60	33.1 <sup>(a)</sup>	34.9 <sup>(a)</sup>	47.3	55.2	36.5	39.7	51.5	58.0	40.3	44.8	55.9	60.9
	65	33.4 <sup>(a)</sup>	35.3	47.5	55.4	36.7	40.1	51.7	58.2	40.5	44.8	56.1	60.9
	70	34.3 <sup>(a)</sup>	37.8	48.3	56.7	37.1	40.4	52.0	58.3	40.8	45.2	56.2	61.1
	75	37.3	42.4	51.7	59.3	37.8	42.5	52.6	59.4	41.2	45.4	56.5	61.2
2800	60	35.3	36.7	48.0	55.4	38.8	41.4	52.2	58.2	42.6	46.4	56.5	61.2
	65	35.9	37.2	48.4	55.7	39.2	41.9	52.5	58.5	42.8	46.5	56.7	61.2
	70	38.0	41.0	50.4	57.8	39.6	42.3	52.8	58.7	43.2	47.0	57.0	61.4
	75	40.8	45.7	53.7	60.6	40.6	45.9	53.6	60.6	43.6	47.4	57.2	61.6



# Reheat Temperature Rise

Table 17. Reheat temperature rise — 10 tons (continued)

Airflow (cfm)	Ent DB (°F)	Entering Wet Bulb (°F)											
		51				55				59			
		Lvg Evap DB (°F)		Lvg Reheat DB (°F)		Lvg Evap DB (°F)		Lvg Reheat DB (°F)		Lvg Evap DB (°F)		Lvg Reheat DB (°F)	
		MIN	MAX	MIN	MAX	MIN	MAX	MIN	MAX	MIN	MAX	MIN	MAX
3200	60	37.2	38.2	48.6	55.6	40.7	42.8	52.8	58.4	44.6	47.7	57.1	61.3
	65	38.1	39.2	49.3	56.1	41.1	43.3	53.1	58.7	44.6	47.8	57.2	61.4
	70	40.8	43.6	52.0	58.7	41.7	44.4	53.5	59.2	45.1	48.4	57.5	61.7
	75	43.7	48.5	55.4	61.6	43.8	48.6	55.5	61.6	45.6	49.4	57.8	62.2
3600	60	38.7	39.5	49.0	55.6	42.1	43.9	53.2	58.5	46.0	48.7	57.5	61.4
	65	39.8	40.7	49.9	56.3	42.7	44.6	53.6	58.8	46.1	49.0	57.5	61.5
	70	43.0	45.9	53.3	59.4	43.6	45.8	54.3	59.4	46.7	49.6	57.9	61.9
	75	46.1	50.9	56.8	62.4	46.2	51.0	56.9	62.5	47.6	50.8	58.6	62.5
4000	60	40.0	40.5	49.4	55.7	43.3	44.9	53.5	58.5	47.2	49.6	57.7	61.4
	65	41.3	42.6	50.5	56.8	44.0	45.6	53.9	58.9	47.4	50.0	57.9	61.7
	70	44.9	47.8	54.4	60.0	45.1	47.9	54.8	60.1	48.0	50.6	58.3	62.0
	75	48.2	52.9	58.0	63.2	48.3	53.0	58.1	63.2	49.1	53.1	59.1	63.3
4400	60	41.1	41.4	49.8	55.6	44.4	45.8	53.7	58.6	48.2	50.1	58.0	61.3
	65	43.2	44.3	51.6	57.3	45.1	46.5	54.3	58.9	48.5	50.8	58.2	61.7
	70	46.5	49.4	55.3	60.6	46.4	49.5	55.3	60.7	49.1	51.5	58.6	62.1
	75	50.0	54.6	59.0	63.8	50.1	54.7	59.1	63.9	50.4	54.8	59.5	64.0
4800	60	42.0	42.2	50.0	55.6	45.4	46.5	54.0	58.6	49.0	50.7	58.1	61.3
	65	44.6	45.6	52.4	57.7	46.0	47.4	54.5	59.1	49.4	51.5	58.4	61.8
	70	48.0	50.8	56.2	61.1	48.0	50.9	56.2	61.1	50.1	52.6	58.9	62.3
	75	51.6	56.1	59.9	64.4	51.7	56.2	60.0	64.5	51.6	56.3	59.9	64.5
<b>Ambient DB 70°F</b>													
2000	60	30.3 <sup>(a)</sup>	31.8 <sup>(a)</sup>	46.8	56.8	34.0 <sup>(a)</sup>	36.7	51.5	59.6	37.5	41.7	55.9	62.4
	65	30.6 <sup>(a)</sup>	32.1 <sup>(a)</sup>	47.0	56.9	34.0 <sup>(a)</sup>	36.9	51.5	59.7	37.7	41.9	56.1	62.5
	70	31.2 <sup>(a)</sup>	32.8 <sup>(a)</sup>	47.4	57.3	34.3 <sup>(a)</sup>	37.2	51.7	59.8	37.8	42.1	56.1	62.6
	75	33.4 <sup>(a)</sup>	37.0	49.9	59.6	34.5 <sup>(a)</sup>	37.9	51.8	60.2	38.0	42.4	56.2	62.8
2400	60	33.3 <sup>(a)</sup>	34.0 <sup>(a)</sup>	47.7	57.1	36.8	38.9	52.2	60.0	40.5	44.1	56.7	63.0
	65	33.6 <sup>(a)</sup>	34.4 <sup>(a)</sup>	47.9	57.3	37.1	39.2	52.4	60.2	40.7	44.0	56.8	63.0
	70	34.5 <sup>(a)</sup>	36.4	48.7	58.3	37.5	39.6	52.6	60.4	40.9	44.4	57.0	63.1
	75	37.8	41.0	52.5	61.0	38.2	40.6	53.3	60.9	41.3	44.8	57.2	63.3
2800	60	35.5	35.8	48.3	57.2	39.1	40.6	52.8	60.2	42.8	45.7	57.2	63.2
	65	36.1	36.4	48.7	57.5	39.5	41.0	53.1	60.4	43.0	45.7	57.4	63.2
	70	38.2	39.5	50.8	59.3	39.9	41.5	53.4	60.7	43.4	46.2	57.7	63.4
	75	41.3	44.3	54.5	62.1	41.0	44.4	54.3	62.2	43.8	46.7	57.9	63.7
3200	60	37.4	37.4	48.9	57.1	40.9	41.9	53.3	60.3	44.8	46.9	57.8	63.3
	65	38.3	38.3	49.6	57.6	41.4	42.5	53.6	60.5	44.9	47.1	57.9	63.3
	70	41.0	42.1	52.4	60.1	41.9	43.4	54.0	61.0	45.3	47.6	58.2	63.6
	75	44.2	47.0	56.2	63.0	44.3	47.1	56.3	63.1	45.8	48.6	58.5	64.1
3600	60	38.9	38.8	49.3	56.8	42.4	43.1	53.6	60.3	46.2	48.0	58.1	63.3
	65	40.0	39.9	50.2	57.6	42.9	43.7	54.0	60.6	46.3	48.2	58.2	63.4
	70	43.3	44.3	53.8	60.7	43.9	44.9	54.8	61.2	46.9	48.8	58.6	63.7
	75	46.6	49.3	57.6	63.8	46.7	49.5	57.7	63.9	47.8	50.0	59.3	64.3

Table 17. Reheat temperature rise — 10 tons (continued)

Airflow (cfm)	Ent DB (°F)	Entering Wet Bulb (°F)											
		51				55				59			
		Lvg Evap DB (°F)		Lvg Reheat DB (°F)		Lvg Evap DB (°F)		Lvg Reheat DB (°F)		Lvg Evap DB (°F)		Lvg Reheat DB (°F)	
		MIN	MAX	MIN	MAX	MIN	MAX	MIN	MAX	MIN	MAX	MIN	MAX
4000	60	40.2	40.0	49.7	56.6	43.6	44.1	53.9	60.2	47.4	48.8	58.3	63.2
	65	41.5	41.3	50.8	57.5	44.2	44.8	54.4	60.6	47.6	49.3	58.5	63.4
	70	45.2	46.3	54.9	61.3	45.4	46.1	55.3	61.3	48.2	49.9	58.9	63.8
	75	48.6	51.3	58.7	64.5	48.7	51.5	58.8	64.5	49.3	51.2	59.8	64.5
4400	60	41.2	41.0	50.0	56.4	44.6	45.0	54.1	60.2	48.4	49.6	58.5	63.1
	65	43.4	43.2	51.9	58.0	45.3	45.7	54.7	60.5	48.7	50.1	58.7	63.4
	70	46.9	47.9	55.9	61.8	46.7	48.0	55.8	61.8	49.3	50.7	59.2	63.8
	75	50.3	53.1	59.7	65.0	50.4	53.2	59.7	65.1	50.6	53.3	60.2	65.2
4800	60	42.2	41.9	50.3	56.2	45.5	45.7	54.4	60.1	49.2	50.1	58.7	63.0
	65	44.8	44.6	52.7	58.4	46.2	46.5	54.9	60.5	49.6	50.8	58.9	63.4
	70	48.4	49.4	56.8	62.2	48.5	49.5	56.8	62.2	50.3	51.7	59.4	63.9
	75	51.8	54.6	60.5	65.6	51.9	54.7	60.6	65.6	51.7	54.8	60.5	65.7

Note: MIN, MAX: The leaving evaporator temperature is affected by the modulating valve position. The MIN and MAX numbers represent modulating valve position impact on both the leaving evaporator temperature and the leaving reheat coil temperature. MAX represents wide open, MIN represents closed to minimum position.

(a) The unit might be tripped by Froststat at these conditions due to low leaving evaporator air temperature.

Table 18. Reheat temperature rise — 12.5 tons

Airflow (cfm)	Ent DB (°F)	Entering Wet Bulb (°F)											
		51				55				59			
		Lvg Evap DB (°F)		Lvg Reheat DB (°F)		Lvg Evap DB (°F)		Lvg Reheat DB (°F)		Lvg Evap DB (°F)		Lvg Reheat DB (°F)	
		MIN	MAX	MIN	MAX	MIN	MAX	MIN	MAX	MIN	MAX	MIN	MAX
<b>Ambient DB 60°F</b>													
2500	60	29.7 <sup>(a)</sup>	32.1 <sup>(a)</sup>	45.5	54.3	33.2 <sup>(a)</sup>	36.9	49.9	57.3	36.9	41.8	54.4	60.4
	65	30.0 <sup>(a)</sup>	32.4 <sup>(a)</sup>	45.7	54.5	33.3 <sup>(a)</sup>	37.1	50.0	57.4	37.1	42.0	54.6	60.5
	70	30.5 <sup>(a)</sup>	33.2 <sup>(a)</sup>	46.1	54.8	33.6 <sup>(a)</sup>	37.5	50.2	57.6	37.2	42.2	54.6	60.6
	75	32.5 <sup>(a)</sup>	37.4	48.3	57.3	33.9 <sup>(a)</sup>	38.2	50.4	57.9	37.4	42.6	54.8	60.7
3000	60	32.7 <sup>(a)</sup>	34.4 <sup>(a)</sup>	46.6	54.7	36.2	39.1	50.9	57.8	39.9	44.2	55.4	61.0
	65	33.1 <sup>(a)</sup>	34.8 <sup>(a)</sup>	46.9	54.9	36.4	39.6	51.1	58.0	40.1	44.2	55.5	61.0
	70	34.0 <sup>(a)</sup>	37.0	47.6	56.1	36.8	40.0	51.4	58.2	40.3	44.6	55.7	61.2
	75	37.0	41.5	51.0	58.9	37.6	41.0	52.0	58.7	40.7	45.0	56.0	61.4
3500	60	35.1	36.2	47.4	55.0	38.6	40.9	51.8	58.1	42.2	45.9	56.0	61.3
	65	35.6	36.9	47.8	55.3	39.0	41.4	52.0	58.3	42.4	45.9	56.3	61.3
	70	37.6	40.2	49.6	57.2	39.4	41.9	52.3	58.6	42.8	46.5	56.5	61.6
	75	40.5	44.8	53.0	60.2	40.4	45.0	53.2	60.3	43.3	47.0	56.9	61.8
4000	60	37.0	37.7	48.1	55.1	40.5	42.2	52.4	58.2	44.3	47.1	56.8	61.4
	65	37.9	38.8	48.8	55.7	40.9	42.9	52.7	58.5	44.3	47.3	56.8	61.5
	70	40.4	42.8	51.4	58.2	41.5	43.9	53.1	59.1	44.8	47.9	57.2	61.8
	75	43.4	47.6	54.7	61.3	43.4	47.7	54.8	61.4	45.3	49.0	57.5	62.3
4500	60	38.5	39.0	48.6	55.2	41.9	43.4	52.8	58.3	45.7	48.2	57.1	61.5
	65	39.7	40.4	49.5	55.9	42.5	44.1	53.3	58.7	45.8	48.5	57.2	61.6
	70	42.8	45.1	52.8	59.0	43.5	45.4	54.0	59.3	46.4	49.2	57.7	62.0
	75	45.8	50.0	56.2	62.2	45.9	50.1	56.3	62.3	47.1	50.4	58.2	62.6



# Reheat Temperature Rise

**Table 18. Reheat temperature rise — 12.5 tons (continued)**

Airflow (cfm)	Ent DB (°F)	Entering Wet Bulb (°F)											
		51				55				59			
		Lvg Evap DB (°F)		Lvg Reheat DB (°F)		Lvg Evap DB (°F)		Lvg Reheat DB (°F)		Lvg Evap DB (°F)		Lvg Reheat DB (°F)	
		MIN	MAX	MIN	MAX	MIN	MAX	MIN	MAX	MIN	MAX	MIN	MAX
5000	60	39.8	40.2	49.1	55.2	43.2	44.4	53.1	58.4	46.9	49.1	57.4	61.5
	65	41.2	41.7	50.2	56.0	43.8	45.2	53.7	58.8	47.1	49.5	57.6	61.8
	70	44.7	47.0	54.0	59.6	45.0	46.7	54.6	59.5	47.8	50.2	58.1	62.1
	75	47.9	52.0	57.5	63.0	48.0	52.1	57.6	63.0	48.8	51.7	58.9	62.9
5500	60	40.9	41.1	49.5	55.2	44.2	45.3	53.4	58.4	47.9	49.8	57.7	61.5
	65	42.7	43.7	50.9	56.7	45.0	46.1	54.0	58.8	48.2	50.4	57.9	61.9
	70	46.4	48.7	54.9	60.2	46.3	48.8	55.1	60.3	48.9	51.1	58.4	62.2
	75	49.6	53.7	58.6	63.7	49.7	53.8	58.6	63.7	50.2	53.9	59.4	63.8
6000	60	41.9	42.0	49.8	55.2	45.2	46.1	53.7	58.4	48.7	50.3	57.9	61.4
	65	44.3	45.0	52.0	57.1	45.9	46.9	54.3	58.9	49.2	51.1	58.2	61.9
	70	47.8	50.1	55.8	60.8	47.4	50.2	55.5	60.8	49.9	52.1	58.7	62.4
	75	51.2	55.2	59.5	64.3	51.3	55.3	59.6	64.3	51.3	55.4	59.9	64.4
<b>Ambient DB 65°F</b>													
2500	60	30.2 <sup>(a)</sup>	31.3 <sup>(a)</sup>	46.1	56.2	33.8 <sup>(a)</sup>	36.2	50.8	59.4	37.3	41.2	55.2	62.5
	65	30.5 <sup>(a)</sup>	31.7 <sup>(a)</sup>	46.3	56.4	33.9 <sup>(a)</sup>	36.4	50.8	59.5	37.6	41.4	55.5	62.6
	70	31.1 <sup>(a)</sup>	32.4 <sup>(a)</sup>	46.8	56.8	34.2 <sup>(a)</sup>	36.8	51.0	59.6	37.6	41.6	55.5	62.7
	75	33.2 <sup>(a)</sup>	36.2	49.1	59.1	34.5 <sup>(a)</sup>	37.4	51.2	60.0	37.9	42.0	55.6	62.8
3000	60	33.2 <sup>(a)</sup>	33.6 <sup>(a)</sup>	47.1	56.5	36.7	38.4	51.6	59.7	40.4	43.6	56.2	63.0
	65	33.6 <sup>(a)</sup>	34.0 <sup>(a)</sup>	47.4	56.7	37.0	38.8	51.8	59.9	40.6	43.6	56.4	63.0
	70	34.5 <sup>(a)</sup>	35.2	48.2	57.3	37.4	39.2	52.1	60.1	40.8	44.0	56.5	63.2
	75	37.7	40.3	51.8	60.5	38.2	40.2	52.8	60.6	41.2	44.4	56.8	63.4
3500	60	35.5	35.5	47.9	56.5	39.0	40.1	52.3	59.9	42.7	45.2	56.8	63.2
	65	35.9	36.1	48.2	56.8	39.4	40.6	52.6	60.1	43.0	45.3	57.1	63.2
	70	38.2	38.9	50.3	58.6	39.9	41.1	52.9	60.4	43.4	45.8	57.3	63.5
	75	41.2	43.6	53.9	61.7	41.0	43.7	53.9	61.8	43.8	46.3	57.6	63.7
4000	60	37.3	37.1	48.5	56.4	40.8	41.5	52.8	59.9	44.7	46.5	57.5	63.2
	65	38.2	38.1	49.2	57.0	41.3	42.1	53.2	60.2	44.8	46.6	57.6	63.3
	70	40.9	41.6	52.0	59.4	41.8	43.1	53.6	60.7	45.3	47.3	57.9	63.6
	75	44.1	46.3	55.7	62.6	44.2	46.5	55.8	62.7	45.8	48.2	58.3	64.1
4500	60	38.9	38.5	49.0	56.2	42.2	42.7	53.2	59.9	46.1	47.6	57.8	63.2
	65	40.0	39.7	49.9	57.0	42.8	43.4	53.7	60.3	46.3	47.8	57.9	63.3
	70	43.2	43.8	53.3	60.1	43.9	44.6	54.5	60.9	46.9	48.5	58.4	63.7
	75	46.5	48.7	57.1	63.5	46.6	48.8	57.2	63.5	47.8	49.7	59.0	64.3
5000	60	40.1	39.8	49.4	56.0	43.5	43.7	53.5	59.8	47.3	48.4	58.1	63.2
	65	41.5	41.2	50.5	57.0	44.1	44.5	54.1	60.3	47.5	48.8	58.2	63.4
	70	45.2	45.7	54.5	60.7	45.4	45.9	55.0	61.0	48.2	49.5	58.7	63.8
	75	48.5	50.7	58.3	64.2	48.6	50.8	58.4	64.2	49.3	50.9	59.6	64.5
5500	60	41.2	40.8	49.8	55.9	44.5	44.6	53.8	59.7	48.3	49.2	58.3	63.1
	65	43.3	42.8	51.6	57.3	45.2	45.4	54.4	60.2	48.7	49.7	58.5	63.4
	70	46.8	47.4	55.5	61.3	46.7	47.3	55.5	61.2	49.3	50.4	59.0	63.8
	75	50.3	52.4	59.4	64.8	50.4	52.5	59.5	64.8	50.6	52.0	60.0	64.6



Table 18. Reheat temperature rise — 12.5 tons (continued)

Airflow (cfm)	Ent DB (°F)	Entering Wet Bulb (°F)											
		51				55				59			
		Lvg Evap DB (°F)		Lvg Reheat DB (°F)		Lvg Evap DB (°F)		Lvg Reheat DB (°F)		Lvg Evap DB (°F)		Lvg Reheat DB (°F)	
		MIN	MAX	MIN	MAX	MIN	MAX	MIN	MAX	MIN	MAX	MIN	MAX
6000	60	42.1	41.8	50.1	55.7	45.5	45.5	54.1	59.7	49.1	49.8	58.4	63.0
	65	44.7	44.3	52.4	57.8	46.2	46.3	54.6	60.2	49.6	50.4	58.7	63.4
	70	48.3	48.9	56.4	61.7	48.1	49.0	56.3	61.8	50.3	51.3	59.3	63.8
	75	51.8	53.9	60.3	65.3	51.9	54.0	60.4	65.4	51.8	54.1	60.4	65.4
<b>Ambient DB 70°F</b>													
2500	60	30.6 <sup>(a)</sup>	30.6 <sup>(a)</sup>	46.7	57.8	34.3 <sup>(a)</sup>	35.5	51.4	61.4	37.9	40.6	56.2	64.6
	65	31.0 <sup>(a)</sup>	31.0 <sup>(a)</sup>	46.9	58.0	34.3 <sup>(a)</sup>	35.7	51.4	61.5	38.1	40.8	56.3	64.7
	70	31.6 <sup>(a)</sup>	31.7 <sup>(a)</sup>	47.4	58.4	34.6 <sup>(a)</sup>	36.0	51.6	61.6	38.3	41.0	56.4	64.8
	75	33.8 <sup>(a)</sup>	35.0	50.0	60.7	34.9 <sup>(a)</sup>	36.6	51.8	61.9	38.5	41.3	56.6	64.9
3000	60	33.6 <sup>(a)</sup>	33.2 <sup>(a)</sup>	47.6	57.4	37.1	37.7	52.2	61.5	40.9	42.6	56.9	64.8
	65	34.0 <sup>(a)</sup>	33.6 <sup>(a)</sup>	47.9	57.7	37.4	38.0	52.4	61.7	41.1	42.9	57.1	65.0
	70	34.9 <sup>(a)</sup>	34.6 <sup>(a)</sup>	48.7	58.4	37.8	38.4	52.7	61.9	41.3	43.3	57.3	65.1
	75	38.2	39.0	52.5	62.0	38.6	39.4	53.3	62.5	41.8	43.7	57.6	65.3
3500	60	35.8	35.3	48.3	57.1	39.4	39.4	52.8	61.5	43.4	44.6	57.7	65.0
	65	36.4	35.8	48.7	57.4	39.8	39.9	53.1	61.7	43.4	44.6	57.7	65.1
	70	38.7	38.2	50.9	59.4	40.2	40.4	53.4	62.0	43.8	45.1	57.9	65.3
	75	41.7	42.3	54.6	63.0	41.4	41.9	54.5	62.9	44.2	45.6	58.3	65.5
4000	60	37.7	37.1	48.9	56.8	41.1	40.9	53.2	61.3	45.1	45.6	58.0	64.8
	65	38.6	38.0	49.6	57.4	41.6	41.5	53.6	61.6	45.2	46.0	58.1	65.1
	70	41.4	40.9	52.6	60.2	42.2	42.2	54.0	62.1	45.7	46.6	58.4	65.4
	75	44.6	45.1	56.3	63.9	44.7	45.2	56.4	64.0	46.2	47.3	58.8	65.8
4500	60	39.2	38.6	49.4	56.5	42.6	42.2	53.6	61.1	46.5	46.9	58.3	64.9
	65	40.3	39.8	50.3	57.3	43.2	42.8	54.1	61.5	46.6	47.1	58.4	65.0
	70	43.7	43.1	53.9	60.8	44.2	44.0	54.9	62.1	47.2	47.8	58.8	65.4
	75	47.0	47.4	57.7	64.6	47.1	47.5	57.8	64.7	48.2	49.0	59.6	65.9
5000	60	40.4	39.9	49.8	56.3	43.8	43.3	53.9	60.8	47.6	47.8	58.5	64.7
	65	41.8	41.2	50.9	57.2	44.5	44.0	54.4	61.2	47.8	48.1	58.6	64.9
	70	45.6	45.0	55.0	61.4	45.7	45.4	55.4	62.1	48.5	48.9	59.2	65.3
	75	49.0	49.4	58.9	65.2	49.1	49.6	59.0	65.3	49.7	50.2	60.1	66.0
5500	60	41.5	41.0	50.1	56.2	44.8	44.3	54.1	60.5	48.5	48.6	58.6	64.6
	65	43.7	42.9	52.0	57.6	45.5	45.1	54.7	61.0	49.0	49.1	58.9	64.8
	70	47.3	46.7	56.0	61.9	47.0	46.6	55.9	62.0	49.6	49.8	59.4	65.3
	75	50.7	51.2	60.0	65.8	50.8	51.3	60.1	65.9	51.0	51.4	60.5	66.1
6000	60	42.4	42.0	50.3	56.0	45.7	45.3	54.4	60.4	49.3	49.3	58.7	64.4
	65	45.1	44.4	52.8	58.1	46.5	46.0	54.9	60.9	49.8	49.9	59.1	64.7
	70	48.7	48.1	56.9	62.3	48.8	48.1	57.0	62.4	50.6	50.6	59.6	65.2
	75	52.3	52.7	60.9	66.3	52.3	52.8	61.0	66.3	52.1	52.8	60.9	66.4

**Note:** MIN, MAX: The leaving evaporator temperature is affected by the modulating valve position. The MIN and MAX numbers represent modulating valve position impact on both the leaving evaporator temperature and the leaving reheat coil temperature. MAX represents wide open, MIN represents closed to minimum position.

<sup>(a)</sup> The unit might be tripped by Froststat at these conditions due to low leaving evaporator air temperature.



# Reheat Temperature Rise

**Table 19. Reheat temperature rise — 15 tons**

Airflow (cfm)	Ent DB (°F)	Entering Wet Bulb (°F)											
		51				55				59			
		Lvg Evap DB (°F)		Lvg Reheat DB (°F)		Lvg Evap DB (°F)		Lvg Reheat DB (°F)		Lvg Evap DB (°F)		Lvg Reheat DB (°F)	
		MIN	MAX	MIN	MAX	MIN	MAX	MIN	MAX	MIN	MAX	MIN	MAX
<b>Ambient DB 60°F</b>													
3000	60	30.9 <sup>(a)</sup>	31.2 <sup>(a)</sup>	39.8	63.0	34.9 <sup>(a)</sup>	36.7	44.6	66.2	38.9	42.4	49.3	69.5
	65	31.1 <sup>(a)</sup>	31.4 <sup>(a)</sup>	40.0	63.1	34.8 <sup>(a)</sup>	36.8	44.5	66.3	39.1	42.3	49.5	69.4
	70	31.4 <sup>(a)</sup>	31.8 <sup>(a)</sup>	40.3	63.3	35.0	37.0	44.5	66.3	39.0	42.4	49.3	69.4
	75	33.9 <sup>(a)</sup>	36.4	43.2	65.8	35.2	37.4	44.7	66.5	39.1	42.6	49.4	69.5
3600	60	34.0 <sup>(a)</sup>	33.4 <sup>(a)</sup>	41.7	62.4	37.9	38.7	46.4	65.7	42.0	44.4	51.2	69.0
	65	34.1 <sup>(a)</sup>	33.6 <sup>(a)</sup>	41.9	62.5	38.0	39.0	46.4	65.8	42.1	44.2	51.2	68.9
	70	35.5	35.3	43.3	63.3	38.2	39.2	46.6	65.9	42.1	44.5	51.2	69.1
	75	38.6	40.4	46.9	66.4	38.7	40.5	47.1	66.4	42.3	44.7	51.3	69.1
4200	60	36.3	35.2	43.2	61.7	40.2	40.3	47.8	65.2	44.5	45.8	52.6	68.5
	65	36.6	35.5	43.5	61.9	40.4	40.7	47.9	65.3	44.4	45.8	52.5	68.5
	70	39.1	38.5	46.1	63.6	40.6	41.0	48.1	65.5	44.6	46.1	52.6	68.7
	75	42.3	43.8	49.8	66.9	42.4	43.9	49.9	67.0	44.8	46.4	52.8	68.7
4800	60	38.1	36.7	44.4	61.1	42.0	41.7	48.8	64.7	46.2	47.0	53.6	68.1
	65	38.7	37.4	44.9	61.5	42.3	42.1	49.0	64.9	46.2	47.0	53.5	68.1
	70	41.9	41.2	48.4	63.9	42.8	42.7	49.5	65.2	46.4	47.5	53.7	68.3
	75	45.3	46.6	52.2	67.4	45.4	46.7	52.3	67.5	46.7	48.1	53.9	68.5
5400	60	39.6	38.0	45.3	60.6	43.4	42.8	49.6	64.3	47.6	48.0	54.3	67.7
	65	40.5	38.9	46.1	61.0	43.8	43.3	49.9	64.5	47.6	48.1	54.2	67.8
	70	44.3	43.5	50.2	64.3	44.5	44.1	50.5	64.8	47.9	48.6	54.5	68.0
	75	47.8	48.9	54.1	67.8	47.9	49.1	54.2	67.9	48.6	49.4	55.1	68.3
6000	60	40.8	39.2	46.0	60.1	44.6	43.7	50.2	63.9	48.7	48.9	54.9	67.3
	65	42.7	40.2	47.8	60.6	45.0	44.3	50.6	64.1	48.8	49.1	54.8	67.5
	70	46.3	45.5	51.8	64.5	46.3	45.3	51.8	64.5	49.2	49.5	55.2	67.7
	75	49.9	51.0	55.8	68.2	50.0	51.1	55.8	68.3	50.0	50.5	55.9	68.0
6600	60	41.8	40.2	46.6	59.7	45.6	44.7	50.8	63.6	49.7	49.6	55.3	67.0
	65	44.3	41.3	49.1	60.3	46.0	45.2	51.2	63.8	49.8	49.9	55.4	67.2
	70	48.0	47.2	53.1	64.8	48.1	47.3	53.2	64.9	50.2	50.3	55.7	67.4
	75	51.7	52.7	57.1	68.5	51.8	52.8	57.2	68.6	51.9	53.0	57.3	68.7
7200	60	42.7	41.1	47.1	59.3	46.5	45.4	51.2	63.2	50.4	50.2	55.7	66.6
	65	45.7	43.6	50.2	61.0	46.9	45.9	51.6	63.5	50.7	50.6	55.8	66.9
	70	49.5	48.7	54.3	65.0	49.6	48.8	54.4	65.1	51.1	51.0	56.2	67.1
	75	53.3	54.3	58.3	68.9	53.3	54.4	58.4	68.9	53.4	54.5	58.5	69.0
<b>Ambient DB 65°F</b>													
3000	60	31.6 <sup>(a)</sup>	29.9 <sup>(a)</sup>	40.6	64.8	35.7	35.6	45.5	68.4	39.8	41.1	50.4	71.5
	65	31.7 <sup>(a)</sup>	30.1 <sup>(a)</sup>	40.7	64.9	35.6	35.5	45.3	68.3	39.8	41.2	50.4	71.6
	70	32.1 <sup>(a)</sup>	30.5 <sup>(a)</sup>	41.1	65.0	35.7	35.7	45.4	68.4	39.8	41.2	50.3	71.6
	75	35.0	34.1 <sup>(a)</sup>	44.4	67.3	36.0	35.9	45.6	68.5	39.9	41.5	50.4	71.6
3600	60	34.6 <sup>(a)</sup>	32.3 <sup>(a)</sup>	42.5	63.6	38.6	37.5	47.2	67.6	43.0	43.3	52.3	71.0
	65	34.8 <sup>(a)</sup>	32.5 <sup>(a)</sup>	42.6	63.7	38.8	37.7	47.2	67.7	42.9	43.2	52.1	71.0
	70	36.5	33.1 <sup>(a)</sup>	44.4	64.1	38.9	38.0	47.4	67.8	43.0	43.4	52.1	71.1
	75	39.7	38.2	48.1	67.7	39.6	38.6	48.1	68.0	43.1	43.6	52.3	71.1

Table 19. Reheat temperature rise — 15 tons (continued)

Airflow (cfm)	Ent DB (°F)	Entering Wet Bulb (°F)											
		51				55				59			
		Lvg Evap DB (°F)		Lvg Reheat DB (°F)		Lvg Evap DB (°F)		Lvg Reheat DB (°F)		Lvg Evap DB (°F)		Lvg Reheat DB (°F)	
		MIN	MAX	MIN	MAX	MIN	MAX	MIN	MAX	MIN	MAX	MIN	MAX
4200	60	36.9	34.4 <sup>(a)</sup>	43.9	62.6	40.9	39.3	48.5	66.9	45.3	44.8	53.5	70.4
	65	37.3	34.7 <sup>(a)</sup>	44.3	62.7	41.1	39.6	48.6	67.0	45.2	44.8	53.4	70.4
	70	40.0	36.7	47.2	64.3	41.3	39.8	48.9	67.1	45.3	45.1	53.5	70.6
	75	43.5	41.7	51.1	68.0	43.5	41.8	51.2	68.1	45.5	45.3	53.7	70.6
4800	60	38.7	36.3	45.0	61.8	42.6	40.7	49.5	66.2	47.0	46.1	54.4	69.9
	65	39.4	36.8	45.6	62.1	42.9	41.1	49.7	66.4	46.9	46.1	54.3	69.9
	70	42.9	39.6	49.5	64.7	43.5	41.5	50.2	66.6	47.2	46.5	54.5	70.1
	75	46.5	44.5	53.5	68.4	46.6	44.7	53.5	68.5	47.7	46.8	54.9	70.2
5400	60	40.2	37.8	45.8	61.1	44.0	42.0	50.2	65.7	48.3	47.2	55.1	69.4
	65	41.5	38.5	47.2	61.5	44.4	42.4	50.5	65.9	48.3	47.2	54.9	69.4
	70	45.3	42.0	51.3	65.0	45.2	43.2	51.3	66.2	48.6	47.6	55.3	69.6
	75	49.0	47.0	55.4	68.8	49.1	47.1	55.5	68.8	49.3	48.4	55.9	69.9
6000	60	41.3	39.1	46.5	60.4	45.2	43.0	50.8	65.2	49.4	48.0	55.6	68.9
	65	43.5	40.0	48.7	61.0	45.6	43.5	51.2	65.4	49.5	48.1	55.5	69.0
	70	47.3	44.1	52.9	65.3	47.4	44.5	53.0	65.8	49.8	48.6	55.9	69.2
	75	51.1	49.1	57.0	69.1	51.1	49.2	57.1	69.1	51.1	49.6	57.1	69.6
6600	60	42.3	40.2	47.1	59.9	46.1	43.9	51.3	64.6	50.3	48.8	56.0	68.5
	65	45.1	41.2	50.0	60.6	46.6	44.5	51.7	65.0	50.4	49.1	56.0	68.7
	70	49.0	45.8	54.2	65.5	49.1	45.6	54.3	65.5	50.8	49.5	56.4	68.9
	75	52.8	50.9	58.4	69.4	52.9	51.0	58.5	69.4	53.0	50.6	58.5	69.3
7200	60	43.4	41.1	47.8	59.5	47.0	44.9	51.7	64.2	50.9	49.5	56.2	68.1
	65	46.5	43.2	51.0	61.3	47.6	45.3	52.4	64.5	51.2	49.8	56.4	68.3
	70	50.5	47.4	55.3	65.8	50.5	47.5	55.4	65.8	51.9	50.3	57.0	68.5
	75	54.4	52.5	59.5	69.6	54.4	52.6	59.6	69.7	54.5	52.7	59.7	69.8
<b>Ambient DB 70°F</b>													
3000	60	32.3 <sup>(a)</sup>	29.2 <sup>(a)</sup>	41.4	65.3	36.5	34.3 <sup>(a)</sup>	46.4	70.3	40.7	40.0	51.5	73.7
	65	32.4 <sup>(a)</sup>	29.4 <sup>(a)</sup>	41.5	65.4	36.4	34.2 <sup>(a)</sup>	46.3	70.2	40.7	40.0	51.4	73.7
	70	32.8 <sup>(a)</sup>	29.7 <sup>(a)</sup>	41.9	65.6	36.6	34.4 <sup>(a)</sup>	46.3	70.3	40.7	40.1	51.4	73.7
	75	36.1	32.0 <sup>(a)</sup>	45.7	68.1	36.9	34.6 <sup>(a)</sup>	46.7	70.3	40.9	40.3	51.4	73.8
3600	60	35.3	32.1 <sup>(a)</sup>	43.2	63.9	39.4	36.5	48.1	69.1	43.9	42.0	53.3	72.9
	65	35.5	32.3 <sup>(a)</sup>	43.4	64.0	39.5	36.6	48.1	69.2	43.8	42.1	53.2	72.9
	70	37.5	32.8 <sup>(a)</sup>	45.6	64.5	39.7	36.9	48.2	69.3	43.8	42.3	53.1	73.0
	75	40.9	36.5	49.5	68.5	41.0	37.4	49.6	69.6	44.0	42.5	53.3	73.1
4200	60	37.6	34.4 <sup>(a)</sup>	44.6	62.9	41.6	38.5	49.3	68.2	46.1	43.9	54.5	72.3
	65	38.0	34.7 <sup>(a)</sup>	45.0	63.0	41.8	38.8	49.4	68.3	46.0	43.8	54.3	72.2
	70	41.1	36.4	48.4	64.6	42.2	39.0	49.8	68.4	46.2	44.1	54.4	72.4
	75	44.7	40.1	52.5	68.9	44.8	39.8	52.6	68.9	46.4	44.3	54.6	72.5
4800	60	39.3	36.3	45.6	62.0	43.3	40.1	50.2	67.3	47.7	45.3	55.3	71.6
	65	40.1	36.9	46.4	62.4	43.6	40.5	50.4	67.4	47.6	45.2	55.1	71.6
	70	44.0	39.3	50.7	65.0	44.2	40.9	51.0	67.6	47.9	45.6	55.3	71.8
	75	47.7	43.0	54.9	69.3	47.8	43.1	55.0	69.4	48.5	46.0	55.9	71.9



## Reheat Temperature Rise

**Table 19. Reheat temperature rise — 15 tons (continued)**

Airflow (cfm)	Ent DB (°F)	Entering Wet Bulb (°F)											
		51				55				59			
		Lvg Evap DB (°F)		Lvg Reheat DB (°F)		Lvg Evap DB (°F)		Lvg Reheat DB (°F)		Lvg Evap DB (°F)		Lvg Reheat DB (°F)	
		MIN	MAX	MIN	MAX	MIN	MAX	MIN	MAX	MIN	MAX	MIN	MAX
5400	60	40.7	37.9	46.5	61.2	44.6	41.6	50.8	66.4	49.0	46.4	55.9	71.1
	65	42.5	38.6	48.2	61.7	45.0	42.0	51.2	66.6	49.0	46.4	55.6	71.1
	70	46.4	41.7	52.5	65.3	46.4	42.7	52.6	67.0	49.3	46.9	56.1	71.2
	75	50.2	45.5	56.8	69.6	50.3	45.6	56.9	69.7	50.2	47.6	56.9	71.5
6000	60	41.9	39.2	47.1	60.6	45.7	42.8	51.4	65.7	50.1	47.3	56.4	70.6
	65	44.4	40.1	49.7	61.2	46.2	43.3	51.8	65.9	50.1	47.4	56.2	70.6
	70	48.4	43.7	54.1	65.5	48.4	44.1	54.1	66.4	50.5	47.9	56.6	70.8
	75	52.3	47.6	58.4	69.9	52.4	47.7	58.5	70.0	52.5	48.8	58.6	71.2
6600	60	42.8	40.3	47.7	60.0	46.7	43.9	51.9	65.0	50.8	48.1	56.6	70.1
	65	46.0	41.4	50.9	60.7	47.1	44.4	52.3	65.3	51.0	48.4	56.6	70.1
	70	50.1	45.5	55.4	65.8	50.1	45.4	55.4	65.9	51.4	48.8	57.1	70.3
	75	54.1	49.4	59.7	70.2	54.1	49.5	59.8	70.3	54.2	49.8	59.9	70.8
7200	60	43.9	41.3	48.3	59.5	47.5	44.9	52.3	64.5	51.5	48.9	56.9	69.5
	65	47.4	43.5	52.0	61.5	48.2	45.3	53.0	64.8	51.8	49.2	57.0	69.6
	70	51.5	47.0	56.5	66.0	51.6	46.5	56.5	65.5	52.5	49.6	57.7	69.9
	75	55.5	51.0	60.9	70.5	55.6	51.1	60.9	70.6	55.7	50.8	61.0	70.5

Note: MIN, MAX: The leaving evaporator temperature is affected by the modulating valve position. The MIN and MAX numbers represent modulating valve position on both the leaving evaporator temperature and the leaving reheat coil temperature. MAX represents wide open, MIN represents closed to minimum position.

(a) The unit might be tripped by Froststat at these conditions due to low leaving evaporator air temperature.

**Table 20. Reheat temperature rise — 17.5 tons**

Airflow (cfm)	Ent DB (°F)	Entering Wet Bulb (°F)											
		51				55				59			
		Lvg Evap DB (°F)		Lvg Reheat DB (°F)		Lvg Evap DB (°F)		Lvg Reheat DB (°F)		Lvg Evap DB (°F)		Lvg Reheat DB (°F)	
		MIN	MAX	MIN	MAX	MIN	MAX	MIN	MAX	MIN	MAX	MIN	MAX
<b>Ambient DB 60°F</b>													
3500	60	30.0 <sup>(a)</sup>	31.4 <sup>(a)</sup>	38.6	62.5	33.8 <sup>(a)</sup>	36.9	43.1	66.0	37.7	42.6	47.8	69.5
	65	30.1 <sup>(a)</sup>	31.6 <sup>(a)</sup>	38.7	62.6	33.8 <sup>(a)</sup>	37.0	43.1	66.0	37.9	42.5	47.9	69.4
	70	30.5 <sup>(a)</sup>	32.1 <sup>(a)</sup>	39.0	62.8	33.9 <sup>(a)</sup>	37.2	43.1	66.0	37.8	42.6	47.8	69.4
	75	32.6 <sup>(a)</sup>	36.9	41.4	65.6	34.0 <sup>(a)</sup>	37.7	43.2	66.2	37.9	42.8	47.9	69.4
4200	60	33.0 <sup>(a)</sup>	33.5 <sup>(a)</sup>	40.5	62.0	36.8	38.9	45.0	65.6	40.8	44.5	49.7	69.1
	65	33.2 <sup>(a)</sup>	33.8 <sup>(a)</sup>	40.7	62.1	37.0	39.1	45.1	65.6	40.9	44.4	49.8	69.0
	70	34.0 <sup>(a)</sup>	35.7 <sup>(a)</sup>	41.5	63.0	37.2	39.4	45.3	65.7	41.0	44.6	49.9	69.1
	75	37.2	40.8	45.0	66.3	37.7	41.0	45.7	66.4	41.2	44.8	50.0	69.2
4900	60	35.3	35.3	42.1	61.6	39.2	40.5	46.5	65.1	43.4	45.9	51.3	68.7
	65	35.6	35.6	42.3	61.7	39.4	40.8	46.7	65.2	43.3	45.9	51.2	68.7
	70	37.7	38.8	44.4	63.5	39.6	41.1	46.8	65.4	43.5	46.2	51.3	68.8
	75	40.9	44.0	48.0	67.0	40.9	44.2	48.0	67.1	43.7	46.6	51.5	68.9
5600	60	37.2	36.8	43.3	61.1	41.0	41.7	47.6	64.7	45.2	47.1	52.4	68.3
	65	37.8	37.5	43.8	61.4	41.3	42.1	47.9	64.9	45.2	47.1	52.3	68.3
	70	40.6	41.5	46.7	63.9	41.7	42.9	48.2	65.2	45.4	47.5	52.5	68.4
	75	43.9	46.7	50.4	67.5	44.0	46.8	50.5	67.6	45.7	48.2	52.7	68.7

**Table 20. Reheat temperature rise — 17.5 tons (continued)**

Airflow (cfm)	Ent DB (°F)	Entering Wet Bulb (°F)											
		51				55				59			
		Lvg Evap DB (°F)		Lvg Reheat DB (°F)		Lvg Evap DB (°F)		Lvg Reheat DB (°F)		Lvg Evap DB (°F)		Lvg Reheat DB (°F)	
		MIN	MAX	MIN	MAX	MIN	MAX	MIN	MAX	MIN	MAX	MIN	MAX
6300	60	38.8	38.0	44.3	60.6	42.5	42.8	48.5	64.3	46.6	48.0	53.2	67.9
	65	39.6	39.0	45.0	61.0	42.8	43.3	48.8	64.5	46.6	48.1	53.2	67.9
	70	43.0	43.7	48.7	64.3	43.6	44.2	49.4	64.9	47.0	48.6	53.4	68.1
	75	46.4	49.0	52.4	68.0	46.5	49.1	52.5	68.1	47.6	49.5	54.0	68.5
7000	60	40.0	39.2	45.1	60.1	43.7	43.7	49.3	63.9	47.8	48.8	53.8	67.5
	65	41.2	40.3	46.2	60.7	44.1	44.3	49.6	64.2	47.9	49.0	53.9	67.6
	70	45.0	45.6	50.3	64.6	45.0	45.4	50.4	64.6	48.3	49.5	54.2	67.8
	75	48.5	51.0	54.1	68.4	48.6	51.1	54.2	68.5	49.1	50.6	54.9	68.3
7700	60	41.1	40.2	45.7	59.6	44.7	44.6	49.9	63.6	48.8	49.5	54.4	67.2
	65	43.1	42.1	47.7	60.8	45.2	45.1	50.2	63.8	48.9	49.8	54.5	67.3
	70	46.7	47.2	51.7	64.9	46.8	47.3	51.7	65.0	49.3	50.3	54.8	67.5
	75	50.3	52.7	55.6	68.8	50.4	52.8	55.6	68.8	50.4	52.9	55.7	68.9
8400	60	42.0	41.0	46.3	59.1	45.6	45.3	50.4	63.2	49.6	50.0	54.8	66.8
	65	44.5	43.5	48.9	61.0	46.1	45.9	50.7	63.5	49.8	50.4	55.0	67.0
	70	48.3	48.7	52.9	65.1	48.3	48.8	52.9	65.2	50.3	51.0	55.3	67.3
	75	51.9	54.2	56.8	69.1	52.0	54.3	56.9	69.2	52.1	54.4	57.0	69.2
<b>Ambient DB 65°F</b>													
3500	60	30.5 <sup>(a)</sup>	30.2 <sup>(a)</sup>	39.1	64.6	34.4 <sup>(a)</sup>	35.8	43.7	68.2	38.4	41.4	48.5	71.6
	65	30.6 <sup>(a)</sup>	30.4 <sup>(a)</sup>	39.2	64.7	34.4 <sup>(a)</sup>	35.8	43.7	68.2	38.4	41.4	48.5	71.6
	70	31.0 <sup>(a)</sup>	30.8 <sup>(a)</sup>	39.5	64.9	34.5 <sup>(a)</sup>	36.0	43.8	68.2	38.5	41.5	48.5	71.7
	75	33.3 <sup>(a)</sup>	34.7 <sup>(a)</sup>	42.2	67.2	34.6 <sup>(a)</sup>	36.1	43.8	68.3	38.6	41.7	48.6	71.7
4200	60	33.4 <sup>(a)</sup>	32.4 <sup>(a)</sup>	41.0	63.6	37.4	37.8	45.6	67.6	41.4	43.5	50.4	71.2
	65	33.7 <sup>(a)</sup>	32.6 <sup>(a)</sup>	41.2	63.7	37.5	38.0	45.7	67.6	41.5	43.4	50.4	71.1
	70	34.5 <sup>(a)</sup>	33.3 <sup>(a)</sup>	42.0	64.2	37.7	38.2	45.8	67.7	41.6	43.6	50.5	71.2
	75	37.9	38.7	45.9	67.8	38.3	38.9	46.4	68.0	41.8	43.8	50.6	71.3
4900	60	35.8	34.4 <sup>(a)</sup>	42.6	62.6	39.7	39.4	47.0	67.0	43.9	45.0	51.9	70.7
	65	36.1	34.7 <sup>(a)</sup>	42.8	62.7	39.9	39.7	47.2	67.1	43.9	44.9	51.9	70.6
	70	38.4	36.9	45.2	64.5	40.1	40.0	47.4	67.2	44.1	45.2	52.0	70.7
	75	41.6	42.0	48.8	68.2	41.7	42.2	48.9	68.3	44.3	45.5	52.1	70.8
5600	60	37.7	36.2	43.7	61.7	41.5	40.8	48.1	66.4	45.7	46.2	52.9	70.1
	65	38.3	36.7	44.3	62.0	41.8	41.1	48.4	66.5	45.7	46.2	52.9	70.1
	70	41.3	39.7	47.5	64.7	42.3	41.7	48.8	66.7	46.0	46.6	53.1	70.3
	75	44.6	44.8	51.2	68.6	44.7	45.0	51.3	68.7	46.3	46.9	53.3	70.4
6300	60	39.2	37.7	44.7	60.9	42.9	42.0	49.0	65.7	47.1	47.2	53.8	69.6
	65	40.0	38.5	45.4	61.4	43.3	42.4	49.3	65.9	47.2	47.3	53.7	69.6
	70	43.6	42.0	49.4	65.0	44.0	43.3	49.9	66.4	47.5	47.7	54.0	69.8
	75	47.2	47.1	53.3	69.0	47.2	47.3	53.4	69.1	48.2	48.6	54.6	70.2
7000	60	40.4	38.9	45.4	60.3	44.1	43.0	49.7	65.2	48.3	48.1	54.4	69.1
	65	42.0	39.9	47.0	60.9	44.5	43.5	50.0	65.4	48.4	48.2	54.4	69.2
	70	45.7	44.1	51.0	65.3	45.5	44.5	50.9	65.9	48.7	48.7	54.7	69.4
	75	49.3	49.2	55.0	69.3	49.4	49.3	55.1	69.4	49.6	49.7	55.5	69.8



# Reheat Temperature Rise

**Table 20. Reheat temperature rise — 17.5 tons (continued)**

Airflow (cfm)	Ent DB (°F)	Entering Wet Bulb (°F)											
		51				55				59			
		Lvg Evap DB (°F)		Lvg Reheat DB (°F)		Lvg Evap DB (°F)		Lvg Reheat DB (°F)		Lvg Evap DB (°F)		Lvg Reheat DB (°F)	
		MIN	MAX	MIN	MAX	MIN	MAX	MIN	MAX	MIN	MAX	MIN	MAX
7700	60	41.4	40.1	46.1	59.8	45.1	43.9	50.3	64.6	49.2	48.8	54.9	68.6
	65	43.7	41.2	48.3	60.5	45.6	44.4	50.6	64.9	49.4	49.0	55.0	68.8
	70	47.4	45.8	52.4	65.5	47.5	45.6	52.4	65.5	49.8	49.5	55.3	69.0
	75	51.1	51.0	56.4	69.6	51.2	51.1	56.5	69.7	51.1	51.0	56.5	69.7
8400	60	42.3	41.0	46.6	59.3	46.0	44.7	50.8	64.1	49.9	49.5	55.2	68.2
	65	45.1	43.2	49.4	61.1	46.5	45.3	51.1	64.4	50.3	49.7	55.4	68.4
	70	48.9	47.3	53.6	65.7	49.0	47.4	53.6	65.8	50.7	50.3	55.8	68.7
	75	52.7	52.6	57.7	69.9	52.8	52.7	57.8	69.9	52.9	52.8	57.8	70.0
<b>Ambient DB 70°F</b>													
3500	60	31.0 <sup>(a)</sup>	29.3 <sup>(a)</sup>	39.7	65.6	35.0	34.7 <sup>(a)</sup>	44.4	70.4	39.0	40.3	49.2	73.9
	65	31.1 <sup>(a)</sup>	29.4 <sup>(a)</sup>	39.8	65.6	35.0	34.6 <sup>(a)</sup>	44.3	70.3	39.1	40.4	49.2	73.9
	70	31.5 <sup>(a)</sup>	29.8 <sup>(a)</sup>	40.1	65.8	35.1	34.8 <sup>(a)</sup>	44.4	70.4	39.1	40.5	49.3	73.9
	75	34.1 <sup>(a)</sup>	32.5 <sup>(a)</sup>	43.1	68.5	35.2	35.0	44.5	70.4	39.3	40.6	49.3	74.0
4200	60	33.9 <sup>(a)</sup>	32.0 <sup>(a)</sup>	41.6	63.9	38.0	36.7	46.2	69.3	42.1	42.2	51.1	73.2
	65	34.2 <sup>(a)</sup>	32.2 <sup>(a)</sup>	41.7	64.0	38.1	36.8	46.3	69.4	42.2	42.4	51.1	73.2
	70	35.6	32.9 <sup>(a)</sup>	43.2	64.5	38.3	37.1	46.4	69.5	42.3	42.5	51.2	73.3
	75	38.7	36.7	46.8	68.8	38.8	37.7	47.0	69.8	42.5	42.8	51.3	73.4
4900	60	36.3	34.3 <sup>(a)</sup>	43.1	62.7	40.2	38.5	47.6	68.2	44.5	44.1	52.6	72.6
	65	36.6	34.5 <sup>(a)</sup>	43.3	62.8	40.4	38.7	47.8	68.3	44.5	44.0	52.5	72.5
	70	39.1	36.4	46.0	64.5	40.7	39.0	47.9	68.5	44.7	44.2	52.6	72.6
	75	42.4	40.2	49.7	69.1	42.5	39.9	49.8	69.0	44.9	44.5	52.8	72.7
5600	60	38.1	36.2	44.2	61.9	42.0	40.2	48.7	67.2	46.3	45.4	53.6	71.8
	65	38.8	36.6	44.8	62.0	42.3	40.5	48.9	67.4	46.3	45.3	53.5	71.8
	70	42.0	39.2	48.2	64.8	42.8	40.8	49.4	67.5	46.5	45.7	53.7	72.0
	75	45.5	43.1	52.2	69.4	45.6	43.3	52.3	69.5	46.8	46.1	53.9	72.1
6300	60	39.6	37.8	45.1	61.1	43.4	41.6	49.5	66.3	47.7	46.5	54.3	71.1
	65	40.5	38.6	46.0	61.6	43.7	41.9	49.8	66.5	47.7	46.5	54.3	71.1
	70	44.4	41.6	50.1	65.1	44.5	42.7	50.5	67.0	48.0	46.9	54.5	71.3
	75	48.0	45.6	54.2	69.6	48.1	45.7	54.3	69.8	48.8	47.7	55.2	71.7
7000	60	40.8	39.1	45.8	60.4	44.6	42.8	50.2	65.6	48.8	47.2	54.9	70.3
	65	42.6	40.0	47.6	61.1	45.0	43.2	50.5	65.8	48.9	47.5	54.9	70.5
	70	46.4	43.7	51.7	65.4	46.2	44.1	51.6	66.4	49.2	48.0	55.2	70.8
	75	50.1	47.7	55.9	69.9	50.2	47.8	56.0	70.0	50.2	48.9	56.0	71.2
7700	60	41.8	40.2	46.5	59.9	45.6	43.8	50.7	65.0	49.7	48.2	55.4	69.9
	65	44.3	41.7	48.9	61.0	46.0	44.3	51.1	65.2	49.9	48.4	55.5	70.0
	70	48.1	45.5	53.1	65.7	48.2	45.4	53.2	65.9	50.3	48.9	55.8	70.2
	75	52.0	49.6	57.4	70.2	52.0	49.7	57.4	70.3	52.1	50.0	57.5	70.8
8400	60	42.8	41.1	47.1	59.4	46.4	44.7	51.2	64.4	50.4	48.9	55.7	69.4
	65	45.7	43.3	50.1	61.3	46.8	45.2	51.5	64.7	50.7	49.2	55.9	69.5
	70	49.6	47.0	54.3	65.9	49.7	46.5	54.4	65.5	51.2	49.7	56.3	69.7
	75	53.5	51.2	58.6	70.5	53.6	51.3	58.7	70.5	53.7	51.0	58.8	70.4

**Note:** MIN, MAX: The leaving evaporator temperature is affected by the modulating valve position. The MIN and MAX numbers represent modulating valve position impact on both the leaving evaporator temperature and the leaving reheat coil temperature. MAX represents wide open, MIN represents closed to minimum position.

<sup>(a)</sup> The unit might be tripped by Froststat at these conditions due to low leaving evaporator air temperature.

Table 21. Reheat temperature rise — 20 tons

Airflow (cfm)	Ent DB (°F)	Entering Wet Bulb (°F)											
		51				55				59			
		Lvg Evap DB (°F)		Lvg Reheat DB (°F)		Lvg Evap DB (°F)		Lvg Reheat DB (°F)		Lvg Evap DB (°F)		Lvg Reheat DB (°F)	
		MIN	MAX	MIN	MAX	MIN	MAX	MIN	MAX	MIN	MAX	MIN	MAX
<b>Ambient DB 60°F</b>													
4000	60	31.0 <sup>(a)</sup>	29.6 <sup>(a)</sup>	44.3	59.8	34.7 <sup>(a)</sup>	33.3 <sup>(a)</sup>	49.1	65.4	38.5	38.0	54.0	69.8
	65	31.6 <sup>(a)</sup>	30.1 <sup>(a)</sup>	44.7	60.1	34.8 <sup>(a)</sup>	33.5 <sup>(a)</sup>	49.1	65.3	38.8	38.3	54.3	70.0
	70	32.1 <sup>(a)</sup>	30.6 <sup>(a)</sup>	45.3	60.6	35.4	34.1 <sup>(a)</sup>	49.5	65.7	38.9	38.4	54.2	70.0
	75	34.4 <sup>(a)</sup>	32.6 <sup>(a)</sup>	47.9	62.9	35.6	34.4 <sup>(a)</sup>	49.7	65.9	39.4	39.1	54.6	70.3
4800	60	34.4 <sup>(a)</sup>	33.1 <sup>(a)</sup>	45.8	59.1	37.6	36.2	50.2	64.4	41.5	40.6	55.2	69.2
	65	34.7 <sup>(a)</sup>	33.3 <sup>(a)</sup>	46.2	59.5	38.4	36.7	50.6	64.5	41.8	40.9	55.4	69.3
	70	35.5	34.1 <sup>(a)</sup>	47.0	60.2	38.7	37.2	51.0	64.9	42.2	41.5	55.4	69.6
	75	39.0	37.1	51.0	63.8	39.4	37.9	51.7	65.5	42.8	42.1	56.0	69.9
5600	60	36.8	35.4	46.9	58.6	39.9	38.5	51.2	63.6	43.8	42.6	56.1	68.6
	65	37.1	35.8	47.3	59.0	40.9	39.4	51.7	64.0	44.1	43.0	56.2	68.8
	70	39.5	36.9	49.6	59.9	41.2	39.7	52.2	64.4	45.0	44.0	56.7	69.2
	75	42.7	40.8	53.4	64.7	42.4	40.8	53.3	65.2	45.4	44.4	57.1	69.5
6400	60	38.7	37.4	47.8	58.2	41.8	40.4	51.8	63.0	45.9	44.3	56.9	68.1
	65	39.4	38.0	48.5	58.8	42.8	41.4	52.6	63.6	46.0	44.7	56.8	68.3
	70	42.3	40.6	51.5	61.3	43.2	41.8	53.0	64.0	47.0	45.8	57.5	68.8
	75	45.7	43.8	55.4	65.5	45.8	43.7	55.5	65.5	47.4	46.3	58.0	69.2
7200	60	40.3	39.0	48.5	57.9	43.4	42.0	52.4	62.5	47.3	45.7	57.4	67.6
	65	41.2	39.9	49.3	58.6	44.5	43.1	53.3	63.2	47.7	46.2	57.2	67.7
	70	44.6	43.0	53.1	61.9	45.2	43.8	54.0	63.8	48.7	47.3	58.2	68.5
	75	48.1	46.3	57.1	66.2	48.2	46.4	57.2	66.3	49.4	47.9	58.9	68.9
8000	60	41.7	40.4	49.2	57.6	44.8	43.5	52.7	62.0	48.4	47.1	57.7	67.3
	65	42.6	41.5	50.0	58.4	45.8	44.5	53.9	62.9	49.7	47.8	57.9	67.3
	70	46.6	45.0	54.4	62.5	46.7	45.4	54.7	63.6	50.1	48.7	58.8	68.1
	75	50.2	48.4	58.5	66.8	50.3	48.5	58.6	66.8	50.9	49.6	59.5	68.7
8800	60	42.8	41.6	49.7	57.4	46.6	45.4	53.5	61.7	49.4	48.0	57.9	66.8
	65	44.6	42.8	51.4	58.3	47.0	45.7	54.4	62.7	51.4	49.5	59.0	67.0
	70	48.3	46.7	55.6	62.9	47.9	46.7	55.3	63.4	51.3	49.9	59.2	67.9
	75	52.0	50.2	59.8	67.3	52.1	50.3	59.8	67.4	52.1	50.9	60.0	68.5
9600	60	43.8	42.7	50.1	57.2	48.0	46.4	54.4	61.4	50.2	48.8	58.1	66.4
	65	46.0	44.6	52.4	58.9	48.0	46.8	54.8	62.4	52.3	50.5	59.3	66.7
	70	49.8	48.2	56.6	63.3	49.9	47.9	56.6	63.2	52.3	50.9	59.6	67.6
	75	53.6	51.8	60.8	67.7	53.7	51.9	60.9	67.8	53.2	52.0	60.5	68.3
<b>Ambient DB 65°F</b>													
4000	60	32.8 <sup>(a)</sup>	29.7 <sup>(a)</sup>	38.4	62.7	36.5	33.6 <sup>(a)</sup>	42.8	68.4	40.6	38.4	47.5	72.7
	65	33.1 <sup>(a)</sup>	30.3 <sup>(a)</sup>	38.8	63.0	36.6	33.7 <sup>(a)</sup>	42.8	68.3	40.8	38.8	47.6	72.9
	70	33.7 <sup>(a)</sup>	30.6 <sup>(a)</sup>	39.4	63.4	37.2	34.3 <sup>(a)</sup>	43.3	68.7	41.0	38.9	47.7	72.9
	75	36.7 <sup>(a)</sup>	32.8 <sup>(a)</sup>	42.6	65.9	37.6	34.7 <sup>(a)</sup>	43.8	68.9	41.5	39.6	48.2	73.2
4800	60	35.9	33.2 <sup>(a)</sup>	40.7	61.6	39.3	36.4	44.9	67.1	43.8	40.9	49.9	71.9
	65	36.1	33.5 <sup>(a)</sup>	41.1	62.0	40.1	36.8	45.3	67.1	43.8	41.2	49.8	72.0
	70	38.0	34.3 <sup>(a)</sup>	42.9	62.7	40.4	37.4	45.7	67.6	44.4	41.9	50.2	72.2
	75	41.3	37.3	46.6	66.5	41.1	38.1	46.5	68.1	44.8	42.4	50.6	72.5



## Reheat Temperature Rise

Table 21. Reheat temperature rise — 20 tons (continued)

Airflow (cfm)	Ent DB (°F)	Entering Wet Bulb (°F)											
		51				55				59			
		Lvg Evap DB (°F)		Lvg Reheat DB (°F)		Lvg Evap DB (°F)		Lvg Reheat DB (°F)		Lvg Evap DB (°F)		Lvg Reheat DB (°F)	
		MIN	MAX	MIN	MAX	MIN	MAX	MIN	MAX	MIN	MAX	MIN	MAX
5600	60	38.2	35.5	42.5	60.8	41.5	38.6	46.4	66.0	46.0	42.8	51.5	71.1
	65	38.6	35.9	42.9	61.2	42.5	39.5	47.1	66.3	46.0	43.2	51.3	71.2
	70	41.5	37.0	45.9	62.2	42.8	39.9	47.6	66.7	46.9	44.1	52.0	71.6
	75	45.0	40.9	49.8	67.1	45.1	40.9	49.9	67.5	47.3	44.6	52.5	71.9
6400	60	40.1	37.4	43.9	60.2	43.3	40.4	47.6	65.2	47.7	44.4	52.6	70.3
	65	40.8	37.9	44.7	60.6	44.4	41.5	48.6	65.7	47.7	44.8	52.3	70.5
	70	44.3	40.7	48.3	63.4	45.0	41.9	49.3	66.1	48.8	45.9	53.4	71.0
	75	48.0	43.9	52.4	67.6	48.1	43.2	52.5	67.0	49.2	46.4	53.9	71.4
7200	60	41.6	39.1	45.1	59.6	44.7	42.0	48.5	64.4	49.0	45.7	53.5	69.6
	65	42.4	40.0	45.9	60.4	45.9	43.1	49.7	65.1	50.7	46.3	54.6	69.7
	70	46.6	43.1	50.3	63.8	46.7	43.9	50.5	65.8	50.4	47.4	54.5	70.5
	75	50.5	46.4	54.6	68.1	50.6	46.5	54.6	68.2	51.1	48.0	55.3	70.9
8000	60	42.9	40.5	46.1	59.2	47.3	43.6	50.6	63.8	50.0	47.1	54.2	69.2
	65	44.6	41.5	47.8	60.0	47.2	44.6	50.7	64.7	51.8	48.1	55.4	69.2
	70	48.6	45.1	52.0	64.2	48.4	45.5	51.9	65.4	51.7	48.8	55.5	70.0
	75	52.6	48.5	56.3	68.6	52.7	48.6	56.4	68.7	52.5	49.7	56.3	70.6
8800	60	44.0	41.7	46.9	58.9	48.3	45.4	51.2	63.2	50.8	48.0	54.7	68.6
	65	46.2	43.0	49.2	59.9	48.3	45.7	51.5	64.3	52.8	49.6	56.0	68.6
	70	50.2	46.8	53.4	64.6	50.3	46.8	53.5	65.0	52.8	50.0	56.2	69.6
	75	54.4	50.4	57.9	69.0	54.4	50.4	57.9	69.1	54.5	51.0	58.0	70.2
9600	60	44.9	42.7	47.6	58.6	49.1	46.5	51.7	62.8	51.4	48.9	55.0	68.0
	65	47.6	44.7	50.3	60.2	49.3	46.8	52.1	63.9	53.5	50.6	56.5	68.2
	70	51.7	48.3	54.7	64.9	51.7	47.9	54.7	64.7	53.7	51.0	56.9	69.2
	75	55.9	51.9	59.1	69.3	55.9	52.0	59.2	69.4	56.0	52.1	59.3	69.9
<b>Ambient DB 70°F</b>													
4000	60	33.5 <sup>(a)</sup>	29.9 <sup>(a)</sup>	39.1	62.9	37.1	33.5 <sup>(a)</sup>	43.5	68.8	41.3	37.7	48.4	74.3
	65	33.7 <sup>(a)</sup>	30.5 <sup>(a)</sup>	39.4	63.2	37.3	33.7 <sup>(a)</sup>	43.5	68.7	41.5	38.1	48.5	74.5
	70	34.3 <sup>(a)</sup>	30.7 <sup>(a)</sup>	40.0	63.5	37.8	34.3 <sup>(a)</sup>	44.0	69.0	41.6	38.1	48.5	74.5
	75	37.6	33.1 <sup>(a)</sup>	43.6	66.3	38.3	34.6 <sup>(a)</sup>	44.6	69.3	42.2	38.8	49.0	74.7
4800	60	36.4	33.3 <sup>(a)</sup>	41.3	61.8	39.9	36.5	45.5	67.5	44.5	40.4	50.7	73.0
	65	36.7	33.6 <sup>(a)</sup>	41.7	62.1	40.7	37.0	46.0	67.4	44.4	40.7	50.5	73.1
	70	38.8	34.4 <sup>(a)</sup>	43.8	62.9	41.0	37.5	46.4	68.0	45.1	41.3	50.9	73.3
	75	42.2	37.6	47.6	66.9	42.0	38.2	47.5	68.5	45.4	41.8	51.4	73.6
5600	60	38.7	35.7	43.1	60.8	42.1	38.7	47.0	66.3	46.6	42.6	52.2	71.9
	65	39.1	36.0	43.5	61.3	43.0	39.7	47.8	66.6	46.5	42.9	51.9	72.0
	70	42.2	37.9	46.8	62.9	43.4	40.0	48.2	67.1	47.5	43.9	52.7	72.3
	75	45.9	41.2	50.8	67.5	46.0	41.1	50.9	67.9	47.9	44.2	53.2	72.8
6400	60	40.6	37.6	44.5	60.2	43.7	40.6	48.1	65.3	48.2	44.3	53.3	70.9
	65	40.8	38.1	44.7	60.7	44.9	41.7	49.1	65.9	48.3	44.8	52.9	71.0
	70	45.0	40.9	49.2	63.5	45.6	42.1	49.9	66.3	49.4	45.8	54.0	71.6
	75	48.9	44.1	53.4	68.0	49.0	43.4	53.5	67.3	50.0	46.2	54.7	72.0



**Table 21. Reheat temperature rise — 20 tons (continued)**

Airflow (cfm)	Ent DB (°F)	Entering Wet Bulb (°F)											
		51				55				59			
		Lvg Evap DB (°F)		Lvg Reheat DB (°F)		Lvg Evap DB (°F)		Lvg Reheat DB (°F)		Lvg Evap DB (°F)		Lvg Reheat DB (°F)	
		MIN	MAX	MIN	MAX	MIN	MAX	MIN	MAX	MIN	MAX	MIN	MAX
7200	60	42.1	39.3	45.6	59.7	45.6	42.2	49.2	64.5	49.5	45.8	54.1	70.0
	65	43.1	40.2	46.6	60.4	46.4	43.3	50.3	65.2	51.2	46.3	55.1	70.1
	70	47.3	43.3	51.2	64.0	47.1	44.1	50.9	65.9	50.9	47.4	55.1	70.9
	75	51.4	46.6	55.5	68.5	51.5	46.7	55.6	68.6	51.7	47.9	55.9	71.4
8000	60	43.4	40.7	46.5	59.3	47.7	43.8	51.0	63.7	50.5	47.2	54.7	69.6
	65	45.2	41.7	48.5	60.0	47.7	44.7	51.2	64.7	52.3	47.8	55.8	69.1
	70	49.3	45.3	52.8	64.3	49.3	45.7	52.9	65.5	52.2	48.9	56.0	70.3
	75	53.4	48.7	57.3	68.9	53.5	48.8	57.3	69.0	53.4	49.7	57.2	71.0
8800	60	44.4	41.9	47.3	58.9	48.7	45.6	51.6	63.2	51.3	48.2	55.2	68.9
	65	46.8	43.0	49.8	59.7	48.8	45.9	51.9	64.3	52.9	49.8	56.2	68.8
	70	50.9	47.0	54.2	64.7	51.0	47.0	54.2	65.1	53.3	50.1	56.7	69.9
	75	55.2	50.5	58.7	69.3	55.2	50.6	58.8	69.4	55.3	51.0	58.9	70.5
9600	60	45.3	42.9	48.0	58.6	49.4	46.6	52.1	62.8	51.8	49.0	55.5	68.3
	65	48.1	44.9	50.9	60.4	49.7	47.0	52.6	63.9	53.9	50.8	56.8	68.3
	70	52.3	48.5	55.4	65.0	52.4	48.1	55.4	64.7	54.2	51.1	57.3	69.4
	75	56.7	52.1	60.0	69.6	56.7	52.2	60.0	69.7	56.8	52.2	60.1	70.2

Note: MIN, MAX: The leaving evaporator temperature is affected by the modulating valve position. The MIN and MAX numbers represent modulating valve position impact on both the leaving evaporator temperature and the leaving reheat coil temperature. MAX represents wide open, MIN represents closed to minimum position.

(a) The unit might be tripped by Froststat at these conditions due to low leaving evaporator air temperature.

**Table 22. Reheat temperature rise — 25 tons**

Airflow (cfm)	Ent DB (°F)	Entering Wet Bulb (°F)											
		51				55				59			
		Lvg Evap DB (°F)		Lvg Reheat DB (°F)		Lvg Evap DB (°F)		Lvg Reheat DB (°F)		Lvg Evap DB (°F)		Lvg Reheat DB (°F)	
		MIN	MAX	MIN	MAX	MIN	MAX	MIN	MAX	MIN	MAX	MIN	MAX
<b>Ambient DB 60°F</b>													
5000	60	33.3 <sup>(a)</sup>	32.4 <sup>(a)</sup>	48.3	59.4	36.6	35.7	52.7	64.5	40.2	39.7	57.4	69.4
	65	34.0 <sup>(a)</sup>	33.1 <sup>(a)</sup>	48.8	59.9	37.1	36.2	53.1	64.9	40.6	40.3	57.9	69.8
	70	35.2	34.3 <sup>(a)</sup>	49.9	60.8	37.7	36.8	53.7	65.3	41.1	40.9	58.3	70.1
	75	38.1	37.0	53.1	63.7	38.6	37.6	54.3	65.8	41.7	41.5	58.8	70.4
6000	60	36.0	35.2	49.0	58.7	39.3	38.5	53.4	63.7	42.9	42.2	58.0	68.7
	65	36.8	36.0	49.7	59.3	40.0	39.1	53.9	64.2	43.4	42.8	58.5	69.1
	70	38.8	37.7	51.4	60.6	40.8	39.9	54.6	64.8	44.0	43.5	59.0	69.5
	75	42.3	41.2	55.5	64.8	42.3	41.4	55.8	65.8	44.8	44.4	59.7	70.0
7000	60	38.1	37.3	49.7	58.2	41.4	40.6	54.0	63.1	44.9	44.1	58.5	68.0
	65	39.1	38.3	50.5	58.8	42.2	41.4	54.6	63.7	45.6	44.8	59.0	68.6
	70	42.3	41.3	53.5	61.4	43.1	42.3	55.3	64.3	46.3	45.7	59.7	69.1
	75	45.6	44.5	57.3	65.6	45.0	44.2	56.9	65.6	47.2	46.6	60.3	69.6
8000	60	39.9	39.1	50.3	57.8	43.1	42.3	54.4	62.6	46.5	45.7	58.8	67.4
	65	41.5	40.7	51.5	58.9	44.0	43.2	55.1	63.3	47.2	46.4	59.4	68.0
	70	44.8	43.9	54.9	62.1	45.4	44.3	56.2	63.9	48.1	47.4	60.1	68.7
	75	48.2	47.2	58.9	66.4	48.3	47.3	59.0	66.5	49.1	48.5	60.8	69.2



## Reheat Temperature Rise

Table 22. Reheat temperature rise — 25 tons (continued)

Airflow (cfm)	Ent DB (°F)	Entering Wet Bulb (°F)											
		51				55				59			
		Lvg Evap DB (°F)		Lvg Reheat DB (°F)		Lvg Evap DB (°F)		Lvg Reheat DB (°F)		Lvg Evap DB (°F)		Lvg Reheat DB (°F)	
		MIN	MAX	MIN	MAX	MIN	MAX	MIN	MAX	MIN	MAX	MIN	MAX
9000	60	41.3	40.6	50.7	57.5	44.4	43.6	54.7	62.1	48.0	47.0	59.2	66.8
	65	43.1	42.4	52.2	58.7	45.4	44.7	55.5	62.9	48.6	47.8	59.7	67.5
	70	46.9	46.0	56.2	62.7	47.1	46.4	56.8	64.0	49.6	48.8	60.5	68.2
	75	50.4	49.5	60.2	67.0	50.5	49.6	60.3	67.1	51.2	50.5	61.7	69.2
10000	60	42.5	41.8	51.1	57.2	45.5	44.8	54.9	61.7	49.1	48.2	59.4	67.0
	65	44.6	43.9	52.8	58.6	46.6	45.9	55.9	62.5	49.7	48.9	59.9	67.9
	70	48.6	47.8	57.2	63.2	48.6	47.9	57.3	63.8	50.8	50.1	60.8	67.9
	75	52.3	51.4	61.3	67.6	52.4	51.5	61.4	67.6	52.6	52.0	62.1	69.0
11000	60	43.5	42.9	51.4	57.0	46.4	45.8	55.1	61.3	49.9	49.2	59.5	66.1
	65	46.4	45.6	53.9	59.0	47.7	47.0	56.1	62.2	50.8	49.9	60.1	66.6
	70	50.1	49.3	58.1	63.6	49.8	49.1	57.8	63.7	51.9	51.2	61.0	67.5
	75	53.9	53.0	62.3	68.0	53.9	53.1	62.4	68.1	53.9	53.2	62.5	68.8
12000	60	44.4	43.8	51.6	56.8	47.3	46.6	55.4	61.1	50.5	49.9	59.4	65.7
	65	47.6	46.9	54.6	59.4	48.5	47.9	56.3	62.0	51.6	50.8	60.3	66.4
	70	51.4	50.7	58.9	64.0	51.5	50.7	58.9	64.0	52.8	52.1	61.2	67.2
	75	55.2	54.4	63.1	68.4	55.3	54.5	63.2	68.5	54.9	54.3	62.9	68.6
<b>Ambient DB 65°F</b>													
5000	60	34.5 <sup>(a)</sup>	32.5 <sup>(a)</sup>	41.7	61.9	38.0	35.8	45.8	67.2	41.7	39.7	50.2	72.3
	65	35.2	33.2 <sup>(a)</sup>	42.3	62.4	38.5	36.3	46.2	67.5	42.2	40.3	50.6	72.7
	70	36.5	34.4 <sup>(a)</sup>	43.5	63.3	39.1	37.0	46.8	68.0	42.7	40.8	51.1	73.0
	75	39.8	37.2	47.1	66.4	40.3	37.7	47.8	68.4	43.3	41.6	51.6	73.4
6000	60	37.2	35.2	43.5	60.8	40.7	38.5	47.5	66.1	44.4	42.7	51.8	71.6
	65	37.9	36.1	44.1	61.4	41.3	39.2	48.1	66.6	44.9	42.9	52.4	71.7
	70	40.6	37.8	46.7	62.7	42.1	40.0	48.8	67.1	45.5	43.5	52.8	72.1
	75	43.9	41.4	50.4	67.1	43.6	41.5	50.2	68.1	46.3	44.3	53.5	72.6
7000	60	39.2	37.4	44.8	60.1	42.7	40.7	48.8	65.2	46.3	44.2	53.1	70.3
	65	40.6	38.4	46.0	60.6	43.4	41.4	49.5	65.8	47.0	44.8	53.6	70.8
	70	43.7	41.4	49.2	63.3	44.5	42.4	50.4	66.4	47.7	45.7	54.3	71.4
	75	47.2	44.7	53.0	67.7	47.3	44.3	53.1	67.7	48.6	46.6	55.0	71.9
8000	60	40.9	39.2	45.9	59.5	44.2	42.3	49.8	64.4	48.1	45.7	54.2	69.4
	65	42.5	40.8	47.3	60.5	45.1	43.2	50.6	65.1	48.6	46.5	54.6	70.0
	70	46.2	44.0	51.2	63.8	46.6	44.4	51.8	65.7	49.5	47.4	55.4	70.7
	75	49.8	47.4	55.1	68.2	49.9	47.5	55.2	68.3	50.8	48.5	56.5	71.2
9000	60	42.3	40.7	46.8	59.0	45.5	43.7	50.5	63.7	49.3	47.0	54.9	68.7
	65	44.2	42.5	48.5	60.2	46.5	44.8	51.4	64.5	49.9	47.8	55.3	69.3
	70	48.2	46.1	52.8	64.2	48.2	46.5	52.9	65.6	50.9	48.9	56.2	70.0
	75	52.0	49.6	56.9	68.7	52.1	49.7	57.0	68.8	52.5	50.5	57.6	71.0
10000	60	43.4	41.9	47.5	58.6	46.5	44.8	51.2	63.2	50.1	48.3	55.3	68.5
	65	46.1	44.0	50.1	60.0	47.6	46.0	52.1	64.0	51.0	49.0	56.0	68.7
	70	50.0	47.9	54.2	64.6	49.6	48.0	53.8	65.2	52.0	50.2	56.9	69.5
	75	53.8	51.5	58.4	69.1	53.9	51.6	58.5	69.2	53.8	52.0	58.5	70.6

**Table 22. Reheat temperature rise — 25 tons (continued)**

Airflow (cfm)	Ent DB (°F)	Entering Wet Bulb (°F)											
		51				55				59			
		Lvg Evap DB (°F)		Lvg Reheat DB (°F)		Lvg Evap DB (°F)		Lvg Reheat DB (°F)		Lvg Evap DB (°F)		Lvg Reheat DB (°F)	
		MIN	MAX	MIN	MAX	MIN	MAX	MIN	MAX	MIN	MAX	MIN	MAX
11000	60	44.3	42.9	48.1	58.3	47.5	45.8	51.7	62.7	50.9	49.2	55.7	67.6
	65	47.5	45.7	51.2	60.3	48.6	47.1	52.7	63.6	51.9	50.0	56.5	68.2
	70	51.4	49.4	55.4	64.9	51.5	49.2	55.5	65.0	53.0	51.3	57.5	69.0
	75	55.4	53.1	59.7	69.4	55.5	53.2	59.7	69.5	55.6	53.3	59.8	70.2
12000	60	45.4	43.8	48.8	58.0	48.2	46.7	52.2	62.3	51.6	50.0	56.1	67.1
	65	48.7	47.0	52.1	60.6	49.7	48.0	53.4	63.2	52.7	50.9	57.0	67.8
	70	52.7	50.7	56.4	65.2	52.8	50.8	56.5	65.3	54.0	52.2	58.1	68.6
	75	56.8	54.5	60.8	69.8	56.8	54.5	60.8	69.8	56.9	54.4	60.9	69.9
<b>Ambient DB 70°F</b>													
5000	60	35.0	32.7 <sup>(a)</sup>	42.3	62.0	38.5	36.0	46.5	67.5	42.3	39.6	50.9	73.1
	65	35.6	33.4 <sup>(a)</sup>	42.9	62.5	39.0	36.5	46.9	67.9	42.8	40.1	51.4	73.5
	70	37.0	34.6 <sup>(a)</sup>	44.1	63.4	39.7	37.2	47.5	68.4	43.2	40.6	51.8	73.9
	75	40.5	37.5	47.9	66.8	40.8	37.9	48.5	68.8	43.9	41.3	52.4	74.3
6000	60	37.6	35.5	44.0	60.9	41.1	38.7	48.1	66.2	44.9	42.3	52.5	71.8
	65	38.4	36.3	44.7	61.5	41.8	39.3	48.7	66.7	45.5	42.9	53.1	72.3
	70	41.2	38.0	47.4	62.8	42.6	40.2	49.4	67.3	46.1	43.5	53.6	72.7
	75	44.6	41.6	51.2	67.4	44.4	41.7	51.0	68.4	46.8	44.3	54.2	73.2
7000	60	39.7	37.6	45.3	60.2	43.1	40.8	49.3	65.3	46.9	44.3	53.7	70.6
	65	41.0	38.5	46.5	60.7	43.9	41.6	50.0	65.9	47.5	45.0	54.3	71.2
	70	44.3	41.7	49.9	63.5	45.1	42.6	51.1	66.4	48.3	45.8	55.0	71.8
	75	47.8	44.9	53.8	68.0	47.9	44.5	53.9	67.8	49.0	46.7	55.6	72.3
8000	60	41.3	39.4	46.4	59.6	44.6	42.5	50.3	64.5	48.6	45.9	54.8	69.6
	65	42.9	41.0	47.8	60.6	45.6	43.4	51.1	65.2	49.1	46.7	55.2	70.3
	70	46.7	44.2	51.8	64.0	47.1	44.9	52.4	66.1	50.0	47.6	56.0	71.0
	75	50.5	47.6	55.9	68.5	50.5	47.7	56.0	68.6	51.3	48.6	57.1	71.5
9000	60	42.6	40.8	47.2	59.1	45.9	43.9	51.0	63.8	49.7	47.2	55.4	68.8
	65	45.0	42.7	49.3	60.3	46.9	44.9	51.9	64.6	50.3	48.0	55.9	69.5
	70	48.8	46.3	53.5	64.4	48.6	46.7	53.4	65.6	51.3	49.1	56.8	70.2
	75	52.6	49.8	57.7	68.9	52.7	49.9	57.8	69.0	52.9	50.7	58.2	71.2
10000	60	43.7	42.1	47.9	58.7	46.9	45.0	51.6	63.2	50.6	48.5	55.8	68.4
	65	46.6	44.1	50.6	60.0	48.0	46.2	52.6	64.1	51.4	49.2	56.5	68.8
	70	50.5	48.1	54.8	64.7	50.6	48.1	54.9	65.3	52.4	50.3	57.4	69.6
	75	54.5	51.7	59.2	69.3	54.6	51.8	59.2	69.4	54.4	52.2	59.2	70.8
11000	60	44.6	43.1	48.5	58.3	47.8	46.0	52.2	62.8	51.4	49.4	56.3	67.7
	65	47.9	45.9	51.7	60.4	49.1	47.2	53.3	63.6	52.3	50.2	57.1	68.3
	70	52.0	49.6	56.0	65.0	52.0	49.4	56.1	65.0	53.5	51.4	58.1	69.1
	75	56.1	53.3	60.4	69.7	56.1	53.4	60.5	69.7	56.2	53.5	60.6	70.4
12000	60	45.7	44.0	49.2	58.0	48.6	46.9	52.6	62.4	52.0	50.0	56.6	67.0
	65	49.1	47.2	52.6	60.7	50.0	48.2	53.8	63.2	53.1	51.1	57.5	67.9
	70	53.2	51.0	57.0	65.3	53.3	51.0	57.1	65.4	54.5	52.3	58.6	68.6
	75	57.4	54.7	61.6	70.0	57.5	54.8	61.6	70.1	57.6	54.6	61.7	70.0

**Note:** MIN, MAX: The leaving evaporator temperature is affected by the modulating valve position. The MIN and MAX numbers represent modulating valve position impact on both the leaving evaporator temperature and the leaving reheat coil temperature. MAX represents wide open, MIN represents closed to minimum position.

<sup>(a)</sup> The unit might be tripped by Froststat at these conditions due to low leaving evaporator air temperature.



# Evaporator Fan Performance

## Tables

**Table 23. Evaporator fan performance - 6 ton (model YSJ), downflow, high heat**

Available External Static Pressure (Inches of Water Gauge)																				
CFM	0.10"		0.20"		0.30"		0.40"		0.50"		0.60"		0.70"		0.80"		0.90"		1.00"	
	RPM	BHP	RPM	BHP	RPM	BHP	RPM	BHP	RPM	BHP	RPM	BHP	RPM	BHP	RPM	BHP	RPM	BHP	RPM	BHP
1800	560	0.11	621	0.16	676	0.21	727	0.26	775	0.32	820	0.37	861	0.43	900	0.49	937	0.56	973	0.62
1920	590	0.13	647	0.18	701	0.23	750	0.29	796	0.34	840	0.40	881	0.47	920	0.53	957	0.59	992	0.66
2040	619	0.15	674	0.20	726	0.26	773	0.32	818	0.37	861	0.44	901	0.50	940	0.57	976	0.63	1011	0.70
2160	649	0.17	702	0.23	751	0.29	797	0.34	841	0.41	882	0.47	922	0.54	960	0.60	996	0.67	1031	0.74
2280	679	0.20	730	0.25	777	0.31	822	0.38	864	0.44	905	0.51	943	0.57	981	0.64	1017	0.72	1051	0.79
2400	709	0.22	758	0.28	804	0.35	847	0.41	888	0.48	928	0.54	965	0.61	1002	0.69	1037	0.76	1071	0.84
2520	739	0.25	787	0.31	831	0.38	873	0.45	913	0.52	951	0.59	988	0.66	1023	0.73	1058	0.81	1091	0.89
2640	770	0.28	816	0.35	858	0.42	899	0.49	938	0.56	975	0.63	1012	0.71	1046	0.78	1080	0.86	1113	0.94
2760	800	0.31	845	0.38	886	0.46	925	0.53	963	0.60	1000	0.68	1035	0.76	1069	0.83	1102	0.91	1134	1.00
2880	831	0.35	874	0.42	914	0.50	952	0.57	989	0.65	1025	0.73	1059	0.81	1093	0.89	1125	0.97	1156	1.05
Available External Static Pressure (Inches of Water Gauge)																				
CFM	1.10"		1.20"		1.30"		1.40"		1.50"		1.60"		1.70"		1.80"		1.90"		2.00"	
	RPM	BHP	RPM	BHP	RPM	BHP	RPM	BHP	RPM	BHP	RPM	BHP	RPM	BHP	RPM	BHP	RPM	BHP	RPM	BHP
1800	1008	0.69	1041	0.75	1073	0.82	1103	0.89	1133	0.97	1162	1.04	1190	1.11	1219	1.19	1248	1.27	1276	1.35
1920	1026	0.73	1059	0.8	1090	0.87	1121	0.94	1150	1.02	1179	1.09	1207	1.17	1234	1.24	1260	1.32	1287	1.41
2040	1044	0.77	1077	0.84	1108	0.92	1138	0.99	1168	1.07	1196	1.14	1224	1.22	1251	1.3	1277	1.38	1303	1.47
2160	1064	0.82	1096	0.89	1126	0.97	1156	1.04	1186	1.12	1214	1.2	1241	1.28	1268	1.36	1294	1.45	1320	1.53
2280	1084	0.86	1115	0.94	1145	1.02	1175	1.1	1204	1.18	1232	1.26	1259	1.34	1286	1.43	1312	1.51	1337	1.6
2400	1104	0.91	1135	0.99	1165	1.07	1194	1.15	1222	1.24	1250	1.32	1277	1.41	1304	1.49	1330	1.58	1355	1.67
2520	1124	0.97	1155	1.05	1185	1.13	1214	1.21	1242	1.3	1269	1.38	1296	1.47	1322	1.56	1348	1.65	1373	1.74
2640	1144	1.02	1175	1.11	1205	1.19	1234	1.28	1262	1.36	1289	1.45	1315	1.54	1341	1.63	1366	1.72	1391	1.82
2760	1165	1.08	1196	1.17	1225	1.25	1254	1.34	1282	1.43	1309	1.52	1335	1.61	1360	1.71	1385	1.8	1410	1.9
2880	1187	1.14	1217	1.23	1246	1.32	1274	1.41	1302	1.5	1328	1.6	1355	1.69	1380	1.78	1405	1.88	1429	1.98

**Notes:**

1. Available External Static Pressure is the static pressure difference between the return duct and the supply duct plus the static pressure drop caused by accessories and options.
2. For direct drive evaporator fan speed (rpm), refer to the applicable table in the fan performance section.
3. Data includes pressure drop due to standard filters and wet coils. No accessories or options are included in pressure drop data.
4. To determine static pressure drop due to other options/accessories, refer to the applicable table in the fan performance section.
5. Direct drive fan motor heat is negligible.
6. Factory supplied motors, in commercial equipment, are definite purpose motors, specifically designed and tested to operate reliably and continuously at all cataloged conditions. Using the full horsepower range of our fan motors as shown in our tabular data will not result in nuisance tripping or premature motor failure. Our product's warranty will not be affected.

**Table 24. Evaporator fan performance - 6 ton (model YSJ), horizontal, high heat**

Available External Static Pressure (Inches of Water Gauge)																				
CFM	0.10"		0.20"		0.30"		0.40"		0.50"		0.60"		0.70"		0.80"		0.90"		1.00"	
	RPM	BHP	RPM	BHP	RPM	BHP	RPM	BHP	RPM	BHP	RPM	BHP	RPM	BHP	RPM	BHP	RPM	BHP	RPM	BHP
1800	631	0.17	684	0.22	732	0.27	777	0.32	819	0.37	859	0.43	896	0.48	932	0.54	968	0.60	1002	0.67
1920	665	0.20	716	0.25	763	0.30	806	0.36	847	0.41	886	0.47	923	0.53	957	0.59	991	0.65	1024	0.72
2040	700	0.23	749	0.28	794	0.34	836	0.40	875	0.46	913	0.52	949	0.58	983	0.64	1016	0.71	1047	0.77
2160	736	0.27	782	0.32	825	0.38	866	0.44	904	0.50	941	0.57	976	0.63	1010	0.70	1042	0.77	1073	0.83
2280	771	0.31	816	0.37	858	0.43	897	0.49	934	0.55	970	0.62	1004	0.69	1037	0.76	1069	0.83	1099	0.90
2400	807	0.35	850	0.41	890	0.48	928	0.54	964	0.61	999	0.68	1033	0.75	1065	0.82	1096	0.89	1126	0.97
2520	843	0.40	885	0.46	923	0.53	960	0.60	995	0.67	1029	0.74	1061	0.81	1093	0.89	1123	0.96	1153	1.04
2640	879	0.45	919	0.52	957	0.59	992	0.66	1026	0.73	1059	0.81	1091	0.88	1122	0.96	1152	1.04	1180	1.12
2760	915	0.51	954	0.58	990	0.65	1025	0.73	1058	0.80	1090	0.88	1121	0.96	1150	1.04	1180	1.12	1208	1.20
2880	951	0.57	989	0.65	1024	0.72	1058	0.80	1090	0.88	1121	0.96	1151	1.04	1180	1.12	1209	1.20	1237	1.29

**Table 24. Evaporator fan performance - 6 ton (model YSJ), horizontal, high heat (continued)**

Available External Static Pressure (Inches of Water Gauge)										
CFM	1.10"	1.20"	1.30"	1.40"	1.50"	1.60"	1.70"	1.80"	1.90"	2.00"
	RPM BHP	RPM BHP	RPM BHP	RPM BHP	RPM BHP	RPM BHP	RPM BHP	RPM BHP	RPM BHP	RPM BHP
1800	1034 0.73	1066 0.79	1096 0.86	1126 0.93	1156 1	1185 1.07	1213 1.15	1241 1.22	1267 1.3	1293 1.38
1920	1057 0.78	1088 0.85	1118 0.92	1147 0.99	1175 1.06	1203 1.13	1231 1.21	1258 1.29	1285 1.36	1311 1.44
2040	1079 0.84	1110 0.91	1140 0.98	1169 1.05	1197 1.13	1224 1.2	1250 1.27	1276 1.35	1303 1.43	1329 1.52
2160	1103 0.9	1133 0.97	1162 1.05	1191 1.12	1219 1.2	1246 1.27	1272 1.35	1297 1.43	1322 1.51	1347 1.59
2280	1129 0.97	1157 1.04	1185 1.11	1214 1.19	1241 1.27	1268 1.35	1294 1.43	1319 1.51	1344 1.59	1368 1.68
2400	1155 1.04	1183 1.12	1210 1.19	1236 1.27	1264 1.35	1290 1.43	1316 1.51	1341 1.6	1366 1.68	1390 1.77
2520	1182 1.12	1209 1.2	1236 1.27	1262 1.35	1287 1.43	1313 1.52	1339 1.6	1364 1.69	1388 1.77	1412 1.86
2640	1209 1.2	1236 1.28	1262 1.36	1288 1.44	1313 1.52	1337 1.61	1362 1.69	1386 1.78	1411 1.87	1434 1.96
2760	1236 1.28	1263 1.37	1289 1.45	1315 1.54	1339 1.62	1363 1.71	1387 1.79	1410 1.88	1434 1.97	1457 2.07
2880	1264 1.37	1290 1.46	1316 1.55	1341 1.64	1366 1.73	1390 1.81	1413 1.9	1436 1.99	1458 2.08	1480 2.17

**Notes:**

1. Available External Static Pressure is the static pressure difference between the return duct and the supply duct plus the static pressure drop caused by accessories and options.
2. For direct drive evaporator fan speed (rpm), refer to the applicable table in the fan performance section.
3. Data includes pressure drop due to standard filters and wet coils. No accessories or options are included in pressure drop data.
4. To determine static pressure drop due to other options/accessories, refer to the applicable table in the fan performance section.
5. Direct drive fan motor heat is negligible.
6. Factory supplied motors, in commercial equipment, are definite purpose motors, specifically designed and tested to operate reliably and continuously at all cataloged conditions. Using the full horsepower range of our fan motors as shown in our tabular data will not result in nuisance tripping or premature motor failure. Our product's warranty will not be affected.

**Table 25. Evaporator fan performance - 7.5 ton (model YSJ), downflow, high heat**

Available External Static Pressure (Inches of Water Gauge)										
CFM	0.10"	0.20"	0.30"	0.40"	0.50"	0.60"	0.70"	0.80"	0.90"	1.00"
	RPM BHP	RPM BHP	RPM BHP	RPM BHP	RPM BHP	RPM BHP	RPM BHP	RPM BHP	RPM BHP	RPM BHP
2250	676 0.19	728 0.25	775 0.31	820 0.37	863 0.44	903 0.50	943 0.57	980 0.64	1016 0.71	1050 0.79
2400	713 0.22	764 0.29	809 0.35	852 0.42	893 0.48	933 0.55	970 0.62	1007 0.70	1042 0.77	1075 0.85
2550	752 0.26	800 0.33	843 0.40	884 0.47	924 0.54	962 0.61	999 0.68	1034 0.76	1069 0.83	1102 0.91
2700	790 0.30	836 0.37	878 0.44	918 0.52	956 0.59	993 0.66	1029 0.74	1063 0.82	1096 0.90	1129 0.98
2850	828 0.35	873 0.42	914 0.50	952 0.57	988 0.65	1024 0.73	1059 0.81	1092 0.89	1125 0.97	1156 1.06
3000	867 0.40	910 0.47	950 0.55	987 0.63	1022 0.71	1056 0.80	1090 0.88	1122 0.96	1154 1.05	1185 1.14
3150	906 0.45	948 0.53	986 0.62	1022 0.70	1056 0.78	1089 0.87	1122 0.96	1153 1.04	1184 1.13	1214 1.22
3300	945 0.51	985 0.59	1023 0.68	1057 0.77	1091 0.86	1123 0.95	1154 1.04	1185 1.13	1215 1.22	1244 1.31
3600	1024 0.64	1061 0.74	1096 0.83	1130 0.93	1161 1.02	1191 1.12	1221 1.22	1249 1.32	1278 1.41	1306 1.51

Available External Static Pressure (Inches of Water Gauge)										
CFM	1.10"	1.20"	1.30"	1.40"	1.50"	1.60"	1.70"	1.80"	1.90"	2.00"
	RPM BHP	RPM BHP	RPM BHP	RPM BHP	RPM BHP	RPM BHP	RPM BHP	RPM BHP	RPM BHP	RPM BHP
2250	1082 0.86	1114 0.94	1144 1.01	1174 1.09	1203 1.17	1231 1.25	1259 1.34	1286 1.42	1312 1.51	1337 1.59
2400	1108 0.93	1139 1	1169 1.08	1198 1.17	1226 1.25	1254 1.33	1281 1.42	1308 1.5	1334 1.59	1359 1.68
2550	1134 0.99	1165 1.08	1194 1.16	1223 1.24	1251 1.33	1278 1.42	1305 1.5	1331 1.59	1356 1.68	1382 1.78
2700	1160 1.07	1190 1.15	1220 1.24	1249 1.33	1276 1.41	1303 1.5	1329 1.59	1355 1.69	1380 1.78	1404 1.87
2850	1187 1.14	1217 1.23	1246 1.32	1274 1.41	1302 1.5	1329 1.6	1355 1.69	1380 1.79	1405 1.88	1429 1.98
3000	1215 1.23	1244 1.32	1273 1.41	1300 1.5	1328 1.6	1354 1.69	1380 1.79	1405 1.89	1430 1.99	1454 2.09
3150	1243 1.31	1272 1.41	1300 1.5	1327 1.6	1354 1.7	1380 1.8	1406 1.9	1431 2	1455 2.1	1479 2.2
3300	1273 1.41	1301 1.5	1328 1.6	1355 1.7	1381 1.8	1407 1.9	1432 2.01	1457 2.11	1481 2.22	1505 2.32
3600	1333 1.61	1360 1.71	1386 1.81	1412 1.92	1437 2.03	1462 2.13	1486 2.24	1510 2.35	1534 2.47	1557 2.58

**Notes:**

1. Available External Static Pressure is the static pressure difference between the return duct and the supply duct plus the static pressure drop caused by accessories and options.
2. For direct drive evaporator fan speed (rpm), refer to the applicable table in the fan performance section.
3. Data includes pressure drop due to standard filters and wet coils. No accessories or options are included in pressure drop data.
4. To determine static pressure drop due to other options/accessories, refer to the applicable table in the fan performance section.
5. Direct drive fan motor heat is negligible.
6. Factory supplied motors, in commercial equipment, are definite purpose motors, specifically designed and tested to operate reliably and continuously at all cataloged conditions. Using the full horsepower range of our fan motors as shown in our tabular data will not result in nuisance tripping or premature motor failure. Our product's warranty will not be affected.



# Evaporator Fan Performance

**Table 26. Evaporator fan performance - 7.5 ton (model YSJ), horizontal, high heat**

Available External Static Pressure (Inches of Water Gauge)										
CFM	0.10"	0.20"	0.30"	0.40"	0.50"	0.60"	0.70"	0.80"	0.90"	1.00"
	RPM BHP	RPM BHP	RPM BHP	RPM BHP	RPM BHP	RPM BHP	RPM BHP	RPM BHP	RPM BHP	RPM BHP
2250	707 0.23	748 0.28	790 0.34	831 0.39	870 0.45	906 0.51	941 0.57	973 0.63	1007 0.70	1039 0.76
2400	748 0.27	788 0.33	826 0.38	865 0.44	903 0.51	939 0.57	973 0.63	1005 0.70	1035 0.76	1066 0.83
2550	790 0.32	828 0.38	863 0.44	900 0.50	937 0.56	972 0.63	1005 0.70	1036 0.77	1066 0.83	1095 0.90
2700	832 0.37	868 0.43	901 0.49	936 0.56	971 0.63	1005 0.70	1038 0.77	1069 0.84	1098 0.91	1127 0.98
2850	874 0.43	909 0.49	941 0.56	973 0.63	1006 0.70	1039 0.77	1071 0.84	1102 0.92	1131 0.99	1158 1.07
3000	916 0.49	950 0.56	981 0.63	1010 0.70	1042 0.77	1073 0.85	1105 0.92	1135 1.00	1163 1.08	1191 1.16
3150	959 0.56	991 0.63	1021 0.71	1049 0.78	1079 0.85	1109 0.93	1139 1.01	1168 1.09	1197 1.18	1224 1.26
3300	1001 0.64	1032 0.72	1061 0.79	1089 0.87	1116 0.94	1145 1.02	1173 1.11	1202 1.19	1230 1.28	1257 1.36
3600	1086 0.81	1116 0.90	1143 0.98	1169 1.06	1194 1.14	1219 1.23	1246 1.32	1271 1.41	1297 1.50	1324 1.59
Available External Static Pressure (Inches of Water Gauge)										
CFM	1.10"	1.20"	1.30"	1.40"	1.50"	1.60"	1.70"	1.80"	1.90"	2.00"
	RPM BHP	RPM BHP	RPM BHP	RPM BHP	RPM BHP	RPM BHP	RPM BHP	RPM BHP	RPM BHP	RPM BHP
2250	1069 0.83	1100 0.9	1130 0.97	1159 1.04	1187 1.12	1214 1.19	1241 1.26	1267 1.34	1292 1.42	1318 1.5
2400	1097 0.9	1126 0.97	1155 1.04	1184 1.12	1211 1.2	1238 1.27	1265 1.35	1290 1.43	1315 1.51	1339 1.59
2550	1124 0.97	1153 1.05	1181 1.12	1208 1.2	1236 1.28	1263 1.36	1289 1.44	1314 1.52	1339 1.6	1363 1.69
2700	1154 1.06	1181 1.13	1209 1.21	1236 1.29	1262 1.37	1287 1.45	1313 1.53	1339 1.62	1363 1.7	1387 1.79
2850	1186 1.15	1212 1.22	1237 1.3	1264 1.38	1289 1.47	1314 1.55	1339 1.63	1363 1.72	1388 1.81	1412 1.9
3000	1217 1.24	1243 1.32	1268 1.4	1292 1.48	1317 1.57	1342 1.66	1366 1.74	1390 1.83	1413 1.92	1436 2.01
3150	1250 1.34	1275 1.43	1300 1.51	1324 1.59	1347 1.68	1370 1.77	1394 1.86	1418 1.95	1440 2.04	1463 2.13
3300	1283 1.45	1307 1.54	1332 1.63	1355 1.71	1378 1.8	1401 1.89	1423 1.98	1446 2.07	1468 2.17	1490 2.26
3600	1349 1.69	1373 1.78	1397 1.87	1420 1.97	1442 2.06	1464 2.16	1486 2.26	1507 2.35	1528 2.45	1548 2.55

**Notes:**

1. Available External Static Pressure is the static pressure difference between the return duct and the supply duct plus the static pressure drop caused by accessories and options.
2. For direct drive evaporator fan speed (rpm), refer to the applicable table in the fan performance section.
3. Data includes pressure drop due to standard filters and wet coils. No accessories or options are included in pressure drop data.
4. To determine static pressure drop due to other options/accessories, refer to the applicable table in the fan performance section.
5. Direct drive fan motor heat is negligible.
6. Factory supplied motors, in commercial equipment, are definite purpose motors, specifically designed and tested to operate reliably and continuously at all cataloged conditions. Using the full horsepower range of our fan motors as shown in our tabular data will not result in nuisance tripping or premature motor failure. Our product's warranty will not be affected.

**Table 27. Evaporator fan performance - 8.5 ton (model YSJ), downflow, high heat**

Available External Static Pressure (Inches of Water Gauge)										
CFM	0.10"	0.20"	0.30"	0.40"	0.50"	0.60"	0.70"	0.80"	0.90"	1.00"
	RPM BHP	RPM BHP	RPM BHP	RPM BHP	RPM BHP	RPM BHP	RPM BHP	RPM BHP	RPM BHP	RPM BHP
2550	752 0.26	800 0.33	843 0.40	884 0.47	924 0.54	962 0.61	999 0.68	1034 0.76	1069 0.83	1102 0.91
2720	795 0.31	841 0.38	883 0.45	923 0.52	960 0.60	997 0.67	1033 0.75	1067 0.83	1100 0.91	1132 0.99
2890	839 0.36	883 0.43	923 0.51	961 0.59	997 0.67	1033 0.75	1067 0.82	1100 0.91	1133 0.99	1164 1.08
3060	883 0.42	925 0.50	964 0.58	1001 0.66	1036 0.74	1069 0.83	1103 0.91	1134 0.99	1166 1.08	1197 1.17
3230	927 0.48	968 0.56	1006 0.65	1041 0.74	1075 0.82	1107 0.91	1139 1.00	1170 1.09	1200 1.17	1230 1.27
3400	971 0.55	1011 0.64	1047 0.73	1081 0.82	1114 0.91	1146 1.00	1176 1.10	1206 1.19	1236 1.28	1264 1.37
3570	1016 0.63	1054 0.72	1089 0.81	1122 0.91	1154 1.00	1184 1.10	1214 1.20	1243 1.30	1271 1.39	1299 1.49
3740	1061 0.71	1097 0.81	1131 0.91	1164 1.01	1194 1.11	1224 1.21	1253 1.31	1281 1.41	1308 1.51	1335 1.61
4080	1151 0.91	1184 1.01	1216 1.12	1247 1.22	1276 1.33	1304 1.44	1331 1.55	1358 1.66	1384 1.77	1409 1.88
Available External Static Pressure (Inches of Water Gauge)										
CFM	1.10"	1.20"	1.30"	1.40"	1.50"	1.60"	1.70"	1.80"	1.90"	2.00"
	RPM BHP	RPM BHP	RPM BHP	RPM BHP	RPM BHP	RPM BHP	RPM BHP	RPM BHP	RPM BHP	RPM BHP
2550	1134 0.99	1165 1.08	1194 1.16	1223 1.24	1251 1.33	1278 1.42	1305 1.5	1331 1.59	1356 1.68	1382 1.78
2720	1163 1.08	1194 1.16	1223 1.25	1252 1.34	1280 1.43	1307 1.52	1333 1.61	1358 1.7	1383 1.79	1408 1.89
2890	1194 1.16	1224 1.25	1253 1.34	1281 1.44	1309 1.53	1335 1.62	1361 1.72	1387 1.81	1411 1.91	1436 2.01
3060	1226 1.26	1255 1.35	1284 1.45	1311 1.54	1338 1.64	1364 1.73	1390 1.83	1415 1.93	1440 2.03	1464 2.13
3230	1259 1.36	1287 1.46	1315 1.55	1342 1.65	1368 1.75	1394 1.85	1420 1.95	1445 2.06	1469 2.16	1493 2.27
3400	1292 1.47	1320 1.57	1347 1.67	1373 1.77	1399 1.87	1425 1.98	1450 2.08	1474 2.19	1498 2.3	1522 2.4
3570	1326 1.59	1354 1.69	1380 1.79	1406 1.9	1431 2	1456 2.11	1481 2.22	1505 2.33	1528 2.44	1551 2.55
3740	1362 1.71	1388 1.82	1414 1.92	1439 2.03	1464 2.14	1488 2.25	1512 2.36	1536 2.48	1559 2.59	1582 2.71

**Table 27. Evaporator fan performance - 8.5 ton (model YSJ), downflow, high heat (continued)**

Available External Static Pressure (Inches of Water Gauge)										
CFM	1.10"	1.20"	1.30"	1.40"	1.50"	1.60"	1.70"	1.80"	1.90"	2.00"
	RPM BHP	RPM BHP	RPM BHP	RPM BHP	RPM BHP	RPM BHP	RPM BHP	RPM BHP	RPM BHP	RPM BHP
4080	1434 1.99	1459 2.1	1484 2.21	1507 2.33	1531 2.44	1555 2.56	1578 2.68	1600 2.8	1622 2.92	1644 3.04

**Notes:**

1. Available External Static Pressure is the static pressure difference between the return duct and the supply duct plus the static pressure drop caused by accessories and options.
2. For direct drive evaporator fan speed (rpm), refer to the applicable table in the fan performance section.
3. Data includes pressure drop due to standard filters and wet coils. No accessories or options are included in pressure drop data.
4. To determine static pressure drop due to other options/accessories, refer to the applicable table in the fan performance section.
5. Direct drive fan motor heat is negligible.
6. Factory supplied motors, in commercial equipment, are definite purpose motors, specifically designed and tested to operate reliably and continuously at all cataloged conditions. Using the full horsepower range of our fan motors as shown in our tabular data will not result in nuisance tripping or premature motor failure. Our product's warranty will not be affected.

**Table 28. Evaporator fan performance - 8.5 ton (model YSJ), horizontal, high heat**

Available External Static Pressure (Inches of Water Gauge)										
CFM	0.10"	0.20"	0.30"	0.40"	0.50"	0.60"	0.70"	0.80"	0.90"	1.00"
	RPM BHP	RPM BHP	RPM BHP	RPM BHP	RPM BHP	RPM BHP	RPM BHP	RPM BHP	RPM BHP	RPM BHP
2550	790 0.32	828 0.38	863 0.44	900 0.50	937 0.56	972 0.63	1005 0.70	1036 0.77	1066 0.83	1095 0.90
2720	838 0.38	873 0.44	907 0.50	941 0.57	975 0.64	1010 0.71	1042 0.78	1073 0.85	1103 0.92	1131 0.99
2890	885 0.45	920 0.51	951 0.58	983 0.65	1016 0.72	1048 0.79	1080 0.87	1110 0.94	1139 1.02	1167 1.09
3060	933 0.52	966 0.59	997 0.66	1026 0.73	1057 0.80	1087 0.88	1118 0.96	1148 1.04	1177 1.12	1204 1.20
3230	982 0.60	1013 0.68	1042 0.75	1070 0.82	1099 0.90	1128 0.98	1157 1.06	1186 1.14	1214 1.23	1241 1.31
3400	1029 0.70	1060 0.77	1088 0.85	1115 0.93	1141 1.01	1170 1.09	1197 1.17	1225 1.26	1252 1.35	1279 1.44
3570	1077 0.80	1107 0.88	1134 0.96	1161 1.04	1186 1.12	1211 1.21	1238 1.29	1264 1.38	1291 1.47	1317 1.57
3740	1126 0.91	1155 0.99	1181 1.08	1206 1.16	1231 1.25	1254 1.34	1280 1.43	1305 1.52	1330 1.61	1355 1.71
4080	1222 1.16	1250 1.25	1275 1.35	1298 1.44	1321 1.53	1344 1.63	1365 1.72	1388 1.82	1412 1.92	1435 2.02

**Available External Static Pressure (Inches of Water Gauge)**

CFM	1.10"	1.20"	1.30"	1.40"	1.50"	1.60"	1.70"	1.80"	1.90"	2.00"
	RPM BHP	RPM BHP	RPM BHP	RPM BHP	RPM BHP	RPM BHP	RPM BHP	RPM BHP	RPM BHP	RPM BHP
2550	1124 0.97	1153 1.05	1181 1.12	1208 1.20	1236 1.28	1263 1.36	1289 1.44	1314 1.52	1339 1.60	1363 1.69
2720	1158 1.07	1185 1.14	1213 1.22	1239 1.30	1265 1.38	1291 1.46	1317 1.55	1342 1.63	1366 1.72	1391 1.80
2890	1194 1.17	1220 1.25	1245 1.33	1271 1.41	1297 1.49	1322 1.58	1346 1.66	1370 1.75	1394 1.84	1418 1.93
3060	1230 1.28	1256 1.36	1281 1.44	1305 1.53	1329 1.61	1353 1.70	1377 1.79	1401 1.88	1424 1.97	1446 2.06
3230	1267 1.40	1292 1.48	1317 1.57	1341 1.66	1364 1.74	1386 1.83	1409 1.92	1432 2.01	1455 2.11	1478 2.20
3400	1305 1.53	1329 1.62	1353 1.70	1377 1.80	1400 1.89	1422 1.98	1444 2.07	1465 2.16	1487 2.26	1509 2.35
3570	1342 1.66	1367 1.75	1390 1.85	1413 1.94	1436 2.04	1458 2.13	1479 2.23	1501 2.32	1521 2.42	1542 2.52
3740	1380 1.80	1404 1.90	1428 2.00	1451 2.10	1473 2.20	1494 2.30	1516 2.40	1536 2.50	1557 2.60	1577 2.70
4080	1457 2.12	1481 2.23	1504 2.33	1526 2.44	1548 2.55	1569 2.65	1589 2.76	1610 2.87	1629 2.98	- -

**Notes:**

1. Available External Static Pressure is the static pressure difference between the return duct and the supply duct plus the static pressure drop caused by accessories and options.
2. For direct drive evaporator fan speed (rpm), refer to the applicable table in the fan performance section.
3. Data includes pressure drop due to standard filters and wet coils. No accessories or options are included in pressure drop data.
4. To determine static pressure drop due to other options/accessories, refer to the applicable table in the fan performance section.
5. Direct drive fan motor heat is negligible.
6. Factory supplied motors, in commercial equipment, are definite purpose motors, specifically designed and tested to operate reliably and continuously at all cataloged conditions. Using the full horsepower range of our fan motors as shown in our tabular data will not result in nuisance tripping or premature motor failure. Our product's warranty will not be affected.

**Table 29. Evaporator fan performance - 10 ton (model YSJ), downflow, high heat**

Available External Static Pressure (Inches of Water Gauge)										
CFM	0.10"	0.20"	0.30"	0.40"	0.50"	0.60"	0.70"	0.80"	0.90"	1.00"
	RPM BHP	RPM BHP	RPM BHP	RPM BHP	RPM BHP	RPM BHP	RPM BHP	RPM BHP	RPM BHP	RPM BHP
<b>3-hp Standard Motor</b>										
3000	867 0.40	910 0.47	950 0.55	987 0.63	1022 0.71	1056 0.80	1090 0.88	1122 0.96	1154 1.05	1185 1.14
3200	919 0.47	960 0.55	998 0.64	1034 0.72	1068 0.81	1100 0.90	1132 0.98	1164 1.07	1194 1.16	1224 1.25
3400	971 0.55	1011 0.64	1047 0.73	1081 0.82	1114 0.91	1146 1.00	1176 1.10	1206 1.19	1236 1.28	1264 1.37
3600	1024 0.64	1061 0.74	1096 0.83	1130 0.93	1161 1.02	1191 1.12	1221 1.22	1249 1.32	1278 1.41	1306 1.51
3800	1077 0.74	1112 0.84	1146 0.94	1178 1.04	1209 1.14	1238 1.24	1266 1.35	1294 1.45	1321 1.56	1348 1.66



# Evaporator Fan Performance

**Table 29. Evaporator fan performance - 10 ton (model YSJ), downflow, high heat (continued)**

Available External Static Pressure (Inches of Water Gauge)										
CFM	0.10"	0.20"	0.30"	0.40"	0.50"	0.60"	0.70"	0.80"	0.90"	1.00"
	RPM BHP	RPM BHP	RPM BHP	RPM BHP	RPM BHP	RPM BHP	RPM BHP	RPM BHP	RPM BHP	RPM BHP
<b>3-hp Standard Motor</b>										
4000	1129 0.86	1164 0.96	1196 1.06	1227 1.17	1257 1.28	1285 1.38	1313 1.49	1340 1.60	1366 1.71	1391 1.82
4200	1183 0.98	1215 1.09	1247 1.20	1277 1.31	1305 1.42	1333 1.53	1360 1.64	1386 1.76	1411 1.87	1436 1.99
4400	1236 1.12	1267 1.23	1297 1.34	1326 1.46	1354 1.58	1381 1.69	1407 1.81	1432 1.93	1457 2.04	1481 2.16
4600	1289 1.27	1319 1.38	1349 1.50	1377 1.62	1404 1.74	1430 1.87	1455 1.99	1480 2.11	1503 2.23	1527 2.36
4800	1343 1.43	1372 1.55	1400 1.67	1427 1.80	1453 1.92	1479 2.05	1503 2.18	1527 2.31	1550 2.43	1573 2.56
Available External Static Pressure (Inches of Water Gauge)										
CFM	1.10"	1.20"	1.30"	1.40"	1.50"	1.60"	1.70"	1.80"	1.90"	2.00"
	RPM BHP	RPM BHP	RPM BHP	RPM BHP	RPM BHP	RPM BHP	RPM BHP	RPM BHP	RPM BHP	RPM BHP
<b>3-hp Standard Motor</b>										
3000	1215 1.23	1244 1.32	1273 1.41	1300 1.50	1328 1.60	1354 1.69	1380 1.79	1405 1.89	1430 1.99	1454 2.09
3200	1253 1.34	1281 1.44	1309 1.53	1336 1.63	1363 1.73	1389 1.83	1414 1.93	1439 2.03	1464 2.14	1488 2.24
3400	1292 1.47	1320 1.57	1347 1.67	1373 1.77	1399 1.87	1425 1.98	1450 2.08	1474 2.19	1498 2.30	1522 2.40
3600	1333 1.61	1360 1.71	1386 1.81	1412 1.92	1437 2.03	1462 2.13	1486 2.24	1510 2.35	1534 2.47	1557 2.58
3800	1375 1.76	1400 1.86	1426 1.97	1451 2.08	1476 2.19	1500 2.30	1523 2.42	1547 2.53	1570 2.65	1593 2.76
4000	1417 1.93	1442 2.03	1467 2.14	1491 2.25	1515 2.37	1539 2.48	1562 2.60	1585 2.72	1607 2.84	1630 2.96
4200	1460 2.10	1485 2.21	1509 2.33	1532 2.44	1555 2.56	1579 2.68	1601 2.80	1624 2.92	1646 3.04	- -
4400	1505 2.29	1528 2.41	1551 2.53	1575 2.64	1597 2.76	1619 2.88	1641 3.01	- -	- -	- -
4600	1550 2.48	1573 2.61	1595 2.74	1617 2.86	1640 2.98	- -	- -	- -	- -	- -
4800	1596 2.69	1618 2.82	1640 2.95	- -	- -	- -	- -	- -	- -	- -

**Notes:**

1. Available External Static Pressure is the static pressure difference between the return duct and the supply duct plus the static pressure drop caused by accessories and options.
2. For direct drive evaporator fan speed (rpm), refer to the applicable table in the fan performance section.
3. Data includes pressure drop due to standard filters and wet coils. No accessories or options are included in pressure drop data.
4. To determine static pressure drop due to other options/accessories, refer to the applicable table in the fan performance section.
5. Direct drive fan motor heat is negligible.
6. Factory supplied motors, in commercial equipment, are definite purpose motors, specifically designed and tested to operate reliably and continuously at all cataloged conditions. Using the full horsepower range of our fan motors as shown in our tabular data will not result in nuisance tripping or premature motor failure. Our product's warranty will not be affected.

**Table 30. Evaporator fan performance - 10 ton (model YSJ), downflow, high heat, high static drive**

Available External Static Pressure (Inches of Water Gauge)										
CFM	0.10"	0.20"	0.30"	0.40"	0.50"	0.60"	0.70"	0.80"	0.90"	1.00"
	RPM BHP	RPM BHP	RPM BHP	RPM BHP	RPM BHP	RPM BHP	RPM BHP	RPM BHP	RPM BHP	RPM BHP
<b>5-hp Oversized Motor</b>										
3000	879 0.42	921 0.49	961 0.57	998 0.65	1035 0.74	1070 0.82	1104 0.90	1137 0.99	1169 1.08	1199 1.17
3200	932 0.49	972 0.57	1010 0.66	1046 0.74	1080 0.83	1114 0.92	1147 1.01	1179 1.10	1210 1.19	1240 1.29
3400	985 0.58	1023 0.67	1059 0.75	1094 0.85	1127 0.94	1159 1.03	1191 1.12	1221 1.22	1252 1.32	1281 1.41
3600	1038 0.68	1075 0.77	1110 0.86	1142 0.96	1174 1.05	1205 1.15	1236 1.25	1265 1.35	1294 1.45	1323 1.55
3800	1092 0.79	1127 0.88	1160 0.98	1192 1.08	1222 1.18	1252 1.28	1281 1.39	1310 1.49	1338 1.60	1365 1.70
4000	1145 0.91	1179 1.01	1211 1.11	1242 1.21	1271 1.32	1300 1.43	1328 1.54	1355 1.65	1383 1.75	1409 1.86
4200	1199 1.04	1232 1.14	1263 1.25	1292 1.36	1320 1.47	1348 1.58	1375 1.70	1402 1.81	1428 1.93	1454 2.04
4400	1253 1.18	1284 1.29	1314 1.41	1343 1.52	1370 1.63	1397 1.75	1423 1.87	1449 1.99	1474 2.11	1499 2.23
4600	1307 1.34	1337 1.46	1366 1.57	1394 1.69	1420 1.81	1446 1.93	1472 2.05	1497 2.18	1521 2.30	1545 2.43
4800	1361 1.51	1391 1.63	1418 1.76	1445 1.88	1471 2.00	1496 2.13	1520 2.25	1545 2.38	1568 2.51	1592 2.64
Available External Static Pressure (Inches of Water Gauge)										
CFM	1.10"	1.20"	1.30"	1.40"	1.50"	1.60"	1.70"	1.80"	1.90"	2.00"
	RPM BHP	RPM BHP	RPM BHP	RPM BHP	RPM BHP	RPM BHP	RPM BHP	RPM BHP	RPM BHP	RPM BHP
<b>5-hp Oversized Motor</b>										
3000	1229 1.26	1258 1.36	1287 1.45	1314 1.55	1342 1.65	1369 1.75	1395 1.86	1421 1.96	1446 2.07	1470 2.18
3200	1269 1.38	1297 1.48	1324 1.58	1351 1.68	1378 1.79	1404 1.89	1430 2	1455 2.11	1480 2.22	1504 2.33
3400	1309 1.51	1337 1.62	1363 1.72	1390 1.82	1415 1.93	1441 2.04	1466 2.15	1490 2.26	1514 2.37	1538 2.49
3600	1350 1.66	1377 1.76	1404 1.87	1429 1.98	1454 2.09	1479 2.2	1503 2.31	1527 2.43	1551 2.54	1574 2.66
3800	1392 1.81	1419 1.92	1444 2.03	1470 2.14	1494 2.26	1518 2.37	1542 2.49	1565 2.61	1588 2.73	1611 2.85
4000	1435 1.97	1461 2.09	1486 2.2	1511 2.32	1535 2.44	1558 2.56	1582 2.68	1604 2.8	1626 2.92	1648 3.05



**Table 30. Evaporator fan performance - 10 ton (model YSJ), downflow, high heat, high static drive (continued)**

Available External Static Pressure (Inches of Water Gauge)										
CFM	1.10"	1.20"	1.30"	1.40"	1.50"	1.60"	1.70"	1.80"	1.90"	2.00"
	RPM BHP	RPM BHP	RPM BHP	RPM BHP	RPM BHP	RPM BHP	RPM BHP	RPM BHP	RPM BHP	RPM BHP
<b>5-hp Oversized Motor</b>										
4200	1479 2.16	1504 2.27	1528 2.39	1552 2.51	1576 2.63	1599 2.76	1622 2.88	1644 3.01	1666 3.13	1688 3.26
4400	1524 2.35	1548 2.47	1571 2.59	1595 2.72	1618 2.84	1641 2.97	1663 3.1	1685 3.23	1706 3.36	1728 3.49
4600	1569 2.56	1592 2.68	1615 2.81	1638 2.93	1660 3.06	1683 3.19	1705 3.33	1726 3.46	1747 3.6	1768 3.73
4800	1614 2.78	1637 2.91	1660 3.04	1682 3.17	1704 3.3	1725 3.43	1747 3.57	1768 3.71	1789 3.85	1810 3.99

**Notes:**

1. Available External Static Pressure is the static pressure difference between the return duct and the supply duct plus the static pressure drop caused by accessories and options.
2. For direct drive evaporator fan speed (rpm), refer to the applicable table in the fan performance section.
3. Data includes pressure drop due to standard filters and wet coils. No accessories or options are included in pressure drop data.
4. To determine static drive pressure drop due to other options/accessories, refer to the applicable table in the fan performance section.
5. Direct drive fan motor heat is negligible.
6. Factory supplied motors, in commercial equipment, are definite purpose motors, specifically designed and tested to operate reliably and continuously at all cataloged conditions. Using the full horsepower range of our fan motors as shown in our tabular data will not result in nuisance tripping or premature motor failure. Our product's warranty will not be affected.

**Table 31. Evaporator fan performance - 10 ton (model YSJ), horizontal, high heat**

Available External Static Pressure (Inches of Water Gauge)										
CFM	0.10"	0.20"	0.30"	0.40"	0.50"	0.60"	0.70"	0.80"	0.90"	1.00"
	RPM BHP	RPM BHP	RPM BHP	RPM BHP	RPM BHP	RPM BHP	RPM BHP	RPM BHP	RPM BHP	RPM BHP
<b>3-hp Standard Motor</b>										
3000	916 0.49	950 0.56	981 0.63	1010 0.70	1042 0.77	1073 0.85	1105 0.92	1135 1.00	1163 1.08	1191 1.16
3200	973 0.59	1005 0.66	1034 0.73	1062 0.81	1091 0.88	1121 0.96	1150 1.04	1179 1.13	1208 1.21	1235 1.29
3400	1029 0.70	1060 0.77	1088 0.85	1115 0.93	1141 1.01	1170 1.09	1197 1.17	1225 1.26	1252 1.35	1279 1.44
3600	1086 0.81	1116 0.90	1143 0.98	1169 1.06	1194 1.14	1219 1.23	1246 1.32	1271 1.41	1297 1.50	1324 1.59
3800	1143 0.95	1171 1.04	1197 1.12	1222 1.21	1247 1.30	1270 1.38	1295 1.47	1320 1.57	1344 1.66	1369 1.76
4000	1199 1.09	1228 1.19	1253 1.28	1277 1.37	1300 1.46	1322 1.55	1344 1.65	1369 1.74	1392 1.84	1415 1.94
4200	1256 1.25	1284 1.36	1308 1.45	1331 1.55	1354 1.64	1375 1.74	1397 1.84	1418 1.93	1441 2.04	1464 2.14
4400	1314 1.43	1341 1.54	1364 1.64	1386 1.74	1408 1.84	1429 1.94	1449 2.04	1469 2.14	1490 2.25	1512 2.35
4600	1371 1.63	1397 1.74	1420 1.84	1441 1.95	1462 2.05	1483 2.16	1503 2.26	1522 2.37	1541 2.48	1562 2.59
4800	1428 1.84	1454 1.96	1476 2.07	1497 2.18	1517 2.28	1537 2.39	1556 2.50	1575 2.61	1594 2.72	1612 2.84
<b>Available External Static Pressure (Inches of Water Gauge)</b>										
CFM	1.10"	1.20"	1.30"	1.40"	1.50"	1.60"	1.70"	1.80"	1.90"	2.00"
	RPM BHP	RPM BHP	RPM BHP	RPM BHP	RPM BHP	RPM BHP	RPM BHP	RPM BHP	RPM BHP	RPM BHP
<b>3-hp Standard Motor</b>										
3000	1217 1.24	1243 1.32	1268 1.40	1292 1.48	1317 1.57	1342 1.66	1366 1.74	1390 1.83	1413 1.92	1436 2.01
3200	1261 1.38	1286 1.46	1310 1.55	1334 1.63	1358 1.72	1380 1.81	1404 1.90	1427 1.99	1450 2.08	1472 2.18
3400	1305 1.53	1329 1.62	1353 1.70	1377 1.80	1400 1.89	1422 1.98	1444 2.07	1465 2.16	1487 2.26	1509 2.35
3600	1349 1.69	1373 1.78	1397 1.87	1420 1.97	1442 2.06	1464 2.16	1486 2.26	1507 2.35	1528 2.45	1548 2.55
3800	1394 1.86	1418 1.96	1441 2.06	1464 2.16	1486 2.26	1507 2.36	1529 2.46	1549 2.56	1570 2.66	1590 2.76
4000	1439 2.04	1463 2.15	1486 2.25	1508 2.36	1530 2.46	1551 2.57	1572 2.67	1592 2.78	1612 2.88	1632 2.99
4200	1486 2.24	1508 2.35	1531 2.46	1553 2.57	1574 2.68	1596 2.79	1616 2.90	1636 3.01	- -	- -
4400	1534 2.46	1555 2.57	1576 2.68	1598 2.80	1619 2.91	1640 3.03	- -	- -	- -	- -
4600	1583 2.70	1603 2.81	1623 2.92	1643 3.04	- -	- -	- -	- -	- -	- -
4800	1632 2.95	- -	- -	- -	- -	- -	- -	- -	- -	- -

**Notes:**

1. Available External Static Pressure is the static pressure difference between the return duct and the supply duct plus the static pressure drop caused by accessories and options.
2. For direct drive evaporator fan speed (rpm), refer to the applicable table in the fan performance section.
3. Data includes pressure drop due to standard filters and wet coils. No accessories or options are included in pressure drop data.
4. To determine static pressure drop due to other options/accessories, refer to the applicable table in the fan performance section.
5. Direct drive fan motor heat is negligible.
6. Factory supplied motors, in commercial equipment, are definite purpose motors, specifically designed and tested to operate reliably and continuously at all cataloged conditions. Using the full horsepower range of our fan motors as shown in our tabular data will not result in nuisance tripping or premature motor failure. Our product's warranty will not be affected.



## Evaporator Fan Performance

**Table 32. Evaporator fan performance - 10 ton (model YSJ), horizontal, high heat, high static drive**

Available External Static Pressure (Inches of Water Gauge)										
CFM	0.10"	0.20"	0.30"	0.40"	0.50"	0.60"	0.70"	0.80"	0.90"	1.00"
	RPM BHP	RPM BHP	RPM BHP	RPM BHP	RPM BHP	RPM BHP	RPM BHP	RPM BHP	RPM BHP	RPM BHP
<b>5-hp Oversized Motor</b>										
3000	920 0.49	958 0.57	993 0.64	1028 0.72	1061 0.80	1093 0.87	1123 0.95	1152 1.03	1181 1.12	1208 1.20
3200	976 0.59	1012 0.66	1046 0.74	1078 0.83	1110 0.91	1141 0.99	1171 1.08	1199 1.16	1227 1.25	1253 1.34
3400	1032 0.69	1067 0.78	1099 0.86	1130 0.94	1160 1.03	1190 1.12	1219 1.21	1247 1.30	1273 1.39	1299 1.48
3600	1089 0.81	1122 0.90	1153 0.99	1182 1.08	1211 1.17	1240 1.26	1268 1.36	1295 1.45	1321 1.55	1346 1.64
3800	1146 0.94	1177 1.04	1207 1.13	1235 1.22	1263 1.32	1290 1.42	1317 1.52	1344 1.62	1369 1.72	1393 1.82
4000	1202 1.09	1233 1.19	1261 1.28	1289 1.38	1315 1.48	1341 1.59	1367 1.69	1393 1.79	1418 1.90	1442 2.00
4200	1259 1.25	1289 1.35	1316 1.46	1343 1.56	1368 1.66	1393 1.77	1417 1.88	1442 1.99	1467 2.10	1490 2.21
4400	1316 1.42	1345 1.53	1371 1.64	1397 1.75	1422 1.86	1446 1.97	1469 2.08	1493 2.19	1516 2.31	1539 2.43
4600	1373 1.61	1401 1.73	1427 1.84	1451 1.96	1475 2.07	1499 2.19	1521 2.30	1543 2.42	1566 2.54	1589 2.66
4800	1431 1.82	1458 1.95	1482 2.06	1506 2.18	1529 2.30	1552 2.42	1574 2.54	1595 2.66	1617 2.78	1639 2.91
<b>Available External Static Pressure (Inches of Water Gauge)</b>										
CFM	1.10"	1.20"	1.30"	1.40"	1.50"	1.60"	1.70"	1.80"	1.90"	2.00"
	RPM BHP	RPM BHP	RPM BHP	RPM BHP	RPM BHP	RPM BHP	RPM BHP	RPM BHP	RPM BHP	RPM BHP
<b>5-hp Oversized Motor</b>										
3000	1237 1.29	1265 1.38	1292 1.47	1319 1.56	1345 1.66	1371 1.75	1396 1.85	1421 1.95	1445 2.05	1468 2.14
3200	1279 1.42	1305 1.52	1332 1.61	1358 1.71	1383 1.81	1408 1.9	1433 2	1457 2.11	1481 2.21	1504 2.31
3400	1325 1.57	1349 1.67	1373 1.76	1398 1.86	1423 1.97	1448 2.07	1472 2.17	1495 2.28	1518 2.38	1541 2.49
3600	1370 1.74	1395 1.84	1418 1.94	1441 2.04	1464 2.14	1488 2.24	1511 2.35	1534 2.46	1557 2.57	1579 2.68
3800	1417 1.92	1440 2.02	1464 2.12	1486 2.22	1508 2.33	1530 2.44	1552 2.55	1574 2.66	1597 2.77	1618 2.89
4000	1465 2.11	1488 2.21	1510 2.32	1532 2.43	1553 2.54	1575 2.65	1595 2.76	1616 2.87	1637 2.99	1658 3.11
4200	1513 2.32	1535 2.43	1557 2.54	1578 2.65	1599 2.76	1620 2.88	1641 2.99	1661 3.11	1680 3.23	1700 3.34
4400	1562 2.54	1584 2.66	1605 2.77	1626 2.89	1646 3	1666 3.12	1686 3.24	1706 3.36	1725 3.48	1744 3.6
4600	1611 2.78	1632 2.9	1653 3.02	1674 3.14	1694 3.26	1713 3.38	1733 3.5	1752 3.63	1771 3.75	1790 3.88
4800	1660 3.04	1681 3.16	1702 3.29	1722 3.41	1742 3.54	1761 3.66	1780 3.79	1799 3.92	1817 4.04	1835 4.17

**Notes:**

1. Available External Static Pressure is the static pressure difference between the return duct and the supply duct plus the static pressure drop caused by accessories and options.
2. For direct drive evaporator fan speed (rpm), refer to the applicable table in the fan performance section.
3. Data includes pressure drop due to standard filters and wet coils. No accessories or options are included in pressure drop data.
4. To determine static drive pressure drop due to other options/accessories, refer to the applicable table in the fan performance section.
5. Direct drive fan motor heat is negligible.
6. Factory supplied motors, in commercial equipment, are definite purpose motors, specifically designed and tested to operate reliably and continuously at all cataloged conditions. Using the full horsepower range of our fan motors as shown in our tabular data will not result in nuisance tripping or premature motor failure. Our product's warranty will not be affected.

**Table 33. Evaporator fan performance - 12.5 ton (model YSJ), downflow, high heat**

Available External Static Pressure (Inches of Water Gauge)										
CFM	0.10"	0.20"	0.30"	0.40"	0.50"	0.60"	0.70"	0.80"	0.90"	1.00"
	RPM BHP	RPM BHP	RPM BHP	RPM BHP	RPM BHP	RPM BHP	RPM BHP	RPM BHP	RPM BHP	RPM BHP
3750	1002 0.58	1036 0.66	1070 0.75	1101 0.83	1130 0.92	1158 1.00	1186 1.09	1213 1.17	1239 1.26	1266 1.35
4000	1065 0.70	1097 0.78	1128 0.87	1158 0.96	1187 1.05	1214 1.14	1240 1.23	1266 1.32	1291 1.41	1316 1.51
4250	1128 0.83	1157 0.91	1187 1.01	1216 1.10	1244 1.20	1271 1.30	1296 1.39	1320 1.48	1344 1.58	1368 1.68
4500	1191 0.97	1218 1.06	1247 1.16	1275 1.26	1301 1.36	1327 1.47	1352 1.57	1375 1.67	1398 1.77	1421 1.87
4750	1255 1.13	1279 1.22	1307 1.33	1334 1.43	1359 1.54	1384 1.65	1408 1.76	1431 1.86	1454 1.97	1475 2.07
5000	1319 1.31	1341 1.40	1367 1.51	1393 1.62	1418 1.74	1442 1.85	1465 1.96	1488 2.08	1510 2.19	1531 2.30
5250	1383 1.51	1403 1.60	1428 1.72	1453 1.83	1477 1.95	1500 2.07	1523 2.19	1545 2.31	1566 2.43	1587 2.54
5500	1446 1.72	1466 1.82	1489 1.94	1513 2.06	1536 2.18	1559 2.31	1581 2.43	1602 2.55	1623 2.68	1643 2.80
5750	1510 1.96	1529 2.06	1550 2.18	1573 2.31	1596 2.43	1618 2.56	1639 2.69	1660 2.82	1680 2.95	1700 3.08
6000	1574 2.21	1593 2.32	1612 2.44	1634 2.57	1656 2.71	1677 2.84	1697 2.97	1718 3.11	1737 3.24	1757 3.38
<b>Available External Static Pressure (Inches of Water Gauge)</b>										
CFM	1.10"	1.20"	1.30"	1.40"	1.50"	1.60"	1.70"	1.80"	1.90"	2.00"
	RPM BHP	RPM BHP	RPM BHP	RPM BHP	RPM BHP	RPM BHP	RPM BHP	RPM BHP	RPM BHP	RPM BHP
3750	1293 1.45	1319 1.55	1345 1.65	1371 1.75	1397 1.86	1422 1.96	1447 2.07	1473 2.18	1497 2.29	1521 2.41
4000	1340 1.61	1366 1.71	1391 1.81	1415 1.92	1440 2.02	1464 2.13	1489 2.25	1512 2.36	1535 2.47	1559 2.59
4250	1392 1.78	1414 1.88	1438 1.99	1462 2.1	1485 2.21	1508 2.32	1531 2.43	1555 2.55	1577 2.67	1599 2.79

**Table 33. Evaporator fan performance - 12.5 ton (model YSJ), downflow, high heat (continued)**

Available External Static Pressure (Inches of Water Gauge)										
	1.10"	1.20"	1.30"	1.40"	1.50"	1.60"	1.70"	1.80"	1.90"	2.00"
CFM	RPM BHP	RPM BHP	RPM BHP	RPM BHP	RPM BHP	RPM BHP	RPM BHP	RPM BHP	RPM BHP	RPM BHP
4500	1444 1.97	1466 2.08	1488 2.19	1510 2.29	1533 2.41	1555 2.53	1577 2.64	1598 2.76	1620 2.88	1642 3.01
4750	1497 2.18	1519 2.29	1540 2.4	1561 2.52	1581 2.63	1602 2.75	1624 2.87	1645 2.99	1666 3.12	1686 3.24
5000	1551 2.41	1572 2.52	1593 2.64	1613 2.76	1633 2.87	1652 2.99	1671 3.11	1692 3.24	1713 3.37	1733 3.5
5250	1607 2.66	1626 2.77	1646 2.89	1666 3.01	1685 3.14	1704 3.26	1723 3.38	1741 3.51	1760 3.64	1780 3.77
5500	1663 2.93	1682 3.05	1701 3.17	1719 3.29	1738 3.42	1757 3.55	1775 3.68	1793 3.8	1811 3.93	1829 4.07
5750	1719 3.21	1738 3.34	1756 3.47	1774 3.59	1792 3.72	1810 3.85	1828 3.99	1846 4.12	1863 4.26	1880 4.39
6000	1776 3.52	1794 3.65	1812 3.79	1830 3.92	1847 4.05	1864 4.18	1881 4.32	1899 4.46	1916 4.6	- -

**Notes:**

1. Available External Static Pressure is the static pressure difference between the return duct and the supply duct plus the static pressure drop caused by accessories and options.
2. For direct drive evaporator fan speed (rpm), refer to the applicable table in the fan performance section.
3. Data includes pressure drop due to standard filters and wet coils. No accessories or options are included in pressure drop data.
4. To determine static pressure drop due to other options/accessories, refer to the applicable table in the fan performance section.
5. Direct drive fan motor heat is negligible.
6. Factory supplied motors, in commercial equipment, are definite purpose motors, specifically designed and tested to operate reliably and continuously at all cataloged conditions. Using the full horsepower range of our fan motors as shown in our tabular data will not result in nuisance tripping or premature motor failure. Our product's warranty will not be affected.

**Table 34. Evaporator fan performance - 12.5 ton (model YSJ), horizontal, high heat**

Available External Static Pressure (Inches of Water Gauge)										
	0.10"	0.20"	0.30"	0.40"	0.50"	0.60"	0.70"	0.80"	0.90"	1.00"
CFM	RPM BHP	RPM BHP	RPM BHP	RPM BHP	RPM BHP	RPM BHP	RPM BHP	RPM BHP	RPM BHP	RPM BHP
3750	1091 0.77	1126 0.87	1159 0.96	1191 1.05	1220 1.14	1249 1.24	1276 1.33	1302 1.42	1328 1.52	1354 1.61
4000	1159 0.93	1192 1.02	1224 1.12	1254 1.22	1283 1.32	1310 1.42	1336 1.52	1362 1.62	1387 1.72	1411 1.82
4250	1227 1.10	1259 1.20	1289 1.31	1318 1.41	1346 1.52	1372 1.62	1398 1.73	1422 1.83	1446 1.94	1470 2.04
4500	1295 1.29	1326 1.40	1355 1.51	1382 1.62	1409 1.73	1435 1.84	1460 1.95	1483 2.07	1507 2.18	1529 2.29
4750	1363 1.50	1393 1.62	1421 1.74	1447 1.85	1473 1.97	1498 2.09	1522 2.21	1545 2.32	1568 2.44	1590 2.56
5000	1431 1.74	1460 1.86	1487 1.98	1513 2.11	1537 2.23	1562 2.35	1585 2.48	1608 2.60	1630 2.73	1651 2.85
5250	1500 1.99	1528 2.13	1554 2.26	1578 2.39	1602 2.51	1626 2.64	1648 2.77	1671 2.91	1692 3.04	1713 3.17
5500	1568 2.28	1596 2.42	1621 2.56	1644 2.69	1668 2.83	1690 2.96	1712 3.10	1734 3.23	1755 3.37	1775 3.51
5750	1637 2.59	1664 2.74	1688 2.88	1711 3.02	1733 3.16	1755 3.30	1776 3.45	1797 3.59	1818 3.73	1838 3.88
6000	1706 2.93	1732 3.09	1755 3.24	1777 3.38	1799 3.53	1820 3.68	1841 3.82	1861 3.97	1881 4.12	1901 4.27

Available External Static Pressure (Inches of Water Gauge)										
	1.10"	1.20"	1.30"	1.40"	1.50"	1.60"	1.70"	1.80"	1.90"	2.00"
CFM	RPM BHP	RPM BHP	RPM BHP	RPM BHP	RPM BHP	RPM BHP	RPM BHP	RPM BHP	RPM BHP	RPM BHP
3750	1380 1.72	1405 1.82	1430 1.92	1455 2.03	1480 2.13	1504 2.24	1527 2.34	1550 2.45	1572 2.56	1593 2.67
4000	1435 1.92	1459 2.03	1484 2.13	1507 2.24	1530 2.35	1554 2.47	1577 2.58	1599 2.69	1622 2.81	1643 2.92
4250	1492 2.15	1515 2.26	1538 2.37	1561 2.48	1584 2.6	1606 2.71	1627 2.83	1650 2.95	1671 3.07	1693 3.19
4500	1551 2.4	1573 2.51	1594 2.63	1616 2.74	1638 2.86	1659 2.98	1681 3.11	1701 3.23	1722 3.35	1743 3.48
4750	1611 2.68	1632 2.79	1653 2.91	1673 3.03	1693 3.15	1714 3.28	1735 3.4	1755 3.53	1775 3.66	1795 3.79
5000	1672 2.98	1692 3.1	1712 3.22	1732 3.35	1751 3.47	1770 3.6	1789 3.72	1809 3.86	1829 3.99	1848 4.13
5250	1733 3.3	1753 3.43	1772 3.56	1792 3.69	1811 3.82	1829 3.95	1847 4.08	1865 4.21	1884 4.35	1903 4.49
5500	1795 3.64	1814 3.78	1833 3.92	1852 4.06	1870 4.19	1888 4.33	1906 4.46	1924 4.6	- -	- -
5750	1857 4.02	1876 4.16	1894 4.3	1913 4.45	1930 4.59	- -	- -	- -	- -	- -
6000	1920 4.42	1938 4.57	- -	- -	- -	- -	- -	- -	- -	- -

**Notes:**

1. Available External Static Pressure is the static pressure difference between the return duct and the supply duct plus the static pressure drop caused by accessories and options.
2. For direct drive evaporator fan speed (rpm), refer to the applicable table in the fan performance section.
3. Data includes pressure drop due to standard filters and wet coils. No accessories or options are included in pressure drop data.
4. To determine static pressure drop due to other options/accessories, refer to the applicable table in the fan performance section.
5. Direct drive fan motor heat is negligible.
6. Factory supplied motors, in commercial equipment, are definite purpose motors, specifically designed and tested to operate reliably and continuously at all cataloged conditions. Using the full horsepower range of our fan motors as shown in our tabular data will not result in nuisance tripping or premature motor failure. Our product's warranty will not be affected.



## Evaporator Fan Performance

**Table 35. Evaporator fan performance - 15 ton (model YSJ), downflow**

Available External Static Pressure (Inches of Water Gauge)										
CFM	0.10"	0.20"	0.30"	0.40"	0.50"	0.60"	0.70"	0.80"	0.90"	1.00"
	RPM BHP	RPM BHP	RPM BHP	RPM BHP	RPM BHP	RPM BHP	RPM BHP	RPM BHP	RPM BHP	RPM BHP
4500	642 0.31	697 0.42	749 0.54	795 0.65	838 0.77	877 0.89	916 1.01	954 1.13	990 1.26	1025 1.40
4800	678 0.37	728 0.48	780 0.61	825 0.73	867 0.85	905 0.97	942 1.10	978 1.23	1014 1.36	1048 1.50
5400	751 0.49	796 0.61	842 0.75	886 0.89	926 1.03	963 1.16	998 1.30	1032 1.44	1064 1.58	1096 1.73
6000	825 0.64	865 0.78	905 0.91	948 1.07	987 1.23	1023 1.38	1057 1.53	1089 1.69	1120 1.84	1150 2.00
6600	900 0.83	936 0.97	973 1.12	1009 1.28	1049 1.46	1084 1.63	1117 1.80	1148 1.96	1178 2.13	1207 2.30
7200	975 1.04	1009 1.20	1042 1.36	1076 1.53	1110 1.71	1146 1.90	1178 2.09	1209 2.27	1238 2.45	1266 2.64
Available External Static Pressure (Inches of Water Gauge)										
CFM	1.10"	1.20"	1.30"	1.40"	1.50"	1.60"	1.70"	1.80"	1.90"	2.00"
	RPM BHP	RPM BHP	RPM BHP	RPM BHP	RPM BHP	RPM BHP	RPM BHP	RPM BHP	RPM BHP	RPM BHP
4500	1058 1.53	1090 1.67	1122 1.81	1153 1.96	1184 2.1	1213 2.26	1241 2.41	1269 2.56	1295 2.72	1322 2.88
4800	1081 1.64	1113 1.78	1143 1.93	1173 2.08	1203 2.23	1232 2.39	1261 2.54	1288 2.7	1315 2.87	1341 3.03
5400	1129 1.88	1160 2.03	1190 2.19	1219 2.35	1247 2.51	1274 2.67	1300 2.83	1328 3.00	1354 3.18	1380 3.35
6000	1179 2.15	1208 2.32	1237 2.48	1266 2.65	1294 2.82	1321 3.00	1347 3.17	1372 3.35	1397 3.53	1421 3.71
6600	1235 2.47	1262 2.64	1289 2.81	1315 2.99	1342 3.17	1368 3.36	1394 3.54	1419 3.73	1444 3.92	1468 4.11
7200	1293 2.82	1320 3.01	1345 3.19	1370 3.38	1394 3.56	1418 3.75	1443 3.95	1467 4.15	1492 4.35	1515 4.55

**Notes:**

1. Available External Static Pressure is the static pressure difference between the return duct and the supply duct plus the static pressure drop caused by accessories and options.
2. For direct drive evaporator fan speed (rpm), refer to the applicable table in the fan performance section.
3. Data includes pressure drop due to standard filters, wet coils, and high gas heat. No accessories or options are included in pressure drop data.
4. To determine static pressure drop due to other options/accessories, refer to the applicable table in the fan performance section.
5. Direct drive fan motor heat is negligible.
6. Factory supplied motors, in commercial equipment, are definite purpose motors, specifically designed and tested to operate reliably and continuously at all cataloged conditions. Using the full horsepower range of our fan motors as shown in our tabular data will not result in nuisance tripping or premature motor failure. Our product's warranty will not be affected.

**Table 36. Evaporator fan performance - 15 ton (model YSJ), horizontal**

Available External Static Pressure (Inches of Water Gauge)										
CFM	0.10"	0.20"	0.30"	0.40"	0.50"	0.60"	0.70"	0.80"	0.90"	1.00"
	RPM BHP	RPM BHP	RPM BHP	RPM BHP	RPM BHP	RPM BHP	RPM BHP	RPM BHP	RPM BHP	RPM BHP
4500	688 0.39	737 0.50	782 0.61	823 0.72	864 0.84	903 0.96	941 1.08	978 1.21	1013 1.34	1047 1.47
4800	727 0.46	774 0.58	817 0.69	857 0.81	895 0.93	933 1.06	970 1.19	1005 1.32	1039 1.46	1073 1.59
5400	805 0.62	849 0.76	890 0.89	927 1.02	962 1.15	995 1.28	1030 1.43	1063 1.57	1096 1.71	1127 1.86
6000	885 0.82	926 0.97	963 1.11	999 1.26	1032 1.40	1064 1.55	1094 1.70	1125 1.85	1155 2.01	1185 2.17
6600	965 1.06	1003 1.22	1039 1.38	1072 1.54	1103 1.70	1134 1.86	1163 2.02	1190 2.18	1217 2.35	1246 2.52
7200	1047 1.35	1082 1.52	1115 1.69	1146 1.87	1176 2.04	1205 2.21	1233 2.39	1260 2.56	1286 2.74	1311 2.92
Available External Static Pressure (Inches of Water Gauge)										
CFM	1.10"	1.20"	1.30"	1.40"	1.50"	1.60"	1.70"	1.80"	1.90"	2.00"
	RPM BHP	RPM BHP	RPM BHP	RPM BHP	RPM BHP	RPM BHP	RPM BHP	RPM BHP	RPM BHP	RPM BHP
4500	1080 1.61	1111 1.74	1142 1.88	1171 2.02	1200 2.17	1228 2.31	1255 2.46	1282 2.62	1307 2.77	1333 2.93
4800	1105 1.73	1136 1.87	1166 2.02	1195 2.16	1224 2.31	1251 2.46	1278 2.62	1304 2.78	1330 2.94	1355 3.10
5400	1158 2.01	1188 2.17	1217 2.32	1246 2.48	1273 2.64	1300 2.8	1326 2.96	1352 3.13	1377 3.29	1401 3.46
6000	1214 2.33	1243 2.50	1271 2.66	1297 2.83	1325 3.00	1351 3.18	1377 3.35	1402 3.53	1427 3.71	1451 3.89
6600	1274 2.70	1301 2.87	1327 3.05	1354 3.23	1379 3.41	1404 3.6	1429 3.78	1453 3.97	1478 4.16	1501 4.35
7200	1336 3.11	1362 3.29	1388 3.48	1412 3.68	1437 3.87	1461 4.06	1485 4.26	1508 4.46	1531 4.66	1553 4.86

**Notes:**

1. Available External Static Pressure is the static pressure difference between the return duct and the supply duct plus the static pressure drop caused by accessories and options.
2. For direct drive evaporator fan speed (rpm), refer to the applicable table in the fan performance section.
3. Data includes pressure drop due to standard filters, wet coils, and high gas heat. No accessories or options are included in pressure drop data.
4. To determine static pressure drop due to other options/accessories, refer to the applicable table in the fan performance section.
5. Direct drive fan motor heat is negligible.
6. Factory supplied motors, in commercial equipment, are definite purpose motors, specifically designed and tested to operate reliably and continuously at all cataloged conditions. Using the full horsepower range of our fan motors as shown in our tabular data will not result in nuisance tripping or premature motor failure. Our product's warranty will not be affected.

**Table 37. Evaporator fan performance - 17.5 ton (model YSJ), downflow**

Available External Static Pressure (Inches of Water Gauge)										
CFM	0.10"	0.20"	0.30"	0.40"	0.50"	0.60"	0.70"	0.80"	0.90"	1.00"
	RPM BHP	RPM BHP	RPM BHP	RPM BHP	RPM BHP	RPM BHP	RPM BHP	RPM BHP	RPM BHP	RPM BHP
5250	733 0.46	779 0.58	826 0.71	871 0.85	911 0.98	949 1.11	984 1.25	1018 1.39	1051 1.52	1084 1.67
5600	776 0.54	819 0.66	862 0.80	907 0.95	946 1.09	983 1.23	1018 1.38	1051 1.52	1082 1.67	1113 1.81
6300	862 0.73	900 0.87	939 1.01	979 1.17	1018 1.34	1053 1.50	1087 1.66	1119 1.82	1149 1.98	1179 2.15
7000	950 0.97	985 1.12	1019 1.28	1053 1.44	1090 1.62	1126 1.81	1158 1.99	1188 2.16	1218 2.34	1246 2.52
7700	1038 1.25	1070 1.42	1101 1.59	1132 1.76	1163 1.94	1197 2.15	1230 2.36	1260 2.56	1289 2.75	1316 2.94
8400	1127 1.59	1156 1.77	1185 1.96	1213 2.14	1242 2.34	1270 2.53	1301 2.76	1332 2.99	1361 3.21	1387 3.42
Available External Static Pressure (Inches of Water Gauge)										
CFM	1.10"	1.20"	1.30"	1.40"	1.50"	1.60"	1.70"	1.80"	1.90"	2.00"
	RPM BHP	RPM BHP	RPM BHP	RPM BHP	RPM BHP	RPM BHP	RPM BHP	RPM BHP	RPM BHP	RPM BHP
5250	1117 1.82	1148 1.97	1178 2.12	1207 2.28	1235 2.43	1262 2.59	1290 2.76	1318 2.93	1344 3.10	1370 3.27
5600	1145 1.97	1176 2.13	1205 2.28	1234 2.45	1262 2.61	1289 2.77	1316 2.94	1341 3.11	1367 3.29	1393 3.47
6300	1207 2.31	1234 2.47	1262 2.64	1290 2.82	1318 2.99	1344 3.17	1370 3.35	1396 3.53	1420 3.72	1444 3.90
7000	1274 2.70	1300 2.88	1326 3.06	1351 3.24	1376 3.43	1401 3.61	1426 3.81	1451 4.00	1476 4.20	1499 4.40
7700	1343 3.14	1368 3.34	1394 3.53	1418 3.73	1442 3.93	1465 4.13	1488 4.33	1510 4.53	1532 4.73	1556 4.95
8400	1413 3.63	1438 3.84	1462 4.05	1486 4.27	1510 4.49	1532 4.70	1554 4.92	1576 5.14	1597 5.35	1618 5.57

**Notes:**

1. Available External Static Pressure is the static pressure difference between the return duct and the supply duct plus the static pressure drop caused by accessories and options.
2. For direct drive evaporator fan speed (rpm), refer to the applicable table in the fan performance section.
3. Data includes pressure drop due to standard filters, wet coils, and high gas heat. No accessories or options are included in pressure drop data.
4. To determine static pressure drop due to other options/accessories, refer to the applicable table in the fan performance section.
5. Direct drive fan motor heat is negligible.
6. Factory supplied motors, in commercial equipment, are definite purpose motors, specifically designed and tested to operate reliably and continuously at all cataloged conditions. Using the full horsepower range of our fan motors as shown in our tabular data will not result in nuisance tripping or premature motor failure. Our product's warranty will not be affected.

**Table 38. Evaporator fan performance - 17.5 ton (model YSJ), horizontal**

Available External Static Pressure (Inches of Water Gauge)										
CFM	0.10"	0.20"	0.30"	0.40"	0.50"	0.60"	0.70"	0.80"	0.90"	1.00"
	RPM BHP	RPM BHP	RPM BHP	RPM BHP	RPM BHP	RPM BHP	RPM BHP	RPM BHP	RPM BHP	RPM BHP
5250	786 0.58	830 0.71	871 0.83	909 0.96	945 1.09	980 1.22	1015 1.36	1048 1.50	1081 1.65	1113 1.79
5600	832 0.69	875 0.82	914 0.96	951 1.09	985 1.23	1018 1.37	1051 1.51	1084 1.66	1115 1.81	1146 1.96
6300	925 0.94	964 1.09	1001 1.24	1035 1.39	1068 1.54	1098 1.70	1128 1.85	1156 2.01	1186 2.18	1215 2.34
7000	1019 1.25	1055 1.41	1089 1.58	1121 1.75	1152 1.92	1181 2.09	1209 2.26	1236 2.43	1263 2.61	1288 2.78
7700	1114 1.62	1147 1.80	1179 1.99	1209 2.18	1238 2.36	1266 2.55	1293 2.73	1318 2.92	1343 3.11	1368 3.30
8400	1210 2.07	1240 2.27	1270 2.47	1298 2.67	1326 2.87	1352 3.08	1377 3.28	1402 3.48	1426 3.68	1449 3.89
Available External Static Pressure (Inches of Water Gauge)										
CFM	1.10"	1.20"	1.30"	1.40"	1.50"	1.60"	1.70"	1.80"	1.90"	2.00"
	RPM BHP	RPM BHP	RPM BHP	RPM BHP	RPM BHP	RPM BHP	RPM BHP	RPM BHP	RPM BHP	RPM BHP
5250	1144 1.94	1175 2.09	1204 2.24	1233 2.40	1261 2.55	1288 2.71	1314 2.87	1340 3.03	1365 3.20	1390 3.37
5600	1176 2.12	1205 2.27	1234 2.43	1263 2.59	1290 2.76	1317 2.92	1343 3.09	1369 3.26	1393 3.43	1418 3.60
6300	1244 2.51	1271 2.68	1299 2.85	1325 3.03	1351 3.20	1377 3.38	1403 3.56	1428 3.74	1452 3.93	1476 4.11
7000	1315 2.96	1342 3.15	1367 3.33	1392 3.52	1417 3.71	1442 3.90	1466 4.10	1489 4.29	1512 4.49	1536 4.69
7700	1391 3.49	1414 3.68	1439 3.88	1463 4.08	1487 4.29	1510 4.49	1533 4.70	1555 4.91	1578 5.12	1600 5.33
8400	1472 4.09	1494 4.30	1516 4.51	1537 4.72	1559 4.94	1582 5.16	1604 5.38	1625 5.60	1647 5.82	1667 6.05

**Notes:**

1. Available External Static Pressure is the static pressure difference between the return duct and the supply duct plus the static pressure drop caused by accessories and options.
2. For direct drive evaporator fan speed (rpm), refer to the applicable table in the fan performance section.
3. Data includes pressure drop due to standard filters, wet coils, and high gas heat. No accessories or options are included in pressure drop data.
4. To determine static pressure drop due to other options/accessories, refer to the applicable table in the fan performance section.
5. Direct drive fan motor heat is negligible.
6. Factory supplied motors, in commercial equipment, are definite purpose motors, specifically designed and tested to operate reliably and continuously at all cataloged conditions. Using the full horsepower range of our fan motors as shown in our tabular data will not result in nuisance tripping or premature motor failure. Our product's warranty will not be affected.



## Evaporator Fan Performance

**Table 39. Evaporator fan performance - 20 ton (model YSJ), downflow**

Available External Static Pressure (Inches of Water Gauge)										
CFM	0.10"	0.20"	0.30"	0.40"	0.50"	0.60"	0.70"	0.80"	0.90"	1.00"
	RPM BHP	RPM BHP	RPM BHP	RPM BHP	RPM BHP	RPM BHP	RPM BHP	RPM BHP	RPM BHP	RPM BHP
6000	825 0.64	865 0.78	905 0.91	948 1.07	987 1.23	1023 1.38	1057 1.53	1089 1.69	1120 1.84	1150 2.00
6400	875 0.76	912 0.9	950 1.05	989 1.21	1029 1.38	1064 1.54	1097 1.70	1128 1.87	1159 2.03	1188 2.20
7200	975 1.04	1009 1.2	1042 1.36	1076 1.53	1110 1.71	1146 1.90	1178 2.09	1209 2.27	1238 2.45	1266 2.64
8000	1076 1.39	1107 1.56	1137 1.74	1167 1.92	1197 2.11	1228 2.31	1260 2.52	1291 2.74	1319 2.94	1346 3.14
8800	1177 1.81	1206 2.00	1234 2.19	1260 2.39	1288 2.59	1315 2.79	1342 3.01	1373 3.25	1402 3.49	1429 3.72
9600	1279 2.31	1306 2.52	1331 2.72	1356 2.94	1381 3.15	1406 3.37	1431 3.59	1455 3.82	1483 4.08	1510 4.34
Available External Static Pressure (Inches of Water Gauge)										
CFM	1.10"	1.20"	1.30"	1.40"	1.50"	1.60"	1.70"	1.80"	1.90"	2.00"
	RPM BHP	RPM BHP	RPM BHP	RPM BHP	RPM BHP	RPM BHP	RPM BHP	RPM BHP	RPM BHP	RPM BHP
6000	1179 2.15	1208 2.32	1237 2.48	1266 2.65	1294 2.82	1321 3.00	1347 3.17	1372 3.35	1397 3.53	1421 3.71
6400	1216 2.36	1244 2.53	1270 2.70	1298 2.87	1326 3.05	1352 3.23	1378 3.41	1403 3.60	1428 3.78	1452 3.97
7200	1293 2.82	1320 3.01	1345 3.19	1370 3.38	1394 3.56	1418 3.75	1443 3.95	1467 4.15	1492 4.35	1515 4.55
8000	1372 3.34	1398 3.55	1423 3.75	1447 3.96	1471 4.17	1494 4.37	1516 4.57	1538 4.78	1560 4.99	1581 5.20
8800	1454 3.94	1479 4.16	1502 4.38	1526 4.6	1549 4.83	1571 5.05	1593 5.28	1615 5.51	1636 5.73	1656 5.96
9600	1537 4.60	1561 4.85	1584 5.09	1607 5.33	1629 5.57	1650 5.81	- -	- -	- -	- -

**Notes:**

1. Available External Static Pressure is the static pressure difference between the return duct and the supply duct plus the static pressure drop caused by accessories and options.
2. For direct drive evaporator fan speed (rpm), refer to the applicable table in the fan performance section.
3. Data includes pressure drop due to standard filters, wet coils, and high gas heat. No accessories or options are included in pressure drop data.
4. To determine static pressure drop due to other options/accessories, refer to the applicable table in the fan performance section.
5. Direct drive fan motor heat is negligible.
6. Factory supplied motors, in commercial equipment, are definite purpose motors, specifically designed and tested to operate reliably and continuously at all cataloged conditions. Using the full horsepower range of our fan motors as shown in our tabular data will not result in nuisance tripping or premature motor failure. Our product's warranty will not be affected.

**Table 40. Evaporator fan performance - 20 ton (model YSJ), horizontal**

Available External Static Pressure (Inches of Water Gauge)										
CFM	0.10"	0.20"	0.30"	0.40"	0.50"	0.60"	0.70"	0.80"	0.90"	1.00"
	RPM BHP	RPM BHP	RPM BHP	RPM BHP	RPM BHP	RPM BHP	RPM BHP	RPM BHP	RPM BHP	RPM BHP
6000	885 0.82	926 0.97	963 1.11	999 1.26	1032 1.40	1064 1.55	1094 1.70	1125 1.85	1155 2.01	1185 2.17
6400	938 0.98	977 1.13	1013 1.29	1047 1.44	1079 1.59	1110 1.75	1139 1.91	1168 2.07	1197 2.23	1226 2.40
7200	1047 1.35	1082 1.52	1115 1.69	1146 1.87	1176 2.04	1205 2.21	1233 2.39	1260 2.56	1286 2.74	1311 2.92
8000	1155 1.80	1187 1.99	1218 2.19	1247 2.38	1275 2.57	1302 2.77	1329 2.96	1354 3.15	1379 3.34	1403 3.54
8800	1265 2.36	1294 2.56	1322 2.78	1350 2.99	1376 3.2	1402 3.41	1426 3.63	1450 3.84	1474 4.05	1497 4.26
9600	1375 3.02	1401 3.24	1428 3.47	1453 3.70	1478 3.94	1502 4.17	1526 4.40	1549 4.63	1571 4.86	1593 5.09
Available External Static Pressure (Inches of Water Gauge)										
CFM	1.10"	1.20"	1.30"	1.40"	1.50"	1.60"	1.70"	1.80"	1.90"	2.00"
	RPM BHP	RPM BHP	RPM BHP	RPM BHP	RPM BHP	RPM BHP	RPM BHP	RPM BHP	RPM BHP	RPM BHP
6000	1214 2.33	1243 2.5	1271 2.66	1297 2.83	1325 3.00	1351 3.18	1377 3.35	1402 3.53	1427 3.71	1451 3.89
6400	1254 2.57	1281 2.74	1308 2.92	1335 3.09	1361 3.27	1386 3.45	1411 3.63	1436 3.82	1460 4.00	1484 4.19
7200	1336 3.11	1362 3.29	1388 3.48	1412 3.68	1437 3.87	1461 4.06	1485 4.26	1508 4.46	1531 4.66	1553 4.86
8000	1426 3.74	1448 3.94	1470 4.14	1494 4.35	1518 4.56	1541 4.77	1563 4.98	1585 5.19	1607 5.41	1628 5.63
8800	1519 4.48	1541 4.69	1562 4.91	1583 5.13	1603 5.35	1623 5.57	1645 5.8	1666 6.03	- -	- -
9600	1614 5.32	1635 5.56	1655 5.79	1675 6.02	- -	- -	- -	- -	- -	- -

**Notes:**

1. Available External Static Pressure is the static pressure difference between the return duct and the supply duct plus the static pressure drop caused by accessories and options.
2. For direct drive evaporator fan speed (rpm), refer to the applicable table in the fan performance section.
3. Data includes pressure drop due to standard filters, wet coils, and high gas heat. No accessories or options are included in pressure drop data.
4. To determine static pressure drop due to other options/accessories, refer to the applicable table in the fan performance section.
5. Direct drive fan motor heat is negligible.
6. Factory supplied motors, in commercial equipment, are definite purpose motors, specifically designed and tested to operate reliably and continuously at all cataloged conditions. Using the full horsepower range of our fan motors as shown in our tabular data will not result in nuisance tripping or premature motor failure. Our product's warranty will not be affected.

**Table 41. Evaporator fan performance - 25 ton (model YSJ), downflow**

Available External Static Pressure (Inches of Water Gauge)										
CFM	0.10"	0.20"	0.30"	0.40"	0.50"	0.60"	0.70"	0.80"	0.90"	1.00"
	RPM BHP	RPM BHP	RPM BHP	RPM BHP	RPM BHP	RPM BHP	RPM BHP	RPM BHP	RPM BHP	RPM BHP
<b>3-hp Standard Motor</b>										
7500	1013 1.16	1046 1.33	1077 1.49	1110 1.67	1141 1.84	1176 2.05	1210 2.25	1239 2.44	1268 2.63	1296 2.82
8000	1076 1.39	1107 1.56	1137 1.74	1167 1.92	1197 2.11	1228 2.31	1260 2.52	1291 2.74	1319 2.94	1346 3.14
9000	1203 1.93	1231 2.12	1258 2.32	1284 2.52	1311 2.72	1338 2.93	1364 3.14	1393 3.38	1422 3.63	1450 3.87
10000	1330 2.60	1356 2.81	1381 3.02	1405 3.24	1428 3.47	1453 3.69	1477 3.92	1500 4.16	1524 4.40	1551 4.67
11000	1458 3.41	1482 3.64	1505 3.87	1527 4.11	1549 4.36	1570 4.60	1592 4.85	1614 5.10	1636 5.36	1657 5.62
12000	1587 4.37	1608 4.63	1630 4.88	1650 5.14	1671 5.40	1691 5.67	1710 5.94	- -	- -	- -
Available External Static Pressure (Inches of Water Gauge)										
CFM	1.10"	1.20"	1.30"	1.40"	1.50"	1.60"	1.70"	1.80"	1.90"	2.00"
	RPM BHP	RPM BHP	RPM BHP	RPM BHP	RPM BHP	RPM BHP	RPM BHP	RPM BHP	RPM BHP	RPM BHP
<b>3-hp Standard Motor</b>										
7500	1323 3.01	1349 3.20	1374 3.40	1399 3.59	1423 3.78	1446 3.97	1469 4.17	1492 4.37	1516 4.58	1540 4.78
8000	1372 3.34	1398 3.55	1423 3.75	1447 3.96	1471 4.17	1494 4.37	1516 4.57	1538 4.78	1560 4.99	1581 5.20
9000	1475 4.10	1499 4.32	1523 4.55	1546 4.78	1569 5.00	1591 5.23	1613 5.47	1634 5.70	1655 5.93	- -
10000	1577 4.95	1602 5.22	1626 5.48	1648 5.72	1670 5.97	- -	- -	- -	- -	- -
11000	1680 5.89	- -	- -	- -	- -	- -	- -	- -	- -	- -
12000	- -	- -	- -	- -	- -	- -	- -	- -	- -	- -

**Notes:**

1. Available External Static Pressure is the static pressure difference between the return duct and the supply duct plus the static pressure drop caused by accessories and options.
2. For direct drive evaporator fan speed (rpm), refer to the applicable table in the fan performance section.
3. Data includes pressure drop due to standard filters, wet coils, and high gas heat. No accessories or options are included in pressure drop data.
4. To determine static pressure drop due to other options/accessories, refer to the applicable table in the fan performance section.
5. Direct drive fan motor heat is negligible.
6. Factory supplied motors, in commercial equipment, are definite purpose motors, specifically designed and tested to operate reliably and continuously at all cataloged conditions. Using the full horsepower range of our fan motors as shown in our tabular data will not result in nuisance tripping or premature motor failure. Our product's warranty will not be affected.

**Table 42. Evaporator fan performance - 25 ton (model YSJ), downflow, high static drive**

Available External Static Pressure (Inches of Water Gauge)										
CFM	0.10"	0.20"	0.30"	0.40"	0.50"	0.60"	0.70"	0.80"	0.90"	1.00"
	RPM BHP	RPM BHP	RPM BHP	RPM BHP	RPM BHP	RPM BHP	RPM BHP	RPM BHP	RPM BHP	RPM BHP
<b>5-hp Oversized Motor</b>										
7500	1128 1.67	1162 1.86	1196 2.05	1228 2.25	1259 2.44	1288 2.63	1317 2.83	1346 3.04	1375 3.25	1403 3.46
8000	1198 2.00	1231 2.20	1263 2.41	1294 2.61	1323 2.82	1351 3.02	1378 3.23	1406 3.45	1433 3.67	1460 3.89
9000	1340 2.79	1370 3.01	1398 3.24	1426 3.47	1454 3.71	1480 3.94	1505 4.17	1530 4.40	1554 4.63	1579 4.88
10000	1483 3.76	1510 4.01	1536 4.27	1561 4.52	1587 4.78	1611 5.04	1635 5.30	1658 5.56	1680 5.81	1703 6.07
11000	1626 4.95	1650 5.23	1674 5.51	1698 5.79	1721 6.07	1744 6.35	1766 6.63	1788 6.92	1809 7.20	1830 7.48
12000	1769 6.37	1792 6.67	1814 6.97	1836 7.28	1857 7.58	1879 7.89	1900 8.20	1920 8.51	1940 8.82	- -
Available External Static Pressure (Inches of Water Gauge)										
CFM	1.10"	1.20"	1.30"	1.40"	1.50"	1.60"	1.70"	1.80"	1.90"	2.00"
	RPM BHP	RPM BHP	RPM BHP	RPM BHP	RPM BHP	RPM BHP	RPM BHP	RPM BHP	RPM BHP	RPM BHP
<b>5-hp Oversized Motor</b>										
7500	1430 3.67	1457 3.89	1483 4.11	1509 4.32	1534 4.54	1558 4.76	1581 4.98	1605 5.20	1627 5.42	1650 5.65
8000	1486 4.11	1513 4.34	1538 4.57	1563 4.80	1587 5.03	1611 5.26	1634 5.49	1657 5.73	1679 5.96	1701 6.20
9000	1603 5.12	1627 5.37	1650 5.62	1674 5.88	1697 6.13	1720 6.39	1742 6.65	1764 6.91	1786 7.17	1807 7.43
10000	1724 6.33	1746 6.59	1769 6.87	1790 7.14	1812 7.42	1833 7.70	1854 7.98	1875 8.26	1896 8.55	1916 8.83
11000	1851 7.77	1871 8.05	1891 8.33	1910 8.62	1931 8.92	- -	- -	- -	- -	- -



## Evaporator Fan Performance

**Table 42. Evaporator fan performance - 25 ton (model YSJ), downflow, high static drive (continued)**

Available External Static Pressure (Inches of Water Gauge)										
CFM	1.10"	1.20"	1.30"	1.40"	1.50"	1.60"	1.70"	1.80"	1.90"	2.00"
	RPM BHP	RPM BHP	RPM BHP	RPM BHP	RPM BHP	RPM BHP	RPM BHP	RPM BHP	RPM BHP	RPM BHP
<b>5-hp Oversized Motor</b>										
12000	-	-	-	-	-	-	-	-	-	-

**Notes:**

1. Available External Static Pressure is the static pressure difference between the return duct and the supply duct plus the static pressure drop caused by accessories and options.
2. For direct drive evaporator fan speed (rpm), refer to the applicable table in the fan performance section.
3. Data includes pressure drop due to standard filters, wet coils, and high gas heat. No accessories or options are included in pressure drop data.
4. To determine static pressure drop due to other options/accessories, refer to the applicable table in the fan performance section.
5. Direct drive fan motor heat is negligible.
6. Factory supplied motors, in commercial equipment, are definite purpose motors, specifically designed and tested to operate reliably and continuously at all cataloged conditions. Using the full horsepower range of our fan motors as shown in our tabular data will not result in nuisance tripping or premature motor failure. Our product's warranty will not be affected.

**Table 43. Evaporator fan performance - 25 ton (model YSJ), horizontal**

Available External Static Pressure (Inches of Water Gauge)										
CFM	0.10"	0.20"	0.30"	0.40"	0.50"	0.60"	0.70"	0.80"	0.90"	1.00"
	RPM BHP	RPM BHP	RPM BHP	RPM BHP	RPM BHP	RPM BHP	RPM BHP	RPM BHP	RPM BHP	RPM BHP
<b>3-hp Standard Motor</b>										
7500	1087 1.51	1121 1.69	1153 1.87	1184 2.05	1213 2.23	1241 2.41	1269 2.59	1295 2.77	1320 2.96	1345 3.14
8000	1155 1.80	1187 1.99	1218 2.19	1247 2.38	1275 2.57	1302 2.77	1329 2.96	1354 3.15	1379 3.34	1403 3.54
9000	1292 2.51	1320 2.72	1348 2.94	1376 3.16	1402 3.38	1427 3.59	1451 3.81	1475 4.03	1498 4.24	1521 4.46
10000	1430 3.40	1455 3.63	1481 3.86	1506 4.10	1530 4.35	1553 4.59	1576 4.83	1598 5.07	1620 5.31	1641 5.55
11000	1568 4.47	1591 4.72	1614 4.97	1637 5.24	1660 5.51	1682 5.77	1703 6.04	-	-	-
12000	1706 5.75	1728 6.02	-	-	-	-	-	-	-	-
<b>Available External Static Pressure (Inches of Water Gauge)</b>										
CFM	1.10"	1.20"	1.30"	1.40"	1.50"	1.60"	1.70"	1.80"	1.90"	2.00"
	RPM BHP	RPM BHP	RPM BHP	RPM BHP	RPM BHP	RPM BHP	RPM BHP	RPM BHP	RPM BHP	RPM BHP
<b>3-hp Standard Motor</b>										
7500	1369 3.33	1393 3.52	1418 3.72	1443 3.92	1467 4.12	1490 4.32	1513 4.52	1536 4.72	1559 4.93	1581 5.14
8000	1426 3.74	1448 3.94	1470 4.14	1494 4.35	1518 4.56	1541 4.77	1563 4.98	1585 5.19	1607 5.41	1628 5.63
9000	1543 4.68	1564 4.90	1585 5.12	1606 5.34	1626 5.57	1645 5.79	1666 6.02	-	-	-
10000	1662 5.79	1683 6.03	-	-	-	-	-	-	-	-
11000	-	-	-	-	-	-	-	-	-	-
12000	-	-	-	-	-	-	-	-	-	-

**Notes:**

1. Available External Static Pressure is the static pressure difference between the return duct and the supply duct plus the static pressure drop caused by accessories and options.
2. For direct drive evaporator fan speed (rpm), refer to the applicable table in the fan performance section.
3. Data includes pressure drop due to standard filters, wet coils, and high gas heat. No accessories or options are included in pressure drop data.
4. To determine static pressure drop due to other options/accessories, refer to the applicable table in the fan performance section.
5. Direct drive fan motor heat is negligible.
6. Factory supplied motors, in commercial equipment, are definite purpose motors, specifically designed and tested to operate reliably and continuously at all cataloged conditions. Using the full horsepower range of our fan motors as shown in our tabular data will not result in nuisance tripping or premature motor failure. Our product's warranty will not be affected.

**Table 44. Evaporator fan performance - 25 ton (model YSJ), horizontal, high static drive**

Available External Static Pressure (Inches of Water Gauge)										
CFM	0.10"	0.20"	0.30"	0.40"	0.50"	0.60"	0.70"	0.80"	0.90"	1.00"
	RPM BHP	RPM BHP	RPM BHP	RPM BHP	RPM BHP	RPM BHP	RPM BHP	RPM BHP	RPM BHP	RPM BHP
<b>5-hp Oversized Motor</b>										
7500	1201 2.11	1230 2.30	1258 2.48	1286 2.67	1313 2.85	1340 3.04	1365 3.23	1390 3.43	1416 3.62	1441 3.82
8000	1277 2.54	1304 2.73	1331 2.93	1358 3.13	1383 3.32	1408 3.53	1433 3.73	1457 3.93	1481 4.14	1504 4.35
9000	1430 3.56	1454 3.78	1478 3.99	1502 4.21	1526 4.44	1549 4.66	1571 4.88	1594 5.11	1615 5.34	1637 5.57
10000	1583 4.83	1606 5.07	1628 5.31	1649 5.55	1671 5.80	1692 6.04	1713 6.29	1733 6.54	1753 6.79	1773 7.04
11000	1737 6.37	1758 6.63	1778 6.90	1798 7.16	1817 7.43	1837 7.70	1856 7.97	1875 8.24	1894 8.52	1912 8.79
12000	1891 8.21	1910 8.50	1929 8.79	-	-	-	-	-	-	-



**Table 44. Evaporator fan performance - 25 ton (model YSJ), horizontal, high static drive (continued)**

Available External Static Pressure (Inches of Water Gauge)										
CFM	1.10"	1.20"	1.30"	1.40"	1.50"	1.60"	1.70"	1.80"	1.90"	2.00"
	RPM BHP	RPM BHP	RPM BHP	RPM BHP	RPM BHP	RPM BHP	RPM BHP	RPM BHP	RPM BHP	RPM BHP
<b>5-hp Oversized Motor</b>										
7500	1465 4.02	1488 4.23	1512 4.43	1535 4.64	1557 4.85	1579 5.06	1601 5.27	1622 5.49	1643 5.72	1664 5.94
8000	1528 4.56	1551 4.77	1573 4.99	1595 5.20	1617 5.42	1639 5.64	1660 5.87	1680 6.09	1700 6.32	1721 6.55
9000	1658 5.80	1679 6.03	1700 6.27	1720 6.51	1741 6.75	1761 6.99	1780 7.23	1800 7.48	1820 7.73	1839 7.97
10000	1793 7.30	1812 7.55	1831 7.81	1850 8.06	1869 8.32	1888 8.59	1906 8.85	1925 9.12	- -	- -
11000	1930 9.07	- -	- -	- -	- -	- -	- -	- -	- -	- -
12000	- -	- -	- -	- -	- -	- -	- -	- -	- -	- -

**Notes:**

1. Available External Static Pressure is the static pressure difference between the return duct and the supply duct plus the static pressure drop caused by accessories and options.
2. For direct drive evaporator fan speed (rpm), refer to the applicable table in the fan performance section.
3. Data includes pressure drop due to standard filters, wet coils, and high gas heat. No accessories or options are included in pressure drop data.
4. To determine static pressure drop due to other options/accessories, refer to the applicable table in the fan performance section.
5. Direct drive fan motor heat is negligible.
6. Factory supplied motors, in commercial equipment, are definite purpose motors, specifically designed and tested to operate reliably and continuously at all cataloged conditions. Using the full horsepower range of our fan motors as shown in our tabular data will not result in nuisance tripping or premature motor failure. Our product's warranty will not be affected.



# Fan Performance

**Table 45. Outdoor sound power level**

Tons	Unit Model Number	Octave Center Frequency								Overall dBA
		63	125	250	500	1000	2000	4000	8000	
6	YSJ072A*	83	84	84	85	82	76	73	67	86
7.5	YSJ090A*	83	84	84	85	82	76	73	67	86
8.5	YSJ102A*	83	84	84	85	82	76	73	67	86
10	YSJ120A*	87	88	86	83	81	77	73	68	86
12.5	YSJ150B*	89	92	89	87	84	80	75	68	89
15	YSJ180A*	83	87	87	85	82	77	74	69	87
17.5	YSJ210A*	89	89	91	89	86	82	79	73	91
20	YSJ240A*	89	89	91	89	86	82	79	73	91
25	YSJ300A*	94	90	92	91	88	84	81	75	93

**Notes:**

1. Outdoor sound rating shown is tested in accordance with AHRI 270/370-2015. For additional information reference the outdoor sound power level data in the performance section.
2. Taken in accordance with AHRI 270/370-2015.
3. Indoor sound in accordance with AHRI 260 is available through Trane's selection software.

**Table 46. Static pressure drop through accessories (inches water column) - standard efficiency- economizer**

Tons	Unit Model Number	cfm	Standard Filters <sup>(a)</sup>	2" MERV 8 Filter <sup>(b)</sup>	2" MERV 13 Filter <sup>(b)</sup>	Reheat Coil	Economizer with OA/RA Dampers <sup>(c)</sup>							
							Downflow		Horizontal		Low Leak Downflow <sup>(d)</sup>		Low Leak Horizontal	
							100% OA	100% RA	100% OA	100% RA	100% OA	100% RA	100% OA	100% RA
6	YSJ072A	1800	0.03	0.04	0.07	0.04	0.05	0.01	0.04	0.02	0.09	0.00	-	-
		2400	0.04	0.06	0.10	0.06	0.10	0.01	0.06	0.03	0.16	0.01	-	-
		2880	0.04	0.07	0.13	0.07	0.14	0.02	0.08	0.04	0.24	0.01	-	-
7.5	YSJ090A	2250	0.03	0.05	0.09	0.05	0.09	0.01	0.05	0.02	0.14	0.01	-	-
		3000	0.05	0.08	0.13	0.07	0.15	0.02	0.09	0.04	0.26	0.01	-	-
		3600	0.05	0.10	0.17	0.09	0.22	0.02	0.12	0.06	0.39	0.02	-	-
8.5	YSJ102A	2550	0.04	0.06	0.11	0.06	0.11	0.01	0.06	0.03	0.19	0.01	-	-
		3400	0.05	0.09	0.16	0.09	0.20	0.02	0.11	0.05	0.34	0.02	-	-
		4080	0.06	0.12	0.20	0.1	0.28	0.03	0.15	0.07	0.50	0.03	-	-
10	YSJ120A	3000	0.05	0.08	0.13	0.07	0.15	0.02	0.09	0.04	0.26	0.01	-	-
		4000	0.06	0.12	0.20	0.10	0.27	0.03	0.15	0.07	0.48	0.03	-	-
		4800	0.07	0.16	0.25	0.12	0.39	0.03	0.20	0.09	0.71	0.05	-	-
12.5	YSJ150B	3750	0.05	0.09	0.16	0.08	0.24	0.02	0.13	0.06	0.42	0.02	-	-
		5000	0.07	0.13	0.22	0.1	0.42	0.04	0.22	0.10	0.78	0.06	-	-
		6000	0.09	0.16	0.27	0.12	0.60	0.05	0.31	0.13	1.16	0.10	-	-
15	YSJ180A	4500	0.03	0.05	0.09	0.04	0.13	0.02	0.13	0.02	0.14	0.11	0.07	0.12
		6000	0.04	0.08	0.13	0.05	0.20	0.04	0.20	0.04	0.23	0.17	0.12	0.18
		7200	0.06	0.10	0.17	0.07	0.27	0.05	0.27	0.05	0.32	0.23	0.16	0.25
17.5	YSJ210A	5250	0.04	0.06	0.11	0.05	0.16	0.03	0.16	0.03	0.19	0.14	0.09	0.15
		7000	0.05	0.10	0.17	0.06	0.26	0.05	0.26	0.05	0.30	0.22	0.15	0.24
		8400	0.07	0.13	0.22	0.08	0.35	0.06	0.35	0.06	0.42	0.29	0.21	0.33
20	YSJ240A	6000	0.04	0.08	0.13	0.05	0.20	0.04	0.20	0.04	0.23	0.17	0.12	0.18
		8000	0.07	0.12	0.21	0.08	0.32	0.06	0.32	0.06	0.39	0.27	0.19	0.3
		9600	0.09	0.16	0.27	0.10	0.44	0.07	0.44	0.07	0.54	0.37	0.27	0.41
25	YSJ300A	7500	0.06	0.11	0.19	0.07	0.29	0.05	0.29	0.05	0.34	0.24	0.17	0.27
		10000	0.09	0.17	0.29	0.11	0.48	0.08	0.48	0.08	0.58	0.40	0.29	0.45
		12000	0.12	0.23	0.39	0.14	0.66	0.11	0.66	0.11	0.82	0.55	0.39	0.62

- <sup>(a)</sup> Tested with: 2-in filters 6 to 25 Tons.  
<sup>(b)</sup> Difference in pressure drop should be considered when utilizing optional 2-in pleated filters.  
<sup>(c)</sup> OA = Outside Air and RA = Return Air.  
<sup>(d)</sup> Horizontal Low Leak is not offered on 6 to 12.5 tonnages.

**Table 47. Static pressure drop through accessories (inches water column) - standard efficiency- gas heater**

Tons	Unit Model Number	cfm	Gas Heater <sup>(a)</sup>					
			Downflow			Horizontal		
			L	M	H	L	M	H
6	YSJ072A	1800	0.04	0.04	-	0.13	0.13	-
		2400	0.05	0.05	-	0.24	0.24	-
		2880	0.07	0.07	-	0.35	0.35	-
7.5	YSJ090A	2250	0.11	0.11	-	0.19	0.19	-
		3000	0.17	0.17	-	0.33	0.33	-
		3600	0.24	0.24	-	0.46	0.46	-
8.5	YSJ102A	2550	0.13	0.13	-	0.24	0.24	-
		3400	0.22	0.22	-	0.41	0.41	-
		4080	0.31	0.31	-	0.59	0.59	-
10	YSJ120A	3000	0.16	0.16	-	0.16	0.16	-
		4000	0.28	0.28	-	0.28	0.28	-
		4800	0.44	0.44	-	0.44	0.44	-
12.5	YSJ150B	3750	0.23	0.23	-	0.11	0.11	-
		5000	0.42	0.42	-	0.27	0.27	-
		6000	0.64	0.64	-	0.46	0.46	-
15	YSJ180A	4500	-0.07	-0.05	-0.06	0.08	0.08	0.10
		6000	-0.03	-0.02	-0.02	0.12	0.13	0.16
		7200	-0.01	0.00	0.01	0.11	0.13	0.19
17.5	YSJ210A	5250	-0.05	-0.03	-0.04	0.11	0.11	0.13
		7000	-0.01	-0.01	0.00	0.11	0.13	0.18
		8400	0.02	0.02	0.04	0.10	0.13	0.20
20	YSJ240A	6000	-0.03	-0.02	-0.02	0.12	0.13	0.16
		8000	0.01	0.01	0.03	0.10	0.13	0.19
		9600	0.04	0.05	0.07	0.10	0.14	0.21
25	YSJ300A	7500	0.00	0.00	0.01	0.11	0.13	0.19
		10000	0.06	0.07	0.08	0.11	0.15	0.21
		12000	0.14	0.15	0.14	0.16	0.21	0.31

<sup>(a)</sup> Model digit 11 selection of Low Gas Heat is 5x5, Medium Gas Heat is 7x7, and High Gas Heat is 8x8 for 15 to 25T units.

**Table 48. Static pressure drop through accessories (inches water column) - standard efficiency — modulating gas heat option**

Tons	Unit Model Number	CFM	Gas Heater <sup>(a)</sup>			
			Downflow		Horizontal	
			L	H	L	H
6	YSJ072A	1800	0.03	0.02	0.22	0.47
		2400	0.05	0.05	0.34	0.81
		2880	0.07	0.08	0.47	1.16
7.5	YSJ090A	2250	0.04	0.09	0.32	0.28
		3000	0.09	0.13	0.61	0.43
		3600	0.14	0.19	0.91	0.59
8.5	YSJ102A	2550	0.06	0.09	0.42	0.33
		3400	0.12	0.17	0.81	0.53
		4080	0.18	0.25	1.19	0.73
10	YSJ120A	3000	0.09	0.13	0.61	0.43
		4000	0.18	0.24	1.14	0.70
		4800	0.27	0.36	1.65	0.97



## Fan Performance

**Table 48. Static pressure drop through accessories (inches water column) - standard efficiency — modulating gas heat option (continued)**

Tons	Unit Model Number	CFM	Gas Heater <sup>(a)</sup>			
			Downflow		Horizontal	
			L	H	L	H
12.5	YSJ150B	3750	0.13	0.15	0.23	0.15
		5000	0.17	0.22	0.35	0.25
		6000	0.20	0.29	0.48	0.29
15	YSJ180A	4500	0.06	0.09	0.11	0.15
		6000	0.11	0.19	0.20	0.28
		7200	0.16	0.28	0.29	0.42
20	YSJ240A	6000	0.11	0.19	0.20	0.28
		8000	0.20	0.36	0.36	0.52
		9600	0.30	0.53	0.52	0.75
25	YSJ300A	7500	0.18	0.31	0.31	0.45
		10000	0.33	0.58	0.56	0.82
		12000	0.49	0.87	0.81	1.17

<sup>(a)</sup> Model digit 10 selection B is Mod Gas of which Low Gas Heat is 2x2 for 6T, 4x4 for 7.5 to 12.5T, High Gas Heat is 4x4 for 6T, 6x6 for 7.5 to 12.5T. 12.5T D.0 is High only with 6-Tube. 15 to 25T units are Low with 6-Tube and High with 8-Tube.



# Heating Performance

**Table 49. Gas-fired heating capacities - staged gas - standard efficiency**

Tons	Unit Model Number	Heating Input BTU (High / Low Stage)	Heating Output BTU (High / Low Stage)	Air Temperature Rise°F
6	YSJ072A**(0,A)L	80,000 / 56,000	64,800 / 45,300	10 - 40
	YSJ072A**(0,A)M	120,000 / 84,000	97,200 / 68,000	20 - 50
	YSJ072A**(0,A)H	150,000 / 105,000	121,500 / 85,000	30 - 60
7.5	YSJ090A**(0,A)L	120,000 / 84,000	97,200 / 68,000	15 - 45
	YSJ090A**(0,A)M	150,000 / 105,000	121,500 / 85,000	20 - 50
	YSJ090A**(0,A)H	200,000 / 140,000	162,000 / 113,400	30 - 60
8.5	YSJ102A**(0,A)L	120,000 / 84,000	97,200 / 68,000	15 - 45
	YSJ102A**(0,A)M	150,000 / 105,000	121,500 / 85,000	20 - 50
	YSJ102A**(0,A)H	200,000 / 140,000	162,000 / 113,400	30 - 60
10	YSJ120A**(0,A)L	150,000 / 105,000	121,500 / 85,000	15 - 45
	YSJ120A**(0,A)M	200,000 / 140,000	162,000 / 113,400	25 - 55
	YSJ120A**(0,A)H	240,000 / 168,000	194,400 / 136,000	30 - 60
12.5	YSJ150B**(0,A)L	150,000 / 105,000	121,500 / 85,000	10 - 40
	YSJ150B**(0,A)M	200,000 / 140,000	162,000 / 113,400	15 - 45
	YSJ150B**(0,A)H	250,000 / 175,000	202,500 / 141,750	25 - 55
15	YSJ180A**(0,A)L	250,000 / 175,000	202,500 / 141,750	15 - 45
	YSJ180A**(0,A)M	320,000 / 224,000	259,200 / 181,440	20 - 50
	YSJ180A**(0,A)H	400,000 / 280,000	324,000 / 226,800	25 - 55
17.5	YSJ210A**(0,A)L	250,000 / 175,000	202,500 / 141,750	15 - 45
	YSJ210A**(0,A)M	320,000 / 224,000	259,200 / 181,440	20 - 50
	YSJ210A**(0,A)H	400,000 / 280,000	324,000 / 226,800	25 - 55
20	YSJ240A**(0,A)L	250,000 / 175,000	202,500 / 141,750	10 - 40
	YSJ240A**(0,A)M	320,000 / 224,000	259,200 / 181,440	15 - 45
	YSJ240A**(0,A)H	400,000 / 280,000	324,000 / 226,800	20 - 50
25	YSJ300A**(0,A)L	250,000 / 175,000	202,500 / 141,750	10 - 40
	YSJ300A**(0,A)M	320,000 / 224,000	259,200 / 181,440	15 - 45
	YSJ300A**(0,A)H	400,000 / 280,000	324,000 / 226,800	20 - 50

**Table 50. Gas-fired heating capacities - modulating gas - standard efficiency**

Tons	Unit Model Number	Heating Input BTU (Maximum / Minimum)	Heating Output BTU (Maximum / Minimum)	Air Temperature Rise°F
6	YSJ072A**BL	80,000 / 8,000	64,800 / 6,480	5 - 40
	YSJ072A**BH	150,000 / 15,000	121,500 / 12,150	5 - 60
7.5	YSJ090A**BL	120,000 / 12,000	97,200 / 9,720	5 - 45
	YSJ090A**BH	200,000 / 20,000	162,000 / 16,200	5 - 60
8.5	YSJ102A**BL	120,000 / 12,000	97,200 / 9,720	5 - 45
	YSJ102A**BH	200,000 / 20,000	162,000 / 16,200	5 - 60
10	YSJ120A**BH	240,000 / 24,000	194,400 / 19,440	5 - 60
12.5	YSJ150B**BL	150,000 / 15,000	121,500 / 12,150	5 - 40
	YSJ150B**BH	250,000 / 25,000	202,500 / 20,250	5 - 55



## Heating Performance

**Table 50. Gas-fired heating capacities - modulating gas - standard efficiency (continued)**

Tons	Unit Model Number	Heating Input BTU (Maximum / Minimum)	Heating Output BTU (Maximum / Minimum)	Air Temperature Rise°F
15	YSJ180A**BL	250,000 / 25,000	202,500 / 20,250	5 - 45
	YSJ180A**BH	400,000 / 40,000	324,000 / 32,400	5 - 55
17.5	YSJ210A**BL	250,000 / 25,000	202,500 / 20,250	5 - 45
	YSJ210A**BH	400,000 / 40,000	324,000 / 32,400	5 - 55
20	YSJ240A**BL	250,000 / 25,000	202,500 / 20,250	5 - 40
	YSJ240A**BH	400,000 / 40,000	324,000 / 32,400	5 - 50
25	YSJ300A**BL	250,000 / 25,000	202,500 / 20,250	5 - 40
	YSJ300A**BH	400,000 / 40,000	324,000 / 32,400	5 - 50



# Controls

## Enhanced BAS Integration and Connectivity

- Symbio™ 700 integrates seamlessly with Trane® Tracer® Synchrony and Tracer Ensemble® to deliver optimized building automation and building management features and functions.
- Easily integrate with open standard protocols to connect seamlessly to a BAS (whether that is Trane or non-Trane).
- Digit 21 must equal 1, 2, or 3 for communication support.

### BACnet® Communications

Symbio™ 700 includes native BACnet communications which allows the unit to communicate directly with a Tracer or non-Trane Building Automation System via open protocol BACnet MS/TP or IP.

### Modbus Communications

Symbio 700 includes native Modbus communications which allows the unit to communicate directly with a Tracer or non-Trane Building Automation System via open protocol Modbus RTU or TCP/IP.

### LonTalk® Communications

The optional LonTalk® communications module allows the unit to communicate directly with a Tracer or non-Trane Building Automation System via open protocol LonTalk.

### Air-Fi® Wireless Communications

The optional Air-Fi communications module allows the unit to communicate directly with a Tracer or non-Trane Building Automation System via open protocol BACnet over Zigbee wireless.

## Secure Remote Connectivity with Trane Connect

The Symbio controller enables secure remote connectivity via Trane Connect to Trane Intelligent Services and remote monitoring. Trane Connect provides anywhere/anytime access to monitor and manage with secure remote access and connectivity options through a multitude of platforms. Peace of mind that the system will be operational and provide comfort to customers.

## Serviceability

### Symbio™ Service and Installation Mobile App

The Symbio™ Service and Installation mobile app is accessible through mobile devices (phones and tablets) via Bluetooth connectivity or via Trane Connect. The intuitive mobile app feels natural to technicians and operators. They will quickly be able to view equipment status and alarms, perform startup tasks, change configurations, test the equipment's performance in specific modes—and much more. Free for download from App Store (Apple iOS) and Google Play (Android devices).

To download the Symbio™ Service and Installation Mobile App use the links below or scan the code with your mobile phone camera.

Apple download link (<https://apps.apple.com/us/app/symbio-service-installation/id1309310176>)

Google Play (Android) download link (<https://play.google.com/store/apps/details?id=com.trane.mobileservicetool>)

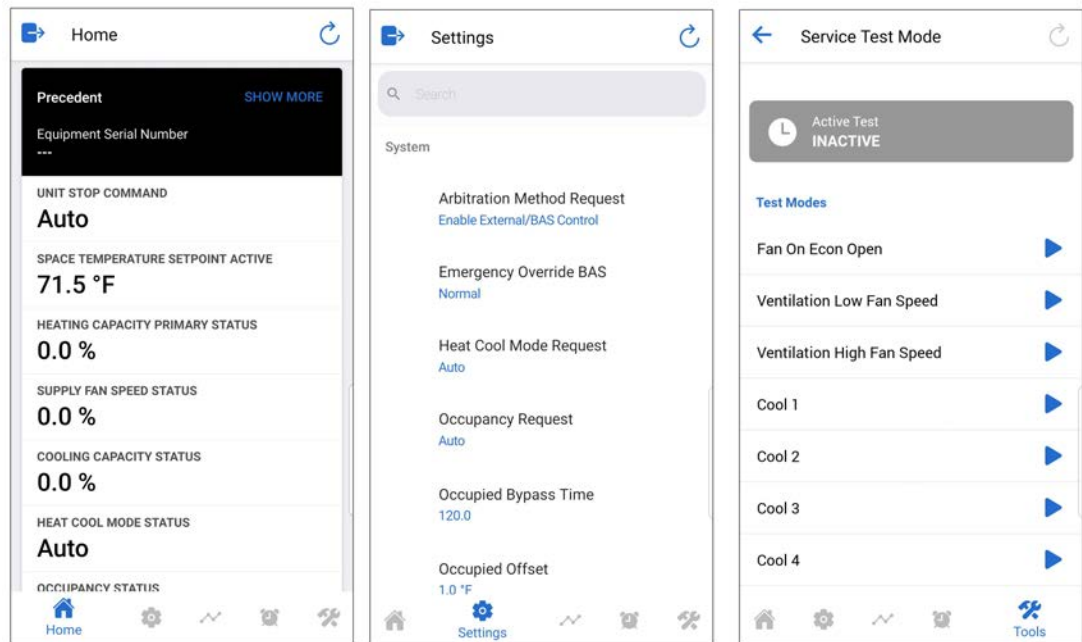
**Figure 1. Scan code****Figure 2. Symbio™ service and installation mobile app**

## Onboard User Interface

An integrated onboard user interface that makes setup and continued operation easy. It provides real time operational performance, status, data, and alarms. It also allows the user to interact with, service, troubleshoot, and control their equipment without additional service software tools or when a mobile interface is not available.



**Figure 3. Onboard user interface**

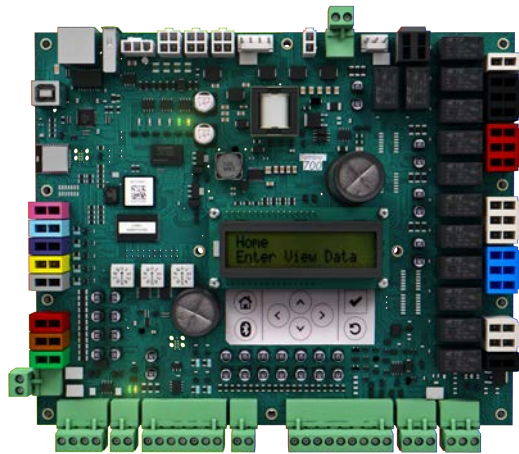

## Service Test Mode

Symbio™ 700 requires no special tools to run the unit through its paces. Simply navigate to the 'Service' section of the on-board user interface or the 'Tools' section of the Symbio™ Service and Installation Mobile App and enter the 'Service Test Mode' section. Here the unit can be placed in the desired operating condition for a pre-determined amount of time supporting troubleshooting efforts in the field. The Symbio™ 700 will return to normal control when the user exits test mode or when the pre-determined, user-selected Service Test time has expired.

## Symbio™ 700 controls with upgradeable software

Trane's equipment and systems feature engineered, tested, and proven applications that meet industry energy standards and provide the flexibility to customize and update over the life of the equipment. Professional operational algorithms are embedded within the Symbio™ 700 controller at the Trane factory. Symbio™ 700 standardizes each equipment unit to maintain standards for comfort, efficiency, and air quality, without additional field programming. Symbio™ 700 provides the flexibility over the life of the equipment to meet changing customer needs and/or industry standards.

## Flexibility

### Expansion Modules (contact Trane for more details)

- XM30 – Provides 4 universal inputs or analog outputs
- XM32 – Provides 4 binary outputs

### Field Programming via TGP2 (contact Trane for more details)

- Control ancillary equipment
- Custom sequences

### TGP2 and XM Limitations:

- Programs will only have access to available BACnet® points. (Ensures system reliability.)
- TGP2 programs will not have direct I/O control access for factory components. (Compressors will not be able to be directly controlled On/Off without going through factory provided protection sequences.)
- Onboard I/O will not be available to custom applied TGP2 programs. If additional I/O is required for a new control loop, a separate expansion module will be required.
- I/O will be limited to a maximum combination of 2 XM modules. Only XM30 or XM32 modules are supported by the Symbio 700.
- Contact Trane to configure XMs and to create, view, or modify TGP2 programs.



## Economizer Controls

There are four options for economizer control, Dry Bulb Temperature, Comparative Enthalpy, Reference Enthalpy and Differential Dry Bulb Temperature.

### Dry Bulb Temperature Control

The dry bulb system measures outdoor temperature comparing it to the economizer enable setpoint. If the outdoor temperature is below the economizer enable setpoint, the economizer will operate freely. This system is best suited for arid regions where the humidity levels of outside air would not be detrimental to building comfort and indoor air quality.

### Comparative Enthalpy Control

The comparative enthalpy system measures the temperature and humidity of both return air and outside air to determine which source has lower enthalpy. This system allows true comparison of outdoor air and return air enthalpy by measurement of outdoor air and return air temperature and humidity.

### Reference Enthalpy Control

The reference enthalpy system compares outdoor air temperature and humidity to the economizer enthalpy enable setpoint. If outdoor air temperature and humidity are below the economizer enthalpy enable setpoint, the economizer will operate freely. This system provides more sophisticated control where outdoor air humidity levels may not be acceptable for building comfort and indoor air quality.

### Differential Dry Bulb Temperature Control

The differential dry bulb system measures the temperature of both return air and outside air to determine when to economize. If outdoor air temperature is below the return air temperature minus a differential, the economizer will operate freely. This system is best suited for arid regions where the humidity levels of outside air would not be detrimental to building comfort and indoor air quality.

## Zone Sensors

Zone Temperature Only

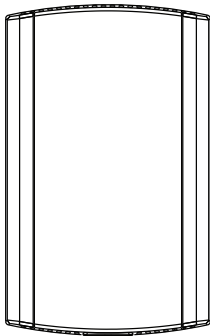

BAYSENS077

Provides temperature input only. Can be used as a secondary remote temperature input for thermostats.

Manual Changeover

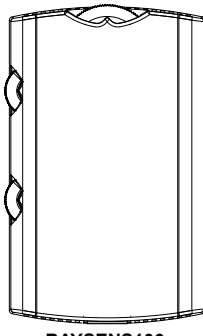

BAYSENS106

Heat, Cool or Off System Switch. Fan Auto or Off Switch. Single temperature setpoint thumbwheel.

Manual/Automatic Changeover

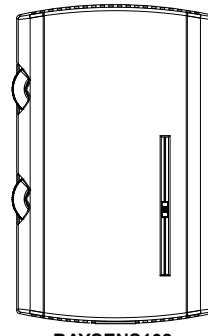

BAYSENS108

Auto, Heat, Cool or Off System Switch. Fan Auto or Off Switch. Dual temperature setpoint sliders

### Integrated Comfort™ System

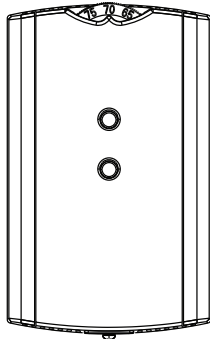

**BAYSENS073 / BAYSENS074 / BAYSENS075**

Sensor(s) available with optional temperature adjustment and override buttons to provide central control through a Trane Integrated Comfort system.

### Wired Display Sensor

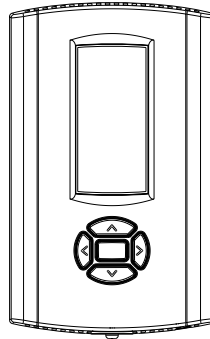

**BAYSENS135**

LCD display that provides heat, cool, auto, or off. Includes two temperature setpoints and a lockable setting with °F or °C indicators.

### Touchscreen Digital Display Communicating Sensor



**BAYSENS800**

Uses BACnet® MS/TP link to communicate zone temperature and setpoints. Auto, Heat, Cool or Off System Switch. Fan Auto or On Switch. 7-day programmable thermostat with night setback.

*Note: Not compatible with VAV units. Requires BACnet communications.*

## Air-Fi Wireless Communicating Zone Sensors

### Wireless Zone Temperature Only

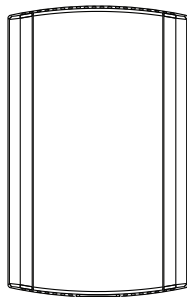

**BAYSENS077**

Measures temperature and optional humidity (with WCS-SH) for use in public spaces where no local user interface is preferred.

*Note: Requires BACnet communications.*

### Wireless Display Sensor

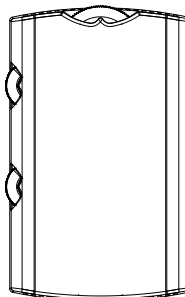

**BAYSENS106**

Easy-to-use interface for clear and simple monitoring and control. Can be configured for any Trane system or to meet the customer's preference.

*Note: Requires BACnet communications.*

### Wired CO<sub>2</sub> Sensor

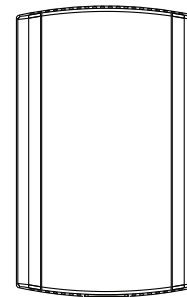

**X13790422010**

The maintenance-free carbon dioxide (CO<sub>2</sub>) sensor is primarily used for demand control ventilation applications.

### Wired Zone Temperature and Humidity Sensor

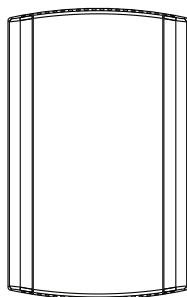

**BAYSENS036**

Measures temperature and relative humidity. Relative humidity input is used to control activation of dehumidification.

# Thermostats

Digital Display Programmable Thermostat (3H/2C)

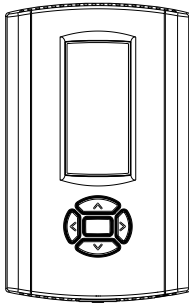

BAYSTAT150

Three Heat/Two Cool Auto changeover digital display thermostat. 7-day programmable thermostat with night setback.

**Note:** Not compatible with VAV units.

Digital Display Programmable Thermostat (1H/1C)

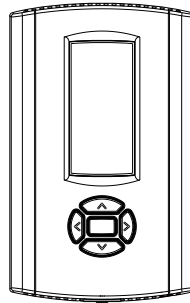

BAYSTAT151

One Heat/One Cool Auto changeover digital display thermostat.

**Note:** Not compatible with VAV units.

Digital Display Thermostat (3H/2C)

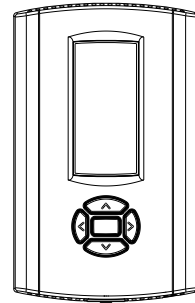

BAYSTAT155

Three Heat/Two Cool Auto changeover display thermostat.

**Note:** Not compatible with VAV units.

Pivot® Web Enabled Smart Thermostat (3H/2C)

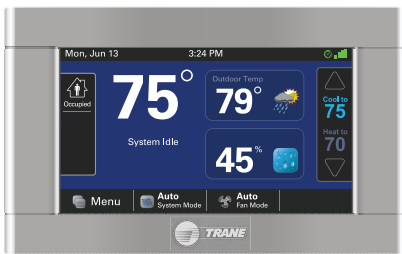

BAYSTAT814

Our Pivot Smart Thermostat system is great for commercial buildings. With its intuitive touchscreen and customizable display, it is easy for occupants to use. The Trane Pivot mobile app enables users to control multiple buildings remotely, making changes in seconds to all systems.

**Note:** Not compatible with VAV units.

Touchscreen Programmable Thermostat with Relative Humidity Sensor (3H/2C)



BAYSTAT152

Three Heat, Two Cool digital display thermostat with built-in humidity control. This thermostat combines both humidity and temperature into one.

**Note:** Not compatible with VAV units.

## Humidity Control (HGRH)

### Sequence of Operations

Humidity Control system capable of operating in normal cooling, dual mode to satisfy cooling and humidity requirements, and hot gas reheat mode when only humidity demand is required. Function between requirements and unit transition seamlessly providing an all-around comfort solution.

**Note:** Supports Humidistat control. When the Humidistat input becomes active, compressors will stage to full capacity and modulate the 3 way valve.

#### Initiation of Humidity Control

- Conforms to ASHRAE standard (62)
- Dehumidification is initiated when too much moisture is in the space (>60°F Dew point)
  - Two measurement options for this dehumidification status:
  - Humidity control is started when:
    - Dew point is too high (60°F is default),

- Relative Humidity is too high (60% is default), DH is started
  - Choice between these values above is user-configurable, and the actual values are adjustable by customer if desired
- Reheat circuit is initiated when space temperature drops below setpoint during humidity control.

### **Humidity Control Routine**

There are two independent control loops: One to control latent load, the other to control sensible load.

Latent load is controlled by compressor staging:

- Compressors initially move up one stage from the last cooling mode stage.
- Compressors are staged up as needed by the controller to achieve a target leaving ID air dew point based on space conditions.

Sensible load is controlled with the Modulating 3 way valve:

- Modulating valve opens when space temperature is below setpoint.
- The reheat valve adjusts the amount of flow to RH coil to achieve the targeted leaving ID air temperature, based on space conditions.

### **Purge Cycle**

During dehumidification, every 120 minutes (default) a 3 minute cooling “purge cycle” will be executed. This purge cycle is executed for system reliability, specifically it helps manage oil return to compressors.

- Modulating valve moves to a fixed position based on OD air and compressor stage.
- Compressors move to full load.

### **Leaving Humidity Control and Returning to Cooling Only**

- When space humidity drops to below the threshold humidity value (60°F dew point or 60% relative humidity), system reverts back to cooling mode. Dead band of ~5°F yields approximately 55°F dew point for switch to cooling.
- Unit can stay in humidity control mode indefinitely, with purge cycles happening regularly.
  - Relative humidity setpoint is 65% for unoccupied mode.
  - Dew point for unoccupied mode is the same as occupied (default 60°F DP).



# Electrical Data

Table 51. Unit wiring

Tons	Unit Model Number	Voltage Range	Standard Indoor Fan Motor		Oversized/High Static Indoor Fan Motor		Optional Power Exhaust Standard Indoor Fan Motor		Optional Power Exhaust Oversized/High Static Indoor Fan Motor	
			MCA	Max Fuse Size or Max Circuit Breaker	MCA	Max Fuse Size or Max Circuit Breaker	MCA	Max Fuse Size or Max Circuit Breaker	MCA	Max Fuse Size or Max Circuit Breaker
6	YSJ072A3	187-253	38	50	-	-	43	50	-	-
	YSJ072A4	414-506	21	20	-	-	22	25	-	-
	YSJ072AW	517-633	17	15	-	-	17	20	-	-
7.5	YSJ090A3	187-253	42	50	-	-	48	60	-	-
	YSJ090A4	414-506	21	25	-	-	24	30	-	-
	YSJ090AW	517-633	17	20	-	-	19	25	-	-
8.5	YSJ102A3	187-253	48	60	-	-	53	70	-	-
	YSJ102A4	414-506	25	30	-	-	28	35	-	-
	YSJ102AW	517-633	19	25	-	-	21	25	-	-
10	YSJ120A3	187-253	54	70	56	80	60	80	62	80
	YSJ120A4	414-506	29	40	30	40	32	40	33	45
	YSJ120AW	517-633	22	30	22	30	24	30	25	30
12.5	YSJ150B3	187-253	67	90	-	-	73	100	-	-
	YSJ150B4	414-506	31	40	-	-	35	45	-	-
	YSJ150BW	517-633	24	30	-	-	26	35	-	-
15	YSJ180A3	187-253	78	100	-	-	83	110	-	-
	YSJ180A4	414-506	41	50	-	-	45	60	-	-
	YSJ180AW	517-633	32	40	-	-	34	45	-	-
17.5	YSJ210A3S(0,A)	187-253	93	125	-	-	98	125	-	-
	YSJ210A4S(0,A)	414-506	49	60	-	-	52	70	-	-
	YSJ210AWS(0,A)	517-633	37	50	-	-	40	50	-	-
	YSJ210A3SB	187-253	93	125	97	125	98	125	103	125
	YSJ210A4SB	414-506	49	60	51	60	52	70	54	70
	YSJ210AWSB	517-633	37	50	39	50	40	50	41	50
20	YSJ240A3S(0,A)	187-253	108	150	-	-	113	150	-	-
	YSJ240A4S(0,A)	414-506	54	70	-	-	57	70	-	-
	YSJ240AWS(0,A)	517-633	47	60	-	-	49	70	-	-
	YSJ240A3SB	187-253	108	150	112	150	113	150	118	150
	YSJ240A4SB	414-506	54	70	55	70	57	70	59	70
	YSJ240AWSB	517-633	47	60	48	60	49	70	51	70
25	YSJ300A3	187-253	119	150	124	150	125	150	129	175
	YSJ300A4	414-506	59	80	61	80	62	80	64	80
	YSJ300AW	517-633	46	60	48	60	48	80	50	60

**Table 52. Electrical characteristics — compressor motor and condenser motor**

Tons	Unit Model Number	No.	Compressor Motors						No.	Condenser Fan Motor				
			Volts	Phase	hp <sup>(a)</sup>	rpm	Amps <sup>(b)</sup>			Volts	Phase	hp	Amps	
							RLA	LRA					FLA	LRA
6	YSJ072A3	2	208/230	3	3.5/1.7	3500/3500	14.1/7.3	83.1/55.4	1	208/230	3	0.7	3.3	12.3
	YSJ072A4	2	460	3	3.5/1.7	3500/3500	6.5/3.6	41/28	1	460	3	0.7	1.5	6.1
	YSJ072AW	2	575	3	3.5/1.7	3500/3500	5.4/3.0	33.0/24.5	1	575	3	0.7	1.4	5.1
7.5	YSJ090A3	2	208/230	3	4.3/2.1	3500/3500	16.4/9.2	110/58	1	208/230	3	0.7	3.3	12.3
	YSJ090A4	2	460	3	4.3/2.1	3500/3500	8.2/4.3	52/28	1	460	3	0.7	1.5	6.1
	YSJ090AW	2	575	3	4.3/2.1	3500/3500	6.6/3.6	38.9/24.0	1	575	3	0.7	1.4	5.1
8.5	YSJ102A3	2	208/230	3	5.1/2.4	3500/3500	20.2/9.7	136/71	1	208/230	3	0.7	3.3	12.3
	YSJ102A4	2	460	3	5.1/2.4	3500/3500	9.9/5.8	66/38	1	460	3	0.7	1.5	6.1
	YSJ102AW	2	575	3	5.1/2.4	3500/3500	8.0/3.9	55/30	1	575	3	0.7	1.4	5.1
10	YSJ120A3	2	208/230	3	6.3/2.4	3500/3500	25.8/9.7	164/71	1	208/230	3	0.75	2.8	10.4
	YSJ120A4	2	460	3	6.3/2.4	3500/3500	13.2/5.8	100/38	1	460	3	0.75	1.4	5.2
	YSJ120AW	2	575	3	6.3/2.4	3500/3500	10.3/3.9	78.0/36.5	1	575	3	0.75	1.14	4.53
12.5	YSJ150B3	2	208/230	3	7.6/3.5	3500/3500	30.5/13.5	207.5/81.3	1	208/230	3	1	4.3	18.9
	YSJ150B4	2	460	3	7.6/3.5	3500/3500	13.6/6.3	100/41	1	460	3	1	2.2	9.5
	YSJ150BW	2	575	3	7.6/3.5	3500/3500	10.4/4.5	78/33	1	575	3	1	1.8	8.1
15	YSJ180A3	2	208/230	3	8.7/4.3	3500/3500	30.9/16.4	240/110	2	208/230	3	0.5	2.3	8.4
	YSJ180A4	2	460	3	8.7/4.3	3500/3500	16.7/8.2	130/52	2	460	3	0.5	1.1	4.2
	YSJ180AW	2	575	3	8.7/4.3	3500/3500	12.8/6.6	93.7/38.9	2	575	3	0.5	1.0	3.6
17.5	YSJ210A3	2	208/230	3	10.2/5.1	3500/3500	35.7/20.2	240/136	2	208/230	3	1	4.3	19.4
	YSJ210A4	2	460	3	10.2/5.1	3500/3500	19.4/9.9	140/66	2	460	3	1	2.2	10.1
	YSJ210AW	2	575	3	10.2/5.1	3500/3500	14.9/8.0	107.6/55.0	2	575	3	1	1.8	8.0
20	YSJ240A3	2	208/230	3	11.4/6.3	3500/3500	43.1/26.1	270/164	2	208/230	3	1	4.3	19.4
	YSJ240A4	2	460	3	11.4/6.3	3500/3500	21.3/12.2	147/84	2	460	3	1	2.2	10.1
	YSJ240AW	2	575	3	11.4/6.3	3500/3500	21.3/9.6	109/60	2	575	3	1	1.8	8.0
25	YSJ300A3	2	208/230	3	12.8/7.6	3500/3500	49.5/29.6	335.5/223.0	2	208/230	3	1	4.3	19.4
	YSJ300A4	2	460	3	12.8/7.6	3500/3500	23.9/14.4	141/100	2	460	3	1	2.2	10.1
	YSJ300AW	2	575	3	12.8/7.6	3500/3500	19.8/10.8	109/70	2	575	3	1	1.8	8.0

<sup>(a)</sup> Hp for each compressor.

<sup>(b)</sup> Amp draw for each motor (compressor and condenser fan motor); multiply value by number of motors to determine total amps.

**Table 53. Electrical characteristics — indoor fan motor**

Tons	Unit Model Number	No.	Volts	Phase	hp	Amps <sup>(a)</sup>	
						FLA	LRA
6	YSJ072A3	1	208/230	3	3	8.8	-
	YSJ072A4	1	460	3	3	4.6	-
	YSJ072AW	1	575	3	3	3.2	-
7.5	YSJ090A3	1	208/230	3	3	8.8	-
	YSJ090A4	1	460	3	3	4.6	-
	YSJ090AW	1	575	3	3	3.2	-
8.5	YSJ102A3	1	208/230	3	3	8.8	-
	YSJ102A4	1	460	3	3	4.6	-
	YSJ102AW	1	575	3	3	3.2	-



## Electrical Data

**Table 53. Electrical characteristics — indoor fan motor (continued)**

Tons	Unit Model Number	No.	Volts	Phase	hp	Amps <sup>(a)</sup>	
						FLA	LRA
10	YSJ120A3	1	208/230	3	3	8.8	-
	YSJ120A4	1	460	3	3	4.6	-
	YSJ120AW	1	575	3	3	3.2	-
12.5	YSJ150B3	1	208/230	3	5	11.0	-
	YSJ150B4	1	460	3	5	5.5	-
	YSJ150BW	1	575	3	5	3.9	-
15	YSJ180A3	2	208/230	3	3	8.8	-
	YSJ180A4	2	460	3	3	4.6	-
	YSJ180AW	2	575	3	3	3.2	-
17.5	YSJ210A3	2	208/230	3	3	8.8	-
	YSJ210A4	2	460	3	3	4.6	-
	YSJ210AW	2	575	3	3	3.2	-
20	YSJ240A3	2	208/230	3	3	8.8	-
	YSJ240A4	2	460	3	3	4.6	-
	YSJ240AW	2	575	3	3	3.2	-
25	YSJ300A3	2	208/230	3	3	8.8	-
	YSJ300A4	2	460	3	3	4.6	-
	YSJ300AW	2	575	3	3	3.2	-

<sup>(a)</sup> Amp draw for each motor (compressor and condenser fan motor); multiply value by number of motors to determine total amps.

**Table 54. Electrical characteristics — oversized indoor fan motor**

Tons	Unit Model Number	No.	Volts	Phase	hp	Amps <sup>(a)</sup>	
						FLA	LRA
10	YSJ120A3	1	208/230	3	5	11.0	-
	YSJ120A4	1	460	3	5	5.5	-
	YSJ120AW	1	575	3	5	3.9	-
17.5	YSJ210A3SB	2	208/230	3	5	11.0	-
	YSJ210A4SB	2	460	3	5	5.5	-
	YSJ210AWSB	2	575	3	5	3.9	-
20	YSJ240A3SB	2	208/230	3	5	11.0	-
	YSJ240A4SB	2	460	3	5	5.5	-
	YSJ240AWSB	2	575	3	5	3.9	-
25	YSJ300A3	2	208/230	3	5	11.0	-
	YSJ300A4	2	460	3	5	5.5	-
	YSJ300AW	2	575	3	5	3.9	-

<sup>(a)</sup> Amp draw for each motor (compressor and condenser fan motor); multiply value by number of motors to determine total amps.

**Table 55. Electrical characteristics — power exhaust**

Tons	Volts	Phase	hp	rpm	FLA	LRA
6-25	208-230	1	0.87	1075	5.7	13.6
6-25	460	1	0.87	1075	3.3	7.2
6-25	575	1	0.80	1075	2.3	5.8

**Note:** For 6 to 10 ton models, rpm = two speed.



**Table 56. Electrical characteristics — inducer motor**

Unit Model Number	Stages	hp	rpm	Volts	Phase	FLA	LRA
YSJ072A**(0,A)(L,M)	2	1/35	3500/2800	208-230	1	0.24/0.18	0.67
YSJ(090,102)A**(0,A)L							
YSJ150B**(0,A)M							
YSJ072A**(0,A)H	2	1/15	3350/2800	208-230	1	0.42/0.50	0.73
YSJ(090,102)A**(0,A)(M,H)							
YSJ120A**(0,A)(L,M,H)							
YSJ150B**(0,A)(L,H)							
YSJ(180,210,240,300)A**(0,A)(L,M)	2	1/15	3300/2800	208-230	1	0.36/0.30	0.73
YSJ(180,210,240,300)A**(0,A)H	2	1/6	3300/2300	208-230	1	0.95/0.49	1.53
YSJ(072,090,102,120,150)***B	Variable	1/8	3400	120	1	1.3	3.3
YSJ(180,210,240,300)A**B	Variable	1/5	3300	115	1	3.4	7.3

# Dimensional Data

Figure 4. 6 to 10 tons standard efficiency

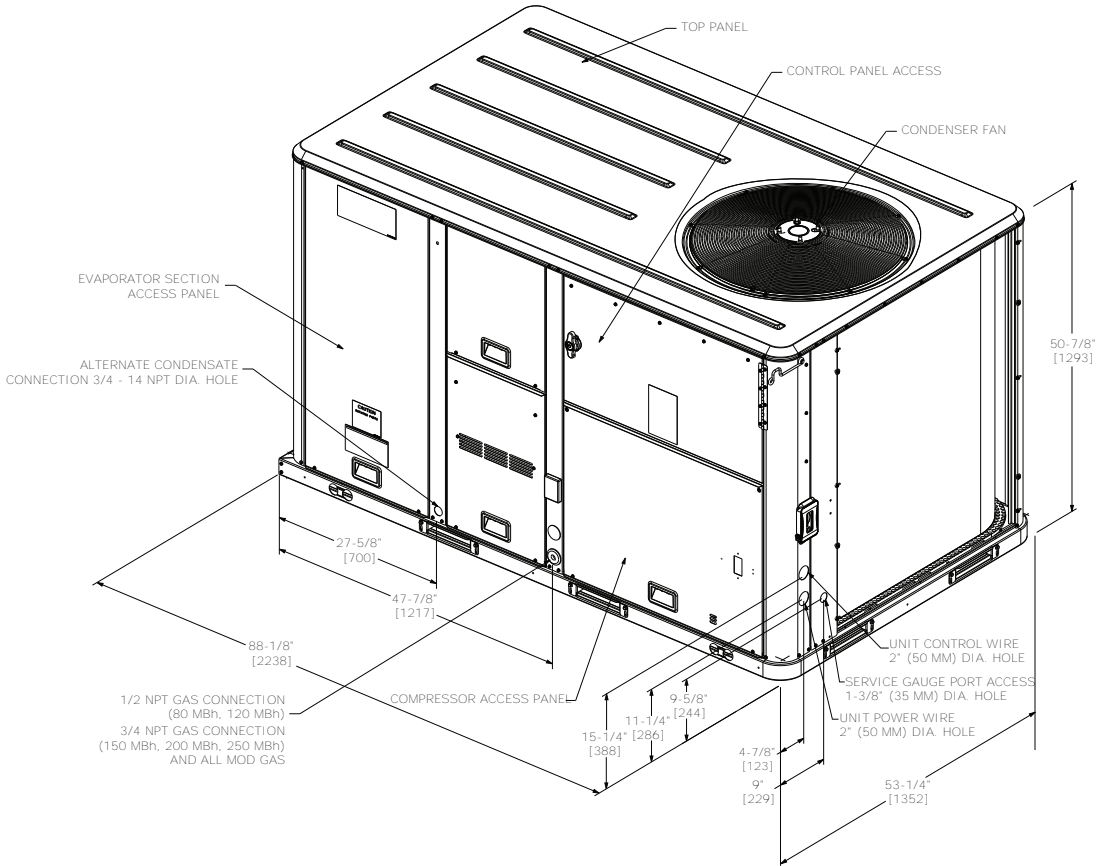

Figure 5. 6 to 10 tons standard efficiency – downflow airflow supply/return, through-the-base utilities

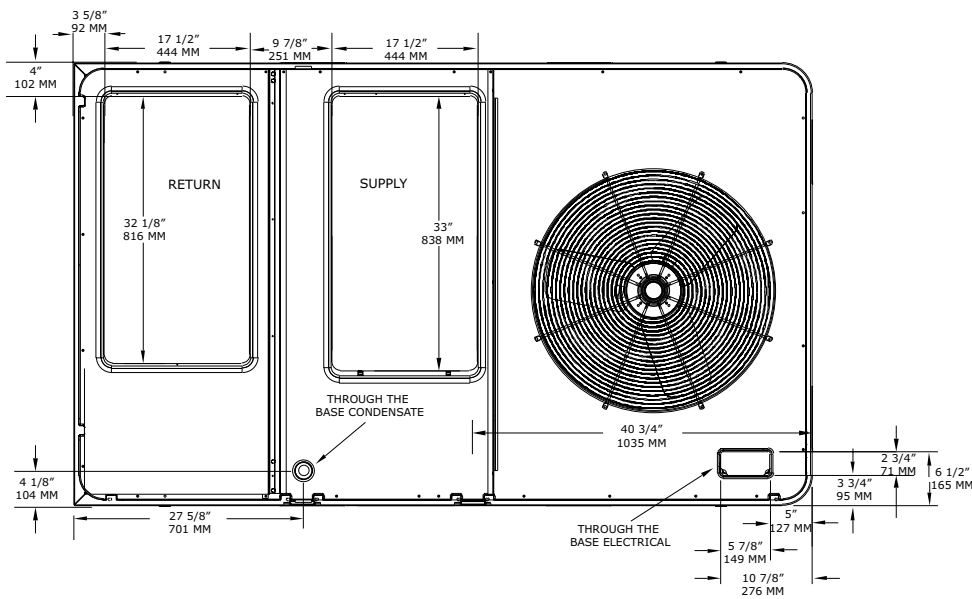

Figure 6. 6 to 10 tons standard efficiency – horizontal airflow supply/return

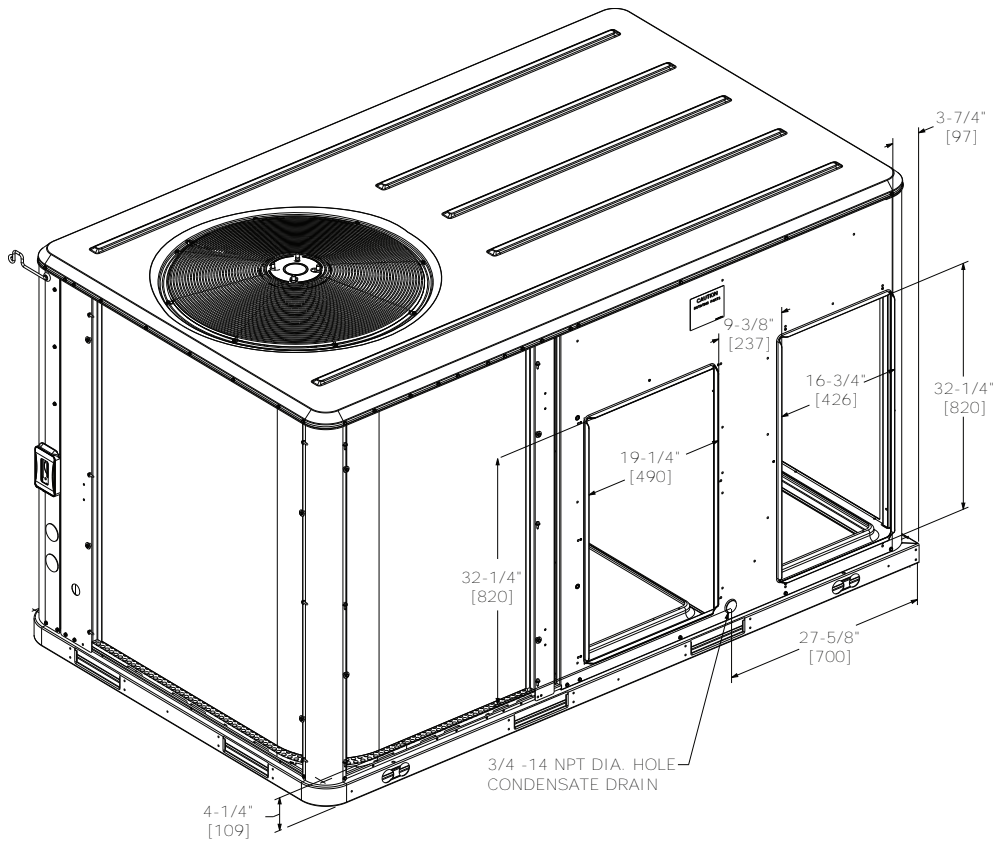
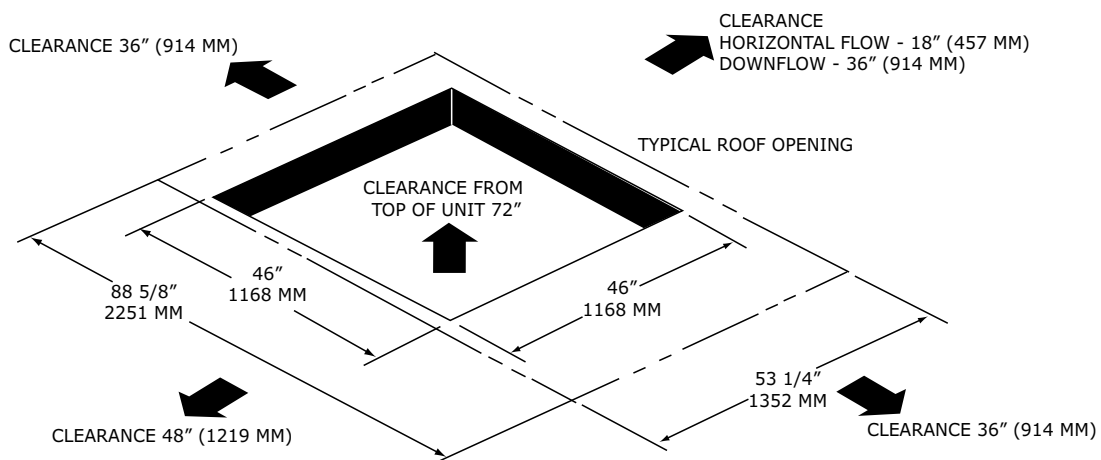
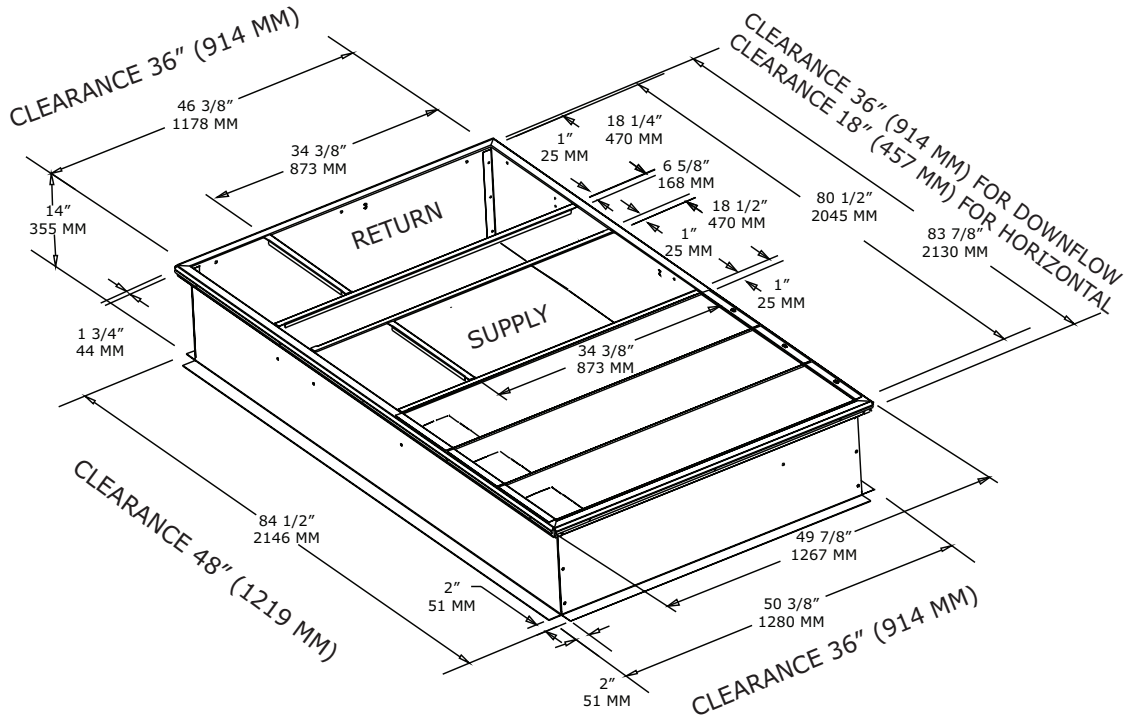

Figure 7. 6 to 10 tons standard efficiency — unit clearance and roof opening



**Figure 8. 6 to 10 tons standard efficiency – roof curb**



**Figure 9. 6 to 10 tons standard efficiency – downflow duct connections, field fabricated**

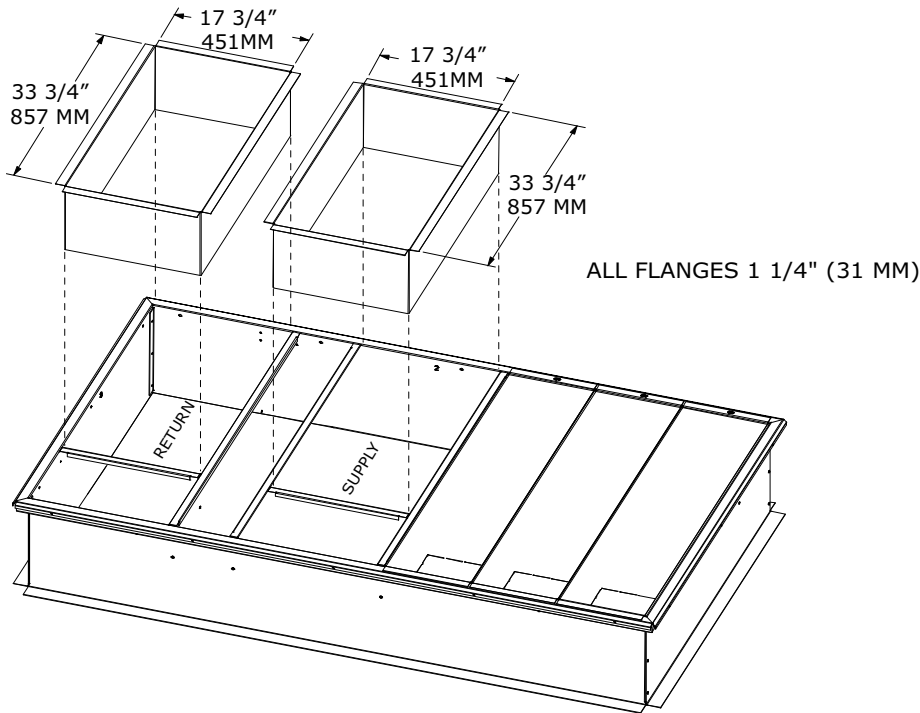

Figure 10. 6 to 10 tons standard efficiency – swing diameter for hinged door(s) option

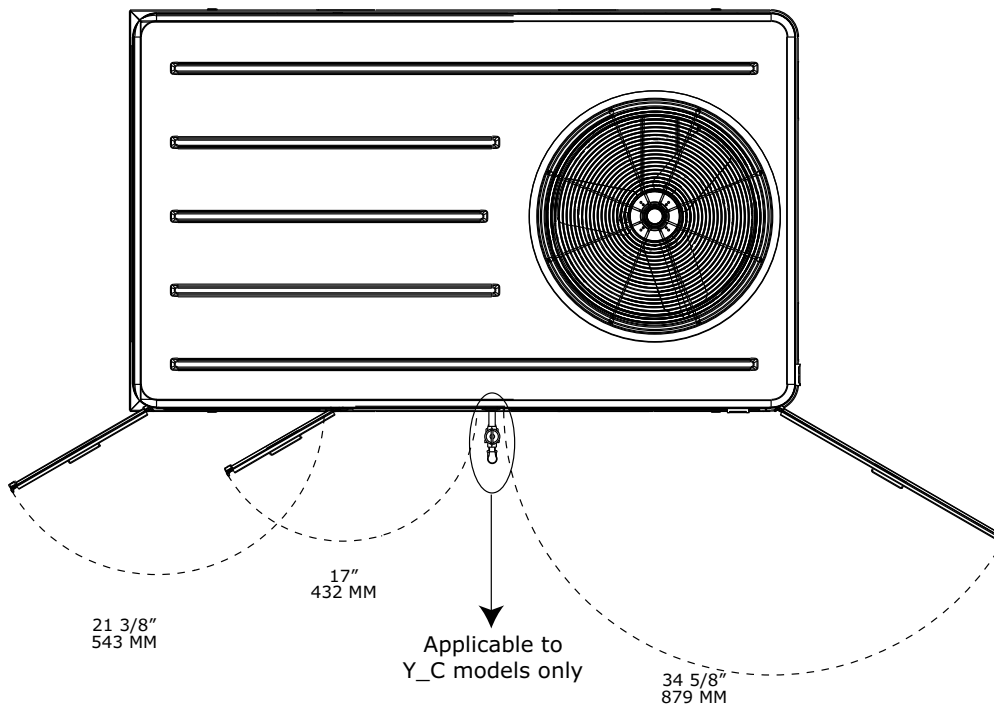
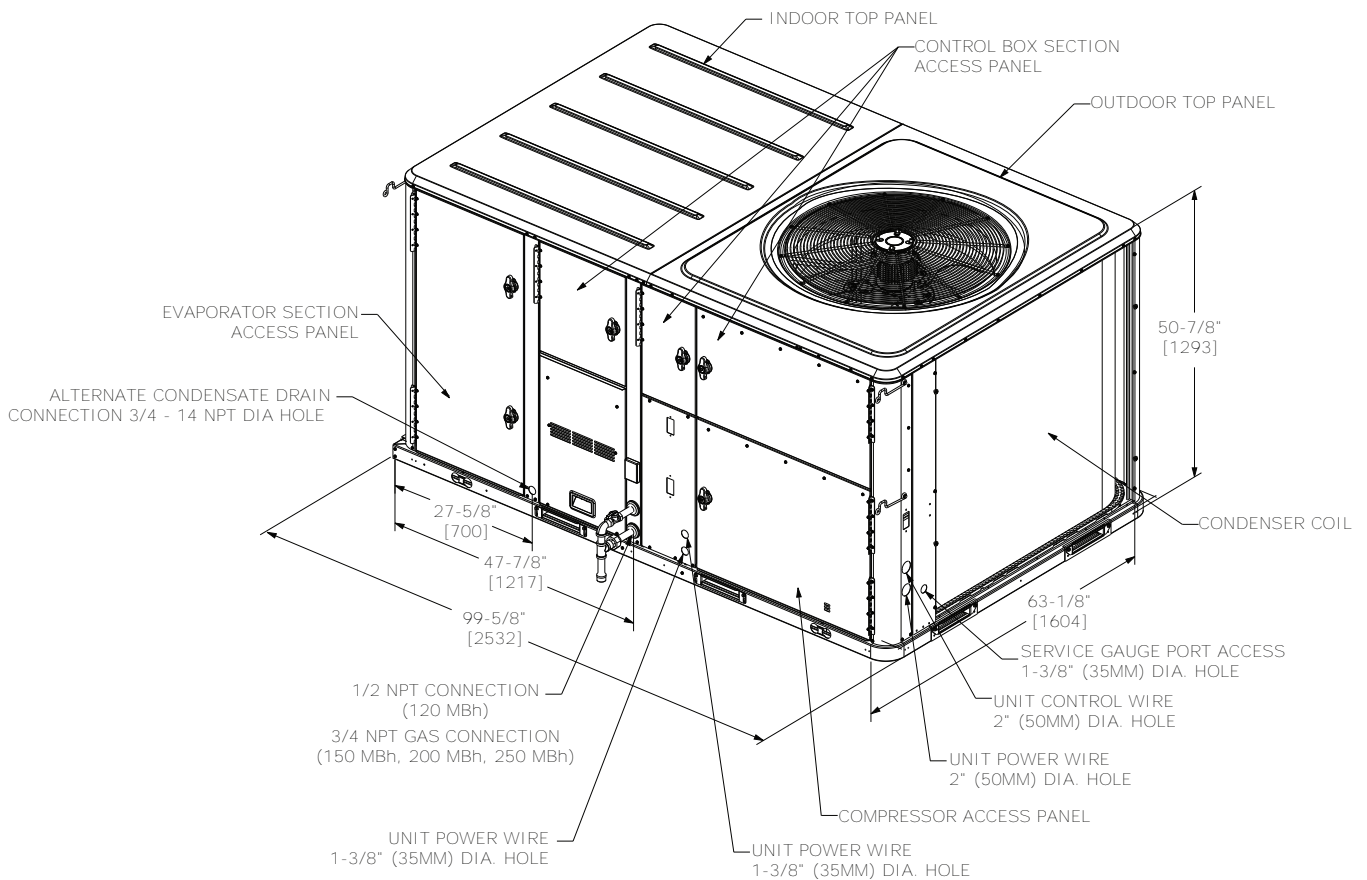
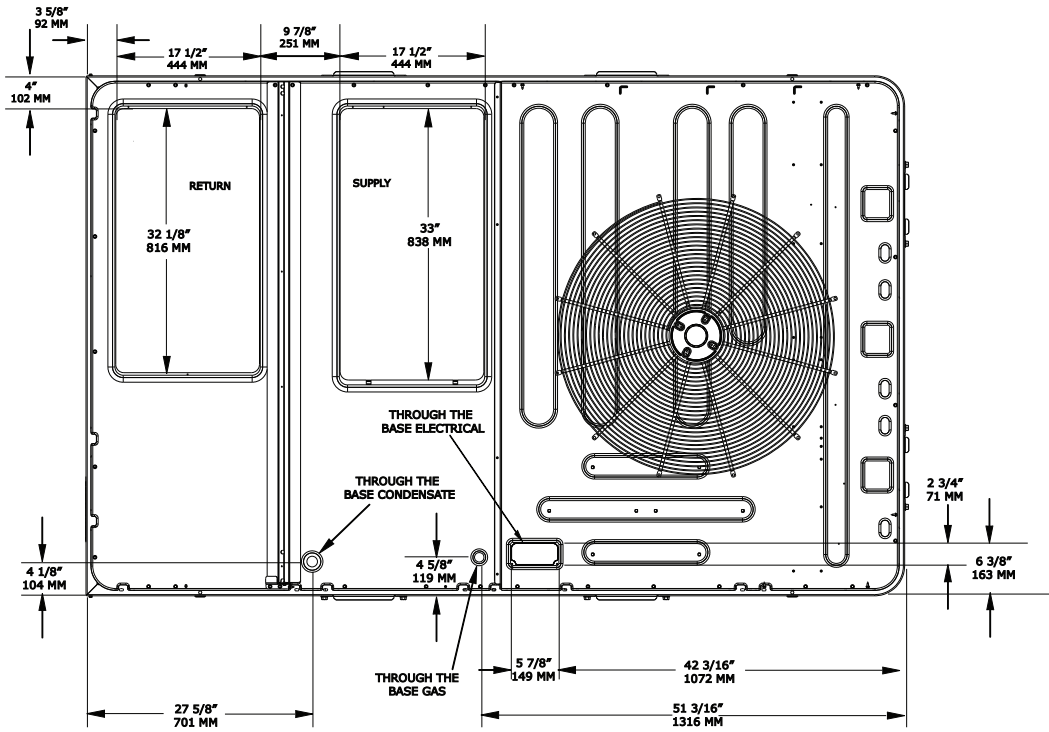

Figure 11. 12.5 tons standard efficiency



**Figure 12. 12.5 tons standard efficiency – downflow airflow supply/return, through-the-base utilities**



**Figure 13. 12.5 tons standard efficiency – horizontal airflow, supply and return**

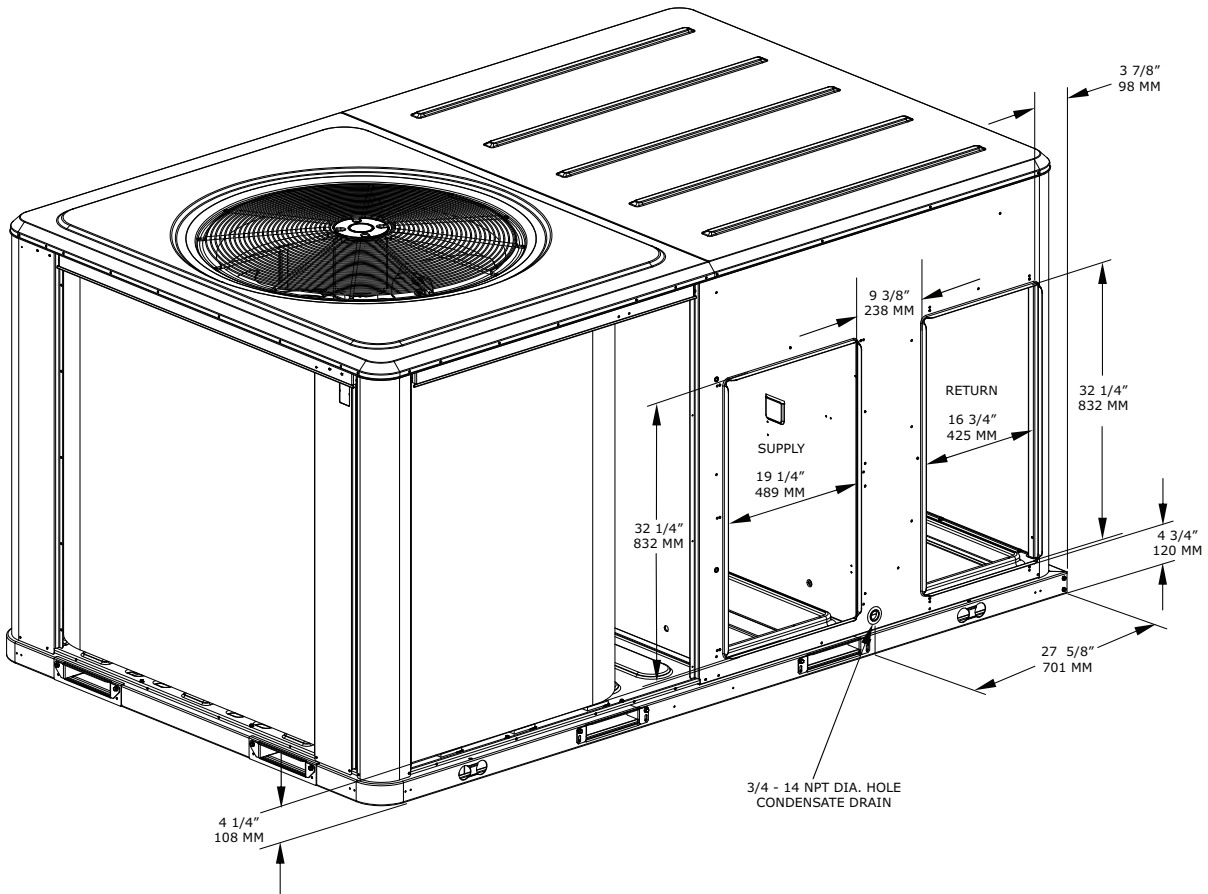

Figure 14. 12.5 tons standard efficiency – unit clearance and roof opening

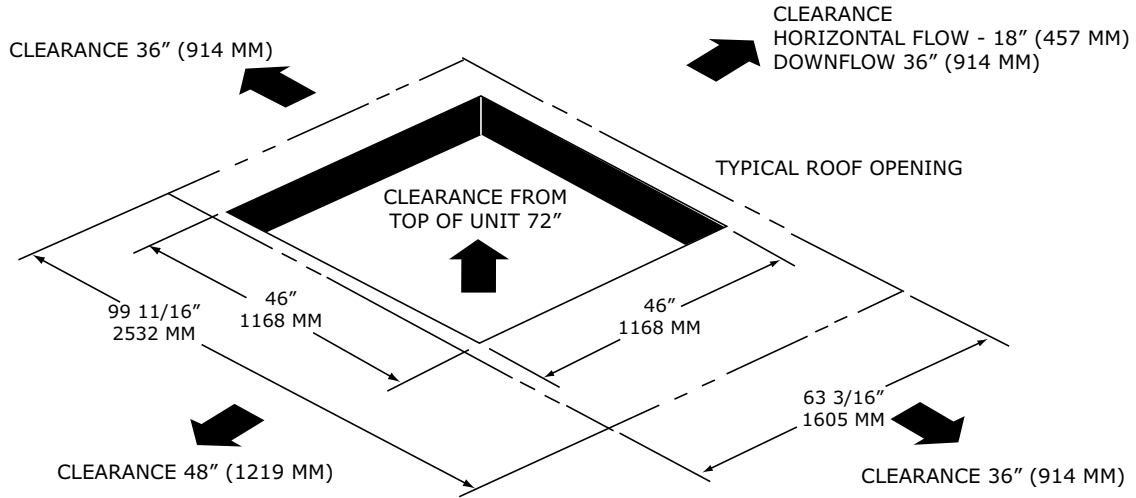
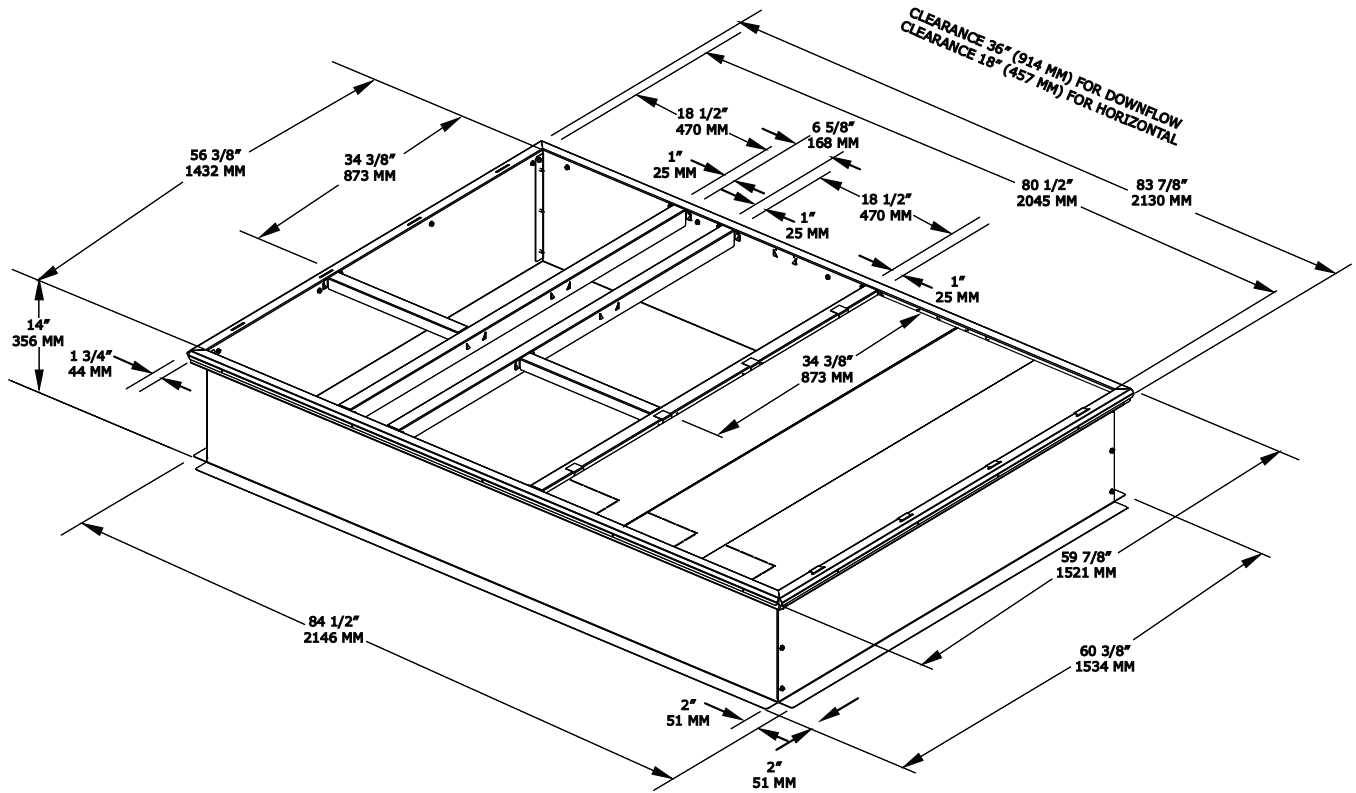

Figure 15. 12.5 tons standard efficiency – roof curb





## Dimensional Data

Figure 16. 12.5 tons standard efficiency – swing diameter for hinged door(s) option

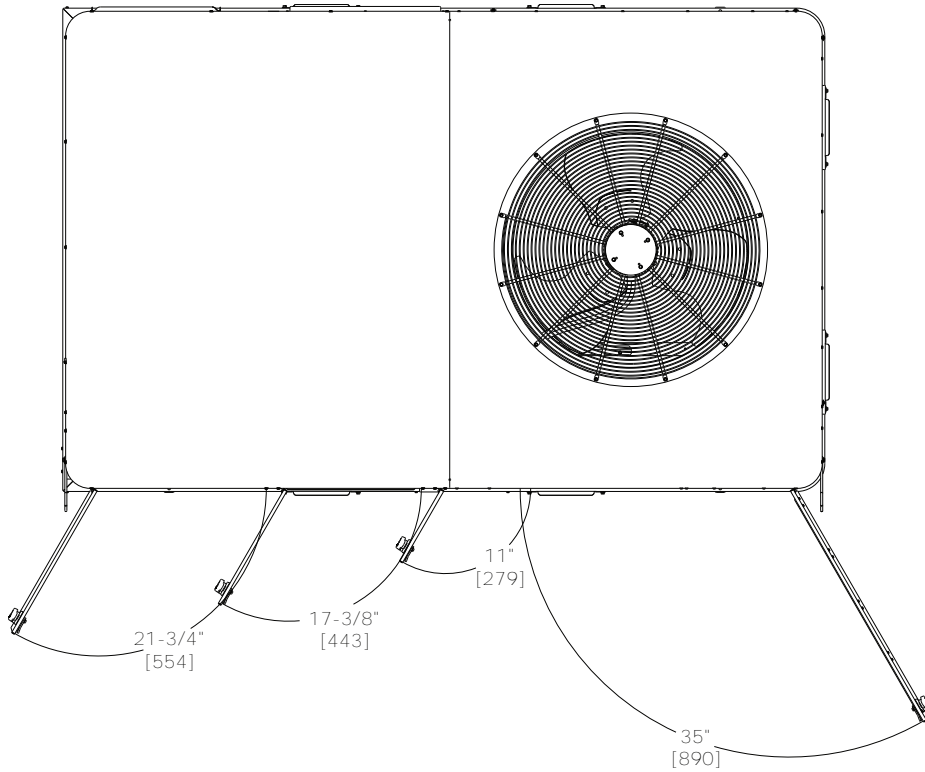

Figure 17. 6 to 12.5 tons standard efficiency – economizer, manual or motorized fresh air damper

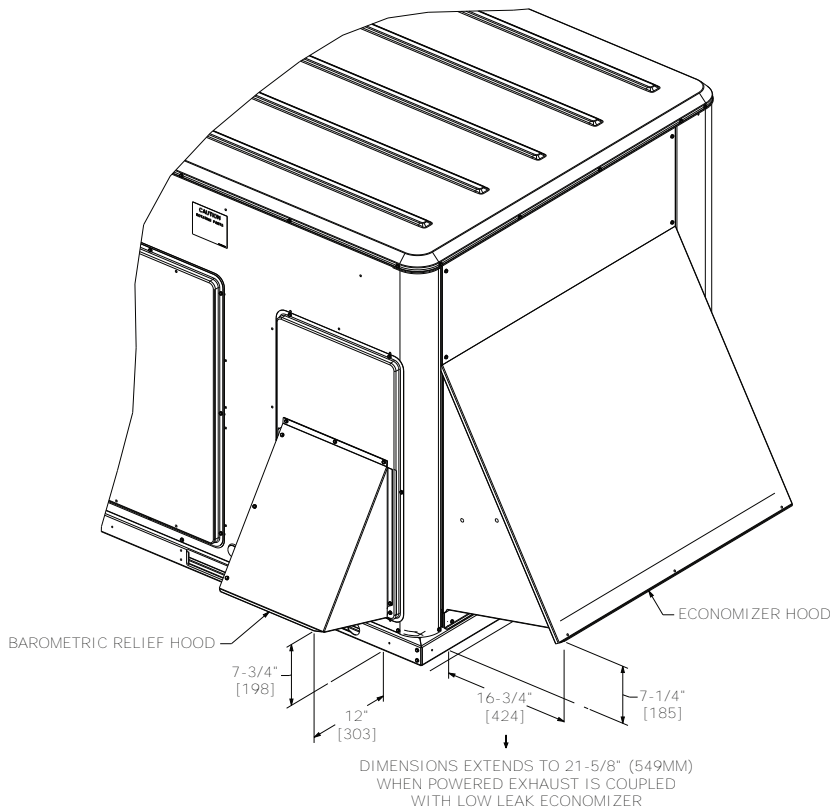
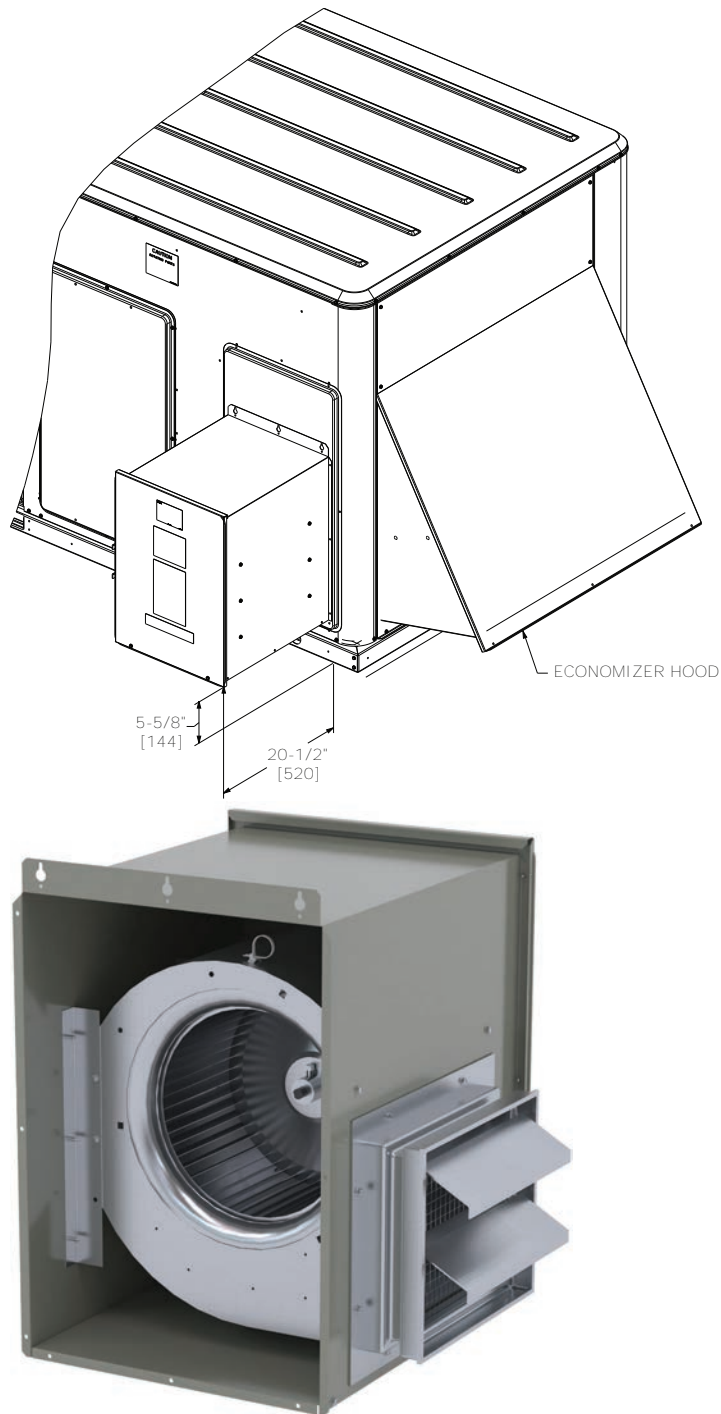



Figure 18. 6 to 12.5 tons standard efficiency – power exhaust





## Dimensional Data

Figure 19. 15 to 25 tons standard efficiency – power exhaust

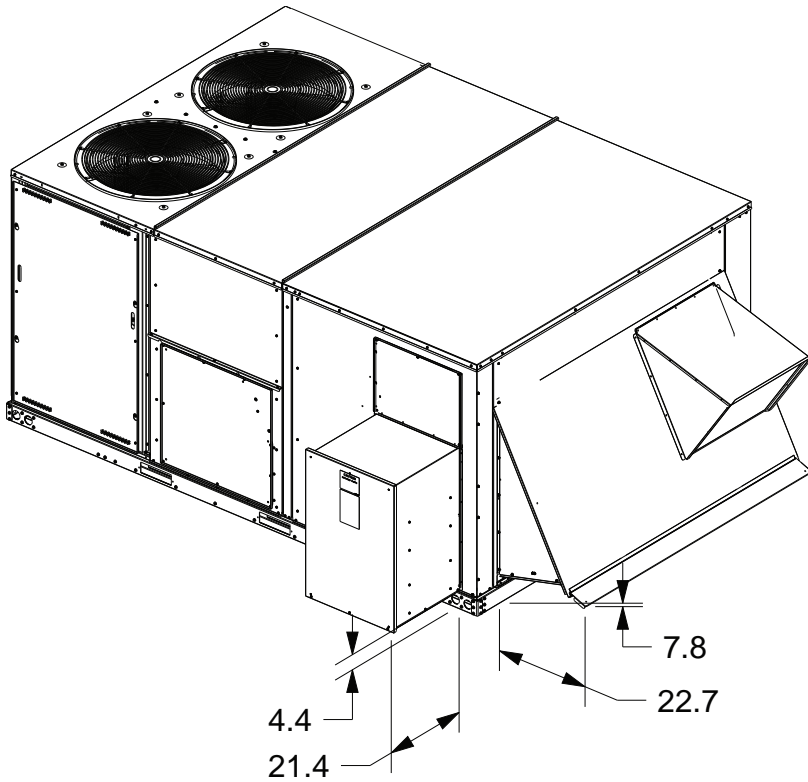
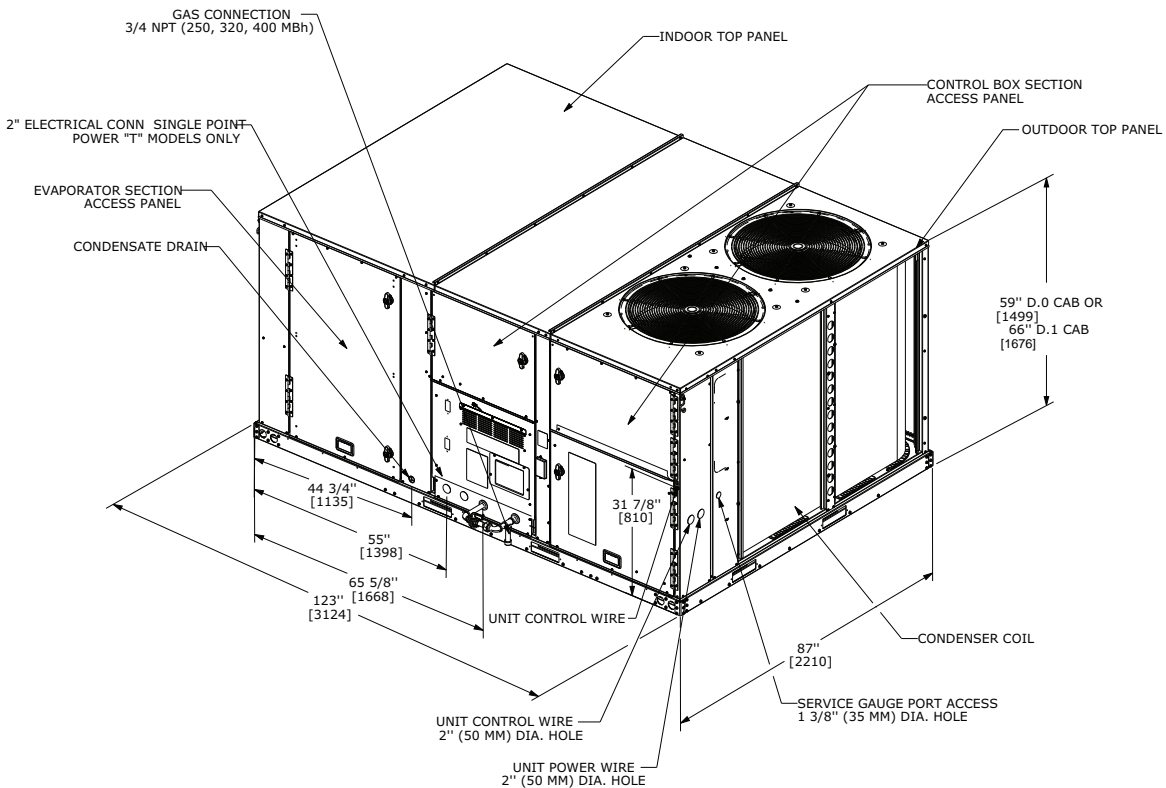
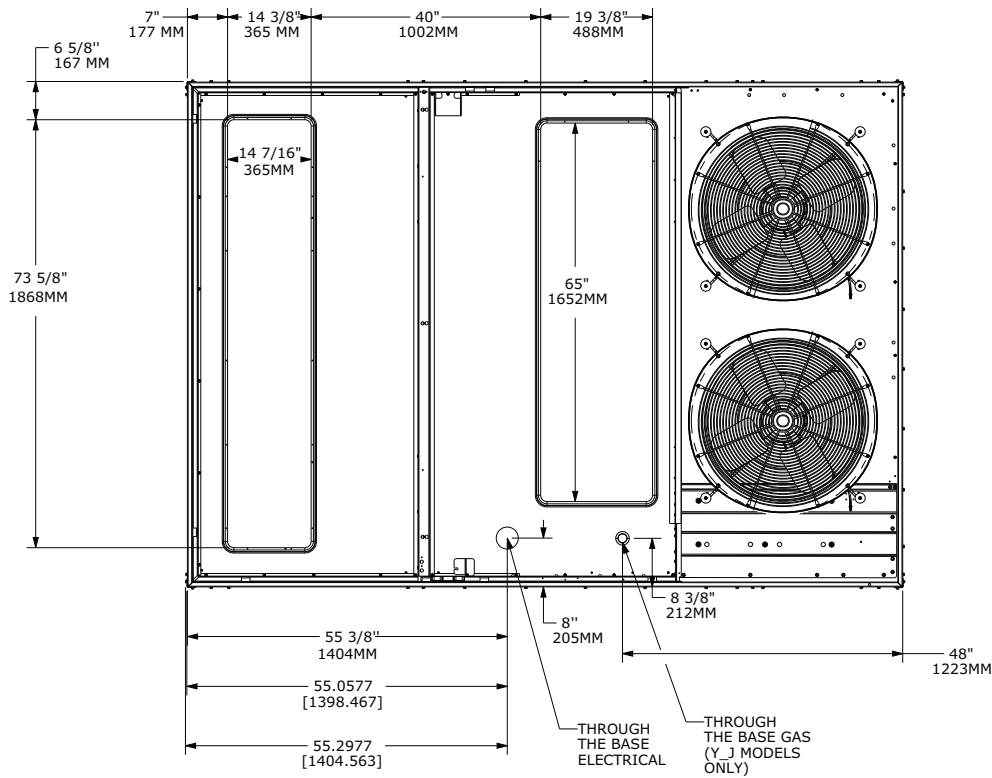

Figure 20. 15 to 25 tons standard efficiency



**Figure 21. 15 to 25 tons standard efficiency – downflow airflow supply/return, through-the-base utilities**



**Figure 22. 15 to 25 ton standard efficiency – horizontal airflow supply/return**

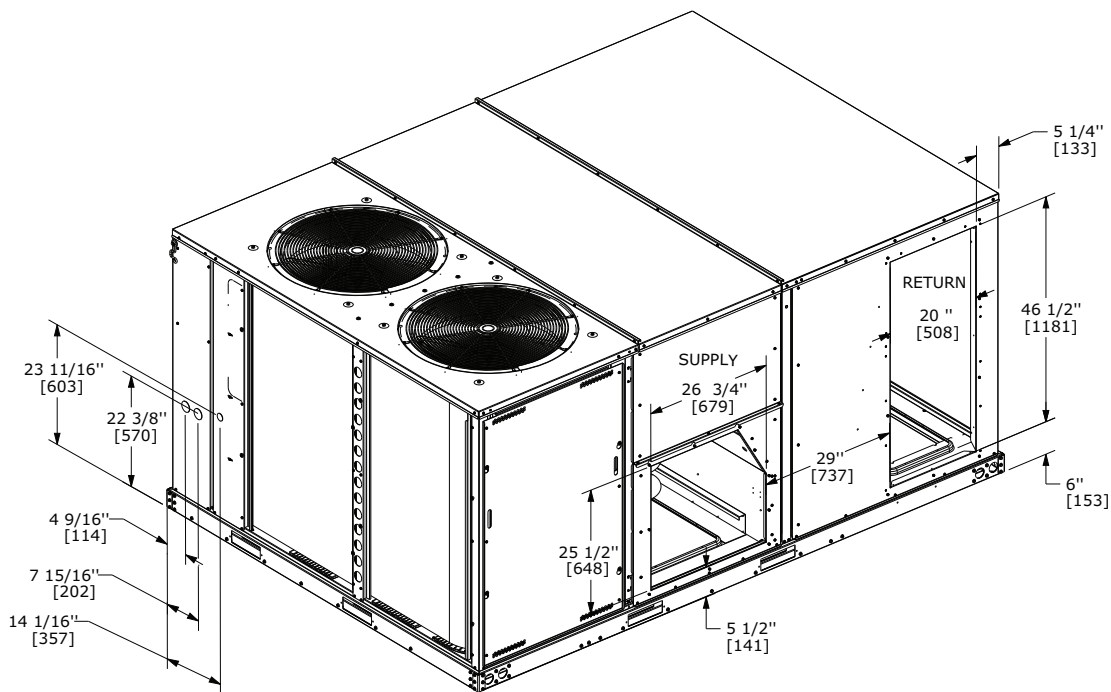

**Figure 23. 15 to 25 tons standard efficiency – unit clearance and roof opening**

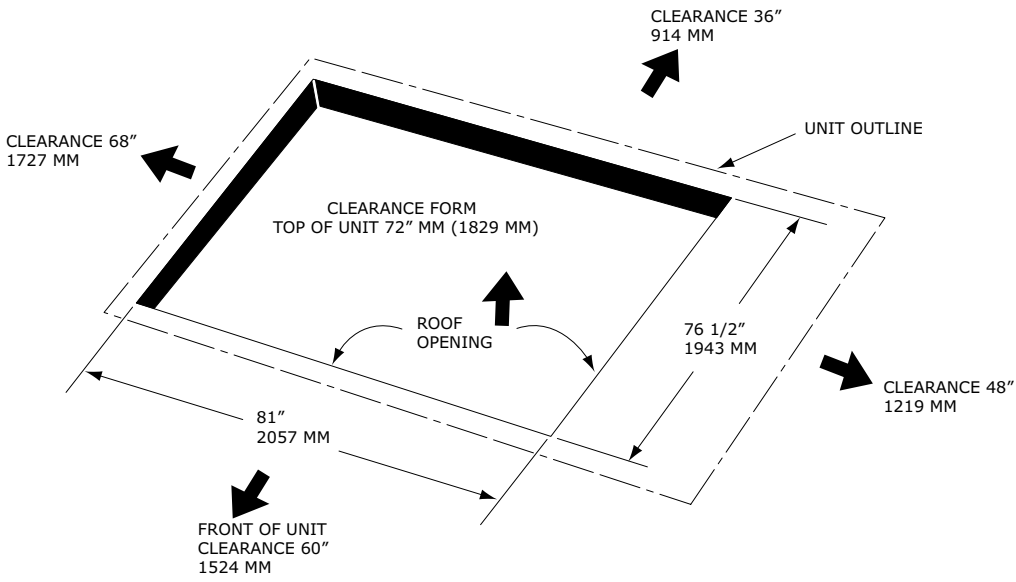

**Figure 24. 15 to 25 tons standard efficiency – roof curb**

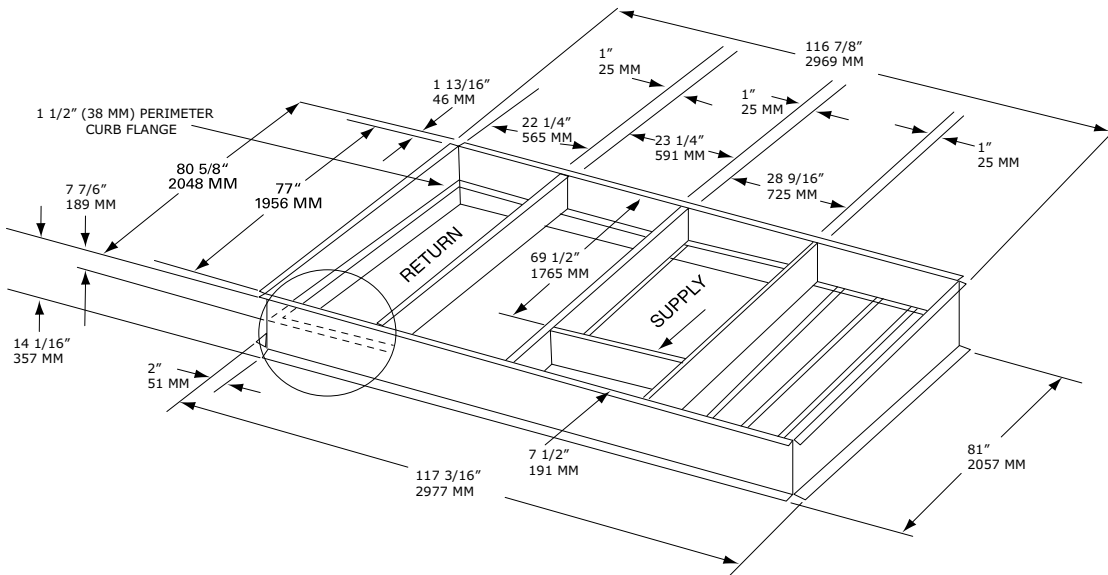

**Figure 25. 15 to 25 ton standard efficiency – swing diameter for hinged door(s) option**

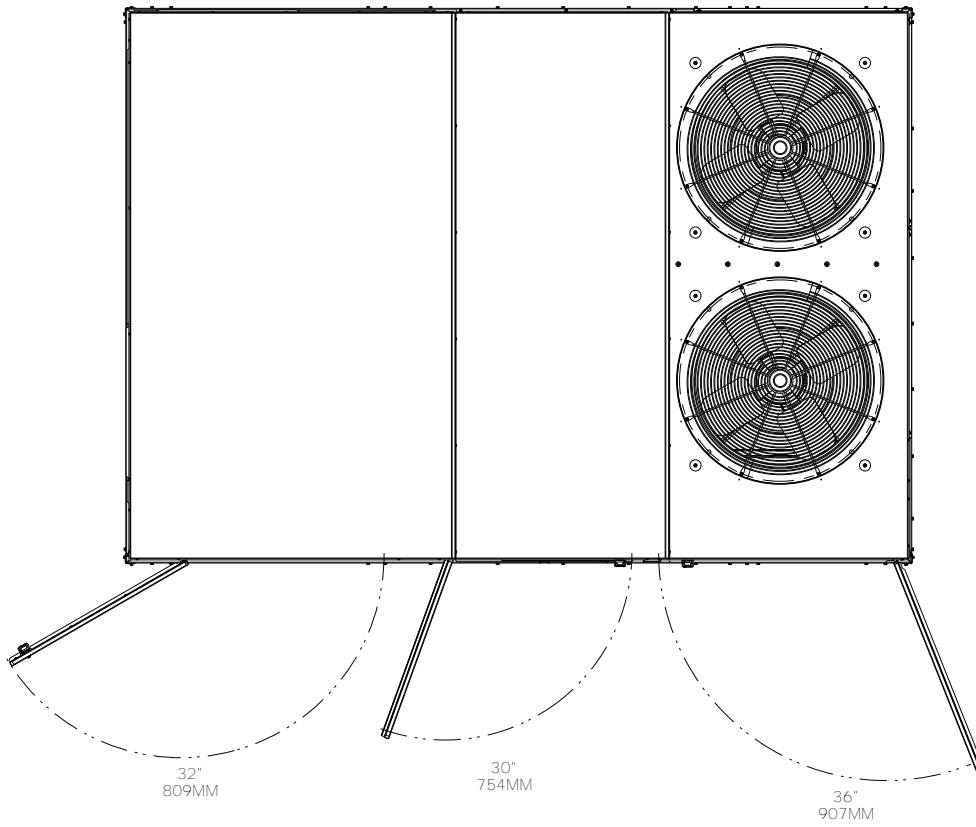

# Weights

**Table 57. Model weights, corner weights (lbs) and center of gravity dimensions (in.)**

Tons	Unit Model No.	Model Weights <sup>(a)</sup>		Corner Weights <sup>(b)</sup>				Center of Gravity (in.)	
		Shipping	Net	A	B	C	D	Length	Width
6	YSJ072	1107	1009	331	309	178	191	43	19
7.5	YSJ090	1111	1013	333	310	178	191	43	19
8	YSJ102	1127	1029	338	315	181	194	43	19
10	YSJ120	1137	1039	341	318	183	196	43	19
12.5	YSJ150	1512	1318	385	389	273	270	50	26
15	YSJ180	2220	2000	671	492	354	483	52	36
17.5	YSJ210	2250	2030	672	509	366	484	53	36
20	YSJ240	2320	2100	754	516	337	493	50	34
25	YSJ300	2370	2150	746	529	363	512	51	35

<sup>(a)</sup> Weights are approximate. Weights do not include additional factory or field installed options/accessories. For option/accessory additional weights to be added to unit weight, reference the following table.

<sup>(b)</sup> Corner weights are given for information only.

**Figure 26. Corner weights**

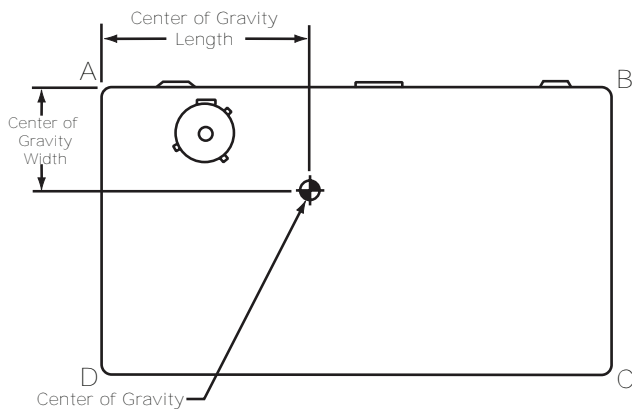

**Table 58. Factory installed options (FIOPS)/accessory net weights (lb)**

Accessory	YSJ072-120	YSJ150	YSJ180-300
	6, 7.5, 8.5, 10 Tons	12.5 Tons	15, 17.5, 20, 25 Tons
Barometric Relief	10	10	40
Economizer	36	36	91
Hinged Doors	12	12	20
Low Leak Economizer - Downflow	91	91	150
Low Leak Economizer - Horizontal	—	—	180
Manual Outside Air Damper	26	26	15
Motorized Outside Air Damper	30	30	82
Oversized Motor	14	—	30
Powered Convenience Outlet	38	50	50
Powered Exhaust	80	80	110
Reheat Coil	16	20	33
Roof Curb	105	111	235
Smoke Detector, Supply	5	5	5
Smoke Detector, Return	7	7	5
Stainless Steel Heat Exchanger	6	6	5
Through-the-Base Electrical	13	13	10

**Table 58. Factory installed options (FIOPS)/accessory net weights (lb) (continued)**

Accessory	YSJ072-120	YSJ150	YSJ180-300
	6, 7.5, 8.5, 10 Tons	12.5 Tons	15, 17.5, 20, 25 Tons
Through-the-Base Gas	5	5	10
Unit Mounted Circuit Breaker	5	5	10
Unit Mounted Disconnect	5	5	10

**Notes:**

1. Weights for options not listed are <5 lbs.
2. Net weight should be added to unit weight when ordering factory-installed accessories.
3. Weights are approximate.



# Mechanical Specifications

## General

- Packaged rooftop units cooling, heating capacities, and efficiencies are AHRI Certified within scope of AHRI Standard 340-360 for 12.5 to 20 tons, and ANSI Z21.47 and 10 CFR Part 431 pertaining to Commercial Warm Air Furnaces (all gas heating units).

**Note:** *The 25 ton units are tested in accordance with the standard.*

- Convertible airflow.
- Symbio™ controls operating range between 40°F and 125°F in cooling mode standard from the factory. Field-installed low ambient kit extended operating range down to 0°F.
- Factory assembled, internally wired, fully charged with R-410A, and 100 percent run tested to check cooling operation, fan and blower rotation, and control sequence before leaving the factory.
- Colored and numbered wiring internal to the unit for simplified identification.
- Units cULus listed and labeled, classified in accordance for Central Cooling Air Conditioners.

## Casing

- Zinc coated, heavy gauge, galvanized steel.
- Weather resistant pre-painted metal with galvanized substrate.
- Meets ASTM B117, 672 hour salt spray test.
- Removable single side maintenance access panels.
- Lifting handles in maintenance access panels (can be removed and reinstalled by removing fasteners while providing a water and air tight seal).
- Exposed vertical panels and top covers in the indoor air section insulated with a cleanable foil-faced, fire-retardant permanent, odorless glass fiber material.
- Base pan shall have no penetrations within the perimeter of the curb other than the raised 1 inch high downflow supply/return openings to provide an added water integrity precaution, if the condensate drain backs up.
- Base of the unit insulated with 1/8 inch, foil-faced, closed-cell insulation.
- Unit base provisions for forklift and/or crane lifting on three sides of unit.

## Coils

### Microchannel Coils

- Optimal heat transfer performance due to flat, streamlined tubes with small ports, and metallurgical tube-to-fin bond.
- Reduce system refrigerant charge by up to 50% leading to better compressor reliability.
- Compact all-aluminum microchannel coils reduce the unit weight.
- Recyclable all-aluminum coils. All-aluminum construction minimizes galvanic corrosion.
- Strong aluminum brazed structure provides better fin protection.
- Flat streamlined tubes more dust resistant and easy to clean.
- Coils leak tested at the factory to ensure the pressure integrity.

### Coil Guards

Provides condenser coil protection.

## Compressors

- All units have direct-drive, hermetic, scroll type compressors with centrifugal type oil pumps.
- Suction gas-cooled motor with voltage utilization range of plus or minus 10 percent of unit nameplate voltage.
- Internal overloads standard with scroll compressors.
- Crankcase heaters are standard on all compressors.
- All units have dual compressors.



- Three stages of cooling available on 6 to 17.5 tons units and four stages of cooling available on 20 and 25 tons units.

## Filters

- Standard throwaway filters
- Optional 2 inch MERV 8 and MERV 13 filters

## Frostat™

- Utilized as a safety device.
- Opens to prevent freezing temperatures on evaporator coil.
- Temperature will need to rise to 50°F before closing.
- Utilized in low airflow or high outside air applications (cooling only).

## Gas Heating Section

- The heating section shall have a progressive tubular heat exchanger with corrosion-resistant aluminized steel tubes and burners as standard on all models.
- Stainless steel heat exchanger with 409 stainless steel tubes and 439 stainless steel burners shall be optional.
- Induced draft combustion blower shall be used to pull the combustion products through the firing tubes.
- Heater shall use a direct spark ignition (DSI) system.
- On initial call for heat, the combustion blower shall purge the heat exchanger for 20 seconds before ignition.
- After three unsuccessful ignition attempts, entire heating system shall be locked out until manually reset at the thermostat/zone sensor.
- Units shall be suitable for use with natural gas or propane (field-installed kit).

## Tubular Gas Heat Exchanger

- Compact cabinet features a tubular heat exchanger in low, medium and high heat capacities.
- Corrosion-resistant aluminized steel tubes and burners are standard on all models.
- Induced draft blower to pull the gas mixture through the burner tubes.
- Direct spark ignition and a flame sensor as a safety device to validate the flame.

## Indoor Fan

- Direct drive plenum fan design – 6 to 25 tons units.
- Plenum fan design — backward-curved fan wheel along with an external rotor direct drive variable speed indoor motor.
- Supply fan speed adjustments can be made using the Symbio 700 or Mobile App.
- Motors are electronically protected.
- Variable speed direct drive motors are high efficiency – 6 to 25 tons.

## Powered or Unpowered Convenience Outlet

- Powered GFCI, 120V/15A, 2 plug, convenience outlet or unpowered GFCI, 120V/20A, 2 plug, convenience outlet.
- When convenience outlet is powered, a service receptacle disconnect will be available.
- Convenience outlet is powered from the line side of the disconnect or circuit breaker, and therefore will not be affected by the position of the disconnect or circuit breaker.
- Available to order when through-the-base electrical with disconnect switch or circuit breaker option is ordered.



## Stainless Steel Drain Pan

- Corrosion and oxidation resistance.
- Constructed of 304 stainless steel.

## Stainless Steel Heat Exchanger

- Constructed of 409 stainless steel tubes and 439 stainless steel burners.
- Resistant to corrosion and oxidation and easy to clean.
- High strength to weight ratio allows for high ventilation rates with gas units.
- Compliment dehumidification option as a high outside air ventilation unit.
- 15 years stainless steel heat exchanger warranty is standard.

## Through-the-Base Electrical with Circuit Breaker

- Thermal magnetic, molded case, HACR circuit breaker with provisions for through-the-base electrical connections.
- Circuit breaker installed within unit in water tight enclosure.
- Wiring provided from the switch to the unit high voltage terminal block.
- Circuit breaker will provide overcurrent protection, sized per NEC and cULus guidelines, and agency recognized by cULus.

## Through-the-Base Electrical with Disconnect Switch

- 3-pole, molded case, disconnect switch with provisions for through-the-base electrical connections.
- Disconnect switch installed within unit in a water tight enclosure.
- Wiring provided from the switch to the unit high voltage terminal block.
- Switch cULus agency recognized.

*Note: Disconnect switch sized per NEC and cULus guidelines but will not be used in place of unit overcurrent protection*

## Economizer (Standard)

- Available with or without barometric relief.
- Fully modulating 0-100 percent motor and dampers, minimum position setting, preset linkage, wiring harness with plug, spring return actuator and fixed dry bulb control.
- Barometric relief shall provide a pressure operated damper that shall be gravity closing.
- Barometric relief shall prohibit entrance of outside air during the equipment "off" cycle.
- Optional solid state or differential enthalpy control.
- Arrives in shipping position and shall be moved to the operating position by the installing contractor.

## Manual Outside Air Damper

Rain hood and screen shall provide up to 50 percent outside air.

## Motorized Outside Air Damper

- Once set, when indoor fan starts, outdoor air dampers shall open to set position.
- When indoor fan shuts down, damper shall close to the full closed position.

## Powered Exhaust

- Available for 6 to 25 ton units.
- Shall provide exhaust of return air, when using an economizer.
- Maintain better building pressurization.

## Roof Curb

- Designed to mate with the unit's downflow supply and return.
- Provide support and a water tight installation when installed properly.
- Shall allow field-fabricated rectangular supply/return ductwork to be connected directly to the curb.
- Curb shall be shipped knocked down for field assembly.
- Shall include wood nailer strips.

## Ventilation Override Operation

- Unit can be set to transition up to 3 different pre-programmed sequences for smoke purge, pressurization, and exhaust.
- Transition occurs when binary input on the Symbio is closed (shorted) (typically hard wired relay output from a smoke detector/ fire control panel).

**Note:** Requires Symbio™ Customer Connection Module, FIASCCM001\*.



The AHRI Certified mark indicates Trane U.S. Inc. participation in the AHRI Certification program. For verification of individual certified products, go to [ahridirectory.org](http://ahridirectory.org).

Trane - by Trane Technologies (NYSE: TT), a global innovator - creates comfortable, energy efficient indoor environments for commercial and residential applications. For more information, please visit [trane.com](http://trane.com) or [tranetechnologies.com](http://tranetechnologies.com).

Trane has a policy of continuous product and product data improvements and reserves the right to change design and specifications without notice. We are committed to using environmentally conscious print practices.