



Product Catalog

Packaged Rooftop Air Conditioners Precedent™ Cooling and Electric Heat

Standard Efficiency
6 to 25 Tons — 60 Hz





Introduction

Packaged Rooftop Air Conditioners

Trane's customers demand products that provide exceptional reliability, meet stringent performance requirements, and are competitively priced. Trane delivers with Precedent™.

Precedent™ features cutting edge technologies: reliable compressors, Trane engineered Symbio controls, computer-aided run testing, and Integrated Comfort™ Systems. So, whether you're the contractor, the engineer, or the owner you can be certain Precedent™ products are built to meet your needs.

The Precedent product is designed for comfort cooling, mixed air applications. If the product is being considered for other types of applications, such as process cooling, dedicated outdoor air, indoor agriculture, etc. Consult with your local Trane Sales Representative. Applying the units in an unintended application could result in inadequate performance and/or premature component failures.

Through the years, Trane has designed and developed the most complete line of Packaged Rooftop products available in the market today. Trane was the first to introduce the Micro—microelectronic unit controls—and has continued to improve and revolutionize this design concept.

Symbio control platform offers the same great features and functionality as the original Micro, with additional benefits for greater application flexibility.

With its sleek, compact cabinet, Precedent™ continues to provide the highest standards in quality and reliability, comfort, ease of service, and the performance of Trane light commercial products.

Copyright

This document and the information in it are the property of Trane, and may not be used or reproduced in whole or in part without written permission. Trane reserves the right to revise this publication at any time, and to make changes to its content without obligation to notify any person of such revision or change.

Trademarks

All trademarks referenced in this document are the trademarks of their respective owners.

Revision History

Updated the following 12.5 ton unit data in the following tables:

- General data table cooling performance
- Gross cooling capacities
- Fan performance
- Electrical data



Table of Contents

Features and Benefits	5
Features	5
Control Options	6
Accessories	7
Key Benefits	9
Model Number Description	17
General Data	19
Gross Cooling Capacities	22
Reheat Temperature Rise	31
Evaporator Fan Performance	54
6 to 10 Ton Units — Downflow	54
6 to 10 Ton Units — Horizontal	58
12.5 Ton Units — Downflow	62
12.5 Ton Units — Horizontal	63
15 to 25 Ton Units — Downflow	65
15 to 25 Ton Units — Horizontal	68
Fan Performance	72
Heating Performance	73
Controls	74
Enhanced BAS Integration and Connectivity	74
Secure Remote Connectivity with Trane Connect	74
Serviceability	74
Flexibility	76
Economizer Controls	77
Zone Sensors	77
Air-Fi Wireless Communicating Zone Sensors	78
Thermostats	79
Humidity Control (HGRH)	79
Electrical Data	81
Dimensional Data	87
Weights	99



Mechanical Specifications	101
General	101
Casing	101
Coils	101
Coil Guards	101
Compressors	101
Filters	102
Frostat™	102
Indoor Fan	102
Powered or Unpowered Convenience Outlet	102
Stainless Steel Drain Pan	102
Through-the-Base Electrical with Circuit Breaker	102
Through-the-Base Electrical with Disconnect Switch	102
Economizer (Standard)	102
Electric Heaters	103
Manual Outside Air Damper	103
Motorized Outside Air Damper	103
Powered Exhaust	103
Roof Curb	103
Ventilation Override Operation	103



Features and Benefits

Features

Note: Equipment feature availability is dependent on unit configuration. For more information, see Packaged Rooftop Air Conditioners Precedent™ Quick Reference Support Guide (PREC-PRC001-EN), the ordering system, or contact product support.*

Table 1. Precedent™ features – standard and optional

	Standard Features	Options		
		Factory Installed	Factory or Field Installed	Field Installed
3-year Limited Parts Warranty	X			
5-year Limited Compressor Warranty	X			
2 inch Filter	X			
2 inch MERV 8 Filters		X		
2 inch MERV 13 Filters		X		
Access Doors		X		
Access Door (Control Box)	X			
Access Panels	X			
Anti-Short Cycle Timer (Standard with Symbio)	X			
Barometric Relief			X	
CO ₂ Sensor				X
Clogged Filter Switch			X	
Coil guards	X			
CompleteCoat™ Condenser Coil		X		
Condensate Overflow Switch			X	
Convertible Airflow	X			
Colored and Numbered Wiring	X			
Crankcase Heaters	X			
Humidity Control (HGRH)		X		
Direct Drive Plenum Fan	X			
Discharge Air Temperature Sensing Kit — MZVAV, SZVAV, Economizer	X			
Discharge Air Temperature Sensing Kit — Standard (Multispeed)			X	
Economizer: Low Leak — Downflow (6 to 25 Tons)			X	
Economizer: Low Leak — Horizontal (6 to 25 Tons)				X
Economizer: Standard — Convertible (6 to 12.5 Tons)			X	
Economizer: Standard — Downflow (15 to 25 Tons)			X	
Economizer: Standard — Horizontal (15 to 25 Tons)				X
Electric Heater			X	
Expansion Modules			X	
Fault Detection and Diagnostics (FDD)	X			
Filter Removal Tool	X			
Foil-Faced and Edge Protected Insulation	X			
Frostat™	X			
High Pressure Control	X			
High Static/Oversized Motor		X		
High Temperature Sensor				X
IAQ Dual Sloped Composite Drain Pan	X			
Liquid Line Refrigerant Drier	X			
Low Ambient Cooling to 0°F				X



Features and Benefits

Table 1. Precedent™ features – standard and optional (continued)

	Standard Features	Options		
		Factory Installed	Factory or Field Installed	Field Installed
Low Ambient Cooling to 40°F	X			
Low Pressure Control	X			
Manual Outside Air Damper			X	
Microchannel Coils	X			
Motorized Outside Air Damper			X	
Multispeed Direct Drive Motors	X			
Multiple Zone VAV (Variable Air Volume)		X		
Operating Charge of R-410A	X			
Phase Balance/Loss/Reversal Protection	X			
Phase Monitor	X			
Powered Exhaust				X
Powered or Unpowered Convenience Outlet		X		
Quick Adapt Curbs				X
Reference or Comparative Enthalpy			X	
Roof Curb				X
Single Point Power	X			
Single Side Service	X			
Smoke Detector - Return		X		
Smoke Detector - Supply		X		
Stainless Steel Drain Pan		X		
Standardized Components	X			
Symbio Controls	X			
Thermal Expansion Valve	X			
Through-the-Base Condensate	X			
Through-the-Base Electrical Access		X		
Through-the-Base Electrical with Circuit Breaker		X		
Through-the-Base Electrical with Disconnect Switch		X		
Variable Air Flow (SZVAV)/Variable Air Flow (MZVAV)		X		
Ventilation Override				X

Control Options

Note: Control option availability is dependent on unit configuration. For more information, see *Packaged Rooftop Air Conditioners Precedent™ Quick Reference Support Guide (PREC-PRC001*-EN)*, the ordering system, or contact product support.

Table 2. Control options — standard and optional

	Standard Features	Options		
		Factory Installed	Factory or Field Installed	Field Installed
Dual Thermistor Remote Zone Sensor				X
Symbio Service and Installation App	X			
Symbio 700 Advanced Module			X	
Humidity Sensor/Humidistat				X
Thermostat				X

Table 2. Control options — standard and optional (continued)

	Standard Features	Options		
		Factory Installed	Factory or Field Installed	Field Installed
Wireless Zone Sensor				X
Zone Sensor				X
LonTalk® Communication Interface (LCI)			X	
Trane® Air-Fi® Wireless Communication Interface (WCI)			X	

Note: For more information, reference the Controls chapter.

Accessories

Note: Accessory availability is dependent on unit configuration. Some accessories may require additional accessories/options for full functionality. For more information, see *Packaged Rooftop Air Conditioners Precedent™ Quick Reference Support Guide (PREC-PRC001*-EN)*, the ordering system, or contact product support.

FIA KIT	DESCRIPTION
FIAEHTB309*	9kW, 208-230V Electric Heater
FIAEHTB318*	18kW, 208-230V Electric Heater
FIAEHTB327*	27kW, 208-230V Electric Heater
FIAEHTB336*	36kW, 208-230V Electric Heater
FIAEHTB354*	54kW, 208-230V Electric Heater
FIAEHTB409*	9kW, 460V Electric Heater
FIAEHTB418*	18kW, 460V Electric Heater
FIAEHTB427*	27kW, 460V Electric Heater
FIAEHTB436*	36kW, 460V Electric Heater
FIAEHTB454*	54kW, 460V Electric Heater
FIAEHTBW09*	9kW, 575V Electric Heater
FIAEHTBW18*	18kW, 575V Electric Heater
FIAEHTBW27*	27kW, 575V Electric Heater
FIAEHTBW36*	36kW, 575V Electric Heater
FIAEHTBW54*	54kW, 575V Electric Heater
FIAEHTC318*	18kW, 208-230V Electric Heater
FIAEHTC327*	27kW, 208-230V Electric Heater
FIAEHTC336*	36kW, 208-230V Electric Heater
FIAEHTC354*	54kW, 208-230V Electric Heater
FIAEHTC418*	18kW, 460V Electric Heater
FIAEHTC427*	27kW, 460V Electric Heater
FIAEHTC436*	36kW, 460V Electric Heater
FIAEHTC454*	54kW, 460V Electric Heater
FIAEHTCW18*	18kW, 575V Electric Heater
FIAEHTCW27*	27kW, 575V Electric Heater
FIAEHTCW36*	36kW, 575V Electric Heater
FIAEHTCW54*	54kW, 575V Electric Heater
FIAEHTD318*	18kW, 208-230V Electric Heater
FIAEHTD336*	36kW, 208-230V Electric Heater
FIAEHTD354*	54kW, 208-230V Electric Heater
FIAEHTD372*	72kW, 208-230V Electric Heater



Features and Benefits

FIA KIT	DESCRIPTION
FIAEHTD418*	18kW, 460V Electric Heater
FIAEHTD436*	36kW, 460V Electric Heater
FIAEHTD454*	54kW, 460V Electric Heater
FIAEHTD472*	72kW, 460V Electric Heater
FIAEHTDW18*	18kW, 575V Electric Heater
FIAEHTDW36*	36kW, 575V Electric Heater
FIAEHTDW54*	54kW, 575V Electric Heater
FIAEHTDW72*	72kW, 575V Electric Heater
FIABARM002*	Barometric Relief
FIABARM003*	Barometric Relief
FIAC02K001*	CO ₂ (DCV) Wall Mounted Sensor
FIAC02K002*	CO ₂ (DCV) Duct Mounted Sensor
FIACURB402*	14-inch Full Perimeter Knockdown Curb
FIACURB403*	14-inch Full Perimeter Knockdown Curb
FIACURB404*	14-inch Full Perimeter Knockdown Curb
FIACLFS001*	Clogged Filter Switch
FIACLFS002*	Clogged Filter Switch (MERV13)
FIACLFS003*	Clogged Filter Switch
FIACLFS004*	Clogged Filter Switch (MERV13)
FIADAST003*	Discharge Air Sensing Tube Kit T/W Models
FIADAST005*	Discharge Air Sensing Tube Kit T/W Models
FIADAST008*	Discharge Air Sensing Tube Kit T/W Models
FIADFDB001*	Differential Dry Bulb Economizer Control
FIADMPR002*	Manual Damper
FIADMPR003*	Manual Damper
FIADMPR102*	Motorized Damper
FIADMPR103*	Motorized Damper
FIAECON002*	Dry Bulb Economizer
FIAECON102*	Dry Bulb Downflow Low Leak
FIAECON003*	Dry Bulb Downflow Economizer
FIAECON303*	Dry Bulb Horizontal Economizer
FIAECON103*	Dry Bulb Downflow Low Leak
FIAECON203*	Dry Bulb Horizontal Low Leak
FIAENTH001*	Reference Enthalpy Economizer Control
FIAENTH002*	Comparative Enthalpy Economizer Control
FIAHTST001*	High Temperature (Fire) Duct Mounted Stat
FIAHZDC001*	Horizontal Conversion Panel
FIALOAM001*	Low Ambient
FIALTCI001*	LonTalk Communication Interface
FIAOPTN001*	Indoor Options Module
FIAOPTN002*	Fresh Air Options Module
FIAOVFL001*	Condensate Overflow Switch
FIAPWRX302*	Power Exhaust 230V
FIAPWRX402*	Power Exhaust 460V
FIAPWRXW02*	Power Exhaust 575V
FIAPWRX303*	Power Exhaust 230V
FIAPWRX403*	Power Exhaust 460V
FIAPWRXW03*	Power Exhaust 575V

FIA KIT	DESCRIPTION
FIQACB026*	Adapter Curb, BAYCURB026 to FIACURB403
FIQACB027*	Adapter Curb, BAYCURB027 to BAYCURB403
FIQACB044*	Adapter Curb, BAYCURB044 to BAYCURB402
FIAS7ADV01*	Symbio 700 Advanced Controls and BACnet BAS Upgrade Kit
FIASCCM001*	Symbio Customer Connection Module
FIAXMOD030*	Symbio 700 XM30 Expansion Module
FIAXMOD032*	Symbio 700 XM32 Expansion Module

Key Benefits

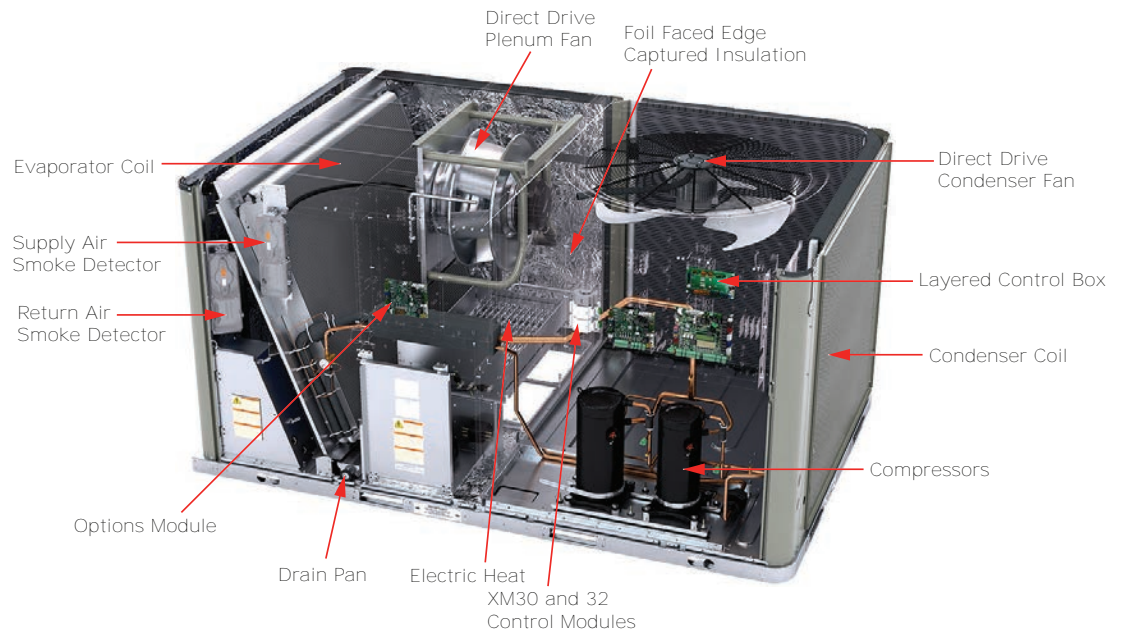

Airflow Distribution

Airflow is outstanding. Precedent™ can replace an older machine with old ductwork and, in many cases, improve the comfort through better air distribution.

Cabinet Integrity

For added water integrity, Precedent™ has a raised 1 inch lip around the supply and return of the downflow units to prevent water from blowing into the ductwork.



Features and Benefits

Coil Guards

Coil guards protect condenser coil during shipping as well as hail, vandals, wind, etc. Toolless design lends itself to ease of maintenance in cleaning coils.



CO₂ Sensor — Demand Control Ventilation (DCV)

Demand-controlled ventilation (DCV) is a control strategy that responds to the actual demand (need) for ventilation by regulating the rate at which the HVAC system brings outdoor air into the building. A CO₂ sensor measures the concentration (parts per million, ppm) of CO₂ (carbon dioxide) in the air. As the CO₂ concentration changes, the outside air damper modulates to meet the current ventilation needs of the zone. The CO₂ sensor kit is available as a field installed accessory and wires directly to the Symbio 700 controller.

CompleteCoat™ Condenser Coil

This optional coated coil provides excellent corrosion resistance as well as uniformity of coverage and coating thickness.

Controls — Symbio™

Enhanced BAS Integration and Connectivity

- Open standard communications
 - BACnet® over Zigbee (Air-Fi Wireless)
 - BACnet MS/TP
 - BACnet IP
 - Modbus™ RTU
 - Modbus TCP/IP
 - LonTalk®
- Securely access, troubleshoot, and monitor equipment from anywhere via Trane Connect™

Serviceability

- Wireless mobile app interface (iPhone and Android) to simplify startup/service
- On-board user interface
- Data Trending
- Real-time, clear language diagnostics
- Historical alarm logs
- Backup and Restore functionality to reduce commissioning and service time

Flexibility

- Future-ready upgradable software, supporting changing codes and new sequences of operation
- Standard, consistent pre-engineered applications that meet industry standards

- Built-in Schedules (requires Tracer® TU)
- Expandable inputs and outputs (requires Tracer TU)
- Ability to add custom programmed sequences (requires Tracer TU)

Accessibility

Control box consists of a multilevel design with Symbio Controls located on hinged panels which provide protection from high voltage components for ease of servicing.

Convenience Outlet

This option is GFCI, 120V/15A, 2 plug, convenience outlet powered or GFCI, 120V/20A, 2 plug convenience outlet unpowered. This option can be ordered when through the base electrical with either the disconnect switch or circuit breaker option is ordered.

**Convertible Units**

Units ship in a downflow configuration and can be easily converted to horizontal by simply removing two panels. Optional field accessory kits required for 15 to 25 ton units.

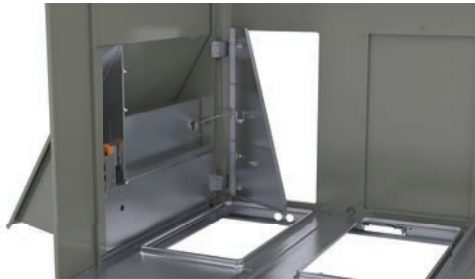



Features and Benefits

Direct Drive Plenum Fans

All 6 to 25 tons units are equipped with a direct drive plenum fan design with the following features.

- Backward-curved fan wheel
- External rotor direct drive variable speed indoor motor
- Variable speed adjustment available in Symbio controller
- Designed to slide out for ease of maintenance



Drain Pan

Every Precedent™ unit has an easy-to-clean, composite removable dual-sloped drain pan (IAQ). On units with B or C (6 to 12.5T) size cabinets, the drain pan is reversible, allowing installation of the draining trap on either side of the unit.



Fault Detection and Diagnostics (FDD)

This offering meets the mandatory requirement of CA Title 24 of fully configurable diagnostics allowing fault history and reading fault codes at the unit via Symbio™ 700 board or app. This feature provides detection of the following faults: Air temperature sensor failure/fault and notification of acceptable economizer mode. The FDD system shall be certified by the Energy Commission as meeting the requirements.

Flexibility

Precedent™ offers ultimate flexibility. Units are built to order in our standard ship cycle time.

High Efficiency Filtration

Precedent™ units offer a variety of high efficiency filtration options. MERV 8 and MERV 13 filters provide additional filtration beyond the capabilities of typical 2 inches throwaway filters.

High Static Motor

Available on 10 and 25 ton models, this high static motor option extends beyond the capability of the standard motor.

Hinged Access Doors

These doors permit easy access to the filter, fan and compressor/control sections. They reduce the potential roof damage from screws or sharp access door corners.



Humidity Control (HGRH)

All 12.5 to 25 tons Precedent units can be ordered with a factory installed modulating humidity control system designed to provide year around comfort by improving indoor air quality while controlling humidity levels.

Humidity Sensor/Humidistat

The humidity sensor/humidistat, when used in conjunction with our dehumidification (hot gas reheat) units will provide outstanding humidity control and comfort. Humidity sensors can be wall or duct mounted. The humidity deadband can be set between 40% and 60% relative humidity.

Low Ambient Cooling

All Precedent™ units have cooling capabilities down to 40°F. Field installed accessory extends operation down to 0°F.

Low Leak Economizer

This accessory meets low leak requirements for ASHRAE 90.1, IECC, and CA Title 24 standards (4 cfm/ft²@1" wg exterior air/return air). This option allows 100% outdoor air supply from 0 to 100% modulating dampers and is standard with barometric relief. It can be paired with powered exhaust for additional building pressure relief. This option can be paired with or without fault detection and diagnostics (FDD) to meet current mandatory CA Title 24 requirements.

The economizers come with four control options, dry bulb, reference enthalpy, comparative enthalpy, or differential dry bulb.



Note: Downflow low leak economizer is available as a factory installed option. Horizontal low leak economizer option is only available as a field installed option.

Microchannel Coils

Microchannel coils are all-aluminum coils with fully-brazed construction. This design reduces risk of leaks and provides increased coil rigidity — making them more rugged on the jobsite. Their flat streamlined tubes with small ports and metallurgical tube-to-fin bond allow for exceptional heat transfer. Microchannel all-aluminum construction provides several additional benefits:

- Light weight (simplifies coil handling)
- Easy to recycle
- Minimize galvanic corrosion

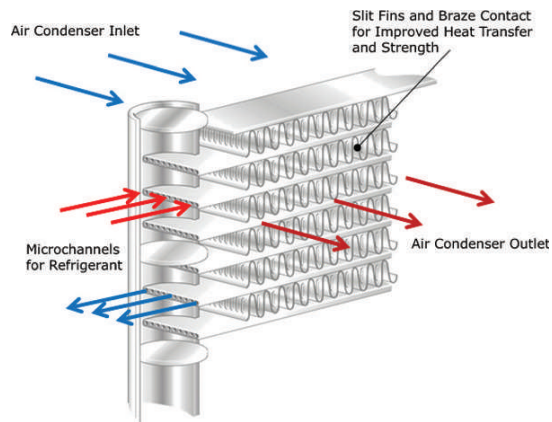

Multi-Speed Indoor Fan System

This system incorporates a multi-speed fan control to change the speed of the fan to 66% of full airflow based off of compressor stages.

Multiple-Zone VAV Control

A multiple-zone VAV (MZVAV) system consists of a packaged rooftop unit that serves several individually controlled zones. Each zone is equipped with a VAV terminal unit that varies the quantity of air delivered to maintain the desired temperature in that zone. The rooftop unit controller varies the speed of the indoor fan to maintain the static pressure in the supply ductwork at a setpoint, ensuring that all zones receive the necessary quantity of air. In addition, cooling capacity is cycled to maintain the supply air temperature at the desired setpoint.

For decades, Trane has been an industry leader in rooftop VAV systems. Now, multiple-zone VAV control is available in the light commercial rooftop platform (6 to 25 tons).

Other Benefits

- Cabinet design ensures water integrity
- Ease of Service, Installation and Maintenance
- Mixed model build enables “fastest in the industry” ship cycle times
- Outstanding Airflow Distribution
- Symbio Controls

Quick Adapt Curbs

Enables easy upgrade of existing Voyager™ 6 to 25 tons units to Precedent™ units on replacement jobs.

Rigorous Testing

All of the Precedent™ designs were rigorously rain tested at the factory to ensure water integrity.

Actual shipping tests were performed to determine packaging requirements. Units were test shipped around the country to determine the best packaging design. Factory shake and drop tests were used as part of the package design process to help assure that the unit arrives at the job site in top condition.

Rigging tests include lifting a unit into the air and letting it drop one foot, assuring that the lifting lugs and rails hold up under stress.

We perform a 100% coil leak test at the factory. The assembled unit is leak tested to 465 psig.

All parts are inspected at the point of final assembly. Sub-standard parts are identified and rejected immediately.

Every unit receives a 100% unit run test before leaving the production line to make sure it meets rigorous requirements.

Single Zone VAV (SZVAV)

SZVAV is fully integrated into the control system. It provides the simplest and fastest commissioning in the industry through proven factory-installed, wired, and tested system controllers. All control modules, logic boards and sensors are factory installed and tested to ensure the highest quality and most reliable system available. This means no special programming of algorithms, or hunting at the jobsite for field installed sensors, boards, etc. SZVAV is a quick and simple solution for many applications and is available from your most trusted rooftop VAV system solution provider -Trane.

Building system modeling in energy simulation software such as TRACE is recommended to evaluate performance improvements for your application.

Supply/Return Air Smoke Detector

With this option installed, if smoke is detected, all unit operation will be shut down. Reset will be manual at the unit. In order for the supply air smoke detector or return air smoke detector to properly sense smoke in the supply air stream or the return air stream, the air velocity entering the smoke detector unit must be between 500 to 4000 feet per minute. Equipment covered in this manual will develop an airflow velocity that falls within these limits over the entire airflow range specified in the evaporator fan performance table. Supply and/or return smoke detectors may not be used with the plenum smoke detector.





Features and Benefits

Through-the-Base Condensate

6 to 12.5 tons unit includes provisions for through-the-base condensate drain connections. This allows the drain to be connected through the roof curb instead of a roof penetration.

Through-the-Base Electrical Access

An electrical service entrance shall be provided allowing electrical access for both control and main power connections inside the curb and through-the-base of the unit. Option will allow for field installation of liquid-tight conduit and an external field installed disconnect switch.

Ventilation Override

Ventilation override allows the unit to be set to transition to up to three different pre-programmed sequences for smoke purge, pressurization, and exhaust. The transition occurs when a binary input on the Customer Connection Module is closed (shorted). This would typically be a hard wired relay output from a smoke detector or fire control panel. The Customer Connection module that allows ventilation override is available as a field installed accessory (FIASCCM001). For more information on functionality, refer to *Symbio™ 700 Controller with Precedent™ Packaged Rooftop Air-Conditioners Application Guide* (ACC-APG002*-EN).



Model Number Description

Digit 1 — Unit Function

T = DX Cooling

Digit 2 — Cooling Efficiency

S = Standard Efficiency

Digit 3 — Refrigerant

J = R-410A

Digit 4,5,6 — Nominal Gross Cooling Capacity (MBh)

072 = 6 Ton

090 = 7.5 Ton

102 = 8.5 Ton

120 = 10 Ton

150 = 12.5 Ton

180 = 15 Ton

210 = 17.5 Ton

240 = 20 Ton

300 = 25 Ton

Digit 7 — Design Sequence

Digit 8 — Voltage Selection

3 = 208–230/60/3

4 = 460/60/3

W = 575/60/3

Digit 9 — Unit Controls

S = Symbio™ 700

Digit 10 — Heat Type

0 = Base Model (None or Electric)

Digit 11 — Heating Capacity

0 = No Heat

C = 9 kW Electric Heat

G = 18 kW Electric Heat

K = 27 kW Electric Heat

N = 36 kW Electric Heat

P = 54 kW Electric Heat

R = 72 kW Electric Heat

Digit 12, 13 — Service Sequence

** = Factory Assigned

Digit 14 — Fresh Air Selection

0 = No Fresh Air

A = Manual Outside Air Damper 0–50%

B = Motorized Outside Air Damper 0–50%

C = Economizer, Dry Bulb 0–100% without Barometric Relief

D = Economizer, Dry Bulb 0–100% with Barometric Relief

E = Economizer, Reference Enthalpy 0–100% without Barometric Relief

F = Economizer, Reference Enthalpy 0–100% with Barometric Relief

G = Economizer, Comparative Enthalpy 0–100% without Barometric Relief

H = Economizer, Comparative Enthalpy 0–100% with Barometric Relief

K = Downflow Low Leak Economizer, Dry Bulb with Barometric Relief

M = Downflow Low Leak Economizer, Reference Enthalpy with Barometric Relief

P = Downflow Low Leak Economizer, Comparative Enthalpy with Barometric Relief

R = Downflow Low Leak Economizer, Differential Dry Bulb with Barometric Relief

Digit 15 — Supply Fan/Motor

0 = Multi-Speed Motor

1 = Optional Oversized/High Static Motor

2 = Single Zone Variable Air Volume with Standard Motor

3 = Single Zone Variable Air Volume with Oversized/High Static Motor

4 = Multiple Zone Variable Air Volume with Standard Motor

5 = Multiple Zone Variable Air Volume with Oversized/High Static Motor

Digit 16 — Hinged Access/Filters

0 = Standard Panels/Standard Filters

A = Hinged Access Panels/Standard Filters

B = Standard Panels/2 inch MERV 8 Filters

C = Hinged Access Panels/2 inch MERV 8 Filters

D = Standard Panels/2 inch MERV 13 Filters

E = Hinged Access Panels/2 inch MERV 13 Filters

Digit 17 — Coil Protection

0 = Standard Coil

1 = Condenser with CompleteCoat™

Digit 18 — Through-the-Base Provisions

0 = No Through-the-Base Provisions

A = Through-the-Base Electric

Digit 19 — Disconnect/Circuit Breaker (three-phase only)

0 = No Disconnect/No Circuit Breaker

1 = Unit Mounted/Non-Fused Disconnect

2 = Unit Mounted Circuit Breaker

Digit 20— Convenience Outlet

0 = No Convenience Outlet

A = Unpowered 20A Convenience Outlet

B = Powered 15A Convenience Outlet (three-phase only)

Digit 21— Communications Options

0 = No Communications Interface

1 = Advanced Controller with BACnet® Communications Interface

2 = Advanced Controller with LonTalk® Communications Interface

3 = Advanced Controller with Air-Fi® Communications Interface

Digit 22— Refrigeration System Option

0 = Standard Refrigeration System

A = Dehumidification Option

Digit 23— Controls Expansion Module

0 = None

1 = XM-30 Expansion Module

2 = XM-32 Expansion Module

3 = XM-30 and XM-32 Expansion Module

4 = XM-30 Expansion Module (Qty 2)

5 = XM-32 Expansion Module (Qty 2)

Digit 24— Smoke Detector

0 = No Smoke Detector

A = Return Air Smoke Detector

B = Supply Air Smoke Detector

C = Supply and Return Air Smoke Detectors



Model Number Description

Digit 25— System Monitoring Controls

- 0 = No Monitoring Control
- 1 = Clogged Filter Switch
- 2 = Condensate Overflow Switch
- 3 = Discharge Air Sensing Tube
- 4 = Clogged Filter Switch and Condensate Overflow Switch
- 5 = Clogged Filter Switch and Discharge Air Sensing Tube
- 6 = Condensate Overflow Switch and Discharge Air Sensing Tube
- 7 = Clogged Filter Switch, Condensate Overflow Switch and Discharge Air Sensing Tube

Digit 26— Not Used

Digit 27— Hardware Enhancements

- 0 = No Enhancements
- 1 = Stainless Steel Drain Pan

Digit 28— Short Circuit Current Rating

- 0 = Standard (5k) SCCR Marking
- A = Tier 2 (=65K) SCCR Marking

Digit 29— Low Ambient

- 0 = None
- A = Low Ambient Cooling to 0°F



General Data

Table 3. General data— 6 to 12.5 tons— standard efficiency

	6 Tons	7.5 Tons	8.5 Tons	10 Tons	12.5 Tons
	TSJ072	TSJ090	TSJ102	TSJ120	TSJ150
Cooling Performance					
Gross Cooling Capacity	73000	91000	104000	122000	147000
EER	11.2	11.2	11.2	11.2	11.0
Nominal cfm/AHRI Rated cfm	1860	2475	2975	3700	4875
AHRI Net Cooling Capacity	72000	90000	102000	120000	144000
IEER (2-Speed)	14.8	14.8	14.8	14.8	14.2
IEER (SZVAV/MZVAV)	15.3/15.3	15.3/15.3	15.3/15.3	15.3/15.3	14.7/14.7
System Power (kW)	6.55	8.18	9.27	10.91	13.09
Compressor					
Number/Type	2/Manifold Scroll	2/Manifold Scroll	2/Manifold Scroll	2/Manifold Scroll	2/Manifold Scroll
Percent Capacity (Stage 1 - Stage 3)	32/68/100	33/67/100	32/68/100	28/72/100	32/68/100
Sound					
Outdoor Sound Rating (dBA)	86	86	86	86	89
Outdoor Coil					
Type	Microchannel	Microchannel	Microchannel	Microchannel	Microchannel
Configuration	Full Face	Full Face	Full Face	Full Face	Full Face
Tube Size (in.)	0.7	0.7	1.0	1.0	1.0
Face Area (sq. ft.)	21.64	21.64	21.64	21.64	28.32
Rows/FPI (Fins per inch)	1/23	1/23	1/21	1/21	1/23
Indoor Coil					
Type	Microchannel	Microchannel	Microchannel	Microchannel	Microchannel
Configuration	Full Face	Full Face	Full Face	Full Face	Full Face
Tube Size (in.)	1.0	1.0	1.0	1.0	1.0
Face Area (sq. ft.)	11.84	11.84	11.84	11.84	14.27
Rows/FPI (Fins per inch)	2/18	2/18	2/18	2/18	2/18
Refrigerant Control	TXV	TXV	TXV	TXV	TXV
Drain Connection No./Size (in.) NPT	1/0.75	1/0.75	1/0.75	1/0.75	1/0.75
Reheat Coil					
Type	Microchannel	Microchannel	Microchannel	Microchannel	Microchannel
Configuration	Full Face	Full Face	Full Face	Full Face	Full Face
Tube Size (in.)	0.6	0.6	0.6	0.6	0.6
Face Area (sq. ft.)	9.04	9.04	9.04	9.04	11.82
Rows/FPI (Fins per inch)	1/23	1/23	1/23	1/23	1/23
Outdoor Fan					
Type	Propeller	Propeller	Propeller	Propeller	Propeller
No. Used/Diameter (in.)	1/26	1/26	1/26	1/26	1/30
Drive Type/No. Speeds	Direct/1	Direct/1	Direct/1	Direct/1	Direct/1
CFM	5900	5900	5900	6700	8200
Motor HP	0.70	0.70	0.70	0.75	1.00
Motor RPM	1100	1100	1100	1100	1100
Indoor Fan					
Type	BC Plenum	BC Plenum	BC Plenum	BC Plenum	BC Plenum



General Data

Table 3. General data— 6 to 12.5 tons— standard efficiency (continued)

	6 Tons	7.5 Tons	8.5 Tons	10 Tons	12.5 Tons
	TSJ072	TSJ090	TSJ102	TSJ120	TSJ150
No. Used/Diameter (in.)/Width (in.)	1/23x6	1/23x6	1/23x6	1/23x6	1/23x6
Drive Type/No. Speeds/RPM	Direct / Variable	Direct / Variable	Direct / Variable	Direct / Variable	Direct / Variable
Motor HP (Standard/Oversized)	3.0 / –	3.0 / –	3.0 / –	3.0 / 4.6	4.6 / –
Max Motor RPM	1850	1850	1850	1850 / 1940	1940
Filters^(a)					
Type Furnished	Throwaway	Throwaway	Throwaway	Throwaway	Throwaway
Number Size Recommended	(2) 18 x 24 x 2 (3) 24 x 16 x 2	(2) 18 x 24 x 2 (3) 24 x 16 x 2	(2) 18 x 24 x 2 (3) 24 x 16 x 2	(2) 18 x 24 x 2 (3) 24 x 16 x 2	(3) 18 x 18 x 2 (3) 24 x 18 x 2
Refrigerant Charge					
lbs of R-410A	9.0	9.0	9.5	10.1	11.4
lbs of R-410A, Hot Gas Reheat	10.3	9.6	10.1	10.7	11.6
Cabinet					
Cabinet Size	B0	B0	B0	B0	C0

^(a) Outdoor sound rating shown is tested in accordance with AHRI 370-2015. For additional information reference the outdoor sound power level data in the performance section.

Table 4. General data— 15 to 25 tons— standard efficiency

	15 Tons	17.5 Tons	20 Tons	25 Tons
	TSJ180	TSJ210	TSJ240	TSJ300
Cooling Performance				
Gross Cooling Capacity	185000	214000	246000	281000
EER	11.0	11.0	10.0	10.0
Nominal cfm/AHRI Rated cfm	5250	6650	8000	10000
AHRI Net Cooling Capacity	182000	210000	240000	271000
IEER (2-Speed)	14.2	14.2	13.2	13.2
IEER (SZVAV/MZVAV)	14.7/14.7	14.7/14.7	13.7/13.7	13.7/13.7
System Power (kW)	16.55	19.09	24.00	27.10
Compressor				
Number/Type	2/Manifold Scroll	2/Manifold Scroll	2/Manifold Scroll	2/Manifold Scroll
Percent Capacity (Stage 1 - Stage 4)	33/67/100/NA	33/67/100/NA	24/36/64/100	25/37/63/100
Sound				
Outdoor Sound Rating (dBA)	87	91	91	93
Outdoor Coil				
Type	Microchannel	Microchannel	Microchannel	Microchannel
Configuration	Full Face	Full Face	Full Face	Full Face
Tube Size (in.)	0.71	0.71	1.0	1.0
Face Area (sq. ft.)	33.90	33.90	33.89	33.89
Rows/FPI (Fins per inch)	1/23	1/23	1/21	1/21
Indoor Coil				
Type	Microchannel	Microchannel	Microchannel	Microchannel
Configuration	Full Face	Full Face	Full Face	Full Face
Tube Size (in.)	1.0	1.0	1.0	1.0
Face Area (sq. ft.)	23.93	23.93	23.93	23.93
Rows/FPI (Fins per inch)	2/18	2/18	2/18	2/18

Table 4. General data— 15 to 25 tons— standard efficiency (continued)

	15 Tons	17.5 Tons	20 Tons	25 Tons
	TSJ180	TSJ210	TSJ240	TSJ300
Refrigerant Control	TXV	TXV	TXV	TXV
STD. Drain Connection No./Size (in.)	1/1.00 PVC Socket	1/1.00 PVC Socket	1/1.00 PVC Socket	1/1.00 PVC Socket
Stainless Drain Connection No./Size (in.)	1/1.00 NPT	1/1.00 NPT	1/1.00 NPT	1/1.00 NPT
Reheat Coil				
Type	Microchannel	Microchannel	Microchannel	Microchannel
Configuration	Full Face	Full Face	Full Face	Full Face
Tube Size (in.)	0.6	0.6	0.6	0.6
Face Area (sq. ft.)	21.83	21.83	21.83	21.83
Rows/FPI (Fins per inch)	1/23	1/23	1/23	1/23
Outdoor Fan				
Type	Propeller	Propeller	Propeller	Propeller
No. Used/Diameter (in.)	2/26x3	2/26x4	2/26x4	2/28x4
Drive Type/No. Speeds	Direct/1	Direct/1	Direct/1	Direct/1
CFM	11520	14660	14220	16600
Motor HP	2/0.50	2/1.0	2/1.0	2/1.0
Motor RPM	1125	1125	1125	1125
Indoor Fan				
Type	BC Plenum	BC Plenum	BC Plenum	BC Plenum
No. Used/Diameter (in.)/Width (in.)	2/23x6	2/23x6	2/23x6	2/23x6
Drive Type/No. Speeds/RPM	Direct/Variable	Direct/Variable	Direct/Variable	Direct/Variable
Motor HP (Standard/Oversized)	3.0 / –	3.0 / –	3.0 / –	3.0 / 4.6
Max Motor RPM	1850	1850	1850	1850 / 1940
Filters^(a)				
Type Furnished	Throwaway	Throwaway	Throwaway	Throwaway
Number Size Recommended	(8) 20 x 24 x 2	(8) 20 x 24 x 2	(8) 20 x 24 x 2	(8) 20 x 24 x 2
Refrigerant Charge				
lbs of R-410A	14.5	14.2	16.6	16.9
lbs of R-410A, Hot Gas Reheat	15.8	15.0	17.2	17.7
Cabinet				
Cabinet Size	D0	D0	D0	D0

^(a) Outdoor sound rating shown is tested in accordance with AHRI 370-2015. For additional information reference the outdoor sound power level data in the performance section.



Gross Cooling Capacities

Table 5. Gross cooling capacities — 6 tons

CFM	Ent DB (°F)	Entering Wet Bulb Temp (°F)						Entering Wet Bulb Temp (°F)						Entering Wet Bulb Temp (°F)					
		61		67		73		61		67		73		61		67		73	
		MBh	SHC	MBh	SHC	MBh	SHC	MBh	SHC	MBh	SHC	MBh	SHC	MBh	SHC	MBh	SHC	MBh	SHC
		Ambient Temperature 85°F						Ambient Temperature 95°F						Ambient Temperature 105°F					
1860	75	67.7	54.1	77.4	43.1	85.4	30.6	63.6	51.8	72.8	40.9	79.9	28.7	59.3	49.4	67.9	38.5	73.9	26.4
	80	67.6	63.1	77.3	52.8	85.7	40.6	63.5	60.8	72.8	50.6	80.4	38.2	59.2	58.3	67.9	48.2	74.6	35.7
	85	69.1	69.1	77.1	62.3	85.9	50.7	65.9	65.9	72.7	60.4	80.8	48.3	62.4	62.4	67.9	55.3	75.0	45.8
	90	76.9	71.5	76.9	71.5	85.9	60.5	70.2	70.2	72.5	69.2	80.8	58.2	66.5	66.5	67.7	66.7	75.1	55.7
2160	75	70.1	58.8	79.8	46.1	87.1	29.2	65.8	56.2	75.0	43.6	81.3	28.9	61.1	52.5	69.8	41.1	74.8	27.1
	80	69.7	68.8	79.7	57.2	87.5	42.8	65.5	65.5	75.0	54.9	81.9	40.5	61.5	61.5	69.8	52.4	75.8	38.0
	85	73.2	73.2	79.5	67.4	87.8	54.4	69.7	69.7	74.8	63.4	82.3	52.0	65.9	65.9	69.6	62.9	76.1	49.4
	90	77.7	77.7	79.1	78.2	87.9	65.8	74.1	74.1	74.5	74.5	82.4	63.4	70.1	70.1	70.2	70.2	76.3	60.8
2400	75	71.5	61.3	81.4	48.1	88.1	31.6	67.1	57.0	76.4	45.7	82.4	29.2	62.1	56.8	71.1	43.2	75.9	28.3
	80	71.1	71.1	81.3	60.6	88.6	44.7	67.6	67.6	76.3	58.2	82.9	42.2	63.7	63.7	71.0	55.7	76.7	39.8
	85	75.9	75.9	80.8	72.1	88.9	57.3	72.3	72.3	75.9	69.6	83.1	54.8	68.2	68.2	70.5	66.9	76.7	52.2
	90	80.6	80.6	80.7	80.7	89.0	69.9	76.7	76.7	76.8	76.8	83.3	67.5	72.3	72.3	72.4	72.4	77.0	63.0
2640	75	72.5	65.1	82.7	50.2	89.3	32.2	67.9	62.6	77.6	47.8	83.3	30.1	62.9	59.9	72.1	45.2	76.8	28.2
	80	73.4	73.4	82.5	63.8	89.6	46.3	69.7	69.7	77.4	61.4	83.9	43.9	65.6	65.6	71.9	58.8	77.4	41.2
	85	78.3	78.3	81.8	76.0	89.7	60.1	74.4	74.4	76.7	73.5	83.8	57.6	70.2	70.2	71.2	71.2	77.3	55.0
	90	83.0	83.0	83.0	83.0	89.9	73.1	78.8	78.8	78.9	78.9	84.0	67.8	74.0	74.0	74.1	74.1	77.1	67.8
2880	75	73.3	68.2	83.8	52.2	90.3	32.8	68.6	65.6	78.5	49.8	84.2	30.4	63.6	62.9	72.8	47.1	77.5	28.8
	80	75.3	75.3	83.5	67.0	90.5	47.9	71.5	71.5	78.3	64.0	84.4	45.4	67.3	67.3	72.7	59.4	78.1	42.8
	85	80.4	80.4	82.5	79.9	90.4	62.9	76.3	76.3	77.3	77.3	84.3	60.4	71.8	71.8	71.9	71.9	78.0	57.8
	90	84.9	84.9	85.0	85.0	90.3	76.9	80.5	80.5	80.5	80.5	84.1	74.2	75.2	75.2	75.3	75.3	77.4	71.3
		Ambient Temperature 115°F						Ambient Temperature 125°F											
1860	75	54.6	46.8	62.6	35.9	67.5	23.2	49.5	42.4	56.8	33.1	60.5	21.3						
	80	54.6	54.6	62.6	45.6	68.1	33.0	50.4	50.4	56.8	42.9	61.1	30.2						
	85	58.5	58.5	62.6	53.5	68.6	43.0	54.3	54.3	56.8	52.1	61.3	40.0						
	90	62.5	62.5	62.5	62.5	68.7	52.9	57.8	57.8	57.8	57.8	61.4	49.9						
2160	75	56.1	50.9	64.3	38.5	68.8	23.7	50.7	48.0	58.1	35.7	61.7	20.9						
	80	57.5	57.5	64.3	49.8	69.2	35.3	53.1	53.1	58.1	47.0	62.3	32.3						
	85	61.7	61.7	64.0	60.2	69.3	46.5	57.0	57.0	57.8	57.2	62.2	43.7						
	90	65.5	65.5	65.6	65.6	69.5	57.1	60.0	60.0	60.0	60.0	62.2	54.4						
2400	75	57.0	54.1	65.3	40.5	69.5	24.3	51.5	51.1	58.9	37.6	62.2	21.8						
	80	59.5	59.5	65.2	53.1	70.1	36.8	54.9	54.9	58.9	48.6	62.8	33.9						
	85	63.7	63.7	64.7	64.1	70.1	49.4	58.6	58.6	58.6	58.6	62.8	46.5						
	90	67.2	67.2	67.3	67.3	69.9	61.2	60.8	60.8	60.9	60.9	62.5	58.1						
2640	75	57.7	57.1	66.1	42.5	70.0	26.4	52.1	52.1	59.5	39.5	62.9	20.2						
	80	61.3	61.3	66.0	54.4	70.7	38.5	56.3	56.3	59.2	52.5	63.3	35.5						
	85	65.4	65.4	65.4	65.4	70.7	52.2	59.8	59.8	59.8	59.8	63.3	48.4						
	90	68.3	68.3	68.4	68.4	70.3	64.8	61.9	61.9	61.9	61.9	62.8	61.7						
2880	75	58.2	58.2	66.7	44.4	70.8	25.8	53.4	53.4	60.0	41.4	63.1	23.3						
	80	62.7	62.7	66.3	58.3	71.3	40.1	57.5	57.5	59.5	55.2	63.7	37.1						
	85	66.7	66.7	66.7	66.7	71.2	55.1	60.6	60.6	60.6	60.6	63.7	50.3						
	90	69.1	69.1	69.2	69.2	70.5	68.4	62.8	62.8	62.9	62.9	62.9	62.9						

Notes:

1. All capacities shown are gross and have not considered indoor fan heat. To obtain NET cooling capacity subtract indoor fan heat. For indoor fan heat formula, refer to appropriate airflow table notes.
2. MBh = Total gross capacity
3. SHC = Sensible heat capacity

Table 6. Gross cooling capacities — 7.5 tons

CFM	Ent DB (°F)	Entering Wet Bulb Temp (°F)						Entering Wet Bulb Temp (°F)						Entering Wet Bulb Temp (°F)					
		61		67		73		61		67		73		61		67		73	
		MBh	SHC	MBh	SHC	MBh	SHC	MBh	SHC	MBh	SHC	MBh	SHC	MBh	SHC	MBh	SHC	MBh	SHC
		Ambient Temperature 85°F						Ambient Temperature 95°F						Ambient Temperature 105°F					
2400	75	84.6	68.9	96.3	54.7	106.0	40.1	79.7	66.3	90.8	52.1	100.3	34.2	74.5	63.6	84.8	49.4	92.8	34.2
	80	84.2	80.1	96.1	67.0	106.7	51.5	79.4	77.5	90.6	64.5	100.5	48.9	74.2	74.2	84.7	61.7	93.6	46.1
	85	86.6	86.6	95.8	79.5	107.0	64.2	82.8	82.8	90.4	76.8	100.7	61.6	78.6	78.6	84.5	72.0	93.8	58.8
	90	95.3	90.5	95.3	90.5	106.8	76.8	87.9	87.9	90.0	87.9	100.6	74.2	83.5	83.5	84.1	84.1	93.8	71.5
2700	75	86.7	73.5	98.5	57.6	107.9	40.8	81.6	69.7	92.7	54.6	101.5	37.2	76.1	65.0	86.5	51.8	94.4	34.1
	80	86.0	86.0	98.3	71.3	108.7	53.8	81.0	81.0	92.6	68.6	102.1	51.2	76.6	76.6	86.4	65.8	95.0	48.4
	85	90.3	90.3	97.9	83.1	108.8	68.0	86.3	86.3	92.1	81.6	102.3	65.3	81.8	81.8	85.9	78.6	95.2	62.4
	90	95.8	95.8	97.2	97.0	108.7	82.1	91.6	91.6	91.7	91.7	102.3	79.5	86.8	86.8	86.9	86.9	95.2	76.6
3000	75	88.3	75.0	100.4	59.9	109.4	39.7	82.8	74.2	94.4	57.2	102.7	38.0	77.1	71.2	88.0	54.4	95.2	35.1
	80	87.8	87.8	100.1	75.3	110.3	56.1	83.6	83.6	94.1	72.7	103.5	53.4	79.1	79.1	87.8	69.8	96.3	50.9
	85	93.5	93.5	99.3	89.3	110.4	71.6	89.2	89.2	93.4	86.5	103.6	68.9	84.5	84.5	87.0	83.5	96.3	66.0
	90	99.2	99.2	99.3	99.3	110.2	87.2	94.6	94.6	94.7	94.7	103.6	84.0	89.5	89.5	89.6	89.6	96.3	77.8
3300	75	89.3	80.8	102.0	62.5	110.6	41.8	83.9	78.0	95.8	59.7	103.8	37.9	78.0	74.9	89.2	56.8	96.0	35.8
	80	90.4	90.4	101.5	79.3	111.7	58.3	86.1	86.1	95.4	76.6	104.8	55.4	81.3	81.3	88.8	72.8	97.3	52.4
	85	96.3	96.3	100.4	94.1	111.6	75.1	91.8	91.8	94.2	94.2	104.7	72.4	86.8	86.8	87.7	87.7	97.1	69.5
	90	102.0	102.0	102.1	102.1	111.4	89.0	97.2	97.2	97.3	97.3	104.3	88.3	91.7	91.7	91.8	91.8	96.6	85.0
3600	75	90.3	84.5	103.2	64.9	111.4	43.3	84.6	84.6	96.9	62.1	104.6	36.0	78.6	78.6	90.1	59.2	96.7	36.0
	80	92.7	92.7	102.6	83.2	112.8	60.1	88.2	88.2	96.4	78.4	105.7	57.4	83.3	83.3	89.4	76.4	98.0	54.3
	85	98.8	98.8	101.1	101.1	112.6	78.6	94.0	94.0	94.9	94.9	105.5	75.9	88.7	88.7	88.8	88.8	97.8	72.9
	90	104.5	104.5	104.6	104.6	111.9	95.6	99.4	99.4	99.4	99.4	104.7	92.6	93.5	93.5	93.6	93.6	96.8	89.3
		Ambient Temperature 115°F						Ambient Temperature 125°F											
2400	75	68.9	59.4	78.3	46.3	85.3	32.3	62.6	57.1	71.4	43.2	77.3	26.0						
	80	69.2	69.2	78.3	58.9	86.1	43.3	64.3	64.3	71.4	55.8	78.0	40.2						
	85	74.0	74.0	78.1	70.5	86.4	55.8	68.8	68.8	71.1	67.2	78.1	52.6						
	90	78.6	78.6	78.7	78.7	86.4	68.5	73.0	73.0	73.1	73.1	78.2	63.7						
2700	75	70.1	64.3	79.9	48.9	86.7	28.5	63.7	61.0	72.7	45.7	77.9	26.8						
	80	71.9	71.9	79.8	62.9	87.4	45.6	66.7	66.7	72.6	59.8	79.1	42.0						
	85	76.8	76.8	79.3	75.5	87.4	59.4	71.3	71.3	72.0	72.0	78.9	56.1						
	90	81.5	81.5	81.6	81.6	87.5	71.6	75.3	75.3	75.4	75.4	78.7	69.2						
3000	75	71.0	68.1	81.1	51.3	87.3	29.8	64.5	64.5	73.7	48.1	78.4	27.3						
	80	74.2	74.2	80.9	66.6	88.4	47.3	68.7	68.7	73.4	62.0	79.7	44.0						
	85	79.2	79.2	80.1	80.1	88.2	62.9	73.3	73.3	73.3	73.3	79.4	60.1						
	90	83.8	83.8	83.8	83.8	87.9	77.3	77.0	77.0	77.0	77.0	78.8	73.6						
3300	75	71.7	71.7	82.1	53.7	87.8	30.3	65.5	65.5	74.4	50.4	78.8	27.8						
	80	76.2	76.2	81.6	69.7	89.1	49.3	70.4	70.4	73.8	66.2	80.1	45.8						
	85	81.2	81.2	81.3	81.3	88.9	66.3	74.8	74.8	74.9	74.9	79.9	62.3						
	90	85.5	85.5	85.6	85.6	88.1	81.6	78.1	78.1	78.1	78.1	78.8	77.9						
3600	75	72.5	72.5	82.9	56.0	88.3	34.4	66.9	66.9	75.1	52.7	79.8	33.0						
	80	77.9	77.9	82.1	73.0	89.6	51.1	71.8	71.8	74.2	69.5	80.5	47.7						
	85	82.9	82.9	82.9	82.9	89.4	69.7	76.1	76.1	76.2	76.2	80.1	64.6						
	90	86.8	86.8	86.9	86.9	88.2	85.8	78.8	78.8	78.8	78.8	78.9	78.9						

Notes:

1. All capacities shown are gross and have not considered indoor fan heat. To obtain NET cooling capacity subtract indoor fan heat. For indoor fan heat formula, refer to appropriate airflow table notes.
2. MBh = Total gross capacity
3. SHC = Sensible heat capacity



Gross Cooling Capacities

Table 7. Gross cooling capacities — 8.5 tons

CFM	Ent DB (°F)	Entering Wet Bulb Temp (°F)						Entering Wet Bulb Temp (°F)						Entering Wet Bulb Temp (°F)					
		61		67		73		61		67		73		61		67		73	
		MBh	SHC	MBh	SHC	MBh	SHC	MBh	SHC	MBh	SHC	MBh	SHC	MBh	SHC	MBh	SHC	MBh	SHC
		Ambient Temperature 85°F						Ambient Temperature 95°F						Ambient Temperature 105°F					
2720	75	96.6	77.8	108.7	61.2	118.4	42.4	91.0	74.8	102.2	58.3	110.4	39.0	85.1	71.6	95.1	54.9	101.9	35.6
	80	96.0	90.3	108.5	75.2	118.6	57.0	90.5	87.2	102.0	72.1	110.7	53.7	84.6	83.9	95.0	68.8	102.1	50.1
	85	97.9	97.9	108.2	87.5	118.9	71.7	93.5	93.5	101.8	82.6	111.2	68.0	88.5	88.5	94.9	80.8	102.6	64.4
	90	107.6	101.4	107.6	101.4	118.8	85.4	98.8	98.8	101.2	98.2	111.1	82.1	93.4	93.4	94.2	94.2	102.6	78.6
3060	75	98.9	82.8	111.0	64.5	120.1	43.1	93.1	79.5	104.2	61.4	111.8	39.7	86.9	75.2	96.8	57.5	103.5	36.4
	80	98.0	96.2	110.8	79.8	120.5	59.5	92.2	92.2	104.0	76.6	112.3	56.1	86.6	86.6	96.7	73.2	103.6	52.9
	85	102.0	102.0	110.4	93.2	120.8	75.3	97.1	97.1	103.5	91.1	112.7	71.9	91.8	91.8	96.1	87.5	103.7	68.3
	90	107.7	107.7	109.4	108.4	120.7	91.2	102.4	102.4	102.7	102.7	112.6	87.8	96.5	96.5	96.6	96.6	103.7	84.2
3400	75	100.7	85.7	112.9	67.0	121.5	43.8	94.5	83.5	105.8	63.7	113.3	40.6	87.9	80.0	98.2	60.2	104.7	35.0
	80	99.5	99.5	112.6	84.3	122.1	62.2	94.5	94.5	105.6	81.0	113.6	58.8	89.2	89.2	97.9	77.6	105.0	55.3
	85	105.4	105.4	111.8	99.9	122.3	79.3	100.2	100.2	104.7	96.4	113.8	75.8	94.4	94.4	97.0	92.7	104.9	72.2
	90	111.1	111.1	111.2	111.2	122.2	96.8	105.5	105.5	105.5	105.5	113.8	92.8	98.9	98.9	99.0	99.0	104.5	88.5
3740	75	101.8	91.0	114.5	69.8	122.9	41.6	95.5	87.7	107.2	66.4	114.6	41.4	88.8	84.1	99.3	62.8	105.6	38.4
	80	102.2	102.2	114.1	88.6	123.5	64.4	97.1	97.1	106.8	85.3	115.1	60.7	91.5	91.5	99.0	81.0	106.0	57.1
	85	108.3	108.3	112.8	105.1	123.5	83.2	102.8	102.8	105.5	101.6	114.8	79.7	96.6	96.6	97.5	97.5	105.8	76.1
	90	114.0	114.0	114.1	114.1	123.4	98.9	107.9	107.9	108.0	108.0	114.4	97.3	100.8	100.8	100.9	100.9	105.0	93.4
4080	75	102.8	95.0	115.8	72.4	124.2	45.4	96.3	91.6	108.3	69.0	115.7	42.1	89.4	88.0	100.1	65.4	106.6	38.7
	80	104.7	104.7	115.3	92.9	124.8	66.4	99.3	99.3	107.8	87.6	115.9	62.8	93.4	93.4	99.4	84.7	107.0	59.3
	85	110.8	110.8	113.5	110.1	124.5	87.0	105.0	105.0	106.0	106.0	115.5	83.4	98.4	98.4	98.4	98.4	106.6	79.9
	90	116.4	116.4	116.5	116.5	123.8	105.9	109.9	109.9	109.9	109.9	114.6	102.0	102.3	102.3	102.3	102.3	105.4	98.2
		Ambient Temperature 115°F						Ambient Temperature 125°F											
2720	75	78.7	67.7	87.4	51.5	93.2	32.1	71.7	61.7	79.0	47.3	83.5	26.7						
	80	78.3	78.3	87.4	65.2	93.5	46.9	72.4	72.4	78.9	61.4	83.9	43.2						
	85	83.0	83.0	87.1	78.3	93.6	60.7	76.4	76.4	78.5	74.1	84.0	56.9						
	90	87.2	87.2	87.3	87.3	93.5	74.9	79.6	79.6	79.7	79.7	84.0	69.5						
3060	75	80.0	72.2	88.8	53.9	94.2	33.6	72.5	68.3	80.0	49.9	84.1	29.3						
	80	81.1	81.1	88.7	69.6	94.8	49.4	74.7	74.7	79.8	65.6	85.1	45.1						
	85	85.7	85.7	88.0	83.6	94.8	64.7	78.4	78.4	79.0	79.0	84.9	60.8						
	90	89.6	89.6	89.6	89.6	94.7	77.4	81.3	81.3	81.3	81.3	84.5	75.4						
3400	75	80.9	76.3	89.9	56.5	95.2	34.4	73.2	72.3	80.7	52.5	85.2	30.0						
	80	83.3	83.3	89.7	73.7	95.9	51.3	76.5	76.5	80.4	68.3	85.8	47.3						
	85	87.8	87.8	88.6	88.6	95.7	68.6	79.9	79.9	80.0	80.0	85.5	64.4						
	90	91.3	91.3	91.3	91.3	95.1	84.6	83.0	83.0	83.0	83.0	84.8	80.3						
3740	75	81.6	80.3	90.7	59.0	96.2	34.4	73.8	73.8	81.3	54.9	85.5	28.1						
	80	85.2	85.2	90.2	77.0	96.7	53.4	77.9	77.9	80.6	72.6	86.4	49.4						
	85	89.4	89.4	89.5	89.5	96.5	72.0	81.0	81.0	81.0	81.0	86.1	67.8						
	90	92.8	92.8	92.9	92.9	95.5	89.4	84.3	84.3	84.3	84.3	84.9	84.9						
4080	75	82.0	82.0	91.4	61.5	96.8	35.6	75.1	75.1	81.8	57.4	86.2	31.2						
	80	86.8	86.8	90.6	80.6	97.4	55.5	79.0	79.0	80.8	76.1	86.9	51.4						
	85	90.8	90.8	90.8	90.8	97.1	76.0	82.0	82.0	82.1	82.1	86.2	71.2						
	90	94.4	94.4	94.4	94.4	95.7	94.2	85.3	85.3	85.4	85.4	85.4	85.4						

Notes:

1. All capacities shown are gross and have not considered indoor fan heat. To obtain NET cooling capacity subtract indoor fan heat. For indoor fan heat formula, refer to appropriate airflow table notes.
2. MBh = Total gross capacity
3. SHC = Sensible heat capacity

Table 8. Gross cooling capacities — 10 tons

CFM	Ent DB (°F)	Entering Wet Bulb Temp (°F)						Entering Wet Bulb Temp (°F)						Entering Wet Bulb Temp (°F)					
		61		67		73		61		67		73		61		67		73	
		MBh	SHC	MBh	SHC	MBh	SHC	MBh	SHC	MBh	SHC	MBh	SHC	MBh	SHC	MBh	SHC	MBh	SHC
		Ambient Temperature 85°F						Ambient Temperature 95°F						Ambient Temperature 105°F					
3200	75	113.3	91.6	127.5	72.0	138.4	47.1	106.8	88.1	119.9	68.7	129.2	43.6	99.8	84.5	111.7	64.9	119.2	41.7
	80	112.4	106.2	127.2	88.5	138.7	66.8	105.9	102.5	119.7	85.0	129.5	63.4	99.0	99.0	111.6	81.1	119.5	59.0
	85	114.8	114.8	126.8	105.0	139.0	84.2	109.6	109.6	119.4	101.5	130.1	80.0	103.9	103.9	111.3	95.1	120.1	75.8
	90	125.9	119.3	125.9	119.3	138.9	100.5	115.9	115.9	118.5	115.5	130.1	96.7	109.6	109.6	110.4	110.4	120.2	92.6
3600	75	115.9	97.5	130.2	75.8	140.2	50.4	109.1	93.6	122.2	72.2	130.5	46.5	101.8	87.1	113.6	67.9	120.9	42.7
	80	114.6	114.6	129.8	93.9	140.7	69.7	107.9	107.9	122.0	90.3	131.2	65.9	101.5	101.5	113.4	87.6	121.1	62.1
	85	119.4	119.4	129.3	109.2	141.1	88.4	113.9	113.9	121.3	107.2	131.7	84.6	107.7	107.7	112.7	103.0	121.3	80.4
	90	126.1	126.1	127.8	127.3	141.0	107.1	120.1	120.1	120.2	120.2	131.7	103.3	113.3	113.3	113.4	113.4	121.4	99.1
4000	75	117.9	100.4	132.3	78.8	141.6	51.1	110.6	98.2	124.1	75.0	132.2	47.4	103.0	94.1	115.2	71.0	122.2	43.6
	80	116.4	116.4	131.9	101.1	142.8	73.7	110.8	110.8	123.7	95.4	132.6	68.6	104.7	104.7	114.9	91.4	122.6	65.2
	85	123.4	123.4	130.7	117.4	142.6	93.0	117.4	117.4	122.6	113.4	132.9	89.1	110.8	110.8	113.6	113.6	122.5	84.9
	90	130.1	130.1	130.2	130.2	142.6	113.7	123.6	123.6	123.7	123.7	133.0	108.1	116.0	116.0	116.1	116.1	122.1	104.0
4400	75	119.1	106.9	134.1	82.0	143.1	52.0	111.8	103.0	125.6	78.2	133.6	48.3	103.9	98.8	116.4	74.0	123.3	44.4
	80	119.6	119.6	133.5	104.2	143.8	75.7	113.8	113.8	125.1	100.4	134.1	71.2	107.3	107.3	116.0	94.7	123.8	67.1
	85	126.7	126.7	131.8	123.4	143.9	97.6	120.4	120.4	123.3	123.3	133.9	93.6	113.3	113.3	114.1	114.1	123.5	89.5
	90	133.4	133.4	133.5	133.5	143.8	117.8	126.4	126.4	126.4	126.4	133.5	114.3	118.2	118.2	118.2	118.2	122.5	109.6
4800	75	120.1	111.6	135.5	85.1	144.4	52.9	112.5	112.5	126.8	81.2	134.7	49.2	104.5	104.5	117.3	77.0	124.3	45.3
	80	122.5	122.5	134.8	109.1	145.2	77.7	116.3	116.3	126.2	101.9	135.0	73.6	109.5	109.5	116.5	99.6	124.8	69.7
	85	129.6	129.6	132.4	132.4	145.0	102.0	122.9	122.9	123.8	123.8	134.8	97.4	115.3	115.3	115.4	115.4	124.4	94.0
	90	136.1	136.1	136.2	136.2	144.1	124.1	128.6	128.6	128.7	128.7	133.7	119.7	119.7	119.7	119.8	119.8	122.7	122.7
		Ambient Temperature 115°F						Ambient Temperature 125°F											
3200	75	92.4	79.7	102.8	60.9	109.0	37.7	84.2	75.7	92.9	56.0	97.6	33.3						
	80	91.9	91.9	102.7	77.0	109.4	55.0	85.3	85.3	92.8	71.9	98.2	51.0						
	85	97.5	97.5	102.3	92.3	109.5	71.5	90.0	90.0	92.3	87.5	98.4	67.1						
	90	102.5	102.5	102.6	102.6	109.4	88.2	93.8	93.8	93.9	93.9	98.4	81.3						
3600	75	93.8	85.0	104.3	63.6	110.3	38.6	85.3	80.6	94.0	59.1	97.8	36.7						
	80	95.2	95.2	104.2	82.8	110.8	57.9	88.0	88.0	93.9	77.6	99.5	53.2						
	85	100.7	100.7	103.3	98.5	110.8	76.2	92.4	92.4	92.9	92.9	99.3	71.7						
	90	105.2	105.2	105.3	105.3	110.6	93.5	95.4	95.4	95.4	95.4	98.8	88.8						
4000	75	94.8	89.9	105.5	66.7	111.4	39.5	86.0	86.0	94.8	62.0	99.3	35.0						
	80	97.9	97.9	105.3	86.6	112.0	60.3	90.0	90.0	94.5	81.4	100.2	55.7						
	85	103.1	103.1	103.9	103.9	111.8	82.3	94.0	94.0	94.1	94.1	99.8	74.7						
	90	107.1	107.1	107.2	107.2	111.1	99.4	97.2	97.2	97.3	97.3	99.1	94.5						
4400	75	95.5	95.5	106.4	69.7	112.2	40.3	86.8	86.8	95.5	64.9	99.9	35.8						
	80	100.0	100.0	105.8	90.7	112.9	62.8	91.7	91.7	94.7	85.6	100.6	57.3						
	85	105.0	105.0	105.1	105.1	112.6	83.0	95.1	95.1	95.2	95.2	100.6	79.2						
	90	108.6	108.6	108.7	108.7	111.5	105.0	98.7	98.7	98.7	98.7	99.2	99.2						
4800	75	96.1	96.1	107.2	72.6	112.9	41.1	88.3	88.3	96.0	67.8	100.5	36.7						
	80	101.9	101.9	106.2	94.8	113.8	66.2	93.0	93.0	94.8	94.8	101.2	61.1						
	85	106.5	106.5	106.5	106.5	113.3	88.0	96.1	96.1	96.2	96.2	100.6	83.7						
	90	110.3	110.3	110.4	110.4	111.6	110.6	99.8	99.8	99.8	99.8	99.9	99.9						

Notes:

1. All capacities shown are gross and have not considered indoor fan heat. To obtain NET cooling capacity subtract indoor fan heat. For indoor fan heat formula, refer to appropriate airflow table notes.
2. MBh = Total gross capacity
3. SHC = Sensible heat capacity



Gross Cooling Capacities

Table 9. Gross cooling capacities — 12.5 tons

CFM	Ent DB (°F)	Entering Wet Bulb Temp (°F)						Entering Wet Bulb Temp (°F)						Entering Wet Bulb Temp (°F)					
		61		67		73		61		67		73		61		67		73	
		MBh	SHC	MBh	SHC	MBh	SHC	MBh	SHC	MBh	SHC	MBh	SHC	MBh	SHC	MBh	SHC	MBh	SHC
		Ambient Temperature 85°F						Ambient Temperature 95°F						Ambient Temperature 105°F					
4000	75	133.7	108.9	152.6	86.0	169.4	60.1	125.6	104.5	143.4	81.5	158.5	55.3	116.9	99.8	133.4	76.7	146.7	50.2
	80	131.8	125.7	152.1	106.1	169.4	81.0	123.8	121.0	142.9	101.5	158.6	76.3	115.3	115.2	133.0	96.6	146.9	71.2
	85	135.1	135.1	150.8	125.9	169.3	101.5	128.8	128.8	141.8	120.3	158.7	96.8	121.9	121.9	132.0	112.8	147.1	91.7
	90	149.0	142.3	149.0	142.3	168.8	121.8	136.8	136.8	140.0	137.5	158.2	117.1	129.5	129.5	130.4	130.4	146.7	112.1
4500	75	136.6	116.0	156.1	90.4	172.5	61.3	128.2	109.6	146.4	85.8	161.0	56.4	118.8	105.0	136.0	80.5	148.6	51.2
	80	134.1	133.6	155.3	112.6	172.6	84.7	125.8	125.8	145.7	107.8	161.2	79.8	118.6	118.6	135.3	102.9	149.1	74.7
	85	140.6	140.6	153.8	130.8	172.5	107.4	133.9	133.9	143.8	127.7	161.3	102.5	126.6	126.6	133.5	122.3	149.1	97.3
	90	149.2	149.2	151.2	151.2	171.6	129.9	142.2	142.2	142.3	142.3	160.6	125.1	134.4	134.4	134.5	134.5	148.7	120.0
5000	75	138.9	119.5	158.9	94.3	174.9	62.5	129.6	115.8	149.0	89.5	163.0	57.5	120.2	110.5	138.3	84.5	150.1	52.2
	80	136.4	136.4	157.8	118.8	175.0	88.2	129.7	129.7	147.8	114.0	163.3	83.3	122.3	122.3	137.2	109.0	150.8	78.1
	85	145.4	145.4	155.2	139.9	174.8	113.0	138.3	138.3	145.3	134.8	163.2	108.0	130.5	130.5	134.7	129.4	150.6	102.7
	90	154.2	154.2	154.4	154.4	173.8	137.8	146.7	146.7	146.9	146.9	162.4	130.9	138.4	138.4	138.5	138.5	149.7	125.5
5500	75	139.8	126.3	161.5	98.3	176.8	63.5	130.8	121.2	151.1	93.4	164.5	58.5	121.1	115.9	140.0	88.2	151.3	53.1
	80	140.4	140.4	159.7	124.8	177.1	91.6	133.3	133.3	149.5	120.0	165.1	86.3	125.6	125.6	138.6	112.3	152.2	80.9
	85	149.5	149.5	156.4	146.8	176.6	118.4	142.1	142.1	146.2	141.7	164.7	113.4	133.9	133.9	135.4	135.4	151.9	108.1
	90	158.6	158.6	158.7	158.7	175.5	140.9	150.6	150.6	150.8	150.8	163.1	137.8	141.8	141.8	141.9	141.9	150.2	132.0
6000	75	140.8	131.6	163.4	102.0	178.3	64.5	131.5	126.5	152.7	97.0	165.7	59.4	121.7	121.1	141.3	91.7	152.2	54.1
	80	143.8	143.8	161.2	130.4	178.8	94.5	136.5	136.5	150.8	121.1	166.5	89.3	128.5	128.5	138.9	118.2	153.2	83.9
	85	153.2	153.2	157.1	153.5	178.1	123.8	145.4	145.4	146.8	146.7	165.9	118.7	136.9	136.9	137.0	137.0	152.9	113.4
	90	162.4	162.4	162.5	162.5	175.7	149.7	154.0	154.0	154.1	154.1	163.5	144.2	144.6	144.6	144.7	144.7	150.5	138.4
		Ambient Temperature 115°F						Ambient Temperature 125°F											
4000	75	107.7	92.7	122.7	71.6	133.8	44.8	97.4	88.0	111.1	65.8	119.5	39.0						
	80	106.9	106.9	122.3	91.5	134.2	65.9	99.0	99.0	110.7	86.0	120.2	60.2						
	85	114.3	114.3	121.1	109.5	134.4	86.3	105.8	105.8	109.6	103.6	120.4	80.4						
	90	121.4	121.4	121.5	121.5	134.2	106.7	112.1	112.1	112.2	112.2	120.4	95.2						
4500	75	109.1	99.5	125.0	75.3	135.2	45.7	98.7	93.7	112.9	69.7	120.3	39.8						
	80	110.9	110.9	124.3	97.7	135.9	69.7	102.5	102.5	112.3	92.1	121.6	63.2						
	85	118.5	118.5	122.5	116.7	135.9	91.8	109.3	109.3	110.6	110.6	121.5	85.8						
	90	125.6	125.6	125.7	125.7	135.7	110.2	115.4	115.4	115.5	115.5	120.9	106.4						
5000	75	110.2	105.0	126.8	79.1	136.2	46.6	99.5	99.2	114.2	73.3	121.0	40.7						
	80	114.3	114.3	125.8	102.7	137.3	72.2	105.4	105.4	113.0	96.3	122.4	66.1						
	85	121.9	121.9	123.4	123.4	137.1	97.1	112.1	112.1	112.2	112.2	122.3	91.2						
	90	129.0	129.0	129.1	129.1	136.1	119.5	117.9	117.9	118.0	118.0	121.0	121.0						
5500	75	111.0	110.4	128.1	82.7	137.0	47.5	100.5	100.5	115.2	76.9	121.6	41.5						
	80	117.2	117.2	126.3	107.5	138.2	75.1	107.8	107.8	113.5	101.2	122.9	69.0						
	85	124.9	124.9	124.9	124.9	138.0	102.5	114.5	114.5	114.5	114.5	123.0	95.8						
	90	131.7	131.7	131.8	131.8	136.3	125.9	119.8	119.8	119.8	119.8	121.1	119.4						
6000	75	111.7	111.7	129.1	86.2	137.7	48.4	102.6	102.6	116.0	80.3	122.1	42.4						
	80	119.8	119.8	126.8	112.3	138.9	78.0	109.9	109.9	113.8	106.1	123.4	71.9						
	85	127.3	127.3	127.4	127.4	138.8	107.1	116.3	116.3	116.4	116.4	123.0	99.8						
	90	133.9	133.9	133.9	133.9	136.4	132.2	121.1	121.1	121.2	121.2	121.2	121.2						

Notes:

1. All capacities shown are gross and have not considered indoor fan heat. To obtain NET cooling capacity subtract indoor fan heat. For indoor fan heat formula, refer to appropriate airflow table notes.
2. MBh = Total gross capacity
3. SHC = Sensible heat capacity

Table 10. Gross cooling capacities — 15 tons

CFM	Ent DB (°F)	Entering Wet Bulb Temp (°F)						Entering Wet Bulb Temp (°F)						Entering Wet Bulb Temp (°F)					
		61		67		73		61		67		73		61		67		73	
		MBh	SHC	MBh	SHC	MBh	SHC	MBh	SHC	MBh	SHC	MBh	SHC	MBh	SHC	MBh	SHC	MBh	SHC
		Ambient Temperature 85°F						Ambient Temperature 95°F						Ambient Temperature 105°F					
4800	75	171.4	138.6	192.9	109.4	211.2	72.4	162.1	133.8	182.5	104.9	199.1	71.7	152.3	128.8	171.4	99.9	186.2	66.6
	80	170.4	160.6	192.6	134.2	211.4	102.3	161.3	155.6	182.2	129.3	199.5	97.5	151.5	151.5	171.2	124.3	186.8	92.4
	85	173.9	173.9	191.9	158.8	211.7	128.2	166.7	166.7	181.7	154.0	200.0	123.5	158.7	158.7	170.7	147.5	187.5	117.7
	90	190.9	180.4	190.9	180.4	211.6	152.6	176.1	176.1	180.6	175.2	199.9	147.8	167.8	167.8	169.6	169.6	187.3	142.6
5400	75	175.4	147.5	197.2	115.2	214.7	78.1	165.8	142.6	186.3	110.3	202.1	73.1	155.5	134.3	174.7	104.9	188.7	67.9
	80	173.9	173.9	196.7	142.3	215.1	106.9	164.4	164.4	185.9	137.4	202.7	101.9	155.1	155.1	174.4	132.2	189.6	96.8
	85	180.9	180.9	195.9	167.0	215.7	135.0	173.2	173.2	185.3	158.3	203.3	130.0	164.7	164.7	173.4	157.3	190.2	124.8
	90	191.0	191.0	194.1	192.6	215.3	162.9	182.9	182.9	183.5	183.5	203.1	157.9	173.8	173.8	174.0	174.0	190.0	152.7
6000	75	178.6	154.8	200.6	120.5	218.0	79.7	168.7	144.8	189.4	114.7	204.6	74.5	157.6	143.6	177.5	109.5	190.7	69.2
	80	176.6	176.6	200.0	150.2	218.3	111.3	168.5	168.5	188.8	146.8	205.5	106.8	160.0	160.0	176.9	139.9	192.1	101.7
	85	186.9	186.9	198.6	177.7	218.7	142.1	178.7	178.7	187.3	172.3	205.9	137.0	169.7	169.7	175.2	166.6	192.4	131.7
	90	197.2	197.2	197.4	197.4	218.3	172.9	188.4	188.4	188.6	188.6	205.7	167.9	178.8	178.8	178.9	178.9	192.2	157.6
6600	75	180.7	161.9	203.5	124.7	221.0	81.2	170.3	156.4	192.0	119.6	207.0	75.9	159.3	150.7	179.7	114.2	192.6	70.6
	80	181.3	181.3	202.7	157.9	221.1	116.2	173.1	173.1	191.2	153.3	208.0	111.3	164.2	164.2	179.0	147.5	194.4	106.3
	85	192.1	192.1	200.4	186.7	221.2	149.0	183.4	183.4	188.8	181.2	208.1	143.9	174.0	174.0	176.4	176.4	194.2	138.6
	90	202.4	202.4	202.6	202.6	220.8	179.3	193.1	193.1	193.3	193.3	207.6	174.4	182.8	182.8	183.0	183.0	193.1	169.1
7200	75	182.4	168.8	206.0	129.4	223.8	82.8	171.8	163.3	194.1	124.2	209.2	77.4	160.5	160.5	181.6	118.8	194.5	71.9
	80	185.6	185.6	204.9	165.4	223.6	120.8	177.1	177.1	193.1	158.8	210.4	114.4	167.8	167.8	180.7	148.6	196.3	108.9
	85	196.6	196.6	201.6	201.6	223.3	155.9	187.5	187.5	189.8	189.8	209.9	154.9	177.5	177.5	177.7	177.7	195.7	145.3
	90	206.8	206.8	207.0	207.0	222.0	189.1	197.0	197.0	197.2	197.2	208.2	183.3	186.2	186.2	186.3	186.3	193.5	177.3
		Ambient Temperature 115°F						Ambient Temperature 125°F											
4800	75	141.8	122.9	159.5	94.4	172.5	61.3	130.5	113.5	146.6	89.1	157.7	55.6						
	80	141.2	141.2	159.3	118.9	173.3	87.1	132.0	132.0	146.4	113.2	158.6	81.8						
	85	150.1	150.1	159.0	137.0	174.0	112.3	140.4	140.4	145.7	135.8	159.2	106.5						
	90	158.6	158.6	158.8	158.8	173.8	137.3	148.1	148.1	148.3	148.3	159.1	131.5						
5400	75	144.3	130.3	162.4	99.1	174.6	62.5	132.4	124.2	149.1	93.3	159.3	56.8						
	80	146.3	146.3	162.1	126.8	175.7	91.9	136.7	136.7	148.7	120.5	160.8	86.4						
	85	155.4	155.4	160.9	151.4	176.2	119.3	145.0	145.0	147.4	147.4	161.0	113.4						
	90	163.9	163.9	164.0	164.0	176.1	146.7	152.5	152.5	152.6	152.6	160.6	139.4						
6000	75	146.2	137.7	164.8	103.9	176.2	63.8	133.9	133.9	151.0	98.0	160.6	58.0						
	80	150.7	150.7	164.2	131.8	178.0	96.5	140.5	140.5	150.5	125.8	163.1	89.6						
	85	159.9	159.9	162.4	162.4	178.0	126.2	148.8	148.8	148.9	148.9	162.4	122.6						
	90	168.1	168.1	168.2	168.2	177.3	154.5	155.9	155.9	156.0	156.0	161.1	147.8						
6600	75	147.6	147.6	166.7	108.5	177.7	65.0	135.1	135.1	152.5	102.5	161.8	59.3						
	80	154.5	154.5	166.0	137.6	180.1	99.4	143.7	143.7	151.3	133.6	164.3	93.4						
	85	163.5	163.5	163.7	163.7	179.4	132.9	151.9	151.9	152.0	152.0	163.5	126.7						
	90	171.4	171.4	171.6	171.6	177.8	162.8	158.5	158.5	158.6	158.6	161.2	156.2						
7200	75	148.6	148.6	168.2	113.1	179.2	66.4	137.5	137.5	153.8	107.0	163.0	60.6						
	80	157.7	157.7	166.6	146.5	181.3	103.2	146.5	146.5	152.0	139.9	165.3	97.1						
	85	166.6	166.6	166.7	166.7	180.7	139.6	154.4	154.4	154.5	154.5	164.5	130.7						
	90	174.2	174.2	174.3	174.3	177.9	171.0	160.5	160.5	160.6	160.6	161.2	161.2						

Notes:

1. All capacities shown are gross and have not considered indoor fan heat. To obtain NET cooling capacity subtract indoor fan heat. For indoor fan heat formula, refer to appropriate airflow table notes.
2. MBh = Total gross capacity
3. SHC = Sensible heat capacity



Gross Cooling Capacities

Table 11. Gross cooling capacities — 17.5 tons

CFM	Ent DB (°F)	Entering Wet Bulb Temp (°F)						Entering Wet Bulb Temp (°F)						Entering Wet Bulb Temp (°F)					
		61		67		73		61		67		73		61		67		73	
		MBh	SHC	MBh	SHC	MBh	SHC	MBh	SHC	MBh	SHC	MBh	SHC	MBh	SHC	MBh	SHC	MBh	SHC
		Ambient Temperature 85°F						Ambient Temperature 95°F						Ambient Temperature 105°F					
5600	75	195.0	155.8	221.2	123.2	241.9	80.7	184.3	149.7	209.0	117.3	226.7	78.3	172.8	143.3	195.9	110.8	210.5	71.2
	80	193.3	180.4	220.7	151.4	241.8	114.4	182.8	174.0	208.6	145.1	226.5	107.5	171.3	171.3	195.5	138.4	210.7	100.5
	85	196.1	196.1	219.5	179.3	241.7	144.0	187.7	187.7	207.6	173.1	226.7	137.3	178.4	178.4	194.7	166.0	210.6	128.9
	90	207.8	207.8	218.0	203.4	241.7	171.7	199.0	199.0	206.1	196.8	226.9	164.9	189.3	189.3	193.2	189.8	210.7	157.6
6300	75	199.7	165.9	226.3	129.9	247.2	87.4	188.6	159.6	213.4	123.5	230.9	80.1	176.6	151.3	199.6	116.8	213.7	72.8
	80	197.3	197.3	225.6	160.5	247.2	119.9	186.3	186.3	212.8	154.1	230.9	112.8	174.5	174.5	199.1	151.6	214.0	106.0
	85	204.4	204.4	224.1	185.8	246.5	151.4	195.4	195.4	211.7	179.8	231.2	143.7	185.6	185.6	197.7	175.7	214.1	137.0
	90	216.5	216.5	221.8	217.0	245.4	182.9	207.0	207.0	209.3	209.3	229.7	175.9	196.4	196.4	196.6	196.6	213.3	168.6
7000	75	203.4	174.4	230.3	135.9	251.4	89.3	191.9	164.0	216.9	129.5	234.2	81.8	179.1	159.8	202.6	121.2	216.2	74.3
	80	200.3	200.3	229.3	169.3	251.3	125.1	189.8	189.8	214.1	162.8	234.3	117.8	179.9	179.9	201.9	155.8	216.7	110.6
	85	211.5	211.5	227.2	200.3	250.7	159.7	202.0	202.0	216.0	193.3	234.0	152.3	191.5	191.5	199.8	185.9	216.6	144.7
	90	223.8	223.8	224.3	224.3	249.0	194.2	213.5	213.5	213.7	213.7	233.3	185.0	201.9	201.9	202.1	202.1	215.9	177.2
7700	75	205.8	181.8	233.5	140.3	254.9	91.1	193.8	174.9	219.7	133.5	237.0	83.5	181.0	167.6	205.0	126.3	218.3	75.8
	80	204.7	204.7	232.7	175.5	254.7	130.9	195.2	195.2	218.6	164.2	237.0	123.6	184.9	184.9	204.0	159.1	218.9	116.3
	85	217.7	217.7	229.3	210.3	253.8	167.5	207.6	207.6	215.4	215.4	236.5	160.0	196.5	196.5	200.9	200.9	218.5	152.3
	90	229.8	229.8	230.0	230.0	252.2	202.9	218.7	218.7	218.9	218.9	235.0	194.6	206.0	206.0	206.2	206.2	216.9	186.7
8400	75	207.7	189.5	236.3	145.5	257.8	92.8	195.9	181.9	222.0	138.5	239.2	85.1	182.2	182.2	206.8	131.3	220.0	77.2
	80	209.9	209.9	234.6	178.2	257.5	135.3	200.0	200.0	220.6	165.6	239.3	126.5	189.3	189.3	205.8	166.9	220.8	118.6
	85	222.9	222.9	230.5	230.5	256.4	175.2	212.4	212.4	216.5	216.5	238.5	173.3	200.6	200.6	201.7	201.7	220.0	158.7
	90	234.8	234.8	235.0	235.0	253.6	212.3	222.8	222.8	223.0	223.0	236.0	204.2	208.9	208.9	209.0	209.0	217.6	195.9
		Ambient Temperature 115°F						Ambient Temperature 125°F											
5600	75	160.6	136.5	181.7	103.9	193.3	63.7	147.4	126.8	166.3	96.5	174.2	55.8						
	80	159.2	159.2	181.4	131.4	193.7	93.1	147.2	147.2	166.1	123.9	175.1	85.3						
	85	168.4	168.4	180.8	154.0	194.1	121.6	157.1	157.1	165.3	149.5	175.6	113.7						
	90	178.5	178.5	179.3	179.3	193.6	150.0	166.0	166.0	166.2	166.2	175.5	142.2						
6300	75	163.9	140.2	184.9	109.8	195.5	65.1	149.7	136.3	168.8	100.9	175.6	57.0						
	80	163.9	163.9	184.4	140.1	196.2	98.2	152.7	152.7	168.4	133.3	176.9	89.9						
	85	174.8	174.8	183.1	168.0	196.4	129.3	162.6	162.6	166.8	166.8	177.1	121.2						
	90	184.5	184.5	184.6	184.6	196.1	160.2	170.3	170.3	170.4	170.4	176.8	150.7						
7000	75	165.8	152.3	187.3	113.8	197.3	66.5	151.3	151.3	170.7	105.9	176.7	58.3						
	80	169.2	169.2	186.7	146.9	198.2	103.7	157.4	157.4	170.2	139.8	178.6	93.9						
	85	180.0	180.0	184.4	184.4	198.2	136.9	166.8	166.8	167.9	167.9	178.1	130.0						
	90	188.6	188.6	188.7	188.7	197.4	169.0	172.3	172.3	172.4	172.4	177.3	160.0						
7700	75	167.2	167.2	189.2	118.8	198.7	67.9	152.6	152.6	172.0	110.7	177.5	59.6						
	80	173.7	173.7	188.5	154.0	200.0	106.4	161.2	161.2	171.1	146.2	179.6	97.8						
	85	184.1	184.1	185.3	185.3	199.5	145.0	169.8	169.8	169.9	169.9	179.1	136.7						
	90	191.1	191.1	191.2	191.2	198.0	178.2	174.4	174.4	174.5	174.5	177.5	169.2						
8400	75	168.4	168.4	190.6	123.6	199.8	69.2	153.8	153.8	173.1	115.5	178.2	60.8						
	80	177.5	177.5	189.1	161.7	201.3	110.5	164.4	164.4	171.5	153.1	180.3	101.9						
	85	187.4	187.4	187.5	187.5	200.7	152.6	171.8	171.8	171.9	171.9	179.8	141.7						
	90	193.4	193.4	193.5	193.5	198.3	187.3	176.4	176.4	176.5	176.5	177.5	177.5						

Notes:

1. All capacities shown are gross and have not considered indoor fan heat. To obtain NET cooling capacity subtract indoor fan heat. For indoor fan heat formula, refer to appropriate airflow table notes.
2. MBh = Total gross capacity
3. SHC = Sensible heat capacity

Table 12. Gross cooling capacities — 20 tons

CFM	Ent DB (°F)	Entering Wet Bulb Temp (°F)						Entering Wet Bulb Temp (°F)						Entering Wet Bulb Temp (°F)					
		61		67		73		61		67		73		61		67		73	
		MBh	SHC	MBh	SHC	MBh	SHC	MBh	SHC	MBh	SHC	MBh	SHC	MBh	SHC	MBh	SHC	MBh	SHC
		Ambient Temperature 85°F						Ambient Temperature 95°F						Ambient Temperature 105°F					
6400	75	226.5	180.4	254.8	142.6	275.1	92.9	213.2	173.3	239.2	135.3	256.8	91.0	198.7	165.7	222.0	127.3	237.1	83.1
	80	224.0	207.9	254.6	174.6	275.4	131.6	210.8	200.4	239.1	167.1	256.9	123.9	196.3	196.3	221.9	159.1	237.3	116.0
	85	225.9	225.9	253.2	206.0	275.9	165.2	215.6	215.6	237.9	198.7	256.9	157.4	204.0	204.0	221.1	181.1	237.5	148.3
	90	238.8	238.8	251.1	233.1	276.0	196.5	227.9	227.9	235.8	225.2	257.0	188.5	215.3	215.3	218.8	216.5	237.0	180.2
7200	75	231.9	190.5	260.3	149.9	280.2	100.7	217.9	184.3	243.8	142.4	261.1	93.0	202.8	175.3	225.7	134.3	240.2	84.8
	80	228.4	228.4	259.8	184.7	280.2	137.3	214.6	214.6	243.4	177.0	261.3	129.6	199.6	199.6	225.3	174.1	240.7	122.2
	85	235.1	235.1	258.2	219.7	280.0	173.1	224.0	224.0	242.2	207.2	261.3	165.4	211.5	211.5	223.9	200.6	240.9	157.1
	90	248.3	248.3	254.9	247.9	279.8	208.9	236.3	236.3	238.8	238.8	260.2	200.8	222.3	222.3	222.5	222.5	240.2	192.7
8000	75	236.1	202.3	264.6	156.5	284.6	102.7	221.6	191.6	247.4	148.0	264.5	94.8	205.2	183.9	228.6	139.2	242.7	86.3
	80	231.6	231.6	263.8	194.4	284.6	143.0	218.0	218.0	246.7	186.5	264.8	135.8	205.6	205.6	228.0	176.6	243.4	127.8
	85	243.0	243.0	261.3	229.4	284.2	182.0	231.1	231.1	244.3	220.8	264.6	174.1	217.6	217.6	225.5	211.6	243.4	165.7
	90	256.1	256.1	257.3	257.3	282.7	221.0	243.0	243.0	243.2	243.2	263.4	213.2	227.6	227.6	227.7	227.7	242.6	198.6
8800	75	239.4	204.6	268.1	161.5	288.1	104.5	223.5	201.2	250.3	153.4	267.2	96.4	207.0	192.4	230.8	144.7	244.5	87.9
	80	235.7	235.7	267.0	203.8	288.2	149.2	224.0	224.0	249.3	193.6	267.7	141.4	210.9	210.9	230.1	178.5	245.7	133.3
	85	249.7	249.7	263.4	240.2	287.5	190.7	237.0	237.0	245.7	231.5	267.2	182.7	222.5	222.5	226.3	226.3	245.3	174.1
	90	262.6	262.6	262.8	262.8	285.5	232.3	248.3	248.3	248.5	248.5	265.4	221.6	231.3	231.3	231.5	231.5	243.3	212.4
9600	75	240.7	217.9	271.0	167.2	291.0	106.2	225.1	209.5	252.6	159.0	269.4	98.0	208.2	208.2	232.4	150.2	246.0	89.3
	80	241.4	241.4	269.5	211.1	291.1	154.4	229.1	229.1	251.5	199.4	270.1	146.5	215.3	215.3	231.8	189.8	247.6	136.3
	85	255.4	255.4	264.5	264.5	290.1	199.2	241.9	241.9	246.4	246.4	269.3	196.8	226.3	226.3	226.7	226.7	246.9	178.7
	90	268.0	268.0	268.1	268.1	286.8	240.8	252.5	252.5	252.6	252.6	266.2	231.9	234.2	234.2	234.4	234.4	243.9	222.5
		Ambient Temperature 115°F						Ambient Temperature 125°F											
6400	75	182.9	157.7	203.0	119.3	215.1	74.5	165.7	144.0	181.8	110.1	190.1	65.0						
	80	180.7	180.7	203.0	150.4	215.6	107.5	166.1	166.1	181.9	141.0	191.2	98.9						
	85	191.0	191.0	202.5	174.6	216.1	139.7	175.5	175.5	180.9	169.3	191.8	130.2						
	90	200.6	200.6	200.8	200.8	215.8	171.7	182.2	182.2	182.3	182.3	191.8	160.4						
7200	75	186.0	165.7	205.9	124.8	217.1	75.9	167.6	156.1	183.7	114.7	191.0	66.3						
	80	186.4	186.4	205.6	159.9	218.0	113.6	171.4	171.4	183.6	146.0	192.9	104.5						
	85	197.1	197.1	203.9	190.9	218.4	148.3	179.8	179.8	181.6	181.6	193.1	138.6						
	90	205.6	205.6	205.7	205.7	218.1	180.4	185.7	185.7	185.8	185.8	192.5	171.1						
8000	75	187.9	174.6	207.9	130.0	218.5	77.3	168.9	168.9	184.9	120.1	191.6	67.5						
	80	191.7	191.7	207.6	161.0	220.1	119.2	175.5	175.5	185.0	153.7	194.4	107.7						
	85	201.8	201.8	204.7	204.7	220.1	156.7	182.6	182.6	182.7	182.7	194.0	141.9						
	90	208.7	208.7	208.8	208.8	218.9	192.2	189.0	189.0	189.1	189.1	192.6	181.4						
8800	75	189.2	189.2	209.4	135.4	219.6	78.7	169.9	169.9	185.9	125.4	192.1	68.8						
	80	196.1	196.1	209.2	172.5	221.8	122.3	178.6	178.6	185.0	164.7	195.0	112.2						
	85	205.3	205.3	205.4	205.4	221.4	165.0	184.6	184.6	184.7	184.7	194.8	153.0						
	90	212.6	212.6	212.7	212.7	219.3	202.4	191.2	191.2	191.3	191.3	192.5	191.5						
9600	75	190.1	190.1	210.6	140.7	220.5	80.0	172.2	172.2	186.8	130.7	192.6	70.2						
	80	199.6	199.6	209.3	183.2	222.9	126.8	181.0	181.0	185.0	172.1	195.4	116.6						
	85	207.8	207.8	207.9	207.9	222.5	174.2	187.1	187.1	187.2	187.2	195.1	160.6						
	90	215.8	215.8	215.9	215.9	219.4	212.4	192.5	192.5	192.6	192.6	192.6	192.6						

Notes:

1. All capacities shown are gross and have not considered indoor fan heat. To obtain NET cooling capacity subtract indoor fan heat. For indoor fan heat formula, refer to appropriate airflow table notes.
2. MBh = Total gross capacity
3. SHC = Sensible heat capacity



Gross Cooling Capacities

Table 13. Gross cooling capacities — 25 tons

CFM	Ent DB (°F)	Entering Wet Bulb Temp (°F)						Entering Wet Bulb Temp (°F)						Entering Wet Bulb Temp (°F)					
		61		67		73		61		67		73		61		67		73	
		MBh	SHC	MBh	SHC	MBh	SHC	MBh	SHC	MBh	SHC	MBh	SHC	MBh	SHC	MBh	SHC	MBh	SHC
		Ambient Temperature 85°F						Ambient Temperature 95°F						Ambient Temperature 105°F					
8000	75	255.1	208.2	290.7	166.0	319.2	115.1	241.0	200.7	274.2	158.4	298.9	106.7	225.7	192.8	256.3	149.9	276.4	97.6
	80	250.0	250.0	289.6	202.5	319.4	154.4	236.1	236.1	273.1	194.7	299.4	146.1	221.1	221.1	255.2	186.3	277.3	137.2
	85	255.1	255.1	286.4	239.3	319.5	194.9	244.4	244.4	270.3	213.6	299.9	184.5	232.5	232.5	252.9	215.2	278.1	175.4
	90	270.3	270.3	281.6	268.6	318.4	230.7	259.0	259.0	265.6	260.3	298.9	222.4	246.3	246.3	248.2	248.2	277.5	213.5
9000	75	260.3	220.8	297.1	174.5	324.1	117.2	245.6	211.2	279.7	166.7	302.6	108.4	228.8	201.7	260.8	156.0	279.2	99.2
	80	253.7	253.7	295.2	225.3	324.6	160.9	239.2	239.2	278.0	206.1	303.6	152.4	226.4	226.4	259.3	200.1	280.6	143.9
	85	265.0	265.0	291.0	250.7	324.9	203.2	253.6	253.6	273.5	242.3	304.0	194.5	240.9	240.9	254.9	232.9	281.2	185.2
	90	280.8	280.8	284.8	284.8	323.2	245.2	268.6	268.6	268.8	268.8	302.9	236.8	254.8	254.8	255.0	255.0	280.6	227.7
10000	75	263.5	228.8	302.0	180.1	327.9	119.0	247.7	220.7	284.1	171.8	305.4	110.1	231.0	211.5	264.8	162.9	282.6	101.2
	80	257.3	257.3	299.5	226.2	328.8	168.5	245.9	245.9	281.6	218.6	307.1	158.7	233.2	233.2	262.3	202.3	283.6	149.5
	85	273.6	273.6	293.3	263.7	328.7	213.1	261.5	261.5	275.6	254.8	307.1	204.3	248.0	248.0	256.3	256.3	283.4	205.7
	90	289.7	289.7	289.9	289.9	326.9	259.5	276.7	276.7	276.9	276.9	305.9	245.6	261.7	261.7	261.9	261.9	281.7	237.0
11000	75	265.4	238.9	306.5	187.1	330.9	120.7	249.4	230.1	288.0	178.6	308.6	112.1	232.2	232.2	267.7	169.5	285.3	103.2
	80	264.4	264.4	302.8	229.2	332.4	175.1	252.4	252.4	284.5	226.8	310.3	164.6	239.2	239.2	264.7	214.8	286.1	154.1
	85	281.1	281.1	294.7	294.7	331.8	222.8	268.3	268.3	276.6	276.6	309.5	226.3	254.0	254.0	257.0	257.0	285.4	205.8
	90	297.4	297.4	297.6	297.6	328.5	268.8	283.4	283.4	283.6	283.6	306.3	258.9	267.4	267.4	267.5	267.5	282.0	248.4
12000	75	266.5	266.5	310.1	193.7	334.3	122.8	250.3	250.3	290.8	185.1	311.8	114.2	232.9	232.9	269.9	175.8	287.6	105.1
	80	270.6	270.6	305.4	229.9	335.6	178.4	258.1	258.1	285.7	235.0	312.6	169.1	244.3	244.3	264.8	224.7	288.0	159.3
	85	287.7	287.7	295.4	295.4	334.3	232.4	274.2	274.2	277.0	277.0	311.6	226.8	259.0	259.0	259.2	259.2	287.0	206.0
	90	304.0	304.0	304.2	304.2	329.2	279.9	289.1	289.1	289.3	289.3	306.5	270.1	271.9	271.9	272.1	272.1	282.2	258.5
		Ambient Temperature 115°F						Ambient Temperature 125°F											
8000	75	209.3	181.4	236.7	141.3	252.1	88.0	190.7	172.0	215.1	130.1	226.8	78.3						
	80	206.0	206.0	235.7	183.0	253.1	128.5	192.1	192.1	214.2	164.6	227.9	118.0						
	85	219.3	219.3	232.8	210.2	254.0	165.5	204.1	204.1	211.3	211.3	227.6	155.0						
	90	231.9	231.9	232.1	232.1	253.8	203.8	214.7	214.7	214.8	214.8	227.5	186.5						
9000	75	211.5	192.2	240.6	146.8	255.4	90.0	192.6	192.6	218.1	136.7	228.9	80.2						
	80	213.2	213.2	239.0	186.0	256.0	133.7	198.2	198.2	216.8	172.2	230.6	123.0						
	85	226.6	226.6	234.6	234.6	256.1	175.2	210.0	210.0	212.5	212.5	229.6	164.8						
	90	238.9	238.9	239.1	239.1	255.5	214.3	219.6	219.6	219.7	219.7	227.7	201.5						
10000	75	213.1	213.1	243.6	153.4	257.9	91.9	193.8	193.8	220.2	143.1	230.7	81.9						
	80	219.3	219.3	241.5	189.1	258.7	138.8	203.3	203.3	217.7	185.7	232.4	128.5						
	85	232.7	232.7	235.6	235.6	257.8	184.7	214.7	214.7	214.8	214.8	231.3	166.7						
	90	244.3	244.3	244.5	244.5	255.7	225.8	223.0	223.0	223.1	223.1	227.8	213.1						
11000	75	214.0	214.0	245.8	159.8	260.0	93.8	194.8	194.8	221.8	149.3	232.1	83.7						
	80	224.4	224.4	242.1	205.6	261.6	142.1	207.6	207.6	218.1	194.3	233.9	133.7						
	85	237.6	237.6	237.7	237.7	259.5	185.1	218.3	218.3	218.4	218.4	232.5	181.7						
	90	248.5	248.5	248.6	248.6	255.8	236.2	225.1	225.1	225.2	225.2	228.0	224.7						
12000	75	214.4	214.4	247.5	166.0	261.7	95.6	198.5	198.5	223.0	163.2	233.5	85.5						
	80	228.8	228.8	242.5	214.1	262.9	149.5	211.1	211.1	218.1	218.1	235.1	138.8						
	85	241.7	241.7	241.8	241.8	260.6	201.7	221.0	221.0	221.1	221.1	232.7	188.8						
	90	251.6	251.6	251.6	251.6	255.8	245.3	228.0	228.0	228.0	228.0	228.1	228.1						

Notes:

1. All capacities shown are gross and have not considered indoor fan heat. To obtain NET cooling capacity subtract indoor fan heat. For indoor fan heat formula, refer to appropriate airflow table notes.
2. MBh = Total gross capacity
3. SHC = Sensible heat capacity



Reheat Temperature Rise

Table 14. Reheat temperature rise — 6 tons

Airflow (cfm)	Ent DB (°F)	Entering Wet Bulb (°F)											
		51				55				59			
		Lvg Evap DB (°F)		Lvg Reheat DB (°F)		Lvg Evap DB (°F)		Lvg Reheat DB (°F)		Lvg Evap DB (°F)		Lvg Reheat DB (°F)	
		MIN	MAX	MIN	MAX	MIN	MAX	MIN	MAX	MIN	MAX	MIN	MAX
Ambient DB 60°F													
1200	60	28.5 ^(a)	32.0 ^(a)	45.9	54.1	32.2 ^(a)	36.9	50.7	56.7	36.3	41.8	55.2	59.0
	65	28.5 ^(a)	32.0 ^(a)	45.9	54.2	32.2 ^(a)	36.9	50.7	56.7	36.4	41.8	55.2	59.0
	70	28.5 ^(a)	32.2 ^(a)	45.8	54.2	32.2 ^(a)	36.9	50.6	56.7	36.3	41.8	55.1	59.0
	75	30.1 ^(a)	36.4	47.7	56.3	32.2 ^(a)	37.1	50.6	56.7	36.3	41.8	55.1	59.1
1440	60	31.5 ^(a)	33.9 ^(a)	46.6	54.8	35.2	38.9	51.3	57.4	39.2	44.0	56.0	60.0
	65	31.6 ^(a)	34.0 ^(a)	46.7	54.9	35.3	39.0	51.3	57.4	39.3	43.9	56.0	59.9
	70	31.9 ^(a)	35.8	47.0	55.7	35.4	39.0	51.4	57.5	39.3	43.9	56.1	60.0
	75	34.6 ^(a)	40.1	50.1	57.9	35.4	40.2	51.4	58.0	39.4	44.0	56.1	60.0
1680	60	33.9 ^(a)	35.5	47.2	55.2	37.7	40.5	51.9	57.9	41.5	45.6	56.6	60.7
	65	34.0 ^(a)	35.7	47.3	55.3	37.8	40.6	52.0	58.0	41.6	45.5	56.6	60.6
	70	35.4	38.7	48.7	56.9	37.9	40.6	52.1	58.0	41.7	45.6	56.7	60.7
	75	38.3	43.2	52.2	59.3	38.4	43.3	52.4	59.3	41.8	45.7	56.8	60.7
1920	60	35.8	36.8	47.8	55.7	39.6	41.7	52.5	58.4	43.6	46.8	57.1	61.1
	65	36.0	37.0	48.0	55.7	39.8	41.9	52.6	58.5	43.5	46.7	57.0	61.1
	70	38.3	41.1	50.4	57.9	39.9	42.1	52.7	58.5	43.6	46.9	57.1	61.2
	75	41.3	45.8	53.9	60.4	41.4	45.9	54.0	60.5	43.8	47.1	57.3	61.3
2160	60	37.4	37.0	48.3	56.1	41.2	42.8	52.9	58.7	45.1	47.8	57.4	61.5
	65	38.0	38.6	48.7	56.2	41.4	43.0	53.0	58.8	45.0	47.8	57.4	61.5
	70	40.8	43.2	51.9	58.7	41.7	43.7	53.2	59.1	45.2	48.0	57.5	61.6
	75	43.8	48.0	55.4	61.4	43.9	48.2	55.5	61.5	45.4	48.7	57.7	61.8
2400	60	38.8	38.9	48.7	56.0	42.5	43.6	53.2	58.9	46.3	48.6	57.7	61.7
	65	39.5	40.0	49.3	56.6	42.7	43.9	53.4	59.0	46.3	48.6	57.7	61.7
	70	42.9	45.0	53.2	59.4	43.4	44.8	53.9	59.4	46.5	48.9	57.8	61.8
	75	45.9	50.0	56.6	62.2	46.0	50.1	56.7	62.3	46.9	49.8	58.1	62.2
2640	60	39.9	39.8	49.1	55.9	43.5	44.4	53.5	59.0	47.4	49.3	57.9	61.9
	65	41.3	41.5	50.4	57.0	43.8	44.7	53.7	59.2	47.4	49.4	57.9	61.9
	70	44.7	46.6	54.2	60.1	44.6	46.7	54.3	60.1	47.7	49.7	58.1	62.0
	75	47.8	51.7	57.7	62.9	47.8	51.8	57.8	63.0	48.4	51.9	58.6	63.1
2880	60	40.8	40.6	49.3	55.7	44.4	45.1	53.7	59.1	48.3	49.8	58.1	61.9
	65	42.8	42.9	51.2	57.4	44.8	45.5	53.9	59.3	48.4	50.1	58.1	62.0
	70	46.2	48.1	55.2	60.6	45.7	48.2	54.7	60.6	48.7	50.4	58.3	62.2
	75	49.4	53.2	58.7	63.6	49.5	53.3	58.8	63.6	49.5	53.5	59.0	63.7
Ambient DB 65°F													
1200	60	29.0 ^(a)	31.4 ^(a)	46.4	56.4	32.6 ^(a)	36.4	51.1	59.0	36.5	41.4	56.1	61.5
	65	29.0 ^(a)	31.5 ^(a)	46.4	56.4	32.6 ^(a)	36.4	51.0	59.0	36.6	41.4	56.2	61.5
	70	29.0 ^(a)	31.7 ^(a)	46.3	56.4	32.6 ^(a)	36.5	51.0	59.0	36.5	41.4	56.0	61.5
	75	30.8 ^(a)	35.6	48.5	58.5	32.6 ^(a)	36.4	51.0	59.0	36.5	41.4	56.0	61.5



Reheat Temperature Rise

Table 14. Reheat temperature rise — 6 tons (continued)

Airflow (cfm)	Ent DB (°F)	Entering Wet Bulb (°F)											
		51				55				59			
		Lvg Evap DB (°F)		Lvg Reheat DB (°F)		Lvg Evap DB (°F)		Lvg Reheat DB (°F)		Lvg Evap DB (°F)		Lvg Reheat DB (°F)	
		MIN	MAX	MIN	MAX	MIN	MAX	MIN	MAX	MIN	MAX	MIN	MAX
1440	60	32.0 ^(a)	33.2 ^(a)	47.0	56.9	35.7	38.3	51.8	59.7	39.5	43.5	56.6	62.4
	65	32.1 ^(a)	33.3 ^(a)	47.1	56.9	35.8	38.4	51.8	59.7	39.6	43.4	56.6	62.4
	70	32.4 ^(a)	34.8 ^(a)	47.4	57.6	35.9	38.5	51.8	59.8	39.6	43.4	56.6	62.4
	75	35.3	39.1	50.9	60.0	35.9	38.9	51.9	59.9	39.7	43.5	56.7	62.4
1680	60	34.3 ^(a)	34.7 ^(a)	47.7	57.4	38.2	39.8	52.4	60.3	42.0	45.0	57.2	63.1
	65	34.5 ^(a)	34.9 ^(a)	47.7	57.4	38.3	39.9	52.5	60.3	42.0	44.9	57.2	63.0
	70	36.1	37.5	49.4	58.8	38.4	40.1	52.6	60.4	42.1	45.0	57.3	63.1
	75	39.0	42.1	53.0	61.3	38.9	42.2	53.0	61.4	42.2	45.1	57.3	63.1
1920	60	36.3	36.1	48.3	57.2	40.1	41.0	52.9	60.7	44.1	46.2	57.8	63.5
	65	36.5	36.3	48.4	57.3	40.2	41.2	53.0	60.7	44.0	46.1	57.7	63.5
	70	39.0	39.8	51.1	59.8	40.4	41.4	53.1	60.8	44.2	46.3	57.8	63.5
	75	42.0	44.5	54.8	62.4	42.1	44.7	54.9	62.5	44.4	46.5	57.9	63.6
2160	60	37.8	37.5	48.7	56.8	41.6	42.0	53.3	60.9	45.6	47.1	58.1	63.8
	65	38.4	38.1	49.1	57.2	41.7	42.2	53.4	61.0	45.5	47.1	58.0	63.8
	70	41.4	41.8	52.5	60.5	42.2	42.8	53.7	61.2	45.7	47.3	58.2	63.9
	75	44.5	46.7	56.2	63.3	44.6	46.8	56.3	63.4	46.0	47.9	58.3	64.1
2400	60	39.1	38.7	49.0	56.5	42.8	42.9	53.5	60.9	46.8	47.9	58.3	64.0
	65	39.9	39.5	49.7	57.0	43.0	43.2	53.7	61.0	46.8	48.0	58.3	64.0
	70	43.4	43.6	53.7	61.1	43.7	44.0	54.2	61.4	47.0	48.2	58.4	64.1
	75	46.7	48.6	57.5	64.1	46.8	48.7	57.6	64.1	47.3	49.0	58.6	64.4
2640	60	40.2	39.8	49.3	56.1	43.8	43.7	53.7	60.7	47.8	48.6	58.4	64.0
	65	41.8	41.2	50.8	57.3	44.1	44.0	54.0	60.9	47.9	48.7	58.5	64.1
	70	45.2	45.2	54.7	61.5	45.0	45.0	54.7	61.5	48.1	49.0	58.7	64.2
	75	48.5	50.2	58.6	64.7	48.6	50.4	58.7	64.7	48.9	50.0	59.2	64.6
2880	60	41.1	40.7	49.6	55.8	44.7	44.5	53.9	60.5	48.7	49.2	58.6	64.1
	65	43.3	42.7	51.7	57.7	45.1	44.9	54.2	60.7	48.8	49.4	58.6	64.1
	70	46.7	46.6	55.6	62.0	46.8	46.7	55.7	62.0	49.1	49.7	58.8	64.3
	75	50.1	51.7	59.6	65.2	50.2	51.8	59.6	65.3	50.0	52.0	59.6	65.4
Ambient DB 70°F													
1200	60	29.5 ^(a)	30.9 ^(a)	46.9	58.4	33.2 ^(a)	36.0	51.7	61.3	37.0	41.0	56.6	63.9
	65	29.5 ^(a)	30.9 ^(a)	46.8	58.4	33.1 ^(a)	35.9	51.6	61.3	37.1	41.0	56.7	63.9
	70	29.5 ^(a)	31.1 ^(a)	46.8	58.5	33.1 ^(a)	36.0	51.5	61.3	37.0	41.0	56.6	63.9
	75	31.5 ^(a)	34.8 ^(a)	49.2	60.6	33.1 ^(a)	36.0	51.5	61.3	37.0	41.0	56.5	63.9
1440	60	32.5 ^(a)	32.6 ^(a)	47.5	58.7	36.3	37.7	52.3	62.0	40.2	43.0	57.4	64.9
	65	32.5 ^(a)	32.7 ^(a)	47.5	58.7	36.3	37.8	52.3	62.1	40.2	42.8	57.4	64.8
	70	33.0 ^(a)	33.1 ^(a)	48.0	59.0	36.4	37.9	52.4	62.1	40.3	42.9	57.4	64.8
	75	36.0	38.1	51.6	62.1	36.4	38.3	52.4	62.3	40.3	43.0	57.4	64.9
1680	60	34.8 ^(a)	34.5 ^(a)	48.1	58.1	38.6	39.1	52.9	62.5	42.5	44.4	57.8	65.5
	65	34.9 ^(a)	34.6 ^(a)	48.2	58.2	38.7	39.2	53.0	62.6	42.6	44.3	57.8	65.4
	70	36.8	36.5	50.1	60.0	38.9	39.4	53.0	62.6	42.6	44.4	57.9	65.5
	75	39.7	40.9	53.8	63.4	39.6	41.0	53.7	63.5	42.8	44.5	58.0	65.5

Table 14. Reheat temperature rise — 6 tons (continued)

Airflow (cfm)	Ent DB (°F)	Entering Wet Bulb (°F)											
		51				55				59			
		Lvg Evap DB (°F)		Lvg Reheat DB (°F)		Lvg Evap DB (°F)		Lvg Reheat DB (°F)		Lvg Evap DB (°F)		Lvg Reheat DB (°F)	
		MIN	MAX	MIN	MAX	MIN	MAX	MIN	MAX	MIN	MAX	MIN	MAX
1920	60	36.7	36.2	48.7	57.4	40.4	40.3	53.3	62.4	44.5	45.5	58.2	65.8
	65	36.9	36.5	48.8	57.7	40.6	40.5	53.4	62.5	44.4	45.4	58.2	65.8
	70	39.6	39.1	51.7	60.5	40.8	40.7	53.5	62.6	44.5	45.6	58.3	65.9
	75	42.6	43.2	55.4	64.3	42.7	43.4	55.5	64.4	44.7	45.8	58.4	65.9
2160	60	38.2	37.7	49.0	56.8	41.9	41.6	53.6	61.9	45.9	46.5	58.5	66.0
	65	38.8	38.3	49.5	57.2	42.1	41.8	53.7	62.1	45.9	46.4	58.4	66.0
	70	41.9	41.4	53.1	61.0	42.5	42.0	54.1	62.2	46.1	46.6	58.6	66.1
	75	45.1	45.3	56.9	65.0	45.2	45.5	57.0	65.1	46.3	47.1	58.7	66.3
2400	60	39.4	38.9	49.4	56.4	43.1	42.7	53.8	61.5	47.1	47.3	58.6	66.0
	65	40.4	39.7	50.2	56.9	43.4	42.9	54.0	61.6	47.1	47.3	58.6	66.0
	70	43.9	43.3	54.2	61.4	44.1	43.7	54.6	62.1	47.4	47.6	58.8	66.1
	75	47.2	47.2	58.1	65.5	47.3	47.3	58.2	65.6	48.0	48.3	59.2	66.5
2640	60	40.5	40.0	49.6	56.2	44.1	43.7	54.0	61.0	48.1	48.0	58.7	65.8
	65	42.3	41.6	51.3	57.5	44.4	44.0	54.2	61.2	48.2	48.0	58.8	65.8
	70	45.7	45.0	55.2	61.8	45.5	44.8	55.1	61.8	48.5	48.4	59.0	66.0
	75	49.0	48.9	59.2	66.0	49.1	49.0	59.2	66.1	49.2	49.3	59.6	66.5
2880	60	41.4	41.0	49.8	55.9	45.0	44.6	54.2	60.6	49.0	48.7	58.8	65.4
	65	43.7	43.1	52.1	57.9	45.3	44.9	54.4	60.8	49.1	48.8	58.9	65.5
	70	47.2	46.5	56.1	62.2	47.2	46.6	56.2	62.3	49.4	49.2	59.1	65.7
	75	50.6	50.4	60.1	66.4	50.7	50.5	60.2	66.5	50.6	50.2	60.2	66.4

Note: MIN, MAX: The leaving evaporator temperature is affected by the modulating valve position. The MIN and MAX numbers represent modulating valve position impact on both the leaving evaporator temperature and the leaving reheat coil temperature. MAX represents wide open, MIN represents closed to minimum position.

(a) The unit might be tripped by Froststat at these conditions due to low leaving evaporator air temperature.

Table 15. Reheat temperature rise — 7.5 tons

Airflow (cfm)	Ent DB (°F)	Entering Wet Bulb (°F)											
		51				55				59			
		Lvg Evap DB (°F)		Lvg Reheat DB (°F)		Lvg Evap DB (°F)		Lvg Reheat DB (°F)		Lvg Evap DB (°F)		Lvg Reheat DB (°F)	
		MIN	MAX	MIN	MAX	MIN	MAX	MIN	MAX	MIN	MAX	MIN	MAX
Ambient DB 60°F													
1500	60	29.5 ^(a)	32.9 ^(a)	46.1	55.0	33.1 ^(a)	38.0	50.7	57.8	36.7	43.2	55.0	60.6
	65	29.7 ^(a)	33.0 ^(a)	46.2	55.1	33.0 ^(a)	38.1	50.6	57.8	36.9	43.1	55.2	60.5
	70	29.7 ^(a)	34.1 ^(a)	46.2	55.5	33.2 ^(a)	38.3	50.7	57.9	36.8	43.2	55.1	60.6
	75	31.9 ^(a)	38.7	48.7	58.0	33.3 ^(a)	38.7	50.7	58.1	36.9	43.4	55.1	60.6
1800	60	32.5 ^(a)	34.8 ^(a)	47.0	55.7	36.1	39.8	51.6	58.5	39.8	45.1	56.0	61.3
	65	32.7 ^(a)	35.0	47.1	55.8	36.3	40.1	51.7	58.6	39.9	45.0	56.0	61.2
	70	33.3 ^(a)	37.6	47.7	57.1	36.5	40.3	51.8	58.7	40.0	45.2	56.1	61.3
	75	36.4	42.3	51.2	59.7	37.0	42.5	52.2	59.7	40.2	45.4	56.2	61.4
2100	60	34.8 ^(a)	36.3	47.7	56.2	38.5	41.3	52.3	58.9	42.2	46.5	56.7	61.7
	65	35.1	36.8	47.9	56.4	38.7	41.6	52.4	59.1	42.3	46.5	56.8	61.7
	70	37.0	40.4	49.8	58.2	39.0	42.0	52.6	59.2	42.5	46.8	56.9	61.9
	75	40.0	45.4	53.3	60.9	39.8	45.5	53.3	61.0	42.8	47.1	57.1	62.0



Reheat Temperature Rise

Table 15. Reheat temperature rise — 7.5 tons (continued)

Airflow (cfm)	Ent DB (°F)	Entering Wet Bulb (°F)											
		51				55				59			
		Lvg Evap DB (°F)		Lvg Reheat DB (°F)		Lvg Evap DB (°F)		Lvg Reheat DB (°F)		Lvg Evap DB (°F)		Lvg Reheat DB (°F)	
		MIN	MAX	MIN	MAX	MIN	MAX	MIN	MAX	MIN	MAX	MIN	MAX
2400	60	36.7	37.5	48.3	56.4	40.3	42.4	52.8	59.2	44.2	47.6	57.4	62.0
	65	37.4	38.3	48.8	56.8	40.6	42.8	53.0	59.4	44.2	47.6	57.3	62.0
	70	39.8	42.8	51.4	59.2	41.0	43.6	53.2	59.7	44.5	48.0	57.5	62.2
	75	42.9	48.0	55.0	62.0	43.0	48.1	55.1	62.0	44.8	48.8	57.7	62.5
2700	60	38.3	38.6	48.7	56.5	41.8	43.4	53.1	59.4	45.7	48.5	57.7	62.2
	65	39.1	39.6	49.4	57.0	42.2	43.9	53.4	59.6	45.7	48.6	57.7	62.2
	70	42.2	44.9	52.8	59.9	42.9	44.9	54.0	60.0	46.1	49.1	57.9	62.4
	75	45.3	50.2	56.4	62.8	45.4	50.3	56.5	62.9	46.6	50.1	58.3	62.9
3000	60	39.5	39.6	49.1	56.4	43.1	44.3	53.4	59.5	46.9	49.3	57.9	62.3
	65	40.6	40.8	50.0	57.1	43.5	44.8	53.8	59.7	47.0	49.5	58.0	62.4
	70	44.2	46.7	54.0	60.5	44.4	46.0	54.5	60.2	47.4	50.0	58.3	62.6
	75	47.4	52.1	57.6	63.6	47.4	52.3	57.7	63.6	48.2	52.4	58.9	63.7
3300	60	40.6	40.5	49.4	56.3	44.1	45.1	53.7	59.6	47.9	49.9	58.1	62.4
	65	42.5	42.8	51.1	57.8	44.6	45.6	54.0	59.8	48.1	50.3	58.2	62.5
	70	45.9	48.3	55.0	61.1	45.7	48.4	54.9	61.1	48.5	50.8	58.5	62.7
	75	49.1	53.8	58.7	64.2	49.2	53.9	58.8	64.3	49.5	54.0	59.3	64.3
3600	60	41.5	41.3	49.7	56.1	45.0	45.7	53.9	59.6	48.8	50.3	58.3	62.3
	65	43.9	44.2	52.0	58.1	45.5	46.3	54.3	59.8	49.0	50.9	58.4	62.6
	70	47.4	49.7	55.9	61.6	47.5	49.8	56.0	61.6	49.5	51.8	58.8	63.0
	75	50.7	55.3	59.6	64.8	50.8	55.4	59.7	64.8	50.7	55.5	59.7	64.9
Ambient DB 65°F													
1500	60	29.9 ^(a)	32.0 ^(a)	46.6	57.3	33.6 ^(a)	37.2	51.4	60.1	37.2	42.5	56.0	62.9
	65	30.1 ^(a)	32.1 ^(a)	46.7	57.3	33.5 ^(a)	37.3	51.3	60.1	37.4	42.4	56.2	62.9
	70	30.4 ^(a)	32.6 ^(a)	47.0	57.6	33.7 ^(a)	37.4	51.4	60.2	37.3	42.5	56.1	62.9
	75	32.4 ^(a)	37.3	49.4	60.0	33.8 ^(a)	37.9	51.5	60.4	37.5	42.7	56.1	63.0
1800	60	32.9 ^(a)	33.7 ^(a)	47.4	57.8	36.5	38.9	52.1	60.7	40.3	44.3	56.9	63.6
	65	33.1 ^(a)	33.9 ^(a)	47.6	57.9	36.7	39.1	52.2	60.8	40.4	44.2	57.0	63.6
	70	33.7 ^(a)	35.9	48.2	58.9	36.9	39.4	52.4	60.9	40.5	44.4	57.1	63.7
	75	36.9	40.7	51.9	61.5	37.4	40.8	52.8	61.6	40.7	44.6	57.2	63.7
2100	60	35.2	35.2	48.1	57.9	38.8	40.3	52.7	61.1	42.9	45.7	57.7	64.0
	65	35.5	35.6	48.3	58.1	39.1	40.6	52.9	61.2	42.8	45.6	57.6	64.0
	70	37.5	38.6	50.4	59.9	39.3	40.9	53.1	61.4	43.0	45.9	57.8	64.1
	75	40.4	43.6	54.0	62.7	40.2	43.8	53.8	62.8	43.3	46.2	57.9	64.2
2400	60	37.0	36.7	48.6	57.6	40.6	41.5	53.2	61.3	44.5	46.7	57.9	64.2
	65	37.7	37.4	49.2	58.1	41.0	41.8	53.4	61.5	44.6	46.8	58.0	64.3
	70	40.3	41.0	52.0	60.7	41.3	42.6	53.6	61.8	44.9	47.1	58.2	64.4
	75	43.4	46.1	55.7	63.6	43.5	46.3	55.8	63.7	45.2	47.9	58.4	64.7
2700	60	38.5	38.1	49.1	57.3	42.1	42.5	53.5	61.3	46.1	47.7	58.3	64.4
	65	39.4	39.0	49.8	57.9	42.5	42.9	53.8	61.6	46.1	47.7	58.3	64.4
	70	42.6	43.0	53.3	61.3	43.3	43.8	54.4	62.0	46.5	48.2	58.6	64.6
	75	45.8	48.3	57.1	64.4	45.9	48.4	57.2	64.5	46.9	49.1	58.8	65.0

Table 15. Reheat temperature rise — 7.5 tons (continued)

Airflow (cfm)	Ent DB (°F)	Entering Wet Bulb (°F)											
		51				55				59			
		Lvg Evap DB (°F)		Lvg Reheat DB (°F)		Lvg Evap DB (°F)		Lvg Reheat DB (°F)		Lvg Evap DB (°F)		Lvg Reheat DB (°F)	
		MIN	MAX	MIN	MAX	MIN	MAX	MIN	MAX	MIN	MAX	MIN	MAX
3000	60	39.8	39.3	49.4	56.9	43.4	43.4	53.8	61.2	47.3	48.4	58.5	64.4
	65	40.9	40.4	50.3	57.7	43.8	43.9	54.1	61.5	47.4	48.6	58.5	64.5
	70	44.6	44.8	54.5	61.8	44.7	45.0	54.9	62.1	47.8	49.1	58.8	64.7
	75	47.9	50.2	58.4	65.1	48.0	50.3	58.5	65.1	48.7	50.2	59.5	65.2
3300	60	40.9	40.4	49.7	56.7	44.4	44.2	54.0	61.1	48.3	49.1	58.6	64.4
	65	42.9	42.2	51.6	58.1	44.9	44.7	54.4	61.3	48.5	49.4	58.7	64.5
	70	46.3	46.4	55.5	62.3	46.1	46.3	55.4	62.2	48.9	49.9	59.1	64.8
	75	49.7	51.8	59.4	65.6	49.8	51.9	59.5	65.7	50.0	52.1	59.9	65.8
3600	60	41.8	41.3	50.0	56.4	45.3	45.0	54.2	60.8	49.1	49.7	58.8	64.3
	65	44.3	43.7	52.4	58.4	45.8	45.5	54.6	61.2	49.4	50.0	58.9	64.5
	70	47.8	47.9	56.4	62.7	47.9	48.0	56.5	62.7	49.9	50.5	59.3	64.8
	75	51.3	53.3	60.4	66.1	51.4	53.4	60.5	66.2	51.1	53.5	60.2	66.2
Ambient DB 70°F													
1500	60	30.3 ^(a)	31.1 ^(a)	47.1	59.4	34.0 ^(a)	36.3	52.0	62.3	37.7	41.8	56.9	65.3
	65	30.4 ^(a)	31.2 ^(a)	47.2	59.4	33.9 ^(a)	36.4	51.9	62.4	37.9	41.6	57.0	65.2
	70	30.8 ^(a)	31.7 ^(a)	47.5	59.7	34.1 ^(a)	36.6	52.0	62.4	37.9	41.7	57.0	65.2
	75	33.0 ^(a)	35.8	50.1	61.9	34.2 ^(a)	37.0	52.0	62.6	38.0	41.9	57.0	65.3
1800	60	33.2 ^(a)	33.0 ^(a)	47.9	59.2	36.9	38.0	52.6	62.9	40.7	43.5	57.6	65.9
	65	33.4 ^(a)	33.2 ^(a)	48.0	59.3	37.1	38.2	52.7	63.0	40.8	43.4	57.6	65.8
	70	34.3 ^(a)	33.8 ^(a)	48.8	59.8	37.3	38.4	52.8	63.1	41.0	43.6	57.7	65.9
	75	37.4	39.1	52.6	63.3	37.8	39.1	53.3	63.4	41.2	43.8	57.8	66.0
2100	60	35.5	34.9 ^(a)	48.5	58.5	39.2	39.4	53.2	63.0	43.2	44.8	58.2	66.2
	65	35.8	35.2	48.7	58.7	39.4	39.7	53.3	63.2	43.2	44.7	58.1	66.2
	70	38.0	37.4	50.9	60.7	39.7	40.0	53.5	63.3	43.4	45.0	58.3	66.3
	75	41.0	41.9	54.6	64.3	40.7	42.0	54.4	64.4	43.6	45.3	58.4	66.5
2400	60	37.3	36.7	49.0	58.0	41.0	40.6	53.6	62.7	45.0	45.9	58.5	66.4
	65	38.0	37.4	49.5	58.4	41.3	41.0	53.8	62.9	45.0	45.9	58.5	66.4
	70	40.8	40.0	52.5	61.2	41.8	41.6	54.2	63.3	45.3	46.2	58.7	66.6
	75	43.9	44.3	56.3	65.1	44.0	44.5	56.4	65.2	45.6	46.8	58.9	66.8
2700	60	38.8	38.3	49.4	57.7	42.4	41.9	53.9	62.3	46.4	46.8	58.7	66.4
	65	39.7	39.1	50.1	58.2	42.8	42.3	54.1	62.5	46.5	46.8	58.7	66.4
	70	43.1	42.3	53.9	61.7	43.6	43.1	54.8	63.1	46.8	47.3	59.0	66.6
	75	46.3	46.5	57.7	65.7	46.4	46.6	57.8	65.8	47.5	48.2	59.5	67.0
3000	60	40.1	39.5	49.7	57.3	43.6	43.1	54.1	61.9	47.6	47.6	58.9	66.2
	65	41.3	40.6	50.8	58.0	44.1	43.5	54.4	62.2	47.7	47.8	58.9	66.3
	70	45.1	44.3	55.0	62.2	45.0	44.5	55.2	62.8	48.1	48.2	59.2	66.5
	75	48.4	48.4	59.0	66.3	48.5	48.5	59.0	66.4	49.0	49.3	59.9	67.1
3300	60	41.1	40.6	50.0	57.0	44.7	44.1	54.3	61.6	48.6	48.4	59.0	66.0
	65	43.3	42.5	52.0	58.5	45.1	44.6	54.7	61.9	48.8	48.6	59.1	66.1
	70	46.8	46.0	56.0	62.7	46.7	45.7	56.0	62.7	49.2	49.1	59.4	66.4
	75	50.2	50.1	60.0	66.7	50.3	50.2	60.1	66.8	50.3	50.3	60.3	67.0



Reheat Temperature Rise

Table 15. Reheat temperature rise — 7.5 tons (continued)

Airflow (cfm)	Ent DB (°F)	Entering Wet Bulb (°F)											
		51				55				59			
		Lvg Evap DB (°F)		Lvg Reheat DB (°F)		Lvg Evap DB (°F)		Lvg Reheat DB (°F)		Lvg Evap DB (°F)		Lvg Reheat DB (°F)	
		MIN	MAX	MIN	MAX	MIN	MAX	MIN	MAX	MIN	MAX	MIN	MAX
3600	60	42.0	41.5	50.2	56.7	45.6	45.0	54.5	61.3	49.4	49.1	59.1	65.9
	65	44.7	43.9	52.8	58.9	46.0	45.5	54.9	61.6	49.7	49.3	59.2	66.0
	70	48.2	47.5	56.9	63.1	48.3	47.5	57.0	63.2	50.1	49.8	59.6	66.3
	75	51.8	51.6	61.0	67.2	51.9	51.7	61.0	67.3	51.8	51.2	61.0	67.0

Note: MIN, MAX: The leaving evaporator temperature is affected by the modulating valve position. The MIN and MAX numbers represent modulating valve position impact on both the leaving evaporator temperature and the leaving reheat coil temperature. MAX represents wide open, MIN represents closed to minimum position.

(a) The unit might be tripped by Froststat at these conditions due to low leaving evaporator air temperature.

Table 16. Reheat temperature rise — 8.5 tons

Airflow (cfm)	Ent DB (°F)	Entering Wet Bulb (°F)											
		51				55				59			
		Lvg Evap DB (°F)		Lvg Reheat DB (°F)		Lvg Evap DB (°F)		Lvg Reheat DB (°F)		Lvg Evap DB (°F)		Lvg Reheat DB (°F)	
		MIN	MAX	MIN	MAX	MIN	MAX	MIN	MAX	MIN	MAX	MIN	MAX
Ambient DB 60°F													
1700	60	29.0 ^(a)	32.9 ^(a)	45.5	51.9	32.7 ^(a)	37.7	49.7	54.6	37.2	42.5	52.8	57.2
	65	29.2 ^(a)	33.2 ^(a)	45.7	52.0	32.8 ^(a)	37.8	49.7	54.6	37.4	42.6	52.9	57.3
	70	29.4 ^(a)	33.9 ^(a)	45.8	52.4	33.0 ^(a)	38.1	49.9	54.8	37.4	42.8	52.9	57.4
	75	31.4 ^(a)	38.4	47.9	54.8	33.2 ^(a)	38.7	50.0	55.0	37.6	43.1	53.0	57.5
2040	60	32.0 ^(a)	35.2	46.4	52.6	35.7	39.9	50.7	55.3	40.1	44.9	53.9	58.1
	65	32.3 ^(a)	35.5	46.6	52.8	35.8	40.3	50.8	55.4	40.2	44.9	54.0	58.0
	70	33.0 ^(a)	38.2	47.3	54.1	36.2	40.6	51.0	55.6	40.4	45.2	54.1	58.2
	75	35.9	42.6	50.4	56.6	36.8	42.7	51.4	56.7	40.8	45.3	54.3	58.3
2380	60	34.3 ^(a)	37.1	47.1	53.1	37.9	41.7	51.3	55.7	42.3	46.6	54.7	58.5
	65	34.7 ^(a)	37.8	47.4	53.4	38.3	42.1	51.6	55.9	42.5	46.6	54.8	58.5
	70	36.3	41.4	48.9	55.4	38.6	42.8	51.8	56.3	42.9	47.0	55.0	58.8
	75	39.5	46.0	52.3	58.0	39.6	46.1	52.5	58.1	43.2	47.4	55.2	58.9
2720	60	36.2	38.5	47.7	53.4	39.8	43.0	51.9	56.0	44.3	47.9	55.4	58.8
	65	36.8	39.5	48.2	53.8	40.2	43.6	52.2	56.3	44.3	48.0	55.4	58.9
	70	39.3	44.1	50.7	56.4	40.6	44.5	52.5	56.7	44.8	48.5	55.7	59.2
	75	42.6	48.8	53.9	59.2	41.8	48.9	53.4	59.2	45.2	49.4	55.9	59.6
3060	60	37.8	39.8	48.2	53.6	41.3	44.2	52.3	56.3	45.7	48.9	55.8	59.1
	65	38.7	41.1	49.0	54.2	41.8	44.8	52.7	56.6	45.8	49.3	55.9	59.2
	70	41.7	46.3	52.0	57.3	42.6	45.9	53.3	57.1	46.3	49.7	56.2	59.5
	75	45.3	51.2	55.2	60.2	45.4	51.3	55.3	60.2	46.9	50.8	56.5	60.0
3400	60	39.1	40.8	48.7	53.7	42.5	45.3	52.7	56.5	46.9	49.8	56.2	59.2
	65	40.2	43.2	49.6	55.0	43.1	45.8	53.1	56.7	47.1	50.2	56.3	59.4
	70	43.7	48.2	53.2	58.1	44.2	48.3	53.9	58.1	47.7	50.7	56.6	59.7
	75	47.6	53.2	56.3	61.0	47.7	53.3	56.4	61.1	48.8	53.4	57.2	61.1
3740	60	40.2	41.7	49.0	53.8	43.6	46.1	53.0	56.6	47.9	50.4	56.4	59.2
	65	41.6	44.8	50.2	55.6	44.2	46.7	53.5	56.9	48.2	51.0	56.7	59.6
	70	45.4	49.9	54.2	58.7	45.5	50.0	54.4	58.8	48.8	51.7	57.0	60.0
	75	49.6	54.9	57.3	61.8	49.7	55.0	57.4	61.8	50.1	55.1	57.7	61.9

Table 16. Reheat temperature rise — 8.5 tons (continued)

Airflow (cfm)	Ent DB (°F)	Entering Wet Bulb (°F)											
		51				55				59			
		Lvg Evap DB (°F)		Lvg Reheat DB (°F)		Lvg Evap DB (°F)		Lvg Reheat DB (°F)		Lvg Evap DB (°F)		Lvg Reheat DB (°F)	
		MIN	MAX	MIN	MAX	MIN	MAX	MIN	MAX	MIN	MAX	MIN	MAX
4080	60	41.2	42.5	49.4	53.9	44.6	46.8	53.3	56.7	48.7	51.0	56.7	59.3
	65	43.4	46.2	51.3	56.1	45.2	47.7	53.8	57.2	49.1	51.7	56.9	59.7
	70	47.0	51.4	55.0	59.3	46.6	51.4	54.8	59.3	49.8	52.7	57.3	60.2
	75	51.4	56.5	58.2	62.5	51.5	56.5	58.3	62.5	51.2	56.6	58.1	62.6
Ambient DB 65°F													
1700	60	29.3 ^(a)	32.2 ^(a)	45.8	54.1	32.9 ^(a)	37.1	50.5	56.8	36.8	41.9	54.7	59.5
	65	29.5 ^(a)	32.4 ^(a)	46.0	54.2	32.9 ^(a)	37.2	50.5	56.9	37.0	42.1	54.9	59.6
	70	29.7 ^(a)	33.0 ^(a)	46.1	54.5	33.2 ^(a)	37.1	50.6	56.8	37.0	42.2	54.8	59.6
	75	31.7 ^(a)	37.3	48.4	56.8	33.3 ^(a)	38.0	50.8	57.3	37.2	42.5	55.0	59.8
2040	60	32.3 ^(a)	34.4 ^(a)	46.8	54.7	35.8	39.2	51.2	57.4	39.7	44.3	55.6	60.3
	65	32.6 ^(a)	34.4 ^(a)	47.0	54.7	36.0	39.6	51.3	57.6	39.9	44.3	55.7	60.2
	70	33.3 ^(a)	36.9	47.6	56.0	36.3	39.5	51.6	57.6	40.0	44.6	55.8	60.4
	75	36.2	41.4	50.9	58.5	36.9	41.5	52.1	58.6	40.4	44.9	56.0	60.5
2380	60	34.7 ^(a)	36.2	47.5	55.1	38.1	40.9	51.8	57.8	42.0	45.9	56.2	60.7
	65	35.0	36.6	47.8	55.3	38.4	41.3	52.1	58.0	42.2	46.0	56.4	60.7
	70	36.9	40.1	49.5	57.1	38.8	41.7	52.3	58.2	42.5	46.4	56.6	60.9
	75	39.7	44.7	52.9	59.8	39.7	44.9	53.1	59.9	42.8	46.8	56.8	61.0
2720	60	36.6	37.7	48.1	55.3	40.0	42.3	52.3	58.1	44.0	47.2	56.9	60.9
	65	37.0	38.6	48.4	55.8	40.4	42.8	52.6	58.3	44.0	47.3	56.9	60.9
	70	39.7	42.7	51.2	58.1	40.8	43.7	53.0	58.7	44.4	47.9	57.2	61.2
	75	42.7	47.5	54.6	60.8	42.8	47.6	54.7	60.9	44.8	48.7	57.4	61.6
3060	60	38.1	38.9	48.6	55.5	41.5	43.4	52.8	58.2	45.4	48.3	57.2	61.1
	65	39.1	40.0	49.4	56.0	42.0	44.0	53.1	58.5	45.5	48.5	57.2	61.1
	70	42.1	44.9	52.6	58.8	42.8	45.1	53.8	59.0	46.0	49.1	57.6	61.4
	75	45.1	49.8	56.1	61.7	45.2	50.0	56.2	61.8	46.5	50.1	57.9	62.0
3400	60	39.4	40.0	49.0	55.5	42.8	44.4	53.1	58.3	46.6	49.1	57.5	61.2
	65	40.5	41.2	50.0	56.1	43.3	45.0	53.5	58.6	46.8	49.5	57.5	61.3
	70	44.0	46.8	53.7	59.5	44.3	46.8	54.3	59.5	47.3	50.1	58.0	61.6
	75	47.2	51.9	57.3	62.5	47.3	52.0	57.4	62.6	48.3	51.3	58.7	62.2
3740	60	40.5	40.9	49.4	55.5	43.9	45.3	53.5	58.4	47.6	49.9	57.7	61.2
	65	42.1	43.4	50.7	56.9	44.5	45.9	53.9	58.7	47.8	50.4	57.8	61.4
	70	45.6	48.5	54.6	60.1	45.6	48.6	54.8	60.1	48.5	50.9	58.3	61.7
	75	49.0	53.6	58.3	63.2	49.1	53.7	58.4	63.2	49.6	53.8	59.1	63.3
4080	60	41.5	41.7	49.7	55.5	44.9	46.1	53.7	58.4	48.5	50.4	57.8	61.1
	65	43.8	44.8	51.8	57.3	45.4	46.7	54.2	58.7	48.8	51.1	58.1	61.5
	70	47.1	50.0	55.5	60.6	47.0	50.1	55.5	60.7	49.4	52.0	58.5	62.0
	75	50.6	55.1	59.3	63.8	50.7	55.2	59.3	63.8	50.8	55.3	59.5	63.9
Ambient DB 70°F													
1700	60	29.6 ^(a)	31.4 ^(a)	46.3	56.3	33.3 ^(a)	36.4	51.0	59.0	36.9	41.4	55.6	61.8
	65	29.9 ^(a)	31.7 ^(a)	46.4	56.4	33.3 ^(a)	36.5	51.0	59.1	37.1	41.5	55.8	61.8
	70	30.0 ^(a)	32.3 ^(a)	46.6	56.7	33.5 ^(a)	36.8	51.1	59.2	37.1	41.6	55.7	61.9
	75	32.2 ^(a)	36.2	49.0	58.8	33.7 ^(a)	37.3	51.2	59.5	37.3	41.9	55.9	62.0



Reheat Temperature Rise

Table 16. Reheat temperature rise — 8.5 tons (continued)

Airflow (cfm)	Ent DB (°F)	Entering Wet Bulb (°F)											
		51				55				59			
		Lvg Evap DB (°F)		Lvg Reheat DB (°F)		Lvg Evap DB (°F)		Lvg Reheat DB (°F)		Lvg Evap DB (°F)		Lvg Reheat DB (°F)	
		MIN	MAX	MIN	MAX	MIN	MAX	MIN	MAX	MIN	MAX	MIN	MAX
2040	60	32.7 ^(a)	33.6 ^(a)	47.2	56.8	36.2	38.5	51.8	59.6	39.9	43.7	56.3	62.5
	65	32.9 ^(a)	33.9 ^(a)	47.4	56.9	36.4	38.8	51.9	59.8	40.0	43.6	56.4	62.5
	70	33.7 ^(a)	34.9 ^(a)	48.1	57.5	36.7	39.1	52.1	59.9	40.2	44.0	56.5	62.6
	75	36.7	40.2	51.6	60.4	37.3	40.0	52.7	60.3	40.5	43.9	56.8	62.6
2380	60	34.9 ^(a)	35.3	47.9	57.0	38.5	40.2	52.4	59.9	42.2	45.3	56.8	62.8
	65	35.3	35.8	48.1	57.2	38.9	40.6	52.6	60.1	42.4	45.3	57.0	62.8
	70	37.3	38.7	50.1	58.8	39.2	40.8	52.9	60.2	42.7	45.7	57.2	63.0
	75	40.3	43.4	53.7	61.5	40.1	43.5	53.7	61.6	43.0	45.8	57.5	63.0
2720	60	36.8	36.9	48.5	56.9	40.4	41.5	52.9	60.1	44.3	46.6	57.5	63.0
	65	37.6	37.7	49.1	57.4	40.8	42.0	53.2	60.3	44.3	46.6	57.5	63.0
	70	40.1	41.3	51.7	59.7	41.3	42.8	53.6	60.7	44.6	47.2	57.7	63.3
	75	43.2	46.1	55.4	62.5	43.3	46.3	55.5	62.6	45.0	48.0	58.0	63.7
3060	60	38.4	38.3	49.0	56.7	41.8	42.7	53.2	60.1	45.7	47.6	57.8	63.1
	65	39.3	39.3	49.7	57.4	42.3	43.2	53.6	60.4	45.8	47.8	57.8	63.1
	70	42.4	43.5	53.1	60.3	43.2	44.3	54.3	60.9	46.3	48.3	58.2	63.4
	75	45.6	48.5	56.8	63.3	45.7	48.6	56.9	63.4	46.9	49.4	58.7	63.9
3400	60	39.7	39.5	49.3	56.5	43.1	43.6	53.5	60.1	46.9	48.5	58.1	63.1
	65	40.8	40.7	50.3	57.3	43.6	44.3	54.0	60.5	47.1	48.8	58.1	63.3
	70	44.4	45.4	54.2	60.9	44.7	45.5	54.8	61.1	47.6	49.4	58.5	63.5
	75	47.7	50.5	58.0	64.0	47.8	50.6	58.1	64.1	48.5	50.6	59.2	64.1
3740	60	40.7	40.6	49.7	56.3	44.1	44.6	53.8	60.1	47.9	49.2	58.3	63.1
	65	42.2	41.9	50.9	57.2	44.7	45.2	54.3	60.4	48.2	49.7	58.4	63.3
	70	46.1	47.1	55.2	61.4	46.0	47.0	55.3	61.4	48.7	50.2	58.8	63.6
	75	49.5	52.2	59.0	64.6	49.5	52.3	59.1	64.6	49.8	52.4	59.7	64.7
4080	60	41.7	41.5	49.9	56.1	45.1	45.3	54.0	60.1	48.8	49.9	58.4	63.0
	65	44.1	43.9	52.2	58.1	45.7	46.0	54.5	60.4	49.1	50.4	58.6	63.3
	70	47.6	48.6	56.1	61.9	47.4	48.7	55.9	61.9	49.7	51.0	59.1	63.6
	75	51.0	53.7	59.9	65.1	51.1	53.8	60.0	65.2	51.0	53.9	60.1	65.2

Note: MIN, MAX: The leaving evaporator temperature is affected by the modulating valve position. The MIN and MAX numbers represent modulating valve position impact on both the leaving evaporator temperature and the leaving reheat coil temperature. MAX represents wide open, MIN represents closed to minimum position.

^(a) The unit might be tripped by Froststat at these conditions due to low leaving evaporator air temperature.

Table 17. Reheat temperature rise — 10 tons

Airflow (cfm)	Ent DB (°F)	Entering Wet Bulb (°F)											
		51				55				59			
		Lvg Evap DB (°F)		Lvg Reheat DB (°F)		Lvg Evap DB (°F)		Lvg Reheat DB (°F)		Lvg Evap DB (°F)		Lvg Reheat DB (°F)	
		MIN	MAX	MIN	MAX	MIN	MAX	MIN	MAX	MIN	MAX	MIN	MAX
Ambient DB 60°F													
2000	60	29.8 ^(a)	33.5 ^(a)	45.8	52.6	33.6 ^(a)	38.3	50.2	55.4	37.9	43.4	53.4	58.3
	65	30.1 ^(a)	33.8 ^(a)	46.1	52.8	33.6 ^(a)	38.5	50.2	55.5	38.1	43.3	53.5	58.2
	70	30.7 ^(a)	35.0	46.5	53.4	33.9 ^(a)	38.5	50.4	55.5	38.2	43.5	53.6	58.3
	75	32.7 ^(a)	39.6	48.7	56.0	34.1 ^(a)	39.6	50.5	56.0	38.5	43.8	53.7	58.5

Table 17. Reheat temperature rise — 10 tons (continued)

Airflow (cfm)	Ent DB (°F)	Entering Wet Bulb (°F)											
		51				55				59			
		Lvg Evap DB (°F)		Lvg Reheat DB (°F)		Lvg Evap DB (°F)		Lvg Reheat DB (°F)		Lvg Evap DB (°F)		Lvg Reheat DB (°F)	
		MIN	MAX	MIN	MAX	MIN	MAX	MIN	MAX	MIN	MAX	MIN	MAX
2400	60	32.8 ^(a)	35.8	46.8	53.2	36.4	40.5	51.0	55.9	40.7	45.5	54.4	58.8
	65	33.1 ^(a)	36.3	47.0	53.4	36.6	40.9	51.2	56.1	40.9	45.5	54.5	58.8
	70	34.0 ^(a)	39.3	47.8	55.0	37.0	41.2	51.4	56.3	41.2	45.9	54.6	59.0
	75	37.2	43.8	51.2	57.7	37.8	43.9	52.0	57.7	41.6	46.2	54.9	59.1
2800	60	35.1	37.7	47.5	53.6	38.7	42.2	51.7	56.3	42.9	47.1	55.1	59.2
	65	35.5	38.5	47.8	54.0	39.0	42.7	52.0	56.5	43.2	47.2	55.2	59.2
	70	37.6	42.5	49.8	56.2	39.5	43.5	52.3	56.9	43.6	47.7	55.5	59.5
	75	40.8	47.2	53.1	59.0	40.6	47.3	53.1	59.1	44.1	48.5	55.7	59.9
3200	60	36.9	39.1	48.1	53.8	40.5	43.6	52.2	56.5	44.9	48.4	55.7	59.4
	65	37.8	40.2	48.8	54.3	40.9	44.2	52.6	56.8	45.0	48.6	55.8	59.5
	70	40.4	45.2	51.4	57.2	41.5	45.3	52.9	57.4	45.5	49.2	56.1	59.8
	75	43.9	50.0	54.7	60.1	44.0	50.1	54.8	60.2	46.0	50.2	56.4	60.3
3600	60	38.5	40.4	48.6	53.9	41.9	44.7	52.6	56.7	46.3	49.4	56.1	59.5
	65	39.6	42.3	49.5	54.9	42.5	45.4	53.1	57.0	46.5	49.8	56.2	59.8
	70	42.7	47.4	52.7	58.1	43.5	47.5	53.8	58.1	47.1	50.4	56.6	60.0
	75	46.5	52.3	55.9	61.1	46.6	52.4	56.0	61.1	48.1	52.6	57.2	61.2
4000	60	39.8	41.4	49.1	54.0	43.2	45.8	53.0	56.8	47.5	50.1	56.4	59.5
	65	41.0	44.2	50.1	55.6	43.8	46.4	53.5	57.2	47.7	50.8	56.6	59.9
	70	44.7	49.3	53.9	58.8	45.0	49.4	54.3	58.8	48.4	51.4	57.0	60.3
	75	48.8	54.3	57.0	61.9	48.9	54.4	57.1	62.0	49.6	54.5	57.7	62.0
4400	60	40.9	42.3	49.4	54.1	44.2	46.6	53.2	56.9	48.4	50.8	56.6	59.6
	65	42.8	45.7	51.0	56.1	44.9	47.3	53.8	57.3	48.8	51.6	56.9	60.0
	70	46.5	50.9	54.8	59.4	46.3	51.0	54.8	59.5	49.5	52.5	57.3	60.5
	75	50.8	56.0	58.0	62.7	50.9	56.1	58.1	62.7	50.9	56.2	58.2	62.8
4800	60	41.8	43.3	49.7	54.3	45.2	47.3	53.5	57.0	49.2	51.4	56.8	59.7
	65	44.3	47.1	51.9	56.6	45.9	48.3	54.1	57.5	49.7	52.2	57.2	60.1
	70	48.0	52.3	55.6	60.0	47.4	52.4	55.2	60.0	50.4	53.3	57.6	60.7
	75	52.5	57.5	58.9	63.3	52.6	57.6	58.9	63.4	52.1	57.7	58.6	63.4
Ambient DB 65°F													
2000	60	30.1 ^(a)	32.6 ^(a)	46.3	54.7	33.6 ^(a)	37.5	50.8	57.5	37.4	42.4	55.1	60.3
	65	30.4 ^(a)	33.0 ^(a)	46.5	54.8	33.6 ^(a)	37.7	50.8	57.6	37.7	42.6	55.3	60.3
	70	30.9 ^(a)	33.7 ^(a)	47.0	55.2	33.9 ^(a)	38.1	51.0	57.7	37.7	42.8	55.3	60.4
	75	32.9 ^(a)	38.3	49.2	57.8	34.2 ^(a)	38.7	51.2	58.1	38.0	43.1	55.4	60.6
2400	60	33.1 ^(a)	34.9 ^(a)	47.3	55.2	36.5	39.7	51.5	58.0	40.3	44.8	55.9	60.9
	65	33.4 ^(a)	35.3	47.5	55.4	36.7	40.1	51.7	58.2	40.5	44.8	56.1	60.9
	70	34.3 ^(a)	37.8	48.3	56.7	37.1	40.4	52.0	58.3	40.8	45.2	56.2	61.1
	75	37.3	42.4	51.7	59.3	37.8	42.5	52.6	59.4	41.2	45.4	56.5	61.2
2800	60	35.3	36.7	48.0	55.4	38.8	41.4	52.2	58.2	42.6	46.4	56.5	61.2
	65	35.9	37.2	48.4	55.7	39.2	41.9	52.5	58.5	42.8	46.5	56.7	61.2
	70	38.0	41.0	50.4	57.8	39.6	42.3	52.8	58.7	43.2	47.0	57.0	61.4
	75	40.8	45.7	53.7	60.6	40.6	45.9	53.6	60.6	43.6	47.4	57.2	61.6



Reheat Temperature Rise

Table 17. Reheat temperature rise — 10 tons (continued)

Airflow (cfm)	Ent DB (°F)	Entering Wet Bulb (°F)											
		51				55				59			
		Lvg Evap DB (°F)		Lvg Reheat DB (°F)		Lvg Evap DB (°F)		Lvg Reheat DB (°F)		Lvg Evap DB (°F)		Lvg Reheat DB (°F)	
		MIN	MAX	MIN	MAX	MIN	MAX	MIN	MAX	MIN	MAX	MIN	MAX
3200	60	37.2	38.2	48.6	55.6	40.7	42.8	52.8	58.4	44.6	47.7	57.1	61.3
	65	38.1	39.2	49.3	56.1	41.1	43.3	53.1	58.7	44.6	47.8	57.2	61.4
	70	40.8	43.6	52.0	58.7	41.7	44.4	53.5	59.2	45.1	48.4	57.5	61.7
	75	43.7	48.5	55.4	61.6	43.8	48.6	55.5	61.6	45.6	49.4	57.8	62.2
3600	60	38.7	39.5	49.0	55.6	42.1	43.9	53.2	58.5	46.0	48.7	57.5	61.4
	65	39.8	40.7	49.9	56.3	42.7	44.6	53.6	58.8	46.1	49.0	57.5	61.5
	70	43.0	45.9	53.3	59.4	43.6	45.8	54.3	59.4	46.7	49.6	57.9	61.9
	75	46.1	50.9	56.8	62.4	46.2	51.0	56.9	62.5	47.6	50.8	58.6	62.5
4000	60	40.0	40.5	49.4	55.7	43.3	44.9	53.5	58.5	47.2	49.6	57.7	61.4
	65	41.3	42.6	50.5	56.8	44.0	45.6	53.9	58.9	47.4	50.0	57.9	61.7
	70	44.9	47.8	54.4	60.0	45.1	47.9	54.8	60.1	48.0	50.6	58.3	62.0
	75	48.2	52.9	58.0	63.2	48.3	53.0	58.1	63.2	49.1	53.1	59.1	63.3
4400	60	41.1	41.4	49.8	55.6	44.4	45.8	53.7	58.6	48.2	50.1	58.0	61.3
	65	43.2	44.3	51.6	57.3	45.1	46.5	54.3	58.9	48.5	50.8	58.2	61.7
	70	46.5	49.4	55.3	60.6	46.4	49.5	55.3	60.7	49.1	51.5	58.6	62.1
	75	50.0	54.6	59.0	63.8	50.1	54.7	59.1	63.9	50.4	54.8	59.5	64.0
4800	60	42.0	42.2	50.0	55.6	45.4	46.5	54.0	58.6	49.0	50.7	58.1	61.3
	65	44.6	45.6	52.4	57.7	46.0	47.4	54.5	59.1	49.4	51.5	58.4	61.8
	70	48.0	50.8	56.2	61.1	48.0	50.9	56.2	61.1	50.1	52.6	58.9	62.3
	75	51.6	56.1	59.9	64.4	51.7	56.2	60.0	64.5	51.6	56.3	59.9	64.5
Ambient DB 70°F													
2000	60	30.3 ^(a)	31.8 ^(a)	46.8	56.8	34.0 ^(a)	36.7	51.5	59.6	37.5	41.7	55.9	62.4
	65	30.6 ^(a)	32.1 ^(a)	47.0	56.9	34.0 ^(a)	36.9	51.5	59.7	37.7	41.9	56.1	62.5
	70	31.2 ^(a)	32.8 ^(a)	47.4	57.3	34.3 ^(a)	37.2	51.7	59.8	37.8	42.1	56.1	62.6
	75	33.4 ^(a)	37.0	49.9	59.6	34.5 ^(a)	37.9	51.8	60.2	38.0	42.4	56.2	62.8
2400	60	33.3 ^(a)	34.0 ^(a)	47.7	57.1	36.8	38.9	52.2	60.0	40.5	44.1	56.7	63.0
	65	33.6 ^(a)	34.4 ^(a)	47.9	57.3	37.1	39.2	52.4	60.2	40.7	44.0	56.8	63.0
	70	34.5 ^(a)	36.4	48.7	58.3	37.5	39.6	52.6	60.4	40.9	44.4	57.0	63.1
	75	37.8	41.0	52.5	61.0	38.2	40.6	53.3	60.9	41.3	44.8	57.2	63.3
2800	60	35.5	35.8	48.3	57.2	39.1	40.6	52.8	60.2	42.8	45.7	57.2	63.2
	65	36.1	36.4	48.7	57.5	39.5	41.0	53.1	60.4	43.0	45.7	57.4	63.2
	70	38.2	39.5	50.8	59.3	39.9	41.5	53.4	60.7	43.4	46.2	57.7	63.4
	75	41.3	44.3	54.5	62.1	41.0	44.4	54.3	62.2	43.8	46.7	57.9	63.7
3200	60	37.4	37.4	48.9	57.1	40.9	41.9	53.3	60.3	44.8	46.9	57.8	63.3
	65	38.3	38.3	49.6	57.6	41.4	42.5	53.6	60.5	44.9	47.1	57.9	63.3
	70	41.0	42.1	52.4	60.1	41.9	43.4	54.0	61.0	45.3	47.6	58.2	63.6
	75	44.2	47.0	56.2	63.0	44.3	47.1	56.3	63.1	45.8	48.6	58.5	64.1
3600	60	38.9	38.8	49.3	56.8	42.4	43.1	53.6	60.3	46.2	48.0	58.1	63.3
	65	40.0	39.9	50.2	57.6	42.9	43.7	54.0	60.6	46.3	48.2	58.2	63.4
	70	43.3	44.3	53.8	60.7	43.9	44.9	54.8	61.2	46.9	48.8	58.6	63.7
	75	46.6	49.3	57.6	63.8	46.7	49.5	57.7	63.9	47.8	50.0	59.3	64.3

Table 17. Reheat temperature rise — 10 tons (continued)

Airflow (cfm)	Ent DB (°F)	Entering Wet Bulb (°F)											
		51				55				59			
		Lvg Evap DB (°F)		Lvg Reheat DB (°F)		Lvg Evap DB (°F)		Lvg Reheat DB (°F)		Lvg Evap DB (°F)		Lvg Reheat DB (°F)	
		MIN	MAX	MIN	MAX	MIN	MAX	MIN	MAX	MIN	MAX	MIN	MAX
4000	60	40.2	40.0	49.7	56.6	43.6	44.1	53.9	60.2	47.4	48.8	58.3	63.2
	65	41.5	41.3	50.8	57.5	44.2	44.8	54.4	60.6	47.6	49.3	58.5	63.4
	70	45.2	46.3	54.9	61.3	45.4	46.1	55.3	61.3	48.2	49.9	58.9	63.8
	75	48.6	51.3	58.7	64.5	48.7	51.5	58.8	64.5	49.3	51.2	59.8	64.5
4400	60	41.2	41.0	50.0	56.4	44.6	45.0	54.1	60.2	48.4	49.6	58.5	63.1
	65	43.4	43.2	51.9	58.0	45.3	45.7	54.7	60.5	48.7	50.1	58.7	63.4
	70	46.9	47.9	55.9	61.8	46.7	48.0	55.8	61.8	49.3	50.7	59.2	63.8
	75	50.3	53.1	59.7	65.0	50.4	53.2	59.7	65.1	50.6	53.3	60.2	65.2
4800	60	42.2	41.9	50.3	56.2	45.5	45.7	54.4	60.1	49.2	50.1	58.7	63.0
	65	44.8	44.6	52.7	58.4	46.2	46.5	54.9	60.5	49.6	50.8	58.9	63.4
	70	48.4	49.4	56.8	62.2	48.5	49.5	56.8	62.2	50.3	51.7	59.4	63.9
	75	51.8	54.6	60.5	65.6	51.9	54.7	60.6	65.6	51.7	54.8	60.5	65.7

Note: MIN, MAX: The leaving evaporator temperature is affected by the modulating valve position. The MIN and MAX numbers represent modulating valve position impact on both the leaving evaporator temperature and the leaving reheat coil temperature. MAX represents wide open, MIN represents closed to minimum position.

(a) The unit might be tripped by Froststat at these conditions due to low leaving evaporator air temperature.

Table 18. Reheat temperature rise — 12.5 tons

Airflow (cfm)	Ent DB (°F)	Entering Wet Bulb (°F)											
		51				55				59			
		Lvg Evap DB (°F)		Lvg Reheat DB (°F)		Lvg Evap DB (°F)		Lvg Reheat DB (°F)		Lvg Evap DB (°F)		Lvg Reheat DB (°F)	
		MIN	MAX	MIN	MAX	MIN	MAX	MIN	MAX	MIN	MAX	MIN	MAX
Ambient DB 60°F													
2500	60	29.7 ^(a)	32.1 ^(a)	45.5	54.3	33.2 ^(a)	36.9	49.9	57.3	36.9	41.8	54.4	60.4
	65	30.0 ^(a)	32.4 ^(a)	45.7	54.5	33.3 ^(a)	37.1	50.0	57.4	37.1	42.0	54.6	60.5
	70	30.5 ^(a)	33.2 ^(a)	46.1	54.8	33.6 ^(a)	37.5	50.2	57.6	37.2	42.2	54.6	60.6
	75	32.5 ^(a)	37.4	48.3	57.3	33.9 ^(a)	38.2	50.4	57.9	37.4	42.6	54.8	60.7
3000	60	32.7 ^(a)	34.4 ^(a)	46.6	54.7	36.2	39.1	50.9	57.8	39.9	44.2	55.4	61.0
	65	33.1 ^(a)	34.8 ^(a)	46.9	54.9	36.4	39.6	51.1	58.0	40.1	44.2	55.5	61.0
	70	34.0 ^(a)	37.0	47.6	56.1	36.8	40.0	51.4	58.2	40.3	44.6	55.7	61.2
	75	37.0	41.5	51.0	58.9	37.6	41.0	52.0	58.7	40.7	45.0	56.0	61.4
3500	60	35.1	36.2	47.4	55.0	38.6	40.9	51.8	58.1	42.2	45.9	56.0	61.3
	65	35.6	36.9	47.8	55.3	39.0	41.4	52.0	58.3	42.4	45.9	56.3	61.3
	70	37.6	40.2	49.6	57.2	39.4	41.9	52.3	58.6	42.8	46.5	56.5	61.6
	75	40.5	44.8	53.0	60.2	40.4	45.0	53.2	60.3	43.3	47.0	56.9	61.8
4000	60	37.0	37.7	48.1	55.1	40.5	42.2	52.4	58.2	44.3	47.1	56.8	61.4
	65	37.9	38.8	48.8	55.7	40.9	42.9	52.7	58.5	44.3	47.3	56.8	61.5
	70	40.4	42.8	51.4	58.2	41.5	43.9	53.1	59.1	44.8	47.9	57.2	61.8
	75	43.4	47.6	54.7	61.3	43.4	47.7	54.8	61.4	45.3	49.0	57.5	62.3
4500	60	38.5	39.0	48.6	55.2	41.9	43.4	52.8	58.3	45.7	48.2	57.1	61.5
	65	39.7	40.4	49.5	55.9	42.5	44.1	53.3	58.7	45.8	48.5	57.2	61.6
	70	42.8	45.1	52.8	59.0	43.5	45.4	54.0	59.3	46.4	49.2	57.7	62.0
	75	45.8	50.0	56.2	62.2	45.9	50.1	56.3	62.3	47.1	50.4	58.2	62.6



Reheat Temperature Rise

Table 18. Reheat temperature rise — 12.5 tons (continued)

Airflow (cfm)	Ent DB (°F)	Entering Wet Bulb (°F)											
		51				55				59			
		Lvg Evap DB (°F)		Lvg Reheat DB (°F)		Lvg Evap DB (°F)		Lvg Reheat DB (°F)		Lvg Evap DB (°F)		Lvg Reheat DB (°F)	
		MIN	MAX	MIN	MAX	MIN	MAX	MIN	MAX	MIN	MAX	MIN	MAX
5000	60	39.8	40.2	49.1	55.2	43.2	44.4	53.1	58.4	46.9	49.1	57.4	61.5
	65	41.2	41.7	50.2	56.0	43.8	45.2	53.7	58.8	47.1	49.5	57.6	61.8
	70	44.7	47.0	54.0	59.6	45.0	46.7	54.6	59.5	47.8	50.2	58.1	62.1
	75	47.9	52.0	57.5	63.0	48.0	52.1	57.6	63.0	48.8	51.7	58.9	62.9
5500	60	40.9	41.1	49.5	55.2	44.2	45.3	53.4	58.4	47.9	49.8	57.7	61.5
	65	42.7	43.7	50.9	56.7	45.0	46.1	54.0	58.8	48.2	50.4	57.9	61.9
	70	46.4	48.7	54.9	60.2	46.3	48.8	55.1	60.3	48.9	51.1	58.4	62.2
	75	49.6	53.7	58.6	63.7	49.7	53.8	58.6	63.7	50.2	53.9	59.4	63.8
6000	60	41.9	42.0	49.8	55.2	45.2	46.1	53.7	58.4	48.7	50.3	57.9	61.4
	65	44.3	45.0	52.0	57.1	45.9	46.9	54.3	58.9	49.2	51.1	58.2	61.9
	70	47.8	50.1	55.8	60.8	47.4	50.2	55.5	60.8	49.9	52.1	58.7	62.4
	75	51.2	55.2	59.5	64.3	51.3	55.3	59.6	64.3	51.3	55.4	59.9	64.4
Ambient DB 65°F													
2500	60	30.2 ^(a)	31.3 ^(a)	46.1	56.2	33.8 ^(a)	36.2	50.8	59.4	37.3	41.2	55.2	62.5
	65	30.5 ^(a)	31.7 ^(a)	46.3	56.4	33.9 ^(a)	36.4	50.8	59.5	37.6	41.4	55.5	62.6
	70	31.1 ^(a)	32.4 ^(a)	46.8	56.8	34.2 ^(a)	36.8	51.0	59.6	37.6	41.6	55.5	62.7
	75	33.2 ^(a)	36.2	49.1	59.1	34.5 ^(a)	37.4	51.2	60.0	37.9	42.0	55.6	62.8
3000	60	33.2 ^(a)	33.6 ^(a)	47.1	56.5	36.7	38.4	51.6	59.7	40.4	43.6	56.2	63.0
	65	33.6 ^(a)	34.0 ^(a)	47.4	56.7	37.0	38.8	51.8	59.9	40.6	43.6	56.4	63.0
	70	34.5 ^(a)	35.2	48.2	57.3	37.4	39.2	52.1	60.1	40.8	44.0	56.5	63.2
	75	37.7	40.3	51.8	60.5	38.2	40.2	52.8	60.6	41.2	44.4	56.8	63.4
3500	60	35.5	35.5	47.9	56.5	39.0	40.1	52.3	59.9	42.7	45.2	56.8	63.2
	65	35.9	36.1	48.2	56.8	39.4	40.6	52.6	60.1	43.0	45.3	57.1	63.2
	70	38.2	38.9	50.3	58.6	39.9	41.1	52.9	60.4	43.4	45.8	57.3	63.5
	75	41.2	43.6	53.9	61.7	41.0	43.7	53.9	61.8	43.8	46.3	57.6	63.7
4000	60	37.3	37.1	48.5	56.4	40.8	41.5	52.8	59.9	44.7	46.5	57.5	63.2
	65	38.2	38.1	49.2	57.0	41.3	42.1	53.2	60.2	44.8	46.6	57.6	63.3
	70	40.9	41.6	52.0	59.4	41.8	43.1	53.6	60.7	45.3	47.3	57.9	63.6
	75	44.1	46.3	55.7	62.6	44.2	46.5	55.8	62.7	45.8	48.2	58.3	64.1
4500	60	38.9	38.5	49.0	56.2	42.2	42.7	53.2	59.9	46.1	47.6	57.8	63.2
	65	40.0	39.7	49.9	57.0	42.8	43.4	53.7	60.3	46.3	47.8	57.9	63.3
	70	43.2	43.8	53.3	60.1	43.9	44.6	54.5	60.9	46.9	48.5	58.4	63.7
	75	46.5	48.7	57.1	63.5	46.6	48.8	57.2	63.5	47.8	49.7	59.0	64.3
5000	60	40.1	39.8	49.4	56.0	43.5	43.7	53.5	59.8	47.3	48.4	58.1	63.2
	65	41.5	41.2	50.5	57.0	44.1	44.5	54.1	60.3	47.5	48.8	58.2	63.4
	70	45.2	45.7	54.5	60.7	45.4	45.9	55.0	61.0	48.2	49.5	58.7	63.8
	75	48.5	50.7	58.3	64.2	48.6	50.8	58.4	64.2	49.3	50.9	59.6	64.5
5500	60	41.2	40.8	49.8	55.9	44.5	44.6	53.8	59.7	48.3	49.2	58.3	63.1
	65	43.3	42.8	51.6	57.3	45.2	45.4	54.4	60.2	48.7	49.7	58.5	63.4
	70	46.8	47.4	55.5	61.3	46.7	47.3	55.5	61.2	49.3	50.4	59.0	63.8
	75	50.3	52.4	59.4	64.8	50.4	52.5	59.5	64.8	50.6	52.0	60.0	64.6

Table 18. Reheat temperature rise — 12.5 tons (continued)

Airflow (cfm)	Ent DB (°F)	Entering Wet Bulb (°F)											
		51				55				59			
		Lvg Evap DB (°F)		Lvg Reheat DB (°F)		Lvg Evap DB (°F)		Lvg Reheat DB (°F)		Lvg Evap DB (°F)		Lvg Reheat DB (°F)	
		MIN	MAX	MIN	MAX	MIN	MAX	MIN	MAX	MIN	MAX	MIN	MAX
6000	60	42.1	41.8	50.1	55.7	45.5	45.5	54.1	59.7	49.1	49.8	58.4	63.0
	65	44.7	44.3	52.4	57.8	46.2	46.3	54.6	60.2	49.6	50.4	58.7	63.4
	70	48.3	48.9	56.4	61.7	48.1	49.0	56.3	61.8	50.3	51.3	59.3	63.8
	75	51.8	53.9	60.3	65.3	51.9	54.0	60.4	65.4	51.8	54.1	60.4	65.4
Ambient DB 70°F													
2500	60	30.6 ^(a)	30.6 ^(a)	46.7	57.8	34.3 ^(a)	35.5	51.4	61.4	37.9	40.6	56.2	64.6
	65	31.0 ^(a)	31.0 ^(a)	46.9	58.0	34.3 ^(a)	35.7	51.4	61.5	38.1	40.8	56.3	64.7
	70	31.6 ^(a)	31.7 ^(a)	47.4	58.4	34.6 ^(a)	36.0	51.6	61.6	38.3	41.0	56.4	64.8
	75	33.8 ^(a)	35.0	50.0	60.7	34.9 ^(a)	36.6	51.8	61.9	38.5	41.3	56.6	64.9
3000	60	33.6 ^(a)	33.2 ^(a)	47.6	57.4	37.1	37.7	52.2	61.5	40.9	42.6	56.9	64.8
	65	34.0 ^(a)	33.6 ^(a)	47.9	57.7	37.4	38.0	52.4	61.7	41.1	42.9	57.1	65.0
	70	34.9 ^(a)	34.6 ^(a)	48.7	58.4	37.8	38.4	52.7	61.9	41.3	43.3	57.3	65.1
	75	38.2	39.0	52.5	62.0	38.6	39.4	53.3	62.5	41.8	43.7	57.6	65.3
3500	60	35.8	35.3	48.3	57.1	39.4	39.4	52.8	61.5	43.4	44.6	57.7	65.0
	65	36.4	35.8	48.7	57.4	39.8	39.9	53.1	61.7	43.4	44.6	57.7	65.1
	70	38.7	38.2	50.9	59.4	40.2	40.4	53.4	62.0	43.8	45.1	57.9	65.3
	75	41.7	42.3	54.6	63.0	41.4	41.9	54.5	62.9	44.2	45.6	58.3	65.5
4000	60	37.7	37.1	48.9	56.8	41.1	40.9	53.2	61.3	45.1	45.6	58.0	64.8
	65	38.6	38.0	49.6	57.4	41.6	41.5	53.6	61.6	45.2	46.0	58.1	65.1
	70	41.4	40.9	52.6	60.2	42.2	42.2	54.0	62.1	45.7	46.6	58.4	65.4
	75	44.6	45.1	56.3	63.9	44.7	45.2	56.4	64.0	46.2	47.3	58.8	65.8
4500	60	39.2	38.6	49.4	56.5	42.6	42.2	53.6	61.1	46.5	46.9	58.3	64.9
	65	40.3	39.8	50.3	57.3	43.2	42.8	54.1	61.5	46.6	47.1	58.4	65.0
	70	43.7	43.1	53.9	60.8	44.2	44.0	54.9	62.1	47.2	47.8	58.8	65.4
	75	47.0	47.4	57.7	64.6	47.1	47.5	57.8	64.7	48.2	49.0	59.6	65.9
5000	60	40.4	39.9	49.8	56.3	43.8	43.3	53.9	60.8	47.6	47.8	58.5	64.7
	65	41.8	41.2	50.9	57.2	44.5	44.0	54.4	61.2	47.8	48.1	58.6	64.9
	70	45.6	45.0	55.0	61.4	45.7	45.4	55.4	62.1	48.5	48.9	59.2	65.3
	75	49.0	49.4	58.9	65.2	49.1	49.6	59.0	65.3	49.7	50.2	60.1	66.0
5500	60	41.5	41.0	50.1	56.2	44.8	44.3	54.1	60.5	48.5	48.6	58.6	64.6
	65	43.7	42.9	52.0	57.6	45.5	45.1	54.7	61.0	49.0	49.1	58.9	64.8
	70	47.3	46.7	56.0	61.9	47.0	46.6	55.9	62.0	49.6	49.8	59.4	65.3
	75	50.7	51.2	60.0	65.8	50.8	51.3	60.1	65.9	51.0	51.4	60.5	66.1
6000	60	42.4	42.0	50.3	56.0	45.7	45.3	54.4	60.4	49.3	49.3	58.7	64.4
	65	45.1	44.4	52.8	58.1	46.5	46.0	54.9	60.9	49.8	49.9	59.1	64.7
	70	48.7	48.1	56.9	62.3	48.8	48.1	57.0	62.4	50.6	50.6	59.6	65.2
	75	52.3	52.7	60.9	66.3	52.3	52.8	61.0	66.3	52.1	52.8	60.9	66.4

Note: MIN, MAX: The leaving evaporator temperature is affected by the modulating valve position. The MIN and MAX numbers represent modulating valve position impact on both the leaving evaporator temperature and the leaving reheat coil temperature. MAX represents wide open, MIN represents closed to minimum position.

^(a) The unit might be tripped by Froststat at these conditions due to low leaving evaporator air temperature.



Reheat Temperature Rise

Table 19. Reheat temperature rise — 15 tons

Airflow (cfm)	Ent DB (°F)	Entering Wet Bulb (°F)											
		51				55				59			
		Lvg Evap DB (°F)		Lvg Reheat DB (°F)		Lvg Evap DB (°F)		Lvg Reheat DB (°F)		Lvg Evap DB (°F)		Lvg Reheat DB (°F)	
		MIN	MAX	MIN	MAX	MIN	MAX	MIN	MAX	MIN	MAX	MIN	MAX
Ambient DB 60°F													
3000	60	30.9 ^(a)	31.2 ^(a)	39.8	63.0	34.9 ^(a)	36.7	44.6	66.2	38.9	42.4	49.3	69.5
	65	31.1 ^(a)	31.4 ^(a)	40.0	63.1	34.8 ^(a)	36.8	44.5	66.3	39.1	42.3	49.5	69.4
	70	31.4 ^(a)	31.8 ^(a)	40.3	63.3	35.0	37.0	44.5	66.3	39.0	42.4	49.3	69.4
	75	33.9 ^(a)	36.4	43.2	65.8	35.2	37.4	44.7	66.5	39.1	42.6	49.4	69.5
3600	60	34.0 ^(a)	33.4 ^(a)	41.7	62.4	37.9	38.7	46.4	65.7	42.0	44.4	51.2	69.0
	65	34.1 ^(a)	33.6 ^(a)	41.9	62.5	38.0	39.0	46.4	65.8	42.1	44.2	51.2	68.9
	70	35.5	35.3	43.3	63.3	38.2	39.2	46.6	65.9	42.1	44.5	51.2	69.1
	75	38.6	40.4	46.9	66.4	38.7	40.5	47.1	66.4	42.3	44.7	51.3	69.1
4200	60	36.3	35.2	43.2	61.7	40.2	40.3	47.8	65.2	44.5	45.8	52.6	68.5
	65	36.6	35.5	43.5	61.9	40.4	40.7	47.9	65.3	44.4	45.8	52.5	68.5
	70	39.1	38.5	46.1	63.6	40.6	41.0	48.1	65.5	44.6	46.1	52.6	68.7
	75	42.3	43.8	49.8	66.9	42.4	43.9	49.9	67.0	44.8	46.4	52.8	68.7
4800	60	38.1	36.7	44.4	61.1	42.0	41.7	48.8	64.7	46.2	47.0	53.6	68.1
	65	38.7	37.4	44.9	61.5	42.3	42.1	49.0	64.9	46.2	47.0	53.5	68.1
	70	41.9	41.2	48.4	63.9	42.8	42.7	49.5	65.2	46.4	47.5	53.7	68.3
	75	45.3	46.6	52.2	67.4	45.4	46.7	52.3	67.5	46.7	48.1	53.9	68.5
5400	60	39.6	38.0	45.3	60.6	43.4	42.8	49.6	64.3	47.6	48.0	54.3	67.7
	65	40.5	38.9	46.1	61.0	43.8	43.3	49.9	64.5	47.6	48.1	54.2	67.8
	70	44.3	43.5	50.2	64.3	44.5	44.1	50.5	64.8	47.9	48.6	54.5	68.0
	75	47.8	48.9	54.1	67.8	47.9	49.1	54.2	67.9	48.6	49.4	55.1	68.3
6000	60	40.8	39.2	46.0	60.1	44.6	43.7	50.2	63.9	48.7	48.9	54.9	67.3
	65	42.7	40.2	47.8	60.6	45.0	44.3	50.6	64.1	48.8	49.1	54.8	67.5
	70	46.3	45.5	51.8	64.5	46.3	45.3	51.8	64.5	49.2	49.5	55.2	67.7
	75	49.9	51.0	55.8	68.2	50.0	51.1	55.8	68.3	50.0	50.5	55.9	68.0
6600	60	41.8	40.2	46.6	59.7	45.6	44.7	50.8	63.6	49.7	49.6	55.3	67.0
	65	44.3	41.3	49.1	60.3	46.0	45.2	51.2	63.8	49.8	49.9	55.4	67.2
	70	48.0	47.2	53.1	64.8	48.1	47.3	53.2	64.9	50.2	50.3	55.7	67.4
	75	51.7	52.7	57.1	68.5	51.8	52.8	57.2	68.6	51.9	53.0	57.3	68.7
7200	60	42.7	41.1	47.1	59.3	46.5	45.4	51.2	63.2	50.4	50.2	55.7	66.6
	65	45.7	43.6	50.2	61.0	46.9	45.9	51.6	63.5	50.7	50.6	55.8	66.9
	70	49.5	48.7	54.3	65.0	49.6	48.8	54.4	65.1	51.1	51.0	56.2	67.1
	75	53.3	54.3	58.3	68.9	53.3	54.4	58.4	68.9	53.4	54.5	58.5	69.0
Ambient DB 65°F													
3000	60	31.6 ^(a)	29.9 ^(a)	40.6	64.8	35.7	35.6	45.5	68.4	39.8	41.1	50.4	71.5
	65	31.7 ^(a)	30.1 ^(a)	40.7	64.9	35.6	35.5	45.3	68.3	39.8	41.2	50.4	71.6
	70	32.1 ^(a)	30.5 ^(a)	41.1	65.0	35.7	35.7	45.4	68.4	39.8	41.2	50.3	71.6
	75	35.0	34.1 ^(a)	44.4	67.3	36.0	35.9	45.6	68.5	39.9	41.5	50.4	71.6
3600	60	34.6 ^(a)	32.3 ^(a)	42.5	63.6	38.6	37.5	47.2	67.6	43.0	43.3	52.3	71.0
	65	34.8 ^(a)	32.5 ^(a)	42.6	63.7	38.8	37.7	47.2	67.7	42.9	43.2	52.1	71.0
	70	36.5	33.1 ^(a)	44.4	64.1	38.9	38.0	47.4	67.8	43.0	43.4	52.1	71.1
	75	39.7	38.2	48.1	67.7	39.6	38.6	48.1	68.0	43.1	43.6	52.3	71.1

Table 19. Reheat temperature rise — 15 tons (continued)

Airflow (cfm)	Ent DB (°F)	Entering Wet Bulb (°F)											
		51				55				59			
		Lvg Evap DB (°F)		Lvg Reheat DB (°F)		Lvg Evap DB (°F)		Lvg Reheat DB (°F)		Lvg Evap DB (°F)		Lvg Reheat DB (°F)	
		MIN	MAX	MIN	MAX	MIN	MAX	MIN	MAX	MIN	MAX	MIN	MAX
4200	60	36.9	34.4 ^(a)	43.9	62.6	40.9	39.3	48.5	66.9	45.3	44.8	53.5	70.4
	65	37.3	34.7 ^(a)	44.3	62.7	41.1	39.6	48.6	67.0	45.2	44.8	53.4	70.4
	70	40.0	36.7	47.2	64.3	41.3	39.8	48.9	67.1	45.3	45.1	53.5	70.6
	75	43.5	41.7	51.1	68.0	43.5	41.8	51.2	68.1	45.5	45.3	53.7	70.6
4800	60	38.7	36.3	45.0	61.8	42.6	40.7	49.5	66.2	47.0	46.1	54.4	69.9
	65	39.4	36.8	45.6	62.1	42.9	41.1	49.7	66.4	46.9	46.1	54.3	69.9
	70	42.9	39.6	49.5	64.7	43.5	41.5	50.2	66.6	47.2	46.5	54.5	70.1
	75	46.5	44.5	53.5	68.4	46.6	44.7	53.5	68.5	47.7	46.8	54.9	70.2
5400	60	40.2	37.8	45.8	61.1	44.0	42.0	50.2	65.7	48.3	47.2	55.1	69.4
	65	41.5	38.5	47.2	61.5	44.4	42.4	50.5	65.9	48.3	47.2	54.9	69.4
	70	45.3	42.0	51.3	65.0	45.2	43.2	51.3	66.2	48.6	47.6	55.3	69.6
	75	49.0	47.0	55.4	68.8	49.1	47.1	55.5	68.8	49.3	48.4	55.9	69.9
6000	60	41.3	39.1	46.5	60.4	45.2	43.0	50.8	65.2	49.4	48.0	55.6	68.9
	65	43.5	40.0	48.7	61.0	45.6	43.5	51.2	65.4	49.5	48.1	55.5	69.0
	70	47.3	44.1	52.9	65.3	47.4	44.5	53.0	65.8	49.8	48.6	55.9	69.2
	75	51.1	49.1	57.0	69.1	51.1	49.2	57.1	69.1	51.1	49.6	57.1	69.6
6600	60	42.3	40.2	47.1	59.9	46.1	43.9	51.3	64.6	50.3	48.8	56.0	68.5
	65	45.1	41.2	50.0	60.6	46.6	44.5	51.7	65.0	50.4	49.1	56.0	68.7
	70	49.0	45.8	54.2	65.5	49.1	45.6	54.3	65.5	50.8	49.5	56.4	68.9
	75	52.8	50.9	58.4	69.4	52.9	51.0	58.5	69.4	53.0	50.6	58.5	69.3
7200	60	43.4	41.1	47.8	59.5	47.0	44.9	51.7	64.2	50.9	49.5	56.2	68.1
	65	46.5	43.2	51.0	61.3	47.6	45.3	52.4	64.5	51.2	49.8	56.4	68.3
	70	50.5	47.4	55.3	65.8	50.5	47.5	55.4	65.8	51.9	50.3	57.0	68.5
	75	54.4	52.5	59.5	69.6	54.4	52.6	59.6	69.7	54.5	52.7	59.7	69.8
Ambient DB 70°F													
3000	60	32.3 ^(a)	29.2 ^(a)	41.4	65.3	36.5	34.3 ^(a)	46.4	70.3	40.7	40.0	51.5	73.7
	65	32.4 ^(a)	29.4 ^(a)	41.5	65.4	36.4	34.2 ^(a)	46.3	70.2	40.7	40.0	51.4	73.7
	70	32.8 ^(a)	29.7 ^(a)	41.9	65.6	36.6	34.4 ^(a)	46.3	70.3	40.7	40.1	51.4	73.7
	75	36.1	32.0 ^(a)	45.7	68.1	36.9	34.6 ^(a)	46.7	70.3	40.9	40.3	51.4	73.8
3600	60	35.3	32.1 ^(a)	43.2	63.9	39.4	36.5	48.1	69.1	43.9	42.0	53.3	72.9
	65	35.5	32.3 ^(a)	43.4	64.0	39.5	36.6	48.1	69.2	43.8	42.1	53.2	72.9
	70	37.5	32.8 ^(a)	45.6	64.5	39.7	36.9	48.2	69.3	43.8	42.3	53.1	73.0
	75	40.9	36.5	49.5	68.5	41.0	37.4	49.6	69.6	44.0	42.5	53.3	73.1
4200	60	37.6	34.4 ^(a)	44.6	62.9	41.6	38.5	49.3	68.2	46.1	43.9	54.5	72.3
	65	38.0	34.7 ^(a)	45.0	63.0	41.8	38.8	49.4	68.3	46.0	43.8	54.3	72.2
	70	41.1	36.4	48.4	64.6	42.2	39.0	49.8	68.4	46.2	44.1	54.4	72.4
	75	44.7	40.1	52.5	68.9	44.8	39.8	52.6	68.9	46.4	44.3	54.6	72.5
4800	60	39.3	36.3	45.6	62.0	43.3	40.1	50.2	67.3	47.7	45.3	55.3	71.6
	65	40.1	36.9	46.4	62.4	43.6	40.5	50.4	67.4	47.6	45.2	55.1	71.6
	70	44.0	39.3	50.7	65.0	44.2	40.9	51.0	67.6	47.9	45.6	55.3	71.8
	75	47.7	43.0	54.9	69.3	47.8	43.1	55.0	69.4	48.5	46.0	55.9	71.9



Reheat Temperature Rise

Table 19. Reheat temperature rise — 15 tons (continued)

Airflow (cfm)	Ent DB (°F)	Entering Wet Bulb (°F)											
		51				55				59			
		Lvg Evap DB (°F)		Lvg Reheat DB (°F)		Lvg Evap DB (°F)		Lvg Reheat DB (°F)		Lvg Evap DB (°F)		Lvg Reheat DB (°F)	
		MIN	MAX	MIN	MAX	MIN	MAX	MIN	MAX	MIN	MAX	MIN	MAX
5400	60	40.7	37.9	46.5	61.2	44.6	41.6	50.8	66.4	49.0	46.4	55.9	71.1
	65	42.5	38.6	48.2	61.7	45.0	42.0	51.2	66.6	49.0	46.4	55.6	71.1
	70	46.4	41.7	52.5	65.3	46.4	42.7	52.6	67.0	49.3	46.9	56.1	71.2
	75	50.2	45.5	56.8	69.6	50.3	45.6	56.9	69.7	50.2	47.6	56.9	71.5
6000	60	41.9	39.2	47.1	60.6	45.7	42.8	51.4	65.7	50.1	47.3	56.4	70.6
	65	44.4	40.1	49.7	61.2	46.2	43.3	51.8	65.9	50.1	47.4	56.2	70.6
	70	48.4	43.7	54.1	65.5	48.4	44.1	54.1	66.4	50.5	47.9	56.6	70.8
	75	52.3	47.6	58.4	69.9	52.4	47.7	58.5	70.0	52.5	48.8	58.6	71.2
6600	60	42.8	40.3	47.7	60.0	46.7	43.9	51.9	65.0	50.8	48.1	56.6	70.1
	65	46.0	41.4	50.9	60.7	47.1	44.4	52.3	65.3	51.0	48.4	56.6	70.1
	70	50.1	45.5	55.4	65.8	50.1	45.4	55.4	65.9	51.4	48.8	57.1	70.3
	75	54.1	49.4	59.7	70.2	54.1	49.5	59.8	70.3	54.2	49.8	59.9	70.8
7200	60	43.9	41.3	48.3	59.5	47.5	44.9	52.3	64.5	51.5	48.9	56.9	69.5
	65	47.4	43.5	52.0	61.5	48.2	45.3	53.0	64.8	51.8	49.2	57.0	69.6
	70	51.5	47.0	56.5	66.0	51.6	46.5	56.5	65.5	52.5	49.6	57.7	69.9
	75	55.5	51.0	60.9	70.5	55.6	51.1	60.9	70.6	55.7	50.8	61.0	70.5

Note: MIN, MAX: The leaving evaporator temperature is affected by the modulating valve position. The MIN and MAX numbers represent modulating valve position on both the leaving evaporator temperature and the leaving reheat coil temperature. MAX represents wide open, MIN represents closed to minimum position.

(a) The unit might be tripped by Froststat at these conditions due to low leaving evaporator air temperature.

Table 20. Reheat temperature rise — 17.5 tons

Airflow (cfm)	Ent DB (°F)	Entering Wet Bulb (°F)											
		51				55				59			
		Lvg Evap DB (°F)		Lvg Reheat DB (°F)		Lvg Evap DB (°F)		Lvg Reheat DB (°F)		Lvg Evap DB (°F)		Lvg Reheat DB (°F)	
		MIN	MAX	MIN	MAX	MIN	MAX	MIN	MAX	MIN	MAX	MIN	MAX
Ambient DB 60°F													
3500	60	30.0 ^(a)	31.4 ^(a)	38.6	62.5	33.8 ^(a)	36.9	43.1	66.0	37.7	42.6	47.8	69.5
	65	30.1 ^(a)	31.6 ^(a)	38.7	62.6	33.8 ^(a)	37.0	43.1	66.0	37.9	42.5	47.9	69.4
	70	30.5 ^(a)	32.1 ^(a)	39.0	62.8	33.9 ^(a)	37.2	43.1	66.0	37.8	42.6	47.8	69.4
	75	32.6 ^(a)	36.9	41.4	65.6	34.0 ^(a)	37.7	43.2	66.2	37.9	42.8	47.9	69.4
4200	60	33.0 ^(a)	33.5 ^(a)	40.5	62.0	36.8	38.9	45.0	65.6	40.8	44.5	49.7	69.1
	65	33.2 ^(a)	33.8 ^(a)	40.7	62.1	37.0	39.1	45.1	65.6	40.9	44.4	49.8	69.0
	70	34.0 ^(a)	35.7 ^(a)	41.5	63.0	37.2	39.4	45.3	65.7	41.0	44.6	49.9	69.1
	75	37.2	40.8	45.0	66.3	37.7	41.0	45.7	66.4	41.2	44.8	50.0	69.2
4900	60	35.3	35.3	42.1	61.6	39.2	40.5	46.5	65.1	43.4	45.9	51.3	68.7
	65	35.6	35.6	42.3	61.7	39.4	40.8	46.7	65.2	43.3	45.9	51.2	68.7
	70	37.7	38.8	44.4	63.5	39.6	41.1	46.8	65.4	43.5	46.2	51.3	68.8
	75	40.9	44.0	48.0	67.0	40.9	44.2	48.0	67.1	43.7	46.6	51.5	68.9
5600	60	37.2	36.8	43.3	61.1	41.0	41.7	47.6	64.7	45.2	47.1	52.4	68.3
	65	37.8	37.5	43.8	61.4	41.3	42.1	47.9	64.9	45.2	47.1	52.3	68.3
	70	40.6	41.5	46.7	63.9	41.7	42.9	48.2	65.2	45.4	47.5	52.5	68.4
	75	43.9	46.7	50.4	67.5	44.0	46.8	50.5	67.6	45.7	48.2	52.7	68.7

Table 20. Reheat temperature rise — 17.5 tons (continued)

Airflow (cfm)	Ent DB (°F)	Entering Wet Bulb (°F)											
		51				55				59			
		Lvg Evap DB (°F)		Lvg Reheat DB (°F)		Lvg Evap DB (°F)		Lvg Reheat DB (°F)		Lvg Evap DB (°F)		Lvg Reheat DB (°F)	
		MIN	MAX	MIN	MAX	MIN	MAX	MIN	MAX	MIN	MAX	MIN	MAX
6300	60	38.8	38.0	44.3	60.6	42.5	42.8	48.5	64.3	46.6	48.0	53.2	67.9
	65	39.6	39.0	45.0	61.0	42.8	43.3	48.8	64.5	46.6	48.1	53.2	67.9
	70	43.0	43.7	48.7	64.3	43.6	44.2	49.4	64.9	47.0	48.6	53.4	68.1
	75	46.4	49.0	52.4	68.0	46.5	49.1	52.5	68.1	47.6	49.5	54.0	68.5
7000	60	40.0	39.2	45.1	60.1	43.7	43.7	49.3	63.9	47.8	48.8	53.8	67.5
	65	41.2	40.3	46.2	60.7	44.1	44.3	49.6	64.2	47.9	49.0	53.9	67.6
	70	45.0	45.6	50.3	64.6	45.0	45.4	50.4	64.6	48.3	49.5	54.2	67.8
	75	48.5	51.0	54.1	68.4	48.6	51.1	54.2	68.5	49.1	50.6	54.9	68.3
7700	60	41.1	40.2	45.7	59.6	44.7	44.6	49.9	63.6	48.8	49.5	54.4	67.2
	65	43.1	42.1	47.7	60.8	45.2	45.1	50.2	63.8	48.9	49.8	54.5	67.3
	70	46.7	47.2	51.7	64.9	46.8	47.3	51.7	65.0	49.3	50.3	54.8	67.5
	75	50.3	52.7	55.6	68.8	50.4	52.8	55.6	68.8	50.4	52.9	55.7	68.9
8400	60	42.0	41.0	46.3	59.1	45.6	45.3	50.4	63.2	49.6	50.0	54.8	66.8
	65	44.5	43.5	48.9	61.0	46.1	45.9	50.7	63.5	49.8	50.4	55.0	67.0
	70	48.3	48.7	52.9	65.1	48.3	48.8	52.9	65.2	50.3	51.0	55.3	67.3
	75	51.9	54.2	56.8	69.1	52.0	54.3	56.9	69.2	52.1	54.4	57.0	69.2
Ambient DB 65°F													
3500	60	30.5 ^(a)	30.2 ^(a)	39.1	64.6	34.4 ^(a)	35.8	43.7	68.2	38.4	41.4	48.5	71.6
	65	30.6 ^(a)	30.4 ^(a)	39.2	64.7	34.4 ^(a)	35.8	43.7	68.2	38.4	41.4	48.5	71.6
	70	31.0 ^(a)	30.8 ^(a)	39.5	64.9	34.5 ^(a)	36.0	43.8	68.2	38.5	41.5	48.5	71.7
	75	33.3 ^(a)	34.7 ^(a)	42.2	67.2	34.6 ^(a)	36.1	43.8	68.3	38.6	41.7	48.6	71.7
4200	60	33.4 ^(a)	32.4 ^(a)	41.0	63.6	37.4	37.8	45.6	67.6	41.4	43.5	50.4	71.2
	65	33.7 ^(a)	32.6 ^(a)	41.2	63.7	37.5	38.0	45.7	67.6	41.5	43.4	50.4	71.1
	70	34.5 ^(a)	33.3 ^(a)	42.0	64.2	37.7	38.2	45.8	67.7	41.6	43.6	50.5	71.2
	75	37.9	38.7	45.9	67.8	38.3	38.9	46.4	68.0	41.8	43.8	50.6	71.3
4900	60	35.8	34.4 ^(a)	42.6	62.6	39.7	39.4	47.0	67.0	43.9	45.0	51.9	70.7
	65	36.1	34.7 ^(a)	42.8	62.7	39.9	39.7	47.2	67.1	43.9	44.9	51.9	70.6
	70	38.4	36.9	45.2	64.5	40.1	40.0	47.4	67.2	44.1	45.2	52.0	70.7
	75	41.6	42.0	48.8	68.2	41.7	42.2	48.9	68.3	44.3	45.5	52.1	70.8
5600	60	37.7	36.2	43.7	61.7	41.5	40.8	48.1	66.4	45.7	46.2	52.9	70.1
	65	38.3	36.7	44.3	62.0	41.8	41.1	48.4	66.5	45.7	46.2	52.9	70.1
	70	41.3	39.7	47.5	64.7	42.3	41.7	48.8	66.7	46.0	46.6	53.1	70.3
	75	44.6	44.8	51.2	68.6	44.7	45.0	51.3	68.7	46.3	46.9	53.3	70.4
6300	60	39.2	37.7	44.7	60.9	42.9	42.0	49.0	65.7	47.1	47.2	53.8	69.6
	65	40.0	38.5	45.4	61.4	43.3	42.4	49.3	65.9	47.2	47.3	53.7	69.6
	70	43.6	42.0	49.4	65.0	44.0	43.3	49.9	66.4	47.5	47.7	54.0	69.8
	75	47.2	47.1	53.3	69.0	47.2	47.3	53.4	69.1	48.2	48.6	54.6	70.2
7000	60	40.4	38.9	45.4	60.3	44.1	43.0	49.7	65.2	48.3	48.1	54.4	69.1
	65	42.0	39.9	47.0	60.9	44.5	43.5	50.0	65.4	48.4	48.2	54.4	69.2
	70	45.7	44.1	51.0	65.3	45.5	44.5	50.9	65.9	48.7	48.7	54.7	69.4
	75	49.3	49.2	55.0	69.3	49.4	49.3	55.1	69.4	49.6	49.7	55.5	69.8



Reheat Temperature Rise

Table 20. Reheat temperature rise — 17.5 tons (continued)

Airflow (cfm)	Ent DB (°F)	Entering Wet Bulb (°F)											
		51				55				59			
		Lvg Evap DB (°F)		Lvg Reheat DB (°F)		Lvg Evap DB (°F)		Lvg Reheat DB (°F)		Lvg Evap DB (°F)		Lvg Reheat DB (°F)	
		MIN	MAX	MIN	MAX	MIN	MAX	MIN	MAX	MIN	MAX	MIN	MAX
7700	60	41.4	40.1	46.1	59.8	45.1	43.9	50.3	64.6	49.2	48.8	54.9	68.6
	65	43.7	41.2	48.3	60.5	45.6	44.4	50.6	64.9	49.4	49.0	55.0	68.8
	70	47.4	45.8	52.4	65.5	47.5	45.6	52.4	65.5	49.8	49.5	55.3	69.0
	75	51.1	51.0	56.4	69.6	51.2	51.1	56.5	69.7	51.1	51.0	56.5	69.7
8400	60	42.3	41.0	46.6	59.3	46.0	44.7	50.8	64.1	49.9	49.5	55.2	68.2
	65	45.1	43.2	49.4	61.1	46.5	45.3	51.1	64.4	50.3	49.7	55.4	68.4
	70	48.9	47.3	53.6	65.7	49.0	47.4	53.6	65.8	50.7	50.3	55.8	68.7
	75	52.7	52.6	57.7	69.9	52.8	52.7	57.8	69.9	52.9	52.8	57.8	70.0
Ambient DB 70°F													
3500	60	31.0 ^(a)	29.3 ^(a)	39.7	65.6	35.0	34.7 ^(a)	44.4	70.4	39.0	40.3	49.2	73.9
	65	31.1 ^(a)	29.4 ^(a)	39.8	65.6	35.0	34.6 ^(a)	44.3	70.3	39.1	40.4	49.2	73.9
	70	31.5 ^(a)	29.8 ^(a)	40.1	65.8	35.1	34.8 ^(a)	44.4	70.4	39.1	40.5	49.3	73.9
	75	34.1 ^(a)	32.5 ^(a)	43.1	68.5	35.2	35.0	44.5	70.4	39.3	40.6	49.3	74.0
4200	60	33.9 ^(a)	32.0 ^(a)	41.6	63.9	38.0	36.7	46.2	69.3	42.1	42.2	51.1	73.2
	65	34.2 ^(a)	32.2 ^(a)	41.7	64.0	38.1	36.8	46.3	69.4	42.2	42.4	51.1	73.2
	70	35.6	32.9 ^(a)	43.2	64.5	38.3	37.1	46.4	69.5	42.3	42.5	51.2	73.3
	75	38.7	36.7	46.8	68.8	38.8	37.7	47.0	69.8	42.5	42.8	51.3	73.4
4900	60	36.3	34.3 ^(a)	43.1	62.7	40.2	38.5	47.6	68.2	44.5	44.1	52.6	72.6
	65	36.6	34.5 ^(a)	43.3	62.8	40.4	38.7	47.8	68.3	44.5	44.0	52.5	72.5
	70	39.1	36.4	46.0	64.5	40.7	39.0	47.9	68.5	44.7	44.2	52.6	72.6
	75	42.4	40.2	49.7	69.1	42.5	39.9	49.8	69.0	44.9	44.5	52.8	72.7
5600	60	38.1	36.2	44.2	61.9	42.0	40.2	48.7	67.2	46.3	45.4	53.6	71.8
	65	38.8	36.6	44.8	62.0	42.3	40.5	48.9	67.4	46.3	45.3	53.5	71.8
	70	42.0	39.2	48.2	64.8	42.8	40.8	49.4	67.5	46.5	45.7	53.7	72.0
	75	45.5	43.1	52.2	69.4	45.6	43.3	52.3	69.5	46.8	46.1	53.9	72.1
6300	60	39.6	37.8	45.1	61.1	43.4	41.6	49.5	66.3	47.7	46.5	54.3	71.1
	65	40.5	38.6	46.0	61.6	43.7	41.9	49.8	66.5	47.7	46.5	54.3	71.1
	70	44.4	41.6	50.1	65.1	44.5	42.7	50.5	67.0	48.0	46.9	54.5	71.3
	75	48.0	45.6	54.2	69.6	48.1	45.7	54.3	69.8	48.8	47.7	55.2	71.7
7000	60	40.8	39.1	45.8	60.4	44.6	42.8	50.2	65.6	48.8	47.2	54.9	70.3
	65	42.6	40.0	47.6	61.1	45.0	43.2	50.5	65.8	48.9	47.5	54.9	70.5
	70	46.4	43.7	51.7	65.4	46.2	44.1	51.6	66.4	49.2	48.0	55.2	70.8
	75	50.1	47.7	55.9	69.9	50.2	47.8	56.0	70.0	50.2	48.9	56.0	71.2
7700	60	41.8	40.2	46.5	59.9	45.6	43.8	50.7	65.0	49.7	48.2	55.4	69.9
	65	44.3	41.7	48.9	61.0	46.0	44.3	51.1	65.2	49.9	48.4	55.5	70.0
	70	48.1	45.5	53.1	65.7	48.2	45.4	53.2	65.9	50.3	48.9	55.8	70.2
	75	52.0	49.6	57.4	70.2	52.0	49.7	57.4	70.3	52.1	50.0	57.5	70.8
8400	60	42.8	41.1	47.1	59.4	46.4	44.7	51.2	64.4	50.4	48.9	55.7	69.4
	65	45.7	43.3	50.1	61.3	46.8	45.2	51.5	64.7	50.7	49.2	55.9	69.5
	70	49.6	47.0	54.3	65.9	49.7	46.5	54.4	65.5	51.2	49.7	56.3	69.7
	75	53.5	51.2	58.6	70.5	53.6	51.3	58.7	70.5	53.7	51.0	58.8	70.4

Note: MIN, MAX: The leaving evaporator temperature is affected by the modulating valve position. The MIN and MAX numbers represent modulating valve position impact on both the leaving evaporator temperature and the leaving reheat coil temperature. MAX represents wide open, MIN represents closed to minimum position.

^(a) The unit might be tripped by Froststat at these conditions due to low leaving evaporator air temperature.

Table 21. Reheat temperature rise — 20 tons

Airflow (cfm)	Ent DB (°F)	Entering Wet Bulb (°F)											
		51				55				59			
		Lvg Evap DB (°F)		Lvg Reheat DB (°F)		Lvg Evap DB (°F)		Lvg Reheat DB (°F)		Lvg Evap DB (°F)		Lvg Reheat DB (°F)	
		MIN	MAX	MIN	MAX	MIN	MAX	MIN	MAX	MIN	MAX	MIN	MAX
Ambient DB 60°F													
4000	60	31.0 ^(a)	29.6 ^(a)	44.3	59.8	34.7 ^(a)	33.3 ^(a)	49.1	65.4	38.5	38.0	54.0	69.8
	65	31.6 ^(a)	30.1 ^(a)	44.7	60.1	34.8 ^(a)	33.5 ^(a)	49.1	65.3	38.8	38.3	54.3	70.0
	70	32.1 ^(a)	30.6 ^(a)	45.3	60.6	35.4	34.1 ^(a)	49.5	65.7	38.9	38.4	54.2	70.0
	75	34.4 ^(a)	32.6 ^(a)	47.9	62.9	35.6	34.4 ^(a)	49.7	65.9	39.4	39.1	54.6	70.3
4800	60	34.4 ^(a)	33.1 ^(a)	45.8	59.1	37.6	36.2	50.2	64.4	41.5	40.6	55.2	69.2
	65	34.7 ^(a)	33.3 ^(a)	46.2	59.5	38.4	36.7	50.6	64.5	41.8	40.9	55.4	69.3
	70	35.5	34.1 ^(a)	47.0	60.2	38.7	37.2	51.0	64.9	42.2	41.5	55.4	69.6
	75	39.0	37.1	51.0	63.8	39.4	37.9	51.7	65.5	42.8	42.1	56.0	69.9
5600	60	36.8	35.4	46.9	58.6	39.9	38.5	51.2	63.6	43.8	42.6	56.1	68.6
	65	37.1	35.8	47.3	59.0	40.9	39.4	51.7	64.0	44.1	43.0	56.2	68.8
	70	39.5	36.9	49.6	59.9	41.2	39.7	52.2	64.4	45.0	44.0	56.7	69.2
	75	42.7	40.8	53.4	64.7	42.4	40.8	53.3	65.2	45.4	44.4	57.1	69.5
6400	60	38.7	37.4	47.8	58.2	41.8	40.4	51.8	63.0	45.9	44.3	56.9	68.1
	65	39.4	38.0	48.5	58.8	42.8	41.4	52.6	63.6	46.0	44.7	56.8	68.3
	70	42.3	40.6	51.5	61.3	43.2	41.8	53.0	64.0	47.0	45.8	57.5	68.8
	75	45.7	43.8	55.4	65.5	45.8	43.7	55.5	65.5	47.4	46.3	58.0	69.2
7200	60	40.3	39.0	48.5	57.9	43.4	42.0	52.4	62.5	47.3	45.7	57.4	67.6
	65	41.2	39.9	49.3	58.6	44.5	43.1	53.3	63.2	47.7	46.2	57.2	67.7
	70	44.6	43.0	53.1	61.9	45.2	43.8	54.0	63.8	48.7	47.3	58.2	68.5
	75	48.1	46.3	57.1	66.2	48.2	46.4	57.2	66.3	49.4	47.9	58.9	68.9
8000	60	41.7	40.4	49.2	57.6	44.8	43.5	52.7	62.0	48.4	47.1	57.7	67.3
	65	42.6	41.5	50.0	58.4	45.8	44.5	53.9	62.9	49.7	47.8	57.9	67.3
	70	46.6	45.0	54.4	62.5	46.7	45.4	54.7	63.6	50.1	48.7	58.8	68.1
	75	50.2	48.4	58.5	66.8	50.3	48.5	58.6	66.8	50.9	49.6	59.5	68.7
8800	60	42.8	41.6	49.7	57.4	46.6	45.4	53.5	61.7	49.4	48.0	57.9	66.8
	65	44.6	42.8	51.4	58.3	47.0	45.7	54.4	62.7	51.4	49.5	59.0	67.0
	70	48.3	46.7	55.6	62.9	47.9	46.7	55.3	63.4	51.3	49.9	59.2	67.9
	75	52.0	50.2	59.8	67.3	52.1	50.3	59.8	67.4	52.1	50.9	60.0	68.5
9600	60	43.8	42.7	50.1	57.2	48.0	46.4	54.4	61.4	50.2	48.8	58.1	66.4
	65	46.0	44.6	52.4	58.9	48.0	46.8	54.8	62.4	52.3	50.5	59.3	66.7
	70	49.8	48.2	56.6	63.3	49.9	47.9	56.6	63.2	52.3	50.9	59.6	67.6
	75	53.6	51.8	60.8	67.7	53.7	51.9	60.9	67.8	53.2	52.0	60.5	68.3
Ambient DB 65°F													
4000	60	32.8 ^(a)	29.7 ^(a)	38.4	62.7	36.5	33.6 ^(a)	42.8	68.4	40.6	38.4	47.5	72.7
	65	33.1 ^(a)	30.3 ^(a)	38.8	63.0	36.6	33.7 ^(a)	42.8	68.3	40.8	38.8	47.6	72.9
	70	33.7 ^(a)	30.6 ^(a)	39.4	63.4	37.2	34.3 ^(a)	43.3	68.7	41.0	38.9	47.7	72.9
	75	36.7 ^(a)	32.8 ^(a)	42.6	65.9	37.6	34.7 ^(a)	43.8	68.9	41.5	39.6	48.2	73.2
4800	60	35.9	33.2 ^(a)	40.7	61.6	39.3	36.4	44.9	67.1	43.8	40.9	49.9	71.9
	65	36.1	33.5 ^(a)	41.1	62.0	40.1	36.8	45.3	67.1	43.8	41.2	49.8	72.0
	70	38.0	34.3 ^(a)	42.9	62.7	40.4	37.4	45.7	67.6	44.4	41.9	50.2	72.2
	75	41.3	37.3	46.6	66.5	41.1	38.1	46.5	68.1	44.8	42.4	50.6	72.5



Reheat Temperature Rise

Table 21. Reheat temperature rise — 20 tons (continued)

Airflow (cfm)	Ent DB (°F)	Entering Wet Bulb (°F)											
		51				55				59			
		Lvg Evap DB (°F)		Lvg Reheat DB (°F)		Lvg Evap DB (°F)		Lvg Reheat DB (°F)		Lvg Evap DB (°F)		Lvg Reheat DB (°F)	
		MIN	MAX	MIN	MAX	MIN	MAX	MIN	MAX	MIN	MAX	MIN	MAX
5600	60	38.2	35.5	42.5	60.8	41.5	38.6	46.4	66.0	46.0	42.8	51.5	71.1
	65	38.6	35.9	42.9	61.2	42.5	39.5	47.1	66.3	46.0	43.2	51.3	71.2
	70	41.5	37.0	45.9	62.2	42.8	39.9	47.6	66.7	46.9	44.1	52.0	71.6
	75	45.0	40.9	49.8	67.1	45.1	40.9	49.9	67.5	47.3	44.6	52.5	71.9
6400	60	40.1	37.4	43.9	60.2	43.3	40.4	47.6	65.2	47.7	44.4	52.6	70.3
	65	40.8	37.9	44.7	60.6	44.4	41.5	48.6	65.7	47.7	44.8	52.3	70.5
	70	44.3	40.7	48.3	63.4	45.0	41.9	49.3	66.1	48.8	45.9	53.4	71.0
	75	48.0	43.9	52.4	67.6	48.1	43.2	52.5	67.0	49.2	46.4	53.9	71.4
7200	60	41.6	39.1	45.1	59.6	44.7	42.0	48.5	64.4	49.0	45.7	53.5	69.6
	65	42.4	40.0	45.9	60.4	45.9	43.1	49.7	65.1	50.7	46.3	54.6	69.7
	70	46.6	43.1	50.3	63.8	46.7	43.9	50.5	65.8	50.4	47.4	54.5	70.5
	75	50.5	46.4	54.6	68.1	50.6	46.5	54.6	68.2	51.1	48.0	55.3	70.9
8000	60	42.9	40.5	46.1	59.2	47.3	43.6	50.6	63.8	50.0	47.1	54.2	69.2
	65	44.6	41.5	47.8	60.0	47.2	44.6	50.7	64.7	51.8	48.1	55.4	69.2
	70	48.6	45.1	52.0	64.2	48.4	45.5	51.9	65.4	51.7	48.8	55.5	70.0
	75	52.6	48.5	56.3	68.6	52.7	48.6	56.4	68.7	52.5	49.7	56.3	70.6
8800	60	44.0	41.7	46.9	58.9	48.3	45.4	51.2	63.2	50.8	48.0	54.7	68.6
	65	46.2	43.0	49.2	59.9	48.3	45.7	51.5	64.3	52.8	49.6	56.0	68.6
	70	50.2	46.8	53.4	64.6	50.3	46.8	53.5	65.0	52.8	50.0	56.2	69.6
	75	54.4	50.4	57.9	69.0	54.4	50.4	57.9	69.1	54.5	51.0	58.0	70.2
9600	60	44.9	42.7	47.6	58.6	49.1	46.5	51.7	62.8	51.4	48.9	55.0	68.0
	65	47.6	44.7	50.3	60.2	49.3	46.8	52.1	63.9	53.5	50.6	56.5	68.2
	70	51.7	48.3	54.7	64.9	51.7	47.9	54.7	64.7	53.7	51.0	56.9	69.2
	75	55.9	51.9	59.1	69.3	55.9	52.0	59.2	69.4	56.0	52.1	59.3	69.9
Ambient DB 70°F													
4000	60	33.5 ^(a)	29.9 ^(a)	39.1	62.9	37.1	33.5 ^(a)	43.5	68.8	41.3	37.7	48.4	74.3
	65	33.7 ^(a)	30.5 ^(a)	39.4	63.2	37.3	33.7 ^(a)	43.5	68.7	41.5	38.1	48.5	74.5
	70	34.3 ^(a)	30.7 ^(a)	40.0	63.5	37.8	34.3 ^(a)	44.0	69.0	41.6	38.1	48.5	74.5
	75	37.6	33.1 ^(a)	43.6	66.3	38.3	34.6 ^(a)	44.6	69.3	42.2	38.8	49.0	74.7
4800	60	36.4	33.3 ^(a)	41.3	61.8	39.9	36.5	45.5	67.5	44.5	40.4	50.7	73.0
	65	36.7	33.6 ^(a)	41.7	62.1	40.7	37.0	46.0	67.4	44.4	40.7	50.5	73.1
	70	38.8	34.4 ^(a)	43.8	62.9	41.0	37.5	46.4	68.0	45.1	41.3	50.9	73.3
	75	42.2	37.6	47.6	66.9	42.0	38.2	47.5	68.5	45.4	41.8	51.4	73.6
5600	60	38.7	35.7	43.1	60.8	42.1	38.7	47.0	66.3	46.6	42.6	52.2	71.9
	65	39.1	36.0	43.5	61.3	43.0	39.7	47.8	66.6	46.5	42.9	51.9	72.0
	70	42.2	37.9	46.8	62.9	43.4	40.0	48.2	67.1	47.5	43.9	52.7	72.3
	75	45.9	41.2	50.8	67.5	46.0	41.1	50.9	67.9	47.9	44.2	53.2	72.8
6400	60	40.6	37.6	44.5	60.2	43.7	40.6	48.1	65.3	48.2	44.3	53.3	70.9
	65	40.8	38.1	44.7	60.7	44.9	41.7	49.1	65.9	48.3	44.8	52.9	71.0
	70	45.0	40.9	49.2	63.5	45.6	42.1	49.9	66.3	49.4	45.8	54.0	71.6
	75	48.9	44.1	53.4	68.0	49.0	43.4	53.5	67.3	50.0	46.2	54.7	72.0

Table 21. Reheat temperature rise — 20 tons (continued)

Airflow (cfm)	Ent DB (°F)	Entering Wet Bulb (°F)											
		51				55				59			
		Lvg Evap DB (°F)		Lvg Reheat DB (°F)		Lvg Evap DB (°F)		Lvg Reheat DB (°F)		Lvg Evap DB (°F)		Lvg Reheat DB (°F)	
		MIN	MAX	MIN	MAX	MIN	MAX	MIN	MAX	MIN	MAX	MIN	MAX
7200	60	42.1	39.3	45.6	59.7	45.6	42.2	49.2	64.5	49.5	45.8	54.1	70.0
	65	43.1	40.2	46.6	60.4	46.4	43.3	50.3	65.2	51.2	46.3	55.1	70.1
	70	47.3	43.3	51.2	64.0	47.1	44.1	50.9	65.9	50.9	47.4	55.1	70.9
	75	51.4	46.6	55.5	68.5	51.5	46.7	55.6	68.6	51.7	47.9	55.9	71.4
8000	60	43.4	40.7	46.5	59.3	47.7	43.8	51.0	63.7	50.5	47.2	54.7	69.6
	65	45.2	41.7	48.5	60.0	47.7	44.7	51.2	64.7	52.3	47.8	55.8	69.1
	70	49.3	45.3	52.8	64.3	49.3	45.7	52.9	65.5	52.2	48.9	56.0	70.3
	75	53.4	48.7	57.3	68.9	53.5	48.8	57.3	69.0	53.4	49.7	57.2	71.0
8800	60	44.4	41.9	47.3	58.9	48.7	45.6	51.6	63.2	51.3	48.2	55.2	68.9
	65	46.8	43.0	49.8	59.7	48.8	45.9	51.9	64.3	52.9	49.8	56.2	68.8
	70	50.9	47.0	54.2	64.7	51.0	47.0	54.2	65.1	53.3	50.1	56.7	69.9
	75	55.2	50.5	58.7	69.3	55.2	50.6	58.8	69.4	55.3	51.0	58.9	70.5
9600	60	45.3	42.9	48.0	58.6	49.4	46.6	52.1	62.8	51.8	49.0	55.5	68.3
	65	48.1	44.9	50.9	60.4	49.7	47.0	52.6	63.9	53.9	50.8	56.8	68.3
	70	52.3	48.5	55.4	65.0	52.4	48.1	55.4	64.7	54.2	51.1	57.3	69.4
	75	56.7	52.1	60.0	69.6	56.7	52.2	60.0	69.7	56.8	52.2	60.1	70.2

Note: MIN, MAX: The leaving evaporator temperature is affected by the modulating valve position. The MIN and MAX numbers represent modulating valve position impact on both the leaving evaporator temperature and the leaving reheat coil temperature. MAX represents wide open, MIN represents closed to minimum position.

(a) The unit might be tripped by Froststat at these conditions due to low leaving evaporator air temperature.

Table 22. Reheat temperature rise — 25 tons

Airflow (cfm)	Ent DB (°F)	Entering Wet Bulb (°F)											
		51				55				59			
		Lvg Evap DB (°F)		Lvg Reheat DB (°F)		Lvg Evap DB (°F)		Lvg Reheat DB (°F)		Lvg Evap DB (°F)		Lvg Reheat DB (°F)	
		MIN	MAX	MIN	MAX	MIN	MAX	MIN	MAX	MIN	MAX	MIN	MAX
Ambient DB 60°F													
5000	60	33.3 ^(a)	32.4 ^(a)	48.3	59.4	36.6	35.7	52.7	64.5	40.2	39.7	57.4	69.4
	65	34.0 ^(a)	33.1 ^(a)	48.8	59.9	37.1	36.2	53.1	64.9	40.6	40.3	57.9	69.8
	70	35.2	34.3 ^(a)	49.9	60.8	37.7	36.8	53.7	65.3	41.1	40.9	58.3	70.1
	75	38.1	37.0	53.1	63.7	38.6	37.6	54.3	65.8	41.7	41.5	58.8	70.4
6000	60	36.0	35.2	49.0	58.7	39.3	38.5	53.4	63.7	42.9	42.2	58.0	68.7
	65	36.8	36.0	49.7	59.3	40.0	39.1	53.9	64.2	43.4	42.8	58.5	69.1
	70	38.8	37.7	51.4	60.6	40.8	39.9	54.6	64.8	44.0	43.5	59.0	69.5
	75	42.3	41.2	55.5	64.8	42.3	41.4	55.8	65.8	44.8	44.4	59.7	70.0
7000	60	38.1	37.3	49.7	58.2	41.4	40.6	54.0	63.1	44.9	44.1	58.5	68.0
	65	39.1	38.3	50.5	58.8	42.2	41.4	54.6	63.7	45.6	44.8	59.0	68.6
	70	42.3	41.3	53.5	61.4	43.1	42.3	55.3	64.3	46.3	45.7	59.7	69.1
	75	45.6	44.5	57.3	65.6	45.0	44.2	56.9	65.6	47.2	46.6	60.3	69.6
8000	60	39.9	39.1	50.3	57.8	43.1	42.3	54.4	62.6	46.5	45.7	58.8	67.4
	65	41.5	40.7	51.5	58.9	44.0	43.2	55.1	63.3	47.2	46.4	59.4	68.0
	70	44.8	43.9	54.9	62.1	45.4	44.3	56.2	63.9	48.1	47.4	60.1	68.7
	75	48.2	47.2	58.9	66.4	48.3	47.3	59.0	66.5	49.1	48.5	60.8	69.2



Reheat Temperature Rise

Table 22. Reheat temperature rise — 25 tons (continued)

Airflow (cfm)	Ent DB (°F)	Entering Wet Bulb (°F)											
		51				55				59			
		Lvg Evap DB (°F)		Lvg Reheat DB (°F)		Lvg Evap DB (°F)		Lvg Reheat DB (°F)		Lvg Evap DB (°F)		Lvg Reheat DB (°F)	
		MIN	MAX	MIN	MAX	MIN	MAX	MIN	MAX	MIN	MAX	MIN	MAX
9000	60	41.3	40.6	50.7	57.5	44.4	43.6	54.7	62.1	48.0	47.0	59.2	66.8
	65	43.1	42.4	52.2	58.7	45.4	44.7	55.5	62.9	48.6	47.8	59.7	67.5
	70	46.9	46.0	56.2	62.7	47.1	46.4	56.8	64.0	49.6	48.8	60.5	68.2
	75	50.4	49.5	60.2	67.0	50.5	49.6	60.3	67.1	51.2	50.5	61.7	69.2
10000	60	42.5	41.8	51.1	57.2	45.5	44.8	54.9	61.7	49.1	48.2	59.4	80.1
	65	44.6	43.9	52.8	58.6	46.6	45.9	55.9	62.5	49.7	48.9	59.9	67.0
	70	48.6	47.8	57.2	63.2	48.6	47.9	57.3	63.8	50.8	50.1	60.8	67.9
	75	52.3	51.4	61.3	67.6	52.4	51.5	61.4	67.6	52.6	52.0	62.1	69.0
11000	60	43.5	42.9	51.4	57.0	46.4	45.8	55.1	61.3	49.9	49.2	59.5	66.1
	65	46.4	45.6	53.9	59.0	47.7	47.0	56.1	62.2	50.8	49.9	60.1	66.6
	70	50.1	49.3	58.1	63.6	49.8	49.1	57.8	63.7	51.9	51.2	61.0	67.5
	75	53.9	53.0	62.3	68.0	53.9	53.1	62.4	68.1	53.9	53.2	62.5	68.8
12000	60	44.4	43.8	51.6	56.8	47.3	46.6	55.4	61.1	50.5	49.9	59.4	65.7
	65	47.6	46.9	54.6	59.4	48.5	47.9	56.3	62.0	51.6	50.8	60.3	66.4
	70	51.4	50.7	58.9	64.0	51.5	50.7	58.9	64.0	52.8	52.1	61.2	67.2
	75	55.2	54.4	63.1	68.4	55.3	54.5	63.2	68.5	54.9	54.3	62.9	68.6
Ambient DB 65°F													
5000	60	34.5 ^(a)	32.5 ^(a)	41.7	61.9	38.0	35.8	45.8	67.2	41.7	39.7	50.2	72.3
	65	35.2	33.2 ^(a)	42.3	62.4	38.5	36.3	46.2	67.5	42.2	40.3	50.6	72.7
	70	36.5	34.4 ^(a)	43.5	63.3	39.1	37.0	46.8	68.0	42.7	40.8	51.1	73.0
	75	39.8	37.2	47.1	66.4	40.3	37.7	47.8	68.4	43.3	41.6	51.6	73.4
6000	60	37.2	35.2	43.5	60.8	40.7	38.5	47.5	66.1	44.4	42.7	51.8	71.6
	65	37.9	36.1	44.1	61.4	41.3	39.2	48.1	66.6	44.9	42.9	52.4	71.7
	70	40.6	37.8	46.7	62.7	42.1	40.0	48.8	67.1	45.5	43.5	52.8	72.1
	75	43.9	41.4	50.4	67.1	43.6	41.5	50.2	68.1	46.3	44.3	53.5	72.6
7000	60	39.2	37.4	44.8	60.1	42.7	40.7	48.8	65.2	46.3	44.2	53.1	70.3
	65	40.6	38.4	46.0	60.6	43.4	41.4	49.5	65.8	47.0	44.8	53.6	70.8
	70	43.7	41.4	49.2	63.3	44.5	42.4	50.4	66.4	47.7	45.7	54.3	71.4
	75	47.2	44.7	53.0	67.7	47.3	44.3	53.1	67.7	48.6	46.6	55.0	71.9
8000	60	40.9	39.2	45.9	59.5	44.2	42.3	49.8	64.4	48.1	45.7	54.2	69.4
	65	42.5	40.8	47.3	60.5	45.1	43.2	50.6	65.1	48.6	46.5	54.6	70.0
	70	46.2	44.0	51.2	63.8	46.6	44.4	51.8	65.7	49.5	47.4	55.4	70.7
	75	49.8	47.4	55.1	68.2	49.9	47.5	55.2	68.3	50.8	48.5	56.5	71.2
9000	60	42.3	40.7	46.8	59.0	45.5	43.7	50.5	63.7	49.3	47.0	54.9	68.7
	65	44.2	42.5	48.5	60.2	46.5	44.8	51.4	64.5	49.9	47.8	55.3	69.3
	70	48.2	46.1	52.8	64.2	48.2	46.5	52.9	65.6	50.9	48.9	56.2	70.0
	75	52.0	49.6	56.9	68.7	52.1	49.7	57.0	68.8	52.5	50.5	57.6	71.0
10000	60	43.4	41.9	47.5	58.6	46.5	44.8	51.2	63.2	50.1	48.3	55.3	82.5
	65	46.1	44.0	50.1	60.0	47.6	46.0	52.1	64.0	51.0	49.0	56.0	68.7
	70	50.0	47.9	54.2	64.6	49.6	48.0	53.8	65.2	52.0	50.2	56.9	69.5
	75	53.8	51.5	58.4	69.1	53.9	51.6	58.5	69.2	53.8	52.0	58.5	70.6

Table 22. Reheat temperature rise — 25 tons (continued)

Airflow (cfm)	Ent DB (°F)	Entering Wet Bulb (°F)											
		51				55				59			
		Lvg Evap DB (°F)		Lvg Reheat DB (°F)		Lvg Evap DB (°F)		Lvg Reheat DB (°F)		Lvg Evap DB (°F)		Lvg Reheat DB (°F)	
		MIN	MAX	MIN	MAX	MIN	MAX	MIN	MAX	MIN	MAX	MIN	MAX
11000	60	44.3	42.9	48.1	58.3	47.5	45.8	51.7	62.7	50.9	49.2	55.7	67.6
	65	47.5	45.7	51.2	60.3	48.6	47.1	52.7	63.6	51.9	50.0	56.5	68.2
	70	51.4	49.4	55.4	64.9	51.5	49.2	55.5	65.0	53.0	51.3	57.5	69.0
	75	55.4	53.1	59.7	69.4	55.5	53.2	59.7	69.5	55.6	53.3	59.8	70.2
12000	60	45.4	43.8	48.8	58.0	48.2	46.7	52.2	62.3	51.6	50.0	56.1	67.1
	65	48.7	47.0	52.1	60.6	49.7	48.0	53.4	63.2	52.7	50.9	57.0	67.8
	70	52.7	50.7	56.4	65.2	52.8	50.8	56.5	65.3	54.0	52.2	58.1	68.6
	75	56.8	54.5	60.8	69.8	56.8	54.5	60.8	69.8	56.9	54.4	60.9	69.9
Ambient DB 70°F													
5000	60	35.0	32.7 ^(a)	42.3	62.0	38.5	36.0	46.5	67.5	42.3	39.6	50.9	73.1
	65	35.6	33.4 ^(a)	42.9	62.5	39.0	36.5	46.9	67.9	42.8	40.1	51.4	73.5
	70	37.0	34.6 ^(a)	44.1	63.4	39.7	37.2	47.5	68.4	43.2	40.6	51.8	73.9
	75	40.5	37.5	47.9	66.8	40.8	37.9	48.5	68.8	43.9	41.3	52.4	74.3
6000	60	37.6	35.5	44.0	60.9	41.1	38.7	48.1	66.2	44.9	42.3	52.5	71.8
	65	38.4	36.3	44.7	61.5	41.8	39.3	48.7	66.7	45.5	42.9	53.1	72.3
	70	41.2	38.0	47.4	62.8	42.6	40.2	49.4	67.3	46.1	43.5	53.6	72.7
	75	44.6	41.6	51.2	67.4	44.4	41.7	51.0	68.4	46.8	44.3	54.2	73.2
7000	60	39.7	37.6	45.3	60.2	43.1	40.8	49.3	65.3	46.9	44.3	53.7	70.6
	65	41.0	38.5	46.5	60.7	43.9	41.6	50.0	65.9	47.5	45.0	54.3	71.2
	70	44.3	41.7	49.9	63.5	45.1	42.6	51.1	66.4	48.3	45.8	55.0	71.8
	75	47.8	44.9	53.8	68.0	47.9	44.5	53.9	67.8	49.0	46.7	55.6	72.3
8000	60	41.3	39.4	46.4	59.6	44.6	42.5	50.3	64.5	48.6	45.9	54.8	69.6
	65	42.9	41.0	47.8	60.6	45.6	43.4	51.1	65.2	49.1	46.7	55.2	70.3
	70	46.7	44.2	51.8	64.0	47.1	44.9	52.4	66.1	50.0	47.6	56.0	71.0
	75	50.5	47.6	55.9	68.5	50.5	47.7	56.0	68.6	51.3	48.6	57.1	71.5
9000	60	42.6	40.8	47.2	59.1	45.9	43.9	51.0	63.8	49.7	47.2	55.4	68.8
	65	45.0	42.7	49.3	60.3	46.9	44.9	51.9	64.6	50.3	48.0	55.9	69.5
	70	48.8	46.3	53.5	64.4	48.6	46.7	53.4	65.6	51.3	49.1	56.8	70.2
	75	52.6	49.8	57.7	68.9	52.7	49.9	57.8	69.0	52.9	50.7	58.2	71.2
10000	60	43.7	42.1	47.9	58.7	46.9	45.0	51.6	63.2	50.6	48.5	55.8	68.4
	65	46.6	44.1	50.6	60.0	48.0	46.2	52.6	64.1	51.4	49.2	56.5	68.8
	70	50.5	48.1	54.8	64.7	50.6	48.1	54.9	65.3	52.4	50.3	57.4	69.6
	75	54.5	51.7	59.2	69.3	54.6	51.8	59.2	69.4	54.4	52.2	59.2	70.8
11000	60	44.6	43.1	48.5	58.3	47.8	46.0	52.2	62.8	51.4	49.4	56.3	67.7
	65	47.9	45.9	51.7	60.4	49.1	47.2	53.3	63.6	52.3	50.2	57.1	68.3
	70	52.0	49.6	56.0	65.0	52.0	49.4	56.1	65.0	53.5	51.4	58.1	69.1
	75	56.1	53.3	60.4	69.7	56.1	53.4	60.5	69.7	56.2	53.5	60.6	70.4
12000	60	45.7	44.0	49.2	58.0	48.6	46.9	52.6	62.4	52.0	50.0	56.6	67.0
	65	49.1	47.2	52.6	60.7	50.0	48.2	53.8	63.2	53.1	51.1	57.5	67.9
	70	53.2	51.0	57.0	65.3	53.3	51.0	57.1	65.4	54.5	52.3	58.6	68.6
	75	57.4	54.7	61.6	70.0	57.5	54.8	61.6	70.1	57.6	54.6	61.7	70.0

Note: MIN, MAX: The leaving evaporator temperature is affected by the modulating valve position. The MIN and MAX numbers represent modulating valve position impact on both the leaving evaporator temperature and the leaving reheat coil temperature. MAX represents wide open, MIN represents closed to minimum position.

^(a) The unit might be tripped by Froststat at these conditions due to low leaving evaporator air temperature.



Evaporator Fan Performance

Fan Curve Limits:

-
- TSJ60-120 Std Motor, Max 3.0 hp or 1850 rpm
- TSJ150 Std Motor, Max 4.55 hp or 1940 rpm
- TSJ120 High Static, Max 4.55 hp or 1940 rpm
- TSJ180-300 Std Motor, Max 6 hp or 1850 rpm
- TSJ300 High static, Max 9.1 hp or 1940 rpm
- Maximum CFM — 480 cfm/ton
- Maximum ESP = 2.0 in-H₂O @ 400 cfm/ton

The fan curve graphs include standard filter and a wet indoor coil. ESP capability is reduced with options based on the accessory table component pressure drop. To determine ESP at rpm/cfm with other options/accessories, select intersection point of the RPM vs CFM and then reduce ESP shown in graph by the sum of additional option static pressure drop listed in the fan performance accessory table section.

6 to 10 Ton Units — Downflow

Figure 1. Fan curves — 6 to 10 tons, downflow

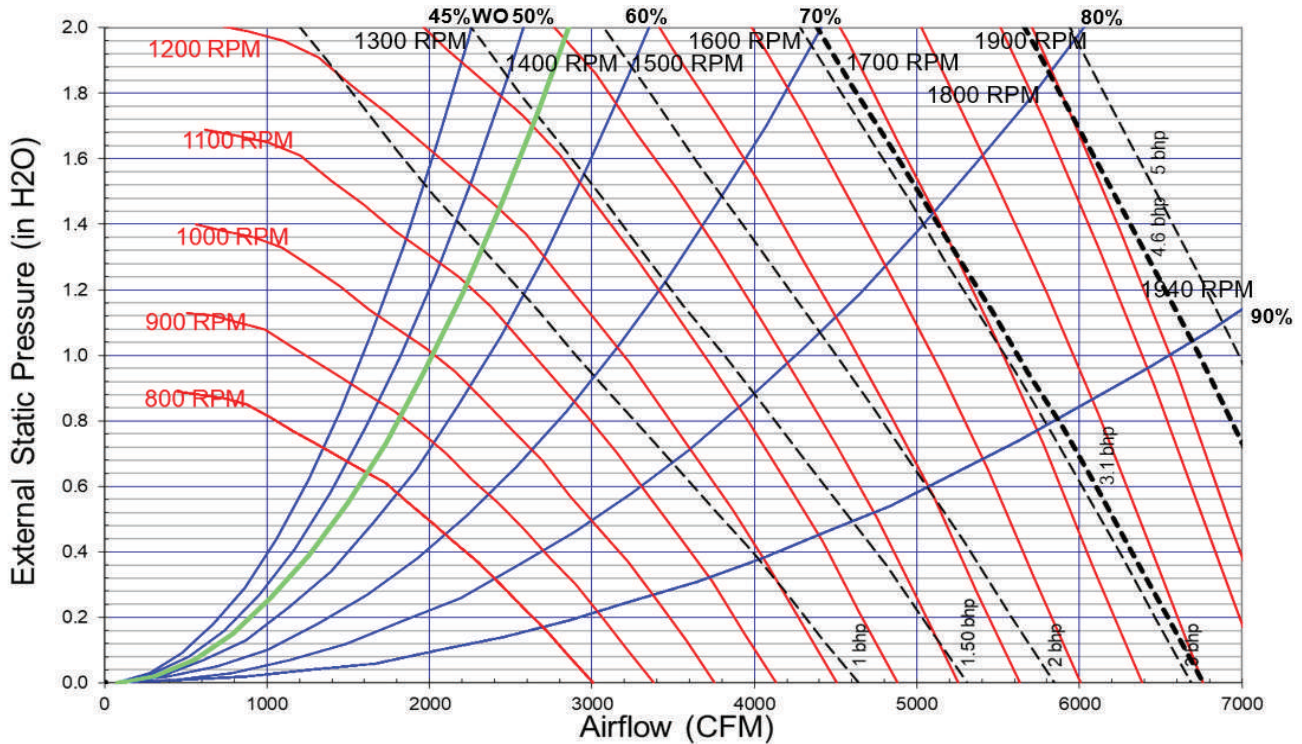

Table 23. Evaporator fan performance - 6 ton (model TSJ), downflow

CFM	Available External Static Pressure (Inches of Water Gauge)																			
	0.10"		0.20"		0.30"		0.40"		0.50"		0.60"		0.70"		0.80"		0.90"		1.00"	
	RPM	BHP	RPM	BHP	RPM	BHP	RPM	BHP	RPM	BHP	RPM	BHP	RPM	BHP	RPM	BHP	RPM	BHP	RPM	BHP
1800	549	0.10	612	0.15	667	0.20	719	0.25	766	0.30	809	0.35	849	0.41	891	0.47	931	0.53	969	0.59
1920	577	0.12	638	0.16	691	0.22	741	0.27	787	0.32	830	0.38	870	0.44	907	0.50	946	0.56	984	0.62
2040	606	0.13	663	0.18	716	0.24	763	0.29	809	0.35	851	0.41	891	0.47	928	0.53	963	0.60	999	0.66
2160	634	0.15	689	0.20	741	0.26	787	0.32	831	0.38	873	0.44	912	0.50	948	0.57	983	0.63	1017	0.70

Table 23. Evaporator fan performance - 6 ton (model TSJ), downflow (continued)

Available External Static Pressure (Inches of Water Gauge)										
CFM	0.10"	0.20"	0.30"	0.40"	0.50"	0.60"	0.70"	0.80"	0.90"	1.00"
	RPM BHP	RPM BHP	RPM BHP	RPM BHP	RPM BHP	RPM BHP	RPM BHP	RPM BHP	RPM BHP	RPM BHP
2280	663 0.17	716 0.23	766 0.29	811 0.35	853 0.41	894 0.47	933 0.54	969 0.61	1004 0.67	1037 0.74
2400	693 0.19	743 0.25	791 0.31	836 0.38	877 0.44	916 0.51	955 0.58	991 0.65	1025 0.72	1058 0.79
2520	723 0.22	771 0.28	817 0.34	861 0.41	901 0.48	939 0.55	977 0.62	1012 0.69	1046 0.76	1079 0.83
2640	753 0.24	799 0.31	843 0.37	886 0.44	925 0.51	963 0.59	999 0.66	1034 0.73	1068 0.81	1100 0.88
2760	783 0.27	827 0.34	869 0.41	911 0.48	950 0.55	987 0.63	1022 0.70	1056 0.78	1089 0.86	1121 0.94
2880	813 0.30	855 0.37	897 0.44	937 0.52	975 0.59	1011 0.67	1046 0.75	1078 0.83	1111 0.91	1143 0.99
Available External Static Pressure (Inches of Water Gauge)										
CFM	1.10"	1.20"	1.30"	1.40"	1.50"	1.60"	1.70"	1.80"	1.90"	2.00"
	RPM BHP	RPM BHP	RPM BHP	RPM BHP	RPM BHP	RPM BHP	RPM BHP	RPM BHP	RPM BHP	RPM BHP
1800	1005 0.65	1040 0.71	1074 0.78	1106 0.84	1137 0.91	1167 0.98	1197 1.04	1225 1.11	1253 1.19	1280 1.26
1920	1020 0.69	1055 0.75	1088 0.82	1121 0.89	1152 0.96	1182 1.03	1211 1.1	1240 1.17	1267 1.24	1294 1.32
2040	1035 0.73	1070 0.8	1103 0.86	1135 0.93	1166 1.01	1196 1.08	1226 1.15	1254 1.23	1282 1.3	1309 1.38
2160	1050 0.77	1085 0.84	1118 0.91	1150 0.98	1181 1.06	1211 1.13	1240 1.21	1269 1.28	1296 1.36	1323 1.44
2280	1069 0.81	1100 0.89	1133 0.96	1165 1.04	1196 1.11	1226 1.19	1255 1.27	1283 1.35	1311 1.43	1338 1.51
2400	1089 0.86	1119 0.94	1149 1.01	1180 1.09	1211 1.17	1241 1.25	1270 1.33	1298 1.41	1326 1.49	1352 1.57
2520	1110 0.91	1140 0.99	1169 1.07	1197 1.15	1226 1.23	1256 1.31	1285 1.39	1313 1.47	1340 1.56	1367 1.64
2640	1131 0.96	1161 1.04	1189 1.12	1217 1.2	1244 1.29	1271 1.37	1300 1.46	1328 1.54	1355 1.63	1382 1.72
2760	1152 1.02	1182 1.1	1210 1.18	1238 1.26	1265 1.35	1291 1.44	1316 1.52	1343 1.61	1371 1.7	1397 1.79
2880	1173 1.07	1203 1.16	1231 1.24	1259 1.33	1285 1.41	1311 1.5	1336 1.59	1361 1.68	1386 1.77	1412 1.87

Notes:

1. Available External Static Pressure is the static pressure difference between the return duct and the supply duct plus the static pressure drop caused by accessories and options.
2. For direct drive evaporator fan speed (rpm), refer to the applicable table in the fan performance section.
3. Data includes pressure drop due to standard filters and wet coils. No accessories or options are included in pressure drop data.
4. To determine static pressure drop due to other options/accessories, refer to the applicable table in the fan performance section.
5. Direct drive fan motor heat is negligible.
6. Factory supplied motors, in commercial equipment, are definite purpose motors, specifically designed and tested to operate reliably and continuously at all cataloged conditions. Using the full horsepower range of our fan motors as shown in our tabular data will not result in nuisance tripping or premature motor failure. Our product's warranty will not be affected.

Table 24. Evaporator fan performance - 7.5 ton (model TSJ), downflow

Available External Static Pressure (Inches of Water Gauge)										
CFM	0.10"	0.20"	0.30"	0.40"	0.50"	0.60"	0.70"	0.80"	0.90"	1.00"
	RPM BHP	RPM BHP	RPM BHP	RPM BHP	RPM BHP	RPM BHP	RPM BHP	RPM BHP	RPM BHP	RPM BHP
2250	656 0.17	709 0.22	759 0.28	805 0.34	848 0.40	889 0.47	928 0.53	964 0.60	999 0.66	1032 0.73
2400	693 0.19	743 0.25	791 0.31	836 0.38	877 0.44	916 0.51	955 0.58	991 0.65	1025 0.72	1058 0.79
2550	730 0.22	778 0.29	823 0.35	867 0.42	907 0.49	945 0.56	982 0.63	1018 0.70	1052 0.77	1084 0.85
2700	768 0.26	813 0.32	856 0.39	898 0.46	938 0.53	975 0.61	1010 0.68	1045 0.76	1079 0.83	1111 0.91
2850	806 0.30	848 0.36	890 0.43	930 0.51	969 0.58	1005 0.66	1040 0.74	1073 0.82	1106 0.90	1138 0.98
3000	844 0.34	884 0.41	924 0.48	963 0.56	1000 0.64	1036 0.72	1070 0.80	1102 0.88	1134 0.96	1165 1.05
3150	882 0.38	920 0.46	959 0.53	996 0.61	1032 0.69	1067 0.78	1100 0.86	1132 0.95	1162 1.03	1193 1.12
3300	920 0.43	957 0.51	994 0.59	1030 0.67	1065 0.76	1099 0.84	1131 0.93	1163 1.02	1192 1.11	1221 1.20
3600	997 0.55	1031 0.63	1065 0.71	1099 0.80	1131 0.90	1163 0.99	1194 1.08	1225 1.18	1254 1.27	1282 1.37
Available External Static Pressure (Inches of Water Gauge)										
CFM	1.10"	1.20"	1.30"	1.40"	1.50"	1.60"	1.70"	1.80"	1.90"	2.00"
	RPM BHP	RPM BHP	RPM BHP	RPM BHP	RPM BHP	RPM BHP	RPM BHP	RPM BHP	RPM BHP	RPM BHP
2250	1064 0.8	1096 0.88	1130 0.95	1161 1.02	1192 1.1	1222 1.17	1251 1.25	1280 1.33	1307 1.41	1334 1.49
2400	1089 0.86	1119 0.94	1149 1.01	1180 1.09	1211 1.17	1241 1.25	1270 1.33	1298 1.41	1326 1.49	1352 1.57
2550	1115 0.92	1145 1	1174 1.08	1202 1.16	1230 1.24	1260 1.32	1289 1.41	1317 1.49	1344 1.58	1371 1.66
2700	1141 0.99	1171 1.07	1200 1.15	1227 1.23	1254 1.32	1280 1.4	1308 1.49	1336 1.58	1363 1.66	1390 1.75
2850	1168 1.06	1197 1.14	1226 1.23	1253 1.31	1280 1.4	1306 1.49	1331 1.57	1356 1.66	1382 1.76	1409 1.85
3000	1195 1.13	1224 1.22	1252 1.3	1280 1.39	1306 1.48	1332 1.57	1357 1.67	1381 1.76	1405 1.85	1428 1.95
3150	1223 1.21	1251 1.3	1279 1.39	1306 1.48	1332 1.57	1358 1.67	1383 1.76	1407 1.86	1431 1.95	1454 2.05
3300	1250 1.29	1279 1.38	1306 1.48	1333 1.57	1359 1.67	1384 1.76	1409 1.86	1433 1.96	1457 2.06	1480 2.16



Evaporator Fan Performance

Table 24. Evaporator fan performance - 7.5 ton (model TSJ), downflow (continued)

Available External Static Pressure (Inches of Water Gauge)										
CFM	1.10"	1.20"	1.30"	1.40"	1.50"	1.60"	1.70"	1.80"	1.90"	2.00"
	RPM BHP	RPM BHP	RPM BHP	RPM BHP	RPM BHP	RPM BHP	RPM BHP	RPM BHP	RPM BHP	RPM BHP
3600	1309 1.47	1335 1.57	1361 1.67	1388 1.77	1413 1.87	1438 1.97	1462 2.08	1486 2.18	1509 2.28	1532 2.39

Notes:

1. Available External Static Pressure is the static pressure difference between the return duct and the supply duct plus the static pressure drop caused by accessories and options.
2. For direct drive evaporator fan speed (rpm), refer to the applicable table in the fan performance section.
3. Data includes pressure drop due to standard filters and wet coils. No accessories or options are included in pressure drop data.
4. To determine static pressure drop due to other options/accessories, refer to the applicable table in the fan performance section.
5. Direct drive fan motor heat is negligible.
6. Factory supplied motors, in commercial equipment, are definite purpose motors, specifically designed and tested to operate reliably and continuously at all cataloged conditions. Using the full horsepower range of our fan motors as shown in our tabular data will not result in nuisance tripping or premature motor failure. Our product's warranty will not be affected.

Table 25. Evaporator fan performance - 8.5 ton (model TSJ), downflow

Available External Static Pressure (Inches of Water Gauge)										
CFM	0.10"	0.20"	0.30"	0.40"	0.50"	0.60"	0.70"	0.80"	0.90"	1.00"
	RPM BHP	RPM BHP	RPM BHP	RPM BHP	RPM BHP	RPM BHP	RPM BHP	RPM BHP	RPM BHP	RPM BHP
2550	730 0.22	778 0.29	823 0.35	867 0.42	907 0.49	945 0.56	982 0.63	1018 0.70	1052 0.77	1084 0.85
2720	773 0.26	817 0.33	860 0.40	903 0.47	942 0.54	979 0.61	1014 0.69	1049 0.76	1082 0.84	1114 0.92
2890	816 0.31	858 0.37	899 0.45	939 0.52	977 0.60	1013 0.67	1048 0.75	1080 0.83	1113 0.91	1145 0.99
3060	859 0.36	898 0.43	938 0.50	976 0.58	1013 0.66	1048 0.74	1082 0.82	1114 0.91	1145 0.99	1176 1.08
3230	902 0.41	940 0.48	977 0.56	1014 0.64	1050 0.73	1084 0.81	1117 0.90	1148 0.98	1178 1.07	1208 1.16
3400	946 0.47	982 0.55	1017 0.63	1052 0.71	1086 0.80	1120 0.89	1152 0.98	1183 1.07	1213 1.16	1241 1.25
3570	989 0.54	1024 0.62	1057 0.70	1092 0.79	1124 0.88	1157 0.97	1188 1.06	1218 1.16	1247 1.25	1275 1.35
3740	1033 0.61	1066 0.69	1098 0.78	1131 0.87	1163 0.97	1193 1.06	1224 1.16	1254 1.26	1283 1.35	1310 1.46
4080	1121 0.77	1152 0.86	1181 0.96	1211 1.06	1241 1.16	1270 1.26	1298 1.36	1326 1.47	1354 1.57	1381 1.68

Available External Static Pressure (Inches of Water Gauge)

CFM	1.10"	1.20"	1.30"	1.40"	1.50"	1.60"	1.70"	1.80"	1.90"	2.00"
	RPM BHP	RPM BHP	RPM BHP	RPM BHP	RPM BHP	RPM BHP	RPM BHP	RPM BHP	RPM BHP	RPM BHP
2550	1115 0.92	1145 1	1174 1.08	1202 1.16	1230 1.24	1260 1.32	1289 1.41	1317 1.49	1344 1.58	1371 1.66
2720	1145 1	1175 1.08	1203 1.16	1231 1.24	1258 1.33	1284 1.41	1310 1.5	1338 1.59	1366 1.68	1392 1.77
2890	1175 1.08	1205 1.16	1233 1.25	1260 1.33	1287 1.42	1313 1.51	1338 1.6	1362 1.69	1387 1.78	1414 1.87
3060	1206 1.16	1235 1.25	1263 1.34	1290 1.43	1317 1.52	1342 1.61	1367 1.7	1391 1.8	1415 1.89	1439 1.99
3230	1237 1.25	1266 1.34	1294 1.44	1320 1.53	1347 1.62	1372 1.72	1397 1.81	1421 1.91	1444 2.01	1468 2.11
3400	1269 1.35	1297 1.44	1325 1.54	1351 1.63	1377 1.73	1402 1.83	1427 1.93	1451 2.03	1474 2.13	1497 2.23
3570	1303 1.45	1329 1.55	1356 1.65	1382 1.75	1408 1.85	1433 1.95	1457 2.05	1481 2.16	1504 2.26	1527 2.37
3740	1337 1.56	1363 1.66	1388 1.76	1414 1.87	1439 1.97	1464 2.08	1488 2.18	1511 2.29	1534 2.4	1557 2.51
4080	1407 1.79	1432 1.9	1456 2.01	1480 2.12	1503 2.24	1526 2.35	1550 2.46	1573 2.58	1596 2.69	1618 2.81

Notes:

1. Available External Static Pressure is the static pressure difference between the return duct and the supply duct plus the static pressure drop caused by accessories and options.
2. For direct drive evaporator fan speed (rpm), refer to the applicable table in the fan performance section.
3. Data includes pressure drop due to standard filters and wet coils. No accessories or options are included in pressure drop data.
4. To determine static pressure drop due to other options/accessories, refer to the applicable table in the fan performance section.
5. Direct drive fan motor heat is negligible.
6. Factory supplied motors, in commercial equipment, are definite purpose motors, specifically designed and tested to operate reliably and continuously at all cataloged conditions. Using the full horsepower range of our fan motors as shown in our tabular data will not result in nuisance tripping or premature motor failure. Our product's warranty will not be affected.

Table 26. Evaporator fan performance - 10 ton (model TSJ), downflow

Available External Static Pressure (Inches of Water Gauge)										
CFM	0.10"	0.20"	0.30"	0.40"	0.50"	0.60"	0.70"	0.80"	0.90"	1.00"
	RPM BHP	RPM BHP	RPM BHP	RPM BHP	RPM BHP	RPM BHP	RPM BHP	RPM BHP	RPM BHP	RPM BHP
3-hp Standard Motor										
3000	844 0.34	884 0.41	924 0.48	963 0.56	1000 0.64	1036 0.72	1070 0.80	1102 0.88	1134 0.96	1165 1.05
3200	894 0.40	932 0.47	970 0.55	1007 0.63	1043 0.71	1078 0.80	1111 0.88	1142 0.97	1172 1.06	1202 1.15
3400	946 0.47	982 0.55	1017 0.63	1052 0.71	1086 0.80	1120 0.89	1152 0.98	1183 1.07	1213 1.16	1241 1.25
3600	997 0.55	1031 0.63	1065 0.71	1099 0.80	1131 0.90	1163 0.99	1194 1.08	1225 1.18	1254 1.27	1282 1.37
3800	1048 0.64	1081 0.72	1113 0.81	1145 0.90	1176 1.00	1206 1.09	1237 1.19	1267 1.29	1295 1.39	1322 1.49

Table 26. Evaporator fan performance - 10 ton (model TSJ), downflow (continued)

Available External Static Pressure (Inches of Water Gauge)										
CFM	0.10"	0.20"	0.30"	0.40"	0.50"	0.60"	0.70"	0.80"	0.90"	1.00"
	RPM BHP	RPM BHP	RPM BHP	RPM BHP	RPM BHP	RPM BHP	RPM BHP	RPM BHP	RPM BHP	RPM BHP
3-hp Standard Motor										
4000	1100 0.73	1132 0.82	1162 0.91	1192 1.01	1222 1.11	1251 1.21	1280 1.31	1309 1.42	1337 1.52	1364 1.63
4200	1152 0.84	1182 0.93	1211 1.03	1240 1.13	1269 1.23	1297 1.34	1324 1.44	1352 1.55	1379 1.66	1406 1.77
4400	1204 0.95	1233 1.05	1261 1.15	1288 1.25	1316 1.36	1343 1.47	1370 1.58	1396 1.69	1422 1.81	1448 1.92
4800	1308 1.22	1335 1.33	1361 1.43	1386 1.54	1411 1.66	1437 1.77	1462 1.89	1486 2.01	1510 2.14	1534 2.26
Available External Static Pressure (Inches of Water Gauge)										
CFM	1.10"	1.20"	1.30"	1.40"	1.50"	1.60"	1.70"	1.80"	1.90"	2.00"
	RPM BHP	RPM BHP	RPM BHP	RPM BHP	RPM BHP	RPM BHP	RPM BHP	RPM BHP	RPM BHP	RPM BHP
3-hp Standard Motor										
3000	1195 1.13	1224 1.22	1252 1.3	1280 1.39	1306 1.48	1332 1.57	1357 1.67	1381 1.76	1405 1.85	1428 1.95
3200	1232 1.24	1260 1.33	1288 1.42	1315 1.51	1341 1.60	1367 1.70	1391 1.79	1416 1.89	1439 1.99	1462 2.09
3400	1269 1.35	1297 1.44	1325 1.54	1351 1.63	1377 1.73	1402 1.83	1427 1.93	1451 2.03	1474 2.13	1497 2.23
3600	1309 1.47	1335 1.57	1361 1.67	1388 1.77	1413 1.87	1438 1.97	1462 2.08	1486 2.18	1509 2.28	1532 2.39
3800	1349 1.60	1375 1.07	1400 1.81	1425 1.91	1450 2.02	1475 2.12	1499 2.23	1522 2.34	1545 2.45	1567 2.56
4000	1390 1.73	1415 1.84	1440 1.95	1464 2.06	1487 2.17	1512 2.28	1535 2.39	1558 2.51	1581 2.62	1603 2.73
4200	1431 1.88	1456 1.99	1481 2.11	1504 2.22	1527 2.34	1550 2.45	1572 2.57	1595 2.69	1618 2.80	1640 2.92
4400	1473 2.04	1498 2.15	1522 2.27	1545 2.39	1568 2.51	1590 2.63	1612 2.75	1633 2.87	1655 3.00	- -
4800	1559 2.38	1582 2.51	1605 2.63	1628 2.76	1650 2.89	1671 3.02	- -	- -	- -	- -

Notes:

1. Available External Static Pressure is the static pressure difference between the return duct and the supply duct plus the static pressure drop caused by accessories and options.
2. For direct drive evaporator fan speed (rpm), refer to the applicable table in the fan performance section.
3. Data includes pressure drop due to standard filters and wet coils. No accessories or options are included in pressure drop data.
4. To determine static pressure drop due to other options/accessories, refer to the applicable table in the fan performance section.
5. Direct drive fan motor heat is negligible.
6. Factory supplied motors, in commercial equipment, are definite purpose motors, specifically designed and tested to operate reliably and continuously at all cataloged conditions. Using the full horsepower range of our fan motors as shown in our tabular data will not result in nuisance tripping or premature motor failure. Our product's warranty will not be affected.

Table 27. Evaporator fan performance - 10 ton (model TSJ), downflow, oversized/high static motor option

Available External Static Pressure (Inches of Water Gauge)										
CFM	0.10"	0.20"	0.30"	0.40"	0.50"	0.60"	0.70"	0.80"	0.90"	1.00"
	RPM BHP	RPM BHP	RPM BHP	RPM BHP	RPM BHP	RPM BHP	RPM BHP	RPM BHP	RPM BHP	RPM BHP
5-hp Oversized Motor										
3000	816 0.31	859 0.38	900 0.46	941 0.53	980 0.62	1018 0.70	1054 0.78	1089 0.87	1123 0.96	1158 1.05
3200	865 0.37	905 0.44	944 0.52	982 0.60	1020 0.69	1057 0.77	1092 0.86	1126 0.95	1159 1.04	1191 1.14
3400	913 0.43	952 0.51	989 0.59	1026 0.68	1061 0.76	1097 0.86	1130 0.95	1163 1.04	1195 1.14	1226 1.24
3600	962 0.50	1000 0.58	1034 0.67	1069 0.76	1103 0.85	1137 0.95	1170 1.04	1202 1.14	1232 1.24	1263 1.34
3800	1012 0.58	1047 0.67	1081 0.75	1114 0.85	1146 0.94	1178 1.04	1210 1.14	1241 1.25	1271 1.35	1300 1.46
4000	1061 0.66	1095 0.76	1128 0.85	1158 0.95	1190 1.05	1220 1.15	1251 1.25	1281 1.36	1310 1.47	1339 1.58
4200	1111 0.76	1144 0.85	1175 0.95	1204 1.05	1234 1.16	1264 1.26	1293 1.37	1322 1.48	1350 1.60	1378 1.71
4400	1160 0.86	1192 0.96	1222 1.07	1251 1.17	1279 1.28	1308 1.39	1335 1.50	1363 1.61	1391 1.73	1418 1.85
4600	1210 0.97	1241 1.08	1270 1.19	1298 1.30	1325 1.41	1352 1.52	1379 1.63	1405 1.75	1432 1.87	1458 2.00
4800	1260 1.10	1290 1.21	1318 1.32	1345 1.43	1371 1.55	1397 1.66	1423 1.78	1448 1.90	1474 2.03	1499 2.15
Available External Static Pressure (Inches of Water Gauge)										
CFM	1.10"	1.20"	1.30"	1.40"	1.50"	1.60"	1.70"	1.80"	1.90"	2.00"
	RPM BHP	RPM BHP	RPM BHP	RPM BHP	RPM BHP	RPM BHP	RPM BHP	RPM BHP	RPM BHP	RPM BHP
5-hp Oversized Motor										
3000	1192 1.15	1224 1.24	1253 1.33	1281 1.43	1308 1.52	1334 1.62	1360 1.71	1384 1.81	1409 1.91	1432 2.01
3200	1223 1.24	1255 1.34	1287 1.44	1315 1.54	1342 1.64	1368 1.74	1393 1.84	1418 1.94	1442 2.05	1466 2.15
3400	1257 1.34	1286 1.44	1317 1.55	1347 1.65	1376 1.76	1402 1.87	1428 1.97	1452 2.08	1476 2.19	1499 2.29
3600	1292 1.45	1321 1.55	1349 1.66	1378 1.77	1407 1.88	1435 2	1462 2.11	1486 2.22	1510 2.34	1533 2.45
3800	1329 1.56	1357 1.67	1384 1.78	1411 1.89	1438 2.01	1466 2.13	1493 2.25	1519 2.37	1545 2.49	1568 2.61
4000	1366 1.69	1393 1.8	1420 1.92	1447 2.03	1473 2.15	1498 2.27	1524 2.39	1550 2.52	1576 2.64	1600 2.77
4200	1405 1.83	1431 1.94	1457 2.06	1483 2.18	1508 2.3	1533 2.42	1557 2.55	1581 2.67	1607 2.8	1631 2.93
4400	1444 1.97	1470 2.09	1495 2.21	1520 2.34	1545 2.46	1569 2.59	1593 2.71	1616 2.84	1639 2.97	1663 3.1



Evaporator Fan Performance

Table 27. Evaporator fan performance - 10 ton (model TSJ), downflow, oversized/high static motor option (continued)

Available External Static Pressure (Inches of Water Gauge)																				
CFM	1.10"		1.20"		1.30"		1.40"		1.50"		1.60"		1.70"		1.80"		1.90"		2.00"	
	RPM	BHP	RPM	BHP	RPM	BHP	RPM	BHP	RPM	BHP	RPM	BHP	RPM	BHP	RPM	BHP	RPM	BHP	RPM	BHP
5-hp Oversized Motor																				
4600	1484	2.12	1509	2.25	1534	2.38	1558	2.5	1582	2.63	1605	2.76	1629	2.89	1652	3.02	1675	3.16	1697	3.29
4800	1525	2.28	1549	2.42	1573	2.55	1597	2.68	1620	2.81	1643	2.94	1666	3.08	1688	3.21	1711	3.35	1733	3.49

Notes:

1. Available External Static Pressure is the static pressure difference between the return duct and the supply duct plus the static pressure drop caused by accessories and options.
2. For direct drive evaporator fan speed (rpm), refer to the applicable table in the fan performance section.
3. Data includes pressure drop due to standard filters and wet coils. No accessories or options are included in pressure drop data.
4. To determine static drive pressure drop due to other options/accessories, refer to the applicable table in the fan performance section.
5. Direct drive fan motor heat is negligible.
6. Factory supplied motors, in commercial equipment, are definite purpose motors, specifically designed and tested to operate reliably and continuously at all cataloged conditions. Using the full horsepower range of our fan motors as shown in our tabular data will not result in nuisance tripping or premature motor failure. Our product's warranty will not be affected.

6 to 10 Ton Units — Horizontal

Figure 2. Fan curves — 6 to 10 tons, horizontal

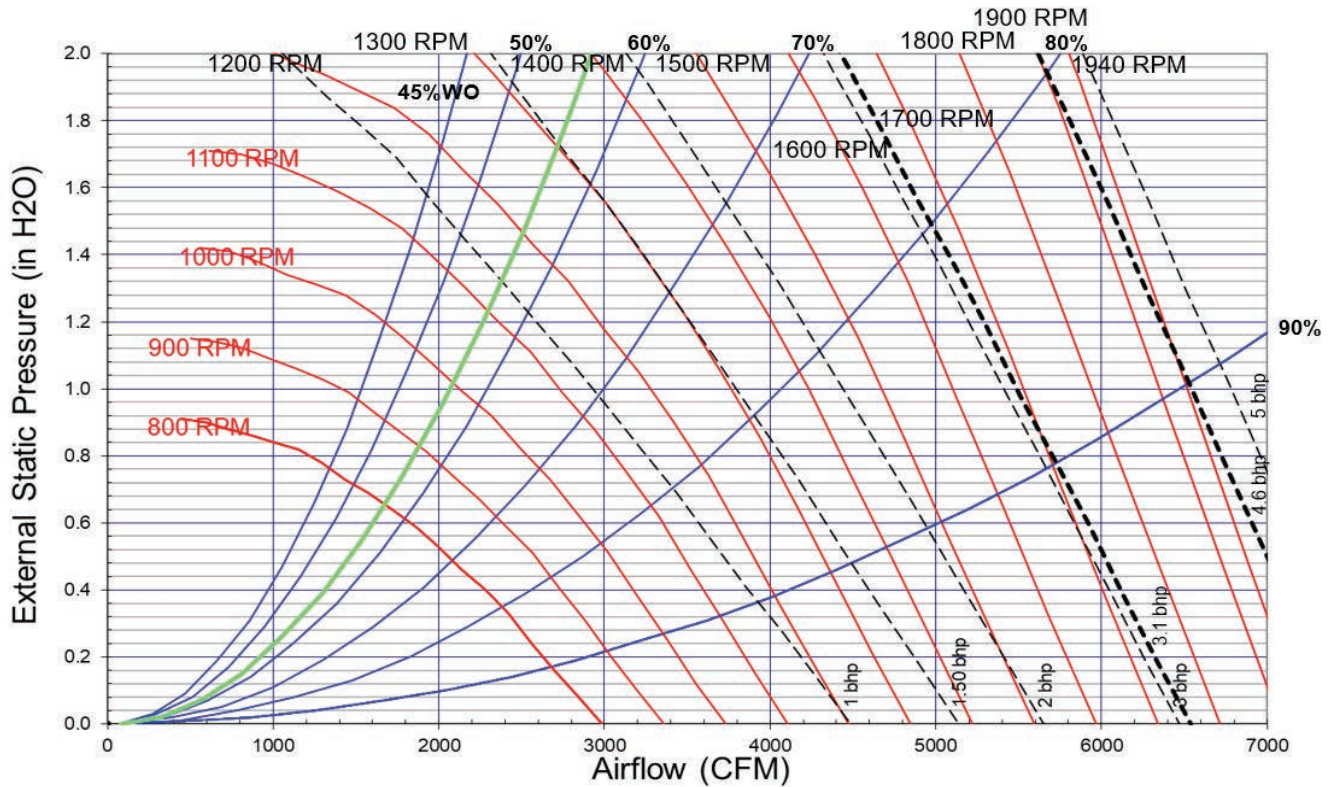

Table 28. Evaporator fan performance - 6 ton (model TSJ), horizontal

Available External Static Pressure (Inches of Water Gauge)																				
CFM	0.10"		0.20"		0.30"		0.40"		0.50"		0.60"		0.70"		0.80"		0.90"		1.00"	
	RPM	BHP	RPM	BHP	RPM	BHP	RPM	BHP	RPM	BHP	RPM	BHP	RPM	BHP	RPM	BHP	RPM	BHP	RPM	BHP
1800	550	0.11	606	0.15	658	0.19	708	0.24	754	0.29	797	0.35	839	0.40	878	0.46	915	0.52	951	0.58
1920	579	0.12	632	0.17	682	0.22	730	0.27	775	0.32	817	0.37	858	0.43	896	0.49	933	0.55	968	0.61
2040	608	0.14	659	0.19	707	0.24	753	0.29	797	0.35	838	0.40	876	0.46	915	0.52	951	0.59	986	0.65
2160	638	0.16	687	0.21	732	0.26	776	0.32	819	0.37	859	0.43	897	0.49	933	0.56	970	0.62	1004	0.69
2280	667	0.18	715	0.24	758	0.29	801	0.35	842	0.41	881	0.47	919	0.53	954	0.59	988	0.66	1023	0.73
2400	697	0.21	744	0.26	785	0.32	825	0.38	865	0.44	904	0.50	940	0.57	975	0.63	1009	0.70	1041	0.77
2520	727	0.24	772	0.29	812	0.35	851	0.41	889	0.48	926	0.54	963	0.61	997	0.68	1030	0.75	1061	0.82

Table 28. Evaporator fan performance - 6 ton (model TSJ), horizontal (continued)

Available External Static Pressure (Inches of Water Gauge)										
CFM	0.10"	0.20"	0.30"	0.40"	0.50"	0.60"	0.70"	0.80"	0.90"	1.00"
	RPM BHP	RPM BHP	RPM BHP	RPM BHP	RPM BHP	RPM BHP	RPM BHP	RPM BHP	RPM BHP	RPM BHP
2640	758 0.26	801 0.33	840 0.39	877 0.45	914 0.52	950 0.58	985 0.65	1019 0.72	1052 0.79	1083 0.87
2760	788 0.30	830 0.36	868 0.42	904 0.49	939 0.56	974 0.63	1008 0.70	1041 0.77	1073 0.84	1104 0.92
2880	818 0.33	859 0.40	896 0.46	930 0.53	965 0.60	998 0.67	1032 0.75	1064 0.82	1096 0.90	1126 0.97
Available External Static Pressure (Inches of Water Gauge)										
CFM	1.10"	1.20"	1.30"	1.40"	1.50"	1.60"	1.70"	1.80"	1.90"	2.00"
	RPM BHP	RPM BHP	RPM BHP	RPM BHP	RPM BHP	RPM BHP	RPM BHP	RPM BHP	RPM BHP	RPM BHP
1800	985 0.64	1018 0.7	1050 0.76	1080 0.83	1109 0.89	1138 0.96	1165 1.03	1193 1.1	1223 1.17	1251 1.25
1920	1002 0.68	1034 0.74	1066 0.81	1096 0.87	1126 0.94	1154 1.01	1181 1.08	1208 1.15	1234 1.22	1260 1.29
2040	1019 0.72	1051 0.78	1083 0.85	1113 0.92	1142 0.99	1170 1.06	1198 1.13	1224 1.21	1250 1.28	1276 1.35
2160	1037 0.76	1069 0.83	1099 0.9	1129 0.97	1158 1.04	1187 1.11	1214 1.19	1241 1.26	1267 1.34	1292 1.42
2280	1056 0.8	1087 0.87	1117 0.94	1147 1.02	1175 1.09	1203 1.17	1231 1.25	1257 1.32	1283 1.4	1308 1.48
2400	1074 0.84	1105 0.92	1135 0.99	1165 1.07	1193 1.15	1220 1.23	1247 1.31	1274 1.39	1300 1.47	1325 1.55
2520	1093 0.89	1124 0.97	1154 1.05	1183 1.12	1211 1.2	1238 1.29	1265 1.37	1291 1.45	1316 1.53	1341 1.62
2640	1113 0.94	1142 1.02	1172 1.1	1201 1.18	1229 1.26	1256 1.35	1283 1.43	1308 1.52	1333 1.6	1358 1.69
2760	1134 1	1163 1.08	1191 1.16	1220 1.24	1248 1.32	1275 1.41	1301 1.49	1326 1.58	1351 1.67	1376 1.76
2880	1156 1.05	1184 1.13	1211 1.22	1238 1.3	1266 1.39	1293 1.47	1319 1.56	1345 1.65	1369 1.74	1394 1.83

Notes:

1. Available External Static Pressure is the static pressure difference between the return duct and the supply duct plus the static pressure drop caused by accessories and options.
2. For direct drive evaporator fan speed (rpm), refer to the applicable table in the fan performance section.
3. Data includes pressure drop due to standard filters and wet coils. No accessories or options are included in pressure drop data.
4. To determine static pressure drop due to other options/accessories, refer to the applicable table in the fan performance section.
5. Direct drive fan motor heat is negligible.
6. Factory supplied motors, in commercial equipment, are definite purpose motors, specifically designed and tested to operate reliably and continuously at all cataloged conditions. Using the full horsepower range of our fan motors as shown in our tabular data will not result in nuisance tripping or premature motor failure. Our product's warranty will not be affected.

Table 29. Evaporator fan performance - 7.5 ton (model TSJ), horizontal

Available External Static Pressure (Inches of Water Gauge)										
CFM	0.10"	0.20"	0.30"	0.40"	0.50"	0.60"	0.70"	0.80"	0.90"	1.00"
	RPM BHP	RPM BHP	RPM BHP	RPM BHP	RPM BHP	RPM BHP	RPM BHP	RPM BHP	RPM BHP	RPM BHP
2250	660 0.18	708 0.23	752 0.28	795 0.34	836 0.40	876 0.46	913 0.52	949 0.58	984 0.65	1018 0.72
2400	697 0.21	744 0.26	785 0.32	825 0.38	865 0.44	904 0.50	940 0.57	975 0.63	1009 0.70	1041 0.77
2550	735 0.24	779 0.30	819 0.36	857 0.42	895 0.49	932 0.55	968 0.62	1003 0.69	1035 0.76	1067 0.83
2700	773 0.28	816 0.34	854 0.40	890 0.47	926 0.54	962 0.60	996 0.67	1030 0.74	1062 0.82	1094 0.89
2850	811 0.32	852 0.39	889 0.45	924 0.52	958 0.59	992 0.66	1026 0.73	1058 0.81	1090 0.88	1121 0.96
3000	849 0.37	889 0.44	925 0.51	958 0.58	991 0.65	1023 0.72	1056 0.80	1087 0.87	1118 0.95	1148 1.03
3150	887 0.42	926 0.49	961 0.56	994 0.64	1025 0.71	1056 0.79	1087 0.87	1117 0.95	1147 1.03	1176 1.11
3300	926 0.47	963 0.55	997 0.63	1029 0.70	1059 0.78	1089 0.86	1118 0.94	1148 1.02	1177 1.11	1205 1.19
3600	1003 0.60	1038 0.68	1070 0.77	1101 0.85	1129 0.93	1156 1.01	1184 1.10	1211 1.19	1238 1.28	1265 1.37
Available External Static Pressure (Inches of Water Gauge)										
CFM	1.10"	1.20"	1.30"	1.40"	1.50"	1.60"	1.70"	1.80"	1.90"	2.00"
	RPM BHP	RPM BHP	RPM BHP	RPM BHP	RPM BHP	RPM BHP	RPM BHP	RPM BHP	RPM BHP	RPM BHP
2250	1051 0.79	1083 0.86	1113 0.93	1142 1.01	1171 1.08	1199 1.16	1226 1.23	1253 1.31	1279 1.39	1304 1.46
2400	1074 0.84	1105 0.92	1135 0.99	1165 1.07	1193 1.15	1220 1.23	1247 1.31	1274 1.39	1300 1.47	1325 1.55
2550	1097 0.9	1128 0.98	1158 1.06	1187 1.14	1215 1.22	1243 1.3	1269 1.38	1295 1.47	1320 1.55	1345 1.63
2700	1123 0.97	1152 1.05	1182 1.13	1210 1.21	1238 1.29	1265 1.38	1292 1.46	1317 1.55	1342 1.64	1367 1.72
2850	1150 1.04	1179 1.12	1206 1.2	1234 1.28	1261 1.37	1288 1.46	1315 1.55	1340 1.63	1365 1.72	1389 1.82
3000	1177 1.11	1206 1.2	1233 1.28	1259 1.37	1285 1.45	1312 1.54	1338 1.63	1363 1.72	1388 1.82	1412 1.91
3150	1205 1.19	1233 1.28	1260 1.36	1286 1.45	1311 1.54	1336 1.63	1361 1.72	1386 1.82	1411 1.92	1435 2.01
3300	1233 1.28	1260 1.36	1287 1.45	1313 1.54	1338 1.64	1363 1.73	1386 1.82	1410 1.92	1434 2.02	1458 2.12



Evaporator Fan Performance

Table 29. Evaporator fan performance - 7.5 ton (model TSJ), horizontal (continued)

Available External Static Pressure (Inches of Water Gauge)										
CFM	1.10"	1.20"	1.30"	1.40"	1.50"	1.60"	1.70"	1.80"	1.90"	2.00"
	RPM BHP	RPM BHP	RPM BHP	RPM BHP	RPM BHP	RPM BHP	RPM BHP	RPM BHP	RPM BHP	RPM BHP
3600	1291 1.46	1317 1.55	1343 1.65	1368 1.74	1393 1.84	1417 1.94	1440 2.04	1463 2.14	1486 2.24	1507 2.34

Notes:

1. Available External Static Pressure is the static pressure difference between the return duct and the supply duct plus the static pressure drop caused by accessories and options.
2. For direct drive evaporator fan speed (rpm), refer to the applicable table in the fan performance section.
3. Data includes pressure drop due to standard filters and wet coils. No accessories or options are included in pressure drop data.
4. To determine static pressure drop due to other options/accessories, refer to the applicable table in the fan performance section.
5. Direct drive fan motor heat is negligible.
6. Factory supplied motors, in commercial equipment, are definite purpose motors, specifically designed and tested to operate reliably and continuously at all cataloged conditions. Using the full horsepower range of our fan motors as shown in our tabular data will not result in nuisance tripping or premature motor failure. Our product's warranty will not be affected.

Table 30. Evaporator fan performance - 8.5 ton (model TSJ), horizontal

Available External Static Pressure (Inches of Water Gauge)										
CFM	0.10"	0.20"	0.30"	0.40"	0.50"	0.60"	0.70"	0.80"	0.90"	1.00"
	RPM BHP	RPM BHP	RPM BHP	RPM BHP	RPM BHP	RPM BHP	RPM BHP	RPM BHP	RPM BHP	RPM BHP
2550	735 0.24	779 0.30	819 0.36	857 0.42	895 0.49	932 0.55	968 0.62	1003 0.69	1035 0.76	1067 0.83
2720	778 0.29	820 0.35	859 0.41	895 0.48	930 0.54	966 0.61	1000 0.68	1034 0.75	1066 0.83	1097 0.90
2890	821 0.33	862 0.40	899 0.47	933 0.53	967 0.61	1001 0.68	1034 0.75	1066 0.82	1097 0.90	1128 0.98
3060	864 0.39	903 0.46	940 0.53	972 0.60	1004 0.67	1036 0.75	1068 0.82	1099 0.90	1129 0.98	1159 1.06
3230	908 0.45	945 0.52	980 0.60	1012 0.67	1043 0.75	1073 0.83	1103 0.91	1133 0.99	1163 1.07	1191 1.15
3400	952 0.51	988 0.59	1021 0.67	1053 0.75	1082 0.83	1111 0.91	1140 0.99	1168 1.08	1197 1.16	1225 1.25
3570	996 0.59	1030 0.67	1063 0.75	1094 0.83	1122 0.92	1150 1.00	1177 1.08	1205 1.17	1232 1.26	1259 1.35
3740	1040 0.67	1073 0.75	1104 0.84	1134 0.92	1163 1.01	1189 1.10	1215 1.18	1242 1.28	1267 1.37	1293 1.46
4080	1128 0.85	1159 0.94	1189 1.03	1217 1.13	1244 1.22	1269 1.32	1294 1.41	1318 1.50	1342 1.60	1366 1.71

Available External Static Pressure (Inches of Water Gauge)										
CFM	1.10"	1.20"	1.30"	1.40"	1.50"	1.60"	1.70"	1.80"	1.90"	2.00"
	RPM BHP	RPM BHP	RPM BHP	RPM BHP	RPM BHP	RPM BHP	RPM BHP	RPM BHP	RPM BHP	RPM BHP
2550	1097 0.9	1128 0.98	1158 1.06	1187 1.14	1215 1.22	1243 1.3	1269 1.38	1295 1.47	1320 1.55	1345 1.63
2720	1127 0.98	1156 1.06	1185 1.14	1214 1.22	1241 1.3	1268 1.39	1295 1.47	1320 1.56	1345 1.65	1370 1.74
2890	1157 1.06	1186 1.14	1213 1.22	1240 1.31	1268 1.39	1295 1.48	1321 1.57	1346 1.66	1371 1.75	1395 1.84
3060	1188 1.14	1216 1.23	1243 1.31	1270 1.4	1295 1.49	1321 1.58	1347 1.67	1372 1.76	1397 1.86	1421 1.95
3230	1220 1.24	1247 1.32	1274 1.41	1300 1.5	1326 1.59	1350 1.68	1374 1.78	1399 1.87	1423 1.97	1447 2.07
3400	1252 1.33	1279 1.42	1305 1.52	1331 1.61	1356 1.7	1380 1.8	1404 1.89	1427 1.99	1450 2.09	1474 2.19
3570	1285 1.44	1311 1.53	1337 1.63	1362 1.72	1387 1.82	1411 1.92	1435 2.02	1458 2.12	1480 2.22	1502 2.32
3740	1319 1.56	1345 1.65	1369 1.75	1394 1.84	1418 1.94	1442 2.04	1466 2.15	1488 2.25	1511 2.35	1532 2.46
4080	1389 1.81	1413 1.91	1437 2.01	1460 2.11	1483 2.22	1506 2.32	1528 2.43	1551 2.54	1573 2.65	1594 2.76

Notes:

1. Available External Static Pressure is the static pressure difference between the return duct and the supply duct plus the static pressure drop caused by accessories and options.
2. For direct drive evaporator fan speed (rpm), refer to the applicable table in the fan performance section.
3. Data includes pressure drop due to standard filters and wet coils. No accessories or options are included in pressure drop data.
4. To determine static pressure drop due to other options/accessories, refer to the applicable table in the fan performance section.
5. Direct drive fan motor heat is negligible.
6. Factory supplied motors, in commercial equipment, are definite purpose motors, specifically designed and tested to operate reliably and continuously at all cataloged conditions. Using the full horsepower range of our fan motors as shown in our tabular data will not result in nuisance tripping or premature motor failure. Our product's warranty will not be affected.

Table 31. Evaporator fan performance - 10 ton (model TSJ), horizontal

Available External Static Pressure (Inches of Water Gauge)										
CFM	0.10"	0.20"	0.30"	0.40"	0.50"	0.60"	0.70"	0.80"	0.90"	1.00"
	RPM BHP	RPM BHP	RPM BHP	RPM BHP	RPM BHP	RPM BHP	RPM BHP	RPM BHP	RPM BHP	RPM BHP
3-hp Standard Motor										
3000	849 0.37	889 0.44	925 0.51	958 0.58	991 0.65	1023 0.72	1056 0.80	1087 0.87	1118 0.95	1148 1.03
3200	900 0.44	938 0.51	973 0.58	1005 0.66	1036 0.73	1067 0.81	1097 0.89	1127 0.97	1157 1.05	1186 1.13
3400	952 0.51	988 0.59	1021 0.67	1053 0.75	1082 0.83	1111 0.91	1140 0.99	1168 1.08	1197 1.16	1225 1.25
3600	1003 0.60	1038 0.68	1070 0.77	1101 0.85	1129 0.93	1156 1.01	1184 1.10	1211 1.19	1238 1.28	1265 1.37
3800	1055 0.70	1088 0.78	1119 0.87	1149 0.96	1177 1.05	1203 1.13	1229 1.22	1255 1.31	1281 1.41	1306 1.50

Table 31. Evaporator fan performance - 10 ton (model TSJ), horizontal (continued)

Available External Static Pressure (Inches of Water Gauge)										
CFM	0.10"	0.20"	0.30"	0.40"	0.50"	0.60"	0.70"	0.80"	0.90"	1.00"
	RPM BHP	RPM BHP	RPM BHP	RPM BHP	RPM BHP	RPM BHP	RPM BHP	RPM BHP	RPM BHP	RPM BHP
3-hp Standard Motor										
4000	1107 0.80	1139 0.89	1169 0.98	1197 1.08	1225 1.17	1250 1.26	1275 1.35	1299 1.45	1324 1.55	1349 1.65
4200	1159 0.92	1190 1.01	1219 1.11	1246 1.21	1273 1.31	1298 1.40	1322 1.50	1345 1.60	1369 1.69	1392 1.80
4400	1211 1.05	1241 1.15	1269 1.25	1295 1.35	1321 1.45	1346 1.55	1370 1.65	1392 1.75	1414 1.86	1437 1.96
4800	1316 1.34	1344 1.45	1370 1.56	1395 1.67	1419 1.78	1442 1.89	1465 2.00	1487 2.11	1508 2.22	1529 2.33
Available External Static Pressure (Inches of Water Gauge)										
CFM	1.10"	1.20"	1.30"	1.40"	1.50"	1.60"	1.70"	1.80"	1.90"	2.00"
	RPM BHP	RPM BHP	RPM BHP	RPM BHP	RPM BHP	RPM BHP	RPM BHP	RPM BHP	RPM BHP	RPM BHP
3-hp Standard Motor										
3000	1177 1.11	1206 1.2	1233 1.28	1259 1.37	1285 1.45	1312 1.54	1338 1.63	1363 1.72	1388 1.82	1412 1.91
3200	1214 1.22	1242 1.31	1269 1.39	1295 1.48	1320 1.57	1345 1.66	1369 1.76	1394 1.85	1419 1.95	1443 2.05
3400	1252 1.33	1279 1.42	1305 1.52	1331 1.61	1356 1.70	1380 1.80	1404 1.89	1427 1.99	1450 2.09	1474 2.19
3600	1291 1.46	1317 1.55	1343 1.65	1368 1.74	1393 1.84	1417 1.94	1440 2.04	1463 2.14	1486 2.24	1507 2.34
3800	1332 1.60	1357 1.69	1381 1.79	1405 1.89	1430 1.99	1453 2.09	1477 2.19	1499 2.3	1521 2.40	1543 2.51
4000	1373 1.75	1397 1.85	1421 1.95	1444 2.05	1467 2.15	1491 2.25	1514 2.36	1536 2.47	1558 2.58	1579 2.69
4200	1415 1.90	1438 2.01	1462 2.11	1485 2.22	1507 2.32	1529 2.43	1551 2.54	1573 2.65	1595 2.76	1616 2.88
4400	1459 2.07	1481 2.18	1503 2.29	1525 2.40	1547 2.51	1569 2.62	1590 2.73	1611 2.84	1632 2.96	- -
4800	1549 2.44	1569 2.56	1590 2.68	1610 2.80	1630 2.92	1650 3.04	- -	- -	- -	- -

Notes:

1. Available External Static Pressure is the static pressure difference between the return duct and the supply duct plus the static pressure drop caused by accessories and options.
2. For direct drive evaporator fan speed (rpm), refer to the applicable table in the fan performance section.
3. Data includes pressure drop due to standard filters and wet coils. No accessories or options are included in pressure drop data.
4. To determine static pressure drop due to other options/accessories, refer to the applicable table in the fan performance section.
5. Direct drive fan motor heat is negligible.
6. Factory supplied motors, in commercial equipment, are definite purpose motors, specifically designed and tested to operate reliably and continuously at all cataloged conditions. Using the full horsepower range of our fan motors as shown in our tabular data will not result in nuisance tripping or premature motor failure. Our product's warranty will not be affected.

Table 32. Evaporator fan performance - 10 ton (model TSJ), oversized/high static motor option

Available External Static Pressure (Inches of Water Gauge)										
CFM	0.10"	0.20"	0.30"	0.40"	0.50"	0.60"	0.70"	0.80"	0.90"	1.00"
	RPM BHP	RPM BHP	RPM BHP	RPM BHP	RPM BHP	RPM BHP	RPM BHP	RPM BHP	RPM BHP	RPM BHP
5-hp Oversized Motor										
3000	856 0.38	894 0.45	929 0.52	962 0.58	995 0.65	1028 0.73	1060 0.80	1092 0.88	1122 0.95	1152 1.03
3200	908 0.45	944 0.52	978 0.60	1010 0.67	1040 0.74	1071 0.82	1102 0.90	1132 0.98	1162 1.06	1190 1.14
3400	960 0.53	994 0.61	1027 0.69	1058 0.76	1087 0.84	1114 0.92	1145 1.00	1174 1.08	1202 1.17	1230 1.25
3600	1012 0.62	1045 0.70	1076 0.78	1106 0.87	1134 0.95	1161 1.03	1188 1.11	1216 1.20	1244 1.29	1270 1.38
3800	1065 0.72	1096 0.81	1126 0.89	1155 0.98	1182 1.07	1208 1.15	1233 1.24	1259 1.33	1286 1.42	1312 1.51
4000	1117 0.84	1148 0.92	1176 1.01	1204 1.10	1231 1.19	1256 1.28	1280 1.37	1304 1.47	1329 1.56	1355 1.66
4200	1170 0.96	1199 1.05	1227 1.14	1254 1.24	1279 1.33	1304 1.43	1328 1.52	1351 1.62	1373 1.72	1398 1.82
4400	1223 1.09	1251 1.19	1278 1.29	1304 1.38	1328 1.48	1352 1.58	1376 1.68	1398 1.78	1420 1.88	1441 1.98
4600	1276 1.24	1303 1.34	1329 1.44	1354 1.54	1378 1.65	1401 1.75	1424 1.86	1446 1.96	1467 2.06	1488 2.17
4800	1329 1.40	1355 1.50	1380 1.61	1404 1.72	1428 1.82	1450 1.93	1472 2.04	1494 2.15	1514 2.26	1535 2.37
Available External Static Pressure (Inches of Water Gauge)										
CFM	1.10"	1.20"	1.30"	1.40"	1.50"	1.60"	1.70"	1.80"	1.90"	2.00"
	RPM BHP	RPM BHP	RPM BHP	RPM BHP	RPM BHP	RPM BHP	RPM BHP	RPM BHP	RPM BHP	RPM BHP
5-hp Oversized Motor										
3000	1180 1.11	1208 1.2	1235 1.28	1261 1.37	1286 1.45	1311 1.54	1337 1.63	1362 1.72	1387 1.81	1411 1.91
3200	1218 1.22	1245 1.31	1271 1.39	1297 1.48	1322 1.57	1346 1.66	1370 1.75	1394 1.85	1418 1.94	1442 2.04
3400	1257 1.34	1283 1.43	1309 1.52	1334 1.61	1359 1.7	1383 1.8	1406 1.89	1429 1.99	1451 2.09	1473 2.18
3600	1297 1.47	1322 1.56	1347 1.65	1372 1.75	1396 1.84	1420 1.94	1443 2.04	1465 2.14	1488 2.24	1509 2.34
3800	1337 1.61	1362 1.7	1387 1.8	1411 1.89	1434 1.99	1458 2.1	1480 2.2	1503 2.3	1524 2.41	1546 2.51
4000	1379 1.76	1403 1.86	1427 1.96	1450 2.06	1473 2.16	1496 2.26	1518 2.37	1540 2.47	1562 2.58	1583 2.69
4200	1422 1.92	1445 2.02	1468 2.12	1491 2.23	1513 2.33	1535 2.44	1557 2.55	1578 2.66	1600 2.77	1620 2.88
4400	1465 2.09	1488 2.2	1510 2.31	1532 2.41	1554 2.52	1576 2.63	1597 2.74	1618 2.86	1638 2.97	1659 3.08



Evaporator Fan Performance

Table 32. Evaporator fan performance - 10 ton (model TSJ), oversized/high static motor option (continued)

Available External Static Pressure (Inches of Water Gauge)																				
CFM	1.10"		1.20"		1.30"		1.40"		1.50"		1.60"		1.70"		1.80"		1.90"		2.00"	
	RPM	BHP	RPM	BHP	RPM	BHP	RPM	BHP	RPM	BHP	RPM	BHP	RPM	BHP	RPM	BHP	RPM	BHP	RPM	BHP
5-hp Oversized Motor																				
4600	1508	2.28	1531	2.39	1553	2.5	1574	2.61	1595	2.72	1616	2.84	1637	2.95	1658	3.07	1678	3.18	1698	3.3
4800	1555	2.48	1574	2.59	1596	2.7	1617	2.82	1638	2.94	1658	3.06	1678	3.17	1698	3.29	1718	3.41	1737	3.53

Notes:

1. Available External Static Pressure is the static pressure difference between the return duct and the supply duct plus the static pressure drop caused by accessories and options.
2. For direct drive evaporator fan speed (rpm), refer to the applicable table in the fan performance section.
3. Data includes pressure drop due to standard filters and wet coils. No accessories or options are included in pressure drop data.
4. To determine static drive pressure drop due to other options/accessories, refer to the applicable table in the fan performance section.
5. Direct drive fan motor heat is negligible.
6. Factory supplied motors, in commercial equipment, are definite purpose motors, specifically designed and tested to operate reliably and continuously at all cataloged conditions. Using the full horsepower range of our fan motors as shown in our tabular data will not result in nuisance tripping or premature motor failure. Our product's warranty will not be affected.

12.5 Ton Units — Downflow

Figure 3. Fan curves — 12.5 ton, downflow

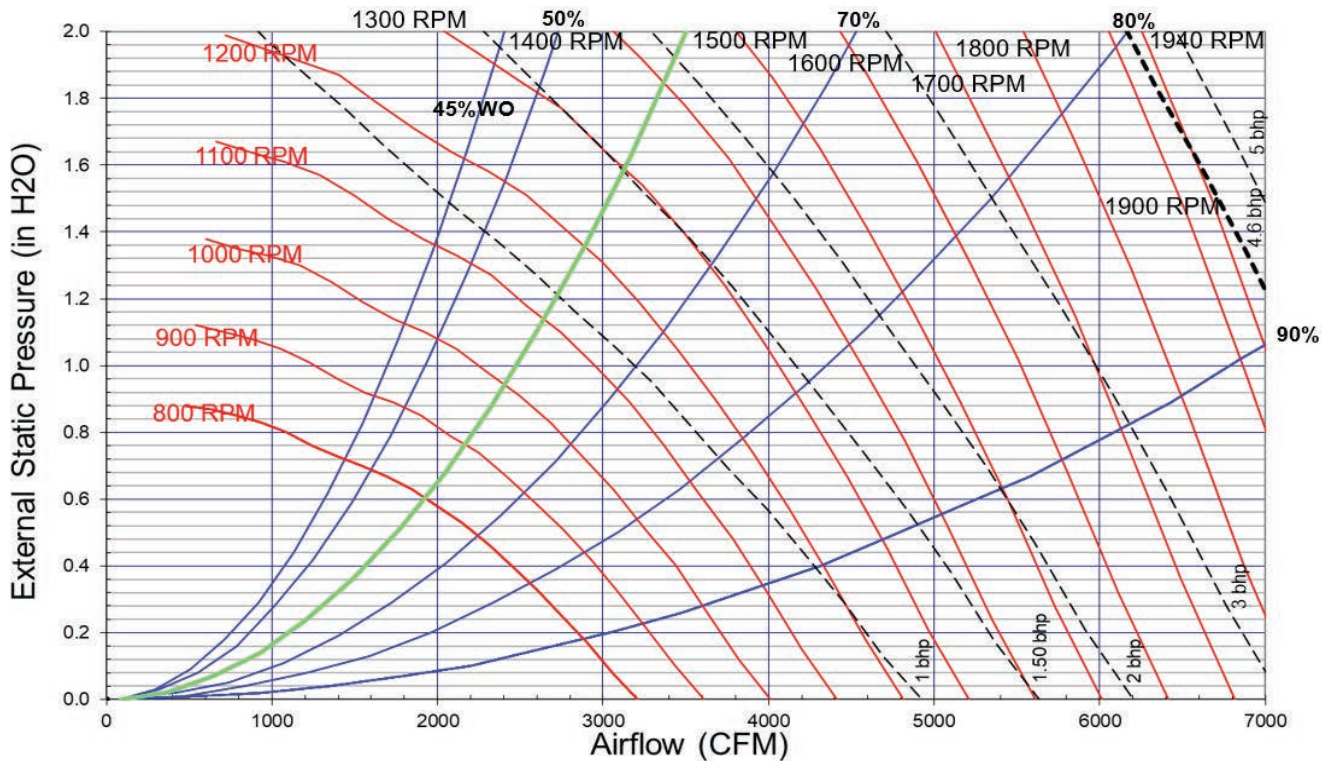

Table 33. Evaporator fan performance - 12.5 ton (model TSJ), downflow

Available External Static Pressure (Inches of Water Gauge)																				
CFM	0.10"		0.20"		0.30"		0.40"		0.50"		0.60"		0.70"		0.80"		0.90"		1.00"	
	RPM	BHP	RPM	BHP	RPM	BHP	RPM	BHP	RPM	BHP	RPM	BHP	RPM	BHP	RPM	BHP	RPM	BHP	RPM	BHP
3750	975	0.52	1008	0.60	1038	0.67	1067	0.75	1099	0.83	1129	0.91	1158	1.00	1186	1.09	1213	1.17	1240	1.26
4000	1036	0.62	1067	0.70	1096	0.78	1124	0.86	1152	0.94	1181	1.03	1209	1.13	1236	1.22	1262	1.31	1288	1.40
4250	1097	0.74	1126	0.82	1154	0.90	1181	0.99	1206	1.07	1233	1.17	1261	1.26	1287	1.36	1313	1.46	1337	1.55
4500	1157	0.86	1186	0.95	1213	1.04	1238	1.13	1263	1.22	1287	1.31	1313	1.41	1339	1.51	1363	1.62	1388	1.72
4750	1218	1.00	1246	1.10	1271	1.19	1296	1.28	1320	1.38	1343	1.47	1366	1.58	1391	1.68	1415	1.79	1438	1.90
5000	1279	1.16	1306	1.26	1331	1.36	1354	1.45	1377	1.55	1399	1.65	1421	1.76	1444	1.86	1467	1.98	1490	2.09
5250	1340	1.33	1367	1.44	1390	1.54	1413	1.64	1435	1.75	1456	1.85	1477	1.96	1498	2.06	1520	2.18	1542	2.30
5500	1401	1.51	1427	1.63	1450	1.74	1472	1.84	1493	1.95	1514	2.06	1534	2.17	1554	2.28	1574	2.40	1595	2.52

Table 33. Evaporator fan performance - 12.5 ton (model TSJ), downflow (continued)

Available External Static Pressure (Inches of Water Gauge)										
CFM	0.10"	0.20"	0.30"	0.40"	0.50"	0.60"	0.70"	0.80"	0.90"	1.00"
	RPM BHP	RPM BHP	RPM BHP	RPM BHP	RPM BHP	RPM BHP	RPM BHP	RPM BHP	RPM BHP	RPM BHP
5750	1462 1.72	1488 1.84	1510 1.95	1531 2.07	1551 2.18	1572 2.29	1591 2.41	1610 2.52	1629 2.64	1648 2.76
6000	1523 1.94	1548 2.07	1570 2.19	1590 2.31	1610 2.42	1630 2.54	1649 2.66	1667 2.78	1686 2.90	1704 3.02
Available External Static Pressure (Inches of Water Gauge)										
CFM	1.10"	1.20"	1.30"	1.40"	1.50"	1.60"	1.70"	1.80"	1.90"	2.00"
	RPM BHP	RPM BHP	RPM BHP	RPM BHP	RPM BHP	RPM BHP	RPM BHP	RPM BHP	RPM BHP	RPM BHP
3750	1267 1.36	1293 1.45	1319 1.55	1345 1.64	1370 1.74	1394 1.85	1419 1.95	1443 2.06	1467 2.17	1490 2.28
4000	1314 1.5	1339 1.59	1363 1.69	1388 1.79	1412 1.9	1436 2	1459 2.11	1483 2.22	1506 2.33	1529 2.44
4250	1362 1.65	1386 1.75	1410 1.86	1433 1.96	1455 2.06	1479 2.17	1502 2.28	1524 2.39	1546 2.51	1568 2.62
4500	1411 1.82	1434 1.93	1457 2.03	1480 2.14	1502 2.25	1523 2.36	1545 2.47	1567 2.59	1589 2.7	1610 2.82
4750	1461 2.01	1484 2.12	1506 2.23	1527 2.34	1549 2.45	1570 2.56	1591 2.68	1612 2.8	1632 2.91	1653 3.04
5000	1512 2.21	1534 2.32	1556 2.43	1577 2.55	1597 2.67	1618 2.78	1638 2.9	1658 3.02	1678 3.15	1697 3.27
5250	1564 2.42	1585 2.54	1606 2.66	1627 2.78	1647 2.9	1667 3.02	1686 3.14	1706 3.27	1725 3.39	1744 3.52
5500	1616 2.65	1637 2.77	1657 2.9	1677 3.02	1697 3.15	1717 3.27	1736 3.4	1754 3.53	1773 3.66	1792 3.79
5750	1669 2.89	1689 3.02	1709 3.15	1729 3.28	1748 3.42	1767 3.55	1786 3.68	1804 3.81	1822 3.94	1840 4.08
6000	1722 3.15	1742 3.29	1762 3.42	1781 3.56	1799 3.7	1818 3.84	1836 3.97	1854 4.11	1872 4.25	1889 4.38

Notes:

1. Available External Static Pressure is the static pressure difference between the return duct and the supply duct plus the static pressure drop caused by accessories and options.
2. For direct drive evaporator fan speed (rpm), refer to the applicable table in the fan performance section.
3. Data includes pressure drop due to standard filters and wet coils. No accessories or options are included in pressure drop data.
4. To determine static pressure drop due to other options/accessories, refer to the applicable table in the fan performance section.
5. Direct drive fan motor heat is negligible.
6. Factory supplied motors, in commercial equipment, are definite purpose motors, specifically designed and tested to operate reliably and continuously at all cataloged conditions. Using the full horsepower range of our fan motors as shown in our tabular data will not result in nuisance tripping or premature motor failure. Our product's warranty will not be affected.

12.5 Ton Units — Horizontal

Figure 4. Fan curves — 12.5 ton, horizontal

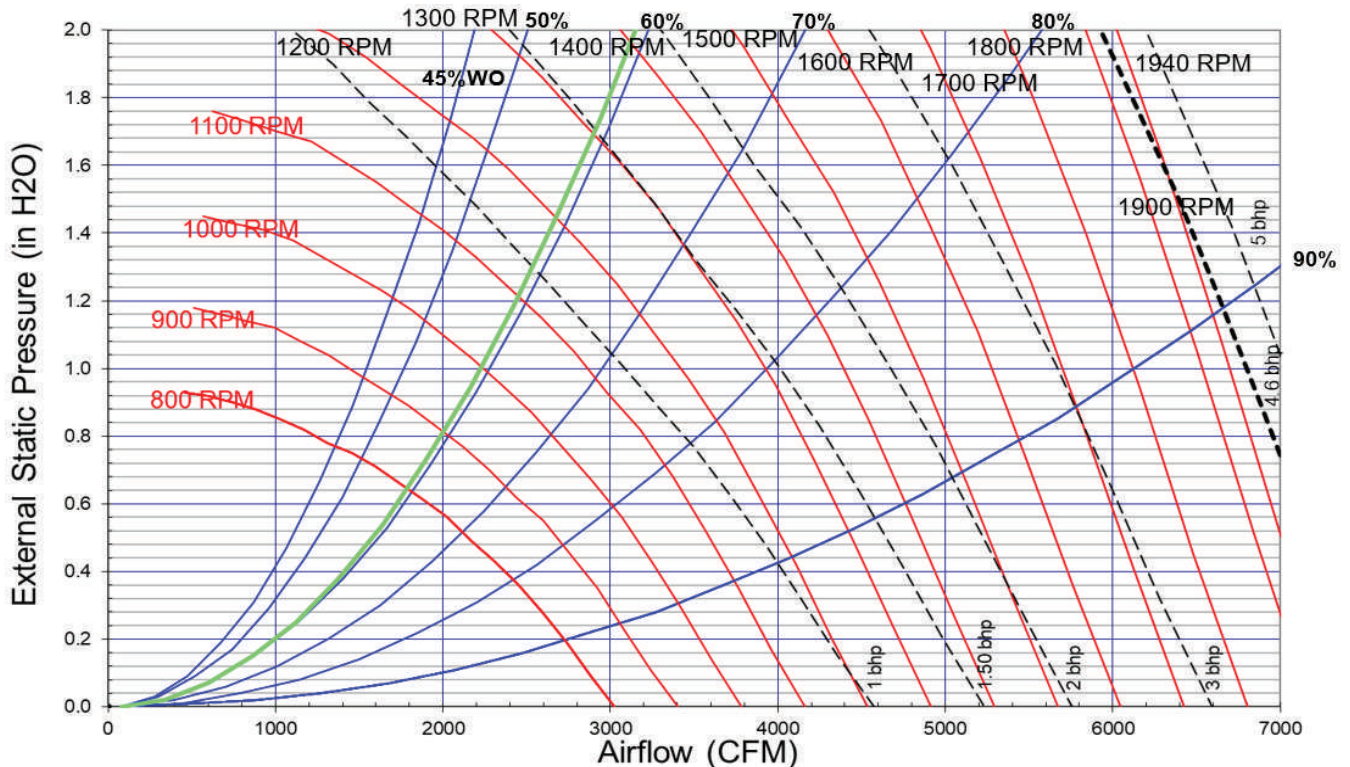



Evaporator Fan Performance

Table 34. Evaporator fan performance - 12.5 ton (model TSJ), horizontal

Available External Static Pressure (Inches of Water Gauge)										
CFM	0.10"	0.20"	0.30"	0.40"	0.50"	0.60"	0.70"	0.80"	0.90"	1.00"
	RPM BHP	RPM BHP	RPM BHP	RPM BHP	RPM BHP	RPM BHP	RPM BHP	RPM BHP	RPM BHP	RPM BHP
3750	1026 0.63	1055 0.70	1083 0.77	1109 0.84	1135 0.92	1162 1.00	1188 1.08	1214 1.16	1239 1.25	1263 1.34
4000	1091 0.75	1118 0.83	1144 0.90	1170 0.98	1194 1.06	1219 1.14	1244 1.23	1268 1.31	1292 1.40	1316 1.49
4250	1155 0.89	1181 0.97	1206 1.05	1231 1.13	1254 1.21	1276 1.30	1300 1.39	1324 1.48	1346 1.57	1369 1.67
4500	1220 1.05	1245 1.13	1269 1.22	1292 1.30	1314 1.39	1336 1.48	1358 1.56	1380 1.66	1402 1.76	1424 1.86
4750	1284 1.22	1309 1.31	1332 1.40	1354 1.49	1375 1.58	1396 1.67	1417 1.76	1437 1.86	1459 1.96	1480 2.07
5000	1349 1.41	1373 1.51	1395 1.60	1416 1.70	1437 1.79	1457 1.89	1477 1.98	1496 2.08	1516 2.18	1536 2.29
5250	1414 1.62	1437 1.73	1458 1.83	1479 1.93	1499 2.02	1518 2.12	1537 2.23	1556 2.33	1574 2.43	1593 2.54
5500	1479 1.86	1502 1.97	1522 2.07	1542 2.17	1561 2.28	1580 2.38	1598 2.49	1616 2.59	1634 2.70	1651 2.81
5750	1544 2.11	1566 2.23	1586 2.34	1605 2.44	1623 2.55	1641 2.66	1659 2.77	1677 2.88	1694 2.99	1711 3.10
6000	1609 2.39	1631 2.51	1650 2.62	1668 2.74	1686 2.85	1704 2.96	1721 3.08	1738 3.19	1754 3.31	1771 3.42
Available External Static Pressure (Inches of Water Gauge)										
CFM	1.10"	1.20"	1.30"	1.40"	1.50"	1.60"	1.70"	1.80"	1.90"	2.00"
	RPM BHP	RPM BHP	RPM BHP	RPM BHP	RPM BHP	RPM BHP	RPM BHP	RPM BHP	RPM BHP	RPM BHP
3750	1289 1.43	1316 1.53	1341 1.63	1366 1.73	1390 1.82	1413 1.92	1436 2.02	1457 2.11	1480 2.21	1503 2.32
4000	1339 1.59	1362 1.68	1387 1.78	1412 1.89	1436 1.99	1459 2.1	1481 2.2	1503 2.31	1524 2.41	1545 2.52
4250	1392 1.76	1414 1.86	1435 1.96	1458 2.06	1481 2.17	1504 2.29	1527 2.4	1549 2.51	1570 2.62	1590 2.73
4500	1445 1.96	1467 2.06	1488 2.16	1508 2.27	1528 2.37	1550 2.49	1573 2.6	1594 2.72	1615 2.84	1636 2.96
4750	1500 2.17	1520 2.28	1541 2.38	1561 2.49	1580 2.6	1600 2.71	1619 2.82	1640 2.94	1661 3.07	1682 3.19
5000	1556 2.4	1575 2.51	1594 2.62	1614 2.73	1633 2.85	1652 2.96	1671 3.08	1689 3.19	1707 3.31	1728 3.44
5250	1612 2.65	1631 2.76	1650 2.88	1668 2.99	1687 3.11	1705 3.23	1723 3.35	1741 3.47	1759 3.59	1776 3.71
5500	1669 2.92	1688 3.04	1706 3.16	1724 3.28	1741 3.4	1759 3.52	1776 3.65	1794 3.77	1811 3.9	1828 4.02
5750	1727 3.21	1745 3.33	1763 3.46	1780 3.58	1797 3.71	1814 3.83	1830 3.96	1847 4.09	1864 4.22	1881 4.35
6000	1787 3.54	1803 3.65	1820 3.78	1837 3.91	1853 4.04	1870 4.17	1886 4.3	1902 4.43	1918 4.57	- -

Notes:

1. Available External Static Pressure is the static pressure difference between the return duct and the supply duct plus the static pressure drop caused by accessories and options.
2. For direct drive evaporator fan speed (rpm), refer to the applicable table in the fan performance section.
3. Data includes pressure drop due to standard filters and wet coils. No accessories or options are included in pressure drop data.
4. To determine static pressure drop due to other options/accessories, refer to the applicable table in the fan performance section.
5. Direct drive fan motor heat is negligible.
6. Factory supplied motors, in commercial equipment, are definite purpose motors, specifically designed and tested to operate reliably and continuously at all cataloged conditions. Using the full horsepower range of our fan motors as shown in our tabular data will not result in nuisance tripping or premature motor failure. Our product's warranty will not be affected.

15 to 25 Ton Units — Downflow

Figure 5. Fan curves — 15 to 25 tons, downflow

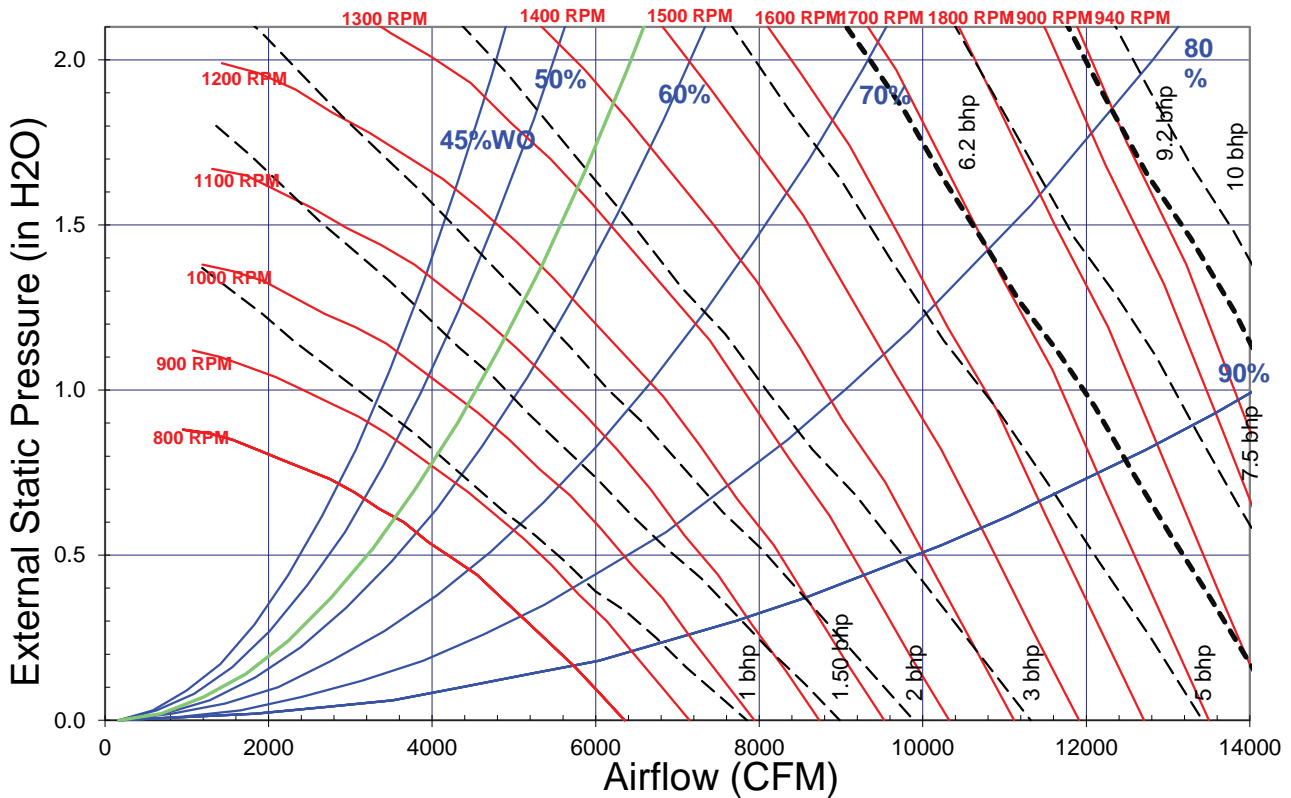

Table 35. Evaporator fan performance - 15 ton (model TSJ), downflow

Available External Static Pressure (Inches of Water Gauge)																				
CFM	0.10"		0.20"		0.30"		0.40"		0.50"		0.60"		0.70"		0.80"		0.90"		1.00"	
	RPM	BHP	RPM	BHP	RPM	BHP	RPM	BHP	RPM	BHP	RPM	BHP	RPM	BHP	RPM	BHP	RPM	BHP	RPM	BHP
4500	628	0.29	684	0.40	734	0.51	779	0.62	825	0.74	869	0.86	910	0.98	948	1.11	984	1.24	1019	1.37
4800	663	0.34	715	0.45	764	0.57	808	0.68	851	0.80	893	0.93	934	1.07	971	1.20	1007	1.33	1042	1.47
5400	734	0.45	778	0.56	827	0.70	868	0.83	907	0.96	944	1.10	983	1.24	1020	1.39	1055	1.54	1089	1.69
6000	804	0.58	847	0.71	888	0.85	930	1.01	967	1.15	1002	1.30	1036	1.44	1070	1.60	1104	1.76	1137	1.93
6600	876	0.74	916	0.89	951	1.03	992	1.20	1028	1.37	1062	1.52	1094	1.68	1125	1.84	1155	2.01	1187	2.18
7200	948	0.93	986	1.09	1020	1.25	1053	1.41	1090	1.61	1123	1.78	1154	1.96	1184	2.13	1213	2.30	1241	2.48
Available External Static Pressure (Inches of Water Gauge)																				
CFM	1.10"		1.20"		1.30"		1.40"		1.50"		1.60"		1.70"		1.80"		1.90"		2.00"	
	RPM	BHP	RPM	BHP	RPM	BHP	RPM	BHP	RPM	BHP	RPM	BHP	RPM	BHP	RPM	BHP	RPM	BHP	RPM	BHP
4500	1054	1.51	1088	1.65	1120	1.79	1151	1.94	1182	2.09	1211	2.24	1239	2.39	1267	2.55	1294	2.71	1322	2.87
4800	1075	1.61	1107	1.75	1140	1.9	1171	2.05	1201	2.21	1230	2.36	1258	2.52	1286	2.68	1313	2.85	1339	3.01
5400	1121	1.84	1152	1.99	1182	2.14	1211	2.3	1240	2.46	1269	2.63	1297	2.8	1325	2.97	1351	3.15	1377	3.32
6000	1169	2.09	1199	2.25	1229	2.42	1258	2.59	1285	2.76	1312	2.93	1338	3.11	1364	3.28	1391	3.47	1417	3.66
6600	1218	2.37	1248	2.55	1277	2.73	1305	2.91	1332	3.09	1359	3.27	1385	3.46	1410	3.64	1435	3.83	1459	4.02
7200	1269	2.66	1298	2.86	1326	3.05	1354	3.25	1381	3.45	1407	3.64	1432	3.84	1457	4.04	1482	4.24	1505	4.44

Notes:

1. Available External Static Pressure is the static pressure difference between the return duct and the supply duct plus the static pressure drop caused by accessories and options.
2. For direct drive evaporator fan speed (rpm), refer to the applicable table in the fan performance section.
3. Data includes pressure drop due to standard filters and wet coils. No accessories or options are included in pressure drop data.
4. To determine static pressure drop due to other options/accessories, refer to the applicable table in the fan performance section.
5. Direct drive fan motor heat is negligible.
6. Factory supplied motors, in commercial equipment, are definite purpose motors, specifically designed and tested to operate reliably and continuously at all cataloged conditions. Using the full horsepower range of our fan motors as shown in our tabular data will not result in nuisance tripping or premature motor failure. Our product's warranty will not be affected.



Evaporator Fan Performance

Table 36. Evaporator fan performance - 17.5 ton (model TSJ), downflow

Available External Static Pressure (Inches of Water Gauge)										
CFM	0.10"	0.20"	0.30"	0.40"	0.50"	0.60"	0.70"	0.80"	0.90"	1.00"
	RPM BHP	RPM BHP	RPM BHP	RPM BHP	RPM BHP	RPM BHP	RPM BHP	RPM BHP	RPM BHP	RPM BHP
5250	716 0.42	761 0.53	811 0.67	853 0.79	893 0.92	931 1.05	970 1.20	1008 1.34	1043 1.48	1077 1.63
5600	757 0.49	801 0.61	847 0.75	888 0.89	927 1.02	963 1.16	1000 1.30	1036 1.46	1071 1.61	1105 1.76
6300	840 0.66	881 0.80	919 0.94	961 1.11	997 1.26	1032 1.41	1065 1.56	1096 1.71	1129 1.88	1162 2.05
7000	924 0.86	963 1.02	997 1.17	1033 1.34	1070 1.53	1103 1.69	1134 1.86	1164 2.03	1193 2.20	1221 2.37
7700	1009 1.11	1045 1.29	1077 1.46	1107 1.62	1141 1.82	1176 2.02	1205 2.21	1234 2.39	1262 2.58	1289 2.76
8400	1094 1.41	1127 1.60	1159 1.79	1187 1.97	1214 2.15	1247 2.37	1278 2.60	1306 2.80	1333 3.00	1358 3.20
Available External Static Pressure (Inches of Water Gauge)										
CFM	1.10"	1.20"	1.30"	1.40"	1.50"	1.60"	1.70"	1.80"	1.90"	2.00"
	RPM BHP	RPM BHP	RPM BHP	RPM BHP	RPM BHP	RPM BHP	RPM BHP	RPM BHP	RPM BHP	RPM BHP
5250	1109 1.78	1141 1.93	1171 2.08	1201 2.24	1230 2.4	1259 2.56	1288 2.73	1315 2.9	1342 3.07	1368 3.24
5600	1137 1.92	1168 2.07	1198 2.23	1227 2.39	1255 2.56	1283 2.73	1311 2.9	1338 3.07	1364 3.25	1390 3.43
6300	1193 2.23	1223 2.4	1253 2.57	1281 2.74	1309 2.92	1336 3.1	1362 3.28	1387 3.46	1412 3.64	1437 3.83
7000	1252 2.56	1281 2.75	1310 2.94	1337 3.14	1364 3.33	1391 3.52	1416 3.71	1441 3.9	1466 4.1	1490 4.3
7700	1315 2.95	1341 3.14	1368 3.34	1395 3.55	1422 3.76	1447 3.98	1473 4.19	1497 4.4	1521 4.6	1545 4.82
8400	1384 3.4	1409 3.6	1433 3.81	1456 4.01	1481 4.23	1506 4.46	1531 4.69	1555 4.92	1578 5.15	1601 5.38

Notes:

1. Available External Static Pressure is the static pressure difference between the return duct and the supply duct plus the static pressure drop caused by accessories and options.
2. For direct drive evaporator fan speed (rpm), refer to the applicable table in the fan performance section.
3. Data includes pressure drop due to standard filters and wet coils. No accessories or options are included in pressure drop data.
4. To determine static pressure drop due to other options/accessories, refer to the applicable table in the fan performance section.
5. Direct drive fan motor heat is negligible.
6. Factory supplied motors, in commercial equipment, are definite purpose motors, specifically designed and tested to operate reliably and continuously at all cataloged conditions. Using the full horsepower range of our fan motors as shown in our tabular data will not result in nuisance tripping or premature motor failure. Our product's warranty will not be affected.

Table 37. Evaporator fan performance - 20 ton (model TSJ), downflow

Available External Static Pressure (Inches of Water Gauge)										
CFM	0.10"	0.20"	0.30"	0.40"	0.50"	0.60"	0.70"	0.80"	0.90"	1.00"
	RPM BHP	RPM BHP	RPM BHP	RPM BHP	RPM BHP	RPM BHP	RPM BHP	RPM BHP	RPM BHP	RPM BHP
6000	804 0.58	847 0.71	888 0.85	930 1.01	967 1.15	1002 1.30	1036 1.44	1070 1.60	1104 1.76	1137 1.93
6400	852 0.68	893 0.83	929 0.97	971 1.14	1008 1.29	1042 1.45	1074 1.60	1106 1.76	1138 1.92	1170 2.10
7200	948 0.93	986 1.09	1020 1.25	1053 1.41	1090 1.61	1123 1.78	1154 1.96	1184 2.13	1213 2.30	1241 2.48
8000	1045 1.23	1080 1.41	1112 1.59	1141 1.76	1172 1.95	1206 2.17	1237 2.37	1265 2.56	1292 2.75	1319 2.94
8800	1143 1.60	1175 1.80	1206 2.00	1233 2.19	1260 2.38	1288 2.59	1319 2.82	1348 3.06	1374 3.26	1399 3.47
9600	1241 2.04	1271 2.25	1300 2.47	1327 2.69	1351 2.89	1375 3.10	1401 3.32	1429 3.58	1457 3.84	1482 4.08
Available External Static Pressure (Inches of Water Gauge)										
CFM	1.10"	1.20"	1.30"	1.40"	1.50"	1.60"	1.70"	1.80"	1.90"	2.00"
	RPM BHP	RPM BHP	RPM BHP	RPM BHP	RPM BHP	RPM BHP	RPM BHP	RPM BHP	RPM BHP	RPM BHP
6000	1169 2.09	1199 2.25	1229 2.42	1258 2.59	1285 2.76	1312 2.93	1338 3.11	1364 3.28	1391 3.47	1417 3.66
6400	1201 2.27	1232 2.45	1261 2.62	1289 2.8	1317 2.98	1343 3.15	1369 3.34	1395 3.52	1419 3.71	1444 3.89
7200	1269 2.66	1298 2.86	1326 3.05	1354 3.25	1381 3.45	1407 3.64	1432 3.84	1457 4.04	1482 4.24	1505 4.44
8000	1345 3.14	1370 3.33	1394 3.53	1421 3.74	1447 3.96	1472 4.18	1497 4.4	1521 4.62	1545 4.84	1569 5.05
8800	1424 3.69	1448 3.9	1472 4.11	1495 4.32	1518 4.54	1540 4.75	1564 4.99	1588 5.23	1611 5.47	1634 5.72
9600	1506 4.3	1529 4.53	1551 4.76	1573 4.99	1595 5.22	1617 5.46	1638 5.69	1659 5.92	-	-

Notes:

1. Available External Static Pressure is the static pressure difference between the return duct and the supply duct plus the static pressure drop caused by accessories and options.
2. For direct drive evaporator fan speed (rpm), refer to the applicable table in the fan performance section.
3. Data includes pressure drop due to standard filters and wet coils. No accessories or options are included in pressure drop data.
4. To determine static pressure drop due to other options/accessories, refer to the applicable table in the fan performance section.
5. Direct drive fan motor heat is negligible.
6. Factory supplied motors, in commercial equipment, are definite purpose motors, specifically designed and tested to operate reliably and continuously at all cataloged conditions. Using the full horsepower range of our fan motors as shown in our tabular data will not result in nuisance tripping or premature motor failure. Our product's warranty will not be affected.

Table 38. Evaporator fan performance - 25 ton (model TSJ), downflow

Available External Static Pressure (Inches of Water Gauge)										
CFM	0.10"	0.20"	0.30"	0.40"	0.50"	0.60"	0.70"	0.80"	0.90"	1.00"
	RPM BHP	RPM BHP	RPM BHP	RPM BHP	RPM BHP	RPM BHP	RPM BHP	RPM BHP	RPM BHP	RPM BHP
3-hp Standard Motor										
7500	984 1.03	1021 1.21	1054 1.37	1085 1.53	1121 1.73	1155 1.92	1185 2.10	1214 2.28	1242 2.46	1270 2.64
8000	1045 1.23	1080 1.41	1112 1.59	1141 1.76	1172 1.95	1206 2.17	1237 2.37	1265 2.56	1292 2.75	1319 2.94
9000	1167 1.70	1199 1.90	1229 2.11	1257 2.31	1283 2.50	1309 2.70	1339 2.94	1368 3.19	1395 3.40	1420 3.62
10000	1290 2.28	1319 2.50	1347 2.73	1374 2.96	1398 3.18	1421 3.39	1444 3.61	1471 3.86	1498 4.13	1524 4.40
11000	1413 2.99	1440 3.23	1466 3.47	1491 3.73	1515 3.98	1536 4.22	1558 4.45	1579 4.69	1601 4.94	1626 5.24
12000	1537 3.83	1561 4.09	1585 4.36	1609 4.63	1631 4.91	1653 5.18	1673 5.44	1693 5.69	1712 5.95	- -
Available External Static Pressure (Inches of Water Gauge)										
CFM	1.10"	1.20"	1.30"	1.40"	1.50"	1.60"	1.70"	1.80"	1.90"	2.00"
	RPM BHP	RPM BHP	RPM BHP	RPM BHP	RPM BHP	RPM BHP	RPM BHP	RPM BHP	RPM BHP	RPM BHP
3-hp Standard Motor										
7500	1296 2.83	1323 3.02	1351 3.22	1379 3.43	1405 3.64	1431 3.84	1456 4.05	1481 4.25	1505 4.46	1529 4.66
8000	1345 3.14	1370 3.33	1394 3.53	1421 3.74	1447 3.96	1472 4.18	1497 4.4	1521 4.62	1545 4.84	1569 5.05
9000	1444 3.83	1468 4.05	1491 4.26	1514 4.48	1537 4.7	1559 4.92	1581 5.15	1605 5.39	1628 5.64	1651 5.89
10000	1547 4.64	1570 4.88	1592 5.12	1614 5.36	1635 5.6	1656 5.84	- -	- -	- -	- -
11000	1650 5.53	1674 5.83	- -	- -	- -	- -	- -	- -	- -	- -
12000	- -	- -	- -	- -	- -	- -	- -	- -	- -	- -

Notes:

1. Available External Static Pressure is the static pressure difference between the return duct and the supply duct plus the static pressure drop caused by accessories and options.
2. For direct drive evaporator fan speed (rpm), refer to the applicable table in the fan performance section.
3. Data includes pressure drop due to standard filters and wet coils. No accessories or options are included in pressure drop data.
4. To determine static pressure drop due to other options/accessories, refer to the applicable table in the fan performance section.
5. Direct drive fan motor heat is negligible.
6. Factory supplied motors, in commercial equipment, are definite purpose motors, specifically designed and tested to operate reliably and continuously at all cataloged conditions. Using the full horsepower range of our fan motors as shown in our tabular data will not result in nuisance tripping or premature motor failure. Our product's warranty will not be affected.

Table 39. Evaporator fan performance - 25 ton (model TSJ), downflow, oversized/high static motor option

Available External Static Pressure (Inches of Water Gauge)										
CFM	0.10"	0.20"	0.30"	0.40"	0.50"	0.60"	0.70"	0.80"	0.90"	1.00"
	RPM BHP	RPM BHP	RPM BHP	RPM BHP	RPM BHP	RPM BHP	RPM BHP	RPM BHP	RPM BHP	RPM BHP
5-hp Oversized Motor										
7500	1114 1.60	1146 1.77	1176 1.94	1207 2.12	1237 2.30	1265 2.48	1294 2.67	1322 2.86	1350 3.05	1376 3.24
8000	1184 1.91	1214 2.09	1243 2.28	1272 2.46	1300 2.66	1328 2.85	1354 3.04	1382 3.25	1408 3.45	1434 3.65
9000	1324 2.67	1352 2.87	1378 3.08	1403 3.28	1429 3.49	1454 3.71	1479 3.93	1503 4.15	1527 4.37	1551 4.59
10000	1466 3.61	1490 3.84	1514 4.06	1538 4.29	1560 4.52	1584 4.75	1607 4.99	1629 5.23	1651 5.47	1673 5.72
11000	1607 4.76	1630 5.00	1652 5.25	1674 5.50	1695 5.75	1715 6.00	1736 6.26	1758 6.52	1778 6.78	1799 7.05
12000	1749 6.13	1770 6.39	1791 6.66	1811 6.93	1831 7.20	1850 7.48	1869 7.75	1888 8.03	1907 8.31	1927 8.6
Available External Static Pressure (Inches of Water Gauge)										
CFM	1.10"	1.20"	1.30"	1.40"	1.50"	1.60"	1.70"	1.80"	1.90"	2.00"
	RPM BHP	RPM BHP	RPM BHP	RPM BHP	RPM BHP	RPM BHP	RPM BHP	RPM BHP	RPM BHP	RPM BHP
5-hp Oversized Motor										
7500	1401 3.44	1426 3.63	1450 3.83	1474 4.03	1496 4.23	1519 4.43	1543 4.65	1568 4.87	1592 5.09	1616 5.31
8000	1458 3.86	1483 4.06	1506 4.27	1529 4.48	1551 4.69	1573 4.91	1595 5.12	1616 5.34	1638 5.56	1662 5.8
9000	1575 4.82	1598 5.05	1620 5.28	1642 5.51	1664 5.74	1685 5.97	1706 6.21	1726 6.45	1746 6.69	1765 6.92
10000	1694 5.96	1716 6.21	1738 6.46	1759 6.72	1779 6.97	1799 7.23	1819 7.48	1839 7.74	1858 8	1877 8.26
11000	1819 7.31	1838 7.58	1858 7.85	1878 8.13	1897 8.4	1917 8.68	1936 8.96	- -	- -	- -



Evaporator Fan Performance

Table 39. Evaporator fan performance - 25 ton (model TSJ), downflow, oversized/high static motor option (continued)

Available External Static Pressure (Inches of Water Gauge)										
CFM	1.10"	1.20"	1.30"	1.40"	1.50"	1.60"	1.70"	1.80"	1.90"	2.00"
	RPM BHP	RPM BHP	RPM BHP	RPM BHP	RPM BHP	RPM BHP	RPM BHP	RPM BHP	RPM BHP	RPM BHP
5-hp Oversized Motor										
12000	-	-	-	-	-	-	-	-	-	-

Notes:

1. Available External Static Pressure is the static pressure difference between the return duct and the supply duct plus the static pressure drop caused by accessories and options.
2. For direct drive evaporator fan speed (rpm), refer to the applicable table in the fan performance section.
3. Data includes pressure drop due to standard filters and wet coils. No accessories or options are included in pressure drop data.
4. To determine static pressure drop due to other options/accessories, refer to the applicable table in the fan performance section.
5. Direct drive fan motor heat is negligible.
6. Factory supplied motors, in commercial equipment, are definite purpose motors, specifically designed and tested to operate reliably and continuously at all cataloged conditions. Using the full horsepower range of our fan motors as shown in our tabular data will not result in nuisance tripping or premature motor failure. Our product's warranty will not be affected.

15 to 25 Ton Units — Horizontal

Figure 6. Fan curves — 15 to 25 tons, horizontal

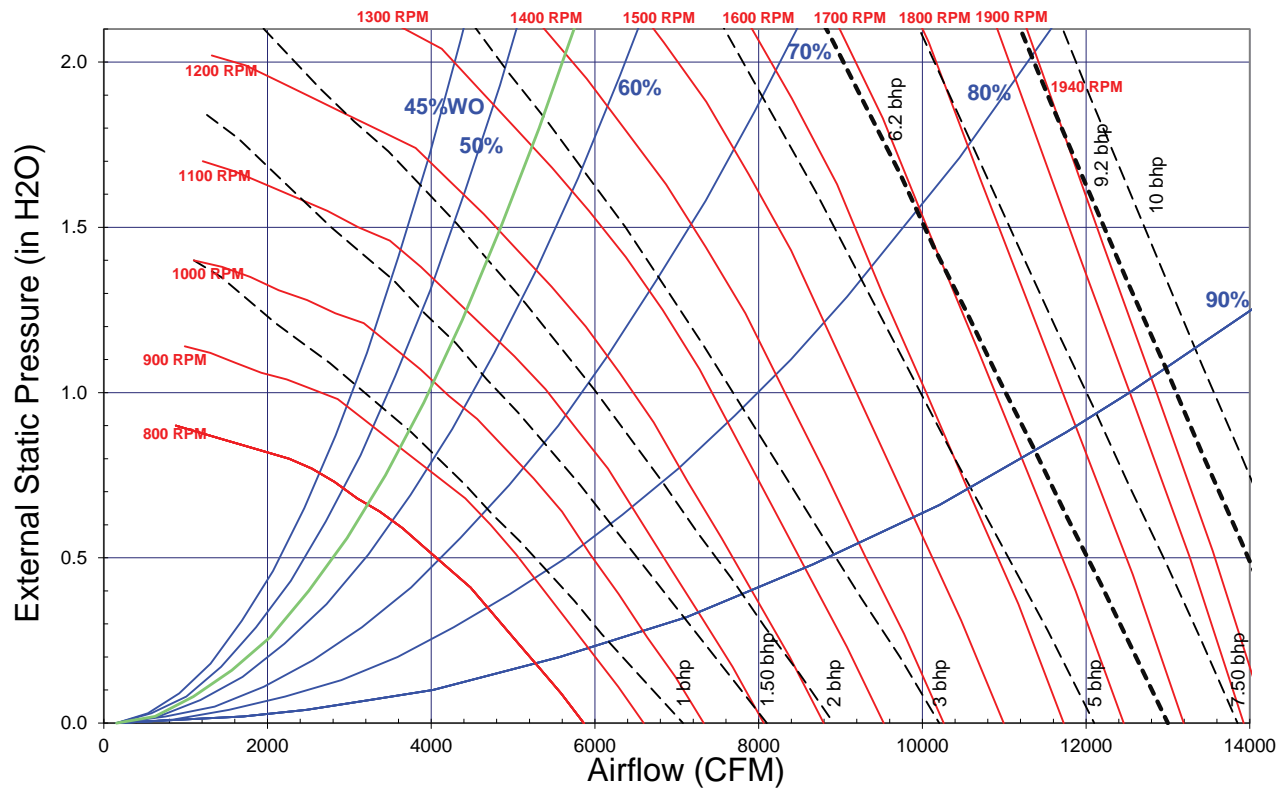

Table 40. Evaporator fan performance - 15 ton (model TSJ), horizontal

Available External Static Pressure (Inches of Water Gauge)										
CFM	0.10"	0.20"	0.30"	0.40"	0.50"	0.60"	0.70"	0.80"	0.90"	1.00"
	RPM BHP	RPM BHP	RPM BHP	RPM BHP	RPM BHP	RPM BHP	RPM BHP	RPM BHP	RPM BHP	RPM BHP
4500	667 0.36	716 0.46	760 0.56	800 0.66	841 0.77	880 0.88	917 1.00	954 1.12	990 1.25	1024 1.38
4800	705 0.42	752 0.52	795 0.63	833 0.74	870 0.85	908 0.97	944 1.09	979 1.22	1014 1.35	1048 1.48
5400	781 0.56	825 0.68	864 0.80	901 0.92	935 1.05	968 1.17	1002 1.31	1035 1.44	1067 1.58	1098 1.72
6000	858 0.74	899 0.87	936 1.01	971 1.14	1003 1.28	1034 1.41	1063 1.55	1094 1.69	1124 1.84	1153 1.99
6600	936 0.95	973 1.10	1008 1.25	1041 1.39	1073 1.54	1102 1.69	1130 1.84	1157 1.99	1184 2.15	1212 2.31
7200	1015 1.21	1049 1.36	1082 1.53	1113 1.69	1143 1.85	1171 2.01	1199 2.17	1225 2.34	1250 2.50	1274 2.66

Table 40. Evaporator fan performance - 15 ton (model TSJ), horizontal (continued)

Available External Static Pressure (Inches of Water Gauge)										
CFM	1.10"	1.20"	1.30"	1.40"	1.50"	1.60"	1.70"	1.80"	1.90"	2.00"
	RPM BHP	RPM BHP	RPM BHP	RPM BHP	RPM BHP	RPM BHP	RPM BHP	RPM BHP	RPM BHP	RPM BHP
4500	1057 1.51	1089 1.64	1120 1.78	1150 1.92	1180 2.06	1208 2.21	1236 2.36	1263 2.51	1289 2.66	1315 2.82
4800	1081 1.62	1112 1.76	1143 1.9	1172 2.04	1200 2.19	1229 2.34	1256 2.5	1283 2.65	1310 2.81	1335 2.97
5400	1128 1.86	1159 2.01	1189 2.16	1218 2.32	1246 2.47	1273 2.63	1300 2.79	1325 2.95	1351 3.12	1376 3.29
6000	1182 2.15	1210 2.3	1237 2.46	1265 2.62	1293 2.79	1320 2.96	1346 3.13	1372 3.3	1396 3.48	1421 3.65
6600	1240 2.47	1266 2.64	1293 2.81	1318 2.97	1343 3.15	1368 3.32	1393 3.5	1419 3.69	1443 3.87	1467 4.06
7200	1299 2.84	1325 3.01	1350 3.19	1374 3.37	1399 3.56	1423 3.74	1446 3.93	1469 4.11	1491 4.3	1515 4.5

Notes:

1. Available External Static Pressure is the static pressure difference between the return duct and the supply duct plus the static pressure drop caused by accessories and options.
2. For direct drive evaporator fan speed (rpm), refer to the applicable table in the fan performance section.
3. Data includes pressure drop due to standard filters and wet coils. No accessories or options are included in pressure drop data.
4. To determine static pressure drop due to other options/accessories, refer to the applicable table in the fan performance section.
5. Direct drive fan motor heat is negligible.
6. Factory supplied motors, in commercial equipment, are definite purpose motors, specifically designed and tested to operate reliably and continuously at all cataloged conditions. Using the full horsepower range of our fan motors as shown in our tabular data will not result in nuisance tripping or premature motor failure. Our product's warranty will not be affected.

Table 41. Evaporator fan performance - 17.5 ton (model TSJ), horizontal

Available External Static Pressure (Inches of Water Gauge)										
CFM	0.10"	0.20"	0.30"	0.40"	0.50"	0.60"	0.70"	0.80"	0.90"	1.00"
	RPM BHP	RPM BHP	RPM BHP	RPM BHP	RPM BHP	RPM BHP	RPM BHP	RPM BHP	RPM BHP	RPM BHP
5250	762 0.52	806 0.64	847 0.76	884 0.88	918 0.99	953 1.12	987 1.25	1021 1.38	1053 1.52	1084 1.65
5600	807 0.62	849 0.74	888 0.87	924 0.99	958 1.12	989 1.25	1022 1.38	1054 1.52	1086 1.66	1116 1.81
6300	897 0.84	936 0.98	972 1.12	1006 1.26	1038 1.40	1068 1.55	1097 1.69	1124 1.84	1154 1.99	1183 2.15
7000	989 1.12	1024 1.27	1057 1.43	1089 1.58	1119 1.74	1148 1.90	1176 2.06	1202 2.22	1227 2.38	1252 2.54
7700	1081 1.45	1113 1.62	1144 1.79	1174 1.96	1202 2.14	1230 2.31	1256 2.48	1282 2.66	1306 2.83	1330 3.01
8400	1175 1.85	1203 2.03	1232 2.22	1260 2.41	1287 2.59	1313 2.78	1338 2.97	1363 3.16	1386 3.35	1409 3.54

Available External Static Pressure (Inches of Water Gauge)										
CFM	1.10"	1.20"	1.30"	1.40"	1.50"	1.60"	1.70"	1.80"	1.90"	2.00"
	RPM BHP	RPM BHP	RPM BHP	RPM BHP	RPM BHP	RPM BHP	RPM BHP	RPM BHP	RPM BHP	RPM BHP
5250	1116 1.8	1147 1.95	1177 2.09	1206 2.25	1234 2.4	1262 2.56	1288 2.71	1314 2.87	1340 3.04	1366 3.21
5600	1145 1.95	1175 2.1	1205 2.26	1234 2.42	1262 2.58	1289 2.74	1315 2.9	1341 3.07	1366 3.23	1390 3.4
6300	1210 2.31	1238 2.47	1265 2.63	1291 2.79	1317 2.96	1344 3.13	1370 3.31	1395 3.49	1420 3.67	1444 3.85
7000	1279 2.71	1305 2.88	1331 3.06	1355 3.24	1380 3.41	1404 3.59	1427 3.78	1451 3.96	1475 4.15	1499 4.35
7700	1353 3.18	1375 3.36	1400 3.55	1424 3.74	1447 3.93	1470 4.12	1492 4.32	1515 4.52	1537 4.71	1558 4.91
8400	1431 3.73	1453 3.92	1474 4.11	1494 4.31	1516 4.51	1539 4.72	1560 4.93	1582 5.13	1602 5.35	1623 5.56

Notes:

1. Available External Static Pressure is the static pressure difference between the return duct and the supply duct plus the static pressure drop caused by accessories and options.
2. For direct drive evaporator fan speed (rpm), refer to the applicable table in the fan performance section.
3. Data includes pressure drop due to standard filters and wet coils. No accessories or options are included in pressure drop data.
4. To determine static pressure drop due to other options/accessories, refer to the applicable table in the fan performance section.
5. Direct drive fan motor heat is negligible.
6. Factory supplied motors, in commercial equipment, are definite purpose motors, specifically designed and tested to operate reliably and continuously at all cataloged conditions. Using the full horsepower range of our fan motors as shown in our tabular data will not result in nuisance tripping or premature motor failure. Our product's warranty will not be affected.

Table 42. Evaporator fan performance - 20 ton (model TSJ), horizontal

Available External Static Pressure (Inches of Water Gauge)										
CFM	0.10"	0.20"	0.30"	0.40"	0.50"	0.60"	0.70"	0.80"	0.90"	1.00"
	RPM BHP	RPM BHP	RPM BHP	RPM BHP	RPM BHP	RPM BHP	RPM BHP	RPM BHP	RPM BHP	RPM BHP
6000	858 0.74	899 0.87	936 1.01	971 1.14	1003 1.28	1034 1.41	1063 1.55	1094 1.69	1124 1.84	1153 1.99
6400	910 0.88	948 1.02	984 1.16	1018 1.30	1049 1.45	1079 1.59	1108 1.74	1135 1.89	1164 2.04	1192 2.20
7200	1015 1.21	1049 1.36	1082 1.53	1113 1.69	1143 1.85	1171 2.01	1199 2.17	1225 2.34	1250 2.50	1274 2.66
8000	1121 1.61	1151 1.79	1182 1.97	1211 2.14	1239 2.32	1265 2.50	1291 2.68	1316 2.86	1341 3.05	1364 3.23
8800	1228 2.11	1254 2.30	1283 2.49	1310 2.69	1336 2.89	1361 3.08	1386 3.28	1409 3.48	1433 3.68	1455 3.88
9600	1335 2.70	1359 2.90	1385 3.12	1410 3.33	1435 3.54	1459 3.76	1482 3.97	1504 4.19	1526 4.40	1548 4.62



Evaporator Fan Performance

Table 42. Evaporator fan performance - 20 ton (model TSJ), horizontal (continued)

Available External Static Pressure (Inches of Water Gauge)											
CFM	1.10"	1.20"	1.30"	1.40"	1.50"	1.60"	1.70"	1.80"	1.90"	2.00"	
	RPM BHP	RPM BHP	RPM BHP	RPM BHP	RPM BHP	RPM BHP	RPM BHP	RPM BHP	RPM BHP	RPM BHP	RPM BHP
6000	1182 2.15	1210 2.3	1237 2.46	1265 2.62	1293 2.79	1320 2.96	1346 3.13	1372 3.3	1396 3.48	1421 3.65	
6400	1220 2.36	1247 2.52	1274 2.69	1300 2.85	1325 3.02	1352 3.2	1378 3.37	1403 3.55	1427 3.74	1452 3.92	
7200	1299 2.84	1325 3.01	1350 3.19	1374 3.37	1399 3.56	1423 3.74	1446 3.93	1469 4.11	1491 4.3	1515 4.5	
8000	1386 3.41	1408 3.59	1430 3.78	1453 3.97	1476 4.17	1499 4.37	1521 4.57	1543 4.77	1565 4.98	1586 5.18	
8800	1477 4.08	1498 4.27	1518 4.47	1539 4.67	1558 4.88	1579 5.09	1600 5.3	1621 5.52	1642 5.74	1662 5.96	
9600	1569 4.84	1589 5.05	1609 5.27	1629 5.49	1648 5.71	1666 5.92	- -	- -	- -	- -	

Notes:

1. Available External Static Pressure is the static pressure difference between the return duct and the supply duct plus the static pressure drop caused by accessories and options.
2. For direct drive evaporator fan speed (rpm), refer to the applicable table in the fan performance section.
3. Data includes pressure drop due to standard filters and wet coils. No accessories or options are included in pressure drop data.
4. To determine static pressure drop due to other options/accessories, refer to the applicable table in the fan performance section.
5. Direct drive fan motor heat is negligible.
6. Factory supplied motors, in commercial equipment, are definite purpose motors, specifically designed and tested to operate reliably and continuously at all cataloged conditions. Using the full horsepower range of our fan motors as shown in our tabular data will not result in nuisance tripping or premature motor failure. Our product's warranty will not be affected.

Table 43. Evaporator fan performance - 25 ton (model TSJ), horizontal

Available External Static Pressure (Inches of Water Gauge)											
CFM	0.10"	0.20"	0.30"	0.40"	0.50"	0.60"	0.70"	0.80"	0.90"	1.00"	
	RPM BHP	RPM BHP	RPM BHP	RPM BHP	RPM BHP	RPM BHP	RPM BHP	RPM BHP	RPM BHP	RPM BHP	RPM BHP
3-hp Standard Motor											
7500	1055 1.35	1087 1.51	1119 1.68	1150 1.85	1178 2.02	1206 2.18	1233 2.35	1259 2.52	1284 2.69	1307 2.86	
8000	1121 1.61	1151 1.79	1182 1.97	1211 2.14	1239 2.32	1265 2.50	1291 2.68	1316 2.86	1341 3.05	1364 3.23	
9000	1255 2.25	1280 2.44	1308 2.64	1335 2.84	1361 3.04	1385 3.24	1409 3.45	1433 3.65	1456 3.85	1478 4.05	
10000	1388 3.03	1412 3.25	1436 3.46	1461 3.69	1485 3.91	1508 4.13	1530 4.36	1552 4.58	1574 4.81	1595 5.03	
11000	1523 3.99	1544 4.22	1565 4.46	1588 4.70	1610 4.95	1632 5.19	1653 5.44	1674 5.68	1694 5.93	- -	
12000	1657 5.13	1677 5.38	1696 5.64	1716 5.90	- -	- -	- -	- -	- -	- -	
Available External Static Pressure (Inches of Water Gauge)											
CFM	1.10"	1.20"	1.30"	1.40"	1.50"	1.60"	1.70"	1.80"	1.90"	2.00"	
	RPM BHP	RPM BHP	RPM BHP	RPM BHP	RPM BHP	RPM BHP	RPM BHP	RPM BHP	RPM BHP	RPM BHP	RPM BHP
3-hp Standard Motor											
7500	1330 3.04	1355 3.22	1380 3.4	1404 3.59	1427 3.78	1451 3.97	1474 4.16	1496 4.35	1518 4.54	1540 4.74	
8000	1386 3.41	1408 3.59	1430 3.78	1453 3.97	1476 4.17	1499 4.37	1521 4.57	1543 4.77	1565 4.98	1586 5.18	
9000	1500 4.26	1521 4.46	1541 4.66	1561 4.87	1580 5.07	1599 5.28	1620 5.5	1641 5.72	1661 5.94	- -	
10000	1615 5.25	1635 5.48	1655 5.71	1675 5.94	- -	- -	- -	- -	- -	- -	
11000	- -	- -	- -	- -	- -	- -	- -	- -	- -	- -	
12000	- -	- -	- -	- -	- -	- -	- -	- -	- -	- -	

Notes:

1. Available External Static Pressure is the static pressure difference between the return duct and the supply duct plus the static pressure drop caused by accessories and options.
2. For direct drive evaporator fan speed (rpm), refer to the applicable table in the fan performance section.
3. Data includes pressure drop due to standard filters and wet coils. No accessories or options are included in pressure drop data.
4. To determine static pressure drop due to other options/accessories, refer to the applicable table in the fan performance section.
5. Direct drive fan motor heat is negligible.
6. Factory supplied motors, in commercial equipment, are definite purpose motors, specifically designed and tested to operate reliably and continuously at all cataloged conditions. Using the full horsepower range of our fan motors as shown in our tabular data will not result in nuisance tripping or premature motor failure. Our product's warranty will not be affected.

Table 44. Evaporator fan performance - 25 ton (model TSJ), horizontal, oversized/high static motor option

Available External Static Pressure (Inches of Water Gauge)											
CFM	0.10"	0.20"	0.30"	0.40"	0.50"	0.60"	0.70"	0.80"	0.90"	1.00"	
	RPM BHP	RPM BHP	RPM BHP	RPM BHP	RPM BHP	RPM BHP	RPM BHP	RPM BHP	RPM BHP	RPM BHP	RPM BHP
5-hp Oversized Motor											
7500	1114 1.60	1146 1.77	1176 1.94	1207 2.12	1237 2.30	1265 2.48	1294 2.67	1322 2.86	1350 3.05	1376 3.24	
8000	1184 1.91	1214 2.09	1243 2.28	1272 2.46	1300 2.66	1328 2.85	1354 3.04	1382 3.25	1408 3.45	1434 3.65	
9000	1324 2.67	1352 2.87	1378 3.08	1403 3.28	1429 3.49	1454 3.71	1479 3.93	1503 4.15	1527 4.37	1551 4.59	
10000	1466 3.61	1490 3.84	1514 4.06	1538 4.29	1560 4.52	1584 4.75	1607 4.99	1629 5.23	1651 5.47	1673 5.72	

Evaporator Fan Performance

Table 44. Evaporator fan performance - 25 ton (model TSJ), horizontal, oversized/high static motor option (continued)

Available External Static Pressure (Inches of Water Gauge)										
CFM	0.10"	0.20"	0.30"	0.40"	0.50"	0.60"	0.70"	0.80"	0.90"	1.00"
	RPM BHP	RPM BHP	RPM BHP	RPM BHP	RPM BHP	RPM BHP	RPM BHP	RPM BHP	RPM BHP	RPM BHP
5-hp Oversized Motor										
11000	1607 4.76	1630 5.00	1652 5.25	1674 5.50	1695 5.75	1715 6.00	1736 6.26	1758 6.52	1778 6.78	1799 7.05
12000	1749 6.13	1770 6.39	1791 6.66	1811 6.93	1831 7.20	1850 7.48	1869 7.75	1888 8.03	1907 8.31	1927 8.6
Available External Static Pressure (Inches of Water Gauge)										
CFM	1.10"	1.20"	1.30"	1.40"	1.50"	1.60"	1.70"	1.80"	1.90"	2.00"
	RPM BHP	RPM BHP	RPM BHP	RPM BHP	RPM BHP	RPM BHP	RPM BHP	RPM BHP	RPM BHP	RPM BHP
5-hp Oversized Motor										
7500	1401 3.44	1426 3.63	1450 3.83	1474 4.03	1496 4.23	1519 4.43	1543 4.65	1568 4.87	1592 5.09	1616 5.31
8000	1458 3.86	1483 4.06	1506 4.27	1529 4.48	1551 4.69	1573 4.91	1595 5.12	1616 5.34	1638 5.56	1662 5.8
9000	1575 4.82	1598 5.05	1620 5.28	1642 5.51	1664 5.74	1685 5.97	1706 6.21	1726 6.45	1746 6.69	1765 6.92
10000	1694 5.96	1716 6.21	1738 6.46	1759 6.72	1779 6.97	1799 7.23	1819 7.48	1839 7.74	1858 8	1877 8.26
11000	1819 7.31	1838 7.58	1858 7.85	1878 8.13	1897 8.4	1917 8.68	1936 8.96	- -	- -	- -
12000	- -	- -	- -	- -	- -	- -	- -	- -	- -	- -

Notes:

1. Available External Static Pressure is the static pressure difference between the return duct and the supply duct plus the static pressure drop caused by accessories and options.
2. For direct drive evaporator fan speed (rpm), refer to the applicable table in the fan performance section.
3. Data includes pressure drop due to standard filters and wet coils. No accessories or options are included in pressure drop data.
4. To determine static pressure drop due to other options/accessories, refer to the applicable table in the fan performance section.
5. Direct drive fan motor heat is negligible.
6. Factory supplied motors, in commercial equipment, are definite purpose motors, specifically designed and tested to operate reliably and continuously at all cataloged conditions. Using the full horsepower range of our fan motors as shown in our tabular data will not result in nuisance tripping or premature motor failure. Our product's warranty will not be affected.



Fan Performance

Table 45. Outdoor sound power level

Tons	Unit Model Number	Octave Center Frequency								Overall dBA
		63	125	250	500	1000	2000	4000	8000	
6	TSJ072A*	83	84	84	85	82	76	73	67	86
7.5	TSJ090A*	83	84	84	85	82	76	73	67	86
8.5	TSJ102A*	83	84	84	85	82	76	73	67	86
10	TSJ120A*	87	88	86	83	81	77	73	68	86
12.5	TSJ150B*	89	92	89	87	84	80	75	68	89
15	TSJ180A*	83	87	87	85	82	77	74	69	87
17.5	TSJ210A*	89	89	91	89	86	82	79	73	91
20	TSJ240A*	89	89	91	89	86	82	79	73	91
25	TSJ300A*	94	90	92	91	88	84	81	75	93

Notes:

1. Outdoor sound rating shown is tested in accordance with AHRI 270/370-2015. For additional information reference the outdoor sound power level data in the performance section.
2. Taken in accordance with AHRI 270/370-2015.
3. Indoor sound in accordance with AHRI 260 is available through Trane's selection software.

Table 46. Static pressure drop through accessories (inches water column) - standard efficiency

Tons	Unit Model Number	cfm	Standard Filters ^(a)	2" MERV 8 Filter ^(b)	2" MERV 13 Filter ^(b)	Reheat Coil	Economizer with OA/RA Dampers ^(c)								Electric Heater			
							Downflow		Horizontal		Low Leak Downflow ^(d)		Low Leak Horizontal		Accessory (kW)			
							100% OA	100% RA	100% OA	100% RA	100% OA	100% RA	100% OA	100% RA	9-18	27-36	54	72
6	TSJ072A	1800	0.03	0.04	0.07	0.04	0.05	0.01	0.04	0.02	0.09	0.00	-	-	0.01	0.02	N/A	N/A
		2400	0.04	0.06	0.10	0.06	0.10	0.01	0.06	0.03	0.16	0.01	-	-	0.02	0.03	N/A	N/A
		2880	0.04	0.07	0.13	0.07	0.14	0.02	0.08	0.04	0.24	0.01	-	-	0.03	0.03	N/A	N/A
7.5	TSJ090A	2250	0.03	0.05	0.09	0.05	0.09	0.01	0.05	0.02	0.14	0.01	-	-	0.02	0.02	N/A	N/A
		3000	0.05	0.08	0.13	0.07	0.15	0.02	0.09	0.04	0.26	0.01	-	-	0.03	0.03	N/A	N/A
		3600	0.05	0.10	0.17	0.09	0.22	0.02	0.12	0.06	0.39	0.02	-	-	0.04	0.05	N/A	N/A
8.5	TSJ102A	2550	0.04	0.06	0.11	0.06	0.11	0.01	0.06	0.03	0.19	0.01	-	-	0.02	0.03	N/A	N/A
		3400	0.05	0.09	0.16	0.09	0.20	0.02	0.11	0.05	0.34	0.02	-	-	0.03	0.04	N/A	N/A
		4080	0.06	0.12	0.20	0.1	0.28	0.03	0.15	0.07	0.50	0.03	-	-	0.05	0.06	N/A	N/A
10	TSJ120A	3000	0.05	0.08	0.13	0.07	0.15	0.02	0.09	0.04	0.26	0.01	-	-	0.02	0.03	0.05	N/A
		4000	0.06	0.12	0.20	0.10	0.27	0.03	0.15	0.07	0.48	0.03	-	-	0.02	0.03	0.05	N/A
		4800	0.07	0.16	0.25	0.12	0.39	0.03	0.20	0.09	0.71	0.05	-	-	0.03	0.04	0.06	N/A
12.5	TSJ150B	3750	0.05	0.09	0.16	0.08	0.24	0.02	0.13	0.06	0.42	0.02	-	-	0.02	0.03	0.05	N/A
		5000	0.07	0.13	0.22	0.1	0.42	0.04	0.22	0.10	0.78	0.06	-	-	0.02	0.03	0.05	N/A
		6000	0.09	0.16	0.27	0.12	0.60	0.05	0.31	0.13	1.16	0.10	-	-	0.03	0.04	0.06	N/A
15	TSJ180A	4500	0.03	0.05	0.09	0.04	0.13	0.02	0.13	0.02	0.14	0.11	0.07	0.12	0.01	0.02	0.02	N/A
		6000	0.04	0.08	0.13	0.05	0.20	0.04	0.20	0.04	0.23	0.17	0.12	0.18	0.01	0.04	0.04	N/A
		7200	0.06	0.10	0.17	0.07	0.27	0.05	0.27	0.05	0.32	0.23	0.16	0.25	0.02	0.06	0.06	N/A
17.5	TSJ210A	5250	0.04	0.06	0.11	0.05	0.16	0.03	0.16	0.03	0.19	0.14	0.09	0.15	N/A	0.03	0.03	0.03
		7000	0.05	0.10	0.17	0.06	0.26	0.05	0.26	0.05	0.30	0.22	0.15	0.24	N/A	0.06	0.06	0.06
		8400	0.07	0.13	0.22	0.08	0.35	0.06	0.35	0.06	0.42	0.29	0.21	0.33	N/A	0.09	0.09	0.09
20	TSJ240A	6000	0.04	0.08	0.13	0.05	0.20	0.04	0.20	0.04	0.23	0.17	0.12	0.18	N/A	0.04	0.04	0.04
		8000	0.07	0.12	0.21	0.08	0.32	0.06	0.32	0.06	0.39	0.27	0.19	0.3	N/A	0.08	0.08	0.08
		9600	0.09	0.16	0.27	0.10	0.44	0.07	0.44	0.07	0.54	0.37	0.27	0.41	N/A	0.12	0.12	0.12
25	TSJ300A	7500	0.06	0.11	0.19	0.07	0.29	0.05	0.29	0.05	0.34	0.24	0.17	0.27	N/A	0.07	0.07	0.07
		10000	0.09	0.17	0.29	0.11	0.48	0.08	0.48	0.08	0.58	0.40	0.29	0.45	N/A	0.13	0.13	0.13
		12000	0.12	0.23	0.39	0.14	0.66	0.11	0.66	0.11	0.82	0.55	0.39	0.62	N/A	0.20	0.20	0.20

- ^(a) Tested with: 2-in filters 6 to 25 Tons.
^(b) Difference in pressure drop should be considered when utilizing optional 2-in pleated filters.
^(c) OA = Outside Air and RA = Return Air.
^(d) Horizontal Low Leak is not offered on 6 to 12.5 tonnages.



Heating Performance

Table 47. Auxiliary electric heat capacity

Tons	Unit Model Number	Total ^(a)		No. of Stages	Stage 1		Stage 2	
		kw Input ^(b)	MBh Output		kw Input	MBh Output	kw Input	MBh Output
6 to 8.5	TS*072*3,4,W	9.00	30.735	1	9.00	30.735	-	-
	TS*090*3,4,W	18.00	61.47	1	18.00	61.47	-	-
	TS*102*3,4,W	27.00	92.205	2	18.00	61.47	9.00	30.735
	TS*102*3,4,W	36.00	122.94	2	18.00	61.47	18.00	61.47
10 to 12.5	TS*120*3,4,W	18.00	61.47	1	18.00	61.47	-	-
	TS*120*3,4,W	27.00	92.205	2	18.00	61.47	9.00	30.735
	TS*150*3,4,W	36.00	122.94	2	18.00	61.47	18.00	61.47
	TS*150*3,4,W	54.00	184.41	2	36.00	122.94	18.00	61.47
15	TS*180*3,4,W	18.00	61.47	1	18.00	61.47	-	-
	TS*180*3,4,W	36.00	122.94	2	18.00	61.47	18.00	61.47
	TS*180*3,4,W	54.00	184.41	2	36.00	122.94	18.00	61.47
17.5 to 25	TS*210*3,4,W	36.00	122.94	2	18.00	61.47	18.00	61.47
	TS*240*3,4,W	54.00	184.41	2	36.00	122.94	18.00	61.47
	TS*300*3,4,W	72.00	245.88	2	36.00	122.94	36.00	122.94

^(a) Heaters are rated at 240V, 480V, and 600V. For other than rated voltage, CAP = (voltage/rated voltage)² x rated cap.

^(b) For all input/output categories, does not include fan power or heat.

Table 48. Air temperature rise

kW	Stages	6 Tons 1800 cfm	7.5 Tons 2250 cfm	8.5 Tons 2550 cfm	10 Tons 3000 cfm	12.5 Tons 3750 cfm
		Three Phase TS*072*3,4,W	Three Phase TS*090*3,4,W	Three Phase TS*102*3,4,2	Three Phase TS*120*3,4,W	Three Phase TS*150*3,4,W
9.00	1	15.81	12.64	11.16	-	-
18.00	1	31.61	25.29	22.31	18.97	15.17
27.00	2	47.42	37.93	33.47	28.45	22.76
36.00	2	63.22	50.58	44.63	37.93	30.35
54.00	2	-	-	-	56.90	45.52
72.00	2	-	-	-	-	-
kW	Stages	15 Tons 4500 cfm	17.5 Tons 5250 cfm	20 Tons 6000 cfm	25 Tons 7500 cfm	
		Three Phase TS*180*3,4,W	Three Phase TS*210*3,4,W	Three Phase TS*240*3,4,W	Three Phase TS*300*3,4,W	
9.00	1	-	-	-	-	
18.00	1	12.64	-	-	-	
27.00	2	-	-	-	-	
36.00	2	25.28	21.67	18.96	15.17	
54.00	2	37.93	32.51	28.45	22.76	
72.00	2	-	43.35	37.93	30.34	

Note: For minimum design airflow, see airflow performance table for each unit. To calculate temp. rise at different airflow, use the following formula:
Temp. rise across Electric Heater = (kW x 3414)/(1.08 x cfm).



Controls

Enhanced BAS Integration and Connectivity

- Symbio™ 700 integrates seamlessly with Trane® Tracer® Synchrony and Tracer Ensemble® to deliver optimized building automation and building management features and functions.
- Easily integrate with open standard protocols to connect seamlessly to a BAS (whether that is Trane or non-Trane).
- Digit 21 must equal 1, 2, or 3 for communication support.

BACnet® Communications

Symbio™ 700 includes native BACnet communications which allows the unit to communicate directly with a Tracer or non-Trane Building Automation System via open protocol BACnet MS/TP or IP.

Modbus Communications

Symbio 700 includes native Modbus communications which allows the unit to communicate directly with a Tracer or non-Trane Building Automation System via open protocol Modbus RTU or TCP/IP.

LonTalk® Communications

The optional LonTalk® communications module allows the unit to communicate directly with a Tracer or non-Trane Building Automation System via open protocol LonTalk.

Air-Fi® Wireless Communications

The optional Air-Fi communications module allows the unit to communicate directly with a Tracer or non-Trane Building Automation System via open protocol BACnet over Zigbee wireless.

Secure Remote Connectivity with Trane Connect

The Symbio controller enables secure remote connectivity via Trane Connect to Trane Intelligent Services and remote monitoring. Trane Connect provides anywhere/anytime access to monitor and manage with secure remote access and connectivity options through a multitude of platforms. Peace of mind that the system will be operational and provide comfort to customers.

Serviceability

Symbio™ Service and Installation Mobile App

The Symbio™ Service and Installation mobile app is accessible through mobile devices (phones and tablets) via Bluetooth connectivity or via Trane Connect. The intuitive mobile app feels natural to technicians and operators. They will quickly be able to view equipment status and alarms, perform startup tasks, change configurations, test the equipment's performance in specific modes—and much more. Free for download from App Store (Apple iOS) and Google Play (Android devices).

To download the Symbio™ Service and Installation Mobile App use the links below or scan the code with your mobile phone camera.

Apple download link (<https://apps.apple.com/us/app/symbio-service-installation/id1309310176>)

Google Play (Android) download link (<https://play.google.com/store/apps/details?id=com.trane.mobileservicetool>)

Figure 7. Scan code



Figure 8. Symbio™ service and installation mobile app

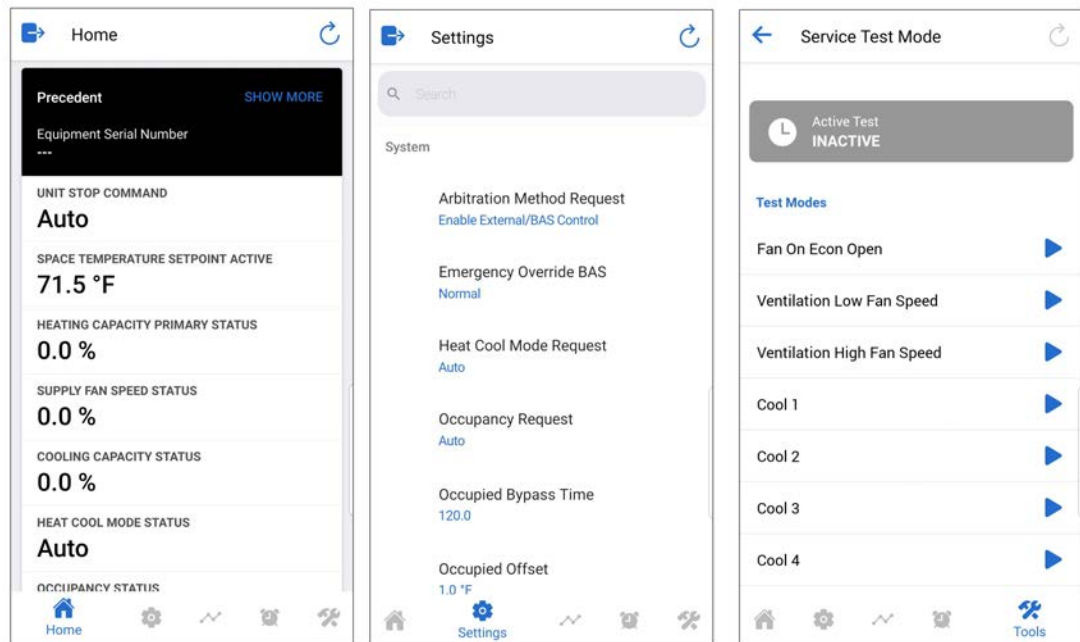

Onboard User Interface

An integrated onboard user interface that makes setup and continued operation easy. It provides real time operational performance, status, data, and alarms. It also allows the user to interact with, service, troubleshoot, and control their equipment without additional service software tools or when a mobile interface is not available.

Figure 9. Onboard user interface

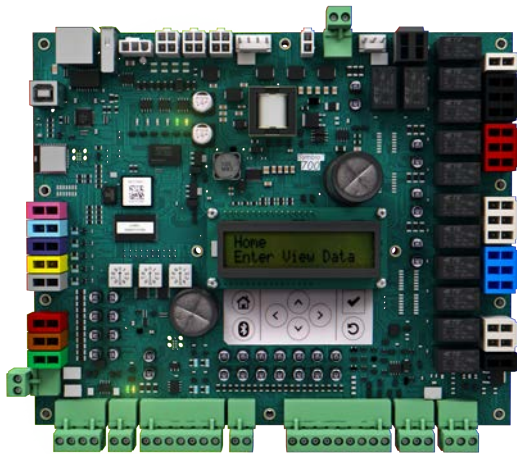

Service Test Mode

Symbio™ 700 requires no special tools to run the unit through its paces. Simply navigate to the 'Service' section of the on-board user interface or the 'Tools' section of the Symbio™ Service and Installation Mobile App and enter the 'Service Test Mode' section. Here the unit can be placed in the desired operating condition for a pre-determined amount of time supporting troubleshooting efforts in the field. The Symbio™ 700 will return to normal control when the user exits test mode or when the pre-determined, user-selected Service Test time has expired.

Symbio™ 700 controls with upgradeable software

Trane's equipment and systems feature engineered, tested, and proven applications that meet industry energy standards and provide the flexibility to customize and update over the life of the equipment. Professional operational algorithms are embedded within the Symbio™ 700 controller at the Trane factory. Symbio™ 700 standardizes each equipment unit to maintain standards for comfort, efficiency, and air quality, without additional field programming. Symbio™ 700 provides the flexibility over the life of the equipment to meet changing customer needs and/or industry standards.

Flexibility

Expansion Modules (contact Trane for more details)

- XM30 – Provides 4 universal inputs or analog outputs
- XM32 – Provides 4 binary outputs

Field Programming via TGP2 (contact Trane for more details)

- Control ancillary equipment
- Custom sequences

TGP2 and XM Limitations:

- Programs will only have access to available BACnet® points. (Ensures system reliability.)
- TGP2 programs will not have direct I/O control access for factory components. (Compressors will not be able to be directly controlled On/Off without going through factory provided protection sequences.)
- Onboard I/O will not be available to custom applied TGP2 programs. If additional I/O is required for a new control loop, a separate expansion module will be required.
- I/O will be limited to a maximum combination of 2 XM modules. Only XM30 or XM32 modules are supported by the Symbio 700.
- Contact Trane to configure XMs and to create, view, or modify TGP2 programs.

Economizer Controls

There are four options for economizer control, Dry Bulb Temperature, Comparative Enthalpy, Reference Enthalpy and Differential Dry Bulb Temperature.

Dry Bulb Temperature Control

The dry bulb system measures outdoor temperature comparing it to the economizer enable setpoint. If the outdoor temperature is below the economizer enable setpoint, the economizer will operate freely. This system is best suited for arid regions where the humidity levels of outside air would not be detrimental to building comfort and indoor air quality.

Comparative Enthalpy Control

The comparative enthalpy system measures the temperature and humidity of both return air and outside air to determine which source has lower enthalpy. This system allows true comparison of outdoor air and return air enthalpy by measurement of outdoor air and return air temperature and humidity.

Reference Enthalpy Control

The reference enthalpy system compares outdoor air temperature and humidity to the economizer enthalpy enable setpoint. If outdoor air temperature and humidity are below the economizer enthalpy enable setpoint, the economizer will operate freely. This system provides more sophisticated control where outdoor air humidity levels may not be acceptable for building comfort and indoor air quality.

Differential Dry Bulb Temperature Control

The differential dry bulb system measures the temperature of both return air and outside air to determine when to economize. If outdoor air temperature is below the return air temperature minus a differential, the economizer will operate freely. This system is best suited for arid regions where the humidity levels of outside air would not be detrimental to building comfort and indoor air quality.

Zone Sensors

Zone Temperature Only

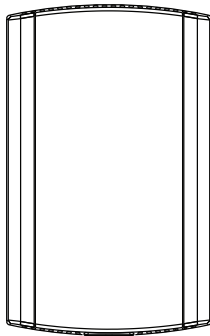

BAYSENS077

Provides temperature input only. Can be used as a secondary remote temperature input for thermostats.

Manual Changeover

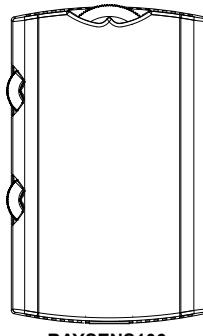

BAYSENS106

Heat, Cool or Off System Switch. Fan Auto or Off Switch. Single temperature setpoint thumbwheel.

Manual/Automatic Changeover

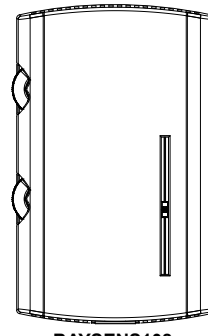

BAYSENS108

Auto, Heat, Cool or Off System Switch. Fan Auto or Off Switch. Dual temperature setpoint sliders

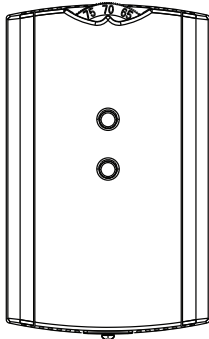
Integrated Comfort™ System

BAYSENS073 / BAYSENS074 / BAYSENS075

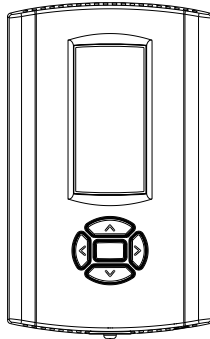
Sensor(s) available with optional temperature adjustment and override buttons to provide central control through a Trane Integrated Comfort system.

Wired Display Sensor

BAYSENS135

LCD display that provides heat, cool, auto, or off. Includes two temperature setpoints and a lockable setting with °F or °C indicators.

Touchscreen Digital Display Communicating Sensor

BAYSENS800

Uses BACnet® MS/TP link to communicate zone temperature and setpoints. Auto, Heat, Cool or Off System Switch. Fan Auto or On Switch. 7-day programmable thermostat with night setback.

Note: Not compatible with VAV units. Requires BACnet communications.

Air-Fi Wireless Communicating Zone Sensors

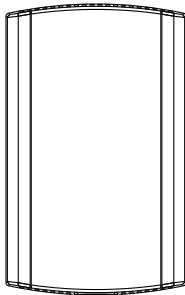
Wireless Zone Temperature Only

BAYSENS077

Measures temperature and optional humidity (with WCS-SH) for use in public spaces where no local user interface is preferred.

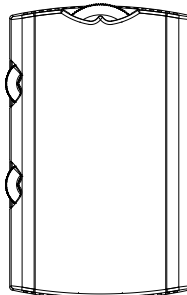
Note: Requires BACnet communications.

Wireless Display Sensor

BAYSENS106

Easy-to-use interface for clear and simple monitoring and control. Can be configured for any Trane system or to meet the customer's preference.

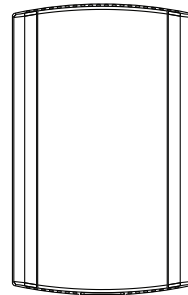
Note: Requires BACnet communications.

Wired CO₂ Sensor

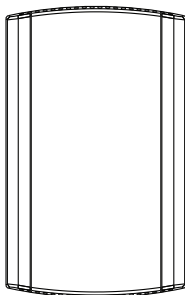
X13790422010

The maintenance-free carbon dioxide (CO₂) sensor is primarily used for demand control ventilation applications.

Wired Zone Temperature and Humidity Sensor

BAYSENS036

Measures temperature and relative humidity. Relative humidity input is used to control activation of dehumidification.

Thermostats

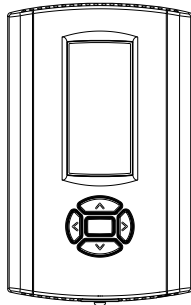
Digital Display Programmable Thermostat (3H/2C)



BAYSTAT150

Three Heat/Two Cool Auto changeover digital display thermostat. 7-day programmable thermostat with night setback.

Note: Not compatible with VAV units.

Digital Display Programmable Thermostat (1H/1C)

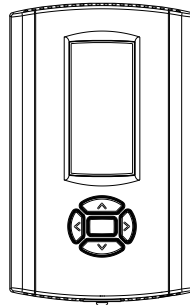

BAYSTAT151

One Heat/One Cool Auto changeover digital display thermostat.

Note: Not compatible with VAV units.

Digital Display Thermostat (3H/2C)

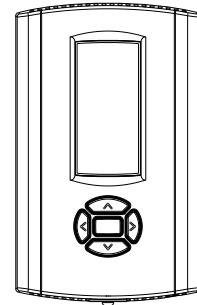

BAYSTAT155

Three Heat/Two Cool Auto changeover display thermostat.

Note: Not compatible with VAV units.

Pivot® Web Enabled Smart Thermostat (3H/2C)

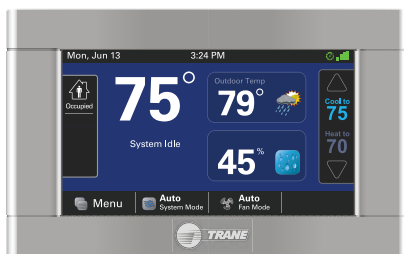

BAYSTAT814

Our Pivot Smart Thermostat system is great for commercial buildings. With its intuitive touchscreen and customizable display, it is easy for occupants to use. The Trane Pivot mobile app enables users to control multiple buildings remotely, making changes in seconds to all systems.

Note: Not compatible with VAV units.

Touchscreen Programmable Thermostat with Relative Humidity Sensor (3H/2C)



BAYSTAT152

Three Heat, Two Cool digital display thermostat with built-in humidity control. This thermostat combines both humidity and temperature into one.

Note: Not compatible with VAV units.

Humidity Control (HGRH)

Sequence of Operations

Humidity Control system capable of operating in normal cooling, dual mode to satisfy cooling and humidity requirements, and hot gas reheat mode when only humidity demand is required. Function between requirements and unit transition seamlessly providing an all-around comfort solution.

Note: Supports Humidistat control. When the Humidistat input becomes active, compressors will stage to full capacity and modulate the 3 way valve.

Initiation of Humidity Control

- Conforms to ASHRAE standard (62)
- Dehumidification is initiated when too much moisture is in the space (>60°F Dew point)
 - Two measurement options for this dehumidification status:
 - Humidity control is started when:
 - Dew point is too high (60°F is default),

- Relative Humidity is too high (60% is default), DH is started
 - Choice between these values above is user-configurable, and the actual values are adjustable by customer if desired
- Reheat circuit is initiated when space temperature drops below setpoint during humidity control.

Humidity Control Routine

There are two independent control loops: One to control latent load, the other to control sensible load.

Latent load is controlled by compressor staging:

- Compressors initially move up one stage from the last cooling mode stage.
- Compressors are staged up as needed by the controller to achieve a target leaving ID air dew point based on space conditions.

Sensible load is controlled with the Modulating 3 way valve:

- Modulating valve opens when space temperature is below setpoint.
- The reheat valve adjusts the amount of flow to RH coil to achieve the targeted leaving ID air temperature, based on space conditions.

Purge Cycle

During dehumidification, every 120 minutes (default) a 3 minute cooling “purge cycle” will be executed. This purge cycle is executed for system reliability, specifically it helps manage oil return to compressors.

- Modulating valve moves to a fixed position based on OD air and compressor stage.
- Compressors move to full load.

Leaving Humidity Control and Returning to Cooling Only

- When space humidity drops to below the threshold humidity value (60°F dew point or 60% relative humidity), system reverts back to cooling mode. Dead band of ~5°F yields approximately 55°F dew point for switch to cooling.
- Unit can stay in humidity control mode indefinitely, with purge cycles happening regularly.
 - Relative humidity setpoint is 65% for unoccupied mode.
 - Dew point for unoccupied mode is the same as occupied (default 60°F DP).



Electrical Data

Table 49. Unit wiring

Tons	Unit Model Number	Voltage Range	Standard Indoor Fan Motor		Oversized/High Static Indoor Fan Motor		Optional Power Exhaust Standard Indoor Fan Motor		Optional Power Exhaust Oversized/High Static Indoor Fan Motor	
			MCA	Max Fuse Size or Max Circuit Breaker	MCA	Max Fuse Size or Max Circuit Breaker	MCA	Max Fuse Size or Max Circuit Breaker	MCA	Max Fuse Size or Max Circuit Breaker
6	TSJ072A3	187-253	38	50	-	-	43	50	-	-
	TSJ072A4	414-506	21	20	-	-	22	25	-	-
	TSJ072AW	517-633	17	15	-	-	17	20	-	-
7.5	TSJ090A3	187-253	42	50	-	-	48	60	-	-
	TSJ090A4	414-506	21	25	-	-	24	30	-	-
	TSJ090AW	517-633	17	20	-	-	19	25	-	-
8.5	TSJ102A3	187-253	48	60	-	-	53	70	-	-
	TSJ102A4	414-506	25	30	-	-	28	35	-	-
	TSJ102AW	517-633	19	25	-	-	21	25	-	-
10	TSJ120A3	187-253	54	70	56	80	60	80	62	80
	TSJ120A4	414-506	29	40	30	40	32	40	33	45
	TSJ120AW	517-633	22	30	22	30	24	30	25	30
12.5	TSJ150B3	187-253	67	90	-	-	73	100	-	-
	TSJ150B4	414-506	31	40	-	-	35	45	-	-
	TSJ150BW	517-633	24	30	-	-	26	35	-	-
15	TSJ180A3	187-253	78	100	-	-	83	110	-	-
	TSJ180A4	414-506	41	50	-	-	45	60	-	-
	TSJ180AW	517-633	32	40	-	-	34	45	-	-
17.5	TSJ210A3	187-253	93	125	-	-	98	125	-	-
	TSJ210A4	414-506	49	60	-	-	52	70	-	-
	TSJ210AW	517-633	37	50	-	-	40	50	-	-
20	TSJ240A3	187-253	108	125	-	-	113	150	-	-
	TSJ240A4	414-506	54	70	-	-	57	70	-	-
	TSJ240AW	517-633	47	60	-	-	49	70	-	-
25	TSJ300A3	187-253	119	150	124	150	125	150	129	175
	TSJ300A4	414-506	59	80	61	80	62	80	64	80
	TSJ300AW	517-633	46	60	48	60	48	80	50	60



Electrical Data

Table 50. Unit wiring with electric heat

Tons	Unit Model Number	Heater Model Number	Heater kW Rating	Control Stages	Standard Indoor Fan Motor ^(a)		Oversized/High Static Indoor Fan Motor		Optional Power Exhaust Standard Indoor Fan Motor		Optional Power Exhaust Oversized/High Static Indoor Fan Motor	
					MCA	Max Fuse Size or Max Circuit Breaker	MCA	Max Fuse Size or Max Circuit Breaker	MCA	Max Fuse Size or Max Circuit Breaker	MCA	Max Fuse Size or Max Circuit Breaker
208/230 Volts Three Phase												
6	TSJ072A3	FIAEHTB309AA	6.8/9.0	1	38/40	50/50	-	-	43/47	50/50	-	-
		FIAEHTB318AA	13.5/18.0	1	60/67	60/70	-	-	67/74	70/80	-	-
		FIAEHTB327AA	20.3/27.0	2	83/94	90/100	-	-	90/101	90/110	-	-
		FIAEHTB336AA	27.0/36.0	2	107/121	110/125	-	-	114/128	125/150	-	-
7.5	TSJ090A3	FIAEHTB309AA	6.8/9.0	1	42/42	50/50	-	-	48/48	60/60	-	-
		FIAEHTB318AA	13.5/18.0	1	60/67	60/70	-	-	67/74	70/80	-	-
		FIAEHTB327AA	20.3/27.0	2	83/94	90/100	-	-	90/101	90/110	-	-
		FIAEHTB336AA	27.0/36.0	2	107/121	110/125	-	-	114/125	125/150	-	-
8.5	TSJ102A3	FIAEHTB309AA	6.8/9.0	1	48/48	60/60	-	-	53/53	70/70	-	-
		FIAEHTB318AA	13.5/18.0	1	60/67	60/70	-	-	67/74	70/80	-	-
		FIAEHTB327AA	20.3/27.0	2	83/94	90/100	-	-	90/101	90/110	-	-
		FIAEHTB336AA	27.0/36.0	2	107/121	110/125	-	-	114/128	125/150	-	-
10	TSJ120A3	FIAEHTB318AA	13.5/18.0	1	60/67	70/70	62/70	80/80	67/74	80/80	70/77	80/80
		FIAEHTB327AA	20.3/27.0	2	83/94	90/100	86/97	90/100	90/101	90/110	93/104	100/110
		FIAEHTB336AA	27.0/36.0	2	107/121	110/125	108/124	110/125	114/128	125/150	116/131	125/150
		FIAEHTB354AA	40.6/54.0	2	153/143	175/175	156/145	175/175	161/150	175/175	163/153	175/175
12.5	TSJ150B3	FIAEHTC318AA	13.5/18.0	1	67/70	90/90	-	-	73/77	100/100	-	-
		FIAEHTC327AA	20.3/27.0	2	86/97	90/100	-	-	93/104	100/110	-	-
		FIAEHTC336AA	27.0/36.0	2	109/124	110/125	-	-	116/131	125/150	-	-
		FIAEHTC354AA	40.6/54.0	2	156/145	175/175	-	-	163/153	175/175	-	-
15	TSJ180A3	FIAEHTD318AA	13.5/18.0	1	78/78	100/100	-	-	83/85	110/110	-	-
		FIAEHTD336AA	27.0/36.0	2	118/132	125/150	-	-	125/139	125/150	-	-
		FIAEHTD354AA	40.6/54.0	2	164/154	175/175	-	-	172/161	175/175	-	-
17.5	TSJ210A3	FIAEHTD336AA	27.0/36.0	2	118/132	125/150	-	-	125/139	125/150	-	-
		FIAEHTD354AA	40.6/54.0	2	164/154	175/175	-	-	172/161	175/175	-	-
		FIAEHTD372AA	54.0/72.0	2	174/197	200/225	-	-	181/204	200/225	-	-
20	TSJ240A3	FIAEHTD336AA	27.0/36.0	2	118/132	150/150	-	-	125/139	150/150	-	-
		FIAEHTD354AA	40.6/54.0	2	164/154	175/175	-	-	172/161	175/175	-	-
		FIAEHTD372AA	54.0/72.0	2	174/197	200/225	-	-	181/204	200/225	-	-
25	TSJ300A3	FIAEHTD336AA	27.0/36.0	2	119/132	150/150	124/138	150/150	125/139	150/150	130/145	175/175
		FIAEHTD354AA	40.6/54.0	2	164/154	175/175	170/159	175/175	172/161	175/175	177/166	200/175
		FIAEHTD372AA	54.0/72.0	2	174/197	200/225	180/203	200/225	181/204	200/225	186/210	200/225

Table 50. Unit wiring with electric heat (continued)

Tons	Unit Model Number	Heater Model Number	Heater kW Rating	Control Stages	Standard Indoor Fan Motor ^(a)		Oversized/High Static Indoor Fan Motor		Optional Power Exhaust Standard Indoor Fan Motor		Optional Power Exhaust Oversized/High Static Indoor Fan Motor	
					MCA	Max Fuse Size or Max Circuit Breaker	MCA	Max Fuse Size or Max Circuit Breaker	MCA	Max Fuse Size or Max Circuit Breaker	MCA	Max Fuse Size or Max Circuit Breaker
460 Volts Three Phase												
6	TSJ072A4	FIAEHTB409AA	9	1	21	25	-	-	25	25	-	-
		FIAEHTB418AA	18	1	35	35	-	-	39	40	-	-
		FIAEHTB427AA	27	2	48	50	-	-	52	60	-	-
		FIAEHTB436AA	36	2	62	70	-	-	66	70	-	-
7.5	TSJ090A4	FIAEHTB409AA	9	1	21	25	-	-	25	30	-	-
		FIAEHTB418AA	18	1	35	35	-	-	39	40	-	-
		FIAEHTB427AA	27	2	48	50	-	-	52	60	-	-
		FIAEHTB436AA	36	2	62	70	-	-	66	70	-	-
8.5	TSJ102A4	FIAEHTB409AA	9	1	25	30	-	-	28	35	-	-
		FIAEHTB418AA	18	1	35	35	-	-	39	40	-	-
		FIAEHTB427AA	27	2	48	50	-	-	52	60	-	-
		FIAEHTB436AA	36	2	62	70	-	-	66	70	-	-
10	TSJ120A4	FIAEHTB418AA	18	1	35	40	36	40	39	40	40	45
		FIAEHTB427AA	27	2	48	50	49	50	52	60	53	60
		FIAEHTB436AA	36	2	62	70	63	70	66	70	67	70
		FIAEHTB454AA	54	2	73	90	74	90	77	90	78	90
12.5	TSJ150B4	FIAEHTC418AA	18	1	36	40	-	-	40	45	-	-
		FIAEHTC427AA	27	2	49	50	-	-	53	60	-	-
		FIAEHTC436AA	36	2	63	70	-	-	67	70	-	-
		FIAEHTC454AA	54	2	74	90	-	-	78	90	-	-
15	TSJ180A4	FIAEHTD418AA	18	1	41	50	-	-	45	60	-	-
		FIAEHTD436AA	36	2	67	70	-	-	72	80	-	-
		FIAEHTD454AA	54	2	78	90	-	-	82	90	-	-
17.5	TSJ210A4	FIAEHTD436AA	36	2	67	70	-	-	72	80	-	-
		FIAEHTD454AA	54	2	78	90	-	-	82	90	-	-
		FIAEHTD472AA	72	2	100	110	-	-	104	110	-	-
20	TSJ240A4	FIAEHTD436AA	36	2	67	70	-	-	72	80	-	-
		FIAEHTD454AA	54	2	78	90	-	-	82	90	-	-
		FIAEHTD472AA	72	2	100	110	-	-	104	110	-	-
25	TSJ300A4	FIAEHTD436AA	36	2	67	70	70	80	72	80	74	80
		FIAEHTD454AA	54	2	78	90	81	90	82	90	85	90
		FIAEHTD472AA	72	2	100	110	102	110	104	110	106	110



Electrical Data

Table 50. Unit wiring with electric heat (continued)

Tons	Unit Model Number	Heater Model Number	Heater kW Rating	Control Stages	Standard Indoor Fan Motor ^(a)		Oversized/High Static Indoor Fan Motor		Optional Power Exhaust Standard Indoor Fan Motor		Optional Power Exhaust Oversized/High Static Indoor Fan Motor	
					MCA	Max Fuse Size or Max Circuit Breaker	MCA	Max Fuse Size or Max Circuit Breaker	MCA	Max Fuse Size or Max Circuit Breaker	MCA	Max Fuse Size or Max Circuit Breaker
575 Volts Three Phase												
6	TSJ072AW	FIAEHTBW09AA	9	1	17	20	-	-	19	20	-	-
		FIAEHTBW18AA	18	1	27	30	-	-	30	30	-	-
		FIAEHTBW27AA	27	2	38	40	-	-	41	45	-	-
		FIAEHTBW36AA	36	2	49	50	-	-	52	60	-	-
7.5	TSJ090AW	FIAEHTBW09AA	9	1	17	20	-	-	19	25	-	-
		FIAEHTBW18AA	18	1	27	30	-	-	30	30	-	-
		FIAEHTBW27AA	27	2	38	40	-	-	41	45	-	-
		FIAEHTBW36AA	36	2	49	50	-	-	52	60	-	-
8.5	TSJ102AW	FIAEHTBW09AA	9	1	19	25	-	-	21	25	-	-
		FIAEHTBW18AA	18	1	27	30	-	-	30	30	-	-
		FIAEHTBW27AA	27	2	38	40	-	-	41	45	-	-
		FIAEHTBW36AA	36	2	49	50	-	-	52	60	-	-
10	TSJ120AW	FIAEHTBW18AA	18	1	27	30	28	30	30	30	31	35
		FIAEHTBW27AA	27	2	38	40	39	40	41	45	42	45
		FIAEHTBW36AA	36	2	49	50	50	50	52	60	53	60
		FIAEHTBW54AA	54	2	57	70	59	70	61	70	61	70
12.5	TSJ150BW	FIAEHTCW18AA	18	1	28	30	-	-	31	35	-	-
		FIAEHTCW27AA	27	2	39	40	-	-	42	45	-	-
		FIAEHTCW36AA	36	2	50	50	-	-	53	60	-	-
		FIAEHTCW54AA	54	2	59	70	-	-	61	70	-	-
15	TSJ180AW	FIAEHTDW18AA	18	1	32	40	-	-	34	45	-	-
		FIAEHTDW36AA	36	2	53	60	-	-	56	60	-	-
		FIAEHTDW54AA	54	2	62	70	-	-	65	70	-	-
17.5	TSJ210AW	FIAEHTDW36AA	36	2	53	60	-	-	56	60	-	-
		FIAEHTDW54AA	54	2	62	70	-	-	65	70	-	-
		FIAEHTDW72AA	72	2	79	90	-	-	82	90	-	-
20	TSJ240AW	FIAEHTDW36AA	36	2	53	60	-	-	56	70	-	-
		FIAEHTDW54AA	54	2	62	70	-	-	65	70	-	-
		FIAEHTDW72AA	72	2	79	90	-	-	82	90	-	-
25	TSJ300AW	FIAEHTDW36AA	36	2	53	60	55	60	58	60	58	60
		FIAEHTDW54AA	54	2	62	70	64	70	66	70	66	70
		FIAEHTDW72AA	72	2	79	90	81	90	84	90	84	90

^(a) The standard motor is a multispeed, direct drive motor.

Table 51. Electrical characteristics - compressor motor and condenser motor

Tons	Unit Model Number	No.	Compressor Motors						No.	Condenser Fan Motor				
			Volts	Phase	hp ^(a)	rpm	Amps ^(b)			Volts	Phase	hp	Amps	
							RLA	LRA					FLA	LRA
6	TSJ072A3	2	208/230	3	3.5/1.7	3500/3500	14.1/7.3	83.1/55.4	1	208/230	3	0.7	3.3	12.3
	TSJ072A4	2	460	3	3.5/1.7	3500/3500	6.5/3.6	41/28	1	460	3	0.7	1.5	6.1
	TSJ072AW	2	575	3	3.5/1.7	3500/3500	5.4/3.0	33.0/24.5	1	575	3	0.7	1.4	5.1
7.5	TSJ090A3	2	208/230	3	4.3/2.1	3500/3500	16.4/9.2	110/58	1	208/230	3	0.7	3.3	12.3
	TSJ090A4	2	460	3	4.3/2.1	3500/3500	8.2/4.3	52/28	1	460	3	0.7	1.5	6.1
	TSJ090AW	2	575	3	4.3/2.1	3500/3500	6.6/3.6	38.9/24.0	1	575	3	0.7	1.4	5.1
8.5	TSJ102A3	2	208/230	3	5.1/2.4	3500/3500	20.2/9.7	136/71	1	208/230	3	0.7	3.3	12.3
	TSJ102A4	2	460	3	5.1/2.4	3500/3500	9.9/5.8	66/38	1	460	3	0.7	1.5	6.1
	TSJ102AW	2	575	3	5.1/2.4	3500/3500	8.0/3.9	55/30	1	575	3	0.7	1.4	5.1
10	TSJ120A3	2	208/230	3	6.3/2.4	3500/3500	25.8/9.7	164/71	1	208/230	3	0.75	2.8	10.4
	TSJ120A4	2	460	3	6.3/2.4	3500/3500	13.2/5.8	100/38	1	460	3	0.75	1.4	5.2
	TSJ120AW	2	575	3	6.3/2.4	3500/3500	10.3/3.9	78.0/36.5	1	575	3	0.75	1.14	4.53
12.5	TSJ150B3	2	208/230	3	7.6/3.5	3500/3500	30.5/13.5	207.5/81.3	1	208/230	3	1	4.3	18.9
	TSJ150B4	2	460	3	7.6/3.5	3500/3500	13.6/6.3	100/41	1	460	3	1	2.2	9.5
	TSJ150BW	2	575	3	7.6/3.5	3500/3500	10.4/4.5	78/33	1	575	3	1	1.8	8.1
15	TSJ180A3	2	208/230	3	8.7/4.3	3500/3500	30.9/16.4	240/110	2	208/230	3	0.5	2.3	8.4
	TSJ180A4	2	460	3	8.7/4.3	3500/3500	16.7/8.2	130/52	2	460	3	0.5	1.1	4.2
	TSJ180AW	2	575	3	8.7/4.3	3500/3500	12.8/6.6	93.7/38.9	2	575	3	0.5	1.0	3.6
17.5	TSJ210A3	2	208/230	3	10.2/5.1	3500/3500	35.7/20.2	240/136	2	208/230	3	1	4.3	19.4
	TSJ210A4	2	460	3	10.2/5.1	3500/3500	19.4/9.9	140/66	2	460	3	1	2.2	10.1
	TSJ210AW	2	575	3	10.2/5.1	3500/3500	14.9/8.0	107.6/55.0	2	575	3	1	1.8	8.0
20	TSJ240A3	2	208/230	3	11.4/6.3	3500/3500	43.1/26.1	270/164	2	208/230	3	1	4.3	19.4
	TSJ240A4	2	460	3	11.4/6.3	3500/3500	21.3/12.2	147/84	2	460	3	1	2.2	10.1
	TSJ240AW	2	575	3	11.4/6.3	3500/3500	21.3/9.6	109/60	2	575	3	1	1.8	8.0
25	TSJ300A3	2	208/230	3	12.8/7.6	3500/3500	49.5/29.6	335.5/223.0	2	208/230	3	1	4.3	19.4
	TSJ300A4	2	460	3	12.8/7.6	3500/3500	23.9/14.4	141/100	2	460	3	1	2.2	10.1
	TSJ300AW	2	575	3	12.8/7.6	3500/3500	19.8/10.8	109/70	2	575	3	1	1.8	8.0

^(a) Hp for each compressor.

^(b) Amp draw for each motor (compressor and condenser fan motor); multiply value by number of motors to determine total amps.

Table 52. Electrical characteristics - indoor fan motor

Tons	Unit Model Number	No.	Volts	Phase	hp	Amps ^(a)	
						FLA	LRA
6	TSJ072A3	1	208/230	3	3	8.8	-
	TSJ072A4	1	460	3	3	4.6	-
	TSJ072AW	1	575	3	3	3.2	-
7.5	TSJ090A3	1	208/230	3	3	8.8	-
	TSJ090A4	1	460	3	3	4.6	-
	TSJ090AW	1	575	3	3	3.2	-
8.5	TSJ102A3	1	208/230	3	3	8.8	-
	TSJ102A4	1	460	3	3	4.6	-
	TSJ102AW	1	575	3	3	3.2	-



Electrical Data

Table 52. Electrical characteristics - indoor fan motor (continued)

Tons	Unit Model Number	No.	Volts	Phase	hp	Amps ^(a)	
						FLA	LRA
10	TSJ120A3	1	208/230	3	3	8.8	-
	TSJ120A4	1	460	3	3	4.6	-
	TSJ120AW	1	575	3	3	3.2	-
12.5	TSJ150B3	1	208/230	3	5	11.0	-
	TSJ150B4	1	460	3	5	5.5	-
	TSJ150BW	1	575	3	5	3.9	-
15	TSJ180A3	2	208/230	3	3	8.8	-
	TSJ180A4	2	460	3	3	4.6	-
	TSJ180AW	2	575	3	3	3.2	-
17.5	TSJ210A3	2	208/230	3	3	8.8	-
	TSJ210A4	2	460	3	3	4.6	-
	TSJ210AW	2	575	3	3	3.2	-
20	TSJ240A3	2	208/230	3	3	8.8	-
	TSJ240A4	2	460	3	3	4.6	-
	TSJ240AW	2	575	3	3	3.2	-
25	TSJ300A3	2	208/230	3	3	8.8	-
	TSJ300A4	2	460	3	3	4.6	-
	TSJ300AW	2	575	3	3	3.2	-

^(a) Amp draw for each motor (compressor and condenser fan motor); multiply value by number of motors to determine total amps.

Table 53. Electrical characteristics - oversized indoor fan motor

Tons	Unit Model Number	No.	Volts	Phase	hp	Amps ^(a)	
						FLA	LRA
10	TSJ120A3	1	208/230	3	5	11.0	-
	TSJ120A4	1	460	3	5	5.5	-
	TSJ120AW	1	575	3	5	3.9	-
25	TSJ300A3	2	208/230	3	5	11.0	-
	TSJ300A4	2	460	3	5	5.5	-
	TSJ300AW	2	575	3	5	3.9	-

^(a) Amp draw for each motor (compressor and condenser fan motor); multiply value by number of motors to determine total amps.

Table 54. Electrical characteristics - power exhaust

Tons	Volts	Phase	hp	rpm	FLA	LRA
6-25	208-230	1	0.87	1075	5.7	13.6
6-25	460	1	0.87	1075	3.3	7.2
6-25	575	1	0.80	1075	2.3	5.8

Note: For 6 to 10 ton models, rpm = two speed.



Dimensional Data

Figure 10. 6 to 10 tons standard efficiency

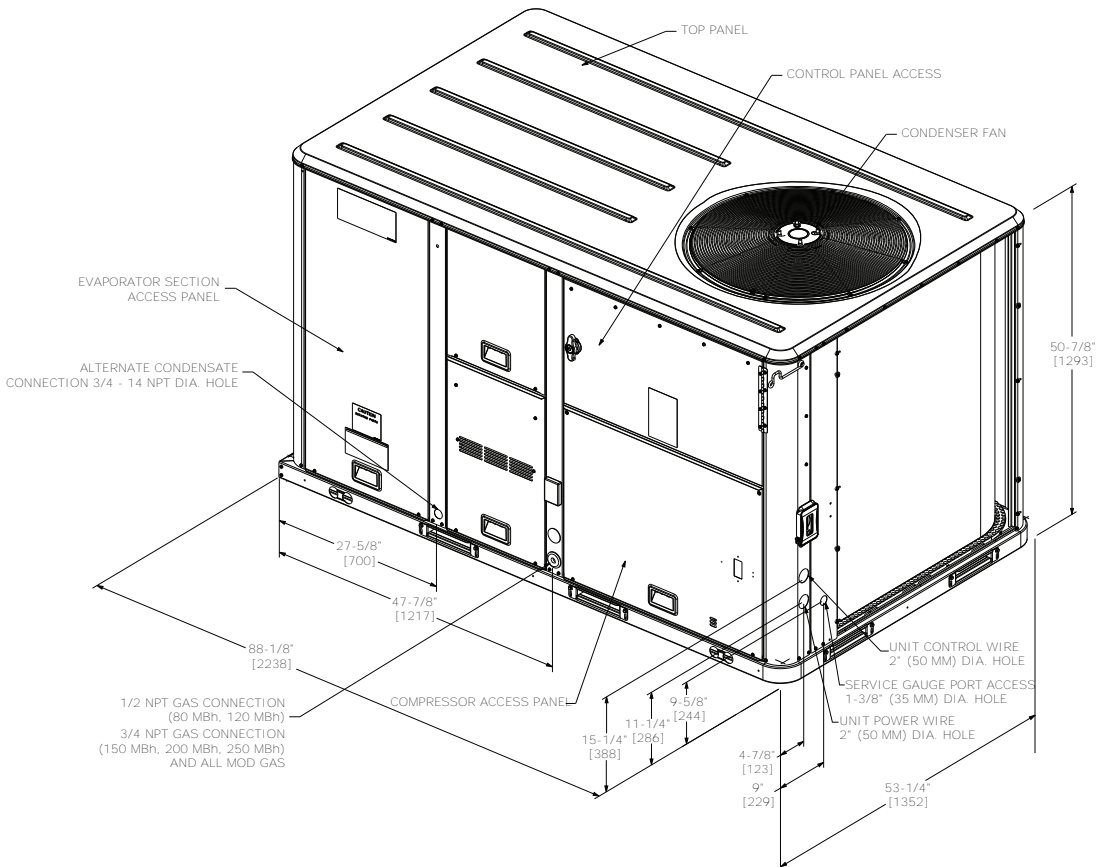
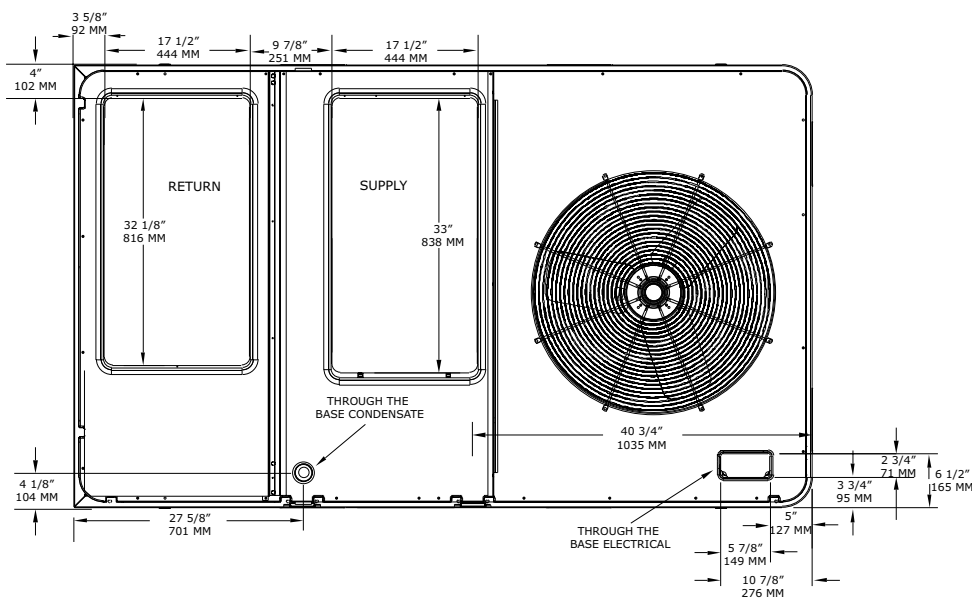

Figure 11. 6 to 10 tons standard efficiency – downflow airflow supply/return, through-the-base utilities





Dimensional Data

Figure 12. 6 to 10 tons standard efficiency – horizontal airflow supply/return

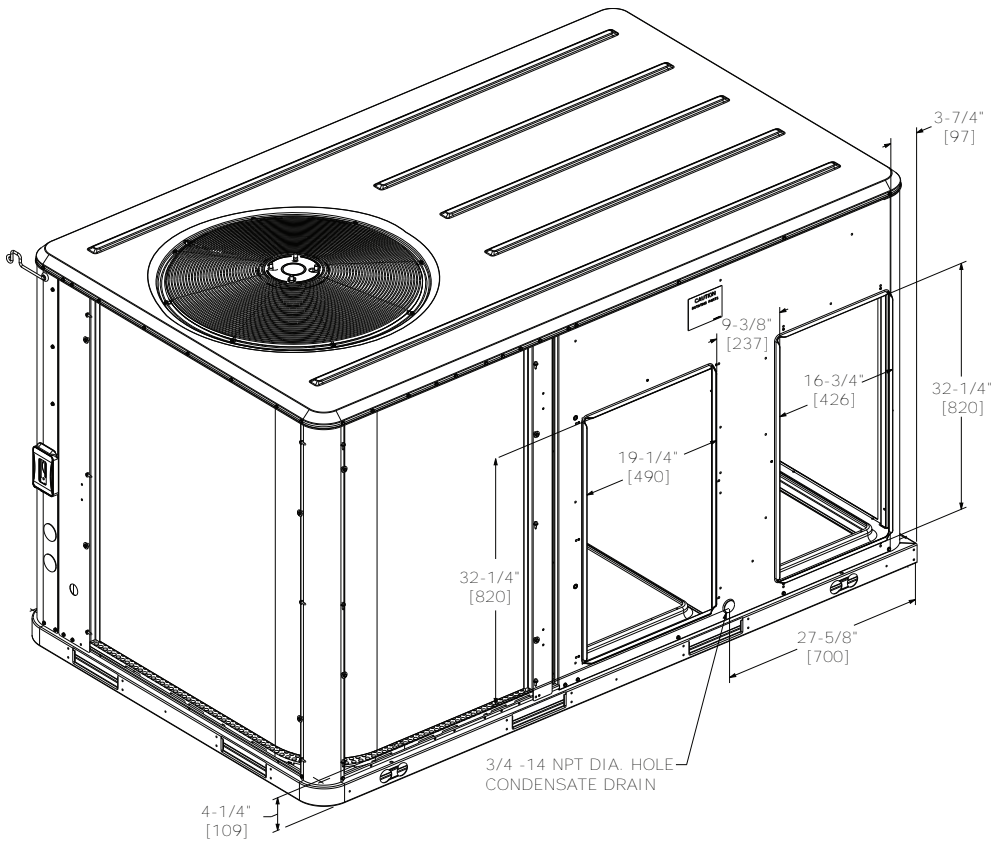

Figure 13. 6 to 10 tons standard efficiency — unit clearance and roof opening

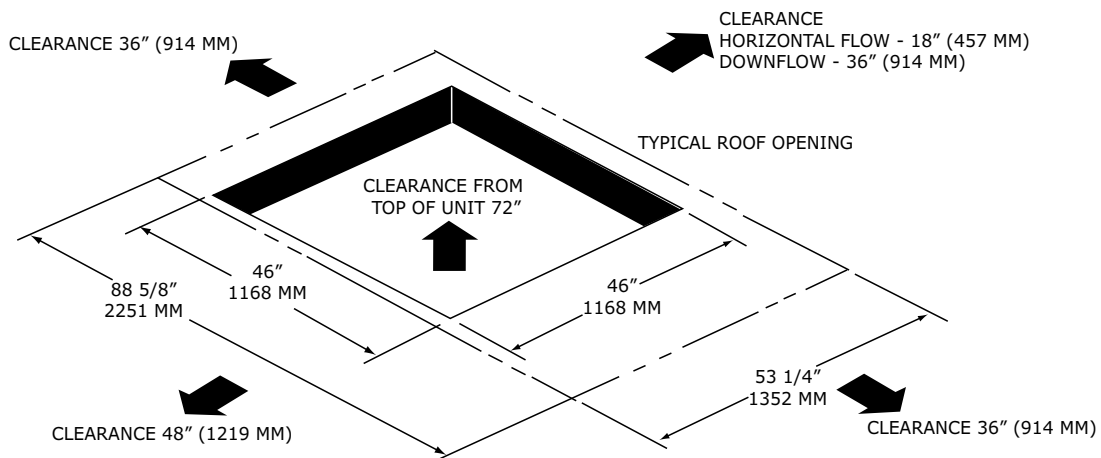

Figure 14. 6 to 10 tons standard efficiency – roof curb

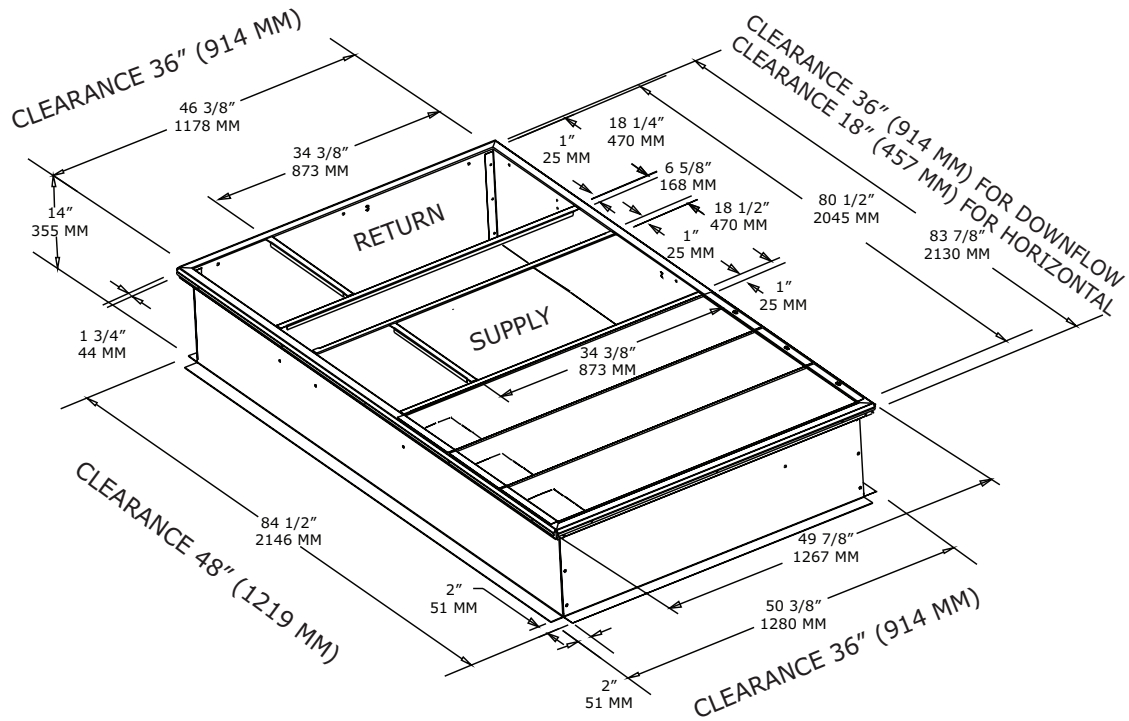
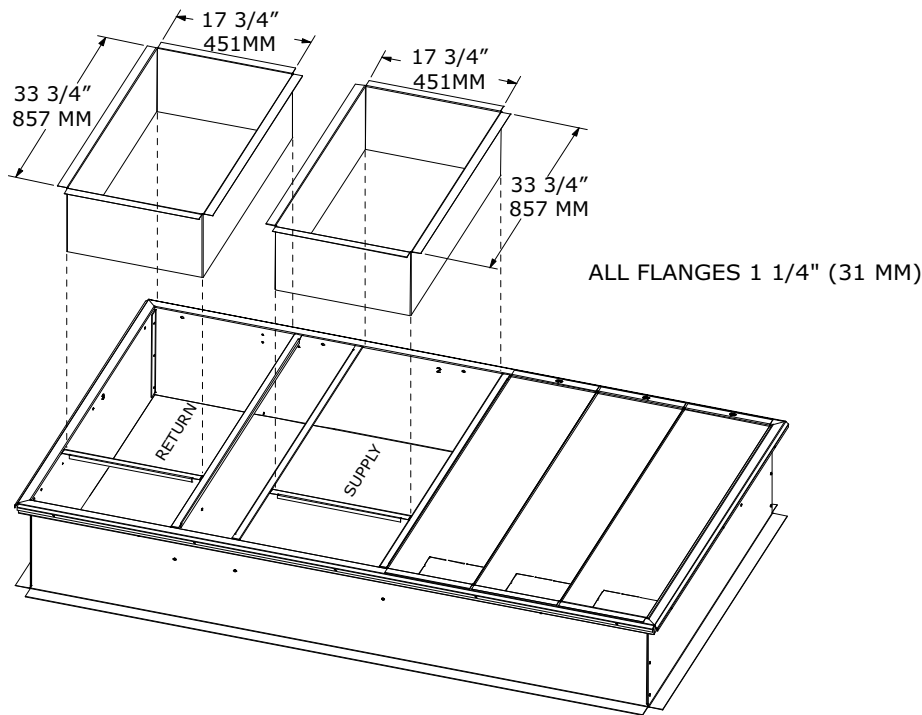

Figure 15. 6 to 10 tons standard efficiency – downflow duct connections, field fabricated





Dimensional Data

Figure 16. 6 to 10 tons standard efficiency – swing diameter for hinged door(s) option

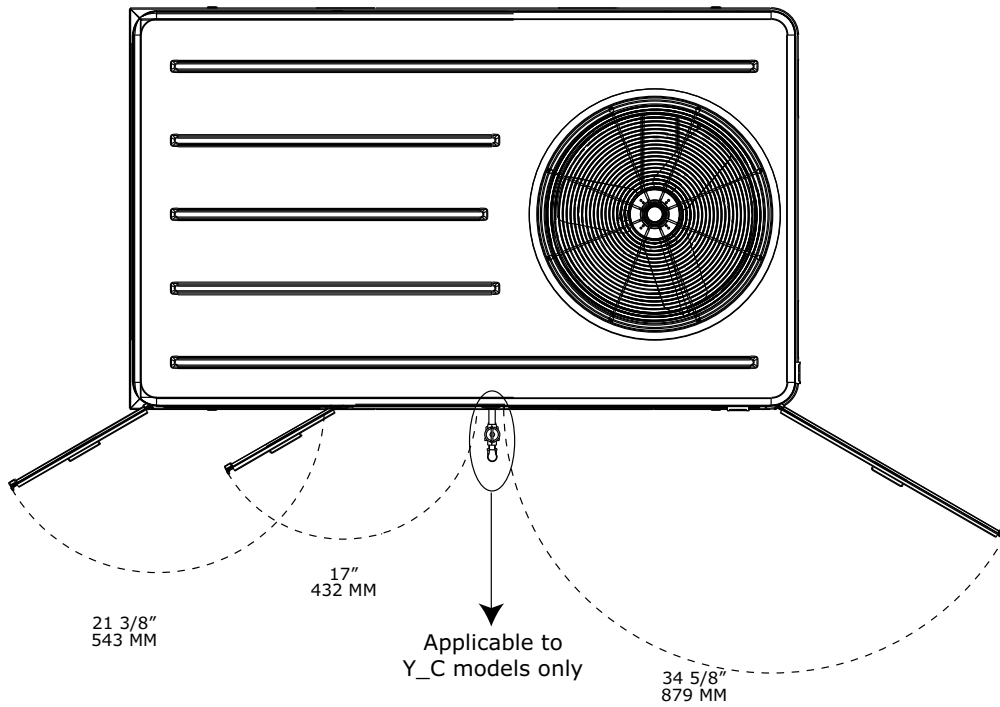

Figure 17. 12.5 tons standard efficiency

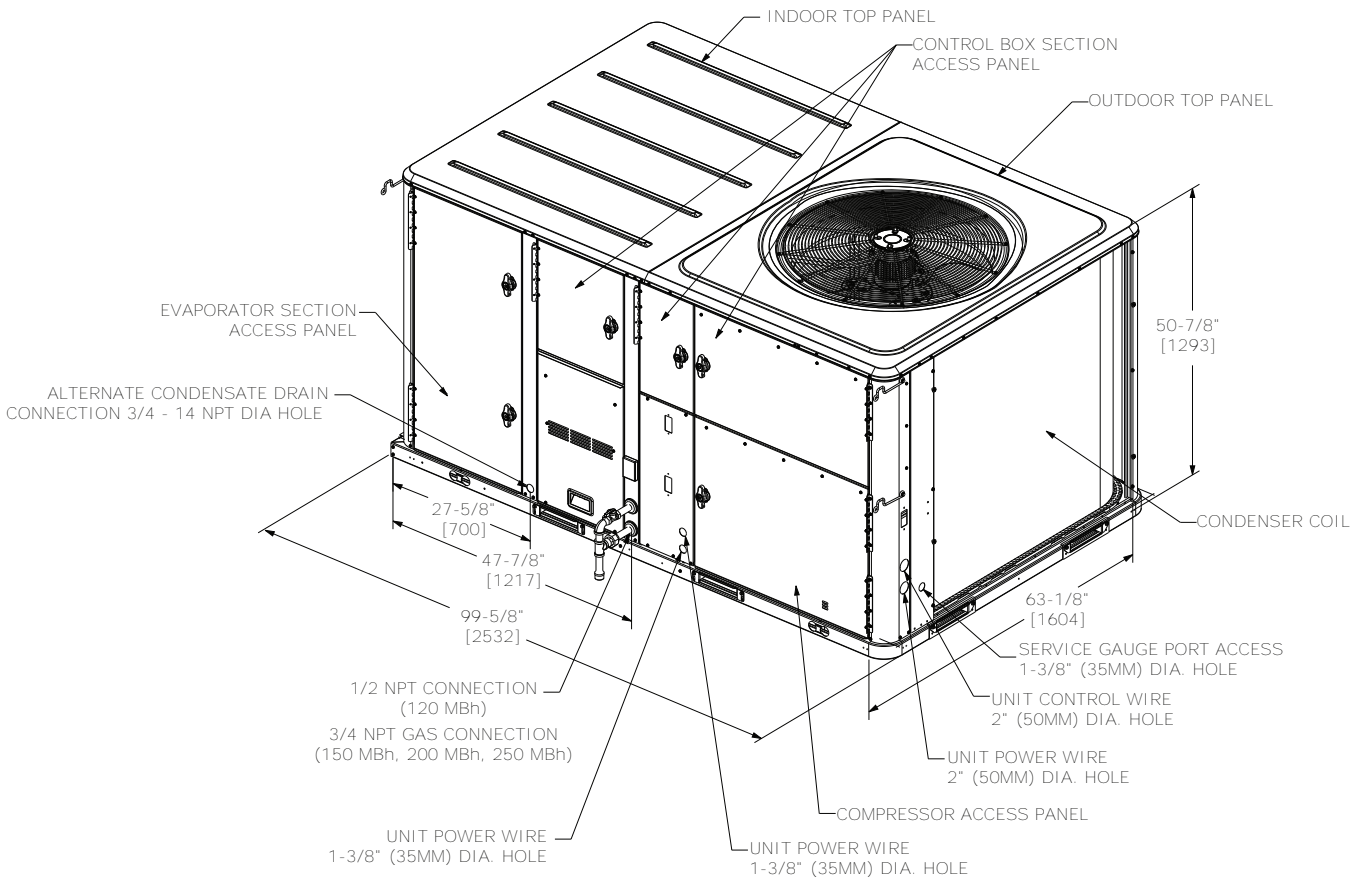

Figure 18. 12.5 tons standard efficiency – downflow airflow supply/return, through-the-base utilities

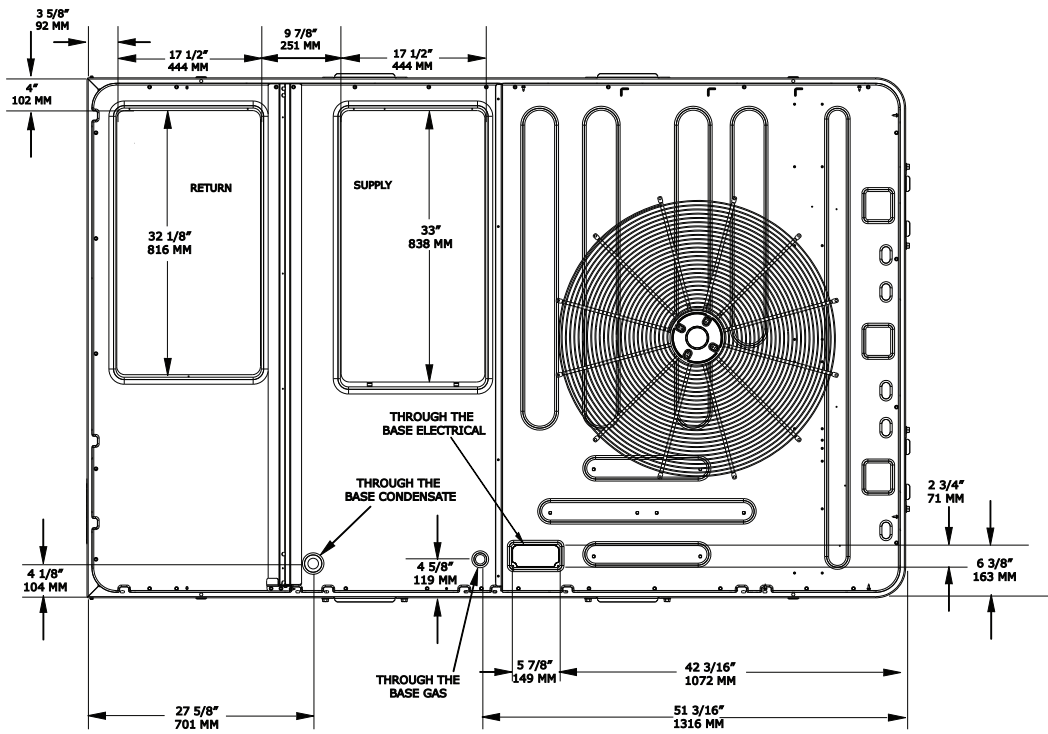

Figure 19. 12.5 tons standard efficiency – horizontal airflow, supply and return

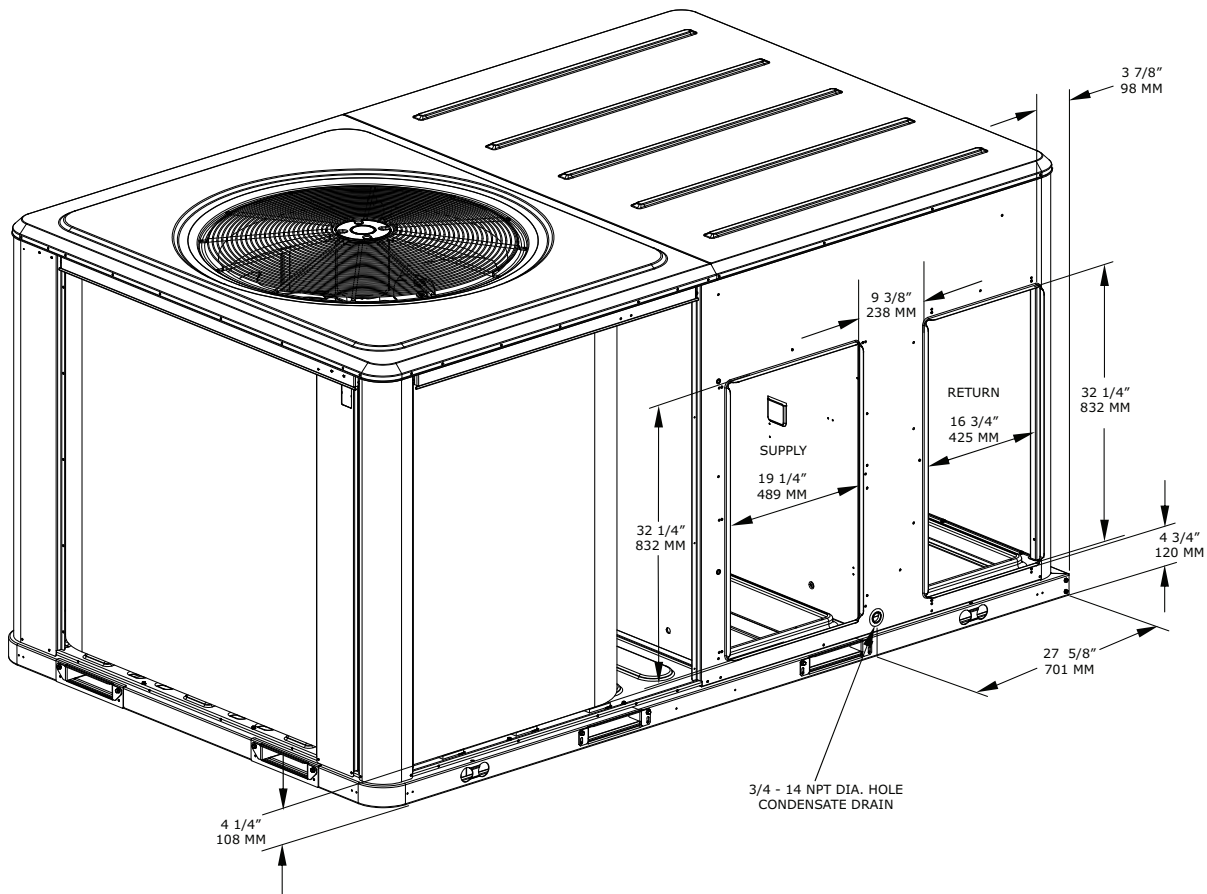

Figure 20. 12.5 tons standard efficiency – unit clearance and roof opening

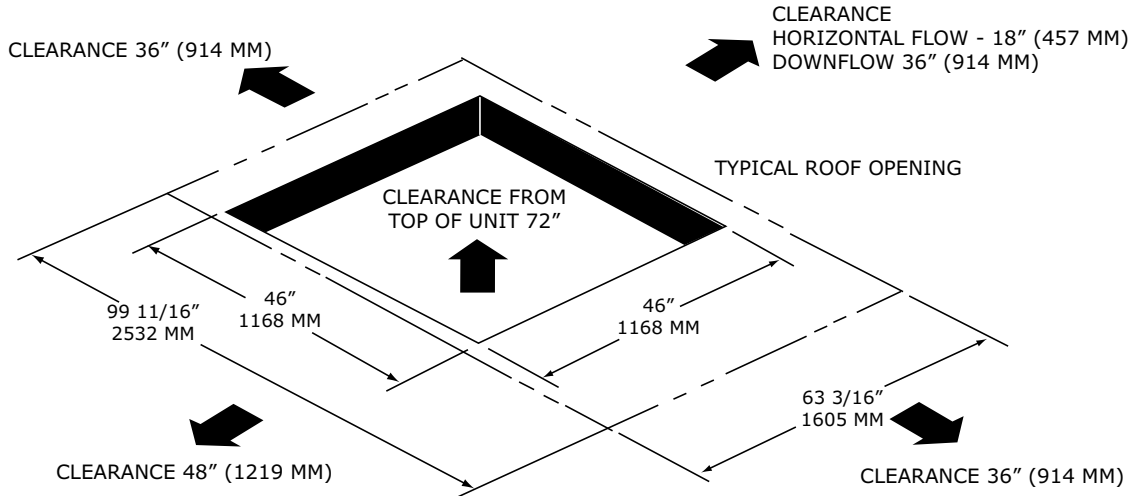

Figure 21. 12.5 tons standard efficiency – roof curb

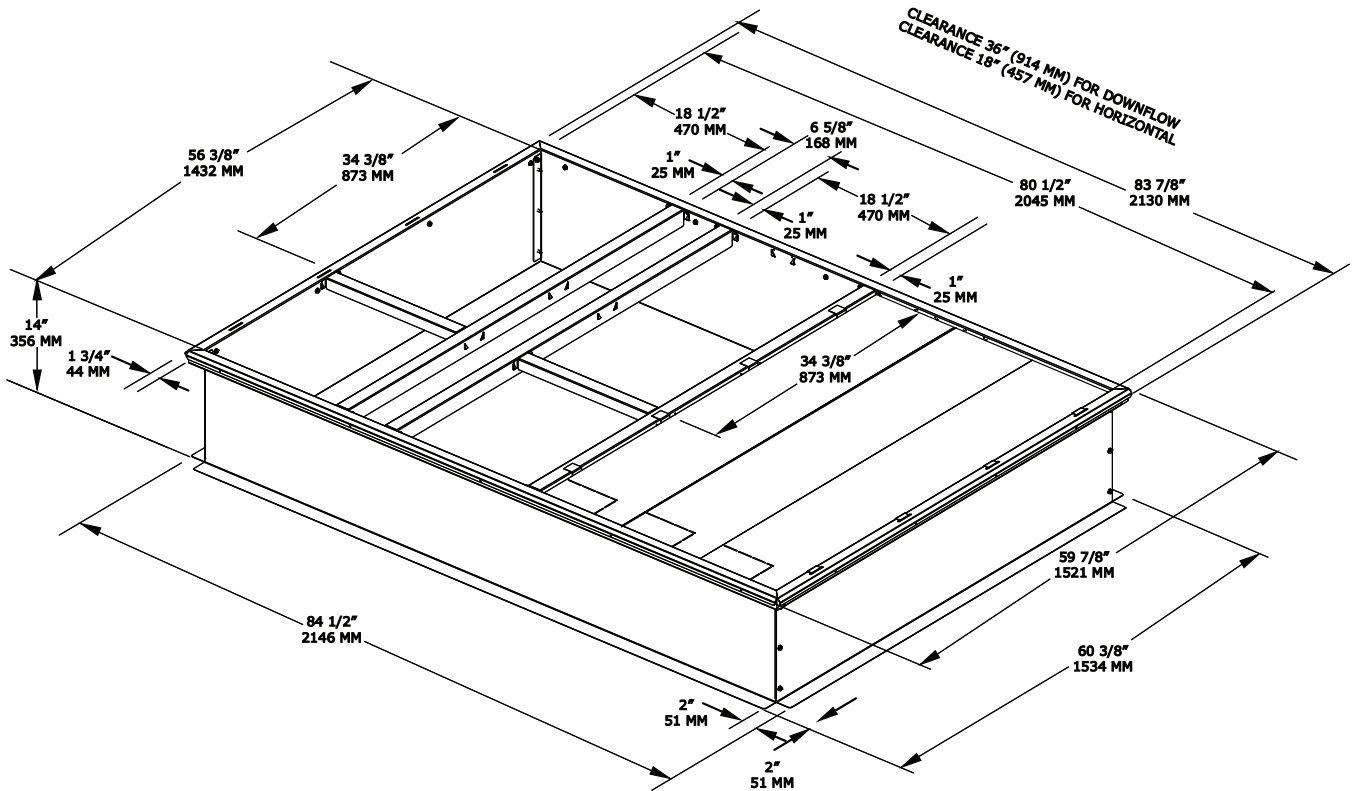

Figure 22. 12.5 tons standard efficiency – swing diameter for hinged door(s) option

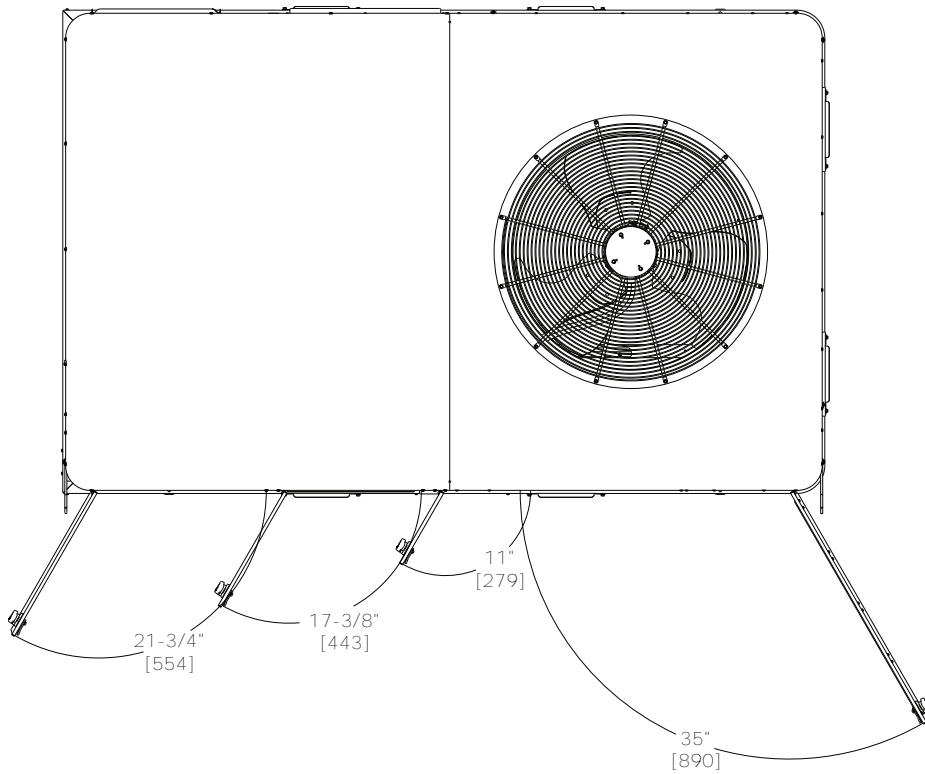
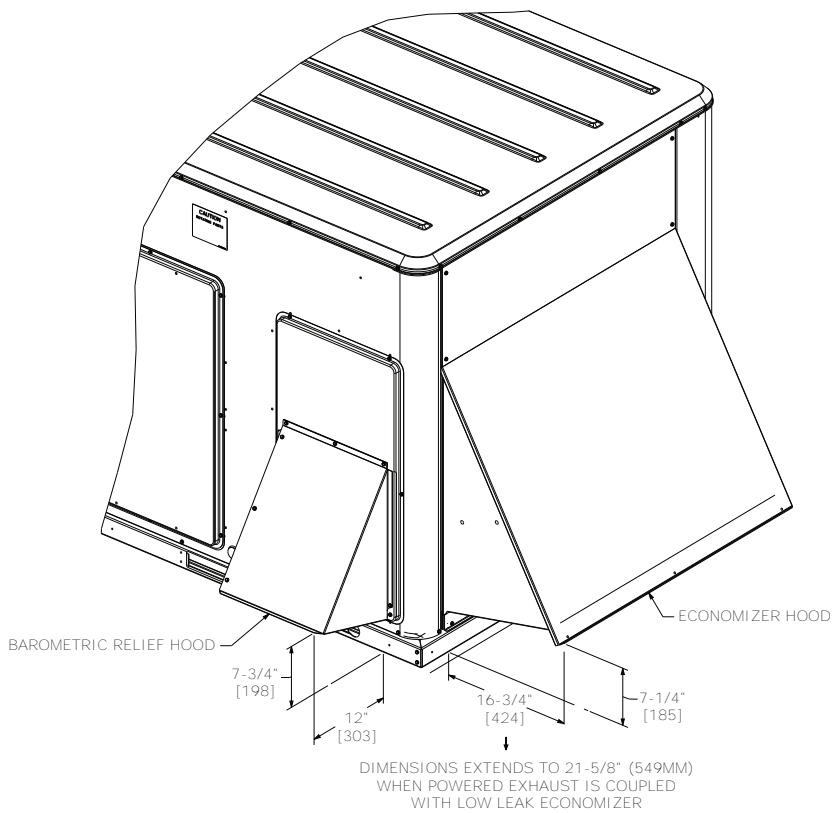

Figure 23. 6 to 12.5 tons standard efficiency – economizer, manual or motorized fresh air damper





Dimensional Data

Figure 24. 6 to 12.5 tons standard efficiency – power exhaust

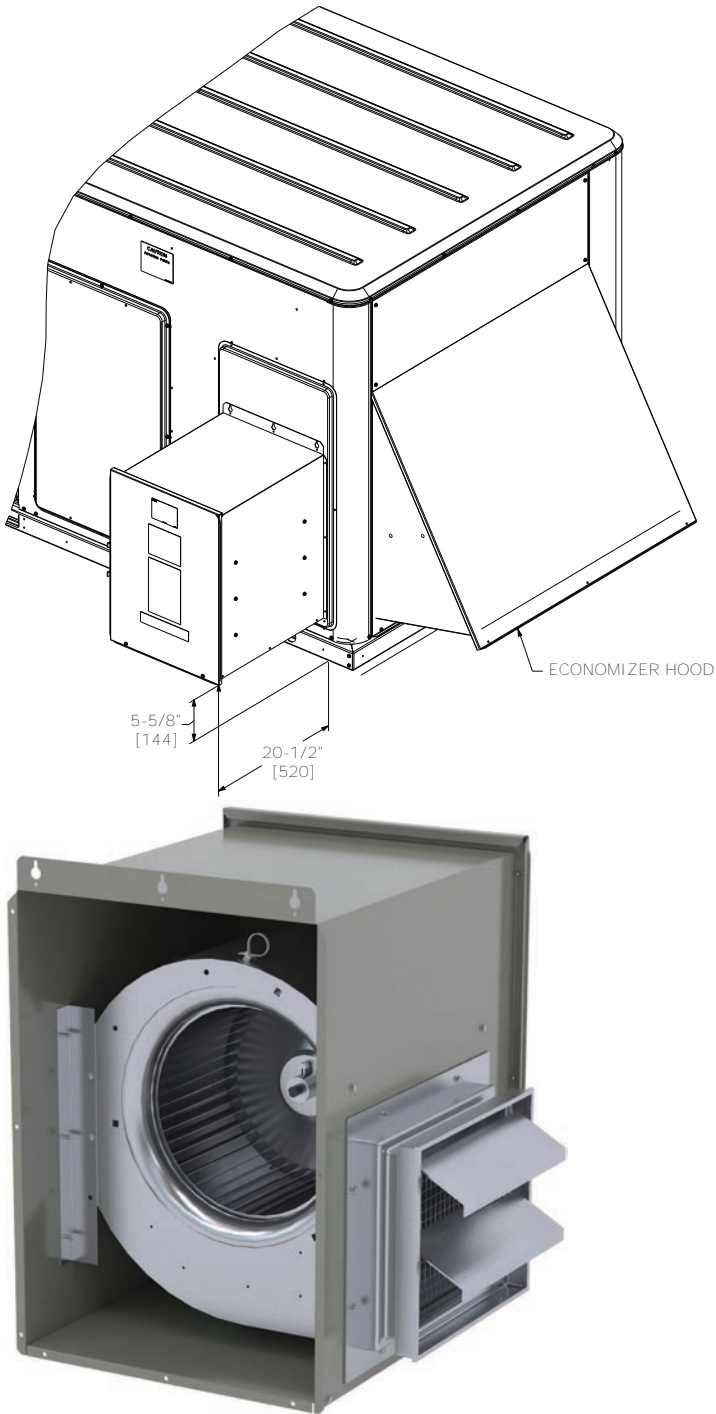

Figure 25. 15 to 25 tons standard efficiency – power exhaust

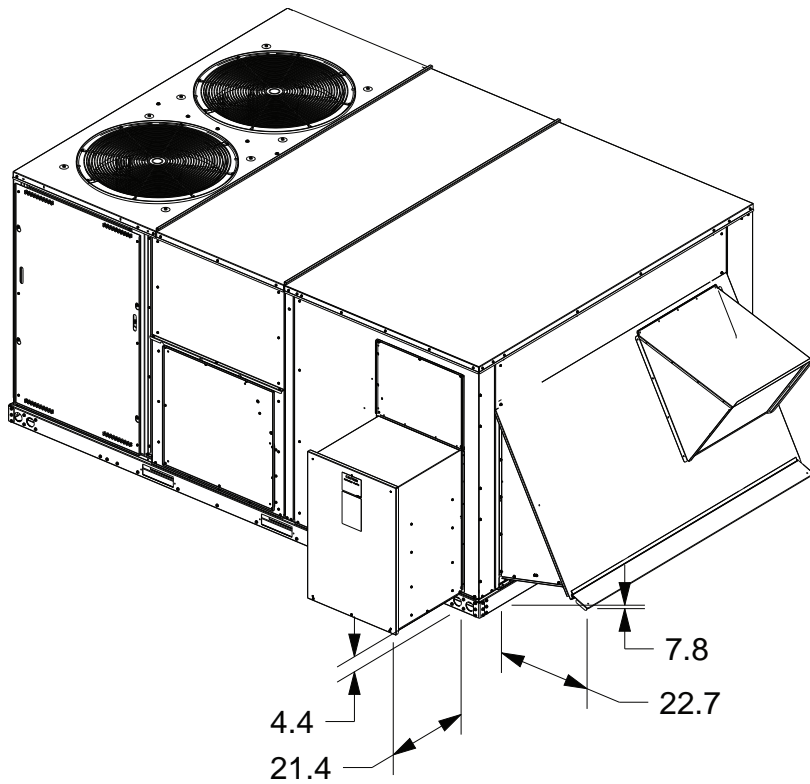

Figure 26. 15 to 25 tons standard efficiency

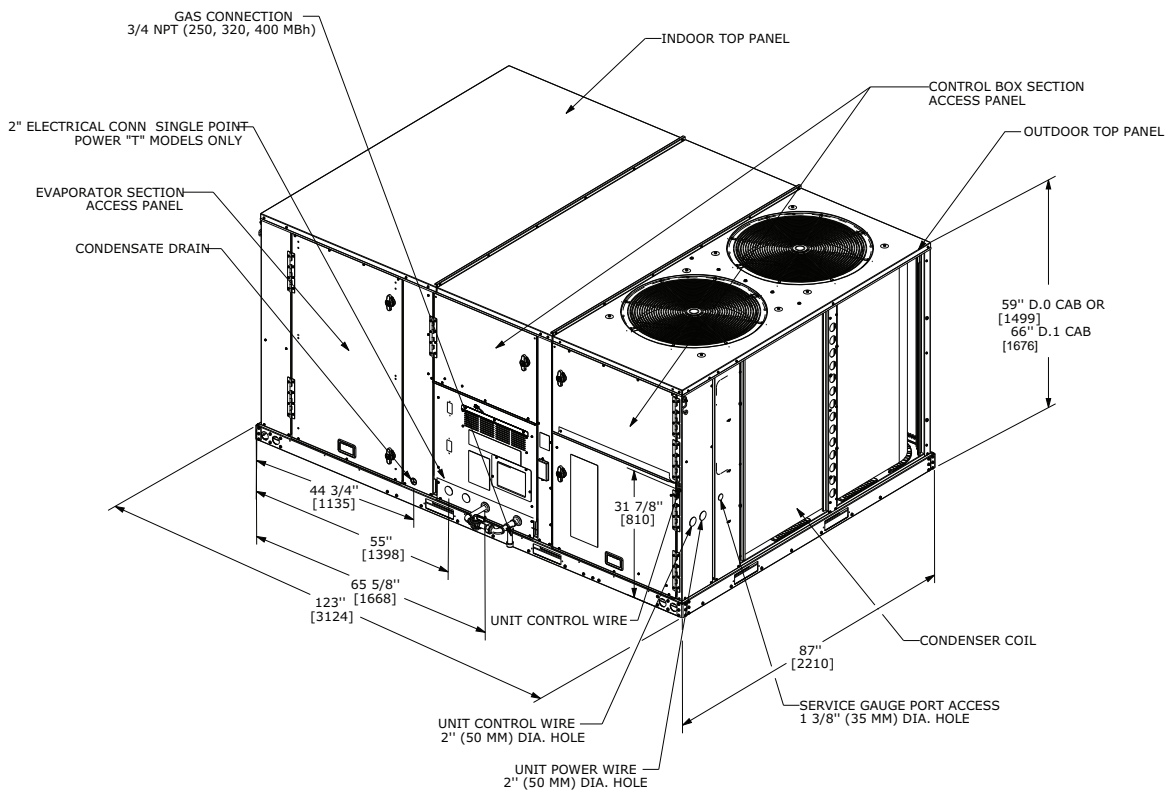

Figure 27. 15 to 25 tons standard efficiency – downflow airflow supply/return, through-the-base utilities

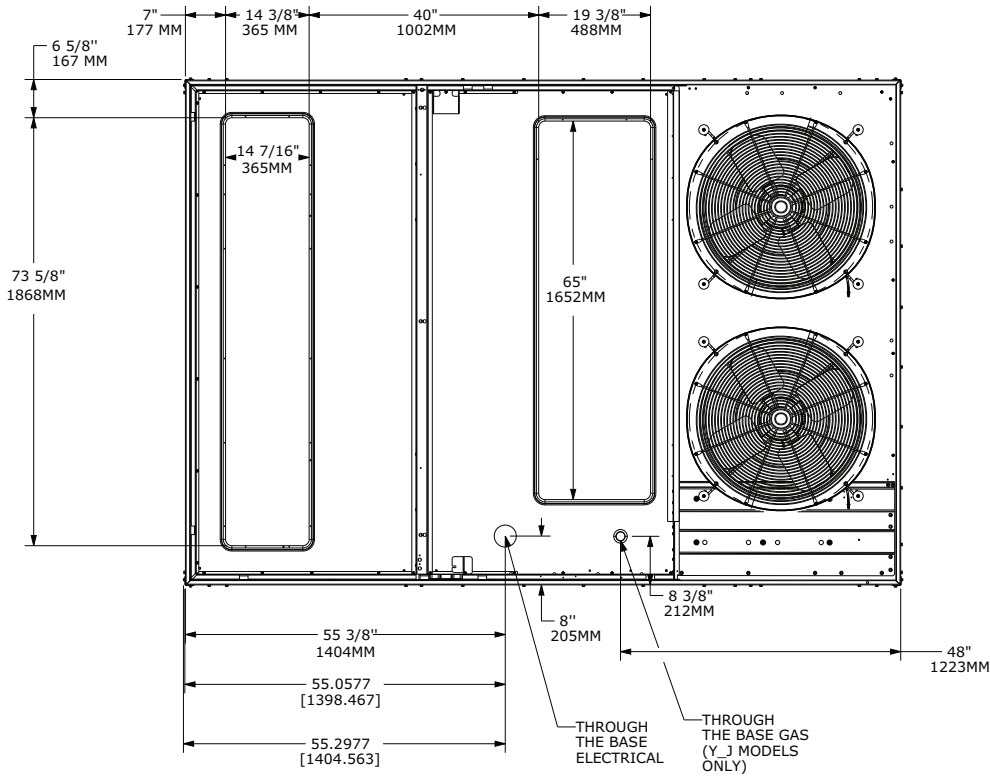

Figure 28. 15 to 25 ton standard efficiency – horizontal airflow supply/return

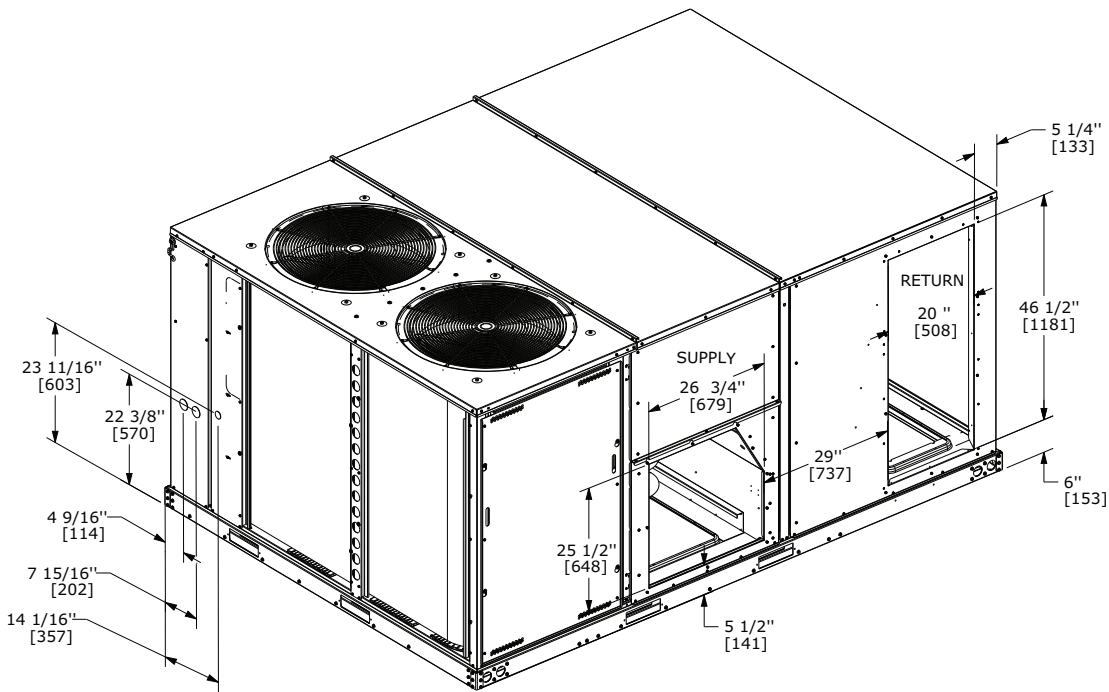

Figure 29. 15 to 25 tons standard efficiency – unit clearance and roof opening

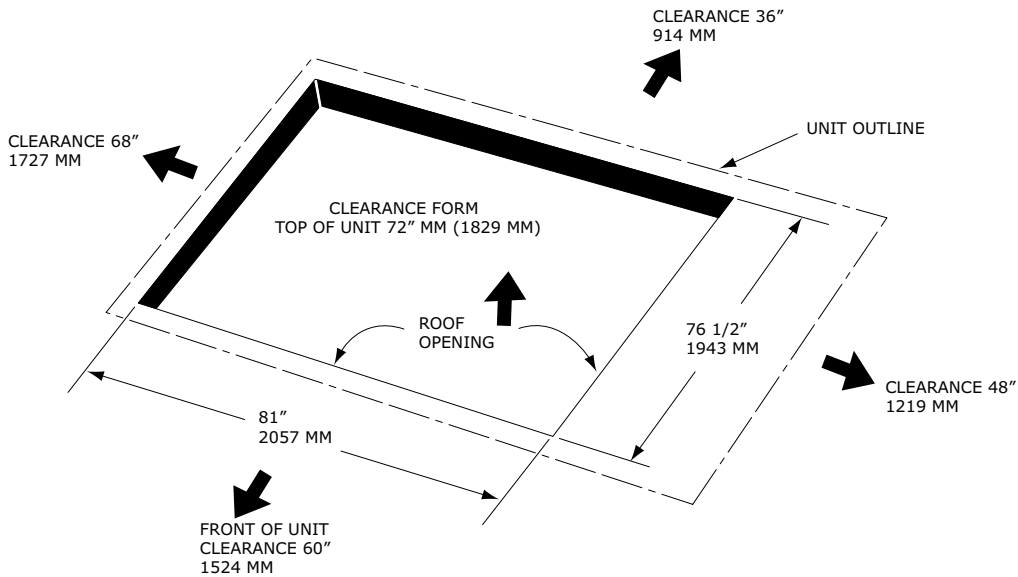
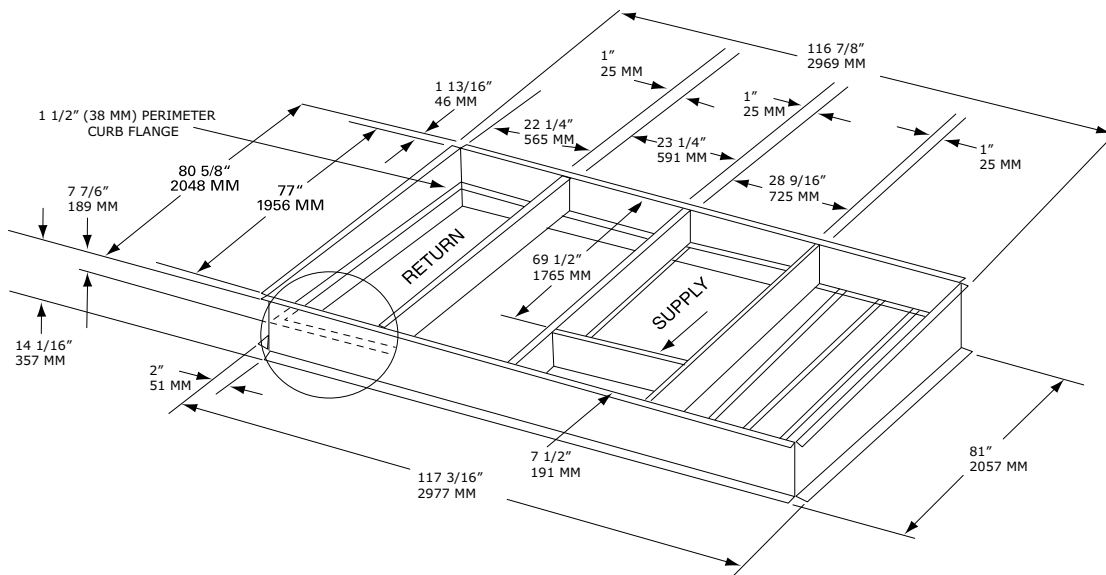

Figure 30. 15 to 25 tons standard efficiency – roof curb





Dimensional Data

Figure 31. 15 to 25 ton standard efficiency – swing diameter for hinged door(s) option

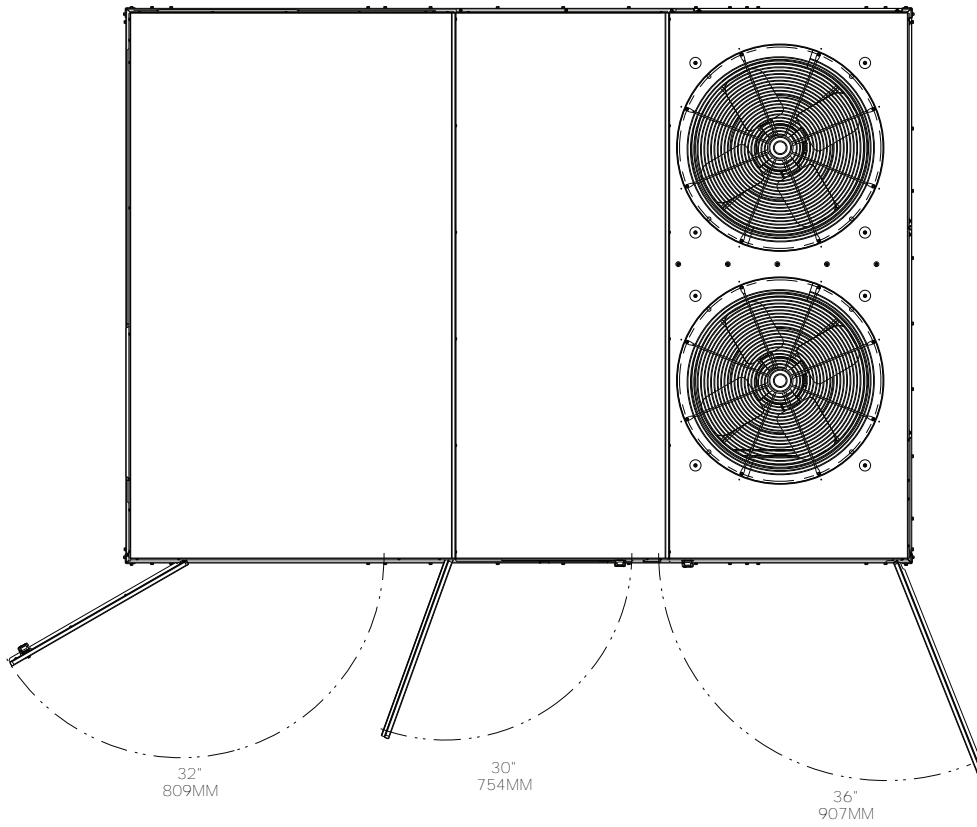



Weights

Table 55. Model weights, corner weights (lbs), and center of gravity dimensions (in.)

Tons	Unit Model No.	Model Weights ^(a)		Corner Weights ^(b)				Center of Gravity (in.)	
		Shipping	Net	A	B	C	D	Length	Width
6	TSJ072	1007	909	298	278	160	172	43	19
7.5	TSJ090	1011	913	300	280	161	172	43	19
8	TSJ102	1027	929	305	285	164	176	43	19
10	TSJ120	1037	939	308	288	165	177	43	19
12.5	TSJ150	1412	1218	356	360	252	250	50	26
15	TSJ180	2040	1820	611	447	322	440	52	36
17.5	TSJ210	2070	1850	612	463	334	441	53	36
20	TSJ240	2140	1920	689	472	309	451	50	34
25	TSJ300	2190	1970	684	484	332	469	51	35

^(a) Weights are approximate. Weights do not include additional factory or field installed options/accessories. For option/accessory additional weights to be added to unit weight, reference the following table.

^(b) Corner weights are given for information only.

Figure 32. Corner weights

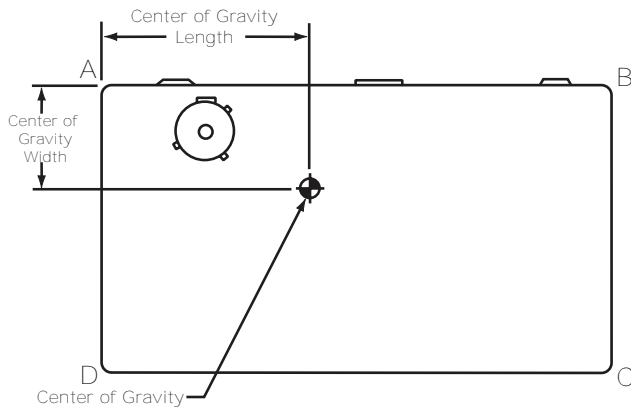

Table 56. Factory installed options (FIOPS)/accessory net weights (lb)

Accessory	TSJ072-120	TSJ150	TSJ180-300
	6, 7.5, 8.5, 10 Tons	12.5 Tons	15, 17.5, 20, 25 Tons
Barometric Relief	10	10	40
Economizer	36	36	91
Electric Heaters	44	50	75
Hinged Doors	12	12	20
Low Leak Economizer - Downflow	91	91	150
Low Leak Economizer - Horizontal	—	—	180
Manual Outside Air Damper	26	26	15
Motorized Outside Air Damper	30	30	82
Oversized Motor	14	—	30
Powered Convenience Outlet	38	50	50
Powered Exhaust	80	80	110
Reheat Coil	16	20	33
Roof Curb	105	111	235
Smoke Detector, Supply	5	5	5
Smoke Detector, Return	7	7	5
Through-the-Base Electrical	13	13	10



Weights

Table 56. Factory installed options (FIOPS)/accessory net weights (lb) (continued)

Accessory	TSJ072-120	TSJ150	TSJ180-300
	6, 7.5, 8.5, 10 Tons	12.5 Tons	15, 17.5, 20, 25 Tons
Unit Mounted Circuit Breaker	5	5	10
Unit Mounted Disconnect	5	5	10

Notes:

1. Weights for options not listed are <5 lbs.
2. Net weight should be added to unit weight when ordering factory-installed accessories.
3. Weights are approximate.



Mechanical Specifications

General

- Packaged rooftop units cooling, heating capacities, and efficiencies are AHRI Certified within scope of AHRI Standard 210-240 for 6 to 25 tons and ANSIZ21.47 and 10 CFR Part 431 pertaining to Commercial Warm Air Furnaces (all gas heating units).
- Convertible airflow.
- Symbio™ controls operating range between 40°F and 125°F in cooling mode standard from the factory. Field-installed low ambient kit extended operating range down to 0°F.
- Factory assembled, internally wired, fully charged with R-410A, and 100 percent run tested to check cooling operation, fan and blower rotation, and control sequence before leaving the factory.
- Colored and numbered wiring internal to the unit for simplified identification.
- Units cULus listed and labeled, classified in accordance for Central Cooling Air Conditioners.

Casing

- Zinc coated, heavy gauge, galvanized steel.
- Weather resistant pre-painted metal with galvanized substrate.
- Meets ASTM B117, 672 hour salt spray test.
- Removable single side maintenance access panels.
- Lifting handles in maintenance access panels (can be removed and reinstalled by removing fasteners while providing a water and air tight seal).
- Exposed vertical panels and top covers in the indoor air section insulated with a cleanable foil-faced, fire-retardant permanent, odorless glass fiber material.
- Base pan shall have no penetrations within the perimeter of the curb other than the raised 1 inch high downflow supply/return openings to provide an added water integrity precaution, if the condensate drain backs up.
- Base of the unit insulated with 1/8 inch, foil-faced, closed-cell insulation.
- Unit base provisions for forklift and/or crane lifting on three sides of unit.

Coils

Microchannel Coils

- Optimal heat transfer performance due to flat, streamlined tubes with small ports, and metallurgical tube-to-fin bond.
- Reduce system refrigerant charge by up to 50% leading to better compressor reliability.
- Compact all-aluminum microchannel coils reduce the unit weight.
- Recyclable all-aluminum coils. All-aluminium construction minimizes galvanic corrosion.
- Strong aluminum brazed structure provides better fin protection.
- Flat streamlined tubes more dust resistant and easy to clean.
- Coils leak tested at the factory to ensure the pressure integrity.

Coil Guards

Provides condenser coil protection.

Compressors

- All units have direct-drive, hermetic, scroll type compressors with centrifugal type oil pumps.
- Suction gas-cooled motor with voltage utilization range of plus or minus 10 percent of unit nameplate voltage.
- Internal overloads standard with scroll compressors.
- Crankcase heaters are standard on all compressors.
- All units have dual compressors.
- Three stages of cooling available on 6 to 17.5 tons units and four stages of cooling available on 20 and 25 tons units.



Mechanical Specifications

Filters

- Standard throwaway filters
- Optional 2 inch MERV 8 and MERV 13 filters

Frostat™

- Utilized as a safety device.
- Opens to prevent freezing temperatures on evaporator coil.
- Temperature will need to rise to 50°F before closing.
- Utilized in low airflow or high outside air applications (cooling only).

Indoor Fan

- Direct drive plenum fan design – 6 to 25 tons units.
- Plenum fan design — backward-curved fan wheel along with an external rotor direct drive variable speed indoor motor.
- Supply fan speed adjustments can be made using the Symbio 700 or Mobile App.
- Motors are electronically protected.
- Variable speed direct drive motors are high efficiency – 6 to 25 tons.

Powered or Unpowered Convenience Outlet

- Powered GFCI, 120V/15A, 2 plug, convenience outlet or unpowered GFCI, 120V/20A, 2 plug, convenience outlet.
- When convenience outlet is powered, a service receptacle disconnect will be available.
- Convenience outlet is powered from the line side of the disconnect or circuit breaker, and therefore will not be affected by the position of the disconnect or circuit breaker.
- Available to order when through-the-base electrical with disconnect switch or circuit breaker option is ordered.

Stainless Steel Drain Pan

- Corrosion and oxidation resistance.
- Constructed of 304 stainless steel.

Through-the-Base Electrical with Circuit Breaker

- Thermal magnetic, molded case, HACR circuit breaker with provisions for through-the-base electrical connections.
- Circuit breaker installed within unit in water tight enclosure.
- Wiring provided from the switch to the unit high voltage terminal block.
- Circuit breaker will provide overcurrent protection, sized per NEC and cULus guidelines, and agency recognized by cULus.

Through-the-Base Electrical with Disconnect Switch

- 3-pole, molded case, disconnect switch with provisions for through-the-base electrical connections.
- Disconnect switch installed within unit in a water tight enclosure.
- Wiring provided from the switch to the unit high voltage terminal block.
- Switch cULus agency recognized.

Note: Disconnect switch sized per NEC and cULus guidelines but will not be used in place of unit overcurrent protection

Economizer (Standard)

- Available with or without barometric relief.

- Fully modulating 0-100 percent motor and dampers, minimum position setting, preset linkage, wiring harness with plug, spring return actuator and fixed dry bulb control.
- Barometric relief shall provide a pressure operated damper that shall be gravity closing.
- Barometric relief shall prohibit entrance of outside air during the equipment “off” cycle.
- Optional solid state or differential enthalpy control.
- Arrives in shipping position and shall be moved to the operating position by the installing contractor.

Electric Heaters

- Constructed of heavy-duty nickel chromium elements internally delta connected for 240V, wye connected for 480V and 600V.
- Staging achieved through Symbio.
- Multiple automatic reset and single operation high temperature limit controls operating to break line power to the heater element.
- Heaters individually fused from the factory.
- Shall meet all NEC and CEC requirements when properly installed.
- Power assemblies shall provide single-point connection.
- Modules shall be cULus listed.

Manual Outside Air Damper

Rain hood and screen shall provide up to 50 percent outside air.

Motorized Outside Air Damper

- Once set, when indoor fan starts, outdoor air dampers shall open to set position.
- When indoor fan shuts down, damper shall close to the full closed position.

Powered Exhaust

- Available for 6 to 25 ton units.
- Shall provide exhaust of return air, when using an economizer.
- Maintain better building pressurization.

Roof Curb

- Designed to mate with the unit’s downflow supply and return.
- Provide support and a water tight installation when installed properly.
- Shall allow field-fabricated rectangular supply/return ductwork to be connected directly to the curb.
- Curb shall be shipped knocked down for field assembly.
- Shall include wood nailer strips.

Ventilation Override Operation

- Unit can be set to transition up to 3 different pre-programmed sequences for smoke purge, pressurization, and exhaust.
- Transition occurs when binary input on the Symbio is closed (shorted) (typically hard wired relay output from a smoke detector/ fire control panel).

Note: Requires Symbio™ Customer Connection Module, FIASCCM001*.



The AHRI Certified mark indicates Trane U.S. Inc. participation in the AHRI Certification program. For verification of individual certified products, go to ahridirectory.org.

Trane - by Trane Technologies (NYSE: TT), a global innovator - creates comfortable, energy efficient indoor environments for commercial and residential applications. For more information, please visit trane.com or tranetechnologies.com.

Trane has a policy of continuous product and product data improvements and reserves the right to change design and specifications without notice. We are committed to using environmentally conscious print practices.