



Product Catalog

Packaged Rooftop Air Conditioners Foundation™

Cooling and Gas/Electric
7.5 to 12.5 Tons, 60 Hz





Introduction

Packaged Rooftop Air Conditioners



Through the years, Trane has designed and developed the most complete line of Packaged Rooftop products available in the market today.

Trane customers demanded a product that provided exceptional reliability, was easy to install, and was competitively priced.

Trane listened and is proud to introduce the new Foundation™ Light Commercial rooftop unit. With Foundation, Trane continues to provide the highest standards in quality and reliability, comfort, performance, and ease of installation. light commercial products.

Copyright

This document and the information in it are the property of Trane, and may not be used or reproduced in whole or in part without written permission. Trane reserves the right to revise this publication at any time, and to make changes to its content without obligation to notify any person of such revision or change.

Trademarks

All trademarks referenced in this document are the trademarks of their respective owners.

Revision History

- Updated Convertible Units, Quick-Access Panels, Field Installed Options sections in Features and Benefits chapter.
- Barometric Relief content moved to Features and Benefits chapter - Field Installed Options from Application Considerations chapter.
- Updated General data tables.
- Updated Gross Cooling Capacities tables.
- Updated Gas fired heating capacities table in Performance Data chapter.
- Updated Electric heater voltage correction factors (applicable to auxiliary heat capacity) table in Performance Data chapter.
- Removed TCONT402AN32DA content in Thermostats in Controls chapter.
- Updated Unit wiring with electric heat (single point connection) table in Electric Data chapter.
- Added 460V information to Unit wiring with cooling only (no electric heat) or gas heat and Electrical characteristics tables in Electric Data chapter.

- Updated Accessory net weight (lb) table in Weights chapter.
- Updated Motorized Outside Air Damper in Mechanical Specifications chapter.



Table of Contents

Features and Benefits	5
Standard and Optional Features	5
Outstanding Standard Features	6
Variety of Options	8
Application Considerations	11
Clearance Requirements	11
Condensate Trap	11
Unit Pitch	11
Selection Procedure	12
Cooling Capacity	12
Heating Capacity	13
Air Delivery Selection	13
Model Number Description	14
General Data	15
Performance Data	18
Gross Cooling Capacities	18
Evaporator Fan Performance	22
Controls	41
Economizer Controls	41
Thermostats	41
Electrical Data	42
Jobsite Connections	45
Dimensional Data	46
Weights	50
Mechanical Specifications	51
General	51
Standard Features	51
Factory Installed Options	53
Field Installed Options	53



Features and Benefits

Foundation™ has features and benefits that make it first class in the light commercial rooftop market. Designed with input from field contractors and technicians, its convertible airflow and ease of installation are outstanding.

Standard and Optional Features

	Medium Foundation		
	Standard	Options ^(a)	
		Factory Installed	Field Installed
1-year Limited Parts Warranty	X		
5-year Limited Compressor Warranty	X		
5-year Limited Heat Exchanger Warranty	X		
5K SCCR	X		
Barometric Relief Damper			X
Belt Drive Motors	X		
CO ₂ sensor - Demand Control Ventilation (DCV)			X
Colored Connectors and Wiring	X		
Compressor Discharge Temperature Limit (DTL)	X		
Condensate Overflow Switch			X
Convertible Airflow	X		
Easy Access Low Voltage Connections	X		
Economizer (Downflow)			X
Electric Heaters			X
Filters	X		
Hail/Vandal Guards			X
High Pressure Control	X		
High Static Motor Kit ^(b)		X	
Insulation - 1/2-inch, 1-lb Density	X		
Liquid Line Refrigerant Drier	X		
Low Ambient Cooling		X	
Low Leak Economizer			X
Low Pressure Control	X		
Low Voltage Circuit Protection	X		
LP Conversion Kit	X		
Manual Outside Air Damper			X
Motorized 2-Position Damper			X
Phase Loss/Reversal Monitor	X		
Powered Exhaust			X
Quick Access Panels	X		
Remote Potentiometer			X
Scroll Compressors	X		
Single Point Power	X		



Features and Benefits

	Medium Foundation		
	Standard	Options ^(a)	
		Factory Installed	Field Installed
Single Side Service	X		
Thermal Expansion Valve	X ^(c)		
Through-the-base electrical & gas connection provisions	X		

- (a) Refer to model number description for option availability or contact Product Support.
 (b) Available on constant volume units only. See Accessories chapter for more information.
 (c) Fixed orifice

Outstanding Standard Features

Colored And Numbered Wiring

Save time and money tracing wires and diagnosing the unit.

Compressors

Foundation™ contains the best compressor technology available to achieve the highest possible performance.

Controls – Electromechanical

This 24-volt control includes the control transformer and contactor pressure lugs for power wiring.

Convertible Units

Foundation™ 7.5 to 12.5 ton units ship in the downflow configuration. Their convertible design makes it easy to convert them to a horizontal airflow configuration without an additional kit.¹

Discharge Line Thermostat

The high pressure controls and the discharge line thermostat signals are wired in series and connected to the safety input of the LSD. The compressor contactor coil is connected to the 'CC' terminal of the LSD. If the high pressure control switch or the discharge line thermostat is open, the 24 Vac signal to the SI input of the LSD is interrupted and the compressor contactor coil supply is disabled by the LSD. It has an automatic lockout. The high pressure controls and discharge line thermostats are wired in the system protection detection port. If the high pressure control switch or the discharge line thermostat is open, the main control board will turn off the compressor of the corresponding system. There is no automatic lockout.

Efficiency

Product efficiencies meet the requirements of ASHRAE 90.1 - 2016.

Easy Access Low Voltage Terminal Board

Foundation™ Low Voltage Terminal Board is mounted outside the main electrical control cabinet. It is extremely easy to locate and attach the thermostat control wiring and also test operation of all unit functions. This is another cost and time saving installation feature.

Insulation

All panels in the evaporator section of the unit have foil-faced, glass fiber insulation. All base panels have foil-faced, glass fiber insulation. All edges are either captured or sealed to ensure no insulation fibers get into the airstream.

¹ The 7.5 ton unit requires a conversion kit.

Heat Exchanger

The cabinet features a tubular heat exchanger in heat capacities – all available for vertical and horizontal discharge directions. The heat exchanger is fabricated using aluminized steel burners and corrosion-resistant, aluminized steel tubes as standard on all models. As part of the heat exchanger assembly, an induced draft blower is used to pull the gas mixture through the burner tubes. A direct spark ignition system, which doubles as a safety device to prove the flame, is used to ignite the gas mixture.

Locking Safety Device with Anti-Short Cycle Timer

This device monitors compressor safety switch trips to prevent short cycling, protecting the compressor. A manual reset is required after a fourth safety switch trip.

Low Ambient Cooling

All Foundation units have cooling capabilities down to 0°F as standard.

Low Voltage Connections

The wiring of the low voltage connections to the unit and the thermostat is as simple as R-R, G-G, Y-Y, and W-W. This simplified system makes it easy for the installer to wire.

Microchannel Condenser Coil

Microchannel condensing coils are all-aluminum coils with fully-brazed construction. This design reduces risk of leaks and provides increased coil rigidity — making them more rugged on the jobsite. Their flat streamlined tubes with small ports and metallurgical tube-to-fin bond allow for exceptional heat transfer. Microchannel all-aluminum construction provides several additional benefits:

- Light weight (simplifies coil handling)
- Easy to recycle
- Minimize galvanic corrosion

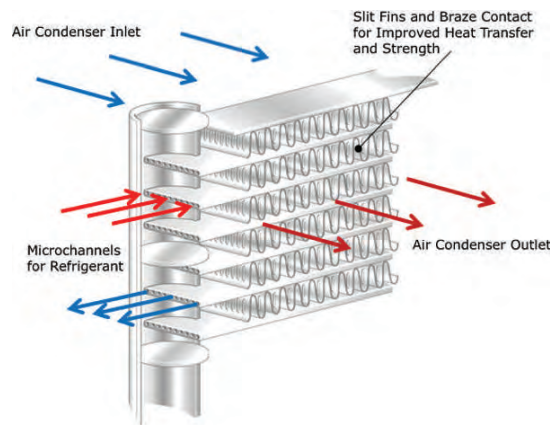

Motors

All indoor fan motors are belt drive as standard.

Pressure Cutouts

Low and high pressure cutouts are standard on all Foundation™ models.

Quick-Access Panels

Remove screws (four or fewer) for access to the standardized internal components and wiring.



Features and Benefits

Quick-Adjust Fan Motor Mounting Plate

With the quick-adjust slider plate, the belt and sheaves can be quickly adjusted without moving the mounted fan motor. This results in reduced time spent on routine maintenance.

Single Point Power

A single electrical connection powers the unit and all on-board options.

Single Side Service

Single side service is standard on all units.

Sloped Drain Pans

Every Foundation™ unit has a non-corrosive, sloped drain pan made of rigid PVC - standard on all units.

LP Conversion Kit

LP kits are provided as standard with each GCC 090-150 unit for conversion of gas heat units from natural gas to propane.

Variety of Options

Factory Installed Options

Oversized Motors

Multi-speed only – Factory installed oversized motors are available for high static applications.

Field Installed Options

Condensate Overflow Switch

A condensate overflow switch is available to shut the unit down in the event that the condensate drain becomes clogged. This option protects the unit from water overflowing from the drain pan and entering the base of the unit.

CO₂ Sensor - Demand Control Ventilation (DCV)

Demand-controlled ventilation (DCV) is a control strategy that responds to the actual demand (need) for ventilation by regulating the rate at which the HVAC system brings outdoor air into the building. A CO₂ sensor measures the concentration (parts per million, ppm) of CO₂ in the air. As the CO₂ concentration changes, the outside air damper modulates to meet the current ventilation needs of the zone. DCV is a passive system; direct control of the indoor fan is not possible with standard or low leak economizers. The CO₂ sensor kit is available as a field installed accessory.

Economizer

Economizers are equipped with either dry bulb, reference, or comparative enthalpy sensing. These economizers provide free cooling as the outdoor temperature and/or humidity decreases. Correctly installed, they offer valuable energy savings.

Electric Heaters

Electric heat is available as a field installed option.

Low Leak Economizer with Fault Detection and Diagnostics

This economizer meets the damper leakage requirements for ASHRAE 90.1, IECC, and California Title 24 standards (3 cfm/ft² at 1.0 in. w.g. for outside air dampers and 4 cfm/ft² for return dampers).

Manual Outside Air Damper

A 0-50 percent manual air damper is available.

Motorized Outside Air Damper

A 0–50 percent motorized outside air dampers is available.

Power Exhaust

This option is available on downflow units and provides exhaust of the return air, when using a downflow economizer, to maintain proper building pressurization. This is an excellent option for relieving most building overpressurization problems.

Barometric Relief

Designed to be used on downflow and horizontal configuration for standard and downflow low leak economizer units, barometric relief is an unpowered means of relieving excess building pressure.

This product line offers an optional barometric relief damper for use in conjunction with economizer option. This accessory consists of gravity dampers which open with increased pressure. As building pressure increases, the pressure in the unit return air section also increases, opening the dampers and relieving the conditioned space.

Notes:

- *The effectiveness of barometric relief damper during economizing operation is system related.*
- *Pressure drop of the return air system should be considered to control building pressurization.*

Reference or Comparative Enthalpy

Measures and communicates humidity while maximizing comfort control.

Remote Potentiometer

When installed in the economizer control circuitry, this accessory provides a method to remotely adjust the minimum damper position.

Roof Curbs

Available for downflow units. Only one roof curb for all 7.5 to 12.5 ton Foundation™ units simplifies curb selection.

Thermostats

Available in programmable and non-programmable.

Through-the-Base Electrical Utility Access

An electrical service entrance shall be provided allowing access for both control and main power connections inside the curb and through the base of the unit. This option will allow for field installation of liquid-tight conduit and an external field installed disconnect switch.

Factory provided through the base openings simplify wiring and piping. Because these utility openings frequently minimize the number of roof penetrations, the integrity of roofing materials is enhanced.

Through-the-Base Gas Piping (Gas Heat Units Only)

This option shall have all piping necessary including, black steel, manual gas shut-off valve, elbows, and union. This assembly will require minor field labor to install.

Tool-less Hail Guards

Tool-less, hail protection quality coil guards shall be field-installed for condenser coil protection. This option protects the condenser coil from vandalism and/or hail damage.

Other Benefits

Easy to Install, Service and Maintain

Because today's owners are very cost-conscious when it comes to service and maintenance, Foundation was designed with direct input from service contractors. This valuable information helped to design a product that would get the service technician off the job quicker and save the owner money. Foundation does this by offering outstanding standard features enhanced by a variety of factory and



Features and Benefits

field installed options, multiple control options, rigorously tested proven designs and superior product and technical support.

Outstanding Flexibility

The Foundation 7.5-12.5 ton units match the footprint of specific Carrier WeatherMaker™ units.

Rigorous Testing

All of Foundation's designs were rigorously rain tested at the factory to ensure water integrity. Each part of the top overlaps in such a way that water cannot leak into the unit. These overlapped edges are gasketed and sealed to ensure superior water integrity.

Actual shipping tests were performed to determine packaging requirements. Factory shake tests were used as part of the package design process to help assure that the unit arrives at the job site in top condition.

For the microchannel coils, the supplier will perform the leak check at 450 psig. The completely assembled refrigerant system is leak tested at a minimum of 225 psig with a refrigerant and nitrogen mixture.

All parts are inspected at the point of final assembly. Sub-standard parts are identified and rejected immediately. Every unit receives a 100% unit run test before leaving the production line to make sure it lives up to rigorous Trane requirements.

Unmatched Support

Trane Sales Representatives are a Support Group that can assist you with:

- Product
- Special Applications
- Application
- Specifications
- Service
- Computer Programs and much more
- Training



Application Considerations

Application of this product should be within the cataloged airflow and cooling considerations.

Clearance Requirements

The recommended clearances identified with unit dimensions should be maintained to ensure adequate serviceability, maximum capacity and peak operating efficiency. Actual clearances which appear inadequate should be reviewed with local Trane sales personnel.

Condensate Trap

The evaporator is a draw-through configuration. A trap must be field provided prior to start-up on the cooling cycle.

Unit Pitch

These units have sloped condensate drain pans. Units must be installed level. Any unit slope must be toward access side of the unit.



Selection Procedure

Cooling Capacity

1. Calculate the building's total and sensible cooling loads for the building at design conditions. Use the following calculation methods or any other standard accepted method.

Factors used in unit selection:

- Total Cooling Load: 120 MBh
- Sensible Cooling Load: 96 MBh
- Airflow: 4000 cfm
- Electrical Characteristics: 460/60/3
- Summer Design Conditions: Entering Evaporator Coil: 80°F DB/67°F WB
- Outdoor Ambient: 95°F
- External Static Pressure: 0.38 in. wg
- Rooftop – Downflow configuration
- Accessories: Roof Curb, Electric Heat

2. As a starting point, a rough determination must be made of the size of the unit. The final selection will be made after examining the performance at the given conditions. Divide the total cooling load by nominal Btuh per ton (12 MBh per ton); then round up to the nearest unit size.

$$120 \text{ MBh} / 12 \text{ MBh} = 10 \text{ Tons}$$

3. shows that a GCC120A has a gross cooling capacity of 122.1 MBh and 96.3 MBh sensible capacity at 4000 cfm and 95 DB outdoor ambient with 80 DB, 67 WB air entering the evaporator.

Find capacity at intermediate conditions not in the table

When the design conditions are between two numbers that are in the capacity table, interpolation is required to approximate the capacity.

Note: *Extrapolation outside of the table conditions is not recommended.*

4. In order to select the correct unit which meets the building's requirements, the fan motor heat must be deducted from the gross cooling capacity. The amount of heat that the fan motor generates is dependent on the effort by the motor - cfm and static pressure. To determine the total unit static pressure you add the external static pressure to the additional static related by the added features:

External Static Duct System	0.38 wg
Standard Filter 2 in. from	0.05 wg
Electric Heater Size kW from	0.07 wg
Total Static Pressure	0.47 wg

Note: *Reference heating capacity section on this page for determination of heater size. No additional static add for gas/heat exchanger.*

Note: *The Evaporator Fan Performance has already accounted for the pressure drop for standard filters and wet coils (see note below in). Therefore, the actual total static pressure is 0.47 - 0.05 (from) = 0.42 wg.*

With 4000 cfm and 0.42 wg. shows 1.9 bhp for this unit. Note below the table is the formula to calculate fan motor heat.

$$3\text{-hp fan motor heat (MBh)} = 2.90 \times \text{fan bhp} + 0.4750$$

$$2.90 \times 2.06 + 0.4750 = 5.435 \text{ MBh}$$

Now subtract the fan motor heat from the gross cooling capacity of the unit:

$$\text{Net Total Cooling Capacity} = 122.1 \text{ MBh} - 5.435 = 116.665 \text{ MBh.}$$

Net Sensible Cooling Capacity = $96.3 \text{ MBh} - 5.435 = 90.865 \text{ MBh}$.

5. Compare your resulting capacities to the building load. If the performance will not meet the required load of the building's total or sensible cooling load, try a selection at the next higher size unit.

Heating Capacity

Note: Heating capacity procedures DIFFER for cooling (E) and gas/electric (G) units.

1. Calculate the building heating load.
2. Size the system heating capacity to match the calculated building heating load. The following are building heating requirements:

460 volt/3 phase Power Supply

Total heating load of 100.0 MBh

4000 cfm

The electric heat accessory capacities are listed in . From the table, a 2 kW heater will deliver 109.2 MBh at 480 volts. In order to determine capacity at 460 volts, the heater voltage correction factor from must be used. Therefore, $109.2 \text{ MBh} \times 0.94$ (voltage correction factor) = 102.6 MBh.

Gas/electric: Fuel natural gas total heating load of 100 MBh. shows 125 MBh and 180 MBh input models. The output capacities of these furnaces are 70 MBh and 100 MBh respectively. The medium heat model with 100 MBh output best matches the building requirements.

Air Delivery Selection

External static pressure drop through the air distribution system has been calculated to be 0.38 inches of water. From the 32 kW heater is 0.04 inches of water ($0.38 + 0.04$). Enter for a EBC120A4E0 at 4000 cfm and 0.42 static pressure. The standard motor will give the desired airflow at 758 rpm and rated bhp of 1.89.



Model Number Description

Digit 1 — Unit Type

E = Packaged Cooling, Electric Heat
G = Packaged Gas/Electric

Digit 2 — Efficiency

C = ASHRAE 90.1 - 2016

Digit 3 — Airflow Configuration

C = Convertible

Digit 4, 5, 6 — Nominal Gross Cooling Capacity (MBh)

090 = 7.5 Tons
102 = 8.5 Tons
120 = 10 Tons
150 = 12.5 Tons

Digit 7 — Major Design Sequence

A = Rev A

Digit 8 — Voltage Selection

3 = 208-230/60/3
4 = 460/60/3

Digit 9 — Unit Controls

E = Electromechanical

Digit 10 — Heating Capacity

0 = Cooling Only (field installed electric heat)
H = Gas Heat - High
L = Gas Heat - Low
M = Gas Heat - Medium
X = Gas Heat - Stainless Steel HX - Low
Y = Gas Heat - Stainless Steel HX - Medium
Z = Gas Heat - Stainless Steel HX - High

Digit 11— Minor Design Sequence

A = Rev A
B = Rev B

Digit 12, 13 — Service Sequence

00 = None

Digit 14 — Fresh Air Selection

0 = No Fresh Air Options

Note: Fresh air options are available as field installed accessories.

Digit 15 — Supply Fan/Drive Type/Motor

7 = Multi-Speed Standard Motor
9 = Multi-Speed Oversized Motor

Digit 16 — Unit

M = Medium Foundation

Digit 17 — Condenser Coil Protection

0 = Standard Coil

Digit 18 — Through The Base Provisions

0 = No Through the Base Provisions

Note: Through the base Provisions are available as field installed accessories.

Digit 19 — Disconnect Switch

0 = No Disconnect/No Circuit Breaker

Note: Non-Fused Disconnect are available as field installed accessories.

Digit 20 to 24

Not Used



General Data

Table 1. General data – 7.5 to 12.5 tons – 230 volts

	7.5 Ton	8.5 Ton	10 Ton	12.5 Ton
	E/GCC090	E/GCC105	E/GCC120	E/GCC150
Cooling Performance^(a)				
Gross Cooling Capacity	90000	102000	120000	150000
EER (Downflow/Horizontal)	11.2	11.2	11.2	11.0
Nominal Airflow CFM / AHRI Rated CFM	3200/3000	3700/3000	3700/3200	4600/4000
AHRI Net Cooling Capacity	86000	104000	114000	140000
Integrated Energy Efficiency Ratio (IEER)	14.8	14.8	14.8	14.2
Percent Capacity @ part load (Stage 1/Stage 2)	58/100	47/100	44/100	32/100
System Power (kW)	7.68	9.29	10.18	12.73
Compressor				
Number/Type	2 / Scrolls	2 / Scrolls	2 / Scrolls	2 / Scrolls
Sound				
Outdoor Sound Rating (BELS)	8.2	8.2	8.2	8.7
Outdoor Coil				
Type	Microchannel	Microchannel	Microchannel	Microchannel
Coil Width (in.) (System A + System B)	0.63+0.63	0.81+1.0	0.81+1.0	1.28+1.28
Face Area (sq. ft.)	23.81	27.38	27.38	27.38
Rows/FPI	1/23	1/23	1/23	1/23
Indoor Coil				
Type	Microchannel	Microchannel	Microchannel	Microchannel
Tube Size (in.) ID	0.98	0.98	1.57	1.57
Face Area (sq. ft.)	12.88	12.88	12.88	12.88
Rows/FPI	3/17	3/17	4/17	4/17
Refrigerant Control	EXV	EXV	EXV	EXV
Drain Connection Number/Size (in.)	1 / 3/4 PVC Pipe Socket	1 / 3/4 PVC Pipe Socket	1 / 3/4 PVC Pipe Socket	1 / 3/4 PVC Pipe Socket
Outdoor Fan				
Type	Propeller	Propeller	Propeller	Propeller
Number Used/Diameter (in.)	2 / 23-1/2	2 / 23-1/2	2 / 23-1/2	2 / 23-1/2
Drive Type/No. Speeds	Direct / 10	Direct / 10	Direct / 10	Direct / 10
cfm	8400	8300	8300	10000
Number Motors/hp	2 / 1/3HP	2 / 1/3HP	2 / 1/3HP	2 / 3/4HP
Motor rpm	960	960	960	1070
Indoor Fan				
Type	FC Centrifugal	FC Centrifugal	FC Centrifugal	FC Centrifugal
Number Used/Diameter (in.)	1 / 15x15	1 / 15x15	1 / 15x15	1 / 15x15
Drive Type/No. Speeds	Belt / 1	Belt / 1	Belt / 1	Belt / 1
Number Motors	1	1	1	1
Motor hp (Standard/Oversized)	2.0 / 3.0	2.0 / 5.0	3.0 / 5.0	3.0 / 5.0
Motor rpm (Standard/Oversized)	1725	1725	1725	1725
Motor Frame Size (Standard/Oversized)	56 / 56	56 / 56	56 / 56	56 / 56
Filters				
Type Furnished	Throwaway	Throwaway	Throwaway	Throwaway
Number Size Recommended	(4) 20*20*2	(4) 20*20*2	(4) 20*20*2	(4) 20*20*2
Refrigerant Charge (Pounds of R-410A)^(b)				
Circuit A	3.97 lbs	4.85 lbs	5.29 lbs	7.50 lbs
Circuit B	3.53 lbs	4.41 lbs	5.07 lbs	5.73 lbs

^(a) Units are AHRI Certified to AHRI Standard 340-360 (I-P). Rating conditions are 95°F outdoor air temperature, 80°F entering dry bulb, 67°F entering wet bulb with minimum external static pressure as determined by rating standard.

^(b) Refrigerant charge is an approximate value. For a more precise value, see unit nameplate and service instructions.



General Data

Table 2. General data – 7.5 to 12.5 tons – 460 volts

	7.5 Ton	8.5 Ton	10 Ton	12.5 Ton
	E/GCC090	E/GCC105	E/GCC120	E/GCC150
Cooling Performance^(a)				
Gross Cooling Capacity	90000	102000	120000	150000
EER (Downflow/Horizontal)	11.2	11.2	11.2	11.0
Nominal Airflow CFM / AHRI Rated CFM	3200/3000	3700/3000	3700/3200	4600/4000
AHRI Net Cooling Capacity	86000	104000	114000	140000
Integrated Energy Efficiency Ratio (IEER)	14.8	14.8	14.8	14.2
Percent Capacity @ part load (Stage 1/Stage 2)	58/100	47/100	44/100	32/100
System Power (kW)	7.68	9.29	10.18	12.73
Compressor				
Number/Type	2 / Scrolls	2 / Scrolls	2 / Scrolls	2 / Scrolls
Sound				
Outdoor Sound Rating (BELS)	8.2	8.2	8.2	9.2
Outdoor Coil				
Type	Microchannel	Microchannel	Microchannel	Microchannel
Coil Width (in.) (System A + System B)	0.63+0.63	1.0+1.0	1.0+1.0	1.28+1.28
Face Area (sq. ft.)	23.81	27.38	27.38	27.38
Rows/FPI	1/23	1/23	1/23	1/23
Indoor Coil				
Type	Microchannel	Microchannel	Microchannel	Microchannel
Tube Size (in.) ID	0.98	0.98	1.57	1.57
Face Area (sq. ft.)	12.88	12.88	12.88	12.88
Rows/FPI	3/17	3/17	4/17	4/17
Refrigerant Control	EXV	EXV	EXV	EXV
Drain Connection Number/Size (in.)	1 / 3/4 PVC Pipe Socket	1 / 3/4 PVC Pipe Socket	1 / 3/4 PVC Pipe Socket	1 / 3/4 PVC Pipe Socket
Outdoor Fan				
Type	Propeller	Propeller	Propeller	Propeller
Number Used/Diameter (in.)	2 / 23-1/2	2 / 23-1/2	2 / 23-1/2	2 / 23-1/2
Drive Type/No. Speeds	Direct / 10	Direct / 10	Direct / 10	Direct / 10
cfm	8400	8300	8300	10000
Number Motors/hp	2 / 1/3HP	2 / 1/3HP	2 / 1/3HP	2 / 3/4HP
Motor rpm	960	960	960	1070
Indoor Fan				
Type	FC Centrifugal	FC Centrifugal	FC Centrifugal	FC Centrifugal
Number Used/Diameter (in.)	1 / 15X15	1 / 15X15	1 / 15X15	1 / 15X15
Drive Type/No. Speeds	Belt / 1	Belt / 1	Belt / 1	Belt / 1
Number Motors	1	1	1	1
Motor hp (Standard/Oversized)	2.0 / 3.0	2.0 / 5.0	3.0 / 5.0	3.0 / 5.0
Motor rpm (Standard/Oversized)	1725	1725	1725	1725
Motor Frame Size (Standard/Oversized)	56/56	56/56	56/56	56/56
Filters				
Type Furnished	Throwaway	Throwaway	Throwaway	Throwaway
Number Size Recommended	(4) 20*20*2	(4) 20*20*2	(4) 20*20*2	(4) 20*20*2
Refrigerant Charge (Pounds of R-410A)^(b)				
Circuit A	3.97 lbs	4.85 lbs	5.29 lbs	7.72 lbs
Circuit B	3.31 lbs	4.41 lbs	4.85 lbs	5.95 lbs

^(a) Units are AHRI Certified to AHRI Standard 340-360 (I-P) . Rating conditions are 95°F outdoor air temperature, 80°F entering dry bulb, 67°F entering wet bulb with minimum external static pressure as determined by rating standard.

^(b) Refrigerant charge is an approximate value. For a more precise value, see unit nameplate and service instructions.

Table 3. General data – heating performance – 7.5 to 12.5 tons

	Heating Performance ^(a)					
	7.5 to 8.5 Tons			10 to 12.5 Tons		
Heating Models	Low	Medium	High	Low	Medium	High
Heating Input (Btu/h)	125000	180,000	225000	180,000	225000	250000
1 st Stage (Btu)	87500	126,000	168000	126,000	168000	200000
Heating Output (Btu/h)	100000	144,000	180,000	144,000	180000	200000
1 st Stage (Btu)	70000	100,000	125,000	100,000	125000	160000
Steady State Efficiency %	81%	81%	81%	81%	81%	81%
No. Burners	3	5	6	5	6	6
No. Stages	2	2	2	2	2	2
Gas Supply Line Pressure (in. wc)						
Natural Gas (minimum/maximum)	4.5 / 14.0 in. wc.	4.5 / 14.0 in. wc.	4.5 / 14.0 in. wc.	4.5 / 14.0 in. wc.	4.5 / 14.0 in. wc.	4.5 / 14.0 in. wc.
LP (minimum/maximum)	11.0/14.0 in. wc.	11.0/14.0 in. wc.	11.0/14.0 in. wc.	11.0/14.0 in. wc.	11.0/14.0 in. wc.	11.0/14.0 in. wc.
Gas Connection Pipe Size (in.)	1/2	1/2	3/4	1/2	3/4	3/4

^(a) Heating Performance limit settings and rating data were established and approved under laboratory test conditions using American National Standards Institute standards (ANSI). Ratings shown are for elevations up to 2000 feet. For elevations above 2000 feet, ratings should be reduced at the rate of 4% for each 1000 feet above sea level.



Performance Data

Gross Cooling Capacities

Table 4. Gross cooling capacities 7.5 tons

CFM	Ent DB (°F)	Ambient Temperature (°F)						Ambient Temperature (°F)						Ambient Temperature (°F)					
		85						95						105					
		Entering Wet Bulb Temp (°F)						Entering Wet Bulb Temp (°F)						Entering Wet Bulb Temp (°F)					
		61		67		73		61		67		73		61		67		73	
	MBh	SHC	MBh	SHC	MBh	SHC	MBh	SHC	MBh	SHC	MBh	SHC	MBh	SHC	MBh	SHC	MBh	SHC	
2400	75	82.8	56.6	92.4	47.8	101.8	36.3	74.8	54.7	87.3	44.7	94.7	36.7	68.4	51.2	78.0	42.8	88.1	35.1
	80	82.0	69.1	91.5	58.3	101.0	49.1	73.9	65.2	86.2	56.8	93.7	43.9	67.6	59.7	77.1	54.3	87.2	45.3
	85	81.6	76.7	91.2	64.7	100.9	61.4	73.5	70.7	85.7	64.5	92.7	52.4	67.2	64.1	76.6	61.6	86.2	50.1
	90	81.4	77.3	90.9	66.7	100.6	76.5	73.3	73.3	85.5	67.5	92.8	55.1	67.0	67.0	76.4	64.5	86.2	52.7
2700	75	86.1	62.2	95.8	52.6	105.2	40.1	78.0	60.2	90.6	49.2	98.3	45.5	71.5	56.3	81.3	47.1	91.6	43.5
	80	85.3	75.6	94.9	63.8	104.7	53.8	77.0	71.3	89.5	62.1	96.7	45.9	70.7	65.3	80.3	59.4	90.0	43.9
	85	84.8	79.2	94.4	70.7	104.3	67.2	76.5	75.1	89.0	70.5	96.3	57.7	70.1	68.7	79.7	67.4	89.7	55.1
	90	84.6	79.0	94.1	71.4	103.9	81.7	76.3	74.9	88.7	72.3	96.2	66.7	69.9	68.5	79.5	69.1	89.6	63.8
3000	75	85.9	67.2	95.8	56.8	105.4	43.3	77.7	65.0	90.6	53.1	97.9	39.4	71.1	60.8	81.0	50.8	91.0	37.8
	80	85.2	80.9	95.0	68.7	104.8	57.9	76.8	76.8	89.5	66.9	97.0	54.8	70.3	70.3	80.1	64.0	90.3	52.3
	85	84.6	80.3	94.3	76.1	104.3	72.4	76.2	76.2	88.7	75.9	96.4	70.1	69.7	69.7	79.4	72.6	89.7	67.0
	90	84.3	80.1	93.9	75.4	103.9	86.4	75.9	75.9	88.4	76.4	96.0	85.0	69.4	69.4	79.1	73.0	89.3	81.1
3300	75	87.6	73.1	97.7	61.9	107.5	47.1	79.4	70.7	92.4	57.9	99.3	34.7	72.6	66.2	82.7	55.3	92.4	33.4
	80	87.0	77.1	97.0	74.4	106.9	62.8	78.6	78.6	91.4	72.5	99.3	65.9	71.8	71.8	81.8	69.4	92.4	63.0
	85	86.2	81.9	96.1	82.5	106.2	78.5	77.8	77.8	90.4	82.3	98.4	85.8	71.2	71.2	81.0	78.7	91.6	82.1
	90	85.9	81.6	95.6	80.1	105.7	91.8	77.3	77.3	90.0	81.2	97.7	97.7	70.8	70.8	80.6	80.6	90.9	90.9
CFM	Ent DB (°F)	Ambient Temperature (°F)						Ambient Temperature (°F)						Ambient Temperature (°F)					
		115						120						125					
		Entering Wet Bulb Temp (°F)						Entering Wet Bulb Temp (°F)						Entering Wet Bulb Temp (°F)					
		61		67		73		61		67		73		61		67		73	
	MBh	SHC	MBh	SHC	MBh	SHC	MBh	SHC	MBh	SHC	MBh	SHC	MBh	SHC	MBh	SHC	MBh	SHC	
2400	75	58.8	48.2	69.2	41.4	79.5	34.0	50.4	43.3	63.9	43.3	73.4	33.1	27.6	24.7	33.6	24.3	38.5	20.3
	80	58.1	51.3	68.4	52.5	78.6	39.5	49.9	44.4	63.2	54.9	72.7	47.2	27.3	24.5	33.2	30.5	38.1	28.5
	85	57.8	56.4	68.0	59.7	77.8	48.4	49.5	49.5	62.8	57.8	71.9	42.8	27.1	27.1	33.0	32.0	37.7	25.9
	90	57.6	57.6	67.9	62.1	77.7	50.9	49.1	49.1	62.7	62.7	71.6	49.7	26.9	26.9	32.9	32.0	37.5	29.9
2700	75	61.7	53.0	72.3	45.7	82.4	36.5	53.2	47.6	67.0	47.6	76.7	41.2	30.0	27.4	36.1	27.0	41.2	25.3
	80	61.0	56.2	71.5	57.6	81.7	42.7	52.5	48.5	66.2	59.6	75.4	41.5	29.7	27.0	35.7	33.3	40.5	25.5
	85	60.6	59.1	71.0	65.3	81.3	55.9	52.1	50.7	65.8	59.3	75.2	52.0	29.5	28.1	35.5	33.2	40.4	31.6
	90	60.4	59.0	70.8	66.6	81.0	65.5	51.8	50.4	65.5	64.1	75.0	60.1	29.4	28.0	35.4	33.0	40.3	36.3
3000	75	61.2	57.2	71.9	49.3	82.2	38.8	53.7	51.8	66.5	51.5	76.0	35.7	29.7	29.7	35.3	29.0	40.2	22.2
	80	60.5	60.5	71.2	62.0	81.5	50.7	53.1	53.1	65.8	60.6	75.4	49.4	29.4	29.4	34.9	33.9	39.9	30.1
	85	60.0	60.0	70.6	70.4	81.0	64.8	52.7	52.7	65.3	60.1	74.9	63.2	29.2	29.2	34.6	33.6	39.6	38.1
	90	59.8	59.8	70.3	70.3	80.7	78.4	52.5	52.5	65.0	65.0	74.9	65.6	29.1	29.1	34.5	33.5	39.6	39.5
3300	75	62.3	62.3	73.5	53.7	83.9	41.8	56.2	56.2	68.0	56.1	77.2	31.6	31.3	31.3	36.3	31.8	41.1	20.0
	80	61.9	61.9	72.8	67.3	83.3	60.7	55.6	55.6	67.3	62.1	77.4	59.5	31.0	31.0	36.0	35.0	41.1	36.2
	85	61.4	61.4	72.1	72.1	82.6	75.7	55.3	55.3	66.7	61.5	76.6	76.6	30.8	30.8	35.6	34.6	40.7	40.7
	90	61.1	61.1	71.7	71.7	82.2	82.2	55.1	55.1	66.4	66.4	76.7	76.7	30.7	30.7	35.5	35.5	40.8	40.8

Notes:

1. All capacities shown are gross and have not considered indoor fan heat. To obtain NET cooling capacity subtract indoor fan heat. For indoor fan heat formula, refer to appropriate airflow table notes.
2. MBh = Total gross capacity
3. SHC = Sensible heat capacity
4. Ambient Temperature above 120°F, the system B shuts down.

Table 5. Gross cooling capacities 8.5 tons

CFM	Ent DB (° F)	Ambient Temperature (°F)						Ambient Temperature (°F)						Ambient Temperature (°F)					
		85						95						105					
		Entering Wet Bulb Temp (°F)						Entering Wet Bulb Temp (°F)						Entering Wet Bulb Temp (°F)					
		61		67		73		61		67		73		61		67		73	
		MBh	SHC	MBh	SHC	MBh	SHC	MBh	SHC	MBh	SHC	MBh	SHC	MBh	SHC	MBh	SHC	MBh	SHC
2700	75	100.4	69.9	112.0	60.4	122.8	45.3	93.5	67.0	106.2	56.3	118.1	45.5	88.4	63.7	101.4	53.4	112.5	44.7
	80	99.5	84.9	110.9	73.2	121.9	60.5	92.4	84.8	105.0	70.8	116.9	54.1	87.3	80.6	100.2	67.2	111.3	57.3
	85	99.1	93.9	110.5	80.9	121.7	75.2	91.2	89.7	104.4	80.0	115.7	64.2	86.2	84.7	99.6	76.0	110.2	63.2
	90	98.8	94.6	110.3	83.4	121.4	93.1	90.9	89.5	104.2	83.7	115.8	67.4	86.0	84.4	99.4	79.5	110.1	66.4
3050	75	102.3	76.3	114.0	65.9	124.9	49.5	95.3	73.2	108.2	61.4	120.5	55.7	90.1	70.5	103.3	59.3	114.6	55.5
	80	101.4	92.2	113.0	79.5	124.2	65.8	92.8	92.1	106.9	76.9	118.5	56.1	87.0	87.8	102.1	73.7	112.7	56.6
	85	100.8	96.6	112.4	87.9	123.8	81.8	92.4	91.2	106.3	86.9	118.0	70.1	86.3	87.1	101.4	82.9	112.3	70.4
	90	100.6	96.3	112.1	88.7	123.3	99.0	92.2	91.0	105.9	88.5	117.9	79.9	86.9	85.9	101.1	83.9	112.2	78.8
3400	75	104.1	83.6	116.1	73.5	127.0	56.7	96.8	80.7	110.0	68.2	121.9	51.0	91.7	76.6	105.1	64.5	116.2	49.7
	80	102.5	99.7	115.1	87.2	126.3	73.1	93.2	95.0	109.1	84.3	120.9	68.3	87.9	89.8	104.2	79.9	115.3	67.4
	85	101.8	98.9	114.2	95.9	125.7	90.3	92.3	94.3	108.1	94.7	120.1	86.0	87.3	89.0	103.3	89.8	114.6	85.3
	90	101.9	98.1	113.8	94.2	125.1	104.3	92.6	93.2	107.7	94.2	119.6	101.5	87.6	87.9	103.0	89.3	114.1	100.2
3750	75	106.1	91.4	118.2	79.8	129.4	60.6	99.0	87.9	112.2	74.5	123.6	46.1	93.6	83.7	107.1	71.0	117.7	46.5
	80	103.6	102.4	117.4	94.6	128.8	78.7	93.7	97.7	111.1	91.7	123.7	81.7	88.3	92.1	106.0	87.2	117.6	81.9
	85	103.4	101.1	116.3	102.9	128.0	95.5	93.9	95.8	109.9	102.4	122.6	104.1	87.9	90.8	104.9	97.1	116.6	102.4
	90	102.4	101.2	115.8	100.7	127.4	111.0	92.7	95.9	109.4	101.9	117.0	121.7	86.8	91.1	104.5	96.4	111.7	114.9
CFM	Ent DB (° F)	Ambient Temperature (°F)						Ambient Temperature (°F)						Ambient Temperature (°F)					
		115						120						125					
		Entering Wet Bulb Temp (°F)						Entering Wet Bulb Temp (°F)						Entering Wet Bulb Temp (°F)					
		61		67		73		61		67		73		61		67		73	
		MBh	SHC	MBh	SHC	MBh	SHC	MBh	SHC	MBh	SHC	MBh	SHC	MBh	SHC	MBh	SHC	MBh	SHC
2700	75	78.9	61.8	89.7	52.6	102.5	43.6	76.2	54.2	84.8	64.9	98.4	61.9	38.4	30.8	45.3	30.4	48.6	25.6
	80	77.4	75.8	88.6	66.2	101.4	50.5	75.5	67.4	82.9	82.0	97.4	88.4	37.4	35.9	44.9	37.4	48.1	34.8
	85	76.9	75.4	88.1	74.9	100.4	61.6	74.1	72.8	82.5	81.4	96.3	80.1	37.1	35.7	44.6	39.2	47.7	31.9
	90	76.7	75.2	88.0	78.3	100.3	64.7	73.6	72.3	82.3	81.2	96.0	93.1	36.9	35.5	44.5	39.1	47.5	36.4
3050	75	80.4	68.5	91.2	58.4	103.9	47.4	77.8	60.6	86.6	71.1	100.5	75.8	39.4	34.4	46.3	33.8	49.7	30.9
	80	78.0	77.8	90.4	72.6	103.0	55.2	77.0	69.5	84.3	83.8	98.8	76.7	37.4	37.3	45.9	40.9	48.9	31.7
	85	77.4	77.2	89.8	81.8	102.5	70.9	74.8	74.6	83.6	83.5	97.8	95.7	37.2	37.0	45.7	40.8	48.8	38.2
	90	77.6	76.5	89.5	82.6	102.2	81.2	74.8	73.7	84.3	82.1	98.3	94.7	37.8	36.0	45.5	40.1	48.7	43.0
3400	75	82.1	74.5	93.1	63.6	105.9	51.0	81.0	66.8	88.4	78.0	101.9	68.0	40.2	38.1	47.4	37.6	50.6	29.6
	80	78.9	79.7	92.3	78.7	105.1	65.6	80.3	73.4	84.6	86.3	101.2	83.2	37.9	39.7	47.1	42.9	50.4	38.1
	85	78.2	79.1	90.9	88.0	104.5	81.8	77.2	78.1	84.7	84.9	99.1	97.8	38.3	39.0	46.7	41.5	50.1	45.4
	90	77.2	79.4	89.4	88.9	104.0	98.4	76.0	78.6	83.8	85.1	98.7	98.2	37.2	39.7	46.6	41.9	48.6	47.4
3750	75	81.2	81.1	94.7	70.0	107.6	56.0	84.3	72.9	90.0	84.7	103.2	60.6	39.8	41.5	48.7	40.9	51.7	27.8
	80	78.1	82.6	94.0	85.8	107.3	78.7	83.5	78.2	85.5	88.6	103.6	83.0	38.9	41.7	48.1	43.8	51.9	44.2
	85	78.7	81.1	89.8	91.6	106.4	95.0	79.6	81.9	85.4	86.9	100.0	100.3	38.2	42.2	47.2	43.9	48.1	49.9
	90	77.7	81.3	88.9	91.6	102.9	104.1	78.5	82.4	84.6	87.0	100.0	100.6	37.6	42.4	46.7	44.0	47.5	50.3

Notes:

- All capacities shown are gross and have not considered indoor fan heat. To obtain NET cooling capacity subtract indoor fan heat. For indoor fan heat formula, refer to appropriate airflow table notes.
- MBh = Total gross capacity
- SHC = Sensible heat capacity
- Ambient Temperature above 120°F, the system B shuts down.



Performance Data

Table 6. Gross cooling capacities 10 tons

CFM	Ent DB (° F)	Ambient Temperature (°F)						Ambient Temperature (°F)						Ambient Temperature (°F)					
		85						95						105					
		Entering Wet Bulb Temp (°F)						Entering Wet Bulb Temp (°F)						Entering Wet Bulb Temp (°F)					
		61		67		73		61		67		73		61		67		73	
		MBh	SHC	MBh	SHC	MBh	SHC	MBh	SHC	MBh	SHC	MBh	SHC	MBh	SHC	MBh	SHC		
3200	75	112.3	80.8	122.7	73.2	135.1	44.7	109.0	70.8	119.1	64.2	131.5	43.8	97.5	62.9	106.5	57.0	121.1	39.7
	80	111.2	99.6	121.5	90.2	134.1	61.5	107.6	91.1	117.6	82.6	130.1	53.1	96.2	80.9	105.1	73.3	119.8	52.1
	85	111.0	110.6	121.0	100.5	133.9	77.8	107.0	104.1	116.9	94.2	128.6	63.9	95.7	92.4	104.5	83.7	118.5	57.9
	90	111.9	110.3	120.7	103.8	133.5	97.6	108.2	106.6	116.6	98.9	128.7	67.4	96.9	95.3	104.2	87.8	118.4	61.1
3600	75	114.8	88.2	125.3	79.8	137.8	48.8	111.4	77.3	121.6	70.0	134.5	54.2	99.7	68.6	108.9	62.2	123.9	49.1
	80	113.7	108.2	124.1	98.0	137.0	66.8	110.0	98.9	120.1	90.6	132.1	54.7	98.5	87.9	107.5	79.6	121.7	49.6
	85	114.5	112.1	123.4	109.1	136.5	84.5	110.7	108.3	119.3	102.3	131.6	69.8	99.2	96.8	106.7	90.9	121.2	63.2
	90	114.2	111.8	123.0	110.2	136.0	103.6	110.4	108.0	118.9	105.0	131.4	81.3	98.9	96.5	106.4	93.2	121.1	73.7
4000	75	117.4	97.4	128.1	88.4	140.8	54.7	114.0	85.6	124.4	77.7	136.7	48.2	102.1	76.2	111.4	69.2	126.0	43.9
	80	117.9	116.4	127.0	107.6	140.0	74.0	112.7	108.7	122.9	98.6	135.5	67.8	100.9	96.7	110.1	87.8	124.9	61.6
	85	117.0	115.5	126.0	119.6	139.3	93.1	113.2	111.7	121.8	112.3	134.6	87.4	101.5	100.0	109.1	100.0	124.1	79.4
	90	116.6	115.1	125.5	118.4	138.7	111.5	112.7	111.2	121.3	113.0	134.0	106.4	101.1	99.6	108.7	100.5	123.5	96.5
4400	75	120.2	106.5	131.1	96.9	144.0	60.2	116.8	93.7	127.4	85.2	139.1	42.7	104.7	83.6	114.1	75.9	128.3	39.0
	80	120.8	119.3	130.1	117.1	143.2	80.9	117.1	115.6	125.9	107.5	139.1	82.5	105.0	103.5	112.9	95.8	128.3	75.0
	85	119.7	118.2	130.1	128.8	142.3	101.5	115.9	114.4	124.5	122.2	137.8	107.9	104.0	102.5	111.7	109.0	127.2	98.2
	90	119.2	117.7	128.2	126.3	141.6	119.0	115.2	113.7	123.9	120.7	137.5	136.8	103.5	102.0	111.2	107.4	126.1	124.6
CFM	Ent DB (° F)	Ambient Temperature (°F)						Ambient Temperature (°F)						Ambient Temperature (°F)					
		115						120						125					
		Entering Wet Bulb Temp (°F)						Entering Wet Bulb Temp (°F)						Entering Wet Bulb Temp (°F)					
		61		67		73		61		67		73		61		67		73	
		MBh	SHC	MBh	SHC	MBh	SHC	MBh	SHC	MBh	SHC	MBh	SHC	MBh	SHC	MBh	SHC		
3200	75	88.6	58.8	96.8	53.2	111.6	36.5	85.2	51.0	91.1	67.0	106.8	53.5	40.4	24.5	43.2	32.1	50.8	25.7
	80	87.5	75.6	95.6	68.4	110.4	42.9	84.3	66.7	90.0	86.1	105.6	78.1	40.0	32.0	42.7	41.2	50.2	37.4
	85	87.0	86.3	95.0	78.2	109.2	53.2	85.1	83.5	90.9	89.3	104.4	70.4	40.8	39.5	43.6	42.3	49.6	33.7
	90	88.2	86.6	94.8	82.0	109.0	56.1	84.5	82.9	90.7	89.1	104.0	82.4	40.5	39.2	43.5	42.2	49.4	39.5
3600	75	90.7	64.1	99.0	58.1	113.6	38.6	87.3	55.5	93.3	73.0	109.4	66.3	41.8	26.7	44.7	35.0	52.4	31.8
	80	89.6	82.1	97.8	74.3	112.6	45.8	86.1	72.2	93.6	91.2	107.4	66.9	41.2	34.6	45.2	43.2	51.4	32.1
	85	90.4	88.0	97.1	84.9	112.0	61.0	86.9	84.5	93.0	90.6	107.0	85.3	42.0	40.0	44.9	42.9	51.2	40.8
	90	90.1	87.7	96.8	87.1	111.6	72.1	86.4	84.0	92.6	90.2	106.8	101.3	41.8	39.8	44.7	42.7	51.1	47.5
4000	75	93.0	71.3	101.4	64.8	116.2	43.1	91.6	62.5	95.6	81.0	111.3	58.5	44.4	31.0	46.3	39.8	53.8	29.1
	80	91.9	90.5	100.3	82.1	115.3	56.8	90.5	81.2	96.0	94.5	110.4	82.5	43.9	39.9	46.9	45.8	53.4	40.5
	85	92.6	91.1	99.4	93.5	114.5	73.1	91.3	89.8	95.2	93.7	109.6	106.5	44.7	43.5	46.5	45.4	53.0	51.9
	90	92.2	90.7	99.0	94.0	114.0	88.8	90.9	89.4	94.8	93.3	110.7	109.6	44.5	43.3	46.3	45.2	53.9	53.0
4400	75	95.5	78.2	104.0	71.2	119.0	47.1	96.2	69.3	98.1	88.8	113.4	51.4	47.2	34.8	48.1	44.1	55.5	26.3
	80	95.9	94.4	103.0	89.7	118.2	68.9	95.2	90.2	98.6	97.1	113.6	100.2	46.8	44.8	48.8	47.7	55.6	49.5
	85	95.0	93.5	101.9	101.9	117.2	86.2	96.0	94.5	97.6	96.1	113.9	112.4	47.5	46.4	48.3	47.2	56.5	55.0
	90	94.5	93.0	101.4	100.5	116.6	107.9	95.7	94.2	97.2	95.7	114.1	112.6	47.4	46.3	48.1	47.0	56.6	55.1

Notes:

1. All capacities shown are gross and have not considered indoor fan heat. To obtain NET cooling capacity subtract indoor fan heat. For indoor fan heat formula, refer to appropriate airflow table notes.
2. MBh = Total gross capacity
3. SHC = Sensible heat capacity
4. Ambient Temperature above 120°F, the system B shuts down.

Table 7. Gross cooling capacities 12.5 tons

CFM	Ent DB (° F)	Ambient Temperature (°F)						Ambient Temperature (°F)						Ambient Temperature (°F)					
		85						95						105					
		Entering Wet Bulb Temp (°F)						Entering Wet Bulb Temp (°F)						Entering Wet Bulb Temp (°F)					
		61		67		73		61		67		73		61		67		73	
		MBh	SHC	MBh	SHC	MBh	SHC	MBh	SHC	MBh	SHC	MBh	SHC	MBh	SHC	MBh	SHC		
4000	75	132.6	110.1	148.7	86.4	164.2	58.0	128.9	108.8	143.8	84.7	155.5	54.8	120.7	105.1	129.6	78.4	145.2	50.8
	80	132.3	132.1	148.3	108.9	163.8	80.0	128.8	123.5	143.5	107.8	155.3	77.2	120.5	116.8	129.1	100.9	145.0	72.9
	85	131.7	131.7	147.9	131.6	163.5	102.4	128.5	128.5	143.2	128.3	155.1	98.1	120.1	120.1	128.8	121.6	144.8	94.3
	90	131.3	131.3	147.6	147.6	163.2	125.2	128.1	128.1	143.0	140.4	154.7	120.2	119.8	119.8	128.5	128.5	144.6	117.1
4500	75	136.3	123.4	152.6	96.8	168.3	65.3	132.4	122.0	147.5	94.9	159.9	70.7	124.0	117.2	133.1	87.7	149.2	65.0
	80	136.0	136.0	152.2	121.4	168.2	89.3	132.3	132.3	147.3	120.1	158.3	81.2	123.9	123.9	132.6	112.0	147.8	70.3
	85	135.1	135.1	151.5	146.4	167.4	114.1	131.8	131.8	146.8	142.8	159.6	110.1	123.1	123.1	132.1	132.1	148.7	105.4
	90	134.7	134.7	151.1	151.1	167.0	135.7	131.4	131.4	146.5	146.5	158.7	151.1	122.8	122.8	131.8	131.8	148.5	146.1
5000	75	139.9	136.6	156.6	107.5	172.6	72.6	136.1	135.0	151.5	105.3	163.0	61.0	127.5	126.4	136.8	97.6	152.3	56.8
	80	139.8	139.8	156.4	133.8	172.5	98.7	136.0	136.0	151.3	132.5	163.1	101.5	126.9	126.9	136.4	124.1	152.4	87.9
	85	138.6	138.6	155.3	155.3	171.5	126.0	135.3	135.3	150.4	150.4	163.8	140.0	126.5	126.5	135.6	135.6	153.0	134.6
	90	138.1	138.1	154.7	154.7	170.9	146.3	134.6	134.6	149.9	149.9	162.4	162.4	126.0	126.0	135.1	135.1	152.1	152.1
5500	75	143.7	142.1	160.7	119.0	177.0	80.4	139.8	138.3	155.6	116.5	166.2	53.0	131.0	129.7	140.4	107.9	155.4	49.6
	80	143.1	143.1	160.4	147.2	176.9	108.9	139.2	139.2	155.4	145.9	168.1	95.8	130.5	130.5	140.3	136.7	157.2	96.1
	85	142.3	142.3	159.1	159.1	175.6	138.7	139.0	139.0	154.1	154.1	168.3	136.4	129.9	129.9	139.1	139.1	157.3	139.8
	90	141.6	141.6	158.4	158.4	174.9	157.5	138.0	138.0	153.5	153.5	166.2	166.2	129.3	129.3	138.5	138.5	155.6	155.6
CFM	Ent DB (° F)	Ambient Temperature (°F)						Ambient Temperature (°F)						Ambient Temperature (°F)					
		115						120						125					
		Entering Wet Bulb Temp (°F)						Entering Wet Bulb Temp (°F)						Entering Wet Bulb Temp (°F)					
		61		67		73		61		67		73		61		67		73	
		MBh	SHC	MBh	SHC	MBh	SHC	MBh	SHC	MBh	SHC	MBh	SHC	MBh	SHC	MBh	SHC		
4000	75	105.5	99.4	122.0	73.9	132.1	44.4	100.8	97.4	114.1	70.5	128.5	44.5	54.5	52.5	62.1	48.5	71.1	30.7
	80	105.2	105.2	121.7	97.6	131.9	68.2	100.5	100.5	113.8	93.4	128.3	66.1	54.3	54.3	61.9	60.0	70.8	45.6
	85	105.0	105.0	121.5	121.1	131.6	92.3	100.3	100.3	113.6	112.9	128.1	87.5	54.0	54.0	61.6	61.6	70.5	61.7
	90	104.7	104.7	121.3	121.3	131.2	116.5	100.1	100.1	113.3	113.3	127.8	108.6	53.8	53.8	61.4	61.4	70.3	70.3
4500	75	108.5	105.9	125.3	82.8	135.0	48.4	103.8	102.5	117.4	78.8	132.3	56.9	56.7	55.8	64.4	54.4	73.7	39.1
	80	108.2	108.2	125.0	104.4	135.1	74.6	103.1	103.1	116.9	102.8	131.0	83.8	56.3	56.3	64.2	64.2	73.4	54.5
	85	107.8	107.8	124.7	124.7	135.6	98.9	102.9	102.9	116.8	116.0	131.9	109.6	56.0	56.0	63.9	63.9	73.1	69.6
	90	107.5	107.5	124.3	124.3	135.0	122.6	102.7	102.7	116.2	116.2	131.6	131.6	55.9	55.9	63.5	63.5	72.9	72.9
5000	75	111.8	110.3	128.9	92.2	139.7	53.3	109.8	108.6	120.8	87.8	135.0	50.0	60.4	58.9	66.9	60.9	75.8	35.2
	80	111.5	111.5	128.7	120.2	139.5	92.9	109.3	108.7	120.5	106.3	135.3	71.2	60.1	60.1	66.7	66.7	75.8	49.9
	85	110.9	110.7	128.1	128.1	139.3	131.8	109.1	109.1	120.0	119.3	135.7	93.2	59.8	59.8	66.2	66.2	75.8	67.2
	90	110.5	110.5	127.6	127.6	138.5	138.5	108.8	108.8	119.4	119.4	136.0	115.6	59.7	59.7	65.9	65.9	75.7	75.7
5500	75	115.1	113.7	132.5	102.1	142.5	58.5	116.0	114.3	124.2	97.4	137.8	44.0	64.3	63.1	69.4	67.6	78.0	31.9
	80	114.9	114.9	132.5	132.4	142.9	99.4	115.7	115.7	124.1	109.6	139.7	88.7	64.1	64.1	69.3	69.3	78.8	61.9
	85	114.1	114.1	131.6	131.6	143.0	137.6	115.6	115.6	123.3	123.3	139.6	124.5	63.8	63.8	68.7	68.7	78.5	78.5
	90	113.6	113.6	130.9	130.9	142.0	142.0	115.3	115.3	122.7	122.7	139.2	139.2	63.4	63.4	68.3	68.3	78.2	78.2

Notes:

- All capacities shown are gross and have not considered indoor fan heat. To obtain NET cooling capacity subtract indoor fan heat. For indoor fan heat formula, refer to appropriate airflow table notes.
- MBh = Total gross capacity
- SHC = Sensible heat capacity
- Ambient Temperature above 120°F, the system B shuts down.



Performance Data

Evaporator Fan Performance

7.5 Tons

Table 8. Belt drive evaporator fan performance - 7.5 tons with low gas heat - GCC90A(3,4)EL - downflow airflow

External Static Pressure (Inches of Water)																					
CFM	0.1		0.2		0.3		0.4		0.5		0.6		0.7		0.8		0.9		1.0		
	RPM	BHP	RPM	BHP	RPM	BHP	RPM	BHP	RPM	BHP	RPM	BHP	RPM	BHP	RPM	BHP	RPM	BHP	RPM	BHP	
Standard Motor																					
2400	—	—	—	—	—	—	—	—	—	—	—	—	—	—	725	1.12	748	1.28	773	1.43	
2700	—	—	—	—	—	—	—	—	—	—	718	1.26	742	1.39	766	1.51	789	1.64	815	1.76	
3000	—	—	—	—	—	—	710	1.25	735	1.37	761	1.49	784	1.61	808	1.74	832	1.86	863	2.02	
3300	—	—	—	—	724	1.36	749	1.49	776	1.63	803	1.77	829	1.89	861	2.06	883	2.18	906	2.31	
External Static Pressure (Inches of Water)																					
CFM	1.1		1.2		1.3		1.4		1.5		1.6		1.7		1.8		1.9		2.0		
	RPM	BHP	RPM	BHP	RPM	BHP	RPM	BHP	RPM	BHP	RPM	BHP	RPM	BHP	RPM	BHP	RPM	BHP	RPM	BHP	
High Static (oversize) Motor																					
2400	799	1.59	823	1.76	854	1.88	877	2.06	900	2.17	924	2.28	949	2.40	971	2.50	996	2.61	1020	2.71	
2700	841	1.88	872	2.04	897	2.16	921	2.27	944	2.38	967	2.50	990	2.62	1013	2.72	1036	2.82	1059	2.93	
3000	885	2.13	908	2.25	933	2.36	956	2.48	979	2.59	1002	2.70	1026	2.80	1049	2.91	1073	3.02	—	—	
3300	930	2.44	954	2.58	977	2.70	999	2.82	1025	2.93	1048	3.03	—	—	—	—	—	—	—	—	

Table 9. Belt drive evaporator fan performance - 7.5 tons with low gas heat - GCC90A(3,4)EL - horizontal airflow

External Static Pressure (Inches of Water)																					
CFM	0.1		0.2		0.3		0.4		0.5		0.6		0.7		0.8		0.9		1.0		
	RPM	BHP	RPM	BHP	RPM	BHP	RPM	BHP	RPM	BHP	RPM	BHP	RPM	BHP	RPM	BHP	RPM	BHP	RPM	BHP	
Standard Motor																					
2400	—	—	—	—	—	—	—	—	—	—	—	—	—	—	711	1.02	734	1.18	759	1.32	
2700	—	—	—	—	—	—	—	—	—	—	—	—	728	1.28	752	1.40	775	1.52	801	1.65	
3000	—	—	—	—	—	—	—	—	721	1.26	747	1.39	768	1.51	794	1.64	818	1.76	849	1.91	
3300	—	—	—	—	713	1.26	739	1.39	766	1.52	789	1.67	815	1.79	847	1.95	869	2.08	892	2.20	
External Static Pressure (Inches of Water)																					
CFM	1.1		1.2		1.3		1.4		1.5		1.6		1.7		1.8		1.9		2.0		
	RPM	BHP	RPM	BHP	RPM	BHP	RPM	BHP	RPM	BHP	RPM	BHP	RPM	BHP	RPM	BHP	RPM	BHP	RPM	BHP	
Standard Motor																					
2400	776	1.41	809	1.66	840	1.76	863	1.94	885	2.05	909	2.15	934	2.27	956	2.37	981	2.48	1005	2.58	
2700	827	1.77	858	1.93	882	2.03	906	2.15	929	2.26	952	2.38	975	2.49	998	2.60	1021	2.69	1044	2.80	
3000	871	2.03	894	2.14	918	2.25	943	2.37	966	2.47	988	2.58	1012	2.69	1037	2.79	1061	2.90	1084	3.01	
3300	915	2.34	939	2.47	962	2.59	985	2.70	1011	2.81	1034	2.90	1056	3.02	—	—	—	—	—	—	

Table 10. Belt drive evaporator fan performance - 7.5 tons with med gas heat - GCC90A(3,4)EM - downflow airflow

External Static Pressure (Inches of Water)																					
CFM	0.1		0.2		0.3		0.4		0.5		0.6		0.7		0.8		0.9		1.0		
	RPM	BHP	RPM	BHP	RPM	BHP	RPM	BHP	RPM	BHP	RPM	BHP	RPM	BHP	RPM	BHP	RPM	BHP	RPM	BHP	
Standard Motor																					
2400	—	—	—	—	—	—	—	—	—	—	—	—	—	—	—	723	1.11	746	1.27	771	1.41
2700	—	—	—	—	—	—	—	—	—	—	716	1.24	740	1.37	764	1.49	787	1.62	813	1.74	
3000	—	—	—	—	—	—	—	—	733	1.36	751	1.39	782	1.60	806	1.73	830	1.85	861	2.00	
3300	—	—	—	—	722	1.36	742	1.41	774	1.62	801	1.76	827	1.88	856	2.04	881	2.16	904	2.29	
External Static Pressure (Inches of Water)																					
CFM	1.1		1.2		1.3		1.4		1.5		1.6		1.7		1.8		1.9		2.0		
	RPM	BHP	RPM	BHP	RPM	BHP	RPM	BHP	RPM	BHP	RPM	BHP	RPM	BHP	RPM	BHP	RPM	BHP	RPM	BHP	
Standard Motor						High Static (oversize) Motor															
2400	797	1.57	821	1.74	852	1.84	875	2.02	898	2.13	922	2.24	946	2.36	968	2.46	993	2.57	1017	2.67	
2700	839	1.86	870	2.02	895	2.13	918	2.23	941	2.35	964	2.47	987	2.58	1010	2.68	1033	2.78	1056	2.89	
3000	883	2.11	906	2.23	931	2.34	953	2.45	976	2.56	999	2.67	1023	2.77	1046	2.87	1067	2.99	—	—	
3300	928	2.42	952	2.56	974	2.67	996	2.79	1022	2.90	1045	3.01	—	—	—	—	—	—	—	—	

Table 11. Belt drive evaporator fan performance - 7.5 tons with med gas heat - GCC90A(3,4)EM - horizontal airflow

External Static Pressure (Inches of Water)																					
CFM	0.1		0.2		0.3		0.4		0.5		0.6		0.7		0.8		0.9		1.0		
	RPM	BHP	RPM	BHP	RPM	BHP	RPM	BHP	RPM	BHP	RPM	BHP	RPM	BHP	RPM	BHP	RPM	BHP	RPM	BHP	
Standard Motor																					
2400	—	—	—	—	—	—	—	—	—	—	—	—	713	1.09	737	1.21	760	1.37	785	1.52	
2700	—	—	—	—	—	—	—	—	—	—	730	1.35	754	1.48	778	1.60	801	1.73	827	1.85	
3000	—	—	—	—	—	—	722	1.34	747	1.46	773	1.58	796	1.70	820	1.83	844	1.95	875	2.11	
3300	—	—	—	—	736	1.45	761	1.58	788	1.72	815	1.86	841	1.98	873	2.15	895	2.27	918	2.40	
External Static Pressure (Inches of Water)																					
CFM	1.1		1.2		1.3		1.4		1.5		1.6		1.7		1.8		1.9		2.0		
	RPM	BHP	RPM	BHP	RPM	BHP	RPM	BHP	RPM	BHP	RPM	BHP	RPM	BHP	RPM	BHP	RPM	BHP	RPM	BHP	
Standard Motor						High Static (oversize) Motor															
2400	811	1.68	835	1.85	866	1.97	889	2.15	912	2.26	936	2.37	961	2.49	983	2.59	1008	2.70	1032	2.80	
2700	853	1.97	884	2.13	909	2.25	933	2.36	956	2.47	979	2.59	1002	2.71	1025	2.81	1048	2.91	1071	3.02	
3000	897	2.22	920	2.34	945	2.45	968	2.57	991	2.68	1014	2.79	1038	2.89	1061	3.00	—	—	—	—	
3300	942	2.53	966	2.67	989	2.79	1011	2.91	1037	3.02	—	—	—	—	—	—	—	—	—	—	



Performance Data

Table 12. Belt drive evaporator fan performance - 7.5 tons with high gas heat - GCC90A(3,4)EH - downflow airflow

External Static Pressure (Inches of Water)																					
CFM	0.1		0.2		0.3		0.4		0.5		0.6		0.7		0.8		0.9		1.0		
	RPM	BHP	RPM	BHP	RPM	BHP	RPM	BHP	RPM	BHP	RPM	BHP	RPM	BHP	RPM	BHP	RPM	BHP	RPM	BHP	
Standard Motor																					
2400	—	—	—	—	—	—	—	—	—	—	—	—	—	—	733	1.17	756	1.32	781	1.47	
2700	—	—	—	—	—	—	—	—	—	—	726	1.30	750	1.43	774	1.55	797	1.68	823	1.80	
3000	—	—	—	—	—	—	718	1.30	743	1.41	760	1.45	792	1.66	816	1.78	840	1.90	871	2.06	
3300	—	—	—	—	732	1.41	752	1.46	784	1.68	811	1.82	837	1.94	869	2.10	891	2.22	913	2.35	
External Static Pressure (Inches of Water)																					
CFM	1.1		1.2		1.3		1.4		1.5		1.6		1.7		1.8		1.9		2.0		
	RPM	BHP	RPM	BHP	RPM	BHP	RPM	BHP	RPM	BHP	RPM	BHP	RPM	BHP	RPM	BHP	RPM	BHP	RPM	BHP	
Standard Motor					High Static (oversize) Motor																
2400	807	1.63	831	1.80	862	1.96	884	2.08	907	2.19	931	2.30	956	2.42	978	2.52	1003	2.63	1027	2.73	
2700	849	1.92	879	2.08	904	2.18	928	2.29	951	2.41	974	2.52	997	2.63	1020	2.74	1043	2.84	1066	2.95	
3000	893	2.17	915	2.29	940	2.39	963	2.51	986	2.62	1009	2.73	1033	2.82	1056	2.93	1078	3.05	—	—	
3300	937	2.48	961	2.61	984	2.73	1006	2.85	1032	2.96	1055	3.07	—	—	—	—	—	—	—	—	

Table 13. Belt drive evaporator fan performance - 7.5 tons with high gas heat - GCC90A(3,4)EH - horizontal airflow

External Static Pressure (Inches of Water)																					
CFM	0.1		0.2		0.3		0.4		0.5		0.6		0.7		0.8		0.9		1.0		
	RPM	BHP	RPM	BHP	RPM	BHP	RPM	BHP	RPM	BHP	RPM	BHP	RPM	BHP	RPM	BHP	RPM	BHP	RPM	BHP	
Standard Motor																					
2400	—	—	—	—	—	—	—	—	—	—	—	—	723	1.15	747	1.27	770	1.43	795	1.58	
2700	—	—	—	—	—	—	—	—	716	1.29	740	1.41	764	1.54	788	1.66	811	1.79	837	1.91	
3000	—	—	—	—	—	—	732	1.40	757	1.52	783	1.64	806	1.76	830	1.89	854	2.01	885	2.17	
3300	—	—	—	—	746	1.51	771	1.64	798	1.78	825	1.92	851	2.04	883	2.21	905	2.33	928	2.46	
External Static Pressure (Inches of Water)																					
CFM	1.1		1.2		1.3		1.4		1.5		1.6		1.7		1.8		1.9		2.0		
	RPM	BHP	RPM	BHP	RPM	BHP	RPM	BHP	RPM	BHP	RPM	BHP	RPM	BHP	RPM	BHP	RPM	BHP	RPM	BHP	
Standard Motor					High Static (oversize) Motor																
2400	821	1.74	845	1.91	876	2.09	899	2.21	922	2.32	946	2.43	971	2.55	993	2.65	1018	2.76	1042	2.86	
2700	863	2.03	894	2.19	919	2.31	943	2.42	966	2.53	989	2.65	1012	2.77	1035	2.87	1058	2.97	1081	3.08	
3000	907	2.28	930	2.40	955	2.51	978	2.63	1001	2.74	1024	2.85	1048	2.95	1071	3.06	—	—	—	—	
3300	952	2.59	976	2.73	999	2.85	1021	2.97	1047	3.08	—	—	—	—	—	—	—	—	—	—	

Table 14. Belt drive evaporator fan performance - 7.5 tons cooling only - ECC150A(3,4)E0 - downflow airflow

External Static Pressure (Inches of Water)																					
CFM	0.1		0.2		0.3		0.4		0.5		0.6		0.7		0.8		0.9		1.0		
	RPM	BHP	RPM	BHP	RPM	BHP	RPM	BHP	RPM	BHP	RPM	BHP	RPM	BHP	RPM	BHP	RPM	BHP	RPM	BHP	
Standard Motor																					
2400	—	—	—	—	—	—	—	—	—	—	—	—	—	—	—	—	—	714	1.05	739	1.20
2700	—	—	—	—	—	—	—	—	—	—	—	—	—	—	—	732	1.27	755	1.40	781	1.52
3000	—	—	—	—	—	—	—	—	—	—	727	1.26	750	1.38	774	1.50	799	1.62	828	1.75	
3300	—	—	—	—	—	—	715	1.26	742	1.40	769	1.53	794	1.65	826	1.79	848	1.95	871	2.08	
External Static Pressure (Inches of Water)																					
CFM	1.1		1.2		1.3		1.4		1.5		1.6		1.7		1.8		1.9		2.0		
	RPM	BHP	RPM	BHP	RPM	BHP	RPM	BHP	RPM	BHP	RPM	BHP	RPM	BHP	RPM	BHP	RPM	BHP	RPM	BHP	
Standard Motor									High Static (oversize) Motor												
2400	765	1.35	789	1.51	820	1.64	843	1.76	866	1.93	889	2.03	914	2.15	936	2.25	961	2.36	985	2.46	
2700	800	1.58	837	1.77	862	1.92	886	2.03	909	2.14	932	2.25	955	2.37	978	2.47	1001	2.57	1024	2.68	
3000	850	1.87	873	2.02	898	2.12	921	2.24	944	2.35	967	2.46	991	2.56	1014	2.66	1038	2.77	1060	2.89	
3300	895	2.20	919	2.34	942	2.46	964	2.58	990	2.68	1013	2.78	1038	2.89	1051	3.01	—	—	—	—	

Table 15. Belt drive evaporator fan performance - 7.5 tons cooling only - ECC150A(3,4)E0 - horizontal airflow

External Static Pressure (Inches of Water)																				
CFM	0.1		0.2		0.3		0.4		0.5		0.6		0.7		0.8		0.9		1.0	
	RPM	BHP	RPM	BHP	RPM	BHP	RPM	BHP	RPM	BHP	RPM	BHP	RPM	BHP	RPM	BHP	RPM	BHP	RPM	BHP
Standard Motor																				
2400	—	—	—	—	—	—	—	—	—	—	—	—	—	—	—	—	728	1.15	753	1.30
2700	—	—	—	—	—	—	—	—	—	—	—	—	722	1.26	746	1.38	769	1.51	795	1.63
3000	—	—	—	—	—	—	—	—	715	1.24	741	1.36	764	1.48	788	1.61	812	1.73	843	1.85
3300	—	—	—	—	—	—	729	1.36	756	1.50	783	1.64	809	1.76	841	1.89	863	2.05	886	2.18
External Static Pressure (Inches of Water)																				
CFM	1.1		1.2		1.3		1.4		1.5		1.6		1.7		1.8		1.9		2.0	
	RPM	BHP	RPM	BHP	RPM	BHP	RPM	BHP	RPM	BHP	RPM	BHP	RPM	BHP	RPM	BHP	RPM	BHP	RPM	BHP
Standard Motor									High Static (oversize) Motor											
2400	779	1.46	803	1.63	834	1.75	857	1.87	880	2.04	904	2.15	929	2.27	951	2.37	976	2.48	1000	2.58
2700	821	1.75	852	1.88	877	2.03	901	2.14	924	2.25	947	2.37	970	2.49	993	2.59	1016	2.69	1039	2.80
3000	865	1.97	888	2.12	913	2.23	936	2.35	959	2.46	982	2.57	1006	2.67	1029	2.78	1053	2.89	1075	3.01
3300	910	2.31	934	2.45	957	2.57	979	2.69	1005	2.80	1028	2.90	1053	3.01	—	—	—	—	—	—



Performance Data

8.5 Tons

Table 16. Belt drive evaporator fan performance - 8.5 tons with low gas heat - GCC102A(3,4)EL - downflow airflow

External Static Pressure (Inches of Water)																					
CFM	0.1		0.2		0.3		0.4		0.5		0.6		0.7		0.8		0.9		1.0		
	RPM	BHP	RPM	BHP	RPM	BHP	RPM	BHP	RPM	BHP	RPM	BHP	RPM	BHP	RPM	BHP	RPM	BHP	RPM	BHP	
Standard Motor																					
2700	—	—	—	—	—	—	—	—	—	—	752	1.17	779	1.34	804	1.50	830	1.66	855	1.82	
3050	—	—	—	—	—	—	—	—	—	745	1.18	771	1.35	796	1.52	820	1.69	845	1.86	878	2.18
3400	—	—	—	—	748	1.29	773	1.44	797	1.59	821	1.77	845	1.94	876	2.29	898	2.46	920	2.62	
3750	747	1.45	773	1.62	799	1.78	824	1.95	847	2.12	875	2.45	897	2.61	919	2.75	941	2.91	963	3.05	
External Static Pressure (Inches of Water)																					
CFM	1.1		1.2		1.3		1.4		1.5		1.6		1.7		1.8		1.9		2.0		
	RPM	BHP	RPM	BHP	RPM	BHP	RPM	BHP	RPM	BHP	RPM	BHP	RPM	BHP	RPM	BHP	RPM	BHP	RPM	BHP	
Standard Motor																					
High Static (oversize) Motor																					
2700	878	1.95	910	2.21	932	2.30	954	2.43	977	2.57	999	2.70	1021	2.82	1043	2.96	1065	3.09	1087	3.21	
3050	900	2.34	922	2.49	944	2.60	966	2.72	988	2.85	1010	2.95	1032	3.04	1054	3.14	1076	3.22	1098	3.30	
3400	942	2.77	964	2.89	986	3.00	1008	3.09	1025	3.20	1051	3.30	1072	3.39	1095	3.47	1117	3.55	1140	3.66	
3750	985	3.20	1007	3.31	1029	3.41	1051	3.52	1071	3.63	1092	3.71	1116	3.82	1135	3.91	1158	4.01	1181	4.08	

Table 17. Belt drive evaporator fan performance - 8.5 tons with low gas heat - GCC102A(3,4)EL - horizontal airflow

External Static Pressure (Inches of Water)																					
CFM	0.1		0.2		0.3		0.4		0.5		0.6		0.7		0.8		0.9		1.0		
	RPM	BHP	RPM	BHP	RPM	BHP	RPM	BHP	RPM	BHP	RPM	BHP	RPM	BHP	RPM	BHP	RPM	BHP	RPM	BHP	
Standard Motor																					
2700	—	—	—	—	—	—	—	—	—	—	—	—	742	1.25	766	1.40	790	1.55	814	1.70	
3050	—	—	—	—	—	—	—	—	—	—	734	1.26	758	1.42	781	1.58	805	1.74	836	2.04	
3400	—	—	—	—	—	—	736	1.35	759	1.49	782	1.65	805	1.81	834	2.14	855	2.30	876	2.45	
3750	—	—	736	1.51	761	1.66	785	1.82	807	1.98	833	2.29	854	2.44	875	2.57	896	2.72	917	2.85	
External Static Pressure (Inches of Water)																					
CFM	1.1		1.2		1.3		1.4		1.5		1.6		1.7		1.8		1.9		2.0		
	RPM	BHP	RPM	BHP	RPM	BHP	RPM	BHP	RPM	BHP	RPM	BHP	RPM	BHP	RPM	BHP	RPM	BHP	RPM	BHP	
Standard Motor																					
High Static (oversize) Motor																					
2700	836	1.82	867	2.07	888	2.15	909	2.27	930	2.40	951	2.52	972	2.64	993	2.77	1014	2.89	1035	3.00	
3050	857	2.19	878	2.33	899	2.43	920	2.54	941	2.66	962	2.76	983	2.84	1004	2.93	1025	3.01	1046	3.08	
3400	897	2.59	918	2.70	939	2.80	962	2.89	983	2.99	1001	3.08	1022	3.17	1042	3.24	1068	3.32	1084	3.42	
3750	938	2.99	959	3.09	980	3.19	1002	3.29	1022	3.39	1042	3.47	1063	3.57	1081	3.65	1103	3.75	1123	3.81	

Table 18. Belt drive evaporator fan performance - 8.5 tons with med gas heat - GCC102A(3,4)EM- downflow airflow

External Static Pressure (Inches of Water)																				
CFM	0.1		0.2		0.3		0.4		0.5		0.6		0.7		0.8		0.9		1.0	
	RPM	BHP	RPM	BHP	RPM	BHP	RPM	BHP	RPM	BHP	RPM	BHP	RPM	BHP	RPM	BHP	RPM	BHP	RPM	BHP
Standard Motor																				
2700	—	—	—	—	—	—	—	—	735	1.21	762	1.36	789	1.52	814	1.68	839	1.83	863	1.98
3050	—	—	—	—	—	—	—	—	771	1.35	796	1.52	820	1.69	845	1.86	878	2.18	900	2.34
3400	—	—	732	1.33	758	1.47	783	1.63	807	1.77	830	1.93	862	2.18	884	2.43	906	2.59	927	2.74
3750	755	1.64	783	1.79	809	1.94	833	2.11	861	2.43	883	2.58	904	2.73	926	2.87	948	3.02	969	3.15
External Static Pressure (Inches of Water)																				
CFM	1.1		1.2		1.3		1.4		1.5		1.6		1.7		1.8		1.9		2.0	
	RPM	BHP	RPM	BHP	RPM	BHP	RPM	BHP	RPM	BHP	RPM	BHP	RPM	BHP	RPM	BHP	RPM	BHP	RPM	BHP
Standard Motor																				
High Static (oversize) Motor																				
2700	896	2.19	918	2.36	939	2.44	961	2.56	983	2.69	1004	2.82	1026	2.94	1048	3.07	1069	3.19	1091	3.30
3050	922	2.49	944	2.60	966	2.72	988	2.85	1010	2.95	1032	3.04	1054	3.14	1076	3.22	1098	3.30	1102	3.38
3400	949	2.89	970	3.00	992	3.10	1014	3.19	1035	3.29	1057	3.38	1078	3.47	1100	3.55	1122	3.63	1143	3.73
3750	991	3.29	1013	3.40	1034	3.50	1056	3.60	1077	3.70	1099	3.78	1121	3.88	1142	3.96	1164	4.05	1185	4.13

Table 19. Belt drive evaporator fan performance - 8.5 tons with med gas heat - GCC102A(3,4)EM- horizontal airflow

External Static Pressure (Inches of Water)																				
CFM	0.1		0.2		0.3		0.4		0.5		0.6		0.7		0.8		0.9		1.0	
	RPM	BHP	RPM	BHP	RPM	BHP	RPM	BHP	RPM	BHP	RPM	BHP	RPM	BHP	RPM	BHP	RPM	BHP	RPM	BHP
Standard Motor																				
2700	—	—	—	—	—	—	—	—	—	—	—	—	752	1.42	775	1.57	799	1.71	822	1.85
3050	—	—	—	—	—	—	—	—	—	—	744	1.43	767	1.59	790	1.74	823	2.02	844	2.18
3400	—	—	—	—	—	—	746	1.52	768	1.65	791	1.81	821	2.04	842	2.27	862	2.42	883	2.57
3750	—	—	746	1.67	770	1.81	794	1.98	820	2.27	841	2.41	861	2.56	882	2.68	903	2.82	923	2.94
External Static Pressure (Inches of Water)																				
CFM	1.1		1.2		1.3		1.4		1.5		1.6		1.7		1.8		1.9		2.0	
	RPM	BHP	RPM	BHP	RPM	BHP	RPM	BHP	RPM	BHP	RPM	BHP	RPM	BHP	RPM	BHP	RPM	BHP	RPM	BHP
Standard Motor																				
High Static (oversize) Motor																				
2700	854	2.05	874	2.20	895	2.28	915	2.39	936	2.52	956	2.63	977	2.75	998	2.87	1018	2.98	1039	3.09
3050	864	2.32	885	2.45	906	2.55	926	2.65	947	2.76	967	2.86	988	2.94	1008	3.02	1029	3.10	1050	3.16
3400	904	2.70	924	2.80	945	2.90	965	2.98	986	3.08	1006	3.16	1027	3.24	1048	3.32	1068	3.39	1089	3.49
3750	944	3.08	964	3.17	985	3.27	1005	3.36	1026	3.46	1047	3.53	1067	3.63	1088	3.70	1108	3.78	1129	3.86



Performance Data

Table 20. Belt drive evaporator fan performance - 8.5 tons with high gas heat - GCC102A(3,4)EH - downflow airflow

External Static Pressure (Inches of Water)																				
CFM	0.1		0.2		0.3		0.4		0.5		0.6		0.7		0.8		0.9		1.0	
	RPM	BHP	RPM	BHP	RPM	BHP	RPM	BHP	RPM	BHP	RPM	BHP	RPM	BHP	RPM	BHP	RPM	BHP	RPM	BHP
Standard Motor																				High Static (oversize) Motor
2700	—	—	—	—	—	—	—	—	753	1.28	780	1.44	805	1.61	831	1.77	856	1.93	881	2.09
3050	—	—	—	—	—	—	742	1.35	774	1.47	797	1.62	822	1.79	846	1.96	882	2.28	904	2.45
3400	—	—	744	1.44	775	1.57	799	1.71	823	1.86	847	2.03	880	2.39	902	2.56	924	2.73	946	2.89
3750	773	1.72	799	1.88	825	2.04	851	2.23	879	2.56	901	2.72	923	2.88	945	3.02	967	3.18	989	3.32
External Static Pressure (Inches of Water)																				
CFM	1.1		1.2		1.3		1.4		1.5		1.6		1.7		1.8		1.9		2.0	
	RPM	BHP	RPM	BHP	RPM	BHP	RPM	BHP	RPM	BHP	RPM	BHP	RPM	BHP	RPM	BHP	RPM	BHP	RPM	BHP
High Static (oversize) Motor																				
2700	915	2.33	937	2.48	959	2.57	981	2.70	1003	2.84	1025	2.96	1047	3.09	1069	3.23	1091	3.36	1113	3.48
3050	926	2.61	948	2.76	970	2.87	992	2.99	1014	3.11	1036	3.22	1058	3.31	1080	3.40	1103	3.49	1125	3.56
3400	968	3.04	990	3.16	1012	3.26	1034	3.36	1056	3.47	1078	3.56	1100	3.65	1122	3.73	1145	3.82	1167	3.93
3750	1011	3.47	1033	3.57	1055	3.68	1077	3.79	1099	3.89	1121	3.98	1143	4.09	1166	4.17	1188	4.26	1210	4.34

Table 21. Belt drive evaporator fan performance - 8.5 tons with high gas heat - GCC102A(3,4)EH - horizontal airflow

External Static Pressure (Inches of Water)																				
CFM	0.1		0.2		0.3		0.4		0.5		0.6		0.7		0.8		0.9		1.0	
	RPM	BHP	RPM	BHP	RPM	BHP	RPM	BHP	RPM	BHP	RPM	BHP	RPM	BHP	RPM	BHP	RPM	BHP	RPM	BHP
Standard Motor																				
2700	—	—	—	—	—	—	—	—	—	—	743	1.35	767	1.50	791	1.65	815	1.80	839	1.95
3050	—	—	—	—	—	—	—	—	737	1.37	759	1.51	783	1.67	806	1.83	840	2.13	861	2.29
3400	—	—	—	—	738	1.47	761	1.60	784	1.74	807	1.90	838	2.23	859	2.39	880	2.55	901	2.70
3750	736	1.61	761	1.76	786	1.91	810	2.08	837	2.39	858	2.54	879	2.69	900	2.82	921	2.97	942	3.10
External Static Pressure (Inches of Water)																				
CFM	1.1		1.2		1.3		1.4		1.5		1.6		1.7		1.8		1.9		2.0	
	RPM	BHP	RPM	BHP	RPM	BHP	RPM	BHP	RPM	BHP	RPM	BHP	RPM	BHP	RPM	BHP	RPM	BHP	RPM	BHP
High Static (oversize) Motor																				
2700	871	2.18	892	2.32	913	2.40	934	2.52	955	2.65	976	2.77	997	2.89	1018	3.02	1039	3.14	1060	3.25
3050	882	2.44	903	2.58	924	2.68	945	2.79	966	2.91	987	3.01	1008	3.09	1029	3.18	1050	3.26	1071	3.33
3400	922	2.84	943	2.95	964	3.05	985	3.14	1006	3.24	1027	3.33	1048	3.41	1069	3.49	1090	3.57	1111	3.67
3750	963	3.24	984	3.34	1005	3.44	1026	3.54	1047	3.64	1068	3.72	1089	3.82	1110	3.90	1131	3.98	1152	4.06

Table 22. Belt drive evaporator fan performance - 8.5 tons cooling only - ECC102A(3,4)E0 - downflow airflow

External Static Pressure (Inches of Water)																				
CFM	0.1		0.2		0.3		0.4		0.5		0.6		0.7		0.8		0.9		1.0	
	RPM	BHP	RPM	BHP	RPM	BHP	RPM	BHP	RPM	BHP	RPM	BHP	RPM	BHP	RPM	BHP	RPM	BHP	RPM	BHP
Standard Motor																				
2700	—	—	—	—	—	—	—	—	—	—	—	—	745	1.14	763	1.31	788	1.45	810	1.59
3050	—	—	—	—	—	—	—	—	732	1.22	753	1.38	775	1.49	799	1.64	819	1.80	840	1.94
3400	—	—	—	—	—	—	745	1.39	766	1.56	794	1.71	817	1.87	842	2.03	866	2.20	892	2.46
3750	—	—	733	1.52	756	1.67	784	1.81	801	1.93	828	2.09	853	2.25	877	2.52	902	2.68	927	2.82
External Static Pressure (Inches of Water)																				
CFM	1.1		1.2		1.3		1.4		1.5		1.6		1.7		1.8		1.9		2.0	
	RPM	BHP	RPM	BHP	RPM	BHP	RPM	BHP	RPM	BHP	RPM	BHP	RPM	BHP	RPM	BHP	RPM	BHP	RPM	BHP
Standard Motor					High Static (oversize) Motor															
2700	828	1.75	848	1.91	876	2.08	899	2.34	921	2.46	945	2.57	968	2.68	992	2.78	1016	2.88	1039	2.98
3050	867	2.22	890	2.35	915	2.47	934	2.59	958	2.70	980	2.80	1005	2.91	1028	3.01	1052	3.11	1073	3.20
3400	918	2.61	939	2.73	960	2.85	986	2.97	1008	3.08	1031	3.17	1050	3.27	1073	3.37	1090	3.47	1113	3.56
3750	951	2.95	974	3.08	994	3.19	1011	3.31	1035	3.42	1054	3.53	1076	3.63	1096	3.73	1120	3.83	1138	3.93

Table 23. Belt drive evaporator fan performance - 8.5 tons cooling only - ECC102A(3,4)E0 - horizontal airflow

External Static Pressure (Inches of Water)																				
CFM	0.1		0.2		0.3		0.4		0.5		0.6		0.7		0.8		0.9		1.0	
	RPM	BHP	RPM	BHP	RPM	BHP	RPM	BHP	RPM	BHP	RPM	BHP	RPM	BHP	RPM	BHP	RPM	BHP	RPM	BHP
Standard Motor																				
2700	—	—	—	—	—	—	—	—	—	—	—	—	—	—	741	1.25	765	1.38	786	1.52
3050	—	—	—	—	—	—	—	—	—	—	731	1.31	752	1.42	776	1.56	795	1.71	816	1.85
3400	—	—	—	—	—	—	—	—	744	1.49	771	1.63	793	1.78	817	1.93	841	2.09	866	2.34
3750	—	—	—	—	734	1.59	761	1.72	778	1.84	804	1.99	828	2.14	851	2.40	876	2.55	900	2.69
External Static Pressure (Inches of Water)																				
CFM	1.1		1.2		1.3		1.4		1.5		1.6		1.7		1.8		1.9		2.0	
	RPM	BHP	RPM	BHP	RPM	BHP	RPM	BHP	RPM	BHP	RPM	BHP	RPM	BHP	RPM	BHP	RPM	BHP	RPM	BHP
Standard Motor					High Static (oversize) Motor															
2700	804	1.66	823	1.82	845	1.98	873	2.23	894	2.34	917	2.45	940	2.55	963	2.65	986	2.74	1009	2.84
3050	842	2.11	864	2.24	888	2.35	907	2.46	930	2.57	951	2.67	976	2.77	998	2.86	1021	2.96	1042	3.05
3400	891	2.48	912	2.60	932	2.72	957	2.83	979	2.93	1001	3.02	1019	3.12	1042	3.21	1058	3.30	1081	3.39
3750	923	2.81	946	2.93	965	3.04	982	3.15	1005	3.26	1023	3.36	1045	3.46	1064	3.55	1087	3.65	1105	3.74



Performance Data

10 Tons

Table 24. Belt drive evaporator fan performance - 10 tons with low gas heat - GCC120A(3,4)EL - downflow airflow

External Static Pressure (Inches of Water)																				
CFM	0.1		0.2		0.3		0.4		0.5		0.6		0.7		0.8		0.9		1.0	
	RPM	BHP	RPM	BHP	RPM	BHP	RPM	BHP	RPM	BHP	RPM	BHP	RPM	BHP	RPM	BHP	RPM	BHP	RPM	BHP
Standard Motor																				
3200	—	—	—	—	—	—	—	—	737	1.34	761	1.49	785	1.64	809	1.79	833	1.94	857	2.09
3600	—	—	—	—	739	1.46	760	1.58	782	1.72	804	1.86	828	2.02	851	2.18	875	2.34	906	2.64
4000	737	1.59	760	1.71	782	1.86	805	1.99	828	2.13	851	2.29	874	2.45	903	2.78	924	2.94	945	3.09
4400	780	2.03	805	2.18	830	2.33	854	2.49	876	2.65	902	2.96	923	3.11	944	3.24	965	3.39	986	3.52
External Static Pressure (Inches of Water)																				
CFM	1.1		1.2		1.3		1.4		1.5		1.6		1.7		1.8		1.9		2.0	
	RPM	BHP	RPM	BHP	RPM	BHP	RPM	BHP	RPM	BHP	RPM	BHP	RPM	BHP	RPM	BHP	RPM	BHP	RPM	BHP
High Static (oversize) Motor																				
3200	879	2.21	910	2.46	931	2.54	952	2.66	973	2.79	994	2.91	1015	3.03	1036	3.16	1057	3.28	1078	3.39
3600	927	2.79	948	2.93	969	3.03	990	3.14	1011	3.26	1032	3.36	1053	3.44	1074	3.53	1095	3.61	1116	3.68
4000	966	3.23	987	3.34	1008	3.44	1031	3.53	1052	3.63	1072	3.72	1093	3.81	1116	3.88	1137	3.96	1159	4.06
4400	1007	3.66	1028	3.76	1049	3.86	1071	3.96	1092	4.06	1113	4.14	1135	4.24	1156	4.32	1178	4.42	1201	4.48

Table 25. Belt drive evaporator fan performance - 10 tons with low gas heat - GCC120A(3,4)EL - horizontal airflow

External Static Pressure (Inches of Water)																				
CFM	0.1		0.2		0.3		0.4		0.5		0.6		0.7		0.8		0.9		1.0	
	RPM	BHP	RPM	BHP	RPM	BHP	RPM	BHP	RPM	BHP	RPM	BHP	RPM	BHP	RPM	BHP	RPM	BHP	RPM	BHP
Standard Motor																				
3200	—	—	—	—	—	—	729	1.36	753	1.51	777	1.66	801	1.81	825	1.96	849	2.11	873	2.26
3600	—	—	733	1.52	755	1.62	776	1.75	798	1.89	820	2.03	844	2.19	867	2.35	891	2.53	922	2.81
4000	753	1.76	776	1.88	798	2.02	821	2.16	844	2.31	867	2.45	892	2.61	919	2.95	940	3.11	961	3.26
4400	796	2.21	821	2.35	846	2.51	866	2.67	887	2.84	918	3.13	939	3.28	960	3.42	981	3.56	1002	3.69
External Static Pressure (Inches of Water)																				
CFM	1.1		1.2		1.3		1.4		1.5		1.6		1.7		1.8		1.9		2.0	
	RPM	BHP	RPM	BHP	RPM	BHP	RPM	BHP	RPM	BHP	RPM	BHP	RPM	BHP	RPM	BHP	RPM	BHP	RPM	BHP
High Static (oversize) Motor																				
3200	905	2.49	926	2.61	947	2.72	968	2.83	989	2.96	1010	3.08	1031	3.2	1052	3.33	1073	3.45	1094	3.56
3600	943	2.96	964	3.09	985	3.22	1006	3.32	1027	3.43	1048	3.53	1069	3.62	1090	3.69	1111	3.78	1132	3.85
4000	982	3.39	1003	3.51	1024	3.61	1045	3.69	1066	3.81	1087	3.89	1108	3.97	1129	4.05	1150	4.13	1171	4.22
4400	1023	3.82	1044	3.93	1065	4.03	1086	4.13	1107	4.23	1128	4.32	1149	4.41	1170	4.49	1191	4.57	1212	4.65

Table 26. Belt drive evaporator fan performance - 10 tons with med gas heat - GCC120A(3,4)EM- downflow airflow

External Static Pressure (Inches of Water)																				
CFM	0.1		0.2		0.3		0.4		0.5		0.6		0.7		0.8		0.9		1.0	
	RPM	BHP	RPM	BHP	RPM	BHP	RPM	BHP	RPM	BHP	RPM	BHP	RPM	BHP	RPM	BHP	RPM	BHP	RPM	BHP
Standard Motor																				
3200	—	—	—	—	—	—	738	1.44	762	1.59	786	1.74	810	1.89	834	2.04	858	2.19	882	2.34
3600	—	—	742	1.59	764	1.71	785	1.83	807	1.97	829	2.11	853	2.27	876	2.43	910	2.73	931	2.89
4000	762	1.84	785	1.96	807	2.11	830	2.24	853	2.38	876	2.54	907	2.87	928	3.03	949	3.19	970	3.34
4400	805	2.28	830	2.43	855	2.58	879	2.75	906	3.06	927	3.21	948	3.36	969	3.49	990	3.64	1011	3.77
External Static Pressure (Inches of Water)																				
CFM	1.1		1.2		1.3		1.4		1.5		1.6		1.7		1.8		1.9		2.0	
	RPM	BHP	RPM	BHP	RPM	BHP	RPM	BHP	RPM	BHP	RPM	BHP	RPM	BHP	RPM	BHP	RPM	BHP	RPM	BHP
High Static (oversize) Motor																				
3200	914	2.57	935	2.71	956	2.79	977	2.91	998	3.04	1019	3.16	1040	3.28	1061	3.41	1082	3.53	1103	3.64
3600	952	3.04	973	3.18	994	3.28	1015	3.39	1036	3.51	1057	3.61	1078	3.69	1099	3.78	1120	3.86	1141	3.93
4000	991	3.48	1012	3.59	1033	3.69	1054	3.78	1075	3.88	1096	3.97	1117	4.05	1138	4.13	1159	4.21	1180	4.31
4400	1032	3.91	1053	4.01	1074	4.11	1095	4.21	1116	4.31	1137	4.39	1158	4.49	1179	4.57	1200	4.65	1221	4.73

Table 27. Belt drive evaporator fan performance - 10 tons with med gas heat - GCC120A(3,4)EM - horizontal airflow

External Static Pressure (Inches of Water)																				
CFM	0.1		0.2		0.3		0.4		0.5		0.6		0.7		0.8		0.9		1.0	
	RPM	BHP	RPM	BHP	RPM	BHP	RPM	BHP	RPM	BHP	RPM	BHP	RPM	BHP	RPM	BHP	RPM	BHP	RPM	BHP
Standard Motor																				
3200	—	—	—	—	—	—	754	1.62	778	1.77	802	1.92	826	2.07	850	2.22	874	2.37	898	2.52
3600	736	1.67	758	1.78	780	1.88	801	2.01	823	2.15	845	2.29	869	2.45	892	2.61	926	2.91	947	3.07
4000	778	2.02	801	2.14	823	2.28	846	2.42	869	2.56	902	2.88	923	3.05	944	3.21	965	3.37	986	3.52
4400	821	2.46	846	2.61	871	2.76	901	3.08	922	3.24	943	3.39	964	3.54	985	3.68	1006	3.82	1027	3.95
External Static Pressure (Inches of Water)																				
CFM	1.1		1.2		1.3		1.4		1.5		1.6		1.7		1.8		1.9		2.0	
	RPM	BHP	RPM	BHP	RPM	BHP	RPM	BHP	RPM	BHP	RPM	BHP	RPM	BHP	RPM	BHP	RPM	BHP	RPM	BHP
High Static (oversize) Motor																				
3200	930	2.75	951	2.88	972	2.98	993	3.09	1014	3.22	1035	3.34	1056	3.46	1077	3.59	1098	3.71	1119	3.82
3600	968	3.22	989	3.35	1010	3.47	1031	3.58	1052	3.69	1073	3.79	1094	3.88	1115	3.96	1136	4.04	1157	4.11
4000	1007	3.66	1028	3.77	1049	3.87	1070	3.96	1091	4.06	1112	4.15	1133	4.23	1154	4.31	1175	4.39	1196	4.48
4400	1048	4.08	1069	4.19	1090	4.29	1111	4.39	1132	4.49	1153	4.58	1174	4.67	1195	4.75	1216	4.83	1237	4.91



Performance Data

Table 28. Belt drive evaporator fan performance - 10 tons with high gas heat - GCC120A(3,4)EH - downflow airflow

CFM	0.1		0.2		0.3		0.4		0.5		0.6		0.7		0.8		0.9		1.0	
	RPM	BHP	RPM	BHP	RPM	BHP	RPM	BHP	RPM	BHP	RPM	BHP	RPM	BHP	RPM	BHP	RPM	BHP	RPM	BHP
Standard Motor																				
3200	—	—	—	—	—	—	738	1.44	762	1.59	786	1.74	810	1.89	834	2.04	858	2.19	882	2.34
3600	—	—	742	1.59	764	1.71	785	1.83	807	1.97	829	2.11	853	2.27	876	2.43	910	2.73	931	2.89
4000	762	1.84	785	1.96	807	2.11	830	2.24	853	2.38	876	2.54	907	2.87	928	3.03	949	3.19	970	3.34
4400	805	2.28	830	2.43	855	2.58	879	2.75	906	3.06	927	3.21	948	3.36	969	3.49	990	3.64	1011	3.77
CFM	1.1		1.2		1.3		1.4		1.5		1.6		1.7		1.8		1.9		2.0	
	RPM	BHP	RPM	BHP	RPM	BHP	RPM	BHP	RPM	BHP	RPM	BHP	RPM	BHP	RPM	BHP	RPM	BHP	RPM	BHP
High Static (oversize) Motor																				
3200	914	2.57	935	2.71	956	2.79	977	2.91	998	3.04	1019	3.16	1040	3.28	1061	3.41	1082	3.53	1103	3.64
3600	952	3.04	973	3.18	994	3.28	1015	3.39	1036	3.51	1057	3.61	1078	3.69	1099	3.78	1120	3.86	1141	3.93
4000	991	3.48	1012	3.59	1033	3.69	1054	3.78	1075	3.88	1096	3.97	1117	4.05	1138	4.13	1159	4.21	1180	4.31
4400	1032	3.91	1053	4.01	1074	4.11	1095	4.21	1116	4.31	1137	4.39	1158	4.49	1179	4.57	1200	4.65	1221	4.73

Table 29. Belt drive evaporator fan performance - 10 tons with high gas heat - GCC120A(3,4)EH - horizontal airflow

CFM	0.1		0.2		0.3		0.4		0.5		0.6		0.7		0.8		0.9		1.0	
	RPM	BHP	RPM	BHP	RPM	BHP	RPM	BHP	RPM	BHP	RPM	BHP	RPM	BHP	RPM	BHP	RPM	BHP	RPM	BHP
Standard Motor																				
3200	—	—	—	—	—	—	754	1.62	778	1.77	802	1.92	826	2.07	850	2.22	874	2.37	898	2.52
3600	736	1.67	758	1.78	780	1.88	801	2.01	823	2.15	845	2.29	869	2.45	892	2.61	926	2.91	947	3.07
4000	778	2.02	801	2.14	823	2.28	846	2.42	869	2.56	902	2.88	923	3.05	944	3.21	965	3.37	986	3.52
4400	821	2.46	846	2.61	871	2.76	901	3.08	922	3.24	943	3.39	964	3.54	985	3.68	1006	3.82	1027	3.95
CFM	1.1		1.2		1.3		1.4		1.5		1.6		1.7		1.8		1.9		2.0	
	RPM	BHP	RPM	BHP	RPM	BHP	RPM	BHP	RPM	BHP	RPM	BHP	RPM	BHP	RPM	BHP	RPM	BHP	RPM	BHP
High Static (oversize) Motor																				
3200	930	2.75	951	2.88	972	2.98	993	3.09	1014	3.22	1035	3.34	1056	3.46	1077	3.59	1098	3.71	1119	3.82
3600	968	3.22	989	3.35	1010	3.47	1031	3.58	1052	3.69	1073	3.79	1094	3.88	1115	3.96	1136	4.04	1157	4.11
4000	1007	3.66	1028	3.77	1049	3.87	1070	3.96	1091	4.06	1112	4.15	1133	4.23	1154	4.31	1175	4.39	1196	4.48
4400	1048	4.08	1069	4.19	1090	4.29	1111	4.39	1132	4.49	1153	4.58	1174	4.67	1195	4.75	1216	4.83	1237	4.91

Table 30. Belt drive evaporator fan performance - 10 tons cooling only - ECC120A(3,4)E0 - downflow airflow

External Static Pressure (Inches of Water)																					
CFM	0.1		0.2		0.3		0.4		0.5		0.6		0.7		0.8		0.9		1.0		
	RPM	BHP	RPM	BHP	RPM	BHP	RPM	BHP	RPM	BHP	RPM	BHP	RPM	BHP	RPM	BHP	RPM	BHP	RPM	BHP	
Standard Motor																					
3200	—	—	—	—	—	—	—	—	—	—	—	—	758	1.55	782	1.69	807	1.84	833	2.01	
3600	—	—	—	—	—	—	—	—	736	1.55	770	1.83	798	1.95	820	2.09	845	2.26	870	2.41	
4000	—	—	—	—	—	—	752	1.85	782	2.06	809	2.21	836	2.37	860	2.54	882	2.71	914	2.99	
4400	—	—	745	2.08	772	2.19	799	2.34	825	2.47	852	2.63	876	2.79	909	3.08	934	3.24	958	3.39	
External Static Pressure (Inches of Water)																					
CFM	1.1		1.2		1.3		1.4		1.5		1.6		1.7		1.8		1.9		2.0		
	RPM	BHP	RPM	BHP	RPM	BHP	RPM	BHP	RPM	BHP	RPM	BHP	RPM	BHP	RPM	BHP	RPM	BHP	RPM	BHP	
Standard Motor											High Static (oversize) Motor										
3200	858	2.17	881	2.34	913	2.62	936	2.74	959	2.85	982	2.96	1005	3.07	1028	3.17	1051	3.27	1074	3.37	
3600	896	2.59	926	2.84	949	2.96	972	3.08	995	3.19	1018	3.3	1041	3.41	1064	3.51	1087	3.61	1110	3.71	
4000	939	3.14	962	3.27	985	3.39	1008	3.51	1031	3.62	1054	3.72	1077	3.82	1100	3.92	1123	4.02	1146	4.12	
4400	981	3.52	1004	3.65	1027	3.77	1050	3.89	1073	3.99	1096	4.11	1119	4.22	1142	4.32	1165	4.42	1188	4.52	

Table 31. Belt drive evaporator fan performance - 10 tons cooling only - ECC120A(3,4)E0 - horizontal airflow

External Static Pressure (Inches of Water)																					
CFM	0.1		0.2		0.3		0.4		0.5		0.6		0.7		0.8		0.9		1.0		
	RPM	BHP	RPM	BHP	RPM	BHP	RPM	BHP	RPM	BHP	RPM	BHP	RPM	BHP	RPM	BHP	RPM	BHP	RPM	BHP	
Standard Motor																					
3200	—	—	—	—	—	—	—	—	—	—	747	1.61	774	1.73	798	1.87	823	2.02	849	2.18	
3600	—	—	—	—	—	—	—	—	752	1.73	786	2.01	814	2.13	836	2.28	861	2.44	886	2.59	
4000	—	—	—	—	742	1.85	768	2.03	798	2.24	825	2.39	852	2.55	876	2.72	898	2.89	930	3.16	
4400	735	2.17	761	2.26	788	2.38	815	2.52	841	2.65	868	2.81	892	2.97	925	3.25	950	3.41	974	3.56	
External Static Pressure (Inches of Water)																					
CFM	1.1		1.2		1.3		1.4		1.5		1.6		1.7		1.8		1.9		2.0		
	RPM	BHP	RPM	BHP	RPM	BHP	RPM	BHP	RPM	BHP	RPM	BHP	RPM	BHP	RPM	BHP	RPM	BHP	RPM	BHP	
Standard Motor											High Static (oversize) Motor										
3200	874	2.35	897	2.52	929	2.79	952	2.91	975	3.02	998	3.13	1021	3.24	1044	3.34	1067	3.44	1090	3.54	
3600	919	2.87	942	3.01	965	3.13	988	3.25	1011	3.36	1034	3.47	1057	3.58	1080	3.68	1103	3.78	1126	3.88	
4000	955	3.31	978	3.44	1001	3.56	1024	3.68	1047	3.79	1070	3.89	1093	3.99	1116	4.09	1139	4.19	1162	4.29	
4400	997	3.69	1020	3.82	1043	3.94	1066	4.06	1089	4.17	1112	4.28	1135	4.39	1158	4.49	1181	4.59	1204	4.69	



Performance Data

12.5 Tons

Table 32. Belt drive evaporator fan performance - 12.5 tons with low heat heat - GCC150A(3,4)EL - downflow airflow

External Static Pressure (Inches of Water)																					
CFM	0.1		0.2		0.3		0.4		0.5		0.6		0.7		0.8		0.9		1.0		
	RPM	BHP	RPM	BHP	RPM	BHP	RPM	BHP	RPM	BHP	RPM	BHP	RPM	BHP	RPM	BHP	RPM	BHP	RPM	BHP	
Standard Motor																					
4000	—	—	—	—	—	—	793	2.09	820	2.24	847	2.38	873	2.52	899	2.66	924	2.77	949	2.89	
4500	—	—	791	2.23	816	2.41	842	2.58	869	2.76	897	2.91	925	3.19	951	3.37	977	3.53	1002	3.69	
5000	822	2.56	848	2.76	874	2.93	899	3.26	924	3.41	950	3.59	976	3.77	1001	3.96	1028	4.11	1056	4.27	
5500	873	2.99	899	3.31	925	3.46	950	3.63	975	3.81	999	3.99	1024	4.17	1049	4.36	1075	4.53	1101	4.71	
External Static Pressure (Inches of Water)																					
CFM	1.1		1.2		1.3		1.4		1.5		1.6		1.7		1.8		1.9		2.0		
	RPM	BHP	RPM	BHP	RPM	BHP	RPM	BHP	RPM	BHP	RPM	BHP	RPM	BHP	RPM	BHP	RPM	BHP	RPM	BHP	
High Static (oversize) Motor																					
4000	973	3.12	997	3.26	1020	3.37	1043	3.48	1065	3.59	1087	3.73	1108	3.86	1129	3.97	1149	4.09	1169	4.18	
4500	1026	3.86	1050	4.01	1073	4.16	1095	4.31	1117	4.44	1141	4.56	1166	4.64	1191	4.72	1213	4.79	1235	4.86	
5000	1083	4.42	1109	4.57	1135	4.72	1160	4.87	1185	5.02	1212	5.18	1236	5.33	—	—	—	—	—	—	
5500	1125	4.89	1149	5.07	1181	5.22	1204	5.34	1228	5.49	—	—	—	—	—	—	—	—	—	—	

Table 33. Belt drive evaporator fan performance - 12.5 tons with low gas heat - GCC150A(3,4)EL - horizontal airflow

External Static Pressure (Inches of Water)																					
CFM	0.1		0.2		0.3		0.4		0.5		0.6		0.7		0.8		0.9		1.0		
	RPM	BHP	RPM	BHP	RPM	BHP	RPM	BHP	RPM	BHP	RPM	BHP	RPM	BHP	RPM	BHP	RPM	BHP	RPM	BHP	
Standard Motor																					
4000	—	—	—	—	773	2.03	801	2.18	828	2.33	855	2.47	881	2.61	907	2.74	932	2.86	957	2.98	
4500	—	—	799	2.32	824	2.51	850	2.67	877	2.84	905	3.02	933	3.28	959	3.46	985	3.62	1010	3.78	
5000	830	2.65	856	2.84	882	3.02	915	3.34	932	3.52	958	3.68	984	3.86	1009	4.04	1036	4.21	1064	4.36	
5500	881	3.08	916	3.41	937	3.54	958	3.72	983	3.89	1007	4.08	1032	4.26	1057	4.44	1083	4.62	1109	4.79	
External Static Pressure (Inches of Water)																					
CFM	1.1		1.2		1.3		1.4		1.5		1.6		1.7		1.8		1.9		2.0		
	RPM	BHP	RPM	BHP	RPM	BHP	RPM	BHP	RPM	BHP	RPM	BHP	RPM	BHP	RPM	BHP	RPM	BHP	RPM	BHP	
High Static (oversize) Motor																					
4000	981	3.21	1005	3.34	1028	3.46	1051	3.57	1073	3.68	1095	3.82	1116	3.94	1137	4.06	1157	4.18	1177	4.27	
4500	1034	3.94	1058	4.12	1081	4.25	1103	4.40	1125	4.53	1149	4.64	1174	4.73	1199	4.81	1221	4.88	1243	4.94	
5000	1091	4.51	1117	4.66	1143	4.81	1168	4.96	1193	5.11	1218	5.24	—	—	—	—	—	—	—	—	
5500	1133	4.98	1157	5.16	1183	5.29	1211	5.42	—	—	—	—	—	—	—	—	—	—	—	—	

Table 34. Belt drive evaporator fan performance - 12.5 tons with med gas heat - GCC150A(3,4)EM- downflow airflow

External Static Pressure (Inches of Water)																					
CFM	0.1		0.2		0.3		0.4		0.5		0.6		0.7		0.8		0.9		1.0		
	RPM	BHP	RPM	BHP	RPM	BHP	RPM	BHP	RPM	BHP	RPM	BHP	RPM	BHP	RPM	BHP	RPM	BHP	RPM	BHP	
Standard Motor																					
4000	—	—	—	—	783	2.09	811	2.24	838	2.39	865	2.53	891	2.67	917	2.81	942	2.92	967	3.04	
4500	—	—	809	2.38	834	2.56	860	2.73	887	2.91	915	3.06	943	3.34	969	3.52	995	3.68	1020	3.84	
5000	840	2.71	866	2.91	892	3.08	917	3.41	942	3.56	968	3.74	994	3.92	1019	4.11	1046	4.26	1074	4.42	
5500	891	3.14	917	3.46	943	3.61	968	3.78	993	3.96	1017	4.14	1042	4.32	1067	4.51	1093	4.68	1119	4.86	
External Static Pressure (Inches of Water)																					
CFM	1.1		1.2		1.3		1.4		1.5		1.6		1.7		1.8		1.9		2.0		
	RPM	BHP	RPM	BHP	RPM	BHP	RPM	BHP	RPM	BHP	RPM	BHP	RPM	BHP	RPM	BHP	RPM	BHP	RPM	BHP	
High Static (oversize) Motor																					
4000	991	3.27	1015	3.41	1038	3.52	1061	3.63	1083	3.74	1105	3.88	1126	4.01	1147	4.12	1167	4.24	1187	4.33	
4500	1044	4.01	1068	4.16	1091	4.31	1113	4.46	1135	4.59	1159	4.71	1184	4.79	1209	4.87	1231	4.94	1253	5.01	
5000	1101	4.57	1127	4.72	1153	4.87	1178	5.02	1203	5.17	1230	5.33	—	—	—	—	—	—	—	—	
5500	1143	5.04	1167	5.22	1199	5.37	1222	5.49	—	—	—	—	—	—	—	—	—	—	—	—	

Table 35. Belt drive evaporator fan performance - 12.5 tons with med gas heat - GCC150A(3,4)EM - horizontal airflow

External Static Pressure (Inches of Water)																					
CFM	0.1		0.2		0.3		0.4		0.5		0.6		0.7		0.8		0.9		1.0		
	RPM	BHP	RPM	BHP	RPM	BHP	RPM	BHP	RPM	BHP	RPM	BHP	RPM	BHP	RPM	BHP	RPM	BHP	RPM	BHP	
Standard Motor																					
4000	—	—	770	2.07	798	2.24	826	2.39	853	2.54	880	2.68	906	2.82	932	2.95	957	3.07	982	3.19	
4500	802	2.35	824	2.53	849	2.71	875	2.88	902	3.05	930	3.21	958	3.49	984	3.67	1010	3.83	1035	3.99	
5000	855	2.86	881	3.05	907	3.23	932	3.55	957	3.71	983	3.89	1009	4.07	1034	4.25	1061	4.41	1089	4.57	
5500	906	3.29	932	3.61	958	3.75	983	3.93	1008	4.11	1032	4.29	1057	4.47	1082	4.65	1108	4.83	1134	5.01	
External Static Pressure (Inches of Water)																					
CFM	1.1		1.2		1.3		1.4		1.5		1.6		1.7		1.8		1.9		2.0		
	RPM	BHP	RPM	BHP	RPM	BHP	RPM	BHP	RPM	BHP	RPM	BHP	RPM	BHP	RPM	BHP	RPM	BHP	RPM	BHP	
High Static (oversize) Motor																					
4000	1006	3.42	1030	3.55	1053	3.67	1076	3.78	1098	3.89	1120	4.03	1141	4.15	1162	4.27	1182	4.39	1202	4.48	
4500	1059	4.15	1083	4.31	1106	4.46	1128	4.61	1150	4.74	1174	4.85	1199	4.94	1224	5.02	1246	5.09	1268	5.15	
5000	1116	4.72	1142	4.87	1168	5.02	1193	5.17	1218	5.32	—	—	—	—	—	—	—	—	—	—	
5500	1158	5.19	1182	5.37	—	—	—	—	—	—	—	—	—	—	—	—	—	—	—	—	



Performance Data

Table 36. Belt drive evaporator fan performance - 12.5 tons with high gas heat - GCC150A(3,4)EH - downflow airflow

External Static Pressure (Inches of Water)																					
CFM	0.1		0.2		0.3		0.4		0.5		0.6		0.7		0.8		0.9		1.0		
	RPM	BHP	RPM	BHP	RPM	BHP	RPM	BHP	RPM	BHP	RPM	BHP	RPM	BHP	RPM	BHP	RPM	BHP	RPM	BHP	
Standard Motor																					
4000	—	—	—	—	783	2.09	811	2.24	838	2.39	865	2.53	891	2.67	917	2.81	942	2.92	967	3.04	
4500	—	—	809	2.38	834	2.56	860	2.73	887	2.91	915	3.06	943	3.34	969	3.52	995	3.68	1020	3.84	
5000	840	2.71	866	2.91	892	3.08	917	3.41	942	3.56	968	3.74	994	3.92	1019	4.11	1046	4.26	1074	4.42	
5500	891	3.14	917	3.46	943	3.61	968	3.78	993	3.96	1017	4.14	1042	4.32	1067	4.51	1093	4.68	1119	4.86	
External Static Pressure (Inches of Water)																					
CFM	1.1		1.2		1.3		1.4		1.5		1.6		1.7		1.8		1.9		2.0		
	RPM	BHP	RPM	BHP	RPM	BHP	RPM	BHP	RPM	BHP	RPM	BHP	RPM	BHP	RPM	BHP	RPM	BHP	RPM	BHP	
High Static (oversize) Motor																					
4000	991	3.27	1015	3.41	1038	3.52	1061	3.63	1083	3.74	1105	3.88	1126	4.01	1147	4.12	1167	4.24	1187	4.33	
4500	1044	4.01	1068	4.16	1091	4.31	1113	4.46	1135	4.59	1159	4.71	1184	4.79	1209	4.87	1231	4.94	1253	5.01	
5000	1101	4.57	1127	4.72	1153	4.87	1178	5.02	1203	5.17	1230	5.33	—	—	—	—	—	—	—	—	
5500	1143	5.04	1167	5.22	1199	5.37	1222	5.49	—	—	—	—	—	—	—	—	—	—	—	—	

Table 37. Belt drive evaporator fan performance - 12.5 tons with high gas heat - GCC150A(3,4)EH - horizontal airflow

External Static Pressure (Inches of Water)																					
CFM	0.1		0.2		0.3		0.4		0.5		0.6		0.7		0.8		0.9		1.0		
	RPM	BHP	RPM	BHP	RPM	BHP	RPM	BHP	RPM	BHP	RPM	BHP	RPM	BHP	RPM	BHP	RPM	BHP	RPM	BHP	
Standard Motor																					
4000	—	—	770	2.07	798	2.24	826	2.39	853	2.54	880	2.68	906	2.82	932	2.95	957	3.07	982	3.19	
4500	802	2.35	824	2.53	849	2.71	875	2.88	902	3.05	930	3.21	958	3.49	984	3.67	1010	3.83	1035	3.99	
5000	855	2.86	881	3.05	907	3.23	932	3.55	957	3.71	983	3.89	1009	4.07	1034	4.25	1061	4.41	1089	4.57	
5500	906	3.29	932	3.61	958	3.75	983	3.93	1008	4.11	1032	4.29	1057	4.47	1082	4.65	1108	4.83	1134	5.01	
External Static Pressure (Inches of Water)																					
CFM	1.1		1.2		1.3		1.4		1.5		1.6		1.7		1.8		1.9		2.0		
	RPM	BHP	RPM	BHP	RPM	BHP	RPM	BHP	RPM	BHP	RPM	BHP	RPM	BHP	RPM	BHP	RPM	BHP	RPM	BHP	
High Static (oversize) Motor																					
4000	1006	3.42	1030	3.55	1053	3.67	1076	3.78	1098	3.89	1120	4.03	1141	4.15	1162	4.27	1182	4.39	1202	4.48	
4500	1059	4.15	1083	4.31	1106	4.46	1128	4.61	1150	4.74	1174	4.85	1199	4.94	1224	5.02	1246	5.09	1268	5.15	
5000	1116	4.72	1142	4.87	1168	5.02	1193	5.17	1218	5.32	—	—	—	—	—	—	—	—	—	—	
5500	1158	5.19	1182	5.37	—	—	—	—	—	—	—	—	—	—	—	—	—	—	—	—	

Table 38. Belt drive evaporator fan performance - 12.5 tons cooling only - ECC150A(3,4)E0 - downflow airflow

External Static Pressure (Inches of Water)																					
CFM	0.1		0.2		0.3		0.4		0.5		0.6		0.7		0.8		0.9		1.0		
	RPM	BHP	RPM	BHP	RPM	BHP	RPM	BHP	RPM	BHP	RPM	BHP	RPM	BHP	RPM	BHP	RPM	BHP	RPM	BHP	
Standard Motor																					
4000	—	—	—	—	—	—	747	1.89	769	2.06	790	2.23	811	2.38	833	2.57	856	2.74	879	2.91	
4500	—	—	759	2.12	787	2.35	808	2.52	829	2.69	851	2.86	874	3.03	906	3.31	929	3.46	952	3.58	
5000	807	2.52	828	2.68	854	2.85	871	3.02	903	3.31	928	3.46	952	3.62	976	3.78	999	3.93	1022	4.07	
5500	870	2.99	882	3.15	914	3.43	937	3.59	960	3.75	983	3.91	1006	4.06	1029	4.22	1052	4.38	1075	4.52	
External Static Pressure (Inches of Water)																					
CFM	1.1		1.2		1.3		1.4		1.5		1.6		1.7		1.8		1.9		2.0		
	RPM	BHP	RPM	BHP	RPM	BHP	RPM	BHP	RPM	BHP	RPM	BHP	RPM	BHP	RPM	BHP	RPM	BHP	RPM	BHP	
High Static (oversize) Motor																					
4000	911	3.19	932	3.33	952	3.45	972	3.56	992	3.66	1011	3.76	1030	3.86	1050	3.95	1071	4.04	1094	4.14	
4500	974	3.74	995	3.88	1015	4.01	1035	4.11	1055	4.21	1074	4.31	1093	4.41	1113	4.51	1134	4.59	1157	4.69	
5000	1044	4.21	1065	4.34	1085	4.46	1105	4.58	1125	4.68	1144	4.78	1163	4.88	1183	4.98	1204	5.08	1227	5.18	
5500	1097	4.66	1118	4.79	1138	4.91	1158	5.02	1178	5.12	1197	5.22	1216	5.32	—	—	—	—	—	—	

Table 39. Belt drive evaporator fan performance - 12.5 tons cooling only - ECC150A(3,4)E0 - horizontal airflow

External Static Pressure (Inches of Water)																					
CFM	0.1		0.2		0.3		0.4		0.5		0.6		0.7		0.8		0.9		1.0		
	RPM	BHP	RPM	BHP	RPM	BHP	RPM	BHP	RPM	BHP	RPM	BHP	RPM	BHP	RPM	BHP	RPM	BHP	RPM	BHP	
Standard Motor																					
4000	—	—	—	—	742	1.85	763	2.02	785	2.19	806	2.36	827	2.53	849	2.7	872	2.87	895	3.04	
4500	745	2.06	775	2.25	803	2.48	824	2.65	845	2.82	867	2.99	890	3.16	922	3.44	945	3.59	968	3.73	
5000	823	2.65	844	2.81	870	2.98	887	3.15	919	3.43	944	3.59	968	3.75	992	3.91	1015	4.06	1038	4.2	
5500	886	3.12	898	3.28	930	3.56	953	3.72	976	3.88	999	4.04	1022	4.19	1045	4.35	1068	4.51	1091	4.65	
External Static Pressure (Inches of Water)																					
CFM	1.1		1.2		1.3		1.4		1.5		1.6		1.7		1.8		1.9		2.0		
	RPM	BHP	RPM	BHP	RPM	BHP	RPM	BHP	RPM	BHP	RPM	BHP	RPM	BHP	RPM	BHP	RPM	BHP	RPM	BHP	
High Static (oversize) Motor																					
4000	927	3.32	948	3.46	968	3.58	988	3.69	1008	3.79	1027	3.89	1046	3.99	1066	4.08	1087	4.17	1110	4.27	
4500	990	3.87	1011	4.01	1031	4.13	1051	4.24	1071	4.34	1090	4.44	1109	4.54	1129	4.63	1150	4.72	1173	4.82	
5000	1060	4.34	1081	4.47	1101	4.59	1121	4.71	1141	4.81	1160	4.91	1179	5.01	1199	5.11	1220	5.21	1243	5.31	
5500	1113	4.79	1134	4.92	1154	5.04	1174	5.15	1194	5.25	1213	5.35	1232	5.45	—	—	—	—	—	—	

Notes:

1. The air distribution system has the greatest effect on airflow. The duct system is totally controlled by the contractor. For this reason, the contractor should use only industry-recognized procedures.
2. Each ton of cooling requires between 300 and 450 cubic feet of air per minute (CFM), or 320 CFM nominally.
3. Duct design and construction should be carefully done. System performance can be lowered dramatically through bad planning or workmanship.
4. Air supply diffusers must be selected and located carefully. They must be sized and positioned to deliver treated air along the perimeter of the space. If they are too small for their intended airflow, they become noisy. If they are not located properly, they cause drafts. Return air grilles must be properly sized to carry air back to the blower. If they are too small, they also cause noise.
5. The installers should balance the air distribution system to ensure proper quiet airflow to all rooms in the home. This ensures a comfortable living space.
6. An air velocity meter or airflow hood can give a reading of system CFM.



Performance Data

Table 40. Standard motor and drive/fan speed (rpm)

Tons	Unit Model Number	Fan Sheave	6 Turns Open	5 Turns Open	4 Turns Open	3 Turns Open	2 Turns Open	1 Turn Open	Closed
7.5	ECC090	15-15	716	743	772	798	824	850	879
	GCC090								
8.5	ECC102	15-15	735	762	790	817	844	871	898
	GCC102								
10	ECC120	15-15	735	762	790	817	844	871	898
	GCC120								
12.5	ECC150	15-16	735	762	790	817	844	871	898
	GCC150		770	806	843	878	912	948	982

Note: Factory Set at closed.

Table 41. High Static (Oversize) motor and drive/fan speed (rpm)

Tons	Unit Model Number	Fan Sheave	6 Turn Open	5 Turn Open	4 Turn Open	3 Turn Open	2 Turn Open	1 Turn Open	Closed
7.5	ECC090	15-15	885	946	978	1047	1108	1175	1229
	GCC090								
8.5	ECC102	15-15	900	959	994	1060	1124	1189	1243
	GCC102								
10	ECC120	15-15	900	959	994	1060	1124	1189	1243
	GCC120								
12.5	ECC150	15-16	916	975	1031	1090	1148	1209	1268
	GCC150								

Note: Factory Set at closed.

Table 42. Static pressure drop through accessories (inches water column)

Tons	Unit Model Number	Cfm	Standard Filters	Standard Economizer	Electric Heater					
					10.4	16	25	32	41	50
7.5	E/GCC090A (Downflow)	2400	0.01	—	0.005	0.005	0.050	0.01	0.01	—
		3000	0.03	—	0.010	0.010	0.010	0.02	0.02	—
		3375	0.04	—	0.015	0.015	0.015	0.03	0.03	—
	E/GCC090A (Horizontal)	2400	0.01	—	0.005	0.005	0.050	0.01	0.01	—
		3000	0.03	—	0.010	0.010	0.010	0.02	0.02	—
		3375	0.04	—	0.015	0.015	0.015	0.03	0.03	—
8.5	E/GCC102A (Downflow)	2720	0.02	—	0.010	0.010	0.010	0.02	0.02	—
		3400	0.04	—	0.015	0.015	0.015	0.03	0.03	—
		3825	0.05	—	0.020	0.020	0.020	0.04	0.04	—
	E/GCC102A (Horizontal)	2720	0.02	—	0.010	0.010	0.010	0.02	0.02	—
		3400	0.04	—	0.015	0.015	0.015	0.03	0.03	—
		3825	0.05	—	0.020	0.020	0.020	0.04	0.04	—
10	E/GCC120A (Downflow)	3200	0.03	—	0.015	0.015	—	0.03	0.03	0.03
		4000	0.05	—	0.020	0.020	—	0.04	0.04	0.04
		4500	0.07	—	0.025	0.025	—	0.05	0.05	0.05
	E/GCC120A (Horizontal)	3200	0.03	—	0.015	0.015	—	0.03	0.03	0.03
		4000	0.05	—	0.020	0.020	—	0.04	0.04	0.04
		4500	0.07	—	0.025	0.025	—	0.05	0.05	0.05
12.5	E/GCC150A (Downflow)	4000	0.05	—	0.020	0.020	—	0.04	0.04	0.04
		5000	0.07	—	0.030	0.030	—	0.06	0.06	0.06
		5625	0.09	—	0.035	0.035	—	0.07	0.07	0.07
	E/GCC150A (Horizontal)	4000	0.05	—	0.020	0.020	—	0.04	0.04	0.04
		5000	0.07	—	0.030	0.030	—	0.06	0.06	0.06
		5625	0.09	—	0.035	0.035	—	0.07	0.07	0.07

Table 43. Gas fired heating capacities

Tons	Gas Heat Option	Heating Input(MBh) ^(a)	Heating Output(MBh) ^(a)	Air Temp Rise
7.5	Low	125/87.5	100/70	15-45
	Medium	180/126	144/100	20-65
	High	225/157.5	180/125	25-70
8.5	Low	125/87.5	100/70	15-45
	Medium	180/126	144/100	20-65
	High	225/157.5	180/125	25-70
10	Low	180/125	144/100	20-50
	Medium	225/157.5	180/125	25-60
	High	250/200	200/160	30-65
12.5	Low	180/125	144/100	15-50
	Medium	225/157.5	180/125	20-60
	High	250/200	200/160	25-65

^(a) For two stage heaters (input or output), second stage is total heating capacity. Second stage/first stage.

Table 44. Auxiliary electric heat capacity

Tons	Unit Model Number	Ton ^(a)		No. of Stages	Stage 1		Stage 2	
		kW	MBh		kW	MBh	kW	MBh
		Input ^(b)	Output		Input	Output	Input	Output
7.5	EHK-10C(UL)	10.4	35.49	1	10.4	35.49	—	—
	EHK-15C(UL)	16	54.59	1	16	54.59	—	—
	EHK-25C(UL)	25	85.30	1	25	85.30	—	—
	EHK-32C(UL)	32	109.19	2	16	54.59	16	54.59
	EHK-41C(UL)	41	139.90	2	25	85.30	16	54.59
8.5	EHK-10C(UL)	10.4	35.49	1	10.4	35.49	—	—
	EHK-15C(UL)	16	54.59	1	16	54.59	—	—
	EHK-25C(UL)	25	85.30	1	25	85.30	—	—
	EHK-32C(UL)	32	109.19	2	16	54.59	16	54.59
	EHK-41C(UL)	41	139.90	2	25	85.30	16	54.59
10	EHK-10C(UL)	10.4	35.49	1	10.4	35.49	—	—
	EHK-15C(UL)	16	54.59	1	16	54.59	—	—
	EHK-32C(UL)	32	109.19	2	16	54.59	16	54.59
	EHK-41C(UL)	41	139.90	2	25	85.30	16	54.59
	EHK-50C(UL)	50	170.61	2	25	85.30	25	85.30
12.5	EHK-10C(UL)	10.4	35.49	1	10.4	35.49	—	—
	EHK-15C(UL)	16	54.59	1	16	54.59	—	—
	EHK-32C(UL)	32	109.19	2	16	54.59	16	54.59
	EHK-41C(UL)	41	139.90	2	25	85.30	16	54.59
	EHK-50C(UL)	50	170.61	2	25	85.30	25	85.30

^(a) Heaters are rated at 240V, 480V, and 600V. For other than rated voltage, CAP = (voltage/rated voltage)² x rated cap.

^(b) For all input/output categories, does not include fan power or heat.



Performance Data

Table 45. Electric heater voltage correction factors (applicable to auxiliary heat capacity)

Nominal Voltage	Distribution Voltage	Capacity Multiplier
240	208	0.75
	230	0.92
	240	1.00
460	460	1.00

Table 46. Air temperature rise across electric heaters(°F)

kW	Stages	7.5 Ton 3000 cfm	8.5 Ton 3400 cfm	10 Ton 4000 cfm	12.5 Ton 5000 cfm
10.4	1	10.7	9.9	8.2	6.8
16	1	14.6	13.8	12.6	10.9
25	1	22.4	22.4	—	—
32	2	28.2	27.1	25.3	22.9
41	2	37.5	35.6	32.4	30.1
50	2	—	—	39.5	37



Controls

Economizer Controls

The standard equipment offering is a fixed dry bulb changeover control. In addition, there are two optional controls, Reference Enthalpy Control and Comparative Enthalpy Control.

Reference Enthalpy Control

Replaces the dry bulb control with a wet bulb changeover controller which has a fully adjustable setpoint. Enthalpy control offers a higher level of comfort control, along with energy savings potential, than the standard dry bulb control. This is due to the additional wet bulb sensing capability.

Comparative Enthalpy Control

Comparative Enthalpy replaces the standard dry bulb control with two sensors that compare total heat content of the indoor air and outdoor air to determine the most efficient air source. This control option offers the highest level of comfort control, plus energy efficiency, available.

Remote Potentiometer

Minimum position setting of economizer can be remotely adjusted with this accessory.

Thermostats

Model #	Type	Stages	Display Type	Features
TCONT302AS42DA	Programmable	4H/2C	Touchscreen	Common preferred, not required 2/ 2 AA battery power
BAYSTAT814	Touchscreen	3H/2C	Touchscreen	Remote access via Pivot Mobile App
BAYSTAT300	Programmable	3H/2C	Backlit Display and Keys	BACnet MS-TP enabled



Electrical Data

Table 47. Unit wiring with cooling only (no electric heat) or gas heat

TONS	Unit Model Number	Unit Operating Voltage Range	Standard Indoor Fan Motor		Oversized Indoor Fan Motor	
			Minimum Circuit Ampacity ^(a)	Maximum Fuse Size or Maximum Circuit Breaker	Minimum Circuit Ampacity	Maximum Fuse Size or Maximum Circuit Breaker
7.5	E/GCC090A	208-230	36	45	40	50
8.5	E/GCC102A	208-230	42	50	49	60
10	E/GCC120A	208-230	54	70	57	70
12.5	E/GCC150A	208-230	66	80	69	80
7.5	E/GCC090A	460	20	25	25	30
8.5	E/GCC102A	460	20	25	27	30
10	E/GCC120A	460	27	30	29	35
12.5	E/GCC150A	460	34	40	35	45

^(a) For Standard and Oversized Indoor Fan Motor, values do not include power exhaust accessory.

Table 48. Unit wiring with electric heat (single point connection)

TONS	Unit Model Number	Heater kW Rating	Control Stages	Standard Indoor Fan Motor		Oversized Indoor Fan Motor	
				Minimum Circuit Ampacity	Maximum Fuse Size or Maximum Circuit Breaker	Minimum Circuit Ampacity	Maximum Fuse Size or Maximum Circuit Breaker
208/230 Volts Three Phase							
7.5	BAYHTMA341A	41.0	2	116/133	125/150	122/139	125/150
	BAYHTMA332A	32.0	2	93/106	100/110	99/112	100/125
	BAYHTMA325A	25.0	1	75/85	80/90	81/91	90/100
	BAYHTMA315A	16.0	1	51/58	60/60	57/64	60/70
	BAYHTMA310A	10.0	1	37/41	45/45	43/47	50/50
8.5	BAYHTMA341A	41.0	2	116/133	125/150	126/142	150/150
	BAYHTMA332A	32.0	2	93/106	100/110	102/115	110/125
	BAYHTMA325A	25.0	1	75/85	80/90	84/94	90/100
	BAYHTMA315A	16.0	1	51/58	60/60	60/67	60/70
	BAYHTMA310A	10.0	1	42/42	50/50	49/50	60/60
10	BAYHTMA350A	50.0	2	146/136	150/150	149/139	150/150
	BAYHTMA341A	41.0	2	122/139	125/150	126/142	150/150
	BAYHTMA332A	32.0	2	99/112	100/125	102/115	110/125
	BAYHTMA315A	16.0	1	57/64	70/70	60/67	70/70
	BAYHTMA310A	10.0	1	54/54	70/70	57/57	70/70
12.5	BAYHTMA350A	50.0	2	146/136	150/150	149/139	150/150
	BAYHTMA341A	41.0	2	122/139	125/150	126/142	150/150
	BAYHTMA332A	32.0	2	99/112	100/125	102/115	110/125
	BAYHTMA315A	16.0	1	66/66	80/80	69/69	90/90
	BAYHTMA310A	10.0	1	66/66	80/80	69/69	90/90
460 Volts Three Phase							
7.5	BAYHTMA441A	41.5	2	70	70	76	80
	BAYHTMA433A	33.0	2	57	60	63	70
	BAYHTMA425A	25.0	1	44	45	50	50
	BAYHTMA416A	15.0	1	31	35	37	40
	BAYHTMA414A	14.0	1	27	30	33	35
8.5	BAYHTMA441A	41.5	2	70	70	78	80
	BAYHTMA433A	33.0	2	57	60	65	70
	BAYHTMA425A	25.0	1	44	45	52	60
	BAYHTMA416A	15.0	1	31	35	39	40
	BAYHTMA414A	14.0	1	27	30	35	40

Table 48. Unit wiring with electric heat (single point connection) (continued)

TONS	Unit Model Number	Heater kW Rating	Control Stages	Standard Indoor Fan Motor		Oversized Indoor Fan Motor	
				Minimum Circuit Ampacity	Maximum Fuse Size or Maximum Circuit Breaker	Minimum Circuit Ampacity	Maximum Fuse Size or Maximum Circuit Breaker
10	BAYHTMA450A	50.0	2	74	80	76	80
	BAYHTMA441A	41.5	2	76	80	78	80
	BAYHTMA433A	33.0	2	63	70	65	70
	BAYHTMA416A	15.0	1	37	40	39	40
	BAYHTMA414A	14.0	1	33	35	35	40
12.5	BAYHTMA450A	50.0	2	74	80	76	80
	BAYHTMA441A	41.5	2	76	80	78	80
	BAYHTMA433A	33.0	2	63	70	65	70
	BAYHTMA416A	15.0	1	37	40	39	45
	BAYHTMA414A	14.0	1	34	40	35	45

Table 49. Electrical characteristics – compressor motor and condenser motor

TONS	Unit Model Number	Compressor Motors						Condenser Fan Motors				
		No.	Volts	Phase	rpm	Amps ^(a)		No.	Volts	Phase	hp	Amps
						RLA	LRA					FLA
7.5	E/GCC090A	2	203-230	3	3500	11.6/10.4	123/73	2	208-230	3	1/3	1.5
8.5	E/GCC102A	2	203-230	3	3500	15.6/11.6	93/123	2	208-230	3	1/3	1.5
10	E/GCC120A	2	203-230	3	3500	15.6/18.6	93/137	2	208-230	3	1/3	1.5
12.5	E/GCC150A	2	203-230	3	3500	23.2/15.6	164/93	2	208-230	3	3/4	4.5
7.5	E/GCC090A	2	460	3	3500	6.0/6.4	60/38	2	460	3	1/3	0.87
8.5	E/GCC102A	2	460	3	3500	6.5/6.0	60/60	2	460	3	1/3	0.87
10	E/GCC120A	2	460	3	3500	6.5/7.8	60/52	2	460	3	1/3	0.87
12.5	E/GCC150A	2	460	3	3500	11.2/6.5	75/60	2	460	3	3/4	2.1

^(a) For Compressor Motors and Condenser Fan Motors: Amp draw for each motor; multiply value by number of motors to determine total amps.

Table 50. Electrical characteristics – evaporator fan motor

TONS	Unit Model Number	Standard Evaporator Fan Motor					Oversized Evaporator Fan Motor				
		No.	Volts	Phase	hp	Amps	No.	Volts	Phase	hp	Amps
						FLA					FLA
7.5	E/GCC090A	1	208-230	3	2	7.2	1	208-230	3	3	12.0
8.5	E/GCC102A	1	208-230	3	2	7.2	1	208-230	3	5	14.6
10	E/GCC120A	1	208-230	3	3	12.0	1	208-230	3	5	14.6
12.5	E/GCC150A	1	208-230	3	3	12.0	1	208-230	3	5	14.6
7.5	E/GCC090A	1	460	3	2	3.5	1	460	3	3	8.7
8.5	E/GCC102A	1	460	3	2	3.5	1	460	3	5	10.3
10	E/GCC120A	1	460	3	3	8.7	1	460	3	5	10.3
12.5	E/GCC150A	1	460	3	3	8.7	1	460	3	5	10.3



Electrical Data

Table 51. Electrical characteristics – combustion blower motor (gas heat units)

TONS	Unit Model Number	Combustion Blower Motor				
		No.	Volts	Phase	rpm	Amps
						FLA
7.5	E/GCC090	1	208/230	1	2100	1.2
8.5	E/GCC105	1	208/230	1	2100	1.2
10	E/GCC120	1	208/230	1	2100	1.2
12.5	E/GCC150	1	208/230	1	2100	1.2
7.5	E/GCC090	1	220	1	2100	1.2
8.5	E/GCC105	1	220	1	2100	1.2
10	E/GCC120	1	220	1	2100	1.2
12.5	E/GCC150	1	220	1	2100	1.2

Jobsite Connections

Table 52. Typical number of wires

Thermostats	
A	3 Wires, 24V, Cooling only 4 Wires 24V, with Electric Heat
B	3 Power Wires + 1 Ground Wire (three phase)

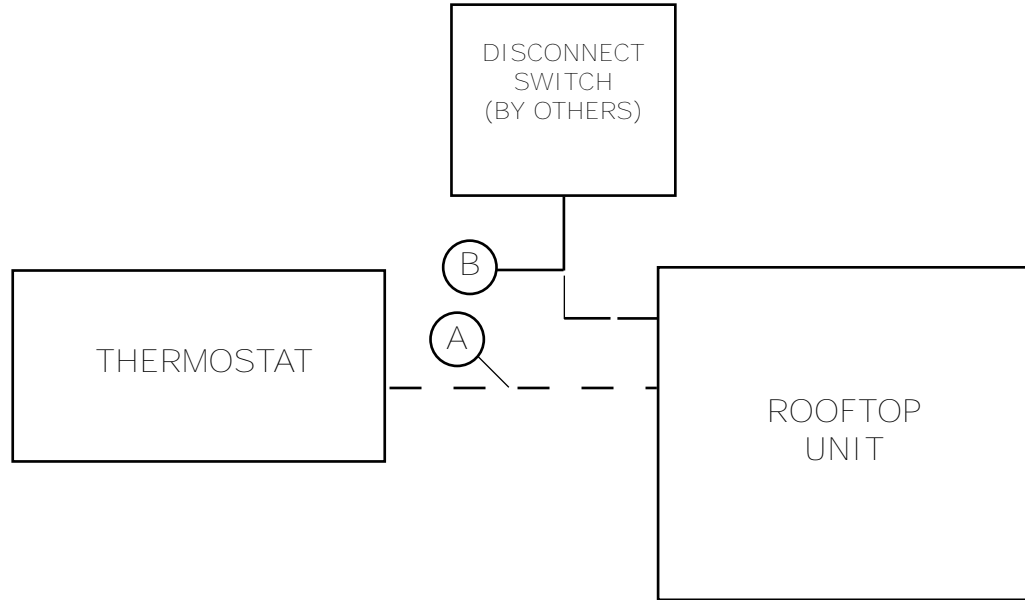

Notes:

- For specific wiring information, see the installation instructions.
- All wiring except power wire is low voltage.
- All customer supplied wiring to be copper and must conform to applicable electrical codes and local electric codes. Wiring shown dotted is to be furnished and installed by the customer.

Dimensional Data

Figure 1. Typical installation clearance for single and multiple unit applications (in inches)

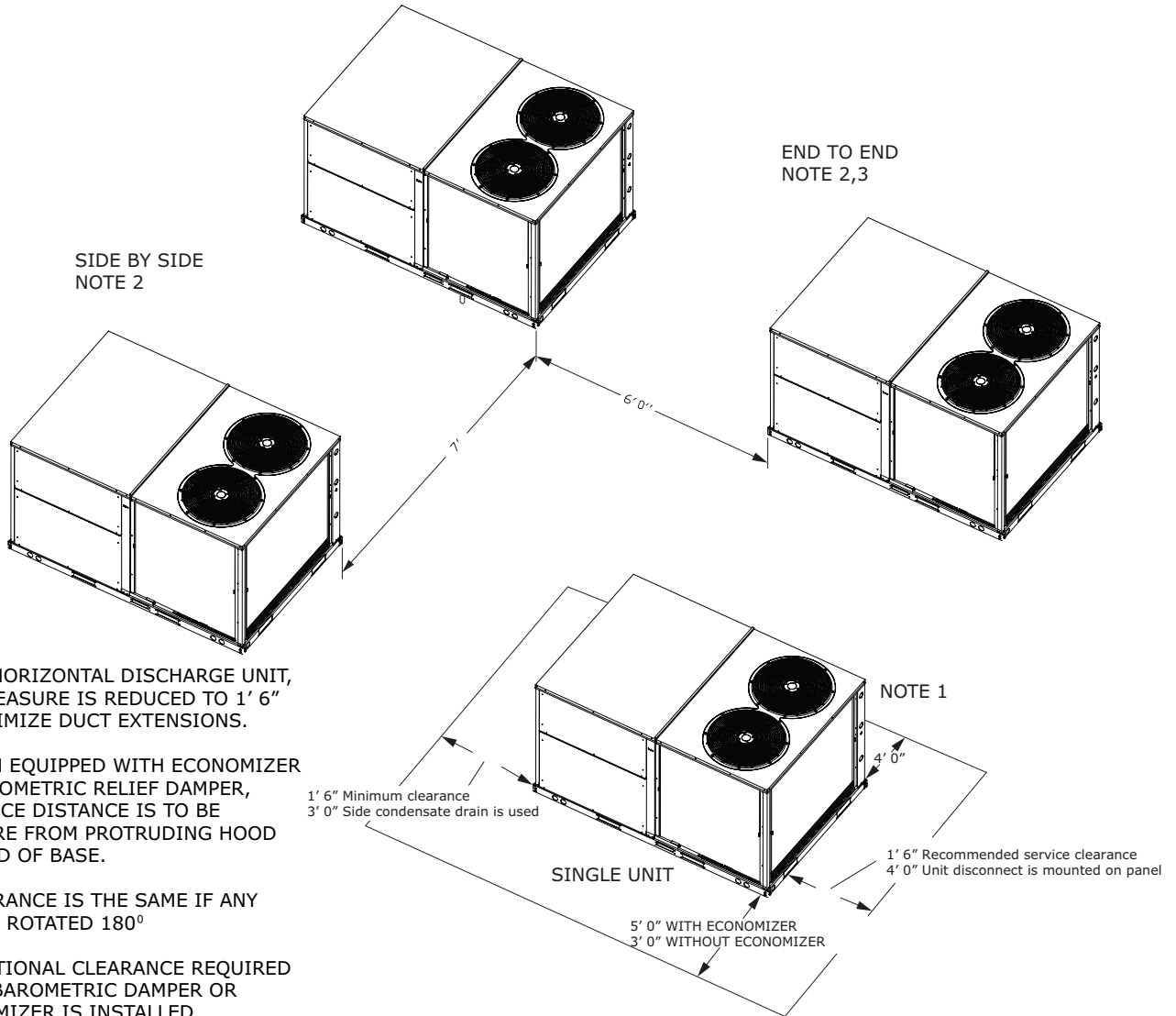

Figure 2. Cooling with optional electrical heat and gas/electric units — overview

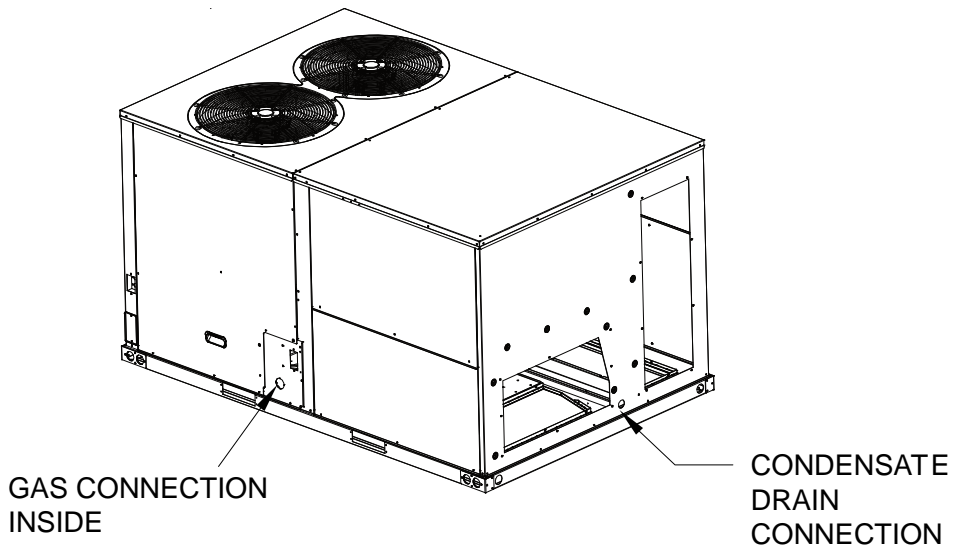

Figure 3. Cooling with optional electrical heat and gas/electric units — front and side views (in inches)

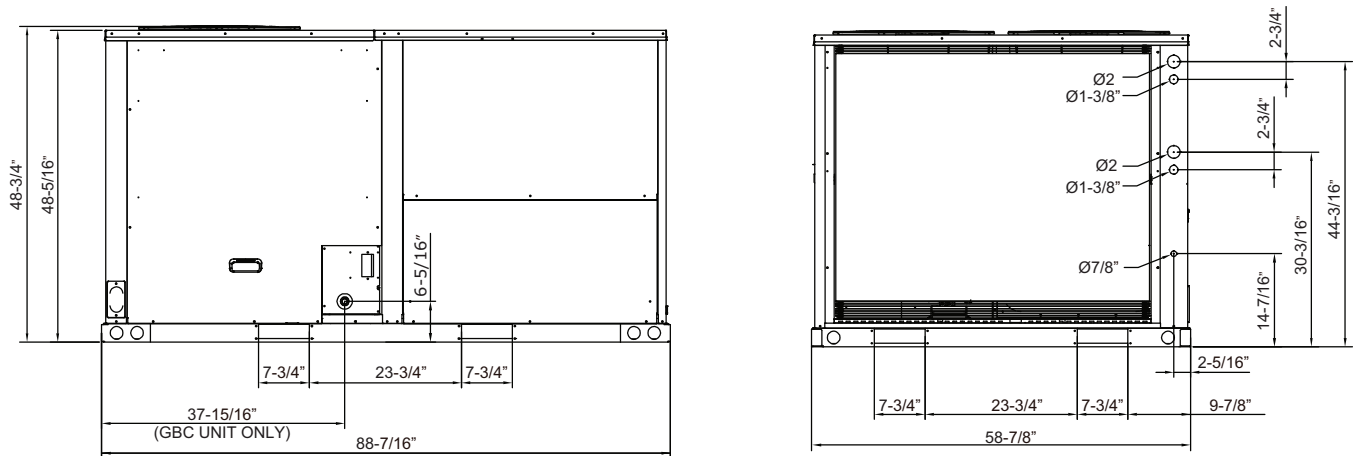
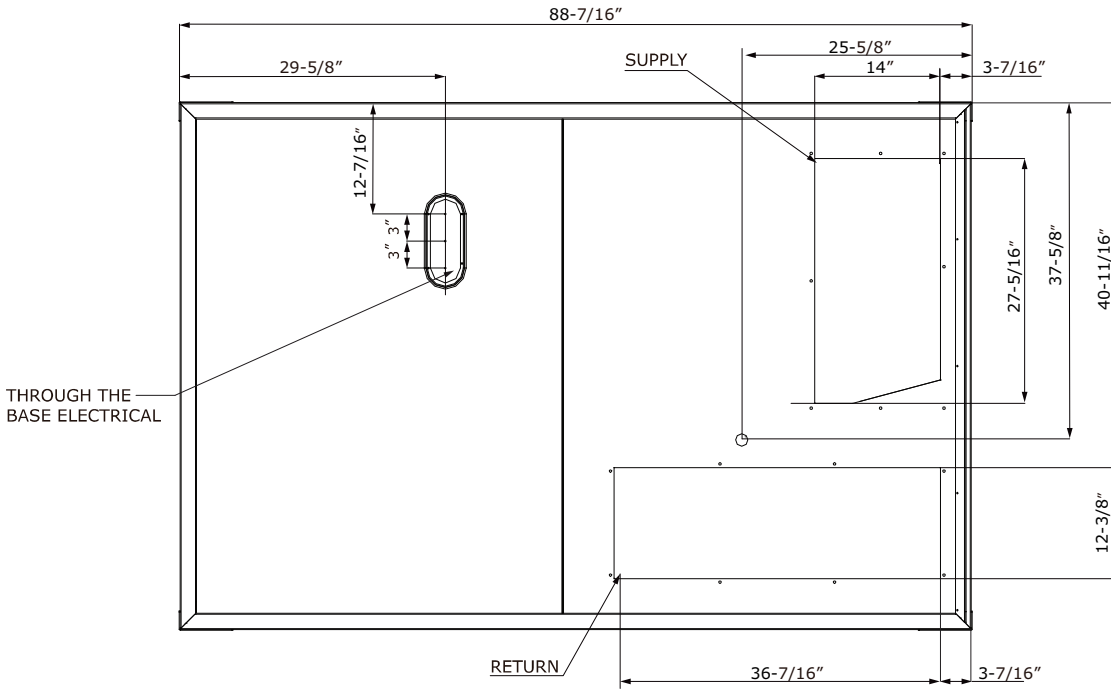

Figure 4. Cooling with optional electrical heat and gas/electric units — bottom view (in inches)



NOTES:

1. THROUGH THE BASE GAS AND ELECTRICAL IS NOT STANDARD ON ALL UNITS.
2. VERIFY WEIGHT, CONNECTION, AND ALL DIMENSION WITH INSTALLER DOCUMENTS BEFORE INSTALLATION.

Figure 5. Cooling with optional electrical heat and gas/electric units — back view (horizontal configuration) (in inches)

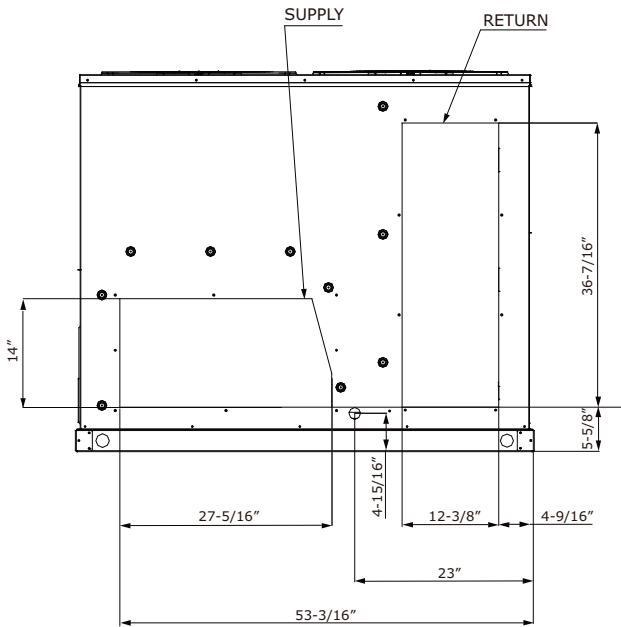

Figure 6. Cooling with optional electric heat and gas/electric models — roof curb (in inches)

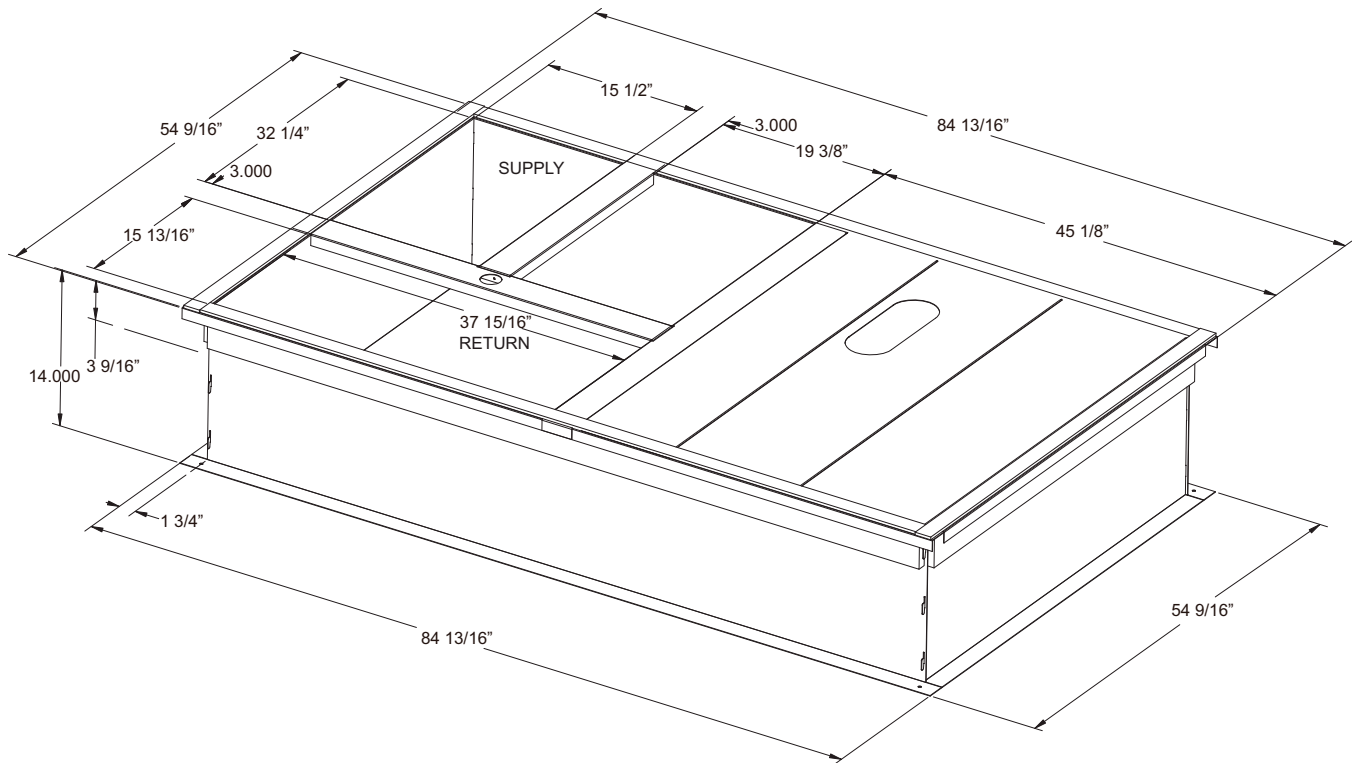
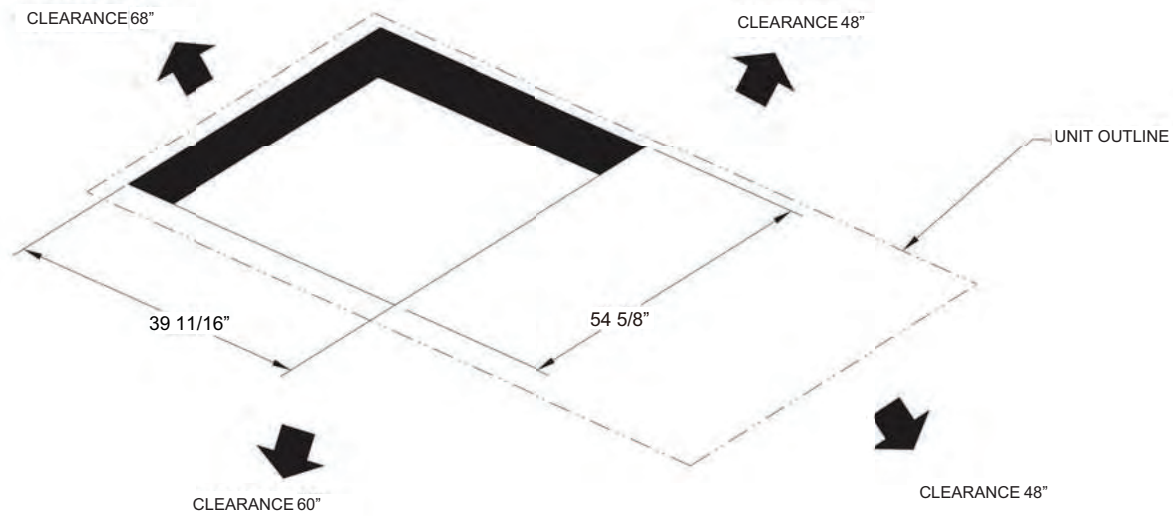

Figure 7. Cooling with optional electric heat and gas/electric models — downflow unit clearance (in inches)



Weights

Table 53. Maximum unit and corner weights (lb) and center of gravity dimensions (in.)

Tons	Unit Model No.	Weights (lb) ^{(a), (b)}		Corner Weights ^(c)				Center of Gravity (in.)	
		Shipping	Net	A	B	C	D	Length	Width
7.5	GCC090A	1087	1012	248	181	334	249	45.0	34.0
8.5	GCC102A	1111	1036	236	176	340	283	44.0	36.0
10	GCC120A	1133	1058	237	190	273	358	39.0	34.0
12.5	GCC150A	1235	1172	264	194	299	416	39.0	35.0
7.5	ECC090A	979	904	250	188	197	269	45.0	34.0
8.5	ECC102A	1003	928	252	187	200	289	44.0	36.0
10	ECC120A	1023	948	277	180	187	304	39.0	34.0
12.5	ECC150A	1124	1049	302	197	208	342	39.0	35.0

^(a) Weights are approximate. Horizontal and downflow unit and corner weights may vary slightly.

^(b) Weights do not include additional factory or field installed options/accessories.

^(c) Corner weights are given for information only. 7.5–12.5 ton models must be supported continuously by a curb or equivalent frame support.

Note: To calculate additional weight for accessories, see Accessory net weights table.

Table 54. Accessory net weight (lb)

Accessories	Model #	Net weight (lb)			
		E/GCC090	E/GCC102	E/GCC120	E/GCC150
Electric Heaters					
10 kW (240V)	BAYHTMA310A	43.65	43.65	43.65	43.65
16 kW (240V)	BAYHTMA315A	45.04	45.04	45.04	45.04
25 kW (240V)	BAYHTMA325A	46.01	46.01	46.01	46.01
32 kW (240V)	BAYHTMA332A	54.59	54.59	54.59	54.59
41 kW (240V)	BAYHTMA341A	55.56	55.56	55.56	55.56
50 kW (240V)	BAYHTMA350A	56.53	56.53	56.53	56.53
Oversized Motor					
2 HP (230 / 460)	—	37.5	37.5	37.5	37.5
3 HP (230 / 460)	—	45.0	45.0	45.0	45.0
5 HP (230 / 460)	—	53.0	53.0	53.0	53.0
External Vent Hood		2.8			

Figure 8. Center of gravity/corner weights

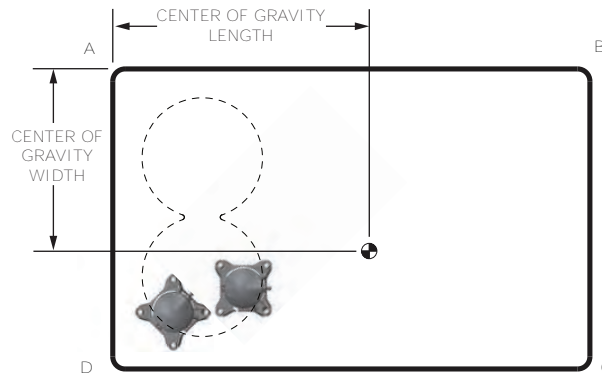



Mechanical Specifications

General

- Packaged rooftop units cooling, heating capacities, and efficiencies are AHRI Certified within scope of AHRI Standard (I-P) and ANSIZ21.47 and 10 CFR Part 431 pertaining to Commercial Warm Air Furnaces
- Packaged rooftop units are dedicated downflow or horizontal airflow
- Operating range between 125°F and 40°F in cooling standard from the factory
- Factory assembled, internally wired, fully charged with R-410A, and 100 percent run tested to check cooling operation, fan and blower rotation, and control sequence before leaving the factory
- Colored and numbered wiring internal to the unit for simplified identification
- Units ETL listed and labeled, classified in accordance

Standard Features

Casing

- Zinc coated, heavy gauge, galvanized steel
- Weather-resistant baked enamel finish on phosphatized exterior surfaces
- Meets ASTM B117, 672 hour salt spray test
- Removable single side maintenance access panels
- Lifting handles in maintenance access panels (can be removed and reinstalled by removing no more than 11 fasteners while providing a water and air tight seal)
- Exposed vertical panels and top covers in the indoor air section shall be insulated with a 1/2-inch, 1-pound density foil-faced, fire-resistant, permanent, odorless, glass fiber material
- Base of unit shall be insulated with 1/2-inch, 1-pound density, foil-faced, glass fiber material
- Base pan shall have no penetrations within the perimeter of the curb other than the raised 1 1/8-inch high downflow supply/return openings to provide an added water integrity precaution, if the condensate drain backs up
- Downflow unit's base pan shall have no penetrations within the perimeter of the curb other than the raised 1 1/8-inch high supply/return openings to provide an added water integrity precaution, if the condensate drain backs up
- Base of unit shall have provisions for forklift and crane lifting

Compressors

- All units have direct-drive, hermetic, scroll type compressors with centrifugal type oil pumps
- Suction gas-cooled motor with voltage utilization range of plus or minus 10 percent of unit nameplate voltage
- Internal overloads standard with scroll compressors
- All models have phase monitors and Low and High Pressure Controls as standard

Discharge Line Thermostat

- A bi-metal element discharge line thermostat is installed as a standard option on the discharge line of each system
- Provides extra protection to the compressors against high discharge temperatures in case of loss of charge, extremely high ambient and other conditions which could drive the discharge temperature higher
- Wired in series with high pressure control
- When discharge temperature rises above the protection limit, the bi-metal disc in the thermostat switches to the off position, opening the 24 Vac circuit
- When temperature on the discharge line cools down, the bi-metal disc closes the contactor circuit, providing power to the compressor



Mechanical Specifications

Evaporator and Condenser Coils

- Microchannel coils burst tested by manufacturer
- Microchannel condenser coils standard on all units
- Coils leak tested to ensure the pressure integrity
- Evaporator coil and condenser coil leak tested to 225 psig and pressure tested to 450 psig
- Sloped condensate drain pans are standard

Filters

Two inch standard filters shall be factory supplied on all units.

Gas Heat Section

- Progressive tubular heat exchanger, stainless steel burners and corrosion resistant steel
- Induced draft combustion blower shall be used to pull the combustion products through the firing tubes
- Heater shall use a direct spark ignition (DSI) system
- On initial call for heat, the combustion blower shall purge the heat exchanger for 20 seconds before ignition
- After three unsuccessful ignition attempts, entire heating system shall be locked out until manually reset at the thermostat/zone sensor
- Units shall be suitable for use with natural gas or propane (field-installed kit)

Indoor Fan

- Belt driven, FC centrifugal fans with adjustable motor sheaves
- Motors thermally protected
- Oversized motors available for high static application
- Indoor fan motors meet the U.S. Energy Policy Act of 1992 (EPACT)

Locking Safety Device

- Pressure switch monitoring allows for lockout in a situation where the switch is opened
- By monitoring the Y input as well as the pressure switches, advanced decision making can be made to identify situations where faults/errors occur

Outdoor Fans

- Outdoor fan shall be externally drive, statically and dynamically balanced, draw-through in the vertical discharge position.
- Fan motor(s) shall be permanently lubricated and shall have current overload protection.

Refrigerant Circuits

- Each refrigerant circuit shall have a fixed orifice, service pressure ports, and refrigerant line filter driers factory installed as standard
- An area shall be provided for replacement suction line driers

Refrigerant Pressure Control

All units include High and Low Pressure Cutouts as standard.

Unit Top

The top cover shall be double hemmed and gasket sealed to prevent water leakage.

Factory Installed Options

Multi-Speed Indoor Fan System

Incorporates a multi-speed fan control to change the speed of the fan to 70% of full airflow based off of compressor stages

Oversized Motors

Oversized motors shall be available as a factory option for High Static applications.

Field Installed Options

Condensate Overflow Switch

This option shall shut the unit down in the event that a clogged condensate drain line prevents proper condensate removal from the unit.

Demand Control Ventilation with CO₂ Sensor

- CO₂ sensor shall have the ability to monitor the concentration (parts per million, ppm) of CO₂ (Carbon Dioxide) in the air
- As the CO₂ concentration changes, the outside air damper modulates to meet the current ventilation needs of the zone

Economizer (Standard) — Downflow

- Assembly includes fully modulating 0–100% motor and dampers, barometric relief, minimum position setting, preset linkage, wiring harness with plug, fixed dry bulb and spring return actuator
- Barometric relief damper shall provide a pressure operated damper that shall be gravity closing and shall prohibit entrance of outside air during the equipment “off” cycle

Economizer — Horizontal

The horizontal economizer shall contain the same features as the downflow economizer with the exception of barometric relief.

Electric Heaters

- Electric heat modules shall be available for installation within the basic unit
- Elements shall be constructed of heavy-duty nickel chromium elements internally delta connected for 240 volt, wye connected for volt
- Power assemblies shall provide single-point connection
- Electric heat modules shall be UL listed or CSA certified
- If ordering the Through the Base Electrical option with an Electric Heater, the heater must be factory installed.

Hail Guards

Tool-less, hail protection quality coil guards are available for condenser coil protection.

Low Leak Economizer with Fault Detection & Diagnostics – Downflow

- Controller shall have the capability to provide the value of each sensor used in controlling the economizer operation
- System status is also indicated for the following conditions:
 - Free cooling available
 - Economizer enabled
 - Compressor enabled
 - Heating Enabled



Mechanical Specifications

- Mixed air low limit cycle active
- Fault Detection and Diagnostic system detects the following faults:
 - Air temperature sensor failure/fault
 - Not economizing when conditions indicate system should be economizing
 - Economizing when conditions indicate system should not be economizing
 - Dampers are not modulating
 - Excessive amounts of outside air are being introduced though the economizer
- Fault Detection and Diagnostic system is certified by the California Energy Commission as meeting requirements of California Title 24 120.2(i)1 through 120.2(i)8 in accordance with Section 100(h)

Manual Outside Air Damper

Manually set outdoor air dampers shall provide up to 50% outside air.

Motorized Outside Air Damper

- Outdoor air dampers shall open to set position when indoor fan starts
- Damper shall close to the full closed position when indoor fan shuts down

Powered Exhaust

The powered exhaust shall provide exhaust of return air, when using an economizer, to maintain better building pressurization.

Reference or Comparative Enthalpy

- Used to measure and communicate outdoor humidity
- Unit receives and uses this information to provide improved comfort cooling while using the economizer
- Comparative Enthalpy measures and communicates humidity for both outdoor and return air conditions, and return air temperature – unit receives and uses this information to maximize use of economizer cooling, and to provide maximum occupant comfort control
- Reference or Comparative Enthalpy option shall be available when a factory or field installed Downflow Economizer is ordered
- Option is available on all models

Remote Potentiometer

The minimum position setting of the economizer shall be adjusted with this accessory.

Through the Base Gas Piping

- Unit shall include a standard through the base gas provision
- Option shall have all piping necessary including, black steel, manual gas shut-off valve, elbows, and union
- Manual shutoff valve shall include a 1/8-inch NPT pressure tap
- Assembly will require minor field labor to install (Gas/Electric Only)

Through the Base Utilities Access

- Electrical service entrance shall be provided allowing electrical access for both control and main power connections inside the curb and through the base of the unit
- Option shall allow for field installation of liquid-tight conduit and an external field installed disconnect switch



The AHRI Certified mark indicates Trane U.S. Inc. participation in the AHRI Certification program. For verification of individual certified products, go to ahridirectory.org.

Trane - by Trane Technologies (NYSE: TT), a global innovator - creates comfortable, energy efficient indoor environments for commercial and residential applications. For more information, please visit trane.com or tranetechnologies.com.

Trane has a policy of continuous product and product data improvements and reserves the right to change design and specifications without notice. We are committed to using environmentally conscious print practices.