



Product Catalog

Packaged Rooftop Air Conditioners Precedent™ with eFlex™ Technology — Cooling and Gas/Electric

3 to 10 Tons — 60 Hz





Introduction

Trane® customers demand products that provide exceptional reliability, meet stringent performance requirements, and are competitively priced. Trane® delivers with Precedent™.

Precedent™ features cutting edge technologies: reliable compressors, Trane® engineered ReliaTel™ controls, computer-aided run testing, and Integrated Comfort™ Systems. So, whether you're the contractor, the engineer, or the owner you can be certain Precedent products are built to meet your needs.

Through the years, Trane® has designed and developed the complete line of Packaged Rooftop products available in the market today. Trane® was the first to introduce the Micro—microelectronic unit controls—and has continued to improve and revolutionize this design concept.

All units utilize ReliaTel™ controls. These are standard for variable staged cooling Precedent™ products. The ReliaTel™ control platform offers the same great features and functionality as the original Micro, with additional benefits for greater application flexibility.

With its sleek, compact cabinet, Precedent™ continues to provide the highest standards in quality and reliability, comfort, ease of service, and the performance of Trane® light commercial products.

Copyright

This document and the information in it are the property of Trane, and may not be used or reproduced in whole or in part without written permission. Trane reserves the right to revise this publication at any time, and to make changes to its content without obligation to notify any person of such revision or change.

Trademarks

All trademarks referenced in this document are the trademarks of their respective owners.

Revision History

- Added EER2/SEER2 information to General data 3 to 5 tons with eFlex™ and eDrive™ technology (208 to 230 Volt) and (460 Volt) table.
- Updated Roof curb weight in Factory installed options (fiops)/accessory net weights table.
- Updated General data 3 to 5 tons with eFlex™ and eDrive™ technology (208 to 230 Volt) and (460 Volt) table.



Table of Contents

Introduction	2
Features and Benefits	5
Standard Features	7
Other Benefits	10
Factory Installed Options	10
Factory or Field Installed Options	14
Field Installed Options	15
Other Benefits	16
Application Considerations	19
Sequence of Operation	20
Selection Procedure	22
Cooling Capacity	22
Heating Capacity	23
Air Delivery Selection	23
Model Number Descriptions	24
Model Number Notes	25
General Data	26
Performance Data	36
Evaporator Fan Performance	52
Fan Performance	82
Heat Performance	85
Controls	88
ReliaTel™ Controlled Units	88
Economizer Controls	88
Differential Pressure Switches	88
Communication Interfaces	89
Electrical Data	91
Jobsite Connections	96
Dimensional Data	97
Weights	114
Mechanical Specifications	116
Standard	116



Table of Contents

Factory Installed Options	118
Factory or Field Installed Options	120
Field Installed Options	121



Features and Benefits

Table 1. Precedent™ options — standard and optional

	Standard Features	Options ^(a)		
		Factory Installed	Factory or Field Installed	Field Installed
1-year Limited Parts Warranty	X			
2-inch MERV 8 Filters or 2-inch MERV 13 Filters with Filter Removal Tool		X		
5-year Limited Compressor Warranty	X			
5-year Limited Heat Exchanger Warranty	X			
Anti-Short Cycle Timer (Standard with ReliaTel™)	X			
Barometric Relief			X	
Black Epoxy Pre-Coated Coils		X		
CO ₂ Sensor ^(b)				X
CO ₂ Sensor (Wiring Only)		X		
Clogged Filter/Fan Failure Switch			X	
Colored and Numbered Wiring	X			
CompleteCoat™ Condenser Coil		X		
Condensate Overflow Switch		X		
Condensing temperature thermistor ^(c)	X			
Convertible Airflow	X			
Crankcase Heaters	X			
Discharge Air Temperature Sensor	X		X	
Easy Access Low Voltage Terminal Board (LTB)	X			
Economizer: Standard and Low Leak			X	
eDrive™ technology - direct drive indoor fan	X			
eFlex™ technology - variable speed compressor, variable speed outdoor fan, variable speed indoor fan	X			
Electric Heaters			X	
Enhanced Dehumidification Functionality	X			
Evaporating temperature thermistor ^(c)	X			
Fault Detection and Diagnostics (FDD) ^(f)		X		
Filters are Standard on all Units	X			
Foil-Faced and Edge Captured Insulation	X			
Frostat™	X			
Hail Guards			X	
High Altitude Kit				X
High Pressure Control	X			
Hinged Access Doors		X		
Humidity Sensor/Humidistat				X
IAQ Dual Sloped, Plastic, Removable, Reversible Drain Pan	X			
Liquid Line Refrigerant Drier	X			
Low Ambient Cooling to 0°F	X			
Low Pressure Control	X			
LP Conversion Kit				X
Modulating gas heat ^(g)		X		
Microchannel coils ^(o)	X			
Motorized Outside Air Dampers				



Features and Benefits

Table 1. Precedent™ options — standard and optional (continued)

	Standard Features	Options ^(a)		
		Factory Installed	Factory or Field Installed	Field Installed
Multiple Zone VAV (MZVAV)		X		
Operating Charge of R-410A	X			
Outside Air Measuring/Monitoring Control (TraQ Dampers)				X
Phase Loss Protection	X			
Phase Monitor				
Phase Reversal Protection	X			
Powered Exhaust				X
Powered ^(d) or Unpowered Convenience Outlet		X		
Progressive Tubular Aluminumized Steel Heat Exchanger	X			
Provisions for through-the-base Condensate Drain Connections	X			
Quick Access Panels	X			
Quick Adapt Curbs				X
Quick Start Kit				X
Reference or Comparative Enthalpy			X	
Remote Potentiometer				X
Roof Curb				X
Scroll Compressors	X			
Single Point Power	X			
Single Side Service Access	X			
Single Zone Variable Air Volume (SZVAV)	X			
Stainless Steel Drain Pan		X		
Stainless Steel Heat Exchanger		X		
Standardized Components	X			
Supply, Return or Plenum ^(e) Air Smoke Detector		X		
Thermal Expansion Valve	X			
Through-the-Base Electrical Access		X		
Through-the-Base Electrical with Circuit Breaker		X		
Through-the-Base Electrical with Disconnect Switch		X		
Through-the-Base Gas Access		X		
Ultra Low NOx Gas Furnace ^{(h)(i)(j)(k)(l)(m)(n)}		X		
Ventilation Override Accessory				X
Voltage imbalance protection	X			

- (a) Refer to model number description for option availability.
 (b) CO₂ sensor always field installed; associated with demand control ventilation.
 (c) Thermistor is standard for T/YZC072-120F models.
 (d) Powered convenience outlet not available on 460V and 575V units.
 (e) Plenum smoke detector not available on T/YZC072-120 models.
 (f) FDD can be accomplished via either (1) TD5 Human Interface (Digit 31=1) or BAYSENS924 with BACnet® card (factory or field installed).
 (g) 6 to 10 Ton Models Only.
 (h) Applicable ONLY for California SCAQMD and SJVAPCD areas.
 (i) Option requires Stainless Steel Heat Exchanger Option (Digit 10=X or Y).
 (j) Only available in 208 to 230V and 460V (no 575V).
 (k) Through-the-Base Gas option not available with Ultra Low NOx gas furnace option.
 (l) Ultra Low NOx gas furnace option does not allow Field Installed LP Conversion Kit.
 (m) Ultra Low NOx gas furnace option does not allow Field Installed High Altitude Kit.
 (n) 3 to 5 Tons only.
 (o) 3 and 5 Ton Models do not have microchannel condenser coils (they have aluminum fin/copper tube).

Table 2. Precedent™ control options — standard and optional

	Standard Features	Options ^(a)		
		Factory Installed	Factory or Field Installed	Field Installed
BACnet® Communications Interface (BCI)			X	
Dual Thermistor Remote Zone Sensor				X
Human Interface		X		
LonTalk® Communications Interface (LCI)			X	
ReliaTel™ Microprocessor Controls	X			
Trane® Air-Fi® Wireless Communication Interface		X		
Wireless Zone Sensor				X
Zone Sensor				X

(a) Refer to model number description for option availability.

Standard Features

Anti-Short Cycle Timer

Provides a 3 minute minimum “ON” time and 3 minute “OFF” time for compressors to enhance compressor reliability by assuring proper oil return.

Colored and Numbered Wiring

Save time and money tracing wires and diagnosing the unit.

Condenser Coil



Precedent™ boasts a patent-pending 1+1+1 condenser coil, permanently gapped for easy cleaning.

Note: 3 and 5 Ton models only.

Controls – ReliaTel™

ReliaTel™ microprocessor controls provide unit control for heating, cooling and ventilating utilizing input from sensors that measure indoor and outdoor temperature and other zone sensors. ReliaTel™ also provides outputs for building automation systems and expanded diagnostics. For a complete list of ReliaTel™ offerings, refer to the “Other Benefits” section within the Features and Benefits section of this catalog.



Features and Benefits

Convertible Units



The units ship in a downflow configuration. They can be easily converted to horizontal by simply moving two panels.

Units come complete with horizontal duct flanges so the contractor doesn't have to field fabricate them. These duct flanges are a time and cost saver.

Crankcase Heaters

These band heaters provide improved compressor reliability by warming the oil to prevent migration during off-cycles or low ambient conditions.

Discharge Air Temperature Sensor

Provides true discharge air temperature sensing in heating and cooling mode.

Drain Pan

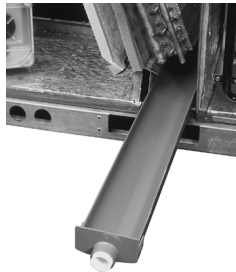

Every Precedent™ unit has a plastic, removable, dual-sloped drain pan that's easy to clean and reversible to allow installation of drain trap on either side of the unit.

Easy Access Low Voltage Terminal Board

The low voltage terminal board is external to the electrical control cabinet. It is extremely easy to locate and attach the thermostat wire and test operation of all unit functions. This is another cost and time saving installation feature.

eDrive™ Indoor Fan Motor

The eDrive™ direct drive indoor fan motor provides superior efficiencies at a wide range of operating conditions and speeds. These direct drive motors are over 20% more efficient than typical permanent split capacitor motors. They also eliminate the need for routine maintenance associated with belts.

eFlex™ Variable Speed Scroll Compressor

Precedent™ eFlex™ variable speed scroll compressors are matched with a specially designed variable frequency drive that allows a modulating ratio of up to 4:1. This allows for unmatched control of leaving air temperatures to meet space loads. The eFlex™ compressors also include brushless permanent magnet motors designed to operate at higher efficiency resulting in significant part load energy savings. This makes units with eFlex™ compressors the most efficient products in their class at part load.

Foil Faced Insulation

All panels in the evaporator section of the unit have cleanable foil-faced insulation. All edges are either captured or sealed to ensure no insulation fibers get into the airstream.

Frostat™

This capillary bulb embedded in the face of the evaporator coil monitors coil temperature to prevent evaporator icing and protect the compressor. Recommended for applications with low leaving air temperatures, low airflow and or high latent load applications.

Heat Exchanger

The compact cabinet features a progressive tubular heat exchanger in low, medium and high heat capacities.

The heat exchanger is fabricated using corrosion-resistant aluminized steel tubes and burners as standard on all models. It has an induced draft blower to pull the gas mixture through the burner tubes. The heater has a direct spark ignition system which doubles as a safety device to prove the flame.

High Pressure Control

All units include high pressure control as standard.

Low Ambient Cooling

All Precedent™ microprocessor units have cooling capabilities down to 0°F as standard.

Low Voltage Connections

The wiring of the low voltage connections to the unit and the zone sensors is as simple as 1-1, 2-2, and 3-3. This simplified system makes it easy for the installer to wire.

Microchannel Condenser Coils

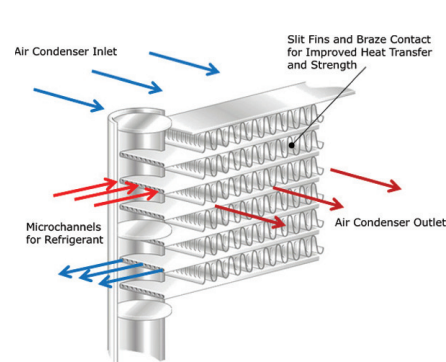

Due to flat streamlined tubes with small ports, and metallurgical tube-to-fin bond, microchannel coil has better heat transfer performance. Microchannel condenser coil can reduce system refrigerant charge by up to 50% because of smaller internal volume, which leads to better compressor reliability. Compact all-aluminum microchannel coils also help to reduce the unit weight. These all aluminum coils are recyclable. Galvanic corrosion is also minimized due to all aluminum construction. Strong aluminum brazed structure provides better fin protection. In addition, flat streamlined tubes also make microchannel coils more dust resistant and easier to clean.

Note: The microchannel type condenser coil is standard for T/YZC048F models.

Phase Monitoring Protection

Note: Available on 3 to 5 ton units only.

Precedent™ units with are equipped with phase monitoring protection as standard. The phase monitor protects motors by preventing unit operation when there is a phase loss, phase imbalance or phase reversal condition. An illuminated green LED indicates proper phase operation, and an illuminated red LED indicates there is a fault.

Features and Benefits

Quick-Access Panels

Remove two screws for access to the standardized internal components and wiring.

Single Zone Variable Air Volume

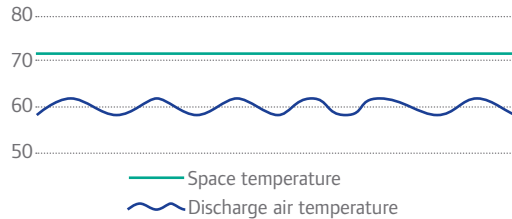

Single Zone VAV control offers full supply fan modulation across the available airflow range. In addition to full supply fan modulation, the unit controls the discharge air temperature to a varying discharge air temperature setpoint in order to maintain space temperature.

Standardized Components

Components are placed in the same location on all Precedent™ units. Due to standardized components throughout the Precedent™ line, contractors/owners can stock fewer parts.

Through-the-Base Condensate

Every unit includes provisions for through-the-base condensate drain connections. This allows the drain to be connected through the roof curb instead of a roof penetration.

Other Benefits

- Cabinet design ensures water integrity.
- Ease of service, installation and maintenance.
- Mixed model build enables “fastest in the industry” ship cycle times.
- Outstanding airflow distribution.
- ReliaTel™ controls.

Factory Installed Options

Black Epoxy Pre-Coated Coils

The pre-coated coils are an economical option for protection in mildly corrosive environments.

Circuit Breaker

This option is a factory installed thermal magnetic, molded case, HACR circuit breaker with provisions for through the base electrical connections.

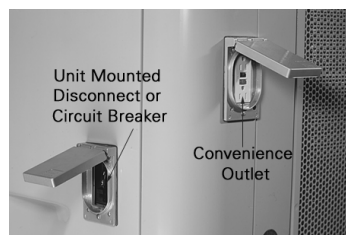

CO₂ Sensor Wiring

This is the unit wiring for field installed CO₂ sensors. Factory-installed CO₂ sensor wiring saves time and ensures proper unit connections for the field installed CO₂ sensor kits.

CompleteCoat™ Condenser Coil

These coils provide excellent corrosion resistance as well as uniformity of coverage and coating thickness.

Condensate Overflow Switch

A condensate overflow switch is available to shut the unit down in the event that the condensate drain line becomes clogged. This option protects the unit from water overflowing from the drain pan and entering the base of the units.

Convenience Outlet

This option is a GFCI, 120V/15amp, 2 plug, convenience outlet, either powered or unpowered. This option can only be ordered when through-the-base electrical with either the disconnect switch or circuit breaker option is ordered.

Note: *Powered convenience outlet not available on 460V units.*



Disconnect Switch

Factory installed 3-pole, molded case, disconnect switch for through-the-base electrical connections.

Codes require a method of assured unit shutdown for servicing. Field-installed disconnects sometimes interfere with service access. Factory installation of unit disconnects reduces costs, assures proper mounting and provides the opportunity to upgrade to unit circuit breaker protection.

Note: *Available on units equipped with through-the-base electrical.*

Fault Detection and Diagnostics (FDD)

This offering meets the mandatory requirement of CA Title 24 of fully configurable diagnostics allowing fault history and reading fault codes at the unit. This option provides detection of the following faults: air temperature sensor failure/fault and notification of acceptable economizer mode. The FDD system shall be certified by the Energy Commission as meeting the requirements.

High Efficiency Filtration

Precedent™ units offer a variety of high efficiency filtration options. MERV 8 and MERV 13 filters provide additional filtration beyond the capabilities of typical 2-inch throwaway filters. Also, when MERV 8 or MERV 13 filters are ordered, units come equipped with a filter removal tool.

Hinged Access Doors

These doors permit easy access to the filter, fan/heat and compressor/control sections. They reduce the potential roof damage from screws or sharp access door corners.



Features and Benefits

Note: A compressor isolation panel is available for 3 to 5 ton units to ease commissioning and servicing of units.



Human Interface



The 5-inch color touchscreen Human Interface provides an intuitive user interface to the rooftop unit that speeds up unit commissioning, shortens unit troubleshooting times, and enhances preventative maintenance measures. The human interface includes several features:

- Data trending capabilities by means of time series graphs.
- Historical alarm messages.
- Real-time sensor measurements.
- On board system setpoints.
- USB port that enables the downloading of component runtime information as well as trended historical sensor data.
- Customized reports.

Note: Refer to RT-SVX49*-EN for additional information.

Multiple-Zone VAV Control

A multiple-zone VAV (MZVAV) system consists of a packaged rooftop unit that serves several individually controlled zones. Each zone is equipped with a VAV terminal unit that varies the quantity of air delivered to maintain the desired temperature in that zone. The rooftop unit controller varies the speed of the indoor fan to maintain the static pressure in the supply ductwork at a setpoint, ensuring all zones receive the necessary quantity of air. In addition, cooling capacity is cycled to maintain the supply air temperature at the desired setpoint.

For decades, Trane has been an industry leader in rooftop VAV systems. Now, multiple-zone VAV control is available in Trane's light commercial rooftop platform (3 to 25 tons).

Stainless Steel Heat Exchanger

The optional stainless steel heat exchanger is constructed of 409 stainless steel tubes and 439 stainless steel burners. It is resistant to corrosion and oxidation and easy to clean. The high strength to weight ratio allows for high ventilation rates with gas units. It is an excellent option to compliment enhanced dehumidification as a high outside air ventilation unit. With this option, a 10-year stainless steel heat exchanger warranty is standard.

Note: *Stainless Steel Heat Exchanger standard with Ultra Low NO_x gas furnace option.*

Stainless Steel Drain Pan

For excellent corrosion and oxidation resistance, the optional stainless steel drain pan provides a cleanable surface that complement other IAQ solutions such as high efficiency filtration (MERV 8 or 13), demand control ventilation (CO₂).

Supply, Return, and Plenum Air Smoke Detector

With this option installed, if smoke is detected, all unit operation will be shut down. Reset will be manual at the unit. In order for the supply air smoke detector or return air smoke detector to properly sense smoke in the supply air stream or the return air stream, the air velocity entering the smoke detector unit must be between 500 to 4000 feet per minute. Equipment covered in this manual will develop an airflow velocity that falls within these limits over the entire airflow range specified in the evaporator fan performance table. Supply and/or return smoke detectors may not be used with the plenum smoke detector.

Note: *Plenum smoke detectors have no auxiliary contacts for external connections.*

Figure 1. Supply/Return air smoke detector



Figure 2. Plenum air smoke detector



Through-the-Base Electrical Utility Access

An electrical service entrance shall be provided allowing electrical access for both control and main power connections inside the curb and through-the-base of the unit. Option will allow for field installation of liquid-tight conduit and an external field installed disconnect switch.

Factory provided through-the-base openings simplify wiring and piping. Because these utility openings frequently minimize the number of roof penetrations, the integrity of roofing materials is enhanced.



Features and Benefits

Through-the-Base Gas Access

Factory provided through-the-base openings simplify wiring and piping. Because these utility openings frequently minimize the number of roof penetrations, the integrity of roofing materials is enhanced.

Note: *Through-the-Base Gas not offered on Ultra Low NO_x gas furnace option.*



Ultra Low NO_x Gas Furnace (CA Only)

Gas heat models that provide 14 ng/J NO_x furnace emissions to comply with California's South Coast Air Quality Management District (SCAQMD) and San Joaquin Valley Air Pollution Control District (SJVAPCD) requirements.

Factory or Field Installed Options

Barometric Relief

Designed to be used on downflow units, barometric relief is an unpowered means of relieving excess building pressure.

Clogged Filter/Fan Failure Switch

A dedicated differential pressure switch is available to achieve active fan failure indication and/or clogged filter indication.

These sensors allow a zone sensor service light or Integrated Comfort System to indicate a dirty filter or a fan that's not working. The field installation charges for these feedback devices often eliminate them from consideration. Factory installation can make such features a good investment.

Economizer (Standard)

This accessory shall be available with or without barometric relief. The assembly includes fully modulating 0-100 percent motor and dampers, minimum position setting, preset linkage, wiring harness with plug, spring return actuator and fixed dry bulb control. The barometric relief shall provide a pressure operated damper that shall be gravity closing and shall prohibit entrance of outside air during the equipment "off" cycle. Optional solid state or differential enthalpy control shall be available for either factory or field installation. The economizer arrives in the shipping position and shall be moved to the operating position by the installing contractor.

Electric Heaters

Electric heat modules are available within the basic unit. If ordering the through-the-base electrical option with an electrical heater, the heater must be factory installed.

Fresh Air Options – Dampers and Economizer

Economizers are equipped with either dry bulb or reference or comparative enthalpy sensing. These economizers provide free cooling as the outdoor temperature and/or humidity decreases. Correctly installed, they offer a valuable energy savings. Factory-installed economizers save time and ensure proper installation.

Low Leak Economizer

This accessory meets low leak requirements for ASHRAE 90.1, IECC, and CA Title 24 standards (3 cfm/ft²@1" wg exterior air, 4 cfm/ft²@1" wg return air). This option allows 100% outdoor air supply from 0 to 100% modulating dampers and is standard with barometric relief. It can be paired with powered exhaust for additional building pressure relief. This option can be paired with or without fault detection & diagnostics (FDD) to meet current mandatory CA Title 24 requirements.

The economizers come with three control options, dry bulb and reference or comparative enthalpy (optional).

Note: *Low leak economizers available on downflow units only.*

Reference or Comparative Enthalpy

Measures and communicates humidity while maximizing comfort control.

Hail Guards

Hail protection quality coil guards protects the condenser coil from vandalism and/or hail damage.

Field Installed Options

CO₂ Sensor - Demand Control Ventilation (DCV)

Demand-controlled ventilation (DCV) is a control strategy that responds to the actual demand (need) for ventilation by regulating the rate at which the HVAC system brings outdoor air into the building. A CO₂ sensor measures the concentration (parts per million, ppm) of CO₂ (carbon dioxide) in the air. As the CO₂ concentration changes, the outside air damper modulates to meet the current ventilation needs of the zone. The CO₂ sensor kit is available as a field installed accessory. Two field installed kits are offered; CO₂ sensor and wiring or CO₂ sensor only. The CO₂ sensor only kit should be ordered with factory installed CO₂ sensor wiring. Factory installed CO₂ sensor wiring saves set-up time and ensures proper unit connections for the CO₂ sensor.

Economizer - Low Leak (0 to 100%)

Meets all leakage requirements for ASHRAE and IECC. With additional fault detection and diagnostics (FDD) complies with California Title 24 requirements.

High Altitude Kit

While recommended for units applied above 2000 feet, domestic contractors should consult with local authority on best practice. High altitude kits contain gas orifices that derate the gas input rate (Btuh/r) by 10%.

Note: *No High Altitude Kit for Ultra Low NO_x gas furnace option.*

LP Conversion Kit

Provided for field conversion of gas/electric units from Natural gas to Propane.

Note: *Ultra Low NO_x gas furnace option is for natural gas operation only.*

Outside Air Measuring/Monitoring Control (TraQ™ Dampers)

Quantity of fresh air entering the unit will be measured and monitored via Trane UC400 controller and series of pressure sensing rings mounted at the outside air intake.

Quick Adapt Curbs

Enables easy conversion of existing Voyager™ 3 to 5 ton units to Precedent™ units on replacement jobs.



Features and Benefits

Quick Start Kits

Single phase equipment to enable startup and prevent building lighting dimming during low voltage.

Roof Curbs

Available for downflow units. Only two roof curbs for the entire line simplifies curb selection.

Remote Potentiometer

When properly installed in the economizer control circuitry, this accessory provides a remote variable resistance to enable the operator to adjust the minimum damper position.

Ventilation Override Accessory

With the ventilation override accessory installed, the unit can be set to transition to up to 3 different pre-programmed sequences for smoke purge, pressurization, and exhaust. The transition occurs when a binary input on the RTOM is closed (shorted). This would typically be a hard wired relay output from a smoke detector or fire control panel. The ventilation override kit is available as a field installed accessory.

Zone Sensors

Available in programmable, automatic and manual styles.

Other Benefits

Airflow Distribution

Airflow is outstanding. Precedent™ can replace an older machine with old ductwork and, in many cases, improve the comfort through better air distribution.

Cabinet Integrity

For added water integrity, Precedent™ has a raised 1 1/8-inch lip around the supply and return of the downflow units to prevent water from blowing into the ductwork.

The compact cabinet with rounded corners takes up less room. The beveled and ribbed top is aesthetically pleasing and designed to prevent water from pooling.



Flexibility

Precedent™ offers ultimate flexibility. Units are built to order in our standard “shortest in the industry” ship cycle time.

Rigorous Testing

All of the Precedent™ designs were rigorously rain tested at the factory to ensure water integrity.

Actual shipping tests were performed to determine packaging requirements. Units were test shipped around the country to determine the best packaging design. Factory shake and drop tests were used as part of the package design process to help assure that the unit arrives at the job site in top condition.

Rigging tests include lifting a unit into the air and letting it drop one foot, assuring that the lifting lugs and rails hold up under stress.

We perform a 100% coil leak test at the factory. The evaporator and condenser coils are leak tested at 600 psig. The assembled unit is leak tested to 465 psig.

All parts are inspected at the point of final assembly. Sub-standard parts are identified and rejected immediately.

Every unit receives a 100% unit run test before leaving the production line to make sure it meets rigorous requirements.

Easy to Install, Service and Maintain

Because today's owners are very cost-conscious when it comes to service and maintenance, this unit was designed with direct input from service contractors. This valuable information helped to design a product that would get the service technician off the job quicker and save the owner money. This product line offers outstanding standard features enhanced by a variety of factory and field installed options, multiple control options, rigorously tested proven designs and superior product and technical support.

ReliaTel™ Controls

Figure 3. ReliaTel™ board

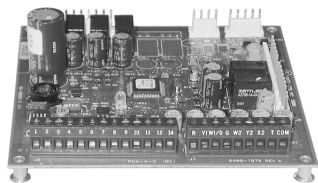

ReliaTel™ controls provide unit control for heating, cooling, and ventilating, utilizing input from sensors that measure outdoor and indoor temperature. ReliaTel™ also provides outputs for building automation systems and expanded diagnostics. Quality and reliability are enhanced through ReliaTel™ control and logic:

- Prevents the unit from short cycling, considerably improving compressor life.
- Ensures the compressor will run for a specific amount of time which allows oil to return for better lubrication, enhancing the reliability of the compressor.
- Reduces the number of components required to operate the unit, reducing possibilities for component failure.

ReliaTel™ Makes Installing and Servicing Easy

ReliaTel™ eliminates the need for field-installed, anti-short cycle timer and time delay relays. The wiring of the low voltage connections to the unit and the zone sensors is as easy as 1-1, 2-2, and 3-3. This simplified system makes wiring easier for the installer.

ReliaTel™ Makes Testing Easy

ReliaTel™ requires no special tools to run the unit through its paces. Simply place a jumper between Test 1 and Test 2 terminals on the Low Voltage Terminal Board and the unit will walk through its operational steps automatically. The unit automatically returns control to the zone sensor after stepping through the test mode a single time, even if the jumper is left on the unit.

As long as the unit has power and the "system on" LED is lit, ReliaTel™ is operational. The light indicates that the controls are functioning properly. ReliaTel™ features expanded diagnostic capabilities when utilized with Trane Integrated Comfort™ Systems. Some zone sensor options have central control panel lights which indicate the mode the unit is in and possible diagnostic information (dirty filters for example).



Features and Benefits

ReliaTel™ Has Other Benefits

- The ReliaTel™ built-in anti-shortcycle timer, time delay relay and minimum “on” time control functions are factory tested to assure proper operation.
- ReliaTel™ softens electrical “spikes” by staging on fans, compressors and heaters.
- Intelligent Fallback is a benefit to the building occupant. If a component goes astray, the unit will continue to operate at predetermined temperature setpoint.
- Intelligent Anticipation is a standard feature. It functions continuously as ReliaTel™ and zone sensor(s) work together in harmony to provide much tighter comfort control than conventional electromechanical thermostats.
- The ReliaTel™ design is standardized across the board, ensuring a lower cost to owners.



Application Considerations

Application of this product should be within the cataloged airflow and cooling considerations.

Barometric Relief

This product line offers an optional barometric relief damper for use in conjunction with economizer option. This accessory consists of gravity dampers which open with increased pressure. As the building air pressure increases, the pressure in the unit return air section also increases, opening the dampers and relieving the conditioned space.

Note: *The effectiveness of barometric relief damper during economizing operation is system related. Pressure drop of the return air system should be considered to control building pressurization.*

Black Epoxy Coil

The coils are manufactured with a thermoset, vinyl coating that is bonded to the aluminum fin stock prior to the fin stamping process. These coils are an economical option for protection in mildly corrosive environments.

Notes:

- *Not to be used where seacoast applications exist.*
- *Not available on microchannel condenser coils.*

Clearance Requirements

The recommended clearances identified with unit dimensions should be maintained to assure adequate service maximum capacity and peak operating efficiency. Actual clearances which appear inadequate should be reviewed with the local Trane® sales personnel.

Model Number	Clearance required from duct to combustible surfaces (inches)
TZC036E	0
TZC048F	0
TZC060E	0
TZC072F	1
TZC090F	1
TZC102F	1
TZC120F	1

CompleteCoat™ Condenser Coil

The coils provide protection from corrosive environments and are ideal for seacoast applications.

Condensate Trap

The evaporator is a draw-thru configuration. A trap must be field provided prior to start-up on the cooling cycle.

Heating Operation

The heat exchanger is manufactured with aluminized steel. To prevent condensation within the heat exchanger, do not exceed 50% outside air or a minimum mixed air temperature of 40°F.



Application Considerations

Low Ambient Cooling

The Precedent™ line features, with ReliaTel™ microprocessor controls, low ambient cooling down to 0°F. The following features or options need to be included/considered when low ambient applications are required: continuous fan operation, crankcase heaters, thermal expansion valves, Froststat™.

Contact a local Trane® Representative for more assistance with low ambient cooling applications.

Optional Stainless Steel Heat Exchanger

The optional stainless steel heat exchanger is manufactured with 409 stainless steel tubes and 439 stainless steel burners. To prevent corrosion and prolong heat exchanger reliability, the minimum mixed air temperature allowed across the heat exchanger is 20°F.

The stainless steel heat exchanger option is an excellent option that compliments the dehumidification package. Whenever high outside air or outside applications exist, these options should be utilized.

Unit Pitch

These units have reversible sloped condensate drain pans. Units must be installed level. Any unit slope must be toward the side of unit where condensate drain is connected.

Optional Ultra Low NO_x Gas Furnace

Units designed for California's mild ambient operating conditions only. Risk of heating failure when start up temperature is below freezing (0°C/32°F).

Sequence of Operation

General Standby Mode

During normal occupied periods, when there is no space cooling or heating demands, the user will be able to choose constant or cycling supply fan operation. During this period, if the supply fan is operating due to a constant fan mode selection or due to a ventilation request, the supply fan will operate at 50% of the user selected, application specific, maximum airflow. The unit controls will be compatible with BACnet® and LonTalk® Building Automation System communication interfaces.

Cooling Operation

Default Operation

During cooling operation, the control will monitor the space temperature and space cooling setpoint and with a PI control algorithm determine if active cooling capacity is required. As the space temperature deviates from the space cooling setpoint, the unit controller will calculate an active discharge air cooling setpoint that the economizer (if installed) and compressor and outdoor fan outputs will be modulated to meet. This active discharge air cooling setpoint will be calculated between the space cooling setpoint and a user adjustable minimum [65°F default for Single Zone Variable Air Volume (SZVAV)]. Once the control determines that a discharge air temperature equal to the user selected minimum (65°F default) is required to meet the space cooling demand, if the space demand continues to increase, the supply fan speed will be allowed to increase above its minimum speed proportionally to meet the additional demand.

Alternate Economizer Operation

Under the default operation, as described above, the supply fan speed will remain at minimum speed, as determined by the active cooling stages, until the space demand requires an increase in supply airflow. The customer will have the ability to choose to allow the supply fan speed to increase when the economizer is enthalpy enabled in order to realize the maximum cooling capacity of the economizer, prior to energizing compressor outputs, when the space requires active cooling capacity. All cooling capacity demand decisions will function as described in the "Default Operation" section above with the exception of the supply fan speed when the unit has an active cooling demand and the economizer is enthalpy enabled.

Heating Operation

During heating operation, the control will monitor the space temperature and space heating setpoint and with a PI control algorithm determine if active heating capacity is required. As the space temperature deviates from the space heating setpoint, the unit controller will increase the supply airflow up to the user selected, application specific, maximum airflow and begin to energize the heating (gas or electric) to meet space demand. The customer will also have the ability to enable supply air tempering control which will allow the unit to bring on one stage of heating when the discharge air temperature falls below the space heating setpoint - 10°F and the unit is operating in a minimum ventilation state with the supply fan running (not actively heating or cooling). The supply fan output will increase to the user selected, application specific, maximum airflow during supply air tempering operation.

Enhanced Dehumidification

Enhanced dehumidification will be available on all units equipped with a space humidity sensor. Once the space humidity value exceeds the dehumidification setpoint and dehumidification is enabled the unit will maintain the compressor operation and reduce the indoor fan airflow to increase latent capacity. If the space humidity value exceeds the dehumidification setpoint during no active call for cooling, the unit will energize the compressor and fans to an optimum capacity for dehumidification. If during active enhanced dehumidification the space humidity falls below the dehumidification setpoint - 2%, dehumidification will be terminated and the unit will transition back to normal cooling or heating control.



Selection Procedure

Cooling Capacity

Note: Cooling Capacity Procedure is the same for electric heat (TZC) and gas heat (YZC).

1. Calculate the building's total and sensible cooling loads at design conditions. Use the Trane® calculation methods or any other standard accepted method.

Factors used in unit selection:

- Packaged Cooling with Optional Electric Heat.
- Total Cooling Load: 44 MBh.
- Sensible Cooling Load: 35 MBh.
- Airflow: 1600 cfm.
- Electrical Characteristics: 460/60/3.
- Summer Design Conditions: Entering Evaporator Coil: 80 DB.
- 67WB Outdoor Ambient: 95.
- External Static Pressure: 0.36 in. wg.
- Downflow Configuration.
- Efficiency: Ultra High.
- Economizer.

2. A rough determination must be made of the size of the unit. The final selection will be made after examining the performance at the given conditions. Divide the total cooling load by nominal Btu/h per ton (12 MBh per ton); then round up to the nearest unit size.

44 MBh/12 MBh = approx. 4 tons.

3. Table 11, p. 38 shows that a TZC048F4 has a **gross** cooling capacity of 46.27 MBh and 37.21 MBh sensible capacity at 1600 cfm and 95 DB outdoor ambient with 80 DB, 67 WB air entering the evaporator.

To Find Capacity at Intermediate Conditions not in the table.

When the design conditions are between two numbers that are in the capacity table, interpolation is required to approximate the capacity.

Note: Extrapolation outside of the table conditions is not recommended.

In order to select the correct unit which meets the building's requirements, the fan motor heat must be deducted from the gross cooling capacity. The amount of heat that the fan motor generates is dependent on the effort by the motor - cfm and static pressure.

4. Determine the total unit static pressure:

External Static Duct System	0.36 wg
Standard Filter from Table 50, p. 83	0.03 wg
Economizer from Table 50, p. 83 (100% Outside Air) *worst case	0.09 wg
Electric Heater Size 6 kW from Table 50, p. 83	0.02 wg
Total Static Pressure	0.50 wg

Note: See "Heating Capacity," p. 23 section for determination of heater size.

Note: The evaporator fan performance Table 20, p. 54 has deducted the pressure drop for a filter already in the unit (see note below Table 20, p. 54). Therefore, the actual total static pressure is 0.50 to 0.03 (from Table 50, p. 83) = 0.47 in. wg.

With 1600 cfm and 0.5 in. wg.

Table 50, p. 83 shows 0.43 bhp for this unit.

Note: Below the table is the formula to calculate fan motor heat.

$$2.9245 \times \text{bhp} + 0.055 = \text{MBh.}$$

$$2.9245 \times 0.43 + 0.055 = 1.3 \text{ MBh.}$$

Now subtract the fan motor heat from the gross cooling capacity of the unit:

Net Total Cooling Capacity

$$= 46.27 \text{ MBh} - 1.3 = 44.97 \text{ MBh.}$$

Net Sensible Cooling Capacity

$$= 37.21 \text{ MBh} - 1.3 = 35.91 \text{ MBh.}$$

Subtracting Sensible from Total Capacity to find Latent Capacity

Net Latent Capacity

$$= 44.97 - 35.91 = 9.06 \text{ MBh.}$$

5. Compare your resulting capacities to the building load. If the performance will not meet the required load of the building's total or sensible cooling load, try a selection at the next higher size unit.

Heating Capacity

Note: Heating capacity procedure DIFFERS for electric heat (TZC) and gas heat (YZC) units.

1. Calculate the building heating load using the Trane® calculation form or other standard accepted method.
2. Size the system heating capacity to match the calculated building heating load. The following are building heating requirements:
 - Total heating load of 15 MBh.
 - 1600 cfm.
 - TZC units with optional electric heat: 460V/3 phase Power Supply.
 - The electric heat accessory capacities are listed in [Table 53, p. 85](#). From the table, a 6kW heater will deliver 20.48 MBh at 480 volts. In order to determine capacity at 460 volts, the heater voltage correction factor from [Table 54, p. 86](#) must be used. Therefore, 20.48 MBh x 0.918 (voltage correction factor) = 18.8 MBh.
 - YZC units with gas heat: Fuel- natural gas.
 - 60 MBh, 80MBh and 120MBh input models shown in [Table 52, p. 85](#). The output capacities of these furnaces are 48 MBh, 64 MBh and 96 MBh respectively. The low heat model with 48 MBh best matches the building requirements.

Air Delivery Selection

Note: Air delivery procedure is the same for electric heat and gas heat units.

External static pressure drop through the air distribution system has been calculated to be 0.5 inches of water. Enter [Table 20, p. 54](#) for a TZC048F4 at 1600 cfm and 0.5 static pressure. The standard direct drive motor will give the desired airflow at a rated bhp of 0.43 and 761 rpm.



Model Number Descriptions

Digit 1 - Unit Type

- T DX Cooling
- Y DX Cooling, Gas Heat

Digit 2 - Efficiency

- Z Ultra High Efficiency

Digit 3 - Airflow

- C Convertible

Digit 4,5,6 - Nominal Gross Cooling Capacity (MBh)

- 036 3 Ton
- 048 4 Ton
- 060 5 Ton
- 072 6 Ton
- 090 7.5Ton
- 102 8.5 Ton
- 120 10 Ton

Digit 7 - Major Design Sequence

- E R-410A Refrigerant
- F Microchannel Type Condenser Coils with R-410A Refrigerant¹¹

Digit 8 - Voltage Selection

- 3 208-230/60/3
- 4 460/60/3
- W 575/60/3

Digit 9 - Unit Controls

- R ReliaTel™ Microprocessor

Digit 10 - Heating Capacity

Note: Applicable to Digit 1, T models only

- 0 No Electric Heat
- B 6 kW (3 phase)
- C 9 kW (3 phase)
- E 12 kW (3 phase)
- G 18 kW (1 and 3 phase)
- J 23 kW (3 phase)
- K 27 kW (3 phase)
- N 36 kW (3 phase)
- P 54 kW (3 phase)

Note: Applicable to Digit 1, Y models only

- L Low Heat
- M Medium Heat
- H High Heat
- X Low Heat, Stainless Steel Heat Exchanger
- Y Medium Heat, Stainless Steel Heat Exchanger
- Z High Heat, Stainless Steel Heat Exchanger
- V Modulating Gas Heat

Digit 11 - Minor Design Sequence

- A First Sequence

Digit 12,13 - Service Sequence

** Factory Assigned

Digit 14 - Fresh Air Selection

- 0 No Fresh Air
- C Economizer, Dry Bulb 0-100% without Barometric Relief²
- D Economizer, Dry Bulb 0-100% with Barometric Relief²
- E Economizer, Reference Enthalpy 0-100% without Barometric Relief²
- F Economizer, Reference Enthalpy 0-100% with Barometric Relief²
- G Economizer, Comparative Enthalpy 0-100% without Barometric Relief²
- H Economizer, Comparative Enthalpy 0-100% with Barometric Relief²
- K Low Leak Economizer with Barometric Relief
- M Low Leak Economizer with Reference Enthalpy with Barometric Relief
- P Low Leak Economizer with Comparative Enthalpy with Barometric Relief

Digit 15 - Supply Fan/Drive Type/ Motor

- 6 Single Zone VAV¹⁰
- E VAV Supply Air Temperature Control - Standard Motor

Digit 16 - Hinged Service Access/ Filters

- 0 Standard Panels/Standard Filters
- A Hinged Access Panels/Standard Filters
- B Standard Panels/2" MERV 8 Filters
- C Hinged Access Panels/2" MERV 8 Filters
- D Standard Panels/2" MERV 13 Filters
- E Hinged Access Panels/2" MERV 13 Filters

Digit 17 - Condenser Coil Protection

- 0 Standard Coil
- 1 Standard Coil with Hail Guard
- 2 Black Epoxy Pre-Coated Condenser Coil¹²
- 3 Black Epoxy Pre-Coated Condenser Coil with Hail Guard¹²
- 4 CompleteCoat™ Condenser Coil
- 5 CompleteCoat™ Condenser Coil with Hail Guard

Digit 18 - Through the Base Provisions

- 0 No Through-the-Base Provisions
- A Through-the-Base Electric³
- B Through-the-Base Gas Piping⁷
- C Through-the-Base Electric and Gas Piping⁷

Digit 19 - Disconnect/Circuit Breaker (three-phase only)

- 0 No Disconnect/No Circuit Breaker
- 1 Unit Mounted Non-Fused Disconnect³
- 2 Unit Mounted Circuit Breaker³

Digit 20 - Convenience Outlet

- 0 No Convenience Outlet
- A Unpowered Convenience Outlet
- B Powered Convenience Outlet (three-phase only)⁴

Digit 21 - Communications Options

- 0 No Communications Interface
- 2 LonTalk® Communications Interface
- 6 BACnet® Communications Interface
- 7 Air-Fi™ Wireless Communications¹⁶

Digit 22 - Refrigeration System Option

- 0 Standard Refrigeration System⁵

Digit 23 - Refrigeration Controls

- 0 Without Refrigeration Controls¹

Digit 24 - Smoke Detector⁸

- 0 No Smoke Detector
- A Return Air Smoke Detector⁶
- B Supply Air Smoke Detector
- C Supply and Return Air Smoke Detectors⁶
- D Plenum Smoke Detector

Digit 25 - System Monitoring Controls¹⁴

- 0 Standard Monitoring System
- 1 Clogged Filter Switch
- 2 Fan Failure Switch
- 4 Clogged Filter Switch and Fan Failure Switch
- A Condensate Drain Pan Overflow Switch
- B Clogged Filter Switch and Condensate Drain Pan Overflow Switch
- C Fan Failure Switch and Condensate Drain Pan Overflow Switch
- E Clogged Filter Switch, Fan Failure Switch and Condensate Drain Pan Overflow Switch

Digit 26 - System Monitoring Controls

- 0 No Monitoring Controls
- A Demand Control Ventilation (CO₂)^{9,13}

Digit 27 - Unit Hardware Enhancements

- 0 No Enhancements
- 1 Stainless Steel Drain Pan

Digit 31 - Advanced Unit Controls

- 0 Standard Unit Controls
- 1 Human Interface

Digit 34 - Ultra Low NOx Gas Furnace (CA Only)

- 0 None
- A 14 ng/J NOx Emissions [17](#) [18](#) [19](#) [20](#) [21](#) [22](#) [23](#)

Model Number Notes

1. Standard on all eFlex™ and eDrive™ units.
2. Economizer with Barometric Relief is for downflow configured units only. Order Economizer without Barometric Relief for horizontal configuration. Barometric Relief for horizontal configured units must be ordered as field installed accessory.
3. Through the base electric required when ordering disconnect/circuit breaker options.
4. Requires use of Disconnect or Circuit Breaker.
5. Standard metering devices are TXVs.
6. The return air smoke detector may not fit up or work properly on the Precedent units when used in conjunction with 3rd party accessories such as bolt on heat wheels, economizers and power exhaust. Do not order the return air smoke detectors when using this type of accessory.
7. Includes gas piping and shutoff (field assembly required).
8. Not available with high temperature duct sensor accessory.
9. Demand Control Ventilation Option includes wiring only. The CO₂ sensor is a field-installed only option.
10. Discharge Air Temperature Sensor is also standard equipment on units with Single Zone.
11. Standard on T/YZC 4 ton models.
12. Epoxy coil and epoxy with hail guard option not available for units with microchannel condenser coil.
13. Requires selection of 2-inch pleated filters (option B or C) for Digit 16.
14. Discharge Air Sensing Tube is standard.
15. Field installed only.
16. Must be used with BACnet® open protocol.
17. No 575V with Ultra Low NOx.
18. Ultra Low NOx requires SSHX Option (Digit 10 = X or Y).
19. Ultra Low NOx has 3T Only available with LOW heat (digit 10=X).
20. Ultra Low NOx has NO High Heat Available.
21. High Altitude kit is not available with Ultra Low NOx option.
22. LP Conversion kit is not available with Ultra Low NOx option.
23. 3 to 5 Tons only.



General Data

Table 3. General data - 3 to 5 tons with eFlex™ and eDrive™ technology (208/230 Volt)

	3 Tons	4 Tons	5 Tons
	T/YZC036E3	T/YZC048F3	T/YZC060E3
Cooling Performance^(a)			
Gross Cooling Capacity - Full Load	36,600	46,000	60,500
EER/SEER ^(b)	13.0/20.1	13.6/19.4	12.9/19.6
EER2/SEER2 ^(c)	13.1/19.2	12.8/18.6	—
Nominal cfm/AHRI Rated cfm	1,200/1,100	1,600/1,350	2,000/1,900
AHRI Net Cooling Capacity - Full Load	35,800	44,500	59,000
System Power (kW)	2.75	3.27	4.58
Compressor			
Number/Type	1/Scroll (Variable Speed)	1/Scroll (Variable Speed)	1/Scroll (Variable Speed)
Sound			
Outdoor Sound Rating (dB) ^(d)	81	87	87
Outdoor Coil - Type			
	Tube-Fin	Microchannel	Tube-Fin
Tube Size (in.) OD	0.3125	—	0.3125
Coil Width (in.)	—	0.71	—
Face Area (sq. ft.)	17.0	17.5	17.0
Rows/FPI	3/16	1/20	3/16
Indoor Coil - Type			
	Lanced	Lanced	Lanced
Tube Size (in.) ID	0.3125	0.3125	0.3125
Face Area (sq. ft.)	7.71	9.27	9.89
Rows/FPI	3/16	3/16	4/16
Refrigerant Control	Thermal Expansion Valve	Thermal Expansion Valve	Thermal Expansion Valve
Drain Connection Number/Size (in.)	1¼ NPT	1¼ NPT	1¼ NPT
Outdoor Fan - Type			
	Propeller	Propeller	Propeller
Number Used/Diameter (in.)	1/22	1/26	1/26
Drive Type/No. Speeds	Direct/Variable	Direct/Variable	Direct/Variable
cfm	3,064	3,982	3,953
Motor hp	0.33	0.5	0.5
Motor rpm	1,100	1,100	1,100
Indoor Fan - Type			
	FC Centrifugal	FC Centrifugal	FC Centrifugal
Number Used/Diameter (in.)/Width (in.)	1/11x11	1/11x11	1/11x11
Drive Type/No. Speeds	Direct/Variable	Direct/Variable	Direct/Variable
Number Motors	1	1	1
Motor hp (Standard/Oversized)	0.75	1.0	1.0
Motor Frame Size (Standard/Oversized)	48	48	48
Filters^(e)			
Type Furnished	Throwaway	Throwaway	Throwaway
Number Size Recommended	(2) 20x30x2	(4) 16x25x2	(4) 16x25x2
Refrigerant Charge^(f)			
Pounds of R-410A	7.8	6.0	11.9

Table 3. General data - 3 to 5 tons with eFlex™ and eDrive™ technology (208/230 Volt) (continued)

	3 Tons	4 Tons	5 Tons
	T/YZC036E3	T/YZC048F3	T/YZC060E3
Heating Performance⁽⁹⁾			
(Gas/Electric Only)			
Heating Input			
Low Heat Input (Btu)	60,000	60,000	60,000
Mid Heat Input (Btu)	80,000	80,000	80,000
High Heat Input (Btu)	100,000	120,000	130,000
Heating Output			
Low Heat Input (Btu)	48,000	49,000	49,000
Mid Heat Input (Btu)	64,000	64,000	64,000
High Heat Input (Btu)	80,000	96,000	104,000
Steady State Efficiency%			
Low Heat Input (Btu)	80	81	81
Mid Heat Input (Btu)	80	80	80
High Heat Input (Btu)	81	81	80
No. Burners			
Low Heat Input (Btu)	2	2	2
Mid Heat Input (Btu)	2	2	2
High Heat Input (Btu)	3	3	3
No. Stages			
Low Heat Input (Btu)	1	1	1
Mid Heat Input (Btu)	1	1	1
High Heat Input (Btu)	1	1	1
Gas Supply Line Pressure			
Natural (minimum/maximum)	4.5/14.0	4.5/14.0	4.5/14.0
LP (minimum/maximum)	11.0/14.0	11.0/14.0	11.0/14.0
Gas Connection Pipe Size (in)			
Low Heat	1/2	1/2	1/2
Mid Heat	1/2	1/2	1/2
High Heat	1/2	1/2	1/2

- (a) High Stage Cooling Performance is rated at 95°F ambient, 80°F entering dry bulb, 67°F entering wet bulb. Gross capacity does not include the effect of fan motor heat. AHRI capacity is net and includes the effect of fan motor heat. Units are suitable for operation to ±20% of nominal cfm. Units are certified in accordance with the Unitary Air-Conditioner Equipment certification program, which is based on AHRI standard 210/240.
- (b) EER and/or SEER are rated at AHRI conditions and in accordance with DOE test procedures.
- (c) EER2 and SEER2 is rated at AHRI conditions and calculated in accordance with AHRI Standard 210/240-2023. Airflow and net cooling capacity not shown.
- (d) Outdoor Sound Rating shown is tested in accordance with AHRI Standard 270. For additional information reference the outdoor sound power level data in the performance section.
- (e) Optional 2" MERV 8 and MERV 13 filters also available.
- (f) Refrigerant charge is an approximate value. For a more precise value, see unit nameplate and service instructions.
- (g) Heating performance limit settings and rating data were established and approved under laboratory test conditions using American National Standards Institute standards. Ratings shown are for elevations up to 2000 feet. For elevations above 2000 feet, ratings should be reduced at the rate of 4% for each 1000 feet above sea level. Applicable to Gas/Electric units only.



General Data

Table 4. General data - 3 to 5 tons with eFlex™ and eDrive™ technology with Ultra Low NOx (208/230 Volt)

Ultra Low NO _x Digit 34 = A	3 Tons		4 Tons		5 Tons	
	YZC036E3,4		YZC048F3,4		YZC060E3,4	
Heating Performance						
Heat Models	Low	Low	Med	Low	Med	
Heating Input (Btu)	60,000	60,000	90,000	60,000	90,000	
Heating Output (Btu)	48,600	48,600	72,900	48,600	72,900	
Stead State Efficiency (%)	81%	81%	81%	81%	81%	
No. Burners	2	2	3	2	3	
No. Stages	1	1	1	1	1	
Gas Supply Line Pressure						
Natural (minimum / maximum)	4.5/14.0		4.5/14.0		4.5/14.0	
Gas Connection Pipe Size (in.)						
	1/2	1/2	1/2	1/2	1/2	1/2

Table 5. General data - 6 to 10 tons with eFlex™ and eDrive™ technology (208/230 Volt)

	6 Tons		7.5 Tons		8.5 Tons		10 Tons	
	T/YZC072F3		T/YZC090F3		T/YZC102F3		T/YZC120F3	
Cooling Performance^(a)								
Gross Cooling Capacity - Full Load	71,000		92,000		103,000		117,000	
EER/IEER ^(b)	12.8/23.2		12.8/22.4		12.6/22.5		12.1/23.0	
Nominal cfm/AHRI Rated cfm	2,400/2,400		3,000/2,850		3,400/2,975		4,000/4,000	
AHRI Net Cooling Capacity - Full Load	70,000		90,000		99,000		114,000	
System Power (kW)	5.47		7.03		7.86		9.42	
Compressor								
Number/Type	1/Scroll (Variable Speed)		1/Scroll (Variable Speed)		1/Scroll (Variable Speed)		1/Scroll (Variable Speed)	
Sound								
Outdoor Sound Rating (dB) ^(c)	89		89		89		89	
Outdoor Coil - Type								
	Microchannel		Microchannel		Microchannel		Microchannel	
Coil Width (in.)	0.8		1.0		1.0		1.0	
Face Area (sq. ft.)	20.8		20.9		20.9		26.7	
Rows/FPI	1/23		1/20		1/20		1/20	
Indoor Coil - Type								
	Lanced		Lanced		Lanced		Lanced	
Tube Size (in.) ID	0.3125		0.3125		0.3125		0.3125	
Face Area (sq. ft.)	12.4		12.4		12.4		16.7	
Rows/FPI	5/16		4/16		4/16		4/16	
Refrigerant Control	Thermal Expansion Valve		Thermal Expansion Valve		Thermal Expansion Valve		Thermal Expansion Valve	
Drain Connection Number/Size (in.)	1½ NPT		1½ NPT		1½ NPT		1½ NPT	
Outdoor Fan - Type								
	Propeller		Propeller		Propeller		Propeller	
Number Used/Diameter (in.)	1/26		1/26		1/26		1/30	
Drive Type/No. Speeds	Direct/Variable		Direct/Variable		Direct/Variable		Direct/Variable	
cfm	5,865		6,806		6,770		7,611	
Motor hp	0.75		0.75		0.75		0.75	
Motor rpm (max.)	1,200		1,200		1,200		1,200	

Table 5. General data - 6 to 10 tons with eFlex™ and eDrive™ technology (208/230 Volt) (continued)

	6 Tons	7.5 Tons	8.5 Tons	10 Tons
	T/YZC072F3	T/YZC090F3	T/YZC102F3	T/YZC120F3
Indoor Fan - Type	EBM	EBM	EBM	EBM
Number Used/Diameter (in.)	1/23.03	1/23.03	1/23.03	1/23.03
Drive Type/No. Speeds	Direct/Variable	Direct/Variable	Direct/Variable	Direct/Variable
Number Motors	1	1	1	1
Motor hp (Standard/Oversized)	2.75	2.75	2.75	2.75
Filters^(d)				
Type Furnished	Throwaway	Throwaway	Throwaway	Throwaway
Number Size Recommended	(4) 2x20x25	(4) 2x20x25	(4) 2x20x25	(3) 2x20x25 (2) 2x20x30
Refrigerant Charge^(e)				
Pounds of R-410A	8.3	8.7	8.9	10.5
Heating Performance^(f)				
(Gas/Electric Only)				
Heating Input				
Low Heat Input (Btu)	80,000	120,000	120,000	150,000
Mid Heat Input (Btu)	120,000	150,000	150,000	200,000
High Heat Input (Btu)	150,000	200,000	200,000	250,000
Modulating Heat Input (Btu)	150,000	200,000	200,000	250,000
Heating Output				
Low Heat Input (Btu)	64,800	97,200	97,200	121,500
Mid Heat Input (Btu)	97,200	121,500	121,500	162,000
High Heat Input (Btu)	121,500	162,000	162,000	202,500
Modulating Heat (Btu)	121,500	162,000	162,000	202,500
Steady State Efficiency%				
Low Heat Input (Btu)	81	81	81	81
Mid Heat Input (Btu)	81	81	81	81
High Heat Input (Btu)	81	81	81	81
Modulating Heat (Btu)	81	81	81	81
No. Burners				
Low Heat Input (Btu)	3	3	3	3
Mid Heat Input (Btu)	3	3	3	4
High Heat Input (Btu)	3	5	5	5
Modulating Heat (Btu)	3	5	5	5
No. Stages				
Low Heat Input (Btu)	1	1	1	2
Mid Heat Input (Btu)	1	2	2	2
High Heat Input (Btu)	2	2	2	2
Modulating Heat (Btu)	2.5:1 Modulating	2.5:1 Modulating	2.5:1 Modulating	2.5:1 Modulating
Gas Supply Line Pressure (w.c.)				
Natural (minimum/maximum) Low/Mid/High	4.5/14.0	4.5/14.0	4.5/14.0	4.5/14.0
Natural (minimum/maximum) Mod Heat	5.5/14.0	5.5/14.0	5.5/14.0	5.5/14.0
LP (minimum/maximum)	11.0/14.0	11.0/14.0	11.0/14.0	11.0/14.0



General Data

Table 5. General data - 6 to 10 tons with eFlex™ and eDrive™ technology (208/230 Volt) (continued)

	6 Tons	7.5 Tons	8.5 Tons	10 Tons
	T/YZC072F3	T/YZC090F3	T/YZC102F3	T/YZC120F3
Gas Connection Pipe Size (in)				
Low Heat	1/2	1/2	1/2	3/4
Mid Heat	1/2	3/4	3/4	3/4
High Heat	3/4	3/4	3/4	3/4
Modulating Heat	3/4	3/4	3/4	3/4

- (a) High stage cooling performance is rated at 95°F ambient, 80°F entering dry bulb, 67°F entering wet bulb. Gross capacity does not include the effect of fan motor heat. AHRI capacity is net and includes the effect of fan motor heat. Units are suitable for operation to ±20% of nominal cfm. Units are certified in accordance with the Unitary Air-Conditioner Equipment certification program, which is based on AHRI standard 340/360.
- (b) EER and/or IEER are rated at AHRI conditions and in accordance with DOE test procedures.
- (c) Outdoor Sound Rating shown is tested in accordance with AHRI Standard 270. For additional information reference the outdoor sound power level data in the performance section.
- (d) Optional 2" MERV 8 and MERV 13 filters also available.
- (e) Refrigerant charge is an approximate value. For a more precise value, see unit nameplate and service instructions.
- (f) Heating performance limit settings and rating data were established and approved under laboratory test conditions using American National Standards Institute standards. Ratings shown are for elevations up to 2000 feet. For elevations above 2000 feet, ratings should be reduced at the rate of 4% for each 1000 feet above sea level. Applicable to gas/electric units only.

Table 6. General data - 3 to 5 tons with eFlex™ and eDrive™ technology (460 Volt)

	3 Tons	4 Tons	5 Tons
	T/YZC036E4	T/YZC048F4	T/YZC060E4
Cooling Performance^(a)			
Gross Cooling Capacity - Full Load	36,600	46,000	58,500
EER/SEER ^(b)	12.9/19.5	13.3/18.5	12.5/18.4
EER2/SEER2 ^(c)	12.9/18.9	12.6/18	12.5/19
Nominal cfm/AHRI Rated cfm	1,200/1,100	1,600/1,350	2,000/1,900
AHRI Net Cooling Capacity - Full Load	35,800	44,500	57,000
System Power (kW)	2.78	3.35	4.56
Compressor			
Number/Type	1/Scroll (Variable Speed)	1/Scroll (Variable Speed)	1/Scroll (Variable Speed)
Sound			
Outdoor Sound Rating (dB) ^(d)	81	87	87
Outdoor Coil - Type	Tube-Fin	Microchannel	Tube-Fin
Tube Size (in.) OD	0.3125	—	0.3125
Coil Width (in.)	—	0.71	—
Face Area (sq. ft.)	10.96	17.5	17.0
Rows/FPI	3/16	1/20	3/16
Indoor Coil - Type	Lanced	Lanced	Lanced
Tube Size (in.) ID	0.3125	0.3125	0.3125
Face Area (sq. ft.)	7.71	9.27	9.89
Rows/FPI	3/16	3/16	4/16
Refrigerant Control	Thermal Expansion Valve	Thermal Expansion Valve	Thermal Expansion Valve
Drain Connection Number/Size (in.)	1¼ NPT	1¼ NPT	1¼ NPT
Outdoor Fan - Type	Propeller	Propeller	Propeller
Number Used/Diameter (in.)	1/22	1/26	1/26
Drive Type/No. Speeds	Direct/Variable	Direct/Variable	Direct/Variable
cfm	3,064	3,982	3,953
Motor hp	0.33	0.5	0.5
Motor rpm	1,100	1,100	1,100

Table 6. General data - 3 to 5 tons with eFlex™ and eDrive™ technology (460 Volt) (continued)

	3 Tons	4 Tons	5 Tons
	T/YZC036E4	T/YZC048F4	T/YZC060E4
Indoor Fan - Type (Optional)	FC Centrifugal	FC Centrifugal	FC Centrifugal
Number Used/Diameter (in.)/Width (in.)	1/11x11	1/11x11	1/11x11
Drive Type/No. Speeds	Direct/Variable	Direct/Variable	Direct/Variable
Number Motors	1	1	1
Motor hp (Standard/Oversized)	0.75	1.0	1.0
Motor Frame Size (Standard/Oversized)	48	48	48
Filters^(e)			
Type Furnished	Throwaway	Throwaway	Throwaway
Number Size Recommended	(2) 20x30x2	(4) 16x25x2	(4) 16x25x2
Refrigerant Charge^(f)			
Pounds of R-410A	7.8	6.0	12.0
Heating Performance^(g)			
(Gas/Electric Only)			
Heating Input			
Low Heat Input (Btu)	60,000	60,000	60,000
Mid Heat Input (Btu)	80,000	80,000	80,000
High Heat Input (Btu)	100,000	120,000	130,000
Heating Output			
Low Heat Input (Btu)	48,000	49,000	49,000
Mid Heat Input (Btu)	64,000	64,000	64,000
High Heat Input (Btu)	80,000	96,000	104,000
Steady State Efficiency%			
Low Heat Input (Btu)	80	81	81
Mid Heat Input (Btu)	80	80	80
High Heat Input (Btu)	81	81	80
No. Burners			
Low Heat Input (Btu)	2	2	2
Mid Heat Input (Btu)	2	2	2
High Heat Input (Btu)	3	3	3
No. Stages			
Low Heat Input (Btu)	1	1	1
Mid Heat Input (Btu)	1	1	1
High Heat Input (Btu)	1	1	1
Gas Supply Line Pressure			
Natural (minimum/maximum)	4.5/14.0	4.5/14.0	4.5/14.0
LP (minimum/maximum)	11.0/14.0	11.0/14.0	11.0/14.0
Gas Connection Pipe Size (in)			
Low Heat	1/2	1/2	1/2
Mid Heat	1/2	1/2	1/2
High Heat	1/2	1/2	1/2

- (a) High Stage Cooling Performance is rated at 95°F ambient, 80°F entering dry bulb, 67°F entering wet bulb. Gross capacity does not include the effect of fan motor heat. AHRI capacity is net and includes the effect of fan motor heat. Units are suitable for operation to ±20% of nominal cfm. Units are certified in accordance with the Unitary Air-Conditioner Equipment certification program, which is based on AHRI standard 210/240.
- (b) EER and/or SEER are rated at AHRI conditions and in accordance with DOE test procedures.
- (c) EER2 and SEER2 is rated at AHRI conditions and calculated in accordance with AHRI Standard 210/240-2023. Airflow and net cooling capacity not shown.
- (d) Outdoor Sound Rating shown is tested in accordance with AHRI Standard 270. For additional information reference the outdoor sound power level data in the performance section.
- (e) Optional 2-inch MERV 8 and MERV 13 filters also available.
- (f) Refrigerant charge is an approximate value. For a more precise value, see unit nameplate and service instructions.
- (g) Heating performance limit settings and rating data were established and approved under laboratory test conditions using American National Standards Institute standards. Ratings shown are for elevations up to 2000 feet. For elevations above 2000 feet, ratings should be reduced at the rate of 4% for each 1000 feet above sea level. Applicable to Gas/Electric units only.



General Data

Table 7. General data - 3 to 5 tons with eFlex™ and eDrive™ technology with Ultra Low NOx (460 Volt)

Ultra Low NO _x Digit 34 = A	3 Tons	4 Tons		5 Tons	
	YZC036E3,4	YZC048F3,4		YZC060E3,4	
Heating Performance					
Heat Models	Low	Low	Med	Low	Med
Heating Input (Btu)	60,000	60,000	90,000	60,000	90,000
Heating Output (Btu)	48,600	48,600	72,900	48,600	72,900
Stead State Efficiency (%)	81%	81%	81%	81%	81%
No. Burners	2	2	3	2	3
No. Stages	1	1	1	1	1
Gas Supply Line Pressure					
Natural (minimum / maximum)	4.5/14.0		4.5/14.0		4.5/14.0
Gas Connection Pipe Size (in.)					
	1/2	1/2	1/2	1/2	1/2

Table 8. General data - 6 to 10 tons with eFlex™ and eDrive™ technology (460 Volt)

	6 Tons	7.5 Tons	8.5 Tons	10 Tons
	T/YZC072F4	T/YZC090F4	T/YZC102F4	T/YZC120F4
Cooling Performance^(a)				
Gross Cooling Capacity - Full Load	71,000	92,000	103,000	117,000
EER/IEER ^(b)	12.6/23.2	12.8/22.4	12.6/22.5	12.2/23.0
Nominal cfm/AHRI Rated cfm	2,400/2,400	3,000/2,850	3,400/2,975	4,000/4,000
AHRI Net Cooling Capacity - Full Load	70,000	90,000	99,000	114,000
System Power (kW)	5.56	7.03	7.86	9.34
Compressor				
Number/Type	1/Scroll (Variable Speed)	1/Scroll (Variable Speed)	1/Scroll (Variable Speed)	1/Scroll (Variable Speed)
Sound				
Outdoor Sound Rating (dB) ^(c)	89	89	89	89
Outdoor Coil - Type				
	Microchannel	Microchannel	Microchannel	Microchannel
Coil Width (in.)	0.8	1.0	1.0	1.0
Face Area (sq. ft.)	20.8	20.9	20.9	26.7
Rows/FPI	1/23	1/20	1/20	1/20
Indoor Coil - Type				
	Lanced	Lanced	Lanced	Lanced
Tube Size (in.) ID	0.3125	0.3125	0.3125	0.3125
Face Area (sq. ft.)	12.4	12.4	12.4	16.7
Rows/FPI	5/16	4/16	4/16	4/16
Refrigerant Control	Thermal Expansion Valve	Thermal Expansion Valve	Thermal Expansion Valve	Thermal Expansion Valve
Drain Connection Number/Size (in.)	1¼ NPT	1¼ NPT	1¼ NPT	1¼ NPT
Outdoor Fan - Type				
	Propeller	Propeller	Propeller	Propeller
Number Used/Diameter (in.)	1/26	1/26	1/26	1/30
Drive Type/No. Speeds	Direct/Variable	Direct/Variable	Direct/Variable	Direct/Variable
cfm	5,864	6,806	6,771	7,613
Motor hp	0.75	0.75	0.75	0.75
Motor rpm	1,200	1,200	1,200	1,200

Table 8. General data - 6 to 10 tons with eFlex™ and eDrive™ technology (460 Volt) (continued)

	6 Tons	7.5 Tons	8.5 Tons	10 Tons
	T/YZC072F4	T/YZC090F4	T/YZC102F4	T/YZC120F4
Indoor Fan - Type (Optional)	EBM	EBM	EBM	EBM
Number Used/Diameter (in.)	1/23.03	1/23.03	1/23.03	1/23.03
Drive Type/No. Speeds	Direct/Variable	Direct/Variable	Direct/Variable	Direct/Variable
Number Motors	1	1	1	1
Motor hp (Standard/Oversized)	2.75	2.75	2.75	2.75
Filters^(d)				
Type Furnished	Throwaway	Throwaway	Throwaway	Throwaway
Number Size Recommended	(4) 2x20x25	(4) 2x20x25	(4) 2x20x25	(3) 2x20x25 (2) 2x20x30
Refrigerant Charge^(e)				
Pounds of R-410A	8.3	8.7	8.9	10.5
Heating Performance^(f)				
(Gas/Electric Only)				
Heating Input				
Low Heat Input (Btu)	80,000	120,000	120,000	150,000
Mid Heat Input (Btu)	120,000	150,000	150,000	200,000
High Heat Input (Btu)	150,000	200,000	200,000	250,000
Modulating Heat Input (Btu)	150,000	200,000	200,000	250,000
Heating Output				
Low Heat Input (Btu)	64,800	97,200	97,200	121,500
Mid Heat Input (Btu)	97,200	121,500	121,500	162,000
High Heat Input (Btu)	121,500	162,000	162,000	202,500
Modulating Heat Input (Btu)	121,500	162,000	162,000	202,500
Steady State Efficiency%				
Low Heat Input (Btu)	81	81	81	81
Mid Heat Input (Btu)	81	81	81	81
High Heat Input (Btu)	81	81	81	81
Modulating Heat Input (Btu)	81	81	81	81
No. Burners				
Low Heat Input (Btu)	3	3	3	3
Mid Heat Input (Btu)	3	3	3	4
High Heat Input (Btu)	3	5	5	5
Modulating Heat Input (Btu)	3	5	5	5
No. Stages				
Low Heat Input (Btu)	1	1	1	2
Mid Heat Input (Btu)	1	2	2	2
High Heat Input (Btu)	2	2	2	2
Modulating Heat Input (Btu)	2.5:1 Modulating	2.5:1 Modulating	2.5:1 Modulating	2.5:1 Modulating
Gas Supply Line Pressure (w.c.)				
Natural (minimum/maximum) Low/Mid/High	4.5/14.0	4.5/14.0	4.5/14.0	4.5/14.0
Natural (minimum/maximum) Mod Heat	5.5/14.0	5.5/14.0	5.5/14.0	5.5/14.0
LP (minimum/maximum)	11.0/14.0	11.0/14.0	11.0/14.0	11.0/14.0



General Data

Table 8. General data - 6 to 10 tons with eFlex™ and eDrive™ technology (460 Volt) (continued)

	6 Tons	7.5 Tons	8.5 Tons	10 Tons
	T/YZC072F4	T/YZC090F4	T/YZC102F4	T/YZC120F4
Gas Connection Pipe Size (in)				
Low Heat	1/2	1/2	1/2	3/4
Mid Heat	1/2	3/4	3/4	3/4
High Heat	3/4	3/4	3/4	3/4
Modulating Heat	3/4	3/4	3/4	3/4

- (a) High stage cooling performance is rated at 95°F ambient, 80°F entering dry bulb, 67°F entering wet bulb. Gross capacity does not include the effect of fan motor heat. AHRI capacity is net and includes the effect of fan motor heat. Units are suitable for operation to ±20% of nominal cfm. Units are certified in accordance with the Unitary Air-Conditioner Equipment certification program, which is based on AHRI standard 340/360.
- (b) EER and/or IEER are rated at AHRI conditions and in accordance with DOE test procedures.
- (c) Outdoor Sound Rating shown is tested in accordance with AHRI Standard 270. For additional information reference the outdoor sound power level data in the performance section.
- (d) Optional 2-inch MERV 8 and MERV 13 filters also available.
- (e) Refrigerant charge is an approximate value. For a more precise value, see unit nameplate and service instructions.
- (f) Heating performance limit settings and rating data were established and approved under laboratory test conditions using American National Standards Institute standards. Ratings shown are for elevations up to 2000 feet. For elevations above 2000 feet, ratings should be reduced at the rate of 4% for each 1000 feet above sea level. Applicable to gas/electric units only.

Table 9. General data - 6 to 10 tons with eFlex™ and eDrive™ technology (575 Volt)

	6 Tons	7.5 Tons	8.5 Tons	10 Tons
	T/YZC072FW	T/YZC090FW	T/YZC102FW	T/YZC120FW
Cooling Performance^(a)				
Gross Cooling Capacity - Full Load	71,000	92,000	103,000	117,000
EER/IEER ^(b)	12.5/22.6	12.8/21.5	12.6/21.5	12.1/22.5
Nominal cfm/AHRI Rated cfm	2,400/2,400	3,000/2,850	3,400/2,975	4,000/4,000
AHRI Net Cooling Capacity - Full Load	70,000	90,000	99,000	114,000
System Power (kW)	5.60	7.03	7.86	9.42
Compressor				
Number/Type	1/Scroll (Variable Speed)	1/Scroll (Variable Speed)	1/Scroll (Variable Speed)	1/Scroll (Variable Speed)
Sound				
Outdoor Sound Rating (dB) ^(c)	89	89	89	89
Outdoor Coil - Type	Microchannel	Microchannel	Microchannel	Microchannel
Coil Width (in.)	0.8	1.0	1.0	1.0
Face Area (sq. ft.)	20.8	20.9	20.9	26.7
Rows/FPI	1/23	1/20	1/20	1/20
Indoor Coil - Type	Lanced	Lanced	Lanced	Lanced
Tube Size (in.) ID	0.3125	0.3125	0.3125	0.3125
Face Area (sq. ft.)	12.4	12.4	12.4	16.7
Rows/FPI	5/16	4/16	4/16	4/16
Refrigerant Control	Thermal Expansion Valve	Thermal Expansion Valve	Thermal Expansion Valve	Thermal Expansion Valve
Drain Connection Number/Size (in.)	1¼ NPT	1¼ NPT	1¼ NPT	1¼ NPT
Outdoor Fan - Type	Propeller	Propeller	Propeller	Propeller
Number Used/Diameter (in.)	1/26	1/26	1/26	1/30
Drive Type/No. Speeds	Direct/Variable	Direct/Variable	Direct/Variable	Direct/Variable
cfm	5,864	6,806	6,771	7,612
Motor hp	0.75	0.75	0.75	0.75
Motor rpm	1,200	1,200	1,200	1,200
Indoor Fan - Type (Optional)	EBM	EBM	EBM	EBM
Number Used/Diameter (in.)	1/23.03	1/23.03	1/23.03	1/23.03
Drive Type/No. Speeds	Direct/Variable	Direct/Variable	Direct/Variable	Direct/Variable
Number Motors	1	1	1	1
Motor hp (Standard/Oversized)	2.75	2.75	2.75	2.75

Table 9. General data - 6 to 10 tons with eFlex™ and eDrive™ technology (575 Volt) (continued)

	6 Tons	7.5 Tons	8.5 Tons	10 Tons
	T/YZC072FW	T/YZC090FW	T/YZC102FW	T/YZC120FW
Filters^(d)				
Type Furnished	Throwaway	Throwaway	Throwaway	Throwaway
Number Size Recommended	(4) 2x20x25	(4) 2x20x25	(4) 2x20x25	(3) 2x20x25 (2) 2x20x30
Refrigerant Charge^(e)				
Pounds of R-410A	8.3	8.7	8.9	10.5
Heating Performance^(f)				
(Gas/Electric Only)				
Heating Input				
Low Heat Input (Btu)	80,000	120,000	120,000	150,000
Mid Heat Input (Btu)	120,000	150,000	150,000	200,000
High Heat Input (Btu)	150,000	200,000	200,000	250,000
Modulating Heat Input (Btu)	150,000	200,000	200,000	250,000
Heating Output				
Low Heat Input (Btu)	64,800	97,200	97,200	121,500
Mid Heat Input (Btu)	97,200	121,500	121,500	162,000
High Heat Input (Btu)	121,500	162,000	162,000	202,500
Modulating Heat Input (Btu)	121,500	162,000	162,000	202,500
Steady State Efficiency%				
Low Heat Input (Btu)	81	81	81	81
Mid Heat Input (Btu)	81	81	81	81
High Heat Input (Btu)	81	81	81	81
Modulating Heat Input (Btu)	81	81	81	81
No. Burners				
Low Heat Input (Btu)	3	3	3	3
Mid Heat Input (Btu)	3	3	3	4
High Heat Input (Btu)	3	5	5	5
Modulating Heat Input (Btu)	3	5	5	5
No. Stages				
Low Heat Input (Btu)	1	1	1	2
Mid Heat Input (Btu)	1	2	2	2
High Heat Input (Btu)	2	2	2	2
Modulating Heat Input (Btu)	2.5:1 Modulating	2.5:1 Modulating	2.5:1 Modulating	2.5:1 Modulating
Gas Supply Line Pressure (w.c.)				
Natural (minimum/maximum) Low/Mid/High	4.5/14.0	4.5/14.0	4.5/14.0	4.5/14.0
Natural (minimum/maximum) Mod Heat	5.5/14.0	5.5/14.0	5.5/14.0	5.5/14.0
LP (minimum/maximum)	11.0/14.0	11.0/14.0	11.0/14.0	11.0/14.0
Gas Connection Pipe Size (in)				
Low Heat	1/2	1/2	1/2	3/4
Mid Heat	1/2	3/4	3/4	3/4
High Heat	3/4	3/4	3/4	3/4
Modulating Heat	3/4	3/4	3/4	3/4

- (a) High stage cooling performance is rated at 95°F ambient, 80°F entering dry bulb, 67°F entering wet bulb. Gross capacity does not include the effect of fan motor heat. AHRI capacity is net and includes the effect of fan motor heat. Units are suitable for operation to ±20% of nominal cfm. Units are certified in accordance with the Unitary Air-Conditioner Equipment certification program, which is based on AHRI standard 340/360.
- (b) EER and/or IEER are rated at AHRI conditions and in accordance with DOE test procedures.
- (c) Outdoor Sound Rating shown is tested in accordance with AHRI Standard 270. For additional information reference the outdoor sound power level data in the performance section.
- (d) Optional 2-inch MERV 8 and MERV 13 filters also available.
- (e) Refrigerant charge is an approximate value. For a more precise value, see unit nameplate and service instructions.
- (f) Heating performance limit settings and rating data were established and approved under laboratory test conditions using American National Standards Institute standards. Ratings shown are for elevations up to 2000 feet. For elevations above 2000 feet, ratings should be reduced at the rate of 4% for each 1000 feet above sea level. Applicable to gas/electric units only.



Performance Data

Table 10. Gross cooling capacities 3 tons with eFlex™ and eDrive™ technology - three phase T/YZC036E3,4

Air Flow cfm	Ent DB (F)	Ambient Temperature						Ambient Temperature						Ambient Temperature					
		85						95						105					
		Entering Wet Bulb						Entering Wet Bulb						Entering Wet Bulb					
		61		67		73		61		67		73		61		67		73	
MBh	SHC	MBh	SHC	MBh	SHC	MBh	SHC	MBh	SHC	MBh	SHC	MBh	SHC	MBh	SHC	MBh	SHC		
600	75	29.27	22.35	32.98	17.67	36.39	8.66	27.33	20.92	30.84	16.53	34.03	8.07	25.31	19.42	28.60	15.35	31.59	7.46
600	80	29.75	25.54	33.10	22.57	36.51	15.89	27.83	23.98	30.98	21.16	34.18	14.88	25.83	22.33	28.77	19.71	31.76	13.84
600	85	30.65	28.08	33.22	26.26	36.63	21.79	28.76	26.46	31.12	24.68	34.32	20.46	26.78	24.76	28.94	23.03	31.93	19.08
600	90	31.98	29.94	33.77	29.09	37.18	26.66	30.11	28.35	31.70	27.42	34.90	25.10	28.16	26.66	29.54	25.67	32.53	23.49
720	75	30.92	24.24	34.44	19.24	37.65	9.93	28.89	22.71	32.20	18.01	35.21	9.27	26.77	21.11	29.87	16.74	32.67	8.59
720	80	31.56	27.70	34.73	24.42	37.94	17.43	29.55	26.03	32.51	22.93	35.52	16.34	27.46	24.29	30.21	21.37	33.01	15.21
720	85	32.63	30.47	35.01	28.38	38.23	23.62	30.65	28.75	32.82	26.70	35.83	22.19	28.58	26.94	30.55	24.95	33.34	20.72
720	90	34.13	32.50	35.73	31.45	38.95	28.76	32.17	30.82	33.56	29.69	36.57	27.11	30.13	29.03	31.31	27.83	34.11	25.39
840	75	32.37	25.98	36.12	20.96	40.28	11.60	30.24	24.35	33.79	19.64	37.38	10.76	28.04	22.66	31.37	18.29	34.76	10.01
840	80	33.17	29.69	36.15	26.15	40.30	19.44	31.08	27.93	33.84	24.56	37.44	18.09	28.89	26.08	31.45	22.91	34.83	16.88
840	85	34.41	32.68	36.60	30.35	40.41	25.83	32.34	30.87	34.32	28.58	37.92	24.32	30.18	28.96	31.95	26.73	35.34	22.75
840	90	36.08	34.89	37.49	33.65	40.51	30.73	34.03	33.11	35.23	31.79	38.04	28.99	31.89	31.23	32.89	29.83	35.49	27.17
960	75	33.61	27.56	37.17	22.31	41.06	12.76	31.40	25.84	34.75	20.91	38.43	11.95	29.10	24.04	32.24	19.47	35.71	11.13
960	80	34.59	31.50	37.37	27.73	41.33	20.82	32.40	29.64	34.97	26.05	38.72	19.56	30.12	27.69	32.48	24.30	36.03	18.26
960	85	35.99	34.70	37.99	32.16	41.60	27.42	33.83	32.79	35.62	30.29	39.02	25.82	31.57	30.79	33.16	28.34	36.35	24.16
960	90	37.82	37.07	39.04	35.66	41.87	32.54	35.68	35.20	36.69	33.70	39.32	30.70	33.46	33.23	34.26	31.65	36.67	28.78
1080	75	34.65	28.96	38.02	23.52	42.57	14.13	32.35	27.15	35.51	22.04	39.85	13.26	29.96	25.25	32.91	20.51	37.04	12.36
1080	80	35.80	33.12	38.38	29.14	42.58	22.30	33.52	31.16	35.89	27.37	39.89	20.96	31.15	29.11	33.32	25.52	37.10	19.57
1080	85	37.37	36.52	39.18	33.78	42.60	28.87	35.11	34.51	36.71	31.81	39.92	27.17	32.77	32.40	34.16	29.76	37.16	25.41
1080	90	39.37	39.04	40.40	37.48	43.03	34.18	37.14	37.08	37.96	35.42	40.39	32.24	34.82	34.82	35.43	33.27	37.65	30.22
1200	75	35.50	30.17	38.67	24.58	43.03	15.14	33.10	28.26	36.07	23.02	40.22	14.19	30.61	26.27	33.37	21.39	37.31	13.22
1200	80	36.81	34.53	39.20	30.37	43.21	23.42	34.43	32.47	36.62	28.51	40.42	22.00	31.97	30.32	33.95	26.56	37.54	20.53
1200	85	38.55	38.11	40.16	35.20	43.39	30.14	36.20	36.01	37.60	33.14	40.62	28.36	33.76	33.76	34.96	30.98	37.77	26.50
1200	90	40.71	40.71	41.55	39.08	43.99	35.63	38.39	38.39	39.02	36.93	41.25	33.60	35.98	35.98	36.40	34.68	38.43	31.48
1320	75	36.13	31.18	39.12	25.47	43.29	16.01	33.65	29.17	36.42	23.82	40.38	15.00	31.07	27.08	33.64	22.11	37.39	13.96
1320	80	37.61	35.71	39.82	31.41	43.63	24.38	35.15	33.56	37.14	29.45	40.75	22.88	32.60	31.31	34.38	27.42	37.78	21.33
1320	85	39.52	39.47	40.94	36.41	43.98	31.23	37.08	37.08	38.29	34.25	41.12	29.36	34.56	34.56	35.56	32.00	38.18	27.41
1320	90	41.86	41.86	42.50	40.46	44.75	36.87	39.44	39.44	39.88	38.21	41.92	34.75	36.94	36.94	37.17	35.86	39.00	32.53
1440	75	36.57	31.96	39.36	26.18	43.77	16.92	33.99	29.87	36.57	24.45	40.54	15.76	31.32	27.68	33.70	22.65	37.46	14.65
1440	80	38.22	36.66	40.23	32.24	43.85	25.17	35.66	34.42	37.46	30.20	40.88	23.60	33.02	32.07	34.61	28.06	37.82	21.96
1440	85	40.29	40.29	41.52	37.39	44.37	32.12	37.76	37.76	38.78	35.14	41.42	30.16	35.15	35.15	35.96	32.79	38.38	28.13
1440	90	42.80	42.80	43.25	41.59	45.31	37.90	40.29	40.29	40.53	39.26	42.38	35.68	37.70	37.70	37.73	36.81	39.37	33.37

Table 10. Gross cooling capacities 3 tons with eFlex™ and eDrive™ technology - three phase T/YZC036E3,4 (continued)

Air Flow cfm	Ent DB (F)	Ambient Temperature						Ambient Temperature					
		115						120					
		Entering Wet Bulb						Entering Wet Bulb					
		61		67		73		61		67		73	
		MBh	SHC	MBh	SHC	MBh	SHC	MBh	SHC	MBh	SHC	MBh	SHC
600	75	23.20	17.85	26.28	14.13	29.06	6.85	22.11	17.04	25.09	13.50	27.76	6.54
600	80	23.74	20.61	26.47	18.19	29.26	12.76	22.67	19.71	25.29	17.40	27.97	12.22
600	85	24.72	22.96	26.67	21.31	29.45	17.65	23.65	22.03	25.50	20.42	28.18	16.92
600	90	26.12	24.88	27.29	23.84	30.07	21.80	25.07	23.95	26.14	22.89	28.81	20.93
720	75	24.57	19.44	27.46	15.43	30.83	8.10	23.43	18.57	26.22	14.75	29.49	7.75
720	80	25.28	22.46	27.82	19.75	31.19	14.41	24.16	21.51	26.60	18.92	29.86	13.82
720	85	26.43	25.04	28.18	23.12	31.55	19.68	25.32	24.06	26.97	22.18	30.24	18.89
720	90	28.00	27.15	28.98	25.89	31.56	23.60	26.90	26.17	27.77	24.89	30.26	22.68
840	75	25.74	20.88	28.87	16.88	31.62	9.12	24.56	19.96	27.58	16.15	30.93	8.93
840	80	26.62	24.14	28.97	21.19	32.15	15.63	25.45	23.14	27.70	20.30	31.12	15.16
840	85	27.93	26.95	29.50	24.79	32.68	21.12	26.78	25.91	28.24	23.79	31.31	20.28
840	90	29.67	29.25	30.46	27.78	32.85	25.27	28.53	28.22	29.21	26.72	31.50	24.29
960	75	26.71	22.16	29.64	17.96	32.90	10.28	25.48	21.19	28.31	17.19	31.47	9.85
960	80	27.76	25.65	29.91	22.47	33.25	16.92	26.55	24.59	28.60	21.53	31.83	16.23
960	85	29.24	28.68	30.61	26.30	33.60	22.43	28.04	27.58	29.31	25.24	32.19	21.54
960	90	31.15	31.15	31.74	29.50	33.94	26.78	29.96	29.96	30.44	28.38	32.54	25.75
1080	75	27.48	23.27	30.22	18.91	34.15	11.44	26.21	22.25	28.84	18.09	32.67	10.97
1080	80	28.69	26.96	30.66	23.59	34.23	18.14	27.44	25.85	29.29	22.60	32.76	17.40
1080	85	30.34	30.19	31.52	27.62	34.31	23.59	29.09	29.04	30.17	26.51	32.86	22.65
1080	90	32.42	32.42	32.82	31.01	34.83	28.12	31.18	31.18	31.48	29.84	33.39	27.04
1200	75	28.04	24.19	30.59	19.70	34.33	12.22	26.73	23.11	29.17	18.84	32.80	11.71
1200	80	29.43	28.07	31.20	24.54	34.58	19.00	28.12	26.91	29.79	23.50	33.07	18.22
1200	85	31.24	31.24	32.23	28.74	34.83	24.58	29.95	29.95	30.83	27.58	33.33	23.59
1200	90	33.49	33.49	33.69	32.32	35.51	29.27	32.21	32.21	32.31	31.10	34.02	28.13
1320	75	28.41	24.90	30.77	20.33	34.51	12.96	27.05	23.77	29.30	19.42	32.94	12.41
1320	80	29.96	28.96	31.54	25.29	34.73	19.72	28.61	27.74	30.08	24.20	33.17	18.89
1320	85	31.94	31.94	32.74	29.65	35.15	25.39	30.61	30.61	31.30	28.43	33.60	24.35
1320	90	34.35	34.35	34.37	33.40	36.00	30.22	32.60	32.60	32.94	32.12	34.46	29.03
1440	75	28.57	25.40	30.94	20.92	34.69	13.65	27.16	24.22	29.42	19.95	33.07	13.06
1440	80	30.29	29.62	31.68	25.84	34.87	20.38	28.90	28.35	30.18	24.70	33.27	19.50
1440	85	32.44	32.44	33.05	30.34	35.26	26.01	31.06	31.06	31.56	29.07	33.67	24.92
1440	90	34.59	34.59	34.84	34.25	36.28	30.96	33.22	33.22	33.37	32.92	34.70	29.72

Notes:

1. All capacities shown are gross and have not considered indoor fan heat. To obtain **NET** cooling capacity subtract indoor fan heat. For indoor fan heat formula, refer to appropriate airflow table notes.
2. MBh = Total Gross Capacity.
3. SHC = Sensible Heat Capacity.



Performance Data

Table 11. Gross cooling capacities 4 tons with eFlex™ and eDrive™ technology - three phase T/YZC048F3,4

Air Flow cfm	Ent DB (F)	Ambient Temperature						Ambient Temperature						Ambient Temperature					
		85						95						105					
		Entering Wet Bulb						Entering Wet Bulb						Entering Wet Bulb					
		61		67		73		61		67		73		61		67		73	
		MBh	SHC	MBh	SHC	MBh	SHC	MBh	SHC	MBh	SHC	MBh	SHC	MBh	SHC	MBh	SHC	MBh	SHC
800	75	37.22	29.31	41.86	23.37	46.17	11.63	35.20	27.92	39.60	22.36	43.68	11.30	33.10	26.44	37.26	21.27	41.10	10.92
800	80	37.86	33.23	42.03	29.52	46.35	20.84	35.88	31.68	39.81	28.20	43.89	20.03	33.81	30.05	37.51	26.80	41.34	19.15
800	85	39.09	36.35	42.21	34.12	46.53	28.37	37.14	34.74	40.02	32.60	44.10	27.18	35.11	33.03	37.75	30.98	41.59	25.91
800	90	40.90	38.63	42.97	37.68	47.28	34.61	38.99	37.02	40.82	36.03	44.89	33.15	36.99	35.33	38.58	34.29	42.42	31.60
960	75	39.06	31.56	43.46	25.31	47.53	13.29	36.95	30.07	41.11	24.20	44.95	12.87	34.75	28.48	38.67	23.01	42.27	12.40
960	80	39.92	35.80	43.85	31.79	47.93	22.81	37.84	34.14	41.53	30.37	45.37	21.90	35.68	32.39	39.13	28.85	42.73	20.92
960	85	41.36	39.19	44.24	36.71	48.32	30.65	39.32	37.47	41.96	35.07	45.80	29.36	37.19	35.65	39.59	33.33	43.19	27.98
960	90	43.38	41.68	45.21	40.54	49.29	37.22	41.37	39.97	42.97	38.78	46.81	35.65	39.28	38.16	40.64	36.92	44.24	33.99
1120	75	40.68	33.65	45.42	27.48	50.67	15.47	38.48	32.04	42.98	26.27	47.99	14.98	36.19	30.34	40.46	24.98	45.22	14.44
1120	80	41.75	38.17	45.45	33.90	50.81	25.42	39.59	36.41	43.04	32.37	48.16	24.42	37.33	34.55	40.55	30.75	45.43	23.35
1120	85	43.41	41.83	46.05	39.11	50.94	33.49	41.28	40.00	43.68	37.36	48.33	32.09	39.06	38.07	41.22	35.51	45.63	30.61
1120	90	45.65	44.52	47.24	43.21	51.08	39.68	43.55	42.71	44.90	41.34	48.50	37.99	41.36	40.79	42.48	39.37	45.84	36.21
1280	75	42.09	35.53	46.60	29.14	51.60	17.00	39.80	33.82	44.06	27.83	48.83	16.42	37.41	32.01	41.44	26.44	45.97	15.78
1280	80	43.38	40.34	46.83	35.83	51.95	27.16	41.12	38.46	44.33	34.19	49.21	26.07	38.77	36.49	41.75	32.46	46.39	24.89
1280	85	45.25	44.25	47.65	41.31	52.30	35.49	43.02	42.30	45.19	39.45	49.60	33.99	40.71	40.26	42.63	37.48	46.81	32.39
1280	90	47.70	47.13	49.05	45.67	52.66	41.94	45.51	45.21	46.62	43.68	49.98	40.14	43.23	43.18	44.11	41.59	47.23	38.24
1440	75	43.29	37.20	47.55	30.63	52.32	18.40	40.90	35.38	44.92	29.22	50.62	18.15	38.42	33.46	42.21	27.73	47.66	17.43
1440	80	44.79	42.27	48.00	37.56	52.88	28.75	42.43	40.28	45.41	35.81	50.63	27.87	39.99	38.19	42.73	33.96	47.72	26.60
1440	85	46.87	46.42	49.04	43.29	53.45	37.30	44.55	44.36	46.48	41.31	50.65	35.69	42.15	42.15	43.83	39.23	47.77	33.98
1440	90	49.54	49.49	50.65	47.89	54.02	43.99	47.25	47.25	48.13	45.79	51.25	42.08	44.88	44.88	45.52	43.58	48.40	40.06
1600	75	44.27	38.64	48.29	31.93	53.99	20.09	41.78	36.71	45.57	30.42	51.02	19.34	39.22	34.68	42.76	28.82	47.98	18.52
1600	80	45.98	43.95	48.96	39.06	54.18	30.49	43.53	41.85	46.27	37.21	51.26	29.19	41.00	39.65	43.50	35.25	48.25	27.81
1600	85	48.28	48.28	50.21	45.03	54.38	38.91	45.87	45.87	47.55	42.94	51.49	37.19	43.37	43.37	44.82	40.75	48.51	35.37
1600	90	51.16	51.16	52.04	49.85	55.16	45.81	48.78	48.78	49.42	47.64	52.30	43.79	46.32	46.32	46.72	45.32	49.36	41.66
1760	75	45.03	39.84	48.82	33.02	54.27	21.21	42.46	37.80	46.00	31.41	51.22	20.37	39.80	35.66	43.10	29.70	48.08	19.46
1760	80	46.96	45.37	49.70	40.34	54.69	31.71	44.42	43.16	46.92	38.37	51.67	30.31	41.79	40.85	44.05	36.31	48.56	28.83
1760	85	49.48	49.48	51.16	46.51	55.10	40.29	46.97	46.97	48.42	44.31	52.11	38.46	44.38	44.38	45.59	42.01	49.04	36.53
1760	90	52.57	52.57	53.21	51.55	56.09	47.39	50.10	50.10	50.50	49.23	53.14	45.25	47.54	47.54	47.70	46.80	50.11	43.00
1920	75	45.58	40.77	49.13	33.89	54.93	22.39	42.91	38.63	46.22	32.18	51.41	21.32	40.16	36.39	43.23	30.37	48.18	20.32
1920	80	47.73	46.51	50.23	41.36	54.97	32.72	45.09	44.20	47.35	39.29	51.86	31.23	42.37	41.77	44.39	37.12	48.66	29.64
1920	85	50.45	50.45	51.90	47.73	55.60	41.43	47.85	47.85	49.06	45.42	52.52	39.49	45.17	45.17	46.14	43.00	49.36	37.46
1920	90	53.76	53.76	54.16	52.97	56.81	48.70	51.20	51.20	51.36	50.53	53.76	46.45	47.97	47.97	48.47	47.99	50.64	44.09

Table 11. Gross cooling capacities 4 tons with eFlex™ and eDrive™ technology - three phase T/YZC048F3,4 (continued)

Air Flow cfm	Ent DB (F)	Ambient Temperature						Ambient Temperature					
		115						120					
		Entering Wet Bulb						Entering Wet Bulb					
		61		67		73		61		67		73	
		MBh	SHC	MBh	SHC	MBh	SHC	MBh	SHC	MBh	SHC	MBh	SHC
800	75	30.91	24.87	34.83	20.11	38.39	10.47	29.79	24.05	33.59	19.50	37.07	10.24
800	80	31.66	28.31	35.11	25.31	38.67	18.18	30.55	27.41	33.89	24.54	37.37	17.70
800	85	32.99	31.22	35.39	29.26	38.94	24.56	31.90	30.28	34.18	28.37	37.66	23.85
800	90	34.90	33.53	36.26	32.44	39.86	29.96	33.83	32.59	35.06	31.49	38.54	29.11
960	75	32.47	26.80	36.11	21.75	40.52	12.16	31.30	25.92	34.86	21.08	39.16	11.90
960	80	33.44	30.55	36.65	27.26	41.01	20.38	32.28	29.58	35.38	26.42	39.67	19.83
960	85	34.98	33.73	37.14	31.50	41.56	27.21	33.84	32.73	35.89	30.55	40.18	26.44
960	90	37.11	36.25	38.22	34.96	41.58	32.23	35.99	35.26	36.98	33.94	40.22	31.32
1120	75	33.82	28.55	37.84	23.61	42.32	13.79	32.60	27.62	36.51	22.90	40.91	13.50
1120	80	34.99	32.58	37.97	29.03	42.56	22.20	33.79	31.56	36.65	28.14	41.17	21.59
1120	85	36.75	36.03	38.68	33.56	42.85	29.04	35.57	34.97	37.37	32.55	41.43	28.22
1120	90	39.09	38.77	39.97	37.29	43.09	34.33	37.93	37.72	38.68	36.21	41.69	33.36
1280	75	34.95	30.10	38.73	24.97	42.97	15.04	33.68	29.11	37.35	24.20	41.52	14.70
1280	80	36.34	34.41	39.08	30.63	43.42	23.63	35.09	33.33	37.71	29.68	41.99	22.97
1280	85	38.31	38.10	40.00	35.41	43.93	30.71	37.08	36.98	38.65	34.34	42.46	29.83
1280	90	40.87	40.87	41.50	39.39	44.39	36.25	39.65	39.65	40.17	38.26	42.93	35.21
1440	75	35.86	31.44	39.41	26.15	44.57	16.63	34.55	30.39	37.98	25.32	43.07	16.21
1440	80	37.47	36.00	39.97	32.02	44.71	25.24	36.17	34.86	38.55	31.02	43.18	24.53
1440	85	39.66	39.66	41.10	37.05	44.80	32.18	38.38	38.38	39.71	35.92	43.28	31.25
1440	90	42.43	42.43	42.82	41.27	45.47	37.95	41.17	41.17	41.44	40.07	43.97	36.85
1600	75	36.56	32.55	39.87	27.13	44.79	17.64	35.20	31.45	38.39	26.25	43.25	17.17
1600	80	38.38	37.34	40.64	33.20	45.15	26.35	37.04	36.15	39.18	32.13	43.57	25.58
1600	85	40.78	40.78	41.99	38.45	45.45	33.45	39.46	39.46	40.55	37.25	43.89	32.46
1600	90	43.77	43.77	43.93	42.89	46.33	39.42	42.46	42.46	42.50	41.63	44.79	38.26
1760	75	37.05	33.42	40.12	27.91	44.80	18.48	35.64	32.26	38.60	26.98	43.43	18.05
1760	80	39.08	38.43	41.10	34.14	45.37	27.26	37.70	37.17	39.60	33.02	43.74	26.44
1760	85	41.70	41.70	42.67	39.59	45.89	34.50	40.33	40.33	41.18	38.34	44.28	33.45
1760	90	44.32	44.32	44.82	44.25	46.99	40.65	42.96	42.96	43.34	42.93	45.39	39.43
1920	75	37.32	34.04	40.15	28.47	44.81	19.22	35.87	32.82	38.80	27.64	43.60	18.86
1920	80	39.57	39.24	41.35	34.84	45.38	27.97	38.13	37.93	39.80	33.66	43.92	27.22
1920	85	42.40	42.40	43.13	40.47	46.11	35.31	40.98	40.98	41.59	39.17	44.45	34.20
1920	90	45.23	45.23	45.49	45.33	47.42	41.62	43.83	43.83	43.97	43.96	45.78	40.34

Notes:

1. All capacities shown are gross and have not considered indoor fan heat. To obtain **NET** cooling capacity subtract indoor fan heat. For indoor fan heat formula, refer to appropriate airflow table notes.
2. MBh = Total Gross Capacity.
3. SHC = Sensible Heat Capacity.



Performance Data

Table 12. Gross cooling capacities 5 tons with eFlex™ and eDrive™ technology - three phase T/YZC060E3

Air Flow cfm	Ent DB (F)	Ambient Temperature						Ambient Temperature						Ambient Temperature					
		85						95						105					
		Entering Wet Bulb						Entering Wet Bulb						Entering Wet Bulb					
		61		67		73		61		67		73		61		67		73	
		MBh	SHC	MBh	SHC	MBh	SHC	MBh	SHC	MBh	SHC	MBh	SHC	MBh	SHC	MBh	SHC	MBh	SHC
1000	75	49.03	37.99	55.10	30.37	61.63	15.90	46.28	35.99	52.25	28.90	58.52	15.16	43.38	33.87	49.01	27.21	54.98	14.31
1000	80	49.66	42.97	55.31	38.24	61.70	27.63	46.95	40.79	52.26	36.26	58.54	26.32	44.09	38.48	49.05	34.19	54.99	24.85
1000	85	50.96	46.80	55.42	44.01	61.90	37.17	48.29	44.56	52.41	41.80	58.55	35.31	45.48	42.18	49.25	39.47	55.04	33.36
1000	90	52.94	49.45	56.21	48.32	62.01	44.38	50.31	47.26	53.24	45.99	58.70	42.21	47.53	44.91	50.12	43.53	55.23	39.93
1200	75	51.48	40.87	57.54	32.95	64.31	18.12	48.57	38.71	54.53	31.34	61.05	17.28	45.51	36.42	51.12	29.51	57.34	16.33
1200	80	52.37	46.26	57.76	41.10	64.39	30.30	49.50	43.91	54.54	38.97	61.06	28.87	46.48	41.42	51.17	36.73	57.35	27.25
1200	85	53.94	50.45	58.13	47.28	64.60	40.19	51.11	48.03	54.96	44.91	61.08	38.17	48.12	45.47	51.63	42.40	57.40	36.07
1200	90	56.18	53.36	59.18	51.95	64.72	47.65	53.39	51.00	56.05	49.45	61.24	45.31	50.44	48.48	52.76	46.81	57.60	42.86
1400	75	53.65	43.54	59.69	35.37	66.71	20.30	50.57	41.20	56.53	33.63	63.29	19.36	47.34	38.74	52.95	31.65	59.41	18.28
1400	80	54.80	49.31	59.91	43.77	66.79	32.86	51.77	46.79	56.53	41.48	63.31	31.30	48.58	44.12	53.00	39.08	59.43	29.54
1400	85	56.63	53.83	60.55	50.33	67.01	43.04	53.63	51.25	57.21	47.78	63.32	40.88	50.48	48.50	53.72	45.10	59.48	38.61
1400	90	59.13	57.01	61.86	55.34	67.13	50.71	56.17	54.48	58.56	52.67	63.48	48.21	53.06	51.78	55.11	49.85	59.68	45.58
1600	75	55.53	45.96	61.56	37.62	68.56	22.30	52.28	43.46	57.97	35.58	64.88	21.22	48.89	40.82	54.23	33.45	60.94	20.07
1600	80	56.94	52.09	61.78	46.22	68.64	35.14	53.74	49.39	58.24	43.77	65.00	33.45	50.38	46.55	54.53	41.20	60.96	31.55
1600	85	59.03	56.94	62.68	53.13	68.87	45.54	55.87	54.18	59.18	50.41	65.01	43.21	52.55	51.25	55.52	47.55	61.01	40.78
1600	90	61.79	60.38	64.26	58.47	69.25	53.55	58.67	57.68	60.79	55.62	65.44	50.88	55.40	54.81	57.17	52.62	61.48	48.08
1800	75	57.11	48.11	62.87	39.51	70.13	24.19	53.70	45.45	59.12	37.32	66.28	23.00	50.14	42.64	55.21	35.04	62.18	21.73
1800	80	58.79	54.59	63.36	48.42	70.21	37.24	55.42	51.71	59.65	45.81	66.41	35.42	51.90	48.69	55.78	43.07	62.20	33.38
1800	85	61.14	59.75	64.52	55.66	70.44	47.81	57.81	56.81	60.85	52.77	66.42	45.33	54.33	53.70	57.03	49.73	62.25	42.73
1800	90	64.16	63.43	66.36	61.30	71.08	56.13	60.88	60.56	62.73	58.28	67.11	53.29	57.44	57.44	58.94	55.10	62.98	50.32
2000	75	58.41	49.99	63.90	41.16	71.40	25.93	54.84	47.15	59.98	38.83	67.14	24.54	51.11	44.17	55.91	36.40	62.87	23.15
2000	80	60.35	56.77	64.65	50.36	71.49	39.15	56.82	53.73	60.77	47.58	67.26	37.05	53.13	50.52	56.74	44.67	62.89	34.86
2000	85	62.96	62.23	66.08	57.90	71.72	49.83	59.47	59.12	62.24	54.84	67.54	47.19	55.82	55.82	58.25	51.62	63.20	44.44
2000	90	66.25	66.16	68.17	63.83	72.63	58.44	62.80	62.80	64.38	60.64	68.49	55.43	59.19	59.19	60.43	57.28	64.19	52.28
2200	75	59.42	51.56	64.64	42.57	72.13	27.40	55.68	48.56	60.56	40.09	67.70	25.90	51.79	45.41	56.32	37.50	63.27	24.40
2200	80	61.62	58.64	65.66	52.01	72.22	40.68	57.92	55.42	61.61	49.07	67.83	38.44	54.07	52.03	57.41	45.99	63.29	36.11
2200	85	64.50	64.37	67.34	59.83	72.72	51.58	60.84	60.84	63.34	56.59	68.37	48.79	57.03	57.03	59.18	53.20	63.86	45.87
2200	90	68.04	68.04	69.70	66.03	73.88	60.45	64.43	64.43	65.74	62.67	69.58	57.27	60.66	60.66	61.62	59.13	65.12	53.95
2400	75	60.14	52.82	65.09	43.71	72.58	28.69	56.24	49.65	60.84	41.08	67.98	27.07	52.18	46.32	56.44	38.34	63.38	25.45
2400	80	62.61	60.16	66.37	53.36	72.66	41.97	58.74	56.77	62.16	50.26	68.11	39.59	54.72	53.20	57.80	47.02	63.40	37.12
2400	85	65.74	65.74	68.31	61.43	73.42	53.05	61.92	61.92	64.15	58.03	68.91	50.10	57.94	57.94	59.82	54.46	64.24	47.02
2400	90	69.55	69.55	70.93	67.89	74.85	62.14	65.77	65.77	66.81	64.35	70.38	58.81	61.83	61.83	62.53	60.64	65.75	55.31

Table 12. Gross cooling capacities 5 tons with eFlex™ and eDrive™ technology - three phase T/YZC060E3 (continued)

Air Flow cfm	Ent DB (F)	Ambient Temperature						Ambient Temperature					
		115						120					
		Entering Wet Bulb						Entering Wet Bulb					
		61		67		73		61		67		73	
		MBh	SHC	MBh	SHC	MBh	SHC	MBh	SHC	MBh	SHC	MBh	SHC
1000	75	40.33	31.62	45.61	25.44	51.37	13.46	38.74	30.45	43.86	24.53	47.77	12.57
1000	80	41.08	36.03	45.70	32.00	51.38	23.35	39.52	34.74	43.96	30.87	49.64	22.62
1000	85	42.51	39.63	45.93	37.00	51.38	31.31	40.96	38.30	44.22	35.72	49.74	30.40
1000	90	44.60	42.40	46.84	40.92	51.61	37.52	43.08	41.08	45.15	39.55	49.74	36.27
1200	75	42.29	34.00	47.56	27.59	53.56	15.36	40.62	32.74	45.72	26.59	49.81	14.34
1200	80	43.30	38.78	47.65	34.38	53.57	25.61	41.66	37.41	45.83	33.16	51.75	24.82
1200	85	44.99	42.74	48.15	39.75	53.58	33.86	43.36	41.32	46.35	38.38	51.86	32.87
1200	90	47.35	45.79	49.32	44.01	53.82	40.28	45.74	44.39	47.54	42.56	51.87	38.94
1400	75	43.96	36.15	49.22	29.58	55.47	17.20	42.21	34.80	47.30	28.50	51.32	15.98
1400	80	45.23	41.30	49.31	36.55	55.48	27.75	43.50	39.83	47.41	35.24	53.32	26.76
1400	85	47.18	45.59	50.07	42.27	55.49	36.23	45.47	44.07	48.19	40.81	53.43	35.00
1400	90	49.80	48.92	51.50	46.87	55.73	42.83	48.12	47.42	49.64	45.32	53.70	41.40
1600	75	45.34	38.05	50.33	31.22	56.75	18.84	43.51	36.62	48.33	30.07	52.55	17.52
1600	80	46.87	43.54	50.68	38.50	56.76	29.57	45.06	41.98	48.70	37.10	54.60	28.54
1600	85	49.09	48.16	51.70	44.55	56.85	38.24	47.29	46.55	49.74	42.99	54.71	36.93
1600	90	51.97	51.76	53.40	49.46	57.36	45.14	50.20	50.17	51.46	47.82	55.24	43.62
1800	75	46.43	39.69	51.15	32.65	57.82	20.37	44.51	38.16	49.07	31.42	53.50	18.93
1800	80	48.23	45.50	51.76	40.20	57.83	31.25	46.33	43.84	49.70	38.71	55.59	30.15
1800	85	50.70	50.42	53.05	46.55	57.93	40.02	48.83	48.72	51.00	44.89	55.71	38.62
1800	90	53.85	53.85	55.01	51.76	58.70	47.21	51.99	51.99	52.98	50.02	56.50	45.59
2000	75	47.23	41.05	51.69	33.85	58.35	21.67	45.23	39.43	49.52	32.53	53.93	20.12
2000	80	49.29	47.15	52.56	41.63	58.36	32.58	47.31	45.39	50.41	40.05	56.03	31.40
2000	85	52.03	52.03	54.10	48.25	58.71	41.56	50.07	50.07	51.97	46.51	56.41	40.07
2000	90	55.43	55.43	56.32	53.75	59.74	48.99	53.50	53.50	54.21	51.92	57.46	47.29
2200	75	47.74	42.10	51.93	34.80	58.58	22.79	45.66	40.39	49.68	33.40	54.07	21.13
2200	80	50.07	48.47	53.06	42.78	58.59	33.68	48.01	46.62	50.83	41.11	56.19	32.42
2200	85	53.06	53.06	54.87	49.65	59.21	42.82	51.02	51.02	52.66	47.81	56.83	41.25
2200	90	56.73	56.73	57.35	55.42	60.50	50.48	54.71	54.71	55.16	53.49	58.14	48.69
2400	75	47.97	42.84	52.14	35.66	58.79	23.82	45.80	41.04	49.81	34.18	54.19	22.07
2400	80	50.55	49.46	53.28	43.63	58.80	34.69	48.41	47.52	50.96	41.87	56.31	33.35
2400	85	53.81	53.81	55.35	50.73	59.42	43.81	51.69	51.69	53.05	48.79	56.95	42.15
2400	90	57.74	57.74	58.09	56.74	60.97	51.66	55.64	55.64	55.82	54.72	58.53	49.78

Notes:

1. All capacities shown are gross and have not considered indoor fan heat. To obtain **NET** cooling capacity subtract indoor fan heat. For indoor fan heat formula, refer to appropriate airflow table notes.
2. MBh = Total Gross Capacity.
3. SHC = Sensible Heat Capacity.



Performance Data

Table 13. Gross cooling capacities 5 tons with eFlex™ and eDrive™ technology - three phase T/YZC060E4

Air Flow cfm	Ent DB (F)	Ambient Temperature						Ambient Temperature						Ambient Temperature					
		85						95						105					
		Entering Wet Bulb						Entering Wet Bulb						Entering Wet Bulb					
		61		67		73		61		67		73		61		67		73	
		MBh	SHC	MBh	SHC	MBh	SHC	MBh	SHC	MBh	SHC	MBh	SHC	MBh	SHC	MBh	SHC	MBh	SHC
1000	75	48.15	37.49	53.82	29.73	59.94	15.08	45.62	35.67	51.00	28.32	56.86	14.44	42.95	33.74	48.03	26.83	53.81	13.81
1000	80	49.02	42.63	53.96	37.62	60.15	27.05	46.50	40.64	51.16	35.86	57.06	25.85	43.84	38.52	48.20	33.99	53.82	24.58
1000	85	50.58	46.64	54.28	43.59	60.28	36.71	48.08	44.59	51.49	41.59	57.20	35.08	45.43	42.38	48.55	39.46	53.98	33.34
1000	90	52.84	49.44	55.30	48.11	60.32	44.01	50.35	47.42	52.52	45.99	57.26	42.06	47.72	45.25	49.60	43.73	54.05	40.00
1200	75	50.38	40.33	56.00	32.34	62.35	17.42	47.70	38.35	53.04	30.78	59.13	16.67	44.89	36.25	49.94	29.14	55.95	15.92
1200	80	51.51	45.87	56.15	40.49	62.58	29.81	48.85	43.72	53.21	38.57	59.34	28.47	46.05	41.42	50.12	36.53	55.96	27.05
1200	85	53.34	50.24	56.74	46.85	62.71	39.80	50.69	48.01	53.81	44.68	59.49	38.00	47.91	45.63	50.73	42.38	56.13	36.11
1200	90	55.86	53.31	58.03	51.73	62.75	47.31	53.24	51.13	55.11	49.44	59.55	45.20	50.46	48.79	52.05	47.00	56.20	42.96
1400	75	52.34	42.94	57.93	34.77	64.24	19.60	49.52	40.80	54.83	33.07	60.88	18.73	46.56	38.54	51.58	31.28	57.57	17.86
1400	80	53.73	48.87	58.08	43.14	64.47	32.30	50.93	46.54	55.00	41.05	61.10	30.81	47.99	44.07	51.76	38.85	57.58	29.25
1400	85	55.83	53.57	58.94	49.87	64.61	42.52	53.05	51.17	55.87	47.54	61.25	40.56	50.12	48.62	52.65	45.06	57.74	38.50
1400	90	58.62	56.91	60.49	55.10	64.92	50.39	55.86	54.56	57.43	52.64	61.58	48.11	52.94	52.05	54.23	50.02	58.09	45.69
1600	75	54.03	45.29	59.33	36.84	65.87	21.66	51.08	42.99	56.08	34.99	62.37	20.66	47.98	40.56	52.70	33.05	58.92	19.67
1600	80	55.70	51.58	59.75	45.54	66.11	34.60	52.76	49.08	56.52	43.30	62.59	32.97	49.67	46.44	53.15	40.93	58.93	31.26
1600	85	58.06	56.61	60.87	52.63	66.25	45.00	55.14	54.04	57.66	50.12	62.75	42.89	52.06	51.32	54.30	47.47	59.10	40.66
1600	90	61.12	60.21	62.69	58.19	66.83	53.22	58.21	57.70	59.49	55.55	63.34	50.76	55.16	55.02	56.15	52.76	59.71	48.17
1800	75	55.47	47.36	60.46	38.67	67.24	23.55	52.37	44.90	57.08	36.67	63.59	22.43	49.13	42.30	53.55	34.58	60.01	21.33
1800	80	57.40	53.98	61.15	47.68	67.48	36.69	54.32	51.32	57.79	45.27	63.82	34.92	51.09	48.51	54.27	42.74	60.02	33.05
1800	85	60.03	59.33	62.54	55.09	67.62	47.23	56.96	56.59	59.19	52.42	63.98	44.96	53.75	53.70	55.69	49.59	60.19	42.57
1800	90	63.36	63.18	64.63	60.96	68.47	55.76	60.31	60.31	61.29	58.16	64.84	53.13	57.11	57.11	57.80	55.19	61.07	50.37
2000	75	56.64	49.13	61.34	40.23	68.08	25.16	53.40	46.50	57.81	38.09	64.29	23.92	50.02	43.74	54.14	35.85	60.57	22.70
2000	80	58.83	56.06	62.29	49.52	68.32	38.39	55.61	53.23	58.78	46.95	64.52	36.48	52.24	50.25	55.13	44.26	60.58	34.46
2000	85	61.73	61.70	63.95	57.23	68.74	49.18	58.52	58.52	60.46	54.39	64.95	46.75	55.17	55.17	56.81	51.40	61.02	44.20
2000	90	65.33	65.33	66.30	63.40	69.85	57.99	62.14	62.14	62.82	60.43	66.08	55.20	58.80	58.80	59.20	57.29	62.16	52.26
2200	75	57.54	50.57	61.95	41.52	68.66	26.55	54.16	47.79	58.28	39.24	64.73	25.20	50.64	44.87	54.47	36.84	60.87	23.86
2200	80	60.01	57.80	63.17	51.04	68.90	39.83	56.65	54.80	59.52	48.32	64.96	37.77	53.14	51.65	55.72	45.47	60.88	35.61
2200	85	63.17	63.17	65.10	59.04	69.58	50.82	59.83	59.83	61.46	56.03	65.66	48.24	56.33	56.33	57.68	52.87	61.59	45.52
2200	90	67.04	67.04	67.72	65.48	70.96	59.89	63.70	63.70	64.09	62.34	67.05	56.93	60.22	60.22	60.33	59.03	63.00	53.83
2400	75	58.19	51.67	62.30	42.51	68.97	27.72	54.67	48.74	58.49	40.09	64.91	26.24	51.00	45.66	54.54	37.55	60.90	24.79
2400	80	60.92	59.17	63.79	52.24	69.22	40.97	57.42	56.01	60.00	49.37	65.14	38.78	53.77	52.70	56.06	46.36	60.91	36.48
2400	85	64.35	64.35	65.98	60.49	70.17	52.14	60.86	60.86	62.20	57.32	66.10	49.41	57.23	57.23	58.28	54.00	61.89	46.54
2400	90	68.48	68.48	68.87	67.19	71.82	61.44	65.01	65.01	65.10	63.89	67.76	58.32	61.10	61.10	61.19	60.41	63.57	55.05

Table 13. Gross cooling capacities 5 tons with eFlex™ and eDrive™ technology - three phase T/YZC060E4 (continued)

Air Flow cfm	Ent DB (F)	Ambient Temperature						Ambient Temperature					
		115						120					
		Entering Wet Bulb						Entering Wet Bulb					
		61		67		73		61		67		73	
		MBh	SHC	MBh	SHC	MBh	SHC	MBh	SHC	MBh	SHC	MBh	SHC
1000	75	40.12	31.68	44.92	25.25	50.26	13.05	38.66	30.60	43.31	24.42	47.44	12.39
1000	80	41.03	36.25	45.11	32.00	50.44	23.22	39.57	35.06	43.50	30.96	48.69	22.52
1000	85	42.64	40.02	45.47	37.19	50.61	31.50	41.19	38.78	43.88	36.01	48.87	30.54
1000	90	44.94	42.91	46.54	41.31	50.70	37.80	43.50	41.68	44.95	40.04	48.96	36.65
1200	75	41.92	34.02	46.68	27.40	52.25	15.02	40.38	32.86	45.00	26.50	49.32	14.26
1200	80	43.10	38.98	46.88	34.37	52.44	25.55	41.57	37.70	45.20	33.25	50.62	24.76
1200	85	44.97	43.10	47.51	39.94	52.62	34.10	43.45	41.77	45.84	38.66	50.80	33.05
1200	90	47.54	46.28	48.84	44.40	52.70	40.58	46.03	44.96	47.18	43.04	50.90	39.34
1400	75	43.46	36.14	48.18	29.38	53.72	16.83	41.85	34.89	46.43	28.40	50.69	15.96
1400	80	44.90	41.45	48.38	36.53	53.91	27.59	43.30	40.08	46.64	35.32	52.02	26.73
1400	85	47.04	45.91	49.28	42.44	54.09	36.32	45.45	44.49	47.55	41.07	52.21	35.19
1400	90	49.88	49.37	50.88	47.24	54.45	43.14	48.30	47.97	49.15	45.79	52.57	41.81
1600	75	44.73	37.99	49.16	31.00	54.92	18.50	43.05	36.66	47.34	29.94	51.80	17.53
1600	80	46.44	43.64	49.63	38.44	55.12	29.45	44.77	42.19	47.81	37.14	53.16	28.51
1600	85	48.85	48.43	50.79	44.68	55.31	38.32	47.18	46.92	48.99	43.22	53.35	37.10
1600	90	51.95	51.95	52.66	49.80	55.93	45.44	50.30	50.30	50.86	48.26	53.98	44.02
1800	75	45.74	39.57	49.87	32.38	55.87	20.02	43.99	38.14	47.98	31.23	52.65	18.95
1800	80	47.72	45.54	50.61	40.08	56.07	31.09	45.98	43.99	48.72	38.70	54.04	30.08
1800	85	50.39	50.39	52.04	46.62	56.26	40.05	48.66	48.66	50.16	45.07	54.24	38.75
1800	90	53.77	53.77	54.17	52.06	57.15	47.46	52.04	52.04	52.30	50.42	55.13	45.95
2000	75	46.49	40.84	50.32	33.50	56.29	21.26	44.67	39.34	48.36	32.28	52.99	20.10
2000	80	48.73	47.11	51.33	41.43	56.49	32.36	46.92	45.48	49.37	39.96	54.39	31.26
2000	85	51.67	51.67	53.03	48.25	56.95	41.51	49.87	49.87	51.08	46.62	54.85	40.13
2000	90	55.31	55.31	55.43	53.98	58.10	49.18	53.38	53.38	53.48	52.26	56.02	47.58
2200	75	46.97	41.80	50.51	34.34	56.44	22.29	45.08	40.21	48.48	33.05	53.08	21.05
2200	80	49.48	48.34	51.78	42.48	56.65	33.36	47.60	46.62	49.75	40.93	54.48	32.19
2200	85	52.69	52.69	53.75	49.55	57.37	42.68	50.82	50.82	51.73	47.83	55.21	41.21
2200	90	56.32	56.32	56.41	55.55	58.79	50.57	54.31	54.31	54.40	53.74	56.64	48.88
2400	75	47.19	42.44	50.70	35.09	56.60	23.21	45.23	40.77	48.60	33.72	53.17	21.88
2400	80	49.97	49.22	51.97	43.21	56.81	34.24	48.02	47.42	49.87	41.58	54.57	33.00
2400	85	53.45	53.45	54.21	50.51	57.53	43.54	51.50	51.50	52.12	48.71	55.30	41.98
2400	90	57.06	57.06	57.14	56.76	59.22	51.63	54.98	54.98	55.06	54.87	57.00	49.86

Notes:

1. All capacities shown are gross and have not considered indoor fan heat. To obtain **NET** cooling capacity subtract indoor fan heat. For indoor fan heat formula, refer to appropriate airflow table notes.
2. MBh = Total Gross Capacity.
3. SHC = Sensible Heat Capacity.



Performance Data

**Table 14. Gross cooling capacities 6 tons with eFlex™ and eDrive™ technology - three phase
T/YZC072F3,4,W**

Air Flow cfm	Ent DB (F)	Ambient Temperature						Ambient Temperature						Ambient Temperature					
		85						95						105					
		Entering Wet Bulb						Entering Wet Bulb						Entering Wet Bulb					
		61		67		73		61		67		73		61		67		73	
		MBh	SHC	MBh	SHC	MBh	SHC	MBh	SHC	MBh	SHC	MBh	SHC	MBh	SHC	MBh	SHC	MBh	SHC
1200	75	57.0	41.7	64.7	34.3	73.2	26.5	54.1	40.0	61.6	32.6	69.8	24.8	51.5	38.5	58.6	31.0	66.4	23.2
1200	80	57.0	48.3	64.7	40.9	73.2	33.2	54.2	46.6	61.7	39.3	69.9	31.6	51.6	45.1	58.6	37.6	66.5	29.9
1200	85	56.9	54.7	64.7	47.5	73.3	39.9	53.9	53.0	61.7	45.9	69.9	38.2	51.2	51.2	58.7	44.3	66.6	36.6
1200	90	55.8	55.8	64.8	54.1	73.3	46.5	53.2	53.2	61.8	52.5	70.0	44.9	51.3	51.3	58.7	50.8	66.6	43.3
1440	75	59.8	45.9	67.8	36.9	76.6	27.5	56.7	44.2	64.5	35.2	73.0	25.7	53.8	42.5	61.2	33.4	69.2	24.0
1440	80	59.9	53.8	67.8	44.8	76.7	35.5	56.8	52.1	64.6	43.1	73.0	33.8	53.9	50.4	61.2	41.4	69.3	32.0
1440	85	59.6	59.6	67.9	52.7	76.7	43.5	56.4	56.4	64.6	51.1	73.1	41.8	53.4	53.4	61.3	49.3	69.4	40.1
1440	90	60.7	60.7	67.9	60.6	76.8	51.5	58.3	58.3	64.7	59.0	73.2	49.8	55.9	55.9	61.4	57.2	69.4	48.0
1680	75	62.0	50.0	70.2	39.3	79.3	28.3	58.8	48.2	66.7	37.5	75.4	26.5	55.6	46.4	63.1	35.7	71.3	24.7
1680	80	62.1	59.2	70.3	48.6	79.3	37.7	58.8	57.4	66.8	46.8	75.4	35.9	55.6	55.6	63.2	45.0	71.4	34.0
1680	85	61.9	61.9	70.3	57.8	79.4	47.0	58.9	58.9	66.8	56.1	75.5	45.2	56.4	56.4	63.3	54.3	71.4	43.4
1680	90	65.1	65.1	70.4	67.0	79.4	56.3	62.5	62.5	66.9	65.3	75.6	54.5	59.9	59.9	63.3	63.3	71.5	52.7
1920	75	63.7	54.0	72.1	41.7	81.3	29.0	60.3	52.1	68.4	39.8	77.2	27.2	56.9	50.2	64.6	38.0	72.9	25.3
1920	80	63.8	63.8	72.2	52.3	81.4	39.7	60.4	60.4	68.5	50.4	77.3	37.9	57.0	57.0	64.7	48.6	73.0	36.0
1920	85	65.0	65.0	72.3	62.8	81.5	50.4	62.3	62.3	68.6	61.0	77.4	48.6	59.5	59.5	64.8	59.1	73.1	46.7
1920	90	68.9	68.9	72.3	72.3	81.5	61.0	66.1	66.1	68.6	68.6	77.5	59.2	63.3	63.3	64.9	64.9	73.2	57.3
2160	75	65.2	57.8	73.7	44.0	83.0	29.7	61.6	55.9	69.8	42.1	78.7	27.8	58.0	54.0	65.8	40.1	74.3	25.8
2160	80	65.3	65.3	73.8	55.9	83.1	41.8	61.8	61.8	69.8	54.0	78.8	39.9	58.4	58.4	65.9	52.1	74.4	37.9
2160	85	68.1	68.1	73.9	67.8	83.2	53.8	65.2	65.2	70.0	65.9	78.9	51.9	62.1	62.1	66.0	64.0	74.4	49.9
2160	90	72.3	72.3	74.0	74.0	83.2	65.7	69.2	69.2	70.2	70.2	79.0	63.8	66.2	66.2	66.5	66.5	74.5	61.9
2400	75	66.3	61.7	75.0	46.2	84.4	30.3	62.7	59.7	70.9	44.2	79.9	28.4	58.9	57.7	66.8	42.3	75.3	26.4
2400	80	66.8	66.8	75.1	59.5	84.5	43.7	63.3	63.3	71.0	57.5	80.0	41.8	60.3	60.3	66.9	55.5	75.4	39.8
2400	85	70.8	70.8	75.2	72.7	84.5	57.1	67.6	67.6	71.1	70.7	80.1	55.1	64.4	64.4	67.1	67.1	75.5	53.1
2400	90	75.2	75.2	75.7	75.7	84.6	70.3	72.0	72.0	72.0	72.0	80.2	68.4	68.7	68.7	68.7	68.7	75.6	66.4
2640	75	67.3	65.4	76.1	48.4	85.5	30.9	63.5	63.4	71.9	46.4	81.0	28.9	59.7	59.7	67.6	44.4	76.2	26.9
2640	80	68.4	68.4	76.2	63.0	85.6	45.7	65.4	65.4	72.0	61.0	81.1	43.7	62.1	62.1	67.7	58.9	76.3	41.6
2640	85	73.1	73.1	76.3	76.3	85.7	60.3	69.8	69.8	72.2	72.2	81.2	58.4	66.5	66.5	68.0	68.0	76.4	56.3
2640	90	77.8	77.8	77.6	77.6	85.8	74.9	74.4	74.4	74.5	74.5	81.3	73.0	70.8	70.8	70.9	70.9	76.6	70.9
2880	75	68.2	68.2	77.0	50.6	86.5	31.5	64.3	64.3	72.7	48.5	81.8	29.5	60.4	60.4	68.3	46.4	76.9	27.4
2880	80	70.5	70.5	77.1	66.5	86.6	47.6	67.2	67.2	72.8	64.5	81.9	45.6	63.7	63.7	68.4	62.3	77.1	43.5
2880	85	75.3	75.3	77.3	77.3	86.7	63.6	71.8	71.8	73.1	73.1	82.0	61.6	68.2	68.2	68.8	68.8	77.2	59.5
2880	90	80.1	80.1	80.2	80.2	86.8	79.5	76.5	76.5	76.6	76.6	82.2	77.5	72.8	72.8	72.9	72.9	77.3	75.4

Table 14. Gross cooling capacities 6 tons with eFlex™ and eDrive™ technology - three phase T/YZC072F3,4,W (continued)

Air Flow cfm	Ent DB (F)	Ambient Temperature						Ambient Temperature					
		115						120					
		Entering Wet Bulb						Entering Wet Bulb					
		61		67		73		61		67		73	
		MBh	SHC	MBh	SHC	MBh	SHC	MBh	SHC	MBh	SHC	MBh	SHC
1200	75	49.7	37.4	56.1	29.6	63.3	21.7	49.1	36.9	55.2	29.1	61.9	21.0
1200	80	49.8	44.0	56.2	36.3	63.3	28.4	49.1	43.5	55.3	35.7	62.0	27.7
1200	85	49.4	49.4	56.3	42.9	63.4	35.1	48.7	48.7	55.4	42.4	62.1	34.4
1200	90	49.9	49.9	56.3	49.5	63.5	41.7	49.3	49.3	55.4	49.0	62.1	41.1
1440	75	51.7	41.3	58.3	31.9	65.7	22.3	51.0	40.8	57.2	31.3	64.1	21.6
1440	80	51.8	49.1	58.4	39.9	65.8	30.4	51.0	48.6	57.3	39.3	64.2	29.6
1440	85	51.4	51.4	58.5	47.8	65.8	38.4	50.6	50.6	57.4	47.2	64.3	37.7
1440	90	54.1	54.1	58.5	55.7	65.9	46.4	53.4	53.4	57.4	55.1	64.3	45.7
1680	75	53.2	45.0	60.0	34.1	67.5	22.9	52.3	44.5	58.7	33.4	65.7	22.1
1680	80	53.2	53.2	60.0	43.4	67.5	32.3	52.3	52.3	58.8	42.7	65.8	31.5
1680	85	54.4	54.4	60.1	52.7	67.6	41.7	53.6	53.6	58.9	52.0	65.9	40.9
1680	90	57.6	57.6	60.1	60.1	67.7	51.0	56.8	56.8	58.8	58.8	66.0	50.2
1920	75	54.3	48.7	61.2	36.2	68.8	23.4	53.4	48.1	59.8	35.5	66.9	22.6
1920	80	54.4	54.4	61.3	46.9	68.9	34.2	53.5	53.5	59.9	46.1	67.0	33.3
1920	85	57.1	57.1	61.4	57.4	69.0	44.8	56.2	56.2	60.0	56.7	67.1	44.0
1920	90	60.6	60.6	61.5	61.5	69.1	55.5	59.6	59.6	60.2	60.2	67.2	54.6
2160	75	55.2	52.4	62.2	38.3	69.8	23.9	54.2	51.7	60.7	37.6	67.8	23.0
2160	80	55.7	55.7	62.3	50.3	69.9	36.0	54.7	54.7	60.8	49.5	67.9	35.1
2160	85	59.5	59.5	62.4	62.2	70.0	48.0	58.4	58.4	60.9	60.9	68.0	47.1
2160	90	63.2	63.2	63.1	63.1	70.1	60.0	62.0	62.0	62.0	62.0	68.1	59.1
2400	75	55.9	55.9	63.0	40.4	70.7	24.4	54.8	54.8	61.4	39.6	68.6	23.4
2400	80	57.6	57.6	63.1	53.7	70.8	37.8	56.6	56.6	61.5	52.8	68.7	36.8
2400	85	61.5	61.5	63.3	63.3	70.9	51.1	60.2	60.2	61.7	61.7	68.8	50.2
2400	90	65.5	65.5	65.6	65.6	71.0	64.4	64.0	64.0	64.1	64.1	68.9	63.5
2640	75	56.5	56.5	63.6	42.4	71.4	24.8	55.3	55.3	62.0	41.6	69.1	23.8
2640	80	59.2	59.2	63.8	57.0	71.5	39.6	58.0	58.0	62.1	56.2	69.2	38.6
2640	85	63.3	63.3	64.1	64.1	71.6	54.2	61.9	61.9	62.4	62.4	69.4	53.3
2640	90	67.4	67.4	67.5	67.5	71.8	68.9	65.8	65.8	65.9	65.9	69.5	67.9
2880	75	57.1	57.1	64.2	44.4	72.0	25.3	55.8	55.8	62.4	43.6	69.6	24.2
2880	80	60.6	60.6	64.3	60.4	72.1	41.3	59.3	59.3	62.5	59.5	69.7	40.3
2880	85	64.8	64.8	64.9	64.9	72.3	57.4	63.3	63.3	63.2	63.2	69.8	56.3
2880	90	69.1	69.1	69.2	69.2	72.4	72.4	67.4	67.4	67.5	67.5	70.0	70.0

Notes:

1. All capacities shown are gross and have not considered indoor fan heat. To obtain **NET** cooling capacity subtract indoor fan heat. For indoor fan heat formula, refer to appropriate airflow table notes.
2. MBh = Total Gross Capacity.
3. SHC = Sensible Heat Capacity.



Performance Data

**Table 15. Gross cooling capacities 7.5 tons with eFlex™ and eDrive™ technology - three phase
T/YZC090F3,4,W**

Air Flow cfm	Ent DB (F)	Ambient Temperature						Ambient Temperature						Ambient Temperature					
		85						95						105					
		Entering Wet Bulb						Entering Wet Bulb						Entering Wet Bulb					
		61		67		73		61		67		73		61		67		73	
MBh	SHC	MBh	SHC	MBh	SHC	MBh	SHC	MBh	SHC	MBh	SHC	MBh	SHC	MBh	SHC	MBh	SHC		
1500	75	75.3	54.5	84.7	44.8	94.8	34.6	72.2	52.6	81.3	42.9	90.8	32.6	69.1	50.8	77.7	41.0	86.7	30.7
1500	80	75.4	62.8	84.8	53.2	94.8	43.0	72.4	61.0	81.4	51.3	90.9	41.1	69.2	59.1	77.8	49.4	86.8	39.1
1500	85	75.5	71.0	84.9	61.5	94.9	51.4	72.4	68.9	81.5	59.7	91.0	49.5	69.3	66.9	78.0	57.7	86.9	47.5
1500	90	75.8	75.8	85.1	69.8	95.0	59.8	73.4	73.4	81.7	68.0	91.1	57.9	70.9	70.9	78.1	66.1	87.0	55.9
1800	75	79.0	59.8	88.6	48.0	98.5	35.5	75.6	57.8	84.8	46.0	94.2	33.5	72.2	55.8	80.9	44.0	89.6	31.4
1800	80	79.2	69.8	88.7	58.0	98.6	45.7	75.9	67.8	85.0	56.1	94.3	43.6	72.4	65.8	81.1	54.0	89.7	41.5
1800	85	79.6	79.2	88.9	68.0	98.7	55.7	76.3	76.3	85.2	66.1	94.4	53.7	72.9	72.9	81.3	64.0	89.9	51.6
1800	90	82.5	82.5	89.1	78.0	98.8	65.8	79.8	79.8	85.4	76.0	94.5	63.8	76.8	76.8	81.5	74.0	90.1	61.7
2100	75	81.8	64.9	91.4	51.0	101.1	36.3	78.2	62.8	87.4	48.9	96.5	34.2	74.5	60.7	83.1	46.7	91.6	32.0
2100	80	82.2	76.5	91.7	62.7	101.2	48.1	78.6	73.9	87.6	60.6	96.6	46.0	74.9	71.8	83.4	58.5	91.7	43.8
2100	85	83.3	83.3	91.9	74.4	101.4	59.9	80.4	80.4	87.9	72.3	96.8	57.8	77.2	77.2	83.7	70.2	91.9	55.6
2100	90	88.1	88.1	92.2	86.0	101.6	71.6	84.9	84.9	88.2	83.3	96.9	69.5	81.6	81.6	84.1	81.1	92.1	67.3
2400	75	84.1	69.8	93.6	53.8	103.1	37.0	80.2	67.7	89.3	51.6	98.1	34.8	76.3	65.5	84.8	49.4	93.0	32.5
2400	80	84.7	82.5	93.9	67.2	103.2	50.5	80.9	80.3	89.6	65.0	98.3	48.3	77.0	77.0	85.1	62.8	93.2	46.0
2400	85	87.7	87.7	94.2	80.5	103.4	63.9	84.4	84.4	89.9	78.4	98.5	61.7	81.0	81.0	85.5	76.2	93.4	59.4
2400	90	92.7	92.7	94.8	93.1	103.5	77.3	89.2	89.2	90.6	90.6	98.6	75.1	85.5	85.5	86.3	86.3	93.5	72.8
2700	75	85.9	74.6	95.4	56.6	104.5	37.6	81.8	72.4	90.8	54.3	99.4	35.4	77.7	70.2	86.1	52.0	94.0	33.0
2700	80	86.9	86.9	95.7	71.6	104.7	52.8	83.0	83.0	91.2	69.4	99.6	50.5	79.1	79.1	86.5	67.1	94.2	48.2
2700	85	91.4	91.4	96.0	86.7	104.9	67.9	87.8	87.8	91.6	83.6	99.7	65.6	84.0	84.0	86.9	81.2	94.4	63.3
2700	90	96.5	96.5	97.1	97.1	105.0	82.9	92.7	92.7	92.8	92.8	99.9	80.6	88.6	88.6	88.8	88.8	94.5	78.3
3000	75	87.4	79.4	96.7	59.3	105.7	38.3	83.2	77.1	92.0	57.0	100.4	35.9	78.9	73.8	87.2	54.6	94.8	33.6
3000	80	89.1	89.1	97.1	76.0	105.9	55.1	85.5	85.5	92.4	73.7	100.5	52.8	81.7	81.7	87.5	71.3	95.0	50.4
3000	85	94.5	94.5	97.6	91.7	106.0	71.8	90.6	90.6	93.0	89.3	100.7	69.5	86.6	86.6	88.2	86.8	95.1	67.1
3000	90	99.6	99.6	99.6	99.6	106.1	88.5	95.5	95.5	95.6	95.6	100.8	86.2	91.1	91.1	91.2	91.2	95.2	83.8
3300	75	88.7	83.1	97.9	62.0	106.6	38.9	84.4	80.7	93.0	59.6	101.2	36.5	80.0	78.1	88.0	57.1	95.5	34.1
3300	80	91.7	91.7	98.2	80.4	106.8	57.4	87.8	87.8	93.4	78.0	101.3	55.0	83.7	83.7	88.3	75.5	95.6	52.5
3300	85	97.1	97.1	98.9	97.4	106.9	75.8	93.0	93.0	94.2	94.2	101.4	73.4	88.6	88.6	89.2	89.2	95.7	70.9
3300	90	102.2	102.2	102.3	102.3	107.2	94.1	97.7	97.7	97.8	97.8	101.6	91.7	93.0	93.0	93.1	93.1	95.9	87.8
3600	75	89.9	87.6	98.8	64.6	107.4	39.5	85.4	85.0	93.8	62.2	101.8	37.1	80.9	80.9	88.6	59.7	96.0	34.6
3600	80	93.9	93.9	99.2	84.7	107.6	59.6	89.8	89.8	94.1	82.2	101.9	57.2	85.5	85.5	89.0	78.4	96.1	54.7
3600	85	99.3	99.3	100.2	100.2	107.7	79.7	94.9	94.9	95.3	95.3	102.0	77.2	90.3	90.3	90.3	90.3	96.1	74.7
3600	90	104.3	104.3	104.4	104.4	108.1	99.8	99.6	99.6	99.6	99.6	102.4	95.7	94.5	94.5	94.6	94.6	96.5	93.0

Table 15. Gross cooling capacities 7.5 tons with eFlex™ and eDrive™ technology - three phase T/YZC090F3,4,W (continued)

Air Flow cfm	Ent DB (F)	Ambient Temperature						Ambient Temperature					
		115						120					
		Entering Wet Bulb						Entering Wet Bulb					
		61		67		73		61		67		73	
		MBh	SHC	MBh	SHC	MBh	SHC	MBh	SHC	MBh	SHC	MBh	SHC
1500	75	65.8	48.9	74.0	39.0	82.4	28.6	64.2	47.9	72.1	38.0	80.0	27.5
1500	80	66.0	57.2	74.1	47.4	82.4	37.1	64.4	56.2	72.2	46.4	80.1	36.0
1500	85	66.1	65.0	74.3	55.8	82.6	45.5	64.5	64.0	72.4	54.8	80.2	44.4
1500	90	68.3	68.3	74.5	64.1	82.7	53.9	66.9	66.9	72.5	63.1	80.4	52.8
1800	75	68.6	53.8	76.8	41.9	84.8	29.2	66.8	52.8	74.6	40.8	82.2	28.1
1800	80	68.9	63.8	77.0	51.9	84.9	39.3	67.1	62.3	74.9	50.9	82.3	38.2
1800	85	69.8	69.8	77.2	62.0	85.1	49.4	68.2	68.2	75.1	60.9	82.5	48.3
1800	90	73.8	73.8	77.4	71.9	85.2	59.5	72.2	72.2	75.3	70.9	82.7	58.3
2100	75	70.7	58.6	78.7	44.5	86.4	29.7	68.7	57.5	76.4	43.4	83.7	28.5
2100	80	71.1	69.6	79.0	56.3	86.6	41.5	69.2	68.5	76.7	55.1	83.8	40.3
2100	85	73.9	73.9	79.3	68.0	86.8	53.3	72.2	72.2	77.0	66.8	84.0	52.1
2100	90	78.2	78.2	79.7	78.9	86.9	65.0	76.3	76.3	77.5	77.5	84.1	63.8
2400	75	72.2	63.3	80.2	47.1	87.6	30.2	70.1	62.1	77.7	45.9	84.6	28.9
2400	80	73.1	73.1	80.5	60.5	87.7	43.7	71.1	71.1	78.0	59.3	84.8	42.4
2400	85	77.3	77.3	80.8	73.9	87.9	57.1	75.4	75.4	78.4	72.7	84.9	55.8
2400	90	81.6	81.6	81.8	81.8	88.0	70.4	79.5	79.5	79.5	79.5	85.0	69.2
2700	75	73.5	67.0	81.2	49.7	88.4	30.6	71.3	65.8	78.7	48.4	85.4	29.4
2700	80	75.5	75.5	81.6	64.7	88.5	45.8	73.5	73.5	79.0	63.5	85.5	44.5
2700	85	80.0	80.0	82.1	78.7	88.6	60.8	77.9	77.9	79.5	77.4	85.6	59.5
2700	90	84.3	84.3	84.4	84.4	88.7	75.8	81.9	81.9	82.0	82.0	85.6	74.5
3000	75	74.5	71.3	82.1	52.2	89.0	31.1	72.3	70.0	79.4	50.9	85.9	29.8
3000	80	77.7	77.7	82.4	68.9	89.1	47.9	75.5	75.5	79.7	67.6	86.0	46.5
3000	85	82.2	82.2	83.1	83.1	89.2	64.6	79.9	79.9	80.5	80.5	86.0	63.2
3000	90	86.3	86.3	86.4	86.4	89.2	81.2	83.7	83.7	83.8	83.8	86.0	78.5
3300	75	75.4	75.4	82.7	54.6	89.5	31.5	73.1	73.1	79.9	53.3	86.3	30.2
3300	80	79.4	79.4	83.0	73.0	89.6	49.9	77.2	77.2	80.3	70.4	86.3	48.6
3300	85	84.0	84.0	84.1	84.1	89.5	68.3	81.4	81.4	81.4	81.4	86.2	66.9
3300	90	87.8	87.8	87.9	87.9	89.8	85.0	85.0	85.0	85.0	85.0	86.5	83.5
3600	75	76.3	76.3	83.2	57.1	89.9	32.0	73.9	73.9	80.3	55.7	86.7	30.6
3600	80	80.9	80.9	83.6	75.6	89.9	52.0	78.5	78.5	80.7	74.2	86.5	50.6
3600	85	85.3	85.3	85.4	85.4	89.8	72.0	82.6	82.6	82.7	82.7	86.5	70.6
3600	90	89.1	89.1	89.1	89.1	90.2	90.1	86.1	86.1	86.1	86.1	86.9	86.9

Notes:

1. All capacities shown are gross and have not considered indoor fan heat. To obtain **NET** cooling capacity subtract indoor fan heat. For indoor fan heat formula, refer to appropriate airflow table notes.
2. MBh = Total Gross Capacity.
3. SHC = Sensible Heat Capacity.



Performance Data

**Table 16. Gross cooling capacities 8.5 tons with eFlex™ and eDrive™ technology - three phase
T/YZC102F3,4,W**

Air Flow cfm	Ent DB (F)	Ambient Temperature						Ambient Temperature						Ambient Temperature					
		85						95						105					
		Entering Wet Bulb						Entering Wet Bulb						Entering Wet Bulb					
		61		67		73		61		67		73		61		67		73	
		MBh	SHC	MBh	SHC	MBh	SHC	MBh	SHC	MBh	SHC	MBh	SHC	MBh	SHC	MBh	SHC	MBh	SHC
1700	75	84.0	61.5	94.5	50.3	105.9	38.5	80.5	59.4	90.6	48.2	101.4	36.3	76.8	57.3	86.4	46.0	96.7	34.1
1700	80	84.2	71.2	94.7	60.0	106.0	48.3	80.7	69.1	90.7	57.9	101.5	46.1	77.0	67.0	86.6	55.7	96.8	43.9
1700	85	84.3	80.8	94.8	69.7	106.0	58.0	80.9	78.2	90.9	67.6	101.6	55.9	77.3	76.1	86.8	65.4	96.9	53.7
1700	90	85.5	85.5	95.0	79.4	106.2	67.8	82.7	82.7	91.1	77.2	101.7	65.6	79.7	79.7	87.0	75.1	97.1	63.4
2040	75	88.0	67.6	98.7	53.9	110.0	39.6	84.1	65.4	94.3	51.7	105.1	37.3	80.1	63.1	89.8	49.3	99.9	34.9
2040	80	88.3	79.2	98.9	65.6	110.1	51.3	84.4	77.0	94.6	63.3	105.2	49.0	80.4	74.7	90.1	61.0	100.0	46.7
2040	85	88.9	88.9	99.2	77.2	110.3	63.0	85.2	85.2	94.9	75.0	105.4	60.8	81.5	81.5	90.4	72.7	100.2	58.4
2040	90	92.9	92.9	99.4	88.8	110.5	74.7	89.6	89.6	95.1	86.6	105.6	72.4	86.2	86.2	90.7	84.3	100.5	70.1
2380	75	91.0	73.4	101.8	57.3	112.9	40.5	86.9	71.1	97.1	55.0	107.6	38.1	82.5	68.7	92.2	52.5	102.1	35.6
2380	80	91.5	87.0	102.1	71.0	113.0	54.2	87.4	83.9	97.4	68.6	107.8	51.8	83.2	81.5	92.6	66.2	102.3	49.3
2380	85	93.6	93.6	102.4	84.5	113.3	67.9	90.1	90.1	97.8	82.2	108.0	65.5	86.5	86.5	93.0	79.7	102.6	63.0
2380	90	99.0	99.0	102.9	98.1	113.5	81.5	95.3	95.3	98.3	94.9	108.3	79.1	91.5	91.5	93.6	92.4	102.8	76.6
2720	75	93.4	79.1	104.2	60.6	115.1	41.3	89.0	76.7	99.2	58.1	109.5	38.8	84.4	74.2	94.1	55.6	103.7	36.2
2720	80	94.3	93.7	104.6	76.2	115.3	57.0	90.0	90.0	99.6	73.7	109.7	54.5	85.6	85.6	94.5	71.2	103.9	51.9
2720	85	98.4	98.4	104.9	91.7	115.5	72.6	94.5	94.5	100.0	89.2	110.0	70.1	90.5	90.5	95.0	86.7	104.2	67.5
2720	90	104.0	104.0	105.8	105.8	115.8	88.1	100.0	100.0	101.1	101.1	110.3	85.6	95.8	95.8	96.2	96.2	104.5	83.1
3060	75	95.4	84.7	106.1	63.8	116.7	42.1	90.7	82.2	100.9	61.3	110.9	39.5	86.0	78.6	95.5	58.6	104.8	36.8
3060	80	96.8	96.8	106.5	81.3	117.0	59.7	92.4	92.4	101.3	78.8	111.2	57.1	88.2	88.2	96.0	76.2	105.2	54.5
3060	85	102.4	102.4	107.0	98.8	117.2	77.2	98.2	98.2	101.9	95.1	111.5	74.7	93.9	93.9	96.7	92.4	105.5	72.0
3060	90	108.2	108.2	108.5	108.5	117.5	94.7	103.8	103.8	103.8	103.8	111.7	92.1	99.2	99.2	99.4	99.4	105.7	89.5
3400	75	97.0	89.1	107.6	67.0	118.0	42.8	92.2	86.4	102.2	64.3	112.0	40.1	87.3	83.6	96.7	61.6	105.7	37.4
3400	80	99.5	99.5	108.1	86.4	118.3	62.4	95.4	95.4	102.7	83.8	112.3	59.7	91.0	91.0	97.2	81.1	106.1	57.0
3400	85	105.8	105.8	108.8	104.5	118.6	81.8	101.3	101.3	103.5	101.7	112.6	79.2	96.7	96.7	98.1	98.1	106.4	76.5
3400	90	111.7	111.7	111.8	111.8	118.8	101.2	107.0	107.0	107.1	107.1	112.8	98.6	102.0	102.0	102.1	102.1	106.6	95.9
3740	75	98.5	94.3	108.9	70.1	119.1	43.5	93.5	91.5	103.3	67.4	112.9	40.8	88.5	88.5	97.6	64.6	106.4	38.0
3740	80	102.4	102.4	109.4	91.5	119.4	65.0	97.9	97.9	103.8	88.7	113.3	62.3	93.2	93.2	98.1	86.0	106.8	59.5
3740	85	108.7	108.7	110.3	110.3	119.7	86.4	103.9	103.9	104.9	104.9	113.5	83.7	99.0	99.0	99.4	99.4	107.1	80.9
3740	90	114.6	114.6	114.7	114.7	119.9	107.7	109.6	109.6	109.7	109.7	113.8	103.4	104.3	104.3	104.4	104.4	107.4	100.4
4080	75	99.8	99.5	109.9	73.2	120.0	44.2	94.7	94.7	104.2	70.4	113.6	41.4	89.5	89.5	98.3	67.5	107.0	38.6
4080	80	104.8	104.8	110.4	96.5	120.3	67.7	100.1	100.1	104.7	93.7	114.0	64.9	95.1	95.1	98.8	89.1	107.4	62.0
4080	85	111.1	111.1	111.8	111.8	120.5	91.0	106.1	106.1	106.3	106.3	114.2	88.2	100.9	100.9	100.7	100.7	107.6	85.3
4080	90	117.0	117.0	117.1	117.1	120.9	112.3	111.7	111.7	111.8	111.8	114.5	109.4	106.0	106.0	106.1	106.1	107.9	106.3

Table 16. Gross cooling capacities 8.5 tons with eFlex™ and eDrive™ technology - three phase T/YZC102F3,4,W (continued)

Air Flow cfm	Ent DB (F)	Ambient Temperature						Ambient Temperature					
		115						120					
		Entering Wet Bulb						Entering Wet Bulb					
		61		67		73		61		67		73	
MBh	SHC	MBh	SHC	MBh	SHC	MBh	SHC	MBh	SHC	MBh	SHC		
1700	75	73.1	55.1	82.2	43.7	91.8	31.8	71.2	54.1	80.0	42.6	89.2	30.6
1700	80	73.3	64.8	82.4	53.5	91.9	41.6	71.4	63.7	80.2	52.4	89.3	40.4
1700	85	73.6	73.6	82.6	63.2	92.0	51.4	71.8	71.8	80.5	62.1	89.4	50.2
1700	90	76.7	76.7	82.8	72.9	92.2	61.1	75.1	75.1	80.7	71.7	89.6	59.9
2040	75	76.0	60.8	85.2	47.0	94.5	32.5	74.0	59.7	82.7	45.8	91.6	31.2
2040	80	76.4	72.4	85.5	58.7	94.6	44.2	74.4	70.6	83.1	57.5	91.8	43.0
2040	85	78.1	78.1	85.8	70.3	94.9	56.0	76.4	76.4	83.4	69.1	92.0	54.7
2040	90	82.7	82.7	86.1	82.0	95.1	67.7	80.9	80.9	83.7	80.0	92.2	66.4
2380	75	78.2	66.3	87.3	50.0	96.3	33.1	76.0	65.1	84.7	48.8	93.2	31.7
2380	80	78.9	78.9	87.6	63.7	96.5	46.8	76.7	76.7	85.1	62.4	93.4	45.4
2380	85	82.7	82.7	88.0	77.3	96.8	60.5	80.7	80.7	85.4	76.0	93.7	59.1
2380	90	87.5	87.5	88.8	88.8	97.0	74.1	85.4	85.4	86.2	86.2	93.9	72.7
2720	75	79.8	71.7	88.8	53.0	97.6	33.6	77.5	70.4	86.1	51.7	94.3	32.2
2720	80	81.2	81.2	89.3	68.6	97.9	49.3	79.1	79.1	86.5	67.3	94.6	47.9
2720	85	86.3	86.3	89.8	83.1	98.1	64.9	84.1	84.1	87.0	81.7	94.9	63.5
2720	90	91.3	91.3	91.3	91.3	98.4	80.4	88.9	88.9	89.1	89.1	95.1	79.0
3060	75	81.2	75.8	90.0	56.0	98.5	34.1	78.7	74.4	87.1	54.6	95.1	32.7
3060	80	84.1	84.1	90.5	73.5	98.8	51.7	81.8	81.8	87.6	72.1	95.4	50.3
3060	85	89.3	89.3	91.2	89.6	99.1	69.3	86.9	86.9	88.3	88.1	95.6	67.8
3060	90	94.3	94.3	94.5	94.5	99.3	86.7	91.7	91.7	91.8	91.8	95.8	85.3
3400	75	82.3	80.8	90.9	58.9	99.2	34.6	79.8	79.3	87.9	57.4	95.7	33.2
3400	80	86.4	86.4	91.4	78.3	99.5	54.2	84.0	84.0	88.4	76.9	96.0	52.7
3400	85	91.7	91.7	92.5	92.5	99.7	73.6	89.1	89.1	89.5	89.5	96.2	72.1
3400	90	96.7	96.7	96.8	96.8	100.0	91.4	93.8	93.8	93.9	93.9	96.4	89.8
3740	75	83.3	83.3	91.6	61.7	99.7	35.1	80.7	80.7	88.5	60.2	96.1	33.6
3740	80	88.4	88.4	92.2	81.5	100.1	56.6	85.8	85.8	89.0	79.9	96.4	55.1
3740	85	93.7	93.7	93.7	93.7	100.2	78.0	90.9	90.9	90.7	90.7	96.5	76.5
3740	90	98.5	98.5	98.6	98.6	100.5	97.2	95.3	95.3	95.4	95.4	96.8	95.5
4080	75	84.3	84.3	92.2	64.6	100.1	35.6	81.6	81.6	89.0	63.0	96.4	34.1
4080	80	90.0	90.0	92.8	85.9	100.5	59.0	87.2	87.2	89.6	84.3	96.7	57.5
4080	85	95.3	95.3	95.4	95.4	100.5	82.3	92.3	92.3	92.4	92.4	96.7	80.8
4080	90	99.9	99.9	99.9	99.9	100.9	100.9	96.5	96.5	96.5	96.5	97.1	97.1

Notes:

1. All capacities shown are gross and have not considered indoor fan heat. To obtain **NET** cooling capacity subtract indoor fan heat. For indoor fan heat formula, refer to appropriate airflow table notes.
2. MBh = Total Gross Capacity.
3. SHC = Sensible Heat Capacity.



Performance Data

Table 17. Gross cooling capacities 10 tons with eFlex™ and eDrive™ technology - three phase T/YZC120F3,4,W

Air Flow cfm	Ent DB (F)	Ambient Temperature						Ambient Temperature						Ambient Temperature					
		85						95						105					
		Entering Wet Bulb						Entering Wet Bulb						Entering Wet Bulb					
		61		67		73		61		67		73		61		67		73	
		MBh	SHC	MBh	SHC	MBh	SHC	MBh	SHC	MBh	SHC	MBh	SHC	MBh	SHC	MBh	SHC	MBh	SHC
2000	75	95.9	70.5	107.7	57.5	120.2	43.8	92.1	68.3	103.5	55.3	115.4	41.5	88.2	66.1	99.1	53.0	110.4	39.2
2000	80	96.0	81.4	107.8	68.5	120.2	54.9	92.3	79.3	103.5	66.3	115.4	52.7	88.4	77.0	99.1	64.1	110.4	50.4
2000	85	95.9	92.2	107.8	79.5	120.2	66.0	92.1	90.0	103.6	77.3	115.5	63.8	88.2	87.3	99.2	75.1	110.5	61.5
2000	90	95.8	95.8	107.9	90.5	120.3	77.1	92.9	92.9	103.8	88.3	115.5	74.9	89.8	89.8	99.4	86.1	110.5	72.6
2400	75	100.4	77.4	112.4	61.6	124.7	45.0	96.3	75.1	107.7	59.3	119.5	42.7	92.0	72.8	102.9	56.9	114.0	40.2
2400	80	100.6	90.6	112.4	74.9	124.8	58.4	96.4	88.3	107.8	72.6	119.5	56.0	92.2	85.9	103.0	70.2	114.1	53.6
2400	85	100.6	100.6	112.6	88.1	124.8	71.7	96.6	96.6	108.0	85.8	119.6	69.4	92.5	92.5	103.2	83.4	114.2	67.0
2400	90	104.1	104.1	112.7	101.3	124.9	85.0	100.7	100.7	108.1	99.0	119.7	82.7	97.2	97.2	103.3	96.6	114.3	80.3
2800	75	103.8	84.1	115.8	65.5	127.9	46.1	99.4	81.7	110.8	63.1	122.4	43.6	94.8	79.3	105.7	60.7	116.6	41.1
2800	80	104.0	99.4	115.9	81.0	128.0	61.7	99.6	97.1	111.0	78.6	122.4	59.2	95.1	93.9	105.9	76.1	116.6	56.7
2800	85	105.1	105.1	116.1	96.4	128.1	77.2	101.5	101.5	111.2	94.0	122.5	74.8	97.7	97.7	106.1	91.6	116.8	72.3
2800	90	110.9	110.9	116.3	111.8	128.2	92.7	107.1	107.1	111.4	109.4	122.7	90.3	103.2	103.2	106.4	106.0	116.9	87.8
3200	75	106.5	90.6	118.4	69.3	130.4	47.0	101.8	88.1	113.2	66.8	124.5	44.5	97.0	85.6	107.8	64.3	118.4	41.9
3200	80	106.9	106.9	118.6	87.0	130.4	64.8	102.3	102.3	113.4	84.5	124.6	62.4	97.7	97.7	108.1	82.0	118.5	59.8
3200	85	110.5	110.5	118.9	104.6	130.6	82.6	106.5	106.5	113.7	102.1	124.8	80.1	102.4	102.4	108.3	99.6	118.7	77.6
3200	90	116.5	116.5	119.3	119.3	130.7	100.3	112.4	112.4	114.2	114.2	124.9	97.8	108.1	108.1	109.0	109.0	118.8	95.3
3600	75	108.6	97.0	120.5	73.0	132.2	47.9	103.8	94.5	115.1	70.4	126.2	45.4	98.8	91.9	109.5	67.8	119.9	42.7
3600	80	109.5	109.5	120.8	92.9	132.3	68.0	104.9	104.9	115.4	90.3	126.3	65.4	100.2	100.2	109.8	87.7	120.0	62.8
3600	85	115.0	115.0	121.0	112.7	132.5	87.9	110.7	110.7	115.6	110.1	126.4	85.4	106.3	106.3	110.1	107.5	120.1	82.8
3600	90	121.2	121.2	122.0	122.0	132.6	107.8	116.7	116.7	116.9	116.9	126.6	105.3	112.0	112.0	112.0	112.0	120.3	102.7
4000	75	110.4	103.4	122.2	76.6	133.7	48.8	105.4	100.7	116.6	74.0	127.5	46.2	100.2	98.1	110.8	71.3	121.0	43.5
4000	80	112.2	112.2	122.5	98.7	133.9	71.0	108.0	108.0	116.9	96.1	127.6	68.5	103.4	103.4	111.1	93.4	121.1	65.8
4000	85	118.8	118.8	122.8	120.7	134.0	93.2	114.3	114.3	117.3	116.8	127.8	90.6	109.5	109.5	111.6	111.6	121.3	88.0
4000	90	125.1	125.1	125.0	125.0	134.1	115.3	120.3	120.3	120.5	120.5	127.9	112.7	115.3	115.3	115.4	115.4	121.4	110.1
4400	75	112.0	109.6	123.7	80.2	135.0	49.6	106.8	105.7	117.9	77.5	128.6	47.0	101.5	101.5	111.9	74.8	121.9	44.3
4400	80	115.4	115.4	123.9	104.5	135.1	74.1	110.8	110.8	118.2	101.8	128.7	71.5	106.1	106.1	112.2	99.1	122.0	68.8
4400	85	122.0	122.0	124.5	124.5	135.2	98.5	117.2	117.2	118.8	118.8	128.8	95.9	112.2	112.2	113.0	113.0	122.2	93.1
4400	90	128.4	128.4	128.5	128.5	135.3	122.8	123.3	123.3	123.4	123.4	128.9	120.1	118.0	118.0	118.1	118.1	122.3	117.4
4800	75	113.4	113.4	124.9	83.8	136.0	50.5	108.1	108.1	118.9	81.0	129.5	47.8	102.7	102.7	112.8	78.3	122.6	45.0
4800	80	118.1	118.1	125.1	110.2	136.1	77.2	113.3	113.3	119.2	107.5	129.6	74.5	108.3	108.3	113.1	104.7	122.8	71.7
4800	85	124.8	124.8	126.0	126.0	136.3	103.8	119.7	119.7	120.3	120.3	129.7	101.1	114.5	114.5	114.5	114.5	122.9	98.3
4800	90	131.2	131.2	131.3	131.3	136.3	130.2	125.8	125.8	125.9	125.9	129.8	127.6	120.2	120.2	120.3	120.3	123.0	122.8

Table 17. Gross cooling capacities 10 tons with eFlex™ and eDrive™ technology - three phase T/YZC120F3,4,W (continued)

Air Flow cfm	Ent DB (F)	Ambient Temperature						Ambient Temperature					
		115						120					
		Entering Wet Bulb						Entering Wet Bulb					
		61		67		73		61		67		73	
MBh	SHC	MBh	SHC	MBh	SHC	MBh	SHC	MBh	SHC	MBh	SHC		
2000	75	84.3	63.8	94.5	50.7	105.1	36.8	82.3	62.7	92.2	49.5	102.2	35.5
2000	80	84.4	74.8	94.6	61.8	105.1	48.0	82.4	73.7	92.3	60.6	102.3	46.7
2000	85	84.2	84.2	94.7	72.8	105.2	59.1	82.2	82.2	92.4	71.6	102.3	57.8
2000	90	86.6	86.6	94.9	83.8	105.3	70.2	85.0	85.0	92.5	82.6	102.4	68.9
2400	75	87.7	70.4	97.9	54.5	108.2	37.7	85.5	69.2	95.3	53.2	105.1	36.4
2400	80	87.8	83.6	98.1	67.8	108.3	51.1	85.6	82.4	95.5	66.5	105.2	49.8
2400	85	88.6	88.6	98.3	81.0	108.4	64.5	86.8	86.8	95.7	79.7	105.3	63.1
2400	90	93.5	93.5	98.4	94.1	108.5	77.8	91.6	91.6	95.8	92.9	105.4	76.4
2800	75	90.2	76.8	100.4	58.1	110.4	38.5	87.8	75.6	97.6	56.8	107.1	37.1
2800	80	90.5	90.5	100.6	73.6	110.5	54.1	88.2	88.2	97.8	72.3	107.2	52.8
2800	85	93.8	93.8	100.8	89.0	110.6	69.7	91.8	91.8	98.0	87.7	107.3	68.3
2800	90	99.0	99.0	101.1	101.1	110.8	85.2	96.8	96.8	98.4	98.4	107.4	83.8
3200	75	92.2	83.1	102.2	61.7	112.0	39.3	89.6	81.8	99.3	60.3	108.5	37.9
3200	80	93.0	93.0	102.5	79.3	112.1	57.1	90.6	90.6	99.5	78.0	108.6	55.7
3200	85	98.1	98.1	102.7	97.0	112.2	74.9	95.8	95.8	99.8	95.6	108.7	73.5
3200	90	103.5	103.5	103.7	103.7	112.4	92.6	101.0	101.0	101.0	101.0	108.9	91.2
3600	75	93.7	89.3	103.6	65.1	113.2	40.0	91.1	87.9	100.6	63.7	109.5	38.6
3600	80	95.9	95.9	103.9	85.0	113.3	60.1	93.6	93.6	100.8	83.6	109.7	58.6
3600	85	101.6	101.6	104.3	103.6	113.4	80.0	99.1	99.1	101.2	101.2	109.8	78.6
3600	90	107.0	107.0	107.1	107.1	113.6	99.9	104.3	104.3	104.4	104.4	109.9	98.5
4000	75	95.0	94.2	104.8	68.6	114.1	40.7	92.3	92.3	101.6	67.1	110.4	39.3
4000	80	98.7	98.7	105.1	90.7	114.2	63.0	96.2	96.2	101.9	89.2	110.5	61.5
4000	85	104.4	104.4	105.7	105.7	114.4	85.2	101.7	101.7	102.6	102.6	110.6	83.7
4000	90	109.9	109.9	110.0	110.0	114.4	107.3	106.9	106.9	107.0	107.0	110.7	105.8
4400	75	96.2	96.2	105.7	72.0	114.8	41.4	93.4	93.4	102.4	70.5	111.0	39.9
4400	80	101.1	101.1	106.0	96.3	115.0	65.9	98.4	98.4	102.7	94.8	111.1	64.4
4400	85	106.8	106.8	107.0	107.0	115.0	90.3	103.9	103.9	103.9	103.9	111.2	88.8
4400	90	112.2	112.2	112.2	112.2	115.2	114.6	109.0	109.0	109.0	109.0	111.3	111.1
4800	75	97.3	97.3	106.4	75.4	115.4	42.2	94.5	94.5	103.0	73.9	111.6	40.6
4800	80	103.0	103.0	106.7	101.9	115.5	68.8	100.2	100.2	103.3	100.4	111.6	67.3
4800	85	108.8	108.8	108.6	108.6	115.6	95.4	105.7	105.7	105.8	105.8	111.6	93.9
4800	90	114.0	114.0	114.1	114.1	115.8	115.8	110.6	110.6	110.7	110.7	111.9	111.9

Notes:

1. All capacities shown are gross and have not considered indoor fan heat. To obtain **NET** cooling capacity subtract indoor fan heat. For indoor fan heat formula, refer to appropriate airflow table notes.
2. MBh = Total Gross Capacity.
3. SHC = Sensible Heat Capacity.



Evaporator Fan Performance

Table 18. Direct drive evaporator fan performance - 3 ton with eFlex™ and eDrive™ technology- T/YZC036E3, E4 downflow airflow

External Static Pressure (Inches of Water)																				
cfm	.10		.20		.30		.40		.50		.60		.70		.80		.90		1.00	
	rpm	bhp	rpm	bhp	rpm	bhp	rpm	bhp	rpm	bhp	rpm	bhp	rpm	bhp	rpm	bhp	rpm	bhp	rpm	bhp
960	—	—	615	0.15	655	0.18	695	0.22	735	0.26	775	0.29	815	0.33	855	0.37	896	0.41	936	0.44
1080	599	0.16	639	0.20	680	0.24	720	0.27	760	0.31	800	0.35	840	0.38	880	0.42	920	0.46	960	0.49
1200	624	0.21	664	0.25	704	0.29	744	0.32	784	0.36	824	0.40	865	0.43	905	0.47	945	0.51	985	0.54
1320	649	0.26	689	0.30	729	0.34	769	0.37	809	0.41	849	0.45	889	0.49	929	0.52	969	0.56	1009	0.60
1440	673	0.31	713	0.35	753	0.39	793	0.43	834	0.46	874	0.50	914	0.54	954	0.57	994	0.61	1034	0.65

External Static Pressure (Inches of Water)										
cfm	1.10		1.20		1.30		1.40		1.50	
	rpm	bhp	rpm	bhp	rpm	bhp	rpm	bhp	rpm	bhp
960	976	0.48	1016	0.52	1056	0.55	1096	0.59	1136	0.63
1080	1000	0.53	1040	0.57	1081	0.60	1121	0.64	—	—
1200	1025	0.58	1065	0.62	1105	0.66	—	—	—	—
1320	1050	0.63	1090	0.67	—	—	—	—	—	—
1440	1074	0.68	—	—	—	—	—	—	—	—

Notes:

1. For Constant CFM Direct Drive Fan, reference the applicable table in the fan performance section for voltage vs. cfm setting.
2. Data includes pressure drop due to standard filters and wet coils.
3. To determine additional static pressure drop due to other options/accessories, refer to the applicable table in the fan performance section.
4. Direct Drive Fan Motor Heat (MBh) = 2.9245 x fan bhp + 0.055.
5. Factory supplied motors, in equipment, are definite purpose motors, specifically designed and tested to operate at all cataloged conditions. Using the full horsepower range of our fan motors as shown in our tabular data will not result in nuisance tripping or premature motor failure. Our product's warranty will not be affected.

Evaporator Fan Performance

Table 19. Direct drive evaporator fan performance - 3 ton with eFlex™ and eDrive™ technology - T/YZC036E3,E4 horizontal airflow

External Static Pressure (Inches of Water)																				
cfm	.10		.20		.30		.40		.50		.60		.70		.80		.90		1.00	
	rpm	bhp	rpm	bhp	rpm	bhp	rpm	bhp	rpm	bhp	rpm	bhp	rpm	bhp	rpm	bhp	rpm	bhp	rpm	bhp
960	596	0.11	634	0.15	673	0.18	711	0.22	750	0.26	788	0.29	827	0.33	865	0.36	904	0.40	942	0.44
1080	618	0.16	656	0.20	695	0.23	733	0.27	772	0.31	810	0.34	849	0.38	887	0.42	926	0.45	964	0.49
1200	640	0.21	678	0.25	717	0.29	755	0.32	794	0.36	832	0.40	871	0.43	909	0.47	948	0.51	986	0.54
1320	662	0.27	700	0.30	739	0.34	777	0.38	816	0.41	854	0.45	893	0.49	931	0.52	970	0.56	1008	0.59
1440	684	0.32	722	0.36	761	0.39	799	0.43	838	0.46	876	0.50	915	0.54	953	0.57	992	0.61	1030	0.65

External Static Pressure (Inches of Water)										
cfm	1.10		1.20		1.30		1.40		1.50	
	rpm	bhp	rpm	bhp	rpm	bhp	rpm	bhp	rpm	bhp
960	981	0.47	—	—	—	—	—	—	—	—
1080	—	—	—	—	—	—	—	—	—	—
1200	—	—	—	—	—	—	—	—	—	—
1320	—	—	—	—	—	—	—	—	—	—
1440	—	—	—	—	—	—	—	—	—	—

Notes:

1. For Constant CFM Direct Drive Fan, reference the applicable table in the fan performance section for voltage vs. cfm setting.
2. Data includes pressure drop due to standard filters and wet coils.
3. To determine additional static pressure drop due to other options/accessories, refer to the applicable table in the fan performance section.
4. Direct Drive Fan Motor Heat (MBh) = 2.9245 x fan bhp + 0.055.
5. Factory supplied motors, in equipment, are definite purpose motors, specifically designed and tested to operate at all cataloged conditions. Using the full horsepower range of our fan motors as shown in our tabular data will not result in nuisance tripping or premature motor failure. Our product's warranty will not be affected.



Evaporator Fan Performance

Table 20. Direct drive evaporator fan performance - 4 ton with eFlex™ and eDrive™ technology - T/YZC048F3, F4 downflow airflow

External Static Pressure (Inches of Water)																				
cfm	.10		.20		.30		.40		.50		.60		.70		.80		.90		1.00	
	rpm	bhp	rpm	bhp	rpm	bhp	rpm	bhp	rpm	bhp	rpm	bhp	rpm	bhp	rpm	bhp	rpm	bhp	rpm	bhp
1280	541	0.07	585	0.12	628	0.18	672	0.23	715	0.28	759	0.33	802	0.39	846	0.44	889	0.49	933	0.55
1440	564	0.15	608	0.20	651	0.25	695	0.30	738	0.36	782	0.41	825	0.46	869	0.51	912	0.57	956	0.62
1600	587	0.22	631	0.27	674	0.33	718	0.38	761	0.43	805	0.48	848	0.54	892	0.59	935	0.64	979	0.70
1760	610	0.30	654	0.35	697	0.40	741	0.45	784	0.51	828	0.56	871	0.61	915	0.66	958	0.72	1002	0.77
1920	634	0.37	677	0.42	721	0.48	764	0.53	808	0.58	851	0.63	895	0.69	938	0.74	982	0.79	1025	0.85

External Static Pressure (Inches of Water)										
cfm	1.10		1.20		1.30		1.40		1.50	
	rpm	bhp	rpm	bhp	rpm	bhp	rpm	bhp	rpm	bhp
1280	976	0.60	1020	0.65	1063	0.70	1107	0.76	1150	0.81
1440	999	0.67	1043	0.73	1086	0.78	1130	0.83	1173	0.88
1600	1022	0.75	1066	0.80	1109	0.85	1153	0.91	1196	0.96
1760	1045	0.82	1089	0.88	1132	0.93	1176	0.98	1219	1.03
1920	1069	0.90	1112	0.95	1156	1.00	1199	1.06	1243	1.11

Notes:

1. For Constant CFM Direct Drive Fan, reference the applicable table in the fan performance section for voltage vs. cfm setting.
2. Data includes pressure drop due to standard filters and wet coils.
3. To determine additional static pressure drop due to other options/accessories, refer to the applicable table in the fan performance section.
4. Direct Drive Fan Motor Heat (MBh) = 2.9245 x fan bhpP + 0.055.
5. Factory supplied motors, in equipment, are definite purpose motors, specifically designed and tested to operate at all cataloged conditions. Using the full horsepower range of our fan motors as shown in our tabular data will not result in nuisance tripping or premature motor failure. Our product's warranty will not be affected.

Evaporator Fan Performance

Table 21. Direct drive evaporator fan performance - 4 ton with eFlex™ and eDrive™ technology - T/YZC048F3, F4 horizontal airflow

External Static Pressure (Inches of Water)																				
cfm	.10		.20		.30		.40		.50		.60		.70		.80		.90		1.00	
	rpm	bhp	rpm	bhp	rpm	bhp	rpm	bhp	rpm	bhp	rpm	bhp	rpm	bhp	rpm	bhp	rpm	bhp	rpm	bhp
1280	591	0.10	632	0.15	674	0.20	715	0.26	756	0.31	798	0.36	839	0.41	880	0.47	922	0.52	963	0.57
1440	621	0.19	663	0.24	704	0.30	745	0.35	787	0.40	828	0.45	869	0.51	911	0.56	952	0.61	993	0.66
1600	652	0.28	693	0.33	734	0.39	776	0.44	817	0.49	858	0.55	900	0.60	941	0.65	982	0.70	1023	0.76
1760	682	0.37	723	0.43	765	0.48	806	0.53	847	0.58	889	0.64	930	0.69	971	0.74	1012	0.80	1054	0.85
1920	712	0.47	754	0.52	795	0.57	836	0.62	878	0.68	919	0.73	960	0.78	1001	0.83	1043	0.89	1084	0.94

External Static Pressure (Inches of Water)										
cfm	1.10		1.20		1.30		1.40		1.50	
	rpm	bhp	rpm	bhp	rpm	bhp	rpm	bhp	rpm	bhp
1280	1004	0.62	1045	0.68	1087	0.73	1128	0.78	1169	0.83
1440	1034	0.72	1076	0.77	1117	0.82	1158	0.87	1200	0.93
1600	1065	0.81	1106	0.86	1147	0.91	1189	0.97	1230	1.02
1760	1095	0.90	1136	0.95	1178	1.01	1219	1.06	1260	1.11
1920	1125	0.99	1167	1.05	1208	1.10	1249	1.15	1291	1.20

Notes:

1. For Constant CFM Direct Drive Fan, reference the applicable table in the fan performance section for voltage vs. cfm setting.
2. Data includes pressure drop due to standard filters and wet coils.
3. To determine additional static pressure drop due to other options/accessories, refer to the applicable table in the fan performance section.
4. Direct Drive Fan Motor Heat (MBh) = 2.9245 x fan bhp + 0.055.
5. Factory supplied motors, in equipment, are definite purpose motors, specifically designed and tested to operate at all cataloged conditions. Using the full horsepower range of our fan motors as shown in our tabular data will not result in nuisance tripping or premature motor failure. Our product's warranty will not be affected.



Evaporator Fan Performance

Table 22. Direct drive evaporator fan performance - 5 ton with eFlex™ and eDrive™ technology - T/YZC060E3,E4 downflow airflow

External Static Pressure (Inches of Water)																				
cfm	.10		.20		.30		.40		.50		.60		.70		.80		.90		1.00	
	rpm	bhp	rpm	bhp	rpm	bhp	rpm	bhp	rpm	bhp	rpm	bhp	rpm	bhp	rpm	bhp	rpm	bhp	rpm	bhp
1600	618	0.13	656	0.18	693	0.23	731	0.28	769	0.33	806	0.38	844	0.43	881	0.48	919	0.53	957	0.58
1800	651	0.24	689	0.29	727	0.34	764	0.39	802	0.44	839	0.49	877	0.54	915	0.59	952	0.64	990	0.69
2000	685	0.35	722	0.40	760	0.45	798	0.50	835	0.55	873	0.60	910	0.65	948	0.70	986	0.75	1023	0.80
2200	718	0.46	756	0.51	793	0.56	831	0.61	869	0.66	906	0.71	944	0.76	981	0.81	1019	0.86	1057	0.91
2400	752	0.57	789	0.62	827	0.67	864	0.72	902	0.77	940	0.82	977	0.87	1015	0.92	1052	0.97	1090	1.02

External Static Pressure (Inches of Water)										
cfm	1.10		1.20		1.30		1.40		1.50	
	rpm	bhp	rpm	bhp	rpm	bhp	rpm	bhp	rpm	bhp
1600	994	0.63	1032	0.68	1069	0.73	1107	0.79	1145	0.84
1800	1027	0.74	1065	0.79	1103	0.84	1140	0.89	—	—
2000	1061	0.85	1098	0.90	1136	0.95	—	—	—	—
2200	1094	0.96	1132	1.01	—	—	—	—	—	—
2400	—	—	—	—	—	—	—	—	—	—

Notes:

1. For Constant CFM Direct Drive Fan, reference the applicable table in the fan performance section for voltage vs. cfm setting.
2. Data includes pressure drop due to standard filters and wet coils.
3. To determine additional static pressure drop due to other options/accessories, refer to the applicable table in the fan performance section.
4. Direct Drive Fan Motor Heat (MBh) = 2.9245 x fan bhp + 0.055.
5. Factory supplied motors, in equipment, are definite purpose motors, specifically designed and tested to operate at all cataloged conditions. Using the full horsepower range of our fan motors as shown in our tabular data will not result in nuisance tripping or premature motor failure. Our product's warranty will not be affected.

Evaporator Fan Performance

Table 23. Direct drive evaporator fan performance - 5 ton with eFlex™ and eDrive™ technology - T/YZC060E3,E4 horizontal airflow

External Static Pressure (Inches of Water)																				
cfm	.10		.20		.30		.40		.50		.60		.70		.80		.90		1.00	
	rpm	bhp	rpm	bhp	rpm	bhp	rpm	bhp	rpm	bhp	rpm	bhp	rpm	bhp	rpm	bhp	rpm	bhp	rpm	bhp
1600	680	0.14	717	0.19	753	0.25	790	0.31	827	0.36	864	0.42	901	0.47	937	0.53	974	0.59	1011	0.64
1800	716	0.27	753	0.32	789	0.38	826	0.44	863	0.49	900	0.55	937	0.61	973	0.66	1010	0.72	1047	0.78
2000	752	0.40	789	0.46	825	0.51	862	0.57	899	0.63	936	0.68	973	0.74	1009	0.80	1046	0.85	1083	0.91
2200	788	0.53	825	0.59	861	0.65	898	0.70	935	0.76	972	0.82	1009	0.87	1045	0.93	1082	0.99	1119	1.04
2400	824	0.67	861	0.72	897	0.78	934	0.84	971	0.89	1008	0.95	1045	1.01	1081	1.06	1118	1.12	1155	1.18

External Static Pressure (Inches of Water)										
cfm	1.10		1.20		1.30		1.40		1.50	
	rpm	bhp	rpm	bhp	rpm	bhp	rpm	bhp	rpm	bhp
1600	—	—	—	—	—	—	—	—	—	—
1800	—	—	—	—	—	—	—	—	—	—
2000	—	—	—	—	—	—	—	—	—	—
2200	—	—	—	—	—	—	—	—	—	—
2400	—	—	—	—	—	—	—	—	—	—

Notes:

1. For Constant CFM Direct Drive Fan, reference the applicable table in the fan performance section for voltage vs. cfm setting.
2. Data includes pressure drop due to standard filters and wet coils.
3. To determine additional static pressure drop due to other options/accessories, refer to the applicable table in the fan performance section.
4. Direct Drive Fan Motor Heat (MBh) = 2.9245 x fan bhp + 0.055.
5. Factory supplied motors, in equipment, are definite purpose motors, specifically designed and tested to operate at all cataloged conditions. Using the full horsepower range of our fan motors as shown in our tabular data will not result in nuisance tripping or premature motor failure. Our product's warranty will not be affected.



Evaporator Fan Performance

Table 24. Direct drive evaporator fan performance - 6 ton with eFlex™ and eDrive™ technology - TZC072F3,F4,FW downflow airflow

External Static Pressure (Inches of Water)																				
cfm	.10		.20		.30		.40		.50		.60		.70		.80		.90		1.00	
	rpm	bhp	rpm	bhp	rpm	bhp	rpm	bhp	rpm	bhp	rpm	bhp	rpm	bhp	rpm	bhp	rpm	bhp	rpm	bhp
1200*	431	0.04	494	0.06	547	0.09	593	0.12	635	0.15	672	0.18	708	0.21	741	0.25	772	0.28	802	0.32
1440*	490	0.06	549	0.09	599	0.12	643	0.15	683	0.18	720	0.21	755	0.25	787	0.29	818	0.33	848	0.37
1680*	551	0.08	606	0.11	653	0.15	695	0.18	734	0.22	770	0.26	804	0.29	835	0.33	865	0.38	894	0.42
1920	613	0.11	664	0.15	709	0.18	749	0.22	786	0.26	821	0.30	854	0.34	884	0.39	914	0.43	942	0.48
2160	676	0.15	724	0.19	766	0.23	805	0.27	841	0.31	874	0.36	906	0.40	936	0.45	965	0.50	992	0.55
2400	740	0.19	785	0.23	825	0.28	862	0.32	896	0.37	929	0.42	959	0.47	988	0.52	1017	0.57	1043	0.62
2640	805	0.24	847	0.29	885	0.34	920	0.39	953	0.44	985	0.49	1014	0.54	1042	0.60	1069	0.65	1096	0.71
2880	871	0.31	910	0.36	947	0.41	980	0.46	1012	0.52	1041	0.57	1070	0.63	1098	0.69	1124	0.75	1149	0.81

External Static Pressure (Inches of Water)																				
cfm	1.10		1.20		1.30		1.40		1.50		1.60		1.70		1.80		1.90		2.00	
	rpm	bhp	rpm	bhp	rpm	bhp	rpm	bhp	rpm	bhp	rpm	bhp	rpm	bhp	rpm	bhp	rpm	bhp	rpm	bhp
1200*	830	0.36	858	0.40	884	0.44	909	0.48	934	0.52	958	0.56	980	0.61	1002	0.65	1024	0.70	1045	0.74
1440*	876	0.41	902	0.45	928	0.49	953	0.53	977	0.58	1001	0.63	1023	0.67	1045	0.72	1067	0.77	1088	0.82
1680*	921	0.46	948	0.51	974	0.55	998	0.60	1022	0.65	1045	0.70	1068	0.74	1089	0.79	1110	0.85	1131	0.90
1920	969	0.52	995	0.57	1020	0.62	1044	0.67	1068	0.72	1091	0.77	1113	0.82	1135	0.88	1156	0.93	1176	0.99
2160	1019	0.60	1043	0.65	1068	0.70	1092	0.75	1115	0.81	1138	0.86	1159	0.91	1180	0.97	1202	1.03	1222	1.09
2400	1069	0.68	1093	0.73	1117	0.78	1141	0.84	1163	0.90	1186	0.96	1208	1.01	1229	1.07	1249	1.13	1269	1.19
2640	1121	0.77	1145	0.82	1169	0.88	1192	0.94	1214	1.00	1235	1.06	1257	1.12	1277	1.19	1298	1.25	1317	1.31
2880	1174	0.87	1198	0.93	1220	0.99	1243	1.05	1264	1.11	1286	1.18	1306	1.24	1326	1.31	1347	1.38	1367	1.44

Notes:

- For direct drive fan speed, reference the applicable table in the fan performance section.
 - Data includes pressure drop due to standard filters and wet coils.
 - To determine additional static pressure drop due to other options/accessories, refer to the applicable table in the fan performance section.
 - Direct drive fan motor heat (MBh) = 2.7912 x fan bhp + 0.1388.
 - Factory supplied motors, in equipment, are definite purpose motors, specifically designed and tested to operate at all cataloged conditions. Using the full horsepower range of our fan motors as shown in our tabular data will not result in nuisance tripping or premature motor failure. Our product's warranty will not be affected.
- * For 1200, 1440, and 1680 cfm, unit application below 320 cfm/ton are only applicable on T_C models and modulating gas. See below for restrictions.
 * For electric heat applications, minimum airflow is set to 320 cfm/ton, unless specified otherwise, values found in electric heat temperature rise table.
 * TXV with Froststat™ and crankcase heaters are required on applications below 320 cfm/ton.

Evaporator Fan Performance

Table 25. Direct drive evaporator fan performance - 6 ton with eFlex™ and eDrive™ technology - TZC072F3,F4,FW horizontal airflow

External Static Pressure (Inches of Water)																				
cfm	.10		.20		.30		.40		.50		.60		.70		.80		.90		1.00	
	rpm	bhp	rpm	bhp	rpm	bhp	rpm	bhp	rpm	bhp	rpm	bhp	rpm	bhp	rpm	bhp	rpm	bhp	rpm	bhp
1200*	430	0.05	501	0.08	562	0.12	614	0.15	660	0.19	703	0.23	743	0.27	779	0.32	815	0.36	848	0.41
1440*	487	0.08	550	0.11	608	0.15	659	0.19	704	0.23	746	0.28	785	0.32	822	0.37	856	0.42	889	0.47
1680*	547	0.10	604	0.15	657	0.19	705	0.23	750	0.28	791	0.33	829	0.38	864	0.43	899	0.48	932	0.54
1920	609	0.14	660	0.19	708	0.23	754	0.28	797	0.34	837	0.39	874	0.44	909	0.50	943	0.56	974	0.62
2160	672	0.19	719	0.24	763	0.29	805	0.35	846	0.40	885	0.46	922	0.52	956	0.58	988	0.64	1020	0.71
2400	735	0.24	780	0.30	820	0.36	859	0.42	896	0.48	934	0.54	969	0.60	1003	0.67	1035	0.74	1066	0.80
2640	800	0.31	841	0.38	880	0.44	916	0.51	950	0.57	984	0.63	1019	0.70	1051	0.77	1082	0.84	1113	0.91
2880	865	0.39	904	0.46	940	0.53	974	0.60	1007	0.67	1038	0.74	1069	0.81	1101	0.88	1131	0.96	1161	1.04

External Static Pressure (Inches of Water)																				
cfm	1.10		1.20		1.30		1.40		1.50		1.60		1.70		1.80		1.90		2.00	
	rpm	bhp	rpm	bhp	rpm	bhp	rpm	bhp	rpm	bhp	rpm	bhp	rpm	bhp	rpm	bhp	rpm	bhp	rpm	bhp
1200*	880	0.46	910	0.50	939	0.55	967	0.61	995	0.66	1021	0.71	1047	0.77	1071	0.82	1094	0.88	1119	0.94
1440*	920	0.52	950	0.57	979	0.63	1007	0.68	1034	0.74	1060	0.80	1085	0.85	1110	0.92	1134	0.98	1156	1.03
1680*	962	0.59	992	0.65	1021	0.71	1047	0.77	1074	0.83	1101	0.89	1125	0.95	1150	1.02	1173	1.08	1196	1.14
1920	1006	0.68	1034	0.74	1063	0.80	1090	0.86	1116	0.93	1142	0.99	1167	1.06	1190	1.12	1215	1.20	1237	1.26
2160	1049	0.77	1078	0.83	1106	0.90	1133	0.97	1158	1.03	1184	1.11	1209	1.18	1233	1.25	1255	1.32	1278	1.39
2400	1094	0.87	1123	0.94	1150	1.01	1177	1.08	1203	1.16	1227	1.23	1253	1.31	1275	1.38	1299	1.46	1321	1.54
2640	1141	0.99	1169	1.06	1196	1.14	1223	1.22	1247	1.29	1272	1.37	1297	1.45	1319	1.53	1342	1.61	1364	1.69
2880	1189	1.12	1216	1.19	1243	1.28	1269	1.36	1293	1.44	1317	1.52	1341	1.60	1364	1.69	1387	1.77	1409	1.86

Notes:

1. For direct drive fan speed, reference the applicable table in the fan performance section.
 2. Data includes pressure drop due to standard filters and wet coils.
 3. To determine additional static pressure drop due to other options/accessories, refer to the applicable table in the fan performance section.
 4. Direct drive fan motor heat (MBh) = 2.7912 x fan bhp + 0.1388.
 5. Factory supplied motors, in equipment, are definite purpose motors, specifically designed and tested to operate at all cataloged conditions. Using the full horsepower range of our fan motors as shown in our tabular data will not result in nuisance tripping or premature motor failure. Our product's warranty will not be affected.
- * For 1200, 1440, and 1680 cfm, unit application below 320 cfm/ton are only applicable on T_C models and modulating gas. See below for restrictions.
 * For electric heat applications, minimum airflow is set to 320 cfm/ton, unless specified otherwise, values found in electric heat temperature rise table.
 * TXV with Froststat™ and crankcase heaters are required on applications below 320 cfm/ton.



Evaporator Fan Performance

Table 26. Direct drive evaporator fan performance - 6 ton with eFlex™ and eDrive™ technology - YZC072F3,F4,FW low and medium gas heat downflow airflow

External Static Pressure (Inches of Water)																				
cfm	.10		.20		.30		.40		.50		.60		.70		.80		.90		1.00	
	rpm	bhp	rpm	bhp	rpm	bhp	rpm	bhp	rpm	bhp	rpm	bhp	rpm	bhp	rpm	bhp	rpm	bhp	rpm	bhp
1920	613	0.11	662	0.15	705	0.19	745	0.23	781	0.27	815	0.31	847	0.35	877	0.39	907	0.44	933	0.48
2160	676	0.15	722	0.19	763	0.23	801	0.28	836	0.32	869	0.36	899	0.41	929	0.46	957	0.50	984	0.55
2400	741	0.20	784	0.24	823	0.29	858	0.33	892	0.38	924	0.43	954	0.48	982	0.53	1009	0.58	1036	0.63
2640	806	0.25	846	0.30	883	0.35	917	0.40	949	0.45	980	0.50	1008	0.56	1036	0.61	1062	0.66	1088	0.72
2880	871	0.32	910	0.37	944	0.42	977	0.48	1007	0.53	1037	0.59	1065	0.65	1091	0.70	1117	0.76	1142	0.82

External Static Pressure (Inches of Water)																				
cfm	1.10		1.20		1.30		1.40		1.50		1.60		1.70		1.80		1.90		2.00	
	rpm	bhp	rpm	bhp	rpm	bhp	rpm	bhp	rpm	bhp	rpm	bhp	rpm	bhp	rpm	bhp	rpm	bhp	rpm	bhp
1920	960	0.53	985	0.58	1010	0.62	1034	0.67	1057	0.72	1079	0.77	1101	0.83	1123	0.88	1143	0.93	1163	0.99
2160	1010	0.60	1035	0.65	1059	0.70	1082	0.76	1105	0.81	1127	0.87	1148	0.92	1169	0.98	1189	1.03	1209	1.09
2400	1060	0.68	1085	0.74	1108	0.79	1131	0.85	1154	0.91	1176	0.96	1196	1.02	1217	1.08	1237	1.14	1257	1.20
2640	1113	0.78	1137	0.84	1160	0.89	1182	0.95	1204	1.01	1225	1.07	1246	1.13	1266	1.20	1286	1.26	1305	1.32
2880	1166	0.88	1189	0.94	1212	1.00	1234	1.07	1256	1.13	1276	1.19	1296	1.26	1316	1.32	1335	1.39	1355	1.46

Notes:

1. For direct drive fan speed, reference the applicable table in the fan performance section.
2. Data includes pressure drop due to standard filters and wet coils.
3. To determine additional static pressure drop due to other options/accessories, refer to the applicable table in the fan performance section.
4. Direct drive fan motor heat (MBh) = 2.7912 x fan bhp + 0.1388.
5. Factory supplied motors, in equipment, are definite purpose motors, specifically designed and tested to operate at all cataloged conditions. Using the full horsepower range of our fan motors as shown in our tabular data will not result in nuisance tripping or premature motor failure. Our product's warranty will not be affected.

Evaporator Fan Performance

Table 27. Direct drive evaporator fan performance - 6 ton with eFlex™ and eDrive™ technology - YZC072F3,F4,FW high gas heat downflow airflow

External Static Pressure (Inches of Water)																				
cfm	.10		.20		.30		.40		.50		.60		.70		.80		.90		1.00	
	rpm	bhp	rpm	bhp	rpm	bhp	rpm	bhp	rpm	bhp	rpm	bhp	rpm	bhp	rpm	bhp	rpm	bhp	rpm	bhp
1200*	438	0.04	504	0.07	558	0.10	606	0.12	650	0.16	689	0.19	726	0.22	760	0.26	792	0.29	823	0.33
1440*	497	0.06	559	0.09	611	0.12	657	0.16	698	0.19	737	0.22	773	0.26	806	0.30	839	0.34	869	0.38
1680*	558	0.09	615	0.12	665	0.16	709	0.19	749	0.23	787	0.27	821	0.31	854	0.35	886	0.39	915	0.43
1920	622	0.12	674	0.16	721	0.20	763	0.24	802	0.28	838	0.32	872	0.36	904	0.41	934	0.45	964	0.50
2160	686	0.16	734	0.20	778	0.24	819	0.29	856	0.33	891	0.38	924	0.43	955	0.47	985	0.52	1013	0.57
2400	752	0.21	796	0.25	838	0.30	876	0.35	912	0.40	946	0.45	978	0.50	1008	0.55	1037	0.60	1064	0.66
2640	819	0.27	859	0.32	898	0.37	935	0.42	969	0.47	1002	0.53	1032	0.58	1062	0.64	1090	0.69	1117	0.75
2880	886	0.34	923	0.39	959	0.45	994	0.50	1027	0.56	1059	0.62	1089	0.68	1117	0.74	1144	0.79	1171	0.86

External Static Pressure (Inches of Water)																				
cfm	1.10		1.20		1.30		1.40		1.50		1.60		1.70		1.80		1.90		2.00	
	rpm	bhp	rpm	bhp	rpm	bhp	rpm	bhp	rpm	bhp	rpm	bhp	rpm	bhp	rpm	bhp	rpm	bhp	rpm	bhp
1200*	853	0.37	881	0.41	908	0.45	934	0.49	960	0.53	985	0.57	1008	0.62	1031	0.66	1053	0.71	1075	0.75
1440*	898	0.42	925	0.46	952	0.50	978	0.55	1004	0.60	1027	0.64	1051	0.69	1073	0.73	1096	0.79	1117	0.83
1680*	944	0.48	971	0.52	998	0.57	1023	0.62	1047	0.67	1072	0.72	1095	0.77	1118	0.82	1139	0.87	1162	0.92
1920	992	0.55	1019	0.60	1044	0.65	1070	0.70	1094	0.75	1118	0.80	1140	0.85	1163	0.91	1185	0.96	1207	1.02
2160	1041	0.63	1067	0.68	1093	0.73	1117	0.78	1141	0.84	1165	0.89	1187	0.95	1209	1.01	1232	1.07	1252	1.13
2400	1092	0.71	1117	0.77	1143	0.83	1166	0.88	1191	0.94	1212	1.00	1235	1.06	1257	1.12	1279	1.18	1300	1.24
2640	1144	0.81	1169	0.87	1194	0.93	1217	0.99	1240	1.05	1263	1.12	1284	1.18	1305	1.24	1327	1.31	1347	1.37
2880	1196	0.92	1221	0.98	1245	1.05	1269	1.11	1291	1.18	1314	1.24	1335	1.31	1356	1.38	1376	1.44	1396	1.51

Notes:

1. For direct drive fan speed, reference the applicable table in the fan performance section.
 2. Data includes pressure drop due to standard filters and wet coils.
 3. To determine additional static pressure drop due to other options/accessories, refer to the applicable table in the fan performance section.
 4. Direct drive fan motor heat (MBh) = 2.7912 x fan bhp + 0.1388.
 5. Factory supplied motors, in equipment, are definite purpose motors, specifically designed and tested to operate at all cataloged conditions. Using the full horsepower range of our fan motors as shown in our tabular data will not result in nuisance tripping or premature motor failure. Our product's warranty will not be affected.
- * For 1200, 1440, and 1680 cfm, unit application below 320 cfm/ton are only applicable on T_C models and modulating gas. See below for restrictions.
 * For electric heat applications, minimum airflow is set to 320 cfm/ton, unless specified otherwise, values found in electric heat temperature rise table.
 * TXV with Froststat™ and crankcase heaters are required on applications below 320 cfm/ton.



Evaporator Fan Performance

Table 28. Direct drive evaporator fan performance - 6 ton with eFlex™ and eDrive™ technology - YZC072F3,F4,FW low and medium gas heat horizontal airflow

External Static Pressure (Inches of Water)																				
cfm	.10		.20		.30		.40		.50		.60		.70		.80		.90		1.00	
	rpm	bhp	rpm	bhp	rpm	bhp	rpm	bhp	rpm	bhp	rpm	bhp	rpm	bhp	rpm	bhp	rpm	bhp	rpm	bhp
1920	618	0.15	670	0.20	718	0.25	764	0.30	808	0.35	847	0.41	884	0.47	920	0.53	953	0.59	985	0.65
2160	681	0.20	730	0.26	774	0.31	816	0.37	858	0.42	896	0.48	932	0.55	967	0.61	999	0.67	1031	0.74
2400	746	0.26	791	0.32	832	0.39	872	0.45	909	0.51	946	0.57	982	0.64	1015	0.70	1047	0.77	1078	0.85
2640	811	0.34	854	0.40	892	0.47	929	0.54	964	0.61	999	0.67	1032	0.74	1065	0.81	1097	0.89	1127	0.96
2880	877	0.42	917	0.49	954	0.57	988	0.65	1021	0.72	1053	0.79	1085	0.86	1116	0.93	1146	1.01	1176	1.09

External Static Pressure (Inches of Water)																				
cfm	1.10		1.20		1.30		1.40		1.50		1.60		1.70		1.80		1.90		2.00	
	rpm	bhp	rpm	bhp	rpm	bhp	rpm	bhp	rpm	bhp	rpm	bhp	rpm	bhp	rpm	bhp	rpm	bhp	rpm	bhp
1920	1015	0.72	1045	0.79	1073	0.85	1100	0.92	1128	1.00	1153	1.07	1178	1.15	1201	1.22	1225	1.30	1249	1.38
2160	1061	0.81	1089	0.88	1118	0.96	1144	1.03	1171	1.11	1196	1.18	1220	1.26	1244	1.34	1268	1.42	1292	1.51
2400	1107	0.92	1136	0.99	1163	1.07	1190	1.15	1216	1.23	1240	1.30	1264	1.38	1289	1.47	1312	1.56	1334	1.64
2640	1155	1.04	1183	1.12	1210	1.20	1237	1.28	1262	1.36	1286	1.44	1310	1.53	1334	1.62	1357	1.71	1378	1.79
2880	1205	1.18	1232	1.26	1258	1.34	1283	1.42	1308	1.51	1332	1.60	1357	1.69	1380	1.78	1402	1.87	1424	1.96

Notes:

1. For direct drive fan speed, reference the applicable table in the fan performance section.
2. Data includes pressure drop due to standard filters and wet coils.
3. To determine additional static pressure drop due to other options/accessories, refer to the applicable table in the fan performance section.
4. Direct drive fan motor heat (MBh) = 2.7912 x fan bhp + 0.1388.
5. Factory supplied motors, in equipment, are definite purpose motors, specifically designed and tested to operate at all cataloged conditions. Using the full horsepower range of our fan motors as shown in our tabular data will not result in nuisance tripping or premature motor failure. Our product's warranty will not be affected.

Evaporator Fan Performance

Table 29. Direct drive evaporator fan performance - 6 ton with eFlex™ and eDrive™ technology - YZC072F3,F4,FW high gas heat horizontal airflow

External Static Pressure (Inches of Water)																				
cfm	.10		.20		.30		.40		.50		.60		.70		.80		.90		1.00	
	rpm	bhp	rpm	bhp	rpm	bhp	rpm	bhp	rpm	bhp	rpm	bhp	rpm	bhp	rpm	bhp	rpm	bhp	rpm	bhp
1200*	436	0.06	507	0.09	567	0.13	619	0.17	665	0.20	708	0.24	747	0.27	784	0.31	819	0.34	852	0.38
1440*	495	0.08	558	0.12	615	0.17	666	0.21	711	0.25	752	0.29	791	0.34	827	0.38	861	0.42	894	0.47
1680*	556	0.11	613	0.16	666	0.21	714	0.26	758	0.31	799	0.36	836	0.41	872	0.46	906	0.51	938	0.56
1920	619	0.16	671	0.21	719	0.26	764	0.32	807	0.38	847	0.43	883	0.49	918	0.55	951	0.60	983	0.66
2160	683	0.21	731	0.26	775	0.32	817	0.38	857	0.45	896	0.51	932	0.58	965	0.64	998	0.71	1029	0.77
2400	748	0.27	792	0.33	833	0.39	873	0.46	910	0.53	946	0.60	981	0.67	1015	0.75	1046	0.82	1077	0.89
2640	814	0.34	855	0.41	893	0.48	930	0.55	965	0.62	999	0.70	1033	0.78	1065	0.86	1096	0.94	1126	1.02
2880	881	0.43	919	0.51	955	0.58	989	0.66	1022	0.73	1055	0.82	1085	0.90	1117	0.99	1146	1.07	1176	1.16

External Static Pressure (Inches of Water)																				
cfm	1.10		1.20		1.30		1.40		1.50		1.60		1.70		1.80		1.90		2.00	
	rpm	bhp	rpm	bhp	rpm	bhp	rpm	bhp	rpm	bhp	rpm	bhp	rpm	bhp	rpm	bhp	rpm	bhp	rpm	bhp
1200*	883	0.41	913	0.45	943	0.48	970	0.52	997	0.55	1024	0.59	1049	0.63	1074	0.66	1097	0.70	1121	0.74
1440*	925	0.51	955	0.55	984	0.59	1011	0.64	1038	0.68	1064	0.72	1090	0.76	1114	0.81	1137	0.85	1160	0.89
1680*	969	0.61	998	0.66	1026	0.71	1053	0.76	1079	0.81	1106	0.86	1131	0.91	1154	0.96	1178	1.01	1201	1.06
1920	1013	0.72	1042	0.78	1070	0.83	1097	0.89	1122	0.94	1148	1.00	1173	1.06	1198	1.12	1220	1.17	1243	1.23
2160	1059	0.84	1088	0.90	1115	0.96	1142	1.03	1167	1.09	1193	1.16	1217	1.22	1241	1.28	1264	1.35	1287	1.41
2400	1106	0.96	1134	1.03	1162	1.11	1188	1.18	1213	1.25	1238	1.32	1262	1.39	1285	1.46	1308	1.53	1330	1.60
2640	1154	1.10	1182	1.18	1209	1.26	1234	1.33	1259	1.41	1284	1.49	1307	1.57	1331	1.65	1353	1.73	1376	1.81
2880	1204	1.25	1230	1.33	1257	1.42	1282	1.50	1307	1.59	1331	1.68	1354	1.76	1377	1.85	1400	1.93	1422	2.02

Notes:

1. For direct drive fan speed, reference the applicable table in the fan performance section.
 2. Data includes pressure drop due to standard filters and wet coils.
 3. To determine additional static pressure drop due to other options/accessories, refer to the applicable table in the fan performance section.
 4. Direct drive fan motor heat (MBh) = 2.7912 x fan bhp + 0.1388.
 5. Factory supplied motors, in equipment, are definite purpose motors, specifically designed and tested to operate at all cataloged conditions. Using the full horsepower range of our fan motors as shown in our tabular data will not result in nuisance tripping or premature motor failure. Our product's warranty will not be affected.
- * For 1200, 1440, and 1680 cfm, unit application below 320 cfm/ton are only applicable on T_C models and modulating gas. See below for restrictions.
 * For electric heat applications, minimum airflow is set to 320 cfm/ton, unless specified otherwise, values found in electric heat temperature rise table.
 * TXV with Froststat™ and crankcase heaters are required on applications below 320 cfm/ton.



Evaporator Fan Performance

Table 30. Direct drive evaporator fan performance - 7.5 ton with eFlex™ and eDrive™ technology - TZC090F3,F4,FW downflow airflow

External Static Pressure (Inches of Water)																				
cfm	.10		.20		.30		.40		.50		.60		.70		.80		.90		1.00	
	rpm	bhp	rpm	bhp	rpm	bhp	rpm	bhp	rpm	bhp	rpm	bhp	rpm	bhp	rpm	bhp	rpm	bhp	rpm	bhp
1500*	494	0.06	552	0.09	602	0.13	646	0.16	686	0.20	723	0.24	757	0.28	789	0.33	820	0.37	849	0.42
1800*	568	0.09	621	0.13	667	0.17	709	0.21	747	0.25	783	0.29	816	0.34	848	0.39	878	0.44	907	0.49
2100*	644	0.13	693	0.17	736	0.21	776	0.26	812	0.31	846	0.36	878	0.41	909	0.46	938	0.51	965	0.57
2400	722	0.18	767	0.23	807	0.27	844	0.32	879	0.38	912	0.43	943	0.48	972	0.54	1000	0.60	1027	0.66
2700	801	0.24	842	0.29	880	0.35	915	0.40	948	0.46	979	0.52	1009	0.58	1037	0.64	1064	0.70	1090	0.76
3000	881	0.32	919	0.37	954	0.43	987	0.49	1018	0.55	1048	0.62	1077	0.68	1104	0.75	1130	0.81	1155	0.88
3300	961	0.41	996	0.47	1030	0.53	1061	0.60	1090	0.67	1119	0.73	1146	0.80	1172	0.87	1197	0.94	1222	1.02
3600	1043	0.51	1075	0.58	1106	0.65	1135	0.72	1164	0.80	1191	0.87	1217	0.94	1242	1.02	1266	1.09	1290	1.17

External Static Pressure (Inches of Water)																				
cfm	1.10		1.20		1.30		1.40		1.50		1.60		1.70		1.80		1.90		2.00	
	rpm	bhp	rpm	bhp	rpm	bhp	rpm	bhp	rpm	bhp	rpm	bhp	rpm	bhp	rpm	bhp	rpm	bhp	rpm	bhp
1500*	878	0.47	904	0.51	930	0.57	955	0.62	980	0.67	1002	0.72	1025	0.78	1047	0.84	1069	0.90	1090	0.95
1800*	934	0.54	960	0.59	985	0.65	1010	0.70	1033	0.76	1057	0.82	1079	0.87	1100	0.93	1122	1.00	1143	1.06
2100*	992	0.62	1018	0.68	1042	0.74	1066	0.79	1090	0.86	1112	0.92	1134	0.98	1156	1.04	1176	1.11	1197	1.17
2400	1053	0.72	1077	0.78	1102	0.84	1125	0.90	1148	0.97	1171	1.04	1192	1.10	1213	1.17	1234	1.24	1254	1.31
2700	1115	0.83	1139	0.89	1163	0.96	1186	1.03	1208	1.09	1229	1.16	1251	1.24	1272	1.31	1292	1.38	1312	1.45
3000	1179	0.95	1203	1.02	1226	1.09	1248	1.16	1270	1.24	1291	1.31	1312	1.38	1332	1.46	1352	1.54	1371	1.62
3300	1246	1.09	1268	1.17	1291	1.24	1312	1.32	1334	1.39	1355	1.47	1374	1.55	1394	1.63	1413	1.71	1432	1.80
3600	1313	1.25	1335	1.33	1357	1.41	1378	1.49	1399	1.57	1419	1.66	1439	1.74	1458	1.82	1477	1.91	1495	1.99

Notes:

1. For direct drive fan speed, reference the applicable table in the fan performance section.
 2. Data includes pressure drop due to standard filters and wet coils.
 3. To determine additional static pressure drop due to other options/accessories, refer to the applicable table in the fan performance section.
 4. Direct drive fan motor heat (MBh) = 2.7912 x fan bhp + 0.1388.
 5. Factory supplied motors, in equipment, are definite purpose motors, specifically designed and tested to operate at all cataloged conditions. Using the full horsepower range of our fan motors as shown in our tabular data will not result in nuisance tripping or premature motor failure. Our product's warranty will not be affected.
- * For 1500, 1800, and 2100 cfm, unit application below 320 cfm/ton are only applicable on T_C models and modulating gas. See below for restrictions.
 * For electric heat applications, minimum airflow is set to 320 cfm/ton, unless specified otherwise, values found in electric heat temperature rise table.
 * Dehumidification (hot gas reheat) or TXV with Froststat™ and crankcase heaters are required on applications below 320 cfm/ton.

Evaporator Fan Performance

Table 31. Direct drive evaporator fan performance - 7.5 ton with eFlex™ and eDrive™ technology - TZC090F3,F4,FW horizontal airflow

External Static Pressure (Inches of Water)																				
cfm	.10		.20		.30		.40		.50		.60		.70		.80		.90		1.00	
	rpm	bhp	rpm	bhp	rpm	bhp	rpm	bhp	rpm	bhp	rpm	bhp	rpm	bhp	rpm	bhp	rpm	bhp	rpm	bhp
1500*	488	0.07	550	0.11	604	0.15	652	0.19	695	0.24	734	0.28	771	0.33	806	0.38	838	0.42	869	0.48
1800*	559	0.11	615	0.15	666	0.20	711	0.25	752	0.29	791	0.34	827	0.40	861	0.45	892	0.50	923	0.56
2100*	634	0.16	685	0.20	730	0.26	773	0.31	813	0.37	850	0.42	884	0.48	917	0.54	949	0.60	978	0.66
2400	711	0.22	756	0.27	798	0.33	837	0.39	876	0.45	911	0.51	944	0.57	976	0.64	1006	0.70	1035	0.77
2700	789	0.29	828	0.35	870	0.41	905	0.48	940	0.55	974	0.62	1006	0.69	1037	0.76	1067	0.83	1095	0.90
3000	868	0.39	904	0.45	941	0.52	976	0.59	1008	0.67	1039	0.74	1070	0.82	1100	0.90	1129	0.97	1156	1.05
3300	947	0.50	981	0.57	1013	0.65	1047	0.72	1079	0.80	1107	0.88	1135	0.97	1164	1.05	1192	1.14	1218	1.22
3600	1027	0.63	1059	0.71	1088	0.79	1118	0.87	1150	0.95	1178	1.04	1204	1.13	1230	1.23	1256	1.32	1282	1.41

External Static Pressure (Inches of Water)																				
cfm	1.10		1.20		1.30		1.40		1.50		1.60		1.70		1.80		1.90		2.00	
	rpm	bhp	rpm	bhp	rpm	bhp	rpm	bhp	rpm	bhp	rpm	bhp	rpm	bhp	rpm	bhp	rpm	bhp	rpm	bhp
1500*	899	0.53	927	0.58	955	0.64	981	0.69	1007	0.75	1031	0.81	1056	0.87	1078	0.93	1102	0.99	1124	1.06
1800*	952	0.62	980	0.68	1007	0.74	1033	0.80	1058	0.86	1082	0.92	1106	0.99	1130	1.05	1152	1.12	1175	1.19
2100*	1007	0.72	1034	0.78	1061	0.85	1087	0.92	1111	0.98	1135	1.05	1159	1.12	1182	1.19	1204	1.26	1226	1.34
2400	1064	0.84	1090	0.91	1116	0.98	1142	1.05	1166	1.12	1190	1.19	1213	1.27	1235	1.34	1257	1.42	1278	1.50
2700	1122	0.97	1149	1.05	1174	1.12	1199	1.20	1223	1.28	1246	1.36	1268	1.44	1291	1.52	1312	1.60	1334	1.68
3000	1182	1.13	1207	1.21	1233	1.29	1257	1.37	1280	1.45	1303	1.54	1325	1.62	1348	1.71	1368	1.79	1390	1.88
3300	1244	1.30	1269	1.39	1293	1.47	1317	1.56	1340	1.65	1362	1.74	1383	1.83	1405	1.92	1426	2.01	1446	2.10
3600	1307	1.50	1331	1.59	1354	1.68	1378	1.78	1400	1.87	1423	1.97	1444	2.06	1465	2.16	1485	2.25	1505	2.35

Notes:

1. For direct drive fan speed, reference the applicable table in the fan performance section.
 2. Data includes pressure drop due to standard filters and wet coils.
 3. To determine additional static pressure drop due to other options/accessories, refer to the applicable table in the fan performance section.
 4. Direct drive fan motor heat (MBh) = 2.7912 x fan bhp + 0.1388.
 5. Factory supplied motors, in equipment, are definite purpose motors, specifically designed and tested to operate at all cataloged conditions. Using the full horsepower range of our fan motors as shown in our tabular data will not result in nuisance tripping or premature motor failure. Our product's warranty will not be affected.
- * For 1500, 1800, and 2100 cfm, unit application below 320 cfm/ton are only applicable on T_C models and modulating gas. See below for restrictions.
 * For electric heat applications, minimum airflow is set to 320 cfm/ton, unless specified otherwise, values found in electric heat temperature rise table.
 * Dehumidification (hot gas reheat) or TXV with Froststat™ and crankcase heaters are required on applications below 320 cfm/ton.



Evaporator Fan Performance

Table 32. Direct drive evaporator fan performance - 7.5 ton with eFlex™ and eDrive™ technology - YZC090F3,F4,FW low and medium gas heat downflow airflow

External Static Pressure (Inches of Water)																				
cfm	.10		.20		.30		.40		.50		.60		.70		.80		.90		1.00	
	rpm	bhp	rpm	bhp	rpm	bhp	rpm	bhp	rpm	bhp	rpm	bhp	rpm	bhp	rpm	bhp	rpm	bhp	rpm	bhp
2400	757	0.26	799	0.32	842	0.38	882	0.44	919	0.51	955	0.57	987	0.64	1018	0.70	1049	0.77	1077	0.84
2700	841	0.36	880	0.42	916	0.48	955	0.56	991	0.63	1024	0.70	1056	0.77	1086	0.84	1115	0.92	1142	0.99
3000	925	0.47	962	0.54	994	0.61	1028	0.68	1064	0.77	1096	0.85	1126	0.92	1155	1.00	1183	1.08	1210	1.17
3300	1010	0.61	1045	0.69	1076	0.76	1105	0.84	1136	0.93	1169	1.02	1198	1.10	1226	1.19	1253	1.28	1279	1.36
3600	1095	0.77	1128	0.86	1158	0.94	1185	1.02	1211	1.11	1241	1.21	1271	1.31	1298	1.40	1324	1.49	1349	1.59

External Static Pressure (Inches of Water)																				
cfm	1.10		1.20		1.30		1.40		1.50		1.60		1.70		1.80		1.90		2.00	
	rpm	bhp	rpm	bhp	rpm	bhp	rpm	bhp	rpm	bhp	rpm	bhp	rpm	bhp	rpm	bhp	rpm	bhp	rpm	bhp
2400	1105	0.91	1131	0.98	1157	1.05	1182	1.13	1206	1.20	1229	1.28	1252	1.35	1275	1.43	1297	1.51	1318	1.59
2700	1170	1.07	1195	1.14	1220	1.22	1245	1.30	1268	1.38	1291	1.46	1314	1.55	1336	1.63	1357	1.71	1377	1.80
3000	1236	1.25	1261	1.33	1285	1.41	1309	1.50	1332	1.59	1354	1.67	1377	1.76	1398	1.85	1420	1.94	1440	2.03
3300	1304	1.45	1328	1.54	1352	1.63	1375	1.72	1397	1.81	1419	1.91	1442	2.00	1462	2.10	1483	2.19	1503	2.29
3600	1374	1.68	1397	1.78	1421	1.88	1443	1.97	1465	2.07	1487	2.17	1507	2.27	1528	2.37	1548	2.47	1568	2.58

Notes:

1. For direct drive fan speed, reference the applicable table in the fan performance section.
2. Data includes pressure drop due to standard filters and wet coils.
3. To determine additional static pressure drop due to other options/accessories, refer to the applicable table in the fan performance section.
4. Direct drive fan motor heat (MBh) = 2.7912 x fan bhp + 0.1388.
5. Factory supplied motors, in equipment, are definite purpose motors, specifically designed and tested to operate at all cataloged conditions. Using the full horsepower range of our fan motors as shown in our tabular data will not result in nuisance tripping or premature motor failure. Our product's warranty will not be affected.

Evaporator Fan Performance

Table 33. Direct drive evaporator fan performance - 7.5 ton with eFlex™ and eDrive™ technology - YZC090F3,F4,FW low and medium gas heat horizontal airflow

External Static Pressure (Inches of Water)																				
cfm	.10		.20		.30		.40		.50		.60		.70		.80		.90		1.00	
	rpm	bhp	rpm	bhp	rpm	bhp	rpm	bhp	rpm	bhp	rpm	bhp	rpm	bhp	rpm	bhp	rpm	bhp	rpm	bhp
2400	734	0.23	780	0.29	823	0.35	862	0.41	899	0.47	934	0.53	966	0.60	998	0.66	1027	0.73	1056	0.79
2700	815	0.32	856	0.38	895	0.44	932	0.51	968	0.58	1001	0.65	1033	0.72	1062	0.79	1092	0.86	1119	0.93
3000	896	0.42	933	0.48	970	0.55	1005	0.63	1039	0.71	1070	0.78	1100	0.86	1130	0.93	1157	1.01	1184	1.09
3300	979	0.54	1013	0.61	1046	0.69	1079	0.77	1111	0.85	1140	0.94	1169	1.02	1198	1.10	1224	1.18	1251	1.27
3600	1061	0.69	1093	0.77	1124	0.85	1154	0.93	1185	1.02	1213	1.11	1240	1.20	1267	1.29	1293	1.38	1318	1.47

External Static Pressure (Inches of Water)																				
cfm	1.10		1.20		1.30		1.40		1.50		1.60		1.70		1.80		1.90		2.00	
	rpm	bhp	rpm	bhp	rpm	bhp	rpm	bhp	rpm	bhp	rpm	bhp	rpm	bhp	rpm	bhp	rpm	bhp	rpm	bhp
2400	1083	0.86	1110	0.93	1135	1.00	1160	1.07	1184	1.15	1208	1.22	1231	1.30	1253	1.37	1273	1.45	1295	1.52
2700	1146	1.00	1171	1.08	1196	1.15	1220	1.23	1244	1.31	1267	1.39	1290	1.47	1311	1.55	1332	1.63	1354	1.72
3000	1210	1.17	1235	1.25	1259	1.33	1282	1.41	1305	1.49	1329	1.58	1350	1.67	1371	1.75	1392	1.84	1412	1.93
3300	1275	1.35	1300	1.44	1323	1.53	1347	1.62	1368	1.70	1391	1.80	1413	1.89	1434	1.98	1454	2.07	1474	2.17
3600	1342	1.56	1367	1.66	1389	1.75	1412	1.84	1434	1.94	1456	2.04	1476	2.13	1497	2.23	1517	2.33	1536	2.43

Notes:

1. For direct drive fan speed, reference the applicable table in the fan performance section.
2. Data includes pressure drop due to standard filters and wet coils.
3. To determine additional static pressure drop due to other options/accessories, refer to the applicable table in the fan performance section.
4. Direct drive fan motor heat (MBh) = 2.7912 x fan bhp + 0.1388.
5. Factory supplied motors, in equipment, are definite purpose motors, specifically designed and tested to operate at all cataloged conditions. Using the full horsepower range of our fan motors as shown in our tabular data will not result in nuisance tripping or premature motor failure. Our product's warranty will not be affected.



Evaporator Fan Performance

Table 34. Direct drive evaporator fan performance - 7.5 ton with eFlex™ and eDrive™ technology - YZC090F3,F4,FW high gas heat downflow airflow

External Static Pressure (Inches of Water)																				
cfm	.10		.20		.30		.40		.50		.60		.70		.80		.90		1.00	
	rpm	bhp	rpm	bhp	rpm	bhp	rpm	bhp	rpm	bhp	rpm	bhp	rpm	bhp	rpm	bhp	rpm	bhp	rpm	bhp
1500*	515	0.09	577	0.13	630	0.17	677	0.21	718	0.26	758	0.31	794	0.36	828	0.41	861	0.46	892	0.52
1800*	593	0.13	649	0.18	698	0.22	742	0.27	783	0.33	820	0.38	855	0.43	889	0.49	920	0.55	951	0.61
2100*	673	0.19	723	0.24	769	0.29	811	0.35	850	0.41	885	0.47	920	0.53	951	0.59	982	0.66	1012	0.72
2400	756	0.26	801	0.32	842	0.38	882	0.44	918	0.51	953	0.57	986	0.64	1017	0.71	1047	0.78	1075	0.85
2700	839	0.35	880	0.42	919	0.48	955	0.56	990	0.63	1023	0.70	1054	0.77	1085	0.85	1113	0.92	1141	1.00
3000	924	0.47	960	0.54	997	0.61	1031	0.69	1063	0.77	1095	0.85	1124	0.93	1154	1.01	1181	1.09	1208	1.17
3300	1010	0.60	1043	0.68	1076	0.76	1108	0.84	1139	0.93	1167	1.02	1197	1.10	1224	1.19	1252	1.28	1277	1.37
3600	1096	0.76	1126	0.85	1156	0.94	1186	1.03	1216	1.12	1243	1.21	1270	1.31	1297	1.40	1322	1.50	1348	1.59

External Static Pressure (Inches of Water)																				
cfm	1.10		1.20		1.30		1.40		1.50		1.60		1.70		1.80		1.90		2.00	
	rpm	bhp	rpm	bhp	rpm	bhp	rpm	bhp	rpm	bhp	rpm	bhp	rpm	bhp	rpm	bhp	rpm	bhp	rpm	bhp
1500*	921	0.57	950	0.63	976	0.69	1003	0.75	1029	0.81	1053	0.87	1077	0.94	1101	1.00	1124	1.07	1146	1.14
1800*	980	0.67	1007	0.73	1034	0.80	1060	0.87	1085	0.93	1110	1.00	1133	1.07	1157	1.14	1179	1.21	1200	1.28
2100*	1040	0.79	1067	0.86	1094	0.93	1119	1.00	1143	1.07	1167	1.14	1190	1.22	1213	1.29	1235	1.37	1257	1.45
2400	1103	0.93	1130	1.00	1155	1.07	1179	1.15	1205	1.23	1227	1.31	1250	1.39	1272	1.47	1295	1.55	1316	1.63
2700	1167	1.08	1193	1.16	1218	1.24	1243	1.32	1266	1.41	1289	1.49	1312	1.58	1333	1.66	1355	1.75	1376	1.84
3000	1234	1.26	1259	1.35	1283	1.43	1307	1.52	1330	1.61	1353	1.70	1375	1.79	1396	1.88	1416	1.97	1437	2.07
3300	1302	1.46	1326	1.55	1350	1.64	1374	1.74	1396	1.84	1418	1.93	1439	2.03	1460	2.13	1481	2.23	1501	2.33
3600	1372	1.69	1395	1.79	1419	1.89	1441	1.99	1463	2.09	1484	2.19	1505	2.29	1526	2.40	1545	2.50	1565	2.61

Notes:

- For direct drive fan speed, reference the applicable table in the fan performance section.
 - Data includes pressure drop due to standard filters and wet coils.
 - To determine additional static pressure drop due to other options/accessories, refer to the applicable table in the fan performance section.
 - Direct drive fan motor heat (MBh) = 2.7912 x fan bhp + 0.1388.
 - Factory supplied motors, in equipment, are definite purpose motors, specifically designed and tested to operate at all cataloged conditions. Using the full horsepower range of our fan motors as shown in our tabular data will not result in nuisance tripping or premature motor failure. Our product's warranty will not be affected.
- * For 1500, 1800, and 2100 cfm, unit application below 320 cfm/ton are only applicable on T_C models and modulating gas. See below for restrictions.
 * For electric heat applications, minimum airflow is set to 320 cfm/ton, unless specified otherwise, values found in electric heat temperature rise table.
 * Dehumidification (hot gas reheat) or TXV with Froststat™ and crankcase heaters are required on applications below 320 cfm/ton.

Evaporator Fan Performance

Table 35. Direct drive evaporator fan performance - 7.5 ton with eFlex™ and eDrive™ technology - YZC090F3,F4,FW high gas heat horizontal airflow

External Static Pressure (Inches of Water)																				
cfm	.10		.20		.30		.40		.50		.60		.70		.80		.90		1.00	
	rpm	bhp	rpm	bhp	rpm	bhp	rpm	bhp	rpm	bhp	rpm	bhp	rpm	bhp	rpm	bhp	rpm	bhp	rpm	bhp
1500*	506	0.08	569	0.12	622	0.17	670	0.22	712	0.26	752	0.32	788	0.37	824	0.43	856	0.49	887	0.55
1800*	581	0.12	638	0.17	688	0.22	733	0.27	774	0.33	813	0.39	848	0.45	882	0.51	913	0.57	944	0.64
2100*	659	0.17	710	0.23	757	0.28	799	0.34	839	0.41	876	0.47	910	0.53	942	0.60	973	0.67	1003	0.74
2400	739	0.24	785	0.30	828	0.37	868	0.43	905	0.50	941	0.57	974	0.64	1005	0.71	1036	0.79	1064	0.86
2700	821	0.33	861	0.39	902	0.47	939	0.53	974	0.61	1008	0.68	1040	0.76	1071	0.84	1099	0.92	1127	1.00
3000	903	0.44	940	0.50	977	0.58	1012	0.67	1045	0.74	1077	0.82	1108	0.90	1138	0.99	1165	1.07	1193	1.16
3300	986	0.57	1020	0.64	1053	0.72	1087	0.81	1118	0.90	1149	0.98	1178	1.06	1206	1.15	1233	1.25	1259	1.34
3600	1070	0.73	1101	0.81	1132	0.88	1162	0.97	1193	1.08	1221	1.17	1249	1.26	1276	1.35	1302	1.45	1328	1.55

External Static Pressure (Inches of Water)																				
cfm	1.10		1.20		1.30		1.40		1.50		1.60		1.70		1.80		1.90		2.00	
	rpm	bhp	rpm	bhp	rpm	bhp	rpm	bhp	rpm	bhp	rpm	bhp	rpm	bhp	rpm	bhp	rpm	bhp	rpm	bhp
1500*	917	0.61	945	0.67	973	0.74	999	0.80	1025	0.87	1050	0.94	1073	1.01	1097	1.08	1121	1.16	1143	1.23
1800*	974	0.71	1001	0.77	1028	0.84	1055	0.92	1080	0.99	1104	1.06	1128	1.14	1151	1.22	1174	1.30	1195	1.37
2100*	1032	0.82	1059	0.89	1086	0.97	1112	1.04	1136	1.12	1160	1.20	1184	1.28	1207	1.37	1228	1.45	1251	1.53
2400	1092	0.94	1120	1.02	1145	1.10	1170	1.18	1194	1.27	1218	1.35	1241	1.44	1263	1.53	1285	1.62	1308	1.71
2700	1155	1.09	1181	1.17	1206	1.26	1230	1.35	1255	1.44	1278	1.53	1301	1.62	1322	1.71	1345	1.81	1365	1.91
3000	1219	1.25	1244	1.34	1269	1.44	1293	1.53	1316	1.63	1339	1.72	1361	1.82	1383	1.92	1404	2.02	1424	2.12
3300	1285	1.44	1309	1.54	1334	1.64	1357	1.74	1380	1.84	1402	1.94	1423	2.04	1446	2.15	1465	2.25	1485	2.36
3600	1352	1.65	1377	1.76	1399	1.86	1423	1.97	1444	2.07	1466	2.18	1488	2.29	1508	2.40	1529	2.52	1548	2.63

Notes:

1. For direct drive fan speed, reference the applicable table in the fan performance section.
 2. Data includes pressure drop due to standard filters and wet coils.
 3. To determine additional static pressure drop due to other options/accessories, refer to the applicable table in the fan performance section.
 4. Direct drive fan motor heat (MBh) = 2.7912 x fan bhp + 0.1388.
 5. Factory supplied motors, in equipment, are definite purpose motors, specifically designed and tested to operate at all cataloged conditions. Using the full horsepower range of our fan motors as shown in our tabular data will not result in nuisance tripping or premature motor failure. Our product's warranty will not be affected.
- * For 1500, 1800, and 2100 cfm, unit application below 320 cfm/ton are only applicable on T_C models and modulating gas. See below for restrictions.
 * For electric heat applications, minimum airflow is set to 320 cfm/ton, unless specified otherwise, values found in electric heat temperature rise table.
 * Dehumidification (hot gas reheat) or TXV with Froststat™ and crankcase heaters are required on applications below 320 cfm/ton.



Evaporator Fan Performance

Table 36. Direct drive evaporator fan performance - 8.5 ton with eFlex™ and eDrive™ technology - TZC102F3,F4,FW downflow airflow

External Static Pressure (Inches of Water)																				
cfm	.10		.20		.30		.40		.50		.60		.70		.80		.90		1.00	
	rpm	bhp	rpm	bhp	rpm	bhp	rpm	bhp	rpm	bhp	rpm	bhp	rpm	bhp	rpm	bhp	rpm	bhp	rpm	bhp
1700*	543	0.08	598	0.12	645	0.15	688	0.19	727	0.23	763	0.28	797	0.32	828	0.37	858	0.41	887	0.46
2040*	629	0.12	678	0.16	722	0.20	762	0.25	799	0.29	834	0.34	866	0.39	896	0.44	926	0.50	953	0.55
2380*	717	0.17	762	0.22	802	0.27	840	0.32	874	0.37	907	0.42	938	0.48	967	0.53	995	0.59	1023	0.65
2720	806	0.24	847	0.30	885	0.35	919	0.41	953	0.46	984	0.52	1013	0.58	1041	0.64	1068	0.71	1095	0.77
3060	897	0.33	934	0.39	969	0.45	1002	0.51	1033	0.58	1062	0.64	1090	0.70	1117	0.77	1143	0.84	1168	0.91
3400	988	0.44	1022	0.51	1055	0.57	1085	0.64	1115	0.71	1143	0.78	1169	0.85	1196	0.92	1220	0.99	1244	1.07
3740	1081	0.57	1112	0.64	1142	0.72	1171	0.79	1199	0.86	1225	0.94	1250	1.01	1275	1.09	1299	1.17	1323	1.25
4080	1174	0.72	1202	0.81	1230	0.88	1257	0.96	1283	1.04	1308	1.12	1333	1.21	1357	1.29	1379	1.37	1401	1.46

External Static Pressure (Inches of Water)																				
cfm	1.10		1.20		1.30		1.40		1.50		1.60		1.70		1.80		1.90		2.00	
	rpm	bhp	rpm	bhp	rpm	bhp	rpm	bhp	rpm	bhp	rpm	bhp	rpm	bhp	rpm	bhp	rpm	bhp	rpm	bhp
1700*	915	0.51	941	0.56	966	0.62	991	0.67	1015	0.73	1038	0.78	1061	0.84	1083	0.90	1104	0.96	1125	1.02
2040*	980	0.60	1006	0.66	1031	0.72	1055	0.78	1078	0.84	1102	0.90	1123	0.96	1145	1.02	1165	1.08	1187	1.15
2380*	1049	0.71	1074	0.77	1098	0.83	1121	0.89	1144	0.96	1167	1.03	1188	1.09	1209	1.16	1230	1.23	1250	1.30
2720	1120	0.83	1144	0.90	1167	0.97	1190	1.04	1213	1.10	1235	1.18	1255	1.25	1276	1.32	1296	1.39	1316	1.46
3060	1193	0.98	1216	1.05	1239	1.12	1261	1.19	1283	1.27	1304	1.34	1324	1.42	1344	1.49	1364	1.57	1384	1.65
3400	1268	1.14	1290	1.22	1313	1.30	1335	1.37	1355	1.45	1376	1.53	1396	1.61	1416	1.70	1435	1.78	1454	1.86
3740	1345	1.33	1367	1.41	1388	1.50	1408	1.58	1429	1.66	1449	1.75	1469	1.83	1488	1.92	1507	2.01	1524	2.09
4080	1424	1.55	1445	1.63	1465	1.72	1486	1.81	1505	1.90	1524	1.99	1544	2.08	1562	2.17	1580	2.26	1598	2.36

Notes:

1. For direct drive fan speed, reference the applicable table in the fan performance section.
 2. Data includes pressure drop due to standard filters and wet coils.
 3. To determine additional static pressure drop due to other options/accessories, refer to the applicable table in the fan performance section.
 4. Direct drive fan motor heat (MBh) = 2.7912 x fan bhp + 0.1388.
 5. Factory supplied motors, in equipment, are definite purpose motors, specifically designed and tested to operate at all cataloged conditions. Using the full horsepower range of our fan motors as shown in our tabular data will not result in nuisance tripping or premature motor failure. Our product's warranty will not be affected.
- * For 1700, 2040, and 2380 cfm, unit application below 320 cfm/ton are only applicable on T_C models and modulating gas. See below for restrictions.
 * For electric heat applications, minimum airflow is set to 320 cfm/ton, unless specified otherwise, values found in electric heat temperature rise table.
 * Dehumidification (hot gas reheat) or TXV with Froststat™ and crankcase heaters are required on applications below 320 cfm/ton.

Evaporator Fan Performance

Table 37. Direct drive evaporator fan performance - 8.5 ton with eFlex™ and eDrive™ technology - TZC102F3,F4,FW horizontal airflow

External Static Pressure (Inches of Water)																				
cfm	.10		.20		.30		.40		.50		.60		.70		.80		.90		1.00	
	rpm	bhp	rpm	bhp	rpm	bhp	rpm	bhp	rpm	bhp	rpm	bhp	rpm	bhp	rpm	bhp	rpm	bhp	rpm	bhp
1700*	535	0.10	593	0.14	645	0.18	691	0.23	733	0.27	772	0.32	807	0.37	841	0.42	874	0.48	905	0.53
2040*	618	0.15	671	0.19	717	0.25	760	0.30	801	0.35	838	0.40	873	0.46	906	0.52	937	0.58	967	0.64
2380*	706	0.21	752	0.27	793	0.32	833	0.39	871	0.44	907	0.51	941	0.57	972	0.63	1002	0.70	1031	0.76
2720	795	0.30	833	0.36	875	0.42	910	0.49	944	0.56	978	0.63	1011	0.70	1041	0.77	1070	0.84	1099	0.91
3060	884	0.41	919	0.48	955	0.54	990	0.61	1022	0.69	1052	0.77	1083	0.85	1113	0.93	1141	1.00	1168	1.08
3400	974	0.54	1007	0.62	1038	0.69	1071	0.77	1102	0.85	1130	0.93	1157	1.02	1185	1.11	1213	1.19	1240	1.28
3740	1065	0.70	1096	0.79	1124	0.87	1152	0.95	1183	1.04	1211	1.12	1237	1.22	1262	1.32	1287	1.41	1312	1.50
4080	1156	0.90	1185	0.99	1212	1.08	1237	1.17	1264	1.26	1292	1.35	1318	1.44	1342	1.55	1365	1.66	1387	1.76

External Static Pressure (Inches of Water)																				
cfm	1.10		1.20		1.30		1.40		1.50		1.60		1.70		1.80		1.90		2.00	
	rpm	bhp	rpm	bhp	rpm	bhp	rpm	bhp	rpm	bhp	rpm	bhp	rpm	bhp	rpm	bhp	rpm	bhp	rpm	bhp
1700*	935	0.59	963	0.64	989	0.70	1016	0.76	1041	0.82	1065	0.88	1089	0.95	1112	1.01	1136	1.08	1157	1.14
2040*	996	0.70	1024	0.76	1050	0.83	1075	0.89	1100	0.95	1125	1.02	1148	1.09	1172	1.16	1193	1.23	1215	1.30
2380*	1060	0.83	1086	0.90	1112	0.97	1138	1.04	1162	1.11	1186	1.18	1209	1.26	1232	1.33	1253	1.41	1275	1.48
2720	1126	0.98	1152	1.06	1178	1.13	1203	1.21	1226	1.29	1250	1.37	1272	1.45	1294	1.53	1316	1.61	1337	1.69
3060	1194	1.16	1219	1.24	1245	1.33	1269	1.41	1292	1.49	1315	1.58	1336	1.66	1358	1.75	1379	1.83	1400	1.92
3400	1265	1.37	1289	1.45	1314	1.54	1337	1.63	1360	1.72	1382	1.81	1403	1.90	1425	2.00	1446	2.09	1466	2.18
3740	1337	1.60	1361	1.69	1384	1.79	1407	1.88	1429	1.98	1451	2.08	1472	2.18	1493	2.28	1513	2.38	1533	2.48
4080	1411	1.86	1434	1.97	1456	2.07	1479	2.17	1500	2.27	1521	2.38	1541	2.48	1562	2.59	1581	2.69	-	-

Notes:

1. For direct drive fan speed, reference the applicable table in the fan performance section.
 2. Data includes pressure drop due to standard filters and wet coils.
 3. To determine additional static pressure drop due to other options/accessories, refer to the applicable table in the fan performance section.
 4. Direct drive fan motor heat (MBh) = 2.7912 x fan bhp + 0.1388.
 5. Factory supplied motors, in equipment, are definite purpose motors, specifically designed and tested to operate at all cataloged conditions. Using the full horsepower range of our fan motors as shown in our tabular data will not result in nuisance tripping or premature motor failure. Our product's warranty will not be affected.
- * For 1700, 2040, and 2380 cfm, unit application below 320 cfm/ton are only applicable on T_C models and modulating gas. See below for restrictions.
 * For electric heat applications, minimum airflow is set to 320 cfm/ton, unless specified otherwise, values found in electric heat temperature rise table.
 * Dehumidification (hot gas reheat) or TXV with Froststat™ and crankcase heaters are required on applications below 320 cfm/ton.



Evaporator Fan Performance

Table 38. Direct drive evaporator fan performance - 8.5 ton with eFlex™ and eDrive™ technology - YZC102F3,F4,FW low and medium gas heat downflow airflow

External Static Pressure (Inches of Water)																				
cfm	.10		.20		.30		.40		.50		.60		.70		.80		.90		1.00	
	rpm	bhp	rpm	bhp	rpm	bhp	rpm	bhp	rpm	bhp	rpm	bhp	rpm	bhp	rpm	bhp	rpm	bhp	rpm	bhp
2720	847	0.36	885	0.42	921	0.49	960	0.56	996	0.64	1029	0.71	1060	0.78	1090	0.85	1119	0.92	1147	1.00
3060	942	0.49	979	0.57	1011	0.64	1043	0.71	1078	0.80	1110	0.88	1140	0.96	1169	1.04	1197	1.12	1224	1.20
3400	1039	0.66	1073	0.74	1103	0.82	1131	0.90	1161	0.98	1193	1.08	1222	1.17	1250	1.26	1276	1.35	1302	1.44
3740	1135	0.85	1168	0.95	1196	1.04	1223	1.12	1249	1.21	1275	1.30	1304	1.41	1332	1.51	1358	1.61	1383	1.70
4080	1233	1.09	1263	1.20	1290	1.30	1316	1.39	1340	1.48	1363	1.57	1388	1.68	1414	1.79	1440	1.90	1464	2.01

External Static Pressure (Inches of Water)																				
cfm	1.10		1.20		1.30		1.40		1.50		1.60		1.70		1.80		1.90		2.00	
	rpm	bhp	rpm	bhp	rpm	bhp	rpm	bhp	rpm	bhp	rpm	bhp	rpm	bhp	rpm	bhp	rpm	bhp	rpm	bhp
2720	1173	1.08	1199	1.15	1224	1.23	1248	1.31	1272	1.40	1295	1.48	1318	1.56	1340	1.64	1361	1.73	1383	1.82
3060	1249	1.29	1274	1.37	1298	1.46	1322	1.54	1345	1.63	1368	1.72	1389	1.81	1411	1.90	1432	1.99	1453	2.08
3400	1327	1.53	1351	1.62	1374	1.71	1397	1.80	1420	1.90	1442	1.99	1463	2.09	1483	2.18	1504	2.28	1524	2.38
3740	1407	1.80	1430	1.90	1453	2.00	1475	2.10	1496	2.20	1518	2.30	1538	2.40	1560	2.51	1579	2.62	1598	2.72
4080	1487	2.11	1510	2.22	1533	2.33	1554	2.44	1575	2.54	1595	2.65	-	-	-	-	-	-	-	-

Notes:

1. For direct drive fan speed, reference the applicable table in the fan performance section.
2. Data includes pressure drop due to standard filters and wet coils.
3. To determine additional static pressure drop due to other options/accessories, refer to the applicable table in the fan performance section.
4. Direct drive fan motor heat (MBh) = 2.7912 x fan bhp + 0.1388.
5. Factory supplied motors, in equipment, are definite purpose motors, specifically designed and tested to operate at all cataloged conditions. Using the full horsepower range of our fan motors as shown in our tabular data will not result in nuisance tripping or premature motor failure. Our product's warranty will not be affected.

Evaporator Fan Performance

Table 39. Direct drive evaporator fan performance - 8.5 ton with eFlex™ and eDrive™ technology - YZC102F3,F4,FW low and medium gas heat horizontal airflow

External Static Pressure (Inches of Water)																				
cfm	.10		.20		.30		.40		.50		.60		.70		.80		.90		1.00	
	rpm	bhp	rpm	bhp	rpm	bhp	rpm	bhp	rpm	bhp	rpm	bhp	rpm	bhp	rpm	bhp	rpm	bhp	rpm	bhp
2720	820	0.32	861	0.38	901	0.45	937	0.52	972	0.59	1005	0.65	1037	0.72	1067	0.80	1095	0.87	1123	0.94
3060	913	0.44	949	0.51	985	0.58	1020	0.65	1052	0.73	1084	0.81	1114	0.89	1143	0.96	1170	1.04	1197	1.12
3400	1006	0.59	1039	0.66	1072	0.74	1104	0.82	1135	0.90	1165	0.99	1193	1.08	1220	1.16	1247	1.25	1273	1.33
3740	1100	0.76	1131	0.85	1160	0.93	1190	1.01	1219	1.10	1247	1.20	1274	1.29	1300	1.39	1326	1.48	1351	1.58
4080	1195	0.97	1223	1.07	1251	1.16	1277	1.24	1304	1.34	1331	1.44	1357	1.54	1382	1.65	1406	1.75	1430	1.86

External Static Pressure (Inches of Water)																				
cfm	1.10		1.20		1.30		1.40		1.50		1.60		1.70		1.80		1.90		2.00	
	rpm	bhp	rpm	bhp	rpm	bhp	rpm	bhp	rpm	bhp	rpm	bhp	rpm	bhp	rpm	bhp	rpm	bhp	rpm	bhp
2720	1150	1.02	1175	1.09	1200	1.17	1225	1.25	1248	1.32	1271	1.40	1293	1.48	1315	1.57	1336	1.65	1357	1.73
3060	1223	1.20	1248	1.29	1273	1.37	1296	1.45	1319	1.54	1341	1.62	1363	1.71	1384	1.80	1404	1.88	1425	1.97
3400	1298	1.42	1322	1.51	1345	1.60	1368	1.69	1390	1.78	1412	1.87	1433	1.96	1454	2.06	1475	2.15	1495	2.25
3740	1374	1.67	1398	1.77	1420	1.86	1442	1.96	1465	2.06	1486	2.15	1506	2.25	1527	2.36	1547	2.46	1566	2.56
4080	1453	1.95	1475	2.06	1498	2.16	1519	2.27	1540	2.37	1560	2.47	1581	2.58	1601	2.69	-	-	-	-

Notes:

1. For direct drive fan speed, reference the applicable table in the fan performance section.
2. Data includes pressure drop due to standard filters and wet coils.
3. To determine additional static pressure drop due to other options/accessories, refer to the applicable table in the fan performance section.
4. Direct drive fan motor heat (MBh) = 2.7912 x fan bhp + 0.1388.
5. Factory supplied motors, in equipment, are definite purpose motors, specifically designed and tested to operate at all cataloged conditions. Using the full horsepower range of our fan motors as shown in our tabular data will not result in nuisance tripping or premature motor failure. Our product's warranty will not be affected.



Evaporator Fan Performance

Table 40. Direct drive evaporator fan performance - 8.5 ton with eFlex™ and eDrive™ technology - YZC102F3,F4,FW high gas heat downflow airflow

External Static Pressure (Inches of Water)																				
cfm	.10		.20		.30		.40		.50		.60		.70		.80		.90		1.00	
	rpm	bhp	rpm	bhp	rpm	bhp	rpm	bhp	rpm	bhp	rpm	bhp	rpm	bhp	rpm	bhp	rpm	bhp	rpm	bhp
1700*	567	0.11	624	0.16	675	0.20	720	0.25	761	0.30	799	0.35	835	0.41	868	0.46	900	0.52	930	0.58
2040*	657	0.17	708	0.22	754	0.28	797	0.33	836	0.39	872	0.45	907	0.51	939	0.57	970	0.63	999	0.70
2380*	750	0.25	795	0.31	837	0.37	877	0.44	914	0.50	949	0.57	981	0.63	1013	0.70	1042	0.77	1071	0.84
2720	845	0.36	885	0.43	924	0.49	960	0.56	995	0.64	1028	0.71	1059	0.78	1089	0.86	1118	0.94	1145	1.01
3060	941	0.49	977	0.57	1012	0.64	1046	0.72	1078	0.80	1109	0.88	1139	0.96	1168	1.04	1195	1.13	1222	1.21
3400	1038	0.65	1070	0.74	1102	0.82	1134	0.90	1164	0.99	1192	1.08	1221	1.17	1248	1.26	1275	1.35	1301	1.44
3740	1136	0.85	1165	0.94	1194	1.03	1223	1.12	1252	1.22	1279	1.31	1306	1.41	1331	1.51	1356	1.61	1381	1.71
4080	1234	1.09	1261	1.19	1288	1.29	1314	1.39	1341	1.48	1367	1.58	1392	1.69	1416	1.79	1440	1.91	1463	2.01

External Static Pressure (Inches of Water)																				
cfm	1.10		1.20		1.30		1.40		1.50		1.60		1.70		1.80		1.90		2.00	
	rpm	bhp	rpm	bhp	rpm	bhp	rpm	bhp	rpm	bhp	rpm	bhp	rpm	bhp	rpm	bhp	rpm	bhp	rpm	bhp
1700*	960	0.64	988	0.70	1015	0.76	1042	0.83	1066	0.89	1090	0.96	1114	1.02	1138	1.10	1160	1.16	1183	1.24
2040*	1027	0.76	1055	0.83	1081	0.90	1106	0.97	1132	1.04	1156	1.12	1179	1.19	1201	1.26	1224	1.34	1246	1.42
2380*	1098	0.91	1126	0.99	1151	1.06	1175	1.14	1201	1.22	1223	1.29	1246	1.37	1268	1.45	1291	1.54	1312	1.62
2720	1172	1.09	1198	1.17	1223	1.26	1247	1.34	1270	1.42	1293	1.50	1315	1.59	1337	1.68	1358	1.76	1380	1.85
3060	1247	1.30	1272	1.38	1297	1.47	1320	1.56	1343	1.65	1366	1.74	1387	1.84	1409	1.93	1429	2.02	1449	2.11
3400	1325	1.53	1350	1.63	1373	1.72	1396	1.82	1417	1.91	1439	2.01	1462	2.12	1482	2.21	1502	2.31	1522	2.42
3740	1405	1.81	1428	1.91	1451	2.01	1473	2.11	1495	2.22	1515	2.32	1536	2.43	1557	2.54	1577	2.64	1597	2.75
4080	1486	2.12	1509	2.23	1530	2.33	1552	2.45	1573	2.56	1593	2.67	-	-	-	-	-	-	-	-

Notes:

- For direct drive fan speed, reference the applicable table in the fan performance section.
 - Data includes pressure drop due to standard filters and wet coils.
 - To determine additional static pressure drop due to other options/accessories, refer to the applicable table in the fan performance section.
 - Direct drive fan motor heat (MBh) = 2.7912 x fan bhp + 0.1388.
 - Factory supplied motors, in equipment, are definite purpose motors, specifically designed and tested to operate at all cataloged conditions. Using the full horsepower range of our fan motors as shown in our tabular data will not result in nuisance tripping or premature motor failure. Our product's warranty will not be affected.
- * For 1700, 2040, and 2380 cfm, unit application below 320 cfm/ton are only applicable on T_C models and modulating gas. See below for restrictions.
 * For electric heat applications, minimum airflow is set to 320 cfm/ton, unless specified otherwise, values found in electric heat temperature rise table.
 * Dehumidification (hot gas reheat) or TXV with Froststat™ and crankcase heaters are required on applications below 320 cfm/ton.

Evaporator Fan Performance

Table 41. Direct drive evaporator fan performance - 8.5 ton with eFlex™ and eDrive™ technology - YZC102F3,F4,FW high gas heat horizontal airflow

External Static Pressure (Inches of Water)																				
cfm	.10		.20		.30		.40		.50		.60		.70		.80		.90		1.00	
	rpm	bhp	rpm	bhp	rpm	bhp	rpm	bhp	rpm	bhp	rpm	bhp	rpm	bhp	rpm	bhp	rpm	bhp	rpm	bhp
1700*	556	0.11	615	0.15	666	0.20	712	0.25	754	0.31	792	0.36	828	0.42	862	0.48	894	0.54	925	0.61
2040*	643	0.16	696	0.22	743	0.27	786	0.33	826	0.39	863	0.45	898	0.52	930	0.58	962	0.65	991	0.72
2380*	734	0.24	780	0.30	823	0.36	864	0.42	901	0.49	936	0.56	969	0.63	1001	0.70	1032	0.78	1060	0.85
2720	826	0.34	867	0.40	907	0.48	944	0.54	979	0.61	1012	0.69	1044	0.77	1075	0.85	1104	0.93	1132	1.01
3060	920	0.47	956	0.53	992	0.61	1027	0.70	1059	0.77	1091	0.85	1122	0.93	1151	1.02	1179	1.11	1206	1.20
3400	1014	0.62	1047	0.69	1080	0.77	1112	0.86	1143	0.96	1172	1.04	1201	1.12	1229	1.22	1256	1.31	1282	1.41
3740	1109	0.81	1139	0.89	1169	0.97	1198	1.06	1228	1.17	1256	1.27	1283	1.36	1309	1.45	1335	1.55	1360	1.65
4080	1204	1.03	1233	1.12	1260	1.21	1287	1.30	1314	1.40	1341	1.52	1367	1.64	1391	1.73	1416	1.83	1439	1.93

External Static Pressure (Inches of Water)																				
cfm	1.10		1.20		1.30		1.40		1.50		1.60		1.70		1.80		1.90		2.00	
	rpm	bhp	rpm	bhp	rpm	bhp	rpm	bhp	rpm	bhp	rpm	bhp	rpm	bhp	rpm	bhp	rpm	bhp	rpm	bhp
1700*	955	0.67	983	0.74	1009	0.81	1036	0.88	1062	0.95	1086	1.02	1110	1.10	1134	1.17	1156	1.25	1178	1.33
2040*	1019	0.79	1048	0.87	1074	0.94	1099	1.01	1124	1.09	1149	1.17	1172	1.25	1196	1.33	1217	1.42	1240	1.50
2380*	1088	0.93	1116	1.01	1141	1.09	1166	1.17	1190	1.26	1214	1.34	1237	1.43	1260	1.52	1282	1.61	1303	1.70
2720	1159	1.10	1184	1.18	1210	1.27	1235	1.36	1259	1.45	1282	1.54	1304	1.63	1327	1.73	1348	1.82	1368	1.92
3060	1232	1.29	1257	1.38	1281	1.47	1306	1.57	1329	1.67	1352	1.76	1373	1.86	1395	1.97	1416	2.07	1437	2.17
3400	1307	1.51	1331	1.61	1355	1.71	1379	1.81	1401	1.91	1424	2.02	1444	2.12	1465	2.23	1487	2.34	1507	2.45
3740	1384	1.76	1408	1.87	1431	1.97	1453	2.08	1475	2.19	1496	2.30	1518	2.42	1538	2.53	1558	2.65	1577	2.76
4080	1462	2.04	1486	2.16	1508	2.27	1529	2.39	1551	2.51	1572	2.63	1592	2.74	-	-	-	-	-	-

Notes:

1. For direct drive fan speed, reference the applicable table in the fan performance section.
 2. Data includes pressure drop due to standard filters and wet coils.
 3. To determine additional static pressure drop due to other options/accessories, refer to the applicable table in the fan performance section.
 4. Direct drive fan motor heat (MBh) = 2.7912 x fan bhp + 0.1388.
 5. Factory supplied motors, in equipment, are definite purpose motors, specifically designed and tested to operate at all cataloged conditions. Using the full horsepower range of our fan motors as shown in our tabular data will not result in nuisance tripping or premature motor failure. Our product's warranty will not be affected.
- * For 1700, 2040, and 2380 cfm, unit application below 320 cfm/ton are only applicable on T_C models and modulating gas. See below for restrictions.
 * For electric heat applications, minimum airflow is set to 320 cfm/ton, unless specified otherwise, values found in electric heat temperature rise table.
 * Dehumidification (hot gas reheat) or TXV with Froststat™ and crankcase heaters are required on applications below 320 cfm/ton.



Evaporator Fan Performance

Table 42. Direct drive evaporator fan performance - 10 ton with eFlex™ and eDrive™ technology - TZC120F3,F4,FW downflow airflow

External Static Pressure (Inches of Water)																				
cfm	.10		.20		.30		.40		.50		.60		.70		.80		.90		1.00	
	rpm	bhp	rpm	bhp	rpm	bhp	rpm	bhp	rpm	bhp	rpm	bhp	rpm	bhp	rpm	bhp	rpm	bhp	rpm	bhp
2000*	593	0.12	650	0.18	702	0.23	748	0.29	791	0.35	831	0.40	868	0.46	904	0.52	938	0.59	970	0.65
2400*	699	0.20	732	0.24	785	0.31	827	0.38	870	0.45	907	0.51	942	0.58	976	0.65	1009	0.72	1040	0.80
2800*	800	0.30	830	0.34	873	0.41	913	0.49	947	0.56	987	0.65	1022	0.73	1053	0.80	1083	0.88	1113	0.96
3200	901	0.42	941	0.50	952	0.52	1001	0.63	1037	0.72	1065	0.79	1098	0.88	1133	0.98	1163	1.07	1192	1.16
3600	1005	0.57	1040	0.66	1065	0.72	1072	0.74	1124	0.89	1158	1.00	1184	1.08	1209	1.17	1240	1.27	1272	1.39
4000	1108	0.77	1141	0.86	1173	0.96	1185	1.00	1191	1.01	1242	1.19	1276	1.33	1300	1.42	1323	1.52	1346	1.61
4400	1213	1.00	1243	1.10	1272	1.21	1298	1.31	1305	1.33	1310	1.35	1356	1.53	1391	1.70	1416	1.83	1437	1.93
4800	1317	1.28	1346	1.39	1372	1.50	1399	1.62	1418	1.71	1424	1.73	1429	1.75	1464	1.91	1502	2.12	1530	2.28

External Static Pressure (Inches of Water)																				
cfm	1.10		1.20		1.30		1.40		1.50		1.60		1.70		1.80		1.90		2.00	
	rpm	bhp	rpm	bhp	rpm	bhp	rpm	bhp	rpm	bhp	rpm	bhp	rpm	bhp	rpm	bhp	rpm	bhp	rpm	bhp
2000*	1001	0.72	1030	0.78	1059	0.85	1086	0.92	1113	0.99	1139	1.07	1165	1.14	1189	1.21	1212	1.29	1235	1.37
2400*	1070	0.87	1099	0.94	1127	1.02	1153	1.09	1180	1.17	1206	1.25	1230	1.33	1254	1.41	1277	1.49	1300	1.58
2800*	1142	1.05	1170	1.13	1197	1.21	1224	1.29	1249	1.38	1274	1.47	1298	1.55	1322	1.64	1345	1.73	1367	1.82
3200	1218	1.25	1244	1.34	1271	1.44	1295	1.52	1321	1.62	1345	1.71	1368	1.80	1392	1.90	1414	2.00	1437	2.10
3600	1299	1.49	1325	1.59	1348	1.69	1372	1.79	1396	1.89	1419	1.99	1441	2.10	1464	2.20	1486	2.30	1508	2.42
4000	1374	1.73	1403	1.86	1430	1.98	1453	2.09	1476	2.20	1497	2.31	1519	2.42	1540	2.53	1561	2.65	1582	2.77
4400	1458	2.03	1478	2.14	1504	2.27	1530	2.40	1556	2.54	1579	2.67	1600	2.79	1620	2.91	-	-	-	-
4800	1550	2.40	1570	2.51	1589	2.63	1607	2.74	1629	2.87	-	-	-	-	-	-	-	-	-	-

Notes:

- For direct drive evaporator fan speed (rpm), refer to the applicable table in the fan performance section.
 - Data includes pressure drop due to standard filters and wet coils.
 - To determine static pressure drop due to other options/accessories, refer to the applicable table in the fan performance section.
 - Direct drive fan motor heat (MBh) = 2.7912 x fan bhp + 0.1388.
 - Factory supplied motors, in commercial equipment, are definite purpose motors, specifically designed and tested to operate reliably and continuously at all cataloged conditions. Using the full horsepower range of our fan motors as shown in our tabular data will not result in nuisance tripping or premature motor failure. Our product's warranty will not be affected.
- * For 2000, 2400, and 2800 cfm, unit application below 320 cfm/ton are only applicable on T_C models and modulating gas. See below for restrictions.
 * For electric heat applications, minimum airflow is set to 320 cfm/ton, unless specified otherwise, values found in electric heat temperature rise table.
 * Dehumidification (hot gas reheat) or TXV with Froststat™ and crankcase heaters are required on applications below 320 cfm/ton.

Evaporator Fan Performance

Table 43. Direct drive evaporator fan performance - 10 ton with eFlex™ and eDrive™ technology - TZC120F3,F4,FW horizontal airflow

External Static Pressure (Inches of Water)																				
cfm	.10		.20		.30		.40		.50		.60		.70		.80		.90		1.00	
	rpm	bhp	rpm	bhp	rpm	bhp	rpm	bhp	rpm	bhp	rpm	bhp	rpm	bhp	rpm	bhp	rpm	bhp	rpm	bhp
2000*	573	0.11	626	0.16	680	0.21	727	0.26	770	0.32	815	0.38	857	0.44	896	0.51	933	0.58	968	0.65
2400*	666	0.17	712	0.22	756	0.28	802	0.34	844	0.41	881	0.47	917	0.53	955	0.61	991	0.68	1025	0.76
2800*	762	0.25	803	0.31	841	0.37	879	0.43	919	0.51	956	0.58	991	0.66	1022	0.73	1052	0.81	1085	0.89
3200	857	0.35	897	0.42	931	0.49	964	0.56	997	0.63	1032	0.72	1065	0.80	1099	0.89	1128	0.97	1156	1.05
3600	954	0.47	991	0.56	1023	0.63	1054	0.71	1082	0.79	1111	0.87	1142	0.96	1172	1.06	1202	1.16	1232	1.25
4000	1051	0.63	1086	0.72	1117	0.81	1145	0.89	1172	0.98	1198	1.06	1225	1.16	1251	1.25	1278	1.36	1306	1.46
4400	1149	0.81	1182	0.92	1212	1.02	1239	1.11	1264	1.21	1288	1.30	1311	1.39	1335	1.49	1360	1.59	1384	1.70
4800	1247	1.04	1279	1.15	1307	1.26	1333	1.36	1357	1.47	1380	1.57	1402	1.67	1424	1.77	1446	1.88	1467	1.98

External Static Pressure (Inches of Water)																				
cfm	1.10		1.20		1.30		1.40		1.50		1.60		1.70		1.80		1.90		2.00	
	rpm	bhp	rpm	bhp	rpm	bhp	rpm	bhp	rpm	bhp	rpm	bhp	rpm	bhp	rpm	bhp	rpm	bhp	rpm	bhp
2000*	1001	0.72	1033	0.79	1064	0.87	1094	0.94	1123	1.02	1150	1.10	1178	1.18	1204	1.27	1230	1.35	1255	1.44
2400*	1058	0.84	1090	0.92	1120	1.00	1150	1.08	1179	1.17	1206	1.25	1233	1.34	1259	1.43	1284	1.52	1309	1.62
2800*	1118	0.98	1149	1.06	1178	1.15	1208	1.24	1236	1.33	1263	1.42	1290	1.52	1315	1.62	1340	1.71	1365	1.81
3200	1182	1.14	1209	1.22	1238	1.32	1267	1.42	1294	1.51	1321	1.61	1347	1.71	1374	1.82	1398	1.92	1422	2.03
3600	1259	1.34	1285	1.44	1309	1.53	1332	1.63	1356	1.73	1383	1.83	1408	1.94	1433	2.05	1457	2.16	1481	2.28
4000	1333	1.58	1360	1.68	1385	1.78	1409	1.88	1432	1.99	1453	2.09	1475	2.20	1495	2.31	1518	2.42	1541	2.54
4400	1410	1.82	1434	1.94	1459	2.06	1483	2.18	1507	2.29	1530	2.41	1552	2.52	1572	2.63	1592	2.75	1611	2.86
4800	1490	2.10	1512	2.22	1535	2.35	1558	2.48	1581	2.61	1603	2.74	1626	2.87	-	-	-	-	-	-

Notes:

1. For direct drive evaporator fan speed (rpm), refer to the applicable table in the fan performance section.
 2. Data includes pressure drop due to standard filters and wet coils.
 3. To determine static pressure drop due to other options/accessories, refer to the applicable table in the fan performance section.
 4. Direct drive fan motor heat (MBh) = 2.7912 x fan bhp + 0.1388.
 5. Factory supplied motors, in commercial equipment, are definite purpose motors, specifically designed and tested to operate reliably and continuously at all cataloged conditions. Using the full horsepower range of our fan motors as shown in our tabular data will not result in nuisance tripping or premature motor failure. Our product's warranty will not be affected.
- * For 2000, 2400, and 2800 cfm, unit application below 320 cfm/ton are only applicable on T_C models and modulating gas. See below for restrictions.
 * For electric heat applications, minimum airflow is set to 320 cfm/ton, unless specified otherwise, values found in electric heat temperature rise table.
 * Dehumidification (hot gas reheat) or TXV with Froststat™ and crankcase heaters are required on applications below 320 cfm/ton.



Evaporator Fan Performance

Table 44. Direct drive evaporator fan performance - 10 ton with eFlex™ and eDrive™ technology - YZC120F3,F4,FW low and medium gas heat downflow airflow

External Static Pressure (Inches of Water)																				
cfm	.10		.20		.30		.40		.50		.60		.70		.80		.90		1.00	
	rpm	bhp	rpm	bhp	rpm	bhp	rpm	bhp	rpm	bhp	rpm	bhp	rpm	bhp	rpm	bhp	rpm	bhp	rpm	bhp
3200	892	0.39	929	0.47	964	0.54	998	0.62	1031	0.70	1064	0.78	1095	0.86	1124	0.94	1153	1.02	1181	1.10
3600	994	0.54	1028	0.63	1060	0.71	1090	0.79	1120	0.87	1151	0.97	1180	1.06	1209	1.15	1236	1.24	1262	1.33
4000	1096	0.72	1128	0.81	1158	0.91	1186	1.00	1213	1.09	1240	1.18	1267	1.28	1294	1.38	1321	1.49	1346	1.59
4400	1199	0.93	1230	1.04	1257	1.14	1284	1.24	1309	1.34	1333	1.44	1358	1.54	1383	1.65	1407	1.77	1432	1.88
4800	1302	1.19	1332	1.30	1357	1.42	1382	1.53	1406	1.64	1429	1.75	1451	1.85	1474	1.97	1496	2.08	1519	2.20

External Static Pressure (Inches of Water)																				
cfm	1.10		1.20		1.30		1.40		1.50		1.60		1.70		1.80		1.90		2.00	
	rpm	bhp	rpm	bhp	rpm	bhp	rpm	bhp	rpm	bhp	rpm	bhp	rpm	bhp	rpm	bhp	rpm	bhp	rpm	bhp
3200	1208	1.19	1234	1.27	1260	1.35	1285	1.44	1308	1.52	1333	1.61	1355	1.70	1377	1.79	1399	1.88	1420	1.97
3600	1287	1.42	1312	1.51	1337	1.60	1361	1.69	1384	1.79	1407	1.88	1429	1.97	1451	2.07	1472	2.17	1493	2.27
4000	1371	1.69	1395	1.79	1417	1.89	1440	1.99	1462	2.09	1484	2.19	1506	2.29	1527	2.40	1548	2.50	1569	2.61
4400	1455	1.99	1479	2.10	1501	2.21	1523	2.33	1544	2.43	1564	2.54	1584	2.65	-	-	-	-	-	-
4800	1542	2.33	1564	2.45	1586	2.58	1607	2.70	-	-	-	-	-	-	-	-	-	-	-	-

Notes:

1. For direct drive fan speed, reference the applicable table in the fan performance section.
2. Data includes pressure drop due to standard filters and wet coils.
3. To determine additional static pressure drop due to other options/accessories, refer to the applicable table in the fan performance section.
4. Direct drive fan motor heat (MBh) = 2.7912 x fan bhp + 0.1388.
5. Factory supplied motors, in equipment, are definite purpose motors, specifically designed and tested to operate at all cataloged conditions. Using the full horsepower range of our fan motors as shown in our tabular data will not result in nuisance tripping or premature motor failure. Our product's warranty will not be affected.

Evaporator Fan Performance

Table 45. Direct drive evaporator fan performance - 10 ton with eFlex™ and eDrive™ technology - YZC120F3,F4,FW low and medium gas heat horizontal airflow

External Static Pressure (Inches of Water)																				
cfm	.10		.20		.30		.40		.50		.60		.70		.80		.90		1.00	
	rpm	bhp	rpm	bhp	rpm	bhp	rpm	bhp	rpm	bhp	rpm	bhp	rpm	bhp	rpm	bhp	rpm	bhp	rpm	bhp
3200	853	0.34	896	0.42	935	0.50	970	0.57	1004	0.65	1037	0.73	1070	0.81	1101	0.90	1130	0.98	1160	1.07
3600	950	0.47	988	0.55	1025	0.64	1058	0.72	1089	0.81	1120	0.89	1149	0.98	1180	1.08	1209	1.17	1235	1.26
4000	1049	0.63	1081	0.71	1116	0.81	1148	0.91	1177	1.00	1206	1.09	1233	1.19	1260	1.28	1286	1.38	1314	1.49
4400	1148	0.81	1176	0.90	1208	1.01	1239	1.12	1267	1.22	1294	1.33	1320	1.42	1344	1.53	1369	1.63	1394	1.74
4800	1247	1.04	1273	1.14	1301	1.24	1330	1.36	1357	1.48	1384	1.59	1408	1.70	1432	1.81	1455	1.92	1478	2.04

External Static Pressure (Inches of Water)																				
cfm	1.10		1.20		1.30		1.40		1.50		1.60		1.70		1.80		1.90		2.00	
	rpm	bhp	rpm	bhp	rpm	bhp	rpm	bhp	rpm	bhp	rpm	bhp	rpm	bhp	rpm	bhp	rpm	bhp	rpm	bhp
3200	1191	1.16	1221	1.25	1248	1.35	1275	1.44	1300	1.53	1325	1.62	1349	1.72	1373	1.81	1396	1.91	1418	2.01
3600	1261	1.36	1287	1.45	1315	1.55	1342	1.66	1367	1.76	1394	1.87	1417	1.97	1441	2.08	1463	2.18	1484	2.28
4000	1339	1.60	1364	1.70	1388	1.80	1411	1.90	1435	2.01	1460	2.12	1484	2.24	1508	2.36	1530	2.47	1553	2.59
4400	1419	1.86	1443	1.98	1466	2.09	1489	2.20	1510	2.31	1532	2.43	1553	2.54	1575	2.65	1597	2.78	1619	2.90
4800	1500	2.16	1523	2.28	1546	2.40	1567	2.52	1589	2.65	1611	2.78	1631	2.90	-	-	-	-	-	-

Notes:

1. For direct drive evaporator fan speed (rpm), refer to the applicable table in the fan performance section.
2. Data includes pressure drop due to standard filters and wet coils.
3. To determine static pressure drop due to other options/accessories, refer to the applicable table in the fan performance section.
4. Direct drive fan motor heat (MBh) = 2.7912 x fan bhp + 0.1388.
5. Factory supplied motors, in commercial equipment, are definite purpose motors, specifically designed and tested to operate reliably and continuously at all cataloged conditions. Using the full horsepower range of our fan motors as shown in our tabular data will not result in nuisance tripping or premature motor failure. Our product's warranty will not be affected.



Evaporator Fan Performance

Table 46. Direct drive evaporator fan performance - 10 ton with eFlex™ and eDrive™ technology - YZC120F3,F4,FW high gas heat downflow airflow

External Static Pressure (Inches of Water)																				
cfm	.10		.20		.30		.40		.50		.60		.70		.80		.90		1.00	
	rpm	bhp	rpm	bhp	rpm	bhp	rpm	bhp	rpm	bhp	rpm	bhp	rpm	bhp	rpm	bhp	rpm	bhp	rpm	bhp
3200	900	0.42	939	0.50	972	0.57	1004	0.64	1037	0.72	1069	0.80	1099	0.88	1127	0.95	1155	1.03	1184	1.12
3600	1005	0.58	1037	0.66	1071	0.74	1099	0.82	1128	0.90	1157	0.99	1186	1.08	1214	1.17	1240	1.26	1265	1.35
4000	1110	0.77	1138	0.86	1170	0.96	1198	1.05	1223	1.13	1249	1.22	1275	1.32	1302	1.42	1327	1.52	1352	1.62
4400	1215	1.01	1241	1.10	1268	1.20	1297	1.31	1321	1.41	1344	1.50	1367	1.60	1391	1.71	1415	1.82	1439	1.93
4800	1321	1.29	1345	1.39	1369	1.49	1395	1.61	1420	1.73	1442	1.83	1463	1.94	1484	2.04	1506	2.16	1529	2.28

External Static Pressure (Inches of Water)																				
cfm	1.10		1.20		1.30		1.40		1.50		1.60		1.70		1.80		1.90		2.00	
	rpm	bhp	rpm	bhp	rpm	bhp	rpm	bhp	rpm	bhp	rpm	bhp	rpm	bhp	rpm	bhp	rpm	bhp	rpm	bhp
3200	1212	1.21	1239	1.29	1266	1.38	1291	1.47	1316	1.56	1342	1.65	1367	1.75	1392	1.84	1415	1.94	1438	2.03
3600	1290	1.44	1316	1.53	1341	1.63	1365	1.72	1390	1.82	1414	1.92	1436	2.02	1459	2.12	1482	2.22	1506	2.33
4000	1375	1.72	1398	1.81	1420	1.91	1443	2.01	1466	2.12	1488	2.23	1511	2.33	1534	2.45	1554	2.55	1575	2.66
4400	1462	2.03	1485	2.15	1506	2.25	1527	2.36	1548	2.47	1567	2.57	1588	2.69	1609	2.80	1631	2.93	-	-
4800	1550	2.39	1572	2.51	1593	2.63	1614	2.75	1634	2.87	-	-	-	-	-	-	-	-	-	-

Notes:

1. For direct drive evaporator fan speed (rpm), refer to the applicable table in the fan performance section.
2. Data includes pressure drop due to standard filters and wet coils.
3. To determine static pressure drop due to other options/accessories, refer to the applicable table in the fan performance section.
4. Direct drive fan motor heat (MBh) = 2.7912 x fan bhp + 0.1388.
5. Factory supplied motors, in commercial equipment, are definite purpose motors, specifically designed and tested to operate reliably and continuously at all cataloged conditions. Using the full horsepower range of our fan motors as shown in our tabular data will not result in nuisance tripping or premature motor failure. Our product's warranty will not be affected.

Evaporator Fan Performance

Table 47. Direct drive evaporator fan performance - 10 ton with eFlex™ and eDrive™ technology - YZC120F3,F4,FW high gas heat horizontal airflow

External Static Pressure (Inches of Water)																				
cfm	.10		.20		.30		.40		.50		.60		.70		.80		.90		1.00	
	rpm	bhp	rpm	bhp	rpm	bhp	rpm	bhp	rpm	bhp	rpm	bhp	rpm	bhp	rpm	bhp	rpm	bhp	rpm	bhp
3200	868	0.37	906	0.44	943	0.51	980	0.59	1014	0.67	1046	0.74	1078	0.82	1109	0.91	1139	0.99	1168	1.08
3600	969	0.50	1001	0.58	1035	0.66	1068	0.74	1100	0.83	1131	0.92	1160	1.01	1189	1.10	1217	1.19	1244	1.28
4000	1070	0.67	1098	0.75	1129	0.84	1159	0.93	1188	1.02	1218	1.12	1245	1.22	1272	1.32	1298	1.41	1324	1.52
4400	1172	0.87	1197	0.96	1224	1.06	1251	1.16	1279	1.26	1306	1.36	1332	1.46	1358	1.57	1383	1.68	1407	1.79
4800	1274	1.12	1297	1.21	1321	1.31	1346	1.42	1371	1.53	1396	1.64	1421	1.75	1445	1.86	1469	1.98	1493	2.10

External Static Pressure (Inches of Water)																				
cfm	1.10		1.20		1.30		1.40		1.50		1.60		1.70		1.80		1.90		2.00	
	rpm	bhp	rpm	bhp	rpm	bhp	rpm	bhp	rpm	bhp	rpm	bhp	rpm	bhp	rpm	bhp	rpm	bhp	rpm	bhp
3200	1196	1.16	1225	1.25	1254	1.34	1280	1.43	1306	1.52	1330	1.61	1355	1.71	1378	1.80	1400	1.89	1424	1.99
3600	1271	1.37	1297	1.47	1323	1.57	1347	1.66	1374	1.77	1398	1.86	1423	1.97	1447	2.07	1470	2.17	1492	2.27
4000	1349	1.62	1375	1.72	1399	1.83	1422	1.93	1445	2.03	1468	2.14	1491	2.25	1514	2.36	1538	2.48	1561	2.59
4400	1431	1.90	1455	2.01	1478	2.12	1499	2.23	1523	2.35	1544	2.46	1565	2.57	1587	2.69	1608	2.81	1629	2.92
4800	1515	2.21	1537	2.33	1559	2.45	1581	2.57	1602	2.69	1623	2.82	1643	2.94	-	-	-	-	-	-

Notes:

1. For direct drive evaporator fan speed (rpm), refer to the applicable table in the fan performance section.
2. Data includes pressure drop due to standard filters and wet coils.
3. To determine static pressure drop due to other options/accessories, refer to the applicable table in the fan performance section.
4. Direct drive fan motor heat (MBh) = 2.7912 x fan bhp + 0.1388.
5. Factory supplied motors, in commercial equipment, are definite purpose motors, specifically designed and tested to operate reliably and continuously at all cataloged conditions. Using the full horsepower range of our fan motors as shown in our tabular data will not result in nuisance tripping or premature motor failure. Our product's warranty will not be affected.



Fan Performance

Table 48. Voltage vs. cfm table

T/YZC036E, T/YZC048F, T/YZC060E		
PWM% Value	Potentiometer Voltage (Vdc)	CFM/Ton
70	<0.1	320
75	0.7	347
80	1.25	373
85	1.65	400
90	1.95	427
95	2.17	453
100	>2.4	480

Table 49. Direct drive plenum fan settings (rpm vs. voltage)

T/YZC072F, T/YZC090F, T/YZC102F, T/YZC120F	
Potentiometer	Motor RPM
1.25	0
1.5	0
1.75	0
2.0	0
2.25	325
2.50	402
2.75	465
3.00	544
3.25	630
3.50	716
3.75	775
4.00	845
4.25	912
4.50	976
4.75	1044
5.00	1115
5.25	1203
5.50	1253
5.75	1312
6.00	1368
6.25	1425
6.50	1475
6.75	1533
7.00	1581
7.25	1615
7.50	1615

Notes:

1. See fan tables for unit rpm and cfm units.
2. Factory setting is 5V.

Table 50. Static pressure drop through accessories (inches water column) - 3 to 10 tons

Tons	Unit Model Number	cfm	Standard Filters ^(a)	2-inch MERV 8 Filter	2-inch MERV 13 Filter	Economizer with OA/RA Dampers ^(b)						Electric Heater Accessory (kW) ^{(c),(d)}			
						100% OA	100% RA	100% OA	100% RA	100% OA	100% RA	5-6	9-18	23-36	54
						Downflow		Low Leak ^(e)		Horizontal					
3	T/YZC036E3,4	600	0.01	0.02	0.03	0.03	0.01	0.03	0.02	0.03	0.01	—	—	—	—
3	T/YZC036E3,4	960	0.01	0.03	0.04	0.04	0.01	0.09	0.03	0.04	0.01	0.01	0.01	0.01	—
3	T/YZC036E3,4	1200	0.02	0.04	0.05	0.06	0.01	0.13	0.05	0.06	0.01	0.02	0.02	0.02	—
3	T/YZC036E3,4	1440	0.03	0.05	0.06	0.08	0.02	0.19	0.07	0.08	0.01	0.02	0.03	0.03	—
4	T/YZC048F3,4	800	0.01	0.03	0.04	0.06	0.00	0.03	0.01	0.03	0.01	—	—	—	—
4	T/YZC048F3,4	1280	0.02	0.04	0.03	0.08	0.00	0.07	0.03	0.04	0.01	0.01	0.00	0.01	—
4	T/YZC048F3,4	1600	0.03	0.06	0.05	0.09	0.01	0.10	0.05	0.05	0.02	0.02	0.01	0.02	—
4	T/YZC048F3,4	1920	0.05	0.08	0.07	0.10	0.01	0.15	0.08	0.07	0.02	0.02	0.01	0.03	—
5	T/YZC060E3,4	1000	0.01	0.04	0.03	0.06	0.01	0.04	0.02	0.06	0.01	—	—	—	—
5	T/YZC060E3,4	1600	0.03	0.06	0.08	0.09	0.01	0.10	0.05	0.05	0.01	0.02	0.01	0.02	—
5	T/YZC060E3,4	2000	0.05	0.08	0.11	0.11	0.01	0.16	0.08	0.07	0.02	0.02	0.02	0.03	—
5	T/YZC060E3,4	2400	0.07	0.10	0.13	0.12	0.03	0.23	0.12	0.09	0.04	0.03	0.02	0.04	—
6	T/YZC072F	1920	0.03	0.04	0.10	0.09	0.01	0.15	0.08	0.06	0.01	—	0.01	0.01	—
6	T/YZC072F	2400	0.04	0.06	0.12	0.11	0.02	0.23	0.12	0.08	0.02	—	0.01	0.01	—
6	T/YZC072F	2880	0.06	0.08	0.13	0.13	0.04	0.34	0.18	0.11	0.04	—	0.01	0.02	—
7.5	T/YZC090F	1500	0.02	0.03	0.08	0.07	0.01	0.09	0.05	0.04	0.01	—	—	—	—
7.5	T/YZC090F	2400	0.04	0.06	0.12	0.11	0.02	0.23	0.12	0.08	0.02	—	0.01	0.01	—
7.5	T/YZC090F	3000	0.06	0.09	0.13	0.14	0.05	0.37	0.19	0.12	0.05	—	0.01	0.02	—
7.5	T/YZC090F	3600	0.09	0.13	0.15	0.21	0.07	0.54	0.27	0.25	0.08	—	0.02	0.03	—
8.5	T/YZC102F	1700	0.02	0.05	0.11	0.07	0.01	0.11	0.06	0.05	0.02	—	—	—	—
8.5	T/YZC102F	2720	0.05	0.08	0.13	0.12	0.03	0.30	0.16	0.09	0.04	—	0.01	0.02	—
8.5	T/YZC102F	3400	0.08	0.11	0.14	0.19	0.06	0.48	0.24	0.18	0.06	—	0.02	0.02	—
8.5	T/YZC102F	4080	0.12	0.16	0.16	0.30	0.07	0.71	0.35	0.31	0.09	—	0.03	0.03	—
10	T/YZC120F	2000	0.03	0.06	0.11	0.08	0.03	0.16	0.08	0.07	0.02	—	—	—	—
10	T/YZC120F	3200	0.07	0.10	0.14	0.17	0.05	0.42	0.22	0.14	0.05	—	0.02	0.03	0.05
10	T/YZC120F	4000	0.11	0.15	0.16	0.26	0.07	0.68	0.34	0.30	0.08	—	0.02	0.03	0.05
10	T/YZC120F	4800	0.16	0.20	0.18	0.34	0.09	0.99	0.48	0.35	0.10	—	0.03	0.04	0.06

(a) Tested with standard filters. Difference in pressure drop should be considered when utilizing optional 2" MERV 8 and MERV 13 filters.

(b) OA = Outside Air and RA = Return Air.

(c) Nominal kW ratings at 240 and 480 volts. Heaters only available on T units.

(d) Electric heaters restricted on applications below 320 cfm/Ton.

(e) Low Leak - downflow only.



Fan Performance

Table 51. Outdoor sound power level - dB (ref. 10 to 12 W)

Tons	Unit Model	Octave Center Frequency								Overall
	Number	63	125	250	500	1000	2000	4000	8000	dBA
3	T/YZC036E	79	85	79	79	77	71	67	58	81
4	T/YZC048F	80	86	84	85	83	79	73	67	87
5	T/YZC060E	80	86	84	85	83	79	73	67	87
6 ^(a)	T/YZC072F	91	95	90	87	84	79	75	68	89
7.5	T/YZC090F	93	91	89	89	85	80	76	72	90
8.5	T/YZC102F	93	91	89	89	85	80	76	72	90
10	T/YZC120F	91	92	89	86	83	78	75	71	88

(a) Tested in accordance with AHRI270-2015. Sound data for T/YZ072 are estimates.



Heat Performance

Table 52. Gas fired heating capacities

Tons	Unit Model Number	Heating Input MBh	Heating Output MBh	Air Temp. Rise, °F
3	YZC036E	60	48	25-55
3	YZC036E and Digit 34 = A	60	48.6	25-55
3	YZC036E	80	64	35-65
3	YZC036E	100	80	55-85
4	YZC048F	60	48	10-40
4	YZC048F and Digit 34 = A	60	48.6	15-45
4	YZC048F	80	64	20-50
4	YZC048F and Digit 34 = A	90	72.9	30-60
4	YZC048F	120	96	40-70
5	YZC060E	60	48	10-40
5	YZC060E and Digit 34 = A	60	48.6	10-40
5	YZC060E	80	64	15-45
5	YZC060E and Digit 34 = A	90	72.9	20-50
5	YZC060E	130	104	35-65
6	YZC072F	80	64.8	15-45
6	YZC072F	120	97.2	20-50
6	YZC072F	150	121.5	25-55
7.5	YZC090F	120	97.2	20-50
7.5	YZC090F	150	121.5	20-50
7.5	YZC090F	200	162	35-65
8.5	YZC102F	120	97.2	20-50
8.5	YZC102F	150	121.5	20-50
8.5	YZC102F	200	162	35-65
10	YZC120F	150	121.5	20-50
10	YZC120F	200	162	25-55
10	YZC120F	250	202.5	35-65

Note: Ratings shown are for elevations up to 2,000 ft. For higher elevations, reduce ratings at a rate of 4% per 1,000 ft. elevation.

Table 53. Auxiliary electric heat capacity

Tons	Unit Model Number	Total ^(a)		No. of Stages	Stage1		Stage 2	
		kW Input ^(b)	MBh Output		kW Input	MBh Output	kW Input	MBh Output
3	TZC036E3,4	6.00	20.48	1	6.00	20.48	—	—
3	TZC036E3,4	12.00	40.97	2	6.00	20.48	6.00	20.48
3	TZC036E3,4	17.40	59.40	2	8.70	29.70	8.70	29.70
4	TZC048F3,4	6.00	20.48	1	6.00	20.48	—	—
4	TZC048F3,4	12.00	40.97	2	6.00	20.48	6.00	20.48
4	TZC048F3,4	17.40	59.40	2	8.70	29.70	8.70	29.70
5	TZC060E3,4	6.00	20.48	1	6.00	20.48	—	—
5	TZC060E3,4	12.00	40.97	2	6.00	20.48	6.00	20.48
5	TZC060E3,4	17.40	59.40	2	8.70	29.70	8.70	29.70
5	TZC060E3,4	23.00	78.52	2	8.70	29.70	14.30	48.82
6	TZC072F3,4	9.00	30.73	1	9.00	30.73	—	—



Heat Performance

Table 53. Auxiliary electric heat capacity (continued)

Tons	Unit Model Number	Total ^(a)		No. of Stages	Stage1		Stage 2	
		kW Input ^(b)	MBh Output		kW Input	MBh Output	kW Input	MBh Output
6	TZC072F3,4,W	18.00	61.45	1	18.00	61.45	—	—
6	TZC072F3,4	27.00	92.18	2	18.00	61.45	9.00	30.73
6	TZC072F3,4,W	36.00	122.90	2	18.00	61.45	18.00	61.45
7.5	TZC090F3,4	9.00	30.73	1	9.00	30.73	—	—
7.5	TZC090F3,4,W	18.00	61.45	1	18.00	61.45	—	—
7.5	TZC090F3,4	27.00	92.18	2	18.00	61.45	9.00	30.73
7.5	TZC090F3,4,W	36.00	122.90	2	18.00	61.45	18.00	61.45
8.5	TZC102F3,4	9.00	30.73	1	9.00	30.73	—	—
8.5	TZC102F3,4,W	18.00	61.45	1	18.00	61.45	—	—
8.5	TZC102F3,4	27.00	92.18	2	18.00	61.45	9.00	30.73
8.5	TZC102F3,4,W	36.00	122.90	2	18.00	61.45	18.00	61.45
10	TZC120F3,4,W	18.00	61.45	1	18.00	61.45	—	—
10	TZC120F3,4	27.00	92.18	2	18.00	61.45	9.00	30.73
10	TZC120F3,4,W	36.00	122.90	2	18.00	61.45	18.00	61.45
10	TZC120F3,4,W	54.00	184.36	2	36.00	122.90	18.00	61.45

(a) Heaters are rated at 240V and 480V. For other than rated voltage, CAP= (voltage/rated voltage)² x rated cap.

(b) All input/output does not include indoor fan power or heat.

Table 54. Electric heater voltage correction factors (applicable to auxiliary heat capacity)

Nominal Voltage	Distribution Voltage	Capacity Multiplier
240	208	0.751
240	230	0.918
240	240	1.000
480	440	0.840
480	460	0.918
480	480	1.000
600	540	0.810
600	575	0.918
600	600	1.000

Table 55. Air temperature rise across electric heaters (°F) - 3 to 5 tons

kW	Stages	3 Tons ^(a)	4 Tons	5 Tons
		1200 cfm	1600 cfm	2000 cfm ^(b)
		Three Phase TZC036E3,4	Three Phase TZC048F3,4	Three Phase TZC060E3,4
6.00	1	18.5	10.5	11.4
12.00	2	36.2	22.3	21.5
17.40	2	48.2	33.0	30.0
23.0	2	—	—	38.8

Notes:

- For minimum design airflow, see airflow performance table for each unit.
- To calculate temp rise at different airflow, use the following formula: Temp. rise across Electric Heater = kW x 3414/1.08 x CFM.

(a) The minimum allowable airflow for a 3 ton with a 17.4 kW heater is 1080 cfm.

(b) The minimum allowable airflow for a 5 ton unit with a 23.0 kW heater is 1900 cfm.

Table 56. Air temperature rise across electric heaters (°F) - 6 to 10 tons

kW	Stages	6 Tons	7.5 tons	8.5 tons	10 Tons
		2000 cfm	3000 cfm	3400 cfm	4000 cfm ^(a)
		TZC072F3,4,W	TZC090F3,4,W	TZC102F3,4,W	TZC120F3,4,W
9.0	1	14.2	9.5	8.4	—
18.0	1	28.5	19.0	16.7	14.2
27.0	2	42.7	28.5	25.1	21.3
36.0	2	56.9	37.9	33.5	28.5
54.0	2	—	—	—	42.7

Notes:

1. For minimum design airflow, see airflow performance table for each unit.
2. To calculate temp rise at different airflow, use the following formula: Temp. rise across Electric Heater = kW x 3414/1.08 x CFM.

(a) The minimum allowable airflow with a 54 kW heater for TZC120F is 3400 cfm.



Controls

ReliaTel™ Controlled Units

Zone sensors are the building occupant's comfort control devices. The following zone sensor options are available for units with ReliaTel™ control.

Economizer Controls

The standard equipment offering is a fixed dry bulb changeover control. In addition, there are two optional controls, Enthalpy and Differential Enthalpy Control.

Enthalpy Control

Replaces the dry bulb control with a wet bulb changeover controller which has a fully adjustable setpoint. Enthalpy control offers a higher level of comfort control, along with energy savings potential, than the standard dry bulb control. This is due to the additional wet bulb sensing capability.

Differential Enthalpy

Differential enthalpy replaces the standard dry bulb control with two enthalpy sensors that compare total heat content of the indoor air and outdoor air to determine the most efficient air source. This control option offers the highest level of comfort control, plus energy efficiency, available.

Remote Potentiometer

Minimum position setting of economizer can be remotely adjusted with this accessory.

Differential Pressure Switches

This factory or field-installed option allows individual fan failure and dirty filter indication. The fan failure switch will disable all unit functions and "flash" the Service LED on the zone sensor. The dirty filter switch will light the Service LED on the zone sensor and will allow continued unit operation.

Remote sensor

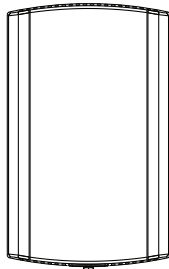

Sensor(s) available for all zone sensors to provide remote sensing capabilities.

Manual changeover

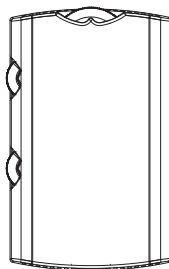

Heat, Cool or Off System Switch. Fan Auto or Off Switch. One temperature setpoint lever.

Manual/Automatic changeover

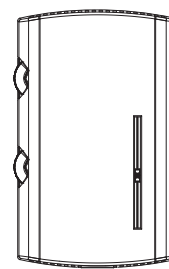

Auto, Heat, Cool or Off System Switch. Fan Auto or Off Switch. Two temperature setpoint levers.

Manual/Automatic changeover-status indicator

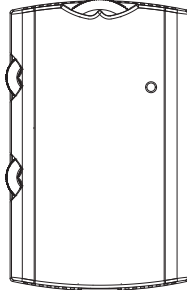

Auto, Heat, Cool or Off System Switch. Fan Auto or Off Switch. Two temperature setpoint levers.

Manual/Automatic changeover- LED status

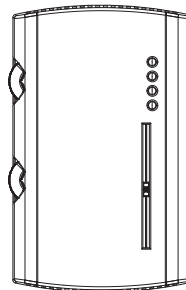

Sensor(s) available for all zone sensors to provide remote sensing capabilities.

Integrated Comfort™ system

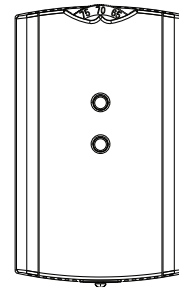

Sensor(s) available with optional temperature adjustment and override buttons to provide central control through a Trane Integrated Comfort™ system.

CO₂ sensing

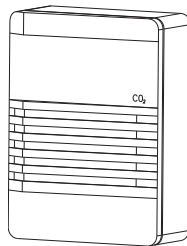

The CO₂ sensor shall have the ability to monitor the concentration (parts per million, ppm) of CO₂ (Carbon Dioxide) in the air. As the CO₂ concentration changes, the outside air damper modulates to meet the current ventilation needs of the zone.

Humidity sensor

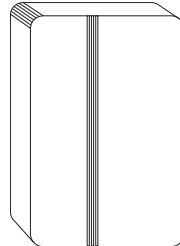

Field installed, wall-mounted or duct-mounted humidity sensor is used to control activation of the enhanced dehumidification option. The humidity sensor can be set for humidity levels between 40% and 60% relative humidity by adjusting the ReliaTel™ Options Module.

RA Remote Sensor

Return air remote sensor which can be mounted in the return air duct to report return air temperature.

Room Remote Sensor

Space Remote Sensor which can be mounted on the wall to report/control from a remote location in the space.

Communication Interfaces

BACnet® Communication Interface

This option shall be provided to allow the unit to communicate directly with a generic open protocol BACnet® MS/TP Network Building Automation System Controls.

LonTalk® Communications Interface - Factory or Field Installed

The LonTalk® communications interface allows the unit to communicate as a Tracer® LCI-V device or directly with a generic open protocol BACnet® MS/TP Network Building Automation System Controls.



Controls

Trane® Air-Fi® Wireless Communication - Factory Installed

Air-Fi® Wireless communication shall be factory installed and tested. Air-Fi® Wireless conforms to ANSI/ASHRAE Standard 135-2016 (BACnet®/ZigBee®¹).

Trane® Communication Interface (TCI)

This factory or field-installed micro-processor interface allows the unit to communicate through a Trane® Integrated Comfort™ system. TCI communication is only for constant volume units. Multi-speed and VAV units require either a BACnet® or LON communication if a BAS is used for control.

¹ ZigBee® is a registered trademark of the ZigBee® Alliance.



Electrical Data

Table 57. Unit wiring with cooling (no electric heat) - 3 to 10 tons

Tons	Unit Model Number	Unit Operating Voltage Range	Standard Indoor Motor	
			MCA	Max Fuse Size or Max Circuit Breaker
3	TZC036E3	208-230	14	20
	TZC036E4	460	7	15
4	TZC048F3	208-230	18	25
	TZC048F4	460	9	15
5	TZC060E3	208-230	26	40
	TZC060E4	460	11	15
6	TZC072F3	187-253	39	50
	TZC072F4	414-506	22	30
	TZC072FW	517-633	20	30
7.5	TZC090F3	187-253	40	60
	TZC090F4	414-506	23	35
	TZC090FW	517-633	21	30
8.5	TZC102F3	187-253	42	60
	TZC102F4	414-506	24	35
	TZC102FW	517-633	22	30
10	TZC120F3	187-253	53	80
	TZC120F4	414-506	31	45
	TZC120FW	517-633	28	40

Table 58. Unit wiring with gas heat - 3 to 10 tons

Tons	Unit Model Number	Unit Operating Voltage Range	Standard Indoor Motor	
			MCA	Max Fuse Size or Max Circuit Breaker
3	YZC036E3	230	14	20
	YZC036E4	460	7	15
4	YZC048F3	230	18	25
	YZC048F4	460	9	15
5	YZC060E3	230	26	40
	YZC060E4	460	11	15
6	YZC072F3	187-253	39	50
	YZC072F4	414-506	22	30
	YZC072FW	517-633	20	30
7.5	YZC090F3	187-253	40	60
	YZC090F4	414-506	23	35
	YZC090FW	517-633	21	30
8.5	YZC102F3	187-253	42	60
	YZC102F4	414-506	24	35
	YZC102FW	517-633	22	30
10	YZC120F3	187-253	53	80
	YZC120F4	414-506	31	45
	YZC120FW	517-633	28	40



Electrical Data

Table 59. Unit wiring with electric heat (single point connection) - 3 to 10 tons

Tons	Unit Model Number	Heater Model Number	Heater kW Rating ^(a)	Control Stages	Heater Amps	Standard Indoor Motor	
						MCA	Max Fuse Size or Max Circuit Breaker
208/230 Volts Three Phase							
3	TZC036E3	BAYHTRE306*	4.5/6.0	1	12.5/14.4	20/22	20/25
	TZC036E3	BAYHTRE312*	9.0/12.0	2	25.0/28.9	36/40	40/40
	TZC036E3	BAYHTRE318*	13.1/17.4	2	36.3/41.9	50/57	50/60
4	TZC048F3	BAYHTRX306*	4.5/6.0	1	12.5/14.4	21/24	25/25
	TZC048F3	BAYHTRX312*	9.0/12.0	2	25.0/28.9	37/42	40/45
	TZC048F3	BAYHTRX318*	13.1/17.4	2	36.3/41.9	51/58	60/60
5	TZC060E3	BAYHTRX306*	4.5/6.0	1	12.5/14.4	26/26	40/40
	TZC060E3	BAYHTRX312*	9.0/12.0	2	25.0/28.9	37/42	40/45
	TZC060E3	BAYHTRX318*	13.1/17.4	2	36.3/41.9	51/58	60/60
	TZC060E3	BAYHTRX323*	17.3/23.0	2	48.0/55.3	66/75	70/80
6	TZC072F3	BAYHTRA309*	6.8/9	1	18.8/21.7	39/39	50/50
	TZC072F3	BAYHTRZ318*	13.5/18	1	37.5/43.3	58/65	60/70
	TZC072F3	BAYHTRA327*	20.3/27	2	56.3/65.0	81/92	90/100
	TZC072F3	BAYHTRZ336*	27/36	2	75.1/86.6	104/119	110/125
7.5	TZC090F3	BAYHTRA309*	6.8/9	1	18.8/21.7	40/40	60/60
	TZC090F3	BAYHTRZ318*	13.5/18	1	37.5/43.3	58/65	60/70
	TZC090F3	BAYHTRA327*	20.3/27	2	56.3/65.0	81/92	90/100
	TZC090F3	BAYHTRZ336*	27/36	2	75.1/86.6	104/119	110/125
8.5	TZC102F3	BAYHTRA309*	6.8/9	1	18.8/21.7	42/42	60/60
	TZC102F3	BAYHTRZ318*	13.5/18	1	37.5/43.3	58/65	60/70
	TZC102F3	BAYHTRA327*	20.3/27	2	56.3/65.0	81/92	90/100
	TZC102F3	BAYHTRZ336*	27/36	2	75.1/86.6	104/119	110/125
10	TZC120F3	BAYHTRD318*	13.5/18	1	37.5/43.3	58/65	80/80
	TZC120F3	BAYHTRD327*	20.3/27	2	56.3/65.0	81/92	90/100
	TZC120F3	BAYHTRZ337*	27/36	2	75.1/86.6	104/119	110/125
	TZC120F3	BAYHTRZ354*	40.6/54	2	112.6/129.9	151/141	175/175
460 Volts Three Phase							
3	TZC036E4	BAYHTRE406*	6.0	1	7.2	12	15
	TZC036E4	BAYHTRE412*	12.0	2	14.4	21	25
	TZC036E4	BAYHTRE418*	17.4	2	20.9	29	30
4	TZC048F4	BAYHTRX406*	6.0	1	7.2	12	15
	TZC048F4	BAYHTRX412*	12.0	2	14.4	21	25
	TZC048F4	BAYHTRX418*	17.4	2	20.9	29	30
5	TZC060E4	BAYHTRX406*	6.0	1	7.2	13	15
	TZC060E4	BAYHTRX412*	12.0	2	14.4	22	25
	TZC060E4	BAYHTRX418*	17.4	2	20.9	30	30
	TZC060E4	BAYHTRX423*	23.0	2	27.7	38	40
6	TZC072F4	BAYHTRA409*	9	1	10.8	22	30
	TZC072F4	BAYHTRA418*	18	1	21.7	33	35
	TZC072F4	BAYHTRA427*	27	2	32.5	47	50
	TZC072F4	BAYHTRA436*	36	2	43.3	60	60

Table 59. Unit wiring with electric heat (single point connection) - 3 to 10 tons (continued)

Tons	Unit Model Number	Heater Model Number	Heater kW Rating ^(a)	Control Stages	Heater Amps	Standard Indoor Motor	
						MCA	Max Fuse Size or Max Circuit Breaker
460 Volts Three Phase							
7.5	TZC090F4	BAYHTRA409*	09	1	10.8	23	35
	TZC090F4	BAYHTRA418*	18	1	21.7	33	35
	TZC090F4	BAYHTRA427*	27	2	32.5	47	50
	TZC090F4	BAYHTRA436*	36	2	43.3	60	60
8.5	TZC102F4	BAYHTRA409*	09	1	10.8	24	35
	TZC102F4	BAYHTRA418*	18	1	21.7	33	35
	TZC102F4	BAYHTRA427*	27	2	32.5	47	50
	TZC102F4	BAYHTRA436*	36	2	43.3	60	60
10	TZC120F4	BAYHTRD418*	18	1	21.7	33	45
	TZC120F4	BAYHTRD427*	27	2	32.5	47	50
	TZC120F4	BAYHTRZ436*	36	2	43.3	60	60
	TZC120F4	BAYHTRZ454*	54	2	65.0	71	90
575 Volts Three Phase							
6	TZC072FW	BAYHTRAW18*	18	1	17.3	28	30
	TZC072FW	BAYHTRAW36*	36	2	34.6	49	50
7.5	TZC090FW	BAYHTRAW18*	18	1	17.3	28	30
	TZC090FW	BAYHTRAW36*	36	2	34.6	49	50
8.5	TZC102FW	BAYHTRAW18*	18	1	17.3	28	30
	TZC102FW	BAYHTRAW36*	36	2	34.6	49	50
10	TZC120FW	BAYHTRBW18*	18	1	17.3	28	40
	TZC120FW	BAYHTRZW36*	36	2	34.6	49	50
	TZC120FW	BAYHTRZW54*	54	2	52.0	58	70

(a) Heater kW ratings are at 208/240V for 208/230V units, 480V for 460V units.

Table 60. Electrical characteristics - compressor motor - variable frequency drive

Ton	Unit Model Number	Volts	Phase	VFD Input Amps
3	T/YZC036E3	208-230	3	8.0
	T/YZC036E4	460	3	4.0
4	T/YZC048F3	208-230	3	9.0
	T/YZC048F4	460	3	4.5
5	T/YZC060E3	208-230	3	16.0
	T/YZC060E4	460	3	6.0
6	T/YZC072F3	187-253	3	20.8
	T/YZC072F4	414-506	3	12.2
	T/YZC072FW	517-633	3	10.5
7.5	T/YZC090F3	187-253	3	21.5
	T/YZC090F4	414-506	3	12.9
	T/YZC090FW	517-633	3	11.3
8.5	T/YZC102F3	187-253	3	22.6
	T/YZC102F4	414-506	3	13.6
	T/YZC102FW	517-633	3	11.9



Electrical Data

Table 60. Electrical characteristics - compressor motor - variable frequency drive (continued)

Ton	Unit Model Number	Volts	Phase	VFD Input Amps
10	T/YZC120F3	187-253	3	31.3
	T/YZC120F4	414-506	3	18.8
	T/YZC120FW	517-633	3	16.5

Table 61. Electrical characteristics - condenser fan motor - 60 cycle

Tons	Unit Model Number	Volts	Hz	Motor Phase	Nameplate Rating	
					FLA	bhp
3	T/YZC036E3	208-230	60	1	1.0	0.33
	T/YZC036E4	460 ^(a)	60	1	0.5	0.33
4	T/YZC048F3	208-230	60	1	2.9	0.50
	T/YZC048F4	460 ^(a)	60	1	1.3	0.50
5	T/YZC060E3	208-230	60	1	2.4	0.50
	T/YZC060E4	460 ^(a)	60	1	1.2	0.50
6	T/YZC072F3	187-253	60	1-PWM	5.7	0.75
	T/YZC072F4	414-506	60	1-PWM	3.1	0.75
	T/YZC072FW	517-633	60	1-PWM	3.1	0.75
7.5	T/YZC090F3	187-253	60	1-PWM	5.7	0.75
	T/YZC090F4	414-506	60	1-PWM	3.1	0.75
	T/ZC090FW	517-633	60	1-PWM	3.1	0.75
8.5	T/ZC102F3	187-253	60	1-PWM	5.7	0.75
	T/ZC102F4	414-506	60	1-PWM	3.1	0.75
	T/ZC102FW	517-633	60	1-PWM	3.1	0.75
10	T/ZC120F3	187-253	60	1-PWM	5.7	0.75
	T/ZC120F4	414-506	60	1-PWM	3.1	0.75
	T/ZC120FW	517-633	60	1-PWM	3.1	0.75

(a) Precedent™ models with 460V supply power will utilize a high efficiency 208-230V powered evaporator and condenser fan motor. Power will be adapted for the fan motors with a 460V/230V autotransformer.

Table 62. Electrical characteristics - evaporator fan motor - 60 cycle

Tons	Unit Model Number	Volts	Hz	Motor Phase	Nameplate Rating	
					FLA	bhp
3	T/YZC036E3	208-230	60	1	2.3	0.75
	T/YZC036E4	460 ^(a)	60	1	1.0	0.75
4	T/YZC048F3	208-230	60	1	3.3	1.00
	T/YZC048F4	460 ^(a)	60	1	1.4	1.00
5	T/YZC060E3	208-230	60	1	3.3	1.00
	T/YZC060E4	460 ^(a)	60	1	1.8	1.00
6	T/YZC072F3	187-253	60	3 DC	7.3	2.7
	T/YZC072F4	414-506	60	3 DC	3.6	2.7
	T/YZC072FW	517-633	60	3 DC	3.6	2.7
7.5	T/YZC090F3	187-253	60	3 DC	7.3	2.7
	T/YZC090F4	414-506	60	3 DC	3.6	2.7
	T/YZC090FW	517-633	60	3 DC	3.6	2.7

Table 62. Electrical characteristics - evaporator fan motor - 60 cycle (continued)

Tons	Unit Model Number	Volts	Hz	Motor Phase	Nameplate Rating	
					FLA	bhp
8.5	T/YZC102F3	187-253	60	3 DC	7.3	2.7
	T/YZC102F4	414-506	60	3 DC	3.6	2.7
	T/YZC102FW	517-633	60	3 DC	3.6	2.7
10	T/YZC120F3	187-253	60	3 DC	7.3	2.7
	T/YZC120F4	414-506	60	3 DC	3.6	2.7
	T/YZC120FW	517-633	60	3 DC	3.6	2.7

(a) Precedent™ models with 460V supply power will utilize a high efficiency 208-230V powered evaporator and condenser fan motor. Power will be adapted for the fan motors with a 460V/230V autotransformer.

Table 63. Electrical characteristics - power exhaust (cooling and gas/electric)

Tons	Volts	Motor Phase	hp	rpm	FLA	LRA
3-5	208-230	1	0.33	1075	2.2	5.5
3-5	460	1	0.33	1075	1.1	2.8
6-10	208-230	1	0.87	1075	5.7	13.6
6-10	460	1	0.87	1075	3.3	6.8
6-10	575	1	0.87	1075	2.3	5.4

Table 64. Electrical characteristics - inducer motor

Tons	Stage	hp	rpm	Volts	Motor Phase	LRA
3-5	1	1/35	3000	208-230	1	0.6
6-10	208-230	1	1/15	3350/2800	0.42/0.5	1.25

Table 65. Electrical characteristics - Ultra-Low NO_x premix blower motor

Unit Model Number	Stage	hp	rpm	Volts	Motor Phase	LRA
Models with digit 34 = A	1	1/2	7500	115	1	NA

Jobsite Connections

Table 66. Typical number of wires

Zone Sensors		
A	Manual Changeover.....	4
	Manual/Auto Changeover.....	5
	Manual/Auto Changeover with Status Indication LED's.....	10
	Programmable Night Setback with Status Indication LED's.....	7

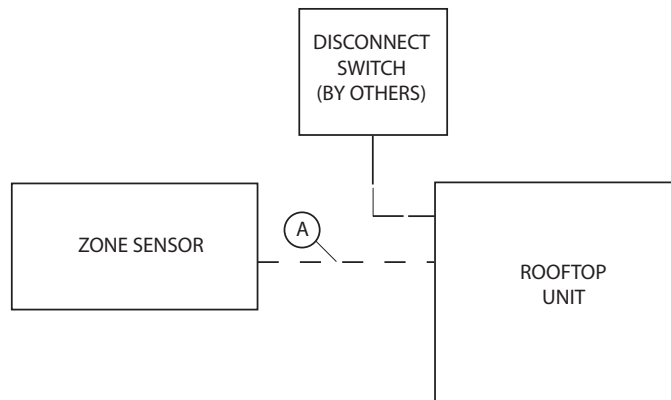

- For specific wiring information, see the installation instructions.
- All wiring except power wire is low voltage.
- All customer supplied wiring to be copper and must conform to applicable electrical codes (such as NEC or CEC) and local electric codes. Wiring shown dotted is to be furnished and installed by the customer.

Dimensional Data

Figure 4. Cooling and gas/electric - 3 tons ultra high efficiency^{(a),(b)}

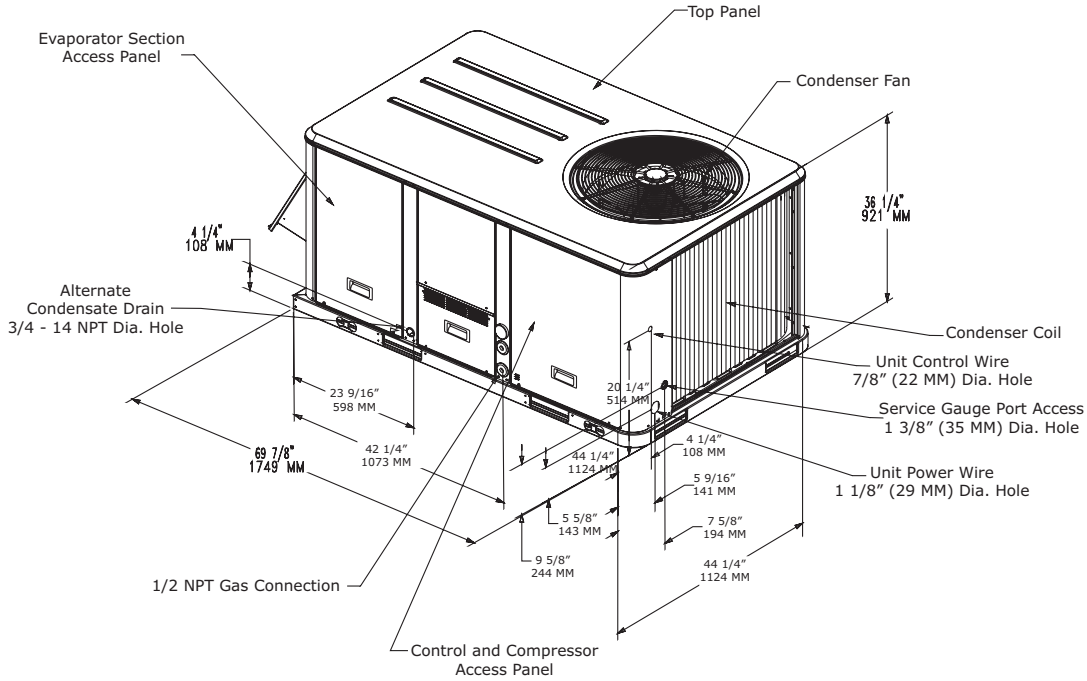

(a) All dimensions are in inches/millimeters.
 (b) 1/2 NPT Gas Connection = (Y_C Models only); 2" Electrical Connection: Single Point Power When Heat Installed (T_C Models only).

Figure 5. Cooling and gas/electric - 3 tons - downflow airflow supply/return - through-the-base utilities^(a)

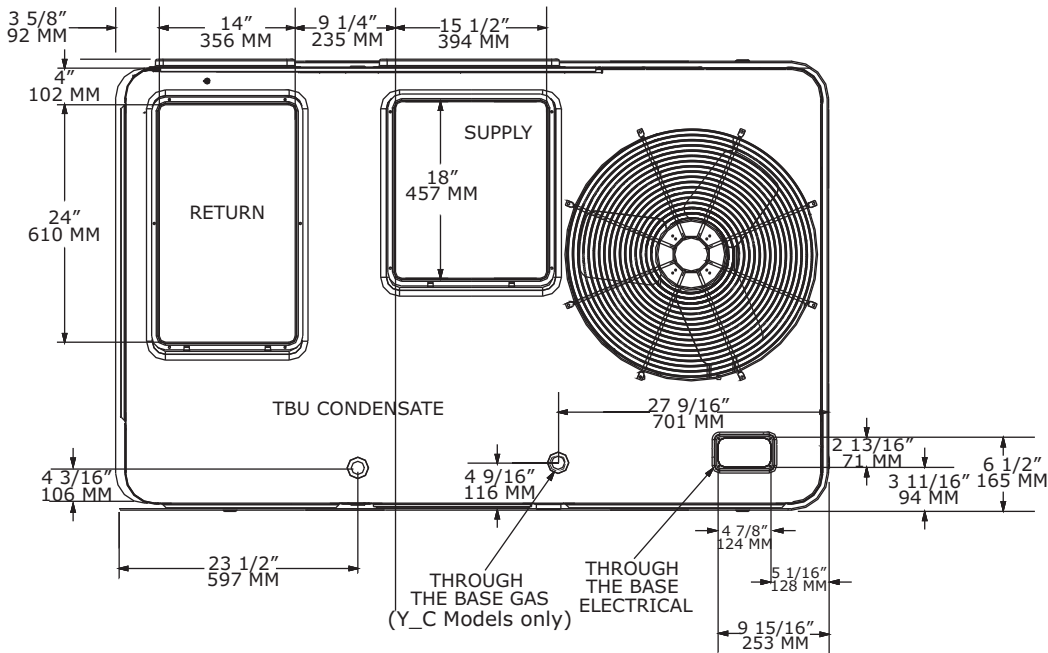

(a) All dimensions are in inches/millimeters.

Dimensional Data

Figure 6. Cooling and gas/electric - 3 tons - horizontal airflow supply/return^(a)

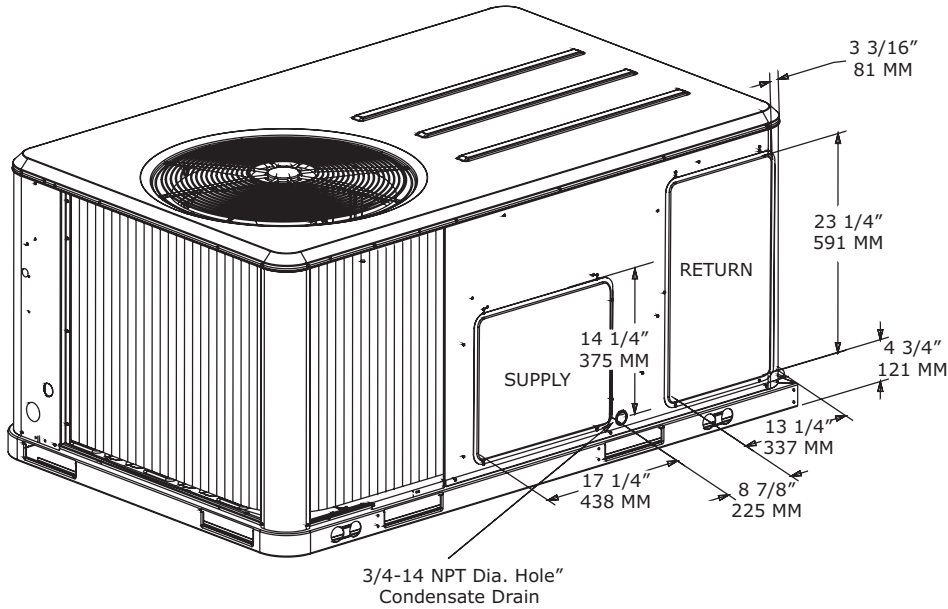

(a) All dimensions are in inches/millimeters.

Figure 7. Cooling and gas/electric - 3 tons ultra high efficiency - unit clearance and roof opening^(a)

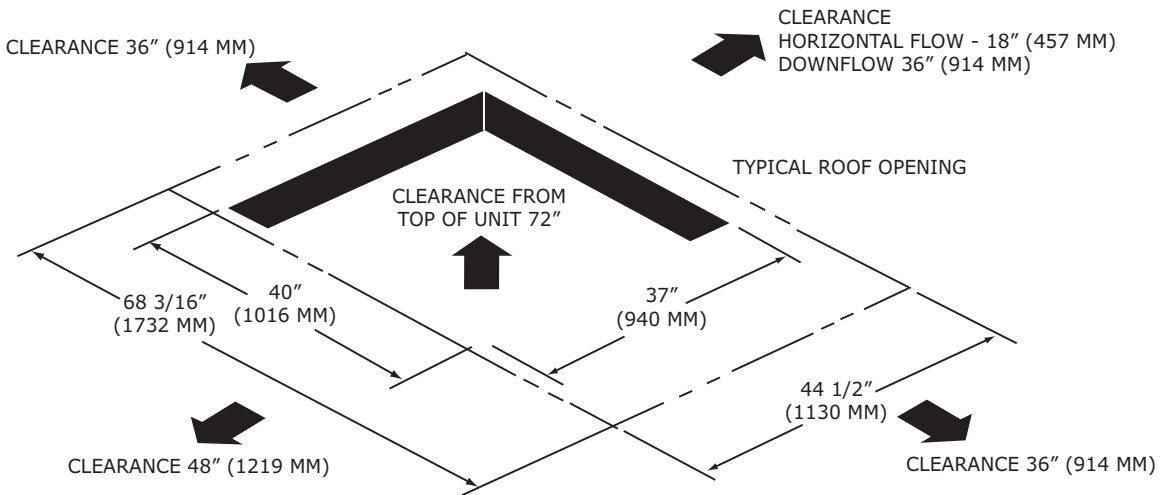

(a) All dimensions are in inches/millimeters.

Figure 8. Cooling and gas/electric - 3 tons ultra high efficiency - roof curb^(a)

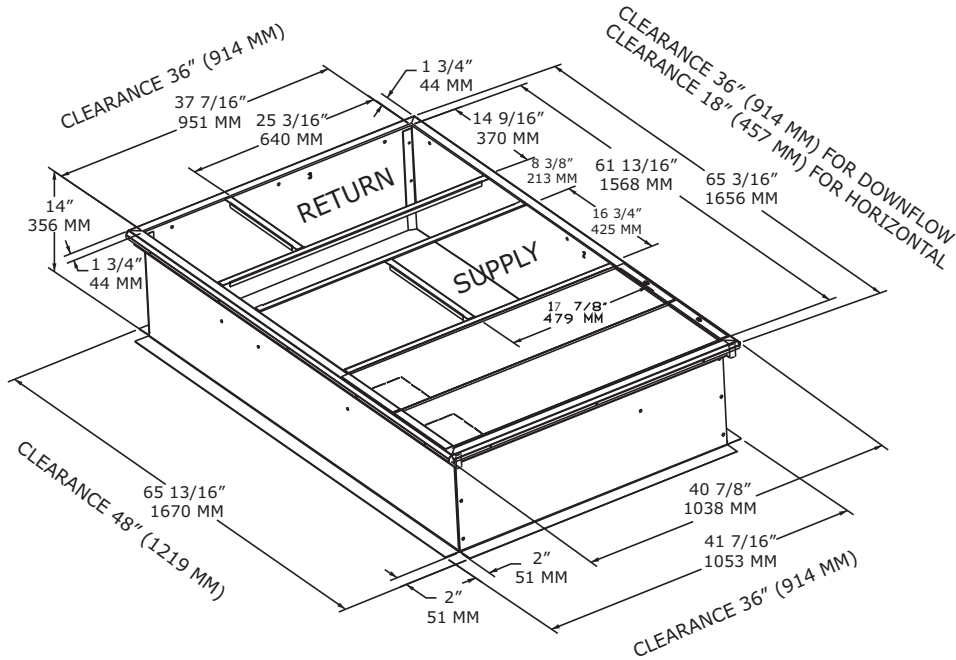

(a) All dimensions are in inches/millimeters.

Figure 9. Cooling and gas/electric - 3 tons ultra high efficiency - downflow duct connections - field fabricated^(a)

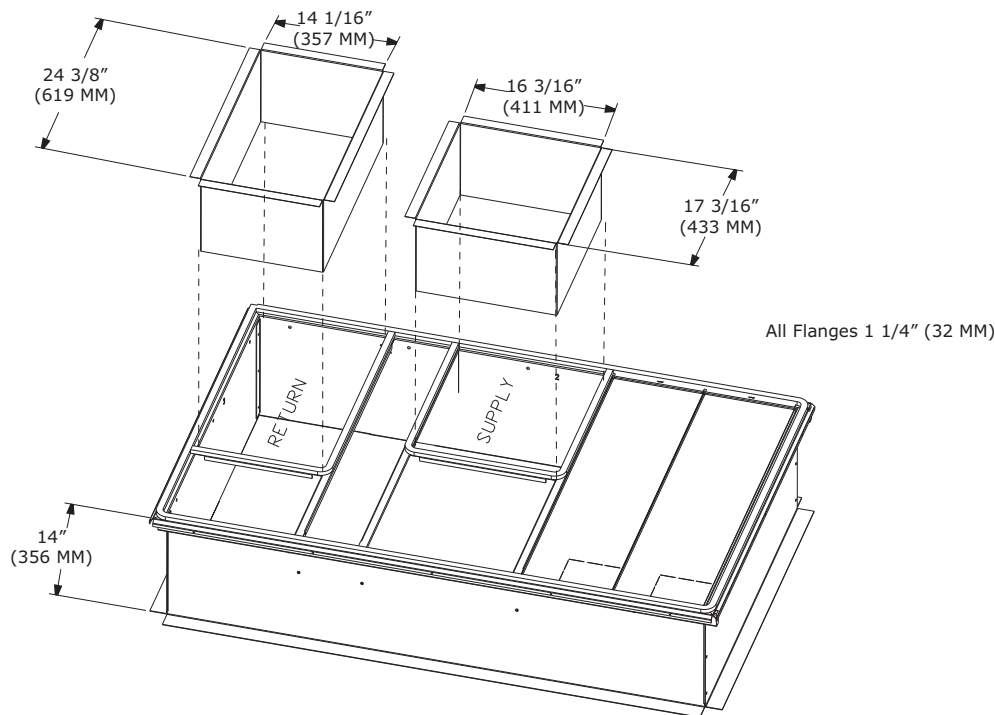

(a) All dimensions are in inches/millimeters.



Dimensional Data

Figure 10. Cooling and gas/electric - 3 tons ultra high efficiency- economizer, manual or motorized fresh air damper; power exhaust^(a)

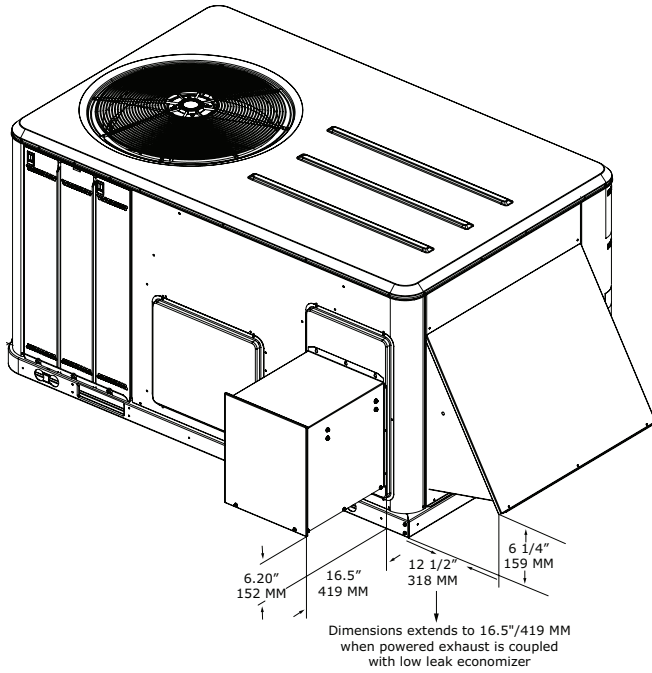

(a) All dimensions are in inches/millimeters.

Figure 11. Cooling and gas/electric - 3 tons ultra high efficiency- economizer and barometric relief damper hood^(a)

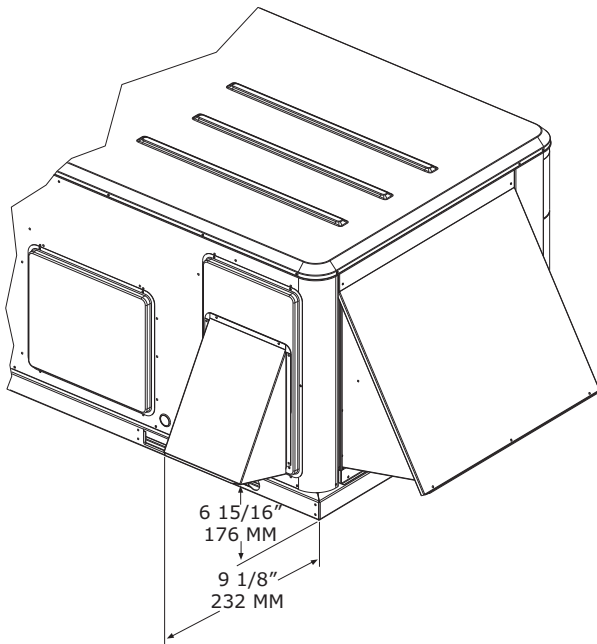

(a) All dimensions are in inches/millimeters.

Figure 12. Cooling and gas/electric models - 3 tons ultra high efficiency- swing diameter for hinged door(s) option^(a)

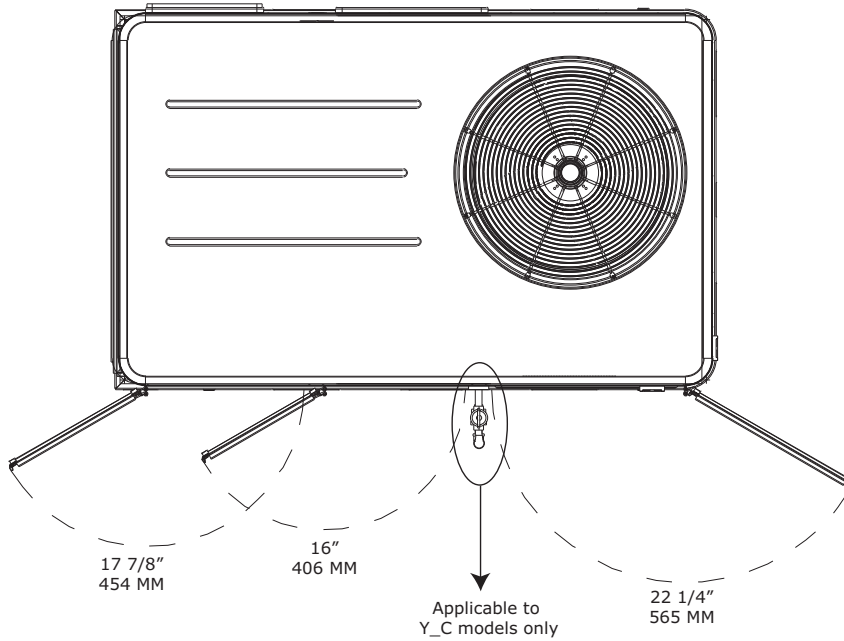

(a) All dimensions are in inches/millimeters.

Figure 13. Gas/electric models - 3 tons ultra high efficiency- height of gas pipe required from inside base of unit to gas shut off assembly (factory provided) - Y_C models only^(a)

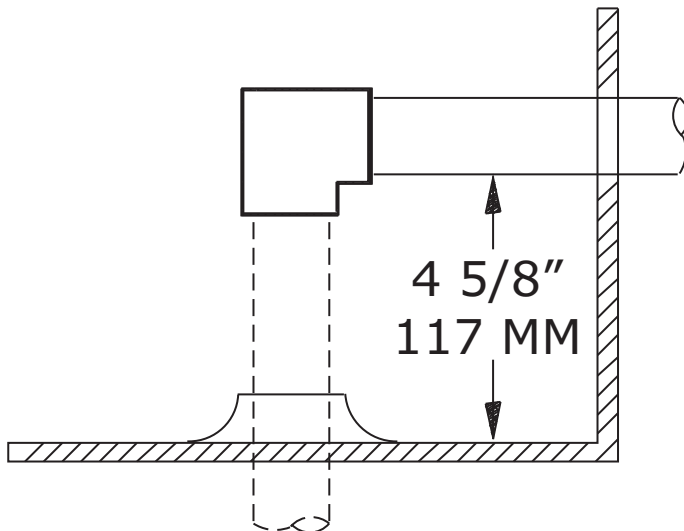

(a) All dimensions are in inches/millimeters.

Dimensional Data

Figure 14. Cooling and gas/electric - 4 to 5 tons ultra high efficiency^(a)

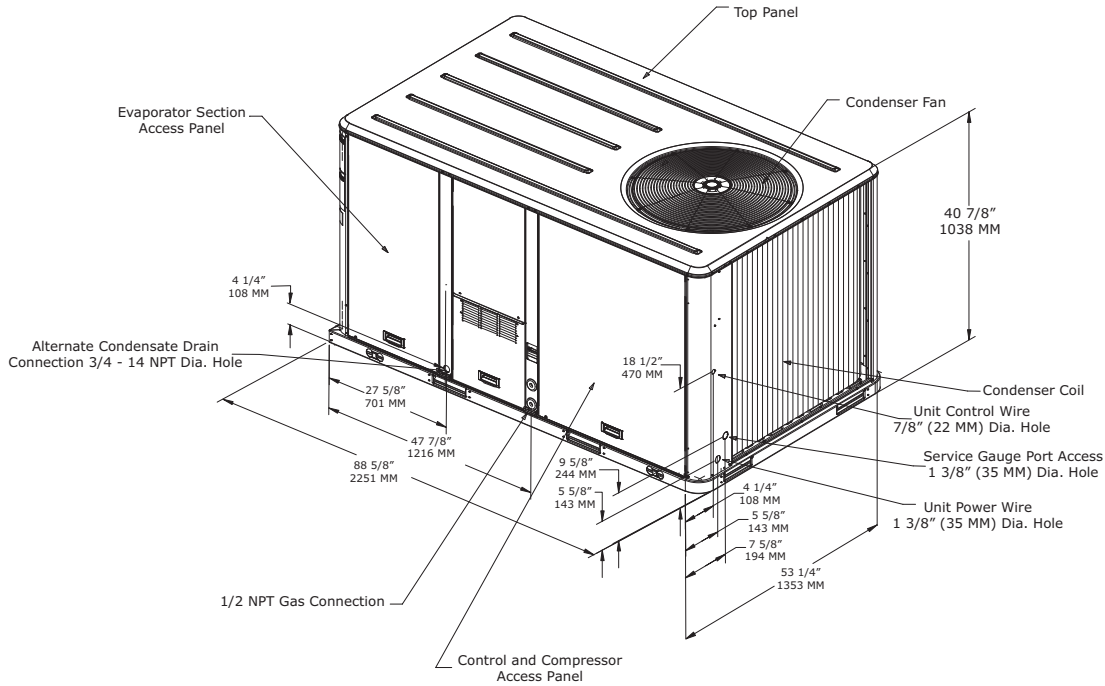

(a) All dimensions are in inches/millimeters.

Figure 15. Cooling and gas/electric - 4 to 5 tons ultra high efficiency- downflow airflow supply/return - through-the-base utilities^(a)

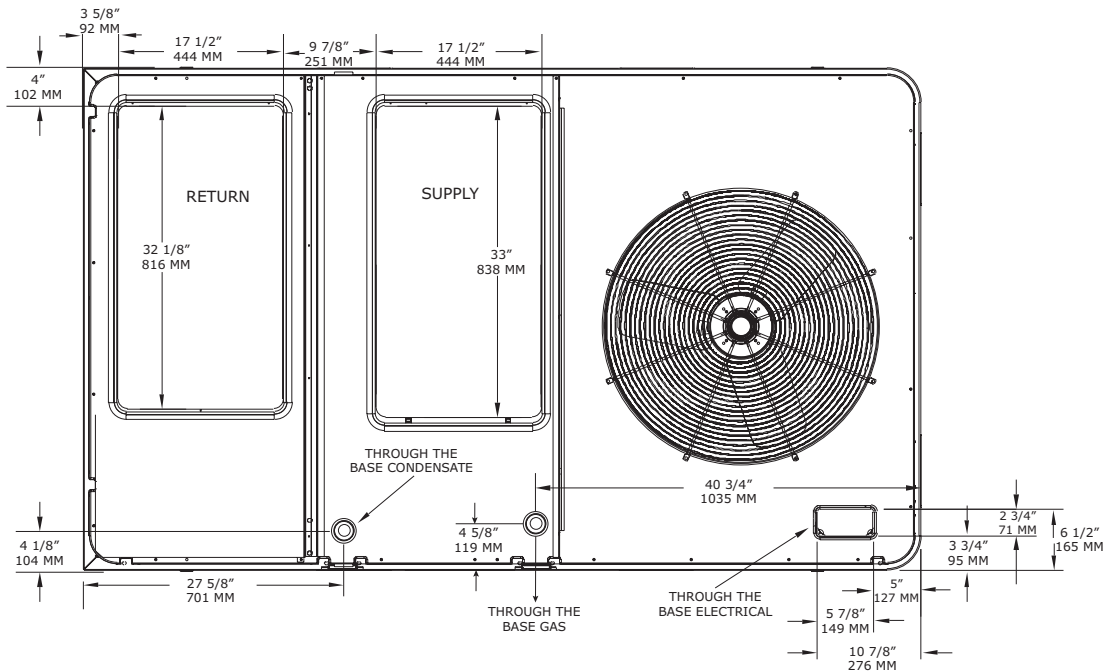

(a) All dimensions are in inches/millimeters.

Figure 16. Cooling and gas/electric - 4 to 5 tons ultra high efficiency- horizontal airflow supply and return^(a)

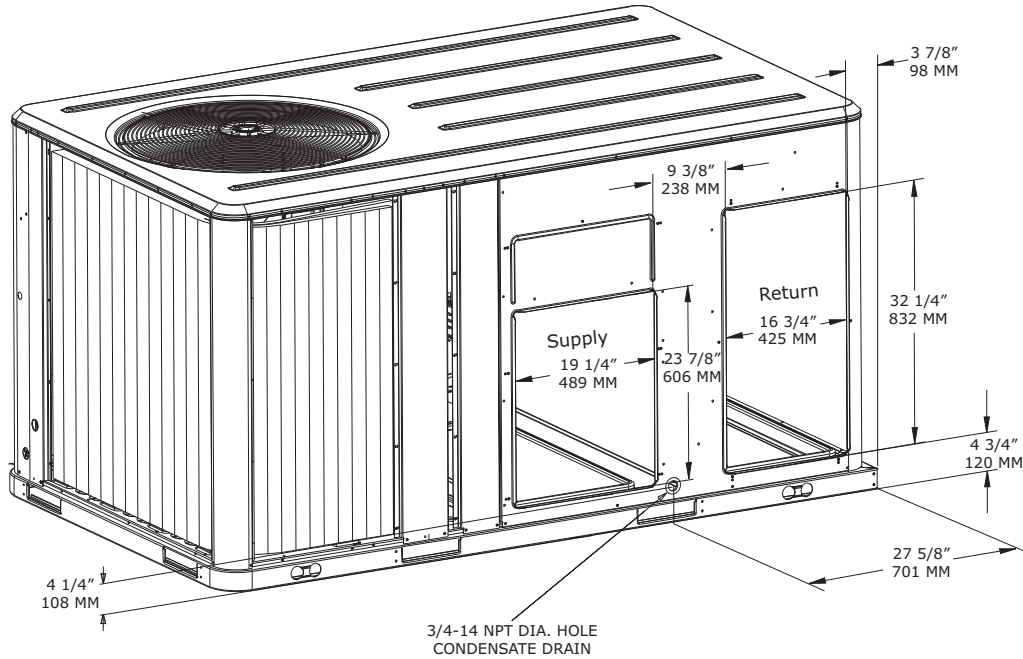

(a) All dimensions are in inches/millimeters.

Figure 17. Cooling and gas/electric - 4 to 5 tons ultra high efficiency- unit clearance and roof opening^(a)

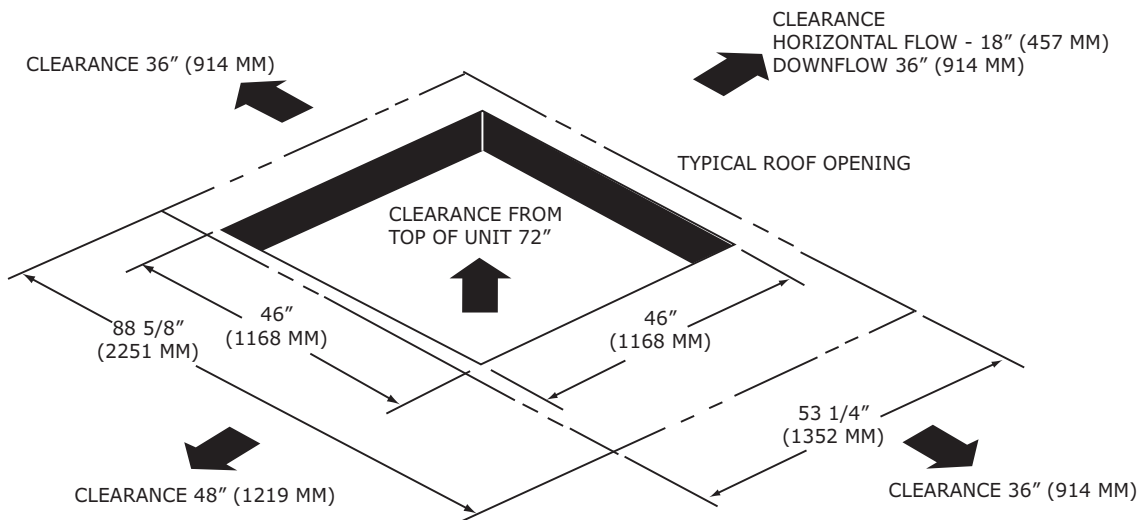

(a) All dimensions are in inches/millimeters.

Dimensional Data

Figure 18. Cooling and gas/electric - 4 to 5 tons ultra high efficiency - roof curb^(a)

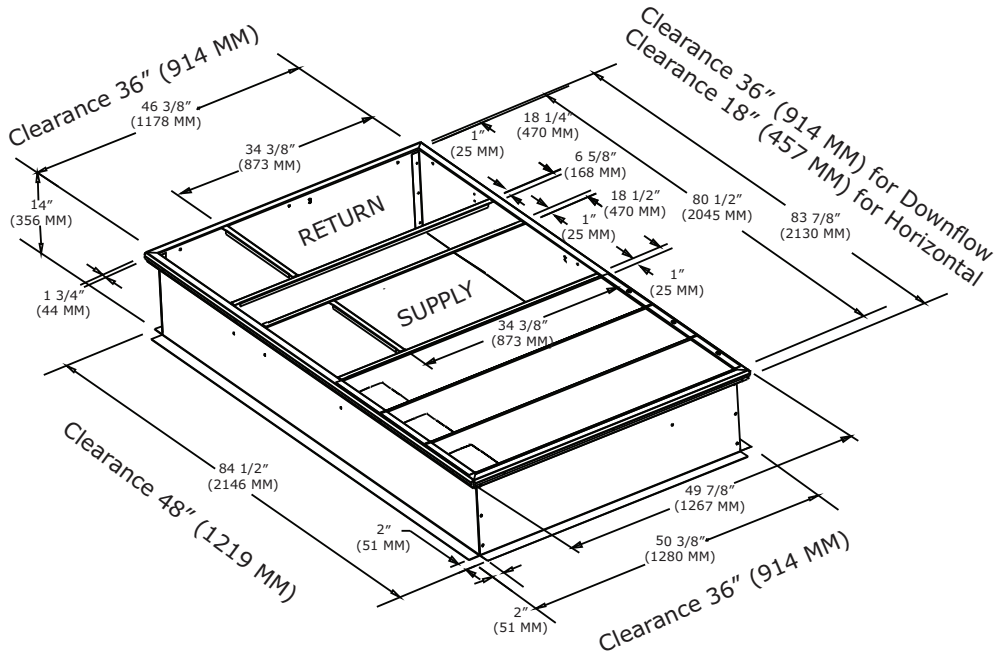

(a) All dimensions are in inches/millimeters.

Figure 19. Cooling and gas/electric - 4 to 5 tons ultra high efficiency- downflow duct connections field fabricated^{(a),(b)}

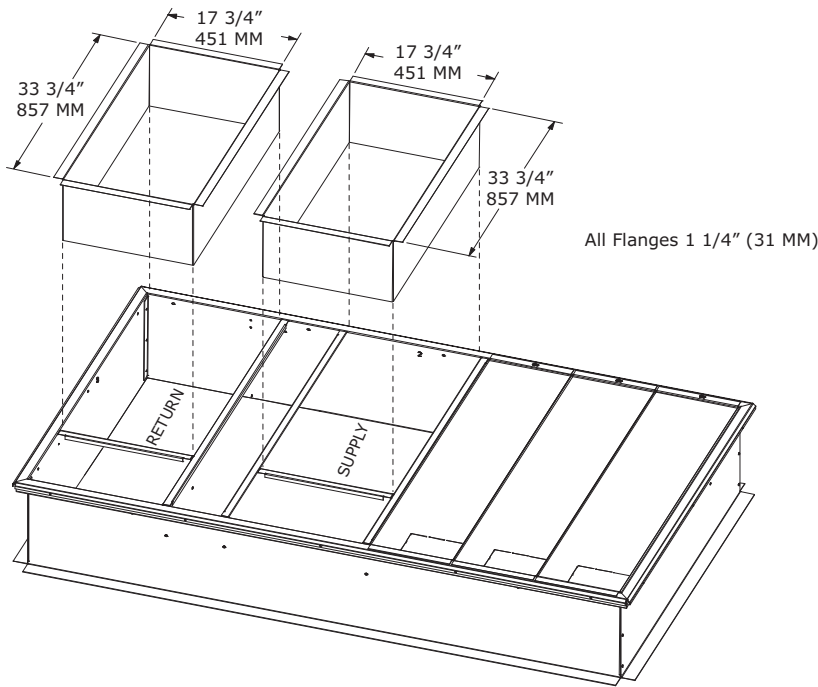

(a) All dimensions are in inches/millimeters.

(b) See the clearance requirement table in the Application Consideration chapter for duct clearance to combustible materials.

Figure 20. Cooling and gas/electric - 4 to 5 tons ultra high efficiency - economizer, manual or motorized fresh air damper^(a)

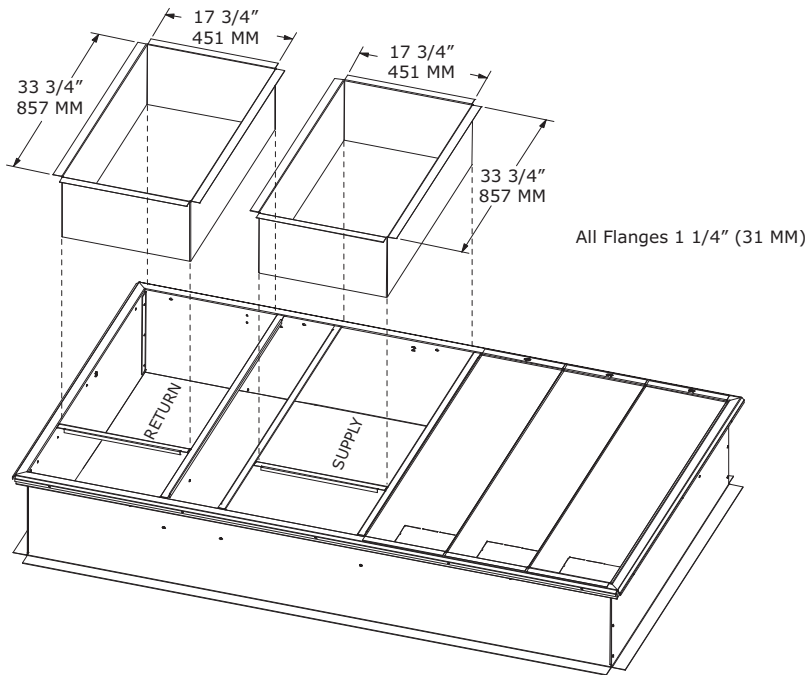

(a) All dimensions are in inches/millimeters.

Figure 21. Cooling and gas/electric - 4 to 5 tons ultra high efficiency- swing diameter for hinged door(s) option^(a)

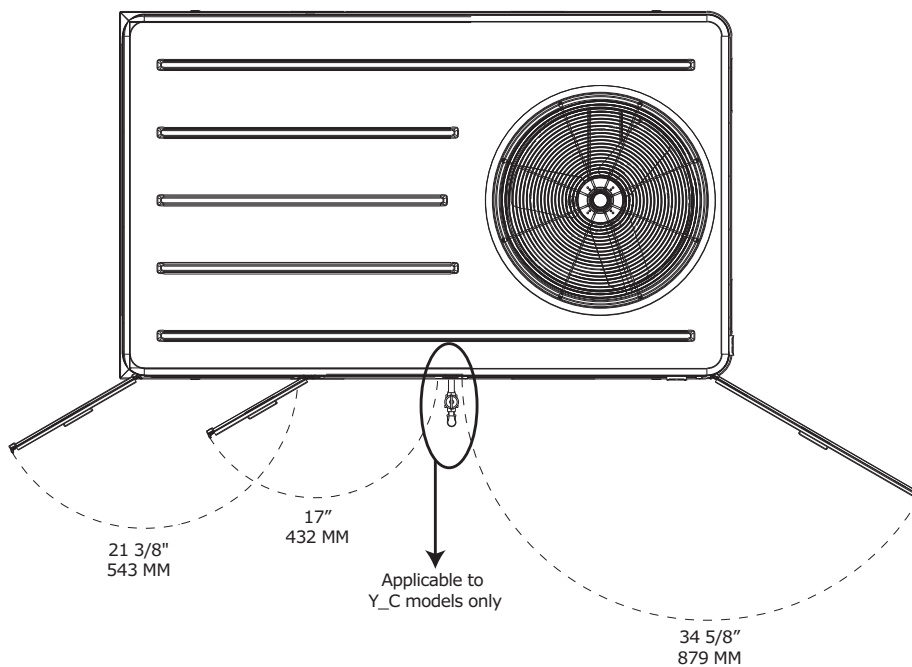

(a) All dimensions are in inches/millimeters.

Dimensional Data

Figure 22. Cooling and gas/electric - 6 to 8.5 tons ultra high efficiency^(a)

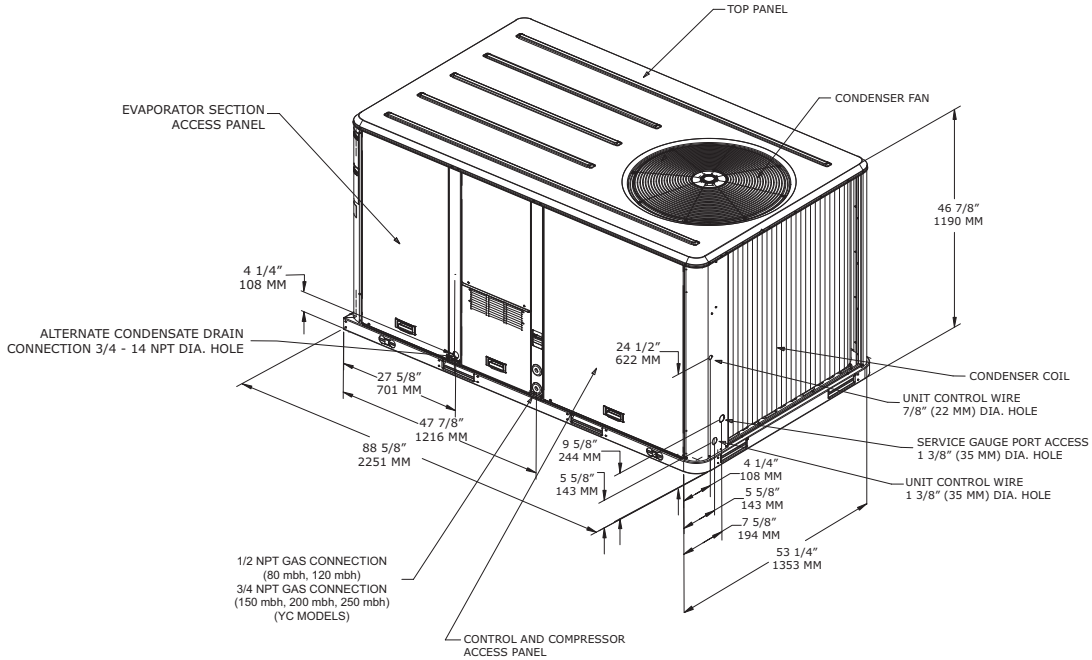

(a) All dimensions are in inches/millimeters.

Figure 23. Cooling and gas/electric - 6 to 8.5 tons ultra high efficiency - downflow supply/return through-the-base utilities^(a)

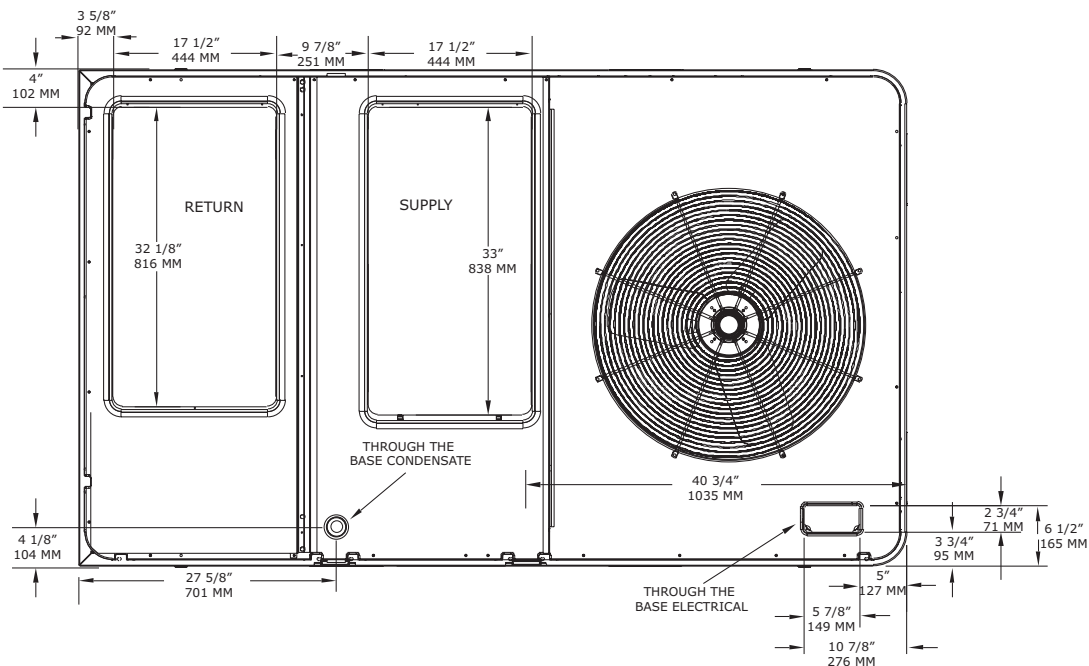

(a) All dimensions are in inches/millimeters.

Figure 24. Cooling and gas/electric - 6 to 10 tons ultra high efficiency - horizontal airflow supply and return^(a)

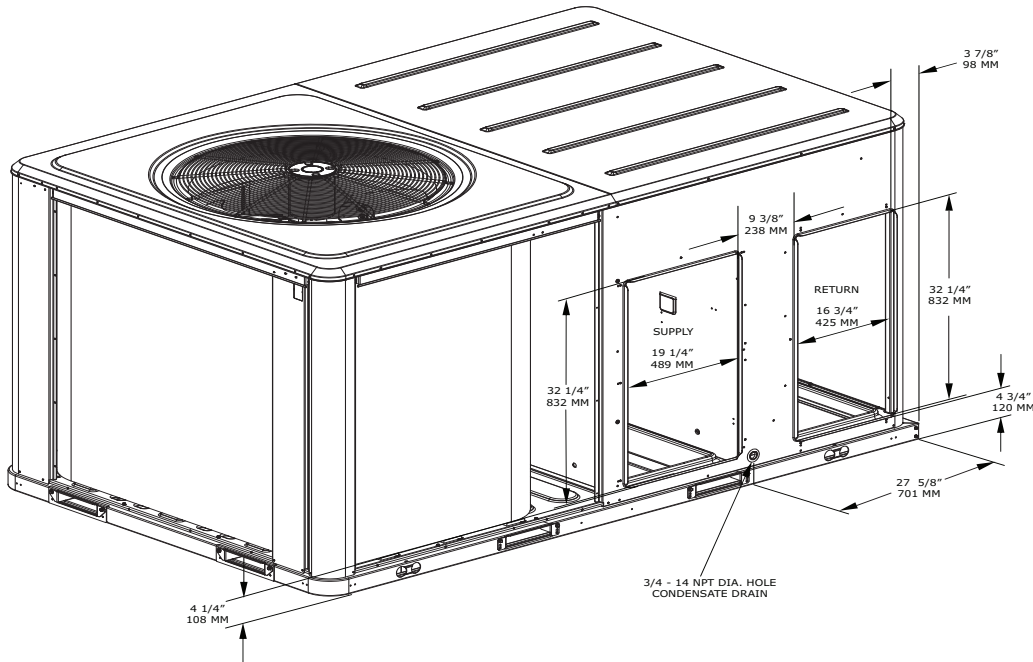

(a) All dimensions are in inches/millimeters.

Figure 25. Cooling and gas/electric - 6 to 8.5 tons ultra high efficiency - unit clearance and roof opening^(a)

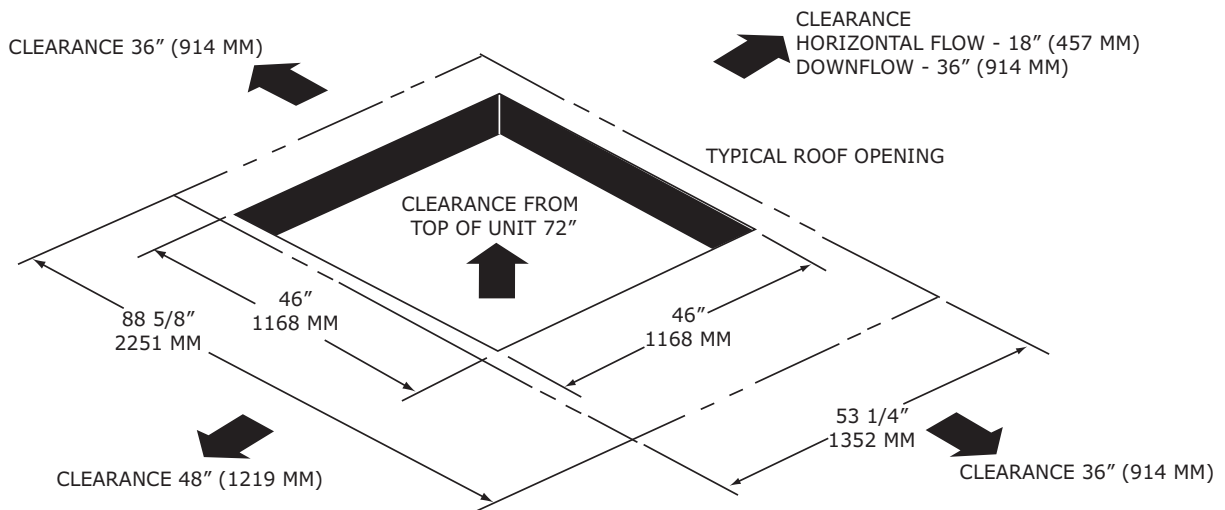

(a) All dimensions are in inches/millimeters.

Dimensional Data

Figure 26. Cooling and gas/electric - 6 to 8.5 tons ultra high efficiency - roof curb^(a)

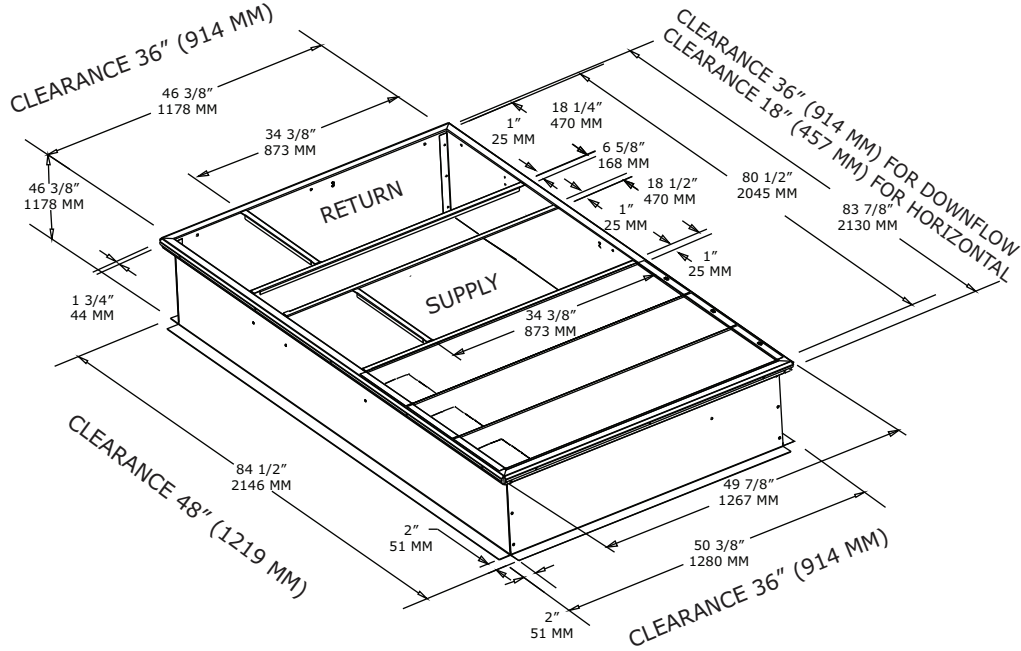

(a) All dimensions are in inches/millimeters.

Figure 27. Cooling and gas/electric - 6 to 10 tons ultra high efficiency - duct connections field fabricated^(a)

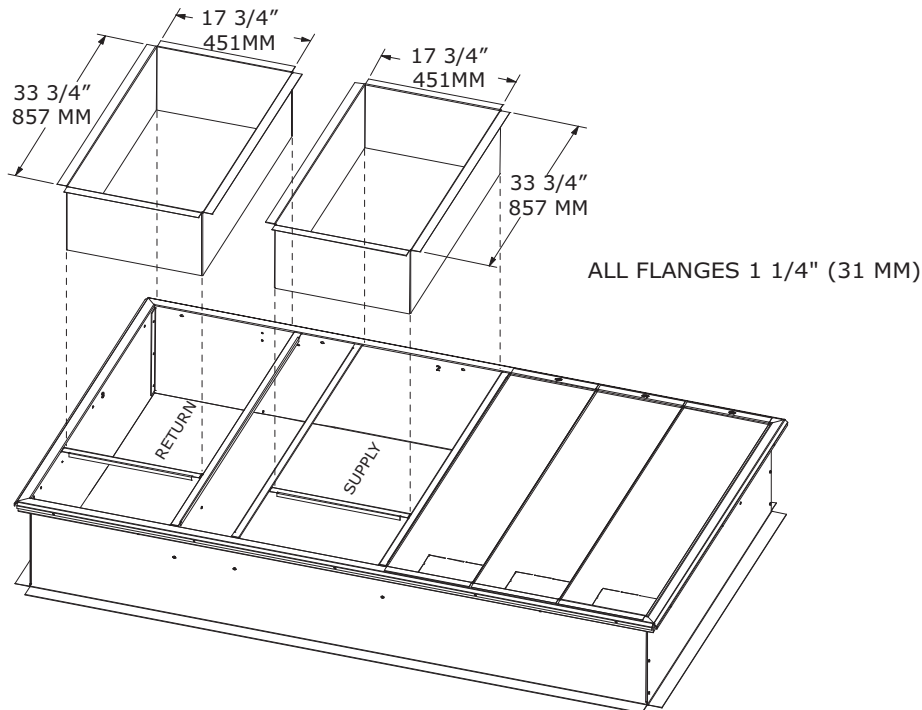

(a) All dimensions are in inches/millimeters.

Figure 28. Cooling and gas/electric - 6 to 8.5 tons ultra high efficiency - power exhaust^(a)

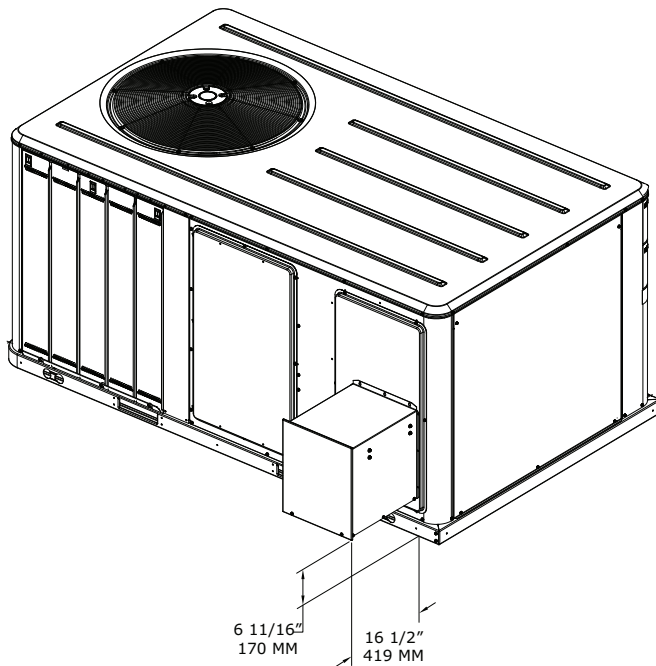

(a) All dimensions are in inches/millimeters.

Figure 29. Cooling and gas/electric - 6 to 8.5 tons ultra high efficiency - swing diameter for hinged door(s) option^(a)

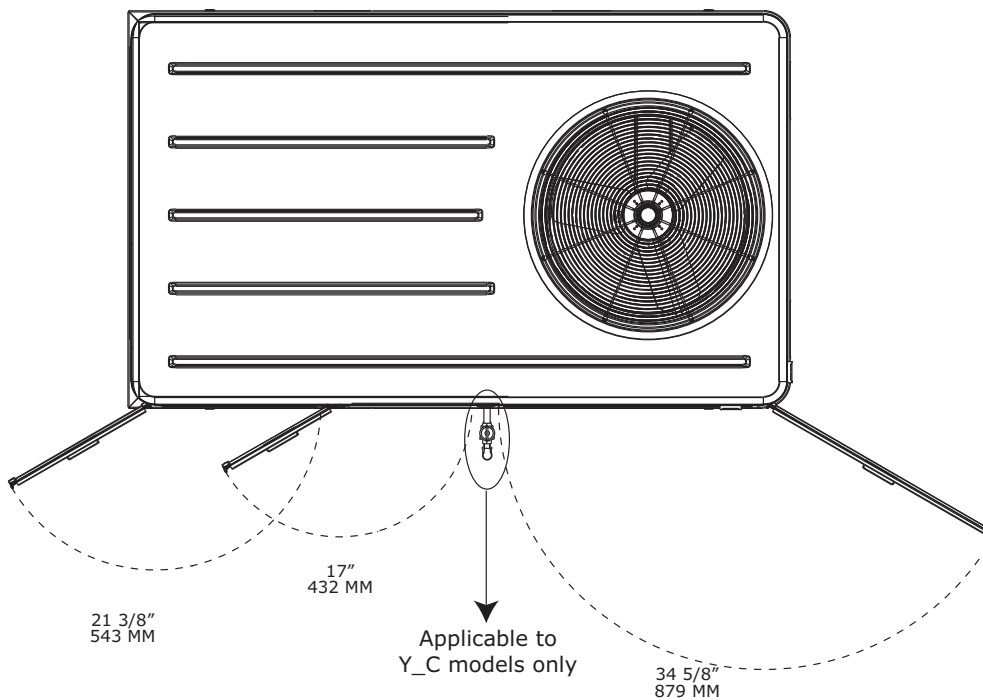

(a) All dimensions are in inches/millimeters.

Dimensional Data

Figure 30. Cooling and gas/electric - 6 to 10 tons ultra high efficiency - economizer, manual or motorized fresh air damper^(a)

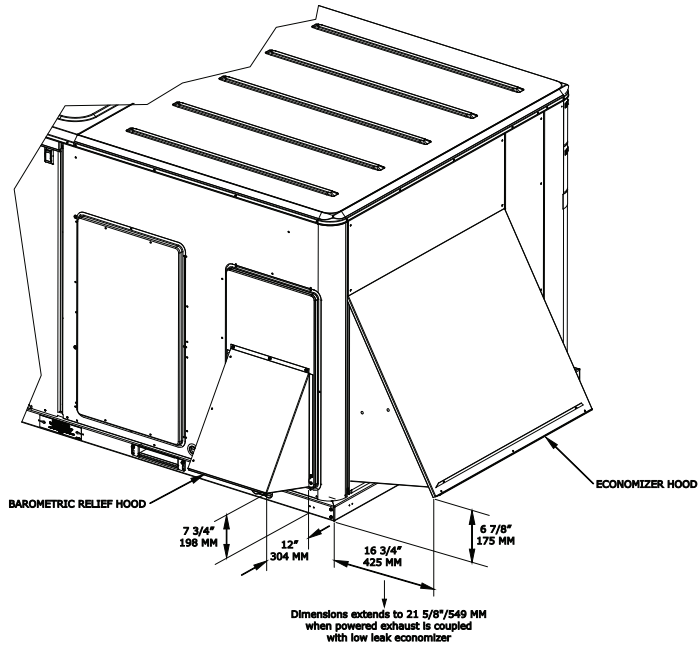

(a) All dimensions are in inches/millimeters.

Figure 31. Gas/electric - 6 to 10 tons ultra high efficiency - height of gas pipe required from inside of base of unit to gas shut-off assembly (factory provided) YZC models only^(a)

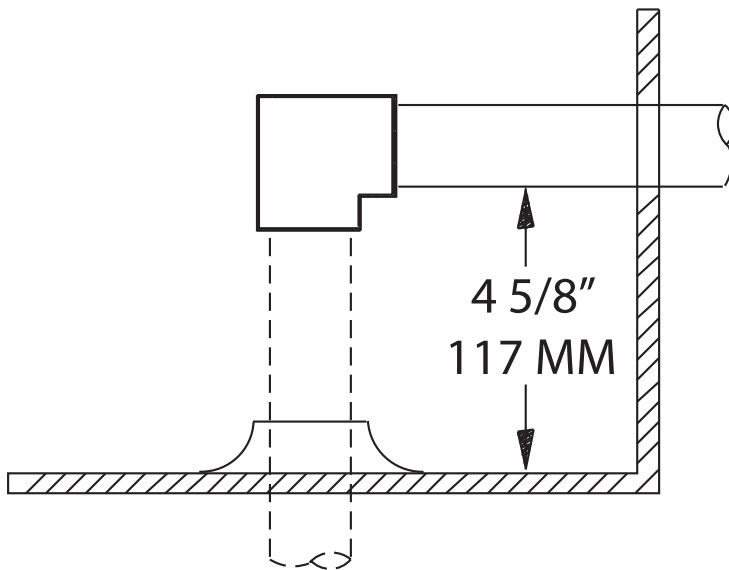

(a) All dimensions are in inches/millimeters.

Figure 32. Cooling and gas/electric - 10 tons ultra high efficiency^(a)

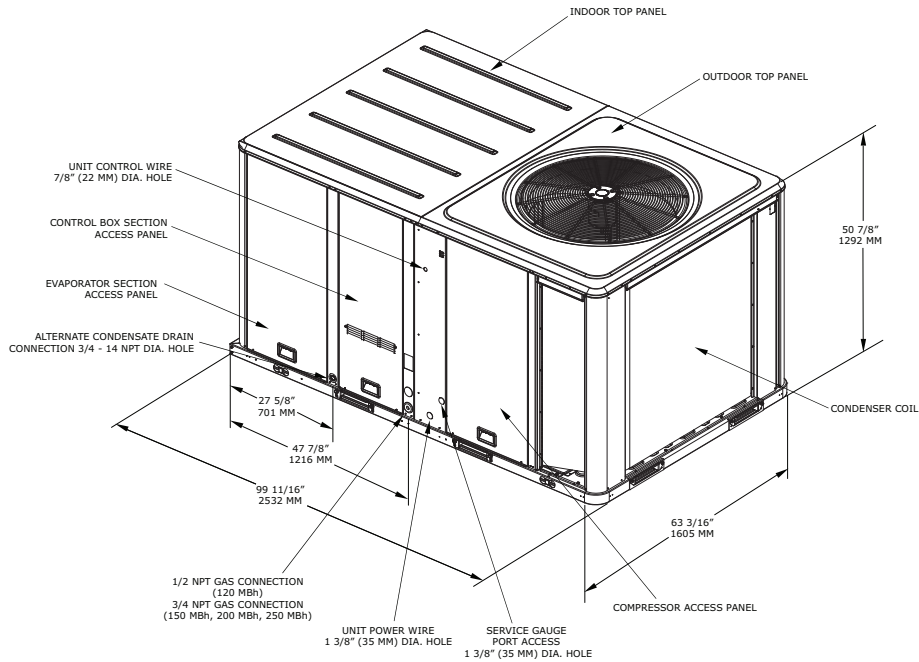

(a) All dimensions are in inches/millimeters.

Figure 33. Cooling and gas/electric - 10 tons ultra high efficiency - downflow airflow supply/return, through-the-base utilities^(a)

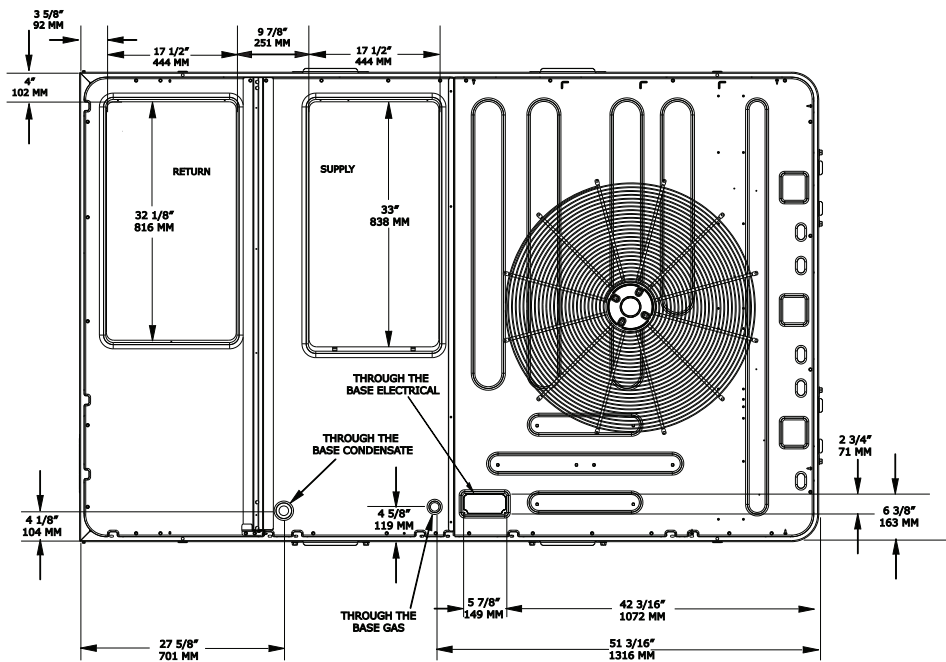

(a) All dimensions are in inches/millimeters.

Dimensional Data

Figure 34. Cooling and gas/electric - 10 tons ultra high efficiency - unit clearance and roof opening^(a)

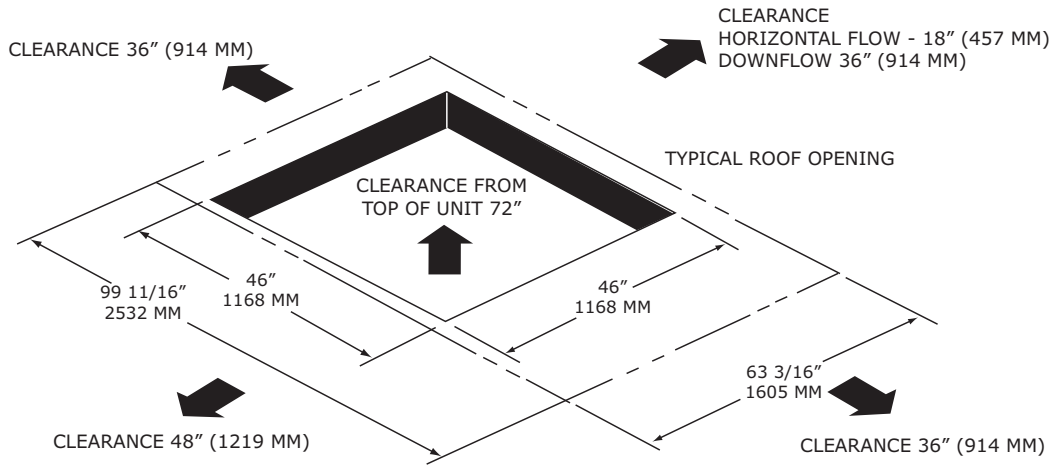

(a) All dimensions are in inches/millimeters.

Figure 35. Cooling and gas/electric - 10 tons ultra high efficiency - roof curb^(a)

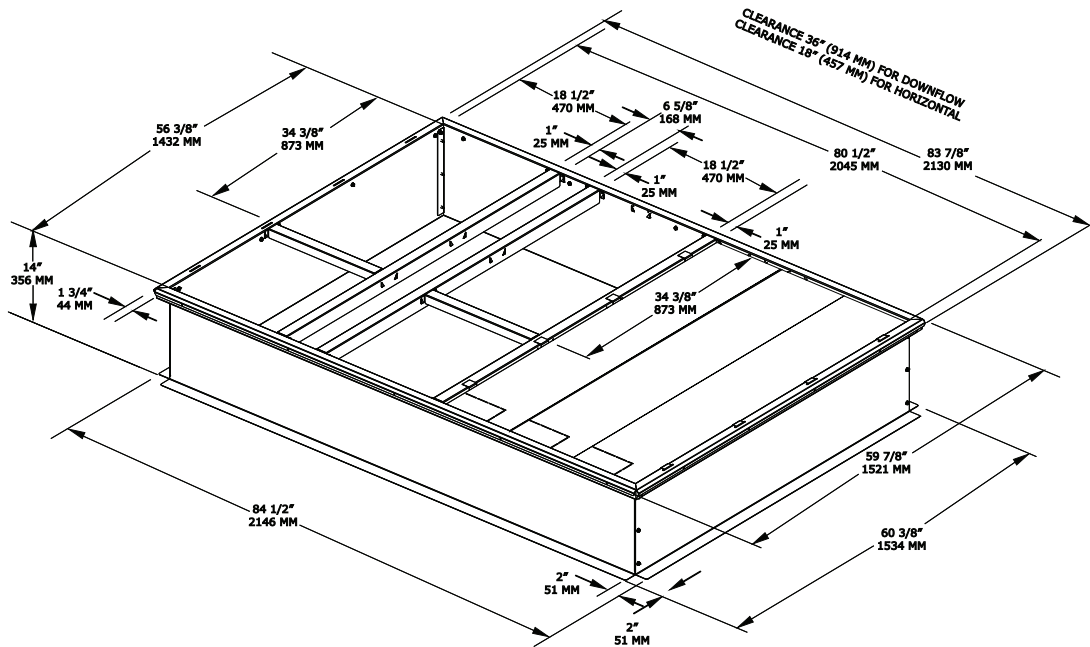

(a) All dimensions are in inches/millimeters.

Figure 36. Cooling and gas/electric - 10 tons ultra high efficiency - power exhaust^(a)

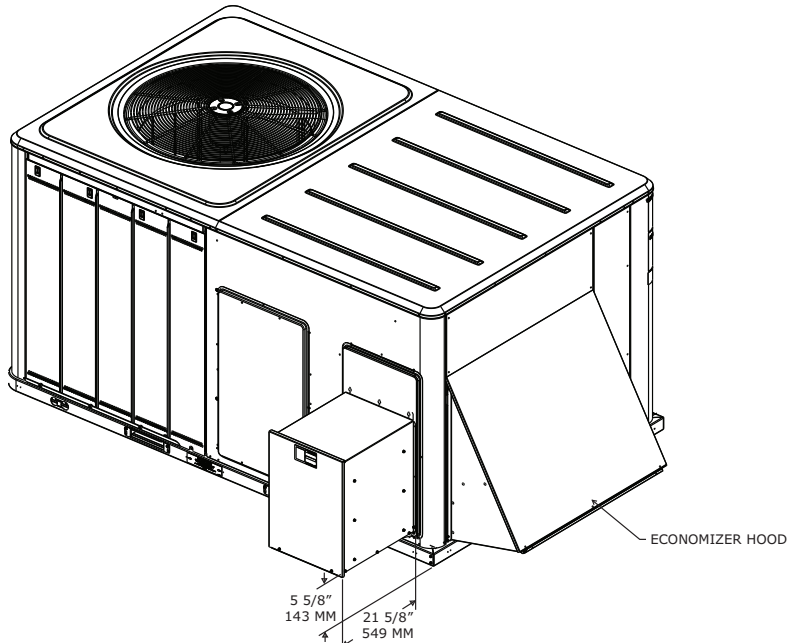

(a) All dimensions are in inches/millimeters.

Figure 37. Cooling and gas/electric - 10 tons ultra high efficiency - swing diameter for hinged door(s) option^(a)

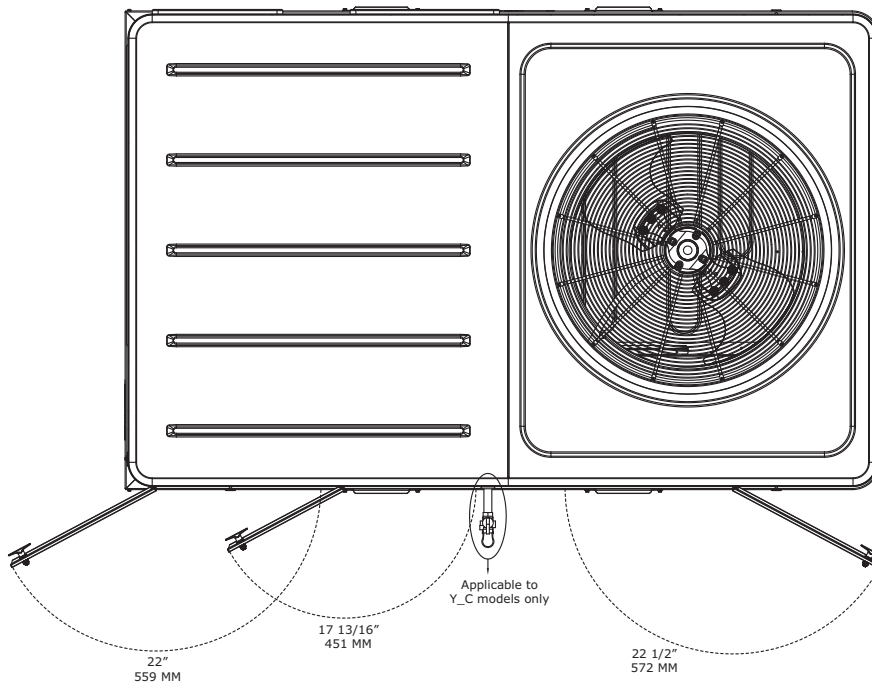

(a) All dimensions are in inches/millimeters.



Weights

Table 67. Maximum base unit and corner weights (lbs) and center of gravity dimensions (in.) - cooling models

Tons	Unit Model No.	Maximum Base Model Weights ^(a)		Corner Weights ^(b)				Center of Gravity (in.)	
		Shipping	Net	A	B	C	D	Length	Width
3	TZC036E	628	553	133	183	61	176	32	18
4	TZC048F	777	682	176	238	112	156	39	22
5	TZC060E	873	778	181	274	102	221	39	22
6	TZC072F	893	795	300	165	242	88	65	22
7.5	TZC090F	908	810	223	186	235	166	52	26
8.5	TZC102F	908	810	223	186	235	166	52	26
10	TZC120F	1302	1108	316	299	275	218	56	28

(a) Weight are approximate for 1st 10 digit model number.

(b) Corner weights are given for information only.

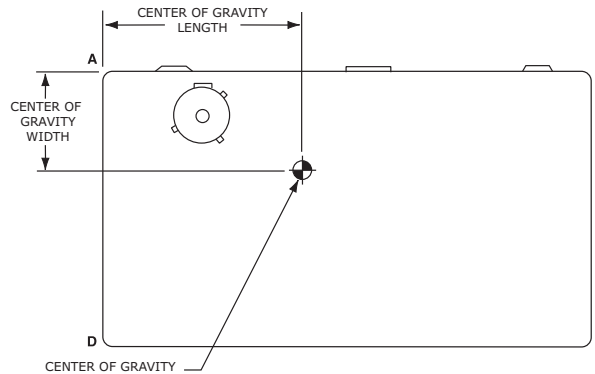

Table 68. Maximum base unit and corner weights (lbs) and center of gravity dimensions (in.) - gas/electric models

Tons	Unit Model No.	Maximum Base Model Weights ^(a)		Corner Weights ^(b)				Center of Gravity (in.)	
		Shipping	Net	A	B	C	D	Length	Width
3	YZC036E	690	615	154	196	73	192	33	19
4	YZC048F	848	753	196	258	126	173	40	23
5	YZC060E	949	854	200	293	121	240	40	23
6	YZC072F	966	868	321	184	262	101	64	22
7.5	YZC090F	1007	909	248	210	261	190	51	26
8.5	YZC102F	1007	909	248	210	261	190	51	26
10	YZC120F	1428	1234	346	344	306	238	56	28

(a) Weight are approximate for 1st 10 digit model number.

(b) Corner weights are given for information only.

Table 69. Factory installed options (fiops)/accessory net weights (lbs)^{(a),(b)}

Accessory	T/YZC036E	T/YZC048F-060E	T/YZC072F	T/YZC090-102F	T/YZC120F
	Net Weight	Net Weight	Net Weight	Net Weight	Net Weight
	3 Tons	4 to 5 Tons	6 Tons	7.5 to 8.5 Tons	10 Tons
Barometric Relief	7	10	10	10	10
Coil Guards	12	20	20	20	30
Economizer	26	36	36	36	36
Electric Heaters ^(c)	15	30	30	44	50
Hinged Doors	10	12	12	12	12
Low Leak Economizer	70	91	91	91	91
Powered Convenience Outlet ^(d)	38	38	38	38	50
Powered Exhaust	40	40	80	80	80
Roof Curb	61	105	105	105	111
Smoke Detector, Supply	5	5	5	5	5
Smoke Detector, Return	7	7	7	7	7
Stainless Steel Heat Exchanger ^(e)	4	6	6	6	6
Through-the-Base Electrical	8	13	13	13	13
Through-the-Base Gas	5	5	5	5	5
Traq Dampers	10	15	15	15	15
Unit Mounted Circuit Breaker	5	5	5	5	5
Unit Mounted Disconnect	5	5	5	5	5
Ultra Low NOx Gas Furnace	22	22	-	-	-

- (a) Weights for options not listed are < 5 lbs.
 (b) Net weight should be added to unit weight when ordering factory-installed accessories.
 (c) Applicable to cooling units only.
 (d) Applicable for 208-230V 3 to 10 Ton units and 460V 6 to 10 Ton units only.
 (e) Applicable to gas/electric units only.



Mechanical Specifications

Standard

General

The units shall be convertible airflow. The operating range shall be between 120°F and 0°F in cooling as standard from the factory. Cooling performance shall be rated in accordance with AHRI testing procedures. All units shall be factory assembled, internally wired, fully charged with R-410A, and 100 percent run tested to check cooling operation, fan and blower rotation, and control sequence before leaving the factory. Wiring internal to the unit shall be colored and numbered for simplified identification. Units shall be cULus listed and labeled, classified in accordance for Central Cooling Air Conditioners.

Casing

Unit casing shall be constructed of zinc coated, galvanized steel. Exterior surfaces shall be cleaned, phosphatized, and finished with a weather-resistant baked enamel finish. Unit's surface shall be tested 672 hours in a salt spray test in compliance with ASTM B117. Cabinet construction shall allow for all maintenance on one side of the unit. Service panels shall have lifting handles and be removed and reinstalled by removing two fasteners while providing a water and air tight seal. All exposed vertical panels and top covers in the indoor air section shall be insulated with a cleanable foil-faced, fire-retardant permanent, odorless glass fiber material. The base of the unit shall be insulated with 1/8 inch, foil-faced, closed-cell insulation. All insulation edges shall be either captured or sealed. The unit's base pan shall have no penetrations within the perimeter of the curb other than the raised 1 1/8 inch high downflow supply/return openings to provide an added water integrity precaution, if the condensate drain backs up. The base of the unit shall have provisions for forklift and crane lifting, with forklift capabilities on three sides of the unit.

Compressors

The eFlex™ variable speed compressor shall be capable of speed modulation from 15Hz to a maximum of 60 Hz. The minimum unit capacity shall be 25% of full load or less. The compressor motor shall be a permanent magnet type. Each variable speed compressor shall be matched with a specially designed, refrigerant-cooled, variable frequency drive which modulates the speed of the compressor motor and provides several compressor protection functions. Control of the variable speed compressor and inverter control, as well as tandem direct-drive, scroll type compressors, shall be integrated with the ReliaTel™ unit controller to ensure optimal equipment reliability and efficiency. Each compressor shall have a crankcase heater installed, properly sized to minimize the amount of liquid refrigerant present in the oil sump during off cycles.

Variable speed compressors are outstanding for humidity control and light load cooling conditions.

Controls

Unit shall be completely factory-wired with necessary controls and contactor pressure lugs or terminal block for power wiring. Unit shall provide an external location for mounting a fused disconnect device.

Microprocessor controls provide for all 24V control functions. The resident control algorithms shall make all heating, cooling, and/or ventilating decisions in response to electronic signals from sensors measuring indoor and outdoor temperatures. The control algorithm maintains accurate temperature control, minimizes drift from set point, and provides better building comfort. A centralized microprocessor shall provide anti-short cycle timing and time delay between compressors to provide a higher level of machine protection.

Enhanced Dehumidification

Enhanced dehumidification will be available on all units equipped with a space humidity sensor. Humidity levels are decreased while increasing the comfort level in an air space through advanced controls of compressor and indoor fan operation.

Evaporator and Condenser Coils

Internally finned, 5/16 inch copper tubes are mechanically bonded to a configured aluminum plate fin. The microchannel type condenser coil uses flat streamlined tubes with small ports, and metallurgical tube-to-fin bond. This allows the microchannel coil better heat transfer performance. Microchannel condenser coil can reduce system refrigerant charge by up to 50% because of smaller internal volume, which leads to better compressor reliability. Compact all-aluminum microchannel coils also help to reduce the unit weight. These all aluminum coils are recyclable. Galvanic corrosion is also minimized due to all aluminum construction. Strong aluminum brazed structure provides better fin protection. In addition, flat streamlined tubes also make microchannel coils more dust resistant and easier to clean. Coils shall be leak tested at the factory to ensure the pressure integrity. The evaporator coil and condenser coil shall be leak tested to 600 psig. The assembled unit shall be leak tested to 465 psig. The plate fin condenser coil shall have a patent pending 1+1+1 hybrid coil designed with slight gaps for ease of cleaning. A plastic, dual-sloped, removable and reversible condensate drain pan with through-the-base condensate drain is standard.

Filters

Throwaway filters shall be standard on all units. Optional 2-inch MERV 8 and MERV 13 filters shall also be available.

Frostat™

This option is to be utilized as a safety device. The Frostat™ opens when temperatures on the evaporator coil fall below 10°F. The temperature will need to rise to 50°F before closing. This feature should be utilized in low airflow or high outside air applications (cooling only).

Gas Heating Section

The heating section has a progressive tubular heat exchanger design using corrosion resistant steel throughout. An induced draft combustion blower pulls the combustion products through the firing tubes. The heater uses a direct spark ignition (DSI) system. On initial call for heat, the combustion blower will purge the heat exchanger for 20 seconds before ignition. After three unsuccessful ignition attempts, the entire heating system will be locked out until manually reset at the thermostat/zone sensor.

High Pressure Control

All units include high pressure cutout as standard.

Indoor Fan

All units have variable speed, direct drive motors. All motors shall be thermally protected. All indoor fan motors meet the U.S. Energy Policy Act of 1992 (EPACT).

Outdoor Fans

The outdoor fan shall be direct-drive, statically balanced, draw-through in the vertical discharge position. The fan motor shall be permanently lubricated and shall have built-in thermal overload protection.

Phase Monitoring Protection

Precedent™ units with 3-phase power are equipped with phase monitoring protection as standard. These devices protect motors and compressors against problems caused by phase loss, phase imbalance and phase reversal indication.

Refrigerant Circuits

Each refrigerant circuit offer thermal expansion valve as standard. Service pressure ports, and refrigerant line filter driers are factory-installed as standard. An area shall be provided for replacement suction line driers.



Mechanical Specifications

Unit Top

The top cover shall be one piece construction or where seams exist, it shall be outside the indoor air-conditioned section. The ribbed top adds extra strength and prevents water from pooling on unit top.

Factory Installed Options

Black Epoxy Pre-Coated Coils

The black epoxy coils have a thermoset vinyl coating that is bonded to the aluminum fin stock prior to the fin-stamping process. The pre-coated coils are an economical option for protection in mildly corrosive environments.

CO₂ Sensor Wiring

The unit wiring for field installed CO₂ sensors. Factory-installed CO₂ sensor wiring saves time and ensures proper unit connections for the field installed CO₂ sensor kits.

Condensate Overflow Switch

This option shall shut the unit down in the event that a clogged condensate drain line prevents proper condensate removal from the unit.

CompleteCoat™ Coils

The cathodic epoxy type electrodisposition coating is formulated for high edge build to plate fin and tube heat exchangers. The coating is selected to provide excellent resistance and durability to corrosive effects of alkalis, acids, alcohols, petroleum, seawater, salt air and corrosive environments.

Fault Detection and Diagnostics (FDD)

This offering meets the mandatory requirement of CA Title 24 of fully configurable diagnostics allowing fault history and reading fault codes at the unit. This option provides detection of the following faults: Air temperature sensor failure/fault and notification of acceptable economizer mode. The FDD system shall be certified by the Energy Commission as meeting the requirements.

Heat Exchanger

The compact cabinet features a tubular heat exchanger in low, medium and high heat capacities.

The heat exchanger is fabricated using corrosion-resistant aluminized steel tubes and burners as standard on all models. It has an induced draft blower to pull the gas mixture through the burner tubes. The heater has a direct spark ignition system which doubles as a safety device to prove the flame.

Hinged Access Doors

Sheet metal hinges are available on the filter/evaporator, supply fan/heat, and the compressor/control access doors.

Human Interface

The Human Interface shall have a 5-inch color touchscreen display that conforms to FCC Part 15 Class B with an Ingress Protection Rating of IP24. The display text shall be readable by a person with 20/20 vision at a distance of 3 feet and 60° angle at lighting levels ranging from 100 lux - 25,000 lux. Also, the display shall operate at temperatures of -40° C to 70° C. Firmware will be restored via a USB storage device.

Multiple-Zone VAV Control

Multiple-zone VAV (MZVAV) control shall vary the speed of the indoor fan to maintain the duct static pressure at a setpoint. In cooling mode, the compressors shall be cycled (or economizer modulated) to

maintain the supply air temperature (SAT) at the desired setpoint. In heating mode, the indoor fan shall operate at maximum speed whenever the heater is operating.

Powered or Unpowered Convenience Outlet

This is a GFCI, 120V/15amp, 2 plug, convenience outlet, either powered or unpowered. When the convenience outlet is powered, a service receptacle disconnect will be available. The convenience outlet is powered from the line side of the disconnect or circuit breaker, and therefore will not be affected by the position of the disconnect or circuit breaker. This option can only be ordered when the through-the-base electrical with either the disconnect switch or circuit breaker option is ordered.

Single Zone Variable Air Volume

Single zone VAV control offers full supply fan modulation across the available airflow range based on zone conditions. In addition to full supply fan modulation, the unit controls the discharge air temperature to a varying discharge air temperature setpoint in order to maintain space temperature.

Stainless Steel Drain Pan

This option provides excellent corrosion and oxidation resistance. The drain pan is reversible and constructed of 304 stainless steel.

Stainless Steel Heat Exchanger

The optional stainless steel heat exchanger is constructed of 409 stainless steel tubes and 439 stainless steel burners. It is resistant to corrosion and oxidation and easy to clean.

The high strength to weight ratio allows for high ventilation rates with gas units. It is an excellent option to compliment the dehumidification option as a high outside air ventilation unit.

With this option, a 10-year stainless steel heat exchanger warranty is standard.

Note: *Stainless steel heat exchanger is required when selecting Ultra Low NOx gas furnace option.*

Supply, Return, and Plenum Air Smoke Detector

With this option installed, if smoke is detected, all unit operation will be shut down. Reset will be manual at the unit. In order for the supply air smoke detector or return air smoke detector to properly sense smoke in the supply air stream or the return air stream, the air velocity entering the smoke detector unit must be between 500 to 4000 feet per minute. Equipment covered in this manual will develop an airflow velocity that falls within these limits over the entire airflow range specified in the evaporator fan performance table. Supply and/or return smoke detectors may not be used with the plenum smoke detector.

Thermal Expansion Valve

Thermal expansion valve is standard for all models.

Through-the-Base Electrical Access

An electrical service entrance shall be provided allowing electrical access for both control and main power connections inside the curb and through the base of the unit. Option will allow for field installation of liquid-tight conduit and an external field-installed disconnect switch.

Through-the-Base Electrical with Circuit Breaker

This option is a thermal magnetic, molded case, HACR Circuit Breaker with provisions for through the base electrical connections. The circuit breaker will be installed in a water tight enclosure in the unit with access through a swinging door. Wiring will be provided from the switch to the unit high voltage terminal block. The circuit breaker will provide overcurrent protection, be sized per NEC and cULus guidelines, and be agency recognized by cULus.



Mechanical Specifications

Through-the-Base Electrical with Disconnect Switch

This 3-pole, molded case, disconnect switch with provisions for through the base electrical connections are available. The disconnect switch will be installed in the unit in a water tight enclosure with access through a swinging door. Wiring will be provided from the switch to the unit high voltage terminal block. The switch will be cULus agency recognized.

Note: *The disconnect switch will be sized per NEC and cULus guidelines but will not be used in place of unit overcurrent protection.*

Through-the-Base Gas Piping

Note: *Through-the-Base Gas not available with Ultra Low NO_x gas furnace option.*

The unit shall include a standard through the base gas provision. This option shall have all piping necessary including, black steel, manual gas shut-off valve, elbows, and union. The manual shutoff valve shall include a 1/8 inch NPT pressure tap. This assembly will require minor field labor to install (gas/electric only).

Trane[®] Air-Fi[™] Wireless

Trane[®] Air-Fi[™] wireless communication shall be factory installed and pre-wired. Air-Fi must also be Zigbee[®] Building Automation certified and the system communicates using standard BACnet[®] open protocol.

Two-Inch Filters

Two-inch MERV 8 and MERV 13 media filters shall be available on all models.

Ultra Low NO_x Gas Furnace (CA Only)

Gas heat models that provide 14 ng/J NO_x furnace emissions to comply with California's South Coast Air Quality Management District (SCAQMD) and San Joaquin Valley Air Pollution Control District (SJVAPCD) requirements.

Factory or Field Installed Options

Clogged Filter/Fan Failure Switch

A dedicated differential pressure switch is available to achieve active fan failure indication and/or clogged filter indication. These indications will be registered with either a zone sensor with status indication lights or an Integrated Comfort[™] System. This option is available for microprocessor controlled units.

Differential Pressure Switches

These sensors allow individual fan failure and dirty filter indication for microprocessor controlled units. The fan failure switch will disable all unit functions and "flash" the Service LED on the zone sensor. The dirty filter switch will light the Service LED on the zone sensor and will allow continued unit operation.

Economizer (Standard)

This accessory shall be available with or without barometric relief. The assembly includes fully modulating 0-100 percent motor and dampers, minimum position setting, preset linkage, wiring harness with plug, spring return actuator and fixed dry bulb control. The barometric relief shall provide a pressure operated damper that shall be gravity closing and shall prohibit entrance of outside air during the equipment "off" cycle. Optional solid state or differential enthalpy control shall be available for either factory or field installation. The economizer arrives in the shipping position and shall be moved to the operating position by the installing contractor.

Electric Heaters

Electric heat modules shall be available for installation within basic unit. Electric heater elements shall be constructed of heavy-duty nickel chromium elements internally delta connected for 240V, wye connected for 480V and 600 V. Staging shall be achieved through ReliaTel™. Each heater package shall have automatically reset high limit control operating through heating element contactors. All heaters shall be individually fused from the factory, where required, and shall meet all NEC and CEC requirements when properly installed. Power assemblies shall provide single-point connection. Electric heat modules shall be cULus listed.

LonTalk® Communication Interface

This option shall be provided to allow the unit to communicate as a Tracer® LCI-R device or directly with generic LonTalk® Network Building Automation System Controls.

Low Leak Economizer

This accessory meets low leak requirements for ASHRAE 90.1, IECC, and CA Title 24 standards (4 cfm/ft²@1" wg external air/return air). This option allows 100% outdoor air supply from 0-100% modulating dampers and is standard with barometric relief. It can be paired with powered exhaust for additional building pressure relief. This option can be paired with or without Fault Detection and Diagnostics (FDD) to meet current mandatory CA Title 24 requirements. Available on downflow units only.

BACnet® Communication Interface

This option shall be provided to allow the unit to communicate directly with a generic open protocol BACnet® MS/TP Network Building Automation System Controls.

Reference or Comparative Enthalpy

Reference enthalpy is used to measure and communicate outdoor humidity. The unit receives and uses this information to provide improved comfort cooling while using the economizer. comparative enthalpy measures and communicates humidity for both outdoor and return air conditions, and return air temperature. The unit receives and uses this information to maximize use of economizer cooling, and to provide maximum occupant comfort control. Reference or comparative enthalpy option shall be available when a factory or field installed downflow economizer is ordered. This option is available on all downflow models.

Hail Guards

Hail protection quality coil guards are available for condenser coil protection.

Field Installed Options

CO₂ Sensor

The CO₂ sensor shall have the ability to monitor the concentration (parts per million, ppm) of CO₂ (Carbon Dioxide) in the air. As the CO₂ concentration changes, the outside air damper modulates to meet the current ventilation needs of the zone.

Two field installed kits are offered; CO₂ sensor and wiring or CO₂ sensor only. The CO₂ sensor only kit should be ordered with factory installed CO₂ sensor wiring. Factory installed CO₂ sensor wiring saves set-up time and ensures proper unit connections for the CO₂ sensor.

Low Leak Economizer

This accessory meets low leak requirements for ASHRAE 90.1, IECC, and CA Title 24 standards (4 cfm/ft²@1" wg external air/return air). This option allows 100% outdoor air supply from 0 to 100% modulating dampers and is standard with barometric relief. It can be paired with powered exhaust for additional building pressure relief. Available on downflow units only.



Mechanical Specifications

Outside Air Measuring/Monitoring Control (Traq™ Dampers)

- Requires Low Leak Economizer (Factory or Field Installed)
- Includes:
 - UC400 Controller.
 - Damper Actuator.
 - Pressure Sensors.

Powered Exhaust

The powered exhaust, available for 3 to 5 ton units, shall provide exhaust of return air, when using an economizer, to maintain better building pressurization.

Programmable Night Setback

Auto or manual changeover with seven-day programming. Keyboard selection of heat, cool, fan, auto, or on. All programmable sensors have system on, heat, cool, service LED/indicators as standard. Night setback sensors have one (1) occupied, one (1) un-occupied, and one (1) override program per day.

Remote Potentiometer

The minimum position setting of the economizer shall be adjusted with this accessory.

Roof Curb

The roof curb shall be designed to mate with the unit's downflow supply and return and provide support and a water tight installation when installed properly. The roof curb design shall allow field-fabricated rectangular supply/return ductwork to be connected directly to the curb. Curb shall be shipped knocked down for field assembly and shall include wood nailer strips.

Ventilation Override Accessory

With the ventilation override accessory installed, the unit can be set to transition up to 3 different pre-programmed sequences for smoke purge, pressurization, and exhaust. The transition occurs when a binary input on the RTOM is closed (shorted). This would typically be a hard wired relay output from a smoke detector or fire control panel. The ventilation override accessory shall be available as field installed.

Wireless Zone Sensor

LCD display that provides heat, cool, auto or off. Includes two temperature setpoints and a lockable setting with °F or °C indicators.

Zone Sensor

This control shall be provided to interface with the Micro equipped units and shall be available in either manual, automatic programmable with night setback, with system malfunction lights, or remote sensor options.



The AHRI Certified mark indicates Trane U.S. Inc. participation in the AHRI Certification program. For verification of individual certified products, go to ahridirectory.org.

Trane - by Trane Technologies (NYSE: TT), a global climate innovator - creates comfortable, energy efficient indoor environments for commercial and residential applications. For more information, please visit trane.com or tranetechnologies.com.

Trane has a policy of continuous product and product data improvement and reserves the right to change design and specifications without notice. We are committed to using environmentally conscious print practices.