



Product Catalog

Sintesis™ Air-Cooled Chillers

Model RTAF

115 to 520 Nominal Tons





Introduction

The new Trane® Sintesis™ model RTAF chiller is the result of a search for higher reliability, higher energy efficiency, and lower sound levels for today's environment.

EcoWise™

Sintesis™ is the newest member of Ingersoll Rand's EcoWise™ portfolio of products, designed to lower environmental impact with next-generation, low global warming potential (GWP) refrigerant and high efficiency operation.

Sintesis™ chillers are designed to operate with either R-134a or DuPont™ Opteon® (R-513A), a next generation refrigerant with 55 percent lower GWP than R-134a.

The Sintesis™ chiller uses the proven design of the Trane helical-rotary compressor, which embraces all of the design features that have made the Trane helical-rotary compressor liquid chillers such a success since 1987.

Sintesis™ chillers offers high reliability coupled with greatly improved energy efficiency, and improved acoustical performance, due to its advanced design, low-speed, direct-drive compressor, and proven Sintesis™ performance. The major advantages of the Sintesis™ chiller are:

- High reliability
- Lower sound level
- Higher energy efficiency at full load & part load

The Sintesis™ model RTAF chiller is an industrial-grade design, built for both the industrial and commercial markets. It is ideal for schools, hotels, hospitals, retailers, office buildings, and industrial applications.

Copyright

This document and the information in it are the property of Trane, and may not be used or reproduced in whole or in part without written permission. Trane reserves the right to revise this publication at any time, and to make changes to its content without obligation to notify any person of such revision or change.

Trademarks

All trademarks referenced in this document are the trademarks of their respective owners.

Revision History

- Updated to Symbio™ 800 Controls.
- Updated fan data due to supplier change.
- Affected chapters include:
 - General Data
 - Features and Benefits
 - Controls
 - Dimensions
 - Mechanical Specifications
- Updated field wiring diagrams.



Table of Contents

- Features and Benefits 5
 - Sintesis Helical Rotary Compressor 5
 - Capacity Control and Load Matching 5
 - Close Spacing Installation 6
 - Factory Testing Means Trouble-Free Start-up 6
 - Integrated Rapid Restart 6
 - Rapid Restart™ Test 6
 - Microchannel Condenser Coil 6
 - CHIL Evaporator 7
 - Fans 7
 - Precision Control 7
- Application Considerations 9
 - Unit Sizing 9
 - Water Treatment 9
 - Effect of Altitude on Capacity 9
 - Ambient Limitations 9
 - Water Flow Limits 9
 - Water Temperature 11
 - Variable Flow in the Evaporator 11
 - Series Chiller Arrangements 12
 - Typical Water Piping 12
 - Multiple Unit Operation 13
 - Free-Cooling 13
 - Thermal Battery Cooling System Operation 13
 - Unit Placement 13
 - Unit Location 14
- Model Number Description 16
 - Unit Model Number 16
- General Data 18
 - Free-Cooling System 21



Table of Contents

Controls	22
Symbio™ 800 Controller	22
Tracer AdaptiView TD7 Operator Interface	22
System Integration.....	23
Symbio 800 Controls.....	24
Integrated Comfort System (ICS).....	27
Electrical.....	28
Electrical Data	28
Customer Wiring	32
Electrical Connections	34
Dimensions.....	44
Service Clearances.....	44
Unit Dimensions.....	45
Weights.....	61
Base Weights.....	61
Option Weights.....	62
Mechanical Specifications	63
General	63
Certified AHRI Performance.....	63
Refrigerant Circuit	63
Evaporator	63
Condenser and Fans	64
Compressor and Lube Oil System	64
Unit Controls	64
Adaptive Frequency Drive (AFD) Compressor Starter	65
Chilled Water Reset	66
Factory Mounted Flow Proving and Flow Control	66
Options	67
Application Options.....	67
Electrical Options	68
Control Options.....	68
Other Options	68



Features and Benefits

Sintesis Helical Rotary Compressor

- Unequaled-reliability. The Sintesis™ Trane helical-rotary compressor is designed, built, and tested to the same demanding and rugged standards as the Trane scroll compressors, the centrifugal compressors, and the previous generation helical-rotary compressors used in both air- and water-cooled chillers for more than 30 years.
- Years of research and testing. The Trane helical-rotary compressor has amassed thousands of hours of testing, much of it at severe operating conditions beyond normal commercial air-conditioning applications.
- Proven track record. The Trane Company is the world's largest manufacturer of large helical-rotary compressors used for refrigeration. Over 300,000 compressors worldwide have proven Trane helical- rotary compressor reliability.
- Resistance to liquid slugging. The robust design of the compressor can ingest amounts of liquid refrigerant that normally would severely damage compressor.
- Fewer moving parts. The helical- rotary compressor has only two rotating parts: the male rotor and the female rotor.
- Direct-drive, low-speed, semi- hermetic compressor for high efficiency and high reliability.
- Suction-gas-cooled motor. The motor operates at lower temperatures for longer motor life.
- Five minute start-to-start and two minute stop-to-start anti-recycle timer allows for closerwater- loop temperature control.

Capacity Control and Load Matching

The combination unloading system onTrane helical- rotary compressors uses the adaptive frequency drive for the majority of the unloading function.This allows the compressor to modulate infinitely, to exactly match building load and to maintain chilled-water supply temperatures within $\pm 0.5^{\circ}\text{F}$ [$\pm 0.3^{\circ}\text{C}$] of the set point. Helical- rotary chillers that rely on stepped capacity control must run at a capacity equal to or greater than the load, and typically can only maintain water temperature to around $\pm 2^{\circ}\text{F}$ [$\pm 1^{\circ}\text{C}$]. Much of this excess capacity is lost because overcooling goes toward removing building latent heat, causing the building to be dried beyond normal comfort requirements.

The combination of the variable unloading valve plus the adaptive frequency drive allow exact load matching and excellent efficiencies at full load and part load.

Figure 1. Cutaway of a compressor

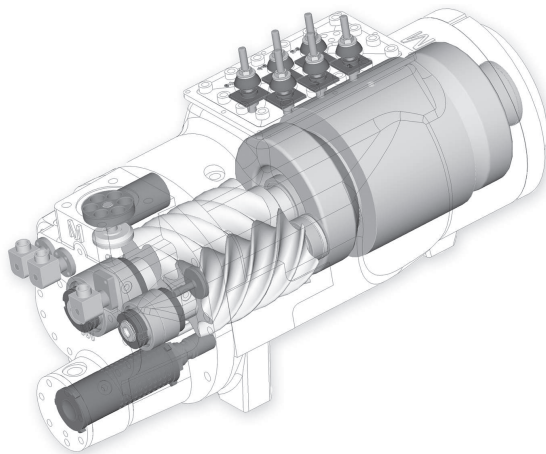



Close Spacing Installation

The Sintesis™ chiller is minimally affected in many restricted air flow situations due to its advanced Adaptive Control™ microprocessor, which has the ability to understand the operating environment of the chiller and adapt to it by first optimizing its performance and then staying on line through abnormal conditions. Consult your sales engineer for more details.

Factory Testing Means Trouble-Free Start-up

All Sintesis™ chillers are given a complete functional test at the factory. This computer-based test program completely checks the sensors, wiring, electrical components, microprocessor function, communication capability, expansion valve performance, and fans. In addition, each compressor is run-tested to verify capacity and efficiency. The result of this test program is that the chiller arrives at the job site fully tested and ready for operation.

Integrated Rapid Restart

Bringing a chiller back online rapidly after a loss of power is critical to operations in mission critical environments like data centers and hospitals which demand the highest levels of reliability.

A loss of cooling capacity can be costly, which is why Trane chillers are designed and engineered for Rapid Restart. In the event of a power interruption, the chiller will start a compressor before the front panel display is fully powered up eliminating the need for UPS. This not only helps the chiller get back online faster, but it also provides a simple and reliable solution to minimize the risks of financially devastating damage to assets caused by overheating due to a power loss.

Of course, the truest test of a chiller's restart capabilities is the amount of time it takes to resume full-load cooling, and this is where the chiller really shines. An 80 percent cooling load can be achieved in less than 2.5 minutes after power restoration—your assurance that the cooling capacity your equipment requires is just a few minutes away.

Rapid Restart™ Test

After completion of a standard full load witness test, power to the chiller will be cut and then reapplied to demonstrate the chiller's rapid restart capabilities for disaster relief.

Microchannel Condenser Coil

Microchannel condensing coils are all-aluminum coils with fully-brazed construction. This design reduces risk of leaks and provides increased coil rigidity — making them more rugged on the jobsite. Their flat streamlined tubes with small ports and metallurgical tube-to-fin bond allow for exceptional heat transfer. Microchannel all-aluminum construction provides several additional benefits:

- Light weight (simplifies coil handling)
- Easy to recycle
- Minimize galvanic corrosion

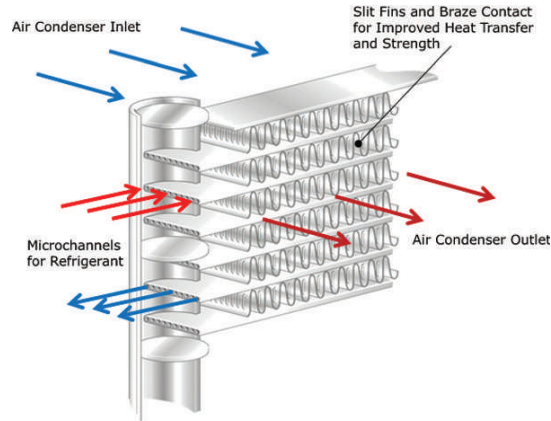

CHIL Evaporator

Compact - High performance - Integrated design - Low refrigerant charge (CHIL) evaporator optimizes the flow of refrigerant for excellent heat transfer and minimizes the volume of refrigerant used.

Figure 2. CHIL evaporator, 115 to 270 ton units, 2-pass

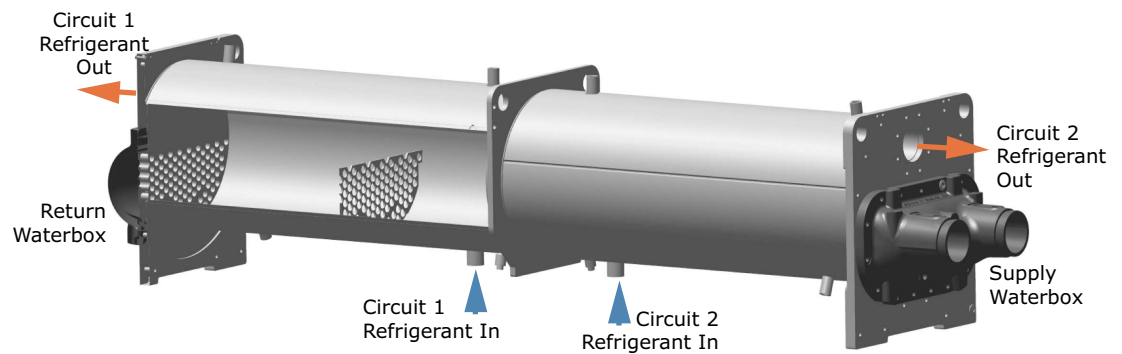
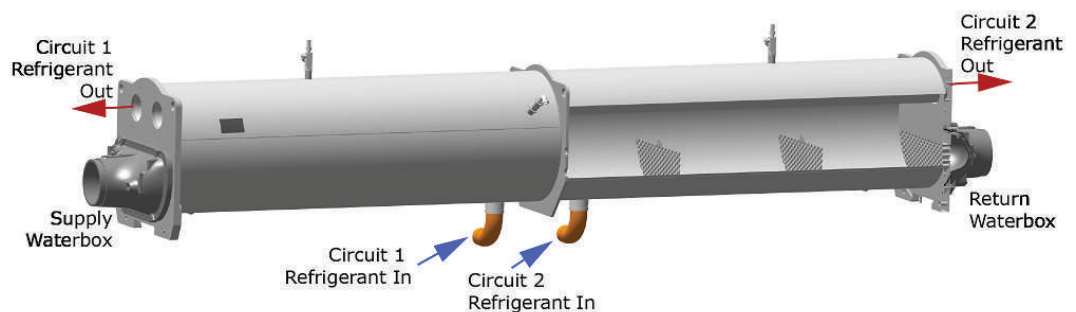

Figure 3. CHIL evaporator, 280 to 520 tons, 1-pass



Fans

Sintesis™ chillers use Electronically Commutated (EC) fans in order to reduce power consumption at full load and at part load. EC fans allow a significant reduction of sound level and a better operation of the chiller at low ambient conditions.

Precision Control

- New 7 inch color touch screen display with graphics



Features and Benefits

- Powered by Symbio™ 800 industry-leading control algorithms
 - Enhanced flow management provides unmatched system performance in variable flow water systems
- Adaptive Control™ keeps the chiller running in extreme conditions
 - Tight set point control
 - Graphical trending
 - Maximized chiller update
- BACnet®, Modbus™, LonTalk®, communications protocol interface available without the need for gateways



Application Considerations

Certain application constraints should be considered when sizing, selecting, and installing Trane chillers. Unit and system reliability is often dependent on properly and completely complying with these considerations. When the application varies from the guidelines presented, it should be reviewed with your local sales engineer.

Note: The terms water and solution are used interchangeably in the following paragraphs.

Unit Sizing

Intentionally oversizing a unit to ensure adequate capacity is not recommended. Erratic system operation and excessive compressor cycling are often a direct result of an oversized chiller. In addition, an oversized unit is usually more expensive to purchase, install, and operate. If oversizing is desired, consider using two units.

Water Treatment

The use of untreated or improperly treated water may result in scaling, erosion, corrosion, and algae or slime buildup. This will adversely affect heat transfer between the water and system components. Proper water treatment must be determined locally and depends on the type of system and local water characteristics.

Neither salt nor brackish water is recommended for use in Trane air-cooled chillers. Use of either will lead to a shortened life. Trane encourages the employment of a qualified water treatment specialist, familiar with local water conditions, to assist in the establishment of a proper water treatment program.

Foreign matter in the chilled water system can also increase pressure drop and, consequently, reduce water flow. For this reason it is important to thoroughly flush all water piping to the unit before making the final piping connections to the unit.

Effect of Altitude on Capacity

At elevations substantially above sea level, the decreased air density will decrease condenser capacity and, therefore, unit capacity and efficiency.

Ambient Limitations

Trane chillers are designed for year-round operation over a range of ambient temperatures. For operation outside of these ranges, contact the local sales office.

- Standard Ambient Range = 14 to 115°F (-10 to 46°C)
- Low Ambient Range = -4 to 115°F (-20 to 46°C)
- High Ambient Range = 14 to 130°F (-10 to 54.4°C)
- Wide Ambient Range = -4 to 130°F (-20 to 54.4°C)

The minimum ambient temperatures are based on still conditions (winds not exceeding five mph). Greater wind speeds will result in a drop in head pressure, therefore increasing the minimum starting and operating ambient temperature. The AdaptiveFrequency™ microprocessor will attempt to keep the chiller on-line when high or low ambient conditions exist, making every effort to avoid nuisance trip-outs and provide the maximum allowable tonnage.

Water Flow Limits

The minimum water flow rates are given in the General Data chapter of this catalog. Evaporator flow rates below the tabulated values will result in laminar flow causing freeze-up problems, scaling, stratification and poor control.

Application Considerations

The maximum evaporator water flow rate is also given in General Data. Flow rates exceeding those listed may result in very high pressure drop across the evaporator and/or excessive tube erosion.

Note: Flow rates in the general data tables are for water only. They do not include freeze inhibitors.

Flow Rates Out of Range

Many process cooling jobs require flow rates that cannot be met with the minimum and maximum published values within the evaporator. A simple piping change can alleviate this problem. For example: a plastic injection molding process requires 80 gpm (5.0 l/s) of 50°F (10°C) water and returns that water at 60°F (15.6°C). The selected chiller can operate at these temperatures, but has a minimum flow rate of 120 gpm (7.6 l/s). The system layout in the figure below can satisfy the process.

Figure 4. Flow rate out of range systems solution

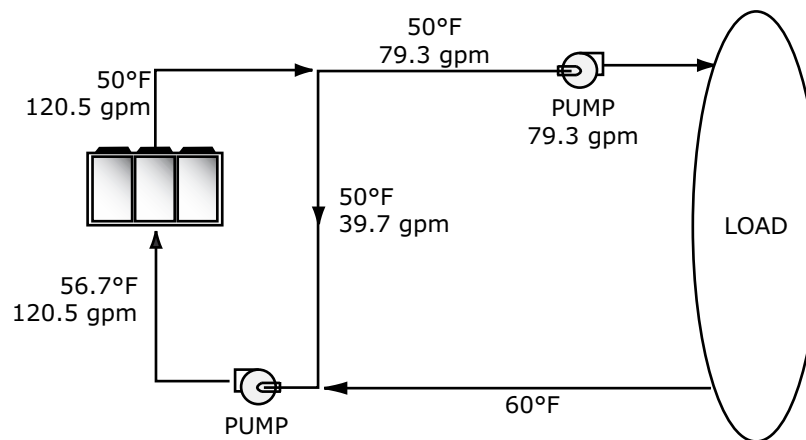

Flow Proving

Trane provides a factory-installed water flow switch monitored by Symbio™ 800 controller which protects the chiller from operating in loss of flow conditions.

Flow Control

Trane requires the chilled water flow control in conjunction with the Sintesis™ Chiller to be done by the chiller. This will allow the chiller to protect itself in potentially harmful conditions.

Variable Flow in the Evaporator

Variable Primary Flow (VPF) systems present building owners with several cost-saving benefits when compared with Primary/Secondary chilled water systems. The most obvious cost savings results from eliminating the constant volume chiller pump(s), which in turn eliminates the related expenses of the associated piping connections (material, labor), and electrical service and switch gear. In addition to the installed cost advantage, building owners often cite pump related energy savings as the reasons that prompted them to select a VPF system.

The chiller is capable of handling variable evaporator flow without losing control of the leaving water temperature. The microprocessor and capacity control algorithms are designed to handle a 10 percent change in water flow rate per minute while maintaining a $\pm 2^\circ\text{F}$ (1.1°C) leaving water temperature control accuracy. The chiller tolerates up to 30 percent per minute water flow variation as long as the flow is equal or above the minimum flow rate requirement.

With the help of a software analysis tool such as System Analyzer™, DOE-2 or TRACE™, anticipated energy savings can be determined, and used to justify variable primary flow in a particular application. Existing constant flow chilled water systems may be relatively easily converted to VPF and benefit greatly from the inherent efficiency advantages.

Water Temperature

Leaving Water Temperature Limits

Trane chillers have distinct leaving water categories:

- Standard, with a leaving solution range of 40 to 68°F (4.4 to 20°C)
- Low temperature process cooling, with leaving solution less than 40°F (4.4°C)
- Ice-making, with a leaving solution range of 10.4 to 68°F (-12 to 20°C)

Since leaving solution temperatures below 40°F (4.4°C) result in suction temperature at or below the freezing point of water, a glycol solution is required for all low temperature and ice-making machines. Ice making control includes dual setpoints and safeties for ice making and standard cooling capabilities. Consult your local Trane account manager for applications or selections involving low temperature or ice making machines.

The maximum water temperature that can be circulated through the evaporator when the unit is not operating is 125°F (52°C). Evaporator damage may result above this temperature.

Leaving Water Temperature Out of Range

Many process cooling jobs require temperature ranges that cannot be met with the minimum and maximum published values for the chiller. A simple piping change can alleviate this problem. For example, a laboratory load requires 120 gpm (7.6 l/s) of water entering the process at 85°F (29.4°C) and returning at 95°F (35°C). The chiller's maximum leaving chilled water temperature of 64°F (18°C) prevents direct supply to the load. In the example shown, both the chiller and process flow rates are equal, however, this is not necessary. For example, if the chiller had a higher flow rate, there would be more water bypassing and mixing with warm water returning to the chiller.

Figure 5. Temperature out of range system solution

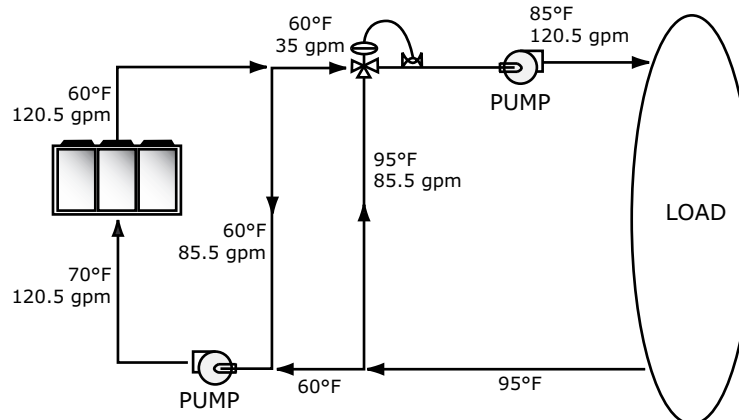

Variable Flow in the Evaporator

An attractive chilled water system option may be a variable primary flow (VPF) system. VPF systems present building owners with several cost saving benefits that are directly related to the pumps. The most obvious cost savings result from eliminating the secondary distribution pump, which in turn avoids the expense incurred with the associated piping connections (material, labor), electrical service, and variable frequency drive. Building owners often cite pump related energy savings as the reason that prompted them to install a VPF system.

The evaporator on the chiller can withstand up to 50 percent water flow reduction as long as this flow is equal to or above the minimum flow rate requirements. For applications in which system energy savings is most important and tight temperature control is classified as $\pm 2^\circ\text{F}$ (1.1°C), up to 30 percent changes in flow per minute are possible.

With the help of a software analysis tool such as System Analyzer™, DOE-2 or TRACE™, you can determine whether the anticipated energy savings justify the use of variable primary flow in a particular application. It may also be easier to apply variable primary flow in an existing chilled

water plant. Unlike the "decoupled" system design, the bypass can be positioned at various points in the chilled water loop and an additional pump is unnecessary.

Series Chiller Arrangements

Another energy saving strategy is to design the system around chillers arranged in series. The actual savings possible with such strategies depends on the application dynamics and should be researched by consulting your Trane® Systems Solutions Representative and applying an analysis tool from the Trace software family. It is possible to operate a pair of chillers more efficiently in a series chiller arrangement than in a parallel arrangement. It is also possible to achieve higher entering to leaving chiller differentials, which may, in turn, provide the opportunity for lower chilled water design temperature, lower design flow, and resulting installation and operational cost savings. The Trane screw compressor also has excellent capabilities for "lift," which provides an opportunity for savings on the evaporator water loop.

Series chiller arrangements can be controlled in several ways. The figure below shows a strategy where each chiller is trying to achieve the system design set point. If the cooling load is less than 50 percent of the systems capabilities, either chiller can fulfill the demand. As system loads increase, the Chiller 2 becomes preferentially loaded as it attempts to meet the leaving chilled water setpoint. Chiller 1 will finish cooling the leaving water from Chiller 2 down to the system design setpoint.

Staggering the chiller set points is another control technique that works well for preferentially loading Chiller 1. If the cooling load is less than 50 percent of the system capacity, Chiller 1 would be able to satisfy the entire call for cooling. As system loads increase, Chiller 2 is started to meet any portion of the load that Chiller 1 can not meet.

Figure 6. Typical series chiller arrangement

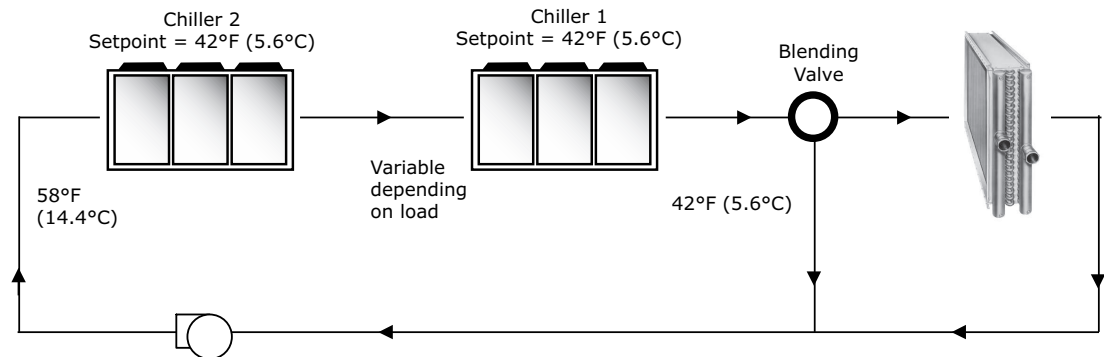

Typical Water Piping

All building water piping must be flushed prior to making final connections to the chiller. To reduce heat loss and prevent condensation, insulation should be applied. Expansion tanks are also usually required so that chilled water volume changes can be accommodated.

Avoidance of Short Water Loops

Adequate chilled water system water volume is an important system design parameter because it provides for stable chilled water temperature control and helps limit unacceptable short cycling of chiller compressors.

The chiller's temperature control sensor is located in the waterbox. This location allows the building to act as a buffer to slow the rate of change of the system water temperature. If there is not a sufficient volume of water in the system to provide an adequate buffer, temperature control can suffer, resulting in erratic system operation and excessive compressor cycling.

Typically, a two-minute water loop circulation time is sufficient to prevent short water loop issues. Therefore, as a guideline, ensure the volume of water in the chilled water loop equals or exceeds two times the evaporator flow rate. For systems with a rapidly changing load profile the amount of volume should be increased.

If the installed system volume does not meet the above recommendations, the following items should be given careful consideration to increase the volume of water in the system and, therefore, reduce the rate of change of the return water temperature.

- A volume buffer tank located in the return water piping.
- Larger system supply and return header piping (which also reduces system pressure drop and pump energy use).

Minimum Water Volume for a Process Application

If a chiller is attached to an on/off load such as a process load, it may be difficult for the controller to respond quickly enough to the very rapid change in return solution temperature if the system has only the minimum water volume recommended. Such systems may cause chiller low temperature safety trips or in the extreme case evaporator freezing. In this case, it may be necessary to add or increase the size of the mixing tank in the return line.

Multiple Unit Operation

Whenever two or more units are used on one chilled water loop, Trane recommends that their operation be coordinated with a higher level system controller for optimum system efficiency and reliability. The Trane Tracer® system has advanced chilled plant control capabilities designed to provide such operation.

Free-Cooling

The free-cooling option takes advantage of operation during cooler ambient air temperature, which becomes attractive due to the ability to reduce energy consumption. The use of economizers, as a positive side effect, helps lessen wear and tear of the chilled water production plant while lowering the operating cost. This application is particularly well suited for applications with high sensible loads and/or continuous cooling loads throughout the year.

Thermal Battery Cooling System Operation

A Thermal Battery™ cooling system uses the chiller to make (cooling) ice at night when utilities generate electricity more efficiently with lower demand and energy charges. The stored cooling energy reduces or even replaces mechanical cooling during the day when utility rates are at their highest. This reduced electrical demand for cooling results in significant utility cost savings and source energy savings.

Another advantage of an ice energy storage system is its ability to eliminate chiller over sizing. A “right-sized” chiller plant with ice energy storage operates more efficiently with smaller support equipment while lowering the connected load and reducing operating costs. Best of all, this system still provides a capacity safety factor and redundancy by designing reserve capacity into the ice storage system for practically no cost compared to oversized systems.

Trane air-cooled chillers are uniquely suited to low temperature applications like ice storage because of the ambient relief experienced at night. Chiller ice making efficiencies are typically similar to or even better than standard cooling daytime efficiencies as a result of night-time dry-bulb ambient relief.

Standard smart control strategies for ice storage systems are another advantage of the chiller. The dual mode control functionality is integrated right into the chiller. Trane Tracer® building management systems can measure demand and receive pricing signals from the utility and decide when to use the stored cooling and when to use the chiller.

Unit Placement

Setting the Unit

A base or foundation is not required if the selected unit location is level and strong enough to support the unit's operating weights shown in Weights chapter.

Application Considerations

For a detailed discussion of base and foundation construction, see the unit Installation, Operation or Maintenance (IOM) manual. Manuals are available through online product portal pages or from your local office.

HVAC equipment must be located to minimize sound and vibration transmission to the occupied spaces of the building structure it serves. If the equipment must be located in close proximity to a building, it should be placed next to an unoccupied space such as a storage room, mechanical room, etc. It is not recommended to locate the equipment near occupied, sound sensitive areas of the building or near windows. Locating the equipment away from structures will also prevent sound reflection, which can increase sound levels at property lines or other sensitive points.

Isolation and Sound Emission

Structurally transmitted sound can be reduced by elastomeric vibration eliminators. Elastomeric isolators are generally effective in reducing vibratory noise generated by compressors, and therefore, are recommended for sound sensitive installations. An acoustical engineer should always be consulted on critical applications.

Figure 7. Installation example

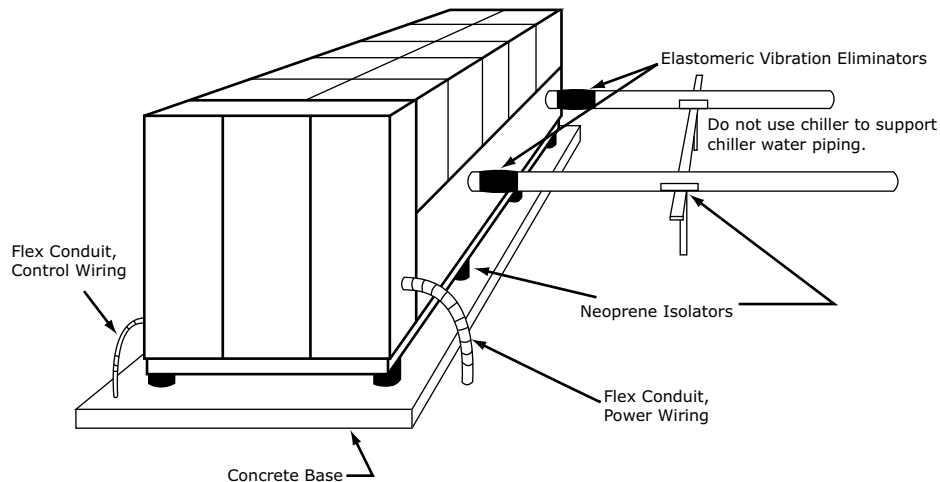

For maximum isolation effect, water lines and electrical conduit should also be isolated. Wall sleeves and rubber isolated piping hangers can be used to reduce sound transmitted through water piping. To reduce the sound transmitted through electrical conduit, use flexible electrical conduit.

Local codes on sound emissions should always be considered. Since the environment in which a sound source is located affects sound pressure, unit placement must be carefully evaluated. Sound power levels for chillers are available on request.

Servicing

Adequate clearance for evaporator, condenser and compressor servicing should be provided. Recommended minimum space envelopes for servicing are located in the dimensional data section and can serve as a guideline for providing adequate clearance. The minimum space envelopes also allow for control panel door swing and routine maintenance requirements. Local code requirements may take precedence.

Unit Location

General

Unobstructed flow of condenser air is essential to maintain chiller capacity and operating efficiency. When determining unit placement, careful consideration must be given to assure a sufficient flow of air across the condenser heat transfer surface. Two detrimental conditions are possible and must be avoided: warm air recirculation and coil starvation. Air recirculation occurs

when discharge air from the condenser fans is recycled back to the condenser coil inlet. Coil starvation occurs when free airflow to the condenser is restricted.

Condenser coils and fan discharge must be kept free of snow or other obstructions to permit adequate airflow for satisfactory unit operation. Debris, trash, supplies, etc., should not be allowed to accumulate in the vicinity of the air-cooled chiller. Supply air movement may draw debris into the condenser coil, blocking spaces between coil fins and causing coil starvation.

Both warm air recirculation and coil starvation cause reductions in unit efficiency and capacity due to higher head pressures. The air-cooled chiller offers an advantage over competitive equipment in these situations. Operation is minimally affected in many restricted air flow situations due to its advanced Adaptive Control™ microprocessor which has the ability to understand the operating environment of the chiller and adapt to it by first optimizing its performance and then staying on line through abnormal conditions. For example, high ambient temperatures combined with a restricted air flow situation will generally not cause the air-cooled chiller to shut down. Other chillers would typically shut down on a high pressure nuisance cut-out in these conditions.

Cross winds, those perpendicular to the condenser, tend to aid efficient operation in warmer ambient conditions. However, they tend to be detrimental to operation in lower ambients due to the accompanying loss of adequate head pressure. Special consideration should be given to low ambient units. As a result, it is advisable to protect air-cooled chillers from continuous direct winds exceeding 10 mph (4.5 m/s) in low ambient conditions.

The recommended lateral clearances are depicted in the close spacing engineering bulletin available from your local office.

Provide Sufficient Unit-to-Unit Clearance

Units should be separated from each other by sufficient distance to prevent warm air recirculation or coil starvation. Doubling the recommended single unit air-cooled chiller clearances will generally prove to be adequate. See Close-Spacing and Restricted Airflow Engineering Bulletin AC-PRB001*-EN for more information.

Walled Enclosure Installations

When the unit is placed in an enclosure or small depression, the top of the surrounding walls should be no higher than the top of the fans. The chiller should be completely open above the fan deck. There should be no roof or structure covering the top of the chiller. Ducting individual fans is not recommended. See Close-Spacing and Restricted Airflow Engineering Bulletin AC-PRB001*-EN for more information.



Model Number Description

Unit Model Number

Digit 1, 2 – Unit Model

RT = Rotary Chiller

Digit 3 – Unit Type

A = Air-cooled

Digit 4 – Development Sequence

F = Development Sequence

Digit 5, 6, 7 – Nominal Capacity

115 = 115 Nominal Tons
130 = 130 Nominal Tons
150 = 150 Nominal Tons
170 = 170 Nominal Tons
180 = 180 Nominal Tons
200 = 200 Nominal Tons
215 = 215 Nominal Tons
230 = 230 Nominal Tons
250 = 250 Nominal Tons
270 = 270 Nominal Tons
280 = 280 Nominal Tons
310 = 310 Nominal Tons
350 = 350 Nominal Tons
390 = 390 Nominal Tons
410 = 410 Nominal Tons
450 = 450 Nominal Tons
500 = 500 Nominal Tons
520 = 520 Nominal Tons

Digit 8 – Voltage Selection

C = 380/60/3
D = 400/50/3
E = 460/60/3
F = 575/60/3

Digit 9 – Manufacturing Location

U = Trane Commercial Systems, Pueblo, CO USA

Digits 10, 11 – Design Sequence

****** = Factory assigned

Digit 12 – Unit Efficiency

H = High Efficiency
N = Standard Efficiency

Digit 13 – Unit Sound Package

X = Standard Noise

Digit 14 – Agency Listing

U = UL/cUL Listing

Digit 15 – Pressure Vessel Code

A = ASME Pressure Vessel Code
C = CRN or Canadian Equivalent Pressure Vessel Code
D = Australia Pressure Vessel Code

Digit 16 – Factory Charge

1 = Refrigerant Charge R-513A
2 = Refrigerant Charge R-134a
3 = Nitrogen Charge (R-513A Field Supplied)
4 = Nitrogen Charge (R-134a Field Supplied)

Digit 17 – Evaporator Application

N = Standard Cooling (above 40°F/5.5°C)
P = Low Temp Process Cooling (below 40°F/5.5°C)
C = Ice Making

Digit 18 – Evaporator Configuration

1 = 1-pass Evaporator
2 = 2-pass Evaporator
R = 1-pass Evaporator with Turbulators
T = 2-pass Evaporator with Turbulators

Digit 19 – Evaporator Fluid Type

1 = Water
2 = Calcium Chloride
3 = Ethylene Glycol
4 = Propylene Glycol
5 = Methanol

Digit 20 – Water Connection

X = Grooved Pipe Connection
W = Grooved Pipe + Flange

Digit 21 – Flow Switch

1 = Factory Installed - Other Fluid (15 cm/s)
2 = Factory Installed - Water (35 cm/s)
3 = Factory Installed - Water (45 cm/s)

Digit 22 – Insulation

N = Factory Insulation — All Cold Parts 0.75"
H = Evaporator-only Insulation for High Humidity/Low Evap Temp
Note: Digit 22 selection H is special order only.

Digit 23 – Unit Application

X = Standard Ambient (14 to 115°F/-10 to 46°C)
L = Low Ambient (-4 to 115°F/-20 to 46°C)
H = High Ambient (14 to 130°F/-10 to 54.4°C)
W = Wide Ambient (-4 to 130°F/-20 to 54.4°C)

Digit 24 – Condenser Fin Options

N = Aluminum Microchannel
C = CompleteCoat™ Microchannel

Digit 25 – Fan Type

C = Variable Speed Fans

Digit 26 – Auxiliary Items

C = Oil Cooler

Digit 27 – Compressor Starter

V = Adaptive Frequency™ Drive

Digit 28 – Incoming Power Line Connection

1 = Single Point Unit Power Connection
2 = Dual Point Unit Power Connection

Digit 29 – Power Line Connection Type

Units with model number digit 28 = 2 OR Units with 2 compressors and model number digit 28 = 1:

X = Terminal Block
C = Circuit Breaker
H = Circuit Breaker with High Fault Rated Control Panel

Unit with 3 or 4 compressors and model number digit 28 = 1:

X = Terminal Block with Individual System Circuit Breaker
C = Circuit Breaker with Individual System Circuit Breaker
H = High Fault Circuit Breaker with Individual System Circuit Breaker in High Fault Rated Control Panel

Digit 30 – Short Circuit Current Rating

A = Default Short Circuit Rating
B = High Fault Short Circuit Rating

Digit 31 – Electrical Accessories

X = No Convenience Outlet
P = 15A 115V Convenience Outlet

Digit 32 — Remote Communication Option

X = None
B = BACnet® Interface
M = Modbus™ Interface
L = LonTalk® Interface

Digit 33 — Hard Wire Communication

X = None
A = Hard Wired Bundle - All
B = Remote Leaving Water Temp Setpoint
C = Remote Leaving Temp and Demand Limit Setpoints
D = Programmable Relay
E = Programmable Relay and Leaving Water and Demand Limit Setpoint
F = Percent Capacity
G = Percent Capacity and Leaving Water and Demand Limit Setpoint
H = Percent Capacity and Programmable Relay

Digit 34 — Energy Meter

X = None

Digit 35 — Smart Flow Control

X = None

Digit 36 — Structural Options

A = Standard Unit Structure
D = Wind Load for Florida Hurricane

Digit 37 — Appearance Options

X = No Appearance Options
A = Architectural Louvered Panels

Digit 38 — Unit Isolation

X = None
1 = Elastomeric Isolators

Digit 39 — Shipping Package

X = No Shipping Package
A = Containerization Package
T = Shipped with Tarp Covering Full Unit

Digit 40, 41

XX = Reserved for future use

Digit 42 — Free-Cooling

X = None
F = Total Free-Cooling — Glycol

Digit 43 — Special Requirement

0 = None
F = Ship to Final Finisher
S = Special Requirement



General Data

Table 1. General data table – 115 to 215 ton units

Unit Size (tons)		115	130	150	170	180	200	215
Compressor Model (ckt1/ckt 2) ^(a)		55/55	65/65	70/70	85/70	85/85	100/85	100/100
Quantity	#	2	2	2	2	2	2	2
Evaporator								
Water Connection Size	in	4	4	5	5	5	6	6
Passes	#	2	2	2	2	2	2	2
Water Storage	gal	14.0	15.8	19.3	20.6	21.6	21.9	23.9
	L	53.1	59.9	73.2	78.0	81.9	82.8	90.5
Minimum Flow ^(b)	gpm	128	150	171	187	199	202	228
	l/s	8.1	9.5	10.8	11.8	12.6	12.8	14.4
Maximum Flow ^(b)	gpm	470	551	626	684	731	742	835
	l/s	29.7	34.8	39.5	43.2	46.1	46.8	52.7
Condenser								
Qty of Coils (ckt 1/ckt 2)		5/5	5/5	6/6	6/6	6/6	7/7	7/7
Coil Length	in	77.4	77.4	77.4	77.4	77.4	77.4	77.4
	mm	1967	1967	1967	1967	1967	1967	1967
Coil Height	in	47.8	47.8	47.8	47.8	47.8	47.8	47.8
	mm	1214	1214	1214	1214	1214	1214	1214
Free-Cooling Coils								
Qty of Coils (ckt 1/ckt 2)		5/4	5/4	6/5	6/5	6/5	7/6	7/6
Coil Length	in	75.8	75.8	75.8	75.8	75.8	75.8	75.8
	mm	1925	1925	1925	1925	1925	1925	1925
Coil Height	in	37.0	37.0	37.0	37.0	37.0	37.0	37.0
	mm	941	941	941	941	941	941	941
Condenser Fans								
Quantity (ckt 1/ckt 2)	#	5/5	5/5	6/6	6/6	6/6	7/7	7/7
Diameter	in	29	29	29	29	29	29	29
	mm	736.6	736.6	736.6	736.6	736.6	736.6	736.6
Nominal speed	rpm	855	855	855	855	855	960	960
Airflow	cfm	9760	9760	9760	9760	9760	11,000	11,000
Airflow with Free-Cooling Coil	cfm	8338	8338	8338	8338	8338	9567	9567
	m ³ /s	4.6	4.6	4.6	4.6	4.6	5.2	5.2

Table 1. General data table – 115 to 215 ton units (continued)

Unit Size (tons)		115	130	150	170	180	200	215
Ambient Temperature Range								
Standard Ambient	°F (°C)	14 to 115 (-10 to 46)						
Low Ambient	°F (°C)	-4 to 115 (-20 to 46)						
High Ambient	°F (°C)	14 to 130 (-10 to 54.4)						
Wide Ambient	°F (°C)	-4 to 130 (-20 to 54.4)						
General Unit								
Refrigerant		R-134a or R-513A						
Refrigerant Ckts	#	2	2	2	2	2	2	2
Minimum Load	%	15	15	15	15	15	15	15
Refrigerant Charge (ckt 1/ckt 2)	lb	86.4/84.9	86.6/84.9	101.4/99.0	111.1/99.0	109.0/96.3	134.3/ 129.4	134.7/ 129.8
	kg	39.2/38.5	39.3/38.5	46.0/44.9	50.4/44.9	49.5/43.7	60.9/58.7	61.1/59.0
Oil		Trane OIL00315 (1 gal)/OIL00317 (5 gal)						
Oil Charge/ckt	gal	1.53	1.56	1.56	1.56	1.64	1.96	2.01
	L	5.8	5.9	5.9	5.9	6.2	7.4	7.6

(a) Nominal tonnage at 60 Hz.

(b) Minimum and maximum flow rates apply to constant-flow chilled water system running at AHRI conditions, without freeze inhibitors added to the water loop.

Table 2. General data table – 230 to 520 ton units

Unit Size (tons)		230	250/ 270	280	310	350/ 390	410	450	500/520
Compressor Model (ckt 1/ckt 2)^(a)		120/100	120/120	100- 100/70	100- 100/100	100- 120/120	100-100/ 100-100	100-120/ 100-120	120-120/ 120-120
Quantity	#	2	2	3	3	3	4	4	4
Evaporator									
Water Connection Size	in	6	6	8	8	8	8	8	8
Passes	#	2	2	1	1	1	1	1	1
Water Storage	gal	28.5	30.6	31.2	32.6	35.8	41.8	44.8	46.1
	L	107.7	115.9	118.1	123.3	135.4	158.1	169.5	174.7
Minimum Flow ^(b)	gpm	261	288	304	323	367	446	487	506
	l/s	16.5	18.2	19.2	20.4	23.1	28.1	30.7	31.9



General Data

Table 2. General data table – 230 to 520 ton units (continued)

Unit Size (tons)		230	250/ 270	280	310	350/ 390	410	450	500/520
Maximum Flow ^(b)	gpm	957	1055	1113	1183	1345	1635	1786	1855
	l/s	60.4	66.6	70.2	74.6	84.9	103.2	112.7	117.1
Condenser									
Qty of Coils (ckt 1/ckt 2)		7/7	7/7	12/6	14/6	14/6	12/12	14/14	14/14
Coil Length	in	77.4	77.4	77.4	77.4	77.4	77.4	77.4	77.4
	mm	1967	1967	1967	1967	1967	1967	1967	1967
Coil Height	in	47.8	47.8	47.8	47.8	47.8	47.8	47.8	47.8
	mm	1214	1214	1214	1214	1214	1214	1214	1214
Free-Cooling Coils^(c)									
Qty of Coils (ckt 1/ckt 2)		7/6	7/6	11/5	13/5	13/5	11/11	13/13	13/13
Coil Length	in	75.8	75.8	75.8	75.8	75.8	75.8	75.8	75.8
	mm	1925	1925	1925	1925	1925	1925	1925	1925
Coil Height	in	37.0	37.0	37.0	37.0	37.0	37.0	37.0	37.0
	mm	941	941	941	941	941	941	941	941
Condenser Fans									
Quantity (ckt 1/ckt 2)	#	7/7	7/7	12/6	14/6	14/6	12/12	14/14	14/14
Diameter	in	29	29	29	29	29	29	29	29
	mm	736.6	736.6	736.6	736.6	736.6	736.6	736.6	736.6
Nominal Speed	rpm	960	960	960	960	960	960	960	960
Airflow	cfm	11,000	11,000	11,000	11,000	11,000	11,000	11,000	11,000
Airflow w/ Free-Cooling Coil ^(c)	cfm	9567	9567	9567	9567	9567	9567	9567	9567
	m3/sec	5.2	5.2	5.2	5.2	5.2	5.2	5.2	5.2
Ambient Temperature Range									
Standard Ambient	°F (°C)	14 to 115 (-10 to 46)							
Low Ambient	°F (°C)	-4 to 115 (-20 to 46)							
High Ambient ^(c)	°F (°C)	14 to 130 (-10 to 54.4)							
Wide Ambient ^(c)	°F (°C)	-4 to 130 (-20 to 54.4)							
General Unit									
Refrigerant		R-134a or R-513A ^(d)							
Refrigerant Ckts	#	2	2	2	2	2	2	2	2
Minimum Load	%	15	15	15	15	15	15	15	15
Refrigerant Charge (ckt 1/ckt 2)	(lbs)	155.4/ 154.8	155.4/ 154.8	263.1/ 118.4	272.5/ 120.0	276.0/ 121.2	253.0/ 259.7	266.9/ 278.8	275.1/ 287.8
	(kg)	70.7/ 70.4	70.7/ 70.4	119.6/ 53.8	123.8/ 54.5	125.4/ 55.1	115.0/ 118.0	121.3/ 126.7	125.0/ 130.8
Oil		OIL00315 (1 gal)/OIL00317 (5 gal)							

Table 2. General data table – 230 to 520 ton units (continued)

Unit Size (tons)		230	250/ 270	280	310	350/ 390	410	450	500/520
Oil Charge (ckt 1/ckt 2)	(gal)	2.35/ 2.35	2.35/ 2.35	4.24/ 2.17	4.26/ 2.17	4.27/ 2.17	4.26/4.29	4.30/4.33	4.33/4.37
	(L)	8.9/8.9	8.9/8.9	16.1/8.2	16.1/8.2	16.2/8.2	16.1/16.2	16.3/16.4	16.4/16.5

(a) Nominal tonnage at 60 Hz. Where there are 2 compressors on a circuit, they are indicated 1A-1B/2A-2B.

(b) Minimum and maximum flow rates apply to constant-flow chilled water system running at AHRI conditions, without freeze inhibitors added to the water loop.

(c) Not available for 270, 390 and 520 ton units. Free cooling is not available for 230, 250, 350 and 500 ton 575V units. High and wide ambient are not available for all 575V units.

(d) R-513A is not available on 270, 390, and 520 tons units.

Free-Cooling System

Glycol Volumes

Note: Volumes listed in table below are in addition to the fluid volume for standard unit configuration.

Table 3. Free-cooling system glycol volume

Unit Size (tons)	Total Glycol Volume	
	gal	l
115	59.25	224.27
130	59.25	224.27
150	75.36	285.26
170	75.36	285.26
180	75.36	285.26
200	89.97	340.59
215	89.97	340.59
230	89.97	340.59
250	89.97	340.59
280	201.53	762.89
310	211.97	802.38
350	211.97	802.38
410	247.12	935.44
450	282.27	1068.50
500	282.27	1068.50



Controls

Symbio™ 800 Controller

Trane Ascend™ chillers offer predictive controls that anticipate and compensate for load changes. Other strategies made possible with the Symbio™ 800 controls are:

Feedforward Adaptive Control

Feedforward is an open-loop, predictive control strategy designed to anticipate and compensate for load changes. It uses evaporator entering-water temperature as an indication of load change. This allows the controller to respond faster and maintain stable leaving-water temperatures.

Soft Loading

The chiller controller uses soft loading except during manual operation. Large adjustments to setpoint changes are made gradually, preventing the compressor from cycling unnecessarily. It does this by internally filtering the setpoints to avoid reaching the differential-to-stop or the demand limit. Soft loading applies to the leaving chilled-water temperature and demand limit setpoints.

Adaptive Controls

Adaptive Controls directly sense the control variables that govern the operation of the chiller: evaporator pressure and condenser pressure. When any one of these variables approaches a limit condition when damage may occur to the unit or shutdown on a safety, Adaptive Controls takes corrective action to avoid shutdown and keep the chiller operating. This happens through combined actions of compressor and/or fan staging. Whenever possible, the chiller is allowed to continue making chilled water. This keeps cooling capacity available until the problem can be solved. Overall, the safety controls help keep the building or process running and out of trouble.

Integrated Rapid Restart

Rapid Restart™ is available on unit sizes larger than 300 tons.

Bringing a chiller back online rapidly after a loss of power is critical to operations in mission critical environments like data centers and hospitals which demand the highest levels of reliability.

A loss of cooling capacity can be costly, which is why Trane chillers are designed and engineered for Rapid Restart™. In the event of a power interruption, the chiller will start a compressor before the front panel display is fully powered up eliminating the need for UPS. This not only helps the chiller get back online faster, but it also provides a simple and reliable solution to minimize the risks of financially devastating damage to assets caused by overheating due to a power loss.

Of course, the truest test of a chiller's restart capabilities is the amount of time it takes to resume full-load cooling, and this is where the chiller really shines. An 80 percent cooling load can be achieved in less than 2.5 minutes after power restoration—your assurance that the cooling capacity your equipment requires is just a few minutes away.

Rapid Restart Test

After completion of a standard full load witness test, power to the chiller will be cut and then reapplied to demonstrate the chiller's rapid restart capabilities for disaster relief.

AdaptiSpeed Control

Compressor speed is used to control capacity of the chiller, optimizing mathematically with the condenser fan speed to provide the highest level of performance. The increased performance of the controller allows the chiller to operate longer at higher efficiency, and with greater stability.

Tracer AdaptiView TD7 Operator Interface

The standard Tracer® AdaptiView™ TD7 display provided with the Symbio™ 800 controller features a 7" LCD touch-screen, allowing access to all operational inputs and outputs. This is an

advanced interface that allows the user to access any important information concerning setpoints, active temperatures, modes, electrical data, pressure, and diagnostics. It uses full text display available in 27 languages.

Display Features Include:

- LCD touch-screen with LED backlighting, for scrolling access to input and output operating information.
- Single-screen, folder/tab-style display of all available information on individual components (evaporator, condenser, compressor, etc.)
- Manual override indication.
- Password entry/lockout system to enable or disable display.
- Automatic and immediate stop capabilities for standard or immediate manual shutdown.
- Fast, easy access to available chiller data in tabbed format, including:
 - Easy to view Operating Modes
 - Logical Sub-Component Reports:
 - Evaporator
 - Condenser
 - Compressor
 - Motor
 - 3 User Programmable Custom Reports
 - ASHRAE Report
 - Log Sheet Report
 - Alarms Report
 - 8 pre-defined Standard Graphs
 - 4 User Programmable Custom Graphs
 - Unit Settings
 - Service Settings
 - Feature Settings
 - Chilled Water Reset
 - Manual Control Settings
 - Display Preferences
 - Support of 27 languages
 - Brightness Setting
 - Cleaning Mode

System Integration

Stand-Alone Controls

Single chillers installed in applications without a building management system are simple to install and control: only a remote auto/stop for scheduling is required for unit operation. Signals from the chilled-water pump contactor auxiliary, or a flow switch, are wired to the chilled-water flow interlock. Signals from a time clock or some other remote device are wired to the external auto/stop input.

- Auto/Stop - A job-site provided contact closure turns the unit on and off.
- Emergency Stop - A job-site provided contact opening wired to this input turns the unit off and requires a manual reset of the unit microcomputer. This closure is typically triggered by a job-site provided system such as a fire alarm.



Hardwire Points

Microcomputer controls allow simple interface with other control systems, such as time clocks, building automation systems, and ice storage systems via hardwire points. This means you have the flexibility to meet job requirements while not having to learn a complicated control system.

Remote devices are wired from the control panel to provide auxiliary control to a building automation system. Inputs and outputs can be communicated via a typical 4–20 mA electrical signal, an equivalent 2–10 Vdc signal, or by utilizing contact closures.

This setup has the same features as a stand-alone water chiller, with the possibility of having additional optional features:

- Ice making control
- External chilled water setpoint, external demand limit setpoint
- Chilled water temperature reset
- Programmable relays - available outputs are: alarm-latching, alarm-auto reset, general alarm-warning, chiller limit mode, compressor running, and Tracer control.

Tracer SC

The Tracer® SC system controller acts as the central coordinator for all individual equipment devices on a Tracer building automation system. The TracerSC scans all unit controllers to update information and coordinate building control, including building subsystems such as VAV and chiller water systems. With this system option, the full breadth of Trane’s HVAC and controls experience are applied to offer solutions to many facility issues. The LAN allows building operators to manage these varied components as one system from any personal computer with web access. The benefits of this system are:

- Improved usability with automatic data collection, enhanced data logging, easier to create graphics, simpler navigation, pre-programmed scheduling, reporting, and alarm logs.
- Flexible technology allows for system sizes from 30 to 120 unit controllers with any combination of LonTalk® or BACnet® unit controllers.
- LEED certification through site commissioning report, energy data collection measurement, optimizing energy performance, and maintaining indoor air quality.

Energy savings programs include: fan pressure optimization, ventilation reset, and chiller plant control (adds and subtracts chillers to meet cooling loads).

Symbio 800 Controls

Overview

The Symbio™ 800 controller is a factory-installed, application specific and programmable controller designed to control chillers and large packaged HVAC equipment. A 7-inch user interface features a touch-sensitive color screen that provides facility managers at-a-glance operating status, performance monitoring, scheduling changes, and operating adjustments. Other advanced features include automated controller back-up, and optional features such as secure remote connectivity, wireless building communications, mobile device connectivity, and custom programming with expandable I/O.

Symbio™ 800 Advantages		Benefits
Connected	Convenient, on-the-go access to advanced monitoring, troubleshooting, and energy management	<ul style="list-style-type: none"> • Minimum first cost • Maximum comfort • Minimized downtime • Minimum operating costs • Superior building and occupant productivity
Flexible	Minimized installation hardware and labor costs – able to use existing devices for maximum convenience, lower controls upgrades and relocation	
Reliable	Maximum equipment uptime and life, minimized maintenance and troubleshooting cost	

Features and Benefits

Symbio™ 800 Feature	Benefits
Multiple, open standard protocol support <ul style="list-style-type: none"> BACnet TP BACnet/IP LON (Optional) Modbus 	Simplified, lower cost, and more flexible integration with all common open standard protocols using Trane or competitive BAS systems and controllers
Remote connection to building or equipment	Trane Connect™ provides an easy, secure option to connect remotely to a Tracer SC+ or directly to your Trane equipment
Common integration strategies and equipment specific points lists	Simplified, lower cost, and uncompromised integration
Application specific and configurable	Reduced project costs with superior reliability, comfort, performance - applications specific and configurable system ensures machine continues to run within operating envelope. Ability to upgrade firmware with a simple file transfer.
Smart Analytics	Smart analytics provide superior reliability through the life of the equipment with minimum downtime
Data logging	Standard, local or remote Intuitive review and analysis of equipment, zone, and building performance
Local scheduling	Capable of operating in stand-alone operation without a building automation system as a temporary back-up schedule for ongoing comfort and energy savings
Rugged, 7-inch color touch screen user interface	Easy, touch navigation for viewing data and making operational changes
Display preferences	Choose how to view dates, times, units (SI, IP), screen brightness, data format, and backlight timeout. A total of 27 built-in languages are supported and selectable for all TD7 screens.
Intuitive navigation	Helps operators access data and alarms for quick and accurate response and resolution
At-a-glance status	Easily readable color display showing key operating parameters of major equipment components
Reports	Quickly summarizes data for clear understanding and interpretation to enable local monitoring of expected performance and operating efficiency
Graphs	Easily visualize trend data for local troubleshooting and fine-tuning
Multiple language support	Suitable for operation in multiple geographies
Adaptive Control™ Algorithms	Pre-empts potential equipment disruptions during rapidly changing conditions - providing consistent equipment performance and building comfort
SD card backup/restore	Faster, lower cost repairs with reduced downtime
Modbus device support	Capable of integrating optional Modbus devices for local or remote diagnostics — provides faster, lower cost troubleshooting and increased equipment performance

Options

Symbio™ 800 Feature	Benefits
Remote connection to building or equipment	Trane Connect™ provides an easy, secure option to connect remotely to a Tracer SC+ or directly to your Trane equipment
Programmable	Equipment application flexibility and cost-reduced control of nearby equipment
Expandable I/O	Field or factory installed I/O for programmable feature for reduced installation costs and increased installation flexibility
User security with audit trail support	Flexible and secure access for multiple users allows monitoring, overriding/releasing points, release of all overrides, custom report editing, and tracking changes by user
LonTalk	



Building Automation Systems

BACnet Building Automation Control Network

The BACnet® control network for Symbio™ 800 expands communications from the unit UCM network to the Tracer® Ensemble™ or Tracer SC+ building automation system or third party building automation system. Utilizing BACnet, the BAS allows external setpoint and configuration adjustment and monitoring of status and diagnostics. The Symbio 800 utilizes the BACnet defined TP protocol as defined in ASHRAE standard 135-2004. This controller works in standalone mode, with Tracer Ensemble, Tracer SC+ or when connected to a third party building automation system that supports BACnet.

Modbus Automation Control Network

Allows the user to easily interface with Modbus™ RTU communication protocol via a single twisted pair wiring from the Symbio 800 controller to a factory installed device.

LonTalk Building Automation Systems

The LonTalk® communication protocol for the Symbio™ 800 controller expands communications from the unit UCM network to a Tracer® Ensemble™ building automation system or third party building automation system. Utilizing LonTalk, the BAS allows external setpoint and configuration adjustment and monitoring of status and diagnostics. The Symbio 800 utilizes an FTT-10A free topology transceiver, which supports non-polarity sensitive, free topology wiring—which in turn allows the system installer to utilize star, bus, and loop architectures. This controller works in standalone mode, peer-to-peer with one or more other units, or when connected to a Tracer Ensemble, Tracer SC+, or a third party building automation system that supports LonTalk.

Specifications

Controller Specifications	
Input power	24 Vdc +/- 10%, 400mA max
Storage temperature	-67°F to 185°F (-55°C to 85°C), Humidity: Between 5% to 100% (Condensing)
Operating temperature	-40°F to 158°F (-40°C to 70°C)
Environmental rating (enclosure)	IP3x
Time clock	On-board real time clock with 10 year battery backup
Mounting weight	Mounting surface must support 1.3 lb. (0.6 kg)
Overall dimensions	5.65 in. (143.5 mm) wide x 4.00 in. (101.6 mm) high x 2.17 in. (55 mm) deep
Agency Compliance	
<ul style="list-style-type: none"> • UL916 PAZX, Open Energy Management Equipment • UL94-5V Flammability • CE • FCC Part 15, Subpart B, Class B Limit • BTL Listed—Advanced Application Profile (B-AAC) 	
User Interface Specifications	
Input power	24 Vac +/- 10%, 21 VA, 50, or 60 Hz
Storage temperature	-67°F to 203°F (-55°C to 95°C), Humidity: Between 5% to 100% (Condensing)
Operating temperature	-40°F to 158°F (-40°C to 70°C), Humidity: Between 5% to 100% (Condensing)
Environmental rating (enclosure)	IP56 (dust and strong water jet protected) with optional sealed Ethernet cable (PN: X19070632020)
Mounting weight	Mounting surface must support 1.6 lb. (0.74 kg)
Overall dimensions	8.3 in. (211.6 mm) wide x 6.3 in. (158.8 mm) high x 2.1 in. (53.2 mm) deep [bezel depth 0.4 in. (11.3 mm)]

Agency Compliance

- UL916 PAZX, Open Energy Management Equipment
- UL94-5V, Flammability
- FCC CFR Title 47, Part 15.109: Class A Limit, (30 MHz—4 GHz)
- CE EMC Directive 2004/108/EC

Integrated Comfort System (ICS)

The onboard chiller controller is designed to be able to communicate with a wide range of building automation systems. In order to take full advantage of chiller's capabilities, incorporate your chiller into a Tracer® SC building automation system.

But the benefits do not stop at the chiller plant. At Trane, we realize that all the energy used in your cooling system is important. That is why we worked closely with other equipment manufacturers to predict the energy required by the entire system. We used this information to create patented control logic for optimizing HVAC system efficiency.

The building owners challenge is to tie components and applications expertise into a single reliable system that provides maximum comfort, control, and efficiency. Trane® Integrated Comfort systems (ICS) are a concept that combines system components, controls, and engineering applications expertise into a single, logical, and efficient system. These advanced controls are fully commissioned and available on every piece of Trane equipment, from the largest chiller to the smallest VAV box. As a manufacturer, only Trane offers this universe of equipment, controls, and factory installation and verification.



Electrical

Electrical Data

Table 4. Electrical data, 115 to 270 ton units

Unit Size (Tons)	Rated Voltage ^(a)	Condenser Fans			CPT Amps	Drive Input Amps		MCA ^(b)	MOP ^(c)
		Qty ^(d)	HP	FLA		Ckt 1	Ckt 2		
115	380/60/3	5/5	2.1	2.9	2.7	99	99	260	350
	460/60/3	5/5	2.1	2.5	2.2	82	82	215	300
	575/60/3	5/5	2.1	2.5	1.8	65	65	183	225
	400/50/3	5/5	2.1	2.7	2.5	94	94	249	300
130	380/60/3	5/5	2.1	2.9	2.7	119	119	305	400
	460/60/3	5/5	2.1	2.5	2.2	98	98	251	300
	575/60/3	5/5	2.1	2.5	1.8	78	78	212	250
	400/50/3	5/5	2.1	2.7	2.5	113	113	292	400
150	380/60/3	6/6	2.1	2.9	2.7	139	139	357	450
	460/60/3	6/6	2.1	2.5	2.2	115	115	295	400
	575/60/3	6/6	2.1	2.5	1.8	91	91	241	300
	400/50/3	6/6	2.1	2.7	2.5	132	132	342	450
170	380/60/3	6/6	2.1	2.9	2.7	164	139	388	500
	460/60/3	6/6	2.1	2.5	2.2	136	115	321	450
	575/60/3	6/6	2.1	2.5	1.8	108	91	262	350
	400/50/3	6/6	2.1	2.7	2.5	155	132	371	500
180	380/60/3	6/6	2.1	2.9	2.7	164	164	413	500
	460/60/3	6/6	2.1	2.5	2.2	136	136	342	450
	575/60/3	6/6	2.1	2.5	1.8	108	108	279	350
	400/50/3	6/6	2.1	2.7	2.5	155	155	394	500
200	380/60/3	7/7	2.1	2.9	2.7	199	164	464	600
	460/60/3	7/7	2.1	2.5	2.2	164	136	383	500
	575/60/3	7/7	2.1	2.5	1.8	132	108	309	400
	400/50/3	7/7	2.1	2.7	2.5	189	155	443	600
215	380/60/3	7/7	2.1	2.9	2.7	199	199	499	600
	460/60/3	7/7	2.1	2.5	2.2	164	164	411	500
	575/60/3	7/7	2.1	2.5	1.8	132	132	333	450
	400/50/3	7/7	2.1	2.7	2.5	189	189	477	600
230	380/60/3	7/7	2.1	2.9	2.7	240	199	550	700
	460/60/3	7/7	2.1	2.5	2.2	198	164	453	600
	575/60/3	7/7	2.1	2.5	1.8	158	132	366	500
250	380/60/3	7/7	2.1	2.9	2.7	240	240	591	800
	460/60/3	7/7	2.1	2.5	2.2	198	198	487	600
	575/60/3	7/7	2.1	2.5	1.8	158	158	392	500
270	460/60/3	7/7	2.1	2.5	2.2	247	247	598	800

^(a) Voltage Utilization Range: +/- 10% of Rated voltage (use range): 200/60/3 (180-220), 230/60/3 (208-254), 380/60/3 (342-418), 400/50/3 (360-440), 460/60/3 (414-506), 575/60/3 (516-633)

^(b) MCA (Minimum Circuit Ampacity) = 125 percent of largest compressor VFD input plus 100 percent of all other loads.

^(c) MOP = 225 percent of largest compressor VFD input plus 100 percent of second compressor VFD input, plus sum of condenser fan FLAs and CPT amps.

^(d) Number of fans is indicated by ckt 1/ckt 2.

Table 5. Electrical data, 280 to 520 ton units

Unit Size (Tons)	Rated Voltage (a)	Condenser Fans			CPT Amps(b)	Compr 1A Drive Input Amps	Compr 1B Y-D			Compr 2A Drive Input Amps	Compr 2B Y-D		
		Qty(c)	HP	FLA			RLA	Y-LRA	XL-LRA		RLA	Y-LRA	XL-LRA
280	380/60/3	12/6	2.1	2.9	2.7	199	203	424	1306	139	-	-	-
	460/60/3	12/6	2.1	2.5	2.2	164	168	346	1065	115	-	-	-
	575/60/3	12/6	2.1	2.5	1.8	132	135	277	853	91	-	-	-
310	380/60/3	14/6	2.1	2.9	2.7	199	203	424	1306	199	-	-	-
	460/60/3	14/6	2.1	2.5	2.2	164	168	346	1065	164	-	-	-
	575/60/3	14/6	2.1	2.5	1.8	132	135	277	853	132	-	-	-
350	380/60/3	14/6	2.1	2.9	2.7	199	245	424	1306	240	-	-	-
	460/60/3	14/6	2.1	2.5	2.2	164	202	346	1065	198	-	-	-
	575/60/3	14/6	2.1	2.5	1.8	132	161	277	853	158	-	-	-
390	460/60/3	14/6	2.1	2.5	2.2	247	202	346	1065	247	-	-	-
410	380/60/3	12/12	2.1	2.9	2.7	199	203	424	1306	199	203	424	1306
	460/60/3	12/12	2.1	2.5	2.2	164	168	346	1065	164	168	346	1065
	575/60/3	12/12	2.1	2.5	1.8	132	135	277	853	132	135	277	853
450	380/60/3	14/14	2.1	2.9	2.7	199	245	424	1306	199	245	424	1306
	460/60/3	14/14	2.1	2.5	2.2	164	202	346	1065	164	202	346	1065
	575/60/3	14/14	2.1	2.5	1.8	132	161	277	853	132	161	277	853
500	380/60/3	14/14	2.1	2.9	2.7	240	245	424	1306	240	245	424	1306
	460/60/3	14/14	2.1	2.5	2.2	198	202	346	1065	198	202	346	1065
	575/60/3	14/14	2.1	2.5	1.8	158	161	277	853	158	161	277	853
520	460/60/3	14/14	2.1	2.5	2.2	247	202	346	1065	247	202	346	1065

Unit Size (Tons)	Rated Voltage (d)	Single Point Power		Dual Point Power			
		MCA	MOP	MCA(e)		MOP(f)	
				Ckt 1	Ckt 2	Ckt 1	Ckt 2
280	380/60/3	659	800	497	197	600	300
	460/60/3	544	700	410	163	500	300
	575/60/3	461	500	335	148	450	225
310	380/60/3	726	800	504	272	700	450
	460/60/3	599	700	416	224	500	350
	575/60/3	502	600	335	200	450	300
350	380/60/3	819	1000	556	324	800	500
	460/60/3	675	800	458	267	600	450
	575/60/3	560	700	368	232	500	350
390	460/60/3	819	1000	553	328	700	500
410	380/60/3	942	1000	497	497	600	600
	460/60/3	778	800	410	410	500	500
	575/60/3	637	700	335	335	450	450
450	380/60/3	1050	1200	556	556	800	800
	460/60/3	866	1000	458	458	600	600
	575/60/3	695	800	368	368	500	500



Electrical

Table 5. Electrical data, 280 to 520 ton units (continued)

Unit Size (Tons)	Rated Voltage (d)	Single Point Power		Dual Point Power			
		MCA	MOP	MCA(e)		MOP(f)	
				Ckt 1	Ckt 2	Ckt 1	Ckt 2
500	380/60/3	-	-	597	597	800	800
	460/60/3	934	1000	492	492	600	600
	575/60/3	747	800	394	394	500	500
520	460/60/3	1043	1200	553	553	700	700

- (a) Voltage Utilization Range: +/- 10% of Rated voltage (use range): 200/60/3 (180-220), 230/60/3 (208-254), 380/60/3 (342-418), 400/50/3 (360-440), 460/60/3 (414-506), 575/60/3 (516-3633)
- (b) CPT amps is the same for circuit 1 and circuit 2.
- (c) Number of fans is indicated by ckt 1/ckt 2.
- (d) Voltage Utilization Range: +/- 10% of Rated voltage (use range): 200/60/3 (180-220), 230/60/3 (208-254), 380/60/3 (342-418), 400/50/3 (360-440), 460/60/3 (414-506), 575/60/3 (516-3633)
- (e) MCA (Minimum Circuit Ampacity) = 125 percent of largest compressor VFD input plus 100 percent of all other loads.
- (f) MOP = 225 percent of largest compressor VFD input plus 100 percent of second compressor VFD input, plus sum of condenser fan FLAs and CPT amps.

Table 6. Electrical data – short circuit ratings

Unit Size (Tons)	Rated Voltage(a)	Single Point Power				Dual Point Power			
		Default Short Circuit Rating (kA)		High Fault Short Circuit Rating (kA)		Default Short Circuit Rating (kA)		High Fault Short Circuit Rating (kA)	
		Term Block	Circuit Breaker(b)	Circuit Breaker(c)	High Fault Circuit Breaker	Term Block	Circuit Breaker(b)	Circuit Breaker(c)	High Fault Circuit Breaker
115	380/60/3	10	10	35	65	-	-	-	-
	460/60/3	10	10	35	65	-	-	-	-
	575/60/3	10	10	18	25	-	-	-	-
	400/50/3	10	10	35	65	-	-	-	-
130	380/60/3	10	10	35	65	-	-	-	-
	460/60/3	10	10	35	65	-	-	-	-
	575/60/3	10	10	18	25	-	-	-	-
	400/50/3	10	10	35	65	-	-	-	-
150	380/60/3	10	10	35	65	-	-	-	-
	460/60/3	10	10	35	65	-	-	-	-
	575/60/3	10	10	18	25	-	-	-	-
	400/50/3	10	10	35	65	-	-	-	-
170	380/60/3	10	10	35	65	-	-	-	-
	460/60/3	10	10	35	65	-	-	-	-
	575/60/3	10	10	18	25	-	-	-	-
	400/50/3	10	10	35	65	-	-	-	-
180	380/60/3	10	10	35	65	-	-	-	-
	460/60/3	10	10	35	65	-	-	-	-
	575/60/3	10	10	18	25	-	-	-	-
	400/50/3	10	10	35	65	-	-	-	-
200	380/60/3	10	10	35	65	-	-	-	-
	460/60/3	10	10	35	65	-	-	-	-
	575/60/3	10	10	18	25	-	-	-	-
	400/50/3	10	10	35	65	-	-	-	-

Table 6. Electrical data – short circuit ratings (continued)

Unit Size (Tons)	Rated Voltage ^(a)	Single Point Power				Dual Point Power			
		Default Short Circuit Rating (kA)		High Fault Short Circuit Rating (kA)		Default Short Circuit Rating (kA)		High Fault Short Circuit Rating (kA)	
		Term Block	Circuit Breaker ^(b)	Circuit Breaker ^(c)	High Fault Circuit Breaker	Term Block	Circuit Breaker ^(b)	Circuit Breaker ^(c)	High Fault Circuit Breaker
215	380/60/3	10	10	35	65	-	-	-	-
	460/60/3	10	10	35	65	-	-	-	-
	575/60/3	10	10	18	25	-	-	-	-
	400/50/3	10	10	35	65	-	-	-	-
230	380/60/3	10	10	35	65	-	-	-	-
	460/60/3	10	10	35	65	-	-	-	-
	575/60/3	10	10	18	25	-	-	-	-
250	380/60/3	10	10	35	65	-	-	-	-
	460/60/3	10	10	35	65	-	-	-	-
	575/60/3	10	10	18	25	-	-	-	-
270	460/60/3	10	10	35	65	-	-	-	-
280	380/60/3	10	10	35	65	10	10	35	65
	460/60/3	10	10	35	65	10	10	35	65
	575/60/3	10	10	18	25	10	10	18	25
310	380/60/3	10	10	35	65	10	10	35	65
	460/60/3	10	10	35	65	10	10	35	65
	575/60/3	10	10	18	25	10	10	18	25
350	380/60/3	10	10	35	65	10	10	35	65
	460/60/3	10	10	35	65	10	10	35	65
	575/60/3	10	10	18	25	10	10	18	25
390	460/60/3	10	10	35	65	10	10	35	65
410	380/60/3	-	10	35	65	10	10	35	65
	460/60/3	10	10	35	65	10	10	35	65
	575/60/3	10	10	18	25	10	10	18	25
450	380/60/3	-	10	35	65	10	10	35	65
	460/60/3	-	10	35	65	10	10	35	65
	575/60/3	-	10	18	25	10	10	18	25
500	380/60/3	-	-	-	-	10	10	35	65
	460/60/3	-	10	35	65	10	10	35	65
	575/60/3	-	10	18	25	10	10	18	25
520	460/60/3	-	10	35	65	10	10	35	65

^(a) Voltage Utilization Range: +/- 10% of Rated voltage (use range): 200/60/3 (180-220), 230/60/3 (208-254), 380/60/3 (342-418), 400/50/3 (360-440), 460/60/3 (414-506), 575/60/3 (516-633)

^(b) This circuit breaker is selected if unit model number digits 29 and 30 are CA.

^(c) This circuit breaker is selected if unit model number digits 29 and 30 are CB.



Customer Wiring

Table 7. Customer wiring selection

Unit Size (tons)	Rated Voltage	Single Point Power ^(a)		Dual Point Power			
		Terminal Block	Circuit Breaker	Terminal Block		Circuit Breaker	
				Ckt 1	Ckt 2	Ckt 1	Ckt 2
115	380	2 x 500 kcmil - #4	2 x 500 kcmil - 2/0	-	-	-	-
	460	2 x 500 kcmil - #4	2 x 500 kcmil - 2/0	-	-	-	-
	575	2 x 500 kcmil - #4	2 x 500 kcmil - 2/0	-	-	-	-
	400	2 x 500 kcmil - #4	2 x 500 kcmil - 2/0	-	-	-	-
130	380	2 x 500 kcmil - #4	2 x 500 kcmil - 2/0	-	-	-	-
	460	2 x 500 kcmil - #4	2 x 500 kcmil - 2/0	-	-	-	-
	575	2 x 500 kcmil - #4	2 x 500 kcmil - 2/0	-	-	-	-
	400	2 x 500 kcmil - #4	2 x 500 kcmil - 2/0	-	-	-	-
150	380	2 x 500 kcmil - #4	2 x 500 kcmil - 2/0	-	-	-	-
	460	2 x 500 kcmil - #4	2 x 500 kcmil - 2/0	-	-	-	-
	575	2 x 500 kcmil - #4	2 x 500 kcmil - 2/0	-	-	-	-
	400	2 x 500 kcmil - #4	2 x 500 kcmil - 2/0	-	-	-	-
170	380	2 x 500 kcmil - #4	2 x 500 kcmil - 2/0	-	-	-	-
	460	2 x 500 kcmil - #4	2 x 500 kcmil - 2/0	-	-	-	-
	575	2 x 500 kcmil - #4	2 x 500 kcmil - 2/0	-	-	-	-
	400	2 x 500 kcmil - #4	2 x 500 kcmil - 2/0	-	-	-	-
180	380	2 x 500 kcmil - #4	2 x 500 kcmil - 2/0	-	-	-	-
	460	2 x 500 kcmil - #4	2 x 500 kcmil - 2/0	-	-	-	-
	575	2 x 500 kcmil - #4	2 x 500 kcmil - 2/0	-	-	-	-
	400	2 x 500 kcmil - #4	2 x 500 kcmil - 2/0	-	-	-	-
200	380	2 x 500 kcmil - #4	2 x 500 kcmil - 2/0	-	-	-	-
	460	2 x 500 kcmil - #4	2 x 500 kcmil - 2/0	-	-	-	-
	575	2 x 500 kcmil - #4	2 x 500 kcmil - 2/0	-	-	-	-
	400	2 x 500 kcmil - #4	2 x 500 kcmil - 2/0	-	-	-	-
215	380	2 x 500 kcmil - #4	2 x 500 kcmil - 2/0	-	-	-	-
	460	2 x 500 kcmil - #4	2 x 500 kcmil - 2/0	-	-	-	-
	575	2 x 500 kcmil - #4	2 x 500 kcmil - 2/0	-	-	-	-
	400	2 x 500 kcmil - #4	2 x 500 kcmil - 2/0	-	-	-	-
230	380	2 x 500 kcmil - #4	3 x 500 kcmil - 3/0	-	-	-	-
	460	2 x 500 kcmil - #4	2 x 500 kcmil - 2/0	-	-	-	-
	575	2 x 500 kcmil - #4	2 x 500 kcmil - 2/0	-	-	-	-

Table 7. Customer wiring selection (continued)

Unit Size (tons)	Rated Voltage	Single Point Power ^(a)		Dual Point Power			
		Terminal Block	Circuit Breaker	Terminal Block		Circuit Breaker	
				Ckt 1	Ckt 2	Ckt 1	Ckt 2
250	380	2 x 500 kcmil - #4	3 x 500 kcmil - 3/0	-	-	-	-
	460	2 x 500 kcmil - #4	2 x 500 kcmil - 2/0	-	-	-	-
	575	2 x 500 kcmil - #4	2 x 500 kcmil - 2/0	-	-	-	-
270	460	2 x 500 kcmil - #4	3 x 500 kcmil - 3/0	-	-	-	-
280	380	4 x 600 kcmil - #2	3 x 500 kcmil - 3/0	2 x 500 kcmil - #4	2 x 500 kcmil - #4	2 x 500 kcmil - 2/0	2 x 500 kcmil - 2/0
	460	4 x 600 kcmil - #2	3 x 500 kcmil - 3/0	2 x 500 kcmil - #4	2 x 500 kcmil - #4	2 x 500 kcmil - 2/0	2 x 500 kcmil - 2/0
	575	4 x 600 kcmil - #2	3 x 500 kcmil - 3/0	2 x 500 kcmil - #4	2 x 500 kcmil - #4	2 x 500 kcmil - 2/0	2 x 500 kcmil - 2/0
310	380	4 x 600 kcmil - #2	3 x 500 kcmil - 3/0	2 x 500 kcmil - #4	2 x 500 kcmil - #4	3 x 500 kcmil - 3/0	2 x 500 kcmil - 2/0
	460	4 x 600 kcmil - #2	3 x 500 kcmil - 3/0	2 x 500 kcmil - #4	2 x 500 kcmil - #4	2 x 500 kcmil - 2/0	2 x 500 kcmil - 2/0
	575	4 x 600 kcmil - #2	3 x 500 kcmil - 3/0	2 x 500 kcmil - #4	2 x 500 kcmil - #4	2 x 500 kcmil - 2/0	2 x 500 kcmil - 2/0
350	380	4 x 600 kcmil - #2	4 x 500 kcmil - 3/0	2 x 500 kcmil - #4	2 x 500 kcmil - #4	3 x 500 kcmil - 3/0	2 x 500 kcmil - 2/0
	460	4 x 600 kcmil - #2	3 x 500 kcmil - 3/0	2 x 500 kcmil - #4	2 x 500 kcmil - #4	2 x 500 kcmil - 2/0	2 x 500 kcmil - 2/0
	575	4 x 600 kcmil - #2	3 x 500 kcmil - 3/0	2 x 500 kcmil - #4	2 x 500 kcmil - #4	2 x 500 kcmil - 2/0	2 x 500 kcmil - 2/0
390	460	4 x 600 kcmil - #2	4 x 500 kcmil - 3/0	2 x 500 kcmil - #4	2 x 500 kcmil - #4	3 x 500 kcmil - 3/0	2 x 500 kcmil - 2/0
410	380	-	4 x 500 kcmil - 3/0	2 x 500 kcmil - #4	2 x 500 kcmil - #4	2 x 500 kcmil - 2/0	2 x 500 kcmil - 2/0
	460	4 x 600 kcmil - #2	3 x 500 kcmil - 3/0	2 x 500 kcmil - #4	2 x 500 kcmil - #4	2 x 500 kcmil - 2/0	2 x 500 kcmil - 2/0
	575	4 x 600 kcmil - #2	3 x 500 kcmil - 3/0	2 x 500 kcmil - #4	2 x 500 kcmil - #4	2 x 500 kcmil - 2/0	2 x 500 kcmil - 2/0
450	380	-	4 x 500 kcmil - 3/0	2 x 500 kcmil - #4	2 x 500 kcmil - #4	3 x 500 kcmil - 3/0	3 x 500 kcmil - 3/0
	460	-	4 x 500 kcmil - 3/0	2 x 500 kcmil - #4	2 x 500 kcmil - #4	2 x 500 kcmil - 2/0	2 x 500 kcmil - 2/0
	575	-	3 x 500 kcmil - 3/0	2 x 500 kcmil - #4	2 x 500 kcmil - #4	2 x 500 kcmil - 2/0	2 x 500 kcmil - 2/0
500	380	-	-	2 x 500 kcmil - #4	2 x 500 kcmil - #4	3 x 500 kcmil - 3/0	3 x 500 kcmil - 3/0
	460	-	4 x 500 kcmil - 3/0	2 x 500 kcmil - #4	2 x 500 kcmil - #4	2 x 500 kcmil - 2/0	2 x 500 kcmil - 2/0
	575	-	3 x 500 kcmil - 3/0	2 x 500 kcmil - #4	2 x 500 kcmil - #4	2 x 500 kcmil - 2/0	2 x 500 kcmil - 2/0
520	460	-	4 x 500 kcmil - 3/0	2 x 500 kcmil - #4	2 x 500 kcmil - #4	3 x 500 kcmil - 3/0	3 x 500 kcmil - 3/0

^(a) For unit sizes 280 to 500 tons, the single point power, listed customer wiring range is for the single unit connection. This range is not applicable to the power connection in the individual circuit panels.



Electrical Connections

The following pages show the field wiring drawings for the Sintesis units.

- For 115 to 270 ton units, see [Figure 8, p. 36](#) and [Figure 9, p. 38](#).
- For 280 to 520 ton units, see [Figure 10, p. 40](#) and [Figure 11, p. 42](#).





Electrical Connections

Figure 8. Field wiring, 115 to 270 ton, sheet 1

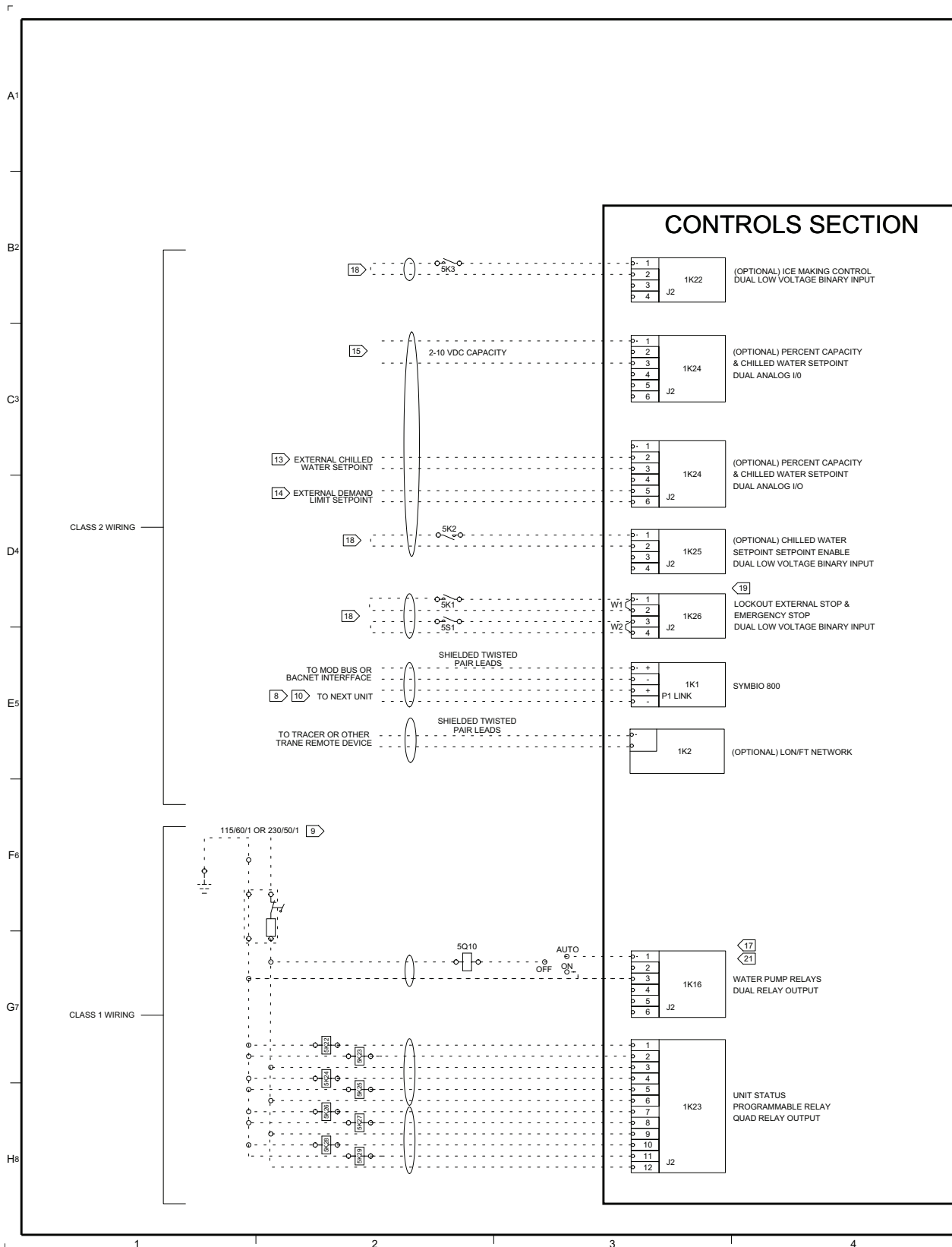

DRAWN BY:	T. GRUBE
© TRANE DATE:	10-FEB-2022
MASTER FILE:	
REVISION DATE:	10-FEB-2022
REPLACES:	
SIMILAR TO:	
USED BY:	

THIS DRAWING IS PROPRIETARY AND SHALL NOT BE COPIED OR ITS CONTENTS DISCLOSED TO OUTSIDE PARTIES WITHOUT THE WRITTEN CONSENT OF TRANE

CAD: CREO SCHEMATICS

57229573	SHEET	REV
	1	A

FIELD WIRING DIAGRAM
RTAF

POWER SECTION

POWER CONNECTION	SELECTOIN CRITERIA	CUSTOMER LUG SIZE
TERMINAL BLOCK	ALL	(2) 500 MCM - #4
CIRCUIT BREAKER	MCA = 300 - 600	(2) 500 MCM - 2/0
	MCA = 700 - 800	(3) 500 MCM - 3/0

⚠ WARNING
HAZARDOUS VOLTAGE!
DISCONNECT ALL ELECTRIC POWER INCLUDING REMOTE DISCONNECTS AND FOLLOW LOCK OUT AND TAG PROCEDURES BEFORE SERVICING. INSURE THAT ALL MOTOR CAPACITORS HAVE DISCHARGED STORED VOLTAGE. UNITS WITH VARIABLE SPEED DRIVE, REFER TO DRIVE INSTRUCTIONS FOR CAPACITOR DISCHARGE. FAILURE TO DO THE ABOVE COULD RESULT IN DEATH OR SERIOUS INJURY.

⚠ AVERTISSEMENT
TENSION DANGEREUSE!
COUPER TOUTES LES TENSIONS ET OUVRIR LES SECTIONNEURS À DISTANCE, PUIS SUIVRE LES PROCÉDURES DE VERROUILLAGE ET DES ÉTIQUETTES AVANT TOUTE INTERVENTION. VÉRIFIER QUE TOUTS LES CONDENSATEURS DES MOTEURS SONT DÉCHARGÉS. DANS LE CAS D'UNITÉS COMPORTANT DES ENTRAÎNEMENTS À VITESSE VARIABLE, SE REPORTER AUX INSTRUCTIONS DE L'ENTRAÎNEMENT POUR DÉCHARGER LES CONDENSATEURS. UN MANQUEMENT À LA PROCÉDURE CI-DESSUS PEUT ENTRAÎNER DES BLESSURES GRAVES, VOIRE LA MORT.

⚠ ADVERTENCIA
¡VOLTAJE PELIGROSO!
DESCONECTE TODA LA ENERGÍA ELÉCTRICA, INCLUSO LAS DESCONECIONES REMOTAS Y SIGA LOS PROCEDIMIENTOS DE CIERRE Y ETIQUETADO ANTES DE PROCEDER AL SERVICIO. ASEGURESE DE QUE TODOS LOS CAPACITORES DEL MOTOR HAYAN DESCARGADO EL VOLTAJE ALMACENADO. PARA LAS UNIDADES CON TRANSMISIÓN DE VELOCIDAD VARIABLE, CONSULTE LAS INSTRUCCIONES PARA LA DESCARGA DEL CONDENSADOR.
NO REALIZAR LO ANTEDICHO PUEDE PROVOCAR LA MUERTE O LESIONES GRAVES.

DEVICE PREFIX LOCATION CODE	
AREA	LOCATION
1	CONTROL PANEL
2	NOT USED
3	CIRCUIT 1
4	CIRCUIT 2
5	CUSTOMER INSTALLED
6	UNIT WIRING

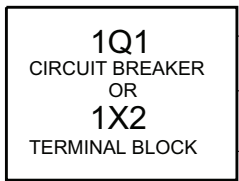
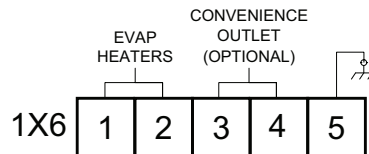

POWER HOOD

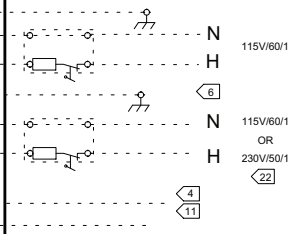



Electrical Connections

Figure 9. Field wiring, 115 to 270 ton, sheet 2

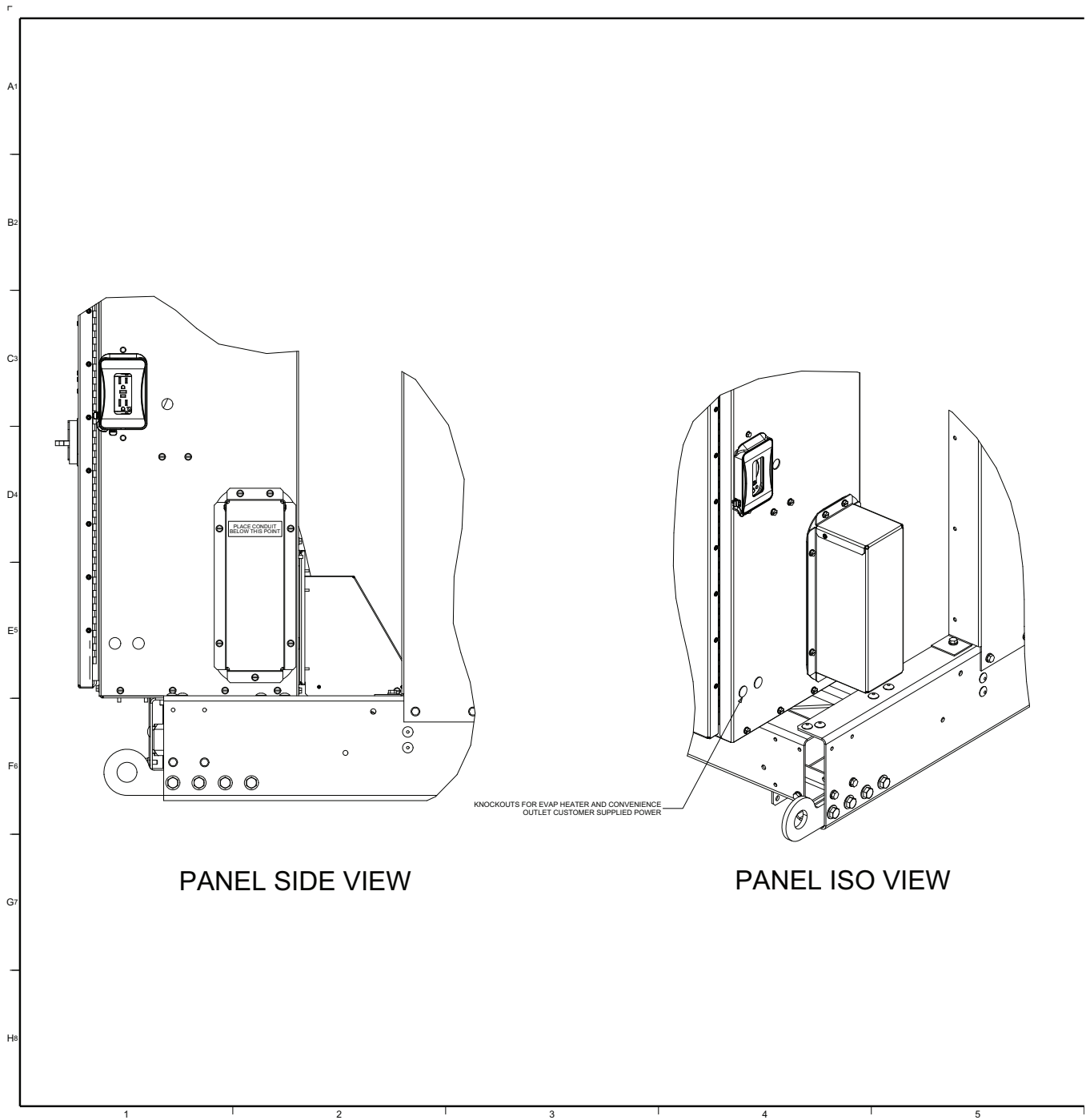

DRAWN BY: T. GRUBE		57229573	REV	A	
© TRANE DATE: 10-FEB-2022			SHEET		FIELD WIRING DIAGRAM RTAF
MASTER FILE:			2		
REVISION DATE: 10-FEB-2022					
REPLACES:					
SIMILAR TO:	THIS DRAWING IS PROPRIETARY AND SHALL NOT BE COPIED OR ITS CONTENTS DISCLOSED TO OUTSIDE PARTIES WITHOUT THE WRITTEN CONSENT OF TRANE.				
USED BY:	CAD: CREO SCHEMATICS				

GENERAL NOTES

1. CAUTION-DO NOT ENERGIZE THE UNIT UNTIL CHECK OUT AND STARTUP PROCEDURES HAVE BEEN COMPLETED.
 2. ALL MOTORS ARE PROTECTED FROM PRIMARY SINGLE PHASE FAILURES.
 3. CAUTION-TRANE PUMP CONTROL MUST BE USED TO PROVIDE PUMP CONTROL. EVAPORATOR CHILLED WATER PUMP MUST BE CONTROLLED BY THE CHILLER OUTPUT. FAILURE TO COMPLY WITH THIS REQUIREMENT MAY RESULT IN DAMAGE TO THE UNIT.
 4. SINGLE SOURCE POWER IS PROVIDED AS STANDARD ON THESE PRODUCTS. FIELD CONNECTIONS ARE MADE TO 1Q1 OR 1X2.
- WIRING REQUIREMENTS
5. RECOMMENDED FIELD WIRING CONNECTIONS ARE SHOWN BY DOTTED LINES
 6. POWER FOR THE EVAPORATOR HEATER AND/OR OPTIONAL CONVENIENCE OUTLET IS SUPPLIED BY A CUSTOMER PROVIDED POWER SUPPLY.
MAX FUSE SIZE FOR 115 TO 180T UNITS IS 20A WHEN HEATER POWER DRAW IS 1840VA.
MAX FUSE SIZE FOR 200 TO 270T UNITS IS 25A WHEN HEATER POWER DRAW IS 2040VA.
MAX FUSE SIZE FOR THE OPTIONAL CONVENIENCE OUTLET IS 25 AMPS.
 7. DO NOT RUN LOW VOLTAGE CONTROL WIRING (30 VOLTS OR LESS) IN CONDUIT WITH 110 VOLT OR HIGHER WIRING. DO NOT EXCEED THE FOLLOWING MAXIMUM RUN LENGTHS FOR A GIVEN SIZE: 14 AWG, 5000 FT; 16 AWG, 2000 FT; 18 AWG, 1000FT.
 8. SHIELDED TWISTED PAIR LEADS ARE REQUIRED FOR CONNECTIONS TO THE COMMUNICATIONS INTERFACE MODULE (1K1 AND 1K2). THE SHIELD SHOULD BE GROUNDED AT THE RTAF CONTROL PANEL END.
 9. CUSTOMER SUPPLIED POWER 115/60/1PH OR 220/60/1PH TO POWER RELAYS. MAX. FUSE SIZE IS 20 AMPS. GROUND ALL CUSTOMER SUPPLIED POWER SUPPLIES AS REQUIRED BY APPLICABLE CODES. GREEN GROUND SCREWS ARE PROVIDED IN UNIT CONTROL PANEL.
 10. WIRED TO NEXT UNIT. 22 AWG SHIELDED COMMUNICATION WIRE EQUIVALENT TO HELIX LF22P0614216 IS RECOMMENDED. THE SUM TOTAL OF ALL INTERCONNECTED CABLE SEGMENTS NOT TO EXCEED 4500 FEET. CONNECTION TOPOLOGY SHOULD BE DAISY CHAIN. REFER TO BUILDING AUTOMATION SYSTEM (BAS) COMMUNICATION INSTALLATION LITERATURE FOR END OF LINE TERMINATION RESISTOR REQUIREMENTS.
 11. ALL UNIT POWER WIRING MUST BE 600 VOLT COPPER CONDUCTORS ONLY AND HAVE A MINIMUM TEMPERATURE INSULATION RATING OF 90 DEGREE C. REFER TO UNIT NAMEPLATE FOR MINIMUM CIRCUIT AMPACITY AND MAXIMUM OVERCURRENT PROTECTION DEVICE. PROVIDE AN EQUIPMENT GROUND IN ACCORDANCE WITH APPLICABLE ELECTRIC CODES. REFER TO WIRERANGE TABLE FOR LUG SIZES.
 12. ALL FIELD WIRING MUST BE IN ACCORDANCE WITH NATIONAL ELECTRIC CODE AND LOCAL REQUIREMENTS.
- CONTACT RATINGS AND REQUIREMENTS
13. CONTACT RATINGS AND REQUIREMENTS
 14. WIRED TO CUSTOMER CHILLED WATER SET POINT 2-10 VDC OR 4-20 mA.
 15. WIRED TO CUSTOMER CURRENT LIMIT SET POINT 2-10 VDC.
 16. WIRED TO CUSTOMER COMPRESSOR % RLA OUTPUT 2-10 VDC.
 17. ALL CUSTOMER CONTROL CIRCUIT WIRING MUST BE COPPER CONDUCTORS ONLY AND HAVE A MINIMUM INSULATION RATING OF 300 VOLTS. EXCEPT AS NOTED, ALL CUSTOMER WIRING CONNECTIONS ARE MADE TO CIRCUIT BOARD MOUNTED BOX LUGS WITH A WIRE RANGE OF 14 TO 18 AWG OR DIN RAIL MOUNTED SPRING FORCE TERMINALS.
 18. UNIT PROVIDED DRY CONTACTS FOR THE CONDENSER/CHILLED WATER PUMP CONTROL. RELAYS ARE RATED FOR 7.2 AMPS RESISTIVE, 2.88 AMPS PILOT DUTY, OR 1/3 HP, 7.2 FLA AT 120 VOLTS 60 HZ, CONTACTS ARE RATED FOR 5 AMPS GENERAL PURPOSE DUTY 240 VOLTS.
 19. CUSTOMER SUPPLIED CONTACTS FOR ALL LOW VOLTAGE CONNECTIONS MUST BE COMPATABLE WITH DRY CIRCUIT 24 VOLTS DC FOR A 12 mA RESISTIVE LOAD. SILVER OR GOLD PLATED CONTACTS RECOMMENDED.
 20. THE CONTACTS FOR AUTO STOP AND EMERGENCY STOP SWITCHES ARE JUMPED AT THE FACTORY BY JUMPERS 1W1 & 1W2 TO ENABLE UNIT OPERATION. IF REMOTE CONTROL IS DESIRED, REMOVED THE JUMPERS AND CONNECT TO THE DESIRED CONTROL CIRCUIT.
 21. SOLID OVALS REPRESENT MAX NUMBER OF CONDITS AND/OR CABLE GLANDS USED.
 22. FIELD WIRING REQUIRED ONLY WITH FIELD INSTALLED PUMP OPTION.
 23. 400V, 50Hz UNITS WILL BE FACTORY WIRED TO UTILIZE 230V ACROSS THE HEATERS.



Electrical Connections

Figure 10. Field wiring, 280 to 520 ton, sheet 1

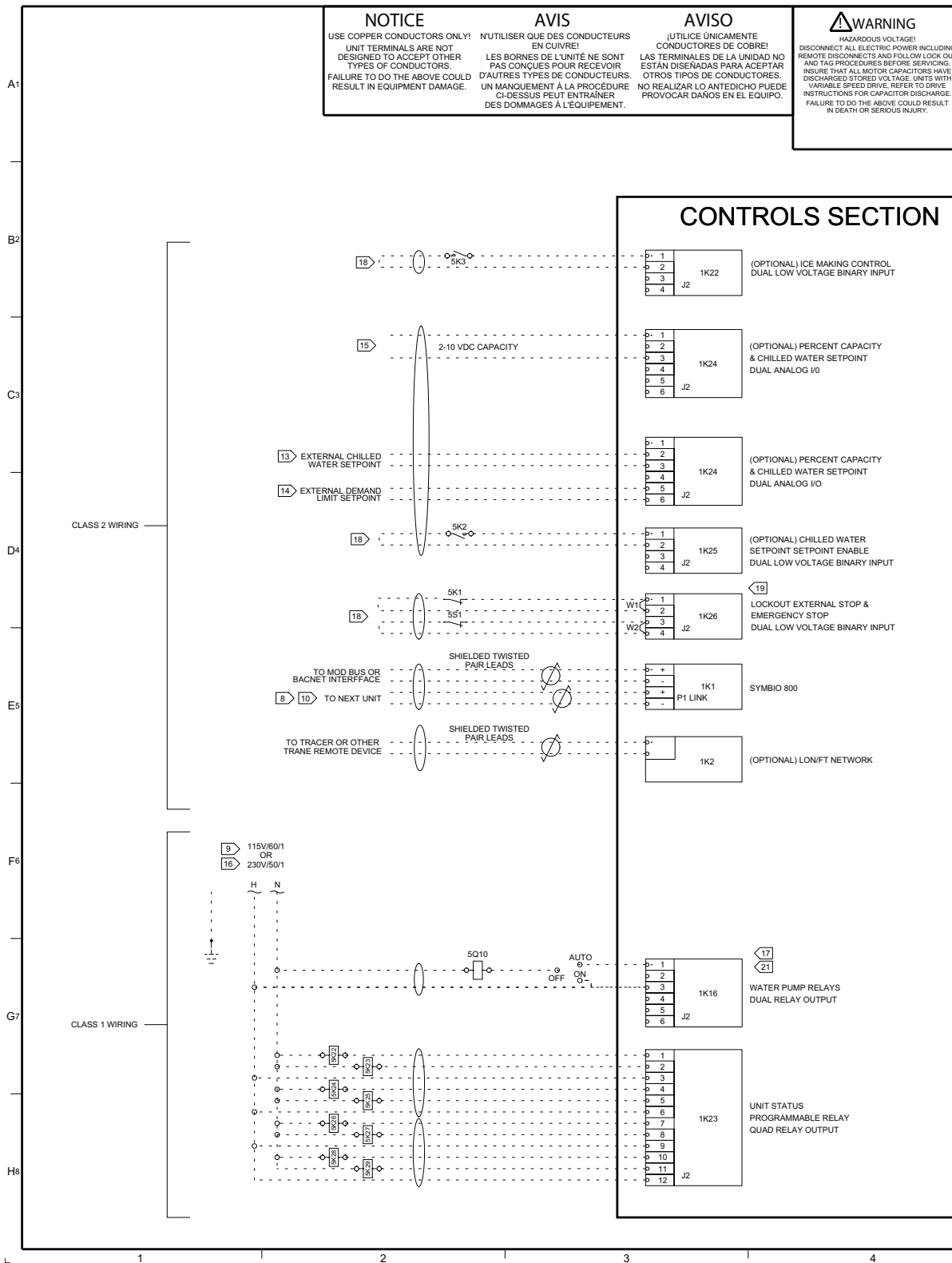

AVERTISSEMENT
 TENSION DANGEREUSE!
 COUPER TOUTES LES TENSIONS ET OUVRIR LES SECTIONNEURS À DISTANCE, PUIS SURVIRE LES PROCÉDURES DE VERROUILLAGE ET DES ÉTIQUETTES AVANT TOUTE INTERVENTION. VÉRIFIER QUE TOUTS LES CONDENSATEURS DES MOTEURS SONT DÉCHARGÉS. DANS LE CAS D'UNITES COMPORTANT DES ENTRAÎNEMENTS À VITESSE VARIABLE, SE REPORTER AUX INSTRUCTIONS DE L'ENTRAÎNEMENT POUR DÉCHARGER LES CONDENSATEURS.
 UN MANQUEMENT À LA PROCÉDURE CI-DESSUS PEUT ENTRAÎNER DES BLESSURES GRAVES, VOIRE LA MORT.

ADVERTENCIA
 ¡VOLTAJE PELIGROSO!
 DESCONECTE TODA LA ENERGÍA ELÉCTRICA, INCLUIDO LAS DESCONEXIONES REMOTAS Y SIGA LOS PROCEDIMIENTOS DE CIERRE Y ETIQUETADO ANTES DE PROCEDER AL SERVICIO. ASEGURESE DE QUE TODOS LOS CAPACITORES DEL MOTOR HAYAN DESCARGADO EL VOLTAJE ALMACENADO PARA LAS UNIDADES CON TRANSMISIÓN DE VELOCIDAD VARIABLE. CONSULTE LAS INSTRUCCIONES PARA LA DESCARGA DEL CONDENSADOR.
 NO REALIZAR LO ANTEDICHO PUEDE PROVOCAR LA MUERTE O LESIONES GRAVES.

DRAWN BY: T. GRUBE
 © TRANE DATE: 10-FEB-2022
 MASTER FILE:
 REVISION DATE: 10-FEB-2022
 REPLACES:
 SIMILAR TO:
 USED BY:

TRANE®
 THIS DRAWING IS PROPRIETARY AND SHALL NOT BE COPIED OR ITS CONTENTS DISCLOSED TO OUTSIDE PARTIES WITHOUT THE WRITTEN CONSENT OF TRANE
 CAD: CREO SCHEMATICS

57229574 SHEET 1 REV A

FIELD WIRING DIAGRAM
 RTAF

AREA	LOCATION
1	CONTROL PANEL #1
2	CONTROL PANEL #2
3	CIRCUIT 1
4	CIRCUIT 2
5	CUSTOMER INSTALLED
6	UNIT WIRING

POWER SECTION

280T-520T DUAL POINT POWER <4>

POWER CONNECTION	SELECTION CRITERIA	CUSTOMER LUG SIZE
TERMINAL BLOCK	ALL	(2) 500 MCM - #4
CIRCUIT BREAKER	MOP = 300 - 600	(2) 500 MCM - 2/0
	MOP = 700 - 800	(3) 500 MCM - 3/0
	MOP = 900 - 1200	(4) 500 MCM - 3/0

280T-500T SINGLE POINT POWER <4>

POWER CONNECTION	SELECTION CRITERIA	CUSTOMER LUG SIZE
TERMINAL BLOCK	ALL	(4) 600 MCM - #2
CIRCUIT BREAKER	MOP = 500 - 800	(3) 500 MCM - 3/0
	MOP = 900 - 1200	(4) 500 MCM - 3/0

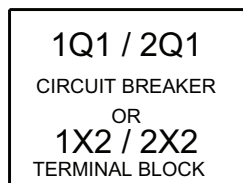
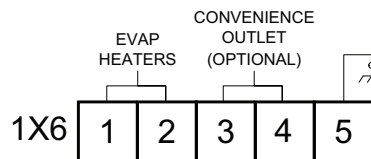

POWER HOOD

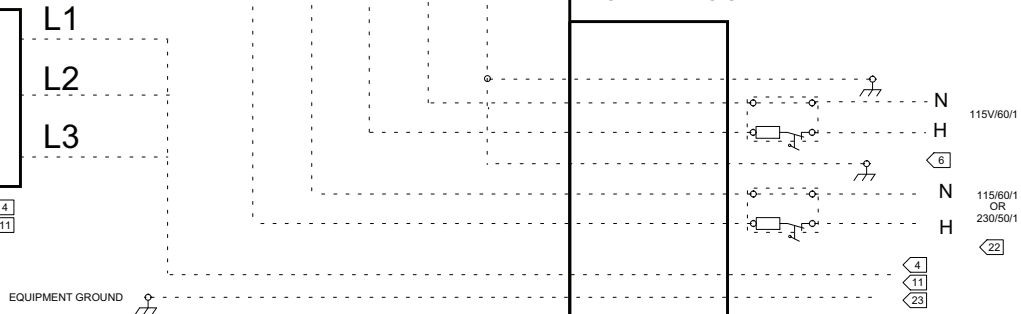
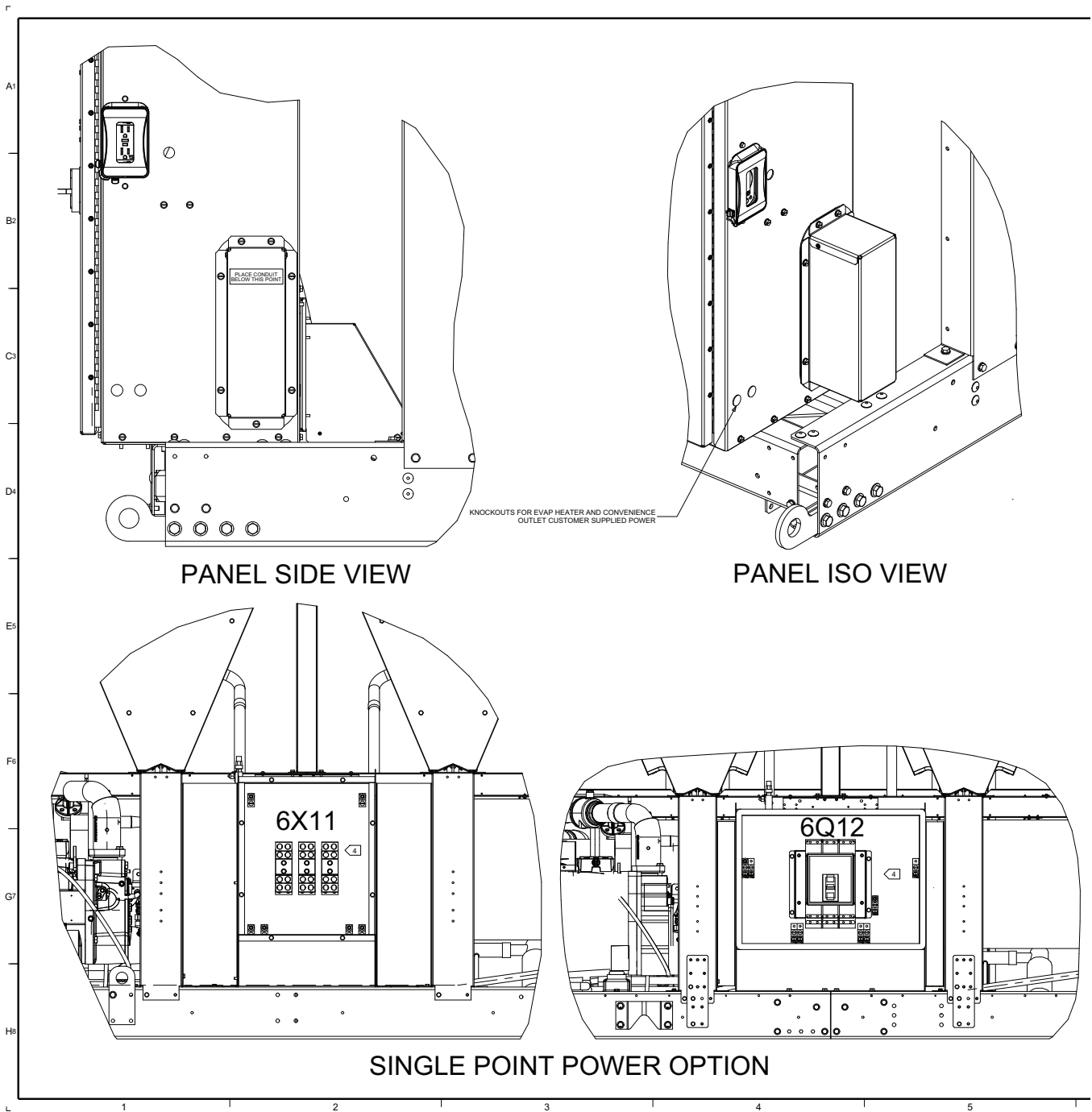

Figure 11. Field wiring, 280 to 520 ton, sheet 2



DRAWN BY: T.GRUBE	<p>THIS DRAWING IS PROPRIETARY AND SHALL NOT BE COPIED OR ITS CONTENTS DISCLOSED TO OUTSIDE PARTIES WITHOUT THE WRITTEN CONSENT OF TRANE.</p> <p>CAD: CREO SCHEMATICS</p>	<p>57229574</p> <p>FIELD WIRING DIAGRAM RTAF</p>	REV
© TRANE DATE: 10-FEB-2022			SHEET
MASTER FILE:			2
REVISION DATE: 10-FEB-2022			A
REPLACES:			
SIMILAR TO:			
USED BY:			

GENERAL NOTES

1. CAUTION-DO NOT ENERGIZE THE UNIT UNTIL CHECK OUT AND STARTUP PROCEDURES HAVE BEEN COMPLETED.
2. ALL MOTORS ARE PROTECTED FROM PRIMARY SINGLE PHASE FAILURES.
3. CAUTION-TRANE PUMP CONTROL MUST BE USED TO PROVIDE PUMP CONTROL. EVAPORATOR CHILLED WATER PUMP MUST BE CONTROLLED BY THE CHILLER OUTPUT. FAILURE TO COMPLY WITH THIS REQUIREMENT MAY RESULT IN DAMAGE TO THE UNIT.
4. FOR DUAL POINT POWER OPTION ON 280T-520T UNITS FIELD CONNECTIONS ARE MADE TO 1Q1/1X2 ON PANEL 1 AND 2Q1/2X2 IN PANEL 2. FOR SINGLE POINT POWER OPTION ON 280T-500T UNITS FIELD CONNECTIONS ARE MADE TO 6X11 OR 6Q12 IN SINGLE POINT POWER BOX.

WIRING REQUIREMENTS

5. RECOMMENDED FIELD WIRING CONNECTIONS ARE SHOWN BY DASHED LINES
6. POWER FOR THE EVAPORATOR HEATER AND/OR OPTIONAL CONVENIENCE OUTLET IS SUPPLIED BY A CUSTOMER SUPPLIED POWER SUPPLY. MAX FUSE SIZE IS 30A WHEN HEATER POWER DRAW IS 2440VA. MAX FUSE SIZE FOR THE OPTIONAL CONVENIENCE OUTLET IS 25 AMPS.
7. DO NOT RUN LOW VOLTAGE CONTROL WIRING (30 VOLTS OR LESS) IN CONDUIT WITH 110 VOLT OR HIGHER WIRING. DO NOT EXCEED THE FOLLOWING MAXIMUM RUN LENGTHS FOR A GIVEN SIZE: 14 AWG, 5000 FT; 16 AWG, 2000 FT; 18 AWG, 1000FT.
8. SHIELDED TWISTED PAIR LEADS ARE REQUIRED FOR CONNECTIONS TO THE COMMUNICATIONS INTERFACE MODULE (1K1 AND 1K2). THE SHIELD SHOULD BE GROUNDED AT THE RTAF CONTROL PANEL END.
9. CUSTOMER SUPPLIED POWER 115/60/1PH OR 230/50/1PH TO POWER RELAYS. MAX. FUSE SIZE IS 20 AMPS. GROUND ALL CUSTOMER SUPPLIED POWER SUPPLIES AS REQUIRED BY APPLICABLE CODES. GREEN GROUND SCREWS ARE PROVIDED IN UNIT CONTROL PANEL.
10. WIRED TO NEXT UNIT: 22 AWG SHIELDED COMMUNICATION WIRE EQUIVALENT TO HELIX LP22P0014216 RECOMMENDED. THE SUM TOTAL OF ALL INTERCONNECTED CABLE SEGMENTS NOT TO EXCEED 4500 FEET. CONNECTION TOPOLOGY SHOULD BE DASHY CHAIN. REFER TO BUILDING AUTOMATION SYSTEM (BAS) COMMUNICATION INSTALLATION LITERATURE FOR END OF LINE TERMINATION RESISTOR REQUIREMENTS.
11. ALL UNIT POWER WIRING MUST BE 600 VOLT COPPER CONDUCTORS ONLY AND HAVE A MINIMUM TEMPERATURE INSULATION RATING OF 90 DEGREE C. REFER TO UNIT NAMEPLATE FOR MINIMUM CIRCUIT AMPACITY AND MAXIMUM OVERCURRENT PROTECTION DEVICE. PROVIDE AN EQUIPMENT GROUND IN ACCORDANCE WITH APPLICABLE ELECTRIC CODES. REFER TO WIRERANGE TABLE FOR LUG SIZES.
12. ALL FIELD WIRING MUST BE IN ACCORDANCE WITH NATIONAL ELECTRIC CODE AND LOCAL REQUIREMENTS.

CONTACT RATINGS AND REQUIREMENTS

13. WIRED TO CUSTOMER CHILLED WATER SET POINT 2-10 VDC FROM FACTORY. SEE OPERATING INSTRUCTIONS TO CONFIGURE FOR 4-20mA.
14. WIRED TO CUSTOMER CURRENT LIMIT SET POINT 2-10 VDC FROM FACTORY. SEE OPERATING INSTRUCTIONS TO CONFIGURE FOR 4-20mA.
15. WIRED TO CUSTOMER COMPRESSOR % RLA OUTPUT 2-10 VDC.
16. ALL CUSTOMER CONTROL CIRCUIT WIRING MUST BE COPPER CONDUCTORS ONLY AND HAVE A MINIMUM INSULATION RATING OF 300 VOLTS. EXCEPT AS NOTED. ALL CUSTOMER WIRING CONNECTIONS ARE MADE TO CIRCUIT BOARD MOUNTED BOX LUGS WITH A WIRE RANGE OF 14 TO 18 AWG OR DIN RAIL MOUNTED SPRING FORCE TERMINALS.
17. UNIT PROVIDED DRY CONTACTS FOR THE CONDENSER/CHILLED WATER PUMP CONTROL. RELAY CONTACT RATINGS FOR 120 VAC 7.2 AMPS RESISTIVE, 2.88 AMPS PILOT DUTY, OR 1/3 HP, 7.2 FLA. CONTACTS ARE RATED FOR 5 AMPS GENERAL PURPOSE DUTY 240 VOLTS.
18. CUSTOMER SUPPLIED CONTACTS FOR ALL LOW VOLTAGE CONNECTIONS MUST BE COMPATABLE WITH DRY CIRCUIT 24 VOLTS DC FOR A 12 mA RESISTIVE LOAD. SILVER OR GOLD PLATED CONTACTS RECOMMENDED.
19. THE CONTACTS FOR AUTO STOP AND EMERGENCY STOP SWITCHES ARE JUMPERED AT THE FACTORY BY JUMPERS 1W1 & 1W2 TO ENABLE UNIT OPERATION. IF REMOTE CONTROL IS DESIRED, REMOVED THE JUMPERS AND CONNECT TO THE DESIRED CONTROL CIRCUIT.
20. SOLID OVALS REPRESENT MAX NUMBER OF CONDUITS AND/OR CABLE GLANDS USED.
21. FIELD WIRING REQUIRED ONLY WITH FIELD INSTALLED PUMP OPTION.
22. 400V, 50Hz UNITS WILL BE FACTORY WIRED TO UTILIZE 230V ACROSS THE EVAP HEATERS.
23. FIELD WIRING TO 1Q1/2Q1/1X1/2X1 ONLY NEEDED ON DUAL POWER POINT UNITS.

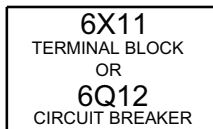

L1 | L2 | L3

EQUIPMENT GROUND

Dimensions

Service Clearances

Figure 12. RTAF service clearances

NO OBSTRUCTIONS ABOVE UNIT

Unit sizes 115 to 270 tons:

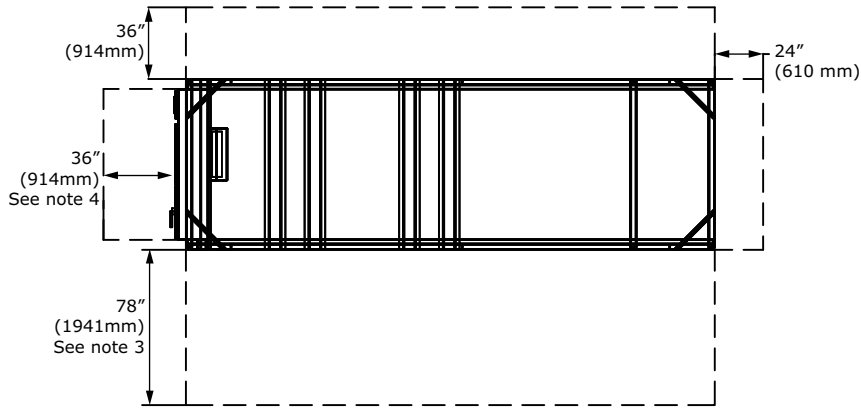

Unit sizes 280 to 520 tons:

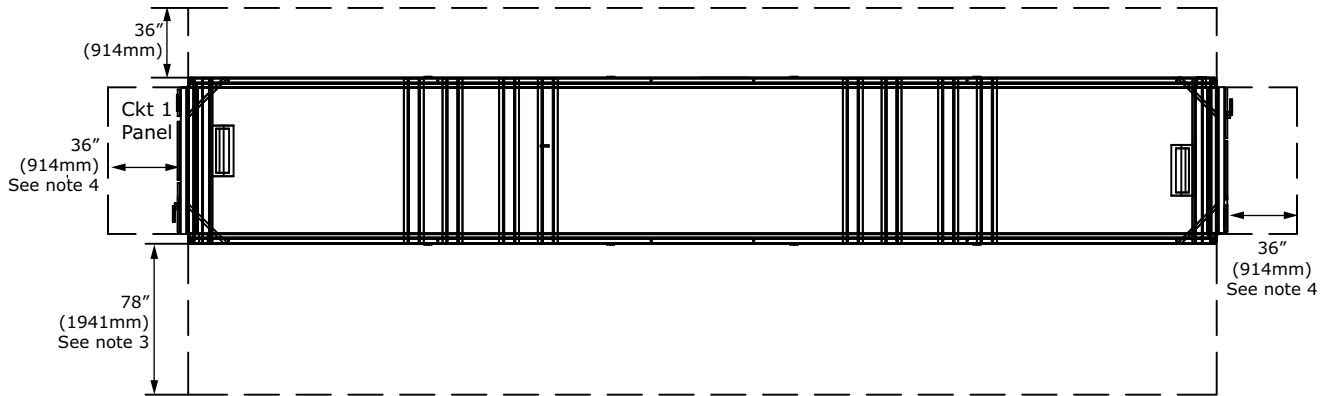

Notes:

- 1. Area above unit required for operation, maintenance, panel access and airflow. **NO OBSTRUCTIONS ABOVE UNIT.**
- 2. For installations with obstructions or multiple units, see *Close Spacing and Restricted Airflow Bulletin RLC-PRB037*-EN.*
- 3. Clearance of 78" (1981 mm) on the side of the unit is required for coil replacement. If sufficient clearance is not available on this side of the unit, coil replacement should be performed through top of unit.
- 4. A full 36" (914 mm) clearance is required in front of the control panels. Must be measured from front of panel, not end of unit base.
- 5. I'veClearances shown are sufficient for tube pull.

Unit Dimensions

Standard Units

Figure 13. RTAF unit dimensions – 115, 130 ton

INLET/OUTLET WATER CONNECTION 4" (100mm) / 4" (100mm)

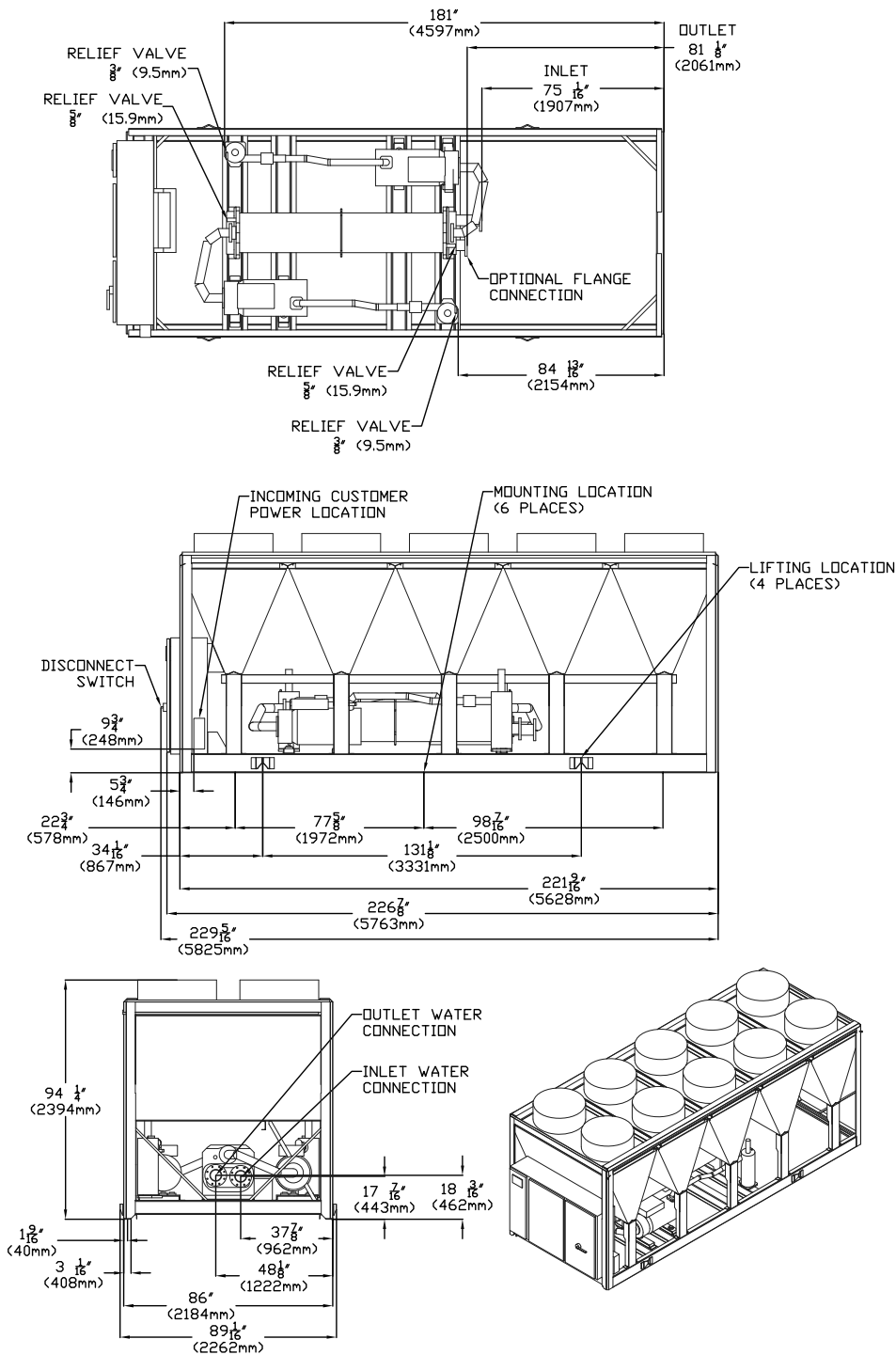
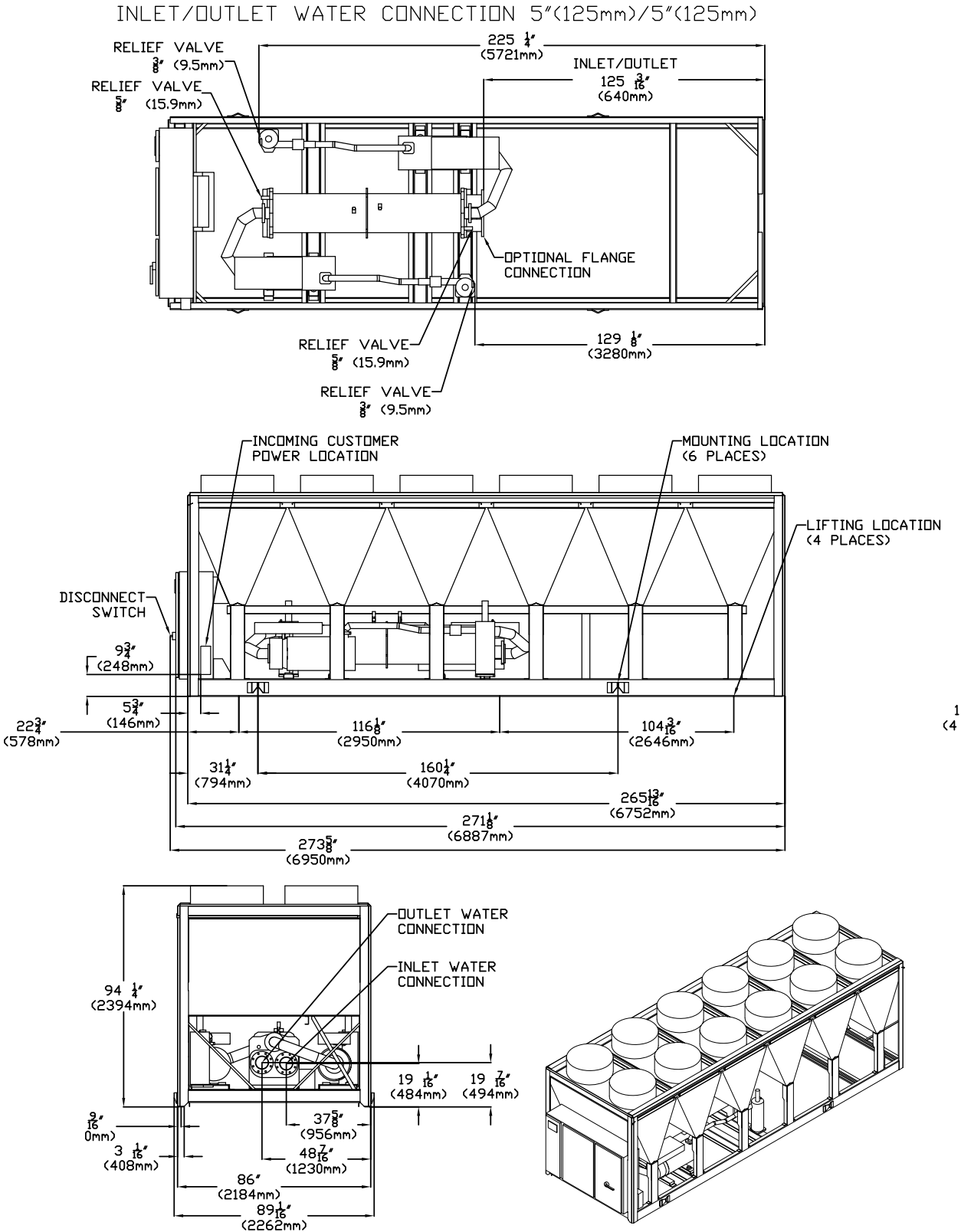

Figure 14. RTAF unit dimensions – 150, 170, 180 ton



1
(4)

Figure 15. RTAF unit dimensions – 200, 215 ton

Figure 16. RTAF unit dimensions – 230, 250, 270 ton

INLET/OUTLET WATER CONNECTION 6" (150mm) / 6" (150mm)

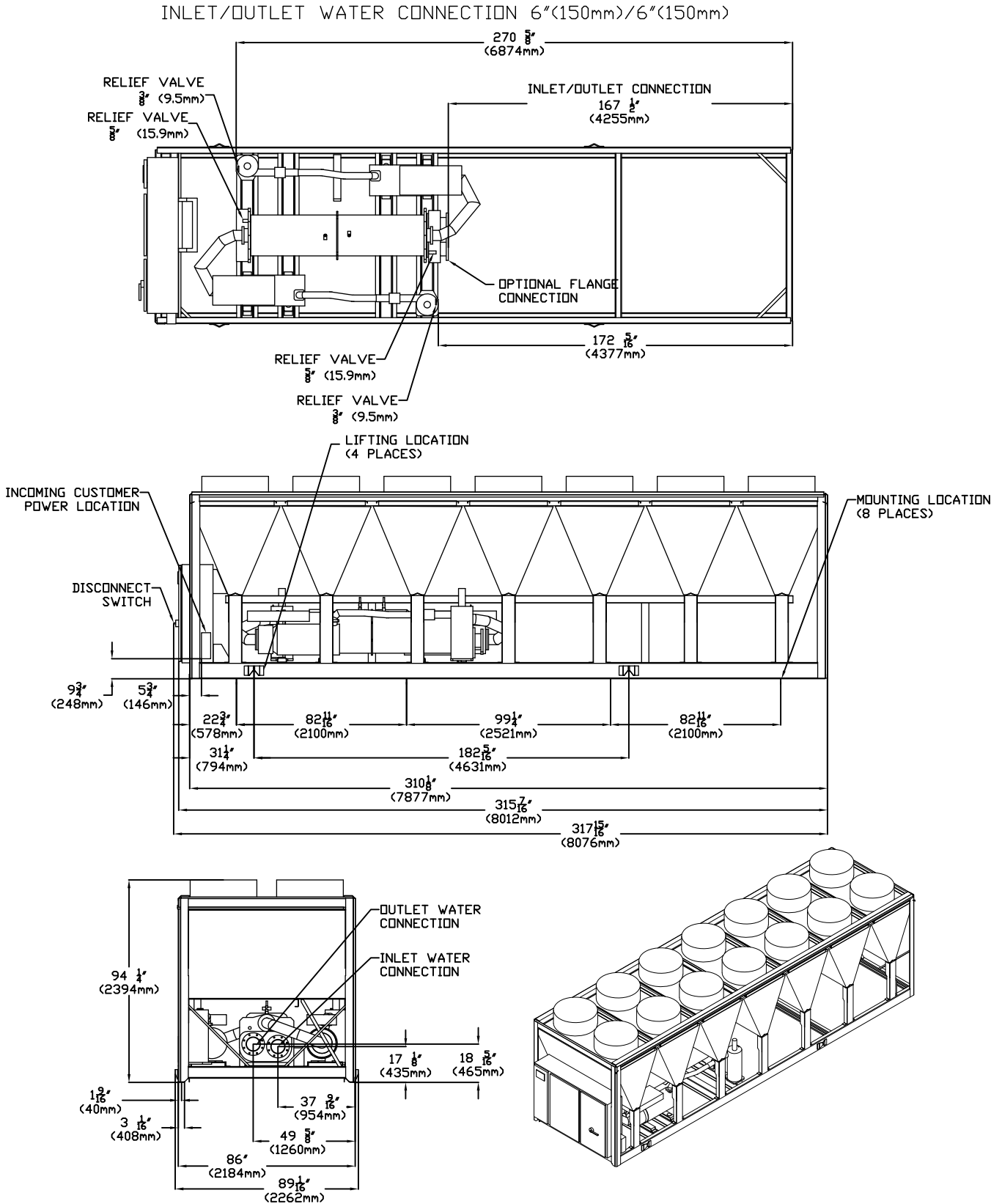
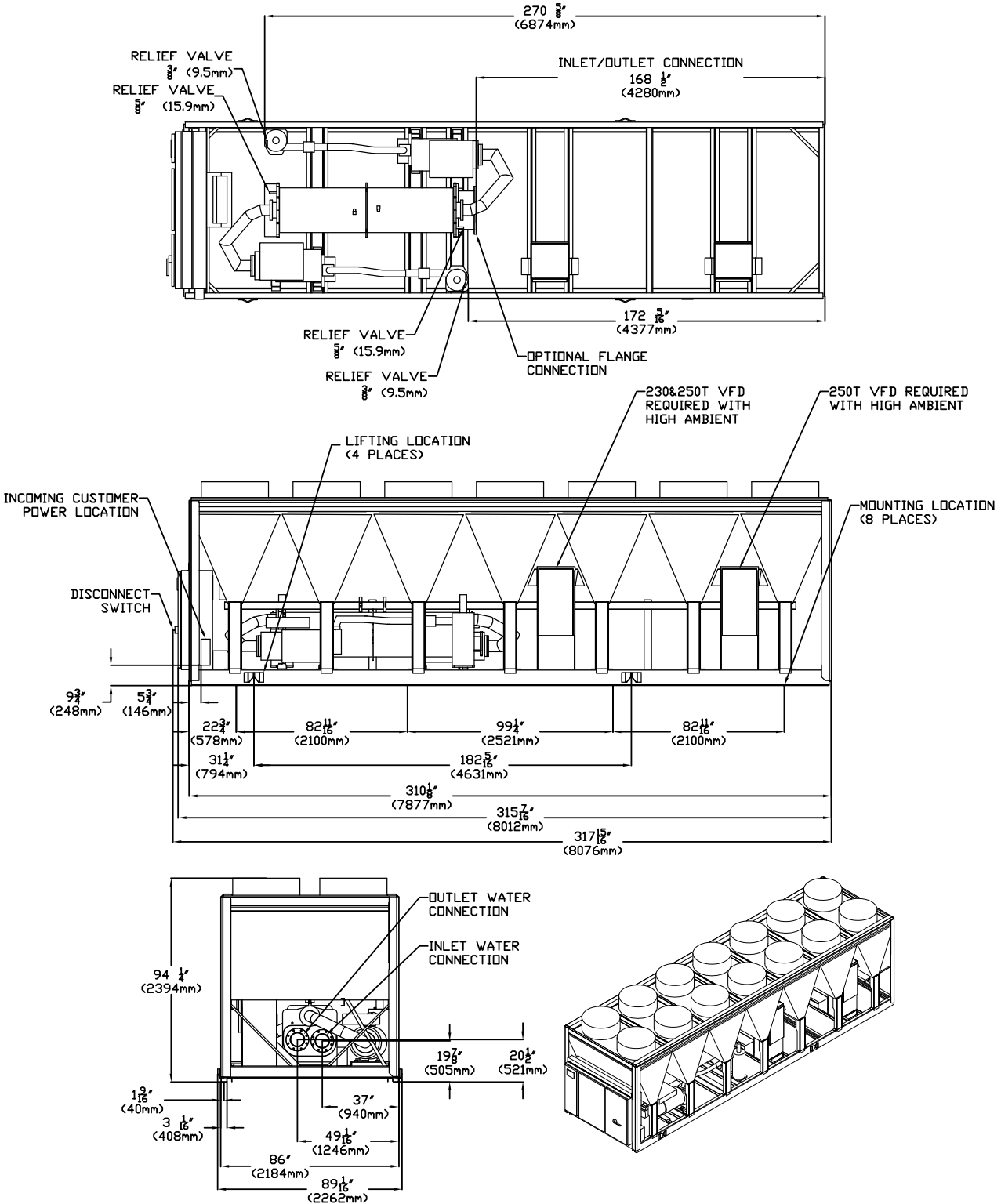
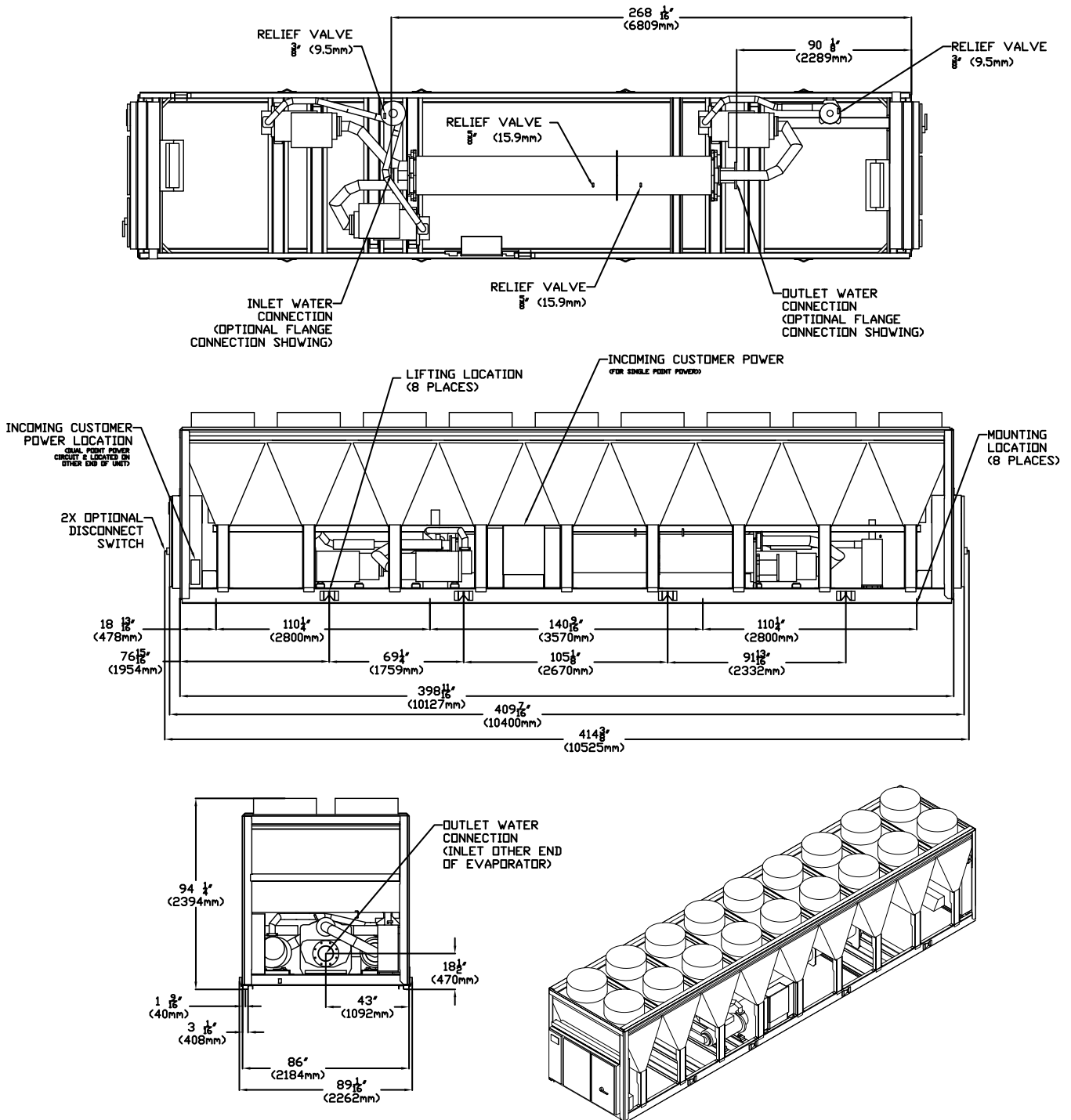

Figure 17. RTAF unit dimensions – 280 ton

INLET/OUTLET WATER CONNECTION 8" (200mm) / 8" (200mm)





Dimensions

Figure 18. RTAF unit dimensions – 310, 350, 390 ton

INLET/OUTLET WATER CONNECTION 8" (200mm) / 8" (200mm)

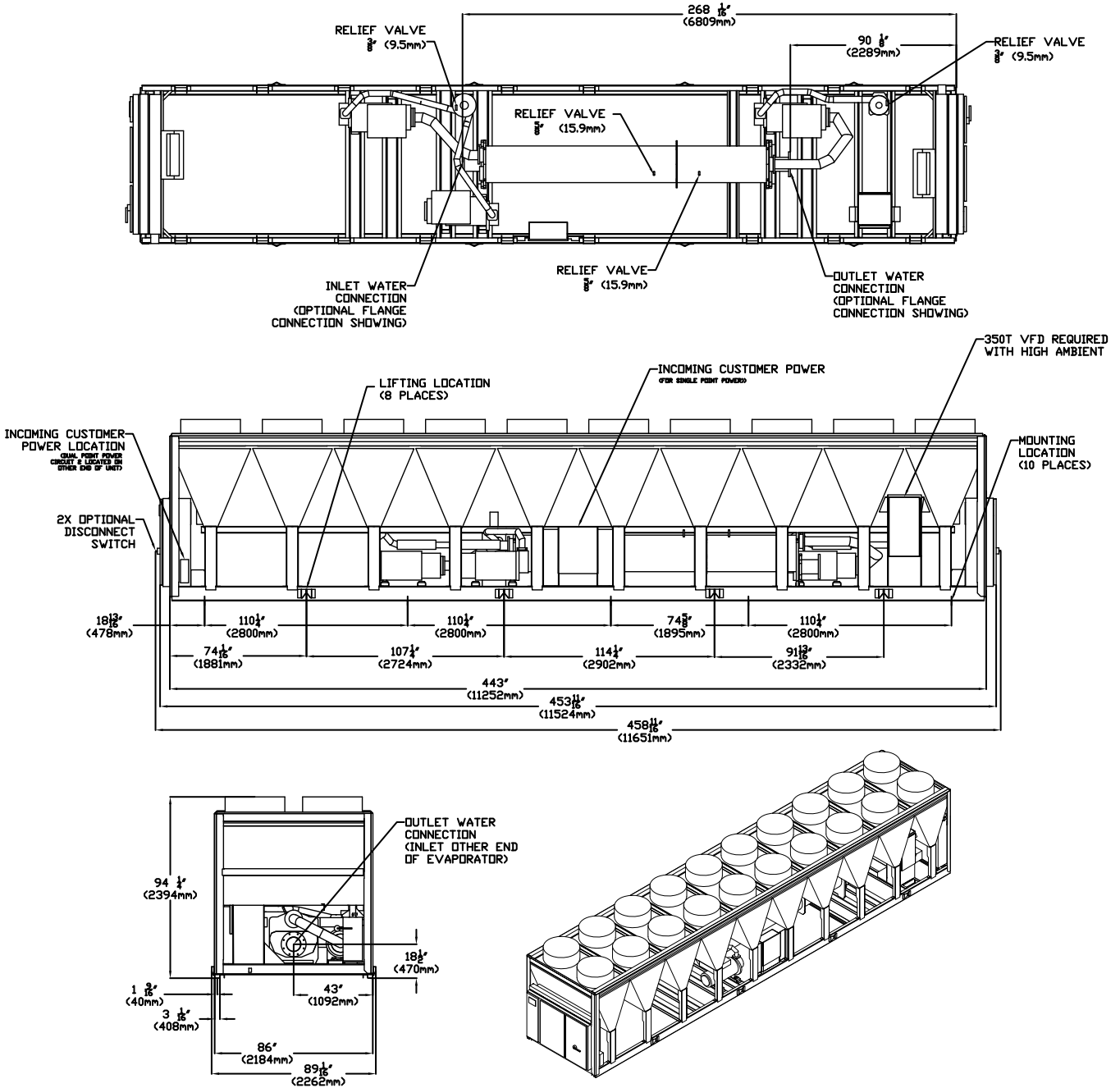
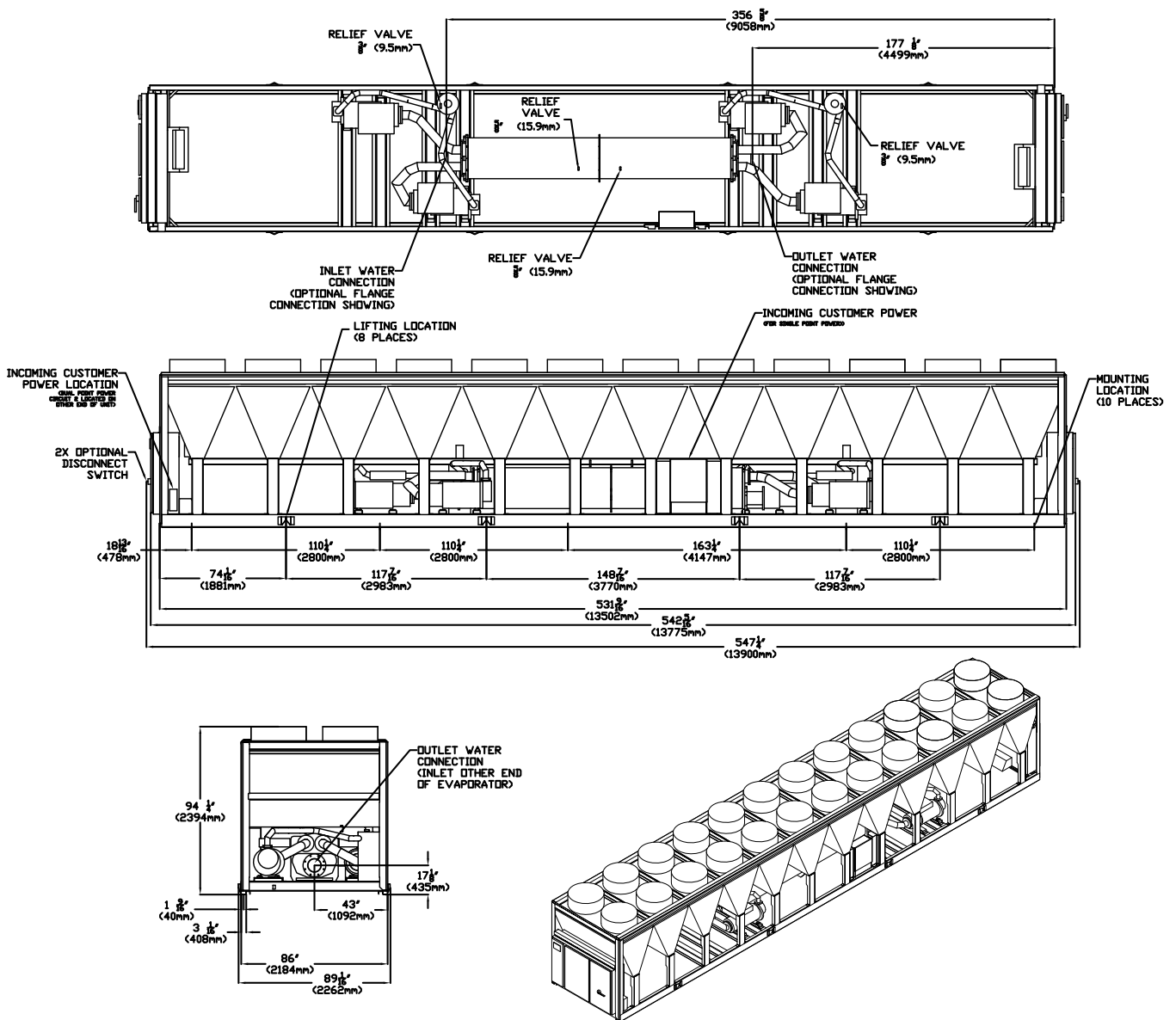

Figure 19. RTAF unit dimensions – 410 ton

INLET/OUTLET WATER CONNECTION 8" (200mm)/8" (200mm)





Dimensions

Figure 20. RTAF unit dimensions — 450, 500, 520 ton

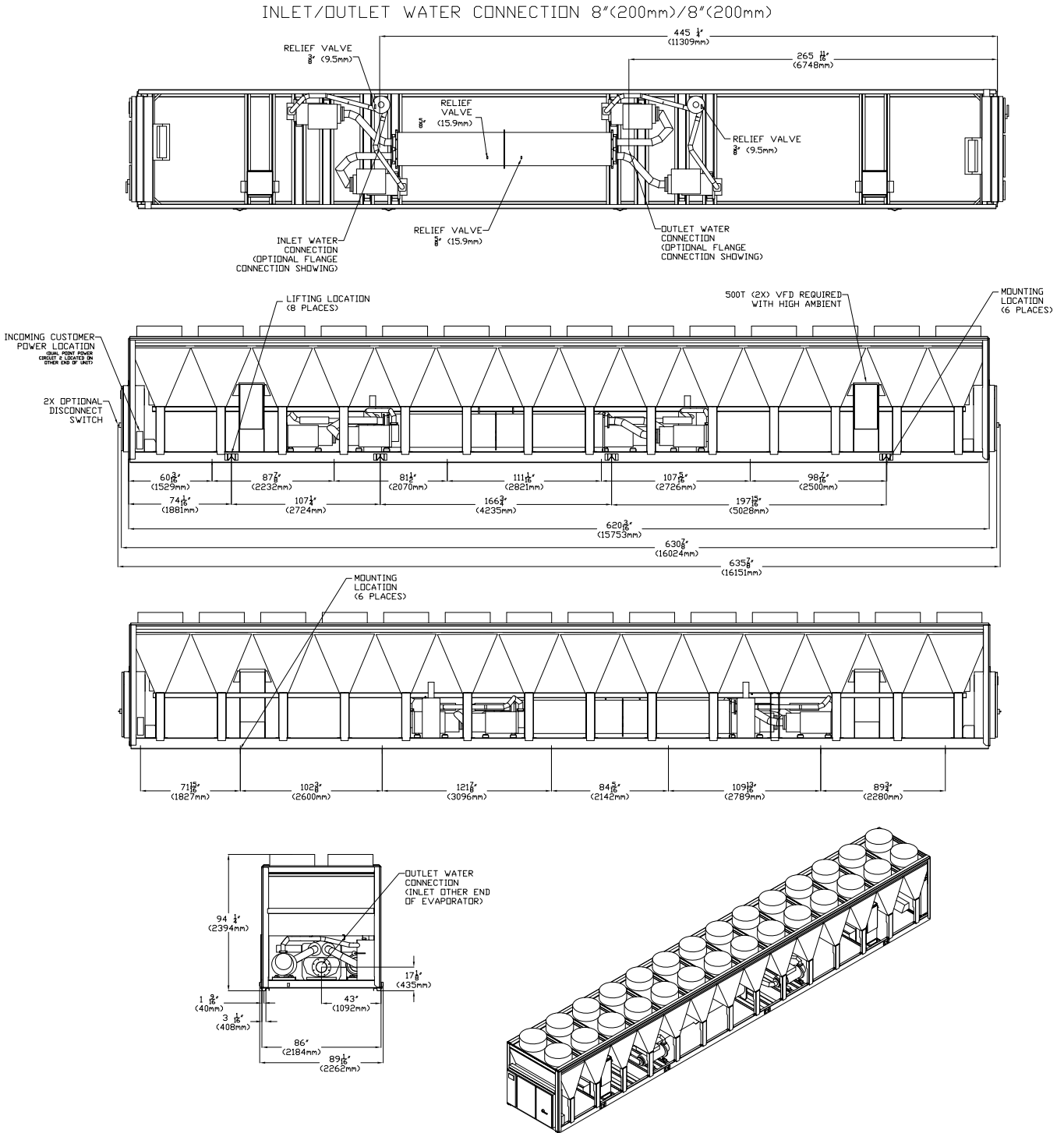

Units with Free-Cooling Option

Dimensions in this section apply to units with free-cooling option (model number digit 42 = F) only. Any dimensions not shown on these figures are the same as standard unit dimensions found in the previous section.

Figure 21. RTAF unit dimensions – 115, 130 ton with free-cooling

115 & 130T

FREE COOLING OPTION
INLET/OUTLET WATER CONNECTION 4" (100mm) / 4" (100mm)

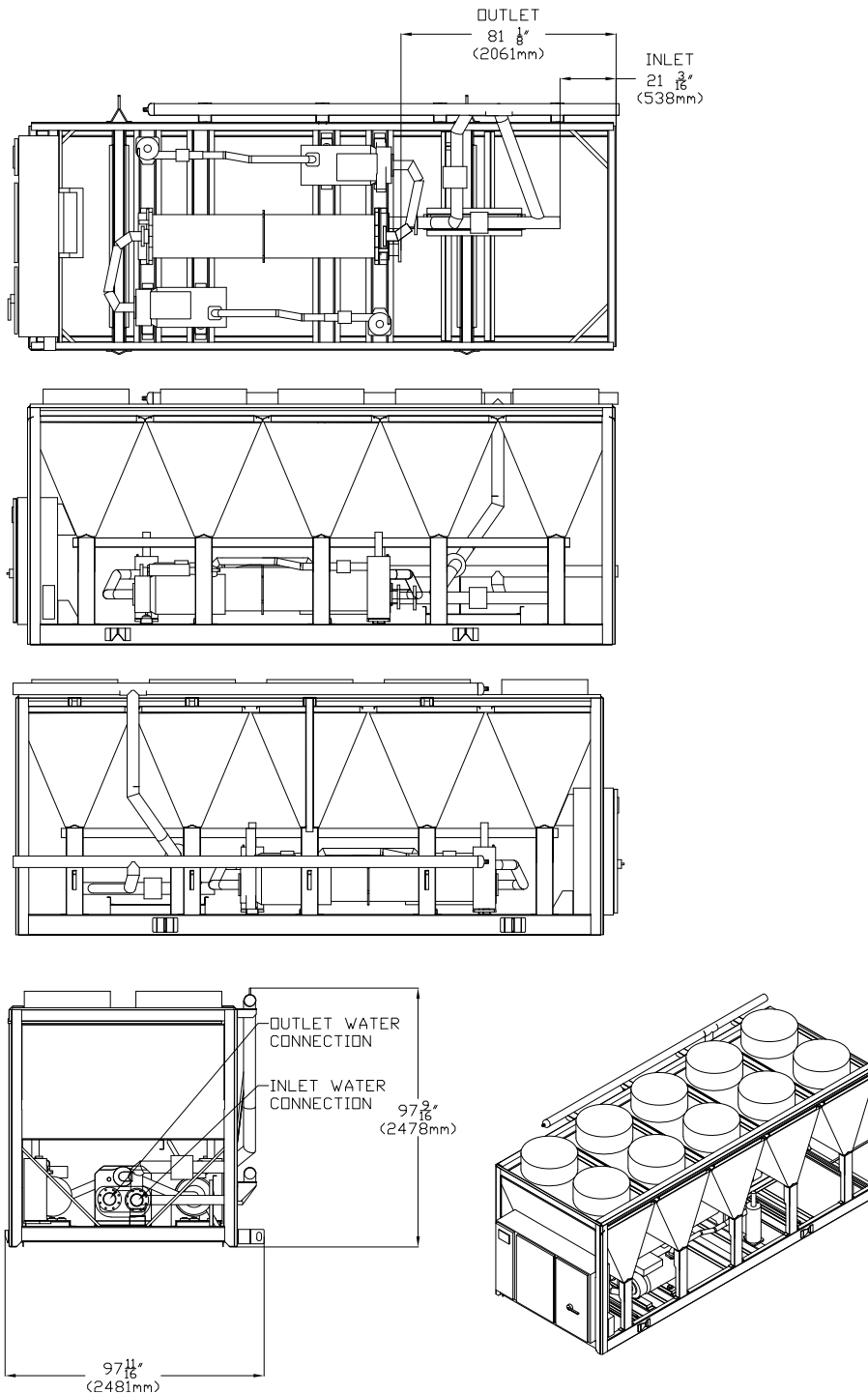



Dimensions

Figure 22. RTAF unit dimensions – 150, 170, 180 ton with free-cooling

150T 170T & 180T

FREE COOLING OPTION

INLET/OUTLET WATER CONNECTION 5"(125mm)/5"(125mm)

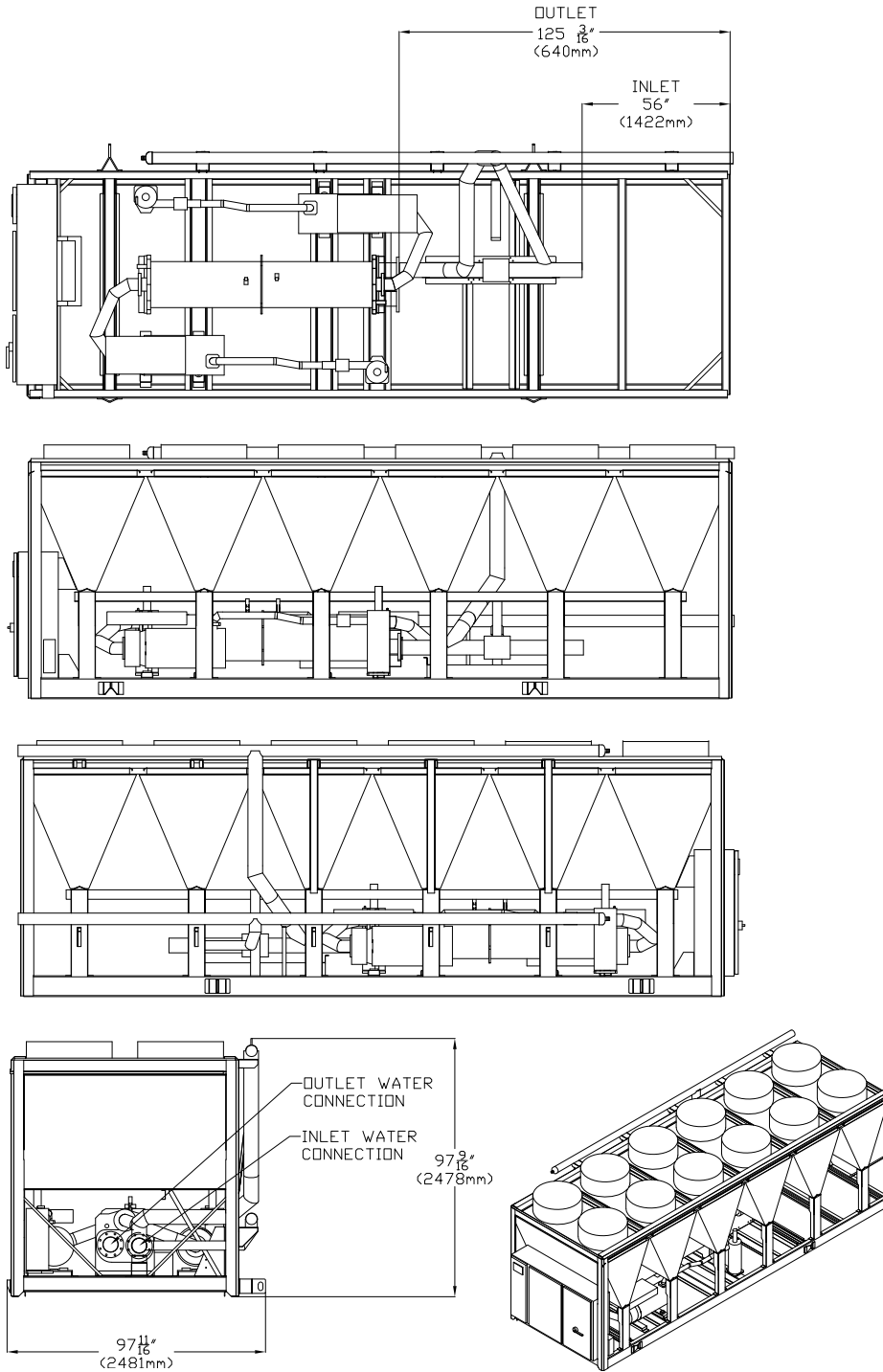
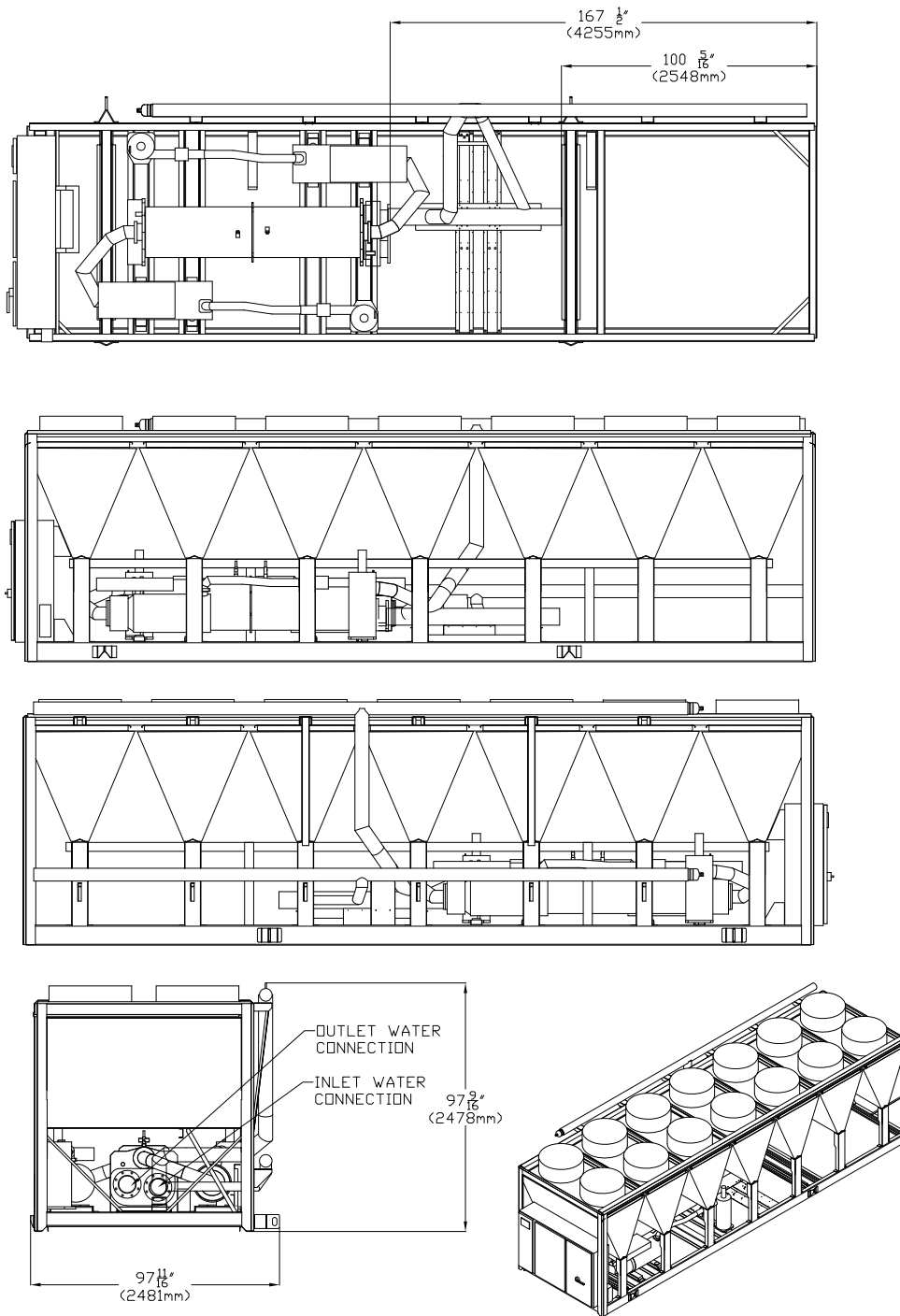

Figure 23. RTAF unit dimensions – 200, 215 ton with free-cooling

200 & 215T
FREE COOLING OPTION
INLET/OUTLET WATER CONNECTION 6" (150mm) / 6" (150mm)





Dimensions

Figure 24. RTAF unit dimensions – 230, 250 ton with free-cooling

230 & 250T

FREE COOLING OPTION

INLET/OUTLET WATER CONNECTION 6" (150mm) / 6" (150mm)

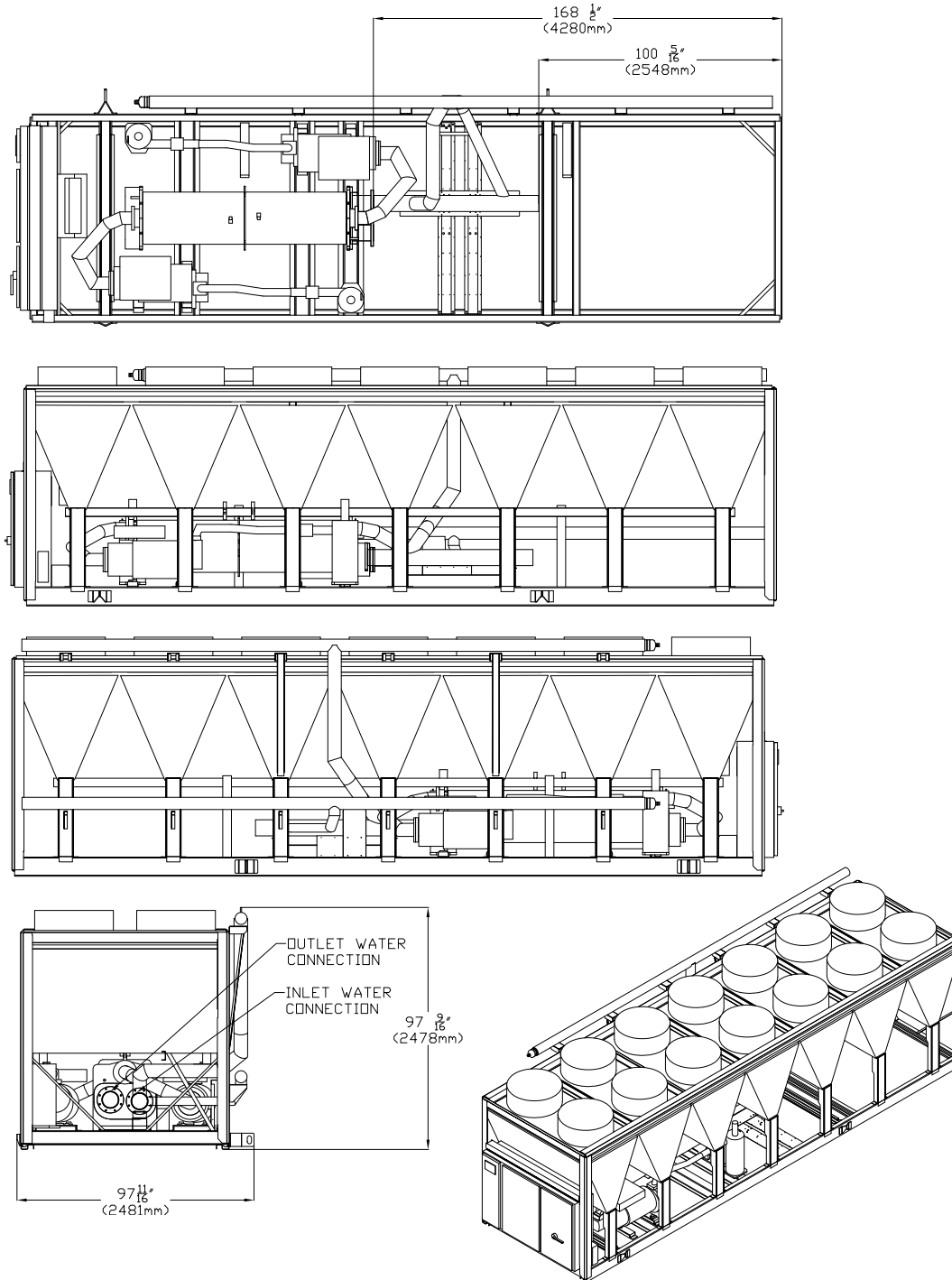
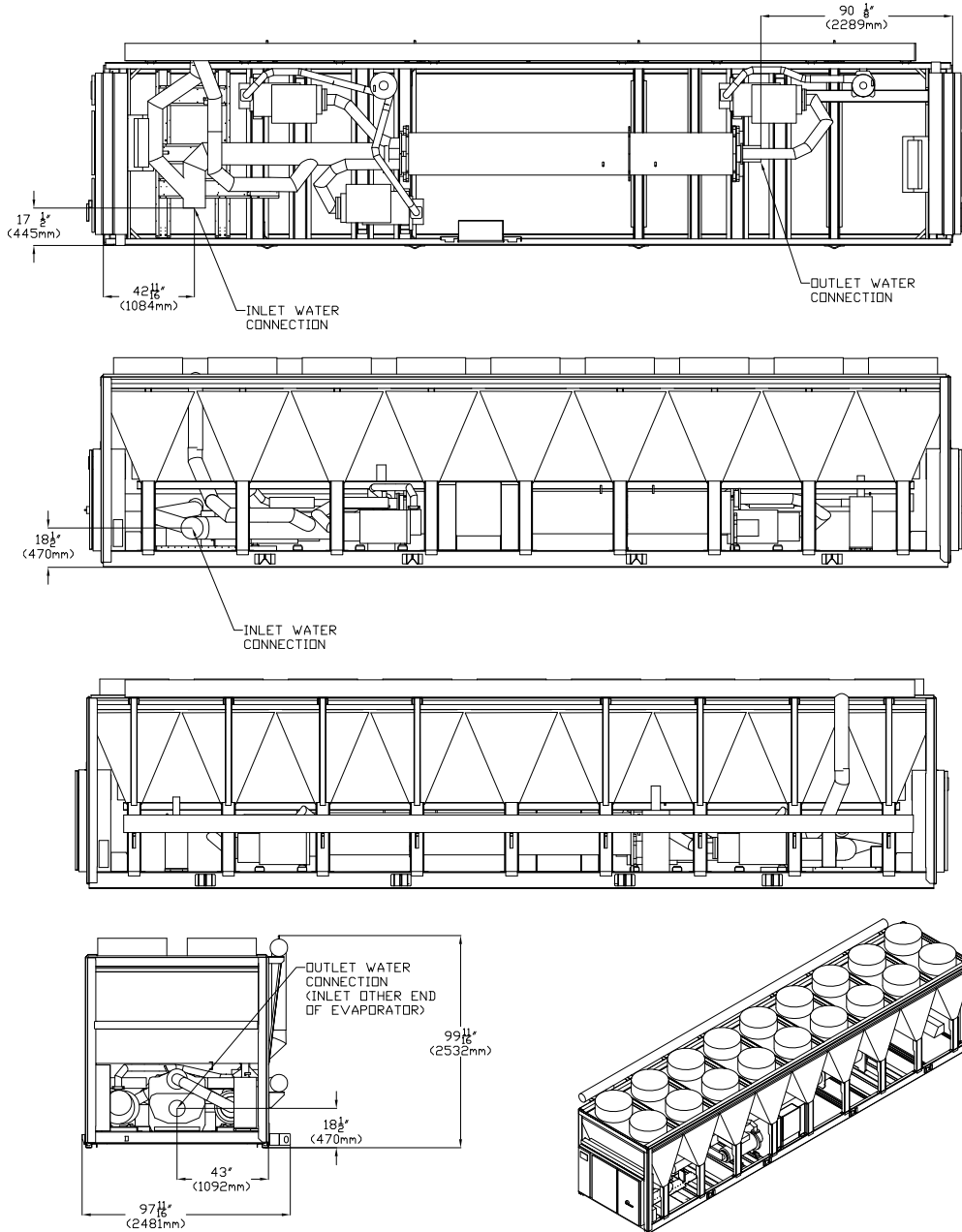

Figure 25. RTAF unit dimensions – 280 ton with free-cooling

280T
FREE COOLING OPTION
INLET/OUTLET WATER CONNECTION 8"(200mm)/8"(200mm)





Dimensions

Figure 26. RTAF unit dimensions — 310, 350 ton with free-cooling

310 & 350T
FREE COOLING OPTION
INLET/OUTLET WATER CONNECTION 8"(200mm)/8"(200mm)

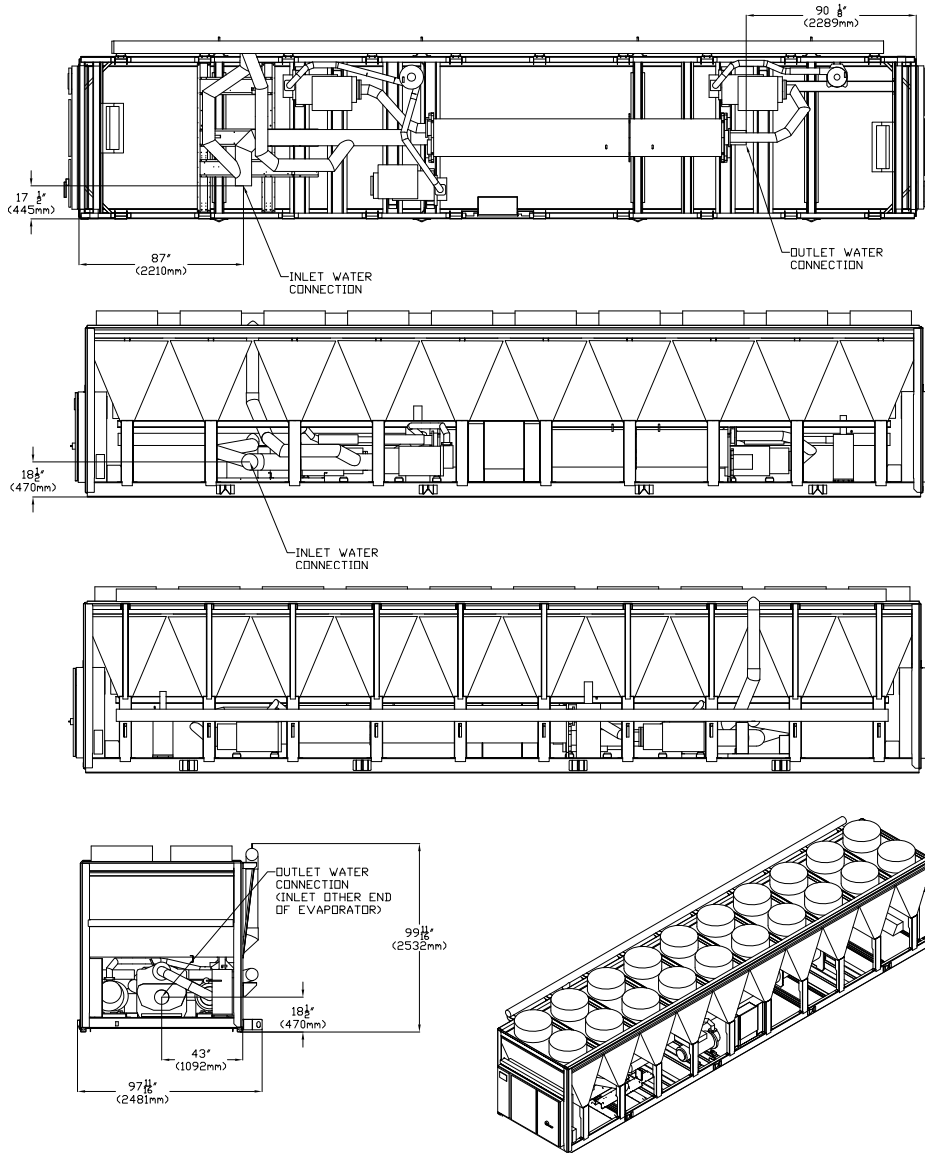
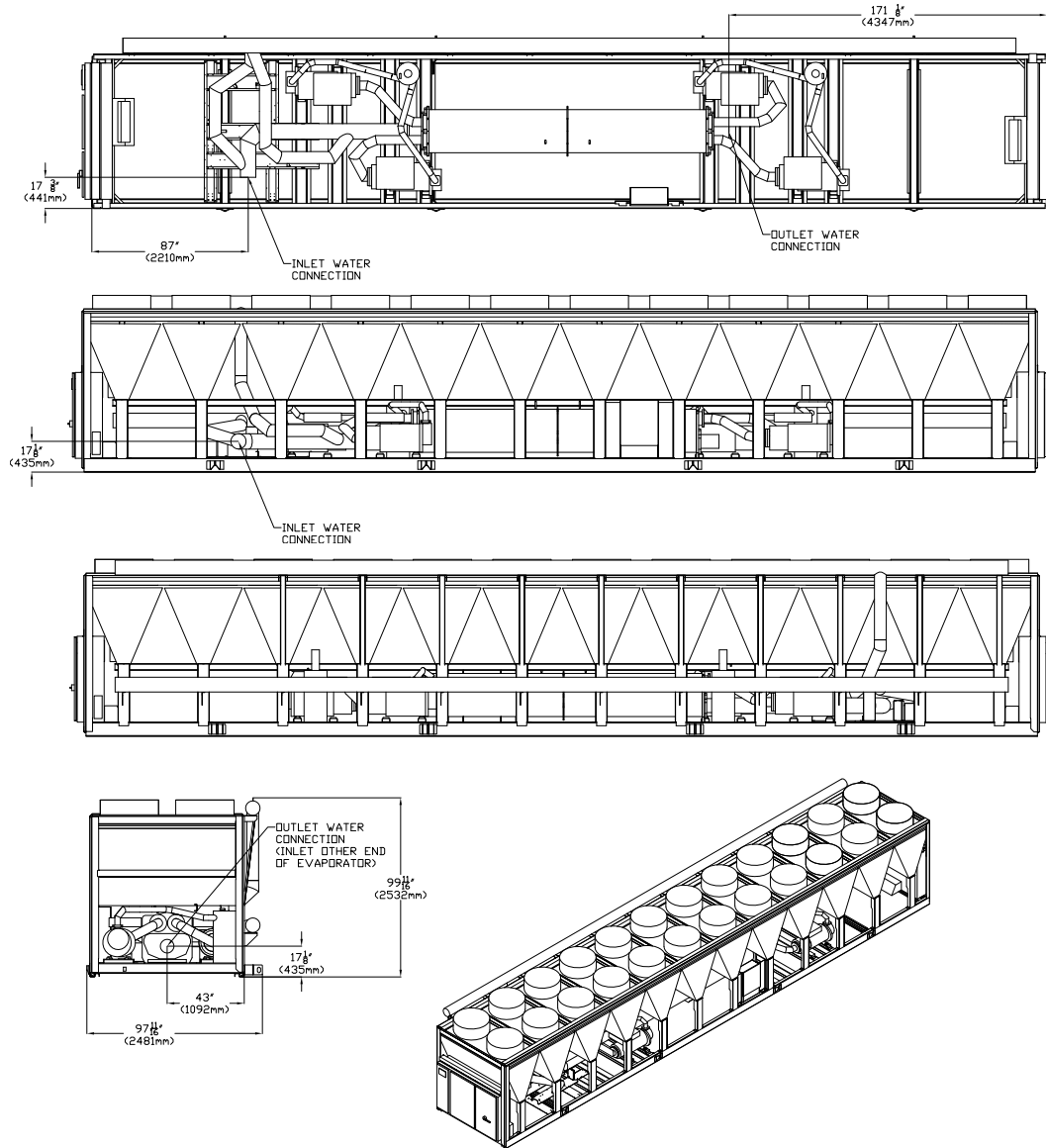

Figure 27. RTAF unit dimensions – 410 ton with free-cooling

410T
FREE COOLING OPTION
INLET/OUTLET WATER CONNECTION 8" (200mm) / 8" (200mm)





Dimensions

Figure 28. RTAF unit dimensions — 450, 500 ton with free-cooling

450 & 500T
FREE COOLING OPTION
INLET/OUTLET WATER CONNECTION 8" (200mm)/8" (200mm)

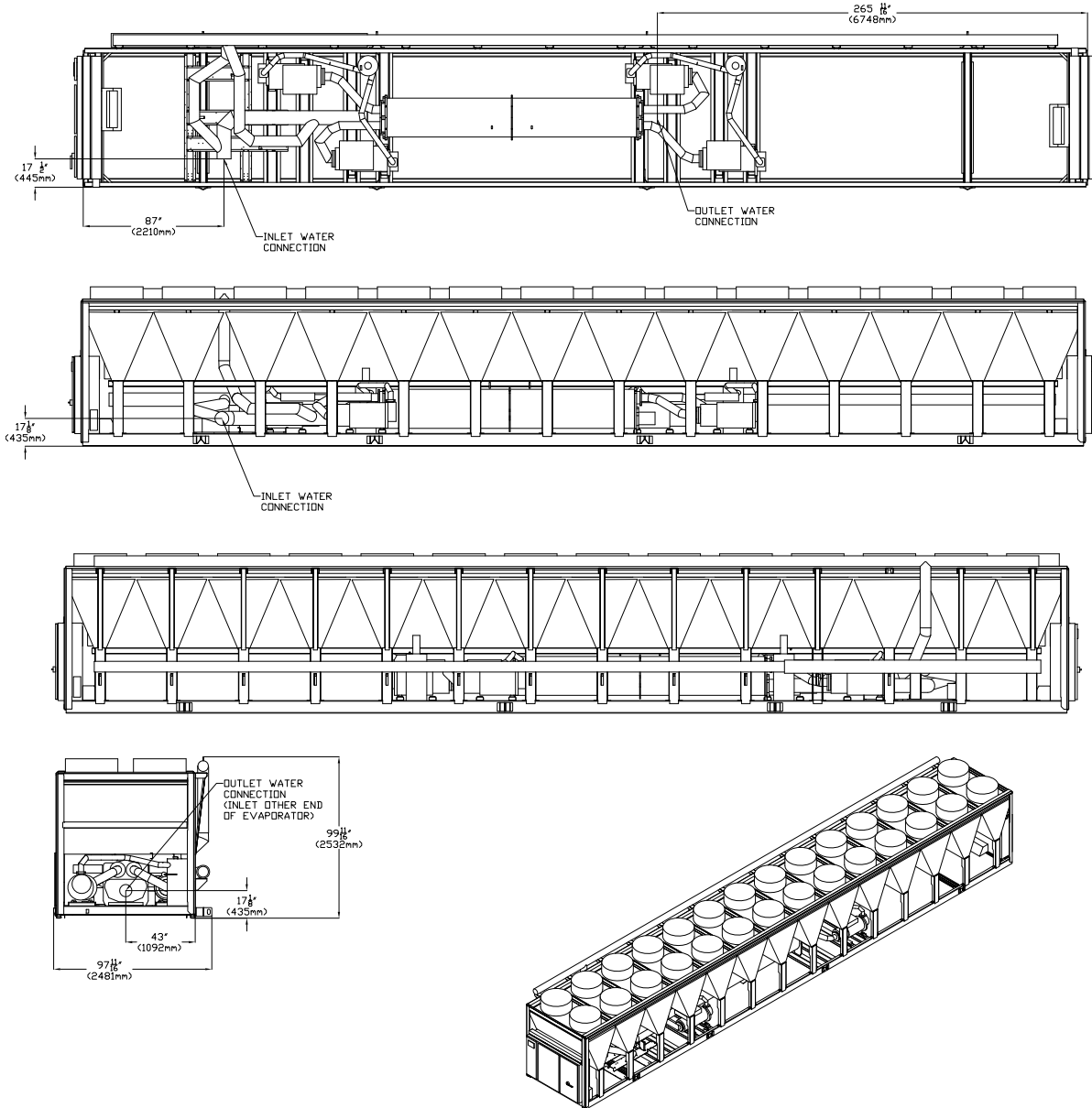



Weights

Base Weights

Note: See Option Weights table for additional weight added by optional features.

Table 8. Weights — base units without free-cooling option

Unit Size (tons)	All units (except 575V) ^(a)				575V Units ^(b)			
	Shipping Weight		Operating Weight		Shipping Weight		Operating Weight	
	lb	kg	lb	kg	lb	kg	lb	kg
115	7974	3617	8091	3670	8369	3796	8486	3849
130	8071	3661	8203	3721	8466	3840	8598	3900
150	9467	4294	9628	4367	9830	4459	9989	4531
170	9497	4308	9669	4386	9861	4473	10031	4550
180	9821	4455	10002	4537	10185	4620	10364	4701
200	10829	4912	11012	4995	11224	5091	11407	5174
215	11155	5060	11355	5151	11550	5239	11751	5330
230	12549	5692	12829	5819	12963	5880	13071	5929
250	12962	5880	13242	6007	12963	5880	13080	5933
270	12962	5880	13242	6007	n/a			
280	16705	7578	16838	7638	17225	7813	17344	7867
310	17228	7815	17367	7878	18457	8372	18581	8428
350	18177	8245	18375	8335	18988	8613	19125	8675
390	18177	8245	18375	8335	n/a			
410	21199	9616	21411	9712	22736	10313	22895	10385
450	23569	10691	23794	10793	24403	11069	24575	11147
500	23669	10736	23907	10844	25232	11445	25406	11524
520	23669	10736	23907	10844	n/a			

^(a) Model number digit 8 = C, D, or E.

^(b) Model number digit 8 = F.

Table 9. Weights — base units with free-cooling option

Unit Size (tons)	All units (except 575V) ^(a)				575V Units ^(b)			
	Shipping Weight		Operating Weight		Shipping Weight		Operating Weight	
	lb	kg	lb	kg	lb	kg	lb	kg
115	9284	4211	9893	4487	9645	4375	10256	4652
130	9381	4255	10005	4538	9742	4419	10368	4703
150	11074	5023	11861	5380	11435	5187	12222	5544
170	11105	5037	11902	5399	11466	5201	12264	5563
180	11429	5184	12235	5550	11790	5348	12597	5714
200	12713	5767	13642	6188	13109	5946	14039	6368
215	13039	5915	13986	6344	13435	6094	14381	6523
230	14457	6558	15483	7023	n/a			
250	14870	6745	15897	7211	n/a			
270	n/a				n/a			
280	19509	8849	21313	9668	20027	9084	21819	9897
310	20294	9205	22192	10066	21519	9761	23404	10616



Weights

Table 9. Weights — base units with free-cooling option (continued)

Unit Size (tons)	All units (except 575V) ^(a)				575V Units ^(b)			
	Shipping Weight		Operating Weight		Shipping Weight		Operating Weight	
	lb	kg	lb	kg	lb	kg	lb	kg
350	21243	9636	23201	10524	n/a			
390	n/a				n/a			
410	24496	11111	26758	12137	26032	11808	28241	12810
450	27283	12375	29850	13540	28116	12753	30629	13893
500	27382	12420	29963	13591	n/a			
520	n/a				n/a			

(a) Model number digit 8 = C, D, or E.

(b) Model number digit 8 = F.

Option Weights

Note: Weights below for each listed option are in addition to base weights shown in table above.

Table 10. Weights — options

Unit Size (tons)	Windload Option ^(a)		Louver Option ^(b)		Single Point Power Option ^(c)	
	lb	kg	lb	kg	lb	kg
115	394	179	428	194	-	-
130	394	179	428	194	-	-
150	394	179	489	222	-	-
170	410	186	489	222	-	-
180	410	186	489	222	-	-
200	410	186	550	249	-	-
215	426	193	550	249	-	-
230	426	193	550	249	-	-
250	426	193	550	249	-	-
270	426	193	550	249	-	-
280	426	193	600	272	461	209
310	459	208	661	300	489	222
350	459	208	661	300	542	246
390	459	208	661	300	542	246
410	491	223	783	355	738	335
450	524	238	905	410	860	390
500	524	238	905	410	813	369
520	524	238	905	410	813	369

(a) Model number digit 36 = D.

(b) Model number digit 37 = A.

(c) Model number digit 28 = 1.



Mechanical Specifications

General

Units are leak tested, pressure tested, then evacuated and charged. All chillers are factory tested prior to shipment. Packaged units ship with a full operating charge of oil and refrigerant as standard. Units can also be shipped with a nitrogen charge if required. Unit panels, structural elements and control boxes are constructed of galvanized steel and mounted on a bolted galvanized steel base. Unit panels, control boxes and the structural base are finished with a baked on powder paint.

Certified AHRI Performance

Trane air-cooled chillers are rated within the scope of the Air-Conditioning, Heating & Refrigeration Institute (AHRI) Certification Program and display the AHRI Certified® mark as a visual confirmation of conformance to the certification sections of AHRI Standard 550/590 (I-P) and ANSI/AHRI Standard 551/591 (SI). The applications in this catalog specifically excluded from the AHRI certification program are:

- Custom Units
- Units produced outside of the USA for installations outside the USA
- Evaporatively-cooled chillers
- Units with evaporators that use fluid other than fresh water except units containing freeze protection fluids in the condenser or in the evaporator with a leaving chilled fluid temperature above 32°F [0°C] are certified when rated per the Standard with water.

Refrigerant Circuit

Each unit has two refrigerant circuits, with one or two rotary screw compressors per circuit. Each refrigerant circuit includes compressor suction and discharge service valves, liquid line shut off valve, removable core filter, liquid line sight glass with moisture indicator, charging port, high pressure and low pressure safety valve and electronic expansion valve. Fully modulating compressor and electronic expansion valve provide variable capacity modulation over the entire operating range.

Evaporator

The evaporator is a tube-in-shell heat exchanger design with internally and externally finned copper tubes roller expanded into the tube sheets. The evaporator is designed, tested and stamped in accordance with the ASME Boiler and Pressure Vessel Code Section VIII for a refrigerant side working pressure of 200 psig. The evaporator is designed for a water side working pressure of 150 psig.

Note: When free-cooling option is selected, water side working pressure is 90 psig.

Waterboxes are provided in a 2-pass configuration on units up to a nominal size of 250 tons. Evaporators for 280 to 500 ton units utilize a 1-pass configuration. Each waterbox includes a vent, a drain and fittings for temperature control sensors.

Standard water connections are grooved for victaulic style pipe couplings, with groove to flange style adapters available. Evaporators are insulated with 0.75 inch closed cell insulation.

Evaporator water heaters with thermostat are provided to help protect the evaporator from freezing at ambient temperatures down to -4°F (-20°C).

Note: A separate field supplied low voltage power source is required to power the evaporator freeze protection.

A factory installed flow switch is installed on the supply water box in the evaporator inlet connection.



Condenser and Fans

The air-cooled microchannel condenser coils use all aluminum brazed fin construction. The condenser coil has an integral subcooling circuit. The maximum allowable working pressure of the condenser is 350 psig. Condensers are factory proof and leak tested at 525 psig. Coils can be cleaned with high pressure water.

Condenser fans features:

- Direct-drive vertical-discharge airfoil.
- Permanent magnet motors with integrated drive to provide variable speed fan control for all fans.
- Permanently lubricated ball bearings.
- Internal temperature and current overload protection.

Compressor and Lube Oil System

The rotary screw compressor is semi-hermetic, direct drive, with capacity control via an adaptive frequency drive, rolling element bearings, differential refrigerant pressure oil pump and oil heater. The motor is a suction gas cooled, hermetically sealed, two-pole squirrel cage induction motor.

Oil separator is provided separate from the compressor. Oil filtration is provided internal to the compressor. Check valves in the compressor discharge and lube oil system are also provided.

Unit Controls

All unit controls are housed in an outdoor rated weather resistant enclosure with removable plates to allow for customer connection of power wiring and remote interlocks. All controls, including sensors, are factory mounted and tested prior to shipment.

Microcomputer controls provide all control functions including startup and shut down, leaving chilled water temperature control, evaporator flow proving, compressor staging and speed control, electronic expansion valve modulation, condenser fan sequencing and speed control, anti-recycle logic, automatic lead/lag compressor starting, and load limiting.

Symbio 800 Controller

The Symbio™ 800 controller is an application-specific, programmable controller that is factory installed and designed to control packaged HVAC equipment. A 7-inch user interface features a touch-sensitive color screen that provides facility managers with at-a-glance operating status, performance monitoring, scheduling changes and operating adjustments. Other advanced features include automated controller backup and optional features such as secure remote connectivity, wireless building communications, and custom programming with expandable I/O.

The Symbio 800 control module, utilizing Adaptive Control™™ microprocessor, automatically takes action to avoid unit shut-down due to abnormal operating conditions associated with low refrigerant pressure, high condensing pressure, AFD/Compressor current overload, low oil return or low AFD cooling, low discharge superheat, and high compressor discharge temperature. Should the abnormal operating condition continue until a protective limit is violated, the unit will be shut down.

Unit protective functions of the controller include: loss of chilled water flow, evaporator freezing, loss of refrigerant, low refrigerant pressure, high refrigerant pressure, high compressor motor temperature, and loss of oil to the compressor.

BACnet Communication Protocol

The Symbio™ 800 controller supports standard BACnet communication protocol through a RS485, two-wire communication link or BACnet/IP over Ethernet.

Trane LonTalk Communication Protocol

The LonTalk® module provides an interface to a Tracer building automation system or other control system that supports LonTalk and is factory installed, allowing for control and monitoring

of the unit through a RS485, two-wire communication link. Requires an additional LonTalk Communication Kit to be installed.

Modbus Communication Protocol

The Symbio™ 800 controller supports standard Modbus® RTU communication protocol through an RS485, two-wire communication link.

Controls Expansion Hardware

Symbio™ 800 includes field applied controls capability. Factory installed expansion hardware (XM70) has 19 inputs/outputs. Additional expansions may be added in the field.

Tracer AdaptiView TD7 Display

A full color Tracer AdaptiView™ TD7 touch screen display indicates all important unit and circuit parameters, in logical groupings on various screens. The parameters including chilled water set point, leaving chilled water temperature, demand limit set point, evaporator and condenser refrigerant temperatures and pressures, compressor and fan speeds, and all pertinent electrical information. The display also provides “on screen” trending graphs of predefined parameters as well as customizable trend graphs based on user defined parameters from a list of all available parameters. The display also provides indication of the chiller and circuits’ top level operating modes with detailed sub-mode reports available with a single key press, as well as diagnostics annunciation and date and time stamped diagnostic history. The color display is fully outdoor rated, and, can be viewed in full daylight without opening any control panel doors.

- Outdoor capable:
 - UV Resistant Touchscreen
 - -40°C to 70°C Operating Temperature
 - IP56 rated (Power Jets of Water from all directions)
- RoHS Compliant
- UL 916 Listed
- CE Certification
- Emissions: EN55011 (Class B)
- Immunity: EN61000 (Industrial)
- Display:
 - 7 inch diagonal
 - 800x480 pixels
 - TFT LCD @ 600 nits brightness
 - 16 bit color graphic display
- Display Features:
 - Alarms
 - Reports
 - Unit Settings
 - Display Settings
- Service Settings
- Graphing
- Global Application with Support for 27 Languages

Adaptive Frequency Drive (AFD) Compressor Starter

SintesisSM chillers utilize Trane’s TR200 series of Adaptive Frequency^{SM™} Drive (AFD) technology for controlling the compressors. TR200 AFD is a family of adaptive frequency drives specifically designed for Trane applications. AFD data such as drive status, temperatures, modes and



Mechanical Specifications

diagnostic information are accessible via a remote mounted keypad and through the Trane Drive Utility service tool.

The AFD contains technology that enables the drive to last the lifetime of the chiller and to operate with less downtime. The technology enables operation on various power systems including alternative energy sources. AFD will protect itself and the compressor motor from overcurrent, low or high line voltage, phase loss, incoming phase imbalance, and over-temperature due to loss of panel ventilation.

The AFD incorporates improved serviceability and troubleshooting tools.

The drive is air-cooled with ventilation fan in the panel.

Chilled Water Reset

Control logic and factory installed sensors are provided to reset leaving chilled water temperature. The set point can be reset based on ambient temperature or return evaporator water temperature.

Factory Mounted Flow Proving and Flow Control

The factory installed evaporator water flow switch is provided with the control logic and relays to turn the chilled water flow on and off as the chiller requires for operation and protection. This function is a requirement on the Sintesis™ chiller.



Options

Application Options

Free-Cooling

The free-cooling option delivers optimal performance by minimizing compressor operation when outdoor air temperatures are low enough to assist in cooling the chilled fluid loop.

Notes:

- *When free-cooling option is selected, water side working pressure is 90 psig.*
- *Glycol solution must be utilized with the direct free-cooling option.*
- *The glycol solution requires an inhibitor package to be carefully chosen and maintained with the aid of a qualified water treatment specialist to protect the mixed metal system.*

Ice Making

The ice making option provides special control logic to handle low temperature brine applications (less than 40°F [4.4°C] leaving evaporator temperature) for thermal storage applications.

Ice Making Contact

Symbio™ 800 provides an output contact closure that can be used as a signal to the system that ice building is in operation. This relay will be closed when ice building is in progress and open when ice building has been terminated by either Symbio™ 800 or the remote interlock. It is used to signal the system changes required to convert to and from ice making.

Low Temperature Brine

Low temperature option provides special control logic and oil cooler is installed to handle low temperature brine applications including part load conditions below 40°F (4.4°C) leaving evaporator temperature.

Low Ambient

The low ambient option adds unit controls to allow start and operation when the unit works with ambient temperatures between 14°F(-10°C) and -4°F (-20°C). High side of ambient range remains at 115°F (46°C).

High Ambient

The high ambient option adds unit controls, oil coolers and oversized electrical components to allow start and operation up to ambient temperatures of 130°F(54.4°C) operation. Low side of ambient range remains at 14°F (-10°C).

Wide Ambient Option

The wide ambient option combines the features of low and high ambient options for an ambient range of -4 to 130°F (-20 to 54.4°C).

Evaporator Turbulators

Turbulators will be installed internal to the tubes to promote turbulent flow for the following:

- Glycol solutions
- Low flow/high evaporator temperature deltas



Electrical Options

Circuit Breaker

A HACR rated molded case capacity circuit breaker (UL approved) is available. Circuit breaker can also be used to disconnect chiller from main power with a through-the-door handle.

High Short Circuit Current Rating

A higher short circuit current rating offers a greater measure of safety for what the starter panel enclosure is able to withstand in the event of an explosion caused by a short circuit.

Control Options

BACnet Communications Interface

Allows the user to easily interface with BACnet® via a single twisted pair or Ethernet wiring to a factory installed and tested communication board.

LonTalk Communications Interface

Provides the LONMARK® chiller profile inputs/outputs for use with a generic building automation system via a single twisted pair wiring to a factory installed and tested communication board.

Modbus Communications Interface

Allows the user to easily interface with Modbus™ via a single twisted pair wiring to a factory installed and tested communication board.

Remote Input Option

Option permits remote chilled liquid setpoint, remote demand limit setpoint, or both by accepting a 4-20 mA or 2-10 Vdc analog signal.

Remote Output Option

Permits alarm relay outputs, chiller Percent Capacity via a 2–10 Vdc signal, or both.

Other Options

Architectural Louvered Panels

Louvered panels cover the complete condensing coil and service area beneath the condenser.

Condenser Corrosion Protection

CompleteCoat™ is available on all size units for corrosion protection. Job site conditions should be considered to determine the need to order coating to inhibit coil corrosion and ensure extended equipment life. CompleteCoat™ option provides fully assembled coils with a flexible dip and bake epoxy coating.

Convenience Outlet

Provides a 15 amp, 115V (60 Hz) convenience outlet on the unit.

Note: An additional field-supplied power connection must be provided to power the convenience outlet.

Flanged Water Connection Kit

Provides raised face flanges to convert grooved pipe evaporator water connections to flange connectors. The victaulic-to-flange adapter will be shipped with the chiller.

Isolators — Elastomeric

Elastomeric Isolators provide isolation between chiller and structure to help eliminate vibration transmission.

Wind Load for Florida Hurricane

Unit is built and certified to meet the requirements of the 2017 Florida Building Code and ASCE 7-10 for 186 mph wind speed, Exposure 'C', Risk Category III. Available for non-rooftop mounted units only.

Containerization Shipping Package

Pull rings are bolted to each side of the formed sheet metal unit base rail in order to pull the unit out of the shipping container once it reaches its destination.

Shipping Tarp

The unit will be covered at the factory with a PVC coated polyester tarp that is tied to the chiller base to help protect the chiller from debris during shipment especially in the winter months and on shipping vessels. This option may also be helpful if the chiller will be stored at the jobsite before use.



Notes



The AHRI Certified mark indicates Trane U.S. Inc. participation in the AHRI Certification program. For verification of individual certified products, go to ahridirectory.org.

Trane - by Trane Technologies (NYSE: TT), a global innovator - creates comfortable, energy efficient indoor environments for commercial and residential applications. For more information, please visit trane.com or tranetechnologies.com.

Trane has a policy of continuous product and product data improvements and reserves the right to change design and specifications without notice. We are committed to using environmentally conscious print practices.