



Product Catalog

Packaged Rooftop Air Conditioners Precedent™ Heat Pump

High Efficiency

12.5 to 25 Tons — 60 Hz





Introduction

Packaged Heat Pumps

Trane's customers demand products that provide exceptional reliability, meet stringent performance requirements, and are competitively priced. Trane delivers with Precedent™.

Precedent™ features cutting edge technologies: reliable compressors, Trane engineered Symbio controls, computer-aided run testing, and Integrated Comfort™ Systems. So, whether you're the contractor, the engineer, or the owner you can be certain Precedent™ products are built to meet your needs.

The Precedent product is designed for comfort cooling, mixed air applications. If the product is being considered for other types of applications, such as process cooling, dedicated outdoor air, indoor agriculture, etc. Consult with your local Trane Sales Representative. Applying the units in an unintended application could result in inadequate performance and/or premature component failures.

Through the years, Trane has designed and developed the most complete line of Packaged Rooftop products available in the market today. Trane was the first to introduce the Micro—microelectronic unit controls—and has continued to improve and revolutionize this design concept.

Symbio control platform offers the same great features and functionality as the original Micro, with additional benefits for greater application flexibility.

With its sleek, compact cabinet, Precedent™ continues to provide the highest standards in quality and reliability, comfort, ease of service, and the performance of Trane light commercial products.

Copyright

This document and the information in it are the property of Trane, and may not be used or reproduced in whole or in part without written permission. Trane reserves the right to revise this publication at any time, and to make changes to its content without obligation to notify any person of such revision or change.

Trademarks

All trademarks referenced in this document are the trademarks of their respective owners.

Revision History

- Corrected low ambient kit installation information.
- Corrected units of measure in Heating Capacity chapter tables.



Table of Contents

Features and Benefits	5
Features	5
Control Options	6
Accessories	7
Key Benefits	9
Model Number Description	16
General Data	18
Gross Cooling Capacities	22
Heating Capacities	26
Reheat Temperature Rise	29
Evaporator Fan Performance - Heat Pump	40
12.5 to 25 Ton Units — Downflow	40
12.5 to 25 Ton Units — Horizontal	43
Evaporator Fan Performance - Dual Fuel	47
12.5 to 25 Ton Units — Downflow	47
12.5 to 25 Ton Units — Horizontal	49
Fan Performance	52
Heating Performance	54
Controls	56
Enhanced BAS Integration and Connectivity	56
Secure Remote Connectivity with Trane Connect	56
Serviceability	56
Flexibility	58
Economizer Controls	58
Zone Sensors	59
Air-Fi Wireless Communicating Zone Sensors	60
Thermostats	60
Humidity Control (HGRH)	61
Electrical Data	63
Dimensional Data	67
Weights	71



Table of Contents

Mechanical Specifications	73
General	73
Casing	73
Coils	73
Coil Guards	73
Compressors	73
Filters	74
Frostat™	74
Gas Heating Section	74
Tubular Gas Heat Exchanger	74
Indoor Fan	74
Powered or Unpowered Convenience Outlet	74
Stainless Steel Drain Pan	74
Stainless Steel Heat Exchanger	75
Through-the-Base Electrical with Circuit Breaker	75
Through-the-Base Electrical with Disconnect Switch	75
Economizer (Standard)	75
Manual Outside Air Damper	75
Motorized Outside Air Damper	75
Powered Exhaust	75
Roof Curb	75
Ventilation Override Operation	76



Features and Benefits

Features

Note: Equipment feature availability is dependent on unit configuration. For more information, see Packaged Rooftop Air Conditioners Precedent™ Quick Reference Support Guide (PREC-PRC001-EN), the ordering system, or contact product support.*

Table 1. Features – standard and optional

	Standard Features	Options		
		Factory Installed	Factory or Field Installed	Field Installed
3-year Limited Parts Warranty	X			
5-year Limited Compressor Warranty	X			
10-year Limited Heat Exchanger Warranty		X		
15-year Limited Warranty Stainless Steel Heat Exchanger		X		
2 inch Filter	X			
2 inch MERV 8 Filters		X		
2 inch MERV 13 Filters		X		
Access Doors		X		
Access Door (Control Box)	X			
Access Panels	X			
Anti-Short Cycle Timer (Standard with Symbio)	X			
Barometric Relief			X	
CO ₂ Sensor				X
Clogged Filter Switch			X	
Coil guards	X			
CompleteCoat™ Condenser Coil		X		
Condensate Overflow Switch			X	
Convertible Airflow	X			
Colored and Numbered Wiring	X			
Crankcase Heaters	X			
Direct Drive Plenum Fan	X			
Discharge Air Temperature Sensing Kit — MZVAV, SZVAV, Economizer, HGRH, Mod Gas	X			
Discharge Air Temperature Sensing Kit — Standard (Multispeed)	X			
Economizer: Low Leak — Downflow			X	
Economizer: Low Leak — Horizontal				X
Economizer: Standard — Downflow			X	
Economizer: Standard — Horizontal				X
Electric Heater			X	
Expansion Modules			X	
Fault Detection and Diagnostics (FDD)	X			
Filter Removal Tool	X			
Foil-Faced and Edge Protected Insulation	X			
Frostat™	X			
High Pressure Control	X			
High Altitude Kit				X
High Static/Oversized Motor		X		
High Temperature Sensor				X
IAQ Dual Sloped Composite Drain Pan	X			
Liquid Line Refrigerant Drier	X			



Features and Benefits

Table 1. Features – standard and optional (continued)

	Standard Features	Options		
		Factory Installed	Factory or Field Installed	Field Installed
Low Ambient Cooling to 0°F				X
Low Ambient Cooling to 40°F	X			
Low Pressure Control	X			
LP Conversion Kit				X
Manual Outside Air Damper			X	
Modulating Gas Heat (10:1)		X		
Modulating Hot Gas Reheat (HGRH)		X		
Motorized Outside Air Damper			X	
Multispeed Direct Drive Motors	X			
Operating Charge of R-410A	X			
Phase Balance/Loss/Reversal Protection	X			
Phase Monitor	X			
Powered Exhaust				X
Powered or Unpowered Convenience Outlet		X		
Reference or Comparative Enthalpy			X	
Roof Curb				X
Single Point Power	X			
Single Side Service	X			
Smoke Detector - Return		X		
Smoke Detector - Supply		X		
Stainless Steel Drain Pan		X		
Standardized Components	X			
Symbio Controls	X			
Thermal Expansion Valve	X			
Through-the-Base Electrical Access		X		
Through-the-Base Electrical with Circuit Breaker		X		
Through-the-Base Electrical with Disconnect Switch		X		
Through-the-Base Gas Piping		X		
Tubular Gas Heat Exchanger		X		
Variable Air Flow (SZVAV)/Variable Air Flow (MZVAV)		X		
Ventilation Override				X

Control Options

Note: Control option availability is dependent on unit configuration. For more information, see *Packaged Rooftop Air Conditioners Precedent™ Quick Reference Support Guide (PREC-PRC001*-EN)*, the ordering system, or contact product support.

Table 2. Control options — standard and optional

	Standard Features	Options		
		Factory Installed	Factory or Field Installed	Field Installed
Dual Thermistor Remote Zone Sensor				X
Symbio Service and Installation App	X			
Symbio 700 Advanced Module			X	
Humidity Sensor/Humidistat				X

Table 2. Control options — standard and optional (continued)

	Standard Features	Options		
		Factory Installed	Factory or Field Installed	Field Installed
Thermostat				X
Wireless Zone Sensor				X
Zone Sensor				X
LonTalk® Communication Interface (LCI)			X	
Trane® Air-Fi® Wireless Communication Interface (WCI)			X	

Note: For more information, reference the Controls chapter.

Accessories

Note: Accessory availability is dependent on unit configuration. Some accessories may require additional accessories/options for full functionality. For more information, see *Packaged Rooftop Air Conditioners Precedent™ Quick Reference Support Guide (PREC-PRC001*-EN)*, the ordering system, or contact product support.

Table 3. Packaged heat pump

FIA KIT	DESCRIPTION
FIAEHWD318*	18kW, 208-230V Electric Heater
FIAEHWD336*	36kW, 208-230V Electric Heater
FIAEHWD354*	54kW, 208-230V Electric Heater
FIAEHWD372*	72kW, 208-230V Electric Heater
FIAEHWD418*	18kW, 460V Electric Heater
FIAEHWD436*	36kW, 460V Electric Heater
FIAEHWD454*	54kW, 460V Electric Heater
FIAEHWD472*	72kW, 460V Electric Heater
FIAEHWDW18*	18kW, 575V Electric Heater
FIAEHWDW36*	36kW, 575V Electric Heater
FIAEHWDW54*	54kW, 575V Electric Heater
FIAEHWDW72*	72kW, 575V Electric Heater
FIABARM003*	Barometric Relief
FIAC02K001*	CO ₂ (DCV) Wall Mounted Sensor
FIAC02K002*	CO ₂ (DCV) Duct Mounted Sensor
FIACURB404*	14-inch Full Perimeter Knockdown Curb
FIACLFS003*	Clogged Filter Switch
FIACLFS004*	Clogged Filter Switch (MERV13)
FIADFB001*	Differential Dry Bulb Economizer Control
FIADMPR003*	Manual Damper
FIADMPR103*	Motorized Damper
FIAECON003*	Dry Bulb Downflow Economizer
FIAECON303*	Dry Bulb Horizontal Economizer
FIAECON103*	Dry Bulb Downflow Low Leak
FIAECON203*	Dry Bulb Horizontal Low Leak
FIAENTH001*	Reference Enthalpy Economizer Control
FIAENTH002*	Comparative Enthalpy Economizer Control
FIAHALT003*	High Altitude Gas Adjustment Kit
FIAHTST001*	High Temperature (Fire) Duct Mounted Stat



Features and Benefits

Table 3. Packaged heat pump (continued)

FIA KIT	DESCRIPTION
FIAHZDC001*	Horizontal Conversion Panel
FIALOAM001*	Low Ambient
FIALTCI001*	LonTalk Communication Interface
FIALPKT003*	LP Gas Conversion Kit
FIAOPTN001*	Indoor Options Module
FIAOPTN002*	Fresh Air Options Module
FIAOVFL001*	Condensate Overflow Switch
FIAPWRX303*	Power Exhaust 230V
FIAPWRX403*	Power Exhaust 460V
FIAPWRXW03*	Power Exhaust 575V
FIAS7ADV01*	Symbio 700 Advanced Controls and BACnet BAS Upgrade Kit
FIASCCM001*	Symbio Customer Connection Module
FIAXMOD030*	Symbio 700 XM30 Expansion Module
FIAXMOD032*	Symbio 700 XM32 Expansion Module

Table 4. Dual fuel heat pump

FIA KIT	DESCRIPTION
FIABARM003*	Barometric Relief
FIAC02K001*	CO ₂ (DCV) Wall Mounted Sensor
FIAC02K002*	CO ₂ (DCV) Duct Mounted Sensor
FIACURB404*	14-inch Full Perimeter Knockdown Curb
FIACLFS003*	Clogged Filter Switch
FIACLFS004*	Clogged Filter Switch (MERV13)
FIADFDB001*	Differential Dry Bulb Economizer Control
FIADMPR003*	Manual Damper
FIADMPR103*	Motorized Damper
FIAECON003*	Dry Bulb Downflow Economizer
FIAECON303*	Dry Bulb Horizontal Economizer
FIAECON103*	Dry Bulb Downflow Low Leak
FIAECON203*	Dry Bulb Horizontal Low Leak
FIAENTH001*	Reference Enthalpy Economizer Control
FIAENTH002*	Comparative Enthalpy Economizer Control
FIHTST001*	High Temperature (Fire) Duct Mounted Stat
FIAHZDC001*	Horizontal Conversion Panel
FIALOAM001*	Low Ambient
FIALTCI001*	LonTalk Communication Interface
FIAOPTN001*	Indoor Options Module
FIAOPTN002*	Fresh Air Options Module
FIAOVFL001*	Condensate Overflow Switch
FIAHALT003*	High Altitude Gas Adjustment Kit - 2-Stage gas
FIALPKT003*	LP Gas Conversion Kit - 2-Stage gas
FIALPKTM08*	LP Gas Conversion Kit - Modulating gas
FIALPKTM09*	LP Gas Conversion Kit - Modulating gas
FIALPKTM10*	LP Gas Conversion Kit - Modulating gas
FIAPWRX303*	Power Exhaust 230V
FIAPWRX403*	Power Exhaust 460V

Table 4. Dual fuel heat pump (continued)

FIA KIT	DESCRIPTION
FIAPWRXW03*	Power Exhaust 575V
FIAS7ADV01*	Symbio 700 Advanced Controls and BACnet BAS Upgrade Kit
FIASCCM001*	Symbio Customer Connection Module
FIAXMOD030*	Symbio 700 XM30 Expansion Module
FIAXMOD032*	Symbio 700 XM32 Expansion Module

Key Benefits

Airflow Distribution

Airflow is outstanding. Precedent™ can replace an older machine with old ductwork and, in many cases, improve the comfort through better air distribution.

Cabinet Integrity

For added water integrity, Precedent™ has a raised 1 inch lip around the supply and return of the downflow units to prevent water from blowing into the ductwork.

Coil Guards

Coil guards protect condenser coil during shipping as well as hail, vandals, wind, etc. Toolless design lends itself to ease of maintenance in cleaning coils.



CO₂ Sensor — Demand Control Ventilation (DCV)

Demand-controlled ventilation (DCV) is a control strategy that responds to the actual demand (need) for ventilation by regulating the rate at which the HVAC system brings outdoor air into the building. A CO₂ sensor measures the concentration (parts per million, ppm) of CO₂ (carbon dioxide) in the air. As the CO₂ concentration changes, the outside air damper modulates to meet the current ventilation needs of the zone. The CO₂ sensor kit is available as a field installed accessory and wires directly to the Symbio 700 controller.

CompleteCoat™ Condenser Coil

This optional coated coil provides excellent corrosion resistance as well as uniformity of coverage and coating thickness.

Controls — Symbio™

Enhanced BAS Integration and Connectivity

- Open standard communications



Features and Benefits

- BACnet® over Zigbee (Air-Fi Wireless)
- BACnet MS/TP
- BACnet IP
- Modbus™ RTU
- Modbus TCP/IP
- LonTalk®
- Securely access, troubleshoot, and monitor equipment from anywhere via Trane Connect™

Serviceability

- Wireless mobile app interface (iPhone and Android) to simplify startup/service
- On-board user interface
- Data Trending
- Real-time, clear language diagnostics
- Historical alarm logs
- Backup and Restore functionality to reduce commissioning and service time

Flexibility

- Future-ready upgradable software, supporting changing codes and new sequences of operation
- Standard, consistent pre-engineered applications that meet industry standards
- Built-in Schedules (requires Tracer® TU)
- Expandable inputs and outputs (requires Tracer TU)
- Ability to add custom programmed sequences (requires Tracer TU)

Accessibility

Control box consists of a multilevel design with Symbio Controls located on hinged panels which provide protection from high voltage components for ease of servicing.

Convenience Outlet

This option is GFCI, 120V/15A, 2 plug, convenience outlet powered or GFCI, 120V/20A, 2 plug convenience outlet unpowered. This option can be ordered when through the base electrical with either the disconnect switch or circuit breaker option is ordered.



Convertible Units

Units ship in a downflow configuration and can be easily converted to horizontal by simply removing two panels. Optional field accessory kits required for 12.5 to 25 ton units.

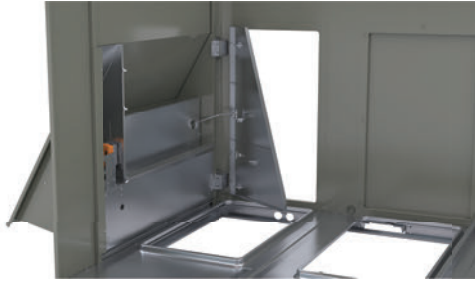

Direct Drive Plenum Fans

All 12.5 to 25 tons units are equipped with a direct drive plenum fan design with the following features.

- Backward-curved fan wheel
- External rotor direct drive variable speed indoor motor
- Variable speed adjustment available in Symbio controller
- Designed to slide out for ease of maintenance

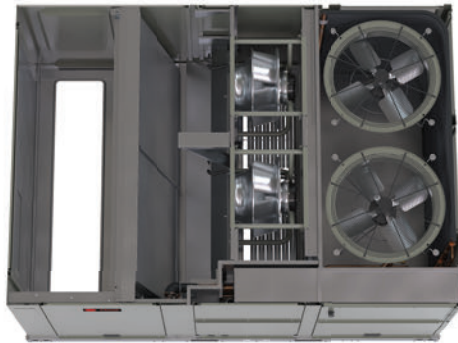

Drain Pan

Every unit has an easy-to-clean, composite removable dual-sloped drain pan (IAQ).



Dual Fuel Operation

For dual fuel models, heat pump with gas auxiliary heat (digit 1 = D). If the call for heat is not satisfied, the final heat pump stage is activated. If ambient temperature is below the adjustable lockout set point, the controller will activate auxiliary gas heat 1st stage, and heat pump operation will be terminated. A



Features and Benefits

continued call for heat will cause the controller to activate auxiliary gas heat 2nd stage. The indoor fan will continue to run and will increase to 100% during transition from heat pump to gas heat.

If continuous fan operation is available and selected from the thermostat, the controller automatically adjusts fan speed for heat pump and gas heat operation. During defrost mode, the controller will activate auxiliary gas heat to maintain comfort.

Fault Detection and Diagnostics (FDD)

This offering meets the mandatory requirement of CA Title 24 of fully configurable diagnostics allowing fault history and reading fault codes at the unit via Symbio™ 700 board or app. This feature provides detection of the following faults: Air temperature sensor failure/fault and notification of acceptable economizer mode. The FDD system shall be certified by the Energy Commission as meeting the requirements.

Flexibility

Precedent™ offers ultimate flexibility. Units are built to order in our standard ship cycle time.

High Altitude Kit

While recommended for units applied above 2,000 feet, domestic contractors should consult with local authority on best practice. High altitude kits contain gas orifices that derate the gas input rate (Btuh/r) by 10%.

High Efficiency Filtration

Precedent™ units offer a variety of high efficiency filtration options. MERV 8 and MERV 13 filters provide additional filtration beyond the capabilities of typical 2 inches throwaway filters.

High Static Motor

Available on 25 ton models, this high static motor option extends beyond the capability of the standard motor.

Hinged Access Doors

These doors permit easy access to the filter, fan and compressor/control sections. They reduce the potential roof damage from screws or sharp access panel corners.



Humidity Sensor/Humidistat

The humidity sensor/humidistat, when used in conjunction with our dehumidification (hot gas reheat) units will provide outstanding humidity control and comfort. Humidity sensors can be wall or duct mounted. The humidity deadband can be set between 40% and 60% relative humidity.

Low Ambient Cooling

All Precedent™ units have cooling capabilities down to 40°F. Field installed accessory extends operation down to 0°F.

Low Leak Economizer

This accessory meets low leak requirements for ASHRAE 90.1, IECC, and CA Title 24 standards (4 cfm/ft²@1" wg exterior air/return air). This option allows 100% outdoor air supply from 0 to 100% modulating dampers and is standard with barometric relief. It can be paired with powered exhaust for additional building pressure relief. This option can be paired with or without fault detection and diagnostics (FDD) to meet current mandatory CA Title 24 requirements.

The economizers come with four control options, dry bulb, reference enthalpy, comparative enthalpy, or differential dry bulb.

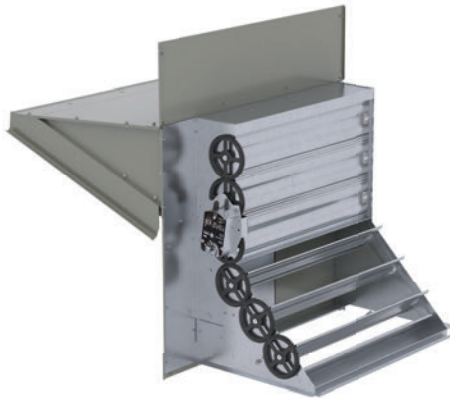

Note: Downflow low leak economizer is available as a factory installed option. Horizontal low leak economizer is only available as a field installed option.

LP Conversion Kit

Provided for field conversion of gas/electric units from natural gas to propane.

Modulating Gas Heat (10:1)

Modulating natural gas heat option, with a high modulation range of 10:1, automatically modulates the gas value and combustion blower motor providing improved comfort with stable temperature control.

- Less on/off cycling
- Continuous heating output
- Wide operation range (low and high heat)
- Coupled with variable speed fan control enables independent control of supply airflow and discharge air temperature
- With Zoned Rooftop Systems, modulating gas heat enables effective supply air tempering as well as warm-up sequences

Modulating Hot Gas Reheat (HGRH)

All 6 to 25 tons units can be ordered with a factory installed modulating hot gas reheat (HGRH) humidity control system designed to provide year around comfort by improving indoor air quality while controlling humidity levels.

- Modulating gas reheat, no more on/off
- Maintains stable neutral leaving air temperature, resulting in less cycling
- Includes both relative humidity and dew point control
- Available on downflow or horizontal

Multi-Speed Indoor Fan System

This system incorporates a multi-speed fan control to change the speed of the fan to 66% of full airflow based off of compressor stages.



Features and Benefits

Multiple-Zone VAV Control

A multiple-zone VAV (MZVAV) system consists of a packaged rooftop unit that serves several individually controlled zones. Each zone is equipped with a VAV terminal unit that varies the quantity of air delivered to maintain the desired temperature in that zone. The rooftop unit controller varies the speed of the indoor fan to maintain the static pressure in the supply ductwork at a setpoint, ensuring that all zones receive the necessary quantity of air. In addition, cooling capacity is cycled to maintain the supply air temperature at the desired setpoint.

For decades, Trane has been an industry leader in rooftop VAV systems. Now, multiple-zone VAV control is available in the light commercial rooftop platform (12.5 to 25 tons).

Other Benefits

- Cabinet design ensures water integrity
- Ease of Service, Installation and Maintenance
- Mixed model build enables “fastest in the industry” ship cycle times
- Outstanding Airflow Distribution
- Symbio Controls

Rigorous Testing

All Precedent™ designs were rigorously tested at the factory to ensure premier quality.

Rain testing is completed to ensure water integrity.

Transportation vibration and forklifting tests are performed to ensure that the unit arrives at the job site in top condition.

Rigging lift and drop tests are completed to assure that the lifting lugs and rails hold up under stress.

During production we perform 100% coil leak test at the factory. The assembled unit is leak tested to 465 psig. All parts are inspected at the point of final assembly. Sub standard parts are identified and rejected immediately. Every unit receives a 100% unit run test before leaving the production line to make sure it meets rigorous requirements.

Single Zone VAV (SZVAV)

SZVAV is fully integrated into the control system. It provides the simplest and fastest commissioning in the industry through proven factory-installed, wired, and tested system controllers. All control modules, logic boards and sensors are factory installed and tested to ensure the highest quality and most reliable system available. This means no special programming of algorithms, or hunting at the jobsite for field installed sensors, boards, etc. SZVAV is a quick and simple solution for many applications and is available from your most trusted rooftop VAV system solution provider -Trane.

Building system modeling in energy simulation software such as TRACE is recommended to evaluate performance improvements for your application.

Supply/Return Air Smoke Detector

With this option installed, if smoke is detected, all unit operation will be shut down. Reset will be manual at the unit. In order for the supply air smoke detector or return air smoke detector to properly sense smoke in the supply air stream or the return air stream, the air velocity entering the smoke detector unit must be between 500 to 4000 feet per minute. Equipment covered in this manual will develop an airflow velocity that falls within these limits over the entire airflow range specified in the evaporator fan performance table.



Through-the-Base Electrical Access

An electrical service entrance shall be provided allowing electrical access for both control and main power connections inside the curb and through-the-base of the unit. Option will allow for field installation of liquid-tight conduit and an external field installed disconnect switch.

Through-the-Base Gas Access

Factory provided through-the-base openings simplify piping. Because these utility openings frequently minimize the number of roof penetrations, the integrity of roofing materials is enhanced.

This option shall have all piping necessary including, black steel, manual gas shut-off valve, elbows, and union. This assembly will require minor field labor to install.

Ventilation Override

Ventilation override allows the unit to be set to transition to up to three different pre-programmed sequences for smoke purge, pressurization, and exhaust. The transition occurs when a binary input on the Customer Connection Module is closed (shorted). This would typically be a hard wired relay output from a smoke detector or fire control panel. The Customer Connection module that allows ventilation override is available as a field installed accessory (FIASCCM001). For more information on functionality, refer to *Symbio™ 700 Controller with Precedent™ Packaged Rooftop Air-Conditioners Application Guide (ACC-APG002*-EN)*.



Model Number Description

Digit 1 — Unit Function

W = Packaged Heat Pump
D = Dual Fuel Heat Pump

Digit 2 — Cooling Efficiency

H = High Efficiency

Digit 3 — Refrigerant

J = R-410A

Digit 4,5,6 — Nominal Gross Cooling Capacity (MBh)

150 = 12.5 Ton
180 = 15 Ton
240 = 20 Ton
300 = 25 Ton

Digit 7 — Design Sequence

Digit 8 — Voltage Selection

3 = 208–230/60/3
4 = 460/60/3
W = 575/60/3

Digit 9 — Unit Controls

S = Symbio™ 700

Digit 10 — Heat Type

0 = Base Model (None or Electric)
A = Stainless Steel Gas Heat
B = Modulating Gas Heat

Digit 11 — Heating Capacity

0 = No Heat
G = 18 kW Electric Heat
K = 27 kW Electric Heat
N = 36 kW Electric Heat
P = 54 kW Electric Heat
R = 72 kW Electric Heat
L = Low Gas Heat
M = Medium Gas Heat
H = High Gas Heat

Digit 12, 13 — Service Sequence

****** = Factory Assigned

Digit 14 — Fresh Air Selection

0 = No Fresh Air
A = Manual Outside Air Damper 0–50%
B = Motorized Outside Air Damper 0–50%
C = Economizer, Dry Bulb 0–100% without Barometric Relief
D = Economizer, Dry Bulb 0–100% with Barometric Relief
E = Economizer, Reference Enthalpy 0–100% without Barometric Relief
F = Economizer, Reference Enthalpy 0–100% with Barometric Relief
G = Economizer, Comparative Enthalpy 0–100% without Barometric Relief
H = Economizer, Comparative Enthalpy 0–100% with Barometric Relief
K = Downflow Low Leak Economizer, Dry Bulb with Barometric Relief
M = Downflow Low Leak Economizer, Reference Enthalpy with Barometric Relief
P = Downflow Low Leak Economizer, Comparative Enthalpy with Barometric Relief
R = Downflow Low Leak Economizer, Differential Dry Bulb with Barometric Relief

Digit 15 — Supply Fan/Motor

0 = Multi-Speed Motor
1 = Optional Oversized/High Static Motor
2 = Single Zone Variable Air Volume with Standard Motor
3 = Single Zone Variable Air Volume with Oversized/High Static Motor
4 = Multiple Zone Variable Air Volume with Standard Motor
5 = Multiple Zone Variable Air Volume with Oversized/High Static Motor

Digit 16 — Hinged Access/Filters

0 = Standard Panels/Standard Filters
A = Hinged Access Panels/Standard Filters
B = Standard Panels/2 inch MERV 8 Filters
C = Hinged Access Panels/2 inch MERV 8 Filters
D = Standard Panels/2 inch MERV 13 Filters
E = Hinged Access Panels/2 inch MERV 13 Filters

Digit 17 — Coil Protection

0 = Standard Coil
1 = Condenser with CompleteCoat

Digit 18 — Through-the-Base Provisions

0 = No Through-the-Base Provisions
A = Through-the-Base Electric
B = Through-the-Base Gas Piping
C = Through-the-Base Electric and Gas Piping

Digit 19 — Disconnect/Circuit Breaker (three-phase only)

0 = No Disconnect/No Circuit Breaker
1 = Unit Mounted/Non-Fused Disconnect
2 = Unit Mounted Circuit Breaker

Digit 20— Convenience Outlet

0 = No Convenience Outlet
A = Unpowered 20A Convenience Outlet
B = Powered 15A Convenience Outlet (three-phase only)

Digit 21— Communications Options

0 = No Communications Interface
1 = Advanced Controller with BACnet® Communications Interface
2 = Advanced Controller with LonTalk® Communications Interface
3 = Advanced Controller with Air-Fi® Communications Interface

Digit 22— Refrigeration System Option

0 = Standard Refrigeration System
A = Dehumidification Option

Digit 23— Controls Expansion Module

0 = None
1 = XM-30 Expansion Module
2 = XM-32 Expansion Module
3 = XM-30 and XM-32 Expansion Module
4 = XM-30 Expansion Module (Qty 2)
5 = XM-32 Expansion Module (Qty 2)

Digit 24— Smoke Detector

0 = No Smoke Detector
A = Return Air Smoke Detector
B = Supply Air Smoke Detector
C = Supply and Return Air Smoke Detectors

Digit 25— System Monitoring Controls

- 0 = No Monitoring Control
- 1 = Clogged Filter Switch
- 2 = Condensate Overflow Switch
- 3 = Discharge Air Sensing Tube
- 4 = Clogged Filter Switch and Condensate Overflow Switch
- 5 = Clogged Filter Switch and Discharge Air Sensing Tube
- 6 = Condensate Overflow Switch and Discharge Air Sensing Tube
- 7 = Clogged Filter Switch, Condensate Overflow Switch and Discharge Air Sensing Tube

Digit 26— Not Used**Digit 27— Hardware Enhancements**

- 0 = No Enhancements
- 1 = Stainless Steel Drain Pan

Digit 28— Short Circuit Current Rating

- 0 = Standard (5k) SCCR Marking
- A = Tier 2 (65K) SCCR Marking

Digit 29— Low Ambient

- 0 = None
- A = Low Ambient Cooling to 0°F



General Data

Table 5. General data — 12.5 to 25 tons, high efficiency (WHJ*)

	12.5 Tons	15 Tons	20 Tons	25 Tons
	WHJ150	WHJ180	WHJ240	WHJ300
Cooling Performance				
Gross Cooling Capacity	154000	182000	246000	272000
EER	12.3	12.0	11.2	10.4
Nominal cfm/AHRI Rated cfm	5000	6000	8000	10000
AHRI Net Cooling Capacity	150000	178000	240000	262000
IEER (2-Speed)	17.8	17.9	17.2	16.1
IEER (SZVAV/MZVAV)	18.3	18.4	17.7	16.6
System Power (kW)	12.20	14.83	21.43	25.19
Heating Performance				
High Temp Btuh Rating	135000	162000	224000	242000
System Power (kW) / COP	10.41 / 3.80	12.05 / 3.90	18.14 / 3.60	20.21 / 3.50
Low Temp Btuh Rating	62500	76000	119000	136000
System Power (kW) / COP	8.81 / 2.08	10.66 / 2.09	16.37 / 2.13	17.11 / 2.33
Compressor				
Number/Type	2/Manifold Scroll	2/Manifold Scroll	2/Manifold Scroll	2/Manifold Scroll
Percent Capacity (Stage 1 - Stage 4)	33/67/100/NA	33/67/100/NA	24/36/64/100	25/37/63/100
Sound				
Outdoor Sound Rating (dBA)	87	87	93	93
Outdoor Coil				
Type	RTPF Lanced	RTPF Lanced	RTPF Lanced	RTPF Lanced
Configuration	Full Face	Full Face	Full Face	Full Face
Tube Size (in.)	0.313	0.313	0.313	0.313
Face Area (sq. ft.)	34.71	34.71	40.05	40.05
Rows/FPI (Fins per inch)	3/16	3/16	3/16	3/16
Refrigerant Control	TXV	TXV	TXV	TXV
Indoor Coil				
Type	RTPF Lanced	RTPF Lanced	RTPF Lanced	RTPF Lanced
Configuration	Full Face	Full Face	Full Face	Full Face
Tube Size (in.)	0.313	0.313	0.313	0.313
Face Area (sq. ft.)	25.83	25.83	30.09	30.09
Rows/FPI (Fins per inch)	4/16	4/16	4/16	4/16
Refrigerant Control	TXV	TXV	TXV	TXV
STD. Drain Connection No./Size (in.)	1/1.00 PVC Socket	1/1.00 PVC Socket	1/1.00 PVC Socket	1/1.00 PVC Socket
Stainless Drain Connection No./Size (in.)	1/1.00 NPT	1/1.00 NPT	1/1.00 NPT	1/1.00 NPT
Reheat Coil				
Type	RTPF Lanced	RTPF Lanced	RTPF Lanced	RTPF Lanced
Configuration	Full Face	Full Face	Full Face	Full Face
Tube Size (in.)	0.313	0.313	0.313	0.313
Face Area (sq. ft.)	25.83	25.83	25.83	25.83

Table 5. General data — 12.5 to 25 tons, high efficiency (WHJ*) (continued)

	12.5 Tons	15 Tons	20 Tons	25 Tons
	WHJ150	WHJ180	WHJ240	WHJ300
Rows/FPI (Fins per inch)	1/16	1/16	1/16	1/16
Outdoor Fan				
Type	Propeller	Propeller	Propeller	Propeller
No. Used/Diameter (in.)	2/26x3	2/26x3	2/28x4	2/28x4
Drive Type/No. Speeds	Direct/1	Direct/1	Direct/1	Direct/1
CFM	10480	10480	15810	15810
Motor HP	2/0.50	2/0.50	2/1.0	2/1.0
Motor RPM	1125	1125	1125	1125
Indoor Fan				
Type	BC Plenum	BC Plenum	BC Plenum	BC Plenum
No. Used/Diameter (in.)/Width (in.)	2/23x6	2/23x6	2/23x6	2/23x6
Drive Type/No. Speeds/RPM	Direct / Variable	Direct / Variable	Direct / Variable	Direct / Variable
Motor HP (Standard/Oversized)	2.9 / –	2.9 / –	2.9 / –	2.9 / 4.2
Max Motor RPM	1850	1850	1850	1850 / 1940
Filters^(a)				
Type Furnished	Throwaway	Throwaway	Throwaway	Throwaway
Number Size Recommended	(8) 20 x 24 x 2	(8) 20 x 24 x 2	(4) 20 x 24 x 2 (4) 20 x 30 x 2	(4) 20 x 24 x 2 (4) 20 x 30 x 2
Refrigerant Charge				
lbs of R-410A	30.0	33.0	39.0	38.0
lbs of R-410A, Hot Gas Reheat	36.0	35.0	42.0	38.0
Cabinet				
Cabinet Size	D0	D0	D1	D1

Note: 12.5-20 ton units are AHRI Certified to AHRI Standard 340-360 (I-P). 25 ton unit tested in accordance with AHRI Standard 340-360.

^(a) Outdoor sound rating shown is tested in accordance with AHRI 370-2015. For additional information reference the outdoor sound power level data in the performance section.

Table 6. General data — 12.5 to 25 tons, high efficiency (DHJ*)

	12.5 Tons	15 Tons	20 Tons	25 Tons
	DHJ150	DHJ180	DHJ240	DHJ300
Cooling Performance				
Gross Cooling Capacity	154000	182000	246000	272000
EER	12.2	11.8	11.0	10.2
Nominal cfm/AHRI Rated cfm	5000	6000	8000	10000
AHRI Net Cooling Capacity	152000	178000	240000	260000
IEER (2-Speed)	17.6	17.7	17.0	15.9
IEER (SZVAV/MZVAV)	18.1	18.2	17.5	16.4
System Power (kW)	12.45	14.83	21.81	25.49
Heating Performance				
High Temp Btuh Rating	135000	162000	224000	242000
System Power (kW) / COP	10.41 / 3.80	12.05 / 3.90	18.14 / 3.60	20.21 / 3.50
Low Temp Btuh Rating	62500	76000	119000	136000
System Power (kW) / COP	8.81 / 2.08	10.66 / 2.09	16.37 / 2.13	17.11 / 2.33



General Data

Table 6. General data — 12.5 to 25 tons, high efficiency (DHJ*) (continued)

	12.5 Tons	15 Tons	20 Tons	25 Tons
	DHJ150	DHJ180	DHJ240	DHJ300
Compressor				
Number/Type	2/Manifold Scroll	2/Manifold Scroll	2/Manifold Scroll	2/Manifold Scroll
Percent Capacity (Stage 1 - Stage 4)	33/67/100/NA	33/67/100/NA	24/36/64/100	25/37/63/100
Sound				
Outdoor Sound Rating (dBA)	87	87	93	93
Outdoor Coil				
Type	RTPF Lanced	RTPF Lanced	RTPF Lanced	RTPF Lanced
Configuration	Full Face	Full Face	Full Face	Full Face
Tube Size (in.)	0.313	0.313	0.313	0.313
Face Area (sq. ft.)	34.71	34.71	40.05	40.05
Rows/FPI (Fins per inch)	3/16	3/16	3/16	3/16
Refrigerant Control	TXV	TXV	TXV	TXV
Indoor Coil				
Type	RTPF Lanced	RTPF Lanced	RTPF Lanced	RTPF Lanced
Configuration	Full Face	Full Face	Full Face	Full Face
Tube Size (in.)	0.313	0.313	0.313	0.313
Face Area (sq. ft.)	25.83	25.83	30.09	30.09
Rows/FPI (Fins per inch)	4/16	4/16	4/16	4/16
Refrigerant Control	TXV	TXV	TXV	TXV
STD. Drain Connection No./Size (in.)	1/1.00 PVC Socket	1/1.00 PVC Socket	1/1.00 PVC Socket	1/1.00 PVC Socket
Stainless Drain Connection No./Size (in.)	1/1.00 NPT	1/1.00 NPT	1/1.00 NPT	1/1.00 NPT
Reheat Coil				
Type	RTPF Lanced	RTPF Lanced	RTPF Lanced	RTPF Lanced
Configuration	Full Face	Full Face	Full Face	Full Face
Tube Size (in.)	0.313	0.313	0.313	0.313
Face Area (sq. ft.)	25.83	25.83	25.83	25.83
Rows/FPI (Fins per inch)	1/16	1/16	1/16	1/16
Outdoor Fan				
Type	Propeller	Propeller	Propeller	Propeller
No. Used/Diameter (in.)	2/26x3	2/26x3	2/28x4	2/28x4
Drive Type/No. Speeds	Direct/1	Direct/1	Direct/1	Direct/1
CFM	10480	10480	15810	15810
Motor HP	2/0.50	2/0.50	2/1.0	2/1.0
Motor RPM	1125	1125	1125	1125
Indoor Fan				
Type	BC Plenum	BC Plenum	BC Plenum	BC Plenum
No. Used/Diameter (in.)/Width (in.)	2/23x6	2/23x6	2/23x6	2/23x6
Drive Type/No. Speeds/RPM	Direct / Variable	Direct / Variable	Direct / Variable	Direct / Variable
Motor HP (Standard/Oversized)	2.9 / –	2.9 / –	2.9 / 4.2	2.9 / 4.2
Max Motor RPM	1850	1850	1850 / 1940	1850 / 1940
Filters^(a)				
Type Furnished	Throwaway	Throwaway	Throwaway	Throwaway
Number Size Recommended	(8) 20 x 24 x 2	(8) 20 x 24 x 2	(4) 20 x 24 x 2 (4) 20 x 30 x 2	(4) 20 x 24 x 2 (4) 20 x 30 x 2
Refrigerant Charge				

Table 6. General data — 12.5 to 25 tons, high efficiency (DHJ*) (continued)

	12.5 Tons	15 Tons	20 Tons	25 Tons
	DHJ150	DHJ180	DHJ240	DHJ300
lbs of R-410A	30.0	33.0	39.0	38.0
lbs of R-410A, Hot Gas Reheat	36.0	35.0	42.0	38.0
Heating Performance (Gas/Electric Only)				
Heating Input: Staged				
Low Heat Input (Btu) (High/Low Stage)	150,000/105,000	250,000/175,000	250,000/175,000	250,000/175,000
Mid Heat Input (Btu) (High/Low Stage)	200,000/140,000	320,000/224,000	320,000/224,000	320,000/224,000
High Heat Input (Btu) (High/Low Stage)	250,000/175,000	400,000/280,000	400,000/280,000	400,000/280,000
Heating Output: Staged				
Low Heat Input (Btu) (High/Low Stage)	121,500/85,000	202,500/141,750	202,500/141,750	202,500/141,750
Mid Heat Input (Btu) (High/Low Stage)	162,000/113,400	259,200/181,440	259,200/181,440	259,200/181,440
High Heat Input (Btu) (High/Low Stage)	202,500/141,750	324,000/226,800	324,000/226,800	324,000/226,800
Heating Input: Modulating				
Low Heat Input (Btu) (Maximum/Minimum)	N/A	250,000/25,000	250,000/25,000	250,000/25,000
High Heat Input (Btu) (Maximum/Minimum)	250,000/25,000	400,000/40,000	400,000/40,000	400,000/40,000
Heating Output: Modulating				
Low Heat Output (Btu) (Maximum/Minimum)	N/A	202,500/20,250	202,500/20,250	202,500/20,250
High Heat Output (Btu) (Maximum/Minimum)	202,500/20,250	324,000/32,400	324,000/32,400	324,000/32,400
Steady State Efficiency %				
Low Heat Input	81	81	81	81
Mid Heat Input	81	81	81	81
High Heat Input	81	81	81	81
No. Burners: Staged				
Low Heat Output	5	5	5	5
Mid Heat Output	5	7	7	7
High Heat Output	7	8	8	8
No. Burners: Modulating				
Low Heat Output	N/A	6	6	6
High Heat Output	6	8	8	8
No. Stages				
Low Heat Input	2	2	2	2
Mid Heat Input	2	2	2	2
High Heat Input	2	2	2	2
Gas Supply Line Pressure (InWC)				
Natural (minimum/maximum) Low Heat	4.5/14.0	4.5/14.0	4.5/14.0	4.5/14.0
Natural (minimum/maximum) Mid Heat	4.5/14.0	4.5/14.0	4.5/14.0	4.5/14.0
Natural (minimum/maximum) High Heat	4.5/14.0	6.0/14.0	6.0/14.0	6.0/14.0
LP (minimum/maximum)	11.5/14.0	11.5/14.0	11.5/14.0	11.5/14.0
Gas Connection Pipe Size (in.)				
Low Heat	3/4	3/4	3/4	3/4
Mid Heat	3/4	3/4	3/4	3/4
High Heat	3/4	3/4	3/4	3/4
Cabinet				
Cabinet Size	D0	D0	D1	D1

^(a) Outdoor sound rating shown is tested in accordance with AHRI 370-2015. For additional information reference the outdoor sound power level data in the performance section.



Gross Cooling Capacities

Table 7. Gross cooling capacities — 12.5 tons

CFM	Ent DB (°F)	Entering Wet Bulb Temp (°F)						Entering Wet Bulb Temp (°F)						Entering Wet Bulb Temp (°F)					
		61		67		73		61		67		73		61		67		73	
		MBh	SHC	MBh	SHC	MBh	SHC	MBh	SHC	MBh	SHC	MBh	SHC	MBh	SHC	MBh	SHC	MBh	SHC
		Ambient Temperature 85°F						Ambient Temperature 95°F						Ambient Temperature 105°F					
3750	75	138.5	109.3	154.1	85.8	169.9	61.2	130.4	105.0	145.1	81.4	159.7	56.9	121.8	100.4	135.8	77.0	149.2	52.5
	80	139.0	127.7	154.9	105.5	171.1	81.1	131.0	123.2	145.9	101.1	161.2	76.8	122.7	118.5	136.7	96.7	151.0	72.4
	85	142.3	142.3	155.3	125.0	171.9	100.8	135.5	135.5	146.5	120.7	162.1	96.5	128.4	128.4	137.2	116.2	152.0	92.2
	90	150.3	150.3	155.8	143.3	172.4	120.4	143.3	143.3	147.2	138.8	162.7	116.2	136.0	136.0	138.2	134.2	152.6	111.8
4500	75	143.5	120.7	159.2	92.5	174.3	63.1	134.9	116.2	149.6	88.0	163.7	58.8	125.8	109.9	139.9	83.5	152.7	54.3
	80	145.0	142.5	160.0	115.9	176.1	86.8	136.8	136.8	150.5	111.4	165.7	82.5	128.9	128.9	140.8	106.9	155.0	78.1
	85	152.3	152.3	160.6	139.2	177.0	110.3	144.8	144.8	151.2	133.1	166.7	106.0	137.0	137.0	141.6	128.4	156.0	101.6
	90	160.9	160.9	162.3	160.8	177.5	133.7	153.2	153.2	153.6	153.6	167.3	129.4	145.2	145.2	145.4	145.4	156.7	125.0
5000	75	146.1	128.0	161.7	96.7	176.6	64.3	137.3	121.6	151.9	92.3	165.6	59.6	128.3	116.6	141.9	87.7	153.6	55.0
	80	148.9	148.9	162.6	122.6	178.7	90.5	141.2	141.2	152.9	118.1	168.0	86.1	133.3	133.3	142.9	113.6	157.0	81.7
	85	157.8	157.8	163.5	146.6	179.6	116.5	149.9	149.9	154.0	141.8	169.0	112.1	141.7	141.7	144.3	137.0	158.1	107.7
	90	166.8	166.8	167.0	167.0	180.2	142.3	158.7	158.7	158.9	158.9	169.7	138.0	150.2	150.2	150.4	150.4	158.9	133.5
5500	75	148.5	133.1	163.8	100.9	178.4	65.5	139.6	128.2	153.8	96.4	167.3	61.1	130.4	123.2	143.6	91.8	155.8	56.6
	80	153.3	153.3	164.7	129.2	180.8	94.1	145.4	145.4	154.8	124.7	169.8	89.7	137.1	137.1	144.6	120.1	158.7	85.3
	85	162.6	162.6	166.1	155.2	181.7	122.5	154.4	154.4	156.6	150.4	170.9	118.1	145.8	145.8	146.8	145.5	159.8	113.6
	90	171.8	171.8	172.1	172.1	182.5	150.7	163.3	163.3	163.6	163.6	171.8	146.4	154.4	154.4	154.7	154.7	160.8	139.2
6000	75	150.7	139.7	165.6	104.9	180.0	66.6	141.6	134.8	155.4	100.4	168.6	62.1	132.4	129.6	145.0	95.8	156.8	57.6
	80	157.3	157.3	166.6	135.6	182.6	97.6	149.0	149.0	156.5	131.1	171.4	93.2	140.4	140.4	146.2	123.5	160.1	88.7
	85	166.8	166.8	168.7	163.6	183.6	128.4	158.2	158.2	159.0	158.8	172.6	124.0	149.3	149.3	149.4	149.4	161.3	119.5
	90	176.3	176.3	176.5	176.5	184.5	159.1	167.4	167.4	167.6	167.6	173.7	151.8	158.2	158.2	158.4	158.4	162.6	146.9
		Ambient Temperature 115°F						Ambient Temperature 125°F											
3750	75	112.8	95.7	126.1	72.4	138.3	48.0	103.0	89.1	115.6	67.5	126.5	43.2						
	80	114.0	113.6	127.0	92.1	140.4	67.9	105.3	105.3	116.5	87.2	128.9	63.2						
	85	120.8	120.8	127.4	110.2	141.4	87.7	112.5	112.5	117.1	105.0	129.9	83.0						
	90	128.2	128.2	128.9	128.9	142.0	107.4	119.7	119.7	119.9	119.9	130.6	102.6						
4500	75	116.6	104.7	129.6	78.8	141.3	49.8	106.7	99.3	118.6	74.0	129.1	45.0						
	80	120.8	120.8	130.6	102.3	143.9	73.5	112.0	112.0	119.6	97.4	131.9	68.8						
	85	128.7	128.7	131.7	123.4	145.0	97.1	119.7	119.7	121.1	118.1	133.0	92.3						
	90	136.6	136.6	136.8	136.8	145.7	120.5	127.3	127.3	127.5	127.5	133.8	113.2						
5000	75	118.8	111.4	131.4	83.0	142.8	50.9	108.7	105.8	120.1	78.1	130.1	46.0						
	80	124.8	124.8	132.4	108.9	145.6	77.1	115.6	115.6	121.2	101.0	133.4	72.4						
	85	133.0	133.0	134.2	131.9	146.8	103.1	123.5	123.5	123.7	123.7	134.6	98.3						
	90	141.1	141.1	141.4	141.4	147.6	126.4	131.3	131.3	131.5	131.5	135.7	121.0						
5500	75	120.8	117.9	132.8	87.1	143.8	51.9	110.7	110.7	121.3	82.1	130.8	47.1						
	80	128.3	128.3	134.0	112.4	147.0	80.7	118.7	118.7	122.8	106.8	134.5	75.9						
	85	136.7	136.7	136.8	136.8	148.3	109.1	126.8	126.8	126.9	126.9	135.9	104.3						
	90	145.0	145.0	145.2	145.2	149.5	134.1	134.7	134.7	134.9	134.9	137.4	128.7						
6000	75	122.8	122.8	134.0	91.0	144.5	52.9	113.0	113.0	122.3	86.1	131.4	48.1						
	80	131.2	131.2	135.5	118.1	148.2	84.1	121.3	121.3	124.2	112.4	135.5	79.3						
	85	139.8	139.8	140.0	140.0	149.5	114.9	129.6	129.6	129.7	129.7	136.9	105.9						
	90	148.4	148.4	148.6	148.6	151.2	141.7	137.7	137.7	137.9	137.9	139.0	136.2						

Notes:

1. All capacities shown are gross and have not considered indoor fan heat. To obtain NET cooling capacity subtract indoor fan heat. For indoor fan heat formula, refer to appropriate airflow table notes.
2. MBh = Total gross capacity
3. SHC = Sensible heat capacity

Table 8. Gross cooling capacities — 15 tons

CFM	Ent DB (°F)	Entering Wet Bulb Temp (°F)						Entering Wet Bulb Temp (°F)						Entering Wet Bulb Temp (°F)					
		61		67		73		61		67		73		61		67		73	
		MBh	SHC	MBh	SHC	MBh	SHC	MBh	SHC	MBh	SHC	MBh	SHC	MBh	SHC	MBh	SHC	MBh	SHC
		Ambient Temperature 85°F						Ambient Temperature 95°F						Ambient Temperature 105°F					
4500	75	165.1	129.5	183.4	101.0	202.7	71.5	155.7	124.2	173.1	95.8	191.4	66.3	145.8	118.8	162.4	90.4	179.6	61.0
	80	165.8	152.9	184.0	124.5	203.1	95.1	156.5	146.8	173.8	119.3	191.9	90.0	146.9	141.3	163.0	113.9	180.2	84.7
	85	169.8	169.8	184.4	147.9	203.6	118.7	161.9	161.9	174.3	142.7	192.5	113.6	153.5	153.5	163.6	137.4	180.9	108.3
	90	179.1	179.1	185.3	171.4	204.1	142.1	171.0	171.0	175.3	166.2	193.0	137.1	162.4	162.4	165.0	159.8	181.4	131.8
5400	75	170.9	142.9	189.1	108.9	208.1	73.7	161.0	137.5	178.3	103.6	196.2	68.5	150.7	132.0	167.1	98.1	183.8	63.2
	80	172.9	169.9	189.8	136.8	208.8	101.8	163.5	163.5	179.0	131.5	197.0	96.6	154.0	154.0	167.8	126.0	184.8	91.3
	85	181.4	181.4	190.5	164.6	209.3	129.8	172.7	172.7	180.0	159.4	197.7	124.6	163.6	163.6	168.9	154.0	185.5	119.3
	90	191.4	191.4	192.9	191.5	209.8	157.7	182.5	182.5	183.0	183.0	198.3	152.5	173.1	173.1	173.3	173.3	186.2	147.3
6000	75	174.0	151.5	192.1	113.9	210.9	75.1	163.9	146.1	181.0	108.5	198.6	69.9	153.4	140.6	169.5	103.0	186.0	64.5
	80	177.4	177.4	192.7	144.6	211.6	106.1	168.5	168.5	181.7	139.3	199.6	100.9	159.2	159.2	170.3	133.8	187.1	95.6
	85	187.7	187.7	194.0	175.5	212.2	137.0	178.6	178.6	183.2	168.9	200.3	131.8	169.1	169.1	172.1	163.2	187.9	126.5
	90	198.1	198.1	198.2	198.2	212.9	167.8	188.7	188.7	189.0	189.0	201.1	162.6	178.8	178.8	179.1	179.1	188.8	157.3
6600	75	176.8	160.0	194.5	118.7	213.1	76.4	166.5	154.6	183.2	113.3	200.6	71.2	156.0	147.2	171.5	107.8	187.8	65.8
	80	182.5	182.5	195.2	152.3	214.0	110.3	173.3	173.3	184.0	147.0	201.8	105.1	163.7	163.7	172.4	141.5	189.1	99.7
	85	193.2	193.2	197.1	184.6	214.6	144.0	183.7	183.7	186.2	179.1	202.5	138.8	173.8	173.8	175.0	173.4	189.8	133.4
	90	203.8	203.8	204.1	204.1	215.5	177.7	194.1	194.1	194.3	194.3	203.5	172.5	183.8	183.8	184.1	184.1	191.0	167.2
7200	75	179.3	166.6	196.6	123.4	215.0	77.7	169.0	160.9	185.1	118.0	202.4	72.5	158.4	155.0	173.2	112.5	189.3	67.1
	80	187.0	187.0	197.4	159.8	216.0	114.4	177.5	177.5	186.1	154.5	203.6	109.1	167.5	167.5	174.3	149.0	190.7	103.7
	85	197.9	197.9	200.0	194.7	216.7	150.8	188.1	188.1	189.2	189.1	204.3	145.6	177.8	177.8	178.1	178.1	191.4	140.3
	90	208.9	208.9	209.1	209.1	217.8	187.4	198.8	198.8	199.0	199.0	205.7	182.3	188.1	188.1	188.3	188.3	193.1	174.8
		Ambient Temperature 115°F						Ambient Temperature 125°F											
4500	75	135.4	113.1	151.1	84.9	167.1	55.6	124.3	107.2	139.0	79.0	153.6	49.8						
	80	136.9	135.5	151.8	108.4	167.9	79.3	126.5	126.5	139.7	102.5	154.6	73.5						
	85	144.5	144.5	152.4	131.8	168.6	102.9	134.9	134.9	140.5	126.0	155.4	97.1						
	90	153.2	153.2	154.3	154.2	169.2	126.4	143.2	143.2	143.5	143.5	156.0	120.6						
5400	75	139.9	126.3	155.3	92.5	170.8	57.7	128.5	118.8	142.6	86.6	156.8	51.9						
	80	144.7	144.7	156.0	120.4	172.0	85.8	134.5	134.5	143.4	114.5	158.2	80.0						
	85	153.9	153.9	157.4	146.9	172.7	113.8	143.3	143.3	145.2	140.8	158.9	108.0						
	90	163.0	163.0	163.3	163.3	173.5	141.8	152.1	152.1	152.4	152.4	159.8	136.0						
6000	75	142.5	133.2	157.4	97.4	172.7	59.0	131.0	126.8	144.5	91.4	158.5	53.2						
	80	149.4	149.4	158.3	128.2	174.0	90.1	138.8	138.8	145.5	122.3	159.9	84.2						
	85	158.9	158.9	160.4	157.3	174.8	120.9	147.9	147.9	148.2	148.2	160.7	115.1						
	90	168.3	168.3	168.6	168.6	175.8	151.9	156.8	156.8	157.1	157.1	161.9	146.1						
6600	75	145.0	141.1	159.2	102.1	174.3	60.3	133.4	133.4	146.0	96.1	159.8	54.4						
	80	153.5	153.5	160.2	135.8	175.7	94.2	142.4	142.4	147.2	129.9	161.4	88.3						
	85	163.2	163.2	163.5	163.5	176.5	127.9	151.7	151.7	151.9	151.9	162.3	122.1						
	90	172.8	172.8	173.1	173.1	177.9	161.8	160.9	160.9	161.1	161.1	164.0	153.4						
7200	75	147.3	147.3	160.7	106.8	175.6	61.5	136.0	136.0	147.3	100.8	161.0	55.7						
	80	157.0	157.0	162.0	143.3	177.2	98.2	145.6	145.6	148.9	134.8	162.6	92.3						
	85	166.9	166.9	167.1	167.1	178.0	134.7	155.0	155.0	155.2	155.2	163.6	128.9						
	90	176.7	176.7	176.9	176.9	179.9	168.9	164.3	164.3	164.5	164.5	165.9	162.5						

Notes:

1. All capacities shown are gross and have not considered indoor fan heat. To obtain NET cooling capacity subtract indoor fan heat. For indoor fan heat formula, refer to appropriate airflow table notes.
2. MBh = Total gross capacity
3. SHC = Sensible heat capacity



Gross Cooling Capacities

Table 9. Gross cooling capacities — 20 tons

CFM	Ent DB (°F)	Entering Wet Bulb Temp (°F)						Entering Wet Bulb Temp (°F)						Entering Wet Bulb Temp (°F)					
		61		67		73		61		67		73		61		67		73	
		MBh	SHC	MBh	SHC	MBh	SHC	MBh	SHC	MBh	SHC	MBh	SHC	MBh	SHC	MBh	SHC	MBh	SHC
		Ambient Temperature 85°F						Ambient Temperature 95°F						Ambient Temperature 105°F					
6000	75	222.9	176.2	248.0	138.3	274.7	98.9	209.8	169.3	233.8	131.5	259.0	92.3	195.7	162.0	218.6	124.4	242.3	85.4
	80	224.4	207.8	248.9	169.8	275.3	130.6	211.6	199.6	234.8	163.0	259.9	124.1	198.0	192.1	219.7	155.9	243.5	117.2
	85	230.4	230.4	249.6	201.1	276.1	162.2	219.6	219.6	235.7	194.4	260.9	155.7	207.8	207.8	220.8	187.4	244.6	148.8
	90	243.2	243.2	251.3	232.8	276.8	193.7	232.1	232.1	237.7	226.2	261.7	187.2	220.2	220.2	223.3	217.5	245.5	180.3
7200	75	231.0	194.2	255.9	148.8	282.1	102.0	217.3	187.2	241.0	141.9	265.7	95.3	202.6	179.9	225.1	134.8	248.1	88.3
	80	234.4	230.4	256.9	186.2	283.2	139.6	221.5	221.5	242.1	179.3	267.0	133.0	208.2	208.2	226.2	172.2	249.9	126.1
	85	246.1	246.1	258.4	223.7	284.1	177.1	234.3	234.3	243.9	217.0	268.2	170.6	221.5	221.5	228.4	209.9	251.1	163.7
	90	259.9	259.9	262.2	259.7	284.9	214.5	247.8	247.8	248.7	248.7	269.2	208.0	234.8	234.8	235.1	235.1	252.3	201.2
8000	75	235.4	205.8	260.0	155.5	285.9	103.8	221.4	198.8	244.7	148.6	269.0	97.1	206.5	189.1	228.4	141.4	251.1	90.1
	80	240.7	240.7	261.0	196.7	287.2	145.4	228.4	228.4	245.9	189.9	270.7	138.7	215.3	215.3	229.8	182.7	253.2	131.8
	85	254.8	254.8	263.3	238.3	288.2	186.8	242.4	242.4	248.5	229.4	271.8	180.1	229.0	229.0	232.9	221.8	254.4	173.2
	90	269.1	269.1	269.5	269.5	289.3	228.1	256.4	256.4	256.8	256.8	273.2	221.5	242.7	242.7	243.0	243.0	256.1	214.7
8800	75	239.3	217.2	263.4	162.0	289.0	105.6	225.1	207.7	247.8	155.0	271.8	98.9	210.2	199.8	231.2	147.8	253.6	91.9
	80	247.5	247.5	264.6	207.0	290.6	151.0	234.9	234.9	249.2	200.2	273.7	144.3	221.3	221.3	232.8	193.0	255.9	137.4
	85	262.2	262.2	267.7	250.2	291.6	196.1	249.3	249.3	252.9	243.1	274.9	189.5	235.4	235.4	237.2	235.5	257.2	182.6
	90	277.0	277.0	277.4	277.4	293.2	241.4	263.7	263.7	264.1	264.1	276.8	234.8	249.5	249.5	249.8	249.8	259.4	228.0
9600	75	242.9	225.7	266.3	168.3	291.6	107.3	228.7	218.1	250.4	161.3	274.2	100.6	213.6	210.2	233.5	154.0	255.7	93.5
	80	253.6	253.6	267.8	217.1	293.4	156.5	240.5	240.5	252.2	210.3	276.3	149.8	226.6	226.6	235.6	203.1	258.2	142.8
	85	268.7	268.7	272.0	263.7	294.5	205.3	255.4	255.4	257.0	256.4	277.5	198.7	241.0	241.0	241.5	241.5	259.6	191.7
	90	283.9	283.9	284.3	284.3	296.6	254.4	270.2	270.2	270.5	270.5	280.0	247.9	255.4	255.4	255.7	255.7	262.4	241.1
		Ambient Temperature 115°F						Ambient Temperature 125°F											
6000	75	180.7	154.3	202.3	117.0	224.3	78.2	164.5	146.3	184.8	109.1	204.9	70.5						
	80	183.7	183.7	203.5	148.5	226.0	110.0	169.5	169.5	186.0	140.7	207.1	102.5						
	85	195.1	195.1	204.8	180.1	227.2	141.7	181.3	181.3	187.6	172.4	208.4	134.1						
	90	207.2	207.2	208.3	208.3	228.2	173.2	193.1	193.1	193.5	193.5	209.5	165.7						
7200	75	187.0	170.0	208.1	127.2	229.5	81.0	170.5	161.3	189.9	119.3	209.3	73.3						
	80	194.8	194.8	209.4	164.7	231.7	118.9	180.2	180.2	191.3	156.9	212.0	111.3						
	85	207.8	207.8	212.0	200.1	233.0	156.5	192.8	192.8	194.7	191.7	213.4	148.9						
	90	220.7	220.7	221.0	221.0	234.4	194.0	205.3	205.3	205.6	205.6	215.1	186.5						
8000	75	190.8	180.8	211.1	133.8	232.1	82.8	174.2	172.0	192.4	125.9	211.6	75.1						
	80	201.3	201.3	212.6	175.2	234.6	124.6	186.0	186.0	194.3	167.3	214.5	116.9						
	85	214.6	214.6	216.5	213.9	235.9	166.0	199.0	199.0	199.3	199.3	216.0	158.4						
	90	227.9	227.9	228.3	228.3	237.9	207.6	211.8	211.8	212.1	212.1	218.2	196.8						
8800	75	194.4	191.4	213.5	140.2	234.3	84.5	177.8	177.8	194.5	132.2	213.4	76.8						
	80	206.8	206.8	215.5	185.5	237.0	130.1	191.0	191.0	196.8	174.0	216.6	122.4						
	85	220.5	220.5	220.9	220.9	238.4	175.3	204.3	204.3	204.5	204.5	218.2	167.7						
	90	234.2	234.2	234.4	234.4	240.9	217.6	217.4	217.4	217.6	217.6	221.3	209.2						
9600	75	197.8	197.8	215.6	146.4	236.1	86.2	181.6	181.6	196.3	138.4	214.9	78.4						
	80	211.5	211.5	217.9	192.1	239.0	135.5	195.3	195.3	199.3	183.3	218.3	127.8						
	85	225.6	225.6	225.8	225.8	240.6	184.5	208.8	208.8	209.0	209.0	220.2	176.9						
	90	239.5	239.5	239.8	239.8	243.9	229.8	222.1	222.1	222.4	222.4	224.2	221.3						

Notes:

1. All capacities shown are gross and have not considered indoor fan heat. To obtain NET cooling capacity subtract indoor fan heat. For indoor fan heat formula, refer to appropriate airflow table notes.
2. MBh = Total gross capacity
3. SHC = Sensible heat capacity

Table 10. Gross cooling capacities — 25 tons

CFM	Ent DB (°F)	Entering Wet Bulb Temp (°F)						Entering Wet Bulb Temp (°F)						Entering Wet Bulb Temp (°F)					
		61		67		73		61		67		73		61		67		73	
		MBh	SHC	MBh	SHC	MBh	SHC	MBh	SHC	MBh	SHC	MBh	SHC	MBh	SHC	MBh	SHC	MBh	SHC
		Ambient Temperature 85°F						Ambient Temperature 95°F						Ambient Temperature 105°F					
7500	75	247.4	201.9	273.9	155.7	301.5	107.9	233.5	194.4	258.6	148.2	284.3	100.4	218.8	186.5	242.5	140.4	266.0	92.7
	80	250.4	238.1	275.3	193.8	303.1	146.3	237.0	230.3	260.1	186.3	286.4	138.9	222.9	222.1	244.0	178.5	268.8	131.3
	85	260.5	260.5	276.6	231.8	304.4	184.4	248.4	248.4	261.7	224.4	288.0	177.1	235.4	235.4	245.9	216.7	270.5	169.5
	90	274.9	274.9	280.0	267.7	305.4	222.4	262.5	262.5	265.6	260.0	289.1	215.2	249.2	249.2	250.6	250.6	271.7	207.6
9000	75	255.6	222.5	281.6	167.6	308.2	111.2	241.2	214.9	265.7	160.0	290.4	103.8	225.8	207.0	248.8	152.1	271.5	96.0
	80	261.5	261.5	283.1	212.5	310.7	156.6	248.1	248.1	267.3	204.9	293.4	149.1	234.5	234.5	250.5	197.0	275.0	141.4
	85	276.3	276.3	285.7	257.7	312.3	201.6	263.1	263.1	270.3	250.3	295.1	194.2	249.1	249.1	253.9	238.4	276.9	186.5
	90	291.7	291.7	292.4	292.4	313.6	246.4	278.2	278.2	278.3	278.3	296.7	239.1	263.7	263.7	264.1	264.1	278.7	231.5
10000	75	260.2	235.7	285.7	175.2	311.9	113.4	245.5	228.1	269.3	167.5	293.6	105.8	230.0	215.4	252.0	159.6	274.4	98.0
	80	268.7	268.7	287.2	224.4	314.7	163.1	255.6	255.6	271.1	216.8	297.0	155.6	241.4	241.4	254.0	209.0	278.2	147.9
	85	284.8	284.8	290.9	270.6	316.3	212.5	271.1	271.1	275.3	262.5	298.8	205.1	256.4	256.4	258.9	253.9	280.1	197.3
	90	300.8	300.8	301.2	301.2	318.1	261.9	286.7	286.7	287.0	287.0	300.9	254.5	271.5	271.5	271.8	271.8	282.6	246.9
11000	75	264.3	248.5	289.0	182.4	314.9	115.4	249.5	235.9	272.4	174.8	296.3	107.8	233.9	227.1	254.8	166.7	276.7	99.9
	80	275.8	275.8	290.8	236.0	318.1	169.4	262.0	262.0	274.5	228.4	300.0	161.9	247.2	247.2	257.2	220.5	280.9	154.1
	85	292.2	292.2	295.8	285.7	319.7	223.0	277.9	277.9	280.1	277.5	301.8	215.6	262.7	262.7	263.6	263.6	282.9	207.8
	90	308.6	308.6	308.9	308.9	322.1	276.9	293.9	293.9	294.2	294.2	304.6	269.5	278.2	278.2	278.4	278.4	286.1	261.9
12000	75	268.2	255.8	291.9	189.5	317.4	117.3	253.2	247.3	275.0	181.7	298.6	109.7	237.4	237.4	257.1	173.7	278.6	101.8
	80	281.8	281.8	294.1	247.3	320.9	175.5	267.5	267.5	277.5	239.7	302.5	167.9	252.3	252.3	260.0	231.7	283.2	160.1
	85	298.5	298.5	300.4	300.4	322.6	233.2	283.8	283.8	284.6	284.6	304.4	225.8	268.1	268.1	268.2	268.2	285.2	218.0
	90	315.3	315.3	315.7	315.7	325.7	291.4	300.1	300.1	300.4	300.4	308.0	284.1	283.9	283.9	284.1	284.1	289.3	269.9
		Ambient Temperature 115°F						Ambient Temperature 125°F											
7500	75	203.0	178.3	225.2	132.2	246.7	84.6	186.2	169.5	206.7	123.5	225.9	76.1						
	80	208.2	208.2	226.8	170.3	250.0	123.3	193.3	193.3	208.4	161.7	229.8	114.8						
	85	221.4	221.4	229.0	208.7	251.9	161.5	206.2	206.2	211.0	196.2	231.7	153.1						
	90	234.8	234.8	235.0	235.0	253.3	199.7	219.1	219.1	219.4	219.4	233.3	191.2						
9000	75	209.6	194.3	230.8	143.8	251.5	87.8	192.5	184.5	211.5	135.1	229.9	79.2						
	80	219.8	219.8	232.7	188.8	255.5	133.4	203.9	203.9	213.7	180.2	234.5	124.8						
	85	234.0	234.0	236.8	229.5	257.5	178.4	217.5	217.5	218.6	218.6	236.6	169.9						
	90	248.1	248.1	248.4	248.4	259.7	223.6	231.1	231.1	231.3	231.3	239.1	215.1						
10000	75	213.7	206.2	233.7	151.2	253.9	89.8	196.3	196.2	214.0	142.4	231.8	81.1						
	80	226.1	226.1	236.0	200.7	258.4	139.8	209.5	209.5	216.5	186.5	237.0	131.2						
	85	240.7	240.7	241.7	241.7	260.4	189.2	223.5	223.5	223.6	223.6	239.1	180.7						
	90	255.2	255.2	255.5	255.5	263.3	239.0	237.4	237.4	237.6	237.6	242.5	224.2						
11000	75	217.4	217.4	236.1	158.4	255.8	91.7	200.0	200.0	216.0	149.5	233.2	82.9						
	80	231.4	231.4	238.9	212.3	260.7	146.0	214.3	214.3	219.3	196.7	239.0	137.3						
	85	246.4	246.4	246.5	246.5	262.8	199.7	228.6	228.6	228.8	228.8	241.3	191.1						
	90	261.3	261.3	261.5	261.5	266.6	247.5	242.7	242.7	243.0	243.0	245.7	237.6						
12000	75	220.9	220.9	238.1	165.3	257.3	93.5	203.7	203.7	217.7	156.3	234.3	84.7						
	80	236.1	236.1	241.5	216.8	262.7	152.0	218.4	218.4	221.8	206.4	240.6	143.3						
	85	251.3	251.3	251.5	251.5	265.0	209.9	232.9	232.9	233.1	233.1	243.3	201.3						
	90	266.4	266.4	266.7	266.7	269.8	260.6	247.3	247.3	247.5	247.5	248.8	248.8						

Notes:

1. All capacities shown are gross and have not considered indoor fan heat. To obtain NET cooling capacity subtract indoor fan heat. For indoor fan heat formula, refer to appropriate airflow table notes.
2. MBh = Total gross capacity
3. SHC = Sensible heat capacity



Heating Capacities

Table 11. Heating capacities — 12.5 tons

Outdoor Temp (°F)	Integrated Heating Capacity (MBh) at Indicated Dry Bulb Temp (°F)				Total Power (kW) at Indicated Dry Bulb Temp (°F)			
	60	70	75	80	60	70	75	80
-8	45.7	43.4	42.3	41.1	9.0	9.9	10.3	10.8
-3	52.6	50.3	49.1	47.9	9.1	10.0	10.5	10.9
2	59.8	57.3	56.1	54.8	9.2	10.1	10.6	11.1
7	67.3	64.6	63.3	61.9	9.4	10.3	10.8	11.3
12	75.3	72.5	71.1	69.7	9.5	10.4	10.9	11.4
17	83.7	80.6	79.1	77.7	9.7	10.6	11.1	11.6
22	92.6	89.3	87.7	86.1	9.8	10.8	11.3	11.8
27	101.9	98.3	96.5	94.8	10.0	10.9	11.5	12.0
32	111.5	107.6	105.7	103.8	10.2	11.1	11.6	12.2
37	121.1	116.8	114.7	112.7	10.4	11.3	11.8	12.4
42	130.9	126.2	124.0	121.8	10.6	11.5	12.0	12.6
47	141.0	136.0	133.5	131.2	10.8	11.7	12.3	12.8
52	151.6	146.1	143.5	140.9	11.0	12.0	12.5	13.0
57	162.5	156.5	153.7	150.9	11.2	12.2	12.7	13.3
62	173.2	166.8	163.8	160.8	11.5	12.4	13.0	13.5
67	185.1	178.1	174.8	171.5	11.7	12.7	13.2	13.8
72	196.6	188.7	185.0	181.3	12.0	12.9	13.5	14.0

Notes:

1. For other airflow conditions, see heating capacity correction factor Net Heating Capacity and Power Input include indoor fan heat at nominal CFM and 0.35 inch ESP. To obtain net heating at other conditions, subtract fan heat at this condition and add fan heat at new condition.
2. Heating capacities and powers are integrated to include the effects of defrost in the frost region.
3. All heating capacities and power (kW) are at 70% OD relative humidity.

Table 12. Heating capacities — 15 tons

Outdoor Temp (°F)	Integrated Heating Capacity (MBh) at Indicated Dry Bulb Temp (°F)				Total Power in Kilowatts at Indicated Dry Bulb Temp (°F)			
	60	70	75	80	60	70	75	80
-8	55.5	54.0	53.2	52.3	11.0	12.1	12.6	13.3
-3	63.6	61.8	60.9	59.9	11.1	12.2	12.8	13.4
2	72.0	70.0	68.9	67.9	11.3	12.4	13.0	13.6
7	80.8	78.6	77.4	76.2	11.5	12.6	13.2	13.9
12	90.2	87.7	86.4	85.1	11.7	12.8	13.4	14.1
17	99.9	97.1	95.7	94.2	11.9	13.0	13.6	14.3
22	110.3	107.2	105.6	104.0	12.1	13.2	13.8	14.5
27	121.0	117.6	115.8	114.0	12.3	13.5	14.1	14.7
32	132.2	128.4	126.5	124.5	12.5	13.7	14.3	14.9
37	143.3	139.0	136.9	134.8	12.7	13.9	14.5	15.2
42	154.7	150.0	147.6	145.3	13.0	14.1	14.8	15.4
47	166.2	161.1	158.6	156.0	13.2	14.4	15.0	15.7
52	178.2	172.6	169.8	167.1	13.4	14.6	15.3	15.9
57	190.5	184.3	181.3	178.3	13.7	14.9	15.5	16.2

Table 12. Heating capacities — 15 tons (continued)

Outdoor Temp (°F)	Integrated Heating Capacity (MBh) at Indicated Dry Bulb Temp (°F)				Total Power in Kilowatts at Indicated Dry Bulb Temp (°F)			
	60	70	75	80	60	70	75	80
62	202.0	195.3	192.0	188.6	14.0	15.1	15.8	16.4
67	213.9	206.6	202.9	199.2	14.3	15.4	16.1	16.7
72	226.9	218.7	214.7	210.8	14.6	15.8	16.4	17.1

Notes:

1. For other airflow conditions, see heating capacity correction factor Net Heating Capacity and Power Input include indoor fan heat at nominal CFM and 0.35 inch ESP. To obtain net heating at other conditions, subtract fan heat at this condition and add fan heat at new condition.
2. Heating capacities and powers are integrated to include the effects of defrost in the frost region.
3. All heating capacities and power (kW) are at 70% OD relative humidity.

Table 13. Heating capacities — 20 tons

Outdoor Temp (°F)	Integrated Heating Capacity (MBh) at Indicated Dry Bulb Temp (°F)				Total Power in Kilowatts at Indicated Dry Bulb Temp (°F)			
	60	70	75	80	60	70	75	80
-8	79.9	76.5	74.7	72.8	16.2	17.7	18.5	19.4
-3	91.0	87.4	85.6	83.7	16.4	17.9	18.8	19.7
2	102.4	98.7	96.8	94.8	16.7	18.2	19.0	19.9
7	114.3	110.4	108.4	106.2	16.9	18.4	19.3	20.2
12	127.1	123.0	120.8	118.5	17.1	18.7	19.5	20.5
17	140.1	135.8	133.5	131.2	17.3	18.9	19.8	20.7
22	154.1	149.5	147.1	144.6	17.6	19.2	20.1	21.0
27	168.6	163.6	161.0	158.4	17.8	19.4	20.3	21.3
32	183.7	178.3	175.5	172.8	18.1	19.7	20.6	21.5
37	198.5	192.7	189.8	186.8	18.3	20.0	20.9	21.8
42	213.9	207.6	204.4	201.2	18.6	20.2	21.1	22.1
47	229.5	222.8	219.4	216.0	18.8	20.5	21.4	22.4
52	245.7	238.5	234.8	231.1	19.1	20.8	21.7	22.7
57	262.5	254.6	250.6	246.7	19.4	21.1	22.0	23.0
62	278.8	270.3	266.0	261.7	19.6	21.3	22.3	23.3
67	295.1	285.8	281.1	276.4	19.9	21.6	22.6	23.6
72	312.8	302.3	297.1	291.9	20.2	22.0	22.9	23.9

Notes:

1. For other airflow conditions, see heating capacity correction factor Net Heating Capacity and Power Input include indoor fan heat at nominal CFM and 0.35 inch ESP. To obtain net heating at other conditions, subtract fan heat at this condition and add fan heat at new condition.
2. Heating capacities and powers are integrated to include the effects of defrost in the frost region.
3. All heating capacities and power (kW) are at 70% OD relative humidity.

Table 14. Heating capacities — 25 tons

Outdoor Temp (°F)	Integrated Heating Capacity (MBh) at Indicated Dry Bulb Temp (°F)				Total Power in Kilowatts at Indicated Dry Bulb Temp (°F)			
	60	70	75	80	60	70	75	80
-8	90.3	88.2	87.4	86.7	17.6	19.2	20.1	21.0
-3	101.7	99.4	98.4	97.7	17.8	19.5	20.4	21.3
2	113.6	111.2	110.1	109.1	18.1	19.7	20.6	21.6
7	126.1	123.4	122.2	121.0	18.3	20.0	20.9	21.8
12	139.1	136.2	134.8	133.6	18.6	20.2	21.2	22.1
17	152.6	149.3	147.8	146.5	18.8	20.5	21.4	22.4



Heating Capacities

Table 14. Heating capacities — 25 tons (continued)

Outdoor Temp (°F)	Integrated Heating Capacity (MBh) at Indicated Dry Bulb Temp (°F)				Total Power in Kilowatts at Indicated Dry Bulb Temp (°F)			
	60	70	75	80	60	70	75	80
22	167.0	163.5	161.8	160.1	19.1	20.8	21.7	22.7
27	182.0	177.9	176.2	174.3	19.3	21.0	22.0	23.0
32	197.9	193.6	191.2	189.3	19.6	21.3	22.3	23.3
37	213.6	208.8	206.4	204.2	19.8	21.6	22.5	23.5
42	230.0	224.7	222.1	219.5	20.1	21.9	22.8	23.8
47	246.6	240.8	237.9	235.0	20.4	22.1	23.1	24.1
52	263.9	257.5	254.3	251.2	20.6	22.4	23.4	24.4
57	282.2	275.2	271.6	268.1	20.9	22.7	23.7	24.7
62	300.4	292.6	288.7	284.8	21.2	23.0	24.0	25.1
67	318.4	309.8	305.4	301.0	21.5	23.3	24.3	25.4
72	338.1	328.1	323.2	318.2	21.9	23.7	24.7	25.7

Notes:

1. For other airflow conditions, see heating capacity correction factor Net Heating Capacity and Power Input include indoor fan heat at nominal CFM and 0.35 inch ESP. To obtain net heating at other conditions, subtract fan heat at this condition and add fan heat at new condition.
2. Heating capacities and powers are integrated to include the effects of defrost in the frost region.
3. All heating capacities and power (kW) are at 70% OD relative humidity.



Reheat Temperature Rise

Table 15. Reheat temperature rise — 12.5 tons

Airflow (cfm)	Ent DB (°F)	Entering Wet Bulb (°F)											
		51				55				59			
		Lvg Evap DB (°F)		Lvg Reheat DB (°F)		Lvg Evap DB (°F)		Lvg Reheat DB (°F)		Lvg Evap DB (°F)		Lvg Reheat DB (°F)	
		MIN	MAX	MIN	MAX	MIN	MAX	MIN	MAX	MIN	MAX	MIN	MAX
Ambient DB 60°F													
2500	60	30.1 ^(a)	27.9 ^(a)	35.0	59.2	34.3	32.5 ^(a)	39.4	63.6	38.6	37.9	44.0	67.5
	65	30.0 ^(a)	27.8 ^(a)	35.0	59.1	34.1	32.3 ^(a)	39.4	63.6	38.5	37.7	44.0	67.4
	70	30.0 ^(a)	27.8 ^(a)	35.1	59.0	34.0	32.2 ^(a)	39.4	63.5	38.3	37.6	44.0	67.4
	75	32.0 ^(a)	29.1 ^(a)	37.4	60.6	34.0	32.1 ^(a)	39.2	63.4	38.2	37.4	43.9	67.3
3000	60	33.3	31.1 ^(a)	37.5	58.4	37.5	35.7	42.0	62.9	41.9	41.0	46.6	67.0
	65	33.2	31.0 ^(a)	37.5	58.4	37.4	35.6	42.0	62.9	41.8	40.8	46.6	66.9
	70	33.5	31.0 ^(a)	38.2	58.5	37.3	35.5	42.0	62.9	41.6	40.7	46.6	66.9
	75	36.5	33.7	41.6	61.5	37.2	35.4	42.2	62.9	41.5	40.6	46.6	66.9
3500	60	35.7	33.6	39.4	57.8	40.0	38.2	43.9	62.4	44.3	43.3	48.4	66.4
	65	35.6	33.5	39.6	57.8	39.9	38.1	43.9	62.4	44.2	43.2	48.4	66.4
	70	37.0	34.0	41.4	58.7	39.8	38.0	43.9	62.4	44.1	43.1	48.5	66.4
	75	40.2	37.5	44.9	62.3	40.3	37.8	44.9	62.4	44.0	43.0	48.5	66.4
4000	60	37.6	35.6	40.9	57.4	41.8	40.1	45.3	61.9	46.2	45.1	49.7	65.9
	65	37.5	35.5	41.1	57.5	41.7	40.0	45.3	61.9	46.1	45.0	49.8	66.0
	70	39.9	37.0	44.0	59.4	41.6	39.9	45.6	62.0	46.0	44.9	49.9	66.0
	75	43.2	40.6	47.6	63.1	43.3	40.7	47.7	63.1	45.9	44.8	50.1	66.0
4500	60	39.1	37.2	42.1	57.0	43.3	41.7	46.4	61.5	47.7	46.5	50.8	65.5
	65	38.9	37.1	42.3	57.2	43.2	41.6	46.5	61.5	47.6	46.4	50.9	65.6
	70	42.4	39.5	46.1	60.0	43.1	41.5	46.8	61.7	47.5	46.3	51.0	65.6
	75	45.8	43.3	49.8	63.7	45.9	43.4	49.9	63.7	47.4	46.3	51.3	65.8
5000	60	40.3	38.5	43.0	56.6	44.5	43.0	47.3	61.1	48.9	47.8	51.6	65.3
	65	40.9	38.3	44.1	56.9	44.5	42.9	47.4	61.2	48.8	47.6	51.8	65.3
	70	44.4	41.6	48.0	60.5	44.3	42.7	47.8	61.4	48.7	47.5	51.9	65.3
	75	48.0	45.6	51.7	64.3	48.1	45.7	51.9	64.3	48.5	47.5	52.3	65.6
5500	60	41.3	39.6	44.0	56.4	45.5	44.0	48.0	60.8	49.9	48.7	52.3	64.9
	65	42.5	39.4	45.6	56.7	45.5	44.0	48.2	60.9	49.8	48.6	52.5	65.0
	70	46.2	43.5	49.5	61.0	46.3	43.8	49.6	61.2	49.7	48.5	52.6	65.1
	75	49.8	47.6	53.4	64.9	49.9	47.7	53.5	64.9	49.5	48.4	53.0	65.4
6000	60	42.1	40.6	44.7	56.1	46.4	44.9	48.7	60.5	50.7	49.6	52.9	64.6
	65	44.0	41.3	46.9	57.5	46.3	44.9	49.1	60.6	50.6	49.5	53.1	64.7
	70	47.8	45.2	50.9	61.5	47.8	44.6	51.0	61.0	50.5	49.4	53.5	64.8
	75	51.5	49.4	54.8	65.4	51.6	49.5	54.9	65.4	51.6	49.2	55.0	65.2
Ambient DB 65°F													
2500	60	30.6 ^(a)	28.1 ^(a)	35.7	60.4	34.8	32.5 ^(a)	40.2	65.1	39.1	37.4	45.0	69.7
	65	30.5 ^(a)	27.8 ^(a)	35.7	60.3	34.7	32.3 ^(a)	40.1	65.1	39.0	37.3	44.8	69.5
	70	30.5 ^(a)	28.0 ^(a)	35.9	60.3	34.6	32.2 ^(a)	40.1	65.0	38.9	37.2	44.8	69.5
	75	32.7 ^(a)	29.3 ^(a)	38.4	62.0	34.5	32.1 ^(a)	40.1	64.9	38.8	37.0	44.8	69.5



Reheat Temperature Rise

Table 15. Reheat temperature rise — 12.5 tons (continued)

Airflow (cfm)	Ent DB (°F)	Entering Wet Bulb (°F)											
		51				55				59			
		Lvg Evap DB (°F)		Lvg Reheat DB (°F)		Lvg Evap DB (°F)		Lvg Reheat DB (°F)		Lvg Evap DB (°F)		Lvg Reheat DB (°F)	
		MIN	MAX	MIN	MAX	MIN	MAX	MIN	MAX	MIN	MAX	MIN	MAX
3000	60	33.8	31.3 ^(a)	38.1	59.5	38.0	35.7	42.6	64.3	42.4	40.6	47.2	68.8
	65	33.7	31.2 ^(a)	38.1	59.4	37.9	35.6	42.6	64.3	42.2	40.5	47.2	68.7
	70	34.2	31.1 ^(a)	39.1	59.5	37.8	35.5	42.7	64.3	42.1	40.3	47.3	68.8
	75	37.3	33.8	42.5	62.8	37.7	35.4	42.8	64.2	42.0	40.2	47.3	68.7
3500	60	36.1	33.8	40.0	58.8	40.4	38.2	44.4	63.5	44.8	43.0	49.0	68.0
	65	36.0	33.7	40.2	58.8	40.3	38.1	44.5	63.6	44.6	42.9	49.0	68.1
	70	37.7	34.2	42.2	59.8	40.2	38.0	44.5	63.6	44.5	42.7	49.1	68.1
	75	40.9	37.5	45.8	63.5	41.0	37.9	45.8	63.8	44.5	42.7	49.1	68.1
4000	60	38.0	35.7	41.4	58.2	42.2	40.2	45.8	62.9	46.6	44.8	50.4	67.4
	65	37.8	35.7	41.6	58.4	42.1	40.1	45.9	63.0	46.5	44.7	50.4	67.5
	70	40.6	37.1	44.8	60.4	42.0	40.0	46.1	63.0	46.4	44.6	50.4	67.5
	75	43.9	40.6	48.4	64.2	44.0	40.7	48.5	64.2	46.3	44.5	50.7	67.5
4500	60	39.4	37.3	42.5	57.8	43.7	41.7	46.9	62.4	48.1	46.4	51.2	66.9
	65	39.2	37.2	42.8	58.0	43.6	41.6	46.9	62.5	47.9	46.2	51.4	66.9
	70	43.0	39.6	46.9	60.9	43.4	41.5	47.3	62.7	47.8	46.1	51.5	67.0
	75	46.4	43.2	50.6	64.8	46.5	43.3	50.7	64.8	47.7	46.1	51.8	67.2
5000	60	40.6	38.7	43.4	57.3	44.9	43.0	47.7	62.0	49.2	47.6	52.0	66.4
	65	41.4	38.5	44.8	57.6	44.8	42.9	47.8	62.0	49.1	47.5	52.2	66.5
	70	45.0	41.8	48.7	61.4	44.6	42.8	48.2	62.3	49.0	47.4	52.3	66.6
	75	48.6	45.4	52.5	65.4	48.7	45.5	52.6	65.4	48.9	47.3	52.7	66.8
5500	60	41.6	39.8	44.4	57.0	45.8	44.1	48.4	61.6	50.2	48.6	52.7	65.9
	65	43.1	39.5	46.2	57.4	45.7	44.0	48.8	61.7	50.1	48.5	52.9	66.1
	70	46.8	43.6	50.2	61.9	46.8	43.8	50.3	62.0	50.0	48.4	53.3	66.2
	75	50.4	47.4	54.1	65.9	50.5	47.5	54.2	65.9	50.6	48.3	54.3	66.5
6000	60	42.4	40.7	45.0	56.7	46.6	45.0	49.0	61.2	51.0	49.5	53.2	65.5
	65	44.5	41.5	47.5	58.2	46.6	44.9	49.4	61.3	50.9	49.4	53.5	65.7
	70	48.3	45.2	51.5	62.3	48.4	44.7	51.6	61.8	50.8	49.3	53.9	65.8
	75	52.0	49.1	55.5	66.3	52.1	49.2	55.6	66.3	52.2	49.1	55.7	66.2
Ambient DB 70°F													
2500	60	31.2 ^(a)	28.3 ^(a)	36.4	61.6	35.4	32.6 ^(a)	40.9	66.5	39.7	37.3	45.6	71.3
	65	31.1 ^(a)	28.1 ^(a)	36.4	61.5	35.2	32.4 ^(a)	40.9	66.5	39.6	37.2	45.6	71.3
	70	31.1 ^(a)	28.1 ^(a)	36.6	61.5	35.1	32.3 ^(a)	40.9	66.5	39.5	37.1	45.6	71.3
	75	33.5	29.5 ^(a)	39.4	63.3	35.1	32.3 ^(a)	40.9	66.3	39.4	37.0	45.6	71.3
3000	60	34.2	31.4 ^(a)	38.8	60.5	38.5	35.9	43.3	65.4	42.9	40.5	47.9	70.4
	65	34.2	31.3 ^(a)	38.8	60.4	38.4	35.7	43.3	65.4	42.7	40.4	47.9	70.3
	70	34.9	31.3 ^(a)	40.0	60.5	38.3	35.6	43.3	65.4	42.6	40.3	48.0	70.3
	75	38.0	34.0	43.4	64.0	38.2	35.6	43.5	65.5	42.5	40.2	48.0	70.3
3500	60	36.5	33.9	40.5	59.7	40.8	38.3	45.0	64.6	45.2	42.9	49.5	69.5
	65	36.5	33.8	40.7	59.6	40.7	38.2	45.0	64.6	45.1	42.8	49.6	69.4
	70	38.3	34.4	43.0	60.8	40.6	38.1	45.2	64.6	45.0	42.7	49.7	69.4
	75	41.6	37.7	46.6	64.6	41.7	38.0	46.7	64.7	44.9	42.6	49.7	69.4

Table 15. Reheat temperature rise — 12.5 tons (continued)

Airflow (cfm)	Ent DB (°F)	Entering Wet Bulb (°F)											
		51				55				59			
		Lvg Evap DB (°F)		Lvg Reheat DB (°F)		Lvg Evap DB (°F)		Lvg Reheat DB (°F)		Lvg Evap DB (°F)		Lvg Reheat DB (°F)	
		MIN	MAX	MIN	MAX	MIN	MAX	MIN	MAX	MIN	MAX	MIN	MAX
4000	60	38.3	35.9	41.9	59.0	42.6	40.3	46.3	63.9	47.0	44.8	50.8	68.6
	65	38.2	35.8	42.2	59.2	42.5	40.2	46.4	63.9	46.9	44.7	50.9	68.6
	70	41.2	37.4	45.5	61.3	42.4	40.1	46.6	63.9	46.8	44.6	51.0	68.7
	75	44.6	40.7	49.2	65.2	44.7	40.8	49.3	65.3	46.7	44.5	51.2	68.7
4500	60	39.8	37.5	42.9	58.5	44.0	41.8	47.3	63.2	48.4	46.4	51.7	67.9
	65	40.0	37.4	43.7	58.7	43.9	41.7	47.4	63.3	48.3	46.2	51.9	68.0
	70	43.6	39.8	47.6	61.8	43.8	41.6	47.8	63.5	48.2	46.1	52.0	68.1
	75	47.1	43.3	51.4	65.8	47.2	43.4	51.5	65.8	48.1	46.1	52.3	68.3
5000	60	40.9	38.8	44.0	58.0	45.2	43.1	48.1	62.7	49.5	47.6	52.5	67.3
	65	41.9	38.6	45.4	58.3	45.1	43.0	48.5	62.8	49.4	47.5	52.7	67.4
	70	45.6	41.9	49.4	62.3	45.6	42.9	49.4	63.1	49.3	47.4	52.8	67.5
	75	49.2	45.5	53.2	66.3	49.3	45.6	53.3	66.3	49.2	47.3	53.2	67.8
5500	60	41.9	39.9	44.8	57.6	46.1	44.2	48.8	62.2	50.5	48.7	53.1	66.8
	65	43.6	39.6	46.8	58.0	46.0	44.1	49.2	62.3	50.3	48.5	53.3	66.9
	70	47.3	43.8	50.9	62.7	47.4	43.9	50.9	62.7	50.3	48.4	53.7	67.0
	75	51.0	47.4	54.8	66.7	51.1	47.5	55.0	66.8	51.2	48.3	55.0	67.4
6000	60	42.6	40.8	45.4	57.2	46.9	45.1	49.4	61.8	51.3	49.6	53.6	66.3
	65	45.0	41.7	48.1	58.8	46.8	45.0	49.8	61.9	51.1	49.4	53.8	66.5
	70	48.8	45.4	52.1	63.0	48.9	44.8	52.2	62.4	51.0	49.3	54.3	66.6
	75	52.6	49.1	56.2	67.2	52.7	49.2	56.3	67.2	52.8	49.1	56.4	67.1

Note: MIN, MAX: The leaving evaporator temperature is affected by the modulating valve position. The MIN and MAX numbers represent modulating valve position impact on both the leaving evaporator temperature and the leaving reheat coil temperature. MAX represents wide open, MIN represents closed to minimum position.

(a) The unit might be tripped by Froststat at these conditions due to low leaving evaporator air temperature.

Table 16. Reheat temperature rise — 15 tons

Airflow (cfm)	Ent DB (°F)	Entering Wet Bulb (°F)											
		51				55				59			
		Lvg Evap DB (°F)		Lvg Reheat DB (°F)		Lvg Evap DB (°F)		Lvg Reheat DB (°F)		Lvg Evap DB (°F)		Lvg Reheat DB (°F)	
		MIN	MAX	MIN	MAX	MIN	MAX	MIN	MAX	MIN	MAX	MIN	MAX
Ambient DB 60°F													
3000	60	30.9 ^(a)	29.6 ^(a)	36.7	61.9	35.1	34.8	41.2	65.6	39.4	40.1	46.1	69.5
	65	30.9 ^(a)	29.5 ^(a)	36.7	61.8	34.9	34.7	41.1	65.6	39.3	40.0	45.9	69.4
	70	30.7 ^(a)	29.4 ^(a)	36.5	61.7	34.9	34.6	41.1	65.6	39.2	39.9	45.9	69.4
	75	33.1	32.0 ^(a)	39.5	63.9	34.9	34.6	41.0	65.6	39.2	39.8	45.9	69.3
3600	60	34.1	32.5 ^(a)	39.0	60.9	38.2	37.6	43.5	64.8	42.6	42.8	48.3	68.6
	65	34.0	32.4 ^(a)	39.0	60.9	38.2	37.6	43.5	64.8	42.5	42.8	48.2	68.6
	70	34.5	32.2 ^(a)	40.0	60.7	38.1	37.5	43.4	64.7	42.4	42.7	48.2	68.6
	75	37.6	36.5	43.5	64.4	38.0	37.3	43.5	64.7	42.3	42.6	48.2	68.6
4200	60	36.4	34.8	40.8	60.1	40.7	39.8	45.3	64.1	45.0	44.9	50.0	68.1
	65	36.3	34.7	40.8	60.1	40.6	39.7	45.3	64.2	44.9	44.8	49.9	68.0
	70	38.0	35.9	43.0	61.5	40.5	39.7	45.3	64.2	44.8	44.8	49.8	68.0
	75	41.3	40.2	46.7	65.0	41.3	40.3	46.7	65.0	44.7	44.7	49.7	68.0



Reheat Temperature Rise

Table 16. Reheat temperature rise — 15 tons (continued)

Airflow (cfm)	Ent DB (°F)	Entering Wet Bulb (°F)											
		51				55				59			
		Lvg Evap DB (°F)		Lvg Reheat DB (°F)		Lvg Evap DB (°F)		Lvg Reheat DB (°F)		Lvg Evap DB (°F)		Lvg Reheat DB (°F)	
		MIN	MAX	MIN	MAX	MIN	MAX	MIN	MAX	MIN	MAX	MIN	MAX
4800	60	38.2	36.6	42.1	59.5	42.4	41.5	46.5	63.6	46.9	46.5	51.2	67.4
	65	38.1	36.5	42.1	59.5	42.4	41.4	46.6	63.5	46.9	46.5	51.3	67.4
	70	40.9	38.8	45.5	62.0	42.3	41.3	46.6	63.6	46.8	46.4	51.3	67.5
	75	44.4	43.3	49.3	65.6	44.5	43.4	49.4	65.6	46.7	46.3	51.3	67.5
5400	60	39.6	38.1	43.1	58.9	43.9	42.9	47.6	63.0	48.4	47.8	52.1	66.9
	65	39.7	37.9	43.7	59.0	43.9	42.8	47.6	63.1	48.3	47.8	52.2	67.0
	70	43.3	41.3	47.6	62.4	43.6	42.7	47.7	63.2	48.2	47.7	52.3	67.0
	75	47.1	45.8	51.7	66.1	46.7	45.9	51.3	66.1	48.1	47.6	52.4	67.1
6000	60	40.8	39.3	44.0	58.5	45.1	44.0	48.4	62.6	49.5	48.9	52.9	66.5
	65	41.7	39.0	45.4	58.6	45.0	43.9	48.5	62.7	49.4	48.8	53.0	66.5
	70	45.6	43.5	49.5	62.8	45.6	43.7	49.6	62.8	49.4	48.8	53.1	66.6
	75	49.2	48.0	53.5	66.6	49.3	48.1	53.6	66.6	49.2	48.6	53.2	66.7
6600	60	41.8	40.3	44.7	58.1	46.0	44.9	49.0	62.2	50.4	49.7	53.5	66.1
	65	43.4	40.9	46.9	59.2	45.9	44.9	49.1	62.3	50.4	49.7	53.6	66.1
	70	47.3	45.3	51.1	63.2	47.4	44.6	51.1	62.5	50.3	49.7	53.8	66.3
	75	51.1	49.9	55.1	67.0	51.1	50.0	55.2	67.0	51.2	49.4	55.2	66.4
7200	60	42.6	41.1	45.3	57.7	46.9	45.7	49.7	61.9	51.2	50.5	54.0	65.7
	65	44.8	42.4	48.1	59.5	46.8	45.7	49.8	62.0	51.2	50.5	54.2	65.8
	70	48.8	46.9	52.4	63.5	48.9	47.0	52.4	63.5	51.1	50.4	54.3	65.9
	75	52.7	51.5	56.5	67.4	52.7	51.6	56.5	67.4	52.8	51.7	56.6	67.5
Ambient DB 65°F													
3000	60	31.4 ^(a)	29.2 ^(a)	37.3	63.3	35.6	34.2	41.9	67.5	39.9	39.6	46.6	71.5
	65	31.3 ^(a)	29.1 ^(a)	37.2	63.3	35.5	34.1	41.8	67.5	39.8	39.5	46.6	71.4
	70	31.3 ^(a)	29.1 ^(a)	37.2	63.2	35.4	34.0	41.8	67.5	39.8	39.4	46.6	71.3
	75	33.8	31.1 ^(a)	40.4	65.4	35.4	33.9	41.8	67.4	39.7	39.3	46.6	71.3
3600	60	34.5	32.2 ^(a)	39.6	62.1	38.7	37.1	44.1	66.5	43.1	42.4	48.8	70.4
	65	34.4	32.1 ^(a)	39.4	62.1	38.7	37.0	44.1	66.5	42.9	42.3	48.8	70.4
	70	35.1	32.0 ^(a)	40.7	62.1	38.5	36.9	44.1	66.5	42.9	42.2	48.9	70.4
	75	38.3	35.6	44.3	65.8	38.4	36.8	44.1	66.5	42.9	42.1	48.9	70.4
4200	60	36.8	34.6	41.2	61.2	41.1	39.3	45.8	65.6	45.4	44.5	50.6	69.7
	65	36.7	34.5	41.3	61.2	40.9	39.3	45.8	65.6	45.3	44.4	50.5	69.6
	70	38.7	35.4	43.8	62.5	40.9	39.2	45.8	65.7	45.2	44.3	50.4	69.6
	75	42.0	39.3	47.5	66.3	42.1	38.9	47.5	65.7	45.1	44.3	50.3	69.7
4800	60	38.6	36.4	42.6	60.4	42.8	41.1	47.0	64.9	47.3	46.1	51.7	68.9
	65	38.4	36.3	42.6	60.4	42.8	41.0	47.1	64.9	47.2	46.0	51.7	68.9
	70	41.5	38.3	46.3	62.9	42.6	40.9	47.1	65.0	47.2	46.0	51.8	69.0
	75	45.0	42.4	50.1	66.7	44.9	42.5	50.0	66.7	47.1	45.9	51.8	69.0
5400	60	39.9	37.9	43.5	59.8	44.2	42.5	48.0	64.2	48.7	47.4	52.6	68.3
	65	40.2	37.8	44.3	59.8	44.1	42.5	48.0	64.3	48.6	47.4	52.7	68.3
	70	43.9	40.8	48.4	63.3	43.9	42.3	48.1	64.4	48.6	47.3	52.7	68.4
	75	47.2	45.0	52.0	67.1	47.8	45.1	52.5	67.1	48.4	47.2	52.8	68.5

Table 16. Reheat temperature rise — 15 tons (continued)

Airflow (cfm)	Ent DB (°F)	Entering Wet Bulb (°F)											
		51				55				59			
		Lvg Evap DB (°F)		Lvg Reheat DB (°F)		Lvg Evap DB (°F)		Lvg Reheat DB (°F)		Lvg Evap DB (°F)		Lvg Reheat DB (°F)	
		MIN	MAX	MIN	MAX	MIN	MAX	MIN	MAX	MIN	MAX	MIN	MAX
6000	60	41.1	39.2	44.4	59.2	45.4	43.7	48.8	63.6	49.8	48.5	53.3	67.7
	65	42.2	38.9	46.0	59.4	45.3	43.6	48.9	63.7	49.7	48.4	53.4	67.8
	70	46.1	42.9	50.2	63.6	46.2	43.4	50.3	63.9	49.7	48.4	53.5	67.9
	75	49.8	47.2	54.2	67.5	49.9	47.3	54.3	67.5	49.4	48.2	53.6	68.0
6600	60	42.0	40.2	45.1	58.7	46.3	44.7	49.4	63.1	50.7	49.4	53.9	67.3
	65	43.9	40.7	47.4	59.8	46.2	44.6	49.5	63.3	50.7	49.4	54.0	67.3
	70	47.8	44.7	51.7	63.9	47.9	44.4	51.7	63.4	50.6	49.3	54.1	67.5
	75	51.6	49.1	55.8	67.9	51.7	49.2	55.8	67.9	51.8	49.1	55.9	67.6
7200	60	42.8	41.1	45.4	58.3	47.2	45.5	50.0	62.7	51.5	50.2	54.4	66.8
	65	45.2	42.2	48.6	60.1	47.1	45.5	50.1	62.8	51.4	50.1	54.5	66.9
	70	49.3	46.3	52.9	64.2	49.4	46.4	53.0	64.2	51.3	50.1	54.6	67.1
	75	53.2	50.8	57.1	68.3	53.3	50.9	57.2	68.3	53.3	51.0	57.2	68.3
Ambient DB 70°F													
3000	60	31.9 ^(a)	29.1 ^(a)	38.0	64.5	36.1	33.8	42.6	69.1	40.5	39.0	47.5	73.3
	65	31.8 ^(a)	29.0 ^(a)	37.9	64.4	36.0	33.7	42.5	69.1	40.4	38.9	47.3	73.3
	70	31.7 ^(a)	29.0 ^(a)	37.8	64.4	35.9	33.6	42.5	69.1	40.3	38.9	47.3	73.3
	75	34.4	30.8 ^(a)	41.2	66.6	35.9	33.5	42.5	69.0	40.2	38.8	47.3	73.3
3600	60	34.9	32.1 ^(a)	40.1	63.1	39.1	36.8	44.8	67.8	43.5	41.8	49.6	72.2
	65	34.9	32.0 ^(a)	40.0	63.1	39.0	36.7	44.7	67.8	43.4	41.8	49.4	72.2
	70	35.8	31.9 ^(a)	41.6	63.1	39.0	36.6	44.6	67.8	43.3	41.7	49.4	72.2
	75	39.0	35.2	45.2	66.9	39.1	36.5	45.3	67.8	43.3	41.6	49.5	72.2
4200	60	37.2	34.5	41.7	62.0	41.4	39.1	46.3	66.8	45.8	44.0	51.1	71.2
	65	37.1	34.4	41.8	62.0	41.3	39.0	46.3	66.8	45.7	43.9	51.0	71.2
	70	39.2	35.3	44.5	63.4	41.3	38.9	46.4	66.8	45.7	43.8	51.1	71.2
	75	42.5	38.9	48.2	67.3	42.6	38.7	48.3	66.9	45.5	43.8	50.8	71.3
4800	60	38.9	36.4	43.0	61.2	43.2	40.9	47.5	65.9	47.6	45.7	52.3	70.4
	65	38.7	36.3	43.0	61.2	43.1	40.8	47.6	65.9	47.6	45.6	52.2	70.4
	70	42.0	38.2	46.9	63.7	43.0	40.7	47.6	66.0	47.5	45.6	52.3	70.4
	75	45.8	41.9	51.0	67.7	45.5	42.0	50.8	67.7	47.4	45.5	52.3	70.4
5400	60	40.2	37.9	43.8	60.4	44.6	42.4	48.4	65.1	49.0	47.1	53.0	69.5
	65	40.8	37.7	45.1	60.5	44.4	42.3	48.5	65.2	48.9	47.0	53.1	69.6
	70	44.5	40.6	49.0	64.0	44.3	42.2	48.5	65.3	48.9	47.0	53.2	69.7
	75	48.3	44.5	53.2	68.1	47.9	44.6	52.8	68.1	48.7	46.8	53.3	69.8
6000	60	41.4	39.2	44.8	59.8	45.7	43.6	49.2	64.5	50.1	48.2	53.7	68.9
	65	42.7	38.9	46.7	60.0	45.6	43.5	49.3	64.5	50.0	48.1	53.8	69.0
	70	46.6	42.7	50.9	64.3	46.7	43.3	50.9	64.7	50.0	48.1	53.9	69.0
	75	50.4	46.7	54.9	68.4	50.4	46.8	55.0	68.4	50.5	47.9	55.1	69.2
6600	60	42.3	40.2	45.4	59.3	46.5	44.6	49.7	63.9	51.0	49.1	54.2	68.3
	65	44.3	40.7	48.0	60.4	46.4	44.5	49.8	64.0	50.9	49.1	54.4	68.4
	70	48.3	44.5	52.3	64.6	48.4	44.3	52.4	64.2	50.8	49.0	54.5	68.5
	75	52.2	48.6	56.4	68.7	52.2	48.7	56.5	68.7	52.3	48.8	56.6	68.7



Reheat Temperature Rise

Table 16. Reheat temperature rise — 15 tons (continued)

Airflow (cfm)	Ent DB (°F)	Entering Wet Bulb (°F)											
		51				55				59			
		Lvg Evap DB (°F)		Lvg Reheat DB (°F)		Lvg Evap DB (°F)		Lvg Reheat DB (°F)		Lvg Evap DB (°F)		Lvg Reheat DB (°F)	
		MIN	MAX	MIN	MAX	MIN	MAX	MIN	MAX	MIN	MAX	MIN	MAX
7200	60	43.0	41.1	45.7	58.8	47.4	45.5	50.3	63.4	51.7	50.0	54.7	67.8
	65	45.8	42.2	49.2	60.6	47.3	45.4	50.5	63.5	51.7	49.9	54.8	67.9
	70	49.8	46.1	53.5	64.9	49.9	46.2	53.6	64.9	51.6	49.9	55.0	68.0
	75	53.7	50.2	57.8	69.0	53.8	50.3	57.8	69.0	53.9	49.6	57.9	68.3

Note: MIN, MAX: The leaving evaporator temperature is affected by the modulating valve position. The MIN and MAX numbers represent modulating valve position impact on both the leaving evaporator temperature and the leaving reheat coil temperature. MAX represents wide open, MIN represents closed to minimum position.

^(a) The unit might be tripped by Froststat at these conditions due to low leaving evaporator air temperature.

Table 17. Reheat temperature rise — 20 tons

Airflow (cfm)	Ent DB (°F)	Entering Wet Bulb (°F)											
		51				55				59			
		Lvg Evap DB (°F)		Lvg Reheat DB (°F)		Lvg Evap DB (°F)		Lvg Reheat DB (°F)		Lvg Evap DB (°F)		Lvg Reheat DB (°F)	
		MIN	MAX	MIN	MAX	MIN	MAX	MIN	MAX	MIN	MAX	MIN	MAX
Ambient DB 60°F													
4000	60	30.2 ^(a)	29.2 ^(a)	33.3	54.3	34.3	34.0	37.7	58.1	38.6	39.0	42.3	61.8
	65	29.9 ^(a)	29.1 ^(a)	33.2	54.3	34.3	33.9	37.6	58.0	38.6	38.9	42.1	61.7
	70	29.8 ^(a)	29.1 ^(a)	33.2	54.5	34.2	33.8	37.5	58.1	38.5	38.9	42.1	61.8
	75	32.2 ^(a)	31.3 ^(a)	35.8	56.2	34.1	33.8	37.4	58.2	38.4	38.8	42.0	61.8
4800	60	33.4	32.2 ^(a)	36.0	54.5	37.6	37.0	40.4	58.3	42.0	42.0	45.1	62.1
	65	33.3	32.1 ^(a)	35.9	54.6	37.6	37.0	40.4	58.4	41.9	41.9	45.0	62.1
	70	33.3	32.2 ^(a)	36.4	54.8	37.5	36.9	40.7	58.5	41.8	41.8	45.0	62.1
	75	36.8	35.8	40.1	57.7	37.5	36.8	40.9	58.5	41.7	41.8	44.9	62.2
5600	60	35.8	34.6	38.1	54.5	40.1	39.3	42.6	58.4	44.4	44.2	47.1	62.1
	65	35.7	34.5	38.4	54.7	40.0	39.3	42.7	58.6	44.3	44.1	47.1	62.2
	70	37.3	35.5	40.1	55.7	39.9	39.2	42.4	58.7	44.3	44.1	47.3	62.4
	75	40.5	39.4	43.6	59.0	39.6	39.2	42.4	58.8	44.2	44.0	47.4	62.5
6400	60	37.7	36.5	39.7	54.6	42.0	41.1	44.1	58.5	46.3	45.9	48.5	62.2
	65	37.6	36.3	40.1	54.7	41.9	41.1	44.1	58.6	46.2	45.9	48.7	62.3
	70	40.2	38.5	42.8	56.7	41.8	41.0	44.5	58.8	46.2	45.8	48.9	62.5
	75	43.6	42.5	46.5	60.1	43.6	42.6	46.5	60.1	46.0	45.7	49.1	62.6
7200	60	39.2	38.0	41.0	54.5	43.4	42.5	45.4	58.5	47.7	47.3	49.7	62.2
	65	39.0	37.9	40.9	54.7	43.4	42.5	45.7	58.7	47.7	47.3	49.9	62.4
	70	42.6	40.9	45.1	57.6	43.2	42.4	45.3	58.8	47.6	47.2	50.2	62.5
	75	46.1	45.1	48.8	61.1	46.2	45.2	48.9	61.1	47.6	47.2	50.4	62.7
8000	60	40.4	39.2	42.3	54.5	44.6	43.7	46.5	58.5	48.9	48.4	50.7	62.1
	65	40.4	39.2	42.6	54.8	44.6	43.7	46.7	58.7	48.9	48.4	51.0	62.4
	70	44.7	43.0	47.1	58.4	44.6	43.8	47.0	59.0	48.8	48.4	51.2	62.6
	75	48.3	47.3	50.9	61.9	48.4	47.4	50.9	62.0	48.9	48.4	51.5	62.8
8800	60	41.4	40.2	43.2	54.4	45.6	44.7	47.3	58.4	49.9	49.4	51.5	62.1
	65	42.8	40.3	44.8	54.8	45.6	44.7	47.6	58.7	49.9	49.3	51.8	62.3
	70	46.5	44.9	48.7	59.1	45.7	44.8	47.9	59.0	49.8	49.3	52.1	62.6
	75	50.2	49.2	52.6	62.7	50.2	49.3	52.7	62.7	50.0	49.5	52.4	62.9

Table 17. Reheat temperature rise — 20 tons (continued)

Airflow (cfm)	Ent DB (°F)	Entering Wet Bulb (°F)											
		51				55				59			
		Lvg Evap DB (°F)		Lvg Reheat DB (°F)		Lvg Evap DB (°F)		Lvg Reheat DB (°F)		Lvg Evap DB (°F)		Lvg Reheat DB (°F)	
		MIN	MAX	MIN	MAX	MIN	MAX	MIN	MAX	MIN	MAX	MIN	MAX
9600	60	42.2	41.1	44.0	54.4	46.5	45.5	48.0	58.4	50.7	50.1	52.1	62.0
	65	44.2	41.2	46.2	54.8	46.4	45.5	48.4	58.6	50.7	50.1	52.5	62.3
	70	48.0	46.5	50.1	59.7	48.1	45.7	50.2	59.0	50.6	50.1	52.8	62.6
	75	51.8	50.9	54.1	63.4	51.9	50.9	54.2	63.4	50.9	50.4	53.2	63.0
Ambient DB 65°F													
4000	60	30.7 ^(a)	29.2 ^(a)	34.0	55.8	34.9	33.8	38.3	59.7	39.2	38.9	42.9	63.6
	65	30.6 ^(a)	29.1 ^(a)	33.8	55.9	34.8	33.7	38.2	59.8	39.1	38.8	42.8	63.5
	70	30.6 ^(a)	29.1 ^(a)	33.9	55.9	34.7	33.6	38.2	59.9	39.0	38.7	42.8	63.6
	75	32.9 ^(a)	31.1 ^(a)	36.7	57.7	34.6	33.6	38.1	59.9	38.9	38.6	43.0	63.6
4800	60	33.8	32.2 ^(a)	36.6	55.7	38.1	36.8	41.0	59.8	42.4	41.8	45.5	63.8
	65	33.8	32.1 ^(a)	36.5	55.8	38.0	36.8	41.0	60.0	42.3	41.7	45.6	63.7
	70	33.7	32.2 ^(a)	36.9	56.0	37.9	36.7	41.3	60.0	42.3	41.7	45.7	63.8
	75	37.5	35.5	41.0	59.1	37.8	36.6	40.9	60.1	42.2	41.6	45.9	63.9
5600	60	36.2	34.6	38.8	55.6	40.5	39.2	43.1	59.8	44.8	44.0	47.5	63.8
	65	36.1	34.5	38.5	55.7	40.4	39.1	43.2	59.9	44.7	44.0	47.6	63.8
	70	37.9	35.5	40.9	56.8	40.3	39.0	43.0	60.1	44.7	43.9	47.8	63.9
	75	41.2	39.1	44.4	60.3	41.3	39.0	44.5	60.2	44.6	43.8	48.0	64.0
6400	60	38.0	36.5	40.4	55.5	42.3	41.0	44.6	59.7	46.6	45.7	49.0	63.6
	65	37.9	36.3	40.1	55.6	42.2	40.9	44.8	59.9	46.6	45.7	49.2	63.7
	70	40.8	38.4	43.6	57.8	42.1	40.8	44.5	60.0	46.5	45.6	49.4	63.9
	75	44.2	42.2	47.2	61.3	44.3	42.3	47.3	61.4	46.4	45.6	49.6	64.0
7200	60	39.5	38.0	41.7	55.4	43.8	42.4	45.9	59.6	48.1	47.1	50.1	63.5
	65	39.5	37.9	41.9	55.5	43.7	42.4	46.1	59.8	48.0	47.1	50.4	63.7
	70	43.2	40.8	45.8	58.6	43.7	42.3	46.4	59.9	48.0	47.0	50.6	63.8
	75	46.7	44.7	49.5	62.2	46.8	44.8	49.6	62.3	47.9	47.0	50.8	64.0
8000	60	40.7	39.2	42.7	55.2	44.9	43.6	46.9	59.4	49.2	48.2	51.1	63.4
	65	40.7	39.3	43.0	55.6	44.9	43.6	47.1	59.7	49.2	48.2	51.3	63.6
	70	45.2	42.9	47.7	59.3	44.9	43.4	47.4	59.4	49.1	48.2	51.6	63.8
	75	48.9	46.9	51.5	63.0	48.9	47.0	51.6	63.0	49.2	48.2	51.9	64.0
8800	60	41.6	40.3	43.1	55.1	45.9	44.6	47.7	59.3	50.2	49.2	51.8	63.2
	65	43.2	40.3	45.4	55.5	45.8	44.6	48.0	59.6	50.1	49.2	52.1	63.5
	70	47.0	44.7	49.3	59.9	47.0	44.7	49.4	59.9	50.1	49.1	52.4	63.7
	75	50.7	48.8	53.2	63.7	50.8	48.9	53.3	63.7	50.3	49.3	52.8	64.1
9600	60	42.4	41.1	44.3	55.0	46.7	45.5	48.4	59.2	51.0	50.0	52.5	63.1
	65	44.7	41.2	46.7	55.5	46.6	45.4	48.7	59.5	50.9	50.0	52.8	63.4
	70	48.5	46.3	50.7	60.5	48.6	45.7	50.8	59.9	50.9	49.9	53.1	63.7
	75	52.3	50.5	54.7	64.3	52.4	50.6	54.8	64.4	52.5	50.2	54.9	64.1
Ambient DB 70°F													
4000	60	31.2 ^(a)	29.2 ^(a)	34.7	57.1	35.4	33.7	38.9	61.3	39.7	38.7	43.7	65.4
	65	31.1 ^(a)	29.1 ^(a)	34.5	57.1	35.3	33.6	38.9	61.4	39.6	38.6	43.6	65.3
	70	31.2 ^(a)	29.1 ^(a)	34.9	57.2	35.2	33.5	38.9	61.2	39.6	38.6	43.6	65.4
	75	33.7	31.1 ^(a)	37.6	59.1	35.2	33.5	38.8	61.5	39.5	38.5	43.5	65.4



Reheat Temperature Rise

Table 17. Reheat temperature rise — 20 tons (continued)

Airflow (cfm)	Ent DB (°F)	Entering Wet Bulb (°F)											
		51				55				59			
		Lvg Evap DB (°F)		Lvg Reheat DB (°F)		Lvg Evap DB (°F)		Lvg Reheat DB (°F)		Lvg Evap DB (°F)		Lvg Reheat DB (°F)	
		MIN	MAX	MIN	MAX	MIN	MAX	MIN	MAX	MIN	MAX	MIN	MAX
4800	60	34.3	32.2 ^(a)	37.2	56.8	38.6	36.8	41.6	61.2	42.9	41.6	46.3	65.4
	65	34.2	32.1 ^(a)	37.1	56.9	38.5	36.7	41.6	61.3	42.8	41.6	46.2	65.3
	70	35.0	32.2 ^(a)	38.4	57.0	38.4	36.7	41.5	61.4	42.7	41.5	46.4	65.4
	75	38.2	35.5	41.8	60.4	38.2	36.6	41.5	61.4	42.7	41.4	46.5	65.5
5600	60	36.6	34.6	39.3	56.5	40.9	39.1	43.6	60.9	45.2	43.8	48.0	65.1
	65	36.5	34.6	39.4	56.6	40.8	39.1	43.8	61.1	45.2	43.8	48.2	65.2
	70	38.5	35.6	41.6	57.8	40.7	39.0	43.9	61.2	45.1	43.7	48.4	65.4
	75	41.8	39.1	45.2	61.5	41.9	39.0	45.3	61.4	45.0	43.7	48.5	65.5
6400	60	38.4	36.5	40.8	56.3	42.7	41.0	45.1	60.7	47.0	45.6	49.5	64.9
	65	38.4	36.4	41.1	56.5	42.6	40.9	45.3	60.9	46.9	45.5	49.7	65.1
	70	41.4	38.5	44.3	58.7	42.5	40.8	45.5	61.0	46.9	45.5	49.9	65.2
	75	44.8	42.1	48.0	62.4	44.9	42.2	48.1	62.5	46.8	45.4	50.0	65.4
7200	60	39.8	38.1	42.1	56.1	44.1	42.5	46.3	60.5	48.4	47.0	50.6	64.7
	65	39.8	38.0	42.3	56.4	44.0	42.4	46.5	60.7	48.3	47.0	50.8	64.8
	70	43.7	40.9	46.5	59.4	44.0	42.3	46.8	60.9	48.3	46.9	51.1	65.1
	75	47.3	44.6	50.3	63.3	47.4	44.7	50.4	63.3	48.3	46.9	51.4	65.2
8000	60	41.0	39.3	42.7	55.9	45.2	43.7	47.2	60.2	49.5	48.1	51.5	64.4
	65	42.1	39.3	44.4	56.2	45.2	43.6	47.5	60.5	49.5	48.1	51.7	64.6
	70	45.8	43.0	48.3	60.1	45.2	43.7	47.8	60.8	49.4	48.1	52.0	64.9
	75	49.4	46.8	52.2	64.0	49.5	46.9	52.3	64.0	49.5	48.1	52.4	65.1
8800	60	41.9	40.3	43.9	55.7	46.2	44.7	48.0	60.0	50.5	49.1	52.2	64.2
	65	43.7	40.4	45.9	56.2	46.1	44.6	48.3	60.3	50.4	49.1	52.5	64.5
	70	47.5	44.8	49.9	60.7	47.6	44.8	50.0	60.7	50.3	49.0	52.8	64.7
	75	51.3	48.7	53.9	64.6	51.3	48.8	54.0	64.7	50.6	49.2	53.2	65.1
9600	60	42.7	41.2	44.6	55.6	47.0	45.5	48.7	59.8	51.2	49.9	52.8	64.0
	65	45.1	42.5	47.2	57.1	46.9	45.5	49.0	60.1	51.2	49.9	53.1	64.3
	70	49.0	46.4	51.3	61.2	49.1	45.7	51.3	60.6	51.1	49.9	53.5	64.6
	75	52.8	50.3	55.4	65.2	52.9	50.4	55.4	65.2	53.0	50.1	55.5	65.0

Note: MIN, MAX: The leaving evaporator temperature is affected by the modulating valve position. The MIN and MAX numbers represent modulating valve position impact on both the leaving evaporator temperature and the leaving reheat coil temperature. MAX represents wide open, MIN represents closed to minimum position.

^(a) The unit might be tripped by Froststat at these conditions due to low leaving evaporator air temperature.

Table 18. Reheat temperature rise — 25 tons

Airflow (cfm)	Ent DB (°F)	Entering Wet Bulb (°F)											
		51				55				59			
		Lvg Evap DB (°F)		Lvg Reheat DB (°F)		Lvg Evap DB (°F)		Lvg Reheat DB (°F)		Lvg Evap DB (°F)		Lvg Reheat DB (°F)	
		MIN	MAX	MIN	MAX	MIN	MAX	MIN	MAX	MIN	MAX	MIN	MAX
Ambient DB 60°F													
5000	60	31.8 ^(a)	30.9 ^(a)	33.8	53.1	36.3	35.2	38.2	56.9	40.8	39.8	43.0	60.6
	65	31.7 ^(a)	30.8 ^(a)	33.9	53.2	36.2	35.1	38.3	57.0	40.8	39.7	42.9	60.5
	70	31.5 ^(a)	30.6 ^(a)	33.7	53.0	36.1	35.0	38.4	56.9	40.7	39.6	43.0	60.5
	75	34.6	33.1	37.1	55.5	36.0	34.9	38.5	57.1	40.6	39.5	43.1	60.4

Table 18. Reheat temperature rise — 25 tons (continued)

Airflow (cfm)	Ent DB (°F)	Entering Wet Bulb (°F)											
		51				55				59			
		Lvg Evap DB (°F)		Lvg Reheat DB (°F)		Lvg Evap DB (°F)		Lvg Reheat DB (°F)		Lvg Evap DB (°F)		Lvg Reheat DB (°F)	
		MIN	MAX	MIN	MAX	MIN	MAX	MIN	MAX	MIN	MAX	MIN	MAX
6000	60	35.0	33.9	36.7	53.3	39.4	38.3	41.1	57.3	44.0	42.8	45.5	61.1
	65	34.9	33.8	36.8	53.5	39.4	38.2	41.2	57.4	43.9	42.7	45.7	61.0
	70	36.0	33.8	38.1	53.7	39.3	38.1	41.4	57.5	43.9	42.6	45.9	61.0
	75	39.5	37.6	41.7	57.3	39.4	38.2	41.6	57.7	43.8	42.6	46.0	61.3
7000	60	37.3	36.2	38.9	53.5	41.8	40.6	43.1	57.5	46.3	45.1	47.5	61.3
	65	37.2	36.1	39.0	53.7	41.7	40.5	43.4	57.7	46.2	45.0	47.7	61.3
	70	39.7	37.8	41.6	55.5	41.6	40.4	43.5	57.8	46.2	44.9	48.0	61.5
	75	43.4	41.3	45.4	58.7	43.5	40.5	45.5	58.1	46.1	44.9	48.1	61.7
8000	60	39.1	38.0	40.5	53.7	43.5	42.3	44.7	57.6	48.0	46.8	49.0	61.5
	65	39.2	37.8	40.8	53.5	43.4	42.3	45.0	57.8	48.0	46.8	49.3	61.5
	70	42.7	40.7	44.4	56.6	43.6	42.2	45.4	58.0	47.9	46.7	49.6	61.7
	75	46.5	38.4	48.4	53.9	46.6	44.3	48.4	60.0	47.9	46.7	49.8	61.9
9000	60	40.5	39.4	41.8	53.7	44.9	43.7	46.0	57.7	49.3	48.2	50.2	61.5
	65	40.7	39.6	42.2	54.1	44.8	43.7	46.3	57.9	49.3	48.1	50.5	61.5
	70	45.2	43.1	46.8	57.6	45.1	43.9	46.7	58.3	49.3	48.1	50.8	61.9
	75	49.1	41.3	50.8	52.7	49.2	46.8	50.9	61.0	49.6	48.1	51.3	62.1
10000	60	41.6	40.5	42.8	53.8	46.0	44.9	47.0	57.7	50.4	49.3	51.1	61.5
	65	43.3	40.8	44.6	54.3	45.9	44.8	47.3	58.0	50.4	49.2	51.5	61.7
	70	47.3	45.1	48.8	58.4	46.4	45.1	47.8	58.5	50.3	49.2	51.8	62.0
	75	51.3	42.8	52.9	53.5	51.4	49.0	53.0	62.0	50.8	49.6	52.4	62.5
11000	60	42.5	41.5	43.7	53.8	46.9	45.8	47.8	57.7	51.3	50.2	51.9	61.5
	65	44.9	41.8	46.2	54.4	46.9	45.8	48.2	58.1	51.3	50.1	52.3	61.8
	70	49.1	46.8	50.4	59.2	49.1	46.2	50.5	58.6	51.3	50.0	52.7	61.5
	75	53.2	50.8	54.6	62.8	53.3	50.8	54.7	62.8	53.3	50.6	54.8	62.6
12000	60	43.3	42.4	44.5	53.8	47.6	46.6	48.5	57.7	52.0	51.0	52.5	61.5
	65	46.4	44.5	47.6	56.0	47.7	46.6	48.9	58.1	52.0	50.9	53.0	61.8
	70	50.6	48.4	51.9	59.8	50.7	47.1	51.9	58.7	51.9	51.0	52.8	62.2
	75	54.8	45.4	56.2	54.4	54.9	45.4	56.2	58.2	54.9	51.5	56.3	62.8
Ambient DB 65°F													
5000	60	32.0 ^(a)	31.0 ^(a)	34.1	54.3	36.5	35.4	38.5	58.3	41.1	39.9	43.3	62.3
	65	31.9 ^(a)	30.9 ^(a)	34.2	54.4	36.4	35.3	38.7	58.4	41.1	39.8	43.2	62.3
	70	32.1 ^(a)	31.0 ^(a)	34.4	54.6	36.3	35.2	38.8	58.5	41.0	39.7	43.3	62.2
	75	35.0	33.4	37.6	56.9	36.3	35.1	38.8	58.6	40.9	39.6	43.5	62.2
6000	60	35.2	34.0	37.0	54.4	39.7	38.4	41.4	58.6	44.2	42.9	45.8	62.5
	65	35.1	33.9	37.1	54.5	39.6	38.3	41.5	58.7	44.2	42.8	46.0	62.6
	70	36.4	33.9	38.5	54.8	39.5	38.2	41.7	58.8	44.1	42.7	46.2	62.7
	75	39.9	37.8	42.2	58.6	39.6	38.3	41.9	59.1	44.0	42.6	46.3	62.5
7000	60	37.5	36.3	39.1	54.4	42.0	40.7	43.4	58.6	46.5	45.1	47.8	62.6
	65	37.4	36.2	39.2	54.6	41.9	40.6	43.6	58.8	46.4	45.1	48.0	62.8
	70	40.1	38.0	42.0	56.6	41.8	40.5	43.8	59.0	46.4	45.0	48.2	62.9
	75	43.7	41.4	45.8	60.0	43.8	40.6	45.9	59.3	46.3	44.9	48.4	63.1



Reheat Temperature Rise

Table 18. Reheat temperature rise — 25 tons (continued)

Airflow (cfm)	Ent DB (°F)	Entering Wet Bulb (°F)											
		51				55				59			
		Lvg Evap DB (°F)		Lvg Reheat DB (°F)		Lvg Evap DB (°F)		Lvg Reheat DB (°F)		Lvg Evap DB (°F)		Lvg Reheat DB (°F)	
		MIN	MAX	MIN	MAX	MIN	MAX	MIN	MAX	MIN	MAX	MIN	MAX
8000	60	39.3	38.1	40.7	54.4	43.7	42.4	45.0	58.6	48.2	46.9	49.2	62.6
	65	39.4	38.2	41.1	54.8	43.6	42.4	45.2	58.8	48.2	46.8	49.5	62.8
	70	43.0	40.8	44.8	57.6	43.8	42.3	45.6	59.1	48.1	46.7	49.8	63.0
	75	46.9	44.4	48.8	61.2	47.0	44.5	48.9	61.2	48.1	46.7	50.0	63.2
9000	60	40.6	39.5	42.0	54.4	45.0	43.8	46.2	58.6	49.5	48.2	50.4	62.7
	65	40.9	39.7	42.4	54.9	45.0	43.8	46.5	58.8	49.5	48.2	50.7	62.8
	70	45.5	43.2	47.1	58.6	45.3	44.0	46.9	59.3	49.4	48.1	51.0	63.1
	75	49.5	46.9	51.2	62.2	49.6	47.0	51.3	62.2	49.8	48.2	51.5	63.3
10000	60	41.7	40.6	43.0	54.4	46.1	44.9	47.1	58.5	50.6	49.3	51.4	62.5
	65	43.5	40.9	44.9	54.9	46.1	44.9	47.5	58.8	50.5	49.3	51.7	62.8
	70	47.6	45.2	49.1	59.4	46.5	45.2	48.0	59.3	50.5	49.2	52.0	63.1
	75	51.7	49.0	53.3	63.1	51.8	49.1	53.4	63.1	51.0	49.6	52.6	63.5
11000	60	42.6	41.6	43.9	54.4	47.0	45.9	48.0	58.4	51.4	50.2	52.0	62.4
	65	45.2	41.9	46.5	55.0	47.0	45.8	48.3	58.8	51.4	50.2	52.5	62.7
	70	49.3	47.0	50.8	60.1	49.4	46.2	50.8	59.4	51.4	50.2	52.9	63.1
	75	53.5	50.8	55.0	63.8	53.6	50.9	55.1	63.8	53.7	50.6	55.2	63.6
12000	60	43.7	42.4	44.9	54.4	47.8	46.7	48.6	58.4	52.2	51.0	52.6	62.3
	65	46.6	44.6	47.9	56.7	47.8	46.7	49.1	58.8	52.1	50.9	53.1	62.7
	70	50.9	48.5	52.2	60.7	50.9	47.1	52.3	59.5	52.2	51.0	53.6	63.1
	75	55.1	52.4	56.5	64.5	55.2	52.5	56.6	64.5	55.3	51.5	56.7	63.7
Ambient DB 70°F													
5000	60	32.3 ^(a)	31.2 ^(a)	34.4	55.3	36.8	35.6	38.9	59.6	41.4	40.0	43.7	63.9
	65	32.1 ^(a)	31.1 ^(a)	34.5	55.4	36.7	35.4	39.0	59.7	41.4	40.0	43.6	63.9
	70	32.3 ^(a)	31.2 ^(a)	34.7	55.6	36.6	35.3	39.1	59.8	41.3	39.9	43.7	64.0
	75	35.5	33.6	38.0	58.2	36.5	35.3	38.8	59.9	41.2	39.8	43.8	64.0
6000	60	35.4	34.2	37.2	55.3	39.9	38.6	41.6	59.7	44.5	43.0	46.1	63.8
	65	35.3	34.1	37.4	55.4	39.8	38.5	41.8	59.8	44.4	43.0	46.3	64.0
	70	36.8	34.1	38.9	55.7	39.7	38.4	42.0	59.9	44.4	42.9	46.5	64.1
	75	40.3	38.1	42.7	59.8	39.9	38.5	42.2	60.2	44.3	42.8	46.6	64.3
7000	60	37.7	36.5	39.3	55.2	42.2	40.8	43.7	59.6	46.7	45.2	48.1	63.8
	65	37.8	36.3	39.7	55.4	42.1	40.7	43.9	59.8	46.7	45.2	48.3	64.0
	70	40.4	38.2	42.4	57.5	42.0	40.6	44.0	60.0	46.6	45.1	48.5	64.1
	75	44.1	41.6	46.3	61.1	44.2	40.7	46.3	60.3	46.5	45.0	48.7	64.3
8000	60	39.4	38.2	40.9	55.1	43.9	42.6	45.2	59.5	48.4	47.0	49.5	63.6
	65	39.6	38.3	41.3	55.5	43.8	42.5	45.5	59.7	48.3	46.9	49.8	63.9
	70	43.4	41.0	45.2	58.5	44.0	42.4	45.8	59.9	48.3	46.8	50.1	64.1
	75	47.3	44.6	49.2	62.2	47.4	44.7	49.3	62.3	48.5	46.8	50.5	64.3
9000	60	40.8	39.6	42.2	55.1	45.2	43.9	46.4	59.3	49.7	48.3	50.6	63.5
	65	41.0	39.8	42.6	55.5	45.1	43.8	46.7	59.6	49.7	48.2	50.9	63.7
	70	45.8	43.4	47.5	59.4	45.5	44.1	47.1	60.1	49.6	48.2	51.2	64.0
	75	49.9	47.0	51.7	63.2	49.9	47.1	51.7	63.2	50.0	48.2	51.8	64.3

Table 18. Reheat temperature rise — 25 tons (continued)

Airflow (cfm)	Ent DB (°F)	Entering Wet Bulb (°F)											
		51				55				59			
		Lvg Evap DB (°F)		Lvg Reheat DB (°F)		Lvg Evap DB (°F)		Lvg Reheat DB (°F)		Lvg Evap DB (°F)		Lvg Reheat DB (°F)	
		MIN	MAX	MIN	MAX	MIN	MAX	MIN	MAX	MIN	MAX	MIN	MAX
10000	60	41.9	40.7	43.2	55.0	46.3	45.0	47.3	59.2	50.7	49.4	51.5	63.3
	65	43.8	41.0	45.2	55.5	46.2	45.0	47.7	59.5	50.7	49.3	51.9	63.6
	70	47.9	45.4	49.4	60.1	48.0	45.3	49.5	60.1	50.6	49.3	52.2	63.9
	75	52.0	49.1	53.7	64.0	52.1	49.2	53.8	64.0	51.2	49.7	52.8	64.5
11000	60	42.8	41.7	44.1	54.9	47.2	46.0	48.1	59.0	51.6	50.3	52.2	63.1
	65	45.5	43.3	46.8	56.7	47.1	45.9	48.5	59.4	51.5	50.2	52.6	63.5
	70	49.6	47.1	51.1	60.8	49.7	46.3	51.1	60.1	51.6	50.2	53.0	63.9
	75	53.9	50.9	55.4	64.7	53.9	51.0	55.5	64.7	54.0	50.7	55.6	64.5
12000	60	43.8	42.5	45.0	54.8	47.9	46.7	48.8	58.9	52.3	51.1	52.8	63.0
	65	46.9	44.7	48.1	57.3	47.9	46.8	49.2	59.4	52.3	51.0	53.3	63.4
	70	51.1	48.6	52.5	61.4	51.2	48.7	52.6	61.4	52.2	51.1	53.2	63.8
	75	55.4	52.5	56.9	65.4	55.5	52.6	57.0	65.4	55.6	51.6	57.1	64.5

Note: MIN, MAX: The leaving evaporator temperature is affected by the modulating valve position. The MIN and MAX numbers represent modulating valve position impact on both the leaving evaporator temperature and the leaving reheat coil temperature. MAX represents wide open, MIN represents closed to minimum position.

^(a) The unit might be tripped by Froststat at these conditions due to low leaving evaporator air temperature.



Evaporator Fan Performance - Heat Pump

Fan Curve Limits:

- WHJ150-300 Std Motor, Max 5.8 hp or 1850 rpm
- WHJ300 High static, Max 8.4 hp or 1940 rpm
- Maximum CFM — 480 cfm/ton
- Maximum ESP = 2.0 in-H₂O @ 400 cfm/ton

The fan curve graphs include standard filter and a wet indoor coil. Available static pressure is reduced with options based on the accessory table component pressure drop. To determine available static pressure at rpm/cfm with other options/accessories, select intersection point of the RPM vs CFM and then reduce available static pressure shown in graph by the sum of additional option static pressure drop listed in the fan performance accessory table section. For more detailed and precise RPM, BHP, and CFM operating points, see evaporator tables below.

12.5 to 25 Ton Units — Downflow

Figure 1. Fan curves — 12.5 to 25 tons, WHJ* downflow

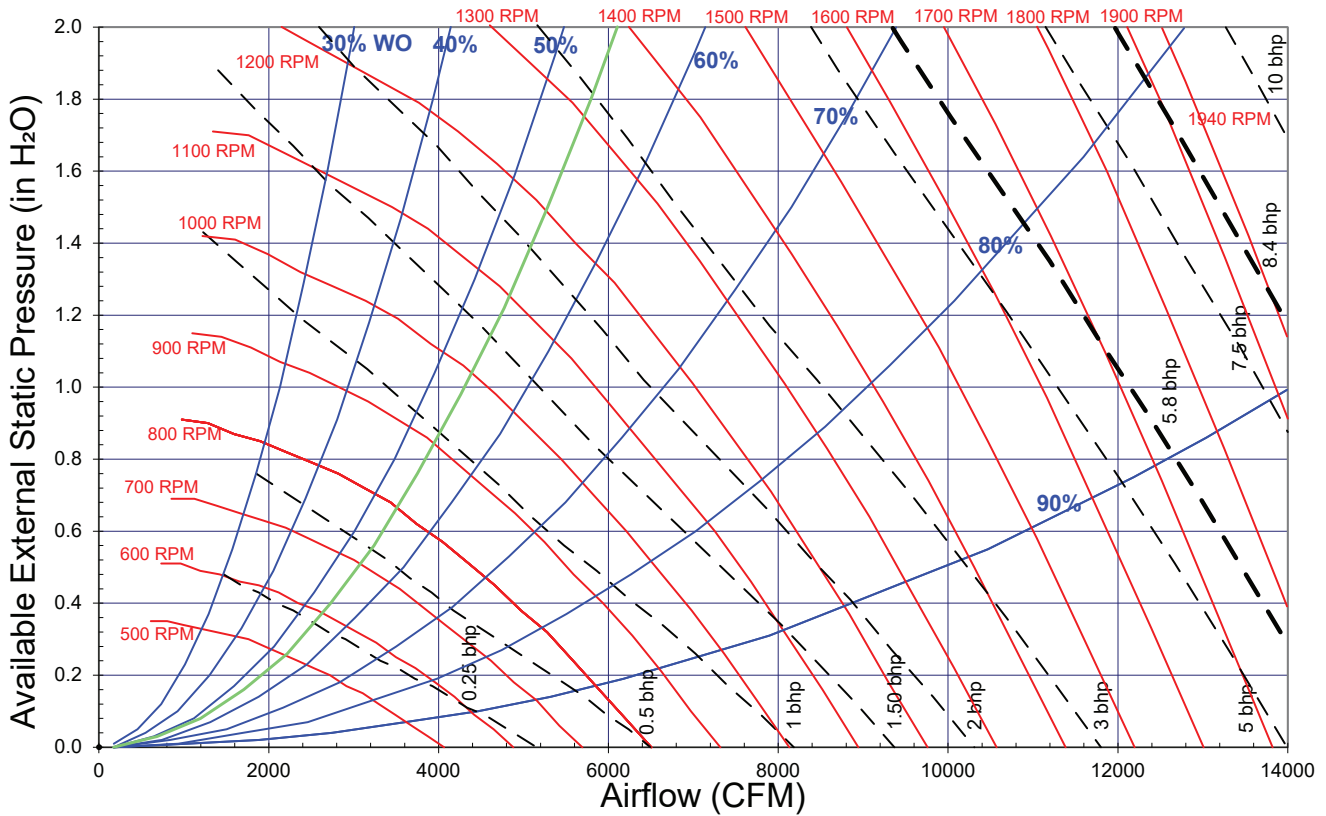

Evaporator Fan Performance - Heat Pump

Table 19. Evaporator fan performance — 12.5 ton, model WHJ, downflow

Available External Static Pressure (Inches of Water Gauge)										
CFM	0.10"	0.20"	0.30"	0.40"	0.50"	0.60"	0.70"	0.80"	0.90"	1.00"
	RPM BHP	RPM BHP	RPM BHP	RPM BHP	RPM BHP	RPM BHP	RPM BHP	RPM BHP	RPM BHP	RPM BHP
3750	541 0.19	604 0.28	661 0.37	713 0.47	761 0.58	807 0.69	850 0.80	891 0.91	930 1.03	968 1.16
4000	568 0.21	629 0.31	684 0.41	734 0.51	781 0.62	825 0.74	868 0.85	908 0.97	947 1.10	983 1.22
4500	625 0.28	679 0.38	731 0.49	779 0.61	823 0.73	866 0.85	905 0.97	944 1.10	982 1.23	1018 1.37
5000	683 0.35	732 0.47	780 0.58	826 0.71	868 0.84	908 0.97	947 1.11	983 1.24	1018 1.38	1053 1.53
5500	742 0.45	786 0.57	831 0.69	874 0.83	915 0.97	953 1.11	989 1.26	1025 1.40	1059 1.55	1092 1.70
6000	801 0.55	842 0.68	883 0.82	924 0.96	962 1.11	999 1.26	1035 1.42	1068 1.58	1102 1.74	1133 1.90
Available External Static Pressure (Inches of Water Gauge)										
CFM	1.10"	1.20"	1.30"	1.40"	1.50"	1.60"	1.70"	1.80"	1.90"	2.00"
	RPM BHP	RPM BHP	RPM BHP	RPM BHP	RPM BHP	RPM BHP	RPM BHP	RPM BHP	RPM BHP	RPM BHP
3750	1005 1.29	1040 1.43	1074 1.57	1106 1.71	1137 1.86	1168 2	1198 2.15	1228 2.31	1257 2.46	1285 2.62
4000	1019 1.36	1054 1.5	1088 1.64	1120 1.79	1152 1.94	1182 2.09	1211 2.24	1240 2.4	1269 2.56	1297 2.72
4500	1052 1.51	1085 1.65	1117 1.79	1149 1.95	1180 2.1	1211 2.26	1240 2.43	1268 2.59	1296 2.76	1323 2.93
5000	1087 1.67	1120 1.82	1151 1.98	1182 2.13	1211 2.29	1240 2.45	1269 2.62	1297 2.79	1325 2.97	1352 3.15
5500	1123 1.86	1155 2.02	1186 2.18	1216 2.34	1246 2.51	1274 2.68	1302 2.85	1328 3.02	1354 3.2	1381 3.38
6000	1164 2.06	1194 2.23	1223 2.4	1252 2.57	1281 2.74	1309 2.92	1336 3.1	1363 3.28	1389 3.47	1414 3.66

Notes:

1. Available External Static Pressure is the static pressure difference between the return duct and the supply duct plus the static pressure drop caused by accessories and options.
2. Data includes pressure drop due to standard filters and wet coils. No accessories or options are included in pressure drop data.
3. To determine static pressure drop due to other options/accessories, refer to the applicable table in the fan performance section.
4. Direct drive fan motor heat is negligible.
5. Factory supplied motors, in commercial equipment, are definite purpose motors, specifically designed and tested to operate reliably and continuously at all cataloged conditions. Using the full horsepower range of our fan motors as shown in our tabular data will not result in nuisance tripping or premature motor failure. Our product's warranty will not be affected.

Table 20. Evaporator fan performance — 15 ton, model WHJ, downflow

Available External Static Pressure (Inches of Water Gauge)										
CFM	0.10"	0.20"	0.30"	0.40"	0.50"	0.60"	0.70"	0.80"	0.90"	1.00"
	RPM BHP	RPM BHP	RPM BHP	RPM BHP	RPM BHP	RPM BHP	RPM BHP	RPM BHP	RPM BHP	RPM BHP
4500	625 0.28	679 0.38	731 0.49	779 0.61	823 0.73	866 0.85	905 0.97	944 1.10	982 1.23	1018 1.37
4800	660 0.32	711 0.43	760 0.54	807 0.67	850 0.79	891 0.92	930 1.05	967 1.18	1003 1.32	1039 1.46
5400	730 0.43	775 0.54	821 0.67	864 0.80	905 0.94	944 1.08	981 1.22	1017 1.37	1051 1.52	1084 1.67
6000	801 0.55	842 0.68	883 0.82	924 0.96	962 1.11	999 1.26	1035 1.42	1068 1.58	1102 1.74	1133 1.90
6600	873 0.71	911 0.85	948 1.00	985 1.15	1022 1.31	1057 1.47	1091 1.63	1123 1.81	1155 1.98	1185 2.16
7200	945 0.89	981 1.04	1014 1.20	1049 1.36	1083 1.53	1116 1.70	1148 1.88	1180 2.06	1210 2.25	1239 2.43
Available External Static Pressure (Inches of Water Gauge)										
CFM	1.10"	1.20"	1.30"	1.40"	1.50"	1.60"	1.70"	1.80"	1.90"	2.00"
	RPM BHP	RPM BHP	RPM BHP	RPM BHP	RPM BHP	RPM BHP	RPM BHP	RPM BHP	RPM BHP	RPM BHP
4500	1052 1.51	1085 1.65	1117 1.79	1149 1.95	1180 2.1	1211 2.26	1240 2.43	1268 2.59	1296 2.76	1323 2.93
4800	1073 1.61	1106 1.75	1137 1.90	1168 2.05	1198 2.21	1228 2.37	1257 2.54	1286 2.71	1313 2.88	1340 3.06
5400	1115 1.82	1148 1.98	1179 2.14	1209 2.3	1239 2.46	1267 2.63	1295 2.80	1322 2.97	1348 3.15	1375 3.33
6000	1164 2.06	1194 2.23	1223 2.40	1252 2.57	1281 2.74	1309 2.92	1336 3.10	1363 3.28	1389 3.47	1414 3.66
6600	1215 2.33	1244 2.51	1272 2.69	1300 2.87	1326 3.05	1352 3.24	1379 3.43	1405 3.62	1431 3.82	1456 4.02
7200	1268 2.63	1295 2.82	1323 3.01	1350 3.2	1376 3.4	1401 3.6	1426 3.79	1450 4.00	1474 4.2	1498 4.41

Notes:

1. Available External Static Pressure is the static pressure difference between the return duct and the supply duct plus the static pressure drop caused by accessories and options.
2. Data includes pressure drop due to standard filters and wet coils. No accessories or options are included in pressure drop data.
3. To determine static pressure drop due to other options/accessories, refer to the applicable table in the fan performance section.
4. Direct drive fan motor heat is negligible.
5. Factory supplied motors, in commercial equipment, are definite purpose motors, specifically designed and tested to operate reliably and continuously at all cataloged conditions. Using the full horsepower range of our fan motors as shown in our tabular data will not result in nuisance tripping or premature motor failure. Our product's warranty will not be affected.



Evaporator Fan Performance - Heat Pump

Table 21. Evaporator fan performance — 20 ton, model WHJ, downflow

Available External Static Pressure (Inches of Water Gauge)										
CFM	0.10"	0.20"	0.30"	0.40"	0.50"	0.60"	0.70"	0.80"	0.90"	1.00"
	RPM BHP	RPM BHP	RPM BHP	RPM BHP	RPM BHP	RPM BHP	RPM BHP	RPM BHP	RPM BHP	RPM BHP
6000	785 0.51	827 0.64	868 0.77	907 0.91	945 1.05	981 1.20	1016 1.35	1049 1.50	1081 1.65	1112 1.80
6400	831 0.61	872 0.74	911 0.88	948 1.02	984 1.17	1019 1.33	1053 1.48	1085 1.64	1116 1.80	1146 1.96
7200	925 0.83	962 0.97	997 1.13	1031 1.28	1064 1.45	1096 1.61	1128 1.79	1158 1.96	1188 2.14	1217 2.32
8000	1020 1.09	1054 1.26	1086 1.42	1117 1.60	1148 1.77	1177 1.95	1206 2.14	1235 2.33	1263 2.52	1290 2.72
8800	1115 1.42	1146 1.60	1176 1.78	1205 1.96	1233 2.15	1261 2.35	1288 2.55	1314 2.75	1341 2.96	1367 3.17
9600	1211 1.81	1240 2.00	1268 2.20	1295 2.39	1321 2.60	1347 2.81	1372 3.02	1397 3.24	1421 3.46	1445 3.68
Available External Static Pressure (Inches of Water Gauge)										
CFM	1.10"	1.20"	1.30"	1.40"	1.50"	1.60"	1.70"	1.80"	1.90"	2.00"
	RPM BHP	RPM BHP	RPM BHP	RPM BHP	RPM BHP	RPM BHP	RPM BHP	RPM BHP	RPM BHP	RPM BHP
6000	1141 1.95	1170 2.1	1198 2.25	1227 2.41	1255 2.57	1282 2.74	1308 2.9	1333 3.07	1358 3.24	1383 3.41
6400	1175 2.12	1203 2.28	1231 2.44	1257 2.6	1284 2.77	1311 2.94	1337 3.11	1362 3.29	1387 3.46	1411 3.64
7200	1245 2.49	1272 2.67	1299 2.85	1324 3.03	1349 3.21	1374 3.39	1397 3.57	1421 3.76	1445 3.95	1469 4.14
8000	1317 2.91	1343 3.11	1369 3.31	1394 3.5	1418 3.7	1442 3.9	1465 4.1	1487 4.31	1510 4.5	1532 4.7
8800	1392 3.38	1417 3.59	1442 3.81	1466 4.02	1489 4.24	1512 4.46	1534 4.68	1557 4.89	1578 5.11	1599 5.33
9600	1469 3.9	1493 4.13	1517 4.37	1539 4.6	1562 4.83	1584 5.07	1606 5.31	1627 5.54	1648 5.78	- -

Notes:

1. Available External Static Pressure is the static pressure difference between the return duct and the supply duct plus the static pressure drop caused by accessories and options.
2. Data includes pressure drop due to standard filters and wet coils. No accessories or options are included in pressure drop data.
3. To determine static pressure drop due to other options/accessories, refer to the applicable table in the fan performance section.
4. Direct drive fan motor heat is negligible.
5. Factory supplied motors, in commercial equipment, are definite purpose motors, specifically designed and tested to operate reliably and continuously at all cataloged conditions. Using the full horsepower range of our fan motors as shown in our tabular data will not result in nuisance tripping or premature motor failure. Our product's warranty will not be affected.

Table 22. Evaporator fan performance — 25 ton, model WHJ, downflow

Available External Static Pressure (Inches of Water Gauge)										
CFM	0.10"	0.20"	0.30"	0.40"	0.50"	0.60"	0.70"	0.80"	0.90"	1.00"
	RPM BHP	RPM BHP	RPM BHP	RPM BHP	RPM BHP	RPM BHP	RPM BHP	RPM BHP	RPM BHP	RPM BHP
3-hp Standard Motor										
7500	961 0.92	996 1.07	1030 1.23	1063 1.40	1095 1.56	1126 1.74	1157 1.91	1187 2.09	1216 2.28	1244 2.46
8000	1020 1.09	1054 1.26	1086 1.42	1117 1.60	1148 1.77	1177 1.95	1206 2.14	1235 2.33	1263 2.52	1290 2.72
9000	1139 1.51	1170 1.69	1199 1.88	1227 2.06	1255 2.26	1282 2.46	1309 2.66	1335 2.87	1360 3.07	1386 3.29
10000	1259 2.02	1287 2.23	1314 2.43	1340 2.64	1365 2.84	1390 3.06	1415 3.28	1439 3.51	1463 3.73	1486 3.96
11000	1379 2.65	1405 2.87	1430 3.09	1454 3.32	1478 3.54	1501 3.77	1523 4.01	1546 4.25	1568 4.50	1590 4.75
12000	1500 3.39	1524 3.63	1547 3.87	1570 4.12	1592 4.37	1613 4.61	1634 4.86	1655 5.12	1676 5.39	1696 5.65
Available External Static Pressure (Inches of Water Gauge)										
CFM	1.10"	1.20"	1.30"	1.40"	1.50"	1.60"	1.70"	1.80"	1.90"	2.00"
	RPM BHP	RPM BHP	RPM BHP	RPM BHP	RPM BHP	RPM BHP	RPM BHP	RPM BHP	RPM BHP	RPM BHP
3-hp Standard Motor										
7500	1272 2.65	1299 2.83	1325 3.02	1350 3.2	1375 3.39	1399 3.58	1422 3.77	1446 3.96	1468 4.15	1491 4.34
8000	1317 2.91	1343 3.11	1369 3.31	1394 3.5	1418 3.7	1442 3.9	1465 4.1	1487 4.31	1510 4.5	1532 4.7
9000	1411 3.5	1436 3.72	1460 3.94	1484 4.16	1507 4.38	1530 4.61	1552 4.83	1574 5.05	1596 5.27	1617 5.5
10000	1509 4.19	1532 4.43	1555 4.67	1577 4.91	1599 5.15	1621 5.4	1643 5.64	- -	- -	- -
11000	1611 4.99	1633 5.25	1653 5.5	1674 5.76	- -	- -	- -	- -	- -	- -
12000	- -	- -	- -	- -	- -	- -	- -	- -	- -	- -

Notes:

1. Available External Static Pressure is the static pressure difference between the return duct and the supply duct plus the static pressure drop caused by accessories and options.
2. Data includes pressure drop due to standard filters and wet coils. No accessories or options are included in pressure drop data.
3. To determine static pressure drop due to other options/accessories, refer to the applicable table in the fan performance section.
4. Direct drive fan motor heat is negligible.
5. Factory supplied motors, in commercial equipment, are definite purpose motors, specifically designed and tested to operate reliably and continuously at all cataloged conditions. Using the full horsepower range of our fan motors as shown in our tabular data will not result in nuisance tripping or premature motor failure. Our product's warranty will not be affected.

Table 23. Evaporator fan performance — 25 ton, downflow, model WHJ, high static drive

Available External Static Pressure (Inches of Water Gauge)																				
CFM	0.10"		0.20"		0.30"		0.40"		0.50"		0.60"		0.70"		0.80"		0.90"		1.00"	
	RPM	BHP	RPM	BHP	RPM	BHP	RPM	BHP	RPM	BHP	RPM	BHP	RPM	BHP	RPM	BHP	RPM	BHP	RPM	BHP
5-hp Oversized Motor																				
7500	983	0.94	1019	1.10	1053	1.26	1086	1.42	1117	1.59	1148	1.76	1179	1.94	1209	2.11	1238	2.29	1266	2.47
8000	1044	1.12	1078	1.28	1110	1.45	1142	1.63	1171	1.80	1200	1.98	1230	2.17	1259	2.36	1287	2.55	1314	2.74
9000	1166	1.55	1197	1.73	1226	1.92	1255	2.11	1283	2.30	1309	2.50	1335	2.70	1361	2.91	1387	3.12	1413	3.33
10000	1289	2.08	1317	2.28	1344	2.48	1370	2.69	1396	2.91	1421	3.12	1445	3.34	1468	3.56	1491	3.79	1515	4.02
11000	1412	2.72	1438	2.94	1463	3.16	1487	3.39	1511	3.62	1534	3.86	1557	4.09	1579	4.33	1601	4.58	1622	4.82
12000	1535	3.48	1560	3.72	1583	3.97	1605	4.21	1628	4.46	1650	4.72	1671	4.97	1692	5.23	1712	5.49	1732	5.75
Available External Static Pressure (Inches of Water Gauge)																				
CFM	1.10"		1.20"		1.30"		1.40"		1.50"		1.60"		1.70"		1.80"		1.90"		2.00"	
	RPM	BHP	RPM	BHP	RPM	BHP	RPM	BHP	RPM	BHP	RPM	BHP	RPM	BHP	RPM	BHP	RPM	BHP	RPM	BHP
5-hp Oversized Motor																				
7500	1294	2.66	1321	2.84	1346	3.03	1371	3.21	1396	3.4	1419	3.6	1442	3.79	1466	3.98	1489	4.18	1511	4.37
8000	1341	2.93	1367	3.12	1392	3.32	1417	3.52	1441	3.72	1464	3.92	1487	4.12	1509	4.32	1531	4.53	1553	4.74
9000	1438	3.54	1463	3.76	1487	3.97	1510	4.19	1534	4.41	1556	4.62	1579	4.85	1600	5.07	1622	5.29	1642	5.52
10000	1539	4.25	1562	4.49	1585	4.72	1607	4.96	1629	5.2	1651	5.43	1672	5.68	1693	5.92	1714	6.16	1734	6.4
11000	1643	5.07	1665	5.32	1686	5.58	1707	5.84	1728	6.1	1749	6.36	1769	6.61	1789	6.88	1809	7.14	1829	7.4
12000	1752	6.02	1771	6.28	1790	6.55	1810	6.83	1830	7.11	1850	7.39	1869	7.67	1888	7.96	1907	8.24	-	-

Notes:

1. Available External Static Pressure is the static pressure difference between the return duct and the supply duct plus the static pressure drop caused by accessories and options.
2. Data includes pressure drop due to standard filters and wet coils. No accessories or options are included in pressure drop data.
3. To determine static pressure drop due to other options/accessories, refer to the applicable table in the fan performance section.
4. Direct drive fan motor heat is negligible.
5. Factory supplied motors, in commercial equipment, are definite purpose motors, specifically designed and tested to operate reliably and continuously at all cataloged conditions. Using the full horsepower range of our fan motors as shown in our tabular data will not result in nuisance tripping or premature motor failure. Our product's warranty will not be affected.

12.5 to 25 Ton Units — Horizontal

Figure 2. Fan curves — 12.5 to 25 tons, WHJ horizontal

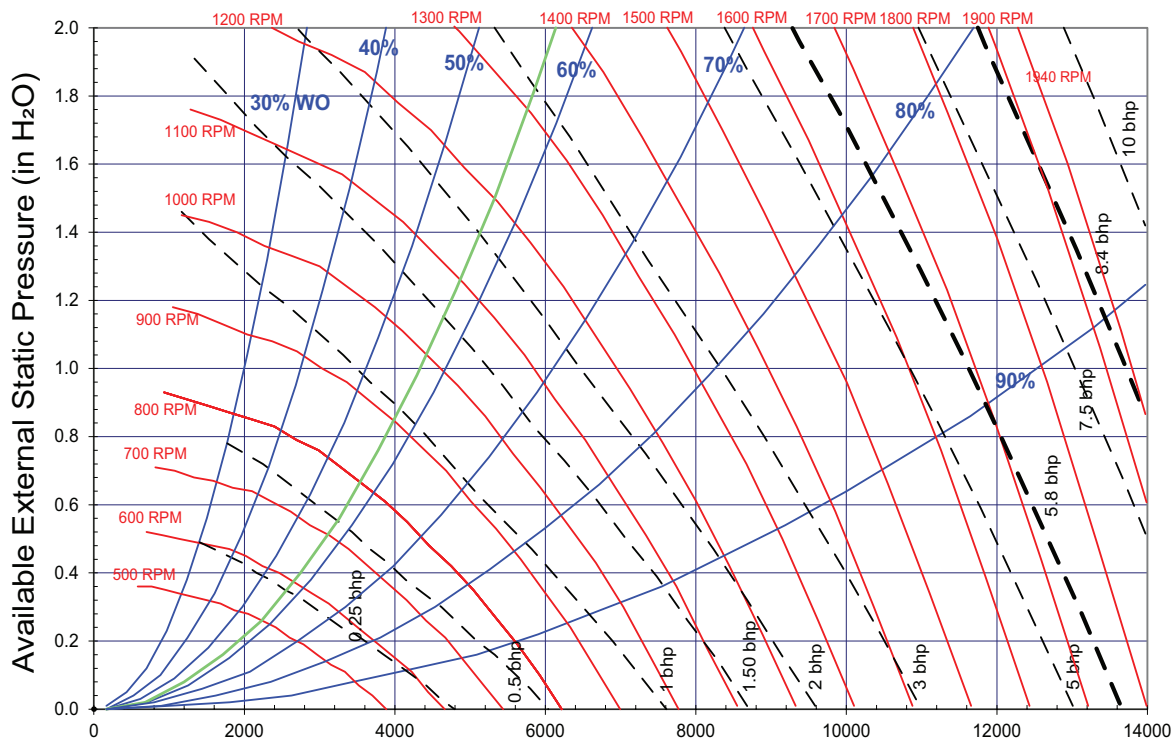



Evaporator Fan Performance - Heat Pump

Table 24. Evaporator fan performance — 12.5 ton, model WHJ, horizontal

Available External Static Pressure (Inches of Water Gauge)										
CFM	0.10"	0.20"	0.30"	0.40"	0.50"	0.60"	0.70"	0.80"	0.90"	1.00"
	RPM BHP	RPM BHP	RPM BHP	RPM BHP	RPM BHP	RPM BHP	RPM BHP	RPM BHP	RPM BHP	RPM BHP
3750	562 0.22	618 0.30	672 0.39	723 0.49	771 0.59	815 0.70	858 0.81	898 0.93	936 1.04	972 1.16
4000	592 0.25	646 0.34	696 0.44	745 0.54	792 0.65	835 0.76	877 0.87	916 0.99	954 1.11	990 1.24
4500	653 0.33	701 0.43	748 0.54	792 0.64	835 0.76	877 0.88	917 1.00	955 1.13	991 1.26	1027 1.39
5000	716 0.43	759 0.54	802 0.65	843 0.77	882 0.89	922 1.02	959 1.15	996 1.29	1031 1.43	1065 1.57
5500	779 0.55	819 0.67	858 0.79	896 0.92	933 1.04	969 1.17	1005 1.32	1039 1.46	1073 1.61	1106 1.76
6000	842 0.69	879 0.82	915 0.95	951 1.08	985 1.22	1020 1.36	1052 1.50	1085 1.66	1117 1.82	1149 1.98
Available External Static Pressure (Inches of Water Gauge)										
CFM	1.10"	1.20"	1.30"	1.40"	1.50"	1.60"	1.70"	1.80"	1.90"	2.00"
	RPM BHP	RPM BHP	RPM BHP	RPM BHP	RPM BHP	RPM BHP	RPM BHP	RPM BHP	RPM BHP	RPM BHP
3750	1007 1.29	1042 1.42	1075 1.55	1107 1.69	1138 1.83	1168 1.97	1197 2.11	1225 2.26	1253 2.41	1280 2.56
4000	1024 1.36	1057 1.49	1090 1.63	1122 1.77	1153 1.91	1183 2.06	1212 2.21	1240 2.36	1268 2.51	1294 2.66
4500	1060 1.53	1093 1.67	1124 1.81	1155 1.95	1184 2.1	1213 2.25	1242 2.41	1270 2.56	1298 2.73	1324 2.89
5000	1098 1.71	1130 1.86	1161 2.01	1191 2.16	1220 2.32	1248 2.47	1275 2.63	1302 2.79	1328 2.96	1355 3.13
5500	1138 1.91	1169 2.07	1199 2.23	1228 2.39	1256 2.55	1284 2.72	1311 2.89	1338 3.06	1364 3.23	1389 3.4
6000	1180 2.14	1210 2.3	1239 2.47	1267 2.64	1295 2.81	1322 2.99	1348 3.16	1375 3.34	1400 3.52	1425 3.7

Notes:

1. Available External Static Pressure is the static pressure difference between the return duct and the supply duct plus the static pressure drop caused by accessories and options.
2. Data includes pressure drop due to standard filters and wet coils. No accessories or options are included in pressure drop data.
3. To determine static pressure drop due to other options/accessories, refer to the applicable table in the fan performance section.
4. Direct drive fan motor heat is negligible.
5. Factory supplied motors, in commercial equipment, are definite purpose motors, specifically designed and tested to operate reliably and continuously at all cataloged conditions. Using the full horsepower range of our fan motors as shown in our tabular data will not result in nuisance tripping or premature motor failure. Our product's warranty will not be affected.

Table 25. Evaporator fan performance — 15 ton, model WHJ, horizontal

Available External Static Pressure (Inches of Water Gauge)										
CFM	0.10"	0.20"	0.30"	0.40"	0.50"	0.60"	0.70"	0.80"	0.90"	1.00"
	RPM BHP	RPM BHP	RPM BHP	RPM BHP	RPM BHP	RPM BHP	RPM BHP	RPM BHP	RPM BHP	RPM BHP
4500	653 0.33	701 0.43	748 0.54	792 0.64	835 0.76	877 0.88	917 1.00	955 1.13	991 1.26	1027 1.39
4800	690 0.39	736 0.49	780 0.60	822 0.72	863 0.83	903 0.96	942 1.09	979 1.22	1015 1.36	1049 1.50
5400	766 0.53	807 0.64	846 0.76	885 0.88	923 1.01	959 1.14	995 1.28	1030 1.43	1065 1.57	1098 1.72
6000	842 0.69	879 0.82	915 0.95	951 1.08	985 1.22	1020 1.36	1052 1.50	1085 1.66	1117 1.82	1149 1.98
6600	919 0.90	953 1.03	986 1.17	1019 1.32	1051 1.47	1082 1.62	1114 1.77	1144 1.93	1173 2.09	1203 2.26
7200	997 1.13	1028 1.28	1058 1.43	1089 1.59	1118 1.75	1148 1.91	1177 2.08	1205 2.25	1233 2.42	1261 2.59
Available External Static Pressure (Inches of Water Gauge)										
CFM	1.10"	1.20"	1.30"	1.40"	1.50"	1.60"	1.70"	1.80"	1.90"	2.00"
	RPM BHP	RPM BHP	RPM BHP	RPM BHP	RPM BHP	RPM BHP	RPM BHP	RPM BHP	RPM BHP	RPM BHP
4500	1060 1.53	1093 1.67	1124 1.81	1155 1.95	1184 2.1	1213 2.25	1242 2.41	1270 2.56	1298 2.73	1324 2.89
4800	1083 1.64	1115 1.78	1146 1.93	1176 2.07	1205 2.23	1234 2.38	1261 2.53	1289 2.7	1316 2.86	1342 3.03
5400	1130 1.87	1161 2.03	1191 2.18	1220 2.34	1249 2.5	1277 2.67	1304 2.83	1331 3	1356 3.17	1382 3.34
6000	1180 2.14	1210 2.3	1239 2.47	1267 2.64	1295 2.81	1322 2.99	1348 3.16	1375 3.34	1400 3.52	1425 3.7
6600	1232 2.44	1261 2.61	1289 2.79	1317 2.97	1343 3.15	1370 3.34	1396 3.53	1421 3.71	1445 3.9	1469 4.1
7200	1288 2.77	1315 2.96	1342 3.15	1368 3.34	1394 3.53	1420 3.73	1445 3.92	1469 4.12	1493 4.33	1517 4.53

Notes:

1. Available External Static Pressure is the static pressure difference between the return duct and the supply duct plus the static pressure drop caused by accessories and options.
2. Data includes pressure drop due to standard filters and wet coils. No accessories or options are included in pressure drop data.
3. To determine static pressure drop due to other options/accessories, refer to the applicable table in the fan performance section.
4. Direct drive fan motor heat is negligible.
5. Factory supplied motors, in commercial equipment, are definite purpose motors, specifically designed and tested to operate reliably and continuously at all cataloged conditions. Using the full horsepower range of our fan motors as shown in our tabular data will not result in nuisance tripping or premature motor failure. Our product's warranty will not be affected.

Evaporator Fan Performance - Heat Pump

Table 26. Evaporator fan performance — 20 ton, model WHJ, horizontal

Available External Static Pressure (Inches of Water Gauge)										
CFM	0.10"	0.20"	0.30"	0.40"	0.50"	0.60"	0.70"	0.80"	0.90"	1.00"
	RPM BHP	RPM BHP	RPM BHP	RPM BHP	RPM BHP	RPM BHP	RPM BHP	RPM BHP	RPM BHP	RPM BHP
6000	810 0.60	847 0.72	883 0.84	920 0.97	956 1.10	989 1.23	1022 1.37	1054 1.52	1085 1.66	1114 1.80
6400	860 0.71	894 0.84	928 0.96	962 1.10	997 1.23	1029 1.37	1061 1.52	1092 1.67	1122 1.82	1150 1.98
7200	958 0.98	990 1.11	1020 1.26	1050 1.40	1081 1.55	1112 1.71	1141 1.86	1169 2.02	1197 2.18	1225 2.35
8000	1058 1.30	1087 1.46	1114 1.61	1142 1.77	1168 1.93	1196 2.10	1224 2.27	1251 2.44	1277 2.62	1303 2.80
8800	1158 1.70	1185 1.87	1210 2.04	1235 2.21	1260 2.38	1284 2.56	1309 2.74	1335 2.93	1359 3.12	1384 3.32
9600	1259 2.17	1283 2.35	1307 2.54	1330 2.72	1353 2.91	1376 3.11	1398 3.30	1420 3.50	1444 3.70	1467 3.91
Available External Static Pressure (Inches of Water Gauge)										
CFM	1.10"	1.20"	1.30"	1.40"	1.50"	1.60"	1.70"	1.80"	1.90"	2.00"
	RPM BHP	RPM BHP	RPM BHP	RPM BHP	RPM BHP	RPM BHP	RPM BHP	RPM BHP	RPM BHP	RPM BHP
6000	1142 1.94	1170 2.09	1197 2.24	1223 2.39	1250 2.54	1276 2.7	1302 2.86	1327 3.02	1352 3.19	1377 3.36
6400	1178 2.13	1204 2.28	1231 2.43	1256 2.59	1282 2.75	1306 2.91	1331 3.07	1356 3.24	1381 3.41	1404 3.59
7200	1252 2.53	1278 2.7	1303 2.87	1327 3.04	1350 3.21	1374 3.39	1397 3.56	1420 3.74	1442 3.92	1464 4.09
8000	1327 2.97	1352 3.16	1377 3.35	1401 3.55	1424 3.74	1446 3.93	1468 4.12	1490 4.31	1511 4.5	1532 4.69
8800	1407 3.51	1431 3.7	1453 3.9	1476 4.1	1498 4.31	1520 4.52	1542 4.74	1563 4.95	1584 5.15	1604 5.36
9600	1490 4.12	1512 4.33	1533 4.53	1555 4.75	1575 4.96	1596 5.17	1617 5.4	1637 5.63	- -	- -

Notes:

1. Available External Static Pressure is the static pressure difference between the return duct and the supply duct plus the static pressure drop caused by accessories and options.
2. Data includes pressure drop due to standard filters and wet coils. No accessories or options are included in pressure drop data.
3. To determine static pressure drop due to other options/accessories, refer to the applicable table in the fan performance section.
4. Direct drive fan motor heat is negligible.
5. Factory supplied motors, in commercial equipment, are definite purpose motors, specifically designed and tested to operate reliably and continuously at all cataloged conditions. Using the full horsepower range of our fan motors as shown in our tabular data will not result in nuisance tripping or premature motor failure. Our product's warranty will not be affected.

Table 27. Evaporator fan performance — 25 ton, model WHJ, horizontal

Available External Static Pressure (Inches of Water Gauge)										
CFM	0.10"	0.20"	0.30"	0.40"	0.50"	0.60"	0.70"	0.80"	0.90"	1.00"
	RPM BHP	RPM BHP	RPM BHP	RPM BHP	RPM BHP	RPM BHP	RPM BHP	RPM BHP	RPM BHP	RPM BHP
3-hp Standard Motor										
7500	996 1.09	1026 1.23	1055 1.38	1084 1.53	1113 1.69	1143 1.85	1172 2.01	1200 2.17	1227 2.34	1253 2.51
8000	1058 1.30	1087 1.46	1114 1.61	1142 1.77	1168 1.93	1196 2.10	1224 2.27	1251 2.44	1277 2.62	1303 2.80
9000	1183 1.81	1209 1.98	1234 2.15	1259 2.33	1283 2.51	1307 2.69	1330 2.87	1356 3.07	1380 3.26	1404 3.46
10000	1309 2.44	1333 2.63	1356 2.82	1378 3.01	1400 3.21	1422 3.41	1443 3.61	1464 3.81	1486 4.02	1509 4.23
11000	1436 3.21	1457 3.41	1478 3.62	1499 3.83	1519 4.05	1539 4.26	1559 4.48	1579 4.70	1598 4.92	1617 5.14
12000	1562 4.12	1582 4.34	1602 4.57	1621 4.80	1640 5.03	1658 5.26	1676 5.5	1695 5.74	- -	- -
Available External Static Pressure (Inches of Water Gauge)										
CFM	1.10"	1.20"	1.30"	1.40"	1.50"	1.60"	1.70"	1.80"	1.90"	2.00"
	RPM BHP	RPM BHP	RPM BHP	RPM BHP	RPM BHP	RPM BHP	RPM BHP	RPM BHP	RPM BHP	RPM BHP
3-hp Standard Motor										
7500	1280 2.69	1305 2.87	1330 3.05	1354 3.23	1378 3.4	1401 3.58	1423 3.76	1445 3.94	1467 4.13	1489 4.31
8000	1327 2.97	1352 3.16	1377 3.35	1401 3.55	1424 3.74	1446 3.93	1468 4.12	1490 4.31	1511 4.5	1532 4.69
9000	1428 3.65	1451 3.85	1473 4.05	1495 4.25	1517 4.46	1539 4.68	1561 4.9	1582 5.11	1602 5.33	1622 5.54
10000	1531 4.45	1553 4.67	1574 4.88	1595 5.1	1616 5.32	1636 5.54	1655 5.77	- -	- -	- -
11000	1637 5.38	1658 5.61	- -	- -	- -	- -	- -	- -	- -	- -
12000	- -	- -	- -	- -	- -	- -	- -	- -	- -	- -

Notes:

1. Available External Static Pressure is the static pressure difference between the return duct and the supply duct plus the static pressure drop caused by accessories and options.
2. Data includes pressure drop due to standard filters and wet coils. No accessories or options are included in pressure drop data.
3. To determine static pressure drop due to other options/accessories, refer to the applicable table in the fan performance section.
4. Direct drive fan motor heat is negligible.
5. Factory supplied motors, in commercial equipment, are definite purpose motors, specifically designed and tested to operate reliably and continuously at all cataloged conditions. Using the full horsepower range of our fan motors as shown in our tabular data will not result in nuisance tripping or premature motor failure. Our product's warranty will not be affected.



Evaporator Fan Performance - Heat Pump

Table 28. Evaporator fan performance — 25 ton, model WHJ, horizontal, high static drive

Available External Static Pressure (Inches of Water Gauge)																				
CFM	0.10"		0.20"		0.30"		0.40"		0.50"		0.60"		0.70"		0.80"		0.90"		1.00"	
	RPM	BHP	RPM	BHP	RPM	BHP	RPM	BHP	RPM	BHP	RPM	BHP	RPM	BHP	RPM	BHP	RPM	BHP	RPM	BHP
5-hp Oversized Motor																				
7500	1023	1.11	1054	1.27	1086	1.42	1119	1.59	1149	1.76	1177	1.92	1205	2.09	1233	2.25	1259	2.42	1286	2.59
8000	1087	1.33	1117	1.49	1145	1.65	1177	1.83	1207	2.02	1234	2.19	1260	2.36	1286	2.54	1312	2.71	1337	2.89
9000	1216	1.85	1242	2.03	1268	2.21	1294	2.40	1323	2.60	1350	2.80	1374	3.00	1398	3.20	1421	3.39	1444	3.59
10000	1346	2.50	1369	2.69	1393	2.89	1416	3.09	1440	3.30	1465	3.53	1490	3.75	1513	3.98	1535	4.19	1556	4.41
11000	1476	3.28	1497	3.48	1519	3.70	1540	3.92	1561	4.15	1583	4.38	1606	4.63	1628	4.88	1650	5.13	1671	5.37
12000	1606	4.22	1626	4.44	1645	4.67	1665	4.91	1685	5.15	1704	5.4	1723	5.65	1745	5.92	1766	6.19	1786	6.47
Available External Static Pressure (Inches of Water Gauge)																				
CFM	1.10"		1.20"		1.30"		1.40"		1.50"		1.60"		1.70"		1.80"		1.90"		2.00"	
	RPM	BHP	RPM	BHP	RPM	BHP	RPM	BHP	RPM	BHP	RPM	BHP	RPM	BHP	RPM	BHP	RPM	BHP	RPM	BHP
5-hp Oversized Motor																				
7500	1311	2.76	1336	2.93	1360	3.11	1384	3.3	1408	3.48	1432	3.67	1454	3.86	1477	4.04	1500	4.23	1522	4.42
8000	1362	3.07	1386	3.25	1410	3.44	1432	3.63	1455	3.82	1478	4.01	1501	4.21	1523	4.41	1544	4.61	1565	4.81
9000	1467	3.79	1490	3.99	1512	4.19	1534	4.39	1555	4.59	1576	4.8	1597	5.01	1617	5.22	1637	5.44	1658	5.66
10000	1576	4.63	1597	4.85	1618	5.07	1639	5.29	1659	5.51	1679	5.73	1699	5.95	1718	6.18	1737	6.41	1756	6.65
11000	1690	5.61	1710	5.85	1728	6.09	1747	6.33	1766	6.57	1785	6.81	1804	7.05	1822	7.29	1841	7.54	1859	7.78
12000	1806	6.74	1825	7	1843	7.26	1860	7.52	1877	7.78	1894	8.04	1911	8.31	-	-	-	-	-	-

Notes:

1. Available External Static Pressure is the static pressure difference between the return duct and the supply duct plus the static pressure drop caused by accessories and options.
2. Data includes pressure drop due to standard filters and wet coils. No accessories or options are included in pressure drop data.
3. To determine static pressure drop due to other options/accessories, refer to the applicable table in the fan performance section.
4. Direct drive fan motor heat is negligible.
5. Factory supplied motors, in commercial equipment, are definite purpose motors, specifically designed and tested to operate reliably and continuously at all cataloged conditions. Using the full horsepower range of our fan motors as shown in our tabular data will not result in nuisance tripping or premature motor failure. Our product's warranty will not be affected.



Evaporator Fan Performance - Dual Fuel

12.5 to 25 Ton Units — Downflow

Table 29. Evaporator fan performance — 12.5 ton, model DHJ, downflow, high gas heat

Available External Static Pressure (Inches of Water Gauge)										
CFM	0.10"	0.20"	0.30"	0.40"	0.50"	0.60"	0.70"	0.80"	0.90"	1.00"
	RPM BHP	RPM BHP	RPM BHP	RPM BHP	RPM BHP	RPM BHP	RPM BHP	RPM BHP	RPM BHP	RPM BHP
3750	558 0.21	619 0.30	674 0.39	724 0.49	771 0.60	815 0.71	859 0.82	901 0.94	940 1.06	977 1.18
4000	586 0.24	645 0.33	698 0.44	747 0.54	793 0.65	835 0.76	876 0.88	918 1.00	957 1.13	994 1.25
4500	645 0.31	699 0.42	749 0.53	795 0.64	838 0.76	879 0.88	918 1.01	955 1.13	991 1.27	1028 1.41
5000	704 0.40	755 0.52	801 0.64	845 0.76	885 0.89	924 1.02	962 1.16	997 1.29	1032 1.43	1065 1.57
5500	765 0.51	811 0.63	855 0.77	896 0.90	935 1.04	972 1.18	1008 1.32	1042 1.47	1075 1.62	1107 1.77
6000	827 0.63	869 0.77	910 0.91	950 1.06	986 1.20	1022 1.36	1056 1.51	1089 1.67	1121 1.82	1152 1.99
Available External Static Pressure (Inches of Water Gauge)										
CFM	1.10"	1.20"	1.30"	1.40"	1.50"	1.60"	1.70"	1.80"	1.90"	2.00"
	RPM BHP	RPM BHP	RPM BHP	RPM BHP	RPM BHP	RPM BHP	RPM BHP	RPM BHP	RPM BHP	RPM BHP
3750	1013 1.32	1048 1.45	1081 1.59	1113 1.73	1144 1.87	1174 2.02	1203 2.17	1233 2.32	1261 2.47	1289 2.63
4000	1029 1.39	1063 1.52	1097 1.67	1129 1.81	1159 1.96	1189 2.11	1218 2.26	1247 2.42	1274 2.57	1302 2.73
4500	1063 1.55	1097 1.69	1129 1.84	1160 1.99	1191 2.14	1220 2.3	1249 2.46	1277 2.62	1305 2.79	1331 2.96
5000	1098 1.72	1131 1.87	1163 2.03	1194 2.19	1224 2.35	1253 2.51	1281 2.68	1309 2.85	1336 3.02	1363 3.2
5500	1138 1.92	1168 2.08	1198 2.24	1228 2.41	1258 2.58	1287 2.75	1315 2.92	1342 3.1	1369 3.28	1395 3.46
6000	1182 2.15	1211 2.31	1239 2.48	1267 2.65	1294 2.82	1322 3	1349 3.19	1377 3.37	1403 3.56	1429 3.75

Notes:

1. Available External Static Pressure is the static pressure difference between the return duct and the supply duct plus the static pressure drop caused by accessories and options.
2. Data includes pressure drop due to standard filters, wet coils, and high gas heat. No accessories or options are included in pressure drop data.
3. To determine static pressure drop due to other options/accessories, refer to the applicable table in the fan performance section.
4. Direct drive fan motor heat is negligible.
5. Factory supplied motors, in commercial equipment, are definite purpose motors, specifically designed and tested to operate reliably and continuously at all cataloged conditions. Using the full horsepower range of our fan motors as shown in our tabular data will not result in nuisance tripping or premature motor failure. Our product's warranty will not be affected.

Table 30. Evaporator fan performance — 15 ton, model DHJ, downflow, high gas heat

Available External Static Pressure (Inches of Water Gauge)										
CFM	0.10"	0.20"	0.30"	0.40"	0.50"	0.60"	0.70"	0.80"	0.90"	1.00"
	RPM BHP	RPM BHP	RPM BHP	RPM BHP	RPM BHP	RPM BHP	RPM BHP	RPM BHP	RPM BHP	RPM BHP
4500	645 0.31	699 0.42	749 0.53	795 0.64	838 0.76	879 0.88	918 1.01	955 1.13	991 1.27	1028 1.41
4800	680 0.36	732 0.48	780 0.59	824 0.71	866 0.84	906 0.96	944 1.09	980 1.23	1015 1.36	1049 1.50
5400	753 0.48	800 0.61	844 0.74	886 0.87	925 1.01	962 1.15	998 1.29	1033 1.43	1066 1.58	1099 1.73
6000	827 0.63	869 0.77	910 0.91	950 1.06	986 1.20	1022 1.36	1056 1.51	1089 1.67	1121 1.82	1152 1.99
6600	901 0.81	940 0.96	978 1.11	1015 1.27	1050 1.43	1083 1.59	1116 1.76	1147 1.93	1177 2.10	1207 2.27
7200	977 1.02	1011 1.18	1047 1.35	1082 1.52	1115 1.69	1147 1.87	1178 2.04	1208 2.22	1236 2.41	1265 2.59
Available External Static Pressure (Inches of Water Gauge)										
CFM	1.10"	1.20"	1.30"	1.40"	1.50"	1.60"	1.70"	1.80"	1.90"	2.00"
	RPM BHP	RPM BHP	RPM BHP	RPM BHP	RPM BHP	RPM BHP	RPM BHP	RPM BHP	RPM BHP	RPM BHP
4500	1063 1.55	1097 1.69	1129 1.84	1160 1.99	1191 2.14	1220 2.3	1249 2.46	1277 2.62	1305 2.79	1331 2.96
4800	1084 1.65	1117 1.8	1149 1.95	1180 2.1	1210 2.26	1240 2.42	1268 2.59	1296 2.75	1323 2.93	1350 3.1
5400	1130 1.88	1160 2.04	1191 2.2	1222 2.36	1251 2.53	1280 2.7	1308 2.87	1336 3.05	1362 3.22	1388 3.4
6000	1182 2.15	1211 2.31	1239 2.48	1267 2.65	1294 2.82	1322 3.00	1349 3.19	1377 3.37	1403 3.56	1429 3.75
6600	1236 2.45	1264 2.62	1292 2.8	1318 2.99	1344 3.17	1370 3.35	1395 3.54	1419 3.73	1445 3.93	1470 4.13
7200	1292 2.78	1319 2.97	1346 3.16	1372 3.35	1397 3.55	1422 3.74	1446 3.94	1470 4.14	1494 4.35	1517 4.55

Notes:

1. Available External Static Pressure is the static pressure difference between the return duct and the supply duct plus the static pressure drop caused by accessories and options.
2. Data includes pressure drop due to standard filters, wet coils, and high gas heat. No accessories or options are included in pressure drop data.
3. To determine static pressure drop due to other options/accessories, refer to the applicable table in the fan performance section.
4. Direct drive fan motor heat is negligible.
5. Factory supplied motors, in commercial equipment, are definite purpose motors, specifically designed and tested to operate reliably and continuously at all cataloged conditions. Using the full horsepower range of our fan motors as shown in our tabular data will not result in nuisance tripping or premature motor failure. Our product's warranty will not be affected.



Evaporator Fan Performance - Dual Fuel

Table 31. Evaporator fan performance — 20 ton, model DHJ, downflow, high gas heat

Available External Static Pressure (Inches of Water Gauge)										
CFM	0.10"	0.20"	0.30"	0.40"	0.50"	0.60"	0.70"	0.80"	0.90"	1.00"
	RPM BHP	RPM BHP	RPM BHP	RPM BHP	RPM BHP	RPM BHP	RPM BHP	RPM BHP	RPM BHP	RPM BHP
6000	808 0.58	848 0.71	888 0.85	927 0.98	964 1.12	999 1.27	1033 1.42	1066 1.57	1098 1.71	1128 1.87
6400	856 0.68	894 0.82	932 0.97	969 1.11	1004 1.26	1038 1.41	1071 1.57	1103 1.73	1134 1.88	1164 2.04
7200	954 0.94	989 1.09	1022 1.25	1056 1.41	1088 1.57	1119 1.74	1150 1.91	1180 2.08	1209 2.26	1238 2.43
8000	1052 1.25	1084 1.41	1114 1.58	1145 1.76	1175 1.94	1204 2.12	1232 2.31	1260 2.49	1288 2.69	1315 2.88
8800	1151 1.62	1180 1.8	1209 1.99	1236 2.18	1263 2.38	1291 2.58	1318 2.78	1344 2.98	1369 3.18	1394 3.39
9600	1251 2.07	1278 2.26	1304 2.46	1329 2.67	1354 2.88	1380 3.1	1405 3.31	1429 3.53	1453 3.75	1477 3.97
Available External Static Pressure (Inches of Water Gauge)										
CFM	1.10"	1.20"	1.30"	1.40"	1.50"	1.60"	1.70"	1.80"	1.90"	2.00"
	RPM BHP	RPM BHP	RPM BHP	RPM BHP	RPM BHP	RPM BHP	RPM BHP	RPM BHP	RPM BHP	RPM BHP
6000	1157 2.02	1185 2.17	1213 2.32	1240 2.48	1267 2.64	1294 2.8	1321 2.96	1346 3.13	1371 3.3	1395 3.47
6400	1192 2.2	1220 2.36	1247 2.53	1274 2.69	1299 2.85	1324 3.02	1350 3.19	1376 3.36	1400 3.54	1424 3.71
7200	1265 2.61	1292 2.79	1318 2.97	1343 3.15	1368 3.33	1392 3.51	1416 3.69	1439 3.88	1462 4.06	1484 4.25
8000	1341 3.07	1367 3.27	1392 3.47	1416 3.67	1440 3.87	1464 4.06	1486 4.26	1509 4.47	1531 4.67	1552 4.87
8800	1419 3.6	1444 3.81	1468 4.03	1491 4.24	1514 4.46	1537 4.68	1559 4.9	1581 5.11	1602 5.33	1623 5.55
9600	1500 4.19	1523 4.42	1546 4.65	1569 4.88	1591 5.12	1613 5.35	1634 5.59	- -	- -	- -

Notes:

1. Available External Static Pressure is the static pressure difference between the return duct and the supply duct plus the static pressure drop caused by accessories and options.
2. Data includes pressure drop due to standard filters, wet coils, and high gas heat. No accessories or options are included in pressure drop data.
3. To determine static pressure drop due to other options/accessories, refer to the applicable table in the fan performance section.
4. Direct drive fan motor heat is negligible.
5. Factory supplied motors, in commercial equipment, are definite purpose motors, specifically designed and tested to operate reliably and continuously at all cataloged conditions. Using the full horsepower range of our fan motors as shown in our tabular data will not result in nuisance tripping or premature motor failure. Our product's warranty will not be affected.

Table 32. Evaporator fan performance — 25 ton, model DHJ, downflow, high gas heat

Available External Static Pressure (Inches of Water Gauge)										
CFM	0.10"	0.20"	0.30"	0.40"	0.50"	0.60"	0.70"	0.80"	0.90"	1.00"
	RPM BHP	RPM BHP	RPM BHP	RPM BHP	RPM BHP	RPM BHP	RPM BHP	RPM BHP	RPM BHP	RPM BHP
3-hp Standard Motor										
7500	991 1.05	1024 1.2	1056 1.37	1089 1.53	1120 1.7	1151 1.87	1180 2.05	1210 2.23	1238 2.41	1266 2.59
8000	1052 1.25	1084 1.41	1114 1.58	1145 1.76	1175 1.94	1204 2.12	1232 2.31	1260 2.49	1288 2.69	1315 2.88
9000	1176 1.73	1205 1.91	1232 2.1	1259 2.3	1286 2.5	1313 2.7	1339 2.9	1365 3.11	1390 3.31	1414 3.52
10000	1301 2.32	1327 2.52	1352 2.73	1376 2.94	1400 3.16	1425 3.39	1449 3.61	1473 3.84	1496 4.07	1519 4.29
11000	1426 3.04	1450 3.26	1473 3.49	1495 3.72	1518 3.96	1539 4.2	1561 4.44	1584 4.69	1605 4.94	1627 5.19
12000	1551 3.9	1573 4.15	1595 4.39	1615 4.63	1636 4.89	1657 5.15	1676 5.41	1696 5.68	- -	- -
Available External Static Pressure (Inches of Water Gauge)										
CFM	1.10"	1.20"	1.30"	1.40"	1.50"	1.60"	1.70"	1.80"	1.90"	2.00"
	RPM BHP	RPM BHP	RPM BHP	RPM BHP	RPM BHP	RPM BHP	RPM BHP	RPM BHP	RPM BHP	RPM BHP
3-hp Standard Motor										
7500	1293 2.78	1320 2.97	1345 3.15	1371 3.34	1395 3.52	1419 3.71	1442 3.9	1465 4.09	1487 4.28	1509 4.47
8000	1341 3.07	1367 3.27	1392 3.47	1416 3.67	1440 3.87	1464 4.06	1486 4.26	1509 4.47	1531 4.67	1552 4.87
9000	1439 3.74	1463 3.96	1487 4.18	1510 4.4	1533 4.62	1556 4.84	1578 5.06	1599 5.29	1620 5.51	1641 5.73
10000	1542 4.52	1564 4.75	1586 4.99	1608 5.23	1630 5.47	1651 5.72	- -	- -	- -	- -
11000	1648 5.44	1669 5.69	- -	- -	- -	- -	- -	- -	- -	- -
12000	- -	- -	- -	- -	- -	- -	- -	- -	- -	- -

Notes:

1. Available External Static Pressure is the static pressure difference between the return duct and the supply duct plus the static pressure drop caused by accessories and options.
2. Data includes pressure drop due to standard filters, wet coils, and high gas heat. No accessories or options are included in pressure drop data.
3. To determine static pressure drop due to other options/accessories, refer to the applicable table in the fan performance section.
4. Direct drive fan motor heat is negligible.
5. Factory supplied motors, in commercial equipment, are definite purpose motors, specifically designed and tested to operate reliably and continuously at all cataloged conditions. Using the full horsepower range of our fan motors as shown in our tabular data will not result in nuisance tripping or premature motor failure. Our product's warranty will not be affected.

Table 33. Evaporator fan performance — 25 ton, model DHJ, downflow, high static drive

Available External Static Pressure (Inches of Water Gauge)										
CFM	0.10"	0.20"	0.30"	0.40"	0.50"	0.60"	0.70"	0.80"	0.90"	1.00"
	RPM BHP	RPM BHP	RPM BHP	RPM BHP	RPM BHP	RPM BHP	RPM BHP	RPM BHP	RPM BHP	RPM BHP
5-hp Oversized Motor										
7500	1005 1.05	1040 1.20	1074 1.37	1106 1.53	1138 1.70	1169 1.88	1199 2.05	1229 2.23	1257 2.41	1284 2.58
8000	1067 1.25	1101 1.41	1132 1.59	1163 1.76	1193 1.94	1223 2.12	1252 2.31	1280 2.50	1308 2.69	1334 2.87
9000	1193 1.72	1223 1.91	1252 2.11	1280 2.30	1307 2.50	1334 2.70	1360 2.90	1386 3.11	1412 3.32	1437 3.53
10000	1319 2.31	1346 2.52	1373 2.74	1398 2.95	1423 3.17	1448 3.39	1472 3.61	1496 3.84	1520 4.06	1543 4.29
11000	1445 3.03	1470 3.26	1495 3.49	1518 3.73	1542 3.97	1565 4.21	1587 4.45	1609 4.69	1631 4.94	1653 5.18
12000	1572 3.89	1595 4.14	1618 4.39	1640 4.65	1662 4.9	1683 5.16	1704 5.42	1725 5.69	1745 5.95	1765 6.22
Available External Static Pressure (Inches of Water Gauge)										
CFM	1.10"	1.20"	1.30"	1.40"	1.50"	1.60"	1.70"	1.80"	1.90"	2.00"
	RPM BHP	RPM BHP	RPM BHP	RPM BHP	RPM BHP	RPM BHP	RPM BHP	RPM BHP	RPM BHP	RPM BHP
5-hp Oversized Motor										
7500	1311 2.77	1336 2.95	1361 3.14	1386 3.33	1410 3.52	1435 3.71	1459 3.9	1483 4.10	1506 4.30	1529 4.50
8000	1360 3.06	1385 3.26	1410 3.45	1434 3.65	1457 3.85	1480 4.05	1503 4.25	1526 4.46	1549 4.66	1571 4.87
9000	1462 3.74	1486 3.95	1509 4.17	1532 4.38	1554 4.60	1576 4.82	1598 5.04	1619 5.26	1639 5.48	1660 5.71
10000	1566 4.52	1589 4.76	1611 4.99	1633 5.23	1655 5.47	1676 5.70	1696 5.94	1717 6.18	1736 6.42	1756 6.67
11000	1674 5.43	1695 5.69	1716 5.94	1737 6.20	1758 6.46	1778 6.72	1798 6.98	1817 7.24	1837 7.50	1855 7.76
12000	1785 6.49	1805 6.76	1824 7.03	1843 7.30	1863 7.58	1882 7.86	1902 8.14	1920 8.42	- -	- -

Notes:

1. Available External Static Pressure is the static pressure difference between the return duct and the supply duct plus the static pressure drop caused by accessories and options.
2. Data includes pressure drop due to standard filters, wet coils, and high gas heat. No accessories or options are included in pressure drop data.
3. To determine static pressure drop due to other options/accessories, refer to the applicable table in the fan performance section.
4. Direct drive fan motor heat is negligible.
5. Factory supplied motors, in commercial equipment, are definite purpose motors, specifically designed and tested to operate reliably and continuously at all cataloged conditions. Using the full horsepower range of our fan motors as shown in our tabular data will not result in nuisance tripping or premature motor failure. Our product's warranty will not be affected.

12.5 to 25 Ton Units — Horizontal

Table 34. Evaporator fan performance — 12.5 ton, model DHJ, horizontal, high gas heat

Available External Static Pressure (Inches of Water Gauge)										
CFM	0.10"	0.20"	0.30"	0.40"	0.50"	0.60"	0.70"	0.80"	0.90"	1.00"
	RPM BHP	RPM BHP	RPM BHP	RPM BHP	RPM BHP	RPM BHP	RPM BHP	RPM BHP	RPM BHP	RPM BHP
3750	572 0.23	629 0.32	683 0.41	734 0.51	779 0.61	822 0.71	864 0.82	903 0.94	941 1.05	977 1.17
4000	603 0.27	656 0.36	708 0.46	757 0.56	802 0.67	844 0.77	884 0.89	922 1.00	960 1.13	995 1.25
4500	666 0.36	713 0.45	760 0.56	805 0.67	849 0.79	890 0.91	928 1.03	964 1.15	999 1.28	1034 1.41
5000	730 0.47	772 0.57	815 0.68	857 0.80	897 0.93	937 1.06	974 1.20	1009 1.33	1042 1.46	1075 1.60
5500	795 0.60	833 0.71	872 0.83	911 0.96	949 1.09	985 1.23	1021 1.38	1056 1.52	1089 1.67	1120 1.81
6000	861 0.75	896 0.88	931 1.00	966 1.14	1002 1.28	1037 1.43	1070 1.58	1103 1.73	1136 1.89	1167 2.05
Available External Static Pressure (Inches of Water Gauge)										
CFM	1.10"	1.20"	1.30"	1.40"	1.50"	1.60"	1.70"	1.80"	1.90"	2.00"
	RPM BHP	RPM BHP	RPM BHP	RPM BHP	RPM BHP	RPM BHP	RPM BHP	RPM BHP	RPM BHP	RPM BHP
3750	1011 1.3	1043 1.42	1074 1.54	1104 1.67	1133 1.8	1161 1.93	1188 2.06	1214 2.19	1240 2.33	1265 2.47
4000	1029 1.38	1062 1.5	1093 1.64	1123 1.77	1152 1.9	1179 2.03	1206 2.17	1233 2.31	1258 2.45	1283 2.59
4500	1067 1.55	1099 1.69	1130 1.83	1160 1.97	1189 2.12	1217 2.26	1244 2.41	1270 2.56	1296 2.71	1321 2.86
5000	1107 1.74	1138 1.89	1168 2.04	1198 2.19	1227 2.34	1254 2.5	1282 2.66	1308 2.82	1334 2.98	1359 3.14
5500	1150 1.96	1180 2.11	1209 2.27	1237 2.43	1265 2.59	1293 2.76	1319 2.92	1345 3.09	1371 3.26	1396 3.44
6000	1196 2.21	1225 2.37	1252 2.53	1280 2.7	1306 2.87	1333 3.04	1358 3.21	1384 3.39	1409 3.57	1434 3.75

Notes:

1. Available External Static Pressure is the static pressure difference between the return duct and the supply duct plus the static pressure drop caused by accessories and options.
2. Data includes pressure drop due to standard filters, wet coils, and high gas heat. No accessories or options are included in pressure drop data.
3. To determine static pressure drop due to other options/accessories, refer to the applicable table in the fan performance section.
4. Direct drive fan motor heat is negligible.
5. Factory supplied motors, in commercial equipment, are definite purpose motors, specifically designed and tested to operate reliably and continuously at all cataloged conditions. Using the full horsepower range of our fan motors as shown in our tabular data will not result in nuisance tripping or premature motor failure. Our product's warranty will not be affected.



Evaporator Fan Performance - Dual Fuel

Table 35. Evaporator fan performance — 15 ton, model DHJ, horizontal, high gas heat

Available External Static Pressure (Inches of Water Gauge)										
CFM	0.10"	0.20"	0.30"	0.40"	0.50"	0.60"	0.70"	0.80"	0.90"	1.00"
	RPM BHP	RPM BHP	RPM BHP	RPM BHP	RPM BHP	RPM BHP	RPM BHP	RPM BHP	RPM BHP	RPM BHP
4500	666 0.36	713 0.45	760 0.56	805 0.67	849 0.79	890 0.91	928 1.03	964 1.15	999 1.28	1034 1.41
4800	705 0.42	749 0.52	793 0.63	836 0.75	878 0.87	918 1.00	955 1.13	991 1.25	1025 1.39	1058 1.52
5400	782 0.57	821 0.68	860 0.80	900 0.93	938 1.06	975 1.20	1012 1.34	1047 1.48	1079 1.62	1111 1.77
6000	861 0.75	896 0.88	931 1.00	966 1.14	1002 1.28	1037 1.43	1070 1.58	1103 1.73	1136 1.89	1167 2.05
6600	940 0.98	972 1.11	1003 1.24	1036 1.39	1068 1.54	1101 1.70	1132 1.86	1163 2.02	1193 2.19	1223 2.36
7200	1020 1.24	1050 1.38	1078 1.53	1108 1.68	1138 1.84	1167 2.01	1197 2.18	1226 2.35	1254 2.53	1282 2.71
Available External Static Pressure (Inches of Water Gauge)										
CFM	1.10"	1.20"	1.30"	1.40"	1.50"	1.60"	1.70"	1.80"	1.90"	2.00"
	RPM BHP	RPM BHP	RPM BHP	RPM BHP	RPM BHP	RPM BHP	RPM BHP	RPM BHP	RPM BHP	RPM BHP
4500	1067 1.55	1099 1.69	1130 1.83	1160 1.97	1189 2.12	1217 2.26	1244 2.41	1270 2.56	1296 2.71	1321 2.86
4800	1090 1.66	1122 1.81	1153 1.95	1183 2.1	1212 2.25	1240 2.4	1267 2.56	1293 2.71	1319 2.87	1343 3.03
5400	1141 1.91	1171 2.07	1200 2.22	1229 2.38	1257 2.54	1285 2.7	1312 2.87	1338 3.04	1363 3.21	1388 3.38
6000	1196 2.21	1225 2.37	1252 2.53	1280 2.7	1306 2.87	1333 3.04	1358 3.21	1384 3.39	1409 3.57	1434 3.75
6600	1252 2.54	1281 2.72	1308 2.89	1334 3.06	1359 3.24	1384 3.41	1409 3.6	1433 3.79	1457 3.98	1481 4.17
7200	1309 2.9	1337 3.09	1364 3.28	1390 3.47	1415 3.66	1439 3.85	1463 4.04	1486 4.23	1509 4.42	1532 4.63

Notes:

1. Available External Static Pressure is the static pressure difference between the return duct and the supply duct plus the static pressure drop caused by accessories and options.
2. Data includes pressure drop due to standard filters, wet coils, and high gas heat. No accessories or options are included in pressure drop data.
3. To determine static pressure drop due to other options/accessories, refer to the applicable table in the fan performance section.
4. Direct drive fan motor heat is negligible.
5. Factory supplied motors, in commercial equipment, are definite purpose motors, specifically designed and tested to operate reliably and continuously at all cataloged conditions. Using the full horsepower range of our fan motors as shown in our tabular data will not result in nuisance tripping or premature motor failure. Our product's warranty will not be affected.

Table 36. Evaporator fan performance — 20 ton, model DHJ, horizontal, high gas heat

Available External Static Pressure (Inches of Water Gauge)										
CFM	0.10"	0.20"	0.30"	0.40"	0.50"	0.60"	0.70"	0.80"	0.90"	1.00"
	RPM BHP	RPM BHP	RPM BHP	RPM BHP	RPM BHP	RPM BHP	RPM BHP	RPM BHP	RPM BHP	RPM BHP
6000	842 0.70	879 0.82	916 0.94	952 1.08	986 1.21	1019 1.35	1052 1.49	1082 1.64	1112 1.78	1140 1.92
6400	894 0.83	928 0.96	963 1.09	997 1.23	1030 1.37	1061 1.51	1093 1.66	1123 1.82	1152 1.97	1179 2.12
7200	997 1.14	1028 1.28	1058 1.43	1089 1.58	1120 1.74	1149 1.90	1178 2.06	1205 2.22	1233 2.39	1260 2.57
8000	1102 1.53	1129 1.69	1157 1.85	1183 2.01	1212 2.18	1240 2.35	1266 2.53	1292 2.71	1318 2.88	1343 3.07
8800	1207 2.00	1232 2.17	1257 2.35	1281 2.52	1306 2.71	1332 2.89	1357 3.08	1382 3.28	1406 3.47	1429 3.66
9600	1312 2.56	1335 2.75	1358 2.94	1381 3.13	1403 3.32	1426 3.52	1450 3.73	1473 3.94	1496 4.14	1518 4.35
Available External Static Pressure (Inches of Water Gauge)										
CFM	1.10"	1.20"	1.30"	1.40"	1.50"	1.60"	1.70"	1.80"	1.90"	2.00"
	RPM BHP	RPM BHP	RPM BHP	RPM BHP	RPM BHP	RPM BHP	RPM BHP	RPM BHP	RPM BHP	RPM BHP
6000	1168 2.07	1195 2.21	1222 2.36	1249 2.52	1275 2.68	1301 2.84	1326 3.00	1352 3.17	1376 3.33	1401 3.50
6400	1206 2.27	1232 2.43	1258 2.58	1284 2.74	1308 2.90	1334 3.07	1359 3.24	1383 3.41	1407 3.58	1430 3.76
7200	1286 2.74	1311 2.91	1335 3.08	1359 3.25	1382 3.42	1405 3.60	1428 3.78	1450 3.95	1472 4.13	1495 4.32
8000	1368 3.26	1392 3.45	1415 3.65	1438 3.83	1460 4.02	1482 4.21	1503 4.40	1525 4.60	1546 4.79	1567 4.99
8800	1452 3.86	1474 4.06	1497 4.27	1520 4.48	1541 4.7	1563 4.91	1583 5.12	1604 5.32	1623 5.53	1643 5.74
9600	1540 4.57	1561 4.78	1582 4.99	1603 5.21	1624 5.44	1644 5.67	- -	- -	- -	- -

Notes:

1. Available External Static Pressure is the static pressure difference between the return duct and the supply duct plus the static pressure drop caused by accessories and options.
2. Data includes pressure drop due to standard filters, wet coils, and high gas heat. No accessories or options are included in pressure drop data.
3. To determine static pressure drop due to other options/accessories, refer to the applicable table in the fan performance section.
4. Direct drive fan motor heat is negligible.
5. Factory supplied motors, in commercial equipment, are definite purpose motors, specifically designed and tested to operate reliably and continuously at all cataloged conditions. Using the full horsepower range of our fan motors as shown in our tabular data will not result in nuisance tripping or premature motor failure. Our product's warranty will not be affected.

Evaporator Fan Performance - Dual Fuel

Table 37. Evaporator fan performance — 25 ton, model DHJ, horizontal, high gas heat

Available External Static Pressure (Inches of Water Gauge)											
CFM	0.10"	0.20"	0.30"	0.40"	0.50"	0.60"	0.70"	0.80"	0.90"	1.00"	
	RPM BHP	RPM BHP	RPM BHP	RPM BHP	RPM BHP	RPM BHP	RPM BHP	RPM BHP	RPM BHP	RPM BHP	RPM BHP
3-hp Standard Motor											
7500	1036 1.28	1066 1.43	1095 1.58	1124 1.73	1154 1.90	1183 2.06	1211 2.22	1238 2.39	1264 2.57	1291 2.75	
8000	1102 1.53	1129 1.69	1157 1.85	1183 2.01	1212 2.18	1240 2.35	1266 2.53	1292 2.71	1318 2.88	1343 3.07	
9000	1233 2.13	1257 2.30	1282 2.48	1306 2.67	1330 2.85	1355 3.04	1380 3.24	1404 3.43	1428 3.63	1451 3.83	
10000	1365 2.88	1387 3.07	1409 3.27	1431 3.47	1453 3.67	1473 3.87	1497 4.09	1519 4.30	1541 4.52	1563 4.74	
11000	1497 3.78	1517 4.00	1537 4.21	1557 4.43	1577 4.65	1597 4.87	1616 5.10	1636 5.33	1657 5.56	-	-
12000	1629 4.87	1648 5.10	1666 5.33	1685 5.57	-	-	-	-	-	-	-
Available External Static Pressure (Inches of Water Gauge)											
CFM	1.10"	1.20"	1.30"	1.40"	1.50"	1.60"	1.70"	1.80"	1.90"	2.00"	
	RPM BHP	RPM BHP	RPM BHP	RPM BHP	RPM BHP	RPM BHP	RPM BHP	RPM BHP	RPM BHP	RPM BHP	RPM BHP
3-hp Standard Motor											
7500	1316 2.93	1341 3.11	1365 3.28	1388 3.46	1411 3.64	1433 3.82	1456 4	1478 4.19	1499 4.37	1520 4.56	
8000	1368 3.26	1392 3.45	1415 3.65	1438 3.83	1460 4.02	1482 4.21	1503 4.4	1525 4.6	1546 4.79	1567 4.99	
9000	1474 4.03	1496 4.23	1518 4.44	1540 4.66	1562 4.87	1583 5.09	1604 5.31	1624 5.52	1643 5.73	-	-
10000	1584 4.95	1605 5.17	1626 5.40	1646 5.62	-	-	-	-	-	-	-
11000	-	-	-	-	-	-	-	-	-	-	-
12000	-	-	-	-	-	-	-	-	-	-	-

Notes:

1. Available External Static Pressure is the static pressure difference between the return duct and the supply duct plus the static pressure drop caused by accessories and options.
2. Data includes pressure drop due to standard filters, wet coils, and high gas heat. No accessories or options are included in pressure drop data.
3. To determine static pressure drop due to other options/accessories, refer to the applicable table in the fan performance section.
4. Direct drive fan motor heat is negligible.
5. Factory supplied motors, in commercial equipment, are definite purpose motors, specifically designed and tested to operate reliably and continuously at all cataloged conditions. Using the full horsepower range of our fan motors as shown in our tabular data will not result in nuisance tripping or premature motor failure. Our product's warranty will not be affected.

Table 38. Evaporator fan performance — 25 ton, model DHJ, horizontal, high static drive

Available External Static Pressure (Inches of Water Gauge)											
CFM	0.10"	0.20"	0.30"	0.40"	0.50"	0.60"	0.70"	0.80"	0.90"	1.00"	
	RPM BHP	RPM BHP	RPM BHP	RPM BHP	RPM BHP	RPM BHP	RPM BHP	RPM BHP	RPM BHP	RPM BHP	RPM BHP
5-hp Oversized Motor											
7500	1054 1.29	1085 1.44	1117 1.60	1147 1.76	1175 1.93	1203 2.09	1231 2.26	1258 2.43	1285 2.60	1312 2.78	
8000	1121 1.54	1149 1.70	1179 1.87	1208 2.04	1235 2.22	1262 2.39	1288 2.57	1314 2.75	1339 2.93	1365 3.11	
9000	1255 2.15	1278 2.32	1306 2.51	1332 2.70	1357 2.90	1382 3.09	1406 3.29	1429 3.49	1452 3.68	1476 3.89	
10000	1389 2.91	1410 3.09	1434 3.29	1458 3.50	1482 3.72	1504 3.93	1527 4.15	1548 4.37	1569 4.59	1590 4.81	
11000	1524 3.83	1543 4.03	1563 4.23	1585 4.47	1607 4.70	1629 4.94	1649 5.18	1670 5.41	1690 5.65	1709 5.89	
12000	1659 4.93	1677 5.15	1694 5.37	1714 5.61	1734 5.86	1754 6.12	1774 6.37	1793 6.63	1812 6.89	1830 7.15	
Available External Static Pressure (Inches of Water Gauge)											
CFM	1.10"	1.20"	1.30"	1.40"	1.50"	1.60"	1.70"	1.80"	1.90"	2.00"	
	RPM BHP	RPM BHP	RPM BHP	RPM BHP	RPM BHP	RPM BHP	RPM BHP	RPM BHP	RPM BHP	RPM BHP	RPM BHP
5-hp Oversized Motor											
7500	1338 2.96	1362 3.14	1385 3.32	1407 3.49	1429 3.67	1452 3.86	1475 4.04	1497 4.22	1518 4.41	1539 4.60	
8000	1390 3.30	1415 3.49	1439 3.69	1461 3.88	1482 4.07	1503 4.26	1523 4.45	1545 4.64	1566 4.83	1587 5.03	
9000	1498 4.09	1520 4.29	1543 4.5	1566 4.72	1587 4.94	1609 5.15	1630 5.37	1649 5.58	1668 5.79	1686 6.01	
10000	1611 5.03	1632 5.25	1653 5.48	1673 5.70	1693 5.93	1714 6.17	1734 6.41	1754 6.65	1773 6.89	1792 7.13	
11000	1729 6.13	1747 6.38	1767 6.62	1786 6.86	1805 7.11	1823 7.36	1841 7.60	1860 7.86	1878 8.12	1897 8.38	
12000	1849 7.41	1867 7.67	1884 7.94	1901 8.20	-	-	-	-	-	-	-

Notes:

1. Available External Static Pressure is the static pressure difference between the return duct and the supply duct plus the static pressure drop caused by accessories and options.
2. Data includes pressure drop due to standard filters, wet coils, and high gas heat. No accessories or options are included in pressure drop data.
3. To determine static pressure drop due to other options/accessories, refer to the applicable table in the fan performance section.
4. Direct drive fan motor heat is negligible.
5. Factory supplied motors, in commercial equipment, are definite purpose motors, specifically designed and tested to operate reliably and continuously at all cataloged conditions. Using the full horsepower range of our fan motors as shown in our tabular data will not result in nuisance tripping or premature motor failure. Our product's warranty will not be affected.



Fan Performance

Table 39. Outdoor sound power level

Tons	Unit Model Number	Octave Center Frequency								Overall dBA
		63	125	250	500	1000	2000	4000	8000	
12.5	W/DHJ150A*	83	87	87	85	82	77	74	69	87
15	W/DHJ180A*	83	87	87	85	82	77	74	69	87
20	W/DHJ240A*	94	90	92	91	88	84	81	75	93
25	W/DHJ300A*	94	90	92	91	88	84	81	75	93

Notes:

1. Outdoor sound rating shown is tested in accordance with AHRI 370-2015.
2. Indoor sound in accordance with AHRI 260 is available through Trane's selection software.

Table 40. Static pressure drop through accessories (inches water column) - high efficiency - economizer

Tons	Unit Model Number	cfm ^(a)	Standard Filters ^(b)	2" MERV 8 Filter ^(c)	2" MERV 13 Filter ^(c)	Reheat Coil	Economizer with OA/RA Dampers ^(d)							
							Downflow		Horizontal		Low Leak Downflow		Low Leak Horizontal	
							100% OA	100% RA	100% OA	100% RA	100% OA	100% RA	100% OA	100% RA
12.5	W/DHJ150A	3750	0.02	0.04	0.07	0.02	0.10	0.02	0.10	0.02	0.11	0.09	0.05	0.09
		5000	0.03	0.06	0.10	0.04	0.15	0.03	0.15	0.03	0.17	0.13	0.09	0.14
		6000	0.04	0.08	0.13	0.04	0.20	0.04	0.20	0.04	0.23	0.17	0.12	0.18
15	W/DHJ180A	4500	0.03	0.05	0.09	0.04	0.13	0.02	0.13	0.02	0.14	0.11	0.07	0.12
		6000	0.04	0.08	0.13	0.04	0.20	0.04	0.20	0.04	0.23	0.17	0.12	0.18
		7200	0.06	0.10	0.17	0.02	0.27	0.05	0.27	0.05	0.32	0.23	0.16	0.25
20	W/DHJ240A	6000	0.04	0.08	0.13	0.04	0.20	0.04	0.20	0.04	0.23	0.17	0.12	0.18
		8000	0.07	0.12	0.21	0.02	0.32	0.06	0.32	0.06	0.39	0.27	0.19	0.30
		9600	0.09	0.16	0.27	0.05	0.44	0.07	0.44	0.07	0.54	0.37	0.27	0.41
25	W/DHJ300A	7500	0.06	0.11	0.19	0.02	0.29	0.05	0.29	0.05	0.34	0.24	0.17	0.27
		10000	0.09	0.17	0.29	0.06	0.48	0.08	0.48	0.08	0.58	0.40	0.29	0.45
		12000	0.12	0.23	0.39	0.06	0.66	0.11	0.66	0.11	0.82	0.55	0.39	0.62

^(a) See below for restrictions:

Multi-speed, single zone VAV or multi-zone VAV applications are capable of running below 300 cfm/ton during low speed airflow operation.

^(b) Tested with: 2-in filters 12.5 to 25 tons.

^(c) Difference in pressure drop should be considered when utilizing optional 2-in pleated filters.

^(d) OA = Outside Air and RA = Return Air.

Table 41. Static pressure drop through accessories (inches water column) - high efficiency - auxiliary heater

Tons	Unit Model Number	cfm ^(a)	Electric Heater				Gas Heater ^(b)					
			Accessory (kW)				Downflow			Horizontal		
			18	36	54	72	L	M	H	L	M	H
12.5	W/DHJ150A	3750	0.00	0.01	0.01	N/A	-0.09	-0.08	-0.08	0.03	0.03	0.06
		5000	0.01	0.03	0.03	N/A	-0.06	-0.04	-0.05	0.10	0.10	0.12
		6000	0.01	0.04	0.04	N/A	-0.03	-0.02	-0.02	0.12	0.13	0.16
15	W/DHJ180A	4500	0.01	0.02	0.02	N/A	-0.07	-0.05	-0.06	0.08	0.08	0.10
		6000	0.01	0.04	0.04	N/A	-0.03	-0.02	-0.02	0.12	0.13	0.16
		7200	0.02	0.06	0.06	N/A	-0.01	0.00	0.01	0.11	0.13	0.19
20	W/DHJ240A	6000	N/A	0.04	0.04	0.04	-0.03	-0.02	-0.02	0.12	0.13	0.16
		8000	N/A	0.08	0.08	0.08	0.01	0.01	0.03	0.10	0.13	0.19
		9600	N/A	0.12	0.12	0.12	0.04	0.05	0.07	0.10	0.14	0.21

Table 41. Static pressure drop through accessories (inches water column) - high efficiency - auxiliary heater (continued)

Tons	Unit Model Number	cfm ^(a)	Electric Heater				Gas Heater ^(b)					
			Accessory (kW)				Downflow			Horizontal		
			18	36	54	72	L	M	H	L	M	H
25	W/DHJ300A	7500	N/A	0.07	0.07	0.07	0.00	0.00	0.01	0.11	0.13	0.19
		10000	N/A	0.13	0.13	0.13	0.06	0.07	0.08	0.11	0.15	0.21
		12000	N/A	0.20	0.20	0.20	0.14	0.15	0.14	0.16	0.21	0.31

^(a) See below for restrictions:

Multi-speed, single zone VAV or multi-zone VAV applications are capable of running below 300 cfm/ton during low speed airflow operation.

^(b) Model digit 11 selection of low gas heat is 5x5, medium gas heat is 7x7, and high gas heat is 8x8 for 12.5 to 25T units.

Table 42. Static pressure drop through accessories (inches water column) - high efficiency - modulating gas heat option

Tons	Unit Model Number	cfm	Gas Heater ^(a)			
			Downflow		Horizontal	
			L	H	L	H
12.5	DHJ150A	3750	-	0.04	-	0.07
		5000	-	0.08	-	0.13
		6000	-	0.11	-	0.20
15	DHJ180A	4500	0.06	0.09	0.11	0.15
		6000	0.11	0.19	0.20	0.28
		7200	0.16	0.28	0.29	0.42
20	DHJ240A	6000	0.11	0.19	0.20	0.28
		8000	0.20	0.36	0.36	0.52
		9600	0.30	0.53	0.52	0.75
25	DHJ300A	7500	0.18	0.31	0.31	0.45
		10000	0.33	0.58	0.56	0.82
		12000	0.49	0.87	0.81	1.17

^(a) Model digit 10 selection B is Mod Gas of which Low Gas Heat is 2x2 for 6T, 4x4 for 7.5 to 12.5T, High Gas Heat is 4x4 for 6T, 6x6 for 7.5 to 12.5T. 12.5T D.0 is High only with 6-Tube. 15 to 25T units are Low with 6-Tube and High with 8-Tube.



Heating Performance

Table 43. Gas fired heating capacities - staged gas - dual fuel high efficiency

Tons	Unit Model Number	Heating Input BTU (High / Low Stage)	Heating Output BTU (High / Low Stage)	Air Temperature Rise°F
12.5	DHJ150A**(0,A)L	150,000 / 105,000	121,500 / 85,000	10 - 40
	DHJ150A**(0,A)M	200,000 / 140,000	162,000 / 113,400	15 - 45
	DHJ150A**(0,A)H	250,000 / 175,000	202,500 / 141,750	25 - 55
15	DHJ180A**(0,A)L	250,000 / 175,000	202,500 / 141,750	15 - 45
	DHJ180A**(0,A)M	320,000 / 224,000	259,200 / 181,440	20 - 50
	DHJ180A**(0,A)H	400,000 / 280,000	324,000 / 226,800	25 - 55
20	DHJ240A**(0,A)L	250,000 / 175,000	202,500 / 141,750	10 - 40
	DHJ240A**(0,A)M	320,000 / 224,000	259,200 / 181,440	15 - 45
	DHJ240A**(0,A)H	400,000 / 280,000	324,000 / 226,800	20 - 50
25	DHJ300A**(0,A)L	250,000 / 175,000	202,500 / 141,750	10 - 40
	DHJ300A**(0,A)M	320,000 / 224,000	259,200 / 181,440	15 - 45
	DHJ300A**(0,A)H	400,000 / 280,000	324,000 / 226,800	20 - 50

Table 44. Gas-fired heating capacities - modulating gas - dual fuel high efficiency

Tons	Unit Model Number	Heating Input BTU (High / Low Stage)	Heating Output BTU (High / Low Stage)	Air Temperature Rise°F
12.5	DHJ150A**BH	250,000 / 25,000	202,500 / 20,250	5 - 55
15	DHJ180A**BL	250,000 / 25,000	202,500 / 20,250	5 - 45
	DHJ180A**BH	400,000 / 40,000	324,000 / 32,400	5 - 55
20	DHJ240A**BL	250,000 / 25,000	202,500 / 20,250	5 - 40
	DHJ240A**BH	400,000 / 40,000	324,000 / 32,400	5 - 50
25	DHJ300A**BL	250,000 / 25,000	202,500 / 20,250	5 - 40
	DHJ300A**BH	400,000 / 40,000	324,000 / 32,400	5 - 50

Table 45. Auxiliary electric heat capacity

Tons	Unit Model Number	Total ^(a)		No. of Stages	Stage 1		Stage 2	
		kw Input ^(b)	MBh Output		kw Input	MBh Output	kw Input	MBh Output
12.5 to 15	WH*150*3,4,W WH*180*3,4,W	18.00	61.47	1	18.00	61.47	–	–
		36.00	122.94	2	18.00	61.47	18.00	61.47
		54.00	184.41	2	36.00	122.94	18.00	61.47
20 to 25	WH*240*3,4,W WH*300*3,4,W	36.00	122.94	2	18.00	61.47	18.00	61.47
		54.00	184.41	2	36.00	122.94	18.00	61.47
		72	245.88	2	36	122.94	36	122.94

^(a) Heaters are rated at 240V, 480V, and 600V. For other than rated voltage, CAP = (voltage/rated voltage)² x rated cap.

^(b) For all input/output categories, does not include fan power or heat.

Table 46. Auxiliary electric heat - air temperature rise

kW	Stages	12.5 Tons 3750 cfm	15 Tons 4500 cfm	20 Tons 6000 cfm	25 Tons 7500 cfm
		Three Phase WH*150*3,4,W	Three Phase WH*180*3,4,W	Three Phase WH*240*3,4,W	Three Phase WH*300*3,4,W
18.00	1	15.17	12.64	-	-
27.00	2	22.76	-	-	-
36.00	2	30.35	25.28	18.96	15.17
54.00	2	45.52	37.93	28.45	22.76
72.00	2	-	-	37.93	30.34

Note: For minimum design airflow, see airflow performance table for each unit. To calculate temp. rise at different airflow, use the following formula:

$$\text{Temp. rise across electric heater} = (\text{kW} \times 34.14) / (1.08 \times \text{cfm}).$$



Controls

Enhanced BAS Integration and Connectivity

- Symbio™ 700 integrates seamlessly with Trane® Tracer® Synchrony and Tracer Ensemble® to deliver optimized building automation and building management features and functions.
- Easily integrate with open standard protocols to connect seamlessly to a BAS (whether that is Trane or non-Trane).
- Digit 21 must equal 1, 2, or 3 for communication support.

BACnet® Communications

Symbio™ 700 includes native BACnet communications which allows the unit to communicate directly with a Tracer or non-Trane Building Automation System via open protocol BACnet MS/TP or IP.

Modbus Communications

Symbio 700 includes native Modbus communications which allows the unit to communicate directly with a Tracer or non-Trane Building Automation System via open protocol Modbus RTU or TCP/IP.

LonTalk® Communications

The optional LonTalk® communications module allows the unit to communicate directly with a Tracer or non-Trane Building Automation System via open protocol LonTalk.

Air-Fi® Wireless Communications

The optional Air-Fi communications module allows the unit to communicate directly with a Tracer Building Automation System via open protocol BACnet over Zigbee wireless.

Secure Remote Connectivity with Trane Connect

The Symbio controller enables secure remote connectivity via Trane Connect to Trane Intelligent Services and remote monitoring. Trane Connect provides anywhere/anytime access to monitor and manage with secure remote access and connectivity options through a multitude of platforms. Peace of mind that the system will be operational and provide comfort to customers.

Serviceability

Symbio™ Service and Installation Mobile App

The Symbio™ Service and Installation mobile app is accessible through mobile devices (phones and tablets) via Bluetooth connectivity or via Trane Connect. The intuitive mobile app feels natural to technicians and operators. They will quickly be able to view equipment status and alarms, perform startup tasks, change configurations, test the equipment's performance in specific modes—and much more. Free for download from App Store (Apple iOS) and Google Play (Android devices).

To download the Symbio™ Service and Installation Mobile App use the links below or scan the code with your mobile phone camera.

Apple download link (<https://apps.apple.com/us/app/symbio-service-installation/id1309310176>)

Google Play (Android) download link (<https://play.google.com/store/apps/details?id=com.trane.mobileservicetool>)

Figure 3. Scan code



Figure 4. Symbio™ service and installation mobile app

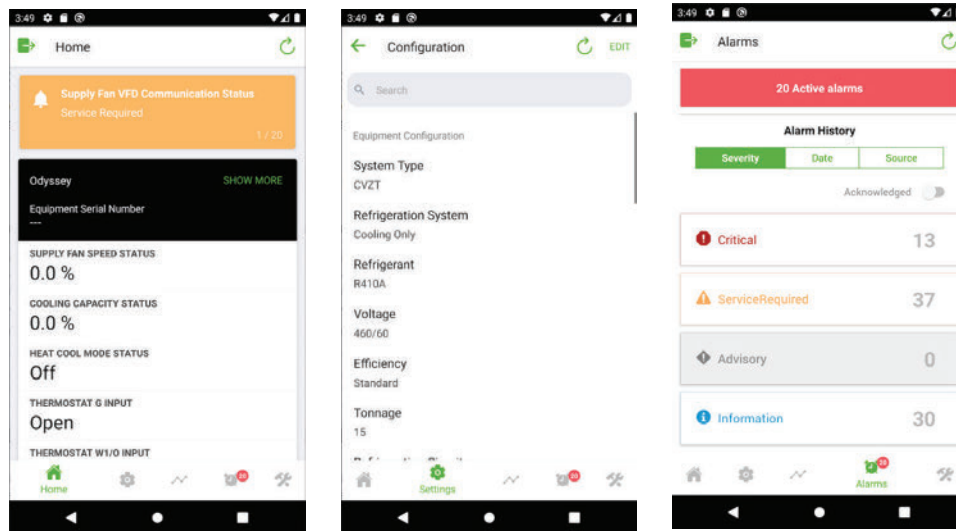

Onboard User Interface

An integrated onboard user interface that makes setup and continued operation easy. It provides real time operational performance, status, data, and alarms. It also allows the user to interact with, service, troubleshoot, and control their equipment without additional service software tools or when a mobile interface is not available.

Figure 5. Onboard user interface

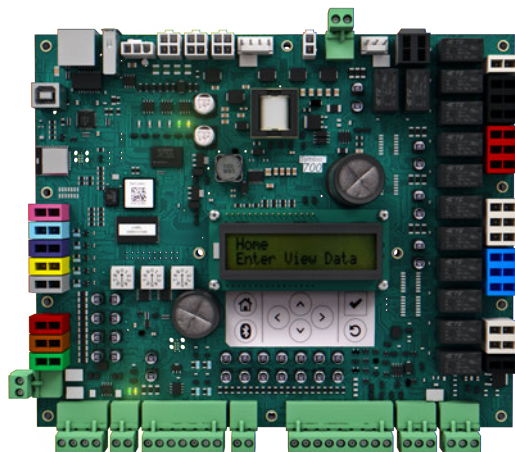



Service Test Mode

Symbio™ 700 requires no special tools to run the unit through its paces. Simply navigate to the 'Service' section of the on-board user interface or the 'Tools' section of the Symbio™ Service and Installation Mobile App and enter the 'Service Test Mode' section. Here the unit can be placed in the desired operating condition for a pre-determined amount of time supporting troubleshooting efforts in the field. The Symbio™ 700 will return to normal control when the user exits test mode or when the pre-determined, user-selected Service Test time has expired.

Symbio™ 700 controls with upgradeable software

Trane's equipment and systems feature engineered, tested, and proven applications that meet industry energy standards and provide the flexibility to customize and update over the life of the equipment. Professional operational algorithms are embedded within the Symbio™ 700 controller at the Trane factory. Symbio™ 700 standardizes each equipment unit to maintain standards for comfort, efficiency, and air quality, without additional field programming. Symbio™ 700 provides the flexibility over the life of the equipment to meet changing customer needs and/or industry standards.

Flexibility

Expansion Modules (requires Tracer® TU)

- XM30 – Provides 4 universal inputs or analog outputs
- XM32 – Provides 4 binary outputs

Field Programming via TGP2 (requires Tracer TU)

- Control ancillary equipment
- Custom sequences

TGP2 and XM Limitations:

- Programs will only have access to available BACnet® points. (Ensures system reliability.)
- TGP2 programs will not have direct I/O control access for factory components. (Compressors will not be able to be directly controlled On/Off without going through factory provided protection sequences.)
- Onboard I/O will not be available to custom applied TGP2 programs. If additional I/O is required for a new control loop, a separate expansion module will be required.
- Customer applied I/O will be limited to a maximum combination of 2 XM modules. Only XM30 or XM32 modules will be supported by the Symbio 700 UC.
- Tracer TU will be required to configure XMs and to create, view, or modify TGP2 programs.

Economizer Controls

There are four options for economizer control, Dry Bulb Temperature, Comparative Enthalpy, Reference Enthalpy and Differential Dry Bulb Temperature.

Dry Bulb Temperature Control

The dry bulb system measures outdoor temperature comparing it to the economizer enable setpoint. If the outdoor temperature is below the economizer enable setpoint, the economizer will operate freely. This system is best suited for arid regions where the humidity levels of outside air would not be detrimental to building comfort and indoor air quality.

Comparative Enthalpy Control

The comparative enthalpy system measures the temperature and humidity of both return air and outside air to determine which source has lower enthalpy. This system allows true comparison of outdoor air and return air enthalpy by measurement of outdoor air and return air temperature and humidity.

Reference Enthalpy Control

The reference enthalpy system compares outdoor air temperature and humidity to the economizer enthalpy enable setpoint. If outdoor air temperature and humidity are below the economizer enthalpy

enable setpoint, the economizer will operate freely. This system provides more sophisticated control where outdoor air humidity levels may not be acceptable for building comfort and indoor air quality.

Differential Dry Bulb Temperature Control

The differential dry bulb system measures the temperature of both return air and outside air to determine when to economize. If outdoor air temperature is below the return air temperature minus a differential, the economizer will operate freely. This system is best suited for arid regions where the humidity levels of outside air would not be detrimental to building comfort and indoor air quality.

Zone Sensors

Zone Temperature Only

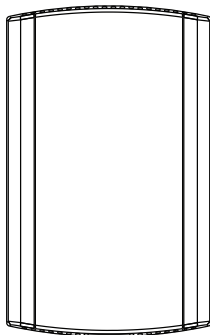

BAYSENS077

Provides temperature input only. Can be used as a secondary remote temperature input for thermostats.

Manual Changeover

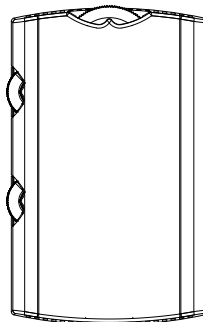

BAYSENS106

Heat, Cool or Off System Switch. Fan Auto or Off Switch. Single temperature setpoint thumbwheel.

Manual/Automatic Changeover

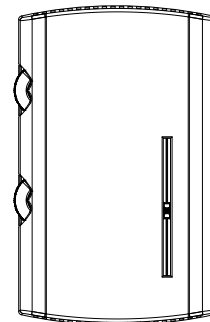

BAYSENS108

Auto, Heat, Cool or Off System Switch. Fan Auto or Off Switch. Dual temperature setpoint sliders

Integrated Comfort™ System

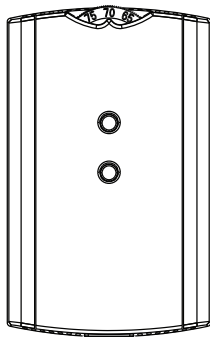

BAYSENS073 / BAYSENS074 / BAYSENS075

Sensor(s) available with optional temperature adjustment and override buttons to provide central control through a Trane Integrated Comfort system.

Wired Display Sensor

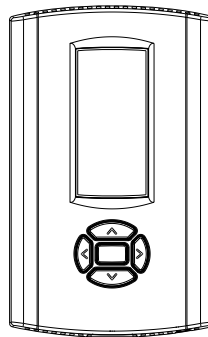

BAYSENS135

LCD display that provides heat, cool, auto, or off. Includes two temperature setpoints and a lockable setting with °F or °C indicators.

Touchscreen Digital Display Communicating Sensor



BAYSENS800

Uses BACnet® MS/TP link to communicate zone temperature and setpoints. Auto, Heat, Cool or Off System Switch. Fan Auto or On Switch. 7-day programmable thermostat with night setback.

Note: Not compatible with VAV units. Requires BACnet communications.



Air-Fi Wireless Communicating Zone Sensors

Wireless Zone Temperature Only

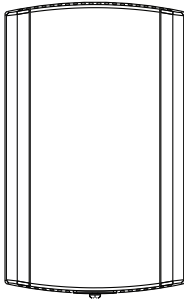

BAYSENS203

Measures temperature and optional humidity (with WCS-SH) for use in public spaces where no local user interface is preferred.

Note: Requires BACnet communications.

Wireless Display Sensor

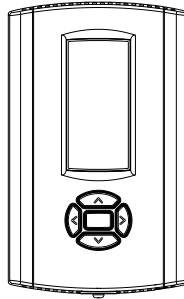

BAYSENS202

Easy-to-use interface for clear and simple monitoring and control. Can be configured for any Trane system or to meet the customer's preference.

Note: Requires BACnet communications.

Wired CO₂ Sensor

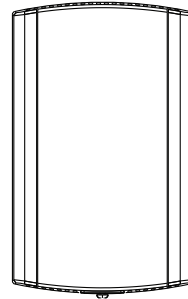

FIACO2K001 wall mount CO₂ Sensor
FIACO2K002 duct mount CO₂ Sensor

The maintenance-free carbon dioxide (CO₂) sensor is primarily used for demand control ventilation applications.

Wired Zone Temperature and Humidity Sensor

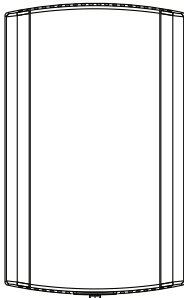

BAYSENS036

Measures temperature and relative humidity. Relative humidity input is used to control activation of dehumidification.

Thermostats

Digital Display Programmable Thermostat (3H/2C)

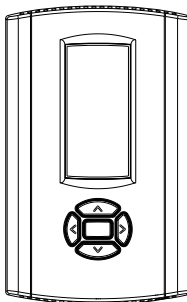

BAYSTAT150

Three Heat/Two Cool Auto changeover digital display thermostat. 7-day programmable thermostat with night setback.

Note: Not compatible with VAV units.

Digital Display Programmable Thermostat (1H/1C)

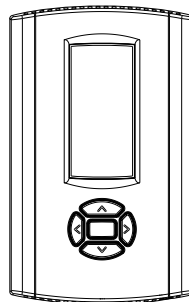

BAYSTAT151

One Heat/One Cool Auto changeover digital display thermostat.

Note: Not compatible with VAV units.

Digital Display Thermostat (3H/2C)

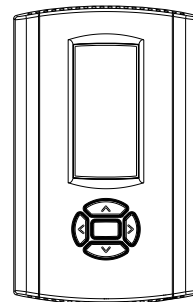

BAYSTAT155

Three Heat/Two Cool Auto changeover display thermostat.

Note: Not compatible with VAV units.

Pivot® Web Enabled Smart Thermostat (3H/2C)

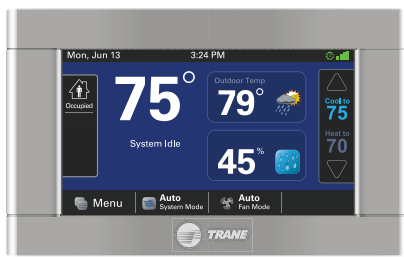

BAYSTAT814

Our Pivot Smart Thermostat system is great for commercial buildings. With its intuitive touchscreen and customizable display, it is easy for occupants to use. The Trane Pivot mobile app enables users to control multiple buildings remotely, making changes in seconds to all systems.

Note: Not compatible with VAV units.

Touchscreen Programmable Thermostat with Relative Humidity Sensor (3H/2C)



BAYSTAT152

Three Heat, Two Cool digital display thermostat with built-in humidity control. This thermostat combines both humidity and temperature into one.

Note: Not compatible with VAV units.

Humidity Control (HGRH)

Sequence of Operations

Humidity Control system capable of operating in normal cooling, dual mode to satisfy cooling and humidity requirements, and hot gas reheat mode when only humidity demand is required. Function between requirements and unit transition seamlessly providing an all-around comfort solution.

Note: Supports Humidistat control. When the Humidistat input becomes active, compressors will stage to full capacity and modulate the 3 way valve.

Initiation of Humidity Control

- Conforms to ASHRAE standard (62)
- Dehumidification is initiated when too much moisture is in the space (>60°F Dew point)
 - Two measurement options for this dehumidification status:
 - Humidity control is started when:
 - Dew point is too high (60°F is default),
 - Relative Humidity is too high (60% is default), DH is started
 - Choice between these values above is user-configurable, and the actual values are adjustable by customer if desired
- Reheat circuit is initiated when space temperature drops below setpoint during humidity control.

Humidity Control Routine

There are two independent control loops: One to control latent load, the other to control sensible load.

Latent load is controlled by compressor staging:

- Compressors initially move up one stage from the last cooling mode stage.
- Compressors are staged up as needed by the controller to achieve a target leaving ID air dew point based on space conditions.

Sensible load is controlled with the Modulating 3 way valve:

- Modulating valve opens when space temperature is below setpoint.
- The reheat valve adjusts the amount of flow to RH coil to achieve the targeted leaving ID air temperature, based on space conditions.



Purge Cycle

During dehumidification, every 120 minutes (default) a 3 minute cooling “purge cycle” will be executed. This purge cycle is executed for system reliability, specifically it helps manage oil return to compressors.

- Modulating valve moves to a fixed position based on OD air and compressor stage.
- Compressors move to full load.

Leaving Humidity Control and Returning to Cooling Only

- When space humidity drops to below the threshold humidity value (60°F dew point or 60% relative humidity), system reverts back to cooling mode. Dead band of ~5°F yields approximately 55°F dew point for switch to cooling.
- Unit can stay in humidity control mode indefinitely, with purge cycles happening regularly.
 - Relative humidity setpoint is 65% for unoccupied mode.
 - Dew point for unoccupied mode is the same as occupied (default 60°F DP).

Indoor Fan

Indoor fan minimum percent follows compressor staging. See Symbio™ 700 Controller with Precedent™ Packaged Rooftop Air Conditioners Application Guide (ACC-APG002*-EN).



Electrical Data

Table 47. Unit wiring, high efficiency

Tons	Unit Model Number	Voltage Range	Standard Indoor Fan Motor		Oversized/High Static Indoor Fan Motor		Optional Power Exhaust Standard Indoor Fan Motor		Optional Power Exhaust Oversized/High Static Indoor Fan Motor	
			MCA	Max Fuse Size or Max Circuit Breaker	MCA	Max Fuse Size or Max Circuit Breaker	MCA	Max Fuse Size or Max Circuit Breaker	MCA	Max Fuse Size or Max Circuit Breaker
12.5	W/DHJ150A3	187-253	72	90	-	-	78	100	-	-
	W/DHJ150A4	414-506	37	50	-	-	40	50	-	-
	W/DHJ150AW	517-633	29	40	-	-	32	40	-	-
15	W/DHJ180A3	187-253	78	100	-	-	83	110	-	-
	W/DHJ180A4	414-506	41	50	-	-	45	60	-	-
	W/DHJ180AW	517-633	32	40	-	-	34	45	-	-
20	WHJ240A3 DHJ240A3S(0,A)	187-253	108	150	-	-	113	150	-	-
	WHJ240A4 DHJ240A4S(0,A)	414-506	54	70	-	-	57	70	-	-
	WHJ240AW DHJ240AWS(0,A)	517-633	47	60	-	-	49	70	-	-
	DHJ240A3SB	187-253	108	150	112	150	113	150	118	150
	DHJ240A4SB	414-506	54	70	55	70	57	70	59	70
	DHJ240AWSB	517-633	47	60	48	60	49	70	51	70
25	W/DHJ300A3	187-253	119	150	124	150	125	150	129	175
	W/DHJ300A4	414-506	59	80	61	80	62	80	64	80
	W/DHJ300AW	517-633	46	60	48	60	48	60	50	60

Table 48. Unit wiring with electric heat, high efficiency

Tons	Unit Model Number	Heater Model Number	Heater kW Rating	Control Stages	Standard Indoor Fan Motor ^(a)		Oversized/High Static Indoor Fan Motor		Optional Power Exhaust Standard Indoor Fan Motor		Optional Power Exhaust Oversized/High Static Indoor Fan Motor	
					MCA	Max Fuse Size or Max Circuit Breaker	MCA	Max Fuse Size or Max Circuit Breaker	MCA	Max Fuse Size or Max Circuit Breaker	MCA	Max Fuse Size or Max Circuit Breaker
208/230 Volts Three Phase												
12.5	WHJ150A3	FIAEHWD318AA	13.5/18.0	1	119/126	125/150	-	-	125/132	125/150	-	-
		FIAEHWD336AA	27.0/36.0	2	166/180	175/200	-	-	172/186	175/200	-	-
		FIAEHWD354AA	40.6/54.0	2	213/202	225/225	-	-	219/208	225/225	-	-
15	WHJ180A3	FIAEHWD318AA	13.5/18.0	1	124/132	125/150	-	-	130/137	150/150	-	-
		FIAEHWD336AA	27.0/36.0	2	171/186	175/200	-	-	177/191	200/200	-	-
		FIAEHWD354AA	40.6/54.0	2	218/207	225/225	-	-	224/213	225/225	-	-



Electrical Data

Table 48. Unit wiring with electric heat, high efficiency (continued)

Tons	Unit Model Number	Heater Model Number	Heater kW Rating	Control Stages	Standard Indoor Fan Motor ^(a)		Oversized/High Static Indoor Fan Motor		Optional Power Exhaust Standard Indoor Fan Motor		Optional Power Exhaust Oversized/High Static Indoor Fan Motor	
					MCA	Max Fuse Size or Max Circuit Breaker	MCA	Max Fuse Size or Max Circuit Breaker	MCA	Max Fuse Size or Max Circuit Breaker	MCA	Max Fuse Size or Max Circuit Breaker
20	WHJ240A3	FIAEHWD336AA	27.0/36.0	2	201/216	225/225	-	-	207/222	225/225	-	-
		FIAEHWD354AA	40.6/54.0	2	248/238	300/300	-	-	254/243	300/250	-	-
		FIAEHWD372AA	54.0/72.0	2	258/281	300/300	-	-	263/287	300/300	-	-
25	WHJ300A3	FIAEHWD336AA	27.0/36.0	2	213/227	225/250	214/232	225/250	219/233	225/250	223/238	250/250
		FIAEHWD354AA	40.6/54.0	2	260/249	300/300	264/254	300/300	266/255	300/300	270/259	300/300
		FIAEHWD372AA	54.0/72.0	2	269/292	300/300	274/297	300/300	275/298	300/300	279/303	300/350
460 Volts Three Phase												
12.5	WHJ150A4	FIAEHWD418AA	18	1	64	70	-	-	67	70	-	-
		FIAEHWD436AA	36	2	91	100	-	-	94	100	-	-
		FIAEHWD454AA	54	2	102	110	-	-	105	110	-	-
15	WHJ180A4	FIAEHWD418AA	18	1	68	70	-	-	72	80	-	-
		FIAEHWD436AA	36	2	96	100	-	-	99	100	-	-
		FIAEHWD454AA	54	2	106	110	-	-	110	125	-	-
20	WHJ240A4	FIAEHWD436AA	36	2	108	110	-	-	111	125	-	-
		FIAEHWD454AA	54	2	119	150	-	-	122	125	-	-
		FIAEHWD472AA	72	2	140	150	-	-	143	150	-	-
25	WHJ300A4	FIAEHWD436AA	36	2	113	125	115	125	116	125	118	125
		FIAEHWD454AA	54	2	124	150	126	150	127	150	129	150
		FIAEHWD472AA	72	2	146	150	147	150	149	150	151	175
575 Volts Three Phase												
12.5	WHJ150AW	FIAEHWDW18AA	18	1	51	60	-	-	53	60	-	-
		FIAEHWDW36AA	36	2	73	80	-	-	75	80	-	-
		FIAEHWDW54AA	54	2	81	90	-	-	84	90	-	-
15	WHJ180AW	FIAEHWDW18AA	18	1	53	60	-	-	56	60	-	-
		FIAEHWDW36AA	36	2	75	80	-	-	77	80	-	-
		FIAEHWDW54AA	54	2	84	90	-	-	86	90	-	-
20	WHJ240AW	FIAEHWDW36AA	36	2	90	100	-	-	93	100	-	-
		FIAEHWDW54AA	54	2	99	125	-	-	101	110	-	-
		FIAEHWDW72AA	72	2	116	125	-	-	119	125	-	-
25	WHJ300AW	FIAEHWDW36AA	36	2	89	100	91	100	92	100	93	100
		FIAEHWDW54AA	54	2	98	125	100	110	100	110	102	110
		FIAEHWDW72AA	72	2	115	125	117	125	118	125	119	125

^(a) The standard motor is a multispeed, direct drive motor.

Table 49. Electrical characteristics - compressor motor and condenser motor

Tons	Unit Model Number	No.	Compressor Motors						No.	Condenser Fan Motor				
			Volts	Phase	hp ^(a)	rpm	Amps ^(b)			Volts	Phase	hp	Amps	
							RLA	LRA					FLA	LRA
12.5	W/DHJ150A3	2	208/230	3	7.6/3.5	3500/3500	28.4/14.1	191.0/83.1	2	208/230	3	0.5	2.2	7.3
	W/DHJ150A4	2	460	3	7.6/3.5	3500/3500	14.6/6.5	100/41	2	460	3	0.5	1.3	4.2
	W/DHJ150AW	2	575	3	7.6/3.5	3500/3500	11.9/5.4	78/33	2	575	3	0.5	1.1	3.6
15	W/DHJ180A3	2	208/230	3	8.7/4.3	3500/3500	30.9/16.4	240/110	2	208/230	3	0.5	2.2	7.3
	W/DHJ180A4	2	460	3	8.7/4.3	3500/3500	16.7/8.2	130/52	2	460	3	0.5	1.3	4.2
	W/DHJ180AW	2	575	3	8.7/4.3	3500/3500	12.8/6.6	93.7/38.9	2	575	3	0.5	1.1	3.6
20	W/DHJ240A3	2	208/230	3	11.4/6.3	3500/3500	43.1/26.1	270/167	2	208/230	3	1	4.8	19.4
	W/DHJ240A4	2	460	3	11.4/6.3	3500/3500	21.3/12.2	147/84	2	460	3	1	2.5	10.1
	W/DHJ240AW	2	575	3	11.4/6.3	3500/3500	21.3/9.6	109/60	2	575	3	1	1.9	8.0
25	W/DHJ300A3	2	208/230	3	12.8/7.6	3500/3500	49.5/29.6	335.5/223.0	2	208/230	3	1	4.8	19.4
	W/DHJ300A4	2	460	3	12.8/7.6	3500/3500	23.9/14.4	141/100	2	460	3	1	2.5	10.1
	W/DHJ300AW	2	575	3	12.8/7.6	3500/3500	19.8/10.8	109/70	2	575	3	1	1.9	8.0

^(a) Hp for each compressor.

^(b) Amp draw for each motor (compressor and condenser fan motor); multiply value by number of motors to determine total amps.

Table 50. Electrical characteristics - indoor fan motor

Tons	Unit Model Number	No.	Volts	Phase	hp	Amps ^(a)	
						FLA	LRA
12.5	W/DHJ150A3	2	208/230	3	3	8.8	-
	W/DHJ150A4	2	460	3	3	4.6	-
	W/DHJ150AW	2	575	3	3	3.2	-
15	W/DHJ180A3	2	208/230	3	3	8.8	-
	W/DHJ180A4	2	460	3	3	4.6	-
	W/DHJ180AW	2	575	3	3	3.2	-
20	W/DHJ240A3	2	208/230	3	3	8.8	-
	W/DHJ240A4	2	460	3	3	4.6	-
	W/DHJ240AW	2	575	3	3	3.2	-
25	W/DHJ300A3	2	208/230	3	3	8.8	-
	W/DHJ300A4	2	460	3	3	4.6	-
	W/DHJ300AW	2	575	3	3	3.2	-

^(a) Amp draw for each motor (compressor and condenser fan motor); multiply value by number of motors to determine total amps.

Table 51. Electrical characteristics - oversized indoor fan motor

Tons	Unit Model Number	No.	Volts	Phase	hp	Amps ^(a)	
						FLA	LRA
20	DHJ240A3SB	2	208/230	3	5	11.0	-
	DHJ240A4SB	2	460	3	5	5.5	-
	DHJ240AWSB	2	575	3	5	3.9	-
25	W/DHJ300A3	2	208/230	3	5	11.0	-
	W/DHJ300A4	2	460	3	5	5.5	-
	W/DHJ300AW	2	575	3	5	3.9	-

^(a) Amp draw for each motor (compressor and condenser fan motor); multiply value by number of motors to determine total amps.



Electrical Data

Table 52. Electrical characteristics - power exhaust

Tons	Volts	Phase	hp	rpm	FLA	LRA
12.5-25	208-230	1	0.87	1075	5.7	13.6
12.5-25	460	1	0.87	1075	3.3	7.2
12.5-25	575	1	0.80	1075	2.3	5.8

Table 53. Electrical characteristics - inducer motor

Unit Model Number	Stages	hp	rpm	Volts	Phase	FLA	LRA
DHJ150A**(0,A)(L,M,H)	2	1/15	3300/2800	208-230	1	0.36/0.30	0.73
DHJ(180-300)A**(0,A)(L,M)	2	1/15	3300/2800	208-230	1	0.36/0.30	0.73
DHJ(180-300)A**(0,A)H	2	1/6	3300/2300	208-230	1	0.95/0.49	1.53
DHJ(150,180,210,240,300)A**B	Variable	1/15	3300	115	1	3.40	7.30

Dimensional Data

Figure 6. 12.5 to 15 tons high efficiency

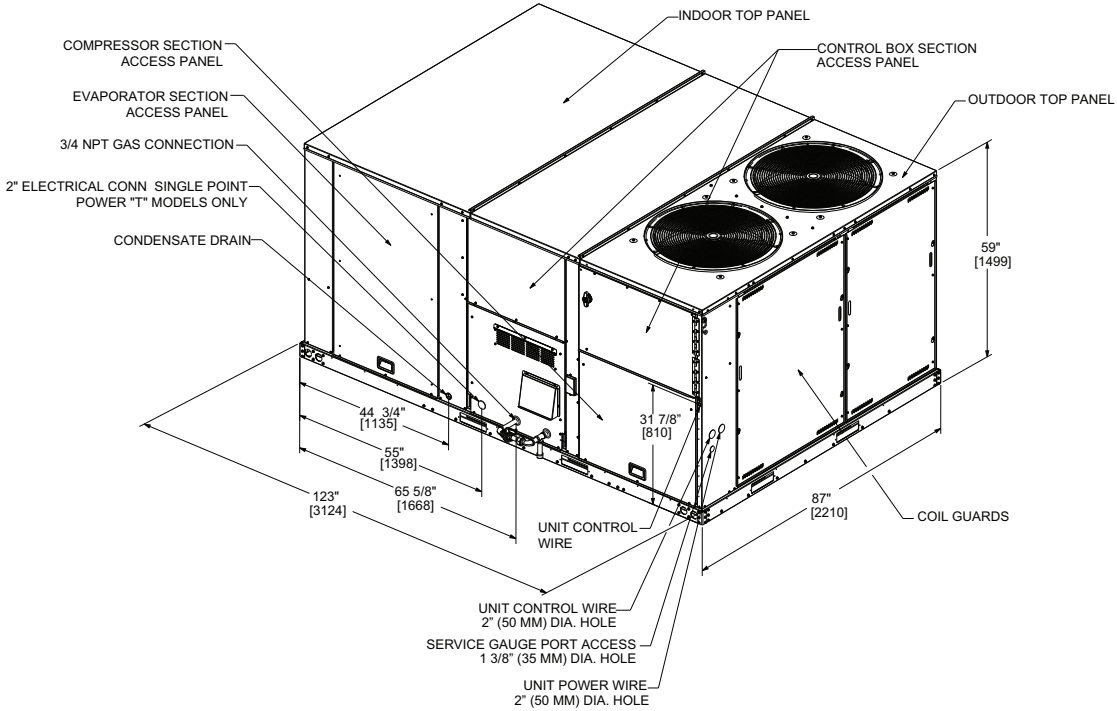
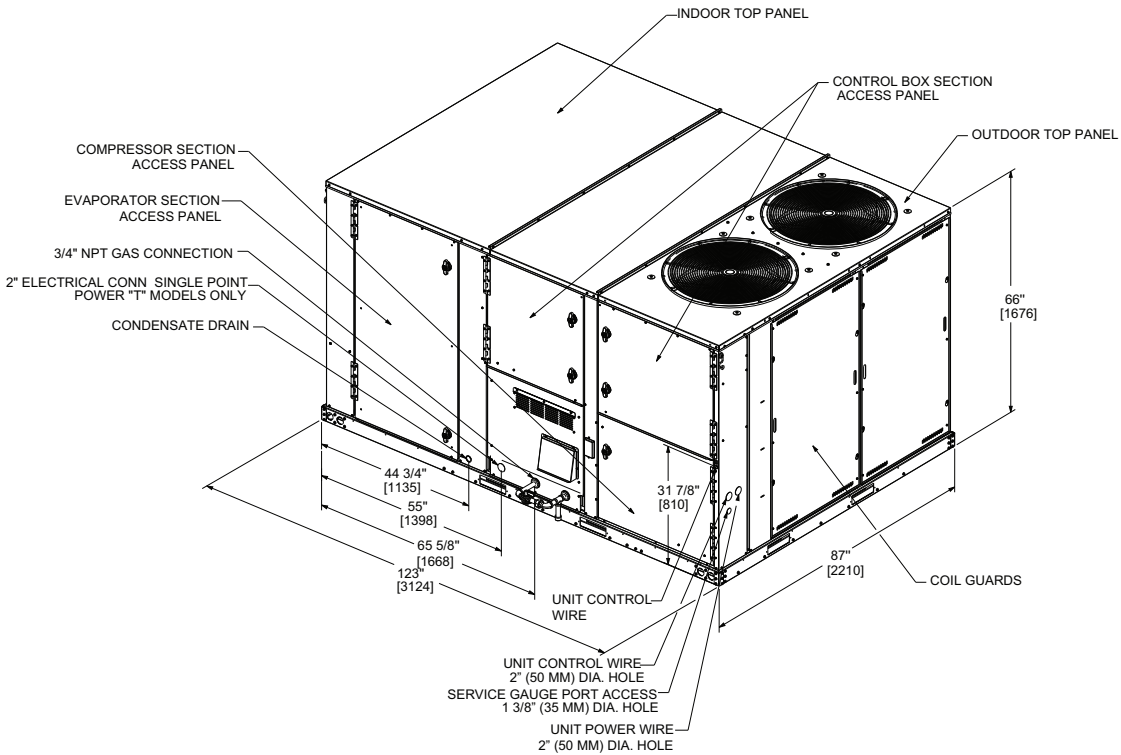

Figure 7. 20 to 25 tons high efficiency





Dimensional Data

Figure 8. 12.5 to 25 tons high efficiency – downflow airflow supply/return, through-the-base utilities

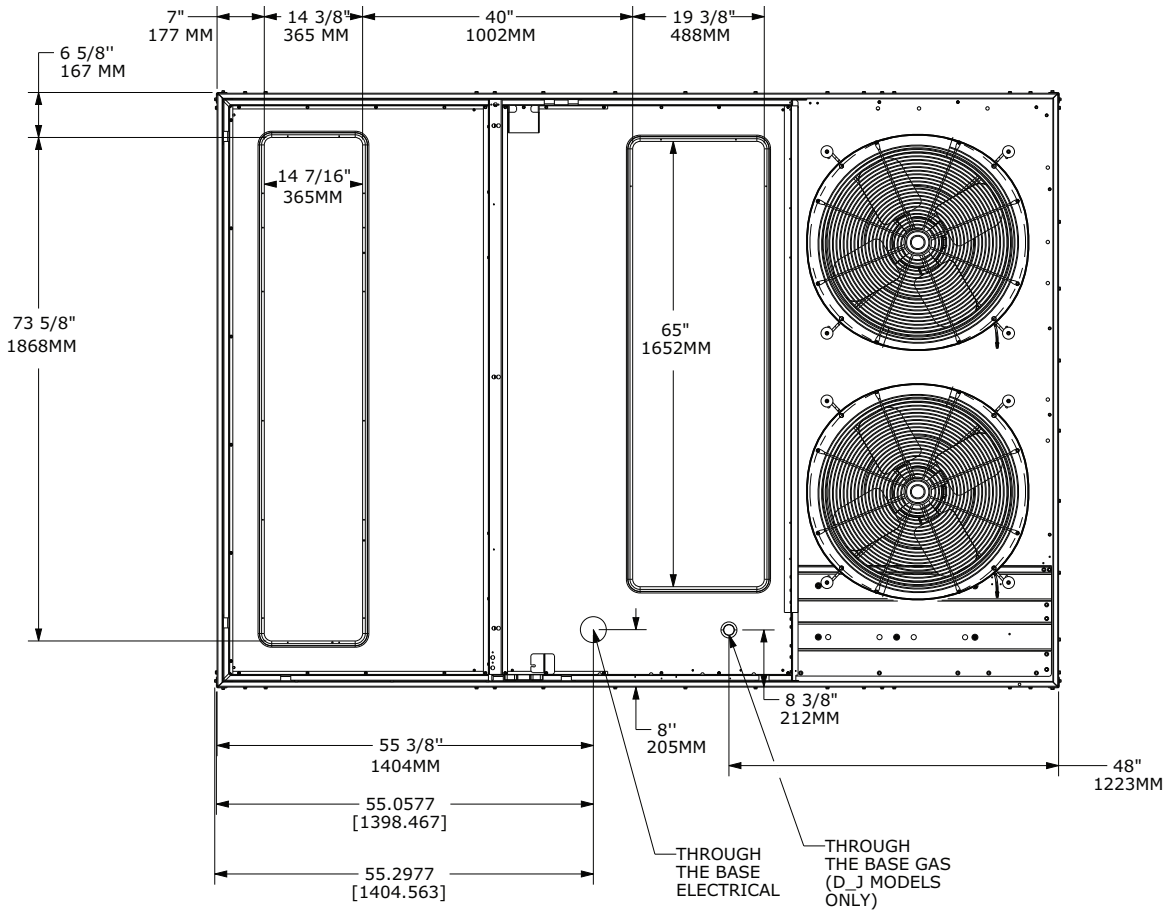

Figure 9. 12.5 to 25 tons high efficiency – horizontal airflow supply/return

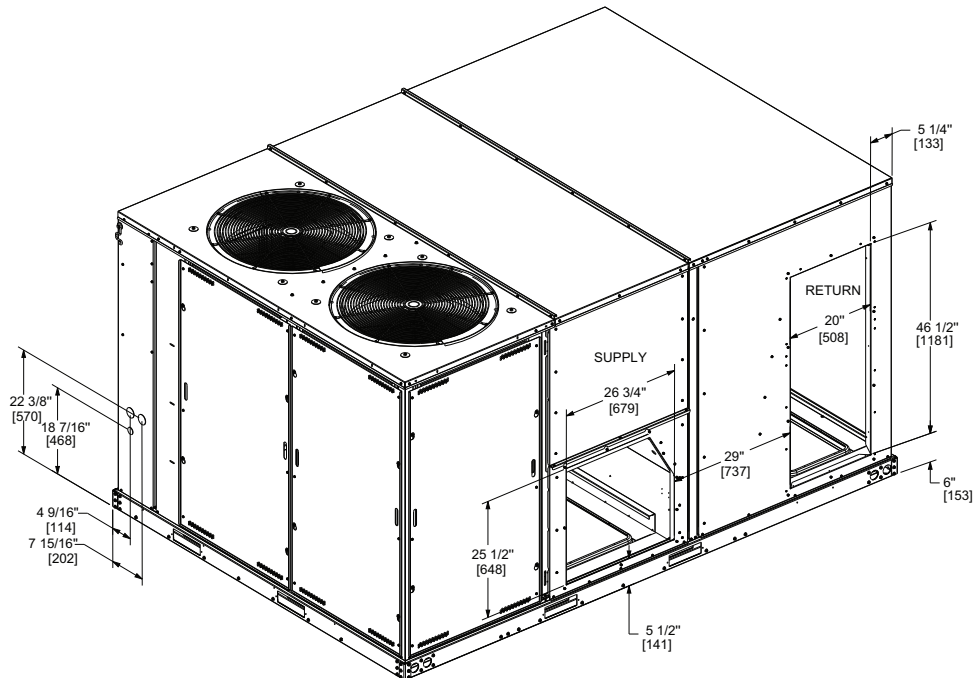

Figure 10. 12.5 to 25 tons high efficiency – power exhaust

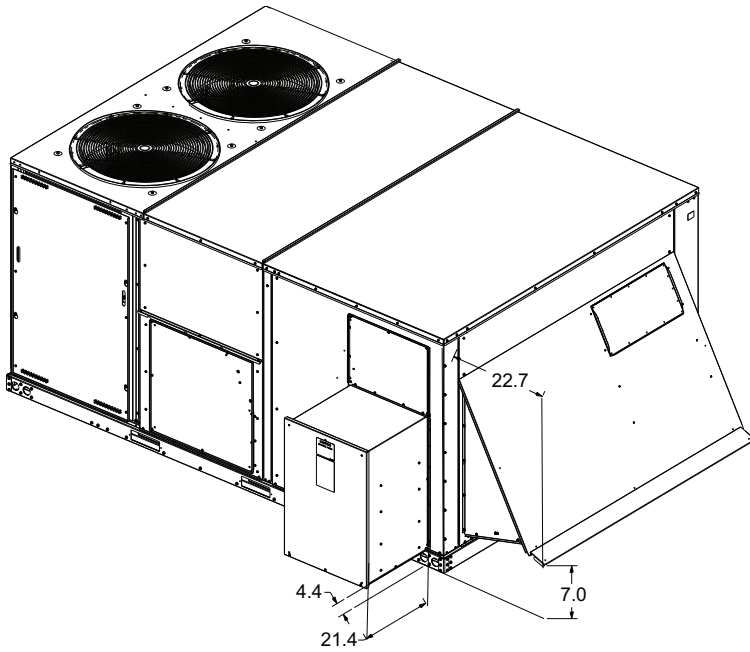

Figure 11. 12.5 to 25 tons high efficiency – unit clearance and roof opening

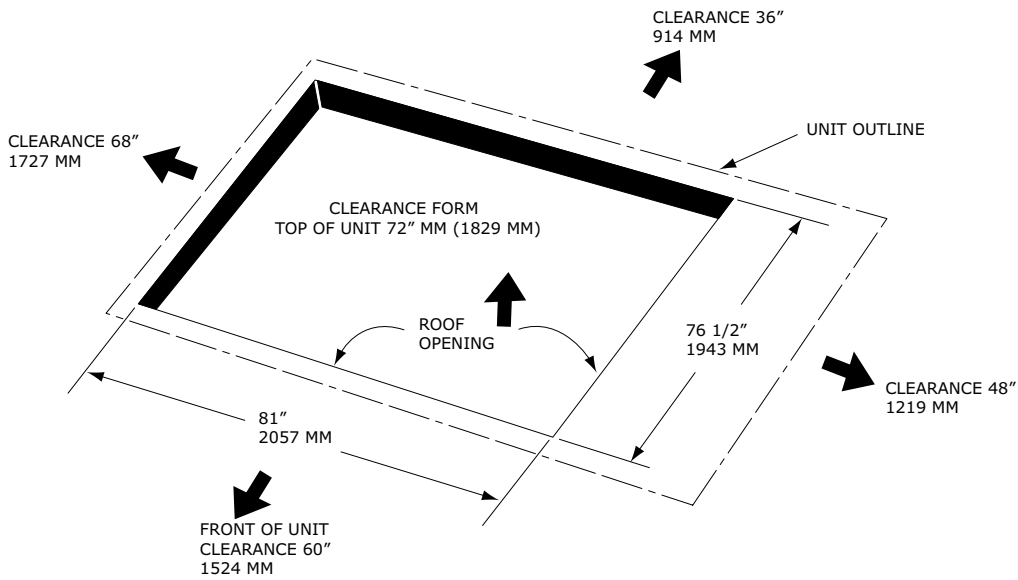

Figure 12. 12.5 to 25 tons high efficiency – roof curb

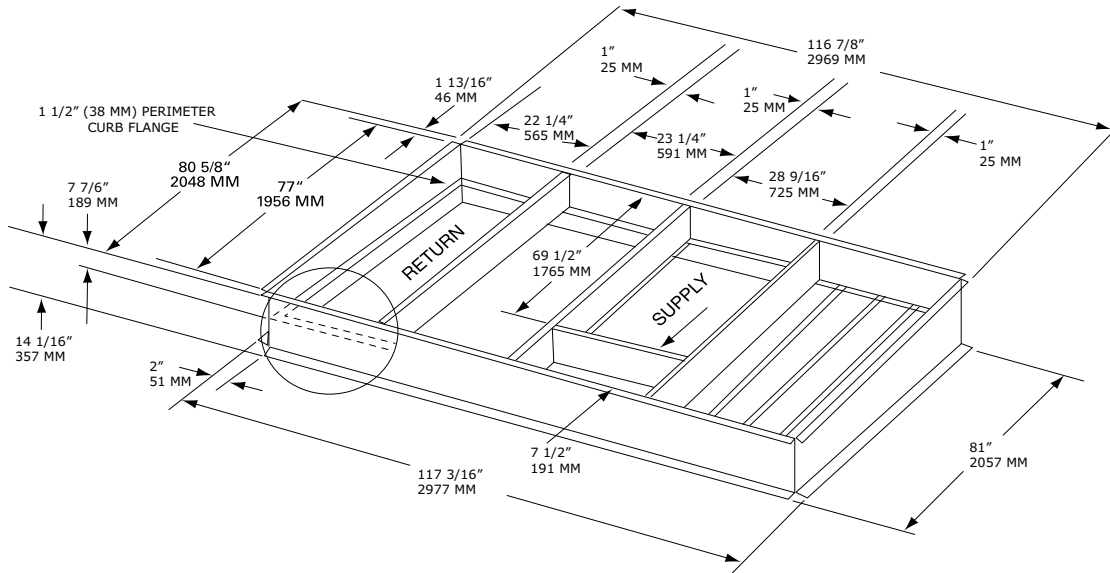
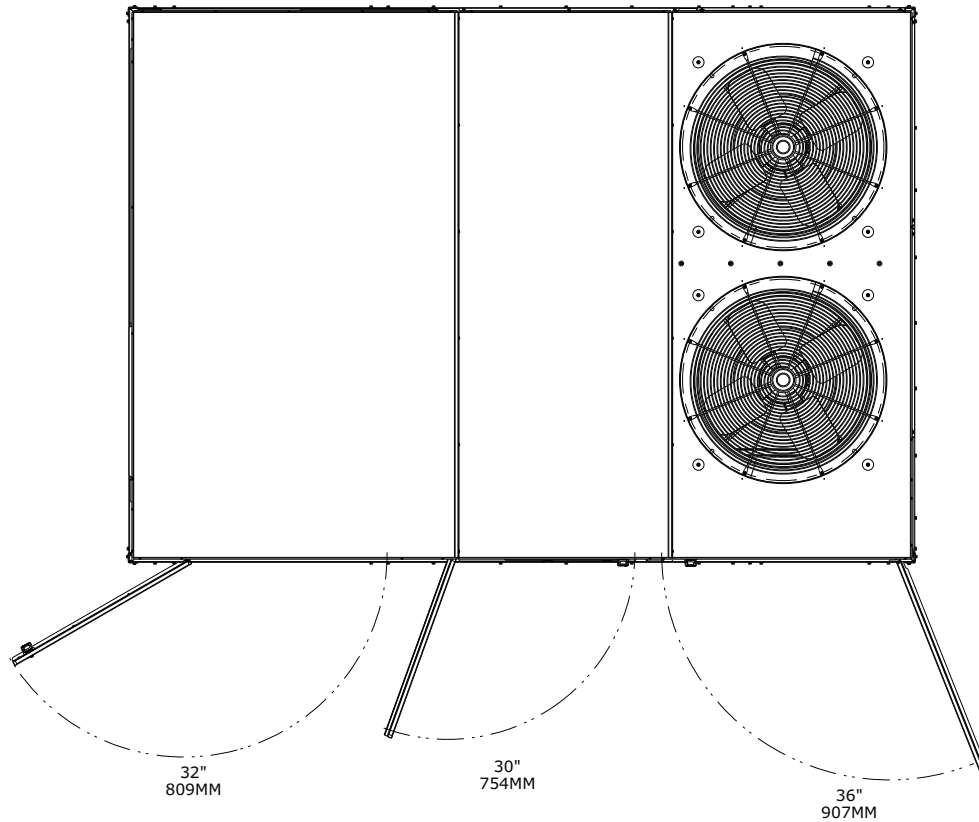

Figure 13. 12.5 to 25 ton high efficiency – swing diameter for hinged door(s) option



Weights

Table 54. Model weights, corner weights (lbs) and center of gravity dimensions (in.)

Tons	Unit Model No.	Model Weights ^(a)		Corner Weights ^(b)				Center of Gravity (in.)	
		Shipping	Net	A	B	C	D	Length	Width
12.5	WHJ150	2225	2005	688	487	344	486	51	36
15	WHJ180	2246	2026	695	492	348	491	51	36
20	WHJ240	2403	2183	680	550	426	527	55	38
25	WHJ300	2405	2185	680	550	427	528	55	38
12.5	DHJ150	2407	2187	750	532	375	530	51	36
15	DHJ180	2427	2207	757	536	379	535	51	36
20	DHJ240	2697	2477	771	624	484	598	55	38
25	DHJ300	2700	2480	772	625	484	599	55	38

^(a) Weights are approximate. Weights do not include additional factory or field installed options/accessories. For option/accessory additional weights to be added to unit weight, reference the following table.

^(b) Corner weights are given for information only.

Figure 14. Corner weights

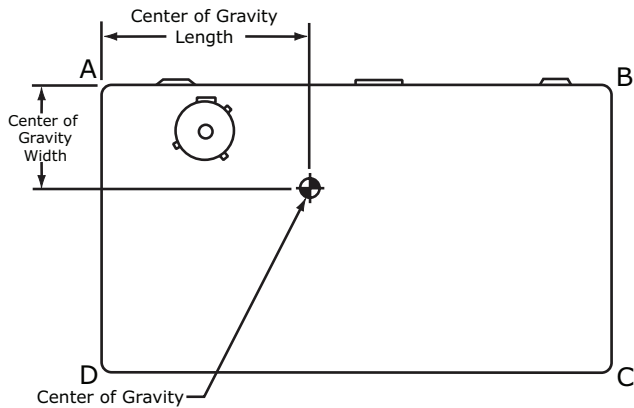

Table 55. Factory installed options (FIOPS)/accessory net weights (lb)

Accessory	W/D*J150-180	W/D*J240-300
	12.5, 15 Tons	20, 25 Tons
Barometric Relief	40	40
Economizer	91	91
Electric Heaters ^(a)	75	75
Hinged Doors	20	30
Low Leak Economizer - Downflow	150	150
Low Leak Economizer - Horizontal	180	180
Manual Outside Air Damper	15	15
Motorized Outside Air Damper	82	82
Oversized Motor	–	30
Powered Convenience Outlet	50	50
Powered Exhaust	110	110
Reheat Coil	100	100
Roof Curb	235	235
Smoke Detector, Supply	5	5



Weights

Table 55. Factory installed options (FIOPS)/accessory net weights (lb) (continued)

Accessory	W/D*J150-180	W/D*J240-300
	12.5, 15 Tons	20, 25 Tons
Smoke Detector, Return	5	5
Stainless Steel Heat Exchanger ^(b)	5	5
Through-the-Base Electrical	10	10
Through-the-Base Gas ^(b)	10	10
Unit Mounted Circuit Breaker	10	10
Unit Mounted Disconnect	10	10

Notes:

1. Weights for options not listed are less than 5 pounds.
2. Net weight should be added to unit weight when ordering factory-installed accessories.
3. Weights are approximate.

^(a) Only applies to W*J models.

^(b) Only applies to D*J models.



Mechanical Specifications

General

- Packaged rooftop units cooling, heating capacities, and efficiencies are AHRI Certified within scope of AHRI Standard 340-360 for 12.5 to 20 tons. The 25 ton units are tested in accordance with the standard.
- Convertible airflow.
- Symbio controls operating range between 40°F and 125°F in cooling mode standard from the factory. Field-installed low ambient kit extended operating range down to 0°F.
- Factory assembled, internally wired, fully charged with R-410A, and 100 percent run tested to check cooling and heat pump operation, fan and blower rotation, and control sequence before leaving the factory.
- Colored and numbered wiring internal to the unit for simplified identification.
- Units cULus listed and labeled, classified in accordance for Central Cooling Air Conditioners.

Casing

- Zinc coated, heavy gauge, galvanized steel.
- Weather resistant pre-painted metal with galvanized substrate.
- Meets ASTM B117, 672 hour salt spray test.
- Removable single side maintenance access panels.
- Lifting handles in maintenance access panels (can be removed and reinstalled by removing fasteners while providing a water and air tight seal).
- Exposed vertical panels and top covers in the indoor air section insulated with a cleanable foil-faced, fire-retardant permanent, odorless glass fiber material.
- Base pan shall have no penetrations within the perimeter of the curb other than the raised 1 inch high downflow supply/return openings to provide an added water integrity precaution, if the condensate drain backs up.
- Base of the unit insulated with 1/8 inch, foil-faced, closed-cell insulation.
- Unit base provisions for forklift and/or crane lifting on three sides of unit.

Coils

Evaporator and Condenser

- Internally finned, 5/16-inch copper tubes mechanically bonded to a configured aluminum plate fin are standard.
- Coils are leak tested at the factory to ensure integrity.
- Evaporator coil and condenser coil are leak tested to 600 psig.
- Assembled unit is leak tested to 465 psig.
- Condenser coil is patent pending 1+1+1 hybrid coil, designed with slight gaps for cleaning ease.
- Composite, dual-sloped, removable condensate drain pan is standard.

Coil Guards

Provides condenser coil protection.

Compressors

- All units have direct-drive, hermetic, scroll type compressors with centrifugal type oil pumps.
- Suction gas-cooled motor with voltage utilization range of plus or minus 10 percent of unit nameplate voltage.
- Internal overloads standard with scroll compressors.
- Crankcase heaters are standard on all compressors.
- All units have dual compressors.
- Three stages of cooling available on 12.5 to 17.5 tons units and four stages of cooling available on 20 and 25 tons units.



Mechanical Specifications

Filters

- Standard throwaway filters
- Optional 2 inch MERV 8 and MERV 13 filters

Frostat™

- Utilized as a safety device.
- Opens to prevent freezing temperatures on evaporator coil.
- Temperature will need to rise to 50°F before closing.
- Utilized in low airflow or high outside air applications (cooling only).

Gas Heating Section

- The heating section shall have a progressive tubular heat exchanger with corrosion-resistant aluminized steel tubes and burners as standard on all models.
- Stainless steel heat exchanger with 409 stainless steel tubes and 439 stainless steel burners shall be optional.
- Induced draft combustion blower shall be used to pull the combustion products through the firing tubes.
- Heater shall use a direct spark ignition (DSI) system.
- On initial call for heat, the combustion blower shall purge the heat exchanger for 20 seconds before ignition.
- After three unsuccessful ignition attempts, entire heating system shall be locked out until manually reset at the thermostat/zone sensor.
- Units shall be suitable for use with natural gas or propane (field-installed kit).

Tubular Gas Heat Exchanger

- Compact cabinet features a tubular heat exchanger in low, medium and high heat capacities.
- Corrosion-resistant aluminized steel tubes and burners are standard on all models.
- Induced draft blower to pull the gas mixture through the burner tubes.
- Direct spark ignition and a flame sensor as a safety device to validate the flame.

Indoor Fan

- Direct drive plenum fan design – 12.5 to 25 tons units.
- Plenum fan design — backward-curved fan wheel along with an external rotor direct drive variable speed indoor motor.
- Supply fan speed adjustments can be made using the Symbio 700 or Mobile App.
- Motors are electronically protected.
- Variable speed direct drive motors are high efficiency – 12.5 to 25 tons.

Powered or Unpowered Convenience Outlet

- Powered GFCI, 120V/15A, 2 plug, convenience outlet or unpowered GFCI, 120V/20A, 2 plug, convenience outlet.
- When convenience outlet is powered, a service receptacle disconnect will be available.
- Convenience outlet is powered from the line side of the disconnect or circuit breaker, and therefore will not be affected by the position of the disconnect or circuit breaker.
- Available to order when through-the-base electrical with disconnect switch or circuit breaker option is ordered.

Stainless Steel Drain Pan

- Corrosion and oxidation resistance.
- Constructed of 304 stainless steel.

Stainless Steel Heat Exchanger

- Constructed of 409 stainless steel tubes and 439 stainless steel burners.
- Resistant to corrosion and oxidation and easy to clean.
- High strength to weight ratio allows for high ventilation rates with gas units.
- Compliment dehumidification option as a high outside air ventilation unit.
- 15 years stainless steel heat exchanger warranty is standard.

Through-the-Base Electrical with Circuit Breaker

- Thermal magnetic, molded case, HACR circuit breaker with provisions for through-the-base electrical connections.
- Circuit breaker installed within unit in water tight enclosure.
- Wiring provided from the switch to the unit high voltage terminal block.
- Circuit breaker will provide overcurrent protection, sized per NEC and cULus guidelines, and agency recognized by cULus.

Through-the-Base Electrical with Disconnect Switch

- 3-pole, molded case, disconnect switch with provisions for through-the-base electrical connections.
- Disconnect switch installed within unit in a water tight enclosure.
- Wiring provided from the switch to the unit high voltage terminal block.
- Switch cULus agency recognized.

Note: Disconnect switch sized per NEC and cULus guidelines but will not be used in place of unit overcurrent protection

Economizer (Standard)

- Available with or without barometric relief.
- Fully modulating 0-100 percent motor and dampers, minimum position setting, preset linkage, wiring harness with plug, spring return actuator and fixed dry bulb control.
- Barometric relief shall provide a pressure operated damper that shall be gravity closing.
- Barometric relief shall prohibit entrance of outside air during the equipment “off” cycle.
- Optional solid state or differential enthalpy control.
- Arrives in shipping position and shall be moved to the operating position by the installing contractor.

Manual Outside Air Damper

Rain hood and screen shall provide up to 50 percent outside air.

Motorized Outside Air Damper

- Once set, when indoor fan starts, outdoor air dampers shall open to set position.
- When indoor fan shuts down, damper shall close to the full closed position.

Powered Exhaust

- Available for 12.5 to 25 ton units.
- Shall provide exhaust of return air, when using an economizer.
- Maintain better building pressurization.

Roof Curb

- Designed to mate with the unit’s downflow supply and return.
- Provide support and a water tight installation when installed properly.



Mechanical Specifications

- Shall allow field-fabricated rectangular supply/return ductwork to be connected directly to the curb.
- Curb shall be shipped knocked down for field assembly.
- Shall include wood nailer strips.

Ventilation Override Operation

- Unit can be set to transition up to 3 different pre-programmed sequences for smoke purge, pressurization, and exhaust.
- Transition occurs when binary input on the Symbio is closed (shorted) (typically hard wired relay output from a smoke detector/ fire control panel).

Note: Requires Symbio™ Customer Connection Module, FIASCCM001*.



Notes



The AHRI Certified mark indicates Trane U.S. Inc. participation in the AHRI Certification program. For verification of individual certified products, go to ahridirectory.org.

Trane - by Trane Technologies (NYSE: TT), a global innovator - creates comfortable, energy efficient indoor environments for commercial and residential applications. For more information, please visit trane.com or tranetechnologies.com.

Trane has a policy of continuous product and product data improvements and reserves the right to change design and specifications without notice. We are committed to using environmentally conscious print practices.