

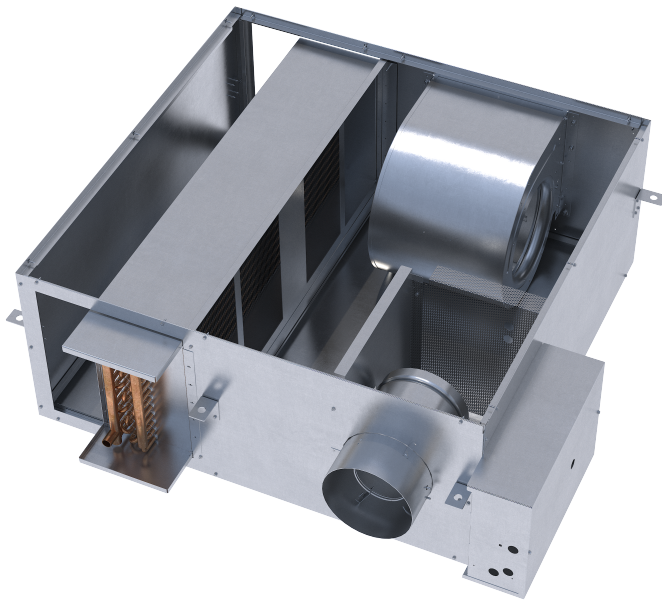

Product Catalog

CoolSense™ Chilled Water Sensible Cooling Terminal Units

Dedicated Outdoor Air System (DOAS)





Introduction

The CoolSense™ Chilled Water Sensible Cooling Terminal Units discussed in the catalog are an integral part of a system that includes a Dedicated Outdoor Air Unit, Water Chiller(s) and Controls. These CoolSense Chilled Water Sensible Cooling Terminal Units are equipped with an air valve for controlling the ventilation air provided from the Dedicated Outdoor Air Unit, a chilled water coil intended to provide sensible cooling of the recirculated air drawn in from the ceiling plenum or space through the coil, a fan to deliver the mixture of ventilation air and cooled recirculated air to the space and optionally a hot water coil or electric heater to heat the air discharged from the unit if needed. Additionally, these CoolSense Chilled Water Sensible Cooling Terminal Units can be equipped from the factory with unit mounted controls.

Copyright

This document and the information in it are the property of Trane, and may not be used or reproduced in whole or in part without written permission. Trane reserves the right to revise this publication at any time, and to make changes to its content without obligation to notify any person of such revision or change.

Trademarks

All trademarks referenced in this document are the trademarks of their respective owners.

Revision History

- Removed UC400 BACnet®, Controller graphic from the Features and Benefits chapter.
- Added Hydronic Branch Conductor section in the Application Considerations chapter.
- Updated Model Number Description chapter.
- Updated tables in the Performance Data chapter.
- Added small, medium, and large performance data fan curves for 4 row and 6 row in the Performance Data chapter.
- Removed Unit air valve and cooling coil air pressure drop tables from the Performance Data chapter.
- Updated Auxiliary Temperature Sensor graphic in the DDC Controls chapter.
- Added Standard height graphics in the Application Consideration chapter.
- Updated Fan electrical performance (ECM) table in the Electrical Data.
- Added VDEG — electric coil kW guidelines, minimum to maximum and Electric heat guidelines (CFM) — VDxG tables to the Electrical Data chapter.
- Added VDCG, VDWG and VDEG standard height dimensional data drawings in the General and Dimensional Data chapter.
- Updated the Insulation and Water Coil sections in the Mechanical Specifications chapter.



Table of Contents

Features and Benefits	5
Construction	6
Indoor Air Quality (IAQ) Features	7
Tracer Building Automation System	7
Indoor Air Quality Management During Construction	10
Trane Systems — Proven Performance	10
Agency Certifications	11
UL-Listed Products	11
AHRI Certified	11
American Society of Heating, Refrigerating and Air-conditioning Engineers (ASHRAE)	11
Air Conditioning and Refrigeration Institute (AHRI)	11
National Fire Protection Association (NFPA)	11
Application Considerations	12
Types of CoolSense™ Chilled Water Sensible Cooling Terminal Units	14
Typical Application of CoolSense™ Chilled Water Sensible Cooling Terminal Units	14
Hydronic Branch Conductor	15
Energy Savings and System Controls	16
Control Types	16
Flow Measurement and Control	17
Cooling/Heating Options	18
Insulation	20
Acoustics	20
Duct Design	22
Selection Procedure	23
Selection Example: LDWF Chilled Water Sensible Cooling Terminal Unit with Hot Water Heat	23
Model Number	26
CoolSense™ Chilled Water Sensible Cooling Terminal Units	26
Performance Data	28
Water Coil Notes	44
Acoustics Data	46



DDC Controls.....	62
Controllers.....	62
Symbio™ 500 Programmable BACnet Controllers.....	63
Trane DDC Controller Logic.....	65
Tracer® Programmable BACnet® Controller—Unit Control Module.....	66
Air-Fi Communications Interface (WCI).....	67
DDC Zone Sensors.....	67
CO ₂ Sensors.....	68
Auxiliary Temperature Sensor.....	68
Trane Control Valves.....	69
Belimo Control Valves.....	69
VAV Piping Package.....	70
Differential Pressure Transducer.....	70
Transformers.....	71
Trane Actuator – 90 Second at 60 Hz Drive Time.....	71
Belimo Actuator – 95 Second Drive Time.....	71
Analog Actuator.....	71
Electric Heater Silicon-Controlled Rectifier (SCR).....	71
Moisture Sensor.....	72
Electrical Data.....	73
Formulas.....	75
General and Dimensional Data.....	77
General Data.....	77
Dimensional Drawings.....	78
Mechanical Specifications.....	87
Chilled Water Sensible Cooling Terminal Unit.....	87



Features and Benefits

These CoolSense™ Chilled Water Sensible Cooling Terminal Units have been specifically designed to be an integral part of a Dedicated Outdoor Air System (DOAS). The unit has been designed with features to make the jobsite coordination and installation easier and with less risk. One of the many challenges on a job site is the coordination of the proper unit orientation for electrical connections and piping connections. An example of a feature to make installation easier, the units have a universal design so they can be flipped in field.

When using sensible cooling terminals like this, it is critically important that the entire building and associated DOAS be designed and operated properly to maintain indoor dew point below the temperature of chilled water supplied to the sensible cooling coils. These units are designed with two integrated features to protect the building and furnishings from unwanted condensation. First, these units are constructed with a drip pan located under the sensible chilled water coil to catch any condensate in the unlikely event that it is produced from the coil. Second, these units are equipped with a moisture sensor that will disable the cooling coil if moisture is detected in this drip pan.

The key to any system is proper control. Trane controller is a BACnet® certified device that can be programmed from the factory with the control sequence to properly operate these terminal units as part of a Dedicated Outdoor Air System. This controller can be mounted, wired, tested and programmed at the factory with the proper control sequence for operation in this system.

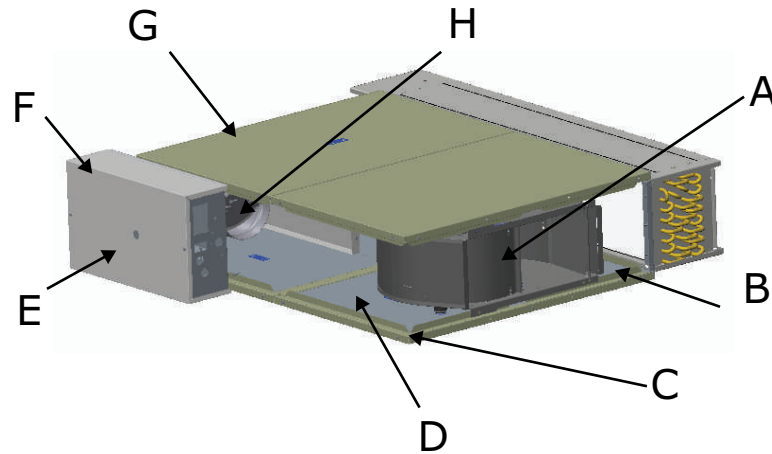

A	Technologically Advanced Units—New fan/motor/wheel assemblies are engineered as an air delivery system to provide the most efficient design available in the industry. For quiet comfort, you can trust and rely on Trane units.
B	Tough Interlocking Panels—Ruggedness and rigidity are assured with Trane’s patent-pending interlocking panel construction.
C	Superior Metal Encapsulated Edges—All Trane chilled water sensible cooling units are complete with metal encapsulated edges to arrest cut insulation fibers and prevent erosion in the airstream.
D	Full Range of Insulation—Whether seeking optimal acoustical performance or cleanability, Trane has a complete line of insulation options, including double-wall, matte-faced, foil-faced, closed cell, etc.
E	Service Friendly: <ul style="list-style-type: none"> • Internal shaft visible through control box cover sight hole for blade orientation verification. • Same-side NEC jumpback clearance provides all high-voltage and low-voltage components on the same side to minimize field labor.
F	Control Flexibility—Trane factory installs more controllers than any other manufacturer in the industry. In addition to Trane DDC controls and simple factory-mounting of non-Trane controllers, Trane now offers a BACnet® controller that is completely factory commissioned to maximize installation quality and system reliability. Labor savings are maximized with Trane factory-commissioned controllers.
G	Accurate Flow Ring—Housed and recessed within the air valve to provide flow ring handling and shipping protection. The patented flow ring provides unmatched airflow measurement accuracy.
H	Rugged Air Valve—Trane air valves are heavy gage steel with a continuously welded seam to limit inlet deformation. This provides consistent and repeatable airflow across the flow ring with performance you can count on.



Construction

UL-Listed Products

All Trane CoolSense™ Chilled Water Sensible Cooling Terminal Units are listed in accordance with UL as terminal units. This listing includes the terminal with electric heaters. Additionally, all insulation materials pass UL 25/50 smoke and flame safety standards.

Performance in Accordance with AHRI Standards

This standard sets forth classifications, performance testing requirements and test reporting requirements for air terminal units. The standard contains very detailed procedures that are to be followed for the testing and certification program associated with this standard. CoolSense™ Chilled Water Sensible Cooling Terminal Units are currently not included in any AHRI certification program, however, all the applicable performance data are obtained and represented in accordance with AHRI 880. The operating characteristics tested include discharge and radiated sound power, wide-open pressure drop and fan motor amp draw.

Casing Design

Interlocking Panels – Patent-pending interlocking panels are designed using integral I-beam construction technology. This minimizes deformation and creates tremendous product rigidity. An additional benefit is a smooth unit exterior with few exposed screws - ideal for exposed ceiling applications. Trane CoolSense™ Chilled Water Sensible Cooling Terminal Units are designed for use in systems that operate up to 5-inch w.c. of inlet static pressure.

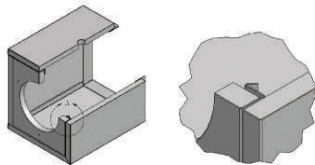

Metal Encapsulated Edges— All Trane CoolSense Chilled Water Sensible Cooling Terminal Units are complete with encapsulated edges to arrest cut fibers and prevent insulation erosion into the airstream. This is important for applications concerned with fiberglass erosion or projects with either double-wall or externally wrapped duct work.



Trane Air Valve— Primary airflow is measured and controlled here for VariTrane™ units. VariTrane™ products are the most rugged and reliable available.

18-gauge Cylinder—The 18-gauge cylinder limits deformation or damage during shipment and job site handling, and provides even airflow distribution across the flow ring for unmatched airflow measurement accuracy.



Flow Ring—The Trane flow ring is time tested to perform under the most demanding conditions. Trane's patented flow ring is recessed within the air valve cylinder to reduce the potential for damage during job site handling and installation.

External Shaft—This simple design provides controller flexibility and is designed to facilitate actuator field replacement.

Position Indicator—The position indicator shows current air valve position to aid in system commissioning. Many times this can be seen from the floor without climbing a ladder.

External Actuator—This feature increases serviceability, control system compatibility, and actuator clutch access for simplified commissioning.

Indoor Air Quality (IAQ) Features

Access is made easy on Trane CoolSense™ Chilled Water Sensible Cooling Terminal Units, as shown below. Top and bottom access for the unit in either orientation.

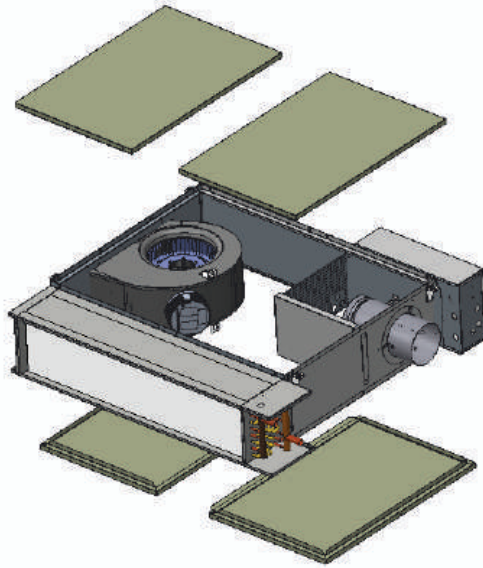

Trane CoolSense™ Chilled Water Sensible Cooling Terminal Units are designed with simplified access and a full line of insulation options including:

Matte-faced—Typical industry standard with reduced first cost.

Closed-cell—This insulation has an R-value and performance equivalent to matte-faced insulation. The main difference is the reduction of water vapor transmission. Closed-cell is designed for use in installations with a high chance of water formation. (It has been used to coat the exterior of chiller evaporator barrels for many years.)

Foil-faced—A fiberglass insulation with a thin aluminum coating on the air stream side to prevent fibers from becoming airborne. The aluminum lining is acceptable for many applications, however it is not as rugged as double-wall.

Double-wall—Premium insulation often used in many health care applications with insulation locked between metal liners. This eliminates the possibility for insulation entering the airstream and allows for unit interior wipe-down as needed.

Tracer Building Automation System

Tracer® Building Automation Systems ensure comfort within your building.

Building controls have a bigger job description than they did a few years ago. It is no longer enough to control heating and cooling systems and equipment. Sophisticated buildings require smarter technology that will carry into the future. Tracer controls provide the technology platform – mobile, easy-to-use, cloud-based, scalable and open - for the next generation of data-driven, technology-enabled services that are creating high performance buildings.

With a Trane Tracer® Building Automation System, you will:

- Reduce operating costs through energy management strategies.
- Consistently provide occupant comfort.
- Enjoy reliable operation with standard, pre-engineered, and pretested applications.
- Easily troubleshoot and monitor either on site or from a remote location.
- Reduce installation time and simplify troubleshooting.



Features and Benefits

Tracer BACnet Controllers

Trane offers a full line of programmable BACnet® controllers designed for simple integration into any system which can communicate via the BACnet® protocol. These controllers are factory-programmed, commissioned, and shipped ready to be installed.

Symbio™ 500 Controller

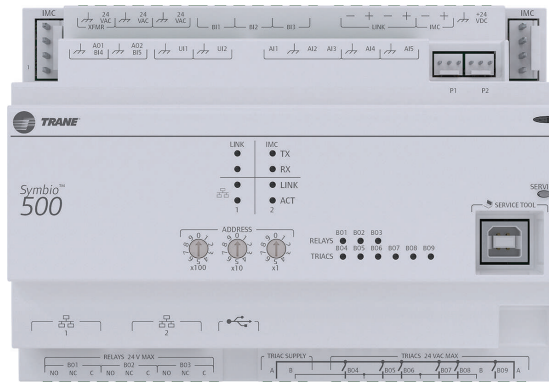

See DDC Controls chapter for additional control options and sequence-of-operations.

Air-Fi® Wireless System

For more detailed information on Air-Fi® Wireless systems and devices, see:

- *Air-Fi® Wireless Systems Installation, Operation, and Maintenance (BAS-SVX40*-EN)*
- *Air-Fi® Wireless Product Systems Product Data Sheet (BAS-PRD021*-EN)*
- *Air-Fi® Network Design Installation, Operation, and Maintenance (BAS-SVX55*-EN)*

Air-Fi® Wireless Communications Interface (WCI)



A factory-installed Air-Fi® Wireless Communications Interface (WCI) provides wireless communication between the Tracer® SC, Symbio™ 500 VAV unit controllers and optionally, Air-Fi® Wireless Communication sensors.

The Air-Fi® WCI's wireless mesh network is the perfect alternative to a wired communication link. Eliminating the low-voltage wire between the zone sensor and the terminal unit controller, and between the unit controllers and the system controller will:

- Reduced installation time and associated risks.
- Completion of projects with fewer disruptions.
- Easier and more cost-effective re-configurations, expansions, and upgrades.

Air-Fi® Wireless Communication Sensor (WCS)



The Wireless Communications Sensor (WCS) communicates wirelessly to a Tracer® BACnet® unit controller that has an Air-Fi® WCI installed. A WCS is an alternative to a wired sensor when access and routing of communication cable are issues. It also allows flexible mounting and relocation. Also available are a non-display version of the WCS with a temperature setpoint knob, an occupancy / CO₂ sensor / zone temperature version of the WCS, and a relative humidity (RH) sensor add-on daughter board accessory.

Factory-installed vs. Factory-commissioned

The terms factory-installed and factory-commissioned are often used interchangeably. Trane takes great pride in being the industry leader in factory-commissioned DDC controllers. The following table differentiates these concepts.

Factory-commissioned controllers provide the highest quality and most reliable units for your system. Additional testing verifies proper unit operation including occupied/unoccupied airflow and temperature setpoints, communication link functionality, and output device functionality. The benefits of factory-commissioning are standard on VariTrane™ terminal units with Trane DDC controls. This means that factory-commissioned quality on VariTrane™ units is now available on ANY manufacturer's control system that can communicate using BACnet® protocol. (See Controls section for complete listing of variables which are communicated.)

Table 1. Factory-installed vs. factory-commissioned

	Factory-installed	Factory-commissioned
Transformer installed (option)	X	X
Wires terminated in reliable/consistent setting	X	X
Controller mounted	X	X
Electric heat contactors and fan relay wired	X	X
Controller addressing and associated testing	—	X
Minimum and Maximum airflows settings (occupied/unoccupied)	—	X
Minimum and Maximum temperature setpoints (occupied/unoccupied)	—	X
Minimum ventilation requirements	—	X
Heating offset	—	X
Trane Air-Fi® wireless communications modules (WCI)	X	X
Trane Air-Fi® Wireless Communications Sensor (WCS)	—	—



Indoor Air Quality Management During Construction

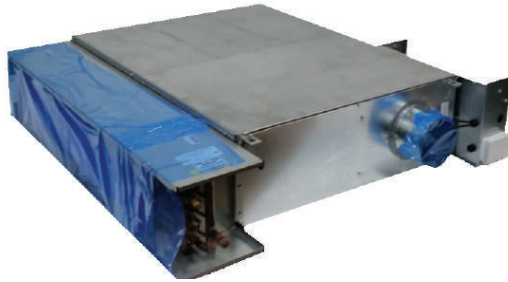

LEED wrap option is a pressure sensitive covering that prevents contamination of the terminal unit during the construction phase. It is utilized to seal all openings without constraining the installation process.

Trane Systems — Proven Performance

Trane continues to be an industry leader in the development and implementation of effective systems strategies. A Dedicated Outdoor Air System coupled with these chilled water sensible cooling units in no different.

At the unit level, these units can be equipped with DDC controllers that follow the successful strategy of factory commissioning. At the terminal unit level, the unit controller will be mounted, wired, tested and programmed with the appropriate operating setpoints and sequences needed for proper operation. This can drastically reduce the system start-up time.

From a system perspective, proper coordination of all aspects of the HVAC system are critical to the effective operation of the system as well as comfortable occupants of the building. Again, Trane leads the way, with proven system level strategies to properly coordinate the control of the individual terminal units with the rest of the HVAC system.



Agency Certifications

There are numerous regulations and standards in the industry that determine the construction and performance parameters for terminal units. Some of the more important of those standards and regulations are listed below.

UL-Listed Products

All Trane CoolSense™ Chilled Water Sensible Cooling Terminal Units are listed in accordance with UL as terminal units. This listing includes the terminal with electric heaters. Additionally, all insulation materials pass UL 25/50 smoke and flame safety standards.

AHRI Certified

American Society of Heating, Refrigerating and Air-conditioning Engineers (ASHRAE)

- ASHRAE - Standard 41.1
- ASHRAE - Standard 41.2
- ASHRAE - Standard 41.3
- ASHRAE - Standard 62.1
- ASHRAE - Standard 111

Air Conditioning and Refrigeration Institute (AHRI)

- AHRI Standard 880
- AHRI Standard 885-2008

National Fire Protection Association (NFPA)

- NFPA 70
- NFPA 90A



Application Considerations

Figure 1. Low height- sensible cooling only (LDCF)

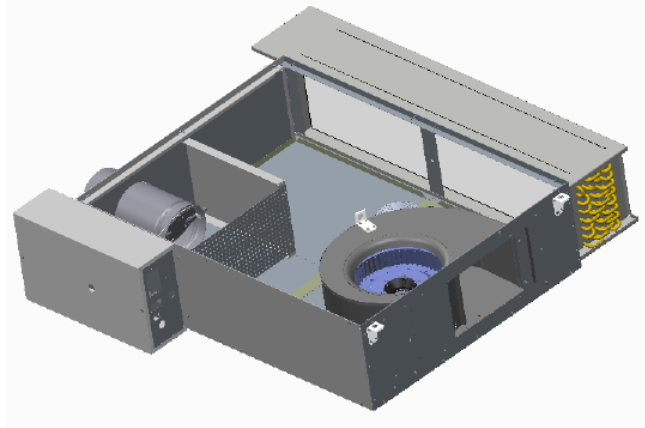

Figure 2. Standard height- sensible cooling only (VDCG)

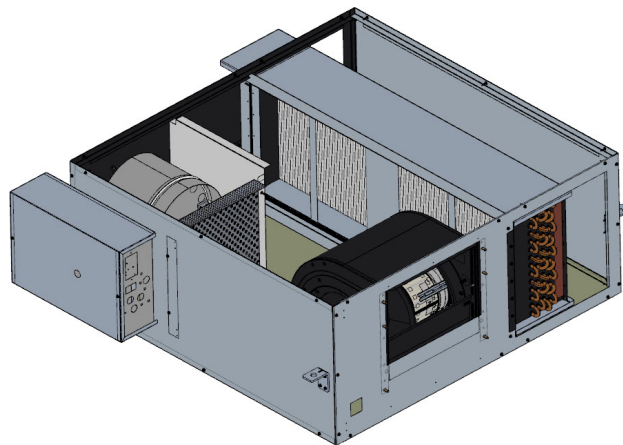

Figure 3. Low height - sensible cooling w/ hot water (LDWF)

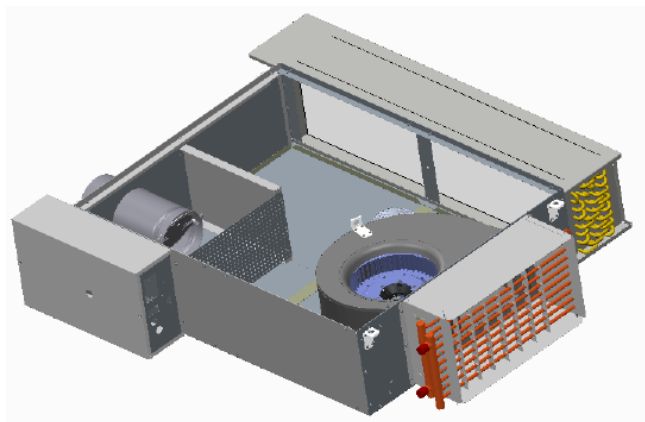
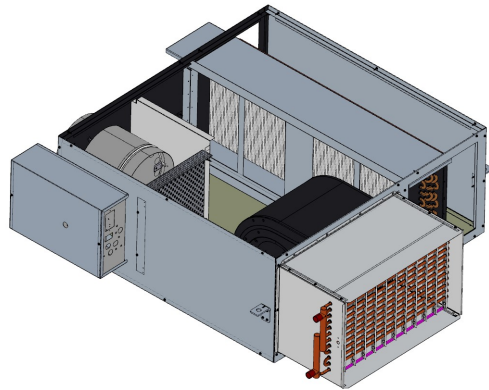

Figure 4. Standard height - sensible cooling w/ hot water (VDWG)



4

Figure 5. Low height - sensible cooling w/ electric heat (LDEF)

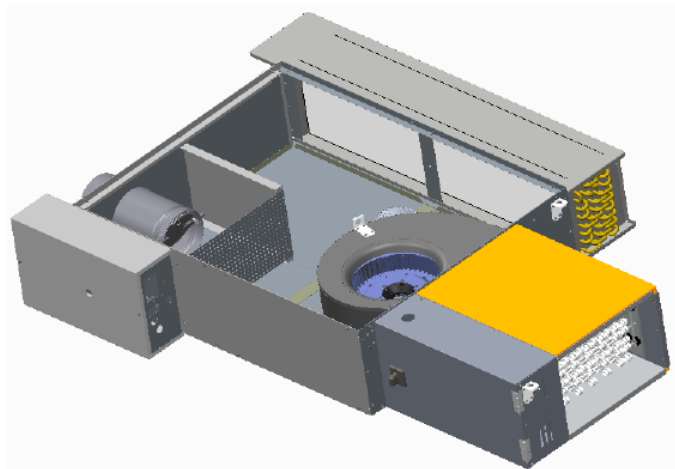
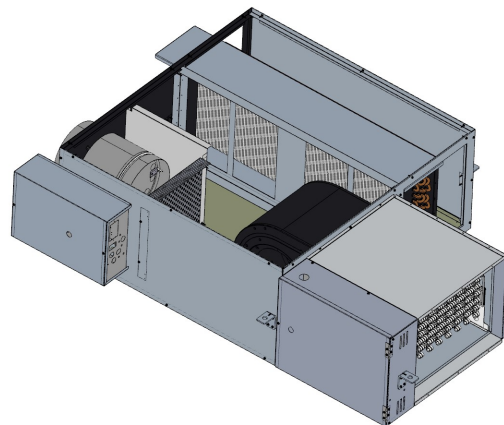

Figure 6. Standard height - sensible cooling w/ electric heat (VDEG)



6

Types of CoolSense™ Chilled Water Sensible Cooling Terminal Units

The function of the Trane CoolSense™ Chilled Water Sensible Cooling Terminal Units is a little different than traditional VAV Terminal Units. These terminal units are part of a **system** that uses a dedicated outdoor-air unit to distribute outdoor air to an air valve on each terminal unit to meet the ventilation requirements of the zone. Each terminal unit is also equipped with a sensible-only cooling coil mounted on the plenum inlet. Recirculated air from the plenum (or directly from the occupied space) is drawn in through this cooling coil by the local fan. This cooled air is then mixed with the conditioned (cooled, dehumidified, heated, or humidified) outdoor air from the dedicated OA unit, and distributed through the downstream ductwork to the zone.

In most applications, the water supplied to this local cooling coil is controlled to a temperature above the dew point in the zone. This avoids moisture in the air from condensing on the coil, so it operates dry and provides only sensible cooling. All the dehumidification must then be provided by the dedicated outdoor-air unit. Trane CoolSense Chilled Water Sensible Cooling Terminal Units are built with a drip pan located beneath the cooling coil, with a moisture sensor installed in it, to detect and prevent any moisture from getting on the ceiling beneath the units or into the occupied space below. These terminal units can be configured with either a hot water coil or electric heater mounted at the unit discharge.

Figure 7. Chilled water sensible cooling terminal unit function

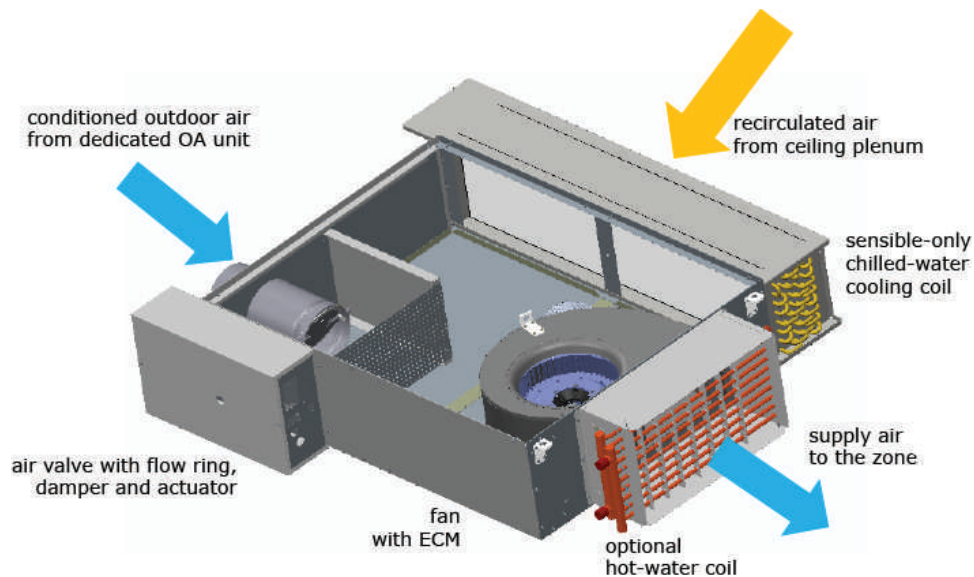

Typical Application of CoolSense™ Chilled Water Sensible Cooling Terminal Units

CoolSense™ Chilled Water Sensible Cooling Terminal Units can be applied in all the zones of a building designed with a dedicated outdoor air system capable of delivering sufficiently dehumidified outdoor air to each of the zones. Typically the chilled water supplied to these terminal units is at a higher temperature (54 to 59°F, warmer than the dew point in the space) than traditional chilled water systems. This is similar to other systems with coils in the occupied space intended to perform sensible cooling only. Additionally the dew point in the space must be controlled to avoid conditions in which condensation can develop on the sensible cooling coils on these terminal units.

Figure 8. Typical chilled water sensible cooling terminal unit application

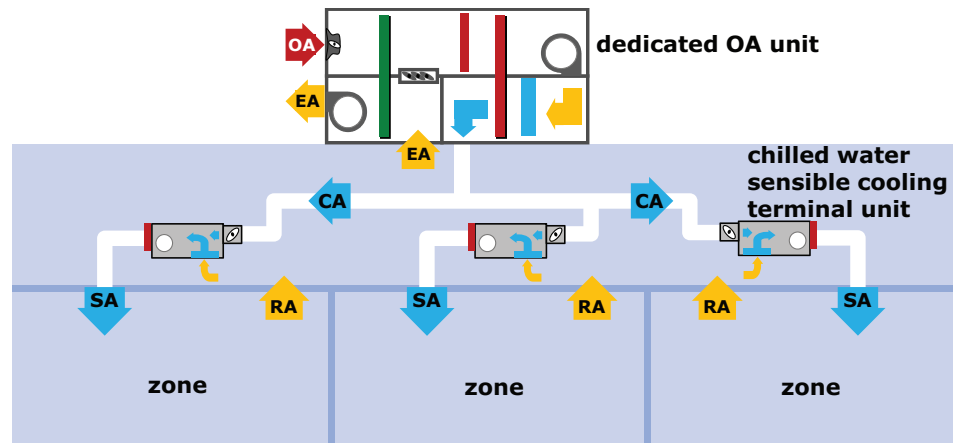

Table 2. DOAS with chilled water sensible cooling terminal units

Parameter	Chilled Water Sensible Cooling Terminal Unit
Fan Operation	Continuous operation during occupied modes, intermittent operation during unoccupied modes.
Operating Sequence	Variable volume: Fan runs at minimum speed when the zone temperature is satisfied. Fan speed modulates up to maximum in conjunction with heating or cooling capacity as needed to maintain desired zone temperature.
Fan Energization	Interlocked with the dedicated outdoor air system fan to deliver required outdoor air to the zone during occupied modes.
Terminal Fan Sizing	Fan should be sized to meet the greater of the design cooling or heating airflow to the zone.
Air Valve Sizing	Sized to meet the design outdoor airflow requirement for the zone.
Minimum Inlet Static Pressure Required for DOAS Fan Sizing	Sufficient to overcome air valve pressure loss only.

Hydronic Branch Conductor

The Hydronic Branch Conductor is a self-contained valve assembly with integrated controls. This innovative system features advanced controller logic that detects both hot and cold water temperatures, seamlessly directing flow from the appropriate heat pump loops to either heat or cool specific thermal areas.

Trane Hydronic Branch Conductor revolutionizes building climate control by enabling the use of dual-purpose coils within a four-pipe distribution system, while efficiently delivering heating or cooling through just two pipes. Unlike traditional two-pipe changeover systems that switch between hot and cold water seasonally for the entire building, this advanced system can adapt to varying heating and cooling demands in different areas multiple times throughout the day.

With a central four-pipe distribution system providing the benefits of year-round heating and cooling, and area branches utilizing a two-pipe setup, the Hydronic Branch Conductor offers reduced piping complexity and enhanced efficiency. Experience the best of both worlds with a heat pump system that combines the advantages of four-pipe and two-pipe configurations for optimal climate control.

Application Considerations for the Hydronic Branch Conductor:

- Hydronic Branch Conductors are for use in hydronic heat pump systems where the cooling fluid and heating fluid are the same fluid from the same central plant. It is not for use in systems with a chiller plant for cooling and a traditional boiler system for heat.
- The Hydronic Branch Conductor conducts commands valves to provide the appropriate fluid to meet the received thermal area HEAT/COOL mode. It also monitors and reports the status of the hydronic flows for the thermal area.
- The Hydronic Branch Conductor is placed between the main building pipe chase and a thermal area's branch piping.
- The Hydronic Branch Conductor does not take the place or function of zone control valves.



Application Considerations

- The Hydronic Branch Conductor does not take the place of any necessary shut off or balancing valves.
- Systems with Hydronic Branch Conductors have airside equipment with dual purpose coils. These coils work well using hot water supply temperature of 100F(+/-10F) and traditional chilled water temperatures.
- See *Hydronic Branch Conductor Application Guide (APP-APG024*-EN)* for more information on system design.

Energy Savings and System Controls

Electrically Commutated Motor

Electrically Commutated Motors (ECM) are standard on CoolSense™ terminal units. ECMs provide premium unit efficiency, quiet unit operation and optimized space comfort control.

Fan-Pressure Optimization

With Trane's Tracer® building automation system, the information from terminal units can be used for other energy-saving strategies. Fan-pressure optimization is the concept of reducing the DOAS supply fan energy usage based on the position of the terminal unit dampers.

The control system polls the terminal units for the air valve damper position on each unit. The duct static pressure setpoint for the DOAS supply fan is reset downward until the furthest-open damper is nearly wide open. The correct airflow is still being sent to each zone since the air valve controls in the terminal units are pressure-independent, but the supply fan uses less energy since it is able to generate less pressure, which results in fan energy savings.

Control Types

Direct Digital Control (DDC) Systems

DDC controls are the industry standard for terminal unit control systems. DDC systems use electronic field devices such as a flow transducer, a primary air modulating damper, and an electronic temperature sensor. These field devices report software instructions of how the outputs are positioned in relation to the inputs to a controller.

DDC controls provide flexibility and considerable diagnostic capability. DDC controllers can be connected together to form a network of controllers which can be monitored from a remote location to ensure proper operation. Commands and overrides can be sent for groups of controllers at one time to make system-wide changes. Commands and overrides can be sent to individual unit controllers to allow problem diagnosis, temporary shutdown, startup schedules or other specialized changes. When integrated into a building automation system, the operation of the terminal units can be coordinated with other components of the overall system to ensure comfortable, efficient operation and even reduce energy use.

DDC control of terminal units is a key element in providing intelligent and responsive building automation. Precision control, flexible comfort, and after hours access are all available with the DDC control system for Trane CoolSense™ Chilled Water Sensible Cooling Terminal Units.

Key features of the system include:

- An advanced unit controller
- Flexible system design
- User-friendly interaction

Flow Measurement and Control

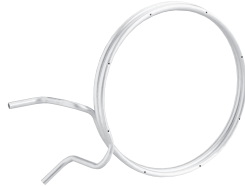

One of the most important characteristics of a terminal unit is its ability to accurately sense and control airflow. The patented, multiple-point, averaging flow ring measures the velocity of the air at the unit ventilation air inlet.

The differential pressure signal output of the flow ring provides the terminal unit controller a measurement of the ventilation airflow through the inlet. The terminal unit controller then opens or closes the inlet damper to maintain the controller airflow setpoint.

Flow Measurement

Most of these terminal units contain a differential pressure airflow measurement device, mounted at the ventilation air inlet, to provide a signal to the terminal unit controller. Numerous names exist for the differential pressure measurement device—flow sensor, flow bar, flow ring. The differential pressure measured at the inlet varies according to the volumetric flow rate of ventilation air entering the inlet.

The total pressure and the static pressure are measurable quantities. The flow measurement device in a terminal unit is designed to measure velocity pressure. Most flow sensors consist of a hollow piece of tubing with orifices in it. The air valve contains a flow ring as its flow measuring device. The flow ring is two round coils of tubing. Evenly spaced orifices in the upstream coil are the high-pressure taps that average the total pressure of air flowing through the air valve. The orifices in the downstream ring are low-pressure taps that average the air pressure in the wake of flow around the tube. By definition, the measurement of static pressure is to occur at a point perpendicular to the airflow. The low-pressure taps on the flow ring measure a pressure that is parallel to the direction of flow but in the opposite direction of the flow. This “wake pressure” that the downstream ring measures is lower than the actual duct static pressure. The difference between the “wake pressure” and the static pressure can be accounted for so that the above relationship between flow and differential pressure remain valid. The difference also helps create a larger pressure differential than the velocity pressure. Since the pressures being measured in terminal unit applications are small, this larger differential allows transducers and controllers to measure and control at lower flow settings than would otherwise be possible.

The average velocity of air traveling through the inlet is expressed in the equation:

$$\text{FPM} = 1096.5 \sqrt{\frac{\text{VP}}{\text{DENS}}}$$

Where:

- FPM = Velocity of air in feet per minute
- 1096.5 = A constant
- VP = The velocity pressure of the air expressed in inches of water
- DENS = The density of the air expressed in pounds per cubic foot

Often, the density is assumed to be a constant for dry air at standard conditions [68°F (20°C)] and sea level pressure of 14.7 psi (101.4 kPa). These conditions have a density of 0.07496 lbs/cubic foot and yield the following commonly used equation:

$$\text{FPM} = 4005 \sqrt{\text{VP}}$$

The amount of air traveling through the inlet is related to the area of the inlet and the velocity of the air:
AIRFLOW (cubic feet per minute, cfm) = **AREA** (square feet) x **AVERAGE VELOCITY** (feet per minute)

Accuracy

The multiple, evenly spaced orifices in the flow ring of the terminal unit provide quality measurement accuracy even if ductwork turns or variations are present before the unit inlet. For the most accurate readings, a minimum of 1½ diameters, and preferably 3 diameters, of straight-run ductwork is recommended prior to the inlet connection. The straight-run ductwork should be of the same diameter as the air valve inlet connection. If these recommendations are followed, and the air density effects mentioned below are addressed, the flow ring will measure ventilation airflow within ±5% of unit nominal airflow.

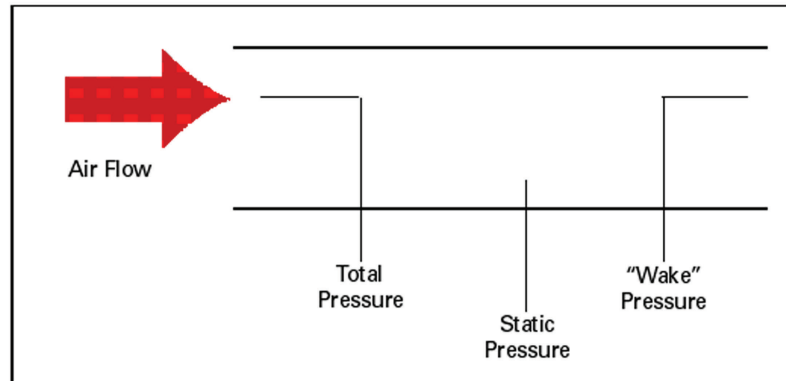
Figure 9. Air pressure measurement orientations

Air Density Effects

Changes in air density due to the conditions listed below sometimes create situations where the standard flow sensing calibration parameters must be modified. These factors must be accounted for to achieve accuracy with the flow sensing ring. Designers, installers, and air balancers should be aware of these factors and know of the necessary adjustments to correct for them.

Elevation

At high elevations the air is less dense. Therefore, when measuring the same differential pressure at elevation versus sea level the actual flow will be greater at elevation than it would be at sea level. To calculate the density at an elevation other than standard conditions (most manufacturers choose sea level as the point for their standard conditions), you must setup a ratio between the density and differential pressure at standard conditions and the density and differential pressure at the new elevation.

$$\frac{\Delta P \text{ Standard Conditions}}{\text{DENS Standard Conditions}} = \frac{\Delta P \text{ New Conditions}}{\text{DENS New Conditions}}$$

Since the data from the manufacturer is published at standard conditions, this equation should be solved for the differential pressure at standard conditions and the other quantities substituted to determine the ratio for the differential pressure measured at the new conditions.

Duct Pressure and Air Temperature Variations

While changes in these factors certainly affect the density of air, most operating parameters which systems need keep these effects very small. The impact on accuracy due to these changes is less than one half of one percent except in very extreme conditions. Extreme conditions are defined as those systems with inlet static pressures greater than 5 in. wg (1245 Pa) and inlet air temperatures greater than 100°F (37.8°C). Since those types of systems occur so infrequently, we assume the effects of duct pressure and air temperature variations to be negligible.

Linearity

With the increased use of DDC controls instead of pneumatic controls, the issue of linearity is not as great as it once was. The important aspect of flow measurement versus valve position is the accuracy of the controller in determining and controlling the flow. Our units are tested for linearity and that position versus airflow curve is downloaded and commissioned in the factory to ensure proper control of the unit.

Cooling/Heating Options

Chilled Water Cooling Coil Valve

A chilled water cooling coil is included in this terminal unit, and is mounted at the induction air inlet of the unit. When applying these coils it is important to make sure that they are operating in the proper airflow and water flow range. (See tables in Performance Data chapter for airflow and water flow rates.) Either a two-way or a three-way water valve can be used to control the coil. It is important to size the valve

correctly, to ensure minimal pressure loss and maximum controllability. See Hot Water Heating Coil section below for details in properly selecting a valve.

Hot Water Heating Coil

A hot water heating coil can be included in this terminal unit, and is mounted at the discharge of the unit. When applying these coils it is important to confirm they are operating in the proper air flow and water flow range. (See tables in Performance Data chapter for airflow and water flow rates.) Either a two-way or a three-way valve controls the coils.

The most important factor when sizing valves is the coefficient of velocity or C_v . This coefficient of velocity, which is commonly called the flow coefficient, is an industry standard rating. Valves having the same flow coefficient rating, regardless of manufacturer, will have the same waterside performance characteristics.

The preferred method is to size the valve for 3 to 5 psi for pressure drop when full open. Generally the rule of thumb is to use 4 psi.

$$C_v = \text{GPM} / 2 \text{ or } \text{GPM} = 2 * C_v \text{ (since square root of } 4 = 2)$$

This formula is very easy to use and is as accurate as any other method. Size the valve for a $C_v = 1/2$ the GPM it must pass in modulating applications

The equation that governs valve sizing is:

$$C_v = \frac{\text{GPM}}{\sqrt{\Delta P}}$$

Where

- C_v = Flow coefficient
- GPM = The maximum water flow rate through the valve in gallons per minute
- ΔP = The maximum allowable differential pressure across the valve in psi

The flow and differential pressure are generally the known quantities. The equation is solved for the flow coefficient. The flow coefficient is then compared to the published C_v values for the control valves that are available. The control valve with the C_v that is the closest, but greater than, the calculated flow coefficient is the correct choice for the control valve. This choice will keep the valve pressure drop below the maximum allowable valve pressure drop. The valve pressure drop should then be checked against the coil pressure drop. If the coil pressure drop is appreciably larger than the valve pressure drop, a valve with a smaller C_v should be selected to produce a larger control valve pressure drop. If this new valve has a pressure drop that is much larger than the maximum allowable pressure drop for valves, the system designer should be consulted to make sure that the system hot water pumps can deliver the water at the new conditions.

Electric Heat

An electric heater can be included in this terminal unit, and is mounted at the discharge of the unit. Electric heat coil capacity is rated in kilowatts (kW). Heaters are available with magnetic contactors for staged control, where total capacity is divided among the stage(s). Heaters are also available with SCR control.

Electric heat coils are available in single-phase or three-phase models. This refers to the type of power source connected to the heater. Single-phase models have resistance elements internally connected in parallel. Three-phase models have resistance elements internally connected in a delta or a wye configuration.

The current draw for the electric heater will depend upon whether it is a single-phase or three-phase heater. The current draw is necessary for determining what size wire should be used to power the electric heater and how big the primary power fusing should be. The equations for current draw for these heaters are:

$$1\phi \text{ amps} = \frac{\text{kW} \times 1000}{\text{Primary Voltage}}$$

$$3\phi \text{ amps} = \frac{\text{kW} \times 1000}{\text{Primary Voltage} \sqrt{3}}$$

Application Considerations

Three-phase electric heat is available in balanced configurations. For example, a 9 kW three-phase coil, each stage would carry 1/3 or 3 kW of the load.

It is important to note that these heaters have certain minimum airflow rates for each amount of kW heat the heater can supply to operate safely. These airflow values are based upon a maximum rise across the electric heater of 50°F (28°C).

The equation that relates the airflow across an electric heater to the temperature rise and the coil change in temperature is:

$$\text{CFM} = \frac{\text{kW} \times 3145}{\Delta T}$$

Where

- CFM = Minimum airflow rate across the coil
- kW = The heating capacity of the electric coil
- 3145 = a constant
- ΔT = The maximum rise in air temperature across the coil, usually 50°F (28°C)

Insulation

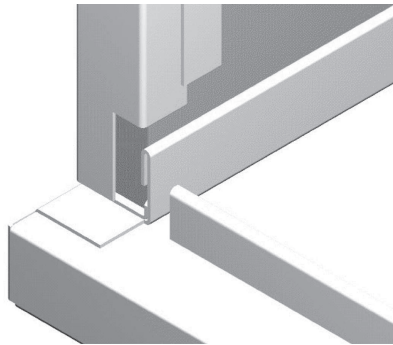

Insulation in a chilled water sensible cooling terminal unit is used to avoid condensation on the outside of the unit, to reduce the heat transfer from the cold ventilation air entering the unit, and to reduce the unit noise. The chilled water sensible cooling terminal product line offers four types of unit insulation. The type of facing classifies the types of insulation. To enhance IAQ effectiveness, edges of **all insulation types have metal encapsulated edges.**

Acoustics

Acoustical Best Practices

Acoustics with terminal units is sometimes more confusing than it needs to be. As we know, lower velocities within a unit leads to improved acoustical performance. Additionally, lower RPM provides better acoustical performance. It is as simple as that—there are some catches, however.

Additional considerations will be discussed in more detail throughout this portion of Application Considerations, such as unit size and type, appurtenance affects (due to insulation, attenuation, etc.), certification, and computer modeling. Let us take a look at the first consideration, sizing of units.

Sizing of Units

Before blindly increasing the size of units, we must first understand what is setting the acoustics within the space. In general, over 95% of acoustics in these terminal units, which set the sound pressure levels and ultimately the NC within the space, is from radiated sound. Radiated sound emanates from the unit and enters the occupied space via means other than through the supply ductwork. The most typical path is through the plenum space, then through the ceiling, then into the occupied space. While discharge sound should never be ignored, radiated sound is the most dominant and usually the most critical sound source.

When increasing **air valve** sizes, BE CAREFUL. **Oversizing an air valve can adversely impact the ability to modulate and properly control ventilation.** In extremely oversized situations, the air valve will operate like a two-position controlled device, with air either being “on”, or “off”, and not really much in between. The best way to avoid this is to understand that the minimum air velocity for most air valves is 300 FPM. This is a function of the flow sensing device and the ability of the pressure transducer and

controller to properly read and report flow. This is not manufacturer specific, as physics applies to all. Therefore, when sizing air valves, minimum velocity for proper pressure independent flow is 300 FPM.

Modulation capability and range is vital for proper operation of the air valve in these terminal units. A good rule of thumb is to size maximum ventilation airflow for around 2000 FPM.

Insulation Types

Insulation is a factor to consider when dealing with the acoustics of terminal units. Most insulation types will provide similar acoustical results, but there are exceptions. Double-wall and closed-cell foam insulation will generally increase your sound levels because of the increased reflective surface area that the solid inner-wall and closed-cell construction provides. This increase in sound will have to be balanced with the IAQ and cleanability considerations of the dual-wall and closed-cell construction.

Placement of Units

Unit placement in a building can have a significant impact on the acceptable sound levels. Locating units above non-critical spaces (hallways, closets, and storerooms) will help to contain radiated sound from entering the critical occupied zones.

Certification and Testing

Terminal units should be submitted based on the same criteria. There are several ways to ensure this by certification and testing.

Raw unit sound data can be good measurement criteria for evaluation. In using this as a basis for comparison, the designer needs to make sure that the information is based on the AHRI Standard 880-2017 that gives the procedure for testing.

Specifying NC or RC sound levels is a possible comparison, but the designer needs to be sure the comparison is fair. Two options are to specify the attenuation effect on which you would like the units to be evaluated or to specify that AHRI Standard 885-2008 transfer functions be used. The importance of AHRI Standard 885-2008 is that it is the first AHRI Standard that specifies exact transfer functions to be used for evaluation. Previous versions of the standard gave guidelines, but the manufacturers could choose their own set of factors.

Path Attenuation

Sound generated by a terminal unit can reach the occupied space along several paths. The terminal unit generated sound will lose energy — i.e. the energy is absorbed by path obstacles—as it travels to the occupied space. This acoustical energy dissipation as it travels to the occupied space is called path attenuation. The amount of energy lost along a particular path can be quantified and predicted using the procedure outlined in AHRI-885. Each path must be considered when determining acceptable sound power generated by a terminal unit.

The term “transfer function” is often used to describe the entire path attenuation value for each octave band (i.e., the sum of all components of a particular path).

Examples of path attenuation include locating the terminal unit away from the occupied space, increasing the STC (sound transmission classification) of the ceiling tile used, internally lining ductwork, drywall lagging the ceiling tiles or enclosing the terminal unit in drywall. All of these choices have costs associated with them that must be weighed against the benefits. Some of these alternatives can be acoustically evaluated from application data provided in AHRI-885. Others may require professional analysis from an acoustical consultant.

Computer Modeling

Computer modeling of acoustical paths is available to help estimate sound levels and determine problem sources. The software used by Trane for computer modeling is called Trane Acoustics Program (TAP™).

This software can analyze different room configurations and materials to quickly determine the estimated total sound levels (radiated and discharged) in a space. Trane Select Assist™ can also be used to determine sound levels of terminal units. You can base selections on a maximum sound level and enter your own attenuation factors (defaults based on AHRI-885 are also available).



Duct Design

Designing cost-effective duct systems is challenging. Some duct design methods result in better pressure balance than others do. Duct shape and duct material can influence duct system design and cost. In addition, duct layout is properly designed for optimal duct installation and operation.

Duct Design Program

Trane has developed a computer program, VariTrane™ Duct Designer, to aid in the duct design process. This program is used to calculate duct sizes, fitting sizes, terminal unit sizes, and pressure drops according to the equal friction or static regain method. The duct design program can be easily incorporated into the selection of terminal units. The inputs and outputs for the program enable terminal units to be selected based on the conditions you require. This makes selecting and scheduling units much easier. Contact the local sales office or the Trane C.D.S.™ department for more details on this program.

Design Methods

The two most widely used supply duct design methods—equal friction and static regain—are discussed below.

Equal Friction – Using this method, ducts are sized at design flow to have roughly the same static pressure drop for every 100 feet of duct. Static pressures throughout the duct system can be balanced at design flow using balancing dampers, but are no longer balanced at part load flows. For this reason, equal friction duct designs are better suited for constant volume systems than for variable volume systems. If the equal friction method is used for the supply duct design, the terminal units usually require pressure-independent (PI) control capability to avoid excessive flow rates when duct pressures are high.

The ducts located downstream of the terminal unit are usually sized for equal friction. The advantage of this design method is its simplicity. Often, calculations can be made using simple tables and duct calculators. Drawbacks include increased higher total pressure drops and higher operating costs.

Static Regain – In the static regain method, ducts are sized to maintain constant static pressure in each section, which is achieved by balancing the total and velocity pressure drops of each section. In other words, static pressure is “regained” by the loss of velocity pressure. Since the static pressures throughout the duct system are roughly balanced at design and part load flow, static regain duct designs can be used successfully for either constant volume or variable volume systems. When the static regain method is used, the system is roughly pressure balanced at design.

Advantages of the static regain method include reduced total pressure drops, lower operating costs, and balanced pressures over a wide range of flows. The drawback of this design is the time-consuming, iterative calculation procedure and for large systems, it is essential to have a duct design computer program.



Selection Procedure

The following is the general selection procedure for the CoolSense™ Chilled Water Sensible Cooling Terminal Units. For particular design conditions not in this catalog, use the Trane Select Assist (TSA) or contact your local Trane Sales office.

1. **Required Information:** Gather all the required information needed to properly select these units. This includes all the unit airflows, applicable air temperatures (ventilation air, heating and cooling zone temperature setpoints, winter and summer plenum temperatures), entering chilled water temperature, entering hot water temperature (if applicable) and zone heating and cooling loads.
2. **Air Valve Selection:** Use the design ventilation airflows and to properly size the air valve. The air valve needs to be large enough to accommodate the max ventilation (primary) airflow. The heating and cooling airflows must be verified to be above the minimum airflow for the air valve selected above.
3. **Cooling Coil Selection:** Use the cooling design criteria and [Table 8, p. 34](#) to determine the cooling coil needed to meet the cooling demand of the coil and unit. Once the coil has been selected, determine the air pressure drop and fluid pressure drop from [Table 8, p. 34](#) and [Table 12, p. 36](#) respectively.
4. **Heating Coil Selection (if needed):** If the unit is equipped with on-board heat, determine the type of heat required.
 - For units with hot water heat use the heating design criteria and [Table 16, p. 38](#) and [Table 7, p. 30](#) to determine the hot water coil, air pressure drop and fluid pressure drop.
 - For units with electric heat use the heating design criteria and [Table 36, p. 73](#) to determine the electric heater to meet the demand.
5. **Fan Selection/Confirmation:** Use the sum of all the air pressure drop values for the coils in the previous steps plus the design downstream static pressure plus any other accessories to determine the static pressure the fan must overcome. Use [Figure 10, p. 31](#) to confirm the fan is capable of delivering the required airflow at the required static pressure.
6. **Acoustic Performance:** Use Acoustics chapter data tables along with the selected unit configuration and operating parameters to determine the acoustical performance of the unit.

Selection Example: LDWF Chilled Water Sensible Cooling Terminal Unit with Hot Water Heat

Required Information

- Max Cooling Fan Airflow = 500 cfm
- Cooling Design Ventilation (Primary) Airflow = 100 cfm
- Max Heating Fan Airflow = 500 cfm
- Heating Design Ventilation (Primary) Airflow = 100 cfm
- Max Ventilation (Primary) Airflow = 150 cfm
- Min Fan Airflow = 200 cfm
- Downstream Static Pressure = 0.25 in. w.g.
- Entering Ventilation (Primary) Air Temperature (EDB) = 49°F
- Cooling Plenum Entering Dry Bulb Temperature (EDB) = 75°F
- Cooling Plenum Entering Wet Bulb Temperature (EWB) = 60.5°F
- Cooling Coil Entering Fluid Temperature = 57°F
- Zone Temperature during Summer/Cooling = 72°F
- Zone Cooling Load = 8.0 MBH (8,000 Btu/hr)
- Heating Plenum Entering Dry Bulb Temperature (EDB) = 70°F
- Heating Coil Entering Fluid Temperature = 180°F



Selection Procedure

- Zone Heating Load = 16.0 MBH (16,000 Btu/hr)
- Zone Temperature during Winter/Heating = 68°F

Air Valve Selection

- Max Ventilation (Primary) Airflow = 150 cfm
- Cooling Design Ventilation (Primary) Airflow = 100 cfm
- Heating Design Ventilation (Primary) Airflow = 100 cfm

A 4-inch air valve is selected since its maximum airflow (225 cfm) is greater than the required 150 cfm. See [Table 4, p. 28](#).

- Check — Are the Cooling and Heating Design Ventilation (Primary) Airflows above 300 FPM?
- Answer — Yes, minimum allowable airflow for a 4" air valve is 25 cfm (see [Table 4, p. 28](#))
- The DS02 fan will be used in this instance. In , the 4-inch air valve has a pressure drop of 0.01 in. w. g. at 150 cfm.

Cooling Coil Selection

- $8,000 \text{ Btu/hr} = 1.085 \times 500 \text{ cfm} \times (72^\circ\text{F} - \text{Clg. SAT})$
- Clg. SAT = 57.25°F

Because the air discharging from the fan is a mixture of the conditioned outdoor air from the DOAS and the air drawn through the cooling coil, the coil leaving air temperature must be calculated.

- $500 \text{ cfm} \times 57.25 \text{ F} = 100 \text{ cfm} \times 49^\circ\text{F} + (500 \text{ cfm} - 100 \text{ cfm}) \times \text{Clg. Coil LAT}$
- Clg. Coil LAT = 59.32°F
- Clg. Coil Capacity = $1.085 \times 400 \text{ cfm} \times (75 - 59.32^\circ\text{F})$
- Clg. Coil Capacity = 6,806 Btu/hr = 6.81 MBH

Interpolating from the Cooling Coil Performance tables ([Table 12, p. 36](#)), the required performance can be met with a 4-row coil operating at 3.53 gpm with approximately 0.06 in. w.g. of air pressure drop per [Table 5, p. 29](#).

Heating Coil Selection

- $16,000 \text{ Btu/hr} = 1.085 \times 500 \text{ cfm} \times (\text{Htg. SAT} - 68^\circ\text{F})$
- Htg. SAT = 97.49°F

Because the hot water coil is on the unit discharge, the heating unit supply air temperature is the same as the heating coil leaving air temperature (LAT). The heating coil entering air temperature (Htg. EAT) is a mixture of the conditioned outdoor air for the DOAS and air drawn in from the plenum. In the heating mode, the chilled water coil will be off so the Cooling Coil leaving air temperature will be the same as the plenum temperature in the heating mode.

- $500 \text{ cfm} \times \text{Htg. EAT} = 100 \text{ cfm} \times 49^\circ\text{F} + (500 \text{ cfm} - 100 \text{ cfm}) \times 70^\circ\text{F}$
- Htg. EAT = 65.8°F
- Htg. Coil Capacity = $1.085 \times 500 \text{ cfm} \times (97.49 - 65.8^\circ\text{F})$
- Htg. Coil Capacity = 17,194 Btu/hr = 17.19 MBH

Interpolating from the heating coil performance tables ([Table 16, p. 38](#)), the required performance can be met with a 1-row coil operating at 3.28 gpm with approximately 0.07 in. w.g. of air pressure drop ([Table 7, p. 30](#)).

Fan Selection/Confirmation

The fan must have the capability to deliver the required airflow and overcome all the static pressure resistances. This includes the downstream static pressure, cooling coil pressure drop and heating coil pressure drop, if applicable.

- Downstream static = 0.25 in. w.g.
- Cooling coil pressure drop = 0.06 in. w.g.

- Heating coil pressure drop = 0.07 in. w.g.
- Total static resistance = 0.35 in. w.g.

The fan curves shown in indicate the DS02 fan has sufficient static pressure capability to overcome all the resistances shown above when delivering the required 500 cfm. For more precise selections, Trane Select Assist™ should be used.

Acoustic Performance

The acoustical performance of the unit will be based on the fan airflow, ventilation (primary) airflow and the pressure drop across the air valve. In this example, assume the pressure drop at the inlet of the air valve is 0.5-inch. Particularly for acoustics, prediction should be developed using an electronic selection program such as Trane Select Assist™ for the specific operating point. As a rough approximation, interpolation from the data points in through [Table 31, p. 55](#) can be used. Once these sound power results are obtained, the appropriate transfer functions shown in [Table 34, p. 61](#) and [Table 35, p. 61](#) can be used to determine the predicted sound pressure. These sound pressure results can be plotted on an NC curve to determine the resulting approximate NC value.

	Octave Bands						NC
	2	3	4	5	6	7	
Discharge	68	63	62	59	54	51	21 (2)
Radiated	61	57	57	52	43	35	31 (4)



Model Number

CoolSense™ Chilled Water Sensible Cooling Terminal Units

Digit 1, 2, 3, 4 — Unit Model

LDCF = LH Series DOAS Fan Powered - Cooling Only
LDEF = LH Series DOAS Fan Powered - With Electric Heat
LDWF = LH Series DOAS Fan Powered - With Hot Water
VDCG = Series DOAS Fan Powered - Cooling Only
VDEG = Series DOAS Fan Powered - With Electric Heat
VDWG = Series DOAS Fan Powered - With Hot Water

Digit 5, 6 — Primary Inlet

04 = 4 in. inlet (225 cfm)
05 = 5 in. inlet (350 cfm)
06 = 6 in. inlet (500 cfm)
08 = 8 in. inlet (900 cfm)
10 = 10 in. inlet (1400 cfm)
12 = 12 in. inlet (2000 cfm)
RT = 8 in. x 14 in. inlet (1800 cfm)

Digit 7, 8 — Secondary Inlet

00 = N/A

Digit 9 — Fan

B = Low Height Fan - 100 to 1300 Cfm
1 = Small
2 = Medium
3 = Large

Digit 10, 11 — Design Sequence

** = Factory Assigned

Digit 12, 13, 14, 15 — Controls

DD00 = Trane Actuator Only
DE41 = Symbio™ 500 DDC - Sensible Cooling - Basic (No Water or Electric Heat)
DE43 = Symbio™ 500 DDC - Sensible Cooling - Basic (Water Heat - Modulating)
DE44 = Symbio™ 500 DDC - Sensible Cooling - Basic (Electric Heat - Staged)
DE62 = Symbio™ 500 DDC - Sensible Cooling - Basic Plus Local (Electric Heat - Staged) Remote (Staged EH)
DE65 = Symbio™ 500 DDC - Sensible Cooling - Basic (Electric Heat - Modulating SCR)
DE66 = Symbio™ 500 DDC - Sensible Cooling - Basic Plus Local (Electric Heat - Modulating SCR) Remote (Staged EH)
ENCL = Shaft Only in Enclosure
FM00 = Other Actuator and Control
FM01 = Trane Supplied Actuator, Other Control
SC41 = UC400 DDC - Sensible Cooling - Basic (No Water or Electric Heat)
SC43 = UC400 DDC - Sensible Cooling - Basic (Water Heat, Modulating)
SC44 = UC400 DDC - Sensible Cooling - Basic (Electric Heat- Staged)

Digit 12, 13, 14, 15 — Unit Controls (continued)

SC62 = UC400 DDC - Sensible Cooling- Basic Plus Local (Electric Heat - Staged), Remote (Staged)
SC65 = UC400 DDC - Sensible Cooling- Basic (Electric Heat Modulating SCR)
SC66 = UC400 DDC - Sensible Cooling- Basic Plus Local (Electric Heat - Modulating SCR) Remote (Staged)

Digit 16 — Insulation

B = 1 in. Matte-faced
D = 1 in. Foil-faced
F = 1 in. Double Wall
G = 3/8 in. Closed-cell
S = Special Motor

Digit 17 — Motor Type

F = Variable Speed High-efficiency Electronically Commutated Motor (ECV)

Digit 18 — Motor Voltage

1 = 115/60/1
2 = 277/60/1
4 = 208/60/1
S = Special Motor

Digit 19 — Outlet Connection

1 = Flanged Connection VDCG and VDEG
2 = Slip and Drive Connection VDWG

Digit 20 — Attenuator

0 = No Attenuator
S = Special Attenuator

Digit 21 — Water Coil

0 = None
3 = 1 Row, Discharge Installed, LH
4 = 1 Row, Discharge Installed, RH
5 = 2 Row, Discharge Installed, LH
6 = 2 Row, Discharge Installed, RH
C = 1 Row Premium, Hot Coil on Discharge, LH
D = 1 Row Premium, Hot Coil on Discharge, RH
E = 2 Row Premium, Hot Coil on Discharge, LH
F = 2 Row Premium, Hot Coil on Discharge, RH
G = One Row Water Coil
H = Two Row Water Coil
J = Three Row Water Coil
K = Four Row Water Coil
L = One Row Premium Water Coil
M = Two Row Premium Water Coil
N = Three Row Premium Water Coil
P = Four Row Premium Water Coil
S = Special Hot Water Coil

Digit 22 — Control, Heat Connection

1 = Same Side Connection - Coil and Control
2 = Coil Connection Opposite of Control
F = Flippable Left and Right Hand

Digit 23 — Unit Filter.

0 = Construction Throw-Away Filter
8 = MERV 8 Filter
3 = MERV 13 Filter
S = Special Filter

Digit 24 — Disconnect Switch

0 = None
W = With

Digit 25 — Power Fuse

0 = None
W = With

Digit 26 — Electric Heater Voltage

0 = None
A = 208/60/1
B = 208/60/3
C = 240/60/1
D = 277/60/1
E = 480/60/1
F = 480/60/3
J = 380/50/3
K = 120/60/1
S = Special Electric Heater Voltage

Digit 27, 28, 29 — Electric Heat kW

000 = None
005 = 0.5 kW
010 = 1.0 kW
015 = 1.5 kW
200 = 20.0 kW

Notes:

- 0.5 to 8.0 kW in 1/2 kW increments
- 8.0 to 18.0 kW in 1 kW increments
- 18.0 to 20.0 kW in 2 kW increments

Digit 30 — Electric Heat Stages

0 = None
1 = 1 Stage
2 = 2 Stages Equal

Digit 31 — Electric Heat Control

0 = None
1 = 24V Magnetic
5 = SCR Heat with Trane Controls
6 = SCR Heat, FM00/ENCL/DD00
7 = Solid State Relay
8 = Special Electric Heater Control

Digit 32 — Airflow Switch

0 = None
W = With

Digit 33 — Not Used

0 = Not Applicable

Digit 34 — Actuator

0 = Standard Actuator - Floating Point
A = Belimo Actuator - Floating Point
B = Spring Return Actuator - Normally Open
C = Spring Return Actuator - Normally Closed
G = Trane Analog Actuator - Trane Controls Only
S = Special Actuator

Digit 35 — Wireless Sensors

0 = None
3 = Air-Fi® Wireless Communications
Note: All sensors selected in accessories.

Digit 36 — Pre-Wired Factory Solutions

0 = None
1 = Factory Terminated/Field Installed DTS
4 = Factory Terminated and Installed - DTS in Plenum
6 = Factory Terminated and Installed - DTS in Plenum and Factory Terminated/Field Installed CW and HW Valve Harness
7 = CW Valve Harness - Factory Wired
8 = CW and HW Valve Harness - Factory Wired
B = DTS with CW Valve Harness - Factory Wired

Digit 37 — Not Used

0 = Not Applicable

Digit 38 — Hot Water Piping Package

0 = None
A = 2-Way Automatic Balancing
B = 3-Way Automatic Balancing
C = 2-Way Standard Valve Only, Floating Point Actuator
D = 3-Way Standard Valve Only, Floating Point Actuator
E = 2-Way Standard Valve Piping Package, Floating Point Actuator
F = 3-Way Standard Valve Piping Package, Floating Point Actuator
G = 2-Way Belimo Valve Only, Floating Point Actuator
H = 3-Way Belimo Valve Only, Floating Point Actuator
J = 2-Way Belimo Valve Piping Package, Floating Point Actuator
K = 3-Way Belimo Valve Piping Package, Floating Point Actuator
L = 2-Way Belimo Valve Only, Analog Actuator

Digit 38 — Hot Water Piping Package (continued)

M = 3-Way Belimo Valve Only, Analog Actuator
N = 2-Way Belimo Valve Piping Package, Analog Actuator
P = 3-Way Belimo Valve Piping Package, Analog Actuator

Digit 39 — Hot Water Valve

0 = None
1 = Trane HW Valve, 0.7 Cv
2 = Trane HW Valve, 2.7 Cv
5 = Analog, HW Valve, field provided (Symbio™ 500, UC400)
6 = Trane HW Valve, 1.7 Cv
7 = Trane HW Valve, 5.0 Cv
A = Belimo HW Valve, 0.3 Cv
B = Belimo HW Valve, 0.46 Cv
C = Belimo HW Valve, 0.8 Cv
D = Belimo HW Valve, 1.2 Cv
E = Belimo HW Valve, 1.9 Cv
F = Belimo HW Valve, 3.0 Cv
G = Belimo HW Valve, 4.7 Cv

Digit 40 — Hot Water Flow Rate

0 = None (No Flow Rate)
A = 0.5 gpm (0.03 L/s)
B = 1 gpm (0.06 L/s)
C = 1.5 gpm (0.09 L/s)
D = 2 gpm (0.13 L/s)
E = 2.5 gpm (0.16 L/s)
F = 3 gpm (0.19 L/s)
G = 3.5 gpm (0.22 L/s)
H = 4 gpm (0.25 L/s)
J = 4.5 gpm (0.28 L/s)
K = 5 gpm (0.32 L/s)
L = 5.5 gpm (0.35 L/s)
M = 6 gpm (0.38 L/s)
N = 6.5 gpm (0.41 L/s)
P = 7 gpm (0.44 L/s)
Q = 7.5 gpm (0.47 L/s)

Digit 41 — Sensible Cooling Coil

4 = 4-Row Standard Cooling Coil
6 = 6-Row Standard Cooling Coil

Digit 42 — Chilled Water Coil Connections

D = Cooling Coil Connections at Unit Discharge End
V = Cooling Coil Connections at Air Valve End

Digit 43 — Chilled Water Piping Package

0 = None
C = 2-Way Standard Valve Only, Floating Point Actuator
D = 3-Way Standard Valve Only, Floating Point Actuator
E = 2-Way Standard Valve Piping Package, Floating Point Actuator

Digit 43 — Chilled Water Piping Package (continued)

F = 3-Way Standard Valve Piping Package, Floating Point Actuator
G = 2-Way Belimo Valve Only, Floating Point Actuator
H = 3-Way Belimo Valve Only, Floating Point Actuator
J = 2-Way Belimo Valve Piping Package, Floating Point Actuator
K = 3-Way Belimo Valve Piping Package, Floating Point Actuator
L = 2-Way Belimo Valve Only, Analog Actuator
M = 3-Way Belimo Valve Only, Analog Actuator
N = 2-Way Belimo Valve Piping Package, Analog Actuator
P = 3-Way Belimo Valve Piping Package, Analog Actuator

Digit 44 — Chilled Water Valve

0 = None
1 = Trane CW Valve, 0.7 Cv
2 = Trane CW Valve, 2.7 Cv
5 = Analog CW Valve, Field-Provided (Symbio™ 500, UC400)
6 = Trane CW Valve, 1.7 Cv
7 = Trane CW Valve, 5.0 Cv
A = Belimo CW Valve, 0.3 Cv
B = Belimo CW Valve, 0.46 Cv
C = Belimo CW Valve, 0.8 Cv
D = Belimo CW Valve, 1.2 Cv
E = Belimo CW Valve, 1.9 Cv
F = Belimo CW Valve, 3.0 Cv
G = Belimo CW Valve, 4.7 Cv

Digit 45 — Chilled Water Flow Rate

0 = None (No Flow Rate)
A = 0.5 gpm (0.03 L/s)
B = 1 gpm (0.06 L/s)
C = 1.5 gpm (0.09 L/s)
D = 2 gpm (0.13 L/s)
E = 2.5 gpm (0.16 L/s)
F = 3 gpm (0.19 L/s)
G = 3.5 gpm (0.22 L/s)
H = 4 gpm (0.25 L/s)
J = 4.5 gpm (0.28 L/s)
K = 5 gpm (0.32 L/s)
L = 5.5 gpm (0.35 L/s)
M = 6 gpm (0.38 L/s)
N = 6.5 gpm (0.41 L/s)
P = 7 gpm (0.44 L/s)
Q = 7.5 gpm (0.47 L/s)
R = 8.0 gpm (0.50 L/s)



Performance Data

Table 3. Ventilation (primary) airflow control factory settings – I-P

Air Valve Size (in.)	Maximum Valve (Cfm)	Maximum Controller (Cfm)	Minimum Controller (Cfm)	Constant Volume (Cfm)
4	225	25-225	0 or 25-225	25-225
5	350	40-350	0 or 40-350	40-350
6	500	60-500	0 or 60-500	60-500
8	900	105-900	0 or 105-900	105-900
10	1400	165-1400	0 or 165-1400	165-1400
12	2000	240-2000	0 or 240-2000	240-2000
8x14	1300	220-1300	0 or 220-1300	220-1300

Table 4. Ventilation (primary) airflow control factory settings – SI

Air Valve Size (in.)	Maximum Valve (L/s)	Maximum Controller (L/s)	Minimum Controller (L/s)	Constant Volume (L/s)
4	106	12-106	0, 12-106	12-106
5	165	19-165	0, 19-165	19-165
6	236	28-236	0, 28-236	28-236
8	425	50-425	0, 50-425	50-425
10	661	77-661	0 or 77-661	77-661
12	944	111-944	0 or 111-944	111-944
8x14	614	104-614	0, 104-614	104-614

Note: Maximum airflow must be greater than or equal to minimum airflow.

Table 5. Cooling coil air pressure drop

Airflow (cfm)	I-P						SI										
	DS02		Small		Medium		Large		DS02		Small		Medium		Large		
	4-row (in. wg)	6-row (in. wg)	4-row (in. wg)	6-row (in. wg)	4-row (in. wg)	6-row (in. wg)	4-row (in. wg)	6-row (in. wg)	Airflow (L/s)	4-row (Pa)	6-row (Pa)	4-row (Pa)	6-row (Pa)	4-row (Pa)	6-row (Pa)	4-row (Pa)	6-row (Pa)
100	0.01	0.01	-	-	-	-	-	-	47	2.5	2.5	-	-	-	-	-	-
200	0.02	0.03	0.01	0.01	-	-	-	-	94	5.0	7.5	2.5	2.5	-	-	-	-
300	0.04	0.06	0.02	0.02	-	-	-	-	142	10.0	14.9	5.0	5.0	-	-	-	-
400	0.06	0.09	0.02	0.04	0.02	0.04	0.02	0.02	189	14.9	22.4	5.0	10.0	5.0	10.0	5.0	5.0
500	0.09	0.13	0.04	0.05	0.04	0.05	0.02	0.04	236	22.4	32.3	10.0	12.4	10.0	12.4	5.0	10.0
600	0.12	0.18	0.05	0.07	0.05	0.07	0.03	0.05	283	29.9	44.8	12.4	17.4	12.4	17.4	7.5	12.4
700	0.15	0.23	0.06	0.09	0.06	0.09	0.04	0.06	330	37.3	57.2	14.9	22.4	14.9	22.4	10.0	14.9
800	0.19	0.29	0.08	0.12	0.08	0.12	0.05	0.08	378	47.3	72.2	19.9	29.9	19.9	29.9	12.4	19.9
900	0.23	0.35	0.09	0.14	0.09	0.14	0.06	0.09	425	57.2	87.1	22.4	34.8	22.4	34.8	14.9	22.4
1000	0.28	0.42	0.11	0.17	0.11	0.17	0.07	0.11	472	69.7	104.5	27.4	42.3	27.4	42.3	17.4	27.4
1100	0.33	0.49	0.13	0.19	0.13	0.19	0.09	0.13	519	82.1	121.9	32.3	47.3	32.3	47.3	22.4	32.3
1200	0.38	0.57	0.15	0.22	0.15	0.22	0.1	0.15	566	94.5	141.8	37.3	54.7	37.3	54.7	24.9	37.3
1300	0.43	0.65	-	-	0.17	0.26	0.11	0.17	614	107.0	161.7	-	-	42.3	64.7	27.4	42.3
1400	-	-	-	-	0.19	0.29	0.12	0.19	661	-	-	-	-	47.3	72.2	29.9	47.3
1500	-	-	-	-	0.22	0.33	0.14	0.21	708	-	-	-	-	54.7	82.1	34.8	52.2
1600	-	-	-	-	0.24	0.36	0.16	0.24	755	-	-	-	-	59.7	89.6	39.8	59.7
1700	-	-	-	-	0.27	0.40	0.18	0.26	802	-	-	-	-	67.2	99.5	44.8	64.7
1800	-	-	-	-	0.29	0.44	0.19	0.29	850	-	-	-	-	72.2	109.5	47.3	72.2
1900	-	-	-	-	0.32	0.48	0.21	0.32	897	-	-	-	-	79.6	119.4	52.2	79.6
2000	-	-	-	-	0.35	0.52	0.23	0.34	944	-	-	-	-	87.1	129.4	57.2	84.6
2100	-	-	-	-	-	-	0.25	0.37	991	-	-	-	-	-	-	62.2	92.1
2200	-	-	-	-	-	-	0.27	0.4	1038	-	-	-	-	-	-	67.2	99.5
2300	-	-	-	-	-	-	0.29	0.43	1085	-	-	-	-	-	-	72.2	107.0



Performance Data

Table 6. Hot water coil pressure drop – LDWF

Unit Size	I-P			SI		
	Airflow (Cfm)	1-Row HW (in. wg)	2-Row HW (in. wg)	Airflow (L/s)	1-Row HW (Pa)	2-Row HW (Pa)
DS02	100	0.00	0.01	47	1	3
	300	0.04	0.08	142	10	20
	500	0.07	0.19	236	17	47
	800	0.12	0.28	378	30	70
	1100	0.22	0.40	519	55	100
	1300	0.30	0.52	614	75	130

Table 7. Hot water coil air pressure drop – VDWG

Unit Size	I-P					SI				
	Airflow (Cfm)	1-Row (in. wg)	2-Row (in. wg)	3-Row (in. wg)	4-Row (in. wg)	Airflow (L/s)	1-Row (Pa)	2-Row (Pa)	3-Row (Pa)	4-Row (Pa)
Small	200	0.01	0.02	0.03	0.04	94	2.7	5.2	8.0	10.9
	400	0.03	0.06	0.09	0.12	189	7.2	14.4	22.1	29.9
	600	0.06	0.11	0.17	0.23	283	13.7	27.6	42.0	56.5
	800	0.09	0.18	0.27	0.36	378	21.9	43.8	66.9	90.1
	1000	0.13	0.26	0.39	0.52	472	31.6	63.4	96.5	130.1
Medium	400	0.02	0.04	0.05	0.07	189	4.2	9.0	13.4	18.2
	750	0.05	0.09	0.14	0.19	354	11.4	23.1	35.3	47.5
	1100	0.09	0.17	0.26	0.36	519	21.1	43.0	65.7	88.3
	1450	0.13	0.27	0.42	0.56	684	33.3	67.9	103.5	139.1
	1800	0.19	0.39	0.59	0.80	850	48.0	97.3	147.8	198.8
Large	500	0.02	0.03	0.05	0.06	236	3.7	7.7	11.7	15.8
	900	0.04	0.08	0.12	0.16	425	9.2	18.9	28.9	38.6
	1300	0.07	0.14	0.21	0.28	614	16.7	34.1	51.8	69.4
	1700	0.10	0.21	0.32	0.43	802	25.9	52.5	79.9	107.7
	2100	0.15	0.30	0.46	0.61	991	36.6	74.6	113.2	152.3

Figure 10. Performance data fan curve, LDxF DS02 – ECM

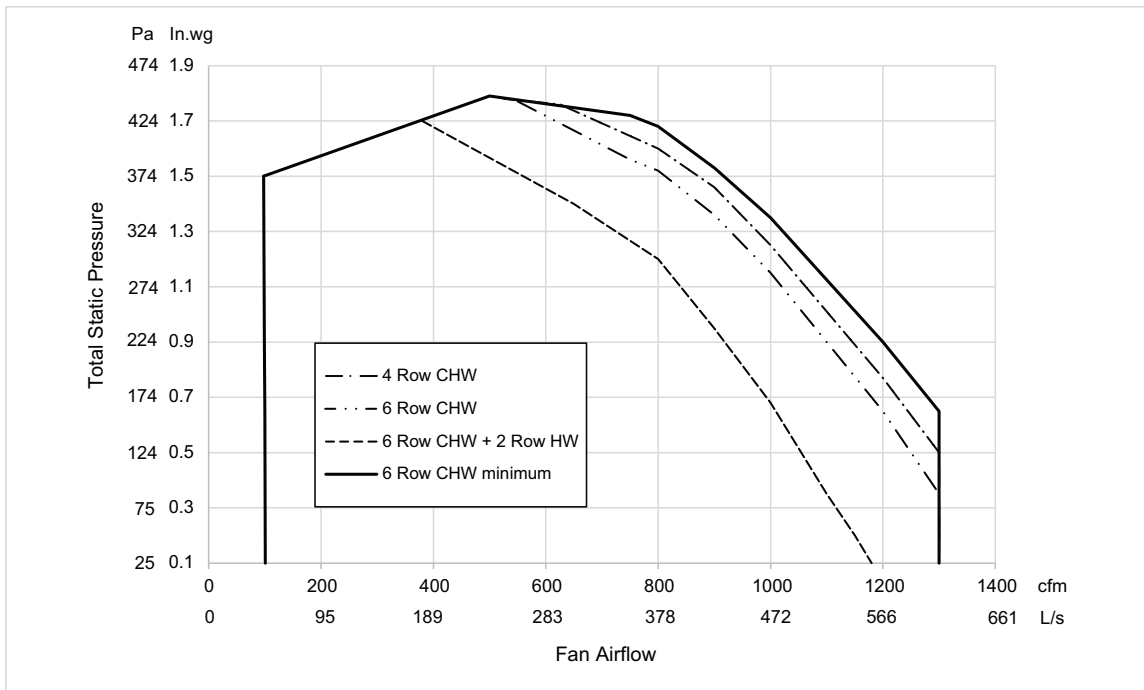

Figure 11. Performance data fan curves, small VDxG – 4 row

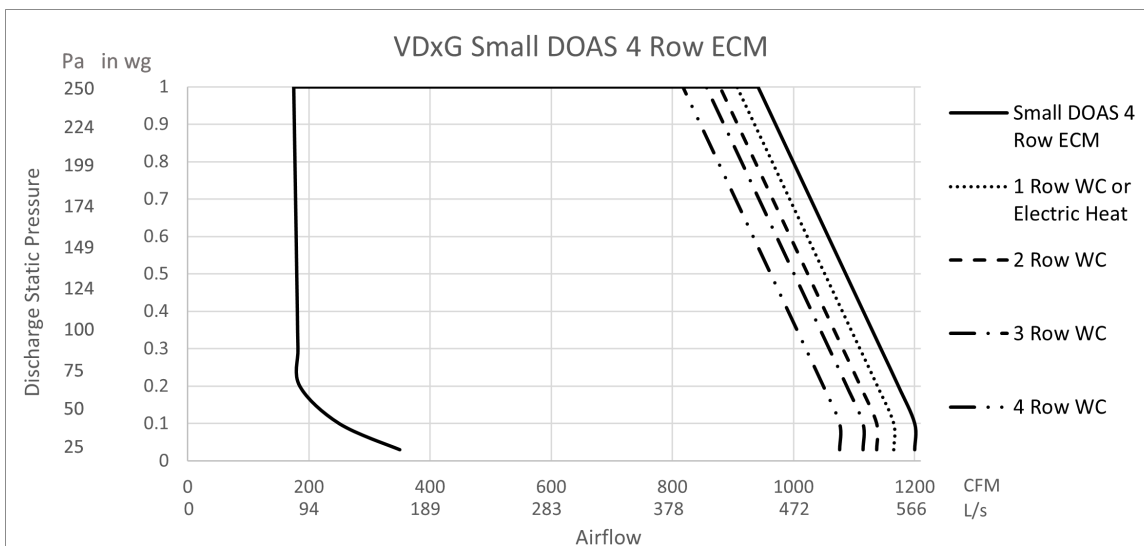

Figure 12. Performance data fan curves, medium VDxG – 4 row

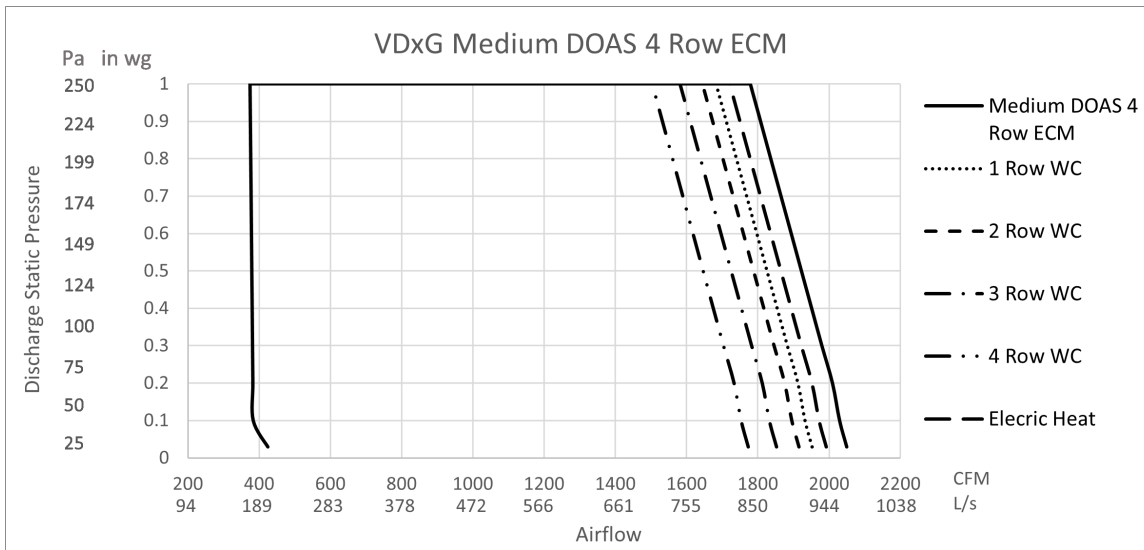

Figure 13. Performance data fan curves, large VDxG – 4 row

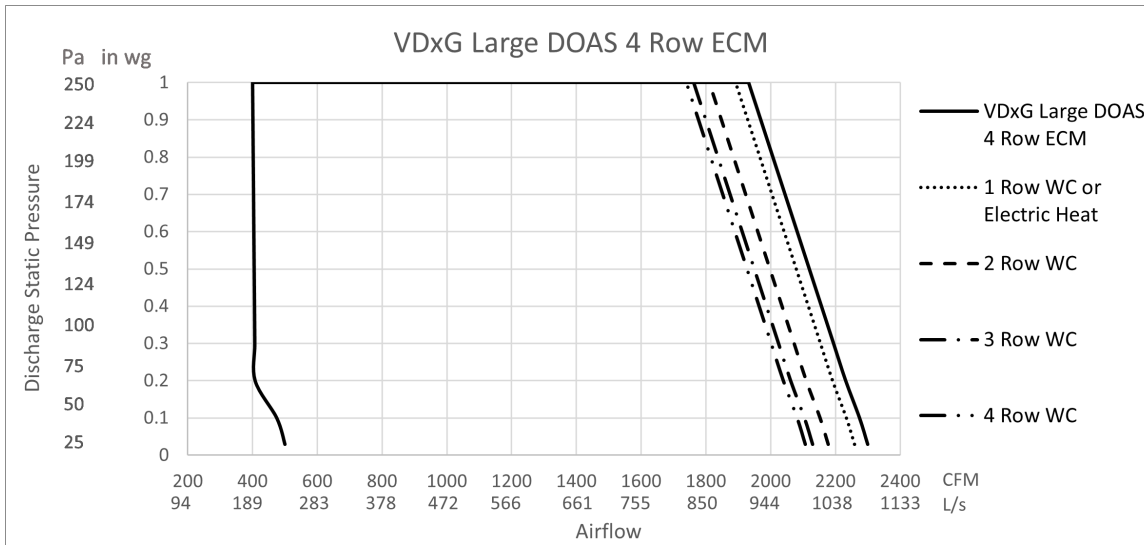

Figure 14. Performance data fan curves, small VDxG – 6 row

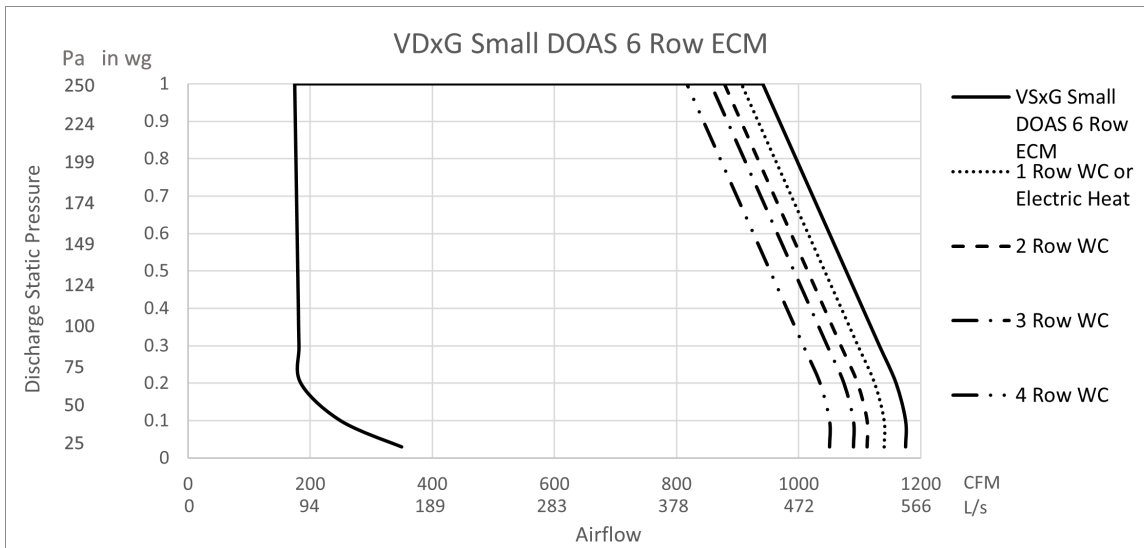
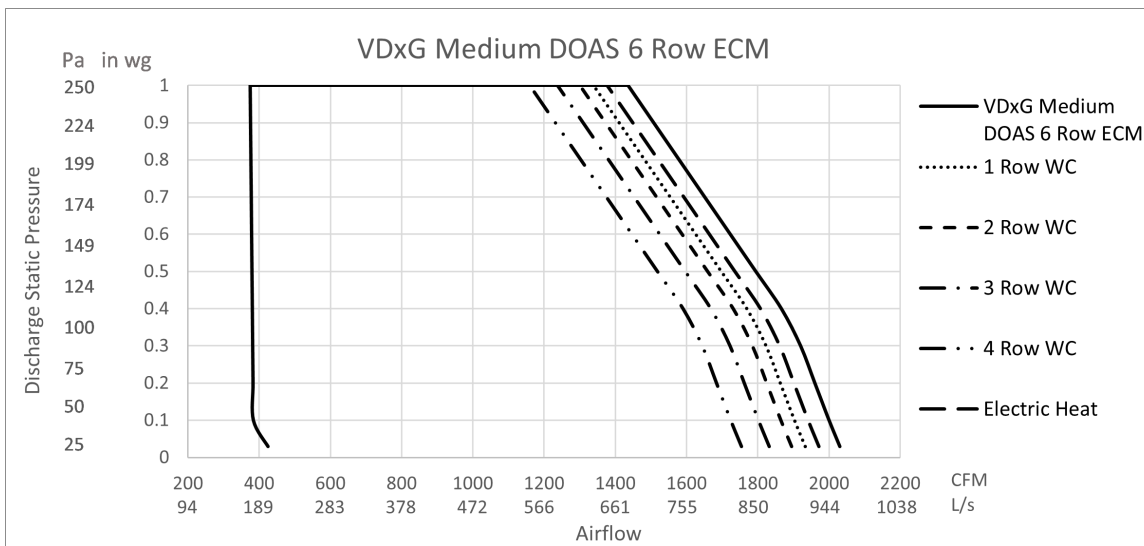

Figure 15. Performance data fan curves, medium VDxG – 6 row





Performance Data

Figure 16. Performance data fan curves, large VDxG – 6 row

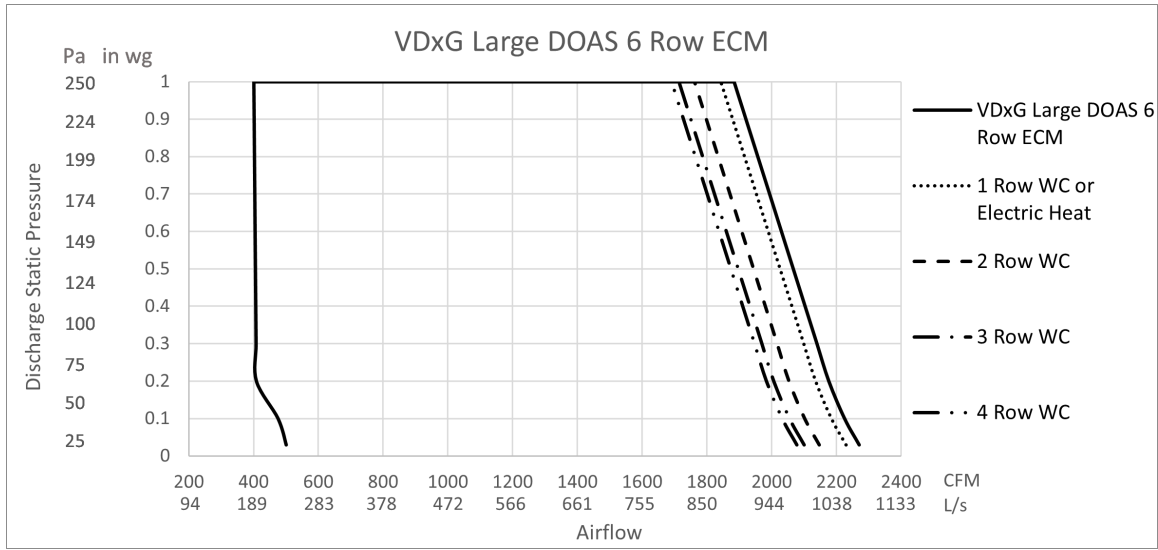

Table 8. Cooling capacity (MBH), LDxF – I-P

Rows	Water Flow Rate (gpm)	Water Pressure Drop (ft)	Cooling Coil Airflow (Cfm)												
			100	200	300	400	500	600	700	800	900	1000	1100	1200	1300
4	1.0	0.37	1.90	3.30	4.20	4.80	5.30	5.60	5.90	6.10	6.30	6.40	6.60	6.70	6.80
	2.0	1.27	2.00	3.70	5.10	6.30	7.20	8.00	8.70	9.30	9.80	10.20	10.60	10.90	11.20
	3.0	2.62	2.00	3.80	5.30	6.70	7.80	8.90	9.70	10.50	11.20	11.90	12.40	12.90	13.40
	4.0	4.44	2.00	3.80	5.40	6.90	8.20	9.30	10.30	11.20	12.10	12.80	13.50	14.20	14.70
	5.0	6.67	2.00	3.80	5.50	7.00	8.30	9.60	10.70	11.70	12.60	13.50	14.20	15.00	15.60
	6.0	9.37	2.00	3.90	5.60	7.10	8.50	9.70	10.90	12.00	13.00	13.90	14.80	15.50	16.30
	7.0	12.44	2.00	3.90	5.60	7.20	8.60	9.90	11.10	12.20	13.30	14.30	15.20	16.00	16.80
	8.0	15.92	2.00	3.90	5.60	7.20	8.70	10.00	11.30	12.40	13.50	14.50	15.50	16.40	17.20
6	1.0	0.34	2.00	3.60	4.70	5.50	6.00	6.40	6.70	6.90	7.10	7.30	7.40	7.60	7.70
	2.0	1.14	2.00	3.90	5.60	7.00	8.20	9.20	10.10	10.80	11.40	11.90	12.30	12.70	13.00
	3.0	2.36	2.00	3.90	5.80	7.40	8.80	10.10	11.20	12.20	13.10	13.90	14.60	15.20	15.80
	4.0	3.96	2.00	3.90	5.90	7.60	9.10	10.50	11.80	13.00	14.10	15.00	15.90	16.70	17.50
	5.0	5.94	2.00	3.90	5.90	7.70	9.30	10.80	12.20	13.50	14.70	15.80	16.80	17.70	18.60
	6.0	8.29	2.00	3.90	5.90	7.70	9.40	11.00	12.40	13.80	15.10	16.20	17.30	18.40	19.30
	7.0	11.11	2.00	3.90	5.90	7.90	9.50	11.10	12.60	14.10	15.40	16.60	17.80	18.90	20.00
	8.0	14.20	2.00	3.90	5.90	7.90	9.60	11.20	12.80	14.20	15.60	16.90	18.10	19.30	20.40

Note: Data taken with entering water temperature 57°F and entering air dry bulb temperature 75°F.

Table 9. Cooling capacity (MBH), small (VDxG) – I-P

Rows	Water Flow Rate (gpm)	Water Pressure Drop (ft)	Airflow (Cfm)								
			200	300	400	500	600	700	800	900	1000
4	1	0.13	3.43	4.50	5.24	5.76	6.13	6.41	6.63	6.81	6.95
	2	0.42	3.65	5.06	6.19	7.10	7.83	8.43	8.92	9.34	9.69
	3	0.86	3.78	5.43	6.88	8.14	9.23	10.18	11.01	11.73	12.37
	4	1.46	3.84	5.60	7.21	8.67	9.98	11.17	12.23	13.39	14.06
	5	2.19	3.86	5.67	7.36	8.93	10.37	11.70	12.92	14.03	15.06
	6	3.05	3.88	5.71	7.45	9.08	10.60	12.02	13.34	14.56	15.69
	7	4.05	3.89	5.74	7.50	9.17	10.75	12.23	13.61	14.91	16.12
	8	5.17	3.89	5.75	7.54	9.24	10.85	12.37	13.81	15.16	16.43
6	1	0.13	3.72	5.06	5.98	6.61	7.04	7.35	7.57	7.74	7.87
	2	0.042	3.86	5.55	6.99	8.17	9.14	9.93	10.58	11.11	11.56
	3	0.86	3.92	5.77	7.49	9.05	10.45	11.68	12.76	13.72	14.56
	4	1.45	4.37	5.85	7.68	9.41	11.02	12.51	13.87	15.11	16.24
	5	2.18	-	5.87	7.75	9.56	11.28	12.9	14.42	15.83	17.15
	6	3.04	-	5.89	7.79	9.64	11.41	13.11	14.72	16.25	17.69
	7	4.04	-	5.89	7.81	9.68	11.49	13.24	14.91	16.51	18.03
	8	5.16	-	6.55	7.82	9.71	11.54	13.32	15.04	16.68	18.26

Note: Data taken with entering water temperature 57°F and entering air dry bulb temperature 75°F.

Table 10. Cooling capacity (MBH), medium (VDxG) – I-P

Rows	Water Flow Rate (gpm)	Water Pressure Drop (ft)	Airflow (Cfm)							
			500	700	900	1100	1300	1500	1700	1900
4	1	0.13	5.76	6.41	6.81	7.06	7.24	7.37	7.48	7.56
	2	0.41	7.10	8.43	9.34	10.00	10.49	10.88	11.19	11.44
	3	0.86	8.14	10.18	11.73	12.94	13.89	14.67	15.31	15.85
	4	1.45	8.67	11.17	13.19	14.84	16.2	17.34	18.3	19.12
	5	2.18	8.93	11.7	14.03	16.00	17.67	19.09	20.32	21.40
	6	3.04	9.08	12.02	14.56	16.75	18.64	20.29	21.74	23.01
	7	4.04	9.17	12.23	14.91	17.26	19.33	21.15	22.77	24.21
	8	5.16	9.24	12.37	15.16	17.63	19.83	21.79	23.54	25.11
6	1	0.13	6.61	7.35	7.74	7.98	8.13	8.24	8.32	8.38
	2	0.41	8.17	9.93	11.11	11.95	12.55	13.01	13.37	13.66
	3	0.86	9.05	11.68	13.72	15.3	16.54	17.53	18.32	18.98
	4	1.45	9.41	12.51	15.11	17.27	19.05	20.54	21.78	22.82
	5	2.18	9.56	12.9	15.83	18.38	20.56	22.44	24.05	25.45
	6	3.04	9.64	13.11	16.25	19.04	21.51	23.68	25.59	27.27
	7	4.04	9.68	13.24	16.51	19.48	22.14	24.53	26.66	28.57
	8	5.16	9.71	13.32	16.68	19.97	22.58	25.13	27.44	29.53

Note: Data taken with entering water temperature 57°F and entering air dry bulb temperature 75°F.



Performance Data

Table 11. Cooling capacity (MBH), large (VDxG) – I-P

Rows	Water Flow Rate (gpm)	Water Pressure Drop (ft)	Airflow (Cfm)								
			500	700	900	1100	1300	1500	1700	1900	2100
4	1	0.08	6.04	6.74	7.15	7.42	7.59	7.72	7.82	7.9	7.96
	2	0.23	7.45	8.93	9.95	10.68	11.23	11.66	12	12.28	12.51
	3	0.48	8	9.94	11.39	12.5	13.38	14.09	14.68	15.17	15.58
	4	0.82	8.67	11.15	13.15	14.77	16.1	17.2	18.14	18.93	19.62
	5	1.23	8.99	11.8	14.16	16.15	17.84	19.28	20.52	21.6	22.54
	6	1.73	9.17	12.17	14.79	17.05	19.00	20.71	22.2	23.52	24.68
	7	2.31	9.27	12.41	15.2	17.65	19.81	21.72	23.42	24.93	26.28
	8	2.97	9.34	12.58	15.48	18.08	20.39	22.47	24.33	26	27.51
6	1	0.09	6.85	7.62	8.01	8.23	8.37	8.47	8.53	8.58	8.62
	2	0.26	8.46	10.38	11.68	12.59	13.24	13.73	14.1	14.4	14.64
	3	0.53	8.96	11.49	13.42	14.91	16.08	17	17.75	18.36	18.87
	4	0.9	9.41	12.5	15.08	17.21	18.97	20.43	21.64	22.67	23.53
	5	1.35	9.59	12.96	15.93	18.51	20.72	22.62	24.25	25.66	26.87
	6	1.88	9.67	13.2	16.4	19.27	21.81	24.04	26.01	27.74	29.27
	7	2.5	9.72	13.34	16.69	19.75	22.52	25	27.23	29.22	31.01
	8	3.19	9.75	13.43	16.87	20.07	23	25.67	28.1	30.3	32.3

Note: Data taken with entering water temperature 57°F and entering air dry bulb temperature 75°F.

Table 12. Cooling capacity (kW), LDxF – SI

Rows	Water Flow Rate (L/s)	Water Pressure Drop (kPa)	Airflow (L/s)												
			47	94	142	189	236	283	330	378	425	472	519	566	614
4	0.06	1.11	0.56	0.97	1.23	1.41	1.55	1.64	1.73	1.79	1.85	1.88	1.93	1.96	1.99
	0.13	3.80	0.59	1.08	1.49	1.85	2.11	2.34	2.55	2.73	2.87	2.99	3.11	3.19	3.28
	0.19	7.83	0.59	1.11	1.55	1.96	2.29	2.61	2.84	3.08	3.28	3.49	3.63	3.78	3.93
	0.25	13.27	0.59	1.11	1.58	2.02	2.40	2.73	3.02	3.28	3.55	3.75	3.96	4.16	4.31
	0.32	19.94	0.59	1.11	1.61	2.05	2.43	2.81	3.14	3.43	3.69	3.96	4.16	4.40	4.57
	0.38	28.01	0.59	1.14	1.64	2.08	2.49	2.84	3.19	3.52	3.81	4.07	4.34	4.54	4.78
	0.44	37.18	0.59	1.14	1.64	2.11	2.52	2.90	3.25	3.58	3.90	4.19	4.45	4.69	4.92
	0.50	47.58	0.59	1.14	1.64	2.11	2.55	2.93	3.31	3.63	3.96	4.25	4.54	4.81	5.04
6	0.06	1.02	0.59	1.06	1.38	1.61	1.76	1.88	1.96	2.02	2.08	2.14	2.17	2.23	2.26
	0.13	3.41	0.59	1.14	1.64	2.05	2.40	2.70	2.96	3.17	3.34	3.49	3.60	3.72	3.81
	0.19	70.50	0.59	1.14	1.70	2.17	2.58	2.96	3.28	3.58	3.84	4.07	4.28	4.45	4.63
	0.25	11.84	0.59	1.14	1.73	2.23	2.67	3.08	3.46	3.81	4.13	4.40	4.66	4.89	5.13
	0.32	17.75	0.59	1.14	1.73	2.26	2.73	3.17	3.58	3.96	4.31	4.63	4.92	5.19	5.45
	0.38	24.78	0.59	1.14	1.73	2.26	2.75	3.22	3.63	4.04	4.43	4.75	5.07	5.39	5.66
	0.44	33.21	0.59	1.14	1.73	2.32	2.78	3.25	3.69	4.13	4.51	4.86	5.22	5.54	5.86
	0.50	42.44	0.59	1.14	1.73	2.32	2.81	3.28	3.75	4.16	4.57	4.95	5.30	5.66	5.98

Note: Data taken with entering water temperature 13.9°C and entering air dry bulb temperature 23.9°C.

Table 13. Cooling capacity (kW), small (VDxG) – SI

Rows	Water Flow Rate (L/s)	Water Pressure Drop (kpa)	Airflow (L/s)								
			94	142	189	236	283	330	378	425	472
4	0.06	0.39	1.01	1.32	1.54	1.69	1.80	1.88	1.94	2.00	2.04
	0.13	1.26	1.07	1.48	1.81	2.08	2.29	2.47	2.61	2.74	2.84
	0.19	2.57	1.11	1.59	2.02	2.39	2.71	2.98	3.23	3.44	3.63
	0.25	4.36	1.13	1.64	2.11	2.54	2.92	3.27	3.58	3.92	4.12
	0.32	6.54	1.13	1.66	2.16	2.62	3.04	3.43	3.79	4.11	4.41
	0.38	9.11	1.14	1.67	2.18	2.66	3.11	3.52	3.91	4.27	4.60
	0.44	12.10	1.14	1.68	2.20	2.69	3.15	3.58	3.99	4.37	4.72
	0.50	15.45	1.14	1.69	2.21	2.71	3.18	3.63	4.05	4.44	4.82
6	0.06	0.39	1.09	1.48	1.75	1.94	2.06	2.15	2.22	2.27	2.31
	0.13	0.13	1.13	1.63	2.05	2.39	2.68	2.91	3.10	3.26	3.39
	0.19	2.57	1.15	1.69	2.20	2.65	3.06	3.42	3.74	4.02	4.27
	0.25	4.33	1.28	1.71	2.25	2.76	3.23	3.67	4.06	4.43	4.76
	0.32	6.51	-	1.72	2.27	2.80	3.31	3.78	4.23	4.64	5.03
	0.38	9.08	-	1.73	2.28	2.83	3.34	3.84	4.31	4.76	5.18
	0.44	12.07	-	1.73	2.29	2.84	3.37	3.88	4.37	4.84	5.28
	0.50	15.42	-	1.92	2.29	2.85	3.38	3.90	4.41	4.89	5.35

Note: Data taken with entering water temperature 13.9°C and entering air dry bulb temperature 23.9°C.

Table 14. Cooling capacity (kW), medium (VDxG) – SI

Rows	Water Flow Rate (L/s)	Water Pressure Drop (kpa)	Airflow (L/s)							
			236	330	425	519	614	708	802	897
4	0.06	0.39	1.69	1.88	2.00	2.07	2.12	2.16	2.19	2.22
	0.13	1.23	2.08	2.47	2.74	2.93	3.07	3.19	3.28	3.35
	0.19	2.57	2.39	2.98	3.44	3.79	4.07	4.30	4.49	4.65
	0.25	4.33	2.54	3.27	3.87	4.35	4.75	5.08	5.36	5.60
	0.32	6.51	2.62	3.43	4.11	4.69	5.18	5.59	5.96	6.27
	0.38	9.08	2.66	3.52	4.27	4.91	5.46	5.95	6.37	6.74
	0.44	12.07	2.69	3.58	4.37	5.06	5.67	6.20	6.67	7.10
	0.50	15.42	2.71	3.63	4.44	5.17	5.81	6.39	6.90	7.36
6	0.06	0.39	1.94	2.15	2.27	2.34	2.38	2.41	2.44	2.46
	0.13	1.23	2.39	2.91	3.26	3.50	3.68	3.81	3.92	4.00
	0.19	2.57	2.65	3.42	4.02	4.48	4.85	5.14	5.37	5.56
	0.25	4.33	2.76	3.67	4.43	5.06	5.58	6.02	6.38	6.69
	0.32	6.51	2.80	3.78	4.64	5.39	6.03	6.58	7.05	7.46
	0.38	9.08	2.83	3.84	4.76	5.58	6.30	6.94	7.50	7.99
	0.44	12.07	2.84	3.88	4.84	5.71	6.49	7.19	7.81	8.37
	0.50	15.42	2.85	3.90	4.89	5.85	6.62	7.36	8.04	8.65

Note: Data taken with entering water temperature 13.9°C and entering air dry bulb temperature 23.9°C.



Performance Data

Table 15. Cooling capacity (kW), large (VDxG) – SI

Rows	Water Flow Rate (L/s)	Water Pressure Drop (kpa)	Airflow (L/s)								
			236	330	425	519	614	708	802	897	991
4	0.06	0.24	1.77	1.98	2.10	2.17	2.22	2.26	2.29	2.32	2.33
	0.13	0.69	2.18	2.62	2.92	3.13	3.29	3.42	3.52	3.60	3.67
	0.19	1.43	2.34	2.91	3.34	3.66	3.92	4.13	4.30	4.45	4.57
	0.25	2.45	2.54	3.27	3.85	4.33	4.72	5.04	5.32	5.55	5.75
	0.32	3.68	2.63	3.46	4.15	4.73	5.23	5.65	6.01	6.33	6.61
	0.38	5.17	2.69	3.57	4.33	5.00	5.57	6.07	6.51	6.89	7.23
	0.44	6.90	2.72	3.64	4.45	5.17	5.81	6.37	6.86	7.31	7.70
	0.50	8.88	2.74	3.69	4.54	5.30	5.98	6.59	7.13	7.62	8.06
6	0.06	9.53	2.01	2.23	2.35	5.88	2.45	2.48	2.50	2.51	2.53
	0.13	0.78	2.48	3.04	3.42	3.69	3.88	4.02	4.13	4.22	4.29
	0.19	1.58	2.63	3.37	3.93	4.37	4.71	4.98	5.20	5.38	5.53
	0.25	2.69	2.76	3.66	4.42	5.04	5.56	5.99	6.34	6.64	6.90
	0.32	4.03	2.81	3.80	4.67	5.42	6.07	6.63	7.11	7.52	7.87
	0.38	5.62	2.83	3.87	4.81	5.65	6.39	7.05	7.62	8.13	8.58
	0.44	7.47	2.85	3.91	4.89	5.79	6.60	7.33	7.98	8.56	9.09
	0.50	9.53	2.86	3.94	4.94	5.88	6.74	7.52	8.24	8.88	9.47

Note: Data taken with entering water temperature 13.9°C and entering air dry bulb temperature 23.9°C.

Table 16. Heating capacity (MBH), LDxF – I-P

Rows	Water Flow Rate (gpm)	Water Pressure Drop (ft)	Airflow (Cfm)												
			100	200	300	400	500	600	700	800	900	1000	1100	1200	1300
1	1.0	0.15	6.87	9.06	10.47	11.53	12.40	13.14	13.77	14.32	14.80	15.07	15.44	15.78	16.09
	2.0	0.58	7.70	10.70	12.78	14.46	15.90	17.15	18.27	19.28	20.20	20.48	21.23	21.93	22.57
	3.0	1.27	7.92	11.16	13.45	15.34	16.97	18.42	19.73	20.92	22.01	23.02	23.83	24.70	25.53
	4.0	2.24	8.08	11.48	13.94	15.98	17.76	19.36	20.82	22.16	23.39	24.54	25.41	26.41	27.36
	5.0	3.48	8.17	11.69	14.25	16.39	18.28	19.99	21.54	22.98	24.32	25.57	26.47	27.57	28.61
	6.0	4.98	8.24	11.83	14.47	16.69	18.65	20.43	22.06	23.58	24.99	26.31	27.24	28.41	29.51
2	1.0	0.76	9.04	14.59	18.26	20.87	22.83	24.35	25.57	26.58	27.42	28.14	28.81	29.34	29.81
	2.0	2.60	9.45	15.95	20.70	24.34	27.24	29.61	31.59	33.28	34.74	36.02	37.48	38.49	39.40
	3.0	5.39	9.59	16.43	21.60	25.68	29.01	31.78	34.14	36.17	37.95	39.53	41.45	42.17	43.86
	4.0	9.06	9.66	16.68	22.08	26.40	29.96	32.96	35.54	37.78	39.75	41.51	43.75	45.19	46.49
	5.0	13.57	9.70	16.83	22.37	26.85	30.56	33.71	36.43	38.80	40.90	42.78	45.25	46.80	48.21

Table 17. Heating capacity (MBH), small (VDxG) – I-P

Rows	Water Flow Rate (gpm)	Water Pressure Drop (kpa)	Airflow (Cfm)							
			300	400	500	600	700	800	900	1000
1	0.50	0.22	13.67	15.11	15.97	16.55	16.98	17.30	17.57	17.80
	1.00	0.74	17.03	19.55	21.40	22.84	23.96	24.87	25.64	26.31
	2.00	2.58	19.34	22.87	25.51	27.58	29.28	30.74	32.03	33.26
	3.00	5.39	20.25	24.23	27.27	29.71	31.74	33.51	35.08	36.50
	4.00	9.13	20.74	24.97	28.24	30.89	33.13	35.08	36.83	38.42
	5.00	13.75	21.04	25.44	28.86	31.66	34.03	36.10	37.97	39.68
2	0.50	0.02	15.18	16.02	16.48	16.78	16.99	17.15	17.28	17.39
	1.00	0.07	21.21	23.47	24.92	25.92	26.67	27.26	27.74	28.14
	2.00	0.26	26.64	31.19	34.53	37.11	39.16	40.86	42.31	43.57
	3.00	0.56	28.47	34.03	38.35	41.82	44.69	47.13	49.25	51.13
	4.00	0.95	29.39	35.50	40.37	44.38	47.76	50.67	53.24	55.54
	5.00	1.45	29.96	36.42	41.66	46.03	49.76	53.01	55.90	58.52
3	0.50	0.03	18.64	19.61	20.14	20.46	20.67	20.83	20.95	21.06
	1.00	0.10	25.85	28.76	30.61	31.89	32.82	33.54	34.12	34.60
	2.00	0.34	31.84	37.79	42.32	45.84	48.66	50.97	52.92	54.60
	3.00	0.72	33.66	40.84	46.68	51.49	55.52	58.95	61.92	64.55
	4.00	1.21	34.51	42.32	48.87	54.42	59.17	63.31	66.97	70.25
	5.00	1.83	35.02	43.21	50.21	56.24	61.48	66.11	70.25	74.00
4	0.50	0.04	21.02	22.04	22.55	22.83	23.02	23.14	23.24	23.31
	1.00	0.12	29.02	32.46	34.64	36.11	37.17	37.96	38.59	39.09
	2.00	0.42	35.01	42.08	47.60	51.94	55.40	58.22	60.57	62.57
	3.00	0.87	36.60	44.99	52.06	58.00	63.02	67.32	69.89	74.31
	4.00	1.47	37.29	46.30	54.15	60.96	66.89	72.10	76.71	80.85
	5.00	2.22	37.68	47.05	55.36	62.72	69.24	75.06	80.29	85.03



Performance Data

Table 18. Heating capacity (MBH), medium (VDxG) – I-P

Rows	Water Flow Rate (gpm)	Water Pressure Drop (kpa)	Airflow (Cfm)							
			500	600	700	900	1100	1300	1500	1700
1	0.50	0.26	19.01	19.65	20.07	20.58	20.90	21.13	21.32	21.47
	1.00	0.98	25.50	27.35	28.74	30.70	32.05	33.08	33.92	34.65
	2.00	3.06	30.32	33.01	35.18	38.55	41.34	43.58	45.48	47.18
	3.00	6.37	32.38	35.57	38.20	42.36	45.61	48.33	50.83	53.11
	4.00	10.50	33.50	36.99	39.89	44.54	48.22	51.34	54.09	56.60
	5.00	16.15	34.22	37.89	40.97	45.95	49.93	53.32	56.33	59.09
2	0.50	0.03	19.75	19.96	20.09	20.22	20.28	20.33	20.37	20.41
	1.00	0.09	28.86	30.99	31.79	32.84	33.52	34.02	34.41	34.74
	2.00	0.30	41.23	44.50	47.07	50.86	53.57	55.66	57.36	58.81
	3.00	0.63	45.41	47.80	53.47	59.15	63.43	66.86	69.74	72.25
	4.00	1.07	47.52	52.60	56.88	63.73	69.07	73.45	77.19	80.48
	5.00	1.63	48.84	47.80	59.05	66.74	72.84	77.92	82.31	86.22
3	0.50	0.03	23.59	23.74	23.80	23.81	23.81	23.81	23.81	24.60
	1.00	0.12	36.00	37.35	38.27	39.44	40.15	40.65	41.03	42.67
	2.00	0.40	49.54	53.82	57.20	62.15	65.61	68.19	70.24	74.38
	3.00	0.83	54.14	59.99	64.90	72.65	78.48	83.08	86.85	93.23
	4.00	1.40	56.32	63.00	68.78	78.25	85.69	91.76	96.88	104.92
	5.00	2.10	57.61	64.81	71.15	81.79	90.37	97.52	103.65	112.95
4	0.50	0.04	25.99	26.02	26.02	26.02	26.02	26.02	26.57	26.57
	1.00	0.15	40.23	41.70	42.67	43.85	44.53	44.98	46.95	47.80
	2.00	0.50	54.95	69.07	64.12	70.00	73.99	76.89	82.16	83.64
	3.00	1.02	59.47	66.46	72.43	81.93	89.05	94.60	103.00	106.39
	4.00	1.72	61.44	69.35	76.36	88.03	97.28	104.80	115.53	120.57
	5.00	2.57	62.54	71.00	78.63	91.71	102.43	111.38	123.83	130.19

Table 19. Heating capacity (MBH), large (VDxG) – I-P

Rows	Water Flow Rate (gpm)	Water Pressure Drop (kpa)	Airflow (Cfm)							
			800	900	1100	1300	1500	1700	1900	2000
1	0.50	0.09	19.41	19.49	19.56	19.60	19.62	19.64	19.66	19.67
	1.00	0.03	31.94	32.71	33.81	34.57	35.14	35.60	35.98	36.16
	2.00	1.21	41.66	43.37	46.37	48.64	50.45	51.96	53.28	53.88
	3.00	2.60	46.16	48.41	52.06	54.96	57.55	59.80	61.78	62.70
	4.00	4.49	48.77	51.36	55.63	59.09	62.00	64.55	66.93	68.07
	5.00	6.86	50.47	53.30	58.01	61.86	65.13	68.01	70.61	71.84
2	0.50	0.15	25.52	25.52	25.52	25.52	25.52	25.52	25.52	25.52
	1.00	0.51	44.79	45.45	46.43	46.81	47.16	47.41	47.61	47.70
	2.00	1.79	62.66	65.23	69.16	72.04	74.26	76.06	77.57	78.24
	3.00	3.76	70.00	73.73	79.78	84.51	88.35	91.57	94.35	95.61
	4.00	6.40	73.94	78.39	85.82	91.82	96.83	101.12	104.89	106.62
	5.00	9.69	76.38	81.30	89.66	96.56	102.41	107.50	112.03	114.12
3	0.50	0.21	28.38	28.38	28.38	28.38	28.38	28.38	28.38	28.38
	1.00	0.69	51.22	51.69	52.17	52.35	52.40	52.40	52.40	52.40
	2.00	2.38	74.08	77.15	81.74	84.94	87.28	89.07	90.49	91.10
	3.00	4.93	83.04	87.83	95.62	101.62	106.39	110.27	113.53	114.97
	4.00	8.32	87.54	93.35	103.18	111.15	117.73	123.29	128.90	130.25
	5.00	12.51	90.19	96.64	107.81	117.13	125.04	131.86	137.86	140.60
4	0.50	0.26	29.80	29.80	29.80	29.80	29.80	29.80	29.80	29.80
	1.00	0.88	51.13	53.56	57.09	59.54	61.33	62.71	63.79	64.25
	2.00	2.97	81.50	84.97	89.92	93.18	95.42	97.00	98.19	98.68
	3.00	6.11	91.29	96.95	106.14	113.12	118.52	122.80	126.28	127.78
	4.00	10.25	95.81	102.72	114.53	124.11	131.98	138.53	144.07	146.54
	5.00	15.35	98.30	105.95	119.41	130.76	140.39	148.65	155.82	159.08



Performance Data

Table 20. Heating Capacity (kW), LDxF – SI

Rows	Water Flow Rate (L/s)	Water Pressure Drop (kPa)	Airflow (L/s)												
			47	94	142	189	236	283	330	378	425	472	519	566	614
1	0.06	0.45	2.01	2.66	3.07	3.38	3.64	3.85	4.04	4.2	4.34	4.42	4.53	4.62	4.72
	0.13	1.73	2.26	3.14	3.75	4.24	4.66	5.03	5.36	5.65	5.92	6	6.22	6.43	6.61
	0.19	3.8	2.32	3.27	3.94	4.5	4.97	5.4	5.78	6.13	6.45	6.75	6.98	7.24	7.48
	0.25	6.7	2.37	3.36	4.09	4.68	5.2	5.67	6.1	6.49	6.86	7.19	7.45	7.74	8.02
	0.32	10.4	2.39	3.43	4.18	4.8	5.36	5.86	6.31	6.74	7.13	7.49	7.76	8.08	8.38
	0.38	14.89	2.41	3.47	4.24	4.89	5.47	5.99	6.47	6.91	7.32	7.71	7.98	8.33	8.65
2	0.06	2.27	2.65	4.28	5.35	6.12	6.69	7.14	7.49	7.79	8.04	8.25	8.44	8.6	8.74
	0.13	7.77	2.77	4.67	6.07	7.13	7.98	8.68	9.26	9.75	10.18	10.56	10.98	11.28	11.55
	0.19	16.11	2.81	4.82	6.33	7.53	8.5	9.31	10.01	10.6	11.12	11.58	12.15	12.36	12.85
	0.25	27.08	2.83	4.89	6.47	7.74	8.78	9.66	10.42	11.07	11.65	12.16	12.82	13.24	13.62
	0.32	40.56	2.84	4.93	6.56	7.87	8.96	9.88	10.68	11.37	11.99	12.54	13.26	13.72	14.13

Table 21. Heating capacity (kW), small (VDxG) – SI

Rows	Water Flow Rate (L/s)	Water Pressure Drop (kpa)	Airflow (L/s)							
			142	189	236	283	330	378	425	472
1	0.03	0.66	4.01	4.43	4.68	4.85	4.98	5.07	5.15	5.22
	0.06	2.21	4.99	5.73	6.27	6.69	7.02	7.29	7.51	7.71
	0.13	7.71	5.67	6.70	7.48	8.08	8.58	9.01	9.39	9.75
	0.19	16.11	5.93	7.10	7.99	8.71	9.30	9.82	10.28	10.70
	0.25	27.28	6.08	7.32	8.28	9.05	9.71	10.28	10.79	11.26
	0.32	41.09	6.17	7.46	8.46	9.28	9.97	10.58	11.13	11.63
2	0.03	0.06	4.45	4.69	4.83	4.92	4.98	5.03	5.06	5.10
	0.06	0.21	6.22	6.88	7.30	7.60	7.82	7.99	8.13	8.25
	0.13	0.78	7.81	9.14	10.12	10.88	11.48	11.97	12.40	12.77
	0.19	1.67	8.34	9.97	11.24	12.26	13.10	13.81	14.43	14.98
	0.25	2.84	8.61	10.40	11.83	13.01	14.00	14.85	15.60	16.28
	0.32	4.33	8.78	10.67	12.21	13.49	14.58	15.54	16.38	17.15
3	0.03	0.09	5.46	5.75	5.90	6.00	6.06	6.10	6.14	6.17
	0.06	0.30	7.58	8.43	8.97	9.35	9.62	9.83	10.00	10.14
	0.13	1.02	9.33	11.08	12.40	13.43	14.26	14.94	15.51	16.00
	0.19	2.15	9.86	11.97	13.68	15.09	16.27	17.28	18.15	18.92
	0.25	3.62	10.11	12.40	14.32	15.95	17.34	18.55	19.63	20.59
	0.32	5.47	10.26	12.66	14.72	16.48	18.02	19.37	20.59	21.69

Table 21. Heating capacity (kW), small (VDxG) – SI (continued)

Rows	Water Flow Rate (L/s)	Water Pressure Drop (kpa)	Airflow (L/s)							
			142	189	236	283	330	378	425	472
4	0.03	0.12	6.16	6.46	6.61	6.69	6.75	6.78	6.81	6.83
	0.06	0.36	8.50	9.51	10.15	10.58	10.89	11.12	11.31	11.46
	0.13	1.26	10.26	12.33	13.95	15.22	16.24	17.06	17.75	18.34
	0.19	2.60	10.73	13.19	15.26	17.00	18.47	19.73	19.60	21.78
	0.25	4.39	10.93	13.57	15.87	17.87	19.60	21.13	22.48	23.69
	0.32	6.63	11.04	13.79	16.22	18.38	20.29	22.00	23.53	24.92

Table 22. Heating capacity (kW), medium (VDxG) – SI

Rows	Water Flow Rate (L/s)	Water Pressure Drop (kpa)	Airflow (L/s)							
			236	283	330	425	519	614	708	802
1	0.03	0.78	5.57	5.76	5.88	6.03	6.13	6.19	6.25	6.29
	0.06	2.93	7.47	8.02	8.42	9.00	9.39	9.69	9.94	10.15
	0.13	9.14	8.89	9.67	10.31	11.30	12.12	12.77	13.33	13.83
	0.19	19.04	9.49	10.42	11.20	12.41	13.37	14.16	14.90	15.57
	0.25	31.38	9.82	10.84	11.69	13.05	14.13	15.05	15.85	16.59
	0.32	48.26	10.03	11.10	12.01	13.47	14.63	15.63	16.51	17.32
2	0.03	0.09	5.79	5.85	5.89	5.93	5.94	5.96	5.97	5.98
	0.06	0.27	8.46	9.08	9.32	9.62	9.82	9.97	10.08	10.18
	0.13	0.90	12.08	13.04	13.79	14.91	15.70	16.31	16.81	17.24
	0.19	1.88	13.31	14.01	15.67	17.34	18.59	19.59	20.44	21.17
	0.25	3.20	13.93	15.42	16.67	18.68	20.24	21.53	22.62	23.59
	0.32	4.87	14.31	14.01	17.31	19.56	21.35	22.84	24.12	25.27
3	0.03	0.09	6.91	6.96	6.98	6.98	6.98	6.98	6.98	7.21
	0.06	0.36	10.55	10.95	11.22	11.56	11.77	11.91	12.02	12.51
	0.13	1.20	14.52	15.77	16.76	18.21	19.23	19.98	20.59	21.80
	0.19	2.48	15.87	17.58	19.02	21.29	23.00	24.35	25.45	27.32
	0.25	4.18	16.51	18.46	20.16	22.93	25.11	26.89	28.39	20.75
	0.32	6.28	16.88	18.99	20.85	23.97	26.48	28.58	30.38	33.10
4	0.03	0.12	7.62	7.63	7.63	7.63	7.63	7.63	7.79	7.79
	0.06	0.45	11.79	12.22	12.51	12.85	13.05	13.18	13.76	14.01
	0.13	1.49	16.10	20.24	18.79	20.51	21.68	22.53	24.08	24.51
	0.19	3.05	17.43	19.48	21.23	24.01	26.10	27.72	30.19	31.18
	0.25	5.14	18.01	20.32	22.38	25.80	28.51	30.71	33.86	35.34
	0.32	7.68	18.33	20.81	23.04	26.88	30.02	32.64	36.29	38.15



Performance Data

Table 23. Heating capacity (kW), large (VDxG) – SI

Rows	Water Flow Rate (L/s)	Water Pressure Drop (kpa)	Airflow (L/s)							
			378	425	519	614	708	802	897	944
1	0.03	0.27	5.69	5.71	5.73	5.74	5.75	5.76	5.76	5.76
	0.06	0.10	9.36	9.59	9.91	10.13	10.30	10.43	10.54	10.60
	0.13	3.62	12.21	12.71	13.59	14.25	14.79	15.23	15.61	15.79
	0.19	7.77	13.53	14.19	15.26	16.11	16.87	17.53	18.11	18.38
	0.25	13.42	14.29	15.05	16.30	17.32	18.17	18.92	19.62	19.95
	0.32	20.50	14.79	15.62	17.00	18.13	19.09	19.93	20.69	21.05
2	0.03	0.45	7.48	7.48	7.48	7.48	7.48	7.48	7.48	7.48
	0.06	1.52	13.13	13.32	13.61	13.72	13.82	13.89	13.95	13.98
	0.13	5.35	18.36	19.12	20.27	21.11	21.76	22.29	22.73	22.93
	0.19	11.24	20.51	21.61	23.38	24.77	25.89	26.84	27.65	28.02
	0.25	19.13	21.67	22.97	25.15	26.91	28.38	29.64	30.74	31.25
	0.32	28.96	22.38	23.83	26.28	28.30	30.01	31.51	32.83	33.45
3	0.03	0.63	8.32	8.32	8.32	8.32	8.32	8.32	8.32	8.32
	0.06	2.06	15.01	15.15	15.29	15.34	15.36	15.36	15.36	15.36
	0.13	7.11	21.71	22.61	23.96	24.89	25.58	26.10	26.52	26.70
	0.19	14.73	24.34	25.74	28.02	29.78	31.18	32.32	33.27	33.69
	0.25	24.86	25.66	27.36	30.24	32.57	34.50	36.13	37.78	38.17
	0.32	37.38	26.43	28.32	31.60	34.33	36.65	38.64	40.40	41.21
4	0.03	0.78	8.73	8.73	8.73	8.73	8.73	8.73	8.73	8.73
	0.06	2.63	14.98	15.70	16.73	17.45	17.97	18.38	18.70	18.83
	0.13	8.88	23.89	24.90	26.35	27.31	27.96	28.43	28.78	28.92
	0.19	18.26	26.75	28.41	31.11	33.15	34.73	35.99	37.01	37.45
	0.25	30.63	28.08	30.10	33.57	36.37	38.68	40.60	41.12	42.95
	0.32	45.87	28.81	31.05	35.00	38.32	41.14	43.57	45.67	46.62

Water Coil Notes

Water Coil Notes (I-P)

- Fouling factor = 0.0005
- Use the following equations to calculate leaving air temperature (LAT) and water temperature difference (WTD).

$$LAT = EAT + \left(\frac{MBH \times 921.7}{Cfm} \right)$$

$$WTD = EWT - LWT = \left(\frac{2 \times MBh}{Gpm} \right)$$

- Capacity based on 70°F entering air temperature and 180°F entering water temperature. Refer to correction factors for different entering conditions.

Table 24. Temperature correction factors for water pressure drop (ft)

Average Water Temperature (°F)	200	190	180	170	160	150	140	130	120	110
Correction Factor	0.970	0.985	1.000	1.020	1.030	1.050	1.080	1.100	1.130	1.150

Table 25. Temperature correction factors for coil capacity (MBh)

Entering Water Minus Entering Air (°F)	40	50	60	70	80	90	100	110	120	130
Correction Factor	0.355	0.446	0.537	0.629	0.722	0.814	0.907	1.000	1.093	1.187

Water Coil Notes (SI)

- Fouling factor = 0.0005
- Use the following equations to calculate leaving air temperature (LAT) and water temperature difference (WTD).

$$LAT = EAT + \left(\frac{kW \times 0.83}{L/s} \right)$$

$$WTD = EWT - LWT = \left(\frac{kW}{(4.19) L/s} \right)$$

- Capacity based on 21°C entering air temperature and 82°C entering water temperature. Refer to correction factors for different entering conditions.

Table 26. Temperature correction factors for water pressure drop (kPa)

Average Water Temperature (°C)	93	88	82	77	71	66	60	54	49	43
Correction Factor	0.970	0.985	1.000	1.020	1.030	1.050	1.080	1.100	1.130	1.150

Table 27. Temperature correction factors for coil capacity (kW)

Entering Water Minus Entering Air (°C)	22	27	33	38	44	50	55	61	67	72
Correction Factor	0.355	0.446	0.537	0.629	0.722	0.814	0.907	1.000	1.093	1.187



Acoustics Data

Table 28. Discharge sound power (dB) — Fan Valve — 0.5 to 1.5 in air valve

Fan Size	Fan Airflow		Inlet Size in.	Primary Airflow							0.5 in. Air Valve Pressure Drop							1.0 in. Air Valve Pressure Drop							1.5 in. Air Valve Pressure Drop						
	cfm	L/s		2	3	4	5	6	7	2	3	4	5	6	7	2	3	4	5	6	7	2	3	4	5	6	7				
DS02	200	91	4	100	45	53	50	45	40	63	58	53	50	45	40	63	58	53	50	45	40	63	58	53	50	45	40				
	400	182		100	45	59	56	50	47	66	60	59	56	50	47	66	60	59	56	50	47	66	60	59	56	50	47				
	600	272		100	45	65	65	62	57	55	71	65	65	62	57	55	71	65	65	62	57	55	71	65	65	62	57	55			
	400	182		200	91	66	60	59	56	47	67	61	59	56	50	47	67	61	59	56	50	47	67	61	59	56	50	47			
	600	272		200	91	71	65	64	62	57	55	72	66	64	62	57	55	72	66	64	62	57	55	72	66	64	62	57	55		
	200	91		5	100	45	53	50	45	40	63	58	53	50	45	40	63	58	53	50	45	40	63	58	53	50	45	40			
400	182	100	45		65	60	59	56	47	66	60	59	56	50	47	66	60	59	56	50	47	66	60	59	56	50	47				
600	272	100	45		71	65	65	62	57	55	71	65	65	62	57	55	71	65	65	62	57	55	71	65	65	62	57	55			
400	182	200	91		66	60	59	56	47	67	61	59	56	50	47	67	61	59	56	50	47	67	61	59	56	50	47				
600	272	200	91		71	65	64	62	57	55	71	65	64	62	57	55	71	65	64	62	57	55	71	65	64	62	57	55			
200	91	DS02	300		136	72	66	64	62	57	55	73	66	64	62	57	55	73	66	64	62	57	55	73	66	64	62	57	55		
700	318		100		45	73	68	67	64	60	58	73	68	67	64	60	58	73	68	67	64	60	58	73	68	67	64	60	58		
900	409		100		45	77	73	72	70	66	65	77	73	72	70	66	65	77	73	72	70	66	65	77	73	72	70	66	65		
1100	499		100		45	81	78	76	75	72	70	81	78	76	75	72	70	81	78	76	75	72	70	81	78	76	75	72	70		
1300	590		100		45	85	82	80	79	76	75	85	82	80	79	76	75	85	82	80	79	76	75	85	82	80	79	76	75		
700	318		200		91	72	68	67	63	59	57	72	68	67	63	59	57	72	68	67	63	59	57	72	68	67	63	59	57		
900	409	200	91		77	72	72	69	65	64	77	72	72	69	65	64	77	72	72	69	65	64	77	72	72	69	65	64			
1100	499	200	91	81	77	76	74	71	70	81	77	76	74	71	70	81	77	76	74	71	70	81	77	76	74	71	70				
1300	590	200	91	84	81	79	78	76	74	84	81	79	78	76	74	84	81	79	78	76	74	84	81	79	78	76	74				
700	318	300	136	73	67	66	62	58	56	73	67	66	62	58	56	73	67	66	62	58	56	73	67	66	62	58	56				
900	409	300	136	76	72	71	68	65	63	76	72	71	68	65	63	76	72	71	68	65	63	76	72	71	68	65	63				
1100	499	300	136	80	76	75	73	70	69	80	76	75	73	70	69	80	76	75	73	70	69	80	76	75	73	70	69				
1300	590	300	136	84	81	79	78	75	74	84	81	79	78	75	74	84	81	79	78	75	74	84	81	79	78	75	74				

Table 28. Discharge sound power (dB) — Fan Valve — 0.5 to 1.5 in air valve (continued)

Fan Size	Fan Airflow		Inlet Size in.	Primary Airflow							0.5 in. Air Valve Pressure Drop							1.0 in. Air Valve Pressure Drop							1.5 in. Air Valve Pressure Drop						
	cfm	L/s		cfm	L/s	2	3	4	5	6	7	2	3	4	5	6	7	2	3	4	5	6	7	2	3	4	5	6	7		
																														2	3
DS02	200	91	200	45	63	58	53	50	45	40	63	58	53	50	45	40	63	58	53	50	45	40	63	58	53	50	45	40			
	400	182	100	45	65	60	59	56	50	47	66	60	59	56	50	47	66	60	59	56	50	47	66	60	59	56	50	47			
	600	272	100	45	71	65	65	62	57	55	71	65	65	62	57	55	71	65	65	62	57	55	71	65	65	62	57	55			
	400	182	200	91	66	60	59	56	50	47	66	60	59	56	50	47	66	61	59	56	50	47	67	61	59	56	50	47			
	600	272	200	91	71	65	64	62	57	55	71	65	64	62	57	55	74	66	64	62	57	55	74	66	64	62	57	55			
	600	272	300	136	72	65	64	62	57	55	72	66	64	62	57	55	73	66	64	62	57	55	73	66	64	62	57	55			
	600	272	400	182	72	65	64	62	57	55	73	66	64	62	57	55	74	66	64	62	57	55	74	66	64	62	57	55			
	700	318	200	91	72	67	67	67	63	59	57	72	67	67	63	59	57	72	67	67	63	59	57	72	67	67	63	59	57		
	900	409	200	91	77	72	72	72	69	65	64	77	72	72	69	65	64	77	73	72	69	65	64	77	73	72	69	65	64		
	1100	499	200	91	81	77	76	74	71	70	81	77	76	74	71	70	81	77	76	74	71	70	81	77	76	74	71	70			
	1300	590	200	91	84	81	79	78	76	74	81	79	79	78	76	74	84	81	79	78	76	74	84	81	79	78	76	74			
	700	318	300	136	72	67	66	66	62	58	56	72	67	66	62	58	56	73	67	66	62	58	56	73	67	66	62	58	56		
	900	409	300	136	76	72	71	71	68	65	63	76	72	71	68	65	63	76	72	71	68	65	63	76	72	71	68	65	63		
	1100	499	300	136	80	80	76	75	73	70	69	80	76	75	73	70	69	80	76	75	73	70	69	80	76	75	73	70	69		
	1300	590	300	136	84	81	79	78	75	74	84	81	79	78	75	74	84	81	79	78	75	74	84	81	79	78	75	74			
	700	318	400	182	72	66	65	65	61	57	55	73	67	65	61	57	55	74	67	65	61	57	55	74	67	65	61	57	55		
900	409	400	182	76	71	71	71	68	64	62	76	71	71	68	64	62	77	72	71	68	64	62	77	72	71	68	64	62			
1100	499	400	182	80	80	76	75	73	69	68	80	76	75	73	69	68	80	76	75	73	69	68	80	76	75	73	69	68			
1300	590	400	182	83	80	80	79	77	74	73	83	80	79	77	74	73	83	80	79	77	74	73	83	80	79	77	74	73			

Table 28. Discharge sound power (dB) — Fan Valve — 0.5 to 1.5 in air valve (continued)

Fan Size	Fan Airflow		Inlet Size in.	Primary Airflow							0.5 in. Air Valve Pressure Drop							1.0 in. Air Valve Pressure Drop							1.5 in. Air Valve Pressure Drop						
	cfm	L/s		2	3	4	5	6	7	2	3	4	5	6	7	2	3	4	5	6	7	2	3	4	5	6	7				
DS02	400	182	8	200	91	65	60	59	56	50	47	66	60	59	56	50	47	66	61	59	56	50	47	66	61	59	56	50	47		
	600	272		200	91	71	65	64	62	57	55	55	73	65	64	62	57	55	71	66	64	62	57	55	71	66	64	62	57	55	
	600	272		300	136	71	65	64	62	57	55	55	72	65	64	62	57	55	72	66	64	62	57	55	72	66	64	62	57	55	
	600	272		400	182	72	65	64	62	57	55	55	72	66	64	62	57	55	72	66	64	62	57	55	72	66	64	62	57	55	
	600	272		500	227	72	65	64	62	56	54	54	72	66	64	62	56	54	74	67	64	62	56	54	74	67	64	62	56	54	
	700	318		250	114	72	67	66	62	58	56	56	72	67	66	62	58	56	72	67	66	62	58	56	72	67	66	62	58	56	
	900	409		250	114	76	72	71	69	65	64	64	76	72	71	69	65	64	76	72	71	69	65	64	76	72	71	69	65	64	
	1100	499		250	114	80	77	76	74	71	69	69	80	80	77	76	74	71	69	80	80	77	76	74	71	69	80	80	77	76	74
	1300	590		250	114	84	81	79	78	75	74	74	84	81	79	78	75	74	74	84	81	79	78	75	74	84	81	79	78	75	74
	700	318		500	227	71	66	65	61	56	54	54	72	66	65	61	56	54	73	67	65	61	56	54	73	67	65	61	56	54	
	900	409		500	227	75	71	70	67	63	62	62	76	71	70	67	63	62	76	71	70	67	63	62	76	71	70	67	63	62	
	1100	499		500	227	79	75	75	72	69	68	68	80	80	75	75	72	69	68	80	80	75	75	72	69	68	80	80	75	72	69
	1300	590		500	227	83	80	78	77	74	73	73	83	83	80	78	77	74	73	83	80	78	77	74	73	83	80	78	77	74	73
	900	318		750	341	75	70	69	66	62	60	60	77	71	69	66	62	60	77	71	69	66	62	60	77	71	69	66	62	60	
1100	409	750	341	79	75	74	71	68	66	66	80	75	74	71	68	66	80	75	74	71	68	66	80	75	74	71	68	66			
1300	499	750	341	83	79	78	76	73	72	72	83	83	79	78	76	73	72	83	79	78	76	73	72	83	79	78	76	73	72		
700	318	500	227	70	66	65	61	56	54	54	71	66	65	61	56	54	71	66	65	61	56	54	71	66	65	61	56	54			
900	409	500	227	75	71	70	67	63	62	62	75	71	70	67	63	62	75	71	70	67	63	62	75	71	70	67	63	62			
1100	499	500	227	79	75	75	72	69	68	68	79	75	75	72	69	68	79	75	75	72	69	68	79	75	75	72	69	68			
1300	590	500	227	83	80	78	77	74	73	73	83	83	80	78	77	74	73	83	80	78	77	74	73	83	80	78	77	74	73		
900	409	750	341	75	70	69	66	62	60	60	75	70	69	66	62	60	75	70	69	66	62	60	75	70	69	66	62	60			
1100	409	750	341	79	75	74	71	68	66	66	79	75	74	71	68	66	79	75	74	71	68	66	79	75	74	71	68	66			
1300	499	750	341	83	79	78	76	73	72	72	83	83	79	78	76	73	72	83	79	78	76	73	72	83	79	78	76	73	72		
700	318	1000	454	79	75	73	70	67	66	66	80	80	75	73	70	67	66	80	80	75	73	70	67	66	80	80	75	73	70		
900	409	1000	454	83	79	77	75	72	71	71	83	83	79	77	75	72	71	83	79	77	75	72	71	83	79	77	75	72	71		

Notes:

1. All data are measured in accordance with industry standard AHRI 880-2011.
2. All sound power levels, dB re: 10-12 Watts
3. The air valve pressure drop values shown are for the pressure drop across the air valve only.
4. All acoustic performance data shown is with 1" matte faced insulation and a 6-row sensible cooling coil.

Table 29. Discharge sound power (dB) — Fan Valve — 2.0 to 3.0 in air valve

Fan Size	Fan Airflow		Inlet Size in.	Primary Airflow							2.0 in. Air Valve Pressure Drop							2.5 in. Air Valve Pressure Drop							3.0 in. Air Valve Pressure Drop											
	cfm	L/s		2	3	4	5	6	7	2	3	4	5	6	7	2	3	4	5	6	7	2	3	4	5	6	7									
DS02	200	91	4	100	45	58	53	50	45	40	63	58	53	50	45	40	64	58	53	50	45	40	64	58	53	50	45	40								
	400	182		100	45	60	59	56	50	47	66	60	59	56	50	47	66	60	59	56	50	47	66	60	59	56	50	47	66	60	59	56	50	47		
	600	272		100	45	71	66	65	62	57	55	71	66	65	62	57	55	71	66	65	62	57	55	71	66	65	62	57	55	71	66	65	62	57	55	
	400	182		200	91	68	61	59	56	50	47	68	62	59	56	50	47	68	62	59	56	50	47	68	62	59	56	50	47	68	62	59	56	50	47	
	600	272		200	91	72	66	64	62	57	55	72	66	64	62	57	55	72	66	64	62	57	55	72	66	64	62	57	55	72	66	64	62	57	55	
	200	91		100	45	63	58	53	50	45	40	64	58	53	50	45	40	64	58	53	50	45	40	64	58	53	50	45	40	64	58	53	50	45	40	
DS02	400	182	5	100	45	60	59	56	50	47	66	60	59	56	50	47	66	60	59	56	50	47	66	60	59	56	50	47	66	60	59	56	50	47		
	600	272		100	45	71	66	65	62	57	55	71	66	65	62	57	55	71	66	65	62	57	55	71	66	65	62	57	55	71	66	65	62	57	55	
	400	182		200	91	67	61	59	56	50	47	67	62	59	56	50	47	67	62	59	56	50	47	67	62	59	56	50	47	67	62	59	56	50	47	
	600	272		200	91	71	66	64	62	57	55	71	66	64	62	57	55	71	66	64	62	57	55	71	66	64	62	57	55	71	66	64	62	57	55	
	600	272		300	136	73	66	64	62	57	55	74	67	64	62	57	55	74	67	64	62	57	55	74	67	64	62	57	55	74	67	64	62	57	55	
	700	318		100	45	73	68	67	64	60	58	73	68	67	64	60	58	73	68	67	64	60	58	73	68	67	64	60	58	73	68	67	64	60	58	
	900	409		100	45	77	73	72	70	66	65	77	73	72	70	66	65	77	73	72	70	66	65	77	73	72	70	66	65	77	73	72	70	66	65	
	1100	499		100	45	81	78	76	75	72	70	81	78	76	75	72	70	81	78	76	75	72	70	81	78	76	75	72	70	81	78	76	75	72	70	
	1300	590		100	45	85	82	80	79	76	75	85	82	80	79	76	75	85	82	80	79	76	75	85	82	80	79	76	75	85	82	80	79	76	75	
	700	318		200	91	72	68	67	63	59	57	72	68	67	63	59	57	72	68	67	63	59	57	72	68	67	63	59	57	72	68	67	63	59	57	
	900	409		200	91	77	72	72	72	69	65	64	77	72	72	69	65	64	77	72	72	69	65	64	77	72	72	69	65	64	77	72	72	69	65	64
	1100	499		200	91	81	77	76	74	71	70	81	77	76	74	71	70	81	77	76	74	71	70	81	77	76	74	71	70	81	77	76	74	71	70	
1300	590	200	91	84	81	79	78	76	74	84	81	79	78	76	74	84	81	79	78	76	74	84	81	79	78	76	74	84	81	79	78	76	74			
700	318	300	136	73	67	66	62	58	56	73	67	66	62	58	56	73	67	66	62	58	56	73	67	66	62	58	56	73	67	66	62	58	56			
900	409	300	136	76	72	71	68	65	63	76	72	71	68	65	63	76	72	71	68	65	63	76	72	71	68	65	63	76	72	71	68	65	63			
1100	499	300	136	80	76	75	73	70	69	80	76	75	73	70	69	80	76	75	73	70	69	80	76	75	73	70	69	80	76	75	73	70	69			
1300	590	300	136	84	81	79	78	75	74	84	81	79	78	75	74	84	81	79	78	75	74	84	81	79	78	75	74	84	81	79	78	75	74			



Acoustics Data

Table 29. Discharge sound power (dB) — Fan Valve — 2.0 to 3.0 in air valve (continued)

Fan Size	Fan Airflow		Inlet Size in.	2.0 in. Air Valve Pressure Drop							2.5 in. Air Valve Pressure Drop							3.0 in. Air Valve Pressure Drop						
	cfm	L/s		2	3	4	5	6	7	2	3	4	5	6	7	2	3	4	5	6	7			
DS02	200	91		64	58	53	50	45	40	64	58	53	50	45	40	64	58	53	50	45	40			
	400	182		66	60	59	56	50	47	66	60	59	56	50	47	66	61	59	56	50	47			
	600	272		71	66	65	62	59	55	71	66	65	62	59	55	71	66	65	62	59	55			
	400	182		68	61	59	56	50	47	68	62	59	56	50	47	69	62	59	56	50	47			
	600	272		72	66	64	62	57	55	72	66	64	62	57	55	72	66	64	62	57	55			
	600	272		73	66	64	62	57	55	73	67	64	62	57	55	74	67	64	62	57	55			
	600	272		75	67	64	62	57	55	75	68	64	62	57	55	76	68	64	62	57	55			
	700	318		72	67	67	63	59	57	72	67	67	63	59	57	72	67	67	63	59	57			
	900	409		77	73	72	69	65	64	77	73	72	69	65	64	77	73	72	69	65	64			
	1100	499	6	81	77	76	74	71	70	81	77	76	74	71	70	81	77	76	74	71	70			
	1300	590		84	81	79	78	76	74	84	81	79	78	76	74	84	81	79	78	76	74			
	700	318		73	67	66	62	58	56	73	68	66	62	58	56	74	68	66	62	58	56			
	900	409		76	72	71	68	65	63	76	72	71	68	65	63	76	72	71	68	65	63			
	1100	499		80	76	75	73	70	69	80	76	75	73	70	69	80	76	75	73	70	69			
	1300	590		84	81	79	78	75	74	84	81	79	78	75	74	84	81	79	78	75	74			
	700	318		74	68	65	61	57	55	75	68	65	61	57	55	75	68	65	61	57	55			
900	409		77	72	71	68	64	62	77	72	71	68	64	62	78	72	71	68	64	62				
1100	499		80	76	75	73	70	69	80	76	75	73	70	69	80	76	75	73	70	69				
1300	590		83	80	79	77	74	73	83	80	79	77	74	73	83	80	79	77	74	73				

Table 29. Discharge sound power (dB) — Fan Valve — 2.0 to 3.0 in air valve (continued)

Fan Size	Fan Airflow		Inlet Size in.	Primary Airflow							2.0 in. Air Valve Pressure Drop							2.5 in. Air Valve Pressure Drop							3.0 in. Air Valve Pressure Drop									
	cfm	L/s		cfm	L/s	cfm	L/s	cfm	L/s	cfm	L/s	cfm	L/s	cfm	L/s	cfm	L/s	cfm	L/s	cfm	L/s	cfm	L/s	cfm	L/s	cfm	L/s	cfm	L/s					
																														2	3	4	5	6
DS02	400	182	200	91	67	61	59	56	50	47	67	62	59	56	50	47	67	62	59	56	50	47	68	62	59	56	50	47	68	62	59	56	50	47
	600	272	200	91	71	66	64	62	57	55	71	66	64	62	57	55	71	66	64	62	57	55	71	66	64	62	57	55	71	66	64	62	57	55
	600	272	300	136	72	66	64	62	57	55	73	67	64	62	57	55	73	67	64	62	57	55	73	67	64	62	57	55	73	67	64	62	57	55
	600	272	400	182	73	67	64	62	57	55	74	68	64	62	57	55	74	68	64	62	57	55	74	68	64	62	57	55	74	68	64	62	57	55
	600	272	500	227	75	68	64	62	56	54	75	69	64	62	56	54	75	69	64	62	56	54	75	69	64	62	56	54	75	69	64	62	56	54
	700	318	250	114	72	67	66	62	58	56	72	68	66	62	58	56	72	68	66	62	58	56	72	68	66	62	58	56	72	68	66	62	58	56
	900	409	250	114	76	72	71	69	65	64	77	72	71	69	65	64	77	72	71	69	65	64	77	72	71	69	65	64	77	72	71	69	65	64
	1100	499	250	114	80	77	76	74	71	69	80	77	76	74	71	69	80	77	76	74	71	69	80	77	76	74	71	69	80	77	76	74	71	69
	1300	590	250	114	84	81	79	78	7	74	84	81	79	78	7	74	84	81	79	78	7	74	84	81	79	78	7	74	84	81	79	78	7	74
	700	318	500	227	74	68	65	61	56	54	75	68	65	61	56	54	75	68	65	61	56	54	75	68	65	61	56	54	75	68	65	61	56	54
	900	409	500	227	77	71	70	67	63	62	77	72	70	67	63	62	77	72	70	67	63	62	77	72	70	67	63	62	77	72	70	67	63	62
	1100	499	500	227	80	76	75	72	69	68	80	76	75	72	69	68	80	76	75	72	69	68	80	76	75	72	69	68	80	76	75	72	69	68
	1300	590	500	227	83	80	78	77	74	73	83	80	78	77	74	73	83	80	78	77	74	73	83	80	78	77	74	73	83	80	78	77	74	73
	900	318	750	341	78	72	69	66	62	60	79	72	69	66	62	60	79	72	69	66	62	60	79	72	69	66	62	60	79	72	69	66	62	60
	1100	409	750	341	81	75	74	71	68	66	81	76	74	71	68	66	81	76	74	71	68	66	81	76	74	71	68	66	81	76	74	71	68	66
1300	499	750	341	84	79	78	76	73	72	84	79	78	76	73	72	84	79	78	76	73	72	84	79	78	76	73	72	84	79	78	76	73	72	
700	318	500	227	73	67	65	61	56	54	74	68	65	61	56	54	74	68	65	61	56	54	74	68	65	61	56	54	74	68	65	61	56	54	
900	409	500	227	76	71	70	67	63	62	76	71	70	67	63	62	76	71	70	67	63	62	76	71	70	67	63	62	76	71	70	67	63	62	
1100	499	500	227	80	76	75	72	69	68	80	76	75	72	69	68	80	76	75	72	69	68	80	76	75	72	69	68	80	76	75	72	69	68	
1300	590	500	227	83	80	78	77	74	73	83	80	78	77	74	73	83	80	78	77	74	73	83	80	78	77	74	73	83	80	78	77	74	73	
DS02	900	409	750	341	77	71	69	66	62	60	78	72	69	66	62	60	78	72	69	66	62	60	78	72	69	66	62	60	78	72	69	66	62	60
	1100	409	750	341	80	75	74	71	68	66	80	75	74	71	68	66	80	75	74	71	68	66	80	75	74	71	68	66	80	75	74	71	68	67
	1300	590	750	341	83	79	78	76	73	72	83	79	78	76	73	72	83	79	78	76	73	72	83	79	78	76	73	72	83	79	78	76	73	72
	1100	499	1000	454	81	75	74	70	67	66	81	75	74	70	67	66	81	75	74	70	67	66	81	75	74	70	67	66	81	75	74	70	67	66
	1300	590	1000	454	84	79	77	75	72	71	84	79	77	75	72	71	84	79	77	75	72	71	84	79	77	75	72	71	84	79	77	75	72	71

Notes:

- All data are measured in accordance with industry standard AHRI 880-2011.
- All sound power levels, dB re: 10-12 Watts
- The air valve pressure drop values shown are for the pressure drop across the air valve only.
- All acoustic performance data shown is with 1" matte faced insulation and a 6-row sensible cooling coil.

Table 30. Radiated sound power (dB) — Fan/Valve — 0.5 to 1.5 in air valve

Fan Size	Fan Airflow		Inlet Size in.	Primary Airflow							0.5 in. Air Valve Pressure Drop							1.0 in. Air Valve Pressure Drop							1.5 in. Air Valve Pressure Drop						
	cfm	L/s		cfm	L/s	2	3	4	5	6	7	2	3	4	5	6	7	2	3	4	5	6	7	2	3	4	5	6	7		
DS02	200	91	4	100	45	57	54	50	44	36	30	58	54	50	44	36	33	58	55	51	44	37	35	58	55	51	44	37	35		
	400	182		100	45	59	55	54	49	40	32	26	59	55	54	49	40	34	59	55	54	49	40	36	59	55	54	49	40	36	
	600	272		100	45	63	59	59	54	45	37	31	63	59	59	54	45	38	64	59	59	54	45	39	64	59	59	54	45	39	
	400	182		200	91	62	57	54	49	40	35	29	63	58	55	49	41	35	64	59	55	50	42	43	64	59	55	50	42	43	
	600	272		200	91	65	60	59	54	45	38	33	65	60	59	54	45	40	66	61	59	54	46	42	66	61	59	54	46	42	
	200	91		100	45	57	54	50	44	36	28	22	57	54	50	44	36	32	58	54	50	44	37	35	58	54	50	44	37	35	
DS02	400	182	5	100	45	58	55	54	49	40	32	59	55	54	49	40	34	59	55	54	49	40	36	59	55	54	49	40	36		
	600	272		100	45	63	59	59	54	45	37	31	63	59	59	54	45	38	64	59	59	54	45	39	64	59	59	54	45	39	
	400	182		200	91	61	55	54	49	40	34	28	62	56	54	49	40	38	63	57	55	49	41	41	63	57	55	49	41	41	
	600	272		200	91	64	59	59	53	45	37	33	65	59	59	54	45	40	66	60	59	54	45	42	66	60	59	54	45	42	
	600	272		300	136	66	60	59	53	44	39	35	68	61	59	54	45	43	69	62	59	54	45	46	69	62	59	54	45	46	
	700	318		100	45	66	59	61	56	44	37	31	66	59	61	56	44	37	66	59	61	56	44	38	66	59	61	56	44	38	
	900	409		100	45	71	63	66	61	50	43	35	71	63	66	61	50	43	71	63	66	61	50	44	71	63	66	61	50	44	
	1100	499		100	45	74	67	69	66	55	49	41	74	67	69	66	55	49	74	67	69	66	55	49	74	67	69	66	55	49	
	1300	590		100	45	77	71	72	69	59	53	45	77	71	72	69	59	53	77	71	72	69	59	53	77	71	72	69	59	53	
	700	318		200	91	66	59	61	55	43	36	31	66	59	61	55	43	36	67	60	61	55	44	42	67	60	61	55	44	42	
	900	409		200	91	70	63	65	61	49	42	37	70	63	65	61	49	43	70	63	65	61	49	44	70	63	65	61	49	44	
	1100	499		200	91	74	67	69	65	54	48	41	74	67	69	65	54	48	74	67	69	65	54	48	74	67	69	65	54	48	
1300	590	200	91	77	70	72	69	58	52	45	77	70	72	69	58	52	77	71	72	69	58	53	77	71	72	69	58	53			
700	318	300	136	67	60	60	54	42	38	33	68	61	60	55	44	42	69	62	61	55	45	45	69	62	61	55	45	45			
900	409	300	136	70	63	64	60	48	42	37	71	64	65	60	49	44	71	64	65	60	49	47	71	64	65	60	49	47			
1100	499	300	136	73	66	68	64	53	47	41	74	67	68	64	53	48	74	67	68	64	53	49	74	67	68	64	53	49			
1300	590	300	136	76	70	72	68	58	52	45	77	70	72	68	58	52	77	70	72	68	58	53	77	70	72	68	58	53			

Table 30. Radiated sound power (dB) — Fan/Valve — 0.5 to 1.5 in air valve (continued)

Fan Size	Fan Airflow		Inlet Size in.	0.5 in. Air Valve Pressure Drop							1.0 in. Air Valve Pressure Drop							1.5 in. Air Valve Pressure Drop						
	cfm	L/s		2	3	4	5	6	7	2	3	4	5	6	7	2	3	4	5	6	7			
	Primary Airflow																							
DS02	200	91	100	45	57	54	50	44	36	28	28	57	54	50	44	36	32	58	54	51	44	37	35	
	400	182	100	45	58	54	54	49	40	32	32	59	55	54	49	40	34	59	55	54	49	40	36	
	600	272	100	45	63	59	59	54	45	37	37	63	59	59	54	45	38	64	59	59	54	45	40	
	400	182	200	91	60	55	54	48	40	33	33	62	56	54	49	40	37	63	57	55	49	41	40	
	600	272	200	91	64	59	59	53	45	37	37	64	59	59	54	45	39	65	60	59	54	45	41	
	600	272	300	136	65	59	59	53	44	38	38	66	60	59	53	45	41	67	61	59	54	45	44	
	600	272	400	182	66	60	57	53	44	39	39	68	61	59	53	45	44	69	63	60	54	45	47	
	700	318	200	91	66	59	61	55	43	36	36	66	59	61	55	43	39	67	60	61	55	44	41	
	900	409	200	91	70	63	65	61	49	42	42	70	63	65	61	49	43	70	63	65	61	49	44	
	1100	499	200	91	74	67	69	65	54	48	48	74	67	69	65	54	48	74	67	69	65	54	48	
	1300	590	200	91	77	70	72	69	58	52	52	77	70	72	69	58	52	77	71	72	69	58	53	
	700	318	300	136	66	59	60	54	42	37	37	67	60	60	54	43	41	68	61	60	55	44	44	
	900	409	300	136	70	62	64	60	48	41	41	70	63	65	60	48	43	71	64	65	60	49	46	
	1100	499	300	136	73	66	68	64	53	47	47	73	66	68	64	53	47	74	67	68	64	53	48	
	1300	590	300	136	76	67	70	68	58	51	51	76	70	72	68	58	52	77	70	72	68	58	52	
700	318	400	182	67	59	59	53	42	38	38	68	61	60	54	43	43	69	63	60	55	44	47		
900	409	400	182	70	62	64	59	47	41	41	71	63	64	59	48	44	71	65	64	59	48	47		
1100	499	400	182	73	66	68	64	53	46	46	73	66	68	64	53	47	74	67	68	64	53	49		
1300	590	400	182	76	67	70	68	57	51	51	76	70	71	68	57	51	76	70	71	68	57	52		

Table 30. Radiated sound power (dB) — Fan/Valve — 0.5 to 1.5 in air valve (continued)

Fan Size	Fan Airflow		Inlet Size in.	Primary Airflow							0.5 in. Air Valve Pressure Drop							1.0 in. Air Valve Pressure Drop							1.5 in. Air Valve Pressure Drop						
	cfm	L/s		cfm	L/s	2	3	4	5	6	7	2	3	4	5	6	7	2	3	4	5	6	7	2	3	4	5	6	7		
DS02	400	182	8	200	91	59	55	54	48	40	33	59	55	54	49	40	38	60	56	54	49	41	60	56	54	49	41	41			
	600	272		200	91	63	59	59	53	45	37	64	64	59	59	54	45	39	64	59	59	54	45	64	59	59	54	45	42		
	600	272		300	136	64	59	59	53	44	39	64	64	59	59	53	45	41	65	60	59	53	45	65	60	59	53	45	44		
	600	272		400	182	64	59	59	53	44	38	65	65	60	59	53	44	42	66	61	59	53	45	66	61	59	53	45	45		
	600	272		500	227	65	59	58	53	44	38	66	66	61	59	53	44	43	68	62	59	53	45	68	62	59	53	45	47		
	700	318		250	114	65	59	60	55	42	36	65	65	59	60	55	43	39	66	60	60	55	44	66	60	60	55	44	43		
	900	409		250	114	70	62	65	60	49	42	70	70	63	65	60	49	43	70	63	65	60	49	70	63	65	60	49	45		
	1100	499		250	114	73	66	69	65	54	47	73	73	66	69	65	54	48	73	67	69	65	54	73	67	69	65	54	48		
	1300	590		250	114	76	70	72	69	58	52	77	77	70	72	69	58	52	77	70	72	69	58	77	70	72	69	58	52		
	700	318		500	227	65	59	59	53	41	37	67	67	60	59	53	43	43	68	62	60	54	44	68	62	60	54	44	47		
	900	409		500	227	69	62	63	58	46	40	69	69	63	64	59	47	44	70	64	64	59	48	70	64	64	59	48	47		
	1100	499		500	227	72	66	68	63	52	45	73	73	66	68	63	52	47	73	67	68	63	52	73	67	68	63	52	49		
1300	590	500	227	75	69	71	67	56	50	76	76	69	71	67	56	50	76	70	71	67	56	76	70	71	67	56	51				
900	318	750	341	69	62	63	57	46	41	70	70	64	63	58	47	46	72	66	64	58	48	72	66	64	58	48	50				
1100	409	750	341	72	66	67	62	50	44	73	73	66	67	62	51	47	74	68	67	62	51	74	68	67	62	51	50				
1300	499	750	341	75	69	71	66	55	48	76	76	69	71	66	55	50	76	70	71	66	55	76	70	71	66	55	52				
700	318	500	227	65	60	60	54	44	40	68	68	63	62	58	50	46	71	65	65	61	53	71	67	65	61	53	50				
900	409	500	227	69	62	64	59	48	42	70	70	65	65	60	51	47	72	67	67	62	54	72	67	67	62	54	50				
1100	499	500	227	72	66	68	63	52	46	73	73	67	68	64	54	48	74	69	69	65	56	74	69	69	65	56	51				
1300	590	500	227	75	69	71	67	56	50	76	76	70	71	67	57	51	76	71	72	68	58	76	71	72	68	58	53				
900	409	750	341	69	63	63	58	49	44	72	72	67	66	61	54	50	74	70	68	64	57	74	70	68	64	57	53				
1100	409	750	341	72	66	67	62	52	46	74	74	68	68	64	55	50	75	71	70	66	58	75	71	70	66	58	54				
1300	590	750	341	75	69	71	66	55	49	76	76	70	71	67	57	52	77	72	72	68	59	77	72	72	68	59	54				
1100	499	1000	454	72	66	67	62	52	47	75	75	69	69	65	57	52	77	72	71	67	60	77	72	71	67	60	56				
1300	590	1000	454	75	69	70	66	55	49	77	77	71	71	67	58	53	78	73	73	69	61	78	73	73	69	61	56				

Notes:

- All data are measured in accordance with industry standard AHR1 880-2011.
- All sound power levels, dB re: 10-12 Watts
- The air valve pressure drop values shown are for the pressure drop across the air valve only.
- All acoustic performance data shown is with 1" matte faced insulation and a 6-row sensible cooling coil.

Table 31. Radiated sound power (dB) — Fan/Valve — 2.0 to 3.0 in air valve

Fan Size	Fan Airflow		Inlet Size in.	Primary Airflow							2.0 in. Air Valve Pressure Drop							2.5 in. Air Valve Pressure Drop							3.0 in. Air Valve Pressure Drop						
	cfm	L/s		cfm	L/s	2	3	4	5	6	7	2	3	4	5	6	7	2	3	4	5	6	7	2	3	4	5	6	7		
DS02	200	91	4	100	45	58	55	51	45	37	37	58	55	51	45	37	38	59	55	51	45	37	59	55	51	45	37	41			
	400	182		100	45	59	55	54	49	41	38	38	60	56	55	49	41	39	60	56	55	49	41	60	56	55	49	41	40		
	600	272		100	45	64	59	59	54	45	40	40	64	59	59	54	45	40	64	59	59	54	45	64	59	59	54	45	41		
	400	182		200	91	65	60	56	50	42	43	43	65	60	56	50	43	45	66	61	56	50	43	66	61	56	50	43	45		
	600	272		200	91	66	61	60	54	46	44	44	67	62	60	54	46	41	67	62	60	54	46	67	62	60	54	46	46		
	200	91		100	45	58	54	51	44	37	37	37	58	55	51	45	37	39	59	55	51	45	37	59	55	51	45	38	40		
DS02	400	182	5	100	45	59	55	54	49	41	37	60	55	55	49	41	39	60	55	55	49	41	60	55	55	49	41	41			
	600	272		100	45	64	59	59	54	45	40	40	64	59	59	54	45	40	64	59	59	54	45	64	59	59	54	45	41		
	400	182		200	91	64	64	58	55	49	41	43	65	59	55	50	42	45	66	60	56	50	42	66	60	56	50	42	47		
	600	272		200	91	66	60	60	59	54	45	44	67	61	59	54	46	43	67	61	60	54	46	67	61	60	54	46	47		
	600	272		300	136	70	63	60	54	46	50	50	70	64	60	54	46	50	71	65	60	54	46	71	65	60	54	47	52		
	700	318		100	45	66	59	61	56	44	39	39	66	60	61	56	45	41	66	60	61	56	45	66	60	61	56	45	42		
	900	409		100	45	71	63	66	61	50	44	44	71	63	66	61	50	44	71	63	66	61	50	71	63	66	61	50	45		
	1100	499		100	45	74	67	69	66	55	49	49	74	67	69	66	55	49	74	67	69	66	55	74	67	69	66	55	49		
	1300	590		100	45	77	71	72	69	59	53	53	77	71	72	69	59	53	77	71	72	69	59	77	71	72	69	59	53		
	700	318		200	91	67	61	61	55	44	44	44	68	61	61	56	45	45	68	62	61	56	45	68	62	61	56	45	47		
	900	409		200	91	71	64	65	61	50	46	46	71	64	65	61	50	46	71	64	65	61	50	71	64	65	61	50	48		
	1100	499		200	91	74	67	69	65	54	49	49	74	67	69	65	54	50	74	67	69	65	54	74	67	69	65	54	50		
1300	590	200	91	77	71	72	69	58	53	53	77	71	72	69	58	53	77	71	72	69	58	77	71	72	69	58	54				
700	318	300	136	70	63	61	55	46	48	48	71	64	61	56	46	46	71	65	62	56	46	71	65	62	56	47	51				
900	409	300	136	72	65	65	60	49	49	49	72	66	65	60	50	50	73	66	65	61	50	73	66	65	61	50	52				
1100	499	300	136	74	68	69	65	54	50	50	75	68	69	65	54	51	75	68	69	65	54	75	68	69	65	54	53				
1300	590	300	136	77	70	72	68	58	53	53	77	71	72	68	58	54	77	71	72	68	58	77	71	72	68	58	55				



Acoustics Data

Table 31. Radiated sound power (dB) — Fan/Valve — 2.0 to 3.0 in air valve (continued)

Fan Size	Fan Airflow		Inlet Size in.	2.0 in. Air Valve Pressure Drop							2.5 in. Air Valve Pressure Drop							3.0 in. Air Valve Pressure Drop						
	cfm	L/s		2	3	4	5	6	7	2	3	4	5	6	7	2	3	4	5	6	7			
DS02	200	91	6	58	54	51	45	37	37	58	55	51	45	38	39	59	55	51	45	38	41			
	400	182		59	55	54	49	41	36	36	59	55	55	49	41	40	59	56	55	49	41	41		
	600	272		64	59	59	54	45	42	42	64	59	59	54	45	43	64	59	59	54	45	45		
	400	182		63	58	55	49	41	43	43	64	59	56	49	42	45	65	60	56	50	42	47		
	600	272		66	60	59	54	45	44	44	66	61	59	54	46	45	66	61	60	54	46	47		
	600	272		68	62	60	54	46	47	47	69	63	60	54	46	46	69	64	60	54	46	51		
	600	272		70	64	60	54	46	46	50	71	65	61	54	46	52	72	66	61	55	47	53		
	700	318		67	61	61	55	44	43	43	67	61	61	56	45	45	68	62	61	56	45	47		
	900	409		70	63	65	61	49	45	45	71	64	65	61	50	47	71	64	65	61	50	48		
	1100	499		74	67	69	65	54	49	49	74	67	69	65	54	49	74	67	69	65	54	50		
	1300	590		77	71	72	69	58	53	53	77	71	72	69	58	53	77	71	72	69	58	54		
	700	318		69	62	61	55	45	47	47	69	63	61	56	46	46	70	64	62	56	46	50		
	900	409		71	64	65	60	49	47	47	71	65	65	60	49	49	72	66	65	60	50	51		
	1100	499		74	67	69	65	54	49	49	74	68	69	65	54	51	74	68	69	65	54	52		
	1300	590		77	70	72	68	58	53	53	77	71	72	68	58	53	77	71	72	68	58	54		
700	318	70	64	61	55	46	49	49	71	66	62	65	47	52	72	67	62	57	48	53				
900	409	72	66	65	60	49	50	50	73	66	65	60	49	52	73	67	65	60	50	53				
1100	499	74	68	68	64	53	51	51	75	68	68	64	53	52	75	69	69	64	53	54				
1300	590	77	70	71	68	57	53	53	77	71	72	68	57	54	77	71	72	68	57	55				

Table 31. Radiated sound power (dB) — Fan/Valve — 2.0 to 3.0 in air valve (continued)

Fan Size	Fan Airflow		Inlet Size in.	2.0 in. Air Valve Pressure Drop							2.5 in. Air Valve Pressure Drop							3.0 in. Air Valve Pressure Drop						
	cfm	L/s		2	3	4	5	6	7	2	3	4	5	6	7	2	3	4	5	6	7			
DS02	400	182	8	200	91	61	57	55	49	41	44	62	57	55	49	42	46	62	58	55	50	43	48	
	600	272		200	91	64	60	59	54	45	44	65	60	59	54	46	46	65	60	59	54	46	46	48
	600	272		300	136	66	61	59	54	45	46	66	61	59	54	45	46	67	62	60	54	46	46	50
	600	272		400	182	67	62	59	54	46	48	68	63	60	54	46	50	69	64	60	54	47	47	52
	600	272		500	227	69	63	60	54	46	50	70	64	60	54	47	52	71	65	61	55	47	54	54
	700	318		250	114	66	60	61	55	44	45	66	61	61	55	45	47	67	61	61	56	46	49	49
	900	409		250	114	70	63	65	60	49	46	70	63	65	60	49	48	70	64	65	60	50	50	50
	1100	499		250	114	74	67	69	65	54	49	74	67	69	65	54	50	74	67	69	65	54	51	51
	1300	590		250	114	77	70	72	69	58	53	77	70	72	69	58	53	77	70	72	69	58	54	54
	700	318		500	227	69	63	60	55	46	50	70	65	61	55	47	52	71	66	62	56	48	54	54
	900	409		500	227	71	65	64	59	48	50	71	66	64	59	49	52	72	67	65	60	50	54	54
	1100	499		500	227	73	67	68	63	52	51	74	68	68	63	53	53	74	68	68	64	53	54	54
	1300	590		500	227	76	70	71	67	56	53	76	70	71	67	57	54	76	71	71	67	57	55	55
900	318	750	341	73	67	64	59	50	53	74	68	65	60	51	55	75	69	65	60	52	57	57		
1100	409	750	341	74	68	68	63	52	53	75	69	68	63	53	55	76	70	68	63	53	57	57		
1300	499	750	341	76	71	71	66	56	54	77	71	71	67	56	56	77	72	71	67	56	57	57		
700	318	500	227	73	69	68	63	56	52	74	71	70	66	58	54	76	73	71	67	60	56	56		
900	409	500	227	73	70	69	64	56	53	75	71	70	66	58	55	76	73	72	68	60	56	56		
1100	499	500	227	75	70	70	66	57	53	76	72	72	67	59	55	77	73	73	69	61	56	56		
1300	590	500	227	77	72	72	69	59	54	78	73	73	69	60	56	78	74	74	70	61	57	57		
900	409	750	341	76	72	71	67	60	56	78	74	73	69	62	58	79	76	75	71	64	60	60		
1100	409	750	341	77	73	72	68	60	56	78	75	73	70	62	58	79	76	75	71	64	60	60		
1300	590	750	341	78	74	73	69	61	57	79	75	75	71	63	58	80	77	76	72	64	60	60		
1100	499	1000	454	79	74	73	69	62	59	80	76	75	71	65	61	81	78	77	73	66	62	62		
1300	590	1000	454	79	75	74	70	63	59	81	77	76	72	65	61	82	78	77	73	66	62	62		

Notes:

1. All data are measured in accordance with industry standard AHRI 880-2011.
2. All sound power levels, dB re: 10-12 Watts
3. The air valve pressure drop values shown are for the pressure drop across the air valve only.
4. All acoustic performance data shown is with 1" matte faced insulation and a 6-row sensible cooling coil.

Table 32. Sound noise criteria — fan/valve

Fan Size	Fan Airflow		Inlet Size	Primary Airflow		Discharge Air Valve Pressure Drop						Radiated Air Valve Pressure Drop						
	cfm	L/s		cfm	L/s	0.5"	1.0"	1.5"	2.0"	2.5"	3.0"	0.5"	1.0"	1.5"	2.0"	2.5"	3.0"	
DS02	200	91	4	100	45	19(2)	19(2)	19(2)	19(2)	19(2)	19(2)	24(4)	24(4)	25(4)	25(4)	25(4)	25(4)	
	400	182		100	45	18(3)	18(3)	18(3)	18(3)	18(3)	18(3)	29(4)	29(4)	29(4)	29(4)	29(4)	29(4)	29(4)
	600	272		100	45	25(2)	25(2)	25(2)	25(2)	25(2)	25(2)	34(4)	34(4)	34(4)	34(4)	34(4)	34(4)	34(4)
	400	182		200	91	19(2)	20(2)	20(2)	21(2)	21(2)	21(2)	29(4)	29(4)	30(4)	30(4)	31(4)	31(4)	31(4)
	600	272		200	91	25(2)	26(2)	26(2)	26(2)	26(2)	26(2)	34(4)	34(4)	34(4)	34(4)	35(4)	35(4)	35(4)
	200	91		100	45	19(2)	19(2)	19(2)	19(2)	19(2)	19(2)	24(4)	24(4)	25(4)	25(4)	25(4)	25(4)	25(4)
DS02	400	182	5	100	45	18(3)	18(3)	18(3)	18(3)	18(3)	18(3)	29(4)	29(4)	29(4)	29(4)	29(4)	29(4)	
	600	272		100	45	25(2)	25(2)	25(2)	25(2)	25(2)	25(2)	34(4)	34(4)	34(4)	34(4)	34(4)	34(4)	
	400	182		200	91	19(2)	20(2)	20(2)	20(2)	20(2)	21(2)	29(4)	29(4)	29(4)	30(4)	30(4)	30(4)	
	600	272		200	91	25(2)	25(2)	25(2)	25(2)	25(2)	25(2)	34(4)	34(4)	34(4)	34(4)	34(4)	34(4)	
	600	272		300	136	27(2)	28(2)	28(2)	28(2)	28(2)	29(2)	36(4)	36(4)	36(4)	36(4)	36(2)	37(2)	
	700	318		100	45	28(3)	28(3)	28(3)	28(3)	28(3)	28(3)	36(4)	36(4)	36(4)	36(4)	36(4)	37(4)	
	900	409		100	45	32(3)	32(3)	32(3)	32(3)	32(3)	32(3)	41(4)	41(4)	41(4)	41(4)	41(4)	41(4)	
	1100	499		100	45	38(3)	38(3)	38(3)	38(3)	38(3)	38(3)	45(4)	45(4)	45(4)	45(4)	45(4)	45(4)	
	1300	590		100	45	42(3)	42(3)	42(3)	42(3)	42(3)	42(3)	48(4)	48(4)	48(4)	48(4)	48(4)	48(4)	
	700	318		200	91	27(3)	27(3)	27(3)	27(3)	27(3)	27(3)	36(4)	36(4)	36(4)	36(4)	36(4)	36(4)	
	900	409		200	91	31(3)	31(3)	31(3)	31(3)	31(3)	31(3)	40(4)	40(4)	40(4)	40(4)	40(4)	40(4)	
	1100	499		200	91	37(3)	37(3)	37(3)	37(3)	37(3)	37(3)	45(4)	45(4)	45(4)	45(4)	45(4)	45(4)	
	1300	590		200	91	42(3)	42(3)	42(3)	42(3)	42(3)	42(3)	48(4)	48(4)	48(4)	48(4)	48(4)	48(4)	
	700	318		300	136	27(2)	28(2)	28(2)	28(2)	28(2)	28(2)	35(4)	35(4)	36(4)	36(4)	36(4)	37(2)	
900	409	300	136	31(3)	31(3)	31(3)	31(3)	31(3)	31(3)	40(4)	40(4)	40(4)	40(4)	40(4)	41(4)			
1100	499	300	136	36(3)	36(3)	36(3)	36(3)	36(3)	36(3)	44(4)	44(4)	44(4)	44(4)	44(4)	44(4)			
1300	590	300	136	41(3)	41(3)	41(3)	41(3)	41(3)	41(3)	48(4)	48(4)	48(4)	48(4)	48(4)	48(4)			

Table 32. Sound noise criteria — fan/valve (continued)

Fan Size	Fan Airflow		Inlet Size	Primary Airflow		Discharge Air Valve Pressure Drop							Radiated Air Valve Pressure Drop						
	cfm	L/s		cfm	L/s	0.5"	1.0"	1.5"	2.0"	2.5"	3.0"	0.5"	1.0"	1.5"	2.0"	2.5"	3.0"		
DS02	200	91	6	100	45	19(2)	19(2)	19(2)	19(2)	20(2)	20(2)	24(4)	24(4)	25(4)	25(4)	25(4)	26(4)		
	400	182		100	45	18(3)	18(3)	18(3)	18(3)	18(3)	19(3)	19(3)	29(4)	29(4)	29(4)	29(4)	29(4)	29(4)	
	600	272		100	45	25(2)	25(2)	25(2)	25(2)	25(2)	25(2)	25(2)	34(4)	34(4)	34(4)	34(4)	34(4)	34(4)	
	400	182		200	91	18(3)	19(2)	20(2)	21(2)	21(2)	22(2)	22(2)	29(4)	29(4)	29(4)	30(4)	30(4)	31(4)	
	600	272		200	91	25(2)	25(2)	25(2)	26(2)	26(2)	26(2)	26(2)	34(4)	34(4)	34(4)	34(4)	34(4)	35(4)	
	600	272		300	136	26(2)	26(2)	27(2)	28(2)	28(2)	28(2)	29(2)	34(4)	34(4)	34(4)	35(2)	36(2)	37(2)	
	600	272		400	182	26(2)	28(2)	29(2)	29(2)	30(2)	31(2)	31(2)	33(4)	34(4)	35(2)	36(2)	37(2)	38(2)	
	700	318		200	91	27(3)	27(3)	27(3)	27(2)	27(2)	27(2)	27(2)	36(4)	36(4)	36(4)	36(4)	36(4)	36(4)	
	900	409		200	91	31(3)	31(3)	31(3)	31(3)	32(3)	32(3)	32(3)	40(4)	40(4)	41(4)	41(4)	41(4)	41(4)	
	1100	499		200	91	37(3)	37(3)	37(3)	37(3)	37(3)	37(3)	37(3)	45(4)	45(4)	45(4)	45(4)	45(4)	45(4)	
	1300	590		200	91	42(3)	42(3)	42(3)	42(3)	42(3)	42(3)	42(3)	48(4)	48(4)	48(4)	48(4)	48(4)	48(4)	
	700	318		300	136	26(3)	26(2)	27(2)	28(2)	28(2)	28(2)	29(2)	35(4)	35(4)	36(4)	36(4)	36(4)	37(2)	
	900	409		300	136	31(3)	31(3)	31(3)	31(3)	31(3)	31(3)	31(3)	40(4)	40(4)	40(4)	40(4)	40(4)	41(4)	
	1100	499		300	136	36(3)	36(3)	36(3)	36(3)	36(3)	36(3)	36(3)	44(4)	44(4)	44(4)	44(4)	44(4)	44(4)	
	1300	590		300	136	41(3)	41(3)	41(3)	41(3)	41(3)	41(3)	41(3)	48(4)	48(4)	48(4)	48(4)	48(4)	48(4)	
700	318	400	182	26(2)	27(2)	28(2)	29(2)	29(2)	30(2)	31(2)	34(4)	35(4)	35(4)	36(4)	37(4)	38(4)			
900	409	400	182	30(3)	30(3)	30(3)	31(3)	31(3)	31(3)	31(3)	39(4)	39(4)	40(4)	40(4)	40(4)	41(4)			
1100	499	400	182	35(3)	35(3)	35(3)	35(3)	35(3)	35(3)	35(3)	44(4)	44(4)	44(4)	44(4)	44(4)	44(4)			
1300	590	400	182	40(3)	40(3)	40(3)	40(3)	40(3)	40(3)	40(3)	47(4)	47(4)	47(4)	47(4)	48(4)	48(4)			



Acoustics Data

Table 32. Sound noise criteria — fan/valve (continued)

Fan Size	Fan Airflow		Inlet Size in	Primary Airflow							Discharge Air Valve Pressure Drop							Radiated Air Valve Pressure Drop						
	cfm	L/s		cfm	L/s	0.5"	1.0"	1.5"	2.0"	2.5"	3.0"	0.5"	1.0"	1.5"	2.0"	2.5"	3.0"	0.5"	1.0"	1.5"	2.0"	2.5"	3.0"	
DS02	400	182	8	200	91	18(3)	18(3)	19(2)	20(2)	20(2)	21(2)	28(4)	29(4)	29(4)	29(4)	29(4)	28(4)	29(4)	29(4)	29(4)	29(4)	30(4)	30(4)	
	600	272		200	91	25(2)	25(2)	25(2)	25(2)	25(2)	25(2)	25(2)	34(4)	34(4)	34(4)	34(4)	34(4)	34(4)	34(4)	34(4)	34(4)	34(4)	34(4)	34(4)
	600	272		300	136	25(2)	26(2)	26(2)	27(2)	27(2)	27(2)	28(2)	34(4)	34(4)	34(4)	34(4)	34(4)	34(4)	34(4)	34(4)	34(4)	34(4)	34(4)	34(4)
	600	272		400	182	26(2)	27(2)	28(2)	28(2)	28(2)	29(2)	29(2)	33(4)	34(4)	35(2)	35(2)	35(2)	33(4)	34(4)	35(2)	35(2)	35(2)	35(2)	35(2)
	600	272		500	277	26(2)	28(2)	29(2)	29(2)	29(2)	30(2)	31(2)	33(4)	34(4)	34(4)	35(2)	35(2)	33(4)	34(4)	34(4)	35(2)	35(2)	35(2)	36(2)
	700	318		250	114	26(3)	26(3)	26(3)	27(3)	27(3)	27(3)	27(2)	35(4)	35(4)	35(4)	36(4)	36(4)	35(4)	35(4)	35(4)	36(4)	36(4)	36(4)	36(4)
	900	409		250	114	31(3)	31(3)	31(3)	31(3)	31(3)	31(3)	31(3)	40(4)	40(4)	40(4)	40(4)	40(4)	40(4)	40(4)	40(4)	40(4)	40(4)	40(4)	40(4)
	1100	499		250	114	36(3)	36(3)	36(3)	36(3)	36(3)	36(3)	36(3)	44(4)	44(4)	44(4)	44(4)	44(4)	44(4)	44(4)	44(4)	44(4)	44(4)	44(4)	44(4)
	1300	590		250	114	41(3)	41(3)	41(3)	41(3)	41(3)	41(3)	41(3)	48(4)	48(4)	48(4)	48(4)	48(4)	48(4)	48(4)	48(4)	48(4)	48(4)	48(4)	48(4)
	700	318		500	227	25(2)	27(2)	28(2)	29(2)	29(2)	30(2)	31(2)	34(4)	34(4)	35(4)	35(4)	35(4)	34(4)	34(4)	35(4)	35(4)	35(4)	36(4)	36(4)
	900	409		500	227	29(3)	30(3)	30(3)	30(3)	30(3)	31(3)	31(3)	39(4)	39(4)	39(4)	39(4)	39(4)	39(4)	39(4)	39(4)	39(4)	39(4)	40(4)	40(4)
	1100	499		500	227	35(3)	35(3)	35(3)	35(3)	35(3)	35(3)	35(3)	43(4)	43(4)	43(4)	43(4)	43(4)	43(4)	43(4)	43(4)	43(4)	43(4)	44(4)	44(4)
	1300	590		500	227	40(3)	40(3)	40(3)	40(3)	40(3)	40(3)	40(3)	47(4)	47(4)	47(4)	47(4)	47(4)	47(4)	47(4)	47(4)	47(4)	47(4)	47(4)	47(4)
	900	318		750	341	29(3)	29(2)	31(2)	32(2)	32(2)	32(2)	33(2)	38(4)	38(4)	39(4)	40(4)	40(4)	38(4)	38(4)	39(4)	39(4)	40(4)	40(4)	41(2)
1100	409	750	341	34(3)	34(3)	34(3)	35(2)	35(2)	35(2)	36(2)	42(4)	43(4)	43(4)	43(4)	43(4)	42(4)	42(4)	43(4)	43(4)	43(4)	43(4)	44(4)		
1300	499	750	341	39(3)	39(3)	39(3)	39(3)	39(3)	39(3)	40(3)	46(4)	46(4)	46(4)	47(4)	47(4)	46(4)	46(4)	47(4)	47(4)	47(4)	47(4)	47(4)		
700	318	500	227	25(3)	25(3)	26(2)	27(2)	27(2)	29(2)	30(2)	34(4)	37(4)	41(4)	43(4)	46(4)	34(4)	37(4)	41(4)	43(4)	43(4)	46(4)	47(4)		
900	409	500	227	29(3)	30(3)	30(3)	30(3)	30(3)	30(3)	31(3)	39(4)	40(4)	42(4)	44(4)	46(4)	39(4)	40(4)	42(4)	44(4)	44(4)	46(4)	48(4)		
1100	499	500	227	35(3)	35(3)	35(3)	35(3)	35(3)	35(3)	35(3)	43(4)	44(4)	45(4)	46(4)	46(4)	43(4)	44(4)	45(4)	46(4)	46(4)	48(4)	49(4)		
1300	590	500	227	40(3)	40(3)	40(3)	40(3)	40(3)	40(3)	40(3)	47(4)	47(4)	48(4)	49(4)	49(4)	47(4)	47(4)	48(4)	49(4)	49(4)	49(4)	50(4)		
900	409	750	341	29(3)	29(3)	29(3)	30(3)	29(3)	31(2)	32(2)	39(4)	41(4)	44(4)	47(4)	49(4)	39(4)	41(4)	44(4)	47(4)	47(4)	49(4)	51(4)		
1100	409	750	341	34(3)	34(3)	34(3)	34(3)	34(3)	34(3)	35(3)	43(4)	44(4)	46(4)	48(4)	50(4)	44(4)	44(4)	46(4)	48(4)	48(4)	50(4)	51(4)		
1300	590	750	341	39(3)	39(3)	39(3)	39(3)	39(3)	39(3)	39(3)	47(4)	47(4)	48(4)	49(4)	51(4)	47(4)	47(4)	48(4)	49(4)	49(4)	51(4)	52(4)		
1100	499	1000	454	34(3)	34(3)	34(3)	35(2)	34(3)	35(2)	36(2)	43(4)	44(4)	47(4)	49(4)	51(4)	44(4)	44(4)	47(4)	49(4)	49(4)	51(4)	53(4)		
1300	590	1000	454	39(3)	39(3)	39(3)	39(3)	39(3)	39(3)	40(2)	46(4)	47(4)	49(4)	50(4)	52(4)	47(4)	47(4)	49(4)	49(4)	50(4)	52(4)	54(4)		

Notes:

1. NC values are calculated using modeling assumption based on AHRI 880-98-02.
2. All sound power levels, dB re: 10-12 Watts
3. The air valve pressure drop values shown are for the pressure drop across the air valve only.
4. All acoustic performance data shown is with 1" matte faced insulation and a 6-row sensible cooling coil.

Table 33. Fan only sound power (dB)

Fan	Fan Airflow		Discharge Octave Bands							Radiated Octave Bands						
	cfm	L/s	2	3	4	5	6	7	2	3	4	5	6	7		
DS02	200	91	64	58	55	51	45	41	57	54	51	44	36	27		
	400	182	66	61	59	57	51	48	59	55	55	49	41	31		
	600	272	71	66	65	63	58	56	63	59	59	54	46	37		
	700	318	71	67	66	62	58	56	64	58	60	54	42	34		
	900	409	76	72	71	68	65	63	69	62	64	60	48	41		
	1100	499	80	76	75	73	70	69	73	66	68	64	53	47		
	1300	590	84	81	79	78	75	74	76	70	72	68	58	51		

Table 34. AHRI 885-2008 add discharge transfer function assumptions

	Octave Band					
	2	3	4	5	6	7
Small Box (< 300 CFM)	-24	-28	-39	-53	-59	-40
Medium Box (300-700 CFM)	-27	-29	-40	-51	-53	-39
Large Box (> 700 CFM)	-29	-30	-41	-51	-52	-39

Notes:

1. Subtract from terminal unit sound power to determine discharge sound pressure in the space.
2. NC Values are calculated using current Industry Standard AHRI 885-2008. Radiated Transfer Function obtained from Appendix E, Type 2 Mineral Fiber Insulation.
3. Application ratings are outside the scope of the Certification Program.

Table 35. AHRI 885-2008 radiated transfer function assumptions

	Octave Band					
	2	3	4	5	6	7
Type 2- Mineral Fiber Insulation	-18	-19	-20	-26	-31	-36
Total dB reduction	-18	-19	-20	-26	-31	-36

Notes:

1. Subtract from terminal unit sound power to determine discharge sound pressure in the space.
2. NC Values are calculated using current Industry Standard AHRI 885-2008. Radiated Transfer Function obtained from Appendix E, Type 2 Mineral Fiber Insulation.
3. Application ratings are outside the scope of the Certification Program.



DDC Controls

Controllers

DDC controllers are today's industry standard. DDC controllers provide system-level data used to optimize system performance. Variables such as occupied/unoccupied status, minimum and maximum primary and fan airflow setpoints, current zone temperature and temperature setpoints, valve position, fan status (on or off, and mode of operation), heat status (on or off), and air valve size, temperature correction offsets, flow correction values, etc. are available on a simple twisted-shielded wire pair or communicated wirelessly.

Trane® DDC controllers provide Trane-designed, solid-state electronics intended specifically for terminal unit control in space comfort applications.

DDC control capabilities include:

- Pressure-independent (PI) operation, which automatically adjusts valve position to maintain required ventilation airflow. In certain low-flow situations or in cases where the flow measurement has failed, the DDC controller will operate in a pressure-dependent (PD) mode of operation.
- Multiple heating control options including staged electric, modulating hot-water, and modulating electric heat (SCR). Modulating heat options utilize a separate proportional-plus-integral control loop from that controlling airflow into the room. Staged heat options utilize a control algorithm based on heating setpoint and room temperature.
- 24 VAC binary input that can be configured as a generic input or as occupancy input. When the DDC controller is operation with Tracer® SC, the status of the input is provided to Tracer® SC for its action. In stand-alone operation and when configured for an occupancy input, the input will control occupancy status of the DDC controller.

Figure 17. Flow sensor single vs. airflow delivery

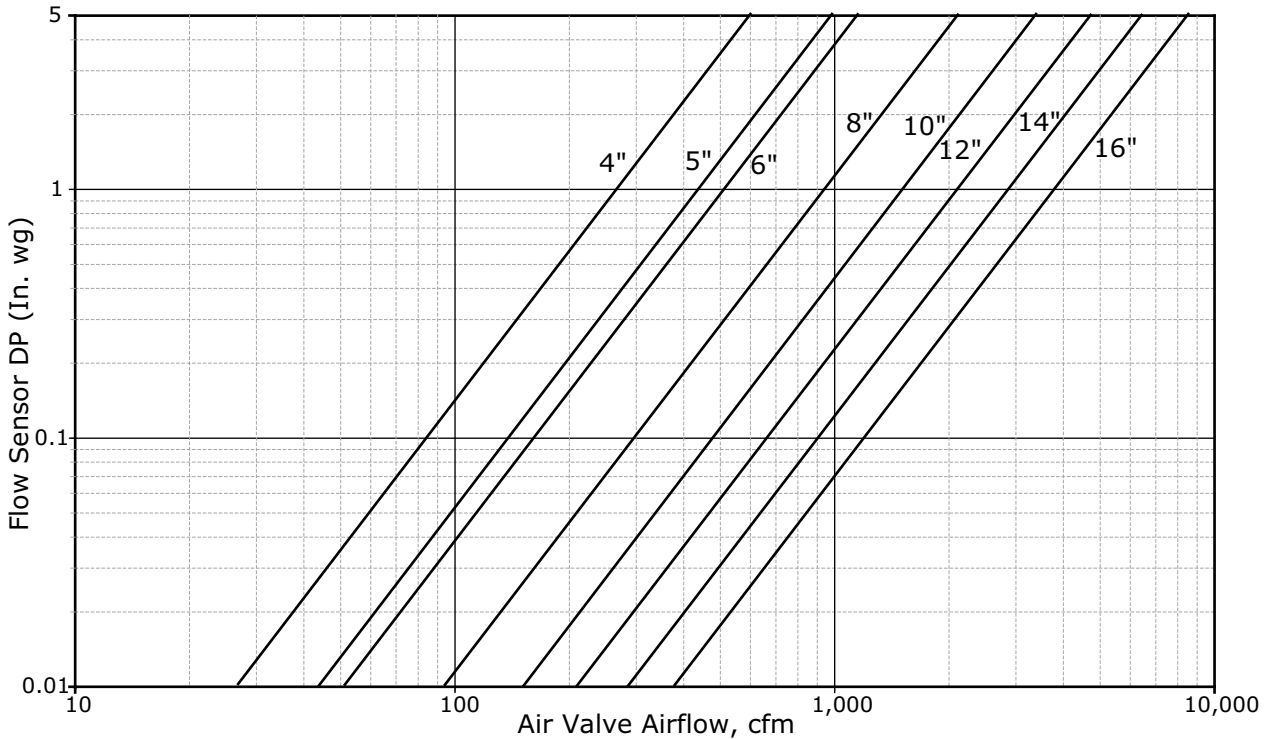

Symbio™ 500 Programmable BACnet Controllers

Introduction

The Symbio™ 500 controller is a programmable general purpose BACnet®, microprocessor-based, Direct Digital Controller (DDC). When factory installed on Trane CoolSense™ Chilled Water Sensible Cooling Terminal Units, it is factory programmed with the appropriate sequences and settings. The control sequence for these units uses space temperature control.

The controller monitors the airflow through the air valve to maintain the required amount of conditioned outdoor air delivered from the Dedicated Outdoor Air Unit. The controller modulates cooling coil capacity and the fan airflow to maintain space temperature in the cooling mode. Similarly, if the unit is equipped with a heating coil (either hot water or electric heat), the controller modulates the heating capacity and the fan airflow to maintain space temperature in the heating mode.

Available Inputs

Required inputs include:

- Twisted/shielded communication link
- Zone sensor
- Setpoint
- Space temperature
- Discharge air temperature (DAT)
- Condensate detection switch
- 24 VAC power

Optional inputs include:

- Space relative humidity
- Supply (inlet) air temperature (SAT)
- CO₂ sensor
- Entering water temperature sensor
- Ancillary control

The spare inputs and outputs on the Symbio™ 500 controller can be programmed using Tracer® TU Tracer Graphical Programming 2 (TGP2).

Note: For more information on using spare points, see *Symbio™ 500 Programmable Controller Installation, Operation, and Maintenance (BAS-SVX090*-EN)*.

General Features and Benefits

Assured Accuracy

- Proportional-plus-integral control loop algorithm for determining required cooling or heating capacity needed to control zone temperature. Fan and ventilation (air valve) airflows are limited by active minimum and maximum airflow setpoints.
- Pressure-independent (PI) operation that automatically adjusts air valve position to maintain required ventilation airflow. In certain low-flow situations or in cases where the flow measurement has failed, the DDC controller will operate in a pressure-dependent (PD) mode of operation.
- When combined with the patented Trane flow ring and pressure transducer, flow is repeatable to +/- 5% accuracy across the pressure independent (PI) flow range. (See Valve/Controller Airflow Guidelines section).
- Improved 2-Point air balancing is available – Assures optimized flow-sensing accuracy across the operating range. This provides a more accurate airflow balancing method when compared to typical single-point flow correction air balancing.
- Analog input resolution of +/- 1/8°F within the comfort range maximizes zone temperature control yielding excellent comfort control.

Reliable Operation

- Built for life – Trane products are designed to stand the test of time, with a proven design life that exceeds 20 years.
- Factory Tested – Symbio™ 500 programmed with appropriate sensible cooling programs and configured per unit parameters and optional customer supplied ventilation and fan airflow configuration values and Symbio™ 500 and/or WCI address values. Features tested in the factory include fan operation, electric heat contactor energization, air valve modulation, flow sensor operation, IMC communication between Symbio™ 500 and WCI, discharge temp sensor operation.

Safe Operation

- All components, including the controller, pressure transducer, transformer, etc. are mounted in a NEMA 1 sheet metal enclosure and are tested as an assembly to UL standards. The result is a rugged and safe controller, and thus, overall unit.
- When in PI-mode, electric heat is disabled when the sensed flow is below the minimum required.

System-level Optimization

Trane controllers are designed to integrate into Trane Tracer® SC and leverage clear and clean unit-controller related data for system level control decisions. Integrating a Trane Symbio™ 500 controller into a Tracer® SC Control System provides the next step in building automation.

Specifically, system-level decisions on how to operate all components can be made. Energy efficient optimization strategies, like fan-pressure optimization, can be employed with the simple press of a button. The end-result is the most efficient and reliable building automation system available.

Simplified Installation

Factory Commissioned Quality – All Trane DDC controllers are factory-commissioned. This means that the DDC boards are powered and run-tested with your specific sequence parameters. They are connected to a communication link to make sure that information and diagnostic data function properly. Before any unit ships it must pass a rigorous quality control procedure. You can be assured that a Trane chilled water sensible cooling terminal unit with Trane DDC controls will work right out of the crate.

Tenant-Finish Heat Mode – In some office projects, the building is being constructed as tenants are being identified. Tenant-finish heat mode is designed for applications when a given floor has not been occupied. The main AHU is used for heat and because the internal furnishings are not complete, the sensors have not been installed. In this case, the air valve drives open using the heat of the main AHU to keep plumbing lines from freezing. Operation of the chilled water sensible cooling terminal unit fan remains unaffected.

Controller Flexibility

- Three configurable 24 Vac binary inputs are provided. When the DDC controller is operating with Tracer® SC, status of each input is provided to Tracer® SC. Defaults are as follows, however all inputs can be configured as the application requires.
 - First — Occupancy
 - Second — Condensate overflow
 - Third — not used
- Symbio™ 500 Programmable BACnet® Controller certified performance ensures that a Trane chilled water sensible cooling terminal unit with controller will provide state-of-the-art, consistent open communication protocol for integration with the industry's latest (Non-Trane) building automation control systems, including Johnson Control, Andover, Siemens, Honeywell, etc.
- CO₂ demand controlled ventilation enables the terminal to adjust ventilation air flow setpoint based on the current occupancy in the zone. Trane demand controlled ventilation strategies are pre-defined for simplified application and can be easily customized to meet the needs of a specific system.
- Supports discharge air temp reset with modulating hot-water and SCR electric heat on units with multipoint-DAT sensor.

Trane DDC Controller Logic

Following is the control sequence used for Trane CoolSense™ Chilled Water Sensible Cooling Terminal Units:

Occupied Mode:

When the unit is in any of the Occupied Modes, the terminal unit fan shall operate continuously and the ventilation air damper shall open to either the Cooling or Heating Design Ventilation Airflow setpoint. If the zone is equipped with a CO₂ sensor, the controller shall continuously calculate the minimum ventilation airflow setpoint using the measured CO₂ concentration in the zone.

Occupied Cooling Mode:

When the unit is in Occupied Cooling Mode, the controller shall maintain the zone temperature at the active cooling setpoint by modulating both the terminal fan speed and chilled-water valve, while the ventilation damper is controlled to its minimum ventilation setpoint and the hot-water valve or electric heat remain off (if equipped). The controller shall first modulate the chilled-water valve to maintain zone temperature at its active cooling setpoint, while the fan operates at its Minimum Fan Airflow setpoint. When the requested cooling capacity has increased to the point where the chiller-water valve is fully open, the controller shall modulate the fan between its Minimum Fan Airflow and Maximum Cooling Fan Airflow setpoints to maintain zone temperature at its active cooling setpoint, while the chilled-water valve remains fully open. If the fan reaches its Maximum Cooling Fan Airflow setpoint, but the unit requires even more cooling capacity, the controller shall modulate the ventilation air damper between its active minimum ventilation airflow and Maximum Primary Airflow setpoints to maintain zone temperature at its active cooling setpoint, while the chilled-water valve remains fully open and the fan operates at its Maximum Cooling Fan Airflow setpoint.

Occupied Heating Mode (for units equipped with a discharge air temperature sensor and hot water heating coil):

When the unit is in Occupied Heating Mode, the controller shall maintain the zone temperature at the active heating setpoint by modulating both the terminal fan speed and hot-water valve, while the ventilation damper is controlled to its minimum ventilation setpoint and the chilled-water valve remains closed.

The controller shall modulate the hot-water valve to maintain zone temperature at its active heating setpoint, while the fan continues to operate at its Minimum Fan Airflow setpoint. When the discharge air temperature reaches the design heating discharge air temperature setpoint, the controller shall modulate the fan between its Minimum Fan Airflow setpoint and Maximum Heating Fan Airflow setpoint, while the hot-water valve modulates to maintain discharge air temperature at the design heating discharge air temperature setpoint. When the requested heating capacity has increased to the point where the fan has reached its Maximum Heating Fan Airflow setpoint, the controller shall modulate the hot-water valve to maintain zone temperature at its active heating setpoint, while the fan continues to operate at its Maximum Heating Fan Airflow setpoint.

Occupied Heating Mode (for units equipped with a discharge air temperature sensor and modulating, SCR, electric heater):

When the unit is in Occupied Heating Mode, the controller shall maintain the zone temperature at the active heating setpoint by modulating both the terminal fan speed and the electric heater (SCR), while the ventilation damper is controlled to its minimum ventilation setpoint and the chilled-water valve remains closed.

The controller shall modulate the electric heater to maintain zone temperature at its active heating setpoint, while the fan continues to operate at its Minimum Fan Airflow setpoint. When the discharge air temperature reaches the design heating discharge air temperature setpoint, the controller shall modulate the fan between its Minimum Fan Airflow setpoint and Maximum Heating Fan Airflow setpoint, while the electric heater modulates to maintain discharge air temperature at the design heating discharge air temperature setpoint. When the requested heating capacity has increased to the point where the fan has reached its Maximum Heating Fan Airflow setpoint, the controller shall modulate the electric heater to maintain zone temperature at its active heating setpoint, while the fan continues to operate at its Maximum Heating Fan Airflow setpoint.

Occupied Heating Mode (for units equipped with one or two stages of electric heat):

When the unit is in Occupied Heating Mode, the controller shall maintain the zone temperature at the active heating setpoint by modulating the terminal fan speed and staging electric heat, while the ventilation damper is controlled to its minimum ventilation setpoint and the chilled-water valve remains closed. The controller shall modulate the fan between its Minimum Fan Airflow setpoint and Maximum Heating Fan Airflow setpoint to maintain zone temperature at its active heating setpoint, while the electric heater remains off. When the requested heating capacity has increased to the point where the fan has reached its Maximum Heating Fan Airflow setpoint, the controller shall stage on electric heat to maintain zone temperature at its active heating setpoint, while the fan continues to operate at its Maximum Heating Fan Airflow setpoint.

Unoccupied Mode:

When in the Unoccupied Mode, the controller shall close the ventilation air damper, turn off the fan, close the chilled-water valve, and close the hot-water valve or turn off the electric heat (if equipped), unless unoccupied cooling, heating, or dehumidification is needed.

If the zone temperature rises above its Unoccupied Cooling Setpoint, the controller shall turn on the fan and operate at its Maximum Cooling Fan Airflow setpoint, fully open the chilled-water valve, close the hot-water valve or turn off the electric heat (if equipped), and close the ventilation air damper, until the zone temperature drops back to 2°F below the Unoccupied Cooling Setpoint. If condensate is detected or if the zone dew point rises above the Unoccupied Dew Point Setpoint, the controller shall close the chilled-water valve and open the ventilation air damper to its Maximum Primary (Ventilation) Airflow setpoint, until condensate is no longer detected and the zone dew point drops back below the Unoccupied Dew Point Setpoint.

[ALTERNATE SEQUENCE: If the zone temperature rises above its Unoccupied Cooling Setpoint, the controller shall turn on the fan and operate at its Maximum Cooling Fan Airflow setpoint, close the chilled-water valve, close the hot-water valve or turn off the electric heat (if equipped), and open the ventilation air damper to its Maximum Primary (Ventilation) Airflow setpoint, until the zone temperature drops back to 2°F below the Unoccupied Cooling Setpoint.]

If the zone dew point rises above its Unoccupied Dew Point Setpoint, but the zone temperature is between the Unoccupied Heating and Unoccupied Cooling Setpoints, the controller shall turn on the fan and operate at its Maximum Cooling Fan Airflow setpoint, close the chilled-water valve, close the hot-water valve or turn off the electric heat (if equipped), and open the ventilation air damper to its Maximum Primary (Ventilation) Airflow setpoint, until the space dew point drops back to 1°F below the Unoccupied Dew Point Setpoint.

If the terminal unit is equipped with hot water or electric heat, and the zone temperature drops below its Unoccupied Heating Setpoint, the controller shall turn on the fan and operate at its Maximum Heating Fan Airflow setpoint, fully open the hot-water valve (or turn on both stages of electric heat), close the chilled-water valve, and close the ventilation air damper, until the zone temperature rises back to 2°F above the Unoccupied Heating Setpoint.

Condensate Avoidance:

If the condensate detector indicates the presence of condensate in the drip pan, the controller shall close the chilled-water valve, and continue operating the terminal fan and ventilation air damper as normal. The unit shall return to normal operation when condensate is no longer detected.

If the measured zone dew point exceeds the entering chilled-water temperature, the controller shall close the chilled-water valve, and continue operating the terminal fan and ventilation air damper as normal. The unit shall return to normal operation when the zone dew point is less than 5°F below the entering chilled-water temperature.

If the zone dew point rises above its Occupied Dew Point Setpoint, the ventilation air damper shall be modulated further open until the zone dew point drops back below the Occupied Dew Point Setpoint.

Tracer® Programmable BACnet® Controller—Unit Control Module

The Symbio™ 500 is a microprocessor-based terminal unit controller with non-volatile memory which provides accurate ventilation and zone temperature control of air terminal units. Symbio™ 500 provides a simple open protocol to allow integration of Trane terminal units and controllers into other existing control systems. The controller can operate in pressure-independent or pressure-dependent mode and uses a proportional plus integral control algorithm.

The controller monitors zone temperature setpoints, the current zone temperature and its rate of change and valve airflow (via flow ring differential pressure). The controller also accepts a supply air temperature value from the BAS. Staged electric heat, modulating (SCR) electric heat, and modulating hot water heat control are available as options. The control board operates using 24-VAC power. When used with a Tracer® SC or other Trane controllers, zone grouping and unit diagnostic information can be obtained. Factory-commissioning of parameters specified by the engineer can also be done. (See Factor Installed vs. Factory Commissioned table in Features and Benefits chapter for more details.)

Air-Fi Communications Interface (WCI)

The Air-Fi® Wireless Communications Interface (WCI) enables wireless communications between system controls, unit controls, and wireless sensors for Trane control products that use the BACnet® protocol. The WCI replaces the need for communications wire in all system applications.

Air-Fi Wireless Communications Sensor (WCS)

The Air-Fi® Wireless Communications Sensor (WCS) is compatible with any Trane controller that uses a WCI. The WCS provides the same functions as many currently available Trane wired sensors. No further software or hardware is necessary for site evaluation, installation, or maintenance. Space temperature is standard on all models. (A service tool cannot be connected to a Trane wireless sensor.)

Five WCS models are available:

- CO₂ with occupancy WCS-SCO₂
- Digital display (WCS-SD) model
- Base (WCS-SB) model has no exposed display or user interface
- 2% relative humidity sensor module (WCS-SH), which can be field installed inside either the WCS-SD, WCS-SB. WCS-SCO₂

In most applications, one WCS sensor will be used per WCI acting as a router. However, up to 6 WCS sensors can be associated to a single equipment controller or BCI.

DDC Zone Sensors

The direct digital control (DDC) zone sensor is an uncomplicated, reliable electro-mechanical room sensor. No programming is required and most sensors contain an internal communications jack. Models are available with combinations of features such as override (on-cancel) buttons and space-mounted setpoint.

Figure 18. DDC zone sensor with LCD



Figure 19. DDC zone sensors without LCD



Four sensor variations are available:

- Sensor only (no communications jack)
- Sensor with override buttons
- Sensor with temperature setpoint only
- Sensor with temperature setpoint and override buttons



DDC Zone Sensor with LCD

The DDC zone sensor with LCD (liquid crystal display or digital) is compatible with VariTrane™ VAV and VariTrac™ controllers.

Digital Zone Sensor Summary

- Displays setpoint adjustment and space temperature in °F or °C.
- Simple, two-button control of space setpoint.
- Setpoint control and room temperature display can be optionally disabled.
- Includes button for timed override and a cancel feature for after-hours system operation.
- An easily accessible communications jack is provided for Trane portable edit terminal devices.
- Nonvolatile memory stores last programmed setpoints.
- For field balancing, maximum and minimum airflow or position can be overridden from the sensor.

CO₂ Sensors

Carbon dioxide (CO₂) sensors are designed for demand-controlled ventilation zone applications. The sensor is compatible with VariTrane™ VAV and VariTrac™ controllers. The Trane CO₂ sensors measure carbon dioxide in parts-per-million (ppm) in occupied building spaces. Outdoor airflow is reduced below design ventilation rates if the CO₂ concentration decreases due to reduced occupancy.

CO₂ Zone Sensor Summary

- Use with the UCM CO₂ input for demand control ventilation.
- Silicone-based NDIR sensor technology for long-term stability.
- Measurement range of 2000 ppm CO₂ input with an output of 0–10 Vdc.
-
-

Auxiliary Temperature Sensor



The auxiliary discharge temperature sensor is used in conjunction with the Trane DDC controller to sense duct temperature. When the DDC controller is used with a Building Automation System, the sensor temperature is reported as status only.

Trane Control Valves



The modulating water valve is used to provide accurate control of either a chilled water coil or a hot water heating coil to help maintain a zone temperature setpoint. The valve plug is an equal percentage design and comes available in four different flow capacities for proper controllability. The valves are field-adjustable for use as a two- or three-way configuration. The valves ship in a two-way configuration with a cap over the bottom port. Conversion to three-way operation is accomplished by removing the plug from the "B" port. The valve actuator contains a three-wire synchronous motor.

The direct digital controller uses a time-based signal to drive the motor to its proper position. When power is removed from the valve, it remains in its last controlled position.

Belimo Control Valves



The modulating water valve is used to provide accurate control of a hot water heating coil to help maintain a zone temperature setpoint. The valves available in seven different flow capacities for proper controllability. The valves are selectable in a two- or three-way configuration. The valve actuator contains a three-wire synchronous motor. The direct digital controller uses a time-based signal to drive the motor to its proper position. When power is removed from the valve, it remains in its last controlled position.

VAV Piping Package

Figure 20. Standard valve piping package



Figure 21. Belimo valve piping package

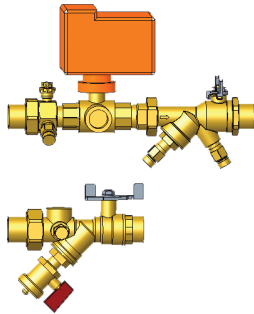

- Offered in both 2-way and 3-way configurations
 - The Automatic Balancing Flow Control sized for the specified VAV coil and gpm.
 - Field connections are NPT with Coil connections Sweat to match the Trane VAV water coil copper
 - For 3-way configuration the connections between the ATC valve and the supply shut off assembly are sweat to allow for field installation of hose or piping connection between the supply and return lines. Included in the package are:
 - P/T Ports for pressure and temperature measurement on both the supply and return sections.
 - Blow down drainable filter on the supply.
 - Y-Ball Combination Mesurflo Automatic Balance Valve on the Return side to isolate the coil.
 - Y-Ball Combination Strainer on the supply to isolate the coil.
- Each piping package is tagged to match the VAV terminal tag it is specified for.
 - Each piping package includes a 24v floating point control modulating control ball valve or a 2V-10V analog control ball valve.
 - The Cv is sized to match the specified gpm/coil performance of the VAV terminal unit. Package includes unions with sweat connections to the coil.

Differential Pressure Transducer



The differential pressure transducer is used in conjunction with the Trane direct digital controller and analog electronic controller. The pressure transducer measures the difference between the high-pressure and low-pressure ports of the Trane flow ring. The transducer is self-adjusting to changes in environmental temperature and humidity.

Transformers



The transformer converts primary power supply voltages to the voltage required by the direct digital controller and analog. The transformer also serves to isolate the controller from other controllers which may be connected to the same power source.

Trane Actuator – 90 Second at 60 Hz Drive Time

This actuator is used with DDC controls and retrofit kits. It is available with a 3-wire floating-point control device. It is a direct-coupled over the shaft (minimum shaft length of 2.1-inch), enabling it to be mounted directly to the damper shaft without the need for connecting linkage. The actuator has an external manual gear release to allow manual positioning of the damper when the actuator is not powered.

Belimo Actuator – 95 Second Drive Time

This actuator is used with DDC controls and retrofit kits. It is available with a 3-wire floating-point control device. It is a direct-coupled over the shaft enabling it to be mounted directly to the damper shaft without the need for connecting linkage. The actuator has an external manual gear release to allow manual positioning of the damper. The actuator is UL listed and carries the CE mark.

Analog Actuator

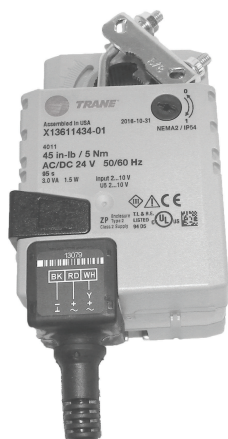

Analog control damper actuators shall be electronic direct-coupled type, which require no crank arm and linkage and be capable of direct mounting to a shaft from 1/4-inch to 5/8-inch. Actuators must provide proportional damper control in response to a 2 to 10 VDC or, with the addition of a 500 ohm resistor, a 4 to 20 mA control input from an electronic controller or positioner. Actuators shall have brushless DC motor technology and be protected from overload at all angles of rotation. Actuators shall have reversing switch and manual override on the cover. Run time shall be constant and independent of torque. Actuators shall be cULus listed, and be manufactured under ISO 9001 International Quality Control Standards.

Electric Heater Silicon-Controlled Rectifier (SCR)

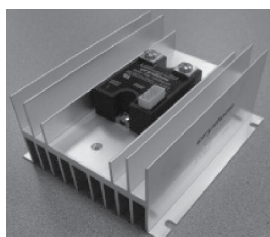

- Microprocessor based burst-fire controller / SSR
- Low-voltage control
- Output status indicator
- 0-100% Control Range
- Synchronized triggering output (P3)
- 20 AC Cycles Base Period



Moisture Sensor



The moisture sensor is used to detect the presence of condensate in the drip pan located under the sensible cooling coil, and to provide a relay output. The device operates on 24 Volts AC and functions as a Normally Closed Sensor (contacts open upon the detection of moisture).



Electrical Data

Table 36. LDEF — electric coil kW guidelines, minimum to maximum

Fan Size	Stages	Single-Phase Voltage				Three-Phase Voltage	
		208V	240V	277V	480V	208V	480V
DS02	1	1.0-8.0 ^(a)	1.0-9.0	1.0-11.0	1.0-14.0	1.0-14.0 ^(b)	1.0-12.0, 14.0
	2	1.0-8.0 ^(a)	1.0-9.0	1.0-11.0	1.0-14.0	1.0-14.0 ^(b)	1.0-12.0, 14.0

Notes:

1. Available kW increments are by 0.5 from 1.0 kW to 8.0 kW and by 1.0 kW afterward.
2. Each stage will be equal in kW output.
3. All heaters contain an auto thermal cutout and a manual reset cutout.
4. The current amp draw for the heater elements is calculated by the formula mentioned in the Formula section below.

^(a) 8 kW not available with 115V motors

^(b) 14kW not available with 115V motor

Table 37. VDEG — electric coil kW guidelines, minimum to maximum

Fan Size	Stages	Single-Phase Voltage					Three-Phase Voltage	
		120V	208V	240V	277V	480V	208V	480V
Small	1	1.0 - 4.5	1.0 - 8.0	1.0 - 10.0	1.0 - 11.0	1.0 - 9.0	1.0 - 14.0	1.0 - 11.0
	2	1.0 - 4.5	1.0 - 8.0	1.0 - 10.0	1.0 - 11.0	1.0 - 9.0	1.0 - 14.0	1.0 - 11.0
Medium	1	-	3.0 - 8.0	3.0 - 9.0	3.0 - 11.0	3.0 - 18.0	3.0 - 13.0	3.0 - 20.0
	2	-	3.0 - 8.0	3.0 - 9.0	3.0 - 11.0	3.0 - 18.0	3.0 - 13.0	3.0 - 20.0
Large	1	-	5.0 - 7.0	5.0 - 9.0	5.0 - 10.0	5.0 - 18.0	5.0 - 12.0	5.0 - 20.0
	2	-	5.0 - 7.0	5.0 - 9.0	5.0 - 10.0	5.0 - 18.0	5.0 - 12.0	5.0 - 20.0

Notes:

1. Heater KW step sizes: 0.5kw for kw's upto 8; 1kw for kw's from 8 to 18kw; 2kw for heater kw's from 18 kw and up.
2. Heaters available in 1 or 2 stages.

Table 38. Fan electrical performance (ECM)

Fan Size	HP	Maximum Fan Motor Amperage (FLA)		
		115V	208V	277V
DS02	3/4	9.6	-	5.2
Small	1/3	7.3	4.4	4.7
Medium	3/4	11.2	8.2	7.5
Large	1	12.8	8.2	7.5

Table 39. Minimum unit electric heat guidelines — LDEF

Unit kW	Cfm	L/s
1.0	100	47
1.5	116	55
2.0	156	74
2.5	195	92
3.0	234	110
3.5	274	129
4.0	313	148
4.5	352	166
5.0	392	185
5.5	431	203
6.0	470	222



Electrical Data

Table 39. Minimum unit electric heat guidelines — LDEF (continued)

Unit kW	Cfm	L/s
6.5	510	241
7.0	549	259
7.5	588	278
8.0	628	296
9.0	700	330
10.0	785	370
11.0	863	407
12.0	942	445
13.0	1021	482
14.0	1099	519

Table 40. Electric heat guidelines (CFM) — VDxG

Unit kW	Heat Guidelines (CFM)		
	Small	Medium	Large
1.0	160	350	360
1.5	160	350	360
2.0	160	350	360
2.5	197	350	360
3.0	236	350	360
3.5	275	350	360
4.0	315	350	360
4.5	354	354	360
5.0	393	393	393
5.5	432	432	432
6.0	472	472	472
6.5	511	511	511
7.0	550	550	550
7.5	590	590	590
8.0	629	629	629
9.0	708	708	708
10.0	786	786	786
11.0	865	865	865
12.0	944	944	944
13.0	1022	1022	1022
14.0	1101	1101	1101
15.0	-	1179	1179
16.0	-	1258	1258
17.0	-	1337	1337
18.0	-	1415	1415
20.0	-	1573	1573
22.0	-	-	1730

Table 41. Electric heat guidelines (L/s) — VDxG

Unit kW	Heat Guidelines (L/s)		
	Small	Medium	Large
1.0	76	165	170
1.5	76	165	170
2.0	76	165	170
2.5	93	165	170
3.0	111	165	170
3.5	130	165	170
4.0	148	165	170
4.5	167	167	170
5.0	186	186	186
5.5	204	204	204
6.0	223	223	223
6.5	241	241	241
7.0	260	260	260
7.5	278	278	278
8.0	297	297	297
9.0	334	334	334
10.0	371	371	371
11.0	408	408	408
12.0	445	445	445
13.0	482	482	482
14.0	519	519	519
15.0	-	557	557
16.0	-	594	594
17.0	-	631	631
18.0	-	668	668
20.0	-	742	742
22.0	-	-	816

Formulas

Minimum Circuit Ampacity (MCA) = (motor amps + heater amps) x 1.25

Maximum Overcurrent Protection (MOP) = (2.25 x motor amps) + heater amps

General Sizing Rules:

- If MOP = 15, then fuse size = 15
- If MOP = 19, then fuse size = 15 with one exception. If heater amps x 1.25 > 15, then fuse size = 20.
- If MOP is less than/equal to MCA, then choose next fuse size greater than MCA.
- Control fusing not applicable.
- Standard Fuse Sizes: 15, 20, 25, 30, 35, 40, 45, 50, and 60.

Useful Formulas:



Electrical Data

$$\text{kW} = \frac{\text{cfm} \times \text{ATD}}{3145} \quad \text{ATD} = \frac{\text{kW} \times 3145}{\text{cfm}}$$

$$\text{kW} = 1214 \times \text{L/s} \times \text{ATD} \quad \text{ATD} = \frac{\text{kW}}{1214 \times \text{L/s}}$$

$$3 \phi \text{ amps} = \frac{\text{kW} \times 1000}{\text{PrimaryVoltage} \times \sqrt{3}}$$

$$1 \phi \text{ amps} = \frac{\text{kW} \times 1000}{\text{PrimaryVoltage}}$$



General and Dimensional Data

General Data

Table 42. CoolSense™ Chilled Water Sensible Cooling Terminal Units, LDxF— general data, dimensions and weights

Description	Units	Cooling Only LDCF	Hot Water LDWF	Electric Heat LDEF
Filter Size	in.	8 x 38 x 1	8 x 38 x 1	8 x 38 x 1
	mm	203 x 965 x 25	203 x 965 x 25	203 x 965 x 25
Inlet Size Availability	in.	4, 5, 6, 8, 8x14	4, 5, 6, 8, 8x14	4, 5, 6, 8, 8x14
	mm	104, 127, 152, 203, 256	104, 127, 152, 203, 256	104, 127, 152, 203, 256
Unit Weight	lb	125	131	143
	kg	57	59	65
Dimensional Data	Reference Dimensional Drawing Section			
Height (H)	in.	10.5	10.5	10.5
	mm	267.0	267.0	267.0
Width (W)	in.	35.0	35.0	35.0
	mm	889.0	889.0	889.0
Length (L)	in.	40.0	40.0	40.0
	mm	1016.0	1016.0	1016.0
Discharge (A)	in.	9.9	18.0	14.0
	mm	251.0	457.0	365.0
Discharge (B)	in.	6.8	10.0	9.0
	mm	173.0	254.0	229.0
Discharge (D)	in.	4.0	4.0	4.0
	mm	102.0	102.0	102.0



Dimensional Drawings

Dimensions — Cooling Only (LDCF)

Figure 22. Chilled water sensible cooling terminal unit — cooling only (LDCF)

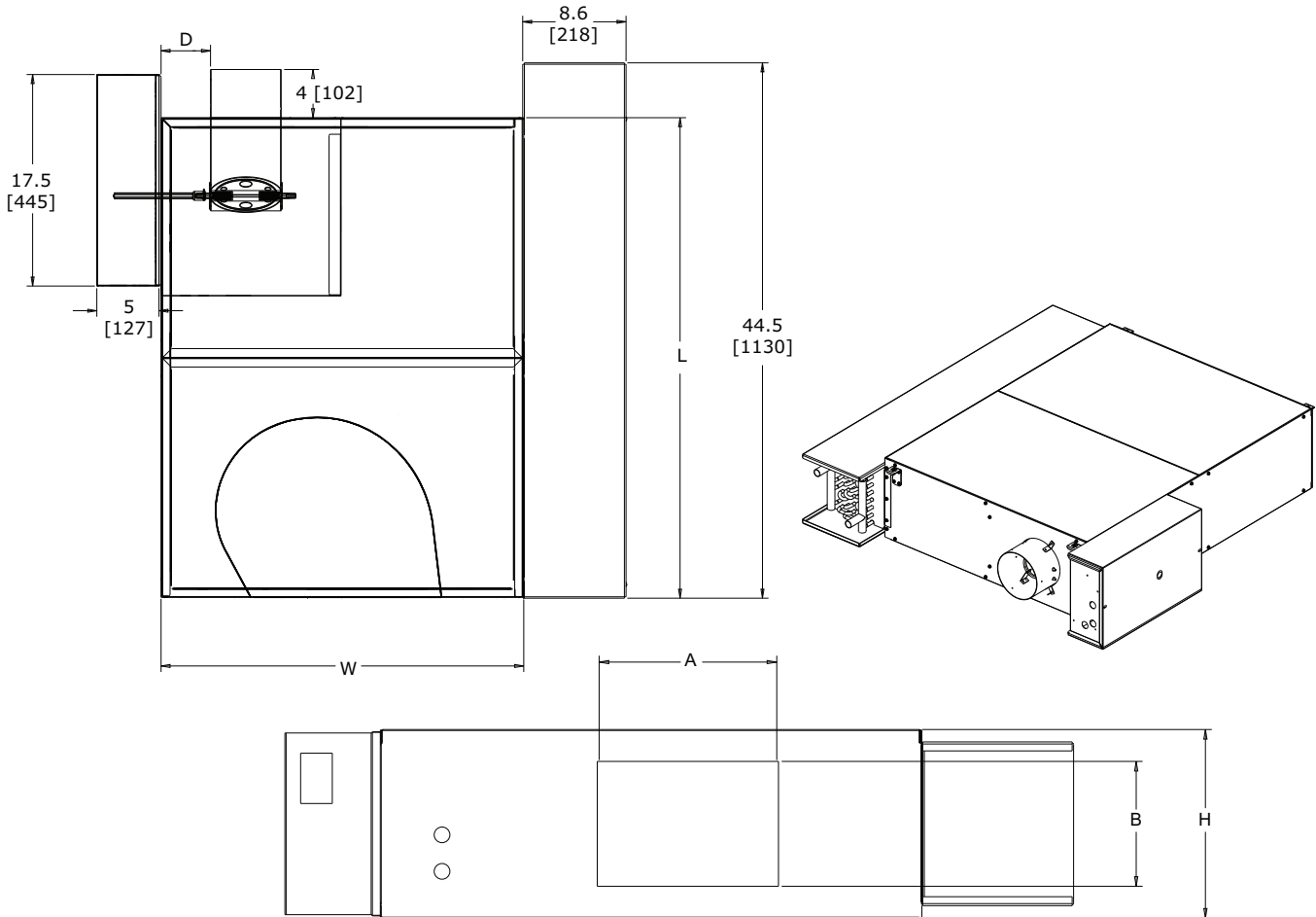

Notes:

- Allow a minimum 6" (152mm) plenum inlet clearance for unducted installations.
- Flanged discharge outlet accepts up to a 1" (25mm) duct flange.
- Bottom access panel(s) standard.
- Control box enclosure provided with all control types
- Air valve centered between top and bottom panel
- All high and low voltage controls have same-side NEC jumpback clearance. (Left-hand shown, facing discharge. Unit can be flipped to right-hand orientation.)

Figure 23. Chilled water sensible cooling terminal unit — cooling only (VDCG)

FAN SIZE	INLET SIZE AVAILABILITY		H	W	L	DISCHARGE DIMENSIONS		C	D	Max Unit Wt Lbs (kg)
	NOMINAL Ø (INCHES)	NOMINAL Ø (mm)				A	B			
SMALL	4,5,6,8,10	102,127,153,204,254	17.50" (445 mm)	33.50" (851 mm)	40.00" (1016 mm)	16.75" (426 mm)	14.25" (362 mm)	16.00" (407 mm)	1.50" (39 mm)	171 (78)
MEDIUM	4,5,6,8,10	102,127,153,204,254	17.50" (445 mm)	41.50" (1055 mm)	40.00" (1016 mm)	23.25" (591 mm)	14.25" (362 mm)	17.50" (445 mm)	1.50" (39 mm)	211 (96)
LARGE	5,6,8,10,12	127,153,204,254,305	20.00" (508 mm)	45.50" (1156 mm)	40.00" (1016 mm)	27.25" (693 mm)	16.50" (420 mm)	17.50" (445 mm)	1.75" (45 mm)	258 (118)

TOP VIEW

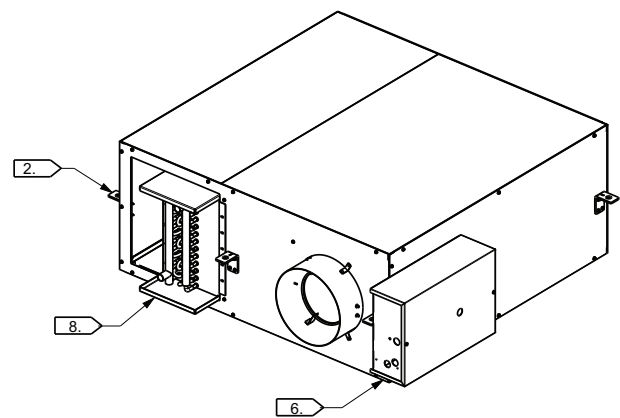
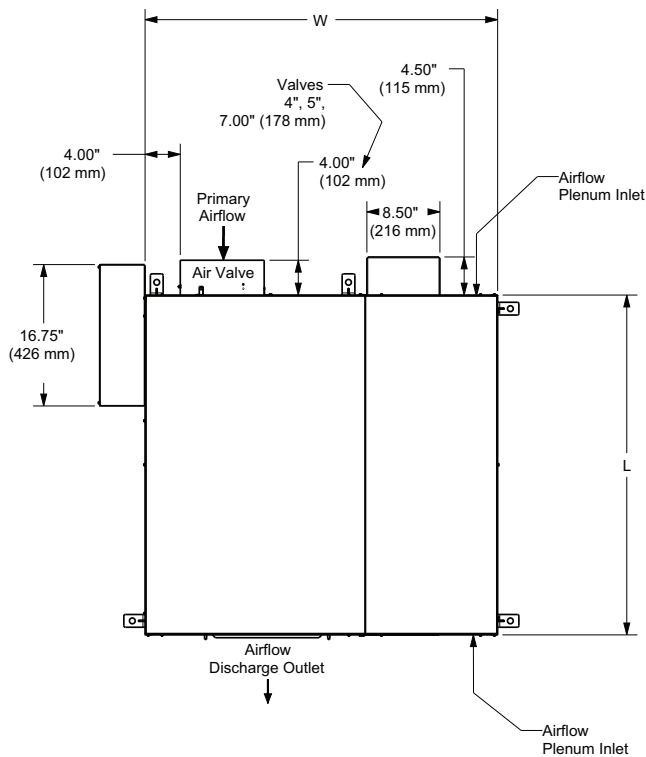

FAN SIZE	FILTER SIZE
SMALL	13" x 38" (331 mm x 966 mm)
MEDIUM	13" x 38" (331 mm x 966 mm)
LARGE	17" x 38" (432 mm x 966 mm)

DISCHARGE VIEW

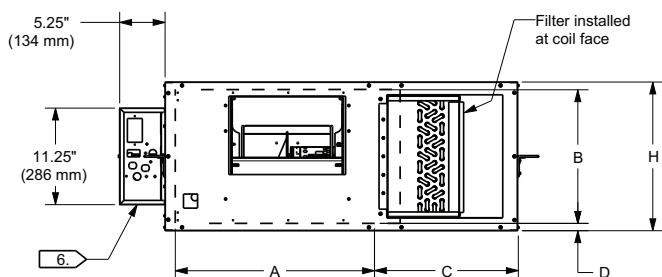



General and Dimensional Data

Notes:

- *Allow a minimum 6" (152 mm) plenum inlet clearance for unducted installations.*
- *See Installation Documents for exact hanger bracket location.*
- *Remove top or bottom panel for motor access.*
- *Air valve centered between top and bottom panel.*
- *All high and low voltage controls have same-side NEC jumpback clearance. (Left-hand shown, facing discharge.)*
- *Control box enclosure provided with all control types. Actuator, controller, and fan controls located in this area.*
- *Left-hand unit shown. Rotate unit 180° to make right-hand.*
- *DOAS coil can be installed with headers to the inlet side, or with headers to the discharge side.*
- *Weights are an estimation and will vary based on selected options.*

Dimensions — Hot Water (LDWF)

Figure 24. Chilled water sensible cooling terminal unit — hot water (LDWF)

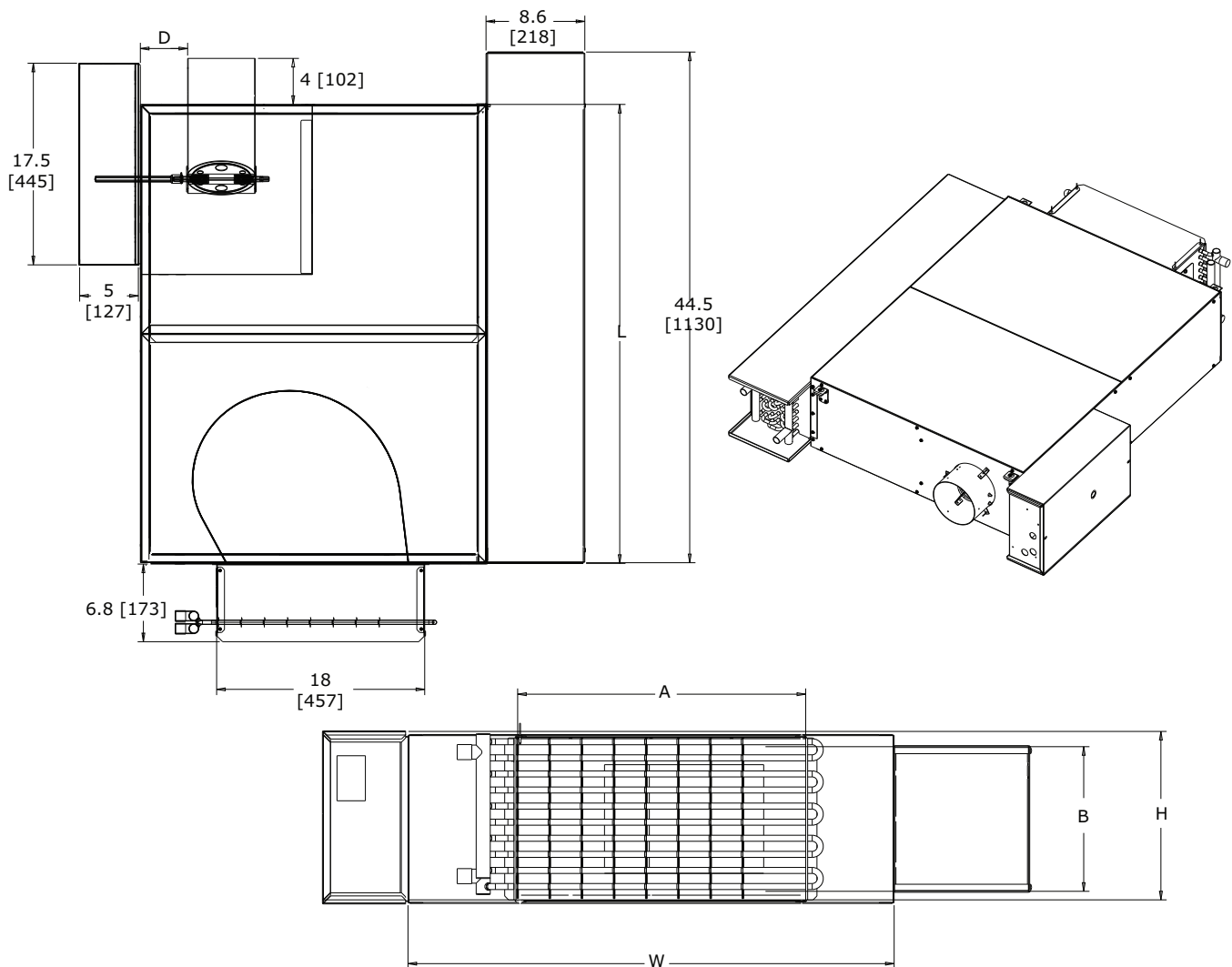

Notes:

- Allow a minimum 6" (152mm) plenum inlet clearance for unducted installations.
- Flanged discharge outlet accepts up to a 1" (25mm) duct flange.
- Bottom access panel(s) standard.
- Control box enclosure provided with all control types
- Air valve centered between top and bottom panel
- Heating coil uninsulated. External insulation may be field supplied and installed as required.
- All high and low voltage controls have same-side NEC jumpback clearance. (Left-hand shown, facing discharge. Unit can be flipped to right-hand orientation.)



General and Dimensional Data

Figure 25. Chilled water sensible cooling terminal unit — hot water (VDWG)

FAN SIZE	INLET SIZE AVAILABILITY		H	W	L	DISCHARGE DIMENSIONS		C	D	Max Unit Wt Lbs (kg)
	NOMINAL Ø (INCHES)	NOMINAL Ø (mm)				A	B			
SMALL	4,5,6,8,10	102,127,153,204,254	17.50" (445 mm)	33.50" (851 mm)	40.00" (1016 mm)	16.75" (426 mm)	14.25" (362 mm)	16.00" (407 mm)	1.50" (39 mm)	171* (78)
MEDIUM	4,5,6,8,10	102,127,153,204,254	17.50" (445 mm)	41.50" (1055 mm)	40.00" (1016 mm)	23.25" (591 mm)	14.25" (362 mm)	17.50" (445 mm)	1.50" (39 mm)	211* (96)
LARGE	5,6,8,10,12	127,153,204,254,305	20.00" (508 mm)	45.50" (1156 mm)	40.00" (1016 mm)	27.25" (693 mm)	16.50" (420 mm)	17.50" (445 mm)	1.75" (45 mm)	258* (118)

TOP VIEW

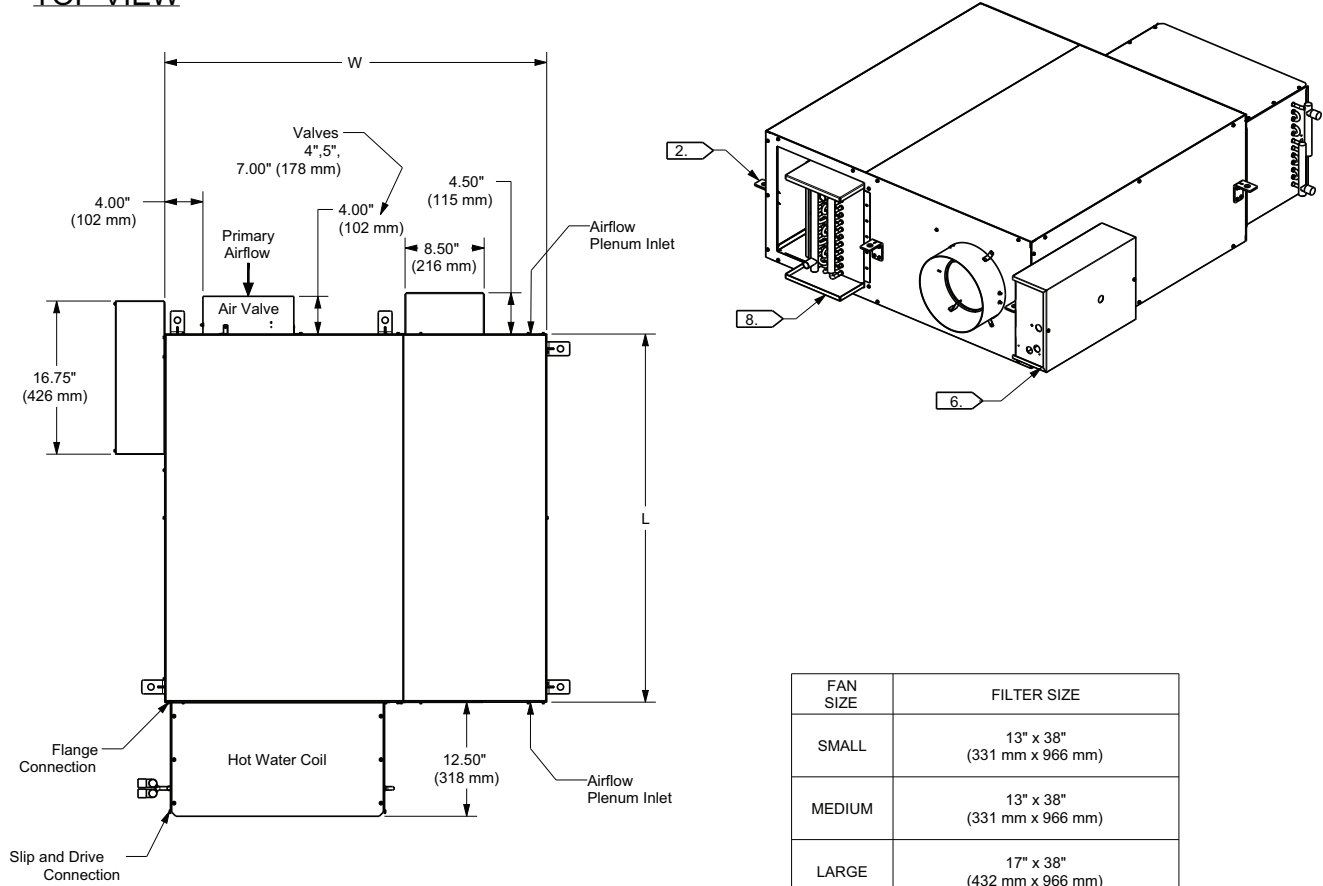

DISCHARGE VIEW

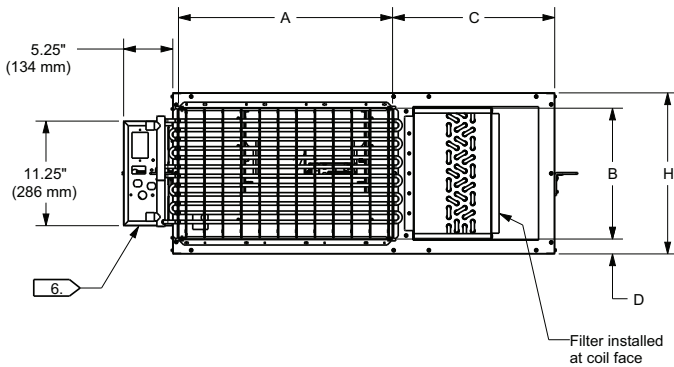

Notes:

- *Allow a minimum 6" (152 mm) plenum inlet clearance for unducted installations.*
 - *See Installation Documents for exact hanger bracket location.*
 - *Remove top or bottom panel for motor access.*
 - *Air valve centered between top and bottom panel.*
 - *All high and low voltage controls have same-side NEC jumpback clearance. (Left-hand shown, facing discharge.)*
 - *Control box enclosure provided with all control types. Actuator, controller, and fan controls located in this area.*
 - *Left-hand unit shown. Rotate unit 180° to make right-hand.*
 - *DOAS coil can be installed with headers to the inlet side, or with headers to the discharge side.*
 - *Weights are an estimation and will vary based on selected options.*
- * Unit weight does not include hot water coil.*



General and Dimensional Data

Dimensions — Electric Heat (LDEF)

Figure 26. Chilled water sensible cooling terminal unit — electric heat (LDEF)

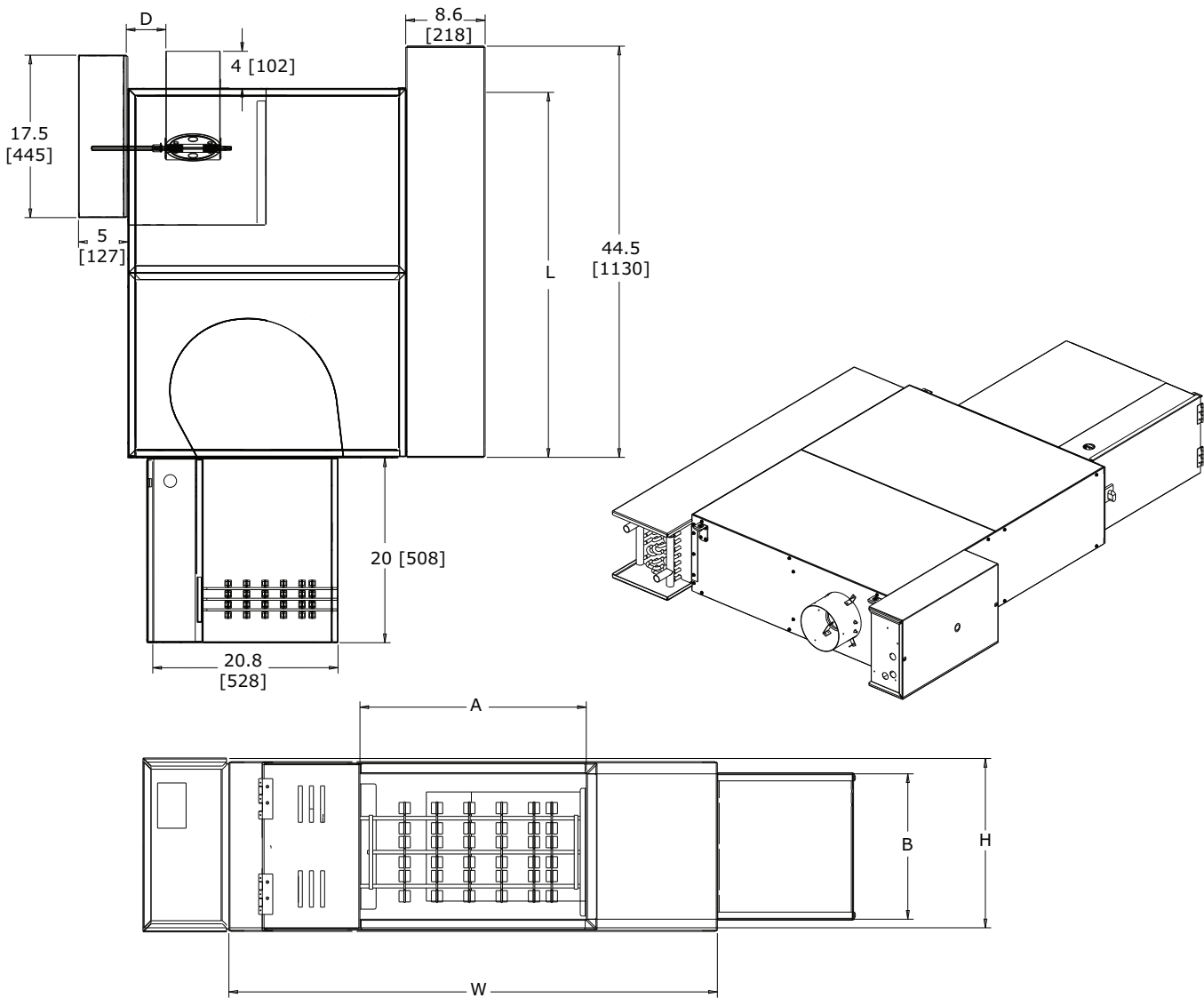

Notes:

- Allow a minimum 6" (152mm) plenum inlet clearance for unducted installations.
- Flanged discharge outlet accepts up to a 1" (25mm) duct flange.
- Bottom access panel(s) standard.
- Control box enclosure provided with all control types
- Air valve centered between top and bottom panel
- Electric heater uninsulated. External insulation may be field supplied and installed as required.
- All high and low voltage controls have same-side NEC jumpback clearance. (Left-hand shown, facing discharge. Unit can be flipped to right-hand orientation.)

Figure 27. Chilled water sensible cooling terminal unit — electric heat (VDEG)

FAN SIZE	INLET SIZE AVAILABILITY		H	W	L	DISCHARGE DIMENSIONS		C	D	Max Unit Wt Lbs (kg)
	NOMINAL Ø (INCHES)	NOMINAL Ø (mm)				A	B			
SMALL	4,5,6,8,10	102,127,153,204,254	17.50" (445 mm)	33.50" (851 mm)	40.00" (1016 mm)	11.50" (293 mm)	14.25" (362 mm)	17.75" (451 mm)	17.50" (445 mm)	206 (94)
MEDIUM	4,5,6,8,10	102,127,153,204,254	17.50" (445 mm)	41.50" (1055 mm)	40.00" (1016 mm)	19.00" (483 mm)	14.25" (362 mm)	17.50" (445 mm)	25.00" (635 mm)	251 (114)
LARGE	5,6,8,10,12	127,153,204,254,305	20.00" (508 mm)	45.50" (1156 mm)	40.00" (1016 mm)	23.00" (585 mm)	16.75" (426 mm)	17.50" (445 mm)	29.00" (737 mm)	303 (138)

TOP VIEW

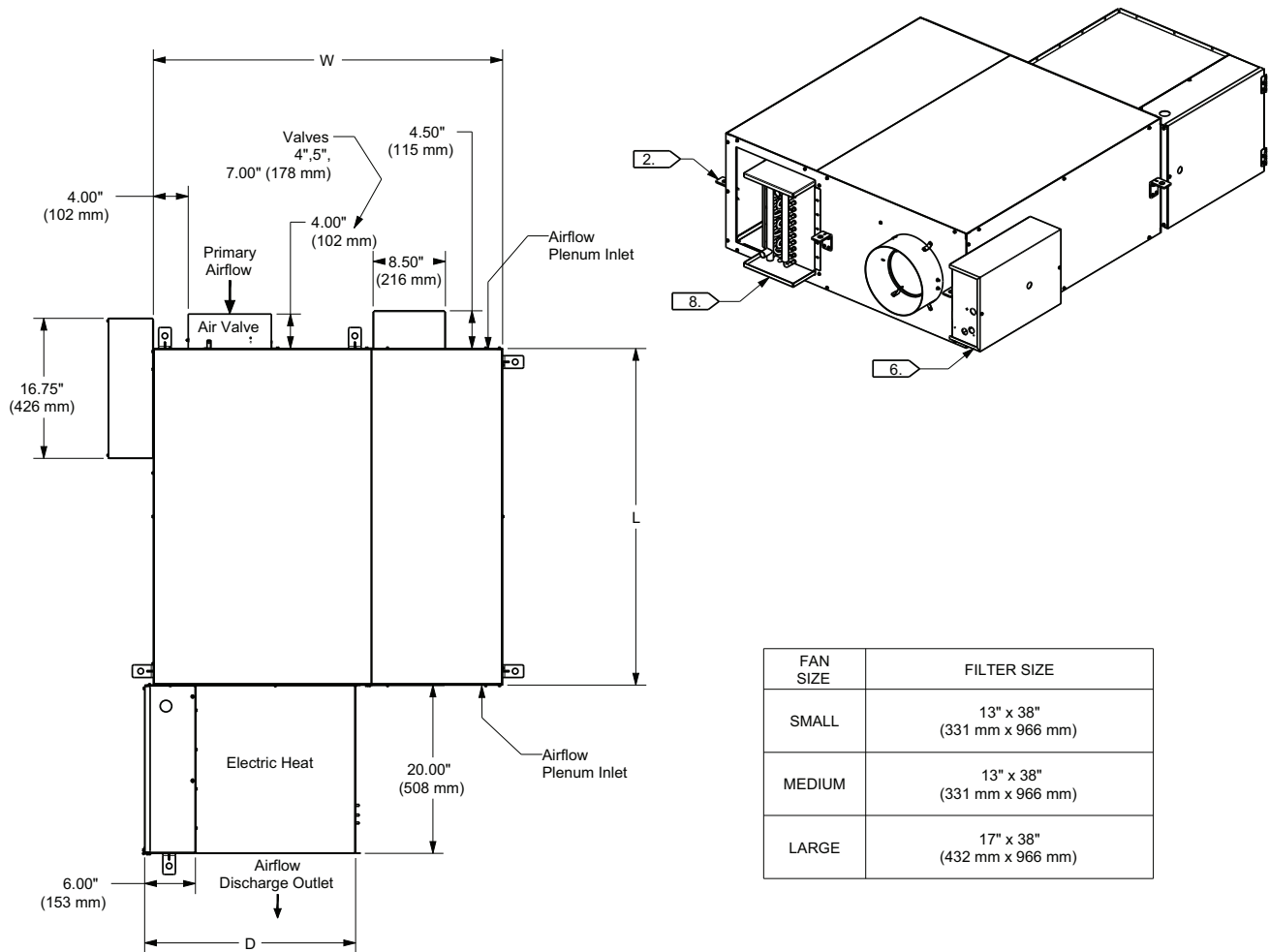

DISCHARGE VIEW

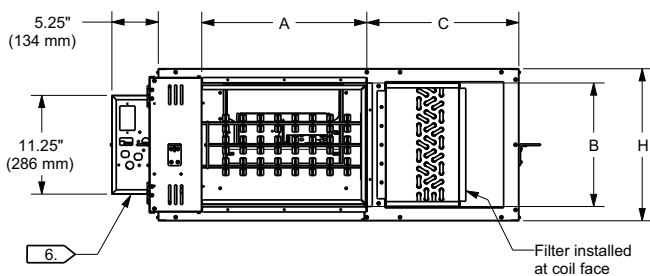



General and Dimensional Data

Notes:

- *Allow a minimum 6" (152 mm) plenum inlet clearance for unducted installations.*
- *See Installation Documents for exact hanger bracket location.*
- *Remove top or bottom panel for motor access.*
- *Air valve centered between top and bottom panel.*
- *All high and low voltage controls have same-side NEC jumpback clearance. (Left-hand shown, facing discharge.)*
- *Control box enclosure provided with all control types. Actuator, controller, and fan controls located in this area.*
- *Left-hand unit shown. Rotate unit 180° to make right-hand.*
- *DOAS coil can be installed with headers to the inlet side, or with headers to the discharge side.*
- *Weights are an estimation and will vary based on selected options.*



Mechanical Specifications

Chilled Water Sensible Cooling Terminal Unit

Casing

Galvanized steel, 22-gauge. Hanger brackets, top and bottom access and plenum filter are provided as standard.

Agency Listing

Unit is UL and Canadian UL Listed as a room air terminal unit.

Insulation

1-inch (25.4 mm) Matte-faced Insulation — Interior surface of unit casing is acoustically and thermally lined with 1-inch, 1.8lb/ft³ (25.4 mm, 16.0 kg/m³) composite density glass fiber with a high-density facing. Insulation R-Value is 4.2. Insulation is UL listed and meets NFPA-90A and UL 181 standards. There are no exposed edges of insulation (complete metal encapsulation).

1-inch (25.4 mm) Foil-faced Insulation — Interior surface of unit casing is acoustically and thermally lined with 1-inch, 1.8lb/ft³ (25.4 mm, 16.0 kg/m³) density glass fiber with foil facing. Insulation R-Value is 4.2. Insulation is UL listed and meets NFPA-90A and UL 181 standards and bacteriological standard ASTM C 665. There are no exposed edges of insulation (complete metal encapsulation).

1-inch (25.4 mm) Double-wall Insulation — Interior surface of unit casing is acoustically and thermally lined with a 1-inch, 1.8lb./ft³ (25.4 mm, 16.0 kg/m³) composite density glass fiber with high-density facing. Insulation R-value is 4.2. Insulation is UL listed and meets NFPA-90A and UL 181 standards. Insulation is covered by interior liner made of 26-gage galvanized steel. All wire penetrations are covered by grommets. There are no exposed edges of insulation (complete metal encapsulation).

3/8-inch (9.5 mm) Closed-cell Insulation — Interior surface of the unit casing is acoustically and thermally lined with 3/8-inch, 4.4 lb/ft³ (9.5 mm, 70.0 kg/m³) closed-cell insulation. Insulation is UL listed and meets NFPA-90A and UL 181 standards. Insulation has an R-Value of 1.5. There are no exposed edges of insulation (complete metal encapsulation).

Air Valve

Air Valve Round — The primary (ventilation) air inlet connection is an 18-gauge galvanized steel cylinder sized to fit standard round duct. A multiple-point, averaging flow sensing ring is provided with balancing taps for measuring +/-5% of unit cataloged airflow. An airflow-versus-pressure differential calibration chart is provided. The damper blade is constructed of a closed-cell foam seal that is mechanically locked between two 22-gauge galvanized steel disks. The damper blade assembly is connected to a cast zinc shaft supported by self-lubricating bearings. The shaft is cast with a damper position indicator. The valve assembly includes a mechanical stop to prevent over-stroking.

Fan Motor

ECM

Electrically commutated motor (ECM) is designed for high-efficient operation with over 70% efficiency throughout the operating range. Motors will prevent backward rotation at start up. The motor and fan wheel assembly is isolated from the terminal unit.

Transformer

The transformer is factory installed in the fan control box to provide 24 Vac for controls.

On/Off Switch

An on/off switch is provided as standard and allows the operator to turn the unit on or off by toggling to the appropriate setting. This switch breaks both legs of power to the fan and the electronic controls (if applicable).



Mechanical Specifications

Filter

As standard, a 1 in (25 mm) filter is provided on the plenum inlet. Optionally, the unit can be configured with a MERV8 or MERV 13 filter in lieu of the standard filter.

Water Coil

Hot Water Coils

Factory installed on the fan discharge. All hot water coils have 144 aluminum-plated fins per foot (0.305 m). Full fin collars provided for accurate fin spacing and maximum fin-tube contact. The 3/8" (9.5 mm) OD seamless copper tubes are mechanically expanded into the fin collars. Coils are proof tested at 450 psig (3102 kPa) and leak tested at 300 psig (2068 kPa) air pressure under water. Coil connections are brazed. Standard top and bottom gasketed access panels are attached with screws.

Chilled Water Coils

Factory installed on the unit plenum inlet. The coils are 4 or 6-rows with 144 aluminum-plated fins per foot (0.305 m). Full fin collars provided for accurate fin spacing and maximum fin-tube contact. The 3/8" (9.5 mm) OD seamless copper tubes are mechanically expanded into the fin collars. Coils are proof tested at 450 psig (3102 kPa) and leak tested at 300 psig (2068 kPa) air pressure under water. Each coil incorporates a drip pan on top and bottom for left or right-hand installations. Coil connections are brazed.

Electric Heater

The electric heater is factory-provided and installed on the fan discharge. It is a UL recognized resistance open-type heater that contains a disc-type automatic pilot duty thermal primary cutout, and manual reset load carrying thermal secondary device. Heater element material is nickel-chromium. The heater terminal box is provided with 7/8" (22 mm) knockouts for customer power supply. Terminal connections are plated steel with ceramic insulators. All units with electric heat are single-point power connections.

Electric Heat Options

Silicon-Controlled Rectifier (SCR) — Optional 0–10 Vdc electric heat control that provides modulation.

Solid State Relay (SSR) – Optional electric 24 Vac solid-state contactor(s) for use with direct digital controls.

Magnetic Contactor — Optional electric heater 24V contactor(s) for use with direct digital controls.

Airflow Switch — Standard air pressure device designed to disable heater when terminal fan is off.

Power Fuse — If a power fuse is chosen with a unit containing electric heat, then a safety fuse is located in the electric heater's line of power to prevent power surge damage to the electric heater. Any electric heat unit with a calculated MCA greater than or equal to 30 will have a fuse provided.

Disconnect Switch — A standard factory-provided door interlocking disconnect switch on the electric heater control panel disengages primary voltage to the terminal.

Unit Controls Sequence Of Operation

See ["Trane DDC Controller Logic," p. 65](#) Trane DDC Controller Logic section for sequence of operation.

Direct Digital Controls

DDC Actuator — Trane 3-wire, 24-Vac, floating-point quarter turn control actuator with linkage release button. Actuator has a constant drive rate independent of load, a rated torque of 35 in-lb, a 90-second drive time, and is non-spring return. Travel is terminated by end stops at fully-opened and -closed positions. An integral magnetic clutch eliminates motor stall.

DDC Actuator (Belimo) — LMB24-3-T TN 3-wire, 24 Vac/Vdc, floating-point, quarter turn actuator with linkage release button. Actuator has constant drive rate independent of load, rated torque 45 in-lb, 95 sec drive time, and non-spring return. Travel is terminated by end stops at fully-opened and -closed positions. Internal electronic control prevents motor stall when motor reaches end stops.

Direct Digital Controller —Microprocessor-based terminal unit controllers provide accurate, pressure-independent control through the use of proportional integral control algorithm and direct digital control technology.

The controller monitors zone temperature setpoints, current zone temperature and its rate of change, and valve airflow using a differential pressure signal from the pressure transducer. Additionally, the controller can monitor either supply duct air temperature or CO₂ concentration via appropriate sensors. Controller is provided in an enclosure with 7/8-in. (22mm) knockouts for remote control wiring. Trane zone sensor or Air-Fi® Receiver Interface Module paired with a Wireless Communications Sensor (WCS) is required.

DDC Zone Sensor —The controller senses zone temperature through a sensing element located in the zone sensor. In addition to the sensing element, zone sensor options may include an externally-adjustable setpoint, communications jack for use with a portable edit device, and an override button to change the individual controller from unoccupied to occupied mode. The override button has a cancel feature that will return the system to unoccupied. Wired zone sensors utilize a thermistor to vary the voltage output in response to changes in the zone temperature. Wiring to the controller must be 18- to 22-awg. twisted pair wiring. The setpoint adjustment range is 50 to 88°F (10 to 31°C). Depending upon the features available in the model of sensor selected, the zone sensor may require from a 2-wire to a 5-wire connection. Wireless zone sensors report the same zone information as wired zone sensors, but do so using radio transmitter technology. Therefore with wireless, wiring from the zone sensor to the controller is unnecessary.

Digital Display Zone Sensor with Liquid Crystal Display (LCD) — A Liquid Crystal Display (LCD) displays setpoint or zone temperature. Sensor buttons allow user to adjust setpoints, and allow zone temperature readings to be turned on or off. Digital display zone sensor also includes a communication jack for use with a portable edit device, and an override button to change UCM from unoccupied to occupied. Override button cancel feature returns system to unoccupied mode.

Power Fuse

Optional power fuse is factory installed.

Trane Water Valve

The valve is a field-adaptable, 2-way or 3-way configuration and ships with a plug in B port. This configures the valve for 2-way operation. For 3-way operation, remove the plug. The intended fluid is water or water and glycol (50% maximum glycol). The actuator is a synchronous motor drive. The valve is driven to a predetermined position by the controller using a proportional plus integral control algorithm. If power is removed, the valve stays in its last position. The actuator is rated for plenum applications under UL 2043 and UL 873 standards.

- Pressure and temperature ratings: The valve is designed and tested in full compliance with ANSI B16.15 Class 250 pressure/temperature ratings, ANSI B16.104 Class IV control shutoff leakage, and ISA S75.11 flow characteristic standards.
- Flow capacity: 0.70 Cv, 1.7 Cv, 2.7 Cv, 5.0 Cv
- Overall diameter: ½-in. NPT
- Maximum allowable pressure: 300 psi (2068 kPa)
- Maximum operating fluid temperature: 201°F (94°C)
- Maximum close-off pressure: 60 psi (0.4 MPa)
- Electrical rating: 3VA at 24 VAC
- 8-in. plenum rated cable with AMP Mate-N-Lok connector

Belimo Water Valve

The intended fluid is water or water and glycol (50% maximum glycol). The actuator is a synchronous motor drive. The valve is driven to a predetermined position by the controller using a proportional plus integral control algorithm. If power is removed, the valve stays in its last position. The actuator is rated for plenum applications under UL 2043 and UL 873 standards.

- Pressure and temperature ratings: The valve is designed and tested in full compliance with ANSI B16.15 Class 250 pressure/temperature ratings, ANSI B16.104 Class IV control shutoff leakage, and ISA S75.11 flow characteristic standards.



Mechanical Specifications

- Flow capacity: 0.3 Cv, 0.46 Cv, 0.8 Cv, 1.2 Cv, 1.9 Cv, 3.0 Cv, 4.7 Cv
- Overall diameter: ½-in. NPT
- Maximum allowable pressure: 600 psi (4137 kPa)
- Maximum operating fluid temperature: 201°F (94°C)
- Maximum close-off pressure: 200 psi (1379 kPa)
- Electrical rating: 1VA at 24 VAC
- 8-in. plenum rated cable with AMP Mate-N-Lok connector.



Trane - by Trane Technologies (NYSE: TT), a global innovator - creates comfortable, energy efficient indoor environments for commercial and residential applications. For more information, please visit trane.com or tranetechnologies.com.

Trane has a policy of continuous product and product data improvements and reserves the right to change design and specifications without notice. We are committed to using environmentally conscious print practices.

DOAS-PRC001L-EN 09 Feb 2025
Supersedes DOAS-PRC001K-EN (November 2022)

©2025 Trane