



Quick Select

Configurations for Performance Climate Changer™ Air Handlers

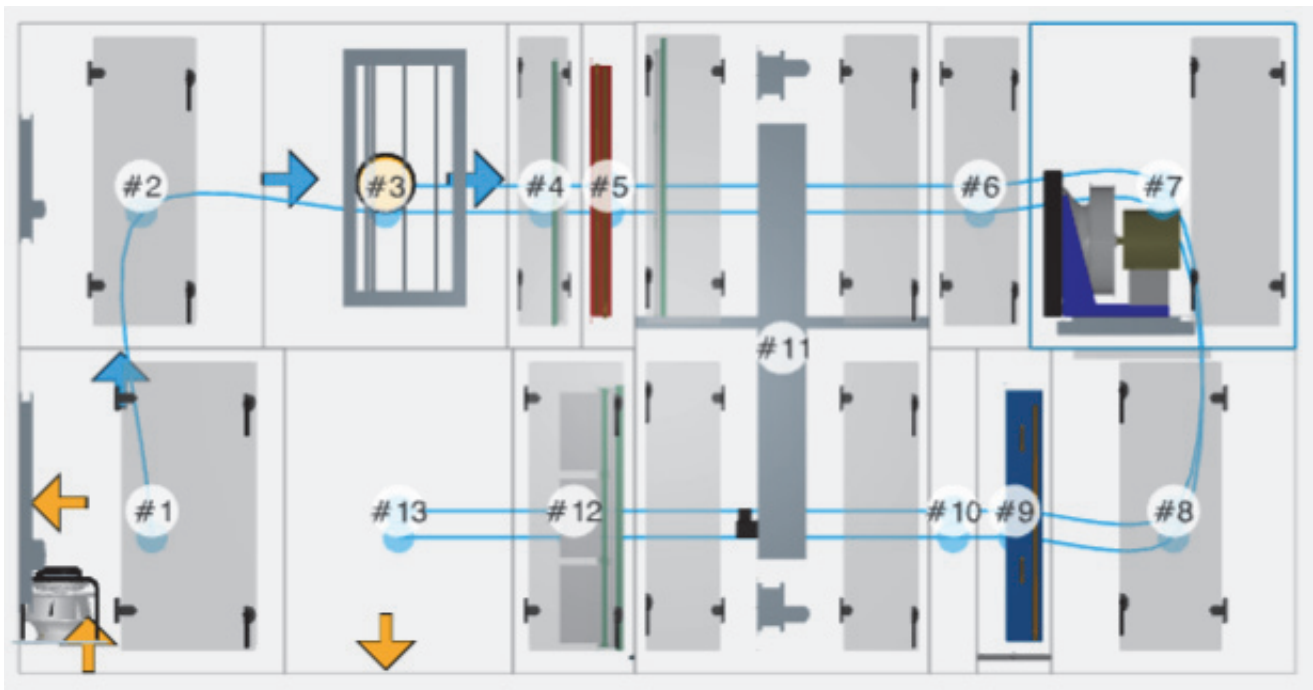



Table of Contents

Common Indoor Configurations	3
Common Outdoor Configurations	11

Common Indoor Configurations

Figure 1. Plenum exhaust fan economizer with exhaust damper on fan section

Number	Section description
1	Exhaust plenum fan with top opposed-blade damper
2	Reduced length mixing box (top rectangular, front and back full face)
3	Filter mixing box (back damper, top damper, front full face)
4, 5	Coils
6	Access section
7	Supply fan

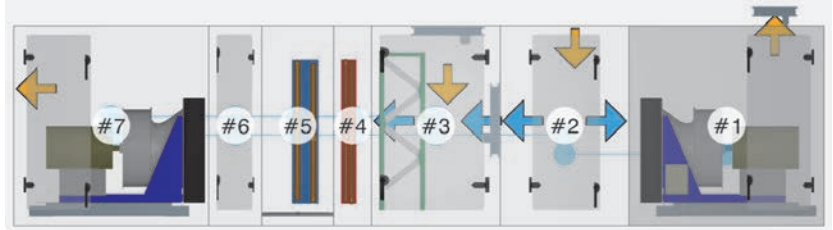

Note: The opposed blade damper on a motorized impeller or direct-drive fan is only available in the top discharge position. This option is not available on direct-drive plenum fan sections in unit sizes 66-120. Use a reduced length mixing box with damper.

Figure 2. Plenum return fan economizer with exhaust damper on fan section

Number	Section description
1	Return plenum fan with top opposed-blade damper
2	Filter mixing box (back damper, top damper, front full face)
3, 4	Coils
5	Access section
6	Supply fan

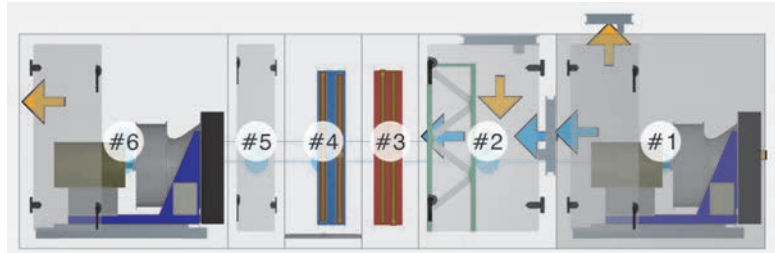

Note: The opposed blade damper on a motorized impeller or direct-drive fan is only available in the top discharge position. This option is not available on direct-drive plenum fan sections in unit sizes 66-120. Use a reduced length mixing box with damper.

Figure 3. Stacked exhaust fan economizer

Number	Section description
1	Exhaust fan
2	Medium access section
3	Mixing box without filter (front damper, back sizable opening, bottom full face)
4	Mixing box with filter (top and back damper, front full face)
5	Heating coil
6	Cooling coil with sizable door
7	Supply fan

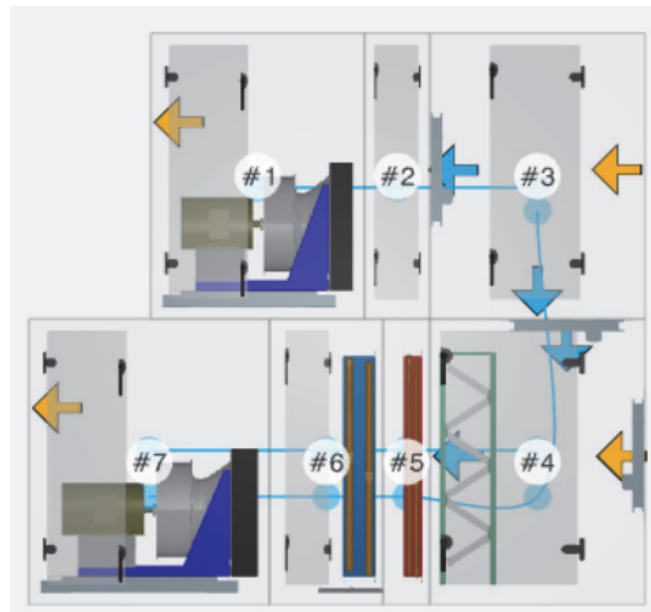

Common Indoor Configurations

Figure 4. Stacked return fan economizer

Number	Section description
1	Return fan
2	Mixing box without filter (front and bottom full face, back damper)
3	Mixing box with filter (top and back damper, front full face)
4	Heating coil
5	Cooling coil with sizable door
6	Supply fan

Note: Second level high voltage panels must be located 72 inches or less from ground level. Unit sizes 17 (with 6-inch base rail) and up must relocate high voltage panel to the first level.

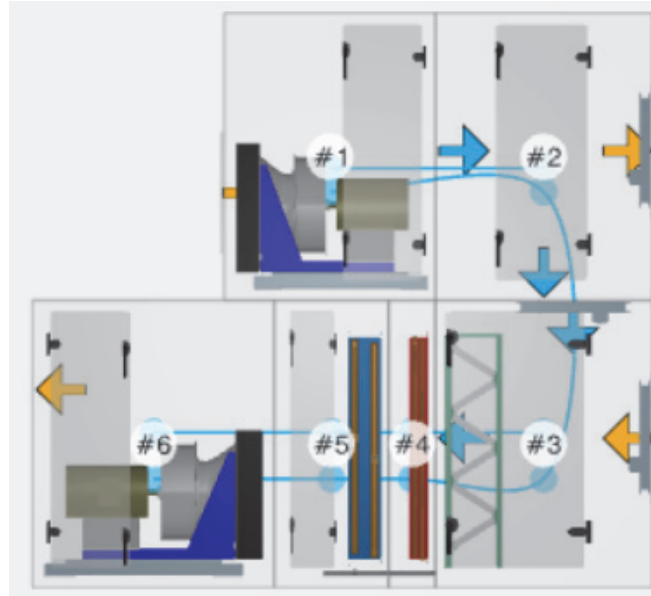

Figure 5. Two-deck multizone/double-duct - Plenum fan

Number	Section description
1	Filter mixing box (back damper, top damper, front full face)
2	Access section
3	Supply fan
4	Multizone
5	Multizone

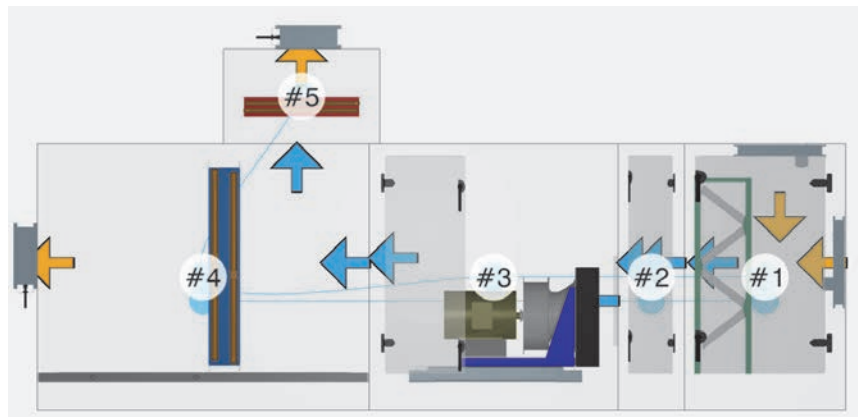

Figure 6. Internal face-and-bypass, one modified-height coil

Number	Section description
1	Mixing box with filter (top and back damper, front full face)
2	Internal face and bypass damper
3	Modified height heating coil
4	Access section (sized to required distance in catalog)
5	Unit height cooling coil with sizable door
6	Supply fan

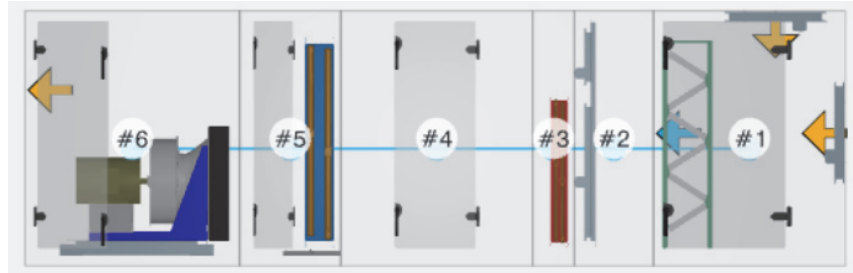

Figure 7. Internal face-and-bypass, two modified-height coil

Number	Section description
1	Mixing box with filter (top and back damper, front full face)
2	Internal face and bypass damper
3	Modified height heating coil with horizontal blockoff
4	Access section (horizontal block-off selected)
5	Modified height cooling coil with sizable door
6	Supply fan

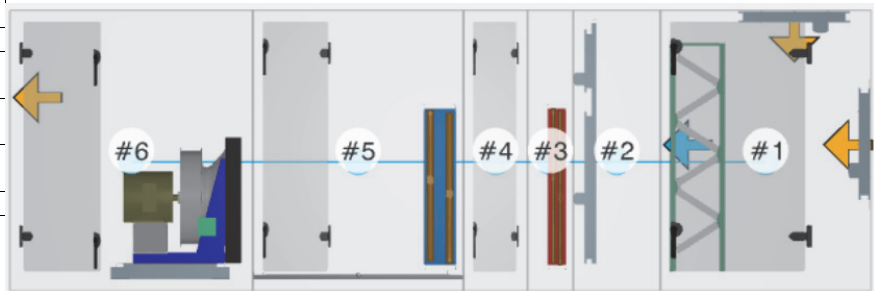
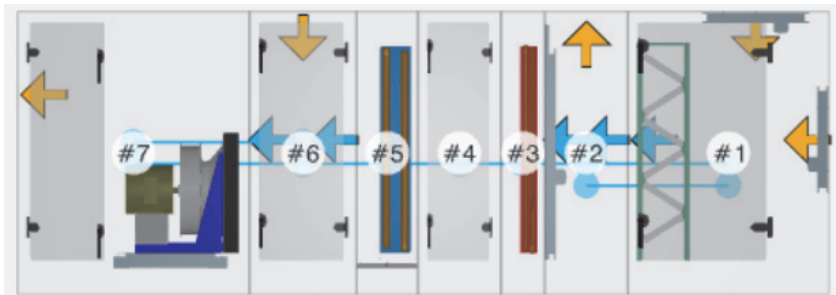

Figure 8. External face-and-bypass with plenum fan

Number	Section description
1	Mixing box with filter (top and back damper, front full face)
2	External face and bypass damper
3	Heating coil
4	Access section
5	Cooling coil
6	Access with secondary air inlet
7	Supply fan



Common Indoor Configurations

Figure 9. Horizontal split dehumidification unit (SDU)/winterizer

Number	Section description
1	SDU outside air filter mixing box (back damper, front full face)
2	SDU outside air heating coil
3	SDU outside air cooling coil
4	SDU outside air turning section
5	Return filter mixing box (back damper, front full face)
6	Access section
7	Return air cooling coil
8	SDU horizontal transition section
9	Supply fan

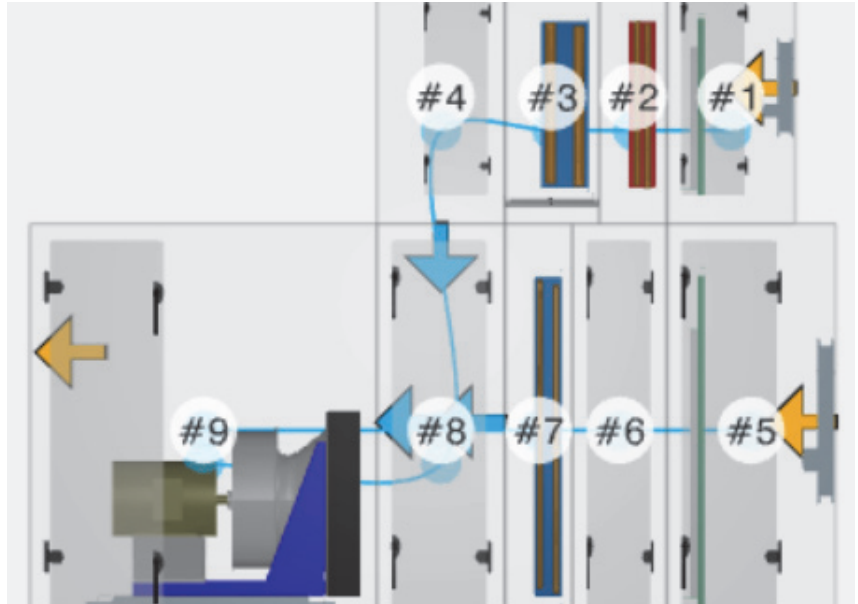

Figure 10. Energy recover wheel - draw-thru exhaust/draw-thru supply

Number	Section description
1	Exhaust fan
2	Filter mixing box (back damper, front full face)
3	Custom length section
4	Energy wheel with return filter
5	Heating coil
6	Cooling coil with sizable door
7	Supply fan

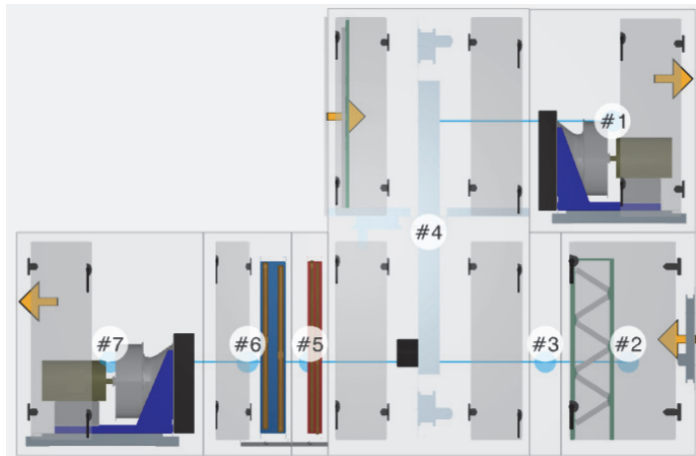

Figure 11. Dedicated outside air split-level preconditioning energy recovery wheel

Number	Section description	Number	Section description
Unit 1	Dedicated Outside Air Energy Wheel	Unit 2	Supply Unit
1	Mixing box w/ filter (back damper)	1	Mixing box w/ filter (top, back damper)
2	Custom length access	2	Heating coil
3	Mixing box w/o filter (front damper)	3	Cooling coil w/ door
4	Exhaust fan (MI)	4	Supply fan (MI)
5	Energy wheel	5	Discharge plenum
6	Mixing box w/o filter (top damper)		

Note: Typically this configuration is used for units over 25,000 cfm that require some type of energy recovery. The units are ordered separately and joined together in the field. The energy wheel can handle up to 25,000 cfm. A return air damper can be added to the mixing box on the supply unit if needed.

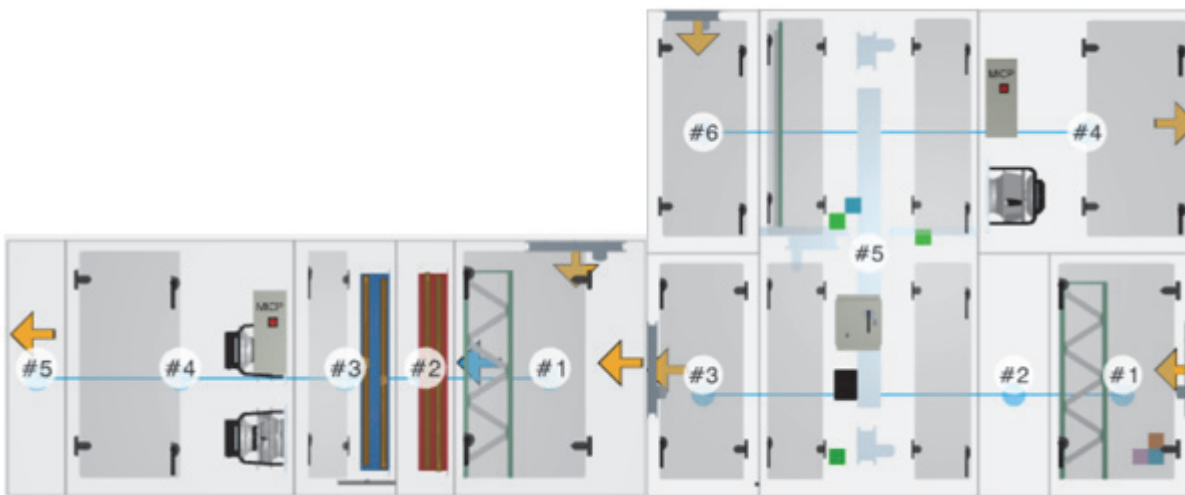
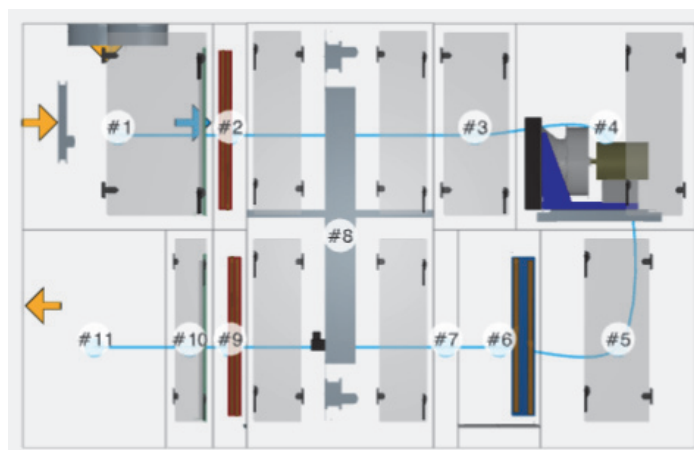

Figure 12. Cool dry quiet (CDQ™) - outside air 0-100%

Number	Section description
1	Filter mixing box (top and front damper, back full face)
2	Pre-heat coil (if needed)
3	Access section
4	Supply fan
5	Access section
6	Cooling coil
7	Custom length section
8	Series CDQ wheel
9	Reheat coil (if needed)
10	Final filter
11	Discharge plenum



Common Indoor Configurations

Figure 13. Cool dry quiet (CDQ™) - outside air 0-40%

Number	Section description
1	Filter mixing box - return air (back full face and front damper)
2	Custom length section
3	Filter mixing box - outside air (top damper, front and back full face)
4	Access section
5	Supply fan
6	Access section
7	Cooling coil
8	Custom length section
9	Dual path CDQ wheel with filter
10	Final filter
11	Discharge plenum

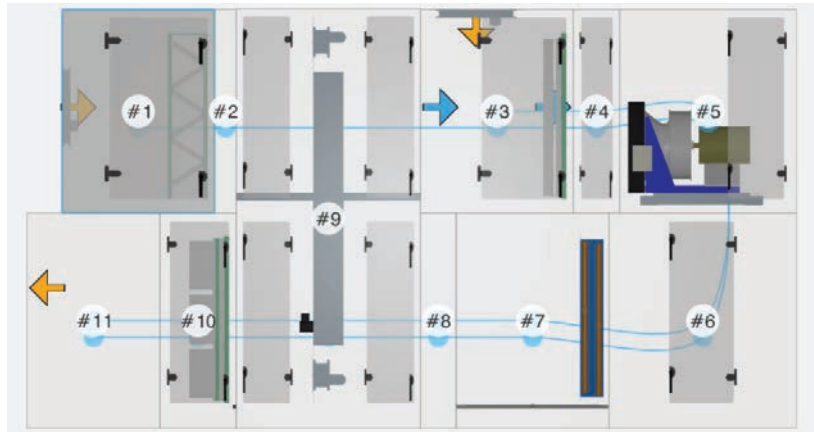

Figure 14. Cool dry quiet (CDQ™) - with return fan

Number	Section description	Number	Section description
1	Mixing box (top damper, back full face)	9	Supply fan
2	Return fan	10	Turning access section
3	Mixing box (front and back damper, bottom full face)	11	Turning access section
4	Mixing box (back damper, front and top full face)	12	Custom length section
5	Filters	13	Cooling coil
6	Controls section	14	Series CDQ wheel
7	Access section	15	Discharge plenum
8	Custom length section		

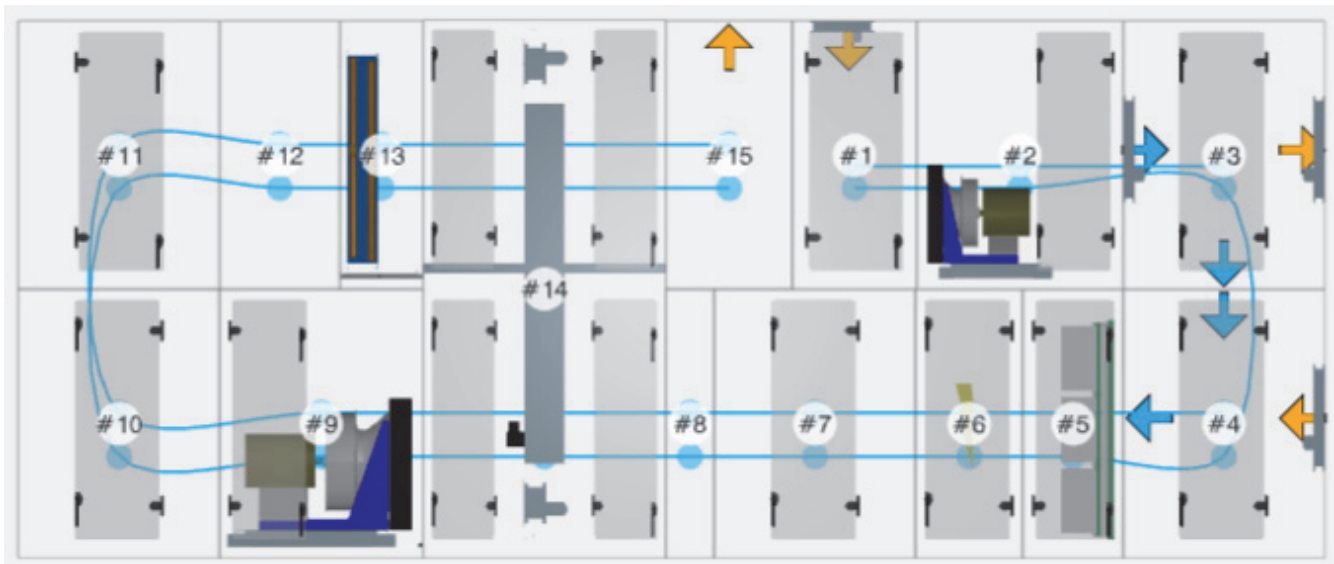

Figure 15. Dual path cool dry quiet (CDQ™)

Number	Section description
1	Exhaust fan
2	Heating coil (if needed)
3	Mixing box with filter - return air (front damper, back full face)
4	Mixing box with filter - return air (back damper, front full face)
5	Access section
6	Supply fan
7	Cooling coil
8	Dual path CDQ wheel
9	Final filter
10	Discharge plenum

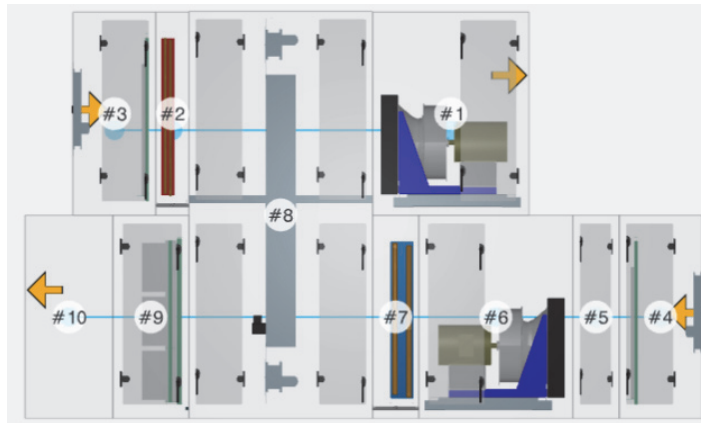
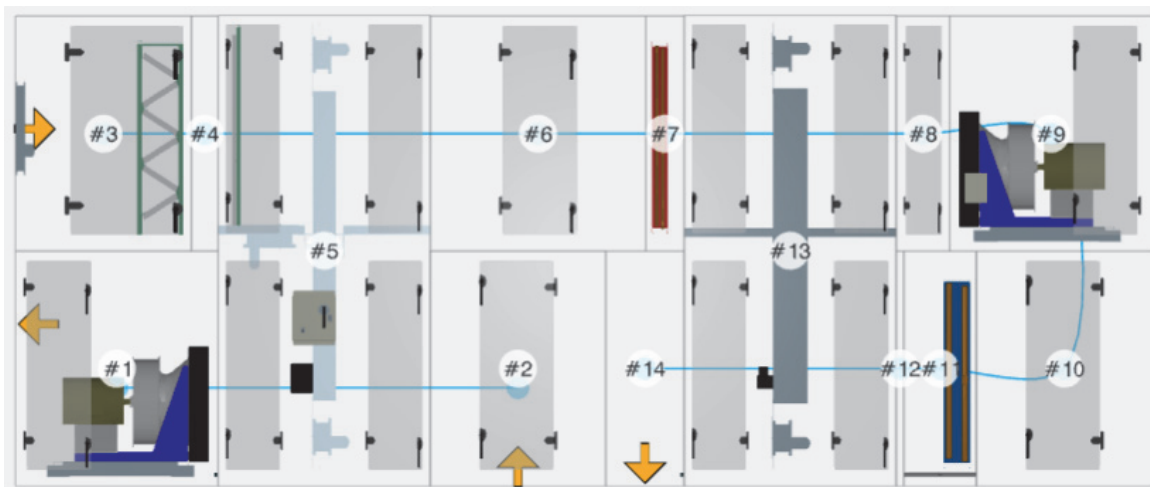

Figure 16. Dual wheel unit - cool dry quiet (CDQ™) with energy wheel

Number	Section description	Number	Section description
1	Exhaust fan	8	Access section
2	Mixing box - return air (bottom or side opening)	9	Supply fan
3	Filter mixing box - outside air (front damper, back full face)	10	Access section
4	Custom length section	11	Cooling coil
5	ERW with return filter and recirculation damper	12	Custom length section
6	Access section	13	Series CDQ wheel
7	Heating coil	14	Discharge plenum



Common Indoor Configurations

Figure 17. Dual-path dual-wheel unit - cool dry quiet (CDQ™) and ERW

Number	Section description	Number	Section description
1	Exhaust fan	6	ERW with recirculation damper
2	Custom length section	7	Supply fan
3	Access section	8	Cooling coil
4	Filter mixing box - outside air (back damper, front full face)	9	Dual path CDQ wheel with return air filter
5	Custom length section	10	Reheat coil (if needed)

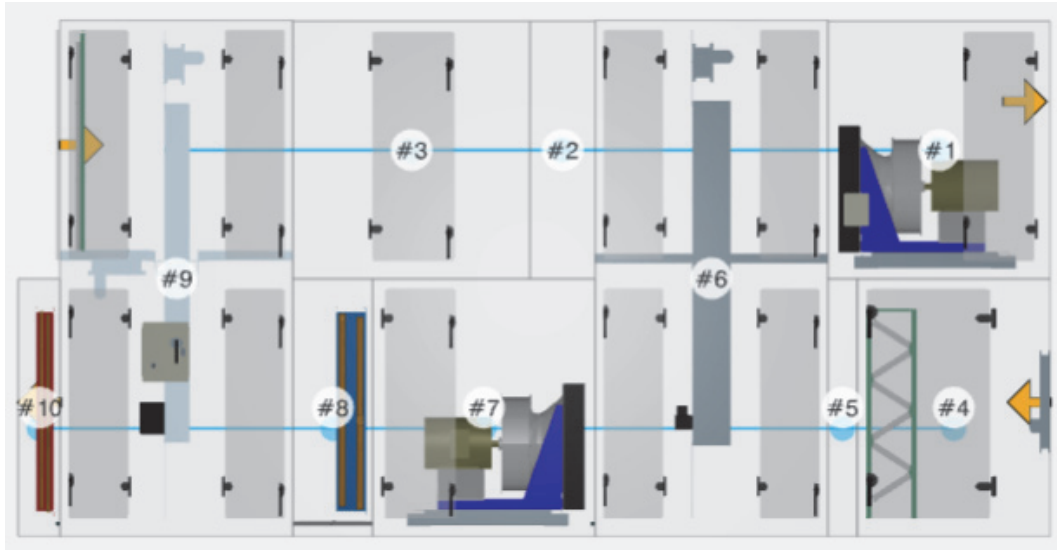

Common Outdoor Configurations

Figure 18. Plenum fan exhaust economizer

Number	Section description	Number	Section description
1	Exhaust fan (DDP)	5	Filters
2	Mixing box w/o filter (bottom rectangular, front, back full face)	6	Heating coil
3	Mixing box w/o filter (left, right, back damper, front full face)	7	Cooling coil
4	Access section	8	Supply fan (DDP)



Figure 19. Plenum return fan economizer

Number	Section description
1	Return Fan - Vertical MI
2	Mixing box w/o filter - side OA inlets
3	Filters
4	Heating coil
5	Cooling coil with door
6	Supply fan (MI)

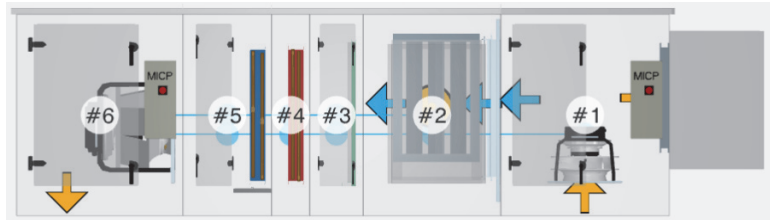

Figure 20. Plenum fan exhaust economizer with VFD/starter and controls

Number	Section description	Number	Section description
1	Exhaust fan (DDP)	6	Heating coil
2	Mixing box w/o filter (bottom rectangular, front, back full face)	7	Cooling coil
3	Mixing box w/o filter (back, left, right damper, front full face)	8	Controls
4	Access section	9	Supply fan (DDP)
5	Filters		

Note: Consider a motorized impeller with external high voltage panel (MICP). DDP fans will require a controls section to house VFDs.



Common Outdoor Configurations

Figure 21. Plenum return fan economizer with VFD/starter and controls

Number	Section description	Number	Section description
1	Return Fan - Vertical MI	4	Heating coil
2	Mixing box w/o filter - side OA inlets	5	Cooling coil with door
3	Filters	6	Supply fan (MI)

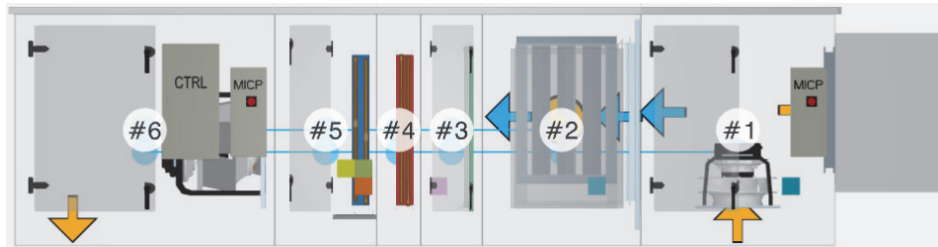

Figure 22. Barometric relief economizer with VFD/starter and controls

Number	Section description	Number	Section description
1	Mixing box (front full face, bottom rectangle)	6	Access section
2	Economizer section with barometric relief damper	7	Supply fan
3	Filters	8	Controls section with front wall, supply fan VFD and controller
4, 5	Coils		

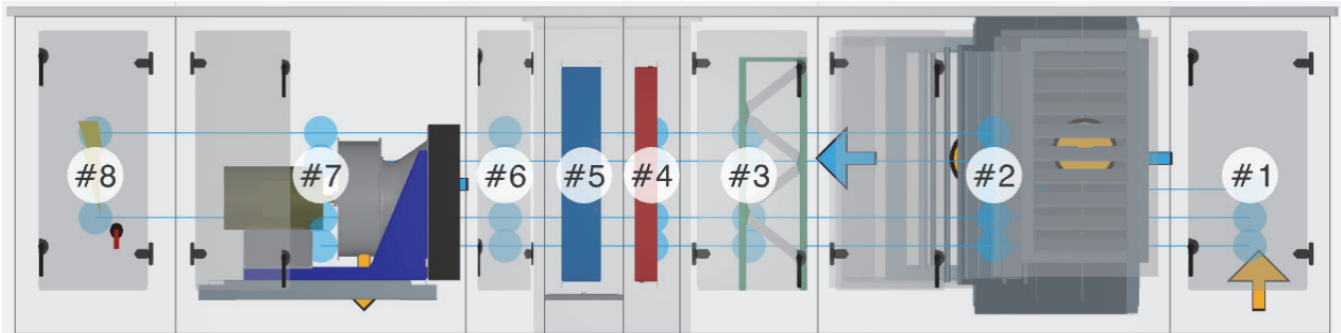
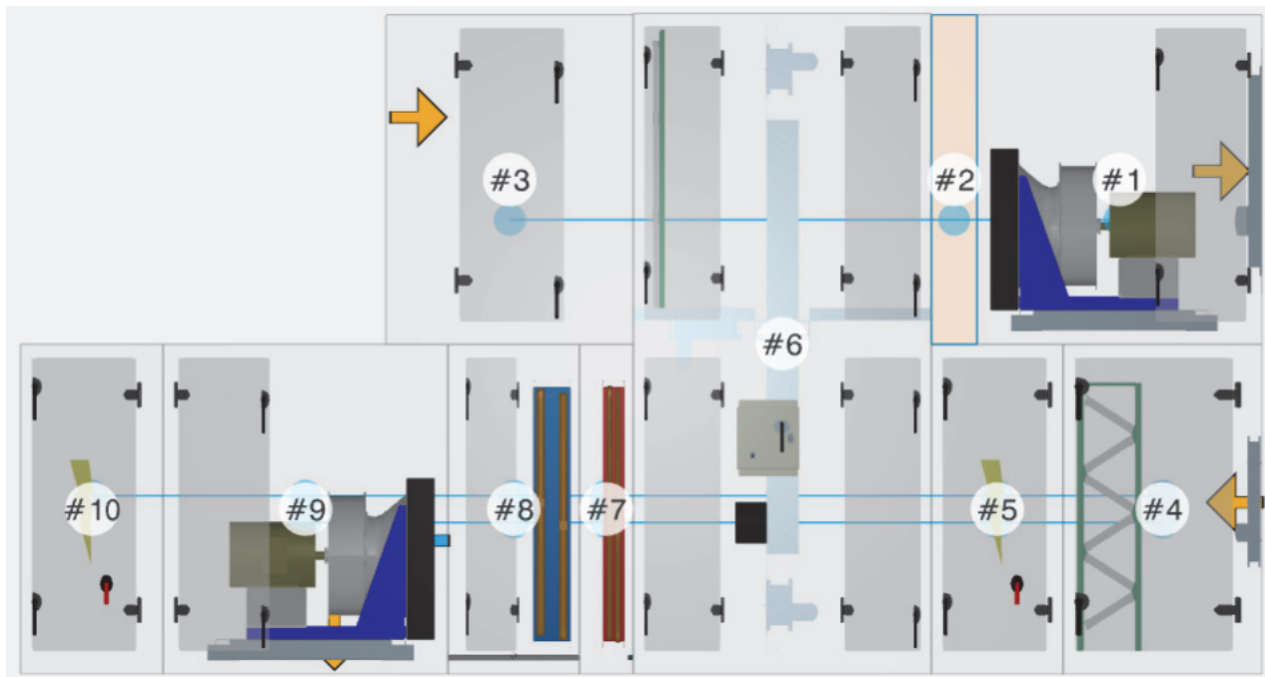

Figure 23. Energy recovery wheel - draw-thru exhaust/draw-thru supply (OA path on the bottom) and controls

Number	Section description	Number	Section description
1	Exhaust fan	6	ERW with return filter
2	Custom length section	7	Heating coil
3	Mixing box (front sizeable opening, back full rest)	8	Cooling coil with 7 inch door
4	Filter mixing box - outside air (back damper, front full face)	9	Supply fan
5	Controls section (exhaust fan VFD)	10	controls section (supply fan VFD with front wall, no airflow)

Note: Consider a motorized impeller fan for outdoor units. The Motorized Impeller Control Panel (MICP) can be mounted on the fan exterior unlike the VFD on DDP fans. First level and second level hoods cannot be on the same plane (i.e. - Both back exhaust and outside air hood). Factory pipe cabinets cover first level coils only.



Common Outdoor Configurations

Figure 24. Energy recovery wheel - draw-thru exhaust/draw-thru supply (OA path on the top) and controls

Number	Section description	Number	Section description
1	Exhaust fan (MI)	7	Mixing box (back full face, bottom rectangular)
2	Mixing box w/o filter (bottom rectangular, back full face)	8	Mixing box (top, front full face)
3	Mixing box w/o filter (back damper, front full face)	9	Heating coil
4	Custom length section	10	Cooling coil with door
5	Energy wheel	11	Supply fan (MI)
6	Mixing box (front, back full face)		

Note: Consider a motorized impeller fan for outdoor units. The Motorized Impeller Control Panel (MICP) can be mounted on the fan exterior unlike the VFD on DDP fans. First level and second level hoods cannot be on the same plane (i.e. - Both front exhaust and outside air hood). Factory pipe cabinets cover first level coils only.

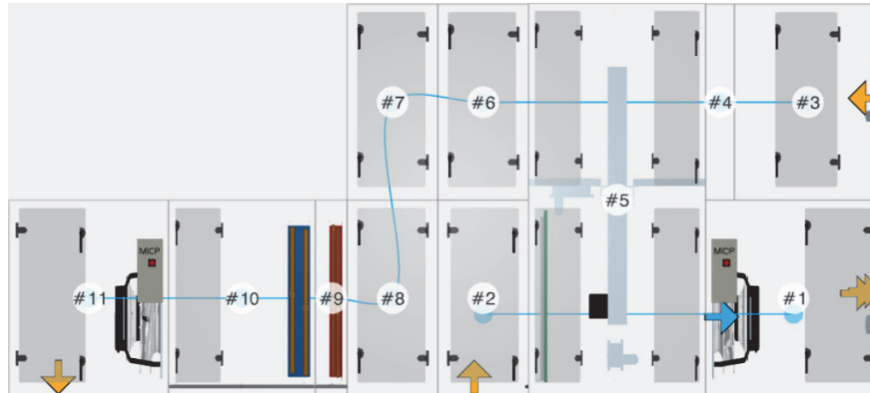

Figure 25. Cool dry quiet (CDQ™) - dedicated outside air

Number	Section description	Number	Section description
1	Filter mixing box	6	Cooling coil
2	Pre-heat coil (if needed)	7	Series CDQ wheel
3	Blank section	8	Variable length custom access section
4	Supply fan	9	Supply fan VFD, discharge plenum
5	Turning access		

Note: Factory pipe cabinets cover first level coils only.

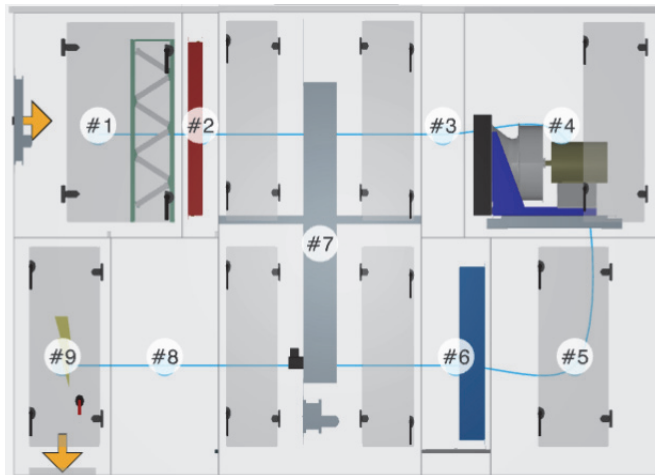

Figure 26. Cool dry quiet (CDQ™) with return fan

Number	Section description	Number	Section description
1	Return fan	7	Supply fan
2	Access section	8	Access section
3	OA mixing box (back full face, front, left, and right damper)	9	Cooling coil
4	Filter	10	Custom length section
5	Heating coil	11	CDQ wheel
6	Access section	12	Filter
		13	Discharge plenum

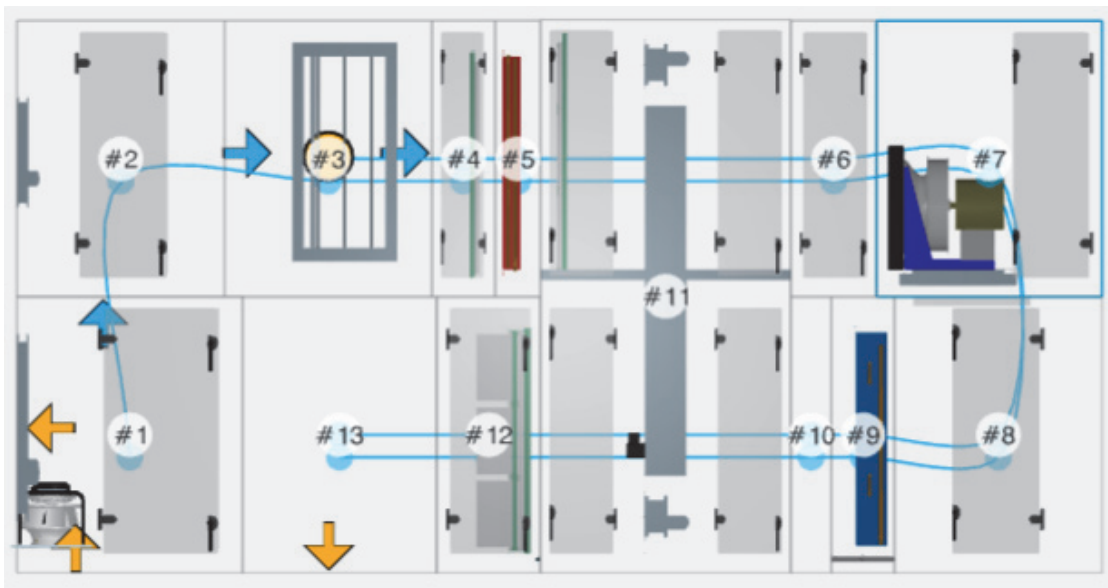

Figure 27. Dual wheel unit - energy wheel, cool dry quite (CDQ™) desiccant dehumidification system and controls

Number	Section description	Number	Section description
1	Exhaust fan (MI)	8	Access section
2	Starter/VFD section	9	Custom length section
3	Mixing box with filter (front damper, back full face)	10	Supply fan (DDP)
4	Custom length section	11	Air mixing section (top, front full face)
5	Energy wheel	12	Cooling coil
6	Access section	13	CDQ
7	Heating coil	14	Controls and starter/VFD section

Note: Consider a motorized impeller fan for outdoor units. The Motorized Impeller Control Panel (MICP) can be mounted on the fan exterior unlike the VFD on DDP fans. First level and second level hoods cannot be on the same plane (i.e. - Both front exhaust and outside air hood). Factory pipe cabinets cover first level coils only.



Common Outdoor Configurations

Figure 28. Air-to-Air plate frame make-up air unit with gas heat

Number	Section description	Number	Section description
1	Exhaust fan with side discharge	6	ATA section
2	Filter section	7	Access section
3	Mixing box	8	Supply fan (DDP)
4	Mixing box with filter	9	Inshot gas heat
5	Blank section		

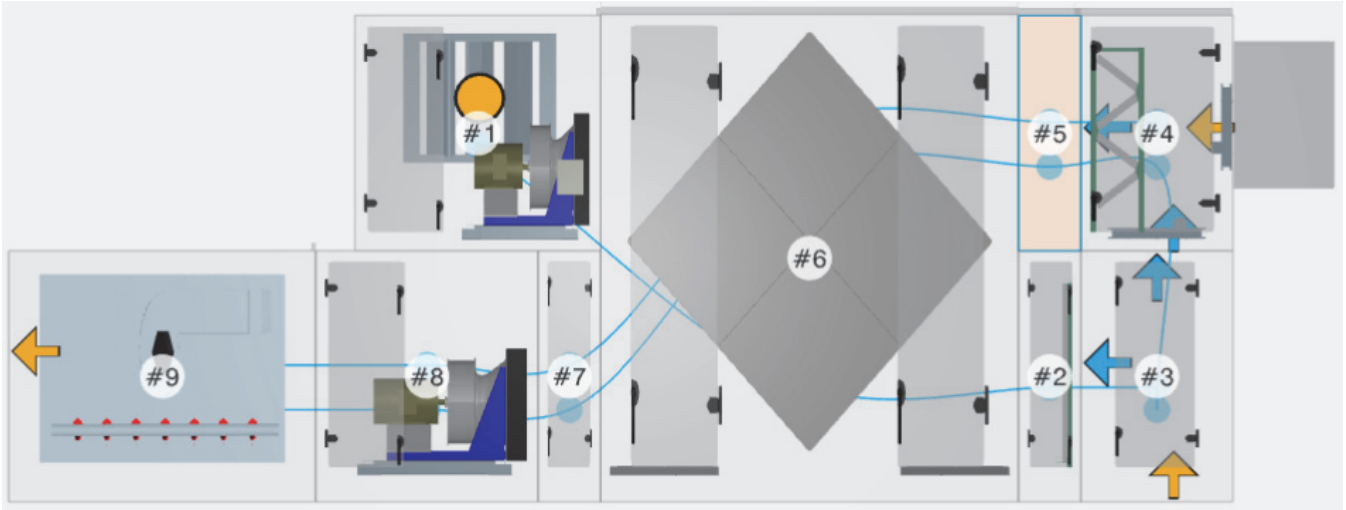

Figure 29. Dual energy recovery unit - energy wheel, Air-to-Air plate frame and controls

Number	Section description	Number	Section description
1	Exhaust mixing box (front full face, left and right side damper)	11	Access
2	Access	12	Supply fan
3	Exhaust fan	13	Energy wheel
4	Control section, supply fan VFD and controller	14	Heating coil
5	Control section, exhaust fan VFD	15	Access
6	Filter	16	Cooling coil
7	Variable length custom access	17	Air-to-air section
8	Turning access	18	Final filter
9	Reduced length mixing box (top full face, bottom rectangular)	19	Discharge plenum
10	OA filter mixing box (back damper, front full face)		

Note: Consider a motorized impeller fan for outdoor units. The Motorized Impeller Control Panel (MICP) can be mounted on the fan exterior unlike the VFD on DDP fans. First level and second level hoods cannot be on the same plane (i.e.-both back exhaust and outside air hood). Factory pipe cabinets cover first level coils only.



Figure 30. Sensible assisted membrane (SAM™)/Air-to-Air (ATA) plate heat exchanger indoor dedicated outside air - fans same side

Number	Section description	Number	Section description
1	Exhaust fan	5	Heating coil
2	Mixing box with filter (back damper, front full face)	6	Cooling coil
3	Mixing box with filter (back Traq™ damper, front full face)	7	Access section
4	SAM/ATA	8	Supply fan

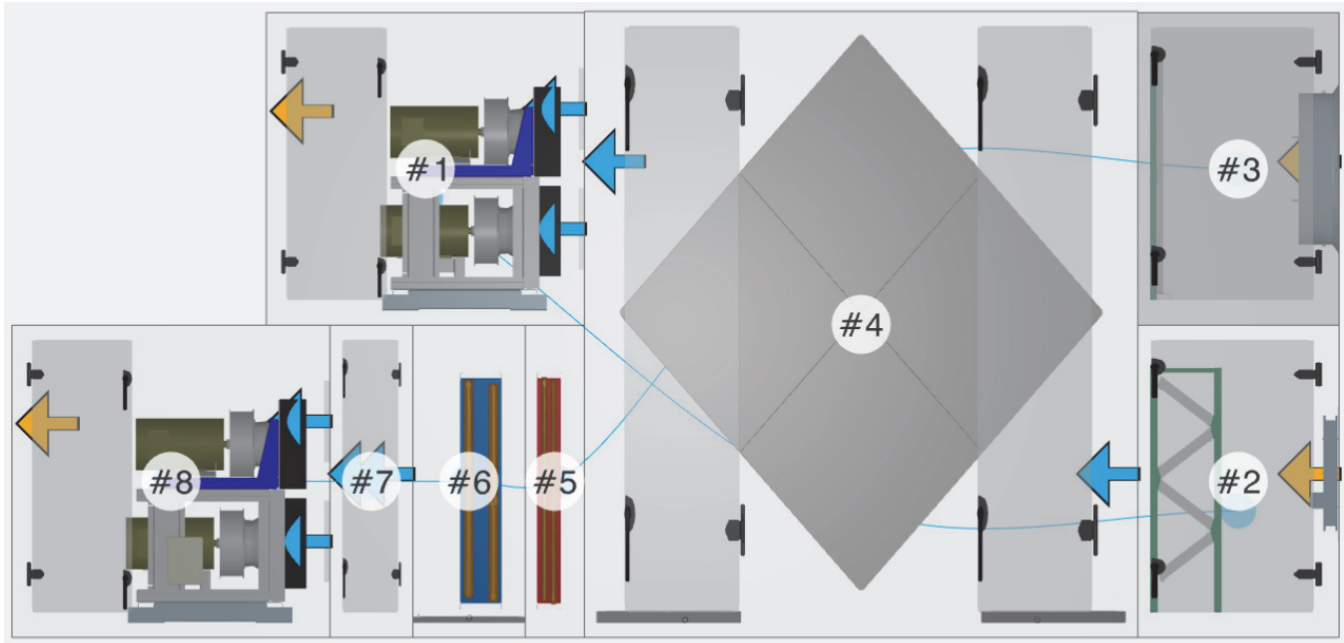
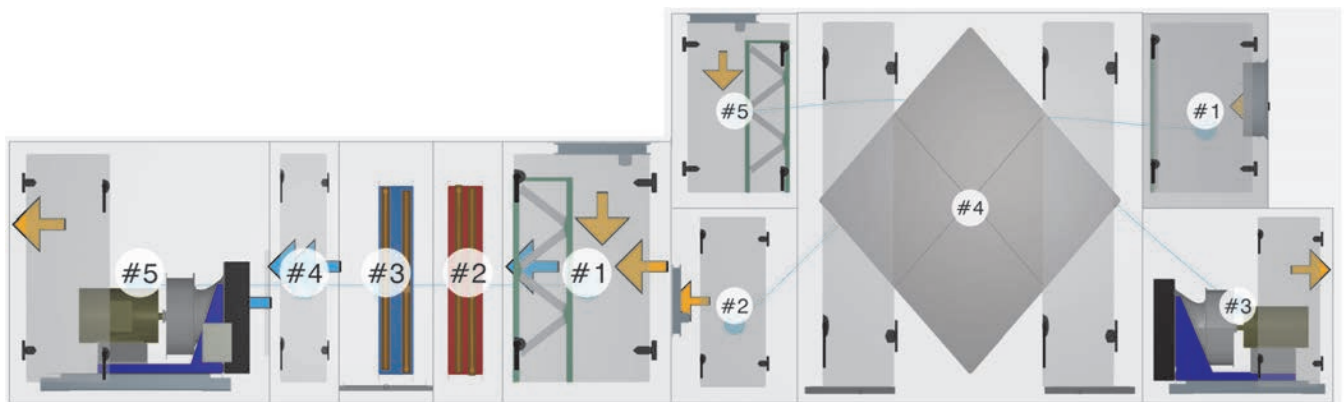

Figure 31. Sensible assisted membrane (SAM™)/Air-to-Air (ATA) plate heat exchanger indoor mixed air - two units

Number	Section description	Number	Section description
1	Mixing box with filter (back Traq™ damper, front full face)	1	Mixing box with filter (back and front full face, top damper)
2	Mixing box (back full face, front damper)	2	Heating coil
3	Exhaust fan	3	Cooling coil
4	SAM/ATA	4	Access section
5	Mixing box with filter (back full face, top damper)	5	Supply fan



Common Outdoor Configurations

Figure 32. SAM/ATA indoor mixed air with external bypass

Number	Section description	Number	Section description
1	Exhaust fan	6	Mixing box (back and front full face, top damper)
2	Mixing box with filter (back Traq damper, front full face)	7, 8	Coils
3	SAM/ATA	9	Access section
4	Mixing box with filter (front damper, back full face)	10	Supply fan
5	Mixing box (back, bottom, and front full face)		

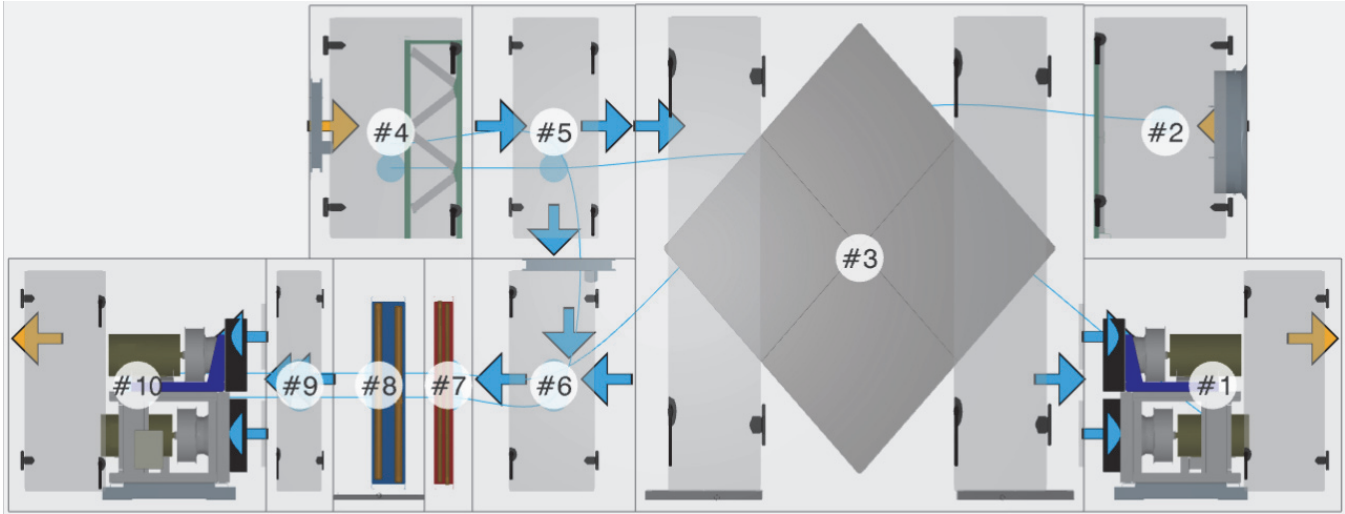
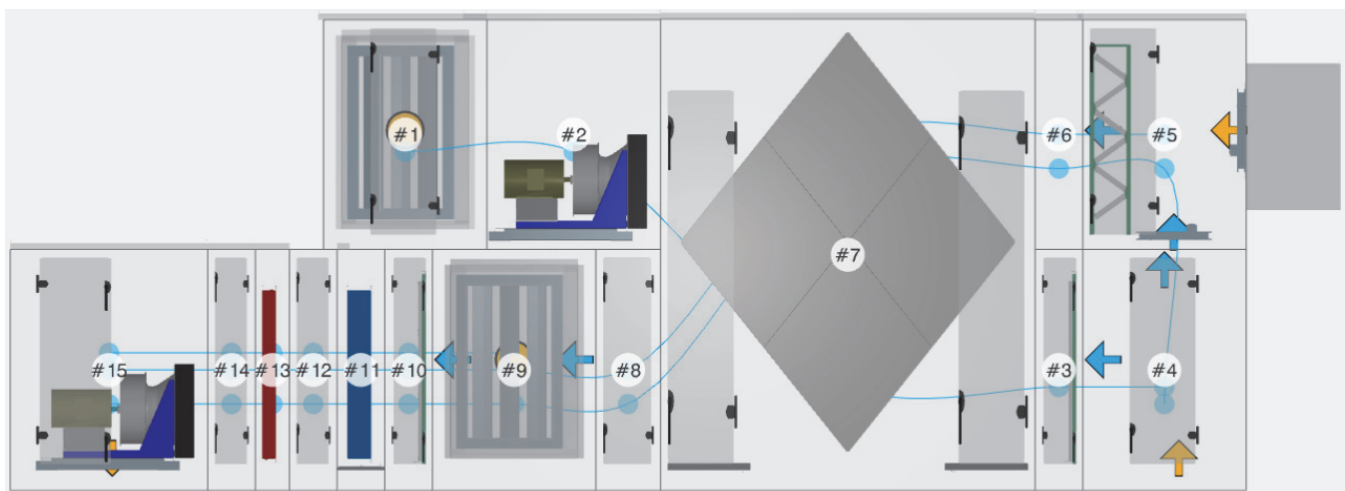

Figure 33. SAM/ATA outdoor dedicated outside air with morning warm-up recirculation

Number	Section description	Number	Section description
1	Mixing box (back full face, left damper)	9	Mixing box (back and front full face, right and left damper)
2	Exhaust fan	10	Filter
3	Filter	11	Cooling coil
4	Mixing box (front and top full face, bottom rectangle)	12	Access section
5	Mixing box with filter (back and bottom damper, front full face)	13	Heating coil
6	Access section	14	Access section
7	SAM/ATA	15	Supply fan
8	Access section		



Common Outdoor Configurations

Figure 34. SAM/ATA outdoor mixed air

Number	Section description	Number	Section description
1	Exhaust fan damper section	9	Mixing box with filter (back and bottom full face, left and right damper)
2	Exhaust fan	10	Mixing box with filter (back, front, and top full face)
3	Mixing box with filter (back full face, bottom rectangle, front damper)	11	Cooling coil
4	Mixing box (back Traq damper, full front face)	12	Access section
5	Filter	13	Heating coil
6	Custom length access section	14	Access section
7	SAM/ATA	15	Supply fan
8	Access section		

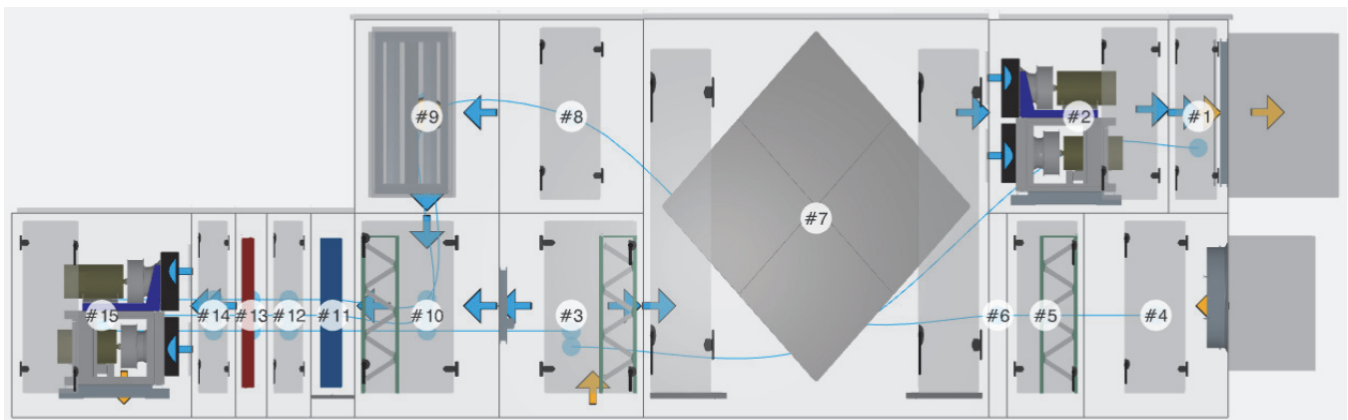

Figure 35. Motorized impeller fan return economizer

Number	Section description
1	Return fan
2	Economizer
3	Filter
4	Heating coil
5	Cooling coil
6	Access section
7	Supply fan

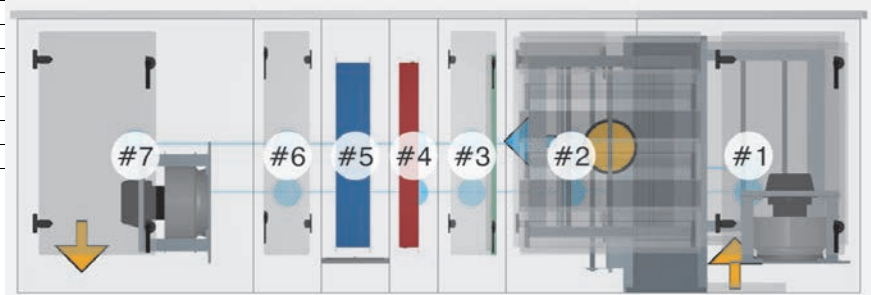
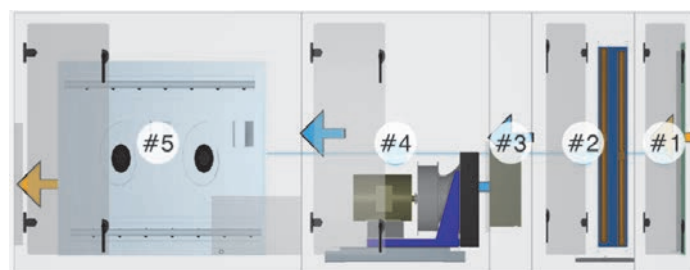

Figure 36. Direct-Drive Plenum fan with indirect gas heater (indoor)

Number	Section description
1	Filter section
2	Cooling coil with door
3	Blank section for backdraft damper
4	Supply fan
5	Inshot gas heat



Common Outdoor Configurations

Figure 37. Direct-Driver Plenum fan with indirect gas heater (outdoor)

Number	Section description
1	Mixing box with filter (back and bottom damper, front full face)
2	Cooling coil
3	Access section
4	Supply fan
5	Diffuser
6	Indirect gas heater

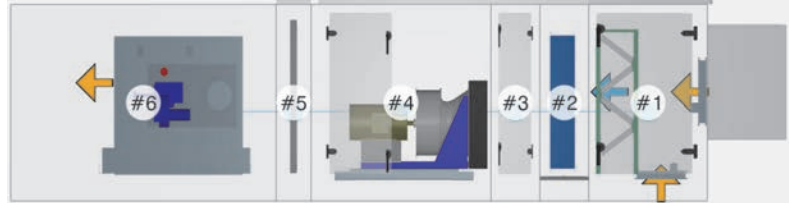
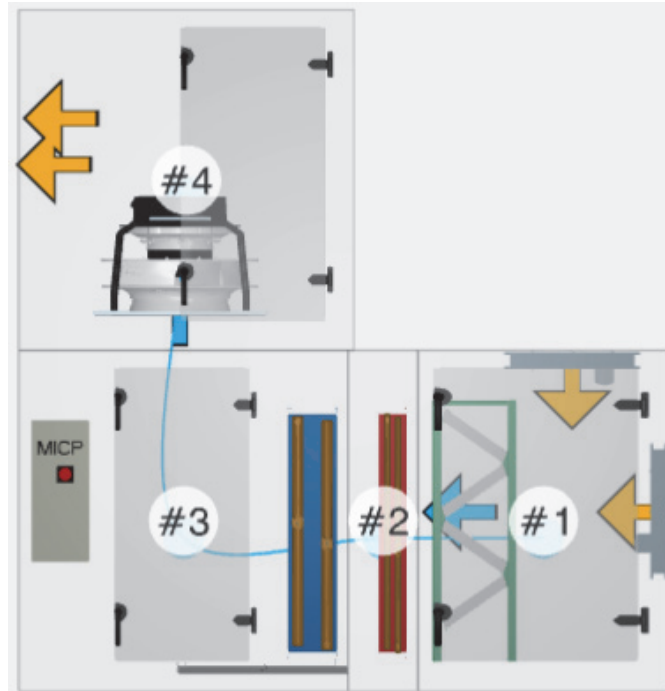

Figure 38. Vertical motorized impeller fan (indoor)

Number	Section description
1	Mixing box with filter
2	Heating coil
3	Cooling coil with door
4	Supply fan (MI)





Trane - by Trane Technologies (NYSE: TT), a global climate innovator - creates comfortable, energy efficient indoor environments for commercial and residential applications. For more information, please visit trane.com or tranetechnologies.com.

Trane has a policy of continuous product and product data improvement and reserves the right to change design and specifications without notice. We are committed to using environmentally conscious print practices.