



Product Catalog

Cold Generator™ Scroll Liquid Chillers - Model CGWR and CCAR

20 to 75 Tons (60 Hz)

Water-Cooled and Compressor Chillers





Introduction

Trane R-410A Scroll Liquid Chiller

Reliability

Trane is a leader in chiller design and reliability. The Cold Generator™ line of scroll chillers continues that tradition.

Efficiency

CGWR scroll chillers are ASHRAE Standard 90.1 compliant up to 2019 at full and part load efficiencies.

Control

Unit controller provides complete chiller control and standard interface to BACnet® IP and Modbus® BMS systems. LonTalk®, Johnson N2, or BACnet MS/TP interface optional. Door mounted display and local PC Ethernet connection provides easy access to set points and diagnostic displays.

Availability

Quick ship cycles are available on select models and voltages.

Installation

Service friendly design and factory run testing of all CGWR and CCAR chillers prior to shipment makes installation and startup trouble free

Operation

Unit Controller stages compressors to maintain chiller's leaving chilled water temperature set-point using proportional, integral and derivative (PID) logic for precise temperature control. Trouble shooting is made easy with up to 99 fault conditions being stored with 120 seconds of history being saved any time a fault occurs.

All operational and fault conditions can be viewed graphically by connection with a remote interface such as a laptop computer or locally with optional color touchscreen display.



Copyright

This document and the information in it are the property of Trane, and may not be used or reproduced in whole or in part without written permission. Trane reserves the right to revise this publication at any time, and to make changes to its content without obligation to notify any person of such revision or change.

Trademarks

All trademarks referenced in this document are the trademarks of their respective owners.



Table of Contents

Introduction	2
Features and Benefits	6
Trane Liquid Chillers	6
Quick Ship Options	6
Installation	6
Service	6
Single Source Responsibility	7
Added Value Expertise	7
Leading in Efficiency and Reliability with State-Of-The-Art Scroll Compressor Technology	7
Application Consideration	8
Product Selection	8
Unit location	8
Ambient Limits — CCAR/CAUJ Combination	8
Condenser Water Limitations	8
Evaporator Water Treatment	9
Condenser Water Treatment	9
Water Pumps	9
Remote Condenser	9
Heat Recovery Operation	9
Model Number Descriptions	11
General Data	12
Control Panel	14
Power Distribution Section	14
Controls Section	14
Available Controls Inputs	14
Available Control Outputs	14
Hardware Protection	14
System Protection	14
Capabilities	15
Operation	15
Standard Local Interface	15
Optional Local Interface — Touchscreen	15
Remote Interface	16
Easy Interface to All Building Management Systems	16

Electrical	17
Electrical Connections	18
CGWR	18
CCAR 20 to 30 ton	19
CCAR 40 to 75 ton	20
Control of CAUJ Fans and Optional Low Ambient Dampers	21
Dimensional Data	22
CGWR/CCAR 20 to 30 ton	22
CGWR/CCAR 40 to 75 ton	24
Weight Data	26
Mechanical Specifications	27
CGWR Water Cooled Chillers	27
CCAR Compressor Chillers	30
Options	33
Operator Interface	33
Communications	33
Electrical Options	33
Other Options	34



Features and Benefits

Trane offers state-of-the-art water cooled and remote condenser scroll liquid chillers for a wide range of comfort and process-cooling applications. These chillers are complete, factory-assembled chillers that offer ease of installation with microprocessor controllers providing maximum operating efficiency. These compact chillers install easily and quickly into most building layouts, making them ideal choices for retrofit or new building designs.

Trane Liquid Chillers

Water-cooled chillers are complete, factory-assembled liquid chillers for comfort or process-cooling applications. They have multiple scroll compressors.

- All CGWR products are ASHRAE Standard 90.1 compliant up to 2019 at full and part load efficiencies.
- Available in six sizes ranging from 20 to 75 nominal tons.
- Compressor chiller version (CCAR 20 to 75 tons) available for use with remote condensers.
- Factory assembled and charged, complete with oil, all refrigerant piping and electrical wiring. CGWR models are charged with refrigerant, CCAR models with dry nitrogen.
- CGWR products ship ready to install, need only electrical and water connections.
- All components mounted in a rugged, open frame for easy access.
- CGWR 20 and 30 have a single refrigerant circuit with single circuit shell-and-tube condenser and brazed plate evaporator. CGWR 40, 50, 65 and 75 have dual refrigerant circuits with dual circuit shell-and-tube condenser and brazed plate evaporator.
- Robust cleanable shell-and-tube condensers are uniquely suited for open loop cooling tower applications.
- The powerful unit controller offers complete chiller control and provides a wealth of information and diagnostics.

Quick Ship Options

Quick ship options are available on selected models. Contact your local Trane account representative for details.

Installation

- Single point power connection for simplified, fast field-wiring.
- The powerful unit controller provides complete chiller controls and interface to a variety of platforms, including BACnet® IP and Modbus® as standard. LonTalk®, Johnson N2 and BACnet MS/TP are available with an optional interface.
- Units are pre-charged with oil and refrigerant (CGWR) from the factory which speeds installation. CCAR units have the proper standard oil charge and a charge of dry nitrogen.
- Units are designed to fit through standard doorways.
- Factory testing ensures first-time smooth operation on start-up, and reduces follow up costs.

Service

Trane 20 to 75 ton scroll chillers are designed with service personnel in mind. Unit design allows replacement of all major components without complete unit teardown. All CGWR units have mechanically cleanable shell-and-tube condensers. The unit controller provides diagnostic capability and remote factory diagnostics to aid local and factory service personnel in analyzing problems quickly. Unanticipated down time is minimized.

Single Source Responsibility

Trane is a single source provider, allowing the customer to obtain all building comfort systems through one source.

Added Value Expertise

Trane has more than 100 years of experience engineered into their products. That means a quality product that works right the first time!

Leading in Efficiency and Reliability with State-Of-The-Art Scroll Compressor Technology

ASHRAE Standard 90.1 Compliance up to 2019

ASHRAE Standard 90.1 defines the minimum requirement for energy efficiency for building designs other than low-rise residential buildings. Regular review and updating of this US standard drives higher and higher efficiency requirements as emerging technologies develop. In many cases, this standard requires higher efficiencies than past technologies can deliver.

All Trane CGWR and CCAR chillers meet or exceed the most current efficiency requirement of ASHRAE Standard 90.1 (compliant to 2019).

Potential Risk

Not only has ASHRAE 90.1 been adopted by the US Federal Government, it's expected to be adopted domestically, if not globally, in the future. Make sure that your chillers, as well as your entire HVAC system, comply or you may be caught retrofitting your project with new equipment and paying extra design dollars if the code changes during construction.

Efficiency

The energy efficiency of Trane scroll chillers results in energy costs lower than most other comparable chillers. Superior engineered efficiencies are obtained by combining advanced scroll compressor energy efficient features with up to date heat exchanger technology and state-of-the-art controls. Here's How:

- Scroll compressor's positive displacement design
- Dual refrigerant circuits on 40 to 75 ton models
- Multiple compressors
- Optimum system design
- Reduced friction
- No valves
- Advanced heat transfer surfaces

Reliability

Trane Scroll Chillers with many new improvements feature highly efficient and reliable scroll compressors. Here's How:

- Scroll compliance allows liquid and dirt to pass through without damaging compressor (liquid slugging resistant).
- Advanced microelectronics protect compressor and motor from typical electrical fault conditions.
- Years of laboratory testing have optimized compressor and chiller systems reliability.
- Each Trane scroll chiller is tested in one of the factories laboratories prior to shipment. Critical performance data is retained on file by serial number.



Application Consideration

Product Selection

Both CGWR and CCAR products are offered in six models each ranging in capacity from 20 to 75 nominal tons. Refer to TOPSS™ performance selection program to select the model best suited for your application. Since actual unit capacity can vary significantly from “nominal capacity”, it is important to base your selection on the actual conditions. Selection of the correct model will require attention to the minimum, as well as the full load capacity required. Selection of the proper equipment is an important part of a successful installation. Equipment sized too large will cycle more frequently and as a potential result lead to poor temperature and humidity control, shortened equipment life and higher utility costs. Equipment sized too small will not be able to meet peak cooling demands.

Unit location

Units should be installed indoors. A level foundation or flooring must be provided which will support at least 150 percent of the operating weight of the unit. Service clearance must allow for removal of compressors. See “[Dimensional Data](#),” p. 22 for specific clearance requirements. All units must also allow for space to service vessels. The unit foundation must be rigid to reduce vibration transmission to a minimum. Use of optional vibration isolation pads is recommended for applications that are sensitive to vibration and noise.

Ambient Limits — CCAR/CAUJ Combination

Minimum Ambient Temperature Limit

Refer to SS-APG014*-EN *Application Guide – Pairing Trane CCAR Compressor Chillers (20 to 75 tons) with Trane CAUJ Air-Cooled Condensers (20 to 80 tons)*.

In general, the minimum outdoor ambient temperature for operation of CCAR compressor chiller in combination with a CAUJ air cooled condenser is 40°F. *In some cases, with factory application approval, the CCAR/CAUJ combination can be operated down to the 20° F ambient.*

This minimum is primarily driven by compressor chiller starting considerations and not by effectiveness of condenser ambient controls once the system is up and running. Fan cycling and optimal low ambient dampers do *not* mitigate the low ambient starting challenge. On a cold day with outdoor ambient temperature below 40° F, the liquid line pressure at the expansion valve inlet, in most circumstances, is extremely low. On start, the suction pressure tends to plunge into the freezing range potentially causing a nuisance fault.

Contact the factory to request application approval for applications where CCAR/CAUJ combination is intended for operation with ambient temperature below 40° F.

Maximum Ambient Temperature Limit

The maximum ambient temperature limit for the CCAR/CAUJ operation is 110° F.

Condenser Water Limitations

CGWR water cooled chiller units start and operate satisfactorily over a wide range of load conditions. Reducing the condenser water temperature below 85° F is an effective method of lowering the power input required. Beyond certain limits, however, the effect of further reducing condenser water temperature causes a reduction in the pressure drop across the expansion valve to a point where system instability may occur.

CGWR products are design for optimum performance with refrigerant saturated discharge pressures between 75° F and 145° F. As a result, a means of discharge pressure control must be considered when entering condenser water temperature falls below 70° F. The exact point at which discharge pressure control is required depends on other system parameters such as leaving chilled water temperature and flow rate, and condenser water flow rate. Contact the factory engineering department for assistance when application require entering condenser water temperature less than 70° F or greater than 95° F.

Heat Recovery using condenser water is an option, however applications must be reviewed by factory engineering department. In general, maximum leaving condenser water temperature is 130° F.

Evaporator Water Treatment

The use of untreated or improperly treated water in chillers may result in scaling, erosion, corrosion, and algae or slime buildup. This will adversely affect heat transfer between the water and system components. Proper water treatment must be determined locally and depends on the type of system and local water characteristics.

Neither salt nor brackish water is recommend for use in Trane chillers. Use of either will lead to a shortened life. Trane encourages the employment of a qualified water treatment specialist, familiar with local water conditions, to assist in the establishment of a proper water treatment program.

Foreign matter in the chilled water system can also increase pressure drop and, consequently, reduce water flow. For this reason it is important to thoroughly flush all water piping to the unit before making the final piping connections to the unit.

The capacities give in the Performance Data section of this catalog are based on water with a fouling factor of 0.0001°F·ft²·h/Btu (in accordance with AHRI 550/590). For capacities at other fouling factors, see Performance Selection Software.

Condenser Water Treatment

Use of untreated or improperly treated condenser cooling water in any water cooled condensing unit could result in tube fouling, scaling, erosion, corrosion, algae, or slime; and, as a result cause reduced performance and increase the potential for unit failure. It is recommended that the services of a qualified water treatment specialist be engaged to determine the proper condenser water treatment and bleed-rate. Trane assumes no responsibility for the results of untreated or improperly treated water.

Water Pumps

Avoid specifying or using 3600 rpm condenser water and chilled water pumps. Such pumps may operate with objectionable noise and vibration. In addition, a low frequency beat may occur due to the slight difference in operating rpm between water pumps and the scroll compressors. Where noise and vibration-free operation is important, Trane encourages the use of 1750 rpm pumps.

Remote Condenser

For application of Trane CCAR Compressor Chiller with Trane CAUJ, refer to SS-APG014*-EN *Application Guide – Pairing Trane CCAR Compressor Chillers (20 to 75 tons) with Trane CAUJ Air-Cooled Condensers (20 to 80 tons)*.

Heat Recovery Operation

At a time when energy costs are high and continue to rise, reducing energy usage has become increasingly important. By using a CGWR chiller with heat recovery, utilization of energy can be improved by using heat from the condenser that would otherwise be wasted.

The use of heat recovery should be considered in any building with simultaneous heating and cooling requirements or in facilities where heat can be stored and used at a later time. Buildings with high year-round internal cooling loads are excellent opportunities for heat recovery. Heat recovery can be accomplished with the CGWR by recovering heat from the water leaving the standard condenser and using it in conjunction with a third party heat exchanger as shown in [Figure 1, p. 10](#).

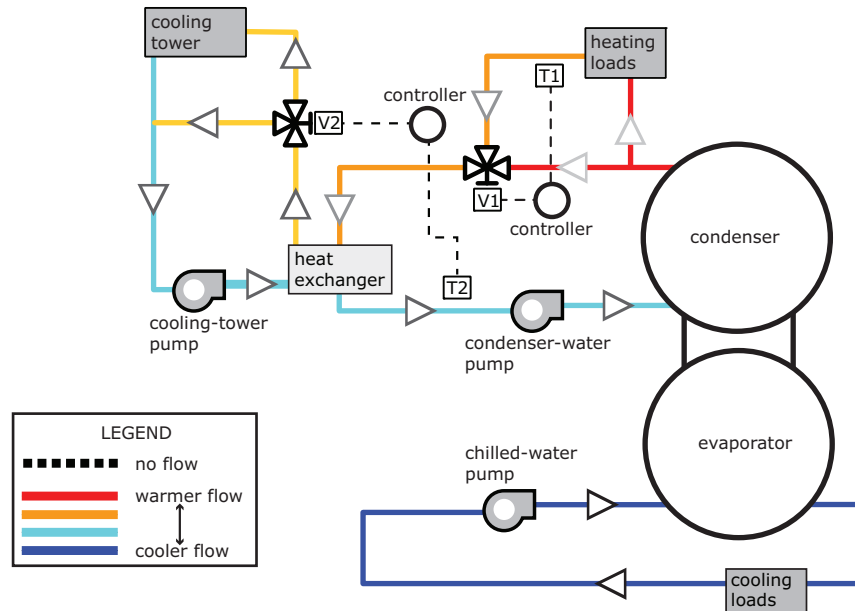
Figure 1. Heat recovery operation

Heat recovery is designed to capture a portion of the heat that is normally rejected to the cooling tower and put it to beneficial use. With the addition of a heat recovery cycle, heat removed from the building cooling load can be transferred to any heating application. The heat recovery cycle is only possible if a cooling load exists to act as a heat source.

The Trane CGWR chiller uses smart control logic to switch the control point between the cooling set point and heating set point, based on the smaller of the loads. This allows the machine to operate in heat recovery mode longer - maximizing the energy saved. In the heat recovery cycle, the unit can control to a hot water set point. During the heat recovery cycle, the unit operates just as it does in the cooling-only mode except that the leaving hot water is the control point instead of the leaving chilled water. Water circulated through the heat recovery heat exchanger (condenser) absorbs cooling load heat from the compressed refrigerant gas discharged by the compressors. The heated water is then used to satisfy heating requirements.

Hospitals dormitories, computer centers, and hotels are opportunities for economical heat recovery due to their needs for hot water for reheat and domestic use, coupled with air-side economizer operation, or in some cases, winter operation of chillers. Heat recovery provides hot water and tight control that minimizes operating costs for the chilled water plant and boiler/hot water heater, while also providing consistent dehumidification. The heat recovery heat exchanger cannot operate alone without a load on the chiller.

Units with a brazed plate heat recovery heat exchanger can produce up to 140° F leaving water temperature and units with the shell and tube heat recovery heat exchanger can produce up to 125° F leaving temperature. For more information see TOPSS performance selection program.



Model Number Description

Digit 1, 2, 3, 4 — Unit Type

CGWR=Water-cooled chiller
CCAR= Compressor chiller

Digit 5, 6, 7 — Unit Nominal Tonnage

020 = 20 nominal tons
030 = 30 nominal tons
040 = 40 nominal tons
050 = 50 nominal tons
065 = 65 nominal tons
075 = 75 nominal tons

Digit 8 — Unit Voltage

A = 208V/60/3
B = 230V/60/3
F = 460V/60/3
G = 575V/60/3

Digit 9, 10 — Design Sequence

A0 = Factory assigned

Digit 11 — Agency Listing

N = None
E = ETL/ETL-C Listed to meet U.S.
and Canadian safety standards

Digit 12 — Condenser Water Regulating Valve

0 = None
1 = With

Digit 13 — Evaporator Wye Strainer

0 = None
1 = Nominal flow wye strainer
2 = Nominal flow wye strainer with
installation kit¹

Digit 14 — Evaporator Temp Range

0 = Standard cooling
42 to 60° F [4.4 to 5.5° C]
1 = Standard cooling/ice making
20 to 60° F [-6.7 to 15.6° C]

Digit 15 — Power Connection

T = Terminal block
D = Non-fused disconnect switch
F = Fused disconnect switch

Digit 16 — Short Circuit Rating (SCCR)

0 = Standard 5 kA rating
1 = Optional 100 kA rating

Digit 17 — Sound Attenuator

0 = No sound attenuation
3 = Compressor sound blanket(s)
9 = Factory sound enclosure
cabinet(s)

Digit 18 — Local Unit Controller Interface

0 = Keypad with dot pixel display
1 = Color touchscreen

Digit 19 — Remote BMS Interface (Digital Comm)

0 = None
2 = LonTalk®
4 = BACnet® Ms/TP
5 = BACnet IP
6 = MODBUS®
8 = Johnson N2

Digit 20 — Power Monitor

0 = None
1 = With

Digit 21 — Neoprene Isolator Pads

0 = None
1 = With

Digit 22 — Flow Switch

0 = None
1 = With

Digit 23 — Evaporator Fluid Type

0 = Water
2 = Ethylene glycol
3 = Propylene glycol

Digit 24 — Condenser Fluid Type

0 = Water
2 = Ethylene glycol
3 = Propylene glycol
9 = Not Applicable —
compressor-chiller

Digit 25 — Special Options

0 = None
1 = With

Digit 26 — Condenser Heat Recovery

0 = No heat recovery
1 = Full heat recovery with auto
changeover

¹ Nominal flow wye strainer installation kit includes pipe
adaptors and blowdown valve.



General Data

Table 1. General data for CGWR water-cooled chillers

Unit Size			20	30	40	50	65	75
Compressor								
Quantity	each		2	2	3	3	3	3
Nominal Tons @ 60 Hz	tons		10/10	15/15	10/10, 20	12/12, 25	15/15, 30	15/15, 40
Steps of Unloading	%		100-50	100-50	100-75-50-25	100-75-50-25	100-75-50-25	100-79-57-21
Compressor Sound Power Data ^(a)	dB(A)		81.0	84.0	87.2	87.5	90.2	91.8
Compressor Sound Data with Sound Blankets Only ^(a)	dB(A)		75.0	78.0	82.8	83.0	85.8	87.5
Evaporator								
Water Storage	gal		2.1	3.0	3.1	3.7	4.6	6.6
Minimum Flow	gpm		30	45	66	82	104	75
Maximum Flow	gpm		104	151	207	237	295	264
Shell and Tube Condenser								
Water Storage	gal		3.0	4.5	5.5	7.4	9.2	9.2
Minimum Flow	gpm		28	39	49	65	84	84
Maximum Flow	gpm		119	167	207	271	342	342
General Unit								
Refrigerant			R-410A	R-410A	R-410A	R-410A	R-410A	R-410A
Number of Independent Refrigerant Circuits			1	1	2	2	2	2
Refrigerant Charge Per Circuit (approximately)	lb		25	37	24, 24	26, 26	31, 31	33, 33
Oil Type			POE 160SZ	POE 160SZ	POE 160SZ	POE 160SZ	POE 160SZ	POE 160SZ
Oil Charge (each compressor)	oz		112/112	113/113	112/112, 227	112/112, 227	112/112, 227	112/112, 227

Notes:

1. Data containing information on two circuits formatted as follows: Circuit 1, Circuit 2.
2. Nominal compressor sizes based on 60 Hz.

(a) Compressor manufacturer sound power is given at rated compressor AHRI conditions measured in free space for tandem compressor sets.

Table 2. General data for CCAR compressor chillers

Unit Size			20	30	40	50	65	75
Compressor								
Quantity	each		2	2	3	3	3	3
Nominal Tons @ 60 Hz	tons		10/10	15/15	10/10, 20	12/12, 25	15/15, 30	15/15, 40
Steps of Unloading	%		100-50	100-50	100-75-50-25	100-75-50-25	100-75-50-25	100-79-57-21
Compressor Sound Power Data ^(a)	dBa		81.0	84.0	87.2	87.5	90.2	91.8
Compressor Sound Data with Sound Blankets Only ^(a)	dBa		75.0	78.0	82.8	83.0	85.8	87.5
Evaporator								
Water Storage	gal		2.1	3.0	3.1	3.7	4.6	6.6
Minimum Flow	gpm		30	45	66	82	104	75
Maximum Flow	gpm		104	151	207	237	295	264
General Unit								
Refrigerant			R-410A	R-410A	R-410A	R-410A	R-410A	R-410A
Number of Independent Refrigerant Circuits			1	1	2	2	2	2
Refrigerant Charge Per Circuit (approximately)	lb		16	19	12, 12	13, 13	16, 16	17, 17
Oil Type			POE 160SZ	POE 160SZ	POE 160SZ	POE 160SZ	POE 160SZ	POE 160SZ
Oil Charge (each compressor)	oz		112/112	113/113	112/112, 227	112/112, 227	112/112, 227	112/112, 227

Notes:

1. Data containing information on two circuits formatted as follows: Circuit 1, Circuit 2.
2. Nominal compressor sizes based on 60 Hz.

(a) Compressor manufacturer sound power is given at rated compressor AHRI conditions measured in free space for tandem compressor sets.



Control Panel

The spacious control panel provides separation between power distribution components and the control components. Controller is located in the controls section with display mounted on the exterior of the control cabinet door.

Power Distribution Section

Power distribution section contains incoming power distribution block, optional fused or non-fused disconnect, ground lugs, across-the-line contactors, current transformers, and control power transformer with primary and secondary fuses.

Controls Section

The controls section of the panel contains the unit controller with standard and optional expansion boards, door mounted keypad and display or optional color touchscreen, power monitor (optional), service-friendly terminal strips to facilitate circuit diagnosis and field connection.

Available Controls Inputs

- **Remote Off/Auto** (digital)
- **Flow Switch** (flow proving device, digital) — REQUIRED
- **Leaving Chilled Water Temperature** offset (0 to 5 Vdc analog signal)

Available Control Outputs

- **Remote Alarm** (digital)
- **Remote Chilled Water Pump Enable** for one chilled water pump (digital) — Optional
- CGWR units only: **Condenser Water Pump Enable** for one condenser water pump (digital)
- Digital outputs for cycling condenser fan motors
 - CCAR 20 and 30 ton units: three outputs
 - CCAR 40, 50, 65 and 75 ton units: six outputs
- Analog outputs for operation of condenser ambient dampers or fan VFDs
 - CCAR 20 and 30 ton units: one output
 - CCAR 40, 50, 65 and 75 ton units: two outputs

Hardware Protection

The heart of the unit controller is a six layer microprocessor printed circuit board which provides the highest level of machine reliability. Each relay output has its own snubber on both the normally open and normally closed contacts. The relay outputs are individually fused to further protect the system from electrical shorts. This protection is rounded out with poly fuse protection on sensor input.

System Protection

A complete safety lockout system minimizes the potential for compressor and evaporator failure. The controller directly senses pressure, temperature, amperage, motor faults, etc. Compressor, condenser, evaporator and overall chiller information is evaluated every second for equipment protection and control of process variables.

Capabilities

The unit controller stores 1,008 packets of information taken at set time intervals. The time interval for collecting data is adjustable, and comes factory set for 15 seconds. Up to 99 fault conditions are stored in the controller, and 120 seconds of history is saved any time a fault occurs that results in a compressor lockout. As an additional benefit, run and fault history can be sent to the factory for troubleshooting assistance.

Operation

Unit controller monitors, displays and logs operating and fault conditions, and provides safety protection for low and high refrigerant operating pressure, low and high refrigerant superheat, low refrigerant differential pressure between low and high side, low chilled water temperature, low chilled water flow, compressor over amperage, and abnormal power conditions when fitted with optional power monitor. Mechanical high and low pressure switches, and compressor overload protection devices are located in the controls section, but are monitored and reported by the controller.

The unit controller stages compressors to maintain the chiller's leaving chilled water temperature set-point using proportional, integral and derivative (PID) logic.

Additional information available includes:

- Number of starts and run time for each compressor.
- Alarm messages based on predetermined criteria.
- Running modes and state of chiller, i.e. Loading, Unloading, Holding, High Disc PSI Hold, Low Suction Hold, In Safety, In Alarm mode, etc.
- Warning and Alarms – Complete Warning/Lockout System.

Standard Local Interface

Unit controller can be accessed using the local keypad and 128 x 64 dot pixel display screen for all unit control setpoints, faults and alarm conditions with history, and operating conditions in a clear language format for easy interpretation by user/operator.

Optional Local Interface — Touchscreen



Optional 15.4 inch color touchscreen comes with chiller specific display screens allowing user to easily view chiller status and operating conditions in *real time* for compressors, and both refrigerant and chilled water circuits. User can also acknowledge alarms and change set points.



Control Panel

Preloaded IOMs, wiring schematics and MCS Connect software expands interface and troubleshooting capabilities by allowing user to set and view schedules, view run history in graphical format, view 120 seconds for history leading up to compressor lockout fault, and more.

Remote Interface

Unit controller can also be accessed from a remote computer such as a laptop using MCS Connect software. Access via a remote computer allows all the functionality of the local interface with the additional ability to download run and fault history, and graphically display history.

Unit controller has RS232, RS485 and Ethernet communications ports for user interactive communication, or for interface with Building Management System (BMS).

Easy Interface to All Building Management Systems

Controlling the scroll chiller with BMS is state-of-the-art, yet simple with BACnet[®], Modbus[®], Johnson N2 or LonTalk[®] Communication Interface for Chiller. The controller supports all of the BMS communication systems.

- BACnet is ASHRAE's standard BMS communications protocol which allows communication between different manufactures' equipment. BACnet IP communication capability is standard, while BACnet MS/TP communication requires an optional gateway interface board.
- Modbus is a popular communications protocol used by many manufacturers. Modbus communication capability is standard.
- Johnson N2 is a proprietary communication system developed for use with Johnson Controls BMS. Johnson N2 communication requires an optional gateway interface board.
- LonTalk is a communications protocol developed by the Echelon Corporation. The LONMARK[®] association develops control profiles using the LonTalk communication protocol. LonTalk communication requires an optional gateway interface board.

The controller is capable of responding to a BMS signal for:

- Run/Stop
- Leaving Chilled Water Temperature Reset
(Leaving Chilled Water Temperature can also be reset using a 0 to 5 VDC input signal.)
- Demand Limiting Reset



Electrical

Table 3. Electrical data — CGWR water cooled chillers & CCAR compressor chillers

Unit Size	Compressors						Unit Wiring Data		
	Rated Voltage	Quantity	Number of Refrigerant Circuits	Nominal Tons	RLA (each)	LRA (each)	Minimum Circuit Ampacity	Maximum Fuse Size	Recommended Dual Element Fuse Size
20	208-230/60/3	2	1	10/10	39/39	267/267	88	125	100
	460/60/3				19/19	142/142	42	60	50
	575/60/3				15/15	103/103	35	50	40
30	208-230/60/3	2	1	15/15	48/48	351/351	108	150	125
	460/60/3				25/25	197/197	56	80	60
	575/60/3				22/22	135/135	50	70	60
40	208-230/60/3	3	2	10/10, 20	39/39, 67	267/267, 485	162	225	175
	460/60/3				19/19, 33	142/142, 215	78	110	90
	575/60/3				15/15, 26	103/103, 175	64	80	70
50	208-230/60/3	3	2	12/12, 25	41/41, 82	304/304, 560	185	250	225
	460/60/3				19/19, 40	147/147, 260	88	125	100
	575/60/3				17/17, 29	122/122, 210	69	90	80
65	208-230/60/3	3	2	15/15, 30	48/48, 109	351/351, 717	232	300	250
	460/60/3				25/25, 51	197/197, 320	113	150	125
	575/60/3				22/22, 38	135/135, 235	93	125	110
75	208-230/60/3	3	2	15/15, 40	48/48, 122	351/351, 1010	248	350	300
	460/60/3				25/25, 68	197/197, 344	134	200	150
	575/60/3				22/22, 46	135/135, 327	102	125	110

Notes:

1. Use copper conductors only. Use copper conductors only.
2. Local codes may take precedence.
3. Data containing information on two circuits formatted as follows: Circuit 1, Circuit 2.
4. Voltage Utilization Range: ± 10% of rated voltage. Rated voltage (use range): 208-230/60/3 (187-253), 460/60/3 (414-506), 575/60/3 (518-632).

Electrical Connections

CGWR

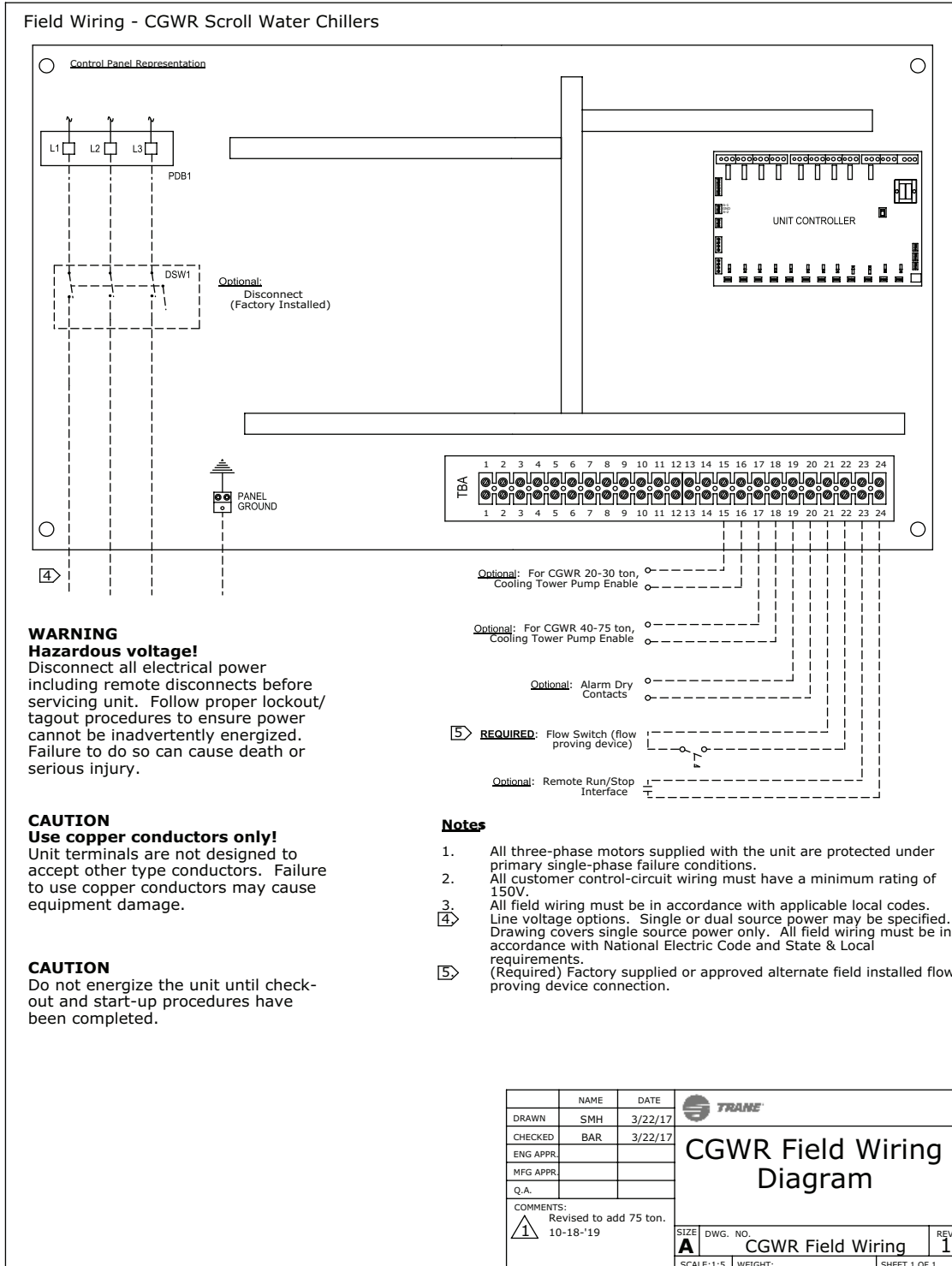

CCAR 20 to 30 ton

Field Wiring - CCAR 20-30 Ton Compressor Chiller

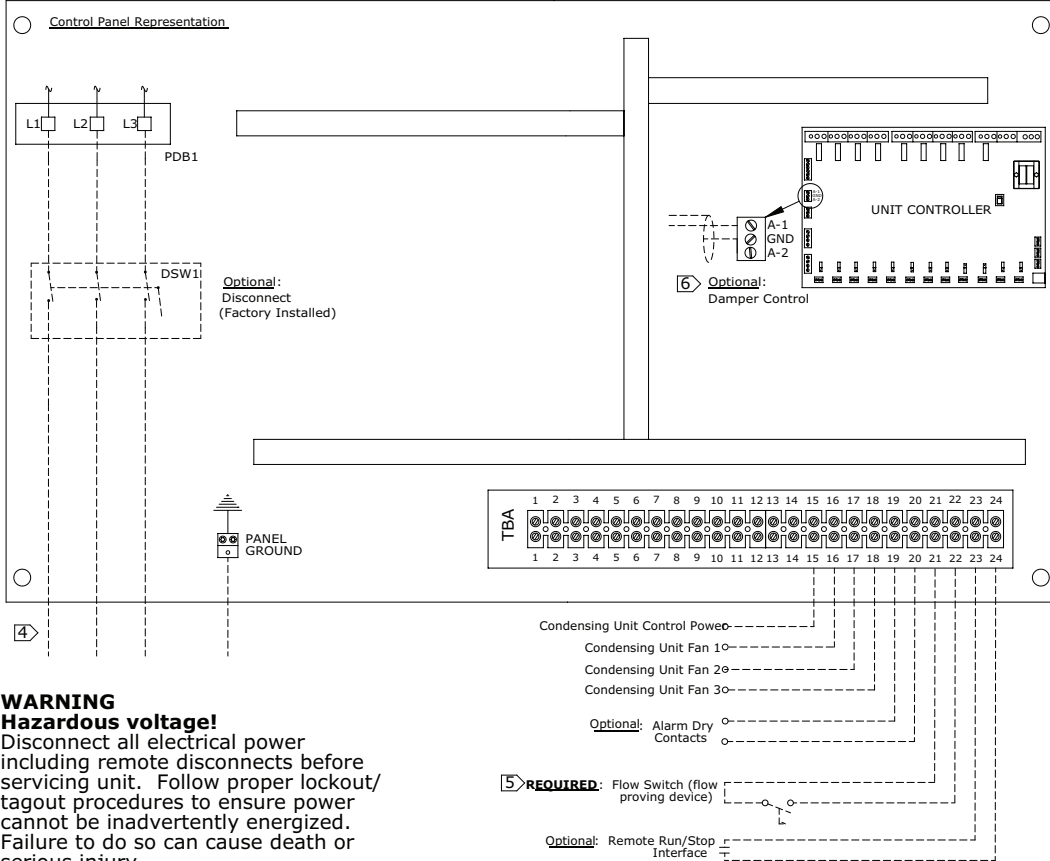

WARNING
Hazardous voltage!
 Disconnect all electrical power including remote disconnects before servicing unit. Follow proper lockout/tagout procedures to ensure power cannot be inadvertently energized. Failure to do so can cause death or serious injury.

CAUTION
Use copper conductors only!
 Unit terminals are not designed to accept other type conductors. Failure to use copper conductors may cause equipment damage.

CAUTION
 Do not energize the unit until check-out and start-up procedures have been completed.

Notes:

1. All three-phase motors supplied with the unit are protected under primary single-phase failure conditions.
2. All customer control-circuit wiring must have a minimum rating of 150V.
3. All field wiring must be in accordance with applicable local codes.
4. Line voltage options. Single or dual source power may be specified. Drawing covers single source power only. All field wiring must be in accordance with National Electric Code and State & Local requirements.
5. (Required) Factory supplied or approved alternate field installed flow proving device connection.
6. (Optional) Damper control option. Refer to operation and maintenance manual for additional information. This point intended to operate a low ambient damper on a remote air-cooled condenser. Wiring to be 2-wire shielded cable between outdoor unit and Trane indoor chiller.
7. If installing with a Trane CAUJ air-cooled condenser, more specific field wiring instructions can be found in the operations and maintenance manual.

	NAME	DATE		
DRAWN	SMH	3/22/17		
CHECKED	BAR	3/22/17		
ENG APPR.				
MFG APPR.				
Q.A.				
COMMENTS:				
SIZE DWG. NO. A Single Circuit CCAR Field Wiring			REV.	0
SCALE:1:5			WEIGHT:	SHEET 1 OF 1

CCAR 40 to 75 ton

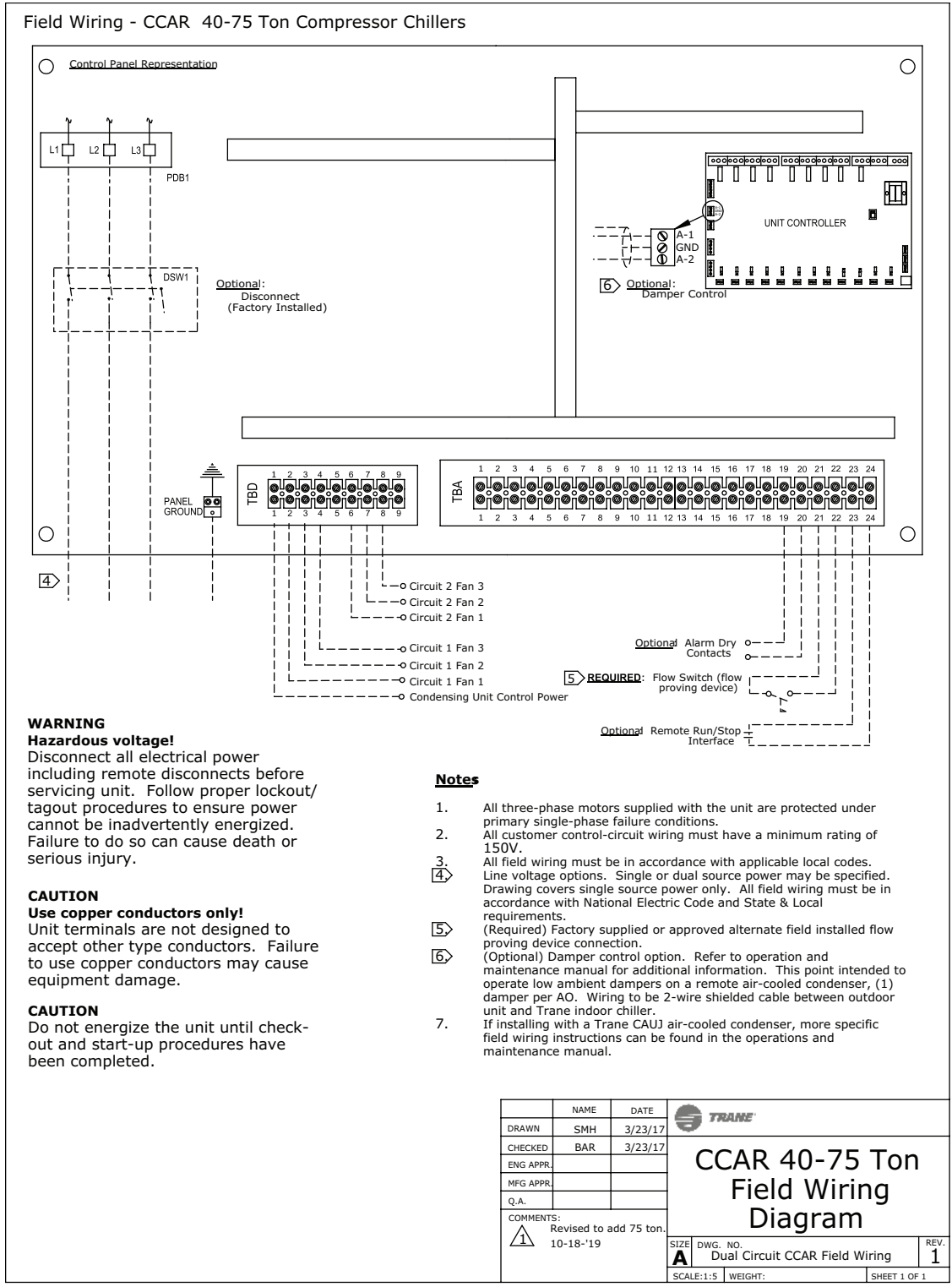

Control of CAUJ Fans and Optional Low Ambient Dampers

Application requirement

CCAR Unit Controller must control condenser ambient control devices such as fan cycling and optional low ambient dampers. As a result the interconnecting field wiring must be done *by others*. For pairing Trane CCAR Compressor Chiller with Trane CAUJ Air Cooled Condenser, the following field wiring is to be done by others:

Fan Cycling Control

One control wire for each condenser fan plus a common must be run between CCAR compressor chiller and CAUJ condenser.

Low Ambient Dampers (when applicable)

One shielded pair for each condenser must be run between CCAR compressor chiller and CAUJ air cooled condenser.

Notes:

- *Refer to SS-APG014*-EN (or latest revision) Application Guide — Pairing Trane CCAR Compressor Chillers (20 to 75 tons) with Trane CAUJ Air-Cooled Condensers (20 to 80 tons) for matching the CCAR scroll compressor chiller with a CAUJ air-cooled condensing unit.*
- *In general, the minimum outdoor ambient temperature for operation of CCAR compressor chiller in combination with a CAUJ air cooled condenser is 40° F, however in some cases, with factory application approval, the CCAR/CAUJ combination can be operated down to the 20° F ambient.*
- *Factory approval is needed for applications where CCAR/CAUJ combination is intended for operation with ambient temperature below 40° F.*

Dimensional Data

CGWR/CCAR 20 to 30 ton

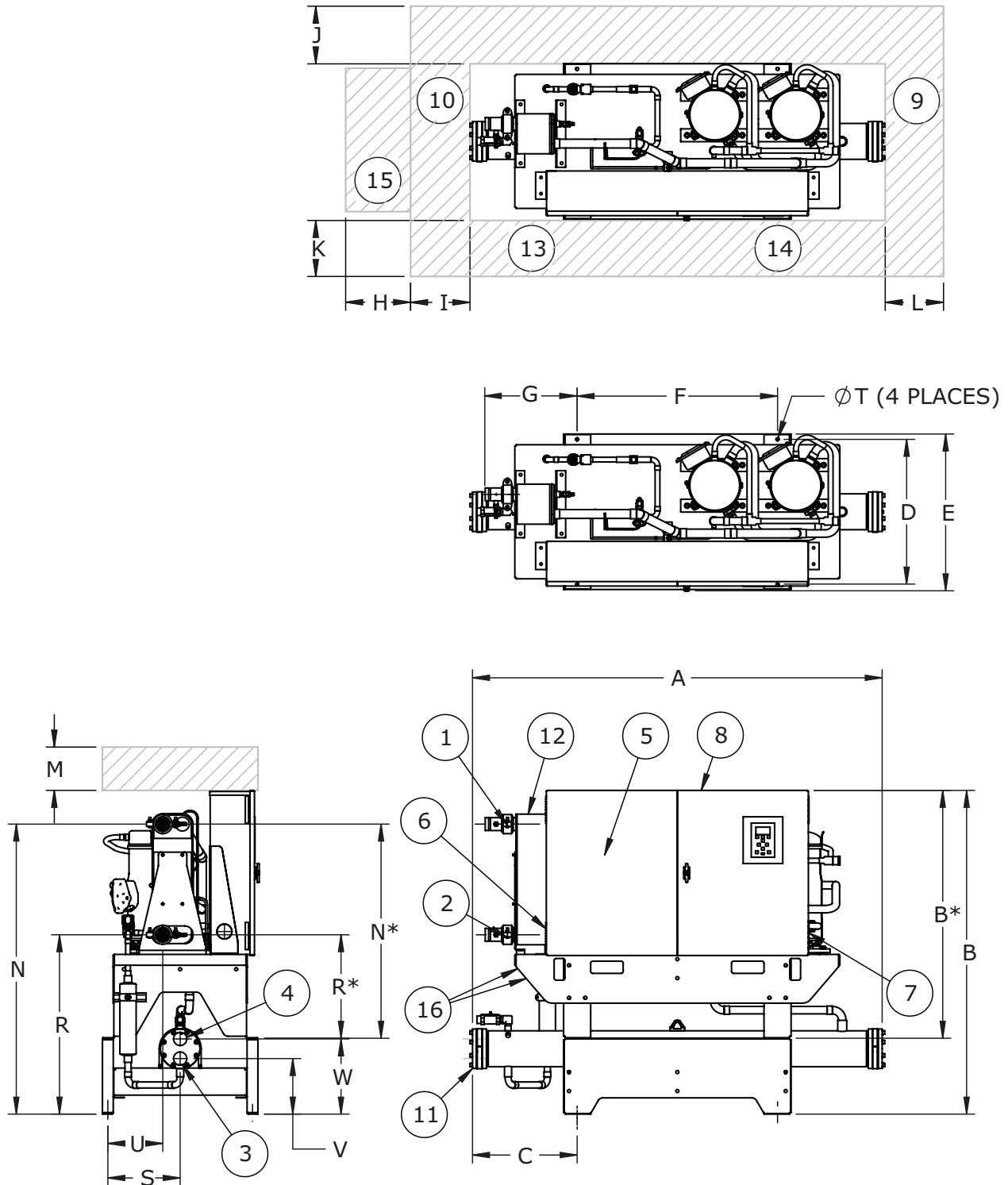

Table 4. CGWR/CCAR 20 to 30 ton — in (mm)

Dimension	CGWR 20	CGWR 30	CCAR 20	CCAR30
A ^(a)	76.6 (1946)	77.5 (1969)	70.4 (1788)	70.4 (1788)
B	59.8 (1519)	59.8 (1519)	45.8 (1163)*	45.8 (1163)*
C	19.3 (490)	20.1 (511)	N/A	N/A
D	26.7 (678)	26.7 (678)	26.7 (678)	26.7 (678)
E	28.9 (734)	28.9 (734)	28.9 (734)	28.9 (734)
F	37.0 (940)	37.0 (940)	37.0 (940)	37.0 (940)
G	17.0 (432)	17.0 (432)	17.0 (432)	17.0 (432)
H	20 (508)	20 (508)	N/A	N/A
I	36 (914)	36 (914)	36 (914)	36 (914)
J ^(b)	36 (914)	36 (914)	36 (914)	36 (914)
K ^(b)	36 (914)	36 (914)	36 (914)	36 (914)
L	24 (610)	24 (610)	24 (610)	24 (610)
M	36 (914)	36 (914)	36 (914)	36 (914)
N	53.5 (1359)	53.5 (1359)	39.5 (1003)*	39.5 (1003)*
R	33.1 (841)	33.1 (841)	19.1 (485)*	19.1 (485)*
S	13.4 (240)	13.4 (240)	N/A	N/A
T	0.6 (15)	0.6 (15)	0.6 (15)	0.6 (15)
U	10.2 (259)	10.2 (259)	10.2 (259)	10.2 (259)
V	10.3 (262)	10.4 (264)	N/A	N/A
W	13.9 (353)	15.3 (389)	N/A	N/A
1	2 (51) VIC	2.5 (64) VIC	2 (51) VIC	2.5 (64) VIC
2	2 (51) VIC	2.5 (64) VIC	2 (51) VIC	2.5 (64) VIC
3	2 (51) FPT	2.5 (64) FPT	N/A	N/A
4	2 (51) FPT	2.5 (64) FPT	N/A	N/A

Reference	Descriptions	Reference	Descriptions
1	Evaporator Water Inlet	9	Condenser Return Waterbox End (CGWR only)- minimum clearance (for maintenance)
2	Evaporator Water Outlet	10	Condenser Inlet/Outlet End (CGWR only) - minimum clearance (for maintenance)
3	Condenser Water Inlet (CGWR only)	11	Condenser (CGWR only)
4	Condenser Water Outlet (CGWR only)	12	Evaporator
5	Power Disconnect (Optional)	13	Panel Power Section — door swing 24 in (610 mm)
6	Power Wire Entry	14	Panel Control Section — door swing 24 in (610 mm)
7	Control Wire Entry	15	Additional minimum clearance needed for units with water regulating valve option
8	Control Panel	16	Location of CCAR refrigerant line connections, 7/8 in liquid line and 1-3/8 in discharge lines

(a) For CGWR020 and 030: If water regulating valve option is ordered, the overall length is 90.9 in and 93.1 in, respectively.

(b) Exceptions:

1. A minimum clearance of 42 in (1067 mm) is required to other electrically grounded parts.
2. A minimum clearance of 48 in (1220 mm) is required between two units opposite each other (front-to-front or back-to-back) or to other electrically live parts. See Section 110.26 of National Electrical code (NEC).

CGWR/CCAR 40 to 75 ton

Table 5. CGWR/CCAR 40 to 75 ton — in (mm)

Dimension	CGWR 40	CGWR 50	CGWR 65	CGWR 75	CCAR 40	CCAR 50	CCAR 65	CCAR 75
A ^(a)	83.8 (2128)	83.8 (2128)	83.8 (2128)	83.8 (2128)	87.6 (2225)	87.6 (2225)	87.6 (2225)	87.6 (2225)
B	59.8 (1519)	59.8 (1519)	59.8 (1519)	59.8 (1519)	45.8 (1163)*	45.8 (1163)*	45.8 (1163)*	45.8 (1163)*
C	13.1 (333)	13.6 (345)	13.6 (345)	13.6 (345)	N/A	N/A	N/A	N/A
D	26.7 (678)	26.7 (678)	26.7 (678)	26.7 (678)	26.7 (678)	26.7 (678)	26.7 (678)	26.7 (678)
E	29.6 (752)	29.9 (759)	29.9 (759)	29.9 (759)	29.0 (737)	29.0 (737)	29.0 (737)	29.0 (737)
F	51.0 (1295)	51.0 (1295)	51.0 (1295)	51.0 (1295)	51.0 (1295)	51.0 (1295)	51.0 (1295)	51.0 (1295)
G	19.2 (488)	19.2 (488)	19.2 (488)	19.2 (488)	19.2 (488)	19.2 (488)	19.2 (488)	19.2 (488)
H	20 (508)	20 (508)	20 (508)	20 (508)	N/A	N/A	N/A	N/A
I	36 (914)	36 (914)	36 (914)	36 (914)	36 (914)	36 (914)	36 (914)	36 (914)
J ^(b)	36 (914)	36 (914)	36 (914)	36 (914)	36 (914)	36 (914)	36 (914)	36 (914)
K ^(b)	36 (914)	36 (914)	36 (914)	36 (914)	36 (914)	36 (914)	36 (914)	36 (914)
L	24 (610)	24 (610)	24 (610)	24 (610)	24 (610)	24 (610)	24 (610)	24 (610)
M	36 (914)	36 (914)	36 (914)	36 (914)	36 (914)	36 (914)	36 (914)	36 (914)
N	49.6 (1260)	49.6 (1260)	49.6 (1260)	48.3 (1227)	35.6 (904)*	35.6 (904)*	35.6 (904)*	34.3 (871)*
R	34.0 (864)	34.0 (864)	34.0 (864)	33 (838)	20.0 (508)*	20.0 (508)*	20.0 (508)*	19 (483)*
S	13.4 (340)	13.4 (340)	13.4 (340)	13.4 (340)	N/A	N/A	N/A	N/A
T	0.6 (15)	0.6 (15)	0.6 (15)	0.6 (15)	0.6 (15)	0.6 (15)	0.6 (15)	0.6 (15)
U	12.2 (310)	12.2 (310)	12.2 (310)	12.2 (310)	12.2 (310)	12.2 (310)	12.2 (310)	12.2 (310)
V	10.6 (269)	11.0 (279)	11.0 (279)	11.0 (279)	N/A	N/A	N/A	N/A
W	15.5 (394)	16.8 (427)	16.8 (427)	16.8 (427)	N/A	N/A	N/A	N/A
1	3.0 (76) VIC	3.0 (76) VIC	3.0 (76) VIC	2.5 (64) VIC	3.0 (76) VIC	3.0 (76) VIC	3.0 (76) VIC	2.5 (64) VIC
2	3.0 (76) VIC	3.0 (76) VIC	3.0 (76) VIC	2.5 (64) VIC	3.0 (76) VIC	3.0 (76) VIC	3.0 (76) VIC	2.5 (64) VIC
3	2.5 (64) FPT	3.0 (76) FPT	4.0 (102) FPT	4.0 (102) FPT	N/A	N/A	N/A	N/A
4	2.5 (64) FPT	3.0 (76) FPT	4.0 (102) FPT	4.0 (102) FPT	N/A	N/A	N/A	N/A

Reference	Description	Reference	Description
1	Evaporator Water Inlet	9	Condenser Opposite Inlet/Outlet End (CGWR only) — minimum clearance (for maintenance)
2	Evaporator Water Outlet	10	Condenser Inlet/Outlet End (CGWR only) — minimum clearance (for maintenance)
3	Condenser Water Inlet (CGWR only)	11	Condenser (CGWR only)
4	Condenser Water Outlet (CGWR only)	12	Evaporator
5	Power Disconnect (Optional)	13	Panel Power Section — door swing 31.3 in (795 mm)
6	Power Wire Entry	14	Panel Control Section — door swing 31.3 in (795 mm)
7	Control Wire Entry	15	Additional minimum clearance needed for units with water regulating valve option
8	Control Panel	16	Location of CCAR refrigerant line connections, (2) 1-1/8 in liquid line and (2) 1-3/8 in discharge lines

(a) For CGWR040, 050, 065 and 075: If water regulating valve option is ordered, the overall length is 90.8 in, 92.4 in, 93.6 in and 93.6 in respectively.

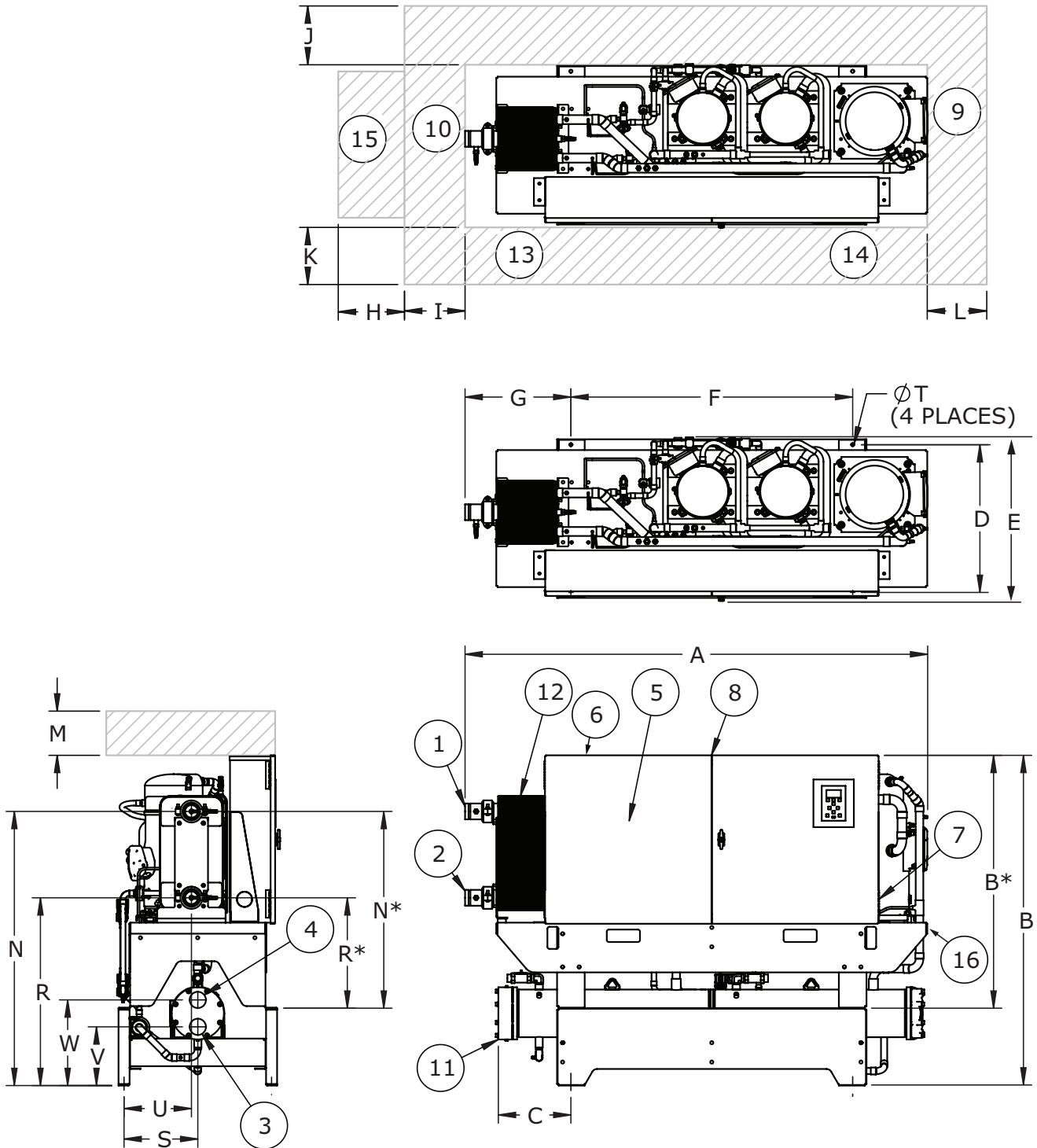
(b) Exceptions:

1. A minimum clearance of 42 in (1067 mm) is required to other electrically grounded parts.
2. A minimum clearance of 48 in (1220 mm) is required between two units opposite each other (front-to-front or back-to-back), or to other electrically live parts. See Section 110.26 of National Electrical code (NEC).



Weight Data

Table 6. Weights

Unit	Size	Shipping		Operating	
		lbs	kg	lbs	kg
CGWR	20	1475	669	1116	506
	30	1745	792	1252	568
	40	2150	975	1659	753
	50	2336	1060	1847	838
	65	2554	1158	2039	925
	75	2888	1310	2326	1055
CCAR	20	1077	489	846	384
	30	1205	547	909	412
	40	1626	738	1265	574
	50	1778	806	1304	591
	65	1898	861	1484	673
	75	2187	992	1672	758



Mechanical Specifications

CGWR Water Cooled Chillers

General

All CGWR series water cooled chillers are pressure tested, dehydrated, charged with refrigerant and oil, and run tested at full and part load conditions prior to shipment. Factory assembled units are shipped complete with operating charge of POE compressor oil and 410A refrigerant. Exposed metal surfaces and finished product are coated with executive beige paint. Units only require the field connection of chilled and condenser water piping, and power and control wiring to control panel terminal block. Chilled water inlet and outlet connections are grooved pipe and condenser water inlet and outlet connections are internally threaded. Chilled water flow proving device such as a flow switch and chilled water wye strainer with 20-mesh straining element or finer are required and must be field installed in the evaporator inlet piping.

Certified AHRI Performance

Trane water-cooled chillers are rated within the scope of the Air-Conditioning, Heating & Refrigeration Institute (AHRI) Certification Program and display the AHRI Certified® mark as a visual confirmation of conformance to the certification sections of AHRI Standard 550/590 (I-P) and ANSI/AHRI Standard 551/591 (SI). The applications in this catalog specifically excluded from the AHRI certification program are:

- Custom Units.
- Condenserless Chillers.
- Evaporatively-cooled Chillers.
- Units with evaporators or condensers that use fluid other than fresh water except units containing freeze protection fluids in the condenser or in the evaporator with a leaving chilled fluid temperature above 32° F (0° C) are certified when rated per the Standard with water.

Agency Listing

ETL Listed to U. S. and Canadian safety standards.

Compressor – Motor

Fully hermetic direct drive scroll compressors are mounted on vibration isolators. Lubrication system – Oil distribution system includes an oil level sight glass and is arranged to ensure adequate lubrication during starting, stopping and normal operation. Motor is suction gas cooled and runs at a constant speed of 3,500 RPM at 60 Hz. Compressors nominal 15 tons and less have internal overload motor protection to protect against excessive current and temperature caused by overloading, low refrigerant flow or phase loss. Compressors nominal 20 tons and greater have a motor protection module inside the terminal box. This device provides for efficient and reliable protection against overheating and overloading as well as phase loss/reversal. CGWR products 30 nominal tons and less have two (2) compressors arranged and piped as a tandem set in a single refrigerant circuit. CGWR products 40 nominal tons and greater have two (2) compressors arranged and piped as a tandem set in one refrigerant circuit and a single compressor in the other refrigerant circuit.

Evaporator

Brazed plate evaporator is UL Listed with refrigerant side working pressure of 650 psig on all models. Water side working pressure for CGWR 20 and 30 is 330 psig, and water side working pressure for CGWR 40, 50, 65 and 75 is 330 psig. CGWR 20 and 30 evaporators have a single refrigerant circuit while CGWR 40, 50, 65 and 75 have two refrigerant circuits. Evaporator is insulated with 0.5 inch (12.7 mm) thick closed-cell flexible insulation with a K value of 0.26 and is furnished with evaporator core, inlet and outlet water temperature sensors.



Mechanical Specifications

Condenser

Condensers are mechanically cleanable shell-and-tube type with enhanced copper tube geometry, with 0.025 inch wall thickness, removable heads to facilitate cleaning. Shell side (refrigerant side) working pressure is 650 psig at 150° F and bears the ASME stamp. The tube side (non-coded, water side) working pressure is 250 psig at 150° F for CGWR 20 and 230 psig at 150° F for CGWR30, 40, 50, 65 and 75. CGWR 20 and 30 have a single refrigerant circuit, while the CGWR 40, 50, 65, and 75 have two refrigerant circuits. All CGWR models have a single condenser with one water inlet and outlet connections. A heat load may be connected to the condenser when simultaneous heating and cooling loads exist. A heat recovery machine with shell and tube condenser shall be capable of producing up to 125° F hot water. Machine shall control to smallest of heating or cooling load and automatically switch between heating and cooling control set points.

Optional Condenser Water Regulating Valve

Provisions must be made for the control of condenser water flow and temperature that results in stable Saturated Discharge Temperature (SDT) between 75° F and 145° F through all steady state, part load and transient operating conditions.

Optional factory installed water regulating valve, controlled by CGWR unit controller, is recommended for this purpose.

Refrigerant Circuit

CGWR 20 and 30 have a single refrigerant circuit, while the CGWR 40, 50, 65 and 75 have two refrigerant circuits. Each refrigerant circuit has refrigerant charging port, multiple access ports, liquid line solenoid valve, hot gas injection circuit with solenoid valve, sight glass with moisture indicator, filter drier, pressure relief valve, and thermal expansion valve.

Control Panel

The spacious control panel provides separation between power distribution components and the control components. Controller is located in the controls section with display mounted on the exterior of the control cabinet door.

Power distribution section contains incoming power distribution block (or optional fused or non-fused disconnect which also serves this purpose) and ground lugs for customer connection, across-the-line contactors, current transformers, and control power transformer with primary and secondary fuses.

Controls section contains the unit controller with standard and optional expansion boards, door mounted key pad and display or optional touchscreen, optional power monitor, service friendly terminal strips to facilitate circuit diagnosis and field connection. Field connection terminal strip has connection points for the following:

- **Remote Off/Auto** (digital input).
- **Remote Alarm** (digital output).
- **Remote Chilled Water Pump Enable** for one chilled water pump (digital output).
- **Condenser Water Pump Enable** for one condenser water pump (digital output).
- **Flow Switch (flow proving device)** REQUIRED (digital input).

Unit controller monitors, displays and logs operating and fault conditions, and provides safety protection for low and high refrigerant operating pressure, low and high refrigerant superheat, low refrigerant differential pressure between low and high side, low chilled water temperature, low chilled water flow, compressor over amperage, and abnormal power conditions when fitted with optional power monitor. Mechanical high and low pressure switches, and compressor overload protection devices are located in the controls section, but are monitored and reported by the controller.

The unit controller stores 1,008 packets of information taken at set time intervals. The time interval is factory set for collecting data every 15 seconds, but the time interval is adjustable. Up to 99 fault conditions

are stored in the controller and 120 seconds of history is saved any time a fault occurs that results in a compressor lockout.

The unit controller stages compressors to maintain the chiller's leaving chilled water temperature set-point using proportional, integral and derivative (PID) logic. Unit controller has RS232, RS485 and Ethernet communications ports for user interactive communication, or for interface with Building Management System (BMS). Controller has standard BMS compatibility with BACnet® IP and Modbus® RTU and can be fitted with an optional interface gateway for compatibility with Johnson N2, LonTalk® and BACnet MS/TP. The controller is capable of responding to a BMS signal for **Run/Stop**, **Leaving Chilled Water Temperature Offset** and **Demand Limiting Reset**. **Leaving Chilled Water Temperature** can also be offset using a 0 to 5 VDC input signal.

Standard Operator Interface

The exterior cabinet door of the chiller control panel includes the unit controller interface with keypad and 128 x 64 dot pixel display screen or optional 15.4 inch color touchscreen. Controller can be accessed using the local keypad or optional touchscreen for all unit control setpoints, faults and alarm conditions with history, and operating conditions in a clear language format for easy interpretation by user/operator.

Optional Operator Interface — Touchscreen

Touchscreen replaces standard unit controller interface.

Optional 15.4 inch Color Touchscreen comes with chiller specific display screens allowing user to easily view chiller status and operating conditions in *real time* for compressors, and both refrigerant and chilled water circuits. User can also acknowledge alarms and change set points.

Preloaded MCS Connect software expands interface and troubleshooting capabilities by allowing user to set and view schedules, view run history in graphical format, view 120 seconds for history leading up to compressor lockout fault, and more. The chiller IOMs, field wiring diagrams, and other shipped-loose documents are also preloaded to the touchscreen for added convenience.

Remote Operator Interface

Unit controller can also be accessed from a remote computer such as a laptop using MCS Connect software. Access via a remote computer allows all the functionality of the standard local interface with the additional ability to download run and fault history, and graphically display history. As an additional benefit, run and fault history can be sent to the factory from the remote computer for trouble shooting assistance.

Insulation

All cold surfaces are insulated with 0.5 inch (20mm) thick closed-cell flexible insulation with a K value of 0.26.

Forklift and Hoisting Provisions

All CGWR units have forklift slots and provisions for hoisting. These beams can be easily secured to the unit base for hoisting.



Mechanical Specifications

CCAR Compressor Chillers

General

All CCAR series compressor chillers are pressure tested, dehydrated, charged with refrigerant (test charge) and oil, and run tested at full and part load conditions prior to shipment. After testing, refrigerant test charge is removed and a holding charge of dry nitrogen is added. Factory assembled units are shipped complete with operating charge of POE oil and dry nitrogen holding charge in the refrigerant circuit(s). Exposed metal surfaces and finished product are coated with executive beige paint. Units only require the field connection of chilled water piping, refrigerant discharge and liquid lines and power and control wiring to control panel terminal block. Chilled water inlet and outlet connections are grooved pipe and refrigerant lines are copper sweat. Units require field installed liquid line filter driers, chilled water wye strainer with 20-mesh or finer straining element, and a chilled water flow proving device such as a flow switch. Additionally, refrigerant circuits are to be sealed, dehydrated, evacuated and charged with refrigerant R-410A in the field by others prior to startup.

Agency Listing

The CCAR compressor chiller is ETL Listed to U. S. and Canadian safety standards.

Application Range — Ambient

In general, the minimum outdoor ambient temperature for operation of CCAR compressor chiller in combination with a CAUJ air cooled condenser is 40° F, however in some cases, with factory application approval, the CCAR/CAUJ combination can be operated down to the 20° F ambient.

Contact the factory for approval of applications where CCAR/CAUJ combination is intended for operation with ambient temperature below 40° F.

Compressor – Motor

Fully hermetic direct drive scroll compressors are mounted on vibration isolators. Lubrication system – Oil distribution system includes an oil level sight glass and is arranged to ensure adequate lubrication during starting, stopping and normal operation. Motor is suction gas cooled and runs at a constant speed of 3,600 RPMs. Compressors nominal 15 tons and less have internal overload motor protection to prevent against excessive current and temperature caused by overloading, low refrigerant flow or phase loss. Compressors nominal 20 tons and greater have a motor protection module inside the terminal box. This device provides for efficient and reliable protection against overheating and overloading as well as phase loss/reversal. CCAR products 30 nominal tons and less have two (2) compressors arranged and piped as a tandem set in a single refrigerant circuit. CCAR products 40 nominal tons and greater have two (2) compressors arranged and piped as a tandem set in one refrigerant circuit and a single compressor in the other refrigerant circuit.

Evaporator

Brazed plate evaporator is UL Listed with refrigerant side working pressure of 650 psig on all models. Water side working pressure for CCAR 20 and 30 is 330 psig, and water side working pressure for CCAR 40, 50, 65 and 75 is 330 psig. CCAR 20 and 30 evaporators have a single refrigerant circuit while CCAR 40, 50, 65 and 75 have two refrigerant circuits. Evaporator is insulated with 0.5 inch (12.7 mm) thick closed-cell flexible insulation with a K value of 0.26 and is furnished with evaporator core, inlet and outlet water temperature sensors.

Refrigerant Circuit

CCAR 20 and 30 have a single refrigerant circuit, while the CCAR 40, 50, 65 and 75 have two refrigerant circuits. Each refrigerant circuit has refrigerant charging port, multiple access ports, liquid line solenoid valve, hot gas injection circuit with solenoid valve, sight glass with moisture indicator and thermal expansion valve.

Control Panel

The spacious control panel provides separation between power distribution components and the control components. Controller is located in the controls section with display mounted on the exterior of the control cabinet door.

Power distribution section contains incoming power distribution block (or optional fused or non-fused disconnect which also serves this purpose) and ground lugs for customer connection, across-the-line contactors, current transformers, and control power transformer with primary and secondary fuses.

Controls section contains the unit controller with standard and optional expansion boards, door mounted key pad and display or optional touchscreen, optional power monitor, service friendly terminal strips to facilitate circuit diagnosis and field connection. Field connection terminal strip has connection points for the following:

- **Remote Off/Auto** (digital input).
- **Remote Alarm** (digital output).
- **Remote Chilled Water Pump Enable** for one chilled water pump (digital output).
- **Air Cooled Condenser Fan Enable** for three condenser fan motors with CCAR20 and 30, and for six condenser fan motors for CCAR40, 50, 65 and 75 (digital output).
- **Damper or Motor VFD** for one condenser ambient damper set or one motor drive for CCAR20 and 30 and for two condenser ambient damper sets or two motor drives for CCAR40, 50, 65 and 75 (analog output(s)).
- **Flow Switch (flow proving device) REQUIRED** (digital input).

Unit controller monitors, displays and logs operating and fault conditions, and provides safety protection for low and high refrigerant operating pressure, low and high refrigerant superheat, low refrigerant differential pressure between low and high side, low chilled water temperature, low chilled water flow, compressor over amperage, and abnormal power conditions when fitted with optional power monitor. Mechanical high and low pressure switches, and compressor overload protection devices are located in the controls section, but are monitored and reported by the controller.

The unit controller stores 1,008 packets of information taken at set time intervals. The time interval is factory set for collecting data every 15 seconds, but the time interval is adjustable. Up to 99 fault conditions are stored in the controller and 120 seconds of history is saved any time a fault occurs that results in a compressor lockout.

The unit controller stages compressors to maintain the chiller's leaving chilled water temperature set-point using proportional, integral and derivative (PID) logic. Unit controller has RS232, RS485 and Ethernet communications ports for user interactive communication, or for interface with Building Management System (BMS). Controller has standard BMS compatibility with BACnet[®] IP and Modbus[®] RTU and can be fitted with an optional interface gateway for compatibility with Johnson N2, LonTalk[®] and BACnet MS/TP. The controller is capable of responding to a BMS signal for **Run/Stop**, **Leaving Chilled Water Temperature Reset** and **Demand Limiting Reset**. **Leaving Chilled Water Temperature** can also be reset using a 0 to 5 VDC input signal.

Standard Operator Interface

The exterior cabinet door of the chiller control panel includes the unit controller interface with keypad and 128 x 64 dot pixel display screen or optional 15.4 in color touchscreen. Controller can be accessed using the local keypad or optional touchscreen for all unit control setpoints, faults and alarm conditions with history, and operating conditions in a clear language format for easy interpretation by user/operator.



Mechanical Specifications

Optional Operator Interface — Touchscreen

Touchscreen replaces standard unit controller interface.

Optional 15.4 inch Color Touchscreen comes with chiller specific display screens allowing user to easily view chiller status and operating conditions in *real time* for compressors, and both refrigerant and chilled water circuits. User can also acknowledge alarms and change set points.

Preloaded MCS Connect software expands interface and troubleshooting capabilities by allowing user to set and view schedules, view run history in graphical format, view 120 seconds for history leading up to compressor lockout fault, and more.

Remote Operator Interface

Unit controller can also be accessed from a remote computer such as a laptop using MCS Connect software. Access via a remote computer allows all the functionality of the standard local interface with the additional ability to download run and fault history, and graphically display history. As an additional benefit, run and fault history can be sent to the factory from the remote computer for trouble shooting assistance.

Discharge Pressure Control Capability

Discharge pressure control must be provided that results in stable Saturated Discharge Temperature (SDT) between 75° F and 145° F through all steady state, part load and transient operating conditions.

The CCAR Unit Controller is capable of controlling remote condenser peripheral devices for ambient control purposes with a proportional 2 to 10 VDC signal and **ON/OFF** contacts. Some applications require optional controller expansion boards.

When the Trane CCAR Compressor Chiller is combined with a Trane CAUJ Air Cooled Condenser, the CCAR Unit Controller *must* be used to control condenser fan motors and optional low ambient dampers if applicable. For details, see SS-APG014*-EN *Trane Application Guide – Pairing Trane CCAR Compressor Chillers (20 to 75 tons) with Trane CAUJ Air-Cooling Condensers (20 to 80 tons)*.

Insulation

All cold surfaces are insulated with 0.5 inch (20mm) thick closed-cell flexible insulation with a K value of 0.26.

Forklift and Hoisting Provisions

All CCAR units have forklift slots and provisions for hoisting.



Options

Operator Interface

Optional 15.4 inch Color Touchscreen replaces standard operator interface and comes with chiller specific display screens allowing user to easily view chiller status and operating conditions in *real time* for compressors, and both refrigerant and chilled water circuits. User can also acknowledge alarms and change set points. See CGWR and CCAR Control Panel section of Mechanical Specification for more details.

Communications

The powerful unit controller provides complete chiller controls and provides interface to a variety of platforms including BACnet[®] IP and Modbus[®] as standard. Available LonTalk[®], Johnson N2 and BACnet MS/TP requires an optional interface.

- All units come standard Ethernet connection.
- A complete software support package is available at no charge for your PC allowing for system configuration, dynamic on-line display screens, remote communication, graphing and more. Much of this utility including preloaded software support package (MCS Connect) is available with optional touchscreen.
- Controller options allow for use of additional features such as power monitoring, control of peripherals (fans and pumps) and sensor inputs.
- A standard option available to operate low ambient dampers when a CCAR model is used with remote condenser having low ambient controls. Using this option can be very effective for low ambient air-cooled starting and operation.

As standard, the controller allows factory configuration for BMS interface to either BACnet IP or Modbus. Once configured, the BMS has the ability to monitor chiller operation and fault status, adjust leaving water setpoint, turn unit on or off, and allow load limiting control of the unit.

As a factory installed option, additional control board(s) can be added and configured for BMS interface to Lon Talk, Johnson N2 and BACnet MS/TP. Once configured, the BMS has the ability to monitor chiller operation and fault status, adjust leaving water setpoint, turn unit on or off, and allow load limiting control of the unit.

Electrical Options

Fused Disconnect

The factory installed fused disconnect has time-delay fuses rated for unit's FLA. Disconnect serves as the 3-phase power input service connection point. Disconnect has a through-the-door handle operator mechanism allowing the service to be engaged and disengaged without opening the control panel door. Handle has a provision for lockout.

Non-Fused Disconnect

The factory installed non-fused disconnect serves as the 3-phase power input service connection point. Disconnect has a through-the-door handle operator mechanism allowing the service to be engaged and disengaged without opening the control panel door. Handle has a provision for lockout.

Unit SCCR Rating

Standard CGWR and CCAR units have a 5 kA Short Circuit Current Rating (SCCR) rating. Optional 100 kA SCCR is available on all models.

Note: *Not all voltage specific CGWR and CCAR units are available with optional disconnect and 100 kA rating.*

Power Monitor

The factory installed power monitor is specifically designed to protect motors and other 3-phase loads from premature failure and damage due to common voltage faults such as voltage imbalance, over/under voltage, phase loss, reversal, incorrect sequencing and rapid short cycling.

Other Options

Wye Strainer — REQUIRED

A 20 mesh wye strainer **must** be installed immediately adjacent the CGWR and CCAR chilled water inlet.

A 20 mesh wye strainer with blow down, removable screen and grooved pipe quick connections is available as a ship loose option.

Flow Proving Device — REQUIRED

A *flow proving device* **must** be field installed in the chilled water inlet pipe serving both the CGWR and CCAR chillers, and must be installed in accordance with *flow proving device* manufacturer recommendations.

An optional shipped-loose flow switch is available with 1 in NPT pipe connection and NEMA 4 housing. When installed in accordance with manufacturer's recommendations, this device meets the requirement for a *flow proving device*.

Water Regulating Valve (CGWR only)

Factory installed condenser water regulating valve controlled by unit controller is a recommended option for all CGWR chillers. Valves are designed to regulate inlet condenser water to maintain stable compressor discharge pressure during full and part load conditions.

Ice Making Controls

In ice making mode, the unit will operate fully loaded in response to a site installed contact closure. Ice making will cease when supply fluid temperature falls below a predetermined adjustable set point (in the range of 26° F). When not in ice making mode, unit will provide modulating capacity based on leaving fluid temperature.

Isolator Pads

This shipped loose option includes four 3/4-inch thick, 6-inch square Mason Super W pads. These pads are designed for maximum resilience and vibration isolation.

Sound Attenuation

For applications where quiet operation is required, two levels of factory-installed sound attenuation are available.

- **Cabinet** - This factory installed option includes compressor compartment cabinetry design for control of compressor noise. Factory painted to match cabinetry. Includes sound absorbing insulation liner and removable panels for access to compressors and all major components for ease of service.
- **Blankets** - This factory installed option includes insulated sound covers for each compressor designed to control compressor noise.



The AHRI Certified mark indicates Trane U.S. Inc. participation in the AHRI Certification program. For verification of individual certified products, go to ahridirectory.org.

Trane - by Trane Technologies (NYSE: TT), a global climate innovator - creates comfortable, energy efficient indoor environments for commercial and residential applications. For more information, please visit trane.com or tranetechnologies.com.

Trane has a policy of continuous product and product data improvement and reserves the right to change design and specifications without notice. We are committed to using environmentally conscious print practices.