



Product Catalog

Air-Cooled Scroll Chillers Model CGAM — Made in USA

With Symbio™ Controls

20 to 130 Nominal Tons (60 Hz)





Introduction

Design and manufacturing excellence makes Trane a leader in the air-cooled chiller market place. This tradition of using excellence to meet market demands is illustrated with the Trane 20 to 130 ton air-cooled scroll chiller. This next-generation chiller is an exciting step forward in energy-efficiency, sound, reliability, ease of serviceability, control precision, application versatility, and operational cost-effectiveness. The chiller is designed to deliver proven Trane performance based on the redesign of a European model that has been a market leader, plus all the benefits of new heat transfer and fan designs, as well as, low-speed, direct-drive scroll compressors.

Important Design Features and New Features

- Higher full-load and part-load energy efficiency that exceed ASHRAE 90.1 and reduce operating costs.
- Significantly lower noise levels than other scroll compressor chillers.
- R-454B optimized design.
- Symbio™ 800 microprocessor controls with Adaptive Control™ has improved fan algorithms for more reliable operation at extreme conditions.
- Single chiller time of day scheduling communication for easier control of small jobs.
- Easily integrated with existing BAS via BACnet®, LonTalk®, or Modbus™ communication interface.
- All major service components are close to the unit edge for safe and easy maintenance.
- The chiller is designed for easy serviceability with input from our extensive experience in design, testing and field operation.

Copyright

This document and the information in it are the property of Trane, and may not be used or reproduced in whole or in part without written permission. Trane reserves the right to revise this publication at any time, and to make changes to its content without obligation to notify any person of such revision or change.

Trademarks

All trademarks referenced in this document are the trademarks of their respective owners.

Revision History

- Updated Digit 17 - Structural Options and 39 - Installation Accessories in Model Number Descriptions chapter.
- Updated Lug size range table in Electrical Data chapter.
- Added a note to Mounting locations, 80 to 120 tons and Mounting locations, 130 tons figures in Dimensions chapter.



Table of Contents

Features and Benefits	5
Reliability	5
Life Cycle Cost-Effectiveness	5
Application Versatility	5
Simple, Economical Installation	5
Precision Control	6
Improved Serviceability	6
Application Considerations	7
Unit Sizing	7
Water Treatment	7
Effect of Altitude on Capacity	7
Ambient Limitations	7
Water Flow Limits	7
Water Temperature	8
Typical Water Piping	9
Multiple Unit Operation	10
Thermal Battery Cooling System Operation	10
Unit Placement	11
Unit Location	12
Model Number Descriptions	13
Unit Model Number	13
General Data	15
Controls	17
Symbio 800 Controller	17
Tracer® AdaptiView™ TD-7 Operator Interface	17
System Integration	18
Symbio™ 800 Controls	20
Electrical Data	22
Dimensions	27
Unit Dimensions	27
Service Clearances	33
Mounting Locations	34
Weights	39
Base Units	39



Table of Contents

Mechanical Specifications	40
General	40
Certified AHRI Performance	40
Compressor and Motor	40
Unit-Mounted Starter	40
Evaporator	40
Condenser	40
Refrigerant Circuit and Capacity Modulation	41
Unit Controls	41
Options	43
Application Options	43
Electrical Options	43
Control Options	44
Other Options	44



Features and Benefits

Reliability

- Years of laboratory testing, including running the chiller at extreme operating conditions, have resulted in optimized compressor and chiller systems reliability by confirming a robust design and verifying quality each step of the way.
- Direct-drive, low-speed scroll compressors with fewer moving parts provide maximum efficiency, high reliability, and low maintenance requirements. Suction gas-cooled motor stays at a uniformly low temperature for long motor life.
- The microprocessor control system provides improved control capabilities with Adaptive Control™ to keep the unit operating even in adverse conditions. Advanced microelectronics protect both the compressor and the motor from typical electrical fault conditions like thermal overload and phase rotation
- Standard factory-installed water strainer helps prevent system debris from affecting unit flow or heat transfer.
- Flow switch is factory-installed at the optimum location in the piping for reduced chiller installation cost and superior flow sensing, reducing the potential for nuisance trips.
- The round tube and plate fin condenser with its exceptionally rigid coil structure is manufactured with hairpin tubes which reduces the number of braze joints by half, significantly reducing the potential for leaks.
- Innovative condenser pressure integrated fan control algorithms and variable frequency drive on circuits' lead fans provides more reliable operation at extreme temperature conditions.

Life Cycle Cost-Effectiveness

- Industry leading full- and part-load efficiencies.
- Electronic expansion valve and high speed suction temperature sensor enables tight chilled water temperature control and low superheat, resulting in more efficient full-load and part-load operation than previously available.
- Optional pump package features variable speed drive on the pump motors, eliminating the need for energy sapping chilled water system triple-duty or balancing valves. Additionally, system commissioning and flexibility is greatly enhanced. Chilled water supply reliability is increased with the dual pump design, due to standard failure/recovery functionality.

Application Versatility

- Industrial/low temperature process cooling - Excellent operating temperature range and precise control capabilities enable tight control.
- Ice/thermal storage - Utilities and owners benefit from reduced cooling energy cost. The chiller dual setpoint control and industry leading energy storage efficiency assures reliable operation and superior system efficiency. Trane partnership with CALMAC brings a proven track record of successful installations across many markets; from churches and schools to skyscrapers and office buildings.

Simple, Economical Installation

- Reduced sound levels, compared to other scroll compressor chillers, perfect for applying outdoor HVAC equipment in neighborhoods, such as K-12 schools.
- System integration available with LonTalk®, BACnet®, or Modbus™ through a single twisted-pair wire for a less expensive translation to an existing building automation system.
- Powder-coated paint provides superior durability, corrosion protection, and is less likely to be damaged while rigging/lifting/installing the chiller.
- Factory commissioned unit-mounted starter reduces overall job cost and improves system reliability by eliminating job site design, installation and labor coordination requirements.



Features and Benefits

Precision Control

- Easily integrated with existing building automation system (BAS) via BACnet® or LonTalk® communication interfaces.
- Microprocessor-based controls monitor and maintain optimal operation of the chiller and its associated sensors, actuators, relays, and switches, all of which are factory installed and tested prior to shipping.
- Adaptive Control™ maintains chiller operation under adverse conditions, when many other chillers might simply shutdown. The chiller control is able to compensate for conditions such as high condensing pressure and low suction pressure.
- Advanced microprocessor controls enable variable primary flow applications providing chilled water temperature control accuracy of $\pm 2^{\circ}\text{F}$ (1.1°C) with flow changes up to 10 percent per minute, while keeping the chiller online through flow changes up to 30 percent per minute.
- Easy-to-use operator interface displays all operating and safety messages, with complete diagnostics information, on a highly readable panel with a scrolling touch-screen display. Status and diagnostic messages are in plain language - no codes to interpret - and are available in 27 languages.

Improved Serviceability

- All major serviceable components are close to the edge. Service shutoff valves and water strainer are conveniently located to enable easy service.
- Water piping connections are factory piped to the edge of the unit to make installation safer and faster.
- Electronic expansion valve designed so controls can be removed and serviced without refrigerant handling.
- The optional pump package is designed to be serviced in place. The unit structure includes a rigging point for pump servicing, making inspection, cleaning and pump seal changes easier.
- High pressure transducer and temperature sensors mountings enable troubleshooting and replacement without removing refrigerant charge, greatly improving serviceability over the life of the unit.
- Touch safe panel construction provides for enhanced service technician safety.



Application Considerations

Certain application constraints should be considered when sizing, selecting, and installing Trane chillers. Unit and system reliability is often dependent on properly and completely complying with these considerations. When the application varies from the guidelines presented, it should be reviewed with your local sales engineer.

Note: *The terms water and solution are used interchangeably in the following paragraphs.*

Unit Sizing

See TSA™ performance selection software for unit capacities. Intentionally oversizing a unit to ensure adequate capacity is not recommended. Erratic system operation and excessive compressor cycling are often a direct result of an oversized chiller. In addition, an oversized unit is usually more expensive to purchase, install, and operate. If oversizing is desired, consider using two units.

Water Treatment

The use of untreated or improperly treated water may result in scaling, erosion, corrosion, and algae or slime buildup. This will adversely affect heat transfer between the water and system components. Proper water treatment must be determined locally and depends on the type of system and local water characteristics.

Neither salt nor brackish water is recommended for use in Trane chillers. Use of either will lead to a shortened life. Trane encourages the employment of a qualified water treatment specialist, familiar with local water conditions, to assist in the establishment of a proper water treatment program.

Foreign matter in the chilled water system can also increase pressure drop and, consequently, reduce water flow. For this reason it is important to thoroughly flush all water piping to the unit before making the final piping connections to the unit.

Effect of Altitude on Capacity

At elevations substantially above sea level, decreased air density will reduce condenser capacity and, therefore, unit capacity and efficiency.

Ambient Limitations

Trane chillers are designed for year-round operation over a range of ambient temperatures.

- High Ambient Range = 32 to 125°F (0 to 52°C)
- Wide Ambient Range = 0 to 125°F (-18 to 52°C)
- Extreme Low Ambient Range = down to -20 (-28.9)

Operation below 32°F requires the use of variable speed fans unless otherwise specified.

The minimum ambient temperatures are based on still conditions (winds not exceeding five mph). Greater wind speeds will result in a drop in head pressure, therefore increasing the minimum starting and operating ambient temperature. The Adaptive Control™ microprocessor will attempt to keep the chiller on-line when high or low ambient conditions exist, making every effort to avoid nuisance trip-outs and provide the maximum allowable tonnage.

Water Flow Limits

The minimum water flow rates are given in the General Data chapter of this catalog. Evaporator flow rates below the tabulated values will result in laminar flow causing freeze-up problems, scaling, stratification and poor control.

The maximum evaporator water flow rate is also given in General Data. Flow rates exceeding those listed may result in very high pressure drop across the evaporator and/or excessive tube erosion.

Note: *Flow rates in the general data tables are for water only. They do not include freeze inhibitors.*

Flow Rate Out of Range

Many process cooling applications require flow rates that cannot be met with the minimum and maximum published values within the evaporator. A simple piping change can alleviate this problem. For example: a plastic injection molding process requires 80 gpm (5.0 l/s) of 50°F (10°C) water and returns that water at 60°F (15.6°C). The selected chiller can operate at these temperatures, but has a minimum flow rate of 106 gpm (6.6 l/s). The system layout in the figure below can satisfy the process.

Figure 1. Flow rate out of range systems solution

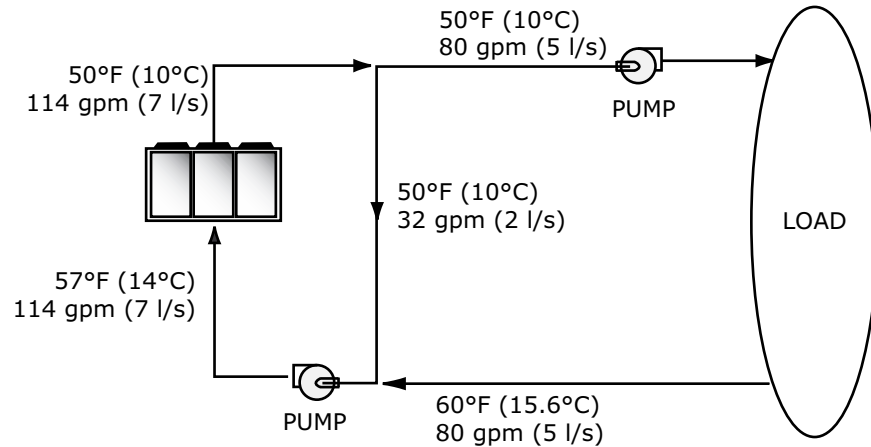

Flow Proving

Trane provides a factory-installed water flow switch monitored by Symbio™ 800 controller which protects the chiller from operating in loss of flow conditions.

Variable Flow in the Evaporator

Variable Primary Flow (VPF) systems present building owners with several cost-saving benefits when compared with Primary/Secondary chilled water systems. The most obvious cost savings results from eliminating the constant volume chiller pump(s), which in turn eliminates the related expenses of the associated piping connections (material, labor), and electrical service and switch gear. In addition to the installed cost advantage, building owners often cite pump related energy savings as the reasons that prompted them to select a VPF system.

The chiller is capable of handling variable evaporator flow without losing control of the leaving water temperature. The microprocessor and capacity control algorithms will respond to a 10 percent change in water flow rate per minute while maintaining a $\pm 2^\circ\text{F}$ (1.1°C) leaving water temperature control accuracy. The chiller tolerates up to 30 percent per minute water flow variation as long as the flow is equal or above the minimum flow rate requirement.

With the help of a software analysis tool such as System Analyzer™, DOE-2 or TRACE™, anticipated energy savings can be determined, and used to justify variable primary flow in a particular application. Existing constant flow chilled water systems may be relatively easily converted to VPF and benefit greatly from the inherent efficiency advantages.

Water Temperature

Leaving Water Temperature Limits

Trane chillers have distinct leaving water categories:

- Standard, with a leaving solution range of 40 to 65°F (4.4 to 18°C)
- Low temperature process cooling, with leaving solution 10 to 40°F (-12 to 4.4°C)
- Ice-making, with leaving solution range of 20 to 65°F (-7 to 18°C)
- Low leaving temperature, with leaving solution below 10°F (-12.2°C)

Since leaving solution temperatures below 42°F (5.5°C) result in suction temperature at or below the freezing point of water, a glycol solution is required for all low temperature and ice-making chillers. Ice making control includes dual setpoint controls and safeties for ice making and standard cooling capabilities. Consult your local Trane account manager for applications or selections involving low temperature or ice making chillers.

The maximum water temperature that can be circulated through the evaporator when the unit is not operating is 125°F (52°C). Evaporator damage may result above this temperature.

Leaving Water Temperature Out of Range

Many process cooling applications require temperature ranges that are outside the allowable minimum and maximum operating values for the chiller. The following figure shows a simple example of a mixed water piping arrangement change that can enable reliable chiller operation while meeting such cooling conditions. For example, a laboratory load requires 238 gpm (5 l/s) of water entering the process at 86°F (30°C) and returning at 95°F (35°C). The chiller maximum leaving chilled water temperature of 65°F (15.6°C) prevents direct supply to the load. In the example shown, both the chiller and process flow rates are equal, however, this is not necessary. For example, if the chiller had a higher flow rate, there would simply be more water bypassing and mixing with warm water returning to the chiller.

Figure 2. Temperature out of range system solution

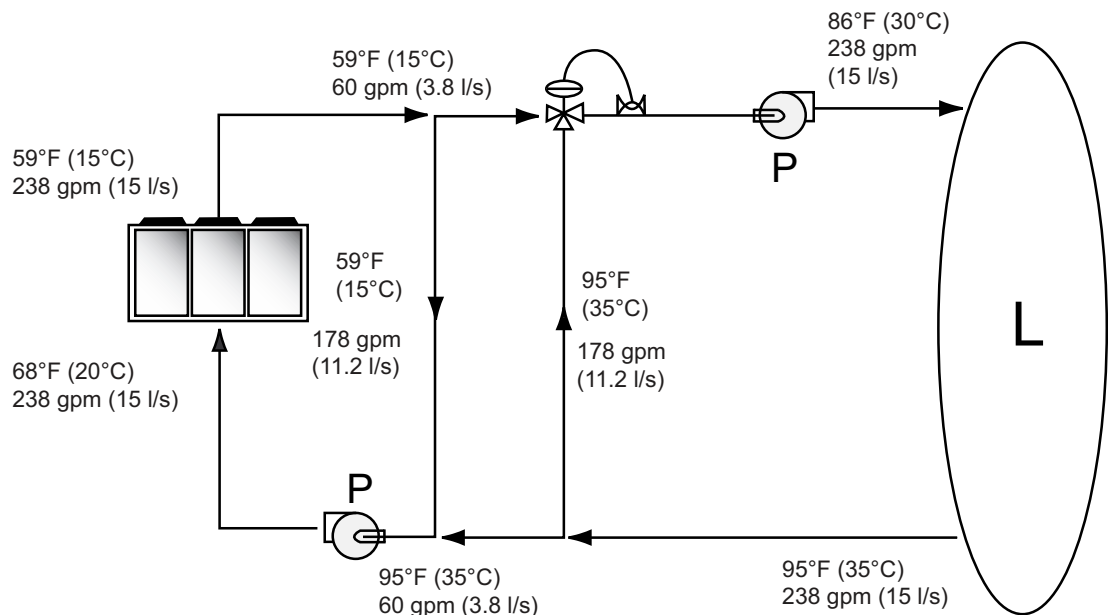

Supply Water Temperature Drop

Cataloged performance data is based on a chilled water temperature drop of 10°F (6°C) for I-P data and 9°F (5°C) for SI data. Full load chilled water temperature drops from 6 to 18°F (3.3 to 10°C) may be used as long as minimum and maximum water temperature and minimum and maximum flow rates are not exceeded. Temperature drops outside this range at full load conditions are beyond the optimum range for control and may adversely affect the microprocessor ability to maintain an acceptable supply water temperature. Furthermore, full load temperature drops of less than 6°F (3.3°C) may result in inadequate refrigerant superheat which is critical to long term efficient and reliable operation. Sufficient superheat is always a primary concern in any refrigerant system and is especially important in a packaged chiller where the evaporator is closely coupled to the compressor.

Typical Water Piping

All building water piping must be flushed prior to making final connections to the chiller. To reduce heat loss and prevent condensation, insulation should be applied. Expansion tanks are also usually required so that chilled water volume changes can be accommodated.



Avoidance of Short Water Loops

Adequate chilled water system water volume is an important system design parameter because it provides for stable chilled water temperature control and limits compressor short cycling.

The chiller temperature control sensor is located in the supply (outlet) water connection or pipe. This location allows the building to act as a buffer to slow the rate of change of the system water temperature. If there is not a sufficient volume of water in the system to provide an adequate buffer, temperature control can suffer, resulting in erratic system operation and excessive compressor cycling.

Typically, a two-minute water loop circulation time is sufficient to prevent short water loop issues. Therefore, as a guideline, ensure the volume of water in the chilled water loop equals or exceeds two times the evaporator flow rate. For systems with a rapidly changing load profile the amount of volume should be increased.

If the installed system volume does not meet the above recommendations, the following items should be given careful consideration to increase the volume of water in the system and, therefore, reduce the rate of change of the return water temperature.

- A volume buffer tank located in the return water piping.
- Larger system supply and return header piping (which also reduces system pressure drop and pump energy use).

Minimum Water Volume for a Process Application

If a chiller is attached to an on/off load such as a process application, it may be difficult for the controller to respond quickly enough to the very rapid change in return solution temperature if the system has only the minimum recommended water volume. Such systems may cause chiller low temperature diagnostics or in the extreme case evaporator freezing. In this case, it may be necessary to add or increase the size of the mixing tank in the return line.

Multiple Unit Operation

Whenever two or more units are used on one chilled water loop, Trane recommends that their operation be coordinated with a higher level system controller for optimum system efficiency and reliability. The Trane Tracer® system has advanced chilled plant control capabilities designed to provide such operation.

Thermal Battery Cooling System Operation

A Thermal Battery™ cooling system uses the chiller to make (cooling) ice at night when utilities generate electricity more efficiently with lower demand and energy charges. The stored cooling energy reduces or even replaces mechanical cooling during the day when utility rates are at their highest. This reduced electrical demand for cooling results in significant utility cost savings and source energy savings.

Another advantage of an ice energy storage system is its ability to eliminate chiller over sizing. A “right-sized” chiller plant with ice energy storage operates more efficiently with smaller support equipment while lowering the connected load and reducing operating costs. Best of all, this system still provides a capacity safety factor and redundancy by designing reserve capacity into the ice storage system for practically no cost compared to oversized systems.

Trane air-cooled chillers are uniquely suited to low temperature applications like ice storage because of the ambient relief experienced at night. Chiller ice making efficiencies are typically similar to or even better than standard cooling daytime efficiencies as a result of night-time dry-bulb ambient relief.

Standard smart control strategies for ice storage systems are another advantage of the chiller. The dual mode control functionality is integrated right into the chiller. Trane Tracer® building management systems can measure demand and receive pricing signals from the utility and decide when to use the stored cooling and when to use the chiller.

Unit Placement

Setting the Unit

A base or foundation is not required if the selected unit location is level and strong enough to support the unit operating weights shown in Weights chapter.

For a detailed discussion of base and foundation construction, see the unit Installation, Operation or Maintenance (IOM) manual. Manuals are available through trane.com or from your local office.

HVAC equipment must be located to minimize sound and vibration transmission to the occupied spaces of the building structure it serves. If the equipment must be located in close proximity to a building, it should be placed next to an unoccupied space such as a storage room, mechanical room, etc. It is not recommended to locate the equipment near occupied, sound sensitive areas of the building or near windows. Locating the equipment away from structures will also prevent sound reflection, which can increase sound levels at property lines or other sensitive points.

Isolation and Sound Emission

Structurally transmitted sound can be reduced by elastomeric vibration eliminators. Elastomeric isolators are generally effective in reducing vibratory noise generated by compressors, and therefore, are recommended for sound sensitive installations. An acoustical engineer should always be consulted on critical applications.

Figure 3. Installation example

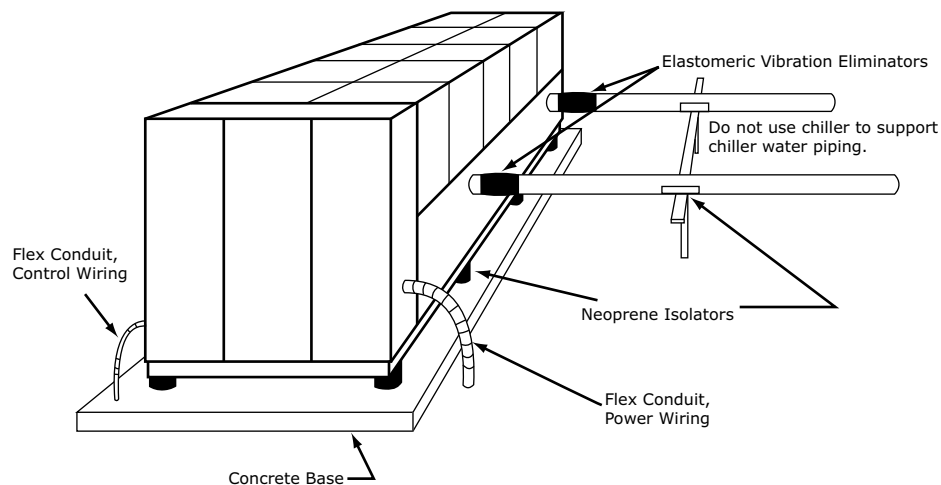

For maximum isolation effect, water lines and electrical conduit should also be isolated. Wall sleeves and rubber isolated piping hangers can be used to reduce sound transmitted through water piping. To reduce the sound transmitted through electrical conduit, use flexible electrical conduit.

Local codes on sound emissions should always be considered. Since the environment in which a sound source is located affects sound pressure, unit placement must be carefully evaluated. Sound power levels for chillers are available on request.

Servicing

Adequate clearance for evaporator, condenser and compressor servicing should be provided. Recommended minimum space envelopes for servicing are located in the dimensional data section and can serve as a guideline for providing adequate clearance. The minimum space envelopes also allow for control panel door swing and routine maintenance requirements. Local code requirements may take precedence.



Unit Location

General

Unobstructed flow of condenser air is essential to maintain chiller capacity and operating efficiency. When determining unit placement, careful consideration must be given to assure a sufficient flow of air across the condenser heat transfer surface. Two detrimental conditions are possible and must be avoided: warm air recirculation and coil starvation. Air recirculation occurs when discharge air from the condenser fans is recycled back to the condenser coil inlet. Coil starvation occurs when free airflow to the condenser is restricted.

Condenser coils and fan discharge must be kept free of snow or other obstructions to permit adequate airflow for satisfactory unit operation. Debris, trash, supplies, etc., should not be allowed to accumulate in the vicinity of the air-cooled chiller. Supply air movement may draw debris into the condenser coil, blocking spaces between coil fins and causing coil starvation.

Both warm air recirculation and coil starvation cause reductions in unit efficiency and capacity due to higher head pressures. The air-cooled chiller offers an advantage over competitive equipment in these situations. Operation is minimally affected in many restricted air flow situations due to its advanced Adaptive Control™ microprocessor which has the ability to understand the operating environment of the chiller and adapt to it by first optimizing its performance and then staying on line through abnormal conditions. For example, high ambient temperatures combined with a restricted air flow situation will generally not cause the air-cooled chiller to shutdown. Other chillers would typically shutdown on a high pressure nuisance cut-out in these conditions.

Cross winds, those perpendicular to the condenser, tend to aid efficient operation in warmer ambient conditions. However, they tend to be detrimental to operation in lower ambients due to the accompanying loss of adequate head pressure. Special consideration should be given to low ambient units. As a result, it is advisable to protect air-cooled chillers from continuous direct winds exceeding 10 mph (4.5 m/s) in low ambient conditions.

The recommended lateral clearances are depicted in the close spacing engineering bulletin available from your local office.

Provide Sufficient Unit-to-Unit Clearance

Units should be separated from each other by sufficient distance to prevent warm air recirculation or coil starvation. Doubling the recommended single unit air-cooled chiller clearances will generally prove to be adequate. See *Close-Spacing and Restricted Airflow Situations Air-Cooled Scroll Chillers 20-120 CGAM, 50-60 Hz, Engineering Bulletin (CG-PRB011*-EN)* for more information.

Walled Enclosure Installations

When the unit is placed in an enclosure or small depression, the top of the surrounding walls should be no higher than the top of the fans. The chiller should be completely open above the fan deck. There should be no roof or structure covering the top of the chiller. Ducting individual fans is not recommended. See *Close-Spacing and Restricted Airflow Situations Air-Cooled Scroll Chillers 20-120 CGAM, 50-60 Hz, Engineering Bulletin (CG-PRB011*-EN)* for more information.



Model Number Descriptions

Unit Model Number

Digit 1, 2, 3, 4 – Unit Model

CGAM = Air-Cooled Scroll Packaged Chiller

Digit 5, 6, 7 – Nominal Tonnage

020 = 20 Tons
026 = 26 Tons
030 = 30 Tons
035 = 35 Tons
040 = 40 Tons
052 = 52 Tons
060 = 60 Tons
070 = 70 Tons
080 = 80 Tons
090 = 90 Tons
100 = 100 Tons
110 = 110 Tons
120 = 120 Tons
130 = 130 Tons

Digit 8 – Unit Voltage

A = 200V/60Hz/3 phase
B = 230V/60Hz/3 phase
D = 380V/60Hz/3 phase
F = 460V/60Hz/3 phase
G = 575V/60Hz/3 phase

Digit 9 – Manufacturing Location

2 = Trane Commercial Systems, Pueblo, CO USA

Digits 10, 11 – Design Sequence

** = Factory assigned

Digit 12 – Unit Type

2 = High Efficiency
3 = Extra Efficiency

Digit 13 – Agency Listing

X = No Agency Listing
E = ETL Listed/Certified to CSA/Conforms to UL

Digit 14 – Pressure Vessel Code

X = Not Applicable
1 = CRN or Canada Equivalent

Digit 15 – Unit Application

B = High Ambient (32-125°F/0-52°C)
D = Wide Ambient (0-125°F/-18-52°C)
J = Extreme Low Ambient — down to -20°F (-28.9°C)

Digit 16 – Refrigerant Isolation Valves

2 = Refrigerant Isolation Valves (Discharge)

Digit 17 – Structural Options

A = Standard Unit Structure
B = Seismic to International Building Code (IBC)
C = California Office of Statewide Health Planning and Development (OSHPD)
D = Wind Load for Florida Hurricane

Digit 18 – Freeze Protection (Factor-Installed Only)

X = Without Freeze Protection
1 = With Freeze Protection (External T-Stat control)

Digit 19 – Insulation

A = Factory Insulation - All Cold Parts
B = Insulation for High Humidity/Low Evap Temp

Digit 20 – Factory Charge

3 = Full Factory Refrigerant Charge R-454B
4 = Nitrogen Charge — R-454B Field Supplied

Digit 21 – Evaporator Application

A = Standard Cooling (40 to 65°F/4.4 to 18°C)
B = Low Temperature Process (10 to 40°F/-12.2 to 4.4°C)
C = Ice-Making - Hardwired Interface (20 to 65°F/-7 to 18°C)
D = Low Leaving Water (Below 10°F/-12.2°C)

Digit 22 – Water Connections

1 = Grooved Pipe Connection

Digit 23 – Condenser Fin Material

A = Lanced Aluminum Fins
D = Lanced Aluminum Fins with CompleteCoat™

Digit 24 – Condenser Heat Recovery

X = No Heat Recovery

Digit 25 – Not Used

Digit 26 – Starter Type

A = Across the Line Starter/Direct On Line

Digit 27 – Incoming Power Line Connection

1 = Single Point Power Connect

Digit 28 – Power Line Connection Type

A = Terminal Block
C = Circuit Breaker Standard Fault
D = Circuit Breaker with High Fault Rated Control Panel
E = Circuit Breaker with High Fault Rated Control Panel with Energy Meter

Digit 29 – Enclosure Type

2 = Enclosure type UL 60335 Rated for Outdoor Applications

Digit 30 – Unit Operator Interface

B = Tracer® AdaptiView™ TD-7

Digit 31 – Remote Interface (Digital Comm)

X = No Remote Digital Communication
2 = LonTalk®/Tracer® Summit Interface
4 = BACNet® Interface

Digit 32 – External Chilled/Hot Water and Current Demand Limit Setpoint

X = No External Chilled Water Setpoint
A = External Chilled Water and Demand Limit Setpoint 4-20 mA
B = External Chilled Water and Demand Limit Setpoint 2-10 Vdc

Digit 33 – Percent Capacity

X = Without Percent Capacity
1 = With Percent Capacity

Digit 34 – Programmable Relays

X = No Programmable Relays
A = With Programmable Relays

Digit 35 – Pump Type

X = No Pumps and No Contactors
8 = Dual High Head Pump



Model Number Descriptions

Digit 36 – Pump Flow Control

X = No Pump Control
B = Pump Flow Controlled by the Variable Speed Drive

Digit 37 – Buffer Tank

X = No Buffer Tank
1 = Buffer Tank

Digit 38 – Short Circuit Rating

X = No Short Circuit Rating
A = Default A Short Circuit Rating
B = High A Short Circuit Rating

Digit 39 – Installation Accessories

X = No Installation Accessories
1 = Elastomeric Isolators
3 = Seismic Neoprene Pads
5 = Elastomeric Pads

Digit 40 – Water Strainer

A = With Water Strainer Factory Installed

Digit 41 – Sound Attenuator Package

3 = Super Quiet
5 = Comprehensive Acoustic Package

Digit 42 – Appearance Options

X = No Appearance Options
A = Architectural Louvered Panels
B = Half Louvers

Digit 43 – Exterior Finish

1 = Standard Paint

Digit 44 – Label, Literature Language

B = Spanish and English
D = English
E = French and English

Digit 45 – Phase Reversal Protection

1 = Phase Reversal Protection
2 = Convenience Outlet and Phase Reversal Protection

Digit 46 – Shipping Package

X = No Skid (Standard)
A = Unit Containerization Package
B = Shipped with tarp Covering Full Unit
C = Unit Containerization Package and Tarp

Digit 47 – Performance Test Options

X = No Performance Test
1 = Customer Inspection
2 = One-Point Test with Report
3 = Witness One-Point Test with Report
4 = Operational Test with Water

Digit 48 – Flow Switch Setpoint

C = Flow Switch Setpoint 15
F = Flow Switch Setpoint 35
H = Flow Switch Setpoint 45
L = Flow Switch Setpoint 60

Digit 49 – Wireless Connectivity Options

X = None
A = Wi-Fi®
B = LTE Modem
C = Air-Fi™
D = Wi-Fi and LTE Modem
E = Wi-Fi and Air-Fi
F = LTE Modem and Air-Fi
G = Wi-Fi, LTE Modem and Air-Fi

Digit 50 – Specials

X = None
S = Special

Note: If a digit is not defined, it may be held for future use.



General Data

Table 1. General data, 60 Hz (I-P)

Size	Unit	20	26	30	35	40	52	60	70	80	90	100	110	120	130
Compressor															
Number	#	2	2	2	2	4	4	4	4	4	4	4	4	4	6
Tonnage/ckt		10+10	13+13	15+15	15+20	10+10	13+13	15+15	15+20	20+20	20+25	25+25	25+30	30+30	20+20 +25
Evaporator															
Water storage	gal	1.4	2.2	2.2	2.8	3.4	4.1	5	6.3	7	8.6	10.3	10.3	11.5	11.5
Min. flow ^(a) (LWT ≥42°F)	gpm	23.2	29.8	33.1	38.5	45	58.8	67.1	79.5	91.8	102.6	115.5	125.2	135.9	146.9
Min. flow ^(a) (LWT 40 to 41.9°F)	gpm	29.1	37.2	41.8	48.2	56.3	73.5	83.9	99.4	114.7	128.3	144.4	156.5	169.9	183.7
Max. flow ^(a)	gpm	69	89	100	115	134.8	176	201	238	275	307	346	375	407	440
Water connection	in.	2.0	2.5	2.5	2.5	3.0	3.0	3.0	3.0	4.0	4.0	4.0	4.0	4.0	4.0
Max. Water Temperature	°F	105	105	105	105	105	105	105	105	105	105	105	105	105	105
Min. Water Pressure	psig	0	0	0	0	0	0	0	0	0	0	0	0	0	0
Max. Water Pressure	psig	150	150	150	150	150	150	150	150	150	150	150	150	150	150
Condenser															
Quantity of coils	#	1	1	1	1	2	2	2	2	4	4	4	4	4	4
Coil length	in.	91	91	127	127	91	91	127	127	121	121	144	144	144	180
Coil height	in.	68	68	68	68	68	68	68	68	42	42	42	42	42	42
Number of rows	#	3	3	3	3	3	3	3	3	3	3	3	3	3	3
Fins per foot	fpf	192	192	192	192	192	192	192	192	192	192	192	192	192	192
Fan															
Quantity	#	2	2	3	3	4	4	6	6	6	6	8	8	8	10
Diameter	in.	28.8	28.8	28.8	28.8	28.8	28.8	28.8	28.8	28.8	28.8	28.8	28.8	28.8	28.8
Airflow per fan	cfm	9413	9420	9168	9173	9413	9420	9168	9173	9470	9472	9094	9096	9098	9094
Power per motor	HP	1.3	1.3	1.3	1.3	1.3	1.3	1.3	1.3	1.3	1.3	1.3	1.3	1.3	1.3
Motor RPM	rpm	840	840	840	840	840	840	840	840	840	840	840	840	840	840
Tip speed	ft/min	6333	6333	6333	6333	6333	6333	6333	6333	6333	6333	6333	6333	6333	6333
General Unit															
Refrig circuits	#	1	1	1	1	2	2	2	2	2	2	2	2	2	2
Capacity steps	%	50-100	50-100	50-100	43-100	25-50- 75-100	25-50- 75-100	25-50- 75-100	21-43- 71-100	25-50- 75-100	22-44- 72-100	25-50- 75-100	23-45- 73-100	25-50- 75-100	15-31- 46-62- 81-100
Min ambient - wide	°F	0	0	0	0	0	0	0	0	0	0	0	0	0	0
Min ambient - high	°F	32	32	32	32	32	32	32	32	32	32	32	32	32	32
Min ambient - extreme low	°F	-20	-20	-20	-20	-20	-20	-20	-20	-20	-20	-20	-20	-20	-20
Refrig charge/ckt ^(b)	lbs	35	37	48	51	34	38	51	52	67	69	81	74	77	93
Oil charge/ckt ^(b)	gal	1.9	1.9	2.1	2.7	1.9	1.9	2.1	2.7	3.9	3.9	3.8	4.1	4.2	7.2
Pump Package															
Avail head pressure ^(c)	ft H2O	78.2	77.7	71.1	67.6	67.1	58.6	76.7	63.5	82	78.1	69	61.9	71.3	62.2
Power	HP	5.0	5.0	5.0	5.0	5.0	5.0	7.5	7.5	10.0	10.0	10.0	10.0	15.0	15.0
Expansion tank volume	gal	5	5	5	5	5	5	5	5	6	6	6	6	6	6
Buffer tank volume	gal	140	140	140	140	140	140	140	140	152	152	195	195	195	195

^(a) Minimum and maximum flow rates apply to constant-flow chilled water sytem running at AHRI conditions, without freeze inhibitors added to the water loop.

^(b) Data shown for one circuit only. The second circuit always matches.

^(c) Pump available head pressure is based on 44/54°F evaporator with water, .0001 hr-ft²-°F/Btu, 95°F ambient and 0 ft elevation.



General Data

Table 2. General data, 60 Hz (SI)

Size	Unit	20	26	30	35	40	52	60	70	80	90	100	110	120	130
Compressor															
Number	#	2	2	2	2	4	4	4	4	4	4	4	4	4	6
Tonnage/ckt		10+10	13+13	15+15	15+20	10+10	13+13	15+15	15+20	20+20	20+25	25+25	25+30	30+30	20+20+25
Evaporator															
Water storage	L	5.3	8.3	8.3	10.6	12.9	15.5	18.9	23.8	26.5	32.6	39.0	39.0	43.5	43.5
Min. flow ^(a) (LWT ≥5.56°C)	L/s	1.5	1.9	2.1	2.4	2.8	3.7	4.2	5.0	5.8	6.5	7.3	7.9	8.6	9.3
Min. flow ^(a) (LWT 4.44 to 5.55°C)	L/s	1.8	2.3	2.6	3.0	3.6	4.6	5.3	6.3	7.2	8.1	9.1	9.9	10.7	11.6
Max. flow ^(a)	L/s	4.4	5.6	6.3	7.3	8.5	11.1	12.7	15.0	17.3	19.4	21.8	23.7	25.7	27.8
Water connection	mm	50.8	63.5	63.5	63.5	76.2	76.2	76.2	76.2	101.6	101.6	101.6	101.6	101.6	101.6
Max. Water Temperature	°C	40.5	40.5	40.5	40.5	40.5	40.5	40.5	40.5	40.5	40.5	40.5	40.5	40.5	40.5
Min. Water Pressure	kPa	0	0	0	0	0	0	0	0	0	0	0	0	0	0
Max. Water Pressure	kPa	1034	1034	1034	1034	1034	1034	1034	1034	1034	1034	1034	1034	1034	1034
Condenser															
Qty of coils	#	1	1	1	1	2	2	2	2	4	4	4	4	4	4
Coil length	mm	2311	2311	3226	3226	2311	2311	3226	3226	3073	3073	3658	3658	3658	4572
Coil height	mm	1727	1727	1727	1727	1727	1727	1727	1727	1067	1067	1067	1067	1067	1067
Number of rows	#	2	2	2	2	2	2	2	2	3	3	3	3	3	3
Fins per foot	fpf	192	192	192	192	192	192	192	192	192	192	192	192	192	192
Fan															
Quantity	#	2	2	3	3	4	4	6	6	6	6	8	8	8	10
Diameter	mm	732	732	732	732	732	732	732	732	732	732	732	732	732	732
Airflow per fan	m³/h	15993	16005	15577	15585	15993	16005	15577	15585	16090	16093	15451	15454	15458	15451
Power per motor	HP	1.3	1.3	1.3	1.3	1.3	1.3	1.3	1.3	1.3	1.3	1.3	1.3	1.3	1.3
Motor RPM	rpm	840	840	840	840	840	840	840	840	840	840	840	840	840	840
Tip speed	m/s	32	32	32	32	32	32	32	32	32	32	32	32	32	32
General Unit															
Refrig circuits	#	1	1	1	1	2	2	2	2	2	2	2	2	2	2
Capacity steps	%	50-100	50-100	50-100	43-100	25-50-75-100	25-50-75-100	25-50-75-100	21-43-71-100	25-50-75-100	22-44-72-100	25-50-75-100	23-45-73-100	25-50-75-100	15-31-46-62-81-100
Min ambient - wide	°C	-18	-18	-18	-18	-18	-18	-18	-18	-18	-18	-18	-18	-18	-18
Min ambient - high	°C	0	0	0	0	0	0	0	0	0	0	0	0	0	0
Min ambient - extreme low	°C	-28.9	-28.9	-28.9	-28.9	-28.9	-28.9	-28.9	-28.9	-28.9	-28.9	-28.9	-28.9	-28.9	-28.9
Refrig charge/ckt ^(b)	kg	15.9	16.8	21.8	23.1	15.4	17.2	23.1	23.6	30.4	31.3	36.7	33.6	34.9	42.2
Oil charge /ckt ^(b)	L	7.2	7.2	7.9	10.2	7.2	7.2	7.9	10.2	14.8	14.8	14.4	15.5	15.9	27.3
Pump Package															
Avail head pressure ^(c)	kPa	233.7	232.2	212.5	202.1	200.6	175.2	229.3	189.8	245.1	233.4	206.2	185.0	213.1	185.9
Power	HP	5	5	5	5	5	5	7.5	7.5	10	10	10	10	15	15
Expansion tank volume	L	18.9	18.9	18.9	18.9	18.9	18.9	18.9	18.9	22.7	22.7	22.7	22.7	22.7	22.7
Buffer tank volume	L	530	530	530	530	530	530	530	530	575	575	738	738	738	738

(a) Minimum and maximum flow rates apply to constant-flow chilled water system running at AHRI conditions, without freeze inhibitors added to the water loop.

(b) Data shown for one circuit only. The second circuit always matches.

(c) Pump available head pressure is based on 6.7/12.2°C evaporator with water, .01761 m³C/kW, 35°C ambient and 0 m elevation.



Controls

Symbio 800 Controller

Trane chillers offer predictive controls that anticipate and compensate for load changes. Other strategies made possible with the Symbio™ 800 controls are:

Feedforward Adaptive Control

Feedforward is an open-loop, predictive control strategy designed to anticipate and compensate for load changes. It uses evaporator entering-water temperature as an indication of load change. This allows the controller to respond faster and maintain stable leaving-water temperatures.

Soft Loading

The chiller controller uses soft loading except during manual operation. Large adjustments to setpoint changes are made gradually, preventing the compressor from cycling unnecessarily. It does this by internally filtering the setpoints to avoid reaching the differential-to-stop or the demand limit. Soft loading applies to the leaving chilled-water temperature and demand limit setpoints.

Adaptive Controls

Adaptive Controls directly sense the control variables that govern the operation of the chiller: evaporator pressure and condenser pressure. When any one of these variables approach a limit condition when damage may occur to the unit or shutdown on a safety, Adaptive Controls take corrective action to avoid shutdown and keep the chiller operating. This happens through combined actions of compressor and/or fan staging. Whenever possible, the chiller is allowed to continue making chilled water. This keeps cooling capacity available until the problem can be solved. Overall, the safety controls help keep the building or process running and out of trouble.

Integrated Rapid Restart

Bringing a chiller back online rapidly after a loss of power is critical to operations in mission critical environments like data centers and hospitals which demand the highest levels of reliability.

A loss of cooling capacity can be costly, which is why Trane chillers are designed and engineered for Rapid Restart™. In the event of a power interruption, the chiller will start a compressor before the front panel display is fully powered up eliminating the need for UPS. This not only helps the chiller get back online faster, but it also provides a simple and reliable solution to minimize the risks of financially devastating damage to assets caused by overheating due to a power loss.

Of course, the truest test of a chiller restart capabilities is the amount of time it takes to resume full-load cooling, and this is where the chiller really shines. An 80 percent cooling load can be achieved in less than 2.5 minutes after power restoration—your assurance that the cooling capacity your equipment requires is just a few minutes away.

Rapid Restart Test

After completion of a standard full load witness test, power to the chiller will be cut and then reapplied to demonstrate the rapid restart capabilities of the chiller for disaster relief.

AdaptiSpeed™ Control

Compressor speed is used to control capacity of the chiller, optimizing mathematically with the condenser fan speed to provide the highest level of performance. The increased performance of the controller allows the chiller to operate longer at higher efficiency, and with greater stability.

Tracer® AdaptiView™ TD-7 Operator Interface

The standard Tracer® AdaptiView™ TD-7 display provided with the Symbio™ 800 controller features a 7-inch LCD touch-screen, allowing access to all operational inputs and outputs. This advanced interface allows the user to access important information concerning setpoints, active temperatures, modes, electrical data, pressure, and diagnostics. The full text display is available in 27 languages.



Display Feature Settings

- LCD touch-screen with LED backlighting, for scrolling access to input and output operating information.
- Single-screen, folder/tab-style display of all available information on individual components (evaporator, condenser, compressor, etc.)
- Manual override indication.
- Password entry/lockout system to enable or disable display.
- Automatic and immediate stop capabilities for standard or immediate manual shutdown.
- Fast, easy access to available chiller data in tabbed format, including:
 - Easy to view Operating Modes
 - Logical Subcomponent Reports:
 - Evaporator
 - Condenser
 - Compressor
 - Motor
 - 3 User Programmable Custom Reports
 - ASHRAE Report
 - Log Sheet Report
 - Alarms Report
 - 8 Pre-defined Standard Graphs
 - 4 User Programmable Custom Graphs
 - Unit Settings
 - Service Settings
 - Feature Settings
 - Chilled Water Reset
 - Manual Control Settings
 - Display Preferences
 - Support of 27 languages
 - Brightness Setting
 - Cleaning Mode

System Integration

Stand-Alone Controls

Single chillers installed in applications without a building management system are simple to install and control: only a remote auto/stop for scheduling is required for unit operation. Signals from the chilled-water pump contactor auxiliary, or a flow switch, are wired to the chilled-water flow interlock. Signals from a time clock or some other remote device are wired to the external auto/stop input.

- Auto/Stop - A job-site provided contact closure turns the unit on and off.
- Emergency Stop - A job-site provided contact opening wired to this input turns the unit off and requires a manual reset of the unit microcomputer. This closure is typically triggered by a job-site provided system such as a fire alarm.

Hardwire Points

Microcomputer controls allow simple interface with other control systems, such as time clocks, building automation systems, and ice storage systems via hardwire points. This means you have the flexibility to meet job requirements while not having to learn a complicated control system.

Remote devices are wired from the control panel to provide auxiliary control to a building automation system. Inputs and outputs can be communicated via a typical 4–20 mA electrical signal, an equivalent 2–10 Vdc signal, or by utilizing contact closures.

This setup has the same features as a stand-alone water chiller, with the possibility of having additional optional features:

- Ice making control.
- External chilled water setpoint, external demand limit setpoint.
- Chilled water temperature reset.
- Programmable relays - available outputs are: alarm-latching, alarm-auto reset, general alarm-warning, chiller limit mode, compressor running, and Tracer® control.

Tracer SC

The Tracer® SC system controller acts as the central coordinator for all individual equipment devices on a Tracer® building automation system. The Tracer®SC scans all unit controllers to update information and coordinate building control, including building subsystems such as VAV and chiller water systems. With this system option, the full breadth of Trane's HVAC and controls experience are applied to offer solutions to many facility issues. The LAN allows building operators to manage these varied components as one system from any personal computer with web access. The benefits of this system are:

- Improved usability with automatic data collection, enhanced data logging, easier to create graphics, simpler navigation, pre-programmed scheduling, reporting, and alarm logs.
- Flexible technology allows for system sizes from 30 to 120 unit controllers with any combination of LonTalk® or BACnet® unit controllers.
- LEED certification through site commissioning report, energy data collection measurement, optimizing energy performance, and maintaining indoor air quality.

Energy savings programs include: fan pressure optimization, ventilation reset, and chiller plant control (adds and subtracts chillers to meet cooling loads).

Building Automation Systems

BACnet® Building Automation Control Network

The BACnet control network for Symbio™ 800 expands communications from the unit controls network to the Tracer® Ensemble™ or Tracer® SC+ building automation system (BAS) or third party building automation system. Utilizing BACnet, the BAS allows external setpoint and configuration adjustment and monitoring of status and diagnostics. The Symbio 800 utilizes the BACnet defined TP protocol as defined in ASHRAE standard 135-2004. This controller works in standalone mode, with Tracer Ensemble, Tracer SC+ or when connected to a third party building automation system that supports BACnet.

Modbus® Automation Control Network

Allows the user to easily interface with Modbus RTU communication protocol via a single twisted pair wiring or Modbus TCP over Ethernet from the Symbio™ 800 controller to a factory installed device.

LonTalk® Building Automation Systems

The LonTalk communication protocol for the Symbio™ 800 controller expands communications from the unit controls network to a Tracer® Ensemble™ building automation system or third party building automation system. Utilizing LonTalk, the BAS allows external setpoint and configuration adjustment and monitoring of status and diagnostics. The Symbio 800 utilizes an FTT-10A free topology transceiver, which supports non-polarity sensitive, free topology wiring—which in turn allows the system installer to utilize star, bus, and loop architectures. This controller works in standalone mode, peer-to-peer with one or more other units, or when connected to a Tracer Ensemble, Tracer SC+, or a third party building automation system that supports LonTalk.

Note: An optional module is required for Symbio 800 support of LonTalk. See Tracer® USB LonTalk Module Installation Instructions (BAS-SVN138*-EN).



Symbio™ 800 Controls

Overview

The Symbio™ 800 controller is a factory-installed, application specific and programmable controller designed to control chillers and large packaged HVAC equipment. A 7–inch user interface features a touch-sensitive color screen that provides facility managers at-a-glance operating status, performance monitoring, scheduling changes, and operating adjustments. Other advanced features include automated controller back-up, and optional features such as secure remote connectivity, wireless building communications, mobile device connectivity, and custom programming with expandable I/O.

Symbio™ 800 Advantages		Benefits
Connected	Convenient, on-the-go access to advanced monitoring, troubleshooting, and energy management	<ul style="list-style-type: none"> • Minimum first cost. • Maximum comfort. • Minimized downtime. • Minimum operating costs. • Superior building and occupant productivity.
Flexible	Minimized installation hardware and labor costs – able to use existing devices for maximum convenience, lower controls upgrades and relocation	
Reliable	Maximum equipment uptime and life, minimized maintenance and troubleshooting cost	

Features and Benefits

Symbio™ 800 Feature	Benefits
Multiple, open standard protocol support <ul style="list-style-type: none"> • BACnet® TP. • BACnet®/IP. • LON (Optional). • Modbus®. 	Simplified, lower cost, and more flexible integration with all common open standard protocols using Trane or competitive BAS systems and controllers.
Remote connection to building or equipment	Trane Connect™ provides an easy, secure option to connect remotely to a Tracer® SC+ or directly to your Trane equipment.
Common integration strategies and equipment specific points lists	Simplified, lower cost, and uncompromised integration.
Application specific and configurable	Reduced project costs with superior reliability, comfort, performance - applications specific and configurable system confirms machine continues to run within operating envelope. Ability to upgrade firmware with a simple file transfer.
Smart Analytics	Smart analytics provide superior reliability through the life of the equipment with minimum downtime.
Data logging	Standard, local or remote Intuitive review and analysis of equipment, zone, and building performance.
Local scheduling	Capable of operating in stand-alone operation without a building automation system as a temporary back-up schedule for ongoing comfort and energy savings.
Rugged, 7-inch color touch screen user interface	Easy, touch navigation for viewing data and making operational changes.
Display preferences	Choose how to view dates, times, units (SI, IP), screen brightness, data format, and backlight timeout. A total of 27 built-in languages are supported and selectable for all TD-7 screens.
Intuitive navigation	Helps operators access data and alarms for quick and accurate response and resolution.
At-a-glance status	Easily readable color display showing key operating parameters of major equipment components.
Reports	Quickly summarizes data for clear understanding and interpretation to enable local monitoring of expected performance and operating efficiency.
Graphs	Easily visualize trend data for local troubleshooting and fine-tuning.
Multiple language support	Suitable for operation in multiple geographies.
Adaptive Control™ Algorithms	Pre-empts potential equipment disruptions during rapidly changing conditions – providing consistent equipment performance and building comfort.

Symbio™ 800 Feature	Benefits
SD card backup/restore	Faster, lower cost repairs with reduced downtime.
Modbus® device support	Capable of integrating optional Modbus® devices for local or remote diagnostics — provides faster, lower cost troubleshooting and increased equipment performance.

Options

Symbio™ 800 Feature	Benefits
Remote connection to building or equipment	Trane Connect™ provides an easy, secure option to connect remotely to a Tracer® SC+ or directly to your Trane equipment.
Programmable	Equipment application flexibility and cost-reduced control of nearby equipment.
Expandable I/O	Field or factory installed I/O for programmable feature for reduced installation costs and increased installation flexibility.
User security with audit trail support	Flexible and secure access for multiple users allows monitoring, overriding/releasing points, release of all overrides, custom report editing, and tracking changes by user.
LonTalk®	

Specifications

Controller Specifications	
Input power	24 Vdc +/- 10%, 400mA max.
Storage temperature	-67°F to 185°F (-55°C to 85°C), Humidity: Between 5% to 100% (Condensing).
Operating temperature	-40°F to 158°F (-40°C to 70°C).
Environmental rating (enclosure)	IP3x.
Time clock	On-board real time clock with 10 year battery backup.
Mounting weight	Mounting surface must support 1.3 lb. (0.6 kg).
Overall dimensions	5.65 in. (143.5 mm) wide x 4.00 in. (101.6 mm) high x 2.38 in. (60.6 mm) deep.
Agency Compliance	
<ul style="list-style-type: none"> UL PAZX, Energy Management Equipment. UL94-5V Flammability. CE. FCC CFR Title 47, Part 15.109: Class B Limit, (30 MHz—10 GHz). BTL Listed—Advanced Application Profile (B-AAC). 	
User Interface Specifications	
Input power	24 Vdc +/- 10%, 400 mA max
Storage temperature	-67°F to 203°F (-55°C to 95°C), Humidity: Between 5% to 100% (Condensing).
Operating temperature	-40°F to 158°F (-40°C to 70°C), Humidity: Between 5% to 100% (Condensing).
Environmental rating (enclosure)	IP56 (dust and strong water jet protected) with optional sealed Ethernet cable (PN: X19070632020).
Mounting weight	Mounting surface must support 1.6 lb. (0.74 kg).
Overall dimensions	8.3 in. (211.6 mm) wide x 6.3 in. (158.8 mm) high x 2.1 in. (53.2 mm) deep [bezel depth 0.4 in. (11.3 mm)].
Agency Compliance	
<ul style="list-style-type: none"> UL PAZX, Energy Management Equipment. UL94-5V, Flammability. FCC CFR Title 47, Part 15.109: Class A Limit, (30 MHz—4 GHz). CE EMC Directive 2004/108/EC. 	



Electrical Data

Table 3. Electrical data

Unit Size	Rated Power	Ckt Qty	Comp Qty	Fans Qty	Cond Fan FLA		Pump FLA	Compressor			No pump			Pump		
					VFD	No VFD		VFD	RLA ^(c)	LRA ^(c)	MCA ^(a)		MOP ^(b)	MCA ^(a)		MOP ^(b)
							VFD				No VFD	VFD		No VFD	VFD	
20	208/60/3	1	2	2	7.0	6.7	13.6	39-39	267-267	106.5	n/a	150	120.1	n/a	175	
	230/60/3	1	2	2	6.7	6.5	12.3	39-39	267-267	105.5	n/a	150	117.8	n/a	175	
	380/60/3	1	2	2	3.9	3.7	n/a	22-22	160-160	60.6	n/a	90	n/a			
	460/60/3	1	2	2	3.5	3.3	6.1	19-19	142-142	50.8	n/a	70	56.9	n/a	80	
	575/60/3	1	2	2	2.8	2.7	4.9	15-15	103-103	41.4	n/a	60	46.3	n/a	70	
26	208/60/3	1	2	2	7.0	6.7	13.6	51-51	315-315	134.2	n/a	200	147.8	n/a	200	
	230/60/3	1	2	2	6.7	6.5	12.3	45-45	315-315	118.8	n/a	175	131.1	n/a	200	
	380/60/3	1	2	2	3.9	3.7	n/a	26-26	177-177	69.4	n/a	100	n/a			
	460/60/3	1	2	2	3.5	3.3	6.1	21-21	158-158	57.3	n/a	80	63.4	n/a	90	
	575/60/3	1	2	2	2.8	2.7	4.9	19-19	126-126	48.6	n/a	70	53.5	n/a	80	
30	208/60/3	1	2	3	7.0	6.7	13.6	50-50	345-345	139.1	137.9	200	152.7	151.5	225	
	230/60/3	1	2	3	6.7	6.5	12.3	48-48	345-345	133.4	132.5	200	145.7	144.8	200	
	380/60/3	1	2	3	3.9	3.7	n/a	32-32	195-195	87.5	n/a	125	n/a			
	460/60/3	1	2	3	3.5	3.3	6.1	25-25	155-155	68.5	68.1	100	74.6	74.2	100	
	575/60/3	1	2	3	2.8	2.7	4.9	22-22	126-126	59.8	n/a	90	64.7	n/a	90	
35	208/60/3	1	2	3	7.0	6.7	13.6	50-74	345-485	168.2	167.0	250	181.8	180.6	250	
	230/60/3	1	2	3	6.7	6.5	12.3	48-67	345-485	156.8	155.9	225	169.1	168.2	250	
	380/60/3	1	2	3	3.9	3.7	n/a	32-40	195-260	96.5	n/a	150	n/a			
	460/60/3	1	2	3	3.5	3.3	6.1	25-33	155-215	78.5	78.1	125	84.6	84.2	125	
	575/60/3	1	2	3	2.8	2.7	4.9	22-26	126-175	64.8	n/a	100	69.7	n/a	100	
40	208/60/3	2	4	4	7.0	6.7	13.6	39-39/39-39	267-267/ 267-267	198.4	n/a	250	212.0	n/a	300	
	230/60/3	2	4	4	6.7	6.5	12.3	39-39/39-39	267-267/ 267-267	196.9	n/a	250	209.2	n/a	250	
	380/60/3	2	4	4	3.9	3.7	n/a	22-22/22-22	160-160/ 160-160	113.0	n/a	150	n/a			
	460/60/3	2	4	4	3.5	3.3	6.1	19-19/19-19	142-142/ 142-142	94.8	n/a	125	100.9	n/a	125	
	575/60/3	2	4	4	2.8	2.7	4.9	15-15/15-15	103-103/ 103-103	77.1	n/a	100	82.0	n/a	100	
52	208/60/3	2	4	4	7.0	6.7	13.6	51-51/51-51	315-315/ 315-315	250.7	n/a	300	264.3	n/a	350	
	230/60/3	2	4	4	6.7	6.5	12.3	45-45/45-45	315-315/ 315-315	222.0	n/a	300	234.3	n/a	300	
	380/60/3	2	4	4	3.9	3.7	n/a	26-26/26-26	177-177/ 177-177	129.6	n/a	175	n/a			
	460/60/3	2	4	4	3.5	3.3	6.1	21-21/21-21	158-158/ 158-158	107.1	n/a	150	113.2	n/a	150	
	575/60/3	2	4	4	2.8	2.7	4.9	19-19/19-19	126-126/ 126-126	90.8	n/a	110	95.7	n/a	125	

Table 3. Electrical data (continued)

Unit Size	Rated Power	Ckt Qty	Comp Qty	Fans Qty	Cond Fan FLA		Pump FLA	Compressor		No pump			Pump		
					VFD	No VFD	VFD	RLA ^(c)	LRA ^(c)	MCA ^(a)		MOP ^(b)	MCA ^(a)		MOP ^(b)
										VFD	No VFD		VFD	No VFD	
60	208/60/3	2	4	6	7.0	6.7	n/a	50-50/50-50	345-345/ 345-345	260.7	258.3	350	n/a		
	230/60/3	2	4	6	6.7	6.5	n/a	48-48/48-48	345-345/ 345-345	250.3	248.5	300	n/a		
	380/60/3	2	4	6	3.9	3.7	n/a	32-32/32-32	195-195/ 195-195	164.2	n/a	200	n/a		
	460/60/3	2	4	6	3.5	3.3	9.0	25-25/25-25	155-155/ 155-155	128.6	127.8	175	137.6	136.8	175
	575/60/3	2	4	6	2.8	2.7	7.2	22-22/22-22	126-126/ 126-126	112.3	n/a	150	119.5	n/a	150
70	208/60/3	2	4	6	7.0	6.7	n/a	50-74/74-50	345-485/ 485-345	313.1	310.7	400	n/a		
	230/60/3	2	4	6	6.7	6.5	n/a	48-67/67-48	345-485/ 485-345	292.4	290.6	400	n/a		
	380/60/3	2	4	6	3.9	3.7	n/a	32-40/40-32	195-260/ 260-195	180.4	n/a	225	n/a		
	460/60/3	2	4	6	3.5	3.3	9.0	25-33/33-25	155-215/ 215-155	146.6	145.8	200	155.6	154.8	200
	575/60/3	2	4	6	2.8	2.7	7.2	22-26/26-22	126-175/ 175-126	121.3	n/a	150	128.5	n/a	175
80	208/60/3	2	4	6	7.0	6.7	26.5	74-74/ 74-74	485-485/ 485-485	359.7	357.3	450	386.2	383.8	500
	230/60/3	2	4	6	6.7	6.5	24.0	67-67/ 67-67	485-485/ 485-485	329.8	328.0	400	353.8	352.0	450
	380/60/3	2	4	6	3.9	3.7	n/a	40-40/ 40-40	260-260/ 260-260	194.8	n/a	250	n/a		
	460/60/3	2	4	6	3.5	3.3	12.0	33-33/ 33-33	215-215/ 215-215	162.6	161.8	200	174.6	173.8	225
	575/60/3	2	4	6	2.8	2.7	9.6	26-26/ 26-26	175-175/ 175-175	129.3	n/a	175	138.9	n/a	175
90	208/60/3	2	4	6	7.0	6.7	26.5	74-91/ 91-74	485-560/ 560-485	398.8	396.4	500	425.3	422.9	600
	230/60/3	2	4	6	6.7	6.5	24.0	67-85/ 85-67	485-560/ 560-485	368.7	366.9	500	392.7	390.9	500
	380/60/3	2	4	6	3.9	3.7	n/a	40-55/ 55-40	260-310/ 310-260	227.6	n/a	300	n/a		
	460/60/3	2	4	6	3.5	3.3	12.0	33-42/ 42-33	215-260/ 260-215	182.6	181.8	225	194.6	193.8	250
	575/60/3	2	4	6	2.8	2.7	9.6	26-34/ 34-26	175-210/ 210-175	146.4	n/a	200	156.0	n/a	200
100	208/60/3	2	4	8	7.0	6.7	26.5	91-91/ 91-91	560-560/ 560-560	447.0	446.4	600	473.5	472.9	600
	230/60/3	2	4	8	6.7	6.5	24.0	85-85/ 85-85	560-560/ 560-560	416.3	415.9	600	440.3	439.9	600
	380/60/3	2	4	8	3.9	3.7	n/a	55-55/ 55-55	310-310/ 310-310	264.2	263.8	350	n/a		
	460/60/3	2	4	8	3.5	3.3	12.0	42-42/ 42-42	260-260/ 260-260	207.0	206.6	250	219.0	218.6	300
	575/60/3	2	4	8	2.8	2.7	9.6	34-34/ 34-34	210-210/ 210-210	167.0	167.8	225	176.6	177.4	225



Electrical Data

Table 3. Electrical data (continued)

Unit Size	Rated Power	Ckt Qty	Comp Qty	Fans Qty	Cond Fan FLA		Pump FLA	Compressor		No pump			Pump		
					VFD	No VFD		VFD	RLA ^(c)	LRA ^(c)	MCA ^(a)		MOP ^(b)	MCA ^(a)	
							VFD				No VFD	VFD		No VFD	VFD
110	208/60/3	2	4	8	7.0	6.7	26.5	91-110/ 110-91	560-680/ 680-560	488.0	487.4	600	514.5	513.9	700
	230/60/3	2	4	8	6.7	6.5	24.0	85-109/ 109-85	560-680/ 680-560	471.2	470.8	600	495.2	494.8	700
	380/60/3	2	4	8	3.9	3.7	n/a	55-60/ 60-55	310-360/ 360-310	275.7	275.3	350	n/a		
	460/60/3	2	4	8	3.5	3.3	12.0	42-51/ 51-42	260-320/ 320-260	226.7	226.3	300	238.7	238.3	300
	575/60/3	2	4	8	2.8	2.7	9.6	34-39/ 39-34	210-235/ 235-210	177.4	178.2	225	187.0	187.8	250
120	208/60/3	2	4	8	7.0	6.7	n/a	110-110/ 110-110	680-680/ 680-680	524.4	523.8	700	n/a		
	230/60/3	2	4	8	6.7	6.5	n/a	109-109/ 109-109	680-680/ 680-680	520.0	519.6	700	n/a		
	380/60/3	2	4	8	3.9	3.7	n/a	60-60/ 60-60	360-360/ 360-360	285.9	285.5	350	n/a		
	460/60/3	2	4	8	3.5	3.3	18.1	51-51/ 51-51	320-320/ 320-320	244.2	243.8	300	262.3	261.9	350
	575/60/3	2	4	8	2.8	2.7	14.5	39-39/ 39-39	235-235/ 235-235	186.6	187.4	250	201.1	201.9	250
130	208/60/3	2	6	10	7.0	6.7	n/a	74-74-91/ 91-74-74	485-485-560/ 560-485-485	573.4	572.8	700	n/a		
	230/60/3	2	6	10	6.7	6.5	n/a	67-67-85/ 85-67-67	485-485-560/ 560-485-485	529.3	528.9	700	n/a		
	380/60/3	2	6	10	3.9	3.7	n/a	40-40-55/ 55-40-40	260-260-310/ 310-260-260	322.2	321.8	400	n/a		
	460/60/3	2	6	10	3.5	3.3	18.1	33-33-42/ 42-33-33	215-215-260/ 260-215-215	261.8	261.4	350	279.9	279.5	350
	575/60/3	2	6	10	2.8	2.7	14.5	26-26-34/ 34-26-26	175-175-210/ 210-175-175	210.0	210.8	250	224.5	225.3	300

Notes:

- Local codes may take precedence.
 - Voltage Utilization Range: +/- 10% of rated voltage. Rated voltage (use range): 208/60/3 (187.2-228.8), 230/60/3(208-254), 380/60/3 (342-418), 460/60/3 (414-506), 575/60/3 (516-633).
 - One separate 120/60/1, 15 amp customer provided power connection is required to power the heaters.
 - n/a - not available.
- (a) MCA - Minimum Circuit Ampacity - 125 percent of largest compressor RLA plus 100 percent of all other loads.
 (b) MOP or Max fuse size - 225 percent of the largest compressor RLA plus all other loads.
 (c) RLA - Rated Load Amps - Rated in accordance with UL Standard 1995.

Table 4. Lug size range

Unit Size	Rated Power	No Pump			Pump		
		Terminal Blocks	Std Fault Ckt Breaker ^(a)	High Fault Ckt Breaker ^(a)	Terminal Blocks	Std Fault Ckt Breaker ^(a)	High Fault Ckt Breaker ^(a)
20	208/60/3	#6 - 350 MCM	#4 - 4/0	#4 - 300MCM	#6 - 350 MCM	#4 - 4/0	#4 - 300MCM
	230/60/3	#6 - 350 MCM	#4 - 4/0	#4 - 300MCM	#6 - 350 MCM	#4 - 4/0	#4 - 300MCM
	380/60/3	#6 - 350 MCM	#8 - 3/0	#14 - 1/0 AWG	n/a		
	460/60/3	#6 - 350 MCM	#8 - 3/0	#14 - 1/0 AWG	#6 - 350 MCM	#8 - 3/0	#14 - 1/0 AWG
	575/60/3	#6 - 350 MCM	#8 - 3/0	#8 - 3/0	#6 - 350 MCM	#8 - 3/0	#8 - 3/0
26	208/60/3	#6 - 350 MCM	#4 - 4/0	#4 - 300MCM	#6 - 350 MCM	#4 - 4/0	#4 - 300MCM
	230/60/3	#6 - 350 MCM	#4 - 4/0	#4 - 300MCM	#6 - 350 MCM	#4 - 4/0	#4 - 300MCM
	380/60/3	#6 - 350 MCM	#8 - 3/0	#14 - 1/0 AWG	n/a		
	460/60/3	#6 - 350 MCM	#8 - 3/0	#14 - 1/0 AWG	#6 - 350 MCM	#8 - 3/0	#14 - 1/0 AWG
	575/60/3	#6 - 350 MCM	#8 - 3/0	#8 - 3/0	#6 - 350 MCM	#8 - 3/0	#8 - 3/0
30	208/60/3	#6 - 350 MCM	n/a	#4 - 300MCM	#6 - 350 MCM	3/0 - 350 MCM	#4 - 300MCM
	230/60/3	#6 - 350 MCM	n/a	#4 - 300MCM	#6 - 350 MCM	#4 - 4/0	#4 - 300MCM
	380/60/3	#6 - 350 MCM	#8 - 3/0	#14 - 1/0 AWG	n/a		
	460/60/3	#6 - 350 MCM	#8 - 3/0	#14 - 1/0 AWG	#6 - 350 MCM	#8 - 3/0	#14 - 1/0 AWG
	575/60/3	#6 - 350 MCM	#8 - 3/0	#8 - 3/0	#6 - 350 MCM	#8 - 3/0	#8 - 3/0
35	208/60/3	#6 - 350 MCM	n/a	#4 - 300MCM	#6 - 350 MCM	3/0 - 350 MCM	#4 - 300MCM
	230/60/3	#6 - 350 MCM	n/a	#4 - 300MCM	#6 - 350 MCM	3/0 - 350 MCM	#4 - 300MCM
	380/60/3	#6 - 350 MCM	#4 - 4/0	#4 - 300MCM	n/a		
	460/60/3	#6 - 350 MCM	#8 - 3/0	#14 - 1/0 AWG	#6 - 350 MCM	#8 - 3/0	#14 - 1/0 AWG
	575/60/3	#6 - 350 MCM	#8 - 3/0	#8 - 3/0	#6 - 350 MCM	#8 - 3/0	#8 - 3/0
40	208/60/3	#4 - 500 MCM	3/0 - 350 MCM	#4 - 300MCM	#4 - 500 MCM	2/0 - 500MCM	2/0 - 500MCM
	230/60/3	#4 - 500 MCM	3/0 - 350 MCM	#4 - 300MCM	#4 - 500 MCM	3/0 - 350 MCM	#4 - 300MCM
	380/60/3	#4 - 500 MCM	#4 - 4/0	#4 - 300MCM	n/a		
	460/60/3	#4 - 500 MCM	#8 - 3/0	#14 - 1/0	#4 - 500 MCM	#8 - 3/0	#14 - 1/0
	575/60/3	#4 - 500 MCM	#8 - 3/0	#8 - 3/0	#4 - 500 MCM	#8 - 3/0	#8 - 3/0
52	208/60/3	#4 - 500 MCM	2/0 - 500 MCM	2/0 - 500MCM	#4 - 500 MCM	2/0 - 500MCM	2/0 - 500MCM
	230/60/3	#4 - 500 MCM	2/0 - 500 MCM	2/0 - 500MCM	#4 - 500 MCM	2/0 - 500MCM	2/0 - 500MCM
	380/60/3	#4 - 500 MCM	#4 - 4/0	#4 - 300MCM	n/a		
	460/60/3	#4 - 500 MCM	#4 - 4/0	#4 - 300MCM	#4 - 500 MCM	#4 - 4/0	#4 - 300MCM
	575/60/3	#4 - 500 MCM	#8 - 3/0	#8 - 3/0	#4 - 500 MCM	#8 - 3/0	#8 - 3/0
60	208/60/3	#4 - 500 MCM	n/a	2/0 - 500MCM	n/a		
	230/60/3	#4 - 500 MCM	n/a	2/0 - 500MCM			
	380/60/3	#4 - 500 MCM	#4 - 4/0	#4 - 300MCM			
	460/60/3	#4 - 500 MCM	#4 - 4/0	#4 - 300MCM	#4 - 500 MCM	#4 - 4/0	#4 - 300MCM
	575/60/3	#4 - 500 MCM	#4 - 4/0	#4 - 300MCM	#4 - 500 MCM	#4 - 4/0	#4 - 300MCM
70	208/60/3	#4 - 500 MCM	n/a	2/0 - 500MCM	n/a		
	230/60/3	#4 - 500 MCM	n/a	2/0 - 500MCM			
	380/60/3	#4 - 500 MCM	3/0 - 350 MCM	#4 - 300MCM			
	460/60/3	#4 - 500 MCM	#4 - 4/0	#4 - 300MCM	#4 - 500 MCM	#4 - 4/0	#4 - 300MCM
	575/60/3	#4 - 500 MCM	#4 - 4/0	#4 - 300MCM	#4 - 500 MCM	#4 - 4/0	#4 - 300MCM



Electrical Data

Table 4. Lug size range (continued)

Unit Size	Rated Power	No Pump			Pump		
		Terminal Blocks	Std Fault Ckt Breaker ^(a)	High Fault Ckt Breaker ^(a)	Terminal Blocks	Std Fault Ckt Breaker ^(a)	High Fault Ckt Breaker ^(a)
80	208/60/3	#4 - 500 MCM	n/a	2/0 - 500 MCM	#4 - 500 MCM ^(b)	2/0 - 500 MCM ^(b)	2/0 - 500 MCM ^(b)
	230/60/3	#4 - 500 MCM	n/a	2/0 - 500 MCM	#4 - 500 MCM	2/0 - 500 MCM	2/0 - 500 MCM
	380/60/3	#4 - 500 MCM	3/0 - 350 MCM	#4 - 300 MCM	n/a		
	460/60/3	#4 - 500 MCM	#4 - 4/0	#4 - 300 MCM	#4 - 500 MCM	3/0 - 350 MCM	#4 - 300 MCM
	575/60/3	#4 - 500 MCM	#4 - 4/0	#4 - 300 MCM	#4 - 500 MCM	#4 - 4/0	#4 - 300 MCM
90	208/60/3	#4 - 500 MCM ^(b)	n/a	2/0 - 500 MCM ^(b)	#4 - 500 MCM ^(b)	2/0 - 500 MCM ^(b)	2/0 - 500 MCM ^(b)
	230/60/3	#4 - 500 MCM	n/a	2/0 - 500 MCM	#4 - 500 MCM ^(b)	2/0 - 500 MCM ^(b)	2/0 - 500 MCM ^(b)
	380/60/3	#4 - 500 MCM	2/0 - 500 MCM	2/0 - 500 MCM	n/a		
	460/60/3	#4 - 500 MCM	3/0 - 350 MCM	#4 - 300 MCM	#4 - 500 MCM	3/0 - 350 MCM	#4 - 300 MCM
	575/60/3	#4 - 500 MCM	#4 - 4/0	#4 - 300 MCM	#4 - 500 MCM	#4 - 4/0	#4 - 300 MCM
100	208/60/3	#4 - 500 MCM ^(b)	n/a	2/0 - 500 MCM ^(b)	#4 - 500 MCM ^(b)	2/0 - 500 MCM ^(b)	2/0 - 500 MCM ^(b)
	230/60/3	#4 - 500 MCM ^(b)	n/a	2/0 - 500 MCM ^(b)	#4 - 500 MCM ^(b)	2/0 - 500 MCM ^(b)	2/0 - 500 MCM ^(b)
	380/60/3	#4 - 500 MCM	2/0 - 500 MCM	2/0 - 500 MCM	n/a		
	460/60/3	#4 - 500 MCM	3/0 - 350 MCM	#4 - 300 MCM	#4 - 500 MCM	2/0 - 500 MCM	2/0 - 500 MCM
	575/60/3	#4 - 500 MCM	3/0 - 350 MCM	#4 - 300 MCM	#4 - 500 MCM	3/0 - 350 MCM	#4 - 300 MCM
110	208/60/3	#4 - 500 MCM ^(b)	n/a	2/0 - 500 MCM ^(b)	#4 - 500 MCM ^(b)	3/0 - 500 MCM ^(b)	2/0 - 400 MCM ^(b)
	230/60/3	#4 - 500 MCM ^(b)	n/a	2/0 - 500 MCM ^(b)	#4 - 500 MCM ^(b)	3/0 - 500 MCM ^(b)	2/0 - 400 MCM ^(b)
	380/60/3	#4 - 500 MCM	2/0 - 500 MCM	2/0 - 500 MCM	n/a		
	460/60/3	#4 - 500 MCM	2/0 - 500 MCM	2/0 - 500 MCM	#4 - 500 MCM	2/0 - 500 MCM	2/0 - 500 MCM
	575/60/3	#4 - 500 MCM	3/0 - 350 MCM	#4 - 300 MCM	#4 - 500 MCM	3/0 - 350 MCM	#4 - 300 MCM
120	208/60/3	#4 - 500 MCM ^(b)	n/a	2/0 - 400 MCM ^(b)	n/a		
	230/60/3	#4 - 500 MCM ^(b)	n/a	2/0 - 400 MCM ^(b)	n/a		
	380/60/3	#4 - 500 MCM	2/0 - 500 MCM	2/0 - 500 MCM	n/a		
	460/60/3	#4 - 500 MCM	2/0 - 500 MCM	2/0 - 500 MCM	#4 - 500 MCM	2/0 - 500 MCM	2/0 - 500 MCM
	575/60/3	#4 - 500 MCM	3/0 - 350 MCM	#4 - 300 MCM	#4 - 500 MCM	3/0 - 350 MCM	#4 - 300 MCM
130	208/60/3	#4 - 500 MCM ^(b)	n/a	2/0 - 400 MCM ^(b)	n/a		
	230/60/3	#4 - 500 MCM ^(b)	n/a	2/0 - 400 MCM ^(b)	n/a		
	380/60/3	#4 - 500 MCM	2/0 - 500 MCM	2/0 - 500 MCM	n/a		
	460/60/3	#4 - 500 MCM	2/0 - 500 MCM	2/0 - 500 MCM	#4 - 500 MCM	2/0 - 500 MCM	2/0 - 500 MCM
	575/60/3	#4 - 500 MCM	3/0 - 350 MCM	#4 - 300 MCM	#4 - 500 MCM	2/0 - 500 MCM	2/0 - 500 MCM

Notes:

1. Copper wire only, based on nameplate Minimum Circuit Ampacity (MCA).
2. Data shown for circuit one. The second circuit is always the same.
3. n/a - not available.

^(a) Optional circuit breaker and high fault circuit breaker.

^(b) Will accept two conduits per phase in this size.



Dimensions

Unit Dimensions

Unit Without Options

Note: The number of fans shown does not represent the number of fans installed.

Figure 4. Dimensions, 20 to 35 ton units, no options

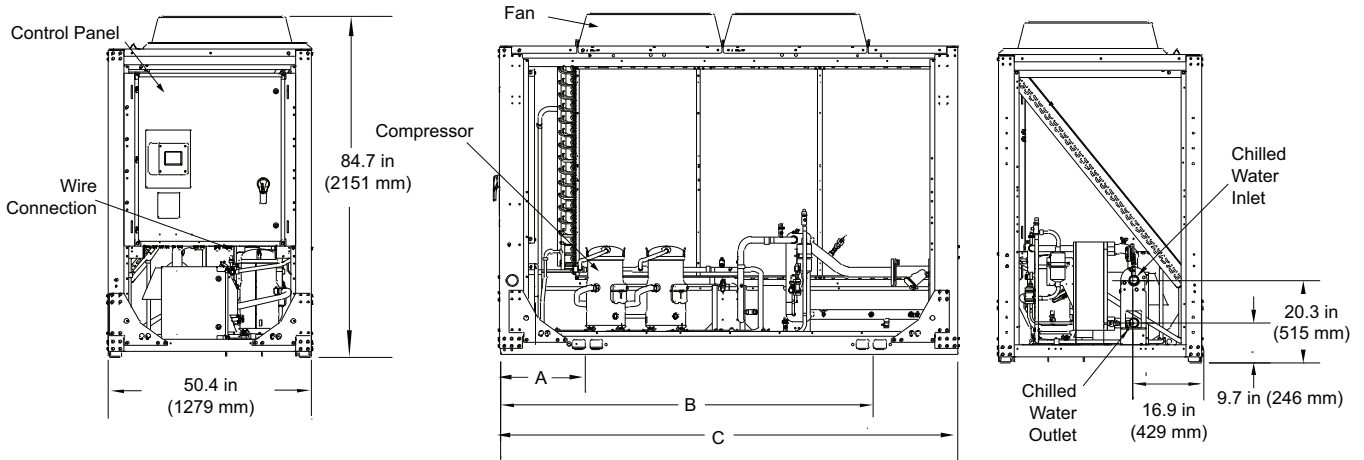
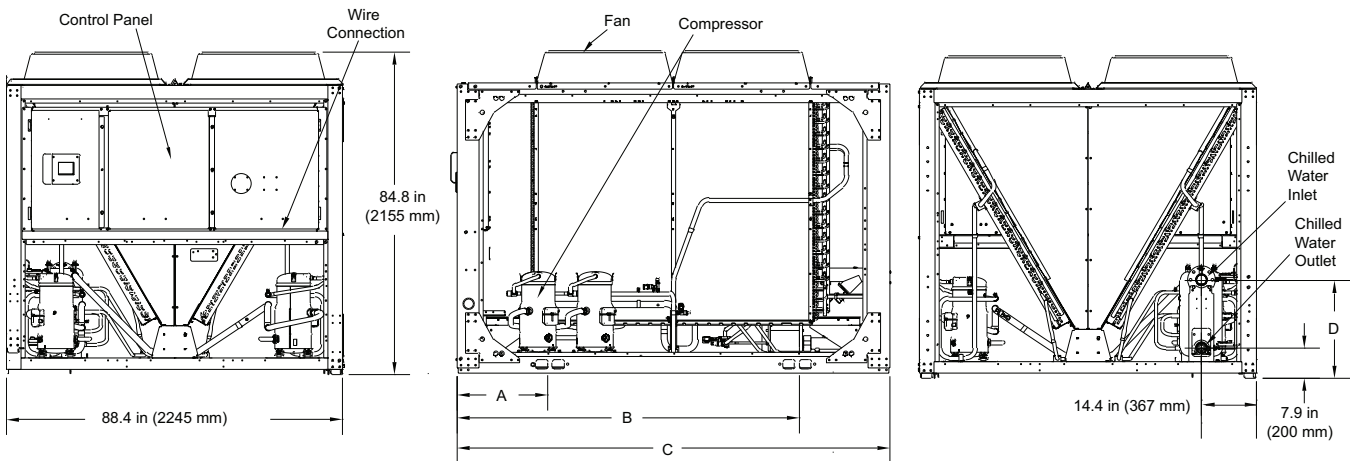

Table 5. Dimensions, 20 to 35 ton units, no options

Unit Size (tons)	A		B		C		Water Connection (from end of chiller)	
	in.	mm	in.	mm	in.	mm	in.	mm
20, 26	21.2	535	92.7	2354	113.8	2890	1.7	44
30, 35	21.3	541	128.4	3263	149.8	3804	1.6	40

Figure 5. Dimensions, 40 to 70 ton units, no options





Dimensions

Table 6. Dimensions, 40 to 70 ton units, no options

Unit Size (tons)	A		B		C		D		Water Connection (from end of chiller)
	in.	mm	in.	mm	in.	mm	in.	mm	
40	23.8	603	89.9	2282	113.8	2890	31.1	790	Even with unit end
52	23.8	603	89.9	2282	113.8	2890	31.1	790	Even with unit end
60, 70	23.8	603	125.8	3196	149.8	3804	31.1	790	Even with unit end

Figure 6. Dimensions, 80 to 120 ton units, no options

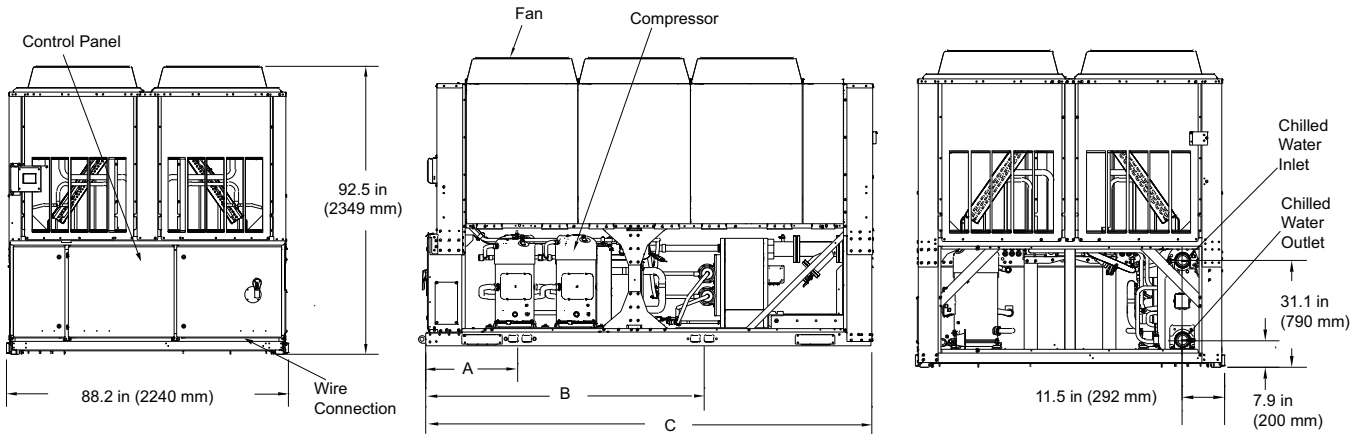
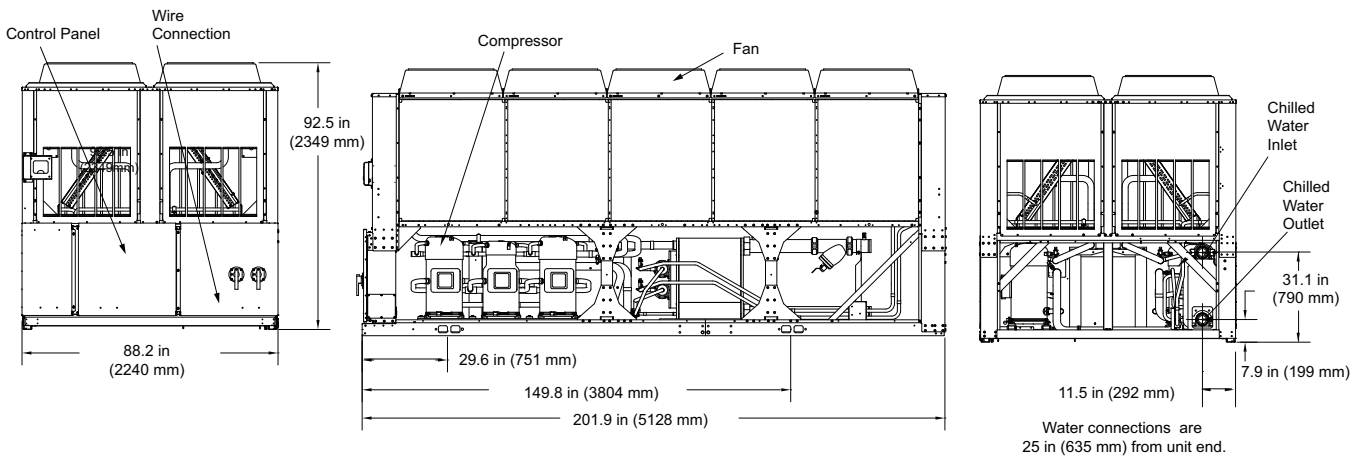

Table 7. Dimensions, 80 to 120 ton units, no options

Unit Size (tons)	A		B		C		Water Connection (from end of chiller)	
	in.	mm	in.	mm	in.	mm	in.	mm
80, 90	29.6	751	89.2	2265	143.1	3634	5.5	139
100, 110, 120	29.6	751	111.7	2837	165.9	4214	5.5	139

Figure 7. Dimensions, 130 ton unit, no options



Unit With Options Pump Package, Buffer Tank

General Dimensions and Components

Notes:

- Graphics in this section, use the following acronyms: PP — Pump Package, BT — Buffer Tank
- See [Table 13, p. 33](#), for dimensions of water connections for various options.

Figure 8. Dimensions, 20 to 35 ton units with options

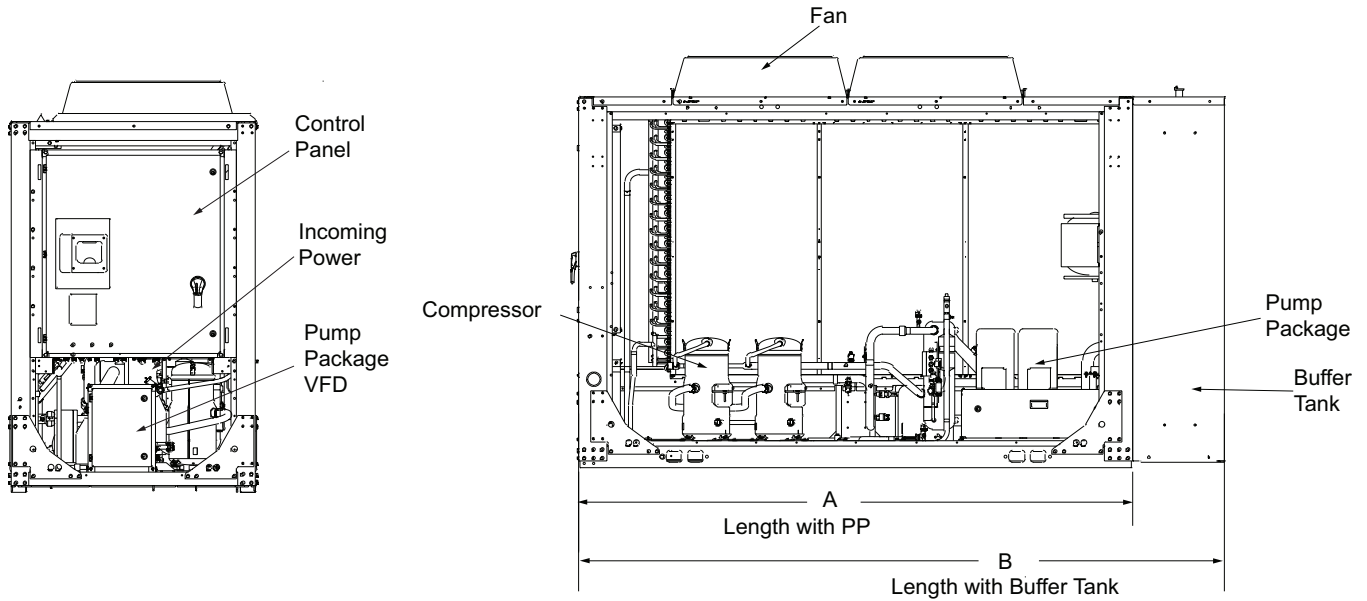

Table 8. Dimensions, 20 to 35 ton units with options

Unit Size (tons)	A		B	
	in.	mm	in.	mm
20, 26	113.8	2890	134	3404
30, 35	149.8	3804	170.1	4320



Dimensions

Figure 9. Dimensions, 40 to 70 ton units with options

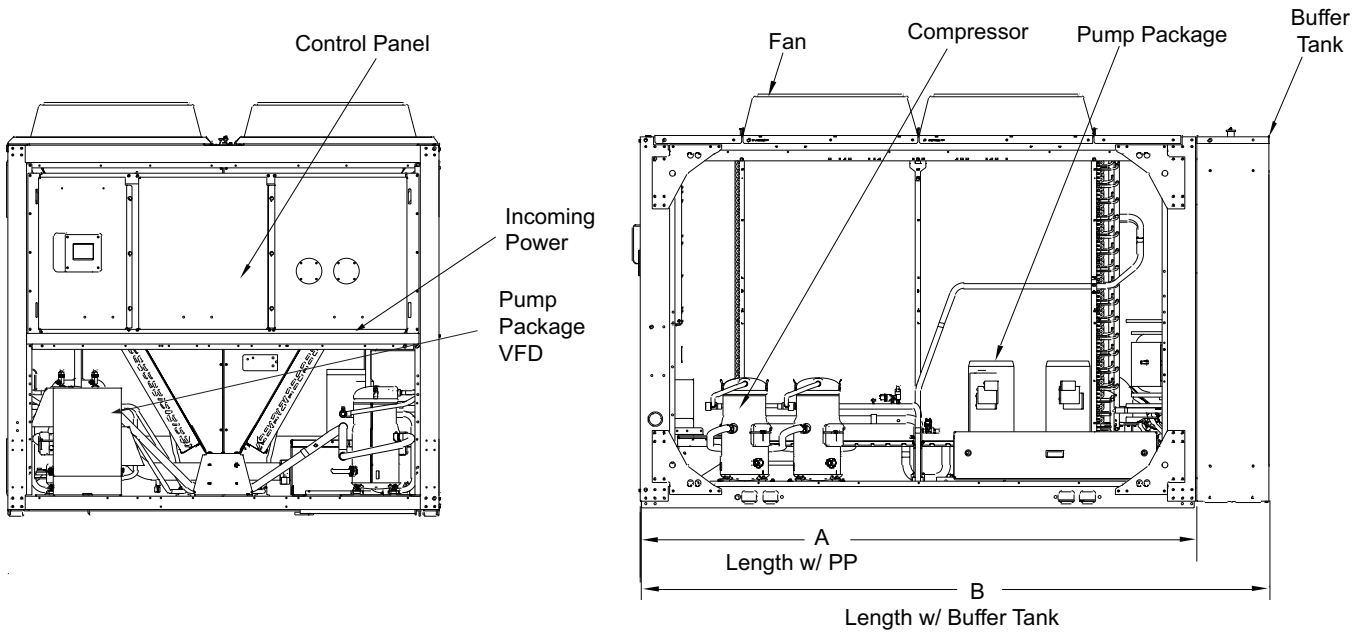

Table 9. Dimensions, 40 to 70 ton units with options

Unit Size (tons)	A		B	
	in.	mm	in.	mm
40, 52	113.8	2890	134.2	3409
60, 70	149.8	3804	170	4318

Figure 10. Dimensions, 80 to 120 ton units with options

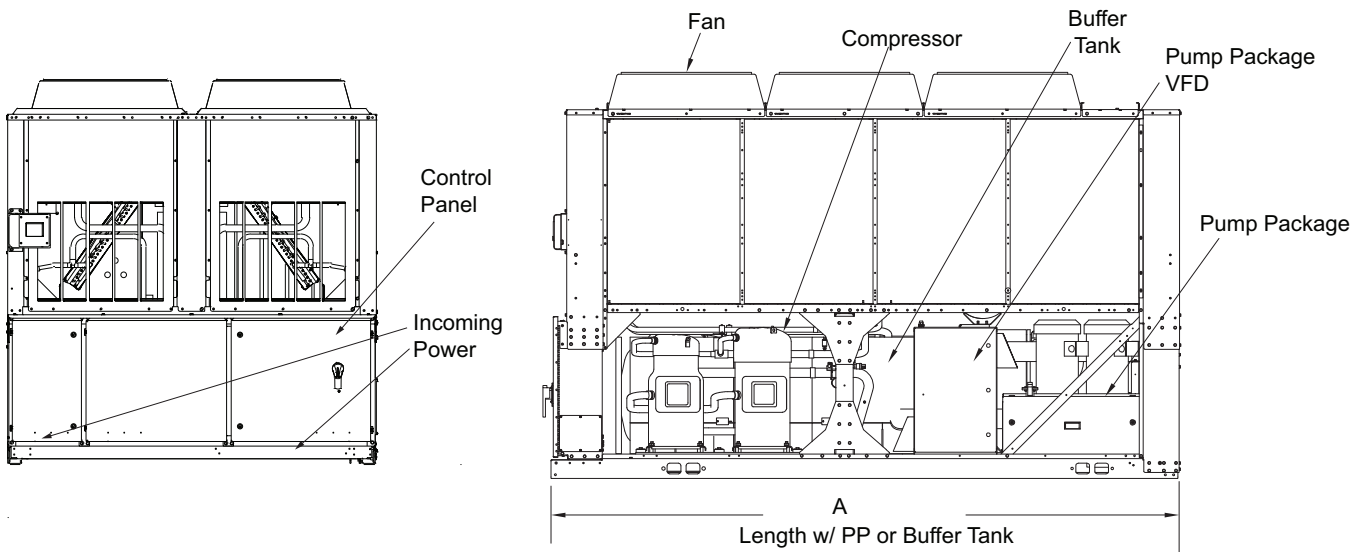
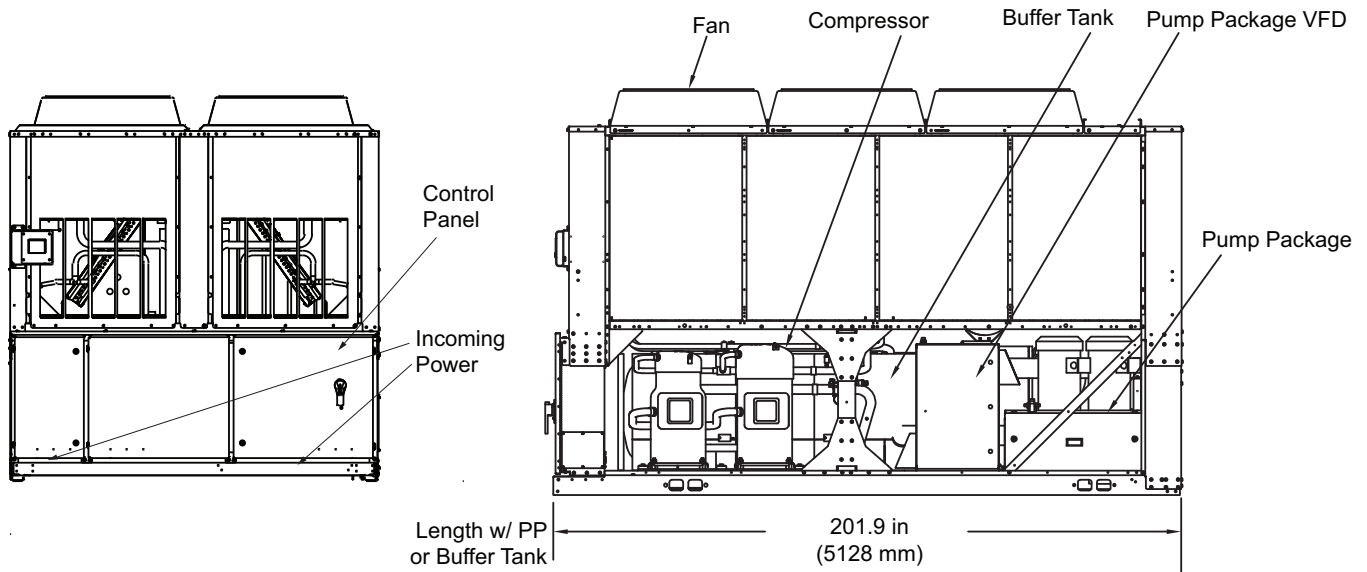

Table 10. Dimensions, 80 to 120 ton units with options

Unit Size (tons)	A	
	in.	mm
80, 90, 100	143.1	3634
110, 120	165.9	4214

Figure 11. CGAM 130 ton, with options



Water Connections

Figure 12. Water connection dimensions, 20 to 35 ton units with options

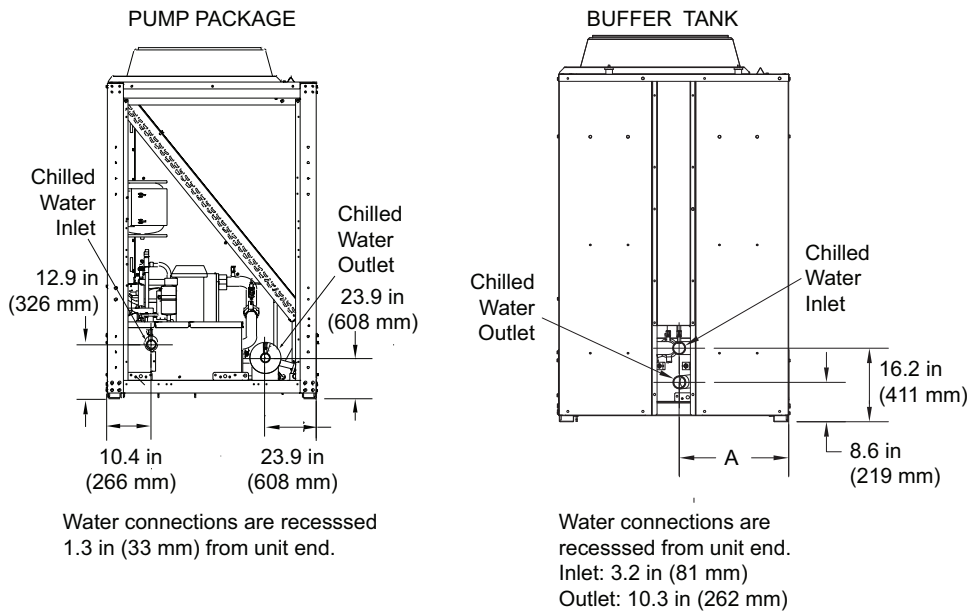

Dimensions

Table 11. Water connection dimensions, 20 to 35 ton units with options

Unit Size (tons)	A		B	
	in.	mm	in.	mm
20, 26	24.1	613	70.3	1784
30, 35	23.9	608	67.4	1712

Figure 13. Water connection dimensions, 40 to 70 ton units with options

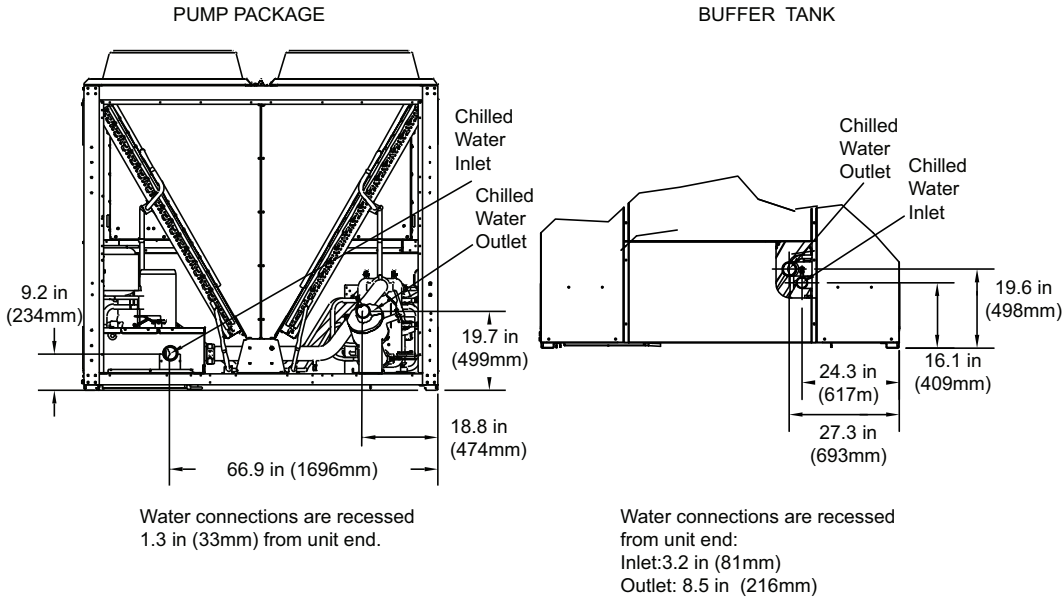

Table 12. Water connection dimensions, 40 to 70 ton units with options

Unit Size (tons)	A		B		C	
	in.	mm	in.	mm	in.	mm
40, 52	24.3	617	45.3	1149	54.8	1392
60, 70	24.2	615	45.6	1158	55.2	1401

Figure 14. Water connection dimensions, 80 to 130 ton units with options

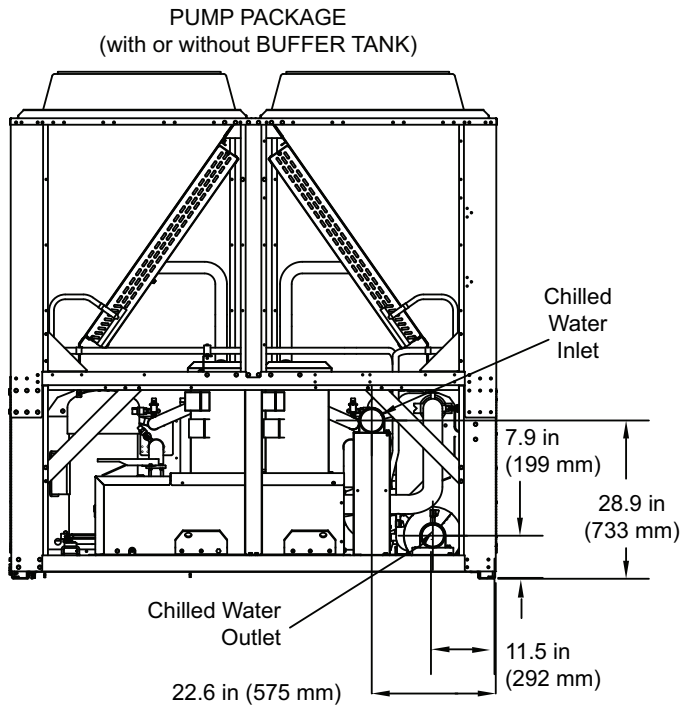

Table 13. Water connection dimensions, 80 to 130 ton units with options

Unit Size (tons)	Pump Package ^(a)				Buffer Tank			
	Inlet		Outlet		Inlet		Outlet	
	in.	mm	in.	mm	in.	mm	in.	mm
80, 90	5.9	151	5.9	151	6.2	158	6.2	158
100, 110, 120	5.9	151	5.9	151	6	153	6	153
130	6.3	159	25	635	5.9	150	27.7	703

^(a) Distance from end of unit.

Service Clearances

Figure 15. CGAM service clearances

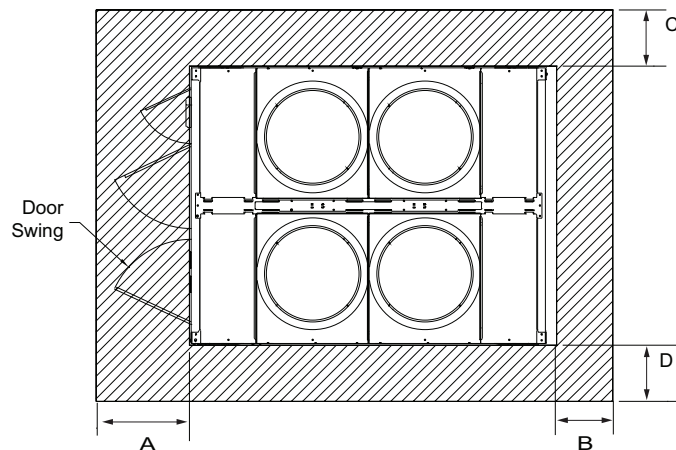

Dimensions

Unit Size (Tons)	A		B		C		D	
	in.	mm	in.	mm	in.	mm	in.	mm
20 to 35	47.2	1200	31.5	800	23.6	600	39.4	1000
40 to 70	47.2	1200	31.5	800	39.4	1000	39.4	1000
80 to 130	47.2	1200	39.4	1000	39.4	1000	39.4	1000

Notes:

- Number of fans and panel doors shown does not represent the number of fans installed.
- More clearance may be needed for airflow, depending on installation.

Mounting Locations

Note: All mounting holes are 0.75 in. (19 mm) in diameter.

Figure 16. Mounting locations, 20 to 35 tons

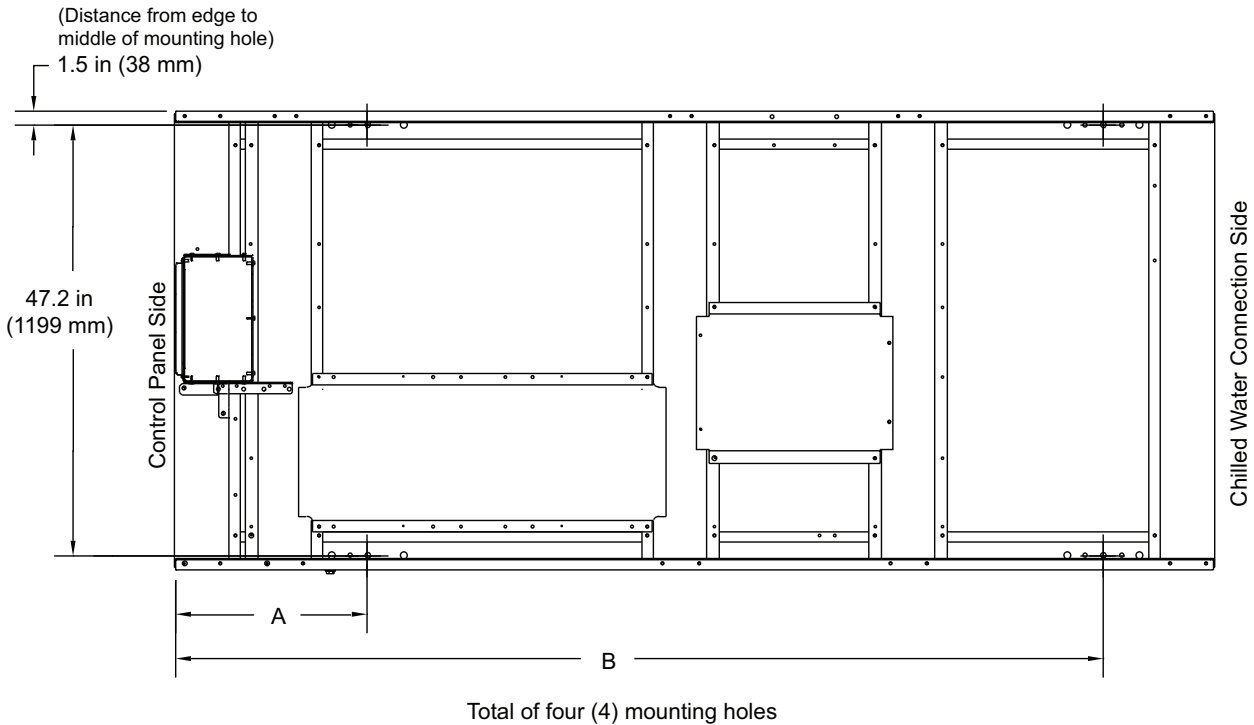
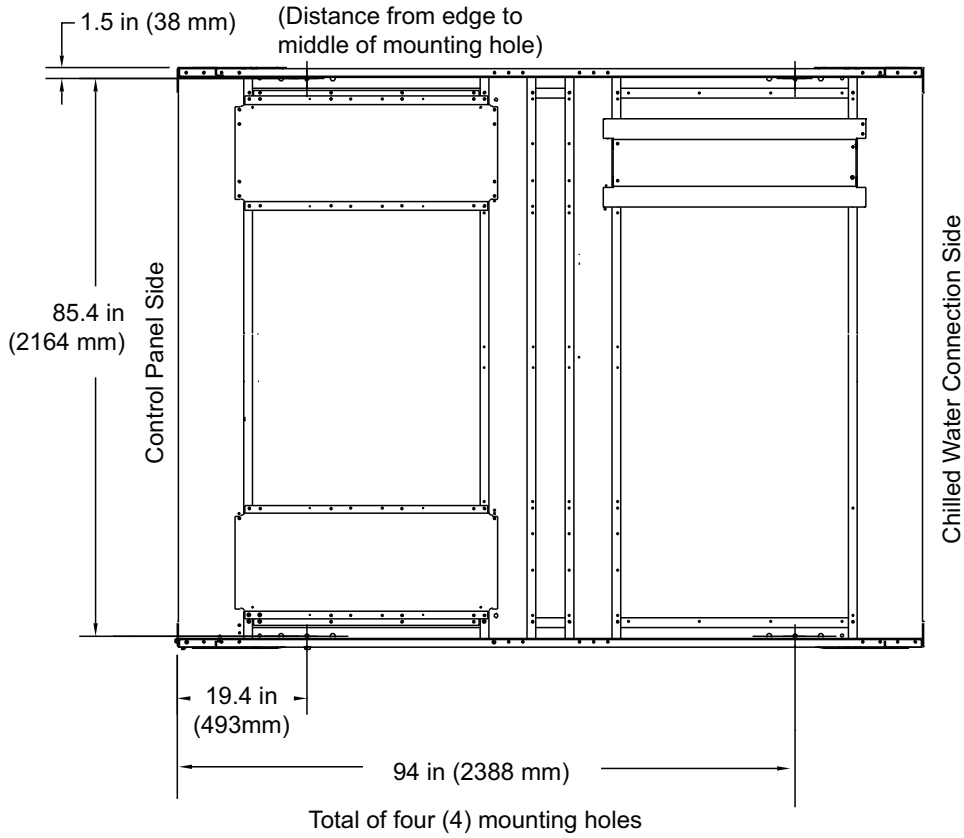

Table 14. Mounting locations, 20 to 35 ton units

Unit Size (tons)	A		B	
	in.	mm	in.	mm
20, 26	21	533	101.2	2570
30, 35	21.9	556	132.2	3358

Figure 17. Mounting locations, 40 and 52 tons





Dimensions

Figure 18. Mounting locations, 60 and 70 tons

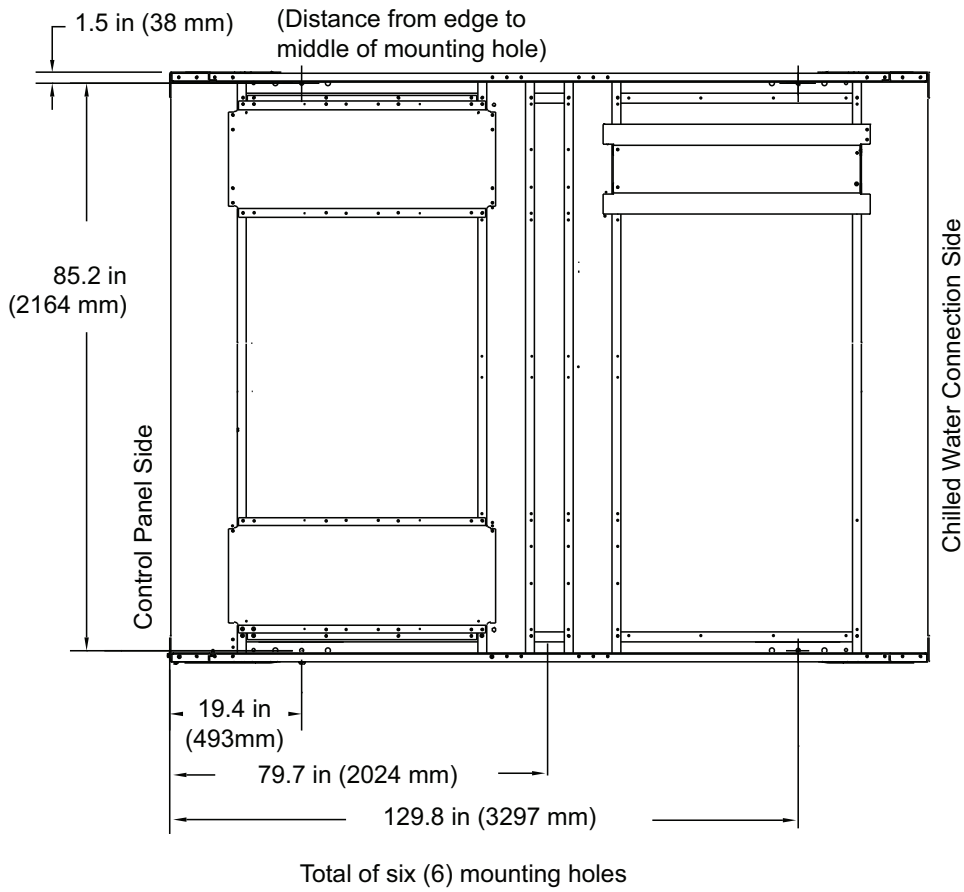
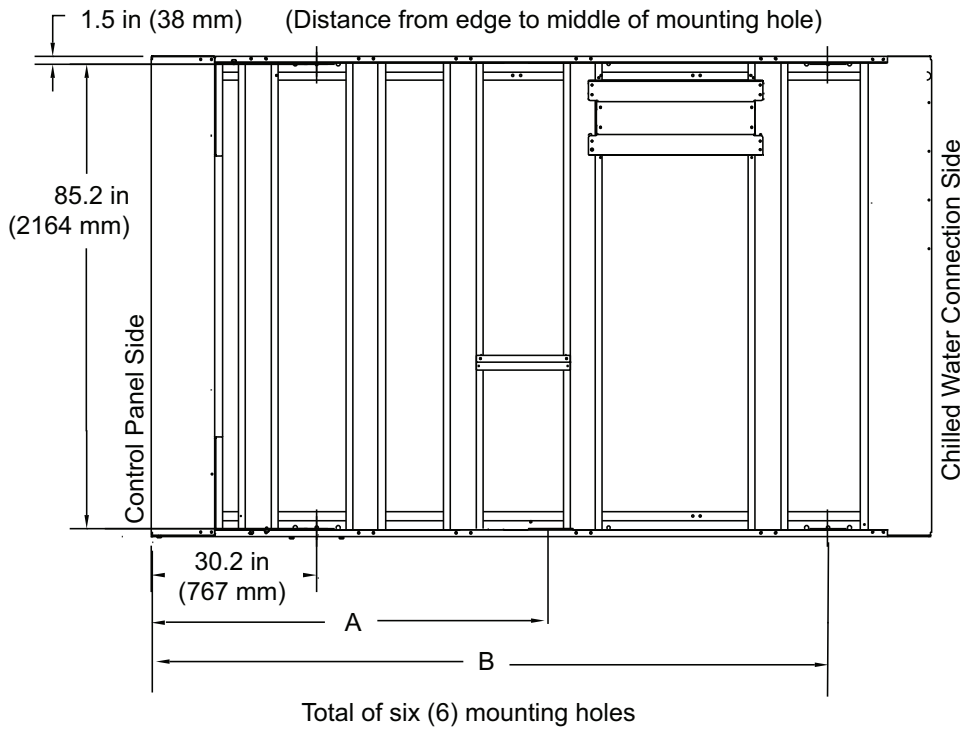

Figure 19. Mounting locations, 80 to 120 tons

Note: For seismic applications, neoprene pads need to be glued down on the mounting surface at the four corner locations of the unit.

Table 15. Mounting locations, 80 to 120 ton units

Unit Size (tons)	A		B	
	in.	mm	in.	mm
80, 90	83.7	2126	123.9	3147
100, 110, 120	89.2	2266	146.9	3731



Dimensions

Figure 20. Mounting locations, 130 tons

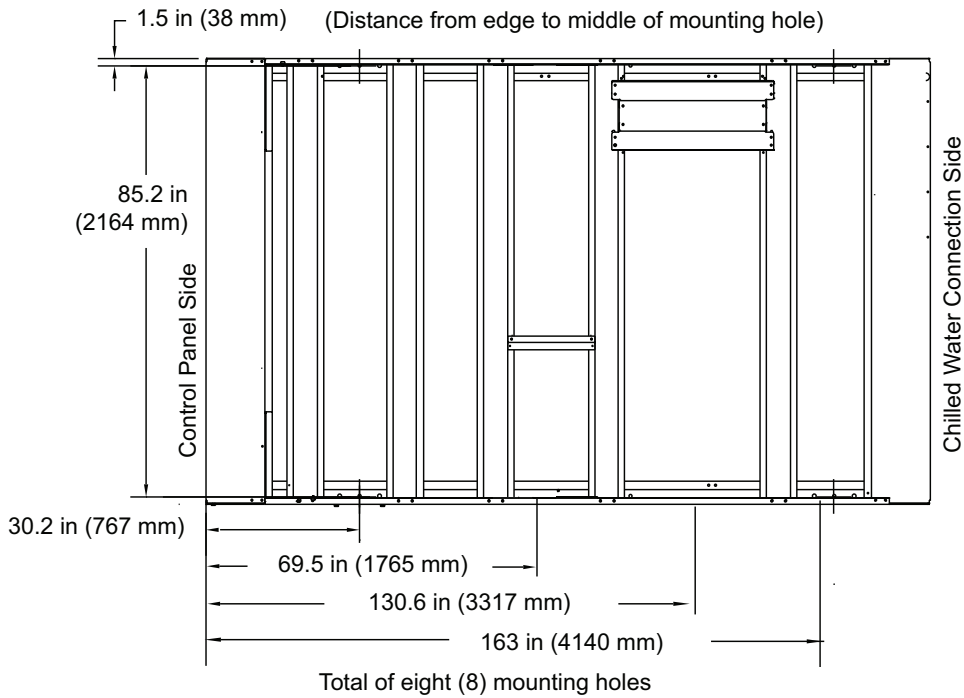

Note: For 130 ton units with seismic option, seismically rated isolator must be glued to the bottom of the unit at each of the four corners for installation.



Weights

Base Units

Note: Weights are applicable to units with seismic or wind load options.

Table 16. Base unit weights — I-P (lb)

Unit Size (Tons)	Base Unit		Base Unit with Pump Package		Base Unit with Pump Package and Buffer Tank	
	Shipping	Operating	Shipping	Operating	Shipping	Operating
20	2258	2281	2798	2887	3325	4564
26	2322	2351	2863	2964	3389	4634
30	2945	2979	3487	3596	4014	5262
35	3023	3065	3565	3691	4092	5349
40	3812	3843	4431	4529	5022	6262
52	3959	4004	4578	4705	5169	6423
60	5177	5232	6013	6184	6604	7893
70	5118	5194	5954	6166	6545	7855
80	5607	5692	6486	6790	7077	8561
90	5859	5961	6738	7075	7329	8830
100	6646	6759	7549	7909	8265	10136
110	6724	6846	7627	8005	8343	10223
120	6762	6884	8018	8396	8733	10614
130	7753	7900	9006	9430	9722	11623

Note: All weights $\pm 3\%$.

Table 17. Base unit weights — SI (kg)

Unit Size (Tons)	Base Unit		Base Unit with Pump Package		Base Unit with Pump Package and Buffer Tank	
	Shipping	Operating	Shipping	Operating	Shipping	Operating
20	1024	1035	1269	1310	1508	2070
26	1053	1066	1298	1344	1537	2102
30	1336	1351	1582	1631	1821	2387
35	1371	1390	1617	1674	1856	2426
40	1729	1743	2010	2054	2278	2840
52	1796	1816	2077	2134	2345	2914
60	2348	2373	2727	2805	2996	3580
70	2322	2356	2701	2797	2969	3563
80	2543	2582	2942	3080	3210	3883
90	2658	2704	3056	3209	3324	4005
100	3015	3066	3424	3587	3749	4598
110	3050	3105	3460	3631	3784	4637
120	3067	3122	3637	3808	3961	4814
130	3517	3583	4085	4277	4410	5272

Note: All weights $\pm 3\%$.



Mechanical Specifications

General

Units are constructed of galvanized steel frame with galvanized steel panels and access doors. Component surfaces are finished with a powder-coated paint. Each unit ships with full operating charges of refrigerant and oil.

Certified AHRI Performance

Trane air-cooled chillers are rated within the scope of the Air-Conditioning, Heating and Refrigeration Institute (AHRI) Certification Program and display the AHRI Certified® mark as a visual confirmation of conformance to the certification sections of AHRI Standard 550/590 (I-P) and ANSI/AHRI Standard 551/591 (SI). The applications in this catalog specifically excluded from the AHRI certification program are:

- Custom Units.
- Units produced outside of the USA for installations outside the USA.
- Evaporatively-cooled chillers.
- Units with evaporators that use fluid other than fresh water except units containing freeze protection fluids in the evaporator with a leaving chilled fluid temperature above 32°F [0°C] are certified when rated per the Standard with water.

Compressor and Motor

The unit is equipped with two or more hermetic, direct-drive, 3600 rpm 60 Hz suction gas-cooled scroll compressors. The simple design has only three major moving parts and a completely enclosed compression chamber which leads to increased efficiency. Overload protection is included. The compressor includes: centrifugal oil pump, oil level sight glass and oil charging valve. Each compressor will have compressor heaters installed and properly sized to minimize the amount of liquid refrigerant present in the oil sump during off cycles.

Unit-Mounted Starter

The control panel is designed per UL 1995. The starter is an across-the-line configuration, factory-mounted and fully pre-wired to the compressor motor and control panel. A factory-installed, factory-wired 820 VA control power transformer provides all unit control power (120 Vac secondary) and chiller control module power (24 Vac secondary). Power line connection type is standard with a terminal block.

Evaporator

Braze plate heat exchanger is made of stainless steel with copper as the braze material. It is designed to withstand a refrigerant side working pressure of 430 psig (29.6 bar) and a waterside working pressure of 150 psig (10.5 bar). Evaporator is tested at 1.1 times maximum allowable refrigerant side working pressure and 1.5 times maximum allowable water side working pressure. It has one water pass. Immersion heaters protect the evaporator to an ambient of -20°F (-29°C).

The evaporator is covered with factory-installed 0.75 inch (19.05 mm) Armaflex II or equal (k=0.28) insulation. Foam insulation is used on the suction line. Water pipe extensions with insulation go from the evaporator to the edge of the unit.

Condenser

Round tube and plate fin (RTPF) air-cooled condenser coils have aluminum fins mechanically bonded to internally-finned copper tubing. The condenser coil has an integral subcooling circuit. The maximum allowable working pressure of the condenser is 650 psig (44.8 bar). Condensers are factory proof tested at 650 psig (44.8 bar) and leak tested at 585 psig (40.3 bar).

Direct-drive vertical discharge condenser fans are balanced. Three-phase condenser fan motors with permanently lubricated ball bearings and external thermal overload protection are provided.

Units start and operate from 0°F to 125°F (-18°C to 52°C) for wide ambient. Wide ambient allows operation down to 0°F which is accomplished by a variable speed fan on each circuit that modulates to maintain system differential pressure.

Refrigerant Circuit and Capacity Modulation

The 20 to 35 ton units have single refrigerant circuits. The 40-130 ton units have dual refrigerant circuits. Each refrigerant circuit has Trane scroll compressors piped in parallel with a passive oil management system. A passive oil management system maintains proper oil levels within compressors and has no moving parts. Each refrigerant circuit includes filter drier, electronic expansion valve, and liquid line and discharge service valves.

Capacity modulation is achieved by turning compressors on and off. The 20 to 35 ton units have two capacity stages. The 40-120 ton units have four capacity stages. The 130 ton unit has six capacity stages.

Unit Controls

All unit controls are housed in an outdoor rated weather tight enclosure with removable plates to allow connection of power wiring and remote interlocks. All controls, including sensors, are factory mounted and tested prior to shipment.

Microcomputer controls provide all control functions including start-up and shutdown, leaving chilled water temperature control, evaporator flow proving, compressor staging and speed control, electronic expansion valve modulation, condenser fan sequencing and speed control, anti-recycle logic, automatic lead/lag compressor starting, and load limiting.

Symbio™ 800 Controller

The Symbio™ 800 controller is an application-specific, programmable controller that is factory installed and designed to control packaged HVAC equipment. A 7-inch user interface features a touch-sensitive color screen that provides facility managers with at-a-glance operating status, performance monitoring, scheduling changes and operating adjustments. Other advanced features include automated controller backup and optional features such as secure remote connectivity, wireless building communications, and custom programming with expandable I/O.

The Symbio™ 800 control module, utilizing Adaptive Control™ microprocessor, automatically takes action to avoid unit shutdown due to abnormal operating conditions associated with low refrigerant pressure, high condensing pressure, compressor current overload, low oil return, low suction superheat, and high compressor discharge temperature. Should the abnormal operating condition continue until a protective limit is violated, the unit will be shutdown.

Unit protective functions of the controller include: loss of chilled water flow, evaporator freezing, loss of refrigerant, low refrigerant pressure, high refrigerant pressure, and high compressor motor temperature.

BACnet® Communication Protocol

The Symbio™ 800 controller supports standard BACnet® communication protocol through a RS485, two-wire communication link or BACnet®/IP over Ethernet.

Trane LonTalk® Communication Protocol

The LonTalk® module provides an interface to a Tracer® building automation system or other control system that supports LonTalk® and is factory installed, allowing for control and monitoring of the unit through a RS485, two-wire communication link. Requires an additional LonTalk® Communication Kit to be installed.

Modbus® Communication Protocol

The Symbio™ 800 controller supports standard Modbus® RTU communication protocol through an RS485, two-wire communication link.

Controls Expansion Hardware

Symbio™ 800 includes field applied controls capability. Factory installed expansion hardware (XM70) has 19 inputs/outputs. Additional expansions may be added in the field.



Mechanical Specifications

Tracer® AdaptiView™ TD-7 Display

A full color Tracer® AdaptiView™ TD-7 touch screen display indicates all important unit and circuit parameters, in logical groupings on various screens. The parameters including chilled water setpoint, leaving evaporator temperature, demand limit setpoint, evaporator and condenser refrigerant temperatures and pressures, compressor and fan speeds, and all pertinent electrical information. The display also provides “on screen” data graphs of predefined parameters as well as customizable data graphs based on user defined parameters from a list of all available parameters. The display also provides indication of the chiller and circuits’ top level operating modes with detailed sub-mode reports available with a single key press, as well as diagnostics annunciation and date and time stamped diagnostic history. The color display is fully outdoor rated, and can be viewed in full daylight without opening any control panel doors.

Standard power connections include main three phase power to the compressors, condenser fans and control power transformer and optional connections are available for the 115 volt/60 Hz single phase power for the thermostatically controlled evaporator heaters for freeze protection.

- Outdoor capable:
 - UV Resistant Touchscreen
 - Operating Temperature: -40°C to 70°C
 - IP56 rated (Power Jets of Water from all directions)
- RoHS Compliant
- UL PAZX, Open Energy Management Equipment
- CE Certification
- Emissions: EN55011 (Class B)
- Immunity: EN61000 (Industrial)
- Display:
 - 7-inch diagonal
 - 800x480 pixels.
 - TFT LCD @ 600 nits brightness
 - 16 bit color graphic display
- Display Features:
 - Alarms
 - Reports
 - Unit Settings
 - Display Settings
- Graphing
- Global Application with Support for 27 Languages



Options

Application Options

Ice-Making with Hardwired Interface

Unit controls are factory set to handle ice-making for thermal storage application. An additional temperature sensor, at the compressor discharge, enables full load operation of the chiller with entering evaporator fluid temperature between 20°F (-7°C) and 65°F (18°C) with glycol.

High Ambient

The unit starts and operates from 32°F to 125°F (0°C to 52°C).

Low-Temperature Processing

An additional temperature sensor, at the compressor discharge, enables leaving evaporator fluid temperature between 10°F (-12.2°C) and 40°F (4.4°C) with glycol.

Leaving evaporator fluid temperatures below 10°F (-12.2°C) are also possible for specific applications.

Dual High Head Pump Package

Pump package includes: two high head pumps, VFD, expansion vessels, drainage valves, shut-off valves at entering and leaving connections.

The pump package is single point power integrated into the chiller unit power with a separate factory wired control panel. The control of the pump is integrated into the chiller controller. The chiller front panel displays evaporator pump starts and run-times. Freeze protection down to -20°F (-29°C) ambient is included as standard. The cold parts of the pump package will also be insulated.

Designed with one redundant pump, the chiller controls both pumps through a lead/lag and failure/recovery functionality.

A variable speed drive is installed in an additional panel to control the pump. The inverter is adjusted upon start-up to balance the system flow and head requirements. The purpose is to save on wasted pump energy caused by a traditional balancing valve.

Buffer Tank

Note: Buffer tank is an option only available on units with pump package option selected.

The water tank is factory-installed for easy installation at the building site. The tank is engineered for continuous flow and is fully insulated as standard and is designed with freeze protection down to -20°F (-29°C). The purpose of the tank is to increase the chilled water circuit inertia, which is necessary with short water loops. A high circuit inertia reduces the compressor's cycling to increase the compressor life span and allow for more precise water temperature accuracy. It also saves energy as compared to hot gas bypass.

Electrical Options

Circuit Breaker

A molded case standard interrupting capacity circuit breaker, factory pre-wired with terminal block power connections and equipped with a lockable external operator handle, is available to disconnect the chiller from main power.

Circuit Breaker with High Fault Rated Control Panel

A molded case high interrupting capacity circuit breaker, factory pre-wired with terminal block power connections and equipped with a lockable external operator handle, is available to disconnect the chiller from main power.



Options

Circuit Breaker — Standard Fault with Energy Meter

A molded case standard interrupting capacity circuit breaker, equipped with a lockable external operating handle to disconnect the main power from the chiller, plus the added features included with the Energy Meter described below.

Circuit Breaker — High Fault with Energy Meter

A molded case high interrupting capacity circuit breaker, equipped with a lockable external operating handle to disconnect the main power from the chiller, plus the added features included with the Energy Meter described below.

Energy Meter

Energy meter capable of measuring line current by phase, average current, voltage by phase, average voltage, frequency, unit power consumption, reactive and apparent power, and power factor.

Short Circuit Rating

Short circuit rating of 5 kA or up to 65 kA is available.

Control Options

BACnet® Communications Interface

Allows the user to easily interface with BACnet via a single twisted pair or Ethernet wiring to a factory-installed Symbio™ 800 controller.

LonTalk® Communications Interface

Provides the LONMARK® chiller profile inputs/outputs for use with a generic building automation system via a single twisted pair wiring to a factory-installed Symbio™ 800 controller.

Modbus® Communications Interface

Allows the user to easily interface with Modbus® via a single twisted pair wiring to a factory-installed Symbio™ 800 controller.

External Chilled Water and Demand Limit Setpoint

Controls, sensors, and safeties allow reset of chilled water temperature, based on temperature signal, during periods of low outdoor air temperature (chilled water reset based on return chilled water temperature is standard). The demand limit setpoint is communicated to a factory-installed communication board through a 2-10 Vdc or 4-20 mA signal.

Percent Capacity

When utilized, the control module will indicate the number of compressors that are operating as an analog 2-10 Vdc or 4-20 mA signal.

Programmable Relays

Predefined, factory-installed, programmable relays allow the operation to select four relay outputs. Available outputs are: Alarm-Latching, Alarm-Auto Reset, General Alarm, Warning, Chiller Limit Mode, Compressor Running, and Tracer Control.

Other Options

Architectural Louvered Panels

Louvered panels cover the entire condensing coil and service area beneath the condenser.

Half Louvers

Louvered panels cover the condenser coil only. Available on 80 to 130 ton units only.

Comprehensive Acoustic Package

This option includes acoustical treatment for compressor.

Condenser Corrosion Protection

CompleteCoat™ is available on all size units for corrosion protection. Job site conditions should be considered to determine the need to order coating to inhibit coil corrosion and ensure extended equipment life. CompleteCoat™ option provides fully assembled coils with a flexible dip and bake epoxy coating.

Isolators - Elastomeric and Neoprene Pads

Elastomeric isolators and neoprene pads provide isolation between chiller and structure to help eliminate vibration transmission.

Insulation for High Humidity

The evaporator is covered with factory-installed 1.25 inch (31.8 mm) Armaflex II or equal (k=0.28) insulation. Foam insulation is used on the suction line.

Nitrogen Charge

Unit is shipped with oil and a nitrogen charge in lieu of refrigerant.

Performance Test

Performance tests are available to certify chiller performance before shipment.



Notes



The AHRI Certified mark indicates Trane U.S. Inc. participation in the AHRI Certification program. For verification of individual certified products, go to ahridirectory.org.

Trane - by Trane Technologies (NYSE: TT), a global innovator - creates comfortable, energy efficient indoor environments for commercial and residential applications. For more information, please visit trane.com or tranetechnologies.com.

Trane has a policy of continuous product and product data improvements and reserves the right to change design and specifications without notice. We are committed to using environmentally conscious print practices.