



Product Catalog

IntelliCore™ Split System

Air-Cooled Condensers – 20 to 120 Tons





Introduction

Trane has the right condenser... If you are designing a new system or replacing an existing air-cooled condenser, Trane can satisfy virtually any application need. Whether coupled with an industrial compressor, a single zone commercial self-contained unit, compressor chiller or a Cold Generator™ chiller, Trane has the right air-cooled condenser for the job. When teamed with any one of a wide range of compressor-evaporator combinations, Trane air-cooled condensers, available in 20 to 120 tons, are ideal for multistory office buildings, hotels, schools, municipal and industrial facilities, and more.



Copyright

This document and the information in it are the property of Trane, and may not be used or reproduced in whole or in part without written permission. Trane reserves the right to revise this publication at any time, and to make changes to its content without obligation to notify any person of such revision or change.

Trademarks

All trademarks referenced in this document are the trademarks of their respective owners.

Revision History

- Added Selection Procedure for R-410A chapter.
- Added R-410A to the General Data and Unit Weights tables.



Table of Contents

Features and Benefits	4
20 to 120 Ton Units	4
Durable Construction	4
Microchannel Condenser Coil	4
Voltage Power Supply	4
Application Considerations	5
Unit Location	5
Effect of Altitude on Capacity	5
Ambient Considerations	6
Corrosive Atmospheres	6
Selection Procedures for R-410A	7
Selection Procedures for R-454B	10
Model Number Description	13
General Data	14
Performance Data	15
Performance Adjustment Factors	15
Performance Data	16
Electrical	17
Unit Dimensions	19
Unit Weights	33
Mechanical Specifications	34
Air-Cooled Condenser - Model CAUK	34
Options	34



Features and Benefits

20 to 120 Ton Units

Trane® 20 to 120 ton model CAUK air-cooled condensers have an operating range of 40°F to 115°F, with a low ambient option down to 0°F.

The control panel is factory-installed and wired to prevent potential damage and to provide weathertight protection.

The control panel contains:

- Fan motor contactors
- Fan cycling controls
- Terminal point connection for compressor interlock
- 115-volt control power transformer

These standard features reduce installation costs and provide easy interface with control logic.

All Trane air-cooled condenser coils are an all aluminum microchannel design. The 20 to 30 ton condensers are single circuit; 40 to 120 ton units are dual circuited; all feature integral subcooling.

Units can have optional corrosion protected condenser coil.

Durable Construction

Trane® 20 to 120 ton condensers are built for long life. The unit frame is constructed of 14 gauge galvanized steel. Louvered panels provide excellent coil protection while enhancing unit appearance and strength. The unit surface is finished with Trane slate grey air-dry paint. This air dry-paint finish exceeds 672 consecutive hour salt spray resistance in accordance with ASTM B117.

Microchannel Condenser Coil

Microchannel condensing coils are all-aluminum coils with fully-brazed construction. This design reduces risk of leaks and provides increased coil rigidity — making them more rugged on the jobsite. Their flat streamlined tubes with small ports and metallurgical tube-to-fin bond allow for exceptional heat transfer. Microchannel all-aluminum construction provides several additional benefits:

- Light weight (simplifies coil handling)
- Easy to recycle
- Minimize galvanic corrosion

Figure 1. Microchannel condenser coil

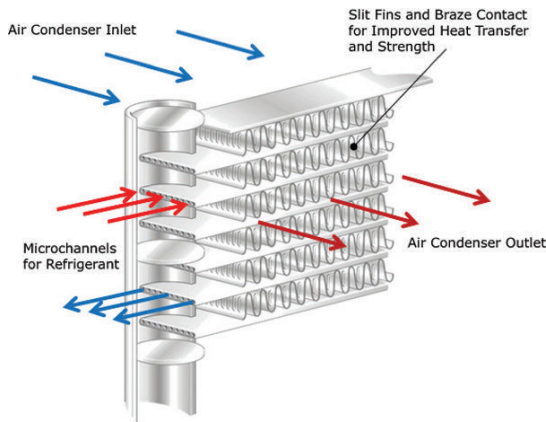

Voltage Power Supply

Four voltage options are available on CAUK 20 to 120 units: 200, 230, 460, and 575V. 380V/50Hz and 415V/50Hz are available as a design special offering.



Application Considerations

Certain application constraints should be considered when sizing, selecting and installing Trane® air-cooled condensers. Unit reliability is dependent upon these considerations. Where your application varies from the guidelines presented, it should be reviewed with the local Trane sales engineer.

Unit Location

Foundation

A base or foundation is not required if the selected unit location is level and strong enough to support the unit's operating weight.

Isolation and Sound Emission

Since the environment in which a sound source is located affects sound pressure, unit placement must be carefully evaluated. The most effective form of noise isolation is proper unit location. Units should be placed away from noise sensitive areas.

Structurally transmitted sound can be reduced by using isolators, which are recommended for sound sensitive installations. For maximum isolation effect, the refrigeration lines and electrical conduit should also be isolated and flexible electrical conduit used.

An acoustical engineer should always be consulted on critical applications.

State and local codes on sound emissions should always be considered.

Airflow Considerations

Unobstructed flow of condenser air is essential for maintaining capacity and operating efficiency. When determining unit placement, careful consideration must be given to assure proper air flow across the condenser heat transfer surface. Inadequate air flow will result in warm air recirculation and coil airflow starvation.

- Warm air recirculation occurs when discharge air from the condenser fans is recycled back at the condenser coil inlet.
- Coil starvation occurs when free air flow to the condenser is restricted.

Both warm air recirculation and coil starvation cause reductions in unit efficiency and capacity. In more severe cases, nuisance unit shutdowns will result from excessive head pressures. Accurate estimates of the degree of efficiency and capacity reduction are not possible due to the unpredictable effect of varying winds.

When hot gas bypass is used, reduced head pressure increases the minimum ambient condition for proper operation. In addition, wind tends to further reduce head pressure. Therefore, it is advisable to protect the air-cooled condensing unit from continuous direct winds exceeding 10 miles per hour.

Debris, trash, supplies, etc., should not be allowed to accumulate in the vicinity of the air-cooled condenser. Supply air movement may draw debris between coil fins and cause coil starvation. Special consideration should be given to units operating in low ambient temperatures. Condenser coils and fan discharge must be kept free of snow and other obstructions to permit adequate air flow for satisfactory unit operation.

Clearances

Adequate service clearance is required for unit access and maintenance. See Dimensions chapter for service clearance recommendations. Local code requirements may take precedence.

Vertical condenser air discharge must be unobstructed. While it is difficult to predict the degree of warm air recirculation, a unit installed with a ceiling or other obstruction above it will lose capacity and the maximum ambient operation will be reduced. Nuisance high head pressure trips may also occur.

The inlet to the coil must also be unobstructed. A unit installed closer than the minimum recommended distance to a wall or other vertical riser may experience a combination of coil starvation and warm air recirculation, resulting in unit capacity and efficiency reductions, as well as possible excessive head pressures. The recommended lateral distances are listed in the ["Unit Dimensions,"](#) p. 19.

Effect of Altitude on Capacity

Capacities given in the performance data tables are at sea level. At elevations substantially above sea level, the decreased air density will decrease condenser capacity. The adjustment factors shown in can be applied directly to the catalog performance data to determine the unit's adjusted performance.



Application Considerations

Ambient Considerations

Trane condensers are designed for year-around applications in ambients from 0°F through 115°F. For operation below 0°F or above 115°F, contact the local Trane sales office.

Start-up and operation at lower ambients requires sufficient head pressure be maintained for proper operation. Minimum operating ambient temperatures for standard unit selections and units with hot gas bypass are shown in the “General Data,” p. 14. These temperatures are based on still conditions (winds not exceeding five mph.) Greater wind velocities will result in a drop in head pressure, therefore, increasing the minimum starting and operating ambient temperatures.

Units with the low ambient option are capable of starting and operating in ambients down to 0°F, 10°F with hot gas bypass. Optional low ambient units use a low ambient controller that maintains head pressure within an acceptable range when ambient temperature falls below 50°F. The low ambient controller reads discharge pressure from the refrigeration circuit and “cycles” the outdoor fan motor on and off to maintain the desired discharge pressure at the selected setpoint anytime the compressor is operating.

Maximum cataloged ambient temperature operation of a standard condenser is 115°F. Operation at design ambients above 115°F can result in excessive head pressures.

For proper operation outside these recommendations, contact the local Trane sales office.

Corrosive Atmospheres

Trane's large condensers are designed and built to industrial standards and will perform to those standards for an extended period depending on the hours of use, the quality of maintenance performed, and the regularity of that maintenance. One factor that can have an adverse effect on unit life is its operation in a corrosive environment. Since the microchannel condenser coil is an all-aluminum design, it provides a high level of corrosion protection on its own. Uncoated, it withstands a salt spray test in accordance with ASTM B117 for 1,000 hours. When condensers are operated in highly corrosive environments, Trane recommends the corrosion protected condenser coil option. This corrosion protection option meets the most stringent testing in the industry, including ASTM B117 Salt Spray test for 6,000 hours and ASTM G85A2 Cyclic Acidified Salt Fog test for 2,400 hours. The acid fog test is the most stringent available today. This coating is added after coil construction covering all tubes, headers, fins and edges. The design provides superior protection from any corrosive agent.

Note: *Field coating is not allowed on microchannel coils.*

The exterior panels are durable enough to withstand a minimum of 672 hours consecutive salt spray application in accordance with standard ASTM B117. All screws are coated with zinc-plus-zinc chromate.



Selection Procedures for R-410A

When manually matching condensers with compressors, performance cross plotting becomes necessary. The following procedure should be used to determine the correct condenser.

1. Determine the total cooling load. Make a preliminary compressor selection based on the expected evaporator SST and condensing temperature.

Example

Given: Total cooling load = 101 tons (1212 Mbh) Design outdoor temperature = 95°F

Assume: Evaporator SST = 45°F (used in this example - application dependent) Condenser SCT between 115°F and 125°F (20-30°F ITD SCT-ambient)

2. Select compressors from manufacturer's data to meet the load at the evaporator SST (for chiller low suction applications contact Trane applications).

Table 1. Compressor capacity with subcooling

(Qty 2) CSHN611 Trane R-410A Trio Scrolls Performance data includes 15°F subcooling			
SST	SCT	Tons	Mbh
45	115	110	1320
45	125	103	1236

Notes:

1. SST = Saturated Suction Temperature
2. SCT = Saturated Condensing Temperature

3. Remove the subcooling effect from the compressor performance at two or more compressor capacity points.
 - a. R-410A capacity increases 0.75% for every degree of subcooling ($0.75\% \times 15^\circ\text{F} = 11.25\%$).
 - b. If compressor performance is at 15°F subcooling, divide capacity by 1.1125 to get capacity at 0°F subcooling.
 - c. Plot these two points (SCT vs. compressor tons at 0°F subcooling) as shown in the selection example. See [Figure 2, p. 7](#).

Figure 2. Selection example

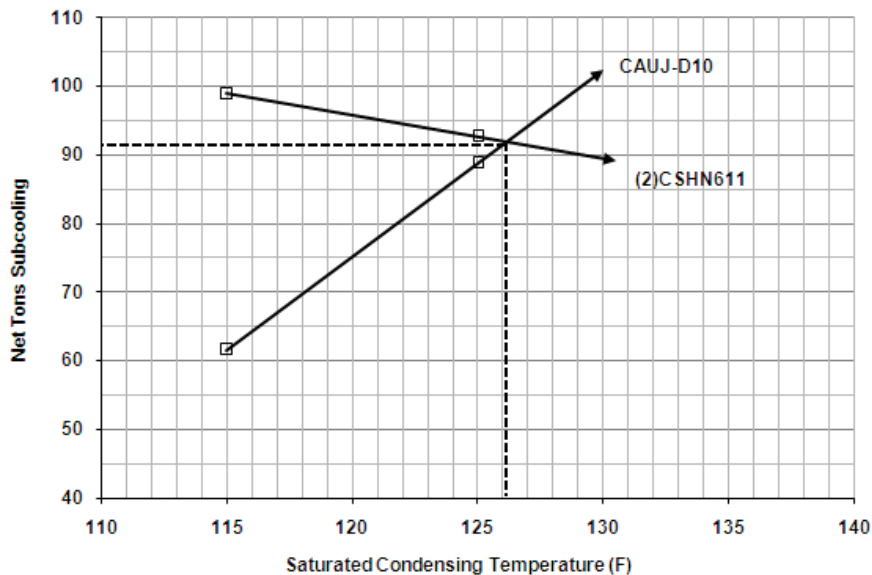



Selection Procedures for R-410A

Table 2. Compressor capacity with subcooling removed

SST ^(a)	SCT ^(b)	(Qty 2) CSHN611 Trane R-410A Trio Scrolls			
		Capacity			
		15°F subcooling		0°F subcooling	
		Tons	Mbh	Tons	Mbh
45	115	110	1320	98.9	1187
45	125	103	1236	92.6	1111

^(a) SST = Saturated Suction Temperature

^(b) SCT = Saturated Condensing Temperature

- Select a condenser on the Condenser Heat Rejection graph in Performance Data chapter and read two condenser-only heat rejection points.
- Divide the condenser heat rejection by the compressor N factor found in [Table 3, p. 8](#) to convert from heat rejection to net capacity (Net Tons Less Subcooling).

Note: The N factor equals the ratio of compressor heat rejection divided by compressor capacity at 0°F subcooling.

Table 3. N factor - Trane R-410A scroll compressors

Sat cond temp °F	Saturated suction temperature, °F				
	30	35	40	45	50
110	1.33	1.30	1.27	1.24	1.22
115	1.36	1.33	1.30	1.27	1.25
120	1.40	1.36	1.33	1.30	1.27
125	1.45	1.40	1.37	1.33	1.30
130	1.50	1.45	1.41	1.37	1.34
135	1.57	1.51	1.46	1.41	1.37
140	1.64	1.57	1.51	1.46	1.42
145	1.73	1.65	1.58	1.53	1.48

- Plot these two points (SCT vs. Net Tons at 0°F subcooling) as shown in [Figure 2, p. 7](#) selection example.

Table 4. Condenser net capacity Mbh (less subcooling)

Assumed ΔT°F ITD (SCT - ambient)	Ambient °F	SCT °F	Cond only heat rejection Mbh	N factor	Net capacity less subcooling	
					Mbh	Tons
20	95	115	938	1.27	739	61.5
30	95	125	1418	1.33	1066	88.8

Notes:

- ITD = Initial Temperature Difference
- SCT = Saturated Condensing Temperature
- N Factor = Compressor Efficiency Ratio

- As shown on [Figure 2, p. 7](#), draw a line through the points representing the compressor capacity at 0°F subcooling.
- Draw a line through the points representing condenser net capacity less subcooling.
- At the point of intersection of the compressor and condenser lines, draw dashed lines to the left and bottom margins as shown in [Figure 2, p. 7](#). The end points of these lines will show a resultant gross capacity of 92 tons at 126.1°F condensing temperature.
- From the condenser heat rejection increase graph:
 - Calculate the percent increase in total heat rejection due to subcooling
 - Multiply by the N factor from [Table 3, p. 8](#) to get the percent increase in net capacity due to subcooling.

Example (using a 100T condenser):

- At **95°F** ambient and **126.1°F** condensing temperature, the condenser heat rejection increase graph shows a **7.8%** increase in total heat rejection due to subcooling.
- N factor table shows a 1.34 N factor by linear interpolation.
- This yields a system capacity of **92 tons** x (1 + **7.8%** x **1.34**) = **102 tons**.

11. If necessary, use the values in the Altitude Correction Multiplier table to adjust the system capacity for altitude.

12. Compare this result with the design capacity and condensing temperature.

Note: *In the example above, the required cooling load is 101 tons. Therefore, the 100T CAUJ is the proper selection.*

13. Repeat [Step 2](#) through [Step 13](#) [Step 12](#) above as necessary to achieve the most economic condenser selection.

Note: *Evaporator selection must also meet performance requirements. For this example, the evaporator needs to provide at least 105 tons at 45°SST. A conservative estimate for liquid temperature entering the evaporator is the SCT minus the design subcooling (125.1 - 15°F = 110.1°F for the example above). Contact Trane Applications if excessive refrigerant line lengths or pressure drops are required.*



Selection Procedures for R-454B

When manually matching condensers with compressors, performance cross plotting becomes necessary. The following procedure should be used to determine the correct condenser.

1. Determine the total cooling load. Make a preliminary compressor selection based on the expected evaporator SST and condensing temperature.

Example

Given: Total cooling load = 101 tons (1212 Mbh) Design outdoor temperature = 95°F

Assume: Evaporator SST = 45°F (used in this example - application dependent) Condenser SCT between 115°F and 125°F (20-30°F ITD SCT-ambient)

2. Select compressors from manufacturer's data to meet the load at the evaporator SST (for chiller low suction applications contact Trane applications).

Table 5. Compressor capacity with subcooling

(Qty 2) CSHP593 Trane R-454B Trio Scrolls Performance data includes 15°F subcooling			
SST	SCT	Tons	Mbh
45	115	110	1321
45	125	103	1239

Notes:

1. SST = Saturated Suction Temperature
2. SCT = Saturated Condensing Temperature

3. Remove the subcooling effect from the compressor performance at two or more compressor capacity points.
 - a. R-454B capacity increases **0.59%** for every degree of subcooling (**0.59% x 15°F=8.88%**) and R-410A capacity increases 0.75% for every degree of subcooling (0.75% x 15°F = 11.25%).
 - b. If compressor performance is at 15°F subcooling, divide capacity by **1.0888 for R-454B** and by **1.1125 for R-410A** to get capacity at 0°F subcooling.
 - c. Plot these two points (SCT vs. compressor tons at 0°F subcooling) as shown in the selection example. See below figure.

Figure 3. Selection example

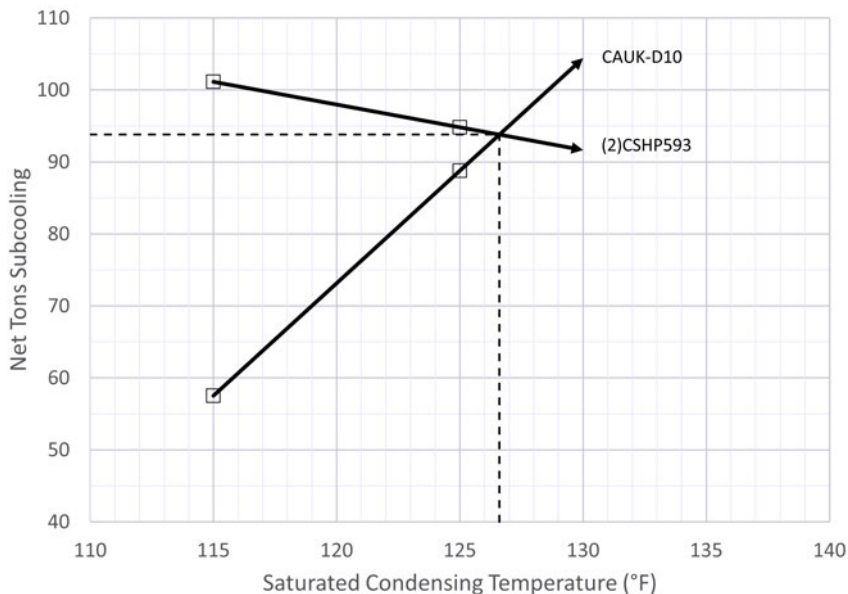

Table 6. Compressor capacity with subcooling removed

SST ^(a)	SCT ^(b)	(Qty 2) CSHP593 Trane R-454B Trio Scrolls			
		Capacity			
		15°F subcooling		0°F subcooling	
		Tons	Mbh	Tons	Mbh
45	115	110	1321	101	1214
45	125	103	1239	95	1138

^(a) SST = Saturated Suction Temperature

^(b) SCT = Saturated Condensing Temperature

- Select a condenser on the Condenser Heat Rejection graph in Performance Data chapter and read two condenser-only heat rejection points.
- Divide the condenser heat rejection by the compressor N factor found in [Table 7, p. 11](#) to convert from heat rejection to net capacity (Net Tons Less Subcooling).

Note: The N factor equals the ratio of compressor heat rejection divided by compressor capacity at 0°F subcooling.

Table 7. N factor - Trane R-454B scroll compressors

Sat cond temp °F	Saturated suction temperature, °F				
	30	35	40	45	50
110	1.30	1.27	1.24	1.22	1.20
115	1.33	1.30	1.27	1.24	1.22
120	1.36	1.33	1.30	1.27	1.24
125	1.40	1.36	1.33	1.30	1.27
130	1.45	1.41	1.37	1.33	1.30
135	1.50	1.45	1.41	1.37	1.33
140	1.56	1.51	1.46	1.41	1.37
145	1.64	1.57	1.51	1.46	1.42

- Plot these two points (SCT vs. Net Tons at 0°F subcooling) as shown in selection example.

Table 8. Condenser net capacity Mbh (less subcooling)

Assumed ΔT°F ITD (SCT - ambient)	Ambient °F	SCT °F	Cond only heat rejection Mbh	N factor	Net capacity less subcooling	
					Mbh	Tons
20	95	115	857	1.24	690	57.5
30	95	125	1382	1.30	1065	88.8

Notes:

- ITD = Initial Temperature Difference
- SCT = Saturated Condensing Temperature
- N Factor = Compressor Efficiency Ratio

- As shown on [Figure 3, p. 10](#), draw a line through the points representing the compressor capacity at 0°F subcooling.
- Draw a line through the points representing condenser net capacity less subcooling.
- At the point of intersection of the compressor and condenser lines, draw dashed lines to the left and bottom margins as shown in [Figure 3, p. 10](#). The end points of these lines will show a resultant gross capacity of **93.8 tons** at **126.6°F** condensing temperature.
- From the condenser heat rejection increase graph:
 - Calculate the percent increase in total heat rejection due to subcooling
 - Multiply by the N factor from [Table 7, p. 11](#) to get the percent increase in net capacity due to subcooling.



Selection Procedures for R-454B

Example (using a 100T condenser):

- At 95°F ambient and 126.6°F condensing temperature, the condenser heat rejection increase graph shows a 6.5% increase in total heat rejection due to subcooling.
- N factor table shows a 1.31 N factor by linear interpolation.
- This yields a system capacity of 93.8 tons $\times (1 + 6.5\% \times 1.31) = 102$ tons

11. If necessary, use the values in the Altitude Correction Multiplier table to adjust the system capacity for altitude.

12. Compare this result with the design capacity and condensing temperature.

Note: In the example above, the required cooling load is 102 tons. Therefore, the 100T CAUK is the proper selection.

13. Repeat [Step 2](#) through [Step 12](#) as necessary to achieve the most economic condenser selection.

Note: Evaporator selection must also meet performance requirements. For this example, the evaporator needs to provide at least 105 tons at 45°SST. A conservative estimate for liquid temperature entering the evaporator is the SCT minus the design subcooling ($126.6 - 15^\circ\text{F} = 111.1^\circ\text{F}$ for the example above). Contact Trane Applications if excessive refrigerant line lengths or pressure drops are required.



Model Number Description

Digit 1 — Unit Type

C = Condenser

Digit 2 — Condenser

A = Air-Cooled

Digit 3 — System Type

U = Upflow

Digit 4 — Development Sequence

K = Fourth

Digit 5, 6, 7 — Nominal Capacity

C20 = 20 Tons
C25 = 25 Tons
C30 = 30 Tons
C40 = 40 Tons
C50 = 50 Tons
C60 = 60 Tons
C80 = 80 Tons
D10 = 100 Tons
D12 = 120 Tons

Digit 8 — Voltage and Start Characteristics

E = 200/60/3
F = 230/60/3
4 = 460/60/3
5 = 575/60/3
* = 380/50/3
* = 415/50/3

Digit 9 — Condenser Circuit

1 = Single
2 = Dual

Digit 10 — Design Sequence

Factory Assigned

Digit 11 — Ambient Control

0 = Standard
1 = 0°F (Low Ambient Option)

Digit 12 — Agency Approval

0 = None
3 = cULus (60 Hz only)

Digit 13 — Not used

0 = Not used

Digit 14 — Not used

0 = Not used

Digit 15 — Not used

0 = Not used

Digit 16 — Not used

0 = Not used

Digit 17 — Not used

0 = Not used

Digit 18 — Corrosion Protected Condenser Coil

0 = None
J = Corrosion Protected Condenser Coil

Digit 19 — Not used

0 = Not used

Digit 20 — Isolators

0 = None
1 = Spring Isolator
2 = Neoprene Isolators

Digit 21 — Unpowered Convenience Outlet

0 = None
2 = Unpowered 20A Convenience Outlet

Digit 22 — Not used

0 = Not used

Digit 23 — Not used

0 = Not used

Digit 24 — Not used

0 = Not used

Digit 25 — Not used

0 = Not used

Digit 26 — Not used

0 = Not used

Digit 27 — Refrigerant Type

A = R-410A
B = R-454B

Notes:

1. The service digit for each model number contains 26 digits. All 26 digits must be referenced.
2. * = Design special.



General Data

Table 9. General data — CAUK condensers

Unit Size (tons)		20	25	30	40	50	60	80	100	120
Condenser Fan Data										
Type/Drive Type		Prop/Direct								
Qty		2	3	3	4	6	6	8	12	12
Diameter	in	26	26	26	26	26	26	26	26	26
Power/motor	hp	1	1	1	1	1	1	1	1	1
Nominal Total Airflow	cfm	14600	20700	20700	26790	36890	40490	56490	73890	76280
Condenser Coil Data										
Type		Microchannel								
Number of Coils		2	2	2	2	2	2	4	4	4
Size	in	42x71	42x71	42x71	59x71	51x96	51x96	59x71	51x96	64x96
Face Area	ft ²	41.4	41.4	41.4	58.2	68	68	116.4	136	170.7
Rows/Fin Per Ft.		1/240	1/240	1/240	1/240	1/240	1/240	1/240	1/240	1/240
Storage Capacity R-410A ^(a)	lbs	18.7	18.7	18.7	23.5	25	25	47.1	50	62.9
Storage Capacity R-454B ^(a)	lbs	11.5	11.5	11.5	22.9	23.9	23.9	45.7	47.8	60.2
Refrigerant Data^(b)										
Type										
Operating Charge R-410A ^(c)	lbs	11.9	11.8	11.8	22.7	23.4	23.8	57.1	59.1	65.3
Operating Charge R-454B ^(c)	lbs	6.8	6.7	8	13.8	14	14.7	38.2	38.2	41.1
Outdoor Air Temperature for Mechanical Cooling										
Standard Ambient Operating Range	°F	40-115	40-115	40-115	40-115	40-115	40-115	40-115	40-115	40-115
Low Ambient Option	°F	0-115	0-115	0-115	0-115	0-115	0-115	0-115	0-115	0-115

^(a) Condenser storage capacity is given at conditions of 95°F outdoor temperature, and 95% full.

^(b) Refer to Refrigerant Piping in the Application Considerations section. Condensing units are shipped with nitrogen holding charge only.

^(c) Operating charge is approximate for condensing unit only, and does not include charge for low side or interconnecting lines. Condensing units are shipped with a nitrogen holding charge only.



Performance Data

Performance Adjustment Factors

Figure 4. Condenser heat rejection increase due to subcooling (R-410A)

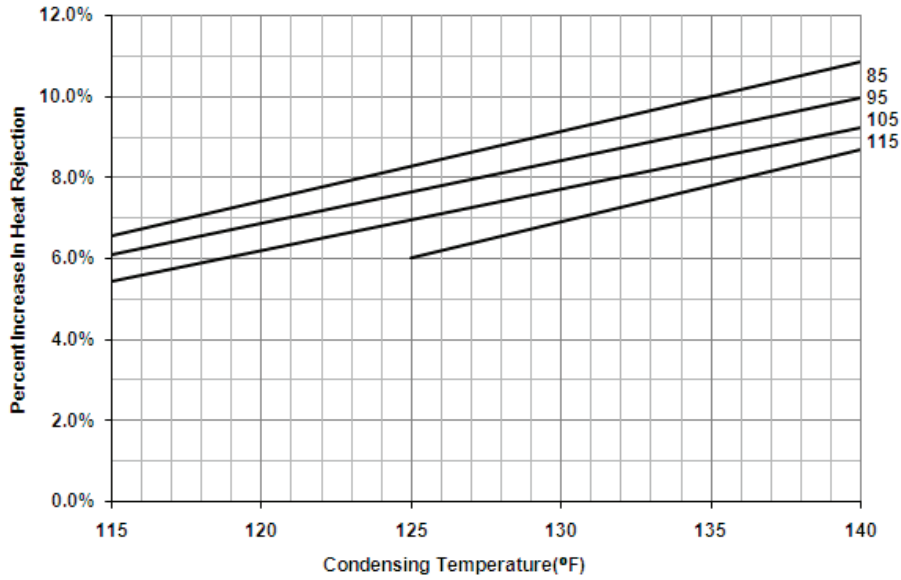
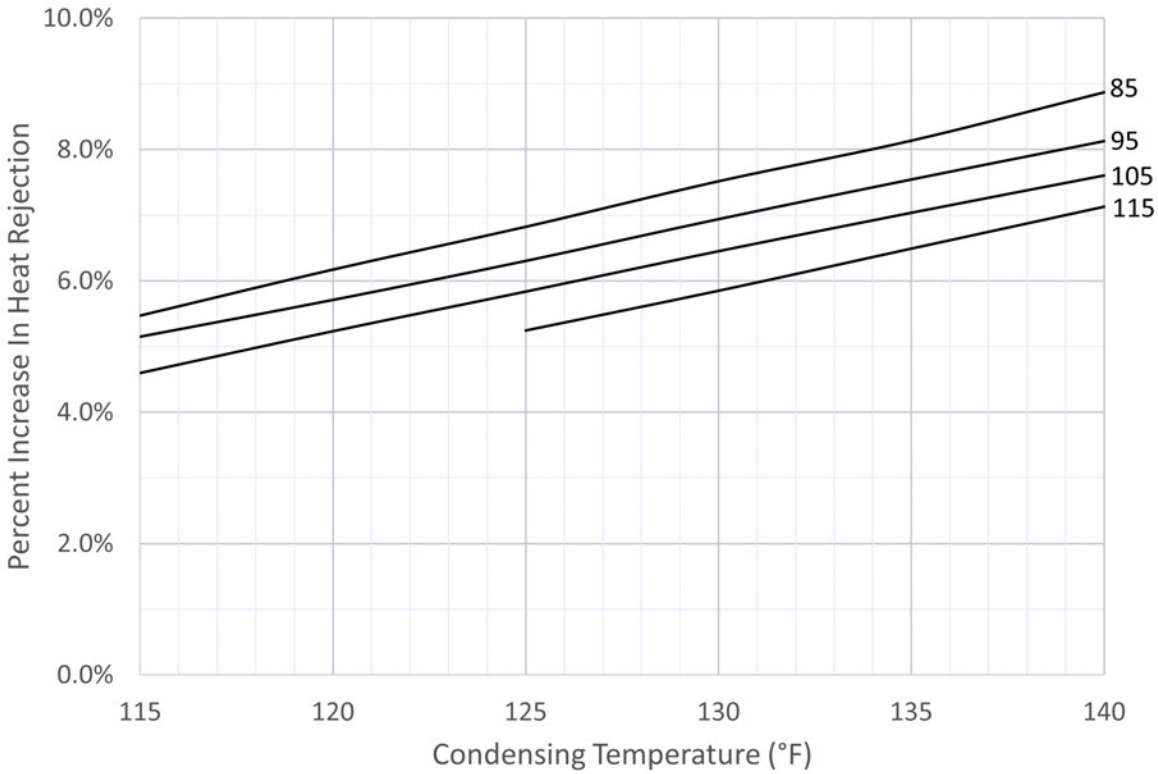

Figure 5. Condenser heat rejection increase due to subcooling (R-454B)





Performance Data

Table 10. Altitude correction multiplier for cooling capacity — air-cooled condenser

Altitude (ft)	2,000	4,000	6,000	8,000	10,000
Correction Multiplier	0.977	0.949	0.917	0.881	0.843

Performance Data

Figure 6. Condenser heat rejection (R-410A/R-454B) — 20 to 120 tons

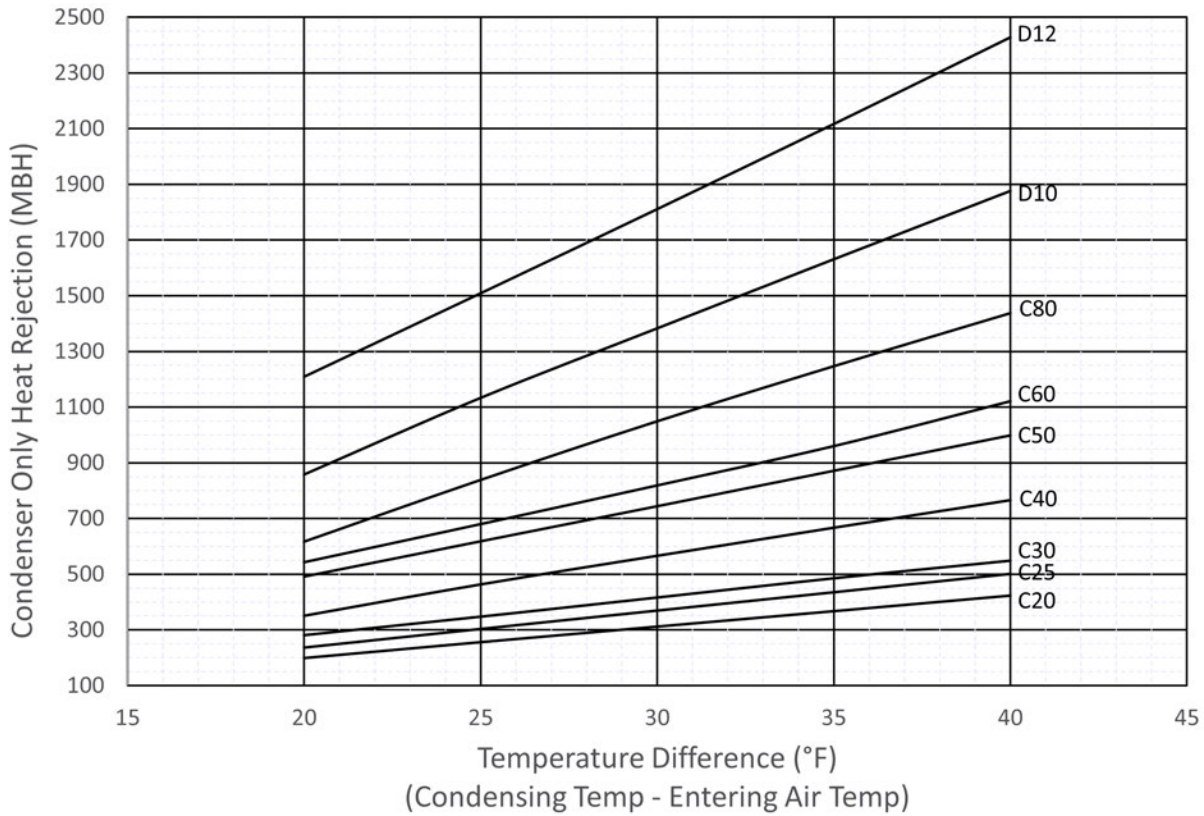



Electrical

Note: Local codes may take precedence.

Table 11. CAUK electrical data

Unit Size (Ton)	Rated Voltage ^(a)	Condenser Fan Motor ^(b)		CPT Amps	Unit Characteristics	
		Qty	FLA		MCA ^(c)	MOP ^(d)
20	200/60/3	2	4.1	1	11	15
	230/60/3	2	4.1	1	11	15
	460/60/3	2	1.8	1	6	15
	575/60/3	2	1.4	1	5	15
25	200/60/3	3	4.1	1	15	15
	230/60/3	3	4.1	1	15	15
	460/60/3	3	1.8	1	7	15
	575/60/3	3	1.4	1	6	15
30	200/60/3	3	4.1	1	15	15
	230/60/3	3	4.1	1	15	15
	460/60/3	3	1.8	1	7	15
	575/60/3	3	1.4	1	6	15
40	200/60/3	4	4.1	1	19	20
	230/60/3	4	4.1	1	19	20
	460/60/3	4	1.8	1	9	15
	575/60/3	4	1.4	1	7	15
50	200/60/3	6	4.1	1	27	30
	230/60/3	6	4.1	1	27	30
	460/60/3	6	1.8	1	13	15
	575/60/3	6	1.4	1	10	15
60	200/60/3	6	4.1	1	27	30
	230/60/3	6	4.1	1	27	30
	460/60/3	6	1.8	1	13	15
	575/60/3	6	1.4	1	10	15
80	200/60/3	8	4.1	1	35	35
	230/60/3	8	4.1	1	35	35
	460/60/3	8	1.8	1	16	20
	575/60/3	8	1.4	1	13	15
100	200/60/3	12	4.1	1	52	60
	230/60/3	12	4.1	1	52	60
	460/60/3	12	1.8	1	24	25
	575/60/3	12	1.4	1	19	20



Electrical

Table 11. CAUK electrical data (continued)

Unit Size (Ton)	Rated Voltage ^(a)	Condenser Fan Motor ^(b)		CPT Amps	Unit Characteristics	
		Qty	FLA		MCA ^(c)	MOP ^(d)
120	200/60/3	12	4.1	1	52	60
	230/60/3	12	4.1	1	52	60
	460/60/3	12	1.8	1	24	25
	575/60/3	12	1.4	1	19	20

^(a) Voltage Utilization Range is +/- 10% of Rated voltage (use range): 200/60/3 (180-220), 230/60/3 (207-253), 460/60/3 (414-506), 575/60/3 (518-633).

^(b) Electrical information is for each individual motor.

^(c) Minimum circuit ampacity (MCA) is 125 percent of the FLA of one motor plus the total FLA of the remaining motors and CPT amps.

^(d) Maximum Overcurrent Protection Device permitted by NEC 440-22 is 225 percent of the FLA of one motor plus the total FLA of the remaining motors and CPT amps.

Unit Dimensions

Figure 7. Air-cooled condenser — 20 ton

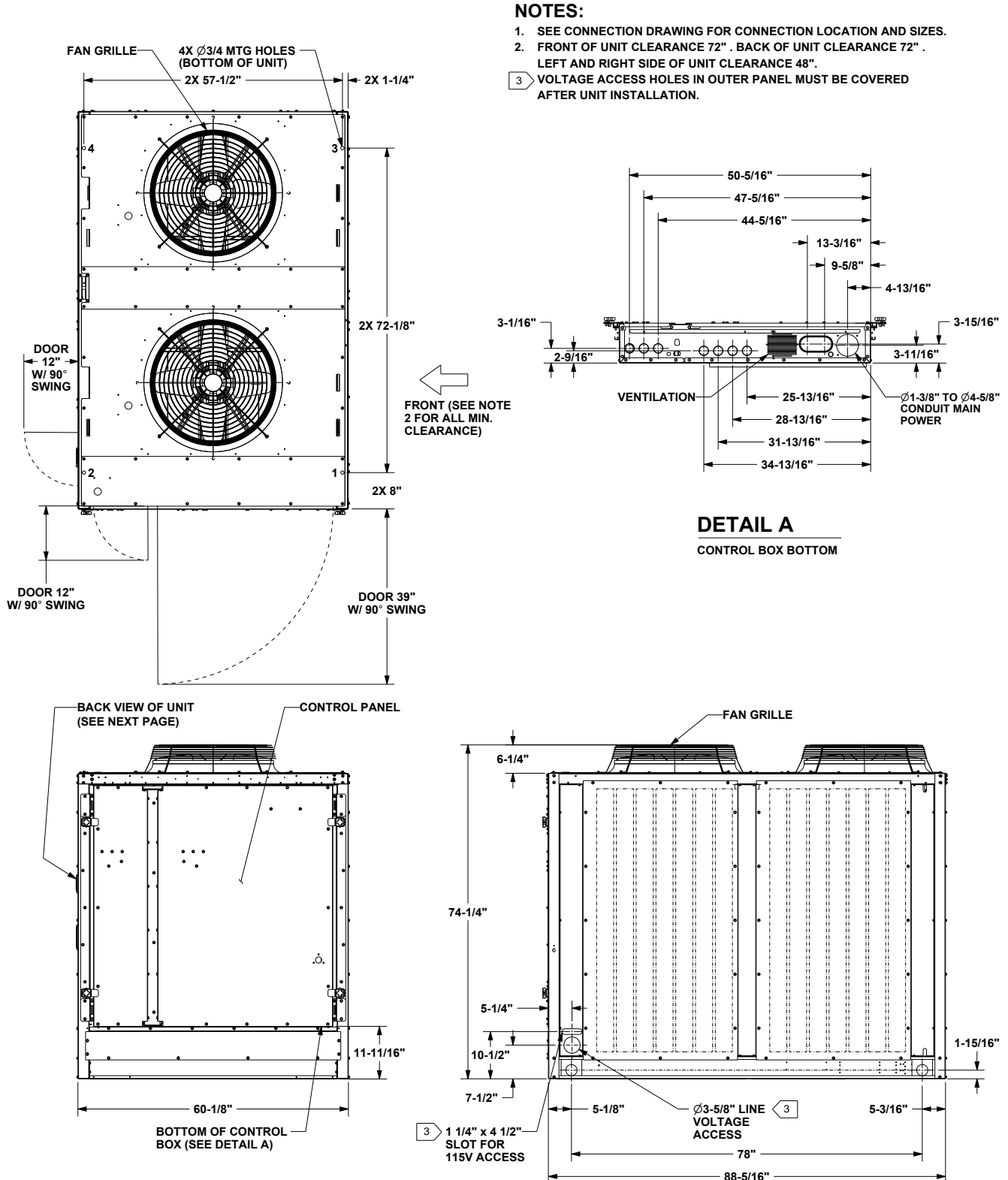



Unit Dimensions

Figure 8. Air-cooled condenser connections — 20 ton

CONTROL PANEL SIDE

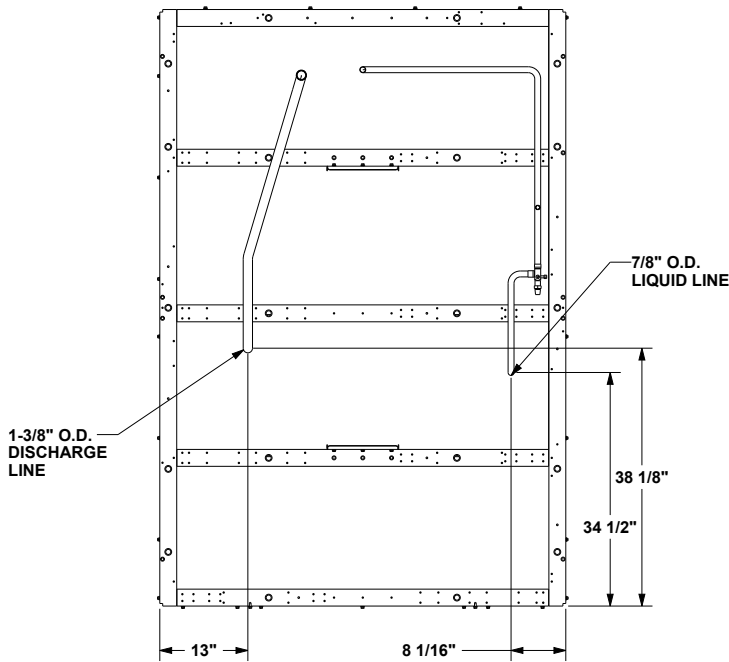

PLAN VIEW OF UNIT
CONNECTION DRAWING

NOTES:

1. VERIFY WEIGHT, CONNECTION, AND ALL DIMENSIONS WITH INSTALLER DOCUMENTS BEFORE INSTALLATION.
2. OPTIONS ONLY COME ON SELECTED UNITS.

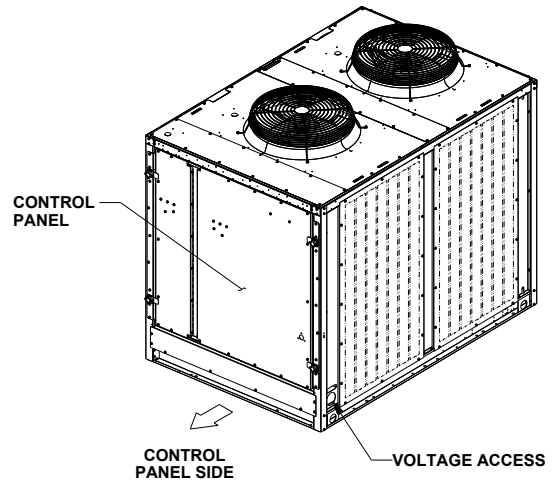

ORIENTATION VIEW OF UNIT
ISOMETRIC DRAWING

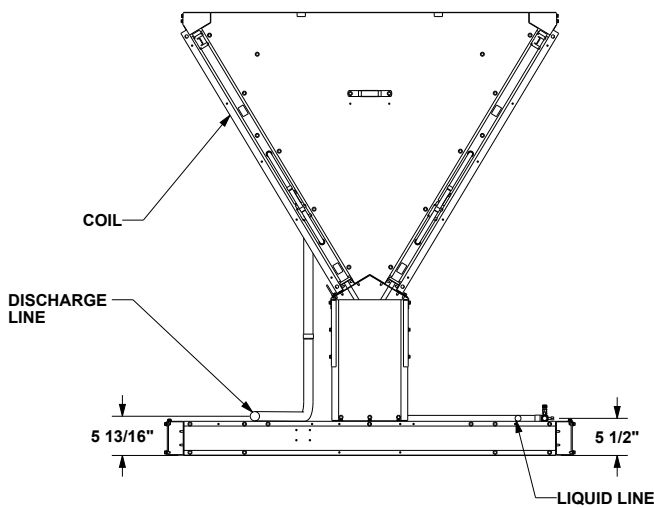

VIEW OPPOSITE OF CONTROL PANEL
CONNECTION DRAWING

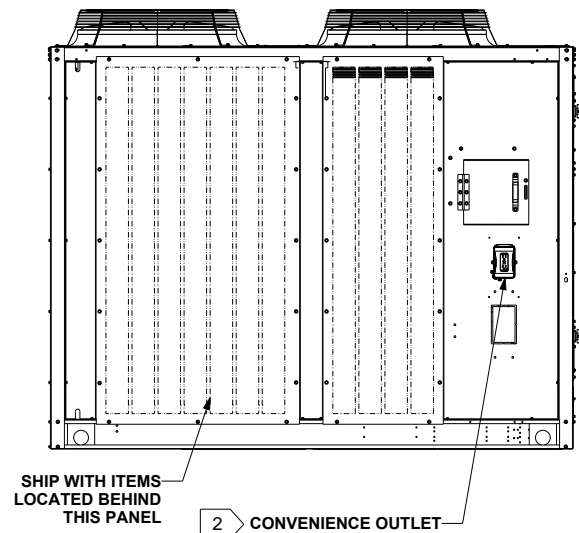

BACK VIEW OF UNIT

20 TON UNIT
DIMENSION CONNECTION DRAWING

Figure 9. Air-cooled condenser — 25 and 30 tons

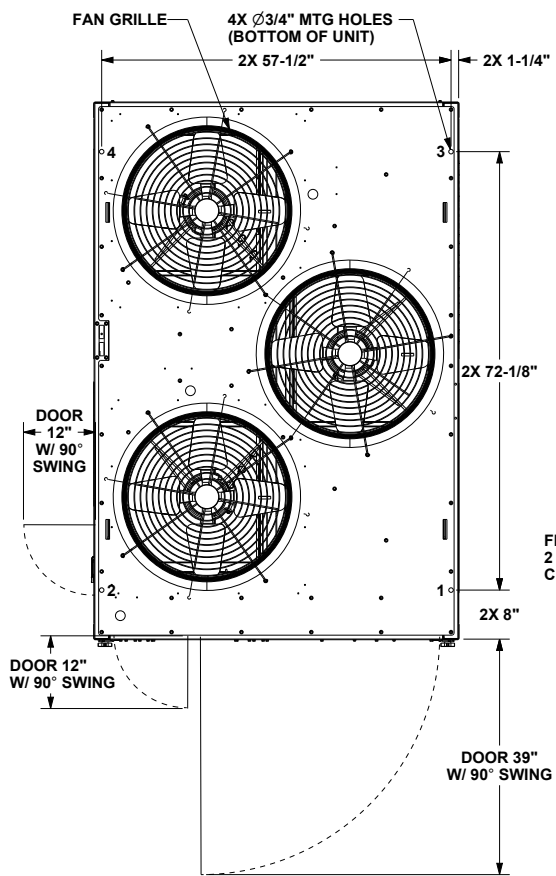

NOTES:

1. SEE CONNECTION DRAWING FOR CONNECTION LOCATION AND SIZES.
2. FRONT OF 25 AND 30 UNIT CLEARANCE 72". BACK OF UNIT CLEARANCE 72". LEFT AND RIGHT SIDE OF 25 AND 30 UNIT CLEARANCE 48"
3. VOLTAGE ACCESS HOLES IN OUTER PANEL MUST BE COVERED AFTER UNIT INSTALLATION

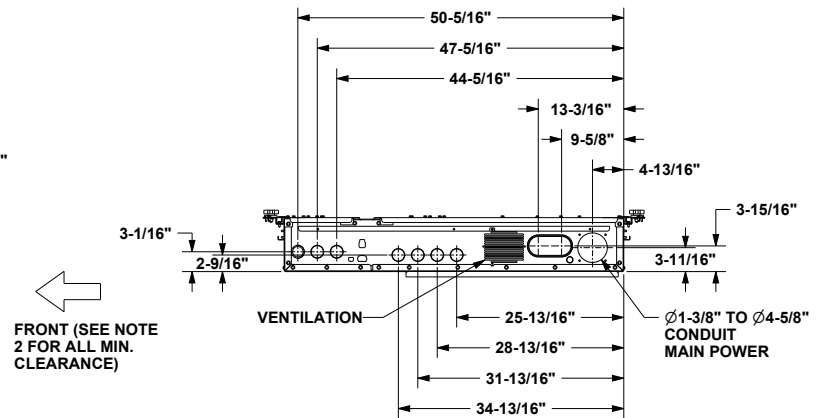

DETAIL A

CONTROL BOX BOTTOM

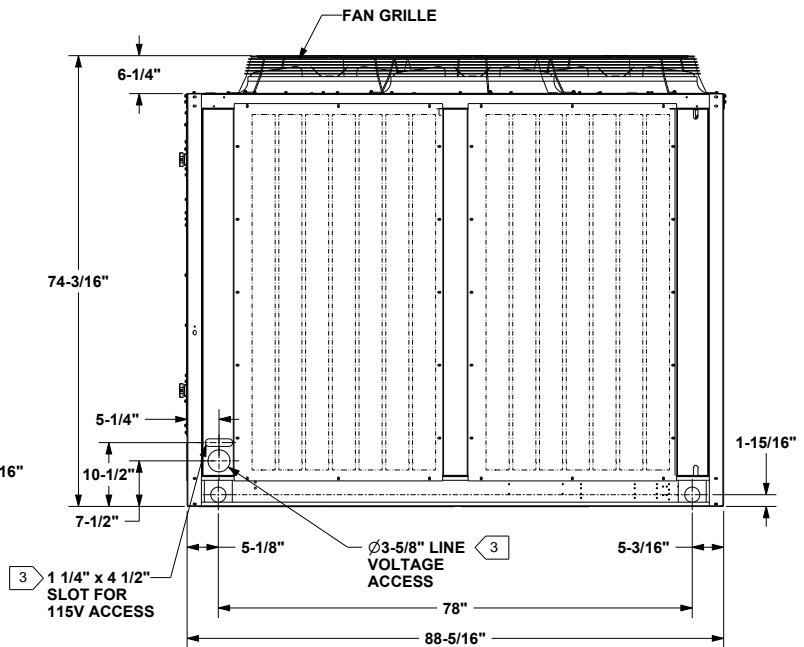
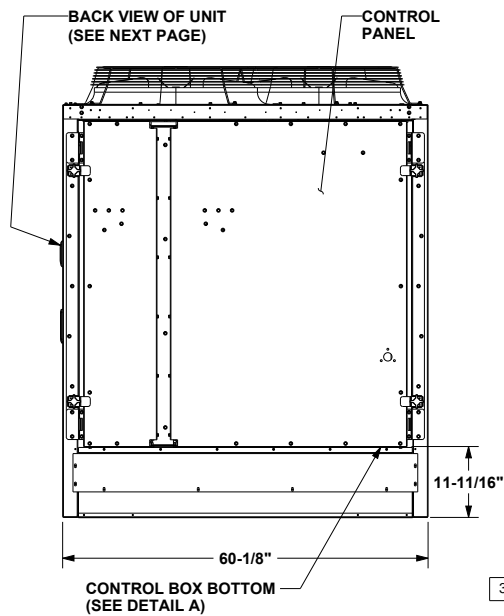



Unit Dimensions

Figure 10. Air-cooled condenser connections — 25 and 30 tons

CONTROL PANEL SIDE



NOTES:

- 1. VERIFY WEIGHT, CONNECTION, AND ALL DIMENSIONS WITH INSTALLER DOCUMENTS BEFORE INSTALLATION.
- 2. OPTIONS ONLY COME ON SELECTED UNITS.

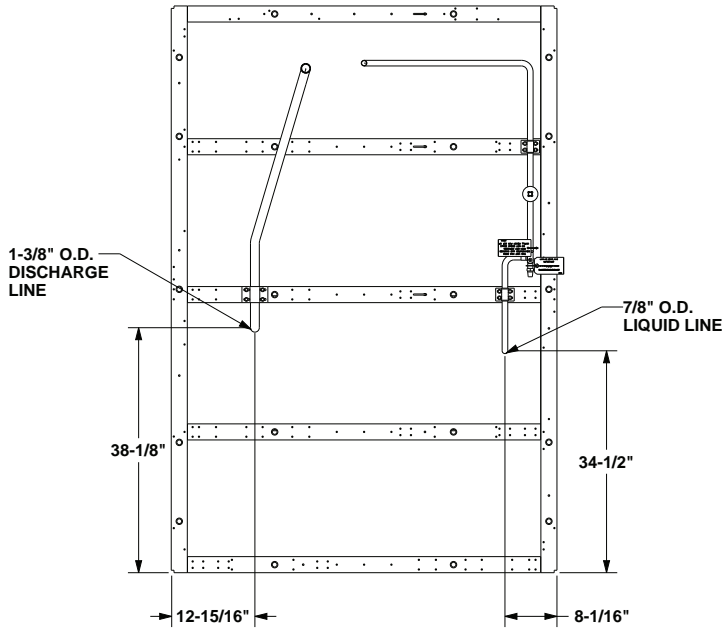

PLAN VIEW OF UNIT

CONNECTION DRAWING

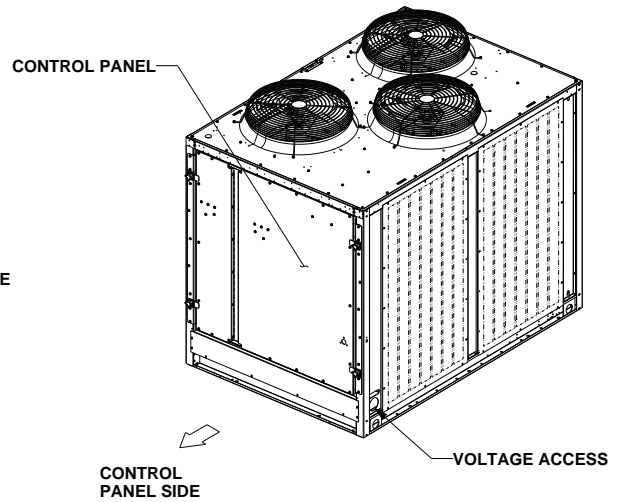

ORIENTATION VIEW OF UNIT

ISOMETRIC DRAWING

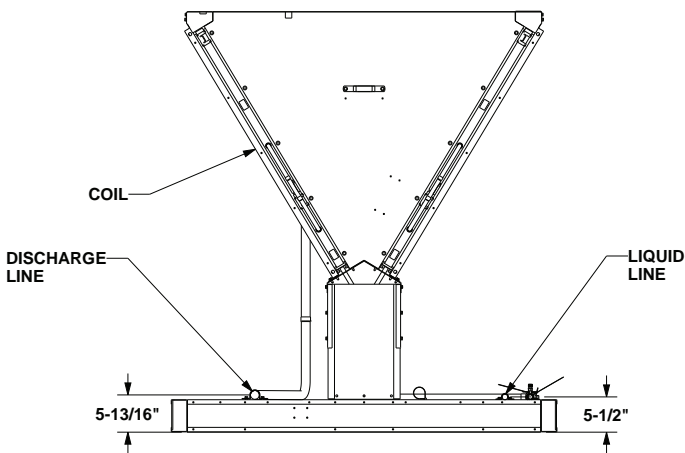

VIEW OPPOSITE OF CONTROL PANEL

CONNECTION DRAWING

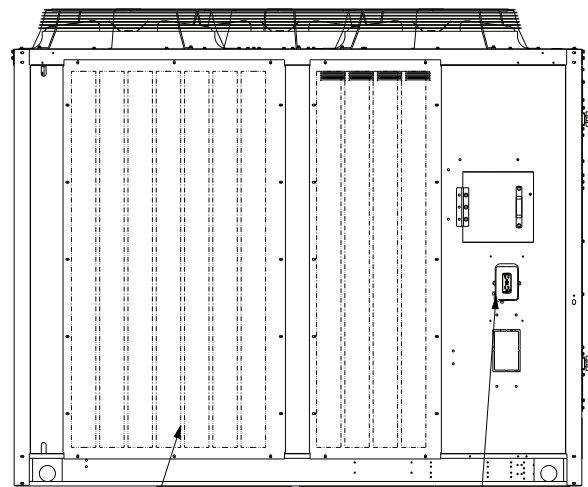

BACK VIEW OF UNIT

Figure 11. Air-cooled condenser — 40 ton

NOTES:

1. SEE CONNECTION DRAWING FOR CONNECTION LOCATION AND SIZES.
2. OPTIONS ONLY COME ON SELECTED UNITS.
3. FRONT AND BACK OF UNIT CLEARANCE 72" . LEFT AND RIGHT SIDE OF UNIT CLEARANCE 48"
4. VOLTAGE ACCESS HOLES IN OUTER PANEL MUST BE COVERED AFTER UNIT INSTALLATION

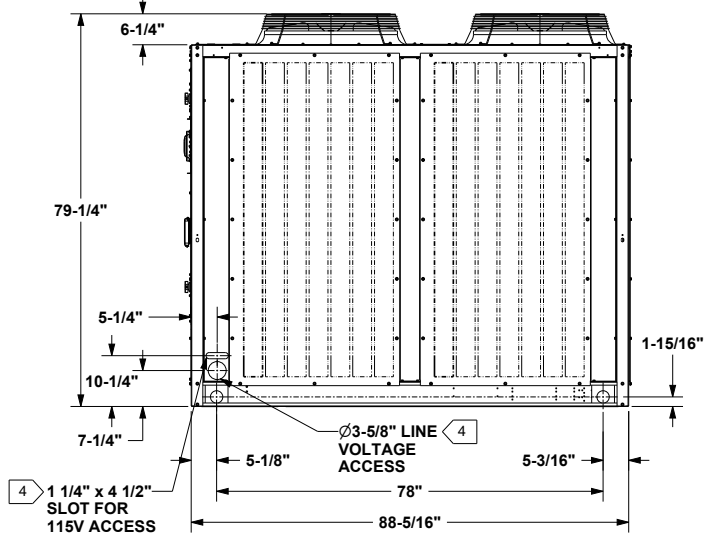
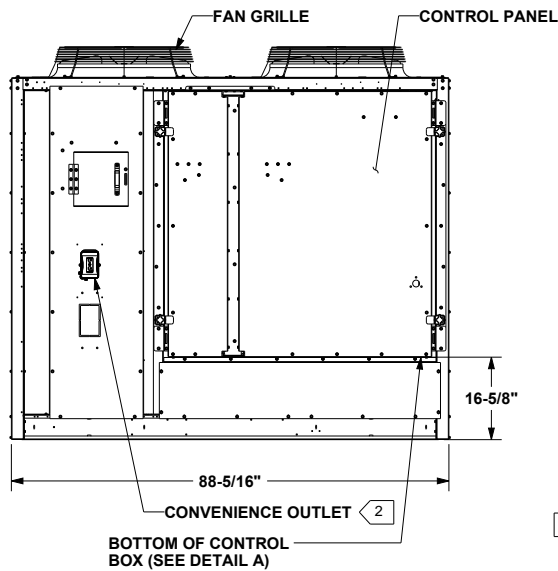
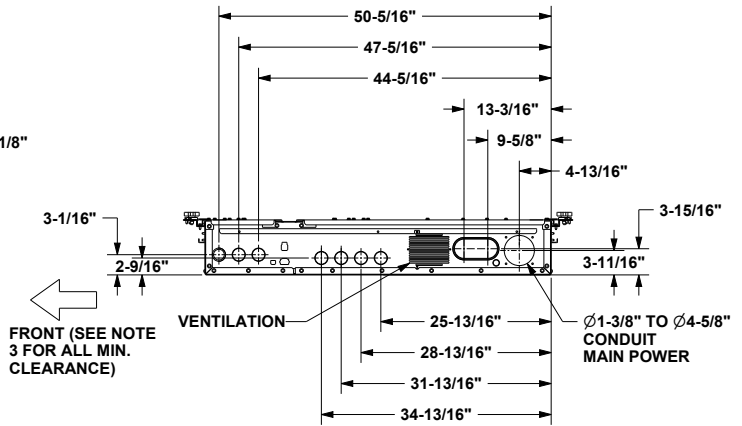
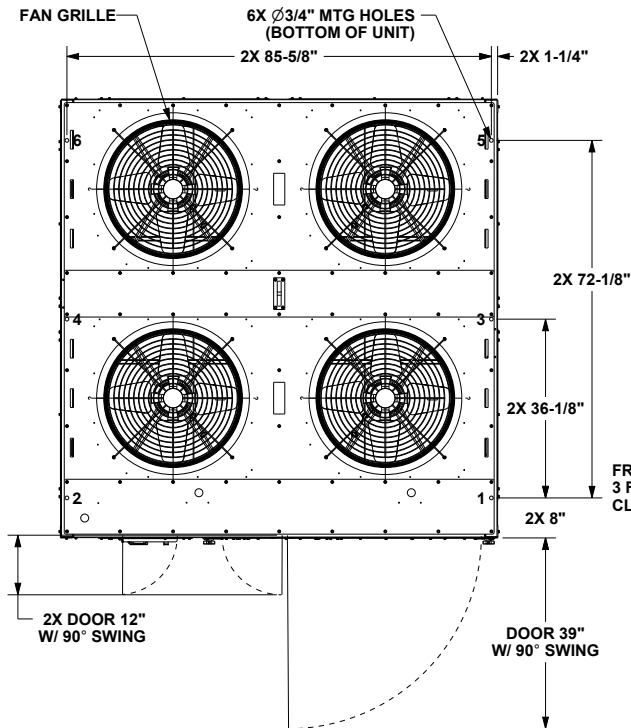



Unit Dimensions

Figure 12. Air-cooled condenser connections — 40 ton

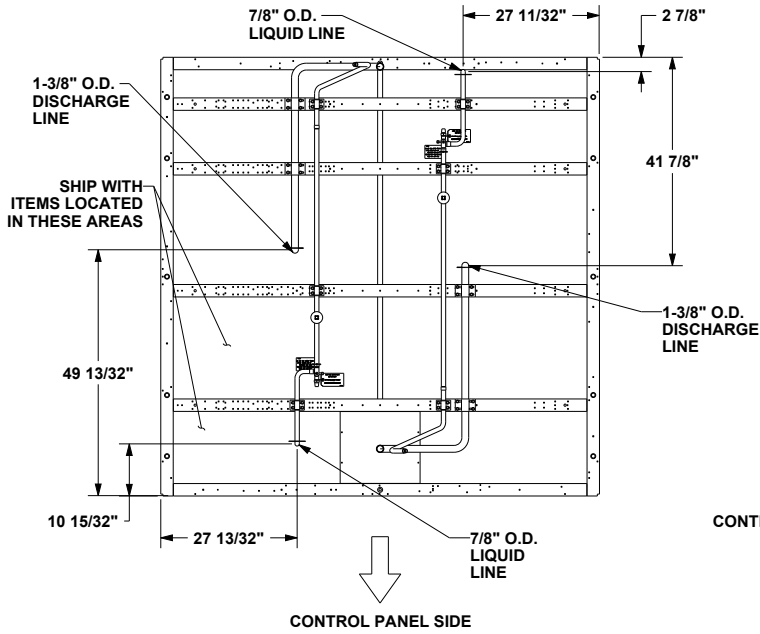

PLAN VIEW OF UNIT
CONNECTION DRAWING

NOTES:

1. VERIFY WEIGHT, CONNECTION, AND ALL DIMENSIONS WITH INSTALLER DOCUMENTS BEFORE INSTALLATION.
2. DUAL CIRCUIT UNIT REQUIRES TWO SEPARATE LINES SETS (TWO SUCTION) LINES AND TWO LIQUID LINES).

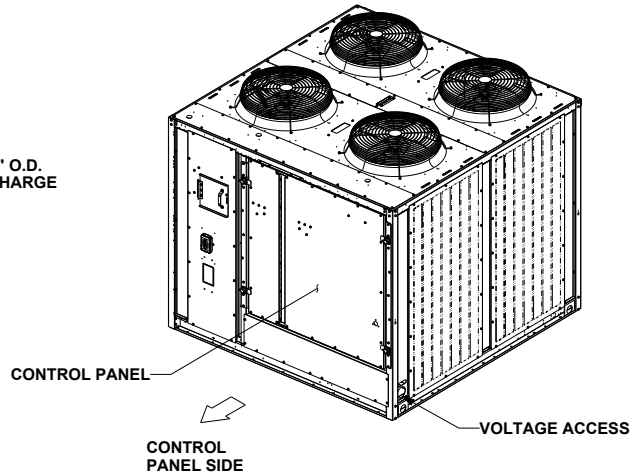

ORIENTATION VIEW OF UNIT
ISOMETRIC DRAWING

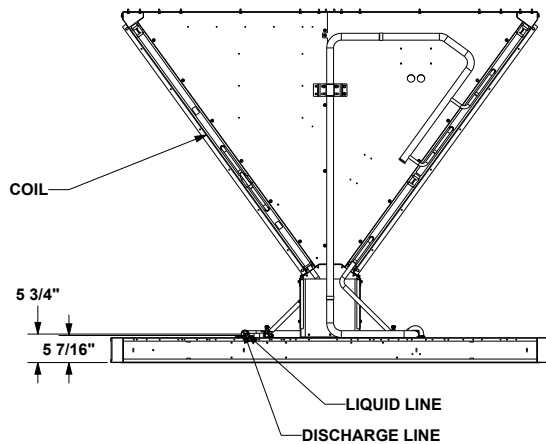

CONTROL PANEL SIDE VIEW OF UNIT
CONNECTION DRAWING

40 TON UNIT
DIMENSION CONNECTION DRAWING

Figure 13. Air-cooled condenser — 50 ton

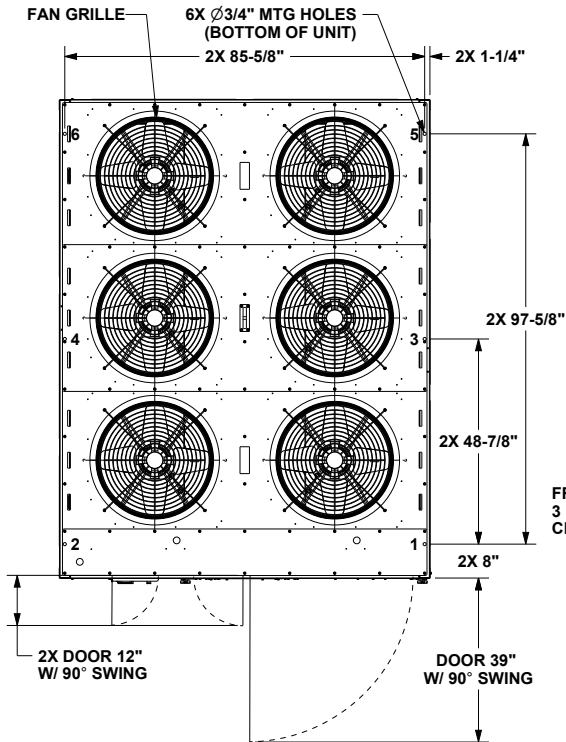

NOTES:

1. SEE CONNECTION DRAWING FOR CONNECTION LOCATION AND SIZES.
2. OPTIONS ONLY COME ON SELECTED UNITS.
3. FRONT AND BACK OF UNIT CLEARANCE 72" . LEFT AND RIGHT SIDE OF UNIT CLEARANCE 48"
4. VOLTAGE ACCESS HOLES IN OUTER PANEL MUST BE COVERED AFTER UNIT INSTALLATION

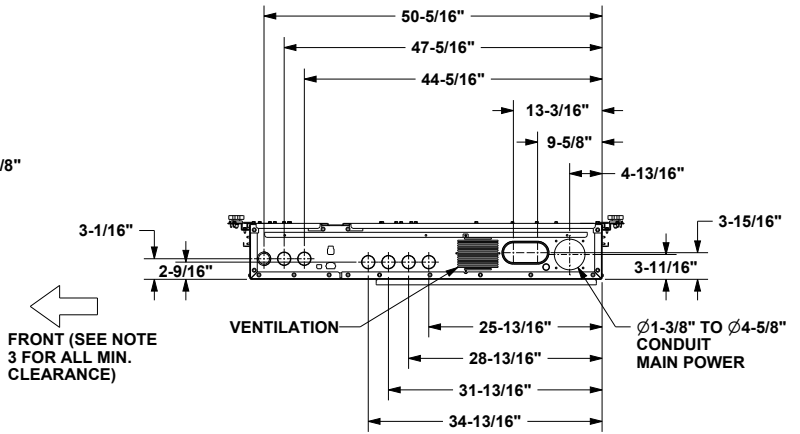

DETAIL A

CONTROL BOX BOTTOM

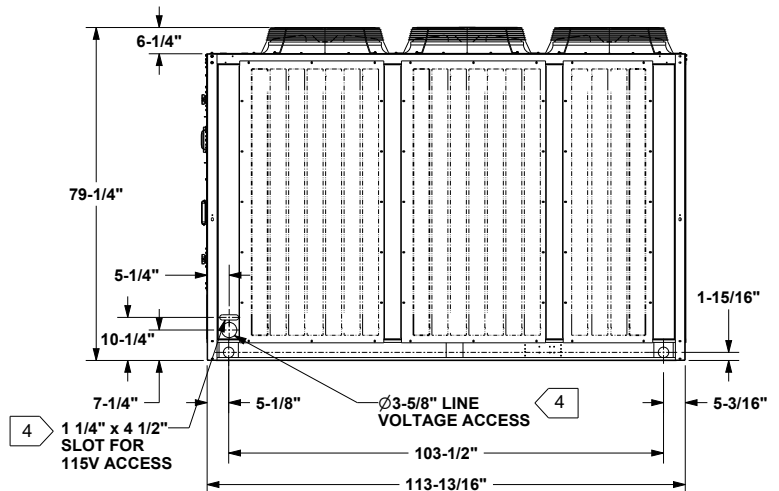
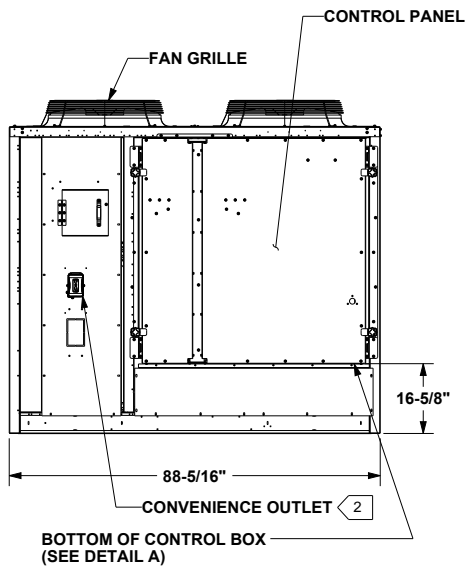



Unit Dimensions

Figure 14. Air-cooled condenser connections — 50 ton

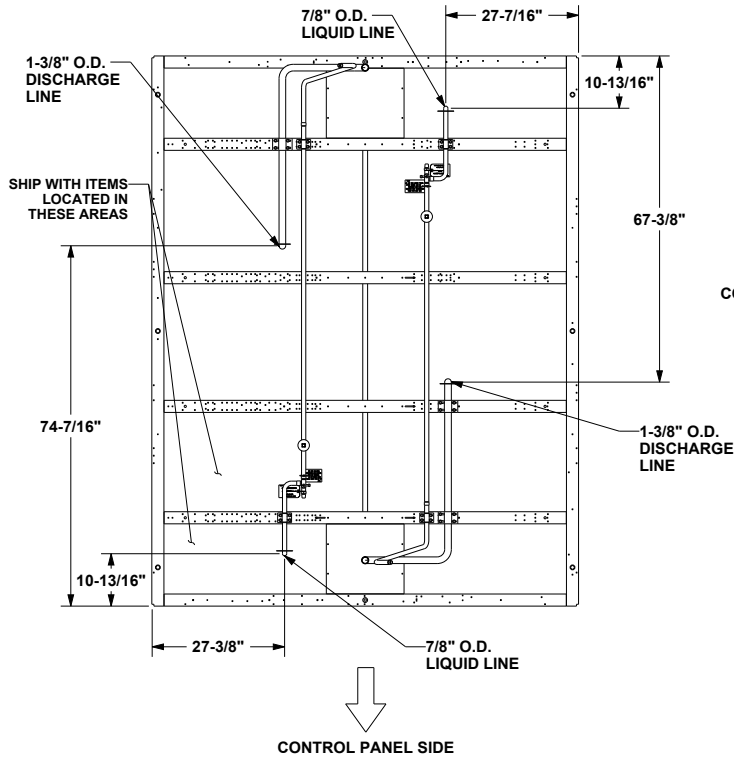

PLAN VIEW OF UNIT
CONNECTION DRAWING

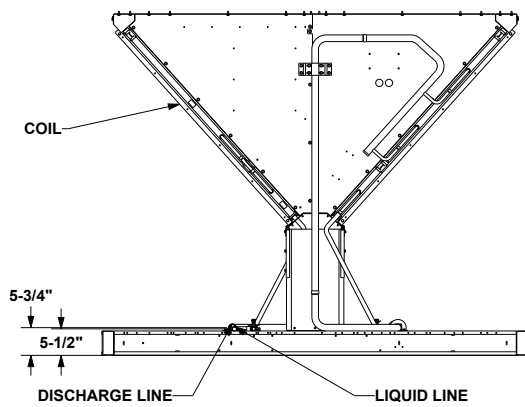

CONTROL PANEL SIDE VIEW OF UNIT
CONNECTION DRAWING

NOTES:

1. VERIFY WEIGHT, CONNECTION, AND ALL DIMENSIONS WITH INSTALLER DOCUMENTS BEFORE INSTALLATION.
2. DUAL CIRCUIT UNIT REQUIRES TWO SEPARATE LINES SETS (TWO SUCTION) LINES AND TWO LIQUID LINES).

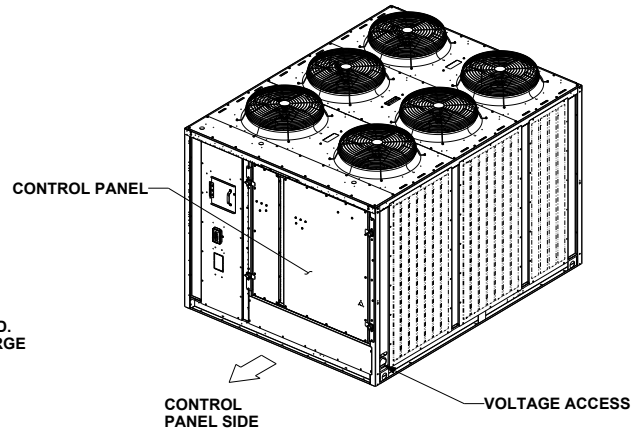

ORIENTATION VIEW OF UNIT
ISOMETRIC DRAWING

50 TON UNIT

DIMENSION CONNECTION DRAWING

Figure 15. Air-cooled condenser — 60 ton

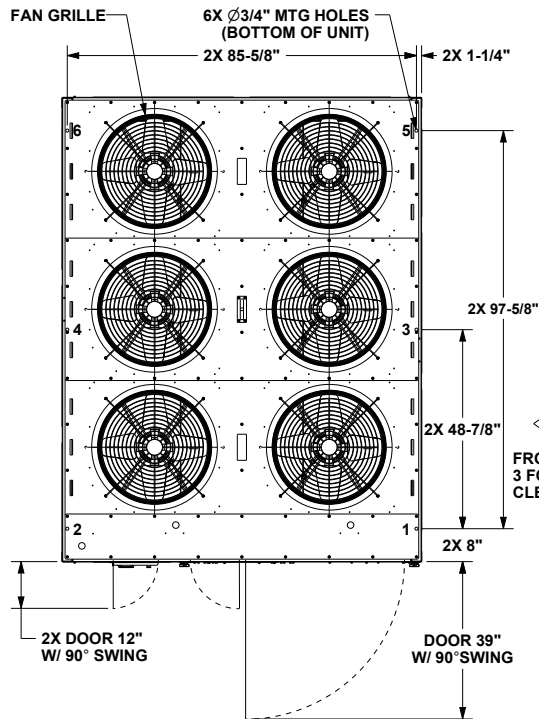

NOTES:

1. SEE CONNECTION DRAWING FOR CONNECTION LOCATION AND SIZES.
2. OPTIONS ONLY COME ON SELECTED UNITS.
3. FRONT AND BACK OF UNIT CLEARANCE 72" . LEFT AND RIGHT SIDE OF UNIT CLEARANCE 48"
4. VOLTAGE ACCESS HOLES IN OUTER PANEL MUST BE COVERED AFTER UNIT INSTALLATION

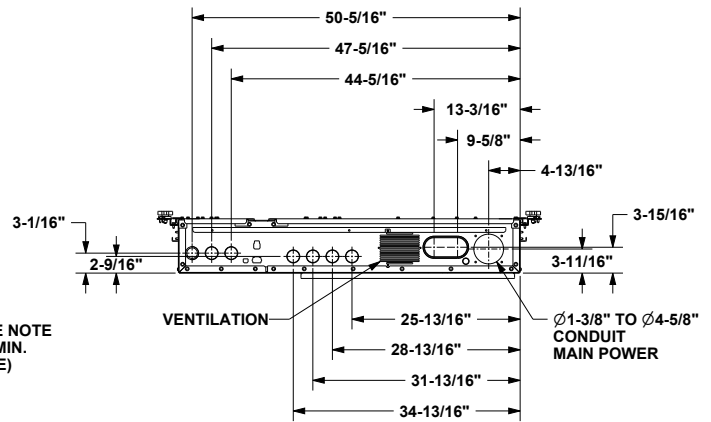

DETAIL A
CONTROL BOX BOTTOM

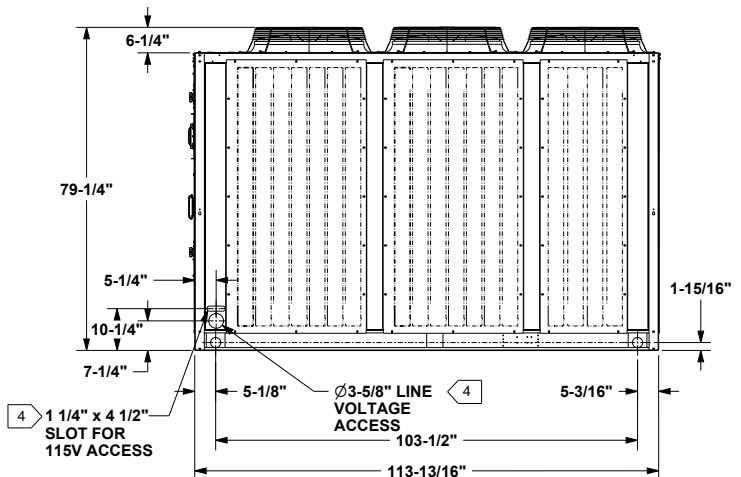
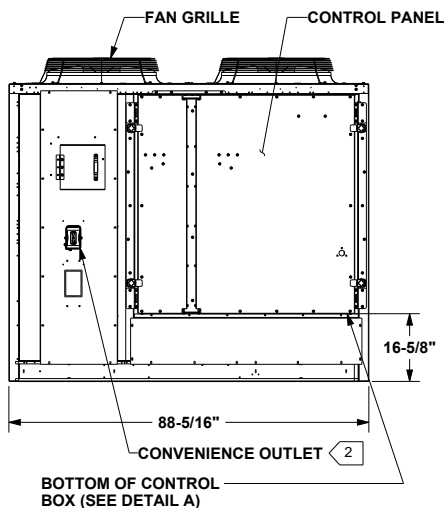



Unit Dimensions

Figure 16. Air-cooled condenser connections — 60 ton

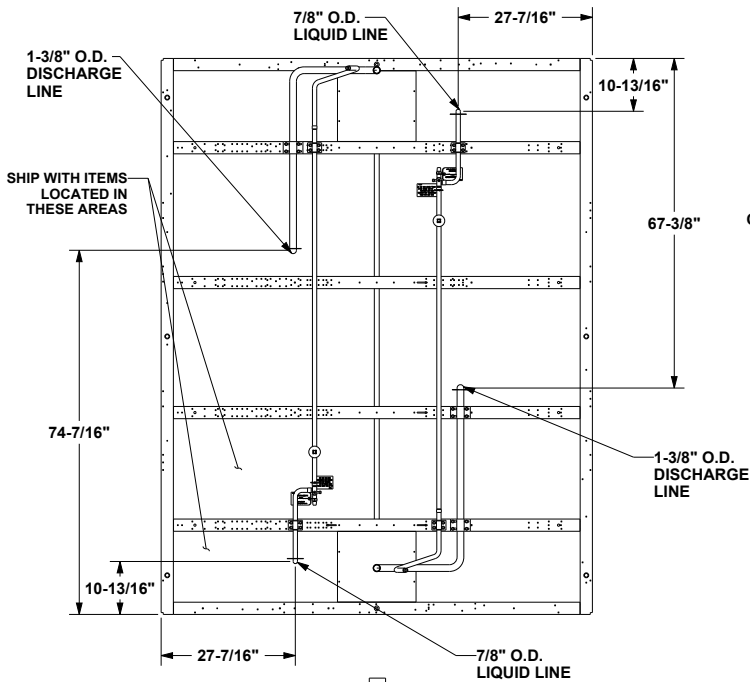

CONTROL PANEL SIDE

PLAN VIEW OF UNIT
CONNECTION DRAWING

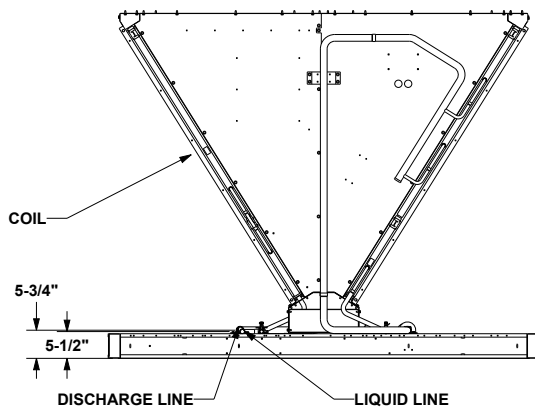

CONTROL PANEL SIDE VIEW OF UNIT
CONNECTION DRAWING

NOTES:

1. VERIFY WEIGHT, CONNECTION, AND ALL DIMENSIONS WITH INSTALLER DOCUMENTS BEFORE INSTALLATION.
2. DUAL CIRCUIT UNIT REQUIRES TWO SEPARATE LINES SETS (TWO SUCTION) LINES AND TWO LIQUID LINES).

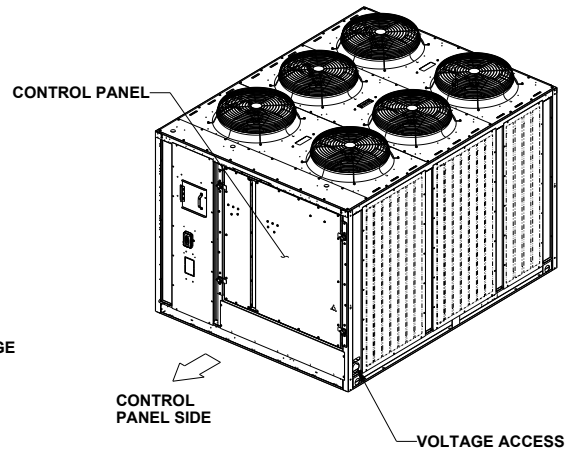

ORIENTATION VIEW OF UNIT
ISOMETRIC DRAWING

60 TON UNIT
DIMENSION CONNECTION DRAWING

Figure 17. Air-cooled condenser — 80 ton

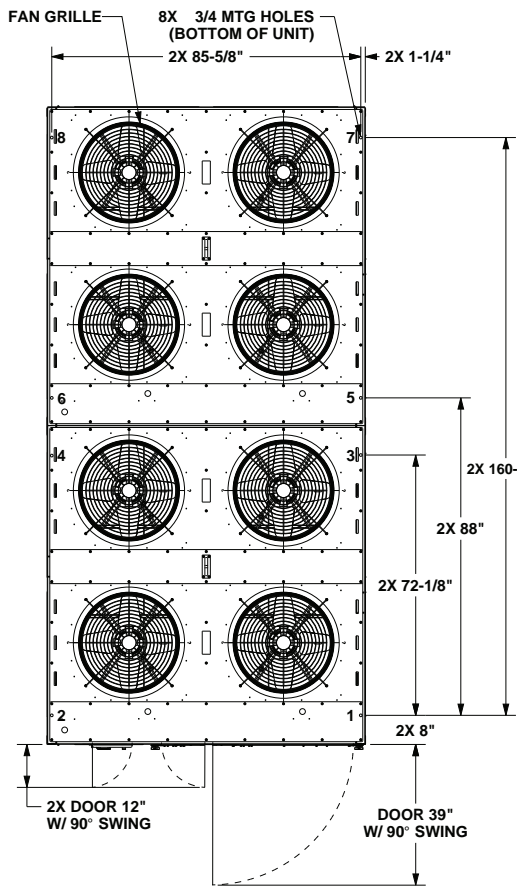

NOTES:

1. SEE CONNECTION DRAWING FOR CONNECTION LOCATION AND SIZES.
2. OPTIONS ONLY COME ON SELECTED UNITS.
3. FRONT AND BACK OF UNIT CLEARANCE 72" . LEFT AND RIGHT SIDE OF UNIT CLEARANCE 48"
4. VOLTAGE ACCESS HOLES IN OUTER PANEL MUST BE COVERED AFTER UNIT INSTALLATION

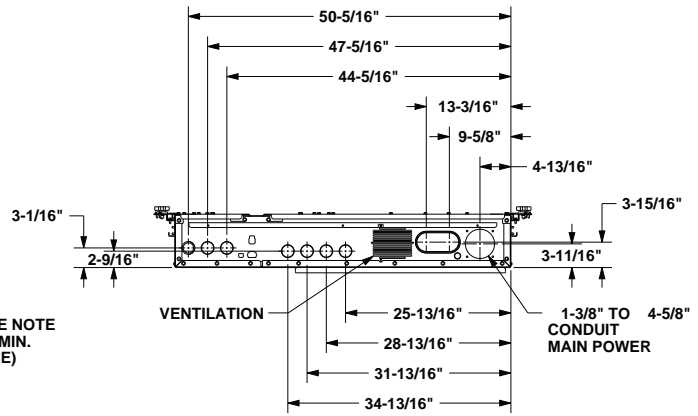

DETAIL A

CONTROL BOX BOTTOM

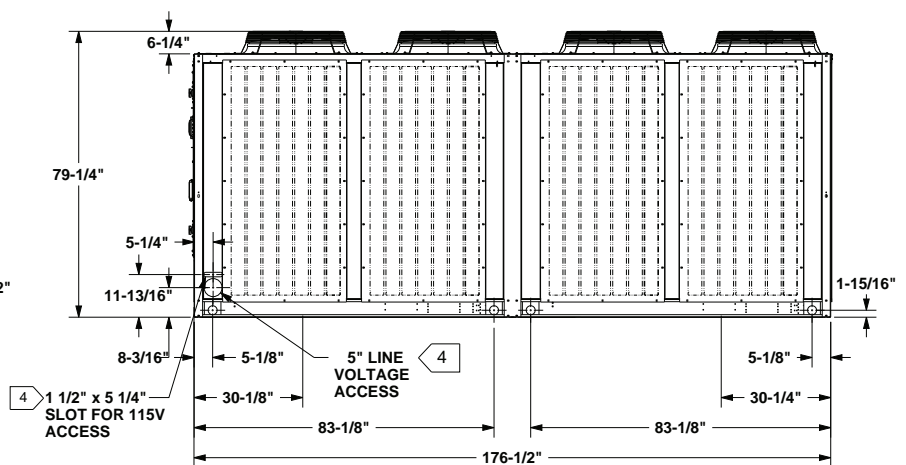
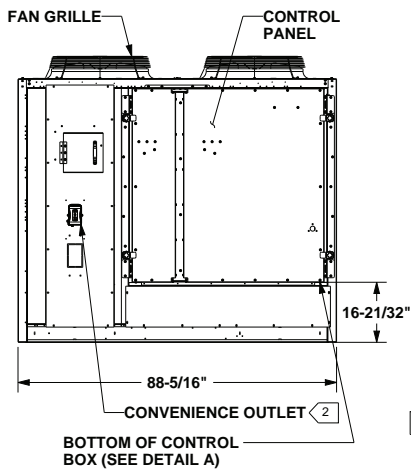



Unit Dimensions

Figure 18. Air-cooled condenser connections — 80 ton

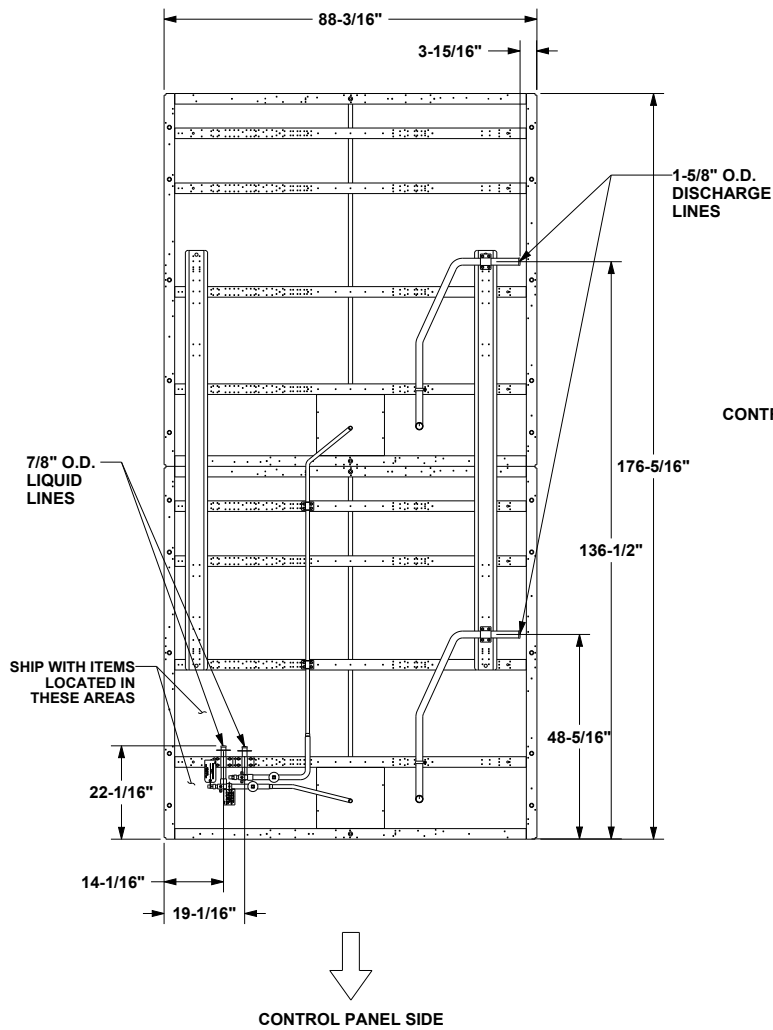

PLAN VIEW OF UNIT
CONNECTION DRAWING

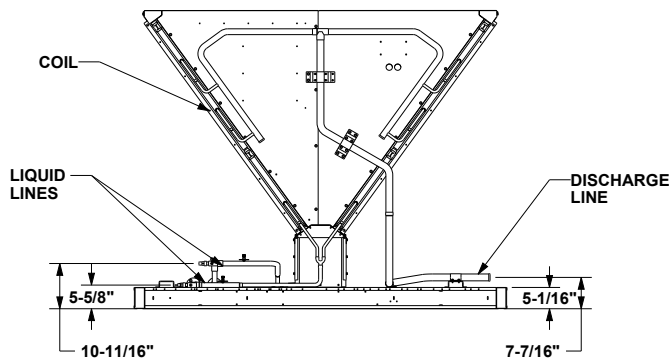

CONTROL PANEL SIDE VIEW OF UNIT
CONNECTION DRAWING

NOTES:

1. VERIFY WEIGHT, CONNECTION, AND ALL DIMENSIONS WITH INSTALLER DOCUMENTS BEFORE INSTALLATION.
2. DUAL CIRCUIT UNIT REQUIRES TWO SEPARATE LINES SETS (TWO SUCTION) LINES AND TWO LIQUID LINES).

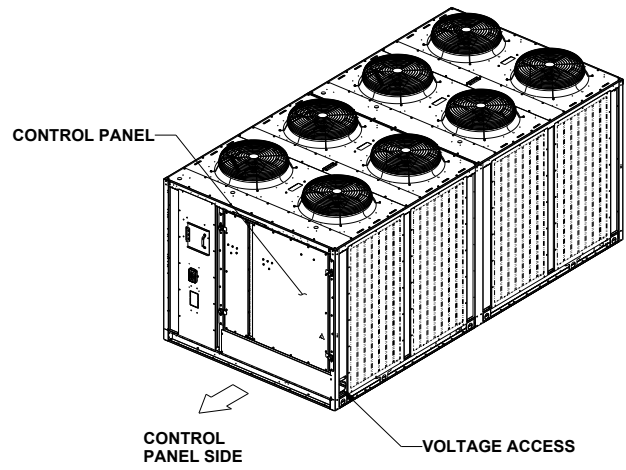

ORIENTATION VIEW OF UNIT
ISOMETRIC DRAWING

Figure 19. Air-cooled condenser — 100 and 120 tons

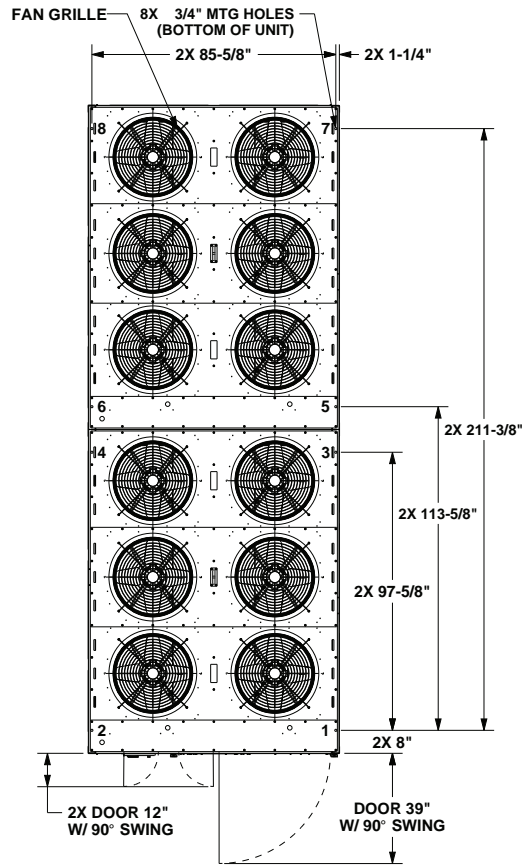

NOTES:

1. SEE CONNECTION DRAWING FOR CONNECTION LOCATION AND SIZES.
2. OPTIONS ONLY COME ON SELECTED UNITS.
3. FRONT AND BACK OF UNIT CLEARANCE 72" . LEFT AND RIGHT SIDE OF UNIT CLEARANCE 48"
4. VOLTAGE ACCESS HOLES IN OUTER PANEL MUST BE COVERED AFTER UNIT INSTALLATION

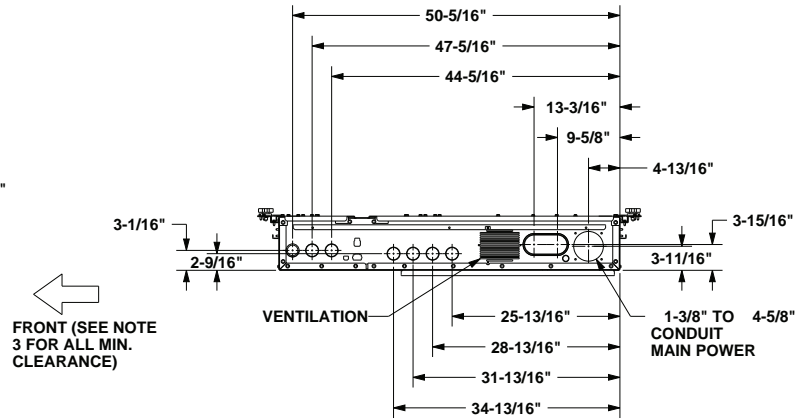

DETAIL A
CONTROL BOX BOTTOM

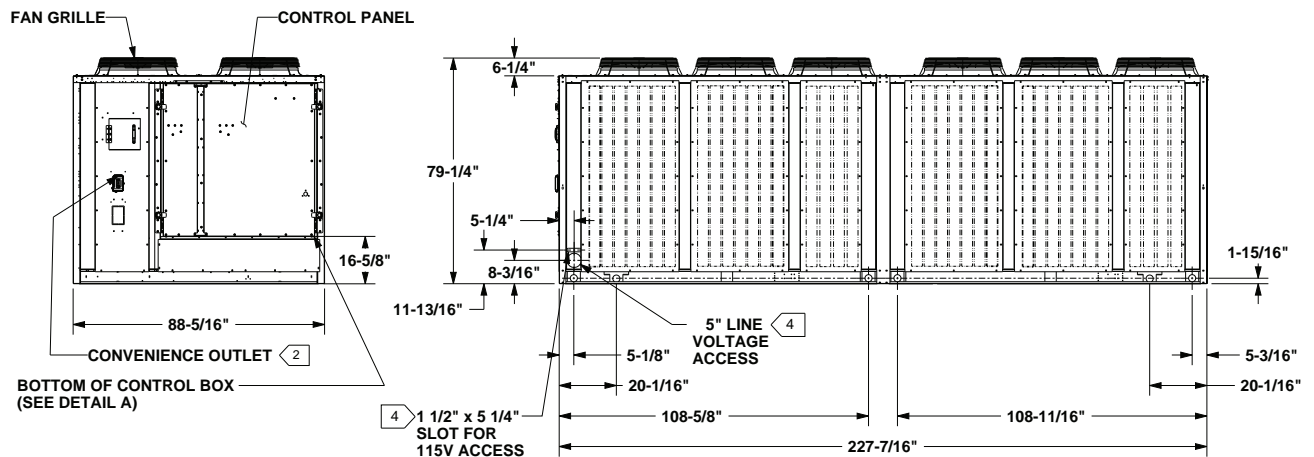



Unit Dimensions

Figure 20. Air-cooled condenser connections — 100 and 120 tons

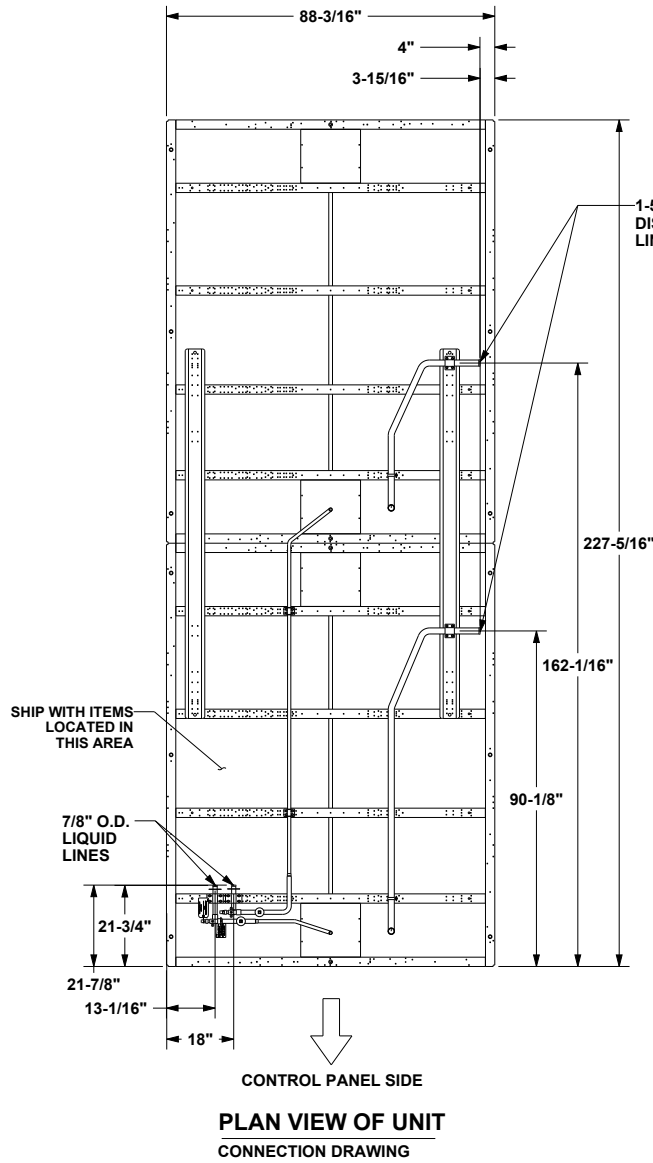

NOTES:

1. VERIFY WEIGHT, CONNECTION, AND ALL DIMENSIONS WITH INSTALLER DOCUMENTS BEFORE INSTALLATION.
2. DUAL CIRCUIT UNIT REQUIRES TWO SEPARATE LINES SETS (TWO SUCTION) LINES AND TWO LIQUID LINES).

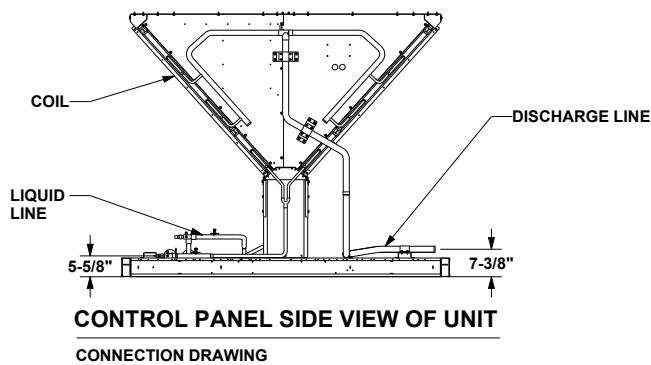
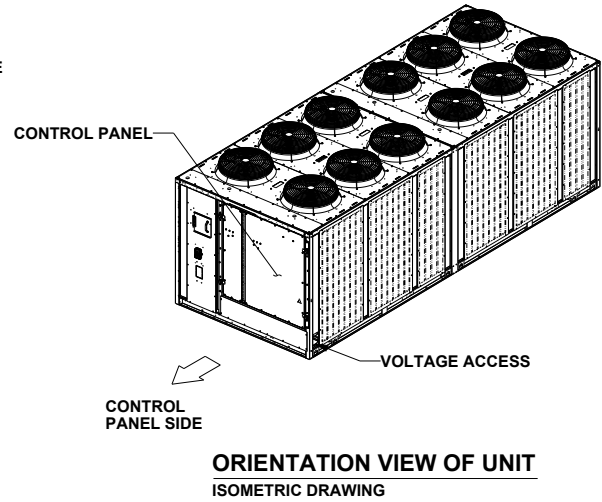

100 AND 120 TON UNITS
DIMENSION CONNECTION DRAWING



Unit Weights

Table 12. CAUK air-cooled condenser weights

Unit Size (tons)	R-454B
20	1389
25	1439
30	1437
40	1964
50	2276
60	2292
80	3319
100	4067
120	4558



Mechanical Specifications

Air-Cooled Condenser - Model CAUK

General

Units shall be constructed of 14-gauge welded galvanized steel frame with 14 and 16-gauge galvanized steel panels and access doors. Units shall have factory mounted, louvered, full-length steel grilles to protect the condenser coils and piping. Unit surface shall be finished with an air-dry paint. This air-dry paint finish shall be durable enough to withstand a minimum of 672-consecutive-hour salt spray application in accordance with standard ASTM B117.

Refrigeration Circuits

The 20 to 30 ton units shall be single circuit. The 40 to 120 ton units shall be dual circuited.

Unit control

The control panel shall contain fan motor contactors, terminal point connection for compressor interlock and 115 volt control power transformer.

Condenser Coils

Condenser coils shall have all aluminum microchannel coils. All coils shall be leak tested at the factory to ensure pressure integrity. The condenser coil shall be pressure tested to 650 psig.

Condenser Fans

All condenser fans shall be vertical discharge, direct drive fans, statically balanced, with aluminum blades and zinc plated steel hubs. Condenser fan motors shall be three-phase motors with permanently lubricated ball bearings, built in current and thermal overload protection and weather-tight slingers over motor bearings.

Options

Low Ambient Control

Low ambient option shall allow operation down to 0°F through the use of fan cycling and head pressure control. Low Ambient Control shall consist of a low ambient controller that “cycles” the outdoor fan motor on and off. The low ambient controller is factory-mounted or field installed.

Corrosion Protected Condenser Coil

All Aluminum Microchannel condenser coil protection shall consist of a corrosion resistant coating that shall withstand ASTM B117 Salt Spray test for 6000 hours and ASTM G85 A2 Cyclic Acidified Salt Fog test for 2400 hours. This coating shall be added after coil construction covering all tubes, headers and fin edges, therefore providing optimal protection in more corrosive environments.

Spring Isolation Package

Spring vibration isolators shall be supplied for field installation under the unit base to minimize transmission of unit vibrations. Isolators shall consist of a cast, spring loaded, telescoping housing as the isolation medium. Mountings shall include built-in leveling bolts, resilient inserts that act as centering guides, and ribbed neoprene acoustical pads bonded to the bottom of the isolator. The kit shall include instructions for field installation.

Neoprene Vibration Isolation Package

Neoprene-in shear isolators shall be supplied for field installation under the unit base to minimize transmission of unit vibration. The isolators shall consist of a steel top plate and base completely imbedded in color coded oil-resistant neoprene stock. Mountings shall have a 1/4-inch deflection. The kit shall include instructions for field installation. (Available on 20 to 60 ton units only).

Unpowered Convenience Outlet

Option shall include a factory-installed GFCI, 20 amp, 115 volt, 2 plug, unpowered convenience outlet.



Trane - by Trane Technologies (NYSE: TT), a global innovator - creates comfortable, energy efficient indoor environments for commercial and residential applications. For more information, please visit trane.com or tranetechnologies.com.

Trane has a policy of continuous product and product data improvements and reserves the right to change design and specifications without notice. We are committed to using environmentally conscious print practices.

ACDS-PRC005C-EN 17 Jul 2026
Supersedes ACDS-PRC005B-EN (April 2025)

©2026 Trane