



Product Catalog

# Ascend™ Air-Cooled Chiller

## Model ACR Series C

150 to 550 Nominal Tons



July 2026

**AC-PRC005E-EN**

**TRANE**  
TECHNOLOGIES™



# Introduction

## Overview of Design

The air-cooled chiller was designed to meet the demanding requirements of today's environment. The design transforms technology into performance on which you can depend.

Trane engineers brought innovation to every component in the next-generation Trane® chiller. The result: the high efficiency, improved system flexibility and performance, and low sound levels—all while delivering improved reliability and lower maintenance requirements.

At the core of the air-cooled chiller's performance is AdaptiSpeed™ technology—the integration of an adaptive frequency drive efficiently tuned to match perfectly the permanent magnet compressor motors. The result is improved full load efficiency, in addition to the typical benefits of part load efficiency.

## AdaptiSpeed™ Technology

AdaptiSpeed™ technology delivers unmatched efficiency with some of the lowest sound levels in the industry.

- Variable volume ratio screw compressor—Optimized for variable-speed operation, it delivers peak efficiency under all operating conditions.
- Variable speed, permanent magnet motors—The compressor's and condenser fans' permanent magnet motor design is up to 4 percent more efficient than conventional induction motors.

## Copyright

This document and the information in it are the property of Trane, and may not be used or reproduced in whole or in part without written permission. Trane reserves the right to revise this publication at any time, and to make changes to its content without obligation to notify any person of such revision or change.

## Trademarks

All trademarks referenced in this document are the trademarks of their respective owners.

## Revision History

- Updated Dimensions table for 375 to 550 ton units.
- Added seismic unit descriptions to the Model Number Descriptions chapter.
- Added Seismically Rated Unit – IBC, Seismically Rated Unit – OSHPD, and Wind Load for Florida Hurricane to the Options chapter.
- Updated Refrigerant Charge for 500 and 550 tons in General data table from the General Information chapter.
- Updated unit weights table.



# Table of Contents

- Features and Benefits ..... 5
  - Technology ..... 5
  - Cost of Ownership ..... 5
  - Reliability ..... 5
  - Precision Control ..... 5
- Application Considerations ..... 7
  - Water Treatment ..... 7
  - Effect of Altitude on Capacity ..... 7
  - Ambient Limitations ..... 7
  - Water Flow Limits ..... 7
  - Water Temperature ..... 8
  - Variable Flow in the Evaporator ..... 9
  - Series Chiller Arrangements ..... 9
  - Typical Water Piping ..... 10
  - Multiple Unit Operation ..... 10
  - Thermal Battery Cooling System Operation ..... 10
  - Unit Placement ..... 11
  - Unit Location ..... 12
- Model Number Descriptions ..... 13
  - Unit Model Number ..... 13
- General Information ..... 15
  - Unit Length ..... 15
  - General Data ..... 15
- Controls ..... 20
  - Symbio 800 Controller ..... 20
  - Tracer® AdaptiView™ TD-7 Operator Interface ..... 20
  - Air-Fi™ Wireless Communication Interface (WCI Indoor) ..... 21
  - Trane Wi-Fi Adapter ..... 21
  - System Integration ..... 21
  - Symbio 800 Controls ..... 23
- Electrical ..... 25
  - Electrical Data ..... 25
  - Electrical Connections ..... 25



## Table of Contents

---

Dimensions and Weights .....	26
Weights .....	26
Service Clearance .....	28
Unit Dimensions .....	29
Mechanical Specifications .....	43
Certified AHRI Performance .....	43
Refrigeration Circuits .....	43
Evaporator .....	43
Condenser and Fans .....	43
Compressor and Lube Oil System .....	43
Unit Controls .....	44
Adaptive Frequency Drive .....	45
Chilled Water Reset .....	45
Options .....	46
Application Options .....	46
Electrical Options .....	46
Control Options .....	46
Sound Options .....	47
Other Options .....	47



# Features and Benefits

## Technology

- AdaptiSpeed™ technology assures optimal performance at all operating conditions.
  - Permanent magnet motor - up to 4% more efficient than an induction motor.
  - AFD Adaptive Frequency™ Drive.
    - Soft start provided as standard to reduce power in-rush at start-up.
    - Available with Passive Harmonic Filtering achieving 5% TDD (optional).
  - Variable volume ratio compressor design optimized for efficiency at all load conditions.
  - Rotor profile designed for maximum efficiency at higher speeds.
- Shuttle valve enhances compressor oil management.
- Variable speed permanent magnet motors on ALL condenser fans for increased efficiency and lower sound.
- Larger diameter condenser fans operate at lower speed with optimized blade design.
- Compact, high-efficiency, integrated low refrigerant charge evaporator design.
- Optional metallic discharge and suction bellows reduce compressor sound by 8 to 10 dB.

## Cost of Ownership

- Industry-leading efficiency.
  - Up to 18% better full load efficiency than ASHRAE 90.1-2019 Path B.
    - Minimizing kW demand and infrastructure.
  - Up to 22% higher IPLV than ASHRAE 90.1-2019 Path B.
    - Minimizing kW usage.
- High power factor at all load points reducing the need for power factor correction capacitors.
- Variable speed drives on all condenser fans save energy at part load operation, as well as lower sound levels even further as fan speeds are reduced during part load operation.
- Transverse modular coil design for easy access for coil cleaning.
- The compact nature of the evaporator design allows it to reach full capacity in a much smaller footprint than many competing designs. Up to a 40% reduction in refrigerant charge is possible in the evaporator compared to competing designs.
- Factory-engineered, tested and installed sound control options reduce jobsite time and cost.
- Three levels of sound reduction available to meet various job site acoustical requirements.

## Reliability

- Industrial bearing system designed for the life of the chiller.
- Shuttle valve reduces the differential oil pressure required for cold weather start-up.
- Factory-applied corrosion protection available.
- Rapid Restart capability minimizes downtime.

## Precision Control

- 7-inch color touch screen display with graphics.
- Powered by Symbio™ 800 industry-leading control algorithms — Enhanced flow management provides unmatched system performance in variable flow water systems.
- Adaptive Control™ keeps the chiller running in extreme conditions.
  - Tight set point control.
  - Graphical trending.
  - Maximized chiller update.



## Features and Benefits

---

- BACnet®, Modbus®, LonTalk®, communications protocol interface available without the need for gateways.
- Optional condenser fan speed control to help meet preset nighttime sound requirements.



# Application Considerations

Certain application constraints should be considered when sizing, selecting, and installing Trane chillers. Unit and system reliability is often dependent on properly and completely complying with these considerations. When the application varies from the guidelines presented, it should be reviewed with your local sales engineer.

**Note:** *The terms water and solution are used interchangeably in the following paragraphs.*

## Water Treatment

The use of untreated or improperly treated water may result in scaling, erosion, corrosion, and algae or slime buildup. This will adversely affect heat transfer between the water and system components. Proper water treatment must be determined locally and depends on the type of system and local water characteristics. The chloride content of the coolant should be no higher than 200PPM to avoid corrosion.

Neither salt nor brackish water is recommended for use in Trane air-cooled chillers. Use of either will lead to a shortened life. Trane encourages the employment of a qualified water treatment specialist, familiar with local water conditions, to assist in the establishment of a proper water treatment program.

Foreign matter in the chilled water system can also increase pressure drop and, consequently, reduce water flow. For this reason it is important to thoroughly flush all water piping to the unit before making the final piping connections to the unit.

## Effect of Altitude on Capacity

At elevations substantially above sea level, decreased air density will reduce condenser capacity and, therefore, unit capacity and efficiency.

## Ambient Limitations

Trane chillers are designed for year-round operation over a range of ambient temperatures.

- Standard Ambient Range = 32 to 105°F (0 to 40.6°C).
- Low Ambient Range = 0 to 105°F (-17.7 to 40.6°C).
- Extreme Low Ambient Range:
  - Unit Start-up: -15° to 105°F (-26.1 to 40.6°C).
  - Continuous Operation: -20° to 105°F (-28.9 to 40.6°C).
- High Ambient Range = 32 to 125°F (0 to 52°C).
- Wide Ambient Range = 0 to 125°F (-17.7 to 52°C).

**Note:** *Direct free-cooling (DFC) option operates down to -40°F (-40°C). The mechanical cooling ambient range is unaffected by the DFC option.*

The minimum ambient temperatures are based on still conditions (winds not exceeding five mph). Greater wind speeds will result in a drop in head pressure, therefore increasing the minimum starting and operating ambient temperature. The Adaptive Frequency™ microprocessor will attempt to keep the chiller on-line when high or low ambient conditions exist, making every effort to avoid nuisance trip-outs and provide the maximum allowable tonnage.

## Water Flow Limits

The minimum water flow rates are given in the General Data chapter of this catalog. Evaporator flow rates below the tabulated values will result in laminar flow causing freeze-up problems, scaling, stratification and poor control.

The maximum evaporator water flow rate is also given in General Data. Flow rates exceeding those listed may result in very high pressure drop across the evaporator and/or excessive tube erosion.

**Note:** *Flow rates in the general data tables are for water only. They do not include freeze inhibitors.*

## Flow Rate Out of Range

Many process cooling applications require flow rates that cannot be met with the minimum and maximum published values within the evaporator. A simple piping change can alleviate this problem. For example: a plastic injection molding process requires 80 gpm (5.0 l/s) of 50°F (10°C) water and returns that water at 60°F (15.6°C). The selected chiller can operate at these temperatures, but has a minimum flow rate of 106 gpm (6.6 l/s). The system layout in the figure below can satisfy the process.

**Figure 1. Flow rate out of range systems solution**

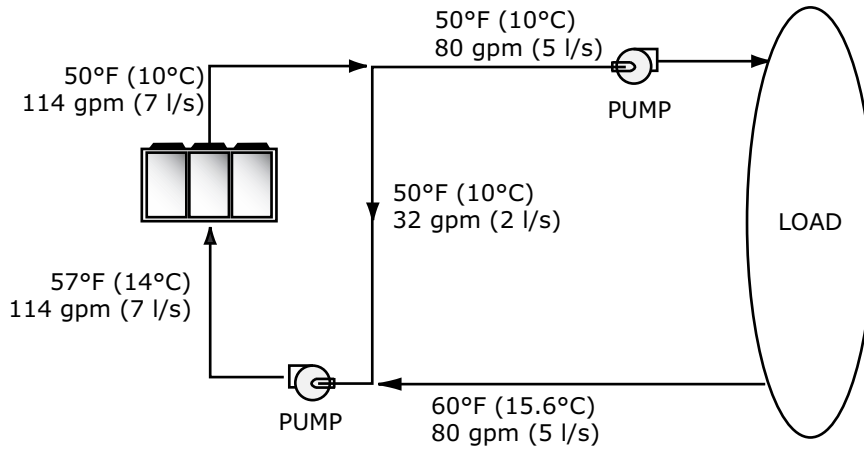

### Flow Proving

Trane provides a factory-installed water flow switch monitored by Symbio™ 800 controller which protects the chiller from operating in loss of flow conditions.

## Water Temperature

### Leaving Water Temperature Limits

Trane chillers have distinct leaving water categories:

- Standard, with a leaving solution range of 40 to 68°F (4.4 to 20°C).
- Low temperature process cooling, with leaving solution less than 40°F (4.4°C).
- Ice-making, with a leaving solution range of 20 to 68°F (-6.7 to 20°C).
- Direct Free Cooling, with leaving solution up to 72°F (22°C).

Since leaving solution temperatures below 40°F (4.4°C) result in suction temperature at or below the freezing point of water, a glycol solution is required for all low temperature and ice-making machines. Ice making control includes dual setpoints and safeties for ice making and standard cooling capabilities. Consult your local Trane account manager for applications or selections involving low temperature or ice making machines.

The maximum water temperature that can be circulated through the evaporator when the unit is not operating is 125°F (52°C). Evaporator damage may result above this temperature.

### Leaving Water Temperature Out of Range

Many process cooling jobs require temperature ranges that cannot be met with the minimum and maximum published values for the chiller. A simple piping change can alleviate this problem. For example, a laboratory load requires 238 gpm (15 l/s) of water entering the process at 86°F (30°C) and returning at 95°F (35°C). The chiller's maximum leaving chilled water temperature of 68°F (20°C) prevents direct supply to the load. In the example shown, both the chiller and process flow rates are equal, however, this is not necessary. For example, if the chiller had a higher flow rate, there would be more water bypassing and mixing with warm water returning to the chiller.

Figure 2. Temperature out of range system solution

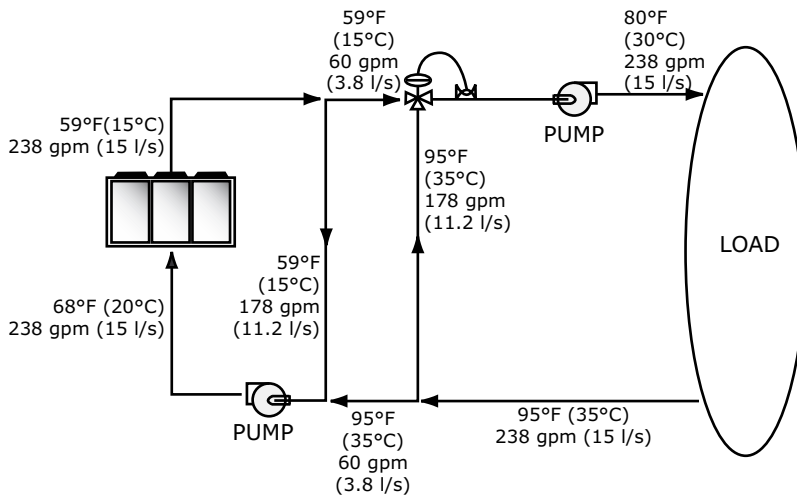

## Variable Flow in the Evaporator

An attractive chilled water system option may be a variable primary flow (VPF) system. VPF systems present building owners with several cost saving benefits that are directly related to the pumps. The most obvious cost savings result from eliminating the secondary distribution pump, which in turn avoids the expense incurred with the associated piping connections (material, labor), electrical service, and variable frequency drive. Building owners often cite pump related energy savings as the reason that prompted them to install a VPF system.

The evaporator on the chiller can withstand up to 50 percent water flow reduction as long as this flow is equal to or above the minimum flow rate requirements.

With the help of a software analysis tool such as System Analyzer™, DOE-2 or TRACE™, you can determine whether the anticipated energy savings justify the use of variable primary flow in a particular application. It may also be easier to apply variable primary flow in an existing chilled water plant. Unlike the "decoupled" system design, the bypass can be positioned at various points in the chilled water loop and an additional pump is unnecessary.

## Series Chiller Arrangements

Another energy saving strategy is to design the system around chillers arranged in series. The actual savings possible with such strategies depends on the application dynamics and should be researched by consulting your Trane® Systems Solutions Representative and applying an analysis tool from the Trace software family. It is possible to operate a pair of chillers more efficiently in a series chiller arrangement than in a parallel arrangement. It is also possible to achieve higher entering to leaving chiller differentials, which may, in turn, provide the opportunity for lower chilled water design temperature, lower design flow, and resulting installation and operational cost savings. The Trane screw compressor also has excellent capabilities for "lift," which provides an opportunity for savings on the evaporator water loop.

Series chiller arrangements can be controlled in several ways. The figure below shows a strategy where each chiller is trying to achieve the system design set point. If the cooling load is less than 50 percent of the systems capabilities, either chiller can fulfill the demand. As system loads increase, the Chiller 2 becomes preferentially loaded as it attempts to meet the leaving chilled water setpoint. Chiller 1 will finish cooling the leaving water from Chiller 2 down to the system design setpoint.

Staggering the chiller set points is another control technique that works well for preferentially loading Chiller 1. If the cooling load is less than 50 percent of the system capacity, Chiller 1 would be able to satisfy the entire call for cooling. As system loads increase, Chiller 2 is started to meet any portion of the load that Chiller 1 can not meet.

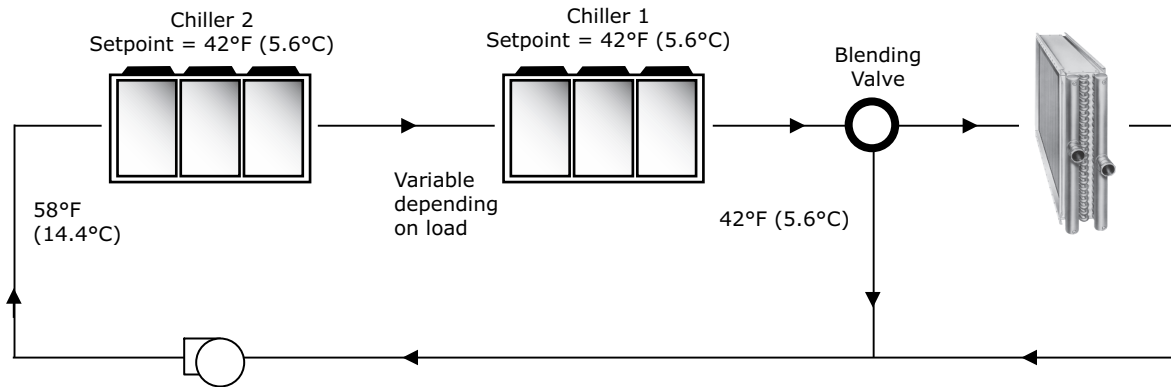
**Figure 3. Typical series chiller arrangement**

## Typical Water Piping

All building water piping must be flushed prior to making final connections to the chiller. To reduce heat loss and prevent condensation, insulation should be applied. Expansion tanks are also usually required so that chilled water volume changes can be accommodated.

### Avoidance of Short Water Loops

Adequate chilled water system water volume is an important system design parameter because it provides for stable chilled water temperature control and limits compressor short cycling.

The chiller temperature control sensor is located in the waterbox. This location allows the building to act as a buffer to slow the rate of change of the system water temperature. If there is not a sufficient volume of water in the system to provide an adequate buffer, temperature control can suffer, resulting in erratic system operation and excessive compressor cycling.

Typically, a two-minute water loop circulation time is sufficient to prevent short water loop issues. Therefore, as a guideline, ensure the volume of water in the chilled water loop equals or exceeds two times the evaporator flow rate. For systems with a rapidly changing load profile the amount of volume should be increased.

If the installed system volume does not meet the above recommendations, the following items should be given careful consideration to increase the volume of water in the system and, therefore, reduce the rate of change of the return water temperature.

- A volume buffer tank located in the return water piping.
- Larger system supply and return header piping (which also reduces system pressure drop and pump energy use).

### Minimum Water Volume for a Process Application

If a chiller is attached to an on/off load such as a process application, it may be difficult for the controller to respond quickly enough to the very rapid change in return solution temperature if the system has only the minimum recommended water volume. Such systems may cause chiller low temperature diagnostics or in the extreme case evaporator freezing. In this case, it may be necessary to add or increase the size of the mixing tank in the return line.

## Multiple Unit Operation

Whenever two or more units are used on one chilled water loop, Trane recommends that their operation be coordinated with a higher level system controller for optimum system efficiency and reliability. The Trane Tracer® system has advanced chilled plant control capabilities designed to provide such operation.

## Thermal Battery Cooling System Operation

A Thermal Battery™ cooling system uses the chiller to make (cooling) ice at night when utilities generate electricity more efficiently with lower demand and energy charges. The stored cooling energy reduces or even replaces mechanical cooling during the day when utility rates are at their highest. This reduced electrical demand for cooling results in significant utility cost savings and source energy savings.

Another advantage of an ice energy storage system is its ability to eliminate chiller over sizing. A “right-sized” chiller plant with ice energy storage operates more efficiently with smaller support equipment while lowering the connected load and reducing

operating costs. Best of all, this system still provides a capacity safety factor and redundancy by designing reserve capacity into the ice storage system for practically no cost compared to oversized systems.

Trane air-cooled chillers are uniquely suited to low temperature applications like ice storage because of the ambient relief experienced at night. Chiller ice making efficiencies are typically similar to or even better than standard cooling daytime efficiencies as a result of night-time dry-bulb ambient relief.

Standard smart control strategies for ice storage systems are another advantage of the chiller. The dual mode control functionality is integrated right into the chiller. Trane Tracer® building management systems can measure demand and receive pricing signals from the utility and decide when to use the stored cooling and when to use the chiller.

## Unit Placement

### Setting the Unit

A base or foundation is not required if the selected unit location is level and strong enough to support the unit operating weights shown in Weights chapter.

For a detailed discussion of base and foundation construction, see the unit Installation, Operation or Maintenance (IOM) manual. Manuals are available through [trane.com](http://trane.com) or from your local office.

HVAC equipment must be located to minimize sound and vibration transmission to the occupied spaces of the building structure it serves. If the equipment must be located in close proximity to a building, it should be placed next to an unoccupied space such as a storage room, mechanical room, etc. It is not recommended to locate the equipment near occupied, sound sensitive areas of the building or near windows. Locating the equipment away from structures will also prevent sound reflection, which can increase sound levels at property lines or other sensitive points.

### Isolation and Sound Emission

Structurally transmitted sound can be reduced by elastomeric vibration eliminators. Elastomeric isolators are generally effective in reducing vibratory noise generated by compressors, and therefore, are recommended for sound sensitive installations. An acoustical engineer should always be consulted on critical applications.

**Figure 4. Installation example**

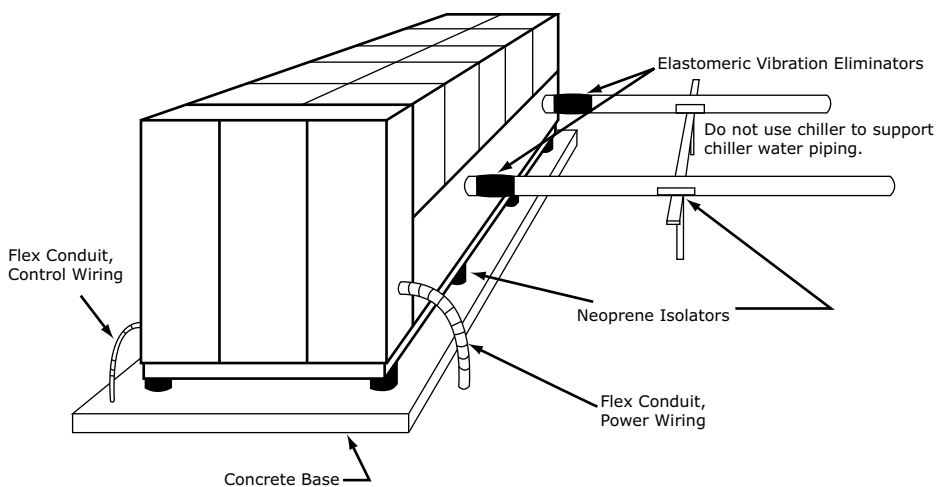

For maximum isolation effect, water lines and electrical conduit should also be isolated. Wall sleeves and rubber isolated piping hangers can be used to reduce sound transmitted through water piping. To reduce the sound transmitted through electrical conduit, use flexible electrical conduit.

Local codes on sound emissions should always be considered. Since the environment in which a sound source is located affects sound pressure, unit placement must be carefully evaluated. Sound power levels for chillers are available on request.

### Servicing

Adequate clearance for evaporator, condenser and compressor servicing should be provided. Recommended minimum space envelopes for servicing are located in the dimensional data section and can serve as a guideline for providing adequate



## Application Considerations

---

clearance. The minimum space envelopes also allow for control panel door swing and routine maintenance requirements. Local code requirements may take precedence.

## Unit Location

### General

Unobstructed flow of condenser air is essential to maintain chiller capacity and operating efficiency. When determining unit placement, careful consideration must be given to assure a sufficient flow of air across the condenser heat transfer surface. Two detrimental conditions are possible and must be avoided: warm air recirculation and coil starvation. Air recirculation occurs when discharge air from the condenser fans is recycled back to the condenser coil inlet. Coil starvation occurs when free airflow to the condenser is restricted.

Condenser coils and fan discharge must be kept free of snow or other obstructions to permit adequate airflow for satisfactory unit operation. Debris, trash, supplies, etc., should not be allowed to accumulate in the vicinity of the air-cooled chiller. Supply air movement may draw debris into the condenser coil, blocking spaces between coil fins and causing coil starvation.

Both warm air recirculation and coil starvation cause reductions in unit efficiency and capacity due to higher head pressures. The air-cooled chiller offers an advantage over competitive equipment in these situations. Operation is minimally affected in many restricted air flow situations due to its advanced Adaptive Control™ microprocessor which has the ability to understand the operating environment of the chiller and adapt to it by first optimizing its performance and then staying on line through abnormal conditions. For example, high ambient temperatures combined with a restricted air flow situation will generally not cause the air-cooled chiller to shutdown. Other chillers would typically shutdown on a high pressure nuisance cut-out in these conditions.

Cross winds, those perpendicular to the condenser, tend to aid efficient operation in warmer ambient conditions. However, they tend to be detrimental to operation in lower ambients due to the accompanying loss of adequate head pressure. Special consideration should be given to low ambient units. As a result, it is advisable to protect air-cooled chillers from continuous direct winds exceeding 10 mph (4.5 m/s) in low ambient conditions.

The recommended lateral clearances are depicted in the close spacing engineering bulletin available from your local office.

### Provide Sufficient Unit-to-Unit Clearance

Units should be separated from each other by sufficient distance to prevent warm air recirculation or coil starvation. Doubling the recommended single unit air-cooled chiller clearances will generally prove to be adequate. See *Close-Spacing and Restricted Airflow Engineering Bulletin (AC-PRB001\*-EN)* for more information.

### Walled Enclosure Installations

When the unit is placed in an enclosure or small depression, the top of the surrounding walls should be no higher than the top of the fans. The chiller should be completely open above the fan deck. There should be no roof or structure covering the top of the chiller. Ducting individual fans is not recommended. See *Close-Spacing and Restricted Airflow Engineering Bulletin (AC-PRB001\*-EN)* for more information.



# Model Number Descriptions

## Unit Model Number

### Digit 1, 2, 3 — Unit Model

ACR = Air-Cooled Screw Chiller

### Digit 4 — Series

C = Series C

### Digit 5, 6, 7 — Nominal Tonnage

150 = 150 Tons  
165 = 165 Tons  
180 = 180 Tons  
200 = 200 Tons  
225 = 225 Tons  
250 = 250 Tons  
275 = 275 Tons  
300 = 300 Tons  
330 = 330 Tons  
375 = 375 Tons  
380 = 380 Tons  
440 = 440 Tons  
450 = 450 Tons  
500 = 500 Tons  
550 = 550 Tons

### Digit 8 — Compressor Type

4 = Mixed screw types  
5 = GP4 — Screw with Variable Volume Ratio

### Digit 9 — Unit Voltage

A = 200/60/3  
B = 230/60/3  
C = 380/60/3  
D = 400/60/3  
E = 460/60/3  
F = 575/60/3

### Digit 10 — Manufacturing Location

U = Trane Commercial Systems,  
Pueblo, CO USA  
G = Trane Commercial Systems,  
Grand Rapids, MI USA

### Digits 11, 12 — Design Sequence

\*\* = Factory assigned

### Digit 13 — Unit Sound Package

R = InvisiSound™ Standard with Noise Reduction Request  
Q = InvisiSound™ Superior with Noise Reduction Request  
E = InvisiSound™ Ultimate

### Digit 14 — Agency Listing

C = No Agency Listing  
E = ETL Listed/Certified to CSA/Conforms to UL

### Digit 15 — Pressure Vessel Code

U = ASME Pressure Vessel Code  
C = CRN or Canadian Equivalent Pressure Vessel Code

### Digit 16 — Factory Charge

E = Refrigerant Charge R-513A  
F = Nitrogen Charge, R-513A Field Supplied

### Digit 17 — Auxiliary Items

X = No Auxiliary Items

### Digit 18 — Evaporator Application

N = Standard Cooling  
P = Low Temp Process Cooling  
C = Ice Making

### Digit 19, 20 — Evaporator Type

C1 = CHIL 1-pass  
C2 = CHIL 2-pass  
C3 = CHIL 3-pass

### Digit 21 — Water Connection

X = Grooved Pipe  
A = Grooved Pipe + Flange

### Digit 22 — Flow Switch

C = Flow Switch Set Point 15 cm/sec  
D = Flow Switch Set Point 25 cm/sec  
F = Flow Switch Set Point 35 cm/sec  
H = Flow Switch Set Point 45 cm/sec  
L = Flow Switch Set Point 60 cm/sec

### Digit 23 — Insulation

N = Factory Insulation — All Cold Parts 0.75"  
H = Evaporator-only Insulation for High Humidity/  
Low Evap Temp 1.25"

### Digit 24 — Unit Application

X = Standard Ambient  
L = Low Ambient  
E = Extreme Low Ambient  
H = High Ambient  
W = Wide Ambient

### Digit 25 — Condenser Length

A = 4V Condenser Coil Modules  
B = 5V Condenser Coil Modules  
C = 6V Condenser Coil Modules  
D = 7V Condenser Coil Modules  
E = 8V Condenser Coil Modules  
F = 9V Condenser Coil Modules  
H = 11V Condenser Coil Modules

### Digit 26 — Condenser Fin Options

M = Aluminum Microchannel  
C = Coated Microchannel  
P = Premium Coated Microchannel

### Digit 27 — Fan Type

E = EC Condenser Fan Motors

### Digit 28 — Compressor Starter

V = Variable Frequency Drive (1 compressor/  
circuit)

### Digit 29 — Incoming Unit Power Line Connection

1 = Single Point Power  
2 = Dual Point Unit Power Connection  
3 = Single Point Power including 115V

### Digit 30 — Power Line Connection Type

T = Terminal Block  
C = Circuit Breaker  
H = Circuit Breaker with High Fault Rated Control Panel

### Digit 31 — Short Circuit Current Rating

A = Default Short Circuit Amp Rating  
B = High Short Circuit Amp Rating

### Digit 32 — Electrical Accessories

N = 20A 115V Convenience Outlet



## Model Number Descriptions

---

### Digit 33 — Remote Communication Option

**X** = None  
**L** = LonTalk® Interface  
**B** = BACnet® TP Interface  
**M** = Modbus® Interface  
**P** = BACnet® Interface (IP)

### Digit 34 — Hard Wire Communication

**X** = None  
**A** = Hard Wired Bundle - All  
**B** = Remote Leaving Water Temp Setpoint  
**C** = Remote Leaving Temp and Demand Limit Setpoints  
**D** = Unit Status Programmable Relay  
**E** = Programmable Relay and Leaving Water and Demand Limit Setpoint  
**F** = Percent Capacity  
**G** = Percent Capacity and Leaving Water and Demand Limit Setpoint  
**H** = Percent Capacity and Programmable Relay

### Digit 35 — Smart Flow Control

**X** = None  
**F** = Flow Measurement Factory Installed

### Digit 36 — Structural Options

**A** = Standard Unit Structure  
**B** = Seismic Unit Structure  
**C** = OSHPD Unit Structure  
**J** = Low Level Wind Structure  
**K** = Low Level Wind and Seismic Structure

### Digit 37 — Appearance Accessories

**X** = No Appearance Options  
**A** = Architectural Louvered Panels

### Digit 38 — Unit Isolation

**X** = None  
**1** = Elastomeric Isolators  
**4** = Neoprene Pad Isolators

### Digit 39 — Shipping Package

**X** = None  
**A** = Containerization  
**T** = Shipping Tarp Covering Full Unit  
**B** = Containerization and Tarp

### Digit 40 — Pump Package

**X** = None  
**5** = 50 HP Single Pump High Pressure with Single VFD  
**6** = 60 HP Single Pump High Pressure with Single VFD  
**7** = 75 HP Single Pump High Pressure with Single VFD

### Digit 41 — Heat Recovery

**X** = None

### Digit 42 — Free-Cooling

**X** = None  
**T** = Total Direct Free-Cooling  
**J** = Total Direct Free Cooling + 1V Free-Cooling Coils  
**H** = Total Direct Free Cooling + 2V Free-Cooling Coils

### Digit 43 — Special

**0** = None  
**S** = Special  
**F** = Ship to Final Finisher

### Digit 44 — Line Voltage Harmonic Mitigation

**X** = DC Reactors (~30% TDD)  
**L** = 5% TDD (IEEE519 Compliant)

### Digit 45 — Wireless Connectivity

**A** = Wi-Fi  
**B** = LTE Modem  
**C** = Air-Fi®  
**D** = Wi-Fi and LTE Modem  
**E** = Wi-Fi and Air-Fi®  
**F** = LTE Modem and Air-Fi®  
**G** = Wi-Fi, LTE Modem, and Air-Fi®



# General Information

## Unit Length

For unit sizes 330 tons and smaller, units are EXTENDED length if either of the following are selected:

- Voltage: 200, 230, 380, 400, or 575V (model number digit 9 = A, B, C, D, or F).
- Harmonic Filtration Option: Filter circuit (model number digit 44 = L).

## General Data

**Table 1. General data - 150 to 330 ton units**

Unit Size (tons)		150	165	180	200	225	250	275	300	330									
Compressor Model		CHHSR	CHHSR	CHHSR	CHHSR	CHHSS	CHHSS	CHHSS	CHHSS	CHHSS									
Quantity	#	2	2	2	2	2	2	2	2	2									
<b>Evaporator</b>																			
Water Storage	gal	17.5	18.7	21.9	23.9	26.6	28.7	33.0	36	37.9									
	L	66.1	70.9	82.8	90.5	100.6	108.8	125.0	136.1	143.3									
Max. Water Temperature	°F	120	120	120	120	120	120	120	120	120									
	°C	48.9	48.9	48.9	48.9	48.9	48.9	48.9	48.9	48.9									
Min. Water Pressure	psig	0	0	0	0	0	0	0	0	0									
	kPa	0	0	0	0	0	0	0	0	0									
Max. Water Pressure	psig	150	150	150	150	150	150	150	150	150									
	kPa	1034.2	1034.2	1034.2	1034.2	1034.2	1034.2	1034.2	1034.2	1034.2									
2 Pass arrangement																			
Evap Water Connection Size <sup>(a)</sup>	in	5	5	6	6	6	6	8	8	8									
	mm	125	125	150	150	150	150	200	200	200									
Minimum Flow <sup>(b)</sup>	gpm	171	187	202	228	261	288	318	354	378									
	l/s	10.8	11.8	12.7	14.4	16.5	18.2	20.1	22.3	23.8									
Maximum Flow <sup>(b)</sup>	gpm	626	684	742	835	957	1055	1165	1299	1386									
	l/s	39.5	43.1	46.8	52.7	60.4	66.5	73.5	81.9	87.4									
3 Pass arrangement																			
Evap Water Connection Size <sup>(a)</sup>	in	4	4	5	5	5	5	6	6	6									
	mm	100	100	125	125	125	125	150	150	150									
Minimum Flow <sup>(b)</sup>	gpm	114	124	135	152	174	192	212	236	252									
	l/s	7.2	7.8	8.5	9.6	11.0	12.1	13.4	14.9	15.9									
Maximum Flow <sup>(b)</sup>	gpm	417	456	495	557	638	703	777	866	924									
	l/s	26.3	28.8	31.2	35.1	40.2	44.3	49.0	54.6	58.3									
<b>Condenser</b>																			
Length - Model Number Digit 25 <sup>(c)</sup>		A	A	B	A	B	B	C	B	C	B	C	C	D	D	E	E	F	
Quantity of Coil Modules		8	8	10	8	10	10	12	10	12	10	12	12	14	14	16	16	18	
Quantity of Fans		8	8	10	8	10	10	12	10	12	10	12	12	14	14	16	16	18	
Fan Diameter	in	37.5																	
	mm	953																	
Coil Length	in	78																	
	mm	1987																	
Coil Height	in	49																	
	mm	1252																	
Fins/Ft		276																	



## General Information

**Table 1. General data - 150 to 330 ton units (continued)**

Unit Size (tons)		150	165	180	200	225	250	275	300	330								
<b>Ambient Temperature Range</b>																		
Standard Ambient	°F (°C)	32 to 105 (0 to 40.6)																
Low Ambient	°F (°C)	0 to 105 (-17.7 to 40.6)																
Extreme Low Ambient	°F (°C)	-20 to 105 (-28.9 to 40.6)																
High Ambient	°F (°C)	32 to 125 (0 to 52)																
Wide Ambient	°F (°C)	0 to 125 (-17.7 to 52)																
<b>General Unit</b>																		
Refrigerant		R-513A																
Refrigerant Ckts	#	2																
Minimum Load	%	20	18	18	17	17	15	15	20	20	18	18	16	16	15	15	14	14
Refrigerant Charge/ckt	lb	170	165	195	176	205	197	225	204	231	194	220	229	254	240	263	248	270
	kg	77	75	89	80	93	89	102	92	105	88	100	104	115	109	119	112	122
Oil		OIL00386																
Oil Charge/ckt	gal	2.7	2.7	2.7	2.7	2.7	2.7	2.7	3.5	3.5	3.5	3.5	3.5	3.5	3.5	3.5	3.5	3.5
	L	10.2	10.2	10.2	10.2	10.2	10.2	10.2	13.2	13.2	13.2	13.2	13.2	13.2	13.2	13.2	13.2	13.2
<b>Relief Valves</b>																		
		<b>High Side</b>																
Relief setting	psig	350																
Rated Capacity	lba/min	29.5																
Quantity per unit		2																
Factory connection		3/8 NPT																
Field Connection		5/8 MFL																
		<b>Low Side</b>																
Relief setting	psig	200																
Rated Capacity	lba/min	28.9																
Quantity per unit		2																
Factory connection		7/8 UNF-2A																
Field Connection		3/4 NPTF																

(a) Inlet and outlet sizing changes with options. Free cooling pipe sizes override evaporator sizes and pumps sizes override all options.

(b) Minimum and maximum flow rates apply to constant-flow chilled water systems running at AHRl conditions, without freeze inhibitors added to the water loop.

(c) Condenser length defined by model number digit 25: A = 4V; B = 5V; C = 6V; D = 7V; E = 8V; F = 9V.

**Table 2. General data - 375 to 550 ton units**

Unit Size (tons)		375		380		440		450		500		550	
<b>Circuit<sup>(a)</sup></b>		<b>1</b>	<b>2</b>	<b>1</b>	<b>2</b>	<b>1</b>	<b>2</b>	<b>1</b>	<b>2</b>	<b>1</b>	<b>2</b>	<b>1</b>	<b>2</b>
<b>Compressor Model</b>	Comp A	CHHSS	CHHSS	CHHSS	CHHSS	CHHSS	CHHSS	CHHSS	CHHSS	CHHSS	CHHSS	CHHSS	CHHSS
	Comp B	N6	—	N6	—	N6	—	N6	—	N6	N6	N6	N6
<b>Evaporator</b>													
Water Storage	gal	36.3	36.3	39.5	39.5	45.0	49.3						
	L	137.3	137.3	149.6	149.6	170.3	186.8						
Max. Water Temperature	°F	120	120	120	120	120	120						
	°C	48.9	48.9	48.9	48.9	48.9	48.9						
Min. Water Pressure	psig	0	0	0	0	0	0						
	kPa	0	0	0	0	0	0						
Max. Water Pressure	psig	150	150	150	150	150	150						
	kPa	1034.2	1034.2	1034.2	1034.2	1034.2	1034.2						

**Table 2. General data - 375 to 550 ton units (continued)**

Unit Size (tons)		375		380		440		450		500		550	
Circuit <sup>(a)</sup>		1	2	1	2	1	2	1	2	1	2	1	2
1 Pass Arrangement													
Evap Water Connection Size <sup>(b)</sup>	in	8		8		8		8		8		8	
	mm	200		200		200		200		200		200	
Minimum Flow <sup>(c)</sup>	gpm	398		398		398		450		523		591	
	l/s	25.1		25.1		25.1		28.4		33.0		37.3	
Maximum Flow <sup>(c)</sup>	gpm	1750		1750		1750		1981		2303		2603	
	l/s	110.4		110.4		110.4		125.0		145.3		164.2	
2 Pass Arrangement													
Evap Water Connection Size <sup>(b)</sup>	in	8		8		8		8		8		8	
	mm	200		200		200		200		200		200	
Minimum Flow <sup>(c)</sup>	gpm	198		198		198		224		260		294	
	l/s	12.5		L		12.5		14		16.4		18.5	
Maximum Flow <sup>(c)</sup>	gpm	871		871		871		986		1146		1295	
	l/s	55.0		55.0		55.0		62.2		72.3		81.7	
<b>Condenser</b>													
Length - Model Number Digit 25 <sup>(d)</sup>		F		H		F		H		H		H	
Quantity of Coil Modules		12	6	14	8	12	6	14	8	12	10	12	10
Quantity of Fans	#	12	6	14	8	12	6	14	8	12	10	12	10
Fan Diameter	in	37.5											
	mm	953											
Coil Length	in	78.22											
	mm	1987											
Coil Height	in	49.31											
	mm	1252											
Fins/Ft		276											
<b>Ambient Temperature Range</b>													
Standard Ambient	°F (°C)	32 to 105 (0 to 40.6)											
Low Ambient	°F (°C)	0 to 105 (-17.7 to 40.6)											
Extreme Low Ambient	°F (°C)	-20 to 105 (-28.9 to 40.6)											
High Ambient	°F (°C)	32 to 125 (0 to 52)											
Wide Ambient	°F (°C)	0 to 125 (-17.7 to 52)											
<b>General Unit</b>													
Refrigerant		R-513A											
Refrigerant Ckts	#	2											
Minimum Load	%	15		15		15		15		10		10	
Refrigerant Charge/ckt	lb	366	177	405	215	366	177	405	215	380	365	380	365
	kg	166	80	184	98	166	80	184	98	172	166	172	166
Oil		OIL00386											
Oil Charge/ckt	gal	4.8	3.5	4.8	3.5	4.8	3.5	4.8	3.5	4.8	4.8	4.8	4.8
	L	18.2	13.2	18.2	13.2	18.2	13.2	18.2	13.2	18.2	18.2	18.2	18.2
<b>Relief Valves</b>													
		<b>High Side</b>											
Relief setting	psig	350											



## General Information

**Table 2. General data - 375 to 550 ton units (continued)**

Unit Size (tons)		375		380		440		450		500		550	
		1	2	1	2	1	2	1	2	1	2	1	2
Circuit <sup>(a)</sup>													
Rated Capacity	lba/min	29.5											
Quantity per unit		2											
Factory connection		3/8 NPT											
Field Connection		5/8 MFL											
		<b>Low Side</b>											
Relief setting	psig	200											
Rated Capacity	lba/min	28.9											
Quantity per unit		2											
Factory connection		7/8 UNF-2A											
Field Connection		3/4 NPTF											

<sup>(a)</sup> Circuit applicable where two values given per tonnage.

<sup>(b)</sup> Inlet and outlet sizing changes with options. Free cooling pipe sizes override evaporator sizes and pumps sizes override all options.

<sup>(c)</sup> Minimum and maximum flow rates apply to constant-flow chilled water systems running at AHRI conditions, without freeze inhibitors added to the water loop.

<sup>(d)</sup> Condenser length defined by model number digit 25: F = 9V; H = 11V.

**Table 3. General data - free cooling specific data**

Description	Units	Values												
		B		C		D		E		F		H		
Condenser Length - Model Number Digit 25 <sup>(a)</sup>														
Free-Cooling Model Number Digit 42 <sup>(b)</sup>		T	J	H	T	J	H	T	J	H	T	J	T	
Customer Water Connection Size <sup>(c)</sup>	in	6						8						
	mm	152						200						
Quantity of Free-Cooling Coils (Extended)		9 (10)	11 (12)	13 (14)	15 (16)	17 (18)	19 (20)	15 (16)	17 (18)	19 (20)	17 (18)	19 (20)	20	
Quantity of Free-Cooling-only fans		—	2	4	—	2	4	—	2	4	—	2	—	
Coil Length	in	72.49												
	mm	1841												
Coil Height	in	40												
	mm	1016												
Fins/Ft		192												
Rows		3												
Free Cooling Customer Side Storage Volume (Extended Length)	gal	123 (129)	145 (151)	173 (179)	212 (218)	234 (240)	212 (218)	234 (240)	212 (218)	234 (240)	276 (282)	234 (240)	276 (282)	232
	L	467 (489)	550 (572)	656 (679)	801 (823)	883 (906)	801 (823)	883 (906)	801 (823)	883 (906)	1043 (1063)	883 (906)	1043 (1063)	878
<b>Pump Package</b>														
Pump Package Option - Model Number Digit 40 <sup>(d)</sup>														
Pump HP														
Customer Water Connection Size <sup>(c)</sup>	in	—												
	mm													
Additional Water Storage in Pump System	gal	117	148	151	117	148	151	117	148	151	117	148	151	151
	L	443	560	572	443	560	572	443	560	572	443	560	572	572

<sup>(a)</sup> Condenser length defined by model number digit 25: B = 5V; C = 6V; D = 7V; E = 8V; F = 9V; H = 11V.

<sup>(b)</sup> Direct Free-Cooling defined by model number digit 42: T = TDFC; J = DFC1; H = DFC2.

<sup>(c)</sup> Inlet and outlet sizing changes with options. Free cooling pipe sizes override evaporator sizes and pumps sizes override all options.

<sup>(d)</sup> Pump Package defined by model number digit 40: 5 = SV50, 6 = SV60, 7 = SV75.



# Controls

## Symbio 800 Controller

Trane chillers offer predictive controls that anticipate and compensate for load changes. Other strategies made possible with the Symbio™ 800 controls are:

### Feedforward Adaptive Control

Feedforward is an open-loop, predictive control strategy designed to anticipate and compensate for load changes. It uses evaporator entering-water temperature as an indication of load change. This allows the controller to respond faster and maintain stable leaving-water temperatures.

### Soft Loading

The chiller controller uses soft loading except during manual operation. Large adjustments to setpoint changes are made gradually, preventing the compressor from cycling unnecessarily. It does this by internally filtering the setpoints to avoid reaching the differential-to-stop or the demand limit. Soft loading applies to the leaving chilled-water temperature and demand limit setpoints.

### Adaptive Controls

Adaptive Controls directly sense the control variables that govern the operation of the chiller: evaporator pressure and condenser pressure. When any one of these variables approach a limit condition when damage may occur to the unit or shutdown on a safety, Adaptive Controls take corrective action to avoid shutdown and keep the chiller operating. This happens through combined actions of compressor and/or fan staging. Whenever possible, the chiller is allowed to continue making chilled water. This keeps cooling capacity available until the problem can be solved. Overall, the safety controls help keep the building or process running and out of trouble.

### Integrated Rapid Restart

Bringing a chiller back online rapidly after a loss of power is critical to operations in mission critical environments like data centers and hospitals which demand the highest levels of reliability.

A loss of cooling capacity can be costly, which is why Trane chillers are designed and engineered for Rapid Restart™. In the event of a power interruption, the chiller will start a compressor before the front panel display is fully powered up eliminating the need for UPS. This not only helps the chiller get back online faster, but it also provides a simple and reliable solution to minimize the risks of financially devastating damage to assets caused by overheating due to a power loss.

Of course, the truest test of a chiller restart capabilities is the amount of time it takes to resume full-load cooling, and this is where the chiller really shines. An 80 percent cooling mechanical load can be achieved in less than 2.5 minutes after power restoration—your assurance that the cooling capacity your equipment requires is just a few minutes away.

### Rapid Restart Test

After completion of a standard full load witness test, power to the chiller will be cut and then reapplied to demonstrate the rapid restart capabilities of the chiller for disaster relief.

### AdaptiSpeed™ Control

Compressor speed is used to control capacity of the chiller, optimizing mathematically with the condenser fan speed to provide the highest level of performance. The increased performance of the controller allows the chiller to operate longer at higher efficiency, and with greater stability.

## Tracer® AdaptiView™ TD-7 Operator Interface

The standard Tracer® AdaptiView™ TD-7 display provided with the Symbio™ 800 controller features a 7-inch LCD touch-screen, allowing access to all operational inputs and outputs. This advanced interface allows the user to access important information concerning setpoints, active temperatures, modes, electrical data, pressure, and diagnostics. The full text display is available in 27 languages.

### Display Feature Settings

- LCD touch-screen with LED backlighting, for scrolling access to input and output operating information.

- Single-screen, folder/tab-style display of all available information on individual components (evaporator, condenser, compressor, etc.)
- Manual override indication.
- Password entry/lockout system to enable or disable display.
- Automatic and immediate stop capabilities for standard or immediate manual shutdown.
- Fast, easy access to available chiller data in tabbed format, including:
  - Easy to view Operating Modes
  - Logical Subcomponent Reports:
    - Evaporator
    - Condenser
    - Compressor
    - Motor
  - 3 User Programmable Custom Reports
  - ASHRAE Report
  - Log Sheet Report
  - Alarms Report
  - 8 Pre-defined Standard Graphs
  - 4 User Programmable Custom Graphs
  - Unit Settings
  - Service Settings
  - Feature Settings
  - Chilled Water Reset
  - Manual Control Settings
  - Display Preferences
  - Support of 27 languages
  - Brightness Setting
  - Cleaning Mode

## **Air-Fi™ Wireless Communication Interface (WCI Indoor)**

Factory installed wireless interface provides wireless communication to Air-Fi™ wireless sensors, service tools, equipment controls, and building controller.

## **Trane Wi-Fi Adapter**

The Trane Wi-Fi adapter kit (equipped with a USB cable) enables communication among devices on a Wi-Fi network to facilitate the wireless integration of client devices such as touch-screen displays and technician laptops as an access point.

## **System Integration**

### **Stand-Alone Controls**

Single chillers installed in applications without a building management system are simple to install and control: only a remote auto/stop for scheduling is required for unit operation. Signals from the chilled-water pump contactor auxiliary, or a flow switch, are wired to the chilled-water flow interlock. Signals from a time clock or some other remote device are wired to the external auto/stop input.

- Auto/Stop - A job-site provided contact closure turns the unit on and off.
- Emergency Stop - A job-site provided contact opening wired to this input turns the unit off and requires a manual reset of the unit microcomputer. This closure is typically triggered by a job-site provided system such as a fire alarm.



### Hardwire Points

Microcomputer controls allow simple interface with other control systems, such as time clocks, building automation systems, and ice storage systems via hardwire points. This means you have the flexibility to meet job requirements while not having to learn a complicated control system.

Remote devices are wired from the control panel to provide auxiliary control to a building automation system. Inputs and outputs can be communicated via a typical 4–20 mA electrical signal, an equivalent 2–10 Vdc signal, or by utilizing contact closures.

This setup has the same features as a stand-alone water chiller, with the possibility of having additional optional features:

- Ice making control.
- External chilled water setpoint, external demand limit setpoint.
- Chilled water temperature reset.
- Programmable relays - available outputs are: alarm-latching, alarm-auto reset, general alarm-warning, chiller limit mode, compressor running, and Tracer® control.

### Tracer SC

The Tracer® SC system controller acts as the central coordinator for all individual equipment devices on a Tracer® building automation system. The Tracer®SC scans all unit controllers to update information and coordinate building control, including building subsystems such as VAV and chiller water systems. With this system option, the full breadth of Trane's HVAC and controls experience are applied to offer solutions to many facility issues. The LAN allows building operators to manage these varied components as one system from any personal computer with web access. The benefits of this system are:

- Improved usability with automatic data collection, enhanced data logging, easier to create graphics, simpler navigation, pre-programmed scheduling, reporting, and alarm logs.
- Flexible technology allows for system sizes from 30 to 120 unit controllers with any combination of LonTalk® or BACnet® unit controllers.
- LEED certification through site commissioning report, energy data collection measurement, optimizing energy performance, and maintaining indoor air quality.

Energy savings programs include: fan pressure optimization, ventilation reset, and chiller plant control (adds and subtracts chillers to meet cooling loads).

### Building Automation Systems

#### BACnet® Building Automation Control Network

The BACnet control network for Symbio™ 800 expands communications from the unit controls network to the Tracer® Ensemble™ or Tracer® SC+ building automation system (BAS) or third party building automation system. Utilizing BACnet, the BAS allows external setpoint and configuration adjustment and monitoring of status and diagnostics. The Symbio 800 utilizes the BACnet defined TP protocol as defined in ASHRAE standard 135-2004. This controller works in standalone mode, with Tracer Ensemble, Tracer SC+ or when connected to a third party building automation system that supports BACnet.

#### Modbus® Automation Control Network

Allows the user to easily interface with Modbus RTU communication protocol via a single twisted pair wiring or Modbus TCP over Ethernet from the Symbio™ 800 controller to a factory installed device.

#### LonTalk® Building Automation Systems

The LonTalk communication protocol for the Symbio™ 800 controller expands communications from the unit controls network to a Tracer® Ensemble™ building automation system or third party building automation system. Utilizing LonTalk, the BAS allows external setpoint and configuration adjustment and monitoring of status and diagnostics. The Symbio 800 utilizes an FTT-10A free topology transceiver, which supports non-polarity sensitive, free topology wiring—which in turn allows the system installer to utilize star, bus, and loop architectures. This controller works in standalone mode, peer-to-peer with one or more other units, or when connected to a Tracer Ensemble, Tracer SC+, or a third party building automation system that supports LonTalk.

**Note:** An optional module is required for Symbio 800 support of LonTalk. See *Tracer® USB LonTalk Module Installation Instructions (BAS-SVN138\*-EN)*.

# Symbio 800 Controls

## Overview

The Symbio™ 800 controller is a factory-installed, application specific and programmable controller designed to control chillers and large packaged HVAC equipment. A 7-inch user interface features a touch-sensitive color screen that provides facility managers at-a-glance operating status, performance monitoring, scheduling changes, and operating adjustments. Other advanced features include automated controller back-up, and optional features such as secure remote connectivity, wireless building communications, mobile device connectivity, and custom programming with expandable I/O.

Symbio™ 800 Advantages		Benefits
Connected	Convenient, on-the-go access to advanced monitoring, troubleshooting, and energy management	<ul style="list-style-type: none"> <li>• Minimum first cost.</li> <li>• Maximum comfort.</li> <li>• Minimized downtime.</li> <li>• Minimum operating costs.</li> <li>• Superior building and occupant productivity.</li> </ul>
Flexible	Minimized installation hardware and labor costs – able to use existing devices for maximum convenience, lower controls upgrades and relocation	
Reliable	Maximum equipment uptime and life, minimized maintenance and troubleshooting cost	

## Features and Benefits

Symbio™ 800 Feature	Benefits
Multiple, open standard protocol support <ul style="list-style-type: none"> <li>• BACnet® TP.</li> <li>• BACnet®/IP.</li> <li>• LON (Optional).</li> <li>• Modbus®.</li> </ul>	Simplified, lower cost, and more flexible integration with all common open standard protocols using Trane or competitive BAS systems and controllers.
Remote connection to building or equipment	Trane Connect™ provides an easy, secure option to connect remotely to a Tracer® SC+ or directly to your Trane equipment.
Common integration strategies and equipment specific points lists	Simplified, lower cost, and uncompromised integration.
Application specific and configurable	Reduced project costs with superior reliability, comfort, performance - applications specific and configurable system confirms machine continues to run within operating envelope. Ability to upgrade firmware with a simple file transfer.
Smart Analytics	Smart analytics provide superior reliability through the life of the equipment with minimum downtime.
Data logging	Standard, local or remote Intuitive review and analysis of equipment, zone, and building performance.
Local scheduling	Capable of operating in stand-alone operation without a building automation system as a temporary back-up schedule for ongoing comfort and energy savings.
Rugged, 7-inch color touch screen user interface	Easy, touch navigation for viewing data and making operational changes.
Display preferences	Choose how to view dates, times, units (SI, IP), screen brightness, data format, and backlight timeout. A total of 27 built-in languages are supported and selectable for all TD-7 screens.
Intuitive navigation	Helps operators access data and alarms for quick and accurate response and resolution.
At-a-glance status	Easily readable color display showing key operating parameters of major equipment components.
Reports	Quickly summarizes data for clear understanding and interpretation to enable local monitoring of expected performance and operating efficiency.
Graphs	Easily visualize trend data for local troubleshooting and fine-tuning.
Multiple language support	Suitable for operation in multiple geographies.
Adaptive Control™ Algorithms	Pre-empts potential equipment disruptions during rapidly changing conditions – providing consistent equipment performance and building comfort.



## Controls

Symbio™ 800 Feature	Benefits
SD card backup/restore	Faster, lower cost repairs with reduced downtime.
Modbus® device support	Capable of integrating optional Modbus® devices for local or remote diagnostics — provides faster, lower cost troubleshooting and increased equipment performance.

## Options

Symbio™ 800 Feature	Benefits
Remote connection to building or equipment	Trane Connect™ provides an easy, secure option to connect remotely to a Tracer® SC+ or directly to your Trane equipment.
Programmable	Equipment application flexibility and cost-reduced control of nearby equipment.
Expandable I/O	Field or factory installed I/O for programmable feature for reduced installation costs and increased installation flexibility.
User security with audit trail support	Flexible and secure access for multiple users allows monitoring, overriding/releasing points, release of all overrides, custom report editing, and tracking changes by user.
LonTalk®	

## Specifications

Controller Specifications	
Input power	24 Vdc +/- 10%, 400mA max.
Storage temperature	-67°F to 185°F (-55°C to 85°C), Humidity: Between 5% to 95% (Non-Condensing).
Operating temperature	-40°F to 158°F (-40°C to 70°C).
Environmental rating (enclosure)	IP3x.
Time clock	On-board real time clock with 10 year battery backup.
Mounting weight	Mounting surface must support 1.3 lb. (0.6 kg).
Overall dimensions	5.65 in. (143.5 mm) wide x 4.00 in. (101.6 mm) high x 2.38 in. (60.6 mm) deep.
Agency Compliance	
<ul style="list-style-type: none"> <li>UL PAZX, Energy Management Equipment.</li> <li>UL94-5V Flammability.</li> <li>CE.</li> <li>FCC CFR Title 47, Part 15.109: Class B Limit, (30 MHz—10 GHz).</li> <li>BTL Listed—Advanced Application Profile (B-AAC).</li> </ul>	
User Interface Specifications	
Input power	24 Vdc +/- 10%, 400 mA max
Storage temperature	-67°F to 203°F (-55°C to 95°C), Humidity: Between 5% to 100% (Condensing).
Operating temperature	-40°F to 158°F (-40°C to 70°C), Humidity: Between 5% to 100% (Condensing).
Environmental rating (enclosure)	IP56 (dust and strong water jet protected) with optional sealed Ethernet cable (PN: X19070632020).
Mounting weight	Mounting surface must support 1.6 lb. (0.74 kg).
Overall dimensions	8.3 in. (211.6 mm) wide x 6.3 in. (158.8 mm) high x 2.1 in. (53.2 mm) deep [bezel depth 0.4 in. (11.3 mm)].
Agency Compliance	
<ul style="list-style-type: none"> <li>UL PAZX, Energy Management Equipment.</li> <li>UL94-5V, Flammability.</li> <li>FCC CFR Title 47, Part 15.109: Class A Limit, (30 MHz—4 GHz).</li> <li>CE EMC Directive 2004/108/EC.</li> </ul>	



# Electrical

## Electrical Data

Refer to Trane Select Assist (TSA) for electrical statistics: MCA, MOP, SCCR, Wire Termination Range.

## Electrical Connections

Refer to schematic and submittal proposal for electrical connection information.



# Dimensions and Weights

## Weights

Table 4. Weights — 150 to 330 ton units

Unit Size (tons)	Condenser Length <sup>(a)</sup>	Free Cooling Option <sup>(b)</sup>	Pump Option <sup>(c)</sup>	Standard Length				Extended Length <sup>(d)</sup>			
				Shipping		Operating		Shipping		Operating	
				lb	kg	lb	kg	lb	kg	lb	kg
150	4V	—	—	12000	5450	12200	5540	14200	6450	14400	6540
165	4V	—	—	12100	5490	12300	5580	14300	6490	14500	6580
	5V	—	—	13100	5950	13200	5990	15200	6900	15400	6990
	5V	TDFC	—	16000	7260	17200	7810	18600	8440	20000	9080
	5V	DFC1	—	17300	7830	19100	8670	20000	9040	21800	9880
180	5V	DFC2	—	18100	8190	20000	9030	20800	9400	22600	10240
	4V	—	—	12200	5540	12400	5630	14600	6630	14800	6720
	5V	—	—	13400	6080	13500	6130	15500	7040	15700	7130
	5V	TDFC	—	16800	7630	18000	8170	18800	8550	20300	9210
	5V	DFC1	—	17800	8040	19600	8890	20200	9160	22100	10000
200	5V	DFC2	—	19200	8680	21000	9530	21000	9530	22900	10380
	5V	—	—	13600	6170	13800	6260	15600	7080	15800	7170
	6V	—	—	14600	6630	14800	6720	16600	7530	16800	7630
	6V	TDFC	—	18600	8440	20000	9080	20900	9490	22400	10170
	6V	DFC1	—	20400	9220	22400	10160	22900	10370	25000	11310
225	6V	DFC2	—	21500	9740	23600	10690	22400	10140	26200	11870
	5V	—	—	14800	6720	15000	6810	17000	7720	17200	7810
	6V	—	—	15900	7220	16100	7310	18100	8220	18300	8310
	6V	TDFC	—	19900	9030	21300	9670	22300	10120	23800	10800
	6V	DFC1	—	20700	9360	22800	10310	23200	10510	25300	11460
250	6V	DFC2	—	21800	9850	23900	10800	24500	11070	26600	12050
	5V	—	—	14900	6760	15100	6850	17300	7850	17500	7940
	6V	—	—	16300	7400	16500	7490	18400	8350	18700	8490
	6V	TDFC	—	20300	9210	21700	9850	22500	10210	24200	10980
	6V	DFC1	—	20800	9440	22900	10390	23300	10530	25400	11490
275	6V	DFC2	—	20900	9480	24000	10890	24600	11160	26700	12080
	6V	—	—	16500	7490	16700	7580	18500	8400	18800	8530
	6V	TDFC	—	20400	9260	21800	9860	22600	10260	24500	11080
	7V	—	—	17400	7900	17700	8030	19600	8900	19800	8990
	7V	TDFC	—	21700	9850	23800	10780	24400	11070	26400	11980
	7V	DFC1	—	22800	10330	24900	11290	25300	11450	27500	12440
	7V	DFC1	PUMP	27000	12220	30700	13910	29400	13340	33200	15060
	7V	DFC2	—	23900	10830	26200	11870	26100	11830	28400	12880
7V	DFC2	PUMP	28100	12720	32000	14490	30300	13720	34200	15500	

**Table 4. Weights — 150 to 330 ton units (continued)**

Unit Size (tons)	Condenser Length <sup>(a)</sup>	Free Cooling Option <sup>(b)</sup>	Pump Option <sup>(c)</sup>	Standard Length				Extended Length <sup>(d)</sup>			
				Shipping		Operating		Shipping		Operating	
				lb	kg	lb	kg	lb	kg	lb	kg
300	7V	—	—	17500	7940	17700	8030	19700	8900	19900	9030
	7V	TDFC	—	21800	9890	23900	10840	24500	11040	26500	11990
	8V	—	—	18500	8400	18800	8530	20700	9390	20900	9490
	8V	TDFC	—	23400	10590	25500	11620	25800	11670	27900	12660
	8V	TDFC	PUMP	27600	12470	31300	14180	29800	13520	33500	15180
	8V	DFC1	—	24700	11180	27000	12210	26900	12180	29300	13260
	8V	DFC1	PUMP	28800	13070	32800	14850	31100	14070	35100	15890
	8V	DFC2	—	25600	11600	28200	12790	27800	12540	30400	13790
330	8V	DFC2	PUMP	29800	13490	33900	15380	31900	14420	36100	16380
	8V	—	—	19100	8650	19500	8830	21400	9680	21800	9870
	8V	TDFC	NONE	23800	10780	26000	11780	26300	11920	28600	12940
	8V	TDFC	PUMP	28000	12670	31800	14410	30500	13800	34400	15570
	9V	—	NONE	20300	9200	20800	9400	22300	10100	22700	10280
	9V	TDFC	NONE	25500	11570	27900	12630	27700	12570	30100	13650
	9V	TDFC	PUMP	29700	13450	33700	15270	31900	14450	35900	16270
	9V	DFC1	—	26200	11870	28700	12980	27900	12640	30500	13830
	9V	DFC1	PUMP	30400	13760	34400	15610	32100	14530	36100	16350

**Notes:**

- Weights include factory charge of refrigerant and oil, ultimate sounds, and architectural louvered panels.
- All weights are plus/minus 10%

<sup>(a)</sup> Condenser length defined by model number digit 25: 4V = A; 5V = B; 6V = C; 7V = D; 8V = E; 9V = F

<sup>(b)</sup> Direct Free Cooling defined by model number digit 42: T=TDFC; J=DFC1; H=DFC2.

<sup>(c)</sup> Pump Package defined by model number digit 40 = 5, 6, 7

<sup>(d)</sup> Extended Length is required for voltages 200V, 230V, 380V, 400V, 575V (model number digit 9 = A, B, C, D, F), and harmonic filtration model number digit 44 = L.

**Table 5. Weights — 375 to 550 ton units**

Unit Size (tons)	Condenser Length <sup>(a)</sup>	Standard Unit with SPP <sup>(b)</sup>				Std Unit with SPP and Options Box <sup>(c)</sup>			
		Shipping		Operating		Shipping		Operating	
		lb	kg	lb	kg	lb	kg	lb	kg
Units without Direct Free-Cooling <sup>(d)</sup>									
375	9V	22900	10390	23300	10570	25500	11570	25900	11750
440	9V	22900	10390	23300	10570	25500	11570	25900	11750
380	11V	25200	11440	25500	11570	27200	12340	27600	12520
450	11V	25200	11440	25500	11570	27200	12340	27600	12520
500	11V	27400	12430	27900	12660	29500	13390	29900	13570
550	11V	27400	12430	27900	12660	29500	13390	29900	13570
Units with Direct Free-Cooling <sup>(d)</sup>									
380	11V	30900	14020	33200	15060	33400	15150	35500	16100
450	11V	30900	14020	33200	15060	33400	15150	35500	16100
500	11V	33100	15020	35500	16100	35200	15600	37600	17060
550	11V	33100	15020	35500	16100	35200	15600	37600	17060

**Notes:**

- Weights include factory charge of refrigerant and oil, architectural louvered panels, and Superior sound option.
- All weights are plus/minus 10%.

<sup>(a)</sup> Condenser length defined by model number digit 25: 9V = F; 11V = H.

<sup>(b)</sup> Single Point Power (SPP) is indicated by model number digit 29 = 1.

<sup>(c)</sup> Options box is used for units with either 575V (model number digit 9 = F) or Low Harmonics Option (model number digit 44 = L).

<sup>(d)</sup> Direct Free-Cooling defined by model number digit 42 = T.

## Service Clearance

**Figure 5. Unit service clearance requirements — 150 to 330 ton units**

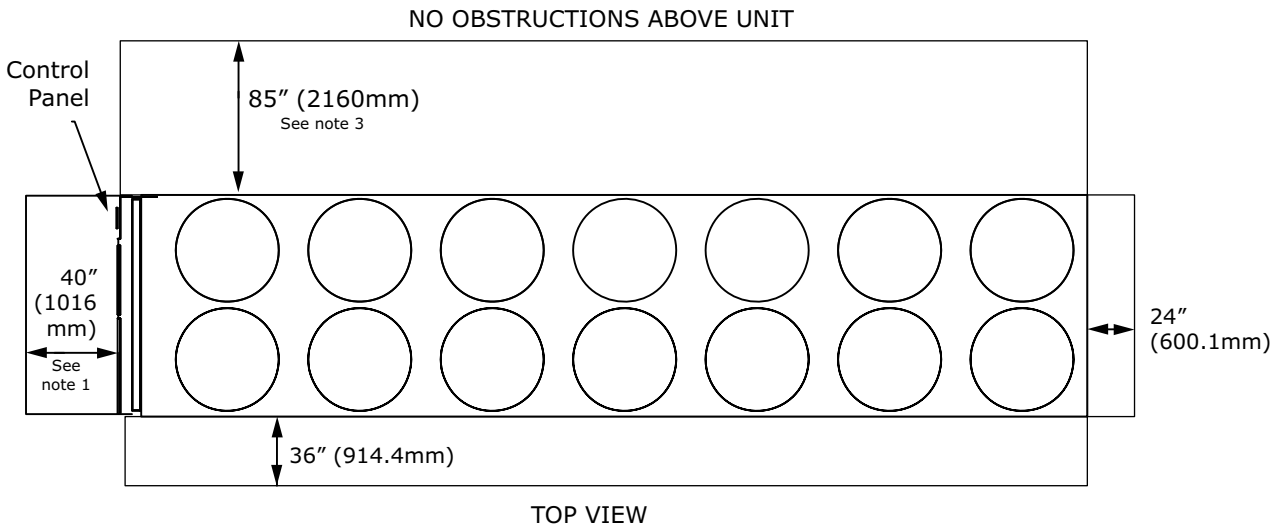

**Figure 6. Unit service clearance requirements — 375 to 550 ton units**

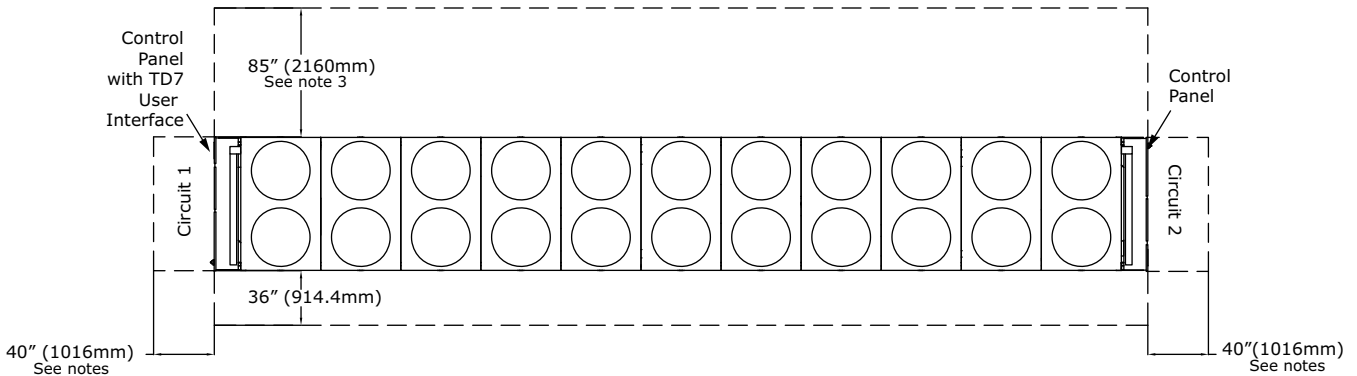

**Notes:**

1. A full 40" clearance is required in front of the control panel(s). Must be measured from front of panel, not end of unit base. Installer must also follow NEC and local/state codes for electrical clearance requirements.
2. Area above unit is required for operation, maintenance, access panel and air flow. No obstructions above unit.
3. Clearance of 85" on the side of the unit is required for coil replacement. Preferred side for coil replacement is shown (left side of the unit, as facing control panel), however either side is acceptable.
4. For obstructions or multiple units, refer to *Close-Spacing and Restricted Airflow Situations, Ascend™ Chiller Models ACR and ACS, Sintesis™ Chiller Model RTAF Engineering Bulletin (AC-PRB001\*-EN)*.

# Unit Dimensions

## Unit Sizes 150 to 330 Tons

Figure 7. Dimensions — 150 to 330 ton units, standard length

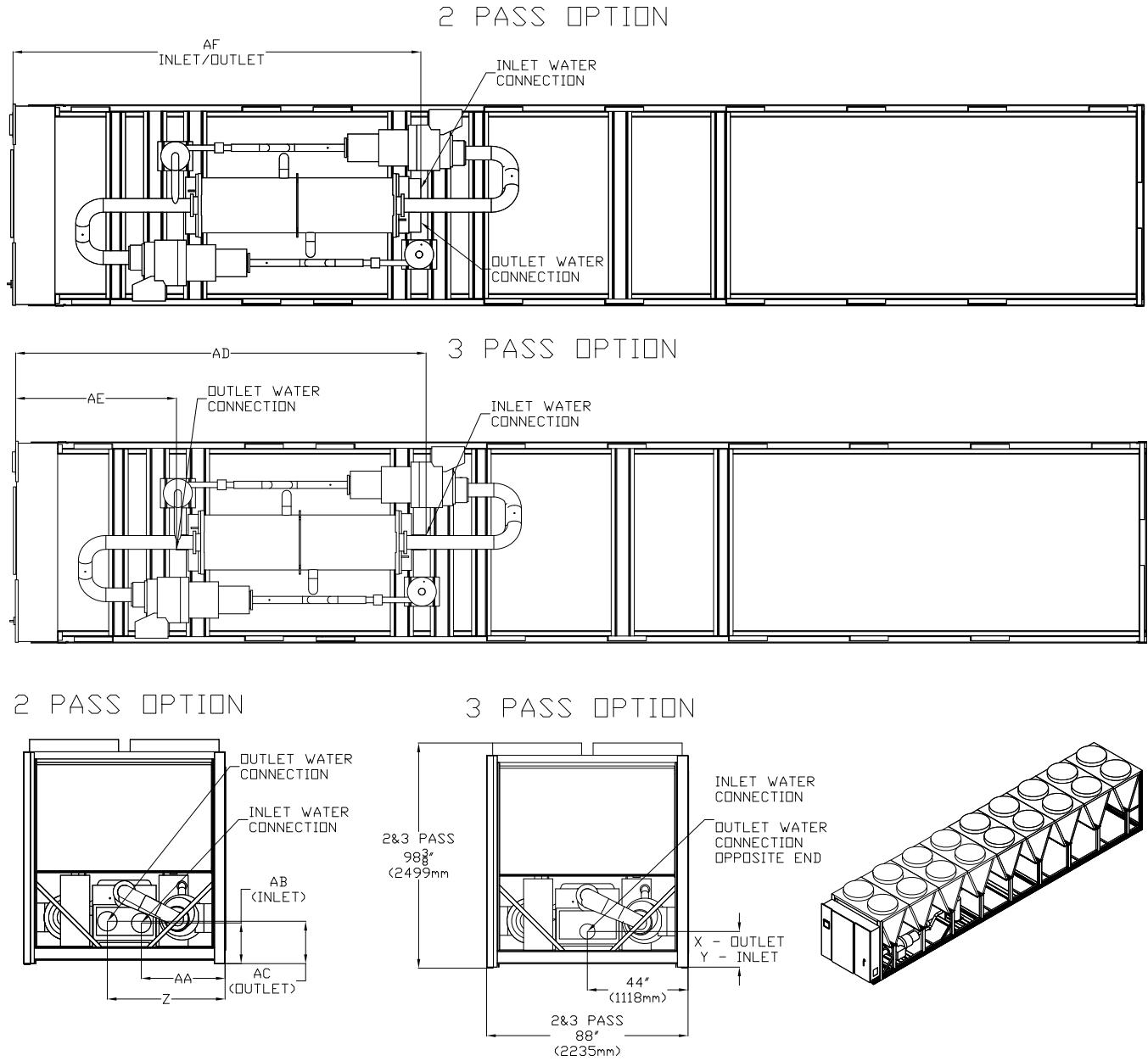



## Dimensions and Weights

Figure 8. Dimensions — 150 to 330 ton units, standard length, mounting and lifting

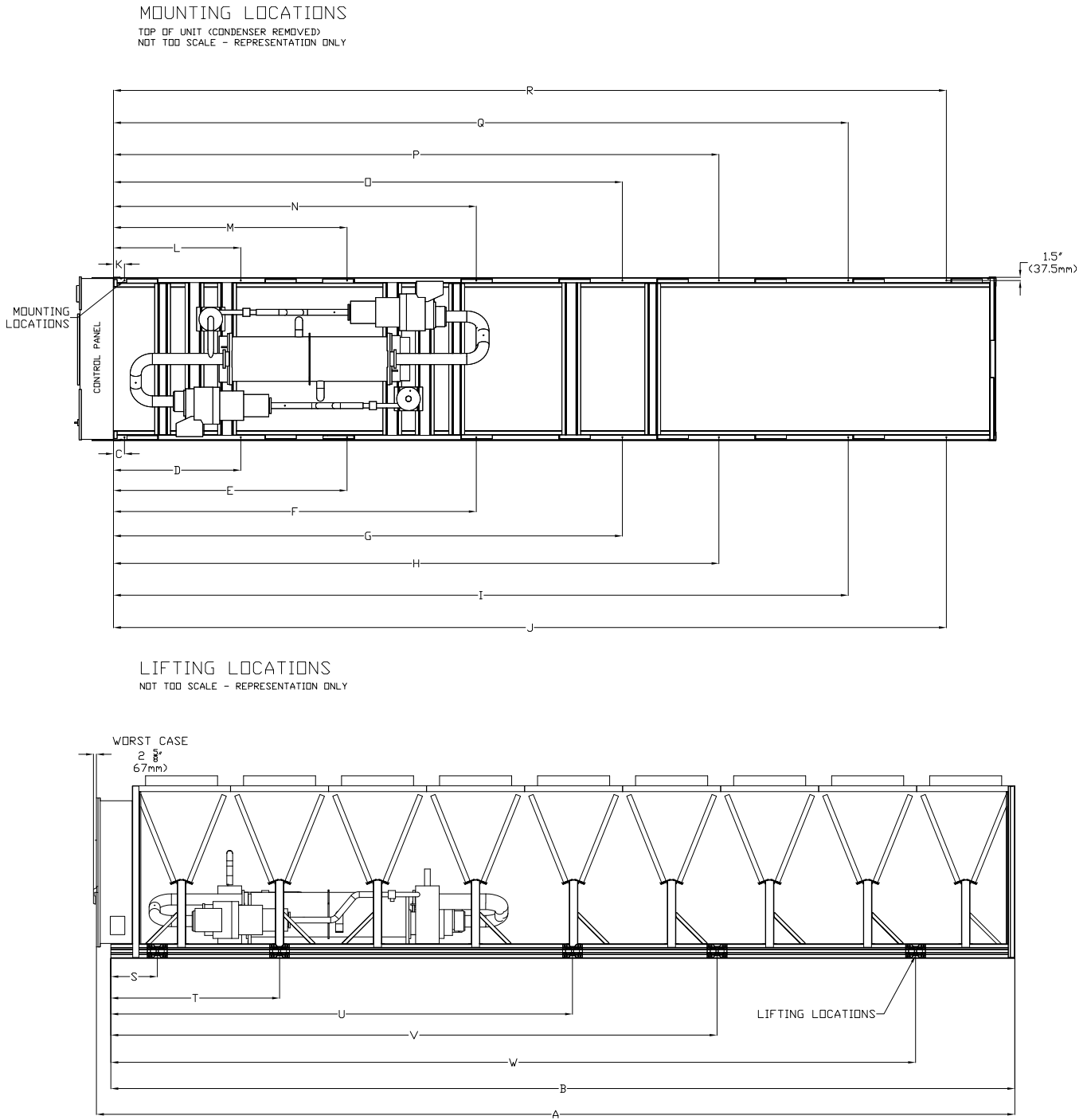

Table 6. Dimensions — 150 to 330 ton units, standard length, I-P (inch)

Cond Length (a)	4V		5V		6V		7V		8V		9V		8V		9V		8V		9V	
	N/A	N/TDFC A	N/A	TDFC DFC1	N/A	TDFC DFC2	N/A	TDFC DFC1	N/A	TDFC DFC2	N/A	TDFC DFC1	N/A	TDFC DFC2	N/A	TDFC DFC1	N/A	TDFC DFC2	N/A	TDFC DFC1
Pump Opt(c)	N/A	N/A	N/A	N/A	N/A	N/A	N/A	N/A	N/A	N/A	N/A	N/A	N/A	N/A	N/A	N/A	N/A	N/A	N/A	N/A
Compr. (e)	GP4V	GP4V	GP4V	GP4V	GP4V	GP4V	GP4V	GP4V	GP4V	GP4V	GP4V	GP4V	GP4V	GP4V	GP4V	GP4V	GP4V	GP4V	GP4V	GP4V
A (e)	233.7	286.4	339.4	392.1	445.0	497.8	550.6	603.4	656.1	708.8	761.5	814.2	866.9	919.6	972.3	1025.0	1077.7	1130.4	1183.1	1235.8
B	223.0	275.8	328.6	381.5	434.3	487.1	539.9	592.7	645.5	698.3	751.1	803.9	856.7	909.5	962.3	1015.1	1067.9	1120.7	1173.5	1226.3
C	11.8	11.8	11.8	11.8	11.8	11.8	11.8	11.8	11.8	11.8	11.8	11.8	11.8	11.8	11.8	11.8	11.8	11.8	11.8	11.8
D	63.0	63.0	63.0	63.0	63.0	63.0	63.0	63.0	63.0	63.0	63.0	63.0	63.0	63.0	63.0	63.0	63.0	63.0	63.0	63.0
E	141.7	137.8	137.8	124.4	137.8	137.8	137.8	137.8	137.8	137.8	137.8	137.8	137.8	137.8	137.8	137.8	137.8	137.8	137.8	137.8
F	204.7	255.9	238.6	196.9	238.6	196.9	196.9	196.9	196.9	196.9	196.9	196.9	196.9	196.9	196.9	196.9	196.9	196.9	196.9	196.9
G	n/a	n/a	315.0	n/a	n/a	n/a	n/a	n/a	n/a	n/a	n/a	n/a	n/a	n/a	n/a	n/a	n/a	n/a	n/a	n/a
H	n/a	n/a	n/a	334.6	413.4	413.4	413.4	413.4	413.4	413.4	413.4	413.4	413.4	413.4	413.4	413.4	413.4	413.4	413.4	413.4
I	n/a	n/a	n/a	n/a	n/a	n/a	n/a	n/a	n/a	n/a	n/a	n/a	n/a	n/a	n/a	n/a	n/a	n/a	n/a	n/a
J	n/a	n/a	n/a	n/a	n/a	n/a	n/a	n/a	n/a	n/a	n/a	n/a	n/a	n/a	n/a	n/a	n/a	n/a	n/a	n/a
K	15.7	15.7	15.7	15.7	15.7	15.7	15.7	15.7	15.7	15.7	15.7	15.7	15.7	15.7	15.7	15.7	15.7	15.7	15.7	15.7
L	82.7	82.7	82.7	82.7	82.7	82.7	82.7	82.7	82.7	82.7	82.7	82.7	82.7	82.7	82.7	82.7	82.7	82.7	82.7	82.7
M	141.7	137.8	137.8	124.4	137.8	137.8	137.8	137.8	137.8	137.8	137.8	137.8	137.8	137.8	137.8	137.8	137.8	137.8	137.8	137.8
N	204.7	255.9	238.6	196.9	238.6	196.9	196.9	196.9	196.9	196.9	196.9	196.9	196.9	196.9	196.9	196.9	196.9	196.9	196.9	196.9
O	n/a	n/a	315.0	n/a	n/a	n/a	n/a	n/a	n/a	n/a	n/a	n/a	n/a	n/a	n/a	n/a	n/a	n/a	n/a	n/a
P	n/a	n/a	n/a	334.6	393.7	393.7	393.7	393.7	393.7	393.7	393.7	393.7	393.7	393.7	393.7	393.7	393.7	393.7	393.7	393.7
Q	n/a	n/a	n/a	n/a	n/a	n/a	n/a	n/a	n/a	n/a	n/a	n/a	n/a	n/a	n/a	n/a	n/a	n/a	n/a	n/a
R	n/a	n/a	n/a	n/a	n/a	n/a	n/a	n/a	n/a	n/a	n/a	n/a	n/a	n/a	n/a	n/a	n/a	n/a	n/a	n/a
S	25.0	25.0	25.0	25.0	25.0	25.0	25.0	25.0	25.0	25.0	25.0	25.0	25.0	25.0	25.0	25.0	25.0	25.0	25.0	25.0
T	153.1	170.6	90.9	90.9	90.9	90.9	90.9	90.9	90.9	90.9	90.9	90.9	90.9	90.9	90.9	90.9	90.9	90.9	90.9	90.9
U	n/a	n/a	211.4	249.4	170.6	170.6	170.6	170.6	170.6	170.6	170.6	170.6	170.6	170.6	170.6	170.6	170.6	170.6	170.6	170.6
V	n/a	n/a	n/a	327.3	355.1	355.1	355.1	355.1	355.1	355.1	355.1	355.1	355.1	355.1	355.1	355.1	355.1	355.1	355.1	355.1
W	n/a	n/a	n/a	n/a	n/a	n/a	n/a	n/a	n/a	n/a	n/a	n/a	n/a	n/a	n/a	n/a	n/a	n/a	n/a	n/a

(a) Condenser length defined by model number digit 25: 4V = A; 5V = B; 6V = C; 7V = D; 8V = E; 9V = F.

(b) Free Cooling defined by model number digit 42: T = TDFC; H = DFC2; J = DFC1.

(c) Pump Package defined by model number digit 40 = 5, 6, 7.

(d) Compressor type defined by model digit 8: 4 = GPMX, 5 = GP4V.

(e) Total unit length includes additional extruded features such as louvers and circuit breaker handles.



## Dimensions and Weights

**Table 7. Dimensions — 150 to 330 ton units, standard length, SI (mm)**

Cond Length (a)	4V		5V		6V		7V		8V		9V		8V		9V		8V		9V			
	N/A	N/ TDFC A	TDFC	DFC1	NA	TDFC	DFC2	DFC1	NA	NA	DFC2	DFC1	TDFC	DFC2	DFC1	TDFC	DFC2	DFC1	TDFC	DFC2	DFC1	
Pump Opt(c)	N/A	N/A	N/A	N/A	N/A	N/A	N/A	N/A	N/A	N/A	N/A	N/A	N/A	N/A	N/A	N/A	N/A	N/A	N/A	N/A	N/A	
Compr (e)	GP4V	GP4V	GP4V	GP4V	GP4V	GP4V	GP4V	GP4V	GP4V	GP4V	GP4V	GP4V	GP4V	GP4V	GP4V	GP4V	GP4V	GP4V	GP4V	GP4V	GP4V	
A (e)	5936	7275	8620	8348	9960	9690	11302	11032	11302	11032	12646	12374	12646	12374	12646	12374	12646	12374	12646	12374	12646	13984
B	5664	7006	8348		9690		11032		11032		1302		11032		12374		13716		13716		13984	13716
C	300	300	300	300	300	300	300	300	300	300	300	300	300	300	300	300	300	300	300	300	300	300
D	1600	1600	1600	1600	1600	1600	1600	1600	1600	1600	1600	1600	1600	1600	1600	1600	1600	1600	1600	1600	1600	1600
E	3600	3500	3500	3500	3160	3500	3500	3500	3500	3500	3500	3500	3500	3500	3500	3500	3500	3500	3500	3500	3500	3500
F	5200	6500	6060	6060	5000	5000	5000	5000	5000	5000	5000	5000	5000	5000	5000	5000	5000	5000	5000	5000	5000	5000
G	n/a	n/a	8000	n/a	n/a	n/a	n/a	n/a	n/a	n/a	n/a	n/a	n/a	n/a	n/a	n/a	n/a	n/a	n/a	n/a	n/a	n/a
H	n/a	n/a	n/a	n/a	8500	8500	10500	10500	10500	10500	7908	7908	10500	10500	7908	7908	10500	10500	7908	7908	7908	7908
I	n/a	n/a	n/a	n/a	n/a	n/a	n/a	n/a	n/a	n/a	n/a	n/a	n/a	n/a	n/a	n/a	n/a	n/a	n/a	n/a	n/a	n/a
J	n/a	n/a	n/a	n/a	n/a	n/a	n/a	n/a	n/a	n/a	n/a	n/a	n/a	n/a	n/a	n/a	n/a	n/a	n/a	n/a	n/a	n/a
K	400	400	400	400	400	400	400	400	400	400	400	400	400	400	400	400	400	400	400	400	400	400
L	2100	2100	2100	2100	2100	2100	2100	2100	2100	2100	2100	2100	2100	2100	2100	2100	2100	2100	2100	2100	2100	2100
M	3600	3500	3500	3500	3160	3500	3500	3500	3500	3500	3500	3500	3500	3500	3500	3500	3500	3500	3500	3500	3500	3500
N	5200	6500	6060	6060	5000	5000	5000	5000	5000	5000	5000	5000	5000	5000	5000	5000	5000	5000	5000	5000	5000	5000
O	n/a	n/a	8000	n/a	n/a	n/a	n/a	n/a	n/a	n/a	n/a	n/a	n/a	n/a	n/a	n/a	n/a	n/a	n/a	n/a	n/a	n/a
P	n/a	n/a	n/a	n/a	8500	8500	10000	10000	10000	10000	7908	7908	11816	11816	8500	8500	7908	7908	8500	8500	7908	7908
Q	n/a	n/a	n/a	n/a	n/a	n/a	n/a	n/a	n/a	n/a	n/a	n/a	n/a	n/a	n/a	n/a	n/a	n/a	n/a	n/a	n/a	n/a
R	n/a	n/a	n/a	n/a	n/a	n/a	n/a	n/a	n/a	n/a	n/a	n/a	n/a	n/a	n/a	n/a	n/a	n/a	n/a	n/a	n/a	n/a
S	635	635	635	635	635	635	635	635	635	635	635	635	635	635	635	635	635	635	635	635	635	635
T	3890	4334	2309	2309	2309	2309	2309	2309	2309	2309	2309	2309	2309	2309	2309	2309	2309	2309	2309	2309	2309	2309
U	n/a	n/a	5370	5370	6335	6335	4333	4333	4333	4333	4333	4333	4333	4333	4333	4333	4333	4333	4333	4333	4333	4333
V	n/a	n/a	n/a	n/a	8314	8314	9019	9019	9019	9019	9019	9019	8315	8315	8315	8315	8315	8315	8315	8315	8315	8315
W	n/a	n/a	n/a	n/a	n/a	n/a	n/a	n/a	n/a	n/a	n/a	n/a	n/a	n/a	n/a	n/a	n/a	n/a	n/a	n/a	n/a	n/a

(a) Condenser length defined by model number digit 25: 4V = A; 5V = B; 6V = C; 7V = D; 8V = E; 9V = F.

(b) Free Cooling defined by model number digit 42: T = TDFC; H = DFC2; J = DFC1.

(c) Pump Package defined by model number digit 40 = 5, 6, 7.

(d) Compressor type defined by model digit 8: 4 = GPMX, 5 = GP4V.

(e) Total unit length includes additional extruded features such as louvers and circuit breaker handles.

**Table 8. Water connection dimensions — 150 to 330 ton units, standard length, without free-cooling or pump package**

Unit Size (tons)	150, 165		180, 200		225, 250		275, 300, 330	
	in	mm	in	mm	in	mm	in	mm
X	20.4	520	19.6	498	21.8	554	20.6	523
Y	17.7	450	15.4	391	17.6	447	16.1	408
Z	49.3	1253	49.9	1268	49.9	1268	51.3	1303
AA	38.5	978	37.9	962	37.9	962	36.5	927
AB	19.3	490	17.6	448	19.8	504	18.2	463
AC	19.7	500	18.2	463	20.4	519	18.9	481
AD	176.5	4483	178.2	4526	178.1	4524	178.4	4531
AE	70.3	1786	69.2	1758	69.2	1758	69.3	1760
AF	175.3	4453	176.2	4475	176.2	4475	177.1	4498

# Dimensions and Weights

Figure 9. Dimensions — 150 to 330 ton units, extended length

## VOLTAGE AUTO TRANSFORMER OPTION

USED WITH 200, 230, 380, 400 AND 575V

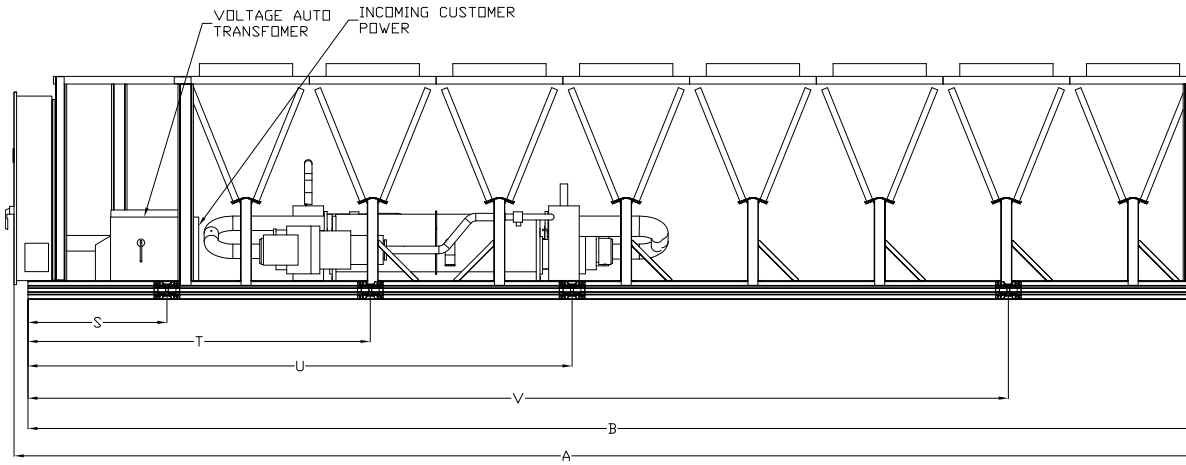

## HARMONIC FILTRATION OPTION

LIFTING DIMENSION SAME AS ABOVE

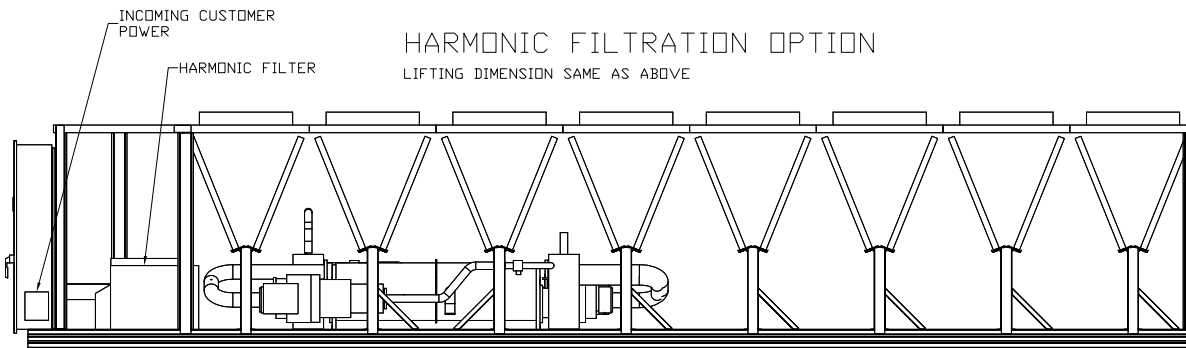

## MOUNTING LOCATIONS

TOP VIEW (CONDENSER REMOVED)  
NOT TO SCALE - REPRESENTATION ONLY

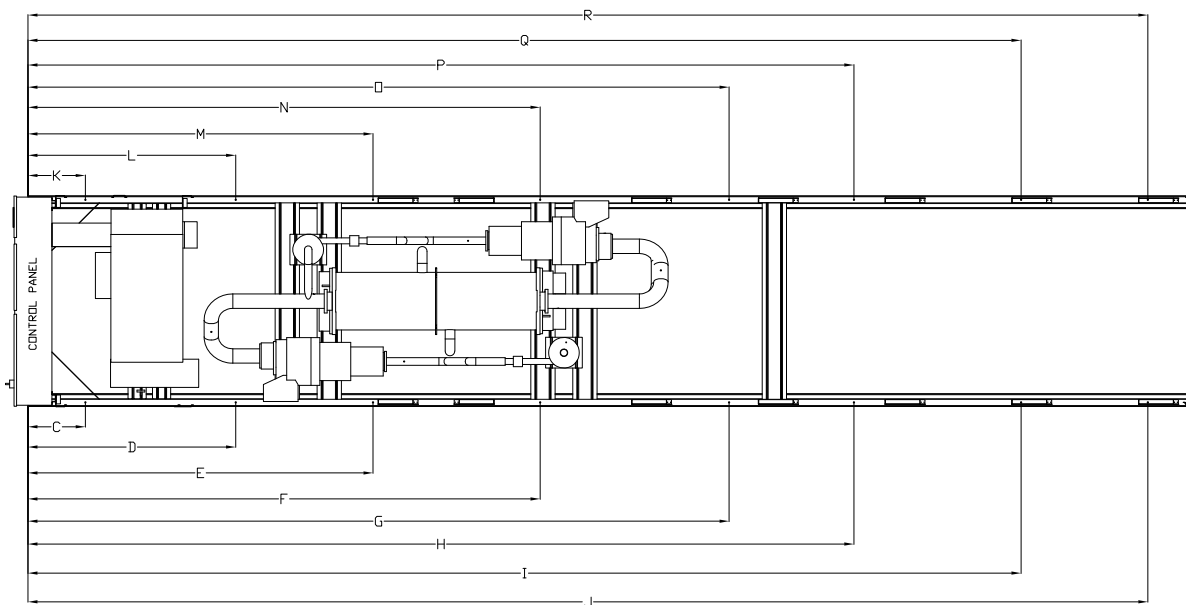

**Table 9. Dimensions — 150 to 330 ton units, extended length, I-P (inch)**

Cond Length (a)	4V	5V	6V	5V	6V	7V	8V	7V	8V	9V	7V	8V	9V	7V	8V	9V	8V	9V
	N/A	N/ TDFC DFC1 A	N/ TDFC DFC2 DFC1 A	N/A	N/A	N/A	NONE	NONE	TDFC DFC1	TDFC DFC2 DFC1	NONE	TDFC DFC1	NONE	TDFC DFC2 DFC1	NONE	TDFC DFC2 DFC1	TDFC DFC2 DFC1	TDFC DFC2 DFC1
Pump Opt(c)	N/A	N/A	N/A	N/A	N/A	N/A	NONE	NONE	NONE	PUMP	NONE	NONE	PUMP	NONE	NONE	PUMP	NONE	PUMP
Compr (d)	GP4V	GP4V	GP4V	GP4V	GP4V	GP4V	GP4V	GP4V	GP4V	GP4V	GP4V	GP4V	GP4V	GP4V	GP4V	GP4V	GP4V	GP4V
A (e)	286.4	339.4	392.1	445.0	497.8	497.8	497.8	497.8	497.8	550.6	550.6	550.6	550.6	550.6	550.6	550.6	603.3	603.3
B	275.8	328.6	381.5	434.3	487.1	487.1	487.1	487.1	487.1	540.0	540.0	540.0	540.0	540.0	540.0	540.0	592.8	592.8
C	27.6	27.6	51.2	51.2	51.2	51.2	51.2	51.2	51.2	27.6	27.6	27.6	27.6	27.6	27.6	27.6	51.2	51.2
D	114.2	114.2	114.2	114.2	114.2	114.2	114.2	114.2	114.2	114.2	114.2	114.2	114.2	114.2	114.2	114.2	114.2	114.2
E	194.6	190.6	190.6	177.2	190.6	190.6	190.6	190.6	190.6	249.7	249.7	249.7	249.7	249.7	249.7	249.7	291.4	291.4
F	257.6	308.7	249.7	249.7	291.4	291.4	291.4	291.4	291.4	344.3	344.3	344.3	344.3	344.3	344.3	344.3	395.7	395.7
G	n/a	n/a	367.8	n/a	n/a	n/a	n/a	n/a	n/a	n/a	n/a	n/a	n/a	n/a	n/a	n/a	421.2	421.2
H	n/a	n/a	n/a	387.5	466.2	466.2	466.2	466.2	466.2	518.0	518.0	518.0	518.0	518.0	518.0	518.0	570.9	570.9
I	n/a	n/a	n/a	n/a	n/a	n/a	n/a	n/a	n/a	n/a	n/a	n/a	n/a	n/a	n/a	n/a	603.3	603.3
J	n/a	n/a	n/a	n/a	n/a	n/a	n/a	n/a	n/a	n/a	n/a	n/a	n/a	n/a	n/a	n/a	654.7	654.7
K	27.6	27.6	51.2	51.2	51.2	51.2	51.2	51.2	51.2	27.6	27.6	27.6	27.6	27.6	27.6	27.6	51.2	51.2
L	114.2	114.2	114.2	114.2	114.2	114.2	114.2	114.2	114.2	114.2	114.2	114.2	114.2	114.2	114.2	114.2	114.2	114.2
M	194.6	190.6	190.6	177.2	190.6	190.6	190.6	190.6	190.6	249.7	249.7	249.7	249.7	249.7	249.7	249.7	291.4	291.4
N	257.6	308.7	249.7	249.7	291.4	291.4	291.4	291.4	291.4	344.3	344.3	344.3	344.3	344.3	344.3	344.3	395.7	395.7
O	n/a	n/a	367.8	n/a	n/a	n/a	n/a	n/a	n/a	n/a	n/a	n/a	n/a	n/a	n/a	n/a	421.2	421.2
P	n/a	n/a	n/a	387.5	446.5	446.5	446.5	446.5	446.5	518.0	518.0	518.0	518.0	518.0	518.0	518.0	570.9	570.9
Q	n/a	n/a	n/a	n/a	n/a	n/a	n/a	n/a	n/a	n/a	n/a	n/a	n/a	n/a	n/a	n/a	603.3	603.3
R	n/a	n/a	n/a	n/a	n/a	n/a	n/a	n/a	n/a	n/a	n/a	n/a	n/a	n/a	n/a	n/a	654.7	654.7
S	55.1	55.1	58.3	58.3	58.3	58.3	58.3	58.3	58.3	58.3	58.3	58.3	58.3	58.3	58.3	58.3	114.2	114.2
T	206.0	223.5	143.7	143.7	143.7	143.7	143.7	143.7	143.7	143.7	143.7	143.7	143.7	143.7	143.7	143.7	194.6	194.6
U	n/a	n/a	264.3	302.2	223.4	223.4	223.4	223.4	223.4	276.0	276.0	276.0	276.0	276.0	276.0	276.0	327.4	327.4
V	n/a	n/a	n/a	380.2	407.9	407.9	407.9	407.9	407.9	479.7	479.7	479.7	479.7	479.7	479.7	479.7	530.2	530.2
W	n/a	n/a	n/a	n/a	n/a	n/a	n/a	n/a	n/a	n/a	n/a	n/a	n/a	n/a	n/a	n/a	603.3	603.3

(a) Condenser length defined by model number digit 25: 4V = A; 5V = B; 6V = C; 7V = D; 8V = E; 9V = F.  
 (b) Free Cooling defined by model number digit 42: T = TDFC; H = DFC2; J = DFC1.  
 (c) Pump Package defined by model number digit 40 = 5, 6, 7.  
 (d) Compressor type defined by model digit 8: 4 = GPMX; 5 = GP4V.  
 (e) Total unit length includes additional extruded features such as lowers and circuit breaker handles.



# Dimensions and Weights

**Table 10. Dimensions — 150 to 330 ton units, extended length, SI (mm)**

Cond Length (a)	4V	5V	5V	6V	6V	7V	7V	8V	8V	9V	9V	7V	8V	8V	9V	9V	8V	8V	9V	9V
	N/A	N/ A	N/ TDFC DFC1 A	N/ TDFC DFC2 DFC1 A	N/A	N/A	N/A	NONE	TDFC DFC1	TDFC DFC2 DFC1	NONE	TDFC DFC1	TDFC DFC2 DFC1	TDFC DFC1	TDFC DFC2 DFC1	NONE	TDFC DFC1	TDFC DFC2 DFC1	TDFC DFC1	TDFC DFC2 DFC1
Free Cool (b)	N/A	N/A	N/A	N/A	N/A	N/A	N/A	NONE	TDFC DFC1	TDFC DFC2 DFC1	NONE	TDFC DFC1	TDFC DFC2 DFC1	TDFC DFC1	TDFC DFC2 DFC1	NONE	TDFC DFC1	TDFC DFC2 DFC1	TDFC DFC1	TDFC DFC2 DFC1
Pump Opt (c)	N/A	N/A	N/A	N/A	N/A	N/A	N/A	NONE	TDFC DFC1	TDFC DFC2 DFC1	NONE	TDFC DFC1	TDFC DFC2 DFC1	TDFC DFC1	TDFC DFC2 DFC1	NONE	TDFC DFC1	TDFC DFC2 DFC1	TDFC DFC1	TDFC DFC2 DFC1
Compr (d)	GP4V	GP4V	GP4V	GP4V	GP4V	GP4V	GP4V	GP4V	GP4V	GP4V	GP4V	GP4V	GP4V	GP4V	GP4V	GP4V	GP4V	GP4V	GP4V	GP4V
A (e)	7275	8620	9960	11302	12646	13984	13984	12646	12374	1300	13715	13984	12646	12374	1300	13715	13984	12646	12374	1300
B	7006	8348	9690	11032	12374	1300	1300	12374	12374	1300	13715	13984	12646	12374	1300	13715	13984	12646	12374	1300
C	700	700	1300	1300	1300	1300	1300	1300	1300	1300	1300	1300	1300	1300	1300	1300	1300	1300	1300	1300
D	2900	2900	2900	2900	2900	2900	2900	2900	2900	2900	2900	2900	2900	2900	2900	2900	2900	2900	2900	2900
E	4942	4842	4842	4502	4842	4842	4842	4842	4842	4842	4842	4842	4842	4842	4842	4842	4842	4842	4842	4842
F	6542	7842	6342	6342	7402	7402	7402	7402	7402	7402	7402	7402	7402	7402	7402	7402	7402	7402	7402	7402
G	n/a	n/a	9342	n/a	n/a	n/a	n/a	n/a	n/a	n/a	n/a	n/a	n/a	n/a	n/a	n/a	n/a	n/a	n/a	n/a
H	n/a	n/a	n/a	9842	11842	11842	11842	11842	11842	11842	11842	11842	11842	11842	11842	11842	11842	11842	11842	11842
I	n/a	n/a	n/a	n/a	n/a	n/a	n/a	n/a	n/a	n/a	n/a	n/a	n/a	n/a	n/a	n/a	n/a	n/a	n/a	n/a
J	n/a	n/a	n/a	n/a	n/a	n/a	n/a	n/a	n/a	n/a	n/a	n/a	n/a	n/a	n/a	n/a	n/a	n/a	n/a	n/a
K	700	700	1300	1300	1300	1300	1300	1300	1300	1300	1300	1300	1300	1300	1300	1300	1300	1300	1300	1300
L	2900	2900	2900	2900	2900	2900	2900	2900	2900	2900	2900	2900	2900	2900	2900	2900	2900	2900	2900	2900
M	4942	4842	4842	4502	4842	4842	4842	4842	4842	4842	4842	4842	4842	4842	4842	4842	4842	4842	4842	4842
N	6542	7842	6342	6342	7402	7402	7402	7402	7402	7402	7402	7402	7402	7402	7402	7402	7402	7402	7402	7402
O	n/a	n/a	9342	n/a	n/a	n/a	n/a	n/a	n/a	n/a	n/a	n/a	n/a	n/a	n/a	n/a	n/a	n/a	n/a	n/a
P	n/a	n/a	n/a	9842	11342	11342	11342	11342	11342	11342	11342	11342	11342	11342	11342	11342	11342	11342	11342	11342
Q	n/a	n/a	n/a	n/a	n/a	n/a	n/a	n/a	n/a	n/a	n/a	n/a	n/a	n/a	n/a	n/a	n/a	n/a	n/a	n/a
R	n/a	n/a	n/a	n/a	n/a	n/a	n/a	n/a	n/a	n/a	n/a	n/a	n/a	n/a	n/a	n/a	n/a	n/a	n/a	n/a
S	1400	1400	1482	1482	1482	1482	1482	1482	1482	1482	1482	1482	1482	1482	1482	1482	1482	1482	1482	1482
T	5232	5676	3651	3651	3651	3651	3651	3651	3651	3651	3651	3651	3651	3651	3651	3651	3651	3651	3651	3651
U	n/a	n/a	6712	7677	5675	5675	5675	5675	5675	5675	5675	5675	5675	5675	5675	5675	5675	5675	5675	5675
V	n/a	n/a	n/a	9657	10361	10361	10361	10361	10361	10361	10361	10361	10361	10361	10361	10361	10361	10361	10361	10361
W	n/a	n/a	n/a	n/a	n/a	n/a	n/a	n/a	n/a	n/a	n/a	n/a	n/a	n/a	n/a	n/a	n/a	n/a	n/a	n/a

(a) Condenser length defined by model number digit 25: 4V = A; 5V = B; 6V = C; 7V = D; 8V = E; 9V = F.

(b) Free Cooling defined by model number digit 42: T = TDFC; H = DFC2; J = DFC1.

(c) Pump Package defined by model number digit 40 = 5, 6, 7.

(d) Compressor type defined by model digit 8: 4 = GPMX; 5 = GP4V.

(e) Total unit length includes additional extruded features such as louvers and circuit breaker handles.

**Table 11. Water connection dimensions — 150 to 330 ton units, extended length, without free-cooling or pump package**

Unit Size (tons)	150, 165		180, 200		225, 250		275, 300, 330	
	in	mm	in	mm	in	mm	in	mm
X	20.4	520	19.6	498	21.8	554	20.6	523
Y	17.7	450	15.4	391	17.6	447	16.1	408
Z	49.3	1253	49.9	1268	49.9	1268	51.3	1303
AA	38.5	978	37.9	962	37.9	962	36.5	927
AB	19.3	490	17.6	448	19.8	504	18.2	463
AC	19.7	500	18.2	463	20.4	519	18.9	481
AD	229.3	5824	231.0	5867	231.0	5867	231.2	5872
AE	123.1	3127	122.1	3101	122.1	3101	122.1	3101
AF	227.9	5794	229.1	5819	229.1	5819	229.9	5839



## Dimensions and Weights

Figure 10. Water connection dimensions — 150 to 330 ton units with free-cooling or pump package option

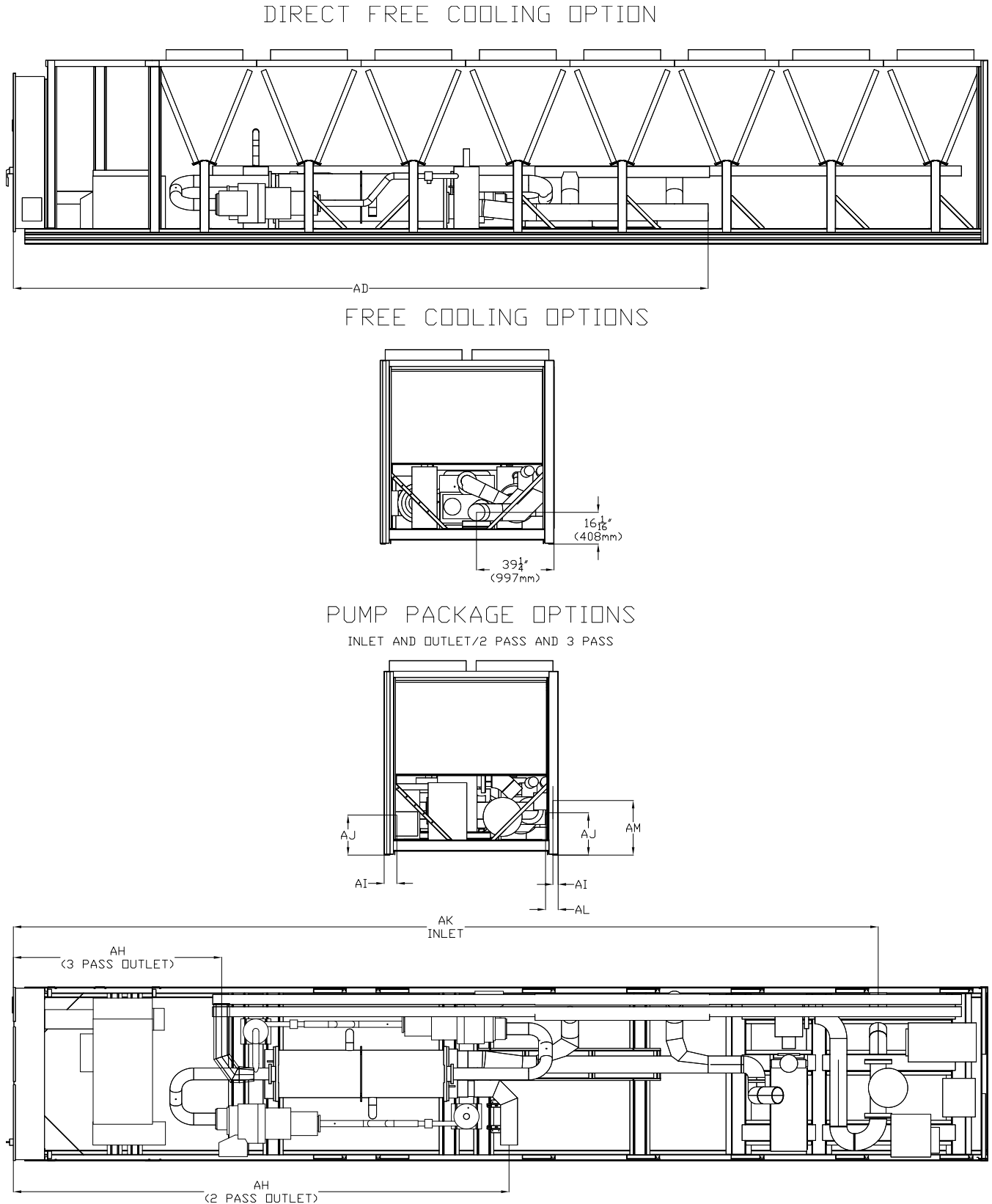

**Table 12. Water connection dimensions — 150 to 330 ton units, with free-cooling (no pump package)**

Unit Size (tons)	165		180, 200		225, 250		275		300, 330	
	in	mm	in	mm	in	mm	in	mm	in	mm
<b>Standard Length</b>										
X	20.4	520	19.6	498	21.8	554	20.6	523	20.6	523
Z	49.3	1253	49.9	1268	49.9	1268	51.3	1303	51.3	1303
AC	19.7	500	18.2	463	20.4	519	18.9	480	18.9	480
AD <sup>(a)</sup>	270.9	6882	270.9	6881	270.9	6881	298.8	7588	298.8	7588
AE	70.3	1786	69.2	1758	69.2	1758	69.3	1760	69.3	1760
AF	176.2	4475	176.2	4475	176.2	4475	177.1	4498	177.1	4498
AG	270.9	6881	270.9	6881	270.9	6881	298.8	7588	298.8	7588
<b>Extended Length<sup>(b)</sup></b>										
X	20.4	520	19.6	498	21.8	554	20.6	523	20.6	523
Z	49.3	1253	49.9	1268	49.9	1268	51.3	1303	51.3	1303
AC	19.7	500	18.2	463	20.4	519	18.9	480	18.9	480
AD <sup>(a)</sup>	323.7	8222	323.7	8222	323.7	8222	351.6	8930	351.6	8930
AE	123.1	3127	122.0	3100	122.0	3100	122.0	3100	122.0	3100
AF	228.0	5791	229.1	5819	229.1	5819	229.1	5819	229.1	5819
AG	323.7	8222	323.7	8222	326.5	8293	351.6	8930	351.6	8930

**Note:** Free-cooling defined by model number digit 42: T = TDFC; J = DFC1; H = DFC2.

<sup>(a)</sup> Only applicable on units with direct free-cooling cooling option (model number digit 42 = T, J, or H).

<sup>(b)</sup> Extended Length is required for voltages 200V, 230V, 380V, 400V, 575V (model number digit 9 = A, B, C, D, F), and harmonic filtration model number digit 44 = L.

**Table 13. Water connection inlet dimensions — 275, 300, 330 ton units with pump package option**

Unit Option	Standard Length		Extended Length <sup>(a)</sup>	
	in	mm	in	mm
AK	383.5	9741	436.3	11081
AL	2.9	73	2.9	73
AM	27.2	691	27.2	691

**Note:** Free-cooling defined by model number digit 42: T = TDFC; J = DFC1; H = DFC2.

<sup>(a)</sup> Extended Length is required for voltages 200V, 230V, 380V, 400V, 575V (model number digit 9 = A, B, C, D, F), and harmonic filtration model number digit 44 = L.

**Table 14. Water connection outlet dimensions — 275, 300, 330 ton units with pump package option**

Unit Option	50HP 2-Pass		60HP or 75HP 2-Pass		50HP 3-Pass		60HP or 75HP 3-Pass	
	in	mm	in	mm	in	mm	in	mm
<b>Standard Length</b>								
AH	191.6	4866	193.4	4913	54.5	1385	52.3	1327
AI	4.5	115	0.6	16	7	177	8	204
AJ	18.9	481	18.9	481	20.6	523	19.6	497
<b>Extended Length<sup>(a)</sup></b>								
AH	244.4	6208	246.3	6255	107.3	2727	105.1	2669
AI	4.5	115	0.6	16	7	177	8	20
AJ	18.9	481	18.9	481	20.6	523	19.6	497

**Note:** Pump Package defined by model number digit 40 = 5 (50 HP), 6 (60 HP), 7 (75 HP). Pass options are defined by model number digits 19 and 20 (C2 or D2 are 2-pass, C3 is 3-pass).

<sup>(a)</sup> Extended Length is required for voltages 200V, 230V, 380V, 400V, 575V (model number digit 9 = A, B, C, D, F), and harmonic filtration model number digit 44 = L.



# Dimensions and Weights

## Unit Sizes 375 to 550 Tons

Figure 11. Dimensions – 375 to 550 ton units without direct-free cooling

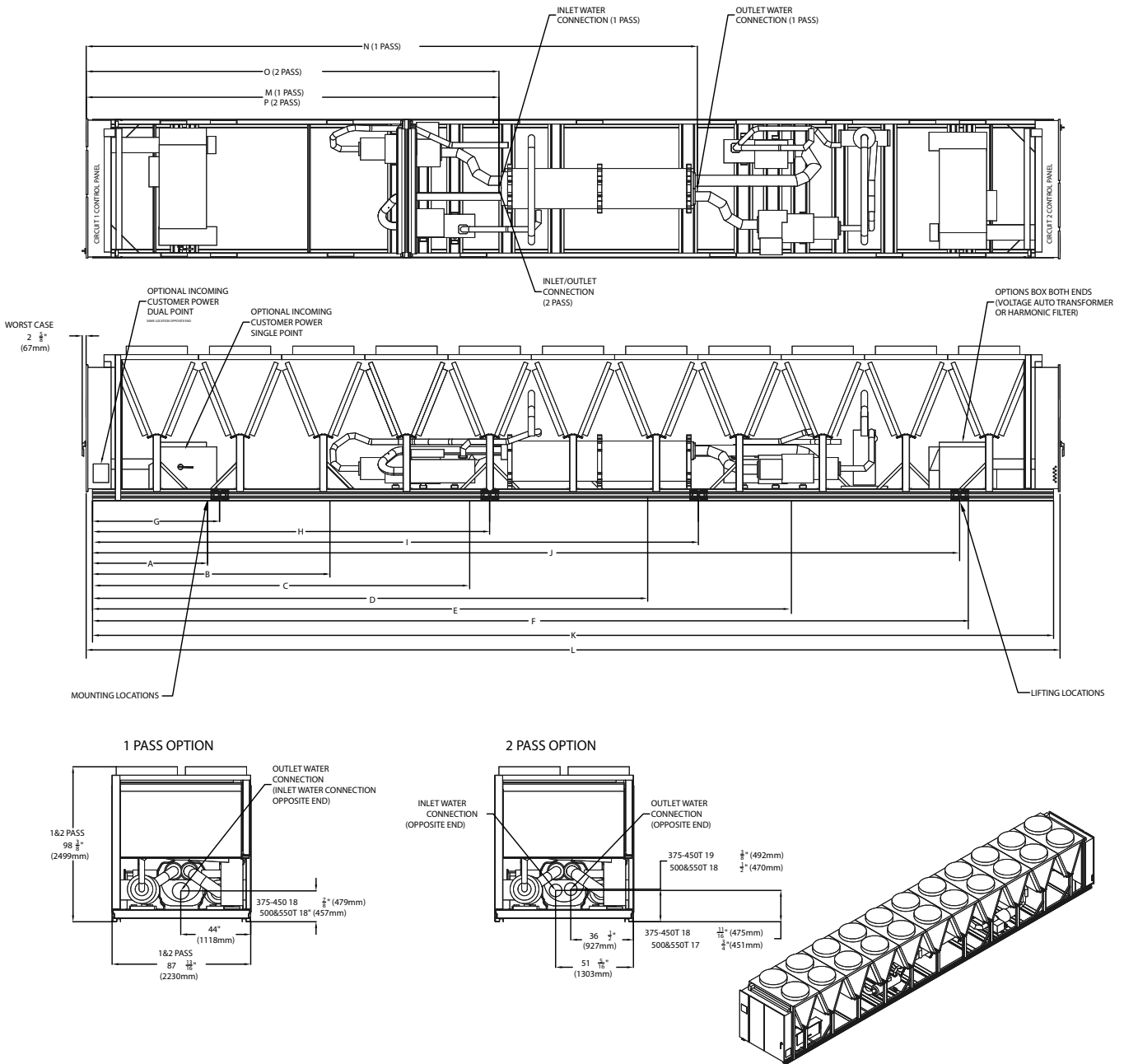

Table 15. Dimensions — 375 to 550 ton units

Unit Size (tons)	375, 440		375, 440		380, 450		500, 550	
	Standard		Extended <sup>(a)</sup>		Standard		Standard	
Unit Length	Standard		Extended <sup>(a)</sup>		Standard		Standard	
Dimension	in	mm	in	mm	in	mm	in	mm
A	52.4	1330	52.4	1330	76.0	1930	76.0	1930
B	99.6	2530	99.6	2530	146.9	3730	146.9	3730
C	180.6	4588	180.6	4588	233.5	5930	233.5	5930

**Table 15. Dimensions — 375 to 550 ton units (continued)**

Unit Size (tons)	375, 440		375, 440		380, 450		500, 550	
	Standard		Extended <sup>(a)</sup>		Standard		Standard	
Dimension	in	mm	in	mm	in	mm	in	mm
D	298.7	7588	298.7	7588	351.6	8930	351.6	8930
E	377.5	9588	377.5	9588	430.3	10930	430.3	10930
F	474.4	12050	495.6	12588	548.4	13930	548.4	13930
G	77.2	1962	77.2	1962	77.2	1962	77.2	1962
H	196.5	4990	196.5	4990	249.3	6332	249.3	6332
I	332.9	8455	332.9	8455	385.7	9797	385.7	9797
J	460.6	11700	490.4	12455	543.2	13797	543.2	13797
K	498.9	12671	551.7	14012	604.5	15355	604.5	15355
L <sup>(b)</sup>	517.5	13146	570.4	14487	623.2	15829	623.2	15829
M	200.7	5098	200.7	5098	253.5	6440	253.5	6440
N	333.9	8480	333.9	8480	386.7	9822	389.8	9902
O	200.7	5098	200.7	5098	253.5	6440	253.5	6440
P	200.7	5098	200.7	5098	253.5	6440	253.5	6440

<sup>(a)</sup> Extended Length Units are defined model number digit 44 = L and model number digit 9: 380 = C, 400=D, 575 = F or model number digit 9: 380 = C, 400 = D ,575 = F.

<sup>(b)</sup> Total unit length includes additional extruded features such as circuit breaker handles.

# Dimensions and Weights

Figure 12. Dimensions — 375 to 550 ton units with direct-free cooling

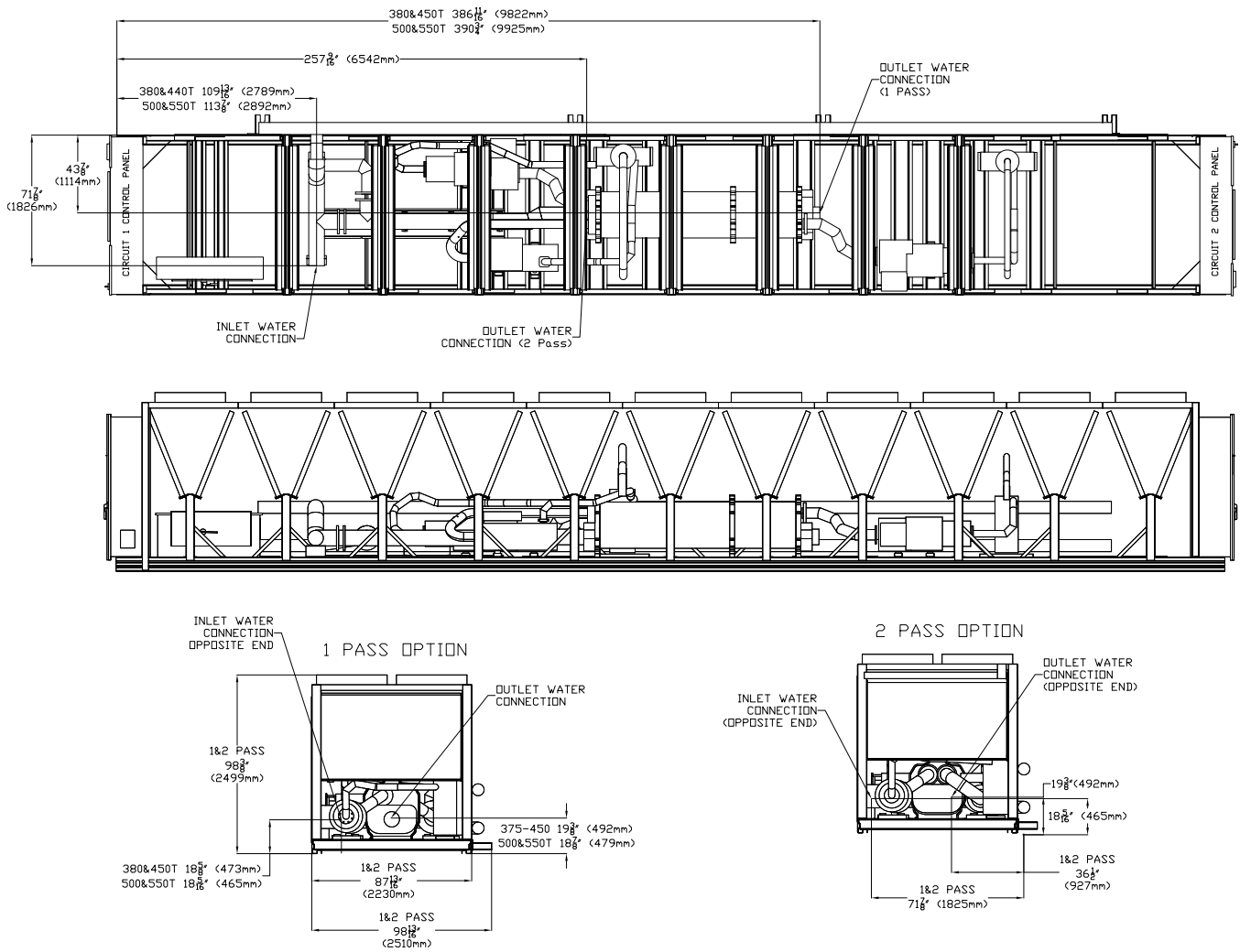



# Mechanical Specifications

## Certified AHRI Performance

The Air-Conditioning, Heating, and Refrigeration Institute (AHRI) is the trade association representing manufacturers of heating, ventilation, air conditioning, commercial refrigeration (HVACR), and water heating equipment. Trane air-cooled chillers participate in the AHRI Product Performance Certification Program, under AHRI Standard 550/590 (I-P): Performance Rating of Water-chilling and Heat Pump Water-heating Packages Using the Vapor Compression Cycle, ensuring product performance. Reference the AHRI Directory of Certified Product Performance ([www.ahridirectory.org](http://www.ahridirectory.org)) for performance certified equipment. The applications in this catalog specifically excluded from the AHRI certification program are:

- Custom Units.
- Units produced outside of the USA for installations outside the USA.
- Evaporatively-cooled chillers.
- Units with evaporators that use fluid other than fresh water except units containing freeze protection fluids in the evaporator with a leaving chilled fluid temperature above 32°F (0°C) are certified when rated per the Standard with water.

## Refrigeration Circuits

All chiller sizes are designed with two refrigerant circuits.

Each refrigeration circuit includes one or two rotary screw compressor(s), a compressor suction and discharge service valve(s), liquid line shutoff valve(s), removable core filter(s), liquid line sight glass with moisture indicator(s), charging port and an electronic expansion valve(s). Fully modulating variable volume ratio compressors and electronic expansion valves provide variable capacity modulation over the entire operating range.

## Evaporator

The evaporator is a tube-in-shell heat exchanger design constructed from carbon steel shells and tubesheets with internally and externally finned seamless copper tubes mechanically expanded into the tube sheets. The evaporator is designed, tested and stamped in accordance with the ASME Boiler and Pressure Vessel Code for a refrigerant side working pressure of 200 psig. The evaporator is designed for a water side working pressure of 150 psig. Standard water connections are grooved for Victaulic style pipe couplings, with groove to flange style adapters available.

Available pass and tube arrangements vary with unit size.

- For 150 to 330 ton units, waterboxes are available in 2 and 3 pass configurations.
- For 375 to 550 ton units, multiple tube types are available to allow tailoring of waterside pressure drop to a wide range of flow conditions. Waterboxes are available in 1 and 2 pass configurations.

All waterboxes include a vent, a drain and fittings for temperature control sensors.

Evaporators are insulated with 3/4 inch closed cell insulation. Evaporator water heaters with thermostat are provided to help protect the evaporator from freezing at ambient temperatures down to -20°F (-29°C). A factory installed flow switch is installed on the supply waterbox in the evaporator inlet connection.

## Condenser and Fans

Condenser configuration is dependent on unit size.

The condenser cassette consists of two all aluminum brazed fin construction microchannel coils. Each cassette contains an integral subcooling section. The maximum allowable working pressure of the condenser is 350 psig.

Condenser fans are direct-drive vertical discharge. The condenser fan motors are permanent magnet motors with integrated drive to provide variable speed fan control for all fans and are designed with permanently lubricated ball bearings, internal temperature and current overload protection, and customer fault feedback as a standard product offering. The fan impeller is a nine bladed-shrouded fan made from heavy-duty molded plastic.

## Compressor and Lube Oil System

The rotary screw compressors used on 150 to 330 ton units are variable volume ratio semi-hermetic, direct drive with capacity control via a variable speed drive, rolling element bearings, differential refrigerant pressure oil flow and oil heater. The motor is a



## Mechanical Specifications

---

suction gas cooled, hermetically sealed, permanent magnet motor. An oil separator is provided separate from the compressor. Oil filtration is provided internal to the compressor.

For 375 to 550 ton units, circuits may include a second rotary screw compressor. This secondary compressor is semi-hermetic, direct drive, with rolling element bearings, differential refrigerant pressure oil flow, and oil heater. The motor is a suction gas cooled, hermetically sealed, two-pole squirrel cage induction motor.

## Unit Controls

All unit controls are housed in an outdoor rated weather tight enclosure with removable plates to allow connection of power wiring and remote interlocks. All controls, including sensors, are factory mounted and tested prior to shipment.

Microcomputer controls provide all control functions including start-up and shutdown, leaving chilled water temperature control, evaporator flow proving, compressor staging and speed control, electronic expansion valve modulation, condenser fan sequencing and speed control, anti-recycle logic, automatic lead/lag compressor starting, and load limiting.

### Symbio™ 800 Controller

The Symbio 800 controller is an application-specific, programmable controller that is factory installed and designed to control packaged HVAC equipment. A 7-inch user interface features a touch-sensitive color screen that provides facility managers with at-a-glance operating status, performance monitoring, scheduling changes and operating adjustments. Other advanced features include automated controller backup and optional features such as secure remote connectivity, wireless building communications, and custom programming with expandable I/O.

The Symbio 800 control module, utilizing Adaptive Control™ microprocessor, automatically takes action to avoid unit shutdown due to abnormal operating conditions associated with low refrigerant pressure, high condensing pressure, AFD/Compressor current overload, low oil return or low AFD cooling, low discharge superheat, and high compressor discharge temperature. Should the abnormal operating condition continue until a protective limit is violated, the unit will be shutdown.

Unit protective functions of the controller include: loss of chilled water flow, evaporator freezing, loss of refrigerant, low refrigerant pressure, high refrigerant pressure, high compressor motor temperature, and loss of oil to the compressor.

### BACnet® Communication Protocol

The Symbio 800 controller supports standard BACnet communication protocol through a RS485, two-wire communication link or BACnet/IP over Ethernet.

### Trane LonTalk® Communication Protocol

The LonTalk module provides an interface to a Tracer® building automation system or other control system that supports LonTalk and is factory installed, allowing for control and monitoring of the unit through a RS485, two-wire communication link. Requires an additional LonTalk Communication Kit to be installed.

### Modbus® Communication Protocol

The Symbio 800 controller supports standard Modbus RTU communication protocol through an RS485, two-wire communication link.

### Controls Expansion Hardware

Symbio 800 includes field applied controls capability. Factory installed expansion hardware (XM70) has 19 inputs/outputs. Additional expansions may be added in the field.

### Tracer® AdaptiView™ TD-7 Display

A full color Tracer® AdaptiView™ TD-7 touch screen display indicates all important unit and circuit parameters, in logical groupings on various screens. The parameters including chilled water setpoint, leaving evaporator temperature, demand limit setpoint, evaporator and condenser refrigerant temperatures and pressures, compressor and fan speeds, and all pertinent electrical information. The display also provides on screen data graphs of predefined parameters as well as customizable data graphs based on user defined parameters from a list of all available parameters. The display also provides indication of the chiller and circuits' top level operating modes with detailed sub-mode reports available with a single key press, as well as diagnostics annunciation and date and time stamped diagnostic history. The color display is fully outdoor rated, and can be viewed in full daylight without opening any control panel doors.

Standard power connections include main three phase power to the compressors, condenser fans and control power transformer and optional connections are available for the 115 volt/60 Hz single phase power for the thermostatically controlled evaporator heaters for freeze protection.

- Outdoor capable:

- UV Resistant Touchscreen
- Operating Temperature: -40°C to 70°C
- IP56 rated (Power Jets of Water from all directions)
- RoHS Compliant
- UL PAZX, Open Energy Management Equipment
- CE Certification
- Emissions: EN55011 (Class B)
- Immunity: EN61000 (Industrial)
- Display:
  - 7-inch diagonal
  - 800x480 pixels.
  - TFT LCD @ 600 nits brightness
  - 16 bit color graphic display
- Display Features:
  - Alarms
  - Reports
  - Unit Settings
  - Display Settings
- Graphing
- Global Application with Support for 27 Languages

## **Adaptive Frequency Drive**

The compressors on the ACR chillers are driven by Adaptive Frequency Drives (AFD). The drives include custom programming for Trane application to provide chiller specific protections and stable compressor operation across the operating map. Protections include compressor overload, low or high line voltage, output phase loss, input phase loss, drive overheating, and more. The drives communicate over a serial connection (Modbus®) to the Symbio™ 800 unit control module for run-time control, real-time data feedback, and diagnostics.

## **Chilled Water Reset**

Control logic and factory installed sensors are provided to reset leaving chilled water temperature. The set point can be reset based on ambient temperature or return evaporator water temperature.



# Options

## Application Options

### Free-Cooling

The free-cooling option delivers optimal performance by minimizing compressor operation when outdoor air temperatures are low enough to assist in cooling the chilled fluid loop.

*Note: Glycol solution must be used in the customer chilled fluid loop for the direct free-cooling options.*

### Ice Building

The ice building option provides special control logic to handle low temperature brine applications (less than 40°F [4.4°C] leaving evaporator temperature) for thermal storage applications.

### Low Temperature Fluid

Low temperature option provides special control logic to handle low temperature brine applications including part load conditions below 40°F (4.4°C) leaving evaporator temperature.

### Low Ambient Option

The low ambient options adds hardware and unit controls to allow start and operation down to ambient temperatures of 0°F (-17.7°C).

### Extreme Low Ambient Option

The extreme low ambient option adds hardware and unit controls to allow operation down to ambient temperatures of -20°F (-28.9°C).

### High Ambient Option

High ambient option consists of special control logic, compressor motors, and variable speed drives to permit high ambient (up to 125°F [51°C]) operation. Low side ambient remains 32°F (0°C).

### Wide Ambient Option

The wide ambient option combines the features of low and high ambient options for an ambient range of 0 to 125°F (-17.7 to 51°C).

## Electrical Options

### Circuit Breaker

A HACR rated molded case capacity circuit breaker (UL approved) is available. Circuit breaker can also be used to disconnect chiller from main power with a through-the-door handle.

### Harmonic Attenuation

Harmonic attenuation to comply with IEEE 519 and achieving 5% TDD when ISC/ILOAD 20. (Reference IEEE-519-2014, table 2.) It is important to recognize that IEEE 519 as a guideline relates to the entire system, not specifically to any one load or product. IEEE 519 establishes requirements at the point of common coupling (PCC) where the building connects to the utility system. The standard contains no specific requirements for the internal electrical loads. Even though Trane AFD-equipped chillers will attenuate their own harmonics, other nonlinear loads on the same system could still create harmonic problems. In buildings where harmonics might be a concern, Trane recommends conducting a power-distribution system analysis to determine if there is a need to further attenuate harmonics at the system level.

## Control Options

### BACnet® Communications Interface

Allows the user to easily interface with BACnet via a single twisted pair or Ethernet wiring to a factory installed and tested communication board.

## **LonTalk® Communications Interface**

Provides the LONMARK® chiller profile inputs/outputs for use with a generic building automation system via a single twisted pair wiring to a factory installed and tested communication board.

## **Modbus® Communications Interface**

Allows the user to easily interface with Modbus® via a single twisted pair wiring to a factory installed and tested communication board.

## **Remote Input Options**

Option permits remote chilled liquid setpoint, remote demand limit setpoint, or both by accepting a 4-20 mA or 2-10 Vdc analog signal.

## **Remote Output Options**

Permits alarm relay outputs, chiller Percent Capacity via a 2–10VDC signal, or both.

## **Sound Options**

### **InvisiSound Standard with Noise Reduction**

For InvisiSound Standard with Noise reduction, each variable speed rotary screw compressor will have a muffler as standard, and reduces the maximum speed (adjustable) of the condenser fans.

### **InvisiSound Superior with Noise Reduction**

In addition to the sound reducing features on the InvisiSound Standard, Superior with Noise Reduction adds insulating sound material to the suction and discharge lines of each refrigerant circuit, a pre-formed “sound box” encapsulating each compressor, and reduces the maximum speed (adjustable) of the condenser fans.

### **InvisiSound Ultimate (150 to 330 ton units only)**

In addition to the sound reducing features on the Superior option, the Ultimate unit adds a flexible, metallic connection at the suction and discharge of each compressor, a pre-formed “sound box” encapsulating each compressor, and reduces the maximum speed (adjustable) of the condenser fans.

## **Other Options**

### **Architectural Louvered Panels**

Louvered panels cover the entire condensing and free cooling coils and service area beneath the coil box assembly.

### **Coil Corrosion Protection**

CompleteCoat™ is available on all size units for corrosion protection. Job site conditions should be considered to determine the need to order coating to inhibit coil corrosion and ensure extended equipment life. CompleteCoat™ option provides fully assembled coils with a flexible dip and bake epoxy coating.

### **Convenience Outlet**

This option provides a 20A, 115V 60Hz, convenience outlet on the unit. The electrical contractor must make a separate connection to this device unless the unit was ordered with the 3-phase to single phase 115V transformer for this feature. See model number, schematics and submittal for details.

### **Factory Mounted Flow Measurement**

The factory mounted flow measurement system is provided to give a flow output to the display and customer BAS. The flow measurement is not used to control the chiller. This option is only available if a factory mounted pump package is ordered.

### **Flanged Water Connection Kit**

Provides raised face flanges to convert grooved pipe evaporator water connections to flange connectors.



## Options

---

### Insulation for High Humidity

The evaporator is covered with factory-installed 1.25 inch (31.8 mm) Armaflex II or equal ( $k=0.28$ ) insulation.

### Isolators — Elastomeric

Elastomeric Isolators provide isolation between chiller and structure to help eliminate vibration transmission. Elastomeric isolators are required with the InvisiSound™ Ultimate option.

### Single High Head Pump Package

The pump package contains a single pump, triple duty valves, service isolation valves, pressure ports, air separator, expansion tank, and fluid strainer.  $-20\text{ }^{\circ}\text{F}$  ( $-29\text{ }^{\circ}\text{C}$ ) ambient freeze protection for water is included.

The pump skid contains an independent pump motor starter panel. The pump starter panel's power supply is prewired into the chiller's control panel assembly, an independent pump motor power supply is not required. Variable pump speed command is integrated with the chiller controller allowing variable flow functionality. Harmonic filtration is standard.

Pump package applications include short loops, decoupled systems and service for an entire loop volume. Because the fluid distribution system beyond the chiller is unknown, Trane Select Assist reports Available Head as the head leaving the chiller at the system supply connection point. Available Head includes the evaporator head loss, pump package and free cooling piping frictional effects head losses, valve head losses, air separator head loss, and strainer head loss summation.

The pump package should not be operated at  $\text{NPSH}_R$ . Operation at this suction head will cause cavitation.  $\text{NPSH}_A$  should be at least 1.5 to 2.5 times  $\text{NPSH}_R$ .

### Seismically Rated Unit – IBC

The unit is built and certified for seismic applications in accordance with the following International Building Code (IBC) releases; 2012, 2015, 2018, and 2021.

### Seismically Rated Unit – OSHPD

The unit is built and certified for seismic applications in accordance with the following International Building Code (IBC) releases; 2012, 2015, 2018, and 2021 and California building Code (CBC) release 2022.

### Wind Load for Florida Hurricane

The unit is built and certified to meet the requirements of International Building Code (IBC) 2018 and 2021 for 116 mph wind speed, Exposure 'C', Risk Category III. This unit is certified for both ground mounted units, and units mounted on rooftops up to 15 ft. Certified wind speeds decrease with increase in building height. Refer to VMA-54288-02 for certified wind speeds at varying heights.





Notes

---





The AHRI Certified mark indicates Trane U.S. Inc. participation in the AHRI Certification program. For verification of individual certified products, go to [ahridirectory.org](http://ahridirectory.org).

Trane - by Trane Technologies (NYSE: TT), a global innovator - creates comfortable, energy efficient indoor environments for commercial and residential applications. For more information, please visit [trane.com](http://trane.com) or [tranetechnologies.com](http://tranetechnologies.com).

Trane has a policy of continuous product and product data improvements and reserves the right to change design and specifications without notice. We are committed to using environmentally conscious print practices.